

LORTONE

6" & 8" Stainless Steel Grinding & Polishing Arbors

Instructions and Parts List



Ideal for lapidary and glass work, Lortone Arbors are used for grinding and polishing. Their widely spaced wheel centers are easy to use and can accommodate a variety of grinding/polishing wheels and drums. We use a sturdy welded stainless steel frame and smooth running rubber mounted bearings for quiet operation. Tapped shaft ends make installing spin-on polish heads simple. Requires the use of an overhead drip or pump fed coolant system. Motor and wheels not included.

- Comfortable, widely spaced wheel centers
- Clean, Quiet and efficient
- Sturdy stainless steel frame
- Replaceable rubber mounted bearings for quite operation

SETTING UP YOUR MACHINE

- Check the parts list to make sure all parts are included. If any parts are missing, please contact your dealer or the factory immediately.

Note: Unit does not come with a drive motor. It may be purchased separately.

- Fasten the rubber feet to the bottom corners of the machine and under the motor mount.
- Place unit on a clean, sturdy work table.

MOTOR INSTALLATION

- Secure motor to motor mount with bolts provided.
- Place motor pulley on the motor shaft and tighten set screw securely.
- Install belt and adjust motor for correct belt alignment and tension. Do not overtighten the belt as this will lead to excessive noise and premature bearing wear.

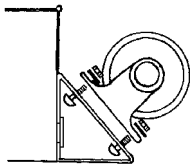

Secure motor to mount with bolts.

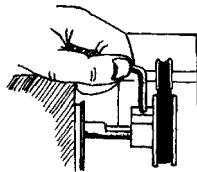

Slide pulley onto shaft and tighten securely.

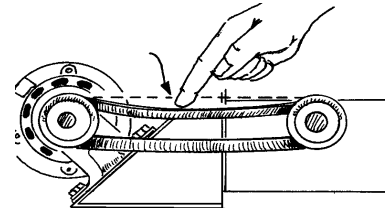

Adjust belt tension to about 3/4".

WHEEL & BELT INSTALLATION

- Carefully install belts on drums. Slightly compress the drums if required.
- Install the drums & wheels on the shaft using the flanges and spacer provided. Flanges must be installed with the concave side toward the grinding wheel or expandable drum. Note the proper direction of rotation.
- Install spacers between wheels as needed and tighten the threaded nuts securely.
- Polish heads may be installed on either side depending upon your preference.

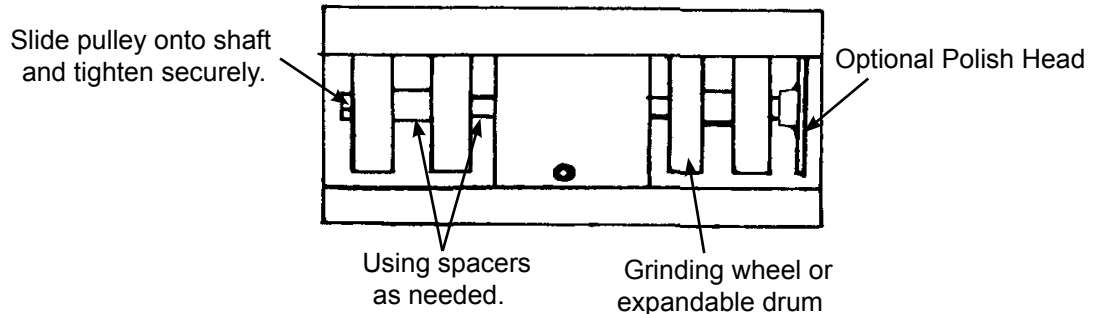

CAUTION!

Do not run drums without belts in place. Failure to follow instructions can result in damage to the machine or serious injury.

OPERATION

- Do Not Operate Without Water! Using this machine without water can generate significant amounts of dust and result in reduced life of sanding belts and wheels.
- A gravity feed water system (Fig. 1) or an under wheel water spitter with pump (Fig. 2) should be used to supply water to the wheels during operation.
- Always wear eye protection and dust mask when using equipment. Failure to do so can result in severe injury or illness.
- Turn on motor and run arbor up to speed prior to applying water to wheels.
- After use, turn water source off and run wheels and drums for several seconds to remove excess water.
- Drain unit and wipe dry after use. If desired, a drain system can be attached for continuous draining during use (Fig. 3). If water will be left in machine, add a small amount of rust inhibitor.

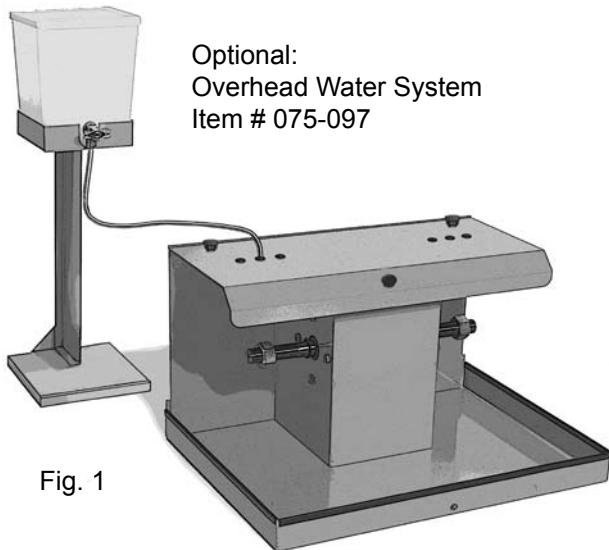

Optional:
Overhead Water System
Item # 075-097

Fig. 1

CAUTION
Do not operate without water.
Injury to operator or damage to
belts and wheels may occur.

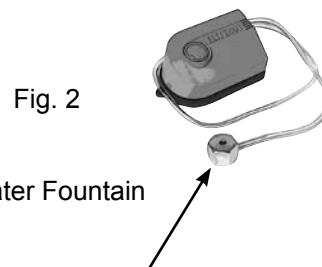

Fig. 2

Optional:
Underwheel Water Fountain
Item # 075-096

If using a spitter head, fill unit with 1/2" of water
and position spitter head below wheel in use.

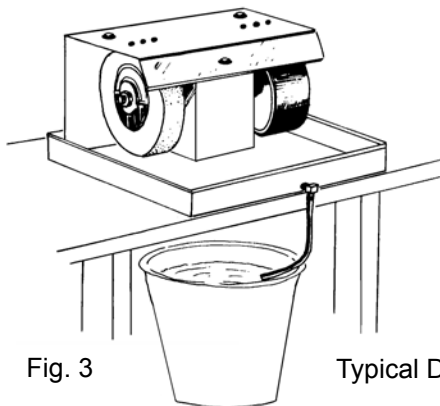
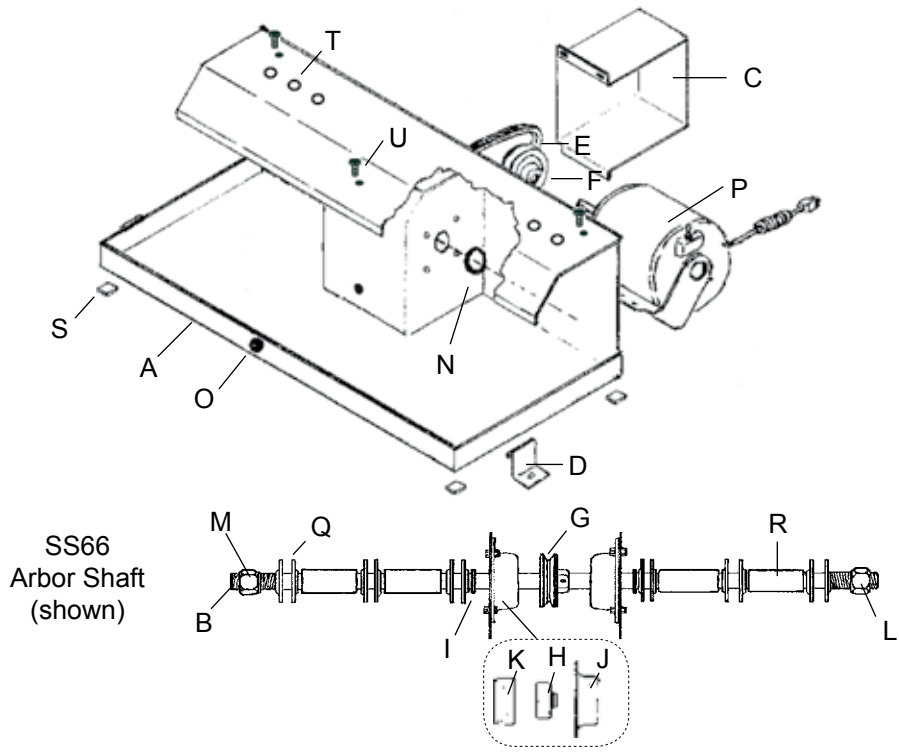

Fig. 3

Typical Drain System



Part No.	Description	Model				
		SS62	SS64	SS66	SS82	SS84
A	Frame	031-100	032-100	033-100	030-100	034-100
B	Arbor Shaft	037-001	036-001	046-003	037-001	036-001
C	Belt Guard	039-205	039-205	039-205	038-205	038-205
D 033-025	Hold Down Clip	2	2	2	2	2
E	Drive Belt	210-030	210-030	210-030	210-031	210-031
F 211-013	Motor Pulley, 2 1/2" x 1/2"	1	1	1	1	1
G 211-015	Arbor Pulley, 2 1/2" x 3/4"	1	1	1	1	1
H 200-006	Arbor Bearing w/ locking collar	2	2	2	2	2
I 206-023	Retaining Ring	2	2	2	2	2
J	Bearing Hat (2)	041-004	041-004	063-008	063-008	063-008
K 240-069	Rubber Bearing Isolator	2	2	2	2	2
L 481-026	Hex Nut, 3/4-16 RH	1	1	1	1	1
M 481-046	Hex Nut, 3/4-16 LH	1	1	1	1	1
N 217-020	Insulating Bushing	2	2	2	2	2
O	Drain Tube w/ brass fitting	1	1	1	1	1
P 300-022	1/3 HP Motor (optional)	-	-	-	-	-
Q 101-013	Plated Flange, 2" x 3/4"	4	8	12	-	-
Q 101-023	Plated Flange, 3" x 3/4"	-	-	-	4	8
R 105-002	1/4" Aluminum Spacer	2	2	-	2	2
R 105-006	3/4" Aluminum Spacer	2	2	-	2	2
R 105-008	1" Aluminum Spacer	2	2	-	2	2
R 105-010	1-1/2" Aluminum Spacer	-	2	-	-	2
R 105-013	2" Aluminum Spacer	-	2	4	-	2
S 209-006	Foot	6	6	6	6	6
T 320-006	Grommets	4	10	10	6	10
U 290-015	Thumb Screw	3	3	3	3	3