

# SEWAGE TREATMENT – TECHNOLOGIES

# Types of contaminants in Sewage

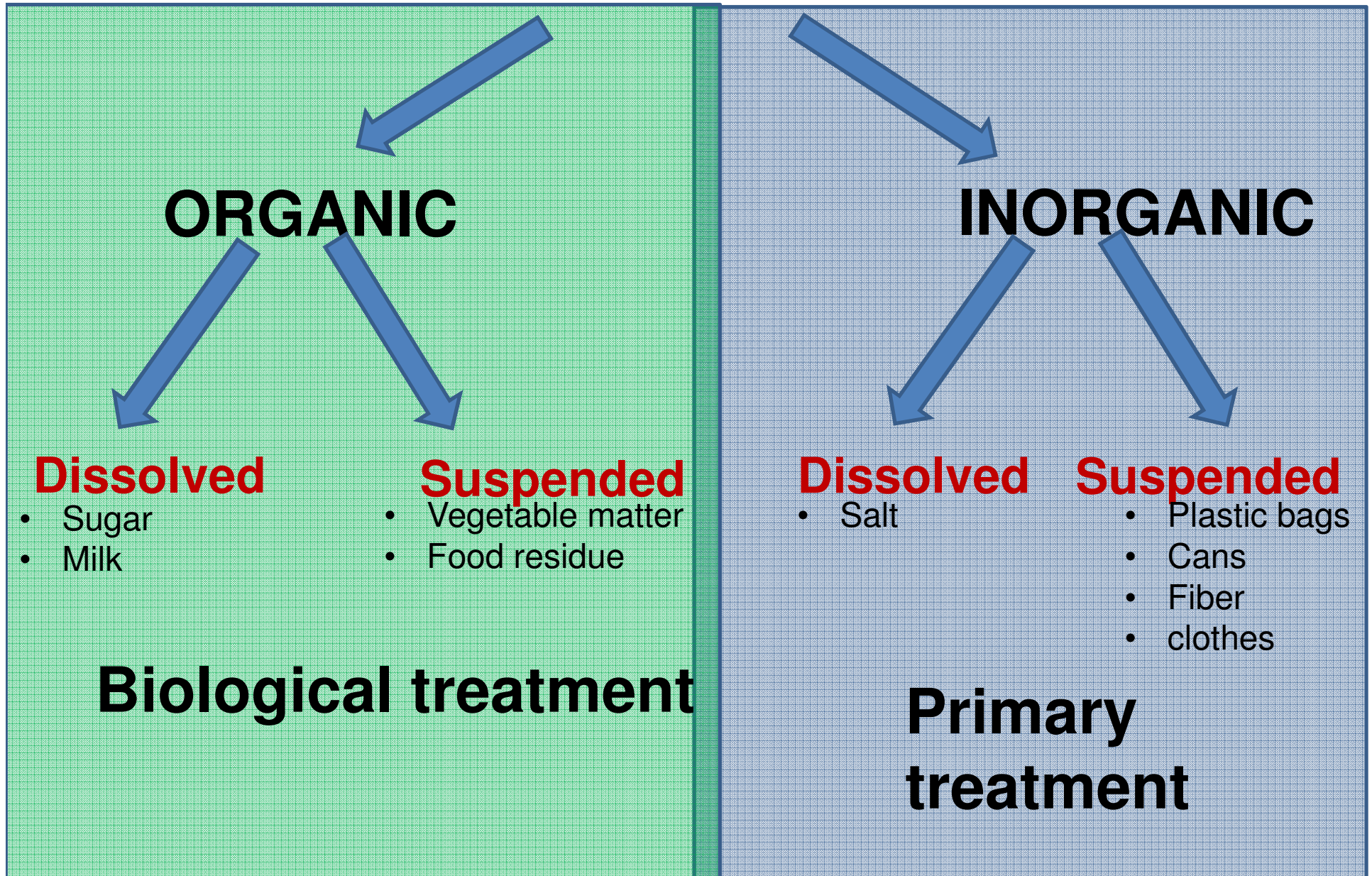

## Important Waste Water Contaminants

Sl. No	Contaminant	Source	Environmental significance
1	Suspended solids	Domestic use, industrial wastes	Cause sludge deposits and anaerobic condition in aquatic environment
2	Biodegradable organic	Domestic use , industrial wastes	Cause biological degradation
3	Pathogens	Domestic water	Transmit communicable disease
4	nutrients	Domestic and industrial waste	Cause eutrophication
5	Refractory organics	Industrial waste	Cause taste and odour problems

# Pollutants in sewage

- BOD(Bio Chemical Oxygen demand)
- COD(Chemical Oxygen demand)
- TSS(Total Suspended Solids)
- PH

### **BOD(Biochemical Oxygen demand)**

The BOD is an important measure of water quality .It is measure of the amount of oxygen needed by bacteria and other organisms to oxidize the organic matter present in a water sample over a period of 5 days at 20 degree C.

### **COD (Chemical Oxygen Demand)**

- COD Measures all organic carbon with the exception of some aeromatics (BENZENE,TOLUENE,PHENOL etc.) which are not completely oxidized in the reaction.
- COD is a chemical oxidation reaction
- Ammonia will not be oxidized.

### **Total Suspended Solids**

- Total suspended solids(TSS) include all particles suspended in water which will pass through a filter.

- As levels of TSS increase, a water body begins to lose its ability to support a diversity of aquatic life.
- Suspended solids absorb heat from sunlight, which increases water temperature and subsequently decreases levels of dissolved oxygen (warmer water holds less oxygen than cooler water)

# STANDARDS OF RAW/ TREATED SEWAGE

Sr. No.	Parameter	Public Sewers	Treated Effluent	
			After secondary treatment	After tertiary treatment
1	pH value	5.5 – 9.0	5.5 – 9.0	5.5-9.0
2	Oil and grease, mg/l max	20	10	2
3	Total residual chlorine, mg/l max	–	1.0	0.5
4	Ammonical nitrogen (as N),mg/l, max	50	50	6
5	Total kjeldahl nitrogen (as N);mg/l, max. mg/l, max	–	100	16
6	Free ammonia (as NH <sub>3</sub> ), mg/l, max	–	5.0	6
7	Biochemical oxygen demand (3 days at 27°C), mg/l, max	350	30	<5
8	Chemical oxygen demand, mg/l, max	–	250	50
9	Suspended solids mg/l, max	600	100	8.00

# Components of Sewage Treatment Plants

- Pumping of Sewage
- Primary Treatment
- Secondary treatment
- Tertiary Treatment



# Typical Flow Diagram of Sewage Treatment Plant

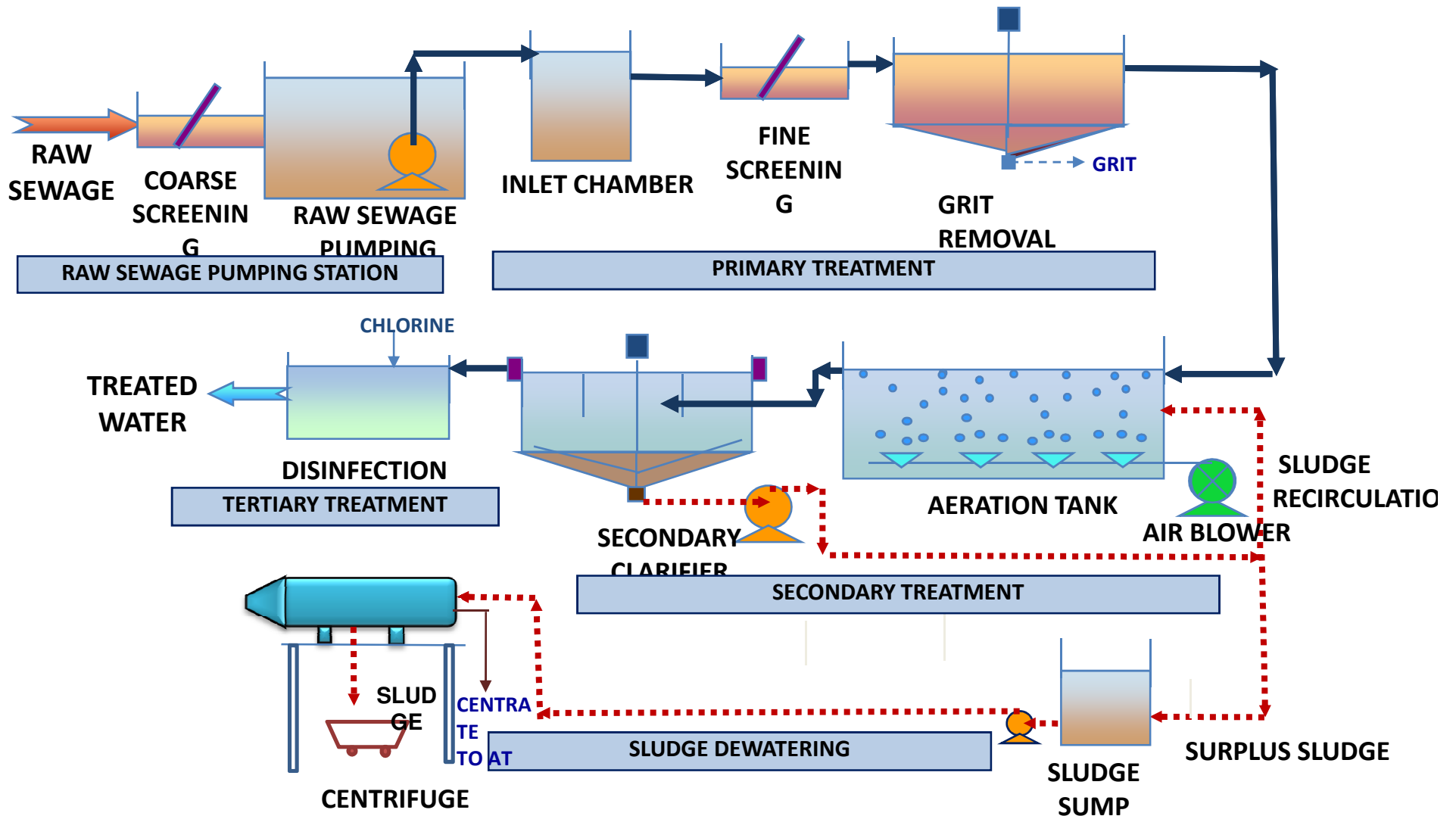

# Pumping Station

- Receiving Chamber
- Coarse Screening
- Wet Well (Raw Sewage Sump)
- Pump House
- Raw Sewage Pumps

# SELECTION OF PUMPS FOR RAW SEWAGE

- FOR MAIN PUMPING STATION (MPS) I:S. 5600-2005  
NUMBER OF PUMPS REQUIRED (INCLUDING STANBY)
  - 2 No. of  $\frac{1}{2}$  DWF
  - 2 No. of 1 DWF
  - 1 No. of 3 DWF
- FOR INTERMEDIATE PUMPING STATION (IPS)  
NUMBER OF PUMPS REQUIRED (INCLUDING STANBY) FOR CAPACITY OF PUMPING STATION UPTO 3 MLD
  - 1 No. of 1 DWF
  - 1 No. of 2 DWF
  - 1 No. of 3 DWF  
NUMBER OF PUMPS REQUIRED (INCLUDING STANBY) FOR CAPACITY OF PUMPING STATION ABOVE 3 MLD
  - 2 No. of  $\frac{1}{2}$  DWF
  - 2 No. of 1 DWF
  - 1 No. of 3 DWF

# VELOCITY CONSIDERATION IN DESIGN OF PUMPING (RISING) MAIN FOR PUMPING SEWAGE

- The size of Rising main should be designed after taking into consideration that:

Maximum velocity at peak flow should not exceed 2.7 m/s.

Minimum velocity at low flows should not be less than 1 m/s.

# Pumping Station with submersible pump set

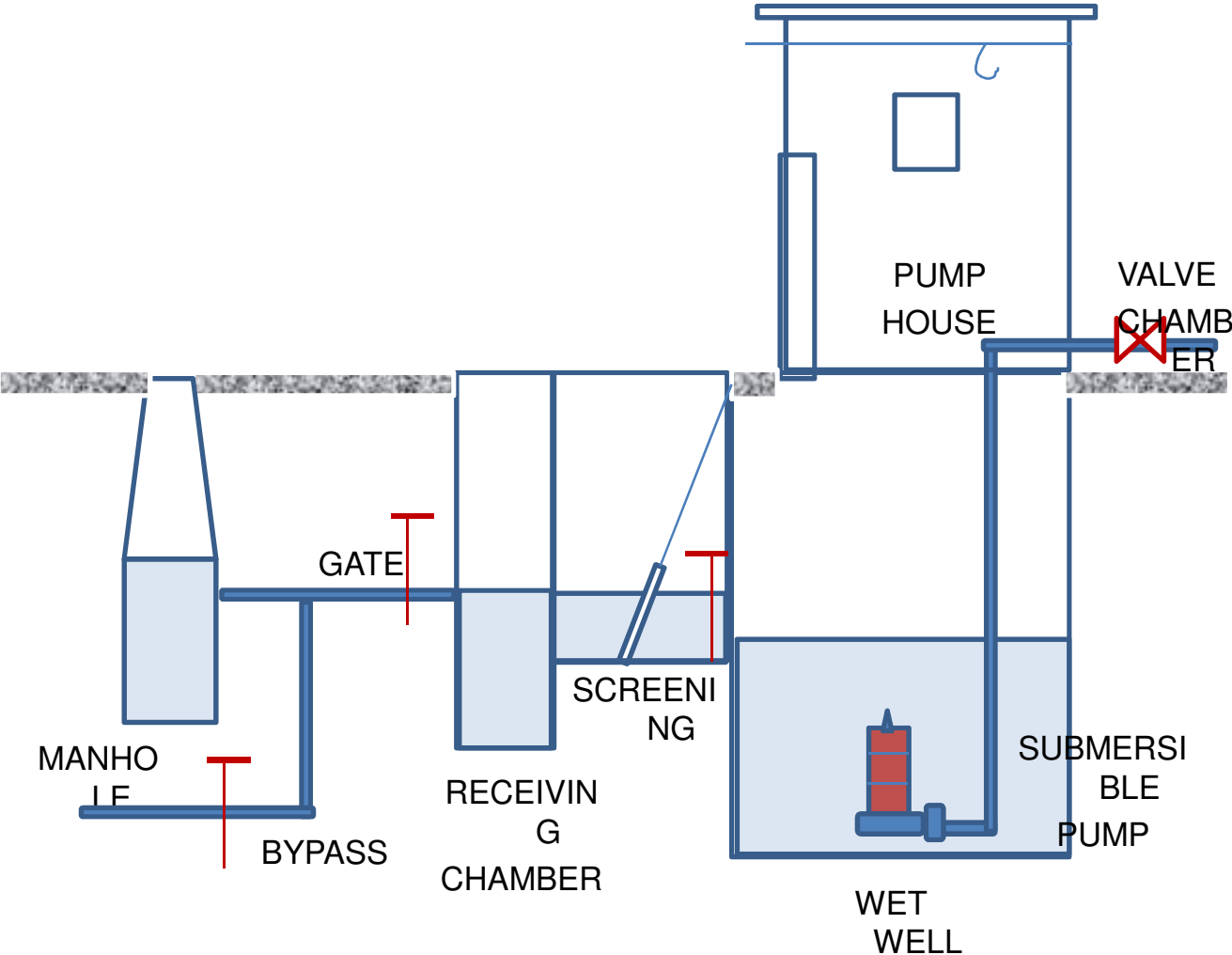

# Pumping Station with Centrifugal Pump set

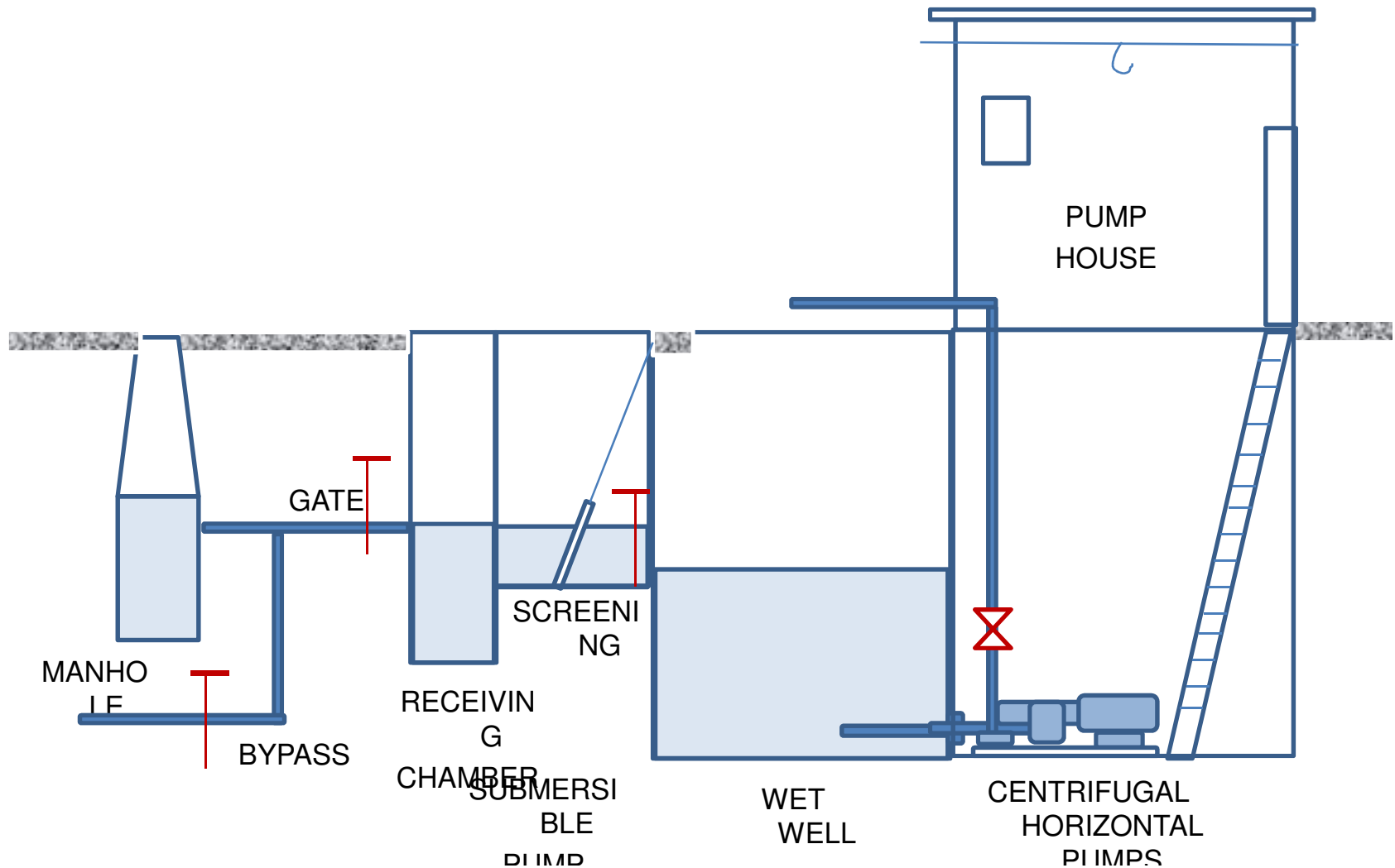

# Primary Treatment

- Fine Screening
- Grit Removal
- Primary Clarification

# Screening

- Objective : Removal of coarse solids
- Types of screens : Fine / medium / coarse
- Cleaning of screens : Manual / mechanical
- Benefits : Protection of pumps
- Coarse Screening : 20mm clear spacing in bars
- Fine screening : 6mm clear spacing in bars



# Screening

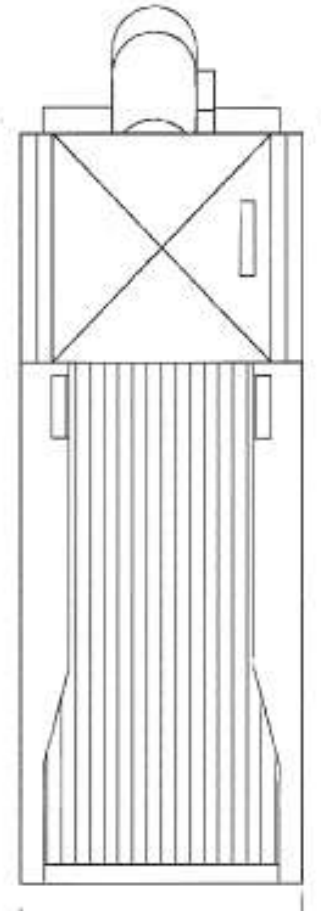
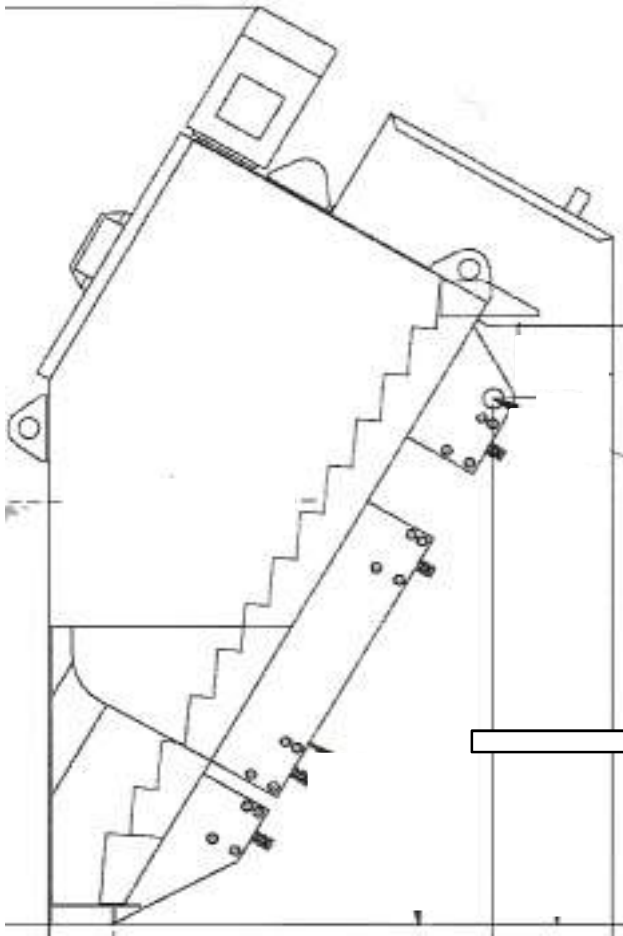

# Screening



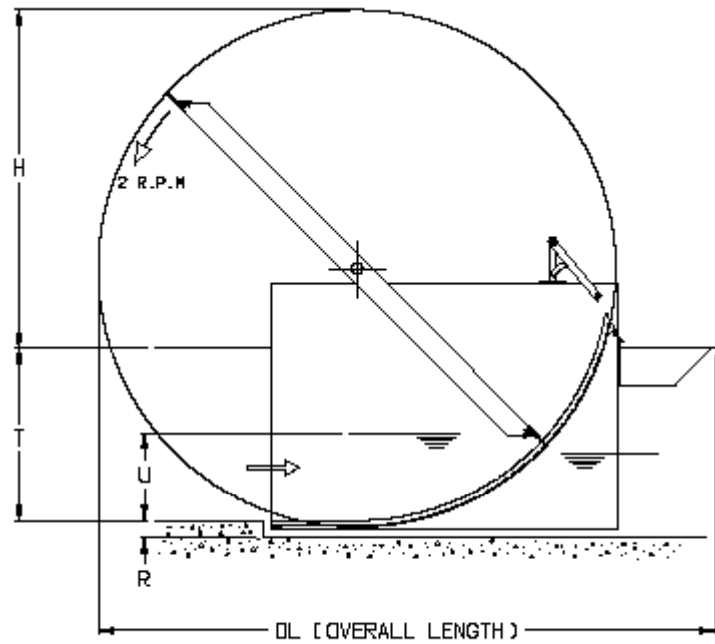

**ARC BAR SCREEN**

# Primary Treatment

## Grit Removal

- Objective : Removal of inorganic solids eg. ebbles/ sand/ Silt to protect moving mechanical equipment
- Principle : Gravity separation (a) effective size 0.15 mm (b) specific gravity – 2.65
- Types : Manual grit removal - Rectangular channel  
Mechanical grit removal - Circular tank
- Grit removal Mechanism : Screw classifier / reciprocating classifier

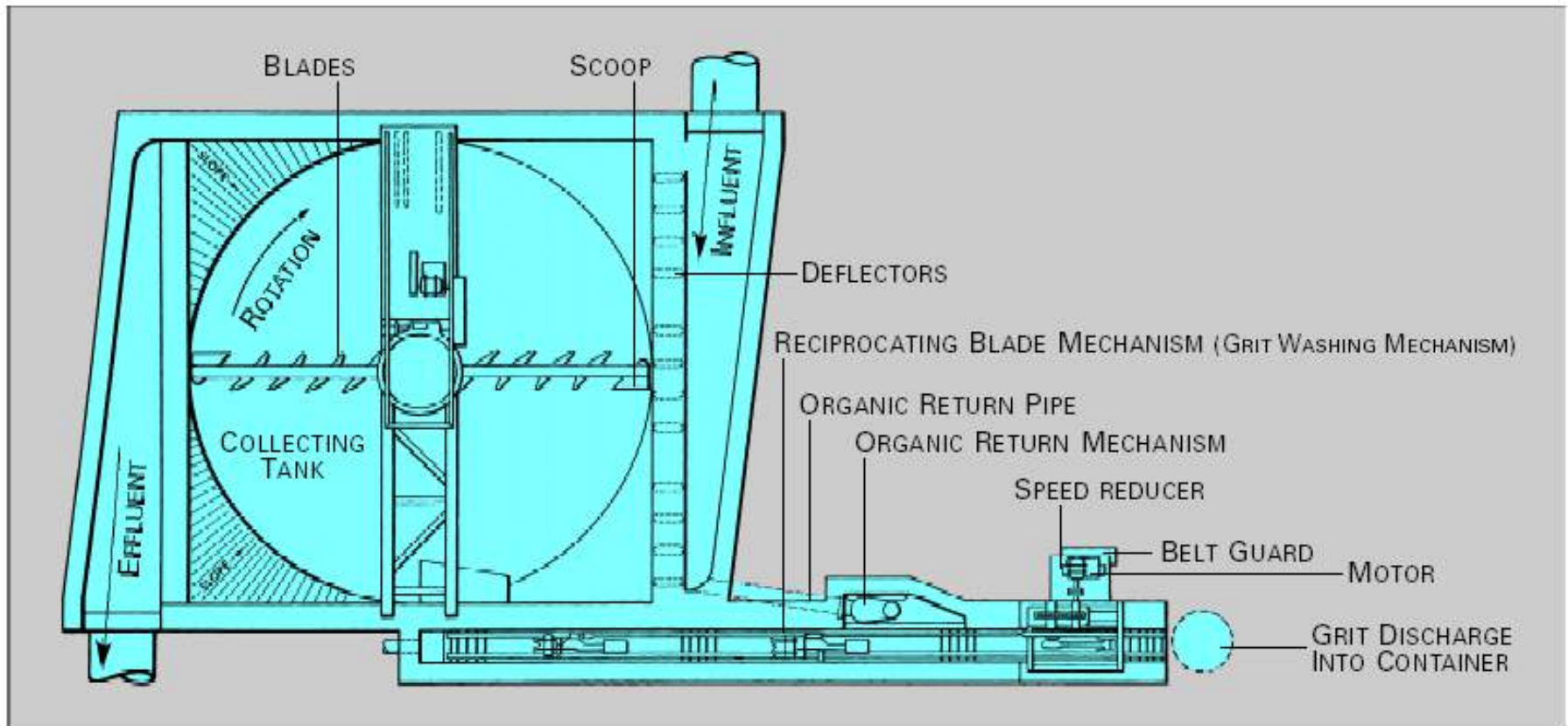

**MECHANICALLY CLEANED GRIT CHAMBER WITH ORGANIC WASHER**



# Grit Removal



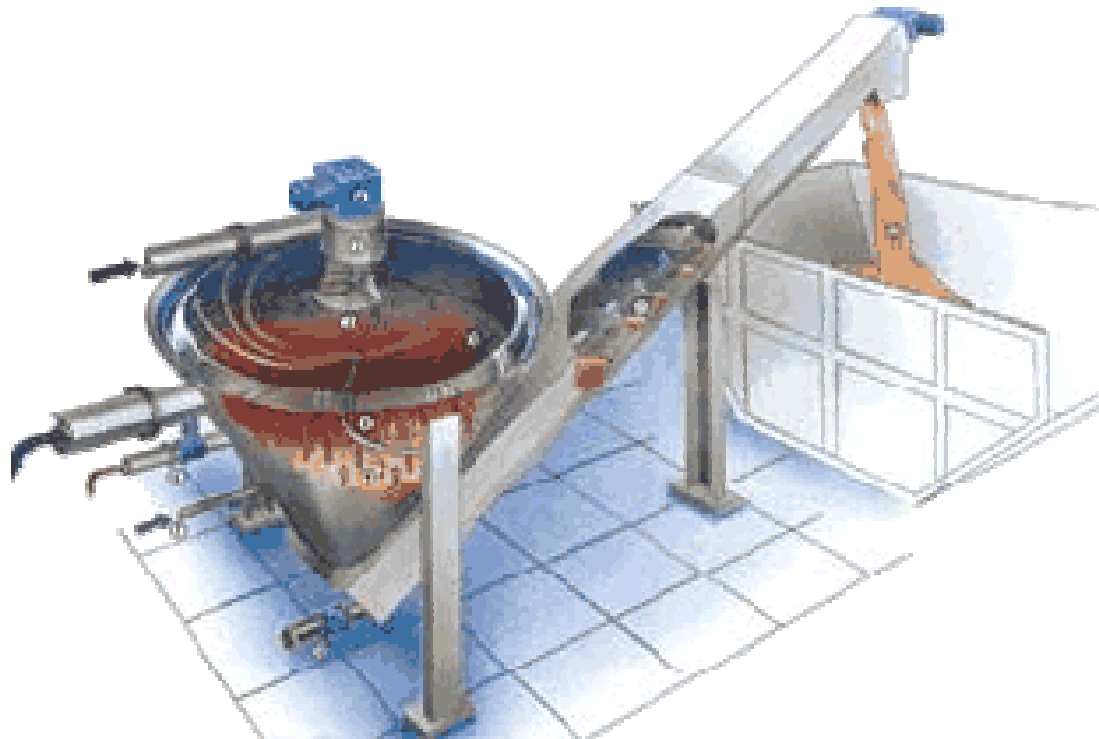

**GRIT CHAMBER WITH CLASSIFIER & WASHER**

# Secondary Treatment

Biological treatment



# Sewage Treatment

## Method of Treatment-Aerobic, Anaerobic.

- **Aerobic**-Sewage treatment in the presence of Oxygen-MBBR, SBR-where aerators/blowers are installed-generally no smell during treatment.
- **Anaerobic**-Sewage treatment in the absence of Oxygen-UASB-No aerators/blowers are required-foul smell during treatment.

## VARIOUS SEWAGE TREATMENT TECHNOLOGIES

- Activated Sludge Process (ASP)
- Upflow Anaerobic Sludge Blanket Reactor (UASB)
- Moving Bed Biofilm Reactor (MBBR)
- Sequential Batch Reactor (SBR)

# Activated Sludge Process - ASP

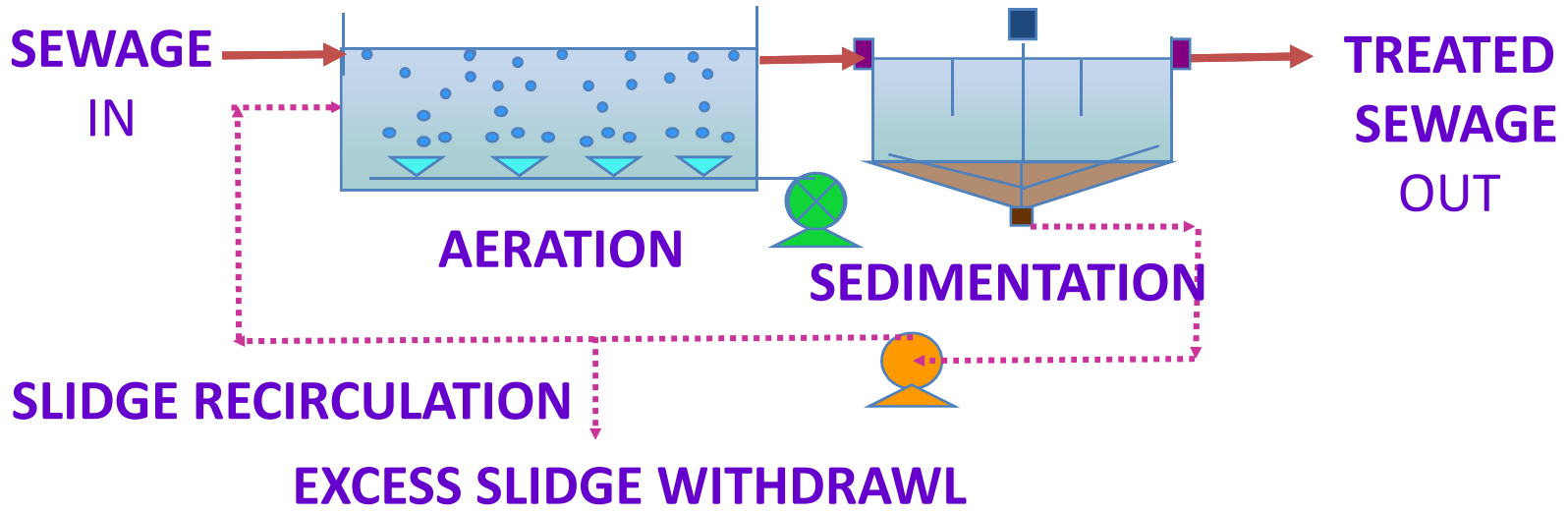

- Raw Effluent In
- Aeration
- Sedimentation
- Treated water out
- Sludge Recirculation
- Sludge withdrawal

# ASP - Flow Diagram

## PC-AT-SC-CHL

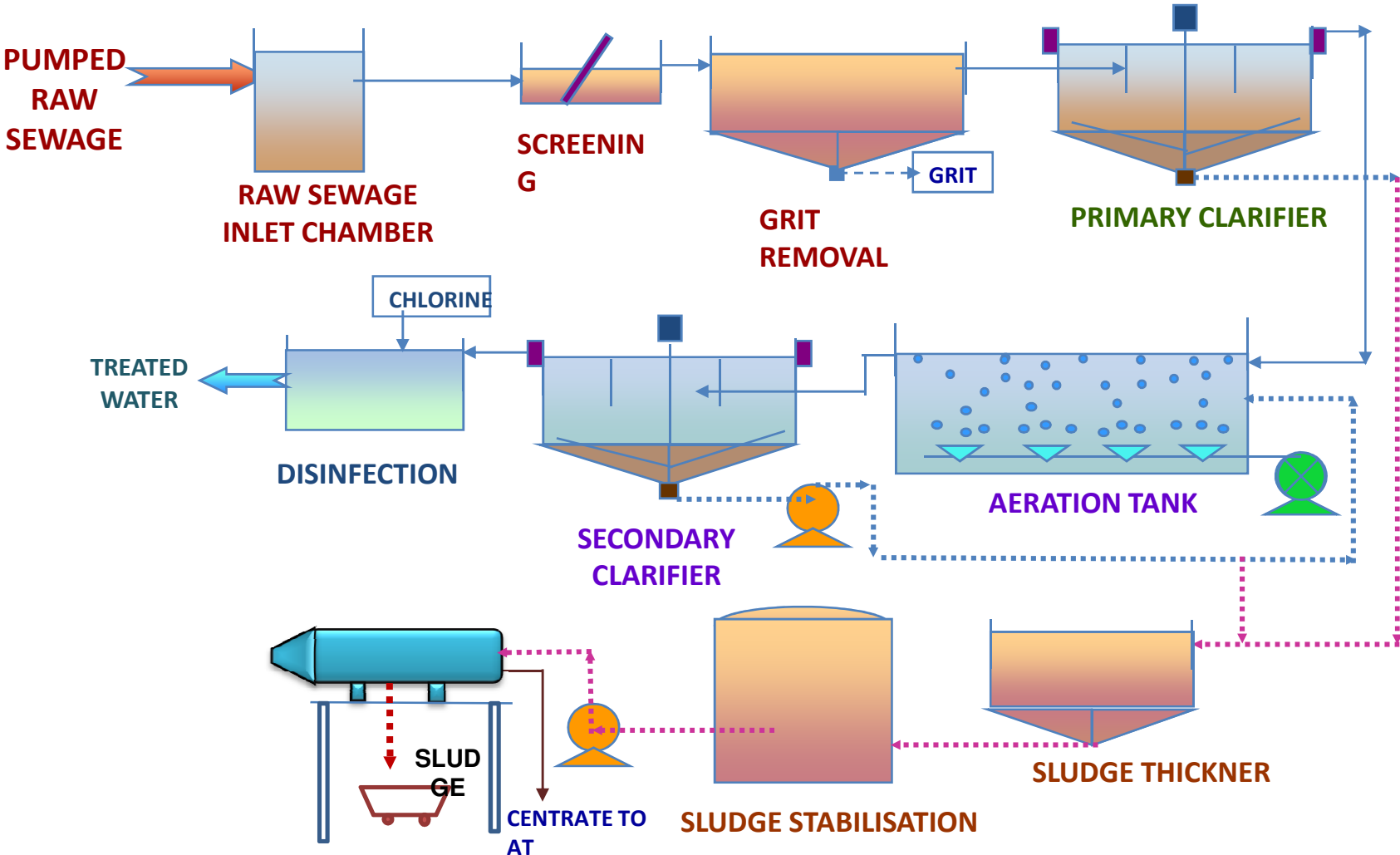

# Activated Sludge Process (ASP) Technology

- An activated sludge plant essentially consists of the following:
  - 1) Aeration tank containing micro organisms in suspension in which reaction takes place.
  - 2) Activated sludge recirculation system.
  - 3) Excess sludge wasting and disposal facilities.
  - 4) Aeration systems to transfer oxygen
  - 5) Secondary sedimentation tank to separate and thicken activated sludge.

# ASP

- **Advantages**
  - Can **sustain seasonal variation**
  - **Less land** requirement **than UASB**
- **Disadvantages**
  - **High energy** consumption
  - **Foaming**, particularly in winter season, may adversely affect the oxygen transfer, and hence performance
  - Requires elaborate **sludge digestion** /drying/disposal arrangement
  - **More land requirement** than SBR & MBBR
  - **Nitrogen and Phosphorous removal** requires additional anoxic tank and > 3 times internal recirculation

# ASP



# Upflow Anaerobic Sludge Blanket Reactor (UASB)

- The Up flow Anaerobic Sludge Blanket reactor (UASB) maintains a high concentration of biomass through formation of highly settleable microbial aggregates. The sewage flows upwards through a layer of sludge.
- The sludge in the UASB is tested for pH, volatile fatty acids (VFA), alkalinity, COD and SS. If the pH reduces while VFA increases, the sewage should not be allowed into the UASB until the pH and VFA stabilise.
- The reactor may need to be emptied completely once in five years, while any floating material (scum) accumulated inside the gas collector channels may have to be removed every two years to ensure free flow of gas.
- All V-notches must be cleaned in order to maintain the uniform withdrawal of UASB effluent coming out of each V-notch. The irregular flow from each V-notch results in the escape of more solids washout. Similarly, blocking of the V-notches of the effluent gutters will lead to uneven distribution of sewage in the reactor.



# Up – Flow Anaerobic Sludge Blanket Reactor (UASB) Flow Diagram

UASB-AT-SC-CHL

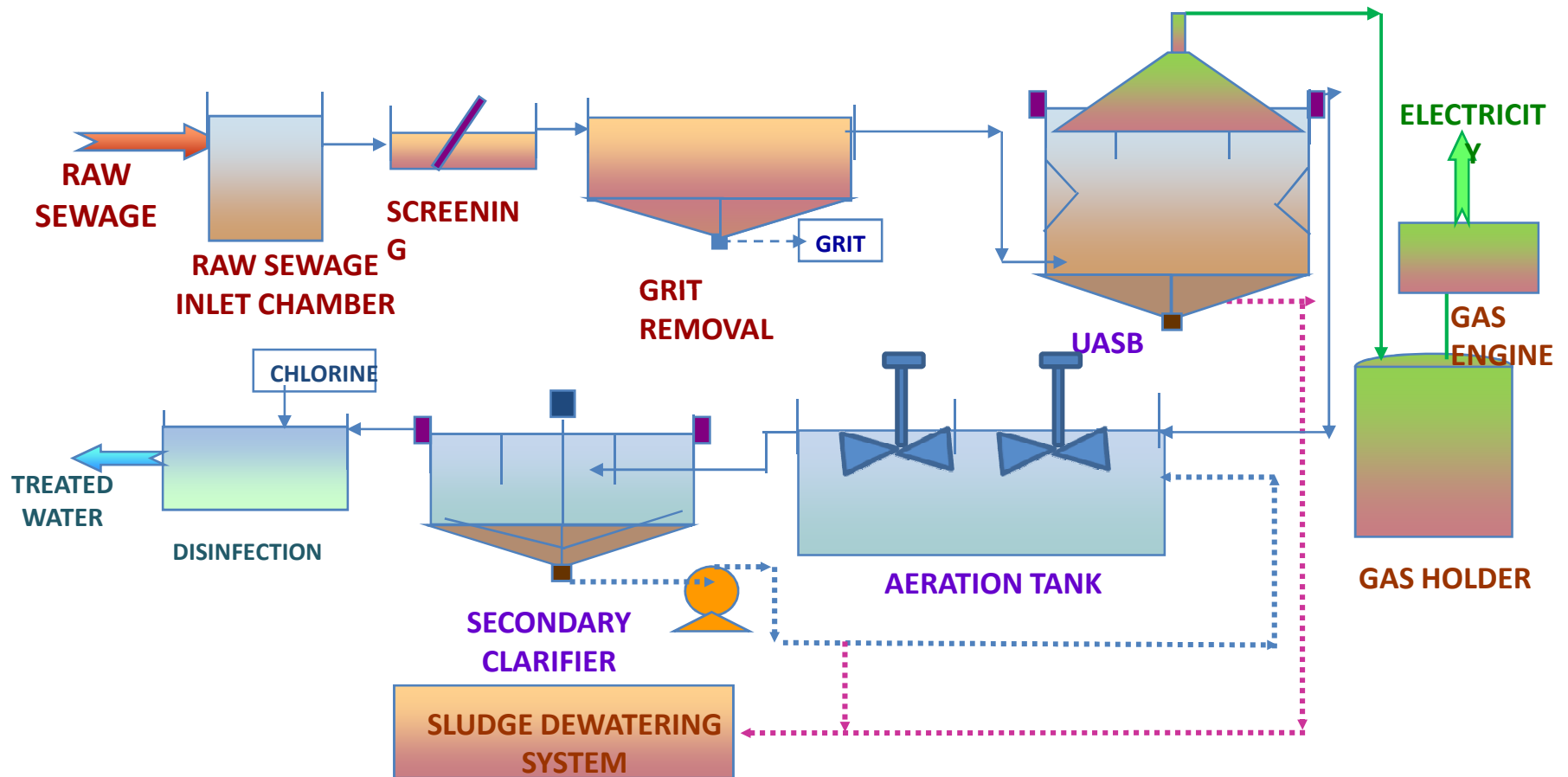

# Upward-flow Anaerobic Sludge Blanket

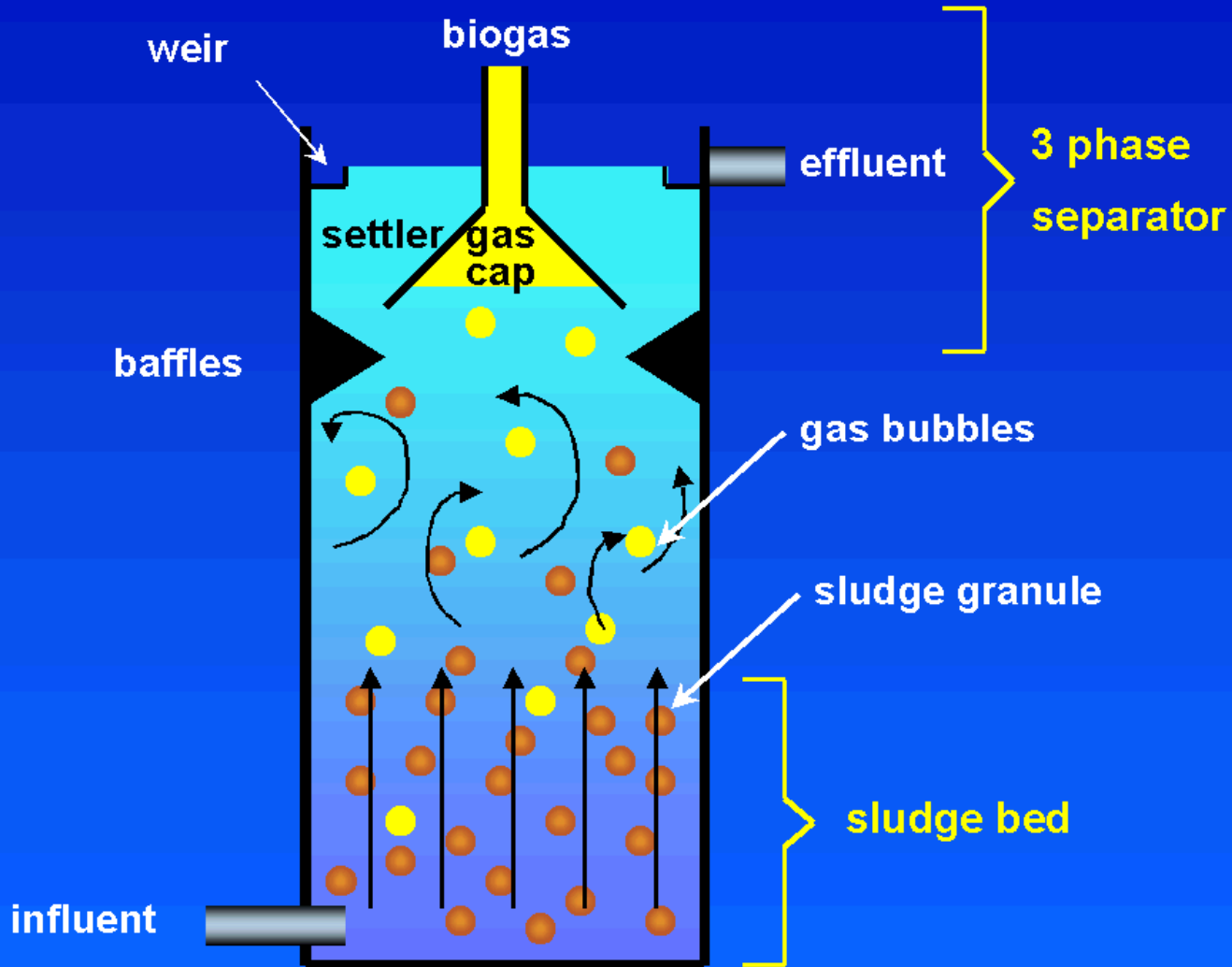



# UASB

## Advantages

- Requires **less power** than aerobic processes
- **Biogas** generated can be used as fuel or electricity.

## Disadvantages

- UASB alone does not treat the sewage to desirable limits, therefore **downstream aerobic treatment** is compulsory
- Requires **very large space** due to post treatment
- **Recovery of biogas is not sufficient** to produce substantial electricity in case of municipal



# UASB + AL+FL



# MOVING BED BIO REACTOR (MBBR) PROCESS

- Moving Bed Bio Reactor (MBBR) process is based on the bio-film of organisms developed on carrier elements.
- This media is floating in the Aeration tank and kept floating by air from diffusers which are placed at the bottom of tank.
- The process is intended to enhance the activated sludge process by providing greater biomass in aeration tank and thus by reducing volume of the tank
- After aeration tank sedimentation tank is provided for settlement of sloughed biomass
- Clear water clarifier overflows from weir and is further subjected to disinfection.

# Moving Bed Bio Reactor (MBBR) - Flow Diagram

## MBBR-SC-CHL

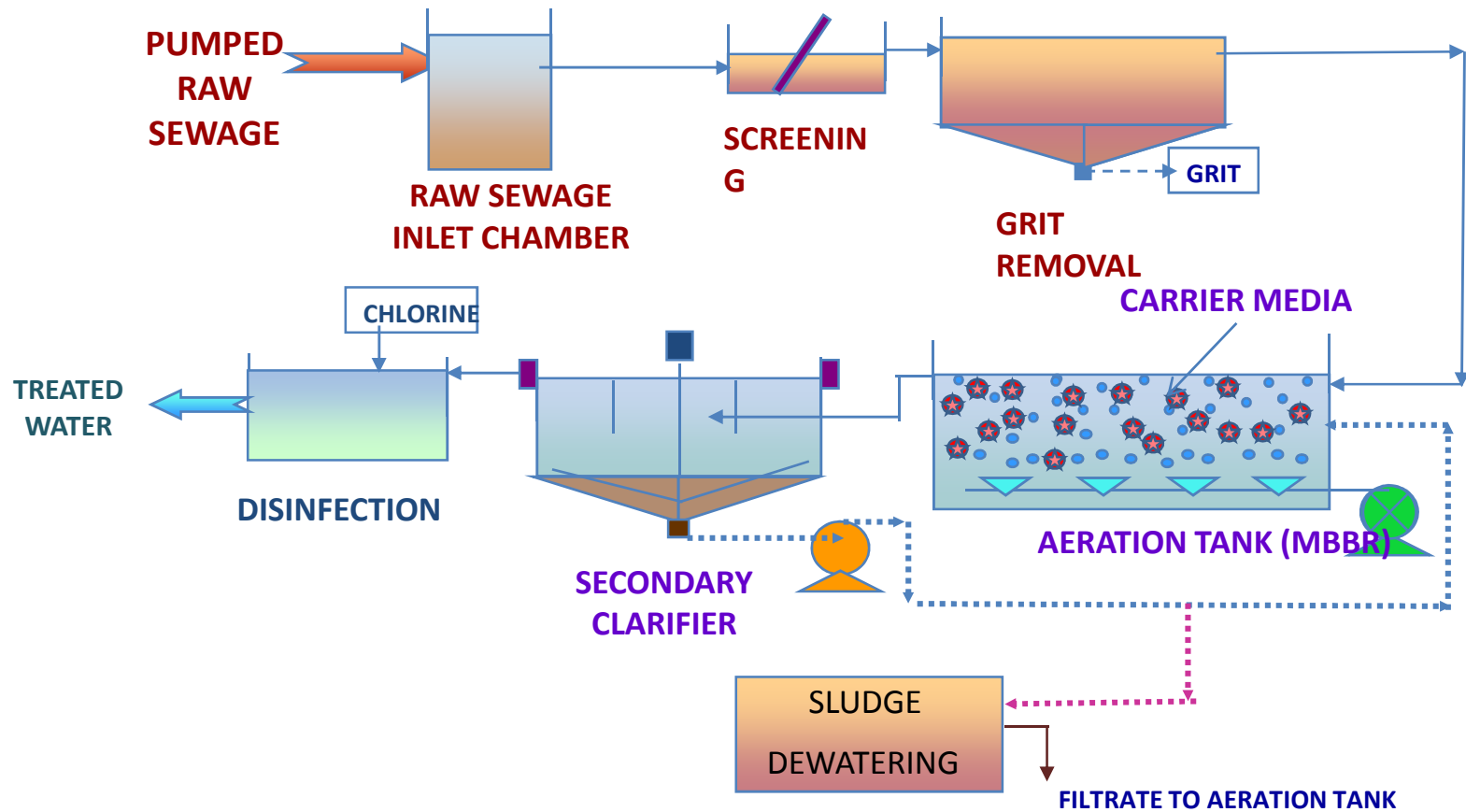

# MBBR





# Quantity of BIO Media

- Check Design approved by SE to see quantity of BIO media  $1\text{m}^3$  per 7.5 Kg BOD considering surface area of media  $250\text{ m}^2/\text{m}^3$
- The specifications are given in agreement. Specific gravity 0.96.
- Make by Kaldnes biofilm carrier

# SEQUENTIAL BATCH REACTOR (SBR) PROCESS

- Sequential Batch Reactor is true batch process where fill, aeration, settle and decant steps are carried out in sequence of batches in a single basin.
- Screened, de-gritted sewage is fed into the SBR Basins for biological treatment to remove BOD, COD, Suspended Solids, Biological Nitrogen and Phosphorous.
- SBR process shall work on batch mode in single step.
- It performs biological organic removal, nitrification, de-nitrification and biological phosphorous removal.

# Sequential Batch Reactor (SBR) - Flow Diagram

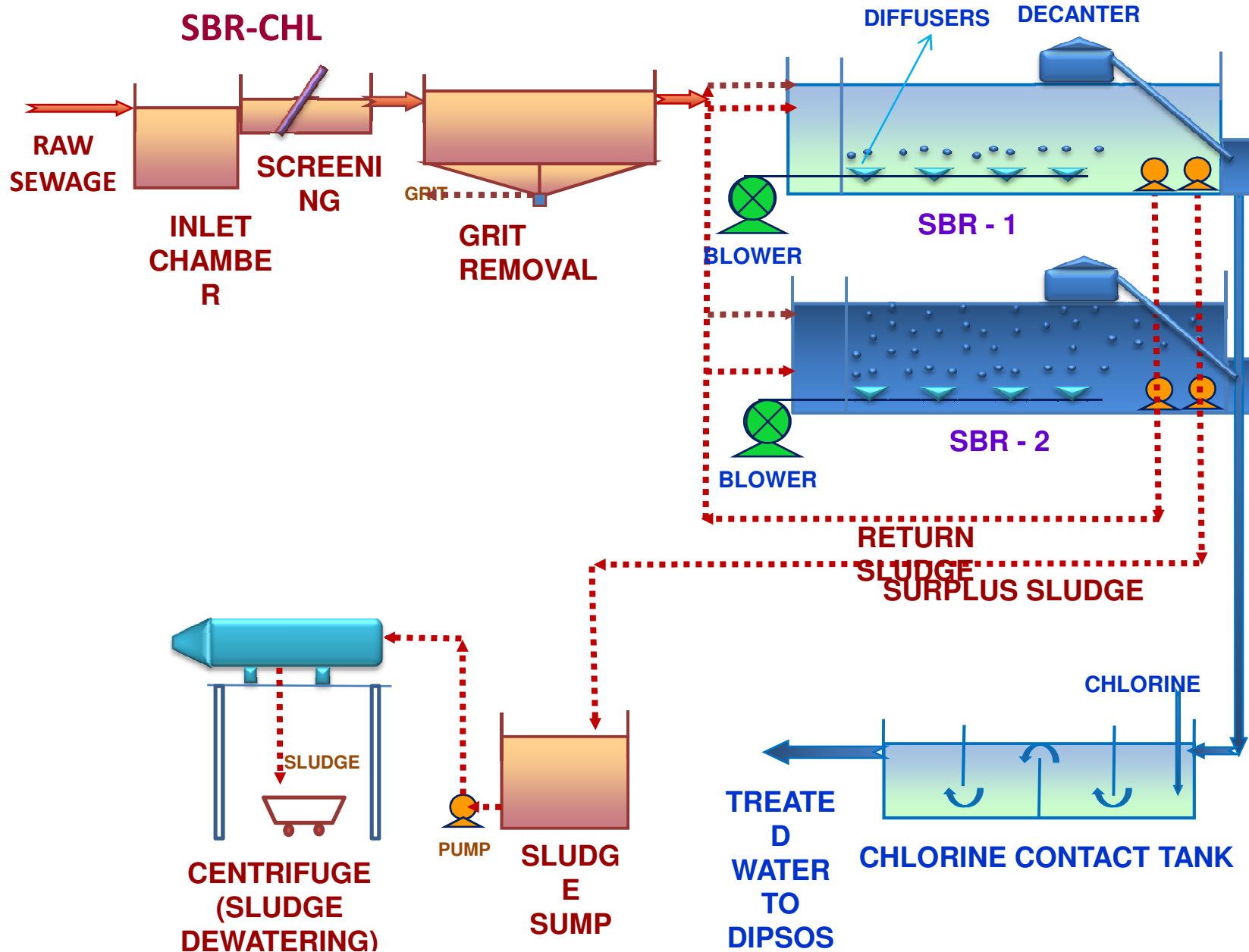

# Modular Design

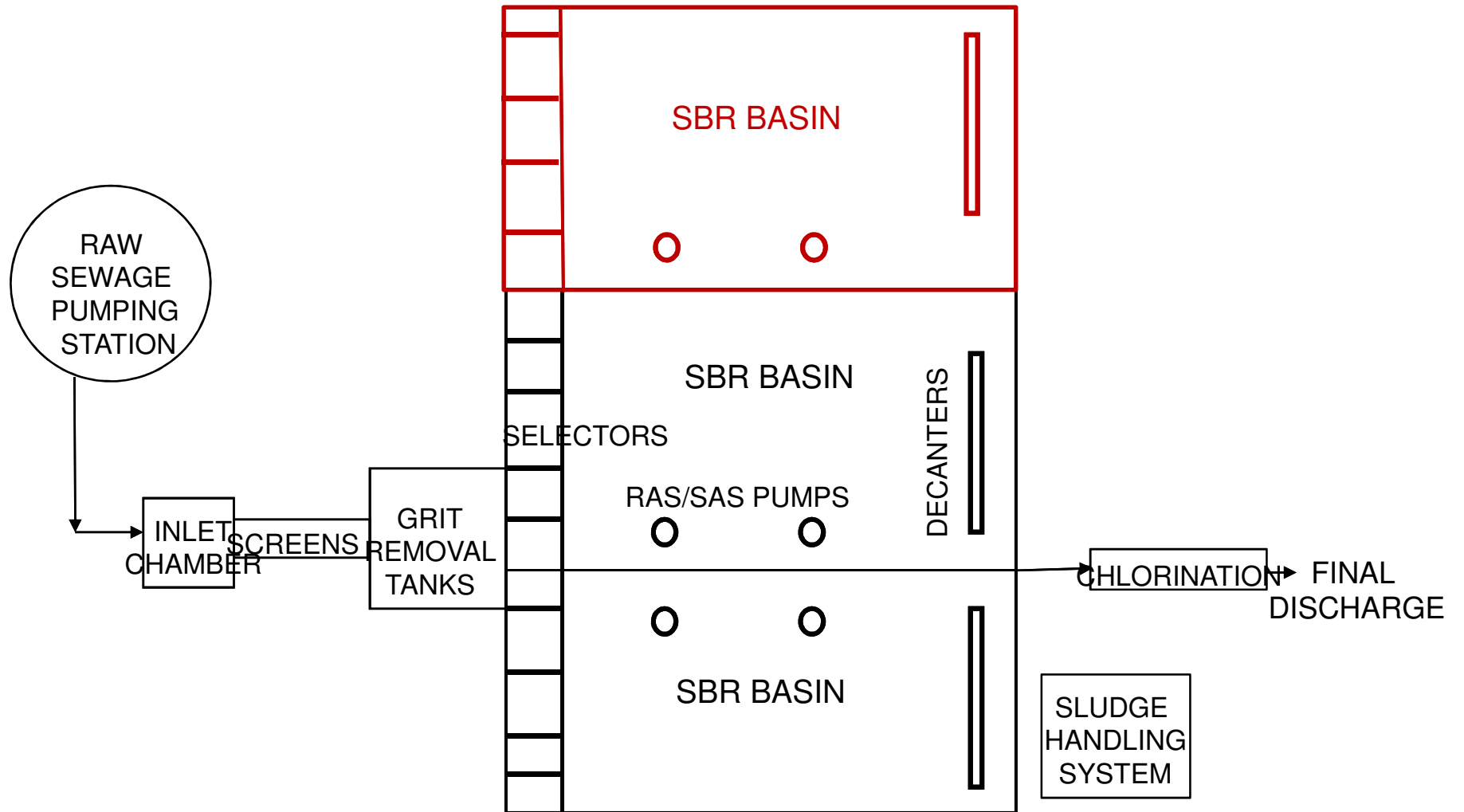

# SBR Process

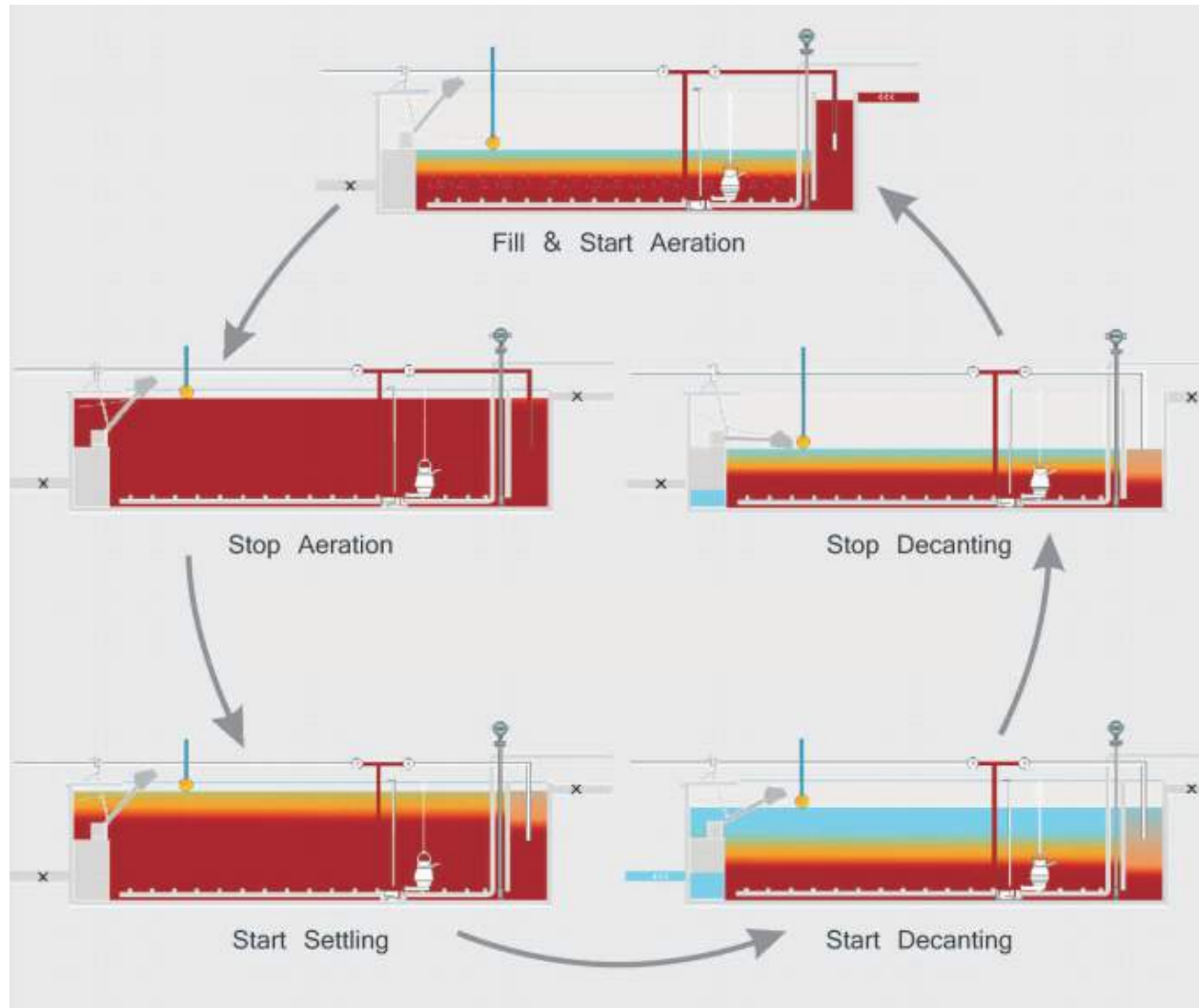

## SBR / Cyclic Activated Sludge Process

- **Better Quality Effluent**: 98 % BOD removal efficiency. Sewage can be treated to reuse/recycle quality of TSS < 10 mg/l, COD < 100 ppm, BOD < 10 ppm, TN < 10 ppm, TP < 2 ppm in a single stage of treatment using Batch process.
- **Bio-nutrient removal** (BNR) : N & P removal
- Secondary clarifier not required, **less foot print area**
- **Flexibility** for efficient removal of BOD, TSS, N& P under all loading conditions.
- Automatically controlled by PLC . Based on process requirement, the aeration facility is optimized based on DO levels and by varying operating frequency of the blowers. **Less power consumption.**

•

# SBR / Cyclic Activated Sludge Process

## Advantages

- Controls growth of filamentous bacteria and **avoids bulking** of sludge.
- Provides **stabilised sludge**.
- Process **with primary clarifier can generate power**
- Allows for easy **modular expansion** for population growth

## Disadvantages

- Compared to the conventional ASP / MBBR /UASB, a **higher level of sophistication** and maintenance is associated due to automation

•

# SBR gives high performance with Nutrient removal

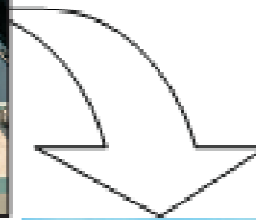

**BOD < 5 ppm**  
**TSS < 10 ppm**  
**NH<sub>4</sub>-N < 1 ppm**  
**TP < 1 ppm**





**Fully Automatic PLC operated**

# Plant Aesthetics







# Sludge Handling – Sludge Drying Beds

- Objective : Dewatering of sludge
- Important Features
  - Conventional method of sludge drying
  - No power requirement
  - **Substantial area** is required
  - Difficult to operate in monsoon
  - Labour intensive
  - Manual scrapping and loading of dried sludge



# SLUDGE DRYING BED

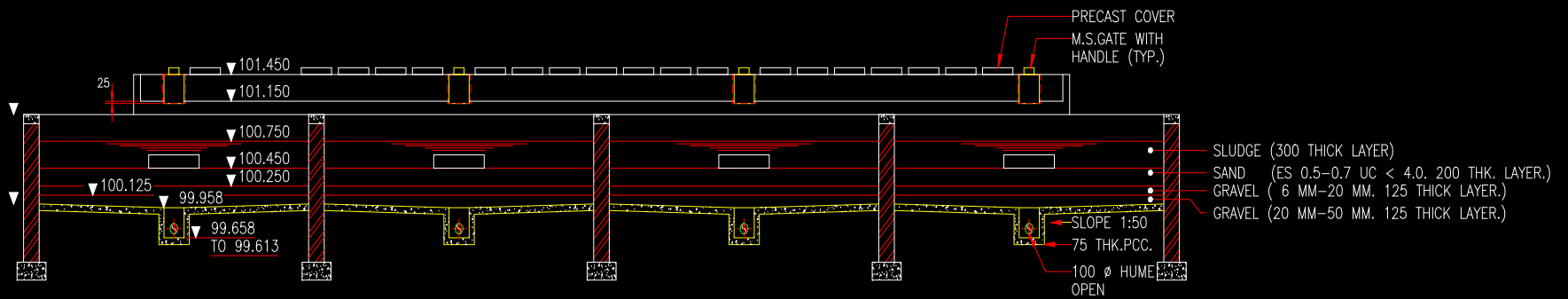

# Sludge Handling – Centrifuge

- Objective : Dewatering of sludge @ 95% of the BOD removed in Kg.
- Important Features
  - Advanced method of solid-liquid separation
  - **Less area**
  - Power required for pumping the sludge and operation of centrifuge
  - **Less time**
  - **Efficient dewatering**
- Design criteria
  - Inlet sludge solid consistency : min 0.8 to 1%
  - Outlet sludge solid consistency : 20% expected
  - Polyelectrolyte dosing increases the efficiency

# Centrifuge



# BELT PRESS





# SOLID BOWL CENTRIFUGE

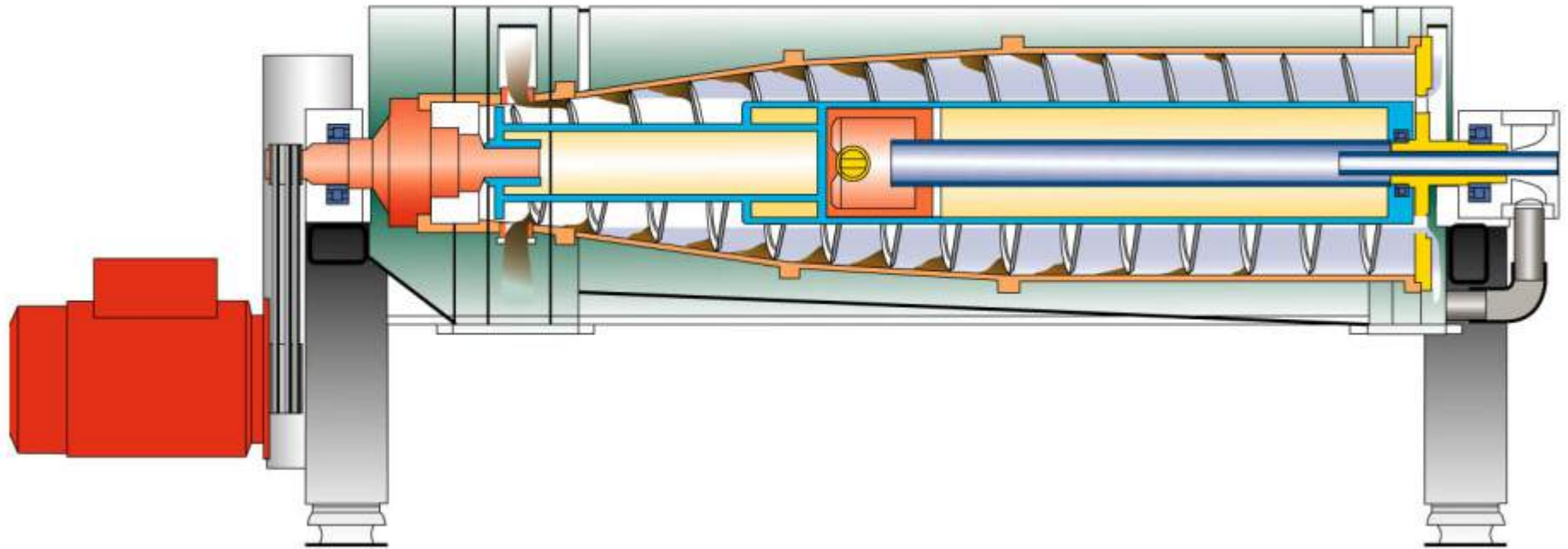

# Tertiary Treatment

It is supplementary to primary and secondary treatment for the purpose of removing the residual organic and inorganic substances for reuse of effluent for the purposes of cooling systems, boiler feed, process water etc.

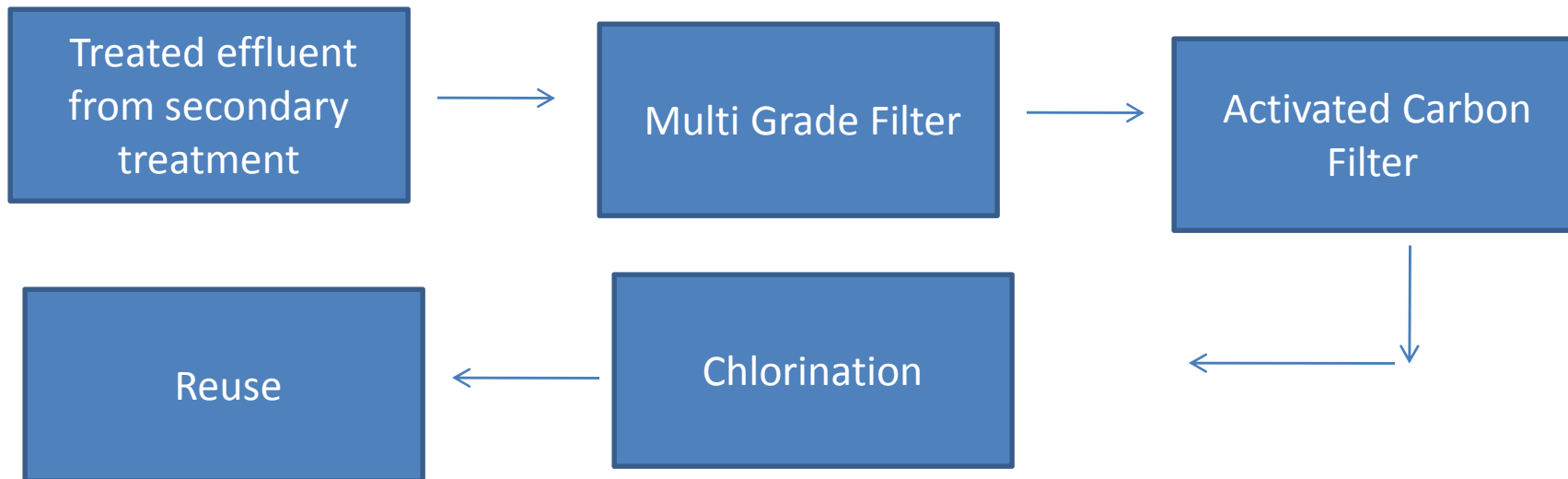

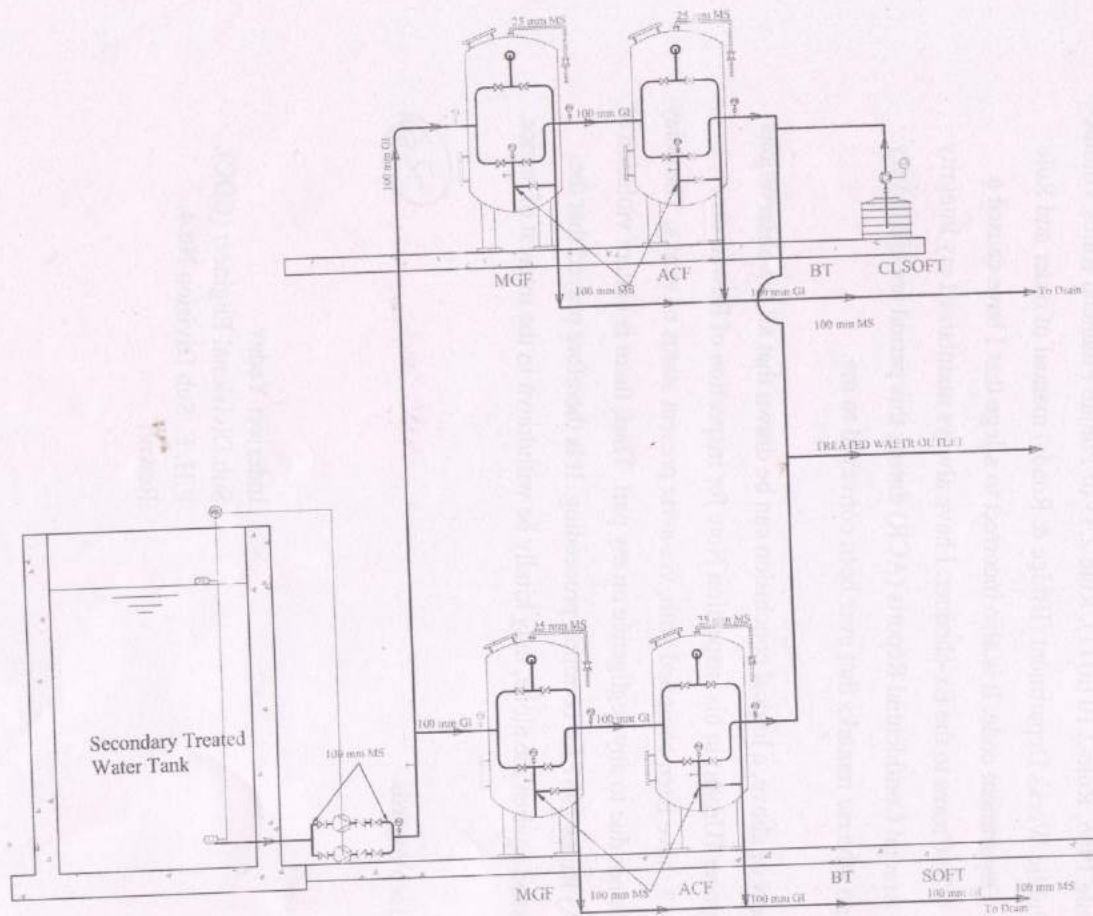

**Legend**

Mark	Description
—	Effluent Line
—	Water Level
Z	Butterfly Valve
Z	Non Return Valve
⊙	Pressure Gauge
⊙	Pressure Switch
⊙	Pump
⊙	Air Blower
⊙	Ball Valve
⊙	High Level
⊙	Low Level
+	Sampling Point

**List of Electromechanical Unit**

Mark	Description	Make	Capacity	Quantity
MGF	Multigrade Filter	Brisa-ria	35000 LPH	2 No's
ACF	Activated Carbon Filter	Brisa-ria	35000 LPH	2 No's
BT	Brine Tank	Stribes	-	2 No's
SOFT	Softener	Brisa-ria	35000 LPH	2 No's
CL	Chlorine Dosing	Asia MI	0-6 LPH	1 No

# Chlorination

- **Objective** : Disinfection of wastewater to kill pathogens
- **Important Features**
  - Simple & widely used method of disinfection
  - Used for wastewater treatment
- **Design criteria :**
  - **Types** : Dosing chemicals – Sodium hypochlorite  
Vacuum Chlorination – Chlorine gas
  - **Contact time** : 30 min
  - Dosage after wastewater treatment  
**Activated sludge** : 3 – 5 mg/l

# Chlorine Contact Tank



**Chlorine is a Hazardous chemical requiring adequate safety while handling**

1. Chlorine leak detector
2. Chlorine absorption system
3. Personal safety eqpt .– mask etc.
4. Safety shower
5. Statutory records



# Other options for disinfection

- Chlorine produces carcinogenic disinfection byproducts that are harmful to human and aquatic life.
- It is banned in developed countries.
- Still used in India as it is cheap
- Other options are;
  - Ultra Violet (UV) - like Aquaguard
  - Ozone