

INTRODUCTION TO AUTOMATIC CONTROL

Control systems are an integral component of any industrial society and are necessary to provide useful economic products for society.

Control engineering is based on the foundation of feedback theory and linear system analysis, and integrates the concepts of network theory and communication theory. Therefore, control engineering is not limited to any engineering discipline but is equally applicable for aeronautical, chemical, mechanical, environmental, civil, and electrical engineering. For example, quite often a control system includes electrical, mechanical, and chemical components. Furthermore, as the understanding of the dynamics of business, social and economical systems increases, the ability to control these systems will increase also.

A control system is an interconnection of components forming a system configuration that will provide a desired response. The automatic toaster, the thermostat, the washer and dryer, the air conditioner, the computer, the microprocessor, the space vehicles, the robots are some of the familiar control systems.

The methods used to accomplish the control objectives can be classified, very generally, as open-loop controls and closed-loop or feedback controls.

1.1 Open-loop control systems

Systems in which the output quantity has no effect upon the input quantity are called open-loop control systems. Open-loop controls are, in general, calibrated systems. An open-loop control system utilizes a controller or control actuator in order to obtain the desired response.

One of the earliest open-loop control systems was Hero's device for opening the door of a temple. The command input to the system (see Figure 1.1) was lighting a fire upon the altar. The expanding hot air under the fire drove the water from the container into the bucket. As the bucket became heavier, it descended and turned the door spindles by means of ropes, causing the counterweight to rise. Dousing the fire could close the door. As the air in the container cooled and the pressure was thereby reduced, the water from the bucket siphoned back into the storage container. Thus the bucket became lighter and the counterweight, being heavier, moved down, thereby closing the door

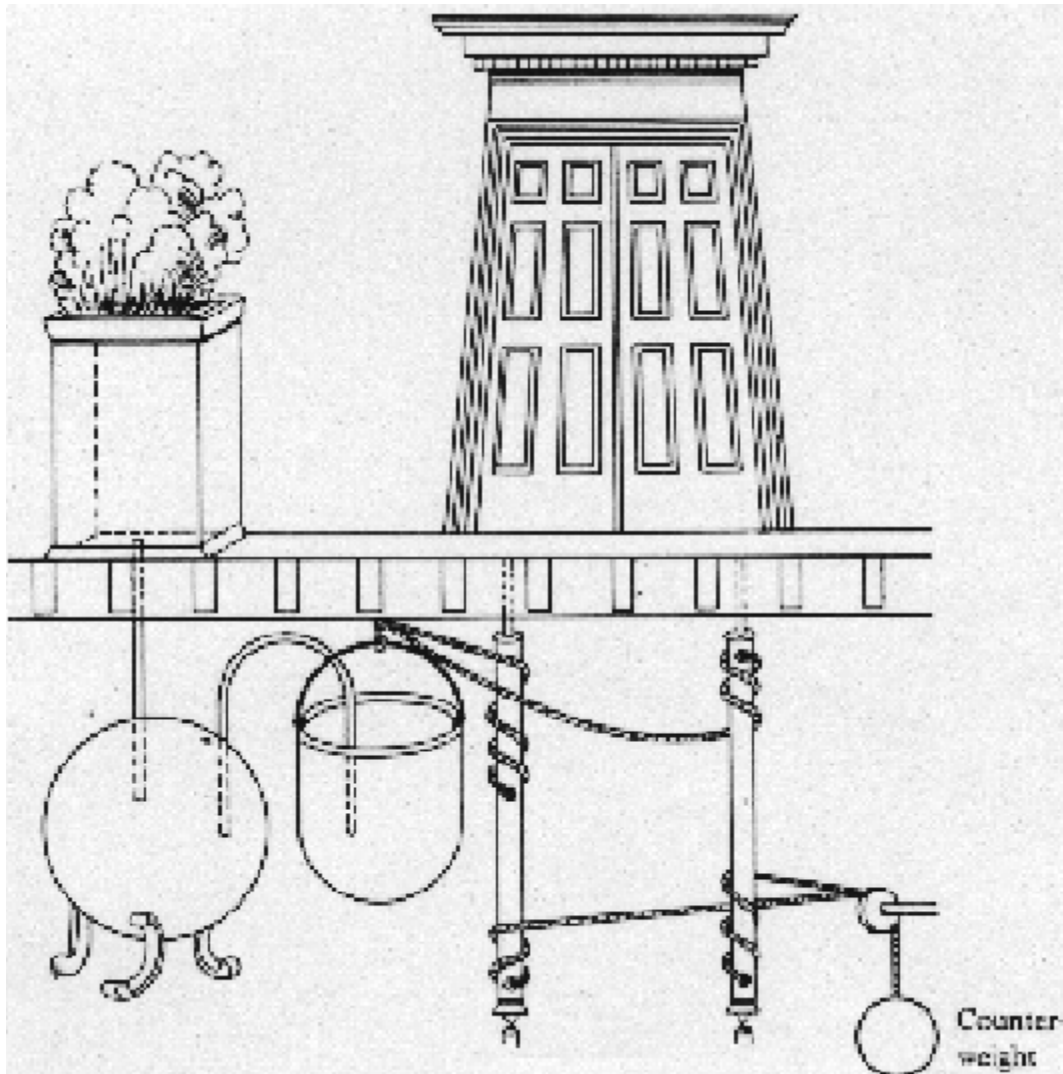

Figure 1.1 Hero's device for opening temple doors

Other examples of open-loop control systems are:

Toaster

Assume that a toaster is set for the desired darkness of the toasted bread. The setting of the darkness, or timer *knob*, represents the *input* quantity, and the degree of darkness of the toast produced is the *output* quantity. If the degree of darkness is not satisfactory, because of the condition of bread or some other reason, this condition in no way automatically alter the length of time that heat is applied. The heater portion of the toaster, excluding the timer unit, represents the dynamic part of the overall system.

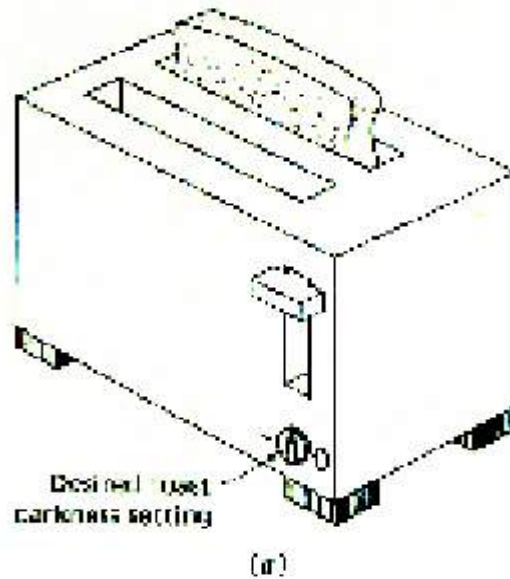

Figure 1.2 Automatic toaster

Automatic washers and dryers

These devices change operating modes and eventually shut themselves off according to a preprogrammed schedule, which is usually based on elapsed time.

DC Motor

Another example is the dc shunt motor. For a fixed armature voltage, the field rheostat resistance setting can be increased to produce the desired increase in the motor speed.

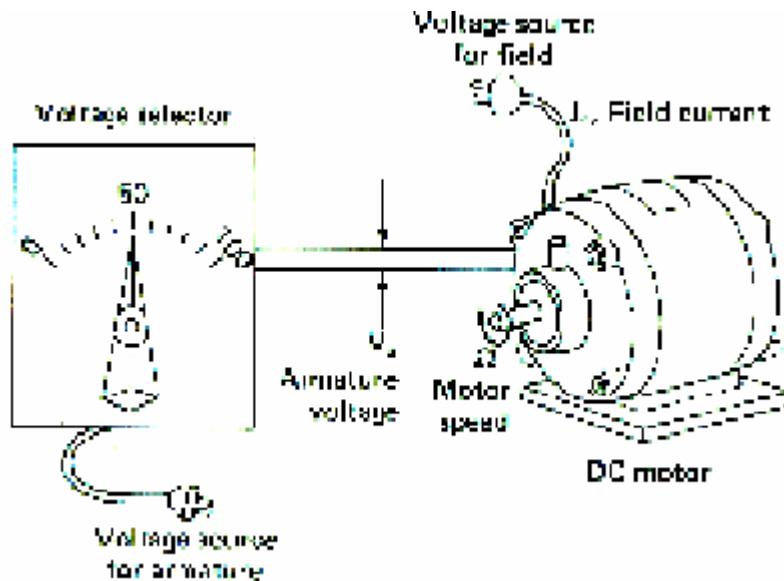

Figure 1.3 DC motor

A functional block diagram, as shown in Figure 1.4, can represent the above examples just cited symbolically.

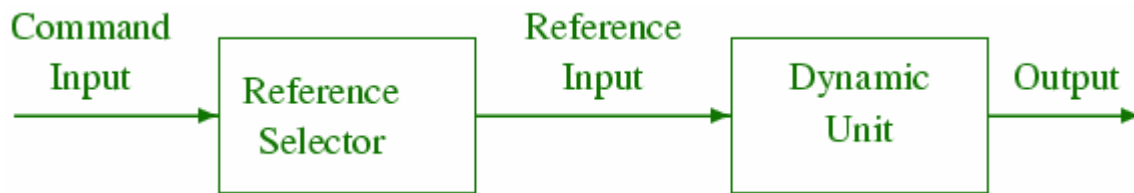

Figure 1.4 Functional block diagram of an Open-loop control

The desired darkness of the toast or the desired speed of the motor is the command input; the selection of the value of time on the toaster timer or the value of the voltage applied to the motor armature is represented by the reference-selector block; and the output of this block is identified as the reference input. The reference input is applied to the dynamic unit that performs the desired control function and the output of this block is the desired output.

1.2 Closed-loop control system

Systems in which the output has an effect upon the input quantity are called closed loop control systems. The feedback action controls the input to the dynamic unit. Closed-loop or feedback controls operate according to a very simple principle:

1. Measure the variable to be controlled.
2. Compare the measured value with the desired (commanded value) and determine the difference (*error*).
3. Use this difference (amplify *if necessary*) to adjust the controlled variable so as to reduce the difference (*error*).

The events of everyday life give evidence of some sophisticated feedback control systems. For example, we eat when we are hungry, and we stop when we are full. This behavior suggest the operation of a feedback loop much like the loops used to control the level of fluid in a tank. In both cases the set point is the desired level of fullness, the process variable is some measure of actual fullness, and the control variable is the rate of intake.

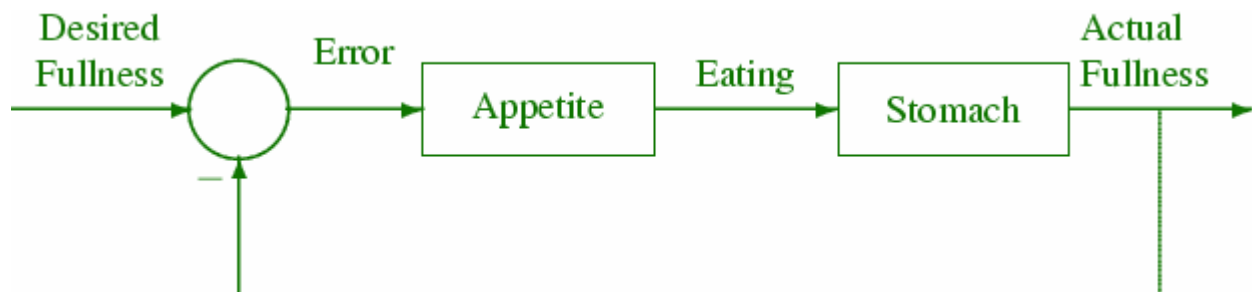
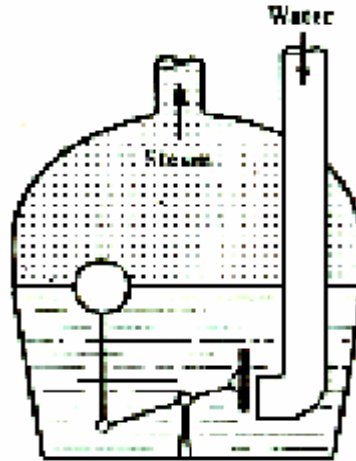

Figure 1.5 Feedback control of eating and appetite.

Water level float regulator

The first historical feedback system claimed by the Russian is the water level float regulator invented by Polson in 1765. The level regulator system is shown in Figure 1.6 (a). The float detects the water level and controls the valve that covers the water inlet in the boiler.



Steam engine fly ball governor

James Watt's fly ball governor for controlling speed, developed in 1769, can be considered the first widely used feedback control system for controlling the speed of a steam engine. The governor measured the speed of the output shaft and utilizes the movement of the fly ball with speed to control the valve and therefore the amount of steam entering the engine.

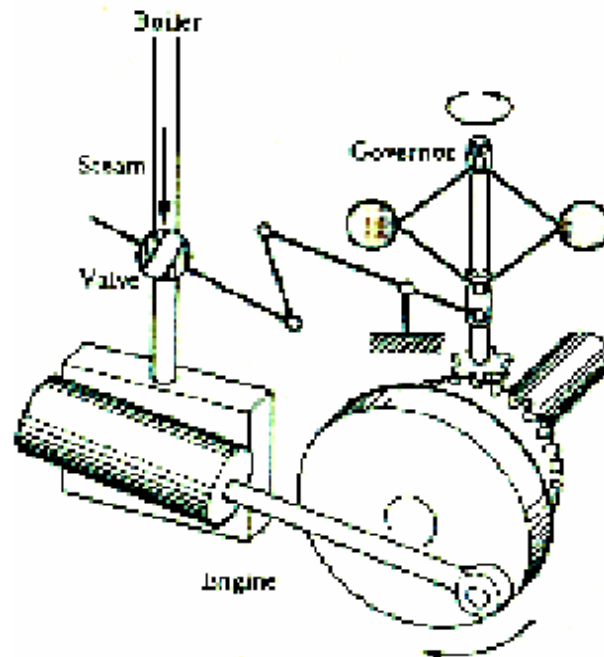

Figure 1.6 (a) Water level float regulator; (b) Watt fly ball governor

Examples of feedback control are numerous: For example in thermostat control of room temperature a person selects the desired room temperature (command input) and adjusts the temperature setting on the thermostat. A bimetallic coil in the thermostat is affected by the actual room temperature (output) and the reference selector setting. If the room temperature is lower than the desired temperature, the coil strip alters its shape and causes a mercury switch to operate a relay, which in turn activates the furnace to produce heat in the room. When the room temperature reaches the desired temperature, the shape of the coil strip is again altered so that the mercury switch opens. This deactivates the relay and in turn shuts off the furnace. In this example the bimetallic coil performs the function of a comparator. The switch, the relay, and furnace are the dynamic elements of this closed loop control system.

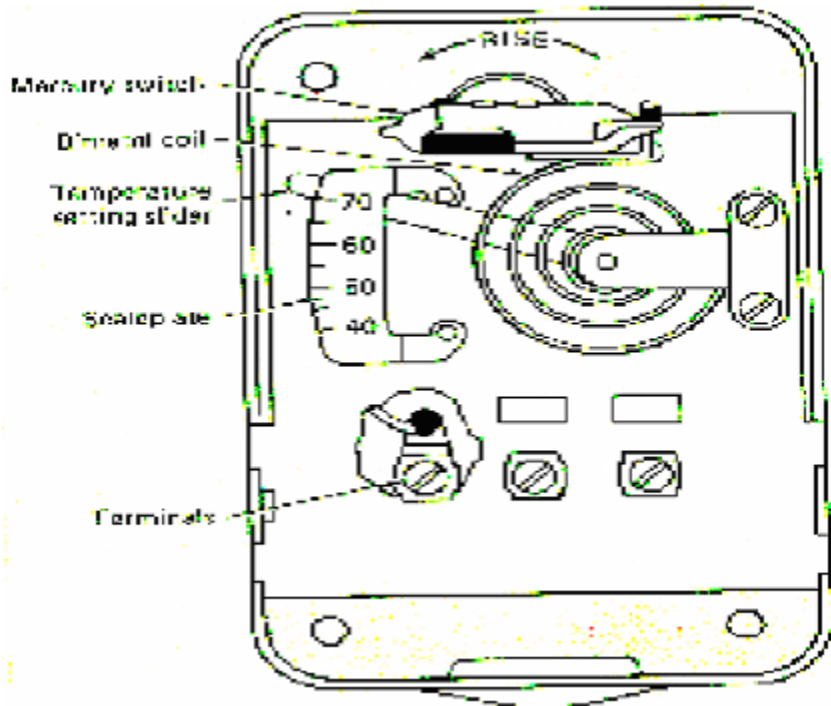

Figure 1.7 Thermostat arrangement

The block diagram of a closed-loop control system is shown in Figure 1.8

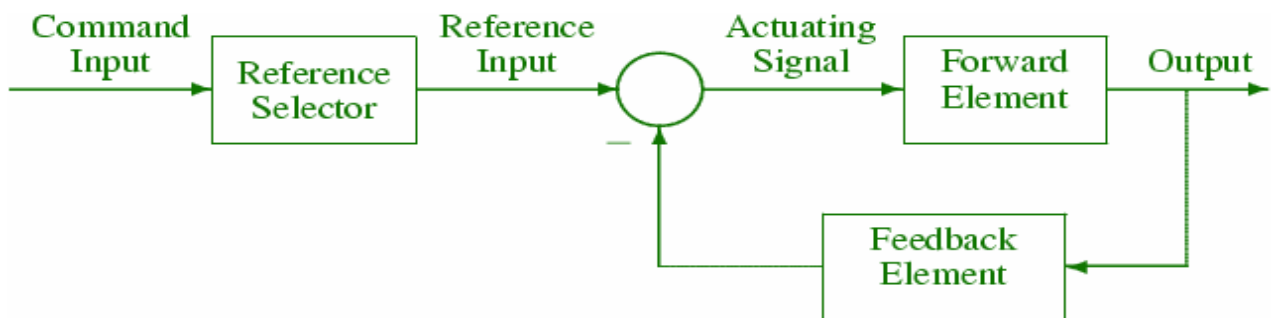

Figure 1.8 Functional block diagram of a closed-loop control system

Other examples of control systems are:

Electric supply voltage and frequency control systems

Voltage and frequency are measured at the generating station and compared with the desired values. If the voltage is in error, the field current of the generator is adjusted; if the frequency is not correct, the turbine speed is adjusted. Figures 1.9 and 1.10 shows the two major control loops, with which most large generators are equipped. In Figure 1.9 the automatic voltage regulator (AVR) loop controls the magnitude of the terminal voltage V . This voltage is continuously sensed, rectified and smoothed. This dc signal, being proportional to $|V|$, is compared with a dc reference V_{ref} . The resulting error voltage after amplification serves as the input to the exciter, which delivers the voltage V_f to the generator field winding. The change in the field excitation will affect the generator terminal voltage.

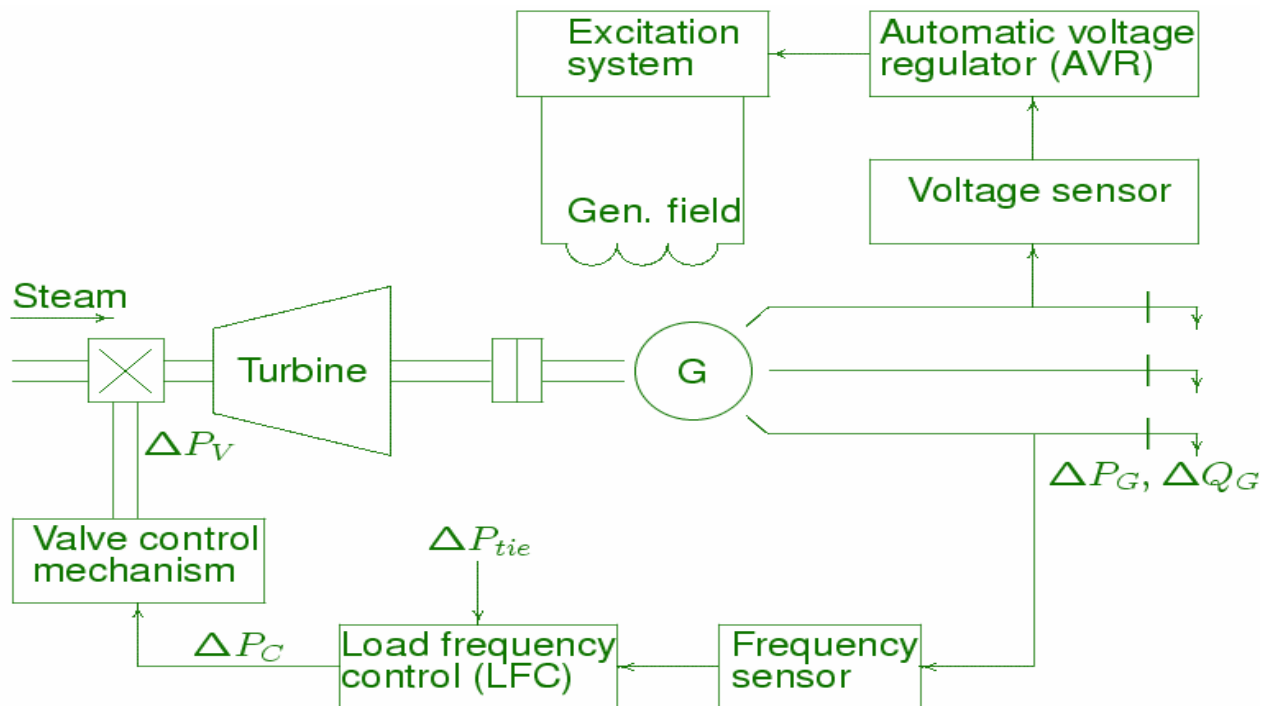

Figure 1.9 The AVR control loop for a synchronous generator.

The automatic load-frequency control (ALFC) loop regulates the megawatt output and frequency (speed) of the generator. The ALFC loop shown in Figure 1.10 will maintain control only during normal (small and slow) changes in load and frequency. When load on the generator is suddenly increased by a small amount this demand is supplied by the kinetic energy of the rotating system causing the reduction of the speed. The speed governor senses this reduction of speed; the governor action after amplification will operate the turbine throttle valve to admit more steam such that the input is increased to maintain the power balance. The speed and frequency will maintain their steady-state value according to the governor drooping characteristic. Additional secondary control loop is required to maintain the fine adjustment of the frequency.

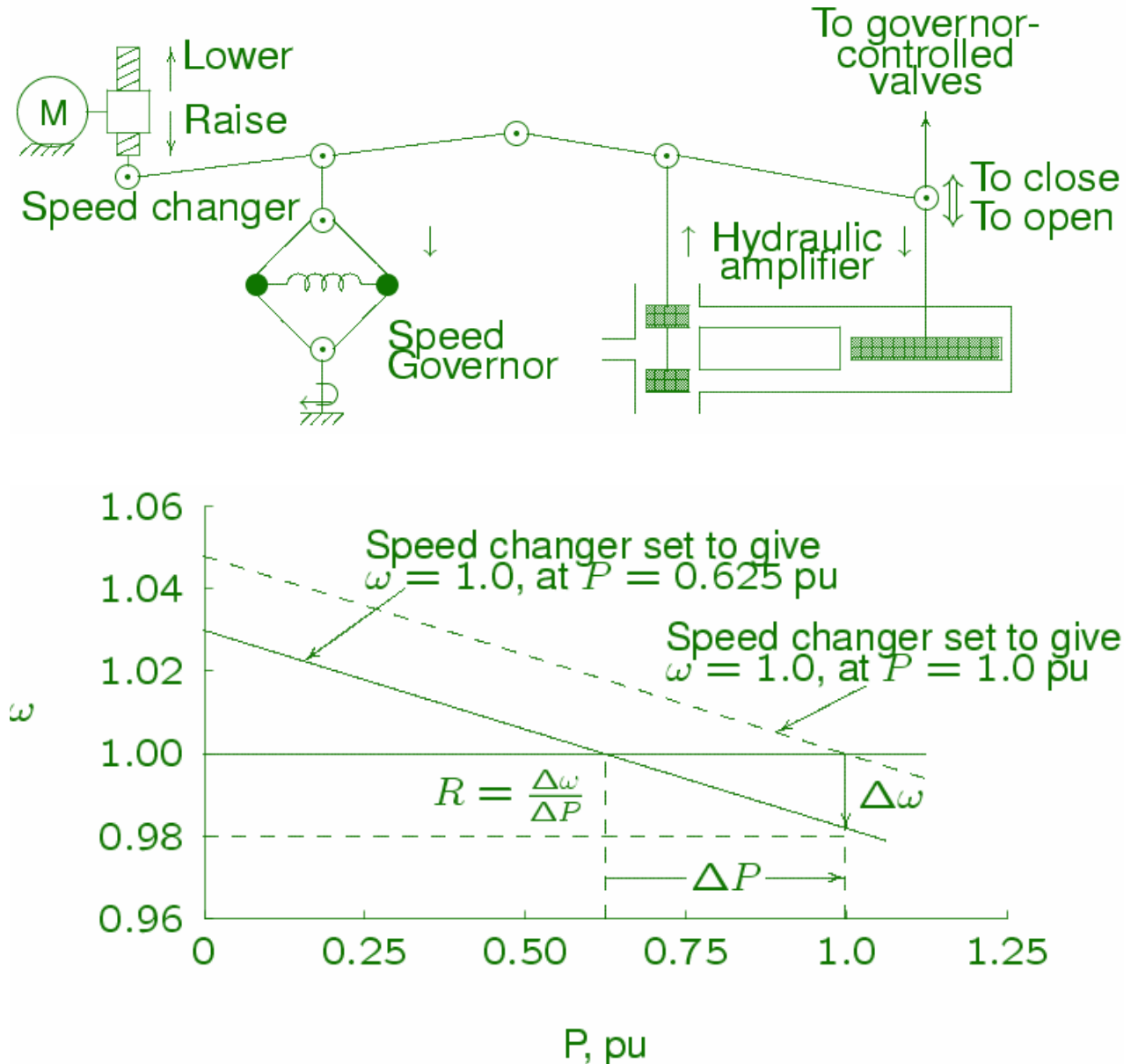

Figure 1.10 The ALFC loop for a synchronous generator.

Antiaircraft radar tracking control systems

An early example of military application of a feedback control system is the aircraft radar tracking control system shown in Figure 1.11. The radar antenna detects the position and velocity of the target airplane, and the computer takes the information and determines the correct firing angle for the gun. This angle includes the necessary lead angle so that shell reaches the projected position at the same time as the airplane. The output signal of the computer, a function of the firing angle, is fed into an amplifier, which provides power for the drive motor. The motor then aims the gun at the necessary firing angle.

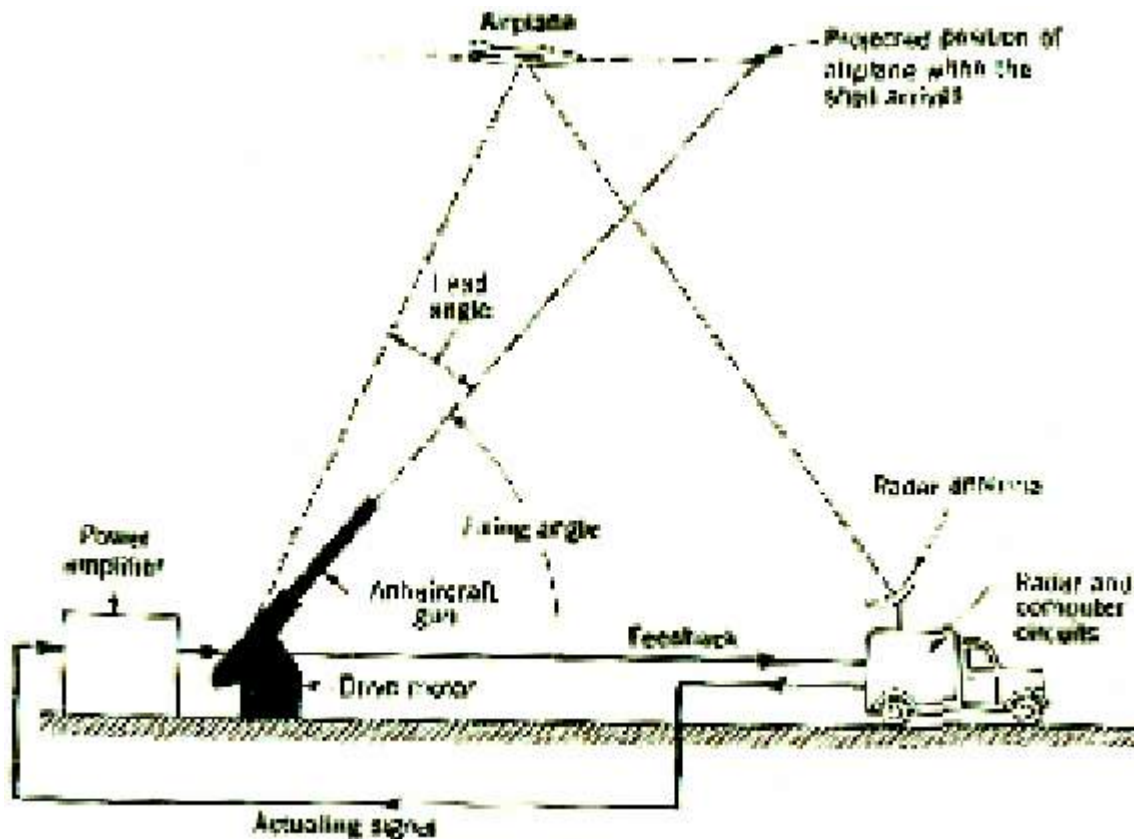

Figure 1.11 Antiaircraft radar tracking control systems.

Temperature control system

Figure 1.12 shows a schematic diagram of temperature control of an electric furnace. A thermometer measures the temperature in the electric furnace, which is an analog device. The analog temperature is converted to a digital temperature by an A/D converter. The digital temperature is fed to a controller through an interface. This digital temperature is compared with the programmed input temperature, and if there is any discrepancy (error), the controller sends out a signal to the heater, through an interface, amplifier, and relay, to bring the furnace temperature to a desired value.

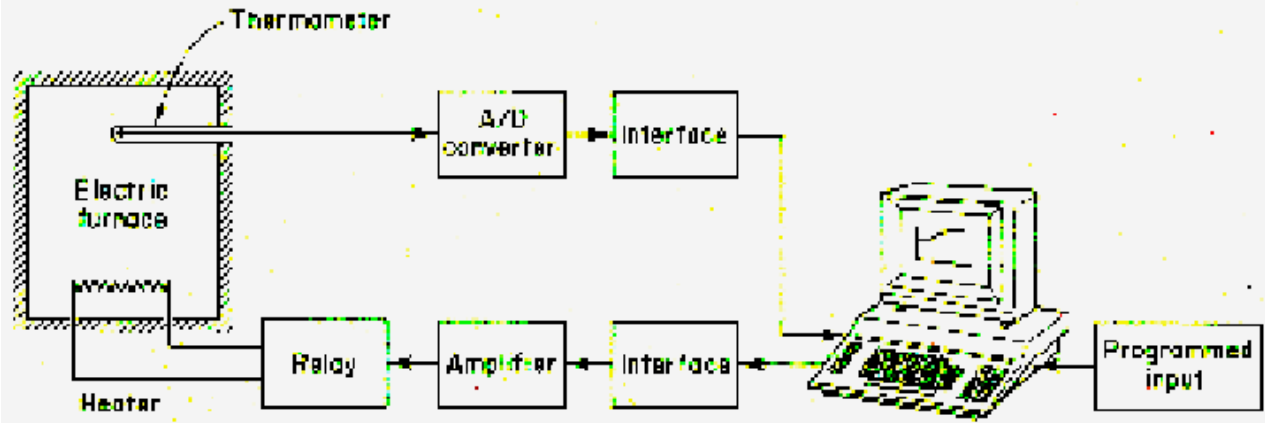

Figure 1.12 Temperature control system.

Robot control system

Industrial robots are frequently used in industry to improve productivity. The industrial robot must have some sensory devices. In low-level robot, micros switches are installed in the arms as sensory devices. The robot first touches an object and then, through the micros switches confirms the existence of the object in space and proceeds in the next step to grasp it.

In a high-level robot, an optical means (such as a television system) is used to scan the background of the object. A digital computer acting as a controller recognizes the presence and orientation of each mechanical part by a pattern recognition process that consists of reading the code numbers attached to it. Then the robot picks up the part and moves it to an appropriate place for assembling.

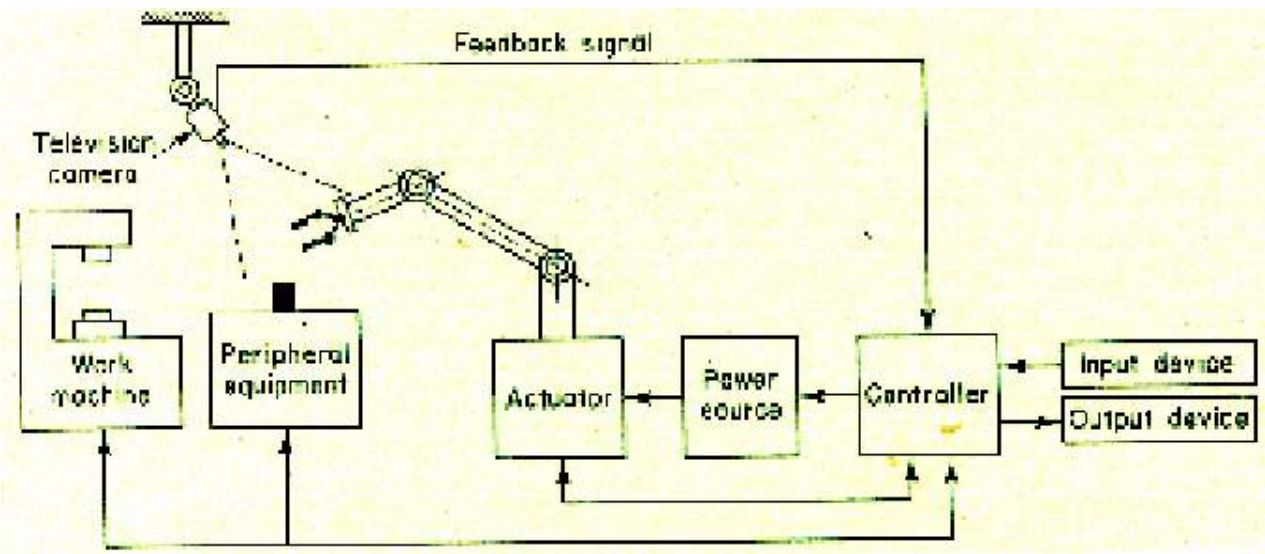

Figure 1.13 Robot using a pattern recognition process.

Also, there have been many applications of control system theory to biomedical experimentation, diagnosis, prosthetics, and biological control systems. The control systems under consideration range from the cellular level to the central nervous system, and include temperature regulation and neurological, respiratory, and cardiovascular control.

The closed loop system can be designed to provide extreme accuracy in the steady-state; also its response time can be reduced by appropriate design. Unfortunately, the feedback link introduces serious problem stability! Feedback systems readily become oscillators; that is, the controlled variables fluctuate continuously at some periodic rate (frequency) and never reach the desired steady-state condition. For any specific system, stable operation can be achieved by proper design, but the design problem is not always an easy one to solve.

1.3 SYSTEM CLASSIFICATIONS AND LINEARIZATION

Feedback control systems may be classified in a number of ways, depending upon the purpose of the classification.

Static or Dynamic Systems: - Static systems are composed of simple linear gains or nonlinear devices and described by algebraic equations, and dynamic systems are described by differential or difference equations.

Continuous-time or Discrete-time Systems: - Continuous-time dynamic systems are described by differential equations and discrete-time dynamic systems by difference equations.

Linear or nonlinear Systems: -Linear dynamic systems are described by differential (or difference) equations having solutions that are linearly related to their inputs. Equations describing nonlinear dynamic systems contain one or more nonlinear terms.

Lumped or Distributed parameters: - **Lumped**-parameter, continuous- time, dynamic systems are described by ordinary differential equations, and distributed parameter, continuous-time, dynamic systems by partial differential equations.

Time-varying and Time invariant Systems: - **Time**-varying dynamic systems are described by differential (or difference) equations having one or more coefficients as functions of time. Time invariant (constant-parameter) dynamic systems are described by differential (or difference) equations having only constant coefficients.

Deterministic or Stochastic Systems: - **Deterministic** systems have fixed (nonrandom) parameters and input, and stochastic systems have randomness in one or more parameters or inputs.

The scope of this course is limited to a consideration of linear, lumped parameter, continuous-time, dynamic systems having only deterministic parameters and input, both time-varying and time-invariant systems are modeled, but the analysis and design emphasis is on time-invariant cases. Nonlinear dynamic systems may often be linearized about either static or dynamic operating points. *Static operating points*, referred to as *equilibrium points*, occur from the application of a constant input, such as a constant force or a constant voltage. *Dynamic operating points* occur when the input varies with time to yield a nominal response as a function of time. Examples are a nominal flight path of an aircraft and a nominal trajectory.

1.4 The control problem

A control engineer's first step is the formation of a suitable model of the dynamic system or process to be controlled. The model may be validated by analyzing its performance for realistic input conditions and then by comparing with field test data taken from the dynamic system in its operating environment. Model validation is often achieved with the aid of computer simulation in which the effects of varying parameters can be determined more easily. Further analysis of the simulated model is usually necessary to obtain the model response for different feedback configurations and parameters settings. Once an acceptable controller has been designed and tested on the model, the feedback control strategy is then applied to the actual system to be controlled.

When we wish to develop a feedback control system for a specific purpose, the general procedure may be summarized as follow:

1. Choose a way to adjust the variable to be controlled; e.g., the mechanical load will be positioned with an electric motor or an electrical resistance heater will control the temperature.
2. Select suitable sensors, power supplies, amplifiers, etc., to complete the loop.
3. Determine what is required for the system to operate with the specified accuracy in steady-state and for the desired response time.
4. Analyze the resulting system to determine its stability.
5. Modify the system to provide stability and other desired operating conditions by redesigning the amplifier/controller, or by introducing additional control loops.

1.5 Transfer function

In control theory, functions called transfer functions are commonly used to characterize the input-output relations of components or systems that can be described by linear, time invariant, differential equations.

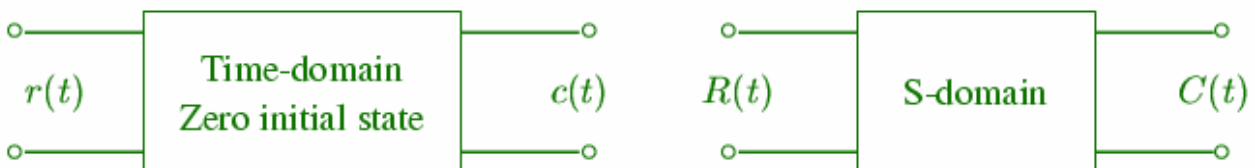

The transfer function of a linear, time-invariant, differential equation system is defined as the ratio of the Laplace transform of the output to the Laplace transform of the input under the assumption that all initial conditions are zero. Consider the linear time-invariant system defined by the following differential equation:

$$a_n \frac{d^n c}{dt^n} + a_{n-1} \frac{d^{n-1} c}{dt^{n-1}} + \dots + a_1 \frac{dc}{dt} + a_0 c = b_n \frac{d^m r}{dt^m} + b_{n-1} \frac{d^{m-1} r}{dt^{m-1}} + \dots + b_1 \frac{dr}{dt} + b_0 r \quad (1.1)$$

Where c is the output, and r is the input of the system. The transfer function is obtained by taking the Laplace transform of both sides of equation (1.1), under the assumption that all initial conditions are zero, or

Transfer function = $\frac{\mathcal{L}[\text{output}]}{\mathcal{L}[\text{input}]}$ | zero initial condition

$$G(s) = \frac{C(s)}{R(s)} = \frac{b_m s^m + b_{m-1} s^{m-1} + \dots + b_1 s + b_0}{a_n s^n + a_{n-1} s^{n-1} + \dots + a_1 s + a_0} \quad (1.2)$$

Note that the denominator polynomial of (1.2) is the coefficient of C(s). This polynomial set equal to zero is the characteristic equation of the differential equation (1.1). It will become apparent in the next chapter that the a_i coefficients in (1.1) are parameters of the physical system described by the differential equation. It follows; therefore, that the characteristic equation does indeed characterize the system, since its roots are dependent only upon the system parameters.

1.6 Linearization of nonlinear systems

A great majority of physical systems are linear within some range of the variables. However all systems ultimately become nonlinear as the variables are increased without limit. A system is called linear if the principle of superposition applies. The principle of superposition states that the response produced by the simultaneous application of two different forcing functions is the sum of the two individual responses. Hence, for the linear system, treating one input at a time and adding the results can calculate the response to several inputs. In the dynamic system if the cause and effects are proportional, thus implying that the principle of superposition holds, and then the system can be considered linear.

Consider a nonlinear system $y(t) = f(x)$ shown graphically as in Figure 1.14.

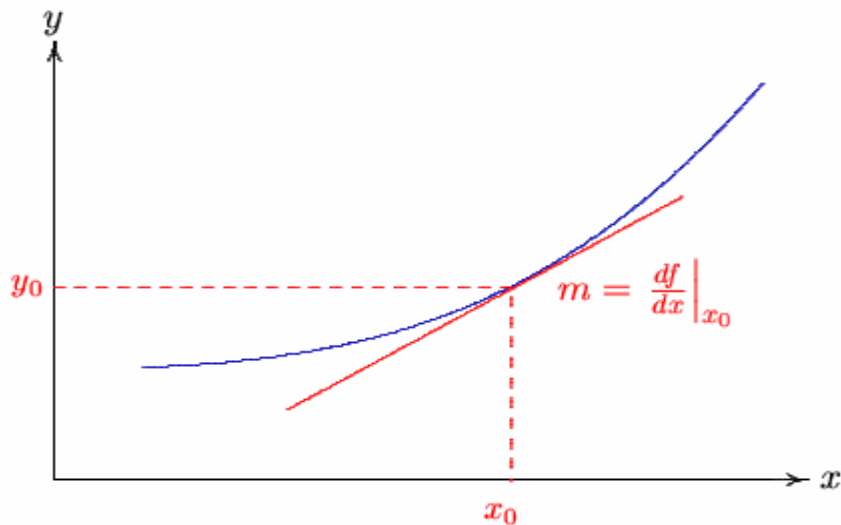

Figure 1.14 A graphical representation of a nonlinear element

If the variation of x about x_0 are small enough, the nonlinear curve can be approximated by its tangent at a .

The Taylor series expansion about the operating point is

A good approximation to the curve over a small range

$$f(x) = f(x_0) + \left. \frac{df}{dx} \right|_{x=x_0} (x - x_0)$$

or

$$y - y_0 = m(x - x_0) \tag{1.3}$$

Where $m = \left. \frac{df}{dx} \right|_{x=x_0}$ is the slope at the operating point

Chapter 2

Mathematical Modeling of Physical Systems

Introduction

The first step in the analysis and design of control systems is mathematical modeling of the system. The two most common methods are the transfer function representation and the state equation approach. The state equations can be applied to portray linear as well as nonlinear system and will be discussed in the next chapter.

All physical systems are nonlinear to some extent; in order to use the transfer function and linear state equations the system must first be linearized. Thus, the first task of the control systems engineer is to make proper assumptions and approximations so that a linear mathematical model can characterize the system.

The dynamic performance of the physical systems is obtained by utilizing the physical laws of electrical, mechanical, fluid and thermodynamic systems. We generally model physical systems with linear differential equations with constant coefficients when possible. Other models can be derived from the differential equation.

2.1 Electrical Systems

Electric systems are often used extensively in a control system to filter or modify a signal in order to obtain satisfactory performance of the system. The model of electrical systems is determined by the application of nodal and loop analysis. The Laplace transform of the resulting integral-differential equation are obtained with zero initial conditions. A detailed transfer function block diagram can be obtained by denoting the relationship between variables graphically by means of the block diagrams. Alternatively, the s-domain equations may be solved for an output/input ratio, which is the desired transfer function.

Example 2.1

Find the transfer function relating the capacitor voltage $V_c(s)$, to the input voltage, $V_i(s)$.

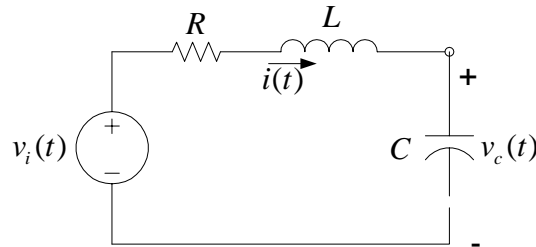

Figure 2.1 Circuit of Example 2.1

Applying KVL

$$Ri(t) + L \frac{di(t)}{dt} + v_c(t) = v_i(t) \quad (2.1)$$

and

$$i(t) = c \frac{dv_c(t)}{dt} \quad (2.2)$$

Taking Laplace transforms with zero initial conditions, we obtain

$$[R + Ls]I(s) + V_c(s) = V_i(s) \quad (2.3)$$

and

$$I(s) = CsV_c(s) \quad (2.4)$$

Substituting from (2.4) into (2.3), the system transfer function is

$$[LCs^2 + RCs + 1]V_c(s) = V_i(s)$$

or

$$\frac{V_c(s)}{V_i(s)} = \frac{1}{LCs^2 + RCs + 1}$$

or

$$G(s) = \frac{\frac{1}{LC}}{s^2 + \frac{R}{L}s + \frac{1}{LC}} \quad (2.5)$$

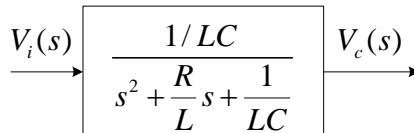

2.2 Block Diagrams

The *block diagram* is a short hand, pictorial representation of the cause and effect relationship between the input and output of a physical system. It provides a convenient and useful method for characterizing the functional relationships among the various components of a control system. The relation $V_2(s) = G(s)V_1(s)$ is represented by a transfer function block as shown:

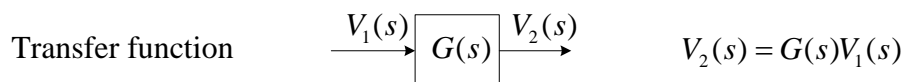

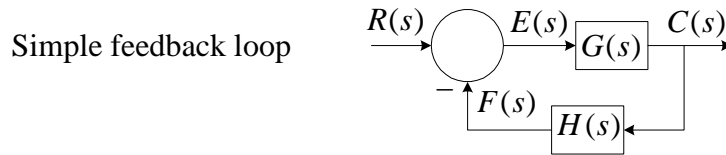
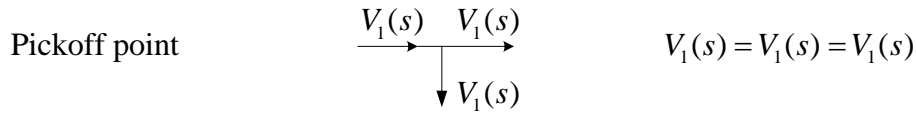
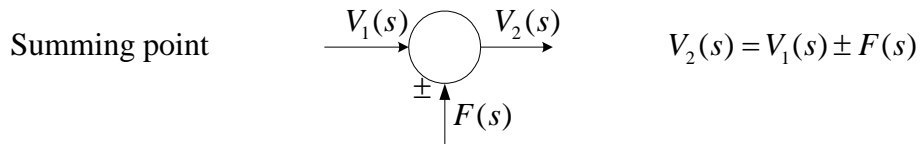

Consider the above simplified feedback system. Where

$G(s)$ is the transfer function of the forward path,

$H(s)$ is the transfer function of the feedback path,

$R(s)$ is the Laplace transform of the reference input $r(t)$

$E(s)$ is the Laplace transform of the actuating signal or error signal $e(t)$

$C(s)$ is the Laplace transform of the controlled variable or output $c(t)$

From the above block diagram the following three equations may be written

$$C(s) = G(s)E(s)$$

$$F(s) = H(s)C(s)$$

$$E(s) = R(s) - F(s)$$

Eliminating $E(s)$ and $F(s)$ will result in

$$\frac{C(s)}{R(s)} = \frac{G(s)}{1 + G(s)H(s)} \quad (2.6)$$

A block diagram representation for the electric system of Example 2.1 with $V_i(s)$ as input and $V_c(s)$ as output is obtained by utilizing Eqs. (2.3) and (2.4), i.e.

$$\frac{1}{R + Ls} [V_i(s) - V_c(s)] = I(s)$$

and

$$\frac{1}{Cs} I(s) = V_c(s)$$

Applying the above pictorial representations to these equations will result in the following block diagram.

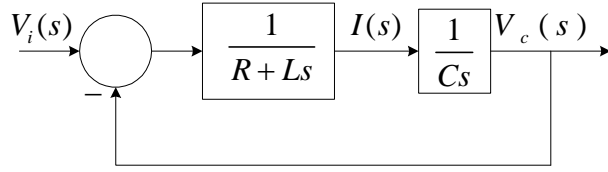

Figure 2.2 Block diagram of Example 2.1.

The above feedback system where $H(s)$, is called a *unity feedback* system. Applying (2.6) we have

$$T(s) = \frac{V_c(s)}{V_i(s)} = \frac{\frac{1}{Cs(R+Ls)}}{1 + \frac{1}{Cs(R+Ls)}} = \frac{1}{LCs^2 + RCs + 1} \quad (1)$$

This is the same as the transfer function obtained in (2.5).

2.3 Block Diagrams Reduction

Example 2.2

Consider the block diagram shown in Figure 2.3

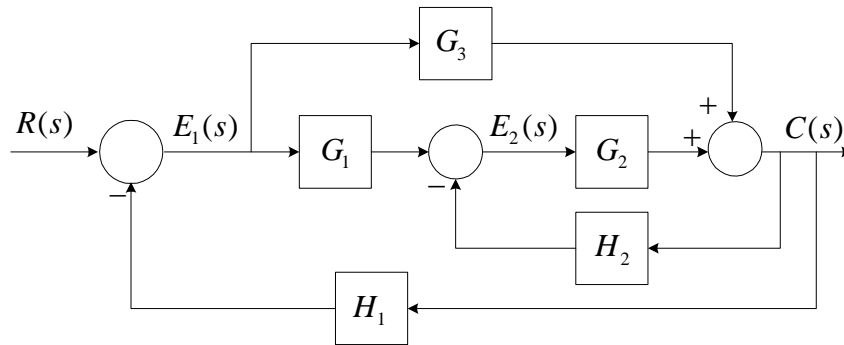

Figure 2.3 Block diagram of Example 2.2

The equation describing the above block diagram is (Write one equation for the output of each summing point)

$$E_1(s) = R(s) - H_1C(s) \quad (2.7)$$

$$E_2(s) = G_1E_1(s) - H_2C(s) \quad (2.8)$$

$$C(s) = G_3E_1(s) + G_2E_2(s) \quad (2.9)$$

Which describe the system completely with variables $E_1(s)$, $E_2(s)$, and $C(s)$.

Method 1 Back substitution

Substituting (2.8) into (2.9) gives

$$C(s) = G_3 E_1(s) + G_2 [G_1 E_1(s) - H_2 C(s)] \quad (2.10)$$

Finally, substituting (2.7) into (2.10) and simplifying yields the desired transfer function

$$\frac{C(s)}{R(s)} = \frac{G_1 G_2 + G_3}{1 + G_2 H_2 + G_1 G_2 H_1 + G_3 H_1}$$

Method 2 Matrix form and Application of Cramer's Rule

Rewriting (2.7)-(2.9), we have

$$\begin{aligned} E_1 + H_1 C &= R \\ G_1 E_1 - E_2 - H_2 C &= 0 \\ G_3 E_1 + G_2 E_2 - C &= 0 \end{aligned} \Rightarrow \begin{bmatrix} 1 & 0 & H_1 \\ G_1 & -1 & -H_2 \\ G_3 & G_2 & -1 \end{bmatrix} \begin{bmatrix} E_1 \\ E_2 \\ C \end{bmatrix} = \begin{bmatrix} R \\ 0 \\ 0 \end{bmatrix}$$

Solving for C

$$\frac{\begin{vmatrix} 1 & 0 & 1 \\ G_1 & -1 & 0 \\ G_3 & G_2 & 0 \end{vmatrix}}{\begin{vmatrix} 1 & 0 & H_1 \\ G_1 & -1 & -H_2 \\ G_3 & G_2 & -1 \end{vmatrix}} R(s) \Rightarrow \frac{C(s)}{R(s)} = \frac{G_1 G_2 + G_3}{1 + G_2 H_2 + G_1 G_2 H_1 + G_3 H_1}$$

2.4 Block Diagram Transformation Rules

Block diagrams of complicated control systems may be simplified using easily derivable transformations.

Block Diagram Transformation Rules

1. Combining cascade blocks



2. Combining parallel blocks

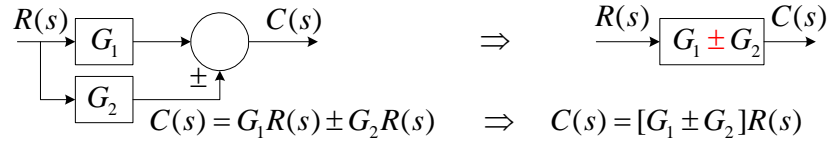

3. Moving a summing point ahead a blocks

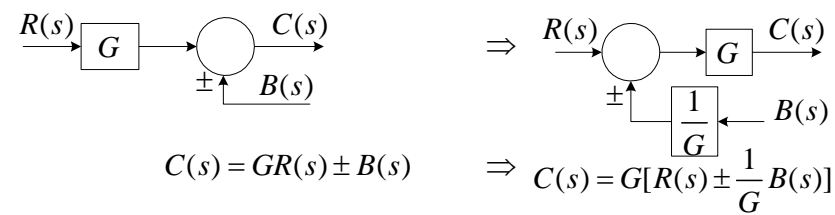

4. Moving a summing point beyond a blocks

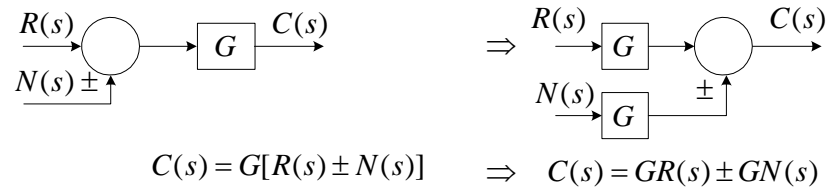

5. Moving a pickoff point ahead of a blocks

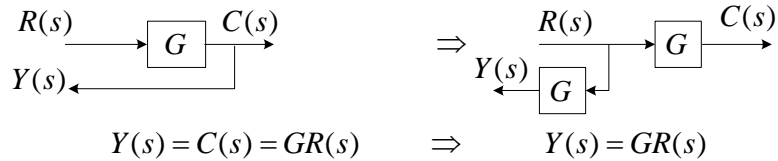

6. Moving a pickoff point beyond a blocks

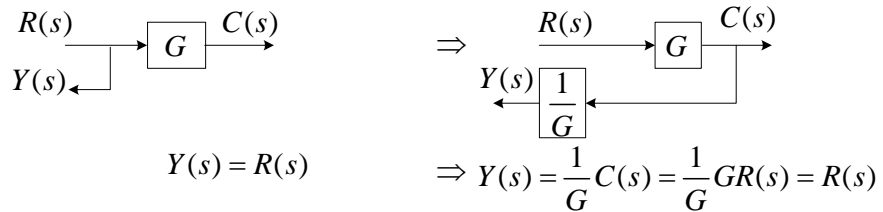

7. Eliminating single feedback loop

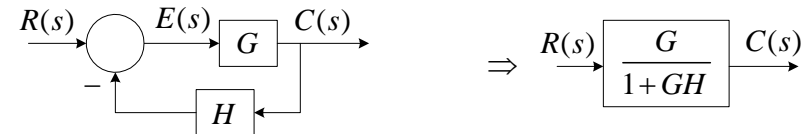
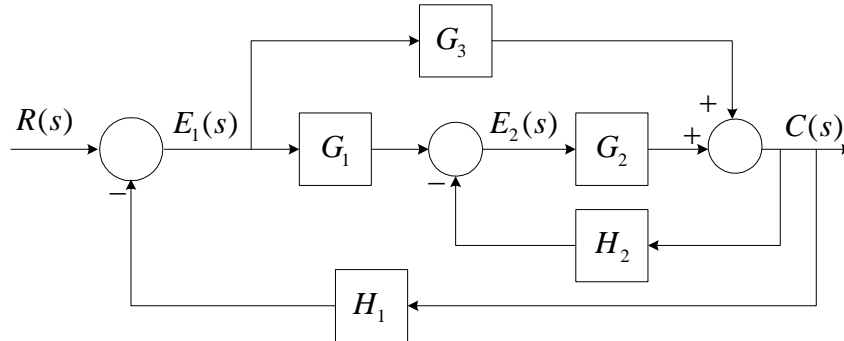

Figure 2.4 Block diagram transformational rules

Example 2.3

Apply the block diagram transformation rules to example 2.2 to determine the system transfer function



Moving the summing point ahead of a block

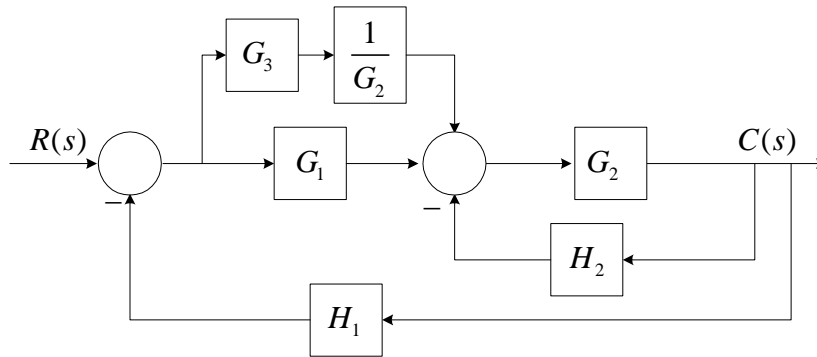

Eliminating parallel block and the feedback loop

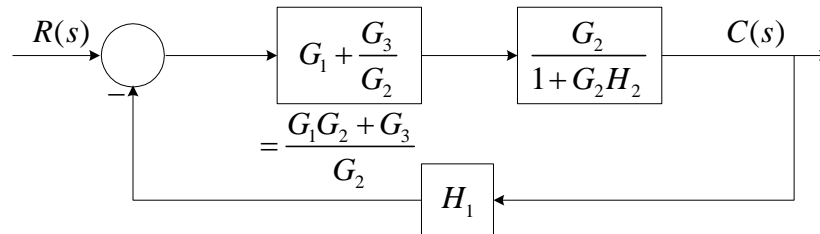

Eliminating the feedback loop

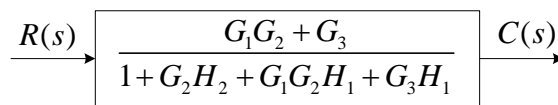

Example 2.4

Using block diagram transformation Determine C/R for the following systems

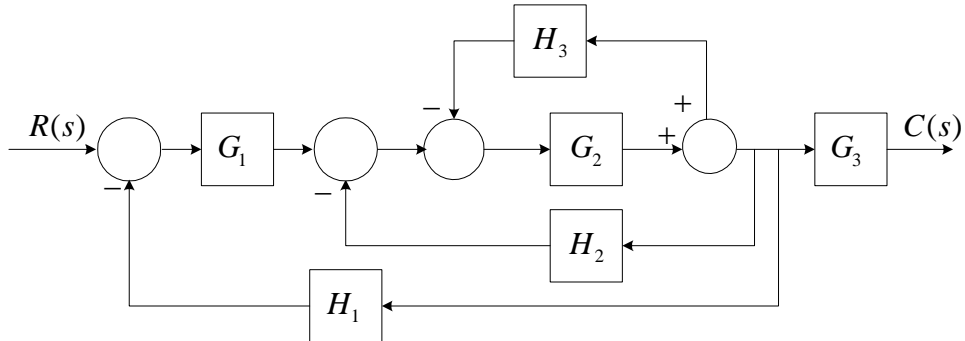

Moving takeoff point beyond block G_3 and eliminating a feedback loop

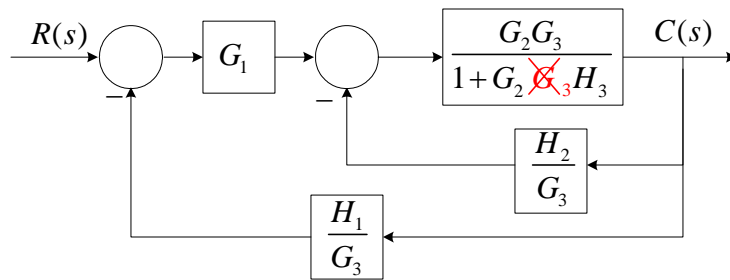

Eliminating the next feedback loop

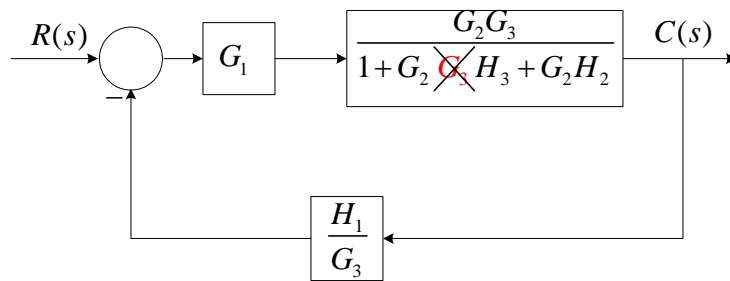

Eliminating the last feedback loop

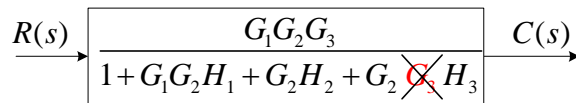

Example 2.5

Determine $\frac{C(s)}{R(s)}$

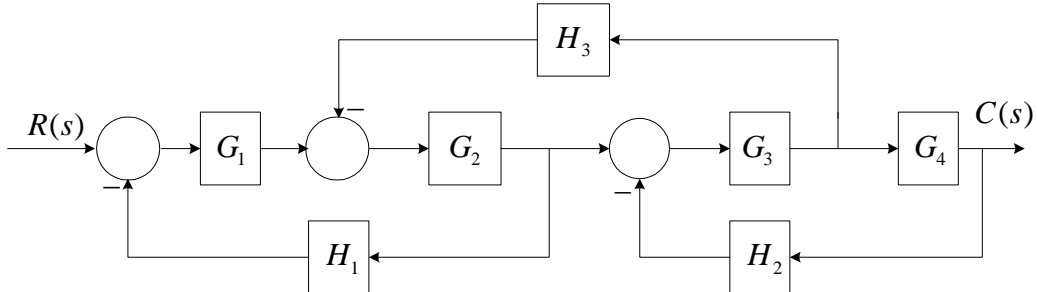

Moving one takeoff beyond G_4 and eliminating the feedback loop $G_3G_4H_2$

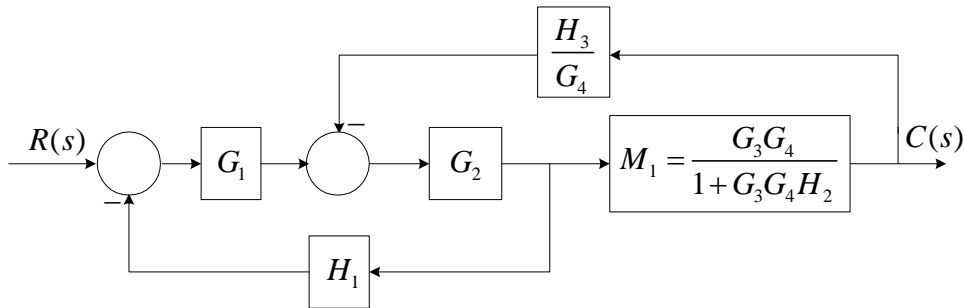

Moving takeoff point beyond block M_1 and eliminating the top feedback loop

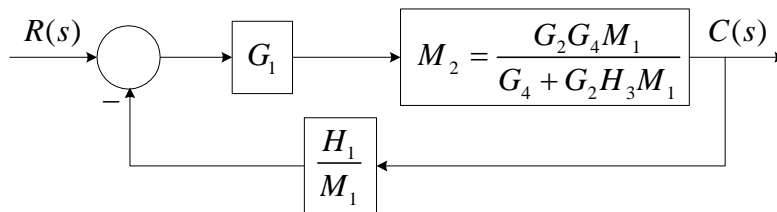

Substituting for M_1 , we have

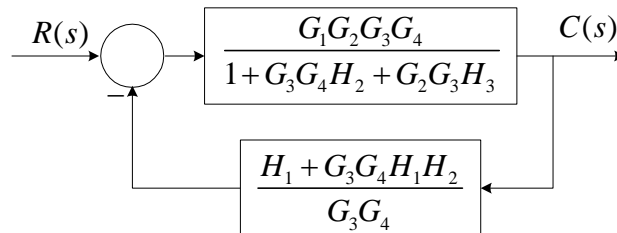

Eliminating the feedback loop

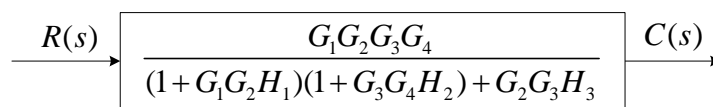

2.5 Transfer Function (Multivariable System)

The definition of transfer function can be extended to a system with a multiple number of inputs and outputs (*multivariable system*). Consider a system with two inputs and two outputs as shown in Figure 2.5.

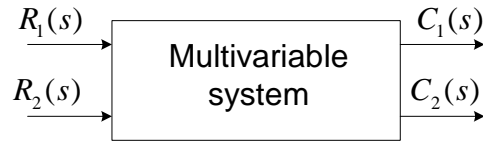

Figure 2.5

When dealing with the relationship between one input and one output, it is assumed that all other inputs are set to zero, e.g.,

$$G_{11} = \left. \frac{C_1(s)}{R_1(s)} \right|_{R_2 = 0} \quad G_{12} = \left. \frac{C_1(s)}{R_2(s)} \right|_{R_1 = 0} \quad (2.11)$$

$$G_{21} = \left. \frac{C_2(s)}{R_1(s)} \right|_{R_2 = 0} \quad G_{22} = \left. \frac{C_2(s)}{R_2(s)} \right|_{R_1 = 0} \quad (2.12)$$

Since the principle of superposition is valid for linear system, the total effect on any output variable due to all the inputs acting simultaneously is obtained by adding up the outputs due to each input acting alone.

$$\begin{aligned} C_1(s) &= G_{11}R_1(s) + G_{12}R_2(s) \\ C_2(s) &= G_{21}R_1(s) + G_{22}R_2(s) \end{aligned} \quad (2.13)$$

Representing the above by matrix equation we have

$$C(s) = G(s)R(s) \quad (2.14)$$

Where

$$G = \begin{bmatrix} G_{11} & G_{12} \\ G_{21} & G_{22} \end{bmatrix}$$

Example 2.6

Determine $\frac{C(s)}{R_2(s)}$

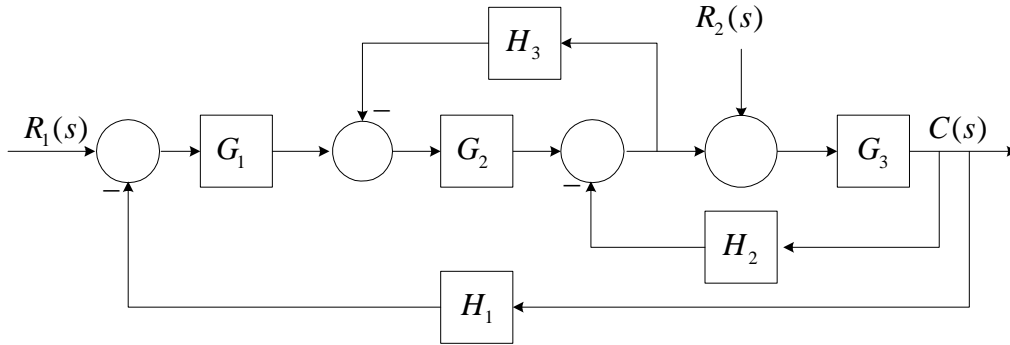

Redrawing the block diagram with $R_1 = 0$ and moving the second summing point beyond block G_2

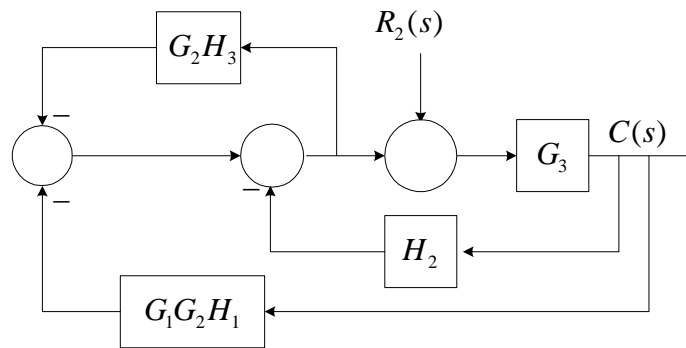

Combining parallel blocks

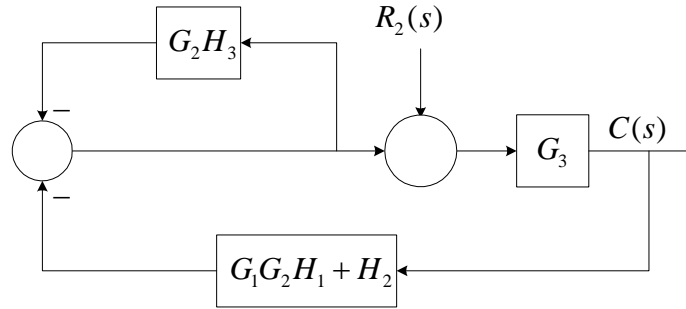

Eliminating the top feedback loop

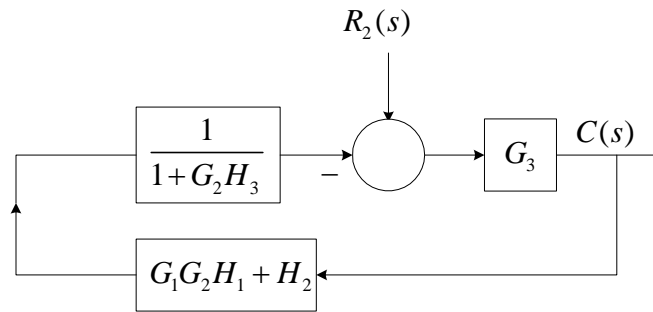

Combining cascade blocks

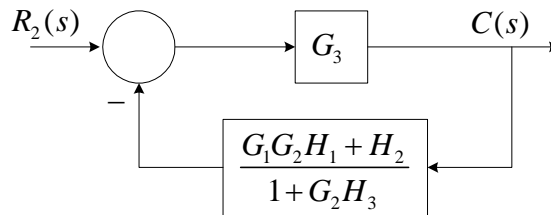

Eliminating the feedback loop

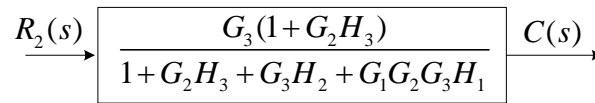

2.7 Signal Flow Graph

A signal Flow Graph is a pictorial representation of the simultaneous equations describing a system. It graphically displays the transmission of signals through the system. It is easier to draw and therefore easier to manipulate than the block diagram. The properties of signal flow graph are as follow:

Let us first consider the simple equation

$$Y = AX \quad (2.15)$$

Where A is a mathematical operator mapping X into Y , and is called the transmission function. The signal flow graph for the above equation is

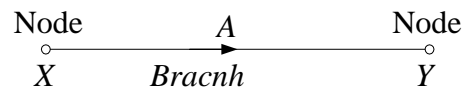

Figure 2.6

Variables X and Y are represented by a small dot called node, and the transmission function A is represented by a line with an arrow, called branch. Signals travel along branches only in the direction described by the arrows of the branches. The branch directing from node X to node Y represent the dependence of variable X upon Y , but not the reverse.

2.8 Signal Flow Graph Definitions

The following terminology is frequently used in signal flow graph theory.

Node Nodes on a signal flow graph represent system variables.

Branch Branches are unidirectional paths that connect the nodes. An arrow is assigned to indicate the direction of cause and effect.

Input node An input node has only outgoing branches

Output node An output node has only incoming branches.

Path A path is a continuous connection of branches with arrows in the same direction.

Loop A loop is a path that starts and ends on the same node with all other nodes in the loop touched only once.

Common node Common node is a node that is contained in two or more loops.

Nontouching loop Nontouching loops are loops that have no common nodes.

Forward path A forward path starts at an input node, ends at an output node, and touches no node more than once. A forward path may traverse one or more feedback branches in proceeding from input to output nodes.

Gains Gains for paths and loops are defined as the products of branch gains for the paths or loops.

Signal Flow Graph Algebra

1. Addition Rule: - The value of a variable designated by a node is equal to the sum of all signals entering the node, i.e. equation

$$Y = a_1X_1 + a_2X_2 + a_3X_3 + a_4X_4$$

is represented by

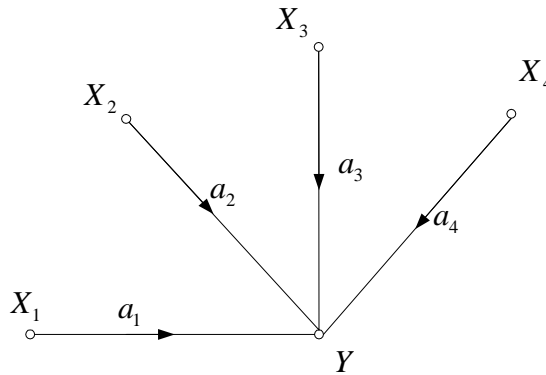

Figure 2.7

2. Transmission Rule: - The value of a variable designated by a node is transmitted on every branch leaving that node. In other words, the equation

$$Y_1 = b_1X, \quad Y_2 = b_2X, \quad Y_3 = b_3X$$

is represented by

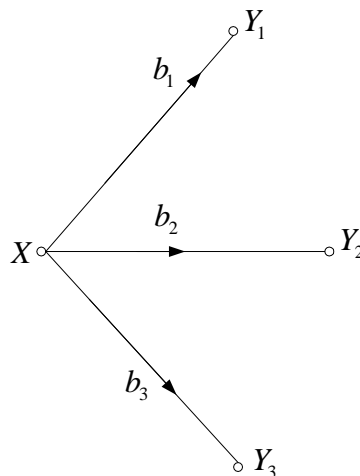

Figure 2.8

3. Parallel Branches: - Parallel branches in the same direction connecting two nodes can be replaced by a single branch with gain equal to the sum of the gains of the parallel branches

4. Multiplication Rule: - A cascade connection or series connection of unidirectional branches can be replaced by a single branch with gain equal to the product of branch gains.

2.9 General Gain Formula (Mason's Gain Rule)

It is possible to simplify signal flow graph in a manner similar to that of block diagram reduction. But it is also possible, and much less time-consuming, to write down the input-output relationship by inspection from the original signal flow graph. This can be accomplished by the use of general gain formula, known as Mason's Gain Formula.

$$G(s) = \frac{C(s)}{R(s)} = \sum_{k=1}^n \frac{M_k \Delta_k}{\Delta} \quad (2.16)$$

where

r = Input node variable

c = Output node variable

G = Gain between input r and output c

n = Total number of forward paths

M_k = Gain of the k th forward path

Δ = 1 - (sum of all individual loop gains) + (sum of gain products of all possible combinations of two nontouching loops) - (sum of the gain products of all possible combinations of three nontouching loops) + . . .

Δ_k = The Δ for the part of the signal flow graph which is nontouching with the k th forward path. If all loops touches path k , $\Delta_k = 1$.

It must be emphasized that the gain formula can be applied only between an input node and an output node.

Example 2.7

Determine the close loop transfer function for the block diagram of example 2.2 by using Mason's gain formula.

The following signal flow graph is obtained from Example 2.2 block diagram or the following equations describing the block diagram.

$$E_1(s) = R(s) - H_1C(s)$$

$$E_2(s) = G_1E_1(s) - H_2C(s)$$

$$C(s) = G_3E_1(s) + G_2E_2(s)$$

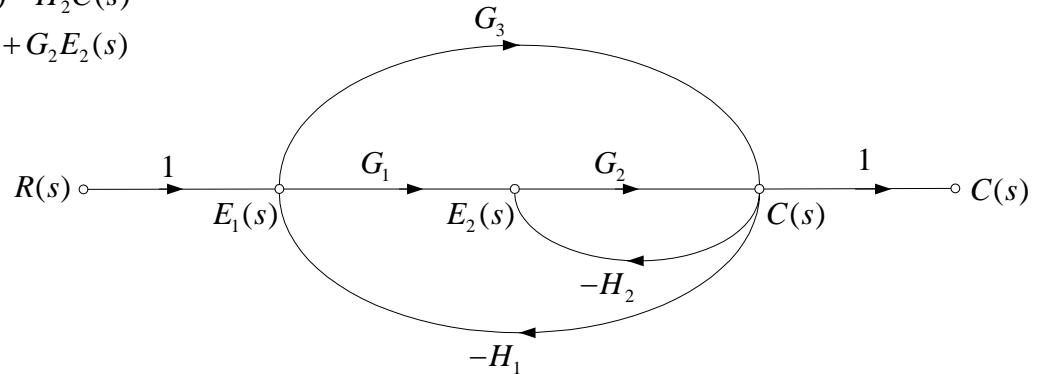

There are two forward paths with gains

$$M_1 = G_1G_2$$

$$M_2 = G_3$$

There are three individual loops, with gains

$$L_1 = -G_2H_2$$

$$L_2 = -G_1G_2H_1$$

$$L_3 = -G_3H_1$$

Since these three single loops have at least one common node, there is no combination of two nontouching loops. Therefore Δ is given by

$$\Delta = 1 - (L_1 + L_2 + L_3)$$

$$= 1 + G_2H_2 + G_1G_2H_1 + G_3H_1$$

Both paths have at least one node in common with every single loop. Therefore

$$\Delta_1 = \Delta_2 = 1.$$

$$\frac{C(s)}{R(s)} = \frac{G_1G_2 + G_3}{1 + G_2H_2 + G_1G_2H_1 + G_3H_1}$$

which agrees with the result in example 2.2.

The above equations describing the system of Example 2.7 can be written in MATLAB and using the Symbolic Toolbox “**solve**” function, the transfer function can be obtained as follows:

```
syms R E1 E2 C G1 G2 G3 H1 H2      % Define the system variables and gains
eq1 = E1 + H1*C -R;
eq2 = G1*E1 - E2 - H2*C;
eq3 = G3*E1+ G2*E2 - C;
S = solve(eq1, eq2, eq3, E1, E2, C);
G=S.C/R                             % Obtains the transfer function C(s)/R(s)
```

The result is

G =

$$(G3+G2*G1)/(G3*H1+G2*G1*H1+G2*H2+1)$$

Example 2.8

For the signal flow graph shown, use the general gain formula to find the transfer function $\frac{C(s)}{R(s)}$

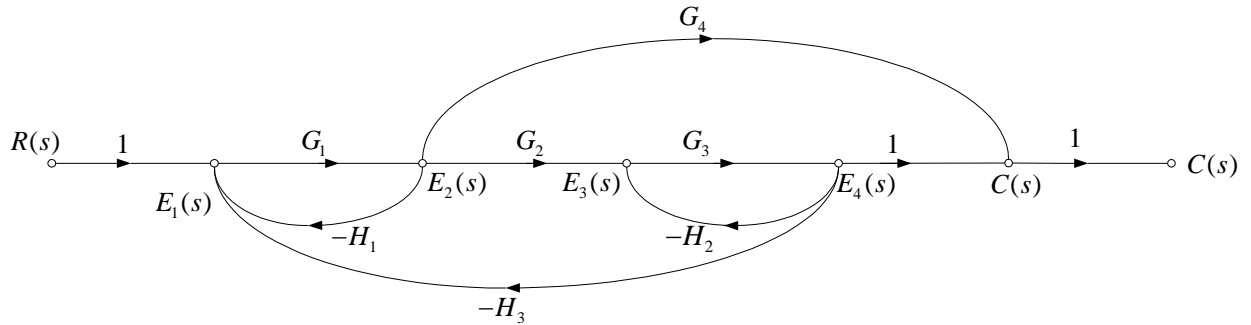

Forward paths:

$$M_1 = G_1 G_2 G_3$$

$$M_2 = G_1 G_4$$

Loops:

$$L_1 = -G_1 H_1$$

$$L_2 = -G_3 H_2$$

$$L_3 = -G_1 G_2 G_3 H_3$$

Nontouching loops:

$$L_1 L_2 = G_1 H_1 G_3 H_2$$

Therefore Δ is given by

$$\Delta = 1 - (-G_1 H_1 - G_3 H_2 + G_1 G_2 G_3 H_3) + G_1 H_1 G_3 H_2$$

M_1 touches all loops, therefore $\Delta_1 = 1$

L_2 does not touch forward path M_2 , therefore $\Delta_2 = 1 + G_3 H_2$

The transfer function is

$$\frac{C(s)}{R(s)} = \frac{G_1 G_2 G_3 + G_1 G_4 (1 + G_3 H_2)}{1 + G_1 H_1 + G_3 H_2 + G_1 G_2 G_3 H_3 + G_1 H_1 G_3 H_2}$$

The following statements

```

syms R E1 E2 E3 E4 C G1 G2 G3 G4 H1 H2 H3
eq1 = E1 + H1*E2 + H3*E4 - R;
eq2 = E2 - G1*E1;
eq3 = E3 - G2*E2 + H2*E4;
eq4 = E4 - G3*E3;
eq5 = C - E4 - G4*E2;
S = solve(eq1, eq2, eq3, eq4, eq5, E1, E2, E3, E4, C);
G=S.C/R % Obtains the transfer function C(s)/R(s)

```

Results in

G =

$$G1*(G3*G2+G4+G4*H2*G3)/(1+H2*G3+G1*H1+H1*G1*H2*G3+H3*G3*G2*G1)$$

Example 2.9

A system with several feedback loops and forward paths is shown. Using Mason's rule, find the transfer function of the system

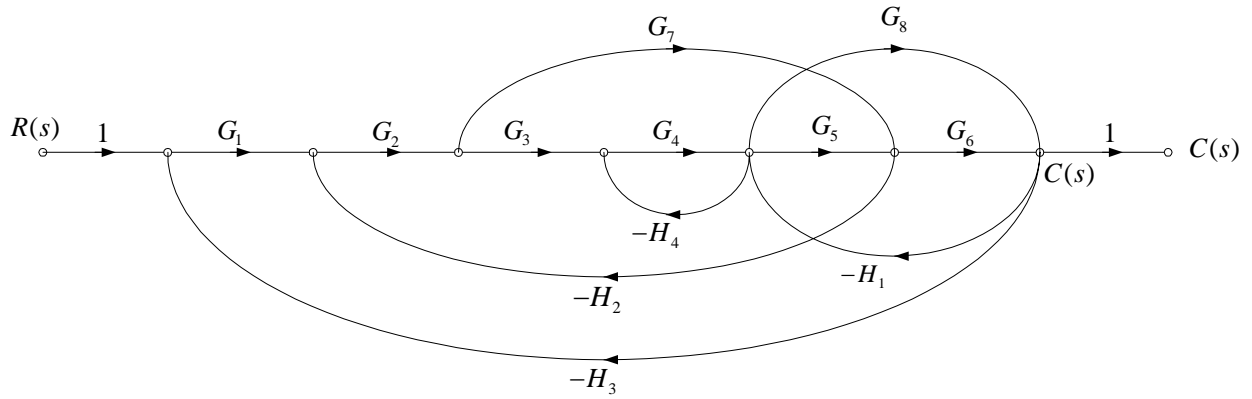

The forward paths are

$$M_1 = G_1 G_2 G_3 G_4 G_5 G_6 \quad \Rightarrow \quad \Delta_1 = 1$$

$$M_2 = G_1 G_2 G_7 G_6 \quad \Rightarrow \quad \Delta_2 = 1 - L_5 = 1 + G_4 H_4$$

$$M_3 = G_1 G_2 G_3 G_4 G_8 \quad \Rightarrow \quad \Delta_3 = 1$$

The feedback loops are

$$L_1 = -G_2 G_3 G_4 G_5 H_2$$

$$L_2 = -G_5 G_6 H_1$$

$$L_3 = -G_8 H_1$$

$$L_4 = -G_2 G_7 H_2$$

$$L_5 = -G_4 H_4$$

$$L_6 = -G_1 G_2 G_3 G_4 G_5 G_6 H_3$$

$$L_7 = -G_1 G_2 G_7 G_6 H_3$$

$$L_8 = -G_1 G_2 G_3 G_4 G_8 H_3$$

Loop L_5 does not touch loops L_4 and L_7 . Also L_3 does not touch L_4 .

$$\Delta = 1 - (L_1 + L_2 + L_3 + L_4 + L_5 + L_6 + L_7 + L_8) + L_5 L_4 + L_5 L_7 + L_3 L_4$$

$$G(s) = \frac{C(s)}{R(s)} = \frac{M_1 + M_2 \Delta_2 + M_3}{\Delta}$$

Substitute and obtain the transfer function

2.10 Modeling of Mechanical System

Most feedback control systems contain mechanical as well as electrical components. The motion of mechanical elements are either translational, rotational, or a combination of both. The equations governing the motions of mechanical systems are formulated from Newton's law of motion.

2.11 Translational Motion

This is the motion of a rigid body along a straight line. Newton's Law of motion states that the algebraic sum of forces acting on a rigid body in a given direction is equal to the product of the mass of the body and its acceleration in the same direction. i.e.

$$\sum \text{forces} = Ma \quad (2.17)$$

For translational motion, the following elements are usually involved.

Mass- Mass is considered as an indication of the property of an element, which stores the kinetic energy of translational motion. It is analogous to inductance of electrical

networks, $M = \frac{W}{g}$

g is the acceleration of the body due to the force of gravity, $g = 9.81 \text{ m/sec}^2$ or 32.2 ft/sec^2 .

The force equation is written as

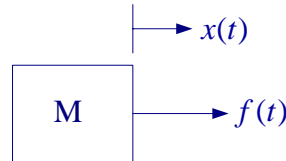

$$f(t) = Ma(t) = M \frac{d^2x(t)}{dt^2} = M \frac{du(t)}{dt} \quad (2.18)$$

Spring- A spring is considered to be an element that stores potential energy. It is analogous to a capacitor in electrical network. Its behavior may be approximated by a linear relationship.

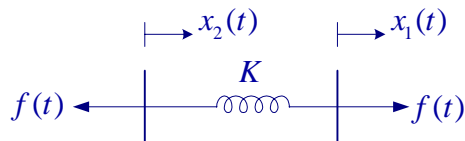

$$f(t) = K[x_1(t) - x_2(t)] \quad (2.19)$$

where K is the spring stiffness (or constant) measured in N/m.

Friction for Translational Motion: - Whenever there is motion between two elements,

frictional forces exist. In practice, frictional forces may be assumed to be *viscous friction*. Viscous friction represents a retarding force that is a linear relationship between the applied force and velocity.

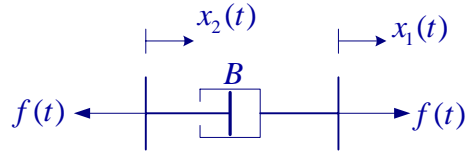

$$f(t) = B \left[\frac{dx_1(t)}{dt} - \frac{dx_2(t)}{dt} \right] \quad (2.20)$$

where B is the viscous frictional coefficient in N-s/m

Example 2.10

Find the transfer function for the system shown in Figure 2.9 (a).

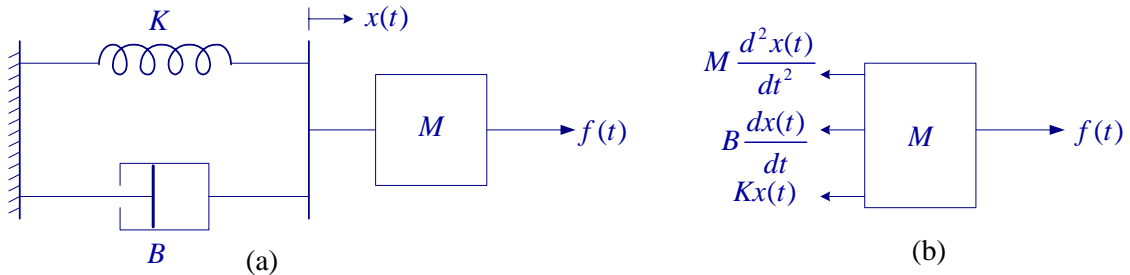

Figure 2.9

We draw the free-body diagram as shown in Figure 2.9 (b). The applied force is directed to the right. Forces due to the acceleration of mass, friction and spring impede the motion and act to oppose it. These forces point to the left as shown. Using Newton’s law of motion we have

$$f(t) = M \frac{d^2x(t)}{dt^2} + B \frac{dx(t)}{dt} + Kx(t)$$

Taking the Laplace transform, we have

$$F(s) = [Ms^2 + Bs + K]X(s)$$

Taking the displacement of the mass $x(t)$ as the output and the applied force $f(t)$ as the input, the transfer function is

$$G(s) = \frac{X(s)}{F(s)} = \frac{1}{Ms^2 + Bs + K}$$

Analogous Systems

We can obtain an analogous electrical system for the above mechanical system.

Mechanical System

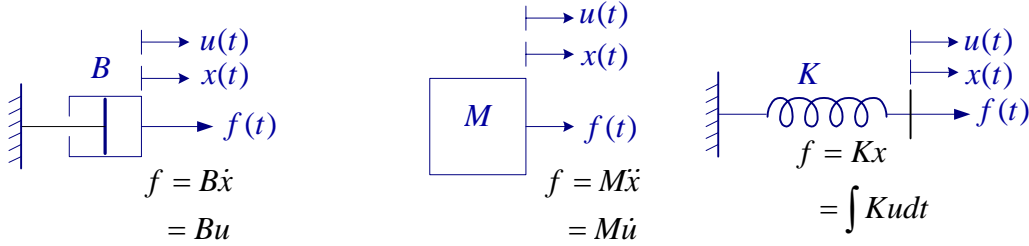

Electrical System

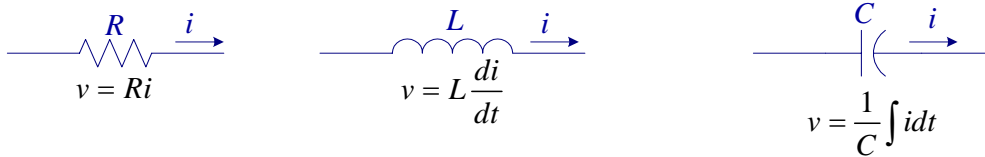

Figure 2.10

From the above relations we can observe the following analogy

Mechanical system

Force	f
Velocity	u
Frictional coefficient	B
Mass	M
Compliance	$\frac{1}{K}$

Electrical system

emf	v
Current	i
Resistance	R
Inductance	L
Capacitance	C

From the force equation it is easy to verify that the above mechanical system is analogous to a series RLC circuit.

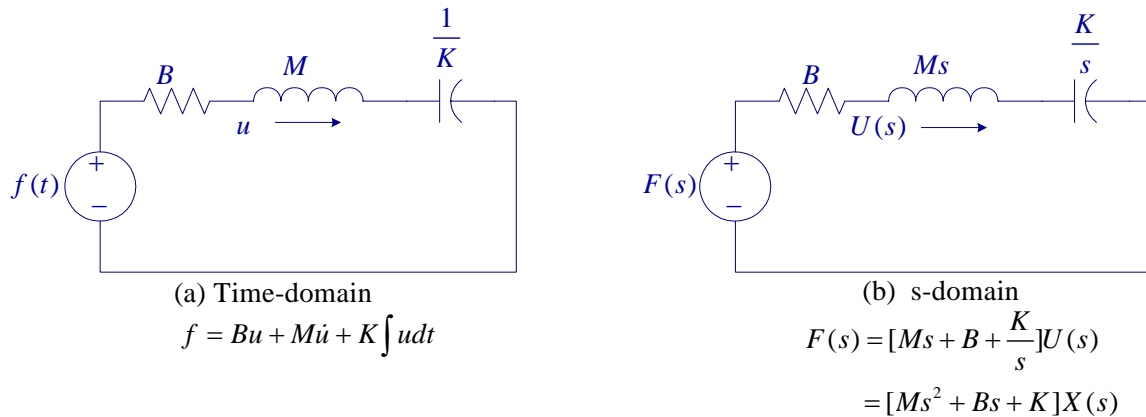
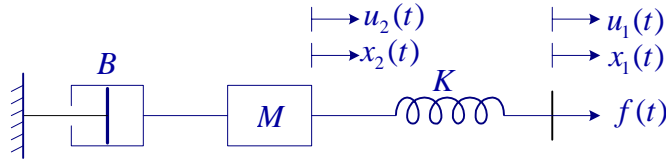

Figure 2.11

Example 2.11

The system shown is initially at rest. Find the transfer function $G(s) = \frac{X_2(s)}{F(s)}$



To draw the electric circuit analogy with velocity analogous to current, note that the spring is moving with velocity $(u_1 - u_2)$. Clearly, we have two loops and the circuit is as shown.

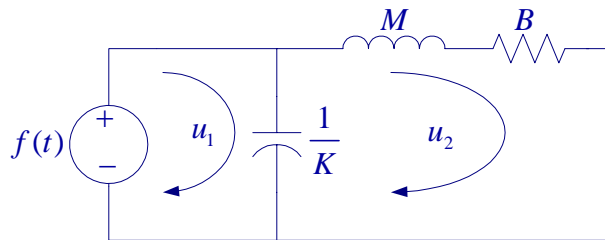

$$f(t) = K \int (u_1 - u_2) dt \quad \Rightarrow \quad f(t) = K(x_1 - x_2)$$

$$M\dot{u}_2 + Bu_2 + K \int (u_2 - u_1) dt = 0 \quad \Rightarrow \quad M\ddot{x}_2 + B\dot{x}_2 + K(x_2 - x_1) = 0$$

Taking Laplace transform, we get

$$F(s) = K[X_1(s) - X_2(s)]$$

$$[Ms^2 + Bs + K]X_2(s) - KX_1(s) = 0$$

Alternatively, we can draw the s-domain equivalent circuit and then write the mesh equations.

Writing mesh equations by inspection in matrix form, we get

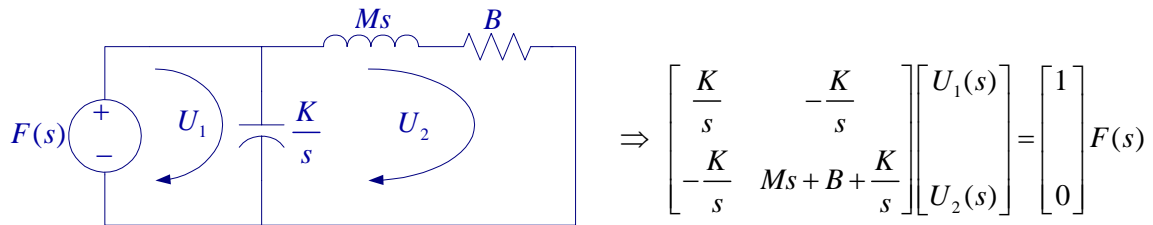

The transfer function with $U_2(s)$ as output and $F(s)$ as input can be found by using Cramer's rule

$$U_2(s) = \frac{\begin{vmatrix} \frac{K}{s} & 1 \\ -\frac{K}{s} & 0 \end{vmatrix} F(s)}{\begin{vmatrix} \frac{K}{s} & -\frac{K}{s} \\ -\frac{K}{s} & Ms + B + \frac{K}{s} \end{vmatrix}} = \frac{\frac{K}{s} F(s)}{\frac{K}{s} \left(Ms + B + \frac{K}{s} \right) - \frac{K^2}{s^2}}$$

Reducing the above expression result in

$$\frac{U_2(s)}{F(s)} = \frac{1}{Ms + B}$$

Since $U_2(s) = sX_2(s)$ then the transfer function in terms of the output $X_2(s)$ is

$$G(s) = \frac{X_2(s)}{F(s)} = \frac{1}{s(Ms + B)}$$

Example 2.12

The system shown is initially at rest. Draw the electric circuit analogy and write the s-domain equation describing the mechanical system.

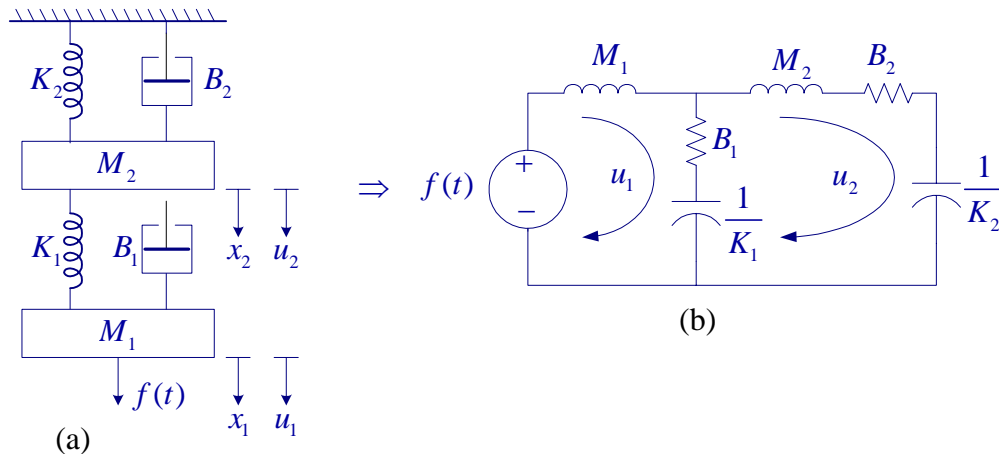

To draw the electric circuit analogy with velocity analogous to current, note that K_1 and B_1 are moving with velocity $(u_1 - u_2)$. Clearly, we have two loops and the circuit is as shown in (b) above.

Or the s-domain circuit is

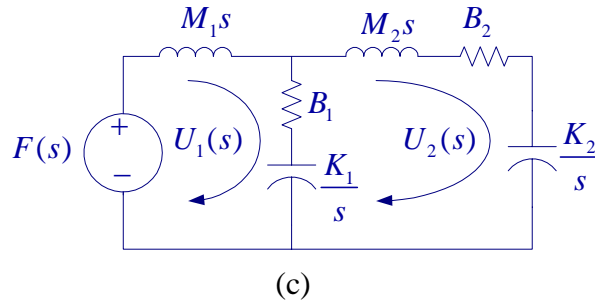

Writing mesh equations by inspection in matrix form, we get

$$\begin{bmatrix} M_1s + B_1 + \frac{K_1}{s} & -\left(B_1 + \frac{K_1}{s}\right) \\ -\left(B_1 + \frac{K_1}{s}\right) & M_2s + B_1 + B_2 + \frac{K_1}{s} + \frac{K_2}{s} \end{bmatrix} \begin{bmatrix} U_1(s) \\ U_2(s) \end{bmatrix} = \begin{bmatrix} 1 \\ 0 \end{bmatrix} F(s)$$

Or in terms of displacements, since $U_1(s) = sX_1(s)$ and $U_2(s) = sX_2(s)$, we have

$$\begin{bmatrix} M_1s^2 + B_1s + K_1 & -(B_1s + K_1) \\ -(B_1s + K_1) & M_2s^2 + (B_1 + B_2)s + K_1 + K_2 \end{bmatrix} \begin{bmatrix} X_1(s) \\ X_2(s) \end{bmatrix} = \begin{bmatrix} 1 \\ 0 \end{bmatrix} F(s)$$

Using Cramer's rule we can find the transfer function.

Example 2.13

The system shown is initially at rest. Draw the electric circuit analogy and write the s-domain equation describing the mechanical system.

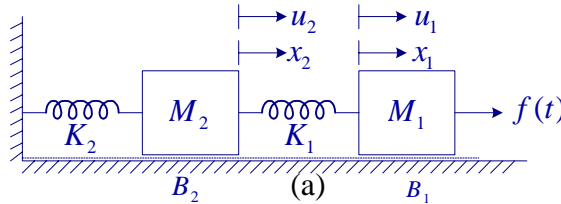

To draw the electric circuit analogy with velocity analogous to current, note that K_1 is moving with velocity $(u_1 - u_2)$. Clearly, we have two loops and the s-domain circuit is as shown in (b).

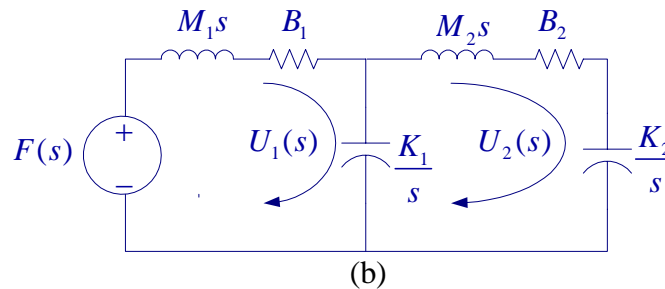

$$\begin{bmatrix} M_1s + B_1 + \frac{K_1}{s} & -\frac{K_1}{s} \\ -\frac{K_1}{s} & M_2s + B_2 + \frac{K_1}{s} + \frac{K_2}{s} \end{bmatrix} \begin{bmatrix} U_1(s) \\ U_2(s) \end{bmatrix} = \begin{bmatrix} 1 \\ 0 \end{bmatrix} F(s)$$

Or in terms of displacements since $U_1(s) = sX_1(s)$ and $U_2(s) = sX_2(s)$, we have

$$\begin{bmatrix} M_1s^2 + B_1s + K_1 & -K_1 \\ -K_1 & M_2s^2 + B_2s + K_1 + K_2 \end{bmatrix} \begin{bmatrix} X_1(s) \\ X_2(s) \end{bmatrix} = \begin{bmatrix} 1 \\ 0 \end{bmatrix} F(s)$$

Using Cramer's rule we can find the transfer function.

2.12 Rotational Motion

The variables generally used to describe the rotational motion are torque; angular acceleration, α ; angular velocity, ω ; and angular displacement, θ . The following elements are usually involved with the rotational motion.

Inertia: - Inertia, J , is considered as an indication of the property of an element, which stores the kinetic energy of rotational motion. Moment of inertia of a given disk about its axis is given by

$$J = \frac{1}{2}Mr^2 \quad (2.21)$$

where M is the mass of the disk and r its radius. Torque due to acceleration is

$$T = J\alpha = J \frac{d^2\theta}{dt^2} = J \frac{d\omega}{dt} \quad (2.22)$$

Torsional spring: - **the torque produced by a torsional spring is**

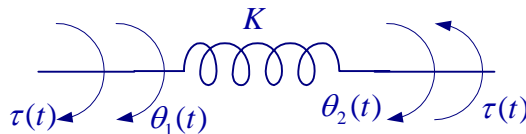

$$\tau(t) = K[\theta_1(t) - \theta_2(t)] \quad (2.23)$$

where K is the spring constant in N-m/rad.

Friction for rotational motion: - As with the linear case viscous frictional torque for rotational motion is

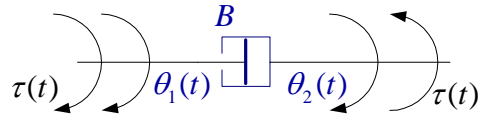

$$\tau(t) = B \left(\frac{d\theta_1(t)}{dt} - \frac{d\theta_2(t)}{dt} \right) = B[\omega_1(t) - \omega_2(t)] \quad (2.24)$$

Example 2.14

The rotational system shown consists of a cylinder of moment of inertia J . The viscous friction coefficient is B and the spring has stiffness K . A torque is applied to the shaft as shown. Write the equations describing the system and obtain the transfer function $\frac{\theta(s)}{T(s)}$

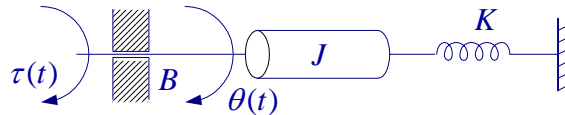

The s-domain electric circuit analogy is

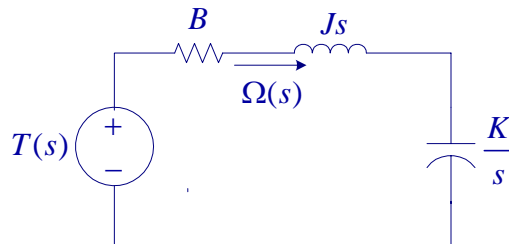

$$T(s) = \left(Js + B + \frac{K}{s} \right) \Omega(s) \quad \text{or}$$

$$T(s) = (Js^2 + Bs + K)\theta(s)$$

$$G(s) = \frac{1}{Js^2 + Bs + K}$$

Example 2.15

Write the equations describing the system shown below.

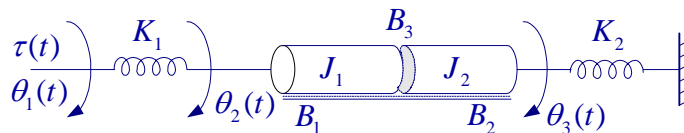

The s-domain electric circuit analogy is

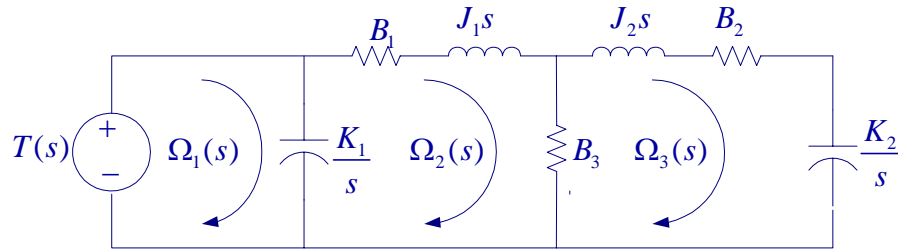

Writing mesh equations result in

$$T(s) = \frac{K_1}{s}(\Omega_1 - \Omega_2)$$

$$(B_1 + J_1s)\Omega_2 + B_3(\Omega_2 - \Omega_3) + \frac{K_1}{s}(\Omega_2 - \Omega_1) = 0$$

$$(B_2 + J_2s + \frac{K_2}{s})\Omega_3 + B_3(\Omega_3 - \Omega_2) = 0$$

or in matrix form we have

$$\begin{bmatrix} \frac{K_1}{s} & -\frac{K_1}{s} & 0 \\ -\frac{K_1}{s} & B_1 + B_3 + J_1s + \frac{K_1}{s} & -B_3 \\ 0 & -B_3 & B_2 + B_3 + J_2s + \frac{K_2}{s} \end{bmatrix} \begin{bmatrix} \Omega_1 \\ \Omega_2 \\ \Omega_3 \end{bmatrix} = \begin{bmatrix} 1 \\ 0 \\ 0 \end{bmatrix} T(s)$$

2.13 Electromechanical Systems

DC Machines

A machine is basically a torque transducer that converts electric energy into mechanical energy or vice versa. DC machines depending on the type of excitations are classified as permanent magnet, separately excited, and self-excited machines. Self-excited machines are either series field excited, shunt field excited or compound excitation.

The emf induced in the armature of a dc machine is proportional to the angular speed of the armature ω , and the field flux ϕ . When saturation is neglected, the field current is proportional to the field flux ($\phi \propto I_f$), and the induced emf can be written as

$$e = K_f I_f \omega \quad (2.25)$$

The electromechanical torque produced in the armature is proportional to the product of armature and field currents, i.e.

$$\tau = K_f I_a I_f \quad (2.26)$$

DC machines are used in control system as a generator to sense the speed, i.e., as

tachometer. Also, DC machine are used widely as motor in control systems, for example to control the position of an antenna. Because of the linear characteristics of the dc motor compared to the AC motor, DC motors are more suitable for control system applications. With the development of the Alnico, ceramic and rare-earth permanent magnet, motors offers very high torque to volume at a reasonable cost. Also, the advancement in the brush-and-commutator technology has resulted in highly reliable DC motors with very low inertia and very small time constant. These motors are used widely in computer peripheral equipment such as tape drives, printers, disk drives, as well as in automation and machine tool industries. Many other motors such as stepper motor, AC servomotor (two-phase induction motor), and synchros are also employed in control systems. Below the transfer function model of a DC motor is developed. Same procedure can be used to obtain a model for other electromechanical devices.

DC Motor Model

Consider a separately excited (or a permanent magnet) dc motor with constant field current as shown in Figure 2.12.

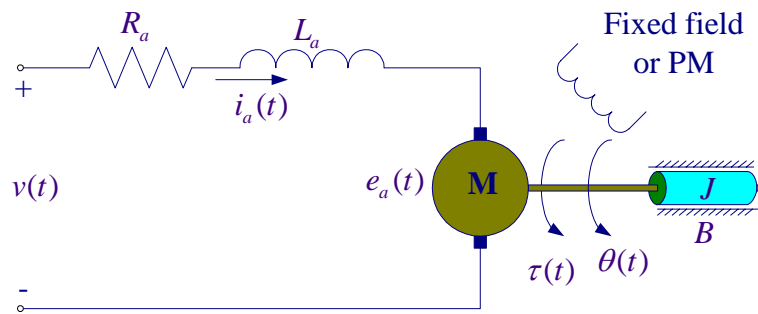

Figure 2.12 A Separately excited dc motor

For constant field current I_f let $K_m = K_\tau = K_f I_f$, then from (2.25) and (2.26) the motor back emf and the developed torque are

$$e = K_m \omega \tag{2.27}$$

$$\tau = K_\tau I_a \tag{2.28}$$

K_m and K_τ are numerically equal, K_m is expressed in Volt-sec/Rad, whereas K_τ is expressed in N-m/A.

You may draw the electric circuit analogy for the mechanical system as shown in Figure 2.13.

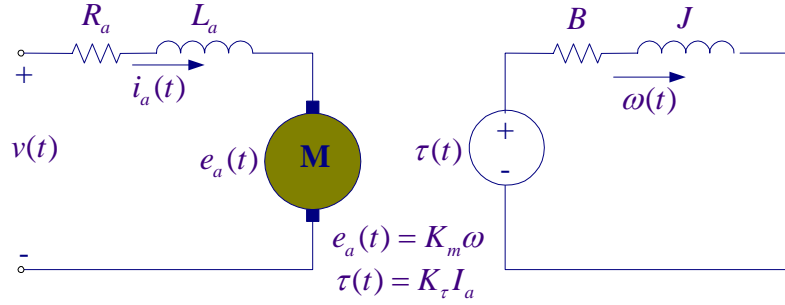

Figure 2.13

Applying the KVL to the armature circuit and the electric circuit analogy, we have

$$v(t) = Ri(t) + L \frac{di(t)}{dt} + e(t) \quad \Rightarrow \quad V(s) = [R + Ls]I_a(s) + E_a(s) \quad (2.29)$$

$$\tau(t) = B\omega(t) + M \frac{d\omega(t)}{dt} \quad \Rightarrow \quad T(s) = [B + Js]\Omega(s) \quad (2.30)$$

You may also draw the s-domain equivalent circuit and write the KVL equations directly in s-domain. From (2.29), (2.28), (2.30), and (2.27), we have the following four s-domain equations,

$$I_a(s) = \frac{1}{R_a + L_a s} [V(s) - E_a(s)]$$

$$T(s) = K_r I_a(s) \quad (2.31)$$

$$\Omega(s) = \frac{1}{B + Js} T(s)$$

$$E_a(s) = K_m \Omega(s)$$

The angular velocity $\omega = \frac{d\theta}{dt}$ or in s-domain $\Omega(s) = s\theta(s)$, therefore the angular position in s-domain is written as

$$\theta(s) = \frac{1}{s} \Omega(s) \quad (2.32)$$

From (2.31) and (2.32), the dc motor block diagram is drawn as shown in Figure 2.14

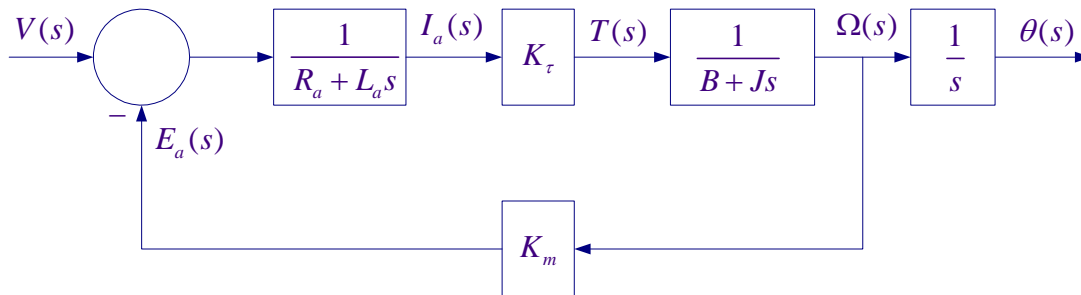

Figure 2.14 Block diagram representation of a dc motor

From the above block diagram, it is clear that the dc motor model has two time constants, one associated with the armature circuit inductance, $\tau_1 = \frac{L_a}{R_a}$, and the other the mechanical time constant due to the motor inertia constant $\tau_2 = \frac{J}{B}$. In most cases the electrical circuit time constant is much smaller than the mechanical circuit time constant and L_a may be neglected.

From the block diagram the dc motor transfer function is

$$\frac{\theta(s)}{V(s)} = \frac{\frac{K_\tau}{s(R_a + L_a s)(B + Js)}}{1 + \frac{K_\tau K_m}{(R_a + L_a s)(B + Js)}} = \frac{K_\tau}{s[(R_a + L_a s)(B + Js) + K_\tau K_m]}$$

or

$$G(s) = \frac{\theta(s)}{V(s)} = \frac{K_\tau}{s[JL_a s^2 + (BL_a + JR_a)s + (BR_a + K_\tau K_m)]} \quad (2.33)$$

Gear Trains

Gear train, lever, or timing belt over a pulley is a mechanical device that transmits energy from one part of the system to another in such a way that force, torque, speed, and displacement may be altered. Gear trains in mechanical systems serve the same purpose, as do transformers in electrical circuits; gear trains are thus mechanical transformers. First we consider two ideal gears as shown in Figure 2.15. In the idea gear train the inertia and friction of the gears are neglected. Later on we will consider these external to the gears.

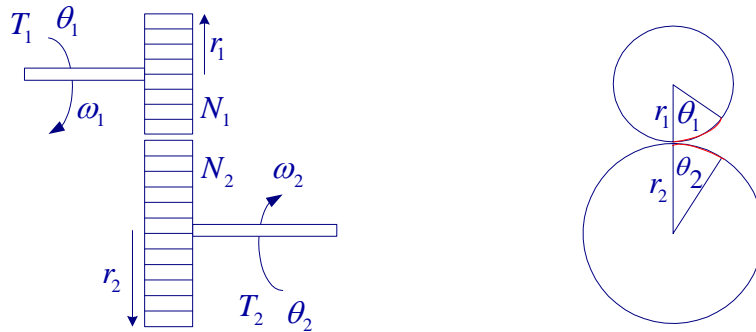

Figure 2.15 Gear train

T_1, T_2 = Torque transmitted to gears

θ_1, θ_2 = Angular displacements

N_1, N_2 = Number of teeth

r_1, r_2 = Radius of gears

ω_1, ω_2 = Angular velocities

The number of teeth on the surface of gears is proportional to the radius r_1 and r_2 , i.e.,

$$\frac{N_1}{N_2} = \frac{r_1}{r_2} \quad (2.34)$$

The arc distance traversed on the surface of gears of the two meshing gears is the same, i.e.,

$$r_1\theta_1 = r_2\theta_2 \quad (2.35)$$

Assuming no losses, the work done by gear 1 is equal to the work done on gear 2., therefore

$$T_1\theta_1 = T_2\theta_2 \quad (2.36)$$

or mechanical power input is equal to the mechanical power output, i.e.,

$$T_1\omega_1 = T_2\omega_2 \quad (2.37)$$

From (2.34)-(2.37), we have

$$\frac{T_1}{T_2} = \frac{\theta_2}{\theta_1} = \frac{\omega_2}{\omega_1} = \frac{r_1}{r_2} = \frac{N_1}{N_2} = a \quad (2.38)$$

The above is analogous to the ideal transformer

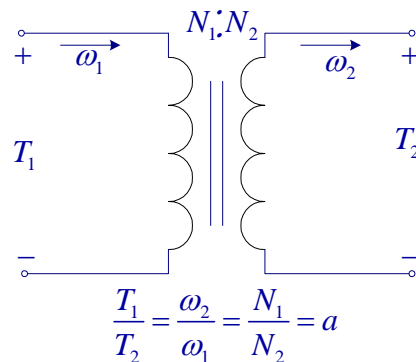

Figure 2.16

In practice, real gears have inertia and friction between coupled gears, and they are included external to the ideal turns ratio.

Example 2.16

In the gear train shown J_1 and B_1 are the inertia and friction of gear 1, J_2 and B_2 include the inertia and friction of gear 2 and the load. A spring with a fixed end is connected to gear 2. A torque T is applied to the input gear. Obtain a transfer function model with T as input and θ_1 as output.

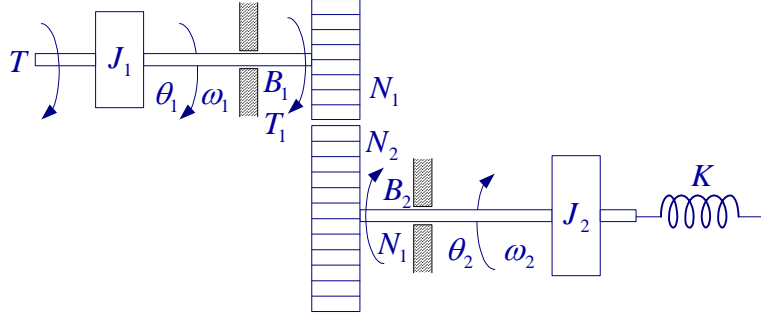

Figure 2.17

The s-domain electric circuit analogy is drawn as shown. This is analogous to a transformer on load.

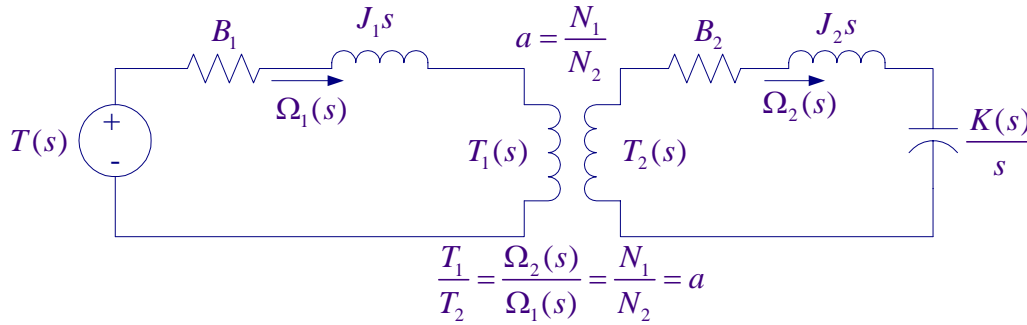

Figure 2.18

Applying analogous KVL equation to the secondary, we have

$$T_2(s) = [B_2 + J_2s + \frac{K}{s}] \Omega_2(s) \quad (2.39)$$

Substituting for T_2 , and Ω_2 in terms of the primary quantities, we get

$$\begin{aligned} \frac{N_2}{N_1} T_1(s) &= \left(B_2 + J_2s + \frac{K}{s} \right) \frac{N_1}{N_2} \Omega_1(s) \quad \text{or} \\ T_1(s) &= \left(B_2 + J_2s + \frac{K}{s} \right) \left(\frac{N_1}{N_2} \right)^2 \Omega_1(s) \end{aligned} \quad (2.40)$$

Applying analogous KVL equation to the primary, we have

$$T_1(s) = [B_1 + J_1s + T_1] \Omega_1(s) + T_1 \quad (2.41)$$

Substituting for T_1 in (2.41) from (2.40), we get

$$\begin{aligned} T_1(s) &= [B_1 + J_1s + T_1] \Omega_1(s) + \left(B_2 + J_2s + \frac{K}{s} \right) (a)^2 \Omega_1(s) \quad \text{or} \\ T_1(s) &= \left(B_1 + J_1s + a^2 B_2 + a^2 J_2s + a^2 \frac{K}{s} \right) \Omega_1(s) \end{aligned} \quad (2.42)$$

Similar to the transformer equivalent circuit reflecting from gear 2 to gear 1 we can draw the equivalent circuit as shown in Figure 2.18. Where the secondary parameters are transferred to the primary with the secondary parameters multiplied by the square of the turn ratios.

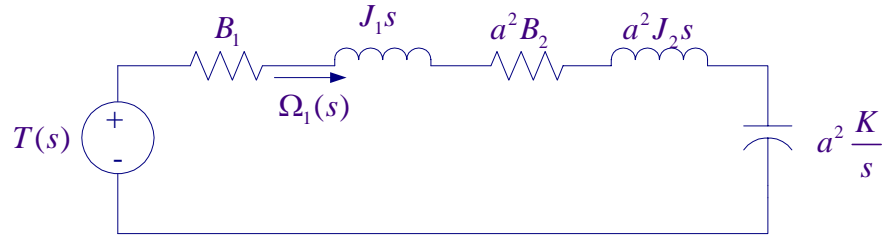

Figure 2.19 The equivalent circuit of the gear train referred to the primary

$$G(s) = \frac{\Omega_1(s)}{T(s)} = \frac{1}{(J_1 + a^2 J_2)s + (B_1 + a^2 B_2) + a^2 \frac{K}{s}}$$

With θ_1 as output, the transfer function is

$$G(s) = \frac{\theta_1(s)}{T(s)} = \frac{1}{(J_1 + a^2 J_2)s^2 + (B_1 + a^2 B_2)s + a^2 K} = \frac{1}{J_{eq}s^2 + B_{eq}s + a^2 K} \quad (2.42)$$

where $B_{eq} = B_1 + a^2 B_2$ is the equivalent friction referred to the primary gear, and $J_{eq} = J_1 + a^2 J_2$ is the equivalent inertia referred to the primary gear.

2.17 Sensors

Sensing devices are needed to provide measurements of the plant variables for use in the feedback control circuits. Some of the common sensors are as follow:

Potentiometers



Angular Displacement Potentiometers

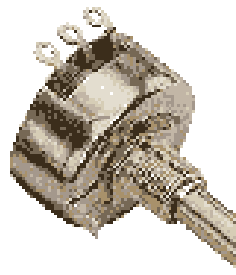

Rotary Potentiometer

Potentiometer is a transducer that converts mechanical energy into electrical energy. The output is a voltage proportional to the displacement. The mechanical displacement can be

either linear or rotational.

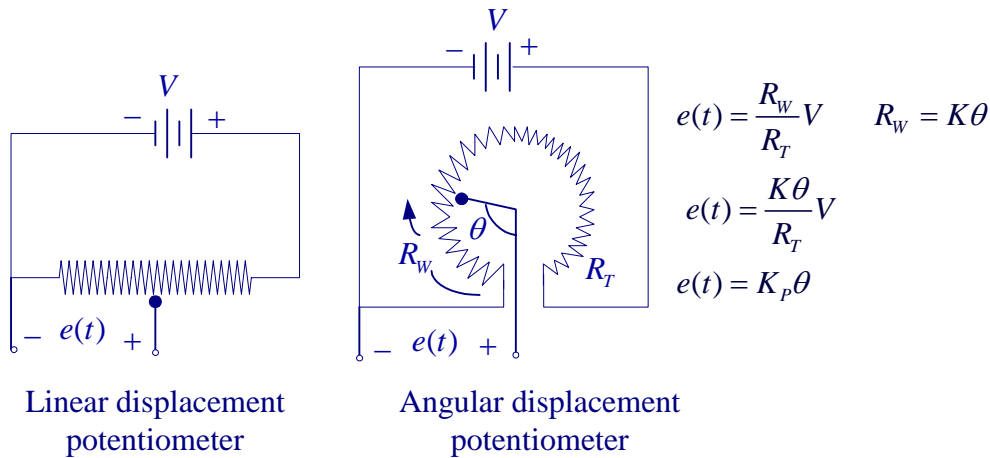

Figure 2.20 Potentiometer used as a position indicator

The mechanical displacement can be either linear or rotational as shown in Figure 2.20, in either case the potentiometer is represented symbolically as shown in Figure 2.21

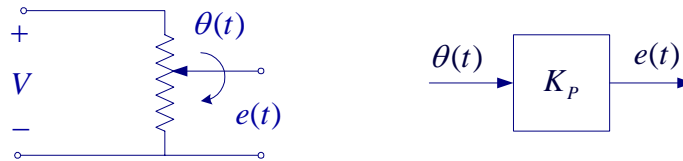

Figure 2.21 Potentiometer symbol and its transfer function

Two potentiometers in parallel will allow the comparison of two remotely located shaft positions.

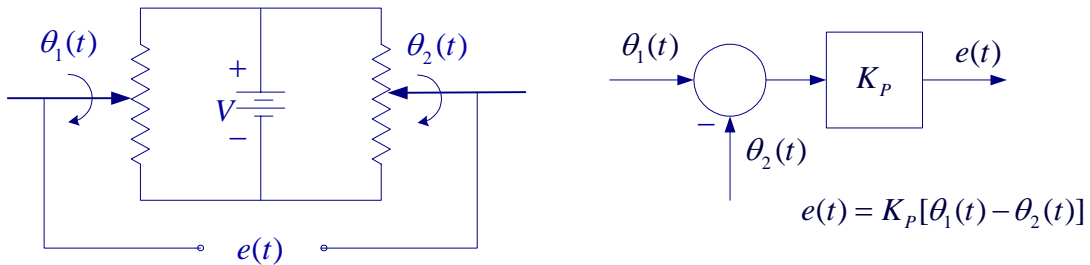

Figure 2.22 Two potentiometers used to sense the position of two shafts.

Schematic diagram below shows a typical dc motor position control system, using dc control.

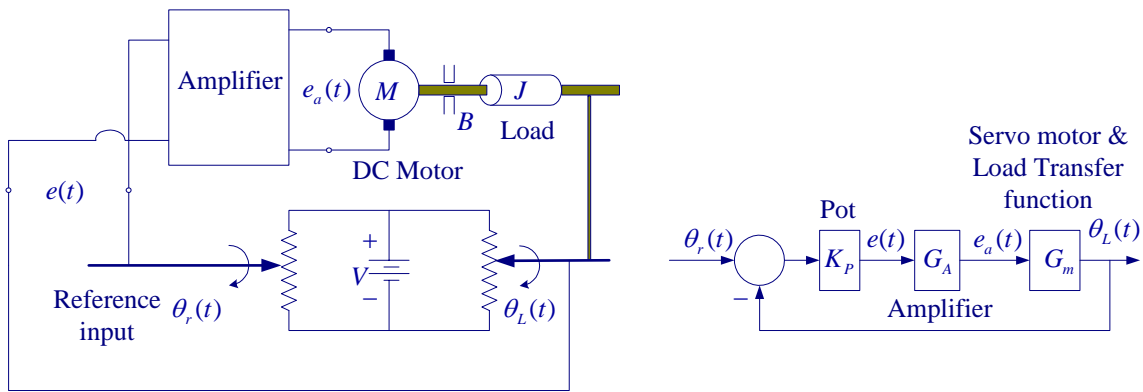

Figure 2.23 A dc motor position control system with potentiometer as sensor

If there is a discrepancy between the load position and reference input, an error signal is generated by the potentiometer. The error signal is amplified and drives the motor.

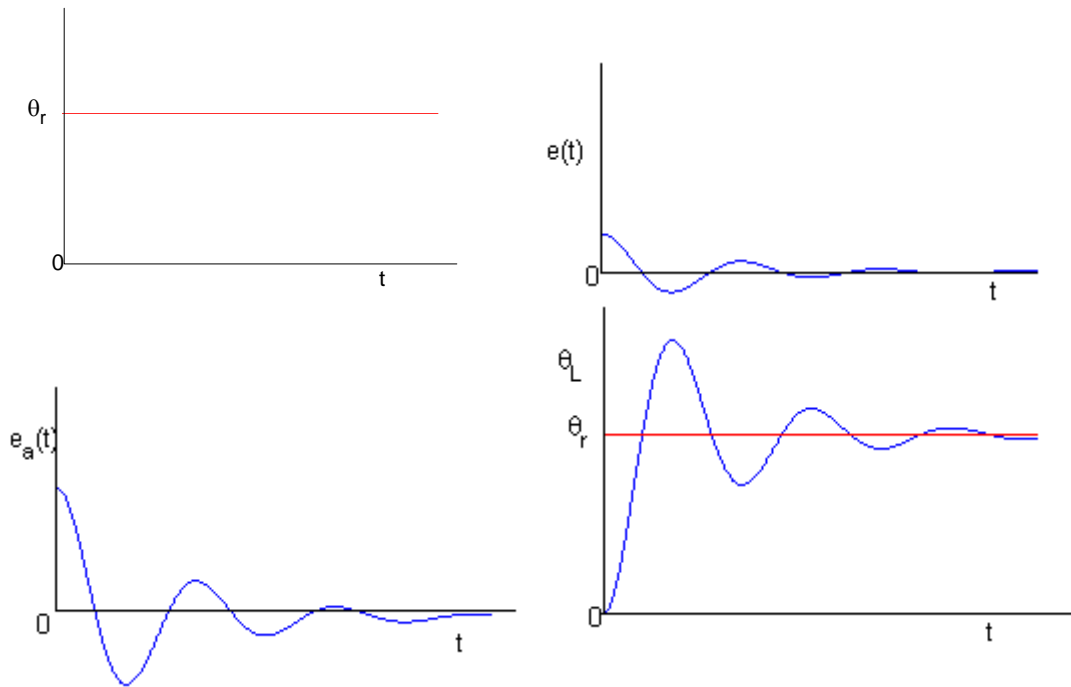

Figure 2.23 Error, amplified error and the motor step response

Tachometers

Tachometers convert mechanical energy into electrical energy. DC Tachometers are used in control system as velocity indicators or for speed control. Figure below shows the block diagram of a typical velocity control system. The output is a voltage proportional to speed.

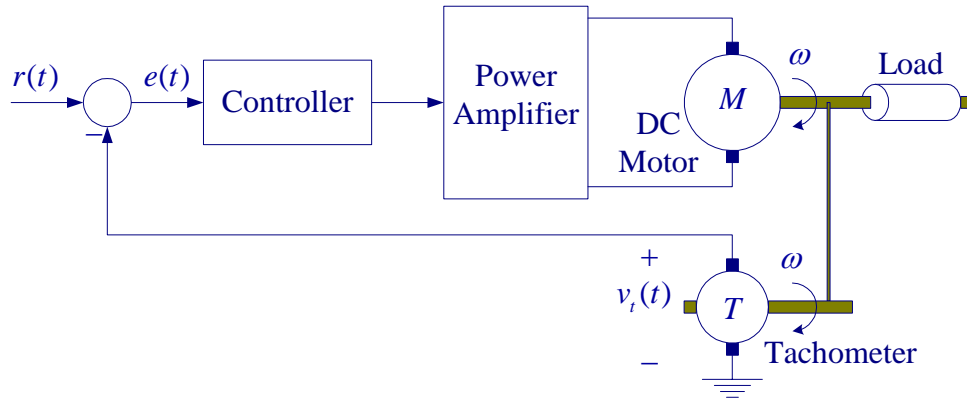

Figure 2.24 Velocity control with tachometer

The transfer function of a tachometer is

$$e(t) = K_T \frac{d\theta(t)}{dt} = K_T \omega(t) \quad \Rightarrow \quad E(s) = K_T s\theta(s) = K_T \Omega(s)$$

The output voltage of a tachometer is proportional to the rotor speed. The difference between the two signals, or the error, is amplified and used to adjust the motor speed, so that the speed will eventually reach the desired value. If the response is not satisfactory a controller is designed to achieve the design specifications.

Incremental Encoder

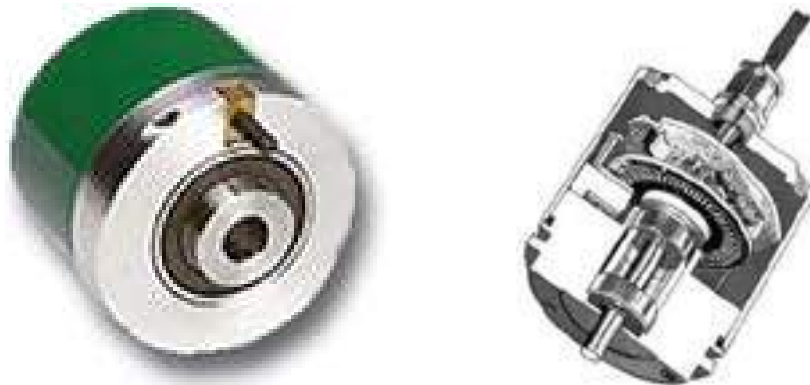

A digital encoder is a device that converts motion into a sequence of digital pulses. Encoders have both linear and rotary configurations, but the most common type is the rotary incremental encoder. A typical rotary incremental encoder has a light source, a

rotary disc, and a sensor. An encoder with three tracks is shown in Figure 2.25. An incremental encoder produces equally spaced pulses from one or more concentric tracks on the code disk. The pulses are produced when a beam of light passes through accurately placed holes in the code disk. Each track has its own light beam. The inside track has only one hole, which is used to locate the home position on the code disk. The holes in the middle track are offset from the holes in the outside track by one-half the width of the hole. The purpose of the offset is to provide directional information.

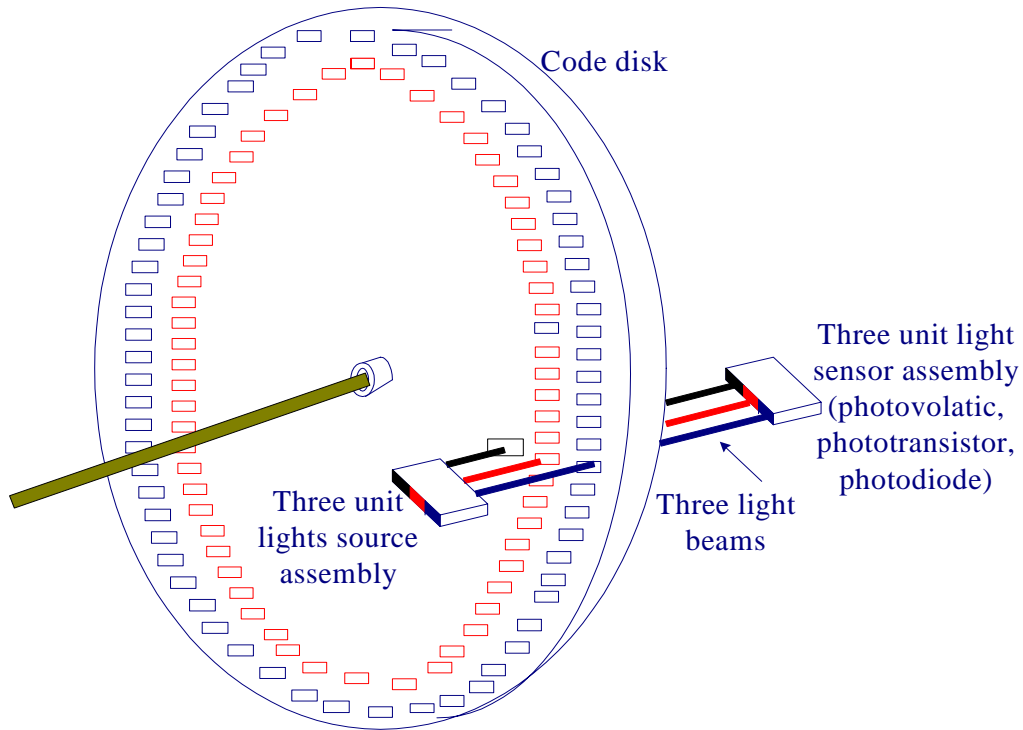

Square-wave signal compatible with digital logic are derived from the sensors.

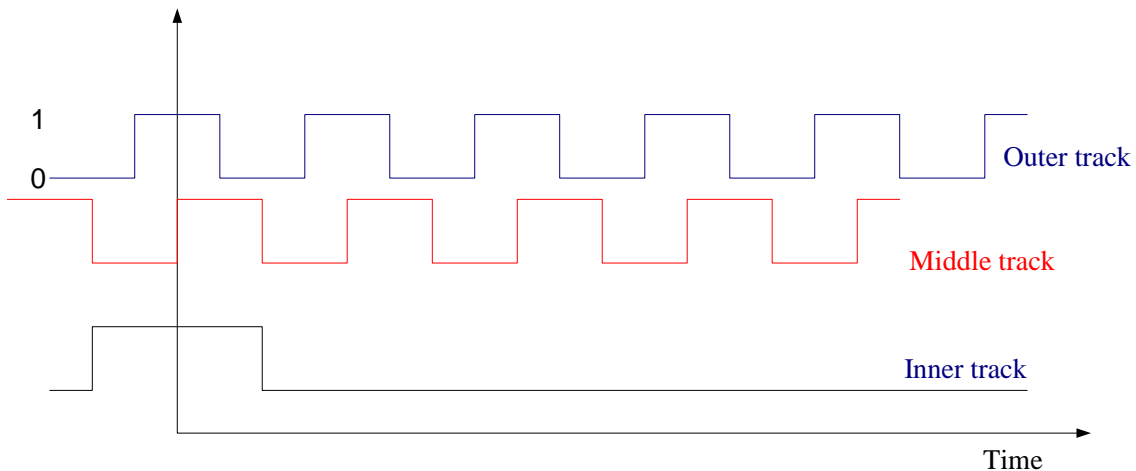

The incremental encoder has three tracks. The inner track provides a reference signal to locate the home position. The middle track provides information about the direction of rotation. In one direction, the middle track lags the outside track; in the other direction, the middle track leads the outside track.

Chapter 3 State Variable Modeling

The differential equations of a lumped linear network can be written in the form

$$\begin{aligned}\dot{\mathbf{x}}(t) &= \mathbf{A}\mathbf{x}(t) + \mathbf{B}\mathbf{u}(t) \\ \mathbf{y}(t) &= \mathbf{C}\mathbf{x}(t) + \mathbf{D}\mathbf{u}(t)\end{aligned}\tag{3.1}$$

This system of first-order differential equations is known as the *state equation* of the system and $\mathbf{x}(t)$ is the state vector and $\mathbf{u}(t)$ is the input vector. The second equation is referred to as the *output equation*. \mathbf{A} is called the state matrix, \mathbf{B} the input matrix, \mathbf{C} the output matrix, and \mathbf{D} the direct transition matrix. One advantage of the state-space method is that the form lends itself easily to the digital and/or analog computer methods of solution. Further, the state-space method can be easily extended to analysis of nonlinear systems. State equations may be obtained from an n th-order differential equation or directly from the system model by identifying appropriate state variables.

To illustrate how we select a set of state variables, consider an n th-order linear plant model described by the differential equation

$$\frac{d^n y}{dt^n} + a_{n-1} \frac{d^{n-1} y}{dt^{n-1}} + \cdots + a_1 \frac{dy}{dt} + a_0 y = u(t)\tag{3.2}$$

where $y(t)$ is the plant output and $u(t)$ is the plant input. A state model for this system is not unique but depends on the choice of a set of state variables. A useful set of state variables, referred to as *phase variables*, is defined as

$$x_1 = y, \quad x_2 = \dot{y}, \quad x_3 = \ddot{y}, \quad \cdots, \quad x_n = y^{(n-1)}$$

Taking the derivatives, we have

$$\begin{aligned}\dot{x}_1 &= x_2, \quad \dot{x}_2 = x_3, \quad \dot{x}_3 = x_4, \quad \cdots, \quad \text{and } \dot{x}_n \text{ is given by (3.2)} \\ \dot{x}_n &= -a_0 x_1 - a_1 x_2 - \cdots - a_{n-1} x_n + u(t)\end{aligned}\tag{3.3}$$

or in matrix form

$$\begin{bmatrix} \dot{x}_1 \\ \dot{x}_2 \\ \vdots \\ \dot{x}_{n-1} \\ \dot{x}_n \end{bmatrix} = \begin{bmatrix} 0 & 1 & 0 & \cdots & 0 \\ 0 & 0 & 1 & \cdots & 0 \\ \vdots & \vdots & \vdots & \vdots & \vdots \\ 0 & 0 & 0 & \vdots & 1 \\ -a_0 & -a_1 & -a_2 & \cdots & -a_{n-1} \end{bmatrix} \begin{bmatrix} x_1 \\ x_2 \\ \vdots \\ x_{n-1} \\ x_n \end{bmatrix} + \begin{bmatrix} 0 \\ 0 \\ \vdots \\ 0 \\ 1 \end{bmatrix} u(t)\tag{3.4}$$

and the output equation is

$$y = [1 \quad 0 \quad 0 \quad \cdots \quad 0] \mathbf{x}\tag{3.5}$$

Example 3.1

Obtain the state equation in phase variable form for the following differential equation.

$$2\frac{d^3y}{dt^3} + 4\frac{d^2y}{dt^2} + 6\frac{dy}{dt} + 8y = 10u(t)$$

The differential equation is third order, thus there are three state variables as follows

$$x_1 = y, \quad x_2 = \dot{y}, \quad x_3 = \ddot{y}$$

and the derivatives are

$$\dot{x}_1 = x_2, \quad \dot{x}_2 = x_3, \quad \text{and} \quad \dot{x}_3 = -4x_1 - 3x_2 - 2x_3 + 5u(t)$$

Or in matrix form

$$\begin{bmatrix} \dot{x}_1 \\ \dot{x}_2 \\ \dot{x}_3 \end{bmatrix} = \begin{bmatrix} 0 & 1 & 0 \\ 0 & 0 & 1 \\ -4 & -3 & -2 \end{bmatrix} \begin{bmatrix} x_1 \\ x_2 \\ x_3 \end{bmatrix} + \begin{bmatrix} 0 \\ 0 \\ 1 \end{bmatrix} 5u(t)$$
$$y = [1 \quad 0 \quad 0] \begin{bmatrix} x_1 \\ x_2 \\ x_3 \end{bmatrix}$$

The M-file **ode2phv.m** is developed which converts an n th-order ordinary differential equation to the state-space phase variable form. $[A, B, C] = \text{ode2phv}(ai, k)$ returns the matrices A, B, C , where ai is a row vector containing coefficients of the equation in descending order and k is the coefficient of the right-hand side.

$$ai = [2 \quad 4 \quad 6 \quad 8];$$
$$k = 10;$$
$$[A, B, C] = \text{ode2phv}(ai, k)$$

produces the following phase variable state representation

$$A = \begin{bmatrix} 0 & 1 & 0 \\ 0 & 0 & 1 \\ -4 & -3 & -2 \end{bmatrix} \quad B = \begin{bmatrix} 0 \\ 0 \\ 5 \end{bmatrix} \quad C = \begin{bmatrix} 1 & 0 & 0 \end{bmatrix}$$

3.1 Equations of Electrical Networks

The state variables are directly related to the energy-storage elements of a system. It would seem, therefore, that the number of independent initial conditions is equal to the number of energy-storing elements. This is true provided that there is no loop containing only capacitors and voltage sources and there is no cut set containing only inductive and current sources. In general, if there are n_C loops of all capacitors and voltage sources, and n_L cut sets of all inductors and current sources, the number of state variables is

$$n = e_L + e_C - n_C - n_L \quad (3.6)$$

where

e_L = number of inductors

e_C = number of capacitors

n_C = number of all capacitive and voltage source loops

n_L = number of all inductive and current source cut sets

Example 3.2

Write the state equation for the network shown in Figure 3.1.

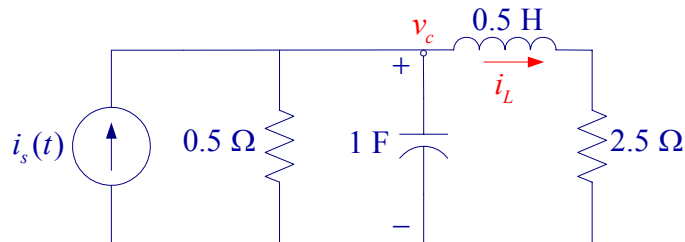

Figure 3.1 Circuit of Example 3.2

Define the state variables as current through the inductor and the voltage across the capacitor. Write a node equation containing capacitor, and a loop equation containing an inductor. The state variables are v_c , and i_L .

The node-voltage equation is

$$1 \frac{dv_c}{dt} + 2v_c + i_L - i_s(t) = 0 \quad \Rightarrow \quad \frac{dv_c}{dt} = -2v_c - i_L + i_s(t)$$

and the loop equation is

$$0.5 \frac{di_L}{dt} + 2.5i_L - v_c = 0 \Rightarrow \frac{di_L}{dt} = 2v_c - 5i_L$$

or

$$\begin{bmatrix} \dot{v}_c \\ \dot{i}_L \end{bmatrix} = \begin{bmatrix} -2 & -1 \\ 2 & -5 \end{bmatrix} \begin{bmatrix} v_c \\ i_L \end{bmatrix} + \begin{bmatrix} 1 \\ 0 \end{bmatrix} i_s$$

Example 3.3

Write the state equation for the network shown in Figure 3.2.

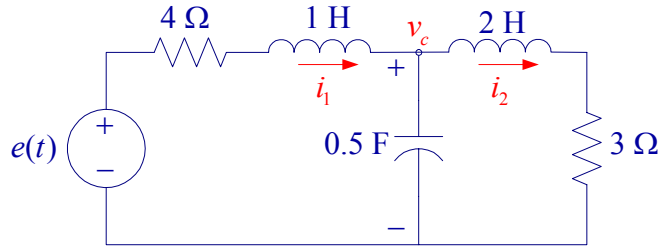

Figure 3.2 Circuit of Example 3.3

Define the state variables as current through the inductors and the voltage across the capacitors. Write a node equation containing the capacitor, and two loop equations containing the inductor. The state variables are i_1 , i_2 , and v_c .

The loop equations are

$$4i_1 + 1 \frac{di_1}{dt} + v_c - e(t) = 0 \quad \Rightarrow \quad \frac{di_1}{dt} = -4i_1 - v_c + e(t)$$

$$2 \frac{di_2}{dt} + 3i_2 - v_c = 0 \quad \Rightarrow \quad \frac{di_2}{dt} = -1.5i_2 + 0.5v_c$$

Node equations is

$$0.5 \frac{dv_c}{dt} + i_2 - i_1 = 0 \quad \Rightarrow \quad \frac{dv_c}{dt} = 2i_1 - 2i_2$$

or

$$\begin{bmatrix} \dot{i}_1 \\ \dot{i}_2 \\ \dot{v}_c \end{bmatrix} = \begin{bmatrix} -4 & 0 & -1 \\ 0 & -1.5 & 0.5 \\ 2 & -2 & 0 \end{bmatrix} \begin{bmatrix} i_1 \\ i_2 \\ v_c \end{bmatrix} + \begin{bmatrix} 1 \\ 0 \\ 0 \end{bmatrix} e(t)$$

Example 3.4

Write the state equation for the network shown in Figure 3.3.

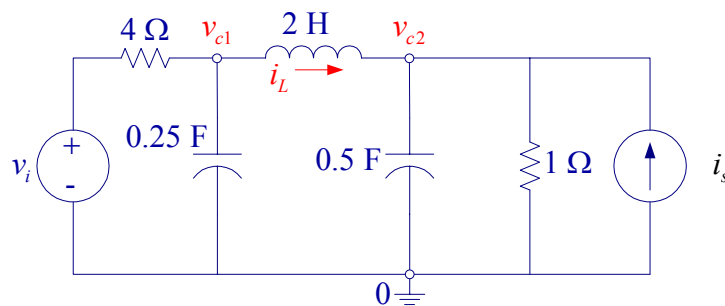

Figure 3.3 Circuit of Example 3.4

Define the state variables as current through the inductor and voltage across the capacitors. Write two node equations containing capacitors and a loop equation containing the inductor. The state variables are v_{c1} , v_{c2} , and i_L .

Node equations are

$$0.25 \frac{dv_{c1}}{dt} + i_L + \frac{v_{c1} - v_i}{4} = 0 \quad \Rightarrow \quad \dot{v}_c = -v_{c1} - 4i_L + v_i$$

$$0.5 \frac{dv_{c2}}{dt} - i_L + \frac{v_{c2}}{1} - i_s = 0 \quad \Rightarrow \quad \dot{v}_{c2} = -2v_{c1} + 2v_{c2} + 2i_s$$

and the loop equation is

$$2 \frac{di_L}{dt} + v_{c2} - v_{c1} = 0 \quad \Rightarrow \quad \dot{i}_L = 0.5v_{c1} - 0.5v_{c2}$$

or

$$\begin{bmatrix} \dot{v}_{c1} \\ \dot{v}_{c2} \\ \dot{i}_L \end{bmatrix} = \begin{bmatrix} -1 & 0 & -4 \\ 0 & -2 & 2 \\ 0.5 & -0.5 & 0 \end{bmatrix} \begin{bmatrix} v_{c1} \\ v_{c2} \\ i_L \end{bmatrix} + \begin{bmatrix} 1 & 0 \\ 0 & 2 \\ 0 & 0 \end{bmatrix} \begin{bmatrix} v_i \\ i_s \end{bmatrix}$$

3.2 Simulation Diagram

Equation (3.3) indicates that state variables are determined by integrating the corresponding state equation. A diagram known as the *simulation diagram* can be constructed to model the given differential equations. The basic element of the simulation diagram is the integrator. The first equation in (3.3) is

$$\dot{x}_1 = x_2$$

Integrating, we have

$$x_1 = \int x_2 dx$$

The above integral is represented by the time-domain diagram shown in Figure 3.4 (a) similar to the block diagram, or the time-domain diagram shown in Figure 3.4 (b) similar to the signal flow graph.



Figure 3.4 Simulation diagram for integrator

It is important to know that although the symbol $1/s$ is used for integration, the simulation diagram is a time domain representation. The number of integrators is equal to the number of state variables. For example, for the state equation in Example 3.1 we have three integrators in cascade, the three state variables are assigned to the output of each integrator as shown in Figure 3.5. The last equation in (3.3) is represented via a summing point and feedback paths. Completing the output equation, the simulation diagram known as the *phase-variable control canonical form* is obtained.

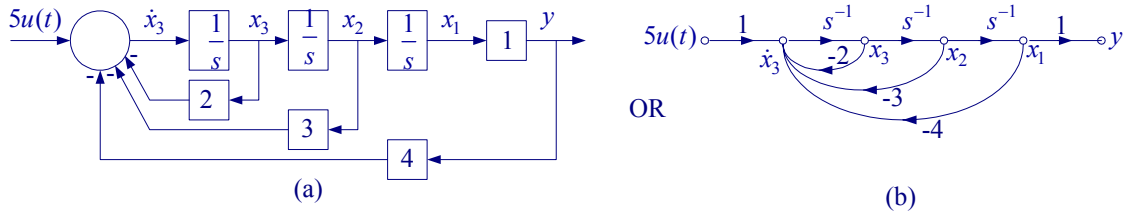

Figure 3.5 Simulation diagram for Example 3.1

3.3 Transfer Function to State-Space Conversion Direct Decomposition

Consider the transfer function of a third-order system

$$\frac{Y(s)}{U(s)} = \frac{b_2s^2 + b_1s + b_0}{s^3 + a_2s^2 + a_1s + a_0} \quad (3.7)$$

where the numerator degree is lower than that of the denominator. The above transfer function is decomposed into two blocks as shown in Figure 3.6.



Figure 3.6 Transfer function in (3.7) arranged in cascade form

Denoting the output of the first block as $W(s)$, we have

$$W(s) = \frac{U(s)}{s^3 + a_2s^2 + a_1s + a_0} \quad \text{and} \quad Y(s) = b_2s^2W(s) + b_1sW(s) + b_0W(s)$$

or

$$s^3W(s) = -a_2s^2W(s) - a_1sW(s) - a_0W(s) + U(s)$$

This results in the following time-domain equation

$$\ddot{w} = -a_2\ddot{w} - a_1\dot{w} - a_0w + u(t) \quad \text{and} \quad y(t) = b_2\ddot{w} + b_1\dot{w} + b_0w \quad (3.8)$$

From the above expression we see that \ddot{w} has to go through three integrators to get w as shown in Figure 3.7. Completing the above equations results in the phase-variable control canonical simulation diagram.

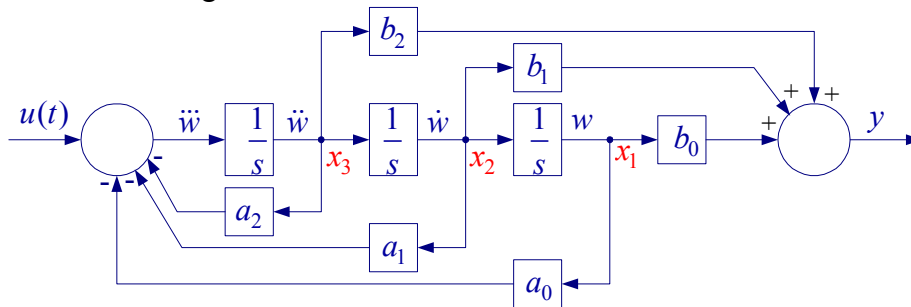

Figure 3.7 Phase variable control canonical simulation diagram

The above simulation in block diagram form is suitable for SIMULINK diagram construction. You may find it easier to construct the simulation diagram similar to the signal flow graph as shown in Figure 3.8.

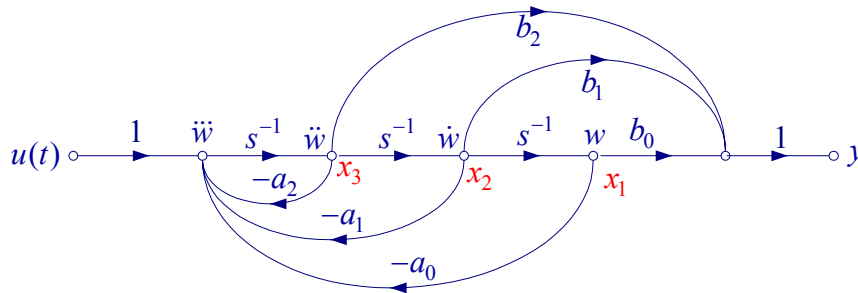

Figure 3.8 Phase variable control canonical simulation diagram

In order to write the state equation, the state variables $x_1(t)$, $x_2(t)$, and $x_3(t)$ are assigned to the output of each integrator from the right to the left. Next an equation is written for the input of each integrator. The results are

$$\begin{aligned}\dot{x}_1 &= x_2 \\ \dot{x}_2 &= x_3 \\ \dot{x}_3 &= -a_0x_1 - a_1x_2 - a_2x_3 + u(t)\end{aligned}$$

and the output equation is

$$y = b_0x_1 + b_1x_2 + b_2x_3$$

or in matrix form

$$\begin{aligned}\begin{bmatrix} \dot{x}_1 \\ \dot{x}_2 \\ \dot{x}_3 \end{bmatrix} &= \begin{bmatrix} 0 & 1 & 0 \\ 0 & 0 & 1 \\ -a_0 & -a_1 & -a_2 \end{bmatrix} \begin{bmatrix} x_1 \\ x_2 \\ x_3 \end{bmatrix} + \begin{bmatrix} 0 \\ 0 \\ 1 \end{bmatrix} u(t) \\ y &= [1 \quad 0 \quad 0] \begin{bmatrix} x_1 \\ x_2 \\ x_3 \end{bmatrix}\end{aligned}\tag{3.9}$$

It is important to note that the Mason's gain formula can be applied to the simulation diagram in Figure 3.6 to obtain the original transfer function. Indeed Δ of Mason's gain formula is the characteristic equation. Also, the determinant of $|sI - A|$ matrix in (3.9), results in the characteristics equation. Keep in mind that there is not a unique state space representation for a given transfer function.

The Control System Toolbox contains a set of functions for model conversion.

$[A, B, C, D] = \text{tf2ss}(\text{num}, \text{den})$ converts the system in transfer function form to state-space phase variable control canonical form.

Example 3.5

For the following transfer function

$$G(s) = \frac{Y(s)}{U(s)} = \frac{s^2 + 7s + 2}{s^3 + 9s^2 + 26s + 24}$$

- (a) Draw the simulation diagram and find the state-space representation of the above transfer function.
 (b) Use MATLAB Control System Toolbox $[A, B, C, D] = \text{tf2ss}(\text{num}, \text{den})$ to find the state model.

(a) Draw the transfer function block diagram in cascade form

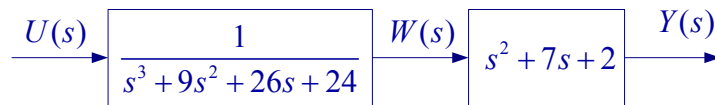

From this we have

$$s^3W(s) = -9s^2W(s) - 26sW(s) - 24W(s) + U(s) \quad \& \quad Y(s) = s^2W(s) + 7sW(s) + 2W(s)$$

or in time-domain

$$\ddot{w} = -9\dot{w} - 26w + u \quad \& \quad y = \ddot{w} + 7\dot{w} + 2w$$

The above time-domain equations yield the following simulation diagram

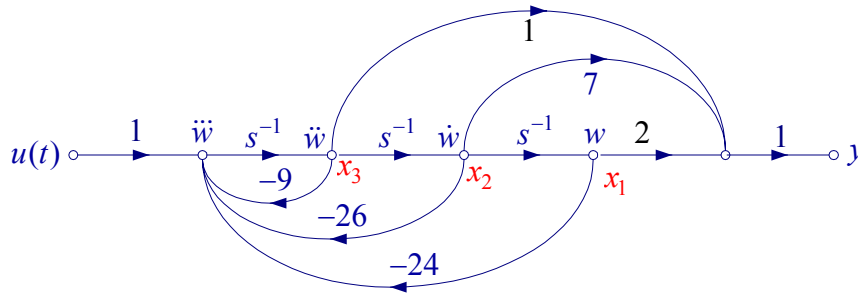

To obtain the state equation, the state variables $x_1(t)$, $x_2(t)$, and $x_3(t)$ are assigned to the output of each integrator from the right to the left. Next an equation is written for the input of each integrator. The results are

$$\dot{x}_1 = x_2$$

$$\dot{x}_2 = x_3$$

$$\dot{x}_3 = -24x_1 - 26x_2 - 9x_3 + u(t)$$

and the output equation is

$$y = 2x_1 + 7x_2 + x_3$$

or in matrix form

$$\begin{bmatrix} \dot{x}_1 \\ \dot{x}_2 \\ \dot{x}_3 \end{bmatrix} = \begin{bmatrix} 0 & 1 & 0 \\ 0 & 0 & 1 \\ -24 & -26 & -9 \end{bmatrix} \begin{bmatrix} x_1 \\ x_2 \\ x_3 \end{bmatrix} + \begin{bmatrix} 0 \\ 0 \\ 1 \end{bmatrix} u(t)$$

$$y = \begin{bmatrix} 2 & 7 & 1 \end{bmatrix} \begin{bmatrix} x_1 \\ x_2 \\ x_3 \end{bmatrix}$$

(b) We write the following statements

```
num = [1 7 2]; den = [1 9 26 24];
[A, B, C, D] = tf2ss(num, den)
```

The result is

```
A =      -9  -26  -24
      1   0   0
      0   1   0

B =      1

C =      1   7   2

D =      0
```

Note that MATLAB assigns x_1 to the output of the first integrator, and x_2 , and x_3 to the output of the second and third integrators.

Functions for Model creation

MALAB Control System Toolbox contains many functions for model creation and inversion, data extraction, and system interconnections. A few of these functions for continuous-time control systems are listed below. For a complete list of all functions type **help/control/control** at MATLAB prompt.

tf	Create transfer function models.
zpk	Create zero/pole/gain models.
ss	Create state-space models.
tfdata	Extract numerator(s) and denominator(s).
zpkdata	Extract zero/pole/gain data.
ssdata	Extract state-space matrices.
append	Group LTI systems by appending inputs and outputs.
parallel	Generalized parallel connection (see also overloaded +).
series	Generalized series connection (see also overloaded *).
feedback	Feedback connection of two systems.
connect	Derive state-space model from block diagram description.
blkbuild	Builds a model from a block diagram.

The Control System Toolbox supports four commonly used representations of linear time-invariant (LTI) systems: **tf**, **zpk**, and **ss** objects. To create an LTI model or object, use the corresponding constructor **tf**, **zpk**, or **ss**. For example,

```
sys = tf(1,[1 0]) .
```

creates the transfer function $H(s) = 1/s$. The result `sys` is a **tf** object containing the numerator and denominator data. You can then manipulate the entire model as the single MATLAB variable `sys`. For more details and examples on how to specify the various types of LTI models, type **ltimodels** followed by **tf**, **zpk**, or **ss**.

The functions **tfdata**, **zpkdata**, and **ssdata** are provided for extracting the parameters of the **tf**, **zpk** and **ss** objects. For example the command **[num, den] = tfdata(T, 'v')** returns the numerator and denominator of the **tf** object. The argument 'v' returns the numerator and denominator as row vectors rather than cell arrays. The Control System Toolbox contains seven more functions, which are useful for creating a single model out of its components.

Example 3.6

Use **feedback** function to obtain the closed-loop transfer function and the **tf2ss** function to obtain the closed-loop state-space model

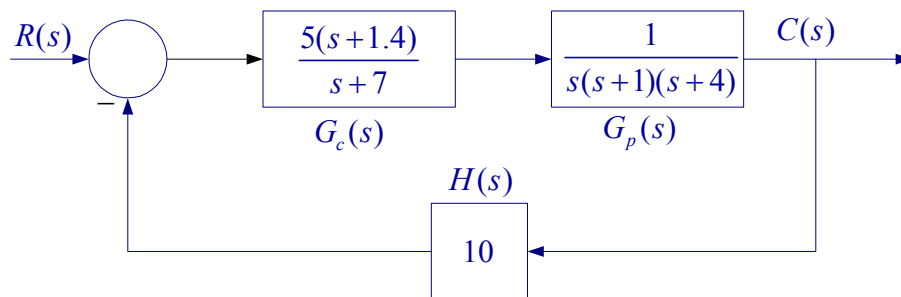

The following commands

```
Gc = tf(5*[1 1.4], [1 7])    % transfer function Gc
Gp = tf([1], [1 5 4 0]);    % transfer function Gp
H = 10;
G = series(Gc, Gp)          % connects Gc & Gp in cascade
T = feedback(G, H)          % obtains the closed loop transfer function
[num, den] = tfdata(T, 'v'); % returns num & den as row arrays
[A, B, C, D]=tf2ss(num, den) % returns the A,B, C, D matrices of the state model
```

result in

Transfer function:

$$\frac{5s + 7}{s^4 + 12s^3 + 39s^2 + 78s + 70}$$

A =	B =	C =	D =
-12 -39 -78 -70	1	[0 0 5 7]	0
1 0 0 0	0		
0 1 0 0	0		
0 0 1 0	0		

3.4 Solution of State Equation

Before presenting a formal solution for the state-space equation, let us review the solution of the linear first-order differential equation due to initial condition. Consider

$$\dot{x}(t) = ax(t) \text{ with initial value } x(0) \quad (3.10)$$

In solving this equation, we can assume a solution of $x(t) = Ke^{mt}$. For this to be the solution it must satisfy the given equation, i.e.,

$$mKe^{mt} = aKe^{mt} \text{ or } (m-a)Ke^{mt} = 0 \Rightarrow m = a$$

Thus

$$x(t) = Ke^{at}$$

Since at $t = 0$, $K = x(0)$, the solution is

$$x(t) = e^{at} x(0) \quad (3.11)$$

We can also solve (3.10) using Laplace transform

$$sX(s) - x(0) = aX(s)$$

or

$$X(s) = \frac{1}{s-a} x(0)$$

The inverse Laplace transform results in the same solution

$$x(t) = e^{at} x(0)$$

Now we consider the solution of the state equation

$$\dot{\mathbf{x}}(t) = \mathbf{A}\mathbf{x}(t) + \mathbf{B}u(t) \text{ with initial value } \mathbf{x}(0)$$

As with a single first-order differential equation, the state equation has two solutions:

1. Solution due to initial condition (Homogenous solution) or zero-input response
2. Solution due to input in the absence of initial condition, known as the zero-state response.

First we consider the zero-input solution

Homogeneous State Equation

$$\dot{\mathbf{x}}(t) = \mathbf{A}\mathbf{x}(t) \text{ given } \mathbf{x}(0) \quad (3.12)$$

Taking Laplace transform

$$s\mathbf{X}(s) - \mathbf{x}(0) = \mathbf{A}\mathbf{X}(s)$$

or

$$[s\mathbf{I} - \mathbf{A}]\mathbf{X}(s) = \mathbf{x}(0)$$

Thus the s-domain solution is

$$\mathbf{X}(s) = [sI - A]^{-1} \mathbf{x}(0) \quad \text{or} \quad \mathbf{X}(s) = \Phi(s) \mathbf{x}(0) \quad (3.13)$$

where

$$\Phi(s) = [sI - A]^{-1} \quad (3.14)$$

Taking the inverse Laplace transform, the time-domain solution is

$$\mathbf{x}(t) = \phi(t) \mathbf{x}(0) \quad (3.15)$$

where $\phi(t) = \mathcal{L}^{-1} [(sI - A)^{-1}]$ is called the state transition matrix

Example 3.7

Consider the state equation for the circuit in Example 3.2.

$$\begin{bmatrix} \dot{v}_c \\ \dot{i}_L \end{bmatrix} = \begin{bmatrix} -2 & -1 \\ 2 & -5 \end{bmatrix} \begin{bmatrix} v_c \\ i_L \end{bmatrix}, \text{ with initial conditions } v_c(0) = 1, \text{ and } i_L(0) = -1$$

Determine the zero-input response that is, the response due to initial condition in the absence of the current source.

The zero-input response is given by

$$\mathbf{X}(s) = [sI - A]^{-1} \mathbf{x}(0)$$

$$[sI - A] = \begin{bmatrix} s+2 & 1 \\ -2 & s+5 \end{bmatrix} \Rightarrow \Phi(s) = [sI - A]^{-1} = \frac{\begin{bmatrix} s+5 & -1 \\ 2 & s+2 \end{bmatrix}}{(s+2)(s+5)+2} = \frac{\begin{bmatrix} s+5 & -1 \\ 2 & s+2 \end{bmatrix}}{s^2 + 7s + 12}$$

The s-domain solution is

$$\mathbf{X}(s) = [sI - A]^{-1} \mathbf{x}(0) = \frac{\begin{bmatrix} s+5 & -1 \\ 2 & s+2 \end{bmatrix} \begin{bmatrix} 1 \\ -1 \end{bmatrix}}{s^2 + 7s + 12} = \frac{\begin{bmatrix} s+6 \\ -s \end{bmatrix}}{(s+3)(s+4)}$$

or

$$\mathbf{X}(s) = \begin{bmatrix} \frac{s+6}{(s+3)(s+4)} \\ \frac{-s}{(s+3)(s+4)} \end{bmatrix} = \begin{bmatrix} \frac{3}{s+3} + \frac{-2}{s+4} \\ \frac{3}{s+3} + \frac{-4}{s+4} \end{bmatrix}$$

Thus the zero-input response is

$$\mathbf{x}(t) = \begin{bmatrix} v_c \\ i_L \end{bmatrix} = \begin{bmatrix} 3e^{-3t} - 2e^{-4t} \\ 3e^{-3t} - 4e^{-4t} \end{bmatrix}$$

Solution of Non-homogenous State Equation

The solution of the linear non-homogenous state equation

$$\dot{\mathbf{x}}(t) = \mathbf{A}\mathbf{x}(t) + \mathbf{B}u(t) \text{ with initial value } \mathbf{x}(0)$$

can be obtained by the Laplace transform approach.

$$\begin{aligned} s\mathbf{X}(s) - \mathbf{x}(0) &= \mathbf{A}\mathbf{X}(s) + \mathbf{B}U(s) \\ [s\mathbf{I} - \mathbf{A}]\mathbf{X}(s) &= \mathbf{x}(0) + \mathbf{B}U(s) \end{aligned}$$

Solving for $\mathbf{X}(s)$, we get

$$\begin{aligned} \mathbf{X}(s) &= [s\mathbf{I} - \mathbf{A}]^{-1} \mathbf{x}(0) + [s\mathbf{I} - \mathbf{A}]^{-1} \mathbf{B}U(s) \\ \mathbf{X}(s) &= \underbrace{[s\mathbf{I} - \mathbf{A}]^{-1} \mathbf{x}(0)}_{\text{zero-input response}} + \underbrace{[s\mathbf{I} - \mathbf{A}]^{-1} \mathbf{B}U(s)}_{\text{zero-state response}} \end{aligned} \quad (3.16)$$

or

$$\mathbf{X}(s) = \underbrace{\Phi(s)\mathbf{x}(0)}_{\text{zero-input response}} + \underbrace{\Phi(s)\mathbf{B}U(s)}_{\text{zero-state response}}$$

where

$$\Phi(s) = [s\mathbf{I} - \mathbf{A}]^{-1}$$

Taking the inverse Laplace transform in (3.16) the zero-input response and the zero-state response are obtained

We can also express the above equation in terms $\phi(t)$ and the convolution integral.

$$\mathbf{x}(t) = \phi(t)\mathbf{x}(0) + \int_0^t \phi(t-\tau)\mathbf{B}u(\tau)d\tau \quad (3.17)$$

where

$$\phi(t) = \mathcal{L}^{-1} \left[(s\mathbf{I} - \mathbf{A})^{-1} \right] \text{ is the state transition matrix}$$

You are required to know and be able to find the zero-input response and the zero-state response using Laplace transform method.

Example 3.8

Determine the state vector $x(t)$ for $t \geq 0$, for the system given below.

$$\begin{bmatrix} \dot{x}_1 \\ \dot{x}_2 \end{bmatrix} = \begin{bmatrix} 0 & 1 \\ -2 & -3 \end{bmatrix} \begin{bmatrix} x_1 \\ x_2 \end{bmatrix} + \begin{bmatrix} 0 \\ 1 \end{bmatrix} r(t)$$

$r(t) = 1u(t)$ is a unit step input, $x_1(0) = 1$, $x_2(0) = -1$,

$$[sI - A] = \begin{bmatrix} s & -1 \\ 2 & s+3 \end{bmatrix} \Rightarrow \Phi(s) = [sI - A]^{-1} = \frac{\begin{bmatrix} s+3 & 1 \\ -2 & s \end{bmatrix}}{s^2 + 3s + 2} = \frac{\begin{bmatrix} s+3 & 1 \\ -2 & s \end{bmatrix}}{(s+1)(s+2)}$$

The zero-input response or the natural response is

$$X(s) = [sI - A]^{-1} x(0)$$

$$X(s) = [sI - A]^{-1} x(0) = \frac{\begin{bmatrix} s+3 & 1 \\ -2 & s \end{bmatrix} \begin{bmatrix} 1 \\ -1 \end{bmatrix}}{(s+1)(s+2)} = \frac{\begin{bmatrix} s+2 \\ -(s+2) \end{bmatrix}}{(s+1)(s+2)} = \begin{bmatrix} \frac{1}{s+1} \\ -\frac{1}{s+1} \end{bmatrix}$$

$$x_n(t) = \begin{bmatrix} e^{-t} \\ -e^{-t} \end{bmatrix}$$

The zero-state response or force response is

$$X(s) = [sI - A]^{-1} BU(s)$$

$$X(s) = [sI - A]^{-1} BR(s) = \frac{\begin{bmatrix} s+3 & 1 \\ -2 & s \end{bmatrix} \begin{bmatrix} 0 \\ 1 \end{bmatrix}}{(s+1)(s+2)} \frac{1}{s} = \frac{\begin{bmatrix} 1 \\ s \end{bmatrix}}{s(s+1)(s+2)} = \begin{bmatrix} \frac{1/2}{s} + \frac{-1}{s+1} + \frac{1/2}{s+2} \\ \frac{1}{s+1} + \frac{-1}{s+2} \end{bmatrix}$$

$$x_s(t) = \begin{bmatrix} \frac{1}{2} - e^{-t} + \frac{1}{2}e^{-2t} \\ e^{-t} - e^{-2t} \end{bmatrix}$$

The complete solution is

$$x(t) = x_n(t) + x_s(t) = \begin{bmatrix} e^{-t} \\ -e^{-t} \end{bmatrix} + \begin{bmatrix} \frac{1}{2} - e^{-t} + \frac{1}{2}e^{-2t} \\ e^{-t} - e^{-2t} \end{bmatrix} = \begin{bmatrix} \frac{1}{2} + \frac{1}{2}e^{-2t} \\ -e^{-2t} \end{bmatrix}$$

3.5 State-Space to Transfer Function Conversion

Consider the state and output equations

$$\begin{aligned}\dot{\mathbf{x}}(t) &= \mathbf{A}\mathbf{x}(t) + \mathbf{B}u(t) \\ y &= \mathbf{C}\mathbf{x}(t) + \mathbf{D}u(t)\end{aligned}$$

Taking the Laplace transform

$$\begin{aligned}sX(s) &= AX(s) + BU(s) \quad \Rightarrow \quad [sI - A]X(s) = BU(s) \\ Y(s) &= CX(s) + DU(s)\end{aligned}$$

Substituting for $X(s)$ in the second equation above, we get

$$Y(s) = C[sI - A]^{-1}BU(s) + DU(s)$$

or

$$G(s) = \frac{Y(s)}{U(s)} = C[sI - A]^{-1}B + D \quad (3.18)$$

Example 3.9

A system is described by the following state-space equations

$$\begin{aligned}\begin{bmatrix} \dot{x}_1 \\ \dot{x}_2 \end{bmatrix} &= \begin{bmatrix} 0 & 1 \\ -6 & -5 \end{bmatrix} \begin{bmatrix} x_1 \\ x_2 \end{bmatrix} + \begin{bmatrix} 0 \\ 1 \end{bmatrix} u(t) \\ y &= [8 \quad 1] \begin{bmatrix} \dot{x}_1 \\ \dot{x}_2 \end{bmatrix}\end{aligned}$$

Obtain the system transfer function using the formula in (3.18)

$$\begin{aligned}[sI - A] &= \begin{bmatrix} s & -1 \\ 6 & s+5 \end{bmatrix} \quad \Rightarrow \quad \Phi(s) = [sI - A]^{-1} = \frac{\begin{bmatrix} s+5 & 1 \\ 6 & s \end{bmatrix}}{s^2 + 5s + 6} \\ G(s) &= C[sI - A]^{-1}B = [8 \quad 1] \frac{\begin{bmatrix} s+5 & 1 \\ 6 & s \end{bmatrix} \begin{bmatrix} 0 \\ 1 \end{bmatrix}}{s^2 + 5s + 6} = \frac{[8 \quad 1] \begin{bmatrix} 1 \\ s \end{bmatrix}}{s^2 + 5s + 6} = \frac{8 + s}{s^2 + 5s + 6}\end{aligned}$$

Therefore

$$G(s) = \frac{s+8}{s^2 + 5s + 6}$$

In MATLAB `[num, den] = ss2tf(A, B, C, D, i)` converts the state equation to a transfer function for the i th input.

Example 3.10

A system is described by the following state-space equations

$$\begin{bmatrix} \dot{x}_1 \\ \dot{x}_2 \\ \dot{x}_3 \end{bmatrix} = \begin{bmatrix} 0 & 1 & 0 \\ 0 & 0 & 1 \\ -1 & -2 & -3 \end{bmatrix} \begin{bmatrix} x_1 \\ x_2 \\ x_3 \end{bmatrix} + \begin{bmatrix} 10 \\ 0 \\ 0 \end{bmatrix} u(t)$$

$$y = [1 \quad 0 \quad 0] \begin{bmatrix} x_1 \\ x_2 \\ x_3 \end{bmatrix}$$

Find the transfer function, $G(s) = \frac{Y(s)}{U(s)}$.

The following statements:

```
A = [0 1 0; 0 0 1; -1 -2 -3]; B = [10; 0; 0];
C = [1 0 0]; D = [0];
[num, den] = ss2tf(A, B, C, D, 1)
G = tf(num, den)
```

result in

```
num =
    0.0000    10.0000    30.0000    20.0000
den =
    1.0000    3.0000    2.0000    1.0000
```

Transfer function:

$$\frac{10 s^2 + 30 s + 20}{s^3 + 3 s^2 + 2 s + 1}$$

Also, $[z, p] = \text{ss2tf}(\mathbf{A}, \mathbf{B}, \mathbf{C}, \mathbf{D}, 1)$ converts the state equation to transfer function in factored form.

Chapter 4

Time-domain Response

Assessing the time-domain performance of closed-loop system models is important because control systems are inherently time-domain systems. The performance of dynamic systems in the time domain can be defined in terms of the time response to standard test inputs. One very common input to control systems is the step function. If the response to a step input is known, it is mathematically possible to compute the response to any input. Another input of major importance is the sinusoidal function. A sinusoidal steady-state output is obtained when an asymptotically stable linear system is subjected to a sinusoidal input. Thus, if we know the response of a linear time-invariant system to sinusoids of all frequencies, we have a complete description of the system.

The following standard inputs are often used in checking the response of a system.

- Unit step (position) function $r(t) = u(t)$
- Unit ramp (velocity) function $r(t) = tu(t)$
- Unit parabolic (acceleration) function $r(t) = \frac{1}{2}t^2u(t)$
- Sinusoidal function $r(t) = A \cos \omega t$

The time response of a control system is usually divided into two parts: the transient response and the steady-state response,

$$c(t) = c_{tr}(t) + c_{ss}(t)$$

The steady-state response $c_{ss}(t)$ is that part of the response, which remains after the transient, has died out.

Since inertia, mass, inductance and capacitance are part of a physical system and we know for some variable instantaneous changes cannot occur and we may go through a transient period. During this period we have deviation between input and output and therefore dynamic behavior of a system is very important. The steady-state response of a control system is also very important. If the output does not agree with the steady-state of the input exactly, the system is said to have a steady-state error. This topic will be discussed in the next chapter.

4.1 Time Response of First-order Systems

Consider the first-order differential equation

$$\frac{dc(t)}{dt} + a_0c(t) = b_0r(t), \text{ with initial condition } c(0) \tag{4.1}$$

Taking the Laplace transform, we have

$$sC(s) - c(0) + a_0C(s) = b_0R(s)$$

or

$$C(s) = \frac{c(0)}{s + a_0} + \frac{b_0}{s + a_0}R(s) \tag{4.2}$$

This equation can be represented in block diagram as shown

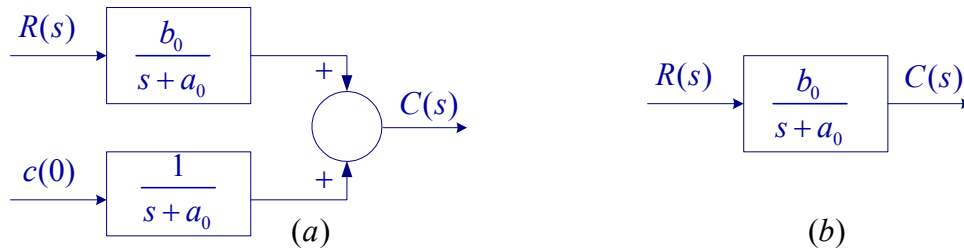

Figure 4.1 Block diagram representation of first-order system

The block diagram shown in Fig. 4.1 (b) is for the zero initial condition. It is only sufficient to obtain the response due to the force function. For example, if the step response is obtained, from property of linear system the response due to initial condition can be obtained from the step response as follow

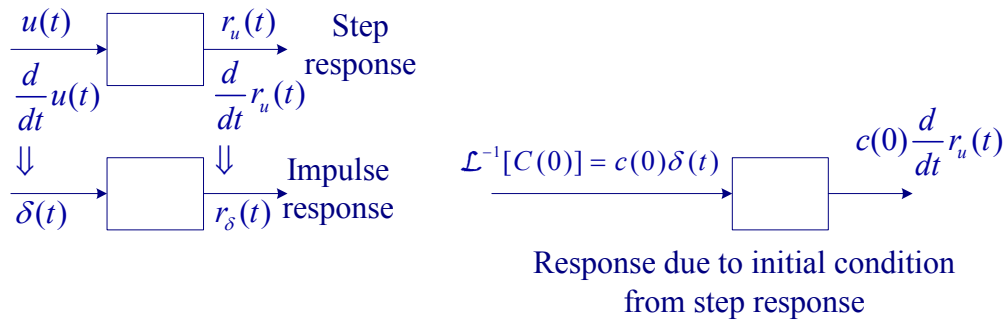

Figure 4.2 Finding response due to initial condition from the step response.

Unit Step response

$$C(s) = \frac{b_0}{s + a_0} R(s)$$

If the input is a unit step function $r(t) = u(t)$, i.e., $R(s) = \frac{1}{s}$, the response is

$$C(s) = \frac{b_0}{(s + a_0)} \frac{1}{s} = \frac{b_0}{a_0} \frac{1}{s} - \frac{b_0}{a_0} \frac{1}{s + a_0}$$

Taking the inverse Laplace transform

$$c(t) = \frac{b_0}{a_0} (1 - e^{-a_0 t})$$

or

$$c(t) = K(1 - e^{-\frac{t}{\tau}}) \tag{4.3}$$

where τ is the time constant and $K = \frac{b_0}{a_0}$. The response is shown in Fig. 4.3

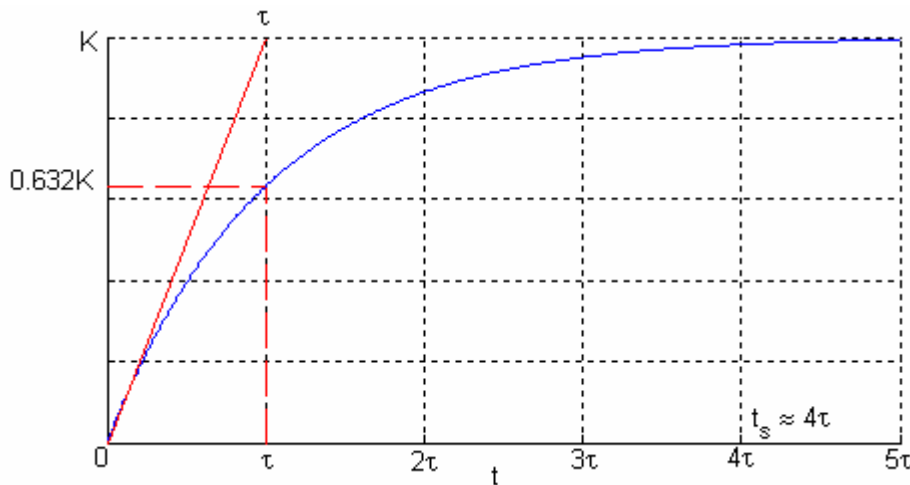

Fig. 4.3 Step response of first-order system

The response will settle to its final value in approximately four to five time constants. In this course we take the settling time to be approximately four time constants, i.e., $\tau = 4t_s$.

The general first-order transfer function can be written in terms of its time constant as follow

$$G(s) = \frac{K}{\tau s + 1} \quad \& \quad C(s) = G(s)R(s) \tag{4.4}$$

The steady-state response to a unit-step input is K . This can also be obtained by applying the final value theorem. $\lim_{t \rightarrow \infty} f(t) = \lim_{s \rightarrow 0} sF(s)$.

$$c_{ss} = c(\infty) = \lim_{s \rightarrow 0} sG(s)R(s) \tag{4.5}$$

For unit step response $R(s) = \frac{1}{s}$, therefore the step response steady-state value is

$$c_{ss} = \lim_{s \rightarrow 0} sG(s) \frac{1}{s} = G(0) = K \quad (4.6)$$

This shows that the step response steady-state value is given by the transfer function gain at $s = 0$ i.e., $G(0)$. This is called the system *DC gain*.

Ramp Response (First order system)

The Laplace transform of a ramp function input is $\mathcal{L}[tu(t)] = \frac{1}{s^2}$

$$C(s) = \frac{K}{\tau s + 1} R(s) \quad (4.7)$$

$$C(s) = \frac{K/\tau}{s^2(s+1/\tau)} = \frac{K}{s^2} + \frac{-K\tau}{s} + \frac{K\tau}{(s+1/\tau)}$$

Taking the inverse Laplace transform

$$c(t) = Kt - K\tau + K\tau e^{-t/\tau} \quad (4.8)$$

The response has the same time constant; this is true, regardless of the input. However the amplitude of the exponential term is different by a factor of τ . If τ is much greater than 1, the exponential term will have a major effect on the system transient response. This can be a problem in designing system to follow ramp inputs. The steady-state response is given by

$$c_{ss} = Kt - K\tau$$

The ramp response for a system with $\tau = 0.5$ sec and $K = 1$ is shown in Figure 4.

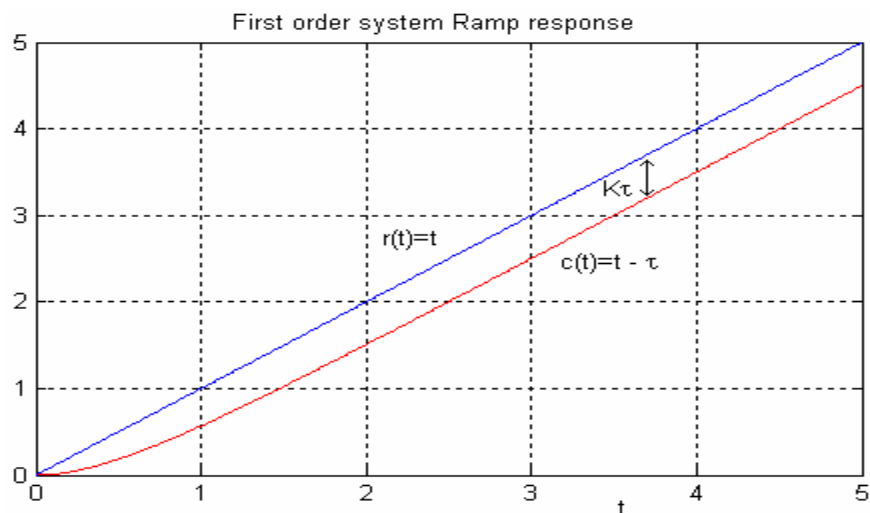

Fig. 4.4 Step response of first-order system

The steady-state error, i.e. the difference between input and the output is $K\tau$. We will discuss the steady-state error in detail in the next chapter.

4.2 Time response of second-order systems

The standard form of the second-order transfer function is
Given by

$$\frac{C(s)}{R(s)} = G(s) = \frac{\omega_n^2}{s^2 + 2\zeta\omega_n s + \omega_n^2} \quad (4.9)$$

The characteristic equation is given by

$$s^2 + 2\zeta\omega_n s + \omega_n^2 = 0 \quad (4.10)$$

For $\zeta > 1$, the poles of the transfer function are

$$s_1 = -\zeta\omega_n + \omega_n\sqrt{\zeta^2 - 1}, \quad s_2 = -\zeta\omega_n - \omega_n\sqrt{\zeta^2 - 1} \quad (4.11)$$

For the unit step response $R(s) = \frac{1}{s}$, and the s-domain step response can be written as

$$C(s) = \frac{\omega_n^2}{(s-s_1)(s-s_2)} \frac{1}{s} = \frac{1}{s} + \frac{K_1}{(s-s_1)} + \frac{K_2}{(s-s_2)}$$

Thus the inverse Laplace transform is

$$c(t) = 1 + K_1 e^{s_1 t} + K_2 e^{s_2 t} = 1 + K_1 e^{-t/\tau_1} + K_2 e^{-t/\tau_2} \quad (4.11)$$

That is, for $\zeta > 1$ the response is overdamped with two time constants $\tau_1 = -\frac{1}{s_1}$ and

$$\tau_2 = -\frac{1}{s_2}.$$

For $\zeta = 1$, the poles of $G(s)$ are real and equal, $s_1 = s_2 = -\zeta\omega_n$, and the response is critically damped

$$c(t) = 1 + e^{-\zeta\omega_n t} (K_1 + K_2 t) = 1 + K_1 e^{-t/\tau} + K_2 t e^{-t/\tau} \quad (4.12)$$

The time constant for critically damped response is $\tau_1 = \frac{1}{\zeta\omega_n}$

The transient response of a practical control system often exhibits damped oscillations before reaching steady-state. For $\zeta < 1$, the roots of the characteristic equation are complex

$$s_{1,2} = -\zeta\omega_n \pm j\omega_n\sqrt{1-\zeta^2} = -\zeta\omega_n \pm j\omega_d \quad (4.13)$$

where $\omega_d = \omega_n\sqrt{1-\zeta^2}$ is the damped frequency of oscillation, and ω_n is the natural frequency. The natural frequency is the frequency of oscillation if all of the damping is

removed. Its value gives us an indication of the speed of the response. ζ is the dimensionless damping ratio. The damping ratio gives us an idea about the nature of the transient response. It gives us a feel for the amount of overshoot and oscillation that the response undergoes.

The underdamped response ($\zeta < 1$) to a unit step input, subject to zero initial condition is given by

$$C(s) = \frac{\omega_n^2}{(s + \zeta\omega_n - j\omega_d)(s + \zeta\omega_n + j\omega_d)} \frac{1}{s} = \frac{1}{s} + \frac{K}{(s + \zeta\omega_n - j\omega_d)} + \frac{K^*}{(s + \zeta\omega_n + j\omega_d)}$$

K is found to be $K = -\frac{1}{2} \frac{1}{\sqrt{1-\zeta^2}} \angle \theta - 90^\circ$ where $\theta = \tan^{-1} \frac{\sqrt{1-\zeta^2}}{\zeta}$, therefore

$$c(t) = 1 - \frac{1}{\sqrt{1-\zeta^2}} e^{-\zeta\omega_n t} (\sin \omega_d t + \theta) \tag{4.14}$$

The response is underdamped as shown in Figure 4.5.

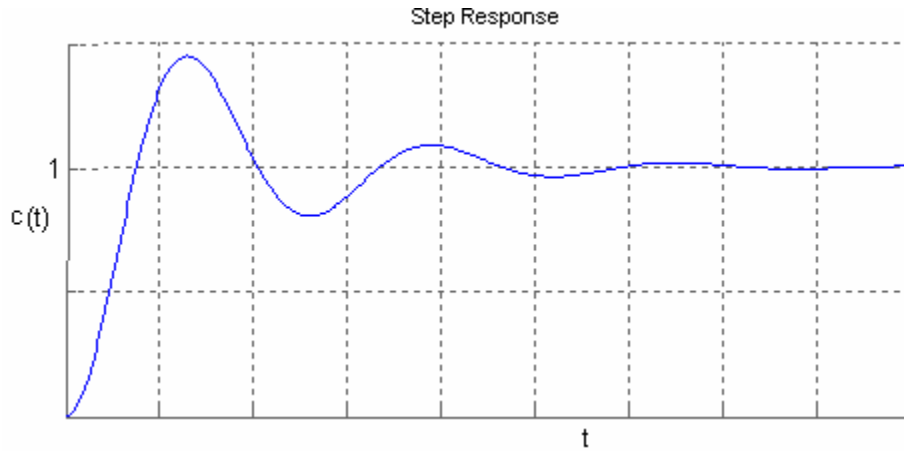

Figure 4.5 Step response of the second order system for $\zeta < 1$.

Roots of the characteristic equations given in (4.11) are marked in the s-plane as shown in Figure 4.6. $s_{1,2} = -\zeta\omega_n \pm j\omega_n\sqrt{1-\zeta^2}$

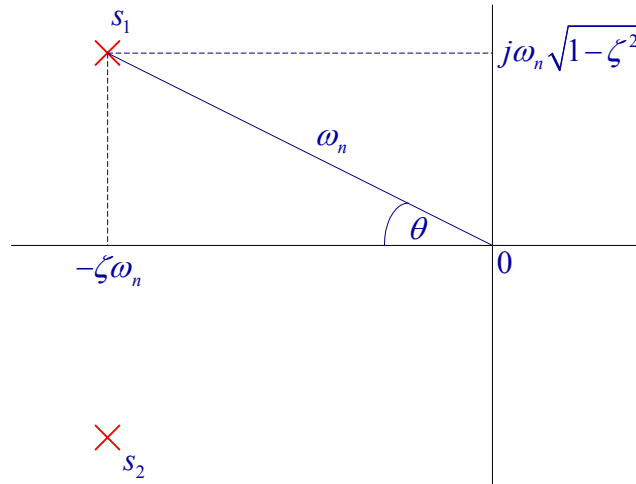

Figure 4.6 Pole locations s-plane

The vector length $|s_1| = [(\zeta\omega_n)^2 + \omega_n^2(1-\zeta^2)]^{1/2} \Rightarrow |s_1| = \omega_n$

The time-constant of the exponentially damped sinusoid is given by the reciprocal of the horizontal component, i.e.,

$$\tau = \frac{1}{\zeta\omega_n} \quad (4.15)$$

Also $\cos\theta = \frac{\zeta\omega_n}{\omega_n}$

That means the damping ratio is given by

$$\zeta = \cos\theta \quad (4.16)$$

The examination of the location of poles of the transfer function reveals the nature of the response. For $\zeta < 1$, as poles move horizontally to the left the response time constant becomes smaller ($\tau = \frac{1}{\zeta\omega_n}$), i.e., a smaller settling time ($t_s \approx 4\tau$). If the poles vertical component increases, that is larger θ , it means smaller damping ratio ($\zeta = \cos\theta$), which results in larger overshoot. If θ is equal to zero ($\zeta = 1$), poles will be equal, resulting in the critically damped response. For $\zeta > 1$, we have two distinct real roots and the response will become overdamped. For $\zeta = 0$, that is if poles are on the $j\omega$ -axis, we have an undamped oscillatory response as is evident from (4.14). It is very important to note that if $\zeta < 0$, the poles real part becomes positive, i.e., the poles lie in the right half s-plane and the response amplitude increase without limit. The response is said to be unbounded and the system is unstable.

Locus of roots when ω_n is held constant while the damping ratio is varied from $-\infty$ to $+\infty$ is shown in Fig. 4.7.

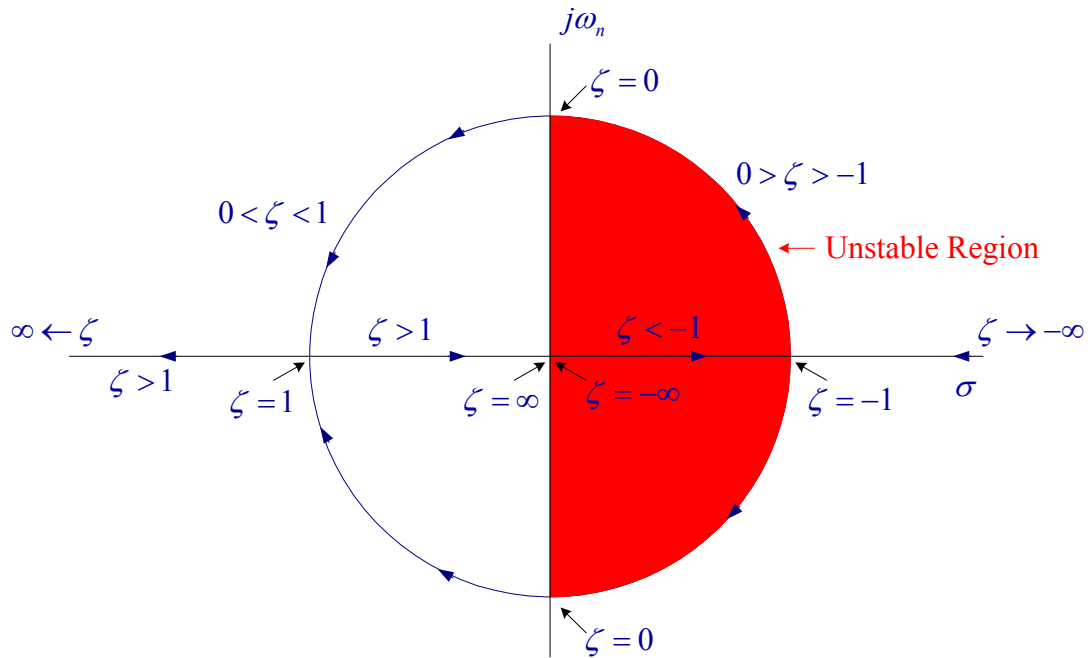
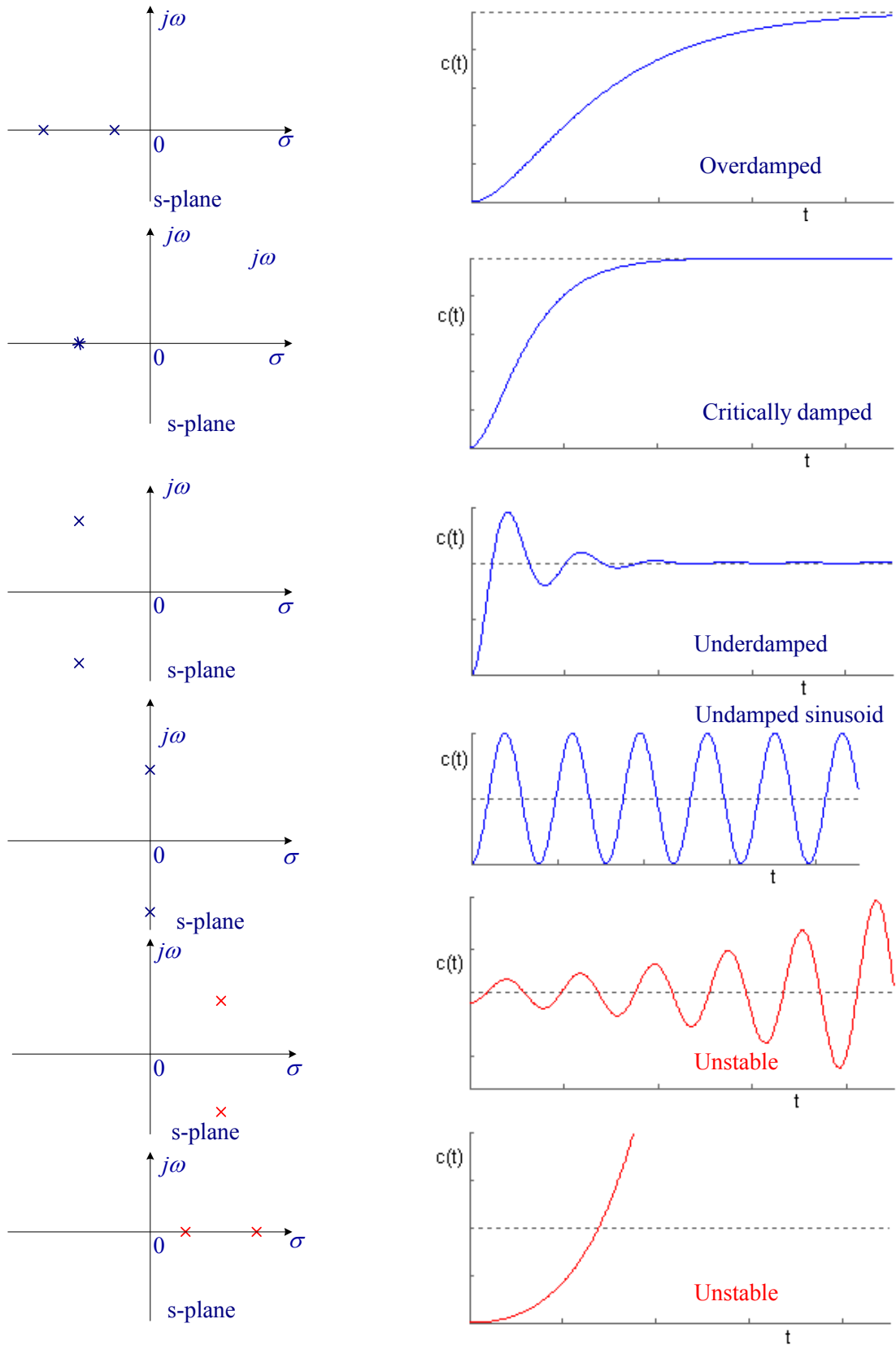

Figure 4.7 Locus of roots of the characteristic equation with constant ω_n , varying ζ

The step response comparison for various root locations in the s-plane is shown in Figure 4.8.

Figure 4.8 Step response comparison for various root locations in the s-domain



4.3 Step response using MATLAB Control System toolbox

Given a transfer function of a closed-loop control system, the function **step(num, den)** produces the step response plot with the time vector automatically determined. **num**, and **den** are the coefficients of the numerator and denominator of the closed loop transfer function in descending order of power. If the above commands are invoked with the left-hand argument **c = step(num, den)**, the response **c** is returned. If the time array **t** is specified, **step(num, den, t)** produces the step response plot over the specified time interval. With the left hand argument **c = step(num, den, t)** returns the response for **c**, over the specified time interval, and we need to use plot function to obtain the plot. Similarly the functions **impz**, **initial**, and **lsim** can be used to obtain the impulse response, response due to initial condition and response to a defined forcing function.

Example 4.1

Obtain the unit step response for the second-order system $\frac{C(s)}{R(s)} = G(s) = \frac{\omega_n^2}{s^2 + 2\zeta\omega_n s + \omega_n^2}$

For the following damping ratios ζ : 0.1 0.2 0.4 0.7 1 4, and $\omega_n = 5$.

We use the following commands

```
wn=5;
num = wn^2;
zeta =[0.1 0.2 0.4 .7 1 4];
for k=1:6
den = [1 2*zeta(k)*wn wn^2];
step(num, den);
hold on
end
legend('\zeta=0.1', '\zeta=0.2', '\zeta=0.4', '\zeta=0.7', '\zeta=1', '\zeta=4')
```

The result is shown in Figure 4.8.

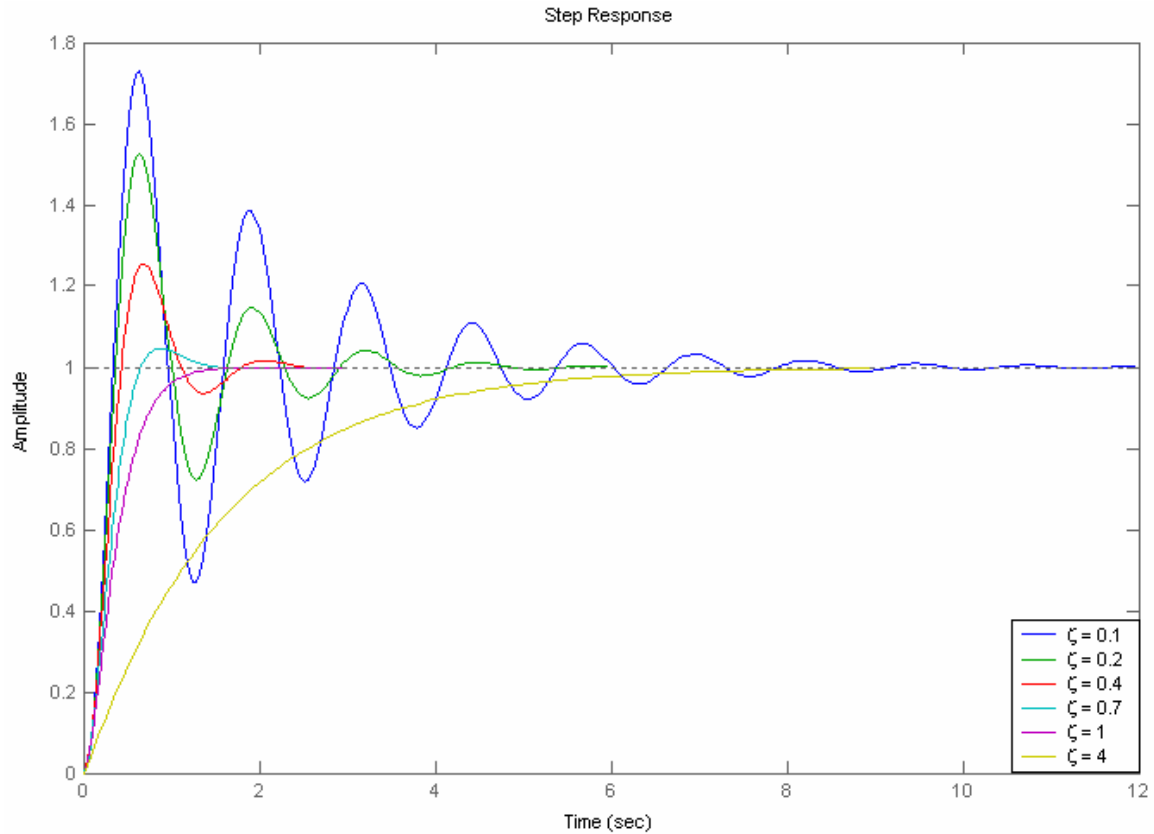

Figure 4.8 Response of a second-order system to a step input for different values of ζ .

4.4 Time -domain performance specification

The performance criteria that are used to characterize the transient response to a unit step input include rise time, peak time, overshoot and settling time. The underdamped step response for a second order system is shown in Figure 4.9. We define the rise time t_r as the time required for the response to rise from 10 % of the final value to 90 % of the final value. The time to reach the peak value is t_p . The swiftness of the response is measured by t_r and t_p . The similarity with which the actual response matches the step input is measured by the percent overshoot and settling time t_s . For underdamped systems the percent overshoot $P.O.$ is defined as

$$P.O. = \frac{\text{Maximum value} - \text{Final value}}{\text{Final value}} \times 100 = \frac{M_{pt} - C_{ss}}{C_{ss}} \times 100 \quad (4.17)$$

The peak time is obtained by setting the derivative of $c(t)$ to zero.

$$t_p = \frac{\pi}{\omega_n \sqrt{1 - \zeta^2}} \quad (4.18)$$

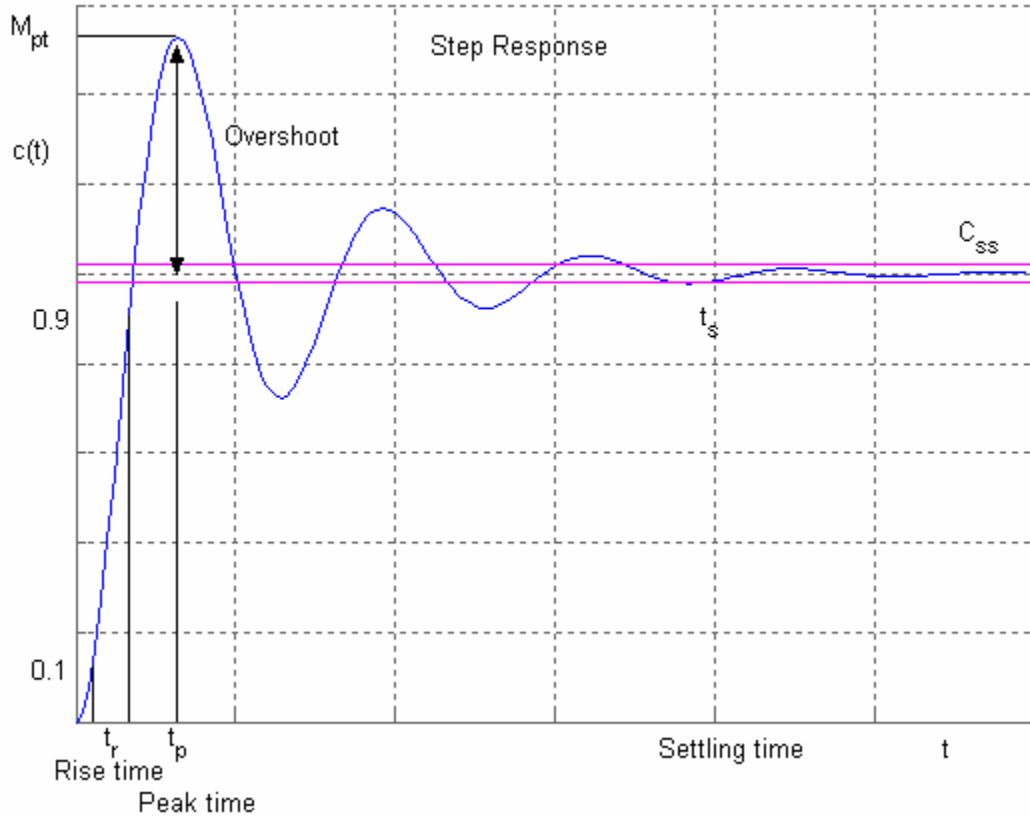

Figure 4.9 Second order system step response for $\zeta < 1$.

The peak value of the step response occurs at this time and evaluating the response at $t = t_p$ yields

$$c(t_p) = M_{pt} = 1 + e^{-\zeta\pi/\sqrt{1-\zeta^2}} \quad (4.19)$$

Therefore, the percent overshoot is

$$P.O. = e^{-\zeta\pi/\sqrt{1-\zeta^2}} \times 100 \quad (4.20)$$

Settling Time: settling time t_s is the time required for the step response to reach within 2% of its final value. These parameters are easy to find graphically once a plot of the response is obtained. Regardless of the percentage used, the settling time will be directly proportional to the time constant τ , i.e.

$$t_s \cong 4\tau = 4 \frac{1}{\zeta\omega_n} \quad (4.21)$$

Example 4.2

The block diagram of a position control servomechanism is as shown in Figure 4.10.

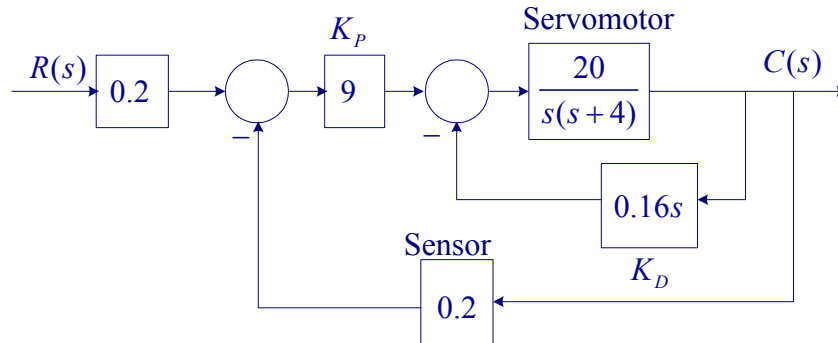

Figure 4.10

Determine the step response percentage overshoot, $P.O.$, peak time, t_p , and settling time t_s .

Applying Mason's gain formula, the closed-loop transfer function is

$$\frac{C(s)}{R(s)} = G(s) = \frac{\frac{36}{s(s+4)}}{1 + \frac{3.2s}{s(s+4)} + \frac{36}{s(s+4)}} = \frac{36}{s(s+4) + 3.2s + 36}$$

or

$$G(s) = \frac{36}{s^2 + 7.2s + 36}$$

Comparing to the standard second order transfer function

$$G(s) = \frac{\omega_n^2}{s^2 + 2\zeta\omega_n s + \omega_n^2}$$

$$\omega_n^2 = 36 \Rightarrow \omega_n = 6 \text{ rad/s, and}$$

$$2\zeta\omega_n = 7.2 \Rightarrow \zeta = \frac{7.2}{(2)(6)} = 0.6$$

The peak time is

$$t_p = \frac{\pi}{\omega_n \sqrt{1-\zeta^2}} = \frac{\pi}{6\sqrt{1-(0.6)^2}} = 0.6545 \text{ sec}$$

$$P.O. = e^{-\zeta\pi} / \sqrt{1-\zeta^2} \times 100 = e^{-(0.6)(\pi)} / \sqrt{1-(0.6)^2} \times 100 = 9.478\%$$

$$\tau = \frac{1}{\zeta\omega_n} = \frac{1}{(0.6)(6)} = 0.2777 \text{ sec}$$

$$t_s \cong 4\tau = 4(0.2777) = 1.11 \text{ sec}$$

For higher order system the time-domain specifications are obtained from step response

using MATLAB. A function named timespec is developed in “Computational Aids in Control Systems Using MATLAB” for finding the time-domain specifications. However, the new MATLAB Control System Toolbox has powerful Itview program obtains the system responses and the time-domain or frequency domain specifications. This is demonstrated in the following Example 4.3. [See Tutorial II MATLAB Functions for Modeling and Time-domain analysis](#)

Example 4.3

Use the **Itview** to obtain the step response time-domain specifications for the system in Example 4.2. We use the following statements

```
num = 36; den = [1 7.2 36];  
G = tf(num, den) % transfer function G  
Itview('step', G)
```

The result is shown in Figure 4.11.

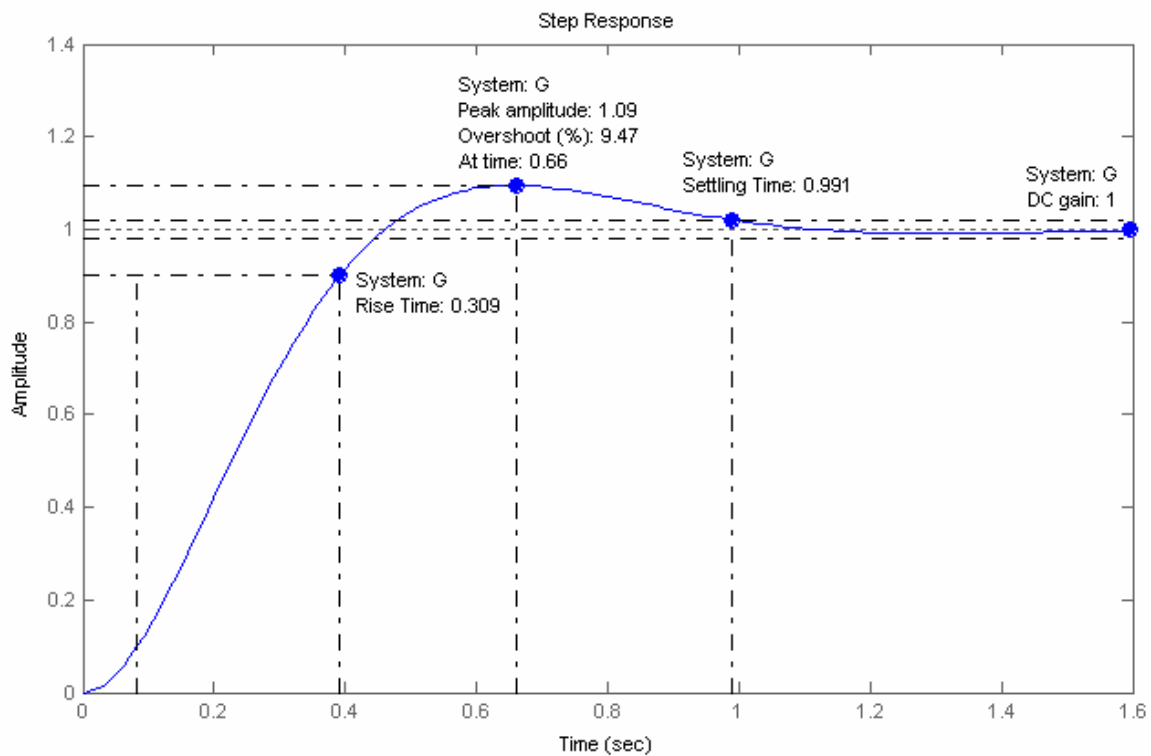

Figure 4.11 Sep response for Example 4.3.

The mouse right-click is used to obtain the time-domain specifications. From File menu you can select **Print to Figure** option to obtain a Figure Window for the LTI Viewer for editing the graph.

Example 4.4

The block diagram of a servomechanism is shown in Figure 4.12. Determine values of d and e so that the maximum overshoot in unit-step response is 40% and the peak time is 0.8 sec.

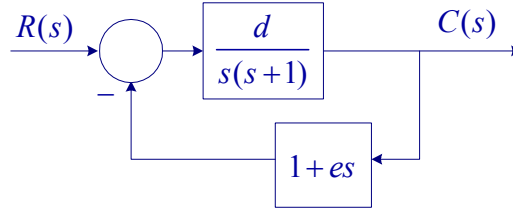

Figure 4.12

$$P.O. = e^{-\zeta\pi} / \sqrt{1-\zeta^2} \times 100$$

$$e^{-\zeta(\pi)} / \sqrt{1-\zeta^2} = 0.4$$

$$\frac{-\zeta(\pi)}{\sqrt{1-\zeta^2}} = \ln 0.4 = -0.91629$$

$$\frac{\zeta^2\pi^2}{1-\zeta^2} = 0.8396 \Rightarrow \zeta^2 = \frac{0.8396}{10.709} = 0.0784 \Rightarrow \zeta = 0.28$$

$$t_p = \frac{\pi}{\omega_n\sqrt{1-\zeta^2}} = 0.8 \Rightarrow \omega_n = \frac{\pi}{0.8\sqrt{1-0.28^2}} = 4.0906 \text{ Rad/s}$$

From the block diagram we have

$$\frac{C(s)}{R(s)} = \frac{d}{s^2 + (de+1)s + d}$$

The characteristic equation is

$$s^2 + (de+1)s + d = s^2 + 2\zeta\omega_n s + \omega_n^2$$

Equating the coefficients

$$d = \omega_n^2 = (4.0906)^2 = 16.733$$

$$de+1 = 2(0.28)(4.0906)$$

$$e = 0.077$$

The closed-loop transfer function is

$$\frac{C(s)}{R(s)} = \frac{16.733}{s^2 + 1.288s + 16.733}$$

We use the following statements to obtain the step response and time-domain specifications.

```
num = 16.733; den =[1 2.29 16.733];  
G = tf(num, den) % transfer function G  
ltiview('step', G)
```

The result is shown in Figure 4.13

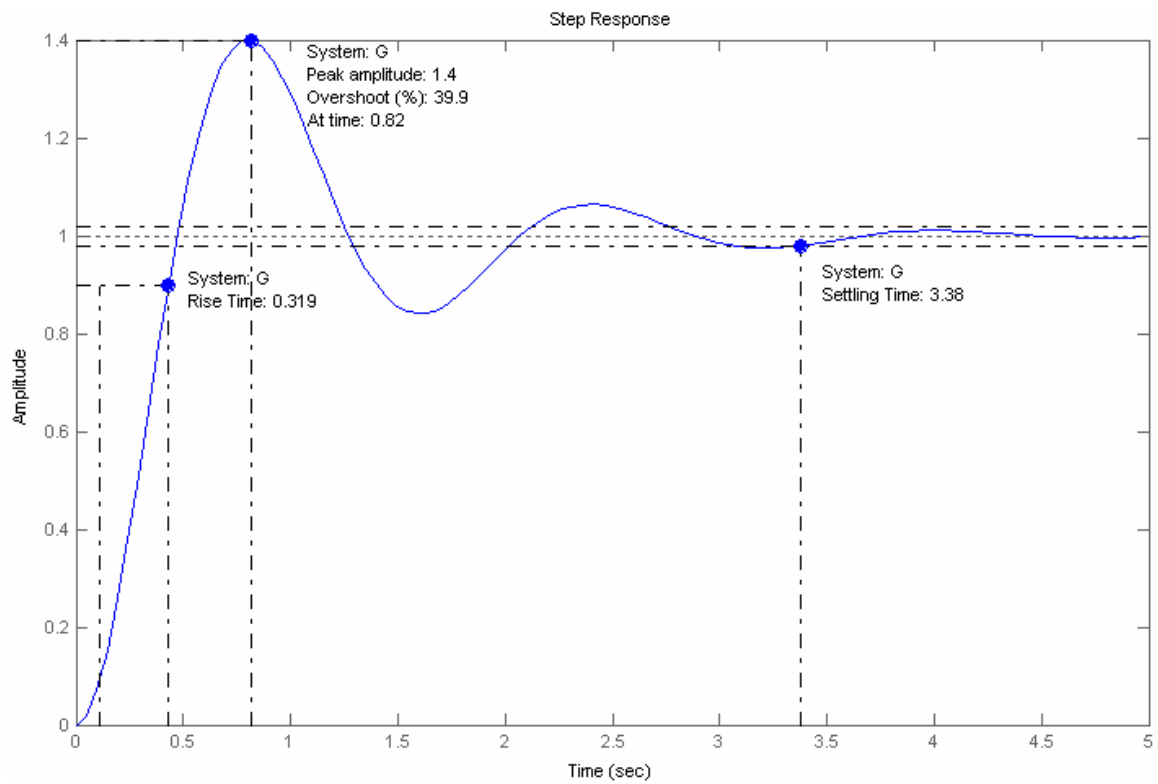

Figure 4.13 Sep response for Example 4.4.

4.5 Frequency Response of systems

The frequency response of a system is defined as the steady-state response of the system to a sinusoidal input signal. Consider a system with transfer function $G(s)$ and a sinusoidal input

$$r(t) = A \cos \omega t \quad (4.22)$$

Substituting for the Laplace transform of $r(t)$, the s-domain response $C(s)$ of the system output is

$$C(s) = \frac{As}{s^2 + \omega^2} G(s) = \frac{As}{(s - j\omega)(s + j\omega)} G(s) \quad (4.23)$$

The partial fraction expansion will result in

$$C(s) = \frac{K}{s - j\omega} + \frac{K^*}{s + j\omega} + \sum \text{of terms generated by the poles of } G(s)$$

where

$$K = \left. \frac{As}{(s + j\omega)} G(s) \right|_{s=j\omega} = \frac{1}{2} AG(j\omega) = \frac{1}{2} A |G(j\omega)| \angle \theta(\omega) \quad (4.23)$$

The poles of $G(s)$ are the natural frequencies (or natural modes). They govern the waveform of the transient component of the response. For the linear lumped network, the terms generated by the poles of $G(s)$ will not contribute to the steady-state response $c(t)$.

The inverse Laplace transform of the partial fraction for complex poles is given by

$$\mathcal{L}^{-1} \left[\frac{K}{s + \alpha - j\beta} + \frac{K^*}{s + \alpha + j\beta} \right] = 2|K| e^{-\alpha t} \cos(\beta t + \theta)$$

Therefore, the steady-state response is given by the inverse Laplace transform of the first two terms of $C(s)$.

$$c(t) = A |G(j\omega)| \cos[\omega t + \theta(\omega)] \quad (4.24)$$

From the above equation it can be seen that system output has the same frequency as the input and can be obtained by multiplying the magnitude of the input by $|G(j\omega)|$ and shifting the phase angle of the input by the angle of the transfer function $\theta(\omega)$. The magnitude $|G(j\omega)|$ and its angle θ for all ω constitute the *system frequency response*, and they provide a significant insight for the analysis and design of control systems. $G(j\omega)$ is

known as the *Frequency Response Transfer Function*. There is a correlation between frequency and transient responses for the case of second-order systems. In practice, the frequency response characteristic is adjusted by using various design criteria, which will normally result in an acceptable transient response.

First-Order System

Consider first the frequency response of a first-order system with the following transfer function

$$G(s) = \frac{1}{\tau s + 1} \quad (4.25)$$

The frequency response transfer function is

$$G(j\omega) = \frac{1}{1 + j\omega\tau} = \frac{1}{[1 + \omega^2\tau^2]} \angle \theta(\omega), \text{ where } \theta(\omega) = -\tan^{-1}(\omega\tau) \quad (4.26)$$

A plot of $|G(j\omega)|$ and $\theta(\omega)$ is given in Figure (4.14).

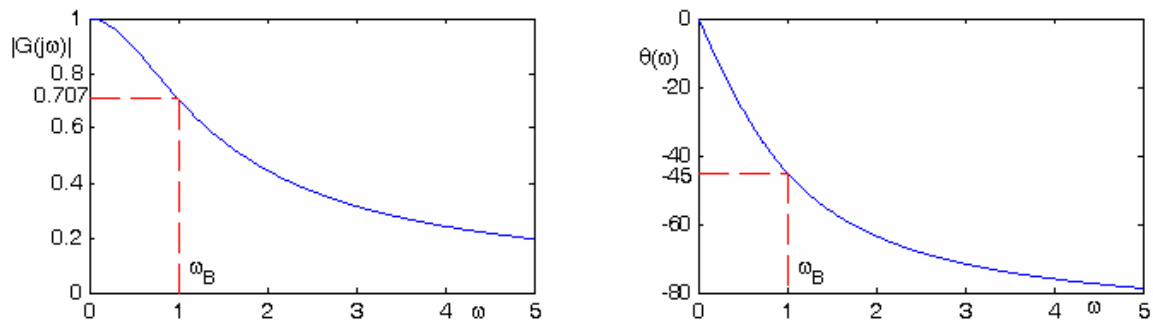

Figure 4.14 Frequency response of a first-order system.

The *system bandwidth* is defined as that value of frequency at which the magnitude of the frequency response is reduced to $\frac{1}{\sqrt{2}}$ of its low frequency value. This frequency is denoted by ω_B . For the first-order system the bandwidth is given by

$$\omega_B = \frac{1}{\tau} \quad (4.27)$$

Equation (4.27) is true only for the first-order systems.

4.6 Frequency response of second-order systems

Now consider the standard second-order transfer function

$$G(s) = \frac{\omega_n^2}{s^2 + 2\zeta\omega_n s + \omega_n^2} \quad (4.28)$$

The frequency response transfer function is

$$G(j\omega) = \frac{\omega_n^2}{-\omega^2 + j2\zeta\omega_n\omega + \omega_n^2} = \frac{1}{1 - \frac{\omega^2}{\omega_n^2} + j2\zeta\frac{\omega}{\omega_n}}$$

The frequency response transfer function amplitude is

$$|G(j\omega)| = \frac{1}{\left[\left(1 - \frac{\omega^2}{\omega_n^2}\right)^2 + \left(2\zeta\frac{\omega}{\omega_n}\right)^2 \right]^{\frac{1}{2}}} \quad (4.29)$$

A plot of frequency response for $\zeta = 0.4$ and $\omega_n = 5$ is given in Figure (4.15).

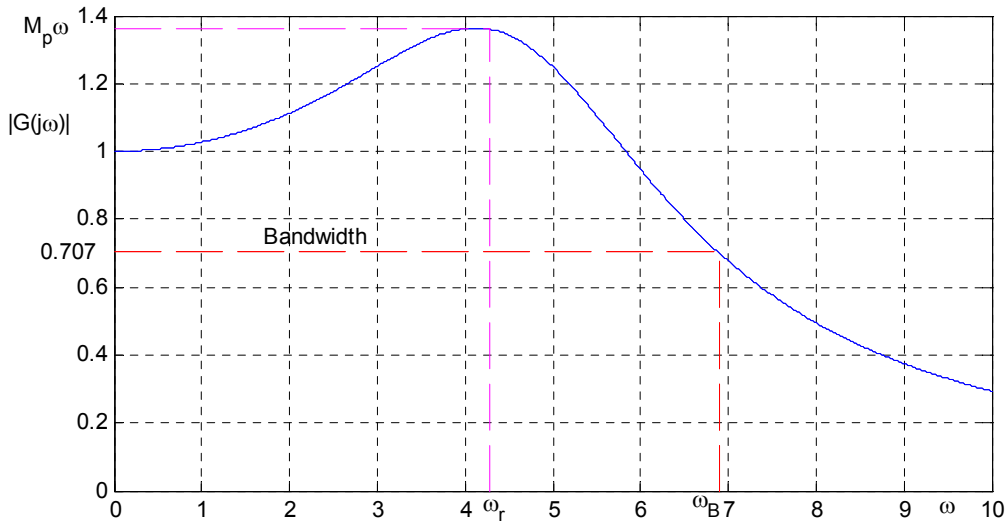

Figure 4.15 Frequency response of a second-order system

For a constant ζ , increasing ω_n causes the bandwidth to increase by the same factor. This corresponds to a decrease in the peak time t_p and the rise time t_r the transient response.

Therefore, to increase the speed of response of a system, it is necessary to increase the system bandwidth. For a particular system, an approximate relationship is given by $\omega_B t_r = \text{constant}$. Where this constant has a value in the neighborhood of 2 for the second-order system, i.e.,

$$\omega_B t_r \approx 2 \quad (4.30)$$

For $\zeta < 0.707$, the amplitude exhibits a peak value. The frequency at which the peak occurs is obtained by setting the derivative of $|G(j\omega)|$ to zero. This frequency is known as the *resonance frequency*. For $\zeta < 0.707$, the resonance frequency ω_r is given by

$$\omega_r = \omega_n \sqrt{1 - 2\zeta^2} \quad (4.31)$$

The maximum value of the magnitude of the step response, denoted by $M_{p\omega}$, is

$$M_{p\omega} = \frac{1}{2\zeta \sqrt{1 - \zeta^2}} \quad (4.32)$$

The peak in the frequency response is directly related to the amount of overshoot in the transient response. The greater the peaks, the more overshoot will occur. Thus, in control system design $M_{p\omega}$ is usually restricted to a maximum allowable value.

Example 4.5

A system is described by the closed loop transfer function

$$G(s) = \frac{25}{s^2 + 2s + 25}$$

(a) Find the resonant frequency ω_r , peak amplitude $M_{p\omega}$ and the bandwidth ω_B of the system.

(b) Use MATLAB to obtain the frequency response and find ω_r , $M_{p\omega}$ and ω_B .

$$\omega_n^2 = 25 \quad \Rightarrow \quad \omega_n = 5 \text{ Rad/s}$$

$$2\zeta\omega_n = 2 \Rightarrow \zeta = \frac{2}{(2)(5)} = 0.2$$

$$\omega_r = \omega_n \sqrt{1 - 2\zeta^2} = 5\sqrt{1 - 2(0.2)^2} = 4.8 \text{ Rad/s}$$

$$M_{p\omega} = \frac{1}{2\zeta \sqrt{1 - \zeta^2}} = \frac{1}{2(0.2)\sqrt{1 - (0.2)^2}} = 2.55 \text{ Rad/s} \quad \Rightarrow \quad dB(\omega_r) = 8.136$$

The bandwidth frequency is found from

$$\frac{1}{\left[1 - \frac{\omega_B^2}{\omega_n^2}\right]^2 + \left[2\zeta \frac{\omega_B}{\omega_n}\right]^2} = \left[\frac{1}{\sqrt{2}}\right]^2$$

This will result in

$$x^2 - 2(1 - 2\zeta^2)x - 1 = 0, \text{ where } x = \left(\frac{\omega_B}{\omega_n}\right)^2$$

or

$$x = 1 - 2\zeta^2 \pm \sqrt{4\zeta^4 - 4\zeta^2 + 2}$$

$$\text{For } \zeta = 0.2, x = 2.2788 = \left(\frac{\omega_B}{\omega_n}\right)^2 \Rightarrow \omega_B = 7.55 \text{ Rad/s}$$

$$\zeta = 0.5 \quad x = 1.618034 = \left(\frac{\omega_B}{\omega_n}\right)^2 \Rightarrow \omega_B = 2.544$$

(b) We use the following statements.

num=25;

den=[1 2 25];

bode(num, den), grid

The result is shown in Figure 4.16

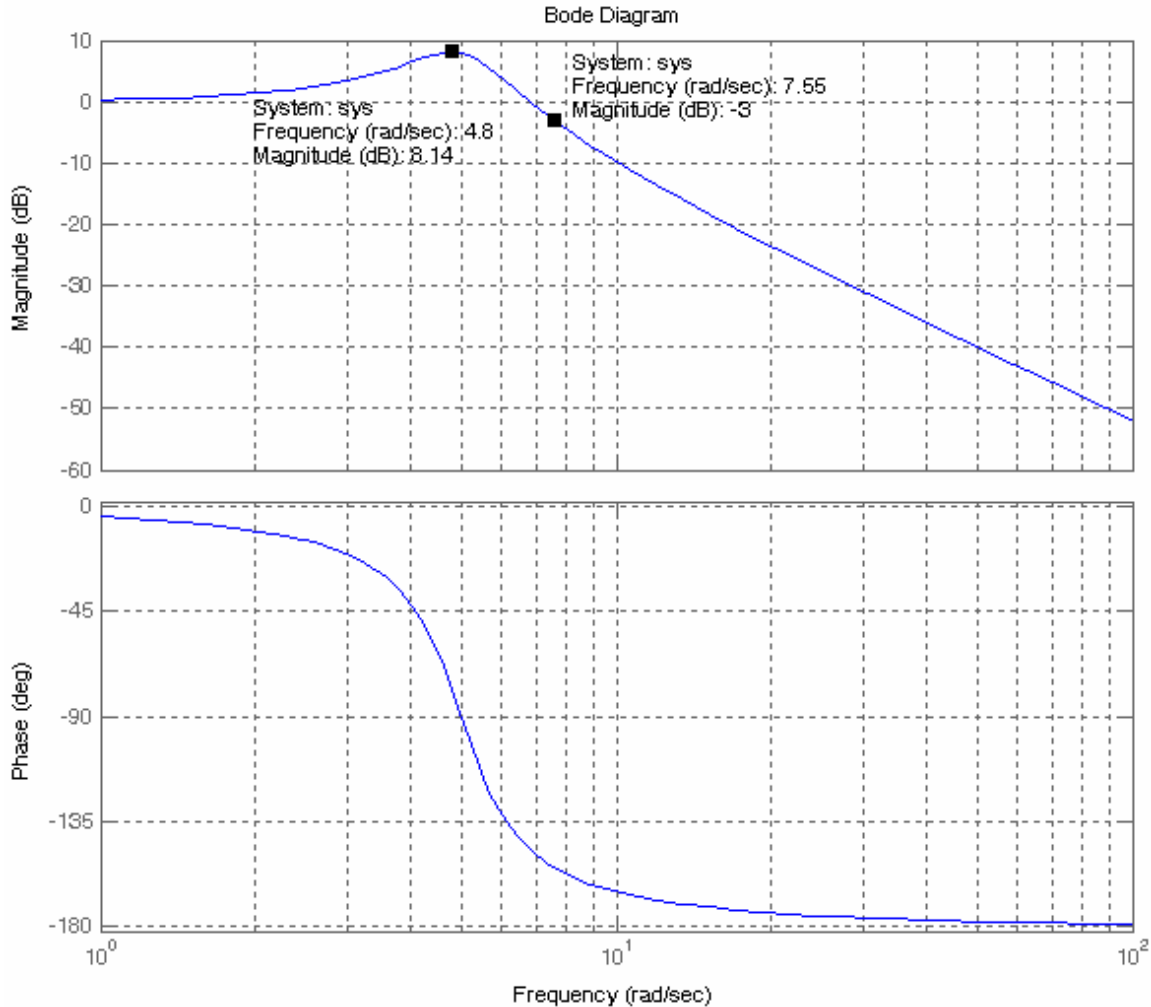

Figure 4.16 The Bode plot for the system of Example 4.5.

To find the peak amplitude right click on the amplitude curve near the peak value, hold and drag back and forth until you locate the peak value $dB(\omega_r) = 8.14$, and $\omega_r = 4.8$ Rad/s.

The bandwidth is the frequency where the amplitude is 0.707 or -3 dB. Right-click on the amplitude curve near -3 dB point, hold and move until gain is -3 dB. The bandwidth is found to be 7.55 Rad/s.

4.7 Reduced order model

Since the poles of the closed-loop transfer function are the roots of the characteristic equation, they control the transient response. Poles in the left half s-plane close to origin are dominant poles since their time constants are large. These poles are referred to as dominant poles. Poles located far away to the left of the dominant poles they have very little effect on the transient response as these poles are much faster than the dominant poles. If the poles are to the left than the dominant poles the system can be represented by reduced-order model.

Example 4.6

The closed-loop transfer function of a control system is described by the following third-order transfer function

$$\frac{C(s)}{R(s)} = T(s) = \frac{750}{s^3 + 36s^2 + 205s + 750}$$

- (a) Find the dominant poles of the system
- (b) Find a reduced-order model
- (c) Obtain the step response of the third-order system and the reduced-order system on the same figure plot, and find their time-domain specifications.
- (d) Obtain the frequency (Bode Magnitude) of the third-order system and the reduced-order system on the same figure plot, and find M_{pw} , ω_r , and ω_B for each model.

(a) The command

```
den = [ 1 36 205 750];  
r = roots(den)
```

result in

```
r =  
-30  
-3 + 4i  
-3 - 4i
```

Therefore the transfer function is

$$T(s) = \frac{750}{(s+30)(s^2+6s+25)} = \frac{25}{(1+0.0333s)(s^2+6s+25)}$$

The time constant of the real pole at $s = -30$ is $\tau_1 = 1/30$ which is negligible compared to the time constant of $\tau_2 = 1/3$ for the dominant poles $-3 \pm j4$. Therefore the approximate reduced model transfer function is

$$T(s) \approx \frac{25}{(s^2+6s+25)}$$

We use the following commands

```
num1 = 750;           % third-order system num  
den1 = [1 36 205 750]; % third-order system den  
num2=25;             % reduced-order system num  
den2 = [1 6 25];     % reduced-order system den
```

```

sys3rd = tf(num1, den1)      % third-order system
sys2nd = tf(num2, den2)     % reduced-order system
ltiview('step', sys3rd, 'b', sys2nd, 'r')

```

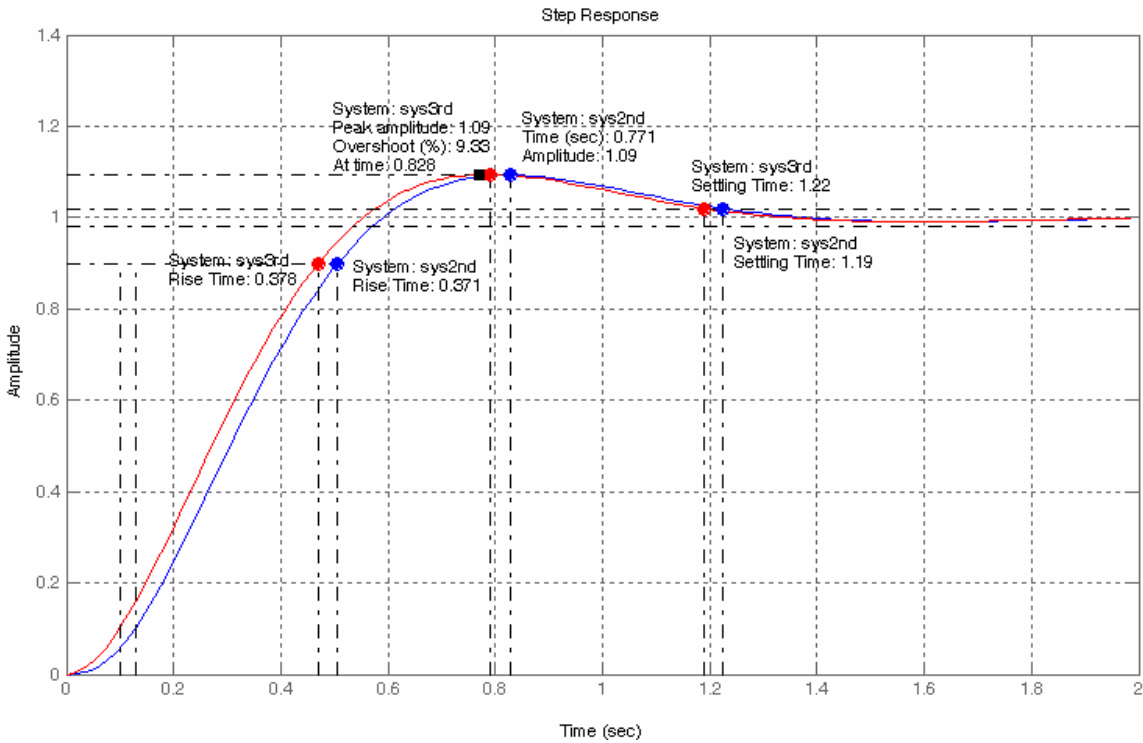

Figure 4.17 Third-order and reduced-order step responses of Example 4.6.

With a simple right-click on the mouse the time-domain specifications are obtained. Next we right-click on the mouse and select the Bode Mag plot. Place the cursor on the response near -3 dB, left-click hold and move to display -3 dB. Also right-click and chose Characteristics/peak value to display the peak.

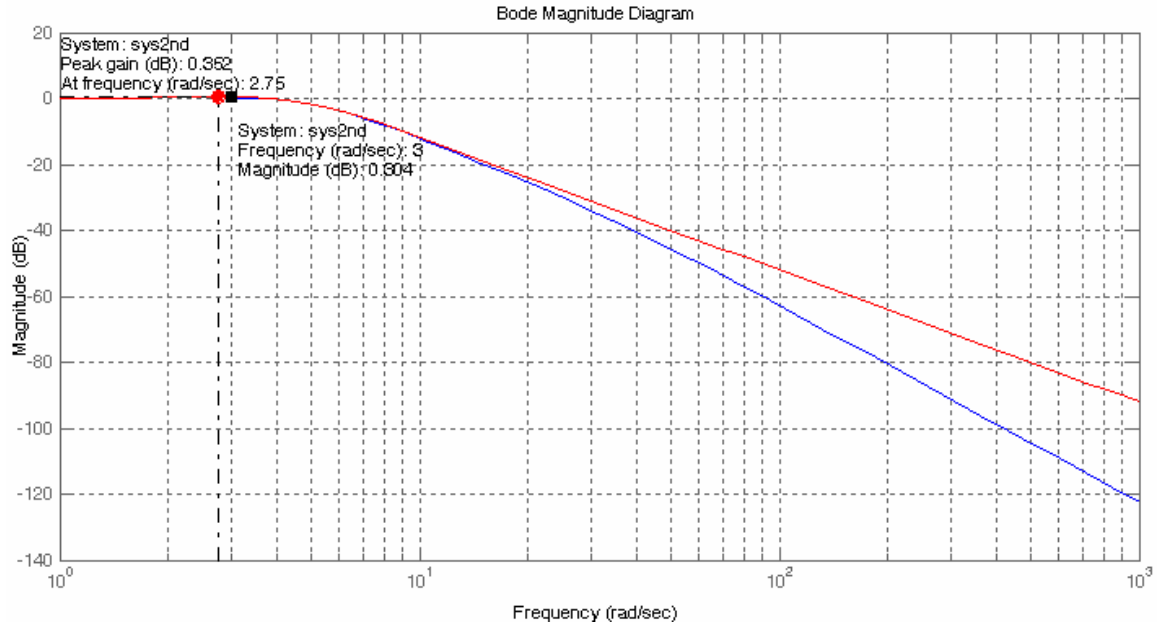

Figure 4.18 Third-order and reduced-order Bode plot of Example 4.6.

Table 4.1

	t_r - s	t_p -s	$P.O.$	t_s - s	$M_{p\omega}$	ω_r - rad/s	ω_B - rad/s
Third-order Model	0.371	0.791	9.47	1.19	0.352	2.75	0.304
Second-ord Model	0.378	0.828	9.33	1.22	0.352	2.75	0.304

Time-domain and frequency-domain specifications are summarized in Table 4.1. As it can be seen the reduced model step response and time-domain specifications are very close to the third-order system. Also peak frequency response and the bandwidth of the two systems are very close to each other. At very high frequency the reduced-order model has more attenuation.

EE-371 Frequency Response Analysis Part I

Frequency Response Analysis and Design

The frequency response method and the root-locus method are simply two different ways of applying the same basic principles of analysis. These methods supplement each other, and in many practical design problems, both techniques are employed. One advantage of the frequency response method is that the transfer function of a system can be determined experimentally by frequency response tests. Furthermore, the design of a system in the frequency domain provides the designer with control over the system bandwidth and over the effect of noise and disturbance on the system response.

As we have seen the phase and gain margins of a control system are a measure of the closeness of the polar plot to the $(-1, 0)$ point. Therefore, the open-loop frequency response gain margin and phase margin may be used in the design criteria.

The gain and phase margins along with ω_{pc} and ω_{gc} are obtained more easily from the Bode plot. The phase margin may be read directly off the Bode plot at the frequency which the amplitude curve crosses the 0 dB line, and the gain margin may be read (in decibels) at the frequency at which the phase angle curve crosses the -180° line. For satisfactory operation the phase margin should be between 30° and 60° , and the gain margin should be greater than 6 dB.

Additional performance specifications in terms of closed-loop frequency response are the closed-loop system *bandwidth*, ω_B , and the closed-loop system *resonant peak magnitude*, M_p . The bandwidth indicates how well the system tracks an input sinusoid and is a measure of the speed of response. If the bandwidth is small, only signals of relatively low frequency are passed, and the response is slow; whereas a large bandwidth corresponds to a faster rise time. Therefore, the rise time and the bandwidth are inversely proportional to each other.

The frequency at which the peak occurs, the *resonant frequency*, is denoted by ω_r , and the maximum amplitude, M_p , is called the resonant peak magnitude. M_p is a measure of the relative stability of the system. A large M_p corresponds to the presence of a pair of dominant closed-loop poles with small damping ratio, which results in a large maximum overshoot of the step response in the time domain. In general, if M_p is kept between 1.0 and 1.7, the transient response will be acceptable.

In summary, the frequency response design provides information on the steady-state response, stability margin, and system bandwidth. The transient response performance can be estimated indirectly in terms of the phase margin, gain margin,

and resonant peak magnitude. Percent overshoot is reduced with an increase in the phase margin, and the speed of response is increased with an increase in the bandwidth. Thus, the gain crossover frequency, resonant frequency, and bandwidth give a rough estimate of the speed of transient response.

A common approach to the frequency response design is to adjust the open-loop gain so that the requirement on the steady-state accuracy is achieved. This is called the *proportional controller*. If the specifications on the phase margin and gain margin are not satisfied, then it is necessary to reshape the open-loop transfer function by adding the additional controller $G_c(s)$ to the open-loop transfer function. $G_c(s)$ must be chosen so that the system has certain specified characteristics. This can be accomplished by combining proportional with integral action (*PI*) or proportional with derivative action (*PD*).

Proportional Controller

The *P* controller is a pure gain controller. The design is accomplished by choosing the gain K_P for the uncompensated system to give the desired steady-state error. When the gain K_P is varied, the phase angle plot will not be affected. The Bode magnitude curve is shifted up or down to correspond to the increase or decrease in K_P . Similarly, the effect of changing K_P on the Nyquist diagram is to enlarge or reduce it; the shape of the Nyquist diagram cannot be changed.

Example 1

A plant has a minimum-phase transfer function

$$G(s) = \frac{K}{s(s+2)(s+8)} = \frac{K}{s^3 + 10s^2 + 16s}$$

sketch the polar plot and determine the closed-loop system stability the phase crossover frequency, and the gain margins for $K = 50.6$, $K = 160$, and $K = 506$

The frequency response transfer function is

$$G(j\omega) = \frac{K}{j\omega(2+j\omega)(8+j\omega)}$$

For $\omega = 0$, $G(j\omega) = \infty \angle -90^\circ$, and at $\omega = \infty$, $G(j\omega) = 0 \angle -270^\circ$. To find the real-axis intersection, we write $G(j\omega)$ as

$$G(j\omega) = \frac{-jK}{\omega[16 - \omega^2 + j10\omega]}$$

Multiplying numerator and denominator by the conjugate of denominator, we get

$$G(j\omega) = \frac{-jK[16 - \omega^2 - j10\omega]}{\omega[(16 - \omega^2)^2 + 100\omega^2]} = \frac{-K[10\omega + j(16 - \omega^2)]}{\omega[(16 - \omega^2)^2 + 100\omega^2]}$$

To find the real -axis crossing and the phase crossover frequency, we set the imaginary part of the numerator to zero, resulting in $\omega_{pc} = \pm 4$ rad/s. Therefore the gain at ω_{pc} is

$$G(j4) = \frac{-10K}{100(4)^2} = \frac{-K}{160}$$

The **Nyquist** function is used to obtain an accurate plot for the three values of K .

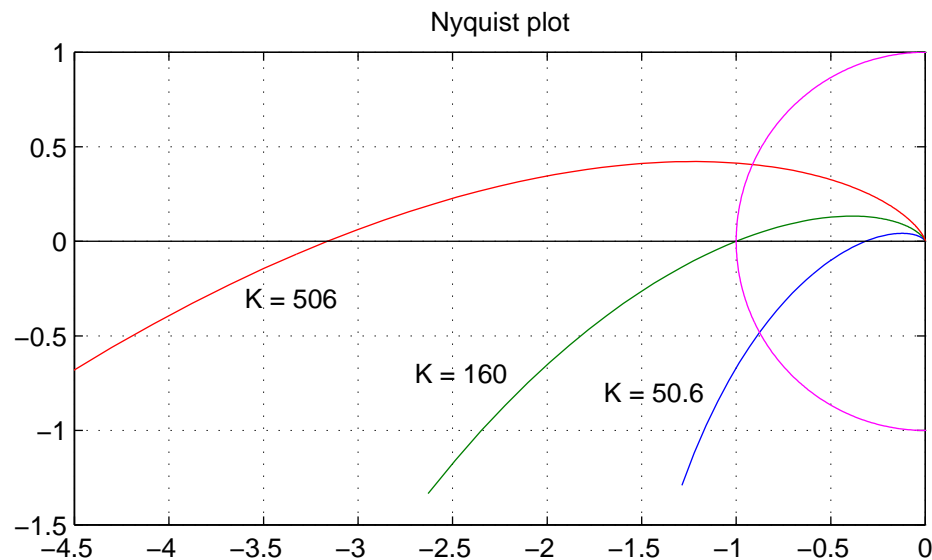

The results for the specified controller gain are

K	$ G(j\omega) $	G.M.	G.M. _{dB}	Stability
50.6	0.31625	3.162	10	Stable
160	1	1	0	Marginally stable
506	3.1625	0.3162	-10	Unstable

Example 2

The bode (magnitude and phase angle) plots of the above open-loop transfer function for $k = 50.6$, $k = 160$, and $k = 506$ are as shown in the next page. From the plots determine the phase and gain crossover frequencies, the gain margin and the phase margin for the specified controller gains.

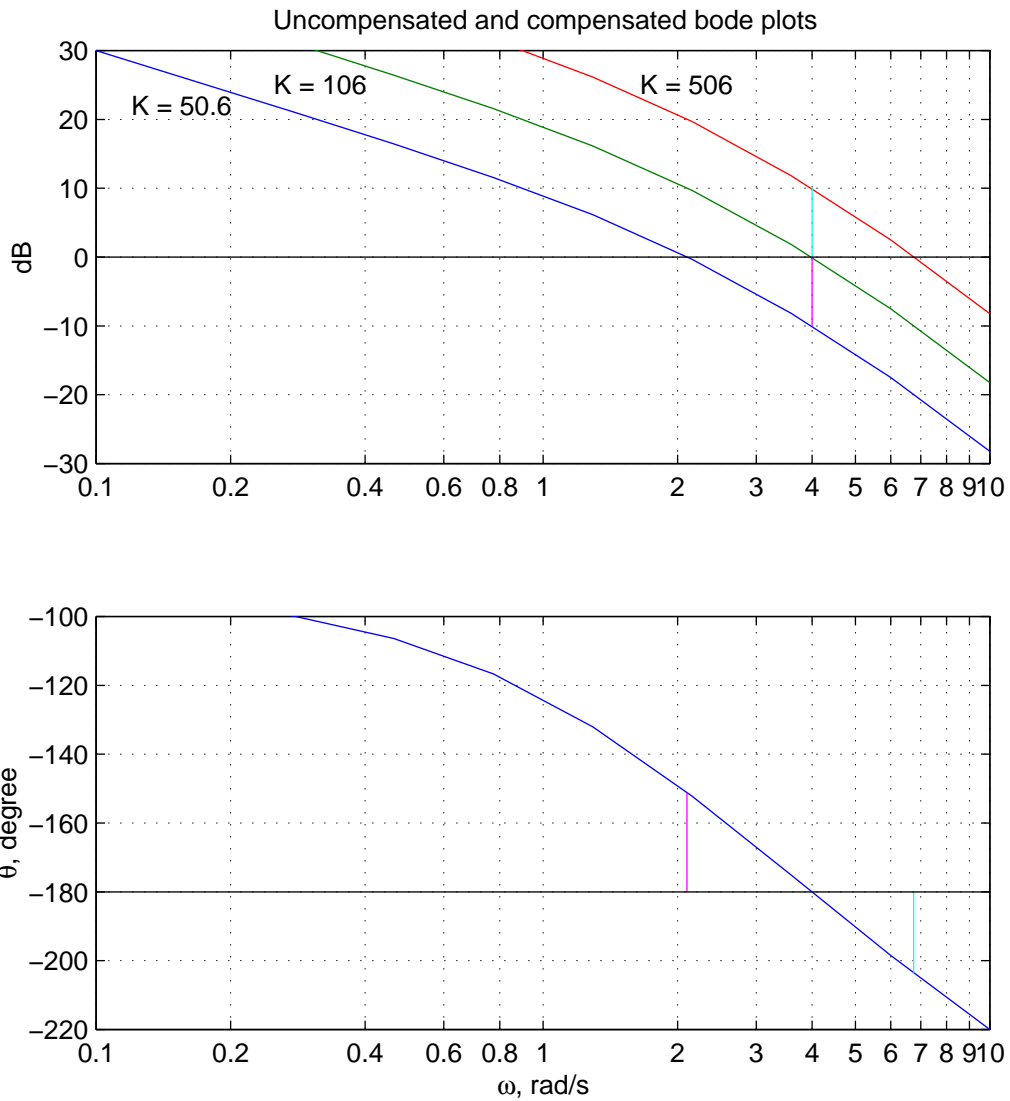

The results from the bode plots are

K	ω_{pc}	ω_{gc}	G.M., dB	P.M.	Stability
50.6	4	2.1	10	29°	Stable
160	4	4	0	0°	Marginally stable
506	4	6.75	-10	-23.5°	Unstable

Example 3

Obtain the Bode plot, gain and phase margins for the feedback control system with the open-loop transfer function

$$G(s) = \frac{8}{s(s+1)(s+4)} = \frac{8}{s^3 + 5s^2 + 4s}$$

Determine the gain factor K_P of a proportional controller such that the steady-state error due to a ramp input will equal 0.25. Obtain the frequency response of the compensated system and the new gain and phase margins.

The steady-state error specification requires

$$e_{ss} = \frac{1}{K_v} = 0.25$$

or

$$K_v = 4$$

where the velocity error constant K_v is given by

$$K_v = \lim_{s \rightarrow 0} s \frac{8K_p}{s(s+1)(s+4)} = 2K_p = 4$$

or

$$K_p = 2$$

The compensated open loop transfer function to satisfy the steady state error is

$$G(s) = \frac{2(8)}{s(s+1)(s+4)} = \frac{16}{s^3 + 5s^2 + 4s}$$

Using **bode** function, the open loop frequency response for the compensated and uncompensated system is obtained as shown.

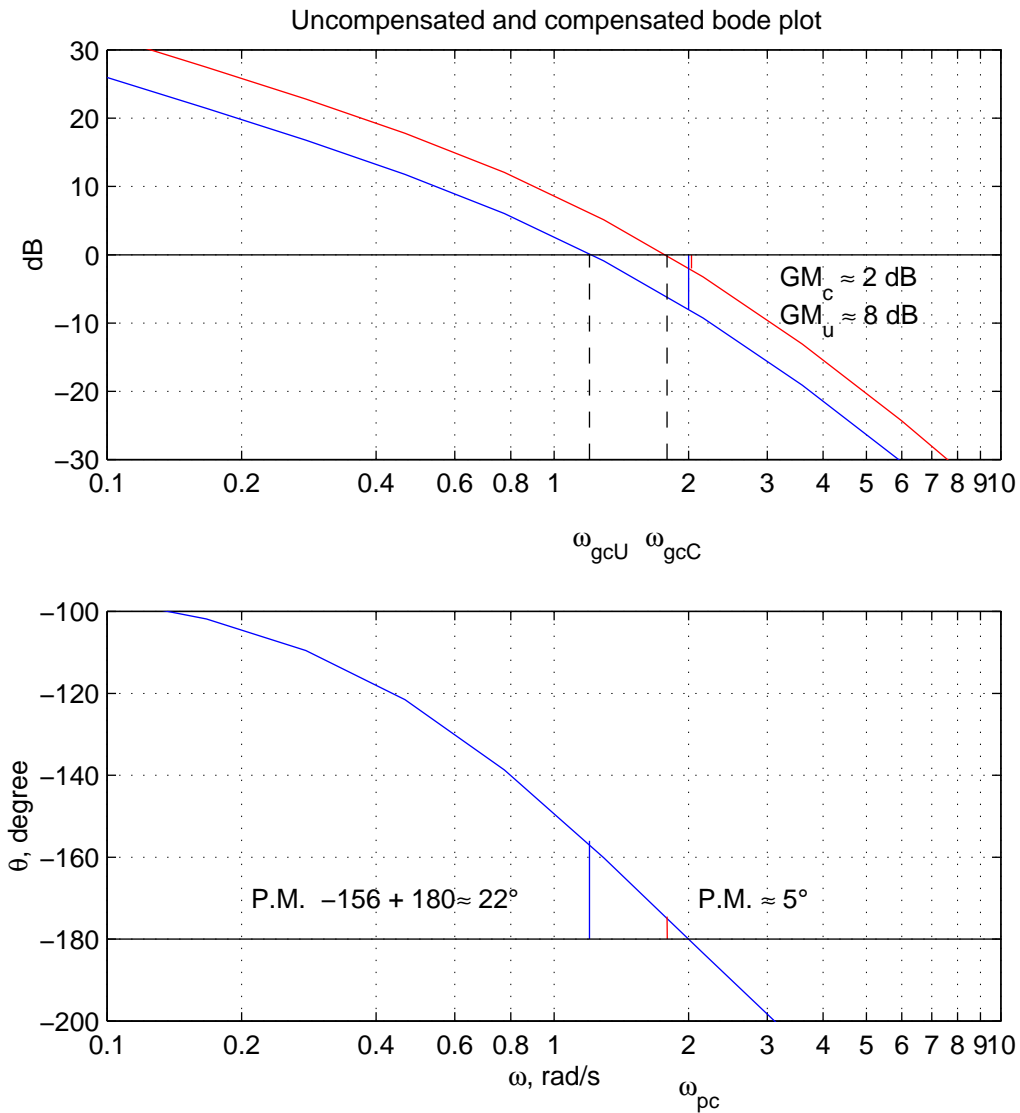

From the frequency response plot, ω_{pc} , ω_{gc} , gain margin and phase margin for the uncompensated and compensated systems are:

Compensated	$\omega_{pc} = 2$	$\omega_{gc} = 1.2$	G.M. _{dB} = 8	P.M. = 22°	$e_{ss} = 0.5$
Uncompensated	$\omega_{pc} = 2$	$\omega_{gc} = 1.79$	G.M. _{dB} = 2	P.M. = 5°	$e_{ss} = 0.25$

It can be seen that increasing the gain values improves the steady-state behavior but will decrease the phase and gain margins resulting in poor stability. It is then necessary to redesign the system by using a suitable controller to alter the frequency response so that the performance specifications will be met.

Operational Amplifier

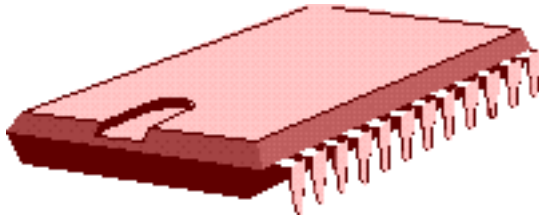

The operational amplifier is an integrated circuit (IC) composed of about thirty transistors, a dozen resistors and several capacitors manufactured on a single piece of silicon crystal called a chip. The Op amps are used in many electronic circuits for both linear and nonlinear operations. The circuit symbol for an op amp with its five essential terminals is shown in Figure 4.1.

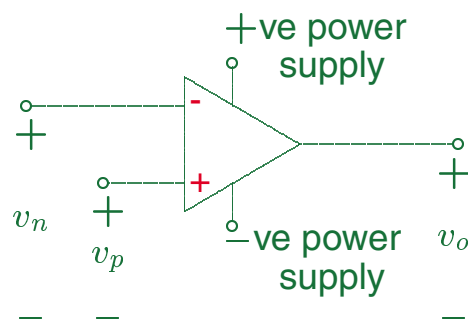

Figure 4.1 Circuit symbol for an op amp.

There are more terminals in a typical op amp, but we are not concerned with the remaining terminals. Our focus is on the terminal behavior of the amplifier as a circuit element and not on the internal structure.

Thus, we treat the op amp as a black box with the following essential terminals:

- The inverting terminal designated by - sign.
- The noninverting terminal designated by + sign.
- The output terminal.
- The positive power supply.
- The negative power supply.

When a voltage v_n is applied to the inverting terminal the output voltage is an inverted amplified signal of the input v_n . The voltage v_p applied to the noninverting terminal is amplified without inversion. Thus, with both input voltages the output voltage is

$$\begin{aligned}v_0 &= -Av_n + Av_p \\ &= -A(v_n - v_p)\end{aligned}$$

Where A is the open-loop gain of the op amp. A is very large, typically in the order of 10^5 – 10^6 for DC and low frequency signals. The gain drops with increase in the frequency and approaches unity with frequency in the range of 50 MHz.

Voltage transfer characteristic

The transfer characteristics describes how the output voltage varies as a function of the input voltage as shown in Figure 4.2.

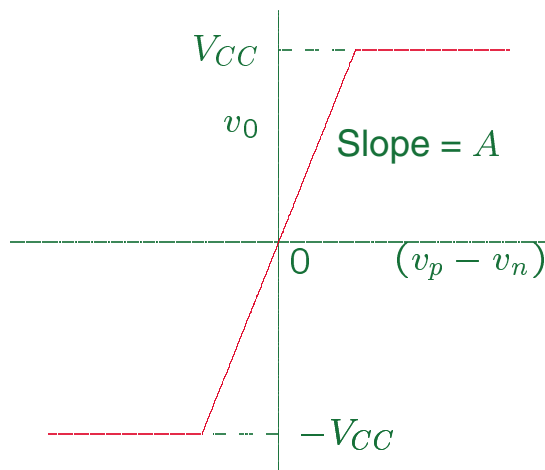

When $|v_p - v_n|$ is small the op amp behaves as a linear device. Outside this linear range the op amp saturates and behaves as a nonlinear device. For operation in the linear range the net input voltage is constrained to the voltage V_{CC} applied to the power terminals. The op amp output is given by

$$v_0 = \begin{cases} -V_{CC} & A(v_p - v_n) < -V_{CC} \\ A(v_p - v_n) & -V_{CC} \leq A(v_p - v_n) \leq V_{CC} \\ V_{CC} & A(v_p - v_n) > V_{CC} \end{cases}$$

For a typical op amp operating on its linear region, the voltage difference between the two inputs is very small, less than 2 mV.

$$v_x = v_p - v_n \approx 0$$

Also the input resistance is very large, and the output resistance is negligibly small. For example, the common 741 op amp has $A_{approx} 10^5$, $R_{in} \approx 2 \text{ M}\Omega$, and $R_{out} \approx 40\Omega$. Because of the high input resistance, negligibly small current flows into the two op amp inputs, usually on the order of μA .

In most practical applications, the circuit analysis can be simplified with good accuracy by assuming the op amp to be ideal, i.e.,

- $A = \infty$, so that $v_n = v_p$
- $R_{in} = \infty$, so that $i_n = i_p = 0$
- $R_{out} = 0$

Inverting Amplifier

Since the open-loop gain of an op amp is infinitely high to stabilize the operation a portion of the output signal is returned to the input inverting terminal, reducing the input voltage applied to this terminal which in turn reduces the output voltage, and the op amp operates on its linear region. Figure 4.3 shows the circuit configuration for an inverting op amp.

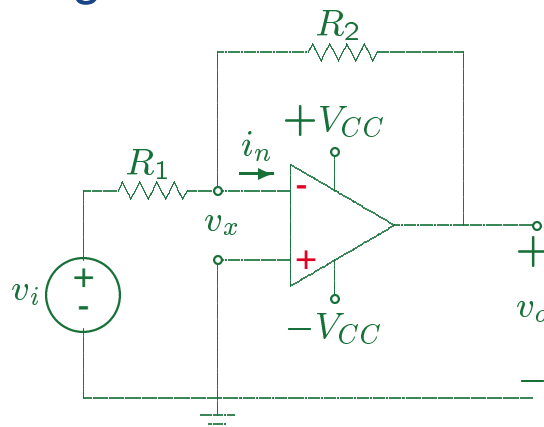

Applying KCL at the inverting node, we have

$$\frac{v_x - v_i}{R_1} + \frac{v_x - v_o}{R_2} + i_n = 0$$

Assuming ideal op amp $i_n = 0$, and $v_x = 0$, we get

$$\frac{-v_i}{R_1} + \frac{-v_o}{R_2} = 0 \quad \text{or} \quad v_o = -\frac{R_2}{R_1}v_i$$

Noninverting Amplifier

The circuit configuration for a noninverting op amp is shown in Figure 4.4

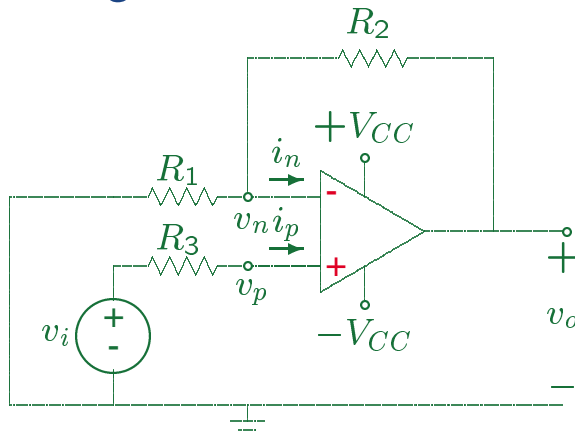

Applying KCL at the inverting node, we have

$$\frac{v_n}{R_1} + \frac{v_n - v_0}{R_2} + i_n = 0$$

At the noninverting terminal $v_p = v_i - R_3 i_p$. Assuming ideal op amp $i_n = i_p = 0$, and $v_n = v_p = v_i$. Substituting in the first equation, we have

$$\frac{v_i}{R_1} + \frac{v_i - v_0}{R_2} = 0$$

or

$$v_0 = \left(1 + \frac{R_2}{R_1}\right)v_i$$

Summing amplifier circuit

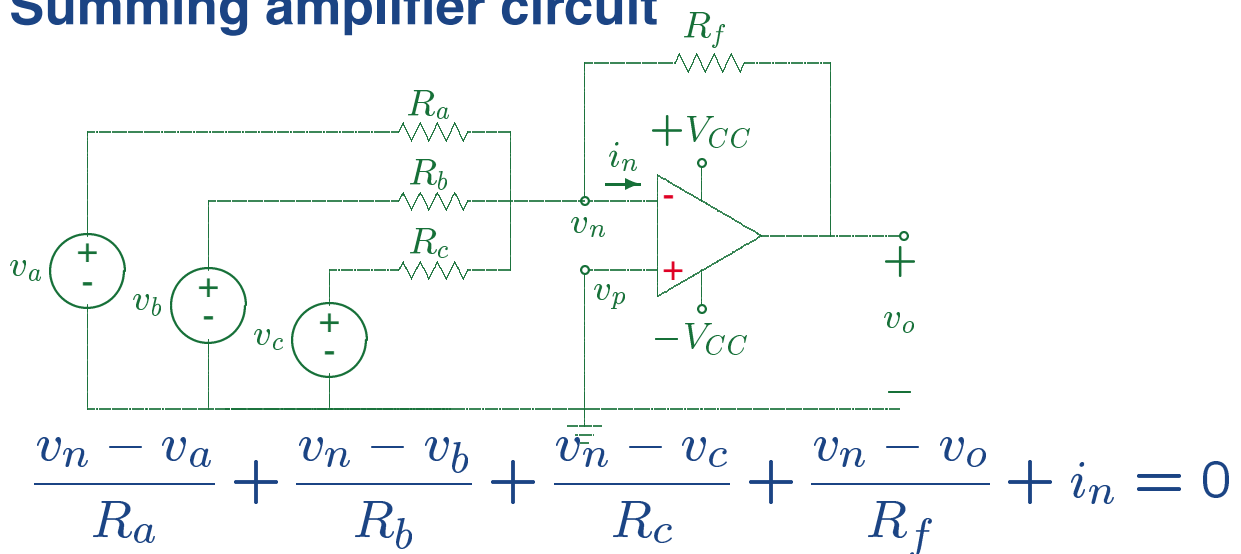

$v_n = v_p \approx 0$, and $i_n = 0$, thus we have

$$-\frac{v_a}{R_a} - \frac{v_b}{R_b} - \frac{v_c}{R_c} - \frac{v_o}{R_f} = 0$$

$$v_o = -\left(\frac{R_f}{R_a}v_a + \frac{R_f}{R_b}v_b + \frac{R_f}{R_c}v_c\right)$$

So the output voltage is an inverted scaled sum of the three input voltages. If $R_a = R_b = R_c = R_s$, then

$$v_o = -\frac{R_f}{R_s}(v_a + v_b + v_c)$$

and if $R_f = R_s$, we have

$$v_o = -(v_a + v_b + v_c)$$

Difference amplifier circuit

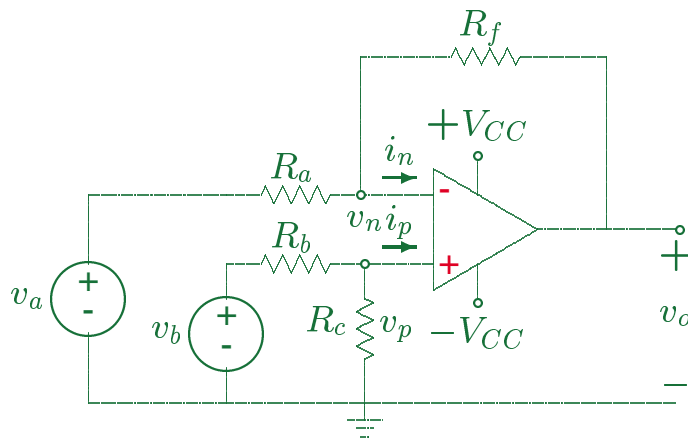

$$\frac{v_n - v_a}{R_a} + \frac{v_n - v_o}{R_f} + i_n = 0$$

$$i_n = 0 = i_p \approx 0, \text{ and } v_n = v_p = \frac{R_c}{R_b + R_c} v_b, \text{ thus}$$

$$\begin{aligned} v_o &= \frac{(R_a + R_f)}{R_a} v_n - \frac{R_f}{R_a} v_a \\ &= \frac{R_c(R_a + R_f)}{R_a(R_b + R_c)} v_b - \frac{R_f}{R_a} v_a \\ &= \frac{R_f(R_a/R_f + 1)}{R_a(R_b/R_c + 1)} v_b - \frac{R_f}{R_a} v_a \end{aligned}$$

The output voltage is equal to the difference between scaled replica of the two inputs. If $R_a/R_f = R_b/R_c$, we get

$$v_o = \frac{R_f}{R_a}(v_b - v_a)$$

and if

$$R_f = R_a$$

we obtain

$$v_o = v_b - v_a$$