

See discussions, stats, and author profiles for this publication at: <https://www.researchgate.net/publication/329023666>

# How to Model Welding Processes

Presentation · April 2015

CITATIONS

0

READS

7,032

1 author:



Francis Thibault

National Research Council Canada

151 PUBLICATIONS 983 CITATIONS

SEE PROFILE

Some of the authors of this publication are also working on these related projects:



Soft Tissue Characterization [View project](#)



Polymer Processing and Optimization [View project](#)



# *Overview of Welding Processes*

*F. Thibault*

April, 2015



National Research  
Council Canada

Conseil national  
de recherches Canada

Canada 

# Welding Process Family Tree



# ***SMAW: Shielded Metal Arc Welding***

- also known as **manual metal arc welding (MMA or MMAW)**, **flux shielded arc welding** or informally as **stick welding**, is a manual arc welding process that uses a consumable electrode covered with a **flux** (a reducing agent which prevented oxides from forming on the surface of the molten metal) to lay the weld (wikipedia)

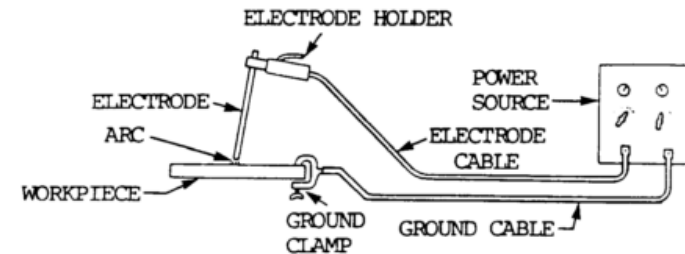
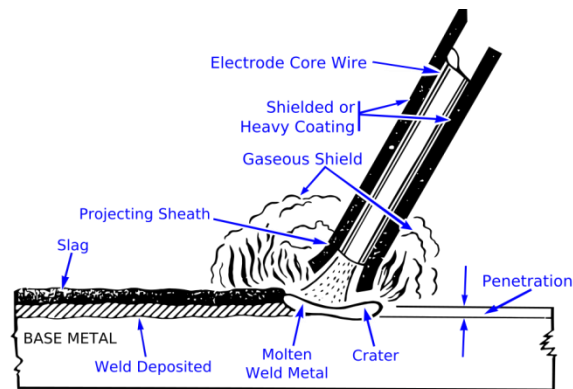

# ***SMAW: Shielded Metal Arc Welding***

- An electric current, in the form of either alternating current or direct current from a welding power supply, is used to form an electric arc between the electrode and the metals to be joined. The work-piece and the electrode melts forming the weld pool that cools to form a joint. As the weld is laid, the flux coating of the electrode disintegrates, giving off vapors that serve as a shielding gas and providing a layer of slag, both of which protect the weld area from atmospheric contamination
- Because of the versatility of the process and the simplicity of its equipment and operation, shielded metal arc welding is one of the world's first and most popular welding processes. It dominates other welding processes in the maintenance and repair industry, and though flux-cored arc welding is growing in popularity, SMAW continues to be used extensively in the construction of heavy steel structures and in industrial fabrication



# GTAW : Gas Tungsten Arc Welding (or TIG - Tungsten Inert Gas)

- is an arc welding process that uses a non-consumable tungsten electrode to produce the weld. The weld area is protected from atmospheric contamination by an inert shielding gas (argon or helium), and a filler metal is normally used, though some welds, known as autogenous welds, do not require it. A constant-current welding power supply produces electrical energy, which is conducted across the arc through a column of highly ionized gas and metal vapors known as a [plasma](#) (wikipedia)

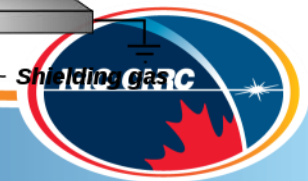
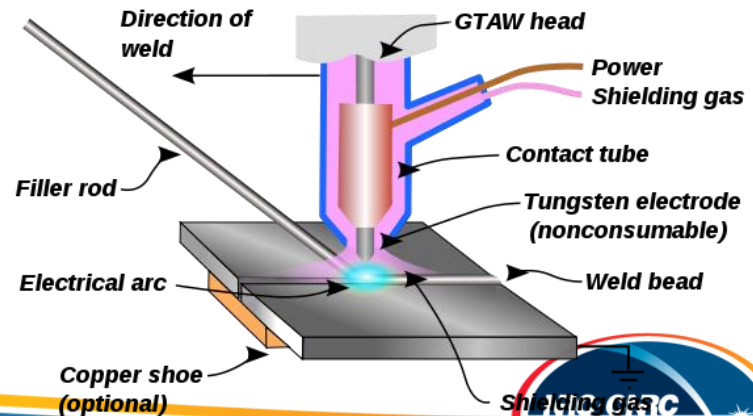

# GTAW : Gas Tungsten Arc Welding

## (or TIG - Tungsten Inert Gas)

- is most commonly used to weld thin sections of stainless steel and non-ferrous metals such as aluminum, magnesium, and copper alloys.
- The process grants the operator greater control over the weld than competing processes such as shielded metal arc welding and gas metal arc welding, allowing for stronger, higher quality welds. However, GTAW is comparatively more complex and difficult to master, and furthermore, it is significantly slower than most other welding techniques



# GTAW : Gas Tungsten Arc Welding (or TIG - Tungsten Inert Gas)

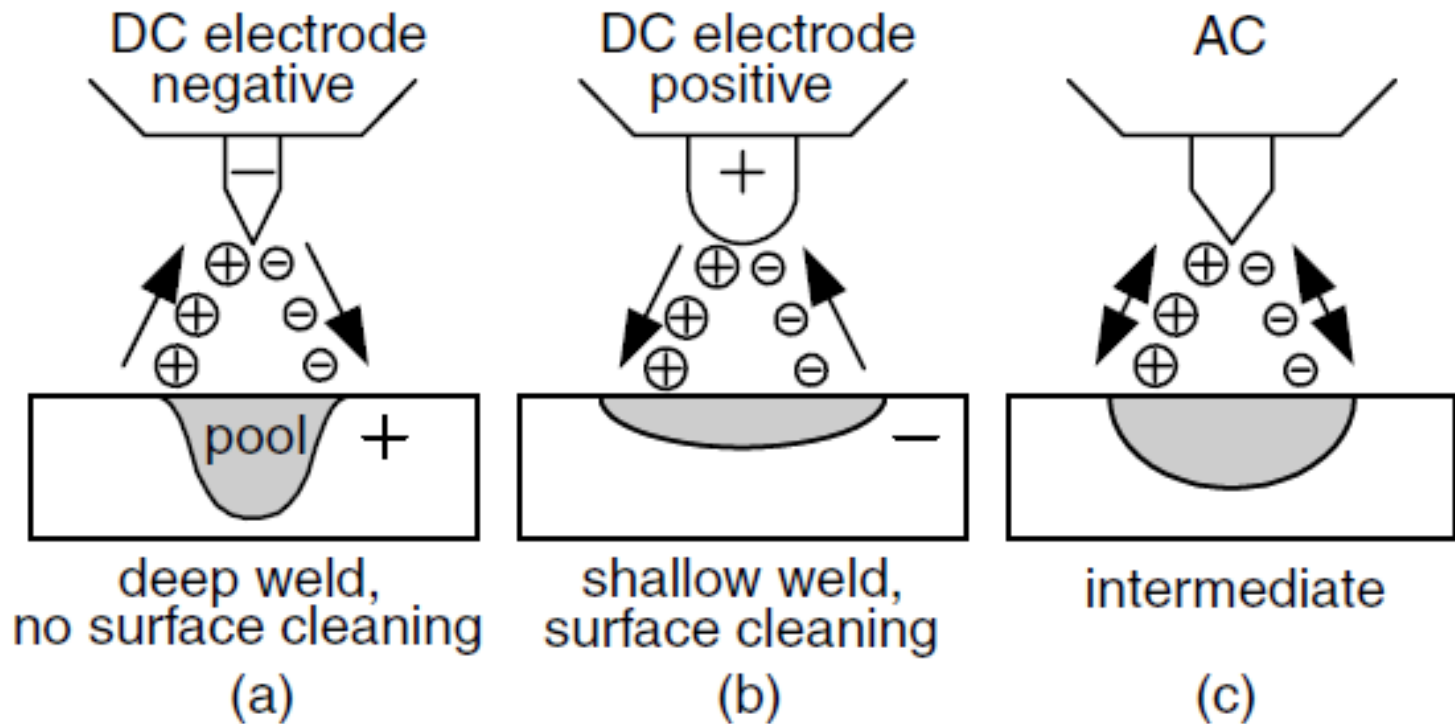
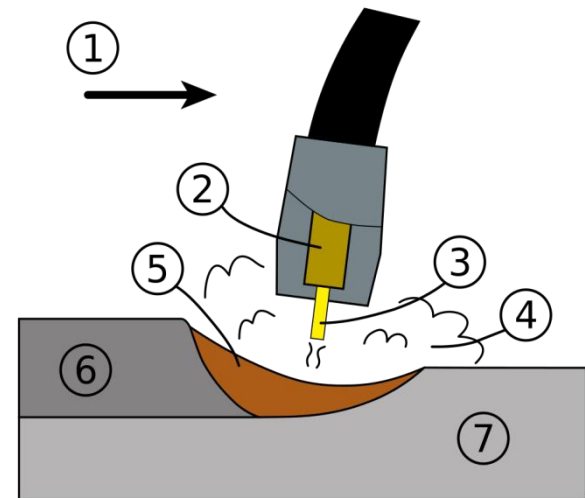
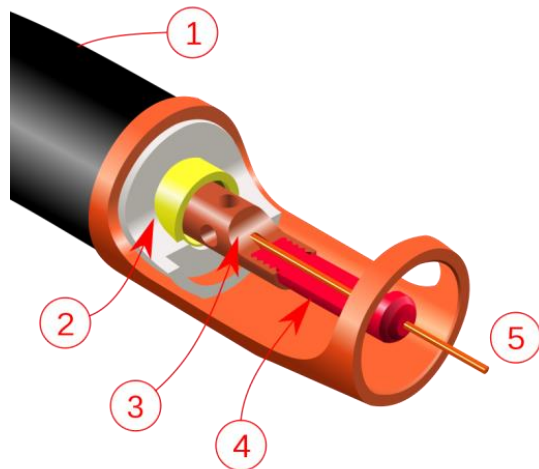

**Figure 1.12** Three different polarities in GTAW.



# GMAW : Gas Metal Arc Welding

- Sometimes referred to by its subtypes **metal inert gas (MIG) welding** or **metal active gas (MAG) welding**, is a welding process in which an electric arc forms between a consumable wire electrode and the work-piece metal(s), which heats the work-piece metal(s), causing them to melt, and join



(1) Torch handle, (2) Molded phenolic dielectric (shown in white) and threaded metal nut insert (yellow), (3) Shielding gas diffuser, (4) Contact tip, (5) Nozzle output face

GMAW weld area. (1) Direction of travel, (2) Contact tube, (3) Electrode, (4) Shielding gas, (5) Molten weld metal, (6) Solidified weld metal, (7) Work-piece.



# GMAW : Gas Metal Arc Welding

- Along with the wire electrode, a shielding gas feeds through the welding gun, which shields the process from contaminants in the air
- The process can be semi-automatic or automatic. A constant voltage, direct current power source is most commonly used with GMAW, but constant current systems, as well as alternating current, can be used

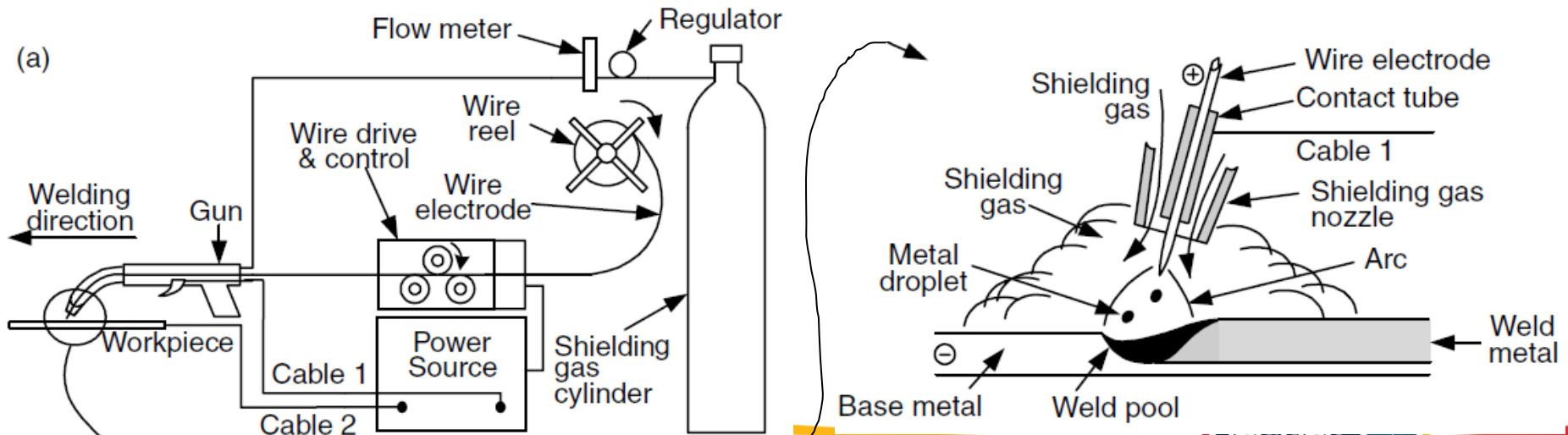

# GMAW : Gas Metal Arc Welding

- There are four primary methods of metal transfer in GMAW: a) globular, b) short-circuiting, c) spray, and d) pulsed-spray, each of which has distinct properties and corresponding advantages and limitations
- Originally developed for welding aluminium and other non-ferrous materials in the 1940s, GMAW was soon applied to steels because it provided faster welding time compared to other welding processes
- The cost of inert gas limited its use in steels until several years later, when the use of semi-inert gases such as carbon dioxide became common
- Today, GMAW is the most common industrial welding process, preferred for its versatility, speed and the relative ease of adapting the process to robotic automation



# GMAW : Gas Metal Arc Welding

- The type of **Inert** gas used for **MIG** welding :
  - **Argon** gas is used pure in the welding of light alloys whereas, in chrome-nickel stainless steel welding, it is preferable using argon with the addition of oxygen and  $\text{CO}_2$  in a percentage of 2% as this contributes to the stability of the arc and improves the form of the bead
  - **Helium** gas is used as an alternative to argon and permits greater penetration (on thick material) and faster wire feeding.
  - **Helium-argon** provides a more stable arc than pure helium, and greater penetration and travel speed than argon



# GMAW : Gas Metal Arc Welding

- The type of **Active** gas used for **MAG** welding :
  - Using CO<sub>2</sub> as a shielding gas, high penetrations and low operating cost are obtained with high feeding speed and good mechanical properties. On the other hand, the use of this gas creates considerable problems with the final chemical composition of the joints as there is a loss of easily oxidisable elements with simultaneous enrichment of carbon in the weld pool.
  - The mixtures **Argon-CO<sub>2</sub>-O<sub>2</sub>** are used in the welding of ferrous materials. Normally the mixture contains a percentage of CO<sub>2</sub> ranging from 8% to 20% and O<sub>2</sub> around 5%



# GMAW : Gas Metal Arc Welding Guns

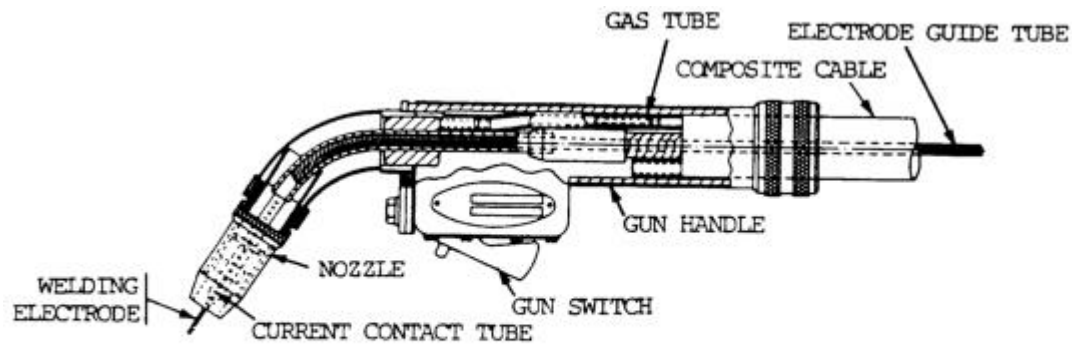
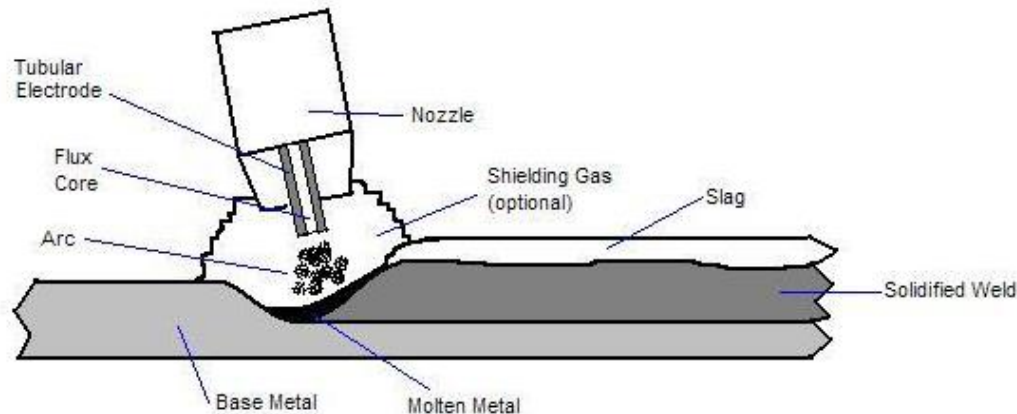

Figure 10-46. Typical semiautomatic gas-cooled, curved-neck gas metal arc welding gun.



# FCAW : Flux Cored Arc Welding (or Core Wire or Self-Shielded Wire Welding)

- is a semi-automatic or automatic arc welding process. FCAW requires a continuously-fed consumable tubular electrode containing a flux and a constant-voltage or, less commonly, a constant-current welding power supply
- An externally supplied shielding gas is sometimes used, but often the flux itself is relied upon to generate the necessary protection from the atmosphere, producing both gaseous protection and liquid slag protecting the weld. The process is widely used in construction because of its high welding speed and portability



# ***Some Other Characteristics of Welding Processes***

- **SMAW** and **GTAM** (TIG) :
  - Use constant current power source
  - Low deposition rate primarily using manual mode of application
  - Filler materials look straight and linear rods
  - Need better skills to operate
  
- **GMAW** (MIG/MAG) and **FCAW** :
  - Use constant voltage power source
  - High deposition rate using semi-automatic method of application
  - Filler materials have a spool of wire
  - Need less skills to operate





# Types of Welded Joints

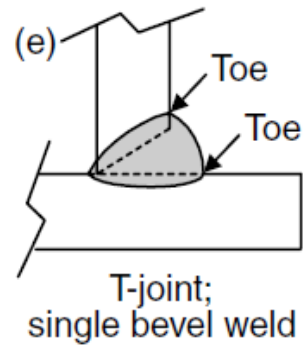
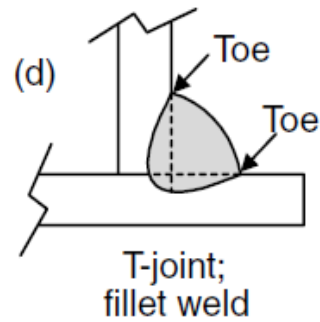
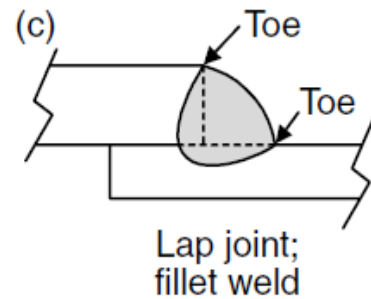
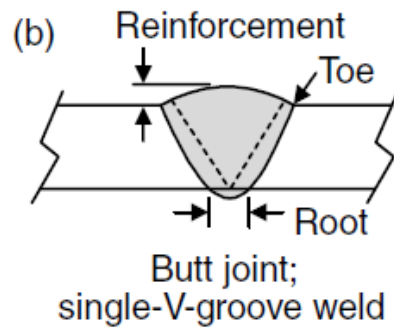
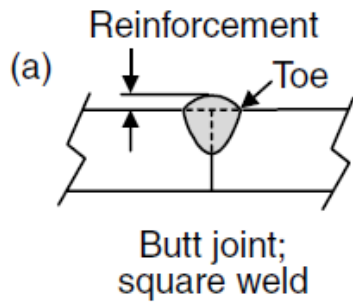

	Butt welding	Fillet welding	Plug welding	Slot welding
Butt joint				
Cross joint T-joint				
Corner joint				
Strapped joint				
Lap joint				
Edge joint				

# Types of Grooves

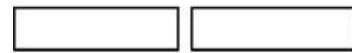

square groove

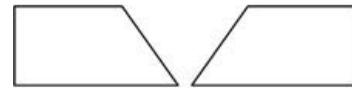

single V groove

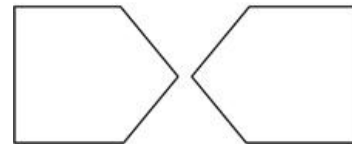

double V groove

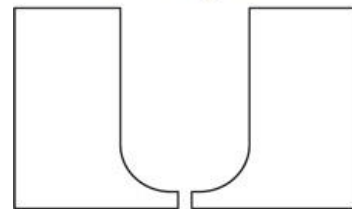

single U groove

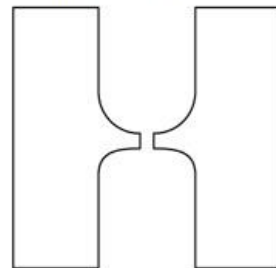

double U groove

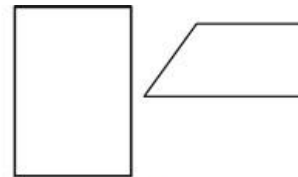

single bevel groove

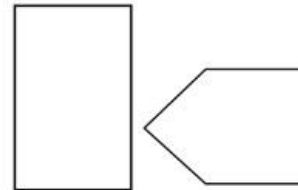

double bevel groove



single J groove

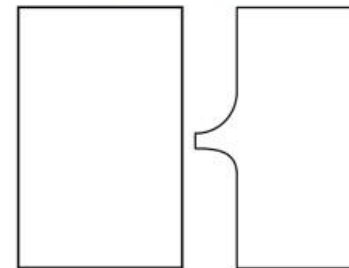

double J groove

# ***MIG/MAG Machine Set-up (steel with solid wire)***

1. **Material thickness determines amperage.** As a guideline, each 0.001 inch of material thickness requires 1 amp: 0.125 in. = 125 amps
2. **Select proper wire size**, according to amperage. Since you don't want to change wire, select one for your most commonly used thicknesses.
  - a. 30-130 A: 0.023-in
  - b. 40-145 A: 0.030 in
  - c. 50-180 A: 0.035 in
  - d. 75-250 A: 0.045 in
3. **Set the voltage.** Voltage determines height and width of bead. If no chart, manual or specifications are available for setting the correct voltage, you can try this: while one person welds on scrap metal, an assistant turns down the voltage until the arc starts stubbing into the work piece



# MIG/MAG Machine Set-up

4. **Set the wire feed speed.** Wire speed controls amperage, as well as the amount of weld penetration. A speed that's too high can lead to burn-through. If a manual or weld specification sheet is not available, use the multipliers in the following chart to find a good starting point for wire feed speed

For example, for 0.030-in. wire, multiply by 2 in. per amp to find the wire feed speed in inches per minute (IPM)

For Wire Size	Multiply by	Ex. Using 1/8 in. (125 amps)
0.023 in.	3.5 in. per amp	$3.5 \times 125 = 437.5$ IPM
0.030 in.	2 in. per amp	$2 \times 125 = 250$ IPM
0.035 in.	1.6 in. per amp	$1.6 \times 125 = 200$ IPM
0.045 in.	1 in. per amp	$1 \times 125 = 125$ IPM













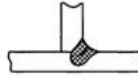

# ***MIG/MAG Machine Set-up***

- 5. Set the gas flow rate.** Finally the gas type and gas flow rate help regulate the transfer type. A high percentage of Argon or Helium added to a mix creates a hotter arc. The main goal of the gas setting is to provide enough gas to shield the weld area from the air.

This is an area that requires experimentation. In a shop setting a rate of 15 CFM may be enough, but a drafty area might require a rate of 50 CFM. Another thing to watch for is not to have the gas setting too high. A flow rate that is too fast can cause turbulence and suck in air to contaminate the weld.



# MIG/MAG Weld Defects and their Causes

FAULT		CAUSE
Porosity		Insufficient Si, Mn in wire Insufficient CO <sub>2</sub> shielding
		because of <ul style="list-style-type: none"> <li>flow rate</li> <li>frozen valve</li> <li>clogged nozzle</li> <li>draughts</li> </ul>
Cracking		Dirty work – grease, paint, scale, rust
		(i) Weld bead too small
		(ii) Weld too deep, greater than 1.2:1
		(iii) High sulphur, low manganese, slow cooling rate
Undercutting		Travel speed too high Backing bar groove too deep Current too low for speed Torch angle too low
Lack of penetration		Current too low – setting wrong
		Wire feed fluctuating
		Electrode extension too great
		Joint preparation too narrow
		Angle too small
		Gap too small
Lack of fusion		Uneven torch manipulation Insufficient inductance (short circuiting arc) Voltage too low
Slag inclusions		Technique – Too wide a weave Current too low Irregular weld shape
Spatter – on work on nozzle in weld		Voltage too high Insufficient inductance Insufficient nozzle cleaning
Irregular weld shape		Excessive electrode extension Wire temper excessive, no straightening rolls Current too high for voltage Travel speed too slow

# MIG/MAG Welding Positions

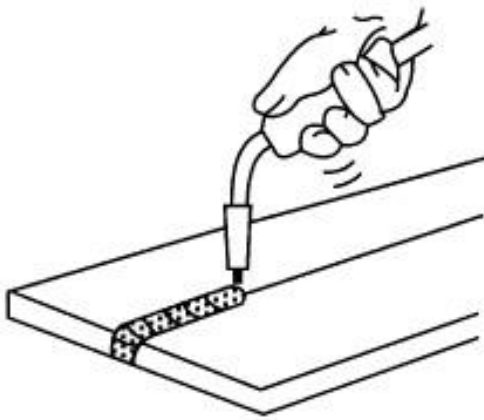

Flat

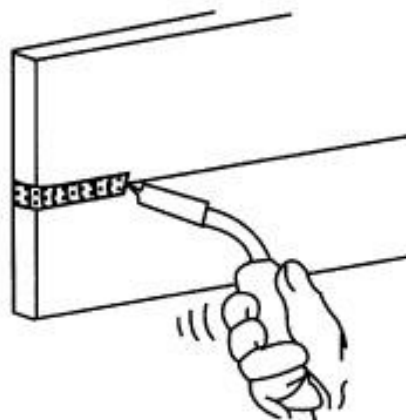

Horizontal

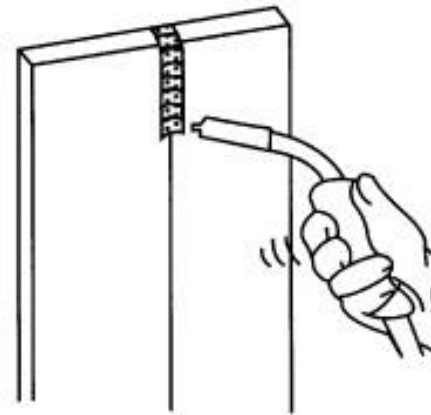

Vertical

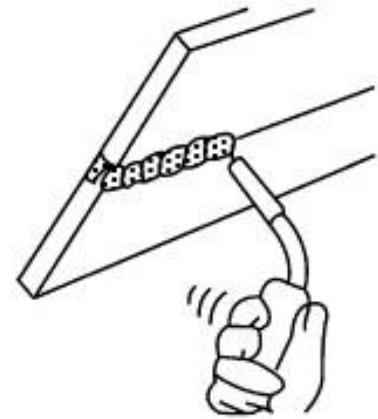

Overhead

# MIG/MAG Material Deposit Modelling

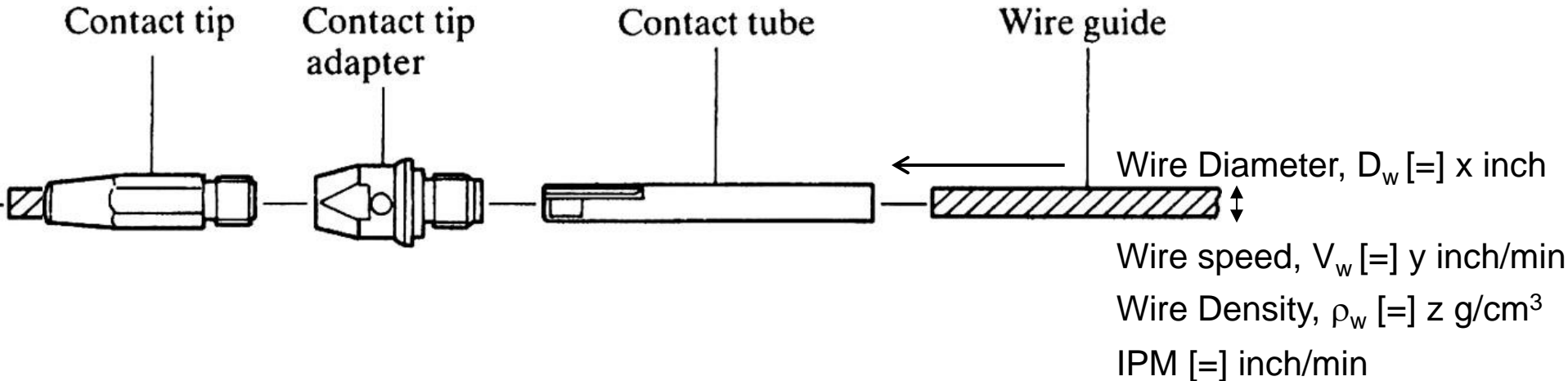

$$\text{Material Deposit Rate} = W = V_w \cdot S_w \cdot \rho_w = V_w \cdot \frac{\pi}{4} D_w^2 \cdot \rho_w$$

$$W [=] \frac{g}{sec} = V_w \frac{in}{min} \cdot \frac{\pi}{4} D_w^2 in^2 \cdot \rho_w \frac{g}{cm^3} \cdot 2.54^3 \frac{cm^3}{in^3} \cdot \frac{min}{60 sec}$$

$$W [=] \frac{g}{sec} = y \cdot \frac{\pi}{4} x^2 \cdot z \cdot 2.54^3 \cdot \frac{1}{60}$$

$$W [=] \frac{g}{sec} [=] 0.215 \cdot x^2 \cdot y \cdot z$$





# MIG/MAG Bead Shape Modelling

- One technique used for estimating the weld bead shape is to use artificial neural networks (ANN). The inputs considered by Chan et al. (1999) are illustrated below

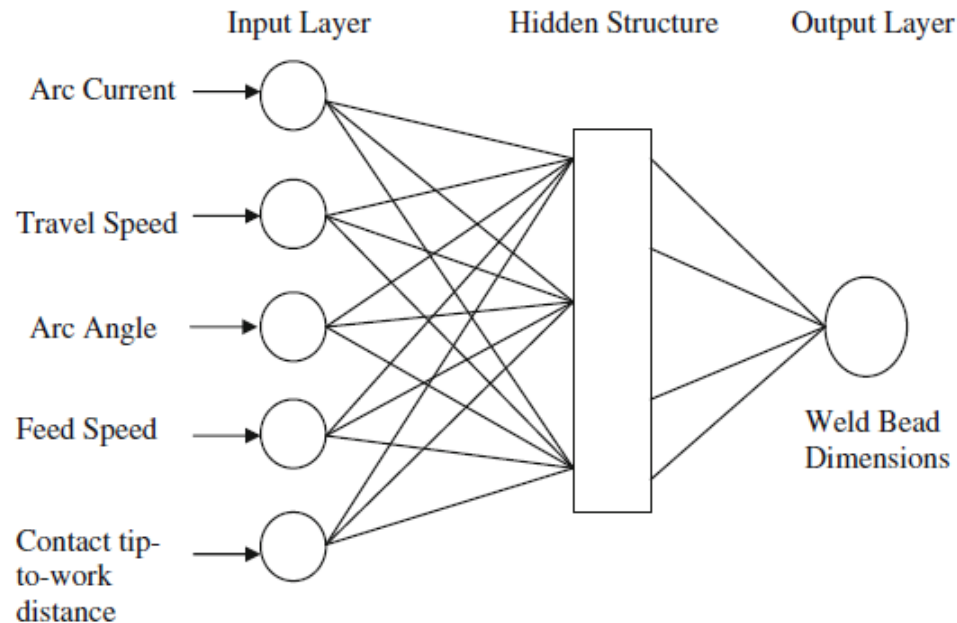

- Different settings of these parameters are used to determine outputs such as weld penetration, bead size, and bead shape

# ***MIG/MAG Bead Shape Modelling***

- Chan et al (1999) developed an ANN model of weld bead shape (they performed 96 bead-on-plate weld experiments and found that there is no simple shape that explains the shape of the weld bead)
  - An ellipse tends to overestimate the size of the weld bead
  - A parabola was found to match the shape of the weld bead most closely
    - It assumes that the weld bead was formed by extruding the 2D parabolic-section at a constant speed along a straight line formed by the weld joint, which produces an hemi-spherical shape
    - The volume of the feed wire deposited is equal to the volume of the hemi-spherical shape
    - The width of the weld bead is obtained from the temperature distribution where temperature exceeds the melting temperature



# MIG/MAG Bead Shape Modelling

Reference: Real-Time Simulation for a Virtual Reality-Based MIG Welding Training System, Chambers et al., 2012

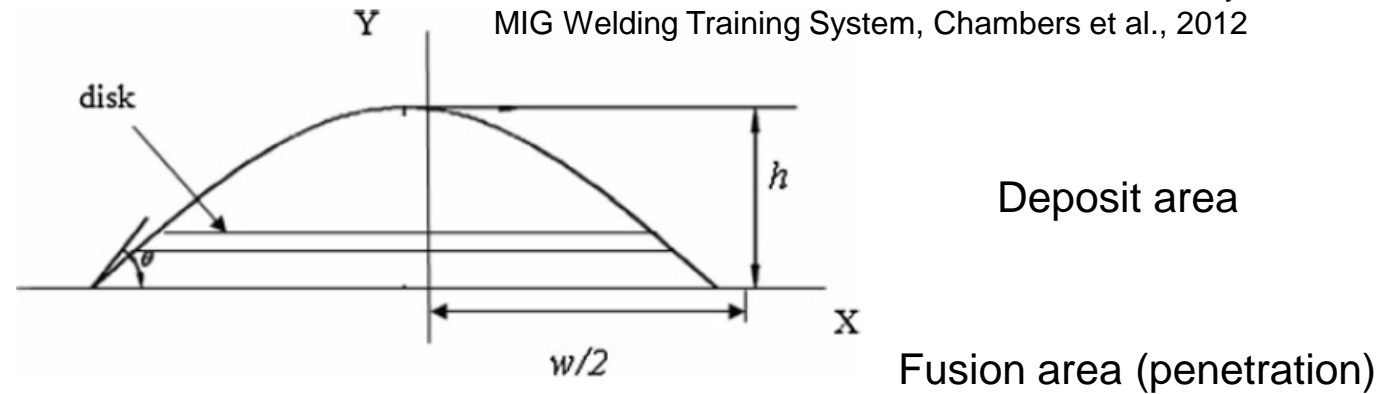

Fig. 5 Cross-section of parabola revolved around Y-axis

$$y = \left( \frac{4D_w^2 V_w \Delta t}{w^4} \right) x^2 + \left( \frac{D_w^2 V_w \Delta t}{w^2} \right) \quad , \quad h = \frac{D_w^2 V_w \Delta t}{w^2}$$

$$w = f(T)$$

The penetration depth =  $f(T)$

Position of weld bead: Pos(x,z) = f(gun tip position)



# MIG/MAG Temperature Distribution Modelling

- We want to model an electrical arc heat source travelling over a metal plate as shown below (Kou, Welding Metallurgy, 2003)

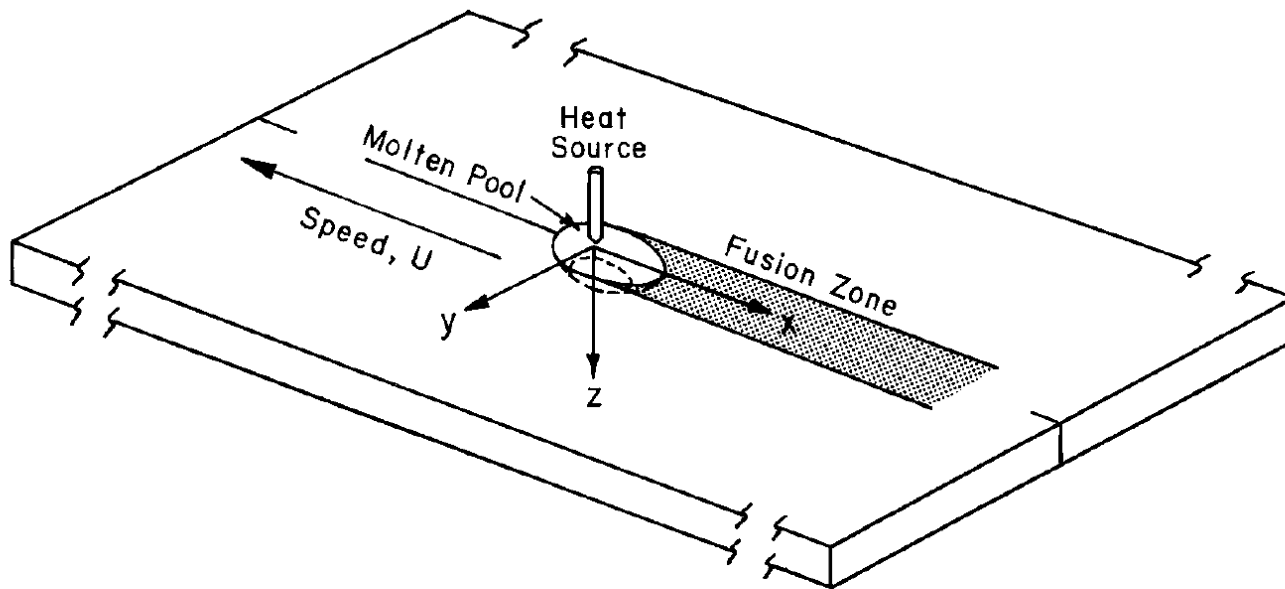

**Figure 2.14** Coordinate system  $(x, y, z)$  moving with heat source. From Kou and Le (24).

# MIG/MAG Temperature Distribution Modelling

- Heat flow in a work-piece of sufficient length is steady, or quasi-stationary, with respect to the moving heat source. In other words, for an observer moving with the heat source, the temperature distribution and pool geometry do not change with time. Rosenthal (1941) proposed the following analytical equation in 3D :

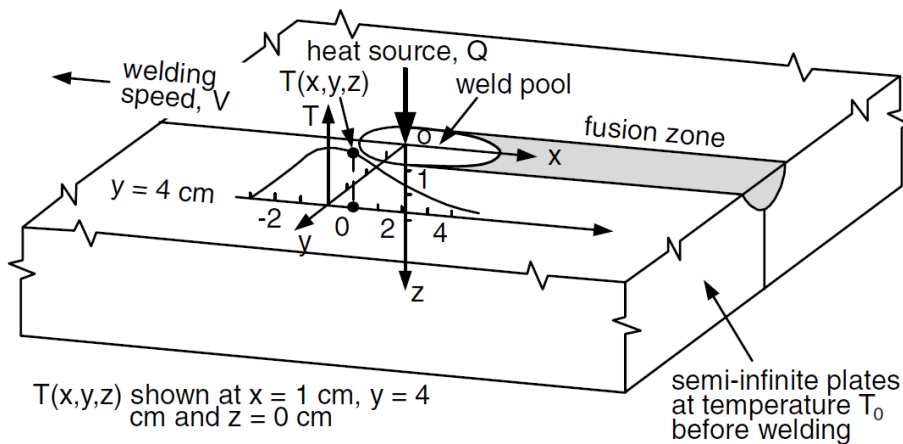

## Assumptions:

1. steady-state heat flow
2. point heat source
3. negligible heat of fusion
4. constant thermal properties
5. no heat losses from the work-piece surface
6. no convection in the weld pool

Figure 2.17 Three-dimensional heat flow during welding of semi-infinite workpiece.

$$T = T_0 + \frac{Q}{2\pi kR} \exp \left[ \frac{-V(R - x)}{2\alpha} \right]$$

$$, x \rightarrow t = \frac{(x - 0)}{V}$$

Q: heat transferred from heat source to work-piece, [=] J/mm<sup>3</sup>  
 R: radial distance from origin, namely  $(x^2+y^2+z^2)^{1/2}$



# MIG/MAG Temperature Distribution Modelling

- Resolution of 3D heat transfer equation in quasi-steady state regime (White et al., 2011; Chambers et al., 2012)

$$\frac{\partial^2 T}{\partial x^2} + \frac{\partial^2 T}{\partial y^2} + \frac{\partial^2 T}{\partial z^2} = 0$$

- The heat source is added to the plate by the welding gun
- The closest node to the gun tip is located in the mesh
- The temperature of that node is considered to be at the fixed input temperature from the electric arc. For aluminum, a value of 6500°C was empirically determined
- Boundary conditions: Dirichlet temperature

$$T(x, y, z, 0) = T_0$$

$$T(x, y, z, t) \Big|_{gun} = 6500^\circ C$$



# MIG/MAG Temperature Distribution Modelling

- Resolution of 3D heat transfer equation in non-stationary state regime (Porter, 20xx; Shunmugam, 2013; Babu, 2012; Satiya, 2009; Dhinakaran, 2014)

$$\rho(T)C_p(T) \left( \frac{\partial T}{\partial t} + (-V_{gun})\nabla T \right) = \nabla^2(k(T)T) + q_v(x, y, z)$$

- The heat source is added to the plate by the welding gun (
- The closest node to the gun tip is located in the mesh and this node got the heat source
- Boundary conditions : {radiation and convection (shield gas)}

$$q = h(T - T_0) + \sigma\varepsilon(T^4 - T_0^4)$$

- Some authors used Vinokurov's empirical relationship by neglecting convection

$$q = 2.41 \times 10^{-3} \varepsilon T^{1.61} \left( \frac{W}{m^2 \text{ } ^\circ C} \right)$$



END





# Typical Temperature Distributions on the Surface of a Thick Plate using a Point Heat source

