

FUNDAMENTAL OF ELECTRICAL AND ELECTRONICS ENG. (NOTES) DIP 1ST YEAR EE

CHAPTER-6 (Electromagnetic Induction)

MMF (Magneto motive force):- The current flowing in an electric circuit is due to the existence of **electromotive force** similarly **magnetomotive force** (MMF) is required to drive the **magnetic flux** in the magnetic circuit. The magnetic pressure, which sets up the magnetic flux in a **magnetic circuit** is called Magnetomotive Force. The SI unit of MMF is Ampere-turn (AT), and their CGS unit is G (gilbert).

Flux:- It is defined as the magnetic field lines around the magnet. It's SI unit is weber.

Reluctance:- **Magnetic reluctance**, or **magnetic resistance**, is a concept used in the analysis of **magnetic circuits**. It is defined as the ratio of **magnetomotive force** (mmf) to **magnetic flux**. It represents the opposition to magnetic flux, and depends on the geometry and composition of an object.

Permeability:- In **electromagnetism**, **permeability** is the measure of the resistance of a material against the formation of a **magnetic field**, otherwise known as distributed inductance in **transmission line theory**. Hence, it is the degree of **magnetization** that a material obtains in response to an applied magnetic field. Magnetic permeability is typically represented by the (italicized) Greek letter μ . The term was coined in September 1885 by **Oliver Heaviside**. The reciprocal of magnetic permeability is magnetic reluctivity.

Analogy between electric and magnetic circuit:-

The **analogies between electric and magnetic circuits** are two: the **electric circuit** quantity of current is **analogous** to **magnetic circuit** quantity flux. ... The **electric circuit** quantity of voltage, or electromotive force (EMF) is **analogous** to the **magnetic circuit** quantity of magnetomotive force (MMF). In electric circuit, there is resistance, but in magnetic circuit there is reluctance.

Concept of electromagnetic field:-

An **electromagnetic field** (also **EM field**) is a classical (i.e. non-quantum) **field** produced by moving **electric charges**. It is the field described by **classical electrodynamics** and is the classical counterpart to the **quantized electromagnetic field tensor** in **quantum electrodynamics**. The electromagnetic field propagates at the speed of light (in fact, this field can be identified *as* light) and interacts with charges and currents. Its **quantum counterpart** is one of the four **fundamental forces** of nature (the others are **gravitation**, **weak interaction** and **strong interaction**.)

The field can be viewed as the combination of an **electric field** and a **magnetic field**. The electric field is produced by stationary charges, and the magnetic field by moving charges (currents); these two are often described as the sources of the field. The way in which charges and currents interact with the electromagnetic field is described by **Maxwell's equations** and the **Lorentz force law**. The force created by the electric field is much stronger than the force created by the magnetic field.

Magnetic circuit:- A **magnetic circuit** is made up of one or more closed loop paths containing a **magnetic flux**. The flux is usually generated by permanent **magnets** or electromagnets and confined to the path by **magnetic cores** consisting of ferromagnetic materials like iron, although there may be air gaps or other materials in the path.

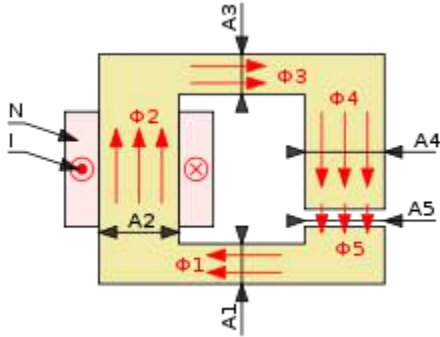

dia of magnetic ckt.

Electric circuit:-

An **electrical circuit** is a path in which electrons from a voltage or current source flow. The point where those electrons enter an **electrical circuit** is called the "source" of electrons.

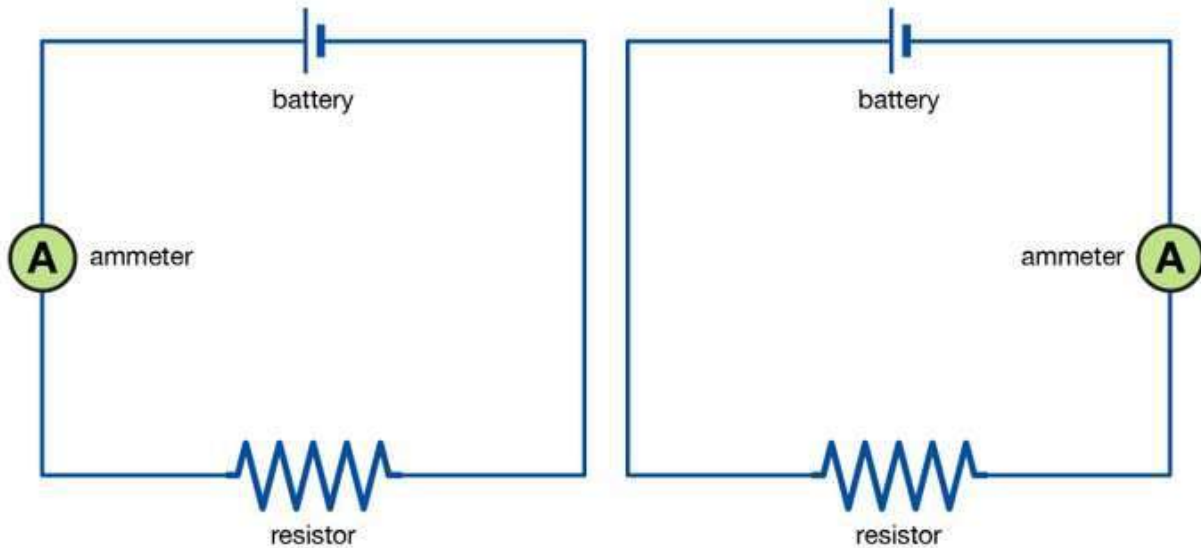

© 2013 Encyclopædia Britannica, Inc.

Faraday law of electromagnetic induction:-

Faraday's law of electromagnetic induction (referred to as **Faraday's law**) is a basic law of [electromagnetism](#) predicting how a [magnetic field](#) will interact with an [electric circuit](#) to produce an electromotive force (EMF). This phenomenon is known as electromagnetic induction.

Faraday's law states that a current will be induced in a conductor which is exposed to a changing magnetic field. **Lenz's law of electromagnetic induction** states that the direction of this induced current will be such that the magnetic field created by the induced current **opposes** the initial changing magnetic field which produced it. The direction of this current flow can be determined using **Fleming's right-hand rule**.

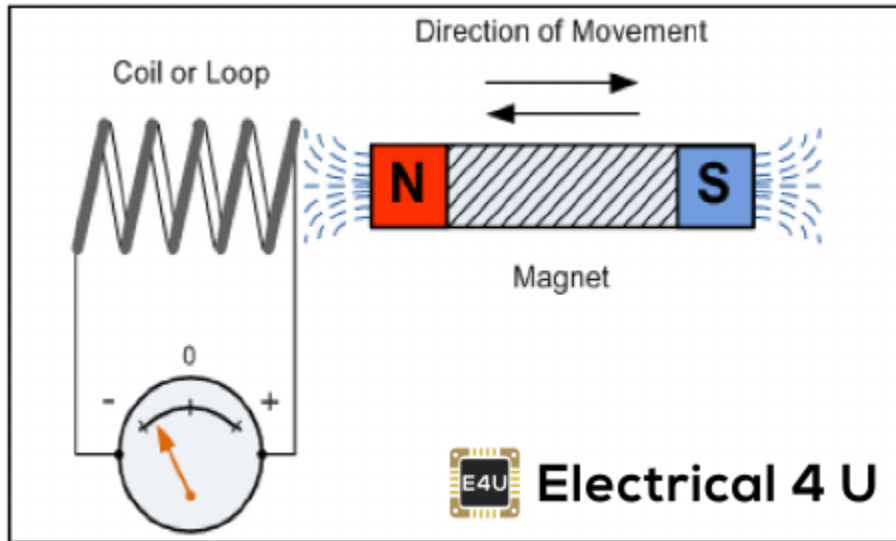

Faraday second law = It states that the magnitude of emf induced in the coil is equal to the rate of change of flux that linkages with the coil. The flux linkage of the coil is the product of the number of turns in the coil and flux associated with the coil.

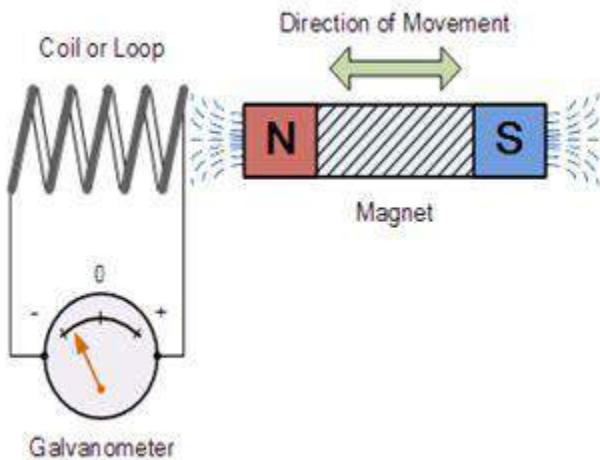

$$E = N \frac{d\phi}{dt}$$

Self Induced Emf:- It is defined as the **emf induced** in the coil due to increase or decrease of the current in the same coil. ... **emf is induced**. When a current is passed to a circuit due to **self induced emf** the flow of current in the circuit is opposed .

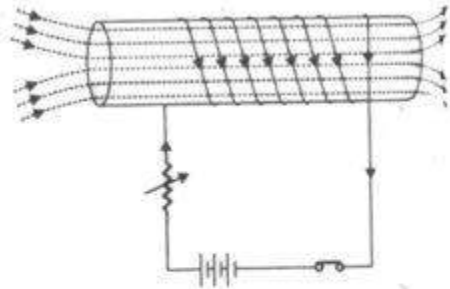

Establishment of magnetic field when a coil is carrying current

AutomationForum.Co

Mutually induced emf:-

The **emf induced** in a coil due to the change of flux produced by another neighbouring coil linking to it, is called **Mutually Induced emf**. ... The direction of the **induced emf** is such that it opposes the cause which produces it, that means it opposes the change of current in the first coil.

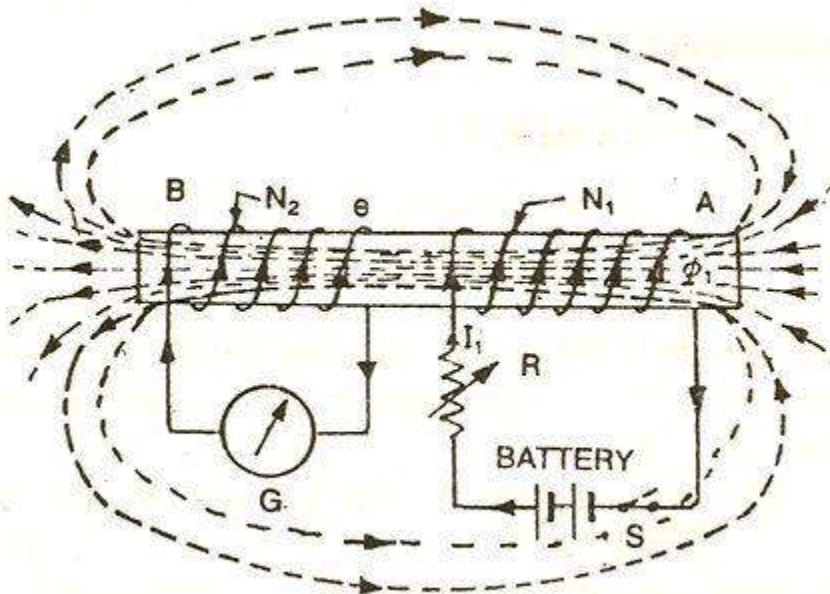

Time constant in an RL circuit:-

A **LR Series Circuit** consists basically of an inductor of inductance, L connected in series with a resistor of resistance, R . The resistance “ R ” is the DC resistive value of the wire turns or loops that goes into making up the inductors coil. Consider the LR series circuit below.

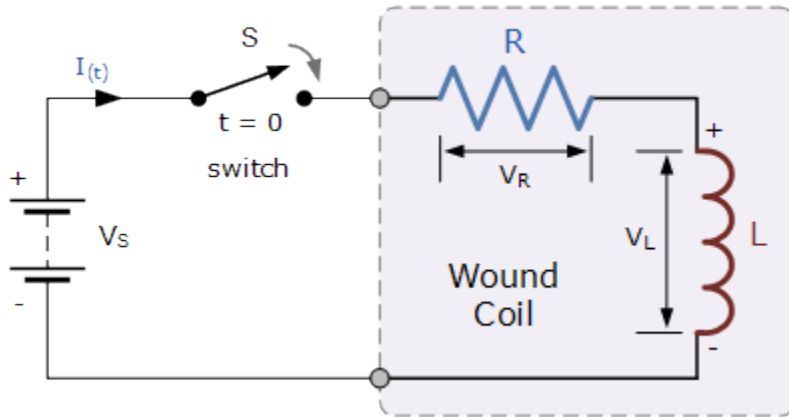

$$I(t) = \frac{V}{R} \left(1 - e^{-Rt/L} \right) \text{ (A)}$$

This is the expression of current in RL series ckt.

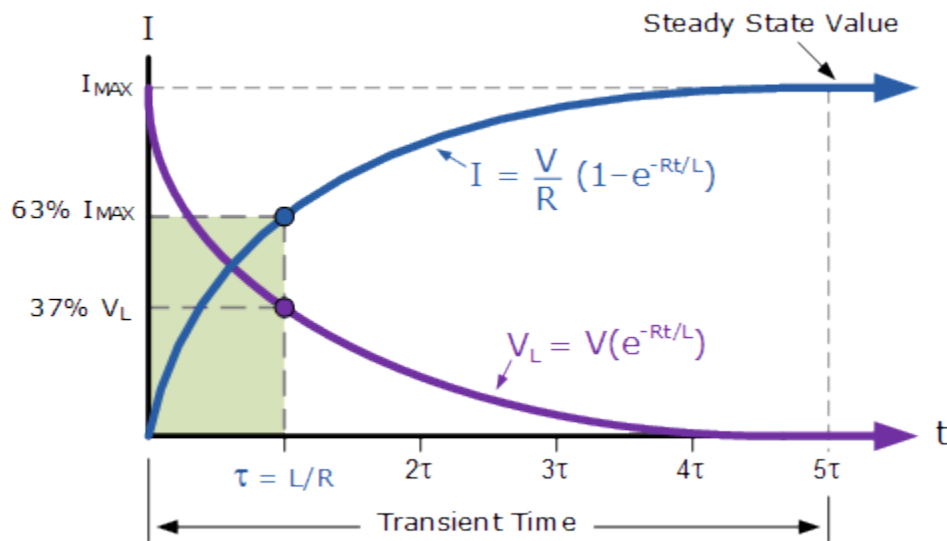

$$\text{Time Constant, } \tau = \frac{L}{R} = \frac{0.04}{2} = 0.02\text{s or } 20\text{mS}$$

Concept of current growth and decay:-

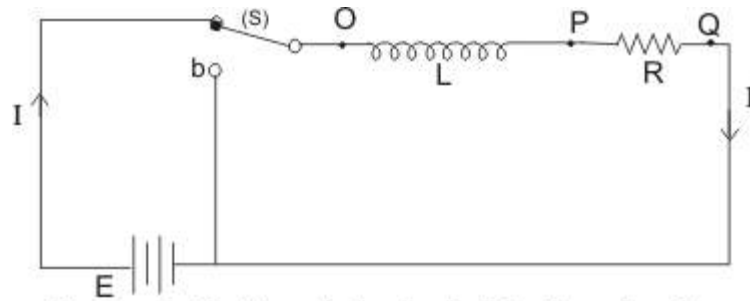

Figure 4. Battery is included in the circuit

a) Growth of current:-

- Switch is now closed and battery E, inductance L and resistance R are now connected in series. Because of self induced emf current will not immediately reach its steady value but grows at a rate depending on inductance and resistance of the circuit

- $V_{op} = L \frac{dI}{dt}$

and across resistor is

$$V_{pq} = IR$$

Since

$$V = V_{op} + V_{pq}$$

so we have,

$$V = L \frac{dI}{dt} + IR \quad \text{---(6)}$$

- Thus rate of increase of current would be,

$$\frac{dI}{dt} = \frac{V - IR}{L} \quad \text{---(7)}$$

- $\left(\frac{dI}{dt}\right)_{t=0} = \frac{V}{L}$

from the above relation we conclude that greater would be the inductance of the inductor, more slowly the current starts to increase.

$$\frac{dI}{dt} = \frac{R}{L} (I_{max} - I_0) = \frac{I_{max} - I_0}{\tau_L}$$

Or,

$$\frac{dI}{dt} \propto \frac{1}{\tau_L}$$

-

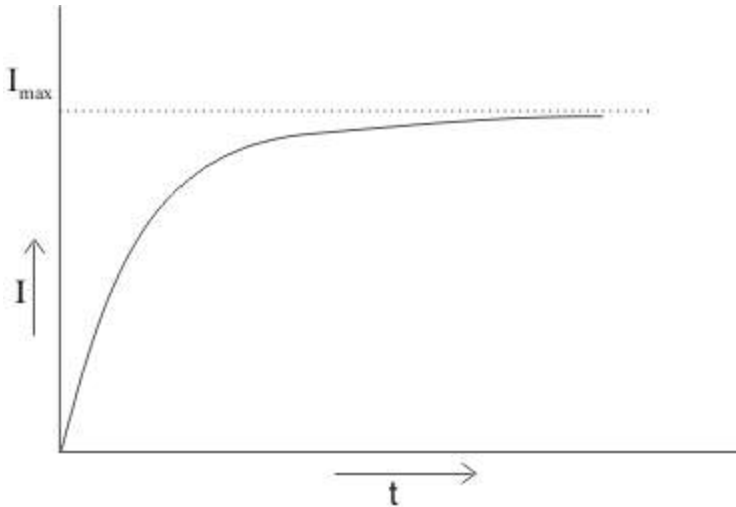

Figure 5. Growth of current in circuit containing inductance and resistance

- Decay of current:-

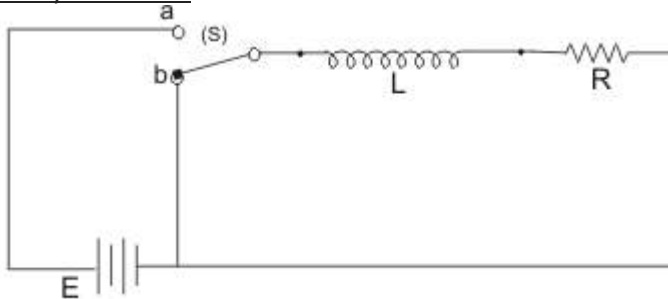

Figure 6. Battery is now cut off from the circuit

- In this condition the current in the circuit begins to decay
- Again from equation (8) since $V=0$ this time, so the equation for decay is

$$L \frac{dI}{dt} + RI = 0$$

Or,

$$\frac{dI}{I} = -\frac{R}{L} dt$$

Integrating on both sides

$$\int \frac{dI}{I} = -\frac{R}{L} \int dt$$

Or,

$$\ln I = -\frac{R}{L} t + C_1 \quad \text{----(12)}$$

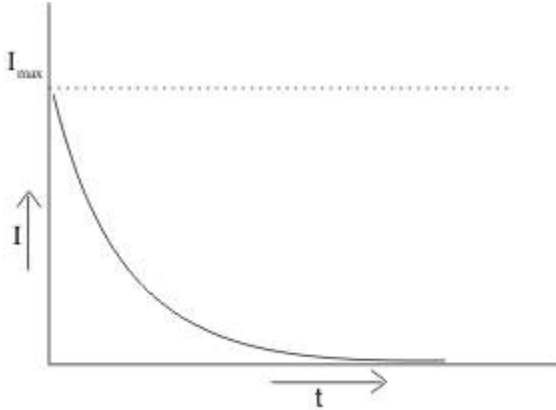

Figure 7. Current decreasing exponentially with time

$$t = \tau_L = L/R$$

then

$$I = I_{\max} e^{-1} = 0.37 I_{\max}$$

hence the time in which the current decrease from the maximum value to 37% of the maximum value I_{\max} is called the time constant of the circuit .

Energy stored in an inductor:-

Suppose that an inductor of inductance L is connected to a variable DC voltage supply. The supply is adjusted so as to increase the current i flowing through the inductor from zero to some final value I .

$$\mathcal{E} = -L di/dt$$

As the current through the inductor is ramped up, an emf is generated, which acts to oppose the increase in the current. Clearly, work must be done against this emf by the voltage source in order to establish the current in the inductor. The work done by the voltage source during a time interval dt is

$$dW = P dt = -\mathcal{E} i dt = i L \frac{di}{dt} dt = L i di. \quad (247)$$

$$P = -\mathcal{E} i$$

Here, is the instantaneous rate at which the voltage source performs work. To find the total work W done in establishing the final current I in the inductor, we must integrate the above expression. Thus,

$$W = L \int_0^I i di,$$

$$W = \frac{1}{2} L I^2.$$

This energy is actually stored in the magnetic field generated by the current flowing through the inductor. In a pure inductor, the energy is stored without loss, and is returned to the rest of the

circuit when the current through the inductor is ramped down, and its associated magnetic field collapses.

Inductors in Series:-

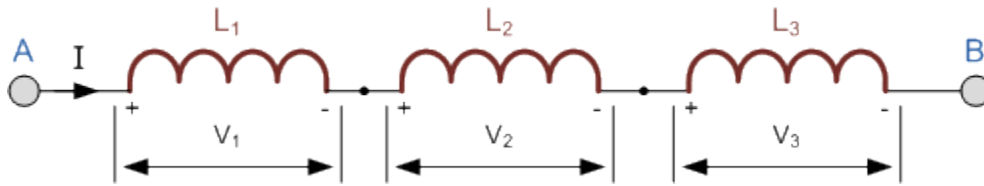

The current, (I) that flows through the first inductor, L₁ has no other way to go but pass through the second inductor and the third and so on. Then, series inductors have a **Common Current** flowing through them.

$$L_T \frac{di}{dt} = L_1 \frac{di}{dt} + L_2 \frac{di}{dt} + L_3 \frac{di}{dt}$$

When inductors are connected together in series so that the magnetic field of one links with the other, the effect of mutual inductance either increases or decreases the total inductance depending upon the amount of magnetic coupling. The effect of this mutual inductance depends upon the distance apart of the coils and their orientation to each other.

Mutually connected series inductors can be classed as either “Aiding” or “Opposing” the total inductance. If the magnetic flux produced by the current flows through the coils in the same direction then the coils are said to be **Cumulatively Coupled**. If the current flows through the coils in opposite directions then the coils are said to be **Differentially Coupled** as shown below.

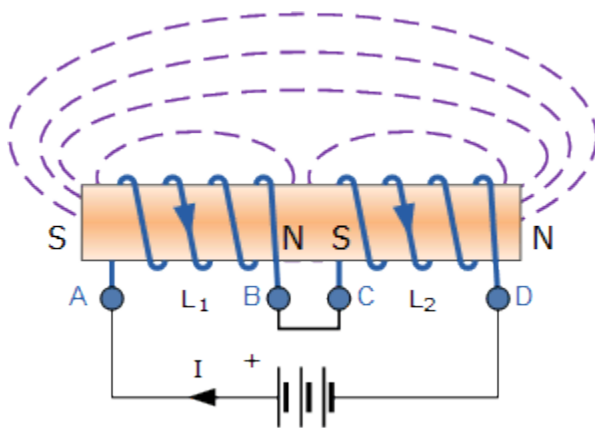

$$L_T \frac{di}{dt} = L_1 \frac{di}{dt} + L_2 \frac{di}{dt} + 2 \left(M \frac{di}{dt} \right)$$

CH-7 (BATTERIES)

Primary cell: A **primary cell** is a **battery** (a galvanic cell) that is designed to be used once and discarded, and not recharged with electricity and reused like a secondary cell (rechargeable **battery**). In general, the electrochemical reaction occurring in the **cell** is not reversible, rendering the **cell** unchargeable.

Secondary cell:-

A rechargeable electric cell that converts chemical energy into electrical energy by a reversible chemical reaction. Also called *storage cell*.

Lead acid Batteries:- The storage **battery** or secondary battery is such a battery where electrical energy can be stored as chemical energy and this chemical energy is then converted to electrical energy as and when required. The conversion of electrical energy into chemical energy by applying external electrical source is known as charging of battery. Whereas conversion of chemical energy into electrical energy for supplying the external load is known as discharging of secondary battery.

we will try to understand the principle **working of lead acid battery** and for that we will first discuss about **lead acid battery** which is very commonly used as storage battery or secondary battery.

The main active materials required to construct a lead acid battery are :

1. Lead peroxide
2. Sponge lead
3. Dilute sulphuric acid

The **lead acid storage battery** is formed by dipping lead peroxide plate and sponge lead plate in dilute sulfuric acid. A load is connected externally between these plates. In diluted sulfuric acid the molecules of the acid split into positive hydrogen ions (H^+) and negative sulfate ions (SO_4^{--}). The hydrogen ions when reach at PbO_2 plate, they receive electrons from it and become hydrogen **atom** which again attack PbO_2 and form PbO and H_2O (water). This PbO reacts with H_2SO_4 and forms $PbSO_4$ and H_2O (water).

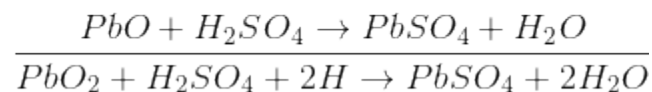
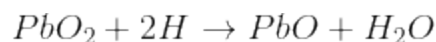

SO_4^{--} ions are moving freely in the solution so some of them will reach to pure Pb plate where they give their extra electrons and become radical SO_4 . As the radical SO_4 cannot exist alone it will attack Pb and will form $PbSO_4$.

As H^+ ions take electrons from PbO_2 plate and SO_4^{--} ions give electrons to Pb plate, there would be an inequality of electrons between these two plates. Hence there would be a flow of current through the

external load between these plates for balancing this inequality of electrons. This process is called discharging of lead acid battery.

Nickle cadmium battery:- The **nickel–cadmium battery (NiCd battery or NiCad battery)** is a type of **rechargeable battery** using **nickel oxide hydroxide** and metallic **cadmium** as **electrodes**. The abbreviation *NiCd* is derived from the **chemical symbols** of **nickel (Ni)** and **cadmium (Cd)**: the abbreviation *NiCad* is a registered trademark of **SAFT Corporation**, although this brand name is **commonly used** to describe all Ni–Cd batteries.

Ni–Cd cells have a nominal cell potential of 1.2 volts (V). This is lower than the 1.5 V of alkaline and zinc–carbon primary cells, and consequently they are not appropriate as a replacement in all applications. However, the 1.5 V of a primary alkaline cell refers to its initial, rather than average, voltage. Unlike alkaline and zinc–carbon primary cells, a Ni–Cd cell's terminal voltage only changes a little as it discharges. Because many electronic devices are designed to work with primary cells that may discharge to as low as 0.90 to 1.0 V per cell, the relatively steady 1.2 V of a Ni–Cd cell is enough to allow operation. Some would consider the near-constant voltage a drawback as it makes it difficult to detect when the battery charge is low.

Ni–Cd batteries used to replace 9 V batteries usually only have six cells, for a terminal voltage of 7.2 volts. While most pocket radios will operate satisfactorily at this voltage, some manufacturers such as **Varta** made 8.4 volt batteries with seven cells for more critical applications.

Silver oxide batteries:- A **silver-oxide battery** is a **primary cell** with a very high **energy-to-weight ratio**. They are available in small sizes as **button cells**, where the amount of silver used is minimal and not a significant contributor to the product cost.

Silver-oxide primary batteries account for over 20% of all primary battery sales in Japan.

A **silver-oxide** battery uses **silver(I) oxide** as the positive **electrode (cathode)**, **zinc** as the negative electrode (**anode**), plus an **alkaline** electrolyte, usually **sodium hydroxide (NaOH)** or **potassium hydroxide (KOH)**. The **silver** is reduced at the cathode from Ag(I) to Ag, and the **zinc** is oxidized from Zn to Zn(II).

Charging Methods used for lead acid batteries:-

The lead-acid battery stores chemical energy and this energy is converted into electrical energy whenever requires. The conversion of energy from chemical to electrical is known as the charging. And when the electric power changes into chemical energy then it is known as discharging of the battery. During the charging process, the current passes inside the battery because of chemical changes. The **lead-acid battery** mainly uses two types of charging methods namely the constant voltage charging and constant current charging.

Constant voltage Charging:- It is the most common method of charging the lead acid battery. It reduces the charging time and increases the capacity up to 20%. But this method reduces the efficiency by approximately 10%.

In this method, the charging voltage is kept constant throughout the charging process. The charging current is high in the beginning when the battery is in the discharge condition. The current is gradually dropping off as the battery picks up charge resulting in increase back emf.

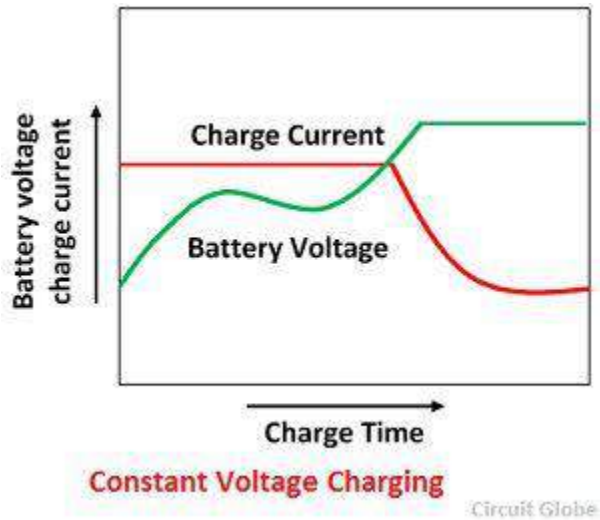

The advantages of charging at constant voltage are that it allows cells with different capacities and at the different degree of discharge to be charges. The large charging current at the beginning of the charge is of relatively short duration and will not harm the cell.

Constant current charging:-

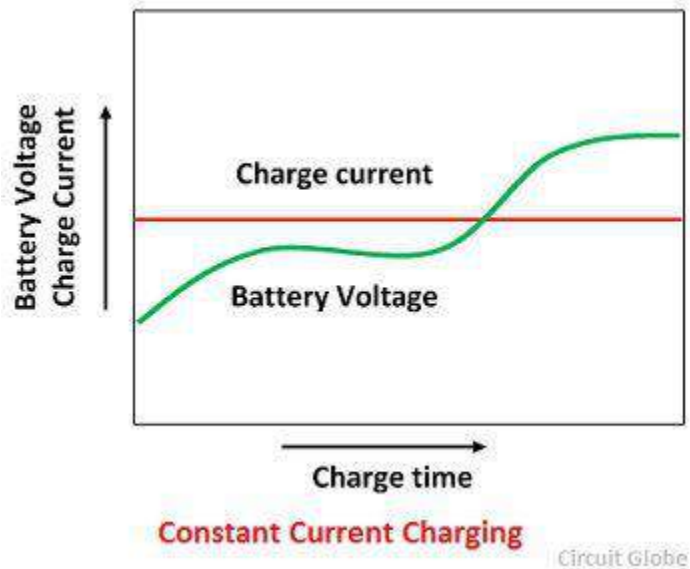

In this method of charging the batteries are connected in series so as to form groups and each group charges from the DC supply mains through loading rheostats. The number of charging in each group depends on the charging circuit voltage which should not be less than the 2.7 V per cell.

The charging current is kept constant throughout the charging period by reducing the resistance in the circuit as the battery voltage goes up. In order of avoiding excessive gassing or overheating, the charging may be carried out in two steps. An initial charging of approximately higher current and a finishing rate of low current.

In this method, the charge current is approximately one-eighth of its ampere ratings. The excess voltage of the supply circuit is absorbed in the series **resistance**. The groups of the battery to be charged should be so connected that the series resistance consumes as little energy as possible.

Care and maintenance of Lead acid battery:-

The quickest way to ruin **lead-acid batteries** is to discharge them deeply and leave them stand 'dead' for an extended period of time. When they discharge, there is a chemical change in the positive plates of the battery. They change from lead oxide when charged to lead sulfate when discharged. If they remain in the lead sulfate state for a few days, some part of the plate does not return to lead oxide when the battery is recharged. If the battery remains discharged longer, a greater amount of the positive plate will remain lead sulfate. The parts of the plates that become "sulfated" no longer store energy. Batteries that are deeply discharged, and then charged partially on a regular basis can fail in less than one year.

Always use extreme caution when handling **lead-acid batteries** and electrolyte. Wear gloves, goggles and old clothes. The sulfuric acid in lead-acid batteries will burn skin and eyes and destroy cotton and wool clothing. Adopt these specific measures for maximum safety:

1. Someone should be within range of your voice to come to your aid when you work near batteries
2. Have plenty of fresh water and soap nearby in case battery acid contact skin, clothing, or eyes
3. Wear complete eye protection and clothing protection. Avoid touching eyes while working near batteries. Wash your hands when done
4. If acid contacts skin or clothing, wash immediately with soap and water. If acid enters eyes, immediately flood eyes with running cool water for at least 15 minutes and get medical attention immediately
5. Baking soda neutralizes lead acid battery electrolyte. Vinegar neutralizes spilled NiCad and NiFe battery electrolyte. Keep a supply on hand in the area of the batteries
6. NEVER smoke or allow a spark or flame in vicinity of a battery or generator
7. Be extra cautious when working with metal tools on, and around batteries. Potential exists to short-circuit the batteries or other electrical parts which may result in a spark which could cause an explosion

Series and parallel connection of batteries:-

If we connect the positive (+) terminal of battery to negative (-) and negative to positive terminal as shown in the below fig, then the batteries configuration would be in series.

In series connection of batteries, current is same in each wire or section while voltage is different i.e. voltages are additive e.g.

www.electricaltechnology.org

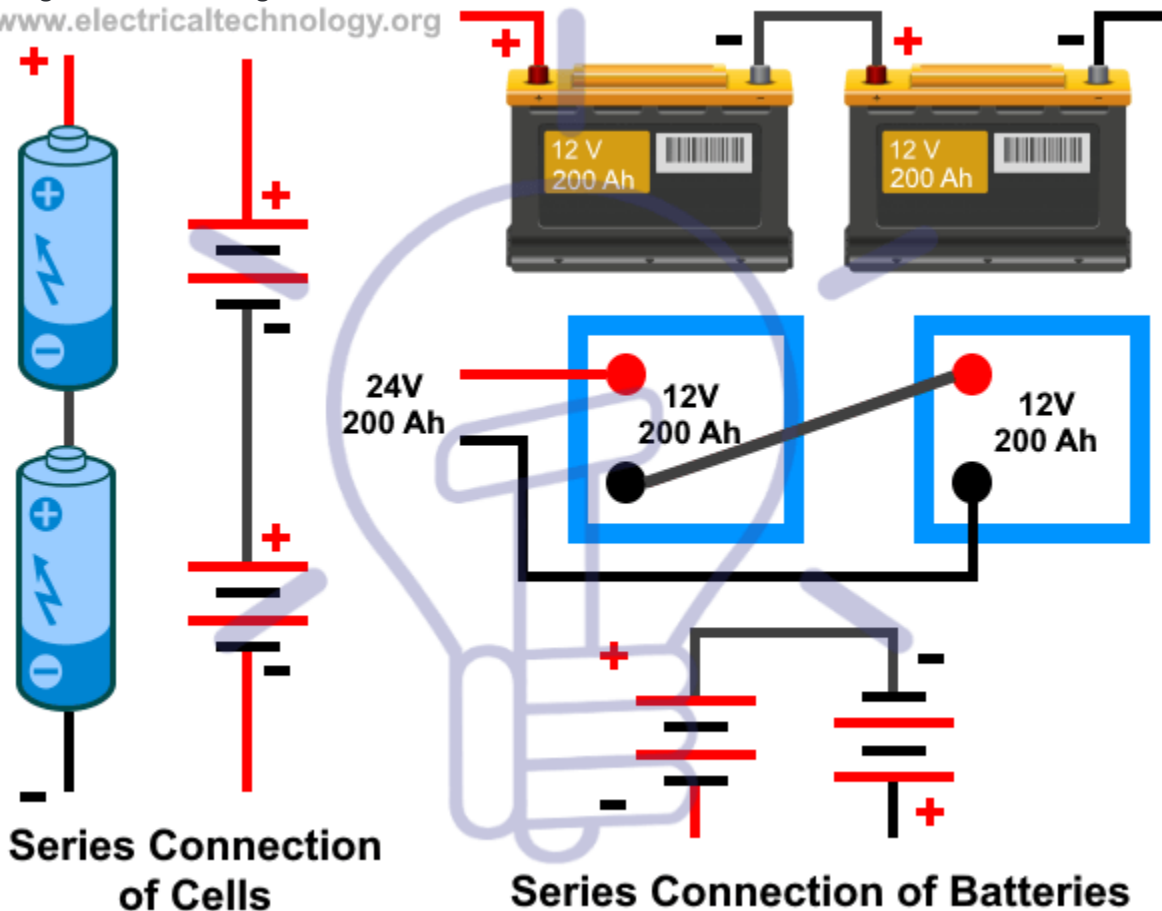

$$V_1 + V_2 + V_3 \dots V_n$$

Parallel connection of batteries:-

If we connect the positive terminal (+) of battery to positive and negative (-) to negative terminal. Then the batteries configuration would be in parallel.

In parallel connection, voltage will be same in each wire or section, while current will be different i.e. current is additive.

$$I_1 + I_2 + I_3 \dots + I_n$$

Keep in mind that battery discharge quickly in parallel as compared to series batteries connection.

Solar cells:-

A **solar cell**, or **photovoltaic cell**, is an electrical device that converts the energy of **light** directly into **electricity** by the **photovoltaic effect**, which is a **physical** and **chemical** phenomenon. It is a form of photoelectric cell, defined as a device whose electrical characteristics, such as **current**, **voltage**, or **resistance**, vary when exposed to light. Individual solar cell devices can be combined to form modules, otherwise known as **solar panels**. The common single junction **silicon** solar cell can produce a maximum open-circuit voltage of approximately 0.5 to 0.6 volts.

Solar cells are described as being **photovoltaic**, irrespective of whether the source is **sunlight** or an artificial light. In addition to producing energy, they can be used as a **photodetector** (for example **infrared detectors**), detecting light or other **electromagnetic radiation** near the visible range, or measuring light intensity.

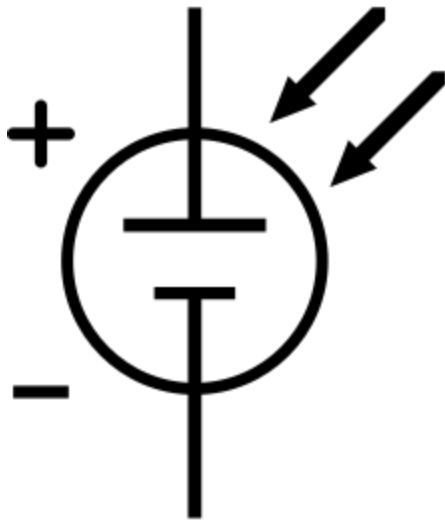

Solar cells Applications:-

1. Standalone devices
2. Embedded in electronics
3. Transparent and coloured photovoltaic facades

Chapter-8 (AC FUNDAMENTALS)

Concept of alternating quantity:-

Alternating quantity: An **alternating quantity** is one which acts in alternate positive and negative directions, whose magnitude undergoes a definite series of changes in definite intervals of time and in which the sequence of changes while negative is identical with the sequence of changes while positive.

Difference between AC and DC:-

Alternating Current

Direct Current

Amount of energy that can be carried	Safe to transfer over longer city distances and can provide more power.	Voltage of DC cannot travel very far until it begins to lose energy.
Cause of the direction of flow of electrons	Rotating magnet along the wire.	Steady magnetism along the wire.
Frequency	The frequency of alternating current is 50Hz or 60Hz depending upon the country.	The frequency of direct current is zero.
Direction	It reverses its direction while flowing in a circuit.	It flows in one direction in the circuit.
Current	It is the current of magnitude varying with time	It is the current of constant magnitude.
Flow of Electrons	Electrons keep switching directions - forward and backward.	Electrons move steadily in one direction or 'forward'.
Obtained from	A.C Generator and mains.	Cell or Battery.
Passive Parameters	Impedance.	Resistance

Alternating Current

Direct Current

only

Power Factor Lies between 0 & 1.

it is always 1.

Cycle:-

The change in an alternating **electrical** sine wave from zero to a positive peak to zero to a negative peak and back to zero. See Frequency. Demand — The average value of power or related quantity over a specified period of time.

Time period:- A **time period** (denoted by 'T') is the **time** taken for one complete cycle of vibration to pass a given point. As the frequency of a wave increases, the **time period** of the wave decreases. The unit for **time period** is 'seconds'.

Frequency:-

It is defined as the reciprocal of time period.

Amplitude:- It is maximum or peak value of the waveform.

Instantaneous value:- The **instantaneous value** is the **value** of an alternating quantity (ac voltage, ac current or ac power) at a particular instant of time in a cycle. The **instantaneous value** of any variable quantity is designated by the smaller case letter of its symbol. For example, v for voltage, i for current, etc.

Average value:- The **average** of all the instantaneous **values** of an alternating voltage and currents over one complete cycle is called **Average Value**. If we consider symmetrical waves like sinusoidal current or voltage waveform, the positive half cycle will be exactly equal to negative half cycle.

Form factor:-

In electronics or **electrical** the **form factor** of an alternating current waveform (signal) is the ratio of the RMS (root mean square) value to the average value (mathematical mean of absolute values of all points on the waveform). ... The former can also be defined as the direct current that will produce equivalent heat.

Peak factor:- **Peak Factor** is defined as the ratio of maximum value to the R.M.S value of an alternating quantity. The alternating quantities can be voltage or current. The maximum value is the **peak** value or the **crest** value or the amplitude of the voltage or current.

RMS Value:- The **RMS value** is the **effective value** of a varying voltage or current. It is the equivalent steady DC (constant) **value** which gives the same effect. For example, a lamp connected to a 6V **RMS** AC supply will shine with the same brightness when connected to a steady 6V DC supply.

Representation of Sinusoidal quantities by phasor diagram:-

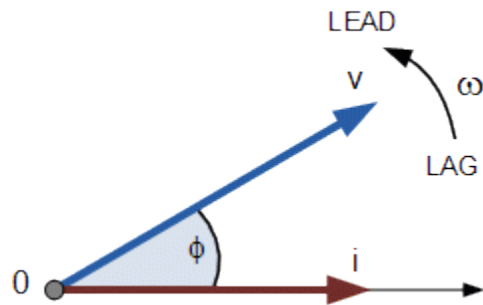

Phasor Diagrams are a graphical way of representing the magnitude and directional relationship between two or more alternating quantities

Sinusoidal waveforms of the same frequency can have a Phase Difference between themselves which represents the angular difference of the two sinusoidal waveforms. Also the terms “lead” and “lag” as well as “in-phase” and “out-of-phase” are commonly used to indicate the relationship of one waveform to the other with the generalized sinusoidal expression given as: $A_{(t)} = A_m \sin(\omega t \pm \Phi)$ representing the sinusoid in the time-domain form.

But when presented mathematically in this way it is sometimes difficult to visualise this angular or phasor difference between two or more sinusoidal waveforms. One way to overcome this problem is to represent the sinusoids graphically within the spacial or phasor-domain form by using **Phasor Diagrams**, and this is achieved by the rotating vector method.

The generalised mathematical expression to define these two sinusoidal quantities will be written as:

$$v_{(t)} = V_m \sin(\omega t)$$

$$i_{(t)} = I_m \sin(\omega t - \phi)$$

The current, i is lagging the voltage, v by angle Φ and in our example above this is 30° . So the difference between the two phasors representing the two sinusoidal quantities is angle Φ and the resulting phasor diagram will be.

Phasor diagram of sinusoidal waveform:-

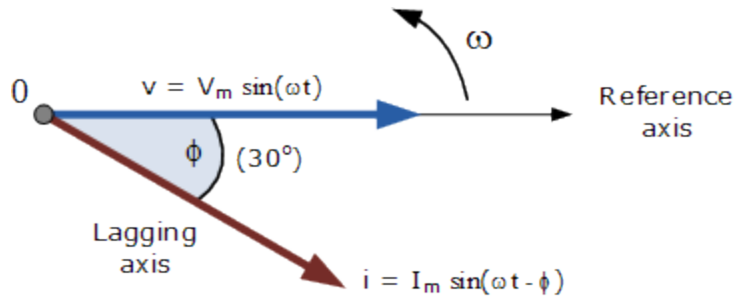

The phasor diagram is drawn corresponding to time zero ($t = 0$) on the horizontal axis. The lengths of the phasors are proportional to the values of the voltage, (V) and the current, (I) at the instant in time that the phasor diagram is drawn. The current phasor lags the voltage phasor by the angle, Φ , as the two phasors rotate in an *anticlockwise* direction as stated earlier, therefore the angle, Φ is also measured in the same anticlockwise direction.

However, as the current waveform is now crossing the horizontal zero axis line at this instant in time we can use the current phasor as our new reference and correctly say that the voltage phasor is “leading” the current phasor by angle, Φ . Either way, one phasor is designated as the *reference* phasor and all the other phasors will be either leading or lagging with respect to this reference.

Effect of alternating voltage applied to pure resistance, inductance and capacitance:-

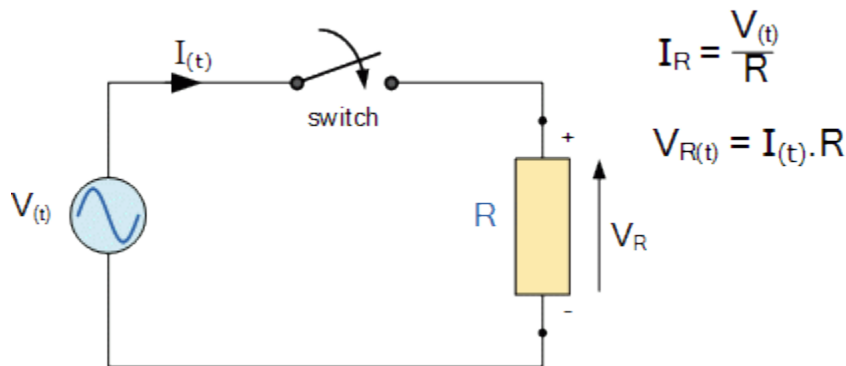

We also saw that sinusoidal waveforms and functions that were previously drawn in the *time-domain* transform can be converted into the spatial or *phasor-domain* so that phasor diagrams can be constructed to find this phasor voltage-current relationship.

Now that we know how to represent a voltage or current as a phasor we can look at this relationship when applied to basic passive circuit elements such as an **AC Resistance** when connected to a single phase AC supply.

Any ideal basic circuit element such as a resistor can be described mathematically in terms of its voltage and current, and in the tutorial about *resistors*, we saw that the voltage across a pure ohmic resistor is linearly proportional to the current flowing through it as defined by Ohm’s Law. Consider the circuit below.

$$V_{R(t)} = R.I_{R(t)} = R.I_m \sin(\omega t + \theta)$$

and the instantaneous value of the current, i will be:

$$i_{R(t)} = I_{R(max)} \sin \omega t$$

So for a purely resistive circuit the alternating current flowing through the resistor varies in proportion to the applied voltage across it following the same sinusoidal pattern. As the supply frequency is common to both the voltage and current, their phasors will also be common resulting in the current being “in-phase” with the voltage, ($\theta = 0$).

In other words, there is no phase difference between the current and the voltage when using an AC resistance as the current will achieve its maximum, minimum and zero values whenever the voltage reaches its maximum, minimum and zero values as shown below.

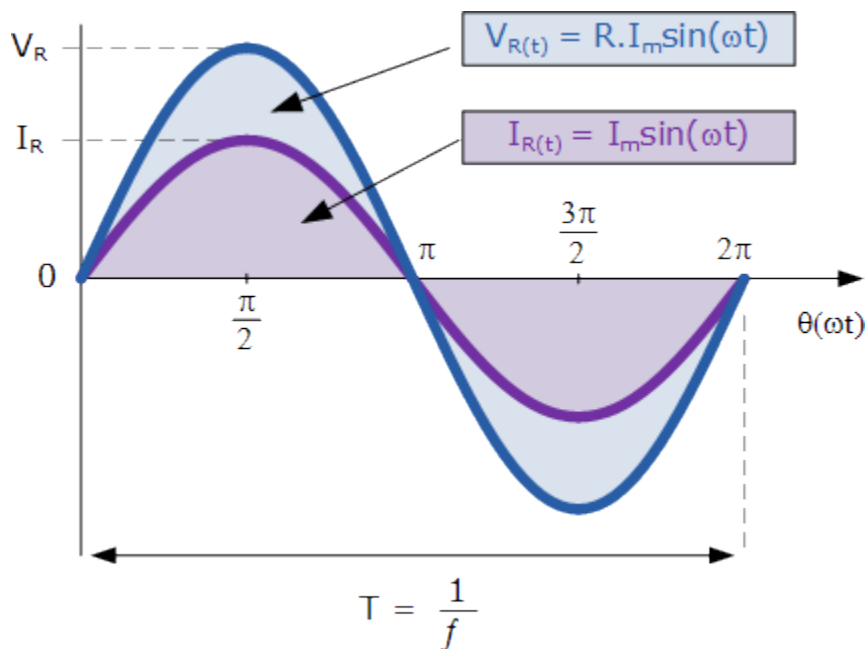

As a phasor represents the RMS values of the voltage and current quantities unlike a vector which represents the peak or maximum values, dividing the peak value of the time-domain expressions above by $\sqrt{2}$.

Inductive Reactance:-

Inductive reactance is the name given to the opposition to a changing current flow. This impedance is measured in ohms, just like resistance. In inductors, voltage leads current by 90 degrees.

Capacitive Reactance:-

Capacitive reactance (symbol X_C) is a measure of a **capacitor's** opposition to AC (alternating current). Like resistance it is measured in ohms, but **reactance** is more complex than resistance because its value depends on the frequency (f) of the signal passing through the **capacitor**.

Alternating voltage applied to Resistance and Capacitance and inductance in series:-

we will study a series combination of a Resistor, an Inductor, and a **Capacitor** also known as the Series LCR circuit. We will study the **growth** of the current and other quantities in this **circuit**. These circuits are the fundamental components of many important devices. Let's study the fundamental **elements** of this circuit.

When a constant voltage **source** or battery is connected across a resistor, **current** is developed in it. This current has a unique **direction** and flows from the negative terminal of the battery to its positive terminal. The magnitude of current remains constant as well.

If the direction of current through this resistor changes periodically or alternately, then the current is called **alternating current**. An alternating current or **AC generator** or AC dynamo can be used as AC voltage source.

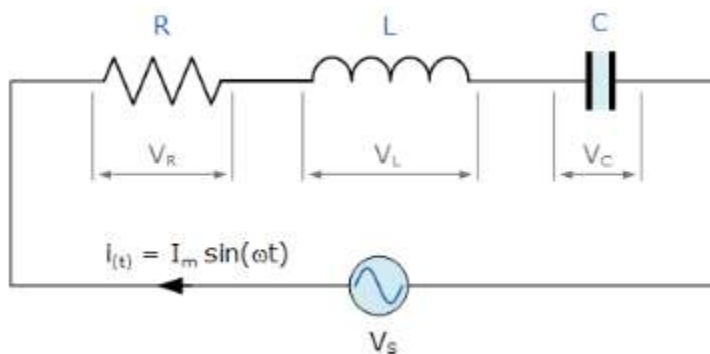

The figure shows basic LCR series circuit where a voltage V_s is applied across RLC series circuit. We will solve this circuit by using **vector** method. Vector drawn for resistance is along the X-axis because current and voltage are in phase in case of a purely resistive circuit and magnitude will be R .

Inductors and capacitors will be represented by their respective reactance. In capacitor current leads the potential by 90° hence reactance will be along the positive Y-axis with magnitude $1/\omega C$ and similarly inductive reactance will be along the negative Y-axis with magnitude ωL as current in inductor lags by 90° .

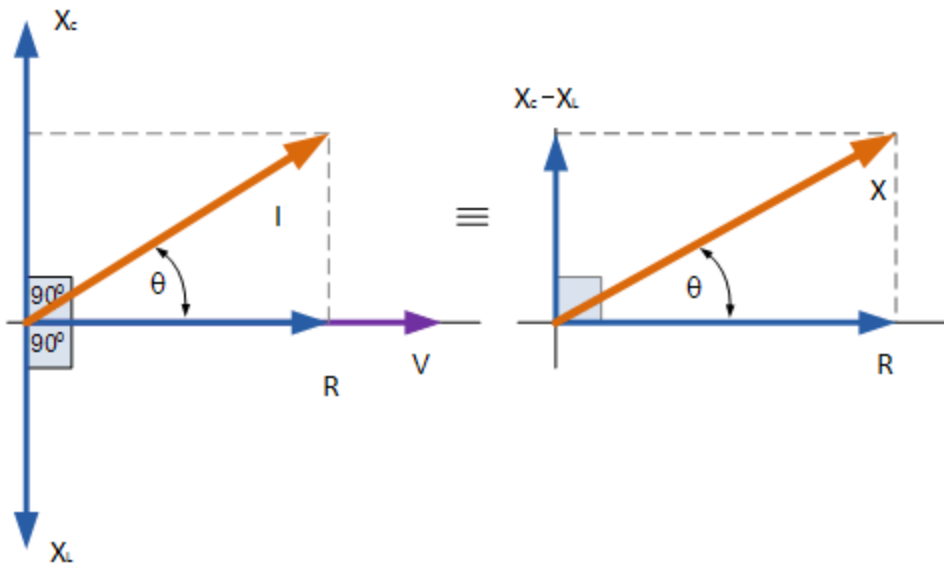
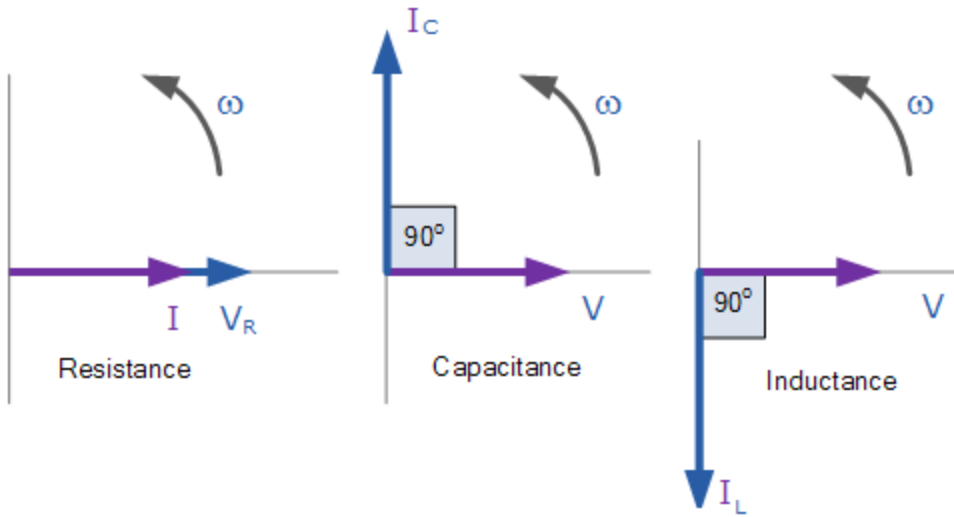

The resultant of X_L and X_C in the positive Y – axis can be given as:

$$X = X_C - X_L = (\frac{1}{\omega C} - \omega L)$$

This is the net reactance of the circuit.

Total Impedance ‘Z’

Now we need to find total impedance of RLC circuit. And it can be given as:

$$Z = \sqrt{R^2 + (\omega C - \omega L)^2}$$

And this resultant impedance makes angle θ with X-axis which can be give as –

$$\tan\theta = (\omega C - \omega L)R$$

Current in The Circuit

Current in circuit can be given as:

$$V_s = V_m \sin\omega t \quad I_s = V_s / Z \quad I_s = V_m \sin\omega t / \sqrt{R^2 + (\omega C - \omega L)^2} \quad I_s = I_m \sin\omega t$$

Where I_m is peak current.

$$I_m = V_m / \sqrt{R^2 + (\omega C - \omega L)^2} = V_m / Z$$

- Case 1. $X_C > X_L$

When $X_C > X_L$, resultant vector for net reactance will be along positive Y-axis and value of θ will be positive. Hence current will lead voltage and circuit will behave as resistive-capacitive circuit.

- $X_C < X_L$

When $X_C < X_L$, the resultant vector for net reactance will be along negative Y-axis and value of θ will be negative. Hence voltage will lead current and the circuit will behave as a resistive-inductive circuit.

- $X_C = X_L$

When $X_C = X_L$, the resultant vector for net reactance will be zero and value of θ will be zero. Hence current and voltage will be in the same phase and circuit will behave as purely resistive circuit and peak current will be maximum.

Resonance

Peak current is maximum when:

$$\omega C - \omega L = 0 \Rightarrow \omega C = \omega L \Rightarrow \omega = \frac{1}{LC} \Rightarrow 2\pi f = \frac{1}{\sqrt{LC}}$$

This [frequency](#) is known as resonance frequency.

Series Resonance:-

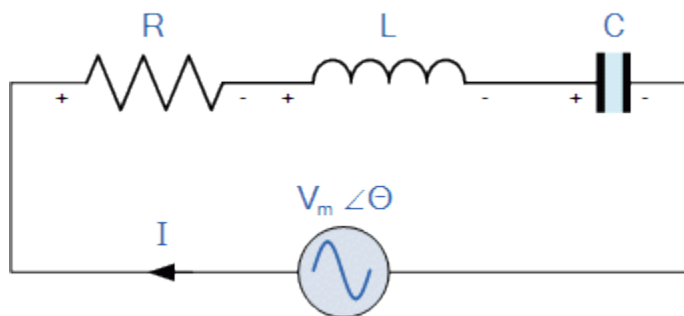

Resonance occurs in a series circuit when the supply frequency causes the voltages across L and C to be equal and opposite in phase

In a series RLC circuit there becomes a frequency point where the inductive reactance of the inductor becomes equal in value to the capacitive reactance of the capacitor. In other words, $X_L = X_C$. The point at which this occurs is called the **Resonant Frequency** point, (f_r) of the circuit, and as we are analysing a series RLC circuit this resonance frequency produces a **Series Resonance**.

- Inductive reactance: $X_L = 2\pi f L = \omega L$
- Capacitive reactance: $X_C = \frac{1}{2\pi f C} = \frac{1}{\omega C}$
- When $X_L > X_C$ the circuit is Inductive
- When $X_C > X_L$ the circuit is Capacitive
- Total circuit reactance = $X_T = X_L - X_C$ or $X_C - X_L$
- Total circuit impedance = $Z = \sqrt{R^2 + X_T^2} = R + jX$

From the above equation for inductive reactance, if either the **Frequency** or the **Inductance** is increased the overall inductive reactance value of the inductor would also increase. As the frequency approaches infinity the inductors reactance would also increase towards infinity with the circuit element acting like an open circuit.

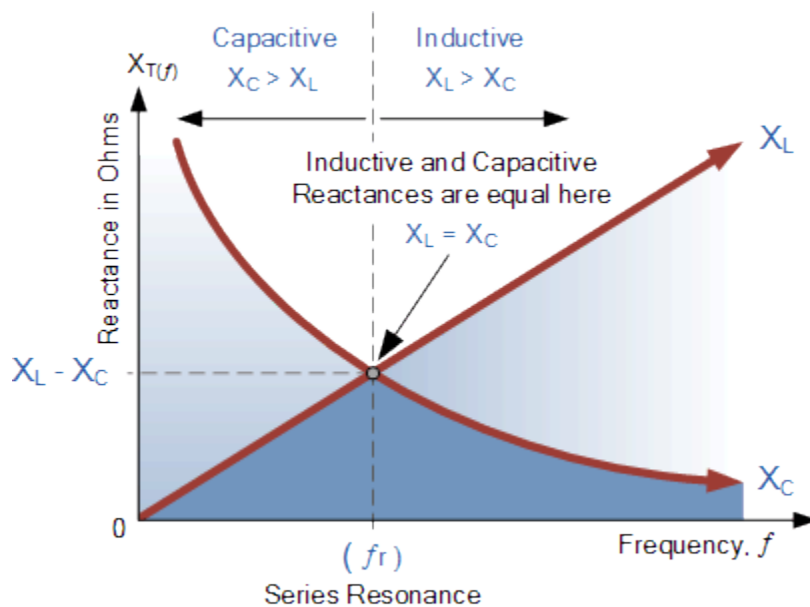

$$X_L = X_C \Rightarrow 2\pi fL = \frac{1}{2\pi fC}$$

$$f^2 = \frac{1}{2\pi L \times 2\pi C} = \frac{1}{4\pi^2 LC}$$

$$f = \sqrt{\frac{1}{4\pi^2 LC}}$$

$$\therefore f_r = \frac{1}{2\pi\sqrt{LC}} \text{ (Hz)} \quad \text{or} \quad \omega_r = \frac{1}{\sqrt{LC}} \text{ (rads)}$$

. Resonant Frequency, (f_r)

$$X_L = X_C \Rightarrow \omega_r L - \frac{1}{\omega_r C} = 0$$

$$\omega_r^2 = \frac{1}{LC} \quad \therefore \omega_r = \frac{1}{\sqrt{LC}}$$

Parallel Resonance:-

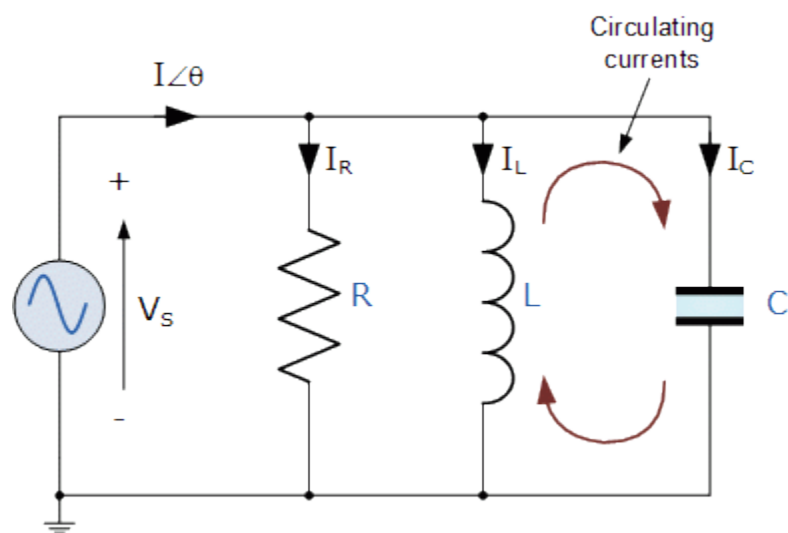

Let us define what we already know about parallel RLC circuits.

$$\text{Admittance, } Y = \frac{1}{Z} = \sqrt{G^2 + B^2}$$

$$\text{Conductance, } G = \frac{1}{R}$$

$$\text{Inductive Susceptance, } B_L = \frac{1}{2\pi fL}$$

$$\text{Capacitive Susceptance, } B_C = 2\pi fC$$

A parallel circuit containing a resistance, R, an inductance, L and a capacitance, C will produce a **parallel resonance** (also called anti-resonance) circuit when the resultant current through the parallel combination is in phase with the supply voltage. At resonance there will be a large circulating current between the inductor and the capacitor due to the energy of the oscillations, then parallel circuits produce current resonance.

A *parallel resonant circuit* stores the circuit energy in the magnetic field of the inductor and the electric field of the capacitor. This energy is constantly being transferred back and forth between the inductor and the capacitor which results in zero current and energy being drawn from the supply.

We know from the previous series resonance tutorial that resonance takes place when $V_L = -V_C$ and this situation occurs when the two reactances are equal, $X_L = X_C$. The admittance of a parallel circuit is given as:

$$Y = G + B_L + B_C$$

$$Y = \frac{1}{R} + \frac{1}{j\omega L} + j\omega C$$

or

$$Y = \frac{1}{R} + \frac{1}{2\pi fL} + 2\pi fC$$

Resonance occurs when $X_L = X_C$ and the imaginary parts of Y become zero.
Then:

$$X_L = X_C \Rightarrow 2\pi fL = \frac{1}{2\pi fC}$$

$$f^2 = \frac{1}{2\pi L \times 2\pi C} = \frac{1}{4\pi^2 LC}$$

$$f = \sqrt{\frac{1}{4\pi^2 LC}}$$

$$\therefore f_r = \frac{1}{2\pi \sqrt{LC}} \text{ (Hz)} \quad \text{or} \quad \omega_r = \frac{1}{\sqrt{LC}} \text{ (rads)}$$

Notice that at resonance the parallel circuit produces the same equation as for the series resonance circuit. Therefore, it makes no difference if the inductor or capacitor are connected in parallel or series.

Also at resonance the parallel LC tank circuit acts like an open circuit with the circuit current being determined by the resistor, R only. So the total impedance of a parallel resonance circuit at resonance becomes just the value of the resistance in the circuit and $Z = R$ as shown.

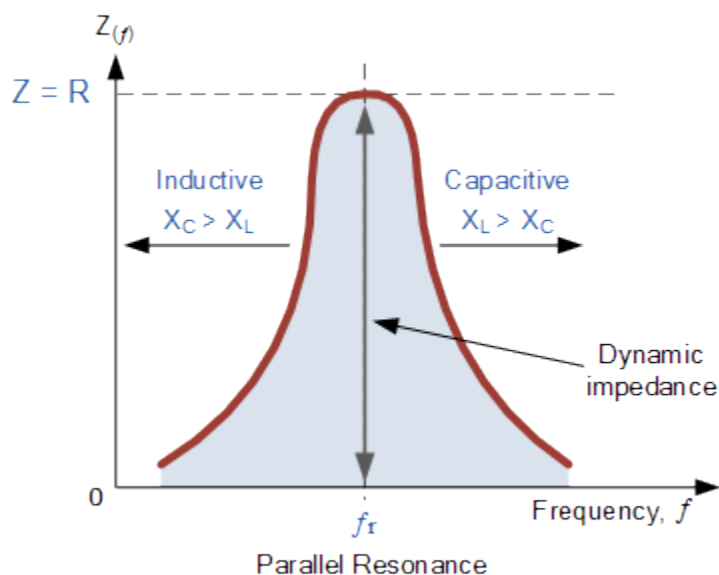

Active Power:- The power which is actually consumed or utilized in an AC Circuit is called True power or Active Power or real power. It is measured in kilo watt (kW) or MW. It is the actual outcomes of the electrical system which runs the electric circuits or load.

Reactive Power:- The power which flows back and forth that mean it moves in both the direction in the circuit or react upon itself, is called Reactive Power. The reactive power is measured in kilo volt ampere reactive (kVAR) or MVAR.

Power Factor:- In **electrical engineering**, the **power factor** of an AC electrical power system is defined as the **ratio** of the **real power** absorbed by the **load** to the **apparent power** flowing in the circuit, and is a **dimensionless number** in the **closed interval** of -1 to 1 . A power factor of less than one indicates the voltage and current are not in phase, reducing the average **product** of the two. Real power is the instantaneous product of voltage and current and represents the capacity of the electricity for performing work. Apparent power is the product of **RMS** current and voltage. Due to energy stored in the load and returned to the source, or due to a non-linear load that distorts the wave shape of the current drawn from the source, the apparent power may be greater than the real power. A negative power factor occurs when the device (which is normally the load) generates power, which then flows back towards the source.

Power-factor correction increases the power factor of a load, improving efficiency for the distribution system to which it is attached. Linear loads with low power factor (such as **induction motors**) can be corrected with a passive network of **capacitors** or **inductors**. Non-linear loads, such as **rectifiers**, distort the current drawn from the system. In such cases, active or passive power factor correction may be used to counteract the distortion and raise the power factor. The devices for correction of the power factor may be at a central **substation**, spread out over a distribution system, or built into power-consuming equipment.

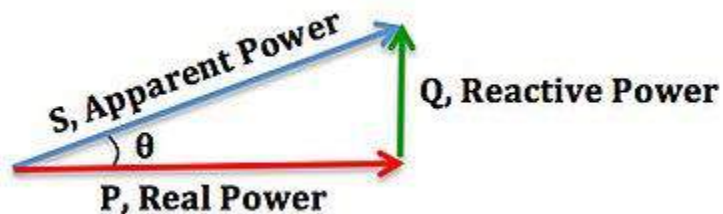

Admittance:- In electrical engineering, admittance is a measure of how easily a circuit or device will allow a current to flow. It is defined as the reciprocal of impedance. The SI unit of admittance is the siemens; the older, synonymous unit is mho, and its symbol is \mathcal{U}

Impedance:- Electrical impedance is the measure of the opposition that a circuit presents to a current when a voltage is applied. The term complex impedance may be used interchangeably. Its SI unit is ohm.

Conductance:- Conductance is an expression of the ease with which electric [current](#) flows through a substance. In equations, conductance is symbolized by the uppercase letter G . The standard unit of conductance is the *siemens* (abbreviated S), formerly known as the *mho*.

Susceptance:- In electrical engineering, **susceptance** (B) is the imaginary part of admittance, where the real part is conductance. The inverse of admittance is impedance, where the imaginary part is reactance and the real part is resistance. In SI units, **susceptance** is measured in siemens.

CHAPTER – 10 (INTRODUCTION TO BIPOLAR TRANSISTORS)

Concept of Bipolar transistor:- A bipolar transistor is a semiconductor device commonly used for amplification. The device can amplify [analog](#) or [digital](#) signals. It can also switch DC or function as an oscillator. Physically, a bipolar transistor amplifies [current](#), but it can be connected in circuits designed to amplify voltage or power.

There are two major types of bipolar transistor, called *PNP* and *NPN*. A PNP transistor has a layer of N-type semiconductor between two layers of P-type material. An NPN transistor has a layer of P-type material between two layers of N-type material. In P-type material, electric charges are carried mainly in the form of [electron](#) deficiencies called *holes*. In N-type material, the charge carriers are primarily electrons.

The bipolar transistor has advantages and disadvantages relative to the field-effect transistor (field-effect transistor). Bipolar devices can switch signals at high speeds, and can be manufactured to handle large currents so that they can serve as high-power amplifiers in audio equipment and in [wireless](#) transmitters. Bipolar devices are not especially effective for weak-signal amplification, or for applications requiring high circuit [impedance](#).

Bipolar transistors are fabricated onto silicon integrated circuit (IC) [chip](#). A single IC can contain many thousands of bipolar transistors, along with other components such as resistors, capacitors, and diodes.

Structure of bipolar transistor:-

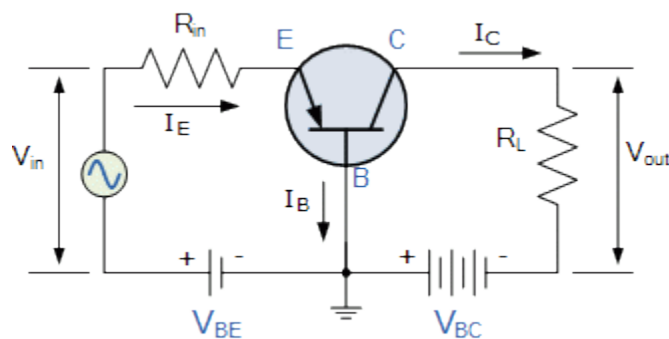

PNP and NPN transistors with their symbols and mechanism of current flow:-

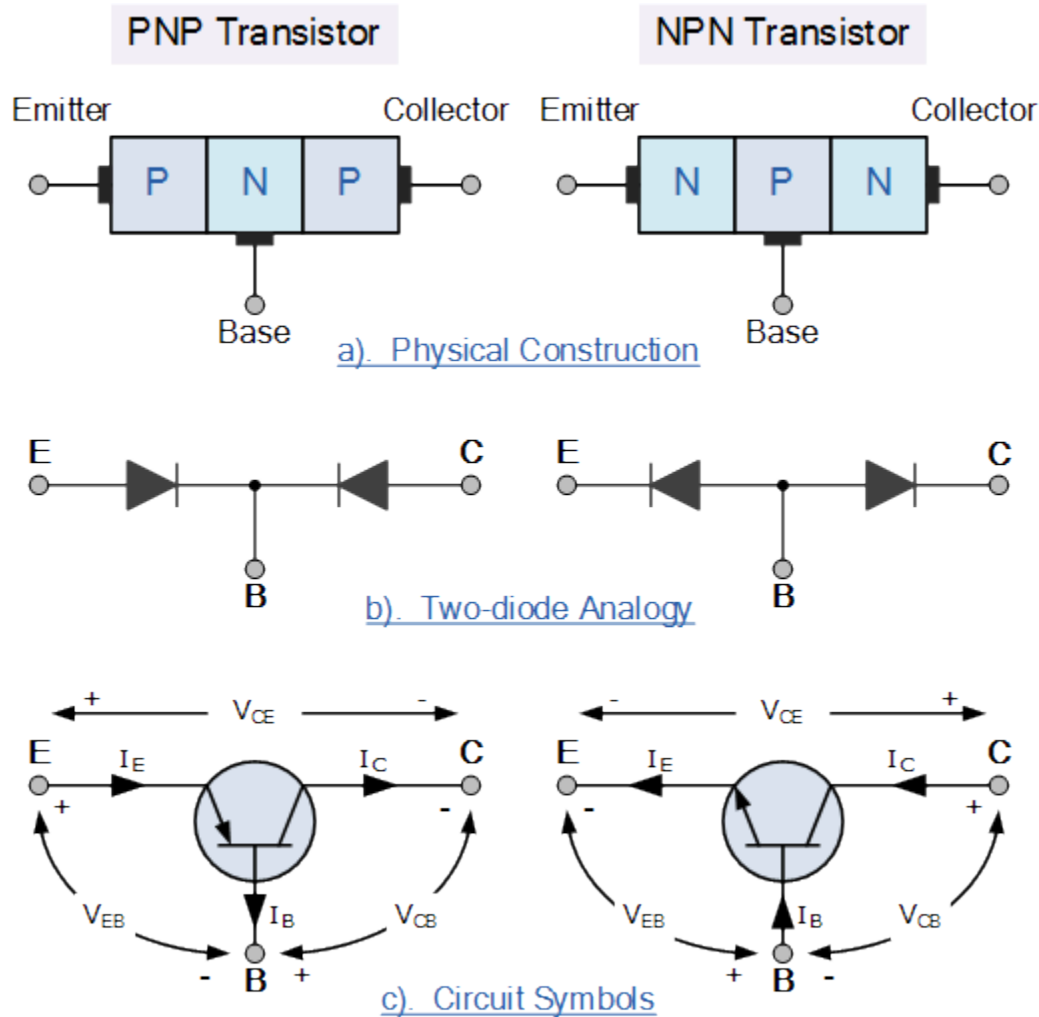

CB, CE and CC configuration of transistor with their comparison and current amplification factors:-

As the **Bipolar Transistor** is a three terminal device, there are basically three possible ways to connect it within an electronic circuit with one terminal being common to both the input and output. Each method of connection responding differently to its input signal within a circuit as the static characteristics of the transistor vary with each circuit arrangement.

Common Base Configuration – has Voltage Gain but no Current Gain.

Common Emitter Configuration – has both Current and Voltage Gain

Common Collector Configuration – has Current Gain but no Voltage Gain.

Common base configuration:-

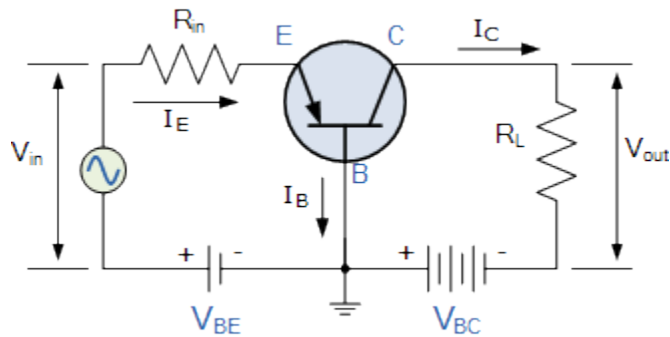

As its name suggests, in the **Common Base** or grounded base configuration, the BASE connection is common to both the input signal AND the output signal. The input signal is applied between the transistors base and the emitter terminals, while the corresponding output signal is taken from between the base and the collector terminals as shown. The base terminal is grounded or can be connected to some fixed reference voltage point.

The input current flowing into the emitter is quite large as its the sum of both the base current and collector current respectively therefore, the collector current output is less than the emitter current input resulting in a current gain for this type of circuit of "1" (unity) or less, in other words the common base configuration "attenuates" the input signal.

$$A_V = \frac{V_{out}}{V_{in}} = \frac{I_C \times R_L}{I_E \times R_{IN}} \text{ it is common base voltage gain}$$

I_C/I_E is the current gain

Common Emitter configuration:-

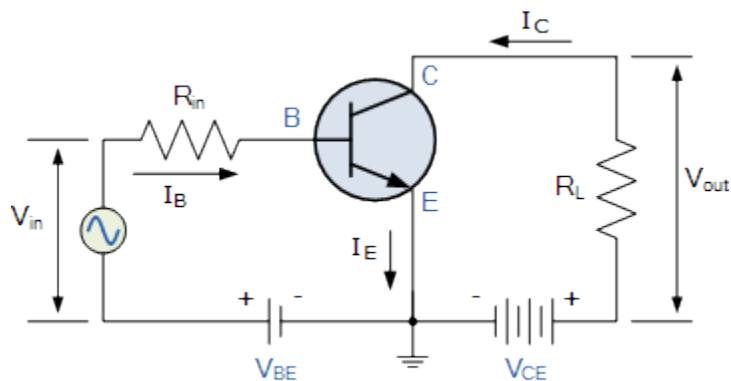

In this type of configuration, the current flowing out of the transistor must be equal to the currents flowing into the transistor as the emitter current is given as $I_e = I_c + I_b$.

As the load resistance (R_L) is connected in series with the collector, the current gain of the common emitter transistor configuration is quite large as it is the ratio of I_c/I_b . A transistor's current gain is given the Greek symbol of Beta, (β).

As the emitter current for a common emitter configuration is defined as $I_e = I_c + I_b$, the ratio of I_c/I_e is called Alpha, given the Greek symbol of α . Note: that the value of Alpha will always be less than unity.

$$\text{Alpha, } (\alpha) = \frac{I_C}{I_E} \quad \text{and} \quad \text{Beta, } (\beta) = \frac{I_C}{I_B}$$

$$\therefore I_C = \alpha \cdot I_E = \beta \cdot I_B$$

$$\text{as: } \alpha = \frac{\beta}{\beta + 1} \quad \beta = \frac{\alpha}{1 - \alpha}$$

$$I_E = I_C + I_B$$

Where: " I_c " is the current flowing into the collector terminal, " I_b " is the current flowing into the base terminal and " I_e " is the current flowing out of the emitter terminal.

Common collector configuration:-

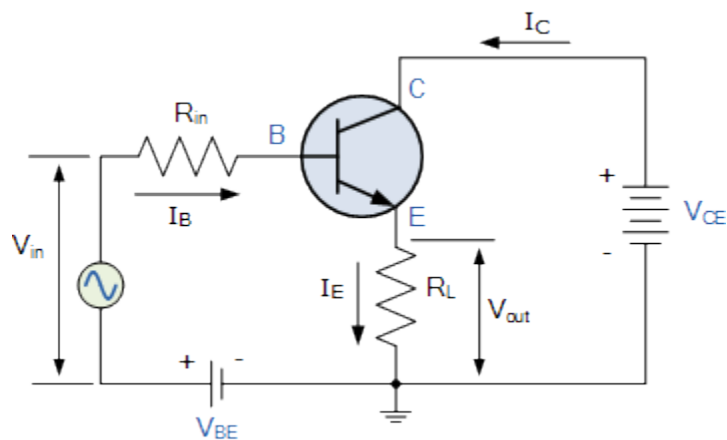

In the **Common Collector** or grounded collector configuration, the collector is now common through the supply so the collector is common to both the input and the output. The input signal is connected directly to the base terminal, while the output signal is taken from across the emitter load as shown. This type of configuration is commonly known as a **Voltage Follower** or **Emitter Follower** circuit.

$$I_E = I_C + I_B$$

$$A_i = \frac{I_E}{I_B} = \frac{I_C + I_B}{I_B}$$

$$A_i = \frac{I_C}{I_B} + 1$$

$$A_i = \beta + 1$$

This type of bipolar transistor configuration is a non-inverting circuit in that the signal voltages of V_{in} and V_{out} are “in-phase”. The common collector configuration has a voltage gain of about “1” (unity gain). Thus it can be considered as a voltage-buffer since the voltage gain is unity.

$I_E = I_B + I_C$ $I_C = I_E - I_B$ $I_B = I_E - I_C$	$\alpha = \frac{I_C}{I_E} = \frac{\beta}{1 + \beta}$ $\beta = \frac{I_C}{I_B} = \frac{\alpha}{1 - \alpha}$
$I_B = \frac{I_C}{\beta} = \frac{I_E}{1 + \beta} = I_E (1 - \alpha)$	

$I_C = \beta \cdot I_B = \alpha \cdot I_E$	$I_E = \frac{I_C}{\alpha} = I_B (1 + \beta)$
--	--

Concept of DC load line:-

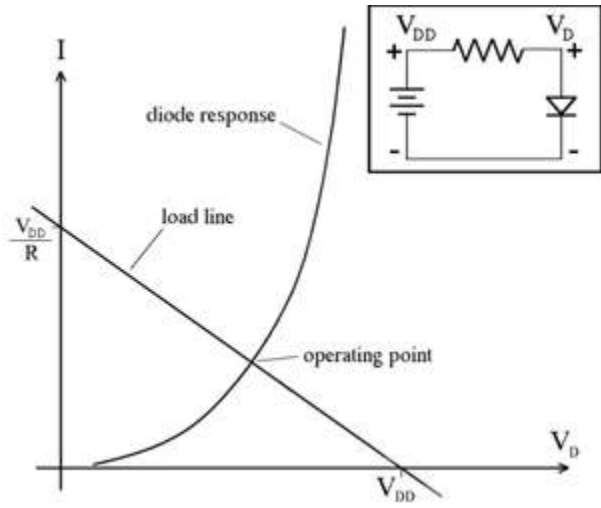

In graphical analysis of **nonlinear electronic circuits**, a **load line** is a line drawn on the **characteristic curve**, a graph of the **current** vs. the **voltage** in a nonlinear device like a **diode** or **transistor**. It represents the constraint put on the voltage and current in the nonlinear device by the external circuit. The load line, usually a straight line, represents the response of the **linear** part of the circuit, connected to the nonlinear device in question. The points where the characteristic curve and the load line intersect are the possible operating point(s) (**Q points**) of the circuit; at these points the current and voltage parameters of both parts of the circuit match.

The example at right shows how a load line is used to determine the current and voltage in a simple **diode** circuit. The diode, a nonlinear device, is in series with a linear circuit consisting of a **resistor**, R and a **voltage** source, V_{DD} . The characteristic curve (*curved line*), representing the current I through the diode for any given voltage across the diode V_D , is an exponential curve. The load line (*diagonal line*) represents the relationship between current and voltage due to **Kirchhoff's voltage law** applied to the resistor and voltage source, is

$$V_D = V_{DD} - I R$$

Since the current going through the three elements in series must be the same, and the voltage at the terminals of the diode must be the same, the operating point of the circuit will be at the intersection of the curve with the load line.

In a BJT circuit, the BJT has a different current-voltage (I_C - V_{CE}) characteristic depending on the base current. Placing a series of these curves on the graph shows how the base current will affect the operating point of the circuit.

Chapter -11 – Transistor biasing circuit

Concept of transistor biasing and selection of operating point and need for stabilization of operating point:-

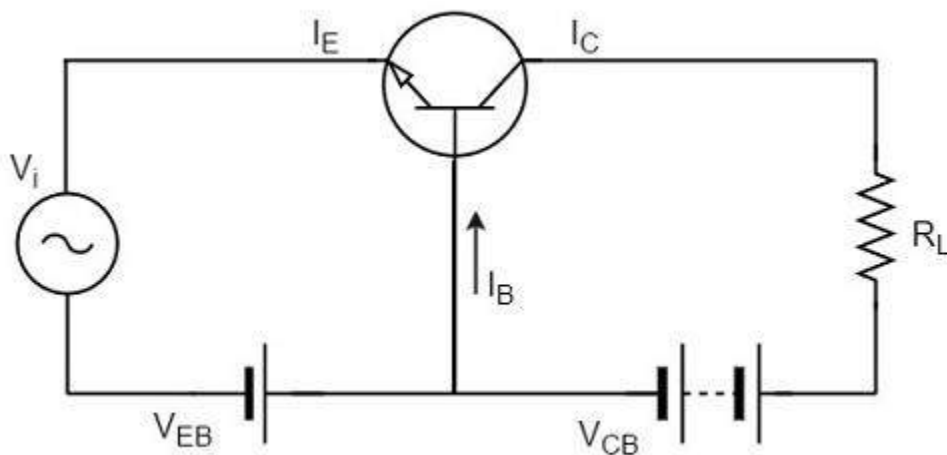

The proper flow of zero signal collector current and the maintenance of proper collector-emitter voltage during the passage of signal is known as **Transistor Biasing**. The circuit which provides transistor biasing is called as **Biasing Circuit**.

If a signal of very small voltage is given to the input of BJT, it cannot be amplified. Because, for a BJT, to amplify a signal, two conditions have to be met.

The input voltage should exceed **cut-in voltage** for the transistor to be **ON**.

The BJT should be in the **active region**, to be operated as an **amplifier**.

If appropriate DC voltages and currents are given through BJT by external sources, so that BJT operates in active region and superimpose the AC signals to be amplified, then this problem can be avoided. The given DC voltage and currents are so chosen that the transistor remains in active region for entire input AC cycle. Hence DC biasing is needed.

Factor affecting the operating point:-

The main factor that affect the operating point is the temperature. The operating point shifts due to change in temperature.

As temperature increases, the values of I_{CE} , β , V_{BE} gets affected.

- I_{CBO} gets doubled (for every 10° rise)
- V_{BE} decreases by 2.5mv (for every 1° rise)

So the main problem which affects the operating point is temperature. Hence operating point should be made independent of the temperature so as to achieve stability. To achieve this, biasing circuits are introduced.

Stabilization:-

The process of making the operating point independent of temperature changes or variations in transistor parameters is known as **Stabilization**.

Once the stabilization is achieved, the values of I_C and V_{CE} become independent of temperature variations or replacement of transistor. A good biasing circuit helps in the stabilization of operating point.

Need for stabilization:-

Stabilization of the operating point has to be achieved due to the following reasons.

- Temperature dependence of I_C
- Individual variations
- Thermal runaway

Let us understand these concepts in detail.

As the expression for collector current I_c is

$$\begin{aligned} I_C &= \beta I_B + I_{CEO} \\ I_C &= \beta I_B + I_{CEO} \\ &= \beta I_B + (\beta + 1) I_{CBO} \end{aligned}$$

Stability factor:-

It is understood that I_c should be kept constant in spite of variations of I_{CBO} or I_{CO} . The extent to which a biasing circuit is successful in maintaining this is measured by **Stability factor**. It denoted by **S**.

By definition, the rate of change of collector current I_c with respect to the collector leakage current I_{CO} at constant β and I_B is called **Stability factor**.

$$S = \frac{dI_c}{dI_{CO}} \quad S = \frac{dI_C}{dI_{CO}} \text{ at constant } I_B \text{ and } \beta$$

The general expression of stability factor for a CE configuration can be obtained as under.

$$I_C = \beta I_B + (\beta + 1) I_{CO}$$

$$S = \beta + 1 \frac{1}{1 - \beta \left(\frac{dI_B}{dI_C} \right)} \quad S = \beta + 1 \frac{1}{1 - \beta \left(\frac{dI_B}{dI_C} \right)}$$

Hence the stability factor S depends on β , I_B and I_C .

Different types of biasing circuits:-

1. Fixed bias
2. Voltage divider biased
3. Collector to base bias

Fixed bias:-

- **This form of biasing is also called Base Bias. In the example image on the right, the single power source (ie. battery) is used for both collector and base of transistor, although separate batteries can also be used.**
- **$V_{CC} = I_B R_B + V_{be}$ Therefore,
 $I_B = (V_{CC} - V_{be})/R_B$
For a given transistor, V_{be} does not vary significantly during use. As V_{CC} is of fixed value, on selection of R_B , the base current I_B is fixed. Therefore this type is called fixed bias type of circuit.
Also for given circuit,
 $V_{CC} = I_C R_C + V_{ce}$
Therefore,
 $V_{ce} = V_{CC} - I_C R_C$
From this equation we can obtain V_{ce} . Since $I_C = \beta I_B$, we can obtain I_C as well. In this manner, operating point given as (V_{CE}, I_C) can be set for given transistor.**

Voltage divider bias:-

- - The voltage divider is formed using external resistors R_1 and R_2 .
 - The voltage across R_2 forward biases the emitter junction. By proper selection of resistors R_1 and R_2 , the operating point of the transistor can be made independent of β .
- In this circuit we get,
 $V_B = V_{\text{across } R_2} = (V_{cc} R_2 / (R_1 + R_2)) - ((I_B R_1 R_2) / (R_1 + R_2))$
 $\sim (V_{cc} (R_2)) / (R_1 + R_2)$
provided $I_B \ll I_2 = V_B / R_2$
Also $V_B = V_{be} + I_E R_E$
- When temperature increases, I_C increases.

- As I_C makes up the majority of I_E , I_E also increases.
When I_E increases, V_{be} decreases. Therefore I_C decreases and the operating point remains stable.
- Also, $V_C = V_{CC} - I_C R_C$
Since I_C is roughly equal to I_E ,
- $V_{ce} = V_C - (R_C + R_E)I_C$
We note that β is absent from all the above equations.
Therefore, if the transistor is replaced by another having a different value of β , the operating point is largely unaffected.

Collector to base bias:-

- **In this form of biasing, the base resistor R_B is connected to the collector instead of connecting it to the battery V_{CC} .**
- **Similarly,**
 $V_{ce} = V_{CC} - I_C R_C$ (Since $I_B \ll I_C$)
- **In case of increase in temperature, collector current tends to increase, causing the voltage drop across resistor R_C to increase. Hence V_{ce} decreases. Therefore base current reduces, thereby compensating for the increase in collector current.**
- **It can be noted that for the given circuit,**
 $I_B = (V_{CC}) / (R_B + \beta R_C)$

CHAPTER – 12 – FIELD EFFECT TRANSISTOR

Field effect transistor and JFET:-

A Field Effect Transistor (FET) is a three-terminal semiconductor device. Its operation is based on a controlled input voltage. By appearance JFET and bipolar transistors are very similar. However, BJT is a current controlled device and JFET is controlled by input voltage. Most commonly two types of FETs are available.

- Junction Field Effect Transistor (JFET)
- Metal Oxide Semiconductor FET (IGFET)

The functioning of Junction Field Effect Transistor depends upon the flow of majority carriers (electrons or holes) only. Basically, JFETs consist of an **N** type or **P** type silicon bar containing PN junctions at the sides. Following are some important points to remember about FET –

- **Gate** – By using diffusion or alloying technique, both sides of N type bar are heavily doped to create PN junction. These doped regions are called gate (G).
- **Source** – It is the entry point for majority carriers through which they enter into the semiconductor bar.
- **Drain** – It is the exit point for majority carriers through which they leave the semiconductor bar.
- **Channel** – It is the area of N type material through which majority carriers pass from the source to drain.

There are two types of JFETs commonly used in the field semiconductor devices: **N-Channel JFET** and **P-Channel JFET**.

N channel JFET:-

It has a thin layer of N type material formed on P type substrate. Following figure shows the crystal structure and schematic symbol of an N-channel JFET. Then the gate is formed on top of the N channel with P type material. At the end of the channel and the gate, lead wires are attached and the substrate has no connection.

When a DC voltage source is connected to the source and the drain leads of a JFET, maximum current will flow through the channel. The same amount of current will flow from the source and the drain terminals. The amount of channel current flow will be determined by the value of V_{DD} and the internal resistance of the channel.

A typical value of source-drain resistance of a JFET is quite a few hundred ohms. It is clear that even when the gate is open full current conduction will take place in the channel.

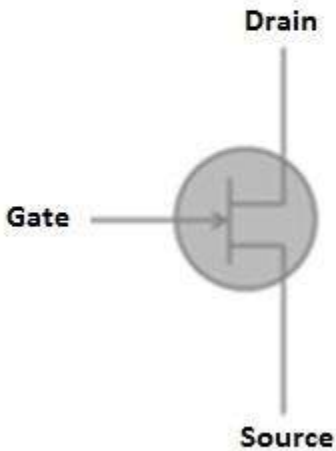

Symbol of N-Channel JFET

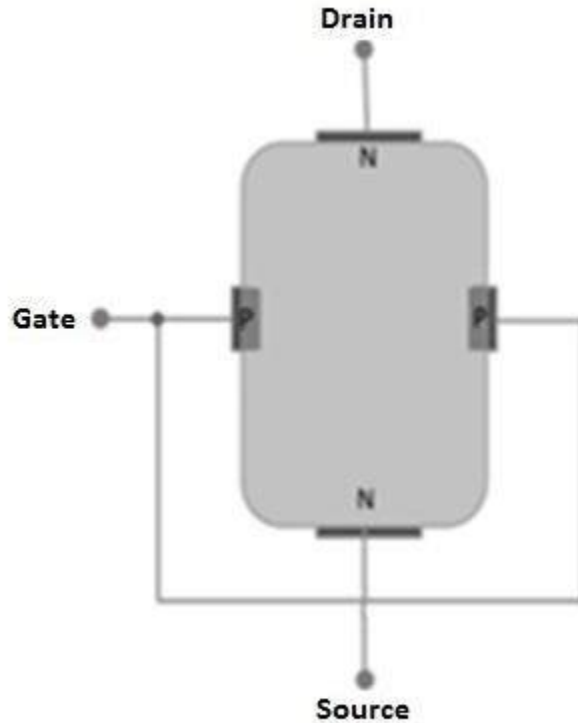

N-Channel JFET

P Channel JFET:-

It has a thin layer of P type material formed on N type substrate. The following figure shows the crystal structure and schematic symbol of an N-channel JFET. The gate is formed on top of the P channel with N type material. At the end of the channel and the gate, lead wires are attached. Rest of the construction details are similar to that of N- channel JFET.

Normally for general operation, the gate terminal is made positive with respect to the source terminal. The size of the P-N junction depletion layer depends upon fluctuations in the values of reverse biased gate voltage. With a small change in gate voltage, JFET can be controlled anywhere between full conduction and cutoff state.

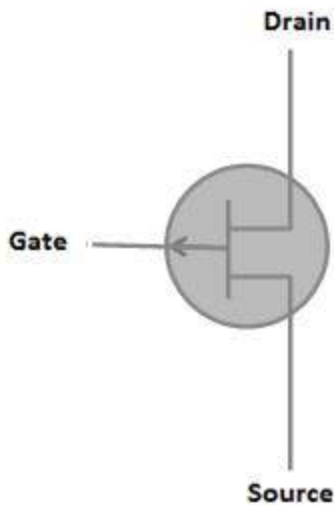

Symbol of P-Channel JFET

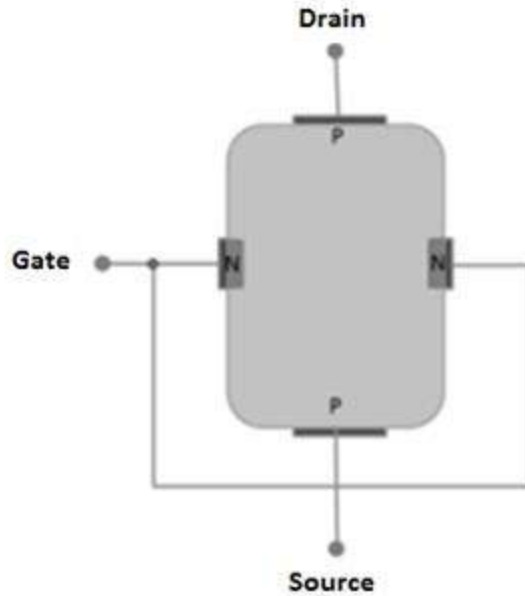

P-Channel JFET

Output characteristics of JFET:-

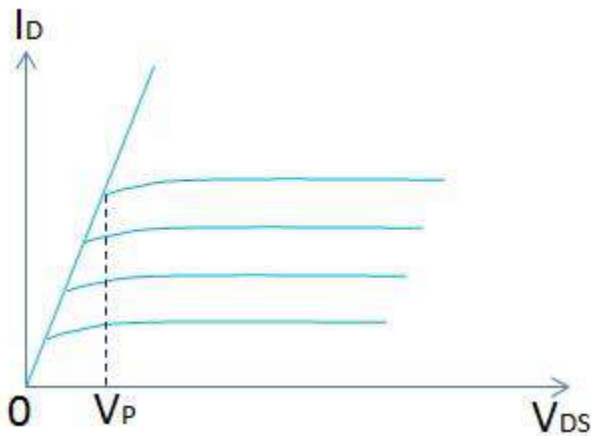

The output characteristics of JFET are drawn between drain current (I_D) and drain source voltage (V_{DS}) at constant gate source voltage (V_{GS}) as shown in the following figure.

Initially, the drain current (I_D) rises rapidly with drain source voltage (V_{DS}) however suddenly becomes constant at a voltage known as pinch-off voltage (V_P). Above pinch-off voltage, the channel width becomes so narrow that it allows very small drain current to pass through it. Therefore, drain current (I_D) remains constant above pinch-off voltage.

MOSFET:-

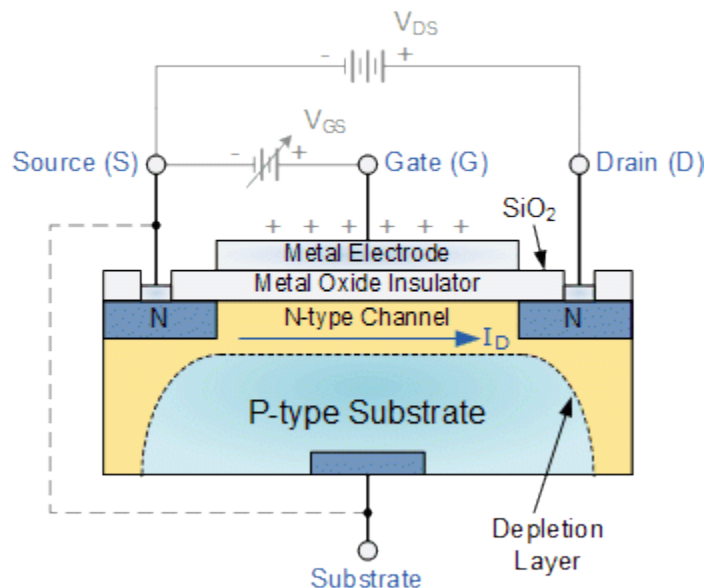

The most common type of insulated gate FET which is used in many different types of electronic circuits is called the **Metal Oxide Semiconductor Field Effect Transistor** or **MOSFET** for short.

The **IGFET** or **MOSFET** is a voltage controlled field effect transistor that differs from a JFET in that it has a “Metal Oxide” Gate electrode which is electrically insulated from the main semiconductor n-channel or p-channel by a very thin layer of insulating material usually silicon dioxide, commonly known as glass.

As the Gate terminal is electrically isolated from the main current carrying channel between the drain and source, “**NO current flows into the gate**” and just like the JFET, the MOSFET also acts like a voltage controlled resistor where the current flowing through the main channel between the Drain and Source is proportional to the input voltage. Also like the JFET, the MOSFETs very high input resistance can easily accumulate large amounts of static charge resulting in the **MOSFET** becoming easily damaged unless carefully handled or protected.

Like the previous JFET tutorial, MOSFETs are three terminal devices with a Gate, Drain and Source and both P-channel (PMOS) and N-channel (NMOS) MOSFETs are available. The main difference this time is that MOSFETs are available in two basic forms:

Depletion Type – the transistor requires the Gate-Source voltage, (V_{GS}) to switch the device “OFF”. The depletion mode MOSFET is equivalent to a “Normally Closed” switch.

Enhancement Type – the transistor requires a Gate-Source voltage, (V_{GS}) to switch the device “ON”. The enhancement mode MOSFET is equivalent to a “Normally Open” switch.

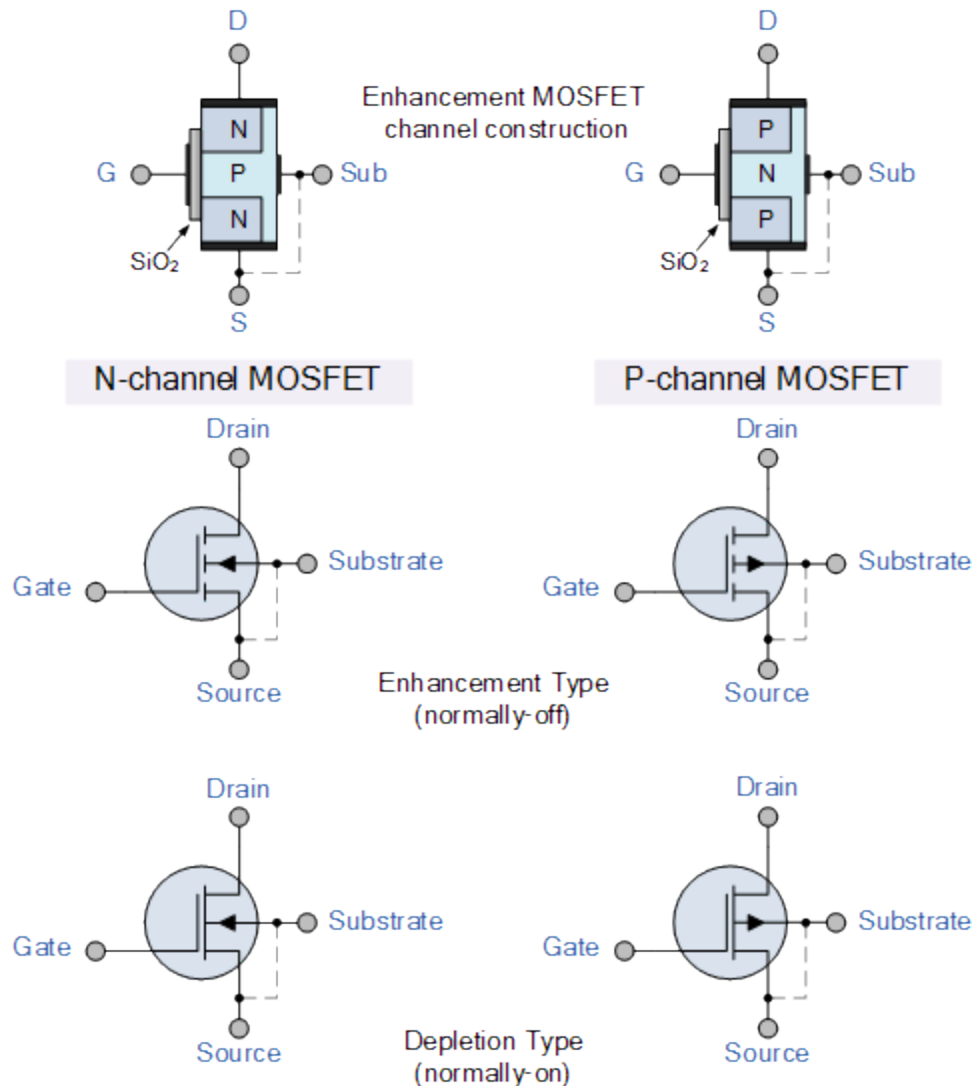

This makes the MOSFET device especially valuable as electronic switches or to make logic gates because with no bias they are normally non-conducting and this high gate input resistance means that very little or no control current is needed as MOSFETs are voltage controlled devices. Both the p-channel and the n-channel MOSFETs are available in two basic forms, the **Enhancement** type and the **Depletion** type.

Depletion mode MOSFET:-

The **Depletion-mode MOSFET**, which is less common than the enhancement mode types is normally switched "ON" (conducting) without the application of a gate bias voltage. That is the channel conducts when $V_{GS} = 0$ making it a "normally-closed" device. The circuit symbol shown above for a depletion MOS transistor uses a solid channel line to signify a normally closed conductive channel.

Depletion-mode N-Channel MOSFET and circuit Symbols

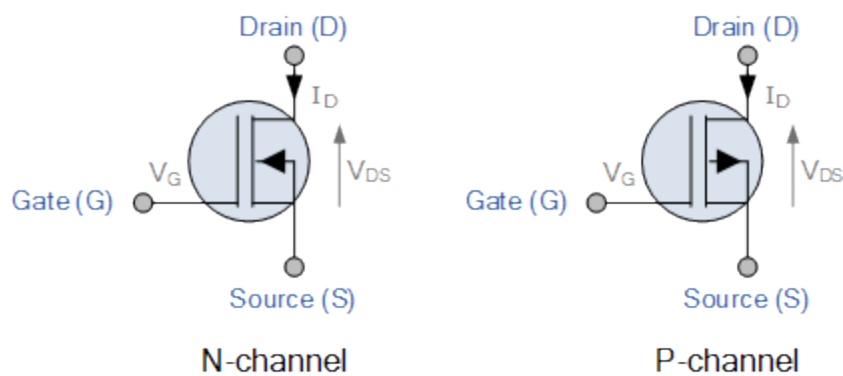
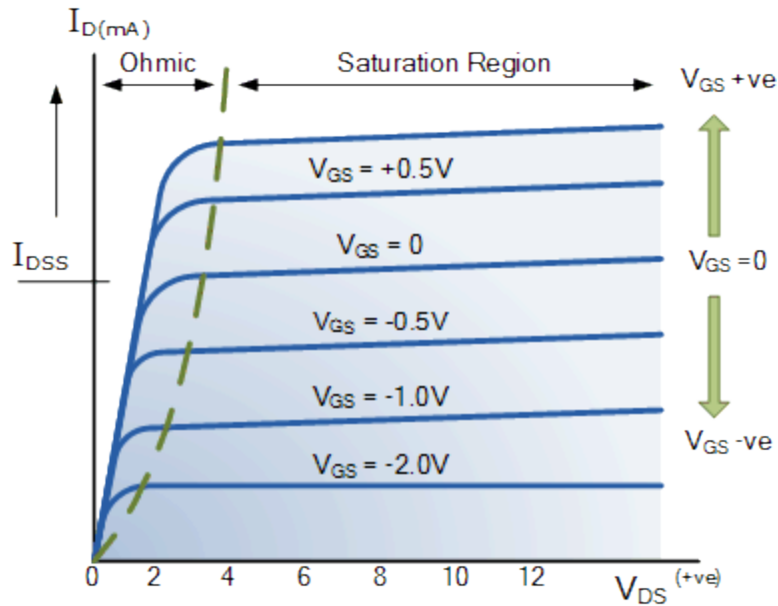

The depletion-mode MOSFET is constructed in a similar way to their JFET transistor counterparts were the drain-source channel is inherently conductive with the electrons and holes already present within the n-type or p-type channel. This doping of the channel produces a conducting path of low resistance between the Drain and Source with zero Gate bias.

Enhancement-mode MOSFET

The more common **Enhancement-mode MOSFET** or eMOSFET, is the reverse of the depletion-mode type. Here the conducting channel is lightly doped or even undoped making it non-conductive. This results in the device being normally "OFF" (non-conducting) when the gate bias voltage, V_{GS} is equal to

zero. The circuit symbol shown above for an enhancement MOS transistor uses a broken channel line to signify a normally open non-conducting channel.

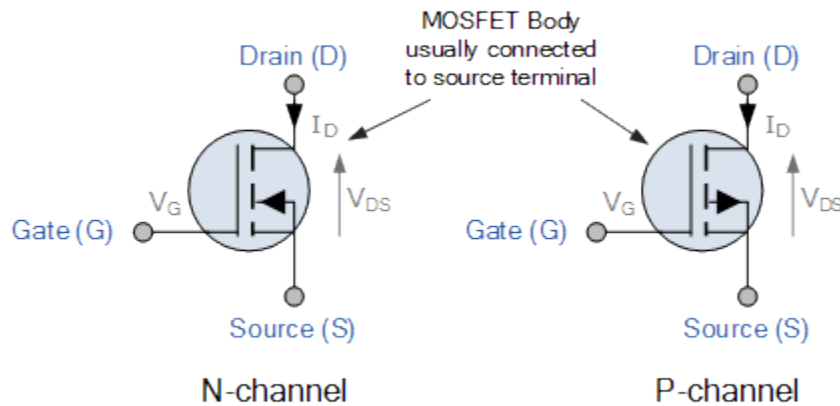
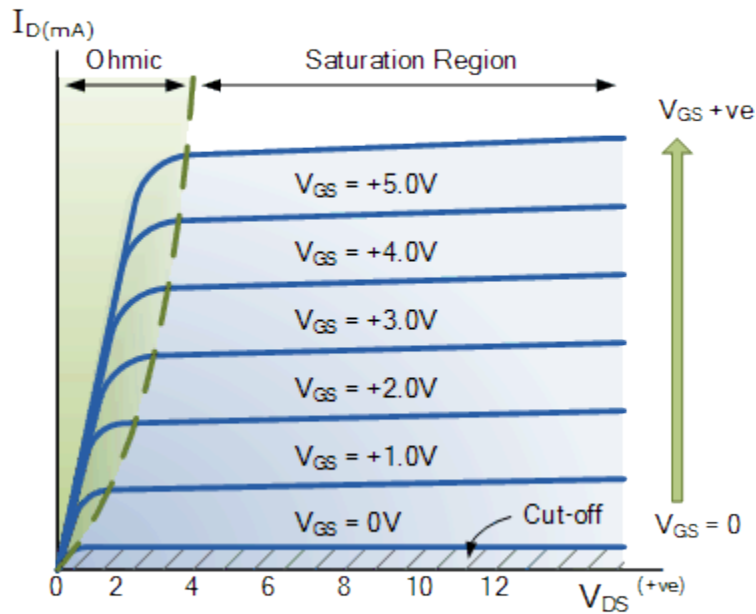

Enhancement-mode MOSFETs make excellent electronics switches due to their low “ON” resistance and extremely high “OFF” resistance as well as their infinitely high input resistance due to their isolated gate.

. Enhancement-mode MOSFETs are used in integrated circuits to produce CMOS type *Logic Gates* and power switching circuits in the form of as PMOS (P-channel) and NMOS (N-channel) gates. CMOS actually stands for *Complementary MOS* meaning that the logic device has both PMOS and NMOS within its design.

CMOS advantages and applications:-

1. Very low static power consumption.
2. Reduce the complexity of the circuit.
3. High density of logic functions on a chip.
4. Low static power consumption.
5. High noise immunity.

CMOS applications:-

1. Computer memories, CPUs
2. Microprocessor designs
3. Flash memory chip designing
4. Used to design application-specific integrated circuits (ASICs)

CHAPTER – 13 – INTRODUCTION TO ELECTRICAL MACHINES

Transformers:-

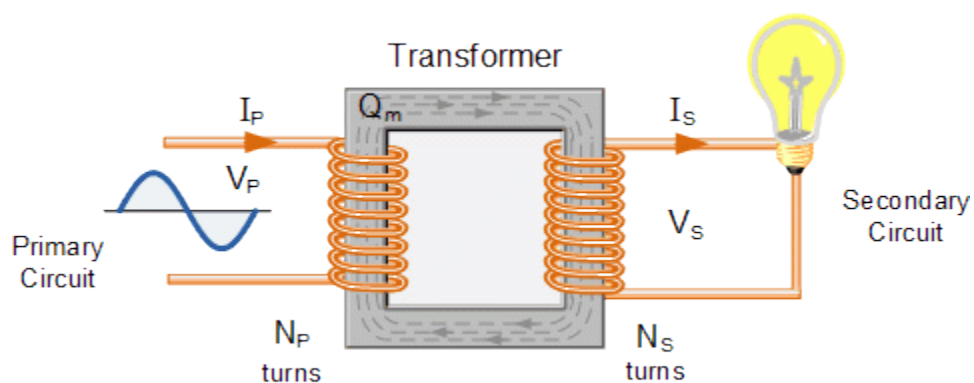

Transformers are electrical devices consisting of two or more coils of wire used to transfer electrical energy by means of a changing magnetic field.

The reason for transforming the voltage to a much higher level is that higher distribution voltages implies lower currents for the same power and therefore lower $I^2 \cdot R$ losses along the networked grid of cables. These higher AC transmission voltages and currents can then be reduced to a much lower, safer and usable voltage level where it can be used to supply electrical equipment in our homes and workplaces, and all this is possible thanks to the basic **Voltage Transformer**.

The **Voltage Transformer** can be thought of as an electrical component rather than an electronic component. A transformer basically is very simple static (or stationary) electro-magnetic passive electrical device that works on the principle of Faraday's law of induction by converting electrical energy from one value to another.

The transformer does this by linking together two or more electrical circuits using a common oscillating magnetic circuit which is produced by the transformer itself. A transformer operates on the principals of "electromagnetic induction", in the form of Mutual Induction.

Mutual induction is the process by which a coil of wire magnetically induces a voltage into another coil located in close proximity to it. Then we can say that transformers work in the "magnetic domain", and transformers get their name from the fact that they "transform" one voltage or current level into another.

A single phase voltage transformer basically consists of two electrical coils of wire, one called the "Primary Winding" and another called the "Secondary Winding". For this tutorial we will define the "primary" side of the transformer as the side that usually takes power, and the "secondary" as the side that usually delivers power. In a single-phase voltage transformer the primary is usually the side with the higher voltage.

Single phase voltage transformers:-

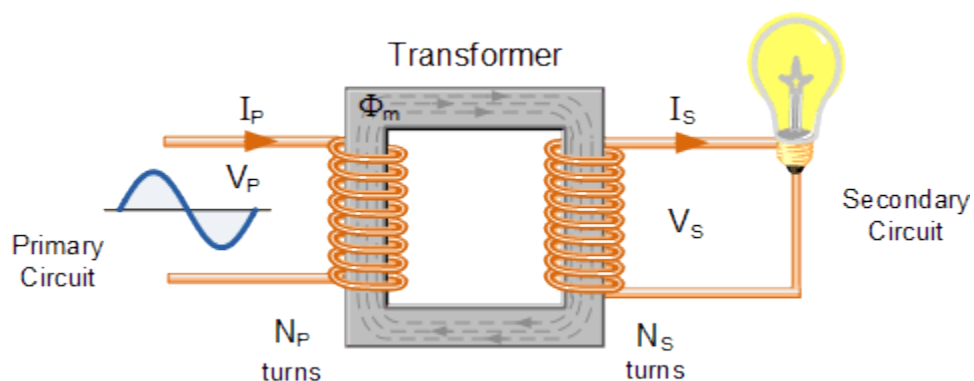

In other words, for a transformer there is no direct electrical connection between the two coil windings, thereby giving it the name also of an **Isolation Transformer**.

Generally, the primary winding of a transformer is connected to the input voltage supply and converts or transforms the electrical power into a magnetic field. While the job of the secondary winding is to convert this alternating magnetic field into electrical power producing the required output voltage as shown.

Transformer Construction (single-phase)

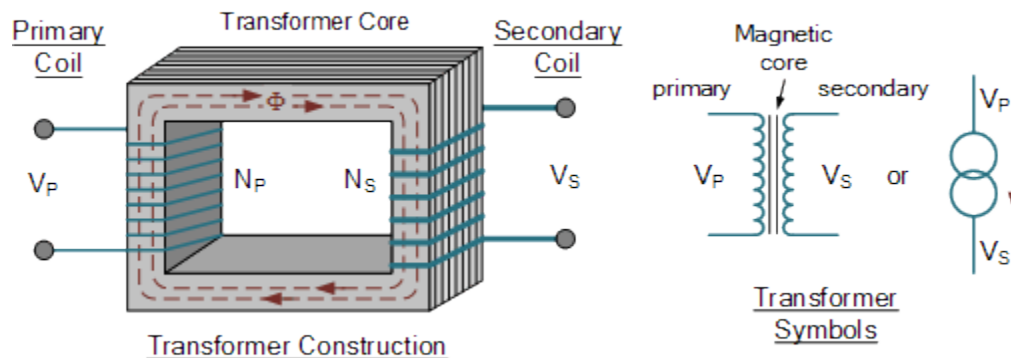

- Where:
- V_P – is the Primary Voltage
- V_S – is the Secondary Voltage
- N_P – is the Number of Primary Windings
- N_S – is the Number of Secondary Windings
- Φ (phi) – is the Flux Linkage

Notice that the two coil windings are not electrically connected but are only linked magnetically. A single-phase transformer can operate to either increase or decrease the voltage applied to the primary winding. When a transformer is used to “increase” the voltage on its secondary winding with respect to the primary, it is called a Step-up transformer. When it is used to “decrease” the voltage on the secondary winding with respect to the primary it is called a Step-down transformer.

Transformer turns ratio:-

$$\frac{N_P}{N_S} = \frac{V_P}{V_S} = n = \text{Turns Ratio}$$

emf = turns x rate of change

$$E = N \frac{d\Phi}{dt}$$

$$E = N \times \omega \times \Phi_{\max} \times \cos(\omega t)$$

$$E_{\max} = N\omega\Phi_{\max}$$

$$E_{\text{rms}} = \frac{N\omega}{\sqrt{2}} \times \Phi_{\max} = \frac{2\pi}{\sqrt{2}} \times f \times N \times \Phi_{\max}$$

$$\therefore E_{\text{rms}} = 4.44 f N \Phi_{\max}$$

- Where:
- f – is the flux frequency in Hertz, $= \omega/2\pi$
- N – is the number of coil windings.
- Φ – is the amount of flux in webers

This is known as the Transformer EMF Equation. For the primary winding emf, N will be the number of primary turns, (N_p) and for the secondary winding emf, N will be the number of secondary turns, (N_s).

Transformer efficiency:-

A transformer does not require any moving parts to transfer energy. This means that there are no friction or windage losses associated with other electrical machines. However, transformers do suffer from other types of losses called “copper losses” and “iron losses” but generally these are quite small.

An ideal transformer is 100% efficient because it delivers all the energy it receives. Real transformers on the other hand are not 100% efficient and at full load, the efficiency of a transformer is between 94% to 96% which is quite good. For a transformer operating with a constant voltage and frequency with a very high capacity, the efficiency may be as high as 98%. The efficiency, η of a transformer is given as:

Transformer Efficiency

$$\begin{aligned}\text{efficiency, } \eta &= \frac{\text{Output Power}}{\text{Input Power}} \times 100\% \\ &= \frac{\text{Input Power} - \text{Losses}}{\text{Input Power}} \times 100\% \\ &= 1 - \frac{\text{Losses}}{\text{Input Power}} \times 100\%\end{aligned}$$

$$\text{Efficiency, } \eta = \frac{\text{Secondary Watts (Output)}}{\text{Primary VA (Input)}}$$

Losses in Transformers:-

1. Iron loss
2. Hysteresis loss
3. Eddy current loss
4. Copper loss or ohmic loss
5. Stray loss
6. Dielectric loss

DC MACHINES:-

The DC machine can be classified into two types namely **DC motors as well as DC generators**. Most of the DC machines are equivalent to AC machines because they include AC currents as well as AC voltages in them. The output of the DC machine is DC output because they convert AC voltage to DC voltage. The conversion of this mechanism is known as the commutator, thus these machines are also named as commutating machines. DC machine is most frequently used for a motor. The main benefits of this machine include torque regulation as well as easy speed. The **applications of the DC machine** is limited to trains, mills, and mines. As examples, underground subway cars, as well as trolleys, may utilize DC motors. In the past, automobiles were designed with DC dynamos for charging their batteries.

A DC machine is an electromechanical energy alteration device. The **working principle of a DC machine** is when electric current flows through a coil within a magnetic field, and then the magnetic force generates a torque which rotates the dc motor. The DC machines are classified into two types such as DC generator as well as DC motor. The main function of the DC generator is to convert mechanical power to DC electrical power, whereas a DC motor converts DC power to mechanical power. The **AC motor** is frequently used in the industrial applications for altering electrical energy to mechanical energy. However, a DC motor is applicable where the good speed regulation & ample range of speeds are necessary like in electric-transaction systems.

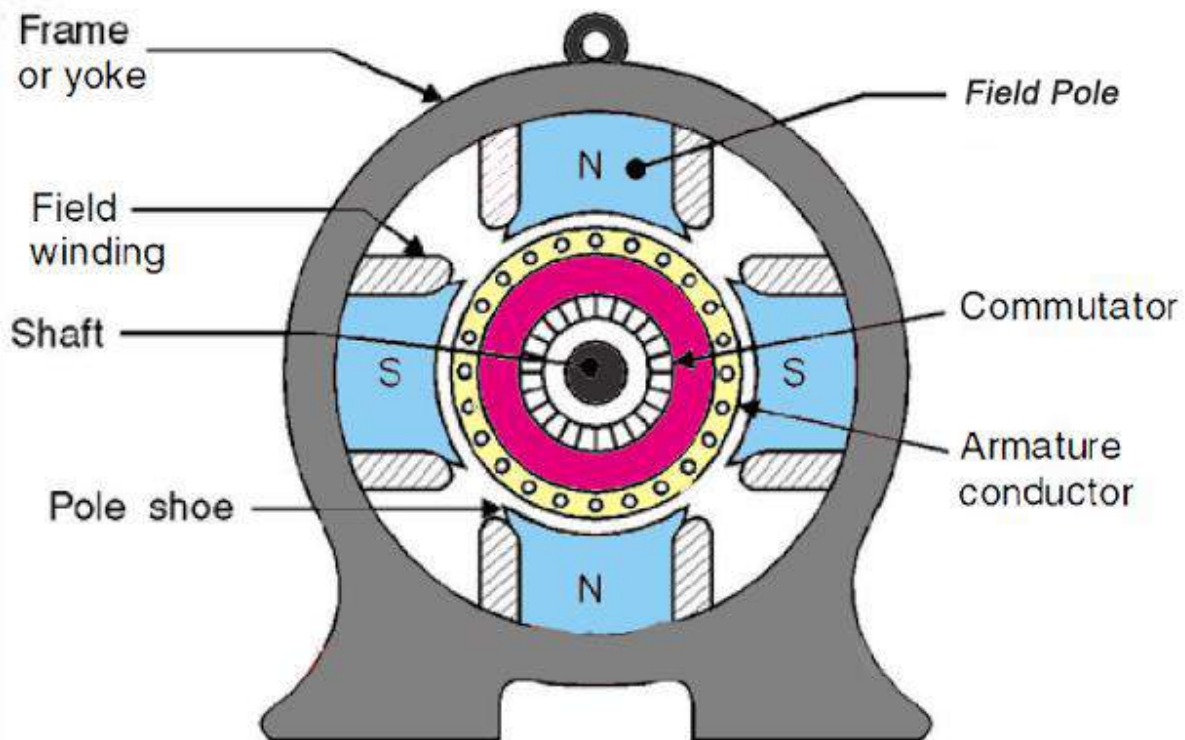

The construction of DC machine can be done using some of the essential parts like Yoke, Pole core & pole shoes, Pole coil & field coil, Armature core, Armature winding otherwise conductor, commutator, brushes & bearings. Some of the **parts of the DC machine** is discussed below.

Yoke

Another name of a yoke is the frame. The main function of the yoke in the machine is to offer mechanical support intended for poles and protects the entire machine from the moisture, dust, etc. The materials used in the yoke are designed with cast iron, cast steel otherwise rolled steel.

Pole and Pole Core

The pole of the DC machine is an electromagnet and the field winding is winding among pole. Whenever field winding is energized then the pole gives magnetic flux. The materials used for this are cast steel, cast iron otherwise pole core. It can be built with the annealed steel laminations for reducing the power drop because of the eddy currents.

Pole Shoe

Pole shoe in DC machine is an extensive part as well as enlarge the region of the pole. Because of this region, flux can be spread out within the air-gap as well as extra flux can be passed through the air space toward armature. The materials used to build pole shoe is cast iron otherwise cast steel, and also used annealed steel lamination to reduce the loss of power because of eddy currents.

Field Windings

In this, the windings are wound in the region of pole core & named as field coil. Whenever current is supplied through field winding then it electromagnetics the poles which generate required flux. The material used for field windings is copper.

Armature Core

Armature core includes the huge number of slots within its edge. Armature conductor is located in these slots. It provides the low-reluctance path toward the flux generated with field winding. The materials

used in this core are permeability low-reluctance materials like iron otherwise cast. The lamination is used to decrease the loss because of the eddy current.

Armature Winding

The armature winding can be formed by interconnecting the armature conductor. Whenever an armature winding is turned with the help of prime mover then the voltage, as well as magnetic flux, gets induced within it. This winding is allied to an exterior circuit. The materials used for this winding are conducting material like copper.

Commutator

The main function of the commutator in the DC machine is to collect the current from the armature conductor as well as supplies the current to the load using brushes. And also provides uni-directional torque for DC-motor. The commutator can be built with a huge number of segments in the edge form of hard drawn copper. The Segments in the commutator are protected from thin mica layer.

Brushes

Brushes in the DC machine gather the current from commutator and supplies it to exterior load. Brushes wear with time to inspect frequently. The materials used in brushes are graphite otherwise carbon which is in rectangular form.

TYPES OF DC MACHINES:-

The excitation of the DC machine is classified into two types namely separate excitation, as well as self-excitation. In separate excitation type of dc machine, the field coils are activated with a separate DC source. In self-excitation type of dc machine, the flow of current throughout the field-winding is supplied with the machine. The principal kinds of DC machine are classified into four types which include the following.

1. Separately excited DC machine
2. Shunt wound machine

3. Series wound machine
4. Compound wound machine

In Separately Excited DC Machine, a separate DC source is utilized for activating the field coils.

In Shunt wound DC Machines, the field coils are allied in parallel through **the armature**. As the shunt field gets the complete o/p voltage of a generator otherwise a motor supply voltage, it is normally made of a huge number of twists of fine wire with a small field current carrying.

In series wound D.C. Machines, the field coils are allied in series through the armature. As series field winding gets the armature current, as well as the armature current is huge, due to this the series field winding includes few twists of wire of big cross-sectional region.

A compound machine includes both the series as well as shunt fields. The two windings are carried-out with every machine pole. The series winding of the machine includes few twists of a huge cross-sectional region, as well as the shunt windings, include several fine wire twists.

The connection of the compound machine can be done in two ways. If the shunt-field is allied in parallel by the armature only, then the machine can be named as the 'short shunt compound machine' & if the shunt-field is allied in parallel by both the armature as well as series field, then the machine is named as the 'long shunt compound machine'.

EMF equation of DC machine:-

The **DC machine e.m.f** can be defined as when the armature in the dc machine rotates, the voltage can be generated within the coils. In a generator, the e.m.f of rotation can be called the generated emf, and $E_r = E_g$. In the motor, the emf of rotation can be called as counter or back emf, and $E_r = E_b$.

Let Φ is the useful flux for every pole within webers

P is the total number of poles

z is the total number of conductors within the armature

n is the rotation speed for an armature in the revolution for each second

A is the no. of parallel lane throughout the armature among the opposite polarity brushes.

The voltage produced for each conductor = flux slash for each revolution in WB / Time taken for a single revolution within seconds

As 'n' revolutions are completed within a single second and 1 revolution will be completed within a 1/n second. Thus the time for a single armature revolution is a 1/n sec.

The standard value of produced voltage for each conductor

$$p \Phi / 1/n = np \Phi \text{ volts}$$

E = standard voltage for each conductor x no. of conductors within series for each lane

$$E = n.P.\Phi \times Z/A$$

The above equation is the e.m.f. the equation of the DC machine.

Starter:-

At starting the motor takes large amount of current which is nearly 25 x full load current. This large amount of current can not be allowed to flow in a motor even for a short period of time. This excessive starting current has to be prevented because

- It cause sudden depression of voltage of supply (large voltage drop occurs) system causing disturbances to other loads connected in the system.
- It would cause heavy sparking at the brushes which may destroy the commutator and brush gear.
- Due to heavy inrush of current at start there is possibility of damage of the motor winding.

Preventing large starting current:-

A resistance is introduced in series with the armature for very start duration of starting period only, which limits the starting current to a very safe value. This starting resistance is

gradually cut out as the motor gains speed and develops the back emf which then regulates the speed of the motor.

Types of starters for dc motors are:

1. 2 point starter
2. 3 point starter
3. 4 point starter

2 point starter:-

Two point starter is used in series motors because in case of series motor, the armature winding and field winding are connected in series. Therefore series motor achieves dangerous high speed. So series motor should not be started without any load. Two point starter construction is very much similar to the combination of rheostat with a tap changing.

The starting resistance and no load release coil is connected in series with the armature of a series motor. When a series motor is given a supply, the handle is moved from OFF position stud no.1 ie) full resistance is given at starting. Therefore inrush of high starting current to the series motor is reduced. Then starting resistance is gradually cut down and the motor gathers speed, which will then develop back emf.

3 point starter:

Three point starter is used in shunt wound DC motor or compound wound DC motor. To start the motor, the starter arm is moved to stud 1 in the clockwise direction ie) whole of the resistance is added to the armature winding of the dc motor. The field winding will also get full supply through the coil of the No-Volt-Release (NVR).

The motor will develop a torque and start rotating with full starting resistance in the armature winding. Once the dc motor starts rotating, the starter arm is moved in clockwise direction and will be brought to the RUN position ie) zero resistance to the armature winding. In RUN position, the soft iron piece fixed on the starter arm will face the NVR magnet piece and remain attracted.

In case of dc motor is over loaded, the armature winding will draw excessive current and there is possibility of damage of armature winding.. Due to this reason, the Over-Load-Release (OLR) coil will short circuited thereby demagnetizing the NVR electromagnet. Thus, the starter arm will eventually return to OFF position stopping the DC motor.

4 Point starter:

Disadvantage in three point starter is overcome in four point starter, Here the NVR coil is connected independently across the supply voltage instead of connecting it in series with the motor field winding. In a four point starter there will be three parallel circuits connected across the supply voltage .

When the starter arm is brought to stud 1 position, current will flow through the armature winding through the starter resistance. This will reduce the high inrush of starting current as a whole resistance is added to the armature winding. At the same time, the field winding will also get full supply through the brass arc. The speed of a dc motor is get control, by varying a field winding current with the variable resistance R1 As in four point starter, NVR coil and field winding are isolated from each of it. Thus any change in field winding current (I_f) will not affect NVR coil unlike three point starter. When started arm is brought to the RUN position, the armature of the dc motor will run at its full speed and remain connected to the supply through the starter arm. Thus the field winding and NVR coil will get full voltage independently. Now its possible for an engineer to release his/her hand from the starter as NVR coil is supplied independently, which means the spring tension cannot bring back the starter arm to OFF position because of the attractive force of the NVR. In case of overload, the OLR terminal will be short circuited to the NVR coil to release the starter arm to the OFF position.

Synchronous machine:-

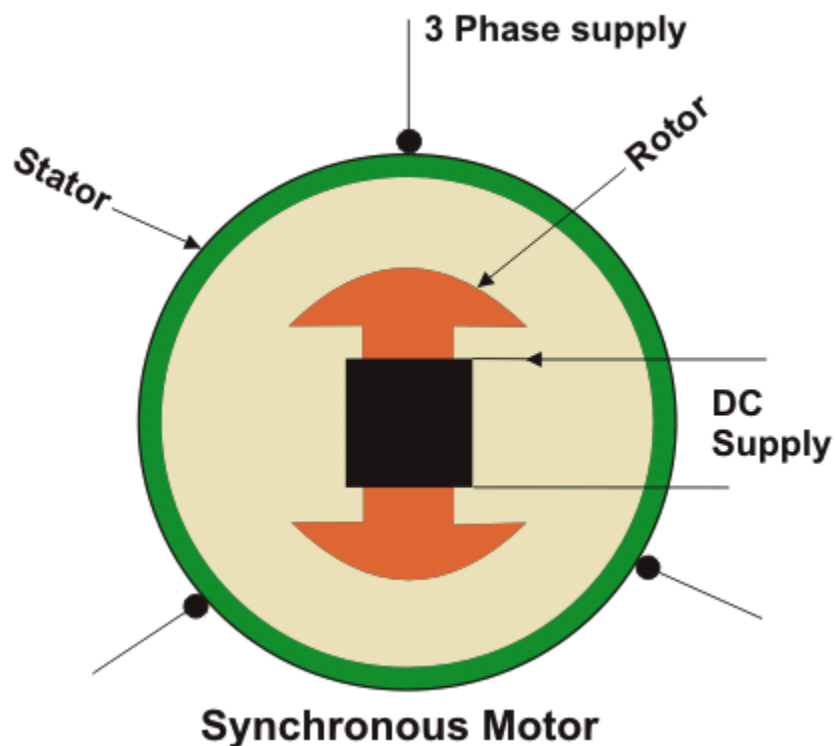

Electrical motors are an electro-mechanical device that converts electrical energy to mechanical energy. Based on the type of input we have classified it into single phase and 3 phase motors.

The most common type of 3 phase motors are **synchronous motors** and **induction motors**. When three-phase electric conductors are placed in certain geometrical positions (i.e. in a certain angle from one another) – an **electrical field** is generated. The rotating **magnetic field** rotates at a certain speed known as the **synchronous speed**.

It is a fixed speed motor because it has only one speed, which is synchronous speed. This speed is synchronised with the supply frequency. The synchronous speed is given by:

$$N_s = \frac{120f}{p}$$

- N = The Synchronous Speed (*in RPM – i.e. Rotations Per Minute*)
- f = The Supply Frequency (*in Hz*)
- p = The number of Poles

Main features of synchronous motors:-

1. **Synchronous motors** are inherently not self starting. They require some external means to bring their speed close to synchronous speed to before they are synchronized.
2. The speed of operation of is in synchronism with the supply frequency and hence for constant supply frequency they behave as constant speed motor irrespective of load condition
3. This motor has the unique characteristics of operating under any electrical power factor. This makes it being used in **electrical power factor** improvement.

Principle of operation synchronous motors:-

Synchronous motors are a doubly excited machine, i.e., two electrical inputs are provided to it. Its stator winding which consists of a We provide three-phase supply to three-phase stator winding, and DC to the rotor winding.

The 3 phase stator winding carrying 3 phase currents produces 3 phase rotating magnetic flux. The rotor carrying DC supply also produces a constant flux. Considering the 50 Hz power frequency, from the above relation we can see that the 3 phase rotating flux rotates about 3000 revolutions in 1 min or 50 revolutions in 1 sec.

Methods of starting synchronous motor:-

1. **Motor starting with an external prime Mover**
2. **Damper winding**

Single phase Induction Motor:-

We use the single-phase power system more widely than **three phase system** for domestic purposes, commercial purposes and some extent in industrial uses. Because, the single-phase system is more economical than a three-phase system and the power requirement in most of the houses, shops, offices are small, which can be easily met by a single phase system.

The single phase motors are simple in construction, cheap in cost, reliable and easy to repair and maintain. Due to all these advantages, the single phase motor finds its application in vacuum cleaners, fans, washing machines, centrifugal pumps, blowers, washing machines, etc.

