

Mecanismos e Dinâmica de Máquinas

Prof. Paulo Boni

Aula I

Aula I

- **Conteúdo da disciplina**
- **Avaliações**
- **Horário do professor**
- **Plano de aula**
- **Livros**

Conteúdo da disciplina

- **Análise e Síntese** de mecanismos

- Mecanismos articulados
- Cames
- Engrenagens
- etc...

CONCEITO

Cinemática e dinâmica de máquinas

envolve projeto de máquinas em função dos movimentos requeridos.

Mecanismo

é um componente de uma máquina que consiste de dois ou mais corpos arrançados de forma que o movimento de um produz o movimento dos outros

CONCEITO

Síntese

é um procedimento no qual um produto é projetado para satisfazer um conjunto de requisitos. Dado um conjunto de requisitos de performance, busca-se um mecanismo que satisfaça essas especificações

Análise de mecanismos

As dimensões de um mecanismo são dadas e deseja-se determinar suas características de movimento, verificação se os requisitos de performance são satisfeito

CONCEITO

Cinemática

estudo do movimento de mecanismos sem referência às forças que agem no sistema.

Dinâmica

é o estudo do movimento de corpos individuais e mecanismos sobre a influência de forças e torques

Exemplos de Mecanismos

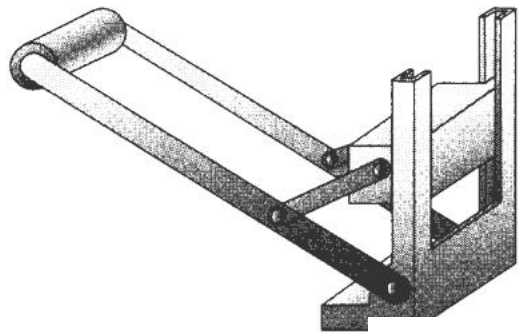

Amassador de latas

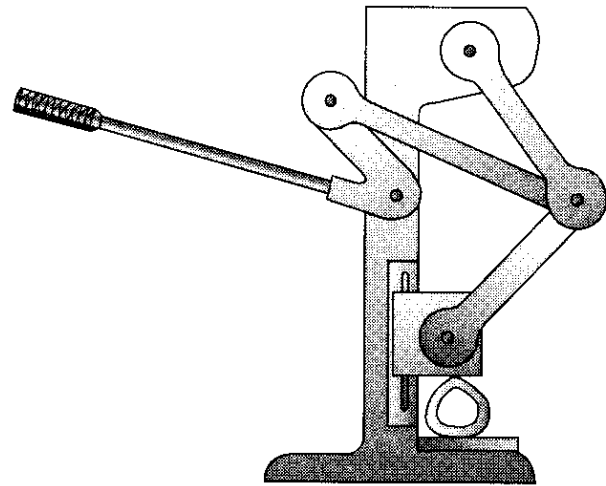

Prensa

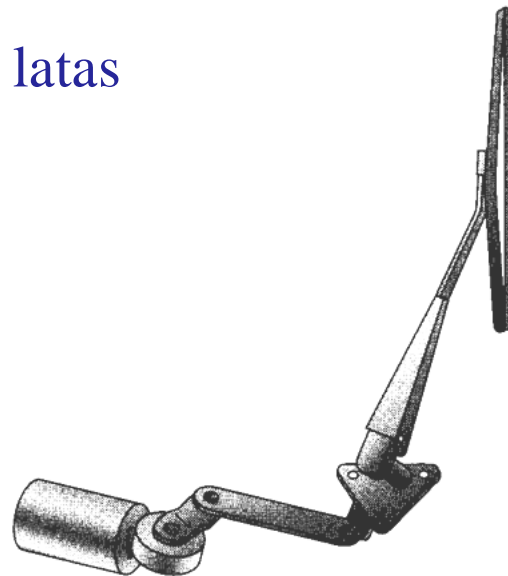

Limpador traseiro

Exemplos de Mecanismos

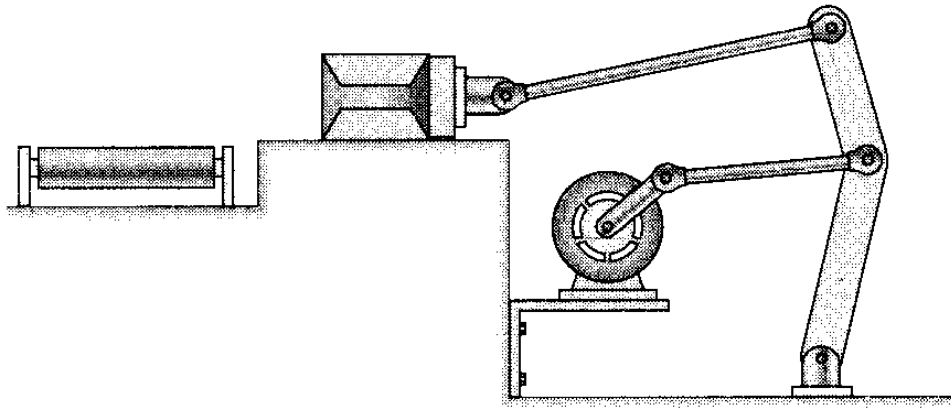

Move embalagens de uma bancada de montagem para uma esteira

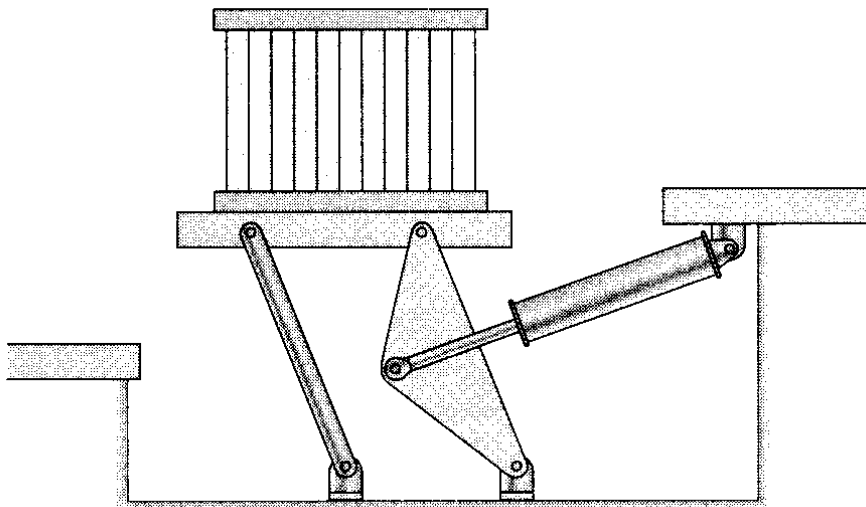

Plataforma de elevação

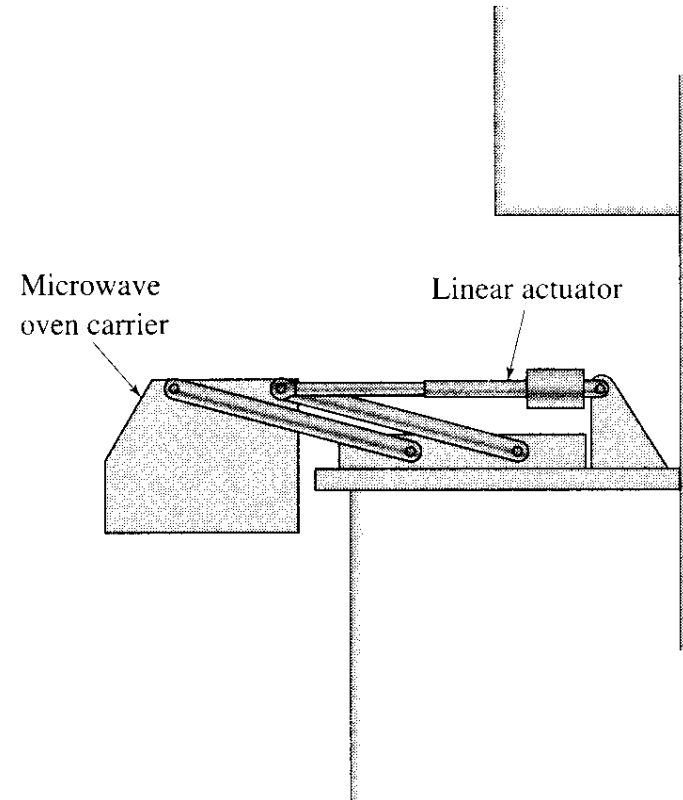

Suporte de microondas para atender pessoas em cadeira de rodas

Exemplos de Mecanismos

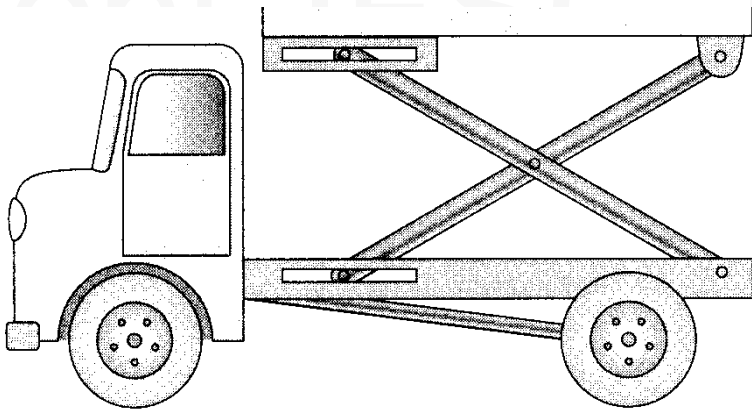

Plataforma de elevação

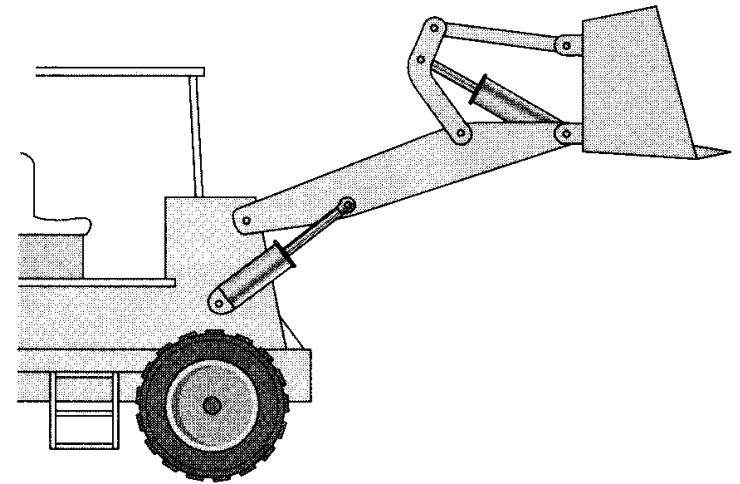

Pá-carregadeira

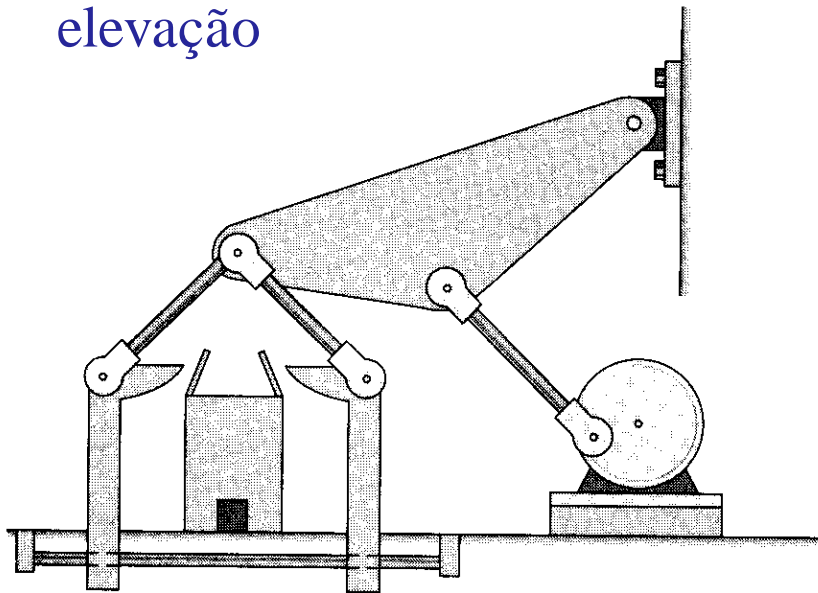

Dispositivo para fechar a tampa da caixa

Exemplos de Mecanismos

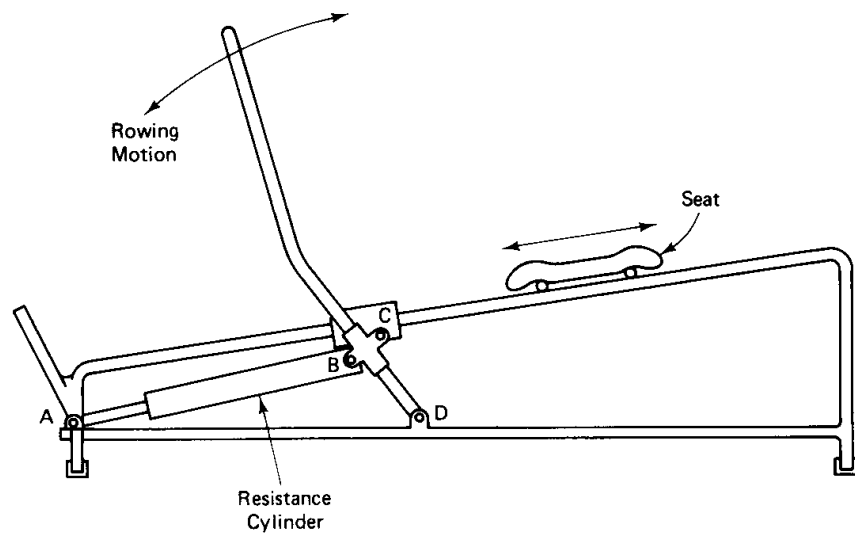

Máquina de academia

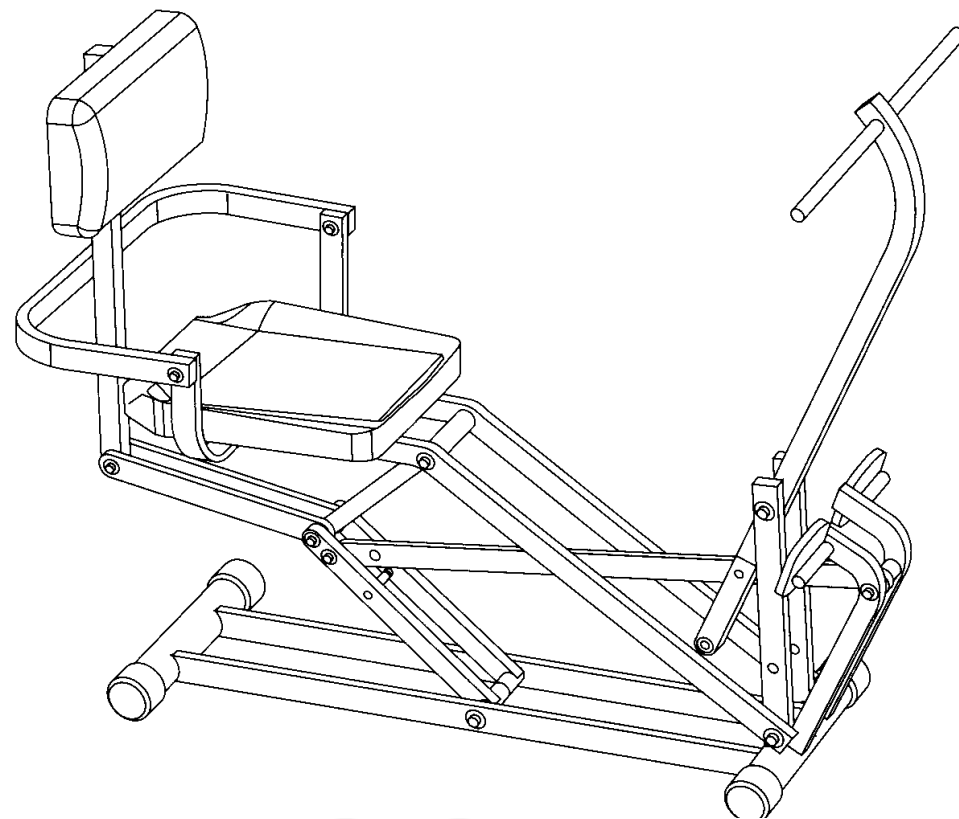

Projeto conceitual

Exemplos de Mecanismos

Posição
estendida

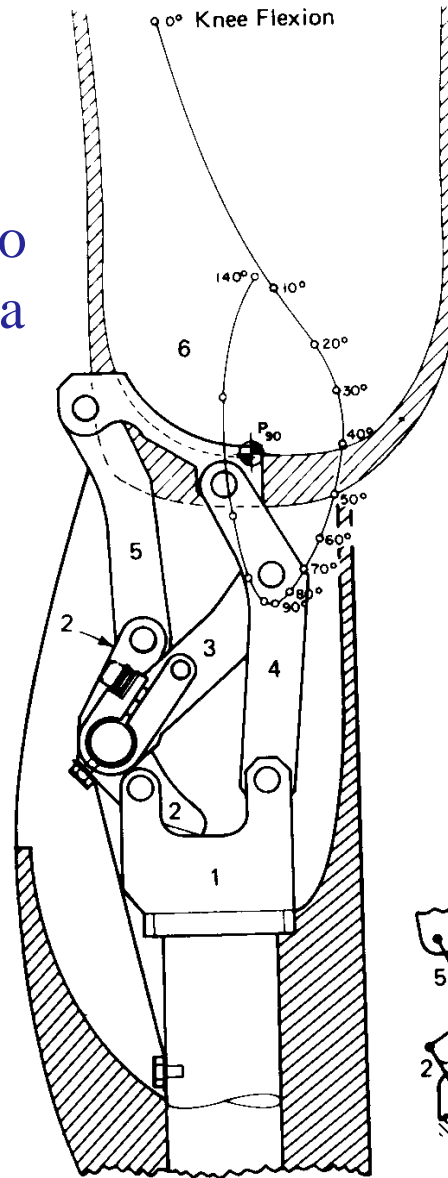

(a)

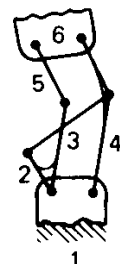

(b)

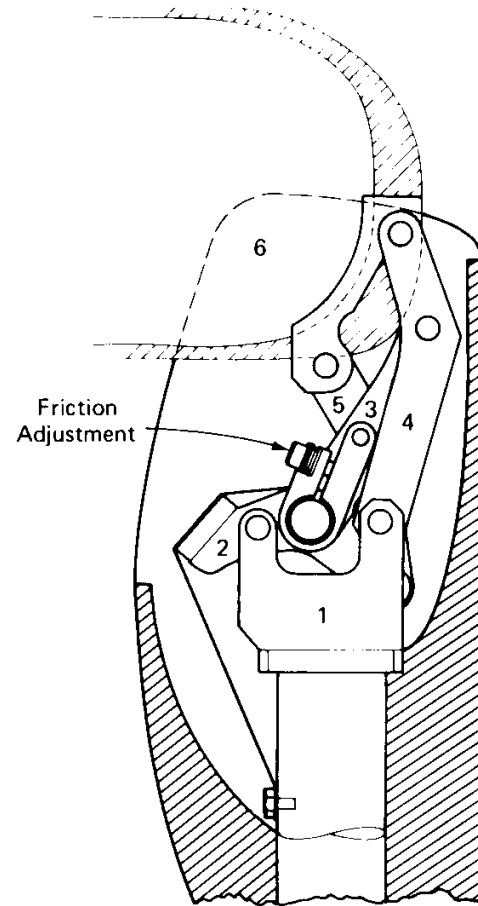

Posição
flexionada

Prótese de joelho com
mecanismo de seis barras

Mecanismo de quatro barras

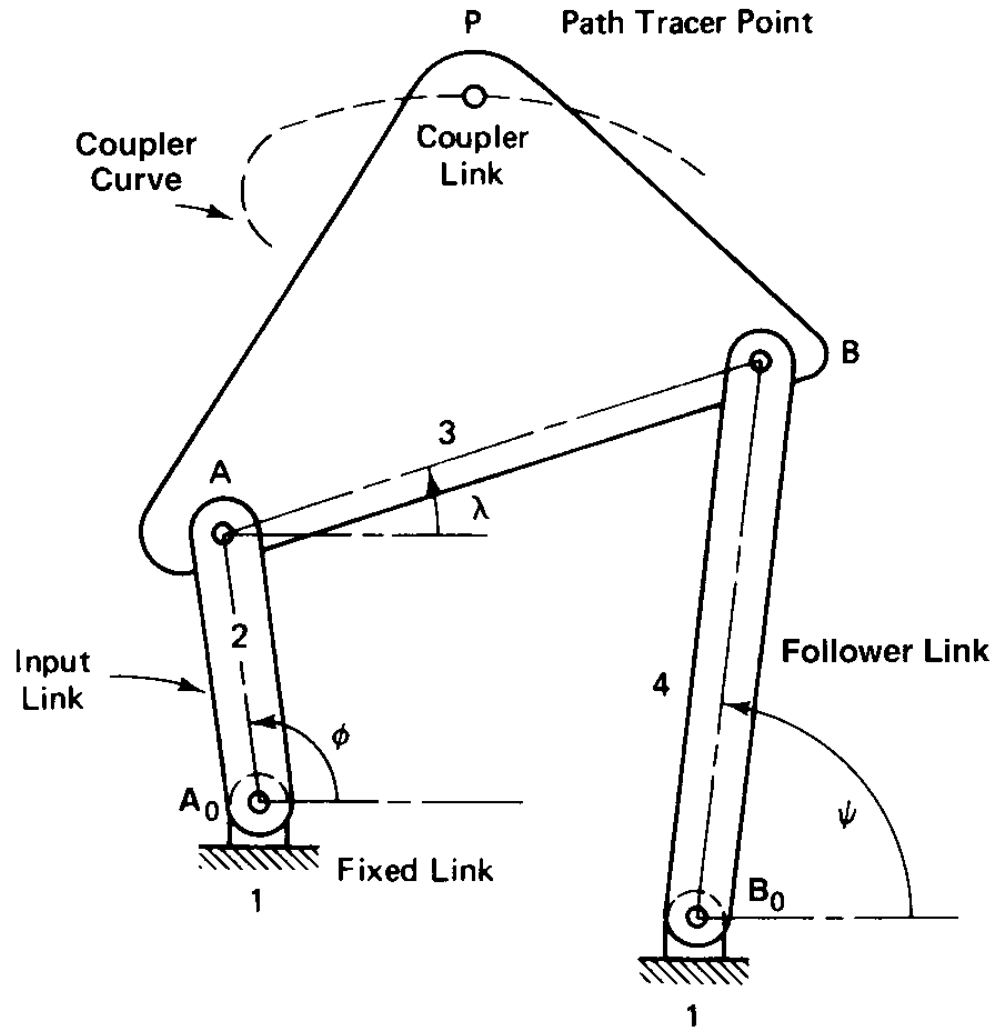

Mecanismo biela-manivela

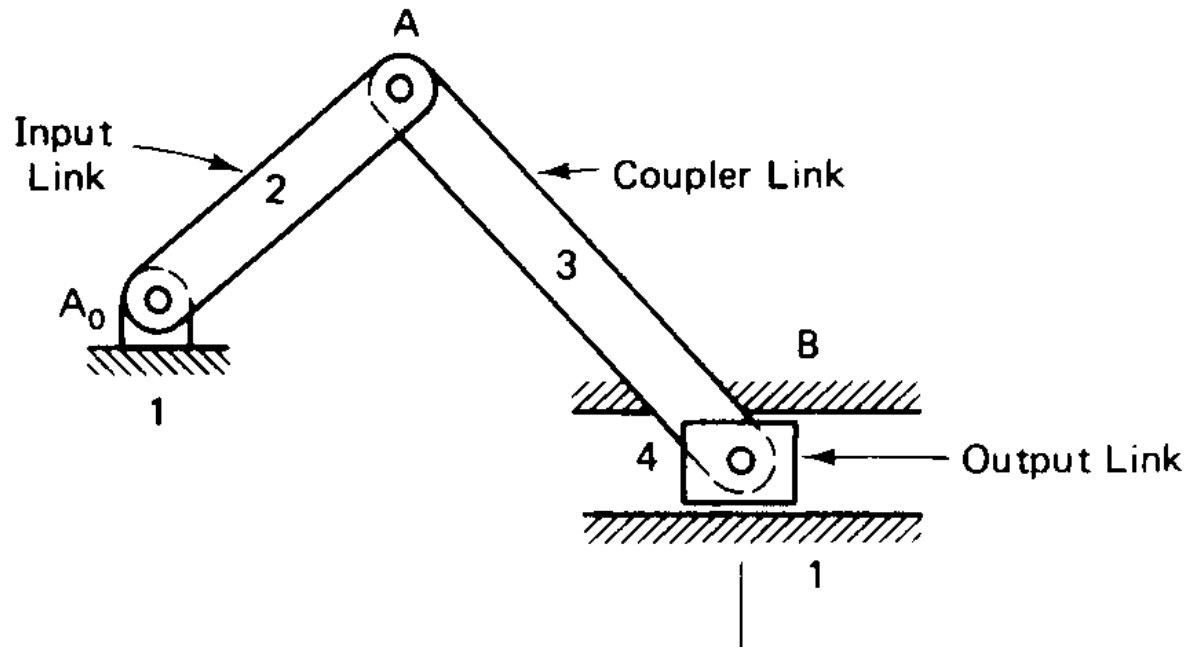

Pares cinemáticos

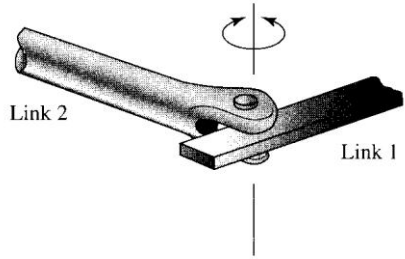

(a) Pin

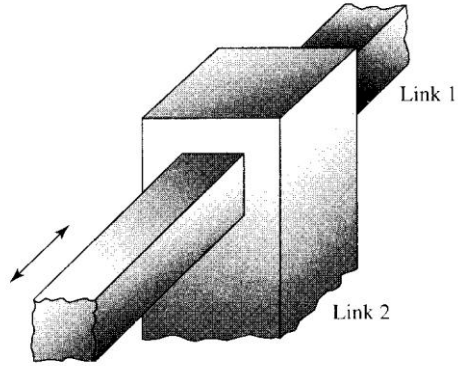

(b) Sliding

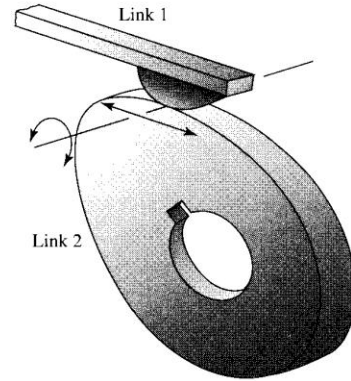

(a) Cam joint

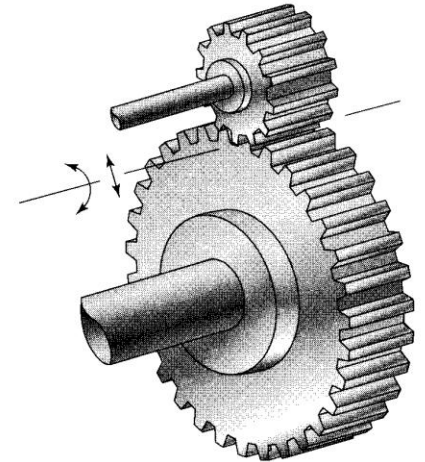

(b) Gear joint

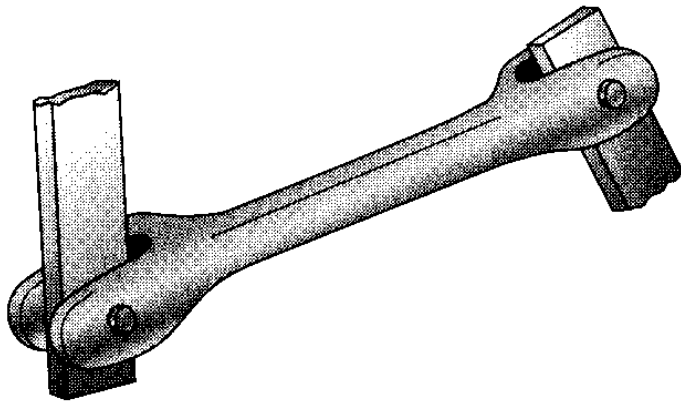

(a) Simple link

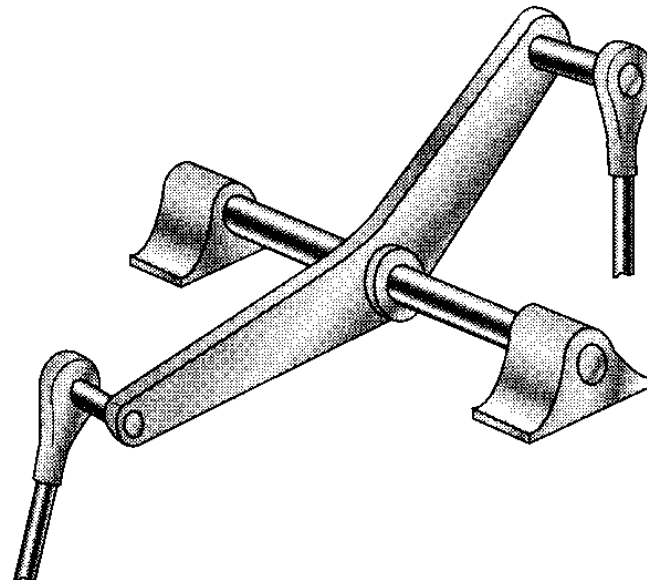

(b) Complex link

Tipos de movimento em mecanismos

A maioria das fontes de potência disponíveis possuem movimento rotacional puro (motor elétrico, manivela) ou translacional puro (cilindros hidráulicos e pneumáticos).

Translação para Translação

Wedge Cam Follower:
(Perpendicular)

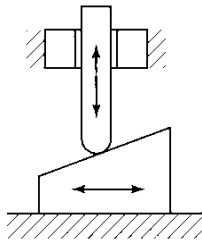

Wedge Cam Follower:
(Perpendicular)

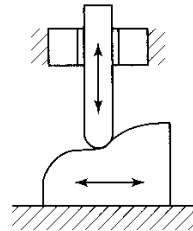

Wedge Cam Follower:
(Skew)

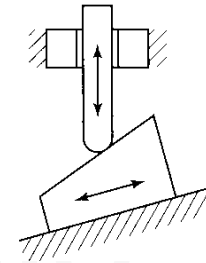

Wedge Cam Follower:
(Skew)

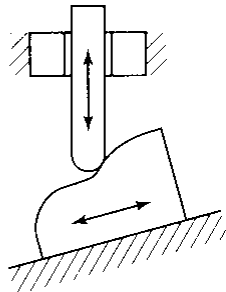

Double-slider:
(Perpendicular)

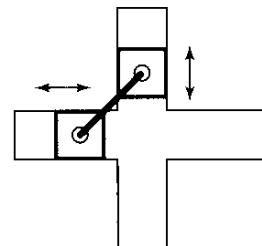

Double-slider:
(Skew)

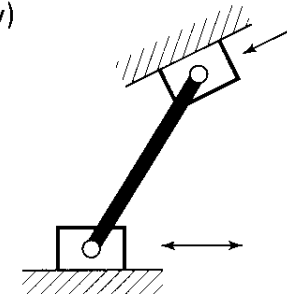

Tipos de movimento em mecanismos

Rotação para Rotação

Spur Gear:
(Parallel)

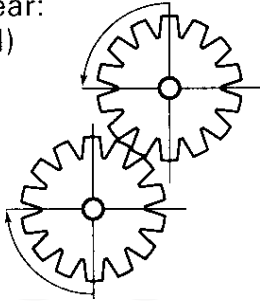

Bevel Gear:
(Perpendicular)

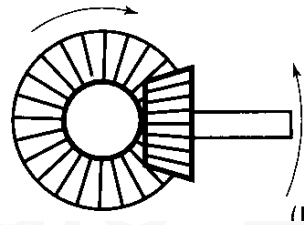

Worm Gear:
(Perpendicular)

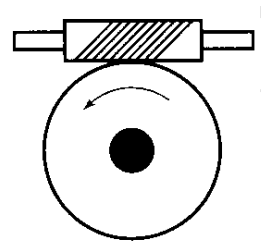

Friction Rollers Pair:
(Parallel)

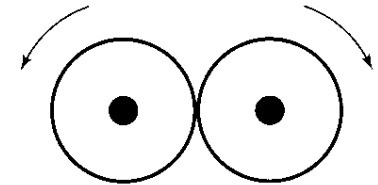

Crank-rocker:
(Parallel)

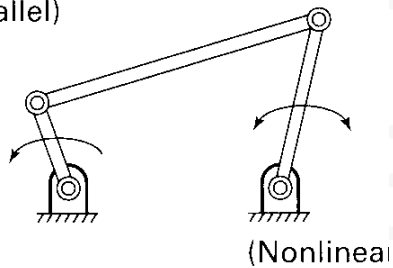

Double-crank:
(Parallel)

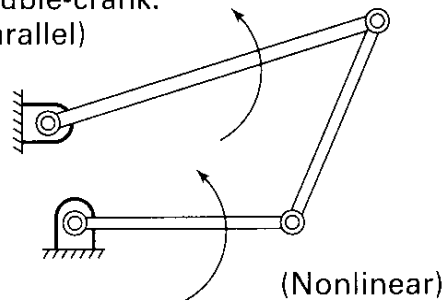

Pulley Belt:
(Parallel)

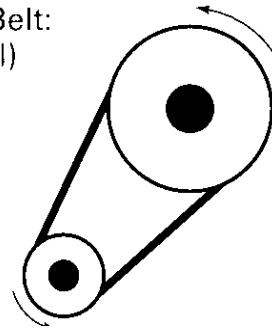

Sprocket and Chain:
Parallel)

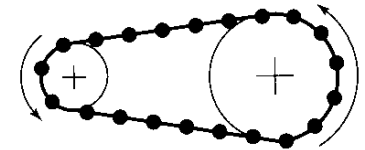

Noncircular Gear:
(Parallel)

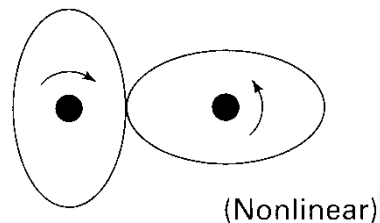

Geneva Wheel:
(Parallel)

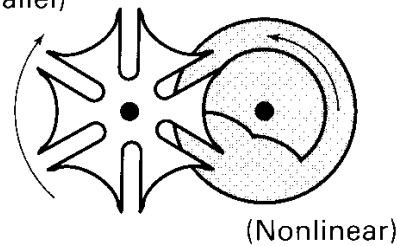

Tipos de movimento em mecanismos

Rotação para translação

Rack-pinion:
(Perpendicular)

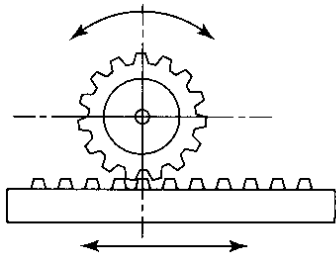

Screw Mechanism:
(Parallel)

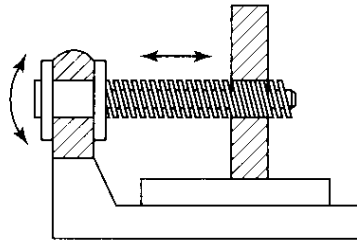

Cam Follower:
(Perpendicular)

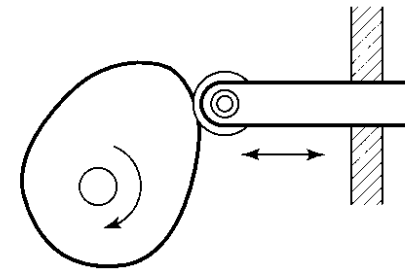

Slider-crank:
(Perpendicular)

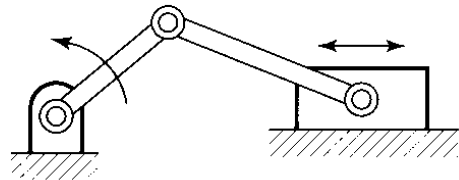

Six-bar Dwell Linkage:
(Perpendicular)

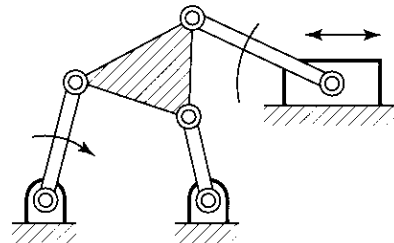

Cylindrical Cam Follower:
(Parallel)

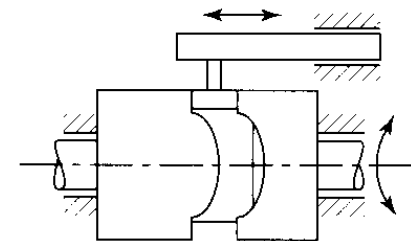

Categorias de Síntese de Mecanismos

Mecanismos para Geração de Função

Interessa o movimento relativo entre os elos.

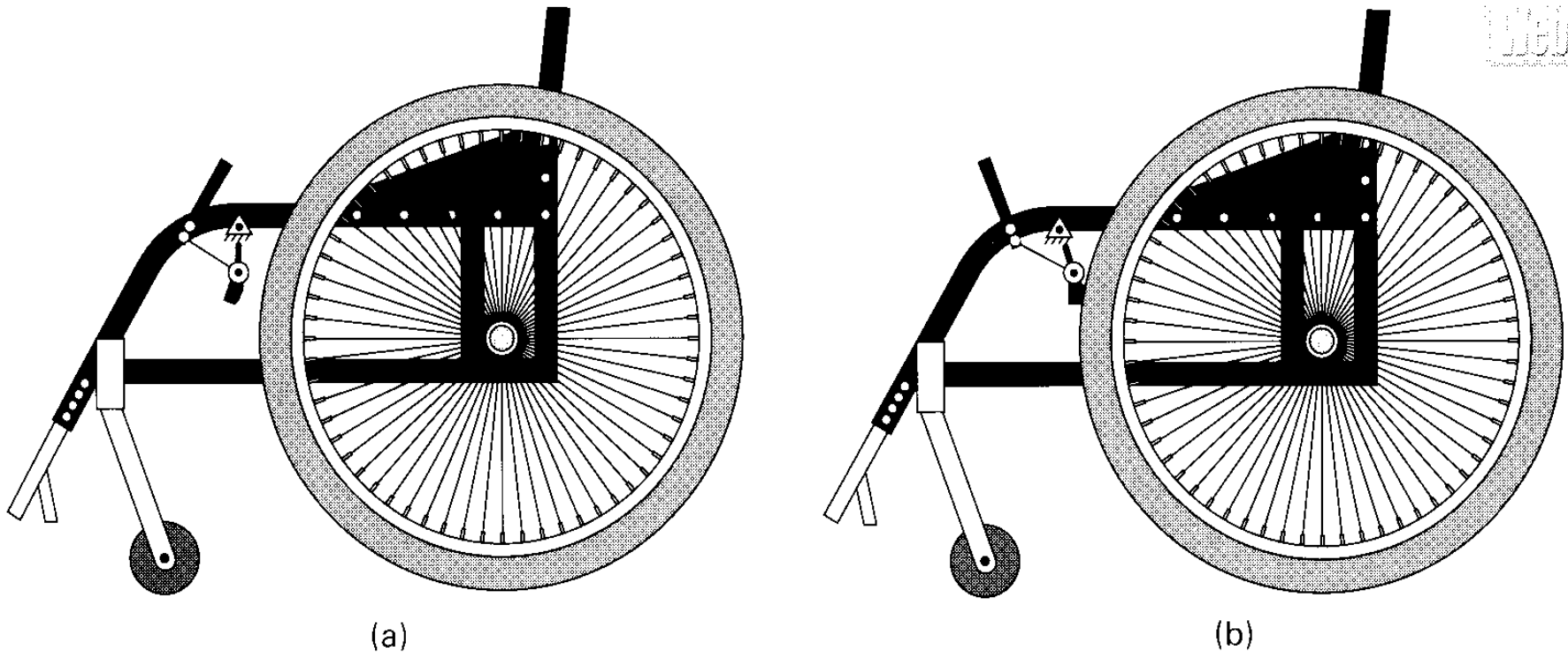

Mecanismo de quatro barras utilizado como freio de uma cadeira de rodas

Mecanismos para Geração de Função

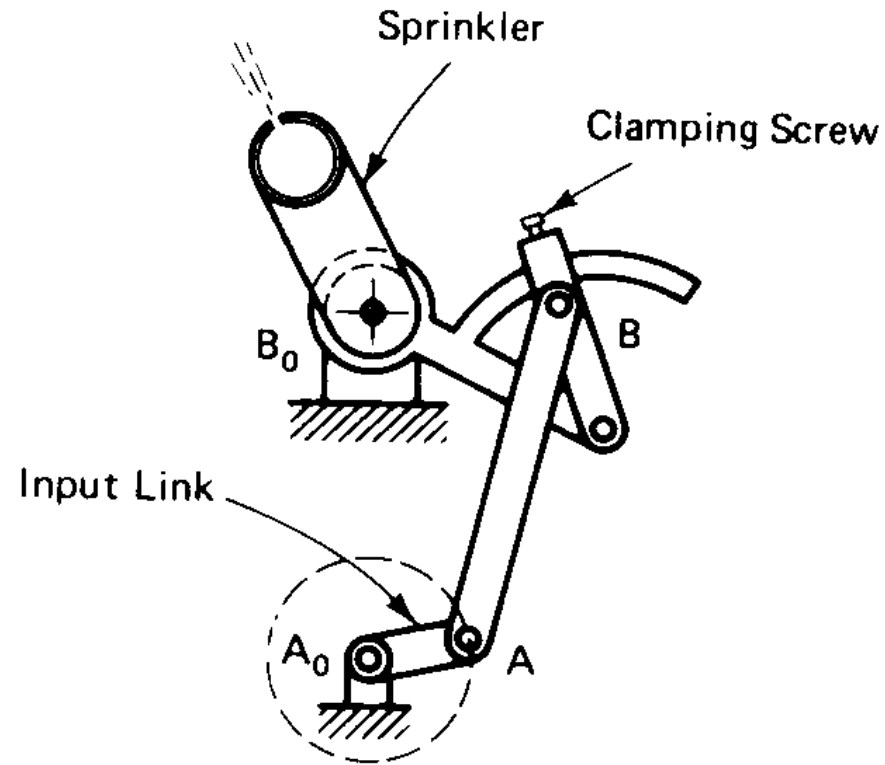

Mecanismo de quatro barras aplicado num irrigador de grama

Mecanismos para Geração de Movimento

Interessa o movimento do elo intermediário

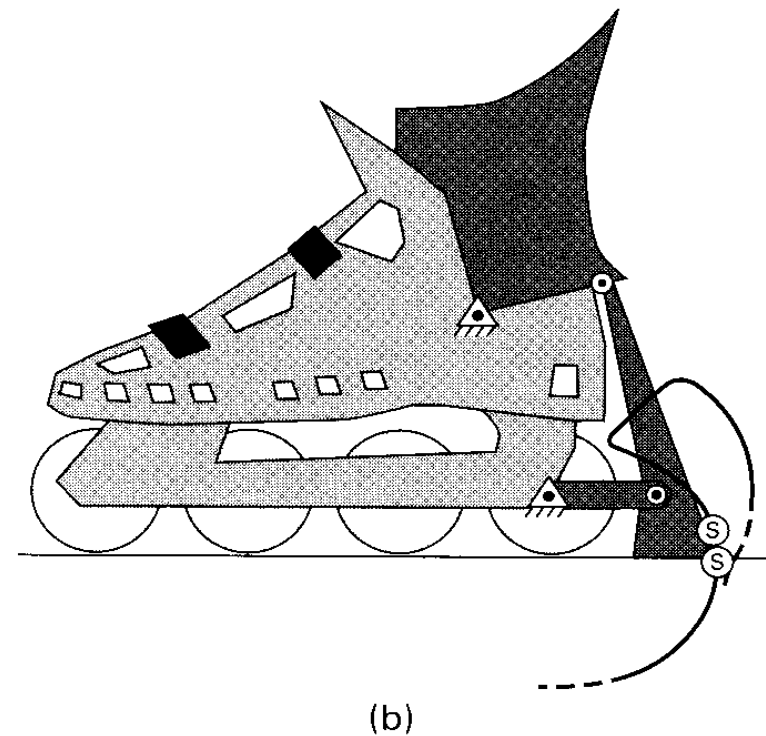
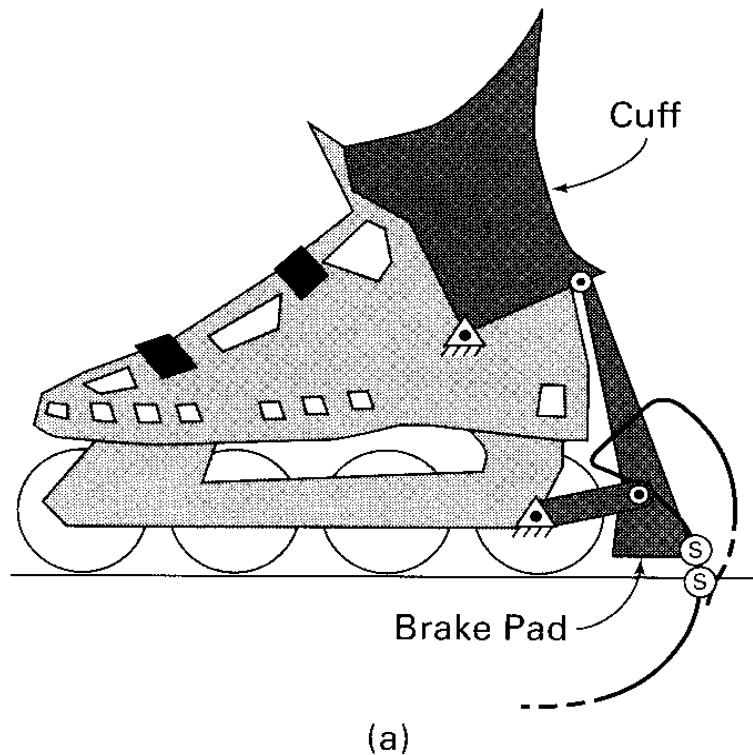

Sistema de freio para *roller*

Mecanismos para Geração de Movimento

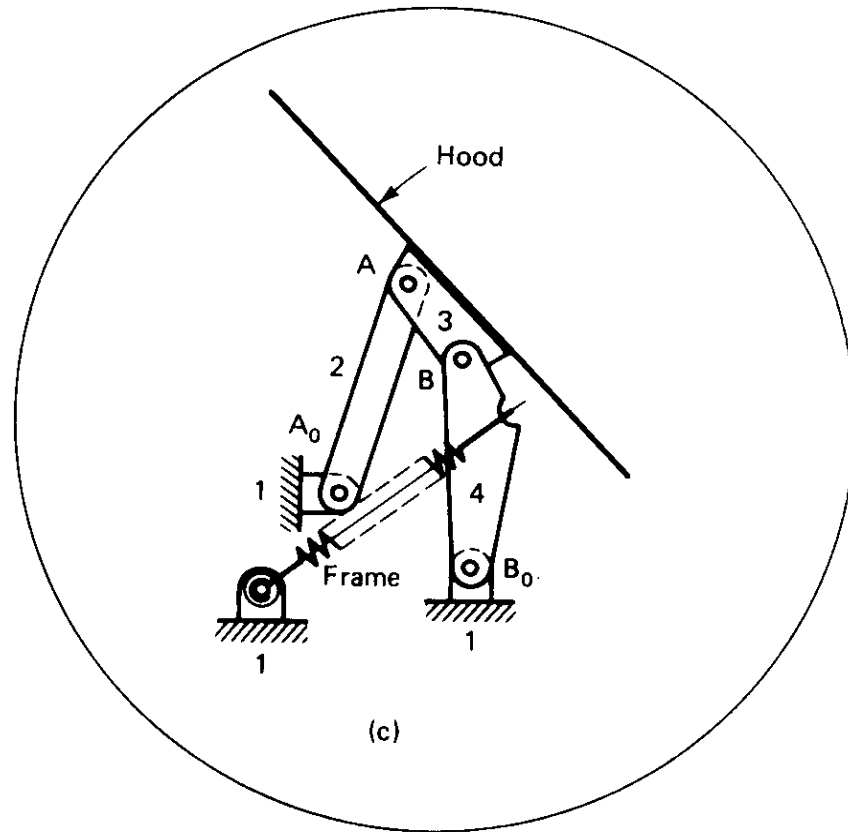
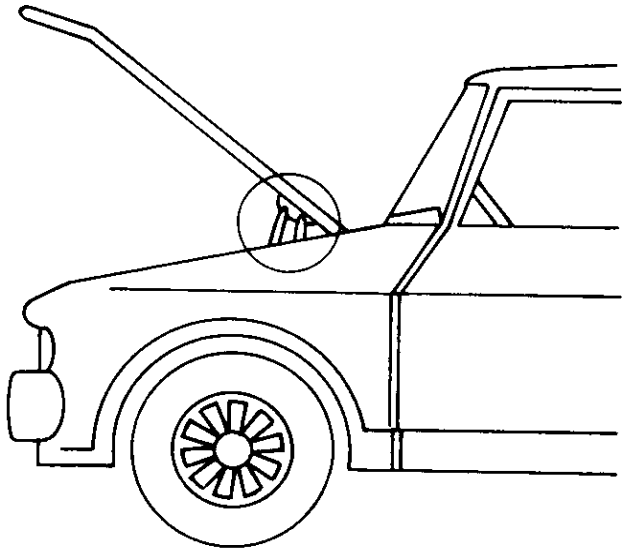

Mecanismo de quatro barras para abertura do compartimento do motor

Mecanismos para Geração de Percurso

Interessa o percurso de um ponto isolado (ponto de interesse)

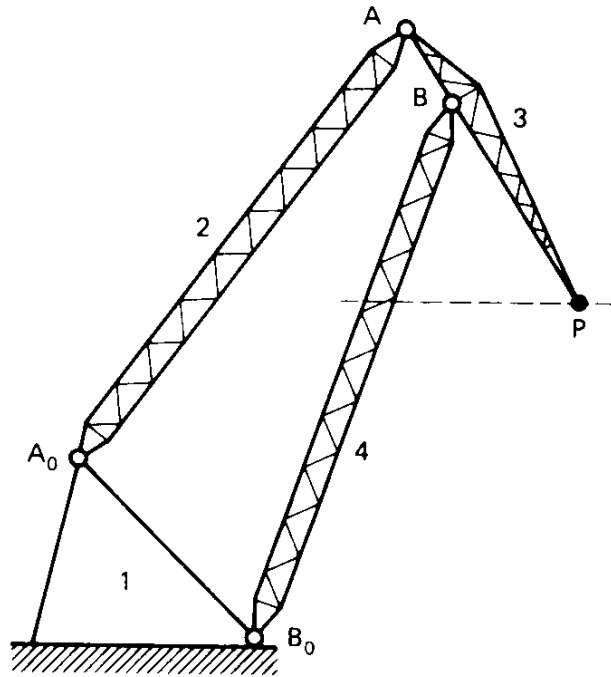

Guindaste – movimento em linha reta

Cames

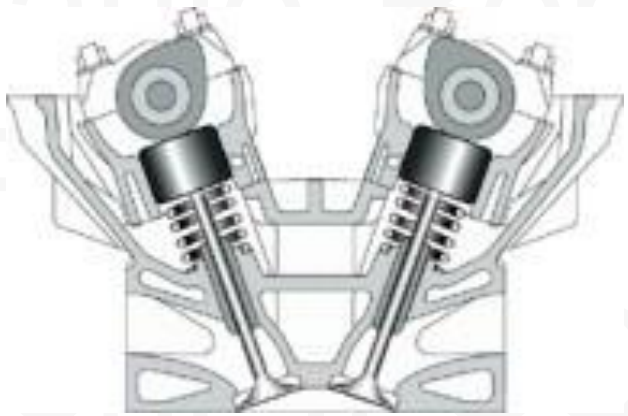

Cames

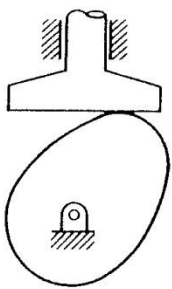

(a) Flat-faced, Translating Follower

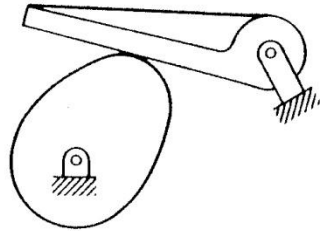

(b) Flat-faced, Pivoted Follower

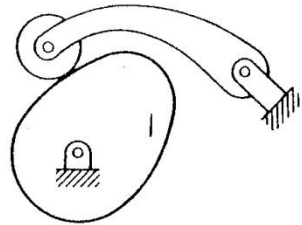
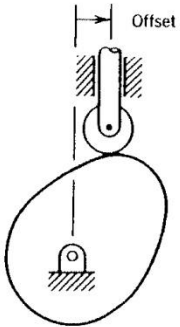

(c) 0
FIGURE

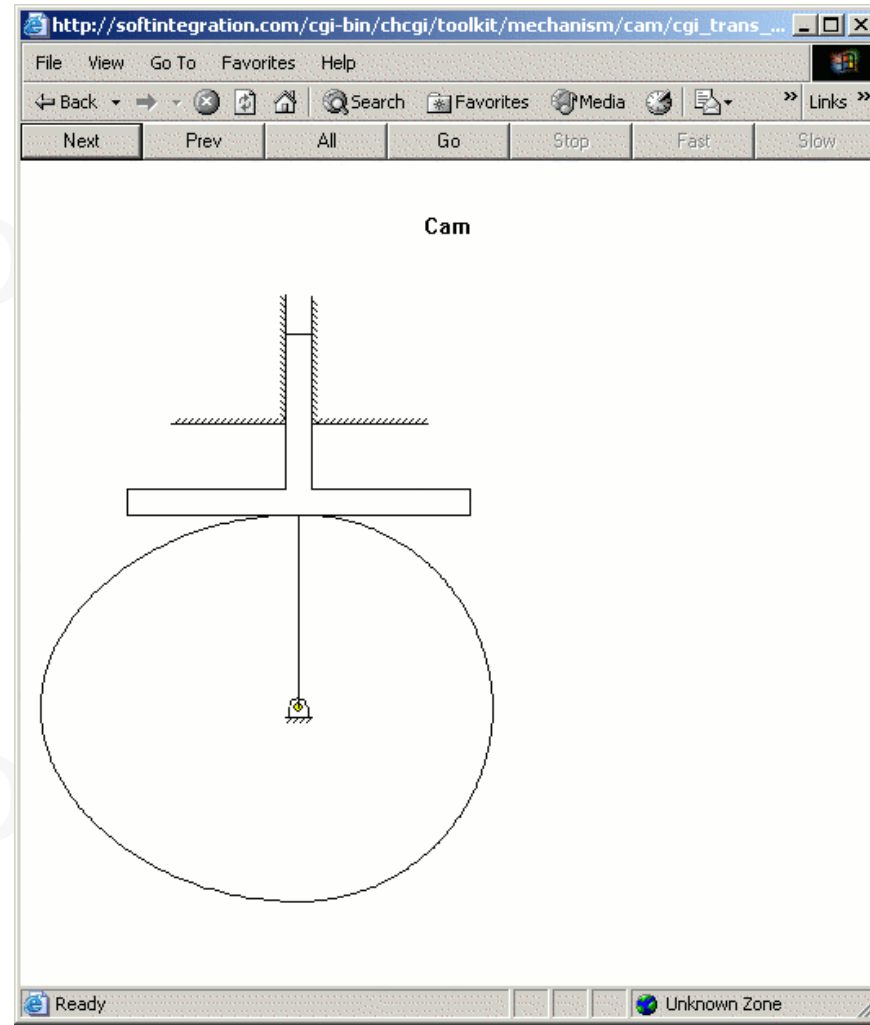
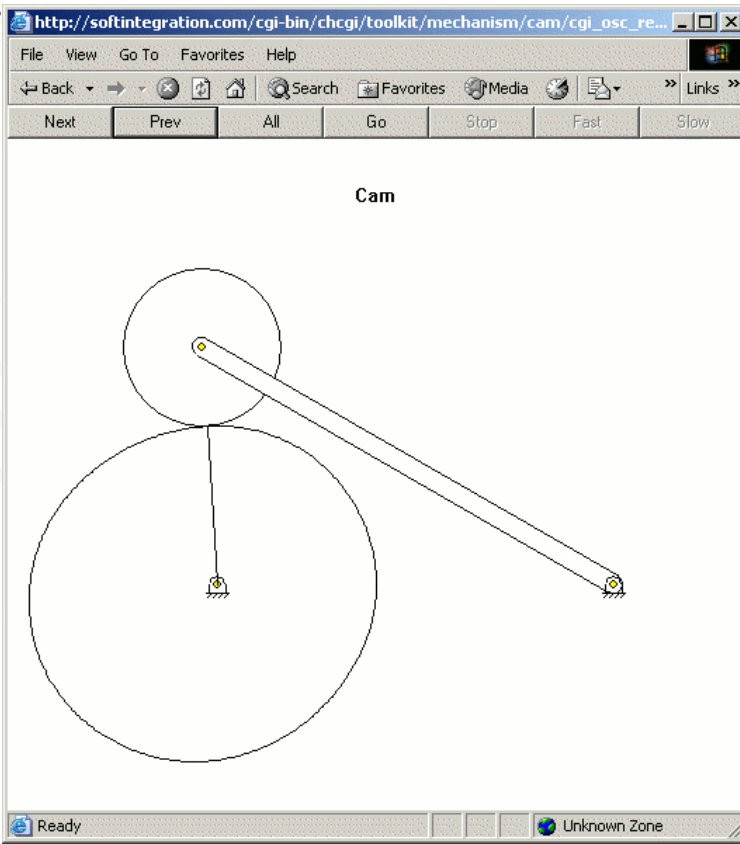

Engrenagens

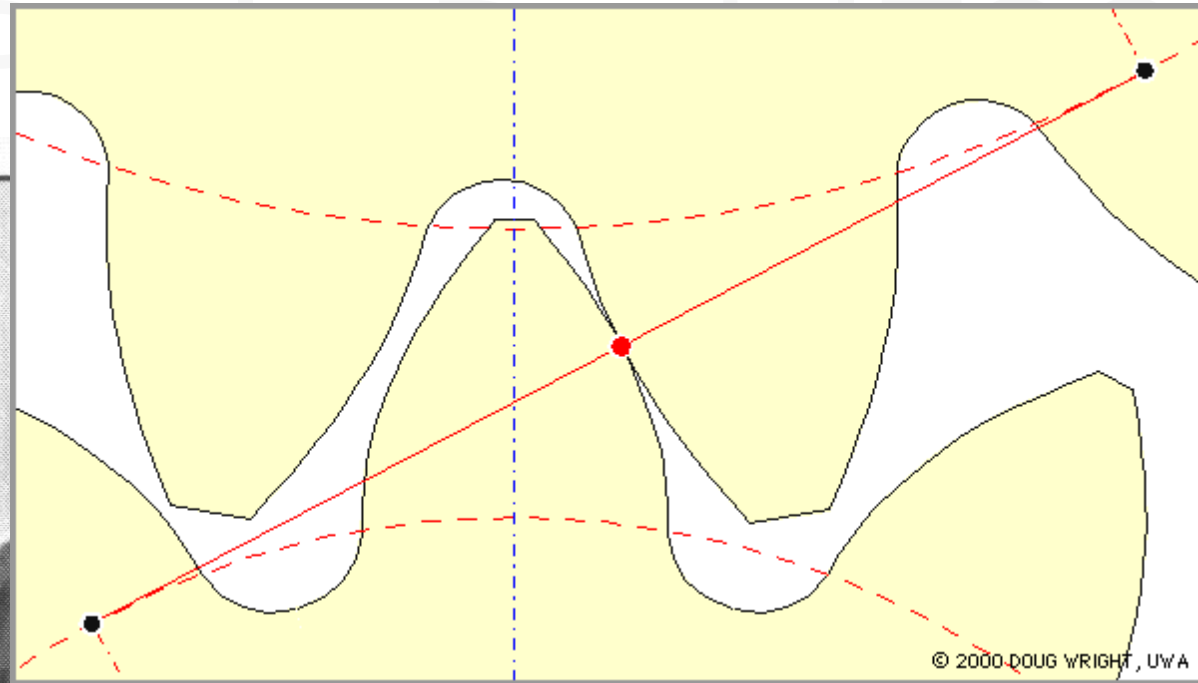
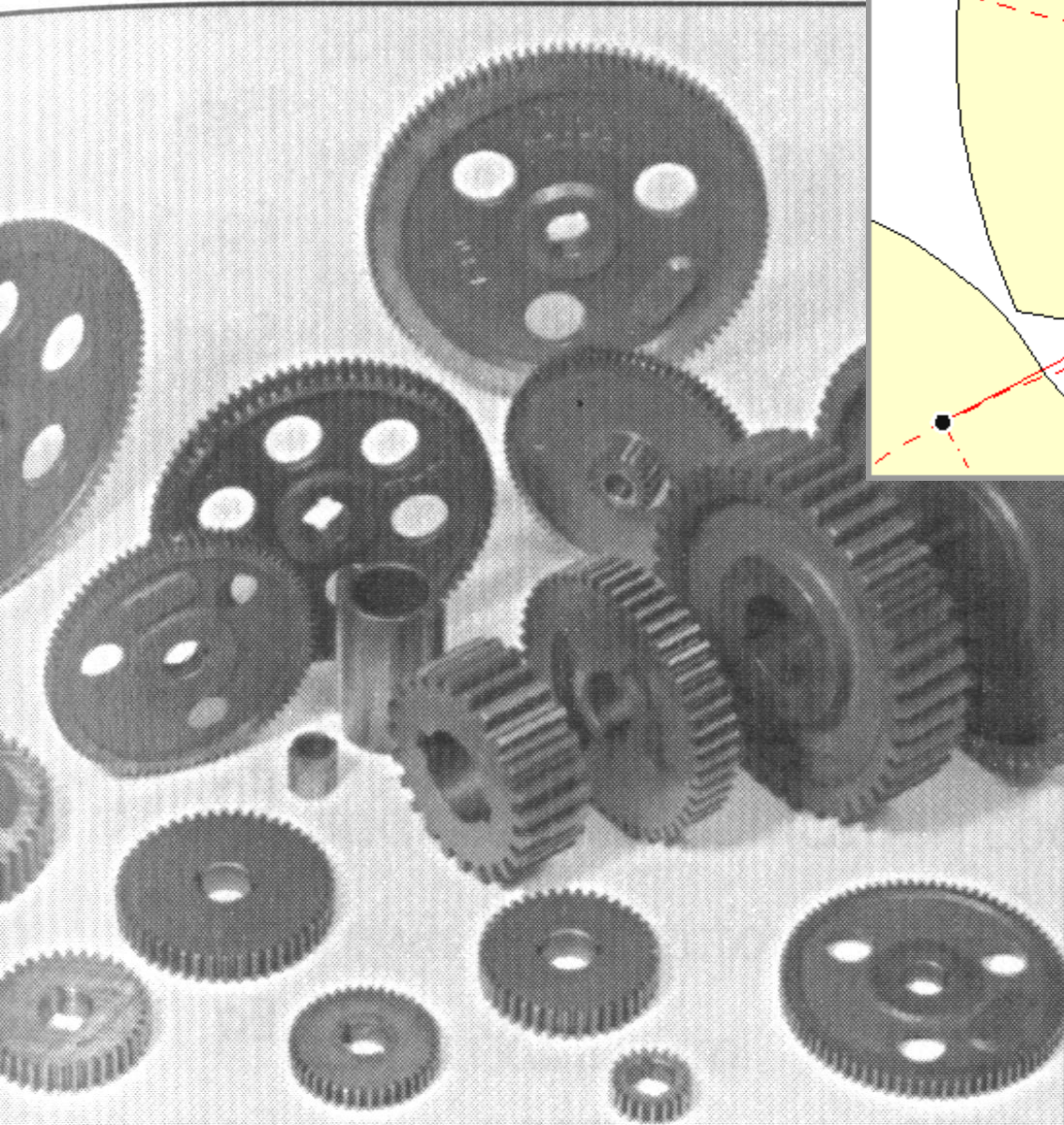

Engrenagens



FIGURA 11-10

Tamanhos verdadeiros de dentes de engrenagem para vários passos diametraes de referênciã. (Cortesia da Barber-Colman Co, Loves Park, Ill.)

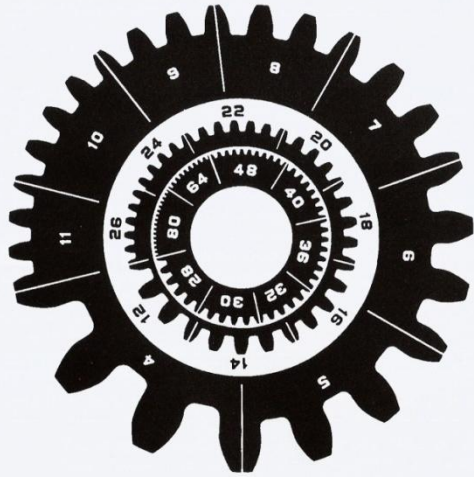
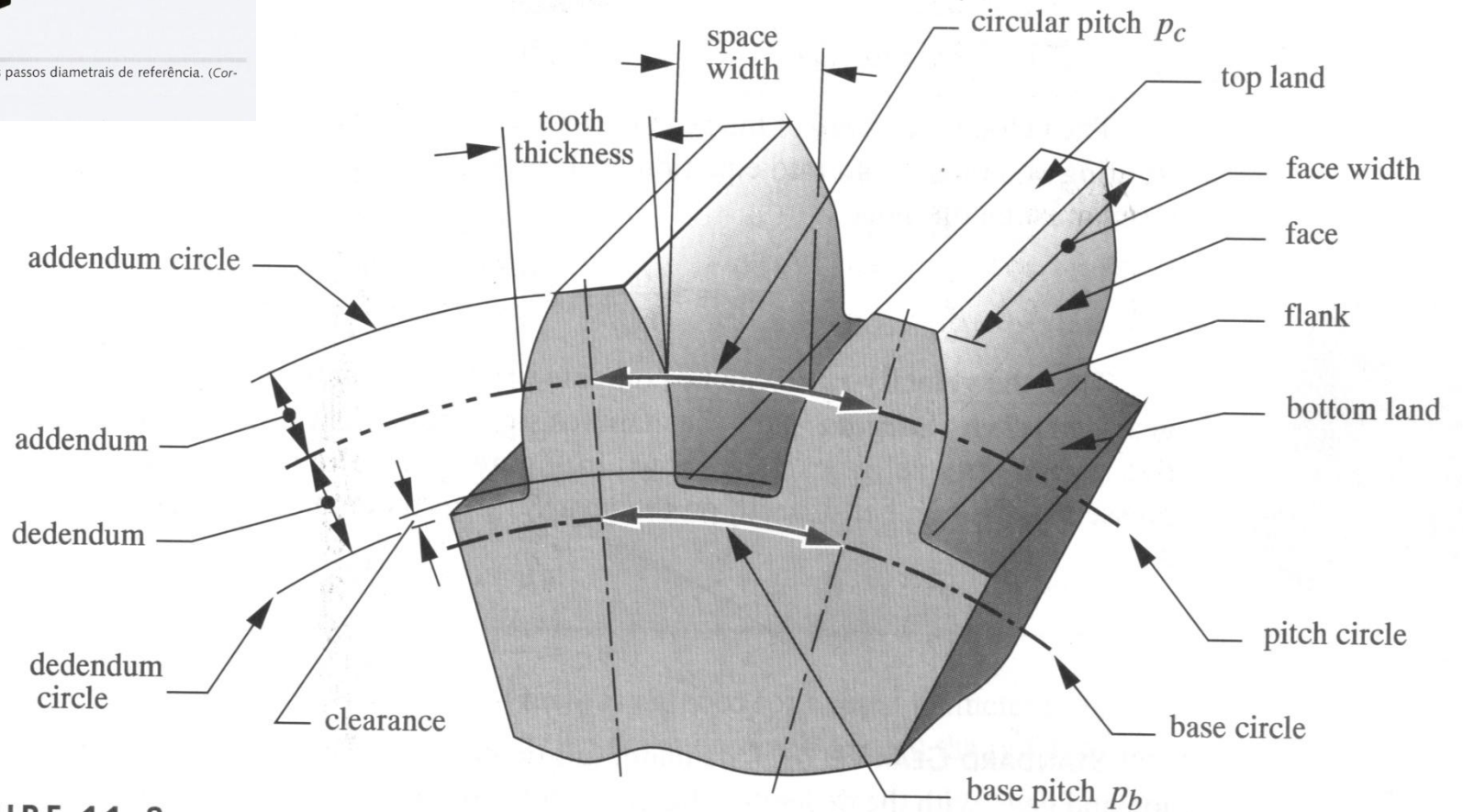
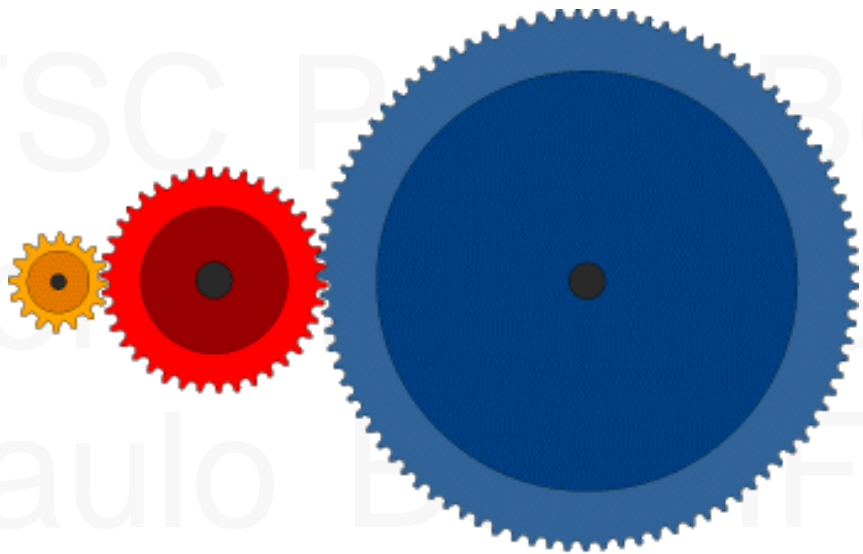

FIGURE 11-8

Gear Tooth Nomenclature

Engrenagens



©2000 How Stuff Works

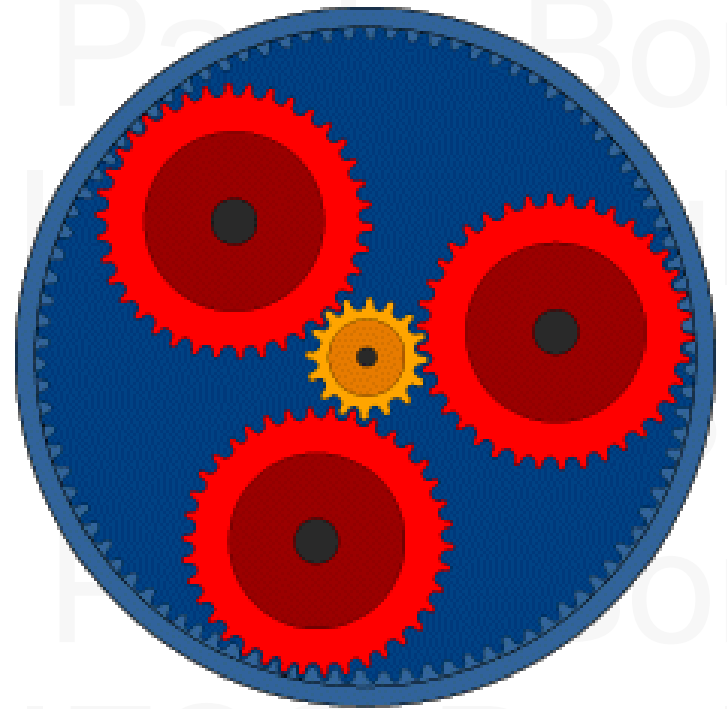

©2000 How Stuff Works

Avaliações

- Avaliações
- 5 Avaliações Escritas
- 1 Avaliação através de seminário

Horário do professor

	TURNO	Seg	Ter	Qua	Quin	Sex
	TARDE					
(18:15 - 20:20) Intervalo (20:40 - 22:45)	NOITE (18:15 - 20:22) (20:40 - 22:45)			Matemática	Mecanismos e Dinâmica de Máquinas	DESENHO II (Cláudio)
			MEC 2	MEC 1	Matemática	MEC 1

Plano de Aula

Unidade Curricular: Mecanismos e dinâmica das máquinas	Carga horária: 40h	Módulo VI
Código: MDM62		
Competências	Habilidades	
Analisar cinematicamente e dinamicamente mecanismos.	Reconhecer, analisar, especificar e sintetizar mecanismos.	
Bases Científicas e Tecnológicas		
<ul style="list-style-type: none">- Conceitos e notações aplicadas a mecanismos;- Tipos de mecanismos;- Conceitos elementares de síntese dimensional de mecanismos articulados- Análise cinemática de cames planos e engrenagens de dentes retos e helicoidais;- Análise gráfica de velocidades;- Análise gráfica de acelerações;- Dinâmica dos cames;- Análise cinemática e síntese.- Dinâmica de Máquinas		

Material de apoio

- **Bibliografia**

Cinemática e Dinâmica dos Mecanismos, Mc Graw Hill
ROBERT L. NORTON

Mecanismos e Dinâmica das Máquinas. IE-WILEY ,1987.
HAMINTON H. MABIE e FRED W. O.

Theory of machines and mechanisms. Oxford USA Trade, 2003.
SHIGLEY, J. E.; UICKER JR., J. J.; PENNOCK, G.

Vibrações Mecânicas, [Pearson Education - Br](#)
SINGIRESU S. RAO

Vibrações Mecânicas
Arthur Palmeira Ripper Neto

- **Internet**

Programas genéricos

Design View

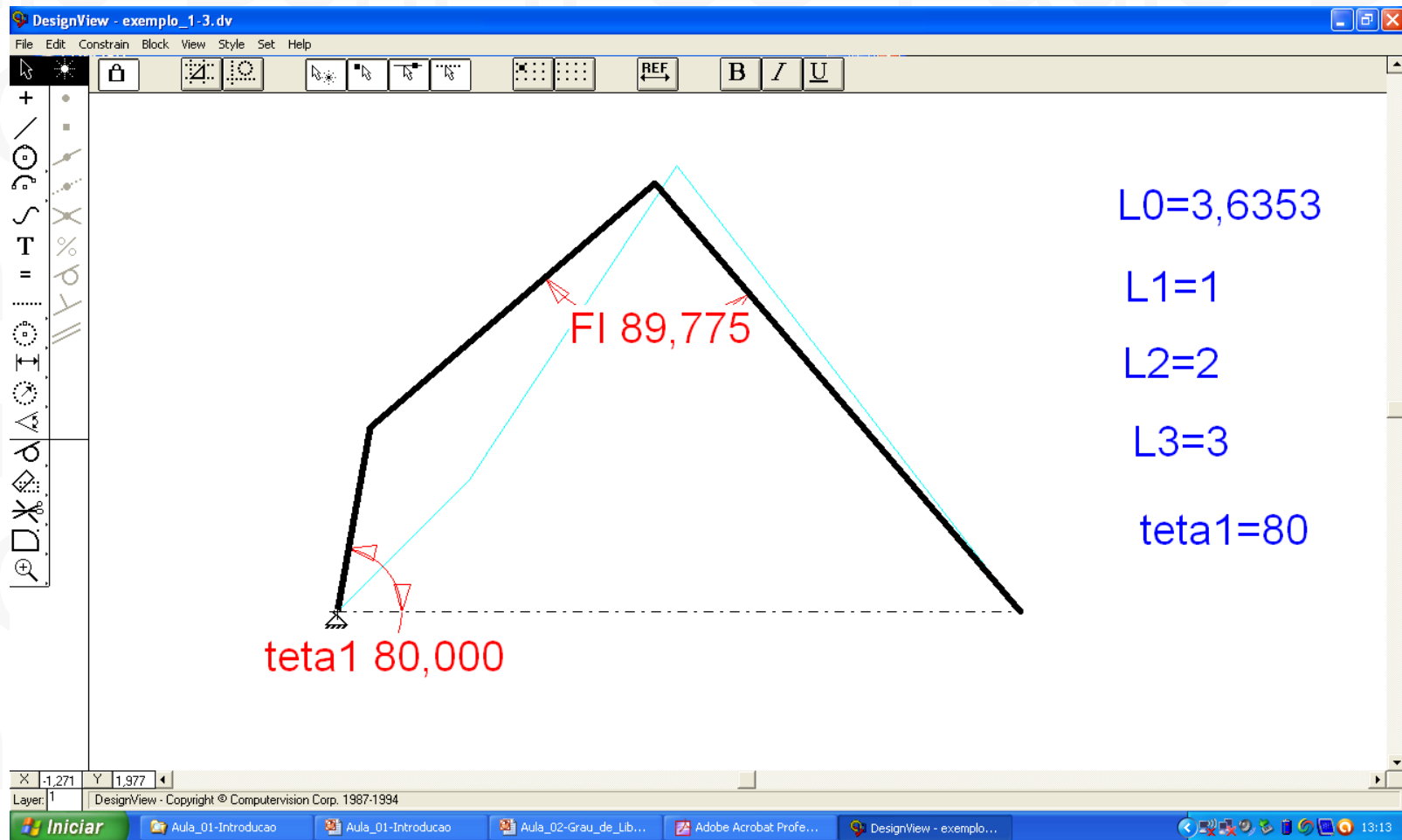

Programas genéricos

Mathcad

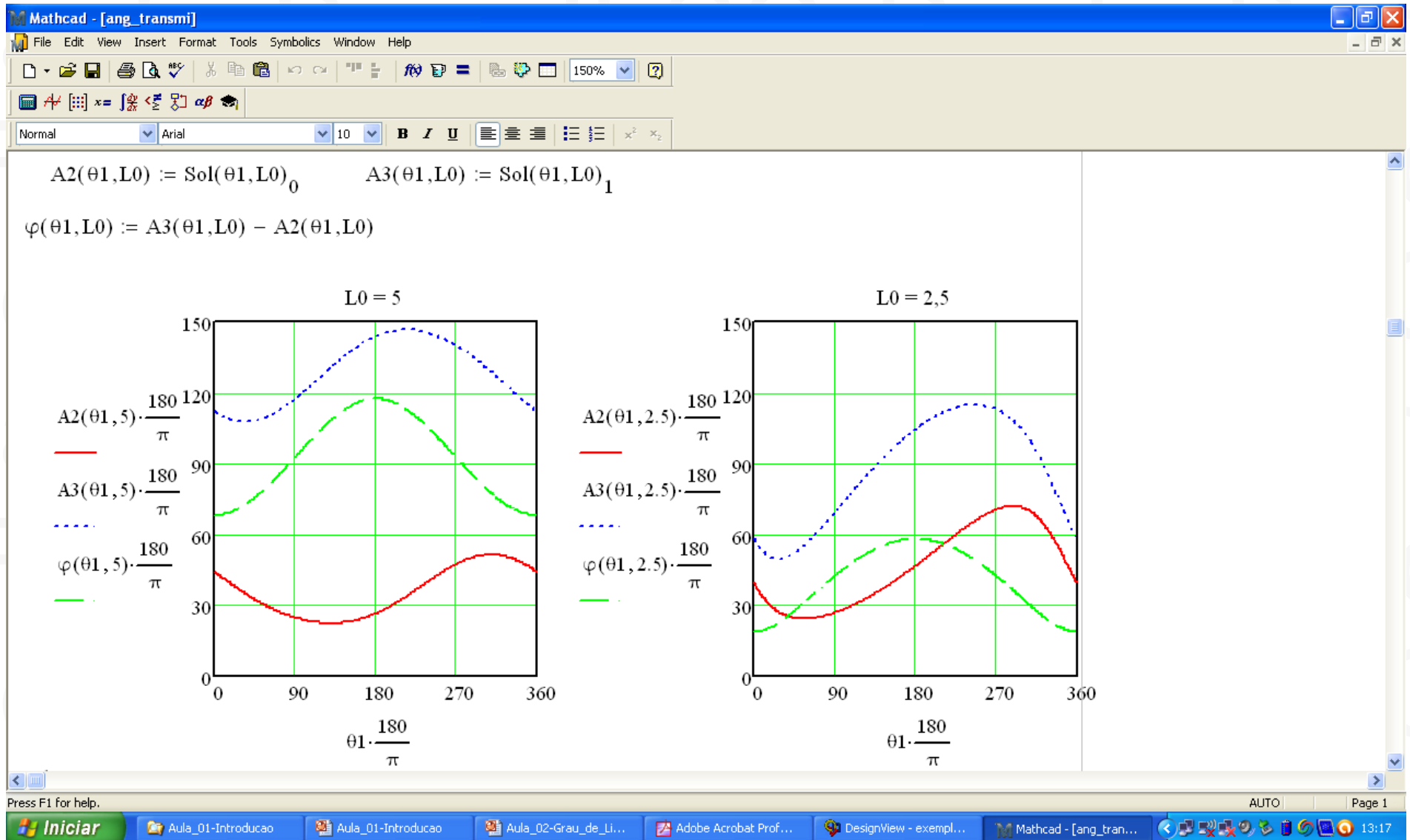

Programas de modelagem 3D

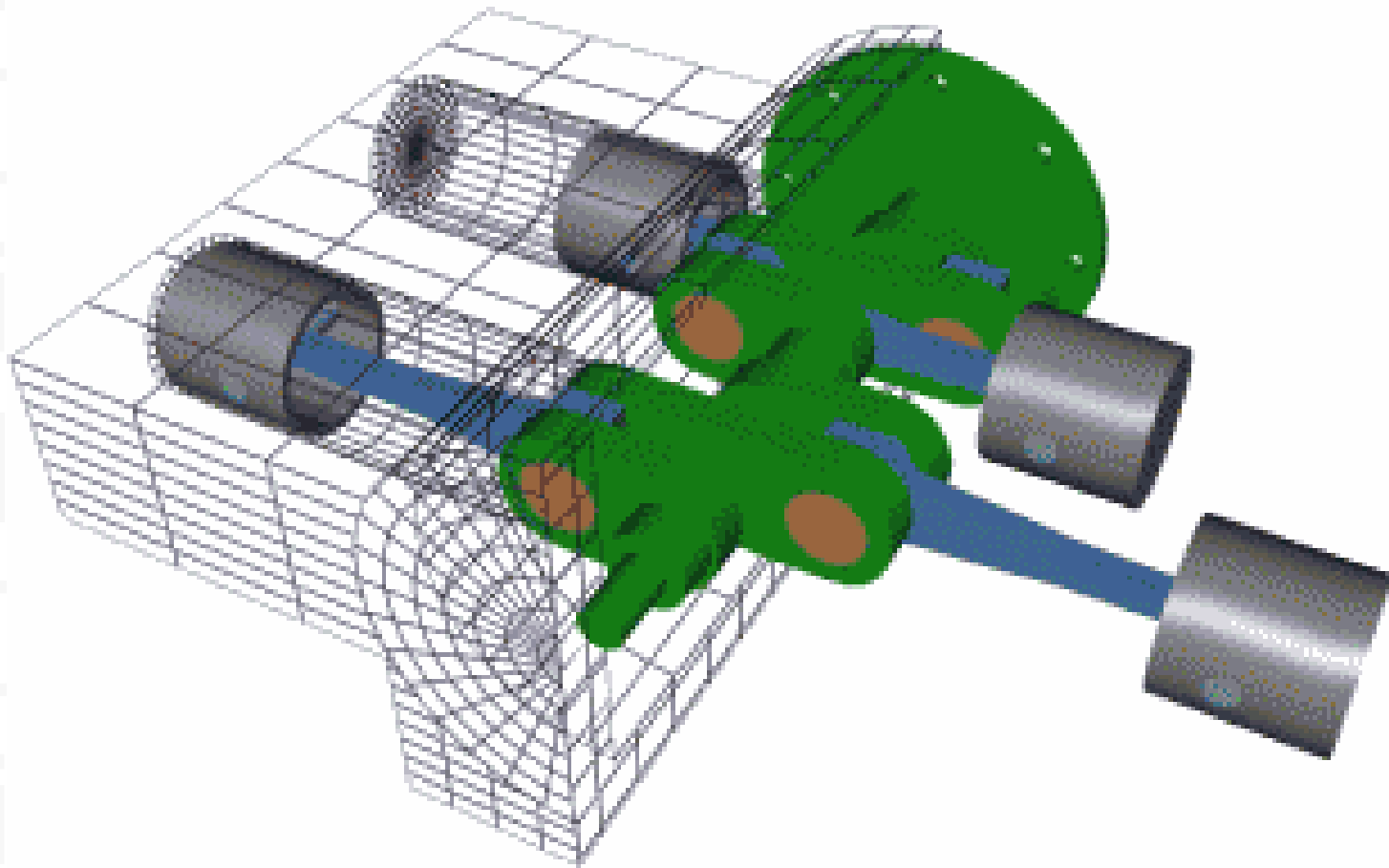

Programas de modelagem 3D

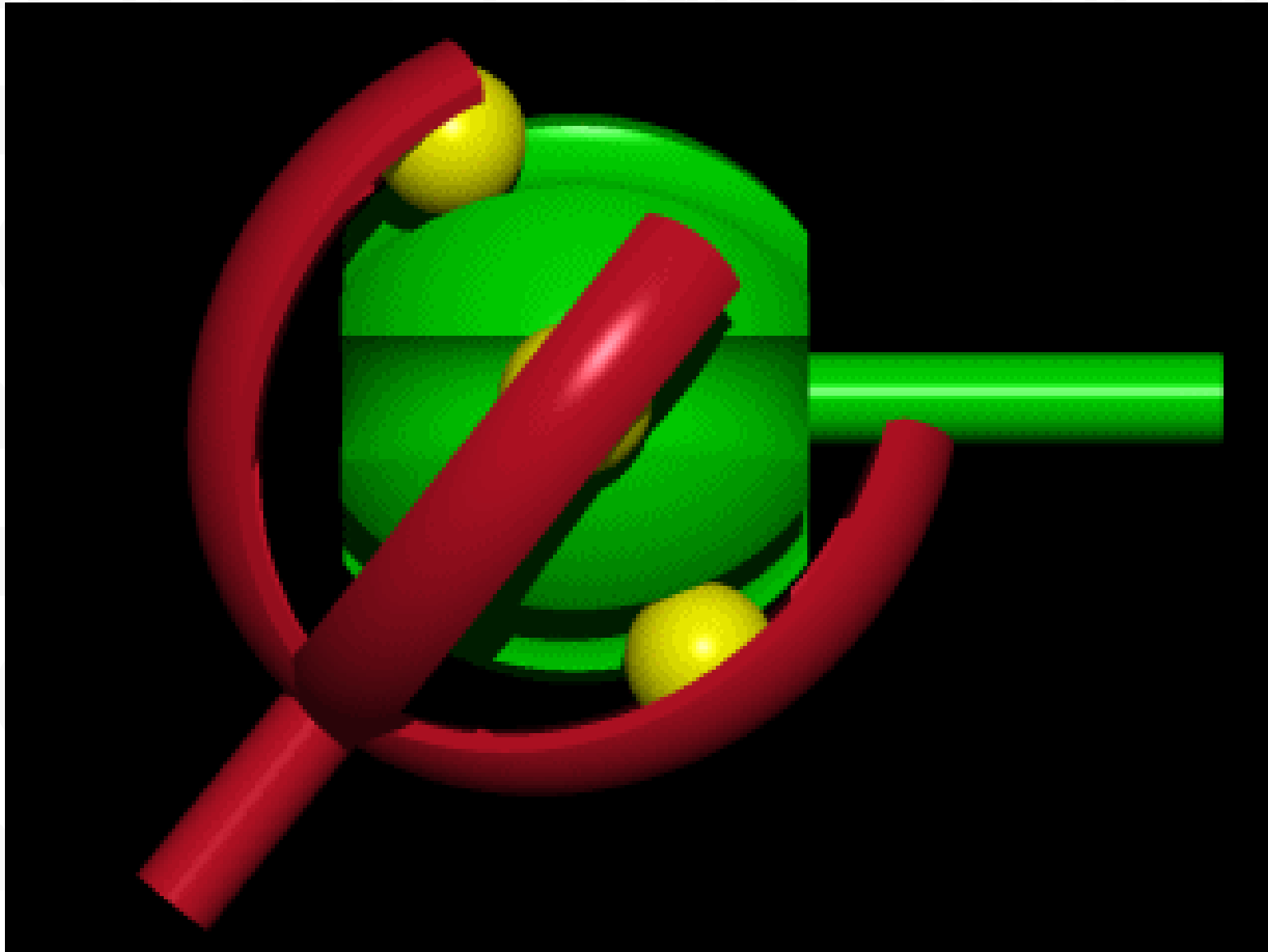

Programas de modelagem 3D

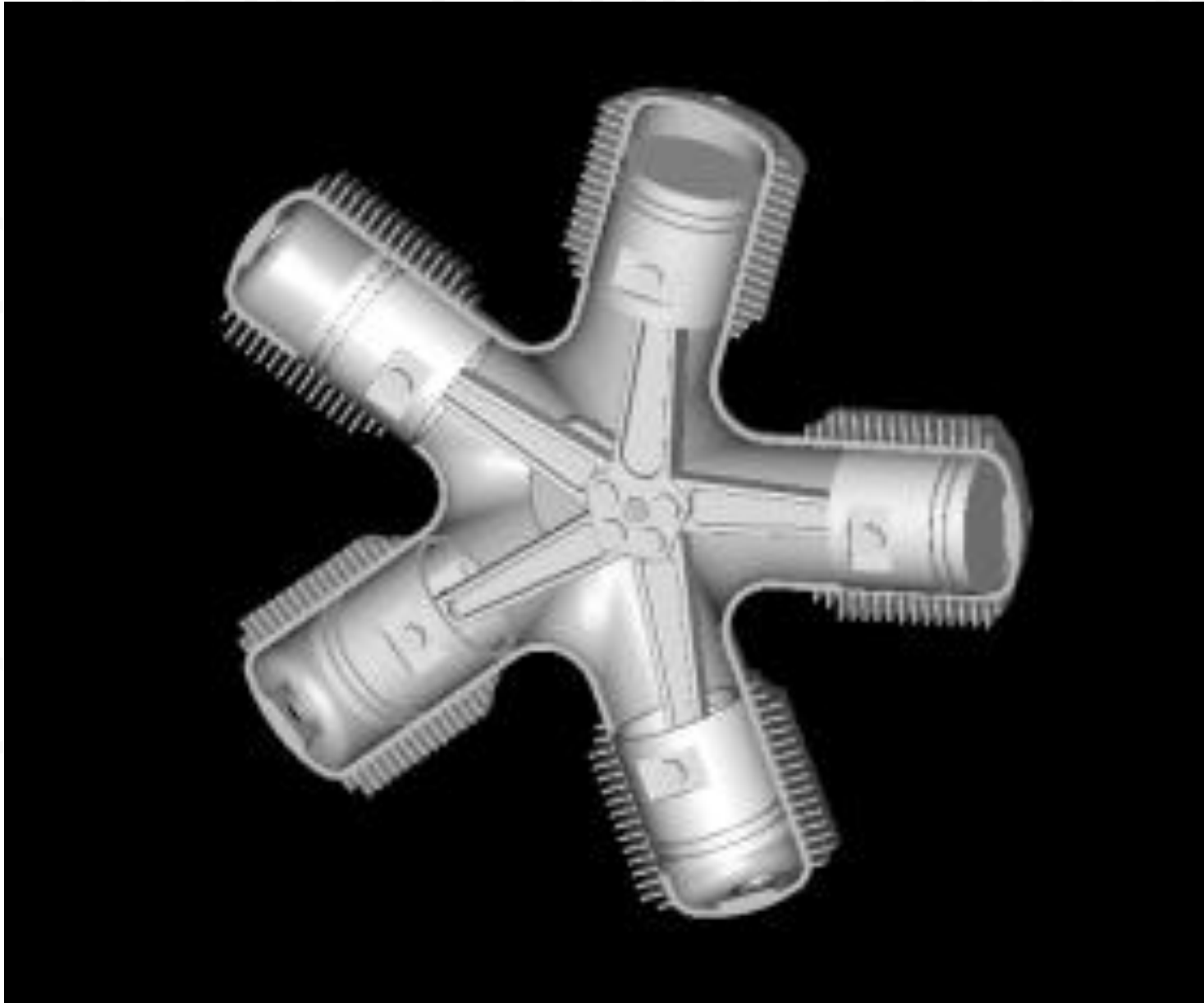

Programas de modelagem 3D

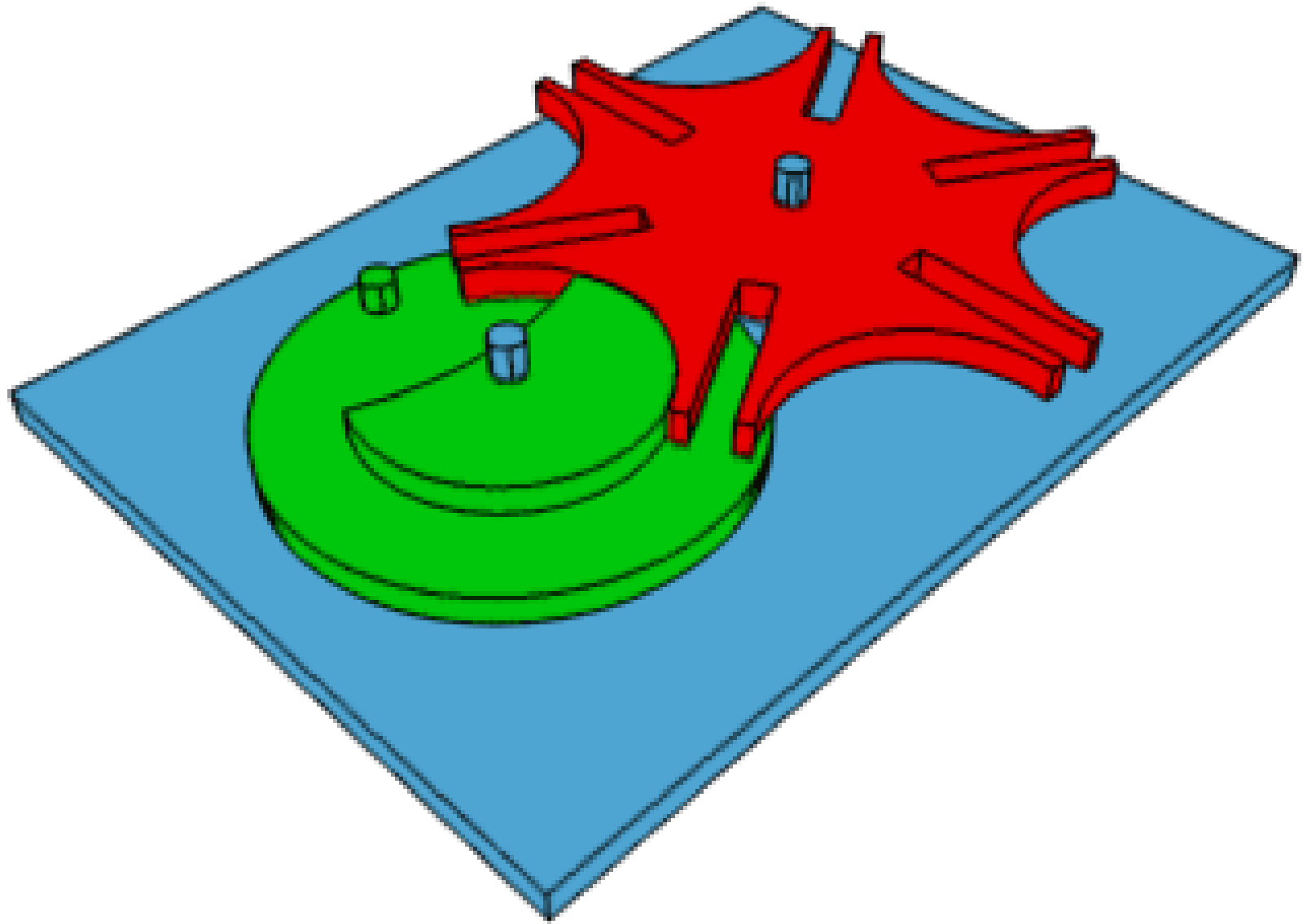

Visualização simplificada

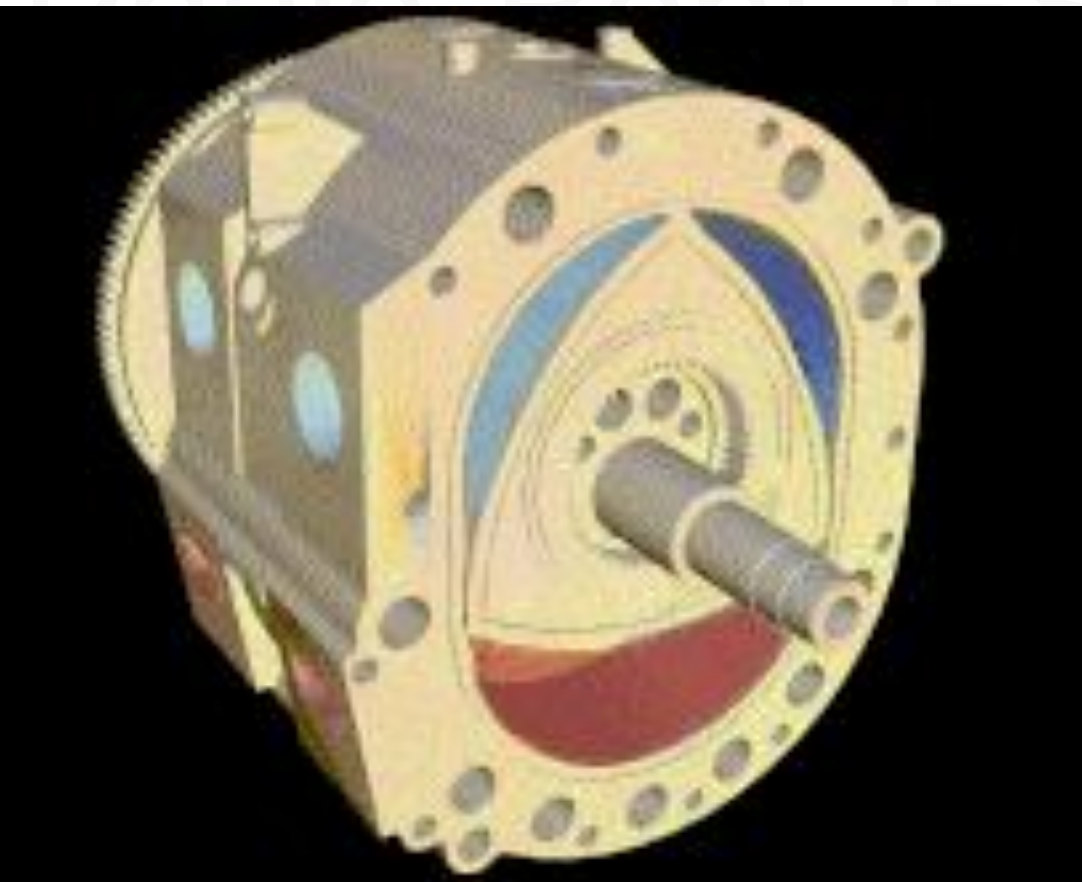

3D

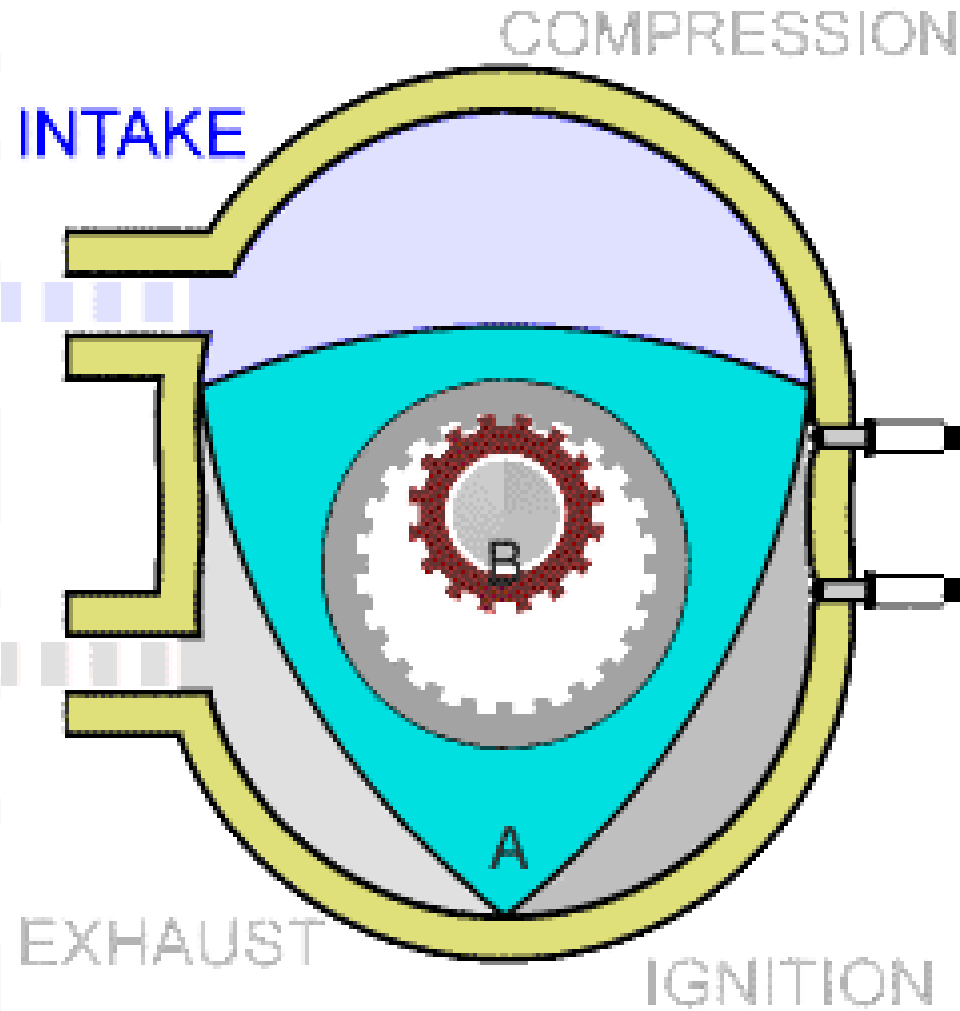

2D

Processo de análise

1-Definição do mecanismo e das juntas

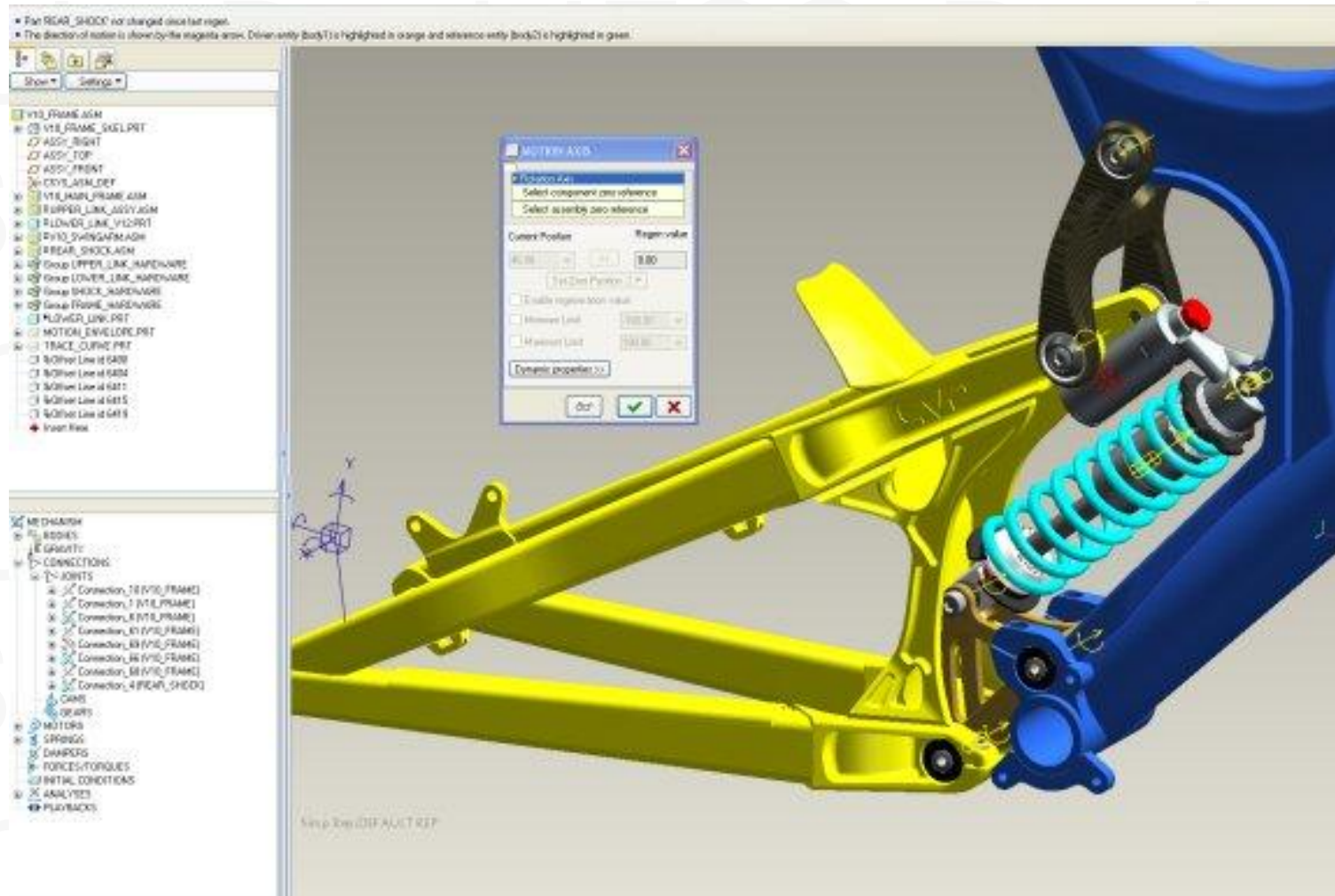

Processo de análise

2-Definição das entidades dinâmicas:
molas, amortecedores, gravidade, atrito ...

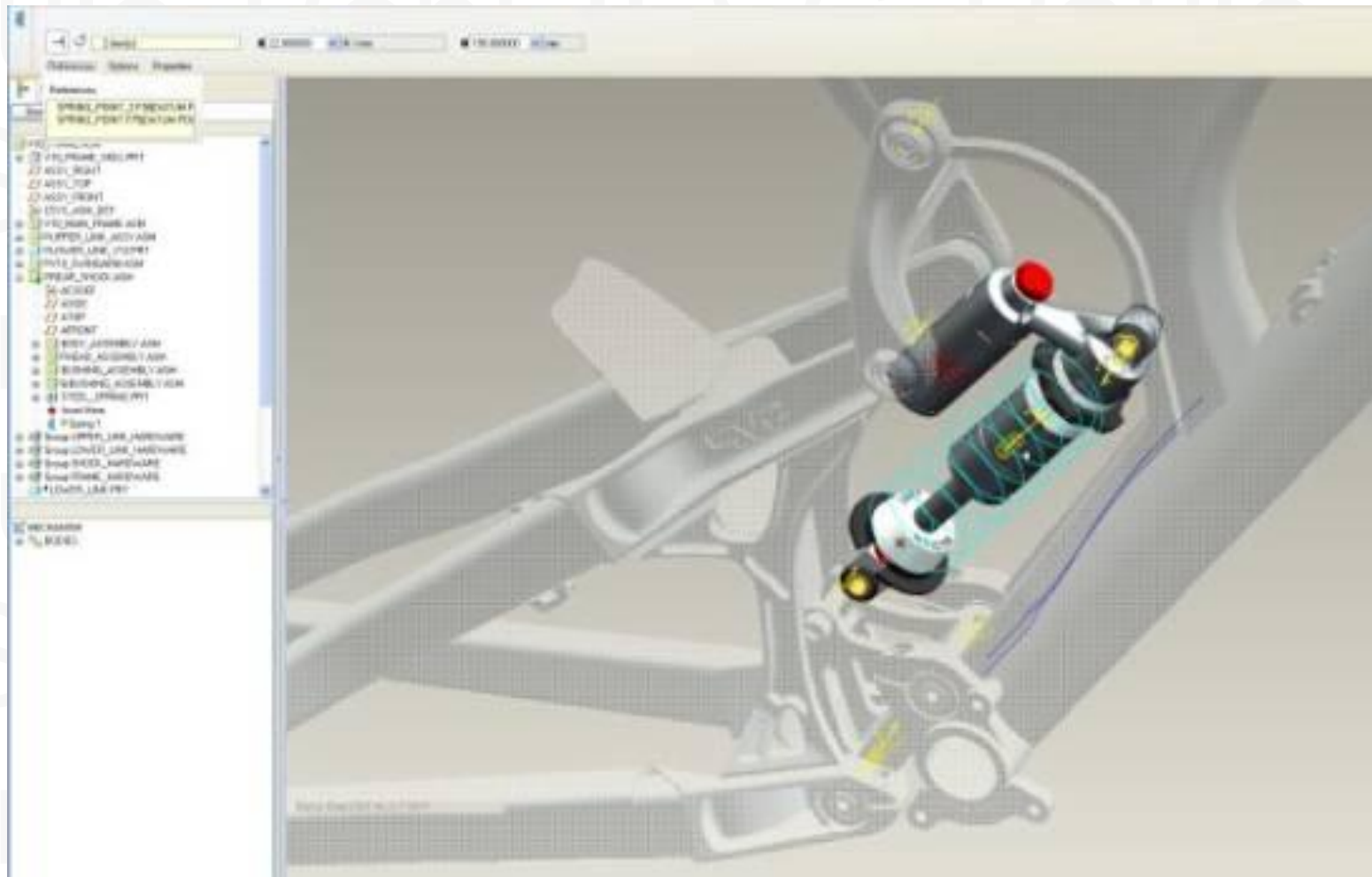

Processo de análise

3-Definição dos acionamentos: motores, atuadores ...

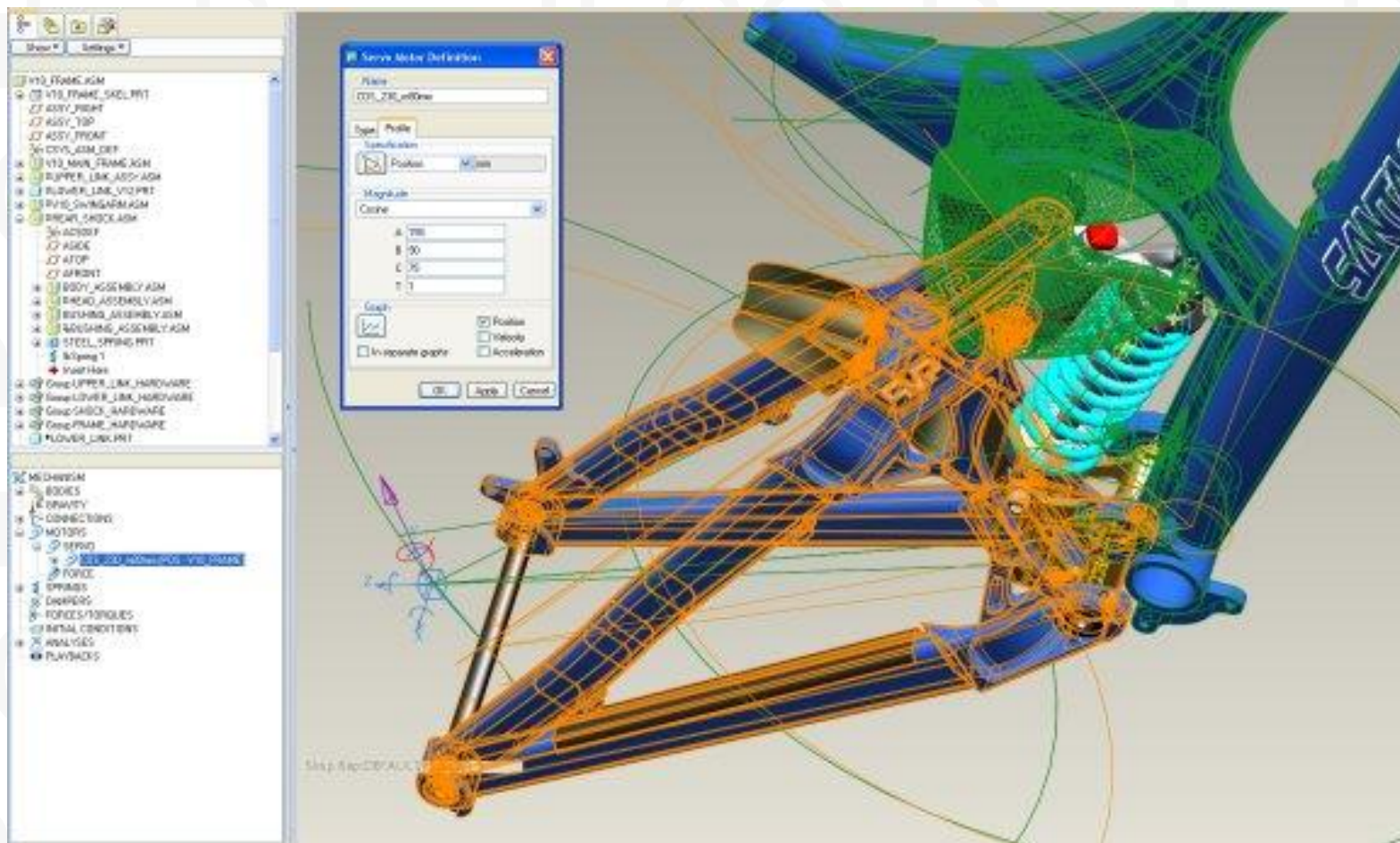

Processo de análise

4-Definição das condições iniciais: posição, velocidade, aceleração

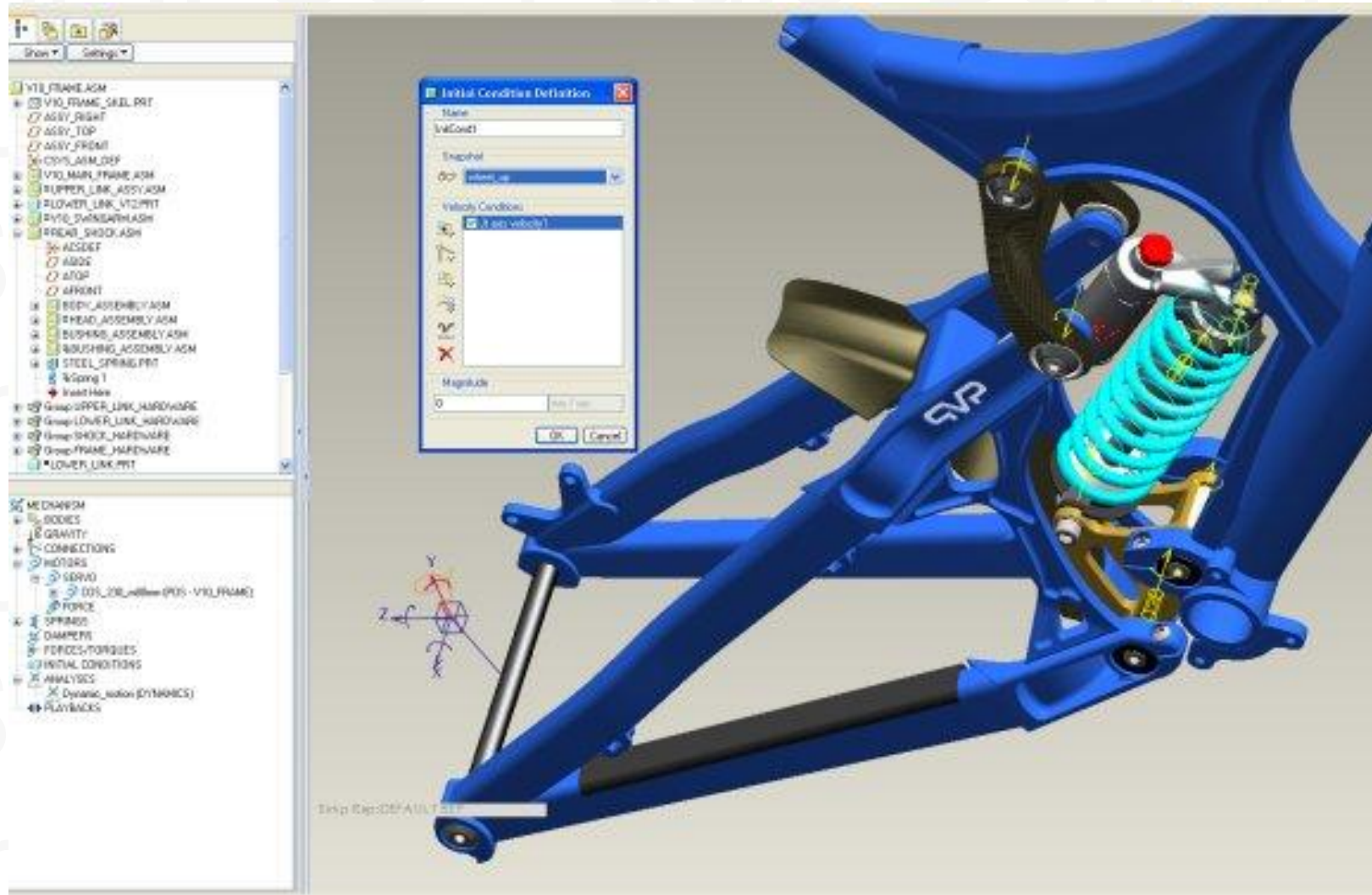

Processo de análise

5-Definição da análise: duração, intervalo de tempo, ...

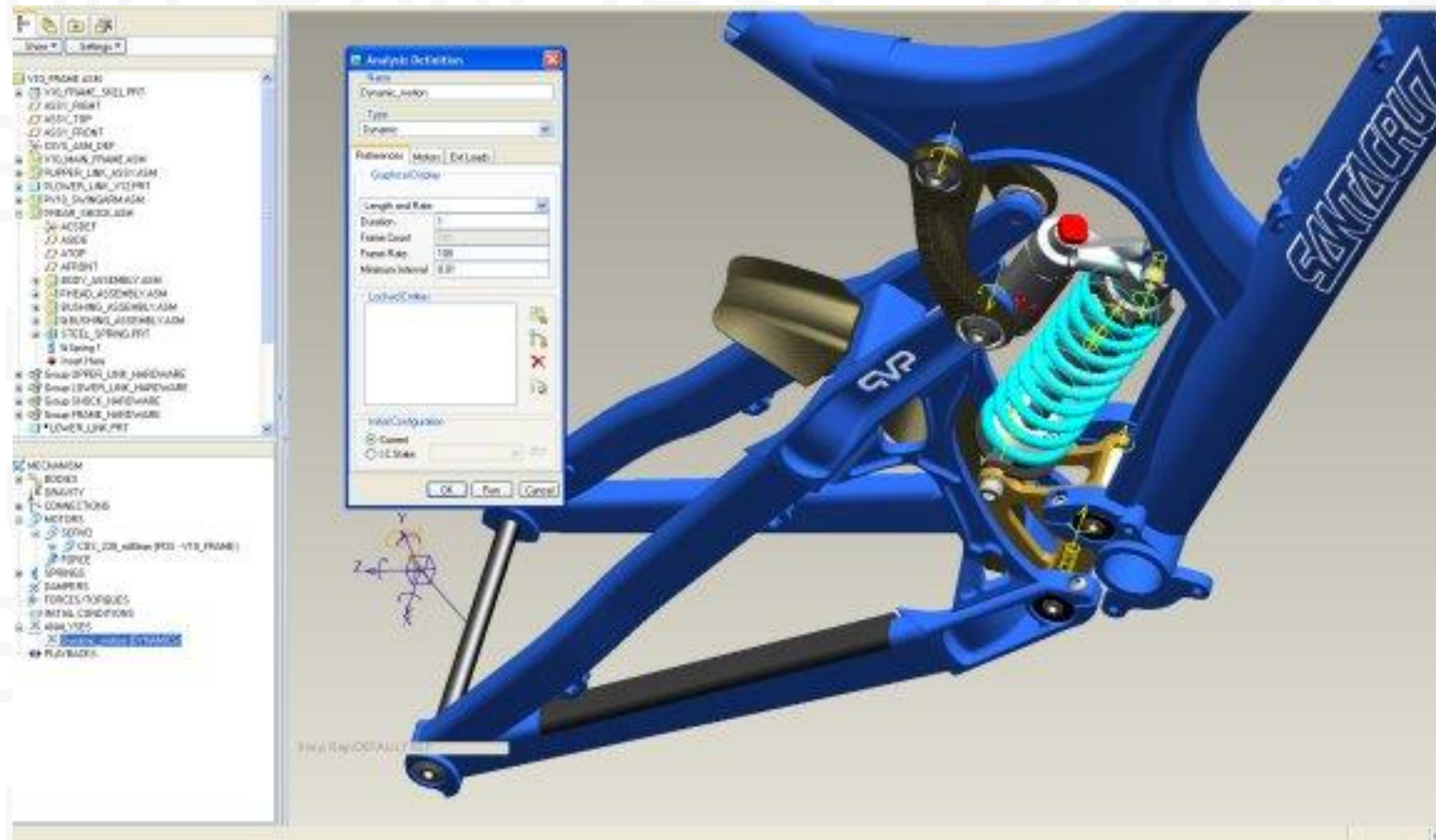

Processo de análise

6-Resultado da análise: movimento, forças atuantes

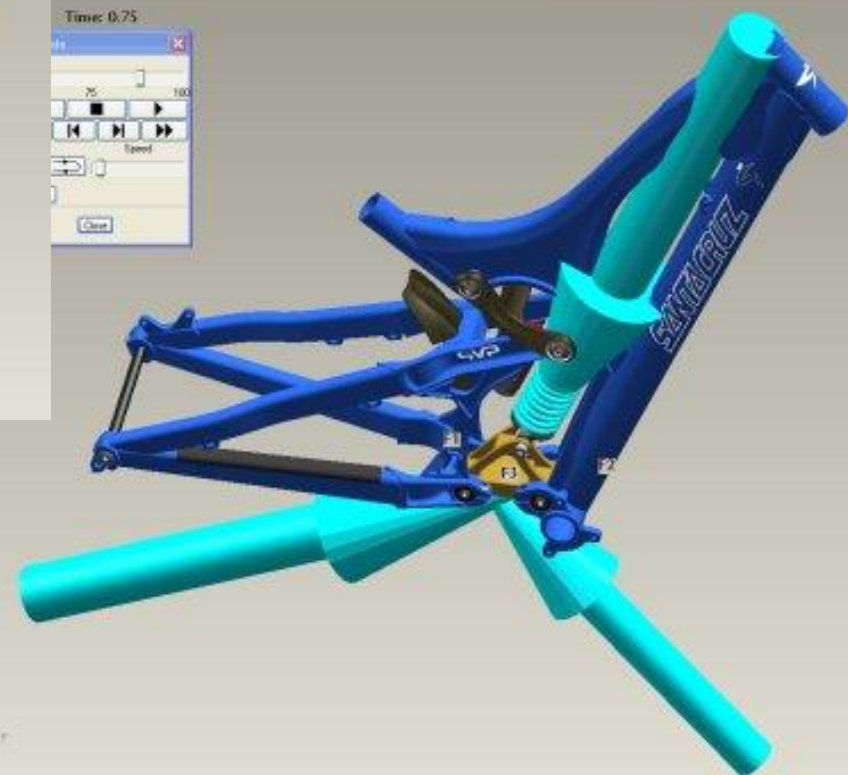
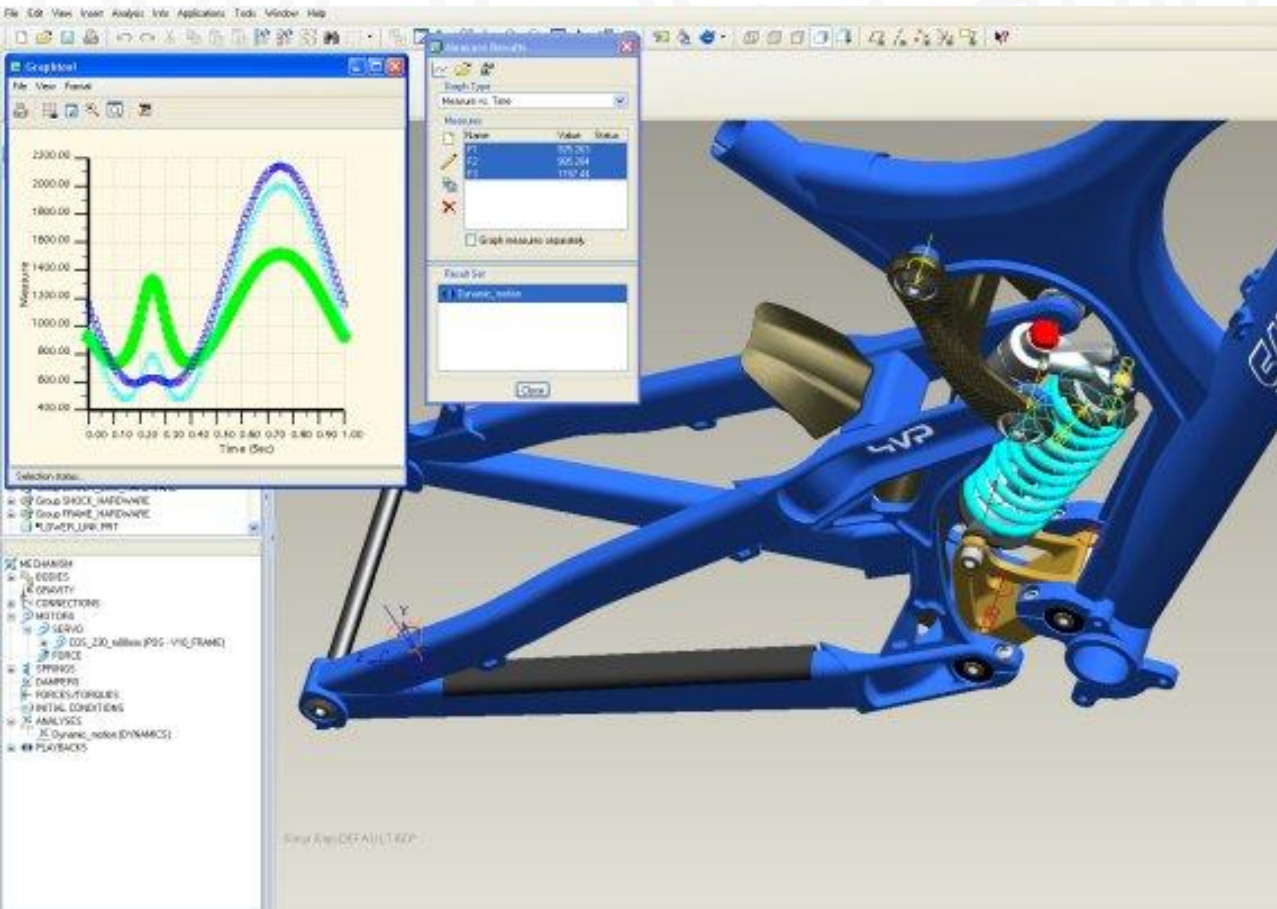

Processo de análise

7-Componente de interesse: cargas de pico, cargas de fadiga

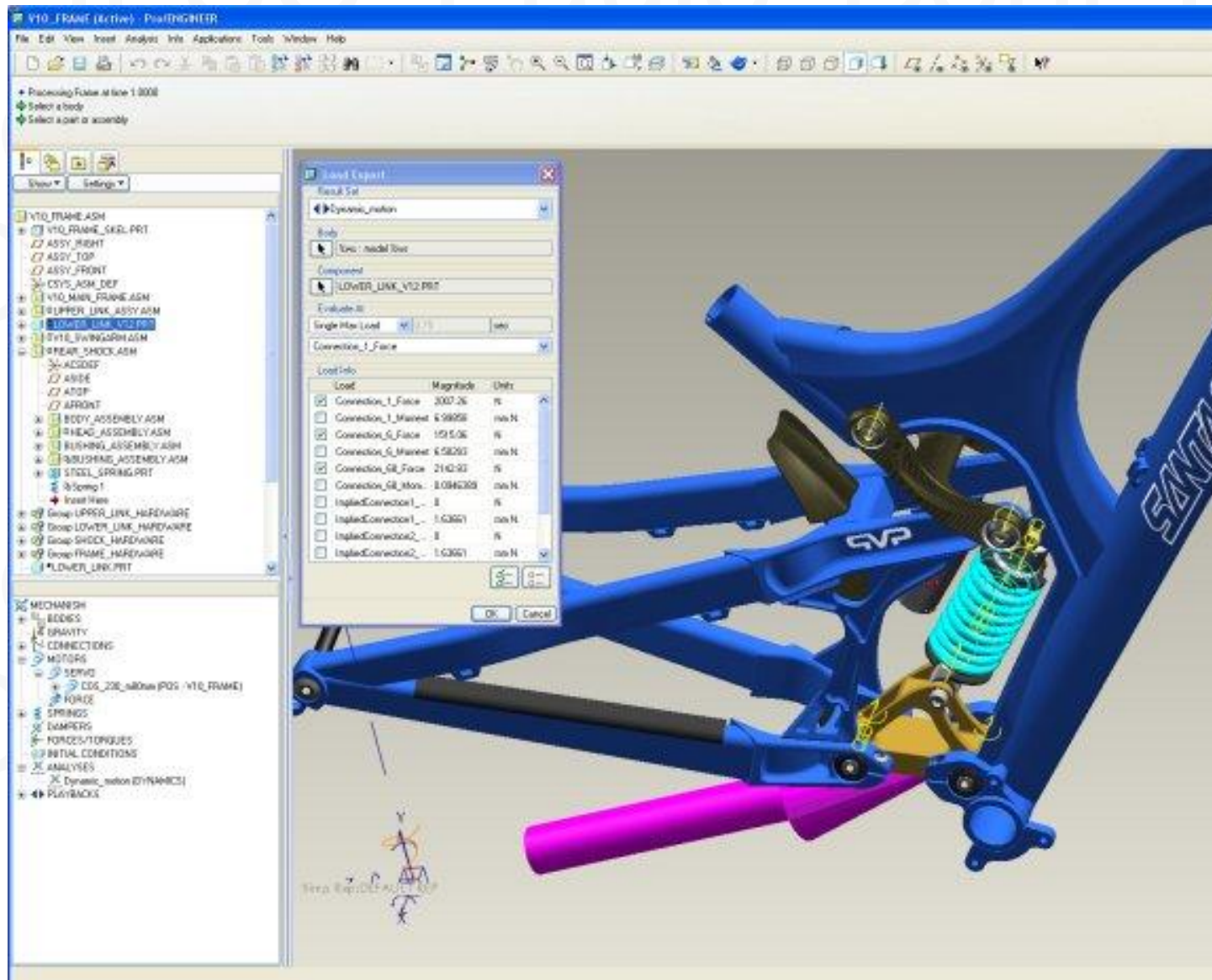

Processo de análise

8-Componente de interesse: propriedades do material

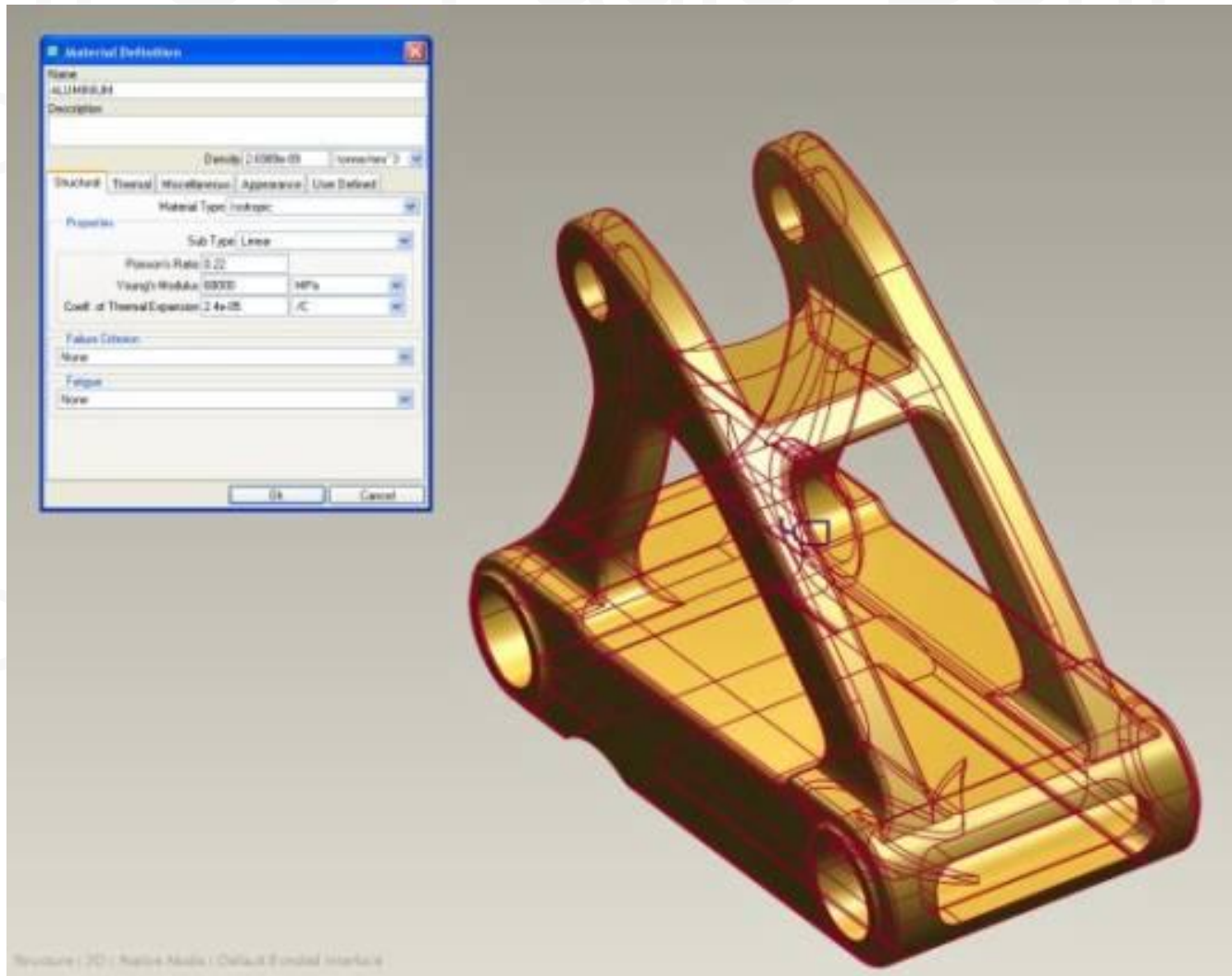

Processo de análise

9-Componente de interesse: refino do carregamento

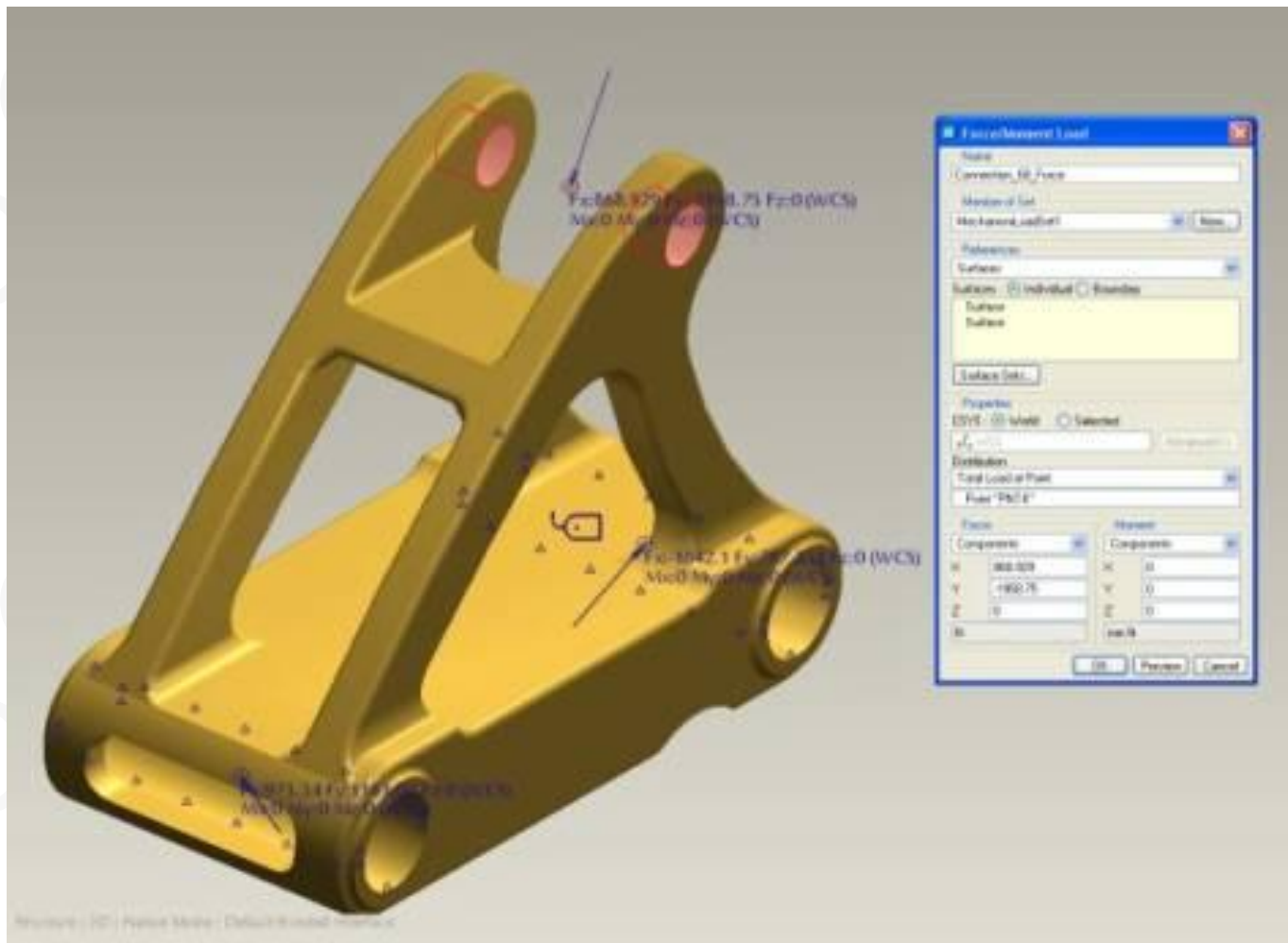

Processo de análise

10-Componente de interesse: tensões e deslocamentos

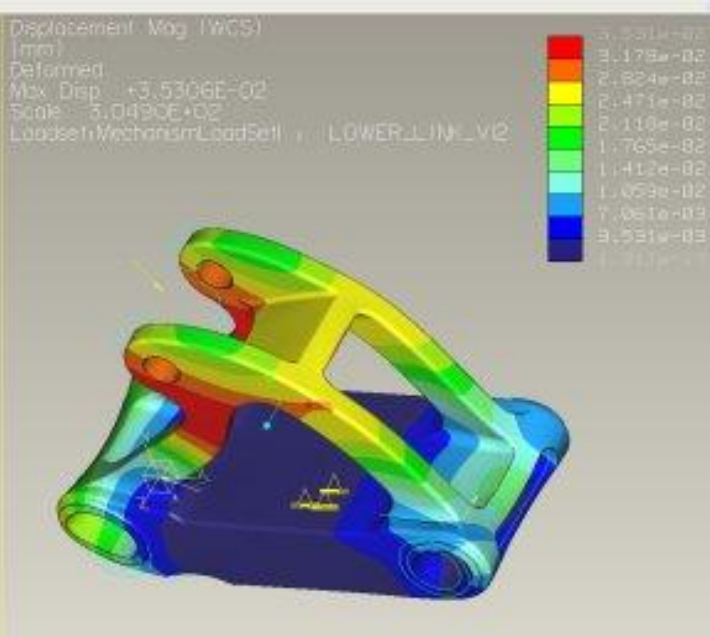
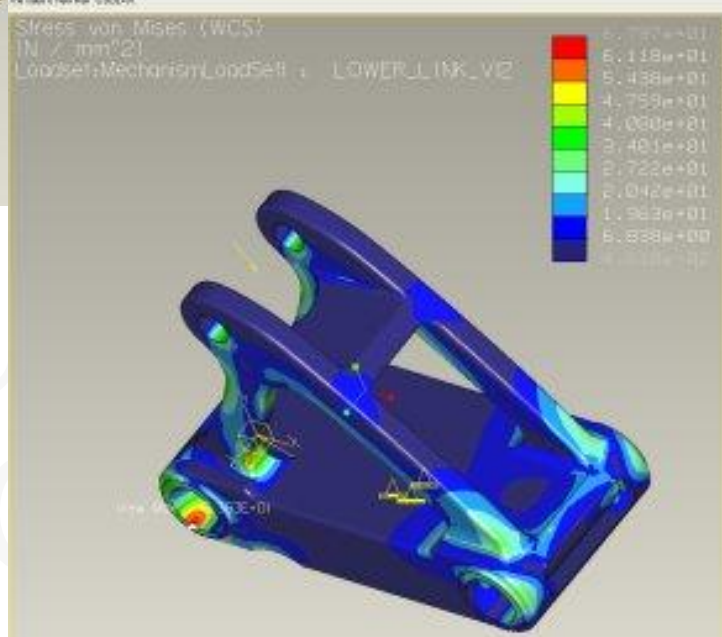
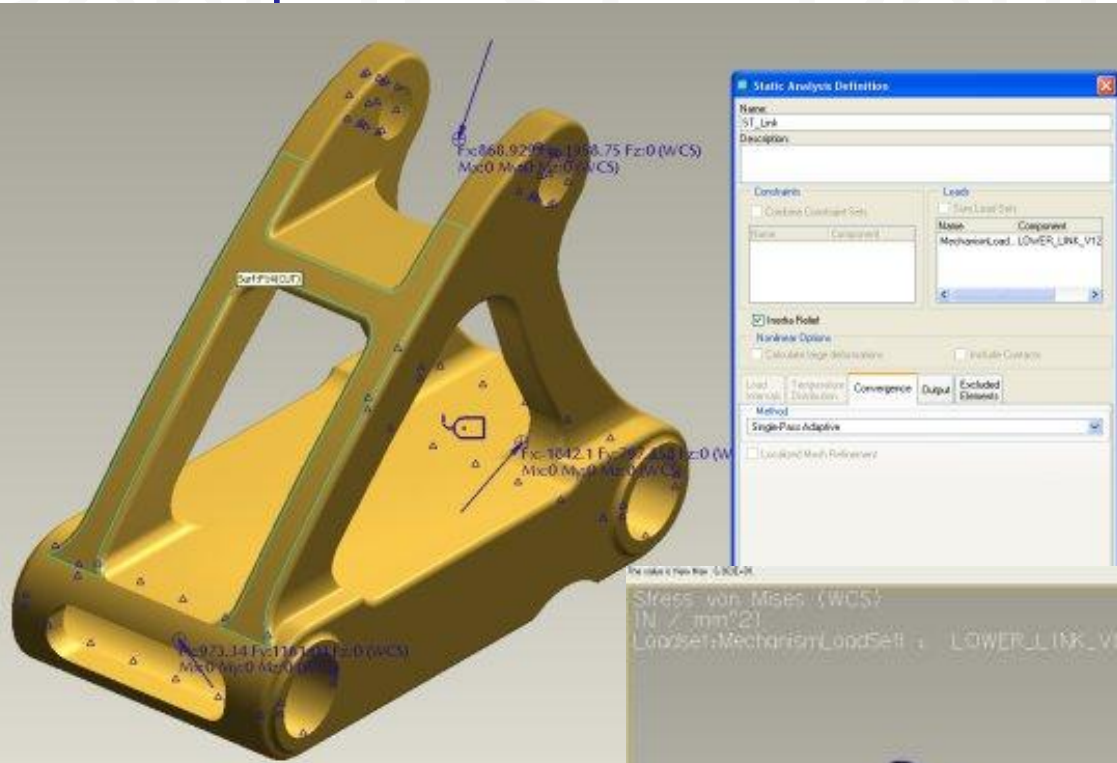

Canais de comunicação

- Email da Turma
- Horários destinados para atendimento