

GRADES

9-12

Parts of an Airplane



parts of an airplane

Aeronautics
Research
Mission
Directorate





Parts of an Airplane

Lesson Overview

In this lesson, students will learn about the abilities of technological design and understandings of science and technology as they analyze the individual components of an aircraft, first learning how to identify them, then gaining an understanding of how each component works.

Objectives

Students will:

1. Learn about the abilities of technological design and understandings about science and technology as they identify individual aircraft components, regardless of design or manufacturer.

Materials:

In the Box

None

Provided by User

None

GRADES 9-12 **Time Requirements:** 1 hour

parts of an airplane

Background

Any vehicle, whether it's a car, truck, boat, airplane, helicopter or rocket, is made up of many individual component parts. Some components are common amongst a variety of vehicles, while others are exclusive to specific types. Occasionally, a component is modified and given a different name, although its basic principle of operation remains intact. This lesson is designed to look at those individual components and allow students to not only identify them, but to understand how they work together to create a functioning aircraft.

Figure 1 shows a typical airplane with its major components listed. Many external airplane components are constructed of metal alloys, although composites made of materials such as carbon fiber and a variety of fiberglass resins are becoming more popular as technology improves.

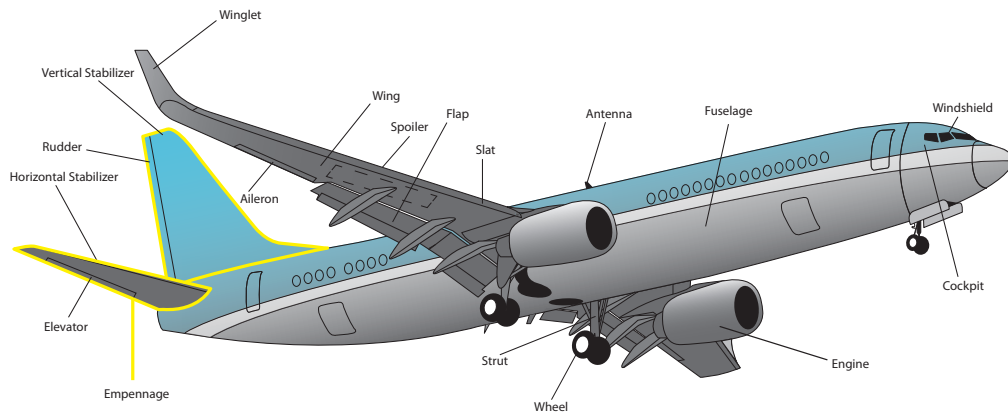

Fig. 1 Airplane Diagram

Aileron

The ailerons are located at the rear of the wing, typically one on each side. They work opposite to each other, meaning that when one is raised, the other is lowered. Their job is to increase the lift on one wing while reducing the lift on the other. By doing this, they roll the aircraft sideways, causing the aircraft to turn. This is the primary method of steering a fixed-wing aircraft.

Antenna

There are numerous radio antennas located around an aircraft, their size and position corresponding to the type of work each antenna must perform and the frequencies being transmitted or received. The GPS antenna, for example, is always mounted to the top of an airplane. This is because the GPS satellites are in Space, and therefore always above the aircraft. As a general rule, longer antennas are used for radio communication and navigation (VHF frequencies), while shorter antennas are reserved for higher frequency data such as the GPS signals and the transponder, which provides air traffic control with information about the aircraft's position and altitude.

Cockpit

The cockpit, sometimes referred to as the Flight Deck, is where the pilots sit. It contains the flight controls, which move the airplane, as well as all the buttons and switches used to operate the various systems.

Elevator

As the name implies, the elevator helps "elevate" the aircraft. It is located on the tail of the aircraft and directs the nose of the aircraft either upwards or downwards (pitch) in order to make the airplane climb and descend.

Empennage

This name stems from the French word “empenner,” meaning “to feather an arrow”. The empennage is the name given to the entire tail section of the aircraft, including both the horizontal and vertical stabilizers, the rudder and the elevator. As a combined unit, it works identically to the feather on the arrow, helping guide the aircraft to its destination.

Engine

An airplane has at least one, or as many as eight engines, which provide the thrust needed to fly. There are many different makes and models on aircraft today but all perform the same basic function of taking the air that’s in front of the aircraft, accelerating it and pushing out behind the aircraft. Jet powered aircraft perform this function by compressing the air using turbines, while propeller-powered aircraft use a propeller mounted to the engine. In general, the propeller works like a big screw, pulling the aircraft forward while pushing the air behind it (Fig. 2).

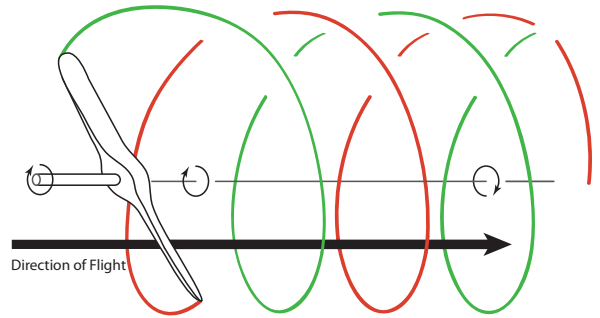

Fig. 2 Propeller path

Flap

Flaps are a “high lift / high drag” device. Not only do they improve the lifting ability of the wing at slower speeds by changing the camber, or curvature of the wing, but when extended fully they also create more drag. This means an aircraft can descend (or lose altitude) faster, without gaining airspeed in the process. Flaps come in 4 main varieties: plain, split, slotted and fowler (Fig. 3).

- The plain flap is the simplest of the four varieties. It works by lowering the aft portion of the wing, increasing its camber, which in turn causes the wing to produce more lift. Plain flaps are typically used only when the aircraft is required to be as simple to construct as possible.
- The split flap works by lowering just the bottom section of the wing. Rather than providing additional lift, the split flap is primarily used to allow an aircraft to descend quickly without gaining forward momentum, or airspeed. As such, it is typically found on aircraft that have to operate in smaller areas, such as those used for crop dusting, or in the Alaskan bush. It was invented by Orville Wright in 1920 and became popular in the 1930’s but, due to the large quantity of drag it produces, has been rarely used since then.
- The slotted and fowler flaps are both designed to physically increase the overall surface area of the wing, literally making the wing bigger. In addition, the slotted flap, as the name implies, creates one or more slots within the wing. These slots provide additional energy to the air on the upper surface of the wing, ensuring that as the airspeed decreases, the air still has sufficient momentum to reach the rear of the wing. In technical terms, it is referred to as preventing the separation of the boundary layer.

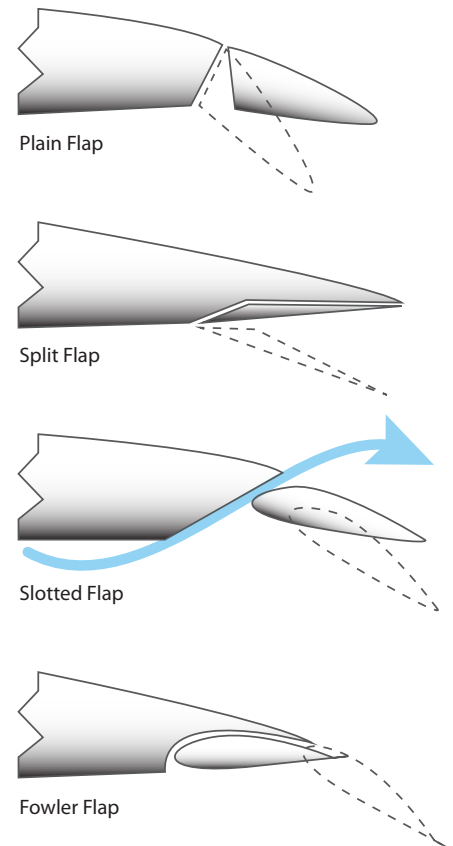

Fig. 3 Flaps

Fuselage

The fuselage, from the French word “fuselé” meaning “spindle shaped”, is the portion of the airplane used to literally join, or fuse, the other parts together. It is commonly thought of as the body of the aircraft and holds the passengers and cargo safely inside.

Horizontal Stabilizer

The horizontal stabilizer is quite simply an upside-down wing, designed to provide a downward force (push) on the tail. Airplanes are traditionally nose-heavy and this downward force is required to compensate for that, keeping the nose level with the rest of the aircraft. Some aircraft can control the angle of the stabilizer and therefore the level of downward force while in flight, while others are fixed in place.

Rudder

The rudder is attached to the vertical stabilizer, located on the tail of the aircraft. It works identically to a rudder on a boat, helping to steer the nose of the aircraft left and right; this motion is referred to as yaw. Unlike the boat however, it is not the primary method of steering. Its main purpose is to counteract certain types of drag, or friction, ensuring that the aircraft’s tail follows the nose, rather than sliding out to the side.

Slat

A slat is a “high lift” device typically found on jet-powered aircraft. Slat is similar to the flaps except they are mounted on the leading edge of the wing. They also assist in changing the camber, or curvature of the wing, to improve lifting ability at slower speeds.

Spoiler

The spoiler’s function is to disrupt, or spoil, the flow of air across the upper surface of the wing. They are usually found on larger aircraft, which can have two types installed. The in-flight spoilers are small and designed to reduce the lifting capability of the wing just enough to allow the aircraft to descend quicker without gaining airspeed. Although the flaps can also perform this function, the spoiler is intended to be used temporarily, while the flaps are typically used for longer durations such as during the approach and landing. The ground spoilers (img. 1) typically deploy automatically on landing and are much larger than their in-flight cousins. They are used to completely destroy the lifting ability of the wing upon landing, ensuring that the entire weight of the airplane rests firmly on the wheels, making the brakes more effective and shortening the length of runway needed to stop the aircraft.



Img. 1 Ground spoilers on an Airbus 320 aircraft

Struts

The struts are part of the undercarriage, more commonly known as the landing gear. There are two main types - straight leg (Img. 2) and trailing link (Img. 3) - but their function is the same: to absorb the impact of the landing as the aircraft touches the ground. Each strut contains a shock absorber (a collection of springs), hydraulic oil and gasses which work together to reduce the impact felt by the passengers.



(Photo courtesy of Lost Tribe Media, Inc.)

Img. 3 Trailing link landing gear

On some aircraft, such as those used by student pilots, the struts are made entirely out of spring steel. This type of steel is treated in such a way that it can absorb the shock of landings repeatedly, bending automatically back into shape (Img. 4).

Vertical Stabilizer

The vertical stabilizer is designed to stabilize the left-right motion of the aircraft. While most aircraft use a single stabilizer, some models, such as the Lockheed C-69 Constellation (Img. 5), use multiple, smaller stabilizers.



(Photo courtesy of www.NASAIMages.org)

Img. 6 A modified Boeing 747 carrying the Space Shuttle Enterprise



(Photo courtesy of NASA)

Img. 2 The straight leg landing gear of the Space Shuttle Atlantis



(Photo courtesy of NASA)

Img. 4 A NASA modified Cessna 190



(Photo courtesy of the United States Air Force)

Img. 5 A Lockheed C-69 Constellation

Wheel

The wheels are another part of the undercarriage, or landing gear. While most aircraft have a minimum of three wheels, larger aircraft require many more to support the immense weight (Img. 6). Typically aircraft wheels are filled with nitrogen instead of air. This is because the pressure of nitrogen gas changes very little with changes in altitude or temperature, which is something aircraft constantly experience.

Windshield

The windshield on smaller aircraft is usually made from polycarbonate, a type of plastic, while pressurized airplanes use a sandwich of plastic and glass layers, called a laminate, up to 20mm thick. This is necessary to absorb the impact of birds, insects and other debris that may collide with the windshield as the airplane flies at close to the speed of sound.

Wing

The wing provides the majority of the lift an airplane requires for flight. Its shape is specifically designed for the aircraft to which it is attached. On most aircraft, the interior of the wing is also used to store the fuel required to power the engines.

Winglet

Some aircraft wings have an additional component called a winglet, which is located at the end of each wing. Its purpose is to reduce the drag (or air resistance) the wing produces as it pushes through the air. This not only allows the airplane to fly faster, but also means it burns less fuel, allowing it to fly longer distances without refuelling.



(Photo courtesy of NASA)

Img. 7 The winglet of a KC-135A cargo plane.

Activity 1

Plane Parts

GRADES 9-12**Time Requirement:** 1 hour**Materials:**In the Box

None

Provided by User

None

WorksheetsPlane Parts
(Worksheet 1)Plane Parts Quiz
(Worksheet 2)Reference Materials

Figure 1

Key Terms:

None

Objective:

Students will learn about the abilities of technological design and understandings about science and technology as they identify individual aircraft components, regardless of design or manufacturer.

Activity Overview:

In this activity, students will identify and label the major components of an aircraft as well as discuss the purpose of each part.

Activity:

1. **Provide each student with a copy of both worksheets and Figure 1 from the Reference Materials section.**
2. **Next, discuss the Background information with the students.** During the discussion, be sure to note that although every airplane looks somewhat different, the names and functions of each part are the mostly the same.
3. **Have the students complete Worksheet 1 by identifying and labeling the components of each aircraft.**
4. **Have the students study the various components in greater detail, either using the Internet or by providing them with a copy of the Background information in its entirety.** The students should then use the information from their research to complete Worksheet 2.

Worksheet 2 Questions

Plane Parts Quiz - Answer Sheet

1. **Describe the following aircraft motions:**
Pitch: *Pitch is the name given to the up-down motion of the nose of the aircraft. The pilot changes an aircraft's pitch to make it climb or descend.*
Roll: *Roll is the name given to the side-to-side rotation of the aircraft, during which time one wing is raised while the other is lowered.*
Yaw: *Yaw is the name given to the left-to-right motion of the nose of the aircraft.*
2. **Which parts of an airplane are used to control lift at low speed for takeoff and landing?**
Flaps and/or Slats
3. **Which aircraft component has two parts, installed one on each wing, that operate in opposite directions (i.e., one up and one down)?**
Ailerons
4. **If the component in question 3 is up on the right wing and down on the left, what will the aircraft do?**
The aircraft will roll to the right. The lowered aileron increases the lift on the left wing, causing it to rise, while the raised aileron on the right wing reduces lift, causing it to lower. This results in a roll towards the upward-facing aileron.
5. **What language do the terms "fuselage" and "empennage" come from?**
French
6. **What is a spoiler and why would a pilot use it?**
A spoiler is designed to interrupt the airflow over the wings. This causes the wings to produce less lift and as such, descend quicker than could be achieved by simply lowering the nose.
7. **There are four main types of flaps; what are they and how does each design differ from the others?**
Plain, Split, Slotted and Fowler. Details of each can be found in the [Background](#) information.

The following questions should only be answered if Internet access is available for additional research. For time purposes, this material is not covered within the [Background](#) information.

8. **If the pilot pushes forwards on the control column or control stick, what will the airplane do?**
By pushing forwards, the pilot lowers the elevator on the rear of the aircraft, lifting the tail, which conversely points the nose downwards. This results in the aircraft descending.
9. **What is a Canard-style airplane?**
Unlike a traditional airplane where the wings are forwards of the elevator, in the Canard design, the elevator is placed ahead of the wings.
10. **What is the difference between a spoiler and a spoileron?**
A spoileron is a combination of an aileron and a spoiler. They are often used on faster aircraft where the additional drag generated by the lowered aileron would be unacceptable. Instead, a single wing's spoileron is raised, which reduces the lift on that wing, causing it to drop and the aircraft to roll in that direction. The spoileron on the other wing remains in place, eliminating any additional drag that would've been caused by an aileron.
11. **What is the difference between a stabilator and an elevator?**
With a stabilator, the entire horizontal surface of the tail moves, as opposed to an elevator, where the horizontal stabilizer remains stationary while just the elevator moves.

NATIONAL SCIENCE STANDARDS 9-12

SCIENCE AS INQUIRY

- Abilities necessary to do scientific inquiry
- Understandings about scientific inquiry

PHYSICAL SCIENCE

- Structure and properties of matter
- Interactions of energy and matter

SCIENCE AND TECHNOLOGY

- Abilities of technological design
- Understanding about science and technology



Reference Materials

Fig. 1 Airplane Diagram

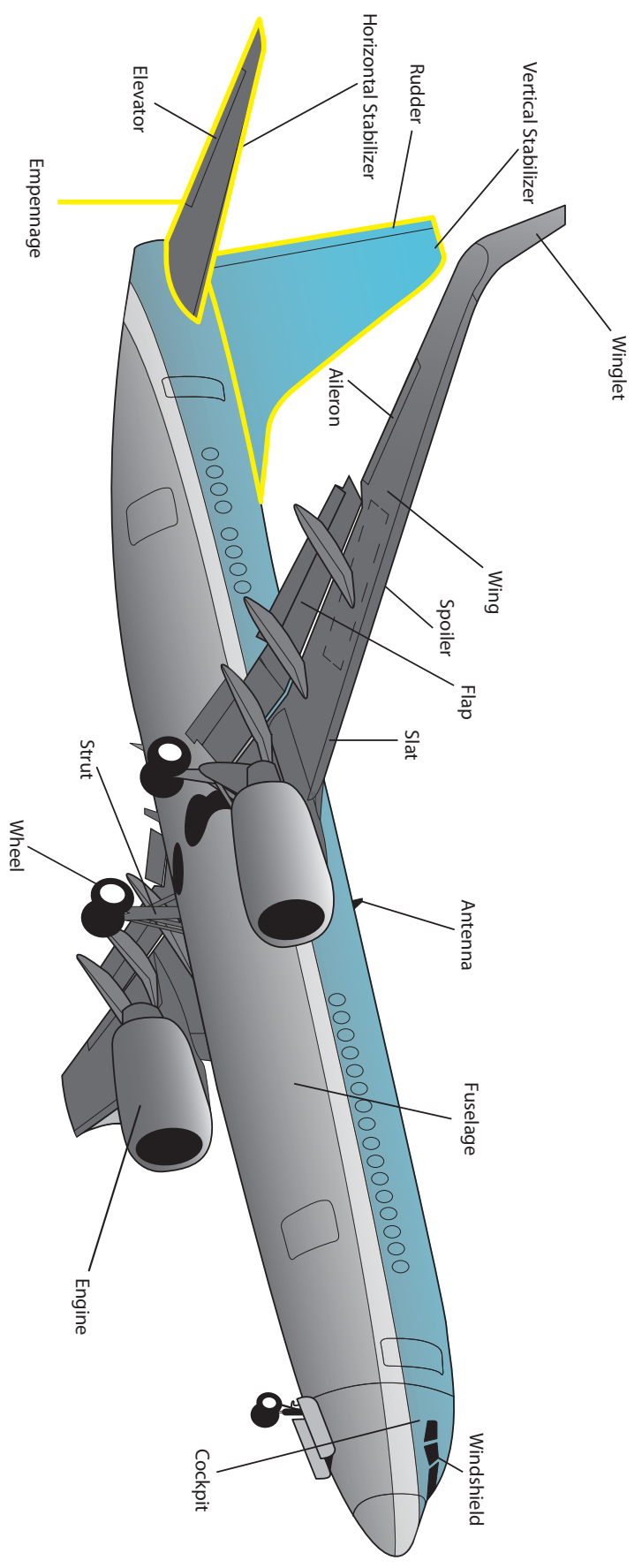

Fig. 2 Propeller Path

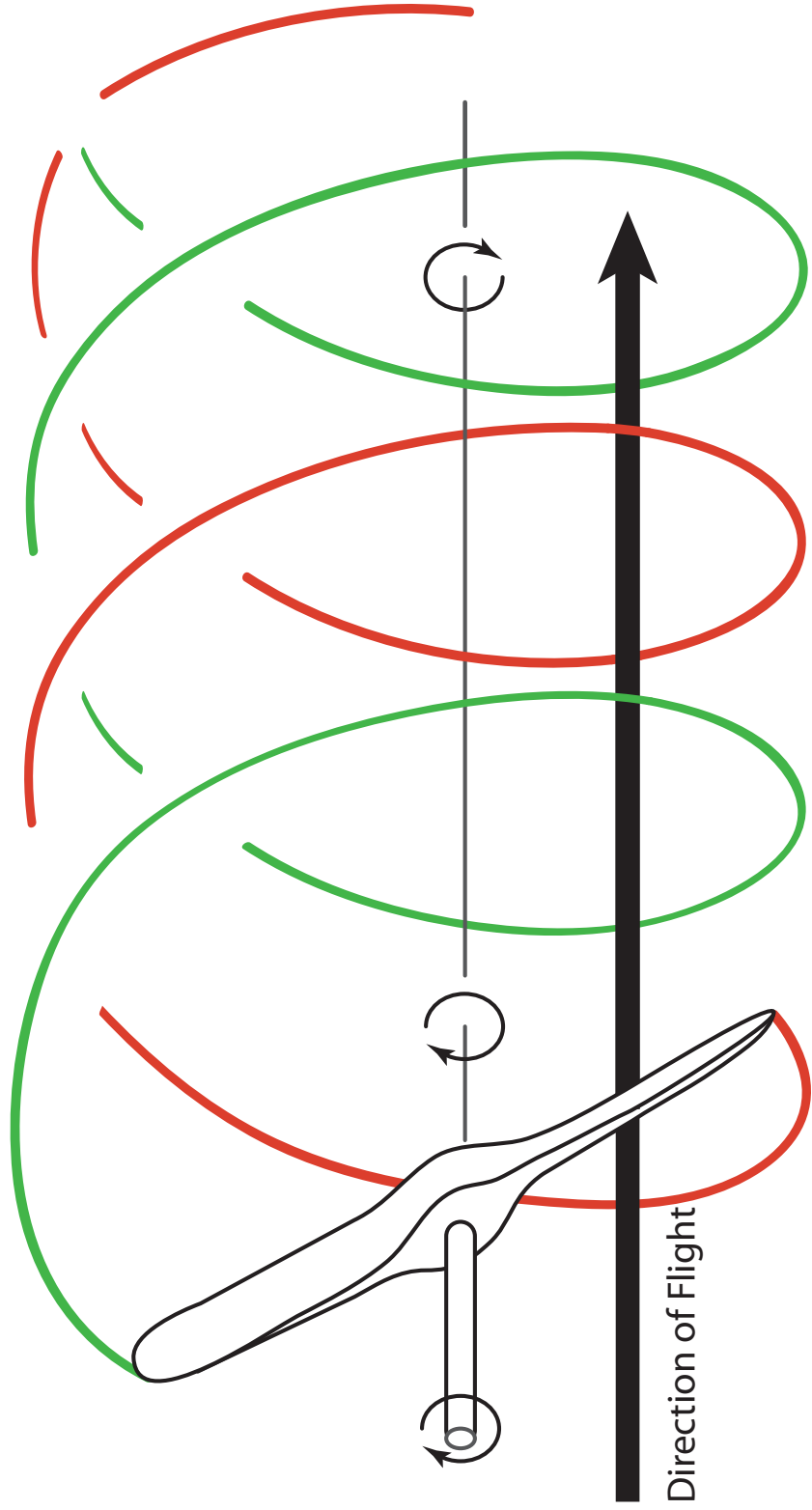
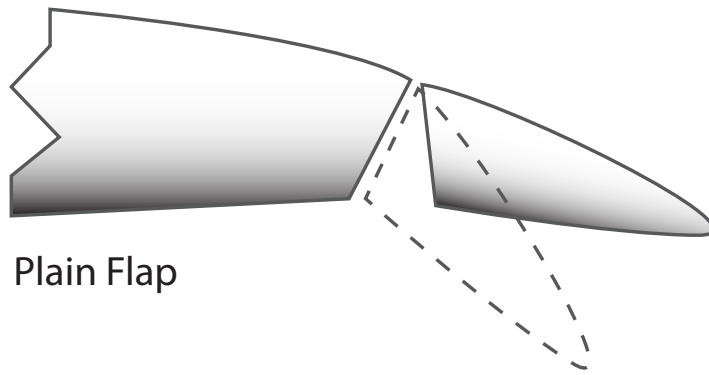
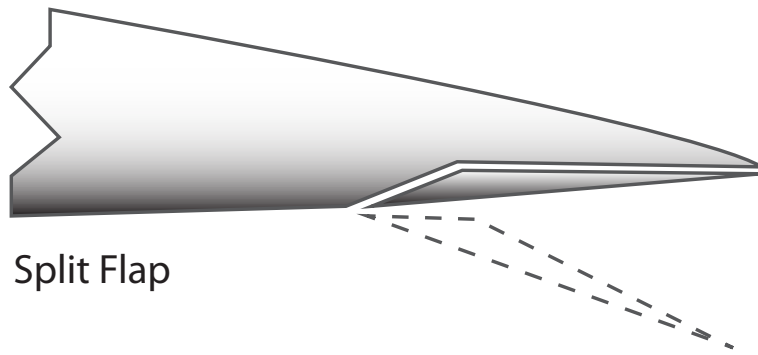

Fig. 3 Flaps



Plain Flap



Split Flap

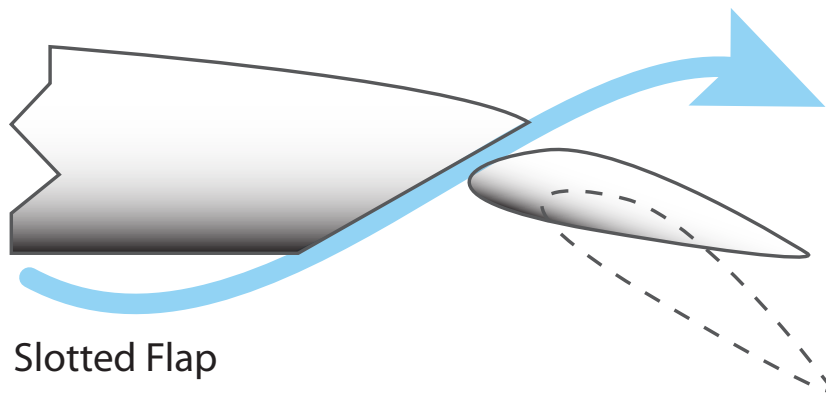

Slotted Flap

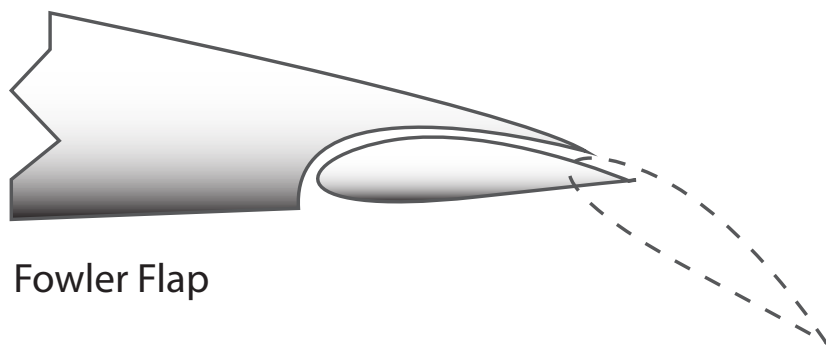

Fowler Flap



Student Worksheets

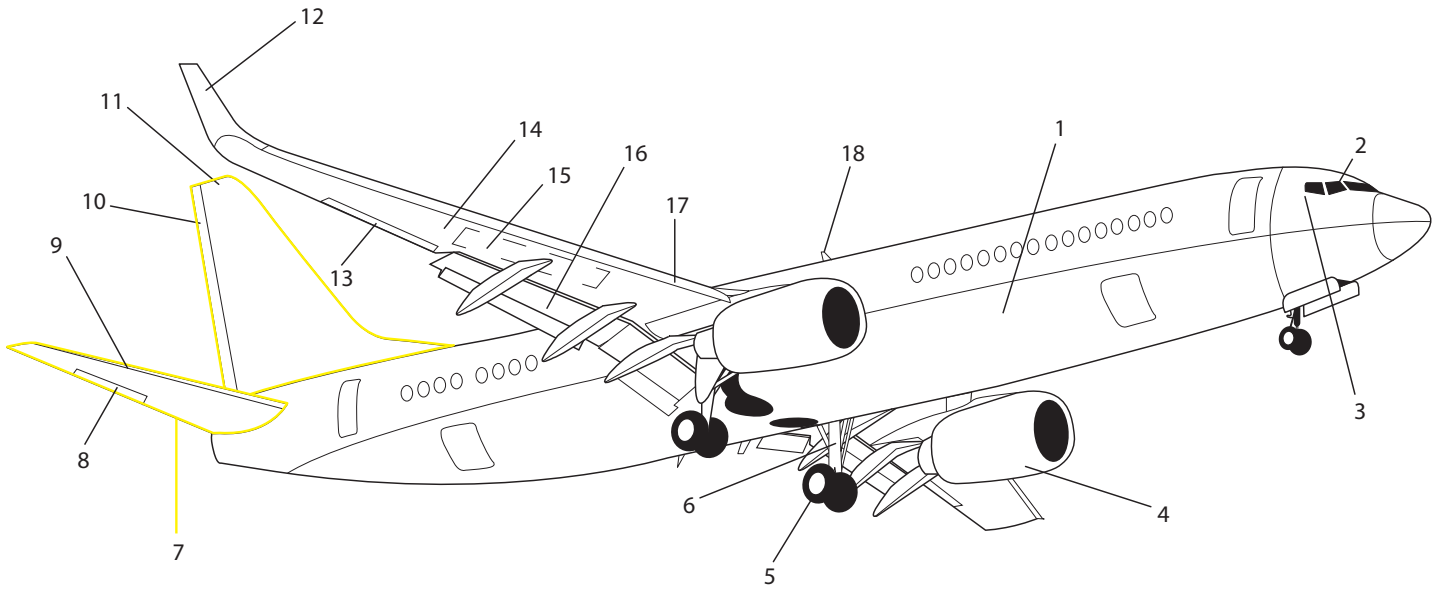

1. _____
2. _____
3. _____
4. _____
5. _____
6. _____
7. _____
8. _____
9. _____
10. _____
11. _____
12. _____
13. _____
14. _____
15. _____
16. _____
17. _____
18. _____

Word Bank	
Aileron	Rudder
Antenna	Slat
Cockpit	Spoiler
Elevator	Strut
Empennage	Vertical Stabilizer
Engine	Wheel
Flap	Windshield
Fuselage	Wing
Horizontal Stabilizer	Winglet

1. Describe the following aircraft motions.
Pitch:

Roll:

Yaw:
2. Which parts of an airplane are used to control lift at low speed for takeoff and landing?
3. Which aircraft component has two parts, installed one on each wing, that operate in opposite directions (i.e., one up and one down)?
4. If the component in question 3 is up on the right wing and down on the left, what will the aircraft do?
5. What language do the terms "fuselage" and "empennage" come from?
6. What is a spoiler and why would a pilot use it?
7. There are four main types of flaps; what are they and how does each design differ from each other?

8. If the pilot pushes forwards on the control column or control stick, what will the airplane do?
9. What is a Canard-style airplane?
10. What is the difference between a spoiler and a spoileron?
11. What is the difference between a stabilator and an elevator?



Images

Img. 1 Ground spoilers on an Airbus 320 aircraft



(Public Domain)

Img. 2 The straight leg landing gear of the Space Shuttle Atlantis



(Photo courtesy of NASA)

Img. 3 Trailing link landing gear



(Photo courtesy of Lost Tribe Media, Inc.)

Img. 4 A NASA modified Cessna 190



(Photo courtesy of NASA)

Img. 5 A Lockheed C-69 Constellation



(photo courtesy of The United States Air Force)

Img. 6 A modified Boeing 747 carrying the Space Shuttle Enterprise



(Photo courtesy of www.NASAIMages.org)

Aeronautics
Research
Mission
Directorate



parts of an airplane