

| | |
|----------------------------|---|
| Subject | Geology |
| Paper No and Title | Hydrogeology & Engineering Geology |
| Module No and Title | Role of Engineering Geology in Civil Construction and Mining Industry |
| Module Tag | HG & EG IX |

| Principal Investigator | Co-Principal Investigator | Co-Principal Investigator |
|---|---|---|
| Prof. Talat Ahmad <i>Vice-Chancellor</i> Jamia Millia Islamia Delhi | Prof. Devesh K Sinha Department of Geology University of Delhi Delhi | Prof. P. P. Chakraborty Department of Geology University of Delhi Delhi |
| Paper Coordinator | Content Writer | Reviewer |
| Prof. P. P. Chakraborty Department of Geology University of Delhi Delhi | Dr. M. Masroor Alam Department of Civil Engineering Aligarh Muslim University Aligarh | Prof. Vinay Jhingran Department of Geology University of Delhi Delhi |
| Anchor Institute: Jamia Millia Islamia, Delhi | | |

GEOLOGY
Paper: Hydrogeology and Engineering Geology
Module: Role of Engineering Geology in Civil Construction and Mining Industry

Learning Outcomes

After studying this module you shall be able to:

- Know about interface between geology and civil engineering.
- Learn about the advent of engineering geology as a specialized discipline.
- Understand different engineering geological investigations.
- Identify problems of rock mass and founding ground.
- Suggest remedial measures for geo-engineering issues.

1.1 Introduction

Human beings are the youngest and perhaps the most intelligent of all life forms thriving on the Earth. It were human beings who when subjected to the vagaries of the weather and natural hazards, they thought of safe shelters. They themselves carved out or found natural

caves in rocks to hide them. They also started constructing shelters using rocks, twigs, leaf and other different materials, sequestered from the Earth itself. Their shelters were different in terms of shape, size, and materials suited for different geographic areas and climatic belts with varied earth surface processes to be negotiated.

For the safe design and longevity of any civil engineering structure specially the mega ones, it is imperative to take into consideration the most critical earth system process. As these processes cannot be generalised as they vary from region to region each and every region need fresh scrutiny. Also as far as construction materials are concerned all are coming directly or indirectly from the rocks, except the materials from the plant system. To get these construction materials and other materials used in the world are to be mined from the rocks, sometimes from great depths.

The Earth is a dynamic planet and is in constant state of change. Its atmosphere, hydrosphere, biosphere, lithosphere, asthenosphere, all

are interacting amongst themselves, are the manifestations of Earth's dynamism. To live on the Earth in harmony and sustainable fashion we have to understand the "operating system", the Earth is run on, so that we can understand its processes and products to make the life of human beings comfortable.

The studies in various disciplines of the "Earth Sciences" help us in understanding this operating system. As the name indicates it is a science which deals with the working processes and products of earth system. It is a vast scientific discipline in the realm of natural sciences, but draws heavily on the basic sciences i.e. physics, chemistry and mathematics. **Geology**, as one of the major discipline of the earth science deals with the "Earth System" in totality to understand processes which are operating on and inside the Earth and has brought the Earth in its present state, since its origin. Genesis of different materials in form of minerals and rocks, their

occurrences, their natural deformation, evolution of life etc., are given prime focus in this discipline.

There are various sub disciplines in geology to understand myriad of processes and products operating in different realm of the earth system involving physics, chemistry and biology. *Engineering Geology* is one of such disciplines, especially important in the arena of construction and mining engineering.

1.2 Engineering Geology

Engineering Geology is the application of the geologic sciences to engineering practice to assure the safe location, design, construction, operation and maintenance of engineering works, which may not be adversely affected by potential geological problems. The working arena of the engineering geologist is essentially in the regions where geological processes and manmade structures interact and latter's safety and longevity are to be ensured. For this they have to

investigate, analyze and provide geologic and geotechnical recommendations to ensure availability of proper construction material and safe founding ground.

Broadly three aspects can be mentioned here, first the study of “*Rock Material*”, used in construction industry such building stones.

Secondly, the study of “*Rock Mass*” or founding rocky ground, over/under which engineering operations are to be carried out leading to loading or unloading of rock mass. Thirdly, the “*endogenous*” and “*exogenous*” geological processes which operate around the construction edifice and either hamper its construction or affect its functioning in future.

Though, the science of geology has been around since the seventeenth century, but the engineering geology was not recognized as a specialized discipline until the early nineteenth century. Despite the fact that geological material and perhaps knowledge of geology was always there knowingly or unknowingly when human beings

made innumerable castles, forts even pyramids etc., are testimony to this, where not only minerals and rocks were used in different ways but also these structures were sound and safe even in adverse ground conditions. The first American engineering geology text book was written in 1914 by *Ries and Watson*. In 1925, *Karl Terzaghi*, an Austrian trained engineer and geologist, published the first text in German language on *Soil Mechanics*. *Terzaghi* is known as the father of soil mechanics, but also had great interest in geology and considered soil mechanics and engineering geology as an important branch of *Geotechnical Engineering*. He too wrote a book in German in 1929, with *Redlich and Kampe*, on engineering geology. In 1947 he came up with first ever standard engineering classification of rock mass known as “Rock Load Theory”, while working in Swiss Alps for constructing a tunnel. He identified nine classes of rocks with different support requirement for a 5.8 m span tunnel opening. He once said:

“The geotechnical engineer should apply theory with experimentation but temper them by putting them into the context of the uncertainty of the nature. Judgment enters through engineering geology.”

The need for geologist on engineering works gained worldwide attention after failure of *Austin Dam* at Colorado River, Texas, USA in 1900 and *St. Francis Dam*, California, USA in 1928. More engineering failures which occurred the following years also prompted the requirement of formal geological knowledge to work on large engineering projects. Charles P. Berkley, an American trained geologist who was considered the first American engineering geologists, worked on multitude of engineering projects and has studied many dam failures in the USA. He later worked as engineering geologist at Hoover dam. He came up with the first ever document linking geology and civil engineering by writing “*Application of Geology to Engineering Practice*” known also as “*Berkley Volume*” in 1950, published by USGS, New York.

One of the earliest definitions of the "Engineering Geologist" or "Professional Engineering Geologist" was provided by the Executive Committee of the Division on Engineering Geology of the Geological Society of America. The engineering geology since then has come off an age and has now become an important discipline aimed to introduce the critical aspect of geology in construction and mining industry. Even the Engineering Geology, especially at undergraduate level to the students of engineering, where emphasis is more on geology and less on engineering being introductory discipline, is replaced by *Geo-Engineering*, where the emphasis

is more on the engineering and less on geology at an advanced field. The Geo-Engineering is taken over by *Rock Mechanics*, which is a branch more akin to geotechnical engineering of civil engineering rather than geology. Large scale underground excavations for mining mineral resources, have led to the development of *Mining Engineering*, which too needs backup knowledge of geology but it is heavily based on rock mechanics and is akin to underground construction, which too requires large scale excavation, banks more on the rock mechanics and civil engineering rather than engineering geology.

1.3 Civil Engineering

Civil Engineering is an amalgamation of science, art, professional skills and engineering achievements. The requirement of the appropriate construction material of required specification plays an important role to achieve strength and construction economy of structure. Civil engineering works are carried out on or inside the ground surface. As the geomorphological and geological processes operate relentlessly and subject an area to continual change, therefore geomorphic setup and geology of the site are vital for the success of all sorts of civil engineering works in general and for structures made in subsurface conditions in particular. *Earthquake Engineering*, an independent and very advance civil engineering subject too need sound knowledge of tectonics and structural geology for identifying the earthquake prone areas. *Coastal and Marine Engineering*, *Environmental engineering* etc. are disciplines which also need interface of civil engineering and engineering geology. The *Natural Disaster* studies also require knowledge of earth science in general and of civil engineering in particular for working out ways of mitigating them.

Engineering geologic studies may ensue at *Initial Stage*, to build up the logistics based on the office study of the available literature in form of reports, maps, aerial photographs, imageries etc. and accordingly the site or field studies can be planned. This is an important step as the pre-construction planning or feasibility studies, cost benefit analysis, environmental impact analysis etc. are undertaken at this stage. During the *Main Stage*, it is decided that how to progress, what field studies, geological, geophysical, laboratory and insitu tests will be required, so that design parameters are decided. During the *Review Stage*, or *Concurrent Stage*, which may start with excavation and go with the construction phase wherein unforeseen problems are encountered and accordingly some changes are incorporated. The *Final Stage*, or post construction phase is basically a forensic phase of the project wherein monitoring is necessary throughout the design life structure or the project to pre-empt any problem in future.

Why do we have to have a good knowledge of the construction site, the reasons are many, such as:

All grounds are not “terra firma” and may lead to unstable foundations because of the fact that unstable grounds do exist;

Unforeseen situation can always occur because of infinitely variable ground conditions and more so due to inadequate site investigations;

Old mines and mining subsidence, development of brown field areas, land reclamation, underground failure and caving, landslides and other slope failures are not uncommon;

Soft ground settlement and subsidence over clayey soil, marl, chalk, loess deposits etc. and caving in karsted regions are encountered more than often;

Instability of hill slopes in residential locales, protection of road and rail network, in hilly areas need continuous attention.

Hence, there are myriad of problems varying from place to place depending upon their geographical, geomorphological and geological setup i.e. desert, flood plains, cyclone belts, permafrost conditions, erosion by river, wind and coastal waves, Earthquake tsunami and volcanic hazard prone areas etc. As such Civil Engineering designs can response and accommodate almost any geological problem, ground conditions and can counter or moderate natural hazards if they are correctly assessed and understood. Some interface where civil engineers require geological information:

Geological Problems

Engineering Responses

Soft ground and settlement
loading

Foundation design to reduce and redistribute

Weak ground and potential failure

Ground improvement & cavity filling; or avoid hazard zone

Unstable slope and potential sliding

Stabilize or support slope, or avoid landslide hazard prone areas

Severe river and coastal erosion
defences

Slow down process with rock/concrete

Potential Earthquake hazard

Seismic zonation and structural design to withstand vibration and evacuation plan ready

| | |
|--------------------------------|--|
| Potential volcanic hazard | <i>Delimit & avoid hazard zone, predict eruption, have evacuation plan ready</i> |
| Rocks as construction material | <i>Resource exploration and estimation, testing and exploitation</i> |
| Site Survey and Investigation | <i>Photogrammetry, remote sensing, geophysical, geological and engineering geological investigations</i> |
| Natural hazards mitigation | <i>Flood, coastal hazards, landslides, earthquake, tsunami, volcanism, caving</i> |
| Groundwater Exploration | <i>Hydrological properties of rocky aquifers, groundwater and rock strength</i> |
| Rock mechanics and engineering | <i>Rock mass classification and stresses in rocks</i> |
| Strategic storage facility | <i>Underground storage of oil and gas for emergency</i> |
| Nuclear waste disposal sites | <i>Underground trapment in stable continental areas</i> |

India is now concentrating on harnessing its energy and on development of infrastructure. This would require large scale demand for construction material, hydroelectric power generation, large scale mining, tunnelling, underground metros, large scale excavations and slope stabilizations.

Some of these activities would be conducted at greater depths, with varied rock properties and insitu stresses. *Engineering Geology, Geo-Engineering and Rock Mechanics* will act as an important tool during planning, logistics development, operation and implementation of such projects in green and brown field areas.

1.4 Engineering Geological Investigations for Civil Engineering Projects

Before starting a construction project the ground need to be assessed in terms of its suitability and probable difficulties that may come across during construction and also after its commissioning. The objectives of investigation vary with the size and nature of the project and include: (i) cost benefit analysis, (ii) site conditions and ground properties (iii) probable difficulties, (iv) accessibility to the site and logistics involved, (v) availability of construction material, (vi) legal and environmental clearances, (vii) data generation for designing the structure etc.

The cost of ground investigation vary from project to project and site to site but is a must and only costs 0.05 to 0.2 % for buildings, 0.2 to 1.5% for roads, 1 to 3% for dams and 0.5 to 4% for tunnels depending upon the size of the structure and differing ground conditions. Once a project is started and complications start cropping

up then the remedial measures alone can increase the project cost by 10%. It is common to see that construction projects are delayed by unforeseen ground problems, poor interpretation of data, environmental and legal litigations. It has been said that:

“You pay for ground investigation whether you have one or not”

A ground investigation is tailored to the requirement of a particular project to find the most suitable site within the ambit of purpose and economy. The area and depth of investigations depends upon the dimensions involved in the project. Data generated during investigations are incorporated during the designing of structure so that it should last at least for designed time span or more.

The investigations should also recognize possibilities of difficult and unforeseen ground conditions in and around the proposed project so that alternate site can be considered or some engineering measures are taken to remedy or improve the site. Some common problems encountered in rocky areas are:

- *Unconsolidated, soft and expansive ground material.*
- *Presence of glacial outwash, drift, colluvial and fluvial gravel deposits with varying thickness and depths.*
- *Weathered, weak and profusely fractured rock outcrops and bed rocks.*
- *Old or abandoned landfill or mining site.*
- *Natural (cavernous ground) or manmade cavities (abandoned shafts and mines) within the bed rocks.*
- *Shallow groundwater table, cutting or breach of a confined aquifer.*
- *Creeping or active slopes or areas of land sliding.*

1.4.1 Stages of Ground Investigations

Any mega project is envisaged to improve the standard of living of the society and not only involves heavy expenditure but lot of time to get completed. Hence before starting a project all of pros and cons are taken into consideration to get maximum benefit out of the

project. The place where a project is to be started for example a dam and reservoir system, the area involved is usually very large and to finalize the site of the dam so that a good founding ground and a proper reservoir site can be located with minimum of environmental degradation and also within proposed budget. Lots of permutations and combinations are to be weighed, in terms of safety and cost benefit analysis before pin pointing the final site. In case a new road or rail line are to be layed, then locations of tunnels, bridges, their alignment, dimensions, methods to be employed for excavation and construction etc. should be worked out prior to starting the tunnelling operation. For example to extend rail line beyond Rishikesh (Uttarakhand) to Karan Prayag (Uttarakhand), based on preliminary investigation using remote sensing and other methods three rail route alignments were recommended by engineers for around 130 km. The first alignment has 82 tunnels, 154 bridges; second alignment has 90 tunnels and 126 bridges while the third

alignment has 84 tunnels and 160 bridges of different lengths. It is after detailed analysis, ground surveys, field checks, geological and geophysical investigations as well as cost benefit analysis will be carried out and any one of these alignments will be finalized before starting the project. Once project is finalized and started, even then some changes may have to be made locally depending upon the situations and requirements during the construction phase.

What we can infer from the above paragraph that investigations of different types are involved at various stages of a project for example: (i) *Preliminary Stage*, (ii) *Main Stage* and (iii) *Concurrent Stage*.

1.4.1.1 Preliminary Stage: It is also called as reconnaissance stage where a project is in planning stage. It requires *Office* or *Deskstudy* which involves gleaning through already available literature in form of topographic maps; aerial photographs satellite imageries, geological maps and reports etc. The available topographic and geological maps

may not be at suitable scales at this stage but will give a broad idea about the area.

Site visit may then be undertaken for visual assessment of the area and to gather information available with local populace. A first hand idea about local topography and geology can be ascertained if experts are available with the team. A *preliminary report* can be made to chalk out detailed field work plan, once the feasibility of the project is established.

1.4.1.2 Main Stage: Once the project gets green signal then multitude of site investigations are undertaken which involves *detailed fieldwork* to have detailed information about the soil and rocks. Fresh surveys are undertaken at small scales for ascertaining the topography and geology of the area. For shallow subsurface information trial pits and trenches, exploratory adits or shaft may be made. For knowing about deep underground conditions drilling, bore hole logging and geophysical surveys can

be carried out. The samples of soil and rocks are collected for the *laboratory tests* and analysis. If some insitu testing is required it is also undertaken at this stage. After corroborating the data from field and laboratory a *final report* is prepared. Final report includes detailed topographic and geological maps at scales which can mirror the minute details of the site. Fence diagrams can be made to get three dimensional perspective of the site.

1.4.1.3 Concurrent Stage: Once it is decided that a particular site is good for the project the work related to construction is started based on the information gathered at main stage of investigations. Now excavations is done for creating opening or for laying foundation and if some new situation arises which could not be detected in previous investigations should be taken into consideration and changes can be recommended accordingly in the design. Because it has been found that unforeseen and

unwarranted problems can come up any time especially in the hilly and/or rocky areas, hence it has been said that:

“Design as you go, be ready for the worst and hope for the best.”

1.5 Desk Study

In the preliminary stage after the conceptualization of a project one starts in his or her office by gleaning through already published and unpublished material. This is the first step to make basis for the feasibility of the project as well as for planning further investigations and explorations. The material may include reports, maps, aerial photographs, remote sensing imageries etc. made either as routine analysis of that region or are the result of some other project. The procurement of these materials requires visit to university libraries, libraries of specific departments or can be requested through post from departments holding these documents. As generation of such material requires lot of finance, the organizations may charge some money while sharing the

information. Some information may be of classified nature due to strategic or security concerns hence may not be easily available.

Depending upon the importance of the project even this information can be sequestered through proper official channel.

In India different organizations are working on generating data base for different kinds of floral, faunal, geological resources.

Maps are the most basic necessity for understanding the topography. Maps are available at different scales with different themes and can be used for developing spatial data base for an area to get information about human habitation if any, related civil utility structures, political boundaries, nature of forest and soil cover.

The important organizations which can provide such information include:

Geological Survey of India (GSI), with its head office at Calcutta and offices at capital of the states provide geological maps at different scales.

Survey of India (SOI), with its head office at Dehradun is entrusted with making surveys to provide maps of different kinds at different scales. The base map on the scale of 1:50,000, popularly known as *topographic sheets* or in short "*toposheets*", is a detailed map providing all the basic information including topography of an area. Aerial photographs are also provided by Survey of India.

National Remote Sensing Agency (NRSA), of Hyderabad has the authority of making satellite photo maps or imageries. The remote sensing data can be had as hard copy or as soft copy or in digital form.

There are many other ministries and organizations such as Ministry of Environment and Forest, Central Pollution Control

Board, New Delhi, Oil and Natural Gas Corporation Ltd., Departments of Mines, Coal India Limited, State Directorates of Geology and Mining, Department of Atomic Energy, Public Work Departments etc. can also provide information about the topography and geology of areas under their control. Now a dayslot of data are available with private organizations which can also be requested for such data. Internet has become a big repository of such material and data and can be accessed to get at least some basic and preliminary data to start with.

Lot of useful information can be gathered from local residents, farmers, teachers from schools, colleges, universities and other academic institutions.

1.6 Detailed Field Study

Depending upon nature and size of the project detailed field study is undertaken which involves surveys of different kinds made on the

surface for alignment, topography, soil and rock types. Sub surface exploration is also carried out to see extension of soil and rock underground and variation therein, depth of soil-rock contact, presence of discontinuity surfaces in terms of kind, number and their potential of causing problems.

1.6.1 *Trial Pit and Trench*

The easiest and cheapest method of exploring shallow depths directly is of digging equidimensional pits and linear trenches. This can be done manually or by using machine with backhoe. 1 to 5m deep pits and trenches can be easily made and can be used for further exploration by plate load test as well as to see old failure surfaces, weak zones etc. More than 2m deep digging may require support bracings so as to avoid their slippage. If the pit or trench is not going to be used for laying foundation then it should be properly back filled by soil, gravel or by lean concrete.

1.6.2 *Exploratory Adits or Drift*

These are horizontal to inclined holes made through exposed rock sections or from already created over or under ground opening. The dimensions can vary depending upon nature of exploration from 1.0 to 1.5m wide, 1.5 to 2.0m and 3.0 to 5.0m deep. The purpose may be to see the type of rock(s), depth of weathering; orientation and extension of discontinuity especially shear zones in to the rock mass. The floor of these openings should slope towards the entrance to help drainage and removal of excavated rocks. The adits or drifts are used for estimating bridging capacity of unsupported span i.e. to carry its own weight without falling. It is also used for making insitu tests for working out geotechnical properties of rock mass (Fig. 1.1).

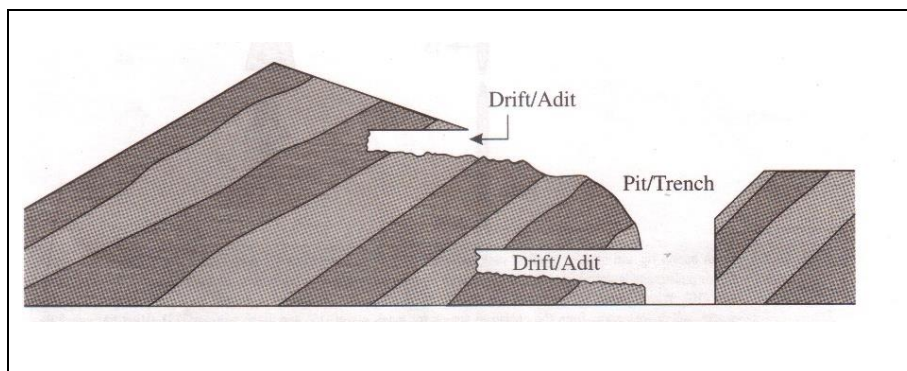

Figure 1.1: Exploratory trench, drift to expose fresh rocks for investigations and insitu testing.

1.6.3 *Borehole Drilling*

Another direct exploration method which is usually employed is exploration by borehole drilling for soil as well as for rock to know deeper ground conditions especially for large scale structures such as dams, bridges, large chimneys, nuclear installations and other strategic buildings. The depth of boring depends primarily on the geology of the area and loads to be exerted by the structure. There are different methods of drilling starting from light percussion drilling used for making boreholes in soil easily up to 25m to rotary core drilling with diamond drill bits, for making boreholes in rocks up to 150m. The drilling methods have seen lot of technological advancements especially due to petroleum industry where drilling up to 5km is not uncommon for oil and gas, but in all kind of engineering explorations drilling rarely goes beyond 50m (Fig. 1.2). The important elements and functioning of drilling system for shallow rock exploration includes a three leg derrick with crown sheave hook

and wheel for pulling and lowering casing using hoisting rope. The system is driven by power generating unit connected with the help of cathead. Water swivel connects drill rod to wash pipe or T-pipe and then to a pump which gets outwash water, soil and rock chips through casing, collected into sumps. Other important parts include T-section for return flow, coupling to join drill rod with casing and drill rod coupling with drill shoe and drill bit. The commonly used drill bits are straight bit or side bit (Krynine and Judd, 2005).

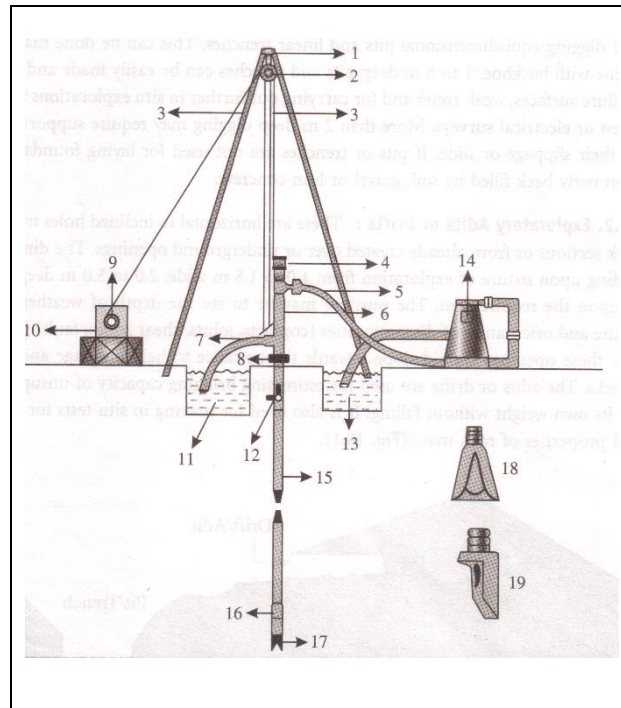

Figure 1.2: Wash boring rig and bits for shallow rock exploration. A (1) three leg derrick, (2) with crown sheave hook and wheel(2), (3) Hoisting rope, (4) Water swivel, (5) Wash pipe or T-pipe, (6) drill rod, (7) T-section for return flow, (8) coupling to join drill rod with casing, (9) cat head, (10) power generating unit, (11) outwash and samples, (12) drilling rod coupling, (13) In wash water storage, (14) pump, (15) casing, (16) drill shoe, (17) drilling bit, (18) straight bit and (f) side bit (Krynine and Judd, 2005).

To optimise the number of drill holes, geophysical methods are employed to make generalizations in between the drill holes and drilling is carried out at identified critical areas.

1.7 Drilling Methods

Most commonly used method not only to extract samples but also to make direct observations regarding rate of drilling and depths of change in lithology. The selection of drilling system depends upon depth of drilling, nature of lithology i.e. soil or rock, soft or hard rock, terrain type, accessibility to the area and economics. Here few simple drilling systems for rocks will be discussed to explore subsurface conditions for civil engineering point of view.

1.7.1 Jack Hammer Rock Probing

It is a manually operated or truck mounted pneumatic rock drilling device using compressed air for making small depth holes in rocks. The samples come in form of dust to small broken rock chips which can be collected and observed to know the rock type. Rate of drilling or penetration indicate strength of rocks, presence of cavities or weak rock zones. Some field geology and previous drill records with jack hammer probing can give working subsurface picture for small sized projects.

1.7.2 Percussion or Cable and Tool Drilling

For soft or weathered rocks using 'A' Frame, cable with powered winch can be used. Its main component is a steel shell, which has a chisel head to cut rock and clack valve to hold sample, mainly as chip. It is repeatedly lifted and dropped with the help of cable, from 1 to 2m. The sampler has usually 100mm diameter and can be lowered through 150mm casing in case of high water table. Ten to twenty five meters of drilling exploration can be done. Apart from getting samples, depth of water table, presence of shear zones and cavities can also be known (Fig. 1.3).

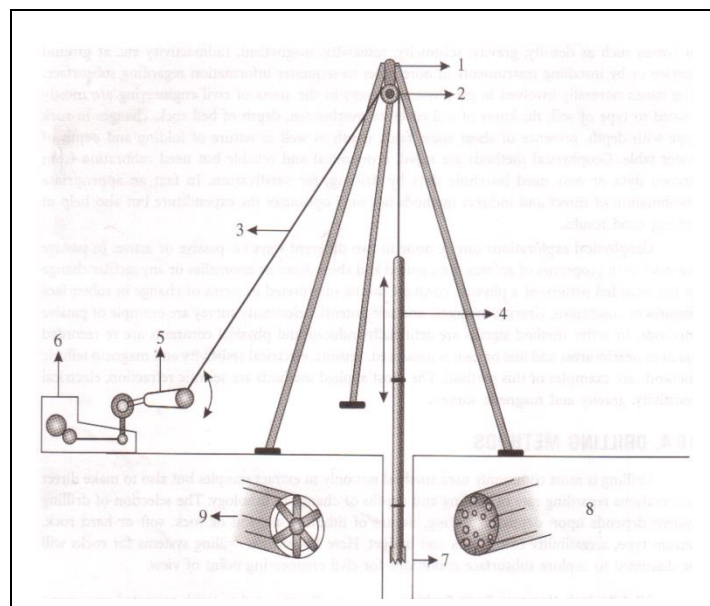

Figure 1.3: Important parts of a cable tool rig. (1) Derrick with (2) sheave attached through a (3) cable to drive (4) drilling stems at one end and to (5) walking beam at another end for imparting up and down percussion movement by (6) power motor. The (7) drill bit is screwed at the end of drill stem. Commonly used bit for rotary-percussion drilling (8) studded bit for drilling in medium to hard rocks and (9) cross-chisel bit for boulder or broken rock debris rich overburden (Bell, 1980; Krynnine and Judd, 2005).

1.7.3 Core Drilling

For hard rocks and deeper investigations 'A' frame on ground rotary drilling for shallow depths (10 - 50m) or truck mounted rig (25 - 100m) with forced rotary drive can be used and rock samples are taken in form of cylindrical core. The rocks are cut by rotational process which may vary from 50 to more than 500 rotations per minute depending upon the machine, drill bits and hardness of the rock (Fig. 1.4a, b). With large diameter core more information about different parameters of rock mass and discontinuities can be worked out and at the same time core recovery also improves with large diameter diamond drill bits. In most of drilling for engineering

purposes such as to workout *Core Recovery Percent* or *Rock Quality*

Designation NX size (54 mm dia) is used.



Figure 1.4: (a) Diamond core drilling setup. (b) Diamond drill core barrel for NX size cores

1.7.3.1 Rock Quality Designation: This index property of rock mass is the extension of core recovery percentage which is calculated as percentage of total core recovered of the total depth of drilling. Deere in 1964 refined this concept by considering only those part of the core which is intact and is more than 10 cm in length and has accordingly gave five classes of rock mass. The premise in this concept is that the incidence of joints or any other discontinuity will automatically inflict a break in a core, unless the joints are healed.

For example if rocks are heavily jointed or a shear or fault zone is passing then even getting a core of 10 cm in length will be difficult.

At the same time the process of drilling and recovery of core may result in to breaking of core at places where as such there is no discontinuity surface. Such breaks can be identified by the absence of discolouration, normally found even along a very tight joint plane.

$$RQD = \frac{\Sigma \text{Length of all core pieces } (> 10 \text{ cm})}{\text{Total core length}} \times 100$$

International Society of Rock Mechanics recommends Double Tube Core Barrel Diamond Drilling System to recover 54.7 mm (NX) diameter with preferable length of drilling of 1.5 to 2.0 m. If drilling is to be done for higher depth then too the RQD should be calculated every six meters and then average may be taken (Fig. 1.5).



Figure 1.5: NX sized core obtained after drilling.

The assumption in this test is that the presence of joints and their inter connection will naturally break the rocks and will be reflected as core length. The closer are joints smaller will be the core while rocks with sparse joints will give bigger cores. The rate of drilling non recovery of cores etc. can also be interpreted in terms of rock strength, presence of shear or crush zones, cavity etc. The RQD values are used as ready reference of rock mass properties as per the following table:

Table 1.1: Rock Quality Designation Classes

| Sr. | Rock Quality Designation | Rock Mass |
|-----|--------------------------|-----------|
| | | |

| No. | (%) | Class |
|-----|---------|-----------|
| 1 | > 90 | Excellent |
| 2 | 75 - 90 | Very Good |
| 3 | 50 - 75 | Good |
| 4 | 25 - 50 | Fair |
| 5 | < 25 | Poor |

1.8 Geophysical Exploration Methods

The geophysical investigations are based on the measurements of different physical properties such as density, gravity, seismicity, resistivity, magnetism, radioactivity etc. using specially designed instruments on the ground points as well as in bore holes to sequester information regarding of subsurface. Geophysical methods are rapid, economical and reliable but need calibration from known data or may need borehole data for verification. In fact an appropriate combination of direct and indirect methods not only

optimizes the expenditure but also help in getting good results. Apart from geological or engineering geological surveys geophysical explorations are also used for detecting subsurface leakage in pipe lines, sewer lines, buried old pipe lines, ammunition storage, abandoned shafts, small mines, and treasures etc. as non geological uses. For some mega civil engineering projects such as site selection of dams, reservoirs, tunnels, bridge foundations etc., geophysical explorations are invariably used to get clear picture of subsurface conditions in following terms:

Thickness of overburden - Presence of soil or weathered rocks, either to be removed for reaching the sound foundation rocks or to be located as thick loose rock debris to be used as construction material.

Depth of bed rock - Depth and three dimensional extent i.e. basement relief of sound rocks suitable for foundation.

Presence of weak zones - Detection of cavities, cavernous rocks, shear and fault zones which may not only act as weak zones but may also act as zones of water leakage as well as major rock structures.

Groundwater potential - Finding out regions with high groundwater potential and its favourability or non favourability for specific project.

Rock mass exploration - To understand weathering extent, type, thickness, attitude and extension of different rocks in subsurface.

Some important geophysical methods are explained in following sections.

1.8.1 Gravity Method

This method uses the earth's natural force of gravitation which pulls down different objects towards it at the rate of 980cm/sec^2 or 980 gal (standard value). One gal is an acceleration of one centimetre per second per second. This value varies from equator (978.049 gal) towards poles (983.221 gal) mainly due to variation in the radius of

the earth. The theory behind this method is that for every place of the earth there is a theoretical value of 'g' called as 'g_T' which is related to the latitude of that place by a formula:

$$g_T = g [1 + 0.0052884 \sin^2 \phi - 0.0000059 \sin^2 2\phi]$$

Where, 'g' is the standard value of acceleration due to gravity (978.049 gal at sea level) and g_T is the theoretical value of 'g' at a place having latitude ϕ . But if we compare gravity measurements of two places at same latitude we may get different results, primarily due to difference in mean sea levels, the rock mass present between sea level and station level and effect of a topographic high or low near the 'g' measuring station. To get exact results following corrections are to be made:

Free air correction: As most of the station are above sea level and 'g' values decreases with increasing altitude. A correction is to be added as +30.86 milligal per 100m increase.

Bouguer reduction: The rocks between sea level and station will add to the gravity values depending upon density of rocks and altitude. Hence in this correction some value is to be detected. Free air correction and Bouguer reduction can be worked out for 100m elevation by formula:

$$g_o'' = g + H(0.0003086 - 0.0000421\rho) \text{ gals}$$

where " g_o'' ", is gravity corrected for free air and Bouguer corrections, H is the height from the mean sea level and ρ , density of rocks.

Terrain correction: The presence of considerable relief near the station has to be taken into account by compartmentalizing the region around the station in radial manner and by taking average height of the compartment as shown in the figure 1.6 and then calculating its effect as:

$$g_t = k \cdot \rho \cdot \phi (r_1 + \sqrt{r_2^2 + h^2} - \sqrt{r_1^2 + h^2} - r_2)$$

where g_t gravity after terrain correction, k is gravitational constant, ρ is density of rocks, h, average elevation in centimetres of the compartment above or below the instrument, ϕ angle between radius

of inner bounding circle, r_1 and r_2 , is of outbounding circle.

Standard charts and tables are available for these corrections.

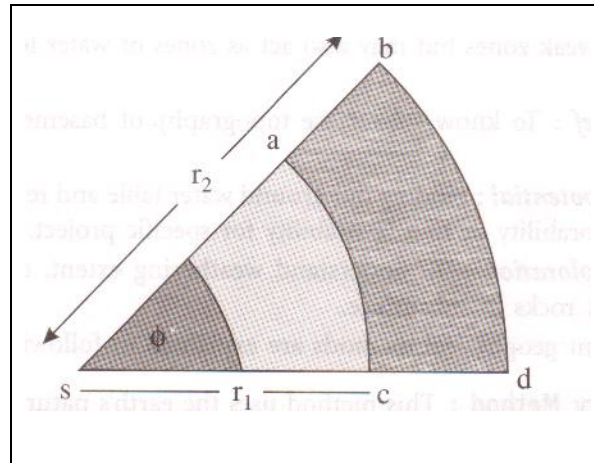

Figure1.6: Topographic correction by compartmentalizing an area. For gravitational effect of compartment, $abcd$ with respect to station S. r_1 and r_2 are radii of inner and outer bounding compartments respectively in centimetres.

The difference still remaining (Δg), positive or negative, is called as *gravity anomaly*, after applying all the corrections and getting ' g_{OIC} ' (observed and corrected), reflects conditions below ground surface in terms of rock type, size, shape and distance from the observer.

$$\Delta g = g_{OIC} - g_T = +ve \text{ anomaly} \quad \text{OR} \quad \Delta g = g_{OIC} - g_T$$

$$= -ve \text{ anomaly}$$

Positive anomaly is an indication of dense material underneath while negative anomaly indicates material of lesser density. The survey is conducted along a linear tract or along the grid lines which can be interpreted in terms of rock types and geological structures. The values observed are usually very small, denoted as milligal or gravitational unit ($1\text{gu} = 10^{-6} \text{ m/sec}^2 = 0.1 \text{ milligal} = 1/10,000 \text{ gal}$) and can be plotted in form of contours termed as *isogals*, to get the regional perspective of the area.

Gravity surveys have been found to be very successful in delineating the fault zones, buried ridges, buried channels, salt domes, igneous intrusions, cavities etc. Gravity surveys are also carried out for very large regions to work out overall geological structure of a region or even of a country. For this airborne gravity surveys are conducted by installing strong gravimeter in aircrafts and equi-potential lines based on observed gravity are drawn in form of contour lines. Some

conceptual models of observed gravity anomaly and its interpretation

is given in figures 1.7a to 1.7f.

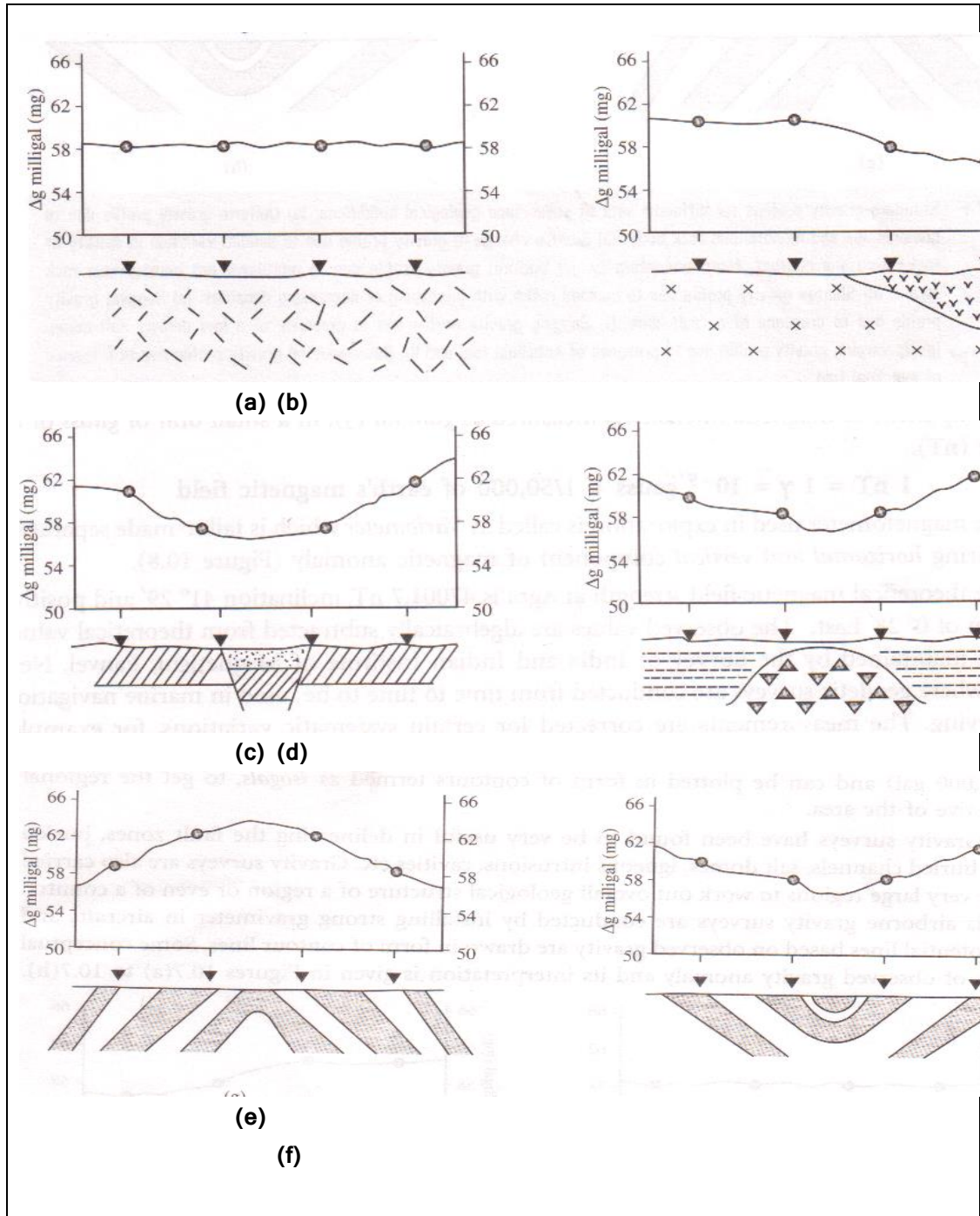

Figure 1.7: Standard gravity profiles for different sets of subsurface geological conditions. (a) Uniform gravity profile due to homogenous and monotonous rock body. (b) Sudden change in gravity profile due to sudden variation in density of rocks across a contact, fault, unconformity.(c) Sagging gravity profile due to presence of a fault zone. (d) Sagging gravity profile due to presence of a low density salt dome. (e) Up warping gravity profile due to presence of anticlinal fold and (f) Down warping gravity profile due to presence of synclinal fold.

1.8.2 *Magnetic Method*

Earth is a huge magnet, it owes its magnetism mainly due to the interaction of solid inner and liquid outer core. A substance lying in the earth's magnetic field will be susceptible (k) to magnetization which is a ratio between strength of the induced magnetization (I) and strength of the magnetic field (H) as:

$$\text{Susceptibility } k = I / H$$

Rocks have minerals and minerals have magnetic susceptibility such as haematite, 0.2 - 0.6; magnetite, 0.3 - 0.8; ilmenite, 0.115 - 0.135; siderite 0.1 - 0.4; pyrrhotite, 0.110 - 0.125 etc. Iron ores, rocks with high magnetic minerals i.e. igneous rocks which are mafic or ultramafic and objects made of iron can be easily detected if

magnetic anomaly is high. For using magnetism for geophysical exploration vertical component of magnetic intensity is measured as *gamma* (γ), a small unit of *gauss* or as *nanotesla*(nT).

$$1 \text{ nT} = 1 \gamma = 10^{-5} \text{ gauss} = 1/50,000 \text{ of earth's magnetic field}$$

The magnetometer used in exploration is called as *Variometer* which is tailor-made separately for measuring *horizontal* and *vertical* component of magnetic anomaly (Fig. 1.8).

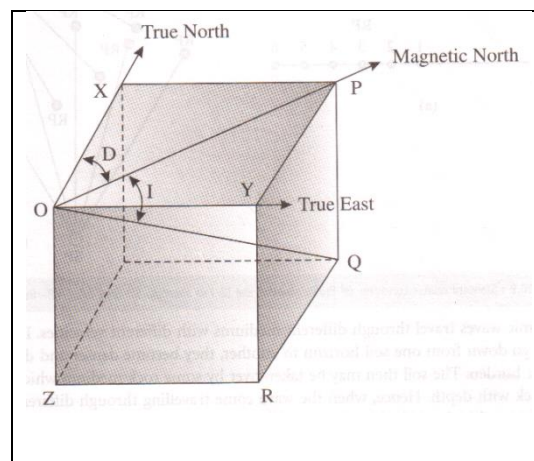

Figure 1.8: Components of earth magnetic field applied to northern hemisphere. X points north and Y points east. Q is the total intensity of the magnetic force whose horizontal component is P and vertical component Z. The magnetic dip I is measured in the plane containing P and Q while magnetic declination D is measured in horizontal plane containing PXOY.

The observed values are algebraically subtracted from theoretical values which are maintained by the Survey of India which conducts geodetic survey from time to time to be used in marine navigation.

The measurements are corrected for certain systematic variations for example *temperature, diurnal changes and secular horizontal declination*. Air bornemagnetic exploration methods have been used to detect intrusive igneous rock bodies especially dikes by comparing the known susceptibility of rocks for example granite, 0.0027; gabbro, 0.0073; basalt, 0.0143 etc. For exploring man made features such as buried or abandoned shafts, pipelines this method is found to be very reliable.

1.8.3 Seismic Methods

As we know that seismic waves originating from earthquake events have been used as 'X' rays for exploring the earth's deep interior.

The small doses of seismic waves produced by hammer drops, explosions etc. are used for exploring shallow parts of the earth crust

for mineral, oil - gas and civil engineering purposes. Seismic waves when travel through different layers of the earth they get reflected and refracted from the strata boundaries and return back to the ground surface where their arrival are recorded with the help of geophones. Geophones are placed at equi distance in linear or radial manner depending upon nature of exploration i.e. profile shooting for linear exploration and fan shooting for covering large area for survey (Fig. 1.9) and are connected by wires to amplifiers and recording camera and a device for noting time every hundredth of a second, usually placed in a designed truck. The distance up to which geophones are to be installed is usually ten times the depth to be explored. Seismic reflection methods are mostly used for very deep explorations usually for petroleum. For exploring shallow depths or for civil engineering purposes seismic refraction method is used. Seismic waves travel through different mediums with different velocities. It has been found that as we go down from one soil horizon to another

they become denser and denser with depth due to over burden. The soil then may be taken over by some rock medium which may change to another rock with depth. Hence, when the wave come travelling through different mediums they record higher and higher velocities, which in turn are recorded in terms of different rock types from the standard chart (table 1.2).The velocities in weathered or heavily fractured rocks will be less while rock saturated with water will give higher seismic wave velocity as compared to non saturated rocks.

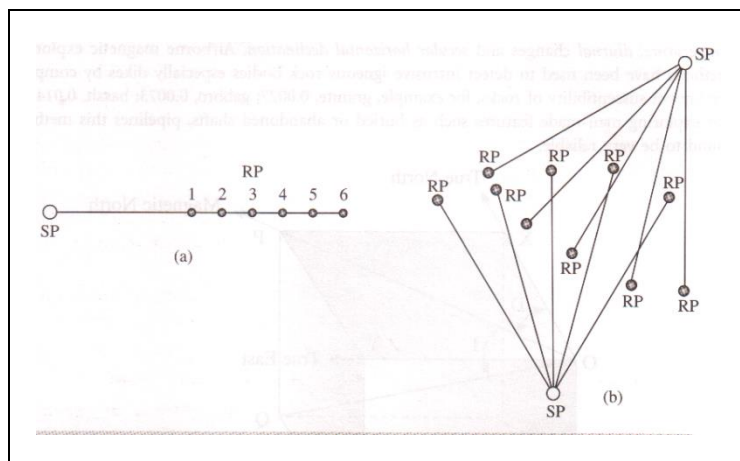

Figure 1.9: Standard seismic surveying. (a) Profile shooting and (b) Fan shooting. SP - Shot point, RP - Receiving points.

Seismic waves have been used for exploration of the subsurface for the minerals, ores and hydrocarbons. For exploring small areas and depths, these waves are generated artificially and are recorded by network of geophones in terms of their arrival time, arrival time gap and arrival locations of direct and indirect waves to know the subsurface distribution of earth materials.

Table 1.2: Average seismic wave velocities in different soil and rock mediums.

| Soil / Rock | Seismic Wave Velocity (km/sec) | Soil / Rock | Seismic Wave Velocity (km/sec) |
|-------------|--------------------------------|-------------|--------------------------------|
| Loose Silt | 0.15 – 0.30 | Limestone | 2.50 – 6.50 |
| Dry Sand | 0.15 – 0.45 | Phyllite | 3.00 – 5.80 |
| Wet Sand | 0.50 – 0.70 | Schist | 3.50 – 5.70 |
| Clay | 1.50 – 2.50 | Gneiss | 4.00 – 6.50 |
| Gravel | 0.50 – 1.50 | Granite | 4.50 – 6.00 |
| Sandstone | 1.50 – 4.00 | Basalt | 5.50 – 6.50 |
| Shale | 2.00 – 4.50 | Gabbro | 6.50 – 7.00 |

Scientists have used a stronger source of seismic waves to fathom the bigger and deeper areas of the earth. The principle of exploring the subsurface can be understood with the help of figure 1.10. When

seismic waves are generated through artificial means, waves travel along surface with velocity V_1 and can be recorded by different seismographs as the “direct” waves. These waves reach these recording devices (I, II, III), closer to the shot site before the “indirect” body waves with velocity V_2 , which are coming through the subsurface lower layers hence travelling longer path requiring more time. But, at device IV both the “direct” and the “indirect” waves reach at the same time because the indirect wave covering longer path has compensated the time loss by achieving higher velocity due to higher density of the subsurface denser material. After the device IV all the devices will first record arrival of the “indirect” waves, followed by the “direct” waves (V, VI, VII etc.) which are much away from the site of the shot. The distance between the shot site and the device IV is called as the “Critical” distance “X” and by using the following formula the depth of first discontinuity surface can be worked out.

$$H = \frac{X}{2} \sqrt{(V_2 - V_1) \div (V_2 + V_1)}$$

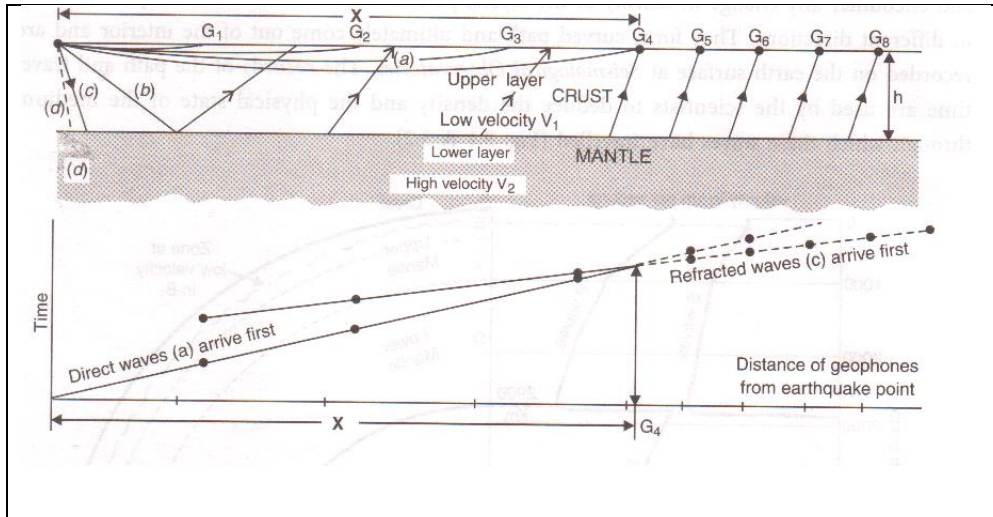

Figure 1,10: Schematics showing wave path from an earthquake site , measured by different geophones (G₁ to G₈) with corresponding time distance graph for arrival of direct and indirect waves. Also see the “Critical Distance - X”.

1.8.4 Electrical Methods

The electrical methods of geophysical exploration measure either the electricity generating capacity termed as *Self Potential* method or resistance to flow of induced electrical currents of earth’s natural material termed as *electrical resistivity* method. The self potential method is normally used to explore the presence of iron and sulphide ores as these materials are capable of generating electricity, though very feeble but can be detected by using sophisticated

instruments. From civil engineering point of view electrical resistivity method is more pertinent especially for detecting thickness of overburden, subsurface distribution of rocks, groundwater resource, leakages from pipe, canal, reservoir etc. The rocks are as such resistant to conduction of electricity but the presence of moisture in rocks or high percentage of iron bearing minerals in a rock will reduce the resistance. It is based on the premise that the free water which moves freely from pore to pore constitutes effective porosity. As an order of magnitude, the effective porosity can be for instance 70 to 80% of the total porosity in gravels and granular sand, 50 to 60% in fissured rock and 30 to 20% in fine sand and silt. This free water due to various dissolved salts is ionically conductive and enables electric currents to flow into the ground. Consequently, measuring the *ground resistivity* can give an idea of the presence of water.

$$\text{Conductivity (micro Siemens/cm)} = 10^4 / \text{Resistivity (ohm.m)}$$

Conductivity (micro Siemens/cm) = 1.4 x Total Dissolved Salts (mg/l)

A standard for drinkable water is 10 ohm.m, or 1000 micro seisms/cm, or 0.7 g/l. Following basic principles are:

(i) A hard rock without pores or fracture and a dry sand without water or clay are highly resistive to flow of electrical currents in order of several tens of thousands ohm.m.

(ii) A porous or fractured rock bearing free water has a resistivity which depends on the resistivity of the water and on the porosity of the rock in order of several tens to several hundred ohm.m.

(iii) An impermeable clay layer, which has bound water, has a low resistivity few units to several tens ohm.m.

(iv) Ametallic mineral or ore bodies (iron, manganese, copper sulphides) have very low resistivity due to their high electrical conductivity mostly lower or much lower than 1 ohm.m.

The resistivity of a porous non-clayey material can be estimated by the following Archie law formula:

$$\text{Rock resistivity} = a \times (\text{water resistivity}) / (\text{porosity})^n$$

Where “a” and “n” are constants which depend on the nature of the rock. In a very rough approximation, “a” can be taken equal to 1 and “n” to 2. For example, 10 ohm.m water and 20% porosity give a rock resistivity of the order of 250 ohm.m.

For measuring the ground resistivity, an electric current has to be transmitted with two electrodes, while the potential created on the surface by the circulation of this current into the ground is measured with two other electrodes. By increasing the distance between the transmitting and the receiving electrodes progressively, permits to explore greater depth, termed as Depth *Profiling* or *Sounding Array*, also to determine aquifer depth and its thickness (Fig. 1.11 a). Setting the four electrodes together at fixed distances along a traverse line helps in to detect lateral change of resistivity, termed as

Horizontal Profiling or **Profiling Array**, mainly to detect fault or fracture zones (Fig. 1.11 b). The shows of potable groundwater with resistivity of 10 to 100 ohm.m range will give aquifer resistivity in the range of 50 and 2000 ohm.m.

The equipments include a generator or high voltage battery as source of current, ammeter and potentiometer to measure current and potential difference four stainless steel, copper or metallic spikes for current and potential electrodes with a length of 80 cm and diameter of 2 cm and insulated cables on reels. The standard resistance of some important rocks are given in table 1.3.

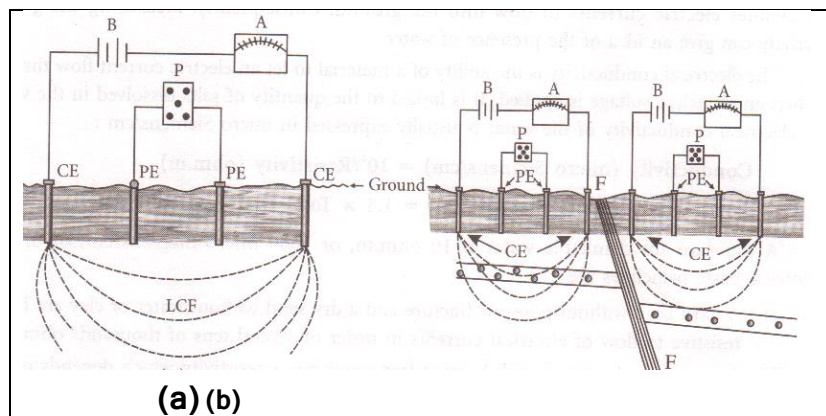

Figure 1.11 (a) Wenner's arrangement for (a) Sounding array and (b) Profiling

array

Table 1.3: Standard resistivity values of some important rocks.

| Rock | Resistivity (<i>ohm-m</i>) | Rock | Resistivity (<i>ohm-m</i>) | Rock | Resistivity (<i>ohm-m</i>) |
|--------|---------------------------------|---------|---------------------------------|-----------|---------------------------------|
| Marble | $10^4 - 10^8$ | Granite | $10^3 - 10^6$ | Limestone | $10^2 - 10^4$ |
| Gneiss | $10^3 - 10^7$ | Gabbro | $10^3 - 10^5$ | Sandstone | $10 - 10^3$ |
| Slate | $10^2 - 10^7$ | Basalt | $10^3 - 10^5$ | Shale | $1 - 10^2$ |

Specific geophysical techniques are being applied successfully in most of the major projects to unravel the unseen portion of the subsurface. Once a two or three dimensional model is established one can visualize the correct picture of distribution of soil, rock head, bedrock profile, rock contacts, fault, heavily fractured zone, presence of cavities, water saturated zone, fault etc. If need be, then based on geophysical data some points can be marked for exploratory drilling to cross check the results.

The site exploration should be suited to the requirement of the project and the techniques employed should be in accordance with the size and importance of the project. If the project is small in terms of area covered and limited expenditure then data collected during reconnaissance stage may be enough but if the project is big covering large area and has ramifications on subsurface structure of the ground then a full fledged site investigation may be required as shown in following flow chart.

Summary

The importance of geology in mining has been known from time immemorial. But its use as engineering geology, in Civil Engineering has been given due importance only in last century or so. The importance of geology in civil engineering can be summarized as follows:

- Geology provides a systematic knowledge of construction material, its occurrence, composition, durability and other physic-mechanical properties.

- The knowledge of the geological work of natural agencies such as water, wind, glaciers, helps in planning and carrying out major civil engineering works in different climatic regions. For example the knowledge of erosion, transportation and deposition helps greatly in solving the expensive problems of river control, coastal and harbor work and soil conservation.
- Some spasmodic but strong events caused by earths dynamism such as landslides, volcanism and earthquake need to be well understood in terms of place and magnitude to save human achievement.
- The knowledge of groundwater system, about its quantity and depth of occurrence in consolidated and unconsolidated earth materials are needed, in connection with water supply, irrigation, excavation and many other civil engineering works.
- The foundation problems of buildings, bridges, retaining/containment walls, dams etc. are directly concerned with the geology of the area. Construction of docks, dikes, jetties etc. need engineering geological investigations.

- Constructing roads, especially in hilly areas in determining the stability of cuts and slopes need proper engineering geological investigations.
- Before starting a major engineering project at a place, a detailed geological report followed by geophysical investigations and drilling to corroborate the data and to prepare detailed engineering geological maps and sections is prepared. Such a report helps in planning, designing and construction. The cost of engineering works will considerably be reduced if proper investigations are made beforehand.
- The geological studies form the basis for identifying locales of interest. It provides the mining engineer with details of the location, structure and distribution of ore in a deposit, using geo-scientific techniques.
- It plays a crucial role in the optimization of the ore body and is intimately involved in the mine planning.
- Geology or mining geology, geo-engineering and rock mechanics play a key role in the development of open pits and

quarries. The underground excavation, design of support system, construction of adits, tunnels, shafts, raise etc. all need proper understanding of rock mechanics, an advance version of engineering geology.

- Working as part of a multidisciplinary team, geologist, mining and civil engineers ensure the safety.

Frequently Asked Questions (FAQs)

1. What is the role of geology in civil engineering projects?

GEOLOGY

Paper: Hydrogeology and Engineering Geology

Module: Role of Engineering Geology in Civil Construction and Mining Industry

Engineering Geology is the application of the geologic sciences to engineering practice to assure the safe location, design, construction, operation and maintenance of civil engineering works, which may not be adversely affected by potential geological problems. The working arena of the engineering geology essentially in the regions where geological processes and manmade structures interact and latter's safety and longevity are to be ensured.

Proper investigations and analyses are needed to provide geological and geotechnical recommendations to ensure availability of proper construction material and safe founding ground.

Broadly three aspects are important i.e. the study of "*Rock Material*", used in construction industry such as building stones in terms of its availability and its strength properties. Secondly, the study of "*Rock Mass*" or founding rocky ground, over/under which engineering operations are to be carried out leading to loading or unloading of rock mass. Thirdly, the "*endogenous*" and "*exogenous*" geological processes which operate around the construction edifice and either hamper its construction or affect its functioning in future.

2. What do you understand by engineering geological investigations?

Any mega project is envisaged to improve the standard of living of the society and not only involves heavy expenditure but lot of time to get completed. Hence before starting a project all of pros and cons are taken into consideration to get maximum benefit out of the project. It is after detailed analysis, ground surveys, field checks, geological and geophysical investigations and cost benefit analysis are carried out before finalizing the project. The engineering

geological investigations are done at different stages of a project such as: *Preliminary Stage, Main Stage* and *Concurrent Stage*.

The investigations may start from the literature survey, followed by field surveys, geophysical investigations, drilling and performing various lab and field tests at different stages of planning and construction.

3. What are the important ground aspects need to be investigated in any mega project?

The nature and type of investigations varies with nature and size of construction. Following are the important aspects invariably investigated:

Thickness of overburden or depth of bed rock - Presence of soil or weathered rocks, either to be removed for reaching the sound foundation rocks or to be located as thick loose rock debris to be used as construction material.

Depth of bed rock - Depth and three dimensional extent i.e. basement relief of sound rocks suitable for foundation.

Presence of weak zones - Detection of cavities, cavernous rocks, shear and fault zones which may not only act as weak zones but may also act as zones of water leakage as well as major rock structures.

Presence of Groundwater - Finding out regions with high groundwater potential and its favourability or non favourability for specific project.

Rock mass exploration - To understand weathering extent, type, thickness, attitude and extension of different rocks in subsurface.

Some other important investigations are to find out:

- *Availability of construction material*
- *Unconsolidated, soft and expansive ground material*
- *Presence of glacial outwash, drift, colluvial and fluvial deposits*

- *Old or abandoned landfill or mining site*
- *Natural caves or manmade cavities such as abandoned shafts and underground mines*
- *Creeping or active slopes or areas of land sliding*
- *Residual stresses in rock masses*

4.What are the direct and indirect methods of investigations?

The direct methods involved construction of equidimensional pits or linear trenches. This can be done manually or by using machine with backhoe this method is cheapest and can be readily employed. Another direct method is excavation of linear drift or adits which are horizontal to inclined holes made through exposed rock sections or from already created over or under ground opening. The dimensions can vary depending upon nature of exploration.

For deeper direct investigations and to extract samples drilling is used. The selection of drilling system depends upon depth of drilling, nature of lithology i.e. soil or rock, soft or hard rock, terrain type, accessibility to the area and economics.

For covering larger area and to economize investigations indirect geophysical methods are most sought after. The important geophysical methods used in construction industry are gravity surveys, seismic surveys, electrical resistivity and magnetic surveys.

5.What do you understand by Rock Quality Designation?

Rock Quality Designation (RQD) is an important parameter which measures the total length of the core greater than 10 cm in length sequestered during drilling, divided by total depth of drilling. The

rocks are cut by rotational process using diamond double barrel drilling system to drill out 54.7 mm (NX) diameter core.

$$RQD = \frac{\Sigma \text{Length of all core pieces } (> 10 \text{ cm})}{\text{Total core length}} \times 100$$

Another parameter i.e. Core Recovery Percent (CRP) is also simultaneously calculated which takes into based on summation of all the cores, irrespective of length taken out during drilling, divided by total depth of drilling. CRP is always greater than RQD. The premise in this test is that the presence of joints and their inter connection will naturally break the rocks and will be reflected as core length. The closer are joints smaller will be the core and vice versa. The rate of drilling non recovery of cores etc. can also be interpreted in terms of rock strength, presence of shear zones etc. The RQD values are used as ready reference of rock mass properties as per the following table:

| RQD (%) | Rock Mass Class |
|---------|-----------------|
| > 90 | Excellent |
| 75 - 90 | Very Good |
| 50 - 75 | Good |
| 25 - 50 | Fair |
| < 25 | Poor |

Multiple Choice Questions (Quiz)

1. The concept of “Rock Load Theory”, was given by

(a) Watson (b) Karl Terzaghi (c) Redlich (d) Charles P Berkley

2. Bouger Anomaly is related to

(a) Magnetic Survey (b) Rock Drilling (c) Gravity Survey (d) Seismic Survey

3. The fair rocks are classed when the RQD values come in between

(a) 0 - 25 (b) 50 - 75 (c) 75 - 90 (d) 25 - 50

4. Self Potential method of geophysical exploration is related to

(a) Seismic Refraction (b) Seismic Reflection (c) Gravity Survey (d) Electrical Survey

5. Which of the following rock will have lowest resistivity to electric current

(a) Sandstone (b) Slate (c) Gabbro (d) Granite

Suggested Readings:

1. Subinoy Gangopadhyay (2013), Engineering Geology, Oxford University Press, New Delhi.
2. Krynine, Dmitri P and Judd, William R (2005), Principles of Engineering Geology and Geotechnics, CBS Publishers, New Delhi.
3. Tony Waltham (2002), Foundation of Engineering Geology, 3rd Edition, CRC Press, London.
4. Bell, F G (1983), Fundamentals of Engineering Geology, Butterworths, London.

5. Alam Masroor M. (2013), Fundamentals of Engineering Geology and Geo-Engineering, Axioe Books, India.