

INTRODUCTION TO TYPOGRAPHY

GRAP2587 | Design for Digital Media 1

INTRO TO TYPOGRAPHY

1. Understanding Typography

The Definition

Seeing Typography

Typography Practice

Font & Typeface

Formats

2. History of Typography

Sounds to Symbols

Evolution of Writing Systems

Gutenberg & Movable Type

Mechanization of Type

Photocomposition

The Digital Age

3. Typography in Use

In Communication Design

In Interactive Design

In Information Design

In Motion Design

4. Learning Typography

The Importance of Typography

All Principles Applied

How to Learn & Train Typography

Resources

THE DEFINITION



(Greek)

/ typos /: form

/ graphein /: to write

Typography is, simply put, the art
& technique of choosing, setting
& arranging type.

Good typography **serves a
purpose.**

THE DEFINITION

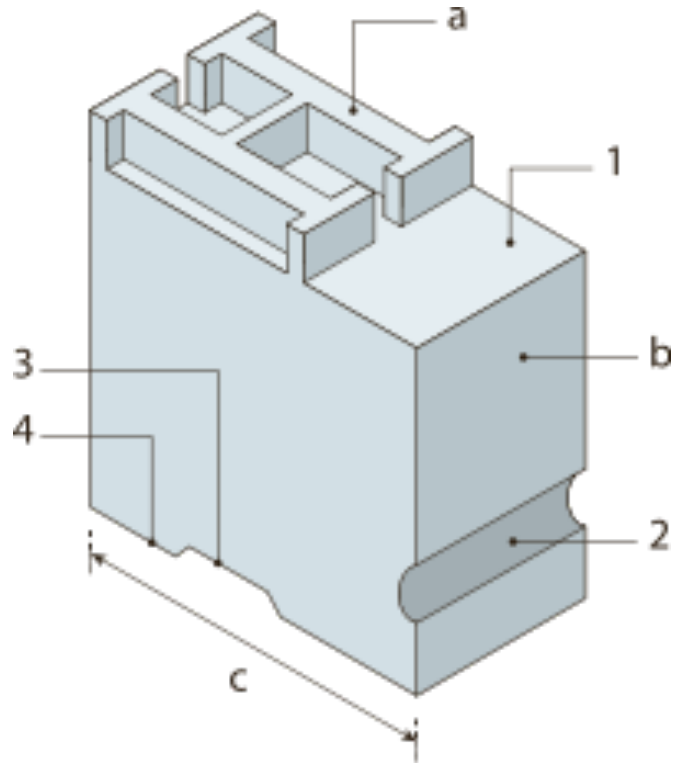

SEEING TYPE

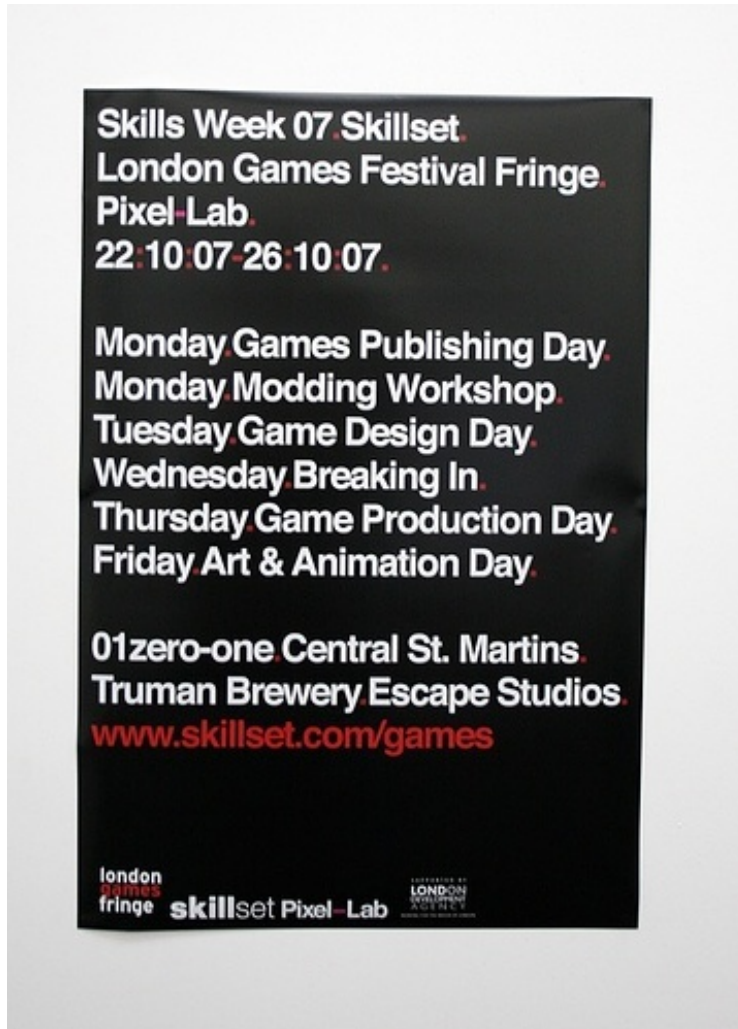

Type exists.

Type is everywhere.

Type is a fundamental part of
human life & society.

SEEING TYPE



SEEING TYPE



SEEING TYPE



SEEING TYPE



SEEING TYPE

Individual letters, when arranged in a particular way, represent the sound of spoken language & visually express ideas in such a way that another person can understand them in the manner intended.

SEEING TYPE



SEEING TYPE



SEEING TYPE



TYPOGRAPHY PRACTICE

Then what exactly what typography is?

Typography engages with people on different levels:

There are:

- **The holistic view (macro-typography):** type choice, visual impact, type choice, layout, compositions, hierarchy, whitespace, grid system (number of columns & rows), etc.
- **The detailed view (micro-typography):** type choice, sizes, spacing between lines, spacing between words, spacing between letters, etc.

MACRO / MICRO



macro-typography

MACRO / MICRO

The facts relating to this apparition agreed in most respects as to the shape of the object or creature in question, the untiring rapidity of its movements, its surprising power of locomotion, and the peculiar life

IN JUSTIFIED TEXT, THE WORD SPACE IS SMALL IN SOME LINES AND BIG IN OTHERS.

WORD SPACE & LINE SPACE

When setting type, the typographer can change the word space independently from the rest of the font's built-in spacing. Unlike tracking, which should be adjusted cautiously in small increments, word space can absorb bigger changes since it's a relatively large space within the paragraph. Of course, the typographer still needs to be careful with the word space, but it's generally less delicate than letter space.

In a column of text, the typographer usually makes any word space adjustments to the whole thing at once. For example, a wide column may have a larger word space to give the words some breathing room. A narrow column may have a smaller word space to make the lines more compact. In a column of justified text, the word space can also be adjusted line by line. You've probably noticed this variation in word space in the narrow justified columns of a newspaper. Suddenly, there's a line with big gaps in it. In unjustified text, the word space stays consistent throughout the column. This will be more fully explained in the section on hyphenation and justification.

THE IMPORTANT THING IS HOW THE SIZE OF THE WORD SPACE RELATES TO THE SIZE OF THE LINE SPACE.

MACRO / MICRO

Stencil 90pt

WAR & *peace*

Dancing Script 96pt

Comic Sans 90pt

WAR & **PEACE**

Rosewood 96pt

MACRO / MICRO

Helvetica Neue 14pt / 18pt

Bacon ipsum dolor sit amet ball tip pork loin cow brisket drumstick bresaola short ribs beef jowl kielbasa pig spare ribs porchetta. Sausage pancetta t-bone chicken, swine filet mignon kevin. Boudin pork belly bacon, chuck pork loin venison ball tip prosciutto chicken leberkas jowl turducken salami swine ham. Hamburger sausage salami biltong bacon filet mignon ham hock. Tongue pork loin swine spare ribs strip steak pork chop shank biltong. Pig doner turducken filet mignon, fatback venison pork loin andouille tenderloin chicken.

Swine spare ribs frankfurter biltong. Rump brisket pork chop leberkas prosciutto hamburger shank sirloin, drumstick pastrami frankfurter jerky. Venison ball tip turducken t-bone sirloin andouille. Ham spare ribs bacon salami filet mignon pork capicola cow rump.

Source Sans Pro 14pt / 18pt

Bacon ipsum dolor sit amet ball tip pork loin cow brisket drumstick bresaola short ribs beef jowl kielbasa pig spare ribs porchetta. Sausage pancetta t-bone chicken, swine filet mignon kevin. Boudin pork belly bacon, chuck pork loin venison ball tip prosciutto chicken leberkas jowl turducken salami swine ham. Hamburger sausage salami biltong bacon filet mignon ham hock. Tongue pork loin swine spare ribs strip steak pork chop shank biltong. Pig doner turducken filet mignon, fatback venison pork loin andouille tenderloin chicken.

Swine spare ribs frankfurter biltong. Rump brisket pork chop leberkas prosciutto hamburger shank sirloin, drumstick pastrami frankfurter jerky. Venison ball tip turducken t-bone sirloin andouille. Ham spare ribs bacon salami filet mignon pork capicola cow rump.

TYPOGRAPHY IS & ISN'T



Isn't!

TYPOGRAPHY IS & ISN'T



Is!

TYPOGRAPHY IS & ISN'T



Isn't!

TYPOGRAPHY IS & ISN'T



Isn't!

TYPEFACE / FONT / FAMILY

144 pt

NULLA PARI
Est laborum.

72 pt

IN VOLUPTATE VELIT ES
Consectetur adipisicing e

48 pt

OFFICIA DESERUNT MOLLIT ANIM ID
Fugiat nulla pariatur. Excepteur sint oc

FONT & TYPEFACE

Font: a set of letters, numbers, symbols, etc. of the same design. Examples:

Helvetica Neue Light is a Font

Typeface: a set of fonts that share common design features. Examples:

Helvetica Neue is a Typeface.

Font family: often used interchangeably with Typeface.

FONT & TYPEFACE

The **physical embodiment** of a collection of letters, numbers, symbols, etc. (whether it's a case of metal pieces or a computer file) is a **font**. When referring to the **design of the collection** (the way it looks) you call it a **typeface**.

FONT & TYPEFACE

Helvetica Neue Std

Helvetica Neue L T Std 85 Heavy

Helvetica Neue Std

Helvetica Neue L T Std 86 Heavy Italic

Helvetica Neue Std

Helvetica Neue L T Std 45 Light

Helvetica Neue Std

Helvetica Neue L T Std 46 Light Italic

Helvetica Neue Std

Helvetica Neue L T Std 66 Medium Italic

Helvetica Neue Std

Helvetica Neue L T Std 65 Medium

FONT & TYPEFACE

!	"	#	\$	%	&	'	()	*	+	,	.	/	0	
1	2	3	4	5	6	7	8	9	:	;	<	=	>	?	@
A	B	C	D	E	F	G	H	I	J	K	L	M	N	O	P
Q	R	S	T	U	V	W	X	Y	Z	[\]	^	_	`
a	b	c	d	e	f	g	h	i	j	k	l	m	n	o	p
q	r	s	t	u	v	w	x	y	z	{		}	~	Ä	Å
Ç	É	Ñ	Ö	Ü	á	à	â	ä	ã	å	ç	é	è	ê	ë
í	ì	î	ï	ñ	ó	ò	ô	ö	õ	ú	ù	û	ü	†	°
φ	£	§	•	¶	β	®	©	™	ˆ	¨	≠	Æ	Ø	∞	±
≤	≥	¥	μ	∂	Σ	Π	π	∫	ª	º	Ω	æ	ø	¿	¡
¬	√	f	≈	Δ	«	»	...	À	Ã	Õ	Œ	œ	-	—	“
”	‘	’	÷	◊	ÿ	ÿ	/	€	‹	›	fi	fl	‡	·	,
„	‰	Â	Ê	Á	Ë	È	Í	Î	Ì	Ó	Ô	Ò	Ú	Û	Ü
Ù	ı	ˆ	˜	-	˘	˙	˚	¸	˝	˛	Š	š	ı	ı	Đ
ó	Ý	ý	ƒ	ƒ	x	¹	²	³	½	¼	¾	—	.	α	

typeface

FONT & TYPEFACE

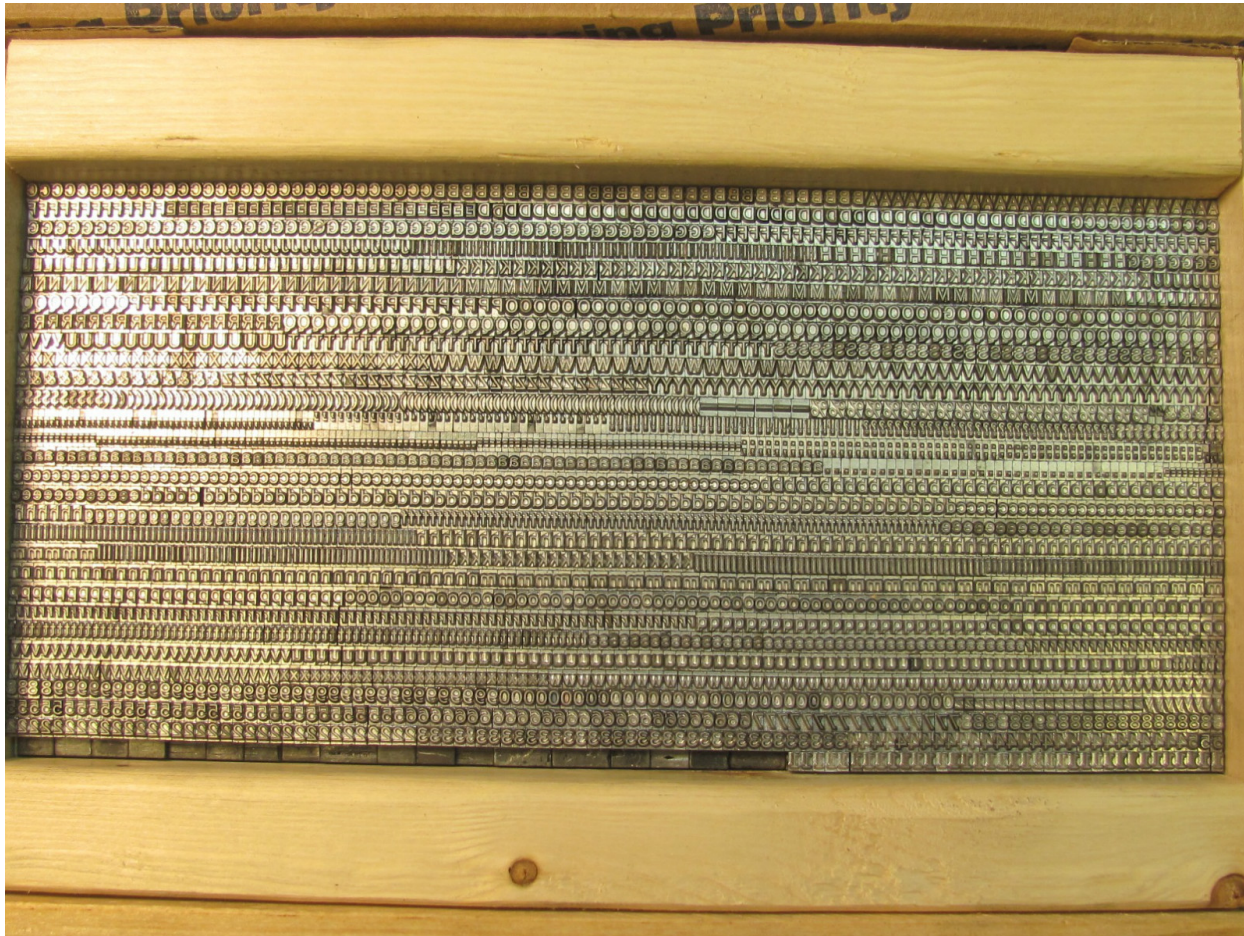

font

FONT & TYPEFACE

A 65	B 66	C 67	D 68	E 69	F 70	G 71	H 72	I 73	J 74	K 75	L 76	M 77	N 78
A	B	C	D	E	F	G	H	I	J	K	L	M	N
O 79	P 80	Q 81	R 82	S 83	T 84	U 85	V 86	W 87	X 88	Y 89	Z 90		
O	P	Q	R	S	T	U	V	W	X	Y	Z		

a 97	b 98	c 99	d 100	e 101	f 102	g 103	h 104	i 105	j 106	k 107	l 108	m 109	n 110
a	b	c	d	e	f	g	h	i	j	k	l	m	n
o 111	p 112	q 113	r 114	s 115	t 116	u 117	v 118	w 119	x 120	y 121	z 122		
o	p	q	r	s	t	u	v	w	x	y	z		

0 48	1 49	2 50	3 51	4 52	5 53	6 54	7 55	8 56	9 57
0	1	2	3	4	5	6	7	8	9

\$ 36	¢ 162	□ 128	£ 163	¥ 165	¤ 164	+ 43	- 45	* 42	/ 47	+ 247	= 61	% 37	□ 137
\$	¢	□	£	¥	¤	+	-	*	/	=	%		
" 34	' 39	# 35	@ 64	& 38	_ 96	(40)) 41	, 44	. 46	; 59	: 58	¿ 191	? 63
"	'	#	@	&	_	()	,	.	;	:	¿	?
i 161	! 33	\ 92	 124	{ 123	} 125	< 60	> 62	[91] 93	\$ 167	¶ 162	μ 181	` 96
i	!	\	 	{	}	<	>	[]	\$	¶	μ	`
^ 94	~ 126	© 169	® 174	□ 153									
^	~	©	®	□									

font (digital)

FONT & TYPEFACE

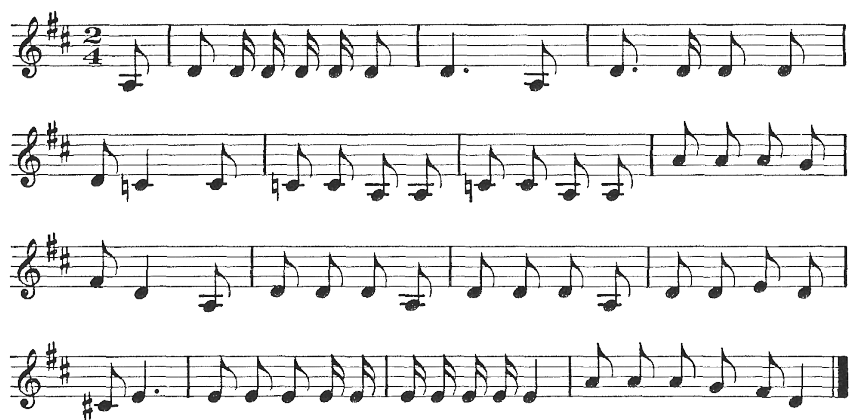

The way I relate the difference between typeface and font to my students is by comparing them to songs and MP3s, respectively (or songs and CDs, if you prefer a physical metaphor). – Nick Sherman

You talk about how much you like a tune, you don't say: "That's a great MP3". You say: "That's a great song". The MP3 is the delivery mechanism, not the creative work; just as in type a font is the delivery mechanism and a typeface is the creative work – Stephen Coles



TYPE DESIGN & DESIGNER

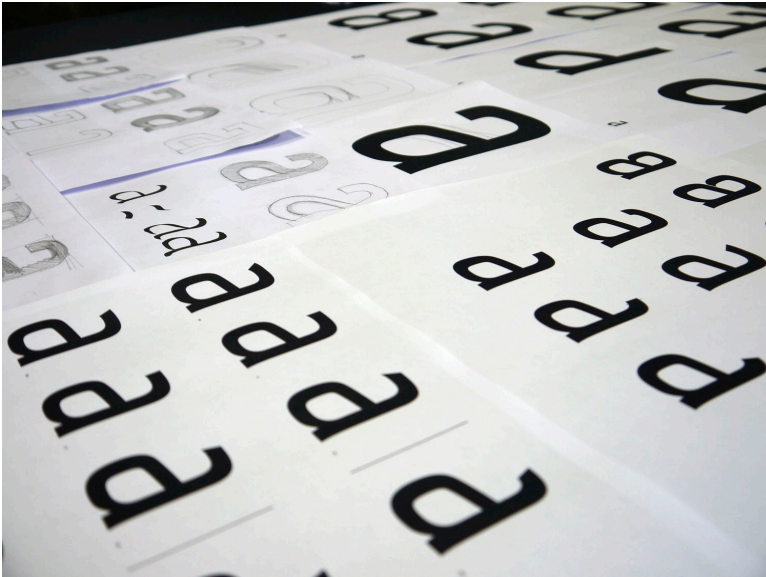

Type design: the art & craft of designing typefaces.

Type designer: designer of typefaces. Don't call them "font designers" (or even "font family designers". Ugh!).



FORMATS



TTF

font.ttf



OTF

font.otf

Desktop font formats

Web font formats

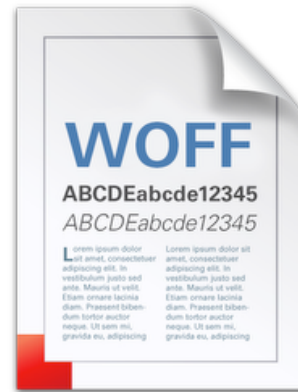

font.woff

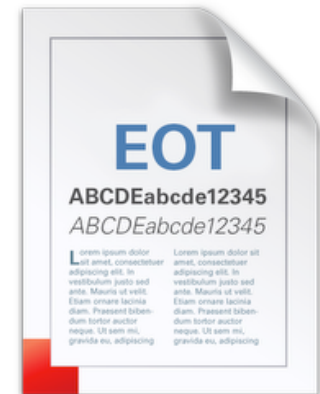

font.eot

INTRO TO TYPOGRAPHY

1. Understanding Typography

The Definition

Seeing Typography

Typography Practice

Font & Typeface

Formats

2. History of Typography

Sounds to Symbols

Evolution of Writing Systems

Gutenberg & Movable Type

Mechanization of Type

Photocomposition

The Digital Age

3. Typography in Use

In Communication Design

In Interactive Design

In Information Design

In Motion Design

4. Learning Typography

The Importance of Typography

All Principles Applied

How to Learn & Train Typography

Resources

HISTORY OF TYPOGRAPHY













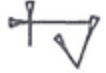





























SOUNDS TO SYMBOLS

















































EVOLUTION OF WRITING SYSTEMS

Sumerians' Cuneiform – one of the earliest known systems of writing, c. 31st century BC to 1st century AD

BIRD					GRAIN				
FISH					ORCHARD				
DONKEY					PLOUGH				
OX					BOOMERANG				
SUN					FOOT				















































EVOLUTION OF WRITING SYSTEMS

Evolution of Alphabets

Values	EGYPTIAN		SEMITIC		LATER EQUIVALENTS.			
	Hieroglyphic	Hieratic.	Phœnician		Greek	Roman.	Hebrew	
<i>a</i>	eagle					A	A	א
<i>b</i>	crane					B	B	ב
<i>k (g)</i>	throne					Γ	C	ג
<i>t (d)</i>	hand					Δ	D	ד
<i>h</i>	mæander					E	E	ה
<i>f</i>	cerastes					Υ	F	ו
<i>z</i>	duck					Ζ	Z	ז
<i>χ (kh)</i>	sieve					H	H	ח
<i>θ (th)</i>	tongs					Θ	...	ט
<i>i</i>	parallels					I	I	י
<i>k</i>	bowl					K	K	כ
<i>l</i>	lioness					Λ	L	ל
<i>m</i>	owl					M	M	מ
<i>n</i>	water					N	N	נ
<i>s</i>	chairback					Ξ	X	ס

EVOLUTION OF WRITING SYSTEMS

Evolution of Alphabets

Values	EGYPTIAN		SEMITIC		LATER EQUIVALENTS.		
	Hieroglyphic	Hieratic.	Phœnician		Greek	Roman.	Hebrew
<i>a</i>	eagle 				A	A	א
<i>b</i>	crane 				B	B	ב
<i>k (g)</i>	throne 				Γ	C	ג
<i>t (d)</i>	hand 				Δ	D	ד
<i>h</i>	mæander 				E	E	ה
<i>f</i>	cerastes 				Υ	F	ו
<i>z</i>	duck 				Ζ	Z	ז
<i>χ (kh)</i>	sieve 				H	H	ח
<i>θ (th)</i>	tongs 				Θ	...	ט
<i>i</i>	parallels 				I	I	י
<i>k</i>	bowl 				K	K	כ
<i>l</i>	lioness 				Λ	L	ל
<i>m</i>	owl 				M	M	מ
<i>n</i>	water 				N	N	נ
<i>s</i>	chairback 				Ξ	X	ס

EVOLUTION OF WRITING SYSTEMS

One of the most important contributions to
early writing by the Romans: Trajan
Columns

113 A.D.



EVOLUTION OF WRITING SYSTEMS

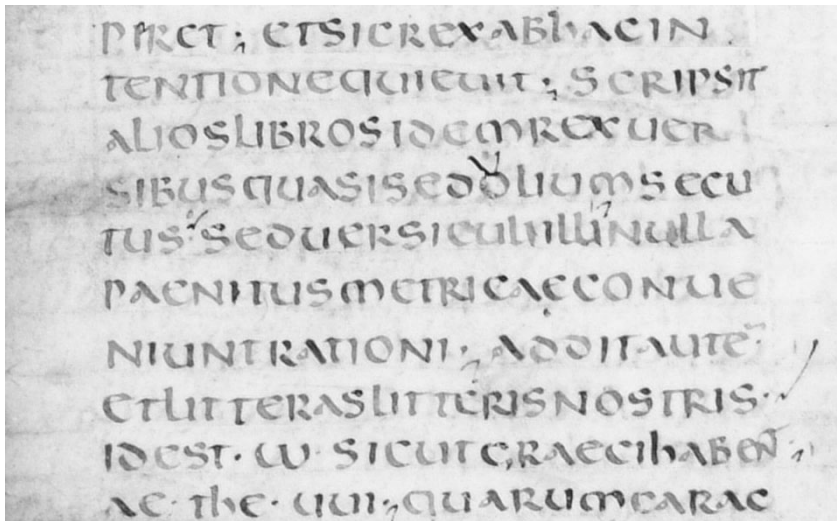

Uncial, France, 7th century.

Gothic Scripts



EVOLUTION OF WRITING SYSTEMS

17th century: the alphabet has 26 characters.

Trajan	A B C D E F G H I J K L M N O P Q R S T U V W X Y Z
Rustic	A B C D E F G H I J K L M N O P Q R S T U V W X Y Z
Greek Uncial	A B Γ Δ E Z H Θ I K Λ M N Σ O Π P C T Y Φ X Ψ Ω
Uncial	A B C D E F G H I J K L M N O P Q R S T U V W X Y Z
Half-Uncial	a b c d e f g h i j k l m n o p q r s t u v w x y z
Visgothic	α β γ δ ε ζ η θ ι κ λ μ ν ο ρ ρ ρ ρ σ τ υ φ χ ψ ζ
Luxeuil	u b c d e f g h i j k l m n o p q r r s t u v w x y z
Beneventan	a b c d e f g h i j k l m n o p q r s t u v w x y z
Caroline	A B C D E F G H I J K L M N O P Q R S T U V W X Y Z
Insular	α β γ δ ε ζ η θ ι κ λ μ ν ο ρ ρ ρ ρ σ τ υ φ χ ψ ζ
Protogothic	a b c d e f g h i j k l m n o p q r s t u v w x y z
Textura quadrata	A B C D E F G H I J K L M N O P Q R S T U V W X Y Z
Fraktur	A B C D E F G H I J K L M N O P Q R S T U V W X Y Z
Humanist	a b c d e f g h i j k l m n o p q r s t u v w x y z
Times	A B C D E F G H I J K L M N O P Q R S T U V W X Y Z

GUTENBERG & MOVABLE TYPE

Before printing:

Scribes with breathtaking
letterings.



GUTENBERG & MOVABLE TYPE



Johannes Gutenberg
& the first printed bible
1450 Germany



GUTENBERG & MOVABLE TYPE



MECHANIZATION OF TYPE

Typesetting machines: the result of Industrial Revolution in 19th & early 20th Century.

Linotype machine invented by Ottman Mergenthaler.

1880s

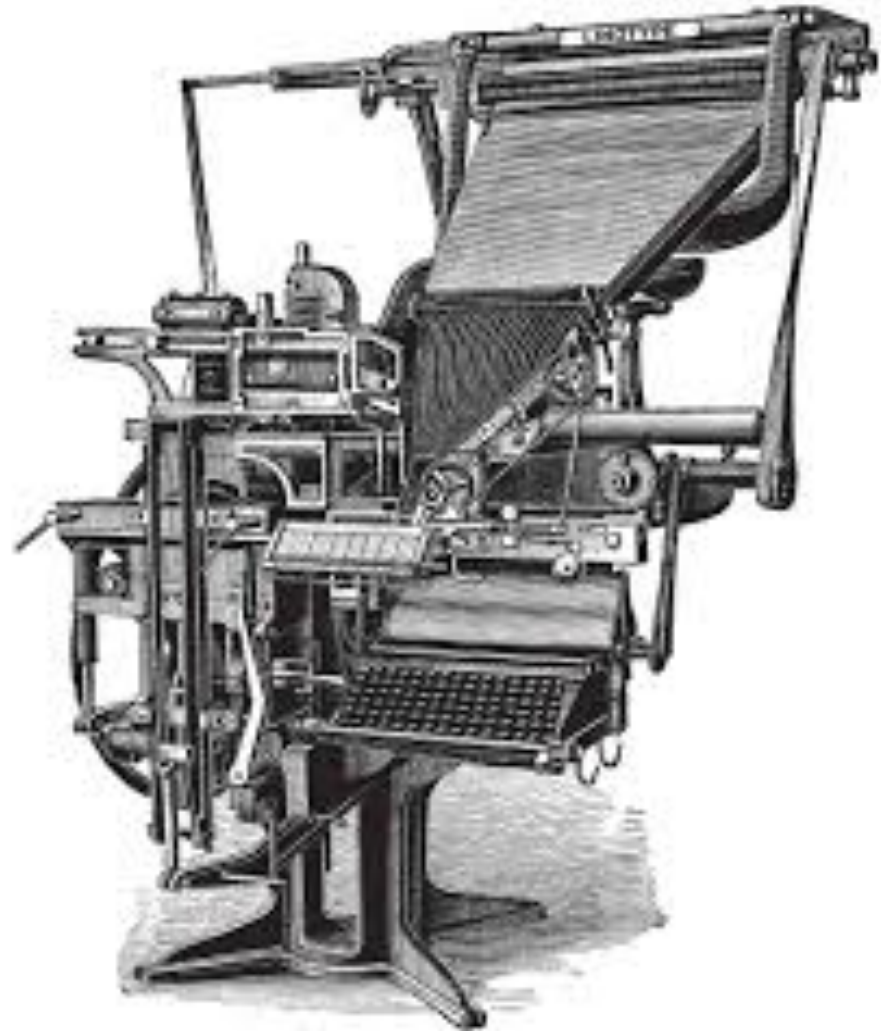

PHOTOTYPESETTING

Applying photographic
process to render type using
“phototypesetters”

1960s – 1980s



THE DIGITAL AGE

Desktop publishing put
typography into the digital
world

1983 – 1984

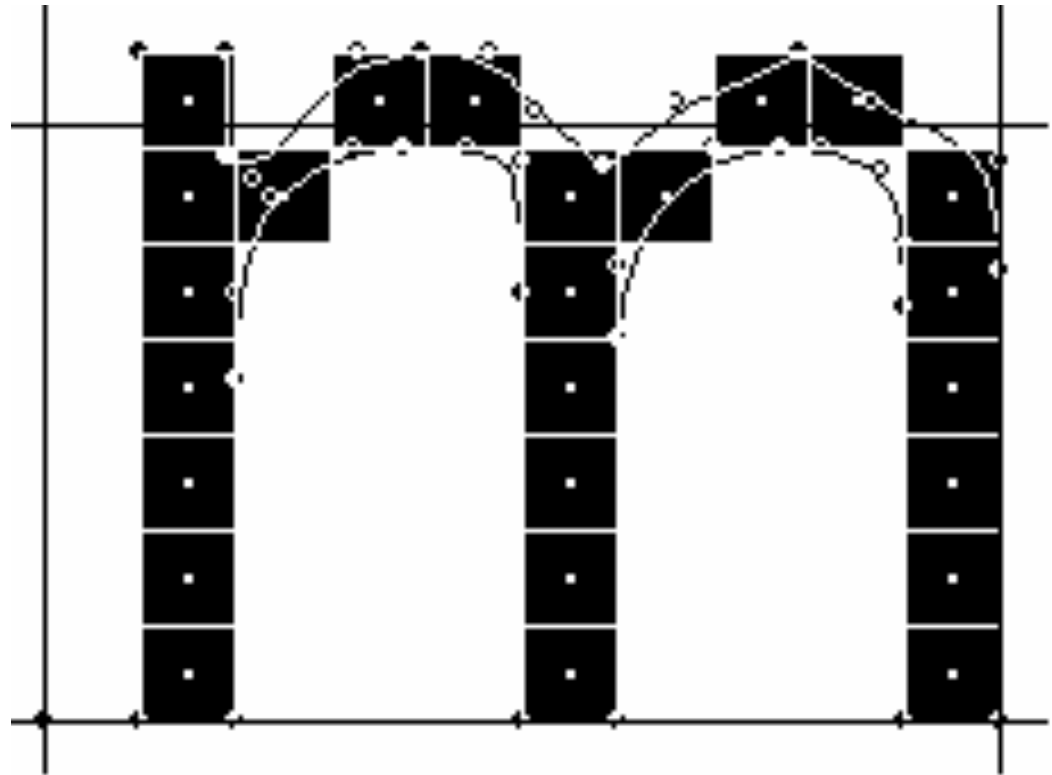

INTRO TO TYPOGRAPHY

1. Understanding Typography

The Definition

Seeing Typography

Typography Practice

Font & Typeface

Formats

2. History of Typography

Sounds to Symbols

Evolution of Writing Systems

Gutenberg & Movable Type

Mechanization of Type

Photocomposition

The Digital Age

3. Typography in Use

In Communication Design

In Interactive Design

In Information Design

In Motion Design

4. Learning Typography

The Importance of Typography

All Principles Applied

How to Learn & Train Typography

Resources

TYPOGRAPHY IN COMMUNICATION DESIGN

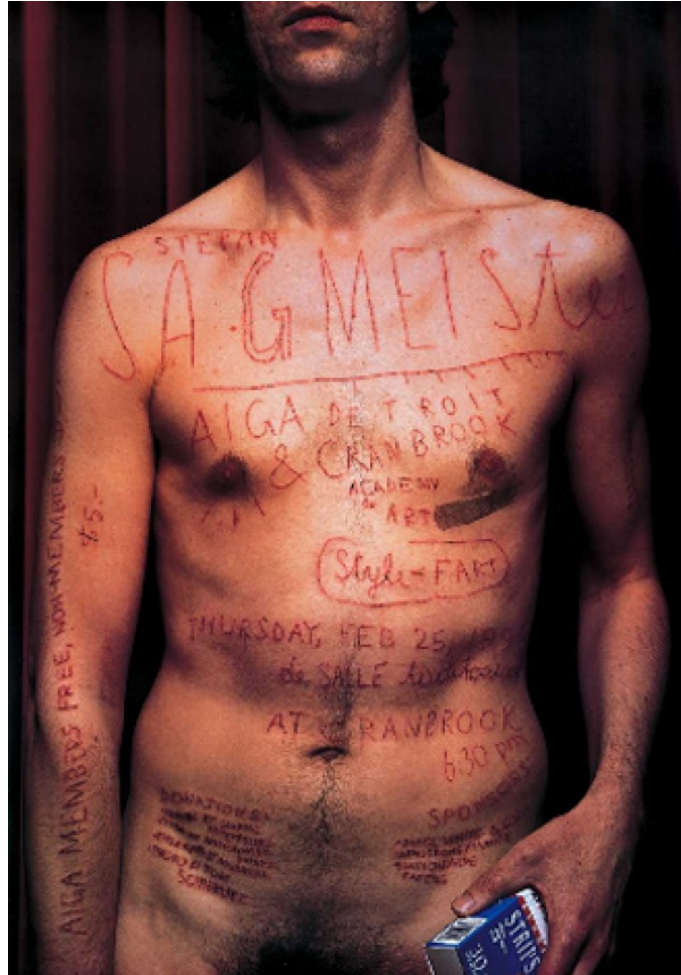

TYPOGRAPHY IN COMMUNICATION DESIGN

freedom³



TYPOGRAPHY IN COMMUNICATION DESIGN

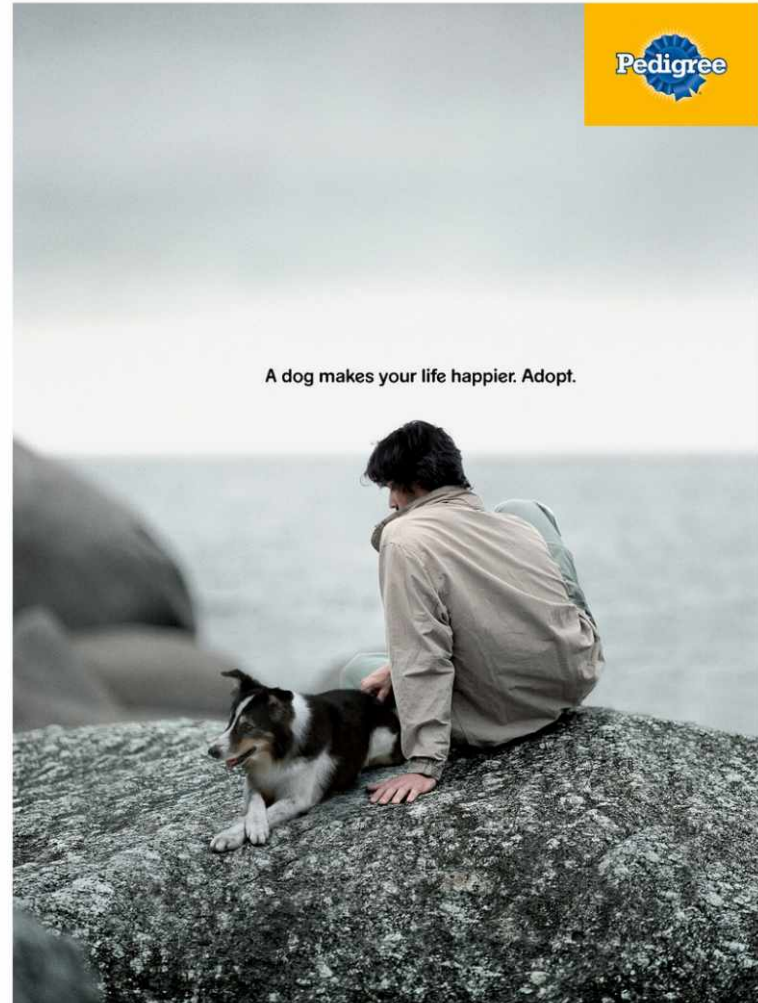
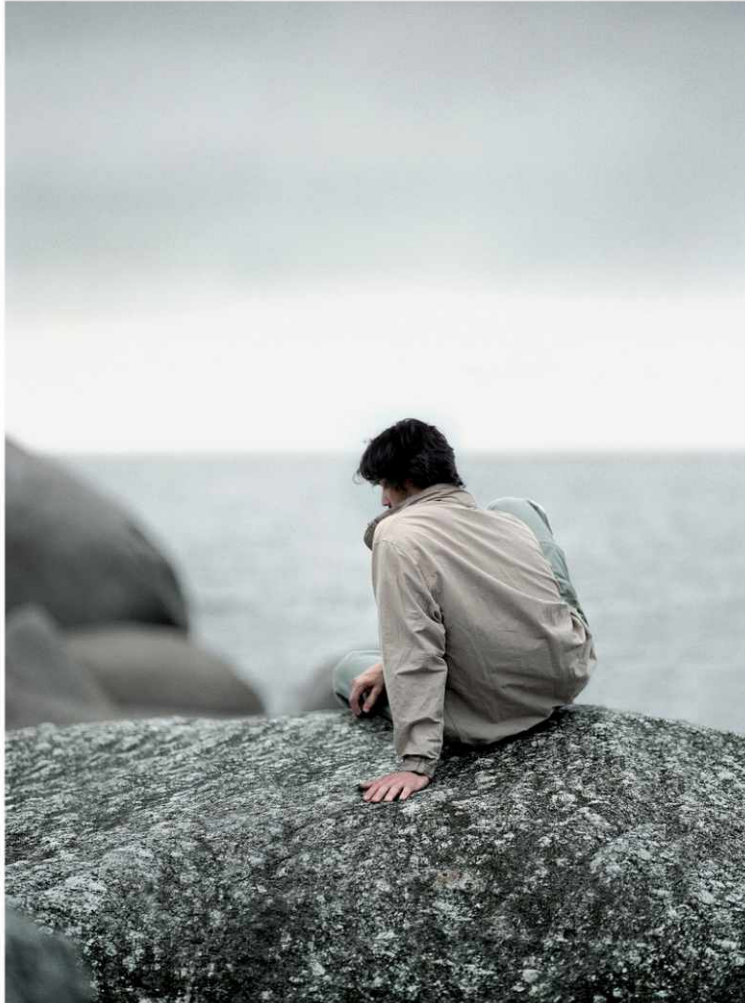

Pedigree

A dog makes your life happier. Adopt.

TYPOGRAPHY IN INTERACTIVE DESIGN

UNLISTED
COLLECTION:

ABOUT
ACCOLADES
CAREERS
CONTACT
RESERVE

THE WATERHOUSE AT SOUTH BUND ON CONDE NAST TRAVELER HOT LIST 2011

PREV NEXT

UNLISTED COLLECTION
ESTABLISHMENTS

SINGAPORE

Hotels
Hotel 1929
New Majestic Hotel
Wanderlust Hotel

Restaurants
Majestic Restaurant
Jing
Restaurant Ember
Coote

LONDON

Hotels
Town Hall Hotel & Apartments
176 Bishopsgate

Restaurants
Vijante
Corner Room

SHANGHAI

Hotels
The Waterhouse at South Bund

Restaurants
Table No. 1

TYPOGRAPHY IN INTERACTIVE DESIGN



TYPOGRAPHY IN INFORMATION DESIGN



The **Schweppes Abbey Well** Alternative Facts and Stats of the London 2012 Olympic and Paralympic Games



270,000
clay targets will be launched into the sky during the shotgun competition¹



The best shuttleracks are said to be made from the feathers on the left wing of a goose²



165,000 towels and **22,000** pillows will be used to kit out the Olympic Village³



Olympic Rowers could use up to **110,000ml** of sunscreen during the week long event⁴



1,630 discs ranging from 5kgs to 25kgs are needed for the weightlifting competition⁵



10 million litres of water will be needed to fill the swimming and diving pools at the Aquatics Centre - that's the same amount of water for **1,250,000** flushes of a toilet!⁶

Stable workers will have the fragrant job of clearing up a predicted

32,000 piles of manure from the equestrian events.⁷ Nice

17,320 beds will be housed at the Olympic Village

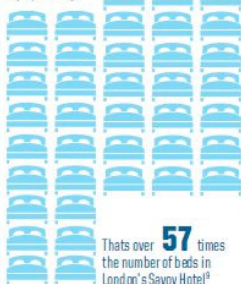

That's over **57** times the number of beds in London's Savoy Hotel!⁸

6 ironing boards and irons will be used during the Rhythmic Gymnastics competition⁹

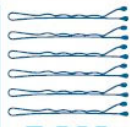

5,820 pieces of hair grips will be used during the Artistic and Rhythmic Gymnast competition¹⁰

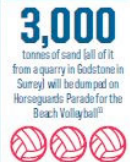

3,000 tonnes of sand (all of it from a quarry in Southwester Surrey) will be dumped on Horseguards Parade for the Beach Volleyball¹¹

Athletes in the Olympic Village will consume **75,000** litres of milk over the course of the London 2012 Games. It would take

1 cow

around **10** years to produce the same amount!¹²

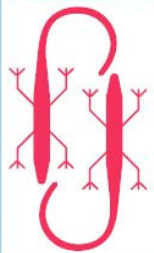

2,000 newts were relocated from the Olympic Park to the Waterworks nature reserve¹³

Over **4,000** trees, **60,000** bulbs, **74,000** plants and **350,000** wetlands plants



have been planted in the Olympic Village - that's over six times the amount of seats in the **80,000** capacity Olympic Stadium!¹⁴



4,000 bins in the Olympic Park will be emptied about

336,000

times throughout the London 2012 Olympic and Paralympic Games!¹⁵

Competitors in the London 2012 boxing competition will get through **356** pairs of gloves!¹⁶

The lightest piece of equipment is the women's Javelin which weighing a mere **600g** the same as a punnet of grapes!¹⁷

The official distance of the marathon is **42,195 metres** and the margin of error measuring the course is **0.1%**¹⁸



4,700 gold, silver and bronze medals will be presented at **805** victory ceremonies!¹⁹



5 million litres of bottled water will be sipped in the Olympic Village supplied by the official water sponsor, Schweppes Abbey Well!²⁰

¹ 1,000,000 clay targets are used in the Olympic Games. ² London 2012 website. ³ London 2012 website. ⁴ London 2012 website. ⁵ Based on 500 athletes using 1 to 200kg barbells of maximum weight throughout the duration of event London 05 website. ⁶ London 2012 website. ⁷ London 2012 website. ⁸ London 2012 website. ⁹ London 2012 website. ¹⁰ London 2012 website. ¹¹ London 2012 website. ¹² London 2012 website. ¹³ London 2012 website. ¹⁴ London 2012 website. ¹⁵ London 2012 website. ¹⁶ London 2012 website. ¹⁷ London 2012 website. ¹⁸ London 2012 website. ¹⁹ London 2012 website. ²⁰ London 2012 website.



TYPOGRAPHY IN INFORMATION DESIGN

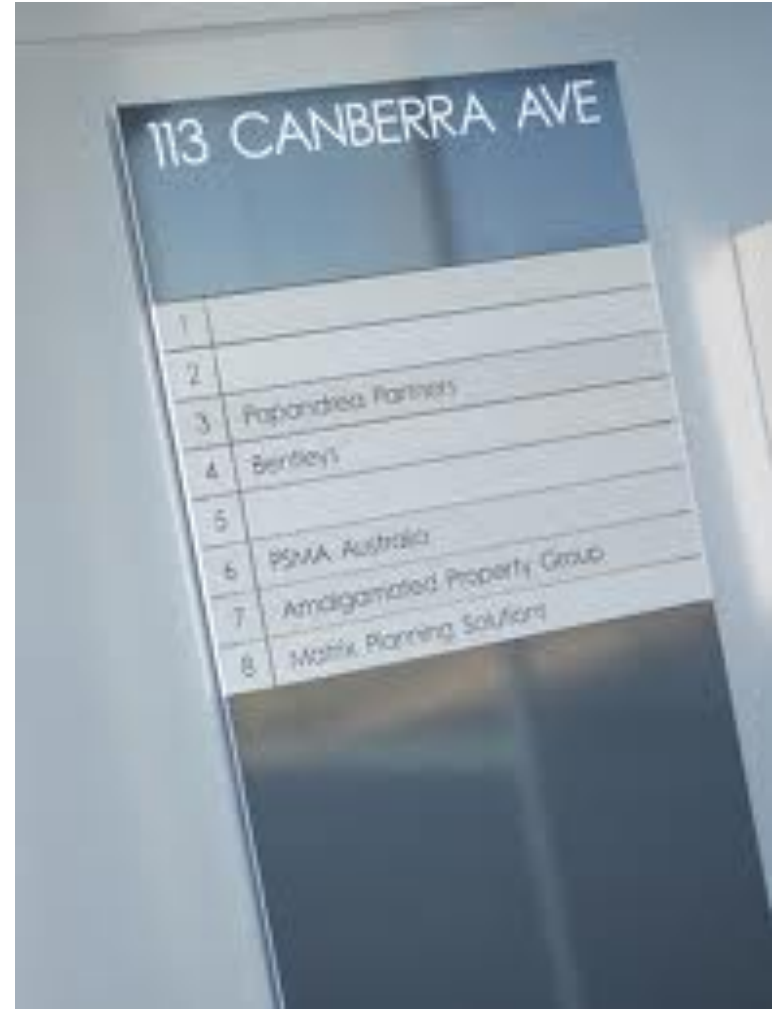

TYPOGRAPHY IN MOTION DESIGN

Written by

CARL REINER
GEORGE GIPE
STEVE MARTIN

TYPOGRAPHY IN MOTION DESIGN



THOR

INTRO TO TYPOGRAPHY

1. Understanding Typography

The Definition

Seeing Typography

Typography Practice

Font & Typeface

Formats

2. History of Typography

Sounds to Symbols

Evolution of Writing Systems

Gutenberg & Movable Type

Mechanization of Type

Photocomposition

The Digital Age

3. Typography in Use

In Communication Design

In Interactive Design

In Information Design

In Motion Design

4. Learning Typography

The Importance of Typography

All Principles Applied

How to Learn & Train Typography

Resources

IMPORTANCE OF TYPOGRAPHY

Typography conveys emotions.

IMPACT ON PRIVATE EQUITY

Iduci nullestium rehendias quuntia voluptem hillatusti quis-
cil moluptaspero beatur, ut ea volorrorem dolupti busaper
ibusam ipsunt pedis a pro que si veniam que venisinieni nobisitem
quam sanditaquam, erferch ilicatin consendem eum corem.

Insert Subtitle Here

Ficit que nonesti onsendant ut pliae eveliquis ad etur alibus
adi dolorpo repedit aturitae voluptin ped magniatus volore sent
volut et receper eptatur, nonsequo con consequiat invenihilia
volore eventia velestestis eum am elia sum vel inverroid et
ut eumenim usante delit porem hitia velecat ulpa pos molo-
ruptam que cum que non cum sum enihillorate consecea que
nimusantem il ipitio.

Impract on Private Equity

Iduci nullestium rehendias quuntia voluptem hillatusti quis-
cil moluptaspero beatur, ut ea volorrorem dolupti busaper
ibusam ipsunt pedis a pro que si veniam que venisinieni no-
bisitem quam sanditaquam, erferch ilicatin consendem.

Insert Subtitle Here

Ficit que nonesti onsendant ut pliae eveliquis ad etur alibus
adi dolorpo repedit aturitae voluptin ped magniatus volore
sent volut et receper eptatur, nonsequo con consequiat
invenihilia volore eventia velestestis eum am elia sum vel
inverroid et ut eumenim usante delit porem hitia velecat
ulpa pos moloruptam que cum que non cum sum enihillorate
consecea que nimusantem il ipitio.

IMPORTANCE OF TYPOGRAPHY

Typography keeps people reading

IMPACT ON PRIVATE EQUITY

Iduci nullestium rehendias quuntia voluptem hillatusti quiscil moluptaspero beatur, ut ea volorrorem dolupti busaper ibusam ipsunt pedis a pro que si veniam que venisinieni nobisitatem quam sanditaquam, erferch ilicatin consendem eum corem.

Insert Subtitle Here

Ficit que nonesti onsendant ut pliae eveliquis ad etur alibus adi dolorpo repedit aturitae voluptin ped magniatus volore sent volut et receper eptatur, nonsequo con consequiat invenihilia volore eventia veleste nostis eum am elia sum vel inverrovid et ut eumenim usante delit porem hitia velecat ulpa pos moloruptam que cum que non cum sum enihillorate consecea que nimusantem il ipitio.

Impact on Private Equity

Iduci nullestium rehendias quuntia voluptem hillatusti quiscil moluptaspero beatur, ut ea volorrorem dolupti busaper ibusam ipsunt pedis a pro que si veniam que venisinieni nobisitatem quam sanditaquam, erferch ilicatin consendem eum corem.

Insert Subtitle Here

Ficit que nonesti onsendant ut pliae eveliquis ad etur alibus adi dolorpo repedit aturitae voluptin ped magniatus volore sent volut et receper eptatur, nonsequo con consequiat invenihilia volore eventia veleste nostis eum am elia sum vel inverrovid et ut eumenim usante delit porem hitia velecat ulpa pos moloruptam que cum que non cum sum enihillorate consecea que nimusantem il ipitio.

IMPORTANCE OF TYPOGRAPHY

Typography is an essential part of design

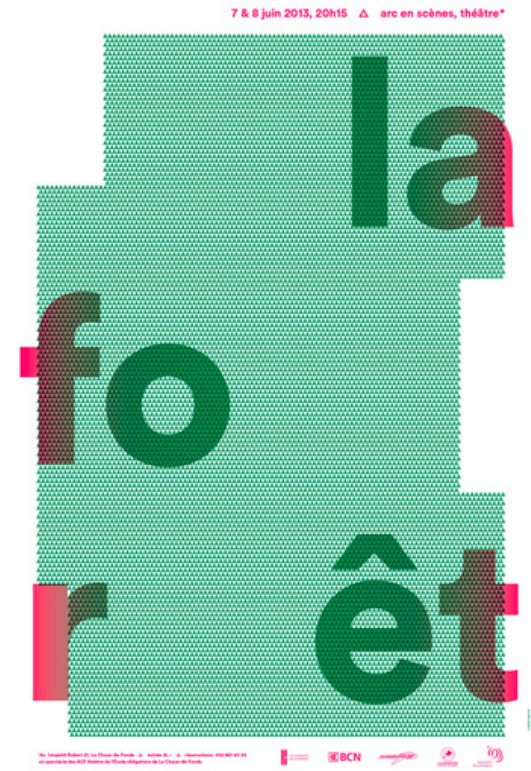

IMPORTANCE OF TYPOGRAPHY



APPLYING DESIGN PRINCIPLES



Proportion, Emphasis & Contrast

APPLYING DESIGN PRINCIPLES

The Grid System

The ultimate resource in grid systems.

"The grid system is an aid, not a guarantee. It permits a number of possible uses and each designer can look for a solution appropriate to his personal style. But one must learn how to use the grid; it is an art that requires practice."
Josef Müller-Brockmann

Show Grid

Join The Forum

Search

Articles	Tools	Books	Templates	Blog	Inspiration
Musings on the Relationship Between Grids and Guides An article that takes a look at the relationship between the grid and the use of guides. 06.Feb.2011	GuideGuide A columns, rows and mid-points panel for Photoshop CS4 & CSS. 06.Feb.2011	Ordering Disorder: Grid Principles for Web Design Ordering Disorder is a book by Khoi Vinh that delivers a definitive take on grids and the Web and provides both the big ideas and techniques of grid-based design. 11.Nov.2010	960px Grid Templates A selection of 960 pixel-wide uniform grid templates ranging from 3-columns to 16-columns, for both Adobe Photoshop and Fireworks. 11.Nov.2010	The Columnist A grid based WordPress theme that features a newspaper column layout and neat typographic hierarchy.. 06.Feb.2011	Ace Jet 170 AisleOne Athletics BBDK Blanka Build Corporate Risk Wa Counter Print David Airey Design Assembly Dirty Mouse Experimental Jets Form Fifty Five Grafik Magazine Grain Edit Graphic Hug I Love Typography Lamosca Mark Boulton Minimal Sites Monocle Neubau
Regulatory Policy Newsletter An article outlining the re-design of ICMA's quarterly publication and its grid. 06.Feb.2011	Modular Grid Pattern A web app and Photoshop extension that aids in creating modular grid systems. 06.Feb.2011	Universal Principles of Design Universal Principles of Design is the first comprehensive, cross-disciplinary encyclopedia of design. 04.Nov.2009	The Golden Grid Template A PSD template based on the CSS framework The Golden Grid by Vladimir Carrer. 02.Mar.2010	Grid-A-Licious 2.0 A beautiful grid based theme for WordPress. 06.Feb.2011	

Balance & Unity

APPLYING DESIGN PRINCIPLES

BEHIND
THIS WALL AT
PLASTIC
PEOPLE
IN SESSION:
NICOLA S
LUTZ
CLUB BER
VISIONAIRE,
TOI.TOI.
MONTEVIDEO
+ RESIDENTS

FRI 20TH DEC
10PM-LATE
ADV. TICKETS:
RESIDENT ADVISOR
+ MOTD



www.behindthiswall.com
@btwldn

Movement & Rhythm

HOW TO LEARN TYPOGRAPHY

- Learn the principles
- Practice a lot
- Train your eyes
- Start noticing type
- Make friends with type
- Explore & experiment

HOW TO LEARN TYPOGRAPHY

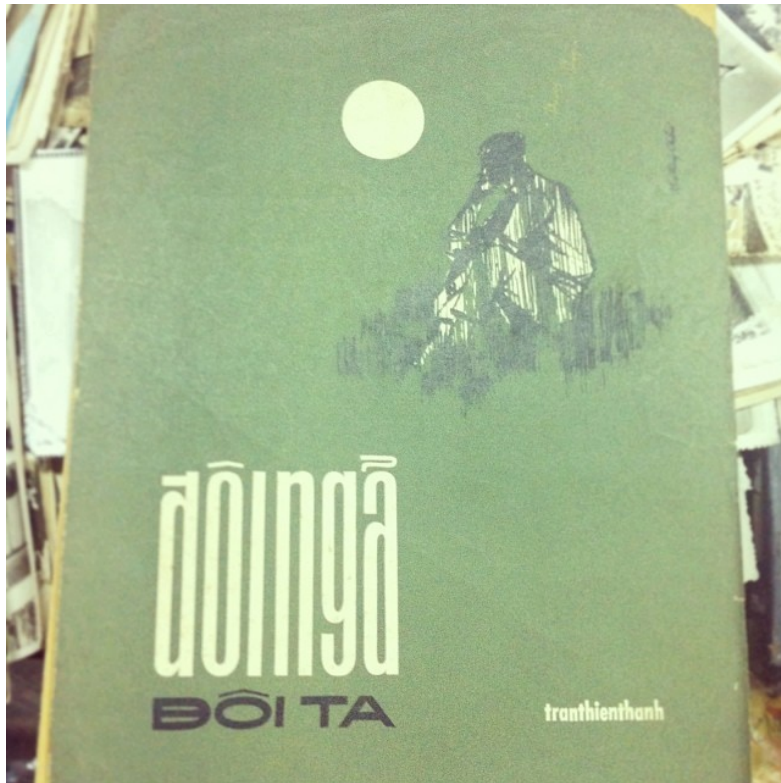

Start noticing type



HOW TO LEARN TYPOGRAPHY

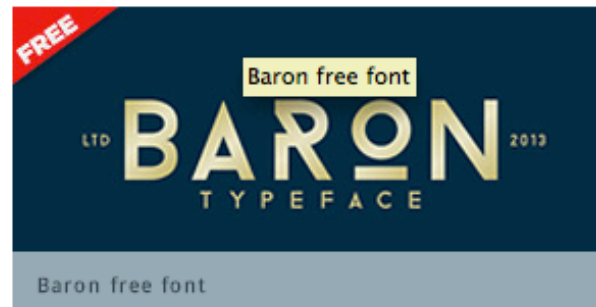
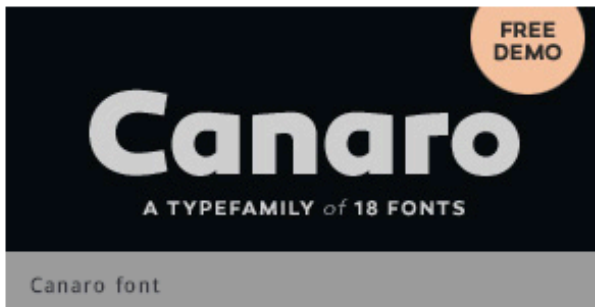

Make friends with type

HOW TO LEARN TYPOGRAPHY

Helvetica Neue 14pt / 18pt

Bacon ipsum dolor sit amet ball tip pork loin cow brisket drumstick bresaola short ribs beef jowl kielbasa pig spare ribs porchetta. Sausage pancetta t-bone chicken, swine filet mignon kevin. Boudin pork belly bacon, chuck pork loin venison ball tip prosciutto chicken leberkas jowl turducken salami swine ham. Hamburger sausage salami biltong bacon filet mignon ham hock. Tongue pork loin swine spare ribs strip steak pork chop shank biltong. Pig doner turducken filet mignon, fatback venison pork loin andouille tenderloin chicken.

Swine spare ribs frankfurter biltong. Rump brisket pork chop leberkas prosciutto hamburger shank sirloin, drumstick pastrami frankfurter jerky. Venison ball tip turducken t-bone sirloin andouille. Ham spare ribs bacon salami filet mignon pork capicola cow rump.

Source Sans Pro 14pt / 18pt

Bacon ipsum dolor sit amet ball tip pork loin cow brisket drumstick bresaola short ribs beef jowl kielbasa pig spare ribs porchetta. Sausage pancetta t-bone chicken, swine filet mignon kevin. Boudin pork belly bacon, chuck pork loin venison ball tip prosciutto chicken leberkas jowl turducken salami swine ham. Hamburger sausage salami biltong bacon filet mignon ham hock. Tongue pork loin swine spare ribs strip steak pork chop shank biltong. Pig doner turducken filet mignon, fatback venison pork loin andouille tenderloin chicken.

Swine spare ribs frankfurter biltong. Rump brisket pork chop leberkas prosciutto hamburger shank sirloin, drumstick pastrami frankfurter jerky. Venison ball tip turducken t-bone sirloin andouille. Ham spare ribs bacon salami filet mignon pork capicola cow rump.

Explore & experiment

RESOURCES

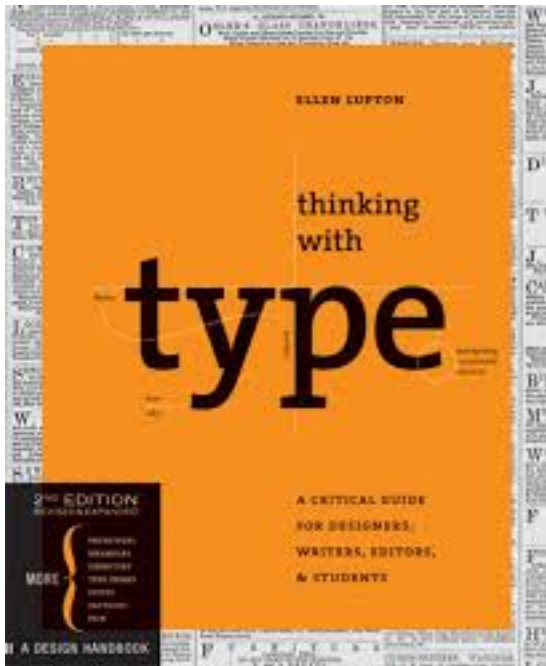

Books on Type
Design & Typography Inspiration books
Any kind of book, actually. Even fictions.

RESOURCES

Resources & Inspirations

<http://ilovetypography.com>

<http://typedia.com/>

<http://welovetypography.com/>

<http://incredibletypes.com/>

<http://fontsinuse.com/>

<http://typeeverything.com/>

Free Fonts

<http://www.fontsquirrel.com>

<http://www.fontfabric.com>

<http://www.theleagueofmoveabletype.com/>

<http://www.losttype.com/>

<http://www.exljbris.com/>

RESOURCES



Any piece of type around you!

RESOURCES

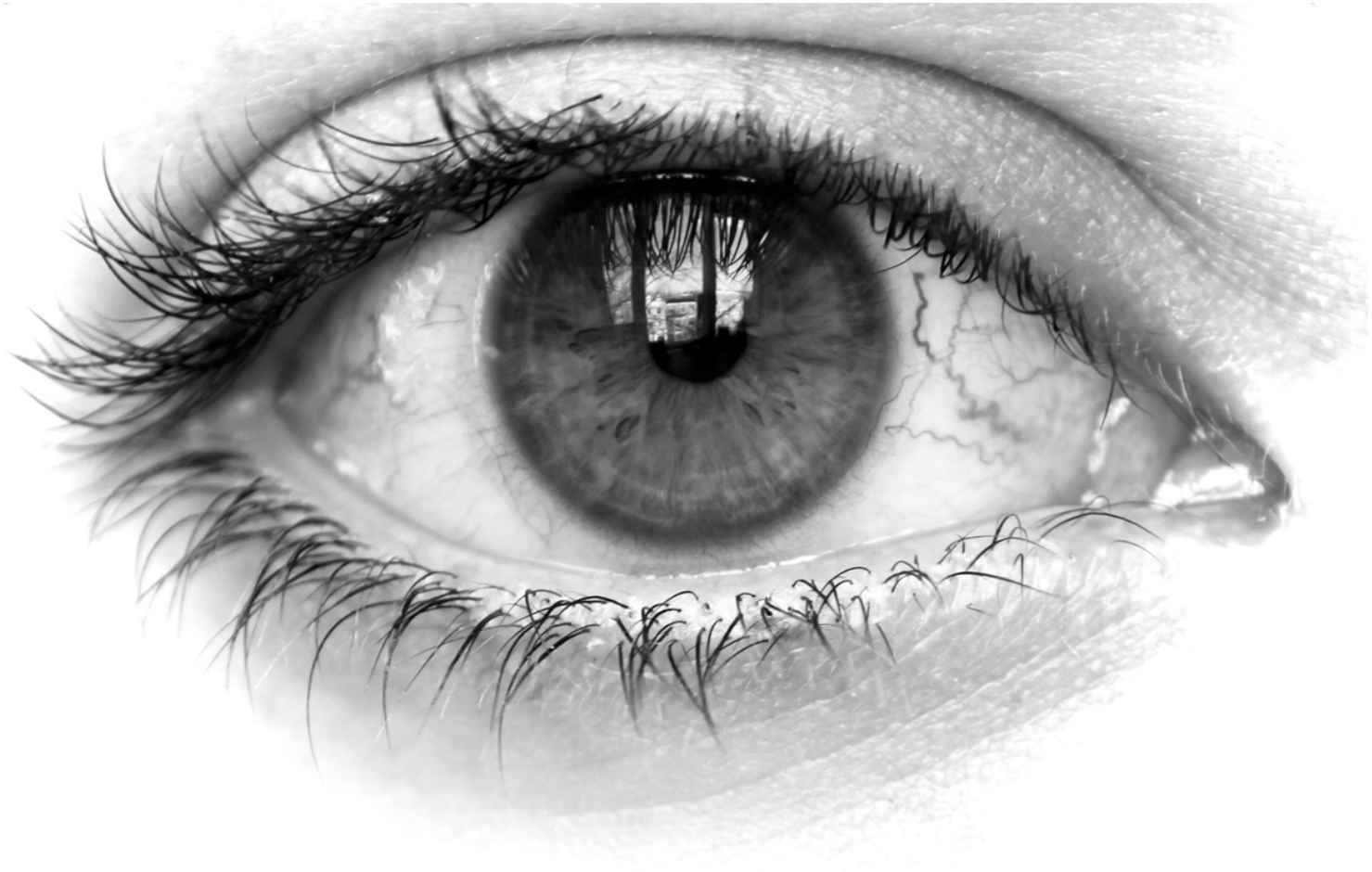

And again, last but not least.