

Woodturning Fundamentals

AAW
EDUCATION

**SPECIAL
EDITION:
Setting Up
Your
Woodturning
Workstation**

AAW | AMERICAN ASSOCIATION
OF WOODTURNERS

woodturner.org

SPECIAL EDITION: Setting Up Your Woodturning Workstation

Woodturning Fundamentals

TABLE OF CONTENTS

AAW
EDUCATION

2014 – Special Edition: Setting Up Your Woodturning Workstation



Rob Wallace

Welcome message from AAW Executive Director,
Phil McDonald 1

A Note from the AAW Safety Chair, Rob Wallace 2

Setting Up Your Woodturning Workstation

By Rob Wallace

- **Part 1:** Space planning, lighting, electrical and provision for dust collection 3
- **Part 2:** Design and layout of the space, how to evaluate the most efficient and ergonomic placement for storage 9
- **Part 3:** Safe operation at the lathe, reaching and repetitive movement, and use of personal protection equipment 16
- **Video:** Adjust the Height of Your Lathe 24

Woodturning Fundamentals

a bimonthly publication by the American Association of Woodturners

222 Landmark Ctr.
75 5th St W

St. Paul, MN 55102
phone 651-484-9094

website woodturner.org

Exec. Director: Phil McDonald

phil@woodturner.org

Program Director:

Linda Ferber

linda@woodturner.org

Board of Directors

Dale Larson, President

Kurt Hertzog, VP

Cassandra Speier, Sec.

Philip Hauser, Treas.

Binh Pho

Rob Wallace

Lou Williams

Denis Delehanty

Art Liestman

Woodturning Fundamentals Committee

Denis Delehanty,
Chair

Linda Ferber

Beth Ireland

Rob Wallace

John Lucas

Alan Zenreich

A Note About Safety:

An accident at the lathe can happen with blinding suddenness. Respiratory and other problems can build over years. Take precautions when you turn. Safety guidelines are published online at

<http://www.woodturner.org/?page=Safety>

Following them will help you continue to enjoy woodturning.

Cover photo: William Meiklejohn

INTRODUCTION

Note from Phil McDonald, Executive Director

AAW staff and board are pleased to present you with this complimentary special edition of *Woodturning Fundamentals*. We've recently given *Woodturning Fundamentals* a facelift and have expanded the educational content in each issue. This is an integral part of our ongoing plan to complement our bi-monthly *American Woodturner* and serve AAW members with a greater variety of woodturning information.

We are introducing more video, with more basic woodturning information. And coming soon, watch soon for the latest installment in our premium-content, Elements of Woodturning project workbook series. The newest title will cover all aspects of sharpening turning tools and will be available for purchase on the AAW website in both a digital download and a print on demand paperback. I would like to express my gratitude to our volunteer member-authors, the Fundamentals Committee and AAW staff for progressively elevating the quantity and quality of our publications.



ABOUT THE AUTHOR

Message from Rob Wallace

Thanks for taking time to read “Setting up Your Woodturning Workstation.”

Every woodturner goes through a learning curve to acquire the knowledge and skills needed to accomplish different turning methods. It is my hope that sharing this series of articles will help you set up a safe and functional workshop.

A great companion to this series is AAW’s *Safety for Woodturners* book which offers a basic understanding of important safety practices and the need to turn safely. Safety will become second nature to every woodturner who reads it and safety-aware turners are better able to experience the enjoyment and thrill of woodturning, as well as an increased confidence in their abilities. You’ll take comfort in knowing you are doing everything possible to maximize safety of yourself and those around you.

Turn SAFELY!
Rob Wallace

Rob Wallace holds a Ph.D. in Botany from Rutgers University, New Jersey and is a biology professor at Iowa State University where he teaches courses in evolution, plant taxonomy and systematics, economic botany, and biogeography. He has been a woodworker since before his teen years and enjoys all aspects of woodworking, especially woodturning. He is a member of the American Association of Woodturners (AAW) and has been an active member and officer of the Ames Woodworkers Club, Iowa for over 16 years. He has coordinated the local group of woodturning enthusiasts, Ames Area Woodturners, since 2005 and has presented demonstrations on various woodturning and woodworking topics to regional and national groups. Wallace is on the AAW Board of Directors and is head of the AAW Safety Committee.



WOODTURNING SHOP

Part 1: Choosing a Location

For the new woodturner, the motivation to “get turning” with your own lathe in your own shop or studio is exciting - as it should be. This situation does not lend itself to deliberate planning in the design and set-up of a woodturning work station, but don’t resist the urge to set up the machine and make some shavings. You may already have experience in knowing how much fun woodturning can be, and getting some lathe time right away with a new machine is always special. Even if you only have your machine set up temporarily, take some time to enjoy getting to know your lathe and how it works. Do this safely, and if you need advice, get it. Doing some woodturning on your new lathe is a great way to get a feel for how much space might be needed around the lathe for your body size. It also might give you some reference about where your lathe tools and accessories might best be located for your turning style. One point to emphasize here is that you will eventually be creating a woodturning workstation that is designed around YOU, and more specifically, how you relate to the lathe and all of the supporting tools, equipment, and supplies. Setting up a temporary woodturning location will enable you to pay special attention to any arrangements of tools, sanding and finishing supplies, or other

turning accessories that might cause you to slow down or stop your operation, or identify those things that make you feel uncomfortable, whether physically or psychologically (i.e., Are you doing everything *safely*? Does it feel OK to do this technique? Are you experiencing body pain or muscle strain after a turning session?) These are areas of concern that need to be addressed when developing the design of your permanent woodturning workstation. You’ll get to know what is needed for your own workstation while gaining some useful experience.

Are you doing everything safely? Does it feel OK to do this technique? Are you experiencing body pain or muscle strain after a turning session?

Whether you are a new woodturner, or one with considerable experience, it is always useful to periodically evaluate the safety and efficiency of your woodturning station to be sure you are maintaining a healthful, safe, and enjoyable work environment. I will review some of the aspects of setting up and maintaining a woodturning station that should be considered as you evaluate and design your own personal turning space.

The available space – Once the time has come to determine where your lathe will reside long-term, some initial planning will go a long way in making sure your woodturning station is set up as safely and efficiently as the resources will allow. A bit of planning for the future growth at your woodturning station's location will pay off in creating a more pleasant and efficient place in the future where you undoubtedly will be spending long hours of enjoyable time turning wood. Your space restrictions may dictate that your turning station may need to be located in a garage, basement, or other shared-use space. Some will have a dedicated space in a large room, out-building, or other location – each space will be unique. General aspects of the space chosen should include ease of access through doors (you'll be bringing in wood blanks, hauling out shavings, etc.), space available for support tools (band saw, drill press, dust collector, etc.), and if you're planning to do segmented woodturning, a table saw and/or miter saw, clamps, and benches), and sufficient space for storage of turning stock, drying roughed pieces, and possibly an area for finishing. A bit of uncommitted elbow-room would also be desirable, and given the fact that eventually you'll probably be inviting woodturning friends over, the extra space is always welcome. Other important things to think about are having sufficient lighting, electrical service and climate control. For those in regions where winter means cold or very cold, or summer means hot or

very hot, considerations of how to deal with heating and cooling of the workspace environment are very important, particularly if you intend to enjoy woodturning at all times of the year. There are a number of books available on the process of setting up a woodworking shop, and with some additional considerations for specializing the design for the lathe and supporting equipment with woodturning as the main focus of the operations, many of these same principles will apply to setting up a safe and efficient woodturning shop/studio.

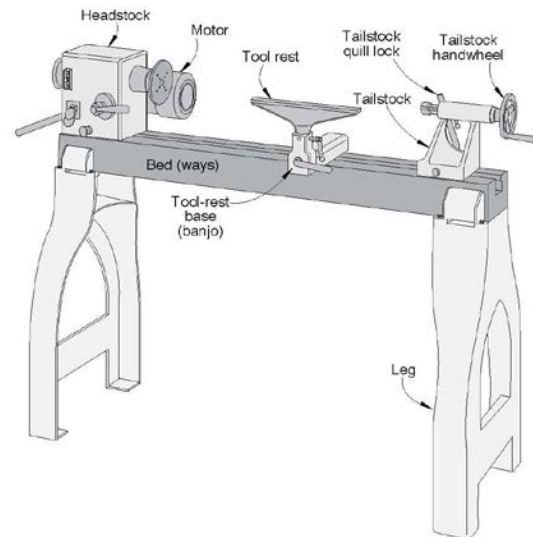

Room for the Lathe and Operating Space Around It –

When choosing the location for the placement of your lathe, you will need to plan for much more space than just the footprint of the machine itself. Obviously, there will need to be space allocated for the operator of the lathe, which is typically a minimum of two to three feet deep along the length of the lathe bed. Depending on the

design of your lathe, access to the headstock and tailstock ends may be important. For lathes with sliding headstocks, or short-bed bowl lathes, having extra room at the tailstock end will improve access to the piece during hollowing operations from the end of the lathe. Most turners would also consider the placement of a grinder (or other sharpening tools) close to the lathe as essential for quick, convenient sharpening operations, which are a standard part of woodturning. In addition to wise placement of sharpening equipment, it is important to define a location (or locations) where one's frequently-used turning tools are stored. Placement of tool racks in ergonomically compatible places adjacent to the operator's position improves efficiency. One should also ensure that the racks are stable, easy to use, and do not pose a safety hazard for the turner. The presence of items on the floor that might pose a tripping hazard (wires, air hoses, turning blanks, etc.) must be avoided, including any form of anti-fatigue floor matting that is used at the operator's location. The positioning of the lathe within the room can be influenced by the availability of electrical outlets, dust collection requirements, and other physical aspects of the space. Whether the lathe is set up parallel to a wall,

Placement of tool racks in ergonomically compatible places adjacent to the operator's position improves efficiency...

perpendicular to a wall, or at some intermediate angle adjacent to a wall is a matter of personal preference, as is the placement of the lathe away from a wall. Left-handed woodturners with reversing lathes may wish to set up their machine with more space at the back of the lathe to accomplish more efficient turning (in reverse) to accommodate the lefty perspective. This is an example of adapting the work station to you, and not you having to adapt to the lathe. The turner can experiment with the positioning of the lathe and other supporting items to maximize the safety, comfort, and efficiency of the turning operation – such experimentation and modification should be encouraged as new techniques are learned, or as new equipment dictates.

Lighting, Electrical, and Other Considerations



When developing plans to set up your turning station, keep in mind that additional, concentrated, and adjustable lighting at the operator's position is a significant improvement beyond having

adequate ambient room lighting. Many turners value the extra light provided by various forms of task lighting which can serve to more

intensely illuminate the “field of action” - where the turning operation actually takes place on the lathe. Whether this task lighting is delivered by some form of flexible arm light, track lighting, or other specialty fixture, this light source should be fairly bright and adjustable to accommodate different needs of the turner, including the ability to illuminate turned forms of different sizes and shapes. It is often helpful to have more than one form of task lighting for additional specialized woodturning operations – for example, a readily-positionable light to assist with hollowing operations. As the turner gains experience and turning methods change and develop, requirements will change for new forms of lighting, so some flexibility in positioning of extra electrical outlets should be considered near the woodturning station to accommodate future requirements. These extra outlets will also come in handy when other electricity-requiring tools, such as sanders/drills, routers, carving tools, vacuum pumps, etc. are used while pieces are still mounted on the lathe. The service needed to supply power to the lathe will necessarily be tailored to the electrical requirements of the machine in question – be sure that the proper voltage and current (amperage) ratings are met with suitably sized service wire gauge, and a

...light source should be fairly bright and adjustable to accommodate different needs of the turner...

properly-rated over-current device (circuit breaker) is used in the supply panel. If adding electrical circuits for use at the lathe, those that supply power to the ambient room lighting should be on a different branch circuit than that used to supply current to the lathe, or to other accessories (e.g., grinder) if possible. The room should not go dark as a result of a circuit tripped by a machine or accessory. Many turners, particularly those that do any kind of hollowing, also feel that having compressed air available at the lathe is a necessity. While not essential, it would be prudent to plan to add this utility to the woodturning station design as a future addition if desired.

Provisions for Dust Collection and Floor Clean-up

A very important consideration of any location that you select for your woodturning station is making provisions for installing some

form of dust collection. Whether the actual dust collector unit is located right next to the operating position, or if it is located some distance from the lathe and connected by an efficient ductwork system, every woodturning workstation should be equipped with a



method of removing the fine dust created during sanding operations. Given the nature of the spinning wooden workpiece and its ability to throw fine dust into the air around the operator, having efficient wood dust extraction should be considered a high priority, mandatory installation for every turner. Remember that it is air flow volume that is the critical feature when selecting a dust collection system, and that capturing the dust at the source as it is created is most desirable. The idea is to capture the airborne dust with a machine before your lungs get filled with it – this is the most important thing you can do for long-term respiratory health if you plan on turning for any length of time. Your turning space should also have floor surfaces which are not only safe to stand and work on, but also are easy to sweep and keep clean. Periodic cleaning of accumulated shavings is highly desirable, if not *required* for fire safety, and from different woodturners you will receive a range of responses about what “periodic” means. The area surrounding the lathe should be planned so that it can be cleaned easily, which means that shavings and chip removal is more likely to actually be done on a regular basis.

...having efficient wood dust extraction should be considered a high priority, mandatory installation for every turner...

Other Resources You Can Use –

When reviewing the possibilities of where you will set up your woodturning workstation, it is a great idea to visit other turners’ shops or studios and see how they have set up their lathe and supporting items. Have a look at their lighting arrangements, where and how they store their turning tools, chucks, faceplates, and other accessory items. Where do they prepare their turning blanks? Do they have adequate dust collection? Don’t be afraid to ask them what they really like about their set-up, and what they do not like about it - particularly what they would do differently. Invite a woodturning friend or two over, let them see the space you’re planning, and get some additional opinions from those who have been down the same road before; nothing beats experience. You can also make use of the broad and deep collective experience available through Internet discussion groups, such as on the [AAW’s Member Forums](#) or the [Woodcentral Turning Messageboard](#). Don’t be shy about asking questions about setting up your work station – there are many experienced turners eager to help that are only a few mouse-clicks away.

Once you have chosen a location for your turning station, the next step is to design the work space to match your body, to the techniques you intend to use, to the kinds of tools you have (or plan to have), and to arrange them for maximum safety, efficiency, and enjoyment.

In part two of the series, I will discuss the design and layout of the space, including the lathe, supporting tools, storage of turning tools, sanding and finishing supplies, and other items normally used around the lathe, and how to evaluate the most efficient and ergonomic placement for the storage of these items.

(Selection from *Woodturning Fundamentals*, May 2012, American Association of Woodturners)

WHERE TO TURN FOR WOODTURNING

Selected readings from *American Woodturner*, journal of the American Association of Woodturners

Getting Started in Woodturning



1. Safety for Woodturners
2. Lathes and Turning Tools
3. Learning at the Lathe
4. Practical Woodturning Projects

Elements of Woodturning

1. Turning Holiday Ornaments
2. Making and Using Turning Tools
3. Turning Bowls



Your source for expert, shop tested materials

Since 1986, *American Woodturner* has been a genuine treasure-trove of practical and reliable information written by woodturners for their fellow woodturners.

ORDER TODAY!

64-page soft cover or digital download

AAW | AMERICAN ASSOCIATION OF WOODTURNERS

877-595-9094

Visit www.woodturner.org > online store

WOODTURNING SHOP

Part 2 – Adjusting Lathe & Workstation Parts

In part one, I reviewed different aspects of selecting an optimal location for your woodturning workstation, which included considerations of available shop/studio locations, tool placement, electrical and lighting requirements, dust collection, and cleaning access. Once you have chosen a location for your turning station, the next step is to adjust the lathe, and to design the work space to match your body to the techniques you intend to use, to the kinds of tools you have (or plan to have), and how to arrange them the best way for maximum safety, efficiency, and enjoyment.

In this article, I review the basics of adjusting the lathe and other parts of the workstation to **your** body, so that you will be relaxed and safe while enjoying efficient woodturning. What I outline here should be considered a *starting point* for adjustments and modifications which ultimately need to suit you as an individual regarding adjustment of the lathe and surroundings, and placement of tools, supplies, and other support items such as lighting, dust collection, and compressed air supply.

Setting up your lathe – In addition to identifying the position of your lathe within the available area discussed in the last installment, the

adjustment of the height of the spindle of the lathe to match the physical body dimensions of the primary operator is of critical importance. In general, the advice has been passed down that the optimal spindle height of the lathe for the operator should be approximately the distance from the floor to the operator's elbow when the forearm is held forward (with the upper arm hanging down in a relaxed position), plus an inch or two, based on personal preference, type of turning operations done, etc. (See Figure 1). This dimension should serve as a *starting point* for periodic review and adjustment until one feels comfortable (literally) with the lathe height, as determined through turning experience. When you are first starting out, this adjustment should not be, “Set it – and forget it.”, but should require periodic evaluation and, if necessary, adjustment. For “height challenged” individuals, if the built-in height adjustment (if present) on the lathe cannot be adjusted any lower, you may need to accommodate your spindle height adjustment by constructing an adequately large

...the optimal spindle height of the lathe for the operator should be approximately the distance from the floor to the operator's elbow when the forearm is held forward plus an inch or two...

sturdy platform which raises you to the correct spindle height. One way or another, this important adjustment of spindle height should be made and evaluated carefully as you get used to your lathe. Take the time early in the lathe set-up process to make sure the spindle height is set correctly and it will pay dividends long into the future in long periods of relaxed, fatigue-free woodturning. And don't forget about the resilient "anti-fatigue" matting, if you intend to use it, and its effect on the measurement of your optimal spindle height – this should be taken into consideration when the desirable spindle height is being measured. Make your measurement from whatever floor surface you will be standing on.

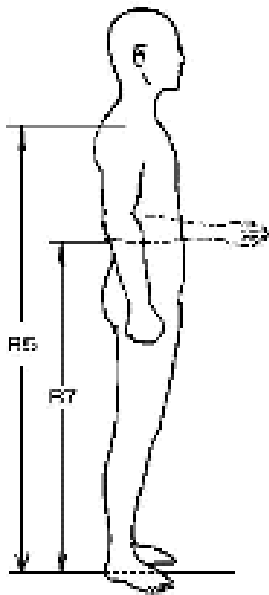

Figure 1: Determining the proper spindle height dimension. The lathe's spindle height should be roughly equivalent to the "R7" dimension, as measured from the floor surface to the base of the elbow when the forearm is positioned up as shown. Some prefer the spindle height an inch or two above this measurement.

The Importance of Being Neutral

– Although this might sound like a great title for a book written on the history of Switzerland, in actuality it is an ergonomic concept where the

operator's body position should be maintained in a neutral posture for the majority of time for the work operation being performed at the workstation. This

means that a woodturner working at their lathe should be standing (or sitting) in a comfortable, relaxed, upright position which does not require leaning, stretching, or expenditure of any additional

Having to lean over or lean back to accommodate an incorrect spindle height adds muscular strain to the body which, over time, can create fatigue, muscular pain, stress, and other discomfort.

muscular exertion while the work is done. Having to lean over or lean back to accommodate an incorrect spindle height adds muscular strain to the body which, over time, can create fatigue, muscular pain, stress, and other discomfort. Having to reach repeatedly out of the neutral comfort zone when doing standard operating tasks should also be avoided. Assuming you intend to spend many long, enjoyable working at your lathe, you should frequently evaluate your body posture as you work, and make corrections as necessary to be neutral for the majority of the time spent turning. If you find yourself developing pain in the lower back, the hamstring region of your upper legs, or in the calf of the lower leg, you should evaluate whether the spindle height is too low or you are assuming a body working position which requires leaning forward repeatedly. Should

you experience muscular discomfort in the abdomen, or have tense, fatigued upper arms, neck, and shoulders, the spindle height may be too high for you. It is important that you evaluate these situations and take appropriate steps so you can turn from a neutral, relaxed position. If necessary, have an experienced turner watch you as you do routine turning operations and see if they can identify problems with your posture or body position while you turn; then take corrective measures. Your turning experience will be much more enjoyable and safer for you and your body.

Your Relationship to the Operating Space – Understanding how the body relates to its work environment is one of the main concepts behind ergonomic design. Since every operator’s body has its own unique dimensions, a design that might work well for one individual may be entirely inefficient (or perhaps even dangerous) for another. Evaluating your own situation and how the size and scale of your body compared to your lathe and the space around it that you are dedicating to your woodturning activities is an important part of making your workstation work best for you. A big component of this is determining how your operating position needs to interface with actual turning operations at the lathe, as well as the placement of all of the “support infrastructure” (tool racks, lighting, sanding and finishing supplies, dust collection, compressed air, etc.), which are the most frequently used among

these, and what kinds of relaxed reaching possibilities there are for the particular operator to access all of these needed things. The concept of determining one’s **reach envelope** includes the assessment of the physical dimensions of the operator’s body and arms to see how far from the main operating position the limits of easy reach (without undue stretching, jumping, leaning, or using aids to reach) can be found. Figure 2 illustrates the general concepts of determining an operator’s reach envelope to determine primary, secondary, and tertiary work zones, based on the body’s dimensions. The take-home message is that the most frequently used tools (for example, your “go-to” gouge, your main skew or parting tool, your favorite scraper, etc.) should be located within or near a primary reach envelope zone, since you use it frequently, and you should expend the least amount of energy trying to access it every time you need it. For that oddball scraper or specialty tool that you use very rarely, these should be located in the secondary or tertiary reach envelope zone, since you won’t lose too much time or energy reaching for these because they’re not used very often. In short, turning tool placement at the lathe workstation should be established by priority and frequency of tool use, on a tool-by-tool basis.

...turning tool placement at the lathe workstation should be established by priority and frequency of tool use, on a tool-by-tool basis.

Positioning of the rack or table where the tools are kept adjacent to the operator at the workstation should also be determined by use priority, within the desired reach envelope, as well as considering the right or left handedness of the operator.

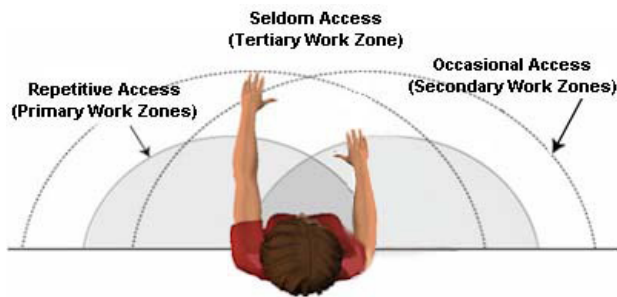

Figure 2: Illustration showing the concept of reach envelopes based upon the arm lengths and arm movement areas of the operator. Placement of tools, supplies, and support equipment should be determined by evaluating the primary types of work performed at the workstation, and then prioritizing the locations for the most frequently used tools and other items within primary and secondary work zones, or within easy reach of them when necessary.

The Concept of Handedness – Most humans have definite preferences regarding tool use being more frequent with one hand than the other – i.e. they can identify with being right-handed or left handed. This preference needs to be incorporated into the design and layout of positioning lathe tool positioning for selection and use by the turner while working at the lathe. Locating tool racks for frequently used turning tools on the non-dominant side of the operator would necessitate twisting or moving the body to pick up a tool with the dominant hand, or picking up a tool

with the non-dominant hand and then transferring the tool to the dominant hand. In either case this is an inefficient situation and adds extra unnecessary muscular expenditure of energy and movement. Thinking through the turning process, knowing what “hand” you are, and positioning your tools within (or close to) the reach envelope on your dominant side will improve the efficiency of your woodturning operation. We turners pick up and put down turning tools very frequently, and it makes sense to maximize the efficiency of this process whenever possible.

Design of the Lathe Workstation – Borrowing from research in the design of efficient operator positions in such diverse applications as emergency communications consoles, aircraft pilot positions, nuclear power plants, industrial machine control positions, and other efficiency-important work locations, the design of a lathe workstation can follow the same basic principles of matching the environment to the operator, the work needs, and efficiencies gained in proper positioning of tools and support equipment and materials. A common feature of these work environments is that the various equipment and controls are arranged in a “U” configuration (inverted) which makes optimal use of the operator’s reach envelope, handedness, and ability to have visual access to the variously located items that enables maximum space efficiency use around the operator.

Taking into account the operator's reach envelope and handedness while standing at the primary work position near the lathe, the arrangement of tool racks, grinder and sharpening equipment, supplies, and specialty equipment should be determined by priority of tool use, safety, and available space surrounding the lathe. Since visually locating, reaching for, and picking up a particular tool are among the most important repetitive processes done at the lathe (as well as returning tools to these same locations) for most turning methods, these operations should take place within a relatively close reach envelope distance on the operator's dominant side. Less frequently used tools can be located at a somewhat farther distance from the operator on the dominant side, but should be placed where they can be easily located visually.



Sharpening also plays a major role in typical woodturning activities, and selection of the location for a grinder or other sharpening station needs to be also considered for a priority location at the workstation, although perhaps not as high as the location for the “go-to”

turning tools. Having the grinder close-by the operator means that it will more likely be used to quickly and frequently touch-up dulling tools while turning, with little effort, resulting in more efficient turning operations. If the operator must repeatedly leave the workstation

If the operator must repeatedly leave the workstation to sharpen dull tools, there will be a tendency to not sharpen as frequently, with negative results...

to sharpen dull tools, there will be a tendency to not sharpen as frequently, with negative results on woodturning quality and efficiency. I would suggest that the grinder/sharpening station be located in a close, relatively high-priority region on the operator's non-dominant side, or (depending on shop layout) located behind them when facing the lathe, so that little extra expenditure of energy or time is required to sharpen a tool while at the lathe. In my opinion, the grinder should never be more than a step or two away from the main operator position at the lathe. Furthermore, it is also recommended that the shaft height of the grinder be at the same height as the lathe for the same reasons outlined above. The body has muscle memory, and accurate manual operations being performed at a particular spindle height at the lathe while turning can also translate into accurate manual operations at the grinder when sharpening.

Turning supplies such as abrasive disks, finishes, and the like, need to share the workspace for your convenience, as do

other priority items such as chucks, tool rests, power sanders, calipers, and other related lathe accessories. Every turner will need to assess their own priorities as to how the valuable near-lathe real estate is shared to develop a safe and efficient work station. In Figure 3, I present a simple diagram of what I consider an efficient lathe workstation, where hand dominance, reach envelope, and the woodturning-specific, unique add-ons to the lathe area such as the placement of vacuum chuck equipment, storage of coring or hollowing tools, etc. are considered, along with placement of tool racks for primary and secondary priority turning tools, location of compressed air and specialty lighting equipment, dust collection hoods and ducting, and other necessary items found at an efficient woodturning station.

I suggest that while developing your own design for how you position all of the various turning-related components that go into what you want at your workstation, you keep the concepts of reach envelope, handedness, and maintaining a neutral posture in mind. Also, minimizing expenditure of extra energy (particularly through repetitive movement) is also important, as is keeping operator safety (from physical injury due to wood blank rotation, flying shavings and other large particles, airborne dust and other debris,

...minimizing expenditure of extra energy is also important, as is keeping operator safety among the highest priorities in your work station design.

and cuts from lathe tools) among the highest priorities in your work station design.

Spend some time investigating your own turning habits and identify what tools you use most frequently. Ask yourself often if the things you have located close to the lathe

deserve to have that space. Do they contribute efficiently to your turning operations? I have seen one turner's

Don't be afraid to re-prioritize and re-position your tools as your needs change!

operating position where an array of faceplates adorned the valuable wall space right in front of the operator. All of them obviously hadn't been used in years, given the layers of dust and rust on them. This wall space could likely be much more efficiently used to store tools and supplies that are frequently part of the turning process. When asked about the faceplates, he said that he never used them, and actually preferred using scroll chucks instead. I then asked him why he had these faceplates all stored in that particular place, his answer was simply, "They went with the lathe." Whether you are a production turner where time is money, or an occasional turner where time may not be much of an issue, safety and efficiency still should be considered very high priorities in the design of your lathe work station. You want to have the most enjoyable time possible at your lathe, while maintaining your safety and health in doing so. Good workstation design goes a long way in making sure you get the most out of your woodturning experience.

WOODTURNING SHOP

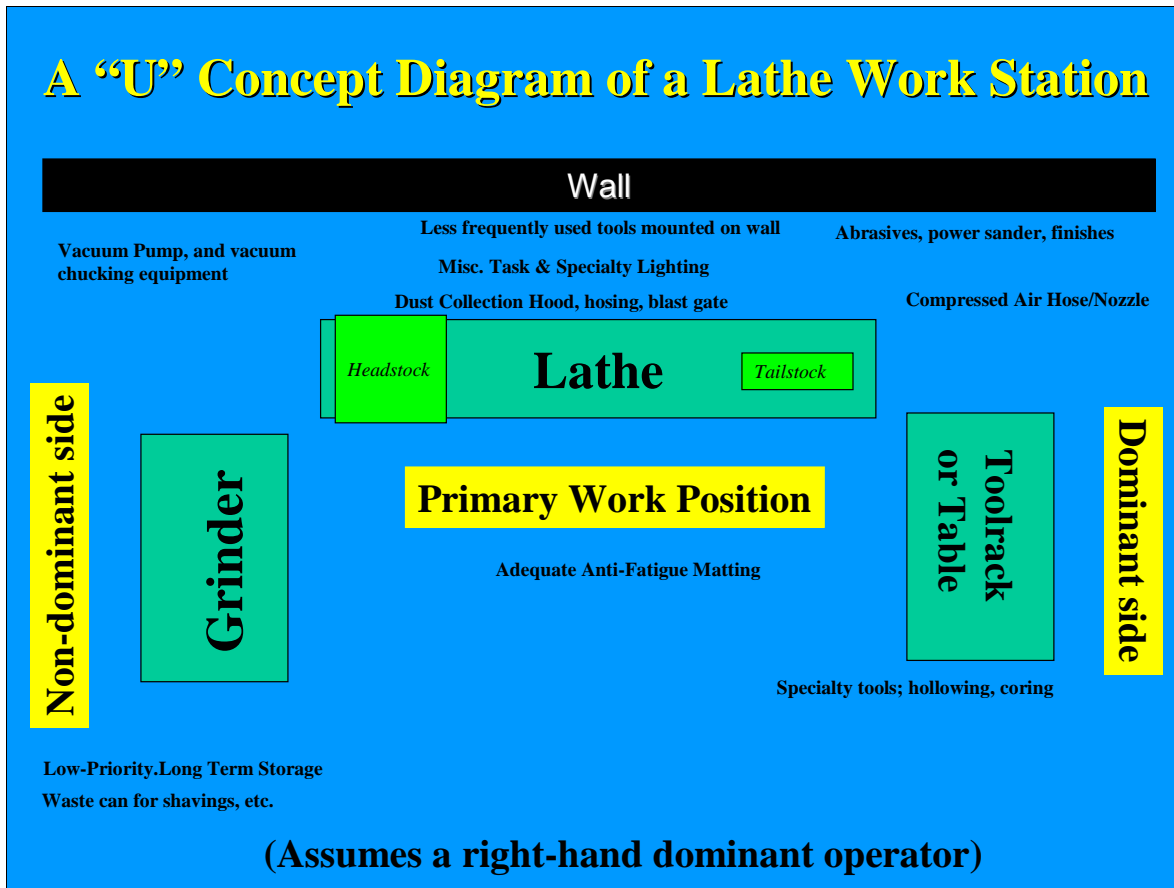

Figure 3: A simple illustration of an efficient lathe workstation which incorporates the “U-Concept” of gathering tools, equipment, and supplies around the primary operating position, taking into account the concepts of reach envelopes and handedness. Although this illustrates the workstation with the lathe parallel with the wall, the same concepts apply wherever the lathe is positioned in the available work area.

In part three, I will discuss several other design factors that might also be considered for efficient and safe operations at your lathe’s workstation. Not only does this involve maintaining minimal reaching and repetitive movement, use of personal protection equipment, and other operator safety practices at the turner’s position, but also the design and placement of tool racks and other storage options.

(Selection from Woodturning Fundamentals, June 2012, American Association of Woodturners)

WOODTURNING SHOP

Part 3 - Tool Racks & Storage

In part three of the series, I include some food for thought about how the woodturner should set up the tool racks and other storage at the lathe workstation for safety and for maximum efficiency. There are many ways of accomplishing the goal of having your turning tools readily available at the time when they are needed during the woodturning process, so some creativity here is needed to allow the turner to adapt their workstation to their specific situation, to fit the available space, and to consider the various turning methods being used. I will also include a few brief comments on use of personal protection equipment, although much more could be written on this topic than I can do in this series.

Recall that in all cases of setting up an ergonomically-designed efficient workspace, the concepts of reach envelope, prioritization of tool use, and handedness (discussed in part two) also come into play with regard to how to store one's turning tools and supplies.

Design of Tool Racks – In each turner's lathe workstation, there is a need to bring the lathe, the operator, and the turning tools together into the same space, and to make sure that this “merging of the forces” results in a place where turning can be done safely, with consideration of how the turning operation can also be done

efficiently. In every case, the design of the turning tool rack (or racks) is a combination of specific requirements that include the physical space available and ergonomics of the operator and the lathe, as well as the requirement to store a certain number of lathe tools safely and conveniently. There are probably as many designs as there are turners, but thinking about how to make your own turning tool rack should be part of the overall workstation design process. The tool rack design can and usually does

evolve over time, given that the tool storage requirements change (almost always in the “need more tool storage” direction) as the turner develops different

skills, tries new techniques, or follows the woodworking adage that “he who dies with the most tools wins.”

Developing a good design for your tool rack can pay off in future efficiency and enjoyment of your turning activities, as well as contributing to the overall safety conditions of your woodturning work station. Having a look at how some of your woodturning



friends have solved their tool storage situations, and perusing images of other turners' shops/studios can provide a wealth of ideas for designing your own tool rack that fits your unique situation. Whether you have shelves, hang tools from nails by holes in the handles (or from screw eyes), build vertical racks of different designs, put together carousel tool holders, or develop your own ideas on how to present and store your turning tools at your lathe workstation, I would like to pass on a few basic design considerations that you might think about when building (or re-designing) your tool rack(s).

Some Desirable Characteristics of Tool Racks – Having looked at the design of many different woodturners' tool racks over the years, both in person and via images seen in on-line woodturning discussion groups and other resources on the Internet, and having undergone three different re-designs of my own racks used for storing my turning tools, I have found that there are some common features that I feel are useful to incorporate in a good tool rack design for both safety and efficiency:

1. In no case should you ever have to reach past the sharpened (“business”) end of one turning tool to reach another tool. This sets up future injury “by design.” DON’T DO IT.

2. Tools placed in racks should be spatially separated by tool type or by process – whatever works for you, logically. Some turners place all gouges

together, all scrapers together, all skewers together, etc. by “type of tool.” Others place all tools necessary to complete specific tasks together, e.g. all tools needed to finish bowl bottoms, all tools needed for hollowing, those needed for turning spindles, etc. The concept of “most frequently used tools being placed within the highest priority reach envelope zone” applies here, as does the complementary idea of storing less frequently used tools farther away from the turner. Rack design can (and should) reflect these priorities.

3. Turning tools should be accessible both VISUALLY and by REACH, usually in that order. You should be able to identify the tool needed *by*

sight first, before reaching for the tool. Having to check the profile of the tool after you have picked it up is not very efficient, particularly if it isn’t what you wanted.

I like to be able to see the cutting end of every tool I need before I reach for it. Some turners make different handles for every tool and can determine what tool they need either by handle recognition (visually or by feel), or by location. The latter requires diligent replacement of the



tool back to the same spot every time it is used. Remember that an array of turning tools purchased from one manufacturer are likely to all have the same handle, so there is a need to see what tool you are selecting by looking at its cutting end – a dozen Sorby turning tools all look the same from the handle end.

4. Turning racks should be equally as convenient for returning tools to during the turning operation as they are when picking them up to use once they are selected.

Easy access for tool selection and return to the same spot increases operator

Easy access for tool selection and return to the same spot increases operator efficiency over the long term.

efficiency over the long term. If you use a carousel-type tool rack, be prepared to “do the spin” to get the tools back to their home position. If you hang tools vertically, upside down by nails or screw-eyes, be prepared to slow down each time when returning the tool to its home location, and expect the occasional crash to the floor, usually with the sharp end hitting first, requiring re-sharpening. Been there, done that.

5. Tools should be held in place securely to prevent falling from the rack. I personally prefer using tilted racks and bar magnets to hold my tools both by gravity and metal attraction, as I find this design very efficient to see, select, grab, use, and replace the tool easily. I

have previously used what I call the “thread the needle” style tool holders where it is necessary to slide one or more parts of the tool through an opening or into a hole of some kind in order to replace the tool, and don’t find this style of rack very efficient for my use. This is a personal preference. Some turners are very happy with this kind of rack design, but it does not work for me. Regardless, turning tools should be held securely for the safety of both the operator and the tool.

6. For turning tools stored at or below waist height, the tool’s cutting ends should be adequately protected to avoid accidental contact by the operator, particularly if the operator slips or falls into the rack. I do not like to see vertical tool holders used if there is a chance that an accidental slip or fall could mean becoming impaled on a turning tool. What’s worse is that I have seen a few turners use a 5-gallon plastic bucket and stand their turning tools in the bucket, sharp side up, which is then placed on the floor. One bucket-based tool holder even had PVC pipe sections arranged in the bucket to ensure that the tools were spaced away from one another nicely. In my opinion, this type of tool “rack” is simply a recipe for disaster. Be your own judge, but think safety first.

7. Tool racks should not be designed such that any parts of the stored tools extend into the operator’s work space and could lead to tripping or other accidental body contact. The work space should be free of obstructions that might create safety hazards of any kind.

Placement of Tool Racks at the Operating Position – It is a fairly easy decision to place your tool rack(s) at your dominant hand side of the lathe within your reach envelope. Use of available cabinet, wall, or other space to set up your tool rack must be determined on an individual basis, but you do want your most frequently used tools to be located within an arm’s length of your dominant side. Many of the considerations regarding tool rack design also apply to locating your tool rack(s) adjacent to your operating position. Before determining a final position for your tool rack, it may be helpful to temporarily position your tool rack at different places and then do some turning – you will soon see which position works best for you regarding tool selection, use, and return. In any case, the highest priority in selecting the location of the tool rack should be determined by ensuring operator safety and freedom from the risk of accidental injury due to tool rack placement. Increasing woodturning efficiency is an important, but secondary, priority relative to operator safety.

...the highest priority in selecting the location of the tool rack should be determined by ensuring operator safety and freedom from the risk of accidental injury due to tool rack placement.

Near-Lathe Storage – Most woodturners require storage for essential, non-tool items and supplies that are used during the woodturning process, such as abrasives, finishes, measuring items such as calipers, rulers, etc., and other items. There should be a landing place for chucks and centers when removed from the lathe, and a place to store extra jaw sets, faceplates, mounting screws, and other high priority items that a turner would need while working at the lathe. Making use of high priority "Reach Envelope Zone Number 1" space should be reserved for those lathe tools and support items that are used most frequently in the majority of woodturning operations. Other potential storage areas at lower priority positions around the lathe can be used creatively to store necessary items for convenient and efficient use. I have seen numerous examples of cabinetry built to use the relatively large amount of close space under the lathe bed, as well as on-wall cabinets and shelves that allow storage of accessories close to the operator position. Each workstation and each operator is unique, and carefully evaluating what space is available, plus applying some creativity in design can result in developing storage space at your lathe workstation that increases productivity and enjoyment of your woodturning.



Personal Protection Equipment (PPE): Vision and “Flying Objects” – Among the most important things all woodturners need to hear over and over again is the requirement that eye protection must be used by the operator for each and every turning operation, without exception. That should probably be extended to FACE and HEAD protection as well. The woodturning operation, by its very nature, generates projectiles of different sizes that are often thrown directly at the operator’s face, head and upper body. Having at least minimal protection in place to reduce the chances that these projectiles will reach and damage the eyes should be a common sense no-brainer for ANYONE who intends to stand at the lathe, spin wood, and put a cutting tool into the wood to shape it. Unfortunately, simple goggles are often inadequate to extend that protection to larger sized projectiles such as chunks of bark, cracked portions of the object, whole blanks, which would suggest that turners should opt for full-face protection,

favoring the use of face shields instead of goggles. I have seen turners use BOTH forms, either simultaneously, with goggles worn under a face shield, or successively, with the full face shield used while roughing and the turner switching to goggles when the turning operation becomes “safer” during refinement stages of completing the piece. It should be noted that this may be a false sense of safety generated if the “dangerous operations” are completed and you can let down your guard, put on the goggles and grab the finishing tool and have at it. Regardless of the stage of turning, the full face shield should be worn throughout the turning operation.



What does give me some concern is the **quality** of face shields I see some turners use. Although there may be a plastic face cover that might protect against small chips, shavings, and dust generated by the turning process, some of these “bottomless” face shields are rather flimsy and would not provide much protection against larger projectiles that might be launched from the piece.

It is advisable to select a face shield that is not simply a piece of plastic hanging from a headband, but one which also includes lower face and jaw protection as well.

I am not ashamed to say that I am a member of the “Flying Bowl Club,” and that I have previously launched a few blanks off of a lathe in the past (even one or two during demonstrations .), and I have been lucky so far that no injuries have occurred. That does not mean that no matter how experienced I become as a turner, that it can’t or won’t happen again in the future. I would hope that learning from each unfortunate experience can improve my turning technique so that I can avoid a similar situation as I continue to turn. Having adequate personal protection that I use regularly increases the chances that I can continue turning without serious injury. This DOES NOT mean that I should develop a false sense of security that “my face shield will protect me,” and more importantly, it SHOULD NOT be an excuse to use unsafe turning methods, put yourself in the line of fire, use unstable wood, etc., simply because you are protected with good PPE. Operator safety practices just don’t work that way.

It is advisable to select a face shield that is not simply a piece of plastic hanging from a headband, but one which also includes lower face and jaw protection as well.



Personal Protection Equipment – Respiratory Protection

– Another safety issue involving the use of personal protection equipment involves ensuring that the operator is adequately protected from fine wood dust carried in inhaled air. Since inhaled fine particulates can represent a significant health risk, particularly in repeated exposures over extended periods of time, it is particularly important that this aspect of woodturning safety be treated very seriously. This, of course, is a huge topic, deserving of its own article, but I do want to include Respiratory PPE as an essential component of a well-designed woodturning workstation. This PPE does not include the related, but separate, installation of an efficient dust collection capability at the workstation. Respiratory PPE involves

...it is particularly important that this aspect of woodturning safety be treated very seriously.

specific devices that are used on the operator to eliminate or reduce the possibility of inhaling fine air-suspended particles deep into the lungs. There are several different kinds of equipment that provide various levels of respiratory protection. The simplest of these (and least effective) are “nuisance dust” type masks, worn over nose and mouth, which provide minimal (if any) protection from the very small (5 microns or less) wood dust generated during sanding that is the greatest health risk. More efficient are half-face or full face masks

that use various cartridges to filter out particulates that are suspended in

the air, but given the number of bearded turners I see at symposia, such contact-mask types are not very effective for the “facially hirsute” among us. Other powered-type PPE devices that provide respiratory protection are those that provide filtered air over the face, nose, and mouth, creating a positive pressure within a gasketed, full-face mask that excludes contaminated air from the possibility of being inhaled. Many of these types have helmet-mounted or belt-mounted battery packs and air-filtering devices that generate the pressurized, filtered air that can then be breathed safely. There are other versions of a “PAPR” (Powered Air-Purifying Respirator) apparatus that provide filtered, pressurized air via long tubes connected to the mask apparatus, instead of having on-operator battery,

Wood dust generated during sanding that is the greatest respiratory health risk.

filter, and fan components. As one would expect, the costs of these devices go up with greater filtering efficiency and operator convenience. The turner needs to assess for himself which level of respiratory PPE should be added to the turning workstation in addition to dust collection, to provide the best available and affordable protection from long-term inhalation of wood (and other) dust.



Personal Protection Equipment – Hearing Protection – In general, woodturning at the lathe is a fairly quiet endeavor, especially when compared to running other woodshop machinery such as surface planers, jointers, miter saws, and table saws. There is a growing group of quite sophisticated woodturners who use these other tools regularly, in addition to their lathe, as part of their woodturning activities – segmented woodturners (the “seggies”). They routinely use these flatwork tools and should certainly heed warnings

about repetitive exposure to high decibel sound levels that they might be exposed to while they work. Additionally, those turners who accompany their turning generate high sound levels (both in sound pressure and frequency) need to also be aware that they should have adequate hearing protection while they use these tools. HEARING LOSS IS CUMULATIVE throughout one's lifetime, and regaining lost hearing ability due to excessive, repetitive damage to various parts of the inner ear is not very likely. You have ONE set of ears (I hope.) that you need to protect throughout your lifetime.

There are numerous kinds of hearing protection (Hearing Protection Devices, HPD)

available of different design. Some prefer an earmuff style hearing protector, with a spring-tension band that can be worn over the top of the head, behind

the head, or even under the chin. Others prefer hearing protection that inserts into the outer ear canal as an ear plug which attenuates high noise levels before they reach the ear drum and inner ear anatomy. The goal here is to reduce the sound pressure level across the range of frequencies to an acceptable level that will not cause permanent and cumulative

The goal here is to reduce the sound pressure level across the range of frequencies to an acceptable level that will not cause permanent and cumulative damage to your ears' hearing apparatus.

work with off-lathe embellishment techniques using high-speed or other air-driven tools that

damage to your ears' hearing apparatus. Be sure the hearing PPE you get is rated appropriately for the amount and kind of noise you expect to encounter; most of these devices are rated with a Noise Reduction Rating (NRR). There is quite a bit of information available on-line regarding selecting appropriate hearing protection devices, and I encourage you to investigate this if you use such noise-generating devices in your turning activities.

Conclusion

I hope that this contribution to Woodturning FUNdamentals has provided you with enough basic information to get a good start in assessing your own individual woodturning station, whether you are building one anew, or might want to re-design one that you have been using for some time. You will find that if you include many of the design principles I have outlined here, your result will be a safe and efficient workstation that will be enjoyable to use. Remember that periodic re-assessment and evaluation of the layout of your woodturning station should be part of the normal growth and development of your skills as a woodturner. Please feel free to contact me if you have specific questions or need further clarification on items I have discussed in these three installments.

(Selection from Woodturning Fundamentals, September 2012, American Association of Woodturner)

LATHE ADJUSTMENTS

Adjust the Height of Your Lathe



<http://vimeo.com/100176408> (If you have trouble opening the video when clicking the link, please copy the link and paste it into your browser.)

Every woodturner goes through a learning curve when acquiring the knowledge and skills needed to accomplish various turning methods. It is our hope that watching this video will help you set up your lathe – and a safe and functional workshop environment.

Rob Wallace serves on the Board of Directors of the American Association of Woodturners (AAW) and is head of the AAW Safety Committee.