

TT 520  
.P46  
Copy 1

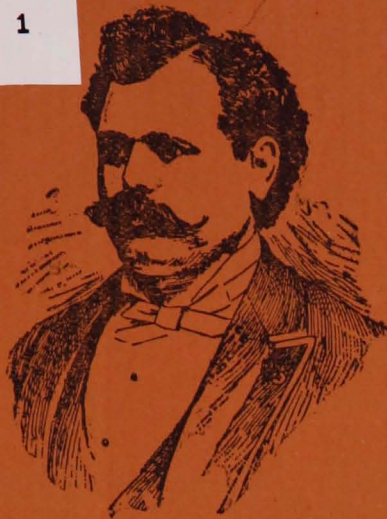

PROF. JEAN B. PEYRY'S SYSTEM METRIQUE.  
INVENTOR AND SOLE PROPRIETOR.

EDITION

..1896..

FOR

Ladies' —  
Garments



RIDING HABIT.



INSTRUCTION BOOK

WITH

DIAGRAM AND MEASURE BOOK

OF

Prof. Jean B. Peyry's System Metrique.

FOR CUTTING LADIES', CHILDREN'S & GENTLEMEN'S GARMENTS.

Entered according to Act of Congress, in the year 1896, by Prof. Jean B. Peyry, in the Office  
of the Librarian of Congress, at Washington, D.C.



PROF. JEAN B. PEYRY,  
PUBLISHER.

P. O. Box 570, New Orleans, Louisiana, U. S. A. P. O. Box 385, Montreal, Can.  
262, Rue de Vaugirard, Paris, France.



... 1896 ...

58106 A2



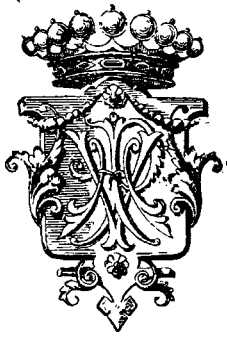

# PROF. JEAN B. PEYRY'S INSTRUCTION BOOK

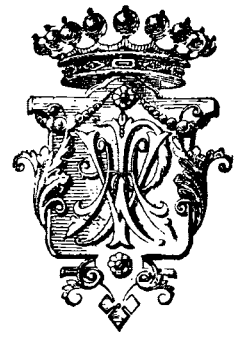

... WITH ...

## DIAGRAM AND MEASURE BOOK

GIVING FULL AND COMPLETE INSTRUCTIONS FOR USING

PROF. JEAN B. PEYRY'S "SYSTEM METRIQUE"

INVENTED FOR

CUTTING LADIES', CHILDREN'S & GENTLEMEN'S GARMENTS

OF EVERY DESCRIPTION—SEAM AND SEAMLESS

Consisting of Perfection Metrique, Tailor System of Garment Cutting, made in Six Pieces. Front Piece, No. 1; Under-Arm, Piece No. 2; Sided-Back, Piece No. 3; Back Piece, No. 4; Dart and Skirt, Piece No. 5. and Sleeve, Piece No. 6.

---

THIS SYSTEM IS COPYRIGHTED OR REGISTERED IN EVERY COUNTRY.

---

## THE INSTRUCTION BOOK

Is Illustrated with a Diagram of every style of Garment; also Diagram for taking the Measures for Basting, Matching Plaids and Stripes. It teaches the entire Art of French Dress Cutting and Making, Basting, Draping, Designing, Taking Measurements, Matching Plaids and Stripes and Finishing, and will furnish Pupils with a Diagram and Instruction of every New Style.

---

The Measure Book is to keep a record of all the Measures, Names and Addresses of Persons; Dates, Styles, Prices, When to be Finished, Remarks, &c., and it will contain 200 Measures in all.

Address all communications to

PROF. JEAN B. PEYRY,

Publisher, Inventor, Proprietor and Manufacturer of said System,  
and all strictly Seamless Garments.

P. O. Box 570, New Orleans, Louisiana, U.S.A. P. O. Box 885, Montreal, Can.  
269, rue de Vaugirard, Paris, France.

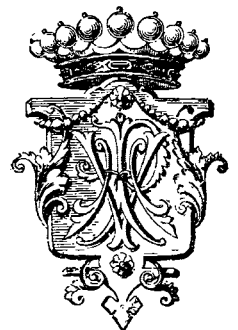

---

AGENTS WANTED EVERYWHERE (either Ladies or Gentlemen).

TT 520  
P 46

CH 10-2255 Unrev'd

# INDEX.

---

	PAGE
INTRODUCTION, - - - - -	3
Dress Cutting, - - - - -	4
Dress-Making, - - - - -	5
The Skirt, - - - - -	5
Sleeves, - - - - -	5
Dress-Makers' Union, - - - - -	5
Directions How to Take the Measures, - - - - -	7
Measure Book, - - - - -	10
Directions for Drafting—First Lesson, - - - - -	11
Important Notice to Pupils, - - - - -	13
Directions for Cutting the Lining, - - - - -	13
Directions for Dartless Front—Figure 10, - - - - -	14
Directions for Drafting French Dart, - - - - -	14
Directions for Drafting Three Darts or Two Under-Arms, - - - - -	15
Directions for Drafting Different Darts, - - - - -	16
Directions for Drafting Different Backs, - - - - -	18
Directions for Drafting Dartless Waists and Jackets, - - - - -	20
Directions for Drafting Jackets, - - - - -	25
Directions for Drafting Skirt, Waist and Vests, - - - - -	27
Directions for Drafting Riding Suits, - - - - -	29
Directions for Drafting Sleeves, - - - - -	31
Directions for Drafting Bicycle Suits, - - - - -	34
Directions for Drafting the Skirts and Sleeves, - - - - -	37
Directions for Drafting the Seamless Waists, - - - - -	46
Directions for Drafting the Seamless Princesses, - - - - -	53
Directions for Drafting Dolman, - - - - -	54
Directions for Drafting Capes and Collars, - - - - -	55
Directions for Matching Stripes and Plaids. - - - - -	56
Directions for Basting Seamless Waist, - - - - -	57
Directions for Drafting the Princesses, - - - - -	59
Seamless and New Sleeves, - - - - -	63
Seamless Waist Put Together, - - - - -	65





# A SYSTEM FOR CUTTING LADIES', CHILDREN'S AND GENTLEMEN'S GARMENTS

INVENTED BY

PROF. JEAN B. PEYRY, OF PARIS, FRANCE.

---



HAVING spent fifteen years in Paris in the line of Dress Cutting, Making and Designing, and having invented several different *Metrique Systems*, published several books (with the object of elevating the art of Dress Cutting and Making), we have therefore spared no time, labor or expense in bringing this *Metrique System* with its illustrated Instruction Book to the highest state of perfection in all points. In the first place we must explain what a True *Metrique System* is. It is a system of decimal measurement; that is to say, that 10 millimetres make one centimetre and 100 centimetres make one metre, or 1000 millimetres make one metre, and as 10 times 100 make 1000, then 25 millimetres are the size of one English inch, or 900 millimetres would make one yard. By this system it reduces an inch 25 times smaller without any fraction; that is to say, the *Metrique System* gives 25 measures in one inch, and if we make four fractions with a millimetre—as we take four quarters to make the inch—we would get a measure 100 times smaller than we get with the four fractions in an inch. It is thus easy to be seen that by cutting with my *Metrique System* you get a measure 25 times smaller than you would get by the inch measurement; consequently you have 25 chances over any other system making use of the inch measurement—only you must understand that when taking measures alone the larger the measurement the more fractions you will get, and the result arrived at be less correct. Now suppose you use a foot instead of an inch measurement: a foot divided into four fractions (which is four quarters) would give three inches for each fraction. Thus, if you were to make a mistake of a fraction when taking the bust or waist measurement, that fraction all round the bust would throw you out 12 inches; that is to say your dress would be 12 inches too large or too small, according as you have made the mistake. By using the inch measurement if you make a mistake of one fraction you lose or gain one inch all round the body, whereas in using the *Metrique System* if you make a mistake of a fraction you lose or gain only one millimetre, and as one millimetre is only the twenty-fifth part of an inch, we think it a great proof of the superiority of the *Metrique System*.

We would call the attention of dressmakers and ladies in general to the fact that the *Metrique System* is the only correct measurement ever invented, and is taught in every first-class college in the world. In Europe it is the standard measurement used by all draughtsmen and in artistic work. The United States and Canada must adopt this scientific measurement before long.

Second,—Prof. JEAN B. PEYRY'S *System Metrique* is a system founded on the art and science of the human form, doing away with all the complicated and tedious studies of scales, fractions and anatomy that persons had to go through in former years. It now being a decided fixture for every form of person—that is, for every part of their body—that is to say, this system gives a different shape to each different figure, even if they are all the same size. Every dressmaker understands that figures of the same size seldom or never agree in shape. You may find ten ladies who take exactly the same measurement everywhere. In those ten ladies you cannot find two who have the same form. This system teaches you how to cut all the different forms with the same measurement. You can get the correct balance for every form of person, therefore you get the correct fit for every person, no matter what disproportion or deformity—tall, short, stout, thin, extra erect, stooping, one-sided, crooked or even a hunchback. Any garment can be cut and made up and will fit perfectly, without any fitting on, and without the least bit of alteration. Enquire of any genuine French ladies' tailor if he could make a lady's dress without even seeing her and without any fitting on, add guarantee a perfect fit. You will surely find his answer, "Why certainly." But your measure must be taken by a French tailor who has well learned the French *System Metrique*, which you must know is far more difficult to do without ever seeing the form of the person, but our check measures prove the exact form of every person; that settles it, and it is easy enough to do.

Third.—Because all kinds of seam and seamless Dresses or Sleeves, seamless Princess Basques and Waists, or French seamless Bell Skirts and seamless Sleeves are drafted upon the lining, thus saving much time and labor; the drafting being done in less than one-third of the time required by any other method.

Because you learn the entire art of French Dress Cutting, Making, Basting, Draping, Designing, Tacking, Matching Plaids and Stripes and Finishing. We teach you how to cut all styles and sizes of garments; any style of Sleeves, straight darts and French bias darts, one dart two dart and three dart Basques, or two under-arm piece for very stout ladies; French dartless Princess

and Basques, no darts in lining or goods and not stretched on the bias ; one, two or three seam Parisian Basques, Parisian Tea Gowns, plain and Fancy Basques, Corset Covers ; any style of double-breasted Princess and Basque, Morning Dresses, Cloaks, Dolmans, Hunting Suits, Riding Suits, Ladies' Tailor Suits, Coats, Jackets, Figaro, Robes, Bicycle Suits, Blazers, Capes ; any style of Skirt and Collar ; any style of garment for ladies, gentlemen, children and infants ; and, in fact, every garment for which a lady or gentleman has need.

Each garment is profusely illustrated in this Instruction Book, for a thorough understanding of which this work is compiled. It forms a system that can be learned by any person of ordinary intelligence without spending much time in its study, and when learned is very easily retained, therefore it will not be necessary to be in constant practice in order to do good and efficient work with it ; by looking at the diagram and directions it will remind you of the drafting.

Any one interested in Artistic Dress Cutting and Making cannot fail to be interested in studying the method used in Prof. Jean B. Peyry's *Metrique System*. It is a work of scientific training and of years of practice, which cannot be shown by any other method of cutting.

It is a mistake for any one to suppose that a smooth fit is all that is desirable in making artistic garments. The great secret in Dress Cutting is, as was stated before, to get the correct balance for every form of person with the outline gracefully curved and applied to the human form. All figures are improved, and many ladies appreciate such work without possessing the training to accomplish it. A short time applied to the study of this method will make them independent ; and we believe that every lady, young, rich or poor, should in justice to herself, become the owner of a *Metrique System*.

Every dressmaker should learn this system. Those who do not will find that their more enterprising competitors, who have learnt it, will capture the trade of their best paying customers. Parents should have their daughters learn this system, and not neglect this important part of their domestic education. Sewing girls should learn this system and have their wages increased more than double, by reason of their being able to cut and fit a faultless and perfect-fitting garment in any style.

Our system is well known in France, Belgium, United States and Canada, and does not need comment, it having received the endorsement of the cutting fraternity as correct in theory and reliable in practice. We have unequalled facilities for imparting a thorough knowledge of scientific cutting in all its branches, and can point with pride to the number of our students who are filling responsible positions throughout the country by the use of Prof. Jean B. Peyry's *Metrique System*. We will complete your course with a diploma.

The great popularity of the *System Metrique* for cutting garments of every variety is undoubtedly due to the fact that it is the only scientific method applied to Dress Cutting, and is exceedingly simple and complete, is easy to learn, rapid to use, follows every fashion and no refitting whatever, no charts palmed off on you as a tailor system ; that is ridiculous. No squares ; they are entirely too slow and complicated. No slides or drafting machines ; their time is past. No French contrivance of any kind like a good many have tried to defraud the public with, but the genuine French *Metrique Method*, with the highest art which skill and genius can invent ; an up-to-date idea and copyrighted 1895 and 1896. This is the only French method that has been taught in America. The actual measurements are taken with the metrique measure, for which it is the decimal measurement, and is the only accurate measure that has ever been invented, from which you can cut a garment from the size of 10 centimetres bust measure up to 150 centimetres.

This Instruction Book contains nearly 250 different figures with the direction for each, and all our seamless garments are copyrighted or enregistered separately from the Instruction Book, thus giving full protection to the inventor and the costumer. It must be borne in mind that we give or sell this Instruction Book to our pupils only. Each Instruction Book is numbered with each System, and we will not sell a second book without the System, but we will sell as many Systems as you wish without the Instruction Book. Pupils can get new books with a new System. When the first System is worn out we will sell a second one at reduced price, but it is not necessary to buy an Instruction Book as the first one may be in good condition.

When writing to us for information or goods give us the particulars of the agent you learnt the System from and number of the System ; write your name and address plainly ; if you are a lady sign your name with the prefix Miss or Mrs., as the case may be ; no attention will be paid to any letter not signed in the above manner.

## DRESS CUTTING.

In this age of advance and improvement there is no grander art or trade—nothing to touch it, as we have constantly new designs to cut by. From one week to another the fashions change. The tailor trade is reckoned a very good one (that is the custom trade), but it cannot rank with Dress Cutting or Dressmaking. They can manufacture gentlemen's garments but they cannot make ladies' dresses. No ; the styles change too often. We designers know well that as the styles change so often a dress would be out of date before it could be manufactured wholesale. They all have to be custom-made. Ladies will be in the style as long as the great City of Paris is in existence, no matter what the style may be. We only make new designs for prominent customers (known as leaders of fashion), who demand something that no one else wears. We are designing all the time, and we have hundreds of customers in all our branches who instruct us never to make the same design for another person, for which they pay us



a big price as well as for the special style, and it gets afloat and is copied as nearly as possible by the dressmakers. Paris houses are in constant demand for new designs, and are willing to pay handsome prices for our work. Our plan is to follow the summer and winter resorts where fashionable people spend their leisure time. At these places we come in contact with every style in the world, which gives us a great advantage in originating new designs for dresses, without copying another's style. A garment well cut is easily made. The well curved-out line gives better shape. It looks better, it wears longer, and gives greater satisfaction to your customer; besides it is an advertisement for you wherever it moves. No matter what part of the world you go to, from a small village to a large city, a good dressmaker need never be idle one hour in the whole year, and can always command high prices by using Prof. Jean B. Peyry's *Metric system*.

Dressmakers that cut by worthless methods or so-called French contrivances—just to sell them—and those who cut to old methods fitting to the figure—as if they were papering a wall—have no chance to come to the front in their trade. We do not intend this explanation to apply to persons young in the trade, but to good cutters and fitters; dressmakers know the trials they have to go through with their old methods.

## DRESSMAKING.

The art of Dressmaking is constantly developing and improving, and we see a grand movement in its development. No expense is spared to obtain the most artistic work from first-class dressmakers. The great success of dressmaking is due to the careful study of cutting; putting the garment together; understanding the art of basting, pressing the seams well, finishing the inside of garments carefully, and displaying taste in draping the outside of the dress.

Fancy dresses are the styles most in demand, as *frou-frou* and *fanfreluche*; but the tailor-made suit is rapidly coming to the front. It looks as if the tailor-made suit will become a leader for street wear, its success being undoubtedly due to its simplicity in making, its durability, its usefulness and ease of adjustment.

## THE SKIRT.

A few words on the making, finishing, and wearing of the skirt. For persons shopping a great deal in cities they are made from one to two centimetres from the ground; those who visit the shops in a carriage, or for housewear, can have the skirt full length all round. Persons of old age or those who are stoutly-built can wear them with a small train at the back about five or six centimetres long. Costumes for the country or the promenade are made with skirts three to four centimetres from the ground—three centimetres if short, four centimetres if tall—thus allowing a lady to walk without having to hold up her skirts. For ceremonies, marriages, balls, official receptions, they are made with a train of 40 to 50 centimetres. In finishing the skirt it is necessary to put hair cloth all round, about 30 to 40 centimetres in depth and light as possible, cut to the same form as the skirt, using the hair cloth in the right way, that is to say, leaving at right and left the barbel of the hair cloth. Plaited skirts or those gathered at the waist are coming in style, and are made in very light goods only.

## SLEEVES.

The new sleeves are transformed very little. They are not so large and more drapery is used in the finishing, and are made flatter from the elbow up to 15 or 20 centimetres from the shoulders. The sleeve is made longer from the elbow to the hand, and is open with a jabot. The foundation is made with tight-fitting lining. This new sleeve keeps its shape better.

## DRESSMAKERS' UNION.

Dressmaking is one of the most important branches, but has no protection. All other trades have Unions to protect them, except the dressmakers. Instead of helping one another they work against each other. What one will make for a dollar the other will do for fifty cents, consequently the dressmaking trade is running down every year, especially in the country towns where the rents are low and having never devoted any time to learning their trade they don't care to spend five cents in improving themselves. The country dressmaker will work for any price. This undoubtedly does a great injury to those who are living in the city where everything costs more and where the expenses are larger. The worst of it all is that the country dressmakers are poorer than those living in the city, because the former will make three or four dresses for \$15 and thinks that at that price she can make it pay, as her motto is: "Work day and night," say from 6 a. m. to 2 a. m. next morning—figuring only for one day's work. People who live in the country towns and have a nice dress to be made will go to the city and pay from \$15 to \$100. The city dressmaker who has real talent and ingenuity in the art of dressmaking will get from \$15 up according to the work and style of dress, thus receiving three or four times as much as the country dressmaker for her work, because she understands her business better. Now, let me tell you that there is more work in three or four badly-made dresses than in a good dress, no matter how badly they are made, even if they were cut with an axe. It takes longer to do the work wrong than to do it right, because the work is not scientifically applied.

Dressmakers in France get from 25 to 100 per cent more than those in the United States or Canada. Many persons wonder why the French dressmakers get such large prices for making ladies garments. The reason is this, they have all learned and use the *Metrique system* to cut their garments by, besides having acquired their trade from a competent dressmaker, and never start business for themselves without having a thorough knowledge of the art. All the dressmakers who have learnt their trade under the same principle form a Union to protect themselves against inferior workers who do their work by means of patterns. The result is that, no matter to what place they go, be it city or country, they all have the same price for the same kind of work, and people who appreciate a well-fitting garment go to them and pay their price. The place has nothing to do with a person who has talent, it makes no difference whether the work is made in the centre of the city or in the middle of the woods, the talent of the dressmaker remains unchanged.

Now, look at the carpenter, bricklayer, mason, etc., they all have the same price for their work, because they have a Union. We would suggest to all American and Canadian dressmakers who are using our *Metrique system* that they form a Union in each city and town where it is used. Make your own prices and raise the price of your work. The better the method you work by the more superior will be your work, and you will get a better price for it. Use Prof. Jean B. Peyry's *Metrique system* and become united and you will protect yourselves against inferior dressmaking, as the French dressmakers have done.

In order to keep up with the times we will send to those pupils who have formed a Union of 15 members or more a supplement of new designs (published by us), giving a full description of change in fashion and style, as they come out. We do this at a considerable expense simply for the benefit of Prof. Jean B. Peyry's *Metrique system*, and every member of this Union will be kept thoroughly posted in regard to all new improvements, and receive a copy of the supplement free of charge.

Respectfully yours,

PROF. JEAN B. PEYRY,



ILLUSTRATED  
**GENERAL \* AND \* COMPLETE \* INSTRUCTION \* BOOK**

FOR USING

PROF. JEAN B. PEYRY'S SYSTEM METRIQUE

—FOR—

**Cutting Ladies', Children's and Gentlemen's Garments.**

CONSISTING OF SIX PIECES.

Front, No. 1. Under-Arm, No. 2. Side Back, No. 3. Back, No. 4. Dart and Skirt Rule, No. 5. Sleeve, No. 6.

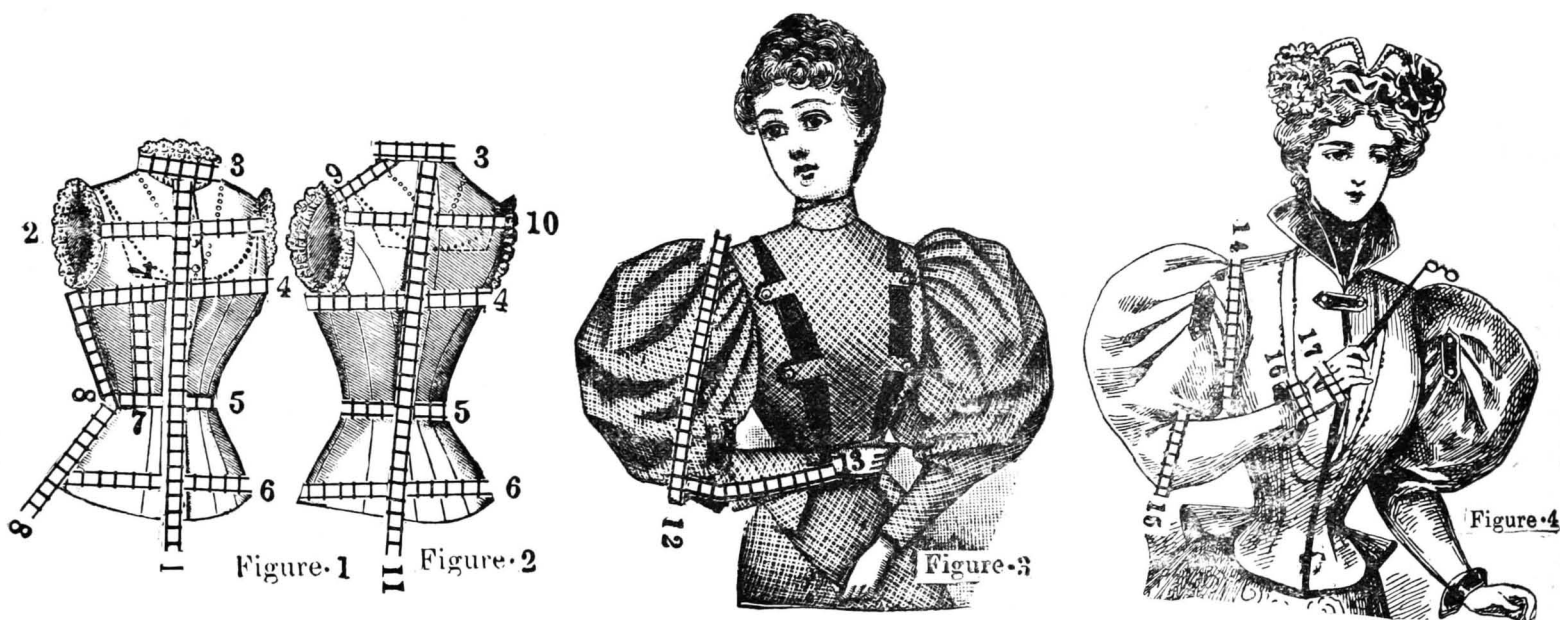

**DIRECTIONS HOW TO TAKE THE MEASURES.**

Figure No. 1 and Figure No. 2 show how to take the measure for the body from neck to hips or below. In order to have all the length measures and waist line in the correct place, tie a small belt or a cord around the waist line, and push it down as low as you wish the waist line to come, and notice that the lady is properly dressed before taking the measure; that her dress and corsets are arranged to suit the figure, and in the way she expects to wear them. Stand in the front of the person except for the two back measures for which you stand at the back of the person, and for the sleeve measure you stand on the side of the person.

All the different measures which are taken around the body, also the chest and back measure, take only half of the measure. For instance, if the bust measure is 100 centimetres around, put only 50 down on your measure book; as you only cut half of the garment you must use only half of the round measure, as the goods are cut double.

**MEASURES FOR WAIST AND JACKET.**

Length of Front Measure, No. 1, is taken where neck joins the body to the point of the fullest part of bust, and from point of bust to the waist line, and from the waist line down below according to how long you wish the garment below the waist.

Width of Chest Measure, No. 2, is taken across the chest from armseye to armseye, and place your tape line so that it passes 5 centimetres below the collar bone.

Neck Measure, No. 3, is taken around the neck inside the collar.

Bust Measure, No. 4, is taken around the fullest part of bust.

Waist Measure, No. 5, is taken around the smallest part of the waist.

Hip Measure, No. 6, is taken around the hips twelve centimetres below the waist.

Height of Dart Measure, No. 7, is taken from waist line to the fullest part of bust, so that they come three centimetres below the bust line. The best way is to not take the measure and use the bust line as you will see in Figure No. 6.

Length of Under Arm Measure, No. 8, is taken from under-arm to waist line; arm resting by side.

Length of Shoulder Measure, No. 9, is taken from side of the neck to armseye over the seam.

Width of Back Measure, No. 10 is taken across the back from armseye to armseye.

Length of Back Measure, No. 11, is taken from prominent bone on the back of neck to shoulder blade and down to waist line.

Figure No. 3 and Figure No. 4 show how to take the measure for the sleeves.

#### MEASURE FOR SLEEVES.

Length of Shoulder to Elbow Measure, No. 12, is taken from the shoulder bone or shoulder joint to the elbow bone.

Length of Elbow to Wrist Measure, No. 13, is taken from elbow bone to wrist bone.

Armseye Measure, No. 14, is taken around the armseye two centimetres above the shoulder bone.

Elbow Measure, No. 15, is taken around the elbow with arm half bent, same as shown in figure 4.

Wrist Measure, No. 16, is taken around the wrist if the sleeves are to be left open at wrist.

Hand Measure, No. 17, is taken around the hand. This measure is used only for jacket and coat sleeves, or any close sleeves, to see the size of the cuff. For open sleeves take the wrist measure only.

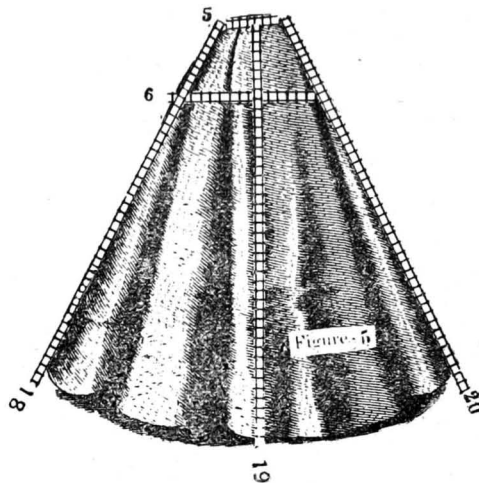

Figure No. 5 shows how to take the measure for the skirt.

#### MEASURE FOR SKIRT.

Waist measure No. 5 is taken around the smallest part of the waist.

Hip measure No. 6 is taken around the hips twelve centimetres below the waist line.

Length of hip measure No. 18 is taken from the waist line to the floor. See that your tape measure passes over the most prominent part of the hips.

Length of front measure No. 19 is taken from the waist line to the floor.

Length of back measure No. 20 is taken from the waist line to the floor.

#### MEASURE FOR TROUSERS AND BLOOMERS.

The waist and hip measures are taken same as for skirt. The seat measure is taken around the seat or lower part of basin, knee measure is taken around the knee, the bottom measure is taken around the ankle-bone, the outside length measure is taken from waist to the knee and from knee to the ankle-bone, tape line passing over the hip-bone, before taking the inside length measure have the person sit down on a chair and the inside length measure is taken from waist to the level of the chair, the tape passing over the hip-bone and that length is deducted from the outside measure. The most important point in the making of ladies trousers has been to find out a method for taking the inside length measure correct, and many experiments have been made to that effect and 15 years ago I had the good fortune to find it out by experimenting, for which this is the only way to get a correct inside length measure for ladies trousers, I know many other ways which are good also but not correct for every form. See figure 86 for taking the inside length.

Take all those measures loose or tight according to the garment your customer wishes to wear.

In taking the measure you cannot always guide yourself to the dress they have on them as it seldom is a perfect fit, the best guide to take the measure is to find out the joints and bones of the body to the termination of your measure, that is a sure guide every time. In drafting the shoulder draft the back shoulder half centimetre longer than the front shoulder, and in basting stretch the front shoulder to the size of the back shoulder. The back shoulder is cut half centimetre longer for everybody and every style of garments. If you make a dress for a person that is far away and you cannot see her form to make all the necessary changes, you must have the three check measure and must be taken same as they are on the *System*, which you must know is far more difficult to do without ever seeing the form of the person, but this three check measure proves the exact form of every person.

#### FOR TAKING CHECK MEASURE.

Check measure, line *K*, is taken from waist line at centre of front to the under-arm seam. Check measure, *K B*, is taken from waist line at centre of front to the shoulder seam at point of shoulder.

Check measure *K B* on the back is taken from shoulder seam at shoulder point to the waist line at centre of back.

**DIRECTIONS FOR A MEDIUM-SIZED FIGURE.**

The measures for a medium, well-proportioned figure are as follows :—

**MEASURE FOR WAIST.**—Length of front, 18 and 38 ; width of chest, 18 ; neck, 16 ; length of shoulder, 14 ; length of under-arm, 22 ; waist, 30 ; hips, 50 ; length of back, 40 ; width of back, 15.

**MEASURE FOR SLEEVE.**—Armseye, 22 ; elbow, 14 ; wrist, 10 ; shoulder to elbow, 37 ; elbow to wrist, 26.

**MEASURE FOR SKIRT AND RIDING HABIT.**—Waist, 30 ; hips, 50 ; length of front, 106 ; length of side, 108 ; length of back, 107.

**MEASURE FOR TROUSERS AND BLOOMERS.**—Waist, 30 ; hips, 50 ; seat, 65 ; knees, 24 ; bottom, 22 ; outside length, 30-32-18 ; inside length, 30.

Everything in this book is drafted to these measurements. When drafted to a different measure the explanation will be given.

Now place on the measure book (as a guide for the pupil in learning) the above measurements. The same measures will be found on the first drafting lessons, figure 6, figure 7, figure 8 and figure 9 ; for the sleeve figure 89 and figure 90 ; for trousers and bloomers figure 84, figure 85 and figure 86 ; for skirts figure 123, figure 124 and figure 125.

**REMARKS.**—In measuring the first and second dart take the straight edge of dart rule and place it from top of dart to the centre of dart and make a dot at hip line. When you take the width of dart at waist line you must always make a dot at the centre, this is your guide to get the bottom dot hip line straight with waist dot and top of dart letter *J*. The dart is half of the width at hips that it is at waist, the first dart is 8 at waist and 4 at hips, so take 2 each side of the hip dot to have the dot in the centre of dart. Now, trace line letter *L* from waist line down to hip line and trace the other line same as line letter *L* the bottom of the second dart is made same as the bottom of front dart, except that being 12 in width at waist line it is 6 in width at hip line, which is half the width from waist.

**NOTICE THE RULES FOR MEASUREMENT.**

The most important measure is the length from neck to the point of bust. If that measure is taken too long the dress will come up too high at neck, too much goods at the shoulder and too large at the arms eye, if taken too short will be vice versa, too low at neck, short of goods at shoulder and too tight at arms-eye.

The next important measure is the under-arm measure. If taken too long it will not fit at waist ; if there is a mistake to be made in taking that measure it is better to take it a little short than too long. The other important measure is the length of back measure from neck to shoulder blade, if taken too long the dress will come too high at back of the neck, if taken too short will come too low at back of neck and make if taken too long at waist it will wrinkle. If the different measurements are taken according to direction there will be no refitting whatever. You can make the dress without trying it on.

**NOTICE TO PUPILS.**

Everything and anything you will find in this Instruction Book is originated, invented and designed by PROF. JEAN B. PEYRY, of Paris, France. For this reason we do not give any other name to the different styles of garments than the name that is called for : Waist, Basque, Skirt, Princess Trousers, Riding Suits, etc.

Date, 189	Bust,		
Name,	Length of Front		
	Width of Chest,		
Address,	Neck, Length of Shoulders, Length of Under-Arm,		
Styles,	Waist, Hips, Height of Darts		
Price,	Length of Back,		
To be finished,	Width of Back, Measure for Sleeves,		
Remarks,	Armseye, Elbow, Wrist or hand, Shoulder to Elbow,		
Date, 189	Elbow to Wrist		
Name,	Measure for Skirt and Riding Habit,		
	Waist, Hips, Length of Front		
Address,	Length of Side, Length of Back,		
Styles,	Measure for Trousers and Bloomers, Waist, Hips, Seat, Knee, Bottom,		
Price,	Outside length, Inside length,		
To be finished,			
Remarks,			

Date, 189	Bust,		
Name,	Length of Front		
	Width of Chest,		
Address,	Neck, Length of Shoulder, Length of Under-Arm,		
Styles,	Waist, Hips, Height of Darts		
Price,	Length of Back,		
To be finished,	Width of Back, Measure for Sleeves,		
Remarks,	Armseye, Elbow, Wrist or hand, Shoulder to Elbow,		
Date, 189	Elbow to Wrist,		
Name,	Measure for Skirt and Riding Habit,		
	Waist, Hips, Length of Front		
Address,	Length of Side, Length of Back,		
Styles,	Measure for Trousers and Bloomers, Waist, Hips, Seat, Knee, Bottom,		
Price,	Outside length, Inside length,		
To be finished,			
Remarks,			





Date, 189	Bust,			Date, 189	Bust,		
Name,	Length of Front			Name,	Length of Front		
	Width of Chest,				Width of Chest,		
	Neck,				Neck,		
Address,	Length of Shoulders,			Address,	Length of Shoulder,		
	Length of Under-Arm,				Length of Under-Arm,		
	Waist,				Waist,		
Styles,	Hips,			Styles,	Hips,		
	Height of Darts				Height of Darts		
Price,	Length of Back,			Price,	Length of Back,		
To be finished,	Width of Back,			To be finished,	Width of Back,		
Remarks,	Measure for Sleeves,			Remarks,	Measure for Sleeves,		
	Armseye,				Armseye,		
	Elbow,				Elbow,		
	Wrist or hand,				Wrist or hand,		
	Shoulder to Elbow,				Shoulder to Elbow,		
Date, 189	Elbow to Wrist			Date, 189	Elbow to Wrist,		
Name,	Measure for Skirt and Riding Habit,			Name,	Measure for Skirt and Riding Habit,		
	Waist,				Waist,		
	Hips,				Hips,		
Address,	Length of Front			Address,	Length of Front		
	Length of Side,				Length of Side,		
	Length of Back,				Length of Back,		
Styles,	Measure for Trousers and Bloomers,			Styles,	Measure for Trousers and Bloomers,		
	Waist,				Waist,		
	Hips,				Hips,		
Price,	Seat,			Price,	Seat,		
To be finished,	Knee,			To be finished,	Knee,		
Remarks,	Bottom,			Remarks,	Bottom,		
	Outside length,				Outside length,		
	Inside length,				Inside length,		

Date, 189	Bust,			Date, 189	Bust,		
Name,	Length of Front			Name,	Length of Front		
	Width of Chest,				Width of Chest,		
	Neck,				Neck,		
Address,	Length of Shoulders,			Address,	Length of Shoulder,		
	Length of Under-Arm,				Length of Under-Arm,		
	Waist,				Waist,		
Styles,	Hips,			Styles,	Hips,		
	Height of Darts				Height of Darts		
Price,	Length of Back,			Price,	Length of Back,		
	Width of Back,				Width of Back,		
To be finished,	Measure for Sleeves,			To be finished,	Measure for Sleeves,		
Remarks,	Armseye,			Remarks,	Armseye,		
	Elbow,				Elbow,		
	Wrist or hand,				Wrist or hand,		
	Shoulder to Elbow,				Shoulder to Elbow,		
Date, 189	Elbow to Wrist			Date, 189	Elbow to Wrist,		
	Measure for Skirt and Riding Habit,				Measure for Skirt and Riding Habit,		
Name,	Waist,			Name,	Waist,		
	Hips,				Hips,		
Address,	Length of Front			Address,	Length of Front		
	Length of Side,				Length of Side,		
	Length of Back,				Length of Back,		
Styles,	Measure for Trousers and Bloomers,			Styles,	Measure for Trousers and Bloomers,		
	Waist,				Waist,		
	Hips,				Hips,		
Price,	Seat,			Price,	Seat,		
	Knee,				Knee,		
To be finished,	Bottom,			To be finished,	Bottom,		
Remarks,	Outside length,			Remarks,	Outside length,		
	Inside length,				Inside length,		

Date, 189	Bust,			Date, 189	Bust,		
Name,	Length of Front			Name,	Length of Front		
	Width of Chest,				Width of Chest,		
Address,	Neck, Length of Shoulders, Length of Under-Arm,			Address,	Neck, Length of Shoulder, Length of Under-Arm,		
Styles,	Waist,			Styles,	Waist,		
	Hips,				Hips,		
	Height of Darts				Height of Darts		
Price,	Length of Back,			Price,	Length of Back,		
To be finished,	Width of Back,			To be finished,	Width of Back,		
Remarks,	Measure for Sleeves,			Remarks,	Measure for Sleeves,		
	Armseye,				Armseye,		
	Elbow,				Elbow,		
	Wrist or hand, Shoulder to Elbow,				Wrist or hand, Shoulder to Elbow,		
Date, 189	Elbow to Wrist			Date, 189	Elbow to Wrist,		
Name,	Measure for Skirt and Riding Habit,			Name,	Measure for Skirt and Riding Habit,		
	Waist,				Waist,		
	Hips,				Hips,		
Address,	Length of Front			Address,	Length of Front		
	Length of Side,				Length of Side,		
	Length of Back,				Length of Back,		
Styles,	Measure for Trousers and Bloomers,			Styles,	Measure for Trousers and Bloomers,		
	Waist,				Waist,		
	Hips,				Hips,		
Price,	Seat,			Price,	Seat,		
To be finished,	Knee,			To be finished.	Knee,		
Remarks,	Bottom,			Remarks,	Bottom,		
	Outside length,				Outside length,		
	Inside length,				Inside length,		

Date,	189	Bust,	Date,	189	Bust,
Name,		Length of Front	Name,		Length of Front
		Width of Chest,			Width of Chest,
		Neck,			Neck,
Address,		Length of Shoulders,	Address,		Length of Shoulder,
		Length of Under-Arm,			Length of Under-Arm,
		Waist,			Waist,
Styles,		Hips,	Styles,		Hips,
		Height of Darts			Height of Darts
Price,		Length of Back,	Price,		Length of Back,
		Width of Back,			Width of Back,
To be finished,		Measure for Sleeves,	To be finished,		Measure for Sleeves,
Remarks,		Armseye,	Remarks,		Armseye,
		Elbow,			Elbow,
		Wrist or hand, Shoulder to Elbow,			Wrist or hand, Shoulder to Elbow,
		Elbow to Wrist			Elbow to Wrist,
Date,	189	Measure for Skirt and Riding Habit,	Date,	189	Measure for Skirt and Riding Habit,
Name,		Waist,	Name,		Waist,
		Hips,			Hips,
Address,		Length of Front	Address,		Length of Front
		Length of Side,			Length of Side,
		Length of Back,			Length of Back,
		Measure for Trousers and Bloomers,			Measure for Trousers and Bloomers,
Styles,		Waist,	Styles,		Waist,
		Hips,			Hips,
Price,		Seat,	Price,		Seat,
		Knee,			Knee,
To be finished,		Bottom,	To be finished,		Bottom,
Remarks,		Outside length,	Remarks,		Outside length,
		Inside length,			Inside length,

Date, 189	Bust,		
Name,	Length of Front		
	Width of Chest,		
Address,	Neck, Length of Shoulders, Length of Under-Arm,		
Styles,	Waist, Hips, Height of Darts		
Price,	Length of Back, Width of Back,		
To be finished,	Measure for Sleeves,		
Remarks,	Armseye, Elbow, Wrist or hand, Shoulder to Elbow,		
Date, 189	Elbow to Wrist		
Name,	Measure for Skirt and Riding Habit,		
	Waist, Hips, Length of Front Length of Side, Length of Back,		
Address,	Measure for Trousers and Bloomers,		
Styles,	Waist, Hips, Seat, Knee, Bottom, Outside length, Inside length,		
Price,			
To be finished,			
Remarks,			

Date, 189	Bust,		
Name,	Length of Front		
	Width of Chest,		
Address,	Neck, Length of Shoulder, Length of Under-Arm,		
Styles,	Waist, Hips, Height of Darts		
Price,	Length of Back, Width of Back,		
To be finished,	Measure for Sleeves,		
Remarks,	Armseye, Elbow, Wrist or hand, Shoulder to Elbow,		
Date, 189	Elbow to Wrist		
Name,	Measure for Skirt and Riding Habit,		
	Waist, Hips, Length of Front Length of Side, Length of Back,		
Address,	Measure for Trousers and Bloomers,		
Styles,	Waist, Hips, Seat, Knee, Bottom, Outside length, Inside length,		
Price,			
To be finished,			
Remarks,			



Date, 189	Bust,			Date, 189	Bust,		
Name,	Length of Front			Name,	Length of Front		
	Width of Chest,				Width of Chest,		
	Neck,				Neck,		
Address,	Length of Shoulders,			Address,	Length of Shoulder,		
	Length of Under-Arm,				Length of Under-Arm,		
	Waist,				Waist,		
Styles,	Hips,			Styles,	Hips,		
	Height of Darts				Height of Darts		
Price,	Length of Back,			Price,	Length of Back,		
	Width of Back,				Width of Back,		
To be finished,	Measure for Sleeves,			To be finished,	Measure for Sleeves,		
Remarks,	Armseye,			Remarks,	Armseye,		
	Elbow,				Elbow,		
	Wrist or hand, Shoulder to Elbow,				Wrist or hand, Shoulder to Elbow,		
Date, 189	Elbow to Wrist			Date, 189	Elbow to Wrist,		
Name,	Measure for Skirt and Riding Habit,			Name,	Measure for Skirt and Riding Habit,		
	Waist,				Waist,		
	Hips,				Hips,		
Address,	Length of Front			Address,	Length of Front		
	Length of Side,				Length of Side,		
	Length of Back,				Length of Back,		
Styles,	Measure for Trousers and Bloomers,			Styles,	Measure for Trousers and Bloomers,		
	Waist,				Waist,		
	Hips,				Hips,		
Price,	Seat,			Price,	Seat,		
To be finished,	Knee,			To be finished,	Knee,		
Remarks,	Bottom,			Remarks,	Bottom,		
	Outside length,				Outside length,		
	Inside length,				Inside length,		

Date, 189	Bust,		
Name,	Length of Front		
	Width of Chest,		
	Neck,		
Address,	Length of Shoulders,		
	Length of Under-Arm,		
	Waist,		
Styles,	Hips,		
	Height of Darts		
Price,	Length of Back,		
To be finished,	Width of Back,		
Remarks,	Measure for Sleeves,		
	Armseye,		
	Elbow,		
	Wrist or hand,		
	Shoulder to Elbow,		
Date, 189	Elbow to Wrist		
Name,	Measure for Skirt and Riding Habit,		
	Waist,		
	Hips,		
Address,	Length of Front		
	Length of Side,		
	Length of Back,		
Styles,	Measure for Trousers and Bloomers,		
	Waist,		
	Hips,		
Price,	Seat,		
To be finished,	Knee,		
Remarks,	Bottom,		
	Outside length,		
	Inside length,		

Date, 189	Bust,		
Name,	Length of Front		
	Width of Chest,		
	Neck,		
Address,	Length of Shoulder,		
	Length of Under-Arm,		
	Waist,		
Styles,	Hips,		
	Height of Darts		
Price,	Length of Back,		
To be finished,	Width of Back,		
Remarks,	Measure for Sleeves,		
	Armseye,		
	Elbow,		
	Wrist or hand,		
	Shoulder to Elbow,		
Date, 189	Elbow to Wrist,		
Name,	Measure for Skirt and Riding Habit,		
	Waist,		
	Hips,		
Address,	Length of Front		
	Length of Side,		
	Length of Back,		
Styles,	Measure for Trousers and Bloomers,		
	Waist,		
	Hips,		
Price,	Seat,		
To be finished,	Knee,		
Remarks,	Bottom,		
	Outside length,		
	Inside length,		

Date, 189	Bust,			Date, 189	Bust,		
Name,	Length of Front			Name,	Length of Front		
	Width of Chest,				Width of Chest,		
	Neck,				Neck,		
Address,	Length of Shoulders,			Address,	Length of Shoulder,		
	Length of Under-Arm,				Length of Under-Arm,		
	Waist,				Waist,		
Styles,	Hips,			Styles,	Hips,		
	Height of Darts				Height of Darts		
Price,	Length of Back,			Price,	Length of Back,		
To be finished,	Width of Back,			To be finished,	Width of Back,		
	Measure for Sleeves,				Measure for Sleeves,		
Remarks,	Armseye,			Remarks,	Armseye,		
	Elbow,				Elbow,		
	Wrist or hand,				Wrist or hand,		
	Shoulder to Elbow,				Shoulder to Elbow,		
Date, 189	Elbow to Wrist			Date, 189	Elbow to Wrist,		
	Measure for Skirt and Riding Habit,				Measure for Skirt and Riding Habit,		
Name,	Waist,			Name,	Waist,		
	Hips,				Hips,		
Address,	Length of Front			Address,	Length of Front		
	Length of Side,				Length of Side,		
	Length of Back,				Length of Back,		
	Measure for Trousers and Bloomers,				Measure for Trousers and Bloomers,		
Styles,	Waist,			Styles,	Waist,		
	Hips,				Hips,		
Price,	Seat,			Price,	Seat,		
To be finished,	Knee,			To be finished,	Knee,		
	Bottom,				Bottom,		
Remarks,	Outside length,			Remarks,	Outside length,		
	Inside length,				Inside length,		

Date, 189	Bust,			Date, 189	Bust,		
Name,	Length of Front			Name,	Length of Front		
	Width of Chest,				Width of Chest,		
Address,	Neck, Length of Shoulders, Length of Under-Arm,			Address,	Neck, Length of Shoulder, Length of Under-Arm,		
Styles,	Waist, Hips, Height of Darts			Styles,	Waist, Hips, Height of Darts		
Price,	Length of Back, Width of Back,			Price,	Length of Back, Width of Back,		
To be finished,	Measure for Sleeves,			To be finished,	Measure for Sleeves,		
Remarks,	Armseye, Elbow, Wrist or hand, Shoulder to Elbow,			Remarks,	Armseye, Elbow, Wrist or hand, Shoulder to Elbow,		
Date, 189	Elbow to Wrist			Date, 189	Elbow to Wrist,		
Name,	Measure for Skirt and Riding Habit,			Name,	Measure for Skirt and Riding Habit,		
	Waist, Hips, Length of Front				Waist, Hips, Length of Front		
Address,	Length of Side, Length of Back,			Address,	Length of Side, Length of Back,		
Styles,	Measure for Trousers and Bloomers, Waist, Hips, Seat, Knee, Bottom, Outside length, Inside length,			Styles,	Measure for Trousers and Bloomers, Waist, Hips, Seat, Knee, Bottom, Outside length, Inside length,		
Price,				Price,			
To be finished,				To be finished,			
Remarks,				Remarks,			

Date, 189	Bust,			Date, 189	Bust,		
Name,	Length of Front			Name,	Length of Front		
	Width of Chest,				Width of Chest,		
	Neck,				Neck,		
Address,	Length of Shoulders,			Address,	Length of Shoulder,		
	Length of Under-Arm,				Length of Under-Arm,		
	Waist,				Waist,		
Styles,	Hips,			Styles,	Hips,		
	Height of Darts				Height of Darts		
Price,	Length of Back,			Price,	Length of Back,		
To be finished,	Width of Back,			To be finished,	Width of Back,		
Remarks,	Measure for Sleeves,			Remarks,	Measure for Sleeves,		
	Armseye,				Armseye,		
	Elbow,				Elbow,		
	Wrist or hand,				Wrist or hand,		
	Shoulder to Elbow,				Shoulder to Elbow,		
Date, 189	Elbow to Wrist			Date, 189	Elbow to Wrist,		
Name,	Measure for Skirt and Riding Habit,			Name,	Measure for Skirt and Riding Habit,		
	Waist,				Waist,		
	Hips,				Hips,		
Address,	Length of Front			Address,	Length of Front		
	Length of Side,				Length of Side,		
	Length of Back,				Length of Back,		
Styles,	Measure for Trousers and Bloomers,			Styles,	Measure for Trousers and Bloomers,		
	Waist,				Waist,		
	Hips,				Hips,		
Price,	Seat,			Price,	Seat,		
To be finished,	Knee,			To be finished,	Knee,		
Remarks,	Bottom,			Remarks,	Bottom,		
	Outside length,				Outside length,		
	Inside length,				Inside length,		

Date,	189	Bust,	
Name,		Length of Front	
		Width of Chest,	
Address,		Neck,	
		Length of Shoulders,	
		Length of Under-Arm,	
Styles,		Waist,	
		Hips,	
		Height of Darts	
Price,		Length of Back,	
To be finished,		Width of Back,	
Remarks,		Measure for Sleeves,	
		Armseye,	
		Elbow,	
		Wrist or hand,	
		Shoulder to Elbow,	
Date,	189	Elbow to Wrist	
Name,		Measure for Skirt and Riding Habit,	
		Waist,	
		Hips,	
Address,		Length of Front	
		Length of Side,	
		Length of Back,	
Styles,		Measure for Trousers and Bloomers,	
		Waist,	
		Hips,	
Price,		Seat,	
To be finished,		Knee,	
Remarks,		Bottom,	
		Outside length,	
		Inside length,	

Date,	189	Bust,	
Name,		Length of Front	
		Width of Chest,	
Address,		Neck,	
		Length of Shoulder,	
		Length of Under-Arm,	
Styles,		Waist,	
		Hips,	
		Height of Darts	
Price,		Length of Back,	
To be finished,		Width of Back,	
Remarks,		Measure for Sleeves,	
		Armseye,	
		Elbow,	
		Wrist or hand,	
		Shoulder to Elbow,	
Date,	189	Elbow to Wrist,	
Name,		Measure for Skirt and Riding Habit,	
		Waist,	
		Hips,	
Address,		Length of Front	
		Length of Side,	
		Length of Back,	
Styles,		Measure for Trousers and Bloomers,	
		Waist,	
		Hips,	
Price,		Seat,	
To be finished,		Knee,	
Remarks,		Bottom,	
		Outside length,	
		Inside length,	



Date,	189	Bust,		Date,	189	Bust,	
Name,		Length of Front		Name,		Length of Front	
		Width of Chest,				Width of Chest,	
		Neck,				Neck,	
Address,		Length of Shoulders,		Address,		Length of Shoulder,	
		Length of Under-Arm,				Length of Under-Arm,	
		Waist,				Waist,	
Styles,		Hips,		Styles,		Hips,	
		Height of Darts				Height of Darts	
Price,		Length of Back,		Price,		Length of Back,	
To be finished,		Width of Back,		To be finished,		Width of Back,	
Remarks,		Measure for Sleeves,		Remarks,		Measure for Sleeves,	
		Armseye,				Armseye,	
		Elbow,				Elbow,	
		Wrist or hand,				Wrist or hand,	
		Shoulder to Elbow,				Shoulder to Elbow,	
Date,	189	Elbow to Wrist		Date,	189	Elbow to Wrist,	
Name,		Measure for Skirt and Riding Habit,		Name,		Measure for Skirt and Riding Habit,	
		Waist,				Waist,	
		Hips,				Hips,	
Address,		Length of Front		Address,		Length of Front	
		Length of Side,				Length of Side,	
		Length of Back,				Length of Back,	
Styles,		Measure for Trousers and Bloomers,		Styles,		Measure for Trousers and Bloomers,	
		Waist,				Waist,	
		Hips,				Hips,	
Price,		Seat,		Price,		Seat,	
To be finished,		Knee,		To be finished.		Knee,	
Remarks,		Bottom,		Remarks,		Bottom,	
		Outside length,				Outside length,	
		Inside length,				Inside length,	

Date, 189	Bust,			Date, 189	Bust,		
Name,	Length of Front			Name,	Length of Front		
	Width of Chest,				Width of Chest,		
	Neck,				Neck,		
Address,	Length of Shoulders,			Address,	Length of Shoulder,		
	Length of Under-Arm,				Length of Under-Arm,		
	Waist,				Waist,		
Styles,	Hips,			Styles,	Hips,		
	Height of Darts				Height of Darts		
	Length of Back,				Length of Back,		
Price,	Width of Back,			Price,	Width of Back,		
To be finished,	Measure for Sleeves,			To be finished,	Measure for Sleeves,		
Remarks,	Armseye,			Remarks,	Armseye,		
	Elbow,				Elbow,		
	Wrist or hand,				Wrist or hand,		
	Shoulder to Elbow,				Shoulder to Elbow,		
Date, 189	Elbow to Wrist			Date, 189	Elbow to Wrist,		
Name,	Measure for Skirt and Riding Habit,			Name,	Measure for Skirt and Riding Habit,		
	Waist,				Waist,		
	Hips,				Hips,		
Address,	Length of Front			Address,	Length of Front		
	Length of Side,				Length of Side,		
	Length of Back,				Length of Back,		
Styles,	Measure for Trousers and Bloomers,			Styles,	Measure for Trousers and Bloomers,		
	Waist,				Waist,		
	Hips,				Hips,		
Price,	Seat,			Price,	Seat,		
To be finished,	Knee,			To be finished,	Knee,		
Remarks,	Bottom,			Remarks,	Bottom,		
	Outside length,				Outside length,		
	Inside length,				Inside length,		

Date, 189	Bust,			Date, 189	Bust,		
Name,	Length of Front			Name,	Length of Front		
	Width of Chest,				Width of Chest,		
	Neck,				Neck,		
Address,	Length of Shoulders,			Address,	Length of Shoulder,		
	Length of Under-Arm,				Length of Under-Arm,		
	Waist,				Waist,		
Styles,	Hips,			Styles,	Hips,		
	Height of Darts				Height of Darts		
Price,	Length of Back,			Price,	Length of Back,		
	Width of Back,				Width of Back,		
To be finished,	Measure for Sleeves,			To be finished,	Measure for Sleeves,		
Remarks,	Armseye,			Remarks,	Armseye,		
	Elbow,				Elbow,		
	Wrist or hand,				Wrist or hand,		
	Shoulder to Elbow,				Shoulder to Elbow,		
Date, 189	Elbow to Wrist			Date, 189	Elbow to Wrist,		
	Measure for Skirt and Riding Habit,				Measure for Skirt and Riding Habit,		
Name,	Waist,			Name,	Waist,		
	Hips,				Hips,		
Address,	Length of Front			Address,	Length of Front		
	Length of Side,				Length of Side,		
	Length of Back,				Length of Back,		
Styles,	Measure for Trousers and Bloomers,			Styles,	Measure for Trousers and Bloomers,		
	Waist,				Waist,		
	Hips,				Hips,		
Price,	Seat,			Price,	Seat,		
To be finished,	Knee,			To be finished,	Knee,		
Remarks,	Bottom,			Remarks,	Bottom,		
	Outside length,				Outside length,		
	Inside length,				Inside length,		

Date,	189	Bust,		Date,	189	Bust,	
Name,		Length of Front		Name,		Length of Front	
		Width of Chest,				Width of Chest,	
Address,		Neck,		Address,		Neck,	
		Length of Shoulders,				Length of Shoulder,	
		Length of Under-Arm,				Length of Under-Arm,	
Styles,		Waist,		Styles,		Waist,	
		Hips,				Hips,	
		Height of Darts				Height of Darts	
Price,		Length of Back,		Price,		Length of Back,	
To be finished,		Width of Back,		To be finished,		Width of Back,	
Remarks,		Measure for Sleeves,		Remarks,		Measure for Sleeves,	
		Armseye,				Armseye,	
		Elbow,				Elbow,	
		Wrist or hand,				Wrist or hand,	
		Shoulder to Elbow,				Shoulder to Elbow,	
Date,	189	Elbow to Wrist		Date,	189	Elbow to Wrist,	
Name,		Measure for Skirt and Riding Habit,		Name,		Measure for Skirt and Riding Habit,	
		Waist,				Waist,	
		Hips,				Hips,	
Address,		Length of Front		Address,		Length of Front	
		Length of Side,				Length of Side,	
		Length of Back,				Length of Back,	
Styles,		Measure for Trousers and Bloomers,		Styles,		Measure for Trousers and Bloomers,	
		Waist,				Waist,	
		Hips,				Hips,	
Price,		Seat,		Price,		Seat,	
To be finished,		Knee,		To be finished,		Knee,	
Remarks,		Bottom,		Remarks,		Bottom,	
		Outside length,				Outside length,	
		Inside length,				Inside length,	

Date, 189	Bust,			Date, 189	Bust,		
Name,	Length of Front			Name,	Length of Front		
	Width of Chest,				Width of Chest,		
	Neck,				Neck,		
Address,	Length of Shoulders,			Address,	Length of Shoulder,		
	Length of Under-Arm,				Length of Under-Arm,		
	Waist,				Waist,		
Styles,	Hips,			Styles,	Hips,		
	Height of Darts				Height of Darts		
Price,	Length of Back,			Price,	Length of Back,		
	Width of Back,				Width of Back,		
To be finished,	Measure for Sleeves,			To be finished,	Measure for Sleeves,		
Remarks,	Armseye,			Remarks,	Armseye,		
	Elbow,				Elbow,		
	Wrist or hand,				Wrist or hand,		
	Shoulder to Elbow,				Shoulder to Elbow,		
Date, 189	Elbow to Wrist			Date, 189	Elbow to Wrist,		
	Measure for Skirt and Riding Habit,				Measure for Skirt and Riding Habit,		
Name,	Waist,			Name,	Waist,		
	Hips,				Hips,		
Address,	Length of Front			Address,	Length of Front		
	Length of Side,				Length of Side,		
	Length of Back,				Length of Back,		
Styles,	Measure for Trousers and Bloomers,			Styles,	Measure for Trousers and Bloomers,		
	Waist,				Waist,		
	Hips,				Hips,		
Price,	Seat,			Price,	Seat,		
To be finished,	Knee,			To be finished.	Knee,		
Remarks,	Bottom,			Remarks,	Bottom,		
	Outside length,				Outside length,		
	Inside length,				Inside length,		

Date,	189	Bust,	
Name,		Length of Front	
		Width of Chest,	
Address,		Neck, Length of Shoulders,	
		Length of Under-Arm,	
Styles,		Waist,	
		Hips,	
		Height of Darts	
Price,		Length of Back,	
To be finished,		Width of Back,	
Remarks,		Measure for Sleeves,	
		Armseye,	
		Elbow,	
		Wrist or hand, Shoulder to Elbow,	
Date,	189	Elbow to Wrist	
Name,		Measure for Skirt and Riding Habit,	
		Waist,	
		Hips,	
Address,		Length of Front	
		Length of Side,	
		Length of Back,	
Styles,		Measure for Trousers and Bloomers,	
		Waist,	
		Hips,	
Price,		Seat,	
To be finished,		Knee,	
Remarks,		Bottom,	
		Outside length,	
		Inside length,	

Date,	189	Bust,	
Name,		Length of Front	
		Width of Chest,	
Address,		Neck; Length of Shoulder,	
		Length of Under-Arm,	
Styles,		Waist,	
		Hips,	
		Height of Darts	
Price,		Length of Back,	
To be finished,		Width of Back,	
Remarks,		Measure for Sleeves,	
		Armseye,	
		Elbow;	
		Wrist or hand, Shoulder to Elbow,	
Date,	189	Elbow to Wrist,	
Name,		Measure for Skirt and Riding Habit,	
		Waist,	
		Hips,	
Address,		Length of Front	
		Length of Side,	
		Length of Back,	
Styles,		Measure for Trousers and Bloomers,	
		Waist,	
		Hips,	
Price,		Seat;	
To be finished,		Knee,	
Remarks,		Bottom,	
		Outside length,	
		Inside length,	

Date, 189	Bust,			Date, 189	Bust,		
Name,	Length of Front			Name,	Length of Front		
	Width of Chest,				Width of Chest,		
	Neck,				Neck,		
Address,	Length of Shoulders,			Address,	Length of Shoulder,		
	Length of Under-Arm,				Length of Under-Arm,		
	Waist,				Waist,		
Styles,	Hips,			Styles,	Hips,		
	Height of Darts				Height of Darts		
Price,	Length of Back,			Price,	Length of Back,		
To be finished,	Width of Back,			To be finished,	Width of Back,		
	Measure for Sleeves,				Measure for Sleeves,		
Remarks,	Armseye,			Remarks,	Armseye,		
	Elbow,				Elbow,		
	Wrist or hand,				Wrist or hand,		
	Shoulder to Elbow,				Shoulder to Elbow,		
Date, 189	Elbow to Wrist			Date, 189	Elbow to Wrist,		
	Measure for Skirt and Riding Habit,				Measure for Skirt and Riding Habit,		
Name,	Waist,			Name,	Waist,		
	Hips,				Hips,		
Address,	Length of Front			Address,	Length of Front		
	Length of Side,				Length of Side,		
	Length of Back,				Length of Back,		
Styles,	Measure for Trousers and Bloomers,			Styles,	Measure for Trousers and Bloomers,		
	Waist,				Waist,		
	Hips,				Hips,		
Price,	Seat,			Price,	Seat,		
To be finished,	Knee,			To be finished,	Knee,		
	Bottom,				Bottom,		
Remarks,	Outside length,			Remarks,	Outside length,		
	Inside length,				Inside length,		

Date, 189	Bust,			Date, 189	Bust,		
Name,	Length of Front			Name,	Length of Front		
	Width of Chest,				Width of Chest,		
	Neck,				Neck,		
Address,	Length of Shoulders,			Address,	Length of Shoulder,		
	Length of Under-Arm,				Length of Under-Arm,		
	Waist,				Waist,		
Styles,	Hips,			Styles,	Hips,		
	Height of Darts				Height of Darts		
	Length of Back,				Length of Back,		
Price,	Width of Back,			Price,	Width of Back,		
To be finished,	Measure for Sleeves,			To be finished,	Measure for Sleeves,		
Remarks,	Armseye,			Remarks,	Armseye,		
	Elbow,				Elbow,		
	Wrist or hand,				Wrist or hand,		
	Shoulder to Elbow,				Shoulder to Elbow,		
Date, 189	Elbow to Wrist			Date, 189	Elbow to Wrist,		
Name,	Measure for Skirt and Riding Habit,			Name,	Measure for Skirt and Riding Habit,		
	Waist,				Waist,		
	Hips,				Hips,		
Address,	Length of Front			Address,	Length of Front		
	Length of Side,				Length of Side,		
	Length of Back,				Length of Back,		
Styles,	Measure for Trousers and Bloomers,			Styles,	Measure for Trousers and Bloomers,		
	Waist,				Waist,		
	Hips,				Hips,		
Price,	Seat,			Price,	Seat,		
To be finished,	Knee,			To be finished,	Knee,		
Remarks,	Bottom,			Remarks,	Bottom,		
	Outside length,				Outside length,		
	Inside length,				Inside length,		



Date, 189	Bust,			Date, 189	Bust,		
Name,	Length of Front,			Name,	Length of Front,		
	Width of Chest,				Width of Chest,		
	Neck,				Neck,		
Address,	Length of Shoulders,			Address,	Length of Shoulder,		
	Length of Under-Arm,				Length of Under-Arm,		
	Waist,				Waist,		
Styles,	Hips,			Styles,	Hips,		
	Height of Darts,				Height of Darts,		
Price,	Length of Back,			Price,	Length of Back,		
To be finished,	Width of Back,			To be finished,	Width of Back,		
	Measure for Sleeves,				Measure for Sleeves,		
Remarks,	Armseye,			Remarks,	Armseye,		
	Elbow,				Elbow,		
	Wrist or hand,				Wrist or hand,		
	Shoulder to Elbow,				Shoulder to Elbow,		
Date, 189	Elbow to Wrist,			Date, 189	Elbow to Wrist,		
	Measure for Skirt and Riding Habit,				Measure for Skirt and Riding Habit,		
Name,	Waist,			Name,	Waist,		
	Hips,				Hips,		
Address,	Length of Front,			Address,	Length of Front,		
	Length of Side,				Length of Side,		
	Length of Back,				Length of Back,		
Styles,	Measure for Trousers and Bloomers,			Styles,	Measure for Trousers and Bloomers,		
	Waist,				Waist,		
	Hips,				Hips,		
Price,	Seat,			Price,	Seat,		
To be finished,	Knee,			To be finished,	Knee,		
	Bottom,				Bottom,		
Remarks,	Outside length,			Remarks,	Outside length,		
	Inside length,				Inside length,		

Date, 189	Bust,		
Name,	Length of Front		
	Width of Chest,		
Address,	Neck, Length of Shoulders, Length of Under-Arm,		
Styles,	Waist, Hips, Height of Darts		
Price,	Length of Back, Width of Back,		
To be finished,	Measure for Sleeves,		
Remarks,	Armseye, Elbow, Wrist or hand, Shoulder to Elbow,		
Date, 189	Elbow to Wrist		
Name,	Measure for Skirt and Riding Habit,		
	Waist, Hips, Length of Front Length of Side, Length of Back,		
Address,	Measure for Trousers and Bloomers,		
Styles,	Waist, Hips, Seat, Knee, Bottom, Outside length, Inside length,		
Price,			
To be finished,			
Remarks,			

Date, 189	Bust,		
Name,	Length of Front		
	Width of Chest,		
Address,	Neck, Length of Shoulder, Length of Under-Arm,		
Styles,	Waist, Hips, Height of Darts		
Price,	Length of Back, Width of Back,		
To be finished,	Measure for Sleeves,		
Remarks,	Armseye, Elbow, Wrist or hand, Shoulder to Elbow,		
Date, 189	Elbow to Wrist		
Name,	Measure for Skirt and Riding Habit,		
	Waist, Hips, Length of Front Length of Side, Length of Back,		
Address,	Measure for Trousers and Bloomers,		
Styles,	Waist, Hips, Seat, Knee, Bottom, Outside length, Inside length,		
Price,			
To be finished,			
Remarks,			

Date,	189	Bust,			Date,	189	Bust,		
Name,		Length of Front			Name,		Length of Front		
		Width of Chest,					Width of Chest,		
		Neck,					Neck,		
Address,		Length of Shoulders,			Address,		Length of Shoulder,		
		Length of Under-Arm,					Length of Under-Arm,		
		Waist,					Waist,		
Styles,		Hips,			Styles,		Hips,		
		Height of Darts					Height of Darts		
Price,		Length of Back,			Price,		Length of Back,		
		Width of Back,					Width of Back,		
To be finished,		Measure for Sleeves,			To be finished,		Measure for Sleeves,		
Remarks,		Armseye,			Remarks,		Armseye,		
		Elbow,					Elbow,		
		Wrist or hand, Shoulder to Elbow,					Wrist or hand, Shoulder to Elbow,		
Date,	189	Elbow to Wrist			Date,	189	Elbow to Wrist,		
Name,		Measure for Skirt and Riding Habit,			Name,		Measure for Skirt and Riding Habit,		
		Waist,					Waist,		
		Hips,					Hips,		
Address,		Length of Front			Address,		Length of Front		
		Length of Side,					Length of Side,		
		Length of Back,					Length of Back,		
Styles,		Measure for Trousers and Bloomers,			Styles,		Measure for Trousers and Bloomers,		
		Waist,					Waist,		
		Hips,					Hips,		
Price,		Seat,			Price,		Seat,		
To be finished,		Knee,			To be finished,		Knee,		
Remarks,		Bottom,			Remarks,		Bottom,		
		Outside length,					Outside length,		
		Inside length,					Inside length,		

Date, 189	Bust,			Date, 189	Bust,		
Name,	Length of Front			Name,	Length of Front		
	Width of Chest,				Width of Chest,		
Address,	Neck, Length of Shoulders, Length of Under-Arm,			Address,	Neck, Length of Shoulder, Length of Under-Arm,		
Styles,	Waist,			Styles,	Waist,		
	Hips,				Hips,		
	Height of Darts				Height of Darts		
Price,	Length of Back,			Price,	Length of Back,		
To be finished,	Width of Back,			To be finished,	Width of Back,		
Remarks,	Measure for Sleeves,			Remarks,	Measure for Sleeves,		
	Armseye,				Armseye,		
	Elbow,				Elbow,		
	Wrist or hand, Shoulder to Elbow,				Wrist or hand, Shoulder to Elbow,		
Date, 189	Elbow to Wrist			Date, 189	Elbow to Wrist,		
Name,	Measure for Skirt and Riding Habit,			Name,	Measure for Skirt and Riding Habit,		
	Waist,				Waist,		
Address,	Hips,			Address,	Hips,		
	Length of Front				Length of Front		
	Length of Side,				Length of Side,		
Styles,	Length of Back,			Styles,	Length of Back,		
	Measure for Trousers and Bloomers,				Measure for Trousers and Bloomers,		
	Waist,				Waist,		
Price,	Hips,			Price,	Hips,		
To be finished,	Seat,			To be finished,	Seat,		
Remarks,	Knee,			Remarks,	Knee,		
	Bottom,				Bottom,		
	Outside length,				Outside length,		
	Inside length,				Inside length,		

Date, 189	Bust,			Date, 189	Bust,		
Name,	Length of Front			Name,	Length of Front		
	Width of Chest,				Width of Chest,		
	Neck,				Neck,		
Address,	Length of Shoulders,			Address,	Length of Shoulder,		
	Length of Under-Arm,				Length of Under-Arm,		
	Waist,				Waist,		
Styles,	Hips,			Styles,	Hips,		
	Height of Darts				Height of Darts		
Price,	Length of Back,			Price,	Length of Back,		
To be finished,	Width of Back,			To be finished,	Width of Back,		
Remarks,	Measure for Sleeves,			Remarks,	Measure for Sleeves,		
	Armseye,				Armseye,		
	Elbow,				Elbow,		
	Wrist or hand, Shoulder to Elbow,				Wrist or hand, Shoulder to Elbow,		
Date, 189	Elbow to Wrist			Date, 189	Elbow to Wrist,		
Name,	Measure for Skirt and Riding Habit,			Name,	Measure for Skirt and Riding Habit,		
	Waist,				Waist,		
	Hips,				Hips,		
Address,	Length of Front			Address,	Length of Front		
	Length of Side,				Length of Side,		
	Length of Back,				Length of Back,		
Styles,	Measure for Trousers and Bloomers,			Styles,	Measure for Trousers and Bloomers,		
	Waist,				Waist,		
	Hips,				Hips,		
Price,	Seat,			Price,	Seat,		
To be finished,	Knee,			To be finished,	Knee,		
Remarks,	Bottom,			Remarks,	Bottom,		
	Outside length,				Outside length,		
	Inside length,				Inside length,		

Date, 189	Bust,			Date, 189	Bust,		
Name,	Length of Front			Name,	Length of Front		
	Width of Chest,				Width of Chest,		
Address,	Neck, Length of Shoulders, Length of Under-Arm,			Address,	Neck, Length of Shoulder, Length of Under-Arm,		
Styles,	Waist,			Styles,	Waist,		
	Hips,				Hips,		
	Height of Darts				Height of Darts		
Price,	Length of Back,			Price,	Length of Back,		
To be finished,	Width of Back,			To be finished,	Width of Back,		
Remarks,	Measure for Sleeves,			Remarks,	Measure for Sleeves,		
	Armseye,				Armseye,		
	Elbow,				Elbow,		
	Wrist or hand, Shoulder to Elbow,				Wrist or hand, Shoulder to Elbow,		
Date, 189	Elbow to Wrist			Date, 189	Elbow to Wrist,		
Name,	Measure for Skirt and Riding Habit,			Name,	Measure for Skirt and Riding Habit,		
	Waist,				Waist,		
Address,	Hips,			Address,	Hips,		
	Length of Front				Length of Front		
	Length of Side,				Length of Side,		
Styles,	Length of Back,			Styles,	Length of Back,		
	Measure for Trousers and Bloomers,				Measure for Trousers and Bloomers,		
	Waist,				Waist,		
Price,	Hips,			Price,	Hips,		
To be finished,	Seat,			To be finished,	Seat,		
Remarks,	Knee,			Remarks,	Knee,		
	Bottom,				Bottom,		
	Outside length,				Outside length,		
	Inside length,				Inside length,		

Date, 189	Bust,			Date, 189	Bust,		
Name,	Length of Front			Name,	Length of Front		
	Width of Chest,				Width of Chest,		
Address,	Neck, Length of Shoulders, Length of Under-Arm,			Address,	Neck, Length of Shoulder, Length of Under-Arm,		
Styles,	Waist, Hips, Height of Darts			Styles,	Waist, Hips, Height of Darts		
Price,	Length of Back, Width of Back,			Price,	Length of Back, Width of Back,		
To be finished,	Measure for Sleeves,			To be finished,	Measure for Sleeves,		
Remarks,	Armseye, Elbow, Wrist or hand, Shoulder to Elbow,			Remarks,	Armseye, Elbow, Wrist or hand, Shoulder to Elbow,		
Date, 189	Elbow to Wrist			Date, 189	Elbow to Wrist,		
Name,	Measure for Skirt and Riding Habit,			Name,	Measure for Skirt and Riding Habit,		
	Waist, Hips, Length of Front Length of Side, Length of Back,				Waist, Hips, Length of Front Length of Side, Length of Back,		
Address,	Measure for Trousers and Bloomers,			Address,	Measure for Trousers and Bloomers,		
Styles,	Waist, Hips, Seat, Knee, Bottom, Outside length, Inside length,			Styles,	Waist, Hips, Seat, Knee, Bottom, Outside length, Inside length,		
Price,				Price,			
To be finished,				To be finished,			
Remarks,				Remarks,			

Date,	189	Bust,			Date,	189	Bust,		
Name,		Length of Front			Name,		Length of Front		
		Width of Chest,					Width of Chest,		
Address,		Neck, Length of Shoulders, Length of Under-Arm,			Address,		Neck, Length of Shoulder, Length of Under-Arm,		
Styles,		Waist,			Styles,		Waist,		
		Hips,					Hips,		
		Height of Darts					Height of Darts		
Price,		Length of Back,			Price,		Length of Back,		
To be finished,		Width of Back,			To be finished,		Width of Back,		
Remarks,		Measure for Sleeves.			Remarks,		Measure for Sleeves.		
		Armseye,					Armseye,		
		Elbow,					Elbow,		
		Wrist or hand, Shoulder to Elbow,					Wrist or hand, Shoulder to Elbow,		
Date,	189	Elbow to Wrist			Date,	189	Elbow to Wrist,		
Name,		Measure for Skirt and Riding Habit,			Name,		Measure for Skirt and Riding Habit.		
		Waist,					Waist,		
Address,		Hips,			Address,		Hips,		
		Length of Front					Length of Front		
		Length of Side,					Length of Side,		
Styles,		Length of Back,			Styles,		Length of Back,		
		Measure for Trousers and Bloomers,					Measure for Trousers and Bloomers,		
		Waist,					Waist,		
Price,		Hips,			Price,		Hips,		
To be finished,		Seat,			To be finished.		Seat,		
Remarks,		Knee,					Knee,		
		Bottom,					Bottom,		
		Outside length,					Outside length,		
		Inside length,					Inside length,		



Date, 189	Bust,			Date, 189	Bust,		
Name,	Length of Front			Name,	Length of Front		
	Width of Chest,				Width of Chest,		
	Neck,				Neck,		
Address,	Length of Shoulders,			Address,	Length of Shoulder,		
	Length of Under-Arm,				Length of Under-Arm,		
	Waist,				Waist,		
Styles,	Hips,			Styles,	Hips,		
	Height of Darts				Height of Darts		
Price,	Length of Back,			Price,	Length of Back,		
To be finished,	Width of Back,			To be finished,	Width of Back,		
	Measure for Sleeves,				Measure for Sleeves,		
Remarks,	Armseye,			Remarks,	Armseye,		
	Elbow,				Elbow,		
	Wrist or hand,				Wrist or hand,		
	Shoulder to Elbow,				Shoulder to Elbow,		
Date, 189	Elbow to Wrist			Date, 189	Elbow to Wrist,		
	Measure for Skirt and Riding Habit,				Measure for Skirt and Riding Habit,		
Name,	Waist,			Name,	Waist,		
	Hips,				Hips,		
Address,	Length of Front			Address,	Length of Front		
	Length of Side,				Length of Side,		
	Length of Back,				Length of Back,		
Styles,	Measure for Trousers and Bloomers,			Styles,	Measure for Trousers and Bloomers,		
	Waist,				Waist,		
	Hips,				Hips,		
Price,	Seat,			Price,	Seat,		
To be finished,	Knee,			To be finished,	Knee,		
Remarks,	Bottom,			Remarks,	Bottom,		
	Outside length,				Outside length,		
	Inside length,				Inside length,		

Date, 189	Bust,			Date, 189	Bust,		
Name,	Length of Front			Name,	Length of Front		
	Width of Chest,				Width of Chest,		
	Neck,				Neck,		
Address,	Length of Shoulders,			Address,	Length of Shoulder,		
	Length of Under-Arm,				Length of Under-Arm,		
	Waist,				Waist,		
Styles,	Hips,			Styles,	Hips,		
	Height of Darts				Height of Darts		
Price,	Length of Back,			Price,	Length of Back,		
	Width of Back,				Width of Back,		
To be finished,	Measure for Sleeves,			To be finished,	Measure for Sleeves,		
Remarks,	Armseye,			Remarks,	Armseye,		
	Elbow,				Elbow,		
	Wrist or hand, Shoulder to Elbow,				Wrist or hand, Shoulder to Elbow,		
Date, 189	Elbow to Wrist			Date, 189	Elbow to Wrist,		
Name,	Measure for Skirt and Riding Habit,			Name,	Measure for Skirt and Riding Habit,		
	Waist,				Waist,		
	Hips,				Hips,		
Address,	Length of Front			Address,	Length of Front		
	Length of Side,				Length of Side,		
	Length of Back,				Length of Back,		
Styles,	Measure for Trousers and Bloomers,			Styles,	Measure for Trousers and Bloomers,		
	Waist,				Waist,		
	Hips,				Hips,		
Price,	Seat,			Price,	Seat,		
To be finished,	Knee,			To be finished,	Knee,		
Remarks,	Bottom,			Remarks,	Bottom,		
	Outside length,				Outside length,		
	Inside length,				Inside length,		

Date, 189	Bust,			Date, 189	Bust,		
Name,	Length of Front			Name,	Length of Front		
	Width of Chest,				Width of Chest,		
Address,	Neck, Length of Shoulders, Length of Under-Arm,			Address,	Neck, Length of Shoulder, Length of Under-Arm.		
Styles,	Waist,			Styles,	Waist,		
	Hips,				Hips,		
	Height of Darts				Height of Darts		
Price,	Length of Back,			Price,	Length of Back,		
To be finished,	Width of Back,			To be finished,	Width of Back,		
Remarks,	Measure for Sleeves,			Remarks,	Measure for Sleeves,		
	Armseye,				Armseye,		
	Elbow,				Elbow,		
	Wrist or hand, Shoulder to Elbow,				Wrist or hand, Shoulder to Elbow,		
Date, 189	Elbow to Wrist			Date, 189	Elbow to Wrist,		
Name,	Measure for Skirt and Riding Habit,			Name,	Measure for Skirt and Riding Habit,		
	Waist,				Waist,		
	Hips,				Hips,		
Address,	Length of Front			Address,	Length of Front		
	Length of Side,				Length of Side,		
	Length of Back,				Length of Back,		
Styles,	Measure for Trousers and Bloomers,			Styles,	Measure for Trousers and Bloomers,		
	Waist,				Waist,		
	Hips,				Hips,		
Price,	Seat,			Price,	Seat,		
To be finished,	Knee,			To be finished,	Knee,		
Remarks,	Bottom,			Remarks,	Bottom,		
	Outside length,				Outside length,		
	Inside length,				Inside length,		

Date, 189	Bust,			Date, 189	Bust,		
Name,	Length of Front			Name,	Length of Front		
	Width of Chest,				Width of Chest,		
	Neck,				Neck,		
Address,	Length of Shoulders,			Address,	Length of Shoulder,		
	Length of Under-Arm,				Length of Under-Arm,		
	Waist,				Waist,		
Styles,	Hips,			Styles,	Hips,		
	Height of Darts				Height of Darts		
Price,	Length of Back,			Price,	Length of Back,		
	Width of Back,				Width of Back,		
To be finished,	Measure for Sleeves,			To be finished,	Measure for Sleeves,		
Remarks,	Armseye,			Remarks,	Armseye,		
	Elbow,				Elbow,		
	Wrist or hand,				Wrist or hand,		
	Shoulder to Elbow,				Shoulder to Elbow,		
Date, 189	Elbow to Wrist			Date, 189	Elbow to Wrist,		
	Measure for Skirt and Riding Habit,				Measure for Skirt and Riding Habit,		
Name,	Waist,			Name,	Waist,		
	Hips,				Hips,		
Address,	Length of Front			Address,	Length of Front		
	Length of Side,				Length of Side,		
	Length of Back,				Length of Back,		
Styles,	Measure for Trousers and Bloomers,			Styles,	Measure for Trousers and Bloomers,		
	Waist,				Waist,		
	Hips,				Hips,		
Price,	Seat,			Price,	Seat,		
	Knee,				Knee,		
To be finished,	Bottom,			To be finished,	Bottom,		
Remarks,	Outside length,			Remarks,	Outside length,		
	Inside length,				Inside length,		

Date,	189
Name,	
Address,	
Styles,	
Price,	
To be finished,	
Remarks,	
Date,	189
Name,	
Address,	
Styles,	
Price,	
To be finished,	
Remarks,	

Bust,	
Length of Front	
Width of Chest,	
Neck,	
Length of Shoulders,	
Length of Under-Arm,	
Waist,	
Hips,	
Height of Darts	
Length of Back,	
Width of Back,	
Measure for Sleeves,	
Armseye,	
Elbow,	
Wrist or hand,	
Shoulder to Elbow,	
Elbow to Wrist	
Measure for Skirt and Riding Habit,	
Waist,	
Hips,	
Length of Front	
Length of Side,	
Length of Back,	
Measure for Trousers and Bloomers,	
Waist,	
Hips,	
Seat,	
Knee,	
Bottom,	
Outside length,	
Inside length,	

Date,	189
Name,	
Address,	
Styles,	
Price,	
To be finished,	
Remarks,	
Date,	189
Name,	
Address,	
Styles,	
Price,	
To be finished,	
Remarks,	

Bust,	
Length of Front	
Width of Chest,	
Neck,	
Length of Shoulder,	
Length of Under-Arm,	
Waist,	
Hips,	
Height of Darts	
Length of Back,	
Width of Back,	
Measure for Sleeves,	
Armseye,	
Elbow,	
Wrist or hand,	
Shoulder to Elbow,	
Elbow to Wrist,	
Measure for Skirt and Riding Habit,	
Waist,	
Hips,	
Length of Front	
Length of Side,	
Length of Back,	
Measure for Trousers and Bloomers,	
Waist,	
Hips,	
Seat,	
Knee,	
Bottom,	
Outside length,	
Inside length,	

Date, 189	Bust,		
Name,	Length of Front		
	Width of Chest,		
Address,	Neck, Length of Shoulders, Length of Under-Arm,		
Styles,	Waist, Hips, Height of Darts		
Price,	Length of Back, Width of Back,		
To be finished,	Measure for Sleeves,		
Remarks,	Armseye, Elbow, Wrist or hand, Shoulder to Elbow,		
Date, 189	Elbow to Wrist		
Name,	Measure for Skirt and Riding Habit,		
	Waist, Hips, Length of Front Length of Side, Length of Back,		
Address,	Measure for Trousers and Bloomers,		
Styles,	Waist, Hips, Seat, Knee, Bottom, Outside length, Inside length,		
Price,			
To be finished,			
Remarks,			

Date, 189	Bust,		
Name,	Length of Front		
	Width of Chest,		
Address,	Neck, Length of Shoulder, Length of Under-Arm,		
Styles,	Waist, Hips, Height of Darts		
Price,	Length of Back, Width of Back,		
To be finished,	Measure for Sleeves,		
Remarks,	Armseye, Elbow, Wrist or hand, Shoulder to Elbow,		
Date, 189	Elbow to Wrist		
Name,	Measure for Skirt and Riding Habit,		
	Waist, Hips, Length of Front Length of Side, Length of Back,		
Address,	Measure for Trousers and Bloomers,		
Styles,	Waist, Hips, Seat, Knee, Bottom, Outside length, Inside length,		
Price,			
To be finished,			
Remarks,			

Date,	189
Name,	
Address,	
Styles,	
Price,	
To be finished,	
Remarks,	
Date,	189
Name,	
Address,	
Styles,	
Price,	
To be finished,	
Remarks,	

Bust,	
Length of Front	
Width of Chest,	
Neck,	
Length of Shoulders,	
Length of Under-Arm,	
Waist,	
Hips,	
Height of Darts	
Length of Back,	
Width of Back,	
Measure for Sleeves,	
Armseye,	
Elbow,	
Wrist or hand,	
Shoulder to Elbow,	
Elbow to Wrist	
Measure for Skirt and Riding Habit,	
Waist,	
Hips,	
Length of Front	
Length of Side,	
Length of Back,	
Measure for Trousers and Bloomers,	
Waist,	
Hips,	
Seat,	
Knee,	
Bottom,	
Outside length,	
Inside length,	

Date,	189
Name,	
Address,	
Styles,	
Price,	
To be finished,	
Remarks,	
Date,	189
Name,	
Address,	
Styles,	
Price,	
To be finished,	
Remarks,	

Bust,	
Length of Front	
Width of Chest,	
Neck,	
Length of Shoulder,	
Length of Under-Arm,	
Waist,	
Hips,	
Height of Darts	
Length of Back,	
Width of Back,	
Measure for Sleeves,	
Armseye,	
Elbow,	
Wrist or hand,	
Shoulder to Elbow,	
Elbow to Wrist,	
Measure for Skirt and Riding Habit,	
Waist,	
Hips,	
Length of Front	
Length of Side,	
Length of Back,	
Measure for Trousers and Bloomers,	
Waist,	
Hips,	
Seat,	
Knee,	
Bottom,	
Outside length,	
Inside length,	

Date, 189	Bust,			Date, 189	Bust,		
Name,	Length of Front			Name,	Length of Front		
	Width of Chest,				Width of Chest,		
Address,	Neck, Length of Shoulders, Length of Under-Arm,			Address,	Neck, Length of Shoulder, Length of Under-Arm,		
	Waist,				Waist,		
Styles,	Hips,			Styles,	Hips,		
	Height of Darts				Height of Darts		
Price,	Length of Back,			Price,	Length of Back,		
To be finished,	Width of Back,			To be finished,	Width of Back,		
Remarks,	Measure for Sleeves,			Remarks,	Measure for Sleeves,		
	Armseye,				Armseye,		
	Elbow,				Elbow,		
	Wrist or hand, Shoulder to Elbow,				Wrist or hand, Shoulder to Elbow,		
Date, 189	Elbow to Wrist			Date, 189	Elbow to Wrist,		
Name,	Measure for Skirt and Riding Habit,			Name,	Measure for Skirt and Riding Habit,		
	Waist,				Waist,		
	Hips,				Hips,		
Address,	Length of Front			Address,	Length of Front		
	Length of Side,				Length of Side,		
	Length of Back,				Length of Back,		
Styles,	Measure for Trousers and Bloomers,			Styles,	Measure for Trousers and Bloomers,		
	Waist,				Waist,		
	Hips,				Hips,		
Price,	Seat,			Price,	Seat,		
To be finished,	Knee,			To be finished,	Knee,		
Remarks,	Bottom,			Remarks,	Bottom,		
	Outside length,				Outside length,		
	Inside length,				Inside length,		



Date,	189	Bust,			Date,	189	Bust,		
Name,		Length of Front			Name,		Length of Front		
		Width of Chest,					Width of Chest,		
		Neck,					Neck,		
Address,		Length of Shoulders,			Address,		Length of Shoulder,		
		Length of Under-Arm,					Length of Under-Arm,		
		Waist,					Waist,		
Styles,		Hips,			Styles,		Hips,		
		Height of Darts					Height of Darts		
Price,		Length of Back,			Price,		Length of Back,		
		Width of Back,					Width of Back,		
To be finished,		Measure for Sleeves,			To be finished,		Measure for Sleeves,		
Remarks,		Armseye,			Remarks,		Armseye,		
		Elbow,					Elbow,		
		Wrist or hand,					Wrist or hand,		
		Shoulder to Elbow,					Shoulder to Elbow,		
Date,	189	Elbow to Wrist			Date,	189	Elbow to Wrist,		
		Measure for Skirt and Riding Habit,					Measure for Skirt and Riding Habit,		
Name,		Waist,			Name,		Waist,		
		Hips,					Hips,		
Address,		Length of Front			Address,		Length of Front		
		Length of Side,					Length of Side,		
		Length of Back,					Length of Back,		
Styles,		Measure for Trousers and Bloomers,			Styles,		Measure for Trousers and Bloomers,		
		Waist,					Waist,		
		Hips,					Hips,		
Price,		Seat,			Price,		Seat,		
		Knee,					Knee,		
To be finished,		Bottom,			To be finished,		Bottom,		
Remarks,		Outside length,			Remarks,		Outside length,		
		Inside length,					Inside length,		

Date, 189	Bust,			Date, 189	Bust,		
Name,	Length of Front			Name,	Length of Front		
	Width of Chest,				Width of Chest,		
	Neck,				Neck,		
Address,	Length of Shoulders,			Address,	Length of Shoulder,		
	Length of Under-Arm,				Length of Under-Arm,		
	Waist,				Waist,		
Styles,	Hips,			Styles,	Hips,		
	Height of Darts				Height of Darts		
Price,	Length of Back,			Price,	Length of Back,		
	Width of Back,				Width of Back,		
To be finished,	Measure for Sleeves,			To be finished,	Measure for Sleeves,		
Remarks,	Armseye,			Remarks,	Armseye,		
	Elbow,				Elbow,		
	Wrist or hand,				Wrist or hand,		
	Shoulder to Elbow,				Shoulder to Elbow,		
Date, 189	Elbow to Wrist			Date, 189	Elbow to Wrist,		
	Measure for Skirt and Riding Habit,				Measure for Skirt and Riding Habit,		
Name,	Waist,			Name,	Waist,		
	Hips,				Hips,		
Address,	Length of Front			Address,	Length of Front		
	Length of Side,				Length of Side,		
	Length of Back,				Length of Back,		
Styles,	Measure for Trousers and Bloomers,			Styles,	Measure for Trousers and Bloomers,		
	Waist,				Waist,		
	Hips,				Hips,		
Price,	Seat,			Price,	Seat,		
	Knee,				Knee,		
To be finished,	Bottom,			To be finished,	Bottom,		
Remarks,	Outside length,			Remarks,	Outside length,		
	Inside length,				Inside length,		

Date,	189	Bust,	
Name,		Length of Front	
		Width of Chest,	
Address,		Neck,	
		Length of Shoulders,	
Styles,		Length of Under-Arm,	
		Waist,	
Price,		Hips,	
To be finished,		Height of Darts	
Remarks,		Length of Back,	
		Width of Back,	
		Measure for Sleeves,	
		Armseye,	
		Elbow,	
		Wrist or hand,	
		Shoulder to Elbow,	
Date,	189	Elbow to Wrist	
Name,		Measure for Skirt and Riding Habit,	
		Waist,	
Address,		Hips,	
		Length of Front	
Styles,		Length of Side,	
		Length of Back,	
Price,		Measure for Trousers and Bloomers,	
To be finished,		Waist,	
Remarks,		Hips,	
		Seat,	
		Knee,	
		Bottom,	
		Outside length,	
		Inside length,	

Date,	189	Bust,	
Name,		Length of Front	
		Width of Chest,	
Address,		Neck,	
		Length of Shoulder,	
Styles,		Length of Under-Arm,	
		Waist,	
Price,		Hips,	
To be finished,		Height of Darts	
Remarks,		Length of Back,	
		Width of Back,	
		Measure for Sleeves,	
		Armseye,	
		Elbow,	
		Wrist or hand,	
		Shoulder to Elbow,	
Date,	189	Elbow to Wrist	
Name,		Measure for Skirt and Riding Habit,	
		Waist,	
Address,		Hips,	
		Length of Front	
Styles,		Length of Side,	
		Length of Back,	
Price,		Measure for Trousers and Bloomers,	
To be finished,		Waist,	
Remarks,		Hips,	
		Seat,	
		Knee,	
		Bottom,	
		Outside length,	
		Inside length,	

Date, 189	Bust,			Date, 189	Bust,		
Name,	Length of Front			Name,	Length of Front		
	Width of Chest,				Width of Chest,		
Address,	Neck, Length of Shoulders, Length of Under-Arm,			Address,	Neck, Length of Shoulder, Length of Under-Arm,		
Styles,	Waist, Hips, Height of Darts			Styles,	Waist, Hips, Height of Darts		
Price,	Length of Back, Width of Back,			Price,	Length of Back, Width of Back,		
To be finished,	Measure for Sleeves,			To be finished,	Measure for Sleeves,		
Remarks,	Armseye, Elbow, Wrist or hand, Shoulder to Elbow,			Remarks,	Armseye, Elbow, Wrist or hand, Shoulder to Elbow,		
Date, 189	Elbow to Wrist			Date, 189	Elbow to Wrist,		
Name,	Measure for Skirt and Riding Habit,			Name,	Measure for Skirt and Riding Habit,		
	Waist, Hips, Length of Front Length of Side, Length of Back,				Waist, Hips, Length of Front Length of Side, Length of Back,		
Address,	Measure for Trousers and Bloomers,			Address,	Measure for Trousers and Bloomers,		
Styles,	Waist, Hips, Seat, Knee, Bottom, Outside length, Inside length,			Styles,	Waist, Hips, Seat, Knee, Bottom, Outside length, Inside length,		
Price,				Price,			
To be finished,				To be finished.			
Remarks,				Remarks,			

Date, 189	Bust,			Date, 189	Bust,		
Name,	Length of Front			Name,	Length of Front		
	Width of Chest,				Width of Chest,		
	Neck,				Neck,		
Address,	Length of Shoulders,			Address,	Length of Shoulder,		
	Length of Under-Arm,				Length of Under-Arm,		
	Waist,				Waist,		
Styles,	Hips,			Styles,	Hips,		
	Height of Darts				Height of Darts		
Price,	Length of Back,			Price,	Length of Back,		
To be finished,	Width of Back,			To be finished,	Width of Back,		
	Measure for Sleeves,				Measure for Sleeves,		
Remarks,	Armseye,			Remarks,	Armseye,		
	Elbow,				Elbow,		
	Wrist or hand,				Wrist or hand,		
	Shoulder to Elbow,				Shoulder to Elbow,		
Date, 189	Elbow to Wrist			Date, 189	Elbow to Wrist,		
	Measure for Skirt and Riding Habit,				Measure for Skirt and Riding Habit,		
Name,	Waist,			Name,	Waist,		
	Hips,				Hips,		
Address,	Length of Front			Address,	Length of Front		
	Length of Side,				Length of Side,		
	Length of Back,				Length of Back,		
Styles,	Measure for Trousers and Bloomers,			Styles,	Measure for Trousers and Bloomers,		
	Waist,				Waist,		
	Hips,				Hips,		
Price,	Seat,			Price,	Seat,		
To be finished,	Knee,			To be finished,	Knee,		
	Bottom,				Bottom,		
Remarks,	Outside length,			Remarks,	Outside length,		
	Inside length,				Inside length,		

Date, 189.	Bust,			Date, 189	Bust,		
Name,	Length of Front			Name,	Length of Front		
	Width of Chest,				Width of Chest,		
Address,	Neck, Length of Shoulders, Length of Under-Arm,			Address,	Neck, Length of Shoulder, Length of Under-Arm,		
Styles,	Waist, Hips, Height of Darts			Styles,	Waist, Hips, Height of Darts		
Price,	Length of Back, Width of Back,			Price,	Length of Back, Width of Back,		
To be finished,	Measure for Sleeves,			To be finished,	Measure for Sleeves,		
Remarks,	Armseye, Elbow, Wrist or hand, Shoulder to Elbow,			Remarks,	Armseye, Elbow, Wrist or hand, Shoulder to Elbow,		
Date, 189	Elbow to Wrist			Date, 189	Elbow to Wrist,		
Name,	Measure for Skirt and Riding Habit,			Name,	Measure for Skirt and Riding Habit,		
	Waist, Hips, Length of Front Length of Side, Length of Back,				Waist, Hips, Length of Front Length of Side, Length of Back,		
Address,	Measure for Trousers and Bloomers,			Address,	Measure for Trousers and Bloomers,		
Styles,	Waist, Hips, Seat, Knee, Bottom, Outside length, Inside length,			Styles,	Waist, Hips, Seat, Knee, Bottom, Outside length, Inside length,		
Price,				Price,			
To be finished,				To be finished.			
Remarks,				Remarks,			

Date, 189	Bust,		Date, 189	Bust,	
Name,	Length of Front		Name,	Length of Front	
	Width of Chest,			Width of Chest,	
	Neck,			Neck,	
Address,	Length of Shoulders,		Address,	Length of Shoulder,	
	Length of Under-Arm,			Length of Under-Arm,	
	Waist,			Waist,	
Styles,	Hips,		Styles,	Hips,	
	Height of Darts			Height of Darts	
	Length of Back,			Length of Back,	
Price,	Width of Back,		Price,	Width of Back,	
To be finished,	Measure for Sleeves,		To be finished,	Measure for Sleeves,	
Remarks,	Armseye,		Remarks,	Armseye,	
	Elbow,			Elbow,	
	Wrist or hand,			Wrist or hand,	
	Shoulder to Elbow,			Shoulder to Elbow,	
Date, 189	Elbow to Wrist		Date, 189	Elbow to Wrist,	
Name,	Measure for Skirt and Riding Habit,		Name,	Measure for Skirt and Riding Habit,	
	Waist,			Waist,	
	Hips,			Hips,	
Address,	Length of Front		Address,	Length of Front	
	Length of Side,			Length of Side,	
	Length of Back,			Length of Back,	
Styles,	Measure for Trousers and Bloomers,		Styles,	Measure for Trousers and Bloomers,	
	Waist,			Waist,	
	Hips,			Hips,	
Price,	Seat,		Price,	Seat,	
To be finished,	Knee,		To be finished,	Knee,	
Remarks,	Bottom,		Remarks,	Bottom,	
	Outside length,			Outside length,	
	Inside length,			Inside length,	

<b>Date,</b>	<b>189</b>	<b>Bust,</b>		<b>Date,</b>	<b>189</b>	<b>Bust,</b>	
<b>Name,</b>		<b>Length of Front</b>		<b>Name,</b>		<b>Length of Front</b>	
		<b>Width of Chest,</b>				<b>Width of Chest,</b>	
<b>Address,</b>		<b>Neck,</b>		<b>Address,</b>		<b>Neck,</b>	
		<b>Length of Shoulders,</b>				<b>Length of Shoulder,</b>	
		<b>Length of Under-Arm,</b>				<b>Length of Under-Arm,</b>	
<b>Styles,</b>		<b>Waist,</b>		<b>Styles,</b>		<b>Waist,</b>	
		<b>Hips,</b>				<b>Hips,</b>	
		<b>Height of Darts</b>				<b>Height of Darts</b>	
<b>Price,</b>		<b>Length of Back,</b>		<b>Price,</b>		<b>Length of Back,</b>	
		<b>Width of Back,</b>				<b>Width of Back,</b>	
<b>To be finished,</b>		<small>Measure for Sleeves,</small>		<b>To be finished,</b>		<small>Measure for Sleeves,</small>	
<b>Remarks,</b>		<b>Armseye,</b>		<b>Remarks,</b>		<b>Armseye,</b>	
		<b>Elbow,</b>				<b>Elbow,</b>	
		<b>Wrist or hand,</b>				<b>Wrist or hand,</b>	
		<b>Shoulder to Elbow,</b>				<b>Shoulder to Elbow,</b>	
<b>Date,</b>	<b>189</b>	<b>Elbow to Wrist</b>		<b>Date,</b>	<b>189</b>	<b>Elbow to Wrist,</b>	
<b>Name,</b>		<small>Measure for Skirt and Riding Habit,</small>		<b>Name,</b>		<small>Measure for Skirt and Riding Habit,</small>	
		<b>Waist,</b>				<b>Waist,</b>	
		<b>Hips,</b>				<b>Hips,</b>	
<b>Address,</b>		<b>Length of Front</b>		<b>Address,</b>		<b>Length of Front</b>	
		<b>Length of Side,</b>				<b>Length of Side,</b>	
		<b>Length of Back,</b>				<b>Length of Back,</b>	
<b>Styles,</b>		<small>Measure for Trousers and Bloomers,</small>		<b>Styles,</b>		<small>Measure for Trousers and Bloomers,</small>	
		<b>Waist,</b>				<b>Waist,</b>	
		<b>Hips,</b>				<b>Hips,</b>	
<b>Price,</b>		<b>Seat,</b>		<b>Price,</b>		<b>Seat,</b>	
		<b>Knee,</b>				<b>Knee,</b>	
<b>To be finished,</b>		<b>Bottom,</b>		<b>To be finished,</b>		<b>Bottom,</b>	
<b>Remarks,</b>		<b>Outside length,</b>		<b>Remarks,</b>		<b>Outside length,</b>	
		<b>Inside length,</b>				<b>Inside length,</b>	



Date, 189	Bust,			Date, 189	Bust,		
Name,	Length of Front			Name,	Length of Front		
	Width of Chest,				Width of Chest,		
Address,	Neck,			Address,	Neck,		
	Length of Shoulders,				Length of Shoulder,		
	Length of Under-Arm,				Length of Under-Arm,		
Styles,	Waist,			Styles,	Waist,		
	Hips,				Hips,		
	Height of Darts				Height of Darts		
Price,	Length of Back,			Price,	Length of Back,		
To be finished,	Width of Back,			To be finished,	Width of Back,		
Remarks,	Measure for Sleeves,			Remarks,	Measure for Sleeves,		
	Armseye,				Armseye,		
	Elbow,				Elbow,		
	Wrist or hand,				Wrist or hand,		
	Shoulder to Elbow,				Shoulder to Elbow,		
Date, 189	Elbow to Wrist			Date, 189	Elbow to Wrist,		
Name,	Measure for Skirt and Riding Habit,			Name,	Measure for Skirt and Riding Habit,		
	Waist,				Waist,		
	Hips,				Hips,		
Address,	Length of Front			Address,	Length of Front		
	Length of Side,				Length of Side,		
	Length of Back,				Length of Back,		
Styles,	Measure for Trousers and Bloomers,			Styles,	Measure for Trousers and Bloomers,		
	Waist,				Waist,		
	Hips,				Hips,		
Price,	Seat,			Price,	Seat,		
To be finished,	Knee,			To be finished,	Knee,		
Remarks,	Bottom,			Remarks,	Bottom,		
	Outside length,				Outside length,		
	Inside length,				Inside length,		

Date, 189
Name,
Address,
Styles,
Price,
To be finished,
Remarks,
Date, 189
Name,
Address,
Styles,
Price,
To be finished,
Remarks,

Bust,
Length of Front
Width of Chest,
Neck,
Length of Shoulders,
Length of Under-Arm,
Waist,
Hips,
Height of Darts
Length of Back,
Width of Back,
Measure for Sleeves,
Armseye,
Elbow,
Wrist or hand, Shoulder to Elbow,
Elbow to Wrist
Measure for Skirt and Riding Habit,
Waist,
Hips,
Length of Front
Length of Side,
Length of Back,
Measure for Trousers and Bloomers,
Waist,
Hips,
Seat,
Knee,
Bottom,
Outside length,
Inside length,

Date, 189
Name,
Address,
Styles,
Price,
To be finished,
Remarks,
Date, 189
Name,
Address,
Styles,
Price,
To be finished,
Remarks,

Bust,
Length of Front
Width of Chest,
Neck,
Length of Shoulder,
Length of Under-Arm,
Waist,
Hips,
Height of Darts
Length of Back,
Width of Back,
Measure for Sleeves,
Armseye,
Elbow,
Wrist or hand, Shoulder to Elbow,
Elbow to Wrist,
Measure for Skirt and Riding Habit,
Waist,
Hips,
Length of Front
Length of Side,
Length of Back,
Measure for Trousers and Bloomers,
Waist,
Hips,
Seat,
Knee,
Bottom,
Outside length,
Inside length,

Date, 189	Bust,		
Name,	Length of Front,		
	Width of Chest,		
	Neck,		
Address,	Length of Shoulders,		
	Length of Under-Arm,		
	Waist,		
Styles,	Hips,		
	Height of Darts,		
Price,	Length of Back,		
	Width of Back,		
To be finished,	Measure for Sleeves,		
Remarks,	Armseye,		
	Elbow,		
	Wrist or hand,		
	Shoulder to Elbow,		
Date, 189	Elbow to Wrist,		
	Measure for Skirt and Riding Habit,		
Name,	Waist,		
	Hips,		
Address,	Length of Front,		
	Length of Side,		
	Length of Back,		
Styles,	Measure for Trousers and Bloomers,		
	Waist,		
	Hips,		
Price,	Seat,		
To be finished,	Knee,		
	Bottom,		
Remarks,	Outside length,		
	Inside length,		

Date, 189	Bust,		
Name,	Length of Front,		
	Width of Chest,		
	Neck,		
Address,	Length of Shoulder,		
	Length of Under-Arm,		
	Waist,		
Styles,	Hips,		
	Height of Darts,		
Price,	Length of Back,		
	Width of Back,		
To be finished,	Measure for Sleeves,		
Remarks,	Armseye,		
	Elbow,		
	Wrist or hand,		
	Shoulder to Elbow,		
Date, 189	Elbow to Wrist,		
	Measure for Skirt and Riding Habit,		
Name,	Waist,		
	Hips,		
Address,	Length of Front,		
	Length of Side,		
	Length of Back,		
Styles,	Measure for Trousers and Bloomers,		
	Waist,		
	Hips,		
Price,	Seat,		
To be finished,	Knee,		
	Bottom,		
Remarks,	Outside length,		
	Inside length,		

Date, 189	Bust,			Date, 189	Bust,		
Name,	Length of Front			Name,	Length of Front		
	Width of Chest,				Width of Chest,		
	Neck,				Neck,		
Address,	Length of Shoulders,			Address,	Length of Shoulder,		
	Length of Under-Arm,				Length of Under-Arm,		
	Waist,				Waist,		
Styles,	Hips,			Styles,	Hips,		
	Height of Darts				Height of Darts		
Price,	Length of Back,			Price,	Length of Back,		
	Width of Back,				Width of Back,		
To be finished,	Measure for Sleeves,			To be finished,	Measure for Sleeves,		
Remarks,	Armseye,			Remarks,	Armseye,		
	Elbow,				Elbow,		
	Wrist or hand,				Wrist or hand,		
	Shoulder to Elbow,				Shoulder to Elbow,		
Date, 189	Elbow to Wrist			Date, 189	Elbow to Wrist,		
Name,	Measure for Skirt and Riding Habit,			Name,	Measure for Skirt and Riding Habit,		
	Waist,				Waist,		
	Hips,				Hips,		
Address,	Length of Front			Address,	Length of Front		
	Length of Side,				Length of Side,		
	Length of Back,				Length of Back,		
Styles,	Measure for Trousers and Bloomers,			Styles,	Measure for Trousers and Bloomers,		
	Waist,				Waist,		
	Hips,				Hips,		
Price,	Seat,			Price,	Seat,		
	Knee,				Knee,		
To be finished,	Bottom,			To be finished,	Bottom,		
Remarks,	Outside length,			Remarks,	Outside length,		
	Inside length,				Inside length,		

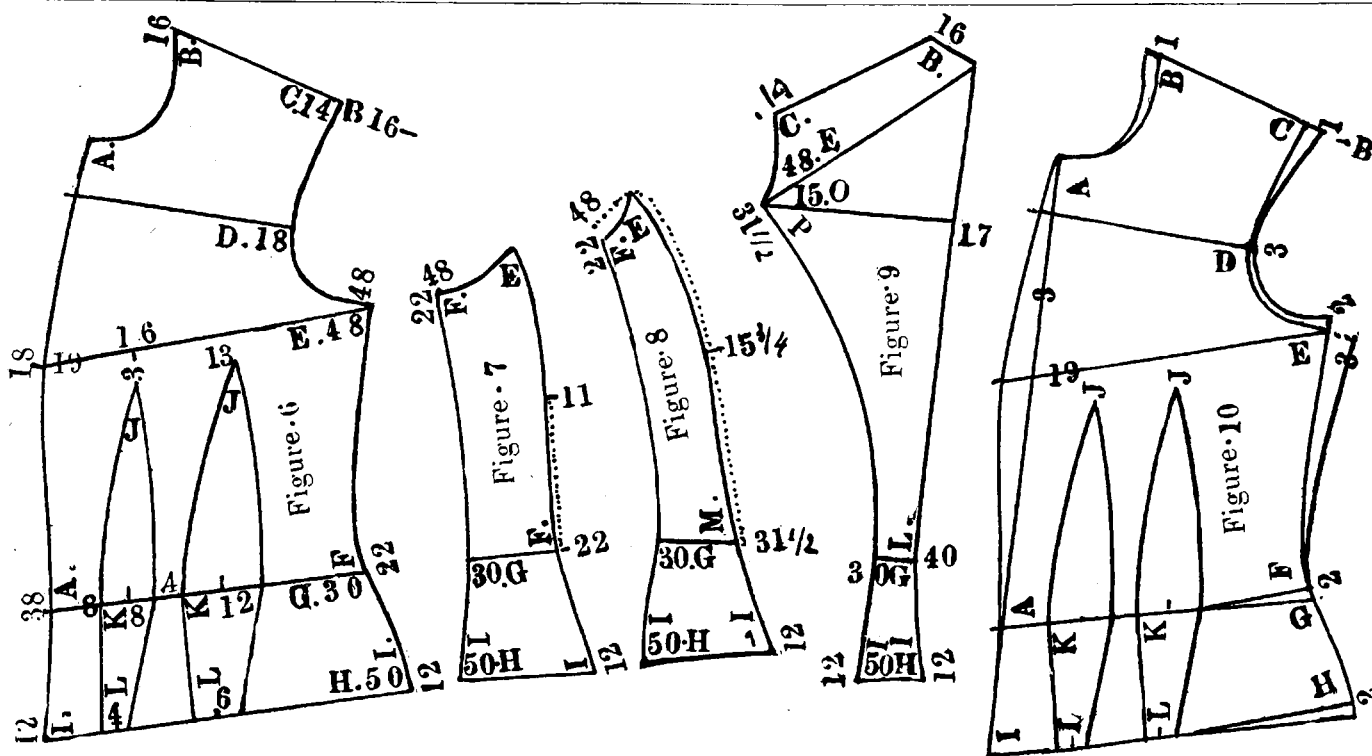

Figure 6 represents the front of a tight-fitting basque or waist.

**DIRECTIONS FOR DRAFTING THE FRONT—FIRST LESSON.**

Place the front of the *System* on the lining or goods, being careful that the front of the *System* is placed straight on the thread line from neck to bust letter *E*, then dot your bust measure 48, and make a mark at the bust line No. 19; commence to trace at bust line up to neck letter *A*, by taking 18, according to the measure given in first lesson, and trace down to waist letter *A*, to 38 and down to letter *I* to 12 below waist line. Notice this important point: The bust line is numbered 19 in every diagram, also on the *System* because the bust line is 19 centimetres from the neck, and every draft is started from the bust line. No matter what will be your measure, always make a mark at bust line and trace up and down according to your measure taken, and whatever is less than 19 centimetres from neck to fullest part of bust must be taken off up near the neck letter *A*, and added down near the waist line letter *A*; for instance, this given measure is 18 from neck to bust and 38 for the front length, as you must take one less above bust line at neck and add one more below bust line at waist; that is to say, trace to No. 39 instead of 38.

Now move the *System* down, bring the neck corner to where you stopped to trace letter *A*, be careful that the *System* is touching the line from neck to bust, then dot the chest measure letter *D* 18, and trace the neck measure from the corner to letter *B* 16. Then follow the line running from neck to armseye and make a dot at the end of line, same as neck letter *B* 16.

Now move the *System* down again and place the neck and shoulder corner of the *System* at the neck; mark where you stopped to trace letter *B* 16, and the shoulder and armseye corner of the *System* to be placed at the dot made at end of line letter *B* 16, then trace the shoulder measure, letter *C* 14, from neck corner to 14.

Notice the small numbers which are at armseye on the *System*, numbered from 10 to 66, and marked Bust letter *E*; those numbers correspond with the bust measure, and whatever is the bust measure you must take the same number to trace the armseye.

After you have traced the length of the shoulder, then place No. 48 at the bust dot, and the edge of the *System* near letter *W*, which is placed at chest dot, then trace from bust dot to chest dot, then place the upper edge of *System* at shoulder length, then trace from chest dot to the shoulder line.

Now move the *System* up; place the waist line of the *System* at letter *A* 38, and see that edge of the *System* is straight with the front line, then dot the waist measure letter *G* 30, and add for the width of the darts. In this given measure we give 20 for the width of the darts, so you must dot at 50 instead of 30.

Now dot the hip measure letter *H* 50, and add to the hips half what you add to the waist; that is to say, if you add 20 centimetres to the waist you must add 10 centimetres to the hips for the opening of the bottom of the darts, then dot 60 instead of 50.

Now move the *System* back and place corner *K* of the *System* at the bust dot letter *E* 48, and the side edge at waist dot letter *G* 30, then mark the under-arm measure letter *F* 22.

Now move the *System* up, place waist line letter *G* at the under-arm dot letter *F* 22, see that the edge of the *System* is placed also at the bust dot letter *E*, then trace up from under-arm dot to bust dot, then trace down from under-arm dot to the hip dot letter *H*, twelve centimetres below the waist line or below under-arm dot, as the under-arm dot regulates the place of the waist line.

Now take the *System*, place the bottom edge at bottom of front and side line, then trace the hip line, also the waist line from under-arm dot letter *F* 22 to the front dot letter *A* 38, and trace also the bust line from the bust corner letter *E* 48 to the front dot 18.

### DIRECTIONS FOR PLACING THE DARTS.

Now place corner of dart rule corner 1 (marked width of dart) at front of waist line, and dot the distance you wish to have the dart from the front line, which is from 6 to 14 measure, according to the size of the person. The larger the person is at waist the further you place the darts from the front line, but in this given measure we give 8.

Now move the dart rule to the bust line and take double distance from the front line to what is taken at waist, that is to say, you take 8 at waist line and 16 at bust line, so that the top of the dart will be at double distance from the front line than it will be at waist. It does not matter what distance you place the dart from the front line at waist ; the top of the dart letter *J* must be at double distance from the front line.

Now place the corner of the *System* edge letter *J*, height of dart, at the bust line dot 16 and at waist line dot 8, then trace from No. 3 down to the waist dot so the top of the dart letter *J* should come 3 centimetres below the bust line.

Now you must remember that you added 20 at waist and 10 at hips to make those two darts ; then take dart rule, place corner No. 1 at waist dot and dot at letter *K* 8 more for the width of the first dart, then reverse the dart rule to the left side and trace from waist dot to No. 3 top of dart.

Place the dart rule on the right side as before, corner No. 1, and measure the distance between the two darts at waist, which is 4, and 5 to 6 for very large persons.

Now measure the distance between the two darts at top of dart letter *J*, which is 13 in this given measure, but you can take more or less according to the bias you wish given to the dart.

Now measure the width of the second dart letter *K* 12, then trace the height of the dart from waist dot 4 to bust dot 13. First of all you must know what is the height of the first dart, and make the second dart one centimetre higher than the first dart. Remember that the second dart must be one centimetre higher than the first every time and for every person. Now reverse the dart rule to the left side and trace from waist dot to top of dart letter *J* 13, now finish the bottom, place the straight edge of the dart rule from top of dart to the dot which is at centre of dart at waist line, and make dot at hip line for the centre of the dart, the width of the bottom of the first dart being 4. Take 2 each side of the dot, then trace line from letter *K* down to *L* hip line, then trace other side of dart from waist line to hip line. The bottom of second dart is drafted same as the first dart, except that it is 6 in width at bottom instead of 4 in width.

Notice on the dart rule that there are three lines on it marked waist. Above these three lines the rule is used to draft the darts above the waist line, and below those three lines the rule is used to draft the dart below the waist line.

Figure 7 represents the under-arm of a tight fitting basque or waist.

### DIRECTIONS FOR DRAFTING THE UNDER-ARM—FIRST LESSON.

Lay the *System* on lining or goods make a dot at Bust measure letter *E* 48, and trace to the corner letter *E* from corner letter *E* and down the length of under-arm measure letter *F* 22, and make another dot at half way from corner *E* to letter *F*, that is to say, if the under-arm length is 22 half is 11.

Now, move the *System* up, place waist line letter *G* to the dot made at letter *F* and see that the edge of the *System* touches dot made at half way 11, then begin to trace from dot 11 down to letter *F* 22 and down to letter *I* 12. Now dot hip measure letter *H* 50 also waist measure letter *G* 30. Then move the *System* back and place the waist line to the dot made at letter *G* 30 and see that the upper edge of the *System* touches the dot made at bust measure letter *E*, then trace up from waist dot to bust dot, or letter *E*, then trace down from waist dot to hip dot by taking same length to letter *I* 12. Letter *I* is for the length of skirt. For basque or waist now take the *System* and with the bottom part trace the waist line.

Figure 9 represents the back of a tight fitting basque or waist.

### DIRECTIONS FOR DRAFTING THE BACK—FIRST LESSON.

Lay the *System* on lining or goods. Now make a dot at the width of back measure letter *O* 15, make another dot at shoulder measure letter *C* 14, make another at dot at neck measure letter *B* 16. Then trace to the corner and from the corner down to the length of back measure letter *L* 40, stop and make a dot. Now move the *System* up, place waist line letter *G* at the last dot and see that the edge of the *System* is placed straight with the back line. Then trace down to letter *I* 12. Now make a dot at hip measure letter *H* 50 and another dot at waist measure letter *G* 30. Now move the *System* back Place the edge of the *System* at dot *G* and *H*, trace down from dot *G* to dot *H*. Now place the top edge of *System* letter *P* at the first dot you made, width of back, then trace up from dot *G* to dot *O* and notice what is the length between dot *G* to dot *O*. Now move the *system* down and place the *system* corner *B* at neck dot 16 and shoulder edge of the *system* at the shoulder dot 14, then trace the length of the shoulder beginning at No. 14 to the neck measure. Now take the arms-eye edge of the *system* to trace the arms-eye curve from dot *O* to dot *C*.

### IMPORTANT NOTICE.

If the person is very short from the neck to the shoulder blade, that is to say, when she is less than 17 centimetres from the neck to the shoulder blade, begin to trace the length of the back measure at line 17 up to the neck and down to the waist and whatever is less than 17 centimetres must be added at bottom of waist same as you do with the front part. Everything is cut

from the point of bust up and down from line 19 for the front part and the back part from the point of the shoulder blade up and down from line 17. If the person is 17 centimetres or more from neck to shoulder blade begin at neck measure. If the person is 19 centimetres or more from neck to the point of bust begin at the bottom of the waist up to the neck measure.

Notice that two different measures come together on the *system*, the bust measure letter *E*, which are numbered from 10 to 66 with small numbers, the other measure is the width of back measure letter *O*, which are numbered from 4 to 21 with large numbers. The width of the back measure is always the guide and you must make the first dot at that measure. The bust measure is there to give the balance and change of measurement, the proportion and shape of the person with those two measures and the three check measures it is easy to tell exactly what is the shape and form of the person.

#### DIRECTIONS FOR THE USE OF BUST AND WIDTH OF BACK MEASURE.

When the person is well proportioned the bust measure and width of back measure will meet evenly together, so there is no change to be made. When the person is out of proportion the bust measure will come above or below the width of back measure dot letter *O*, that is to say, larger or smaller than the width of back measure. For instance 16 across the back and  $50\frac{1}{2}$  around the bust would meet even together; supposing that the measure is 16 across the back and  $54\frac{1}{2}$  around the bust the bust measure would be 4 measures larger than the width of the back, then add half of the difference to the front part, which would be 2. No matter how big the measure over the back always take half the difference and add it to the front. Persons who are prominent on the bust and chest the bust measure will come above the width of back measure; if it is vice versa the width of the back measure will come above the bust measure, that is to say, if the width of the back measure was 16 and the bust measure  $46\frac{1}{2}$  the difference would be 4. When the width of back measure is above the bust there is no change to be made, because persons who take such measures have large and longer shoulder blades and need the extra goods across the back, because the back is longer from neck to shoulder blade and their shoulder blade is above the bust line. Persons who are short from the neck to the point of the shoulder blade or narrower across the back, their shoulder blade comes down to the bust line and their bust measure comes always above the width of the back measure, that is the reason why half the difference must be added to the front.

Figure 8 represents the side back of a tight fitting basque or waist.

#### DIRECTIONS FOR DRAFTING THE SIDE BACK—FIRST LESSON.

Lay the *system* on lining or goods. Now make a dot at bust measure letter *E* 48, then trace to the corner letter *E* and from the corner down the length of side of the back letter *M*  $31\frac{1}{2}$ . Notice that  $31\frac{1}{2}$  is the same measure I get from the big back one—the curved side—when I trace the curved line from waist dot to width of back dot, the same measure must be used when you draft the length of the side back.

Now make a dot where you stopped to trace  $31\frac{1}{2}$ , make another dot at half way of the length of side back  $15\frac{3}{4}$ , then move the *system* up, place the waist letter *G* at dot  $31\frac{1}{2}$ , and the edge of the *system* at dot  $15\frac{3}{4}$ , then trace down again from dot  $15\frac{3}{4}$  down to letter *I* 12, then dot the hip measure letter *H* 50, now swing the bottom corner of the *system* one centimetre from the back line and see that the edge of the *system* at waist line dot has not moved from its place, then dot the waist measure letter *G* 30. The reason I move the *system* one centimetre in at the bottom before I dot the waist line is to give a slope to waist line.

Now move the *system* back and place the waist line of the *system* at waist dot letter *G*, then trace down to hip dot letter *H*; now place top edge of the *system* at bust dot letter *E* and trace up to letter *F* 22 by taking the same measure as under-arm length, make a dot at 22, and what is over 22, that is to say what is over the under-arm length, must be cut off to the corner *E*.

Now take the top of the *system* and place bust measure 48 at dot 22 and measure again 48 across the pattern; you will find that the corner of the *system* does not reach the first line you drafted, so make a dot at the edge of the *system*, and place the edge at dot  $15\frac{3}{4}$  and at the last dot you made, and trace a second line from dot  $15\frac{3}{4}$  up to the bust line *E*, I mean to the first line you drafted from letter *E* 48 to corner *E*,—then trace another line from dot 22 to corner *E*. The inside lines are the good lines; those small dots at figure 8 represent the outside lines.

NOTICE.—If the person has a perfect and well proportioned form, there would be no change made, as dot 22 would meet even with bust dot.

#### IMPORTANT NOTICE TO ALL PUPILS.

Any place in this Instruction Book where we say add so many numbers, or take out so many numbers, we mean the numbers which are on the *system* or the numbers which are on the dart rule. Those we use to make the width of darts only, to add or take off anything that the numbers are not in the *system* we use those dart numbers in place of bust, waist or hip numbers for the front part of the *system* only, and when we say add so many centimetres, then we mean to use the tape line or the centimetres which are on the dart rule on the straight edge. The word centimetre means the real centimetre, and the word at number means only the fraction of a centimetre, and those fractions are added or taken off with the *system* itself or the measure of the dart rule.

When we say draft from dot *G*, or waist line, down to hips dot or letter *I*, we mean to go every time to the bottom of the *system* 12 centimetres below the waist line.

#### DIRECTIONS FOR CUTTING THE LINING.

Take our double tracing wheel, set the two wheels apart two centimetres more or less, according to how big you want the seam. Trace all over the pencil drafting. The first wheel must pass right on the pencil lines, the second wheel tracing is the

size of seams. Cut the lining in the last tracing, that is 2 centimetres from the pencil tracing, except at neck and armseye, which should be cut in the pencil tracing at neck and armseye. The *system* gives its own seam for the waist and for the sleeves at neck and armseye.

Figure 10 represents the front of a tight-fitting basque or waist.

#### DIRECTIONS FOR FIGURE 10.

Figure 10 is drafted same as Figure 6 with the same measurement, and shows how it is drafted for different forms with the same measure. When you draft for persons who have short and fleshy necks swing the *system* 1 or 2 centimetres back at neck measure letter *B* No. 1. It will bring the shoulder more over the armseye, and see that every change is made as the figure represents it.

No. 2 represents how to make a change for a person who has a slender arm at armseye measure. You can see that difference when you take the armseye measure for the sleeve. Persons of such build have the under-arm longer than usual, and to find out how much it is too long draw a line at waist, being square with line 3, and if the under-arm length comes to that line it must be raised at armseye, because the under-arm length must come from 1 to 3 centimetres from the square line. One centimetre is the minimum and 3 centimetres is the maximum.

How to raise it.—Take 1 or 2 centimetres above the bust dot and place the edge of the *system* letter *W* at chest dot, and trace from chest dot to the dot you made above bust dot; then trace the under-arm length same as figure 6. That will reduce the armseye.

No. 3 represents how to cut a front for a person who does not want a curve at the front, so-called French bust. For straight front add 3 measures more at bust and 1 at chest, then draw straight line from waist to neck.

I call the attention of all pupils to learn how to draft Figure 6, Figure 7, Figure 8 and Figure 9 without faults, because all other figures drafted with seams are based on the same principle.

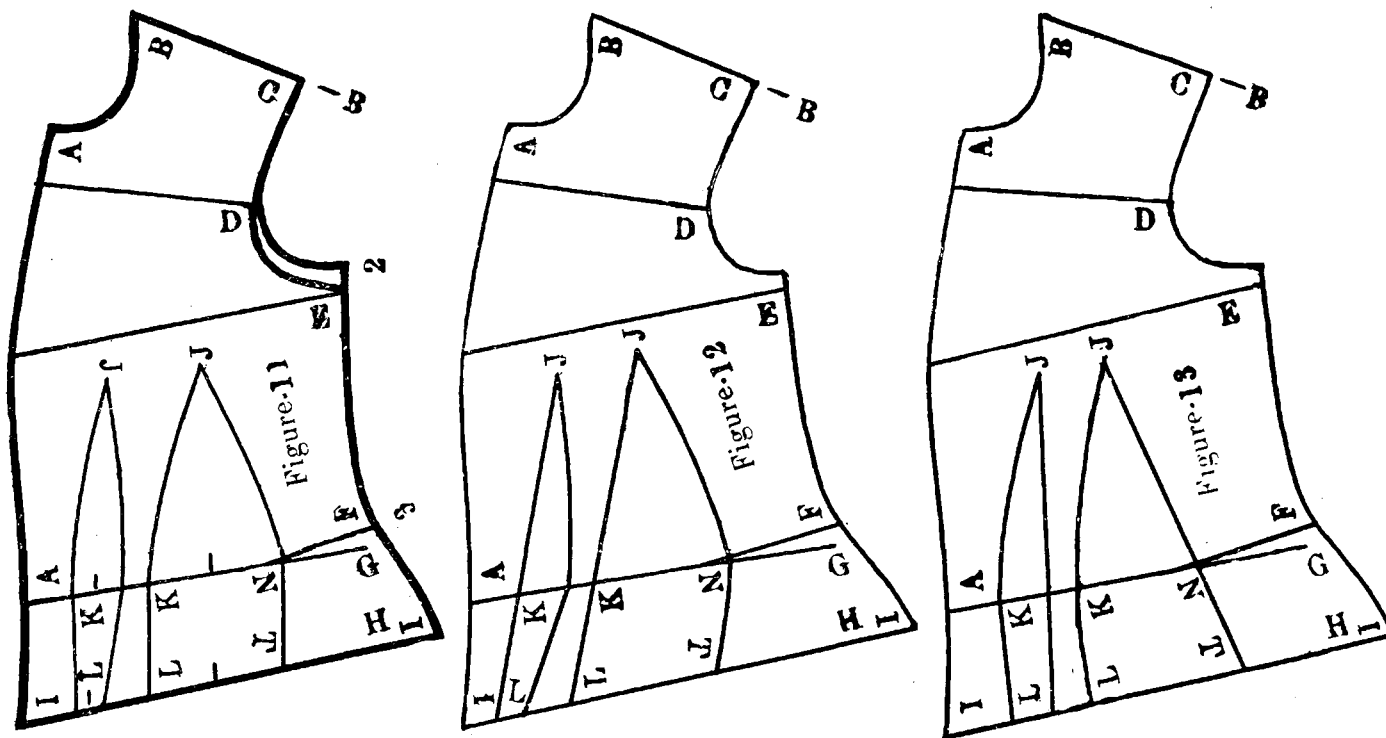

Figure 11 represents the front of a tight-fitting basque or waist with a French bias dart.

#### DIRECTIONS FOR DRAFTING THE FRENCH BIAS DART.

This front is cut same as figure 6, except that the dart and the arms-eye change. For the darts I add from 25 to 35 at the waist measure and 5 less at hip measure to what I add at waist measure. For instance, if I add 30 at waist for the width of darts at waist I will add 25 at hip measure for the width of darts at hip measure.

For the under-arm change the height is raised from 1 to 2 centimetres at the armseye, No. 2 shows the raised line from bust dot letter *E*; No. 3 shows the raised line from under-arm dot letter *F*; letter *G* shows the waist line traced same as in figure 6 line, No. 3 raised from the dart line to dot letter *F*; waist line and bust and armseye curve are traced same as in figure 6, then trace over the armseye curve from chest dot to the raised dot at bust, then trace under-arm length from the raised dot to waist. Notice, the wider the dart is the more it is raised at armseye.



For those darts in figure 11 I add 30 at waist measure and 25 at hip measure ; I give 8 to the first and 22 for the second dart at waist and at bottom 12 centimetres below waist, which is the hip measure ; I give 4 to the first dart and 21 for the second dart. The distance for placing the first dart from the front at waist line is same as in figure 6, except at bust line or top of dart letter *J* it is set one more further from the front than it is in figure 6, also one more between the two darts than it is in figure 6. The reason why I place the top of dart letter *J* further from the front line is to give more bias to the darts.

The first dart is drafted same as in figure 6 except that the top of dart letter *J* is at 17 from the front line ; second dart 4 at waist and 14 at top letter *J* from the first dart. Now measure the height of your dart from *K* to *J* and from *J* to *N* and see that line *N* is a trifle shorter than line *K*, then trace the bottom of dart, trace from *K* to *L*, then trace from *N* to *T*.

Figure 12 represents the front of a tight-fitting basque or waist, with Prof. Jean B. Peyry's bias dart.

**DIRECTIONS FOR DART ONLY.**

As figure 12 is drafted same as figure 6 and figure 11, those darts have the same width as in figure 11, but they will make the garment more bias with the same width of a French dart, because all the bias comes from the under-arm ; first dart, trace straight line from hip line to letter *J* and trace the side line same as in figure 11. Second dart, measure the dart from *K* to *J* and from *J* to *N*, make line *N* half centimetre shorter than line *K* ; now trace straight line from *L* to *J*, finish line *N* same as figure 11, except that the line between *J* to *N* must curve a little more than in figure 11, then trace from *N* to *T*.

Figure 13 represents the front of a tight-fitting basque or waist, with Prof. Jean B. Peyry's bias dart.

**DIRECTION FOR DART.**

This dart is vice versa of figure 12, that is to say, the straight lines are placed on the under-arm side instead of on the front ; the two darts are drafted same as figure 12, except that the top of dart letter *J* the second dart is only 12 from the first dart, and at the bottom of dart at hip line is two wider, and the first dart one wider than they are in figure 12 ; also that line *K* to *J* and *J* to *N* are both made the same length. To make that I take only 2 less at the hip measure than I take at waist measure, that is to say, I add 30 at waist measure and 28 at hip measure.

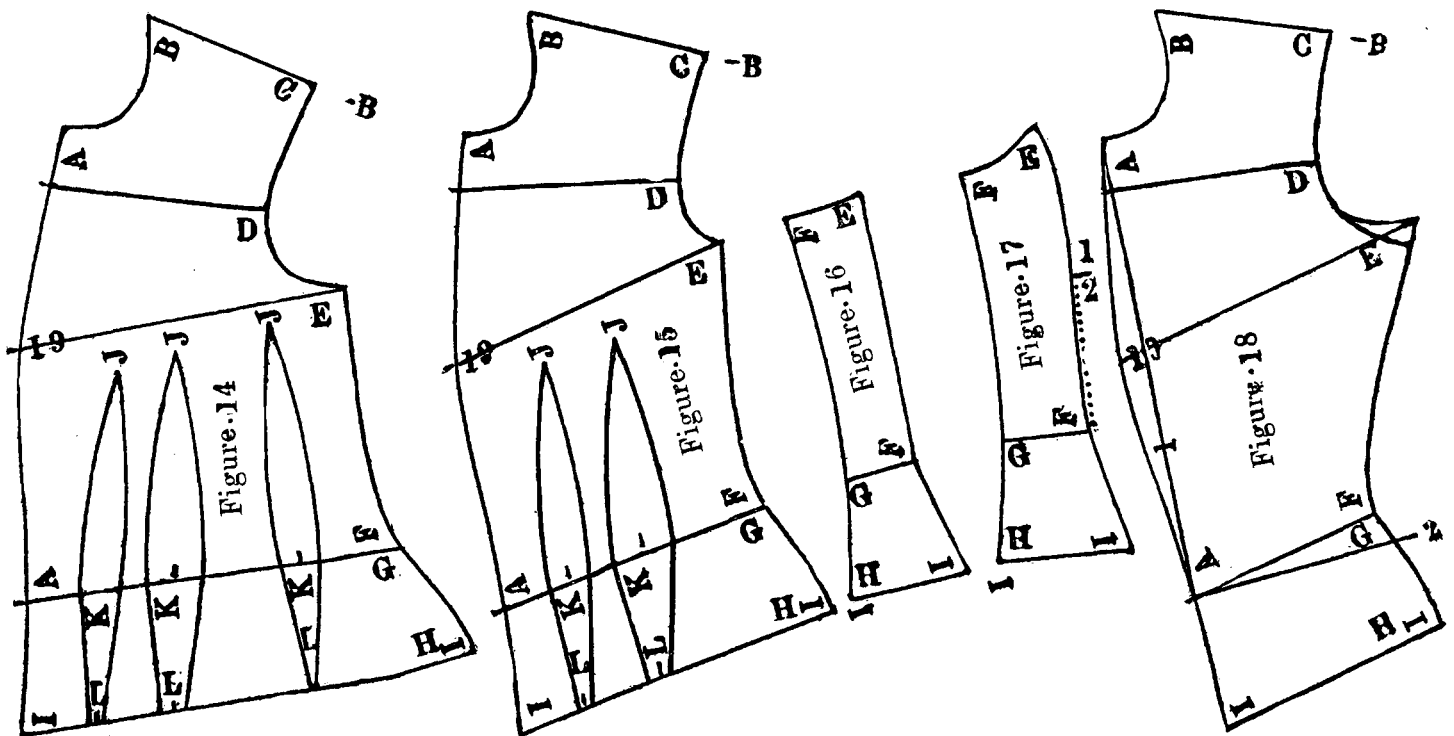

Figure 14 represents the front of a tight-fitting basque or waist for a large person, consisting of three darts.

**DIRECTIONS TO DRAFT FIGURE 14.**

The front is drafted same as Figure 6, and add 22 at waist and 11 at hip measure, which is half of what I add at waist.

**DIVISION OF THE DARTS.**—At waist first dart 6, second dart 10, third dart 6. At hips first dart 3, second 5, third dart 3. Now draft the two first darts exactly same as in Figure 6, except that we only make the second dart a half centimetre higher than the first. Now measure the space which is left between the second dart and under-arm seam, also from the top of second dart letter *J* to the bust dot letter *E*. Now place the dart at the centre of the space which is left at waist and bust and make the dart a half centimetre higher than the second dart, and finish bottom of dart same as first dart.

Figure 15, Figure 16 and Figure 17 represent the front of tight-fitting basque or waist, consisting of two darts and two under-arms for very large persons.

#### DIRECTIONS TO DRAFT FIGURE 15—THE FRONT PART.

Now I take the size of measurement, 58 bust measure, 44 waist measure and 64 hip measure. Place the *system* on lining or goods, and draft the front same as Figure 6, except that 14 measures are taken off at bust measure and waist measure and 18 at hip measure, that is to say, when you dot the bust, waist and hip measure, instead of dotting at 58 bust, 44 waist and 64 hip, dot only 44 bust, 30 waist and 46 hip, and you will use the 14 and 18 to make the extra under-arm. Now add 20 for both darts and place them at the front same as in Figure 6.

#### DIRECTIONS TO DRAFT THE EXTRA UNDER-ARM—FIGURE 16.

Take the dart rule and draw square line with line letter *G* and line letter *F*, and see that the line from *G* to *F* is the same length as under-arm line. Now take the measure with the dart rule, which is used for darts only, and take the width 14 at waist and bust, then trace bust line letter *E* 14 and trace down to letter *F* or letter *G* dot. The line from *E* to *F* is the same length as line from *G* to *F*, and the waist line must be raised a half centimetre at letter *F* to give a slope to the waist at letter *G* then draw the width of hip line letter *H* 18, then trace the length from *F* to *I* and from *G* to *H*.

Figure 17 represents the second under-arm, and is drafted same as Figure 7.

Figure 18 represents the front of a tight fitting basque or waist without any dart.

#### DIRECTIONS TO DRAFT THE DARTLESS FRONT.

Figure 18 is drafted same as Figure 6, except the bust measure and under-arm length. Now add 4 at bust measure, that is to say, if the bust is 48 take 52. Trace line No. 1 straight from waist to the neck, and line No. 2 square with line No. 1. Now raise the waist line two centimetres from line 2, make a dot for width of waist measure *G*, and for length of under-arm measure *F*. Place the edge of the *system* at dot *E* and dot *F*, and measure the length of under-arm from *F* to *E*, make a dot, move the *system* up, place waist line at dot *F*, trace up to dot *E*, then trace down to *I* or hip dot. Now trace a second line at armseye to cut off what is too long.

#### NOTICE TO PUPILS.

When we say add to bust or waist or any other place, that means to add only to the piece named in drafting, that is to say, if we say add 4 at bust measure when we draft the front, that means only for the front, all other pieces remaining unchanged. Under-arm, side-back and back are drafted to their usual measures, and nothing is added to the armseye numbers to trace the armseye curve. Trace the armseye curve by using same numbers as bust measure without adding anything from the usual measure.

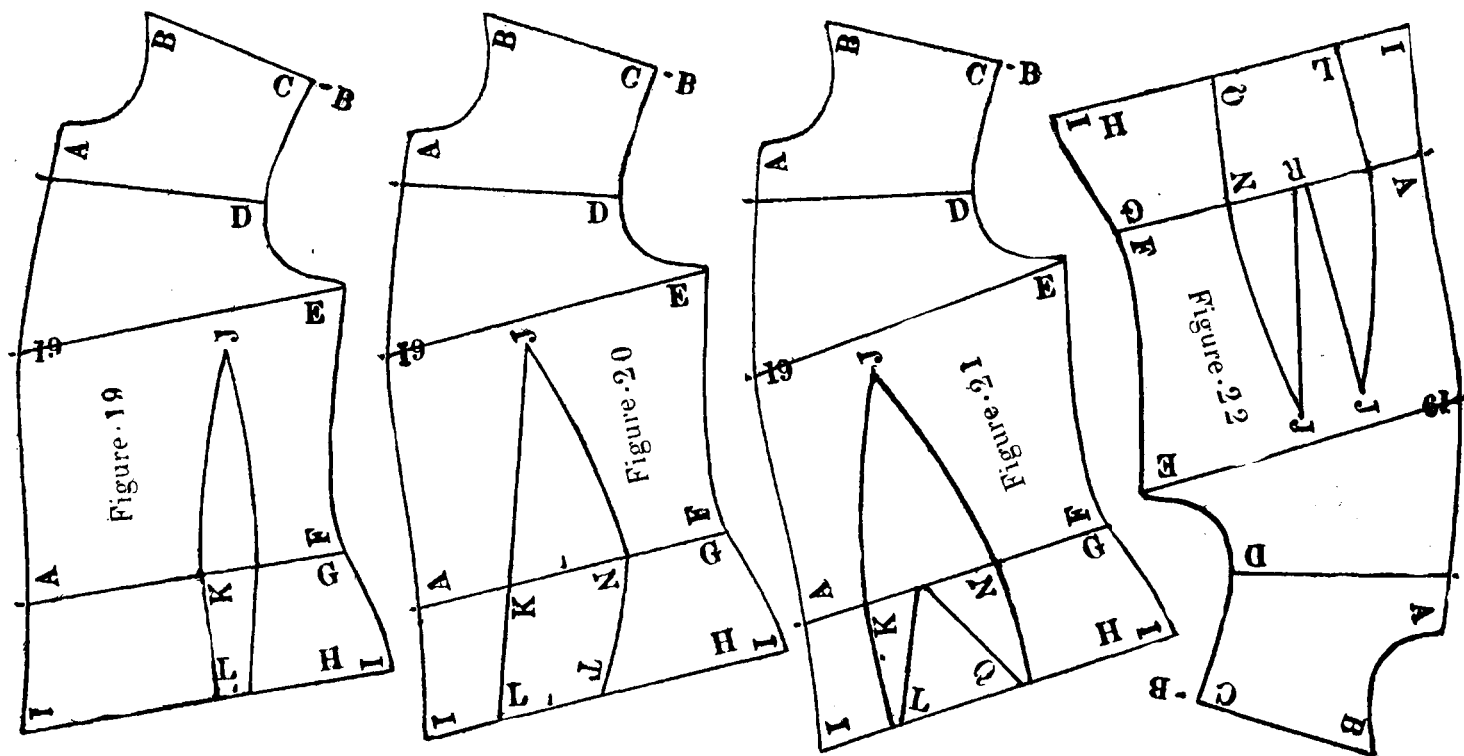

Figure 19 represents the front of a tight fitting basque or waist with one dart only for large persons.

**DIRECTIONS FOR DRAFTING THE DART.**

Draft figure 19 same as figure 6, except that at waist measure you add only 10 for the width of the dart and see that the distance between the dart and the under-arm line is the same width as the under-arm piece. This style of dart is used for large persons to make them look as if it was a dartless front with two under-arms.

Figure 20 represents the front of a tight fitting basque or waist, consisting of one of Prof. Jean B. Peyry's bias darts.

**DIRECTIONS FOR DRAFTING FIGURE 20.**

The front is drafted same as figure 6. The dart is 20 in width and is placed at the centre of front, or that is to say, if the waist measure is 30 place the dart 15 from the front line of waist. Now measure the length of dart from *K* to *J* and from *J* to *N*; the line from *J* to *N* is a half centimetre shorter than line *K*. Now trace a straight line from letter *L* to *J*, then take the width of dart at waist 20, and 18 for width at hips. Then reverse the dart rule and trace line from *J* to *N* and from *N* to *T*.

Figure 21 represents the front of tight fitting basque or waist, consisting of one Grecian bias dart. This dart is for persons who have very large hips, the goods being left at the centre of dart from waist line to hip line.

**DIRECTIONS FOR DRAFTING FIGURE 21.**

The front being drafted same as figure 6, this then is only the direction for the dart, place the dot at 10 distances from front line, the width of this dart is 22 at waist and 2 at hips, one on each side. Now take the width of dart at waist and measure the height of dart same as figure 20, line from *J* to *N* half a centimetre shorter than line *K* to *J*, now trace from *K* to hip line and from *N* to hip line. Now make a dot at the centre of dart and trace a line from waist dot to *Q*, and one from line *N*, trace another line from waist dot to *L*, and one from *K* to hip line.

Figure 22 represents the front for a tight fitting basque or waist, consisting of one Grecian bias dart. This is for persons who have hips smaller than the bust and for those who want to have the goods come bias from the front and from the back with one dart.

**DIRECTIONS FOR DRAFTING FIGURE 22.**

The front being drafted same as figure 6 this is only the direction for the dart, place the dart 8 from the front line at waist and 16 from front line at bust, the width of this dart is 20 at waist and 20 at hip. At waist it is divided in two, 10 for each side of letter *R*. Now measure the width of the dart with dart rule, make a dot at centre of dart, then trace line from *K* to *J*, trace straight line from *J* to *R*, trace another straight line from *R* to *J*, make that side of dart half a centimetre higher, then trace line from *J* to *N* and from *N* to *Q* also from *K* to *L*.

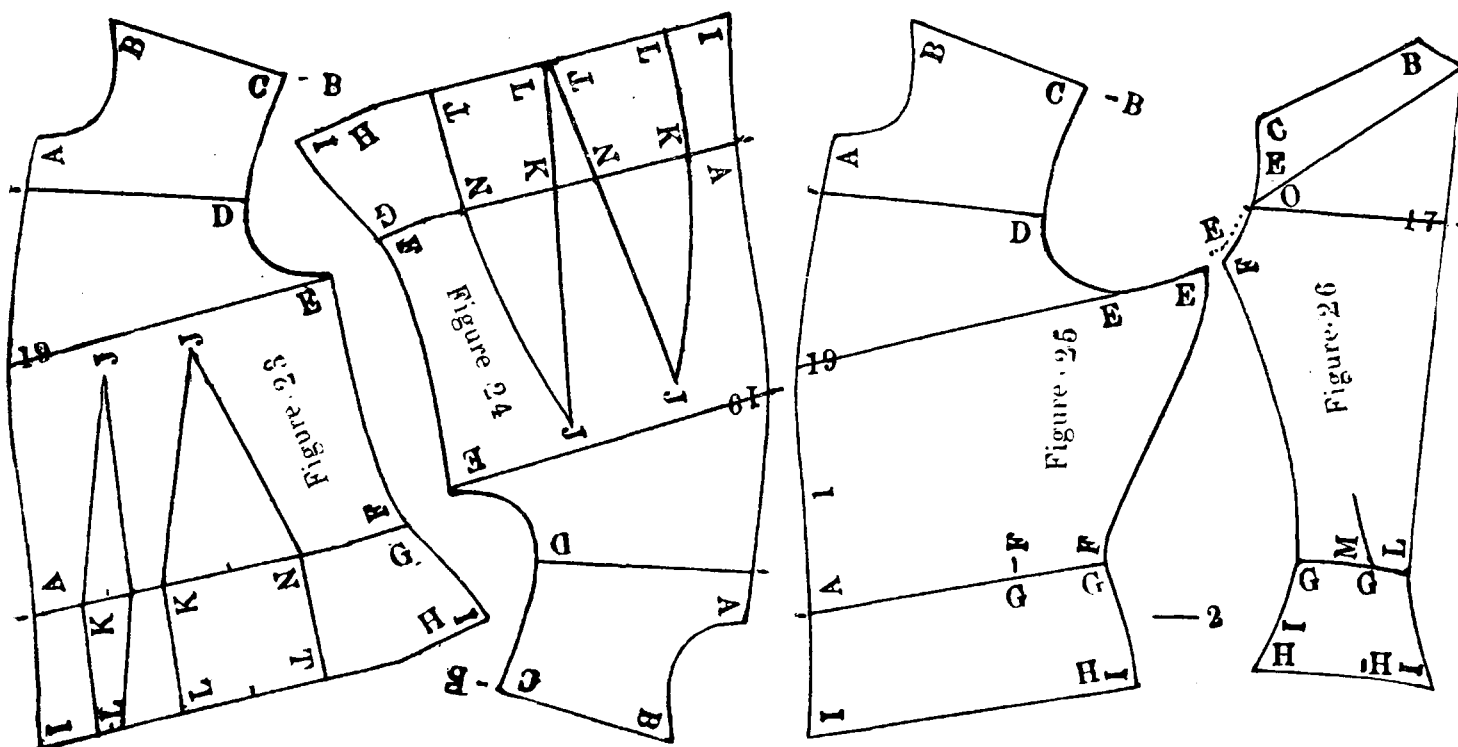

Figure 23 represents the front for a tight-fitting basque or waist, consisting of Prof. Jean B. Peyry's bias dart. This bias dart is for persons who are full between the bust and waist, or for persons who are suffering from the stomach. This dart having no curve from waist to bust, it gives more comfort to persons who are suffering.

**DIRECTIONS FOR DRAFTING FIGURE 23.**

The front and darts are drafted same as figure 11, except that the lines of the dart are straight instead of being curved.

Figure 24 represents the front of a tight-fitting basque or waist, consisting of Prof. Jean B. Peyry's bias dart. These two bias darts are to make the goods come in even bias from the front and from the back, and are better adapted to persons who have small hips.

**DIRECTIONS FOR DRAFTING FIGURE 24.**

The front is same as figure 11, the width of dart is 30; for both darts the two darts are of even width—15 each at waist and 18 each at hips. Distance from front line is 8 at waist, and at bust there is no determined space, as all depends on the shape of the person. The space between the two darts is from 6 to 8. Now measure the height of the dart from waist line to letter *J*, also the width of dart. Draw straight line from *T* to *J*, draw curved line from *J* to *K*, and from *K* to *L*, the line from *N* to *J* must be a quarter of a centimetre shorter than the line from *K* to *J*. The second dart is drafted same as the first dart, except that line from *N* to *J* is a half centimetre shorter than line from *K* to *J*.

Figure 25 and figure 26 represent the front and back of a dartless, tight-fitting basque or waist; figure 25 consists of a front and under-arm together.

**DIRECTIONS FOR DRAFTING FIGURE 25.**

The front is drafted same as figure 18, except that the waist line is raised one centimetre more from the square.

**HOW TO PLACE THE UNDER-ARM.**

Take the *system* and turn it upside down, place waist line of the *system* at dot letter *F*, then dot the waist letter *G* 30, now place the *system* in its right position, join the under-arm to the front at bust measure letter *E*, and place the edge of the *system* at waist dot letter *G* 30, I mean the last dot you made at waist, then trace from letter *E* to corner *E*. Keep corner *E* at point of line and swing the *system* to the front so that the outside edge is placed at letter *G* waist dot, then trace the length of under-arm from corner *E* to letter *F*, swing back the top of the *system* so that the bottom corner will touch the hip dot or hip measure, then trace down from *G* to *I*, now draw the waist line from dot *F* to dot *A*.

**DIRECTIONS FOR DRAFTING THE BACK—FIGURE 26.**

Lay the *system* on the straight of lining. Dot letter *O* width of back, dot letter *C*, dot letter *B*, begin to trace from letter *B* to the corner and down to letter *L* length of back, make dot at back length, move the *system* up, place waist line at dot *L*, the *system* being straight with back line, then dot waist measure letter *G*, dot hip measure letter *H*, trace down from dot *L* to bottom of *system* letter *I*. Now move the *system* and place corner *B* of the *system* at neck dot letter *B*, and the shoulder edge at shoulder dot letter *C*, then trace shoulder length from *C* to *B*, and with armseye curve trace from letter *O* to letter *C*. Now take the side back and join it to the back by placing corner *E* of the *system* to dot letter *O*, and the edge of the *system* letter *M* to dot letter *G*; when the *system* is in that position draw a line between side back and back at edge letter *M* to be about 7 centimetres long, then trace the bust measure from *E* to *O*, now move the *system* up, place waist line at *G* dot and see that the edge of the *system* is straight with line *M*, now dot waist measure letter *G*, dot also hip measure letter *H*. Now move the *system* back and place under-arm edge waist line of system at waist dot letter *G*, the top edge at bust dot letter *E*, then trace length of under-arm from dot *G* to dot *E*, make dot at letter *F*, which is the length of under-arm, and trace again the bust measure from dot *F* to dot *O*, now trace down from waist to hips *H*, or length of skirt letter *I* 12, then trace the waist line from *G* to *L*.

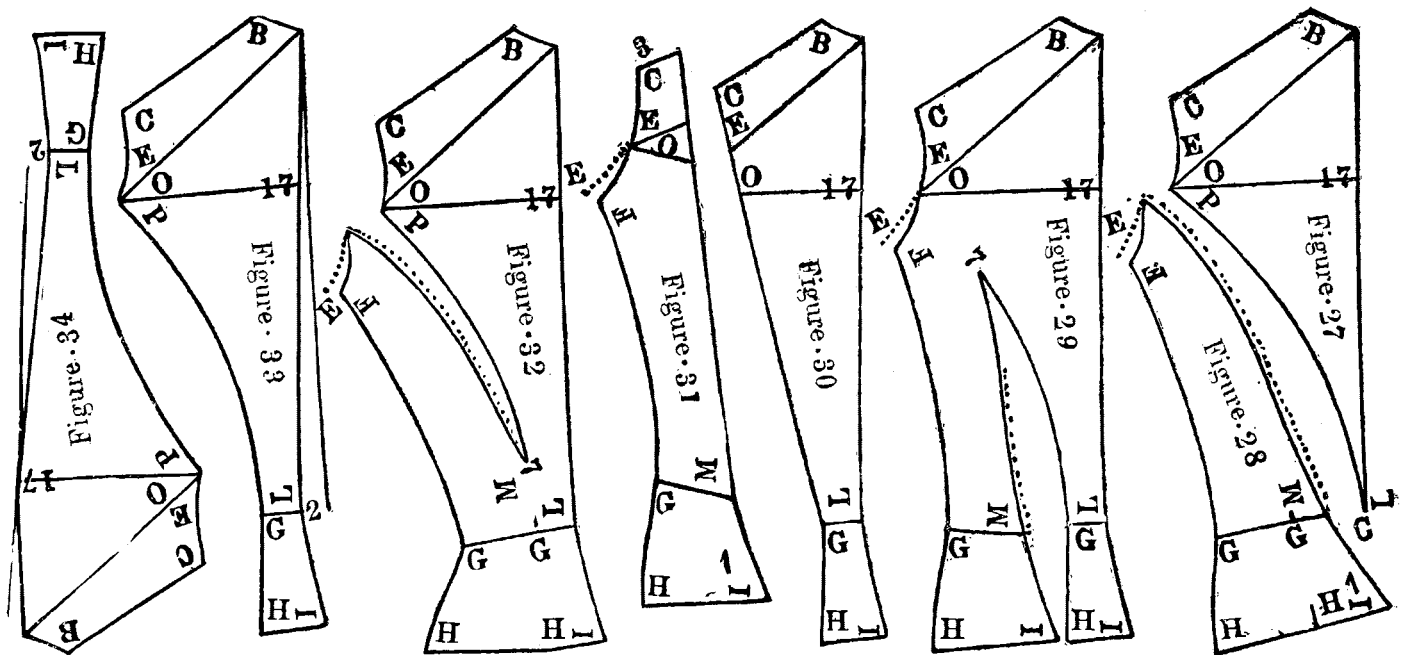

Figure 27 represents a V back for a tight fitting basque or waist.

**DIRECTIONS FOR DRAFTING FIGURE 27.**

This back is drafted same as figure 9, except that line *P* is traced from dot letter *L* to dot letter *O*, nothing is left for the width of back at waist and notice what is the length from *G* to *P*.

Figure 28 represents the side back to fit with figure 27.

**DIRECTIONS FOR DRAFTING FIGURE 28.**

Figure 28 is drafted same as figure 8, except that the width that is taken off from figure 27 is added at figure 28 at the waist and hip measure. Dot letter *G* at waist and dot letter *H* at hips, the width that was taken off from the back of figure 27 must be added at figure 28 before tracing the waist line letter *G*.

Figure 29 represents the back and side back of a tight fitting basque or waist. This style of back is made especially for women who have narrow backs and large waists. It will greatly improve their shape.

**DIRECTIONS FOR DRAFTING FIGURE 29.**

Figure 29 is drafted same as figure 9 and figure 8, except that from waist dot letter *G* to dot letter *O* the curved line is traced to 7 centimetres from dot letter *O*, the side back line is traced from No. 7 to letter *I* and finish the side back same as figure 8.

Figure 30 represents the back for tight fitting basque or waist with side seam from waist to shoulder.

**DIRECTIONS FOR DRAFTING FIGURE 30.**

Figure 30 is drafted same as figure 9, except that the length of the shoulder is cut 3 centimetres shorter than it is in figure 9 and the side line is traced straight from *G* to *C*.

Figure 31 represents the side back that fits with figure 30.

**DIRECTIONS FOR DRAFTING FIGURE 31.**

Take the back of the *system* and place it same as for drafting a back, and dot at shoulder the 3 centimetres taken off from figure 30; for instance, the length of shoulder was 14, take 3 off and 11 is left, then dot at 11 and 14 to get the 3 off, now dot width of back measure letter *O*, dot also length back *M*, move the *system* and trace the arms-eye curve from dot *O* to dot *C*, now take side back, place corner *E* at dot *O* and edge *M* of the *system* to be placed at dot *M*, then dot bust measure letter *E*, trace line to dot *O*, move the *system* up, place waist line at dot *M*, and trace down from waist line to letter *I*, dot hip measure, swing the *system* one centimetre in then dot the waist measure letter *G*, move the *system* back, place the waist line at dot *G* and edge of the *system* at dot *E*, trace up to letter *F* length of under-arm measure, trace down from *G* to dot *H*, trace the waist line from dot *G* to dot *M*, trace another line from dot *F* to dot *O* at arms-eye.

Figure 32 represents the back and side back for a tight fitting basque or waist.

**DIRECTIONS FOR DRAFTING FIGURE 32.**

Figure 32 is drafted same as figure 9 and figure 8, except that the two side lines are drafted 7 centimetres from the waist lines.

Figure 33 represents the back for a jacket, basque or cloak; it is also used for waists for persons who have strong and short shoulder blades.

**DIRECTIONS FOR DRAFTING FIGURE 33.**

Lay the *system* on the straight edge of lining or goods and dot width of back *O*, shoulder length *C*, neck measure *B*, trace from dot *B* to the corner, and from the corner down to length of back *L*, now swing the *system* to you about 2 centimetres from the first line and trace another line from neck corner down length of back *L*, move the *system* up, place waist line at dot *L* and trace down to *I*, dot hip measure *H*, also waist measure *G*. Now move the *system* and measure the width of the back over at line 17. The goods that are cut off at line 17 must be added at dot *O* line 17; make a new dot, then place the waist line at *G*, dot and trace down to *H* dot, then swing the edge of the *system* at dot *O*, trace from *G* up to *P*, trace the length of shoulder *C*, then trace armseye curve from dot *O* to dot *C*.

**IMPORTANT NOTICE TO PUPILS.**

For every outside garment the back must be cut like figure 33 and the front cut like figure 10 at neck, that the neck will come one centimetre further back; it will give more curve to the armseye and will send the jacket more to the front, the back will fit right in with the shape of the person without being buttoned. For persons who have a deep curve from shoulder blade to waist, cut the back like this for tight-fitting garments, and for loose garments swing the *system* 3 centimetres instead of 2 centimetres.

Figure 34 represents the back of a basque or jacket for a person who is hunchbacked.

**DIRECTIONS FOR DRAFTING FIGURE 34.**

Figure 34 is drafted same as figure 33, except that the second line is traced from line 17 down to waist 2 centimetres from the first line, and from line 17 to neck swing the *system* 1 centimetre from the first line. It is not necessary to measure over the width of back as in figure 33, because nothing is taken off at line 17. A person who is hunchbacked needs all the goods at shoulder blade line 17, as they are bent from shoulder blade to waist and from shoulder blade to the neck.

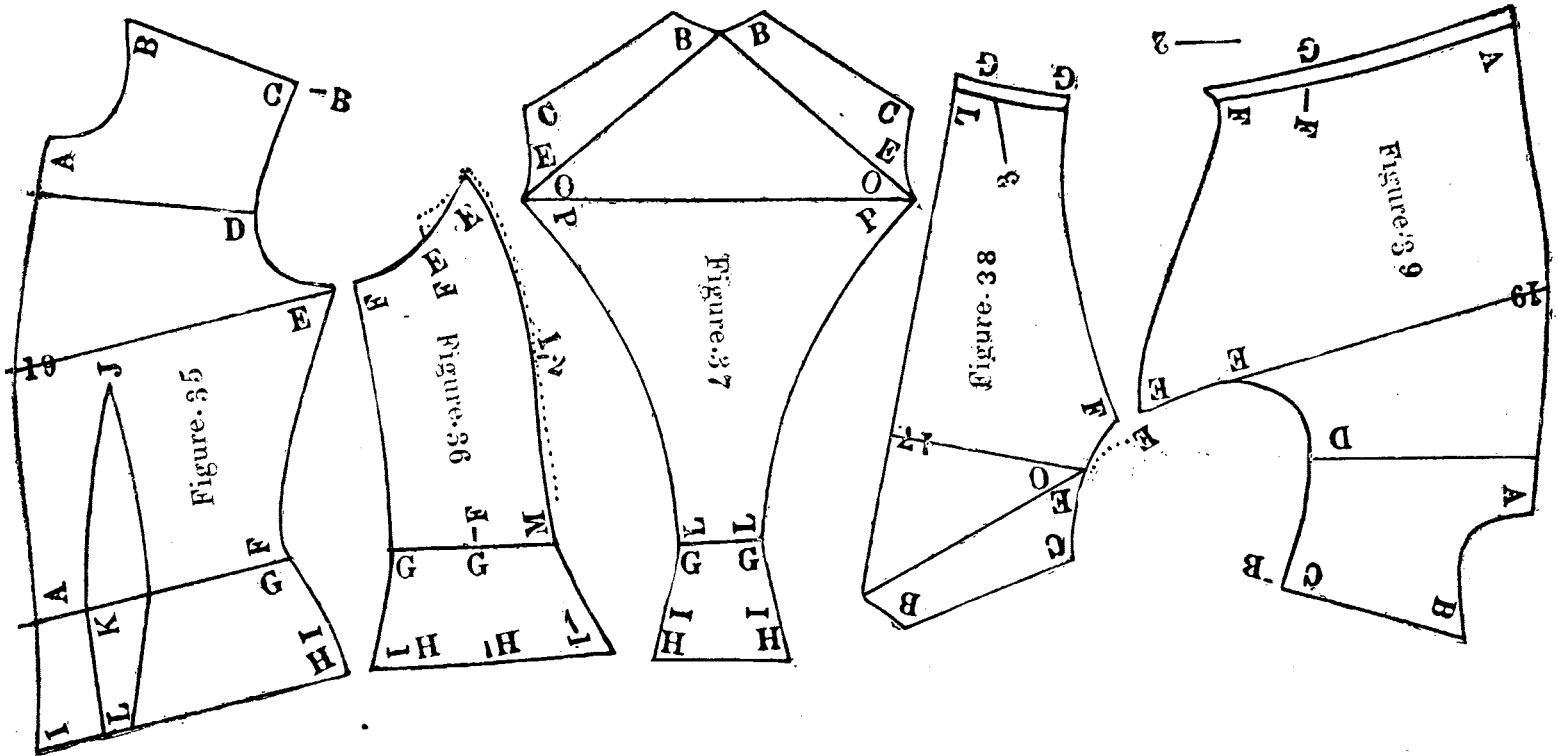

Figure 35 represents the front of a tight-fitting basque, jacket or waist.

**DIRECTIONS FOR DRAFTING FIGURE 35.**

Figure 35 is drafted same as figure 6, except that figure 35 has only one dot, 10 in width, 8 from the front line at waist, and 16 at bust; add one measure at bust for persons who are large.

Figure 36 represents the under-arm and side to fit with figure 35.

**DIRECTIONS FOR DRAFTING FIGURE 36.**

Begin with side back. Draft side back same as figure 8, then join the under-arm to the side back, place corner *E* at arms-eye dot *F*, and edge of the *system* at dot *G*, then trace bust measure at arms-eye *E*, move the *system* up, place waist line at dot *G*, upper edge of the *system* at dot *E F*, dot waist measure *G*, and dot hip measure *H*, move the *system* back, place waist line at dot *G* and trace down from *G* to *I*, then trace up under-arm length *F* from *G* to bust dot *E*.

Figure 37 represents a double back to fit with figure 36 and figure 35.

**DIRECTIONS FOR DRAFTING FIGURE 37.**

Figure 37 is drafted same as figure 9, except that the goods are folded in two, this prevents having a seam at the centre of the back. Place the *system* straight with the fold of the goods and draft the back same as in figure 9.

Figure 38 represents the back and side back for a tight fitting waist or jacket.

**DIRECTIONS FOR DRAFTING FIGURE 38.**

Lay the back of *system* on lining or goods. Dot width of back *O*, length of shoulder *C*, neck *B*, trace from *B* to the corner and down length of back *L*, move the *system* up, place waist line at dot *L*, and dot waist measure *G*, now trace length of shoulder *C*, trace arms-eye curve from dot *O* to dot *C*. Now take side back, place corner *E* at dot *O*, the edge of *system* at dot *G*, trace from *E* to dot *O*, then trace line 3, move the *system* up, place waist line at dot *G*, edge of *system* straight with line 3 and dot waist measure *G*; move the *system* back, place to waist line at dot *G* and top edge of *system* at dot *E* then trace from dot *G* to dot *E*, dot length of under-arm *F*, trace from dot *F* to dot *E*, then trace waist line.

Figure 39 represents the front and under-arm of a tight fitting waist or jacket ; this front fits with figure 38.

**DIRECTIONS FOR DRAFTING FIGURE 39.**

Lay the *system* on lining or goods, dot bust *E* and add 3 at bust, dot bust line 19, trace down to *A* and up to *A*, move the *system* down, place corner of the *system* at dot *A*, the edge of the *system* straight with the line traced from bust line up to dot *A*, now dot chest measure, trace neck measure from *A* to *B*, follow line *B* dot at end of line *B*, move the *system*, trace length of shoulder letter *C*, place edge of the *system* from dot *B* to dot *B*, place waist line at dot *A*, take waist measure dot *G*, place that dot *G* three centimetres above the square line No. 2 Now measure under-arm length *F* from dot *G* to dot *E*, make another dot at *E*, then trace arms-eye curve from last dot made to the chest dot and from chest to shoulder dot. Now take under-arm *system* and take the waist measure *G* by turning the *system*, the bust part down. Now take the bust measure *E*, place bust number at dot *E* and the inside edge of the *system* at letter *F*, then trace bust measure from dot *E* to corner *E*, now swing the *system* in the outside edge of the *system* to be placed at letter *F*, then trace length of under-arm measure from corner *E* to letter *F*, trace the waist line from *F* to *A*.

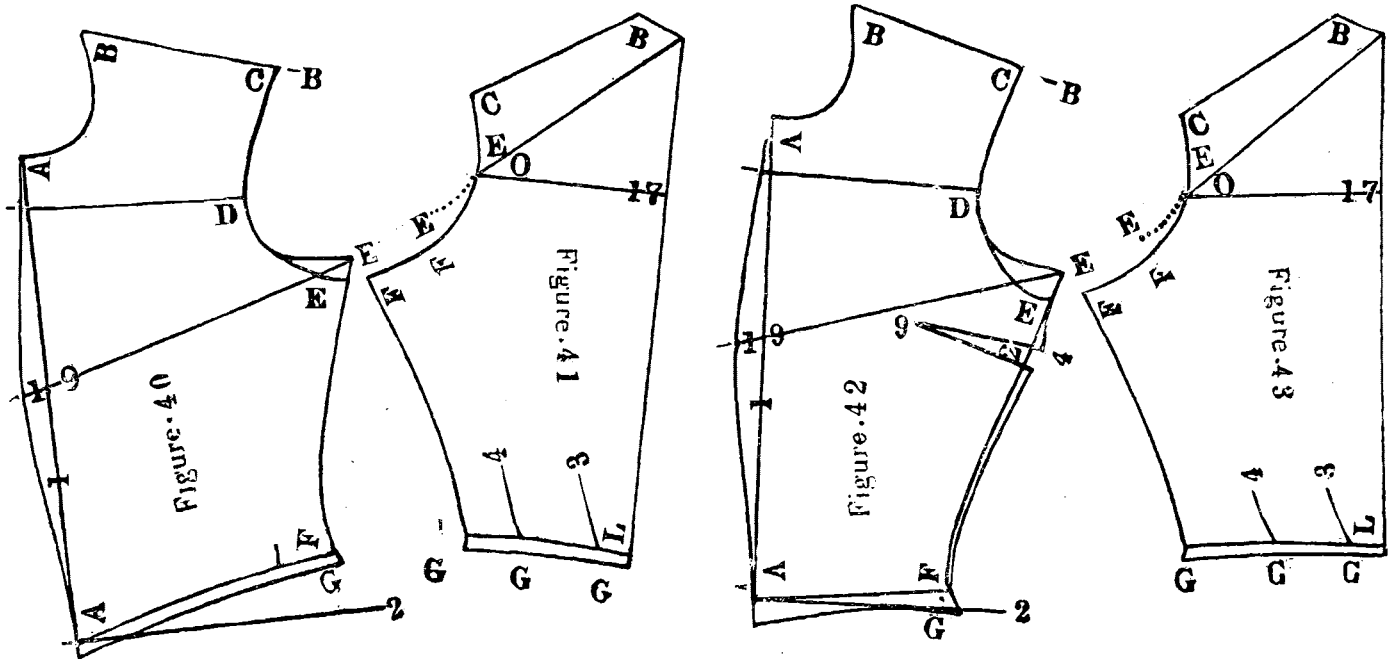

Figure 40 represents the front of tight-fitting waist or jacket.

**DIRECTIONS FOR DRAFTING FIGURE 40.**

Figure 40 is drafted same as figure 18, except that 6 are added at waist measure and is cut 2 centimetres below the waist line, 4 are added at bust measure, same as in figure 18.

Figure 41 represents the back, side-back, and under-arm to fit with figure 40.

**DIRECTIONS FOR DRAFTING FIGURE 41.**

Figure 41 is drafted same as figure 33, except that the under-arm piece is added to it, and the six numbers which are added to the front at waist measure are taken off from the back at waist.

**HOW TO PLACE THE UNDER-ARM.**

Place the edge of the *system* at dot *E* and at dot *G*, trace from *E* to *E*, trace line 4, move the *system*, place waist line at dot *G*, the edge of the *system* straight with line 4 and take waist measure *G*, take six off from dot *G*, then trace length of under-arm *F* from dot at waist up to *F*, trace waist line.

Figure 42 represents the front of a tight fitting waist or basque.

**DIRECTIONS FOR DRAFTING FIGURE 42.**

Figure 42 is drafted same as figure 40, except that nothing is added at waist, and has a dart in the side. This dart is made in lining only.

**HOW TO PLACE THE DART.**

The waist is raised one centimetre from square line No. 2, place the edge of the *system* at dot *G* and dot *E*, trace line from *F* to *E* bust line, then take length of under-arm, measure from *F* to *E*, add 2 centimetres more to make the dart, place the dart 4 centimetres from dot *E*, make it 2 centimetres in width and 9 in length, trace a second line from *F* to point of dart and from *E* to point of dart, the second line is a half centimetre from the first line, the second line is the good one.

Figure 43 represents the back, side back and under-arm to fit with figure 42.

**DIRECTIONS FOR DRAFTING FIGURE 43.**

Figure 43 is drafted same as figure 41, except that nothing is taken off at waist measure.

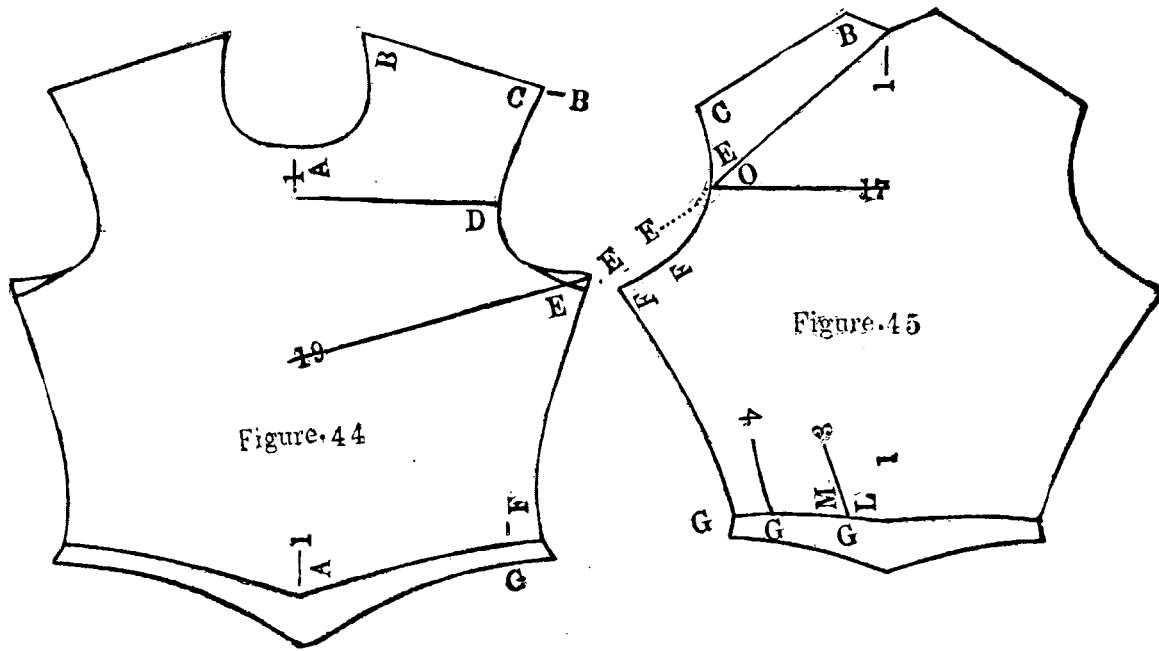

Figure 44 represents a double front for a tight fitting waist.

**DIRECTIONS FOR DRAFTING FIGURE 44.**

Figure 44 is drafted same as figure 40, except that the goods are folded at front to prevent them from having a seam in the front and we add 6 at bust measure instead of 4 and 6 at waist measure same as figure 40, and when we draft the neck measure we place the edge of the *system* a half centimetre out of fold of goods, and that half centimetre must be added at chest measure, then trace the neck and shoulder, arms-eye, under-arm and waist same as figure 40.

Figure 45 represents the double back to fit with figure 44.

**DIRECTIONS FOR DRAFTING FIGURE 45.**

Figure 45 is drafted same as figure 41, except that the goods are folded at centre of back to prevent them from having a seam in centre of back.

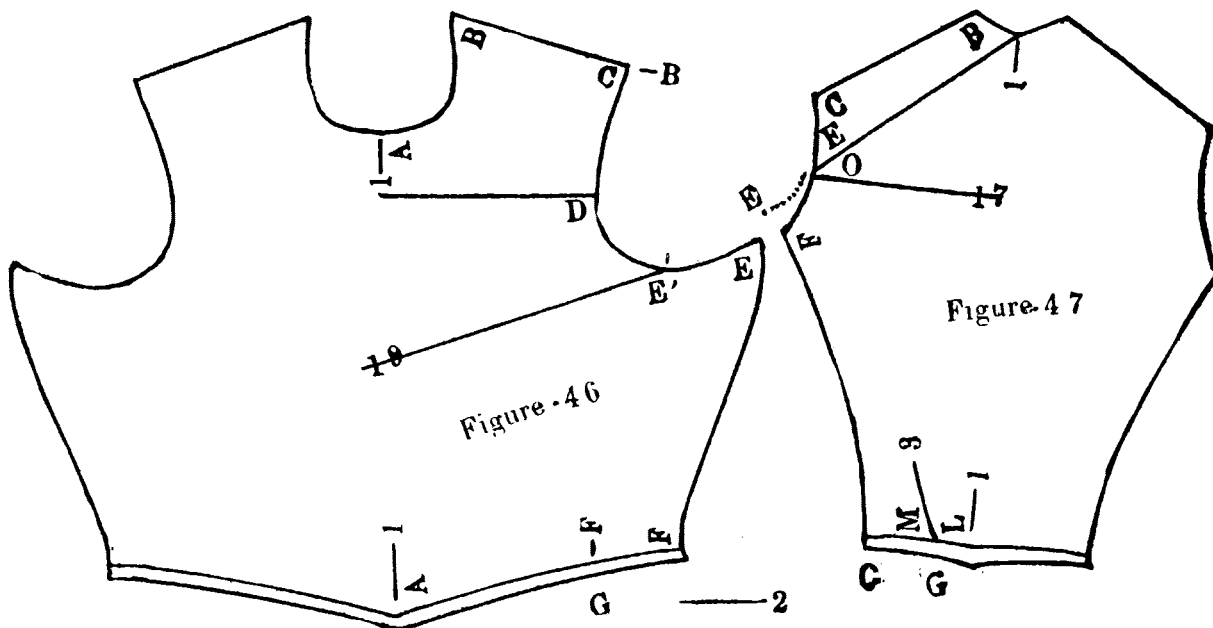

Figure 46 and Figure 47 represent a waist with one seam at the under-arm.



**DIRECTIONS FOR DRAFTING FIGURE 16.**

The front is drafted same as figure 39, except that the goods are folded at front and we add six at bust measure, and when we draft the neck measure we place the edge of the *System* a half centimetre out of fold of goods and that half centimetre is added to chest measure, then trace the neck and shoulder, armseye, under-arm and waist same as figure 39.

**DIRECTIONS FOR DRAFTING FIGURE 47.**

The back is drafted same as figure 38, except that the goods are folded at the centre of back.

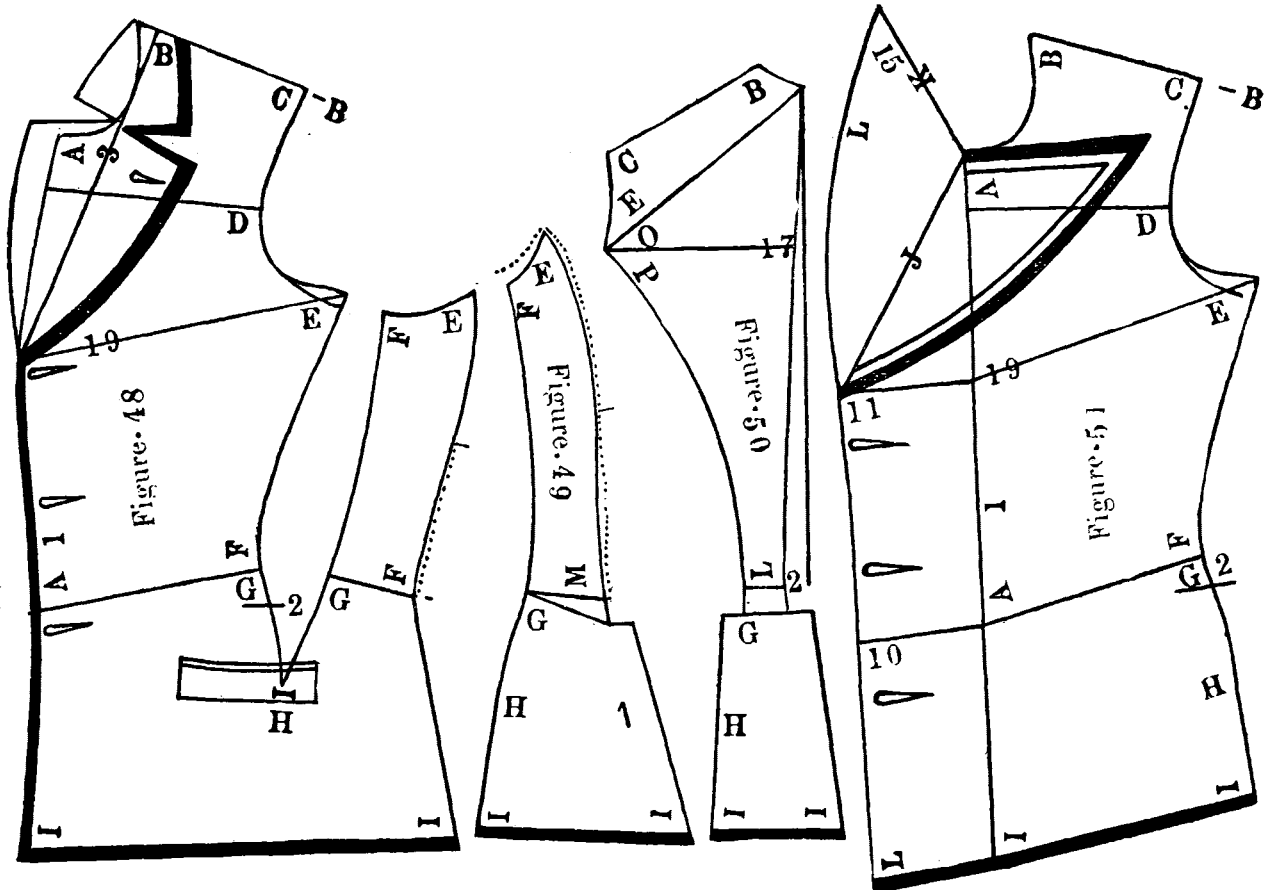

Figure 48 represents the front and under-arm of a tight-fitting jacket or basque without darts.

**DIRECTIONS FOR DRAFTING FIGURE 48.**

The front of figure 48 is drafted same as figure 18, except that they are for jackets or basques to wear over other garments. Add at bust measure 6 to 14 and at waist measure 2 to 10, at hip measure 2 to 10. Add according to the thickness of the under garment and how they want to wear it, whether tight or loose. This jacket is 20 centimetres long below the waist line. NOTICE.— For this style of jacket for persons who have large hips, we take off from the front at hips 3 to 7 and we add it at the side back.

**HOW TO PLACE THE UNDER-ARM.**

Place the hip corner at letter *I*, make sure that it is 12 centimetres each side from *G* to *I*, place the top of the *System* 3 to 4 centimetres from the front dot *E*, then trace a line from *I* to *F*, 2 above the length of under-arm, dot *G* at *F*, dot waist line at both sides of the *System* at *G* and *F*; now turn the *system* upside down and place waist at both dots *G* and *F*, and dot waist measure *G*, move the *system* down, dot hip measure *H*, now turn the *system* to its right position and place bust measure of the *system* at line *F*, place edge of *system* under-arm length at waist dot, trace from the corner *E* down to letter *F*, move the *system* up and place waist line at dot *F* and trace down from *F* to *I*.

**HOW TO DRAFT THE LAPEL.**

Line No. 3 is drawn from bust line to 5 centimetres above the shoulder seam, the point of the lapel is 7 centimetres from line No. 3 and the small point at 4 from line No. 3. Use the back part of the *system* curve *P* to draft the outside lines.

Figure 49 represents the side back to fit with figure 48.

**DIRECTIONS FOR DRAFTING FIGURE 49.**

Figure 49 is drafted same as figure 8, except that the waist line slopes 2 centimetres more at back line and leaves 2 centimetres for plait between side back and back.

Figure 50 represents the back to fit with figure 49. Figure 50 is drafted same as figure 33, except that the waist line is sloped 2 centimetres below to make the jacket longer waisted and leave 2 centimetres each side for plaits.

Figure 51 represents the front of dartless and double breasted jacket or basque, and can be used with any style of back and side pieces.

**DIRECTIONS FOR DRAFTING FIGURE 51.**

Figure 51 is drafted same as figure 48, except that the under-arm is drafted separate.

**HOW TO DRAFT THE LAPEL AND DOUBLE BREAST.**

Draw a straight line from neck down to hips, the waist dot being the guide. The width for the double breast is from 10 to 18 centimetres in figure 51 is 10 at hips and at waist, 11 at bust. Trace the outside line from hip to bust line with the dart rule. Line *J* is traced with dart rule from bust line to neck; line *K* is traced by placing dart rule at neck corner and at waist and under-arm corner *F* and *G* and traced from neck corner up 15 centimetres; line *L* is traced with back curve traced from bust line to the point of line *K*.

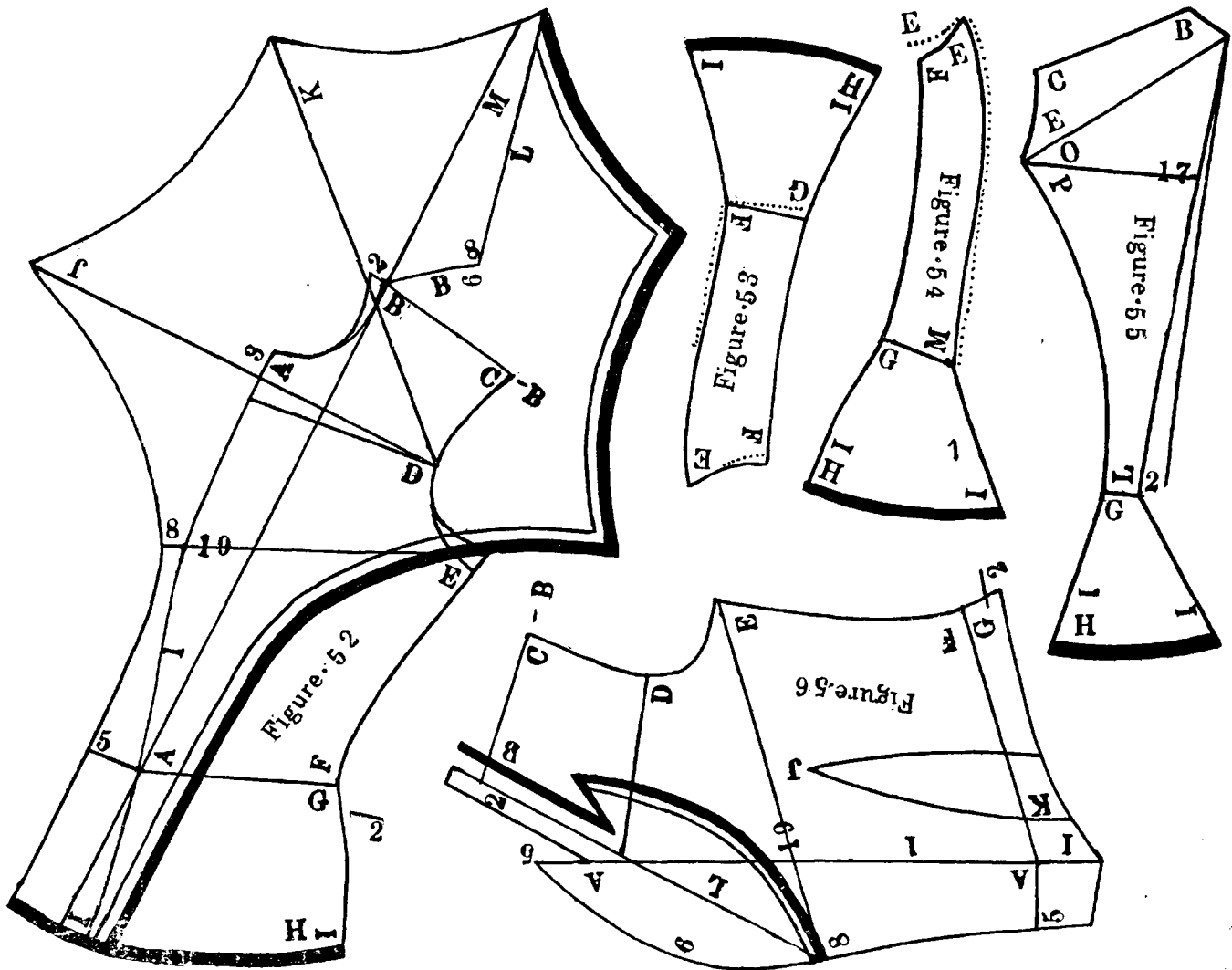

Figure 52 represents the front of a dartless sailor blazer or jacket, with a sailor collar drafted with the front.

**DIRECTIONS FOR DRAFTING FIGURE 52.**

Figure 52 is drafted same as figure 48.

HOW TO DRAFT THE SAILOR JACKET.—Trace line *M* from hips to 27 centimetres above the shoulder line, trace line *K* from chest dot, passing 2 centimetres below the shoulder line at line *M* up to 25 centimetres from line *M*. trace line *J* from chest dot passing 3 centimetres from neck up to 28 centimetres from line *M*, trace line *B* so that the end of line is 6 centimetres from the shoulder line and 8 centimetres long. Trace line *L* from end of line *B* up to 23 centimetres, the top of line coming one centimetre from line *M*. Now trace the front line all round at hips and waist is 5 centimetres from line *M* and 8 centimetres at bust. To trace the curved line use the curved part of the back piece, trace from line bust line to line *J*, from line *J* to line *K* and from line *K* to line *L*.

Figure 53, figure 54 and figure 55 represent the under-arm, side back and back to fit with figure 52 or with any other front

**DIRECTIONS FOR DRAFTING FIGURES 53, 54 & 55.**

The two first figures, 53 and 54, are drafted same as figure 7 and figure 8. The back figure 55 is drafted same as figure 33, except that the skirt part is longer and larger. The skirt for this jacket is 17 centimetres for the length and 17 centimetres for the width. For this style of jacket the skirt part is the same size in width as it is in length, except the front, which is 10 to 16 centimetres more in width than it is in length.

**NOTICE TO PUPILS.**

The under arm piece, figure 53 at waist line *G*, the waist line is lowered a half centimetre on the side of the under-arm seam, only the second line with little dots shows how the waist line must be, and the other second line at arms-eye shows that it is cut off a half centimetre at arms-eye for persons who are long waisted at front and short waisted at under-arm. The front under-arm seam is made a half centimetre longer than the measure calls for and the under-arm piece is not cut off at arms-eye where the front piece is made half centimetre longer. Remember that the under-arm piece is drafted same as figure 53 for every dartless garment.

Figure 56 represents the front of a double-breasted ladies' vest with lapels.

**DIRECTIONS FOR DRAFTING FIGURE 56.**

Lay the *system* on lining or goods and dot bust measure *E*, dot bust line 19, dot length of front at waist *A*, and neck *A*, then move the *system* down same as in figure 52, dot chest measure *D*, dot neck measure *B*, follow line *B*, dot at end of line *B*, now trace shoulder measure *C*, trace armseye from *E* to *D* and from *D* to *C*, take waist measure *G*, add 14 for the dart, dot square line No. 2, place *G* dot 2 centimetres from the square line No. 2, measure the under-arm length from *F* to *E*, make dot at *E*, place waist line at *G* dot, and top edge of the *system* at dot *E*, trace up from *F* to *E* and down waist dot 4 centimetres. If there is anything left too long at dot *E* trace a second line same as in figure 52. Trace waist line from *A* to *G*, trace straight line at front from 5 centimetres above dot *A* at neck to dot *A* at waist, then place the dart same as in figure 35, the distance from the straight line being 8 at waist and 16 at bust. The width of the double-breasted is 5 centimetres from straight line at waist line and 9 at bust line, trace line *L* from bust point to 6 centimetres above the shoulder line and leave line passing 2 centimetres below dot *A* at neck, then trace the outside line with dart rule from waist to bust, then use the curved part to trace from bust to point of front line, which is 6 centimetres from line *L*, trace another line from dot *A* to point of line *L*, 2 centimetres from line *L*.

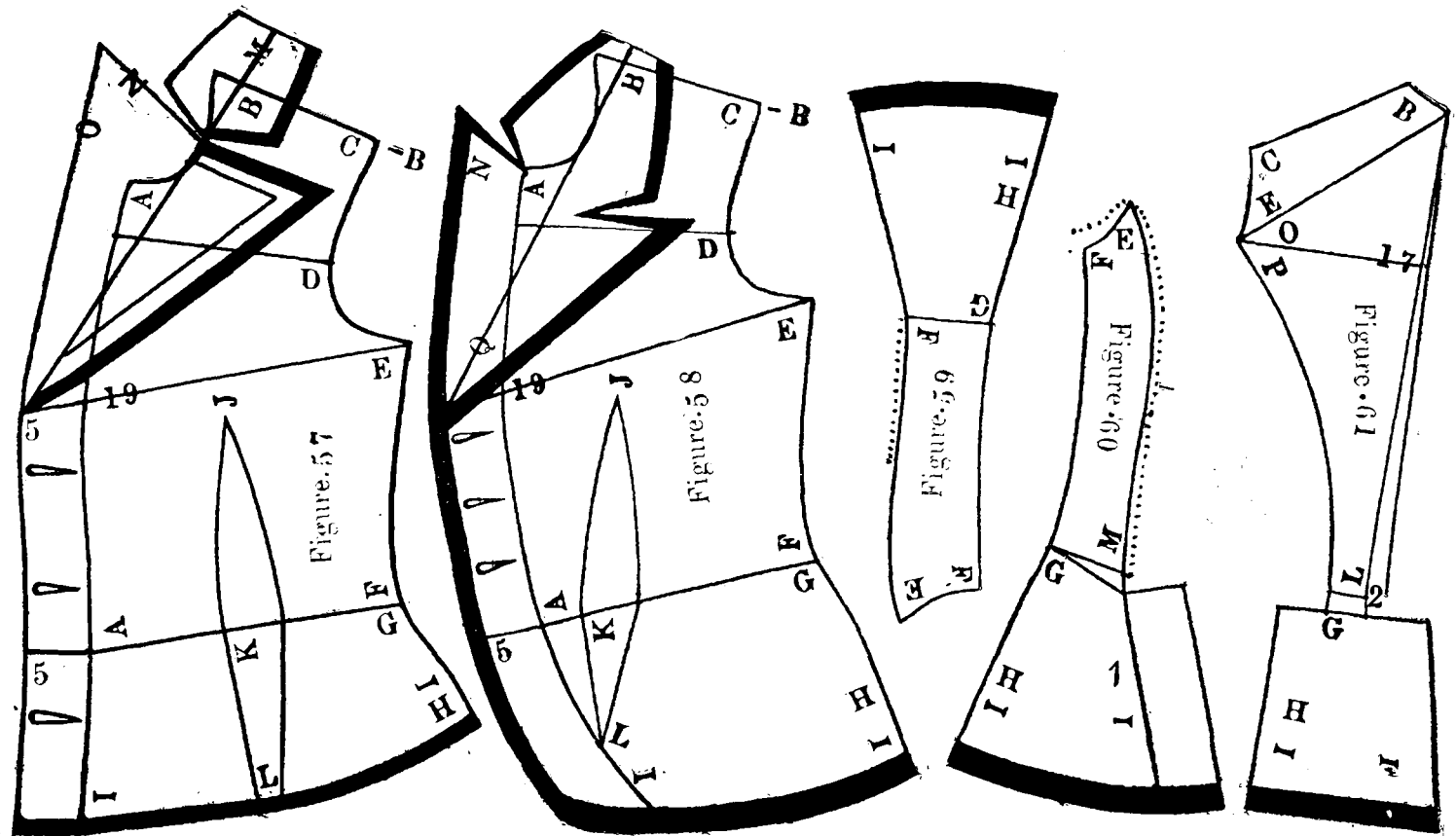

Figure 57 represents the front of a jacket or basque with one dart.

**DIRECTIONS FOR DRAFTING FIGURE 57.**

Figure 57 is drafted same as figure 6, except that in figure 57 it has only one dart and is 12 in width. The dart is placed in the centre of the front at waist and at bust. If it is to be worn over another garment add from 2 to 8 at bust, waist and hips. Add 5 centimetres to the front for lapel line *O*.

HOW TO DRAFT THE LAPEL—Trace line *M* from bust line 19 to 6 centimetres above shoulder line, trace line *N* by placing the dart rule at centre of neck and at chest dot *D*, trace 12 centimetres up from line *M*, then trace line *O* from bottom of jacket to the point of line *N*, then trace collar.

Figure 58 represents the front of lady's cutaway with one dart and lapel.

**DIRECTIONS FOR DRAFTING FIGURE 58.**

Figure 58 is drafted same as figure 57, except that in figure 58 the dart is 10 in width and is placed 8 from the front line at waist and 20 at bust, and the points of the dart finishes at front line *L*. The skirt part is traced on a rounding shape from waist line *A* to *I*; use the curved part of the back to give that curve. Now add 5 at the front for the lapel, trace line *Q* from bust line 19 to 6 centimetres above the shoulder line, trace line from corner *A* up 8 centimetres long, then trace the collar.

Figure 59, figure 60 and figure 61 represent the under-arm, the side-back and the back to fit with figure 58 or with any other front.

**DIRECTIONS FOR DRAFTING FIGURES 59, 60 & 61.**

These three figures, 59, 60 and 61, are drafted same as Figure 48, Figure 49 and Figure 50, except that the under-arm is drafted separate from the front. The length of the skirt is 20 centimetres long, and the back plaits are 5 centimetres in width.

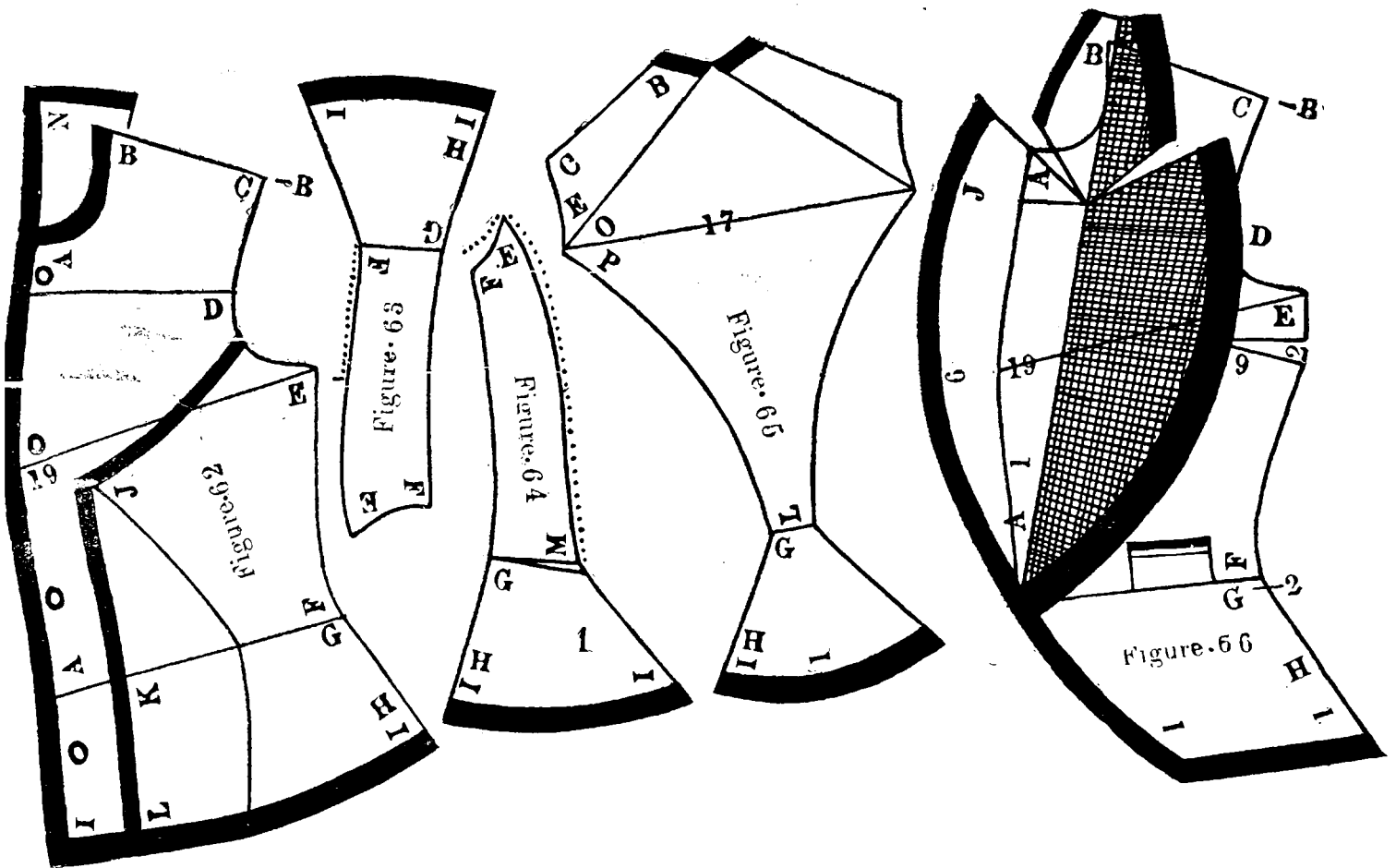

Figure 62 represents the front for a jacket or basque cut in two pieces and drafted in one.

**DIRECTIONS FOR DRAFTING FIGURE 62.**

Figure 62 is drafted same as Figure 6. Add 20 at waist measure and 20 at hip measure, trace line *K* from *L* to *J* at 10 from the front line, trace a curved line from corner *J* to armseye, trace a line from corner *J* down to waist line at 20 from line *K*,

trace a line from waist line down to hip line at 20 from line *K*, now cut out the front at line *K* from hips to armseye, then cut out at the second line from hip up to corner *J*. Figure 62 has no dart and line *K* represents a seam from armseye to hips, the seam being covered with lace, the seam is basted from waist line up. The front of the jacket is finished with lace and 4 large buttons. Letter *N* represents the collar. The collar is straight at front and square at top. Length of skirt 17 centimetres. For Figure 62 draft a pattern on paper.

Figure 63, Figure 64 and Figure 65 represent the under-arm, side-back and back to fit with Figure 62.

**DIRECTIONS FOR DRAFTING FIGURES 63, 64 & 65.**

These three figures are drafted same as Figures 53, 54 and 55, except that the under-arm of Figure 63 is not made a half centimetre longer at under-arm seam, and the back, Figure 65, is drafted double by folding the goods and is only 5 centimetres in width at waist line; what is over 5 centimetres is taken off and added at side-back, Figure 64, The skirt has plenty flaring at bottom and is 5 centimetres more in width than it is in length.

Figure 66 represents the front of a dartless cutaway with large lapel and pocket.

**DIRECTIONS FOR DRAFTING FIGURE 66.**

Figure 66 is drafted same as Figure 18. The under-arm dart is made same as Figure 24. From waist line down to hips it is traced with the curved part of the back. Trace straight from waist up to 6 centimetres above the shoulder line, trace from chest line up to neck corner *A* 14 centimetres long, trace line *J* from waist line to the point of line *A*, then trace the collar.

**THE CENTIMETRE TAPE MEASURE.**

Figure 67 represents the Centimetre Tape measure which is used to take the measurement. The length of the tape measure is 150 centimetres or 1,500 millimetres or one metre and a half, and those 150 centimetres are reduced to 25 centimetres, so it takes six of the reduced measure to make one centimetre. The diagrams which are in this instruction book are measured and drafted with this reduced measure, so you can cut this out and use it to find out any distance which is named in the directions, except in the length of skirts and princess and a few of the seamless garments which have been reduced in the drafting in order to take less space in the instruction book.

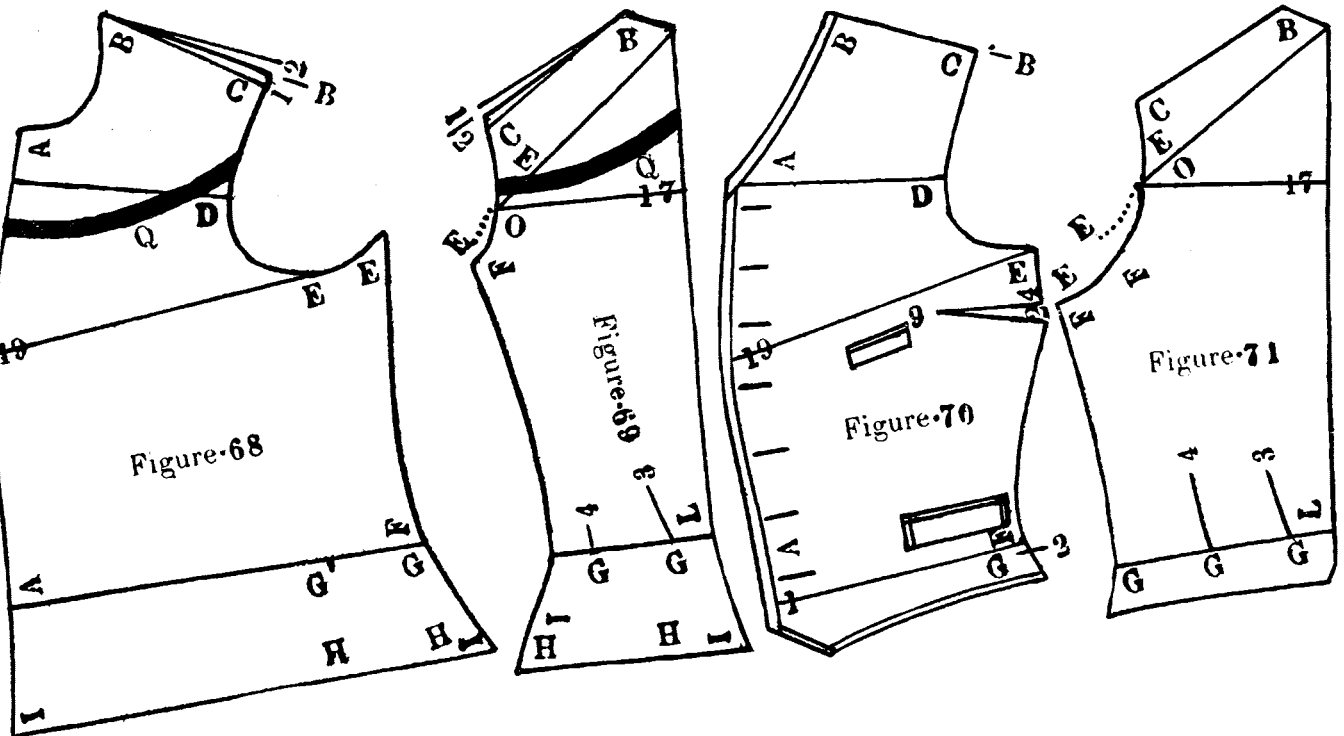

Figure 68 represents the front of a shirt-waist with yoke or without.

**DIRECTIONS FOR DRAFTING FIGURE 68.**

To draft shirt waists begin same as for plain waist figure 6, except that you will add one measure at length of shoulder *C*, one at chest measure *D*, 2 or 4 to bust measure *E*, and 10 to 20 at waist measure *G*, 10 to 20 at hip measure *H*. You add at waist and hip measure according to how many plaits you wish to have on the front.

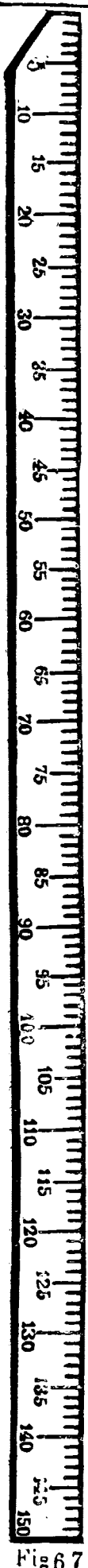

Fig 67

### DIRECTIONS TO PLACE THE UNDER-ARM.

Place waist of the *system* at waist dot letter *G* so that the point of the *system* letter *E* is downward, then dot waist measure letter *G*, move the *system* down to dot letter *H* and dot hip measure letter *H*, now turn the *system* and join the under-arm at bust *E* and the edge of the *system* to dot *G*, now trace from *E* to corner *E* then make a dot at under-arm length letter *F*, now take the dart rule to trace the under-arm line, trace from letter *F* dot up to bust corner letter *E* and down from dot *F* to letter *I* or hip dot. Now trace waist line from the front dot to the under-arm dot *F*. Line letter *Q* shows where it is cut when you want to make it with a yoke. Line No. 1 shows how to make change for a sloping shoulder, letter *B* shows the usual line, No. 2 shows how to make a change for a prominent shoulder bone or high shoulders.

Figure 69 represents the back of a shirt-waist.

### DIRECTIONS FOR DRAFTING THE BACK.

This shirt back is drafted same as figure 26, except that at waist we add 8 or more to make a few plaits on the back and we add one measure more at shoulder and one across the back. Line letter *Q* shows the back yoke where it must be cut, line No. 2 shows how to make a change for sloping shoulders, line No. 1 shows the change for high shoulders. When the check measure is taken those shoulder changes are easier to be made. The measure will tell you where to set the shoulder seam.

Figure 70 represents the front of a lady's single breasted vest, better known as a dartless riding vest.

### DIRECTIONS FOR DRAFTING FIGURE 70.

Lay the *system* on the lining or goods, and begin at bust dot bust measure letter *E*, add 4 at the bust measure, dot bust line 19, trace up to *A* and down to *A* waist line, move the *system* down and dot chest measure letter *D*, dot neck measure *B*, take dart rule and trace line with the curved side from chest dot to neck dot, now trace shoulder length letter *C*, draw the arms-eye from *E* to *D* and from *D* to *C*, now place waist line of the *system* at dot *A* and dot waist measure letter *G*, add 5 at waist measure, take the under-arm length *F*, take it 2 centimetres large, dot at *F*, move the *system* up place waist line at dot *F* and trace from *F* to *E* bust dot. Now make a dart 2 centimetres large, 9 centimetres deep and 4 centimetres from bust dot; now draw waist line and finish the bottom. The dart is placed in a way that it makes the two points come out a half centimetre. This dart is made in lining only and is a great benefit for large women. It gives plenty room to the fleshy part. No. 2 shows the square line and to what distance the waist line should come.

Figure 71 represents the back of a lady's vest.

### DIRECTIONS FOR DRAFTING THE BACK.

Lay *system* on lining or goods and begin to dot width of back *O*, dot shoulder measure *C*, neck measure *B*, trace from dot *B* to the corner and down to *L*, make dot at *L*, move the *system* up, place waist line at dot *L* and dot waist measure *G*. Draw shoulder measure from *C* to *B* dot, trace from dot *O* to dot *C*, take side back, place corner *E* at *O* dot, place the edge of the *system* at *G* dot, then trace bust measure from *E* to dot *O*, now trace line No. 3, moving the *system* up, place waist at *G* dot and the edge of the *system* straight with line 3, then dot waist measure letter *G*, now take the under-arm length from dot *G* to dot *E*, make dot at *F* and trace from *F* dot to *O* dot. Now take the under-arm piece and place corner *E* at dot *T* and place edge of *system* at dot *G*, now dot bust measure letter *E* and trace line No. 4, move the *system* up and place the waist line at dot *G*. The edge of the *system* straight with line No. 4, then dot waist measure *G*, then take under-arm length from *G* dot to *E* dot, make dot at *F* and trace from dot *F* to dot *E*, finish the bottom with dart rule.

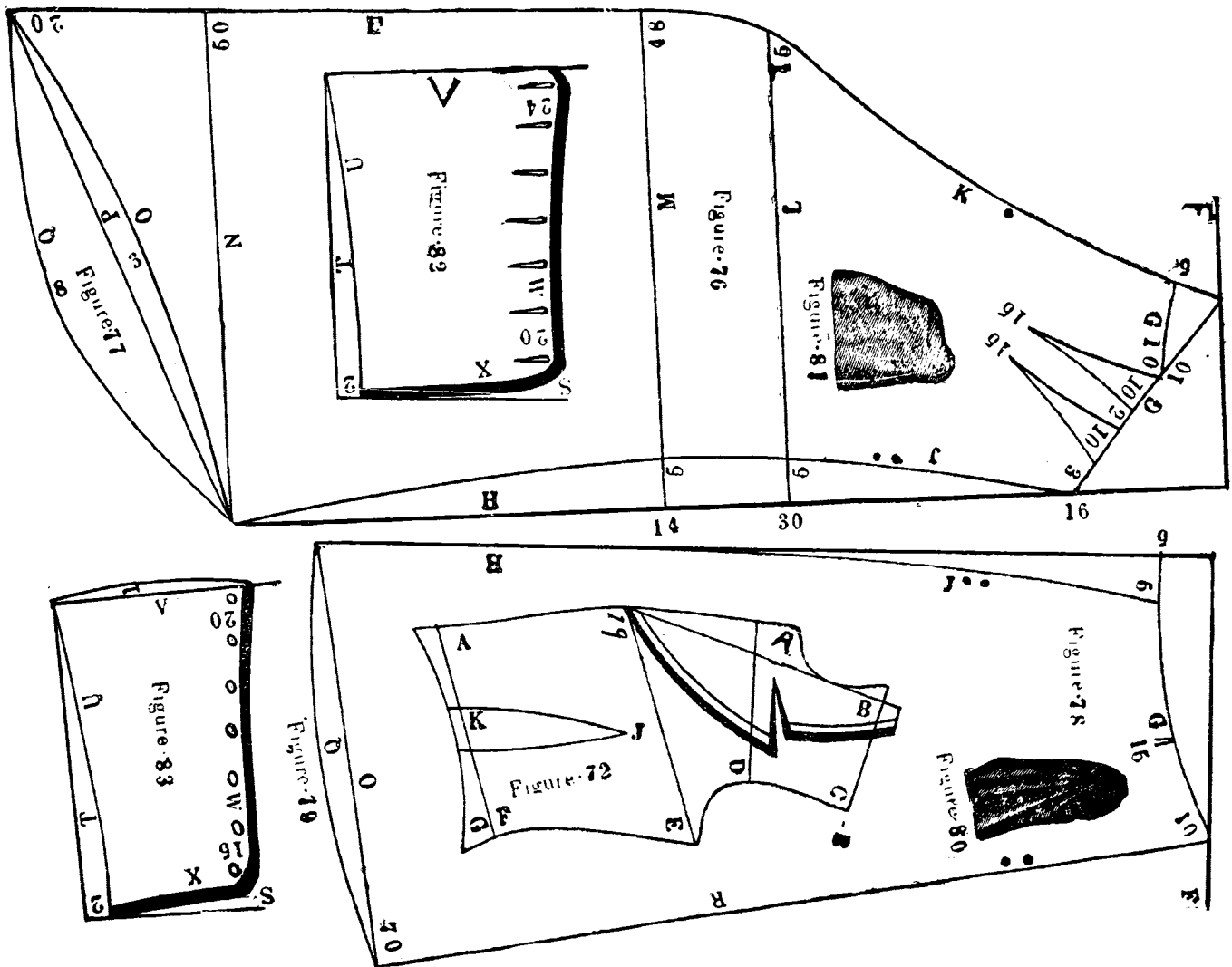

Figure 72 represents the front of a riding jacket.

**DIRECTIONS FOR DRAFTING THE JACKET FRONT.**

This jacket front is drafted same as figure 6, except that it has only one dart, 10 in width and is cut 2 or 3 centimetres below the waist line, and the lapel is drafted from the bust line to 4 centimetres above the shoulder line.

Figure 73 represents the under-arm for the riding jacket.

**DIRECTIONS FOR DRAFTING THE UNDER-ARM.**

This under-arm is drafted same as figure 7, except that the skirt is drafted 16 to 20 centimetres below the waist line, and at letter *G* same length as the front of the jacket.

Figure 74 represents the side-back of the riding jacket.

**DIRECTIONS FOR DRAFTING THE SIDE-BACK.**

Figure 74 is drafted same as figure 8, except that the waist line slopes one centimetre more and 3 centimetres are left for the back plait. Length from waist line to hip line 16, width at hip measure 60.

Figure 75 represents the back of the riding jacket.

**DIRECTIONS FOR DRAFTING THE BACK.**

Figure 75 is drafted same as figure 33, except that 2 centimetres are added at back for plaits and 2 centimetres at letter *G* for plaits also. Length of skirt 16 centimetres, width at hips 10 centimetres.

Figure 76 and figure 78 represent the right part of a riding skirt.

Figure 77 and figure 79 represent the left part of the riding skirt.

**DIRECTIONS FOR DRAFTING FIGURE 76.**

First trace line *F* and line *H*, square with line *F*, take 16 centimetres below the square line, make a dot from 16 to line *F*, trace line *G*, which is the waist line, the waist measure is 30; we take half for the front and half for the back. Now place the dart at waist line, the width of the darts being 10 each, and the length is 15 centimetres. Place first dart 3 centimetres from line *H*, second dart 2 centimetres from the first dart, now trace second line *G* from the point of dart to 5 centimetres below line *F*, and 5 centimetres long. Now take the length of inside measure which is 30 centimetres, take 30 below, 16 at line *H*, and trace line *L* to be square with line *H* and 45 centimetres long, take 14 centimetres below line *L* and trace line *M* 48 centimetres long, so as to be square with line *H*. Now trace *N* for which is traced at bottom of length of side measure, trace it square with line *H*; it is to be 50 centimetres long. Trace line *K* from line *F* to the point of line *G* and line *L* by using the curved part of the dart rule, then trace line *E* from line *L* to 20 centimetres below line *N*, trace line *P* straight from line *H* to line *E*, now trace line *O* 3 centimetres from line *P*. Line *O* is the bottom of Figure 76. Figure 77 is the left front gore and Figure 76 is the right front gore. The left gore, Figure 77, is from 10 to 12 centimetres longer at bottom. For left gore trace line *Q* 8 centimetres below line *P* by using curved part of dart rule. Trace line *J* from number 16 down to the bottom of skirt, passing 5 centimetres from line *H* at line *L* and line *M*; line *J* is the same.

**DIRECTIONS FOR DRAFTING FIGURE 78.**

Trace line *F*, trace line *H*, square with line *F*, trace line *G* 5 centimetres below line *F* from line *H* to line *F*, trace line *J* at 5 centimetres from line *H* from line *G* down to half the length of line *H*. Now take 15 centimetres at waist line *G* from *G* dot to line *F*, add 10 centimetres or more for plaits at back. Trace line *O* bottom of skirt 70 centimetres long.

Figure 79 is the left back gore and Figure 78 is the right back gore, and the left gore, Figure 79, is from 3 to 5 centimetres longer. Trace line *Q* 3 centimetres from line *O*.

Figure 80 represents the skirt when the person is walking.

Figure 81 represents the skirt when the person is riding.

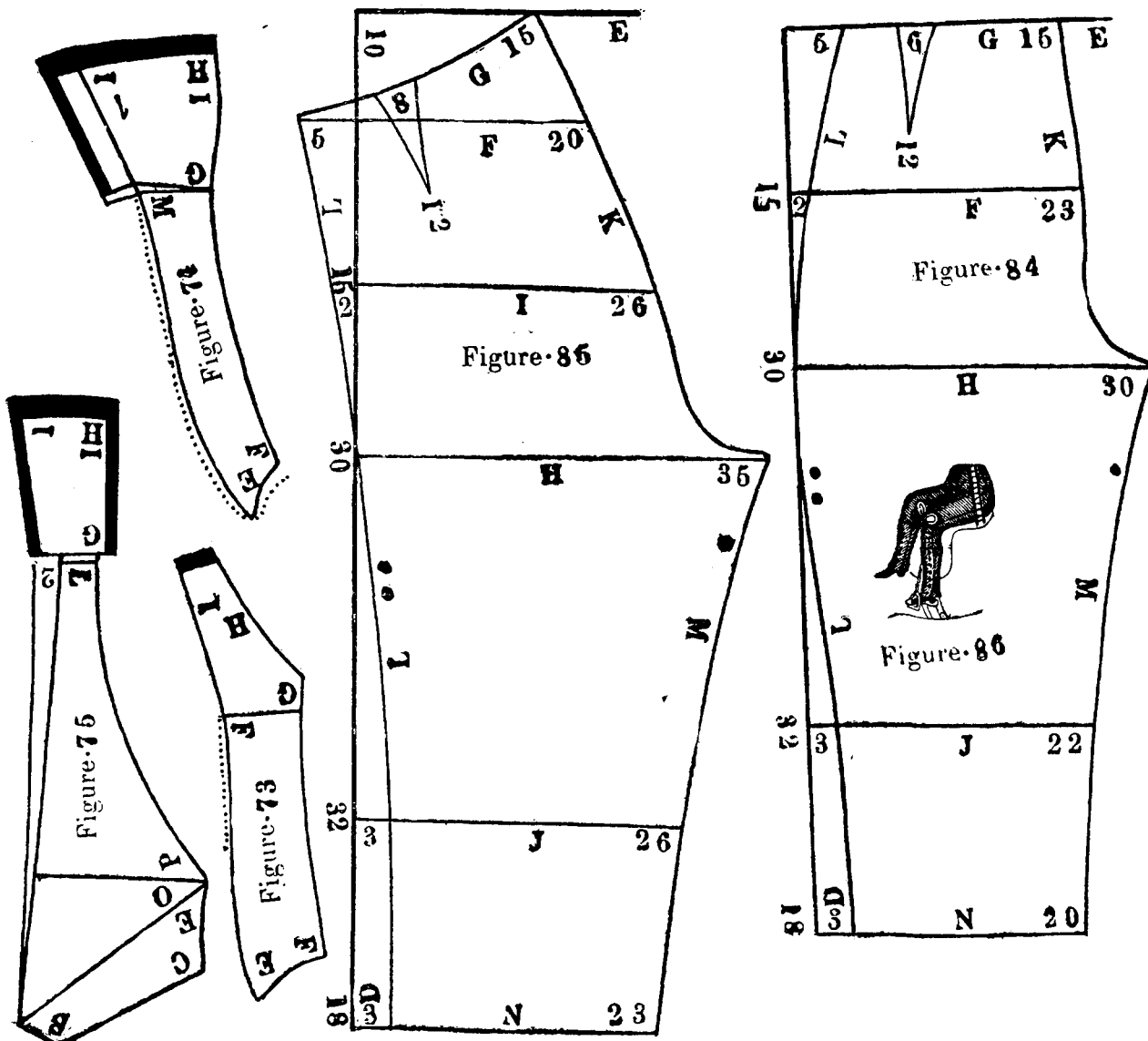



Figure 82 and Figure 83 represents the legging for riding horse back or for riding bicycles.

**DIRECTIONS FOR DRAFTING FIGURE 82.**

**THE BACK LEGGING.**—Trace line *S*, trace line *F*, square with line *S*, trace line *V*, square with line *T*, trace line *U* two centimetres from line *T*; trace line *X* 20 centimetres long, trace line *W* down to line *V* 24 centimetres width at bottom.

Figure 83 back legging is drafted same as figure 82, except that the width at top is only 15 centimetres and at bottom 20 from line *V*, and is made one centimetre longer.

Figure 84 and figure 85 represent a tight-fitting lady's riding trousers.

**DIRECTIONS FOR DRAFTING FIGURE 84.—FRONT LEGGING.**

The different measures given for these trousers are as follows:—waist 30 centimetres, hips 50, seat 65, knee 24, bottom 22, outside seam 70, inside seam 30. Now trace line *E*, trace line *D*, square with line *E*. Line *E* for the front legging is used for waist line *G*; trace line *F* 15 centimetres below line *E*, square with line *D*; line *G* is the waist measure, 15 centimetres; line *F* is the hip measure, 23 centimetres long. Trace line *H* 30 centimetres below line *E*; line *H* is the seat measure, 30 centimetres long, and is traced square with line *D*; trace line *J* 32 centimetres from line *H*, square with line *D*, and 22 centimetres long. Trace line *N* 18 centimetres from line *J* and square with line *D* and 20 centimetres long. Trace line *L* from line *N* to line *H* and from line *H* to line *E*; line *J* is traced 3 centimetres from line *D* at bottom and 5 centimetres at waist. Now trace line *K* from line *E* to line *H*; trace line *M* from line *H* to line *N*. Place the dart at 5 centimetres from line *N*. The dart is 6 in width and 12 centimetres in length. Line *L* is the outside seam and line *M* is the inside seam and line *K* is the opening.

**DIRECTIONS FOR DRAFTING FIGURE 85.—BACK LEGGING.**

Trace line *E*, trace line *D*, square with line *E*, trace line *F* coming 5 centimetres out from line *D* and 10 centimetres below line *E*; line *F* is to be square with line *D* and 20 centimetres long. Trace line *G*, waist measure 15, from point of line *F* to line *E*, trace line *I*, hip measure 26 centimetres long; line *I* is at 15 centimetres below line *F*. Trace line *H*, seat measure, 35 centimetres long; line *H* is also the inside measure which is 30 centimetres below line *F*. The hip line is always placed at half the distance between waist line and seat line or inside line. Trace line *J* 26 centimetres long and 32 centimetres below line *H*. Trace line *N*, bottom line 23 centimetres long, 18 centimetres below line *J*. All the cross lines are drafted square with line *D*. Trace line *L* from line *N* to line *H* and from line *H* to the point of line *F* and line *G*, trace line *K* from line *E* to line *H*, trace line *M* from line *H* down to line *N*; line *L* is the outside seam, line *M* is the inside seam, line *K* is the back seam. Place the dart 2 centimetres from line *D*, the dart is 8 in width and 12 centimetres in length.

Figure 86 represents the trousers and leggings when the person is riding. It shows also how to take the inside measure for trousers and riding suits. The measure is taken from the waist to the level of the chair and gives the correct inside measure every time.

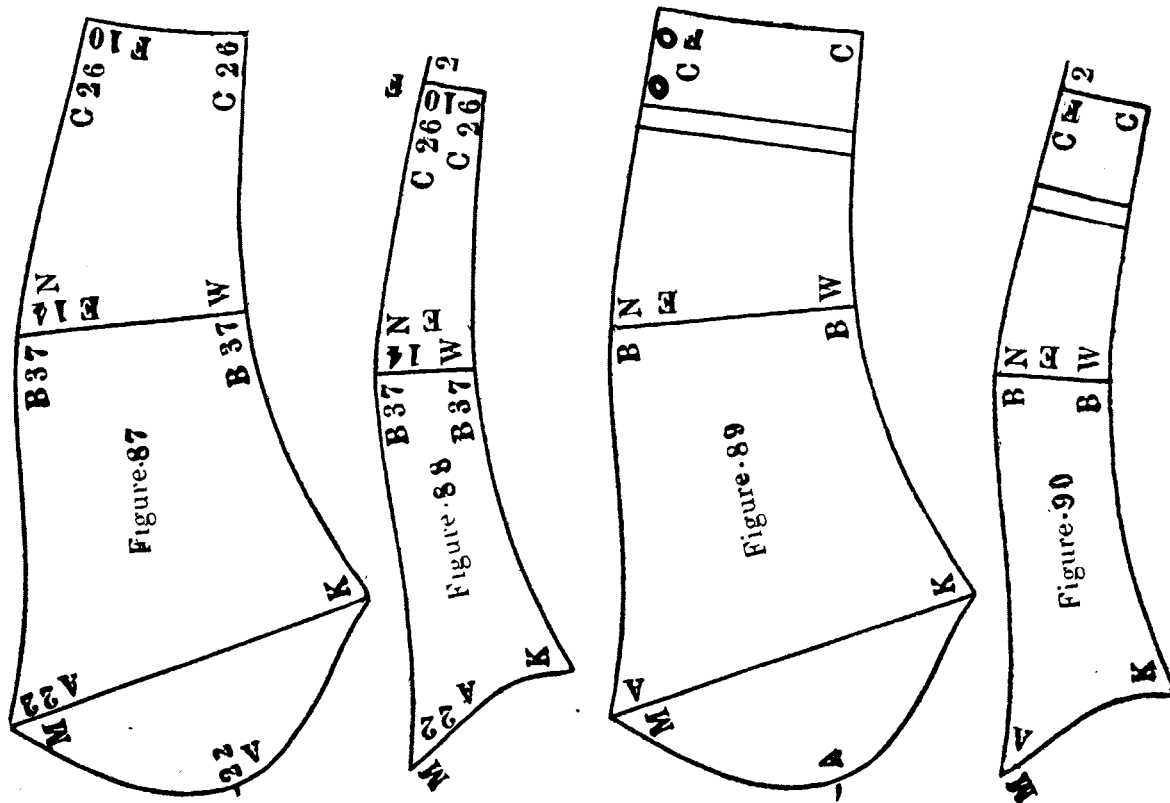

Figure 87 and figure 88 represent a tight-fitting sleeve or the foundations for any style of sleeves.

#### DIRECTIONS FOR DRAFTING FIGURE 87.

The different measurements we use to draft figure 87 and figure 88 are given to pupils as a guide, and we will draft all the different styles of sleeves given in this book from those measures. The measures are as follows: Armseye 22, elbow 14, wrist 10, shoulder to elbow 37, elbow to wrist 26.

Lay the *system* on lining or goods and dot armseye *A* 22, dot elbow *E* 14, then dot at the outside edge of the *system* by taking same number as the armseye measure *A* 22. Now trace from *A* 22 down to corner *K* and from corner *K* down to *B* 37, length from shoulder to elbow; move the *system* up, place elbow line at dot *B*, place the edge of the *system* 2 centimetres in from corner *K*, then trace from *W* down to *C* 26, length from elbow to wrist; move the *system* up again, place corner of *system* at dot *C*, then dot wrist *F* 10, now trace the back part of the sleeve, place corner *M* of the *system* at dot *A* 22 and the edge of the *system* at the outside dot *A* 22, then trace from outside *A* 22 to the corner armseye dot *A* 22 without moving corner *M* of the *system* from dot *A* 22, swing the edge of the *system* to elbow dot *E* 14, then trace from armseye dot *A* 22 down to *B* 37, length from shoulder to elbow. Move the *system* up, place elbow line at dot *B* 37 and the bottom edge of *system* at wrist dot *F* 10, then trace from *N* down to *C* 26, length from elbow to wrist; then trace width of wrist from back dot *C* 26 to the front dot *C* 26.

#### DIRECTIONS FOR DRAFTING FIGURE 88.

Lay the *system* on lining or goods, dot armseye *A* 22, dot elbow *E* 14, trace from corner *K* down to *B* 37, length from shoulder to elbow, move the *system* up, place elbow line at dot *B* 37 and place the upper edge of the *system* 2 centimetres out of corner *K*, then trace from *W* down to *C* 26, length from elbow to wrist; before moving the *system* dot wrist *F* 10, width of wrist; now place corner *M* of the *system* at armseye dot *A* 22 and at elbow dot *E* 14, trace from dot *A* 22 down to *B* 37, length from shoulder to elbow; move the *system* up, place elbow line at dot *B* 37 and the bottom edge at dot *F* 10, then trace from *N* down to *C* 26, length from elbow to wrist; the back line *F* at wrist is cut 2 or 2½ centimetres shorter than the back line in figure 87, the reason we cut it short is to make a little plait at elbow. Now trace wrist from back dot *C* 26 to the front dot *C* 26. No. 2 shows how the back line is made short; the front line is not shortened. Now trace the under-armseye curve, place the outside number *A* 22 at corner *K* and edge of *system* at dot *A* 22; trace from *K* to dot *A* 22. We take the same number to trace the armseye curve as we use in armseye measure. For instance, if the armseye measure was 24, would place 24 at *K*.

#### NOTICE TO PUPILS.

The under sleeve is always drafted at the measure as top sleeve, but for certain styles of sleeves we take off from the upper sleeve to add at the under sleeve, or vice versa, we take off from the under sleeve to add at the top sleeve, but when such change is made we will give direction for same. Before tracing the length from elbow to wrist for the top sleeve, we place the edge of the *system* two centimetres in from corner *K*, we do that to give more circle to the top sleeve and for the under sleeve we place the edge of the *system* two centimetres out of corner *K*, we do that to give less circle to the under sleeve, and by so doing the inside seam of sleeve will never turn crooked over the arm and the seam will stay in its right place. The extra number on the under sleeve numbered from 1 to 12 letter *Y*, are used only in case you wish the under sleeve larger. You can add as many numbers as you wish and take off from the top sleeve what you add to the under sleeve.

Figure 89 and figure 90 represent a coat, jacket or riding suit sleeve.

#### DIRECTIONS FOR DRAFTING FIGURES 89 & 90.

Figure 89 and figure 90 are drafted same as figure 87 and figure 88, except that the sleeves are one measure larger at armseye, two measures at elbow and four measures at wrist.

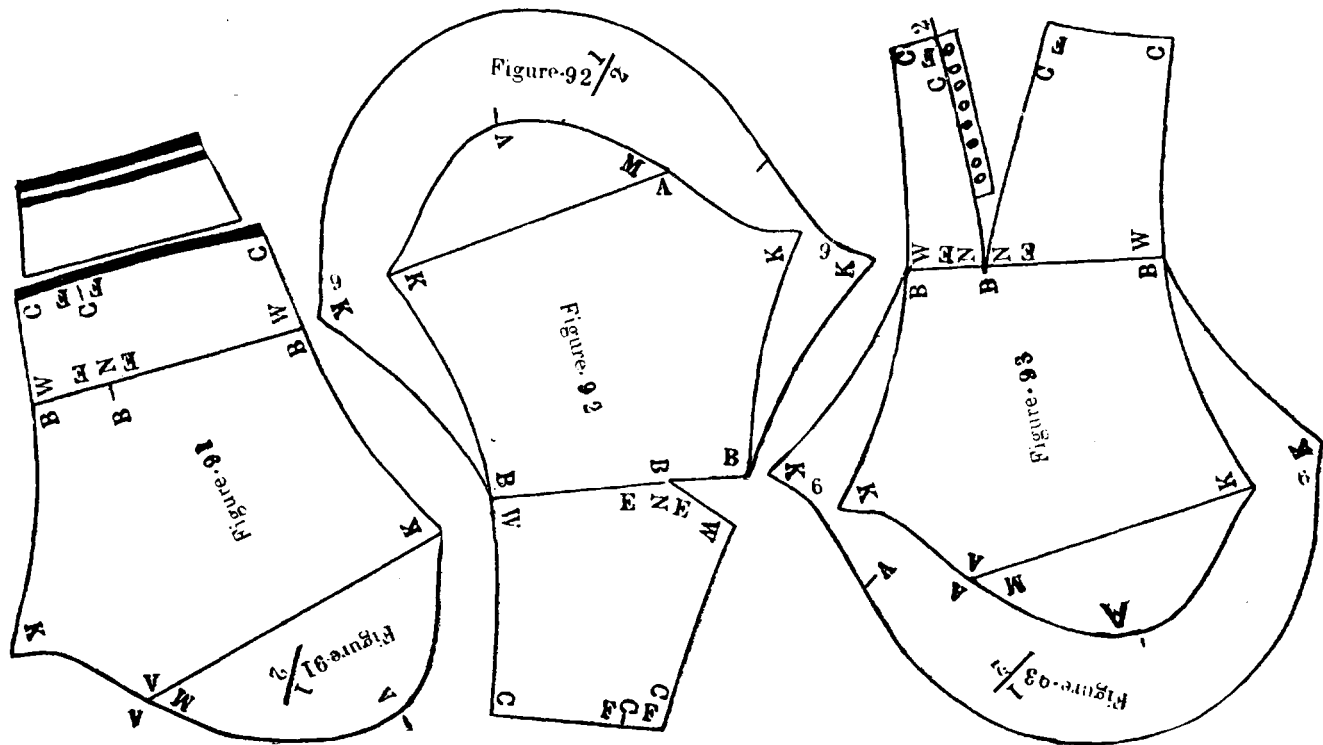

Figure 91 represents a one-seam, tight-fitting sleeve for foundation, and is to wear with cuffs.

**DIRECTIONS FOR DRAFTING FIGURE 91.**

Lay the *system* on lining or goods and draft the upper sleeve same as in Figure 87, except that the back line is not traced, only make dot at *B* and at *C* for length of back seam; place elbow line of the *system*, I mean *W* edge to be placed at dot *B*, and dot width of elbow measure for under-sleeve *E* and dot width of wrist *F*. Now reverse the *system*, put the pencil on the perforated armseye, measure *A* and place it at dot *A* of the top sleeve, place edge of sleeve at dot *E*, then trace from corner *K* down to *B* move the *system* up, place elbow line of the *system* at dot *B* and place bottom edge of *system* at dot *F*, and trace from *W* down to *C*, then trace from *C* to *C*; the sleeve is drafted same as if it was the full length. After it is drafted you cut the sleeve as high as you wish. The cuffs are drafted separate by using the low part of *system* wrist and elbow measure. Then trace armseye curve by placing the outside armseye number *A* at corner *K* and edge of *system* at dot *A*, trace from *K* to *A*.

Figure 92 represents a tight-fitting sleeve or foundation for any style of sleeve.

**DIRECTIONS FOR DRAFTING FIGURE 92.**

Lay the *system* on lining or goods and draft the top sleeve same as figure 87, except that the back seam is not traced. Now dot width of elbow measure *E* and width of wrist measure *F* for under-sleeve. Then reverse the *system*, put the pencil in the armseye perforation and place it at dot *A* of top sleeve, place the edge of *system* at dot *E*, then trace from corner *K* down to *B*; now put the pencil in the elbow perforation and place it at dot *B* of top sleeve, and swing the bottom edge of the *system* at dot *F*, now trace from *W* down to *C*, now trace width of wrist measure *F*.

Figure 92½ represents the outside goods of a puff sleeve.

**DIRECTIONS FOR DRAFTING FIGURE 92½.**

Figure 92½ is drafted same as Figure 92, except that it is larger at top. Take from 6 to 12 centimetres from corner *K* and trace from *B* to *K*, swing the *system* and trace the upper line from *K* to the centre of sleeve, now reverse the *system* and take same distance at corner *K* and trace from *B* up to *K*, dot armseye *A*, turn the *system* and trace armseye curve from *K* to dot *A*, swing the *system* and finish the upper line, trace from dot *A* to centre of sleeve.

Figure 93 represents a tight-fitting sleeve or foundation for any style of sleeve, when used as tight-fitting sleeve it buttons from elbow to wrist.

**DIRECTIONS FOR DRAFTING FIGURE 93.**

Figure 93 is drafted same as Figure 87 for the top sleeve, except that the back seam is measured for length of shoulder to elbow measure, but is not traced. Trace from elbow to wrist same as in Figure 87.

**DIRECTIONS FOR DRAFTING THE UNDERSLEEVE.**

Take the elbow width  $E$  by placing elbow line of the *system* at dot  $B$ , now reverse the *system* same as in Figure 92, put the pencil in armseye dot and place it at dot  $A$  and edge of *system* at dot  $E$ , trace from  $K$  down to  $B$ , move the *system* up, place elbow line of *system* at dot  $B$ , trace from  $W$  down to  $C$ , dot wrist  $F$ . Now trace back line from  $A$  to dot  $F$ , trace waist line from  $F$  to  $C$ , add for button.

Figure 93½ represents the outside of goods used for puff sleeves.

**DIRECTIONS FOR DRAFTING FIGURE 93½.**

The same as for drafting Figure 92½.

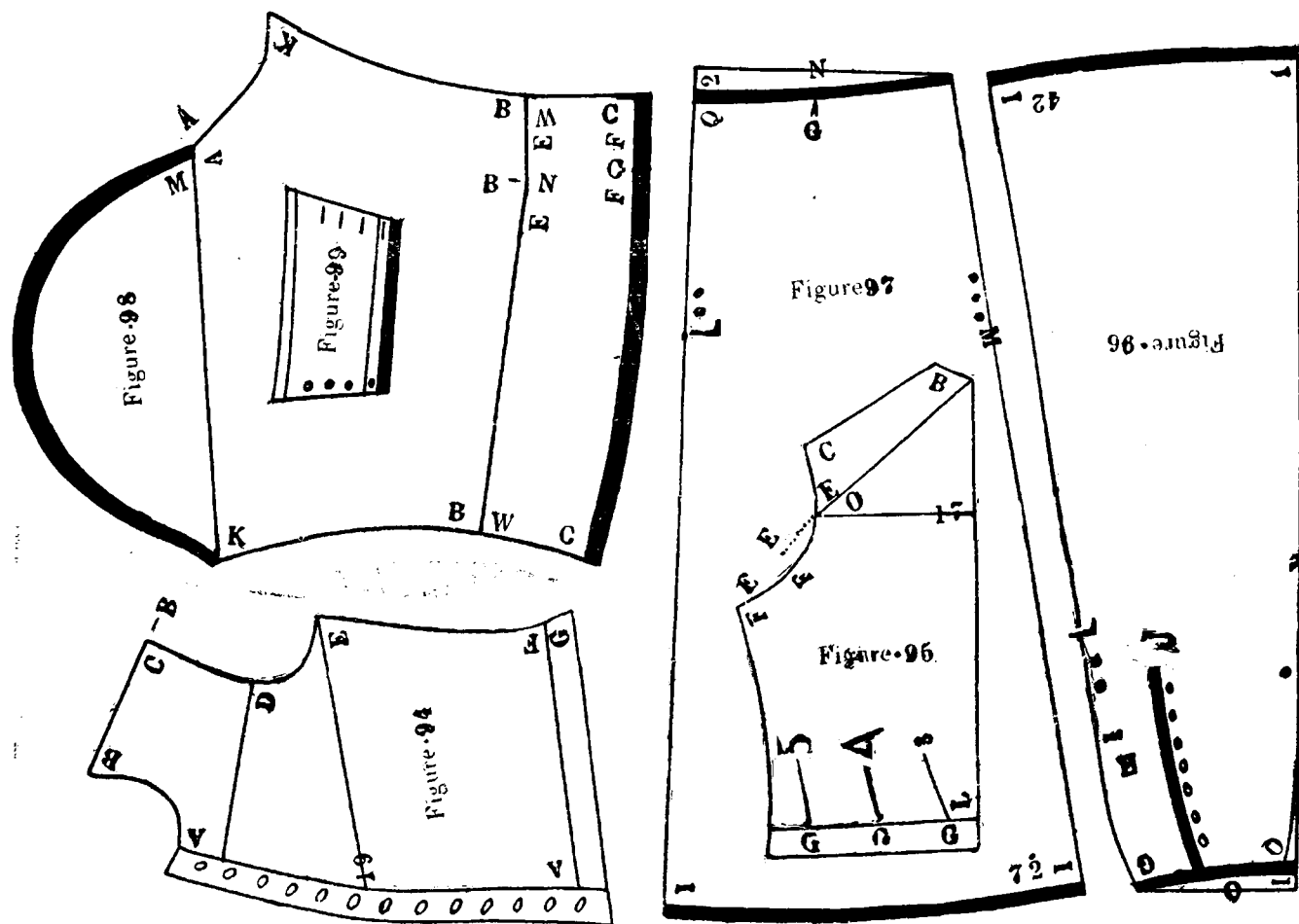

Figure 94 and Figure 95 represent the front and back of a bicycle waist.

**DIRECTIONS FOR DRAFTING FIGURE 94.**

Figure 94 is drafted same as Figure 40, except that we add 20 at waist to plait at front.

**DIRECTIONS FOR DRAFTING FIGURE 95.**

Figure 95 is drafted same as Figure 43, except we add 10 at waist, to be plaited at back.

Figure 96 and Figure 97 represent three-gored bicycle skirts with side opening.

**DIRECTIONS FOR DRAFTING FIGURE 96.**

The measure for this skirt is as follows :—Waist 60 centimetres, half 30 divided in two, 15 centimetres for each gore. Hip measure 100 centimetres, half 50 divided in two is 25 centimetres for each gore ; width at bottom is from 2 metres to 2½ metres or 200 to 250 centimetres. This skirt is 228 centimetres, half 114 front is 42 centimetres, 30 centimetres less than the back gore ; back gore 72 centimetres. Trace line  $O$ , trace line  $K$  square with line  $O$ , trace line  $Q$  half centimetre from line  $K$ , trace line  $G$  one centimetre below line  $O$ , trace bottom line  $I$ , trace line from line  $G$  to line  $I$ .

**DIRECTIONS FOR DRAFTING BACK GORE—FIGURE 97.**

Trace line *N*, trace line *L* square with line *N*, trace line *Q* two centimetres below line *N*, dot *G* is the size of waist measure, from *G* to line *M* is to be plaited at back, add from 15 to 25 centimetres for plaits, now trace line *I* width of bottom, trace line *M* from line *N* to line *I*, line *L* is drafted to the side length and line *M* to the back length. A four-gored skirt is drafted same except that the front gore is seamed at front.

Figure 98 and Figure 99 represents bishop sleeve with cuff.

**DIRECTIONS FOR DRAFTING FIGURE 98 & 99.**

Figure 98 and Figure 99 are drafted same as Figure 91, except that Figure 98 is much larger at elbow, add from 10 to 15 at elbow measure, cut the sleeve 10 centimetres below elbow line and plait in the cuff.

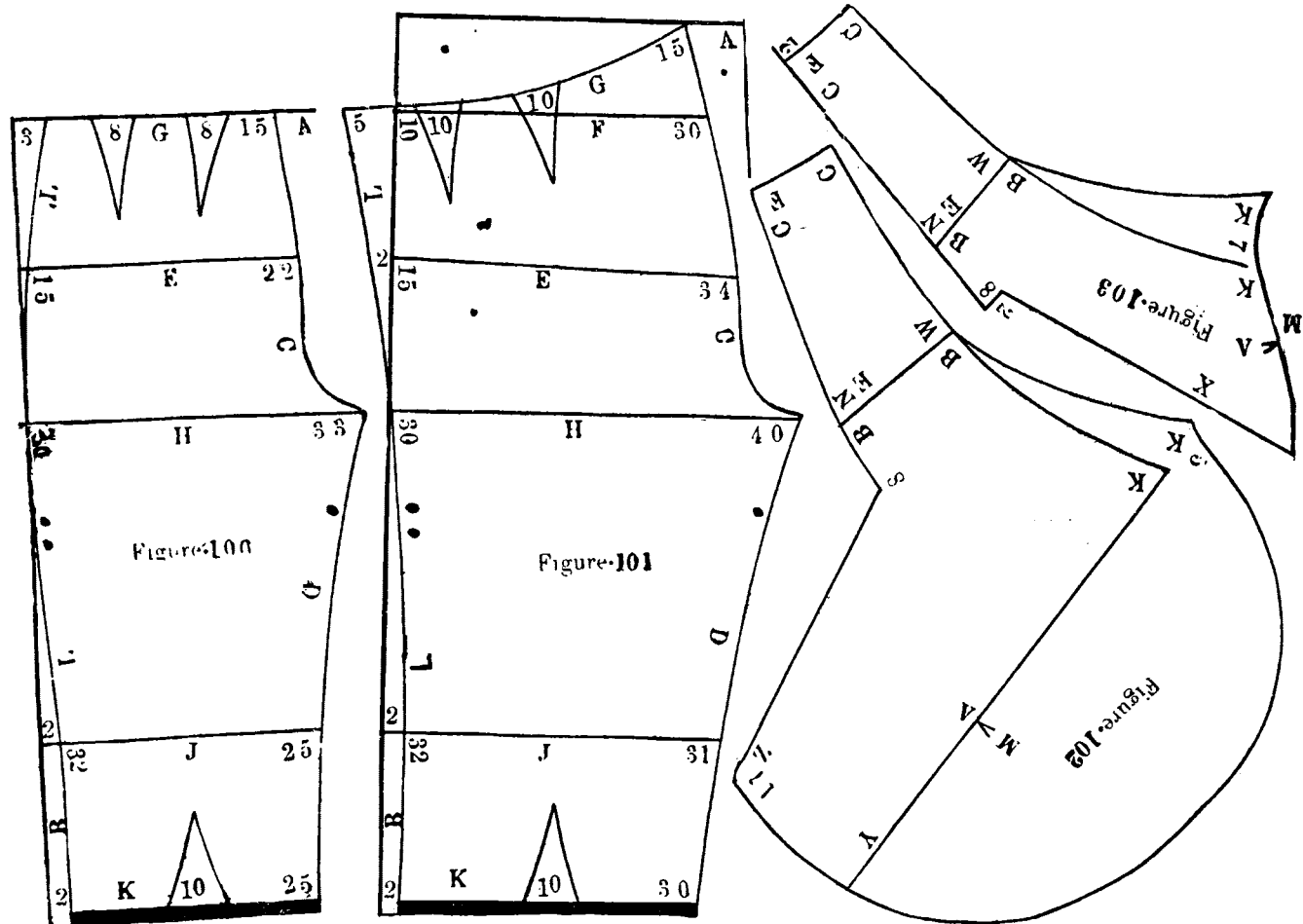

Figures 100 and 101 represent Ladies Bloomer.

**DIRECTIONS FOR DRAFTING FRONT LEGGING—FIGURE 100.**

Figure 100 is drafted same as figure 84, except that we take the measure larger, and the darts are larger, to give more fullness at hips and at the seat, also at bottom, and we place dart for fullness and line *L* is only 2 centimetres at bottom from square line *B* and 3 centimetres at waist.

**DIRECTIONS FOR DRAFTING BACK LEGGING—FIGURE 101.**

Figure 101 is drafted same as figure 85, except the measures and darts are larger, and we put dart at bottom; line *L* is only 2 centimetres from square line *B* at bottom, and is 5 centimetres out of line *B* at waist, same as figure 84.

Figure 102 and figure 103 represent a sleeve in two pieces.

**DIRECTIONS FOR DRAFTING FIGURE 102.**

Figure 102 is drafted same as figure 87, except we take off 2 measures from the top sleeve at elbow and wrist measure, and we add 5 measures to the under sleeve at elbow and wrist measure. Now trace line *Y* from corner *K* to dot *A*, extend the line from dot *A* from 20 to 30 centimetres according to the width of the sleeve you wish to have. Then take the length of back seam

from dot *A* to dot *E*, dot length *B* and dot 8 centimetres above dot *B*, and trace from No. 8 down to *C*, length from elbow to wrist, trace wrist from *F* to *C*, now trace a second line from elbow up to *K* to be at 5 centimetres from first line, now trace a circle line from corner *K* to end of line *Y* and down to 17 centimetres below line *Y*, now trace line *Z* from No. 8 to No. 17.

**DIRECTIONS FOR DRAFTING FIGURE 103.**

Lay the *system* on lining or goods, and trace from *K* down to *B*, dot elbow *E* and add 5 measures to it, move the *system* up, place elbow line of the *system* at dot *B* and place upper edge of the *system* 2 centimetres in from *K*, now trace from *W* down to *C* dot wrist measure, and add 5 measures to it, now trace a second time from elbow line up to *K* by using the same length as first line and it should be at 7 centimetres from the first line, dot armseye measure *A*, trace armseye curve from corner *K* to dot *A* and extend the line 10 centimetres, now measure the back length of sleeve from dot *A* to dot *E*, dot length *B*, measure length of elbow to wrist from dot *B* to dot *F*, dot length *C*, trace width of wrist from *F* to *C*, now trace straight line from wrist line up to 8 centimetres above elbow line, take 2 centimetres in for plait and trace line *X* from corner 8 up to the end of armseye line.

NOTICE.—Line *X* must be the same length as line *Z* and it is line *Z* that regulates the length of line *X*.

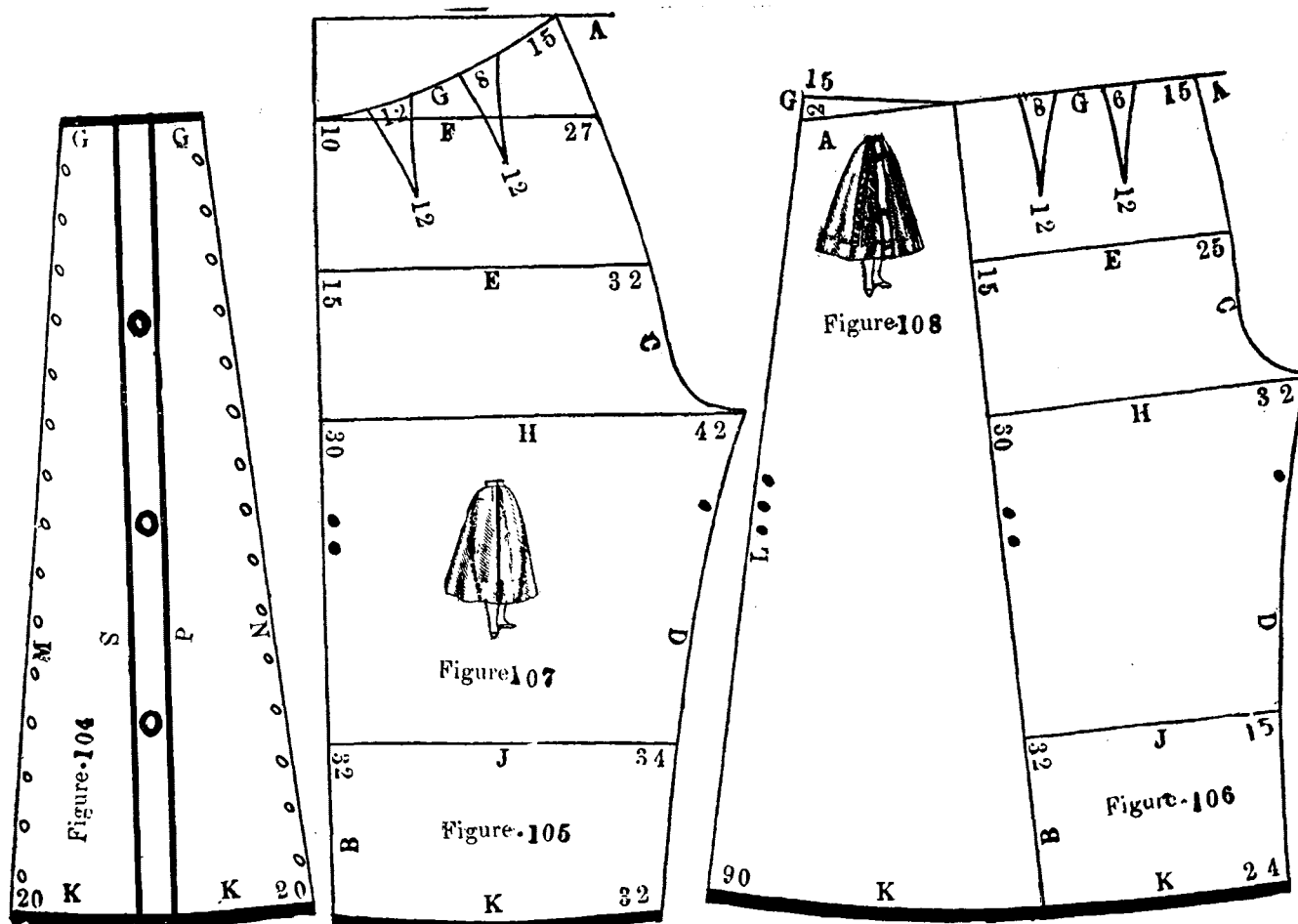

Figure 104, figure 105 and figure 106 represent a bicycle skirt and trousers combination. The skirt and trousers are cut in three pieces, the skirt open at the front fastened with three buttons. When the person is mounted on her bicycle the skirt opens in the front and the trousers appear as large bloomers on front and a skirt on the back, and when she is off the bicycle the trousers do not show by buttoning the front of the skirt and it forms a walking skirt.

Figure 104 represents the front of the skirt.

**DIRECTIONS FOR DRAFTING THE FRONT.**

Trace straight line at waist *G* about 30 centimetres long or more, lines *S* and *P* represent the opening of the skirt and are 10 centimetres in width for the laps of the opening, trace lines *S* and *P* straight and square with line *G*, then trace line *A* from waist to bottom of skirt, with 10 centimetres at waist and 20 or 25 at bottom, trace line *M* same as line *N*, line *K* is the bottom of skirt, trace line *K* from line *M* to line *N*.

**NOTICE TO PUPILS.**

In drafting skirts, trousers or bloomers, we only use the dart and skirt rule piece No. 5, and for placing darts we use same numbers as for waists or jackets which are specially for darts and spaces of measures when we do not name the word centimetres, when we say so many centimetres they are measured with the numbers which are on the straight edge of the dart and skirt rule, as they are the same size as the centimetres on tape lines. For drafting this skirt take an extra measure, same as for drafting the riding pants and is used same. For direction see figure 86

Figure 105 represents the back part of the trousers.

**DIRECTIONS FOR DRAFTING FIGURE 105.**

Figure 105 is drafted same as figure 85, except that we use the straight line for side seam, instead of drafting a second line to give the curve of the leg as in riding trousers. Figure 105 is cut larger and does not need any curve from the back.

Figure 106 represents the front part of the trousers and the back part of the skirt.

**DIRECTIONS FOR DRAFTING FIGURE 106.**

Figure 106 is drafted same as figure 84, except that we use the straight line same as in figure 105. To draft the skirt part trace line *A* 15 centimetres from line *B*, trace line *G* 2 centimetres from line *A*, then trace line *L* at 90 centimetres from line *B* at bottom of skirt, trace line *K* bottom of skirt and trousers from line *D* to line *L*.

Figure 105 and figure 106 represent half of the trousers and skirt, the dots showing how to put trousers and skirt together.

Figure 107 represent the trousers and skirt put together without the front part figure 104, the two side seams show where the trousers are fixed to the skirt, the front seam shows the inside seam of trousers also the division of the skirt.

Figure 108 represents the skirt and trousers finished with the front part on it, figure 104 covers the front opening division of skirt.

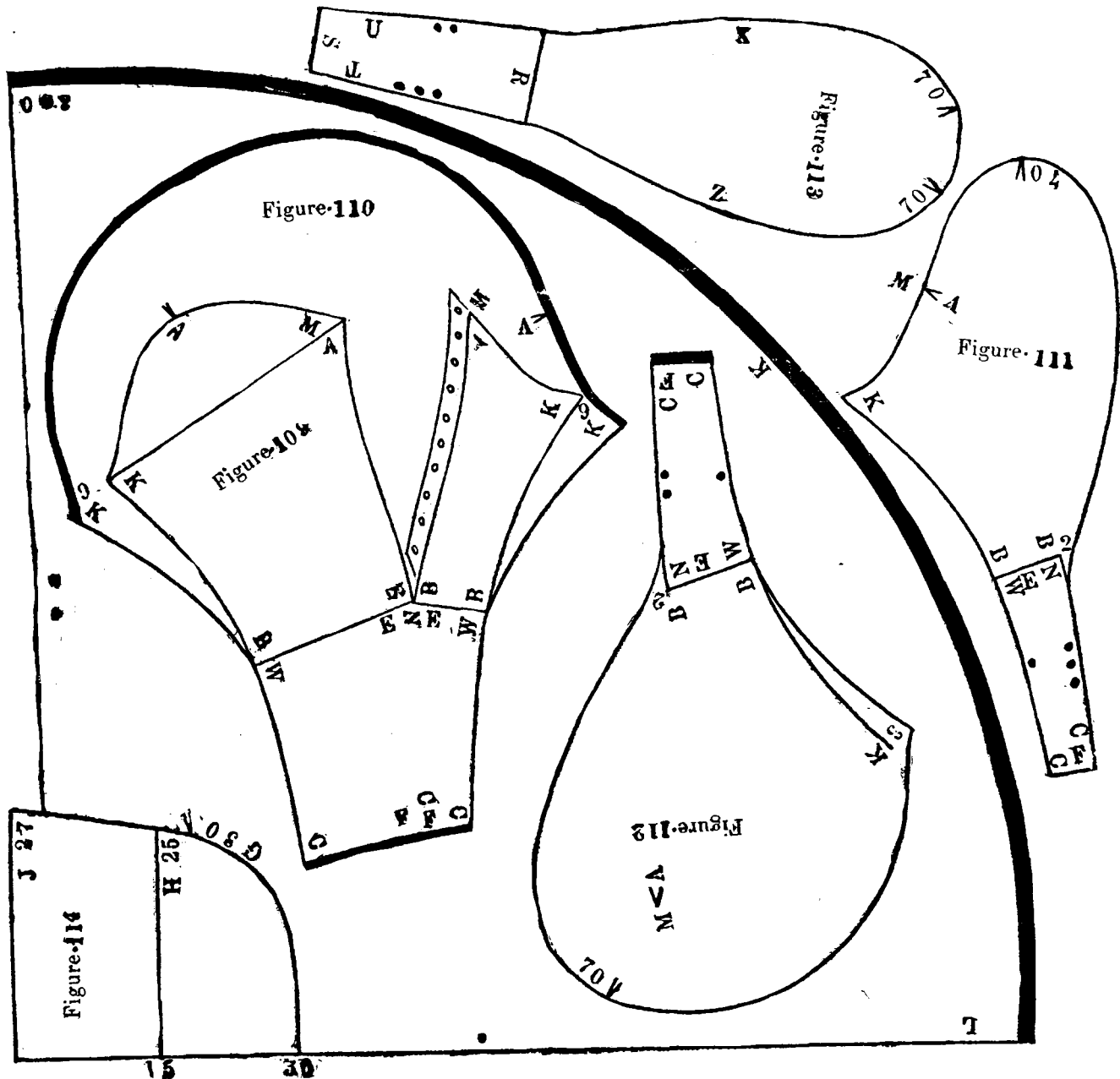

Figure 109 represents a plain sleeve used for foundation or for plain sleeve buttoned from elbow to the shoulder.

#### DIRECTIONS FOR DRAFTING FIGURE 109.

The upper sleeve is drafted same as Figure 93, except that the seam from elbow to wrist is not traced. Take the width of under-arm part at wrist, then reverse the *system*, place the pencil in the perforated number at elbow on the under-arm part, place the point of pencil at dot *B*, hold the pencil with left hand, with right hand swing the edge of the *system* at wrist dot *F*, trace from elbow line *W* down to *C* length from elbow to wrist, trace wrist from *C* to *F*, move the *system* down, place *B* edge length from shoulder to elbow at elbow line, then trace up to corner *K*, dot armseye measure *A*, trace back line *M* from dot *A* down to *B*, add 2 or 4 centimetres for button holes, then trace the armseye curve with top of *system*, placing same number as armseye measure at dot *K*, trace up to dot *A*. This under-sleeve is drafted same as figure 88, except that figure 109 is drafted with the *system* turned on the wrong side.

Figure 110 represents the leg of mutton sleeve with one seam.

#### DIRECTIONS FOR DRAFTING FIGURE 110.

Figure 110 is drafted same as 109, except that Figure 110 is made from 9 to 20 centimetres each side of corner *K*, according to the size you wish to draft. Trace line from *W* to *K*, swing the *system* back and trace the large circle of the sleeve at half way, now reverse the *system* to draft the under-part, trace line from *W* to corner *K*, dot armseye measure *A*, then trace the curve from *K* to dot *A*, swing the *system* and finish to trace the circular line.

Figure 111, Figure 112 and Figure 113 represent a watermelon sleeve made in three pieces.

#### DIRECTIONS FOR DRAFTING FIGURE 111.

Figure 111 is the under-sleeve ; dot armseye measure *A* and elbow measure *E*, trace from corner *K* to *B* length of shoulder to elbow, move the *system* up, place elbow line at dot *B*, the upper edge of the *system* corner *K*, then trace from *W* to *C* length of elbow to wrist ; dot wrist measure *F*, take the back edge of the *system*, measure length of shoulder to elbow from dot *A* to dot *B*, place elbow line at dot *B* and edge of *system* at dot *F*, trace from *N* down to *C* length of elbow to wrist, trace wrist from *F* to *C*, place corner *K* of the *system* at dot *A*, trace up from *M* to the centre dot, reverse the *system*, place elbow edge 2 centimetres from line *N*, trace up to centre dot 70 centimetres from dot *B* to the centre dot. Seventy centimetres is the size we give for that sleeve ; that is a medium size—70 centimetres in length from elbow to shoulder seam.

Figure 112 is the upper part of the sleeve.

#### DIRECTIONS FOR DRAFTING FIGURE 112.

Figure 112 is drafted same as figure 87, except that at elbow measure and at wrist measure we take only half of the width of the sleeve, the other half is to draft Figure 113, and a second line is traced from dot *B* to corner *K* to give more fullness to the sleeve, about 3 centimetres from first line, now swing the *system*, trace armseye line from corner to the dot ; measure back length from *M* to *B*, reverse the *system* and trace back line same as in Figure 111, at armseye line from corner *K* to the dot. Seventy is to be plaited in Figure 112 and in Figure 111 only between dot *A* and dot 70.

Figure 113 is the middle part of sleeve.

#### DIRECTIONS FOR DRAFTING FIGURE 113.

Take dart rule, trace line *R* to the width of elbow, measure the length of elbow to wrist, then trace line *S* to the width of wrist measure, trace line *T* and line *U*, take the sleeve *system*, place elbow at line *R* and trace line *X* up to 70 dot, reverse the *system* and trace line *Z* same way ; between the two dots is to be plaited, the different dots at seams show how the pieces go together.

Figure 114 represents a one-seam circular skirt.

#### DIRECTIONS FOR DRAFTING FIGURE 114.

Trace line *L* and line *J* square with line *L*, line *L* represents the fold of the goods at the front of the skirt. Suppose the waist measure is 30, then make a dot 30 centimetres below line *J*, make another dot half way 15, now trace line *H*, if the waist is 30 line *H* must be 25 centimetres long, always 5 centimetres less than the size of waist measure, take the sleeve *system*, place corner *M* at dot 30 and the edge of armseye at the end of line *H*, trace line *G* from dot 30 to line *H*, then measure the size of waist measure with the dart rule from dot 30 to the size of 30 and make a dot, line *J* is 2 centimetres longer than line *H*, with dart rule finish trace line *G* from line *H* to line *J*, measure from dot 30 what you want to be plaited at back of skirt, the size is from 15 to 35 centimetres. 25 is left for the back plaiting of this skirt ; now measure the bottom size, this skirt is 300 centimetres at bottom, then trace *M* length of back from waist to bottom, line *L* is the front length from dot 30 to the bottom. Trace bottom of skirt from line *L* to line *M*, using the tape line to shape the bottom circle. Figure 114 is only half of the skirt,



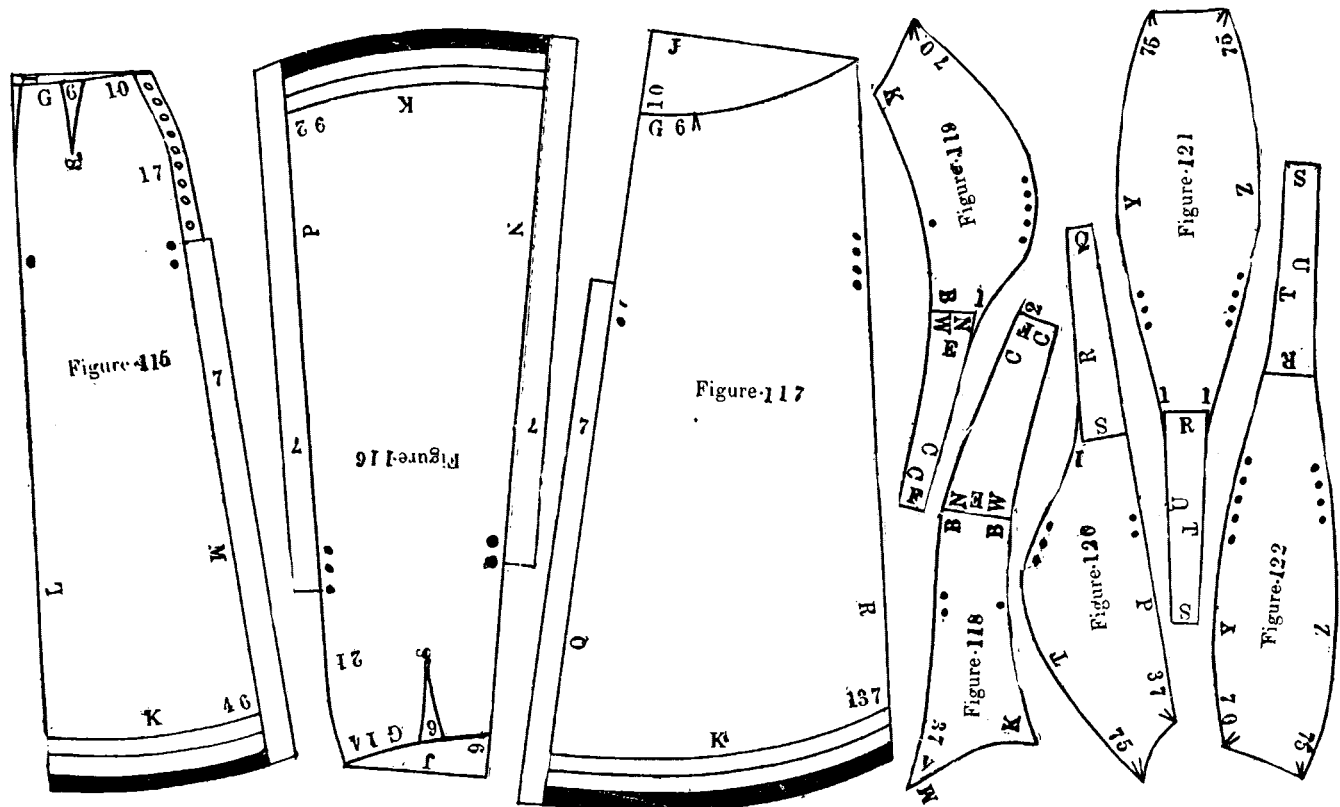

Figure 115, figure 116 and figure 117 represent a 5 gored circular skirt.

**DIRECTIONS FOR DRAFTING FIVE GORED CIRCULAR SKIRT.**

Waist measure is 60 centimetres, half 30 divided into 3 make 10 for each gore, first gore 10, second gore 14, third gore 6, add from 20 to 30 centimetres to be plaited at back, addition 10, 14, 6=30.

Hip measure is 100 centimeters—half 30 divided in 3 make  $16\frac{3}{4}$  for each gore; first gore 17, second gore 21, third gore 12, plus what is added for plaits, addition 17, 21, 12=50. The width at bottom is  $5\frac{1}{2}$  metres or 550 centimetres, which divided in three make 92 centimetres for each gore; make first gore half of the division, that is to say, half of 92. First gore 46, second gore to the size of the division 92, third gore the balance of the width 137 centimetres, addition 46, 92, 137=275.

**DIRECTIONS FOR DRAFTING FIGURE 115.**

Trace line *J*, trace line *L* square with line *J*, trace line *G* one centimetre below line *J*, add 6 for dart, trace line *K*, trace from line *G* to line *K* is to be the same length as line *L*, fold of goods, add 7 centimetres for plait on each seam, except the back seam. A first seam has an opening of 15 centimetres long, the opening is to conceal the pockets; the darts are 6 in width by using the dart measure, and are 8 centimetres in length. These darts are in lining only.

**DIRECTIONS FOR DRAFTING FIGURE 116.**

Trace line *J*, trace line *N* square with line *J*, trace line *G* at 6 centimetres below line *J*, add for dart, trace line *K*, trace line *P* from line *G* to line *K*, line *N* is to be traced at the front length and line *P* is to be traced at the side length.

**DIRECTIONS FOR DRAFTING FIGURE 117.**

Trace line *J*, trace line *Q* square with line *J*, trace line *G* 10 centimetres below line *J*, add from 20 to 35 centimetres from dot *G* to be plaited at back, trace line *K*, trace line *R* from line *G* to line *K*, line *Q* is to be traced at the side length and line *R* is to be traced at the back length.

**NOTICE TO PUPILS.**

In drafting skirts we only take half of the round measures same as in waist or sleeves, and we figure on even gores, that is to say, if we draft a five gored skirt we divide them same as if it was a six gored skirt, because the front gore counts double. A six gored skirt is drafted same as a five gored skirt, except that that there is one seam at front gore. For drafting skirt we only use the skirt rule piece No. 5.

Figure 118, figure 119, figure 120, figure 121 and figure 122 represent a five gored balloon sleeve.

**DIRECTIONS FOR DRAFTING FIGURE 118.**

Figure 118 is drafted same as figure 88, except that when tracing line from *W* to *C* the upper edge of the *system* is placed two centimetres in from corner *K* instead of two centimetres out as in figure 88.

**DIRECTIONS FOR DRAFTING FIGURE 119.**

Lay the *system* on lining or goods, trace from *K* down to *B*, move the *system* up, place elbow line of the *system* at dot *B*, place upper edge of *system* at 3 centimetres in from *K*, now trace from *W* down to *C*. The width at elbow and at wrist measure is the upper sleeve divided by four to make the last four figures, now dot the elbow and wrist width and trace back line from *N* to *C*, trace wrist then finish back line from *N* up to 70 centimetres, which is the length of back seam, trace from *K* to dot 70, the curved lines are drafted with the curved part of dart, but it is easier to draft them with tailor's chalk.

**DIRECTIONS FOR DRAFTING FIGURE 120.**

Trace line *P* straight and make it the same length as the back seam of the under sleeve. Trace line *Q*, trace line *S*, trace line *R* from *S* to *Q*, trace line *T*, passing one centimetre from line *S*, and is to be 75 centimetres long, then trace armseye.

**DIRECTIONS FOR DRAFTING FIGURE 121.**

Trace line *R*, trace line *S* square with line *R*, trace line *T* from *R* to *S*, trace line *U* from *R* to *S*, trace line *Y* passing one centimetre from line *R*, and is to be 75 centimetres long, trace line *Z* same as line *Y*, trace armseye.

**DIRECTIONS FOR DRAFTING FIGURE 122.**

Figure 122 is drafted same as figure 121, except that line *Y* is only 70 centimetres long. The different dots show how to put the sleeve together. The last three figures are drafted with dart rule only. Each gore is from 10 to 15 centimetres at arms-eye, except the under sleeve, which remains unchanged.

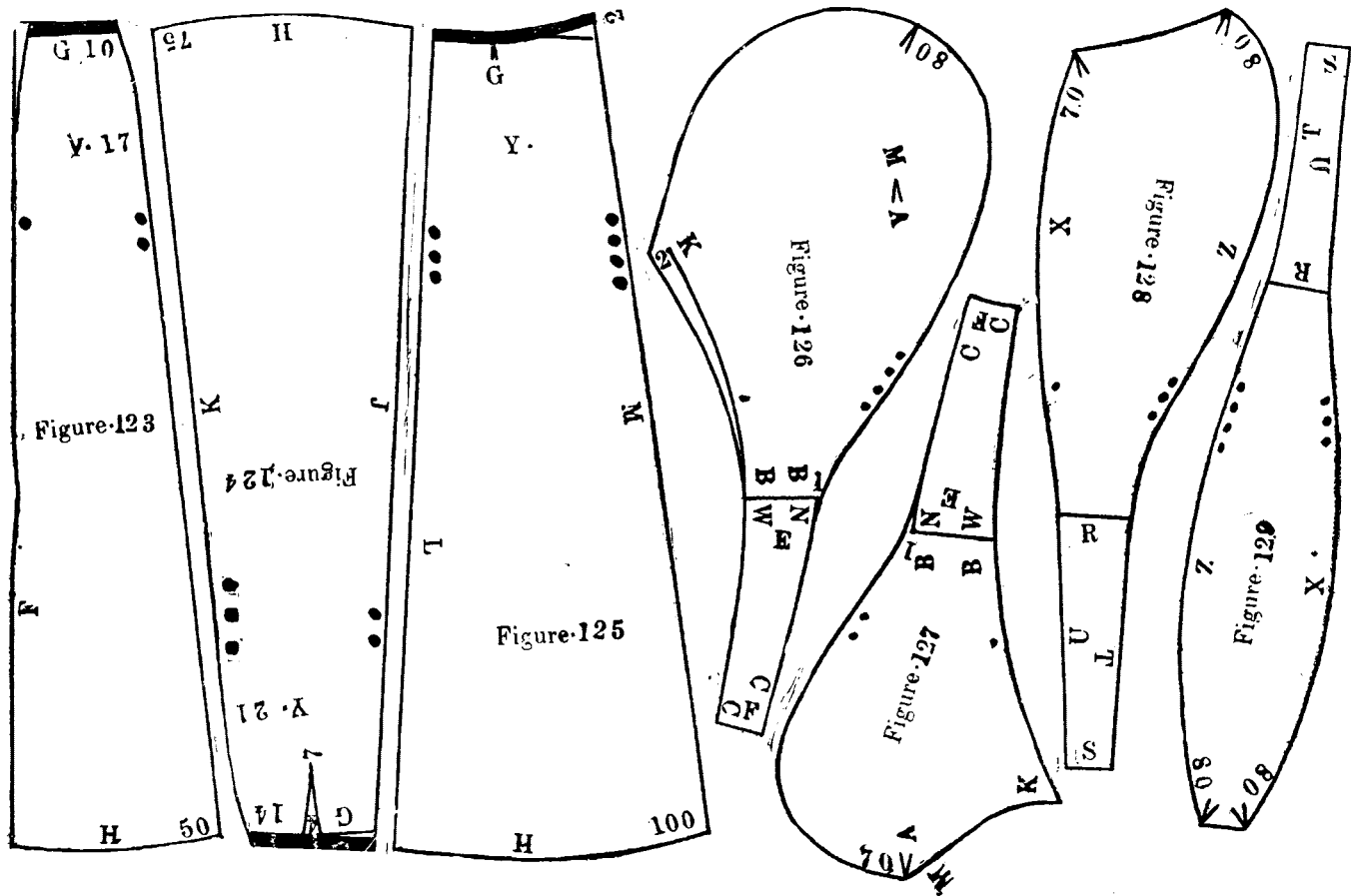

Figure 123, figure 124 and figure 125 represent a five gored skirt.

**DIRECTIONS FOR DRAFTING FIVE GORED SKIRT.**

The waist measure is 60 centimetres. Half 30 divided in three make 10 centimetres for each gore ; first gore 10, second gore 14, third gore 6 centimetres, make addition 10, 14, 6=30 Hip measure is 100 centimetres. Half 50 divided in three make  $16\frac{3}{4}$  for each gore ; first gore 17 centimetres, second gore 21, third gore 12 centimetres, make addition 17, 21, 12=50. The width at bottom is  $4\frac{1}{2}$  metres or 450 centimetres ; half is 225, divided in three make 75 centimetres for each gore. First gore is to be 50 centimetres, 25 less than the division by three. Second gore 75, the size of the division by three. Third gore 100 centimetres, balance of width, make addition 50, 175, 100=225.

**DIRECTIONS FOR DRAFTING FIGURE 123.**

Trace line *G*, trace line *F* square with line *G*, trace line *H*, trace side line from line *G*. to line *H*, fold of goods ; line *F* and side line are drafted to the front measure and we place a little dart at front on waist about a half centimetre in width. This dart is in lining only.

**DIRECTIONS FOR DRAFTING FIGURE 124.**

Trace line *G*, trace line *J* square with line *G*, trace line *H*, trace line *K* from line *G* to line *H*. We place a dart at waist at 4 and 7 centimetres long in lining only, and *G* line is one centimetre below square line, line *J* is traced to the front length and line *K* to the side length.

**DIRECTIONS FOR DRAFTING FIGURE 125.**

Trace line *G*, trace line *L* square with line *G*, trace line *H*, now trace from dot *G* to No. 2, add from 20 to 30 centimetres from dot *G*, to be plaited at back and is to be 2 centimetres above the square line, now trace line *M* from line *G* to line *H*, line *L* is traced at the side length and line *M* is traced at the back length.

Figure 126, figure 127, figure 128 and figure 129 represent a four gored balloon sleeve.

**DIRECTIONS FOR DRAFTING FIGURE 126.**

The top sleeve is divided in three at elbow and wrist measure. Lay the *system* on lining or goods and dot armseye measure *A*, trace from *K* down to *B*, move the *system* up, place elbow line of the *system* at *B* dot. and upper edge of *system* 2 centimetres from *K*, trace from *W* down to *C*, take width of elbow and wrist measure, then take back length from dot *A* to elbow dot *E*, then dot shoulder to elbow length *B*, trace from *N* to *C*, trace wrist line, trace elbow line. Trace a second line from elbow line up to two centimetres from line *K*, now trace armseye line from No. 2 up to the centre of sleeve, trace back line from *N* up to the dot and is to be 80 centimetres long.

**DIRECTIONS FOR DRAFTING FIGURE 127.**

Under sleeve figure 127 is drafted same as figure 88, except that we do not trace the length from shoulder to elbow. We only take the measure and make a dot *B* ; when drafting from *W* to *C* we place the upper edge of the *system* two centimetres in at *K* instead of putting it two centimetres out as in figure 88. Now trace back line from *N* up to dot *A*, and is to be 70 centimetres long.

**DIRECTIONS FOR DRAFTING FIGURE 128.**

For drafting 128 and 129 we use the dart rule only. Trace line *R*, trace line *S*, square with line *R*, trace line *T* from line *R* to line *S*, trace line *U* from *R* to *S*, trace line *X* is to be 70 centimetres long, trace *Z* is to be 80 centimetres long, trace armseye and is to be from 10 to 20 centimetres in width.

**DIRECTIONS FOR DRAFTING FIGURE 129.**

Trace line *R*, trace line *S*, square with line *R*, trace line *T* from *R* to *S*, trace line *U* from *R* to *S*, trace line *X* and is to be 80 centimetres long, trace line *Z* and is to be 80 centimetres long, trace armseye and is to be from 5 to 10 centimetres in width.

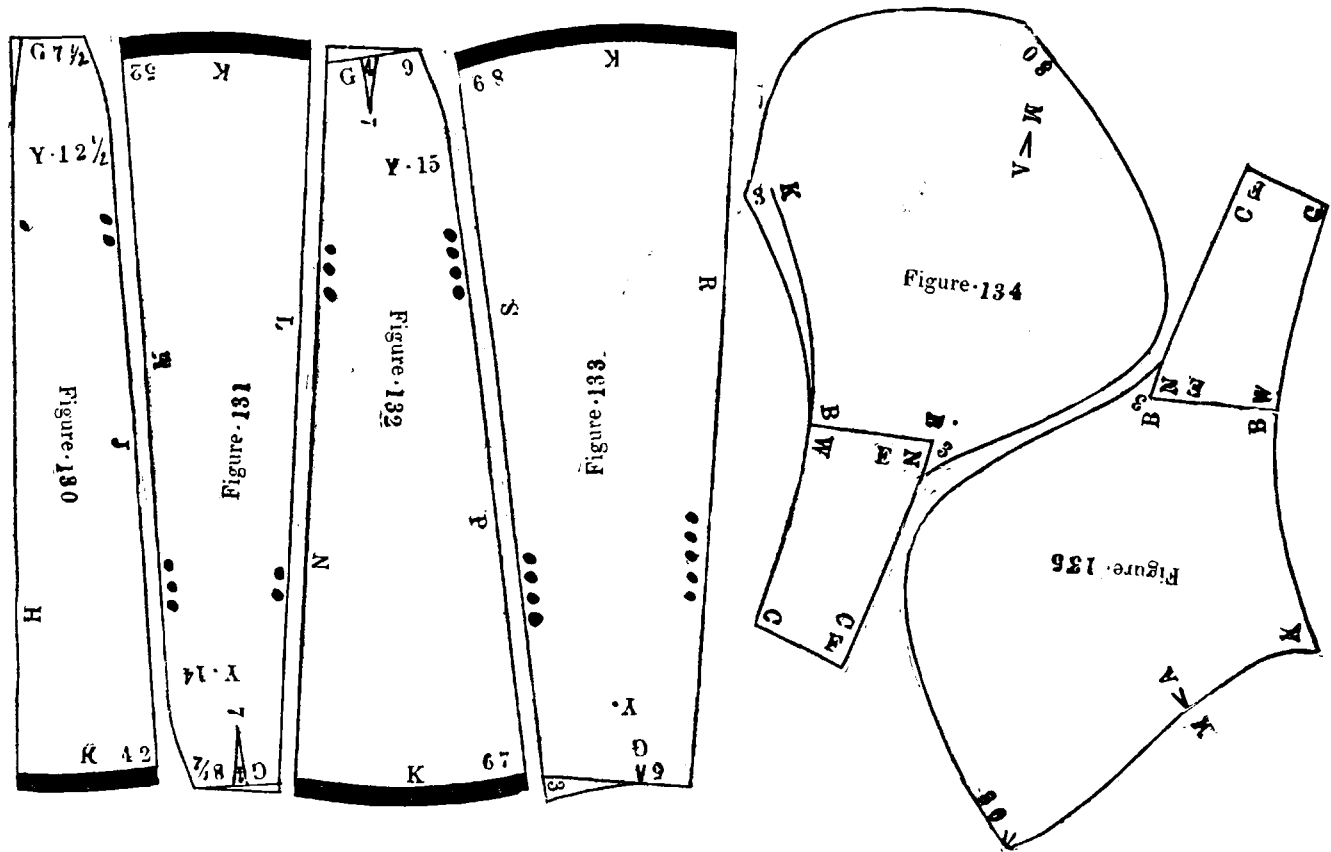

Figure 130, Figure 131, Figure 132 and Figure 133 represents a seven-gored skirt.

#### DIRECTIONS FOR DRAFTING THE SEVEN GORED SKIRT.

After having taken all the measures as required, we proceed by making the division of waist, hip and bottom measure for each gore, and we use only half of the measure as we only draft half of the skirt. The goods are cut double and Figure 130 has no seam. At front line *H* is the fold of the goods. DIVISIONS.—Waist measure 60 centimetres; half 30 centimetres divided by four make  $7\frac{1}{2}$ . Whatever is the size of waist measure the first gore is made at the size of your division; first gore  $7\frac{1}{2}$  centimetres, second  $8\frac{1}{2}$  centimetres, third gore 9 centimetres, fourth gore 5 centimetres and add from 15 to 30 centimetres for the back plaits. This skirt is 20 centimetres for plaits. In each seven-gored skirt leave only 5 centimetres for the back gore, and in your division the difference between the first and back gore is used for the two side gores by making the third gore one or two centimetres larger than the second gore. Now make the addition,  $7\frac{1}{2}$ ,  $8\frac{1}{2}$ , 9, 5=30.

DIVISION.—Hip measure 100 centimetres; half 50 divided by four make  $12\frac{1}{2}$  for each gore, first gore  $12\frac{1}{2}$  centimetres, second gore  $13\frac{1}{2}$  centimetres, third gore 14 centimetres, fourth gore 10 centimetres and what is added from the waist measure; when you add to the waist measure the same proportion must be added to the hip measure. Now make the addition,  $12\frac{1}{2}$ ,  $13\frac{1}{2}$ , 14, 10=50.

DIVISION OF BOTTOM.—Size 5 metres—which make 500 centimetres; half 250 centimetres divided by 4 make  $62\frac{1}{2}$  centimetres for each gore. We make the first gore at bottom 20 centimetres less than whatever the division may be, that is to say, this skirt is  $62\frac{1}{2}$  centimetres for each gore, 20 less for first gore, it makes the first gore  $42\frac{1}{2}$  centimetres, raise second 10 centimetres, second gore 52 centimetres, raise third gore 15 centimetres, third gore 67 centimetres, fourth gore 89 centimetres, that is the balance left of the skirt. Now make the addition, 42, 52, 67, 89=250.

#### DIRECTIONS FOR DRAFTING SEVEN GORED SKIRT.

FIRST GORE.—Trace line *G* waist measure square with line *H* length of front, dot waist measure, hip measure and bottom measure, trace line *J* from waist dot to hip dot by using the curved part of skirt rule, and from hip dot to the bottom dot by using the straight edge of skirt rule, then trace bottom line *K* from line *H* to line *J*, use the tape line to trace line *K*, roll your pencil at end of tape line, place your left hand at wrist line holding tape line, trace line *K* with right hand by swinging from line *H* to line *J* and both lines being the same length. At corner of line *H* and line *G*, make a little dart of half a centimetre in width; this is made in lining only. SECOND GORE is drafted same as first gore, except that waist is raised one centimetre from the square line *G*, from line *M* to line *L* at the centre we place a dart of 4, all the darts are made by using the dart measure same as in waists or jackets. The dart is 7 centimetres long, line *L* is traced to the length of front measure, and line *M* is traced to the length of hip measure, then trace line *K*. THIRD GORE is drafted same as second gore, except that the third gore is raised 2 centimetres from

the square line *G*, line *N* is traced to the length of hip measure, line *P* is traced to the length of back measure, then trace line *K*. FOURTH GORE is drafted same as third gore, except that back gore has no dart and is raised 3 centimetres from the square line *G*, beginning at dot 5 to line *S*, line *R* and line *S* are traced to the length of back measure, trace line *K*.

**NOTICE TO PUPILS.**

You must not think that this skirt is drafted the same for every form. The skirt we give here is drafted for persons who have large hips. For an ordinary form we raise the waist line from the square line *G* only half of what we give here; for a person under the medium size we put no darts in lining, and for slim persons we only raise the back gore 2 centimetres and we use the square line *G* for waist line. Remember that the darts are put in lining only and not in the goods.

An eight gored skirt is drafted same as seven gored skirt, except that on the front of the skirt is a seam, and the goods are not folded.

Figure 134 and figure 135 represent Prof. Jean B. Peyry's sleeve made in two pieces.

**DIRECTIONS FOR DRAFTING PEYRY'S SLEEVE.**

At elbow measure and at wrist measure the under part of sleeve and the upper part of sleeve are the same width in lieu to have the outside seam on the center of arm. To do this take off 4 measures at elbow from the upper part and add 9 measures at under part. Take off 3 measures at wrist from the upper part and add 7 measures at the under part.

Figure 134. — Dot armseye measure *A*, dot elbow measure *E*, trace from corner *K* down to *B*, swing the *system*, trace second line 3 centimetres from *K*, move the *system* up, place waist line at dot *B*, trace from *W* to *C*, move the *system* up and dot wrist measure *F*, place corner *M* at dot *A* and edge of *system* at dot *E*, and measure length of shoulder to elbow from *A* to *B* dot, then move the *system*, place elbow line at dot *B*, and trace down from *N* to *C*, dot *F*, then trace wrist measure from *F* to *C*. Now trace armseye line, place corner *K* of *system* at No. 3, trace around to center dot 80, reverse the *system*, and place elbow edge at *N*, 3 centimetres from dot *B*, then trace up to dot 80 from dot *B* to the upper dot. Eighty is the length of the outside seam and the under part is the same length.

Figure 135, Under Sleeve.—Dot at armseye measure *A* and at elbow measure *E*, trace from *K* to *B*, trace armseye curve from *K* to *A* dot, trace from *A* dot to dot 80. The back part of the sleeve and from elbow down is drafted same as figure 134.

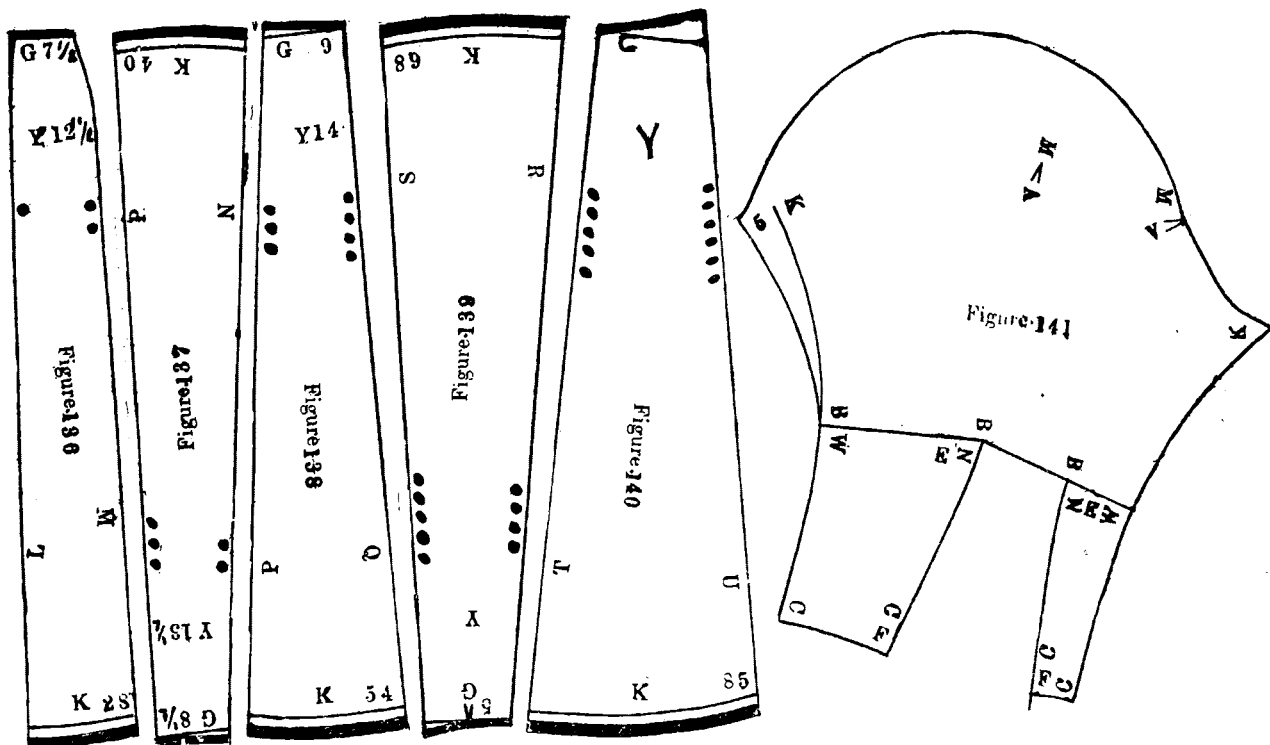

Figure 136, figure 137, figure 138, figure 139 and figure 140 represent a nine gored skirt.

**DIRECTIONS FOR DRAFTING THE NINE GORED SKIRT.**

After having taken the different measurements, we proceed to make all the divisions of waist, hips and bottom measure for each gore, and we use only half the measure. The front gore is drafted with the goods double.

**DIVISION OF GORES.**—This skirt is divided by four at waist and hips measure, as the back gore is added to be plaited at waist, the back gore does not figure for the waist and hips division, but only for the bottom division which is divided by five. Waist division, waist measure 60 centimetres ; half 30 divided by 4 make  $7\frac{1}{2}$  each, front gore  $7\frac{1}{2}$ , second gore  $8\frac{1}{2}$ , third gore 9, fourth gore 5, fifth gore 0, addition  $7\frac{1}{2}$ ,  $8\frac{1}{2}$ , 9, 5, 0 = 30.

**HIPS DIVISION.**—Hips measure 100 centimetres ; half 50 divided by 4 make  $12\frac{1}{2}$  each, front gore,  $12\frac{1}{2}$  second gore,  $13\frac{1}{2}$  third gore 14, fourth gore 10, fifth gore 0, addition  $12\frac{1}{2}$ ,  $13\frac{1}{2}$ , 14, 10, 0, = 50. At waist measure add 10 centimetres at 4th gore from dot *G* for plait and 15 or 20 centimetres for the back gore to be plaited also. Size of bottom of skirt  $5\frac{1}{2}$  metres or 550 centimetres : half 275 centimetres divided by 5 make 55 centimetres each for front gore. We take half of the division : first gore 28, second gore 40 (12 more than the first), third gore 54 (14 more than the second), fourth gore 68 (14 more than the third), fifth gore 85 balance of skirt, make addition 28, 40, 54, 68, 85 = 275. Draft front gore same as for a seven gored skirt, the other four gores being drafted bias on both sides, and if the straight line passes above the hip dot it will be all right as the skirt does not need to be so tightly fitted at hips. To draft second gore trace straight line at waist *G* to the size you need the gore, make a dot at bottom letter *K* and see that dot is square with the centre of waist line *G*, dot *K* must be at the centre of the gore ; take the width of gore from dot *K* ; if the gore is 20 in width take 20 each side of dot *K*, trace line *N* and line *P* to the length of line *M*, raise of waist  $\frac{1}{2}$  centimetre from the square line. Draft the third gore same as the second, trace line *P* to the front length and trace line *Q* to the hip length. Raise at waist centimetre from square line. Draft fourth gore same as second and trace line *R* to the hip length, trace line *S* to the back length ; raise waist one centimetre from square line. Draft back gore same as second gore, except that the back seam line *U* has more bias than in line *T*. Trace line *U* and line *T* to the back length, raise at waist two centimetres from the square line, then trace the bottom line *K*. The different dots show how to put the skirt together. This skirt is drafted for a large person. For an extra large person raise the waist from the square line double what we give here, and for a medium sized person only half of what we give here. For slim persons raise only the back gore 3 centimetres. A ten gored skirt is drafted same as a nine gored skirt, except that the front gore has a seam on the front.

Figure 141 represents a bouffon sleeve plaited at elbow.

**DIRECTIONS FOR DRAFTING FIGURE 141.**

Place the *system* on lining or goods, dot armseye measure *A* and elbow measure *B*, trace from *K* down to *B*, move the *system* up, place elbow line at dot *B*, trace from *W* down to *C*, move the *system* up and dot wrist measure *F*, place corner *M* at dot *A*, and the edge of *system* at dot *B*, then measure shoulder to elbow length from *A* to *B*, move the *system* up, place elbow line at dot *B* and the edge at dot *F*, trace from *N* down to *C*, trace wrist measure from *F* to *C*. Place under sleeve from 10 to 20 centimetres from the top sleeve, reverse the *system* and dot armseye measure *A* and elbow measure *E*, trace from corner *K* down to *B*, move the *system* up and place elbow line to dot *B*, trace from *W* down to *C*, and dot wrist measure *F* ; with the back of the *system* measure from dot *A* to dot *B* length of shoulder to elbow, move the *system* up, place elbow line to dot *B* and edge of *system* at dot *F*, trace from *N* down to *C*, trace wrist measure from *F* to *C*.

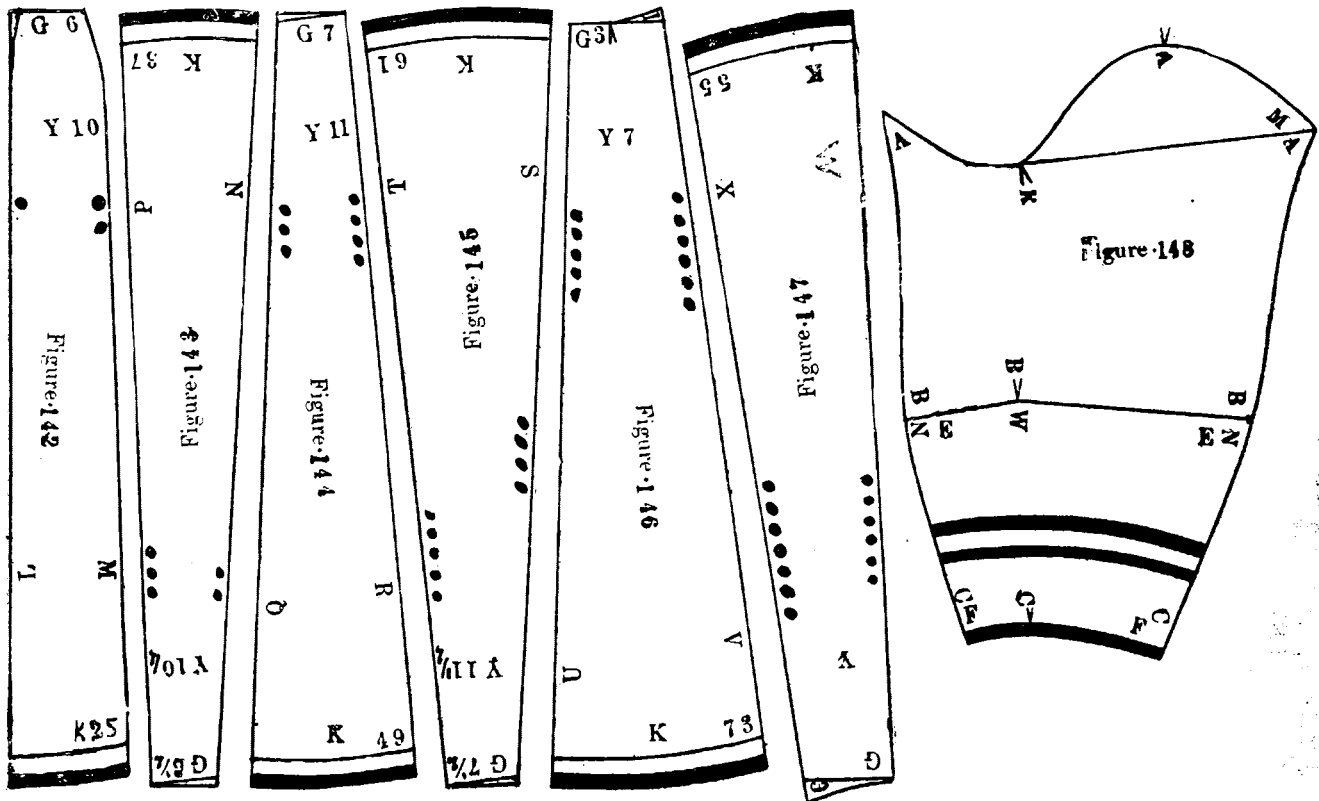

Figure 142, Figure 143, Figure 144, Figure 145, Figure 146 and Figure 147 represent an eleven-gored skirt.

**DIRECTIONS FOR DRAFTING AN ELEVEN GORED SKIRT.**

After all the measures are taken we proceed to make all the divisions same as for any other gored skirt. The waist and hip measure are divided by 5 and the bottom is divided by 6. Waist measure is 60 centimetres; half 30 divided by 5 make 6 centimetres for each gore. First gore 6, second gore  $6\frac{1}{2}$ , third gore 7, fourth gore  $7\frac{1}{2}$ , fifth gore 8, sixth gore 9, make the addition, 6,  $6\frac{1}{2}$ , 7,  $7\frac{1}{2}$ , 8, 9=30.

Hip measure is 100 centimetres; half 50 divided by 5 make 10 centimetres for each gore—first gore 10, second gore  $10\frac{1}{2}$ , third gore 11, fourth gore  $11\frac{1}{2}$ , fifth gore 12, sixth gore 13—addition 10,  $10\frac{1}{2}$ , 11,  $11\frac{1}{2}$ , 12, 13=50.

The width of bottom is 6 metres or 600 centimetres; half is 300, divided by six, make 50 centimetres for each gore. Make first gore half of the division 25 centimetres; make every other gore 12 centimetres more than the first gore, except the back gore for which is put the balance of the skirt. First gore 25, second gore 37, third gore 49, fourth gore 61, fifth gore 73, sixth gore 85, balance of skirt, make addition, 25, 37, 49, 61, 73, 85=300.

An eleven-gored skirt is drafted same as a nine-gored skirt with bias gores each side, and is raised same at waist from the square line, part of fifth gore and the back gore are plaited at waist. We add 10 centimetres at the fifth gore from dot *G* and we make the back gore from 15 to 20 centimetres at waist, and line *X* is more in bias than line *W*. A twelve-gored skirt is drafted same as an eleven-gored skirt, except that the front gore has a seam at the front of the skirt.

Figure 148 represents Prof. Jean B. Peyry's one outside seam sleeve.

**DIRECTIONS FOR DRAFTING FIGURE 148.**

The upper sleeve is drafted same as plain sleeve figure 87, except that the front part is not traced and is only dotted at elbow and wrist. Reverse the *system* and place inside edge of *system* at *K* and *B* dot, now dot armseye measure *A* and elbow measure *E*, move the *system* up and dot wrist measure *F*, now trace length of shoulder to elbow measure from dot *A* down to dot *B*, move the *system* up, trace from *N* to *C*, then trace wrist measure from *F* to *G*.

Figure 149 represents the foundation of a seamless waist and the drafting of the lining.

**DIRECTIONS FOR DRAFTING FIGURE 149.**

First fold lining to prevent seam on the back. Lay the back of the *system* (piece No. 4) straight with the fold of the lining and see that the lining has not wrinkled. Now dot width of back measure *O*, shoulder measure *C*, neck measure *B*, then trace from neck dot to the corner and down to length of back *L*, now move the *system* up, place waist line at dot *L*, by having the back of *system* straight with back line, then dot waist measure *G*, trace length of shoulder *C* from *B* to *C*, trace armseye from dot *O*, to dot *C*.

Take side back of *system* (piece No. 3), place corner *E* of *system* at dot *O* and edge *M* at waist dot *G*, now dot bust measure *E*, then trace the small line between *L* and *M* about 6 or 7 centimetres long. Now move the system up, and place waist line at dot *G*, edge *M* straight with the small line, then dot waist measure *G*. Now move the *system* back, place edge of *system* at *G* dot, and dot at *E*, then dot length of under-arm *F*, trace from *F* to *O* at armseye.

Take under-arm *system* (piece No. 2). Place corner *E* at dot *F* and edge of *system* at *G* dot; now bust measure *E* and trace another small line like the first one above *G* dot. Move the *system* up, place waist line at *G* dot, the edge of the *system* straight with the small line, then dot waist measure *G*. Now move the *system* back and place edge of *system* at *G* and *E* dot, then take length of under-arm measure *F*, then trace from *F* to *F* at armseye.

**NOTICE TO PUPILS.**

The back, side back and under-arm are half of the garment and the front is the other half. For instance, we draft this waist for persons who are 30 centimetre waist measure. Dot *G* is half of 30, we want 15 centimetres more for the other half. How to get them—take under-arm piece (No. 2) and put pin on the last perforated hole and place the pin at dot *G*, hold the pin with the left hand and with the right hand place the pencil at the edge of the *system* at No. 15, which makes the other half, then swing to the right to trace circle *T* without displacing the pin from dot *G*, trace another circle 8 centimetres from the first one, place the pencil at the edge of *system* No. 23, swing the *system* to the right and trace circle *U*. After the two circles are traced, take the front part of the *system* (piece No. 1), put the pencil on the bust measure perforation, and add 3 measures at bust to the front piece only; if the bust measure is 48 put the pencil on perforation 51 and place the pencil at dot *F*, and hold the pencil with the right hand and with the left hand place the front edge of the *system* *A* at circle *U* on the measure we are using. For the front length 38 and from neck to bust line is 18. Now dot the bust line 19, make two other dots of two centimetres, part one centimetre above bust line and one centimetre below bust line, and these two centimetres are to make a little dart across the bust in lining only, and those two centimetres are added at the front length, also what is less than 19 centimetres from neck to bust line. The front length is 38 and two for the dart makes 40, one that is less than 19 from neck to bust line makes 41 centimetres.

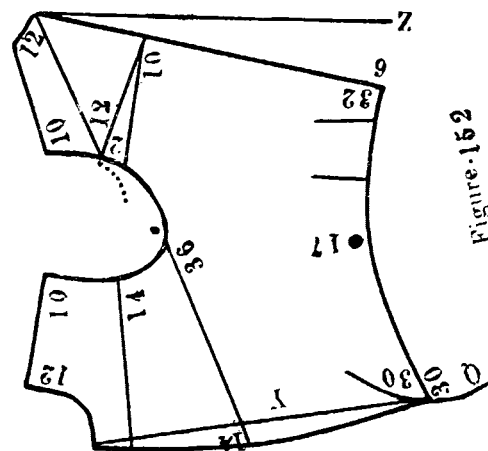
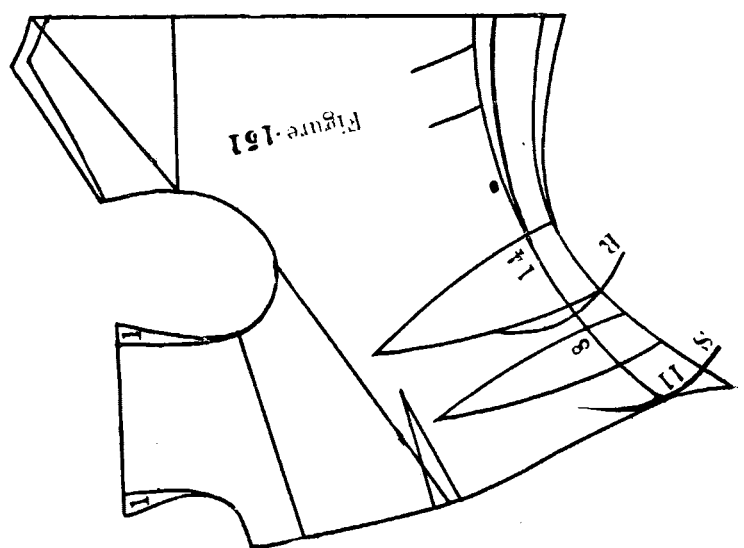
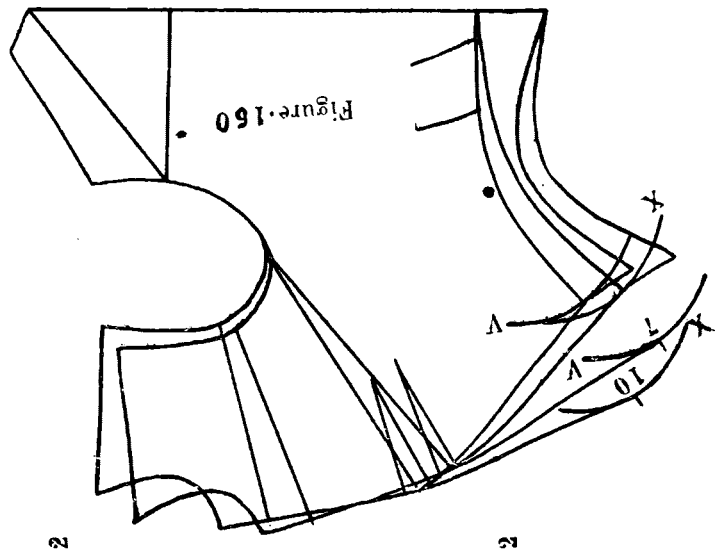
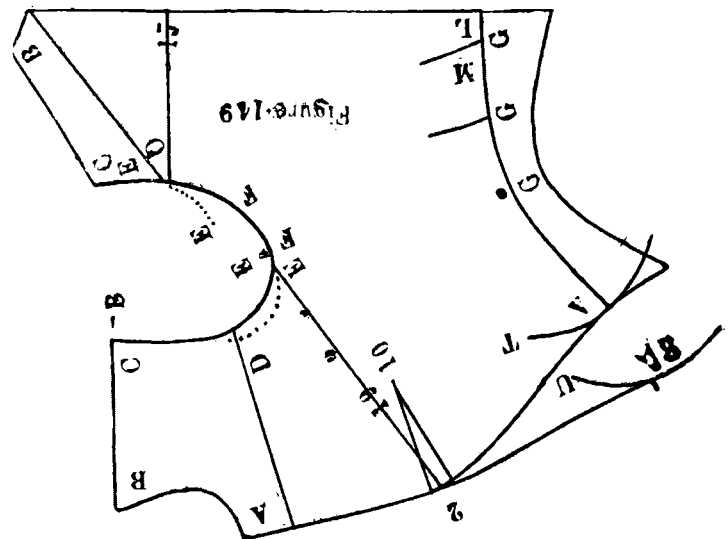



Then place 41 at circle *U*, trace from 41 *A* up to bust line 19, and from bust line up to one less from neck corner *A*. Before taking off the pencil from the bust perforation to trace the front line, be careful that the *system* does not move when tracing the front line by holding the *system* firmly in its place with the left hand. Now move the *system* down from neck corner to dot *A*, the edge of *system* straight with the front line from bust line to dot *A*, now dot chest measure *D*, trace neck measure *B*, follow line to end dot *B*, then move the *system* down, place edge of *system* at dot *B*, then trace shoulder length *C*, now place the armseye No. 48 at bust dot *E* and at chest dot *D*, trace from *E* to *D* and from *D* to *C* shoulder length. Now trace a second line from chest *D* to bust *E*. This line is traced with the hand to give more rounding shape to the armseye. The little dots represent the first line traced with the *system*. Now finish the front and bottom of waist, place bust line of *system* at bust line dot and at circle *T*; then trace from bust line down to waist *A*, stop at front length 41, make a dot at circle *T* and 41. Now trace waist line with dart rule from back length *L* to under-arm length dot *G* and from dot *G* to front length *A*. To have the seamless waist come down below waist line, trace at back and front from 5 to 10 centimetres below waist and 3 to 5 centimetres at under-arm length dot *G*, according how long you wish it to come below waist line. Now take the back of *system* (piece No. 4) and trace from *G* to end of back line and from *G* to end of front line by using the curved part of *system*. Now take dart rule (piece No. 5) and trace bust dot same as represented in figure 149, two centimetres in width and ten centimetres in length.

#### IMPORTANT NOTICE TO PUPILS.

The distance given here between circle *T* and circle *U* is 8 centimetres, but the distance between the first and second circle is not 8 centimetres for everybody and for every form and shape of person. The distance that we place between the first and second circle is what we have over ten of difference between waist measure and bust measure. For instance, this is drafted by 48 bust measure and 30 waist measure, then the difference between 30 to 48 would be 18, it would be eight over ten the difference between waist and bust measure; then you must add 8 centimetres from circle *T* to circle *U*. If the bust measure is only 46 and waist measure 30 the difference between bust and waist measure would be only 16. It would make only six over ten, then the distance between first and second circle will be only 6 centimetres, so one of the waist measure is 38 and bust measure 48 the difference will be 10, then it is not necessary to trace a second circle or add anything as the first circle *T* will do. For persons that are very fleshy add one or two more from circle *T* to circle *U* take only 8 over the difference instead of 10.

#### HOW TO DRAFT FOR DEFORMED PERSONS.

If the person is very curved in the back begin to draft the back same as Figure 33. For hunchback persons begin to draft the back same as figure 34, for such persons it is best to draft the pattern on paper and for hunchbacks to have a seam on the back, in the lining only; if they are too much deformed put a seam on the back in lining and goods. What we take off at back of waist from the first Line *L* when we swing the *system* as in figure 33 does not change anything on the two circles.

We call the attention of all pupils to learn Figure 149 to perfection, as all other linings for foundations are drafted more or less on the same principle as Figure 149. In other figures we will only give directions for the changes which are made from Figure 149. For all other garments where the lining is drafted same as Figure 149, we will refer the pupils to Figure 149.

Figure 150 represents the lining or foundation for a seamless garment.

#### DIRECTIONS FOR DRAFTING FIGURE 150.

Figure 150 is drafted same as Figure 149, except that the circles are placed at different distances by using the same waist and bust measure as in Figure 149. It is to show to pupils what difference it will make if you do not exactly follow the instructions given in Figure 149.

Circle *X* and circle *V* are of 7 centimetres distance from each other, that is to show that shoulder line, the neck, chest line, bust line and bust dot, also waist line, come lower than in Figure 149 where the circles are 8 centimetres distance from each other, and the armseye would be larger than is in figure 149.

Circle *V* and Circle *X* are of 10 centimetres distance from each other. It shows how the shoulder line, neck, chest line, bust line, bust dart and waist line are much higher than is in Figure 149, and the armseye is smaller.

Figure 151 represents the lining or foundation for a seamless waist with two darts.

#### DIRECTIONS FOR DRAFTING FIGURE 151.

Figure 151 is drafted same as figure 149, except that the space between the two circles are used for the dart. If the darts are wanted larger than the space that is between the two circles, you can add from one to four centimetres over the regular space. Circle *R* is the size of the waist, same as circle *T* in figure 149. Circle *S* is 11 centimetres from circle *R*, which will make it 22 for the two darts. The space between first and second circle is regulated according to the width of the dart you want to have in the waist, but you cannot go over the rule given in figure 149 and in figure 151. That is to say, that you cannot add over four centimetres from the regular space or make it less than the regular space. The darts are placed in same way as in figure 6. The first dart is 8 and 14 for the second dart, the bust dart is same as in figure 149.

No. 1 and No. 2 show the change that is made in seamless garments for persons who have large necks and short shoulder blades. No. 1 shows how to take off the goods from neck and to be added at armseye. Persons who have large necks need less goods near the neck at shoulder seam and they need more at armseye from chest line to shoulder line. What is taken off the upper part of neck is added at the upper part of armseye. No. 2 shows the change that is made at back for persons with short necks or short shoulder blades and who are fleshy at the back of neck, as they need less goods at neck and more from shoulder blade to waist. What is taken off at neck is added at waist and their shoulders are more square at the back. The back length measure taken from neck to shoulder blade and from shoulder blade to waist will tell you what must be taken off at neck. What is less than 17 centimetres from neck to shoulder blade is taken off at neck and added at waist and at armseye.

Figure 152 represents the lining or foundation of a seamless garment for children.

#### DIRECTIONS FOR DRAFTING FIGURE 152.

For drafting figure 152 we use the following measures:—Bust 36, length of front neck to bust line 14, to waist 30, width of chest 14, neck 12, length of shoulder 10, length of under-arm 17, waist 30, length of back 32, width of back 12. Figure 152 is drafted same as figure 149, except that for children we do not allow ten between waist and bust measure. We take all the difference that is between the waist and bust measure and the space given is placed at back from the straight line *Z* and circle *Q* is the size of waist, same as circle *T* in figure 149. The bust dot is placed at back instead of at front and nothing is added anywhere to make the dart where it is placed, as the *system* adds that itself. Line *Z* represents the fold of lining, and the difference between waist and bust measure will be the space that the edge of the *system* is placed at waist from line *Z*. For instance, the bust measure is 36 and waist measure 30, the difference between waist and bust measure is 6 centimetres, then make a dot at 6 centimetres from line *Z*, and lay the back of *system* from point of line *Z* at neck to the dot made at waist, then draft this waist same as figure 149, except at front, then we trace straight line from waist to neck and we cut the pattern on the straight line: we fold the goods at front as the dress opens at back. No. 2 represents the width of the dart, No. 10 represents the length of the dart and how to place it. Trace line from dot *O* to the back seam, take two centimetres for the width and trace another line 10 centimetres long.

Registered according to Act of Parliament of Canada, by Prof. Jean B. Egry, in the year 1886, at the Office of Minister of Agriculture, at Ottawa.

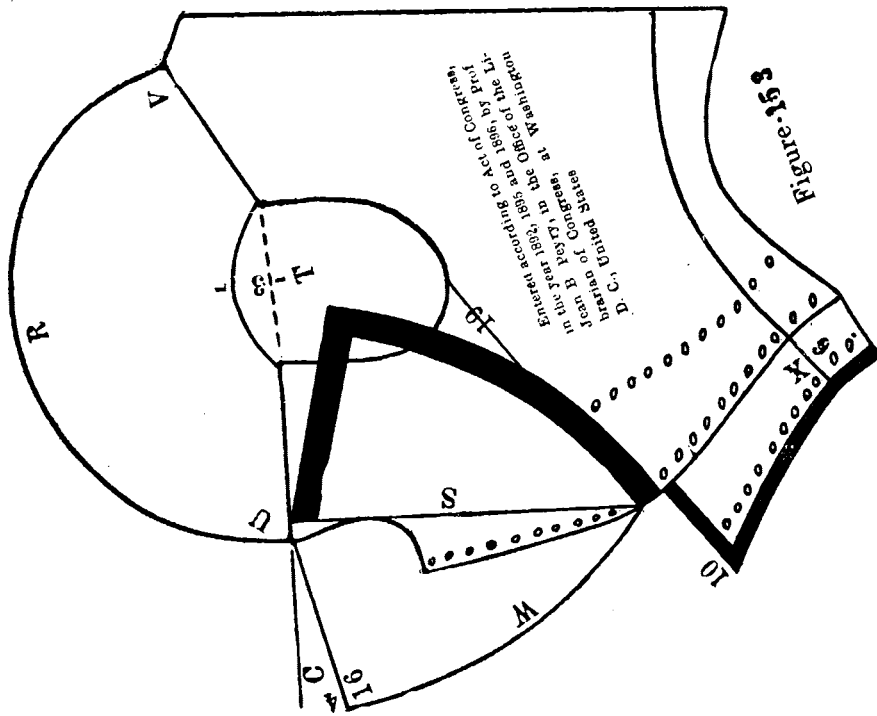

Figure 153

Figure 153 represents a tight-fitting, seamless waist with lapel, double breasted and plaited at shoulder.

**DIRECTIONS FOR DRAFTING FIGURE 153.**

Figure 153 is drafted same as Figure 149.

**DIRECTIONS FOR DRAFTING THE LAPEL.**

Trace line *S* from shoulder line to the bust line, trace line *C* straight with shoulder line, trace another line 4 centimetres below line *C* and trace it 16 centimetres long. Now trace line *W* from bust line to the point of line 16 centimetres long, by using the curved part of the back.

**DIRECTIONS FOR THE DOUBLE-BREASTED PART.**

Trace a line 10 centimetres long, 2 or 4 centimetres below bust line, trace line at waist and at bottom of waist 6 centimetres long, then trace from line 10 to waist and bottom by using the dart rule.

**DIRECTIONS FOR DRAFTING THE SHOULDER PLAITS.**

Trace line *T* at shoulder point and trace another line 3 centimetres from line *T* forming a circle, now trace line *R*, roll your pencil at end of tape line, hold it with right hand and hold the tape line with left hand at No. 3 and trace from *U* to *V*.

Figure 154 represents a tight-fitting, seamless waist with lapel and double breast.

**DIRECTIONS FOR DRAFTING FIGURE 154.**

Figure 154 is drafted same as Figure 149.

**DIRECTIONS FOR LAPEL.**

Trace line *Z* from bust line to 12 centimetres above shoulder line, trace *Y* straight with shoulder line 14 centimetres long, trace line *X* from bust line to point of line *Y*, by using the curved part of the back of the *system*, trace line *W* from line *Y* to point of line *Z*, trace line *I* 3 centimetres above shoulder line, 5 centimetres from line *Z* to corner *I*, and from corner *I* up to point of line *Z*.

**DIRECTIONS FOR DOUBLE BREAST.**

Double breasts are drafted same Figure 153.

Figure 155 represents a loose-fitting Figaro or Bolero with lapel.

**DIRECTIONS FOR DRAFTING FIGURE 155.**

Figure 155 is drafted same as Figure 149, except that the space between the two circles are left in it to make it fit loose at waist.

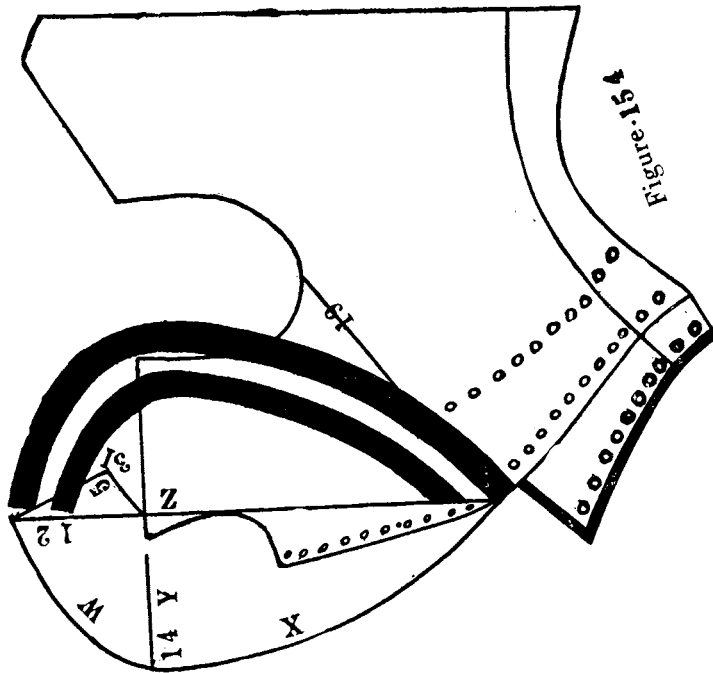

Figure 154

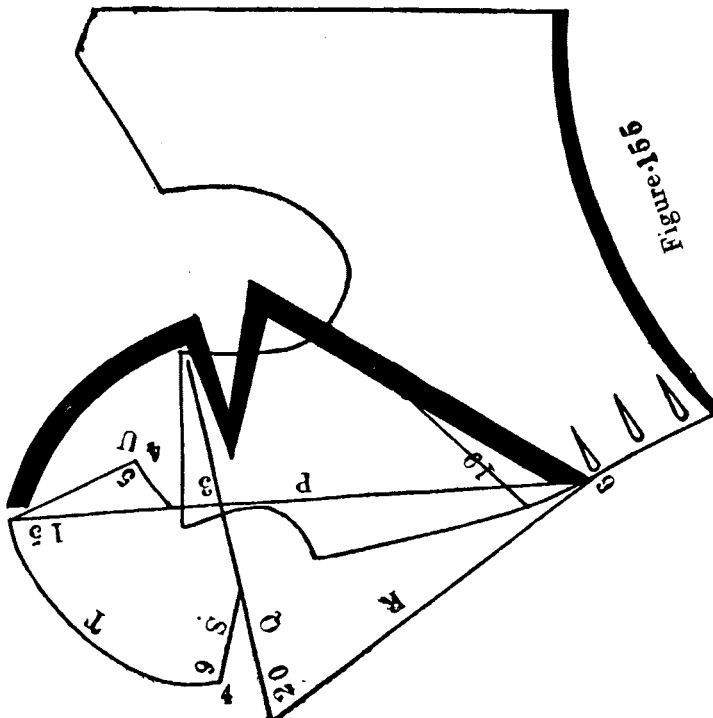

Figure 155

**DIRECTIONS FOR LAPEL.**

Trace line *P* from 6 centimetres below the bust line up to 15 centimetres above shoulder line, trace line *Q* passing 3 centimetres below neck corner and 20 centimetres long measuring from line *P*, trace line *R* from point of line *P* to the point of line *Q*, trace line *S* 4 centimetres from line *Q* and 6 centimetres long, trace line *T* from point of line *S* to the point of line *P*, trace line *U* 4 centimetres from shoulder line at corner, 5 centimetres from line *P* to the corner *U* and from corner *U* up to point of line *P*.

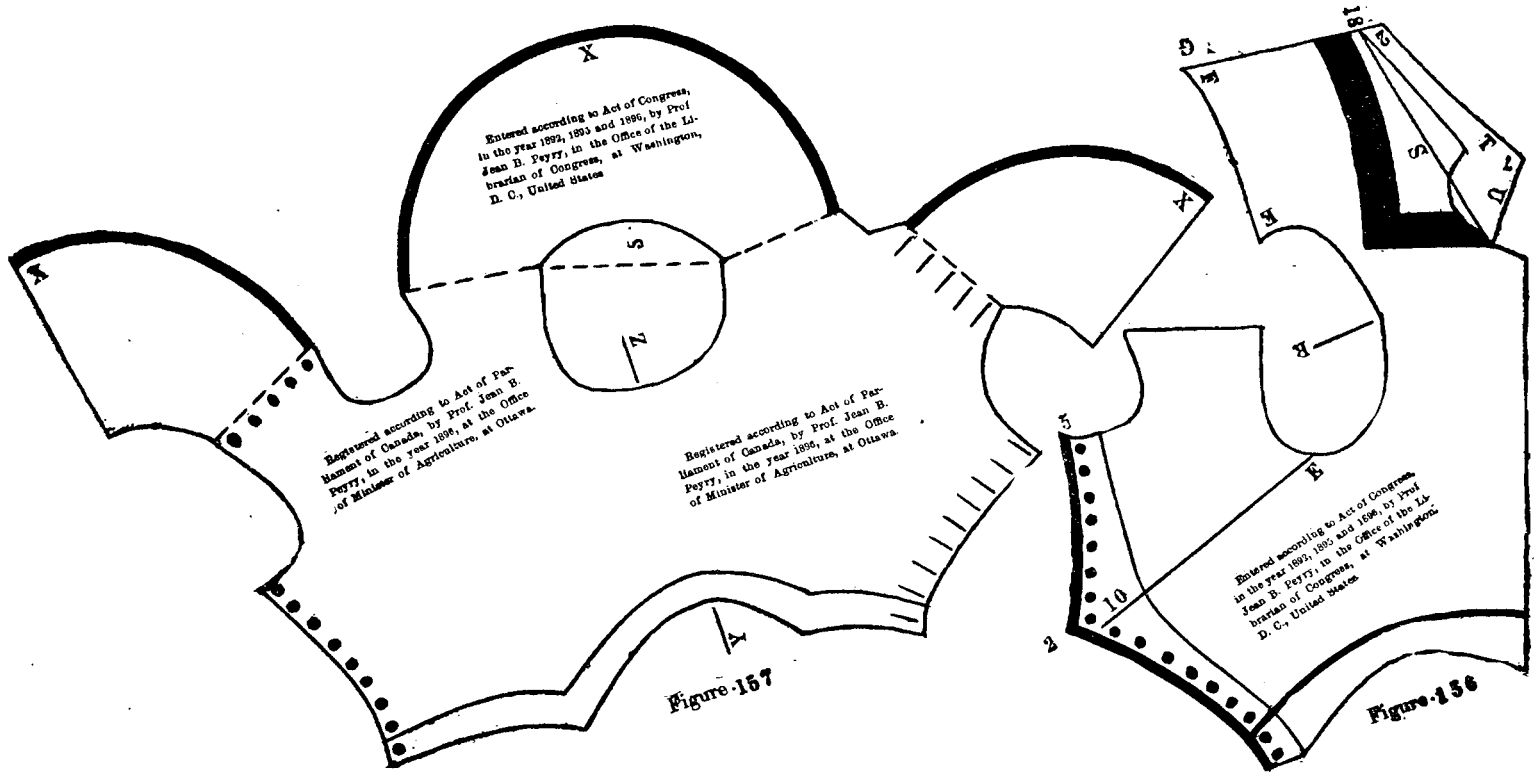

Figure 156 represents a seamless waist with jacket front and a double breast.

**DIRECTIONS FOR DRAFTING FIGURE 156.**

Figure 156 is drafted same as figure 149, except the jacket and double breast part.

**DIRECTIONS FOR DOUBLE BREAST.**

Take 5 centimetres at neck and at waist, 10 at bust, place corner of double breast two centimetres above bust line, trace with dart rule; the dart in lining for double breast is 4 centimetres in width.

**DIRECTIONS FOR JACKET.**

Trace line *R* straight with shoulder line, place neck line of *system B* at the back of neck and line *B* to be straight with line *R*, now trace neck measure down to the corner, trace front length 18 centimetres, dot chest measure *D*, move the *system* up, place bust line 19 at dot 18 and dot bust measure *E*, dot waist measure *G*, now trace under-arm measure *F* from *E* to *G*, trace line *S*, which represents the fold of the lapel, trace line *U* at 7 centimetres from neck corner, trace line *T* at two centimetres from line *S* and to the point of line *U*.

Figure 157 represents a seamless waist with plaits on the shoulders and with under-arm opening.

**DIRECTIONS FOR DRAFTING FIGURE 157.**

Figure 157 is drafted same as figure 44 and figure 45, except the pattern is drafted on the paper first to prevent having seam on the under-arm. Now join the two patterns together, line *Y* and line *Z* show where to join the pattern. If you wish the under-arm seam you can draft on the lining.

**DIRECTIONS TO DRAFT THE PLAITS.**

The plaits are drafted same as in figure 153, except that we draft on in paper and we cut it in two at *X* and we join half at each shoulder, and when the waist is put together the two *X*'s join together.

Entered according to Act of Congress,  
in the year 1892, 1893 and 1896, by Prof.  
Jean B. Peyry, in the Office of the Li-  
brarian of Congress, at Washington,  
D. C., United States

Figure 158 represents a seamless waist with front yoke and small lapel at front. The yoke passes under the lapel when the waist is put together. The waist opens under arm.

**DIRECTIONS FOR DRAFTING FIGURE 158.**

Figure 158 is drafted same as figure 157.

**DIRECTIONS FOR LAPEL.**

Letter *X* represents the middle of neck, trace a line from *X* to bust line, and is to be 27 centimetres long, trace two other lines from shoulder corner to 27.

**DIRECTIONS FOR YOKE.**

Place front part of the *system* same as for drafting jacket in figure 156, except that we take one less at neck and we do not move the system up to dot bust measure *E*. Now trace arms-eye from *E* to line *Z*, trace line *Y* from neck to 5 centimetres above bust dot *E*.

Figure 159 represents a seamless waist with back yoke and front lapel, with under-arm opening.

**DIRECTIONS FOR DRAFTING FIGURE 159.**

Figure 159 is drafted same as figure 157.

**DIRECTIONS FOR DRAFTING LAPEL.**

They are drafted same as figure 158, except that they are larger and we use the curved part of the back to trace from 27 up to the corner.

**DIRECTIONS FOR THE YOKE.**

Dot *Z* is the shoulder line, join back of *system* at neck and dot *Z*, now dot width of back, letter *Y* is the back, dot *X* is the side back, dot *W* is the under-arm dot. Join side back and under-arm piece same as in drafting a double back; it is to get the armseye correct. Trace a circle line from neck to 5 centimetres above *W*.

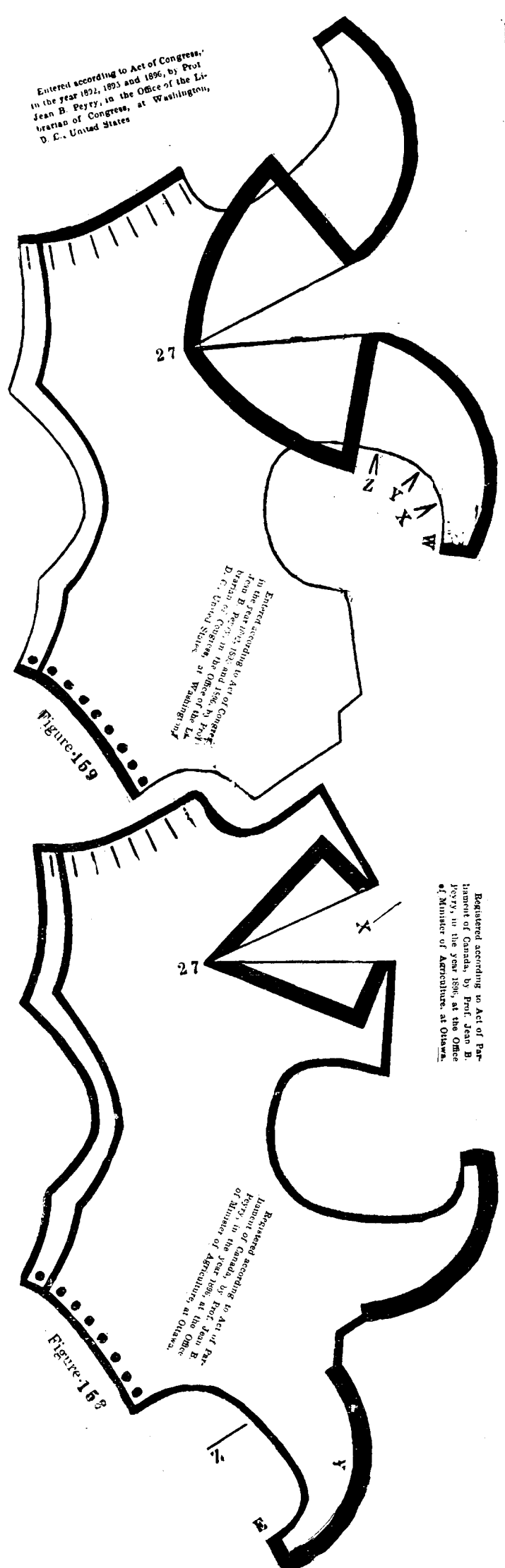

Entered according to Act of Congress,  
in the year 1892, 1893 and 1896, by Prof.  
Jean B. Peyry, in the Office of the Li-  
brarian of Congress, at Washington,  
D. C., United States

Registered according to Act of Par-  
liament of Canada, by Prof. Jean B.  
Peyry, in the year 1896, at the Office  
of Minister of Agriculture, at Ottawa.

Registered according to Act of Par-  
liament of Canada, by Prof. Jean B.  
Peyry, in the year 1896, at the Office  
of Minister of Agriculture, at Ottawa.

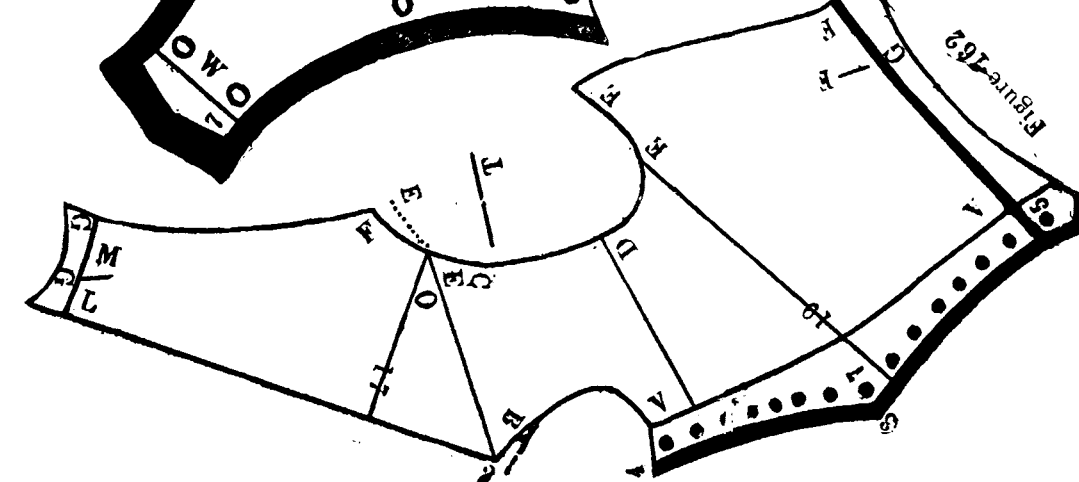
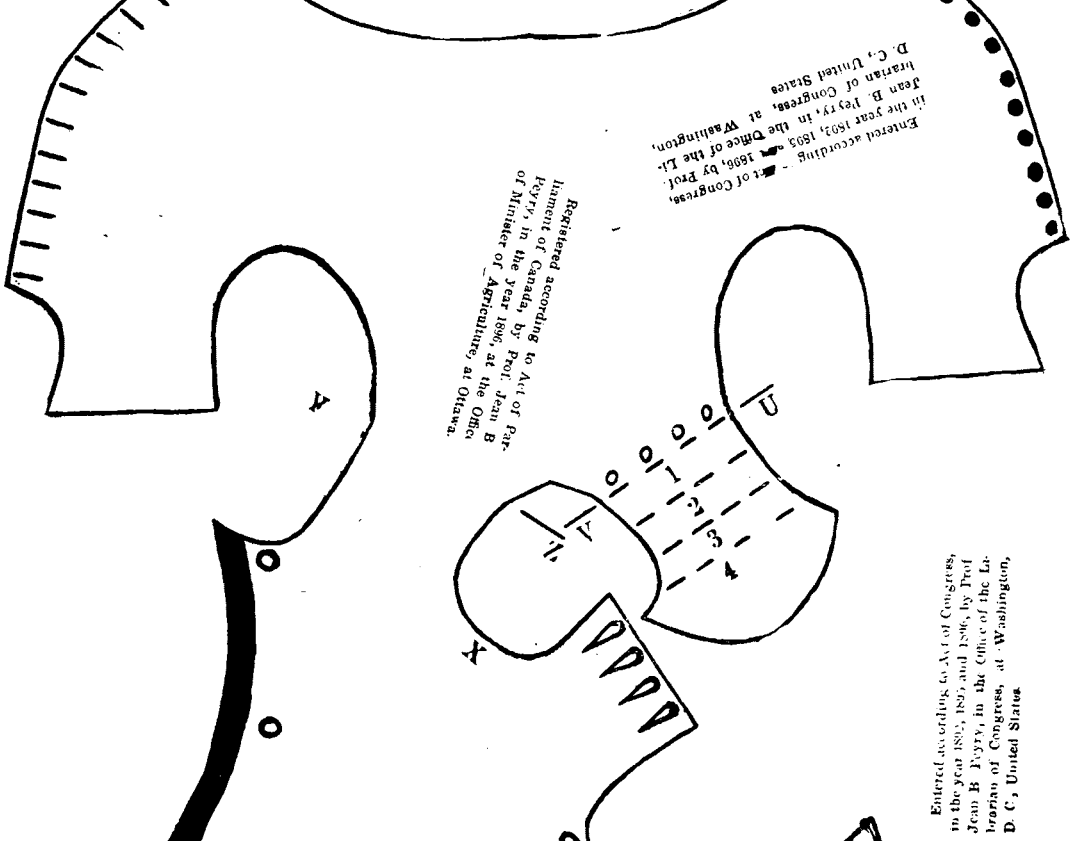
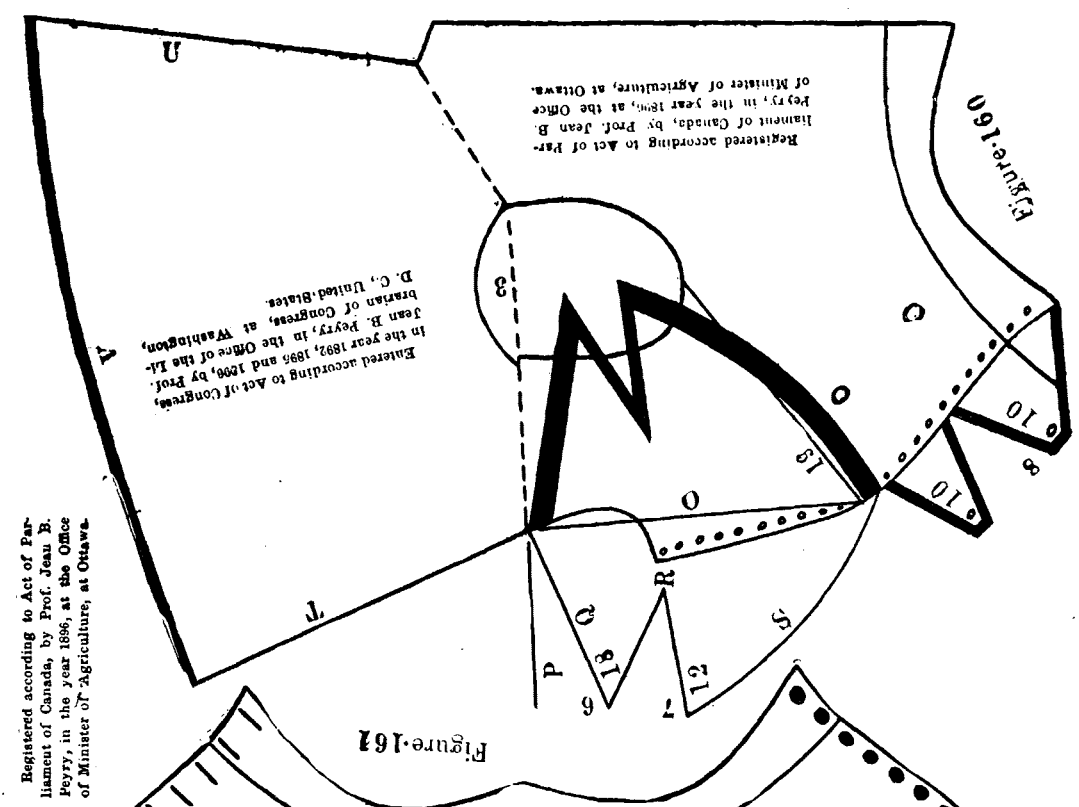

Figure 161

Figure 162

Figure 163

Figure 160 represents a seamless waist and sleeves with lapel and double breast.

#### DIRECTIONS FOR DRAFTING FIGURE 160.

The seamless waist is drafted same as Figure 149.

#### DIRECTIONS FOR DRAFTING THE SLEEVES.

We take 3 length measures. Inside length from under-arm to elbow, outside length from back of shoulder to elbow, top length from shoulder bone to elbow bone. This sleeve is plaited at elbow or below elbow if wanted, and it has a foundation and an under-sleeve. Now trace *U* from neck up to back length, trace line *T* from neck up to inside length, trace line *V* from line *T* to *V*, and from *V* to line *U*; letter *V* is the top length from shoulder bone to elbow bone, measure from No. 3 to letter *V*.

#### DIRECTIONS FOR LAPEL.

Trace line *O* from shoulder line to bust line, trace line *P* straight with shoulder line, trace line *Q* 6 centimetres below line *P* and is to be 18 centimetres long, trace line from line *Q* to *R*, trace another line at 7 centimetres below line *Q* and is to be 12 centimetres long, trace line *S* from bust line up to line *R*.

#### DIRECTIONS FOR DOUBLE BREAST.

Trace two bias lines 10 centimetres long and trace two others at 8 centimetres from the first two.

Figure 161 represents a seamless waist and a tablier front all cut in one piece. The waist opens at front and when the waist is put together the tablier front covers the front opening, and the tablier front buttons at the left shoulder.

#### DIRECTIONS FOR DRAFTING FIGURE 161.

The seamless waist is drafted same as Figure 149.

#### DIRECTIONS FOR DRAFTING THE TABLIER FRONT.

The tablier front is drafted on lining, but it is easier to draft a pattern first to join it to the lining of the waist. Letter *X* and *W* represent the fold of paper. Now place the front of *system* straight with the fold of paper and dot bust measure *E*, dot front length. move the *system* down, place the edge of the *system* at neck half centimetre out of paper, then dot chest measure *D*, trace neck measure *B*, follow line *B* dot to end of line, move the *system* down, trace shoulder length *C*, trace armseye curve from bust dot to chest dot, and from chest dot to shoulder dot. Now take 7 centimetres at waist line for the width of tablier front, trace from bust dot to No. 7 by using the back curve, now join the pattern to the waist at line *Y* and line *Z*. Line *U* and line *V* shows where the tablier front will be buttoned above shoulder seam; one, two, three and four shows how far below the shoulder seam it is buttoned.

#### HOW TO DRAFT BELOW THE SHOULDER.

Place neck of *system* at line *V* and armseye at line *U*, dot chest *D* and trace down to neck corner *A*, and trace armseye from chest dot to *U*.

Figure 162 represents a seamless waist without seam on the under-arm.

#### DIRECTIONS FOR DRAFTING FIGURE 162.

The front part is drafted same as figure 39. Now place the back of *system* at *B* and line *T*, take off at No. 2 neck to be added at waist length; we take off at neck from a half centimetre to two centimetres, now draft the back same as figure 38.

Figure 163 represents a seamless waist with jacket front and under arm opening.

#### DIRECTIONS FOR DRAFTING FIGURE 163.

The waist is drafted same as figure 157, and the jackets are drafted same as in figure 156. Figure 154 represents a seamless princess with Vato back.

#### DIRECTIONS FOR DRAFTING FIGURE 164.

The waist part is drafted same as figure 149, except that the back is not placed on the fold of goods. We leave 10 to 20 centimetres to be plaited at waist, line letter *Q* is the fold of goods, line *R* is the back, line from *T* to *U* is a seam on the waist to plait the goods in that seam is covered by the wato, line *S* is the back line, from *Y* to *Z* is to be plaited same as back, *W* is the front line of first circle, *X* is the front line of second circle, line *V* is the front line trace a little on the bias from bust line to the front length, trace bottom line, the width at bottom is to be from 100 to 150 centimetres, if we cannot find goods wide enough we put seam on the back.

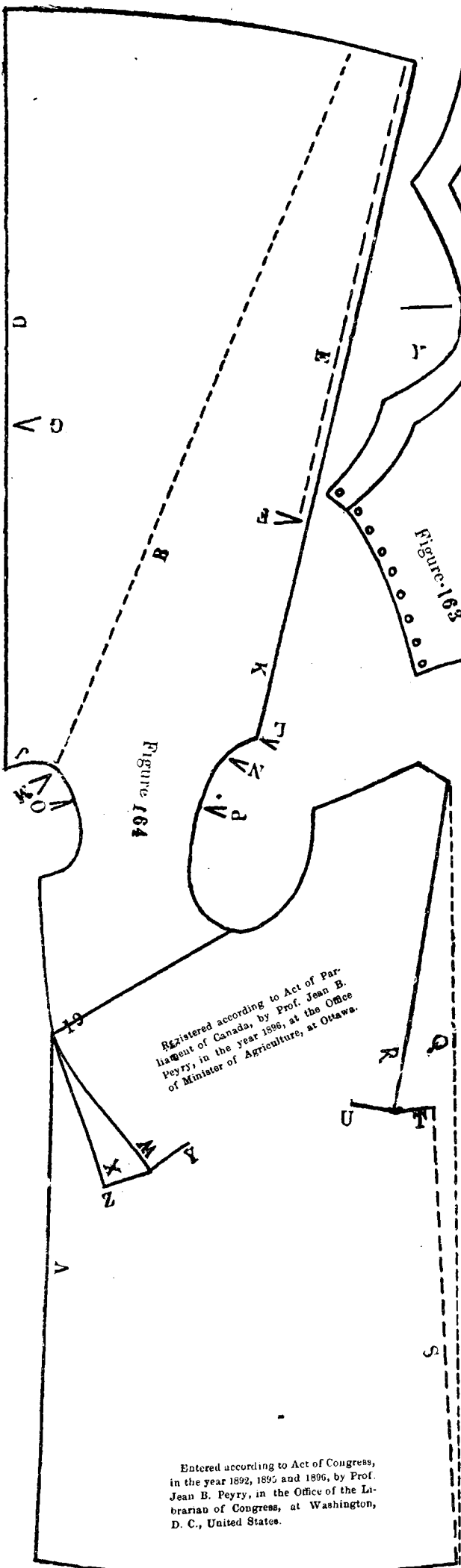

Figure 164

Registered according to Act of Parliament of Canada, by Prof. Jean B. Peyry, in the year 1896, at the Office of Minister of Agriculture, at Ottawa.

Entered according to Act of Congress, in the year 1892, 1895 and 1896, by Prof. Jean B. Peyry, in the Office of the Librarian of Congress, at Washington, D. C., United States.

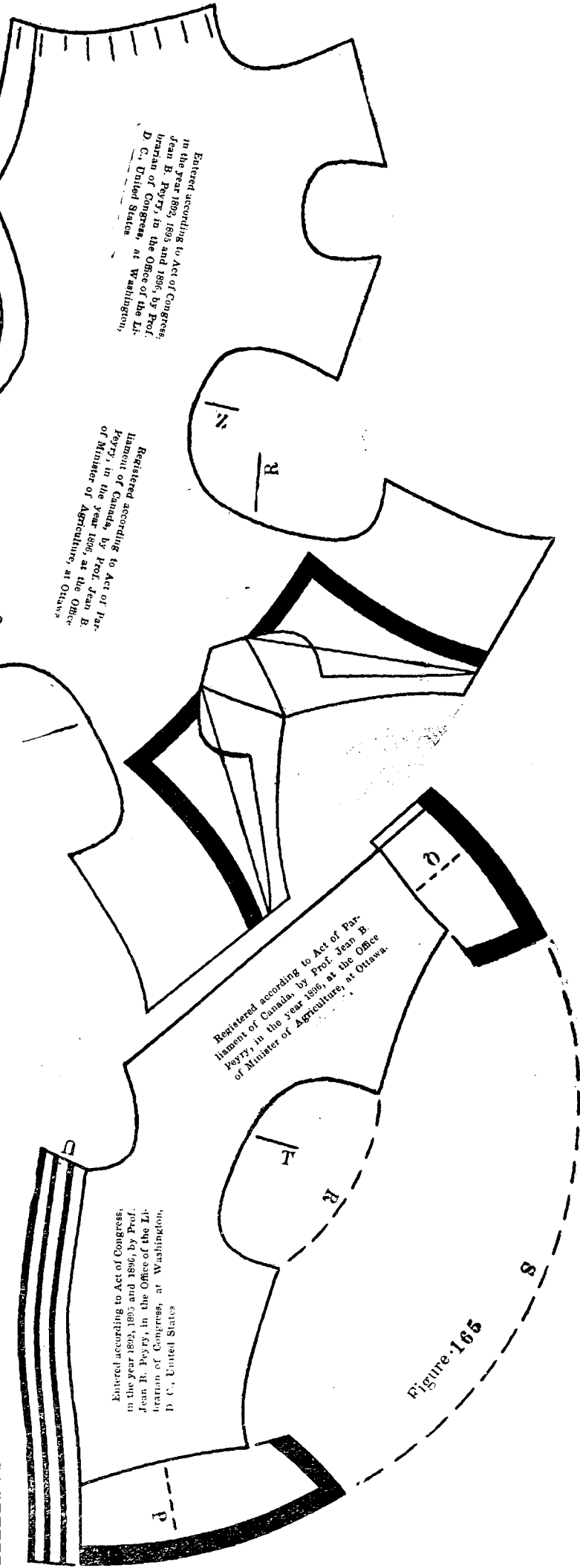

Figure 165

Entered according to Act of Congress, in the year 1892, 1895 and 1896, by Prof. Jean B. Peyry, in the Office of the Librarian of Congress, at Washington, D. C., United States.

Registered according to Act of Parliament of Canada, by Prof. Jean B. Peyry, in the year 1896, at the Office of Minister of Agriculture, at Ottawa.

Entered according to Act of Congress, in the year 1892, 1895 and 1896, by Prof. Jean B. Peyry, in the Office of the Librarian of Congress, at Washington, D. C., United States.

**DIRECTIONS FOR DRAFTING THE VATO PART.**

Take the back of the *system* and place it at dot *P* and dot *O*, now dot neck measure dot *M*, dot width of back dot *N*, join side back to back dot *L*, and trace line *K* on the bias, dot *F* is the side length to match at *U*, line *E* is side line to stitch with line *S*, line *B* represents the fold of vato part, from line *B* to *J* corner is to be plaited at neck, dot *G* is the length, length from neck to waist, line *D* is the back line, now trace bottom line and is to be from 100 to 150 centimetres in width.

Figure 165 represents a seamless waist and basque or Russian blouse.

**DIRECTIONS FOR DRAFTING FIGURE 165.**

The waist part is drafted same as figure 162.

**DIRECTIONS FOR BASQUE.**

Line *U* represents plaits at front. The skirt for basque is from 15 to 20 centimetres, add 10 centimetres at waist to be plaited at under-arm seam, cut at line *P* to give room for the hips and put some lace at line *P* to cover that opening, do the same at line *Q* on back and add 10 centimetres, also at under-arm seam and add 5 centimetres at back from waist line down ; as there is no seam at back cut a piece separate from the waist of 5 centimetres in width.

**DIRECTIONS FOR RUSSIAN BLOUSE.**

Trace line *R* from back to front, and trace line *S* from back to front. Now begin to plait the front to letter *R* and *S*, and plait the back to letter *R* and *S*. The blouse is plaited all round.

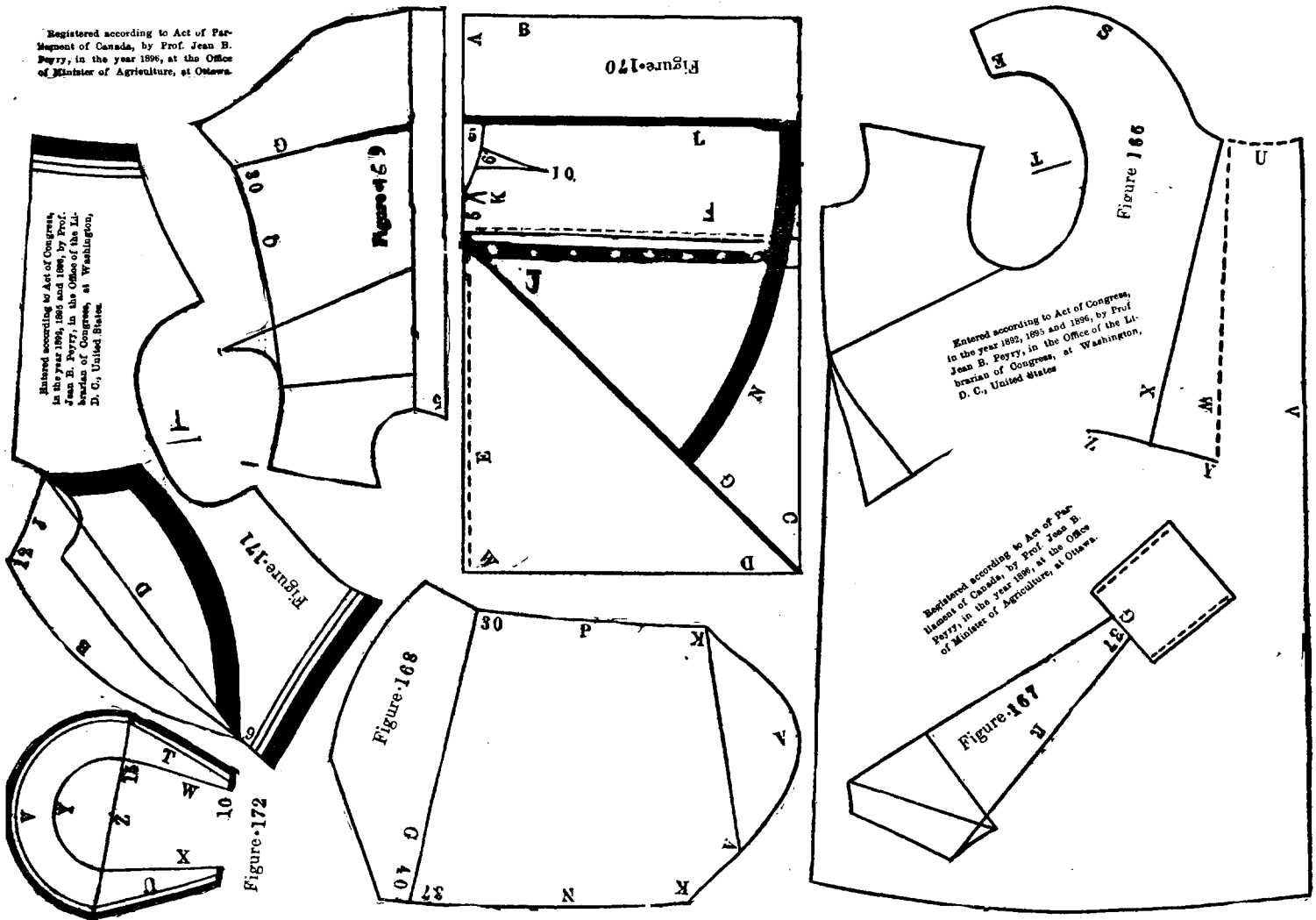

Figure 166 represents a seamless Princess with a front yoke.

**DIRECTIONS FOR DRAFTING FIGURE 166.**

The waist and skirt part are drafted same as Figure 164, except that we add 10 centimetres at line *U* to be plaited at neck.

**DIRECTIONS FOR YOKE.**

Place front of *system* same as in Figure 158, dot bust measure *E*, trace armseye and trace line *S* from neck to 5 centimetres from dot *E*.



Figure 167, Figure 168 and Figure 169 represent a Dolman in three pieces.

**DIRECTIONS FOR DRAFTING FIGURE 167.**

The back is drafted same as Figure 9, except that we add at waist 5 centimetres each side for plaits, and line *R* is traced straight from waist dot to the shoulder dot.

**DIRECTIONS FOR DRAFTING FIGURE 168.**

Take the sleeve *system* (piece No. 6), lay the *system* on lining or goods, dot armseye measure *A*, and dot outside *A*, trace from dot *A* down to *K*, now trace *P* for which is the same length as line *Q* on Figure 169, trace from *K* down to 30 and from 30 down. Line *G* is the waist line and the width of it is regulated by the front width Figure 169; if the front is 30 at waist the sleeve at line *G* is 40, ten more than the front. Now measure the length of line *G*, but do not trace it. Make a dot, finish the armseye, trace from *A* to dot *A*, reverse the *system*, take the width of under-sleeve and trace from *A* to *K*, now trace line *N* which is the same length as line *R* on Figure 167, trace from *K* to three centimetres below length 37, now trace line *G* from dot 37 to dot 30, then finish bottom of sleeve.

**DIRECTIONS FOR DRAFTING FIGURE 169.**

Figure 169 is drafted same as Figure 18, except that the front is drafted straight and we add 5 centimetres at front for double breast, and the under-arm seam line *Q* is traced from chest line *D* down to waist line *G*.

Figure 170 represents a seamless Bell skirt, opening at the right side, with a row of buttons.

**DIRECTIONS FOR DRAFTING FIGURE 170.**

The width of the goods must be the length of the skirt; place the goods before you length ways, take corner of goods *W*, and fold the goods at line *G*, so that line *D* falls over line *C* and line *E* falls straight over line *F*, from line *F* to dot *K* we give 5 to 10 centimetres to be plaited at back; now from dot *K* to *A* is the waist measure, if the waist measure is 60 centimetres measure 60 at line *A* and add for dart, line *B* is where the goods are cut out. Line *J* is the opening of the skirt. After the goods are cut out at line *B*, fold the goods at line *L* so that line *B* falls over line *J*; from line *L* to dot *G* is half of the waist measure, now trace a line from dot *G* to line *L* coming 5 centimetres below line *A*, now place the dart; for large persons we put two darts in the skirt, now trace line *N* from line *L* to line *G*, line *N* is the bottom of skirt.

Figure 171 represents a seamless Figaro with lapel.

**DIRECTIONS FOR DRAFTING FIGURE 171.**

Figure 171 is drafted same as Figure 40 and Figure 41, except that we take off from back of neck from a half to two centimetres.

**DIRECTIONS TO DRAFT THE LAPEL.**

Trace line *D* from shoulder line down to 6 centimetres from the waist line, trace line *J* and is to be 12 centimetres long, trace line *B* from No. 6 to line *J*.

**DIRECTIONS FOR DRAFTING FIGURE 172.**

Figure 172 represents a collar.

Trace line *Z*, take half of neck measure 15 and trace line *Y* forming the circle, trace line *W*, trace line *X* at 10 centimetres from line *W*, trace line *V* forming the circle, then trace line *T* and line *U*.

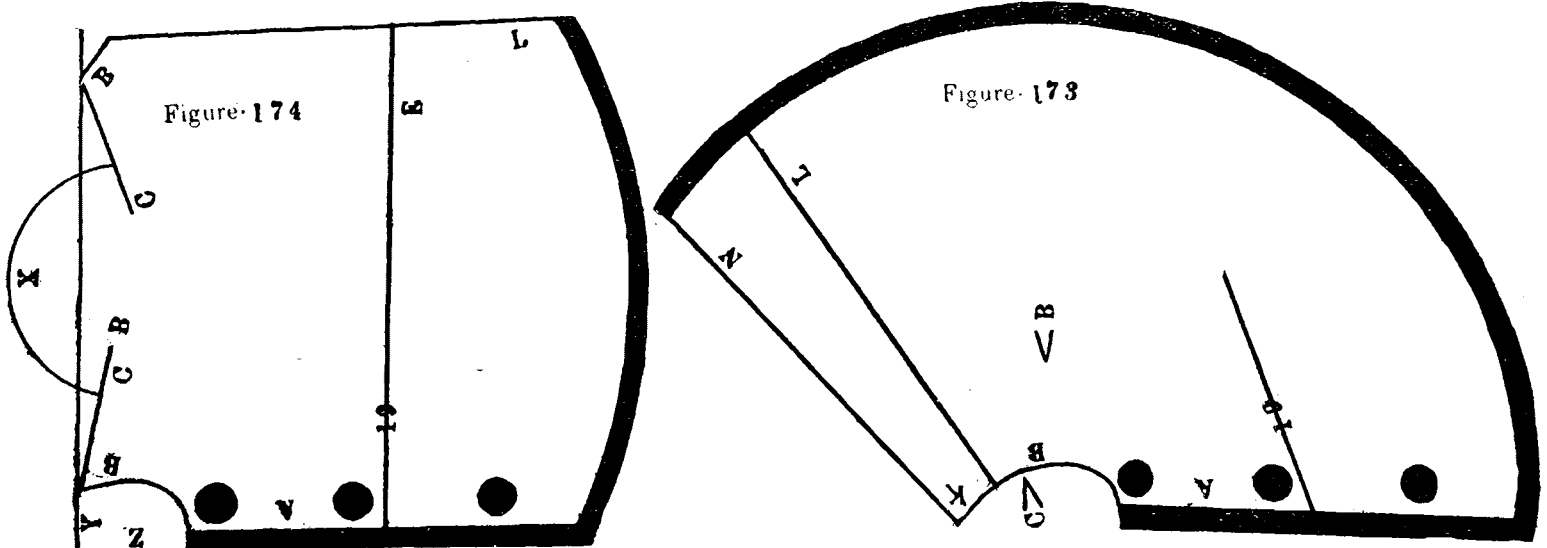

Figure 173 represents a circular and military cape.

#### DIRECTIONS FOR DRAFTING FIGURE 173.

Lay the *system* on lining or goods, trace front *A* to bust line 19, trace straight from bust line to the bottom, trace neck measure *B*, take the back of the *system*, place it at dot *C* and dot *B*, trace back of neck to line *L*, now trace line *L*, now roll your pencil on your tape line, place it at dot *C* and trace from line *L* to the front, for military capes add from 10 to 20 centimetres at neck to be plaited from dot *C* to corner *K*, add at bottom from 20 to 40 centimetres, now trace line *L* from neck to bottom.

Figure 174 represents a cape with puff on shoulder.

#### DIRECTIONS FOR DRAFTING FIGURE 174.

Trace line *Z* straight down to the bottom, and trace line *Y* square with line *Z*; now place front edge of *system* *A* straight with line *Z*, then trace neck measure *B*, follow line *B*, then trace length of shoulder *C*, trace line *E* square with line *Z* by beginning at bust line 19; line *E* is the bust measure and the bust measure for cape is taken with the arm inside of tape line, line *E* is traced to the length of size of bust measure, take the same length at line *Y*, then place back of *system* at line *Y* and line *E*, and trace length of shoulder *C*, trace neck *B*, and trace from *B* down to *L*, now trace bottom of cape, for puff at shoulder trace line *X* from *C* to *C*.

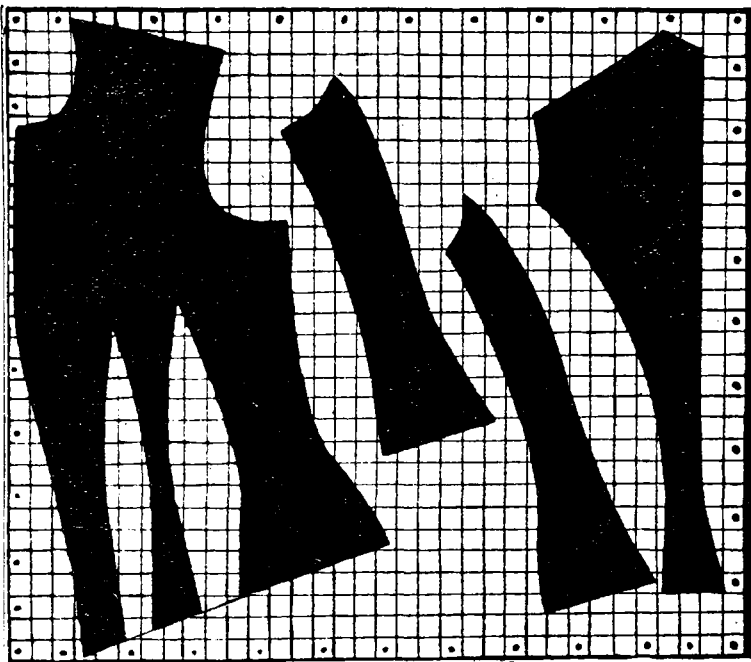

Figure-176

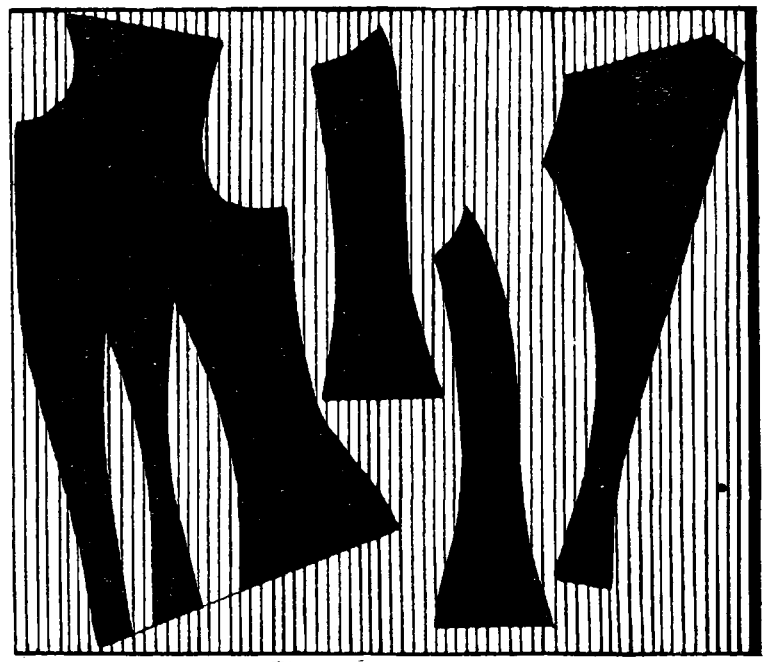

Figure-175

Figure 175 represents the goods and lining and shows how to put the lining over the goods for matching all the stripes.

Figure 176 represents the goods and lining and shows how to put the lining over the goods for matching all the plaids and shows also how to arrange the goods for the basting. Now place the goods on top of a large table and pull it tight and smooth, it must not be stretched as it would pull the goods all crooked, Just smooth it so that there will be no wrinkles left on the goods. The little dots around the goods show how to put the nails on the goods to hold it fast to the table. Now baste the lining on top of goods and do not pull the lining. Just put the lining on without wrinkle and baste with back, stitch the basting around the seams so that the goods will not slip from the lining after every piece is cut or in basting it together.

#### NOTICE TO PUPILS.

In basting waists, basques, jackets or any other garments, baste from waist line up and from waist line down, and see that all the waist lines are together. Baste the dart from top of dart to waist and from waist down. Baste the shoulder from neck to arms-eye by stretching the front shoulder a half centimetre. In basting the sleeve begin at wrist to armseye for the inside seam, and for the outside baste from wrist to elbow, and from arms-eye to elbow, and what is too long of the top sleeve is plaited at elbow.

#### HOW TO PLACE THE SLEEVE TO THE WAIST.

Place back seam of sleeve at back seam of under-arm, that is to say, the seam between under-arm and side-back. In basting the under-sleeve to the waist, full the under-sleeve one centimetre between the back and front seam. The top sleeve is gathered at shoulder. For basting skirt baste from waist down. For basting trousers and bloomers baste inside seam first from the seat down to the bottom and from the seat up to waist; baste the outside seam from waist down. For riding skirts the front seam is basted from the knee to waist and from knee to the bottom.

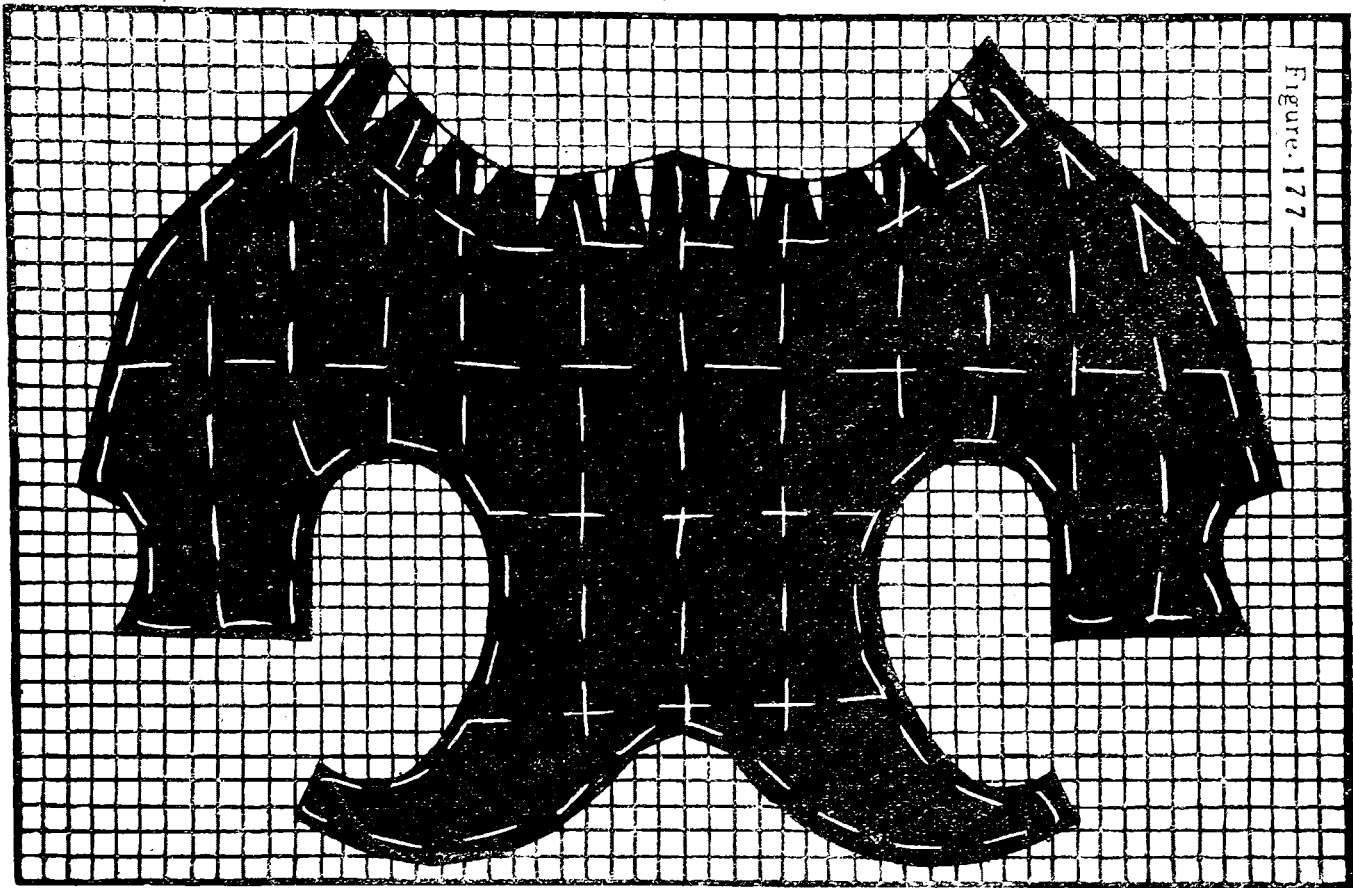

Figure 177 represents the goods and linings of a seamless waist and shows how the lining is basted on the goods, and the goods are stretched on a table same as in figure 176. The stronger the goods are the harder it is to stretch them. For instance, velvet and silk are stretched twice as much as wool goods. The lining is put smooth on the goods without fullness. Begin to baste at centre of back from neck to waist, baste up and down until you get at front neck, finish at front and go all round arms-eye and yoke, then baste crossway, around the waist is the last basting and don't forget to baste with back stitches. Now cut out the waist and assemble the shoulders same as for any waist, and the yoke will fall over the front.

#### DIRECTIONS FOR FITTING A SEAMLESS GARMENT.

It is best to fit the lining first to get the correct size at waist. Begin to pin the lining from neck to waist and pull it tight at waist; now clip the waist all round the waist to the waist line, after it is fitted, finish the bottom with a band of canvas cut on a bias and press it to the shape of the hips, put another band at the front from neck to waist cut in the straight of the canvas, that will keep the hook and eyes in their position. Now put stay tapes around the neck and arms-eye so that they will not get out of shape, now baste the lining on top of goods as mentioned above and after it is cut out take a hot iron and shape the goods around the waist to the same shape as the canvas, now fit the waist with goods and lining; this is the second and last fitting; pin the waist at front firmly, especially at waist part. After the waist is pinned at front cut off the cross basting at waist and pull the goods down to the waist tight and smooth, pin the goods at waist so that it cannot go back; pin it like this all around the waist; pin the goods at end of waist also. Take off the waist from the person and stitch it solid; before taking out the pins press the bottom over again until the goods are the same shape as the canvas, then finish the waist.

For skirts or any other garment we stretch the goods on a table and when we do not need to match the stripes in the skirts, we place the lining same as represented on these plates, up and down, so as no goods are lost. We have different ways for basting but the one I give you is the best and the easiest way.

Figure 178 represents a sailor collar.

#### DIRECTIONS FOR DRAFTING FIGURE 178.

Trace from bust line to *A* corner, trace neck measure *B*, trace length of shoulders *C*, place back of *system* at *B* and *C*, and trace neck *B*, trace line *L*, trace line *Z*, trace line *Y* from front to back, passing at shoulder point, trace width of back collar. If you wish it to have a projecting corner, trace line *X*.

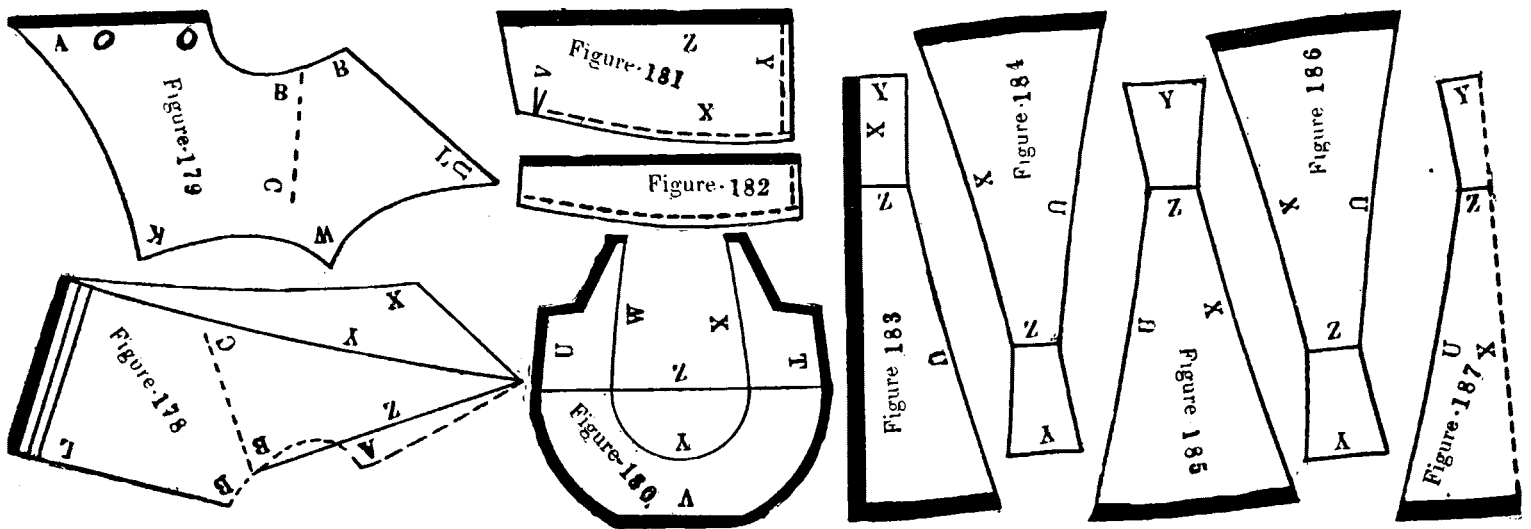

Figure 179 represents a collarette.

#### DIRECTIONS FOR DRAFTING FIGURE 179.

Trace from bust line to neck and trace neck measure *B*, place the back of *system* at *B* and *C*, and trace neck *B*, trace line *L*, now trace from *A* to *K*, trace from *K* to *W*, and from *W* to *U*.

Figure 180 represents a round sailor collar.

#### DIRECTIONS FOR DRAFTING FIGURE 180.

Figure 180 is drafted same as figure 172, except that the back line *V* is square.

Figure 181 represents a large coat collar.

#### DIRECTIONS FOR DRAFTING FIGURE 181.

Trace line *Z*, trace line *Y*, square with line *Z*, trace line *X*; curved dot *V* is the front end of collar, line *Y* is the back part of collar, and *X* is the sewing seam with the coat.

Figure 182 represents a narrow coat collar.

#### DIRECTIONS FOR DRAFTING FIGURE 182.

Figure 182 is drafted same as figure 181, except that it is not so large.

Figure 183, figure 184, figure 185, figure 186 and figure 187 represent a nine-gored circular cape.

#### DIRECTIONS FOR DRAFTING FIGURE 183.

Trace line *X*, trace line *Z*, square with line *X*, trace line *Y*, and trace line *U* from line *Y* to line *Z*, from *Z* to the bottom trace the bottom.

#### DIRECTIONS FOR DRAFTING FIGURE 184.

Trace line *Z*, trace *Y*, square with line *Z*, trace line *U*, trace line *X*, trace the bottom.

Figure 185 and figure 186 are drafted same as figure 184.

Figure 187 is the back gore and is drafted same as front gore figure 183, line *X* representing the folding of the goods.

Figure 188, figure 189 and figure 190 represent a tight fitting Princess with two darts and vato back.

#### DIRECTIONS FOR DRAFTING THE PRINCESS.

The front figure 188 is drafted same as figure 6 from shoulder to hip, and the under-arm part is added to it in the same way as in figure 48. The darts are placed at the same distance from the front as in figure 6, except they are only 6 each in width and nothing is added at hip measure, dot hip measure only from the waist line down to 12 centimetres; they are drafted with the curved part of the dart rule, that is to say, with the same edge that is used to draft from waist line up to bust line, and place the dart rule in the position as to make the low part of darts curve in instead of curving out to opposite directions of the upper part, the dart being so placed as to prevent it from having any fullness at the front of the Princess.

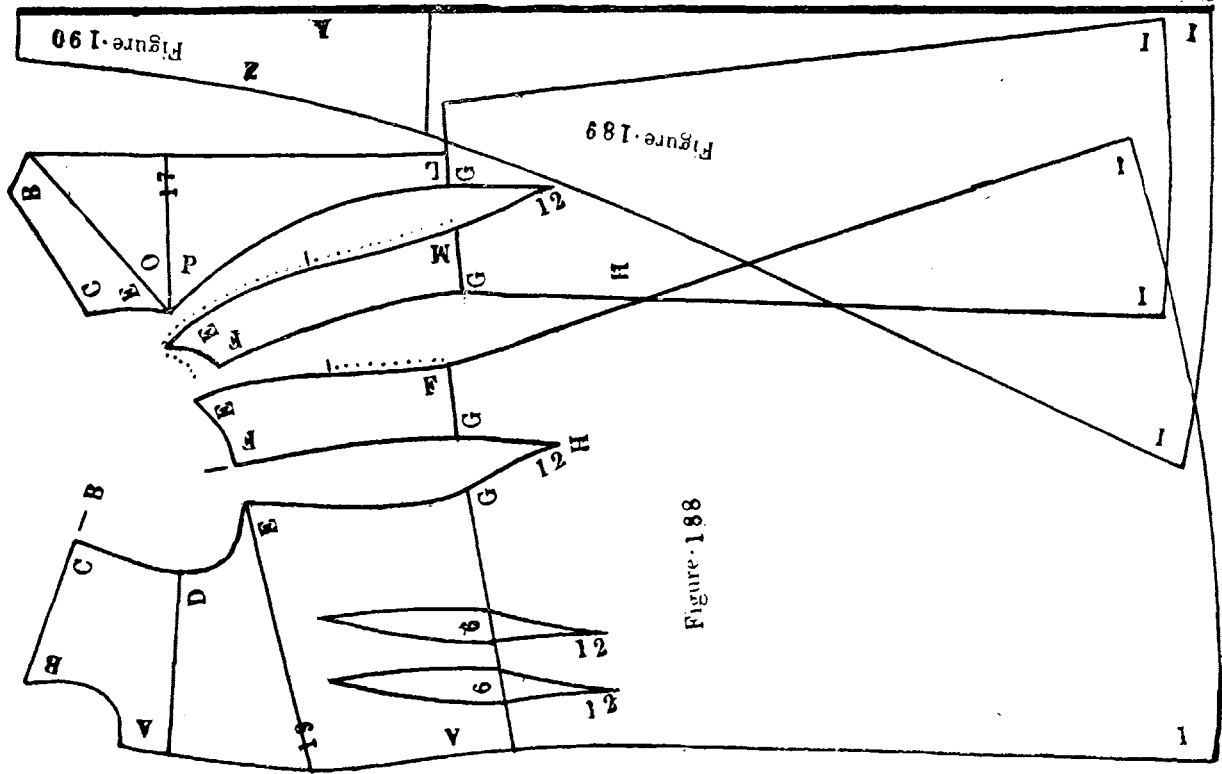
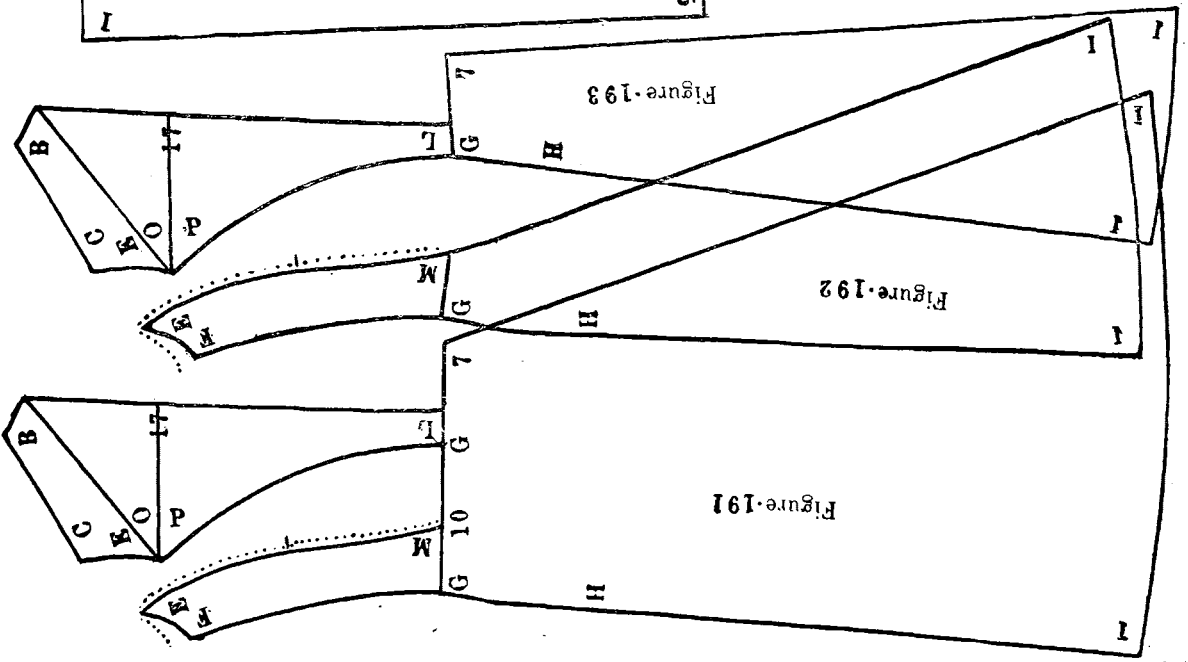
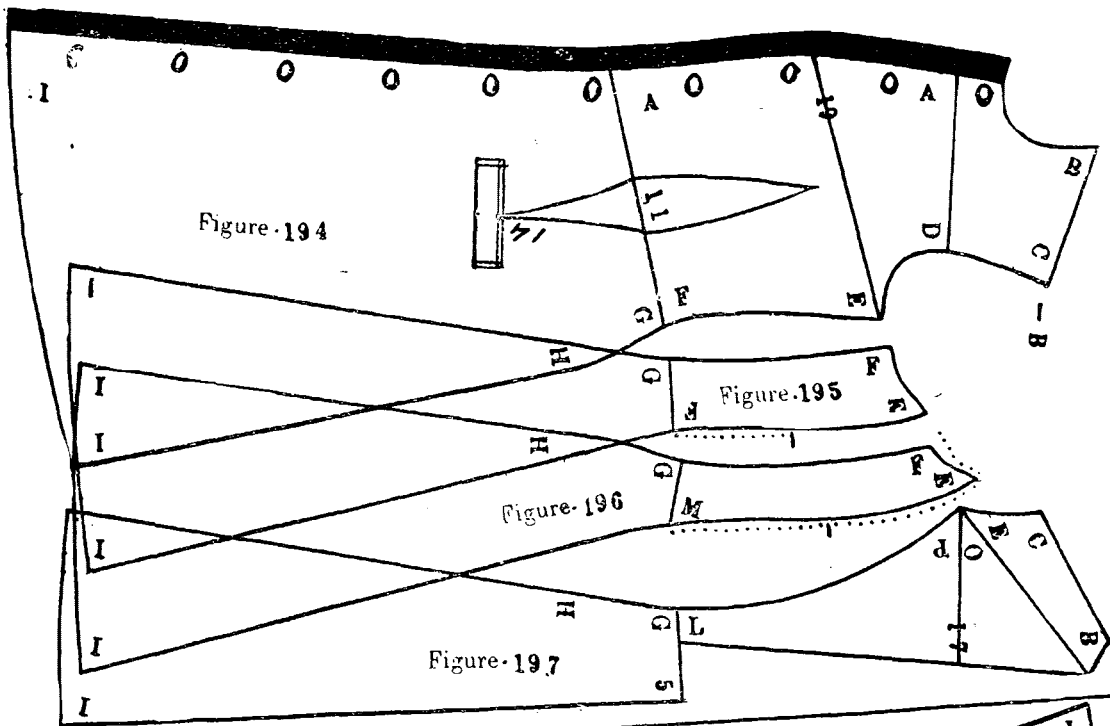

Now trace front length of skirt from waist line down to letter *J*; the front line is drafted a little on the bias from waist line to the bottom, the bias varies from two centimetres to twelve centimetres, according to the size and shape of the person. For young girls who have hardly any stomach we draft the front line straight from waist line to the bottom; the larger their stomachs are the more bias we draft the front line. For persons of 100 centimetres around the hips we trace the front line on a 5 centimetre bias. The width at bottom for Figure 188 is from 90 to 120 centimetres, the bottom line is drafted same as for any other skirt, and the length of skirt is taken from waist to the floor.

#### DIRECTIONS FOR DRAFTING BACK AND SIDE-BACK—FIGURE 189.

The back is drafted same as Figure 9, except that at waist on the back seam we leave 10 centimetres for plaits and we trace down the back line bias; the side-back is drafted same as Figure 8, except that we join side-back to back at end of the *system* 12 centimetres below waist line, the side line from *H* to *I* is traced straight, the two side lines are drafted to the hip length, the back line to back length and the front line to the front length. This Princess is worn with a train of 10 to 20 centimetres long and the sloping begins at the side seam

The width at bottom for the back Figure 189 is from 70 to 100 centimetres.

#### DIRECTIONS FOR DRAFTING THE VATO—FIGURE 190.

Line *Y* represents the fold of the goods and has no seam at back; line *Z* is the side seam, which must be the same length as waist and skirt, from neck to waist and from waist to the bottom; the width at neck is 20 centimetres, at waist line 40 centimetres, at bottom 90 to 120 centimetres. The width at bottom for this Princess is from 5 to 7 metres, which is from 500 to 700 centimetres.

Figure 191 represents the back and side-back of a tight-fitting Princess, which can be used with any style of Princess front.

#### DIRECTIONS FOR DRAFTING FIGURE 191.

This back and side-back is drafted same as Figure 189, except that we leave space of 10 to 20 centimetres between back and side-back for plaits, and we add at back from 10 to 20 centimetres for plaits also, the width at bottom is from 100 to 150 centimetres.

Figure 192 and Figure 193 represent the back and side-back of a tight-fitting Princess to fit with any style of Princess front.

#### DIRECTIONS FOR DRAFTING FIGURE 192.

Figure 192, side-back, is drafted same as Figure 8, except that we draft the skirt longer and the width at bottom is from 90 to 110 centimetres.

#### DIRECTIONS FOR DRAFTING FIGURE 193.

Figure 193, back, is drafted same as Figure 9, except that the skirt is longer and we add from 15 to 30 centimetres for plaits at back, and the width at bottom is from 90 to 120 centimetres.

Figure 194, Figure 195, Figure 196 and Figure 197 represent a tight overcoat, mantle or cloak.

#### DIRECTIONS FOR DRAFTING THE FRONT—FIGURE 194.

Figure 194 is drafted same as Figure 57, with one dart at centre, except that the low part of the dart is close at 14 centimetres below waist line and finished with the same shape as Princess dart, and nothing is added at hip measure because the dart ends at hips; the pocket is placed at end of dart. The width at bottom for the front is 50 centimetres, the hip seam is drafted at hip length, the measure for the length of skirt is taken same as Princess, from waist down to the floor.

#### DIRECTIONS FOR DRAFTING FIGURE 195.

Figure 195, the under-arm, is drafted same as Figure 188, except that the skirt part is not so large at bottom and is separate from the front. Width at bottom is 35 centimetres.

#### DIRECTIONS FOR DRAFTING FIGURE 196.

Figure 196, side back is drafted same as Figure 192, except that it is not so large at bottom, the width at bottom is 35 centimetres.

#### DIRECTIONS FOR DRAFTING FIGURE 197.

The back is drafted same as Figure 193, except that it is not so large at bottom and at waist we have 6 centimetres for plaits. The width at bottom for this cloak is three metres or 300 centimetres. How to make the division,—half of 300 is 150, the front is 50 centimetres, the under-arm is 35, and side-back 35, the back is 30, addition, 50, 35, 35, 30=150 centimetres. The front is from 15 to 25 centimetres larger than the under-arm and side-back, and the back is 5 centimetres less than side-back and under-arm.

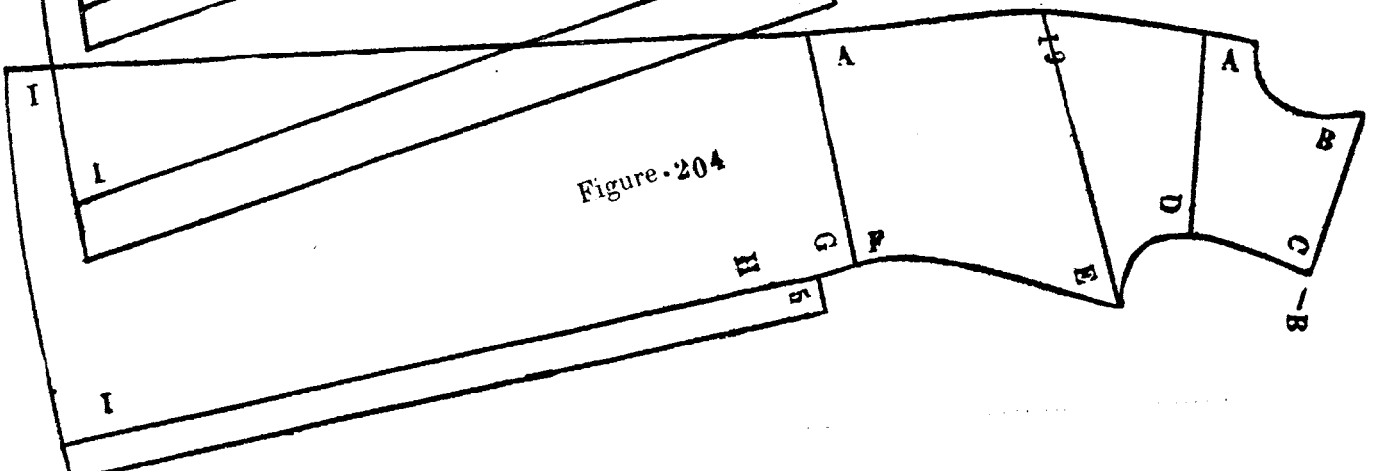
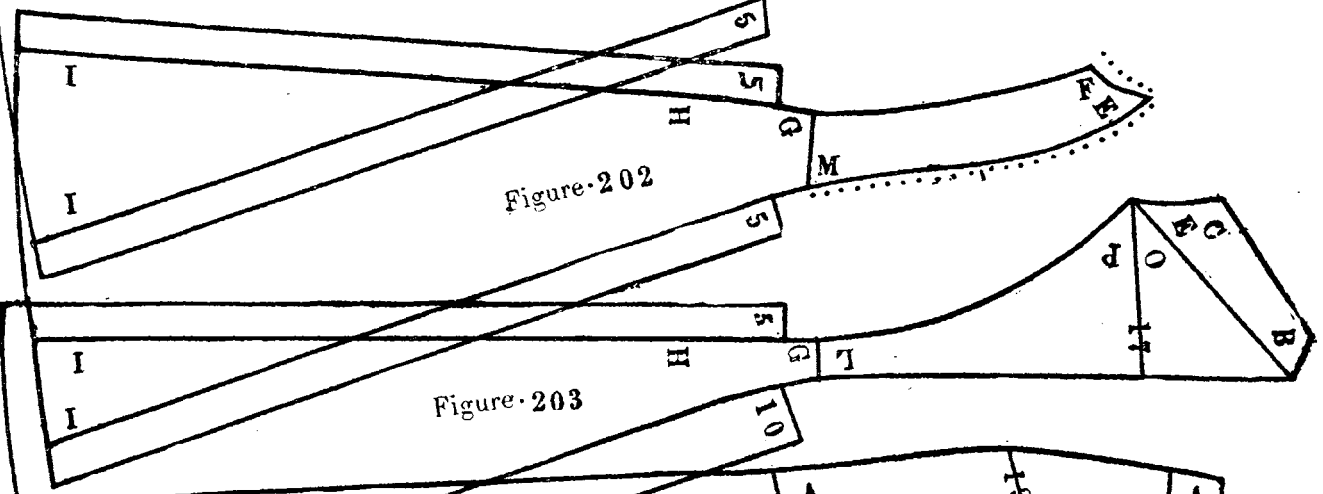
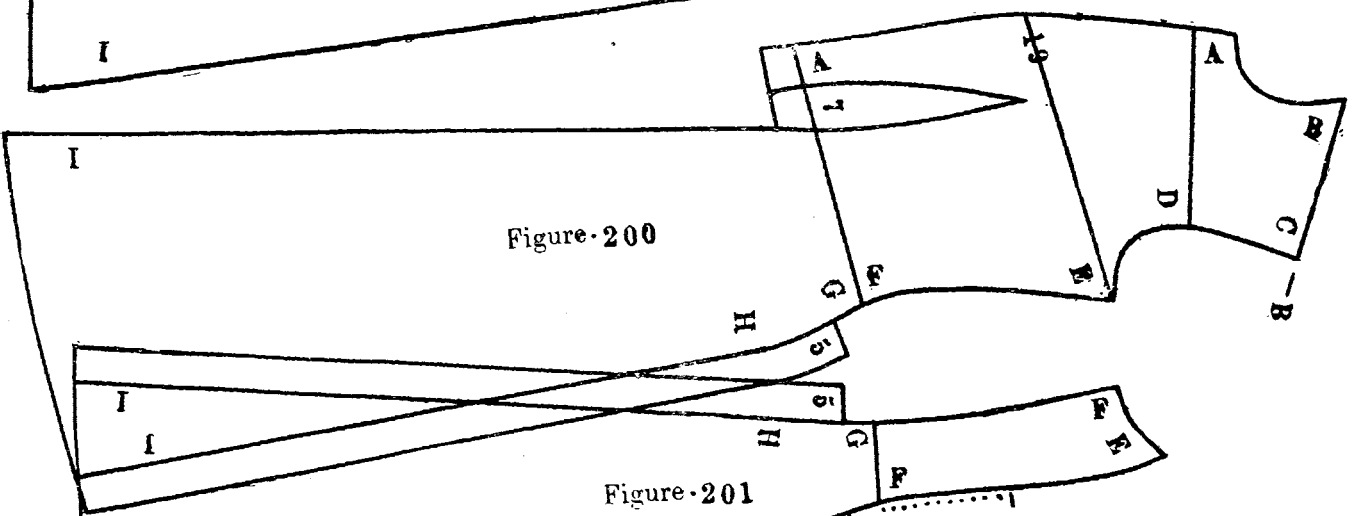
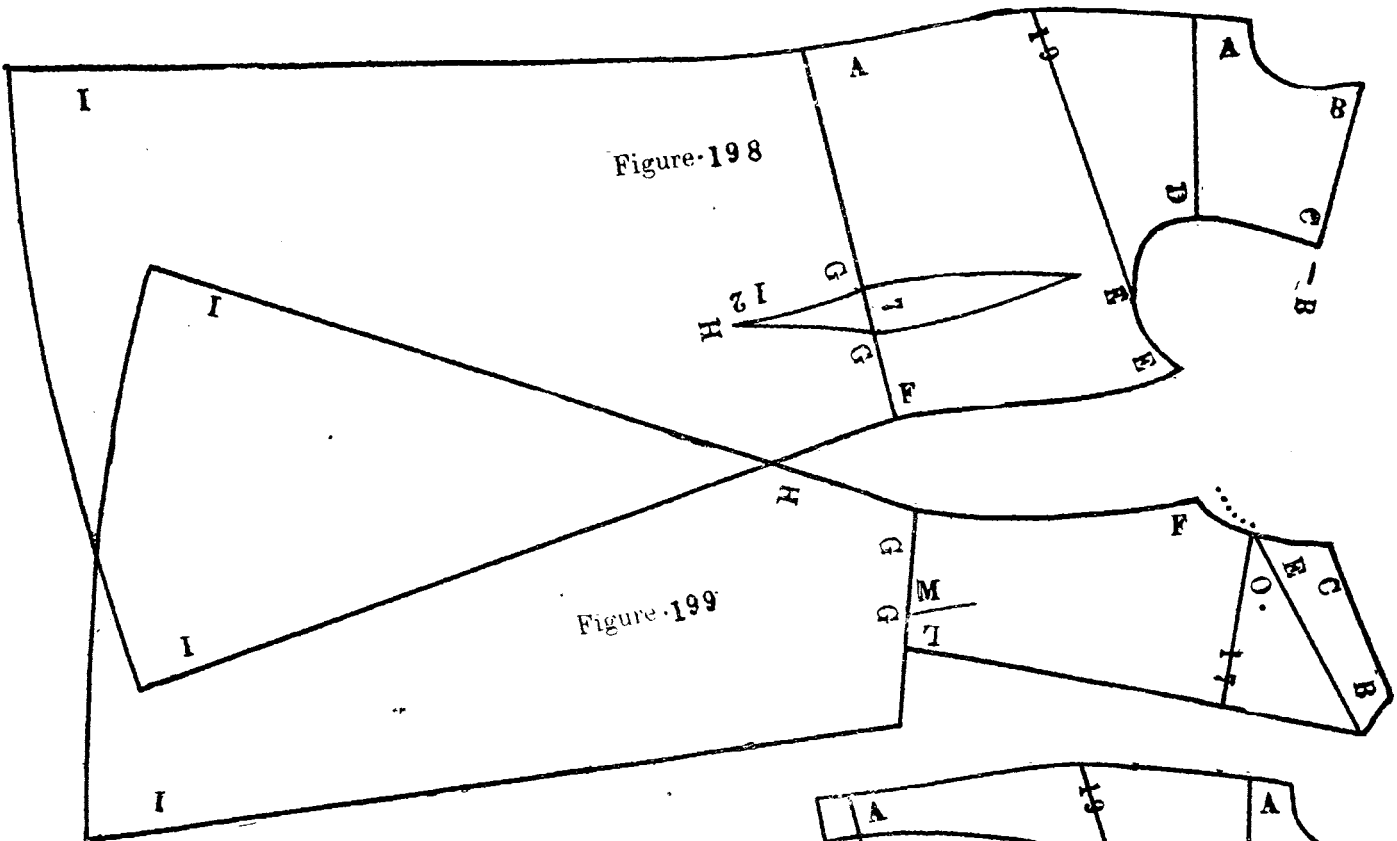

Figure 198 and figure 199 represent a loose fitting wrapper with one dart.

#### DIRECTIONS FOR DRAFTING FIGURE 198.

The front is drafted same as figure 188, except that there is no dart at front. We leave the dart out for gathering and between the front and under-arm we leave 10 to make the dart, now trace front line from waist line down to *I*, take the width of bottom and make dot, take the width of under-arm at waist *G*, dot *G* and *E*, join under-arm edge at bust dot *E*, and at waist dot *G*, trace from bust dot to corner *E*, swing the *system* to dot *F*, and trace from corner *E* down to dot *F*, and from *F* down to *I*, the width at bottom is from 100 to 130 centimetres. Trace under-arm seam to the under-arm length, place the dart same as for princess.

#### DIRECTIONS FOR DRAFTING FIGURE 199.

The back is drafted same as figure 33, except that we add 10 at waist for the gather, from under-arm seam to *G* at back seam we add from 15 to 30 for plaits, trace under-arm line from *H* to *I* in bias. measure width of bottom which is from 100 to 130 centimetres, trace back line and finish the bottom ; the back line is drafted at the back length.

Figure 200, figure 201, figure 202 and figure 203 represent a tight fitting princess with one dart and plaits at seams, the front being finished with silk from waist to bottom.

#### DIRECTIONS FOR DRAFTING FIGURE 200.

The front is drafted same as figure 35 except that the skirt is longer and the front is cut 3 centimetres below waist line to the dart, add 5 centimetres at side seam for plaits, the plaits begin 3 centimetres below waist line, trace front line from waist to bottom *I*, take width at bottom and trace side line from *H* to *I*, width at bottom is 40 centimetres.

#### DIRECTIONS FOR DRAFTING FIGURE 201.

The under-arm is drafted same as figure 7 except that the skirt is longer and larger, trace from *H* down to *I*, line *H* is traced to the front length, take the width at bottom, then trace line *F* to the length of hip measure, trace a second line for plaits 5 centimetres each, finish the bottom ; the width at bottom is 55 centimetres.

#### DIRECTIONS FOR DRAFTING FIGURE 202.

The side back is drafted same as figure 8 except that the skirt is longer and larger at bottom, trace line *H* down to *I*, trace it to hips length, take the width at bottom, then trace line *M* from waist line down to *I*, trace it at back length, trace bottom and for plaits. The width at bottom is 70 centimetres.

#### DIRECTIONS FOR DRAFTING FIGURE 203.

The back is drafted same as figure 9, except that the skirt is longer and larger at bottom. Trace *H* line from *H* to *I*, take width of bottom and trace line *L* from waist line to *I*, trace both lines at the back length, trace second line for plaits ; the back plaits are from 10 to 20 centimetres, the width at bottom is 85 centimetres. The width of this princess at bottom is 5 metres or 500 centimetres ; half of 500 is 250 divided as follows:—front 40 centimetres, under-arm 55, side back 70, the back 85, make addition 40, 55, 70, 85=250.

Figure 204 represents a dartless front for princess to fit with figure 201, figure 202 and figure 203.

#### DIRECTIONS TO DRAFT FIGURE 204.

This front is drafted same as figure 18, except that the skirt is longer and larger at bottom ; trace front line from waist line to the bottom *I*, take width at bottom, trace line *H* from *H* down to *I*, finish the bottom ; the width at bottom is 40 centimetres, add 5 centimetres for side plaits.



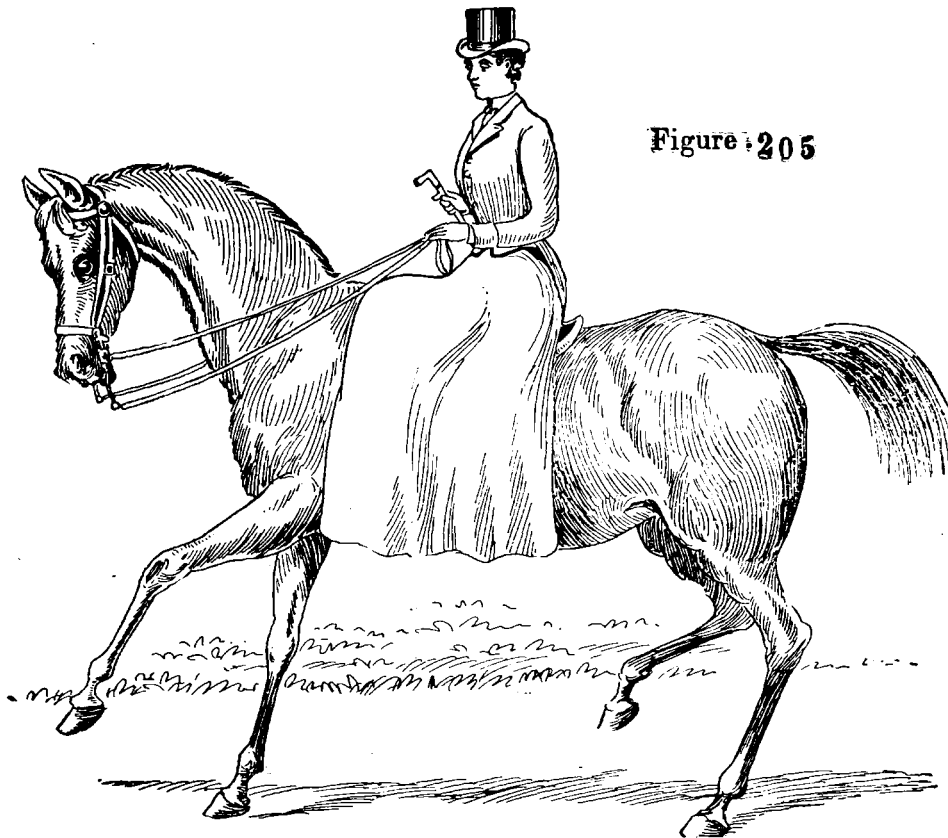

Figure 205

Figure 205 represents a ladies riding suit, for directions of diagram see figures 76, 77, 78, 79, 82, 83, 72, 73, 74, 75, 84 and 85.

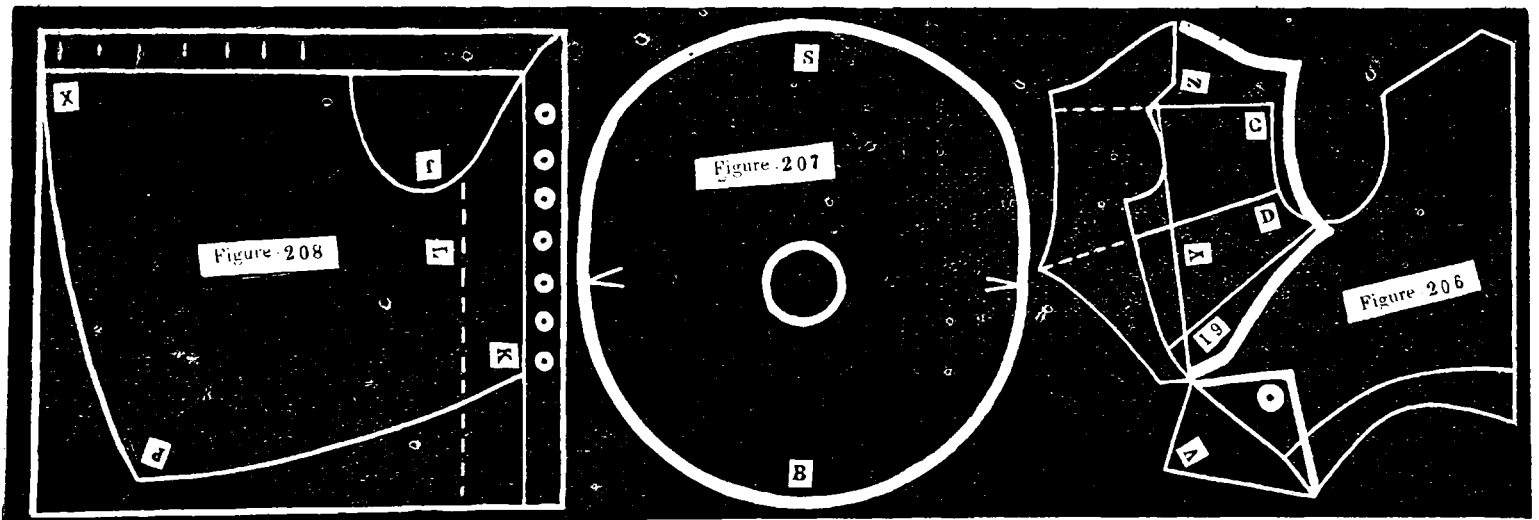

Figure 206 represents a seamless waist with lapel.

**DIRECTIONS FOR DRAFTING FIGURE 206.**

The waist part is drafted same as figure 149.

**DIRECTIONS FOR LAPEL.**

Trace line *Y* from shoulder line to two centimetres below bust line, trace line *Z* 5 centimetres long from neck to *Z*, passing at three centimetres from shoulder line; trace from *Z* up to ten centimetres, trace to the continuation of chest line *D* 18 centimetres long from line *Y*, trace the continuation of shoulder line *C* 14 centimetres long from neck. Now trace the outside lines:— Trace from end of line *Y* to the point of line *D*, and from line *D* to the point of line *C*, from line *C* to the point of line *Z*; trace line *V* at 12 centimetres from front line.

Figure 207 represents a seamless sleeve.

### DIRECTIONS FOR DRAFTING FIGURE 207.

To draft this seamless sleeve we take two length measures,—inside length and outside length,—trace the armseye circle, as it must be larger than the armseye itself, because the sleeve is plaited on top of shoulder. Now make two dots straight with armseye center; letter *S* is the length from shoulder bone to elbow and letter *B* is the length from under-arm to elbow; then trace line *S* from dot to dot and trace line *B* from dot to dot. This sleeve is plaited at elbow and is fitted at elbow with a tight sleeve from elbow to wrist.

Figure 208 represents a seamless bell sleeve. This sleeve has no puff at armseye and is very large at wrist. The width at wrist is from 75 to 100 centimetres and is finished with a row of buttons. It is the most appropriate sleeve for an opera cloak.

### DIRECTIONS FOR DRAFTING FIGURE 208.

We take a piece of goods nearly square. The width of the goods must be the length of the sleeve, and we take two length measures, inside length and outside length, trace line *K*, trace line *X*, square with line *K*, trace two other lines at 5 centimetres from line *K* and line *X*, now trace armseye letter *J*.

### HOW TO GET THE SIZE OF THE ARMSEYE.

Take half the measure same as for any other sleeve, armseye 44 centimetres; half 22, now measure 22 on line *X*, and 16 centimetres from line *X* to letter *J*, 6 centimetres less in depth than it is in length, then trace line *J* from line *X* to line *L*, which is the size of top sleeve and from line *L* to the corner is the size of under sleeve, trace from line *L* to the first corner. Now measure the under-arm length at line *L*, measure outside length from line *J* to *X*, and top length from corner *J* and *X* down to letter *P*, now fold the goods at corner *X*, so that they will fall on top of corner *K*, now cut out the sleeve at bottom from *X* to *P* and from *P* to *K*.

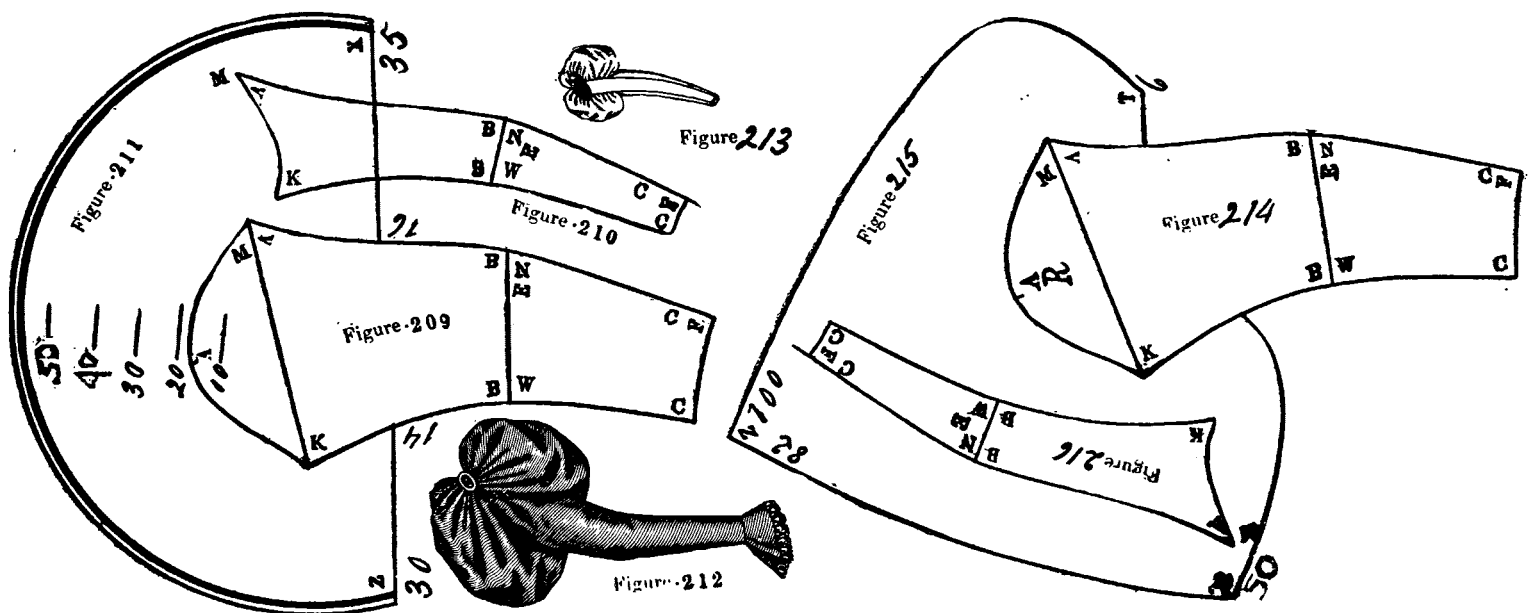

Figure 209, Figure 210 and Figure 211 represent a Butterfly sleeve in two pieces—under-arm and top.

### DIRECTIONS FOR DRAFTING THE BUTTERFLY SLEEVE.

Figure 209 is drafted same as Figure 87. Figure 211 is not separated from Figure 209 as all are in one piece.

### DIRECTIONS FOR FIGURE 211.

Trace line *X* at 16 centimetres from elbow line and is to be 35 centimetres long, trace line *Z* at 14 centimetres from elbow line and is to be 35 centimetres long, now trace a circular line from line *Z* to line *X* and is to be from 40 to 60 centimetres high at centre, and every ten centimetres is to be a plait.

Figure 210 is drafted same as Figure 88.

Figure 212 represents the outside of the sleeve finished.

Figure 213 represents the inside of sleeve finished.

Figure 214, Figure 215 and Figure 216 represent a pointed butterfly sleeve in two pieces—top and under-sleeve.

**DIRECTIONS FOR DRAFTING THE BUTTERFLY SLEEVE.**

Figure 214 is drafted same as Figure 87 ; Figure 215 is not separated from Figure 214, all are cut in one piece.

**DIRECTIONS FOR DRAFTING FIGURE 215.**

Trace line *T* at 10 centimetres from corner *A* and 6 centimetres long, and from *T* to *Z* is to be 100 centimetres long. To trace the curve use the armseye of *system*. Trace line *X* 12 centimetres below corner *K* and is to be 30 centimetres long from sleeve line to *X*, and from corner *X* to corner *Z* is to be 82 centimetres, trace from *X* to *Z*, from letter *R* to corner *Z* is to be from 50 to 60 centimetres and is plaited to line *A*.

**DIRECTIONS FOR DRAFTING FIGURE 216.**

The under-sleeve is drafted same as Figure 88.

Figure 217 represents figure 153. Figure 218 represents figure 154. Figure 219 represents figure 155. Figure 220 represents figure 158. Figure 221 represents figure 159. Figure 222 represents figure 161. Figure 223 represents figure 163. Figure 224 represents figure 171, when they are all finished.

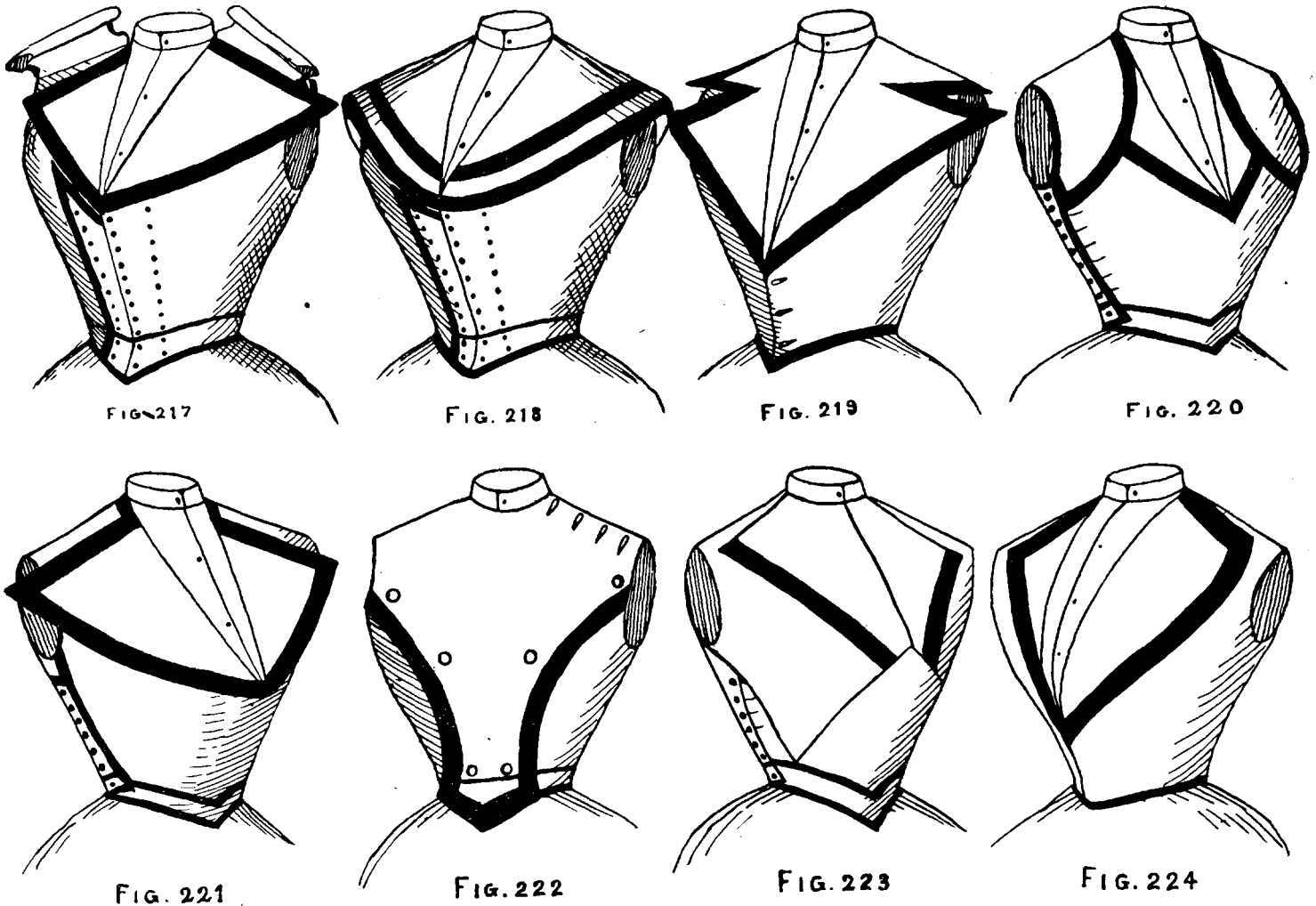

**NOTICE TO PUPILS.**

This Instruction Book is published for the benefit of our pupils. and we respectfully request them not to show or hand it to any person or persons who are not our pupils.

Yours respectfully,

PROF. JEAN B. PEYRY.  
Publisher

Address all communications to PROF. JEAN B. PEYRY, inventor and proprietor of said *System* and all strictly seamless garments : P.O. Box 570, New Orleans, La., U.S.A. ; P.O. Box 885, Montreal, Que., Canada ; or 269 Rue de Vaugirard, Paris, France.

Patterns cut to measure and guaranteed to fit. Fashion Books are published weekly in Paris.

Entered according to act of Congress, in the year 1896, by Prof. Jean B. Peyry, in the office of the Librarian of Congress, at Washington, D.C.









LIBRARY OF CONGRESS



0 013 973 136 0



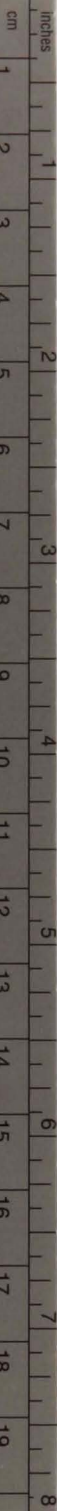

# Kodak Color Control Patches

© Kodak, 2007 TM: Kodak

Blue	Cyan	Green	Yellow	Red	Magenta	White	3/Color	Black
Light purple patch	Light blue patch	Light green patch	Light yellow patch	Light orange patch	Light pink patch	White patch	Light gray patch	Black patch
Dark purple patch	Blue patch	Green patch	Yellow patch	Red patch	Magenta patch	White patch	Dark gray patch	Black patch

# Kodak Gray Scale



© Kodak, 2007 TM: Kodak

- A** 1 2 3 4 5 6 **M** 8 9 10 11 12 13 14 15 **B** 17 18 19