

# BASIC ELECTRONICS

Student Handbook

Class - XI



**CENTRAL BOARD OF SECONDARY EDUCATION**

Shiksha Kendra, 2, Community Centre, Preet Vihar, Delhi-110092



# **BASIC ELECTRONICS**

## **Student Handbook**

### **Class - XI**



**CENTRAL BOARD OF SECONDARY EDUCATION**

Shiksha Kendra, 2, Community Centre, Preet Vihar, Delhi-110092



**Basic Electronics**  
**Student Handbook, Class - XI**

Price: ₹

First Edition : January 2018, CBSE

No. of Copies :

Paper Used : 80 GSM CBSE Water Mark White Maplitho

**“This book or part thereof may not be reproduced by any person  
any agency in any manner.”**

**Published By** : The Secretary, Central Board of Secondary Education,  
Shiksha Kendra, 2, Community Centre, Preet Vihar, Delhi-110092

**Design Layout  
&  
Composed By** : Vijaylakshmi Printing Works Pvt. Ltd.,  
B-117, Sector-5, Noida-201301(U.P.)

# भारत का संविधान

## उद्देशिका

हम, भारत के लोग, भारत को एक सम्पूर्ण<sup>1</sup> प्रभुत्व-संपन्न समाजवादी पंथनिरपेक्ष लोकतंत्रात्मक गणराज्य बनाने के लिए, तथा उसके समस्त नागरिकों को:

सामाजिक, आर्थिक और राजनैतिक न्याय,  
विचार, अभिव्यक्ति, विश्वास, धर्म

और उपासना की स्वतंत्रता,  
प्रतिष्ठा और अवसर की समता

प्राप्त कराने के लिए  
तथा उन सब में व्यक्ति की गरिमा

<sup>2</sup>और राष्ट्र की एकता और अखंडता  
सुनिश्चित करने वाली बंधुता बढ़ाने के लिए

दृढ़संकल्प होकर अपनी इस संविधान सभा में आज तारीख 26 नवम्बर, 1949 ई० को एतद्वारा इस संविधान को अंगीकृत, अधिनियमित और आत्मार्पित करते हैं।

1. संविधान ( बयालीसवां संशोधन ) अधिनियम, 1976 की धारा 2 द्वारा ( 3.1.1977 ) से “प्रभुत्व-संपन्न लोकतंत्रात्मक गणराज्य” के स्थान पर प्रतिस्थापित।
2. संविधान ( बयालीसवां संशोधन ) अधिनियम, 1976 की धारा 2 द्वारा ( 3.1.1977 ) से “राष्ट्र की एकता” के स्थान पर प्रतिस्थापित।

## भाग 4 क

## मूल कर्तव्य

51 क. मूल कर्तव्य - भारत के प्रत्येक नागरिक का यह कर्तव्य होगा कि वह -

- (क) संविधान का पालन करे और उसके आदर्शों, संस्थाओं, राष्ट्रध्वज और राष्ट्रगान का आदर करे;
- (ख) स्वतंत्रता के लिए हमारे राष्ट्रीय आंदोलन को प्रेरित करने वाले उच्च आदर्शों को हृदय में संजोए रखे और उनका पालन करे;
- (ग) भारत की प्रभुता, एकता और अखंडता की रक्षा करे और उसे अक्षुण्ण रखे;
- (घ) देश की रक्षा करे और आह्वान किए जाने पर राष्ट्र की सेवा करे;
- (ङ) भारत के सभी लोगों में समरसता और समान भ्रातृत्व की भावना का निर्माण करे जो धर्म, भाषा और प्रदेश या वर्ग पर आधारित सभी भेदभाव से परे हों, ऐसी प्रथाओं का त्याग करे जो स्त्रियों के सम्मान के विरुद्ध हैं;
- (च) हमारी सामासिक संस्कृति की गौरवशाली परंपरा का महत्त्व समझे और उसका परिरक्षण करे;
- (छ) प्राकृतिक पर्यावरण की जिसके अंतर्गत वन, झील, नदी, और वन्य जीव हैं, रक्षा करे और उसका संवर्धन करे तथा प्राणी मात्र के प्रति दयाभाव रखे;
- (ज) वैज्ञानिक दृष्टिकोण, मानववाद और ज्ञानार्जन तथा सुधार की भावना का विकास करे;
- (झ) सार्वजनिक संपत्ति को सुरक्षित रखे और हिंसा से दूर रहे;
- (ञ) व्यक्तिगत और सामूहिक गतिविधियों के सभी क्षेत्रों में उत्कर्ष की ओर बढ़ने का सतत प्रयास करे जिससे राष्ट्र निरंतर बढ़ते हुए प्रयत्न और उपलब्धि की नई उंचाइयों को छू ले;
- <sup>1</sup>(ट) यदि माता-पिता या संरक्षक हैं, छह वर्ष से चौदह वर्ष तक की आयु वाले अपने, यथास्थिति, बालक या प्रतिपाल्य के लिये शिक्षा के अवसर प्रदान करे।

1. संविधान ( छयासीवां संशोधन ) अधिनियम, 2002 की धारा 4 द्वारा प्रतिस्थापित।

# THE CONSTITUTION OF INDIA

## PREAMBLE

**WE, THE PEOPLE OF INDIA**, having solemnly resolved to constitute India into a <sup>1</sup>**SOVEREIGN SOCIALIST SECULAR DEMOCRATIC REPUBLIC** and to secure to all its citizens :

**JUSTICE**, social, economic and political;

**LIBERTY** of thought, expression, belief, faith and worship;

**EQUALITY** of status and of opportunity; and to promote among them all

**FRATERNITY** assuring the dignity of the individual and the<sup>2</sup> unity and integrity of the Nation;

**IN OUR CONSTITUENT ASSEMBLY** this twenty-sixth day of November, 1949, do **HEREBY ADOPT, ENACT AND GIVE TO OURSELVES THIS CONSTITUTION.**

- 
1. Subs, by the Constitution (Forty-Second Amendment) Act. 1976, sec. 2, for "Sovereign Democratic Republic" (w.e.f. 3.1.1977)
  2. Subs, by the Constitution (Forty-Second Amendment) Act. 1976, sec. 2, for "unity of the Nation" (w.e.f. 3.1.1977)
- 

# THE CONSTITUTION OF INDIA

## Chapter IV A

### FUNDAMENTAL DUTIES

#### ARTICLE 51A

**Fundamental Duties** - It shall be the duty of every citizen of India-

- (a) to abide by the Constitution and respect its ideals and institutions, the National Flag and the National Anthem;
- (b) to cherish and follow the noble ideals which inspired our national struggle for freedom;
- (c) to uphold and protect the sovereignty, unity and integrity of India;
- (d) to defend the country and render national service when called upon to do so;
- (e) to promote harmony and the spirit of common brotherhood amongst all the people of India transcending religious, linguistic and regional or sectional diversities; to renounce practices derogatory to the dignity of women;
- (f) to value and preserve the rich heritage of our composite culture;
- (g) to protect and improve the natural environment including forests, lakes, rivers, wild life and to have compassion for living creatures;
- (h) to develop the scientific temper, humanism and the spirit of inquiry and reform;
- (i) to safeguard public property and to abjure violence;
- (j) to strive towards excellence in all spheres of individual and collective activity so that the nation constantly rises to higher levels of endeavour and achievement;
- <sup>1</sup>(k) to provide opportunities for education to his/her child or, as the case may be, ward between age of 6 and 14 years.

- 
1. Subs. by the Constitution (Eighty - Sixth Amendment) Act, 2002



## Preface

The technology is changing very fast. The invention of Electron was breakthrough towards the modernized shape of Electrical, Analog Electronics, Digital Electronics and Nanotechnology. From Electron to Electronics, from Diode to Transistor, from Transistor to Logic Gates from Logic Gates to Chips (Integrated Circuits) and further advancements in Nanotechnology and applications of Micro-Electro-Mechanical System (MEMS) has revolutionized the electronics area.

Any advanced technology is basically dependent on basic concepts. Keeping this in perspective CBSE has introduced Electronics Technology as a Vocational Course at Senior Secondary level in class-XI (Level-3) and class-XII (Level-4). The Basic Electronics, Student Handbook for class XI has been designed to help the students to understand the basics of electronics. The units of the book have been designed in a way that students can get the concept of basics in sequence.

The Student Handbook encompasses the evolution of electronics, atoms and element, atomic energy level, field intensity, current density, electric field, magnetic field and cathode ray oscilloscope etc. The units relate to voltage and current where fundamentals of current, resistors, voltage source, battery etc., have been discussed. In addition, it focuses on basics of semiconductors which give an insight into metals, semiconductors, insulators, PN Junction diode, rectifiers etc. The content provides information about various configurations of Junction Transistor, FET, MOSFET Transistor amplifier and its applications, SCR, DIAC and TRIAC etc.

The language used in this book is simple and easily understandable to the student at class XI level. Relevant pictorial illustrations, examples and simplified concepts help the student to learn with ease and comfort.

This book is authored by competent educationists in the field of Electronics and Communication in association with CBSE focussing on helping the students to learn without any difficulty and use this book as a tool for easy learning.

Chairperson, CBSE



## Acknowledgements

### • ADVISORS •

- **Smt. Anita Karwal**, IAS, Chairperson, CBSE

### • CONTENT DEVELOPED BY •

- **Sh. Rakesh Kr. Dhammi**, HOD, Department of Mechatronics, Delhi - **(Convener)**
- **Smt. Monika Garg**, Assistant Professor, GP Pant Government Engineering College, Okhla, New Delhi
- **Smt. Charu Gaur**, Assistant Professor, Department of Physics, Delhi Institute of Tool Engineering, Govt. of Delhi, Okhla, New Delhi

### • EDITING & COORDINATION •

- **Dr. Biswajit Saha**, Director (Vocational & Training), CBSE



## Contents

### Unit-1 **Overview of Atom, Sub Atomic Particles & CRO**

1.0	Unit Overview and Description	...	1
1.1	Brief History of Electronics	...	2
1.2	Atoms and its Elements	...	4
1.3	Bohr's Atomic Model	...	4
1.4	Atomic Energy Level	...	5
1.5	Electron	...	7
1.6	Field Intensity	...	7
1.7	Potential Energy	...	7
1.8	Current and Current Density	...	8
1.9	Electric Field	...	9
1.10	Magnetic Field	...	9
1.11	Motion of Charged Particles in Electric Field	...	10
1.12	Cathode Ray Oscilloscope	...	10

### Unit-2 **Voltage & Current**

2.0	Unit Overview and Description	...	18
2.1	Current Flow Theories	...	19
2.2	Resistors	...	23
	2.2.1 Fixed Resistors	...	23
	2.2.2 Variable Resistors	...	29
2.3	Introduction to Capacitors	...	30
2.4	The Inductors	...	38
2.5	Voltage Source	...	40
2.6	Battery (Electricity)	...	45

### Unit-3 **Basics of Semiconductor**

3.0	Unit Overview and Description	...	52
3.1	Semiconductor Materials	...	54
3.2	Energy Band	...	54
3.3	Material Structure	...	55
3.4	Energy Gap	...	56
3.5	Field and Photo Electric Emission	...	56
3.6	Intrinsic & Extrinsic Semiconductor (n-type & p-type Semiconductors)	...	57
3.7	Drift Current	...	58
3.8	Diffusion Current	...	58



3.9	Effects of Temperature on Conductivity of Semiconductor	...	59
3.10	PN Junction Diode (Semiconductor Diode)	...	60
3.11	Depletion Layer	...	60
3.12	Potential Barrier	...	61
3.13	Forward & Reverse Biasing	...	61
3.14	V-I Characteristic of Semiconductor	...	62
3.15	Resistance Level	...	63
3.16	Breakdown in Junction Diode	...	63
3.17	Zener Diode	...	64
3.18	Photo Diode	...	65
3.19	LED (Light Emitting Diode)	...	66
3.20	Diode as a Rectifier	...	66
3.21	Voltage Multipliers	...	68
3.22	Zener Diode Regulator	...	68
3.23	Special Information - (Introduction to Filters, Clippers, Clampers)	...	69

#### **Unit - 4** **Bipolar Junction Transistor**

4.0	Unit Overview and Description	...	74
4.1	Bipolar Junction Transistor (BJT)	...	75
4.2	BJT Biasing	...	78
4.3	CB, CE and CC Configuration	...	78
4.4	Characteristics and Transistor Parameters for CB, CE, CC, Configuration	...	80
4.5	Introduction to FET, JFET, MOSFET, CMOS and VMOS	...	85
4.6	Characteristics of Various Transistors	...	91

#### **Unit - 5** **Transistor Amplifier and Applications**

5.0	Unit Overview and Description	...	93
5.1	Introduction to Amplifiers	...	95
5.2	Single and Multistage Amplifiers	...	96
5.3	Amplifier Characteristics	...	97
5.4	Feedbacks in Amplifiers	...	97
5.5	Introduction to Oscillators	...	98
5.6	Multivibrators (MVS)	...	99
5.7	Signal Generator	...	99
5.8	Thyristors	...	100
5.9	Light Activated SCR (LASCR)	...	102



# UNIT 1

## Overview of Atom, Sub-Atomic Particles & CRO

### 1.0 Unit Overview and Description

- Overview
- Knowledge and Skill Outcomes
- Assessment Plan
- Learning Outcomes
- Resource Material
- Topics Covered

Brief History of Electronics, Atoms and its Elements, Atomic Energy Level, Electron, Field Intensity, Potential Energy, Current and Current Density, Electric Field, Magnetic Field, Motion of Charged Particles in Electric Field, Cathode Ray Oscilloscope.

### Overview

This unit starts with the understanding of History of Electronics and Fundamentals Elements such as Atoms and its Elements, Atomic Energy Level, Electron, Field Intensity, Potential Energy, Current and Current Density, Electric Field, Magnetic Field, Motion of Charged Particles in Electric Field, Cathode Ray Oscilloscope.

### Knowledge and Skill Outcomes

- Understanding of fundamentals of basic electronics elements.
- Understanding of all about the atom and electron.
- Knowledge of various types of fields.
- Knowledge of Cathode Ray Oscilloscope.

### Assessment Plan: (For the Teachers)

Unit-1	Topic	Assessment Method	Time Plan	Remarks
	Brief History of Electronics, Atoms and its Elements, Bohr's Atomic Model, Atomic Energy Level.	Exercise: Question & Answer	Two Hours	
	Electron, Field Intensity, Potential Energy, Current and Current Density.	Exercise: Question & Answer	Two Hours	
	Electric Field, Magnetic Field, Motion of Charged Particles in Electric Field, Cathode Ray Oscilloscope.	Exercise: Question & Answer	Two Hours	



## Learning Outcomes

Unit-1	Overview of Atom, Sub-Atomic Particles & CRO	Outcomes
	Brief History of Electronics.	(i) Understanding the Brief History of Electronics.
	Overview of Atoms.	(ii) Understanding the Atoms and its Elements.
	Sub-Atomic Particles.	(i) Identification of Sub-Atomic Particles.
	CRO (Cathode Ray Oscilloscope).	(i) Understanding of Cathode Ray Oscilloscope.

### 1.1 Brief History of Electronics

The word ‘Electronics’ is originated from the word electron which is a branch of science dealing with theory and use of devices in which the electrons travel through a vacuum, gas or a semiconductor medium. Electronics is that field of science which deals with the motion of electrons under the influence of applied electric and/or magnetic field. Electronics can be classified into two branches: Physical Electronics and Electronics Engineering. Physical electronics deals with the motion of electronics in a vacuum, gas or semiconductor. Whereas, electronics engineering deals with the design, fabrication and application of electronic devices.

Alternatively we can define Electronics as the science of how to control the electric energy, energy in which the electrons have a fundamental role. Electronics deals with electrical circuits that involve active electrical components such as vacuum tubes, transistors, diodes, integrated circuits, and associated passive electrical components and interconnection technologies. Commonly, electronic devices contain circuitry consisting primarily or exclusively of active semiconductors supplemented with passive elements; such a circuit is described as an electronic circuit.

Electronics has evolved around three components; vacuum tubes, transistor, and integrated circuits. In 1883, Thomas Alva Edison discovered that electrons will flow from one metal conductor to another through vacuum. This discovery of conductor is known as Edison Effect. In 1897, John Fleming applied Edison Effect in inventing a two- element electron tube called diode. In 1906, Lee de Forest utilized Edison Effect to invent a three-element tube called triode. Diode and triode were instrumental in amplification and transmission of electrical energy. But vacuum tubes were bulky, fragile and had high power consumption. Therefore, it gave rise to another invention, and it was a prominent development in the field of electronics. In 1948 John Bardeen, Walter Brattain and William Shockley at Bell Laboratories developed Transistor and they received Nobel Prize for their creation. These metal transistors replaced vacuum tubes as this semiconductor device are compact in size, light in weight, low cost, less power consumption, fast and have longer life if operated within same operating conditions.

The concept of the integrated circuit was proposed in 1952 by Geoffrey W. A. Dummer, a British electronics expert with the Royal Radar Establishment. Throughout the 1950s, transistors were



mass produced on single wafers and cut apart. The total semiconductor circuit was a simple step away from this; it combined transistors and diodes (active devices) and capacitors and resistors (passive devices) on a planar unit or chip. The semiconductor industry and the silicon integrated circuit (SIC) evolved simultaneously at Texas Instruments and Fairchild Semiconductor Company. By 1961, integrated circuits were in full production at a number of firms, and designs of equipment changed rapidly and in several directions to adapt to the technology. Bipolar transistors and digital integrated circuits were made first, but analog ICs, large-scale integration (LSI), and very-large-scale integration (VLSI) followed by the mid-1970s. VLSI consists of thousands of circuits with on-and-off switches or gates between them on a single chip. Microcomputers, medical equipment, video cameras, and communication satellites are only examples of devices made possible by integrated circuits.

The history of electronics can be summarized as:

### **Evolution of Electronics**

- 1890: Hertz performed experiment on generation of electromagnetic waves.
- 1894: Sir J. C. Bose discovered the propagation of radio waves.
- 1895: H. A. Lorentz postulated the existence of electron.
- 1897: J. J. Thomson experimentally verified the existence of electron.
- 1897: Braun invented first electron tube.
- 1904: Fleming invented diode.
- 1906: De Forest invented triode.
- 1912: Application of radio and birth of Institute of Radio Engineers at USA.
- 1930: Monochrome Television invented.
- 1950: Colour TV came to existence.
- 1963: IEEE introduced.

### **Evolution of Transistors**

- 1948: Brattain, Bardeen invented point contact transistor.
- 1948: Shockley discovered junction transistor.
- 1951: Commercial production of transistor.
- 1958: Kilby (Texas Instruments, USA) gave idea of monolithic.
- 1961: Fairchild and Texas Instruments commercially produced Integrated Circuits(IC).

### **Evolution of ICs**

- 1960: Small Scale Integration (SSI) (<100 components per chip).
- 1966: Medium Scale Integration (MSI) (>100 and <1000 components per chip).
- 1969: Large Scale Integration (LSI) (>1000 and <10000 components per chip).
- 1975: Very Large Scale Integration (VLSI) (>10000 components per chip).



## 1.2 Atoms and its Elements

### 1.2.1 Definition of Atom

Atom is the smallest unit of matter that defines the chemical element. Every solid, liquid, gas and plasma is made up of atom. The atoms are very small: the size of atoms is measured in picometers – trillionths ( $10^{-12}$ ) of a meter. Every atom is composed of a nucleus and one or more electrons that orbit the nucleus. Protons and neutrons are called nucleons. Over 99.94% of the atom's mass is in the nucleus. The protons have a positive electric charge, the electrons have a negative electric charge, and the neutrons have no electric charge. If the number of protons and electrons are equal, that atom is electrically neutral. If an atom has a surplus or deficit of electrons relative to protons, then it has an overall positive or negative charge, and is called an ion.

### 1.2.2 Elements of Atom

Elements consist of only one kind of atom and can't be decomposed into simpler substance. Therefore, atom is the most fundamental unit of matter which is capable of independent existence in the atom is defined as its element. An atom consists of a central unit called nucleus around which a number of smaller particles move around the nucleus. The nuclei of all the elements (except hydrogen which has only one proton in its nucleus) contains two types of particles called protons and neutrons. The protons and neutrons have same mass. Protons are positively charged particles whereas neutrons are electrically neutral. The mass of an atom is concentrated in its nucleus. The electrons revolving around the nucleus are very light in weight. An electron is 1850 times lighter than a proton or neutron. An electron has same amount of charge as proton. However, the charge on electron is negative. Since matter in its normal state is electrically neutral, therefore the atom should be neutral. In an atom, the number of orbiting electron must be the same as the number of protons in its nucleus.

## 1.3 Bohr's Atomic Model

By early 1900s, the scientists understood that matter is composed of atoms and that the atom of Hydrogen contained positive charge  $+e$  at its centre and  $-e$  outside at its centre. However, no one understood why the electrical attraction between the electron and positive charge did not cause the two to collapse. One clue came from the fact that a hydrogen atom cannot emit and absorb all wavelengths of visible light. Rather, it can emit and absorb only four particular wavelengths of visible range. Johann Balmer devised a formula that gave those wavelengths:

$$\frac{1}{\lambda} = R \left( \frac{1}{2^2} - \frac{1}{n^2} \right) \quad \text{for } n = 3, 4, 5, \text{ and } 6. \quad (1.1)$$

Here R is constant. No one knew why this formula gave the right wavelength or why no other visible wavelengths are emitted or absorbed until 1913 when Bohr saw Balmer's equation and quickly realized that he could derive it after few assumptions:

1. The electron in hydrogen atom orbits the nucleus in a circle.
2. The magnitude of angular momentum L of electron in its orbit is restricted to the values  $L = nh$  ( $h$  – bar) for  $n = 1, 2, 3, \dots$  (1.2)

Where  $h$  ( $h$  – bar) is  $h/2\pi$  and  $n$  is the quantum number.

Let us consider the simplest example of hydrogen atom, which contains an electron that is trapped to be near proton, which forms atom's nucleus. We will not consider about nucleus, in fact, we



will use the fact that negatively charged electron is attracted by coulomb force to positively charged proton. As the mass of proton is greater than mass of electron, we assume that proton is fixed in place.

We know that electron energy  $E$  and change in energy  $\Delta E$  is quantized therefore in this section, quantized energy of hydrogen atom will be calculated. The orbital motion of electron is examined in Bohr Model. The force holding the electron in an orbit of radius  $r$  is the coulomb force.

The magnitude of force  $F = k q_1 q_2 / r^2$

Where  $k = 1/4\pi\epsilon_0$ . Here  $q_1$  is the  $-e$  charge of electron and  $q_2$  is the  $+e$  charge of proton. The electron's acceleration is centripetal acceleration with a magnitude given by  $a = v^2 / r$ , where  $v$  is the velocity of electron. Both Force  $F$  and acceleration  $a$  are radial inward (negative direction on radial axis), thus we can write Newton's second law ( $F = ma$ ) for radial axis as:

$$\frac{1}{4\pi\epsilon_0} \frac{e^2}{r^2} = m \left( -\frac{v^2}{r} \right) \quad (1.3)$$

Here  $m$  is the mass of electron.

Let us now consider quantization using Bohr's assumption expressed in equation (1.2) .

$$mvr = n\hbar$$

$$\text{or } v = \frac{n\hbar}{rm} \quad (1.4)$$

**Substituting equation (1.3) and replacing  $h$  by  $h/2\pi$**

$$\text{we get } r = \frac{h^2\epsilon_0}{\pi m e^2} n^2 \quad \text{for } n = 1, 2, 3, \dots \quad (1.5)$$

$$\text{we can rewrite this as } r = an^2 \text{ for } n=1,2,3, \dots \quad (1.6)$$

Where  $a$  is a constant and its value is  $5.291 \times 10^{-11} \text{ m}$

These last three equations tell us that in Bohr's Model of Hydrogen atom, the electron's orbital radius  $r$  is quantized and smallest possible orbital radius (for  $n=1$ ) is  $a$ , which is called Bohr's radius. According to Bohr Model, the electron cannot get any closer to nucleus than orbital radius  $a$  and that is why the attraction between electron and nucleus does not collapse.

### 1.4 Atomic Energy Level

An atom of an element is generally made up of electrons, protons, and neutrons. The only exception is the hydrogen atom which possesses one electron and one proton, but no neutrons. While an electron is negatively charged, the proton is a positively charged particle. The charge of proton is numerically equal to charge on electron, but the mass of proton is 1837 times greater than that of electron. A neutron is a neutral particle having a mass nearly equal to the proton mass. Because the neutrons and protons carry practically the entire mass of the atom, they remain almost immobile in a region called atomic nucleus. The electrons revolve around the nucleus in definite orbit, which are circular or elliptical. The motion is analogous to that of planets around sun. The atom is electrically neutral because the number of orbital electrons is equal to the number of protons in the nucleus. The atom of one element differs from another due to different number of protons, neutrons and electrons in the atom.



In the Bohr atomic model, the electrons are assumed to move about the nucleus in certain discrete circular orbits without radiating any energy. In any orbit, the angular momentum of electron is equal to integral multiple of  $h/2\pi$ , where  $h$  is Plank's constant ( $h= 6.626 \times 10^{-34}$  Js). The integral number  $n$  has values 1, 2, 3, etc. for different orbits. The higher the value of  $n$ , the larger is the radius of orbit.

The allowable discrete values of  $n$  show that all energies are not permitted for electrons. The electrons can have only certain discrete energies corresponding to different values of  $n$ . In other words, the electron energy is quantized. The allowable energy levels are shown by horizontal lines called energy level diagram of electron.

Figure shows the energy diagram of atom

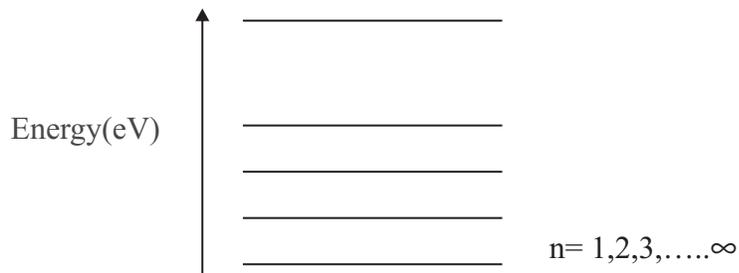

when an electron jumps from higher state to a lower state, an electromagnetic radiation of frequency is emitted, where

$$\nu = \frac{E_h - E_l}{h} \quad (1.7)$$

On the contrary, on absorbing a photon of energy  $h\nu$ , an electron initially at energy state  $E_l$  can move to higher energy state  $E_h$ .

An electron normally occupies the lowest energy state, called ground level in the atom. However with some energy supplied to atom, it goes to higher energy state, called excited level of atom. By absorbing more and more energy, an electron can move into excited states which are farther and farther away from the nucleus. If the energy is sufficiently high, the electron can overcome the attraction of nucleus and gets detached from the atom. The energy level corresponding to  $n = \infty$  is called ionization level.

As the electrons are electrostatically attracted by a positively charged nucleus, the allowed energies for electrons are negative. The ionization level represents the zero level of energy. The energies become more and more negative with decreasing value of  $n$ .

The wavelengths emitted from the atom due to electronic transitions from higher energy states to lower energy state give the spectral lines characterizing the atom.

The specific value of principal quantum number  $n$  determines an electronic shell. All the electrons of given atom having the same value of  $n$  belong to the same direction shell. The letters K, L, M, N,..... denote the shells for  $n=1, 2, 3, 4, \dots$  respectively. The different values of  $l$  for a given  $n$  define the subshells for the shell. The subshells are represented by  $s, p, d, f, \dots$  corresponding to  $l= 0, 1, 2, 3, \dots$  respectively. The number of protons in the nucleus is the atomic number  $Z$ . The atomic number of sodium is 11. The electronic configuration of the sodium atom is  $1s^2 2s^2 2p^6 3s^1$ , where the superscripts denote the number of electrons in a particular subshell. Clearly, the sodium atom has one electron in the outermost subshell.



## 1.5 Electron

Electron is a subatomic particle, with negative elementary electric charge. The electron is one of the fundamental particles constituting the atom. The charge of an electron is negative and is denoted by  $e$ . the magnitude of  $e$  is  $1.6 \times 10^{-19}$  coulomb.

The mass of an electron changes with its velocity in accordance with the theory of relativity. An electron moving with a velocity  $v$  has the mass

$$m = \frac{m_0}{\sqrt{1 - \frac{v^2}{c^2}}} \quad (1.8)$$

Where  $c$  is the velocity of light in free space. ( $c = 3.00 \times 10^8$  m/s) if  $v \ll c$ , then  $m = m_0$ , called the rest mass of electron. The rest mass of electron has a value of  $9.1 \times 10^{-31}$  Kg.

Equation 1.1 shows that the mass of electron increases with the velocity  $v$  and approaches infinity as  $v \rightarrow c$ , the radius of electron is very small and is considered as point mass.

## 1.6 Field Intensity

The electric field intensity is the force on a unit positive charge placed at that point in the field. In a uniform field the electric field intensity is constant (the same at any point in the field) while in a radial field the electric field intensity decreases as the distance from the central charge increases.

The electric field  $E$  at a given point is defined as the vectorial force  $F$  that would be exerted on a stationary test particle of unit charge by electromagnetic forces (i.e. the Lorentz force). A particle of charge  $q$  would be subject to a force.

$$F = qE \quad (1.9)$$

Its SI units are Newton per coulomb ( $N.C^{-1}$ ) or, equivalently, volts per metre ( $Vm^{-1}$ ), which in terms of SI base units are  $kg.m.s^{-3} A^{-1}$ .

## 1.7 Potential Energy

When an electrostatic force acts between two or more charged particles within a system of particles, we assign an electric potential energy  $U$  to the system. If the system changes its configuration from initial state  $i$  to different final state  $f$ , then the electrostatic force does work  $W$  on particles.

$$\Delta U = U_f - U_i = -W \quad (1.10)$$

The potential energy of charged particle in an electric field depends on the charge magnitude. However, potential energy per unit charge has a unique value at any point in an electric field. For example, suppose we place a test particle of positive charge  $1.6 \times 10^{-19}$  C at a point in an electric field where particle has an electric potential energy of  $2.4 \times 10^{-17}$  J. Then, the potential energy per

unit charge is  $\frac{2.4 \times 10^{-17}}{1.6 \times 10^{-19}} = 150$  J/C

Next, suppose we replace that test particle with one having twice as much positive charge,  $3.20 \times 10^{-19}$  C. we would find that second particle has an electric potential energy of  $4.8 \times 10^{-17}$  J, twice that of first particle. However, the potential energy per unit charge would be the same, still 150J/C. Thus, potential energy per unit charge, which can be symbolized as  $U/q$ , is independent of charge  $q$  of particle.



The potential difference  $\Delta V$  between any two points  $i$  and  $f$  in an electric field is equal to the difference in potential energy per unit charge between two points.

$$\Delta V = V_f - V_i = \frac{U_f}{q} - \frac{U_i}{q} = \frac{\Delta U}{q} \quad (1.11)$$

One electron-volt (eV) is the energy equal to the work required to move a single elementary charge  $e$ , such as electron or proton, through a potential difference of exactly one volt.

$$1\text{eV} = 1.6 \times 10^{-19} \text{ C} \times 1\text{J/C} = 1.6 \times 10^{-19} \text{ J} \quad (1.12)$$

## 1.8 Current and Current Density

Electric current is the stream of moving charge. If there is any electric current through a given surface, there must be a net flow of charge through that surface. For example, the free electrons in a conducting medium travel with random motion. If a voltage is applied, free electrons will flow under the influence of voltage and there will be a net transport of charge thus an electric current will start flowing through the conducting medium e.g. Copper wire.

Therefore, current  $i = \frac{dq}{dt}$  (1.13)

The SI unit of current is Coulomb per second or the Ampere (A) which is an SI base unit. Current is a scalar quantity as both charge and time are scalar quantities. Current is often expressed with an arrow mark to show that it is moving, not for vector quantity.

### Current Density

Sometimes, we are interested in current  $i$  in a conductor and then we can study the flow of charge through a cross section of conductor at a particular point. Current density  $J$  is used to describe this flow, which has the same direction as the velocity of moving charge if charge carriers are positive and it has opposite direction if charge carriers are negative. For each element of cross-section, the magnitude  $J$  is equal to the current per unit area through that element.

$$i = \int J \cdot dA = JA \quad (1.14)$$

$$J = i/A \quad (1.15)$$

Here  $A$  is the total area of surface.

The SI unit for current density is Ampere per square meter ( $\text{A/m}^2$ ).

**Ionization Potential:** The potential difference through which a bound electron must be raised to free it from the atom or molecule to which it is attached. In particular, the ionization potential is the difference in potential between the initial state, in which the electron is bound, and the final state, in which it is at rest at infinity.

The ionization potential for the removal of an electron from a neutral atom other than hydrogen is more correctly designated as the first ionization potential. The potential associated with the removal of a second electron from a singly ionized atom or molecule is then the second ionization potential, and so on. A physical quantity determined by the ratio of the least energy necessary for single ionization of an atom (or molecule) in the ground state to the charge of the electron. The ionization potential is a measure of the ionization energy, which is equal to the work expended in emitting the electron from the atom or molecule and characterizes the electron's bond strength in the atom or molecule. The ionization potential commonly is expressed in volts and is numerically equal to the ionization energy in electron volts.



The values of the ionization potential can be determined experimentally by studying the ionization induced by an electron impact or by measuring the energy of photons during photoionization. Highly accurate values of the ionization potential for atoms and the simplest molecules can be obtained from spectroscopic data on energy levels and their convergence toward the ionization boundary.

For atoms the values of the first ionization potential, which corresponds to the removal of the most weakly bound electron from a neutral atom in its ground state, range from 3.894 V for cesium to 24.587 V for helium.

## 1.9 Electric Field

The electric field is the component of electromagnetic field. It is a vector field and is generated by electric charges or time varying magnetic field. The concept of electric field was introduced by Michael Faraday. However, since the magnetic field is described as a function of electric field, the equations of both fields are coupled and together form Maxwell's equations that describe both fields as a function of charges and currents.

A uniform electric field is constant at every point. It can be approximated by placing two conducting plates parallel to each other and maintaining a voltage (potential difference) between them; it is only an approximation because of boundary effects (near the edge of the planes, electric field is distorted because the plane does not continue). Assuming infinite planes, the magnitude of the electric field  $E$  is:

$$E = V/d \quad (1.16)$$

where  $V$  is the potential difference between the plates and  $d$  is the distance separating the plates. The negative sign arises as positive charges repel, so a positive charge will experience a force away from the positively charged plate, in the opposite direction to that in which the voltage increases. In micro and nano applications, for instance in relation to semiconductors, a typical magnitude of an electric field is in the order of  $10^6 \text{ V}\cdot\text{m}^{-1}$ , achieved by applying a voltage of the order of 1 volt between conductors spaced  $1 \mu\text{m}$  apart.

## 1.10 Magnetic Field

A magnetic field is the magnetic effect of electric currents and magnetic materials. The magnetic field at any given point is specified by both a direction and a magnitude (or strength); as such it is a vector field. The term is used for two distinct but closely related fields denoted by the symbols  $B$  and  $H$ , where  $H$  is measured in units of amperes per meter (symbol:  $\text{A}\cdot\text{m}^{-1}$  or  $\text{A}/\text{m}$ ) in the SI.  $B$  is measured in teslas (symbol:  $\text{T}$ ) and newtons per meter per ampere (symbol:  $\text{N}\cdot\text{m}^{-1}\cdot\text{A}^{-1}$  or  $\text{N}/(\text{m}\cdot\text{A})$ ) in the SI.  $B$  is most commonly defined in terms of the Lorentz force it exerts on moving electric charges.

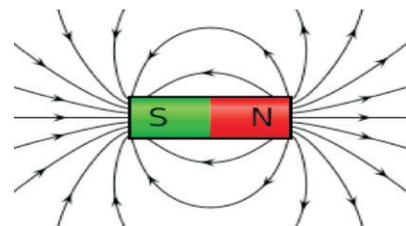

Figure-1

Magnetic fields can be produced by moving electric charges and the intrinsic magnetic moments of elementary particles associated with a fundamental quantum property, their spin. In special relativity, electric and magnetic fields are two interrelated aspects of a single object, called the electromagnetic tensor; the split of this tensor into electric and magnetic fields depends on the relative velocity of the observer and charge. In quantum physics, the electromagnetic field is quantized and electromagnetic interactions result from the exchange of photons.



In everyday life, magnetic fields are most often encountered as a force created by permanent magnets, which pull on ferromagnetic materials such as iron, cobalt, or nickel, and attract or repel other magnets. Magnetic fields are widely used throughout modern technology, particularly in electrical engineering and electromechanics. The Earth produces its own magnetic field, which is important in navigation, and it shields the Earth's atmosphere from solar wind. Rotating magnetic fields are used in both electric motors and generators. Magnetic forces give information about the charge carriers in a material through the Hall Effect. The interaction of magnetic fields in electric devices such as transformers is studied in the discipline of magnetic circuits.

### 1.11 Motion of Charged Particles in Electric Field

Consider a particle of mass  $m$  and electric charge  $q$  moving in the uniform electric and magnetic fields,  $E$  and  $B$ . Suppose that the fields are “crossed” (i.e., perpendicular to one another), so that  $E \cdot B = 0$

The force acting on the particle is given by the familiar Lorentz law:

$$F = q(E + v \times B) \quad (1.17)$$

Where  $v$  is the particle's instantaneous velocity. Hence, from Newton's second law, the particle's equation of motion can be written

$$m \frac{dv}{dt} = q(E + v \times B) \quad (1.18)$$

It turns out that we can eliminate the electric field from the above equation by transforming to a different inertial frame. Thus, writing

$$v = \frac{E \times B}{B^2} + v' \quad (1.19)$$

Equation (1.18) reduces to

$$m \frac{dv'}{dt} = qv' \times B \quad (1.20)$$

We know,  $E \cdot B = 0$ . Hence, we conclude that the addition of an electric field perpendicular to a given magnetic field simply causes the particle to drift perpendicular to both the electric and magnetic field with the fixed velocity

$$V(EB) = \frac{E \times B}{B^2} \quad (1.21)$$

It follows that the electric field has no effect on the particle's motion in a frame of reference which is co-moving with the so-called E-cross-B velocity given above.

We conclude that the general motion of a charged particle in crossed electric and magnetic field is a combination of  $E \times B$  drift and spiral motion aligned along the direction of the magnetic field. Particles drift parallel to the magnetic field with constant speeds, and gyrate at the cyclotron frequency in the plane perpendicular to the magnetic field with constant speeds. Oppositely charged particles gyrate in opposite directions.

### 1.12 Cathode Ray Oscilloscope

Cathode Ray Oscilloscope is an extremely versatile and useful laboratory instrument used for displaying shapes of alternating current and voltages and measures voltage, current, power, time



period and frequency of the waveforms. It allows the user to see amplitude of electrical signal as a function of time. It is used for troubleshooting radio receivers and Television receivers. In fact, Cathode Ray Oscilloscope is one of the most important tools in design, development, and analysis of transient response, measurement and troubleshooting of electronic circuits. With the help of transducers, many physical quantities like pressure, strain, temperature, acceleration, etc. can be converted into voltages which can be displayed on CRO. Therefore dynamic behaviour of these physical quantities can be studied by means of CRO. Basically CRO is a fast X-Y Plotter that shows an input signal versus another signal or versus time.

### 1.12.1 Block Diagram

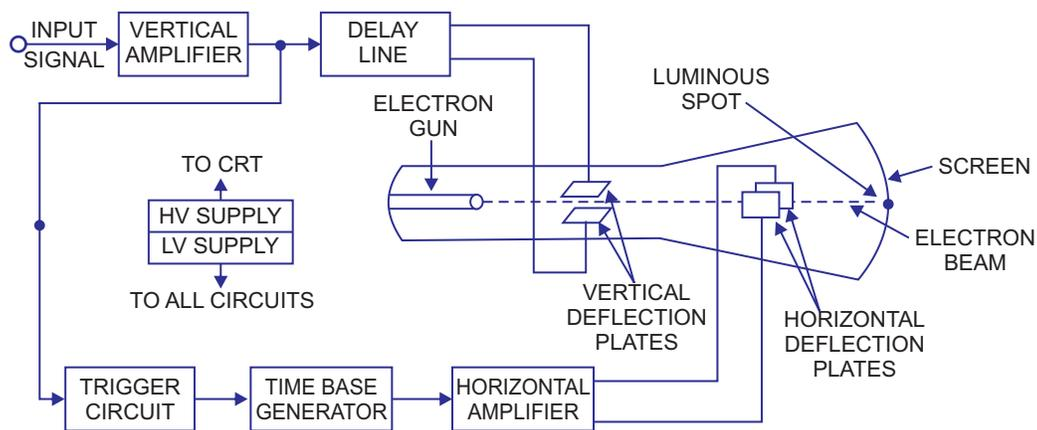

**Figure-2 : Block Diagram of a General Purpose CRO**

The major components of CRO are depicted in simplified block diagram. These components are:

- (i) Cathode Ray Tube
- (ii) Vertical Amplifier
- (iii) Delay Line
- (iv) Trigger Circuit
- (v) Time Base Generator
- (vi) Horizontal Amplifier
- (vii) Power Supply

The horizontal displacement of CRT spot is obtained by sweep generator incorporated in CRO assembly or by an external signal applied to horizontal input terminal. The vertical displacement of the spot is caused by the signal applied to vertical input terminal. The bandwidth of the amplifier determines the frequency range over which the oscilloscope can be used. The gain and bandwidth of horizontal amplifier are usually less than vertical amplifier. The trigger circuit of time base generator can be activated either by the signal applied to vertical input terminal or by external trigger signal. The power supply incorporated in the CRO assembly has a high voltage section to operate the CRT and a low voltage section to operate the associated electronic circuitry. These supplies are conveniently designed.



### 1.12.2 Cathode Ray Tube

Cathode Ray Tube (CRT) is the heart of oscilloscope. It generated electron beam, accelerates the beam to a high velocity, deflects the beam to create the image, and phosphor screen become visible. The internal structure of CRT is schematically shown in figure.

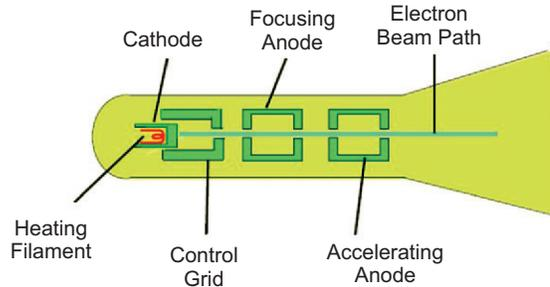

**Figure-3 : Operation of an Electron Gun with an Accelerating Anode**

The CRT consists of highly evacuated funnel shaped glass tube. The electrons are emitted from an indirectly heated thermionic cathode. A number of electrodes transform the emitted electrons into a high velocity electron beam known as cathode ray. This cathode ray travels through evacuated space of the tube towards fluorescent screen. When the beam strikes the screen, the kinetic energy of electrons is converted into light emission. Therefore a small light spot is created on the screen. The location of the spot is varied by deflection system in accordance with the input voltage. Usually, the signal under test deflects the spot vertically and another voltage proportional to time is used to deflect the spot horizontally. Thus, the time variation of voltage is displayed on the screen.

The main components of general purpose CRT are:

- (i) Electron Gun
- (ii) Deflection System
- (iii) Fluorescent Screen

These components are briefly discussed below:

**Electron Gun:** This part of CRT emits electrons, transforms them into a narrow beam and focuses the beam on fluorescent screen. It consists of indirectly heated cathode, control grid, accelerating electrode, focusing anode and final accelerating anode. These electrodes have cylindrical shape and they are connected to the pins on the base.

The name electron gun originated from the analogy between motion of electron and bullet fired from a gun as these electrons acquire very high velocity. The brightness and intensity of electron beam is controlled by the control grid. A very high positive voltage is applied to accelerating electrode to speed up the electron passing through it. The main purpose of focusing anode and final accelerating anode is to focus the electron beam into a small spot on the screen.

**Deflection System:** The deflection system comprises of a pair of horizontal deflection plates and vertical deflection plates. The electron beam is deflected and the spot on the screen is changed by voltages applied to deflection plates. Let us consider the case when we do not apply any voltage to the deflection plates AB, then there will not be any change in the direction of electron beam. But



now, when we apply some positive voltage to deflection plate A w.r.t. deflection plate B, then electrons being negatively charged, will have some deviation in path towards deflection plate A. The voltage applied to horizontal plate deflects the beam in horizontal direction and voltage applied to vertical deflection plates deflects the beam in vertical direction. However, this shift is dependent on the intensity of voltage applied. This moving spot appears as continuous luminous waveform owing to the persistence of the screen and human eye.

**Fluorescent Screen:** The inner surface of the face plate of CRT is coated with a fluorescent material known as phosphor. The phosphor absorbs the kinetic energy of cathode ray and re-emits the energy as light.

### 1.12.3 Deflection Sensitivity

In the electrostatic deflection, the spot is deflected on the screen by applying the voltage on vertical and/or horizontal deflection plates. The dc or peak-to-peak ac voltage applied to the deflecting plates to displace the spot by 1mm on the screen is termed the deflection factor. The reciprocal of the deflection factor is called the deflection sensitivity. The deflection factor is expressed in V/mm and deflection sensitivity in mm/V.

Instead of electrostatic deflection, magnetic deflection can also be employed. The electrons are deflected by a magnetic field applied perpendicular to the beam over a short distance of its path. The electrons experience a magnetic force in a direction perpendicular to both the direction of the motion and direction of magnetic field. Consequently, on emerging from the magnetic field, the electrons travel at an angle to their original direction. The deflection of the spot on the screen per unit magnetic field is termed the magnetic field sensitivity. It is expressed in mm/gauss.

#### (i) Electrostatic Deflection

The electrostatic deflection of an electron beam is depicted in the figure. Let  $s$  be the separation between the deflecting plates,  $D$  be the distance from the screen  $S$  and  $l$  be the length of each deflection plate. Suppose that the deflecting voltage applied between the plates is  $V_d$ . If  $m$  and  $e$  be respectively the mass and charge of an electron entering the deflecting system with a velocity  $v$  and  $V_a$  be the final accelerating anode voltage, then we have

$$\frac{1}{2}mv^2 = eV_a \tag{1.22}$$

$$\text{Or } v^2 = \frac{2eV_a}{m} \tag{1.23}$$

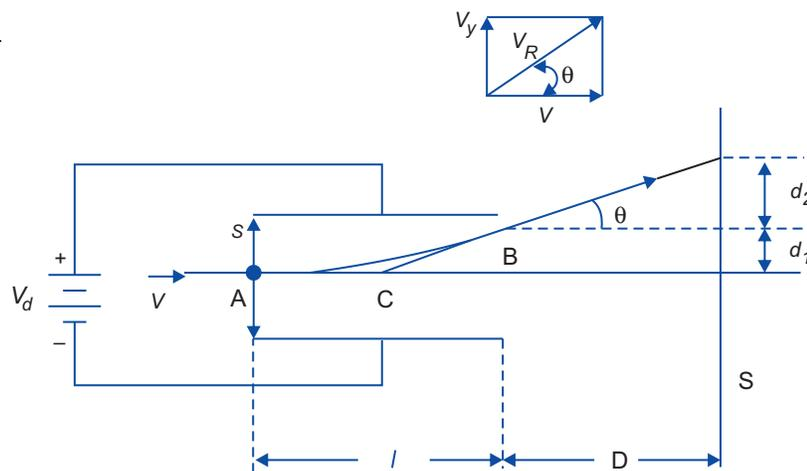

Figure-4



The force exerted on the electron towards the positive deflection plate

$$F = \frac{e Vd}{s} \quad (1.24)$$

The acceleration of electron is  $a = \frac{F}{m} = \frac{e Vd}{ms}$  (1.25)

The time taken by electron to move through the deflection plate is  $l/v$ . the upward velocity  $v_y$  acquired by electron on emergence from deflecting system is

$$v_y = \frac{al}{v} = \frac{e Vd}{ms} \frac{l}{v} \quad (1.26)$$

The electron leaves the region of the deflecting plates, no deflecting force exists, and the electron moves in a straight line at an angle  $\theta$  with the initial direction, we have

$$\tan \theta = \frac{v_y}{v} = \frac{d2}{D} \quad (1.27)$$

The vertical displacement of electron in this interval is

$$d_1 = \frac{al^2}{2v^2} = \frac{e Vd}{ms} \frac{l^2}{2v^2} \quad (1.28)$$

Here  $d_2$  is the additional deflection on the screen.

$$d_2 = D \frac{v_y}{v} = \frac{e Vd l D}{sm v^2} \quad (1.29)$$

The total deflection  $d = d_1 + d_2 = \frac{e Vd l}{sm v^2} \left( \frac{l}{2} + D \right)$  (1.30)

The deflection sensitivity of CRT is  $S = \frac{d}{Vd} = \frac{1L}{2sVa}$  (1.31)

The expression for S shows that deflection sensitivity is independent of the deflecting voltage but is inversely proportional to the final anode voltage. Thus, deflection sensitivity can be enhanced by reducing the anode voltage. But then the brightness of the spot is reduced. The disadvantage is removed by employing post acceleration. Here the beam is accelerated after it is deflected by deflecting system. Equation (1.31) shows that deflection sensitivity varies directly as the length  $l$  of deflecting plates and as length  $L$  of the screen from the centre of plates. Also, S varies inversely as separation  $s$  between deflection plates.

### (ii) Magnetic Deflection

Let a uniform field  $B$  act on the electron beam  $AC$  emitted from electron gun over a length  $l$  of its path (see figure).

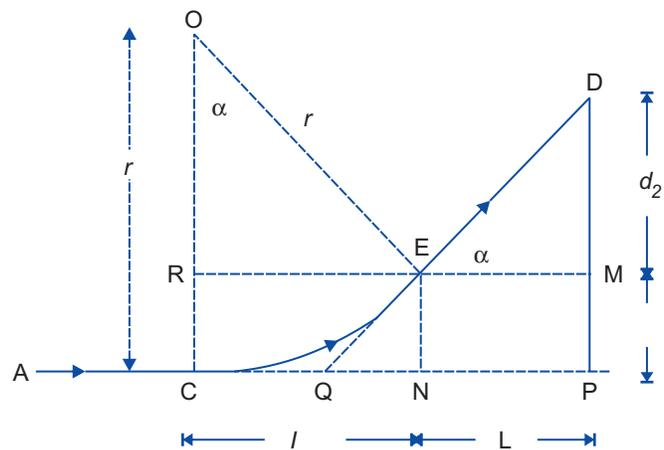

Figure-5



If the magnetic field is perpendicular to the plane of the paper, a magnetic force acts on the electron along the plane of paper at right angles to magnetic field and the direction of motion of electron. As a result, the electron beam moves along a circular arc CE in the magnetic field. The radius  $r$  of circle is found by equating magnetic force  $Bev$  to the centripetal force  $mv^2/r$ ,  $v$  being the velocity of an electron of mass  $m$  and charge  $e$ . Hence

$$Bev = \frac{mv^2}{r} \quad (1.32)$$

$$r = \frac{mv}{Be} \quad (1.33)$$

Let accelerating potential be  $V$ , then

$$\frac{1}{2} mv^2 = eV$$

$$v = \sqrt{\frac{2eV}{m}} \quad (1.34)$$

Using equation (1.34) in equation (1.33), we get

$$r = \frac{1}{B} \sqrt{\frac{2mV}{e}} \quad (1.35)$$

The deflection  $d_1$  of electron is

$$d_1 = PM = NE = CR = OC - OR = r(1 - \cos\alpha) \quad (1.36)$$

$$\text{Where as, } d_2 = L \tan\alpha \quad (1.37)$$

In practice, the angle  $\alpha$  is small enough so that only the terms up to  $\alpha^2$  are important. Therefore

$$\tan\alpha \sim \alpha \sim \frac{l}{r} \quad (1.38)$$

$$\cos\alpha \sim 1 - \frac{\alpha^2}{2} = 1 - \frac{1}{2} \frac{l^2}{r^2} \quad (1.39)$$

Substituting the value of  $\tan\alpha$  and  $\cos\alpha$  from equations (1.38) and (1.39)

$$d_2 = \frac{Ll}{r} \quad (1.40)$$

$$d_1 = \frac{l^2}{2r} \quad (1.41)$$

$$\text{The total spot deflection on the screen is } d = d_1 + d_2 = \frac{l}{r} \left( L + \frac{l}{2} \right) \quad (1.42)$$

The distance  $(L + \frac{l}{2})$  equals QP, the distance of the screen from the centre of magnetic field region. Substituting value of  $r$  from equation (1.35), we get

$$d = \sqrt{\frac{e}{2mV}} \frac{l}{r} \left( L + \frac{l}{2} \right) \quad (1.43)$$

by definition, magnetic deflection sensitivity is

$$S_m = \frac{d}{B} = l \sqrt{\frac{e}{2mV}} \left( L + \frac{l}{2} \right) \quad (1.44)$$



### 1.12.3 Electrostatic Deflection versus Magnetic Deflection

1. The electrostatic deflection needs little power for deflection. Whereas, magnetic deflection needs large power for the same deflection.
2. The electrostatic deflection can be employed at higher frequencies than magnetic deflection.
3. In electrostatic deflection, the deflection sensitivity falls more rapidly with increasing anode voltage than that in case of magnetic deflection.

### 1.12.4 Applications of Cathode Ray Oscilloscope

- (i) **Visual Display and Qualitative Study of Signal Waveforms:** To display a signal on the CRT screen, the signal is applied to the vertical input terminals. The time variation of the signal is visualized by means of time base generator displacing a spot in proportion to time in the horizontal direction. The nature of the signal can be qualitatively studied from the trace on CRT screen.
- (ii) **Measurement of Voltage:** The calibration of vertical scale gives the voltage corresponding to the vertical deflection of the spot on the CRT screen. Thus the magnitude of an applied voltage at different times of time varying signal can be measured.
- (iii) **Measurement of Frequency:** The calibration of horizontal scale i.e. the time base helps to determine the frequency of time varying signal displayed on the CRT screen. If  $N$  complete cycles of ac signal are found to appear in a time interval  $t$ , then time period of signal is

$$T = t/N$$

And frequency of signal is  $f = 1/T = N/t$

- (iv) **Measurement of Phase:** The two signals, whose phase difference is to be measured, are applied to the two channels of double beam CRO. The same trigger is used for two sweep voltages. The phase difference between two waveforms displayed on CRT screen can be found from time base. If two sinusoidal signals of time period  $T$  are found to attain same phase at times  $t_1$  and  $t_2$  respectively, the phase difference between them is

$$\Phi = \frac{2\pi}{T} (t_2 - t_1) \quad (1.45)$$

#### Resource Material

- (1) Electrical technology by V.K. Mehta & Rohit Mehta.
- (2) Few reference from Wikipedia free encyclopedia.



## Exercise

### 1. Short questions:

- (a) Define Atoms.
- (b) Define Transistors.
- (c) Define ICs.
- (d) Define Electron.
- (e) What are the elements of Atoms?

### 2. Write short note on:

- (a) What is Atomic Energy Level?
- (b) Explain about Field Intensity.
- (c) What is Potential Energy?
- (d) What do you mean about Electric Field?

### 3. Explain the following:

- (a) What is Bohr's Atomic Model? Write the mathematical expression with your answer.
- (b) What do you mean about Current and Current Density?
- (c) What is Magnetic Field? Explain motion of charged particles in Electric Field.

### 4. Long questions:

- (a) What are the applications of Cathode Ray Oscilloscope?
- (b) Explain with block diagram Cathode Ray Oscilloscope.

## UNIT 2

### Voltage & Current

#### 2.0 Unit Overview and Description

- Overview
- Knowledge and Skill Outcomes
- Assessment Plan
- Learning Outcomes
- Resource Material
- Topics Covered

Resistance, Ohm's law, V-I Characteristics, Resistors, Capacitors, Inductors, Voltage and Current Sources, Symbols and Graphical Representation, Conversion of Current and Voltage Sources, Overview of AC, DC, Cells and Batteries, Energy and Power.

#### Overview

This unit starts with the understanding of fundamentals of electrical parameter (Resistor, capacitor, inductor) their Properties etc. Further different types of electrical sources such as voltage and current sources has been discussed along with the symbols and graphical representation also conversion of current and voltage source have been presented. A comparative study of various electrical signals (AC & DC) has been discussed. Proper explanation of cells and batteries, energy and power finally whatever discussed and presented in various chapters has been summarized as a quick review.

#### Knowledge and Skill Outcomes

- Understanding of fundamentals of electrical parameter i.e, voltage, current and all their associated parts.
- Understanding of all the electrical passive components (resistor, inductor and capacitor).
- Knowledge of various types of voltage and current sources.
- Difference between energy, work and power.

#### Assessment Plan: (For the Teachers)

Unit-2	Topic	Assessment Method	Time Plan	Remarks
	Resistance, Ohm's law, V-I Characteristics, Resistors, Capacitors, Inductors.	Exercise: Question & Answer	Two Hours	
	Voltage and Current Sources, Symbols and Graphical Representation, Conversion of Current and Voltage sources.	Exercise: Question & Answer	Two Hours	
	Overview of AC, DC, Cells and Batteries, Energy and Power.	Exercise: Question & Answer	Two Hours	



## Learning Outcomes

Unit-2	Voltage & Current	Outcomes
	Resistance, Ohm's law, V-I Characteristics, Resistors, Capacitors, Inductors.	(i) Understanding the concept of electrical fundamentals. (ii) Understanding the passive components and their Characteristics.
	Voltage and Current Sources, Symbols and Graphical Representation, Conversion of Current and Voltage sources.	(i) Identification of voltage and current sources and their conversion. (ii) Graphical representation and symbols of electrical sources.
	Overview of AC, DC, Cells and Batteries, Energy and Power.	(i) Understanding of AC, DC, Cells and batteries. (ii) To know the difference of work energy and power.

### 2.1. Current Flow Theories

Two theories describe current flow. The conventional theory commonly used for automotive system says current flow from (+) to (-)...excess electrons flow from an area of high potential to one of low potential (-).

The electron theory commonly used for electronics says current flows from(-) to (+)...excess electron cause an area of negative potential (-) and flow toward an area lacking electrons , an area of positive potential(+), to balance the charges.

While the direction of current flow makes a difference in the operation of some devices, such as diodes, the direction makes no difference to the three measurable units of electricity; voltage, current, and resistance.

#### 2.1.1. Terms of Electricity

Electricity cannot be weighted on a scale or measured into a container. But certain electrical “action” can be measured.

These actions or terms are used to describe electricity, voltage, current, resistance, and power.

Voltage is pressure.

Current is flow.

Resistance opposes flow.

Power is that amount of work performed. It depends on the amount of pressure and the volume of flow.

##### (i) Voltage

Voltage is the electrical pressure, a potential force or difference in electrical charge between two points. It can push electrical current through a wire, but not through its insulation.



Voltage is measured in volts. One volt can push a certain amount of current, two volts twice as much and so on. A voltmeter measures the difference in electrical pressure between two points in volts. A voltmeter is used in parallel.

### **(ii) Current**

Current is electrical flow moving through a wire. Current flow in a wire pushed by voltage.

Current is measured in amperes, or amps, for short. An ammeter measures current flow in ampere. It is inserted into the path of current flow, or in series, in a circuit.

### **(iii) Resistance**

Resistance opposes current flow. It is like electrical “friction”. This resistance slows the flow of current. Every electrical component or circuit has resistance. And this resistance changes electrical energy into another form of energy- heat, light, motion.

Resistance is measured in ohms. A special meter called ohmmeter, can measure the resistance of a device in ohms when no current is flowing.

### **(iv) Factors Affecting Resistance**

Five factors determine the resistance of conductors. These factors are length of the conductor, diameter of the conductor, temperature, physical condition and conductor material. The filament of a lamp, the winding of a motor or coil, and the bimetal element in sensors are conductors. So these factors apply to circuit wiring as well working devices or loads.

$$R = P \frac{L}{A}$$

R = Resistance of Conductor

P = Resistivity; L = Length of Conductor

A = Area of Conductor

### **(v) Length**

Electrons in motion are constantly colliding as voltage pushes them through a conductor. If two wires are of the same material and diameter, the longer wire has more resistance than shorter wire. Wire resistance is often listed in ohms per foot (e.g., spark plug cables at 5 ohm per foot). Length must be considered when replacing wires.

### **(vi) Diameter**

Large diameter allows more current to flow. If two wires are the same material and length, the thinner wire has more resistance than the thicker wire. Wire resistance tables list ohm per foot for wires of various thickness.

Replacement of wires and splices must be of the proper size for the circuit current.

### **(vii) Temperature**

In most conductors, resistance increases as the wire temperature increases. Electrons move faster but not necessarily in the right direction. Most insulators have less, resistance at higher temperatures.

Semiconductor device called thermister have negative temperature coefficient (NTC) resistance decrease as temperature increase.



**(viii) Physical Condition**

Partially cut or nicked wire will act like smaller wire with high resistance in the damaged area. A kink in the wire, poor splices, and loose or corroded connections also increase resistance. Take care not to damage wires during testing or stripping insulation.

**(ix) Material**

Material with many free electrons is good conductors with low resistance to current flow. Material with many bound electrons is poor conductors (insulators) with high resistance to current flow. Copper, aluminium, gold, and silver have low resistance. Rubber, glass, paper, ceramics, plastics, and air have high resistance.

**2.1.2. Voltage, Current, and Resistance in a Circuit**

A simple relationship exists between voltage, current & resistance in electrical circuits. Understanding this relationship is important for fast accurate electrical problem diagnosis and repair.

**2.1.2.1. OHM'S LAW**

Ohm's law says: the current in a circuit is directly proportional to the applied voltage and inversely proportional to the amount of resistance.

This means that if the voltage goes up, the current flow will go up, and vice versa. Also as the resistance goes up, the current goes down and vice versa.

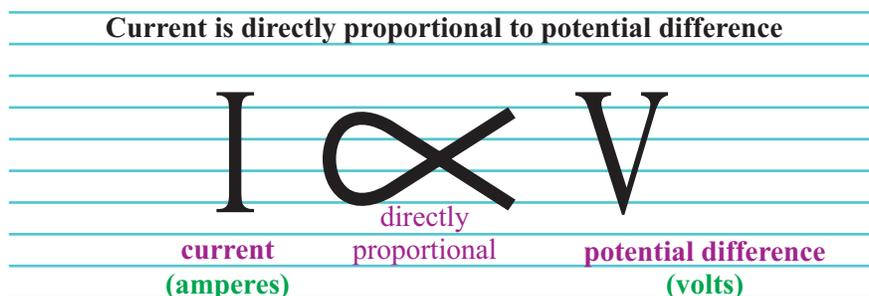

**Figure-1**

also  $I \propto \frac{1}{R}$

$I = \frac{V}{R}$

- where V = Voltage
- I = Current
- R = Resistance

**(i) I-V Characteristic Curves**

The I-V characteristic curves, which is short for current-voltage characteristic curves or simply I-V curves of an electrical/electronic device or component, are a set of graphical curves which are used to define its operation within an electrical circuit. As its name suggests, I-V characteristic



curves show the relationship between the current flowing through an electronic device and the applied voltage across its terminals.

I-V characteristic curves are generally used as a tool to determine and understand the basic parameters of a component or device and which can also be used to mathematically model its behavior within an electronic circuit.

But as with most electronic devices, there are an infinite number of I-V characteristic curves representing the various inputs or parameters and as such we can display a family or group of curves on the same graph to represent the various values.

For example, the “current-voltage characteristics” of a bipolar transistor can be shown with various amounts of base drive or the I-V characteristic curves of a diode operating in both its forward and reverse regions.

But the static current–voltage characteristics of a component or device need not be a straight line. Take for example the characteristics of a fixed value resistor, we would expect them to be reasonably straight and constant within certain ranges of current, voltage and power as it is a linear or ohmic device.

There are however, other resistive elements such as LDR’s, thermistors, varistors, and even the light bulb, whose I-V characteristic curves are not straight or linear lines but instead are curved or shaped and are therefore called non-linear devices because their resistances are non-linear resistances.

If the electrical supply voltage,  $V$  applied to the terminals of the resistive element  $R$  above was varied, and the resulting current,  $I$  measured, this current would be characterized as:  $I = V/R$ , being one of Ohm’s Law equations.

We know from Ohm’s Law that as the voltage across the resistor increases so too does the current flowing through it, it would be possible to construct a graph to show the relationship between the voltage and current as shown with the graph representing the volt-ampere characteristics (its I-V characteristic curves) of the resistive element. Consider the circuit below. (Fig.-2)

### I-V Characteristic Curves of an Ideal Resistor

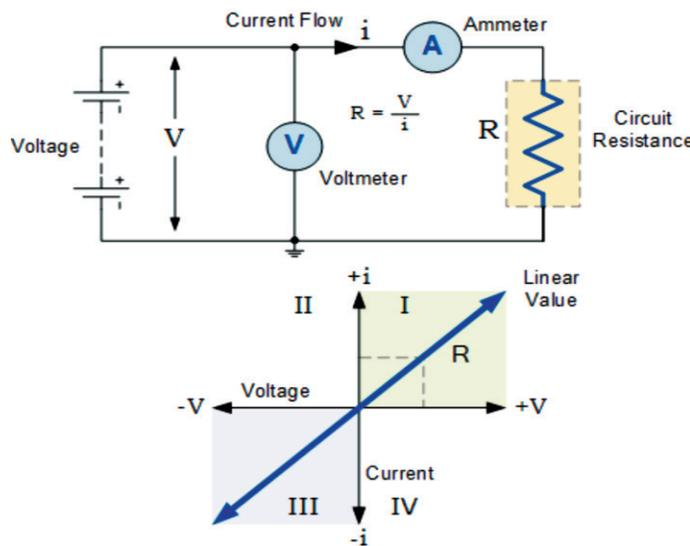

Figure-2



## 2.2. Resistors

A resistor is a passive two-terminal component that implements electrical resistance as a circuit element. Resistors act to reduce current flow, and, at the same time, act to lower voltage levels within circuits. In electronic circuits, resistors are used to limit current flow, to adjust signal levels, bias active elements and terminate transmission lines among other uses. High-power resistors, that can dissipate many watts of electrical power as heat, may be used as part of motor controls, in power distribution systems or as test loads for generators. Fixed resistors have resistances that only change slightly with temperature, time or operating voltage. Variable resistors can be used to adjust circuit elements (such as a volume control or a lamp dimmer), or as sensing devices for heat, light, humidity, force, or chemical activity.

Resistors are common elements of electrical networks and electronic circuits and are ubiquitous in electronic equipment. Practical resistors as discrete components can be composed of various compounds and forms. Resistors are also implemented within integrated circuits.

The electrical function of a resistor is specified by its resistance: common commercial resistors are manufactured over a range of more than nine orders of magnitude. The nominal value of the resistance will fall within a manufacturing tolerance.

### 2.2.1. Fixed Resistors

A single in line (SIL) resistor package with 8 individual, 47 ohm resistors. One end of each resistor is connected to a separate pin and the other ends are all connected together to the remaining (common) pin – pin 1, at the end identified by the white dot. (Fig. - 3)



Figure-3

#### (i) Lead Arrangements (Fig. - 4)

Resistors with wire leads for through-hole mounting through-hole components typically have “leads” leaving the body “axially,” that is, on a line parallel with the part’s longest axis. Others have leads coming off their body “radially” instead. Other components may be SMT (surface mount technology), while high power resistors may have one of their leads designed into the heat sink.



Figure-4



### **(ii) Carbon Composition (Fig.-5)**

Three carbon composition resistors in a 1960s valve (vacuum tube) radio.

Carbon composition resistors consist of a solid cylindrical resistive element with embedded wire leads or metal end caps to which the lead wires are attached. The body of the resistor is protected with paint or plastic. Early 20th-century carbon composition resistors had uninsulated bodies; the lead wires were wrapped around the ends of the resistance element rod and soldered. The completed resistor was painted for color-coding of its value.



**Figure-5**

The resistive element is made from a mixture of finely ground (powdered) carbon and an insulating material (usually ceramic). A resin holds the mixture together. The resistance is determined by the ratio of the fill material (the powdered ceramic) to the carbon. Higher concentrations of carbon- a good conductor- result in lower resistance. Carbon composition resistors were commonly used in the 1960s and earlier, but are not so popular for general use now as other types have better specifications, such as tolerance, voltage dependence, and stress (carbon composition resistors will change value when stressed with over-voltages). Moreover, if internal moisture content (from exposure for some length of time to a humid environment) is significant, soldering heat will create a non-reversible change in resistance value. Carbon composition resistors have poor stability with time and were consequently factory sorted to, at best, only 5% tolerance. These resistors, however, if never subjected to overvoltage or overheating were remarkably reliable considering the component's size.

Carbon composition resistors are still available, but comparatively quite costly. Values ranged from fractions of an ohm to 22 megaohms. Due to their high price, these resistors are no longer used in most applications. However, they are used in power supplies and welding controls.

### **(iii) Carbon Pile**

A carbon pile resistor is made of a stack of carbon disks compressed between two metal contact plates. Adjusting the clamping pressure changes the resistance between the plates. These resistors are used when an adjustable load is required, for example in testing automotive batteries or radio transmitters. A carbon pile resistor can also be used as a speed control for small motors in household appliances (sewing machines, hand-held mixers) with ratings up to a few hundred watts. A carbon pile resistor can be incorporated in automatic voltage regulators for generators, where the carbon pile controls the field current to maintain relatively constant voltage. The principle is also applied in the carbon microphone.



#### (iv) Carbon film (Fig. - 6)

Carbon film resistor with exposed carbon spiral.

A carbon film is deposited on an insulating substrate, and a helix is cut in it to create a long, narrow resistive path. Varying shapes, coupled with the resistivity of amorphous carbon, can provide a wide range of resistance values. Compared to carbon composition they feature low noise, because of the precise distribution of the pure graphite without binding. Carbon film resistors feature a power rating range of 0.125 W to 5 W at 70 °C. Resistances available range from 1 ohm to 10 megaohm. The carbon film resistor has an operating temperature range of -55°C to 155 °C. It has 200 to 600 volts maximum working voltage range. Special carbon film resistors are used in applications requiring high pulse stability.



Figure-6

#### (v) Printed Carbon Resistor (Fig. - 7)

Carbon composition resistors can be printed directly onto printed circuit board (PCB) substrates as part of the PCB manufacturing process. Although this technique is more common on hybrid PCB modules, it can also be used on standard fibreglass PCBs. Tolerances are typically quite large, and can be in the order of 30%. A typical application would be non-critical pull-up resistors.



Figure-7 : A Carbon Resistor Printed Directly onto the SMD pads on a PCB

#### (vi) Thick and Thin Film (Fig. - 8)

Laser Trimmed Precision Thin Film Resistor Network from Fluke, used in the Keithley DMM7510 multimeter. Ceramic backed with glass hermetic seal cover.

Thick film resistors became popular during the 1970s, and most SMD (surface mount device) resistors today are of this type. The resistive element of thick films is 1000 times thicker than thin films, but the principal difference is how the film is applied to the cylinder (axial resistors) or the surface (SMD resistors).



Thin film resistors are made by sputtering (a method of vacuum deposition) the resistive material onto an insulating substrate. The film is then etched in a similar manner to the old (subtractive) process for making printed circuit boards; that is, the surface is coated with a photo-sensitive material, then covered by a pattern film, irradiated with ultraviolet light, and then the exposed photo-sensitive coating is developed, and underlying thin film is etched away.

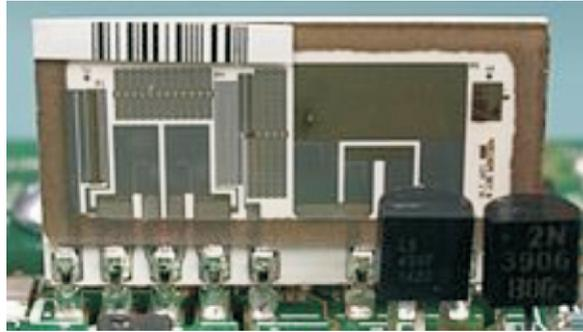

Figure-8

Thick film resistors are manufactured using screen and stencil printing processes.

Because the time during which the sputtering is performed can be controlled, the thickness of the thin film can be accurately controlled. The type of material is also usually different consisting of one or more ceramic (cermet) conductors such as tantalum nitride (TaN), ruthenium oxide (RuO<sub>2</sub>), lead oxide (PbO), bismuth ruthenate (BiO<sub>2</sub>), nickel chromium (NiCr).

The resistance of both thin and thick film resistors after manufacture is not highly accurate; they are usually trimmed to an accurate value by abrasive or laser trimming. Thin film resistors are usually specified with tolerances of 0.1, 0.2, 0.5, or 1%, and with temperature coefficients of 5 to 25 ppm/K. They also have much lower noise levels, on the level of 10-100 times less than thick film resistors.

Thick film resistors may use the same conductive ceramics, but they are mixed with sintered (powdered) glass and a carrier liquid so that the composite can be screen-printed. This composite of glass and conductive ceramic (cermet) material is then fused (baked) in an oven at about 850°C.

Thick film resistors, when first manufactured, had tolerances of 5%, but standard tolerances have improved to 2% or 1% in the last few decades. Temperature coefficients of thick film resistors are high, typically  $\pm 200$  or  $\pm 250$  ppm/K; a 40 kelvin (70 °F) temperature change can change the resistance by 1%.

Thin film resistors are usually far more expensive than thick film resistors. For example, SMD thin film resistors, with 0.5% tolerances, and with 25 ppm/K temperature coefficients, when bought in full size reel quantities, are about twice the cost of 1%, 250 ppm/K thick film resistors.

### (vii) Metal Film

A common type of axial-leaded resistor today is the metal-film resistor. Metal Electrode Leadless Face (MELF) resistors often use the same technology, and are also cylindrically shaped but are designed for surface mounting. Note that other types of resistors (e.g., carbon composition) are also available in MELF packages.



Metal film resistors are usually coated with nickel chromium (NiCr), but might be coated with any of the cermet materials listed above for thin film resistors. Unlike thin film resistors, the material may be applied using different techniques than sputtering (though this is one of the techniques). Also, unlike thin-film resistors, the resistance value is determined by cutting a helix through the coating rather than by etching. (This is similar to the way carbon resistors are made.) The result is a reasonable tolerance (0.5%, 1%, or 2%) and a temperature coefficient that is generally between 50 and 100 ppm/K. Metal film resistors possess good noise characteristics and low non-linearity due to a low voltage coefficient. Also beneficial are their tight tolerance, low temperature coefficient and long-term stability.

#### (viii) Metal Oxide Film

Metal-oxide film resistors are made of metal oxides which results in a higher operating temperature and greater stability/reliability than Metal film. They are used in applications with high endurance demands.

#### (ix) Wire Wound (Fig. - 9)

High-power wire wound resistors used for dynamic braking on an electric railway car. Such resistors may dissipate many kilowatts for an extended length of time.



Figure-9

Types of windings in wire resistors: (Fig. - 10)

1. Common
2. Bifilar
3. Common on a thin former
4. Ayrton-Perry

Wire wound resistors are commonly made by winding a metal wire, usually nichrome, around a ceramic, plastic, or fiberglass core. The ends of the wire are soldered or welded to two caps or rings, attached to the ends of the core. The assembly is protected with a layer of paint, molded plastic, or an enamel coating baked at high temperature. These resistors are designed to withstand unusually high temperatures of up to 450°C. Wire leads in low power wire wound resistors are usually between 0.6 and 0.8 mm in diameter and tinned for ease of soldering. For higher power wire wound resistors, either a ceramic outer case or an aluminum outer case on top of an insulating layer is used – if the outer case is ceramic, such resistors are sometimes described as “cement” resistors, though they do not actually contain any traditional cement. The aluminum-



cased types are designed to be attached to a heat sink to dissipate the heat; the rated power is dependent on being used with a suitable heat sink, e.g., a 50 W power rated resistor will overheat at a fraction of the power dissipation if not used with a heat sink. Large wire wound resistors may be rated for 1,000 watts or more.

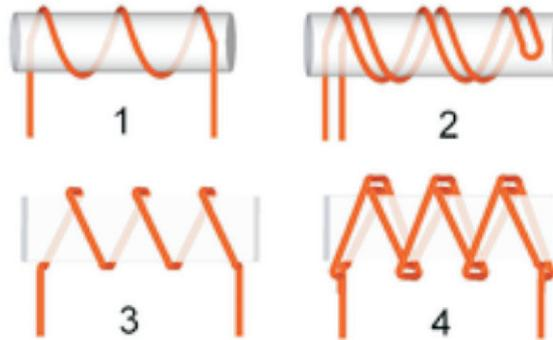

**Figure-10**

Because wire wound resistors are coils they have more undesirable inductance than other types of resistor, although winding the wire in sections with alternately reversed direction can minimize inductance. Other techniques employ bifilar winding, or a flat thin former (to reduce cross-section area of the coil). For the most demanding circuits, resistors with Ayrton-Perry winding are used.

Applications of wire wound resistors are similar to those of composition resistors with the exception of the high frequency. The high frequency response of wire wound resistors is substantially worse than that of a composition resistor.<sup>m</sup>

### **(x) Foil Resistor**

The primary resistance element of a foil resistor is a special alloy foil several micrometers thick. Since their introduction in the 1960s, foil resistors have had the best precision and stability of any resistor available. One of the important parameters influencing stability is the temperature coefficient of resistance (TCR). The TCR of foil resistors is extremely low, and has been further improved over the years. One range of ultra-precision foil resistors offers a TCR of 0.14 ppm/°C, tolerance  $\pm 0.005\%$ , long-term stability (1 year) 25 ppm, (3 years) 50 ppm (further improved 5-fold by hermetic sealing), stability under load (2000 hours) 0.03%, thermal EMF 0.1  $\mu\text{V}/^\circ\text{C}$ , noise “42 dB, voltage coefficient 0.1 ppm/V, inductance 0.08  $\mu\text{H}$ , capacitance 0.5 pF.”

### **(xi) Ammeter Shunts**

An ammeter shunt is a special type of current-sensing resistor, having four terminals and a value in milliohms or even micro-ohms. Current-measuring instruments, by themselves, can usually accept only limited currents. To measure high currents, the current passes through the shunt across which the voltage drop is measured and interpreted as current. A typical shunt consists of two solid metal blocks, sometimes brass, mounted on an insulating base. Between the blocks, and soldered or brazed to them, are one or more strips of low temperature coefficient of resistance (TCR) manganin alloy. Large bolts threaded into the blocks make the current connections, while much smaller screws provide volt meter connections. Shunts are rated by full-scale current, and often have a voltage drop of 50 mV at rated current. Such meters are adapted to the shunt full current rating by using an appropriately marked dial face; no change need to be made to the other parts of the meter.



**(xii) Grid Resistor**

In heavy-duty industrial high-current applications, a grid resistor is a large convection-cooled lattice of stamped metal alloy strips connected in rows between two electrodes. Such industrial grade resistors can be as large as a refrigerator; some designs can handle over 500 amperes of current, with a range of resistances extending lower than 0.04 ohms. They are used in applications such as braking and load banking for locomotives and trams, neutral grounding for industrial AC distribution, control loads for cranes and heavy equipment, load testing of generators and harmonic filtering for electric substations.

The term grid resistor is sometimes used to describe a resistor of any type connected to the control grid of a vacuum tube. This is not a resistor technology; it is an electronic circuit topology.

**2.2.2. Variable Resistors**

**(a) Adjustable Resistors**

A resistor may have one or more fixed tapping points so that the resistance can be changed by moving the connecting wires to different terminals. Some wire wound power resistors have a tapping point that can slide along the resistance element, allowing a larger or smaller part of the resistance to be used.

Where continuous adjustment of the resistance value during operation of equipment is required, the sliding resistance tap can be connected to a knob accessible to an operator. Such a device is called a rheostat and has two terminals.

**(b) Potentiometers (Fig. - 11)**



Typical Panel Mount Potentiometer

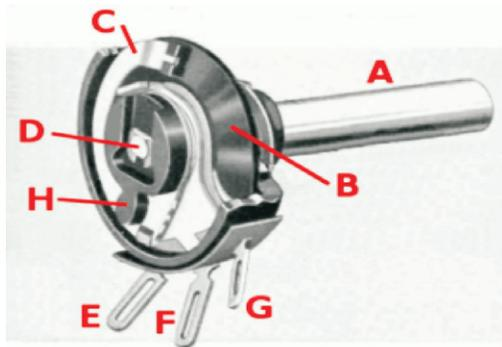

Drawing of potentiometer with case cut away, showing parts: (A) shaft, (B) stationary carbon composition resistance element, (C) phosphor bronze wiper, (D) shaft attached to wiper, (E, G) terminals connected to ends of resistance element, (F) terminal connected to wiper.

Figure-11



## Potentiometer

A potentiometer or pot is a three-terminal resistor with a continuously adjustable tapping point controlled by rotation of a shaft or knob or by a linear slider. It is called a potentiometer because it can be connected as an adjustable voltage divider to provide a variable potential at the terminal connected to the tapping point. A volume control for an audio device is a common use of a potentiometer. A typical low power potentiometer (see drawing) is constructed of a flat resistance element (B) of carbon composition, metal film, or conductive plastic, with a springy phosphor bronze wiper contact (C) which moves along the surface. An alternate construction is resistance wire wound on a form, with the wiper sliding axially along the coil. These have lower resolution, since as the wiper moves the resistance changes in steps equal to the resistance of a single turn.



Figure-12

### An Assortment of Small Through-Hole Potentiometers Designed for Mounting on Printed

High-resolution multiturn potentiometers are used in a few precision applications. These have wire wound resistance elements typically wound on a helical mandrel, with the wiper moving on a helical track as the control is turned, making continuous contact with the wire. Some include a conductive-plastic resistance coating over the wire to improve resolution. These typically offer ten turns of their shafts to cover their full range. They are usually set with dials that include a simple turns counter and a graduated dial, and can typically achieve three digit resolution. Electronic analog computers used them in quantity for setting coefficients, and delayed-sweep oscilloscopes of recent decades included one on their panels.

## 2.3. Introduction to Capacitors

Just like the Resistor, the Capacitor, sometimes referred to as a Condenser, is a simple passive device that is used to “store electricity”. The capacitor is a component which has the ability or “capacity” to store energy in the form of an electrical charge producing a potential difference (Static Voltage) across its plates, much like a small rechargeable battery.



Figure-13 : A Typical Capacitor



There are many different kinds of capacitors available from very small capacitor beads used in resonance circuits to large power factor correction capacitors, but they all do the same thing, they store charge.

In its basic form, a Capacitor consists of two or more parallel conductive (metal) plates which are not connected or touching each other, but are electrically separated either by air or by some form of a good insulating material such as waxed paper, mica, ceramic, plastic or some form of a liquid gel as used in electrolytic capacitors. The insulating layer between capacitors plates is commonly called the Dielectric.

Due to this insulating layer, DC current cannot flow through the capacitor as it blocks it allowing instead a voltage to be present across the plates in the form of an electrical charge.

The conductive metal plates of a capacitor can be square, circular or rectangular, or they can be of a cylindrical or spherical shape with the general shape, size and construction of a parallel plate capacitor depending on its application and voltage rating.

When used in a direct current or DC circuit, a capacitor charges up to its supply voltage but blocks the flow of current through it because the dielectric of a capacitor is non-conductive and basically an insulator. However, when a capacitor is connected to an alternating current or AC circuit, the flow of the current appears to pass straight through the capacitor with little or no resistance.

There are two types of electrical charge, positive charge in the form of Protons and negative charge in the form of Electrons. When a DC voltage is placed across a capacitor, the positive (+ve) charge quickly accumulates on one plate while a corresponding negative (-ve) charge accumulates on the other plate. For every particle of +ve charge that arrives at one plate a charge of the same sign will depart from the -ve plate.

Then the plates remain charge neutral and a potential difference due to this charge is established between the two plates. Once the capacitor reaches its steady state condition an electrical current is unable to flow through the capacitor itself and around the circuit due to the insulating properties of the dielectric used to separate the plates.

The flow of electrons onto the plates is known as the capacitor's charging current which continues to flow until the voltage across both plates (and hence the capacitor) is equal to the applied voltage  $V_c$  (Fig. - 14). At this point the capacitor is said to be “fully charged” with electrons. The strength or rate of this charging current is at its maximum value when the plates are fully discharged (initial condition) and slowly reduces in value to zero as the plates charge up to a potential difference across the capacitors plates equal to the source voltage.

The amount of potential difference present across the capacitor depends upon how much charge was deposited onto the plates by the work being done by the source voltage and also by how much capacitance the capacitor has and this is illustrated below.

### Capacitor Construction

The parallel plate capacitor is the simplest form of capacitor. It can be constructed using two metal or metallised foil plates at a distance parallel to each other, with its capacitance value in Farads, being fixed by the surface area of the conductive plates and the distance of separation between them. Altering any two of these values alters the value of its capacitance and this forms the basis of operation of the variable capacitors.



$$C = \frac{\epsilon A}{d}$$

C : Capacitance in Farad

$\epsilon$  : Di-electric constant : (F/m)

A : Area of plates ( $m^2$ )

d : Distance between plates (m)

Also, because capacitors store the energy of the electrons in the form of an electrical charge on the plates the larger the plates and/or smaller their separation the greater will be the charge that the capacitor holds for any given voltage across its plates. In other words, larger plates, smaller distance, more capacitance.

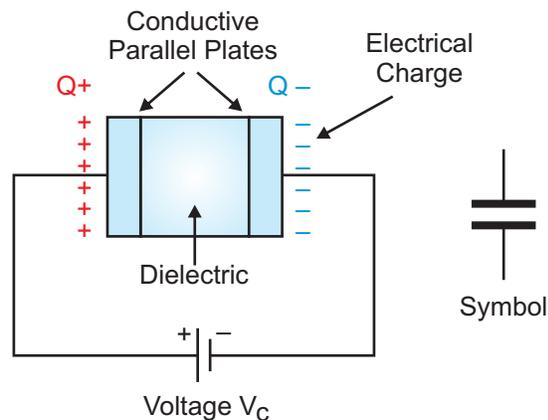

**Figure-14**

By applying a voltage to a capacitor and measuring the charge on the plates, the ratio of the charge Q to the voltage V will give the capacitance value of the capacitor and is therefore given as:  $C = Q/V$  this equation can also be re-arranged to give the more familiar formula for the quantity of charge on the plates as:  $Q = C \times V$

Although we have said that the charge is stored on the plates of a capacitor, it is more correct to say that the energy within the charge is stored in an “electrostatic field” between the two plates. When an electric current flows into the capacitor, charging it up, the electrostatic field becomes more stronger as it stores more energy. Likewise, as the current flows out of the capacitor, discharging it, the potential difference between the two plates decreases and the electrostatic field decreases as the energy moves out of the plates.

The property of a capacitor to store charge on its plates in the form of an electrostatic field is called the Capacitance of the capacitor. Not only that, but capacitance is also the property of a capacitor which resists the change of voltage across it.

### The Capacitance of a Capacitor

Capacitance is the electrical property of a capacitor and is the measure of a capacitors ability to store an electrical charge onto its two plates with the unit of capacitance being the Farad (abbreviated to F) named after the British physicist Michael Faraday.

Capacitance is defined as being that a capacitor has the capacitance of One Farad when a charge of One Coulomb is stored on the plates by a voltage of One volt. Capacitance, C is always



positive and has no negative units. However, the Farad is a very large unit of measurement to use on its own so sub-multiples of the Farad are generally used such as microfarads, nanofarads and picofarads, for example.

### Standard Units of Capacitance

- Microfarad ( $\mu\text{F}$ )  $1\mu\text{F} = 1/1,000,000 = 0.000001 = 10^{-6} \text{ F}$
- Nanofarad ( $\text{nF}$ )  $1\text{nF} = 1/1,000,000,000 = 0.000000001 = 10^{-9} \text{ F}$
- Picofarad ( $\text{pF}$ )  $1\text{pF} = 1/1,000,000,000,000 = 0.000000000001 = 10^{-12} \text{ F}$

### Types of Capacitor

There are a very, very large variety of different types of capacitor available in the market place and each one has its own set of characteristics and applications, from very small delicate trimming capacitors up to large power metal-can type capacitors used in high voltage power correction and smoothing circuits.

The comparisons between the different types of capacitor is generally made with regards to the dielectric used between the plates. Like resistors, there are also variable types of capacitors which allow us to vary their capacitance value for use in radio or “frequency tuning” type circuits.

Commercial types of Capacitors are made from metallic foil interlaced with thin sheets of either paraffin-impregnated paper or Mylar as the dielectric material. Some capacitors look like tubes, this is because the metal foil plates are rolled up into a cylinder to form a small package with the insulating dielectric material sandwiched in between them.

Small capacitors are often constructed from ceramic materials and then dipped into an epoxy resin to seal them. Either way, capacitors play an important part in electronic circuits so here are a few of the more “common” types of capacitor available.

#### (i) Dielectric Capacitor

Dielectric Capacitors are usually of the variable type where a continuous variation of capacitance is required for tuning transmitters, receivers and transistor radios. Variable dielectric capacitors are multi-plate air-spaced types that have a set of fixed plates (the stator vanes) and a set of movable plates (the rotor vanes) which move in between the fixed plates.

The position of the moving plates with respect to the fixed plates determines the overall capacitance value. The capacitance is generally at maximum when the two sets of plates are fully meshed together. High voltage type tuning capacitors have relatively large spacings or air-gaps between the plates with breakdown voltages reaching many thousands of volts.

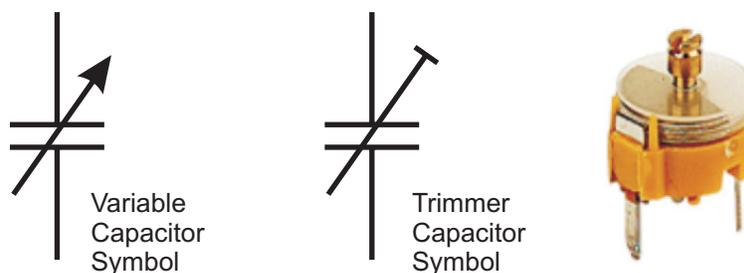

Figure-15 : Variable Capacitor Symbols



As well as the continuously variable types, preset type variable capacitors are also available called Trimmers. These are generally small devices that can be adjusted or “pre-set” to a particular capacitance value with the aid of a small screwdriver and are available in very small capacitance’s of 500pF or less and are non-polarized.

## (ii) Film Capacitor

Film Capacitors are the most commonly available of all types of capacitors, consisting of a relatively large family of capacitors with the difference being in their dielectric properties. These include polyester (Mylar), polystyrene, polypropylene, polycarbonate, metalized paper, Teflon etc. Film type capacitors are available in capacitance ranges from as small as 5pF to as large as 100uF depending upon the actual type of capacitor and its voltage rating.

Film capacitors also come in an assortment of shapes and case styles which include:

- Wrap & Fill (Oval & Round) – where the capacitor is wrapped in a tight plastic tape and have the ends filled with epoxy to seal them.
- Epoxy Case (Rectangular & Round) – where the capacitor is encased in a moulded plastic shell which is then filled with epoxy.
- Metal Hermetically Sealed (Rectangular & Round) – where the capacitor is encased in a metal tube or can and again sealed with epoxy with all the above case styles available in both Axial and Radial Leads.

Film Capacitors which use polystyrene, polycarbonate or Teflon as their dielectrics are sometimes called “Plastic capacitors”. The construction of plastic film capacitors is similar to that for paper film capacitors but use a plastic film instead of paper. The main advantage of plastic film capacitors compared to impregnated paper types is that they operate well under conditions of high temperature, have smaller tolerances, a very long service life and high reliability. Examples of film capacitors are the rectangular metalized film and cylindrical film & foil types as shown below.

The film and foil types of capacitors are made from long thin strips of thin metal foil with the dielectric material sandwiched together which are wound into a tight roll and then sealed in paper or metal tubes.

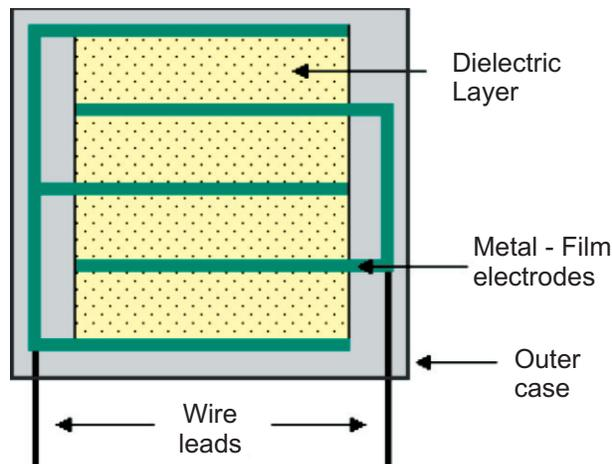
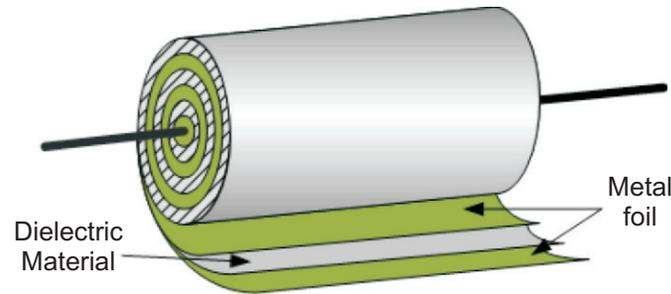
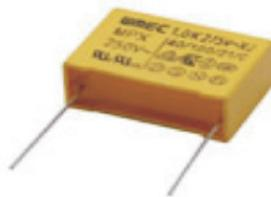

Figure-16 : Radial Lead Type



**Figure-17 : Axial Lead Type**

These film types require a much thicker dielectric film to reduce the risk of tears or puncture in the film, and are therefore more suited to lower capacitance values and larger case sizes.



**Figure-18 : Film Capacitor**

Metalized foil capacitors have the conductive film metalized sprayed directly onto each side of the dielectric which gives the capacitor self-healing properties and can therefore use much thinner dielectric films. This allows for higher capacitance values and smaller case sizes for a given capacitance. Film and foil capacitors are generally used for higher power and more precise applications.

**(iii) Ceramic Capacitors**

Ceramic Capacitors or Disc Capacitors as they are generally called are made by coating two sides of a small porcelain or ceramic disc with silver and are then stacked together to make a capacitor. For very low capacitance values a single ceramic disc of about 3-6mm is used. Ceramic capacitors have a high dielectric constant (High-K) and are available so that relatively high capacitances can be obtained in a small physical size.



**Figure-19 : Ceramic Capacitor**

They exhibit large non-linear changes in capacitance against temperature and as a result are used as de-coupling or by-pass capacitors as they are also non-polarized devices. Ceramic capacitors have values ranging from a few picofarads to one or two microfarads, (  $\mu\text{F}$  ) but their voltage ratings are generally quite low.



Ceramic types of capacitors generally have a 3-digit code printed onto their body to identify their capacitance value in pico-farads. Generally the first two digits indicate the capacitors value and the third digit indicates the number of zero's to be added. For example, a ceramic disc capacitor with the markings 103 would indicate 10 and 3 zero's in pico-farads which is equivalent to 10,000 pF or 10nF.

Likewise, the digits 104 would indicate 10 and 4 zero's in pico-farads which is equivalent to 100,000 pF or 100nF and so on. So on the image of the ceramic capacitor above the numbers 154 indicate 15 and 4 zero's in pico-farads which is equivalent to 150,000 pF or 150nF or 0.15uF. Letter codes are sometimes used to indicate their tolerance value such as: J = 5%, K = 10% or M = 20% etc.

#### (iv) Electrolytic Capacitors

Electrolytic Capacitors are generally used when very large capacitance values are required. Here instead of using a very thin metallic film layer for one of the electrodes, a semi-liquid electrolyte solution in the form of a jelly or paste is used which serves as the second electrode (usually the cathode).



**Figure-20 : Electrolytic Capacitor**

The dielectric is a very thin layer of oxide which is grown electro-chemically in production with the thickness of the film being less than ten microns. This insulating layer is so thin that it is possible to make capacitors with a large value of capacitance for a small physical size as the distance between the plates,  $d$  is very small.

The majority of electrolytic types of capacitors are Polarised, that is the DC voltage applied to the capacitor terminals must be of the correct polarity, i.e. positive to the positive terminal and negative to the negative terminal as an incorrect polarization will break down the insulating oxide layer and permanent damage may result.

All polarized electrolytic capacitors have their polarity clearly marked with a negative sign to indicate the negative terminal and this polarity must be followed.

Electrolytic Capacitors are generally used in DC power supply circuits due to their large capacitance's and small size to help reduce the ripple voltage or for coupling and decoupling applications. One main disadvantage of electrolytic capacitors is their relatively low voltage rating and due to the polarization of electrolytic capacitors, it follows then that they must not be used on AC supplies. Electrolytic's generally come in two basic forms; Aluminium Electrolytic Capacitors and Tantalum Electrolytic Capacitors.

#### **1. Aluminium Electrolytic Capacitors**

There are basically two types of Aluminium Electrolytic Capacitor, the plain foil type and the etched foil type. The thickness of the aluminium oxide film and high breakdown voltage give these capacitors very high capacitance values for their size.



The foil plates of the capacitor are anodized with a DC current. This anodizing process sets up the polarity of the plate material and determines which side of the plate is positive and which side is negative.

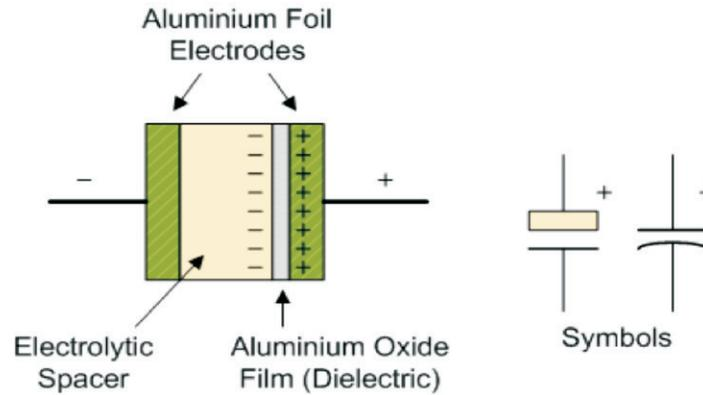

**Figure-21**

The etched foil type differs from the plain foil type in that the aluminium oxide on the anode and cathode foils has been chemically etched to increase its surface area and permittivity. This gives a smaller sized capacitor than a plain foil type of equivalent value but has the disadvantage of not being able to withstand high DC currents compared to the plain type. Also their tolerance range is quite large at up to 20%. Typical values of capacitance for an aluminium electrolytic capacitor range from 1uF up to 47,000 uF.

Etched foil electrolytics are best used in coupling, DC blocking and by-pass circuits while plain foil types are better suited as smoothing capacitors in power supplies. But aluminium electrolytics are “polarized” devices so reversing the applied voltage on the leads will cause the insulating layer within the capacitor to become destroyed along with the capacitor. However, the electrolyte used within the capacitor helps heal a damaged plate if the damage is small.

Since the electrolyte has the properties to self-heal a damaged plate, it also has the ability to re-anodize the foil plate. As the anodizing process can be reversed, the electrolyte has the ability to remove the oxide coating from the foil as would happen if the capacitor was connected with a reverse polarity. Since the electrolyte has the ability to conduct electricity, if the aluminium oxide layer was removed or destroyed, the capacitor would allow current to pass from one plate to the other destroying the capacitor, “so be aware”.

## 2. Tantalum Electrolytic Capacitors

Tantalum Electrolytic Capacitors and Tantalum Beads, are available in both wet (foil) and dry (solid) electrolytic types with the dry or solid tantalum being the most common. Solid tantalum capacitors use manganese dioxide as their second terminal and are physically smaller than the equivalent aluminium capacitors.

The dielectric properties of tantalum oxide is also much better than those of aluminium oxide giving a lower leakage currents and better capacitance stability which makes them suitable for use in blocking, by-passing, decoupling, filtering and timing applications.

Also, Tantalum Capacitors although polarized, can tolerate being connected to a reverse voltage much more easily than the aluminium types but are rated at much lower working voltages. Solid



tantalum capacitors are usually used in circuits where the AC voltage is small compared to the DC voltage.

However, some tantalum capacitor types contain two capacitors in-one, connected negative-to-negative to form a “non-polarized” capacitor for use in low voltage AC circuits as a non-polarised device. Generally, the positive lead is identified on the capacitor body by a polarity mark, with the body of a tantalum bead capacitor being an oval geometrical shape. Typical values of capacitance range from 47nF to 470uF.

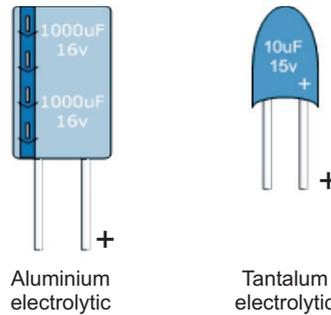

**Figure-22 : Aluminium & Tantalum Electrolytic Capacitor**

Electrolytics are widely used capacitors due to their low cost and small size but there are three easy ways to destroy an electrolytic capacitor:

- Over-Voltage – Excessive voltage will cause current to leak through the dielectric resulting in a short circuit condition.
- Reversed Polarity – Reverse voltage will cause self-destruction of the oxide layer and failure.
- Over Temperature – Excessive heat dries out the electrolytic and shortens the life of an electrolytic capacitor.

## 2.4. The Inductor

When an electrical current flows through a wire conductor, a magnetic flux is developed around the conductor producing a relationship between the direction of this magnetic flux which is circulating around the conductor and the direction of the current flowing through the same conductor. This well known relationship between current and magnetic flux direction is called, “Fleming’s Right Hand Rule”.

But there is also another important property relating to a wound coil that also exists, which is that a secondary voltage is induced into the same coil by the movement of the magnetic flux as it opposes or resists any changes in the electrical current flowing it.



**Figure-23 : A Typical Inductor**



In its most basic form, an Inductor is nothing more than a coil of wire wound around a central core. For most coils the current, (i) flowing through the coil produces a magnetic flux, (NΦ) around it that is proportional to this flow of electrical current.

The Inductor, also called a choke, is another passive type electrical component which is just a coil of wire that is designed to take advantage of this relationship by inducing a magnetic field in itself or in the core as a result of the current passing through the coil. This results in a much stronger magnetic field than one that would be produced by a simple coil of wire.

Inductors are formed with wire tightly wrapped around a solid central core which can be either a straight cylindrical rod or a continuous loop or ring to concentrate their magnetic flux.

The schematic symbol for an inductor is that of a coil of wire so therefore, a coil of wire can also be called an Inductor. Inductors usually are categorized according to the type of inner core they are wound around, for example, hollow core (free air), solid iron core or soft ferrite core with the different core types being distinguished by adding continuous or dotted parallel lines next to the wire coil as shown below.

The current, i that flows through an inductor produces a magnetic flux that is proportional to it. But unlike a Capacitor which opposes a change of voltage across their plates, an inductor opposes the rate of change of current flowing through it due to the build up of self-induced energy within its magnetic field.

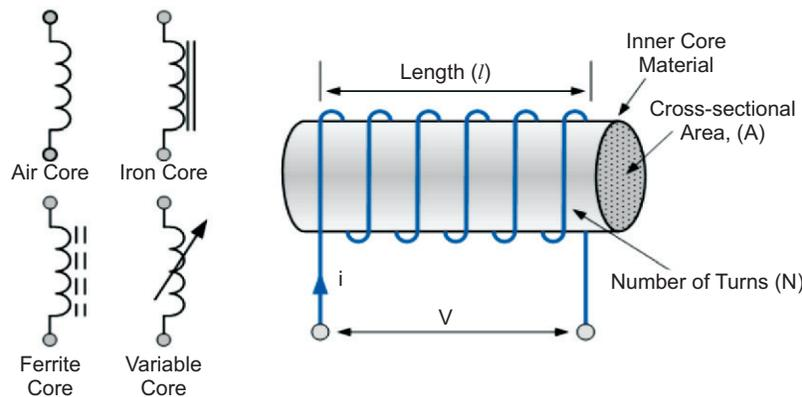

**Figure-24 : Inductor Symbols**

In other words, inductors resist or oppose changes of current but will easily pass a steady state DC current. This ability of an inductor to resist changes in current and which also relates current, I with its magnetic flux linkage, NΦ as a constant of proportionality is called Inductance which is given the symbol L with units of Henry, (H) after Joseph Henry.

Because the Henry is a relatively large unit of inductance, for the smaller inductors sub-units of the Henry are used to denote its value.

$$1\text{mH} = 10^{-3}\text{H}$$

$$1\mu\text{H} = 10^{-6}\text{H}$$



## Different Inductor Core Types

Like other types of components such as the capacitor, there are many different types of inductor also. However it can be a little more difficult to exactly define the different types of inductor because the variety of inductor applications is so wide.

Although it is possible to define an inductor by its core material, this is not the only way in which they can be categorized. However for the basic definitions, this approach is used.

- **Air Cored Inductor:** This type of inductor is normally used for RF applications where the level of inductance required is smaller. The fact that no core is used has several advantages: there is no loss within the core as air is lossless, and this results in a high level of  $Q$ , assuming the inductor or coil resistance is low. Against this the number of turns on the coil is larger to gain the same level of inductance and this may result in a physical increase in size.
- **Iron Cored Inductor:** Iron cores are normally used for high power and high inductance types of inductor. Some audio coils or chokes may use iron laminate. They are generally not widely used.
- **Ferrite Cored Inductor :** Ferrite is one of the most widely used cores for a variety of types of inductor. Ferrite is a metal oxide ceramic based around a mixture of Ferric Oxide  $Fe_2O_3$  and either manganese-zinc or nickel-zinc oxides which are extruded or pressed into the required shape.
- **Iron Power Inductor :** Another core that can be used in a variety of types of inductor is iron oxide. Like ferrite, this provides a considerable increase in the permeability ( $\mu$ ), thereby enabling much higher inductance coils or inductors to be manufactured in a small space.

## 2.5. Voltage Source

A voltage source is a two terminal device which can maintain a fixed voltage.<sup>[1]</sup> An ideal voltage source can maintain the fixed voltage independent of the load resistance or the output current. However, a real-world voltage source cannot supply unlimited current. A voltage source is the dual of a current. Real-world sources of electrical energy, such as batteries, generators, and power systems, can be modeled for analysis purposes as a combination of an ideal voltage source and additional combinations of impedance elements.

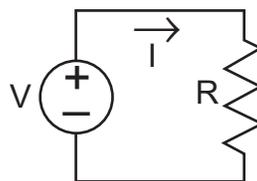

Figure-25

[A Schematic Diagram of a Real Voltage Source,  $V$ , Driving a Resistor,  $R$ , and Creating A Current  $I$ ]

## Ideal Voltage Sources

An ideal voltage source is a two-terminal device that maintains a fixed voltage drop across its terminals. It is often used as a mathematical abstraction that simplifies the analysis of real electric circuits. If the voltage across an ideal voltage source can be specified independently of any other variable in a circuit, it is called an independent voltage source. Conversely, if the voltage across an ideal voltage source is determined by some other voltage or current in a circuit, it is called a



dependent or controlled voltage source. A mathematical model of an amplifier will include dependent voltage sources whose magnitude is governed by some fixed relation to an input signal, for example, in the analysis of faults on electrical power systems, the whole network of interconnected sources and transmission lines can be usefully replaced by an ideal (AC) voltage source and a single equivalent impedance.

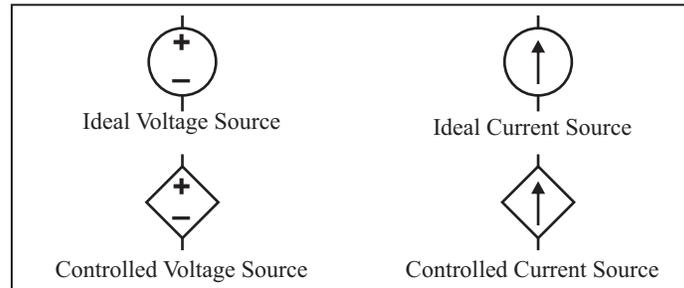

**Figure 26 : Symbols used for Voltage Sources & Current Sources**

The internal resistance of an ideal voltage source is zero; it is able to supply or absorb any amount of current. The current through an ideal voltage source is completely determined by the external circuit. When connected to an open circuit, there is zero current and thus zero power. When connected to a load resistance, the current through the source approaches infinity as the load resistance approaches zero (a short circuit). Thus, an ideal voltage source can supply unlimited power.

No real voltage source is ideal; all have a non-zero effective internal resistance, and none can supply unlimited current. However, the internal resistance of a real voltage source is effectively modeled in linear circuit analysis by combining a non-zero resistance in series with an ideal voltage source (a Thévenin equivalent circuit).

## Current Source

A **current source** is an electronic circuit that delivers or absorbs an electric current which is independent of the voltage across it.

A current source is the dual of a voltage source. The term constant-current ‘sink’ is sometimes used for sources fed from a negative voltage supply. Figure 27 shows the schematic symbol for an ideal current source, driving a resistor load. There are two types of current source: An independent current source (or sink) delivers a constant current. A dependent current source delivers a current which is proportional to some other voltage or current in the circuit.

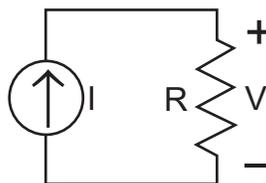
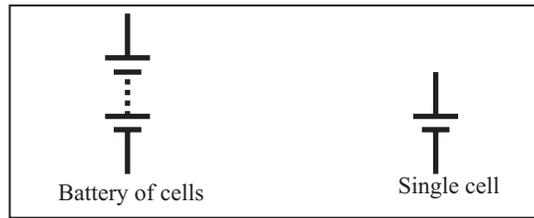

**Figure 27: An Ideal Current Source,  $I$ , Driving a Resistor,  $R$ , and Creating a Voltage  $V$**

In circuit theory, an ideal current source is a circuit element where the current through it is independent of the voltage across it. If the current through an ideal current source can be specified independently of any other variable in a circuit, it is called an independent current source. Conversely, if the current through an ideal current source is determined by some other voltage or



current in a circuit, it is called a dependent or controlled current source. Symbols for these sources are shown in Figure 28.



**Figure 28: Source Symbols of Cells & Battery**

The internal resistance of an ideal current source is infinite. An independent current source with zero current is identical to an ideal open circuit. The voltage across an ideal current source is completely determined by the circuit it is connected to. When connected to a short circuit, there is zero voltage and thus zero power delivered. When connected to a load, the voltage across the source approaches infinity as the load resistance approaches infinity (an open circuit). Thus, an ideal current source, if such a thing existed in reality, could supply unlimited power and so would represent an unlimited source of energy.

No physical current source is ideal. For example, no physical current source can operate when applied to an open circuit. There are two characteristics that define a current source in real life. One is its internal resistance and the other is its compliance voltage. The compliance voltage is the maximum voltage that the current source can supply to a load. Over a given load range, it is possible for some types of real current sources to exhibit nearly infinite internal resistance. However, when the current source reaches its compliance voltage, it abruptly stops being a current source.

In circuit analysis, a current source having finite internal resistance is modeled by placing the value of that resistance across an ideal current source (the Norton equivalent circuit). However, this model is only useful when a current source is operating within its compliance voltage.

### Voltage Source to Current Source Conversion

Conversion of voltage source into current source is possible when a voltage source is equal to current source. Figure 29 is a circuit of constant voltage source and figure 30 is a circuit of constant current source. If the two circuits are satisfied electrically the same way under all condition then we can convert voltage source to current source having no doubt.

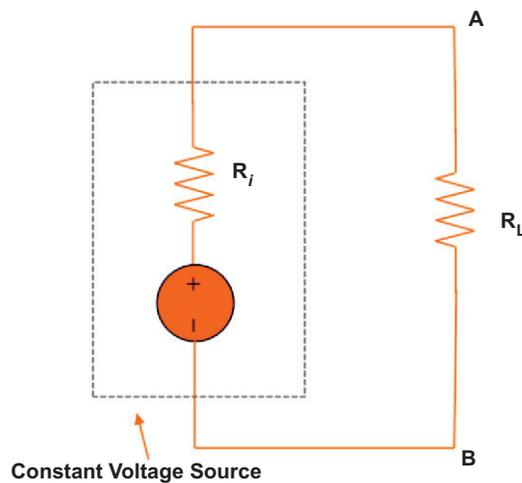

**Figure-29**

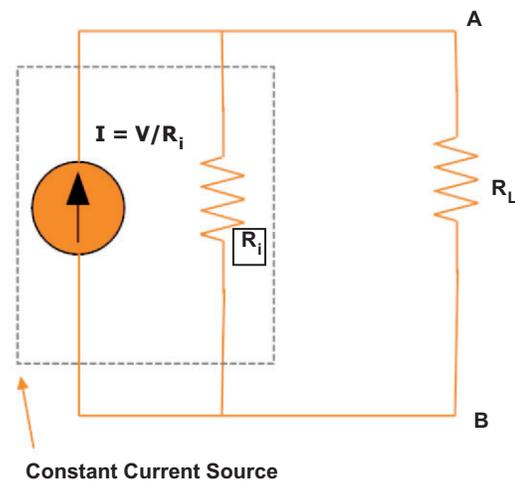

**Figure-30**



**Condition 1:** In figure 29 if the supply voltage is  $V$  and we remove the load resistance  $R_L$  then it becomes open circuit (Fig.-31) . In this situation the terminal voltage between point A and B is  $V$ . In figure 30 if we remove the load resistance  $R_L$  then all the current goes through the internal resistance  $R_i$ . (Fig. - 32) The terminal voltage between A and B is the same of internal resistance  $R_i$  voltage for open circuit. Voltage across the internal resistance  $R_i$  is  $V = I R_i$ . As open circuit voltage between two circuits is electrically equal and that is  $V$ . So the circuits are equivalent.

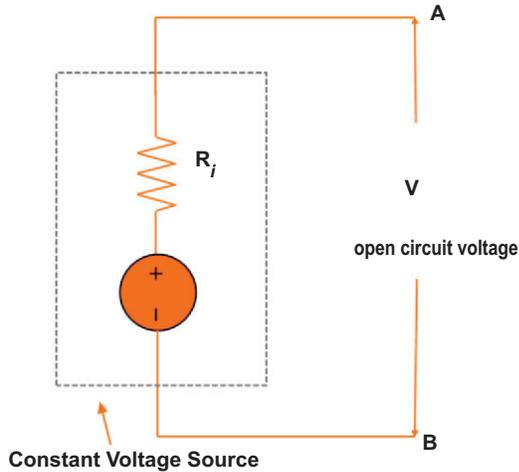

Figure-31

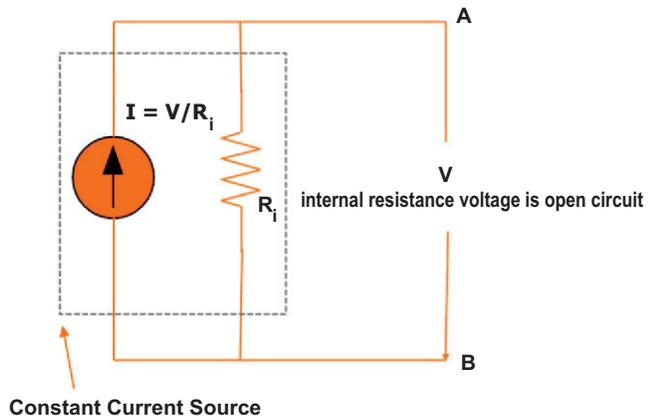

Figure-32

**Condition 2:** In figure 29 if we make the load  $R_L$  to short circuit then we get short circuit current,  $I_{short} = V / R_i$  (Fig. - 33)

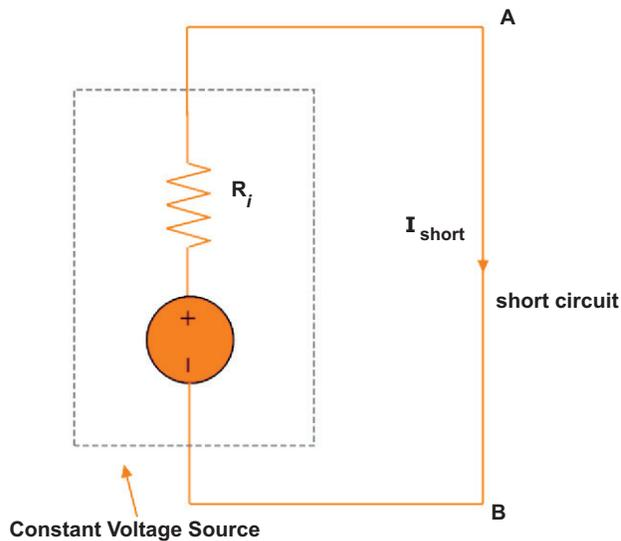

Figure-33

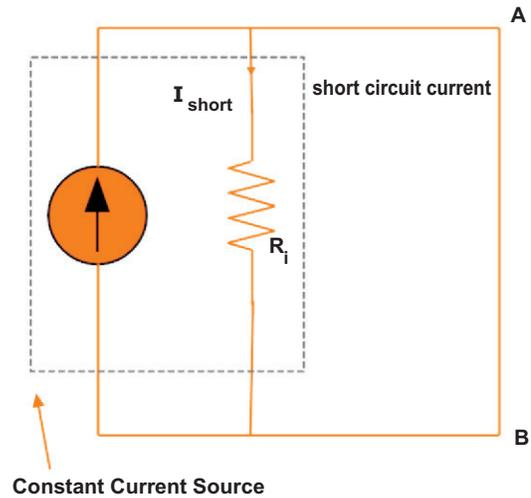

Figure-34

Similarly we get short circuit current from figure 30. If we short the path removing  $R_L$  load resistance current  $I_{short}$  bypasses  $R_i$  in favour of short circuit (fig. - 34). This is clear indication that the current  $I_{short}$  is electrically same between two circuits.



In this way we can convert a constant voltage source to a constant current source. Following steps should be taken:

1. Make short circuit between two terminals A and B as we have done in above figure. Find the short circuit current and let it be I.
2. Measure the resistance at the terminals with load removed and sources of e.m.f s replaced by their internal resistances if any. Let the resistance is R.
3. Then equivalent current source can be represented by a single current source of magnitude I in parallel with resistance R.

Let's see a problem. By solving this you will get clear concept if any trouble.

### Conversion of Voltage Source to Current Source Problem

**Problem:** Convert the constant voltage source shown in figure 35 to constant current source.

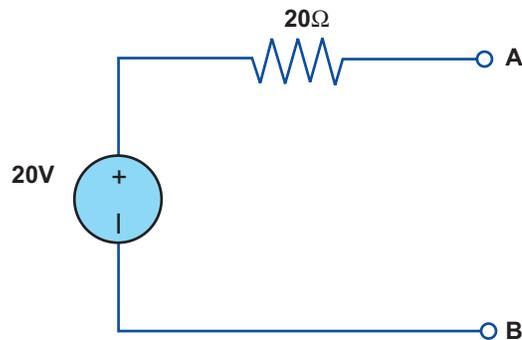

Figure-35

Here we get 20 V constant voltage source and  $20\Omega$  resistance. We have to follow the steps for conversion

- (i) First place a short across A and B and find short circuit current I.  
Short circuit current,  $I = 20/20 = 1 \text{ A}$   
Equivalent current source has a magnitude of 1 A.
- (ii) At AB terminal measure the resistance with load removed and 20V source replaced by its internal resistance. The voltage source has negligible resistance so that resistance at terminals AB is  $R = 20\Omega$ .
- (iii) The equivalent current source is a source of 1 A in parallel with a resistance of  $20\Omega$  as shown in figure 36.

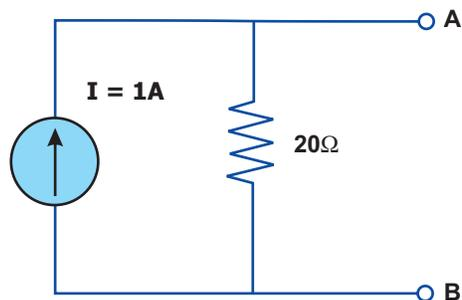

Figure-36



If we apply ohm's law in this circuit we get the voltage which is same in previous circuit so figure 35 and figure 36 are equivalent circuit and source conversion done properly.  $V = IR = 1 \times 20 = 20V$ .

### Conversion of Current Source to Voltage Source

**Problem:** Convert the current source to voltage source for figure 37.

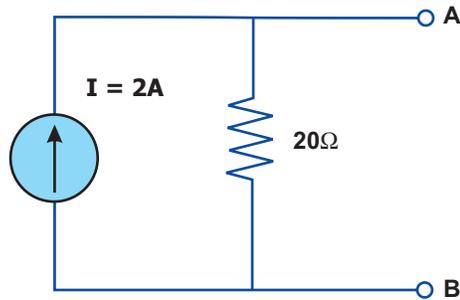

Figure-37

We have to do same inverse procedure.

From ohm's law  $V = IR = 2 \times 20 = 40V$ . So when we convert the current source to voltage source it will give 40V supply. Redrawing the circuit for voltage source we get as figure 38 equivalent circuit.

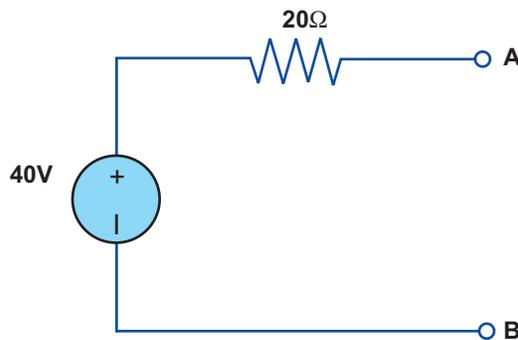

Figure-38

In this way source conversion or source transformation can be possible.

## 2.6. Battery (Electricity)

Various cells and batteries (top-left to bottom-right): two AA, one D, one handheld ham radio battery, two 9-volt (PP3), two AAA, one C, one camcorder battery, one cordless phone battery



Figure-39

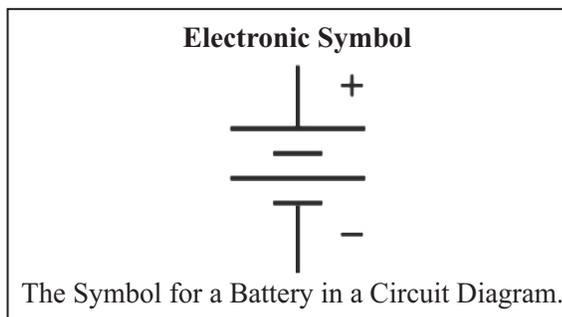

Figure-40



An electric battery is a device consisting of two or more electrochemical that converts stored chemical energy into electrical energy. Each cell has a positive terminal, or anode, and a negative terminal, or cathode. The terminal marked positive is at a higher electrical potential energy than is the terminal marked negative. The terminal marked negative is the source of electrons that when connected to an external circuit will flow and deliver energy to an external device. When a battery is connected to an external circuit, electrolytes are able to move as ions within, allowing the chemical reactions to be completed at the separate terminals and so deliver energy to the external circuit. It is the movement of those ions within the battery which allows current to flow out of the battery to perform work. Although the term battery technically means a device with multiple cells, single cells are also popularly called batteries.

Primary (single-use or “disposable”) batteries are used once and discarded; the electrode materials are irreversibly changed during discharge. Common examples are the alkaline battery used for flashlights and a multitude of portable devices. Secondary (rechargeable batteries) can be discharged and recharged multiple times; the original composition of the electrodes can be restored by reverse current. Examples include the lead-acid batteries used in vehicles and lithium-ion batteries used for portable electronics.

Batteries come in many shapes and sizes, from miniature cells used to power hearing aids and wrist watches to battery banks of the size of rooms that provide standby power for exchanges and computer data centers.

Batteries have much lower specific energy (energy per unit mass) than common fuels such as gasoline. This is somewhat offset by the higher efficiency of electric motors in producing mechanical work, compared to combustion engines.

### Principle of Operation

A voltaic cell for demonstration purpose is shown in fig. 41. In this example the two half-cells are linked by a bridge separator that permits the transfer of ions.

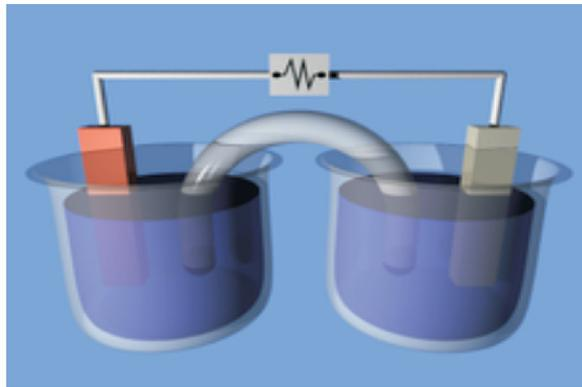

Figure-41

Batteries convert chemical energy directly to electrical energy. A battery consists of some number of voltaic cells. Each cell consists of two half-cells connected in series by a conductive electrolyte containing anions and cations. One half-cell includes electrolyte and the negative electrode, the electrode to which anions (negatively charged ions) migrate; the other half-cell includes electrolyte and the positive electrode to which cations (positively charged ions) migrate. Redox reactions power the battery. Cations are reduced (electrons are added) at the cathode during



charging, while anions are oxidized (electrons are removed) at the anode during charging. During discharge, the process is reversed. The electrodes do not touch each other, but are electrically connected by the electrolyte. Some cells use different electrolytes for each half-cell. A separator allows ions to flow between half-cells, but prevents mixing of the electrolytes.

Each half-cell has an electromotive force (or emf), determined by its ability to drive electric current from the interior to the exterior of the cell. The net emf of the cell is the difference between the emfs of its half-cells. Thus, if the electrodes have emfs  $\epsilon_1$  and  $\epsilon_2$ , then the net emf is  $\epsilon_2 - \epsilon_1$ ; in other words, the net emf is the difference between the reduction potentials of the half-reactions.

The electrical driving force or  $\Delta V$  across the terminals of a cell is known as the terminal voltage (difference) and is measured in volts. The terminal voltage of a cell that is neither charging nor discharging is called the open-circuit voltage and equals the emf of the cell. Because of internal resistance, the terminal voltage of a cell that is discharging is smaller in magnitude than the open-circuit voltage and the terminal voltage of a cell that is charging exceeds the open-circuit voltage.

An ideal cell has negligible internal resistance, so it would maintain a constant terminal voltage of  $\epsilon$  until exhausted, then dropping to zero. If such a cell maintained 1.5 volts and stored a charge of one coulomb then on complete discharge it would perform 1.5 joules of work. In actual cells, the internal resistance increases under discharge and the open circuit voltage also decreases under discharge. If the voltage and resistance are plotted against time, the resulting graphs typically are a curve; the shape of the curve varies according to the chemistry and internal arrangement employed.

The voltage developed across a cell's terminals depends on the energy release of the chemical reactions of its electrodes and electrolyte. Alkaline and zinc-carbon cells have different chemistries, but approximately the same emf of 1.5 volts; likewise NiCd and NiMH cells have different chemistries, but approximately the same emf of 1.2 volts. The high electrochemical potential changes in the reactions of lithium compounds give lithium cells emfs of 3 volts or more.

### Categories and Types of Batteries (Fig. 42)

List of battery types



Figure-42

From left to right : A large 4.5-volt (3R12) battery, a D Cell, a C cell, an AA cell, an AAA cell, an AAAA cell, an A23 battery, a 9-volt PP3 battery, and a pair of button cells (CR2032 and LR44).



Batteries are classified into primary and secondary forms:

- Primary batteries irreversibly transform chemical energy to electrical energy. When the supply of reactants is exhausted, energy cannot be readily restored to the battery.
- Secondary batteries can be recharged; that is, they can have their chemical reactions reversed by supplying electrical energy to the cell, approximately restoring their original composition.

Some types of primary batteries used, for example, for telegraph circuits, were restored to operation by replacing the electrodes. Secondary batteries are not indefinitely rechargeable due to dissipation of the active materials, loss of electrolyte and internal corrosion.

### 2.6.1. Primary Batteries

#### Primary Cell

Primary batteries, or primary cells, can produce current immediately on assembly. These are most commonly used in portable devices that have low current drain, are used only intermittently, or are used well away from an alternative power source, such as in alarm and communication circuits where other electric power is only intermittently available. Disposable primary cells cannot be reliably recharged, since the chemical reactions are not easily reversible and active materials may not return to their original forms. Battery manufacturers recommend against attempting to recharge primary cells.

In general, these have higher energy densities than rechargeable batteries, but disposable batteries do not fare well under high-drain applications with loads under 75 ohms (75 mA).

Common types of disposable batteries include zinc–carbon batteries and alkaline.

### 2.6.2. Secondary Batteries

#### Main Article: Rechargeable Battery

Secondary batteries, also known as secondary cells, or rechargeable batteries, must be charged before first use; they are usually assembled with active materials in the discharged state. Rechargeable batteries are recharged by applying electric current, which reverses the chemical reactions that occur during discharge/use. Devices to supply the appropriate current are called chargers.

The oldest form of rechargeable battery is the lead–acid battery. This technology contains liquid electrolyte in an unsealed container, requiring that the battery be kept upright and the area be well ventilated to ensure safe dispersal of the hydrogen gas it produces during overcharging. The lead–acid battery is relatively heavy for the amount of electrical energy it can supply. Its low manufacturing cost and its high surge current levels make it common where its capacity (over approximately 10 Ah) is more important than weight and handling issues. A common application is the modern car battery, which can, in general, deliver a peak current of 450 amperes.

The sealed valve regulated lead–acid battery (VRLA battery) is popular in the automotive industry as a replacement for the lead–acid wet cell. The VRLA battery uses an immobilized sulfuric acid electrolyte, reducing the chance of leakage and extending shelf life. VRLA batteries immobilize the electrolyte. The two types are:

- Gel batteries (or “gel cell”) use a semi-solid electrolyte.
- Absorbed Glass Mat (AGM) batteries absorb the electrolyte in special fiberglass matting.



Other portable rechargeable batteries include several sealed “dry cell” types, that are useful in applications such as mobile phones and laptop computers. Cells of this type (in order of increasing power and cost) include nickel–cadmium (NiCd), nickel–zinc (NiZn), nickel metal hydride (NiMH), and lithium-ion (Li-ion) cells. Li-ion has by far the highest share of the dry cell rechargeable market. NiMH has replaced NiCd in most applications due to its higher capacity, but NiCd remains in use in power tools, two-way radios, and medical equipment.

Recent developments include batteries with embedded electronics such as USBCELL, which allows charging an AA battery through a USB connector, nanoball batteries that allow for a discharge rate about 100x greater than current batteries, and smart battery packs with state-of-charge monitors and battery protection circuits that prevent damage on over-discharge. Low self-discharge (LSD) allows secondary cells to be charged prior to shipping.

### 2.6.3. Battery Cell Types

Many types of electrochemical cells have been produced, with varying chemical processes and designs, including galvanic cells, electrolytic cells, fuel cells, flow cells and voltaic piles.

#### (a) Wet Cell

A wet cell battery has a liquid electrolyte. Other names are flooded cell, since the liquid covers all internal parts, or vented cell, since gases produced during operation can escape to the air. Wet cells were a precursor to dry cells and are commonly used as a learning tool for electrochemistry. They can be built with common laboratory supplies, such as beakers, for demonstrations of how electrochemical cells work. A particular type of wet cell known as a concentration cell is important in understanding corrosion.

Wet cells may be primary cells (non-rechargeable) or secondary cells (rechargeable). Originally, all practical primary batteries such as the Daniell cell were built as open-top glass jar wet cells. Other primary wet cells are the Leclanche cell, Grove cell, Bunsen cell, Chromic acid cell, Clark cell, and Weston. The Leclanche cell chemistry was adapted to the first dry cells. Wet cells are still used in automobile and in industry for standby power for switchgear, telecommunication or large uninterruptible, but in many places batteries with gel cells have been used instead. These applications commonly use lead–acid or nickel–cadmium cells.

#### (b) Dry Cell (Fig. - 43)

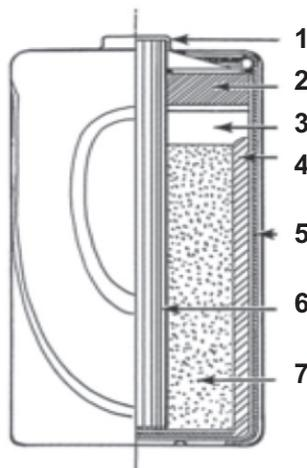

Figure-43



Line art drawing of a dry cell:

1. Brass cap, 2. Plastic seal, 3. Expansion space, 4. Porous cardboard, 5. Zinc can, 6. Carbon rod, 7. Chemical mixture.

A dry cell uses a paste electrolyte, with only enough moisture to allow current to flow. Unlike a wet cell, a dry cell can operate in any orientation without spilling, as it contains no free liquid, making it suitable for portable equipment. By comparison, the first wet cells were typically fragile glass containers with lead rods hanging from the open top and needed careful handling to avoid spillage. Lead–acid batteries did not achieve the safety and portability of the dry cell until the development of the gel battery.

A common dry cell is the zinc–carbon battery, sometimes called the dry Leclanché cell, with a nominal voltage of 1.5 volts, the same as the alkaline battery (since both use the same zinc–manganese dioxide combination).

A standard dry cell comprises a zinc anode, usually in the form of a cylindrical pot, with a carbon cathode in the form of a central rod. The electrolyte is ammonium chloride in the form of a paste next to the zinc anode. The remaining space between the electrolyte and carbon cathode is taken up by a second paste consisting of ammonium chloride and manganese dioxide, the latter acting as a depolarizer. In some designs, the ammonium chloride is replaced by zinc chloride.

### Molten Salt

Molten salt batteries are primary or secondary batteries that use a molten salt as electrolyte. They operate at high temperatures and must be well insulated to retain heat.

### 2.6.4. Reserve

A reserve battery can be stored unassembled (inactivated and supplying no power) for a long period (perhaps years). When the battery is needed, then it is assembled (e.g., by adding electrolyte); once assembled, the battery is charged and ready to work. For example, a battery for an electronic artillery fuse might be activated by the impact of firing a gun: The acceleration breaks a capsule of electrolyte that activates the battery and powers the fuse’s circuits. Reserve batteries are usually designed for a short service life (seconds or minutes) after long storage (years). A water-activated battery for oceanographic instruments or military applications becomes activated on immersion in water.

<b>Work</b>	<b>Energy</b>	<b>Power</b>
Refers to an activity involving a force and movement in the direction of the force. A force of 20 newtons pushing an object 5 meters in the direction of the force does 100 joules of work.	Is the capacity for doing work. You must have energy to accomplish work - it is like the “currency” for performing work. To do 100 joules of work, you must expend 100 joules of energy.	Is the rate of doing work or the rate of using energy, which are numerically the same. If you do 100 joules of work in one second (using 100 joules of energy), the power is 100 watts.
<b>Work Concepts</b>	<b>Energy Concepts</b>	<b>Power Concepts</b>

### Reference:-

- (1) Electrical Technology by V.K. Mehta & Rohit Mehta.
- (2) Fundamentals of Electrical by Dr. Wasif Naeem.
- (3) Free reference from wikipedia free encyclopedia.



## Exercise

### 1. Short questions:

- (a) Define current.
- (b) Define voltage.
- (c) Define work, energy and power.
- (d) One coulomb of charge is equal to.
- (e) What are the effect of temperature on conductivity on a material?

### 2. Write short note on:

- (a) How can you relate voltage and current in physical terms? Explain.
- (b) What are the different parameters at which resistance in a conductor depends?
- (c) What is unit of current, voltage, resistance, capacitance, inductance, energy, work & power?
- (d) A wire is carrying current. Is it charged?

### 3. Explain the following:

- (a) What is ohm's law? Write the mathematical expression to justify your answer? Draw its V-I Characteristics.
- (b) What is voltage and current sources? How will you convert it from one another?
- (c) What are cells and batteries? Explain their types.

### 4. Long questions:

- (a) Why do conductors have positive temperature co-efficient of resistance?
- (b) Why does a positive charge attracts a negative charge?



## UNIT 3

### Basics of Semiconductor

#### 3.0 Unit Overview and Description

- Overview
- Knowledge and Skill Outcomes
- Assessment Plan
- Learning Outcomes
- Resource Material
- Topics Covered

Semiconductor materials, Energy band structure of Insulators, Metals and Semiconductors, Energy gap, Field and Photo-electric emission, Intrinsic & Extrinsic semiconductor, N-type and P-type semiconductor, Drift current, Diffusion current and Total current, Mobility of charges, Effects of temperature on conductivity of semiconductor, PN junction diode, Depletion layer, Potential barrier, Forward & reverse bias, V-I Characteristic, Effects of temperature, Resistance levels, Breakdown in Junction diode, Zener diode, Photo diode, LED, Types and applications of diode, Diode as a rectifier, Half wave and full wave rectification, Voltage multipliers, Zener diode Regulator.

Special information -(Introduction to Filters, Clippers, Clampers).

#### Overview

This unit starts with the understanding of fundamentals of semiconductor materials and their properties etc. Further different types of energy band structure of Insulators, metals and semiconductors has been discussed along with the symbols and graphical representation . N-type and P-type semiconductor with their associated concepts have been presented. A detailed study of semiconductor diode and others types of diode with their characteristics has been discussed, proper explanation of Diode as a Rectifier, Voltage multipliers, Zener diode as Regulator is explained in this chapter, also the chapter contains special information -(Introduction to Filters, Clippers, Clampers). Finally whatever discussed and presented in various chapters has been summarized as a quick review.

#### Knowledge and Skill Outcomes

- i) Understanding of fundamentals of electrical Semiconductor materials, Energy band structure of solids.
- ii) Understanding of Mobility of charges, Effects of temperature on conductivity of semiconductor etc.
- iii) Knowledge of various types of semiconductor diodes and their characteristics.
- iv) Study of Diode as a rectifier, Half wave and full wave rectification, Voltage multipliers, Zener diode Regulator.
- v) Special information on- (Introduction to Filters, Clippers, Clampers).



### Assessment Plan: (For the Teachers)

Unit-3	Topic	Assessment Method	Time Plan	Remarks
	Semiconductor materials, Energy band structure of Insulators, Metals and Semiconductors, Energy gap, Field and Photo-electric emission.	Exercise: Question & Answer	Two Hours	
	Intrinsic & Extrinsic semiconductor, N-type and P-type semiconductor, Drift current, Diffusion current and Total current, Mobility of charges, Effects of temperature on Conductivity of semiconductor.	Exercise: Question & Answer	Two Hours	
	PN junction diode, depletion layer, potential barrier, Forward & Reverse bias, V-I Characteristic, Effects of temperature, Resistance levels, Breakdown in Junction diode, Zener diode, Photo diode, LED, Types and applications of diode.	Exercise: Question & Answer	Two Hours	
	Diode as a rectifier, Half wave and full wave rectification, Voltage multipliers, Zener diode Regulator.	Exercise: Question & Answer	Two Hours	
	Special information on- (Introduction to Filters, Clippers, Clampers).	Exercise: Question & Answer	Two Hours	

### Learning Outcomes

Unit-3	Basic of Semiconductor	Outcomes
	Semiconductor materials, Energy band structure of Insulators, Metals and Semiconductors, Energy gap, Field and Photo-electric emission.	(i) Brief knowledge of different semiconductor materials and their energy bands. (ii) Principle knowledge of photoelectric emission.
	Intrinsic & Extrinsic semiconductor, N-type and P-type semiconductor, Drift current, Diffusion current and Total current, Mobility of charges, Effects of temperature on conductivity of semiconductor.	(i) Kind of semiconductors and explanation of associate terms. (ii) Dependability of conductivity in semiconductor.



Unit-3	Basic of Semiconductor	Outcomes
	PN junction diode, Depletion layer, Potential barrier, Forward & Reverse bias, V-I Characteristic, Effects of temperature, Resistance levels, Breakdown in Junction diode, Zener diode, Photo diode, LED, Types and applications of diode.	(i) Knowledge of semiconductor diodes, there V-I characteristic and associated important. (ii) Applications of diodes.
	Diode as rectifier, Half wave and full wave rectification, Voltage multipliers, Zener diode Regulator.	(i) Knowledge of rectification and regulation of electrical signs using semiconductor diodes.
	Special information on - (Introduction to Filters, Clippers, Clampers).	(i) Overview of filters, clippers clampers etc.

### 3.1. Semiconductor Materials

In general, **semiconductors are special class of elements having a conductivity between that of a good conductor and that of an insulator**

Semiconductor materials fall into one of two classes: Single crystal and Compound. Single crystal semiconductor such as germanium (GE) and silicon (Si) have a repetitive crystal structure, whereas compound semiconductors such as gallium arsenide (GaAs), cadmium sulphide (CdS), gallium nitride (GaN), and gallium arsenide phosphide (GaAsP) are constructed of two or more semiconductor materials of different atomic structure.

**The three semiconductors used most frequently in the construction of electronic device are Ge, Si, and GaAs.**

### 3.2 Energy Band

**The range of energies possessed by electrons of the same orbit in a solid is known as energy band.**

In case of a single isolated atom, the electrons revolving in any orbit possess a definite energy. However in a solid an atom is greatly influenced by the closely packed neighbouring atoms. Because of this the electrons in the same orbit have a range of energies rather than a single energy. This is known as energy band.

Fig 1 shows how energy levels are changed into energy bands. All the electrons moving in the first orbit have slightly different energy levels because no two electrons see exactly the same charge environment. As there are billions of first orbit electrons in the solid with slightly different energy levels which is called energy bands.

#### Important Energy Bands in Solids

Although there are number of energy bands in solids, but we are more concerned with the following:

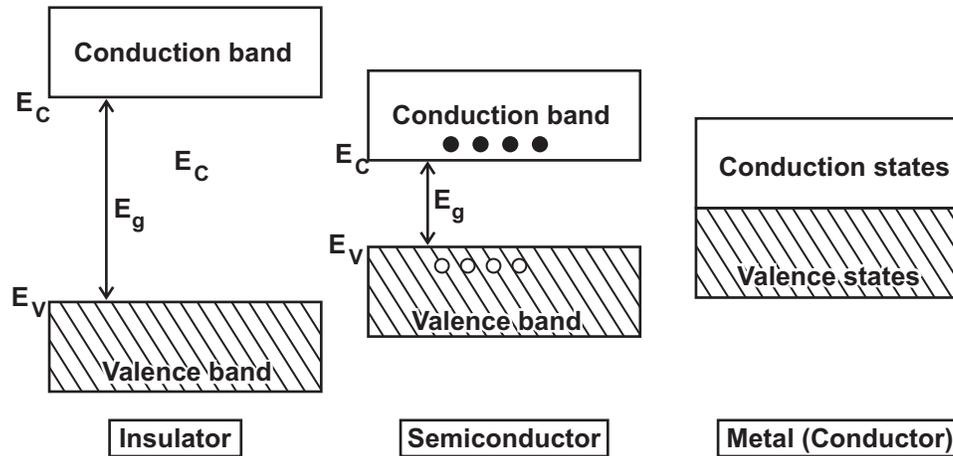

Figure-1

- (i) **Valence Band:** The electrons in the outermost orbit of an atom are known as valence electrons. Under normal condition of an atom, valence band contains the electrons of highest energy. This band may be filled completely or partially.

The energy band which possesses the valence electrons is called valence band.

- (ii) **Conduction Band:** In some of the materials (eg metals), the valence electrons are loosely attached to the nucleus and can be detached very easily. These electrons are known as free electrons and are responsible for the conduction of current. For this reason these electrons are known as conduction electrons.

The energy band which possesses the conduction electrons is called conduction band.

- (iii) **Forbidden Energy Gap:** The energy gap between the valence band and conduction band is known as forbidden energy gap.

### 3.3. Material Structure

#### a) Structure of Insulators

The substance (like, wood, glass, mica etc.) which do not allow the passage of current through them are known as insulators. The valence band of these substance is full, whereas the conduction band is completely empty. Moreover the forbidden energy gap between valence band and conduction band is large (15ev nearly). Therefore a large amount of energy i.e a very high electric field is required to push the valence electrons to the conduction band. This is the reason why such materials under ordinary condition do not conduct at all and are designed as insulators.

#### b) Metals

The substance (like copper, aluminium, silver etc.) which allow the passage of current through them are known as conductors. The valence band of these substance overlap the conduction band as shown in fig. 3.1. Due to this overlapping, a large number of free electrons are available for conduction. This the reason, why a slight potential difference applied across such substance causes a heavy flow of current through them.



### c) Semiconductors

The substance (like carbon, silicon, germanium etc.) whose electrical conductivity lies in between the conductor and insulators are known as semiconductors. Although the valence band of these substances is almost filled and conduction band is almost empty as in case of insulators. But the forbidden energy gap between valence band and conduction band is very small (nearly 1 eV). Therefore comparatively a smaller electric field (much smaller than insulator but much greater than conductors) is required to push the valence electrons to the conduction band. This is the reason why such materials under ordinary conditions do not conduct current and behave as an insulators.

However even at room temperature some heat energy is imparted to the valence electrons and a few of them cross over to the conduction band imparting minor conductivity to the semiconductors. As the temperature is increased more valence electrons cross over to the conduction band and the conductivity of the material increases. Thus these materials have negative temperature coefficient of resistance.

### 3.4. Energy Gap

Fig. 2 Shows the energy gap of conductor, insulators and semiconductors.

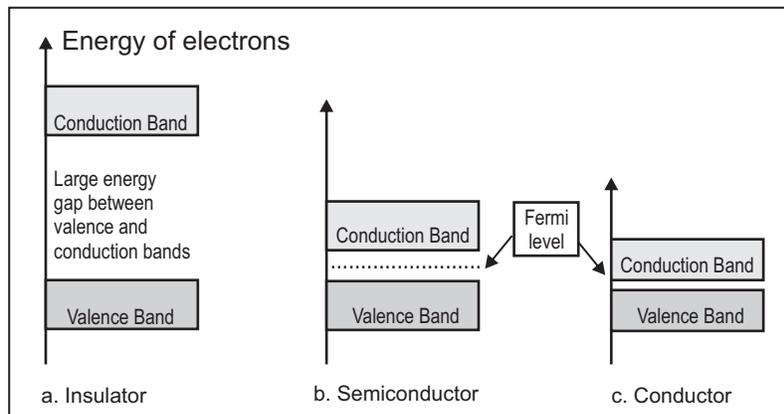

Figure-2

### 3.5. Field and Photo-Electric Emission

The emission of electrons from a metallic surface by the application of light energy is called photoelectric emission.

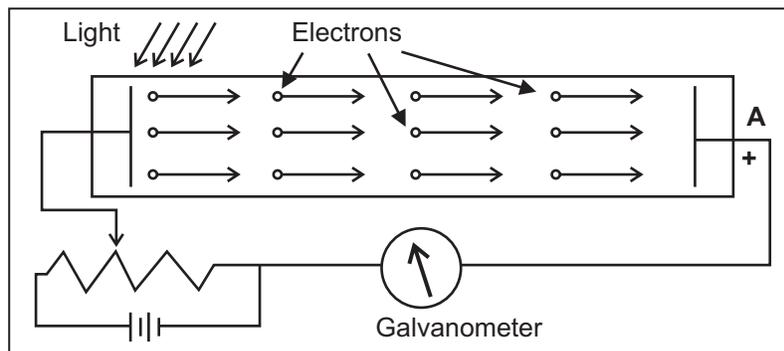

Figure-3



When a beam of light strikes at the surface of certain metals of low work function such as potassium, sodium and cesium, the electrons may be emitted from their surface if the quantum of energy carried by the photons is equal to or greater than the work function of the metal. Such a phenomenon is termed as photo-electric emission and emitted electrons are known as photo electrons.

The amount of photoelectric emission depends upon the intensity of light falling upon the emitter and the frequency of radiation. The amount of energy of a photon is given by the relation:

$$E=hf$$

Where, E = the energy of photon in joules

h = plank's constant in joules second =  $6.625 \times 10^{-34}$

f = frequency of photons in HZ

### 3.6. Intrinsic & Extrinsic Semiconductor

#### (i) Intrinsic Semiconductor

An extremely pure semiconductor is called intrinsic semiconductor.

On the basis of energy band phenomenon, an intrinsic semiconductor at absolute zero temperature is shown in fig. 2 its valence band is completely filled and the conduction band is completely empty.

When some heat energy is supplied to it (i.e its temperature is raised say to room temperature) some of the valence electrons are lifted to conduction band and are free to move at random. The holes created in the crystal also move at random in the crystal. The behaviour of semiconductor shows that they have negative temperature co-efficient of resistance i.e the resistivity decreases or conductivity increases with the rise in temperature.

#### (ii) Extrinsic Semiconductor

Although an intrinsic semiconductor is capable to conduct a little current even at room temperature but as it is, it is not useful for the preparation of various electronic devices. To make it conductive a small amount of suitable impurity is added. It is then called extrinsic (impure) semiconductor.

**Doping :** The process by which an impurity is added to a semiconductor is known as doping.

The amount and type of such impurities have to be closely controlled during the preparation of extrinsic semiconductor. Generally one impurity atom is added to  $10^8$  atoms of a semiconductor.

Thus, a semiconductor to which an impurity at controlled rate is added to make it conductive is known as an extrinsic semiconductor.

Depending upon the type of impurity added extrinsic semiconductor may be classified as :

- (i) n- type semiconductor
- (ii) p-type semiconductor

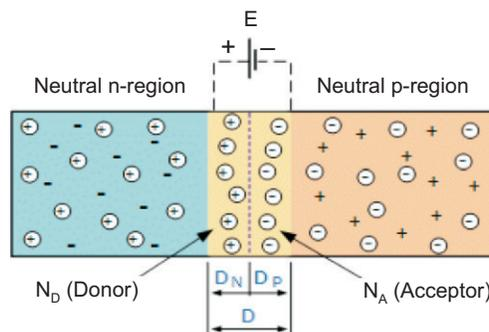

Figure-4



### (i) n- type semiconductor

When a small amount of pentavalent impurity is added to a pure semiconductor providing a large number of free electrons in it, the extrinsic semiconductor thus formed is known as n-type semiconductor.

The addition of pentavalent impurities such as arsenic (atomic number 33) and antimony (atomic number 51) provide a large number of free electrons in the semiconductor crystal. Such impurities which produce n-type semiconductor are known as donor impurities because each atom of them donate one free electron to the semiconductor crystal as explained below:

When a small amount of pentavalent impurity like arsenic (At no 33 : 2,8,18,5) having five valence electrons is added to germanium crystal each atom of the impurity fits in the germanium crystal in such a way that its four valence electrons form covalent bonds with four germanium atoms as shown. Whereas the fifth electron of the impurity (arsenic) atom finds no place in covalent bonds and is thus free. Hence each arsenic atom provides one free electron in the germanium crystal. Since, an extremely small amount of arsenic impurity has a large number of atoms, therefore it provides millions of free electrons for conduction.

### (ii) p- type semiconductors

When a small amount of trivalent impurity is added to a pure semiconductor providing a large number of free holes in it, the extrinsic semiconductor thus formed is known as p-type semiconductor.

The addition of trivalent impurities such as gallium (atomic number 31) and indium (atomic number 49) provide a large number of free holes in the semiconductor crystal. Such impurities which produce p-type semiconductor are known as acceptor impurities because each atom of them create one hole which can accept one electron from the semiconductor crystal as explained below.

When a small amount of trivalent impurity like gallium (At no 31:2,8,18,3) having three valence electrons is added to germanium crystal each atom of the impurity fits in the germanium crystal in such a way that its three valence electrons form covalent bonds with four germanium atoms, in the fourth covalent bond, only germanium atom contributes one valence electron, while gallium atom has no valence electron to contribute, as all its three valence electron are already engaged in the covalent bonds. Hence the covalent bond is incomplete having one electron short. The amount of gallium impurity has a large number of atoms, therefore it provides millions of holes in the semiconductor.

## 3.7. Drift Current

The flow of current in the semiconductor constituted by the drift electrons available in the conduction band and holes available in the valence band, which are formed due to external (heat) energy supplied to them, is known as drift current.

## 3.8. Diffusion Current

When the two pieces are joined together and suitably treated, they form a pn junction. The moment they form a pn junction, some of the conduction electrons from n- type material diffuse over to the p-type material and undergo electrons holes recombination with the holes available in the valence band. Simultaneously holes from p-type material diffuse over to the n-type material and undergo hole-electron combination with the electron available in the conduction band. This process is called diffusion.



Thus the current which obtained while having diffusion is called diffusion current.

**(a) Total Current**

It is possible that a potential gradient and a concentration gradient may exist within semiconductor. In such a case the total current is the sum of drift current due to potential gradient and the diffusion current due to charge carrier concentration gradient.

**(b) Mobility of Charges**

The mobility of charge carriers (electrons and holes) varies as  $T^{-m}$  over a temperature range of 100 and 400 K. for silicon  $m = 2.5$  for electrons and  $2.7$  for holes. For germanium  $m = 1.66$  for electrons and  $2.33$  for holes.

The carriers currents are also due to concentration gradients in the doped material which leads to diffusion of carriers from high concentration region to low concentration region.

**3.9. Effects of Temperature on Conductivity of Semiconductor**

The change in temperature changes the electrical conductivity of semiconductor appreciably. Let us see how conductivity changes with the change in temperature.

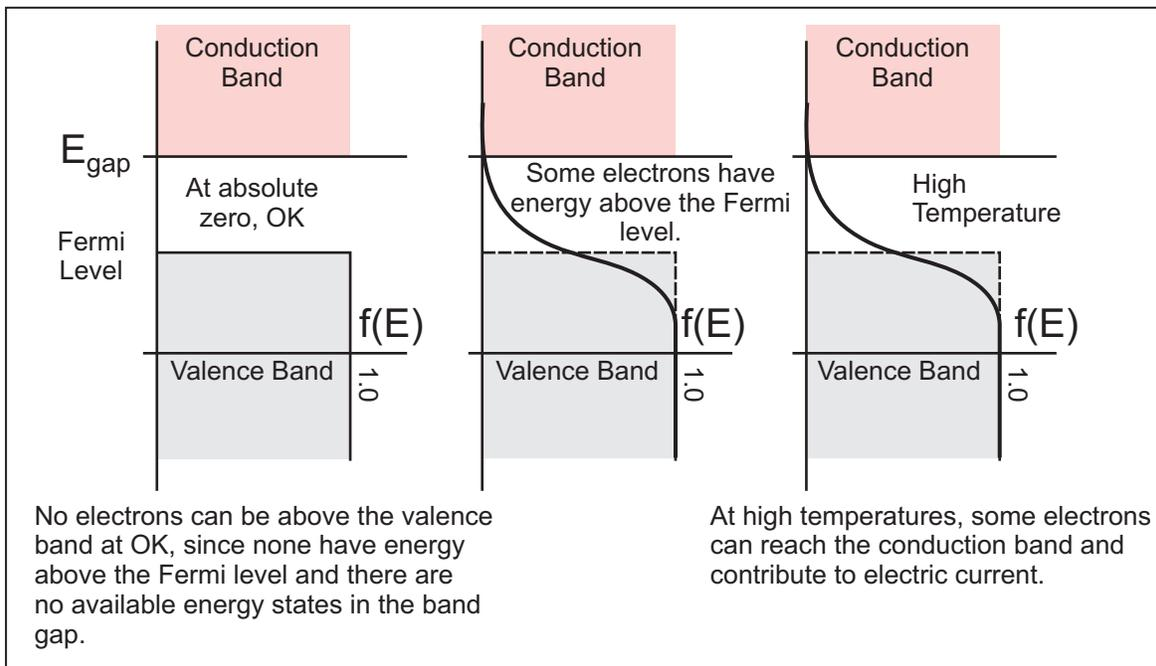

Figure-5

**(i) At absolute zero**

At absolute zero temperature all the electrons of semiconductor are held tightly by their atom. The inner orbit electrons are bound to the nucleus whereas the valence electrons are bound by the forces of covalent bonds. Therefore at this temperature no free electrons is available in semiconductor. Hence the semiconductor crystal behaves like a perfect insulator.



**(i) Above absolute zero**

When a temperature of semiconductor is raised, some of its covalent bonds break due to the thermal energy supplied to it. The breaking of bonds sets those electrons free which were engaged in the formation of these bonds. Thus at higher temperature few electrons exist in the semiconductor and they no longer behave as a perfect insulator.

Now if some potential difference is applied across the semiconductor as shown in fig.-5. a tiny current will flow through the circuit because of a minute quantity of free electrons existing in the semiconductor.

**3.10. PN Junction Diode (Semiconductor Diode)**

A pn junction is known as a semiconductor diode.

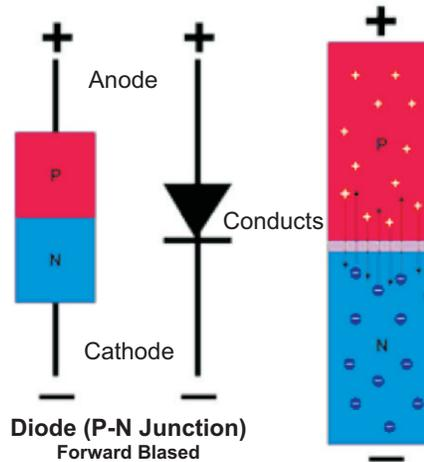
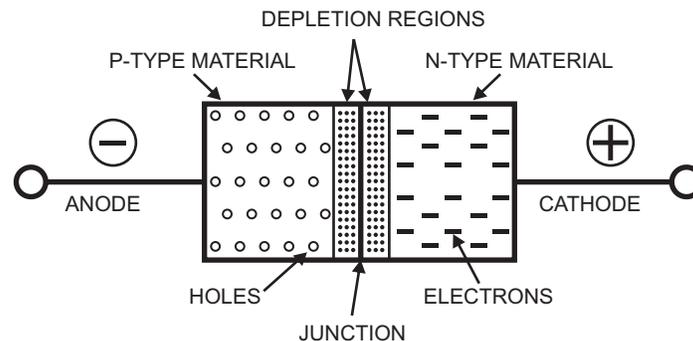

**Figure-6**

It is also known as crystal diode since it is grown out of a crystal (like germanium or silicon). A semiconductor diode has two terminals. Its symbol is shown in fig.-6. It conducts only when it is forward biased i.e when terminal connected with overhead is at higher potential than the terminal connected to the bar. However when it is reversed biased practically it does not conduct any current through it.

**3.11. Depletion Layer**

A region around the junction from which the charge carriers (free electrons and holes) are depleted is called depletion layer.



**Figure-7**



### 3.12. Potential Barrier

A potential difference built up across the pn junction which restricts further movement of charge carriers across the junction is known as potential barriers.

### 3.13. Forward & Reverse Biasing

When a pn junction is connected across an electric supply (potential difference) the junction is said to be under biasing. The type of biasing can be

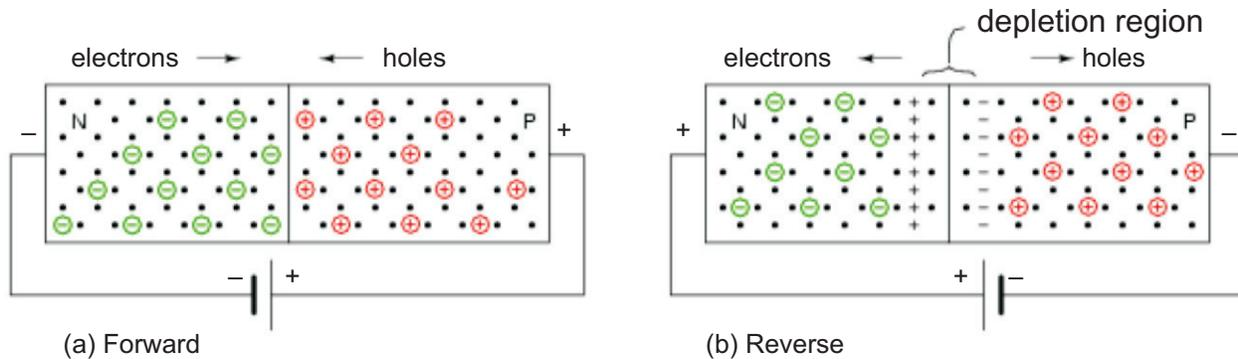

Figure-8

#### (a) Forward Biasing

When the positive terminal of a d.c. source or battery is connected to p-type and negative terminal is connected to n-type semiconductor of a pn junction, the junction is said to be in forward biasing the following points are worth noting, when a junction is forward biased:

- (i) The junction potential barrier is reduced and at some forward voltage (0.3 v for germanium and 0.7 v for silicon). It is eliminated altogether.
- (ii) The junction offers low resistance to the flow of current through it.
- (iii) The magnitude of flow of current through the circuit depends upon the applied forward voltage.

#### (b) Reverse Biasing

When the positive terminal of a d.c. source or battery is connected to n-type and negative terminal is connected to p-type semiconductor of a pn junction, the junction is said to be in reverse biasing.

The following points are worth noting, when a junction is forward biased:

- (i) The junction potential barrier is strengthened.
- (ii) The junction offers high resistance to the flow of current through it.
- (iii) The magnitude of flow of current through the circuit depends upon the applied reverse voltage.



### 3.14. V-I Characteristic of Semiconductor

The volt ampere (v-i) characteristics of a pn junction is just a curve between voltage across the junction and the circuit current. To draw the curve the circuit is arranged. In the circuit it is important to note that a resistor R is connected in series with the pn junction which limits the forward diode current from exceeding the permitted value. The characteristics are studied under three heads viz. zero external voltage, forward biasing and reverse biasing.

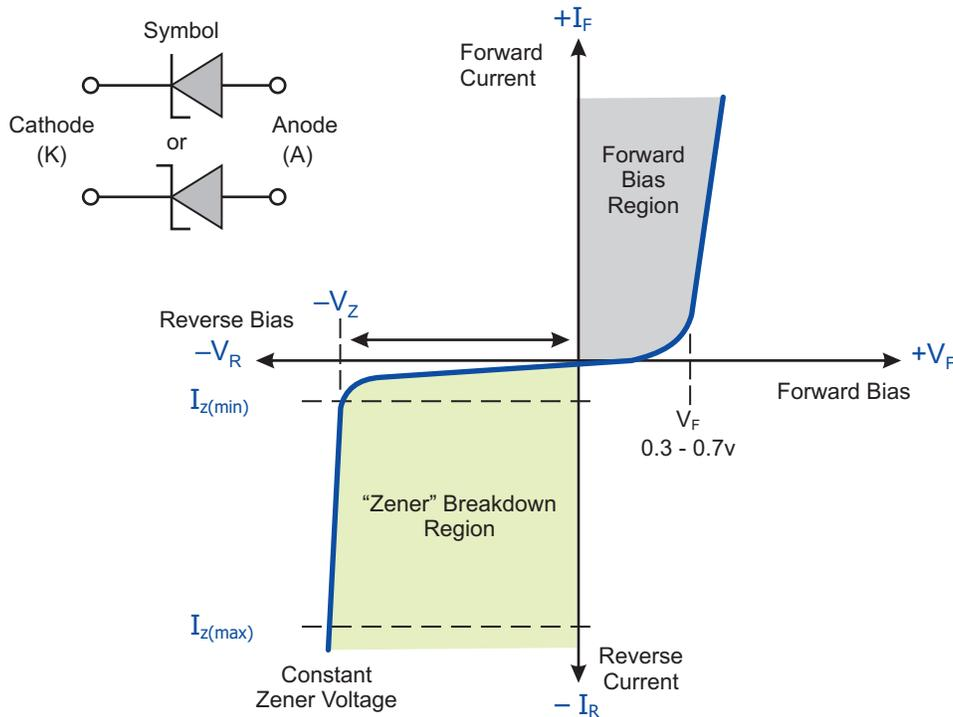

Figure - 9

(i) **Zero External Voltage:** When no external voltage is applied i.e circuit is open at key k. no current flow through the circuit. It is indicated by points 0 on the graph.

(ii) **Forward Biasing:** When key k is closed and double pole double throw switch is thrown to position 1. the pn junction is forward biased as p-type semiconductor is connected to the positive terminal and n-type to the negative terminal of the supply. Now when supply voltage is increased by changing the variable resistor R the circuit current increases very slowly and the curve is non linear. The slow rise in current in this region is because the external applied voltage is used to overcome the potential barrier (0.3V for Ge and 0.7V for Si) of the pn junction.

However once the potential barrier is eliminated and external voltage is increased further the pn junction behaves like an ordinary conductor and the circuit current rises very sharply. At this instant the circuit current is limited by the series resistance R and a small value of the junction forward resistance R. The curve is almost linear. If the current rises more than the rated value of the diode the diode may change.



(iii) **Reverse Biasing:** When the double pole double throw switch is thrown to position 2, the pn junction is reverse biased as p- type semiconductor is connected to the negative terminal and n- type to the positive terminal of the supply. Under this condition the potential barrier at the junction is increased. Therefore the junction resistance becomes very high and practically no current flows through the circuit. However in actual practice a very small current flows in the circuit as shown, this current is called reverse current and is due to minority carriers available at room temperature in the two types of semiconductor. The reverse bias appears as a forward biased for these undesirable minority carriers and thus they constitute a minor current in reverse direction. The reverse current increases slightly with the increase in reverse bias supply voltage.

The reverse voltage at which pn junction breaks is known as breakdown voltage.

### 3.15. Resistance Level

An actual diode offers a very small resistance when forward biased and is called a forward resistance whereas it offers a very high resistance when reverse biased and is called a reverse resistance.

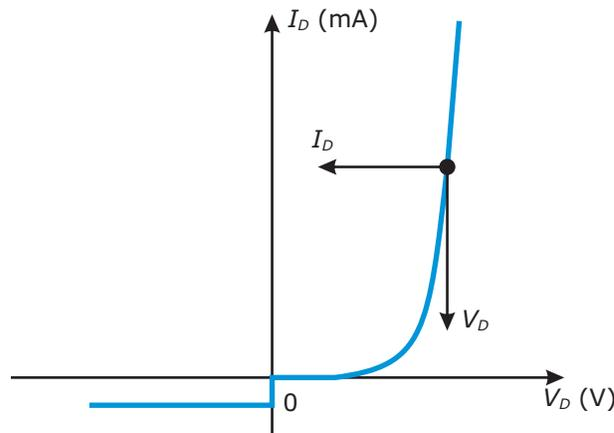

Figure-10 : Determining the DC Resistance of a Diode at a Particular Operating Point

### 3.16. Breakdown in Junction Diode

The breakdown of the pn junction can be of two types, these are

#### (i) Avalanche Breakdown

For thicker junctions the breakdown mechanism is by the process of avalanche breakdown. In this mechanism when the electric field existing in the depletion layer is sufficiently high, the velocity of the carriers (minority carriers) crossing the depletion layer increases. These carriers collide with the crystal atoms. Some collisions are so violent that electrons are knocked off the crystal atoms, thus creating electron hole pairs as the pair of electron hole is created in the midst of the high field, they quickly separate and attain high velocities to cause further pair generation through more collisions. This is cumulative process and as we approach the breakdown voltage, the field becomes so large that the chain of collisions can give rise to an almost infinite current with very slight additional increase in voltage. The process is known as avalanche breakdown. Once this breakdown occurs, the junction cannot regain its original position. Thus the diode is said to be burnt off.



### (i) Zener Breakdown

This breakdown takes place in a very thin junction i.e. when both sides of the junction are very heavily doped and consequently the depletion layer is narrow. In the zener breakdown mechanism, the electric field becomes as high as  $10^7$  v/m in the depletion layer with only a small applied reverse bias voltage.

In his process it becomes possible for some electrons to jump across the barrier from the valence band in p- type material to some of the unfilled conduction band in n-material. This process is known as zener breakdown. In this process the junction is not damaged.

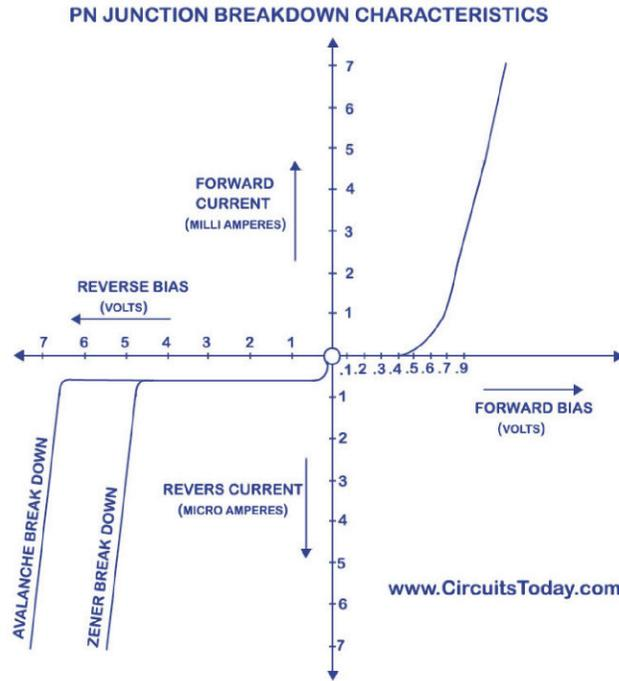
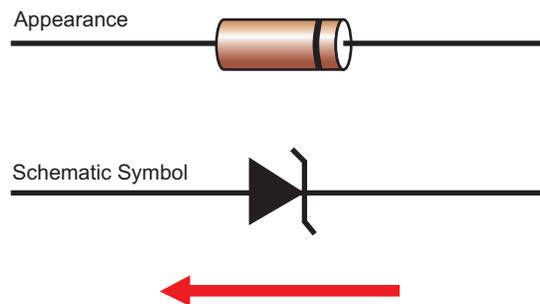

Figure-11

### 3.17. Zener Diode

A specially designed silicon diode which is optimised to operate in the breakdown region is known as as zener diode.



Backwards Current Flow Too, but only Past the “Zener” Breakdown Voltage

Figure-12



### 3.17.1. Characteristics of Zener Diode

- (i) Its characteristics are similar to an ordinary diode with the exception that it has a sharp (or distinct) breakdown voltage called zener voltage  $V_z$ .
- (ii) It can be operated in any of the three region i.e. forward, leakage or breakdown. But usually it is operated in the breakdown region as shown in fig.11.
- (iii) The voltage is almost constant ( $V_z$ ) over the operating region.
- (iv) Usually, the value of  $V_z$  at particular test current  $I_{zT}$  is specified in the data sheet.
- (v) During operation it will not burn as long as the external circuit limits the current flowing through it below the burn out value i.e  $I_{zm}$  (the maximum rated zener current).

### 3.17.2. Application

- (i) Meter Protection
- (ii) Voltage Regulator
- (iii) Wave Shaping Circuit

### 3.18. Photo Diode

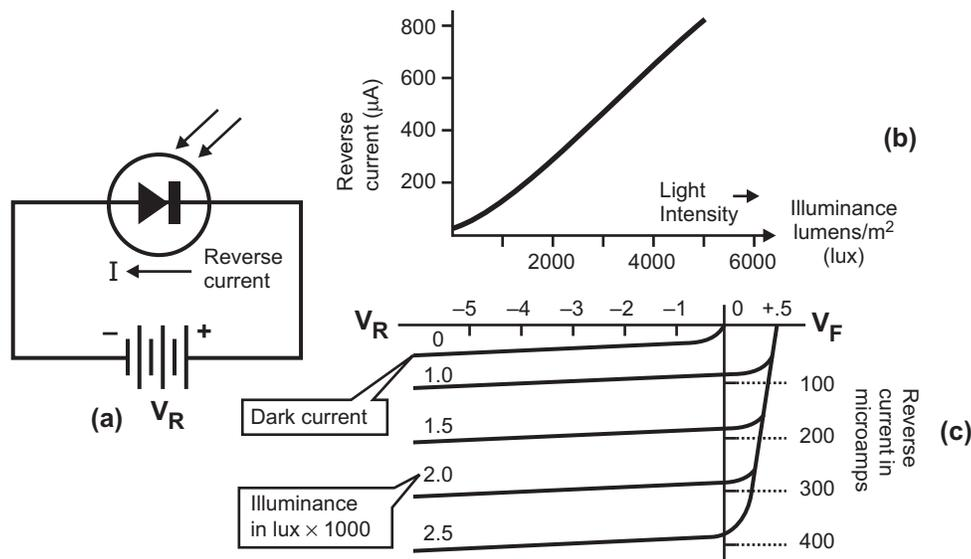

Figure-13

When a diode is reverse biased a minute current flows in the diode due to minority carriers. These carriers exist because of thermal energy which dislodge the valence electrons from their orbits producing free electrons and holes in the process.

When light energy falls on a pn junction, it also imparts energy to dislodge valence electron. In other words the amount of light striking on the junction can control the reverse current in a diode.

A diode that is optimised for its sensitivity to light is known as photo diode.



### 3.19. LED (Light Emitting Diode)

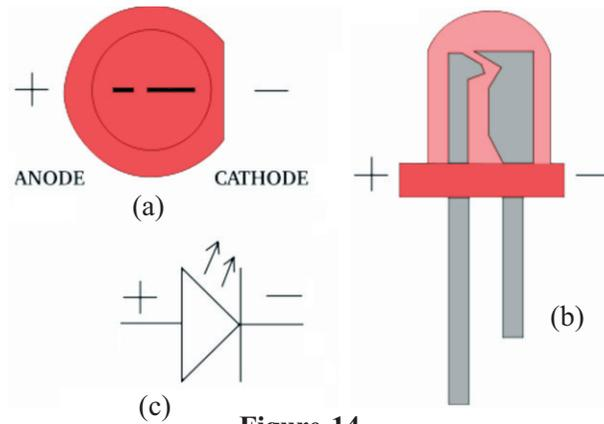

Figure-14

When a diode is forward biased the potential barrier is lowered. The conduction band free electrons from n- region cross the barrier and enter the p-region, as these electrons enter the p- region they fall into the holes lying in the valence band. Hence they fall from a higher energy level to a lower energy level in the process they radiate energy.

The LED are different. These are made of gallium arsenide phosphide (GaAsP) and gallium phosphide (GaP). In LED the energy is radiated in the form of light and hence they glow.

A manufacturer can produce LED that radiate red, green, yellow, blue, orange light.

#### Application

Instrument display, panel indicators, digital watches, calculator etc.

### 3.20. Diode as a Rectifier

The electrical power is generated transmitted and distributed as d.c. for economical reasons. As an alternating voltage is available at the mains. But most of the electronic circuit need d.c. voltage for their operation. Therefore the rectifier is the heart of power supply. The rectifier can be of two types:

- (i) Half Wave Rectifier
- (ii) Full Wave Rectifier

#### (i) Half Wave Rectifier

In half wave rectifier when a.c. supply is applied at the input only positive half cycle appears across the load, whereas the negative half cycle is suppressed.

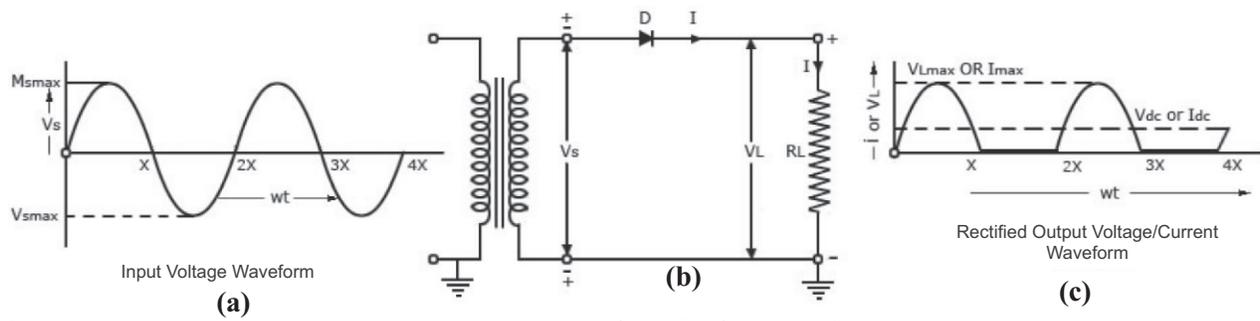

Half-Wave Rectifier

Figure-15

www.CircuitsToday.com



## Circuit

For half wave rectification only one crystal diode is used. It is connected in the circuit as shown in fig. 15 the a.c. supply to be rectified is generally given through a transformer. The transformer is used to step down or step up as per requirement. It also isolates the rectifier circuit from power lines and thus reduce the risk of electric shock.

## Operation

when an a.c. supply is switched on, the alternating voltage ( $V_{in}$ ) as shown fig.-15(a). Appears across the terminal AB at secondary winding. During positive half cycle. The terminal A is positive w.r.t. B and the crystal diode is forward biased. Therefore it conducts and current ( $i$ ) flows through the load resistor  $R_L$ . This current varies in magnitude as shown fig.-15(c). Thus a positive half cycle of the output voltage appears, across the load resistor as shown.

During the negative half cycle the terminal A is negative w.r.t. B and the crystal diode is reverse biased. Under this condition the diode does not conduct and no current flows through the circuit.

### (ii) Full Wave Rectifier

Fig. 16 shows the circuit of a full wave bridge rectifier. In this case an ordinary transformer is used in place of a centre taped transformer. The circuit contains four diodes  $D_1$ ,  $D_2$ ,  $D_3$  and  $D_4$  connected to form a bridge. The a.c. supply to be rectified is applied to the diagonally opposite ends of the bridge. Whereas the load resistor  $R_L$  is connected across the remaining two diagonally opposite ends of the bridge.

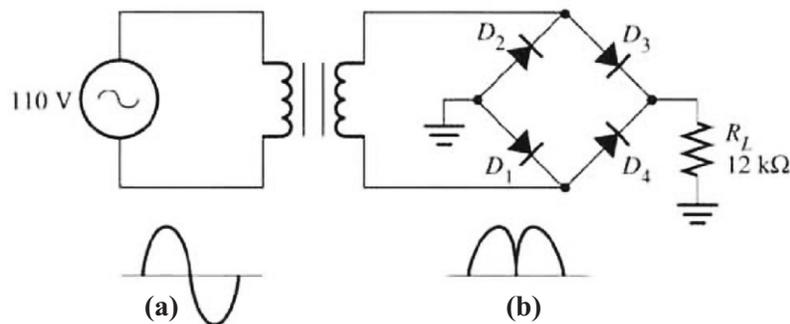

Figure-16

## Operation

When an a.c. supply is switched on, the alternating voltage  $V_{in}$  appears across the terminal AB of secondary winding of transformer which needs rectification.

During positive half cycle of secondary voltage the end A becomes positive and end B negative. This makes diode  $D_1$  and  $D_3$  forward biased and diodes  $D_2$  and  $D_4$  reverse biased. Therefore diodes  $D_1$  and  $D_3$  conduct while diodes  $D_2$  and  $D_4$  do not. Thus current ( $i$ ) flows through diode  $D_1$ , load resistor  $R_L$  diode  $D_3$  and the transformer secondary as shown 16(c). The wave shape is shown in fig. 16(b).

During negative half cycle of secondary voltage the end A becomes negative and end B positive. This makes diode  $D_2$  and  $D_4$  forward biased and diodes  $D_1$  and  $D_3$  reverse biased. Therefore diodes  $D_2$  and  $D_4$  conduct while diodes  $D_1$  and  $D_3$  do not. Thus current ( $i$ ) flows through diode  $D_2$ , load resistor  $R_L$  diode  $D_4$  and the transformer secondary as shown. The wave shape is shown in fig.16(b)



### 3.21. Voltage Multipliers

An electronic circuit that produce a dc voltage equal to a multiple of the peak of input ac voltage (i.e  $2V_m$ ,  $3V_m$ ,  $4V_m$  and so on) is called a voltage multiplier.

A voltage multiplier is basically a combination of two or more peak rectifiers. Each peak rectifier consists of a diode and a capacitor. Thus circuit is generally employed in the power supplies used for high voltage/low current devices like cathode ray tubes (such as picture tubes in TV receivers , oscilloscopes and computer displays). By using voltage multipliers the voltage level is usually raised well into hundred or thousand of volts.

Types :-

- (i) Half Wave Voltage Doubler
- (ii) Full Wave Voltage Doubler
- (iii) Voltage Tripler
- (iv) Voltage Quadrupler and so on

### 3.22. Zener Diode Regulator

The major application of zener diode in the electronic circuit is as a voltage regulator. It provides a constant voltage to the load from a source whose voltage may vary over sufficient range. The zener diode of zener voltage  $V_z$  is reverse connected across the load  $R_L$  across which constant voltage is desired. A resistor  $R$  is connected in series with the circuit which absorbs the output voltage fluctuation so as to maintain constant voltage ( $V_0$ ) across the load.

Let a variable voltage  $V_{in}$  be applied across the load  $R_L$ . When the value of  $V_{in}$  is less than zener voltage  $V_z$  of the zener diode. No current flows through it and the same voltage appears across the load. When the input voltage  $V_{in}$  is more than  $V_z$  this will cause the zener diode to conduct a large current  $I_z$ .

In the above discussion it has been seen that when a zener diode of zener voltage  $V_z$  is connected in reverse direction parallel to the load. It maintains a constant voltage across the load equal yp  $V_z$  and hence stablises the output voltage.

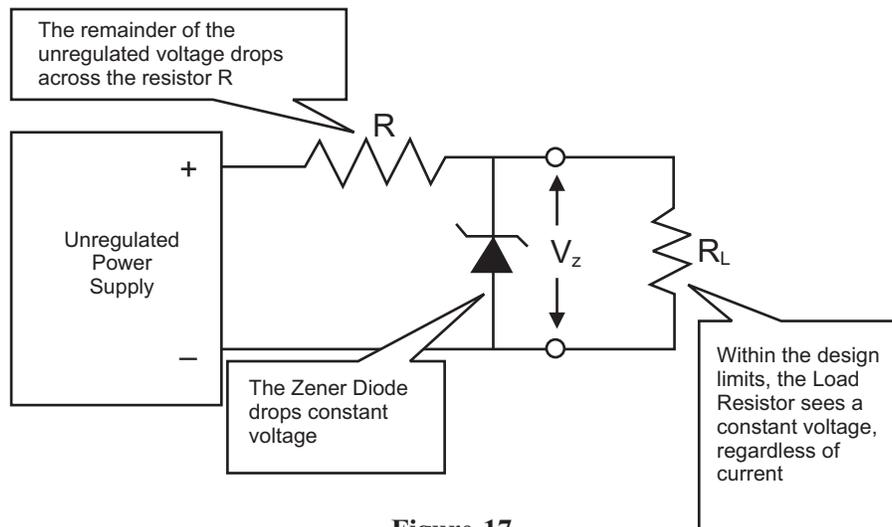

Figure-17



### 3.23. Special Information – (Introduction to Filters, Clippers, Clampers)

#### 3.23.1. Filters Circuit

An electronic circuit or device which blocks the a.c. components but allows the d.c. components of the rectifiers to pass to the load is called a filter circuit.

Types of filter circuit:-

- (i) Shunt Capacitor Filter
- (ii) Series Inductor Filter
- (iii) Choke Input (LC) Filter
- (iv) Capacitor Input (pi) Filter
- (i) Shunt Capacitor Filter**

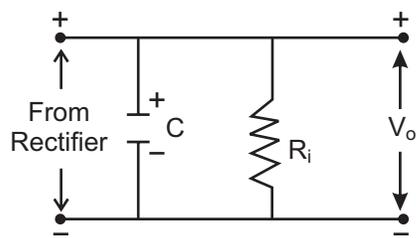

a) Capacitor Filter

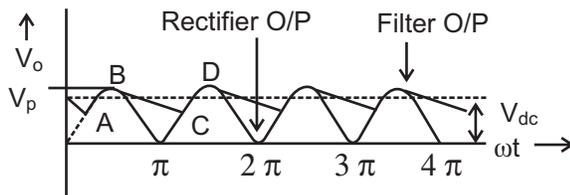

b) Waveform

**Figure-18**

#### Working

The working of a shunt capacitor filter can be explained with the help of a wave diagram shown in fig.18 the dotted pulsating wave shows the output of a full wave rectifier. When the rectifier voltage is increasing the capacitor is charged to  $+V_m$ . at point b the rectifier voltage tries to fall but the charged capacitor immediately tries to send the current back to rectifier. In the process the rectifier diodes are reverse biased and stop giving supply to the load. Thus the capacitor discharges (B to C) through the load. The capacitor continues to discharge until the source voltage becomes more than the capacitor voltage. The diode again starts conducting and the capacitor is again charged to peak value  $+V_m$  (point ). During this time the rectifier supplies the charging current  $I$  and the load current.

From above it is clear that capacitor not only remove the a.c. component but also improves the output voltage. The smoothness and magnitude of output voltage depends upon the time constant  $CR$ . The longer the time period the steadier is the output voltage. This can be achieved by using a large value of capacitor.

However the maximum value of the capacitance that can be employed is limited by the current that can be safely handled by the diode. The diodes employed in the rectifier circuit can deliver maximum current as per their rating. Therefore the size of the capacitor has to be limited so that it may not draw current more than the rating of the diodes.



**(ii) Series Inductor Filter**

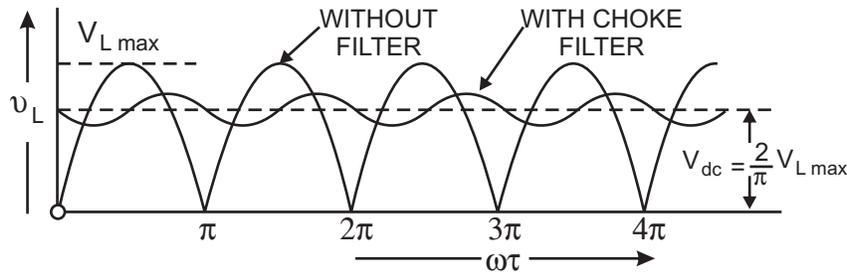
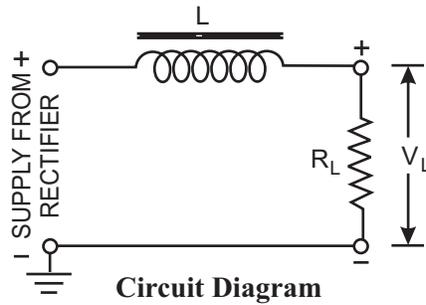

**Output Voltage Waveforms Full-Wave Rectifier with Series Inductor Filter  
Figure-19**

A series inductor filter is shown. In this case an inductor is just connected in series with load. The inductor has the inherent property to oppose the change of current. This property of inductor utilised here to suppress the a.c. component (ripples) from the output of the rectifier.

The reactance ( $X=2\pi fL$ ) of the inductor is large for high frequencies and offers more opposition to them but it allows the d.c. component of the rectifier output. Hence an inductance blocks the a.c. components but allows the d.c. components to reach the load. Thus it smooths out the rectifier output as shown fig.-19.

**(iii) Choke Input LC Filter**

A choke input LC filter is shown fig.-20. In this case an inductor is connected in series and a capacitor is parallel with the load.

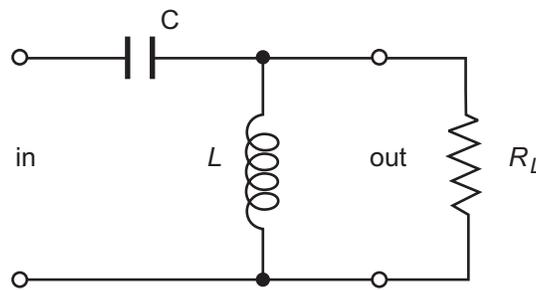

**Figure-20**

The output of a full wave rectifier contains a.c. components of a fundamental frequencies 100 Hz. The inductor offers a high opposition to the a.c component and blocks it but allows the d.c. component to pass through the low reactance of the capacitor. Hence almost pure d.c. reaches at



the load. Although the output of this filter is almost d.c. but still it contains small a.c. component. To improve it further one or more sets of LC filter may be applied further.

#### (iv) Capacitor Input (PIE) Filter

A capacitor input filter is shown fig.-21(a). In this case an additional capacitor C, is connected in the beginning across the output terminals of the rectifier. Since its shape is like the Greek letter (PIE) it is named as pie rectifier.

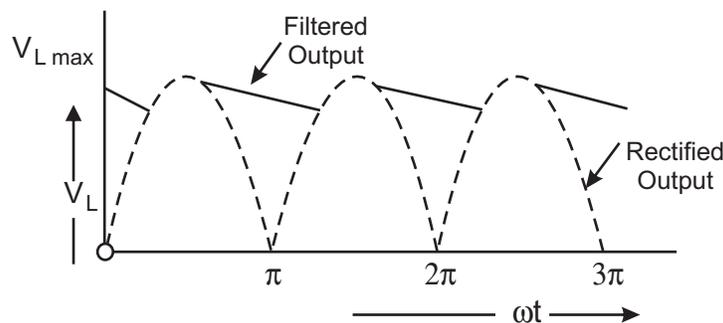
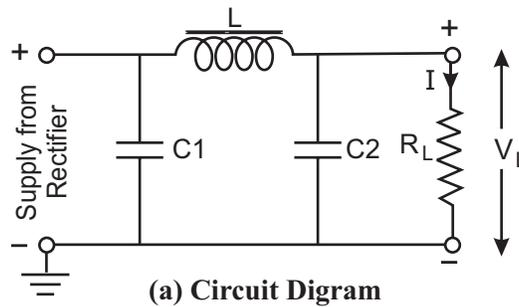

**(b) Rectified and Filtered Output Voltage Waveform Full-Wave Rectifier with Capacitor Input Filter**  
**Figure-21**

The filter action of three components C1, L and C2 is described below:

- (I) **Action of C1:** It provides an easy path to the a.c. components and by pass it and blocks d.c. components which continues its journey through the inductor choke. It also increases the magnitude of  $V_{av}$  because of its charging and discharging action.
- (II) **Action of L:** It provides an easy path to d.c. component but blocks the a.c. components because of its high reactance.
- (III) **Action of C2:** Any a.c component which the inductor has failed to block is by passed by this capacitor and only pure d.c. appears across the load.

### 3.23.2. Clippers

A circuit used to change the shape of an input wave by clipping or removing a portion of it is called a clipping circuit.



(i) **Positive Clipper:** A circuit that removes positive half cycles of the signal (input voltage) is called a positive clipper.

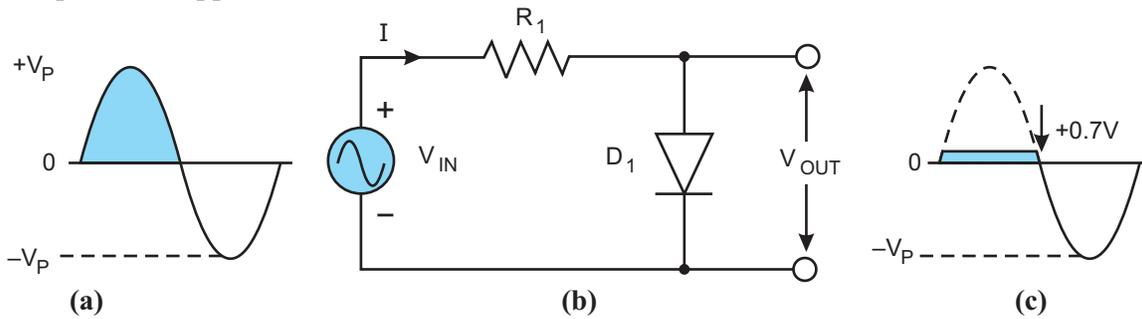

Figure-22

### Working

During positive half cycle of input voltage, the diode  $D$  is forward biased and conducts heavily. Ideally it acts as a closed switch and hence the voltage across the diode or the load is zero and hence positive half cycle clipped off. In other words the positive half cycle does not appear at the output.

During negative half cycle the diode is reverse biased and behaves as an open switch. Then the current flows through  $RL$  and  $R$  which are connected in series. In this condition the circuit behaves as a voltage divider, while the output voltage is taken across  $RL$ .

### 3.23.3. Clamping Circuit

A circuit that shifts either positive or negative peak of the signal at a desired dc level is known as a clamping circuit or clamper.

**Positive Clamper:** A circuit that shifts the signal in the positive side in such a way that the negative peak of the signal falls on the zero level, is called a positive clamper.

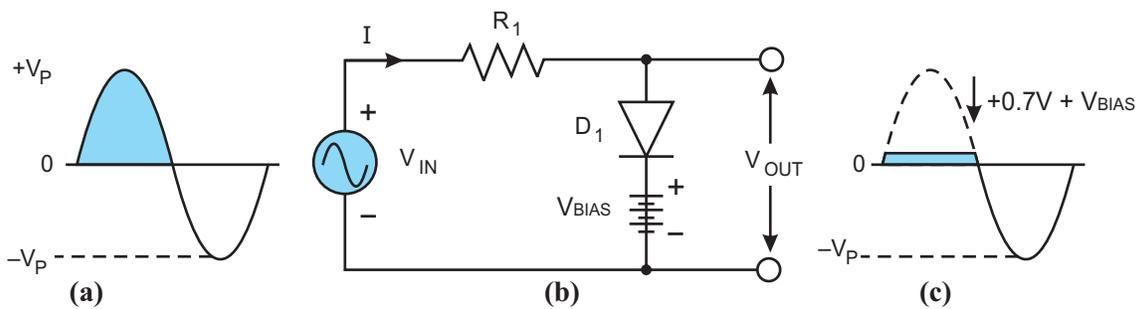

Figure-23

### Working

During negative half cycle of the input signal, the diode conducts heavily and acts like a closed switch. The capacitor  $C$  is charged to  $V_m$  at that negative peak of the signal with the polarity as marked. Slightly beyond the negative peak, the diode stops conduction through it and behaves as an open switch. The charged ( $V_m$ ) just behaves as a battery which adds the signal voltage during its positive half cycle.



During positive half cycle of the signal the diode is reversed biased and acts as an open switch. The resultant output voltage coming across the load resistor the load resistor  $R_L$  will be:

Output Voltage =  $V_m + V_m = 2V_m$

### Resource Material

1. Electronics devices and circuit theory by Robert L. Boylestad & Louis Nashelsky, ninth edition.
2. Electronics devices and circuit by S.K. Sahdev, Dhanpat Rai Publications.

### Exercise

#### 1. Short questions:

- (a) What are the two common semiconductors which are mostly used in electronics?
- (b) When a pure semiconductor is heated its resistivity increases, decreases or remains constant?
- (c) The leakage current is least in?
- (d) The process of adding impurities in an intrinsic semiconductor is called?
- (e) What is forward and reverse biasing?

#### 2. Write short note on:

- (a) What is intrinsic and extrinsic semiconductor?
- (b) Define Energy band structure of Insulators, Metals and Semiconductors.
- (c) What is Photo-electric emission?
- (d) Define Drift current.

#### 3. Explain the following:

- (a) Effects of temperature on Conductivity of semiconductor.
- (b) Why Zener diode connected reverse across the supply?
- (c) Why do we use transformer in a rectifier circuit?

#### 4. Long questions:

- (a) Explain full wave and half wave rectifier with their types.
- (b) Give the brief introduction of Filters, Clippers, Clampers.

# UNIT 4

## Bipolar Junction Transistor

### 4.0 Unit Overview and Description

- Overview
- Knowledge and Skill Outcomes
- Assessment Plan
- Learning Outcomes
- Resource Material
- Topics Covered

Construction and operation of NPN and PNP transistors, Biasing of BJT, CB, CE and CC configuration, Characteristics and transistor parameters for CB, CE, CC configuration, Introduction to FET, JFET, MOSFET, CMOS and VMOS, Characteristics of various transistors, Comparison of various transistors.

### Overview

This unit starts with the understanding of fundamentals of a transistor, types of transistors and biasing of transistor. Further three types of transistor configuration has been discussed along with the characteristics of transistor. Fundamentals of FET, JFET, MOSFET, CMOS and VMOS have been presented. A comparative study of various transistors has been conducted. Finally whatever discussed and presented in various chapters has been summarized as a quick review.

### Knowledge and Skill Outcomes

- Understanding of construction and working of Bipolar Junction Transistor.
- Difference between operation of NPN and PNP transistor.
- Knowledge of various types of transistor configuration.
- Difference between CB, CE and CC configuration.
- Knowledge about transistor parameters.
- Knowledge of FET, JFET and MOSFET.
- Knowledge of CMOS and VMOS
- Learn about characteristics and comparison between various configuration.

### Assessment Plan: (For the Teachers)

Unit-1	Topic	Assessment Method	Time Plan	Remarks
	Construction and operation of NPN and PNP transistors, Biasing of BJT.	(i) An interactive session: Question & Answer	One Hour	



Unit-1	Topic	Assessment Method	Time Plan	Remarks
	CB, CE and CC configuration, Characteristics and Transistor parameters for CB, CE, CC configuration	(ii) Assignment	After one day	
	Introduction to FET, JFET, MOSFET, CMOS and VMOS, Characteristics of various transistors, Comparison of various transistors	(i) An interactive session: Question & Answer ii) Assignment	One hour After one day	

### Learning Outcomes

Unit-3	Bipolar Junction Transistor	Outcomes
	Construction and operation of NPN and PNP transistors, Biasing of BJT.	i) Understanding the basics of transistors. ii) Understanding the fundamentals of biasing.
	CB, CE and CC configuration, Characteristics and transistor parameters for CB, CE, CC configuration.	i) Understanding the various configurations of transistor. ii) To have the knowledge of various parameters of a transistor
	Introduction to FET, JFET, MOSFET, CMOS and VMOS, Characteristics of various transistors, Comparison of various transistors.	i) Understanding various UJTs ii) To know the characteristics of all types of transistors. iii) A comparison study of various transistors.

### 4.1. Bipolar Junction Transistor (BJT)

A Semiconductor device consisting of two pn junctions formed by sandwiching either p type or n type semiconductor between a pair of opposite types is known as a transistor thus it is also well known by the name bipolar junction transistor because its operation depends upon both the majority and minority carriers.

Accordingly, there are two types of transistors namely;

- (i) NPN Transistor
- (ii) PNP Transistor
- (I) **NPN Transistor:** A transistor in which two blocks of n-type semiconductor are separated by a thin layer of p-type semiconductor is known as NPN Transistor.
- (II) **PNP Transistor:** A transistor in which two blocks of p-type semiconductors are separated by a thin layer of n- type semiconductor is known as PNP Transistor.

#### NPN and PNP Transistor (Construction and Working)



## Construction: or Transistor Terminals

Every transistor has three terminals called emitter, base and collector.

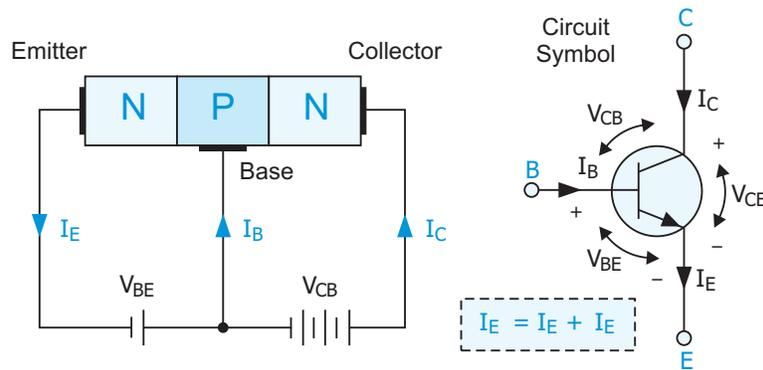

Figure-1

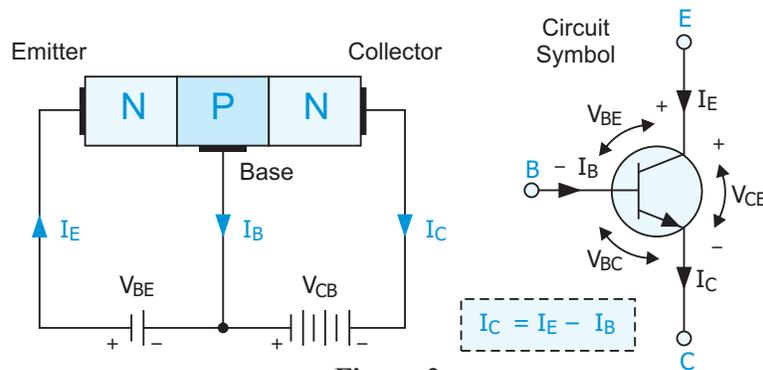

Figure-2

### (i) Emitter

The Section on one side of the transistor that supplies a large number of majority carriers (electrons if emitter is n- type and holes if the emitter is of p-type) is called emitter. The emitter is always forward biased w'r't. base so that it can supply a large number of majority carriers to its junction with the base. The biasing of emitter base junction of npn transistor and pnp transistor is shown in fig. 1 & fig. 2. Since emitter is to supply or inject a large amount of majority carriers into the base, it is heavily doped but moderate in size.

### (ii) Base

The middle section which forms two pn junctions between emitter and collector is called base. The base form two circuits, one input circuit with emitter and other output circuit with collector. The base emitter junction is forward biased, providing low resistance to the emitter circuit. The base collector junction is reversed biased, offering high resistance path to the collector circuit. The base is lightly doped and very thin so that it can pass on most of the majority carriers supplied by emitter to the collector.

### (iii) Collector

The section on the other side of the transistor that collects the major portion of the majority carriers supplied by the emitter is called collector. The collector base junction is always reverse biased. Its main function is to remove majority carriers (or charges) from its junction with base. The collector is



moderately doped but larger in size so that it can collect most of the majority carriers supplied by the emitter. The biasing of collector base junction of npn & pnp transistor is shown.

### 4.1.1. Working of NPN Transistor

The npn transistor circuit is shown in fig.1 the emitter base junction is forward biased while collector base junction is reverse biased. The forward biased voltage  $V_{BE}$  is quite small, whereas reverse biased voltage for  $V_{CB}$  is considerably high.

As the emitter base junction is forward biased, a large number of electrons (majority carriers) in the emitter (N-TYPE) region are pushed toward the base. This constitutes the emitter current  $I_e$ . when these electron enter the p-type material(base) they tend to combine with holes. Since the base is lightly doped and very thin, only a few electron (less than 5 %) combine with holes to constitute base current  $I_b$ . The remaining electrons (more than 95%) diffuse across the thin base region and reach the collector space charge layer. These electron then come under the influence of the positively biased n-region and are attracted or collected by the collector. This constitutes the collector current  $I_c$  thus it is seen that almost the entire emitter current flows into the collector circuit. However to be more precise the emitter current is the sum of collector current and base current .i.e

$$I_e = I_c + I_b$$

### 4.1.2. Working of PNP Transistor

The pnp transistor circuit is shown in fig.2 the emitter base junction is forward biased while collector base junction is reverse biased. The forward biased voltage  $V_{BE}$  is quite small, whereas reverse biased voltage  $V_{CB}$  is considerably high.

As the emitter base junction is forward biased, a large number of holes (majority carriers) in the emitter (P-TYPE) region are pushed toward the base. This constitutes the emitter current  $I_e$ . when these electron enter the n-type material (base) they tend to combine with electrons. Since the base is lightly doped and very thin, only a few electron (less than 5 %) combine with holes to constitute base current  $I_b$ . The remaining electrons (more than 95%) diffuse across the thin base region and reach the collector space charge layer. These holes then come under the influence of the negatively biased p-region and are attracted or collected by the collector. This constitutes the collector current  $I_c$  thus it is seen that almost the entire emitter current flows into the collector circuit. However to be more precise the emitter current is the sum of collector current and base current. i.e

$$I_e = I_c + I_b$$

### 4.1.3 Current Voltage Characteristics of BJT

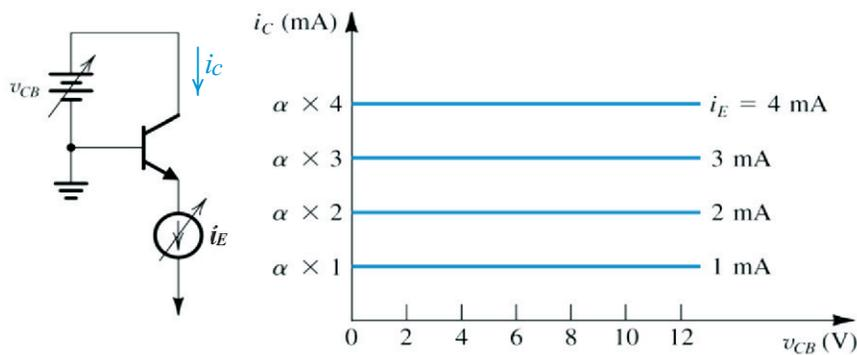

Figure-3 : The  $i_c$   $V_{CB}$  Characteristics

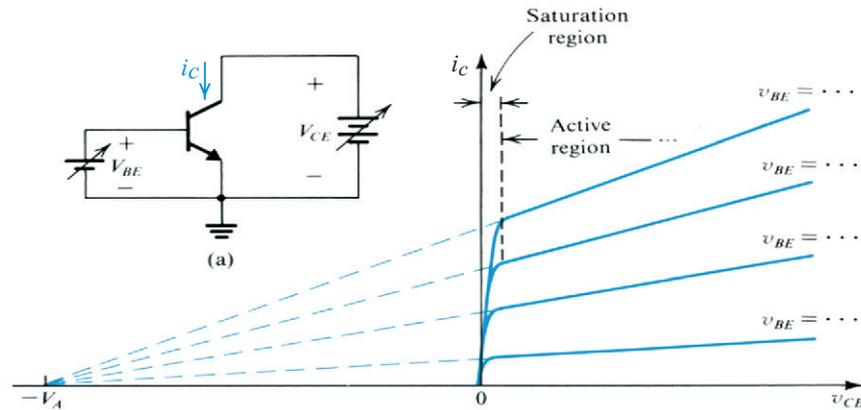

Figure-4 : The  $i_C V_{CE}$  Characteristics

## 4.2. BJT Biasing

The process by which required condition such as proper flow of zero signal collector current and the maintenance of proper collector emitter voltage during the passage of signal are obtained is known as transistor biasing.

The basic procedure of transistor biasing is to keep the emitter junction forward biased and the collector junction properly reverse biased during the application of signal so that faithful amplification can be achieved. The biasing can be achieved either by using bias batteries  $V_{bb}$  and  $V_{cc}$  or by applying associating circuitry with the transistor. Generally, the latter method is employed since it is more efficient.

The circuitry which provides the necessary conditions of transistor biasing is known as biasing circuit. While designing a biasing circuit, various transistor rating such as maximum collector current  $I_{C_{MAX}}$ , maximum collector emitter voltage  $V_{CE_{MAX}}$  etc. are kept in view for safe operation of the transistor. In the amplifier circuits, a load resistance  $R_C$  is connected in the collector circuit. Then a d.c. load line AB corresponding to this resistance  $R_C$  is drawn on the output characteristics as shown in fig. 4. The operating point will lie somewhere on this load line. Depending upon the base current, the operating point may lie at C, D or E.

When an a.c signal is applied at the input, the base current varies instant to instant. As a result of this, the current and collector voltage also vary with time. Thus an amplified signal is obtained at the output.

If point D is the as the operating point, the upper portion of the positive half will be clipped off as the point lies very near to the saturation region. On the other hand if point E is selected as the operating point., the peak of negative half will be clipped off as this point lies very near to the cut off region. Thus, in both the cases, distorted signal is obtained at the output.

However, if point C is selected as the operating point, full cycle of the signal is obtained in the amplified form at the output in this case, signal is not distorted at all.

## 4.3. CB, CE and CC Configuration

A transistor has three leads, namely emitter, base and collector. However, to handle input and output four terminals are needed (two for input and two for output). Therefore to connect transistor in the



circuit, one lead or terminal is made common. The input is fed between common and one of the remaining terminals whereas, output is connected between the common and other terminal of the transistor. Accordingly a transistor can be connected in the circuit in the following three ways: (see fig. 5)

- (i) Common Base Connection (CB Configuration)
- (ii) Common Emitter Connections (CE Configuration)
- (iii) Common Collector Connection (CC Configuration)

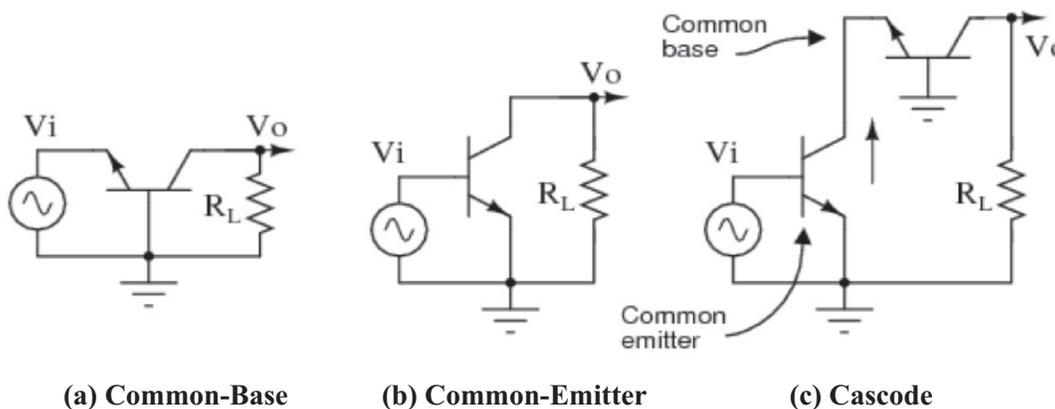

Figure-5

It is important to note that transistor may be connected in any one of the above said three ways, the emitter base junction is always forward biased and collector base junction is always reverse biased to operate the transistor in active region.

### 4.3.1. Common Base Connection (or CB Configuration)

The common base circuit arrangement for npn transistor and pnp transistor is shown in fig. (a) and (b) respectively. In this case, the input is connected between emitter and base while output is taken across collector and base. Thus the base of the transistor is common to both input and output circuit and hence the name common base connection or common base configuration.

#### Current Amplification Factor (Alpha)

The ratio of output to input current is known as current amplification factor in a common base connection the output current is collector current  $I_c$  whereas the input current is emitter current  $I_e$ .

Thus the ratio of change in collector current to the change in emitter current at constant collector base voltage  $V_{cb}$  is known as current amplification factor of transistor in common base configuration. It is generally represented by Greek letter (alpha).

### 4.3.2. Common Emitter Connection (or CE Configuration)

The common emitter circuit arrangement for npn transistor and pnp transistor is shown in fig. (a) and (b) respectively. In this case, the input is connected between emitter and base while output is taken across collector and emitter. Thus the emitter of the transistor is common to both input and output circuit and hence the name common emitter connection or common emitter configuration.



### Base Current Amplification Factor (Beta)

The ratio of output to input current is known as base current amplification factor. In a common emitter connection the output current is collector current  $I_c$  whereas the input current is base current  $I_b$ .

**beta** ( $\beta_{DC}$ )

$$I_C = \beta_{DC} I_B$$

Thus the ratio of change in collector current to the change in base current is known as base current amplification factor of transistor in common emitter configuration. It is generally represented by Greek letter (beta).

### 4.3.3. Common Collector Connection (or CC Configuration)

The common collector circuit arrangement for npn transistor and pnp transistor is shown in fig. (a) and (b) respectively. In this case, the input is connected between base and collector while output is taken across emitter and collector. Thus the collector of the transistor is common to both input and output circuit and hence the name common collector connection or common collector configuration.

#### Current Amplification Factor (Gama)

The ratio of output to input current is known as current amplification factor. In a common collector connection the output current is emitter current  $I_e$  whereas the input current is base current  $I_b$ .

Thus the ratio of change in emitter current to the change in base current is known as current amplification factor of transistor in common collector configuration. It is generally represented by Greek letter (Gama).

## 4.4 Characteristics and Transistor Parameters for CB, CE, CC Configuration

### (i) Characteristics of Common Base (CB) Configuration

To determine the characteristics of a transistor in cb configuration, the circuit is arranged as shown in fig.5(a) The emitter to base voltage  $V_{CB}$  can be varied by adjusting the potentiometer R1. A series resistor  $R_s$  is inserted in the emitter circuit to limit the emitter current  $I_e$  otherwise the value of  $I_e$  may change to a large value even if the setting of potentiometer R1 is changed slightly.

The collector voltage can be varied by adjusting the setting of potentiometer R2. For different settings, the current and voltages are read from the milliammeters and voltmeter connected in the circuit.

#### 1. Input Characteristics

In cb configuration the curve plotted between emitter current  $I_e$  and the emitter base voltage  $V_{EB}$  at constant collector base voltage  $V_{CB}$  is called input characteristics.

A number of characteristics curves can be plotted for different settings of  $V_{CB}$ . Fig.6 shows the input characteristics of a typical pnp transistor in common base configuration.



The following points may be noted from these characteristics:

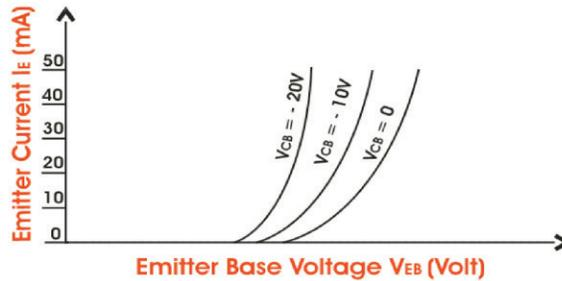

Figure-6

- (i) For a particular value of  $V_{cb}$  the curve is just like a diode characteristic in the forward region. In fact here the pn emitter junction is forward biased.
- (ii) When  $V_{cb}$  is increased the value  $I_e$  increase slightly for the given value of  $V_{eb}$ . Hence the junction becomes a better diode. It also reveals that emitter current and hence collector current is almost independent of collector base voltage  $V_{cb}$ .
- (iii) The emitter current  $I_e$  increase rapidly with a small increase in emitter base voltage  $V_{eb}$ . It shows that input resistance is very small.

**1. (a) Input Resistance**

The ratio of change in emitter base voltage ( $\Delta V_{eb}$ ) to the resulting change in emitter current ( $\Delta I_e$ ) at constant collector base voltage ( $V_{cb}$ ) is known as input resistance, i.e

Input resistance,  $\pi_1 = \Delta V_{eb} / \Delta I_e$  at constant  $V_{cb}$

The value of input resistance  $\pi_1$  is very low. Its value further decrease with the increase in collector base voltage  $V_{cb}$  since the curve tends to become more vertical. The typical value of input resistance varies from a few ohms to 100 ohms.

**2. Output Characteristics**

In CB configuration, the curve plotted between collector current  $I_c$  and collector base voltage  $V_{cb}$  at constant emitter current  $I_g$  is called output characteristics. Number of characteristics curves can be plotted for different settings of  $V_{cb}$ . Fig.7 shows the input characteristics of a typical pnp transistor in common base configuration.

The following points may be noted from these characteristics:

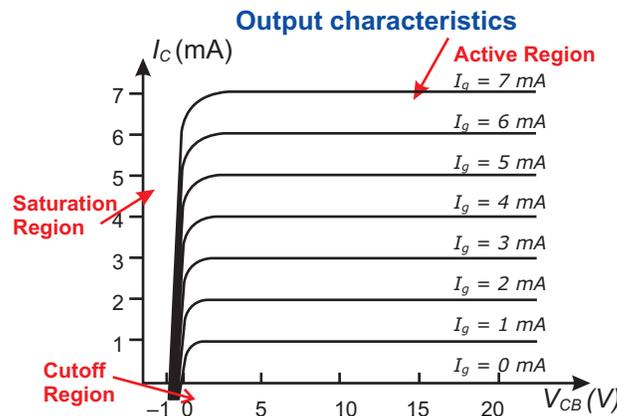

Figure-7 : Output Characteristics for Common-Base Transistor



- (i) In the active region, where collector base junction is reverse biased, the collector current  $I_c$  is almost equal to the emitter current  $I_e$ . The transistor is always operated in this region.
- (ii) In the active region. The curve are almost flat. A very large change in  $V_{cb}$  produces only a tiny change in  $I_c$ . It means that the circuit has very high output resistance  $r_b$ .
- (iii) When  $V_{CB}$  becomes positive i.e the collector base junction is forward biased the collector current  $I_c$  decrease abruptly. This is the saturated region. In this region  $I_c$  does not depend much upon  $I_e$ .
- (iv) When  $I_e=0$ , collector current  $I_c$  is not zero although its value is very small. In fact, this is the reverse leakage current i.e  $I_{CBO}$  that flows in the collector circuit. This current is temperature dependent and its value ranges from 0.1 to 1.0 micro A for silicon transistor and 2 to 5 micro A for germanium transistor.

## 2. (a) Output Resistance

The ratio of change in collector base voltage ( $\Delta V_{cb}$ ) to the resulting change in collector current ( $\Delta I_c$ ) at constant emitter current ( $I_e$ ) is known as output resistance, i.e

output resistance,  $r_0 = \Delta V_{cb} / \Delta I_c$  at constant  $I_e$

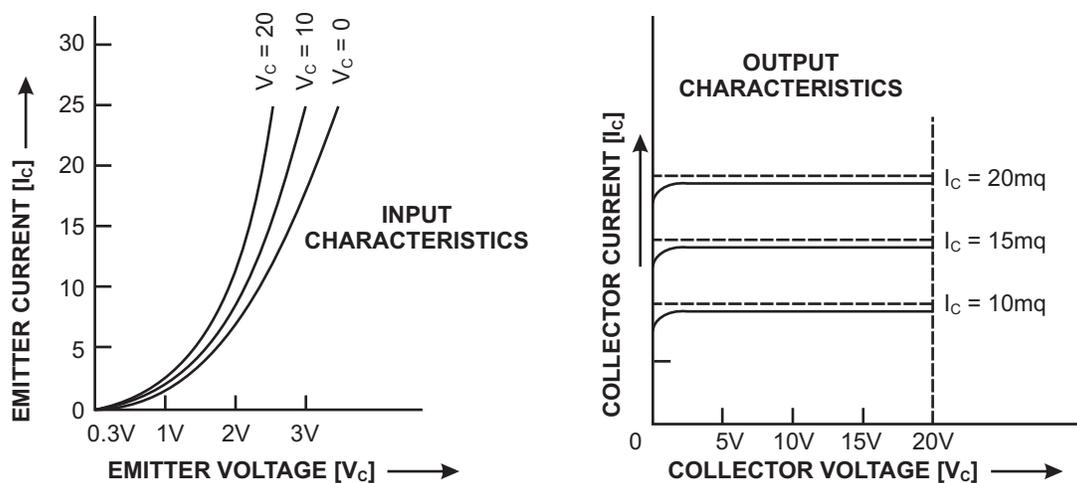

Figure-8

## (ii) Characteristics of Common Emitter (CE) Configuration

To determine the characteristics of a transistor in ce configuration, the circuit is arranged as shown in fig. 5(b). The emitter to base voltage  $V_{eb}$  can be varied by adjusting the potentiometer  $R_1$ . A series potentiometer  $R_2$  is inserted to vary the collector to emitter voltage otherwise the value of  $I_e$  may change to a large value even if the setting of potentiometer  $R_1$  is changed slightly. The collector voltage can be varied by adjusting the setting of potentiometer  $R_2$ . For different settings, the current and voltages are read from the milliammeters and voltmeter connected in the circuit.

## 2. Input Characteristics

In CE configuration the curve plotted between base current  $I_b$  and the emitter base voltage  $V_{eb}$  at constant collector emitter voltage  $V_{ce}$  is called input characteristics.



To draw the input characteristics note down the reading of ammeter ( $I_b$ ) connected in the base circuit for various values of  $V_{be}$  at constant  $V_{ce}$ . Plot the curve on the graph taking  $I_b$  along Y-axis and  $V_{be}$  along X-axis as shown in fig. 9. A number of characteristics curves can be plotted for different settings of  $V_{cb}$ . Fig.9 shows the input characteristics of a typical PNP transistor in common base configuration.

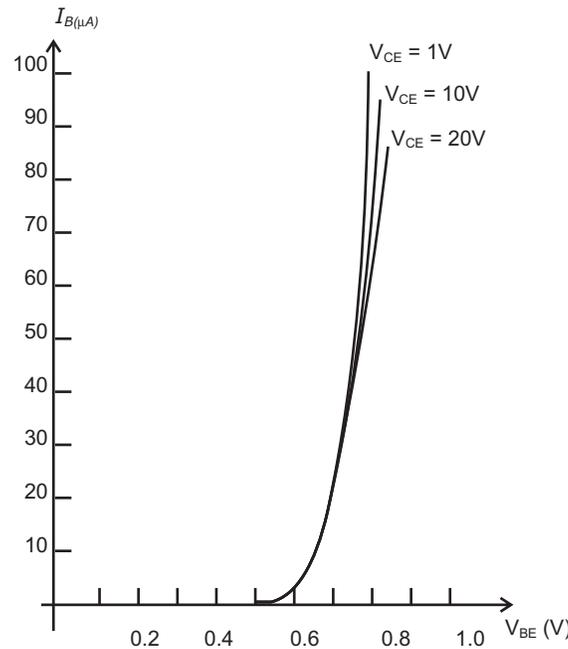

**Figure-9**

The following points may be noted from these characteristics:

- (i) These curves are similar to those obtained for CB configuration i.e like a forward diode characteristics. The only differences is that in this case  $I_g$  increase less rapidly with increase in  $V_{be}$ . Hence the input resistance of CE configuration is comparatively higher than of CB configuration.
- (ii) The change in  $V_{ce}$  does not result in a large deviation of the curves and hence the effect of change in  $V_{ce}$  on the input characteristics is ignored for all practical purposes.

### 1. (a) Input Resistance

The ratio of change in emitter base voltage ( $\Delta V_{be}$ ) to the resulting change in base current ( $\Delta I_b$ ) at constant collector emitter voltage ( $V_{ce}$ ) is known as input resistance, i.e

Input resistance, 
$$r_i = \Delta V_{be} / \Delta I_b \text{ at constant } V_{cb}$$

In CE configuration, the typical value of input resistance is of the order of a few hundred ohms.

### 2. Output Characteristics

In CE configuration, the curve plotted between collector current  $I_c$  and collector emitter voltage  $V_{ce}$  at constant base current  $I_b$  is called output characteristics. A number of characteristics curves



can be plotted for different settings of  $I_b$ . Fig shows the output characteristics of a typical npn transistor in common emitter configuration. The following points may be noted from these characteristics:

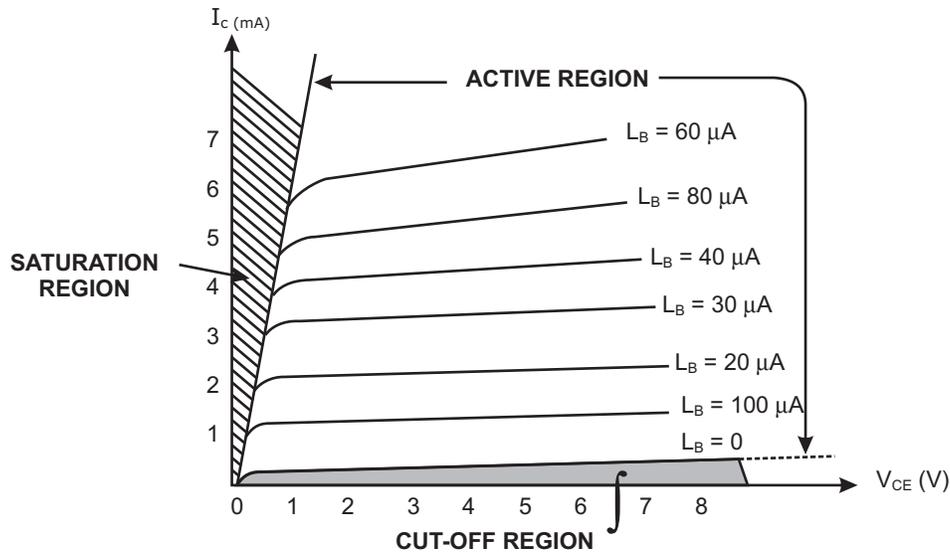

**Figure-10**

- (i) In the active region,  $I_c$  increase slightly as  $V_{ce}$  increase. The slope of the curve is little bit more than the output characteristics of CB configuration. Hence the output resistance ( $r_0$ ) of this configuration is less as compared to CB configuration.
- (ii) Since the value of  $I_c$  increase with the increase in  $V_{ce}$  at constant  $I_b$ , the value of current amplification factor (beta) also increases.
- (iii) When  $V_{ce}$  falls below the value of  $V_{be}$ ,  $I_c$  decreases rapidly. In fact, at this stage, the collector base junction is also forward biased and the transistor works in the saturation region. In the saturation region,  $I_c$  becomes independent and it does not depend upon the input current  $I_b$ .
- (iv) In the active region,  $I_c = \beta I_b$ . Hence, a small change in base current  $I_b$  produces a large change in output current ( $I_c$ ).
- (iv) When input current  $I_b = 0$ , collector current  $I_c$  is not zero although its value is very small. In fact, this is the reverse leakage current i.e  $I_{ce0}$  that flows in the collector circuit. This current is temperature dependent and its value ranges from 0.1 to 1.0 micro A for silicon transistor and 2 to 5 micro A for germanium transistor.

## 2. (a) Output Resistance

The ratio of change in collector emitter voltage ( $\Delta V_{ce}$ ) to the resulting change in collector current ( $\Delta I_c$ ) at constant base current ( $I_b$ ) is known as output resistance, i.e

Output resistance, 
$$r_0 = \Delta V_{ce} / \Delta I_c \text{ at constant } I_b$$

The output resistance of CE configuration is less than the CB configuration as the slope of output characteristics is more in this case. Its value is of the order of 50 kiloohm.



## 4.5. Introduction to FET, JFET, MOSFET, CMOS and VMOS

### (i) Field Effect Transistor

A field effect transistor is a three terminal semiconductor device in which current conduction is by one type of carriers (i.e either electrons or holes) and is controlled by the effect of electric field.

Unlike the usual transistor, its operation depends upon the flow of majority carriers only i.e. the current conduction in this case is either by electrons or holes. The flow of current is controlled by means of an electric field developed between the gate electrode and the conducting channel of the device. Although the working of FET was first given by Schocklery in 1952 but it commercialised only in late 1960's.

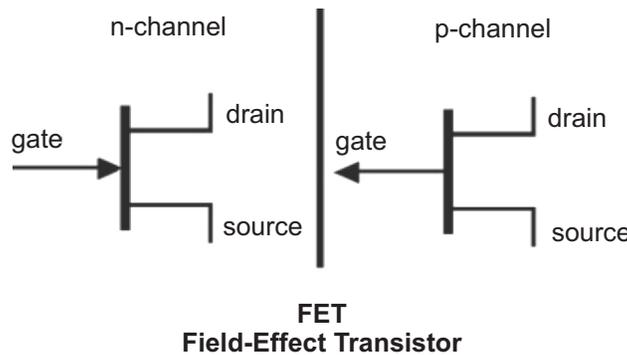

Figure-11

### Construction

An n-channel field effect transistor is shown in fig. 12. It consists of an n-type silicon bar with two islands of p- type semiconductor material embedded in the sides, thus forming two pn junctions. The two p region are connected with each other (externally or internally) and are called gate (G). Ohmic contacts are made at the two ends of the n- type semiconductor bar. One terminal is known as the source (S) through which the majority carriers (electrons in this case) enter the bar. The other terminal is known as the drain (D) through which these majority carriers leave the bar. Thus a FET has essentially three terminals called gate(G), source(S) and drain(D).

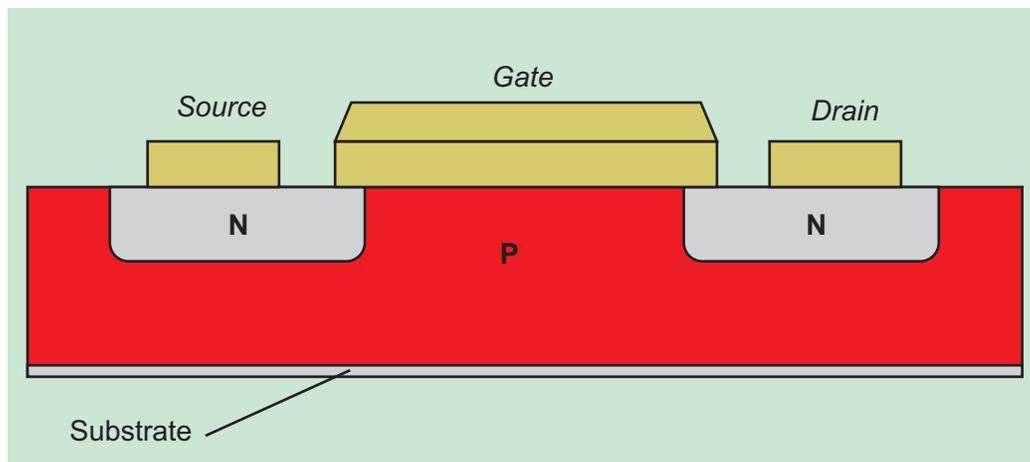

Figure-12



## Working of FET

The circuit diagram of an n- channel FET with normal polarities is shown.

When a voltage  $V_{ds}$  is applied across the drain and source terminals and voltage applied across the gate and source  $V_{gs}$  is zero (i.e gate circuit is open) as shown in fig., the two pn junction establish a very thin depletion layer. Thus a large amount of electrons will flow from source to drain through a wide channel formed between the two depletion layers.

When a reverse  $V_{gs}$  is applied across the gate and source as shown in fig. the width of the depletion layer is increased. This reduces the width of the conducting channel thereby decreasing the conduction (flow of electrons) through it. Thus the current flowing from source to drain depends upon the width of the conducting channel which depends upon the thickness of depletion layer establish by the two pn junctions depends upon the voltage applied across the gate source terminals.

Hence it is clear that the current from source to drain can be controlled by the application of potential (I.e electric field) on the gate. That is why the device is called field effect transistor. It may be noted that a p- channel FET also operates in the same manner as an n-channel FET except that the channel current carriers will be holes instead of electrons and all the polarities will be reversed.

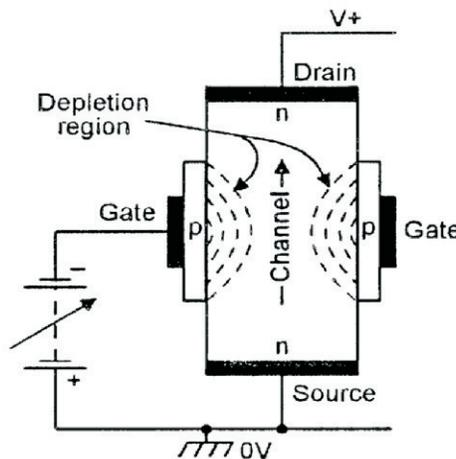

Figure-13

## Advantages

A FET is a voltage controlled device. In which the output current (drain current) is controlled by the input (gate) voltage, therefore it has the following important advantages.

- (i) FET has a very high input impedance which shows a high degree of isolation between the input and output circuit.
- (ii) The operation of FET depends upon the majority carriers (i.e. electron in n-channel and holes in P-channel FET) which do not cross junctions. Therefore, the inherent noise of tubes (because of high temperature operation) and those of ordinary transistor are not present in a FET.
- (iii) In FET the risk of thermal runaway is avoided since it has a negative temperature coefficient of resistance.
- (iv) A FET has smaller size, longer life and higher efficiency.



## Disadvantages

- (I) Since FET has high input impedance the gate voltage has less voltage and has less control over the drain current. Therefore FET amplifier has much less voltage gain than a bipolar amplifier.

There are two major categories of field effect transistors namely:

- (i) Junction field effect transistors(JFET)
- (ii) Metal oxide field effect transistor (MOSFET)

### (ii) Construction and Characteristics of JFETs

JFET are of two types viz. N-channel JFET and P-channel JFETs. Generally N-channel JFET are preferred.

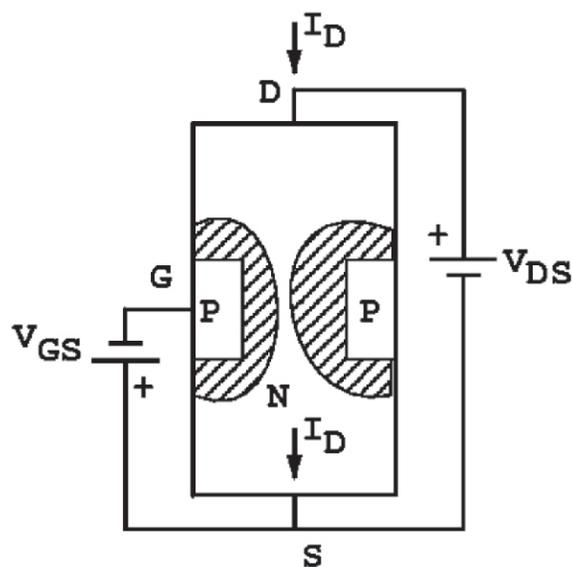

### Basic Construction (Fig. 14)

In an N- channel JFET an N-type silicon bar, referred to as the channel, has two smaller pieces of P-type silicon material diffused on the opposite sides of its middle part, forming P-N junctions as shown in fig.14. The two P-n junctions forming diodes or gates are connected internally and a common terminal called the gate terminal is brought out. Ohmic contacts are made at the two ends of the channel-one lead is called the source terminal S and the other drain terminal D.

The silicon bar behaves like a resistor between its two terminals D and S. The gate terminal is analogous to the base of an ordinary transistor (BJT). It is used to control the flow of current from source to drain. Thus source and drain terminal are analogous to emitter and collector terminals respectively of a BJT.

### Operation

Let us consider n- channel JFET for discussing its operation:

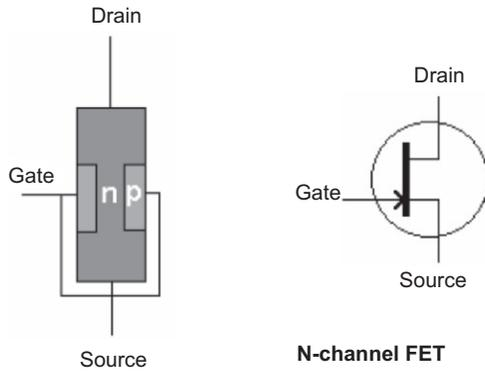

Figure-14

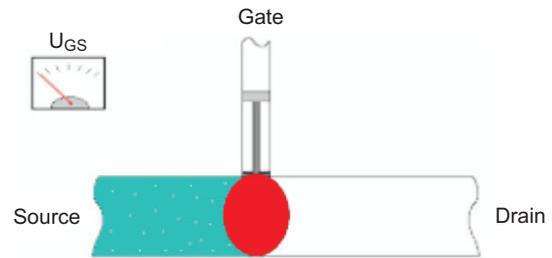
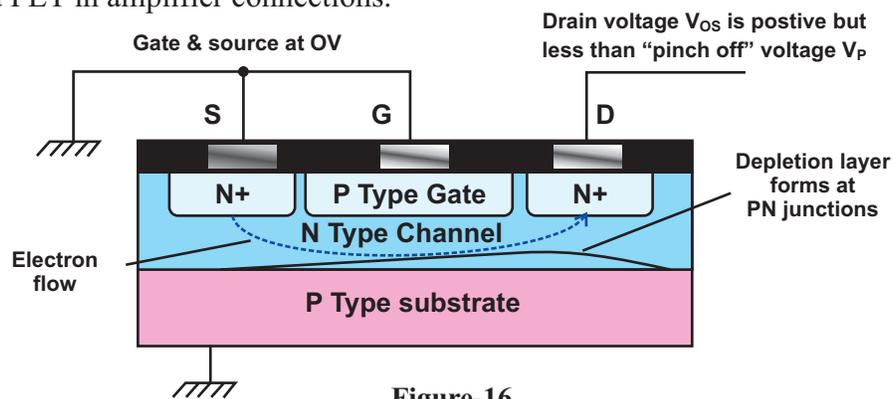

Figure-15

- (i) When neither any bias is applied to the gate (i.e when  $V_{gs}=0$ ) nor any voltage to the drain w.r.t, sources (i.e. when  $V_{ds}=0$ ), the depletion regions around the P-N junctions are of equal thickness and symmetrical.
- (ii) When positive voltage is applied to the drain terminals D w.r.t sources terminals S without connecting gate terminals G to supply as shown. The electrons flow from terminals S to terminal D whereas conventional drain current  $I_d$  flows through the channel from D to S. Due to flow of this current there is a uniform voltage drop across the channel resistance as we move from terminal D to terminal S. Due to flow of this current there is a uniform voltage drop across the channel resistance as we move from terminal D to terminal S. This voltage drop reverse biases the diode. The gate is more negative with respect to those points in the channel which are nearer to D than to S. Hence depletion layer penetrate more rapidly into the channel at points lying closer to D than to S. thus wedge shape depletion layer is formed as shown in fig.14 when  $V_{ds}$  is applied the size of the depletion layer formed determines the width of the channel and hence the magnitude of current  $I_d$  flowing through the channel.

**(iii) Metal Oxide Semiconductor Field Effect Transistor (MOSFET)**

A metal oxide semiconductor field effect transistor is a three terminal semiconductor device. The three terminal are source, gate and drain. Unlike a FET in this device the gate is insulate from the channel and therefore sometimes it is also known as insulated gate FET (IGFET). Because of this reason the gate current is very small whether the gate is positive or negative. The MOSFET can be used in any of the circuits covered for the FET. Therefore all the equations apply equally well to MOSFET and FET in amplifier connections.





## Construction

The simple side view of an n-channel MOSFET is shown in fig.15 the figure shows 16 its constructional details it is similar to FET except with following modifications:

- (i) There is only one p-region instead of two this region is known as substrate.
- (ii) Over the left side of the channel, a thin layer of metal oxide (usually silicon dioxide  $\text{SiO}_2$ ) is deposited. A metallic gate is deposited over the layer of silicon dioxide as shown 16. The gate is insulated from the channel since silicon dioxide is an insulator. That is why it is also known as insulated gate FET.
- (iii) Since the gate is insulated from the channel by a thin layer of silicon dioxide, the input impedance of MOSFET is very high (of the order of  $10^{10}$  to  $10^{15}$  ohms).
- (iv) Unlike the FET, a MOSFET has no gate diode rather it forms a capacitor. The capacitor has gate and channel as electrodes and the oxide layer as dielectric. Because of this property, the device can be operated with negative as well as positive gate voltage.

## Working

The circuit diagram of an n-channel MOSFET with normal polarities is shown fig.16. Unlike the FET a MOSFET has no gate rather it forms a capacitor which has two electrodes i.e. gate and channel. The oxide layer acts as dielectric. When negative voltage is applied to the gate, electrons accumulate on it. These electrons repel the conduction band electrons in the n- channel. Therefore the number of conduction electrons available for current conduction through the channel will reduce. The greater the negative potential on the gate, the lesser is the current conduction from source to drain. However in this case if the gate is given positive voltage, more electrons are made available in the n- channel. Consequently, current from source to drain increases.

## (iv) Complementary MOSFET or CMOS

### CMOS Transistor

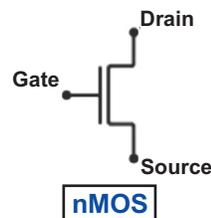
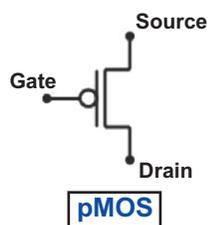

- **Complementary MOS**

- P-channel MOS (pMOS)
- N-channel MOS (nMOS)

- **pMOS**

- P-type source and drain diffusions
- N substrate
- Mobility by holes

- **nMOS**

- N-type source and drain diffusions
- P substrate
- Mobility by electrons

Figure-17



A very effective logic can be established by constructing a p- channel and n- channel MOSFET on the same substrate as shown in fig.17 note the induced p- channel on the left and the induced n- channel on the right for the p-and n- channel devices, respectively. The configuration is referred to as a complementary MOSFET arrangement CMOS. It has extensive application in computer logic design the relatively high input impedance, fast switching speeds, and lower operating power levels of the CMOS configuration have resulted in a whole new discipline referred to as CMOS logic design.

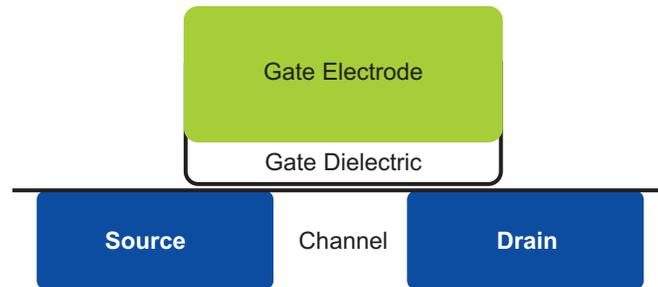

**Figure-18 : Basic CMOS Transistor**

**(v) VMOS**

One of the disadvantage of the typical MOSFET is the reduced power-handling levels compared to BJT transistors. This shortfall for a device with so many positive characteristics can be softened by changing the construction mode from one of a planar nature such as shown in to one with a vertical structure as shown in fig.19. All the elements of the planar MOSFET are present in the vertical metal oxide silicon FET(VMOS). The term vertical is due primarily to the fact that the channel is now formed in the vertical direction rather than the horizontal direction as for the planar device. However the channel has the appearance of a V cut in the semiconductor base, which often stands out as a characteristic for memorization of the name of the device.

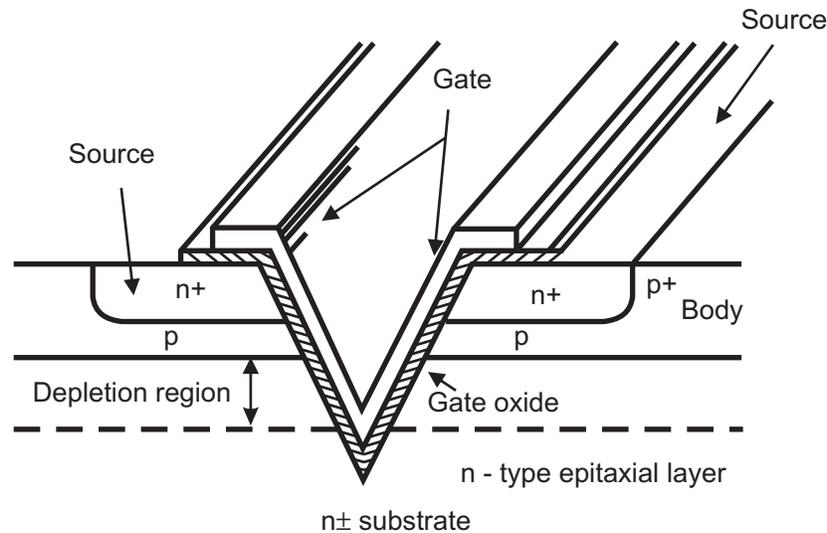

**Figure-19 : VMOS Structure, Drain Terminal is on Underside**



## 4.6. Characteristics of Various Transistors

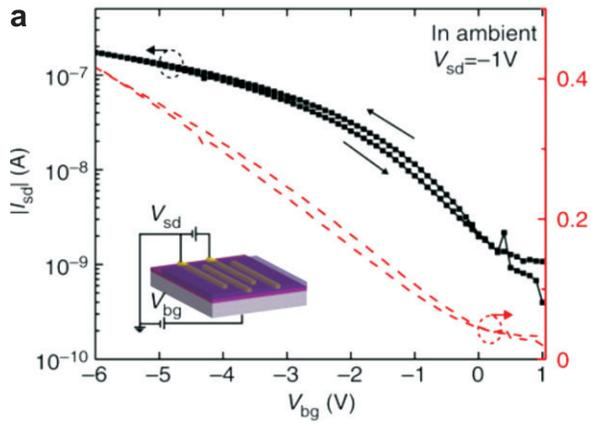

Figure-20

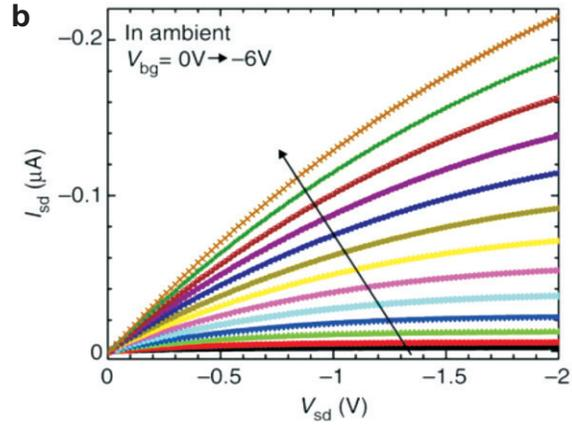

Figure-21

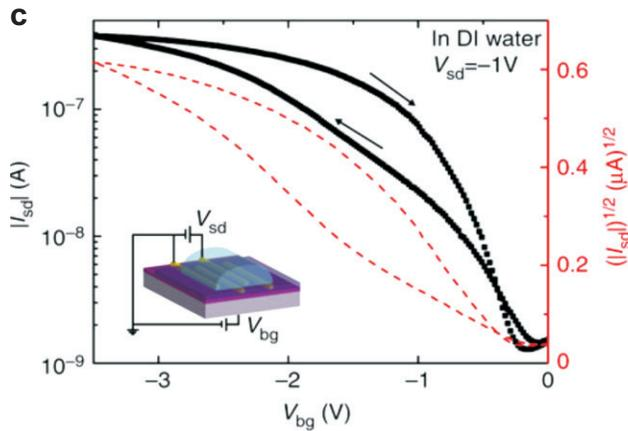

Figure-22

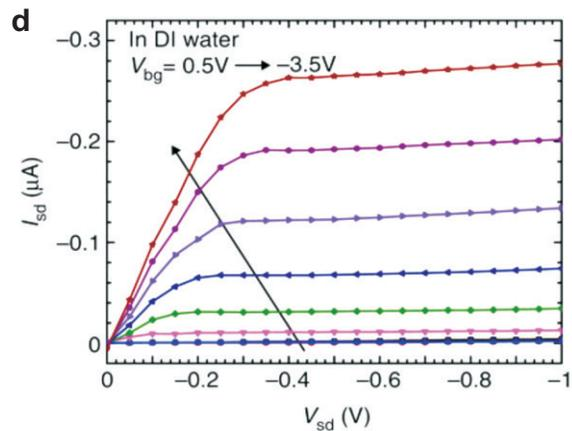

Figure-23

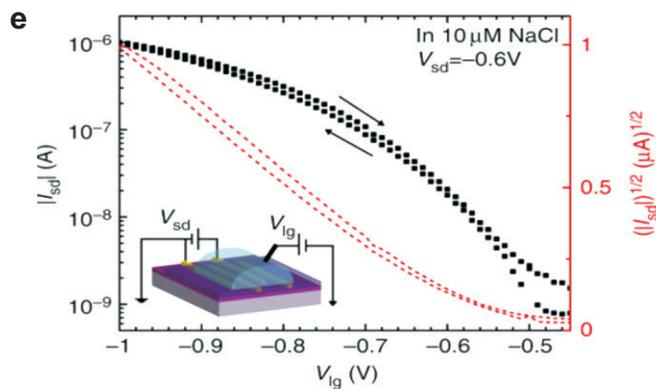

Figure-24

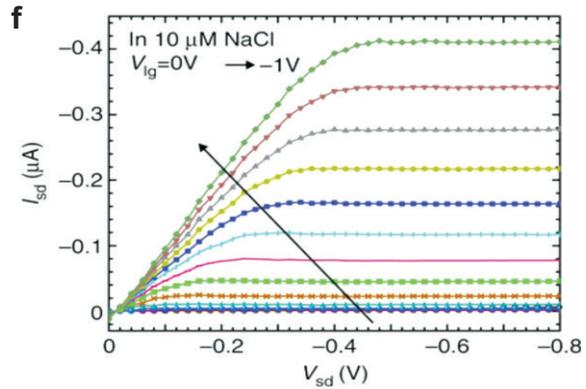

Figure-25



## Resource Material

1. Digital Logic and Computer Design by M. Morris Mano, Prentice Hall India Publication, New Delhi, 2002.
2. Digital Principles and Applications by A. P. Malvino & D. P. Leach, Tata McGraw-Hill Publication, New Delhi 1995.
3. Modern Digital Electronics by R. P. Jain, Tata McGraw- Hill Publication, New Delhi 2010.
4. Digital Electronics by G. K. Kharate, Oxford University Press Publication, New Delhi 2011.
5. Digital Electronics: Principles and Integrated Circuits by A. K. Maini, Wiley India Publication, New Delhi 2010.
6. Digital Technology: Principles and Practice by Virendra Kumar, New Age International Publishers, New Delhi 2002.
7. Digital Circuits and Design by S. Salivahanan & S. Arivazhagan, Vikas Publishing, Noida, Uttar Pradesh, 2012.

## Exercise

### 1. Very short answers:

- (a) The output impedance of a transistor is \_\_\_\_\_.
- (b) The phase difference between input and output voltage of a transistor connected in common emitter arrangement is \_\_\_\_\_.
- (c) As the temperature of a transistor goes up, the base emitter resistance \_\_\_\_\_.
- (d) What are the three common transistor connections?
- (e) The most commonly used transistor connection is \_\_\_\_\_.

### 2. Short answers:

- (a) If emitter current in a transistor is 2mA, then the collector will be nearly \_\_\_\_\_.
- (b) CC configuration is generally used for \_\_\_\_\_.
- (c) The silicon transistor is generally used than germanium transistor because \_\_\_\_\_.
- (d) The transistor is said to be in quiescent state when \_\_\_\_\_.

### 3. Write short note on:

- (a) Draw the circuit symbol for an NPN transistor and indicate the reference polarities for the voltage and the reference direction for the three currents.
- (b) Repeat the above for PNP transistor.
- (c) Why is an ordinary junction transistor called bipolar transistor?

### 4. Explain in detail:

- (a) Draw the output characteristics of a transistor in CE configuration and label all the parameters.
- (b) A properly connected transistor can do amplification. Is transistor a source of energy.



# UNIT 5

## Transistor Amplifier and Applications

### 5.0 Unit Overview and Description

- Overview
- Knowledge and Skill Outcomes
- Assessment Plan
- Learning Outcomes
- Resource Material
- Topics Covered

Introduction to Amplifiers, Single and Multistage Amplifiers, Amplifier Characteristics, Feedbacks in Amplifiers, Introduction to Oscillators, Multivibrators, Signal Generator, Thyristors, Light Activated SCR.

### Overview

This unit starts with the understanding of Amplifiers. It includes description of single and multi stage amplifiers and their characteristics. Concept of Positive Feedback and Negative Feedback is discussed. Damped and Undamped oscillations have been explained using suitable diagrams. Brief introduction to Multivibrator and Signal Generator has been given. Introduction to Thyristors and various types of Thyristors like SCR, TRIAC and DIAC are discussed with their symbols. Operation of Light Activated SCR is discussed along with its symbol.

### Knowledge and Skill Outcomes

- i) Understanding of amplifier
- ii) Understanding the singlestage and multistage amplifier
- iii) Knowledge about circuit diagram of singlestage and multistage amplifiers.
- iv) To know various types of characteristics of an amplifier.
- v) Understanding the concept of feedback in amplifiers.
- vi) Understanding the sinusoidal, non-sinusoidal, damped and undamped oscillations.
- vii) Basic idea about multivibrator and its various uses.
- viii) To understand the block diagram of signal generator.
- ix) Understanding of Thyristors- SCR, TRIAC and DIAC with their symbols.
- x) To understand the operation of Light Activated SCR.

### Assessment Plan: (For the Teachers)

Unit-1	Topic	Assessment Method	Time Plan	Remarks
	Introduction to Amplifier	Interactive session	20 Minutes	
	Single and Multistage amplifier	Assignment	To be submitted after one day	



Unit-1	Topic	Assessment Method	Time Plan	Remarks
	Amplifier characteristics	Internal Test	25 Minutes	
	Feedback in amplifier	Presentation by group of students	45 Minutes	
	Introduction oscillators	Interactive session and Test	45 Minutes	
	Multivibrators	Assignment	To be submitted after one day	
	Signal Generator	Assignment	To be submitted after one day	
	Thyristors	Assignment	To be submitted after one day	
	Light Activated SCR	Assignment	To be submitted after one day	

### Learning Outcomes

Unit-5	Transistor Amplifier and Applications	Outcomes
	Introduction to Amplifiers	i) Understanding of concept of amplification and amplifier. ii) Understanding the basic circuit diagram of Transistor amplifier.
	Single and Multistage amplifier	i) Identification single stage and multistage amplifier. ii) Understanding of basic circuit diagram of single stage and multistage amplifier.
	Amplifier characteristics	i) To know various characteristics of an amplifier.
	Feedback in amplifier	i) Understanding the basic concept of feedback ii) Understanding of concept of positive and negative feedback.
	Introduction to Oscillators	i) To learn about sinusoidal, non-sinusoidal, damped and undamped oscillations with their wave forms.
	Multivibrators	i) To understand the basic idea about multivibrator and its uses.
	Signal Generator	i) To understand the signal generator and its various categories.
	Thyristors	i) To understand the basic concept of Thyristors-SCR, TRIAC and DIAC
	Light Activated SCR	i) To understand the basic operation of LASCR



## 5.1. Introduction to Amplifiers

No electronic system can work without an amplifier. Can the voice of a singer reach everybody in the audience in a hall if PA system (Public Address system) fails? It is just because of the enlargement or the amplification of the signal picked up by microphone that we can enjoy a music orchestra. We are able to hear the news, cricket commentary or football match on radio receiver and also we are able to watch and listen (Audio and Visual) the cricket match or some other programs on TV because the radio receiver or TV catches the weak signal through antenna and amplifies it.

Amplification means enlargement of a weak signal by an electronic circuit without any distortion in the signal. The electronic circuit or device which amplifies the signal is known as Amplifier.

In previous chapters we have studied how a transistor works in different regions after getting the biasing. We know if emitter-base junction of a transistor is forward biased and collector-base junction is reverse biased it can work in active region. This biasing is called DC biasing which is required for a transistor to work as an amplifier. Active region is the only region in which by carefully choosing the operating point transistor can amplify the input weak signal and produce the fruitful output without distortion. After proper DC biasing AC signal to be amplified is fed to the input of a transistor which is amplified by the transistor as per its configuration. Now the transistor works as an amplifier. Fig. 1 shows the circuit diagram of DC biasing for a transistor to work in active region. Fig. 2 shows the circuit diagram of a transistor amplifier which amplifies weak input signal.

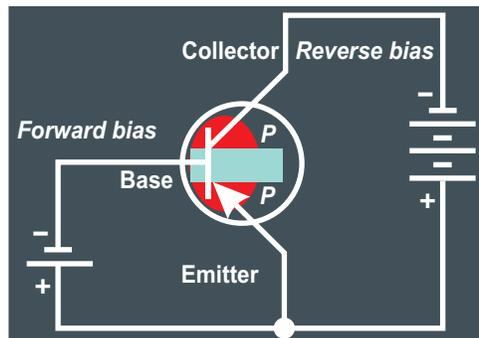

Figure-1

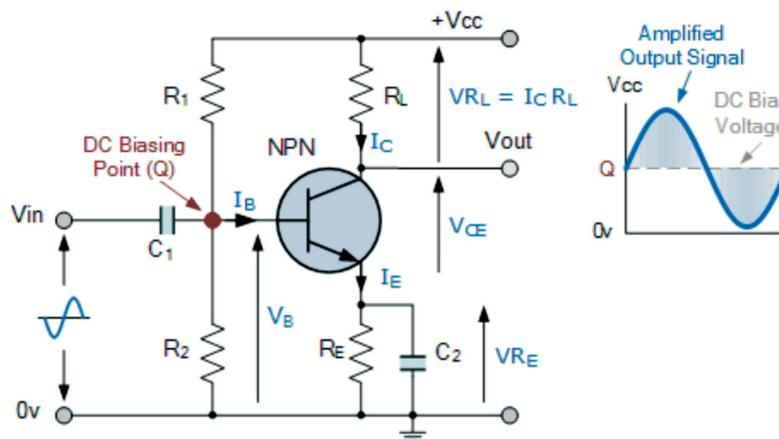

Figure-2



It means now it is clear from above discussion that an Amplifier is more precisely an electronic device that increases the voltage, current or power of an input signal with the aid of transistor by furnishing the additional power from a separate power source. At that time we can also say that it is a Transistor Amplifier.

## 5.2. Single and Multistage Amplifiers

When only one transistor is used in a transistor amplifier to amplify weak input signal then it is known as Single Stage Amplifier. A practical amplifier generally uses a number of stages for amplification and is known as Multistage Amplifier. Fig. 3 and Fig. 4 are examples of single and multistage amplifiers respectively.

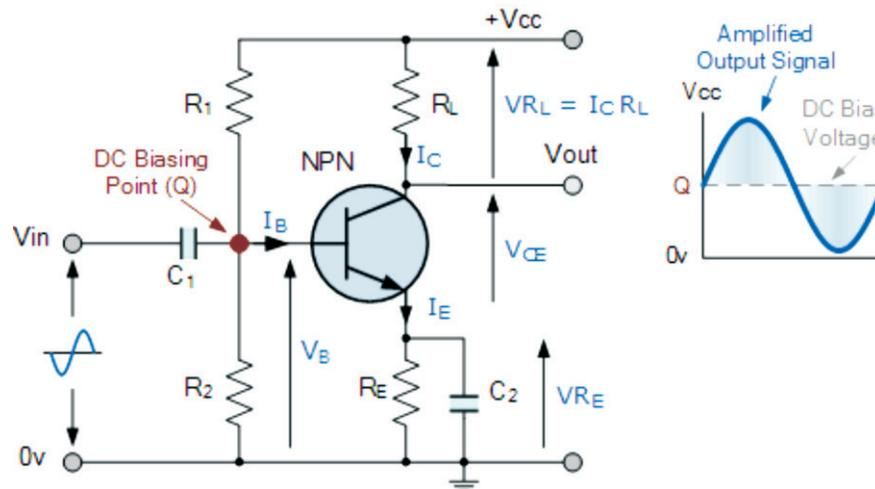

Figure-3

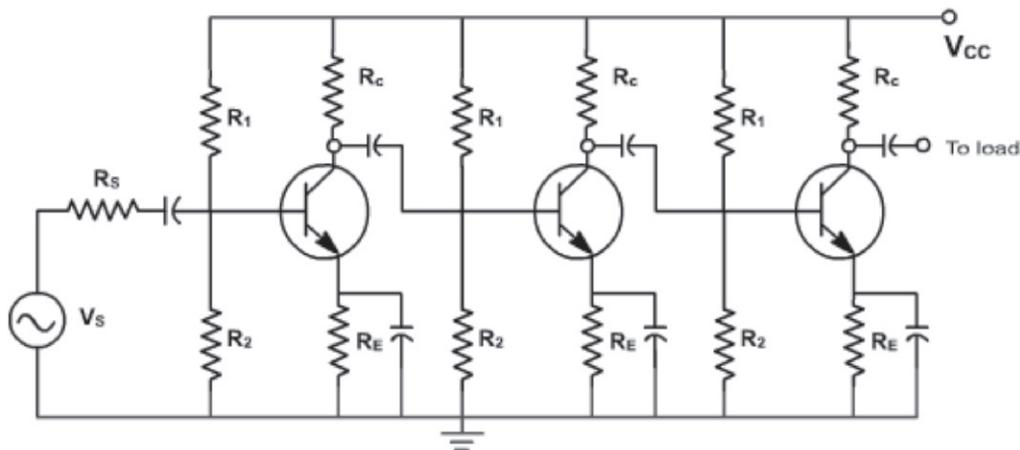

Figure-4

In single stage amplifier the input signal is multiplied by the gain or amplification factor of a single amplifier. If input current is  $i_b$  then output current for CE amplifier will be  $\beta i_b$  that shall flow through output collector circuit. Here  $\beta$  is the current amplification factor for CE amplifier. If input voltage is  $v_i$  then output amplified voltage will be  $Axv_i$  where A is the



voltage gain of the amplifier. The amplified output voltage of amplifier will be  $180^\circ$  out of phase with its input voltage signal for CE amplifier circuit as shown in fig. 2 & 3.

The output from a singlestage amplifier is usually not sufficient to drive an output device. In other words, the gain of a single amplifier is inadequate for practical purposes. Consequently, additional amplification over two or three stages is necessary. To achieve this, the output of each amplifier stage is coupled in some way to the input of the next stage. The resulting system is referred to as multistage amplifier. It may be emphasised here that a practical amplifier is always a multistage amplifier. For example, in a transistor radio receiver, the number of amplification stages may be six or more. A multistage amplifier is shown in Fig. 4

### 5.3. Amplifier Characteristics

Any amplifier is characterised with its following characteristics:

- (1) Input Resistance
- (2) Output Resistance
- (3) Voltage Gain
- (4) Current Gain
- (5) Power Gain
- (6) Phase Reversal

### 5.4. Feedbacks in Amplifiers

Feedback : (Fig. 5) When a fraction of output is fed back to the input circuit, it is known as feedback. The fraction of output may either be current or voltage. A feedback amplifier consists of two parts: an amplifier and a feedback circuit. There are two types of feedback: (1) Positive feedback (2) Negative feedback.

- (1) **Positive Feedback:** If the feedback voltage (or current) is so applied that it increases the input voltage (or current) then it is called positive feedback. In this case applied feedback voltage is in phase with input voltage. It is also known as regenerative or direct feedback. Positive feedback is used in oscillator circuits.
- (2) **Negative Feedback:** If the feedback voltage (or current) is so applied that it reduces the amplifier input then it is called negative feedback. In this case applied feedback voltage is  $180^\circ$  out of phase with input voltage. It is also known as degenerative or inverse feedback. Negative feedback is frequently used in amplifier circuits.

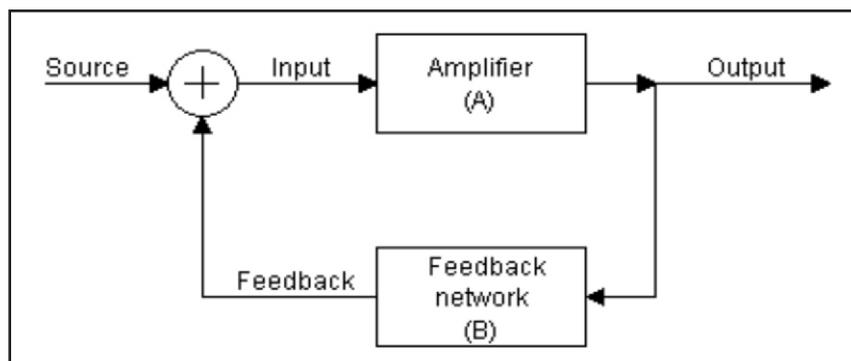

Figure-5



## 5.5. Introduction to Oscillators

Any circuit that generates an alternative voltage is called an oscillator. Output of an oscillator may be a sine wave, square wave, sawtooth wave or pulses. Electronic oscillators may be broadly divided into following two groups:

- (i) **Sinusoidal (or Harmonic) Oscillators:** Which produce an output having sine wave form.
- (ii) **Non-Sinusoidal Oscillators:** They produce an output which has rectangular, square or saw tooth waveform or is of pulse shape.

Sinusoidal Oscillators may be damped and undamped.

- (i) **Damped Oscillations:** Oscillations whose amplitude keeps decreasing (or decaying) with time are called damped or decaying oscillations. Wave form of such oscillations are shown in Fig.6(a)
- (ii) **Undamped Oscillations:** Oscillations whose amplitude remains constant i.e. does not change with time are called undamped oscillations. Such oscillations are shown in Fig.6(b)

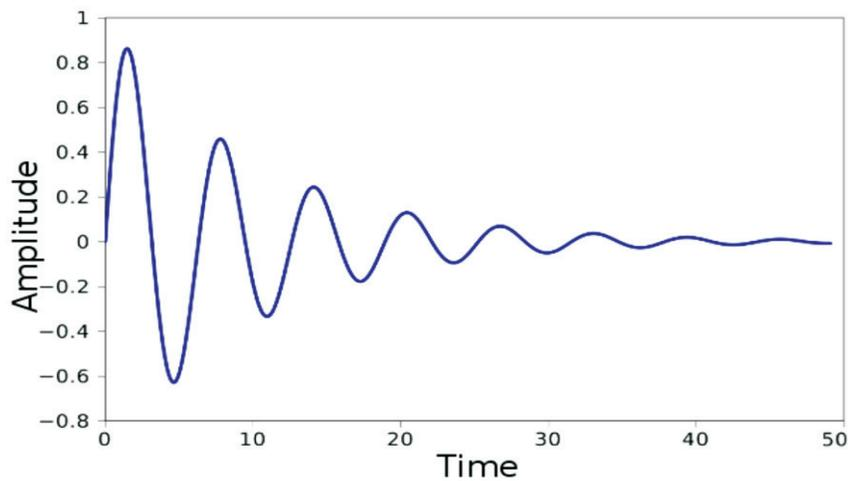

Figure-6(a)

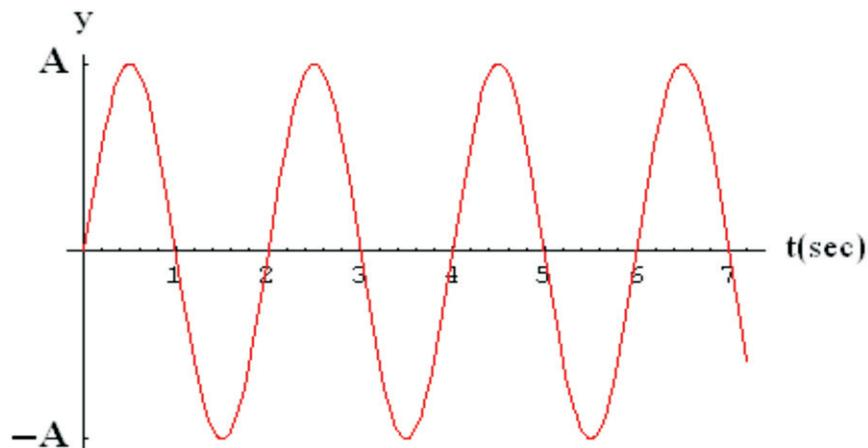

Figure-6(b)



## 5.6. Multivibrators (MVS)

These devices are very useful as pulse generating, storing and counting circuits. They are basically two-stage amplifiers with positive feedback from the output of one amplifier to the input of the other as shown in Fig. 7



Figure-7

Feedback is supplied in such a manner that one transistor is driven to saturation and the other to cut-off. There are three basic types of AMVs:

- (i) Astable multivibrator (AMV)
- (ii) Monostable multivibrator (MMV)
- (iii) Bistable multivibrator (BMV)

### Uses of Multivibrators

- (i) As frequency divider.
- (ii) As sawtooth generators.
- (iii) As square wave and pulse generators.
- (iv) As a standard frequency source.
- (v) Specialised uses in radar and TV circuits.
- (vi) As memory elements in computers.

## 5.7. Signal Generator

Signal generator is an instrument that generates an electrical signal in either the audio or radio-frequency range. Audio signal generator produces audio frequencies (sine wave and/or square waves). It is very popular instrument and is extensively used for testing amplifiers. Block diagram is shown in Fig. 8

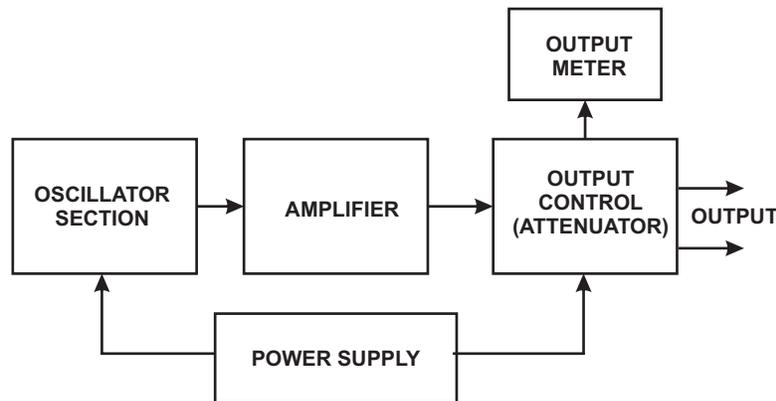

Figure-8



The signal generators can be classified into the following categories:

- (i) Audio Generators
- (ii) Function Generators
- (iii) Pulse Generators
- (iv) RF Generators

## 5.8. Thyristors

### Introduction

Thyristor means a solid-state device with two or more junctions. A thyristor may be switched from ON state to OFF state between two conducting layers or vice versa. These are capable of handling large currents, even upto hundreds of amperes. The three widely used thyristors are :

- (i) Silicon-Controlled Rectifier (SCR)
- (ii) TRIAC
- (iii) DIAC

### 5.8.1. Silicon-Controlled Rectifier (SCR)

It is a semiconductor device which acts as an electronic switch. A silicon-controlled rectifier can change an alternating current into direct one and also it can control the amount of power fed to the load. Means an SCR combines the features of both rectifier and transistor.

#### 5.8.1.1. Construction of SCR

If a P-N junction is added to a junction transistor then the resulting P-N junction device is termed as a silicon-controlled rectifier. Construction of SCR is shown in Fig. 9 (a) and symbolic representation is shown in Fig. 9 (b). It is a combination of a rectifier (P-N) and a junction transistor (N-P-N) in one unit to form a **P-N-P-N device**. There are three terminals as shown in the fig. 13 (a). One terminal from the outer P-type material is called anode (A), the second from the outer N-type material is called cathode (K) and the third from the base of transistor section is the gate (G). The anode is kept at high positive potential with respect to cathode while gate is held at small positive potential with respect to cathode.

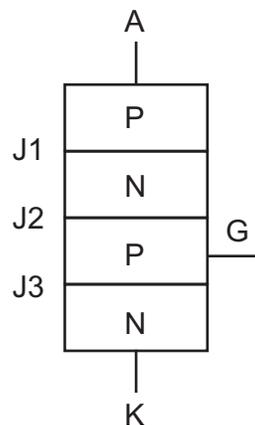
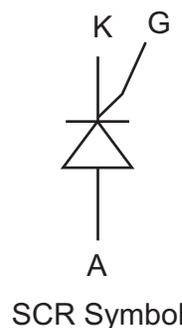

Figure - 9(a)



SCR Symbol

Figure - 9 (b)



### 5.8.1.2. SCR as a Switch

SCR has two states (i) ON state and (ii) OFF state. If an appropriate value of the gate current is passed, the SCR begins to conduct heavily and remains in the position for an indefinite period even if the gate voltage is removed. This is the ON state of the SCR. But if the anode current is further reduced a point comes when SCR becomes OFF. This particular anode current at which the SCR becomes OFF is known as “Holding current”. Thus SCR behaves as Switch. Being an electronic device this may be termed as an “Electronic Switch”.

### 5.8.2. TRIAC

The major drawback of an SCR is that it can conduct current in one direction only. Therefore an SCR can only control d.c. power i.e it controls only forward biased half cycles of a.c. However in an a.c. system it is required to control both positive and negative half cycles. For this purpose, a semiconductor device called triac is used.

A triac is a three-terminal five-layer semiconductor switching device which can control alternating current in a load. Triac is an abbreviation for triac a.c. switch. Tri-indicates that device has three terminals and a.c. means that the device controls alternating current or can conduct current in either direction. The three terminals are designated as main terminal MT1, main terminal MT2 and gate G. Triac physical construction, two thyristor analogy and circuit symbol are shown in Fig. 13.

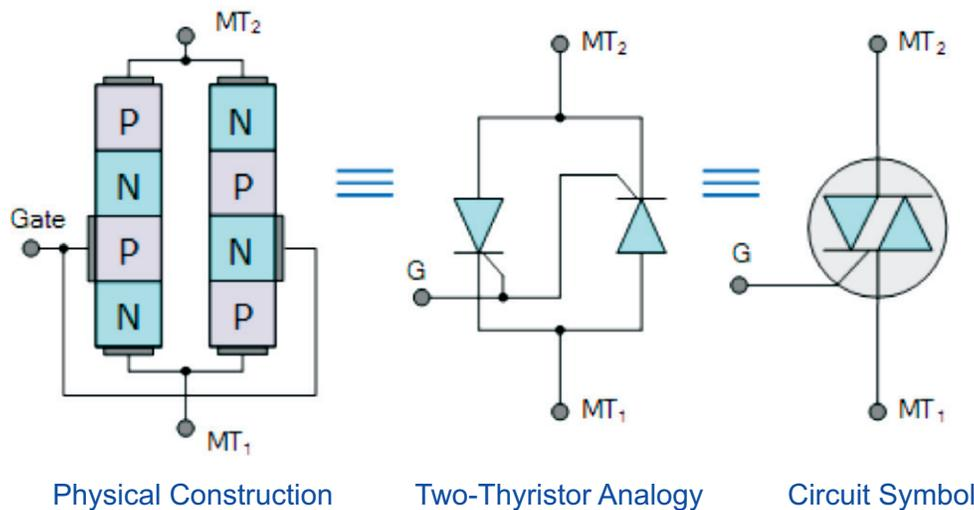

Figure-10

### 5.8.3. DIAC

A DIAC is a two terminal three layer bidirectional device which can be switched from its OFF state to ON state for either polarity of applied voltage.

The diac can be constructed in either npn or pnp form. Fig. 11 and Fig. 12 shows the basic structure of a diac in pnp form and symbol of DIAC respectively. Two leads are connected to p-regions of silicon separated by an n-region. The structure of diac is very much similar to that of a transistor. However there are some important differences:



- (i) There is no terminal attached to the base layer.
- (ii) The three regions are nearly identical in size.
- (iii) The doping concentrations are identical to give the device symmetrical properties.

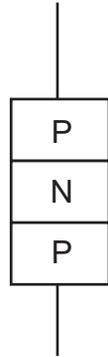

Figure-11

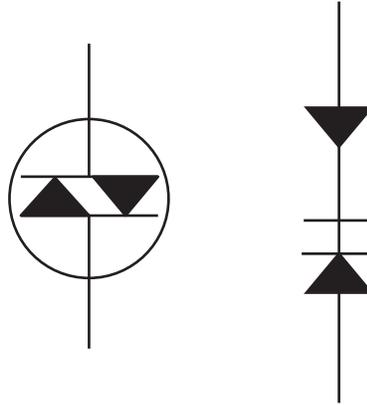

Figure-12

### 5.9. Light Activated SCR (LASCR)

Operation of LASCR is similar to SCR one only difference is that it is activated through light. It has window and lens which focuses the light on gate junction area. The LASCR works as a latch. It can be triggered ON by a light input on the gate area but does not turn OFF when light source is removed. It can be turned OFF only by reducing current through it below its holding current. Depending on the size, a LASCR is capable of handling large amount of current that can be handled by a photodiode or a photo-transistor. Fig. 13 shows construction of LASCR and its symbol.

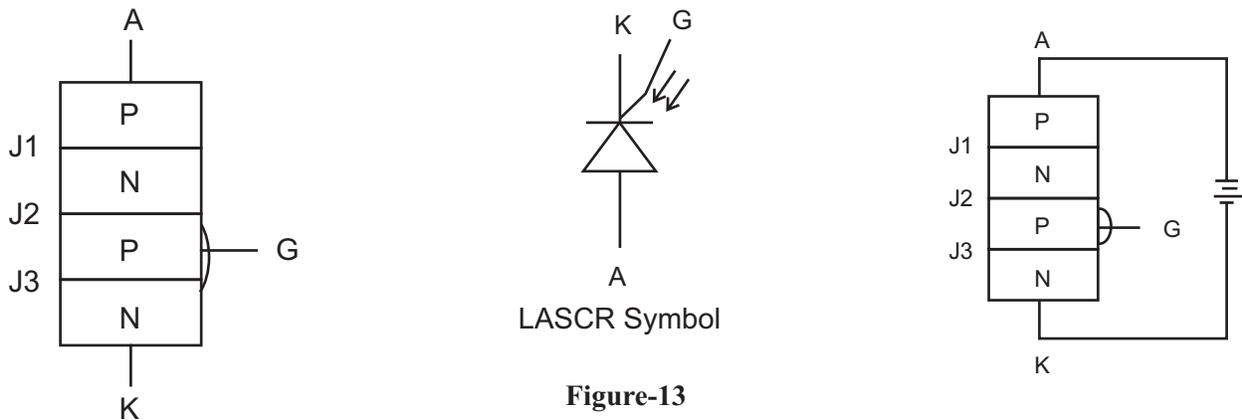

Figure-13

#### Summary

This unit explains about the basic circuit of an amplifier as a single-stage and multistage with the use of a basic element that is transistor. Feedback concept and difference between positive and negative feedback has been explained. Introduction to oscillator, multivibrator and signal generator has been included in this unit. Construction, symbol and operation of SCR, TRIAC, DIAC and LASCR has been described. Wherever necessary circuit diagram and symbols have been drawn which are self explanatory.



## Resource Material

1. Basic Electronics Engineering by Dr. N. K. Dutta, New Central Book Agency Publication.
2. Electronic Devices & Circuits by Sanjeev Gupta, Dhanpat Rai Publications.
3. Basic Electronics and Linear Circuits by N N Bhargava, D C Kulshreshtha and S C Gupta, McGraw Hill Education.
4. Electronics Engineering by Sanjay Sharma, S.K. Kataria & Sons.
5. Principles of Electronics by V.K.Mehta and Rohit Mehta, S. Chand.
6. Electronic Devices and Circuit Theory by Robert L. Boylestad and Louis Nashelsky, Pearson Publishers.

## Exercise

### Questions:

- (a) Define amplification and amplifier.
- (b) In which region transistor should be biased so that it works as an amplifier.
- (c) Draw the circuit diagram of a single and multistage amplifier.
- (d) For a three stage transistor amplifier if total gain is 1000 and each stage has the same gain then what is the gain of individual stage? If input signal is 1 mv then what will be the final output of this three stage amplifier?
- (e) Write down various characteristics of an amplifier.
- (f) Define feedback with block diagram. Explain positive and negative feedback.
- (g) What do you understand by an oscillator? Explain damped and undamped oscillations with the help of suitable diagrams.
- (h) What do you mean by multivibrator? What are the basic types of multivibrators.
- (i) Enumerate various applications of a multivibrator.
- (j) Write symbol of :
  - i) SCR
  - ii) TRIAC
  - iii) DIAC
  - iv) LASCR
- (k) Write short note on:
  - (i) SCR
  - (ii) TRIAC
  - (iii) DIAC



## Web references for Chapter: 1

1. <http://encyclopedia2.thefreedictionary.com/ionization+potential>
2. <https://en.wikipedia.org/wiki/Electronics>
3. <http://farside.ph.utexas.edu/teaching/336k/Newtonhtml/node30.html>
4. <http://www.amigainformatics.com/industries/electronics/>
5. <http://article.sapub.org/10.5923.j.mm.20170701.05.html>
6. [https://en.wikipedia.org/wiki/Magnetic\\_field](https://en.wikipedia.org/wiki/Magnetic_field)
7. [http://wikivisually.com/wiki/Magnetic\\_viewing\\_film](http://wikivisually.com/wiki/Magnetic_viewing_film)
8. <https://www.youtube.com/watch?v=8QY0zIX2YV4>
9. <https://www.collaborizm.com/project/Nk2i5Fcx>
10. [https://www.revolvvy.com/main/index.php?s=Teltron%20tube&item\\_type=topic](https://www.revolvvy.com/main/index.php?s=Teltron%20tube&item_type=topic)
11. <https://www.newagepublishers.com/samplechapter/001410.pdf>
12. [https://en.wikipedia.org/wiki/Electric\\_field](https://en.wikipedia.org/wiki/Electric_field)
13. [http://www.idc-online.com/technical\\_references/pdfs/electrical\\_engineering/Quantum\\_Mechanics\\_Electric\\_Field.pdf](http://www.idc-online.com/technical_references/pdfs/electrical_engineering/Quantum_Mechanics_Electric_Field.pdf)
14. <https://www.quora.com/Why-does-a-magnet-produce-a-magnetic-field-1>
15. <http://www.ocr.org.uk/Images/208240-unit-02-delivery-guide.pdf>
16. <https://www.scribd.com/doc/91954223/Laboratory-REPORT-Physics-Electric-Field>
17. <https://www.youtube.com/watch?v=6WTohdnUV4s>
18. <https://www.physicsforums.com/threads/what-is-a-uniform-electric-field-is-the-acceleration-of-a-charge-in-it-constant.778497/>
19. <http://www.smashinglists.com/10-first-electricity-milestones/2/>
20. <https://www.slideshare.net/SriKumaran4/swg-dreams>
21. <http://science.jrank.org/pages/2385/Electronics.html>
22. <https://www.pinterest.com/catiemouse/computers-technology/>
23. <http://www.icym.edu.my/v13/about-us/our-news/general/582-electronics.html>
24. <https://ahduni.edu.in/seas/ict-lab-facilities/electronics-lab>
25. <https://www.softtrix.com/trainings/electronics-training/>
26. [http://www.bluebird-electric.net/artificial\\_intelligence\\_autonomous\\_robotics/Robots\\_Hexapods\\_Insects\\_Animatronics/Electronics.htm](http://www.bluebird-electric.net/artificial_intelligence_autonomous_robotics/Robots_Hexapods_Insects_Animatronics/Electronics.htm)
27. <http://dbpedia.org/page/Electronics>
28. <http://science.jrank.org/pages/2376/Electronics-History.html>
29. <http://www.guidebuz.com/electronics>
30. <https://www.slideshare.net/VishwasAgarwal4/application-of-electronics>
31. [http://www.physchemres.org/article\\_11968\\_ef8c31fb13b165c7b5efe3ecd530d6c8.pdf](http://www.physchemres.org/article_11968_ef8c31fb13b165c7b5efe3ecd530d6c8.pdf)



## Web references for Chapter: 2

1. <https://en.wikipedia.org/wiki/Resistor>
2. <http://en.academic.ru/dic.nsf/enwiki/15781>
3. <https://www.linkedin.com/pulse/dont-resist-resistorthey-deserve-more-respect-rick-grigalunas>
4. <https://www.scribd.com/doc/46665699/Seismic-Sensor>
5. <https://www.quora.com/Is-electrolytic-capacitor-variable>
6. [http://www.electronics-tutorials.ws/capacitor/cap\\_2.html](http://www.electronics-tutorials.ws/capacitor/cap_2.html)
7. <https://www.slideshare.net/LorenzAlfuentes/resistors-11251561>
8. <https://www.youtube.com/watch?v=TqOsvfi7QZM>
9. <http://www.radio-electronics.com/info/data/inductors/inductor-types.php>
10. <https://www.criticalpowersupplies.co.uk/How-batteries-work-and-their-different-types>
11. <http://www.newworldencyclopedia.org/entry/Resistor>
12. <https://www.slideshare.net/shashankdevvrath/electronic-devices-and-circuits-manual>
13. <https://www.scribd.com/doc/28788258/Resistors-Colour-Coding>
14. <https://www.slideshare.net/ayeshamubeen37/mini-final-docmtn-final>
15. [https://en.wikipedia.org/wiki/Current\\_source](https://en.wikipedia.org/wiki/Current_source)
16. <https://www.slideshare.net/MdAshikurRahman14/research-methodology-presentation-66119877>
17. <http://www.rockstone-research.com/index.php/en/research-reports/915-Prima-Diamond-becomes-Voltaic-Minerals-with-focus-on-energy-metals>
18. [https://en.wikipedia.org/wiki/Battery\\_\(electricity\)](https://en.wikipedia.org/wiki/Battery_(electricity))
19. <http://ocw.ump.edu.my/mod/resource/view.php?id=73>
20. <https://www.ukessays.com/essays/chemistry/electrochemical-battery.php>
21. <https://en.wikipedia.org/wiki/Potentiometer>
22. <https://www.quora.com/Why-do-voltage-source-is-represented-as-short-circuit-and-current-source-as-open-circuit-while-taking-single-source>
23. <https://www.scribd.com/doc/86589859/Over-under-Voltage-Cut-Off-With-on-Time-Delay-PROJECT-REPORT>
24. [http://www.electronics-tutorials.ws/capacitor/cap\\_1.html](http://www.electronics-tutorials.ws/capacitor/cap_1.html)
25. [https://en.wikipedia.org/wiki/Dry\\_cell](https://en.wikipedia.org/wiki/Dry_cell)
26. <http://www.ijimt.org/papers/504-H1011.pdf>
27. <http://www.amateur-radio-wiki.net/index.php?title=Resistors>
28. <http://www.robotpark.com/Resistor>
29. [https://www.revolvy.com/main/index.php?s=Current%20source&item\\_type=topic](https://www.revolvy.com/main/index.php?s=Current%20source&item_type=topic)
30. <http://www.wikiwand.com/en/Potentiometer>
31. <http://www.wow.com/wiki/Resistor>
32. <https://www.revolvy.com/topic/Dry%20cell>



33. <http://wikivisually.com/wiki/Potentiometer>
34. <http://diodetech.blogspot.com/2013/07/types-of-capacitor.html>
35. <http://www.rechargebatteries.org/knowledge-base/batteries/other-technologies/>
36. <https://www.revolvvy.com/main/index.php?s=Ayrton-Perry%20winding>
37. [http://wikivisually.com/wiki/Dry\\_cell](http://wikivisually.com/wiki/Dry_cell)
38. <http://www.robotiik.com/Resistor>
39. [http://dspace.ewubd.edu/bitstream/handle/123456789/1786/Arefeen\\_Binta\\_Belal.pdf?sequence=1](http://dspace.ewubd.edu/bitstream/handle/123456789/1786/Arefeen_Binta_Belal.pdf?sequence=1)
40. <https://www.scribd.com/doc/138081352/Automotive-electrics-and-autotronics-by-M-A-Qadeer-Siddiqui>
41. <http://eeeinterviewtips.blogspot.com/>
42. [http://www.mojotone.com/amp-parts/Resistors\\_1/Ceramic-5W-10K-OHM-Resistor](http://www.mojotone.com/amp-parts/Resistors_1/Ceramic-5W-10K-OHM-Resistor)
43. [https://en.wikipedia.org/wiki/Laser\\_trimming](https://en.wikipedia.org/wiki/Laser_trimming)
44. <http://www.freeway-batteries.com/faqs/where-are-primary-non-rechargeable-cells-used-mostly/>
45. <https://upload.wikimedia.org/wikipedia/commons/d/d3/1.Resistors.wiki.20150309.pdf>
46. <https://www.youtube.com/watch?v=b8BxFrIj85I>
47. [https://hi.wikipedia.org/wiki/%E0%A4%9A%E0%A4%BF%E0%A4%A4%E0%A5%8D%E0%A4%B0:Laser\\_Trimmed\\_Precision\\_Thin\\_Film\\_Resistor\\_Network.JPG](https://hi.wikipedia.org/wiki/%E0%A4%9A%E0%A4%BF%E0%A4%A4%E0%A5%8D%E0%A4%B0:Laser_Trimmed_Precision_Thin_Film_Resistor_Network.JPG)
48. [https://en.m.wikipedia.org/wiki/File:Laser\\_Trimmed\\_Precision\\_Thin\\_Film\\_Resistor\\_Network.JPG](https://en.m.wikipedia.org/wiki/File:Laser_Trimmed_Precision_Thin_Film_Resistor_Network.JPG)
49. <https://www.pulsetech.net/support/lead-acid-batteries.html>
50. [https://www.researchgate.net/publication/286194982\\_Design\\_Fabrication\\_Of\\_A\\_Gravity\\_Powered\\_Light](https://www.researchgate.net/publication/286194982_Design_Fabrication_Of_A_Gravity_Powered_Light)
51. <https://answers.yahoo.com/question/index?qid=20120905094415AAcmtIU>
52. <http://www.digitalpower.in/product.html>
53. <https://www.slideshare.net/shashank571/electronic-letter-box-47643938>
54. <http://www.c-sharpcorner.com/article/python-scripting-on-gpio-in-raspberry-pi/>
55. <http://www.scullcom.uk/resistor-basics/>
56. <https://www.slideshare.net/OmkarRane15/lab-manual-for-basic-electrical-and-electronics-engineering-for-first-year>
57. <http://www.ebay.com/itm/100K-Ohm-104-3296W-Cermet-Potentiometer-Trimpot-Trimmer-50-pcs-DT-/262465521913>
58. <https://www.slideshare.net/VivekVenugopal11/an-integrated-fourport-dcdc-convertercei0080-56679170>
59. <https://www.scribd.com/doc/88678560/Foot-Step-Power-Generation>
60. <http://wikivisually.com/wiki/Resistor>
61. <http://byjus.com/physics/cells-electromotive-force-and-internal-resistance/>



62. <https://www.amazon.com/a13081500ux0324-3296W-104-Potentiometer-Variable-Resistors/dp/B00D2JRALS>
63. [http://www.ht.energy.lth.se/fileadmin/ht/Kurser/MVKF25/Batteries\\_Introduction.pdf](http://www.ht.energy.lth.se/fileadmin/ht/Kurser/MVKF25/Batteries_Introduction.pdf)
64. <https://www.amazon.com/uxcell-Through-Hole-Trimmer-Potentiometer/dp/B008LT4IGY>
65. <https://www.scribd.com/document/85566835/Capacitor>
66. <http://www.sankethika.in/types-of-capacitors/>
67. <http://www.linguee.es/espanol-ingles/traduccion/cloruro+de+amonio.html>
68. <http://www.e-gourakani.blogfa.com/post/139>
69. <https://www.h2sys.fr/en/electric-storage-system/>
70. <http://www.circuitstoday.com/2-km-fm-transmitter>

### Web references for Chapter: 3

1. <https://www.scribd.com/document/176253818/Engineering-Material-Questions>
2. <https://www.quora.com/Electronics-What-is-the-full-wave-bridge-rectifier>
3. <http://analyseameter.com/2016/03/rectifiers-types-efficiency-comparison-basics.html>
4. [www.circuitstoday.com](http://www.circuitstoday.com)

### Web references for Chapter: 4

1. <http://www.circuitstoday.com/jfet-junction-field-effect-transistor>
2. <http://www.rgceitpdy.ac.in/Notes/ECE/II%20YEAR/EC%20T34-EDC/Unit%202.pdf>
3. <http://analyseameter.com/2016/02/jfet-mosfet-difference-comparison.html>
4. <https://www.scribd.com/document/331926881/EC6464-Electro-Micro-Proc-Notes-Typed>
5. <http://sctevtodisha.nic.in/docs/website/pdf/140296.pdf>
6. <http://slideplayer.com/slide/10835710/>
7. <https://www.slideshare.net/KrishnaPrasad126/ece-50416328>
8. <https://www.coursehero.com/file/11706491/Transistor-Biasing/>
9. <https://www.scribd.com/doc/146444258/Ece-III-Analog-Electronic-Ckts-10es32-Notes>
10. [http://www.neduet.edu.pk/electronics/pdf/Lab\\_Work\\_Books/EDC.pdf](http://www.neduet.edu.pk/electronics/pdf/Lab_Work_Books/EDC.pdf)
11. <http://circuitglobe.com/common-base-connection-cb-configuration.html>
12. [https://www.ikbooks.com/home/samplechapter?filename=187\\_Sample-Chapter.pdf](https://www.ikbooks.com/home/samplechapter?filename=187_Sample-Chapter.pdf)
13. <https://www.slideshare.net/shankhaShankhamitras/aec-ppt2-75625241>
14. <http://slideplayer.com/slide/8551848/>
15. <http://slideplayer.com/slide/10868731/>
16. [http://m.kkhsou.in/EBIDYA/BPP/MODIFY\\_electronics.html](http://m.kkhsou.in/EBIDYA/BPP/MODIFY_electronics.html)
17. <http://www.bhojvirtualuniversity.com/slm/mscphy1p4.pdf>
18. <https://www.scribd.com/doc/51854658/BJT>
19. <https://www.slideshare.net/AnisurRahmanNayem/transistor-biasing-69604669>
20. <http://sctevtodisha.nic.in/docs/website/pdf/140292.pdf>



## Web references for Chapter: 5

1. <http://www.talkingelectronics.com/Download%20eBooks/Principles%20of%20electronics/CH-21.pdf>
2. <https://www.slideshare.net/mhmdenab/ch-65>
3. <http://slideplayer.com/slide/5277224/>
4. <http://repository.unn.edu.ng:8080/xmlui/bitstream/handle/123456789/1690/Arilesere%20Opeyemi%20Munirudeen.pdf?sequence=1>
5. <https://www.scribd.com/document/255258868/CHAPTER-2-Oscillator-pdf>
6. [http://wikieducator.org/Sinusoidal\\_Oscillator](http://wikieducator.org/Sinusoidal_Oscillator)
7. <http://documents.mx/engineering/sinusoidal-and-non-sinusoidal-oscillations.html>
8. <https://www.slideshare.net/awaisahmad24/electronic-circuit-design-lab-manual>
9. [https://www.tutorialspoint.com/amplifiers/amplifiers\\_based\\_on\\_configurations.htm](https://www.tutorialspoint.com/amplifiers/amplifiers_based_on_configurations.htm)
10. <https://parthoduet.files.wordpress.com/2013/02/ch-65.pdf>



## **CENTRAL BOARD OF SECONDARY EDUCATION**

Shiksha Kendra, 2, Community Centre, Preet Vihar, Delhi-110092

Tel: 011-22527183, 22421438 • Fax: 011-22526580

Website: [www.cbse.nic.in](http://www.cbse.nic.in)