

Chapter 7

Structural design

INTRODUCTION

Structural design is the methodical investigation of the stability, strength and rigidity of structures. The basic objective in structural analysis and design is to produce a structure capable of resisting all applied loads without failure during its intended life. The primary purpose of a structure is to transmit or support loads. If the structure is improperly designed or fabricated, or if the actual applied loads exceed the design specifications, the device will probably fail to perform its intended function, with possible serious consequences. A well-engineered structure greatly minimizes the possibility of costly failures.

Structural design process

A structural design project may be divided into three phases, i.e. planning, design and construction.

Planning: This phase involves consideration of the various requirements and factors affecting the general layout and dimensions of the structure and results in the choice of one or perhaps several alternative types of structure, which offer the best general solution. The primary consideration is the function of the structure. Secondary considerations such as aesthetics, sociology, law, economics and the environment may also be taken into account. In addition there are structural and constructional requirements and limitations, which may affect the type of structure to be designed.

Design: This phase involves a detailed consideration of the alternative solutions defined in the planning phase and results in the determination of the most suitable proportions, dimensions and details of the structural elements and connections for constructing each alternative structural arrangement being considered.

Construction: This phase involves mobilization of personnel; procurement of materials and equipment, including their transportation to the site, and actual on-site erection. During this phase, some redesign may be required if unforeseen difficulties occur, such as unavailability of specified materials or foundation problems.

Philosophy of designing

The structural design of any structure first involves establishing the loading and other design conditions, which must be supported by the structure and therefore must be considered in its design. This is followed by the analysis and computation of internal gross forces, (i.e.

thrust, shear, bending moments and twisting moments), as well as stress intensities, strain, deflection and reactions produced by loads, changes in temperature, shrinkage, creep and other design conditions. Finally comes the proportioning and selection of materials for the members and connections to respond adequately to the effects produced by the design conditions.

The criteria used to judge whether particular proportions will result in the desired behavior reflect accumulated knowledge based on field and model tests, and practical experience. Intuition and judgment are also important to this process.

The traditional basis of design called elastic design is based on allowable stress intensities which are chosen in accordance with the concept that stress or strain corresponds to the yield point of the material and should not be exceeded at the most highly stressed points of the structure, the selection of failure due to fatigue, buckling or brittle fracture or by consideration of the permissible deflection of the structure. The allowable – stress method has the important disadvantage in that it does not provide a uniform overload capacity for all parts and all types of structures.

The newer approach of design is called the strength design in reinforced concrete literature and plastic design in steel-design literature. The anticipated service loading is first multiplied by a suitable load factor, the magnitude of which depends upon uncertainty of the loading, the possibility of it changing during the life of the structure and for a combination of loadings, the likelihood, frequency, and duration of the particular combination. In this approach for reinforced-concrete design, theoretical capacity of a structural element is reduced by a capacity-reduction factor to provide for small adverse variations in material strengths, workmanship and dimensions. The structure is then proportioned so that depending on the governing conditions, the increased load cause fatigue or buckling or a brittle-failure or just produce yielding at one internal section or sections or cause elastic-plastic displacement of the structure or cause the entire structure to be on the point of collapse.

Design aids

The design of any structure requires many detailed computations. Some of these are of a routine nature. An example is the computation of allowable bending moments for standard sized, species and grades of dimension timber. The rapid development of the

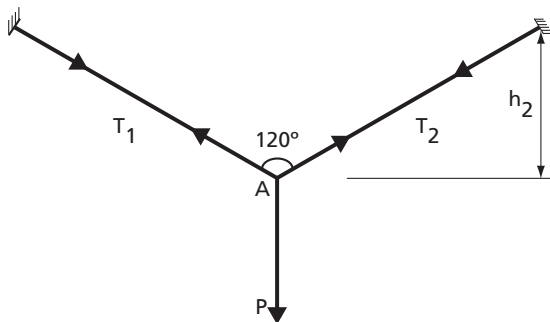
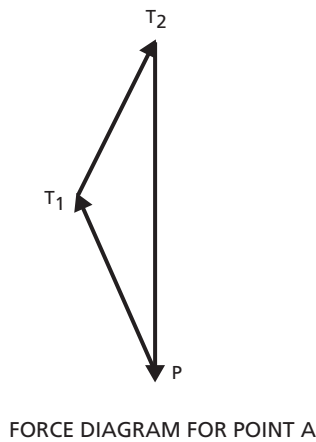
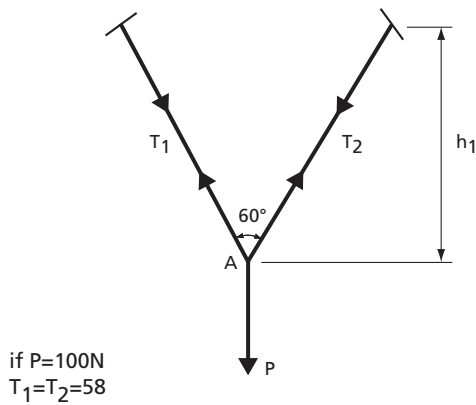

if $P=100\text{N}$
 then
 $T_1=T_2=100\text{N}$

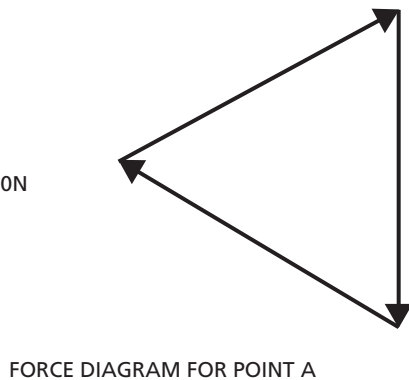

computer in the last decade has resulted in rapid adoption of Computer Structural Design Software that has now replaced the manual computation. This has greatly reduced the complexity of the analysis and design process as well as reducing the amount of time required to finish a project.

Standard construction and assembly methods have evolved through experience and need for uniformity in the construction industry. These have resulted in standard details and standard components for building construction published in handbooks or guides.

Design codes

Many countries have their own structural design codes, codes of practice or technical documents which perform a similar function. It is necessary for a designer to become familiar with local requirements or recommendations in regard to correct practice. In this chapter some examples are given, occasionally in a simplified form, in order to demonstrate procedures. They should not be assumed to apply to all areas or situations.

DESIGN OF MEMBERS IN DIRECT TENSION AND COMPRESSION

Tensile systems

Tensile systems allow maximum use of the material because every fibre of the cross-section can be extended to resist the applied loads up to any allowable stress.

As with other structural systems, tensile systems require depth to transfer loads economically across a span. As the sag (h) decreases, the tensions in the cable (T_1 and T_2) increase. Further decreases in the sag would again increase the magnitudes of T_1 and T_2 until the ultimate condition, an infinite force, would be required to transfer a vertical load across a cable that is horizontal (obviously an impossibility).

A distinguishing feature of tensile systems is that vertical loads produce both vertical and horizontal reactions. As cables cannot resist bending or shear, they transfer all loads in tension along their lengths. The connection of a cable to its supports acts as a pin joint (hinge), with the result that the reaction (R) must be exactly equal and opposite to the tension in the cable (T). The R can be resolved into the vertical and horizontal directions producing the forces V and H . The horizontal reaction (H) is known as the thrust.

The values of the components of the reactions can be obtained by using the conditions of static equilibrium and resolving the cable tensions into vertical and horizontal components at the support points.

Example 7.1

Two identical ropes support a load P of 5 kN, as shown in the figure. Calculate the required diameter of the rope, if its ultimate strength is 30 MPa and a safety factor of 4.0 is applied. Also determine the horizontal support reaction at B .

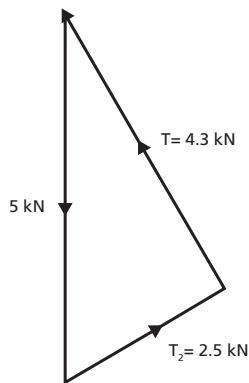
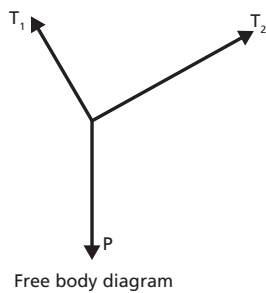
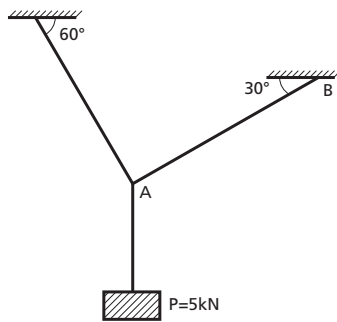

The allowable stress in the rope is

$$\frac{30}{4} = 7.5 \text{ N/mm}^2 = 7.5 \text{ MPa}$$

$$\text{Stress} = \frac{\text{Force}}{\text{Area}}$$

Therefore:

$$\text{Area required} = \frac{4.3 \times 10^3}{7.5} = 573 \text{ mm}^2$$

$$A = \pi r^2 = \frac{\pi d^2}{4}$$

Thus:

$$d = \sqrt{\frac{4 \times 573}{\pi}} = 27 \text{ mm (min)}$$

At support B, the reaction is composed of two components:

$$B_v = T_2 \sin 30^\circ = 2.5 \sin 30^\circ = 1.25 \text{ kN}$$

$$B_H = T_2 \cos 30^\circ = 2.5 \cos 30^\circ = 2.17 \text{ kN}$$

Short columns

A column which is short (i.e. the height is small compared with the cross-section area) is likely to fail because of crushing of the material.

Note, however, that slender columns, which are tall compared with the cross-section area, are more likely to fail from buckling under a load much smaller than that needed to cause failure from crushing. Buckling is dealt with later.

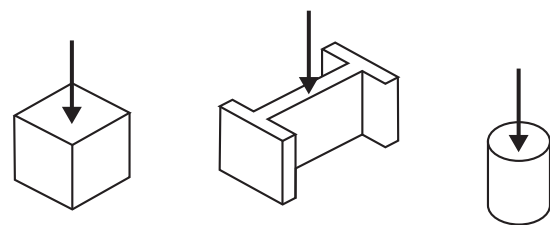

Short columns



Slender columns

Example 7.2

A square concrete column, which is 0.5 m high, is made of a nominal concrete mix of 1:2:4, with a permissible direct compression stress of 5.3 MPa (N / mm²). What is the required cross-section area if the column is required to carry an axial load of 300 kN?

$$A = \frac{F}{\sigma} = \frac{300\,000 \text{ N}}{5.3 \text{ N/mm}^2} = 56\,604 \text{ mm}^2$$

i.e. the column should be minimum 238 mm square.

DESIGN OF SIMPLE BEAMS

Bending stresses

When a sponge is put across two supports and gently pressed downwards between the supports, the pores at the top will close, indicating compression, and the pores at the bottom will open wider, indicating tension. Similarly, a beam of any elastic material, such as wood or steel, will produce a change in shape when external loads are acting on it.

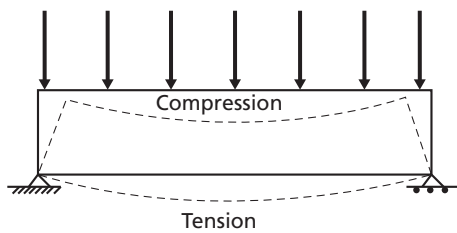
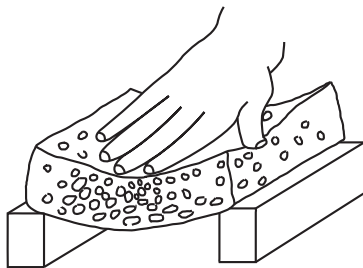

Figure 7.1 Bending effects on beams

The stresses will vary from maximum compression at the top to maximum tension at the bottom. Where the stress changes from compressive to tensile, there will be one layer that remains unstressed and this is called the neutral layer or the neutral axis (NA).

This is why beams with an I-section are so effective. The main part of the material is concentrated in the flanges, away from the neutral axis. Hence, the maximum stresses occur where there is maximum material to resist them.

If the material is assumed to be elastic, then the stress distribution can be represented by two triangular shapes with the line of action of the resultant force of each triangle of stress at its centroid.

The couple produced by the compression and tension triangles of stress is the internal-reaction couple of the beam section.

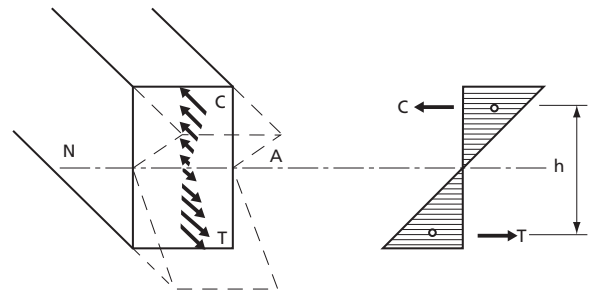

The moment caused by the external loads acting on the beam will be resisted by the moment of this internal couple. Therefore:

$$M = M_R = C \text{ (or } T) \times h$$

where:

M = the external moment

M_R = the internal resisting moment

C = resultant of all compressive forces on the cross-section of the beam

T = resultant of all tensile forces on the cross-section of the beam

h = lever arm of the reaction couple

Now consider a small element with the area (R) at a distance (a) from the neutral axis (NA).

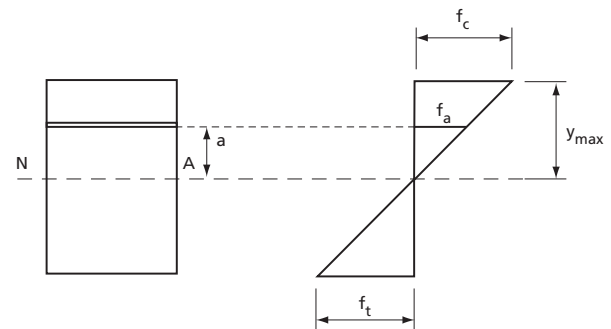

Note that it is common practice to use the symbol f for bending stress, rather than the more general symbol. Maximum compressive stress (f_c) is assumed to occur in this case at the top of the beam. Therefore, by similar triangles, the stress in the chosen element is:

$$\frac{f_a}{a} = \frac{f_c}{y_{max}}, \quad f_a = a \times \frac{f_c}{y_{max}}$$

As force = stress \times area, then the force on the element = $f_a \times R = a \times (f_c / y_{max}) \times R$

The resisting moment of the small element is:
force \times distance (a) = $a \times (f_c / y_{max}) \times R \times a = Ra^2 \times (f_c / y_{max})$

The total resisting moment of all such small elements in the cross-section is:

$$M_R = \Sigma Ra^2 \times (f_c / y_{max})$$

But $\Sigma Ra^2 = I$, the moment of inertia about the neutral axis, and therefore

$$M_R = I \times (f_c / y_{max})$$

As the section modulus $Z_c = I / y_{max}$, therefore

$$M_R = f_c \times Z_c = M;$$

Similarly

$$M_R = f_t \times Z_t = M$$

The maximum compressive stress (f_c) will occur in the cross-section area of the beam where the bending moment (M) is greatest. A size and shape of cross-section, i.e. its section modulus (Z), must be selected so that the f_c does not exceed an allowable value. Allowable working stress values can be found in building codes or engineering handbooks.

As the following diagrams show, the concept of a ‘resisting’ couple can be seen in many structural members and systems.



Rectangular beams

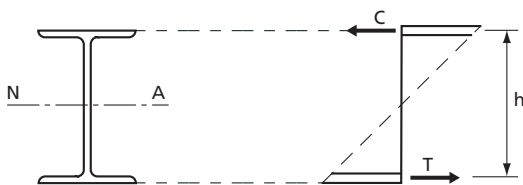

Girders and I-beams (1/6 web area can be added to each flange area for moment resistance)

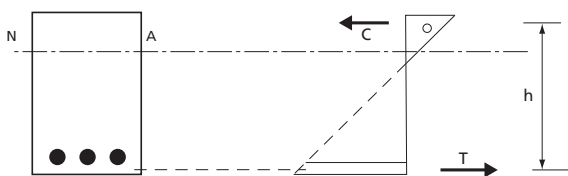

Rectangular reinforced-concrete beams (note that the steel bars are assumed to carry all the tensile forces).

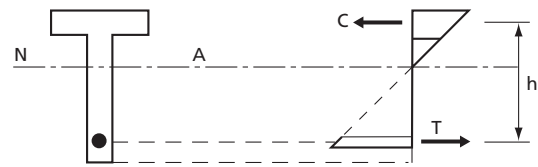

Reinforced-concrete T-beams

In summary the following equation is used to test for safe bending:

$$f_w \geq f = M_{max} / Z$$

where:

f_w = allowable bending stress

f = actual bending stress

M_{max} = maximum bending moment

Z = section modulus

Horizontal shear

The horizontal shear force (Q) at a given cross-section in a beam induces a shearing stress that acts tangentially to the horizontal cross-sectional plane. The average value of this shear stress is:

$$\tau = \frac{Q}{A}$$

where A is the transverse cross-sectional area.

This average value is used when designing rivets, bolts and welded joints.

The existence of such a horizontal stress can be illustrated by bending a paper pad. The papers will slide relative to each other, but in a beam this is prevented by the developed shear stress.

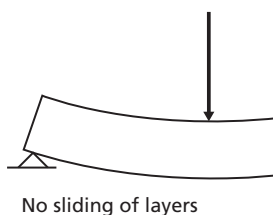
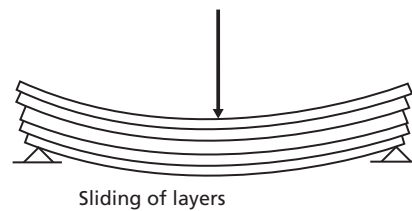

Figure 7.2 Shearing effects on beams

However, the shear stresses are not equal across the cross-section. At the top and bottom edge of the beam they must be zero, because no horizontal shear stresses can develop.

If the shear stresses at a certain distance from the neutral axis are considered, their value can be determined according to the following formula:

$$\tau = \frac{Q \times \Delta A \times \bar{y}}{I \times b}$$

where:

τ = shear stress

Q = shear force

ΔA = area for the part of the section being sheared off

\bar{y} = perpendicular distance from the centroid of ΔA to the neutral axis

I = moment of inertia for the entire cross-section

b = width of the section at the place where shear stress is being calculated.

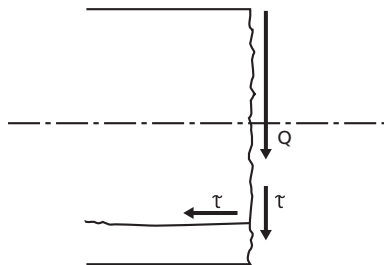
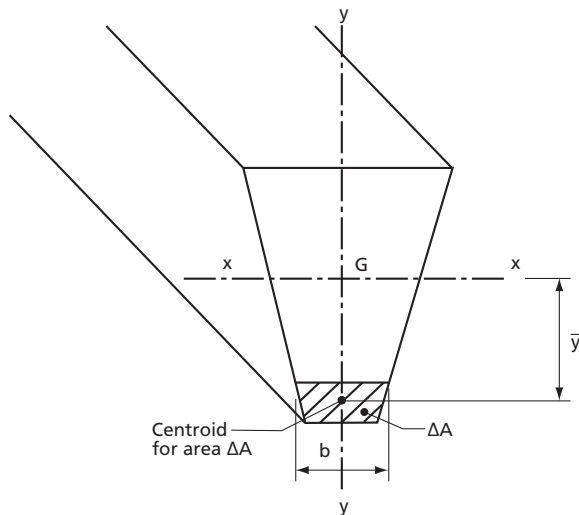

Maximum horizontal shear force in beams

It can be shown that the maximum shear stress τ_{max} in a beam will occur at the neutral axis. Thus, the following relations for the maximum shear stress in beams of different shapes can be deduced, assuming the maximum shear force (Q) to be the end reaction at a beam support (column).

$$\text{For rectangular sections } \tau_{max} = \frac{3Q}{2bd} = \frac{3Q}{2A} = 1.5 \frac{Q}{A}$$

$$\text{For square sections } \tau_{max} = \frac{3Q}{2a^2} = 1.5 \frac{Q}{A}$$

$$\text{For circular sections } \tau_{max} = \frac{16Q}{3\pi D^2} = \frac{4Q}{3A}$$

For I-shaped sections of steel beams, a convenient approximation is to assume that all shearing resistance is afforded by the web plus the part of the flanges that forms a continuation of the web.

Thus:

$$\text{For I-sections } \tau_{max} \approx \frac{Q}{d \times t}$$

where:

d = depth of beam

t = thickness of web

If timber and steel beams with spans normally used in buildings are made large enough to resist the tensile and compressive stresses caused by bending, they are usually strong enough to resist the horizontal shear stresses also. However, the size or strength of short, heavily loaded timber beams may be limited by these stresses.

Deflection of beams

Excessive deflections are unacceptable in building construction, as they can cause cracking of plaster in ceilings and can result in jamming of doors and windows. Most building codes limit the amount of allowable deflection as a proportion of the member's length, i.e. $1/180$, $1/240$ or $1/360$ of the length.

For standard cases of loading, the deflection formulae can be expressed as:

$$\delta_{max} = K_c \times \frac{WL^3}{EI}$$

where:

δ_{max} = maximum deflection (mm)

K_c = constant depending on the type of loading and the end support conditions

W = total load (N)

L = effective span (mm)

E = modulus of elasticity (N/mm²)

I = moment of inertia (mm⁴)

It can be seen that deflection is greatly influenced by the span L , and that the best resistance is provided by beams which have the most depth (d), resulting in a large moment of inertia.

Note that the effective span is greater than the clear span. It is convenient to use the centre to centre distance of the supports as an approximation of the effective span.

Some standard cases of loading and resulting deflection for beams can be found later in this section.

Design criteria

The design of beams is dependent upon the following factors:

1. Magnitude and type of loading
2. Duration of loading
3. Clear span
4. Material of the beam
5. Shape of the beam cross-section

Beams are designed using the following formulae:

1. Bending stress

$$f_w \geq f = \frac{M_{max}}{Z}$$

where:

f_w = allowable bending stress

f = actual bending stress

M_{max} = maximum bending moment

Z = section modulus

This relationship derives from simple beam theory and

$$\frac{M_{max}}{I_{NA}} = \frac{f_{max}}{y_{max}}$$

and

$$\frac{I_{NA}}{y_{max}} = Z$$

The maximum bending stress will be found in the section of the beam where the maximum bending moment occurs. The maximum moment can be obtained from the bending-moment diagram.

2. Shear stress

For rectangular cross-sections:

$$\tau_w \geq \tau = \frac{3 \times Q_{max}}{2 \times A} = \frac{3Q_{max}}{2bd}$$

For circular cross-sections:

$$\tau_w \geq \tau = \frac{4 \times Q_{max}}{3 \times A} = \frac{16Q_{max}}{3\pi d^2}$$

For I-shaped cross-sections of steel beams

$$\tau_w \geq \tau = \frac{Q_{max}}{A}$$

where:

τ_w = allowable shear stress

τ = actual shear stress

Q_{max} = maximum shear force

A = cross-section area

Like allowable bending stress, allowable shear stress varies for different materials and can be obtained from a building code. Maximum shear force is obtained from the shear-force diagram.

3. Deflection

In addition, limitations are sometimes placed on maximum deflection of the beam (δ_{max}):

$$\delta_{max} = K_c \times \frac{WL^3}{EI}$$

Example 7.3

Consider a floor where beams are spaced at 1 200 mm and have a span of 4 000 mm. The beams are seasoned cypress with the following properties:

$f_w = 8.0 \text{ N/mm}^2$, $\tau_w = 0.7 \text{ MPa (N/mm}^2)$, $E = 8.400 \text{ MPa (N/mm}^2)$, density 500 kg/m^3

Loading on floor and including floor is 2.5 kPa.

Allowable deflection is $L/240$

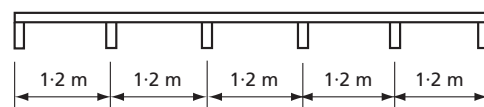
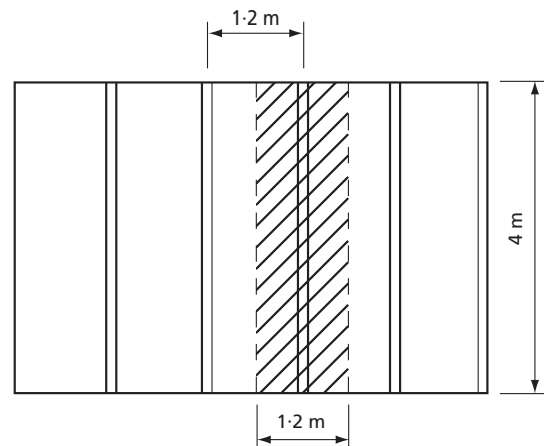

(i) Beam loading: $w = 1.2 \text{ m} \times 2.5 \text{ kN/m}^2 = 3 \text{ kN/m}$

Assume a 100 mm by 250 mm cross-section for the beams.

(ii) Beam mass = $0.1 \times 0.25 \times 500 \times 9.81 = 122.6 \text{ N/m}$
= 0.12 kN/m

Total $w = 3 + 0.12 = 3.12 \text{ kN/m}$

(iii) Calculate reactions and draw shear-force and bending-moment diagrams

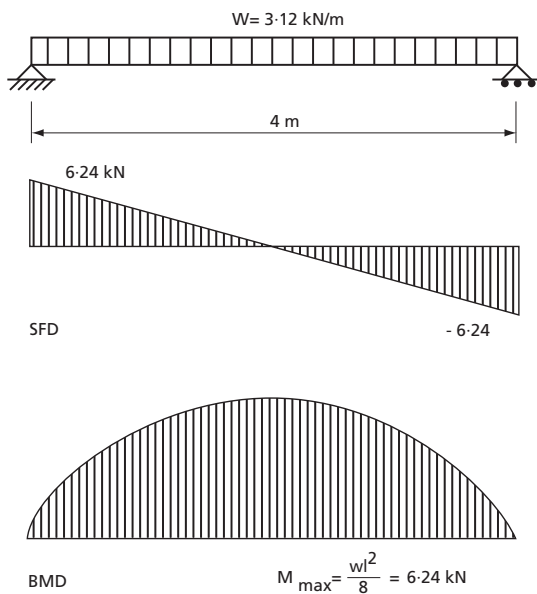

iii) Calculate maximum bending moment (M_{max}) using the equation for a simple beam, uniformly loaded (see Table 7.1)

$$M_{max} = \frac{wL^2}{8} = \frac{3.12 \times 4^2}{8} = 6.24 \text{ kNm} = 6.24 \times 10^6 \text{ Nmm}$$

iv) Find the required section modulus (Z)

$$Z_{req} = \frac{M_{max}}{f_w} = \frac{6.24 \times 10^6}{8} = 0.78 \times 10^6 \text{ mm}^3$$

v) Find a suitable beam depth, assuming 100 mm breadths:

From Table 6.3, the section modulus for a rectangular shape is $Z = \frac{1}{6} \times bd^2$

$$\therefore d = \sqrt{\frac{6Z}{b}} = \sqrt{\frac{6 \times 0.78 \times 10^6}{100}} = 216 \text{ mm}$$

Choose a 100 mm by 225 mm timber. The timber required is a little less than that assumed. No recalculations are required unless it is estimated that a smaller size timber would be adequate if a smaller size had been assumed initially.

vi) Check for shear loading:

$$\tau = \frac{3Q_{max}}{2A} = \frac{3 \times 6.24 \times 10^3}{2 \times 100 \times 225} = 0.42 \text{ MPa}$$

As the safe load for the timber is 0.7 N/mm² (MPa) the section is adequate in resistance to horizontal shear.

vii) Check deflection to ensure that it is less than $1/240$ of the span (from Table 7.1)

$$\delta_{max} = \frac{-5}{384} \times \frac{WL^3}{EI}$$

where:

$$E = 8\,400 \text{ MPa (N/mm}^2\text{)}$$

$$I = \frac{bd^3}{12} = \frac{100 \times 225^3}{12} = 95 \times 10^6 \text{ mm}^4$$

$$W = 3.12 \text{ kN/m} \times 4 \text{ m} = 12.48 \text{ kN} = 12.48 \times 10^3 \text{ N}$$

$$L = 4 \times 10^3 \text{ mm}$$

$$\delta_{max} = \frac{-5}{384} \times \frac{12.48 \times 10^3 \times 4^3 \times 10^9}{8400 \times 95 \times 10^6} = -13 \text{ mm}$$

The allowable deflection, $400/240 = 16.7 > 13$. The beam is therefore satisfactory.

Bending moments caused by askew loads

If the beam is loaded so that the resulting bending moment is not about one of the main axes, the moment has to be resolved into components acting about the main axes. The stresses are then calculated separately relative to each axis and the total stress is found by adding the stresses caused by the components of the moment.

Example 7.4

Design a timber purlin that will span rafters 2.4 m on centre. The angle of the roof slope is 30° and the purlin will support a vertical dead load of 250 N/m and a wind load of 200 N/m acting normal to the roof. The allowable bending stress (f_w) for the timber used is 8 MPa. The timber density is 600 kg/m³.

1. Assume a purlin cross-section size of 50 mm × 125 mm. Find an estimated self-load.

$$W = 0.05 \times 0.125 \times 600 \times 9.81 = 37 \text{ N/m}$$

The total dead load becomes $250 + 37 = 287 \text{ N/m}$

2. Find the components of the loads relative to the main axes.

$$W_x = 200 \text{ N/m} + 287 \text{ N/m} \times \cos 30^\circ = 448.5 \text{ N/m}$$

$$W_y = 287 \text{ N/m} \times \sin 30^\circ = 143.5 \text{ N/m}$$

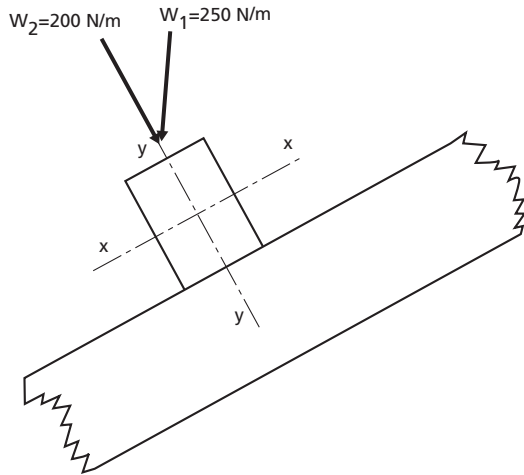

3. Calculate the bending moments about each axis for a uniformly distributed load. The purlin is assumed to be a simple beam.

$$M_{max} = \frac{WL}{8} = \frac{\omega L^2}{8}$$

$$M_{max x} = \frac{\omega_x \times L^2}{8} = \frac{448.5 \times 2.4^2}{8} = 323 \times 10^3 \text{ Nmm}$$

$$M_{max y} = \frac{\omega_y \times L^2}{8} = \frac{143.5 \times 2.4^2}{8} = 103 \times 10^3 \text{ Nmm}$$

4. The actual stress in the timber must be no greater than the allowable stress.

$$f = \frac{M_{max x}}{Z_x} + \frac{M_{max y}}{Z_y} \leq f_w$$

5. Try the assumed purlin size of 50 × 125 mm.

$$Z_x = \frac{bd^2}{6} = \frac{50 \times 125^2}{6} = 130 \times 10^3 \text{ mm}^3$$

$$Z_y = \frac{bd^2}{6} = \frac{125 \times 50^2}{6} = 52 \times 10^3 \text{ mm}^3$$

$$f = \frac{323 \times 10^3}{130 \times 10^3} + \frac{103 \times 10^3}{52 \times 10^3} = 2.5 + 2 = 4.5 \text{ N/mm}^2 = 4.5 \text{ MPa}$$

This size is safe, but a smaller size may be satisfactory. Try 50 mm × 100 mm.

$$Z_x = \frac{bd^2}{6} = \frac{50 \times 100^2}{6} = 83 \times 10^3 \text{ mm}^3$$

$$Z_y = \frac{bd^2}{6} = \frac{100 \times 50^2}{6} = 42 \times 10^3 \text{ mm}^3$$

$$f = \frac{323 \times 10^3}{83 \times 10^3} + \frac{103 \times 10^3}{42 \times 10^3} = 3.9 + 2.5 = 6.4 \text{ N/mm}^2 = 6.4 \text{ MPa}$$

This is much closer to the allowable stress. To save money, 50 mm × 75 mm should also be tried. In this case $f > f_w$ and therefore 50 mm × 100 mm is chosen.

Universal steel beams

Steel beams of various cross-sectional shapes are commercially available. Even though the properties of their cross-sections can be calculated with the formulae given in the section 'Design of members in direct tension and compression', it is easier to obtain them from handbook tables. These tables will also take into consideration the effect of rounded edges, welds, etc.

Sections of steel beams are indicated with a combination of letters and a number, where the letters represent the shape of the section and the number represents the dimension, usually the height, of the section in millimetres, e.g. IPE 100. In the case of HE sections, the number is followed by a letter indicating the thickness of the web and flanges, e.g. HE 180B.

An example of an alternative method of notation is 305 × 102 UB 25, i.e. a 305 mm by 102 mm universal beam weighing 25 kg/m.

The following example demonstrates another method of taking into account the self-weight of the structural member being designed.

Example 7.5

Design a steel beam, to be used as a lintel over a door opening, which is required to span 4.0 m between centres of simple supports. The beam will be carrying a 220 mm thick and 2.2 m high brick wall, weighing 20 kN/m³. Allowable bending stress is 165 MPa.

Uniformly distributed load caused by brickwork is $0.22 \times 2.2 \times 4.0 \times 20 = 38.7 \text{ kN}$.

Assumed self-weight for the beam is 1.5 kN.

(Note: the triangular load distribution for bricks above the lintel would result in a slightly lower load value).

Total uniformly distributed load $W = 38.7 + 1.5 = 40.2 \text{ kN}$

$$M_{max} = \frac{WL}{8} = \frac{40.2 \times 4.0}{8} = 20.1 \text{ kNm} = 20.1 \times 10^6 \text{ Nmm}$$

$$Z_{req} = \frac{20.1 \times 10^6}{165} = 0.122 \times 10^6 \text{ mm}^3 = 122 \text{ cm}^3$$

Suitable sections as found in a handbook would be:

Section	Z _{x-x}	Mass
INP 160	117 cm ³	17.9 kg/m
IPE 180	146 cm ³	18.8 kg/m
HE 140A	155 cm ³	24.7 kg/m
HE 120A	144 cm ³	26.7 kg/m

Choose INP 160 because it is closest to the required section modulus and has the lowest weight. Then recalculate the required Z using the INP 160 weight: $4.0 \times 17.9 \times 9.81 = 702 \text{ N}$, which is less than the assumed self-weight of 1.5 kN. A recheck on the required Z reveals a value of 119 cm³, which is close enough.

Continuous beams

A single continuous beam extending over a number of supports will safely carry a greater load than a series of simple beams extending from support to support. Consider the shear force and bending moment diagrams for the following two beam loadings:

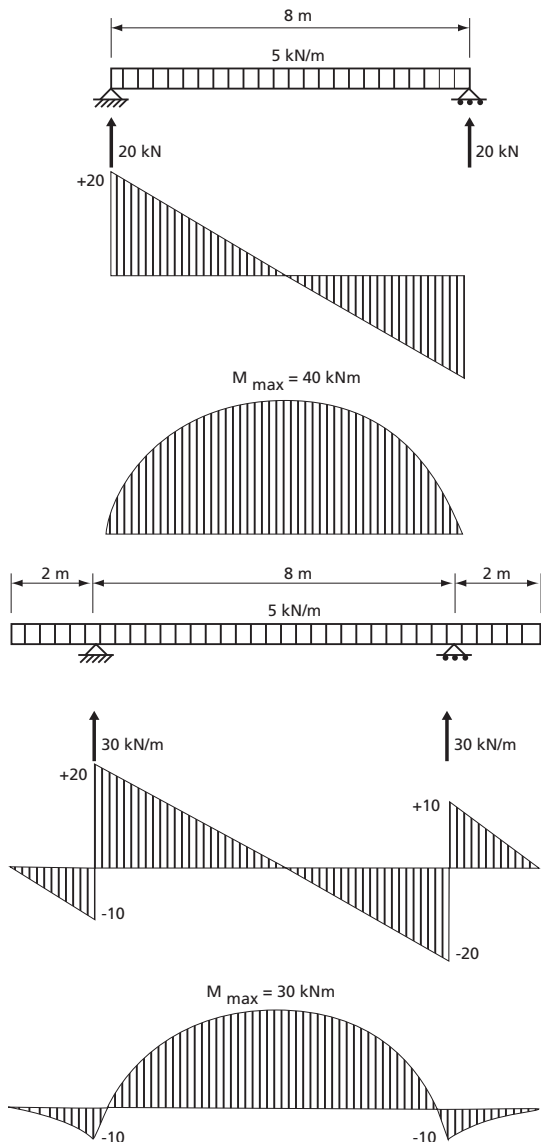

Although the total value of the load has increased, the maximum shear force remains the same but the maximum bending is reduced when the beam is cantilevered over the supports.

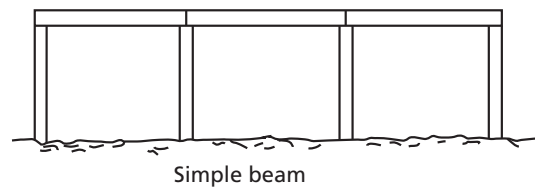
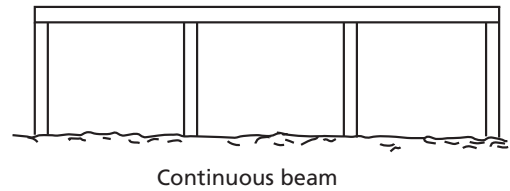

Although continuous beams are statically indeterminate and the calculations are complex, approximate values can be found with simplified equations. Conservative equations for two situations are as follows:

Load concentrated between supports: $BM = \frac{WL}{6}$

Load uniformly distributed: $BM = \frac{WL}{12}$

It is best to treat the two end sections as simple beams.

STANDARD CASES OF BEAM LOADING

A number of beam loading cases occur frequently and it is useful to have standard expressions available for them. Several of these cases will be found in Table 7.1.

COMPOSITE BEAMS

In small-scale buildings the spans are relatively small and, with normal loading, solid rectangular or square sections are generally the most economical beams. However, where members larger than the available sizes and/or length of solid timber are required, one of the following combinations may be chosen:

1. Arranging several pieces of timber or steel into a structural frame or truss.
2. Universal steel beams.
3. Built-up timber sections with the beam members nailed, glued or bolted together into a solid section, or with the beam members spaced apart and only connected at intervals.
4. Strengthening the solid timber section by the addition of steel plates to form a 'flitch-beam'.
5. Plywood web beams with one or several webs.
6. Reinforced-concrete beams.

TABLE 7.1
Beam equations

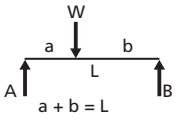
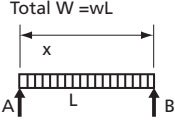
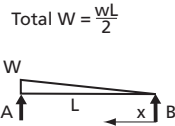
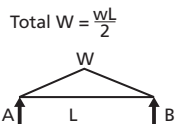
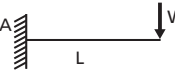
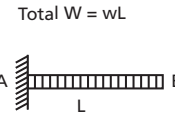
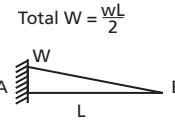
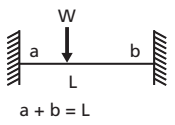
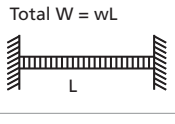
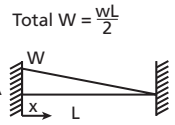
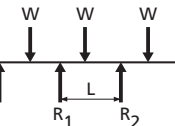
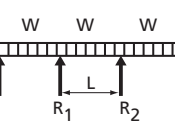
Loading diagram	Shear force at x : Q_x	Bending moment at x : M_x	Deflection at x : δ_x
	$Q_A = \frac{Wb}{L}$ $Q_B = -\frac{Wa}{L}$	$M_c = \frac{Wab}{L}$ <p>When $a = b$</p> $M_c = \frac{WL}{4}$	$\delta_c = \frac{Wa^2b^2}{3EI}$
	$Q_A = \frac{W}{2}$ $Q_B = -\frac{W}{2}$	$M_{max} = \frac{WL}{8}$ <p>at $x = \frac{L}{2}$</p>	$\delta_{max} = \frac{5WL^3}{384EI}$ <p>at $x = \frac{L}{2}$</p>
	$Q_A = \frac{2W}{3} = \frac{wL}{3}$ $Q_B = -\frac{W}{3} = -\frac{wL}{6}$	$M_{max} = 0.064mL^2$ <p>at $x = 0.577L$</p>	$\delta_{max} = 0.00652 \frac{wL^4}{EI}$ <p>at $x = 0.519$</p>
	$Q_A = \frac{W}{2} = \frac{wL}{4}$ $Q_B = -\frac{W}{2} = -\frac{wL}{4}$	$M_{max} = \frac{wL^2}{12}$ <p>at $x = \frac{L}{2}$</p>	$\delta_{max} = \frac{wL^4}{120EI}$ <p>at $x = \frac{L}{2}$</p>
	$Q_A = Q_B = W$	$M_A = -WL$	$\delta_B = \frac{WL^3}{3EI}$
	$Q_A = W$ $Q_A = 0$	$M_A = -\frac{WL}{2} = -\frac{wL^2}{2}$	$\delta_B = \frac{WL^3}{3EI} = \frac{wL^4}{3EI}$
	$Q_A = W$ $Q_A = 0$	$M_A = -\frac{WL}{3} = -\frac{wL^2}{6}$	$\delta_B = \frac{wL^4}{30EI}$
	$Q_A = \frac{Wb}{L}$ $Q_B = -\frac{Wa}{L}$	$M_A = -\frac{Wab^2}{L^2}$ $M_B = -\frac{Wa^2b}{L^2}$	$\delta_c = \frac{Wa^2b^3}{3EI}$
	$Q_A = \frac{W}{2}$ $Q_B = -\frac{W}{2}$	$M_A = M_B = -\frac{WL}{12}$	$\delta_c = \frac{WL^3}{384EI}$
	$Q_A = \frac{2W}{3}$ $Q_B = -\frac{W}{3}$	$M_A = -\frac{WL}{10} = -\frac{wL^2}{20}$ $M_B = -\frac{WL}{15} = -\frac{wL^2}{30}$	$\delta_{max} = \frac{wL^4}{764EI}$ <p>at $x = 0.475L$</p>
	$Q_A = \frac{W}{2}$	$M_{max} = \frac{WL}{6}$	$\delta_{max} = \frac{wL^3}{192EI}$
	$Q_A = \frac{W}{2}$	$M_{max} = \frac{WL}{12}$	$\delta_{max} = \frac{wL^3}{384EI}$

Built-up timber beams

When designing large members, there are advantages in building up solid sections from smaller pieces because these are less expensive and easier to obtain. Smaller pieces also season properly without checking. The composite beams may be built up in ways that minimize warping and permit rigid connections between columns and beams. At the same time the importance of timber defects is decreased, because the load is distributed to several pieces, not all with defects in the same area.

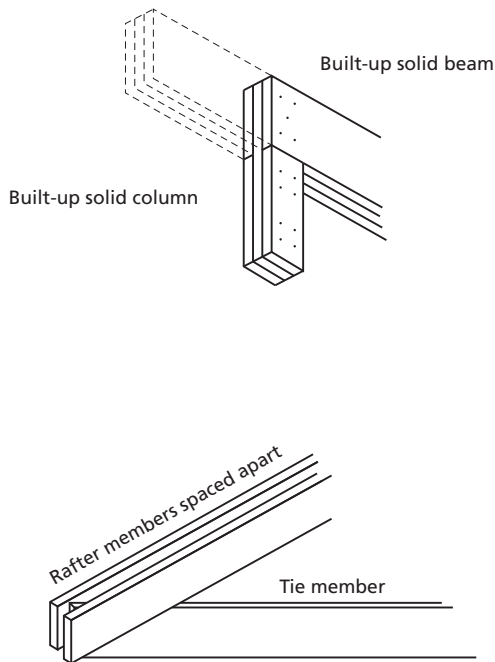

Figure 7.3 Built-up beams and trusses

Built-up solid beams are normally formed by using vertical pieces nailed or bolted together: Nailing is satisfactory for beams up to about 250 mm in depth, although these may require the use of bolts at the ends if the shear stresses are high. Simply multiplying the strength of one beam by the number of beams is satisfactory, provided that the staggered joints occur over supports.

Built-up sections with the members spaced apart are used mainly where the forces are tensile, such as in the bottom chords of a truss. Where used in beams designed to resist bending, buckling of the individual members may have to be considered if those members have a large depth-to-width ratio. However, this can be avoided by appropriate spacing of stiffeners that connect the spaced members at intervals.

Where the loading is heavy, the beam will require considerable depth, resulting in a large section modulus to keep the stresses within the allowable limit. If sufficient depth cannot be obtained in one member, it may be achieved by combining several members, such as gluing the members together to form a laminate.

COLUMNS

Although the column is essentially a compression member, the manner in which it tends to fail and the amount of load that causes failure depend on:

1. The material of which the column is made.
2. The shape of cross-section of the column.
3. The end conditions of the column.

The first point is obvious: a steel column can carry a greater load than a timber column of similar size.

Columns with a large cross-section area compared with the height are likely to fail by crushing. These 'short columns' have been discussed earlier.

Buckling of slender columns

If a long, thin, flexible rod is loaded axially in compression, it will deflect a noticeable amount. This phenomenon is called buckling and occurs when the stresses in the rod are still well below those required to cause a compression/shearing-type failure. Buckling is dangerous because it is sudden and, once started, is progressive.

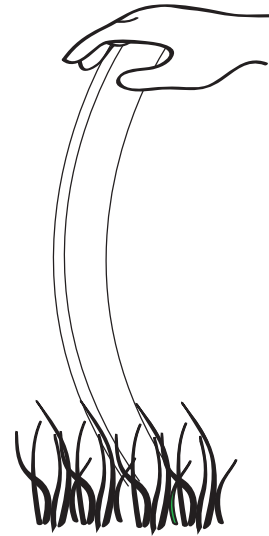

Although the buckling of a column can be compared with the bending of a beam, there is an important difference in that the designer can choose the axis about which a beam bends, but normally the column will take the line of least resistance and buckle in the direction where the column has the *least lateral unsupported dimension*.

As the loads on columns are never perfectly axial and the columns are not perfectly straight, there will always be small bending moments induced in the column when it is compressed.

There may be parts of the cross-section area where the sum of the compressive stresses caused by the load on the column could reach values larger than the allowable or even the ultimate strength of the material.

Therefore the *allowable compressive strength* δ_{cw} is reduced by a factor k_λ , which depends on the slenderness ratio and the material used.

$$P_{bw} = k_\lambda \times \delta_{cw} \times A$$

where:

P_{bw} = allowable load with respect to buckling

k_λ = reduction factor, which depends on the slenderness ratio

δ_{cw} = allowable compressive stress

A = cross-section area of the column

When the load on a column is not axial but eccentric, a bending stress is induced in the column as well as a direct compressive stress. This bending stress will need to be considered when designing the column with respect to buckling.

Slenderness ratio

As stated earlier, the relationship between the length of the column, its lateral dimensions and the end fixity conditions will strongly affect the column’s resistance to buckling. An expression called the slenderness ratio has been developed to describe this relationship:

$$\lambda = \frac{KL}{r} = \frac{l}{r}$$

where:

λ = slenderness ratio

K = effective length factor whose value depends on how the ends of the column are fixed

L = length of the column

r = radius of gyration ($r = I / A$)

l = effective length of the column ($K \times L$)

There are four types of end condition for a column or strut:

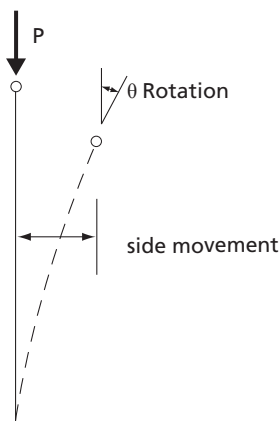

1. Total freedom of rotation and side movement – like the top of a flagpole. This is the weakest end condition.

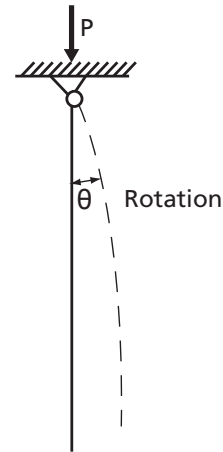

2. Fixed in position but not in direction (pinned).

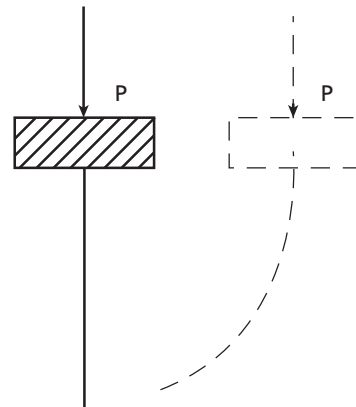

3. Fixed in direction but not in position.

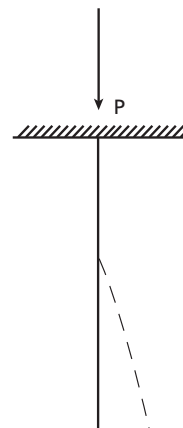

4. Fixed in position and in direction.

The consideration of the two end conditions together results in the following theoretical values for the effective length factor (K_p is the factor usually used in practice).

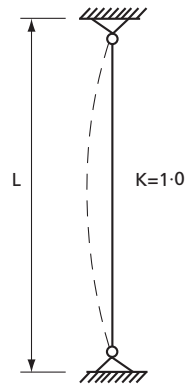

Both ends pinned

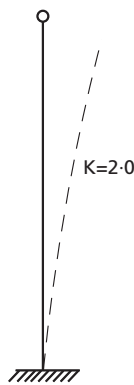

One end fixed in direction and position, the other free

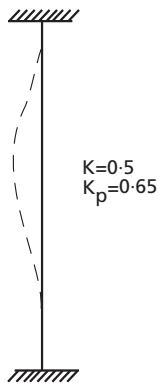

Both ends fixed in direction and position

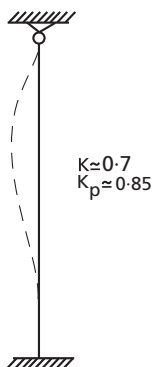

One end pinned, the other fixed in direction and position

Columns and struts with both ends fixed in position and effectively restrained in direction would theoretically have an effective length of half the actual length. However, in practice this type of end condition is almost never perfect and therefore somewhat higher values for K are used and can be found in building codes. In fact, in order to avoid unpleasant surprises, the ends are often considered to be pinned ($K_p = 1.0$) even when, in reality, the ends are restrained or partially restrained in direction.

The effective length can differ with respect to the different cross-sectional axes:

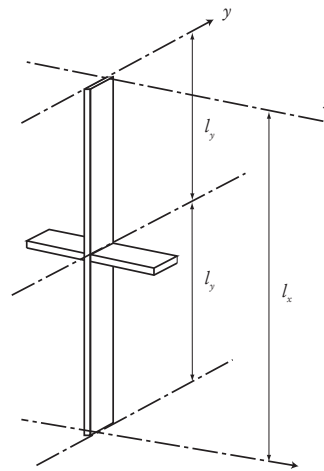

1. A timber strut that is restrained at the centre has only half the effective length when buckling about the y - y axis as when buckling about the x - x axis. Such a strut can therefore have a thickness of less than its width.

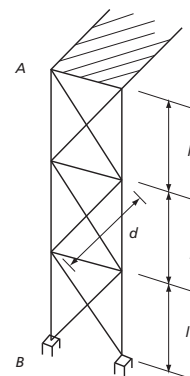

2. In the structural framework, the braces will reduce the effective length to l when the column A - B is buckling sideways but, as there is no bracing restricting buckling forwards and backwards, the effective length for buckling in these directions is $3l$. Similarly, the bracing struts have effective lengths of $1/2 d$ and d respectively.

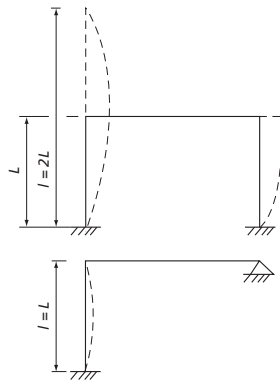

- The leg of a frame, which is pinned to the foundation, has the effective length $l = 2 L$ but, if the top is effectively secured for sideways movement, the effective length is reduced to $l = L$.

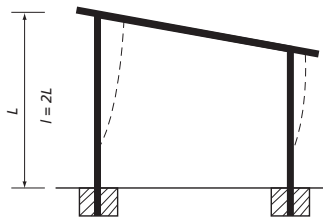

- In a system of post and lintel where the bottom of the post is effectively held in position and secured in direction by being cast in concrete, the effective length $l = 2 L$.

Axially loaded timber columns

Timber columns are designed with the following formulae:

$$\lambda = \frac{KL}{r} \text{ and } P_{bw} = k_{\lambda} \times \delta_{cw} \times A$$

Note that in some building codes a value of slenderness ratio in the case of sawn timber is taken as the ratio between the effective length and the least lateral width of the column l/b .

Example 7.6

Design a timber column that is 3 metres long, supported as shown in the figure and loaded with a compressive

load of 15 kN. Allowable compressive stress (σ_{cw}) for the timber is 5.2 MPa.

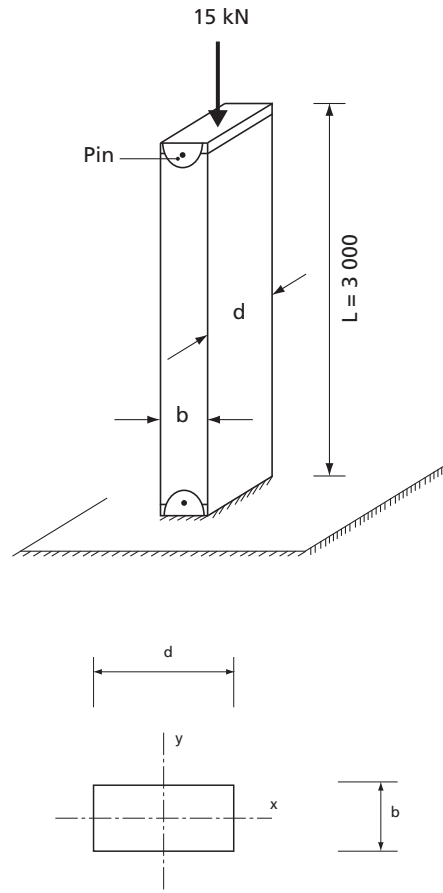

- In this case, the end conditions for buckling about the x - x axis are not the same as about the y - y axis. Therefore both directions must be designed for buckling (Where the end conditions are the same, it is sufficient to check for buckling in the direction that has the least radius of gyration).

Find the effective length for buckling about both axes. Buckling about the x - x axis, both ends pinned:

$$l_x = 1.0 \times 3\,000 = 3\,000 \text{ mm}$$

Buckling about the y - y axis, both ends fixed:

$$l_y = 0.65 \times 3\,000 = 1\,950 \text{ mm}$$

TABLE 7.2

Reduction factor (k_{λ}) for stresses with respect to the slenderness ratio for wood columns

Slenderness ratio	l/b	2.9	5.8	8.7	11.5	14.4	17.3	20.2	23.0	26.0	28.8	34.6	40.6	46.2	52.0
	l/r	10	20	30	40	50	60	70	80	90	100	120	140	160	180
	k_{λ}	1.0	1.00	0.91	0.81	0.72	0.63	0.53	0.44	0.35	0.28	0.20	0.14	0.11	0.40

b = least dimension of cross-section; r = radius of gyration

2. Choose a trial cross-section, which should have its largest lateral dimension resisting the buckling about the axis with the largest effective length. Try 50 mm × 125 mm. The section properties are:

$$A = b \times d = 50 \times 125 = 6\,250 \text{ mm}^2$$

$$r_x = \frac{d}{2\sqrt{3}} = \frac{125}{2\sqrt{3}} = 36.1 \text{ mm}$$

$$r_y = \frac{b}{2\sqrt{3}} = \frac{50}{2\sqrt{3}} = 14.4 \text{ mm}$$

3. Find the allowable load with regard to buckling on the column for buckling in both directions.

$$\lambda_x = \frac{l_x}{r_x} = \frac{3\,000}{36.1} = 83 \text{ gives } k_{\lambda x} = 0.41 \text{ (from Table 7.2)}$$

$$\lambda_y = \frac{l_y}{r_y} = \frac{1\,950}{14.4} = 135 \text{ gives } k_{\lambda y} = 0.16 \text{ (from Table 7.2)}$$

$$P_w = k_{\lambda} \times \sigma_c \times A$$

$$P_{wx} = 0.41 \times 5.2 \times 6\,250 \text{ mm}^2 = 13\,325 \text{ N}$$

$$P_{wy} = 0.16 \times 5.2 \times 6\,250 \text{ mm}^2 = 5\,200 \text{ N}$$

4. As the allowable load with respect to buckling is smaller than the actual load, a bigger cross-section needs to be chosen. Try 75 mm × 125 mm and repeat steps 2 and 3.

Section properties:

$$A = 75 \times 125 = 9\,375 \text{ mm}^2$$

$$r_x = \frac{125}{2\sqrt{3}} = 36.1 \text{ mm}$$

$$r_y = \frac{75}{2\sqrt{3}} = 21.7 \text{ mm}$$

Find the allowable buckling load for the new cross-section:

$$\lambda_x = \frac{l_x}{r_x} = \frac{3\,000}{36.1} = 83 \text{ gives } k_{\lambda x} = 0.41$$

$$\lambda_y = \frac{l_y}{r_y} = \frac{1\,950}{21.7} = 90 \text{ gives } k_{\lambda y} = 0.16$$

$$P_{wx} = 0.41 \times 5.2 \times 9\,375 = 19\,988 \text{ N, say } 20 \text{ kN}$$

$$P_{wy} = 0.35 \times 5.2 \times 9\,375 = 17\,063 \text{ N, say } 17 \text{ kN}$$

The allowable load with respect to buckling on the column with cross-section 75 mm × 125 mm is therefore 17 kN. Although this is bigger than the actual load, further iterations to find the precise section to carry the 15 kN are not necessary.

The compressive stress in the chosen cross-section will be:

$$\sigma_c = \frac{F}{A} = \frac{15\,000}{9\,375} = 1.6 \text{ MPa}$$

This is much less than the allowable compressive stress, which makes no allowance for slenderness.

Axially loaded steel columns

The allowable loads for steel columns with respect to buckling can be calculated in the same manner as for timber. However, the relation between the slenderness ratio and the reduction factor (k_{λ}) is slightly different, as seen in Table 7.3.

Example 7.7

Calculate the safe load on a hollow square steel stanchion whose external dimensions are 120 mm × 120 mm. The walls of the column are 6 mm thick and the allowable compressive stress $\sigma_{cw} = 150 \text{ MPa}$. The column is 4 metres high and both ends are held effectively in position, but one end is also restrained in direction.

The effective length of the column $l = 0.85L = 0.85 \times 4\,000 = 3\,400 \text{ mm}$.

$$r_x = r_y = \sqrt{\frac{I}{A}} = \sqrt{\frac{BD^3 - bd^3}{12(BD - bd)}} = \sqrt{\frac{120^4 - 108^4}{12(120^2 - 108^2)}} = 46.6$$

$$\lambda = \frac{l}{r} = \frac{3\,400}{46.6} = 73 \text{ gives } k_{\lambda} = 0.72 \text{ by interpolation}$$

$$P_w = k_{\lambda} \times \sigma_{cw} \times A = 0.72 \times 150 (120^2 - 108^2) = 295 \text{ kN.}$$

TABLE 7.3

Reduction factor (k_{λ}) for stresses with respect to the slenderness ratio for steel columns

λ	10	20	30	40	50	60	70	80	90	100	110	120	130	140
k_{λ}	0.97	0.95	0.92	0.90	0.86	0.81	0.74	0.67	0.59	0.51	0.45	0.39	0.34	0.30
λ	150	160	170	180	190	200	210	220	230	240	250	300	350	
k_{λ}	0.26	0.23	0.21	0.19	0.17	0.15	0.14	0.13	0.12	0.11	0.10	0.07	0.05	

Axially loaded concrete columns

Most building codes permit the use of plain concrete only in short columns, that is to say, columns where the ratio of the effective length to least lateral dimension does not exceed 15, i.e. $l/r \leq 15$. If the slenderness ratio is between 10 and 15, the allowable compressive strength must be reduced. The tables of figures relating to l/b in place of a true slenderness ratio are only approximate, as radii of gyration depend on both b and d values in the cross-section and must be used with caution. In the case of a circular column:

$$b = \frac{D}{4} \times \sqrt{12} \approx 0.87D, \text{ where}$$

D = the diameter of the column.

TABLE 7.4
Permissible compressive stress (P_{cc}) in concrete for columns (MPa or N/mm²)

Concrete mix	Slenderness ratio, l/b					
	≤ 10	11	12	13	14	15
Prescribed						
C10	3.2	3.1	3.0	2.9	2.8	2.7
C15	3.9	3.8	3.7	3.6	3.5	3.4
C20	4.8	4.6	4.5	4.3	4.2	4.1
Nominal						
1:3:5	3.1	3.0	2.9	2.8	2.7	2.6
1:2:4	3.8	3.7	3.6	3.5	3.4	3.3
1:1.5:3	4.7	4.5	4.4	4.2	4.1	4.0

Higher stress values may be permitted, depending on the level of work supervision.

Example 7.8

A concrete column with an effective length of 4 metres has a cross-section of 300 mm by 400 mm. Calculate the allowable axial load if a nominal 1:2:4 concrete mix is to be used.

Slenderness ratio

$$\frac{l}{b} = \frac{4000}{300} = 13.3$$

Hence Table 7.4 gives $P_{cc} = 3.47$ N/mm² by interpolation.

$$P_w = P_{cc} \times A = 3.47 \times 300 \times 400 = 416.4 \text{ kN.}$$

Eccentrically loaded timber and steel columns

Where a column is eccentrically loaded, two load effects need to be considered:

The axial compressive stress caused by the load and the bending stresses caused by the eccentricity of the load.

Obviously, by the law of superposition, the added stresses of the two load effects must be below the allowable stress.

$$\text{Therefore } \frac{\sigma}{P_{cw}} + \frac{f}{f_w} \leq 1 \text{ i.e.}$$

$$\frac{\text{axial compressive stress}}{\text{allowable compressive stress}} + \frac{\text{bending stress}}{\text{allowable bending stress}} \leq 1$$

$$\frac{\sigma_c}{k_\lambda \times \sigma_{cw}} + \frac{f}{f_w} \leq 1 \text{ which can be transferred to:}$$

$$\frac{P_l}{K_\lambda \times A} + \frac{\sigma_{cw}}{f_w} \times \frac{M}{Z} \leq \sigma_{cw}$$

Example 7.9

Determine within 25 mm the required diameter of a timber post loaded as shown in the figure. The bottom of the post is fixed in both position and direction by being cast in a concrete foundation. Allowable stresses for the timber used are $\sigma_{cw} = 9$ MPa and $f_w = 10$ MPa.

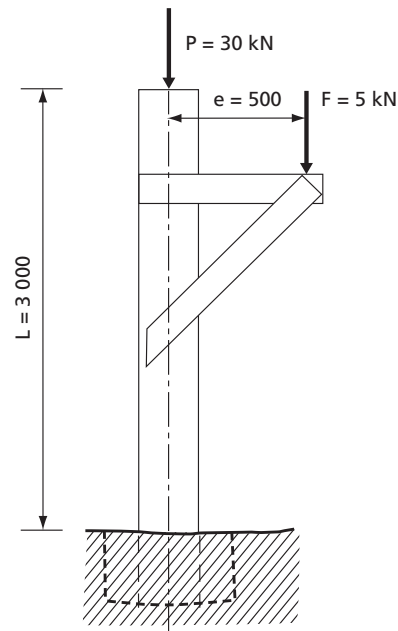

The load of 5 kN on the cantilever causes a bending moment of $M = F \times e = 5 \text{ kN} \times 0.5 \text{ m} = 2.5 \text{ kNm}$ in the post below the cantilever.

The effective length of the post = $L \times K = 3\,000 \times 2.1 = 6\,300 \text{ mm}$. Try a post with a diameter of 200 mm.

The cross-sectional properties are:

$$A = \frac{\pi D^2}{4} = \frac{\pi \times 200^2}{4} = 31\,400 \text{ mm}^2$$

$$Z = \frac{\pi D^3}{32} = \frac{\pi \times 200^3}{32} = 785\,400 \text{ mm}^3$$

$$r = \frac{D}{4} = \frac{200}{4} = 50 \text{ mm}$$

$$\text{The slenderness ratio} = \frac{l}{r} = \frac{6\,300}{50} = 126$$

Interpolation in Table 7.3 gives $k_\lambda = 0.18$

$$\frac{P_l}{K_\lambda \times A} + \frac{\sigma_{cw}}{f_w} \times \frac{M}{Z} \leq \sigma_{cw}$$

$$\frac{30\,000}{0.18 \times 31\,400} + \frac{9}{10} \times \frac{2.5 \times 10^6}{785\,400} = 8.17 \text{ N/mm}^2 \leq 9 \text{ N/mm}^2$$

If the post has a diameter of 200 mm, it will be able to carry the loads, but the task was to determine the diameter within 25 mm. Therefore a diameter of 175 mm should also be tried.

$$\lambda = \frac{6\,300}{43.75} = 144 \quad k_\lambda = 0.13$$

$$\frac{30\,000}{0.13 \times 24\,050} + \frac{9}{10} \times \frac{2.5 \times 10^6}{167\,480} = 23 \text{ N/mm}^2 > 9 \text{ N/mm}^2$$

This diameter is too small, so a diameter of 200 mm should be chosen. It will be appreciated that the choice of effective length based on end fixity has a great effect on the solution.

Plain and centrally reinforced concrete walls

Basically walls are designed in the same manner as columns, but there are a few differences. A wall is distinguished from a column by having a length that is more than five times the thickness.

Plain concrete walls should have a minimum thickness of 100 mm.

Where the load on the wall is eccentric, the wall must have centrally placed reinforcement of at least 0.2 percent of the cross-section area if the eccentricity ratio e/b exceeds 0.20. This reinforcement may not be included in the load-carrying capacity of the wall.

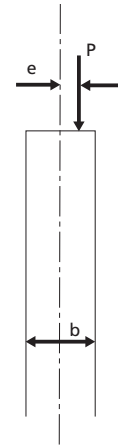

Many agricultural buildings have walls built of blocks or bricks. The same design approach as that shown for plain concrete with axial loading can be used. The maximum allowable compressive stresses must be ascertained, but the reduction ratios can be used as before.

Example 7.10

Determine the maximum allowable load per metre of a 120 mm thick wall, with an effective height of 2.8 metres and made from concrete grade C 15: (a) when the load is central; (b) when the load is eccentric by 20 mm.

$$\text{Slenderness ratio, } \frac{l}{b} = \frac{2\,800}{120} = 23.3$$

Interpolation gives:

$$P_{cw} = 2.8 - \frac{3.3}{5}(2.8 - 2.0) = 2.27 \text{ N/mm}^2 = 2.27 \text{ MPa}$$

$$\text{Allowable load } P_w = A \times P_{cw} = 1.0 \times 0.12 \times 2.27 \times 10^6 = 272.4 \text{ kN/m wall}$$

$$\text{Ratio of eccentricity } \frac{e}{b} = \frac{20}{120} = 0.167$$

A double interpolation gives:

$$P_{cw} = 1.06 \text{ N/mm}^2 = 1.06 \text{ MPa}$$

Allowable load

$$P_w = A \times P_{cw} = 1.0 \times 0.12 \times \frac{1.06 \times 10^6}{1\,000} = 127.2 \text{ kN/m wall}$$

Central reinforcement is not required because $\frac{e}{b} < 0.20$

TABLE 7.5
Allowable compressive stress, P_{cw} for concrete used in walls (N/mm²)

Concrete grade or mix	Slenderness ratio l/b	Ratio of eccentricity of the load e/b					
		Plain concrete walls			Centrally reinforced concrete walls		
		0.00	0.10	0.20	0.30	0.40	0.50
C20	25	2.4	1.7	0.9	-	-	-
	20	3.3	2.3	1.4	0.8	0.4	0.3
	15	4.1	3.0	2.0	0.8	0.4	0.3
	≤ 10	4.8	3.7	2.7	0.8	0.4	0.3
C15	25	2.0	1.3	0.7	-	-	-
	20	2.8	1.9	1.1	0.7	0.35	0.25
	15	3.4	2.4	1.7	0.7	0.35	0.25
	≤ 10	3.9	3.0	2.2	0.7	0.35	0.25
C10	20	2.3	1.6	1.0	0.5	0.3	0.2
	15	2.7	2.0	1.4	0.5	0.3	0.2
	≤ 10	3.2	2.5	1.8	0.5	0.3	0.2
1:1:3	25	2.3	1.6	0.8	-	-	-
1:1:2	20	3.2	2.2	1.3	0.8	0.4	0.3
	15	4.1	2.9	1.9	0.8	0.4	0.3
	≤ 10	4.7	3.6	2.6	0.8	0.4	0.3
1:2:3	20	3.0	2.1	1.3	0.7	0.35	0.25
	15	3.7	2.7	1.9	0.7	0.35	0.25
	≤ 10	4.3	3.4	2.5	0.7	0.35	0.25
1:2:4	20	2.7	1.8	1.0	0.6	0.3	0.2
	15	3.3	2.3	1.6	0.6	0.3	0.2
	≤ 10	3.8	2.9	2.1	0.6	0.3	0.2

Higher values of stress may be permitted, depending on the level of work supervision.

TRUSSES

It can be seen from the stress distribution of a loaded beam that the greatest stress occurs at the top and bottom extremities of the beam.

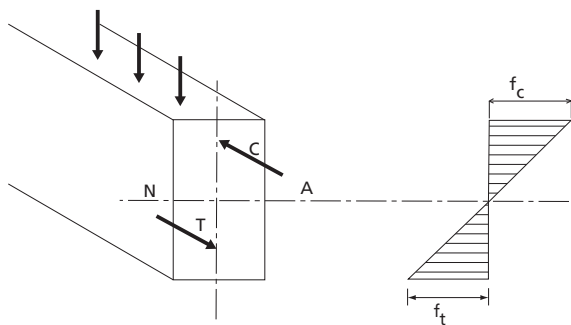

This led to the improvement on a rectangular section by introducing the I-section in which the large flanges were situated at a distance from the neutral axis. In effect, the flanges carried the bending in the form of tension stress in one flange and compression stress in the other, while the shear was carried by the web.

For these situations where bending is high but shear is low, for example in roof design, material can be saved by raising a framework design. A truss is a pinpointed framework.

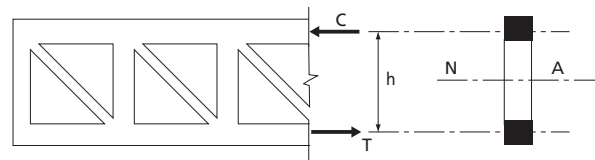

A truss concentrates the maximum amount of materials as far away as possible from the neutral axis. With the resulting greater moment arm (h), much larger moments can be resisted.

Resistance of a truss at a section is provided by:

$$M = C \times h = T \times h$$

where:

$C = T$ in parallel chords and:

C = compression in the top chord of the truss.

T = tension in bottom chord of a simply supported truss.

h = vertical height of truss section.

If either C or T or h can be increased, then the truss will be capable of resisting heavier loads. The value of h can be increased by making a deeper truss.

Allowable C - or T -stresses can be increased by choosing a larger cross-section for the chords of the truss, or by changing to a stronger material.

A framework or truss can be considered as a beam with the major part of the web removed. This is possible where bending stresses are more significant than shear stresses. The simple beam has a constant section along its length, yet the bending and shear stresses vary. The truss, comprising a number of simple members, can be fabricated to take into account this change in stress along its length.

The pitched-roof truss is the best example of this, although the original shape was probably designed to shed rainwater. Roof trusses consist of sloping rafters that meet at the ridge, a main tie connecting the feet of the rafters and internal bracing members. They are used to support a roof covering in conjunction with purlins, which are laid longitudinally across the rafters, with the roof cover attached to the purlin. The arrangement of the internal bracing depends on the span.

Rafters are normally divided into equal lengths and, ideally, the purlins are supported at the joints so that the rafters are only subjected to axial forces. This is not always practicable because purlin spacing is dependent on the type of roof covering. When the purlins are not supported at the panel joints, the rafter members must be designed for bending as well as axial force. See Figure 7.2.

The internal bracing members of a truss should be triangulated and, as far as possible, arranged so that long members are in tension and compression members are short to avoid buckling problems.

The outlines in Figure 7.3 give typical forms for various spans. The thick lines indicate struts.

The lattice girder, also called a truss, is a plane frame of open web construction, usually with parallel chords

or booms at top and bottom. There are two main types, the N- (or Pratt) girder and the Warren girder. They are very useful in long-span construction, in which their small depth-to-span ratio, generally about $1/10$ to $1/14$, gives them a distinct advantage over roof trusses.

Steel and timber trusses are usually designed assuming pin-jointed members. In practice, timber trusses are assembled with bolts, nails or special connectors, and steel trusses are bolted, riveted or welded. Although these rigid joints impose secondary stresses, it is seldom necessary to consider them in the design procedure. The following steps should be considered when designing a truss:

1. Select general layout of truss members and truss spacing.
2. Estimate external loads to be applied including self-weight of truss, purlins and roof covering, together with wind loads.
3. Determine critical (worst combinations) loading. It is usual to consider dead loads alone, and then dead and imposed loads combined.
4. Analyse the framework to find forces in all members.
5. Select the material and section to produce in each member a stress value that does not exceed the permissible value. Particular care must be taken with compression members (struts), or members normally in tension but subject to stress reversal caused by wind uplift.

Unless there are particular constructional requirements, roof trusses should, as far as possible, be spaced to achieve minimum weight and economy of materials used in the total roof structure. As the distance between trusses is increased, the weight of the purlins tends to increase more rapidly than that of the trusses. For spans up to around 20 m, the spacing of steel trusses is likely to be about 4 metres and, in the case of timber, 2 metres.

The pitch, or slope, of a roof depends on locality, imposed loading and type of covering. Heavy rainfall may require steep slopes for rapid drainage; a slope of 22° is common for corrugated steel and asbestos roofing sheets. Manufacturers of roofing material usually make recommendations regarding suitable slopes and fixings.

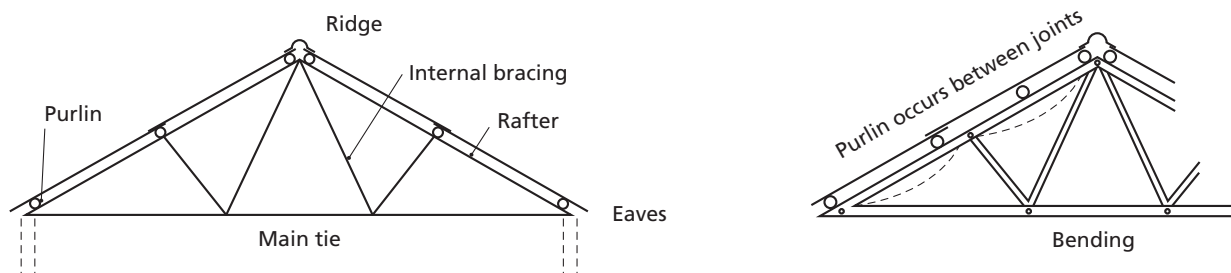

Figure 7.4 Truss components

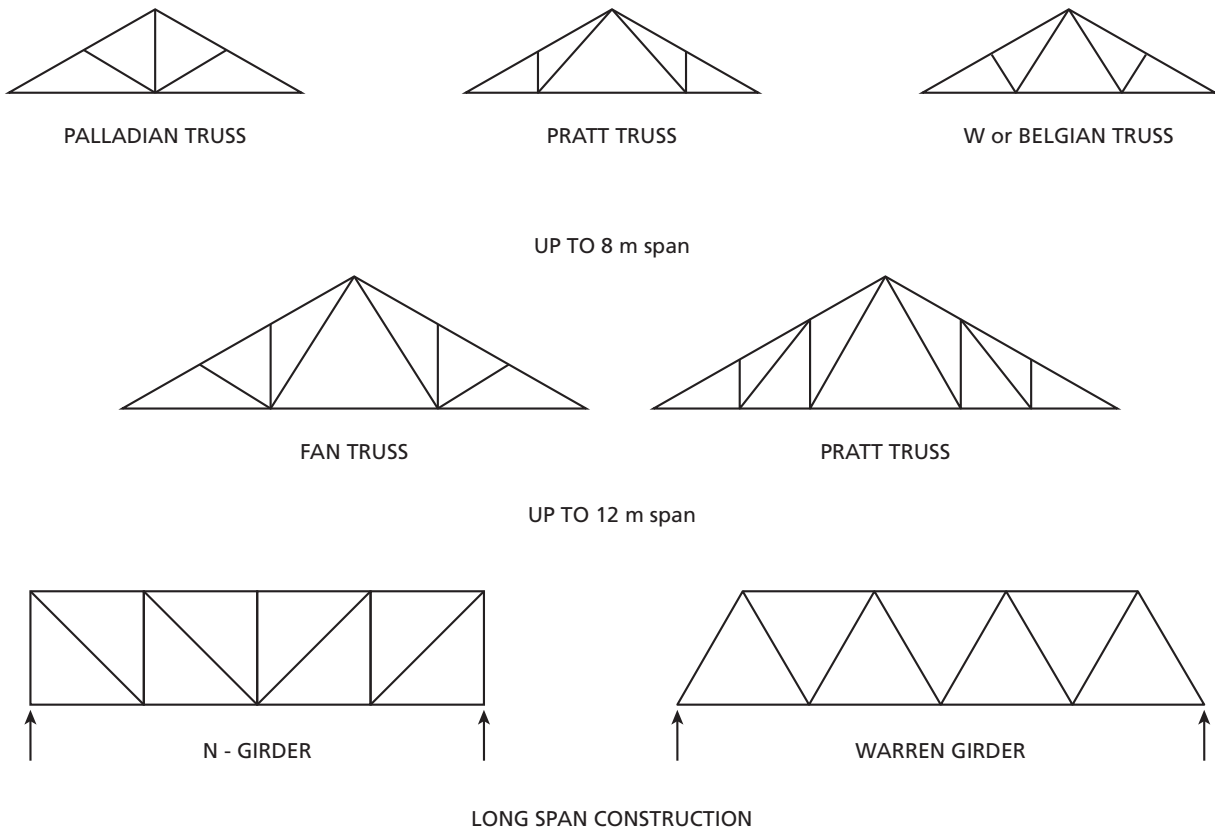
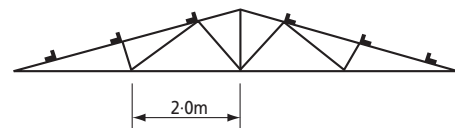
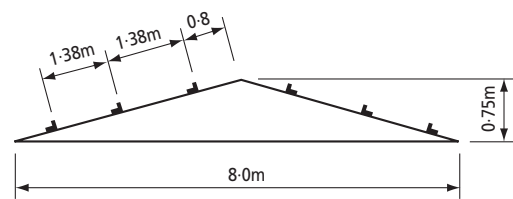

Figure 7.5 Types of trusses

To enable the designer to determine the maximum design load for each member, the member forces can be evaluated either by calculation or graphical means, and the results tabulated as shown:

Member	Dead Load D	Imposed Load I	Dead + imposed Load D + I	Wind Load W	Design Load



LAYOUT CHOSEN
(nodes at purlin points)

A simplified approach can be taken if the intention is to use a common section throughout. Once the layout has been chosen, the member that will carry the maximum load can be established. An understanding of the problems of instability of compression members will lead the designer to concentrate on the top chord or rafter members. A force diagram or method of sections can then be used to determine the load on these members and the necessary size.

Example 7.11

A farm building comprising block walls carries steel roof trusses over a span of 8 metres. Roofing sheets determine the purlin spacings. Design the roof trusses.

Assume a force analysis shows maximum rafter forces of approximately 50 kN in compression ($D + I$) and 30 kN in tension ($D + W$), outer main tie member 50 kN tension ($D + I$) and 30 kN compression ($D + W$). A reversal of forces caused by the uplift action of wind will cause the outer main tie member to have 50 kN of tension and 30 kN of compression.

Consulting a structural engineering handbook reveals that a steel angle with a section of 65 mm × 50 mm × 6 mm and an effective length of 1.8 m can safely carry 29 kN in compression.

Rafter: Using two angles back-to-back will be satisfactory because the distance between restraints is only 1.38 m. (Note that angles must be battened together along the length of the rafter).

Main Tie: The 65 mm × 50 mm × 6 mm section can carry the required tensile force. Although its length is a little greater than 1.8 m, the compressive load brought about by wind uplift is safe as the design codes allow a greater slenderness ratio for intermittent loads such as wind.

Finished Design: Note the use of a sole plate to safely distribute the load to the blockwork wall to ensure that the bearing stress of the blocks is not exceeded. See Figure 7.4.

FRAMES

Apart from the roof truss, there are a number of other structural frames commonly used in farm building construction. They include portal frames, pole barns and post-and-beam frames.

A single-bay *portal frame* consists of a horizontal beam or pitched rafters joined rigidly to vertical stanchions on either side to form a continuous plane frame. For design purposes, portal frames can be classified into three types: fixed base, pinned base (two pins), pinned base and ridge (three pins).

The rigid joints and fixed bases have to withstand bending moments and all bases are subjected to horizontal, as well as vertical, reactions. Hence foundation design requires special attention. The externally applied loads cause bending moments, shear forces and axial forces in the frame.

Portal frames are statically indeterminate structures and the complexity of the analysis precludes coverage here. However, the results of such calculations for a number of standard cases of loading are tabulated in handbooks. Using these and the principle of superposition, the designer can determine the structural section required for the frame. Determining the maximum values of the bending moment, shear force and axial force acting anywhere in the frame allows the selection of an adequate section for use throughout the frame. Care must be exercised to ensure that all joints and connections are adequate.

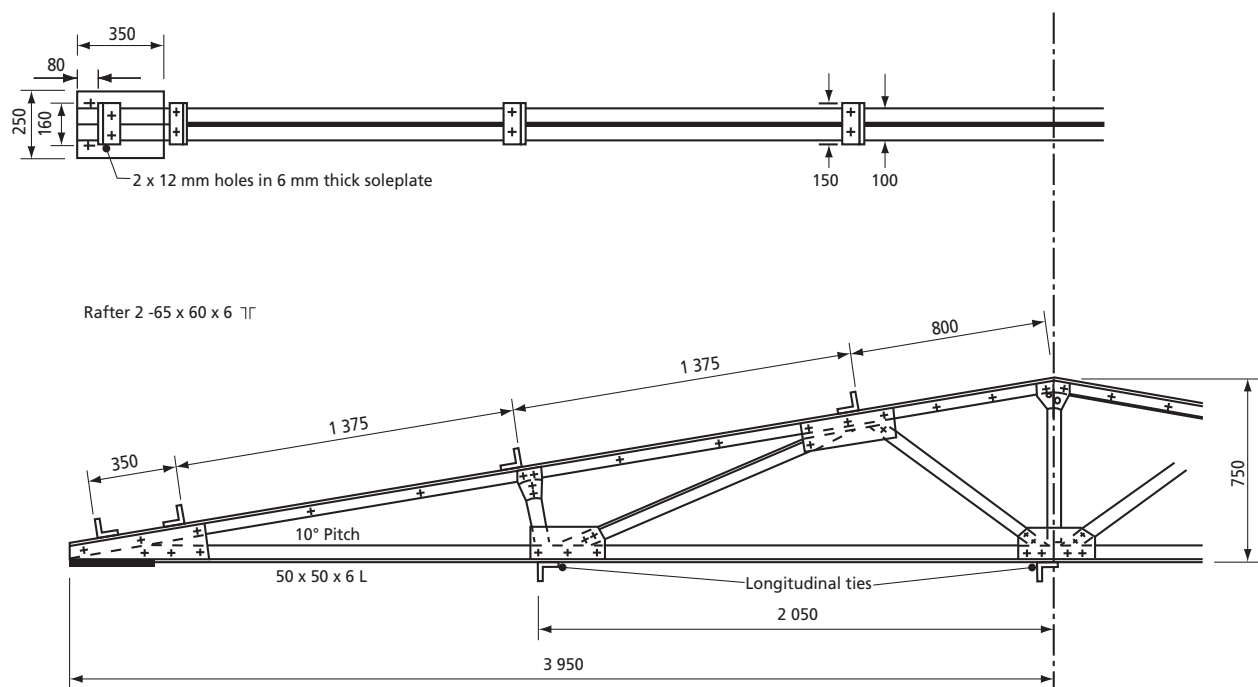

Notes:

- All welds to be 4mm fillet
- All bolts to be M16
- Gusset plates to be 8mm thick
- Internal bracing shown 65 x 50 x 6 to use common section (size can be reduced if others available)
- All sections in grade 43 steel
- Purlin supports: 70 x 70 x 6 with 2 x 6 \emptyset holes

Figure 7.6 Finished design of the roof truss

Portal frames may be made of steel, reinforced concrete or timber. With wider spans the structural components become massive if timber or reinforced concrete is used. Hence, steel frames are most common for spans over 20 m. At the eaves, where maximum bending moments occur, the section used will need a greater depth than at other points in the frame.

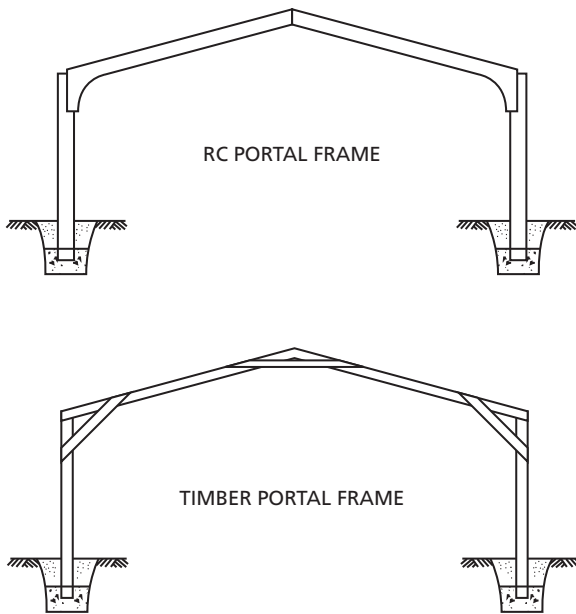

Figure 7.7 Portal or rigid frame

Pole barns are usually built with a relatively simple foundation, deeper than usual, and backfilled with rammed earth. Pole barns are braced between columns and rafters in each direction. The braces serve to reduce the effective length of compression members and the effective span of rafters and other beam members. This leads to a structure that is simple to analyse and design, and can be a low-cost form of construction.

A *shed-type* building is a simple construction consisting of beams (horizontal or sloping), supported at their ends on walls or posts. There may be one or more intermediate supports depending on the width of the building. Purlins running longitudinally support the roof cover.

As the principal members are simple or continuous beams (very often timber of rectangular section), the stress-analysis aspect of the design is straightforward. When the beam is supported by timber posts, the design of the posts is not difficult because the load is assumed to be axial. Like the poles in the pole barn, the foundation can consist of a simple pad of concrete beneath the post, or the base of the post can be set into concrete.

Example 7.12

Design the roof of a building using block walls, timber posts and rafters as shown in the figures below.

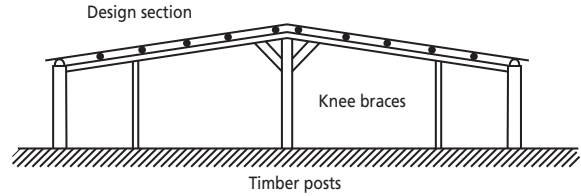

It is assumed that the knee braces reduce the effective span of the rafters between the central wall and the timber posts.

The moments and forces involved are as shown in the diagram below. Self-weights and service load have been estimated. Continuity over post and brace has been disregarded. This provides a simple but safe member.

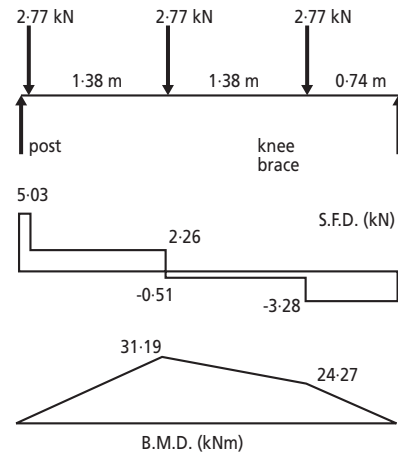

Self-weights and service load have been estimated. Continuity over post and brace have been disregarded. This provides a simple safe member.

Maximum shear force = 5 kN

Maximum bending moment = 3 120 kN/ mm².

Try two rafters at 38 × 200 (back to back)

$$\begin{aligned} \text{Maximum shear stress} &= \frac{3Q}{2bd} = \frac{3}{2} \times \frac{5\,000}{76 \times 200} \\ &= 0.49 \text{ N/mm}^2 = 0.49 \text{ MPa} \end{aligned}$$

$$\begin{aligned} \text{Maximum bending stress} &= \frac{M_y}{I} = \frac{M}{Z} \\ &= \frac{3\,120 \times 10^3 \times 6}{76 \times 200^2} = 6.2 \text{ N/mm}^2 \end{aligned}$$

Tables of allowable stresses indicate that most hardwoods, but not all softwoods, are adequate.

The load transferred to the outer wall by rafters is a little over 3 kN. Assuming that the strength of the blocks is at least 2.8 MPa (N/mm²), the area required is:

$$\frac{3\,000}{2.8} = 1\,072 \text{ mm}^2$$

As the rafter underside is 76 mm, the minimum interface across the wall is:

$$\frac{1\,072}{76} = 14 \text{ mm}$$

Hence there is no problem of load transfer to the wall.

Assume posts are 100 mm × 100 mm and 2.5 m long, then $l/b = 25$ and Table 7.2 gives $K = 0.38$

With $\sigma_c = 5.2$ MPa (N/mm²) allowable for design, $0.38 \times 5.2 \text{ N/mm}^2 \times 100^2 \approx 20 \text{ kN}$.

Therefore the load is within the safety margin.

CONNECTIONS

Timber structure

The methods used to join members include lapped and butt connectors. Bolt and connector joints, nailed joints and glued joints, and sometimes a combination of two types, are examples of lapped connections. Butt connections require the use of plates or gussets. In all cases the joints should be designed by calculating the shear forces that will occur in the members.

If two members overlap, the joint is called a *single-lap joint*. If one is lapped by two other members, i.e. sandwiched between them, it is called a *double-lap joint*.

With a single lap, the joint is under eccentric loading. While for small-span trusses carrying light loads this is not significant, when the joints carry large loads eccentricity should be avoided by the use of double-lap joints. Double members are also used to obtain a satisfactory arrangement of members in the truss as a whole.

Sandwich construction enables the necessary sectional area of a member to be obtained by the use of relatively thin timbers, with any double members in compression being blocked apart and fixed in position to provide the necessary stiffness.

Butt joints

The use of gussets permits members to butt against each other in the same plane, avoids eccentric loading on the joints and, where necessary, provides a greater

joining area than is possible with lapped members. This is often an important factor in nailed and glued joints. Arrangement of members on a single centre line is usually possible with gussets.

When full-length timber is not available for a member, a butt joint with cover plates can be used to join two pieces together. This should be avoided, if possible, for the top members (rafters) of a truss and positioned near mid-span for the bottom member (main tie).

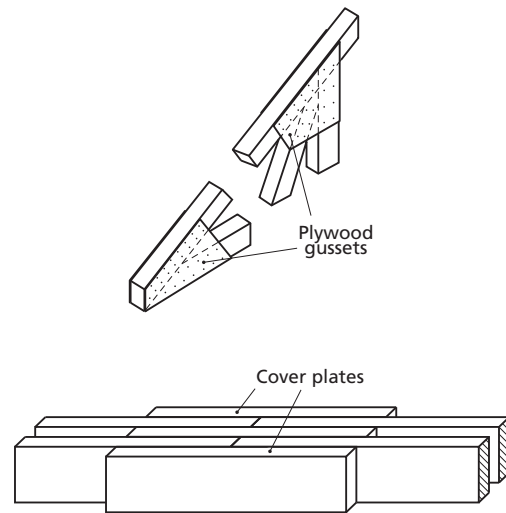

Figure 7.8 Butt joints

Bolt and connector joints

Simple bolted joints should only be used for lightly loaded joints because the bearing area at the hole (hole diameter × member thickness) and the relatively low bearing stress allowed for the timber compared with that of the steel bolt, may cause the timber hole to elongate and fail.

Timber connectors are metal rings or toothed plates used to increase the efficiency of bolted joints. They are embedded half into each of the adjacent members and transmit loads from one to the other. The type most commonly used for light structures is the toothed-plate connector, a mild-steel plate cut and stamped to form triangular teeth projecting on each side that embed in the surfaces of the members on tightening the bolt that passes through the joint. The double-sided toothed connector transmits the load and the bolt is assumed to take no load.

Glued joints

Glues made from synthetic resins produce the most efficient form of joint, as strong as or even stronger than the timber joint, and many are immune to attack by dampness and decay. With this type of joint,

all contact surfaces must be planed smooth and the necessary pressure applied during setting of the glue. Bolts or nails that act as clamps are often used and left in place.

The members may be glued directly to each other using lapped joints, or single-thickness construction may be used by the adoption of gussets. As with nailed joints, lapped members may not provide sufficient gluing area and gussets must then be used to provide the extra area.

Glued joints are more often used when trusses are prefabricated because control over temperature, joint fit and clamping pressure is essential. For home use, glue is often used together with nail joints.

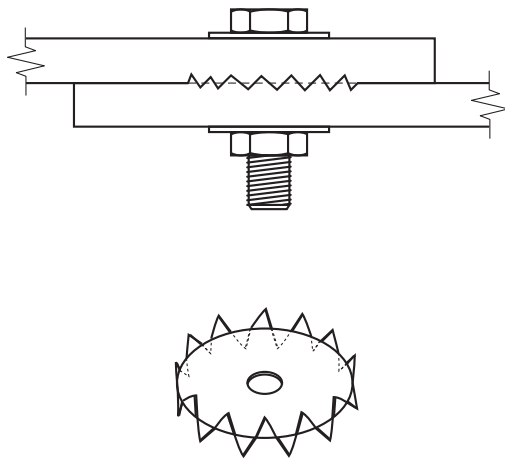

Figure 7.9 Double-sided toothed plate connector

Nailed joints

Although joining by nails is the least efficient of the three methods mentioned, it is an inexpensive and simple method, and can be improved upon by using glue in combination with the nails.

When trusses are prefabricated in factories, nailing plates are often used to connect the member. These fasteners come in two types:

1. A thin-gauge plate called a *pierced-plate fastener*, which has holes punched regularly over its surface to receive nails. The pierced plate can also be used for on-site fabrication.
2. A heavier plate with teeth punched from the plate and bent up 90 degrees, called a *toothed-plate fastener*, or connector. This type, in which the teeth are an integral part of the plate, must be driven in by a hydraulic press or roller.

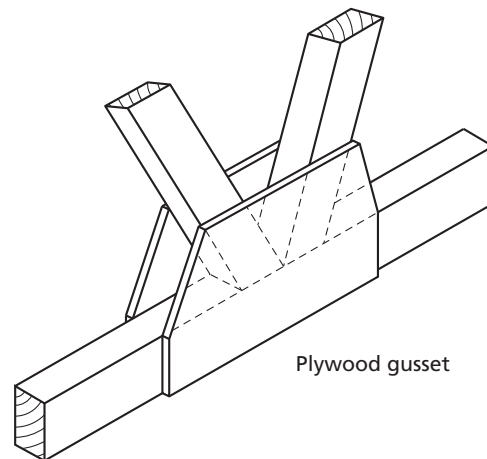
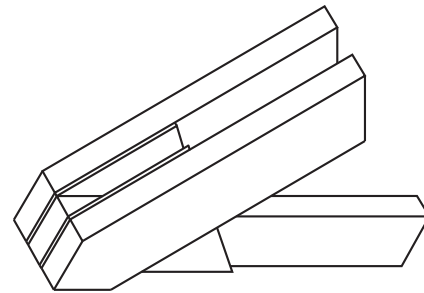
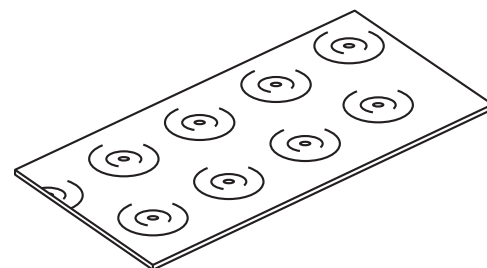
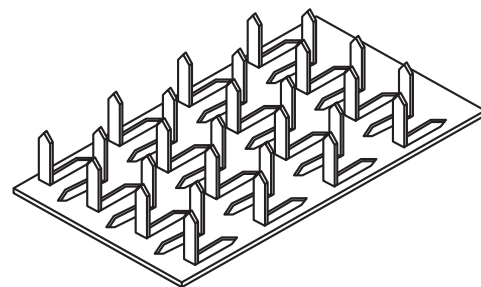

Figure 7.10 Truss gussets



Pierced plate fastener



Toothed plate fastener

Figure 7.11 Nailing plates for truss construction

TABLE 7.6
Minimum nailing distances

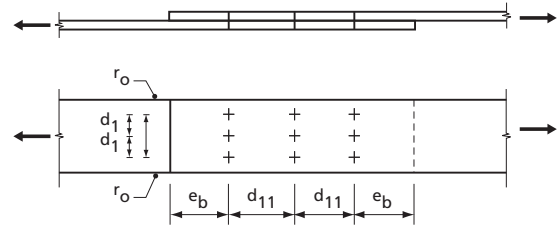
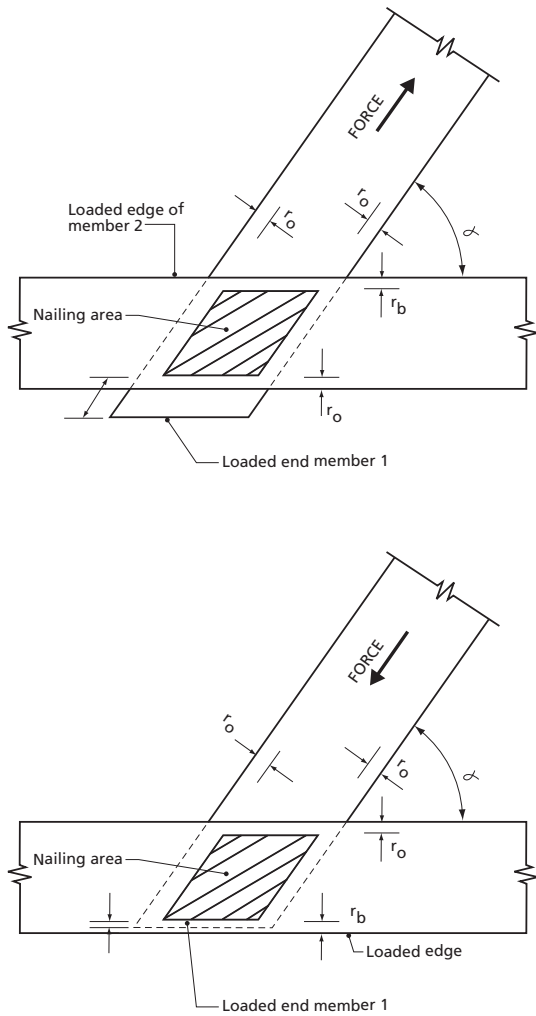

x	Nailing area					
	r_o	d_1	d_{11}	r_b	e_o	e_b
0	5d	5d	10d	5d	-	15d
10	5d	5d	10d	5.5d	8d	15d
20	5d	5d	10d	6d	8d	15d
30	5d	5d	10d	6.5d	8d	15d
40	5d	5d	10d	7d	8d	15d
50	5d	5d	10d	7.5d	8d	15d
≤ 60	5d	5d	10d	8d	8d	15d

- d : Diameter of the nail (mm).
- r_o : Distance from the extreme row of nails to the unloaded edge of member.
- d_1 : Distance between two nails in the nailing area, measured perpendicular to the axis of the member.
- d_{11} : Distance between two nails measured parallel to the axis of the member.
- r_b : Distance from the extreme row of nails to the loaded edge of the member.
- e_o : Distance from the nearest row of nails to the unloaded end of member.
- e_b : Distance from the nearest row of nails to the loaded end of the member.

In order to permit the development of the full load at each nail and to avoid splitting the wood, minimum spacing between nails and distances from the edges and ends of the member are necessary.

Nailing patterns for use on timber structures are usually available locally. They depend on the quality and type of nails and timber used, and are based on the safe lateral nail load.

The Housing Research and Development Unit of the University of Nairobi investigated timber nailed joints made with spacings in accordance with the continental standard for timber joints, which proved to be satisfactory. The main principles are given in tables 7.6 and 7.7.

Connections in steel structures

Connections may be bolted, riveted or welded. The principal design considerations are shear, tension and compression, and the calculations are relatively straightforward for the types of design covered.

STABILITY

Stability problems in a building are chiefly the result of horizontal loads, such as those resulting from wind pressure, storage of granular products against walls, soil pressure against foundations and sometimes earthquakes.

Overturning of foundation walls and foundation piers and pads is counteracted by the width of the footing and the weight of the structure. Only in special cases will it be necessary to give extra support in the form of buttresses.

Overturning of external walls is counteracted by the support of perpendicular walls and partitions. Note, however, that not all types of wall, for example framed walls, are adequately rigid along their length without diagonal bracing. If supporting walls are widely spaced and/or the horizontal loads are large, extra support can be supplied by the construction of piers, columns or buttresses. See Chapter 8.

Diagonal bracing is used to make framed walls and structures stiff. Long braces should preferably transfer the load with a tensile stress to avoid buckling. Braces

TABLE 7.7
Basic lateral loads per nail

Continental nail diameter (mm)	2.1	2.4	2.8	3.1	3.4	3.8	4.2	4.6	5.1	5.6	6.1							
Kenya nail diameter (mm)	1.8	2.0	2.65		3.35	3.75		4.5		5.6	6.0							
Basic lateral nail load (N)	90	120	140	190	220	250	310	350	370	430	450	540	600	630	750	880	960	1 000

(If the case of pre-bored nail holes 0.8 times nail diameter, the lateral nail load can be increased by 25%)

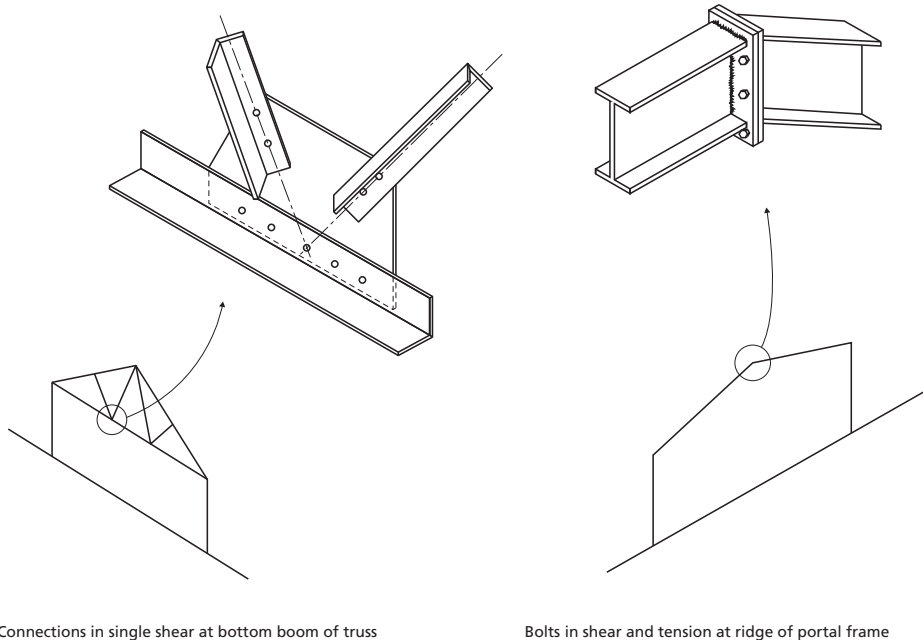
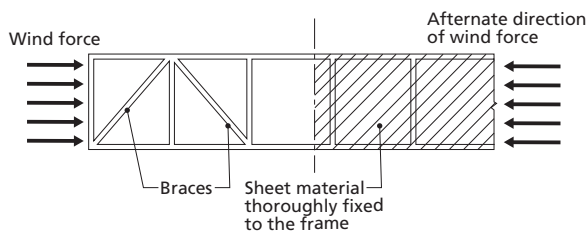

Figure 7.12 Connections for steel frames

are usually supplied in pairs, i.e. on both diagonals, so that one will always be in tension independently of the wind direction.

If the framed wall is covered with a sheet material, such as plywood, chipboard or metal sheets, the lateral forces on the frame can be counteracted by shear in the sheets. This design requires the sheets to be securely fixed to the frame, both horizontally and vertically. The sheets must be strong enough to resist buckling or failure through shear.



the frames may need extra support from longitudinal bracing. Tension rods are frequently used.

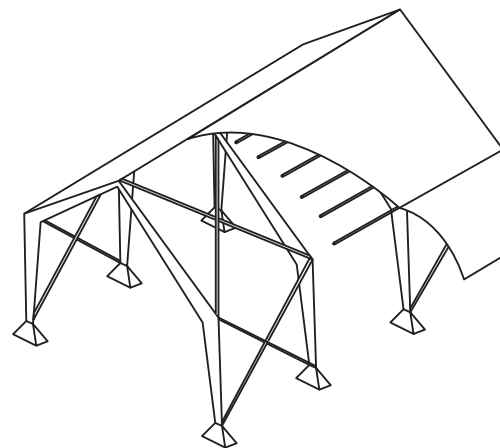

Figure 7.13 Bracing for portal frame

Masonry and concrete walls that are stiff and capable of resisting lateral wind loading are called shear walls.

Portal or rigid frame buildings are normally stable laterally, when the wind pressure acts on the long sides. However, when the wind loads occur at the gable ends,

Post-and-beam or shed-frame buildings will, in most cases, require wind bracing, both along and across the building because there are no rigid connections at the top of the wall to transfer loads across and along the building. The same applies to buildings employing roof trusses. End bracing should be installed.

Walls with long spans between the supporting crosswalls, partitions or buttresses tend to bend inwards under the wind load, or outwards if bulk grain or other produce is stored against the wall. At the bottom of the wall this tendency is counteracted by the rigidity of the foundation (designed not to slide) and the support of a floor structure. The top of the wall is given stability by the support of the ceiling or roof structure, or a specially designed wall beam that is securely anchored to the wall.

The designer must consider the ability of the building to withstand horizontal loading from any and all directions, without unacceptable deformation.

RETAINING WALLS

Wall failure

Walls are commonly used to retain soil on sloping sites, water in a pond or bulk products within a storage area. There are several limiting conditions which, if exceeded, can lead to the failure of a retaining wall. Each must be addressed in designing a wall.

1. *Overturning:* This occurs when the turning moment resulting from lateral forces exceeds that exerted by the self-weight of the wall. The factor of safety against overturning should be at least two.

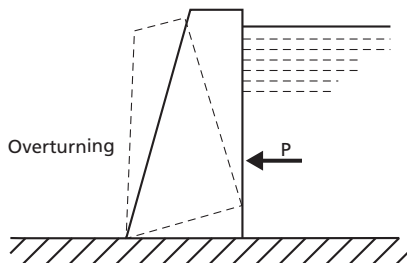

2. *Sliding:* The wall will slide if the lateral thrust exceeds the frictional resistance developed between the base of the wall and the soil. The factor of safety against sliding should be about two.

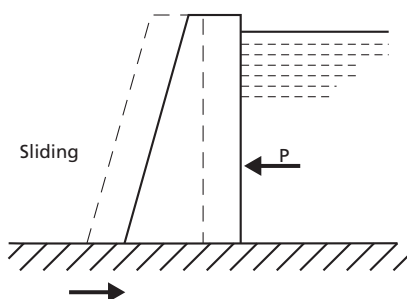

3. *Bearing on ground:* The normal pressure between the base of the wall and the soil beneath can cause a bearing failure of the soil, if the ultimate bearing capacity is exceeded. Usually the allowable bearing pressure will be one-third of the ultimate value. Note that the pressure distribution across the base is not constant.

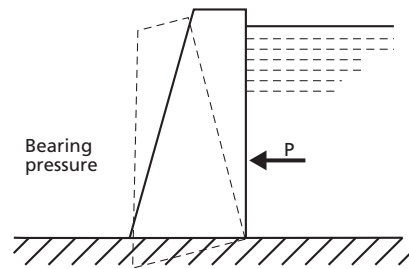

4. *Rotational Slip:* The wall and a large amount of the retained material rotate about point O if the shear resistance developed along a circular arc is exceeded. The analysis is too complex to include here.

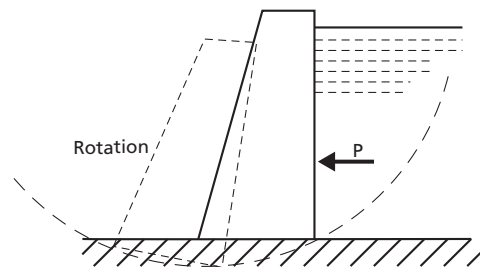

5. *Wall material failure:* The structure itself must be capable of withstanding the internal stresses set up, that is to say, the stresses must not exceed allowable values. Factors of safety used here depend on the material and the level of the designer's knowledge of the loads actually applied. Naturally, both shear and bending must be considered, but the most critical condition is likely to be tension failure of the 'front' facet.

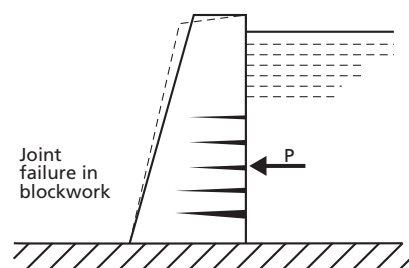

Gravity walls and dams are dependent on the effect of gravity, largely from the self-weight of the wall itself, for stability. Other types of wall rely on a rigid base, combined with a wall designed against bending, to provide an adequate structure.

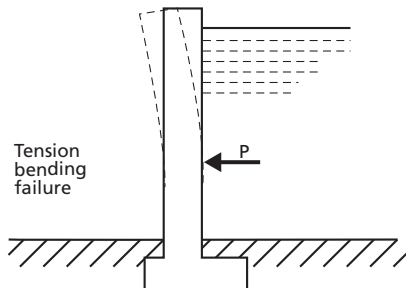

Pressure exerted by retained material

Liquid pressure

The pressure in a liquid is directly proportional to both the depth and the specific weight of the liquid (w) which is the weight per unit volume, $w = \rho g$ (N/m³),

where:

ρ = density of liquid (kg/m³)

g = gravitational acceleration (9.81 m/s²)

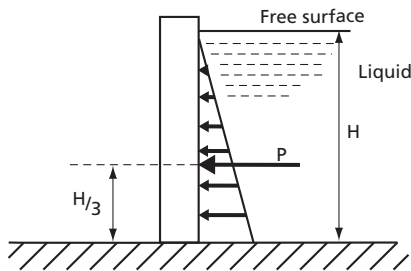

The pressure at a given depth acts equally in all directions, and the resultant force on a dam or wall face is normal to the face. The pressure from the liquid can be treated as a distributed load with linear variation in a triangular load form, with a centroid two-thirds of the way down the wet face.

$p = \rho g H = w H$ (N/m²) and:

$P = \frac{w H^2}{2}$ acting at a depth of $\frac{2}{3} H$

It should be noted that a wall retaining a material that is saturated (waterlogged) must resist this liquid pressure in addition to the lateral pressure from the retained material.

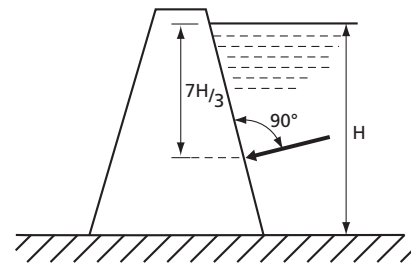

Example 7.13

Design of a gravity wall retaining water

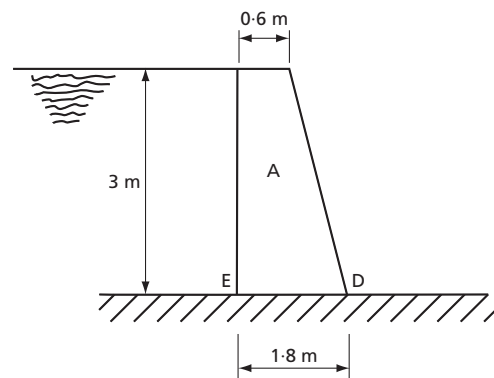

Consider a mass concrete dam with the cross-section shown, which retains water to 3 m depth.

Assume:

Ground safe bearing capacity: 300 kPa.

Coefficient of sliding friction at base: 0.7.

Specific weight of concrete: 23 kN/m³.

1. Find water force P :

All calculations per metre length of wall:

$$P = \frac{w H^2}{2} = \frac{9.8 \times 10^3 \times 3^2}{2} = 44.1 \text{ kN}$$

(acting one metre up face)

2. Find mass of one metre length of wall:

$W = A \times \text{specific weight}$

$$= 3 \times \frac{(0.6 + 1.8)}{2} \times 23 = 82.8 \text{ kN}$$

3. Find line of action of w : Taking moments of area about vertical face:

$$\bar{X} = \frac{A_1 X_1 + A_2 X_2}{A_1 + A_2}$$

$$= \frac{(3 \times 0.6 \times 0.3) + (0.6 \times 3 \times 1.0)}{1.8 + 1.8} = 0.65 \text{ m}$$

Hence the self-weight of the wall acts 0.25 m to left of the base centre line.

4. Find the vertical compressive stress on the base:

$$P_c = \frac{W}{A} = \frac{82.8}{1 \times 1.8} = 46 \text{ kPa}$$

5. Find the moment about the centre line of the base

$$M = (1 \times 44.1) - (0.25 \times 82.8); (\text{clockwise}) - (\text{anticlockwise})$$

$$M = 23.4 \text{ kNm}$$

6. Find the bending stresses/pressures

$$\sigma_b = P_b = \frac{MI}{Y_{max}} \quad \text{where:}$$

$$I = \frac{bd^3}{12} = \frac{1 \times 1.8^3}{12} = 0.486 \text{ m}^4$$

$$Y_{max} = \pm \frac{1.8}{2} = \pm 0.9 \text{ m}$$

$$\sigma_b = P_b = \pm \frac{23.4 \times 0.486}{0.9} = 12.6 \text{ kPa}$$

7. Find the actual stresses/pressures

$$\sigma = P = \frac{W}{A} + \frac{M_y}{I}$$

$$\sigma_E = P_E = 46 + 12.6 = 58.6 \text{ kPa (compression)}$$

$$\sigma_D = P_D = 46 - 12.6 = 33.4 \text{ kPa (compression)}$$

(Note: Compression only indicates the resultant P , and W would intersect the base line within its middle third).

8. Compare maximum pressure with allowable bearing capacity:

$$P_{max} = 58.6 \text{ kPa}$$

This is less than the allowable safe bearing capacity of the soil. Hence the wall-soil interface is safe against bearing failure.

9. Compare actual stresses in the wall with allowable values:

Maximum stress = 58.6 kPa (compression) and no tensile stress at any point across wall. Hence the wall material is safe.

10. Check overturning

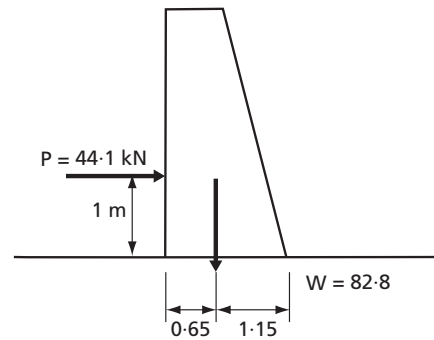

Overturning moment about $D = 44.1 \times 1 = 44.1 \text{ kNm}$
Stabilising moment about $D = 82.8 \times 1.15 = 95.22 \text{ kNm}$

Factor of safety against overturning = $95.22 / 44.1 = 2.16$

The wall is safe against overturning.

11. Check sliding

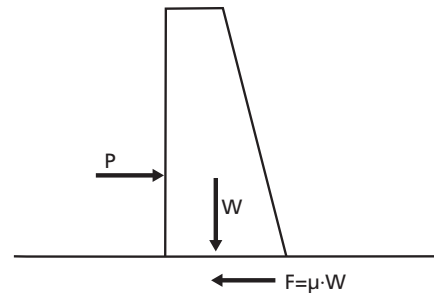

Frictional resistance = μW

$$\mu W = 0.7 \times 82.8 = 58 \text{ kN}$$

Horizontal thrust = $P = 44.1 \text{ kN}$

As the required factor against sliding is 2, there is a deficiency of $(2 \times 44.1) - 58 = 30.2 \text{ kN}$.

Additional anchorage against sliding should be provided.

Example 7.14

Design a circular water tank with the following dimensions/properties:

Diameter 5 m, depth of water 3 m

Water weighs $9.8 \times 10^3 \text{ N/m}^3$

Pressure (P) at a depth of 3 m

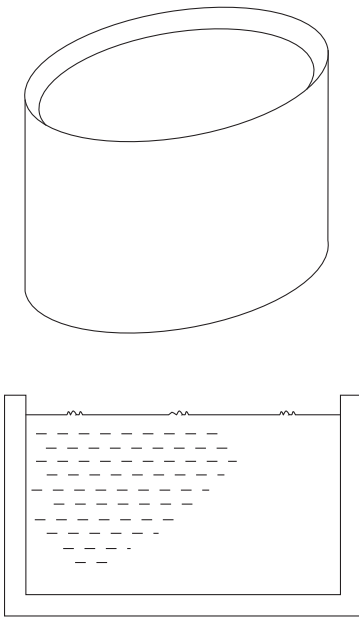

$$P_3 = wH = 9.8 \times 10^3 \times 3 = 29.4 \text{ kPa}$$

This acts vertically over the entire base; therefore the base should be designed for a uniformly distributed load (UDL) of 29.4 kPa.

Pressure P_3 also acts laterally on the side wall at its bottom edge. This pressure decreases linearly to zero at the water surface.

$$\text{Total force on base} = P_3 A_B = 29.4 \times \frac{(\pi \times 5^2)}{4} = 577.3 \text{ kN}$$

(acting at the centre of the base)

Total force on the side per metre of perimeter wall:

$$\frac{P_3 H}{2} = \frac{29.4 \times 3}{2} = 44.1 \text{ kN/m run}$$

(acting one metre above base)

Pressure exerted by granular materials

Granular materials such as sandy soils, gravelly soils and grain possess the property of internal friction (friction between adjacent grains), but are assumed not to possess the property of cohesion. If a quantity of such material in a dry condition is tipped on to a flat surface, it will form a conical heap: the shape maintained by this internal friction between grains. The angle of the sloping side is known as the *angle of repose*.

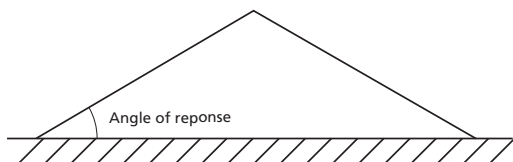

For a dry material, the angle of repose is usually equal to the angle of shearing resistance of the material. This angle of shearing resistance is called the *angle of internal friction* (θ). The angle of friction is the essential property of a granular material on which Rankine's theory is based. This theory enables the lateral pressure to be expressed as a proportion of the vertical pressure, which was shown (before) to depend on specific weight and depth only.

In this case, at a depth b the active lateral pressure is given by:

$$P = k \times w \times b$$

where:

k = a constant dependent on the materials involved.

Although there is some friction between the retained material and the wall face, usually this is disregarded, giving a relatively simple relationship for k :

$$k = \frac{1 - \sin\theta}{1 + \sin\theta}$$

where:

θ = the angle of friction

$$p_a = \frac{1 - \sin\theta}{1 + \sin\theta} \times wH \text{ (N/m}^2\text{)}$$

where:

P_a = total force per metre of wall-face (N)

$$P_a = \frac{1 - \sin\theta}{1 + \sin\theta} \times \frac{wH^2}{2} \text{ (N/m length of wall)}$$

P_a = total force per metre of wall face (N)

This gives the approximate horizontal resultant force on a vertical wall face when it is retaining material that is level with the top of the wall. If the surface of the retained material is sloping up from the wall at an angle equal to its angle of repose, a modification is required.

Example 7.15

Wall retaining soil

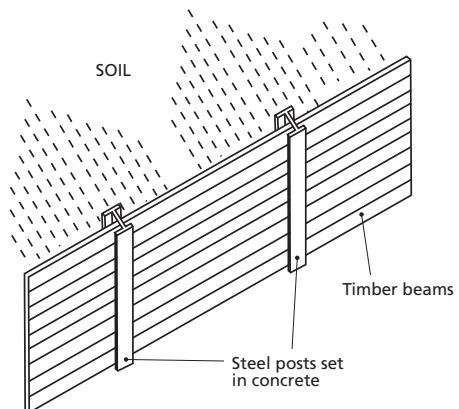

Consider the wall shown retaining loose sandy soil to a depth of 2 metres. Tables provide angle of friction equal to 35° and specific weight equal to 18.6 kN/m^3 . Assuming a smooth vertical surface and horizontal soil surface, Rankine's theory gives:

$$P = \frac{1 - \sin\theta}{1 + \sin\theta} \times \frac{wH^2}{2}$$

$$P = \frac{1 - \sin 35^\circ}{1 + \sin 35^\circ} \times \frac{18.6 \times 2^2}{2} \text{ kN/m length of wall}$$

$$P = 10.1 \text{ kN/m length of wall.}$$

If steel posts are placed at 2.5 m centres, each post can be approximated to a vertical cantilever beam 2.5 m long, carrying a total distributed load of $10.1 \times 2.5 = 25.25 \text{ kN}$ of linear variation from zero at the top to a maximum at the base. The steel post and foundation concrete must be capable of resisting the applied load, principally in bending but also in shear.

The timber crossbeams can be analysed as beams simply supported over a span of 2.5 m, each carrying a uniformly distributed load. This load is equal to the product of the face area of the beam and the pressure in the soil at a depth indicated by the centroid of the area of the beam face.

$$p_a = \frac{1 - \sin\theta}{1 + \sin\theta} \times wh$$

if beam face is 0.3 m high,

$$h = 2.0 - 0.15 = 1.85 \text{ m}$$

$$P = 0.27 \times 18.6 \times 1.85 = 9.29 \text{ kN/m}^2$$

Total uniformly distributed load on the beam
 $= 9.29 \times 0.3 \times 2.5 = 6.97 \text{ kN}$

The maximum bending moment at the centre of the span can be determined and the beam section checked.

Example 7.16

Grain storage bin

(The theory given does not apply to deep bins). A shallow bin can be defined as one with a sidewall height of less than

$$\frac{S}{2} \tan \left(45^\circ + \frac{\theta}{2} \right) \text{ for a square bin of side length } S.$$

Consider a square bin of side length 4 metres retaining shelled maize/corn to a depth of 2 metres. Assume $\theta = 27^\circ$; specific weight is 7.7 kN/m^3 .

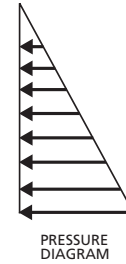
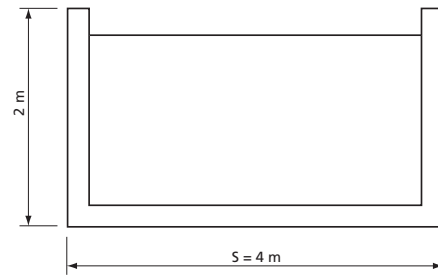

Critical height is:

$$\frac{S}{2} \tan \left(45^\circ + \frac{\theta}{2} \right) = \frac{4}{2} \tan (45^\circ + 13.5^\circ) = 2 \times 1.63 = 3.26 \text{ m}$$

Design in the same way as the shallow bin because the depth of grain is only 2 metres.

Maximum pressure at the base of the wall:

$$P = \frac{1 - \sin\theta}{1 + \sin\theta} \times wH$$

$$= \frac{1 - \sin 27^\circ}{1 + \sin 27^\circ} \times 7.7 \times 2 = 5.78 \text{ kN/m}^2$$

$$\text{or resultant force } P = \frac{5.78 \times 2^2}{2} = 11.56 \text{ kN/m}$$

(acting $2/3$ m above the base of the wall).

Note that the design of the wall is complex if it consists of a plate of uniform thickness, but if the wall is thought of as comprising a number of vertical members cantilevered from the floor, an approach similar to that for the soil-retaining wall can be used.

DESIGNING FOR EARTHQUAKES

In areas where earthquakes occur frequently, buildings must be designed to resist the stresses caused by tremors. While the intensity of tremors can be much greater in loosely compacted soil than in firm soil or solid bedrock, one- and two-storey buildings are at greater risk on firm ground or bedrock because of the shorter resonance periods.

Casualties are most likely to be caused by the collapse of walls causing the roof to fall, and the failure of projecting elements such as parapets, water tanks, non-monolithic chimneys and loose roof coverings. Outbreaks of fire caused by fractures in chimneys or breaks in mains supply lines present an additional hazard.

While small buildings with timber frame walls, or a wooden ring beam supported by the posts of a mud-and-pole wall, can resist quite violent earthquakes, the following measures will increase the resistance of a large building to collapse from earth tremors:

- Use a round or rectangular shape for the building. Other shapes such as 'L' 'T' or 'U' should be divided into separate units. To be effective, this separation must be carried down through to the foundation.
- Avoid large spans, greatly elongated walls, vault-and-dome construction and wall openings in excess of one-third of the total wall area.
- Construct a continuously reinforced footing that rests on uniform soil at a uniform depth – even on sloping ground.
- Fix the roof securely, either to a continuously reinforced ring beam on top of the walls, or to independent supports, which will not fail even if the walls collapse.
- Avoid projecting elements, brittle materials and heavy materials on weak supports.
- Avoid combustible materials near chimneys and power lines.

Ductile structures have many joints that can move slightly without failing, e.g. bolted trusses. Such structures have a greater capacity to absorb the energy of earthquake waves. A symmetrical, uniformly distributed ductile framework with the walls securely fixed to the frame is suitable for large buildings.

Masonry walls are sensitive to earthquake loads and tend to crack through the joints. It is therefore important to use a good mortar and occasionally reinforcing will be required.

REVIEW QUESTIONS

1. Define structural design.
2. Briefly describe the structural design process.
3. Why is it important to take into account deflection of structural elements during design phase?
4. Outline factors that influence design of beams.
5. Which measures improve the resistance of buildings to earthquake?
6. Calculate section moduli for a T-section, flange 150 mm by 25 mm, web thickness 25 mm and overall depth, 150 mm.
7. A 10 m long T section beam is simply supported, with the flange uppermost, from the right-hand end and at a point 2.5 m from the left-hand end. The beam is to carry a uniformly distributed load of 8 kN/m over the entire length. The allowable flange and web thickness is 25 mm. If the allowable maximum tensile strength and compressive stress are 125 MPa and 70 MPa respectively. Determine the size of the flange.
8. A short hollow cylindrical column with an internal diameter of 200 mm and external diameter of 250 mm carries a compressive load of 600 kN. Find the maximum permissible eccentricity of the load if (a) the tensile stress in the column must not exceed 15 MPa; (b) the compressive stress must not exceed 76 MPa.
9. Design a section of a trapezoidal masonry retaining wall 10 metres high, to retain earth weighing 16 000 N/m³. The angle of repose for the earth is 25° when the earth surface is horizontal and level with the top of the wall. The weight of the masonry wall is 25 000 N/m³.
10. A reinforced concrete beam is 200 mm wide, has an effective depth of 450 mm and four 20 mm diameter reinforcing bars. If the section has to resist a bending moment of 50×10^6 N mm, calculate the stresses in steel and concrete. The modular ratio of steel to concrete is equal to 18.

FURTHER READING

- Al Nageim, H., Durka, F., Morgan, W. & Williams, D.T. 2010. *Structural mechanics: loads, analysis, materials and design of structural elements*. 7th edition. London, Pearson Education.
- Nelson, G.L., Manbeck, H.B. & Meador, N.F. 1988. *Light agricultural and industrial structures: analysis and design*. AVI Book Co.
- Prasad, I.B. 2000. *A text book of strength of materials*. 20th edition. 2B, Nath Market, Nai Sarak, Delhi, Khanna Publishers.
- Roy, S.K. & Chakrabarty, S. 2009. *Fundamentals of structural analysis with computer analysis and applications*. Ram Nagar, New Delhi, S. Chand and Co. Ltd.
- Salvadori, M. & Heller, R. 1986. *Structure in architecture: the building of buildings*. 3rd edition. Englewood Cliffs, New Jersey, Prentice-Hall.
- Whitlow, R. 1973. *Materials and structures*. New York, Longman.

