

## Hydraulic System Solutions in Marine Technology



Precision engineering, robust and reliable



# At Home on the Ocean Wave – Rexroth in Marine Technology



Nowadays sea travel without hydraulics is unthinkable. Hydraulic drive systems are used to power essential operational units on ships. Wherever the situation calls for maximum power in a confined space, Rexroth is there – your competent partner.

Worldwide Service



These days ships represent an up-to-the-minute mode of travel. The marine travel sector calls for technically innovative solutions, which meet sea-going requirements in the best possible way. Reliability, robustness, permanent readiness for operation, low-maintenance and long service life – these are the pre-requisites for technical systems of this kind. Hydraulic drive and control solutions meet these requirements to a major extent.

Our specialists in this sector are used to working with the ship fitters right from the development phase. This is where application-specific know-how and decades of experience on the part of the Rexroth hydraulics specialists come into their own – with convincing results. The ship fitter has at his disposal complete systems or component solutions based on components specially developed for maritime applications.

The most up-to-date calculation processes and simulation software are used to check these solutions for functionality, performance and life span. Rexroth ensures trouble-free acceptance and certification.

Rexroth products for ship travel are low-maintenance, robust and reliable. To ensure their safe use around the globe there are subsidiaries in more than 70 countries offering on-site consultancy and guaranteeing rapid service and spares deliveries. Leading shipyards, ship fitters and suppliers all over the world rely on Rexroth systems to deliver safety and economic viability on the high seas.

#### System Know-how



#### Quality and Reliability



**Rexroth systems in marine technology: leading technology hand in hand with highly specialized applications know-how. The right partner for the demanding conditions at sea.**

Contents:

<b>Winches</b>	<b>4–5</b>
<b>Rudder systems</b>	<b>6</b>
<b>Cranes and davits</b>	<b>7</b>
<b>Hatch covers</b>	<b>7</b>
<b>Special valves</b>	<b>8</b>
<b>Control technology</b>	<b>9</b>
<b>Classifications</b>	<b>10</b>
<b>Applications example</b>	<b>11</b>
<b>Service</b>	<b>12</b>

Bosch Rexroth offers more system solutions in the following areas:

- Cargo pumps
- Thrusters and propeller drives
- Bow and stern doors
- Bulkhead and hull seals
- RoRo equipment
- Lifts
- Water jet
- Marine diesel control
- Underwater applications
- Generator drives
- Centralized oil supply

## Winch Drives – Sensitive and Reliable

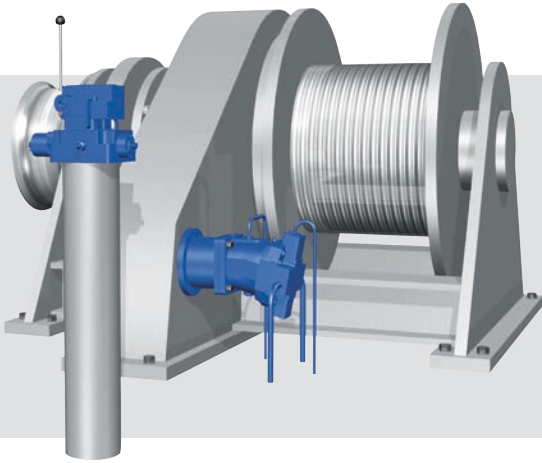

In addition to an extensive range of standard products, Rexroth offers solutions specially developed for marine applications. This means optimum adaptation of your requirements to the winch drive.

Depending on what the ship is to be used for, Rexroth is able to supply drive solutions for a very wide range of winch systems:

- Anchor and mooring winches
- Fishery winches
- Cranes
- Towing winches
- Dynamic winches for swell compensation
- Deep sea winches
- Winch systems for yachts

Winches with high pressure hydraulics are characterized by the fact that they need only a small installation space and that their operation is infinitely controllable and load-independent. Whether it's compact winches in closed circuit, winch drives in open circuit or secondary control drives for maximum dynamics: Rexroth is the right partner when it comes to winch drives in all performance categories.

### Our specialty – compact winches in closed cycle operation

Rexroth's compact winches are characterized by their flexible and straightforward installation. This dispenses with the need for complicated pipework.

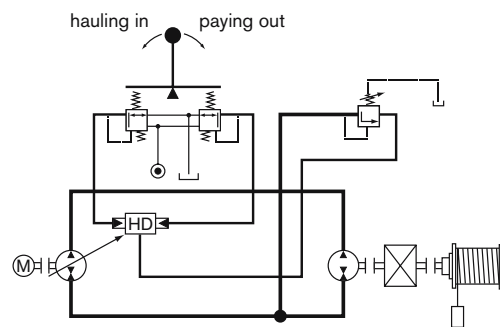

**Hydrostatic MOBILEX gearbox**  
MOBILEX GFT-W-gearboxes are ideal drive components for crane winches with low-noise operation. As a result of their extremely installation-friendly and compact design they can be fitted directly into the cable reels, thus saving space.



MOBILEX GFT-W



#### Winch control block

Whether it's a topline winch with high unladen rope speed, a mooring winch with automatic rope tightening or an anchor winch with an initial break-away torque increased by 50%: the WCB, with its seawater-resistant deck construction and modular design, caters for every eventuality, both on its own or when used in combination. The WCB also features a choice between manual, hydraulic or electric controls.



WCB

#### Hydraulic motors

The robust A6VM hydraulic motor with its broad adjustment range and high power-density permits high unladen rope speeds.



A6VM

#### Swashplate pump

The A10VSO open circuit swashplate pump has proved itself as a standard for winch units. And this is not the only reason why these pumps have been used for more than 20 years in maritime applications all over the world.



A10VSO

#### Remote control devices

The TH7 remote control device enables sensitive control of the winch by using different control curves.



TH7

#### Winch valves

The WMM 16 SO840 proportional valve, featuring an electric or hydraulic remote control facility, has been specially developed to meet the demand for smooth and jerk-free start-up of winch drums. This is in part achieved by means of a particularly low-friction valve piston.



4WMM16

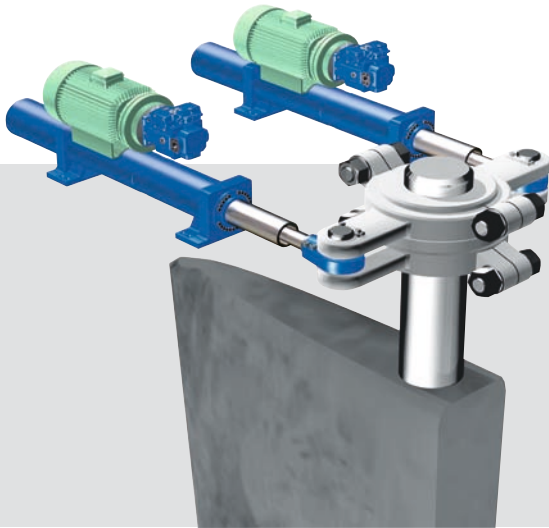

## Rudder Systems – Right on Course

Maximum maneuverability, optimum efficiency, safety and economy in operation – Rexroth supplies the technology to ensure that you steer the right course.

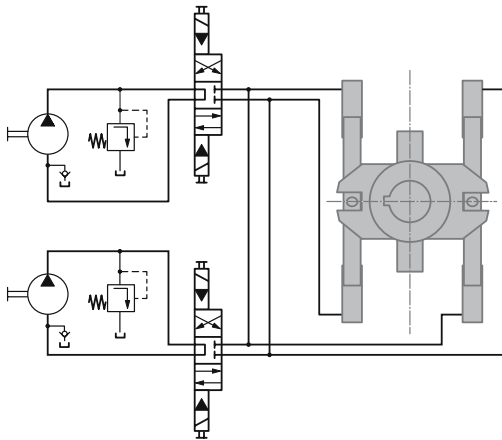

Redundant rudder system for a 7,500 TEU container freighter

In order to ensure smooth operation of the rudder system, Rexroth supplies robust and reliable components reflecting state-of-the-art technology.

### Proportional valves with integrated switch position monitoring

So as to enabling monitoring of the function and position of the rudder at any time, Rexroth has opted for the WRZ proportional valve with integrated switch position monitoring. This valve has been specially developed for these applications.

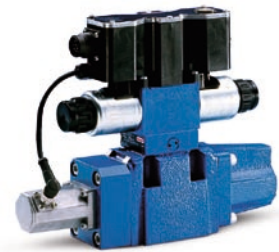

WRZ



A4CSG

### Axial piston pumps

The extremely robust and reliable A4CSG axial piston pump, with integral feed pump and valve technology, has proved itself in relation to these applications.

### Cylinders

Rexroth supplies the right cylinder for all the steering power required. The pressurized parts of the cylinders are supplied with certified material in accordance with the relevant classification specifications.



Cylinder

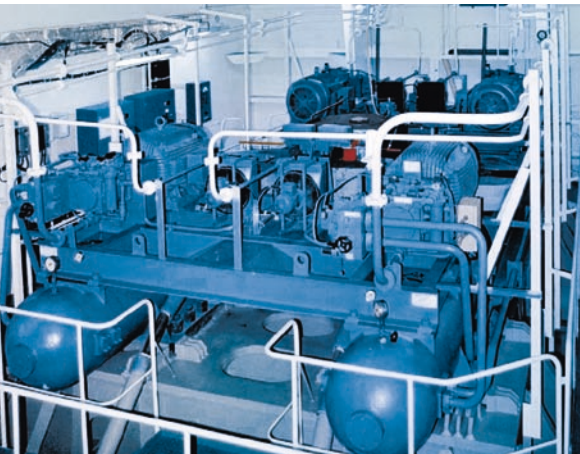

# Cranes, Davits, Hatch Covers – Motion with Rexroth Systems

Powerful, safe and efficient operation – Rexroth brings motion into play.

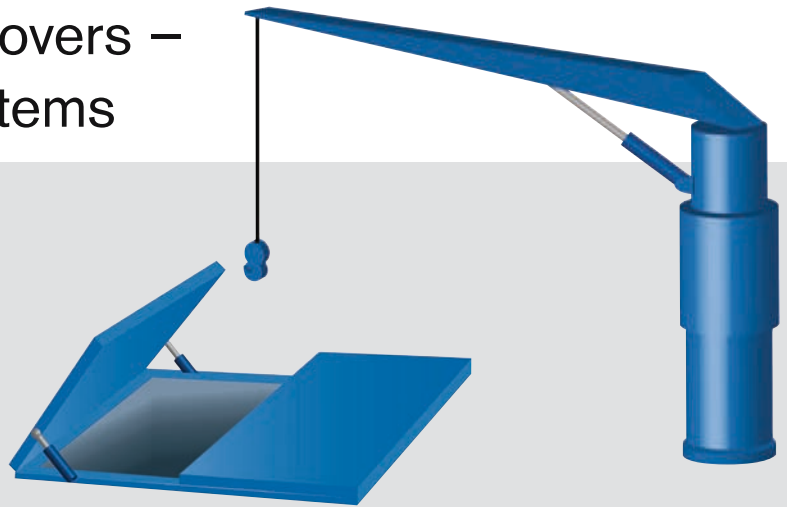

Turning, lifting, pushing: efficient power application hand-in-hand with maximum reliability in operation – behind all this is Rexroth technology.

## Power Units

Rexroth supplies matching “power packs” to meet the requirements of every drive in marine technology – manufactured to a uniform standard, as with all our components and systems. This guarantees economic efficiency, long service life and reliability.

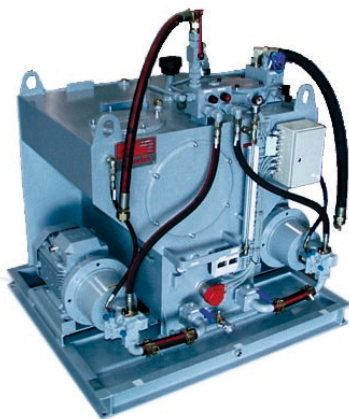

Power Unit

## Swivel Drives

The hydrostatic MOBILEX-GFB swivel drives are used for the rotary movements in ships’ cranes and with side rolling hatch cover drives. They have proved themselves in tough applications and under adverse conditions of use.

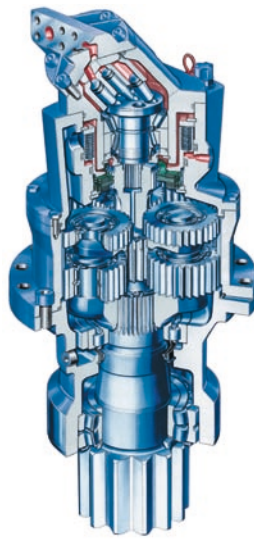

MOBILEX-GFB

## High Pressure Control Blocks

The crane is controlled by the high pressure control blocks M4-12, 15 and 22 in disc design. These blocks operate with load sensing to save energy. For different loads and where a number of actuators are operated at the same time, load pressure compensation ensures that the same speed can be maintained. The blocks can be operated mechanically, hydraulically, electro-hydraulically or with on-board electronics. In addition, the M7-22 monoblock with its load-independent flow distribution ensures that all the actuators can continue to run at a proportionally reduced speed even where the volume flow is insufficient.



M4-12

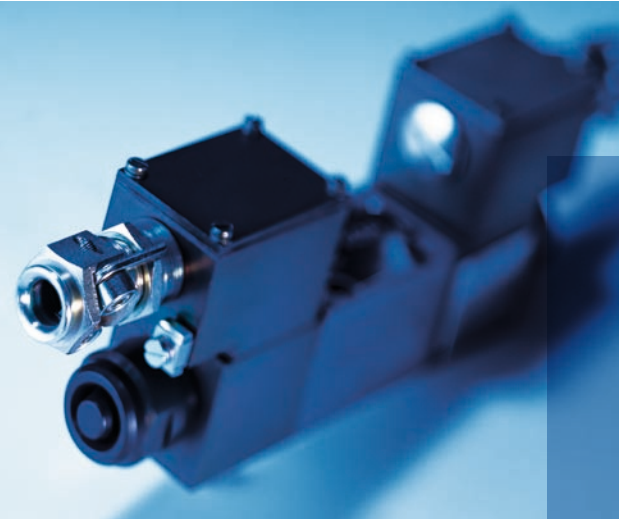

## Hydraulics in Special Applications

Arctic temperatures, extreme conditions in relation to pressure in the deep seas, hazardous situations in environments at risk from explosions – everywhere Rexroth components developed specially for your application operate automatically, safely and reliably.

### Valves and Cylinders with protection against seawater

Rexroth offers you a unique range of components featuring protection against seawater. Seawater-resistant steel or even brass is used at critical points in construction. It goes without saying that robust electrical interfaces with corresponding IP Protection are included. For harsh conditions of use in aggressive seawater our cylinders feature the piston rod coating from Ceramax Engineered Coatings, based on the latest oxide coating (plasma).

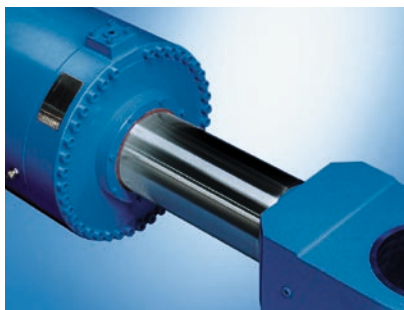

### Special Projects for deep sea applications

Deep water projects place particular demands on the components as regards pressure and temperature ratios. Rexroth offers specially designed valves and components for pressure-compensated sub-oil application. With these, usage is possible down to a depth of 3,500 meters.

### Components for sub-zero temperature applications

Rexroth even supplies solutions and special technologies for use under the harshest conditions of the Arctic regions. These include special valves for open deck applications at ambient temperatures of down to 50°C below zero.



### Components in accordance with ATEX Directives

In close co-operation with the customer Rexroth has implemented complete drive and control solutions for areas at risk from explosions. The products used for this, such as valves, hydraulic cylinders and power units are produced and supplied under strict observance of the ATEX Directive 94/9/EG.

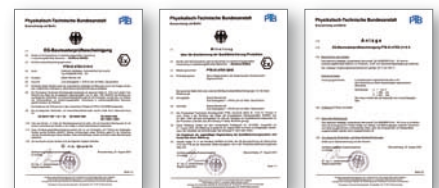



# Control and Automation Technology – Everything to Hand on Board

Complete control and automation technology, along with co-ordinated power electronics – with our individual total concepts we offer solutions that provide for the future.

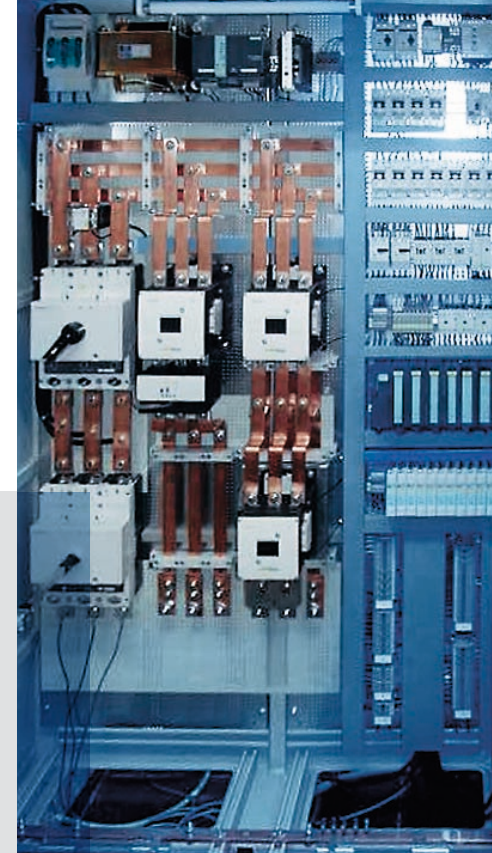

Power component with PLC and isolating amplifier

## Example: Cargo Pump Drive

The requirements:

Control concept for loading and unloading a bitumen and chemical tanker in an area at risk from explosion. Depending on the medium to be conveyed, the housing and storage temperatures of the cargo pump, together with the suction and delivery pressure of the pump, must be variable. As bitumen has to be kept permanently at a minimum temperature and circulated, a high level of availability is required.

The solution:

Visualization via touch panel with bus link to PLC. Inputting of sensor technology in the field via intrinsically safe circuits is followed by processing in the PLC. Monitoring and control of hydraulics, cooling and lubrication systems. Complete switching system designed for 300 KW in each case. In order to guarantee the required availability the complete system has been designed so as to be redundant.

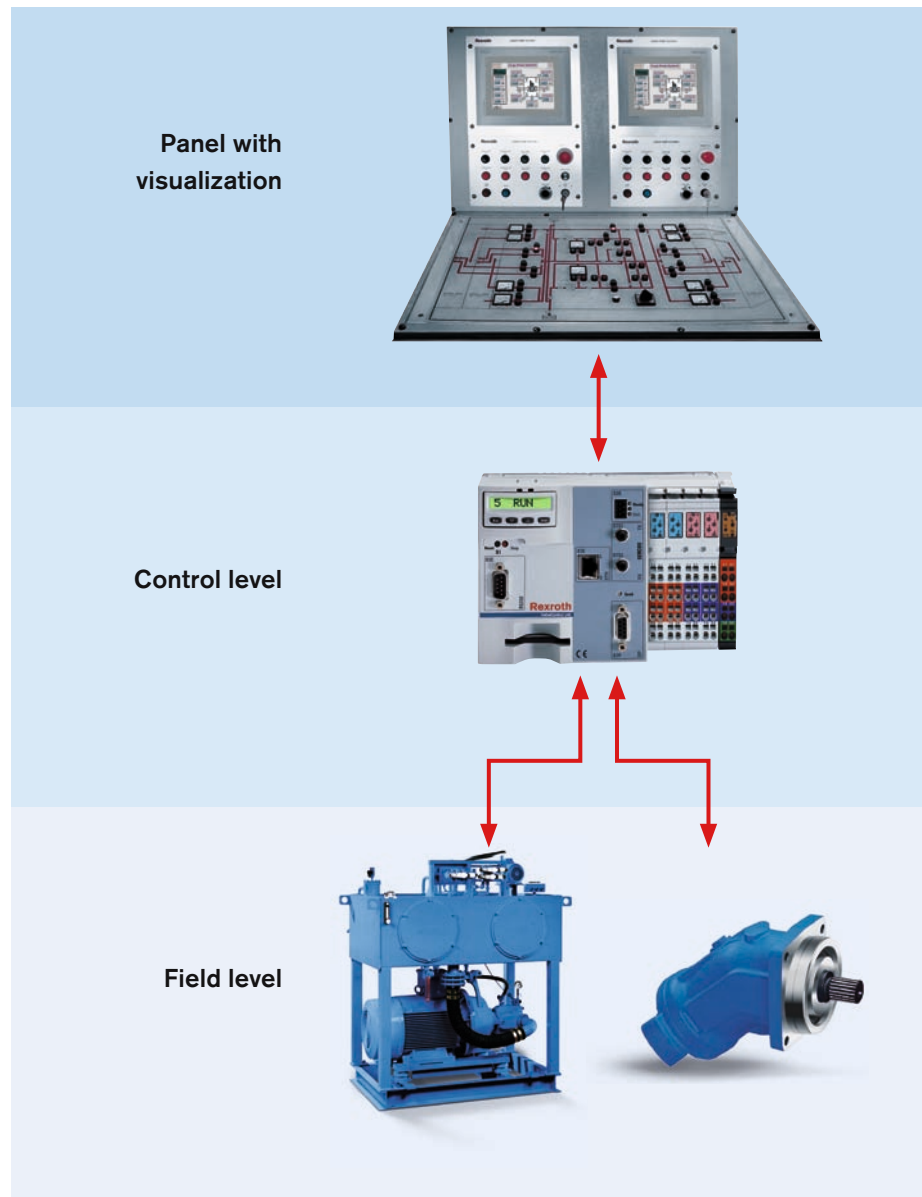

**Voith-Schneider propeller used as a ships's propulsion:** Bosch Rexroth supplies the system, approved by the Classification Society, for pitch adjustment of the VSP (power unit, control block and cylinder). It permits precision control and positioning of the ship.



## Classified Products

**Bosch Rexroth has decades of experience in working with Classification Societies. Test engineers from all the well-known classification societies conduct regular acceptance tests at our premises.**

Rexroth components meet the strict specifications of the Classification Societies as regards design principles, the selection of materials and environmental requirements for the electronic components. Right at the beginning of the project the test criteria that are to be observed are defined together with the test engineer. Collaboration with the customer at an early stage guarantees that the project runs smoothly and on schedule.

### Examples of type-tested components

#### A4V Pump

Axial piston variable displacement pump with hp control for constant power, tested in accordance with Det Norske Veritas.

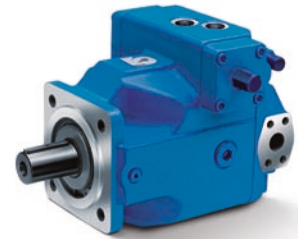

A4VS pump



#### WREA Proportional Valve

WREA proportional valve with integrated electronics for position control, tested in accordance with IACS (International Association of Classification Societies)  
Application example: Voith-Schneider propeller



WREA proportional valve

IACS E.10			
Dry Heat:	2 cycles	70°C	(Duration 2h)
Damp Heat:	2 cycles	55°C	Humidity 95% (Duration 2h)
Cold:	2 cycles	-25°C	(Duration 2h)
Vibration:	2 Hz-25 Hz	± 1.6 mm (amplitude)	
	25 Hz-100 Hz	± 4 g (acceleration)	
Electromagn. Field:	80 MHz-2 GHz	10 V/m (field strength)	
Burst:	± 2 kV	5 kHz	(spike frequency) (Duration 5 min.)

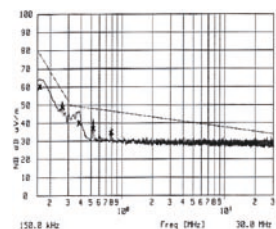

# Intelligent Hydraulics in New Dimensions

Wherever forces need to be utilized economically, the advantages of industrial hydraulics are obvious – whether it is required to lift and lower loads smoothly, perform linear or rotary movements, achieve constant acceleration, maintain given speeds, approach positions exactly, transmit powers or interlink sequences.

Rexroth is the technology and market leader in industrial hydraulics with a comprehensive product range and distinct application expertise.

At Rexroth you can select from the worlds' largest standard product range in the field of hydraulics, application and customer-specific

system solutions of high quality. With advanced micro-electronics Rexroth has made hydraulics even more powerful.

For you, Rexroth is the ideal partner for developing highly efficient machines and production facilities – from the first point of contact to commissioning and throughout the entire life cycle. Teams that operate worldwide carry out the complete engineering of your systems and, if requested, up to the hand-over of turnkey systems and beyond – service included.

Thanks to the use of hydraulic drive and control technology from Rexroth you will be more competitive than ever.

Electric  
Drives and  
Controls

Hydraulics

Linear  
Motion and  
Assembly  
Technologies

Pneumatics

Service

## **The Drive & Control Company**

Rexroth offers a unique and comprehensive range of products and services across technologies in its five fields of technology and service areas – strong in high-quality individual technologies, combined with highest application-specific competence in system packages with integrated complete solutions.

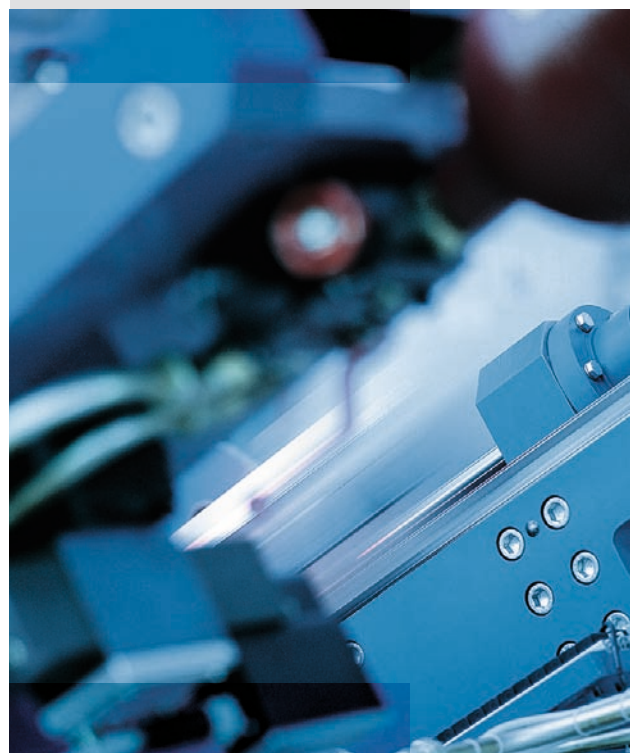

## **Rely on service across technologies**

Rexroth integrates all services for the entire product spectrum in the field of factory and industrial automation into a single organization: from immediate support, spare parts service, field and repair service, retrofit/modernization through to training.

Bosch Rexroth AG  
Hydraulics  
BRH/STI11  
Zum Eisengießer 1  
97816 Lohr, Germany  
Phone: +49(0)9352/18-4695  
Fax: +49(0)9352/18-1293  
info.bri@boschrexroth.de  
www.boschrexroth.com