

MRCET

BASIC MECHANICAL ENGINEERING

B.Tech II-YEAR

2018

AUTONOMOUS  
MAISAMMAGUDA

**UNIT-1**  
**ENGINEERING THERMODYNAMICS**

**What is Thermodynamics?**

Thermodynamics is a science dealing with Energy and its transformation and its effect on the physical properties of substances.

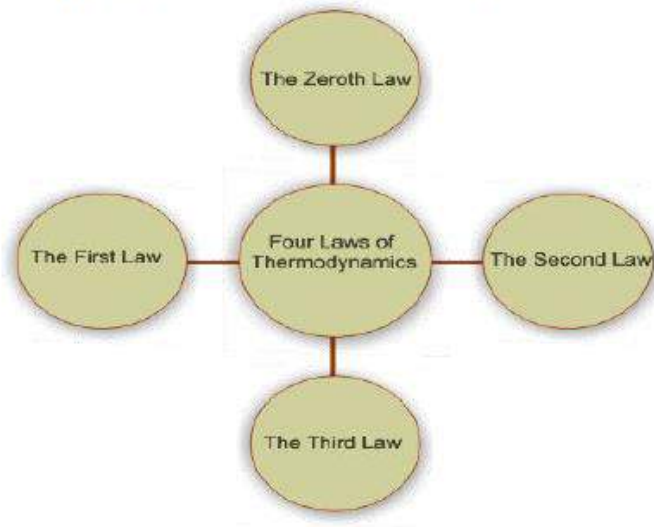
It deals with equilibrium and feasibility of a process.

Deals with the relationship between heat and work and the properties of systems in equilibrium.

**Scope of Thermodynamics:**

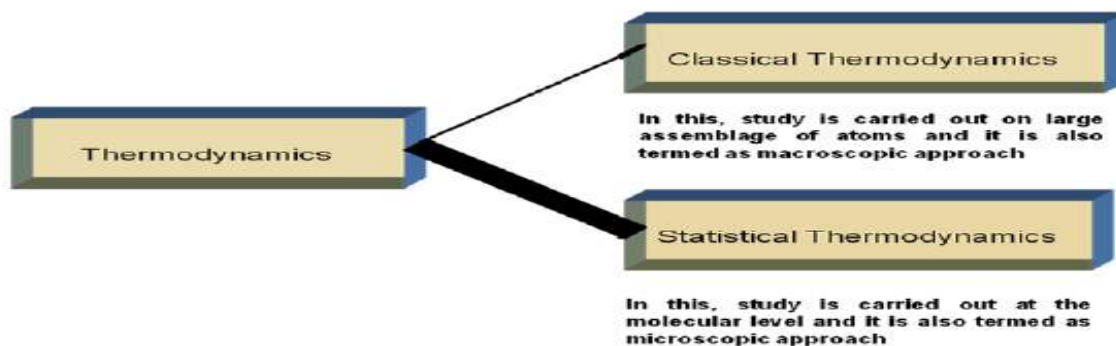
- Steam power plant
- Separation and Liquification Plant
- Refrigeration
- Air-conditioning and Heating Devices.
- Internal combustion engine
- Chemical power plants
- Turbines
- Compressors, etc

The principles of thermodynamics are summarized in the form of four thermodynamic laws:



1. **The Zeroth Law** deals with thermal equilibrium and provides a means for measuring temperatures.
2. **The First Law** deals with the conservation of energy and introduces the concept of internal energy.
3. **The Second Law** of thermodynamics provides with the guidelines on the conversion of internal energy of matter into work. It also introduces the concept of entropy.
4. **The Third Law** of thermodynamics defines the absolute zero of entropy. The entropy of a pure crystalline substance at absolute zero temperature is zero.

**Different Approaches of Thermodynamics :**



**Write the difference between Macroscopic and Microscopic approach of Thermodynamics:**

<b>Macroscopic Approach</b>	<b>Microscopic Approach</b>
1. Macroscopic approach is known as Classical Thermodynamics.	1. Microscopic approach is known as Statistical Thermodynamics
2. Attention is focussed on a certain quantity of matter without taking into account the events occurring at molecular level.	2. A knowledge of the structure of matter under consideration is essential.

3. Only a few variables are used to describe the state of the matter under consideration.	3. A large no. of variables are required for a complete specification of the state of matter under consideration.
4. The values of the variables used to describe the state of the matter are easily measurable.	4. The variables used to describe the state of matter cannot be measured easily and precisely

**Define Thermodynamic System?**

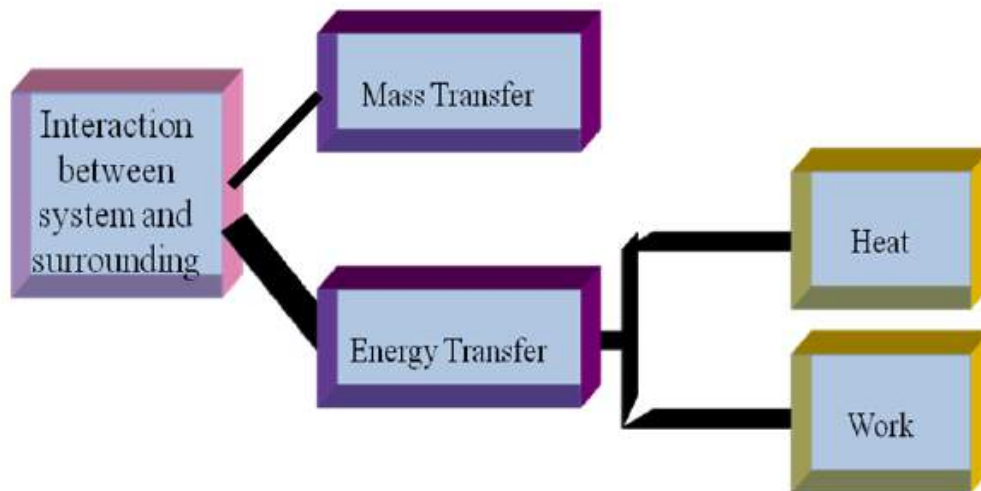
A thermodynamic system is defined as a definite quantity of matter or a region of space within a prescribed boundary upon which attention is focussed in the analysis of a problem.

**Surrounding:** Everything external to the system is Surroundings.

**Boundary:**

- The surface which separates the system from the surrounding.
- System and surrounding interact through boundary in the form of Heat and Work.
- Boundary can be real (or) imaginary.
- Boundary can be fixed (or) moving.
- System and Surrounding put together is known as **Universe**

### Interaction Between System and Surrounding



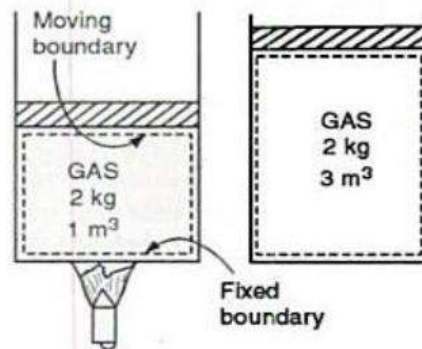
Based on the type of interaction, the systems are classified as

- **CLOSED SYSTEM**
- **OPEN SYSTEM**
- **ISOLATED SYSTEM**

**CLOSED SYSTEM (Control Mass)** : It is also termed as control mass or fixed mass analysis.

There is no mass transfer across the system boundary but energy in the form of Heat or Work can cross the system boundary.

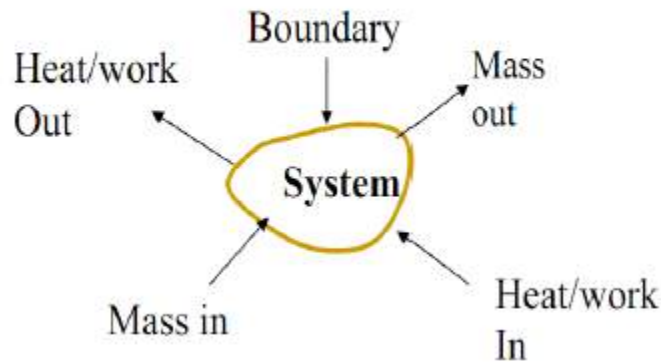
Eg.



Eg. A certain amount of gas enclosed in a cylinder piston arrangement.

**Open System(Control Volume):** The open system is one in which both mass and energy can cross the boundary of the system.

Open



Open system is also termed as control volume analysis

**Write down the concept of Control Volume:**

A large engineering problems involve mass flow in and out of a system and therefore, are modeled as control volumes.

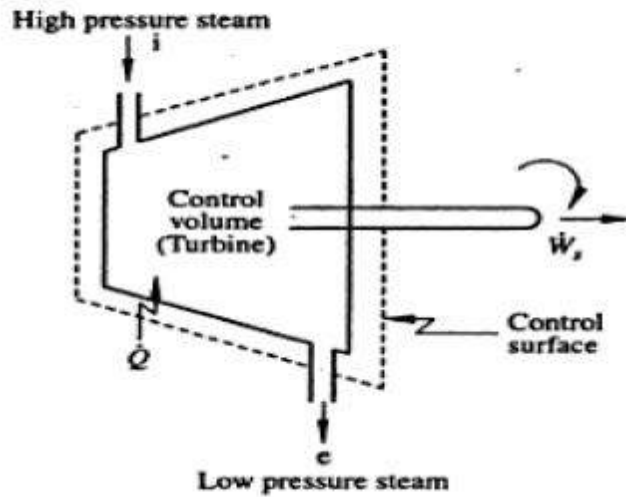
**Control volume** refers to a definite volume on which attention is focussed for energy analysis.

Examples: Nozzles, Diffusers, Turbines, Compressors,

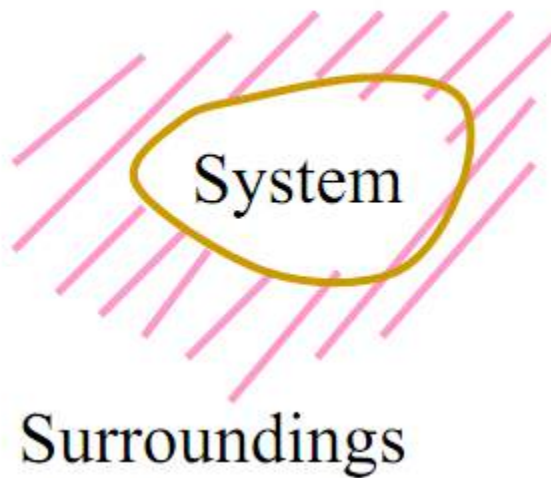
Heat Exchanger, De-superheater, Throttling valves,

I.C engine etc.

**Control Surface:** The closed surface that surrounds the control volume is called **CONTROL SURFACE**. Mass as well as energy crosses the control surface. Control surface can be real or imaginary.



**Isolated System:** The isolated system is one in which there is no interaction between the system and the surroundings that neither the mass nor the energy interactions. Therefore it is of fixed mass and energy.

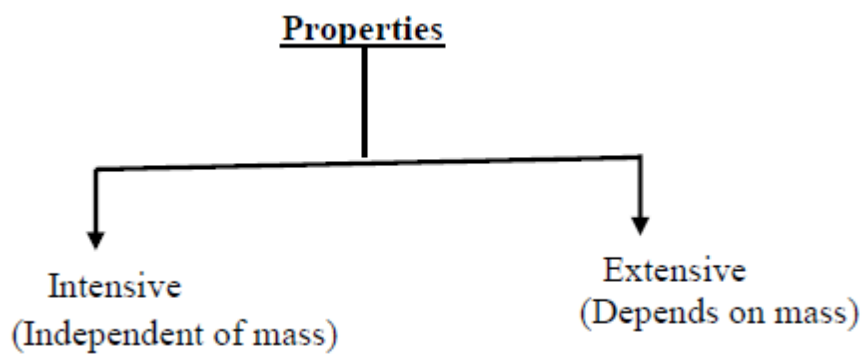


**Note:**

<b>Mass Transfer</b>	<b>Energy Transfer</b>	<b>Type of System</b>
No	Yes	Closed System
Yes	Yes	Open System
No	No	Isolated System
Yes	No	Impossible

**What do you mean by Property?**

Any observable characteristics required to describe the conditions or state of a system is known as Thermodynamic property of a system.





**Differentiate Intensive and Extensive Property?**

<b>Extensive Property</b>	<b>Intensive Property</b>
1. Extensive properties are dependent on the mass of a system.	1. Intensive properties are independent of the mass of a system.
2. Extensive properties are additive.	2. Intensive properties are not additive.
3. Its value for an overall system is the sum of its values for the parts into which the system is divided.	3. Its value remains the same whether one considers the whole system or only a part of it.
4. Example: mass(m), volume(V), Energy(E), Enthalpy(H) etc.	4. Example: Pressure(P), Temperature(T), Density etc.
5. Uppercase letters are used for extensive properties except mass.	5. Lowercase letters are used for intensive properties except pressure(P) and temp.(T)

**FIRST LAW OF THERMODYNAMICS**

- This is based on Law of Conservation of Energy.
- This is also called as First Principle.

**For a closed system, undergoing a cycle**

Sum of all Work transfers = Sum of all Heat Transfers

$$(W_1+W_2+W_3+\dots) = \Sigma(Q_1 +Q_2+Q_3+\dots\dots\dots)$$

$$\Sigma(W) = \Sigma(Q)$$

$$\oint dW = \oint dQ$$

**For a closed system,undergoing a Process**

Whenever heat is absorbed by a system it increases its internal energy and does some work.

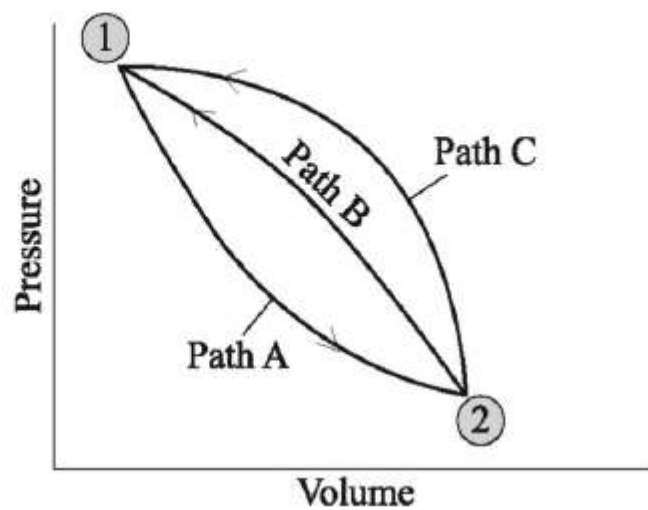
$$Q = \Delta E + W$$

Where  $Q$  – heat absorbed by the system

$W$  – Work output from the system

$\Delta E$  – Change in Stored Energy of the system

**Show that Energy is a property of the system**



For path A,

$$Q_A = W_A + \Delta E_A \quad (1)$$

For path B,

$$Q_B = W_B + \Delta E_B \quad (2)$$

For path C,

$$Q_C = W_C + \Delta E_C \quad (3)$$

For Cycle 1-A-2-B-1,

$$W_A + W_B = Q_A + Q_B \quad (4)$$

$$Q_A - W_A = -(Q_B - W_B)$$

$$\Delta E_A = -\Delta E_B \quad (A)$$

For Cycle 1-A-2-C-1,

$$W_A + W_C = Q_A + Q_C$$

$$Q_A - W_A = -(Q_C - W_C)$$

$$\Delta E_A = -\Delta E_C \quad (C)$$

Comparing A and C

$$\Delta E_B = \Delta E_C$$

**Enthalpy:**

- It is the energy content of the flowing fluid.
- It is defined by the summation of internal energy and flow work.

$$H = U + PV$$

Note: For an ideal gas  $h = u + Pv$ .

$$= u + RT$$

$$\text{So, } h = f(T)$$

$$C_v = \left( \frac{\partial u}{\partial T} \right)_v$$

is also defined as the change of internal energy of the substance per unit change in temperature at constant volume. C

**Define Cp with the help enthalpy and Temperature:**

The amount of heat required to raise the temperature of unit mass of a substance by 1o C in a

$$C_p = \left( \frac{\partial h}{\partial T} \right)_p$$

reversible constant pressure process.

is also defined as the change of internal energy of the substance per unit change in temperature at constant volume. C

**Define Cp with the help enthalpy and Temperature:**

The amount of heat required to raise the temperature of unit mass of a substance by 1o C in a reversible constant pressure process.

$$C_p = \left( \frac{\partial h}{\partial T} \right)_p$$

$C_p$  is also defined as the change of internal energy of the substance per unit change in temperature at constant pressure.

**Application of First law to different Thermodynamic process:**

Process	Index=n	Q	$W = \int PdV$	P-V-T Relation
Rev. Const.Vol.	$\infty$	$Q = \Delta U$ $= mC_v(T_2 - T_1)$	$W=0$	$\frac{P_1}{T_1} = \frac{P_2}{T_2}$
Rev.Const.pressure	$n=0$	$Q = \Delta H$ $= mC_p(T_2 - T_1)$	$W = P(V_2 - V_1)$ $= mR(T_2 - T_1)$	$\frac{V_1}{T_1} = \frac{V_2}{T_2}$
Rev. Isothermal	$n=1$	$Q = W = P_1V_1 \ln\left(\frac{V_2}{V_1}\right)$	$W = P_1V_1 \ln\left(\frac{V_2}{V_1}\right)$	$P_1V_1 = P_2V_2$
Rev.Adiabatic	$n=\gamma$	$Q=0$	$W = \frac{P_1V_1 - P_2V_2}{\gamma - 1}$	$P_1V_1^\gamma = P_2V_2^\gamma$
Rev.Polytropic	$n$	$Q = \Delta U + W$	$W = \frac{P_1V_1 - P_2V_2}{n - 1}$	$P_1V_1^n = P_2V_2^n$

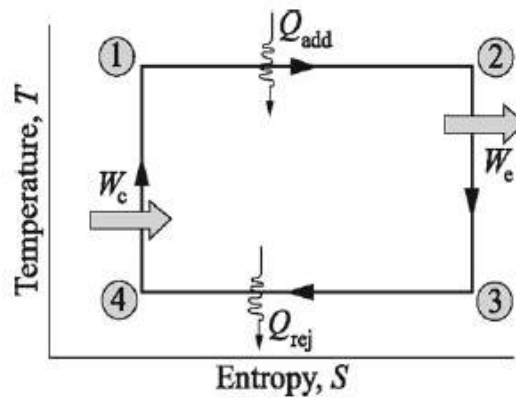
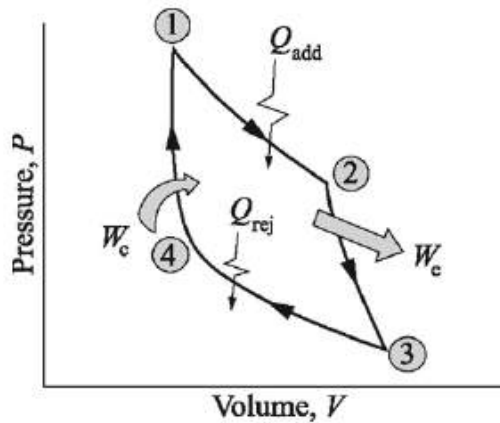
**Carnot Cycle:** Carnot cycle is a reversible cycle that is composed of four reversible processes, two isothermal and two adiabatic.

**Process 1 - 2 (Reversible Isothermal Heat Addition)**

**Process 2 – 3 (Reversible Adiabatic Expansion)**

**Process 3 – 4 (Reversible Isothermal Heat Rejection)**

**Process 4 – 1 (Reversible Adiabatic Compression)**



$$\Sigma(Q_{\text{net}})_{\text{cycle}} = \Sigma(W_{\text{net}})_{\text{cycle}}$$

$$Q_{\text{add}} - Q_{\text{rej}} = W_e - W_c$$

$$\eta = \frac{W_{\text{net}}}{Q_{\text{add}}} = \frac{Q_{\text{add}} - Q_{\text{rej}}}{Q_{\text{add}}}$$

$$\boxed{\eta = 1 - \frac{Q_{\text{rej}}}{Q_{\text{add}}}}$$

From T-S diagram

$$\eta = 1 - \frac{T_2 (\Delta S)}{T_1 (\Delta S)}$$

$$\boxed{\eta = 1 - \frac{T_2}{T_1}}$$

### Carnot's Theorem:

1. The efficiency of an irreversible heat engine is always less than efficiency of a reversible one operating between the same two reservoirs.
2. The efficiencies of all reversible heat engines operating between the same reservoirs are the same.

### Clausius Inequality

The cycle integral of  $\frac{\delta Q}{T}$  is always less than or equal to zero.

Mathematically it can be expressed as  $\oint \frac{\delta Q}{T} \leq 0$ . The equality in the Clausius inequality holds for totally or just reversible cycle and the inequality for the irreversible ones.

### Otto cycle:

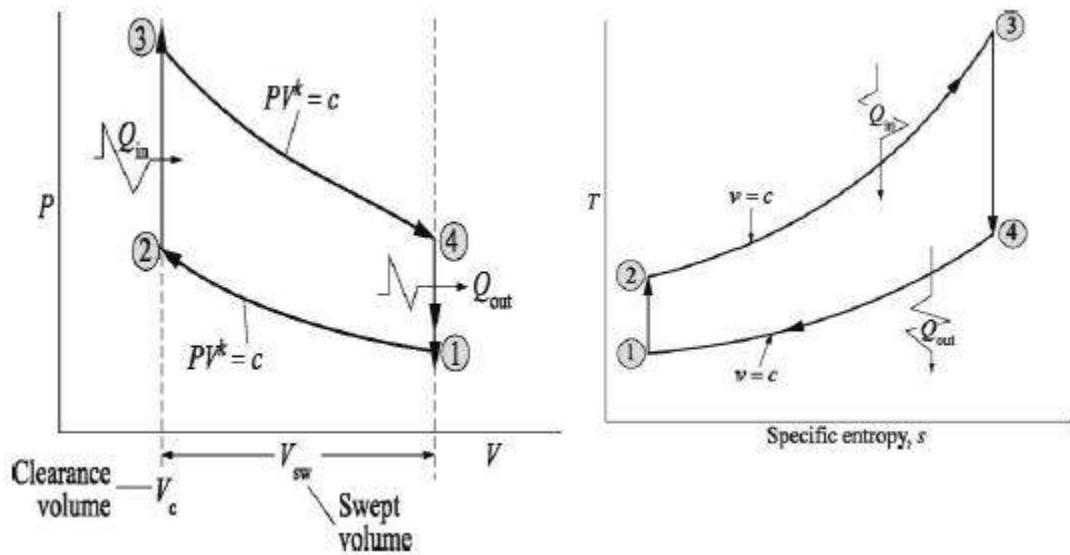
The processes in Otto cycle are

(1 – 2) Isentropic Compression

(2 – 3) Constant volume heat addition.

(3 – 4) Isentropic Expansion.

(4 – 1) Constant volume heat rejection.



### Efficiency of Otto Cycle

$$\eta_{Oto} = \frac{W_{net}}{\text{Heat Supplied}}$$

$$W_{net} = W_{3-4} - W_{2-1}$$

$$W_{3-4} = C_v (T_3 - T_4) = C_v T_3 \left( 1 - \frac{1}{r_k^{\gamma-1}} \right)$$

$$W_{2-1} = C_v (T_2 - T_1) = C_v T_1 (1 - r_k^{\gamma-1})$$

$$W_{net} = C_p \left( 1 - \frac{1}{r_k^{\gamma-1}} \right) T_3 - T_1 r_k^{\gamma-1}$$

$$\eta_{Oto} = \left[ 1 - \frac{1}{r_k^{\gamma-1}} \right]$$

$$\text{Work ratio} = \frac{W_{net}}{W_{turbine}} = 1 - \left[ \frac{T_1}{T_3} \right] r_k^{(\gamma-1)}$$

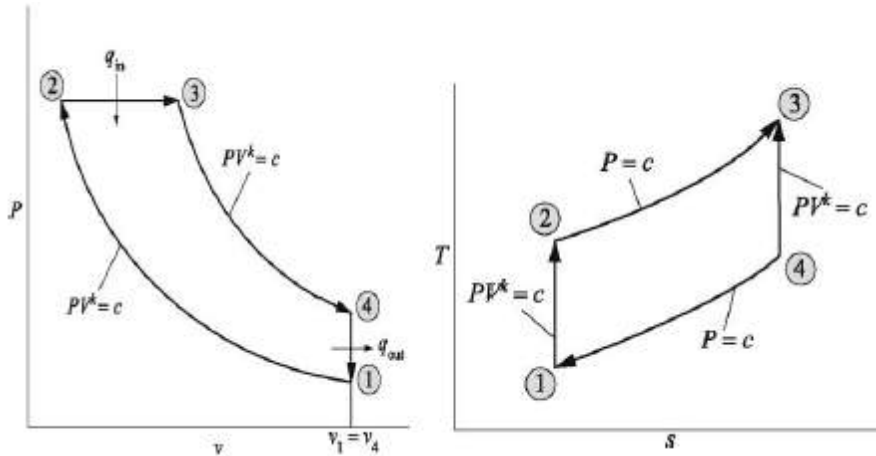
342134 3431121 2111311 1 1 C() C T1 C (T) C T(1 r)1 = C1 r1 1 WWork ratio =  
netOttovkvvknetpkkottoknetturbWHeatSuppliedWnetWWWTTTrWTWTTTrW(1)131kineTrT

### Diesel cycle

The processes in Diesel cycle are:

- (1 – 2) Isentropic Compression
- (2 – 3) Constant pressure heat addition.
- (3 – 4) Isentropic Expansion.
- (4 – 1) Constant volume heat rejection.





### Efficiency of Diesel cycle

$$\eta_{\text{Diesel}} = \frac{W_{\text{net}}}{\text{Heat Supplied}} = \frac{q_{\text{in}} - q_{\text{out}}}{q_{\text{in}}}$$

Now  $q_{\text{in}} = c_p(T_3 - T_2)$  and  $q_{\text{out}} = c_v(T_4 - T_1)$

$$\text{Hence } \eta_{\text{th}} = \frac{c_p(T_3 - T_2) - c_v(T_4 - T_1)}{c_p(T_3 - T_2)}$$

$$= 1 - \frac{(T_4 - T_1)}{\gamma((T_3 - T_2))} = 1 - \frac{T_1 \left[ \frac{T_4}{T_1} - 1 \right]}{\gamma T_2 \left[ \frac{T_3}{T_2} - 1 \right]}$$

$$\text{Now } \frac{T_1}{T_2} = \left( \frac{v_2}{v_1} \right)^{\gamma-1} = \left( \frac{1}{r_c} \right)^{\gamma-1}$$

$$\text{Also since } p_3 = p_2, \text{ hence } \frac{T_3}{T_2} = \frac{v_3}{v_2} = \rho$$

where  $\rho$  is the cut-off ratio.

$$\text{Again since } v_4 = v_1, \frac{T_4}{T_1} = \frac{p_4}{p_1} = \rho^\gamma$$

Substituting the values of  $\frac{T_1}{T_2}$ ,  $\frac{T_3}{T_2}$ , and  $\frac{T_4}{T_1}$ , the value of thermal efficiency

$$\eta_{th} = 1 - \left( \frac{1}{r_c} \right)^{\gamma-1} \left[ \frac{\rho^\gamma - 1}{\gamma(\rho - 1)} \right]$$

## UNIT-2

**BOILERS STEAM GENERATOR** Boiler is an apparatus to produce steam. Thermal energy released by combustion of fuel is transferred to water, which vaporizes and gets converted into steam at the desired temperature and pressure. The steam produced is used for: (i) Producing mechanical work by expanding it in steam engine or steam turbine. (ii) Heating the residential and industrial buildings (iii) Performing certain processes in the sugar mills, chemical and textile industries. Boiler is a closed vessel in which water is converted into steam by the application of heat. Usually boilers are coal or oil fired. A boiler should fulfill the following requirements (i) Safety. The boiler should be safe under operating conditions. (ii) Accessibility. The various parts of the boiler should be accessible for repair and maintenance. (iii) Capacity. The boiler should be capable of supplying steam according to the requirements. (iv) Efficiency. To permit efficient operation, the boiler should be able to absorb a maximum amount of heat produced due to burning of fuel in the furnace. (v) It should be simple in construction and its maintenance cost should be low. (vi) Its initial cost should be low. (vii) The boiler should have no joints exposed to flames. (viii) The boiler should be capable of quick starting and loading. The performance of a boiler may be measured in terms of its evaporative capacity also called power of a boiler. It is defined as the amount of water evaporated or steam produced in kg per hour. It may also be expressed in kg per kg of fuel burnt or kg/hr/m<sup>2</sup> of heating surface. The boilers can be classified according to the following criteria. According to flow of water and hot gases. 1. Water tube. 2. Fire tube. In water tube boilers, water circulates through the tubes and hot products of combustion flow over these tubes. In fire tube boiler the hot products of combustion pass through the tubes, which are surrounded, by water. Fire tube boilers have low initial cost, and are more compact. But they are more likely to explosion, water volume is large and due to poor circulation they cannot meet quickly the change in steam demand. For the same output the outer shell of fire tube boilers is much larger than the shell of water-tube boiler. Water tube boilers require less weight of metal for a given size, are less liable to explosion, produce higher pressure, are accessible and can response quickly to change in steam demand. Tubes and drums of water-tube boilers are smaller than that of fire-tube boilers and due to smaller size of drum higher pressure can be used easily. Water-tube boilers require lesser floor space. The

efficiency of water-tube boilers is more. Water tube boilers are classified as follows. 1. Horizontal straight tube boilers (a) Longitudinal drum (b) Cross-drum. 2. Bent tube boilers (a) Two drum (b) Three drum (c) Low head three drum (d) Four drum. 3. Cyclone fired boilers

Various advantages of water tube boilers are as follows. (i) High pressure of the order of 140 kg/cm<sup>2</sup> can be obtained. (ii) Heating surface is large. Therefore steam can be generated easily. (iii) Large heating surface can be obtained by use of large number of tubes. (iv) Because of high movement of water in the tubes the rate of heat transfer becomes large resulting into a greater efficiency.

Fire tube boilers are classified as follows. 1. External furnace: (i) Horizontal return tubular (ii) Short fire box (iii) Compact. 2. Internal furnace: (i) Horizontal tubular (a) Short firebox (b) Locomotive (c) Compact (d) Scotch. (ii) Vertical tubular. (a) Straight vertical shell, vertical tube (b) Cochran (vertical shell) horizontal tube.

Various advantages of fire tube boilers are as follows. (i) Low cost (ii) Fluctuations of steam demand can be met easily (iii) It is compact in size. According to position of furnace. (i) Internally fired (ii) Externally fired In internally fired boilers the grate combustion chamber are enclosed within the boiler shell whereas in case of externally fired boilers and furnace and grate are separated from the boiler shell. According to the position of principle axis. (i) Vertical (ii) Horizontal (iii) Inclined. According to application. (i) Stationary (ii) Mobile, (Marine, Locomotive). According to the circulating water. (i) Natural circulation (ii) Forced circulation. According to steam pressure. (i) Low pressure (ii) Medium pressure (iii) Higher pressure.

**PRINCIPLE OF OPERATION OF STEAM TURBINE** The principle of operation of steam turbine is entirely different from the steam engine. In reciprocating steam engine, the pressure energy of steam is used to overcome external resistance and the dynamic action of steam is negligibly small. But the steam turbine depends completely upon the dynamic action of the steam. According to Newton's Second Law of Motion, the force is proportional to the rate of change of momentum (mass × velocity). If the rate of change of momentum is caused in the steam by allowing a high velocity jet of steam to pass over curved blade, the steam will impart a force to the blade. If the blade is free, it will move off (rotate) in the direction of force. In other words,

the motive power in a steam turbine is obtained by the rate of change in moment of momentum of a high velocity jet of steam impinging on a curved blade which is free to rotate. The steam from the boiler is expanded in a passage or nozzle where due to fall in pressure of steam, thermal energy of steam is converted into kinetic energy of steam, resulting in the emission of a high velocity jet of steam which, Principle of working impinges on the moving vanes or blades of turbine (Fig. 6.1). . Attached on a rotor which is mounted on a shaft supported on bearings, and here steam undergoes a change in direction of motion due to curvature of blades which gives rise to a change in momentum and therefore a force. This constitutes the driving force of the turbine. This arrangement is shown. It should be realized that the blade obtains no motive force from the static pressure of the steam or from any impact of the jet, because the blade is designed such that the steam jet will glide on and off the blade without any tendency to strike it. when the blade is locked the jet enters and leaves with equal velocity, and thus develops maximum force if we neglect friction in the blades. Since the blade velocity is zero, no mechanical work is done. As the blade is allowed to speed up, the leaving velocity of jet from the blade reduces, which reduces the force. Due to blade velocity the work will be done and maximum work is done when the blade speed is just half of the steam speed. In this case, the steam velocity from the blade is near about zero i.e. it is trail of inert steam since all the kinetic energy of steam is converted into work. The force and work done become zero when the blade speed is equal to the steam speed. From the above discussion, it follows that a steam turbine should have a row of nozzles, a row of moving blades fixed to the rotor, and the casing (cylinder). A row of nozzles and a row of moving blades constitutes a stage of turbine. . CLASSIFICATION OF STEAM TURBINE Steam turbine may be classified as follows: - (A) On the Basis of Principle of Operation : (i) Impulse turbine (a) Simple, (b) Velocity stage, (c) Pressure stage, (d) combination of (b) and (c). STEAM TURBINE 197 (ii) Impulse-reaction turbine (a) 50% (Parson's) reaction, (b) Combination of impulse and reaction. (i) Impulse Turbine: If the flow of steam through the nozzles and moving blades of a turbine takes place in such a manner that the steam is expanded only in nozzles and pressure at the outlet sides of the blades is equal to that at inlet side; such a turbine is termed as impulse turbine because it works on the principle of impulse. In other words, in impulse turbine, the drop in pressure of steam takes

place only in nozzles and not in moving blades. This is obtained by making the blade passage of constant cross-section area. As a general statement it may be stated that energy transformation takes place only in nozzles and moving blades (rotor) only cause energy transfer. Since the rotor blade passages do not cause any acceleration of fluid, hence chances of flow separation are greater which results in lower stage efficiency. (ii) Impulse-Reaction Turbine: In this turbine, the drop in pressure of steam takes place in fixed (nozzles) as well as moving blades. The pressure drop suffered by steam while passing through the moving blades causes a further generation of kinetic energy within the moving blades, giving rise to reaction and adds to the propelling force which is applied through the rotor to the turbine shaft. Since this turbine works on the principle of impulse and reaction both, so it is called impulse-reaction turbine. This is achieved by making the blade passage of varying cross-sectional area (converging type). In general, it may be stated that energy transformation occurs in both fixed and moving blades. The rotor blades cause both energy transfer and transformation. Since there is an acceleration of flow in moving blade passage hence chances of separation of flow is less which results in higher stage efficiency. (B) On the basis of "Direction of Flow" : (i) Axial flow turbine, (ii) Radial flow turbine, (iii) Tangential flow turbine. (i) Axial Flow Turbine. In axial flow turbine, the steam flows along the axis of the shaft. It is the most suitable turbine for large turbo-generators and that is why it is used in all modern steam power plants. (ii) Radial Flow Turbine. In this turbine, the steam flows in the radial direction. It incorporates two shafts end to end, each driving a separate generator. A disc is fixed to each shaft. Rings of 50% reaction radial-flow bladings are fixed to each disk. The two sets of bladings rotate counter to each other. In this way, a relative speed of twice the running speed is achieved and every blade row is made to work. The final stages may be of axial flow design in order to achieve a larger area of flow. Since this type of turbine can be warmed and started quickly, so it is very suitable for use at times of peak load. Though this type of turbine is very successful in the smaller sizes but formidable design difficulties have hindered the development of large turbines of this type. In Sweden, however, composite radial/axial flow turbines have been built of outputs upto 275 MW. Sometimes, this type of turbine is also known as Liungstrom turbine after the name of its inventor B and F. Liungstrom of Sweden. (iii) Tangential Flow Turbine. In this type, the steam

flows in the tangential direction. This turbine is very robust but not particularly efficient machine, sometimes used for driving power station auxiliaries. In this turbine, nozzle directs steam tangentially into buckets milled in the periphery of a single wheel, and on exit the steam turns through a reversing chamber, reentering bucket further round the periphery. This process is repeated several times, the steam flowing a helical path. Several nozzles with reversing chambers may be used around the wheel periphery. (C) On the Basis of Means of Heat Supply: (i) Single pressure turbine, (ii) Mixed or dual pressure turbine (iii) Reheated turbine. (a) Single (b) Double (i) Single Pressure Turbine : In this type of turbine, there is single source of steam supply. (ii) Mixed or Dual Pressure Turbine : This type of turbines, use two sources of steam, at different pressures. The dual pressure turbine is found in nuclear power stations where it uses both sources continuously. The mixed pressure turbine is found in industrial plants (e.g., rolling mill, colliery, etc.) where there are two supplies of steam and use of one supply is more economical than the other; for example, the economical steam may be the exhaust steam from engine which can be utilised in the L. P. stages of steam turbine. Dual pressure system is also used in combined cycle. (iii) Reheated Turbine : During its passage through the turbine steam may be taken out to be reheated in a reheater incorporated in the boiler and returned at higher temperature to be expanded in (Fig. 6.6). This is done to avoid erosion and corrosion problems in the bladings and to improve the power output and efficiency. The reheating may be single or double or triple. (D) On the Basis of Means of Heat Rejection : (i) Pass-out or extraction turbine, (ii) Regenerative turbine, (iii) Condensing turbine, (iv) Noncondensing turbine, (v) Back pressure or topping turbine. (i) Pass-out Turbine. In this turbine, (Fig. 6.4), a considerable proportion of the steam is extracted from some suitable point in the turbine where the pressure is sufficient for use in process heating; the remainder continuing through the turbine. The latter is controlled by separate valve-gear to meet the STEAM TURBINE 199 difference between the pass-out steam and electrical load requirements. This type of turbine is suitable where there is dual demand of steam-one for power and the other for industrial heating, for example sugar industries. Double pass-out turbines are sometimes used. (ii) Regenerative Turbine. This turbine incorporates a number of extraction branches, through which small proportions of the steam are continuously extracted for the purpose of heating the boiler feed water in a feed heater in

order to increase the thermal efficiency of the plant. Now a days, all steam power plants are equipped with reheating and regenerative arrangement. (iii) Condensing Turbine. In this turbine, the exhaust steam is condensed in a condenser and the condensate is used as feed water in the boiler. By this way the condensing turbine allows the steam to expand to the lowest possible pressure before being condensed. All steam power plants use this type of turbine. (iv) Non-Condensing Turbine. When the exhaust steam coming out from the turbine is not condensed but exhausted in the atmosphere is called non-condensing turbine. The exhaust steam is not recovered for feed water in the boiler. (v) Back Pressure or Topping Turbine. This type of turbine rejects the steam after expansion to the lowest suitable possible pressure at which it is used for heating purpose. Thus back pressure turbine supplies power as well as heat energy. The back pressure turbine generally used in sugar industries provides low pressure steam for heating apparatus, where as a topping turbine exhausts into a turbine designed for lower steam conditions. (E) On the Basis of Number of Cylinder: Turbine may be classified as (i) Single cylinder and (ii) Multi-cylinder. (i) Single Cylinder. When all stages of turbine are housed in one casing, then it is called single cylinder. Such a single cylinder turbine uses one shaft. (ii) Multi-Cylinder. In large output turbine, the number of the stages needed becomes so high that additional bearings are required to support the shaft. Under this circumstances, multi-cylinders are used. (F) On the Basis of Arrangement of Cylinder Based on General Flow of Steam. (i) Single flow, (ii) Double flow, and (iii) Reversed flow Single Flow. In a single flow turbines, the steam enters at one end, flows once [Fig. 6.5(a)] through Single flow (a) (b) (c) Double flow Reversed flow Fig. 6.5 the bladings in a direction approximately parallel to this axis, emerges at the other end. High pressure cylinder uses single flow. This is also common in small turbines. Double Flow. In this type of turbines, the steam enters at the centre and divides, the two portions passing axially away from other through separate sets of blading on the same rotor Fig. The low pressure cylinder normally uses double flow). This type of unit is completely balanced against the end thrust and gives large area of flow through two sets of bladings. This also helps in reducing the blade height as mass flow rate becomes half as compared to single flow for the same conditions. Reversed Flow. Reversed flow arrangement is sometimes used in h.p, cylinder where higher temperature steam is used on the larger sets in order to minimise differential



expansion i.e. unequal expansion of rotor and casing. The use of single, double and reversed flow is shown in the layout Fig. 6.5(c). (G) On the Basis of Number of Shaft (i) Tandem compound, (ii) Cross compound (i) Tandem Compound. Most multi-cylinder turbines drive a single shaft and single generator Such turbines are termed as tandem compound turbines. (ii) Cross Compound. In this type, two shafts are used driving separate generator. The may be one of turbine house arrangement, limited generator size, or a desire to run shafting at half speed. The latter choice is sometimes preferred so that for the same centrifugal stress, longer blades may be used, giving a larger leaving area, a smaller velocity and hence a small leaving loss. (H) On the Basis of Rotational Speed (i) constant speed turbines (ii) Variable speed turbines (i) Constant Speed Turbines. Requirements of rotational speed are extremely rigid in turbines which are directly connected to electric generators as these must be a-c unit except in the smallest sizes and must therefore run at speeds corresponding to the standard number of cycles per second and governed by the following equation :  $N = 120 \times \text{Number of cycles per second} = 120 f/p$  Number of poles The minimum number of poles, in a generator is two and correspondingly the maximum possible speed for 60 cycle is 3,600 rpm; for 50 c/s of frequency, the speeds would be 3,000, 1500 and 750 rpm for 2, 4 and 8 poles machines respectively. (ii) Variable Speed Turbines. These turbines have geared units and may have practically any speed ratio between the turbine and the driven machine so that the turbine may be designed for its own most efficient speed. Such turbines are used to drive ships, compressors, blowers and variable frequency generators. THE SIMPLE IMPULSE TURBINE This type of turbine works on the principle of impulse and is shown diagrammatically. It mainly consists of a nozzle or a set of nozzles, a rotor mounted on a shaft, one set of moving blades attached to the rotor and a casing. The uppermost portion of the diagram shows a longitudinal section through the upper half of the turbine, the middle portion shows the development of the nozzles and blading i.e. the actual shape of the nozzle and blading, and the bottom portion shows the variation of absolute velocity and absolute pressure during flow of steam through passage of nozzles and blades. The example of this type of turbine is the de-Laval Turbine. It is obvious from the figure that the complete expansion of steam from the steam chest pressure to the exhaust pressure or condenser pressure takes place only in one set of nozzles i.e. the pressure drop takes place

only in nozzles. It is assumed that the pressure in the recess between nozzles and blades STEAM TURBINE 201 remains the same. The steam at condenser pressure or exhaust pressure enters the blade and comes out at the same pressure i.e. the pressure of steam in the blade passages remains approximately constant and equal to the condenser pressure. Generally, converging-diverging nozzles are used. Due to the relatively large ratio of expansion of steam in the nozzles, the steam leaves the nozzles at a very high velocity (supersonic), of about 1100 m/s. It is assumed that the velocity remains constant in the recess between the nozzles and the blades. The steam at such a high velocity enters the blades and reduces along the passage of blades and comes out with an appreciable amount of velocity (Fig. 6.6). As it has been already shown, that for the good economy or maximum work, the blade speed should be one half of the steam speed so blade velocity is of about 500 m/s which is very high. This results in a very high rotational speed, reaching 30,000 r.p.m. Such high rotational speeds can only be utilised to drive generators or machines with large reduction gearing arrangements. In this turbine, the leaving velocity of steam is also quite appreciable resulting in an energy loss, called "carry over loss" or "leaving velocity loss". This leaving loss is so high that it may amount to about 11 percent of the initial kinetic energy. This type of turbine is generally employed where relatively small power is needed and where the rotor diameter is kept fairly small.

FUNDAMENTALS OF GAS TURBINE ENGINES INTRODUCTION The gas turbine is an internal combustion engine that uses air as the working fluid. The engine extracts chemical energy from fuel and converts it to mechanical energy using the gaseous energy of the working fluid (air) to drive the engine and propeller, which, in turn, propel the airplane. THE GAS TURBINE CYCLE The basic principle of the airplane turbine engine is identical to any and all engines that extract energy from chemical fuel. The basic 4 steps for any internal combustion engine are: 1. Intake of air (and possibly fuel). 2. Compression of the air (and possibly fuel). 3. Combustion, where fuel is injected (if it was not drawn in with the intake air) and burned to convert the stored energy. 4. Expansion and exhaust, where the converted energy is put to use. In the case of a piston engine, such as the engine in a car or reciprocating airplane engine, the intake, compression, combustion, and exhaust steps occur in the same place (cylinder head) at different times as the piston goes up and down. In the turbine engine, however, these same

four steps occur at the same time but in different places. As a result of this fundamental difference, the turbine has engine sections called: 1. The inlet section 2. The compressor section 3. The combustion section (the combustor) 4. The turbine (and exhaust) section. The turbine section of the gas turbine engine has the task of producing usable output shaft power to drive the propeller. In addition, it must also provide power to drive the compressor and all engine accessories. It does this by expanding the high temperature, pressure, and velocity gas and converting the gaseous energy to mechanical energy in the form of shaft power. A large mass of air must be supplied to the turbine in order to produce the necessary power. This mass of air is supplied by the compressor, which draws the air into the engine and squeezes it to provide high-pressure air to the turbine. The compressor 2 does this by converting mechanical energy from the turbine to gaseous energy in the form of pressure and temperature. If the compressor and the turbine were 100% efficient, the compressor would supply all the air needed by the turbine. At the same time, the turbine would supply the necessary power to drive the compressor. In this case, a perpetual motion machine would exist. However, frictional losses and mechanical system inefficiencies do not allow a perpetual motion machine to operate. Additional energy must be added to the air to accommodate for these losses. Power output is also desired from the engine (beyond simply driving the compressor); thus, even more energy must be added to the air to produce this excess power. Energy addition to the system is accomplished in the combustor. Chemical energy from fuel as it is burned is converted to gaseous energy in the form of high temperatures and high velocity as the air passes through the combustor. The gaseous energy is converted back to mechanical energy in the turbine, providing power to drive the compressor and the output shaft.

**SOME BASIC PRINCIPLES** As air passes through a gas turbine engine, aerodynamic and energy requirements demand changes in the air's velocity and pressure. During compression, a rise in the air pressure is required, but not an increase in its velocity. After compression and combustion have heated the air, an increase in the velocity of gases is necessary in order for the turbine rotors to develop power. The size and shape of the ducts through which the air flows affect these various changes. Where a conversion from velocity to pressure is required, the passages are divergent. Conversely, if a conversion from pressure to velocity is needed, a

convergent duct is used. Before further discussion, an explanation of convergent ducts, divergent ducts, and the behavior of air within these ducts should be made. An understanding of the difference between static pressure ( $P_s$ ), impact pressure, ( $P_i$ ), and total pressure ( $P_t$ ) is also needed. The difference between static, impact, and total pressures is as follows. Static pressure is the force per unit area exerted on the walls of a container by a stationary fluid. An example is the air pressure within a car tire. Impact pressure, on the other hand, is the force per unit area exerted by fluids in motion. Impact pressure is a function of the velocity of the fluid. An example of impact pressure is the pressure exerted on one's hand held outside a moving car's window. Total pressure is the sum of static and impact pressures. Figure 2-1 illustrates the methods used to measure pressures. Part (a) illustrates the measurement of static pressure. Static pressure will not take into account the velocity of the air. Part (b) illustrates the measurement of total pressure, which accounts for both static pressure and the pressure due to the moving fluid (impact pressure). In order to obtain impact pressure, the value of the static pressure is subtracted from the value of total pressure. Figure 2-2 shows the principle of divergent ducts, where energy is neither being added or taken away, but where the gaseous energy is being converted from velocity to pressure and temperature. There is a velocity decrease as air flows from a small inlet to a larger outlet. As velocity decreases, impact pressure ( $P_i$ ) also decreases. Since no energy is added or subtracted from the system, total pressure ( $P_t$ ) for the air remains constant and static pressure ( $P_s$ ) increases. One way of viewing this is that the impact pressure is converted to static pressure; thus, a static pressure rise is seen as air flows through a divergent duct and is compressed. A temperature rise is also noticed since compression is a heating process. The convergent duct operates exactly in reverse of the divergent duct. Figure 2-3 shows the principle of convergent ducts, where energy is neither being added or taken away, but where the gaseous energy is being converted from pressure and temperature to velocity. There is a velocity increase as air flows from a large inlet to a smaller outlet. As velocity increases, impact pressure also increases. Since no energy is added or subtracted from the system, total pressure remains constant and static pressure decreases. One way of viewing this is that the static pressure is converted to impact pressure; thus, a static pressure decrease is seen as air flows through a convergent duct and goes through expansion. A

temperature drop is associated with any expansion process. 4 NOTE: Even though the static and impact pressures are changing as fluids flow through either convergent or divergent ducts, the total pressure does not change. This is true if fluid friction is neglected and energy is not added or taken away from the fluid flow. In actuality, there will be a slight decrease in total pressure because of fluid frictional losses.

**PERFORMANCE AND EFFICIENCY** The type of operation for which the engine is designed dictates the performance requirement of a gas turbine engine. The performance requirement is mainly determined by the amount of shaft horsepower (s.h.p.) the engine develops for a given set of conditions. The majority of aircraft gas turbine engines are rated at standard F and 29.92 inches Hg. This provides a baseline to which gas<sup>o</sup>day conditions of 59 turbine engines of all types can be compared. The need for high efficiency in the engine becomes more important as fuels become more costly. Engine efficiency is primarily defined by the specific fuel consumption (s.f.c.) of the engine at a given set of conditions. Many factors affect both the efficiency and the performance of the engine. The mass flow rate of air through the engine will dictate engine performance. Any restrictions acting against the smooth flow of air through the engine will limit the engine's performance. The pressure ratio of the compressor, the engine operating temperatures (turbine inlet temperature), and the individual component efficiencies will also influence both the performance and the efficiency of the overall engine. All these factors are considered during the design of the engine. An optimum pressure ratio, turbine inlet temperature, and air mass flow rate are selected to obtain the required performance in the most efficient manner. In addition, individual engine components are designed to minimize flow losses to maximize component efficiencies. 5 The following graphic shows the typical temperature and pressure rise through the gas flow path.

**ENGINE SECTIONS Inlet** The air inlet duct must provide clean and unrestricted airflow to the engine. Clean and undisturbed inlet airflow extends engine life by preventing erosion, corrosion, and foreign object damage (FOD). Consideration of atmospheric conditions such as dust, salt, industrial pollution, foreign objects (birds, nuts and bolts), and temperature (icing conditions) must be made when designing the inlet system. Fairings should be installed between the engine air inlet housing and the inlet duct to ensure minimum airflow losses to the engine at all airflow conditions. The inlet duct

assembly is usually designed and produced as a separate system rather than as part of the design and production of the engine. Compressor The compressor is responsible for providing the turbine with all the air it needs in an efficient manner. In addition, it must supply this air at high static pressures. The example of a large turboprop axial flow compressor will be used. The compressor is assumed to contain fourteen stages of rotor blades and stator vanes. The overall pressure ratio (pressure at the back of the compressor compared to pressure at the front of the compressor) is approximately 9.5:1. At 100% (>13,000) RPM, the engine compresses approximately 433 cubic feet of air per second. At standard day air conditions, this equals approximately 33 pounds of air per second. The compressor F as the air is compressed and°also raises the temperature of the air by about 550 moved rearward. The power required to drive a compressor of this size at maximum rated power is approximately 7000 horsepower. In an axial flow compressor, each stage incrementally boosts the pressure from the previous stage. A single stage of compression consists of a set of rotor blades attached to a rotating disk, followed by stator vanes attached to a stationary ring. The flow area between the compressor blades is slightly divergent. Flow area between compressor vanes is also divergent, but more so than for the blades. In general terms, the compressor rotor blades convert mechanical energy into gaseous energy. This energy conversion greatly increases total pressure ( $P_t$ ). Most of the increase is in the form of velocity ( $P_i$ ), with a small increase in static pressure ( $P_s$ ) due to the divergence of the blade flow paths. The stator vanes slow the air by means of their divergent duct shape, converting 'the accelerated velocity ( $P_i$ ) to higher static pressure ( $P_s$ ). The vanes are positioned at an angle such that the exiting air is directed into the rotor blades of the next stage at the most efficient angle. This process is repeated fourteen times as the air flows from the first stage through the fourteenth stage. Figure 2-4 shows one stage of the compressor and a graph of the pressure characteristics as the air flows through the stage. In addition to the fourteen stages of blades and vanes, the compressor also incorporates the inlet guide vanes and the outlet guide vanes. These vanes, located at the inlet and the outlet of the compressor, are neither divergent nor convergent. The inlet guide vanes direct air to the first stage compressor blades at the "best" angle. The outlet guide vanes "straighten" the air to provide the combustor with the proper airflow direction.

## IMPULSE TURBINE



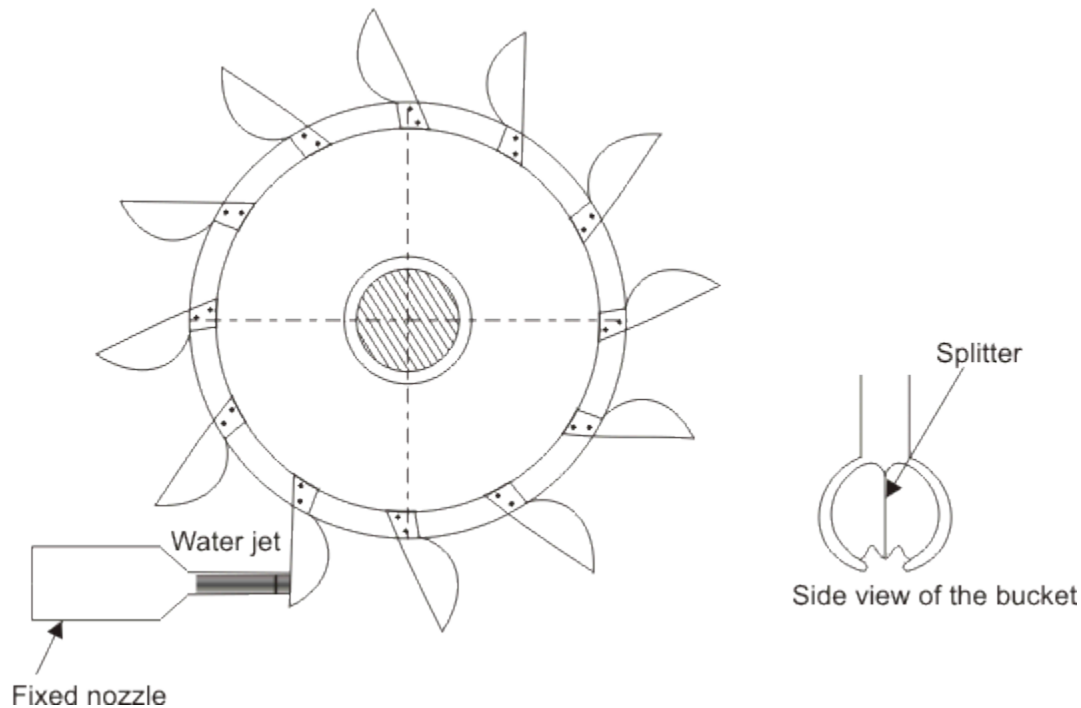
**Figure 26.1 Typical PELTON WHEEL with 21 Buckets**

Hydropower is the longest established source for the generation of electric power. In this module we shall discuss the governing principles of various types of hydraulic turbines used in hydro-electric power stations.

### **Impulse Hydraulic Turbine : The Pelton Wheel**

The only hydraulic turbine of the impulse type in common use, is named after an American engineer Laster A Pelton, who contributed much to its development around the year 1880. Therefore this machine is known as Pelton turbine or Pelton wheel. It is an efficient machine particularly suited to high heads. The rotor consists of a large circular disc or wheel on which a number (seldom less than 15) of spoon shaped buckets are spaced uniformly round its periphery as shown in Figure 26.1. The wheel is driven by jets of water being discharged at atmospheric pressure from pressure nozzles. The nozzles are mounted so that each directs a jet along a tangent to the circle through the centres of the buckets (Figure 26.2). Down the centre of each

bucket, there is a splitter ridge which divides the jet into two equal streams which flow round the smooth inner surface of the bucket and leaves the bucket with a relative velocity almost opposite in direction to the original jet.



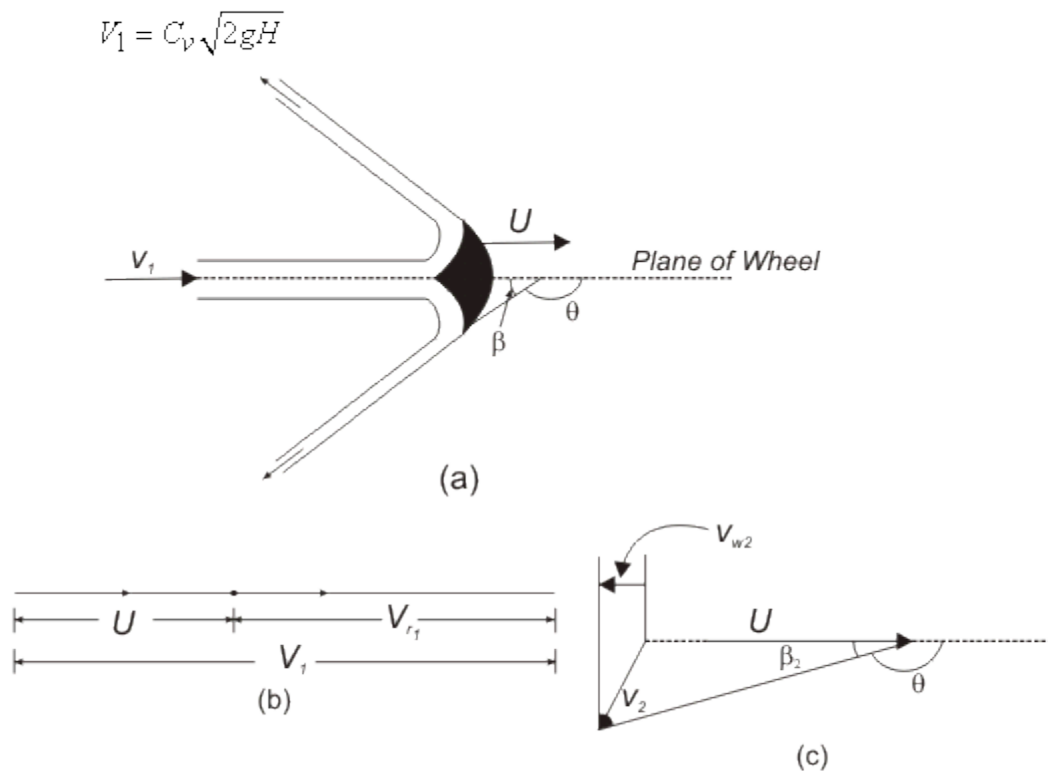
**Figure 26.2 A Pelton wheel**

For maximum change in momentum of the fluid and hence for the maximum driving force on the wheel, the deflection of the water jet should be  $180^\circ$ . In practice, however, the deflection is limited to about  $165^\circ$  so that the water leaving a bucket may not hit the back of the following bucket. Therefore, the camber angle of the buckets is made as  $165^\circ$  ( $\theta = 165^\circ$ ). Figure(26.3a)

The number of jets is not more than two for horizontal shaft turbines and is limited to six for vertical shaft turbines. The flow partly fills the buckets and the fluid remains in contact with the atmosphere. Therefore, once the jet is produced by the nozzle, the static pressure of the fluid remains atmospheric throughout the machine. Because of the symmetry of the buckets, the side thrusts produced by the fluid in each half should balance each other.



**Analysis of force on the bucket and power generation** Figure 26.3a shows a section through a bucket which is being acted on by a jet. The plane of section is parallel to the axis of the wheel and contains the axis of the jet. The absolute velocity of the jet  $V_1$  with which it strikes the bucket is given by



**(a)Flow along the bucket of a pelton wheel**

**Figure 26.3**

**(b) Inlet velocity triangle**

**(c)Outlet velocity triangle**

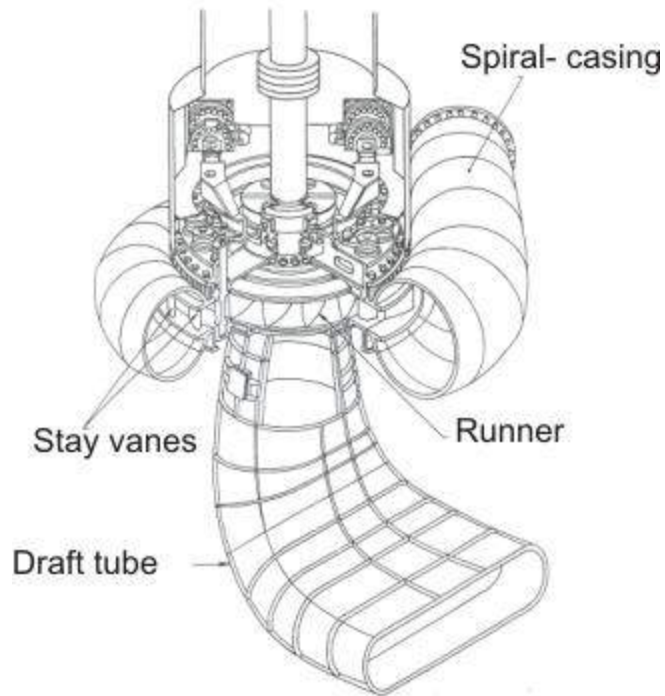
where,  $C_v$  is the coefficient of velocity which takes care of the friction in the nozzle.  $H$  is the head at the entrance to the nozzle which is equal to the total or gross head of water stored at high altitudes minus the head lost due to friction in the long pipeline leading to the nozzle. Let the velocity of the bucket (due to the rotation of the wheel) at its centre where the jet strikes be  $U$ . Since the jet velocity  $V_1$  is tangential, i.e.  $V_1$  and  $U$  are collinear, the diagram of velocity vector at inlet (Fig 26.3.b) becomes simply a straight line and the relative velocity is given by

$$V_{r1} = V_1 - U$$

It is assumed that the flow of fluid is uniform and it glides the blade all along including the entrance and exit sections to avoid the unnecessary losses due to shock. Therefore the direction of relative velocity at entrance and exit should match the inlet and outlet angles of the buckets respectively. The velocity triangle at the outlet is shown in Figure 26.3c. The bucket velocity  $U$  remains the same both at the inlet and outlet. With the direction of  $U$  being taken as positive, we can write. The tangential component of inlet velocity (Figure 26.3b)

### Francis Turbine

**Reaction Turbine:** The principal feature of a reaction turbine that distinguishes it from an impulse turbine is that only a part of the total head available at the inlet to the turbine is converted to velocity head, before the runner is reached. Also in the reaction turbines the working fluid, instead of engaging only one or two blades, completely fills the passages in the runner. The pressure or static head of the fluid changes gradually as it passes through the runner along with the change in its kinetic energy based on absolute velocity due to the impulse action between the fluid and the runner. Therefore the cross-sectional area of flow through the passages of the fluid. A reaction turbine is usually well suited for low heads. A radial flow hydraulic turbine of reaction type was first developed by an American Engineer, James B. Francis (1815-92) and is named after him as the Francis turbine. The schematic diagram of a Francis turbine is shown in Fig. 28.1

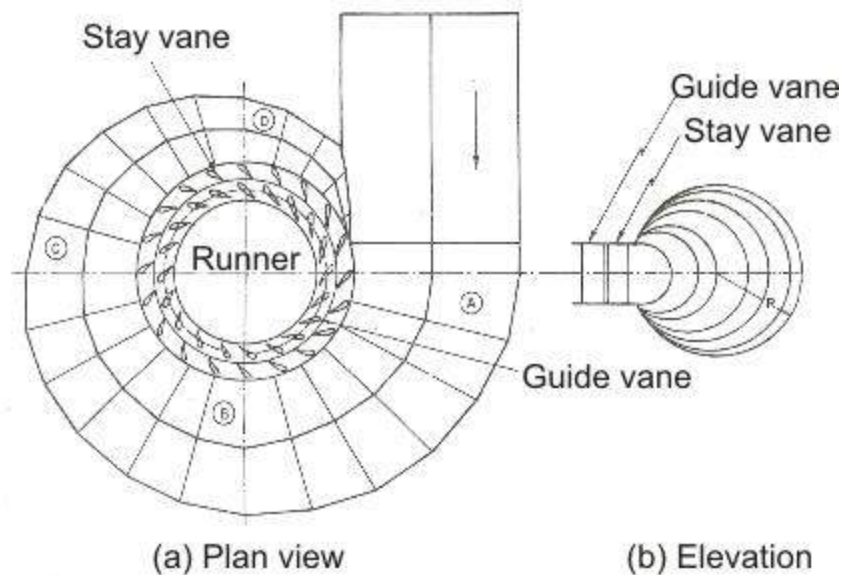


**Figure 28.1 A Francis turbine**

A Francis turbine comprises mainly the four components:

- (i) spirical casing,
- (ii) guide on stay vanes,
- (iii) runner blades,
- (iv) draft-tube as shown in Figure 28.1 .

**Spiral Casing :** Most of these machines have vertical shafts although some smaller machines of this type have horizontal shaft. The fluid enters from the penstock (pipeline leading to the turbine from the reservoir at high altitude) to a spiral casing which completely surrounds the runner. This casing is known as scroll casing or volute. The cross-sectional area of this casing decreases uniformly along the circumference to keep the fluid velocity constant in magnitude along its path towards the guide vane.



**Figure 28.2 Spiral Casing**

This is so because the rate of flow along the fluid path in the volute decreases due to continuous entry of the fluid to the runner through the openings of the guide vanes or stay vanes.

Guide or Stay vane:

The basic purpose of the guide vanes or stay vanes is to convert a part of pressure energy of the fluid at its entrance to the kinetic energy and then to direct the fluid on to the runner blades at the angle appropriate to the design. Moreover, the guide vanes are pivoted and can be turned by a suitable governing mechanism to regulate the flow while the load changes. The guide vanes are also known as wicket gates. The guide vanes impart a tangential velocity and hence an angular momentum to the water before its entry to the runner. The flow in the runner of a Francis turbine is not purely radial but a combination of radial and tangential. The flow is inward, i.e. from the periphery towards the centre. The height of the runner depends upon the specific speed. The height increases with the increase in the specific speed. The main direction of flow change as water passes through the runner and is finally turned into the axial direction while entering the draft tube.

Draft tube:

The draft tube is a conduit which connects the runner exit to the tail race where the water is

being finally discharged from the turbine. The primary function of the draft tube is to reduce the velocity of the discharged water to minimize the loss of kinetic energy at the outlet. This permits the turbine to be set above the tail water without any appreciable drop of available head. A clear understanding of the function of the draft tube in any reaction turbine, in fact, is very important for the purpose of its design. The purpose of providing a draft tube will be better understood if we carefully study the net available head across a reaction turbine.

Net head across a reaction turbine and the purpose to providing a draft tube . The effective head across any turbine is the difference between the head at inlet to the machine and the head at outlet from it. A reaction turbine always runs completely filled with the working fluid. The tube that connects the end of the runner to the tail race is known as a draft tube and should completely to filled with the working fluid flowing through it. The kinetic energy of the fluid finally discharged into the tail race is wasted. A draft tube is made divergent so as to reduce the velocity at outlet to a minimum. Therefore a draft tube is basically a diffuser and should be designed properly with the angle between the walls of the tube to be limited to about 8 degree so as to prevent the flow separation from the wall and to reduce accordingly the loss of energy in the tube. Figure 28.3 shows a flow diagram from the reservoir via a reaction turbine to the tail race.

The total head  $H_0$  at the entrance to the turbine can be found out by applying the Bernoulli's equation between the free surface of the reservoir and the inlet to the turbine as

$$H_0 = \frac{P_1}{\rho g} + \frac{V_1^2}{2g} + z + h_f \quad (28.1)$$

$$\text{or, } H_1 = H_0 - h_f = \frac{P_1}{\rho g} + \frac{V_1^2}{2g} + z \quad (28.2)$$

where  $h_f$  is the head lost due to friction in the pipeline connecting the reservoir and the turbine. Since the draft tube is a part of the turbine, the net head across the turbine, for the conversion of mechanical work, is the difference of total head at inlet to the machine and the total head at discharge from the draft tube at tail race and is shown as H in Figure 28.3

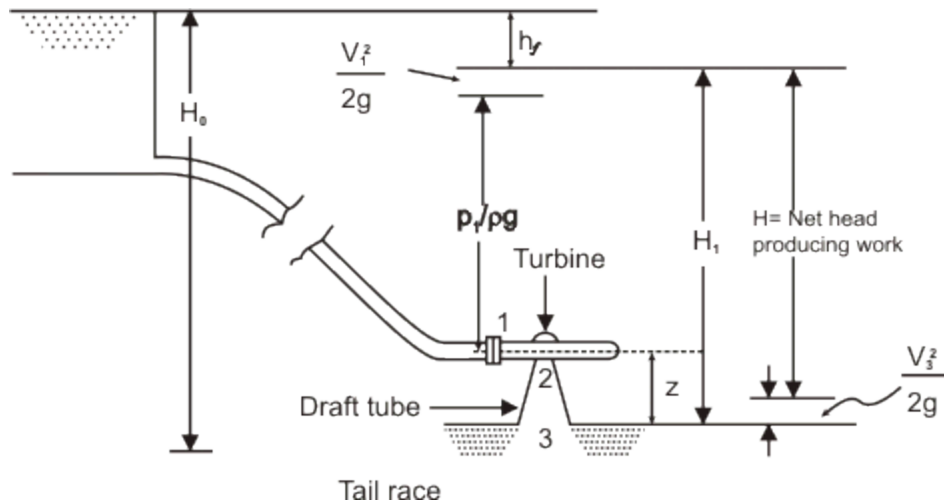


Figure 28.3 Head across a reaction turbine

Therefore,  $H$  = total head at inlet to machine (1) - total head at discharge (3)

$$= \frac{P_1}{\rho g} + \frac{V_1^2}{2g} + z - \frac{V_3^2}{2g} = H_1 - \frac{V_3^2}{2g} \quad (28.3)$$

$$= (H_0 - h_f) - \frac{V_3^2}{2g} \quad (28.4)$$

The pressures are defined in terms of their values above the atmospheric pressure. Section 2 and 3 in Figure 28.3 represent the exits from the runner and the draft tube respectively. If the losses in the draft tube are neglected, then the total head at 2 becomes equal to that at 3. Therefore, the net head across the machine is either  $(H_1 - H_3)$  or  $(H_1 - H_2)$ . Applying the Bernoulli's equation between 2 and 3 in consideration of flow, without losses, through the draft tube, we can write.

$$\frac{P_2}{\rho g} + \frac{V_2^2}{2g} + z = 0 + \frac{V_3^2}{2g} + 0 \quad (28.5)$$

$$\frac{P_2}{\rho g} = - \left[ z + \frac{V_2^2 - V_3^2}{2g} \right] \quad (28.6)$$

Since  $V_3 < V_2$ , both the terms in the bracket are positive and hence  $p_2/\rho g$  is always

negative, which implies that the static pressure at the outlet of the runner is always below the atmospheric pressure. Equation (28.1) also shows that the value of the suction pressure at runner outlet depends on  $z$ , the height of the runner above the tail race and  $(V_2^2 - V_3^2)/2g$ , the decrease in kinetic energy of the fluid in the draft tube. The value of this minimum pressure  $P_2$  should never fall below the vapour pressure of the liquid at its operating temperature to avoid the problem of cavitation. Therefore, we find that the incorporation of a draft tube allows the turbine runner to be set above the tail race without any drop of available head by maintaining a vacuum pressure at the outlet of the runner.

## INTERNAL COMBUSTION ENGINE

### INTRODUCTION

Heat engine:

A heat engine is a device which transforms the chemical energy of a fuel into thermal energy and uses this energy to produce mechanical work. It is classified into two types-

- (a) External combustion engine
- (b) Internal combustion engine

External combustion engine:

In this engine, the products of combustion of air and fuel transfer heat to a second fluid which is the working fluid of the cycle.

Examples:

\*In the steam engine or a steam turbine plant, the heat of combustion is employed to generate steam which is used in a piston engine (reciprocating type engine) or a turbine (rotary type engine) for useful work.

\*In a closed cycle gas turbine, the heat of combustion in an external furnace is transferred to gas, usually air which the working fluid of the cycle.

Internal combustion engine:

In this engine, the combustion of air and fuels take place inside the cylinder and are used as

the direct motive force. It can be classified into the following types:

1. According to the basic engine design- (a) Reciprocating engine (Use of cylinder piston arrangement), (b) Rotary engine (Use of turbine)
2. According to the type of fuel used- (a) Petrol engine, (b) diesel engine, (c) gas engine (CNG, LPG), (d) Alcohol engine (ethanol, methanol etc)
3. According to the number of strokes per cycle- (a) Four stroke and (b) Two stroke engine
4. According to the method of igniting the fuel- (a) Spark ignition engine, (b) compression ignition engine and (c) hot spot ignition engine
5. According to the working cycle- (a) Otto cycle (constant volume cycle) engine, (b) diesel cycle (constant pressure cycle) engine, (c) dual combustion cycle (semi diesel cycle) engine.
6. According to the fuel supply and mixture preparation- (a) Carburetted type (fuel supplied through the carburettor), (b) Injection type (fuel injected into inlet ports or inlet manifold, fuel injected into the cylinder just before ignition).
7. According to the number of cylinder- (a) Single cylinder and (b) multi-cylinder engine
8. Method of cooling- water cooled or air cooled
9. Speed of the engine- Slow speed, medium speed and high speed engine
10. Cylinder arrangement-Vertical, horizontal, inline, V-type, radial, opposed cylinder or piston engines.
11. Valve or port design and location- Overhead (I head), side valve (L head); in two stroke engines: cross scavenging, loop scavenging, uniflow scavenging.
12. Method governing- Hit and miss governed engines, quantitatively governed engines and qualitatively governed engine
14. Application- Automotive engines for land transport, marine engines for propulsion of ships, aircraft engines for aircraft propulsion, industrial engines, prime movers for electrical generators.



**Comparison between external combustion engine and internal combustion engine:**

External combustion engine	Internal combustion engine
*Combustion of air-fuel is outside the engine cylinder (in a boiler)	* Combustion of air-fuel is inside the engine cylinder (in a boiler)
*The engines are running smoothly and silently due to outside combustion	* Very noisy operated engine
*Higher ratio of weight and bulk to output due to presence of auxiliary apparatus like boiler and condenser. Hence it is heavy and cumbersome.	* It is light and compact due to lower ratio of weight and bulk to output.
*Working pressure and temperature inside the engine cylinder is low; hence ordinary alloys are used for the manufacture of engine cylinder and its parts.	* Working pressure and temperature inside the engine cylinder is very much high; hence special alloys are used
*It can use cheaper fuels including solid fuels	*High grade fuels are used with proper filtration
*Lower efficiency about 15-20%	*Higher efficiency about 35-40%
* Higher requirement of water for dissipation of energy through cooling system	*Lesser requirement of water
*High starting torque	*IC engines are not self-starting

**Main components of reciprocating IC engines:**

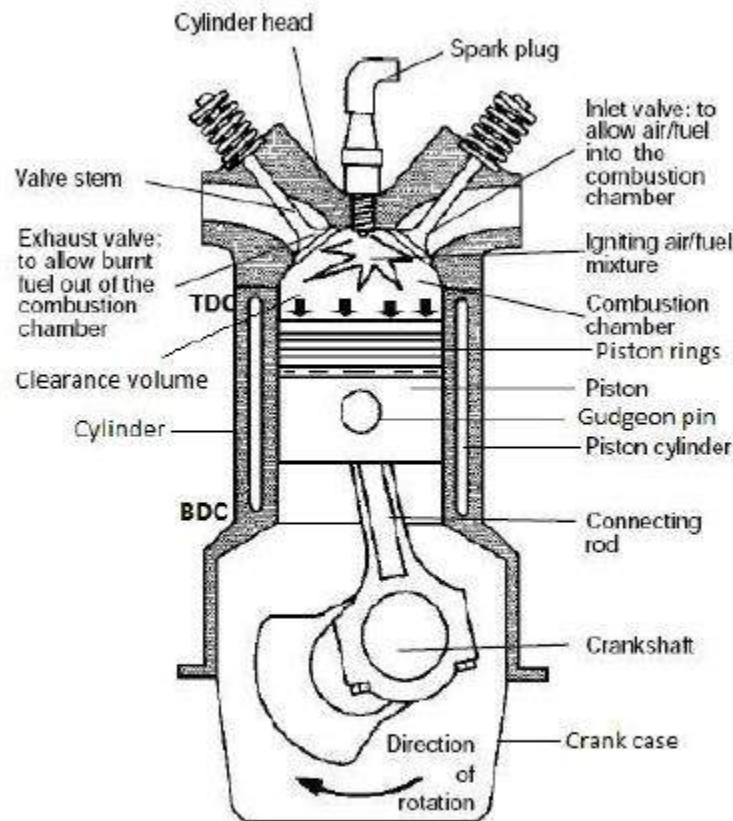
**Cylinder:** It is the main part of the engine inside which piston reciprocates to and fro. It should have high strength to withstand high pressure above 50 bar and temperature above

2000 oC. The ordinary engine is made of cast iron and heavy duty engines are made of steel alloys or aluminum alloys. In the multi-cylinder engine, the cylinders are cast in one block known as cylinder block.

**Cylinder head:** The top end of the cylinder is covered by cylinder head over which inlet and exhaust valve, spark plug or injectors are mounted. A copper or asbestos gasket is provided between the engine cylinder and cylinder head to make an air tight joint.

**Piston:** Transmit the force exerted by the burning of charge to the connecting rod. Usually made of aluminium alloy which has good heat conducting property and greater strength at higher temperature.

Figure 1 shows the different components of IC engine.



**Fig. 1. Different parts of IC engine**

**Piston rings:** These are housed in the circumferential grooves provided on the outer surface of the piston and made of steel alloys which retain elastic properties even at high temperature. 2 types of rings- compression and oil rings. Compression ring is upper ring of the piston which provides air tight seal to prevent leakage of the burnt gases into the lower portion. Oil ring is lower ring which provides effective seal to prevent leakage of the oil into the engine cylinder.

**Connecting rod:** It converts reciprocating motion of the piston into circular motion of the crank shaft, in the working stroke. The smaller end of the connecting rod is connected with the piston by gudgeon pin and bigger end of the connecting rod is connected with the crank. with crank pin. The special steel alloys or aluminium alloys are used for the manufacture of connecting rod.

**Crankshaft:** It converts the reciprocating motion of the piston into the rotary motion with the help of connecting rod. The special steel alloys are used for the manufacturing of the crankshaft. It consists of eccentric portion called crank.

**Crank case:** It houses cylinder and crankshaft of the IC engine and also serves as sump for the lubricating oil.

**Flywheel:** It is big wheel mounted on the crankshaft, whose function is to maintain its speed constant. It is done by storing excess energy during the power stroke, which is returned during other stroke.

### Terminology used in IC engine:

1. Cylinder bore (D): The nominal inner diameter of the working cylinder.
2. Piston area (A): The area of circle of diameter equal to the cylinder bore.
3. Stroke (L): The nominal distance through which a working piston moves between two successive reversals of its direction of motion.
4. Dead centre: The position of the working piston and the moving parts which are mechanically connected to it at the moment when the direction of the piston motion is reversed (at either end point of the stroke).
  - (a) Bottom dead centre (BDC): Dead centre when the piston is nearest to the crankshaft.
  - (b) Top dead centre (TDC): Dead centre when the position is farthest from the crankshaft.
5. Displacement volume or swept volume ( $V_s$ ): The nominal volume generated by the working piston when travelling from the one dead centre to next one and given as,

$$V_s = A \times L$$

6. Clearance volume ( $V_c$ ): the nominal volume of the space on the combustion side of the piston at the top dead centre.

7. Cylinder volume (V): Total volume of the cylinder.

$$V = V_s + V_c$$

8. Compression ratio (r):  $r = \frac{V_s}{V_c}$

**Four stroke engine:**

- Cycle of operation completed in four strokes of the piston or two revolution of the piston.

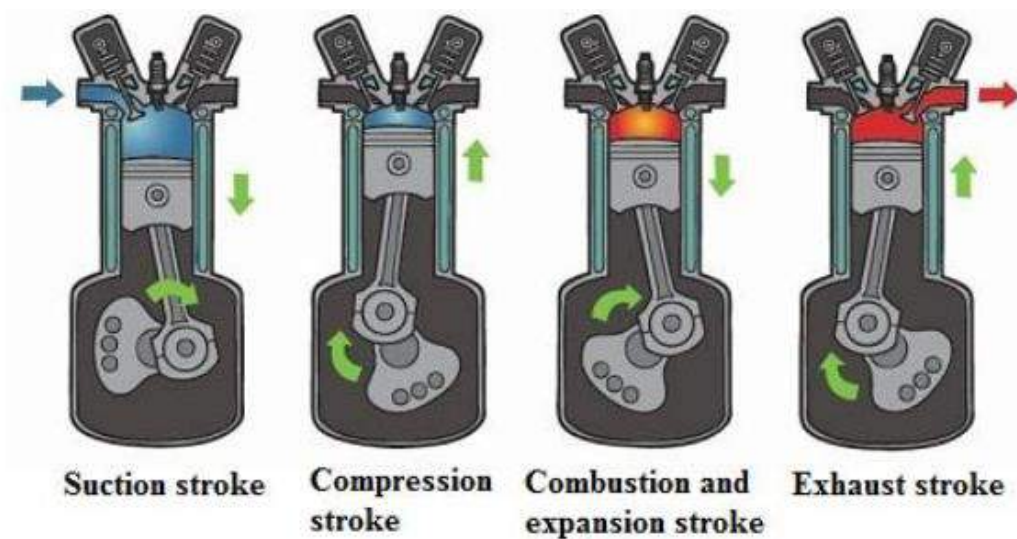
(i) Suction stroke (suction valve open, exhaust valve closed)-charge consisting of fresh air mixed with the fuel is drawn into the cylinder due to the vacuum pressure created by the movement of the piston from TDC to BDC.

(ii) Compression stroke (both valves closed)-fresh charge is compressed into clearance volume by the return stroke of the piston and ignited by the spark for combustion. Hence pressure and temperature is increased due to the combustion of fuel

(iii) Expansion stroke (both valves closed)-high pressure of the burnt gases force the piston towards BDC and hence power is obtained at the crankshaft.

(iv) Exhaust stroke (exhaust valve open, suction valve closed)- burnt gases expel out due to the movement of piston from BDC to TDC.

Figure 2 show the cycle of operation of four stroke engine.

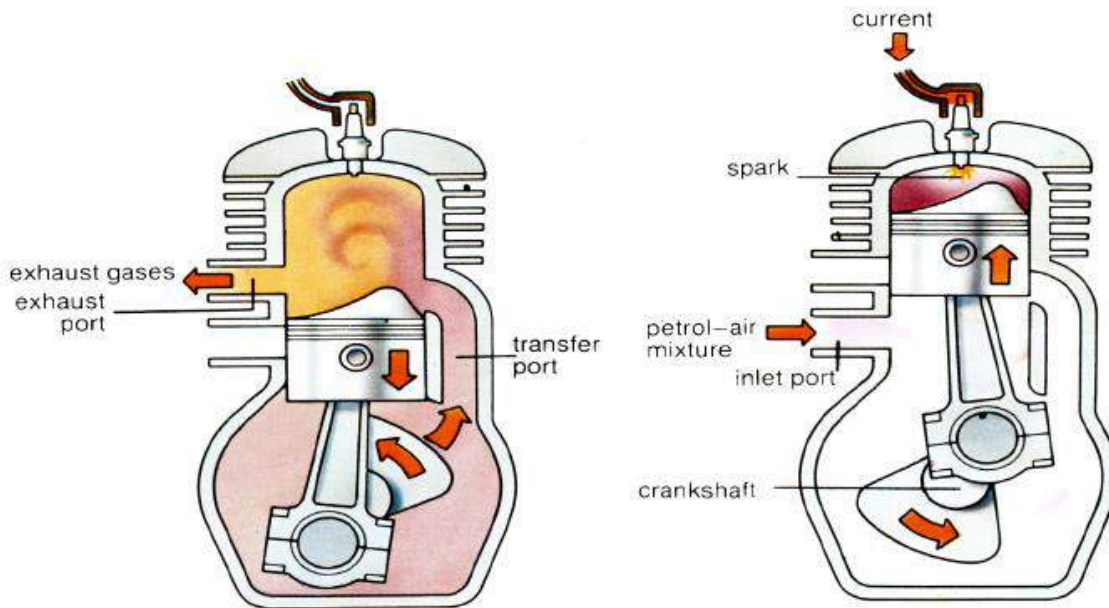


**Fig. 2.** Cycle of operation in four stroke engine

**Two stroke engine:**

- No piston stroke for suction and exhaust operations
- Suction is accomplished by air compressed in crankcase or by a blower
- Induction of compressed air removes the products of combustion through exhaust ports
- Transfer port is there to supply the fresh charge into combustion chamber

Figure 3 represents operation of two stroke engine



**Fig. 3.** Cycle of operation in two stroke engine

**Comparison of Four-stroke and two-stroke engine:**

	<b>Four-stroke engine</b>	<b>Two-stroke engine</b>
1.	Four stroke of the piston and two revolution of crankshaft	Two stroke of the piston and one revolution of crankshaft
2.	One power stroke in every two revolution of crankshaft	One power stroke in each revolution of crankshaft
3.	Heavier flywheel due to non-uniform turning movement	Lighter flywheel due to more uniform turning movement
4.	Power produce is less	Theoretically power produce is twice than the four stroke engine for same size
5.	Heavy and bulky	Light and compact
6.	Lesser cooling and lubrication requirements	Greater cooling and lubrication requirements
7.	Lesser rate of wear and tear	Higher rate of wear and tear
8.	Contains valve and valve mechanism	Contains ports arrangement
9.	Higher initial cost	Cheaper initial cost
10.	Volumetric efficiency is more due to greater time of induction	Volumetric efficiency less due to lesser time of induction
11.	Thermal efficiency is high and also part load efficiency better	Thermal efficiency is low, part load efficiency lesser
12.	It is used where efficiency is important.	It is used where low cost, compactness and light weight are important.
	Ex-cars, buses, trucks, tractors, industrial engines, aero planes, power generation etc.	Ex-lawn mowers, scooters, motor cycles, mopeds, propulsion ship etc.

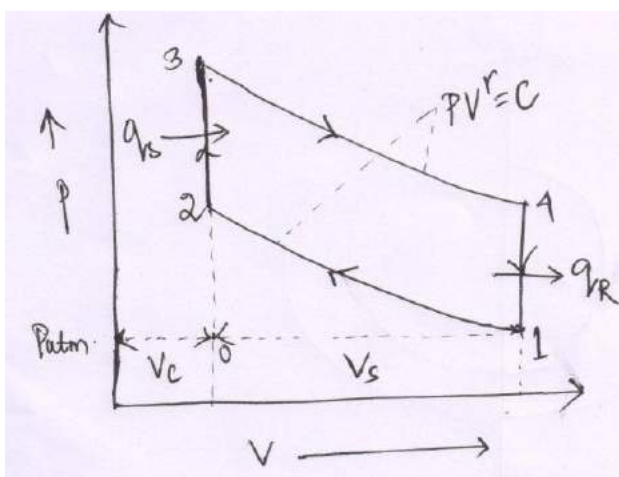
**Comparison of SI and CI engine:**

SI engine	CI engine
Working cycle is Otto cycle.	Working cycle is diesel cycle.
Petrol or gasoline or high octane fuel is used.	Diesel or high cetane fuel is used.
High self-ignition temperature.	Low self-ignition temperature.
Fuel and air introduced as a gaseous mixture in the suction stroke.	Fuel is injected directly into the combustion chamber at high pressure at the end of compression stroke.
Carburettor used to provide the mixture. Throttle controls the quantity of mixture introduced.	Injector and high pressure pump used to supply of fuel. Quantity of fuel regulated in pump.
Use of spark plug for ignition system	Self-ignition by the compression of air which increased the temperature required for combustion
Compression ratio is 6 to 10.5	Compression ratio is 14 to 22
Higher maximum RPM due to lower weight	Lower maximum RPM
Maximum efficiency lower due to lower compression ratio	Higher maximum efficiency due to higher compression ratio
Lighter	Heavier due to higher pressures

**Working cycle:****(a) Otto cycle-** thermodynamic cycle for SI/petrol engine

- Reversible adiabatic compression and expansion process
- Constant volume heat addition (combustion) and heat rejection process (exhaust)

Figure 7 depicts the Otto cycle



Heat supplied,  $q_s = C_v(T_3 - T_2)$

Heat rejection,  $q_R = C_v(T_4 - T_1)$

Compression ratio,  $r_k = \frac{V_1}{V_2}$

Thermal efficiency,  $\eta_{th} = \frac{q_s - q_R}{q_s} = \frac{C_v(T_3 - T_2) - C_v(T_4 - T_1)}{C_v(T_3 - T_2)} = 1 - \frac{T_4 - T_1}{T_3 - T_2}$

In process 1-2, adiabatic compression process,

$$\frac{T_2}{T_1} = \left(\frac{V_1}{V_2}\right)^{\gamma-1}$$

$$\Rightarrow T_2 = T_1 \cdot (r_k)^{\gamma-1}$$

In adiabatic expansion process, i.e. 3-4,

$$\frac{T_4}{T_3} = \left(\frac{V_3}{V_4}\right)^{\gamma-1} = \left(\frac{V_2}{V_1}\right)^{\gamma-1}$$

$$\Rightarrow T_3 = T_4 \cdot (r_k)^{\gamma-1}$$

$$\eta_{th} = 1 - \frac{T_4 - T_1}{T_4 \cdot (r_k)^{\gamma-1} - T_1 \cdot (r_k)^{\gamma-1}}$$

$$= 1 - \frac{1}{(r_k)^{\gamma-1}}$$



Work done (W)

$$\text{Pressure ratio, } r_p = \frac{P_3}{P_2} = \frac{P_4}{P_1}$$

$$\frac{P_2}{P_1} = \frac{P_3}{P_4} = \left(\frac{V_1}{V_2}\right)^\gamma = (r_k)^\gamma$$

$$\begin{aligned} W &= \frac{P_3V_3 - P_4V_4}{\gamma - 1} - \frac{P_2V_2 - P_1V_1}{\gamma - 1} \\ &= \frac{1}{\gamma - 1} \left[ P_4V_4 \left( \frac{P_3V_3}{P_4V_4} - 1 \right) - P_1V_1 \left( \frac{P_2V_2}{P_1V_1} - 1 \right) \right] \\ &= \frac{1}{\gamma - 1} [P_4V_1(r_k^{\gamma-1} - 1) - P_1V_1(r_k^{\gamma-1} - 1)] \\ &= \frac{P_1V_1}{\gamma - 1} [r_p(r_k^{\gamma-1} - 1) - (r_k^{\gamma-1} - 1)] \\ &= \frac{P_1V_1}{\gamma - 1} [(r_k^{\gamma-1} - 1)(r_p - 1)] \end{aligned}$$

$$\text{Mean effective pressure, } P_m = \frac{\text{work done}}{\text{Swept volume}} = \frac{\text{work done}}{V_1 - V_2}$$

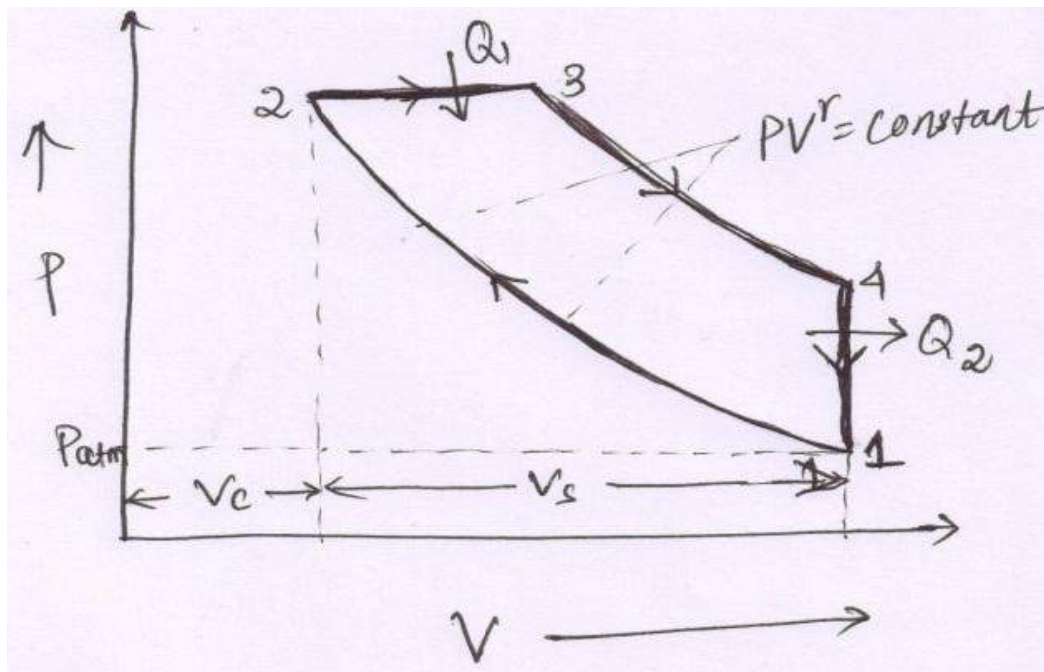
$$P_m = \frac{\frac{P_1V_1}{\gamma - 1} [(r_k^{\gamma-1} - 1)(r_p - 1)]}{V_1 - V_2} = \frac{P_1r_k [(r_k^{\gamma-1} - 1)(r_p - 1)]}{(\gamma - 1)(r_k - 1)}$$

**(b) Diesel cycle-** thermodynamic cycle for low speed CI/diesel engine

-Reversible adiabatic compression and expansion process

-Constant pressure heat addition (combustion) and heat rejection process (exhaust)

Figure 8 depicts the diesel cycle.



Heat supplied,  $Q_1 = C_p(T_3 - T_2)$

Heat rejection,  $Q_2 = C_v(T_4 - T_1)$

Compression ratio,  $r_k = \frac{V_1}{V_2}$

Cut off ratio,  $r_c = \frac{V_3}{V_2}$

Thermal efficiency,  $\eta_{th} = \frac{Q_1 - Q_2}{Q_1} = \frac{C_p(T_3 - T_2) - C_v(T_4 - T_1)}{C_p(T_3 - T_2)} = 1 - \frac{1}{\gamma} \frac{(T_4 - T_1)}{(T_3 - T_2)}$

In adiabatic compression process i.e. 1-2,

$$\frac{T_2}{T_1} = \left(\frac{V_1}{V_2}\right)^{\gamma-1}$$

$$\Rightarrow T_2 = T_1 \cdot (r_k)^{\gamma-1}$$

In process 2-3, pressure constant, then

$$\frac{T_3}{T_2} = \frac{V_3}{V_2} = r_c$$

$$\Rightarrow T_3 = T_2 \cdot r_c = T_1 \cdot (r_k)^{\gamma-1} \cdot r_c$$

In adiabatic expansion process i.e. 3-4,

$$\frac{T_4}{T_3} = \left(\frac{V_3}{V_4}\right)^{\gamma-1} = \left(\frac{V_3}{V_2} \cdot \frac{V_2}{V_4}\right)^{\gamma-1} = (r_c)^{\gamma-1} \cdot \frac{1}{(r_k)^{\gamma-1}}$$

$$\Rightarrow T_4 = T_3 \cdot (r_c)^{\gamma-1} \cdot \frac{1}{(r_k)^{\gamma-1}} = T_1 \cdot (r_k)^{\gamma-1} \cdot r_c \cdot (r_c)^{\gamma-1} \cdot \frac{1}{(r_k)^{\gamma-1}} = T_1 \cdot r_c$$

$$\eta_{th} = 1 - \frac{1}{\gamma} \frac{(T_4 - T_1)}{(T_3 - T_2)} = 1 - \frac{1}{\gamma \cdot (r_k)^{\gamma-1}} \left[ \frac{(r_c)^\gamma - 1}{r_c - 1} \right]$$

Work done (W)

$$W = P_2(V_3 - V_2) + \frac{P_3V_3 - P_4V_4}{\gamma-1} - \frac{P_2V_2 - P_1V_1}{\gamma-1}$$

$$= P_2(r_c V_2 - V_2) + \frac{P_2 r_c V_2 - P_4 r_k V_2}{\gamma-1} - \frac{P_2 V_2 - P_1 r_k V_2}{\gamma-1} \quad \text{since } V_4 = V_1$$

$$= P_2 V_2 \left[ \frac{(r_c-1)(\gamma-1) + (r_c - r_c^\gamma \cdot r_k^{-\gamma} \cdot r_k) - (1 - r_k^{1-\gamma})}{\gamma-1} \right]$$

$$= P_1 V_1 \cdot r_k^{\gamma-1} \left[ \frac{\gamma(r_c-1) - r_k^{1-\gamma}(r_c^\gamma - 1)}{\gamma-1} \right]$$

Mean effective pressure,

$$P_m = \frac{P_1 V_1 \cdot r_k^{\gamma-1} \left[ \frac{\gamma(r_c-1) - r_k^{1-\gamma}(r_c^\gamma - 1)}{\gamma-1} \right]}{V_1 - V_2} = \frac{P_1 r_k^\gamma [\gamma(r_c-1) - r_k^{1-\gamma}(r_c^\gamma - 1)]}{(\gamma-1)(r_k-1)}$$

## UNIT-3

### AN INTRODUCTION TO REFRIGERATION

#### Introduction

Refrigeration may be defined as the process of achieving and maintaining a temperature below that of the surroundings, the aim being to cool some product or space to the required temperature. One of the most important applications of refrigeration has been the preservation of perishable food products by storing them at low temperatures. Refrigeration systems are also used extensively for providing thermal comfort to human beings by means of air conditioning. Air Conditioning refers to the treatment of air so as to simultaneously control its temperature, moisture content, cleanliness, odour and circulation, as required by occupants, a process, or products in the space. The subject of refrigeration and air conditioning has evolved out of human need for food and comfort, and its history dates back to centuries. The history of refrigeration is very interesting since every aspect of it, the availability of refrigerants, the prime movers and the developments in compressors and the methods of refrigeration all are a part of it. The French scientist Roger Thývenot has written an excellent book on the history of refrigeration throughout the world. Here we present only a brief history of the subject with special mention of the pioneers in the field and some important events.

#### Natural Refrigeration

In olden days refrigeration was achieved by natural means such as the use of ice or evaporative cooling. In earlier times, ice was either:

1. Transported from colder regions,
2. Harvested in winter and stored in ice houses for summer use or,
3. Made during night by cooling of water by radiation to stratosphere.

In Europe, America and Iran a number of icehouses were built to store ice. Materials like sawdust or wood shavings were used as insulating materials in these icehouses. Later on, cork

was used as insulating material. Literature reveals that ice has always been available to aristocracy who could afford it. In India, the Mogul emperors were very fond of ice during the harsh summer in Delhi and Agra, and it appears that the ice used to be made by nocturnal cooling.

In 1806, Frederic Tudor, (who was later called as the “ice king”) began the trade in ice by cutting it from the Hudson River and ponds of Massachusetts and exporting it to various countries including India. In India Tudor’s ice was cheaper than the locally manufactured ice by nocturnal cooling. The ice trade in North America was a flourishing business. Ice was transported to southern states of America in train compartments insulated by 0.3m of cork insulation. Trading in ice was also popular in several other countries such as Great Britain, Russia, Canada, Norway and France. In these countries ice was either transported from colder regions or was harvested in winter and stored in icehouses for use in summer. The ice trade reached its peak in 1872 when America alone exported 225000 tonnes of ice to various countries as far as China and Australia. However, with the advent of artificial refrigeration the ice trade gradually declined.

### **Introduction To air-condition**

Design and analysis of air conditioning systems involves selection of suitable inside and outside design conditions, estimation of the required capacity of cooling or heating equipment, selection of suitable cooling/heating system, selecting supply conditions, design of air transmission and distribution systems etc. Generally, the inputs are the building specifications and its usage pattern and any other special requirements. Figure 29.1 shows the schematic of a basic summer air conditioning system. As shown in the figure, under a typical summer condition, the building gains sensible and latent heats from the surroundings and also due to internal heat sources (RSH and RLH). The supply air to the building extracts the building heat gains from the conditioned space. These heat gains along with other heat gains due to ventilation, return ducts etc. have to be extracted from the air stream by the cooling coil, so that air at required cold and dry condition can be supplied to the building to complete the cycle. In general, the sensible and latent heat transfer rates (GSH and GLH) on the cooling coil

are larger than the building heat gains due to the need for ventilation and return duct losses. To estimate the required cooling capacity of the cooling coil (GTH), it is essential to estimate the building and other heat gains. The building heat gains depend on the type of the building, outside conditions and the required inside conditions. Hence selection of suitable inside and outside design conditions is an important step in the design and analysis of air conditioning systems.

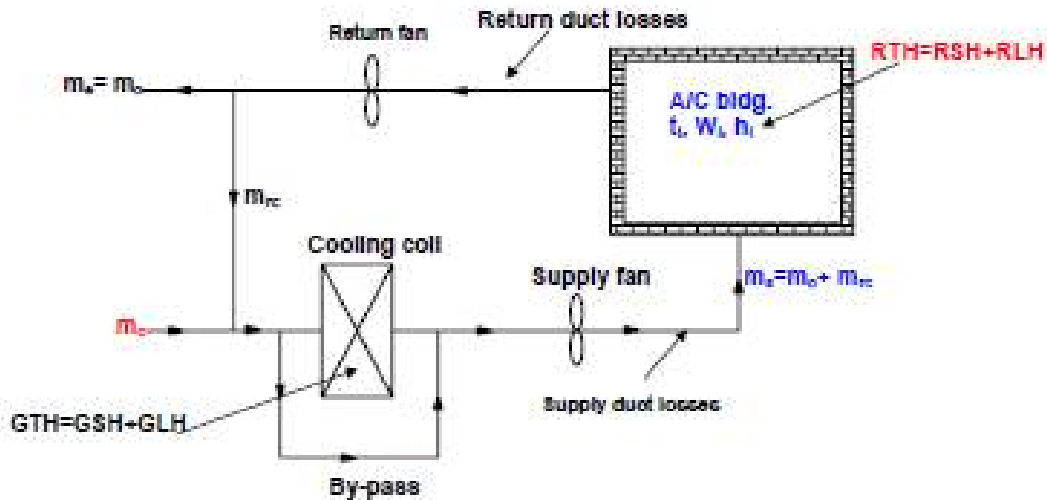


Fig.29.1: Schematic of a basic summer air conditioning system

## BASIC REFRIGERATION PRINCIPLES

If you were to place a hot cup of coffee on a table and leave it for a while, the heat in the coffee would be transferred to the materials in contact with the coffee, i.e. the cup, the table and the surrounding air. As the heat is transferred, the coffee in time cools. Using the same principle, refrigeration works by removing heat from a product and transferring that heat to the outside air.

## REFRIGERATION SYSTEM COMPONENTS

- There are five basic components of a refrigeration system, these are:
  - Evaporator
  - Compressor

- Condenser
- Expansion Valve
- Refrigerant; to conduct the heat from the product

In order for the refrigeration cycle to operate successfully each component must be present within the refrigeration system.

### **The Evaporator**

The purpose of the evaporator is to remove unwanted heat from the product, via the liquid refrigerant. The liquid refrigerant contained within the evaporator is boiling at a low-pressure. The level of this pressure is determined by two factors:

- The rate at which the heat is absorbed from the product to the liquid refrigerant in the evaporator
- The rate at which the low-pressure vapour is removed from the evaporator by the compressor.

To enable the transfer of heat, the temperature of the liquid refrigerant must be lower than the temperature of the product being cooled. Once transferred, the liquid refrigerant is drawn from the evaporator by the compressor via the suction line. When leaving the evaporator coil the liquid refrigerant is in vapour form.

### **The Compressor**

The purpose of the compressor is to draw the low-temperature, low-pressure vapour from the evaporator via the suction line. Once drawn, the vapour is compressed. When vapour is compressed it rises in temperature. Therefore, the compressor transforms the vapour from a low-temperature vapour to a high-temperature vapour, in turn increasing the pressure. The vapour is then released from the compressor in to the discharge line.

## **The Condenser**

The purpose of the condenser is to extract heat from the refrigerant to the outside air. The condenser is usually installed on the reinforced roof of the building, which enables the transfer of heat. Fans mounted above the condenser unit are used to draw air through the condenser coils. The temperature of the high-pressure vapour determines the temperature at which the condensation begins. As heat has to flow from the condenser to the air, the condensation temperature must be higher than that of the air; usually between  $-12^{\circ}\text{C}$  and  $-1^{\circ}\text{C}$ . The high-pressure vapour within the condenser is then cooled to the point where it becomes a liquid refrigerant once more, whilst retaining some heat. The liquid refrigerant then flows from the condenser in to the liquid line.

## **The Expansion Valve**

Within the refrigeration system, the expansion valve is located at the end of the liquid line, before the evaporator. The high-pressure liquid reaches the expansion valve, having come from the condenser. The valve then reduces the pressure of the refrigerant as it passes through the orifice, which is located inside the valve. On reducing the pressure, the temperature of the refrigerant also decreases to a level below the surrounding air. This low-pressure, low-temperature liquid is then pumped in to the evaporator.

## **The Refrigerant**

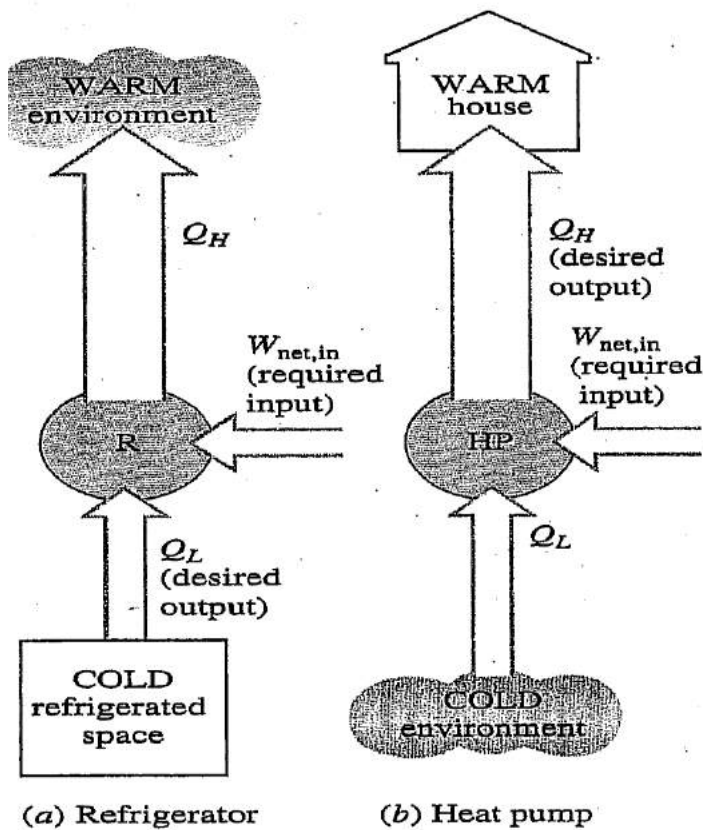
The type of refrigerant used will depend on the pressure capabilities of the system and the temperatures that have to be achieved during refrigeration. The following brief table shows the relationship between temperature and pressure, given in bar, for two common refrigerants.

This gas cycle refrigeration systems based on air, namely

1. Reverse Carnot cycle & its limitations
2. Reverse Brayton cycle – Ideal & Actual
3. Aircraft refrigeration cycles, namely Simple system, Bootstrap system, Regenerative system.



## 4. COP.



COP = coefficient of performance Air conditioners,

Refrigerators:  $COP = Q_L / W_{net}$

Heat pumps:  $COP = Q_H / W_{net}$

Energy balance:  $W_{net} + Q_L = Q_H$

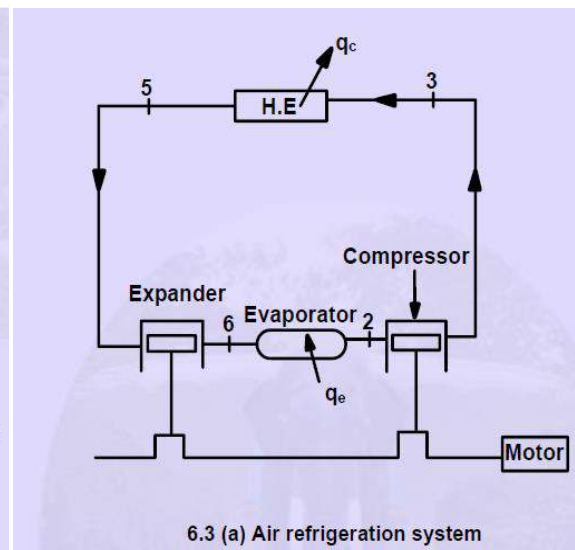
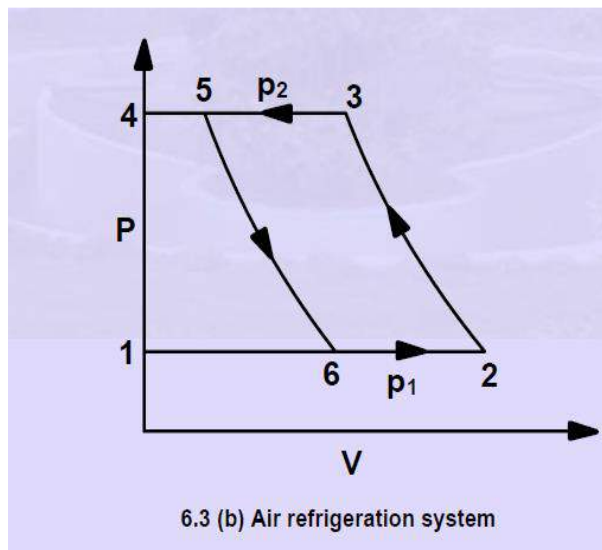
Reversed Carnot cycle – ideal:

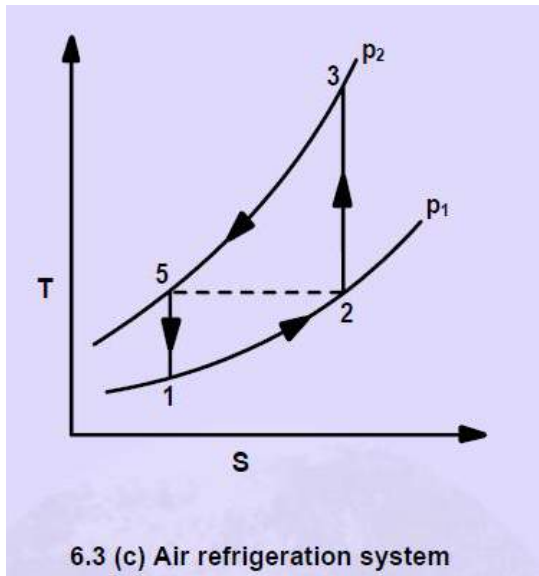
$$COP_{R,Carnot} = \frac{1}{T_H/T_L - 1}$$

$$COP_{HP,Carnot} = \frac{1}{1 - T_L/T_H}$$

Air Refrigeration System And Bell-Coleman Cycle Or Reversed Brayton Cycle:

The components of the air refrigeration system are shown in Fig. 6.3(a). In this system, air is taken into the compressor from atmosphere and compressed. The hot compressed air is cooled in heat exchanger up to the atmospheric temperature (in ideal conditions). The cooled air is then expanded in an expander. The temperature of the air coming out from the expander is below the atmospheric temperature due to isentropic expansion. The low temperature air coming out from the expander enters into the evaporator and absorbs the heat. The cycle is repeated again. The working of air refrigeration cycle is represented on p-v and T-s diagrams in Fig. 6.3(b) and (c). Process 1-2 represents the suction of air into the compressor. Process 2-3 represents the isentropic compression of air by the compressor. Process 3-5 represents the discharge of high pressure air from the compressor into the heat exchanger. The reduction in volume of air from  $v_3$  to  $v_5$  is due to the cooling of air in the heat exchanger. Process 5-6 represents the isentropic expansion of air in the expander. Process 6-2 represents the absorption of heat from the evaporator at constant pressure.





### 1. Analysis of Bell-Coleman Cycle:

The air refrigeration system works on Bell-Coleman cycle.

#### Assumptions:

- 1) The compression and expansion processes are reversible adiabatic processes.
- 2) There is a perfect inter-cooling in the heat exchanger.
- 3) There are no pressure losses in the system.

$$\text{COP} = \frac{\text{Net refrigeration effect}}{\text{Net work supplied}}$$

Work done per kg of air for the isentropic compression process 2-3 is given by,

$$W_C = C_p (T_3 - T_2)$$

Work developed per kg of air for the isentropic expansion process 5-6 is given by

$$W_E = C_p(T_5 - T_6)$$

$$\text{Net work required} = W_{\text{net}} = (W_C - W_E) = C_p(T_3 - T_2) - C_p(T_5 - T_6)$$

Net refrigerating effect per kg of air is given by,

$$R_{\text{net}} = C_p(T_2 - T_6)$$

$$\text{COP} = \frac{R_{\text{net}}}{W_{\text{net}}} = \frac{C_p(T_2 - T_6)}{C_p\{(T_3 - T_2) - (T_5 - T_6)\}}$$

For perfect inter-cooling, the required condition is  $T_5 = T_2$

$$\text{COP} = \frac{(T_2 - T_6)}{(T_3 - T_2) - (T_2 - T_6)}$$

$$= \frac{1}{\frac{(T_3 - T_2)}{(T_2 - T_6)} - 1} \quad (\text{for isentropic process})$$

$$= \frac{1}{\frac{T_3(1 - T_2/T_3)}{T_2(1 - T_6/T_2)} - 1}$$

For isentropic compression process 2-3 and for expansion process 5-6, we have,

$$\frac{T_3}{T_2} = \left(\frac{P_1}{P_2}\right)^{\gamma-1} \quad \text{and} \quad \frac{T_5}{T_6} = \left(\frac{P_2}{P_1}\right)^{\gamma-1}$$

Therefore,  $\frac{T_3}{T_2} = \frac{T_5}{T_6}$  or  $\frac{T_6}{T_5} = \frac{T_2}{T_3} \therefore (T_5 = T_2)$

$$\text{COP} = \frac{T_2}{T_3 - T_2}$$

### Advantages:

- a) Air is a cheaper refrigerant and available easily compared to other refrigerants.
- b) There is no danger of fire or toxic effects due to leakage.

c) The total weight of the system per ton of refrigerating capacity is less.

**Disadvantages:**

(a) The quantity of air required per ton refrigerating capacity is far greater than other systems.

(b) The COP is low and hence maintenance cost is high.

(c) The danger of frosting at the expander valves is more as the air taken into the system always contains moisture.

**Work done during Compression and Expansion Processes (for polytropic processes) (Refer P-V-diagram) (For problem solving)**

$$\begin{aligned}
 W_C &= P_3 V_3 + \frac{P_3 V_3 - P_2 V_2}{n - 1} - P_2 V_2 \\
 &= (P_3 V_3 - P_2 V_2) + \frac{(P_3 V_3 - P_2 V_2)}{n - 1} \\
 &= \frac{n}{n - 1} (P_3 V_3 - P_2 V_2)
 \end{aligned}$$

This lesson discusses various gas cycle refrigeration systems based on air, namely:

1. Reverse Carnot cycle & its limitations.
2. Reverse Brayton cycle – Ideal & Actual.
3. Aircraft refrigeration cycles, namely Simple system, Bootstrap system, Regenerative system, etc.

At the end of the lesson the student should be able to:

1. Describe various air cycle refrigeration systems.
2. State the assumptions made in the analyses of air cycle systems.
3. Show the cycles on T-s diagrams.
4. Perform various cycle calculations.

5. State the significance of Dry Air Rated Temperature.

## **Vapour Compression Refrigeration Systems**

### **Introduction**

A vapour compression refrigeration system is an improved type of air refrigeration system in which a suitable working substance, termed as refrigerant, is used. It condenses and evaporates at temperatures and pressures close to the atmospheric conditions. The refrigerants, usually, used for this purpose are ammonia (NH<sub>3</sub>), carbon dioxide (CO<sub>2</sub>) and sulphur dioxide (SO<sub>2</sub>). The refrigerant used, does not leave the system, but is circulated throughout the system alternately condensing and evaporating. In evaporating, the refrigerant absorbs its latent heat from the brine (salt water) which is used for circulating it around the cold chamber. While condensing, it gives out its latent heat to the circulating water of the cooler. The vapour compression refrigeration system is, therefore a latent heat pump, as it pumps its latent heat from the brine and delivers it to the cooler.

The vapour compression refrigeration system is now-a-days used for all purpose refrigeration. It is generally used for all industrial purposes from a small domestic refrigerator to a big air conditioning plant.

### **Advantages and Disadvantages of vapour Compression Refrigeration System over Air Refrigeration System**

Following are the advantages and disadvantages of the vapour compression refrigeration system over air refrigeration system:

#### **Advantages**

1. It has smaller size for the given capacity of refrigeration.
2. It has less running cost.
3. It can be employed over a large range of temperatures.

4. The coefficient of performance is quite high.

Disadvantages 1. The initial cost is high

2. The prevention of leakage of the refrigerant is the major problem in vapour compression system

### 2.3 Mechanism of a Simple Vapour Compression Refrigeration System

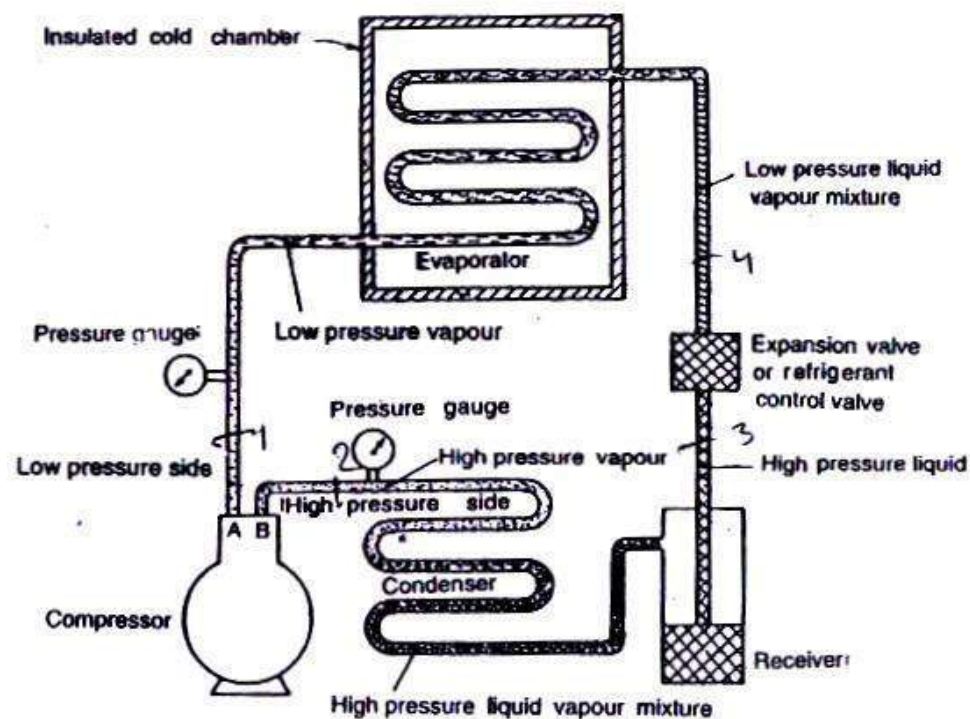


Fig. 2.1 shows the schematic diagram of a simple vapour compression refrigeration system.

It consists of the following five essential parts :

1. Compressor. The low pressure and temperature vapour refrigerant from evaporator is drawn into the compressor through the inlet or suction valve A, where it

is compressed to a high pressure and temperature. This high pressure and temperature vapor refrigerant is discharged through the condenser through the delivery or discharge valve B.

2. Condenser. The condenser or cooler consists of coils of pipe in which the high pressure and temperature vapour refrigerant is cooled and condensed. The refrigerant, while passing through the condenser, gives up its latent heat to the surrounding condensing medium which is normally air or water.

3. Receiver. The condensed liquid refrigerant from the condenser is stored in a vessel known as receiver from where it is supplied to the evaporator through the expansion valve or refrigerant control valve.

4. Expansion valve. It is also called throttle valve or refrigerant control valve. The function of the expansion valve is to allow the liquid refrigerant under high pressure and temperature to pass at a controlled rate after reducing its pressure and temperature. Some of the liquid refrigerant evaporates as it passes through the expansion valve, but the greater portion is vaporised in the evaporator at the low pressure and temperature.

5. Evaporator. An evaporator consists of coils of pipe in which the liquid-vapour refrigerant at low pressure and temperature is evaporated and changed into vapour refrigerant at low pressure and temperature. In evaporating, the liquid vapour refrigerant absorbs its latent heat of vaporisation from the medium (air, water or brine) which is to be cooled.

**Note :** In any compression refrigeration system, there are two different pressure conditions. One is called the high pressure side and other is known as low pressure side. The high pressure side includes the discharge line (i.e. piping from the evaporator to the suction valve A).



## 2.4 Pressure-Enthalpy (p-h) Chart

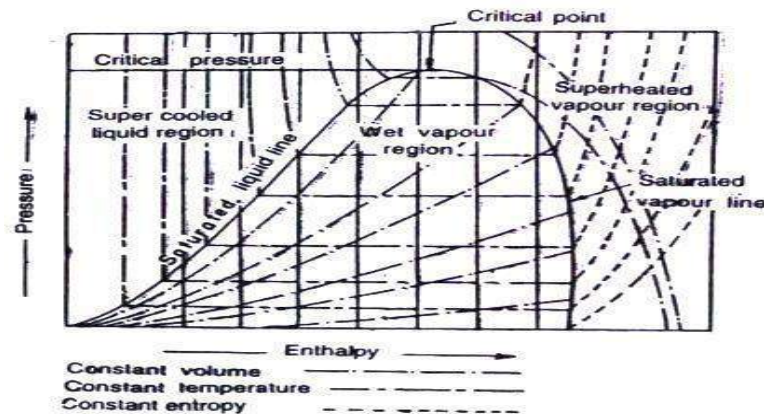


Fig 2.2 pressure enthalpy [p-h] chart

The most convenient chart for studying the behavior of a refrigerant is the p-h chart, in which the vertical ordinates represent pressure and horizontal ordinates represent enthalpy (i.e. total heat). A typical chart is shown in Fig. 2.2, in which a few important lines of the complete chart are drawn. The saturated liquid line and the saturated vapour line merge into one another at the critical point. A saturated liquid is one which has a temperature equal to the saturation temperature corresponding to its pressure. The space to the left of the saturated liquid line will, therefore, be sub-cooled liquid region. The space between the liquid and the vapour lines is called wet vapour region and to the right of the saturated vapour line is a superheated vapour region.

In the following pages, we shall draw the p-h chart along with the T-s diagram of the cycle.

## Vapour Absorption Refrigeration Systems

### Introduction

The vapour absorption refrigeration system is one of the oldest method of producing refrigerating effect. The principle of vapour absorption was first discovered by Michael Faraday in 1824 while performing a set of experiments to liquify certain gases. The first vapour absorption refrigeration machine was developed by a French

scientist Ferdinand Carre in 1860. This system may be used in both the domestic and large industrial refrigerating plants. The refrigerant, commonly used in a vapour absorption system, is ammonia.

The vapour absorption system uses heat energy, instead of mechanical energy as in vapour compression systems, in order to change the conditions of the refrigerant required for the operation of the refrigeration cycle. We have discussed in the previous chapters that the function of a compressor, in a vapour compression system, is to withdraw the vapour refrigerant from the evaporator. It then raises its temperature and pressure higher than the cooling agent in the condenser so that the higher pressure vapours can reject heat in the condenser. The liquid refrigerant leaving the condenser is now ready to expand to the evaporator conditions again.

In the vapour absorption system, the compressor is replaced by an absorber, a pump, a generator and a pressure reducing valve. These components in vapour absorption system perform the same function as that of a compressor in vapour compression system. In this system, the vapour refrigerant from the evaporator is drawn into an absorber where it is absorbed by the weak solution of the refrigerant forming a strong solution. This strong solution is pumped to the generator where it is heated by some external source. During the heating process, the vapour refrigerant is driven off by the solution and enters into the condenser where it is liquefied. The liquid refrigerant then flows into the evaporator and thus the cycle is completed.

### **Simple Vapour Absorption System –**

The simple vapour absorption system, as shown in Fig. 3.1, consists of an absorber, a pump, a generator and a pressure reducing valve to replace the compressor of vapour compression system. The other components of the system are condenser, receiver, expansion valve and evaporator as in the vapour compression system.

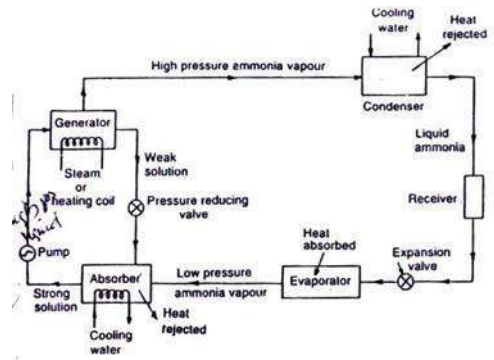


Fig 3.1 Simple vapour absorption system

In this system, the low pressure ammonia vapour leaving the evaporator enters the absorber where it is absorbed by the cold water in the absorber. The water has the ability to absorb very large quantities of ammonia vapour and the solution thus formed, is known as aqua-ammonia. The absorption of ammonia vapour in water lowers the pressure in the absorber which in turn draws more ammonia vapour from the evaporator and thus raises the temperature of solution. Some form of cooling arrangement (usually water cooling) is employed in the absorber to remove the heat of solution evolved there. This is necessary in order to increase the absorption capacity of water, because at higher temperature water absorbs less ammonia vapour. The strong solution thus formed in the absorber is pumped to the generator by the liquid pump. The pump increases the pressure of the solution upto 10 bar.

The \*strong solution of ammonia in the generator is heated by some external source such as gas or steam. During the heating process, the ammonia vapour is driven off the solution at high pressure leaving behind the hot weak ammonia solution in the generator. This weak ammonia solution flows back to the absorber at low pressure after passing through the pressure reducing valve. The high pressure ammonia vapour from the generator is condensed in the condenser to a high pressure liquid ammonia. This liquid ammonia is passed to the expansion valve through the receiver and then to the evaporator. This completes the simple vapour absorption cycle.

### 3.3 practical Vapour Absorption System

The simple absorption system as discussed in the previous article is not very economical. In order to make the system more practical, it is fitted with an analyser, a rectifier and two heat exchangers as shown in Fig. 3.2. These accessories help to improve the performance and working of the plant, as discussed below :-

Fig. 3.2. Practical vapour absorption system.

1. Analyser. When ammonia is vaporised in the generator, some water is also vaporised and will flow into the condenser along with the ammonia vapours in the simple system. If these unwanted water particles are not removed before entering into the condenser, they will enter into the expansion valve where they freeze and choke the pipe line. In order to remove these unwanted particles flowing to the condenser, an analyser is used. The analyser may be built as an integral part of the generator or made as a separate piece of equipment. It consists of a series of trays mounted above the generator. The strong solution from the absorber and the aqua from the rectifier are introduced at the top of the analyser and flow downward over the trays and into the generator. In this way, considerable liquid surface area is exposed to the vapour rising from the generator. The vapour is cooled and most of the water vapour condenses, so that mainly ammonia vapour leaves the top of the analyser. Since the aqua is heated by the vapour, less external heat is required in the generator.

2. Analyser. When ammonia is vaporised in the generator, some water is also vaporised and will flow into the condenser along with the ammonia vapours in the simple system. If these unwanted water particles are not removed before entering into the condenser, they will enter into the expansion valve where they freeze and choke the pipe line. In order to remove these unwanted particles flowing to the condenser, an analyser is used. The analyser may be built as an integral part of the generator or made as a separate piece of equipment. It consists of a series of trays mounted above the generator. The strong solution from the absorber and the aqua from the rectifier are introduced at the top of the analyser and flow downward over the trays and into the

generator. In this way, considerable liquid surface area is exposed to the vapour rising from the generator. The vapour is cooled and most of the water vapour condenses, so that mainly ammonia vapour leaves the top of the analyser. Since the aqua is heated by the vapour, less external heat is required in the generator.

3. Rectifier. In case the water vapours are not completely removed in the analyser, a closed type vapour cooler called rectifier (also known as dehydrator) is used. It is generally water cooled and may be of the double pipe, shell and coil or shell and tube type. Its function is to cool further the ammonia vapours leaving the analyser so that the remaining water vapours are condensed. Thus, only dry or anhydrous ammonia vapours flow to the condenser. The condensate from the rectifier is returned to the top of the analyser by a drip return pipe.

4. Heat exchangers. The heat exchanger provided between the pump and the generator is used to cool the weak hot solution returning from the generator to the absorber. The heat removed from the weak solution raises the temperature of the strong solution leaving the pump and going to analyser and generator. This operation reduces the heat supplied to the generator and the amount of cooling required for the absorber. Thus the economy of the plant increases.

The heat exchanger provided between the condenser and the evaporator may also be called liquid sub-cooler. In this heat exchanger, the liquid refrigerant leaving the condenser is sub-cooled by the low temperature ammonia vapour from the evaporator as shown in Fig. 7.2. This sub-cooled liquid is now passed to the expansion valve and then to the evaporator.

In this system, the net refrigerating effect is the heat absorbed by the refrigerant in the evaporator. The total energy supplied to the system is the sum of work done by the pump and the heat supplied in the generator. Therefore, the coefficient of performance of the system is given by

(Heat absorbed in evaporator)

### Advantages of Vapour Absorption Refrigeration System over Vapour Compression Refrigeration System

Following are the advantages of vapour absorption system over vapour compression system:

1. In the vapour absorption system, the only moving part of the entire system is a pump which has a small motor. Thus, the operation of this system is essentially quiet and is subjected to little wear. The vapour compression system of the same capacity has more wear, tear and noise due to moving parts of the compressor.

2. The vapour absorption system uses heat energy to change the condition of the refrigerant from the evaporator. The vapour compression system uses mechanical energy to change the condition of the refrigerant from the evaporator.

3. The vapour absorption systems are usually designed to use steam, either at high pressure or low pressure. The exhaust steam from furnaces and solar energy may also be used. Thus this system can be used where the electric power is difficult to obtain or is very expensive.

4. The vapour absorption systems can operate at reduced evaporator pressure and temperature by increasing the steam pressure to the generator, with little decrease in capacity. But the capacity of vapour compression system drops rapidly with lowered evaporator pressure.

5. The load variations does not effect the performance of a vapour absorption system. The load variations are met by controlling the quantity of aqua circulated and the quantity of steam supplied to the generator.

The performance of a vapour compression system at partial loads is poor.

6. In the vapour absorption system, the liquid refrigerant leaving the evaporator has no bad effect on the system except that of reducing the refrigerating effect. In the vapour compression system, it is essential to superheat the vapour refrigerant leaving the evaporator so that no liquid may enter the compressor.

7. The vapour absorption systems can be built in capacities well above 1000 tonnes of refrigeration each which is the largest size for single compressor units.

8. The space requirements and automatic control requirements favour the absorption system more and more as the desired evaporator temperature drops.

## Psychrometry

### Introduction:

Atmospheric air makes up the environment in almost every type of air conditioning system. Hence a thorough understanding of the properties of atmospheric air and the ability to analyze various processes involving air is fundamental to air conditioning design.

Psychrometry is the study of the properties of mixtures of air and water vapour.

Atmospheric air is a mixture of many gases plus water vapour and a number of pollutants (Fig.27.1). The amount of water vapour and pollutants vary from place to place. The concentration of water vapour and pollutants decrease with altitude, and above an altitude of about 10 km, atmospheric air consists of only dry air. The pollutants have to be filtered out before processing the air. Hence, what we process is essentially a mixture of various gases that constitute air and water vapour. This mixture is known as moist air.

The moist air can be thought of as a mixture of dry air and moisture. For all practical purposes, the composition of dry air can be considered as constant. In 1949, a standard composition of dry air was fixed by the International Joint Committee on Psychrometric data. It is given in Table

Constituent	Molecular weight	Mol fraction
Oxygen	32.000	0.2095
Nitrogen	28.016	0.7809
Argon	39.944	0.0093
Carbon dioxide	44.010	0.0003

### Composition of standard air

Based on the above composition the molecular weight of dry air is found to be **28.966** and the gas constant R is **287.035 J/kg.K**.

As mentioned before the air to be processed in air conditioning systems is a mixture of dry air and water vapour. While the composition of dry air is constant, the amount of water vapour present in the air may vary from zero to a maximum depending upon the temperature and pressure of the mixture (dry air + water vapour).

At a given temperature and pressure the dry air can only hold a certain maximum amount of moisture. When the moisture content is maximum, then the air is known as saturated air, which is established by a neutral equilibrium between the moist air and the liquid or solid phases of water.

For calculation purposes, the molecular weight of water vapour is taken as **18.015** and its gas constant is **461.52 J/kg.K**.

Methods for estimating properties of moist air: In order to perform air conditioning calculations, it is essential first to estimate various properties of air. It is difficult to estimate the exact property values of moist air as it is a mixture of several permanent gases and water vapour. However, moist air upto 3 atm. pressure is found to obey perfect gas law with accuracy sufficient for engineering calculations. For higher accuracy Goff and Gratch tables can be used for estimating moist air properties. These tables are obtained using mixture models based on fundamental principles of statistical mechanics that take into account the real gas behaviour of dry air and water vapour. However, these tables are valid for a barometric pressure of 1 atm. only. Even though the calculation procedure is quite complex, using the mixture models it is possible to estimate moist air properties at other pressures also. However, since in most cases the pressures involved are low, one can apply the perfect gas model to estimate psychrometric properties.



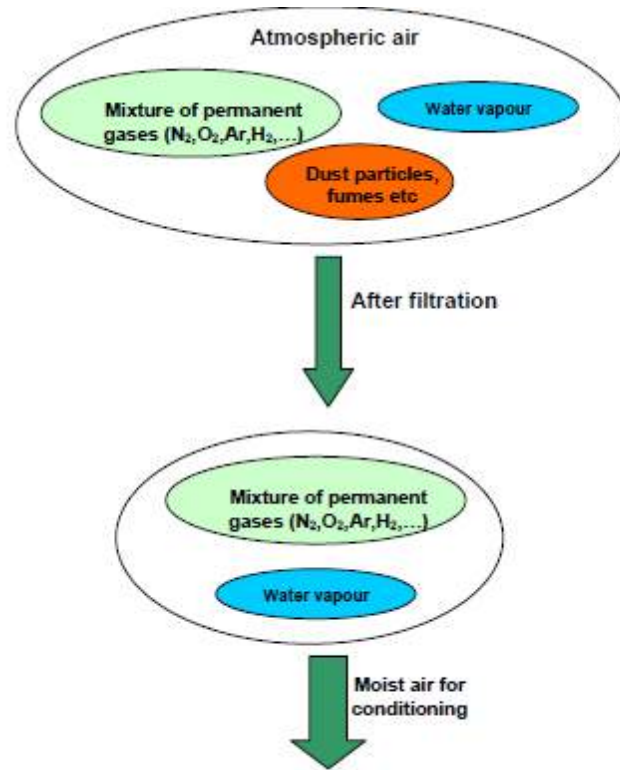
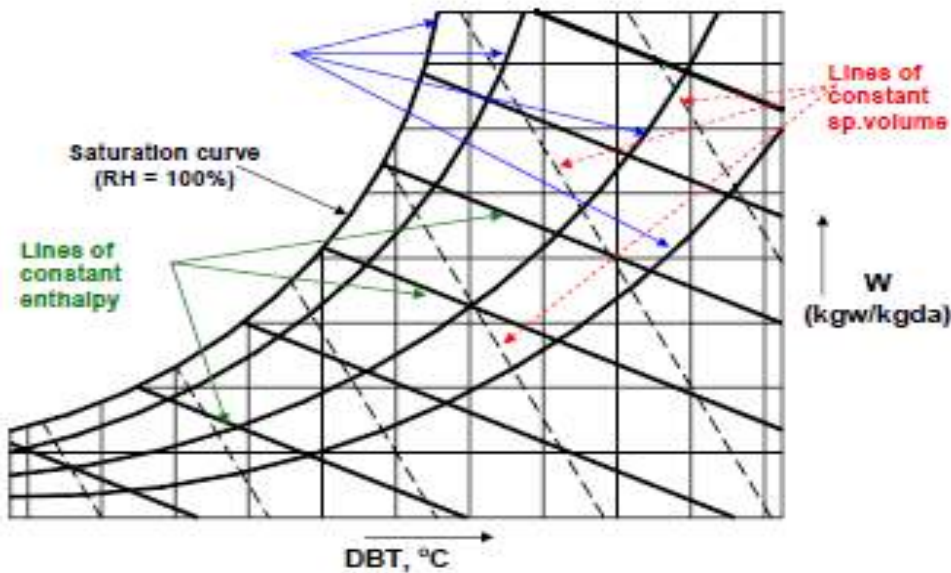


Fig. 27.1: Atmospheric air

### Psychrometric chart

A Psychrometric chart graphically represents the thermodynamic properties of moist air. Standard psychrometric charts are bounded by the dry-bulb temperature line (abscissa) and the vapour pressure or humidity ratio (ordinate). The Left Hand Side of the psychrometric chart is bounded by the saturation line. Figure 27.2 shows the schematic of a psychrometric chart. Psychrometric charts are readily available for standard barometric pressure of 101.325 kPa at sea level and for normal temperatures (0-50 °C). ASHRAE has also developed psychrometric charts for other temperatures and barometric pressures (for low temperatures: -40 to 10 °C, high temperatures 10 to 120 °C and very high temperatures 100 to 120 °C)



Schematic of a psychrometric chart for a given barometric pressure

#### Measurement of psychrometric properties:

Based on Gibbs' phase rule, the thermodynamic state of moist air is uniquely fixed if the barometric pressure and two other independent properties are known. This means that at a given barometric pressure, the state of moist air can be determined by measuring any two independent properties. One of them could be the dry-bulb temperature (DBT), as the measurement of this temperature is fairly simple and accurate. The accurate measurement of other independent parameters such as humidity ratio is very difficult in practice. Since measurement of temperatures is easier, it would be convenient if the other independent parameter is also a temperature. Of course, this could be the dew-point temperature (DPT), but it is observed that accurate measurement of dew-point temperature is difficult. In this context, a new independent temperature parameter called the wet-bulb temperature (WBT) is defined. Compared to DPT, it is easier to measure the wet-bulb temperature of moist air. Thus knowing the dry-bulb and wet-bulb temperatures from measurements, it is possible to find the other properties of moist air.

To understand the concept of wet-bulb temperature, it is essential to understand the process of combined heat and mass transfer.

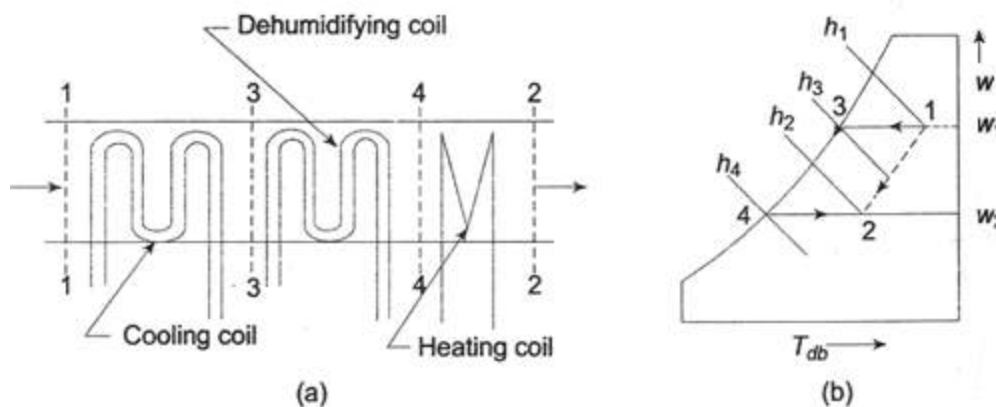
## PSYCHROMETRIC PROCESSES IN AIR CONDITIONING EQUIPMENT

Eight basic parametric processes together cannot be achieved in practice in air conditioning equipment.

- Different types of equipments are used for this purpose.
- By pass factor is a vital parameter signifying the performance of A/C equipment

## COOLING & DEHUMIDIFICATION

- Industrial applications: air conditioning, cold storages, paper industry, photography.
- Lowering the temperature & reducing the moisture content in air.
- Process used in summer air conditioning : air passes over cooling coil or through cold spray.

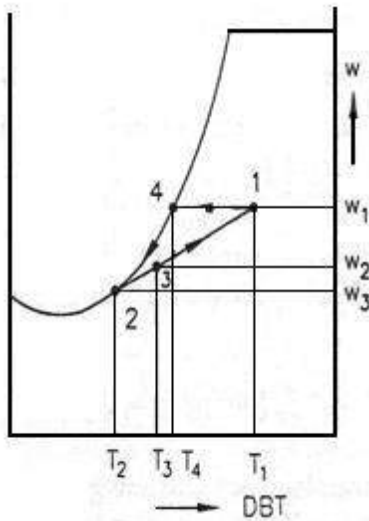


**Fig. Cooling and dehumidification.**

## COOLING & DEHUMIDIFICATION

- The removal of water vapour from the air is termed as dehumidification of air. The dehumidification of air is only possible if the air is cooled below the dew point temperature of the air..

- It is necessary to maintain the coil surface temperature of air for effective dehumidification.



The process of cooling and dehumidification is shown in Fig.

$T_1$  = Temperature of air entering the coil.

$T_2$  = Coil surface temperature.

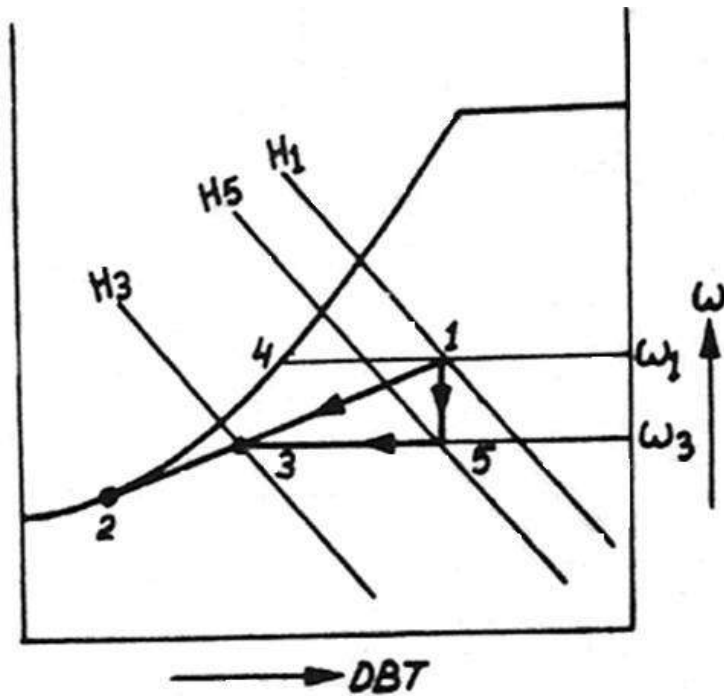
$T_4$  = Dew point temperature of air.

Under the ideal condition, the air condition coming out of the coil will be 2.

No cooling coil is hundred per cent efficient, so the condition of the air coming out of the coil will be represented by the point 3.

The bypass factor of the cooling coil in this case is given by

$$B = \frac{h_3 - h_2}{h_1 - h_2} = \frac{\omega_3 - \omega_2}{\omega_1 - \omega_2} = \frac{T_{d3} - T_{d2}}{T_{d1} - T_{d2}} = \frac{T_{d3} - ADP}{T_{d1} - ADP}$$



The total heat removed from the air is given by

$$Q_t = h_1 - h_3 = (h_1 - h_5) + (h_5 - h_3)$$

$$= Q_l + Q_s$$

where  $(h_1 - h_5)$  is the latent heat removed and  $(h_5 - h_3)$  is the sensible heat removed.

The cooling coil capacity in tons of refrigeration is given by

$$\text{Capacity in tons} = \frac{(h_1 - h_3) \times m_a}{3.5}$$

where  $m_a$  is the mass of air in kg per second passing over the coil.

The *SHRs* for few applications are recommended as follows.

Residence or Private office = 0.9

Restaurant or Busy office = 0.8

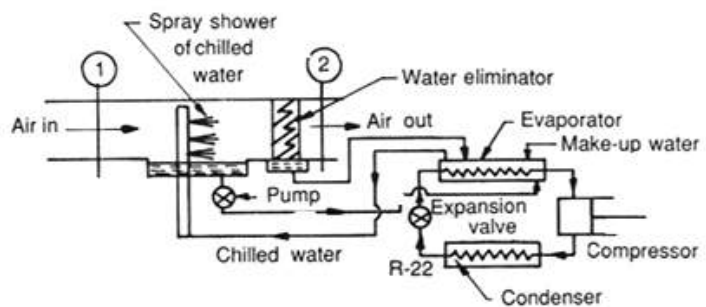
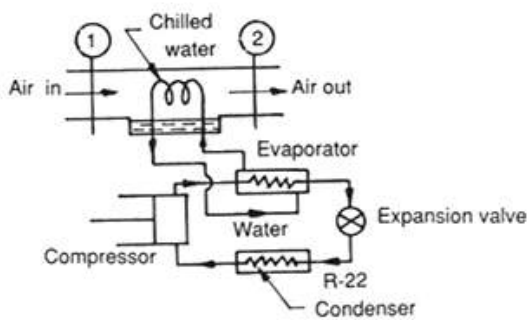
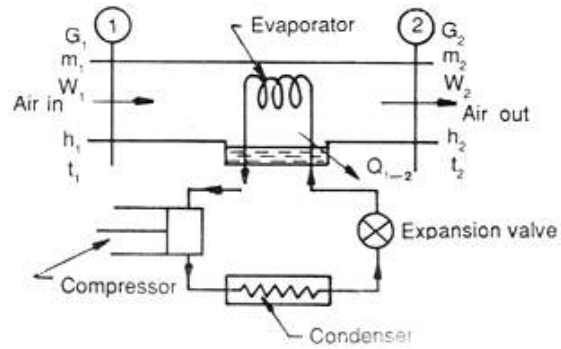
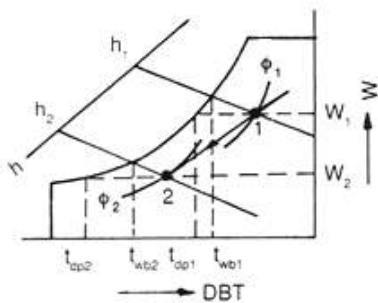
Auditorium of full capacity = 0.7

Ball dancing room at full capacity = 0.6.

#### COOLING & DEHUMIDIFICATION

- Air may be cooled and dehumidified by
  - 1. By placing the evaporator coil across the air flow
  - 2. By circulating chilled water in a tube placed across the air flow
  - 3. By spraying chilled water to air in the form of fine mist to expose a large surface area.

When the humidity ratio of air decreases, air is said to be dehumidified,



[b] by circulating chilled water tube across the air flow [c] By spraying chilled water in the form of fine mist

### HEATING AND HUMIDIFICATION

- In winter air conditioning, heating and humidification are very common.
- System consists of a coil for sensible heating of air from state 1 to 3 then along the wet bulb temperature line through state 2. then humidification along wet bulb line until the required moisture is added to reach state 2.

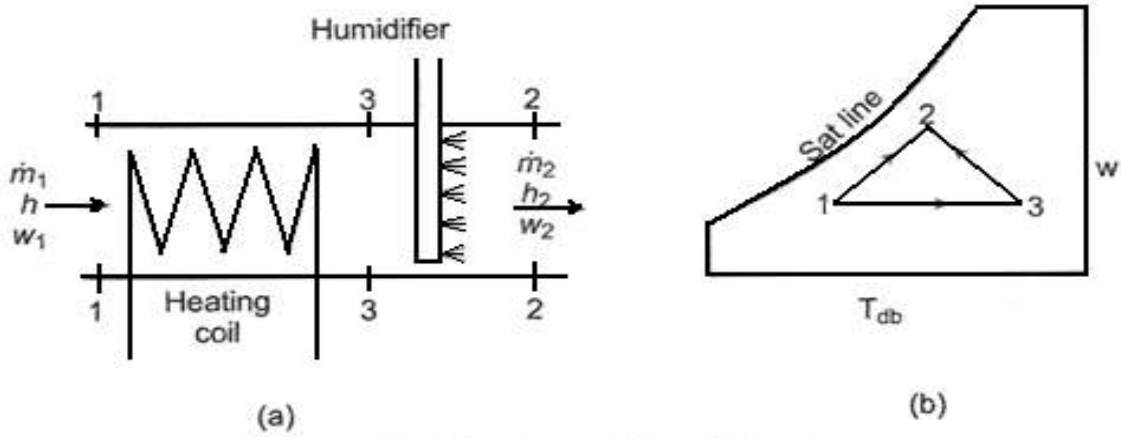


Fig. Heating and humidification

HEATING AND HUMIDIFICATION

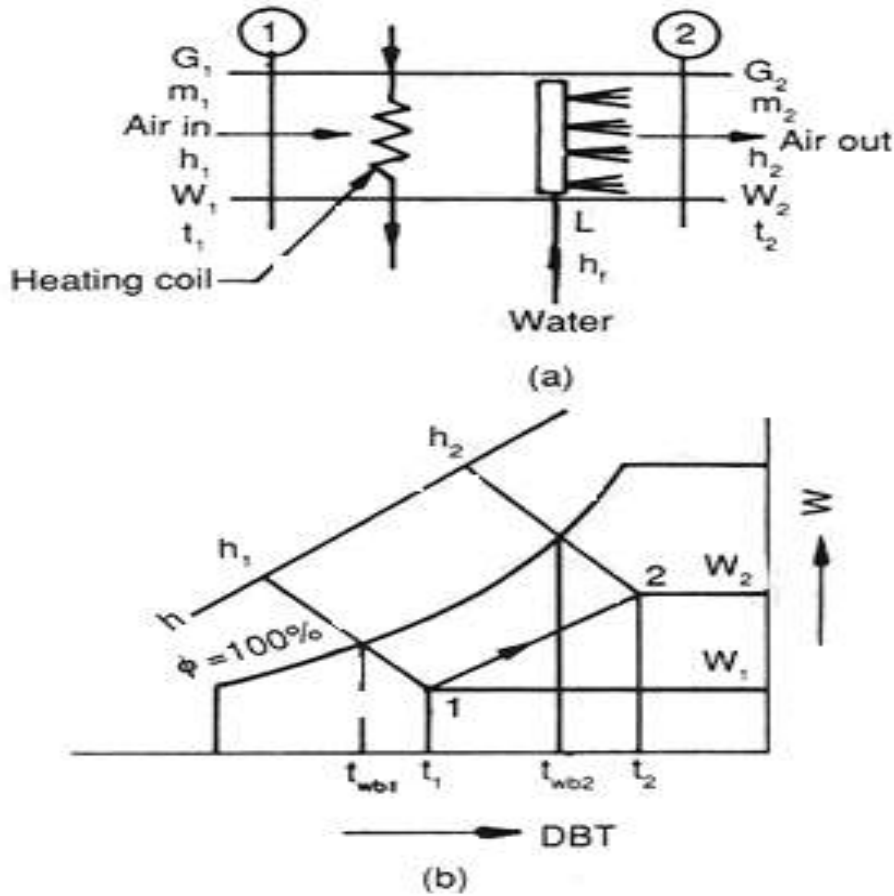


FIG. Heating and humidification



### BYPASS FACTOR & CONTACT FACTOR

- For large commercial systems, adopt simpler and economical technique.
- Part of air should be cooled to such a low temperature that the desired mass of moisture is removed.
- Air at state 1 is at much higher temperature than at state 2, it would work as heating of the cooled air. Hence no extra energy for heating and cooling is needed.
- This type of cooling and dehumidification is accomplished using
- By-pass as shown in fig.
- A part of the inlet air is by passed without being cooled and rest air is cooled over the coil.
- X- By pass factor, 1-X amount of air cooled over the coil from state 1 to temp  $t_s$  of the coil surface, is mixed with the rest air to get it at state 2, a desired value.
- This desired lowest temperature is called apparatus dew point ADP

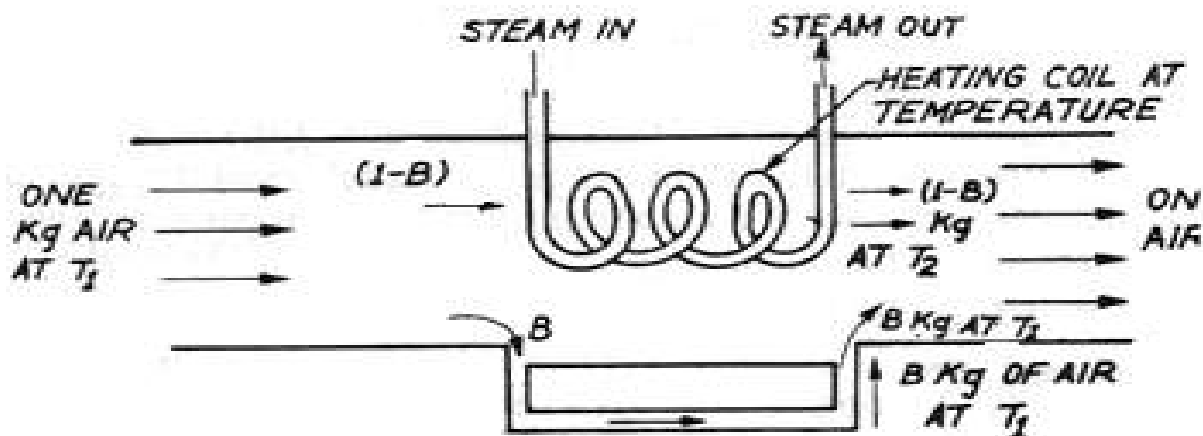
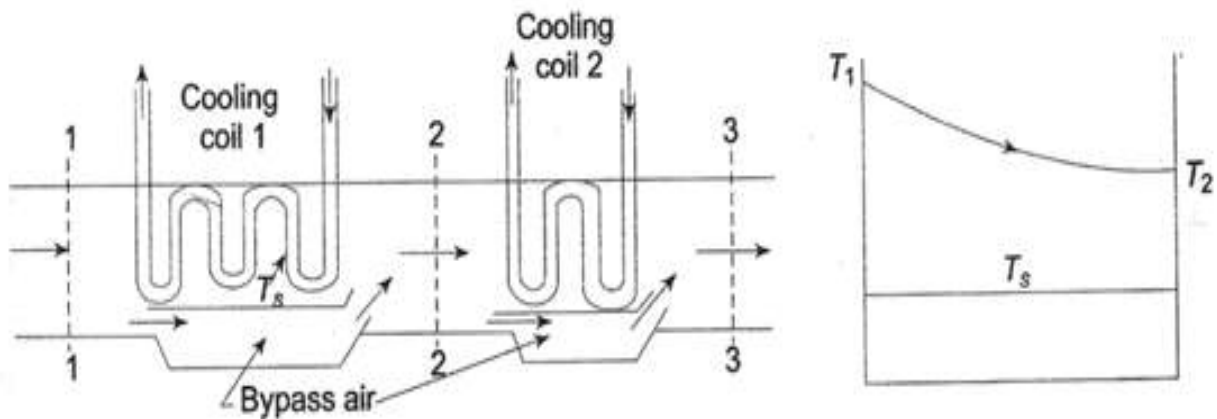
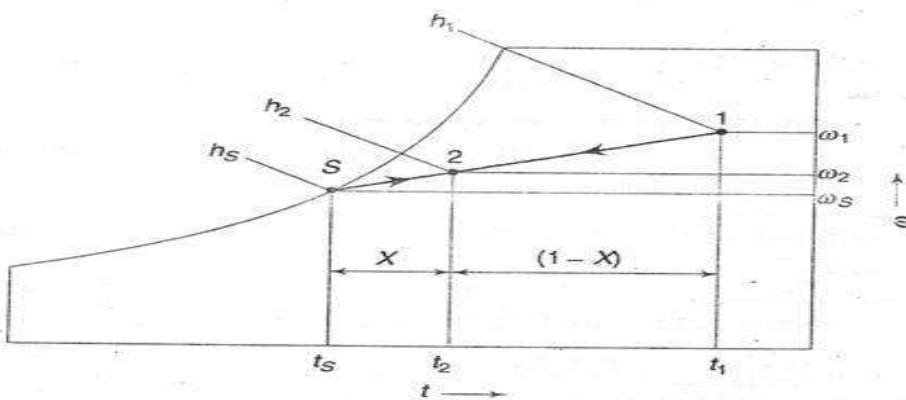


Fig. Illustration of bypass factor.



**Fig. By-pass arrangement**

**BYPASS FACTOR & CONTACT FACTOR**



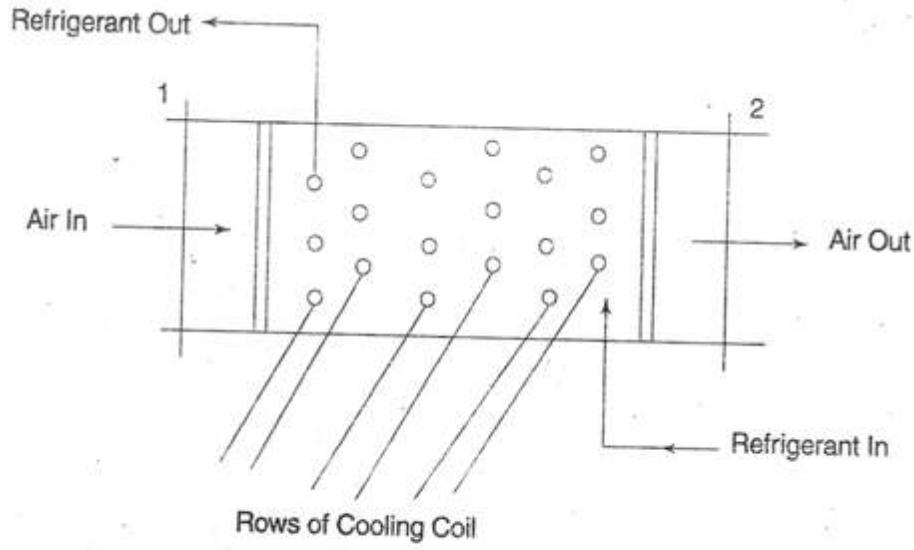
**Fig. Bypass Factor and Leaving Air State**

Thus one can define a *bypass factor* (BPF) of the apparatus representing the fraction of “uncontacted” air in terms of the states 1, 2 and S, as

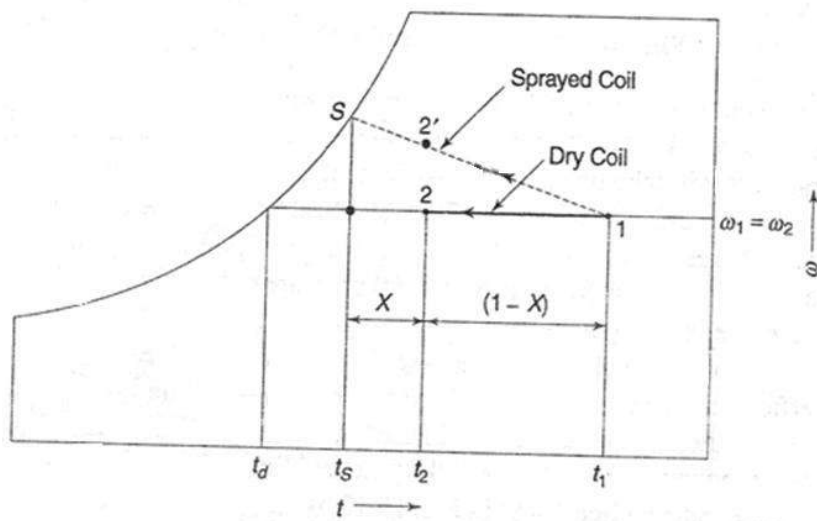
$$X = \frac{t_2 - t_s}{t_1 - t_s} = \frac{\omega_2 - \omega_s}{\omega_1 - \omega_s} = \frac{h_2 - h_s}{h_1 - h_s}$$

Conversely, one can define a *contact factor*  $(1 - X)$  representing a fraction of the contacted air. Thus the bypass factor can be defined in terms of temperature or specific humidity or enthalpy of air.

**COOLING & DEHUMIDIFYING COILS –ADP OF COIL**

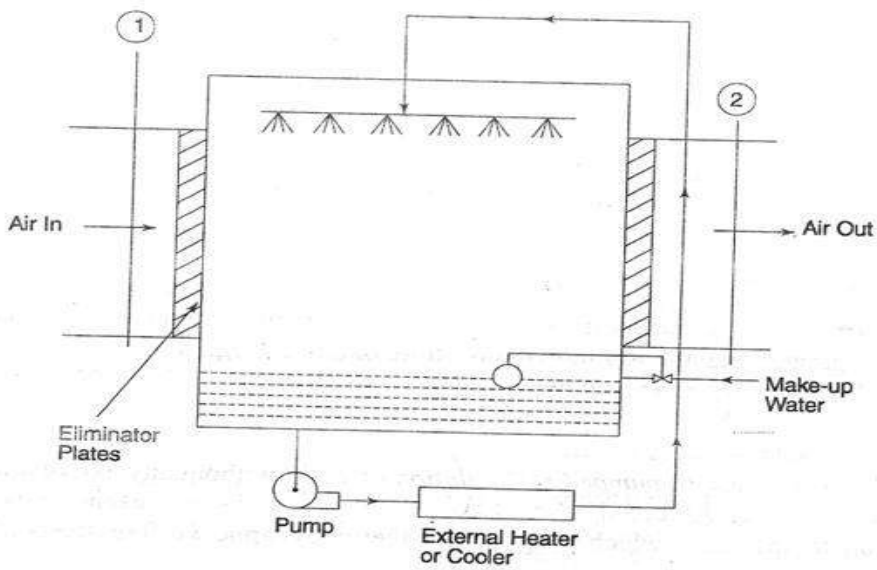


**Fig.** Cooling and Dehumidifying Coil



**Fig.** Simple Cooling, and Sprayed Coil Processes

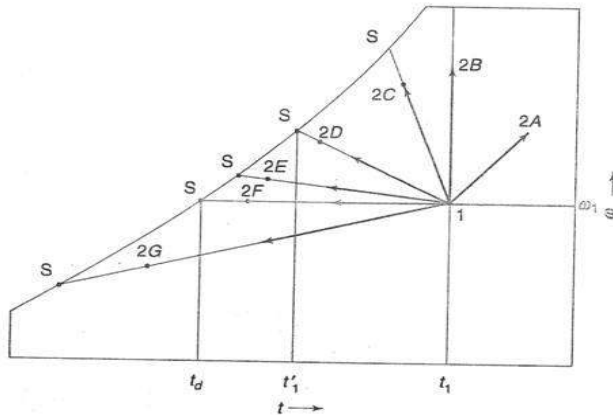
## AIR WASHER



**Fig. Air Washer**

Air washer – flow of air through a spray of water.

- During the course of flow, the air may be cooled or heated or dehumidified, depending on the mean surface temperature of water.
- Water accordingly, externally cooled or heated or simply recirculated by a pump.
- Eliminator plates are provided to minimize the loss of water
- Droplets of water act as wetted surface, both sensible and latent heat transfer take place.



**Fig.** Range of Psychrometric Processes with an Air Washer

### Different possible processes:

1. **Process 1-2 A :** Heating & Humidification [  $t_s > t_1$  ], where  $t_s$  is the mean surface temperature of water droplets. Mean surface temperature ( $t_s$ ) greater than the dry bulb temperature. Here water is externally heated.
2. **Process 1-2 B :** Humidification [  $t_s = t_1$  ] Enthalpy of air increases. Water is required to be externally heated.
3. **Process 1-2 C:** Cooling & Humidification [  $t_1 < t_s < t_1$  ] where is  $t_1$  wet temperature. Air is cooled, enthalpy increases as a result of humidification. Water is required to be externally heated.
4. **Process 1-2 D** Adiabatic saturation [  $t_1 = t_s$  ] where is  $t_1$  wet temperature .Pumped circulation of water. Without any external heating or cooling.
5. **Process 1-2 E :** Cooling & Humidification [  $t_d < t_s < t_1$  ] Similar to 1-2C with difference that the enthalpy of air decreases. Water is required to be externally cooled.
6. **Process 1-2 F :** Cooling [  $t_s = t_d$  ] where  $t_d$  is the dew point temperature. . Water is required to be externally cooled.
7. **Process 1-2 G:** Cooling & Dehumidification [  $t_s < t_d$  ] air is simultaneously cooled and dehumidified.

Window AC:

**window.** The interior air is cooled as a fan blows it over the evaporator. On the exterior the heat drawn from the interior is dissipated into the environment as a second fan blows outside air over the condenser.

Split AC

The two are connected via pipes or other tubing. Central air conditioners are a type of **split air conditioner**, but the unit most people see as a **split** unit has a smaller compressor/condenser coil box on the outside and individual room units on the inside. These are made to cool a room without the need for ducting

## Refrigerants

The last decade has seen radical changes in the selection and use of refrigerants, mainly in response to the environmental issues of 'holes in the ozone layer' and 'global warming or greenhouse effect'. Previously there had not been much discussion about the choice of refrigerant, as the majority of applications could be met by the wellknown and well-tested fluids, R11, R12, R22, R502 and ammonia (R717). The only one of these fluids to be considered environmentally friendly today is ammonia, but it is not readily suited to commercial or air-conditioning refrigeration applications because of its toxicity, flammability and attack by copper.

This topic is about the new refrigerants and the new attitude needed in design, maintenance and servicing of refrigeration equipment.

### Ideal properties for a refrigerant

It will be useful to remind ourselves of the requirements for a fluid used as a refrigerant.

- A high latent heat of vaporization
- A high density of suction gas
- Non-corrosive, non-toxic and non-flammable
- Critical temperature and triple point outside the working range
- Compatibility with component materials and lubricating oil
- Reasonable working pressures (not too high, or below atmospheric pressure)
- High dielectric strength (for compressors with integral motors)
- Low cost
- Ease of leak detection
- Environmentally friendly

No single fluid has all these properties, and meets the new environmental requirements, but this chapter will show the developments that are taking place in influencing the selection and choice of a refrigerant.

### **Ozone depletion potential**

The ozone layer in our upper atmosphere provides a filter for ultraviolet radiation, which can be harmful to our health. Research has found that the ozone layer is thinning, due to emissions into the atmosphere of chlorofluorocarbons (CFCs), halons and bromides. The Montreal Protocol in 1987 agreed that the production of these chemicals would be phased out by 1995 and alternative fluids developed. From Table 3.1, R11, R12, R114 and R502 are all CFCs used as refrigerants, while R13B1 is a halon. They have all ceased production within those countries which are signatories to the Montreal Protocol. The situation is not so clear-cut, because there are countries like Russia, India, China etc. who are not signatories and who could still be producing these harmful chemicals. Table 3.2 shows a comparison between old and new refrigerants.

**Table 3.1** Typical uses of refrigerants before 1987

<i>Typical application</i>	<i>Refrigerants recommended</i>
Domestic refrigerators and freezers	R12
Small retail and supermarkets	R12, R22, R502
Air-conditioning	R11, R114, R12, R22
Industrial	R717, R22, R502, R13B1
Transport	R12, R502

**Global warming potential (GWP)**

Global warming is the increasing of the world's temperatures, which results in melting of the polar ice caps and rising sea levels. It is caused by the release into the atmosphere of so-called 'greenhouse' gases, which form a blanket and reflect heat back to the earth's surface, or hold heat in the atmosphere. The most infamous greenhouse gas is carbon dioxide (CO<sub>2</sub>), which once released remains in the atmosphere for 500 years, so there is a constant build-up as time progresses. The main cause of CO<sub>2</sub> emission is in the generation of electricity at power stations. Each kWh of electricity used in the UK produces about 0.53 kg of CO<sub>2</sub> and it is estimated that refrigeration compressors in the UK consume 12.5 billion kWh per year.

Table 3.3 shows that the newly developed refrigerant gases also have a global warming potential if released into the atmosphere.

For example, R134a has a GWP of 1300, which means that the emission of 1 kg of R134a is equivalent to 1300 kg of CO<sub>2</sub>. The choice of refrigerant affects the GWP of the plant, but other factors also contribute to the overall GWP and this has been represented by the term total equivalent warming impact (TEWI). This term shows the overall impact on the global warming effect, and includes refrigerant leakage, refrigerant recovery losses and energy consumption. It is a term which should be calculated for each refrigeration plant. Figures 3.1 and 3.2 show the equation used and an example for a medium temperature R134a plant.