



# *Aerodynamics*

## *AE 301*

Assoc. Prof. Dr. Y . Volkan PEHLİVANOĞLU  
volkan.pehlivanoglu@ieu.edu.tr





## Contents

- a. Importance of Aerodynamics,
- b. Aerodynamics: Classification and Practical Objectives
- c. Some Fundamental Aerodynamic Variables
- d. Aerodynamic Forces and Moments
- e. Center of Pressure
- f. Dimensional Analysis: The Buckingham Pi Theorem
- g. Flow Similarity
- h. Fluid statics
- i. Types of Flow
- j. Applied aerodynamics

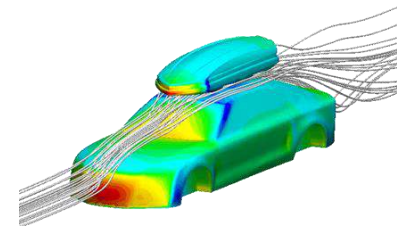
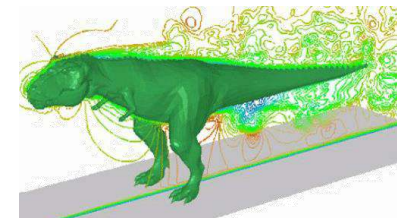
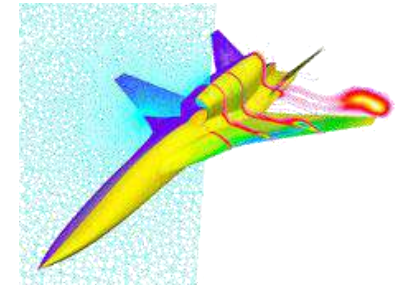
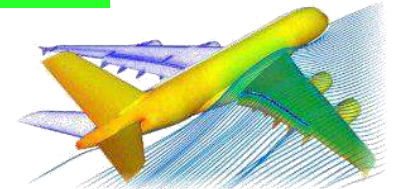



## Importance of aerodynamics

- Natural Philosophy
  - Physics
    - Mechanics
      - Dynamics
        - Aerodynamics...



*“The term “aerodynamics” is generally used for problems arising from flight and other topics involving the flow of air”.*

**Ludwig Prandtl, 1949**

*Aerodynamics: The dynamics of gases, especially atmospheric interactions with moving objects.*

**The American Heritage Dictionary of the English Language,  
1969**





## Importance of aerodynamics

- On August 8, 1588, The great Spanish Armada was met head-on by the English fleet under the command of Sir Francis Drake.
- The Spanish ships were large and heavy, in contrast, the English ships were smaller and lighter.
- England won the naval war.
- Naval power was going to depend greatly on the speed and maneuverability of ships.
- To increase the speed of a ship, it is important to reduce the resistance created by the water flow around the ship's hull.
- Suddenly, the drag on ship hulls became an engineering problem of great interest, thus giving impetus to the study of fluid mechanics.





## Importance of aerodynamics

- in 1687, Isaac Newton (1642–1727) published his famous *Principia*, in which the entire second book was devoted to fluid mechanics.
- In 1777, a series of experiments was carried out by Jean Le Rond d'Alembert (1717–1783) in order to measure the resistance of ships in canals.
- In 1781, Leonhard Euler (1707–1783) pointed out the physical inconsistency of Newton's model and modified it.
- The rapid rise in the importance of naval architecture made fluid dynamics an important science, occupying the minds of Newton, d'Alembert, and Euler, among many others in Europe.

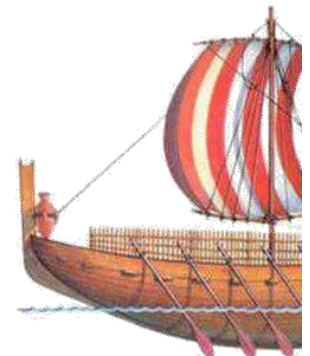
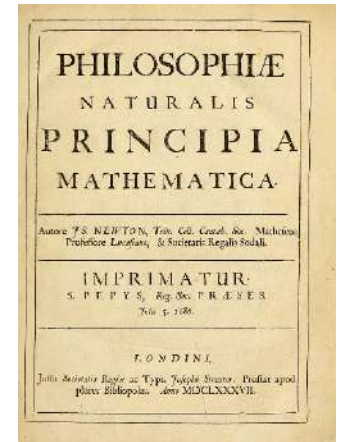



## Importance of aerodynamics

- In the US, since their 1901 glider was of poor aerodynamic design, the Wright Brothers set about determining what constitutes good aerodynamic design.
- In the fall of 1901, they design and build a wind tunnel powered by a two-bladed fan connected to a gasoline engine.
- The aerodynamic data are taken logically and carefully.
- Armed with their new aerodynamic information, the Wrights design a new glider in the spring of 1902 and flew successfully.
- The good aerodynamics was vital to the ultimate success of the Wright brothers and, of course, to all subsequent successful airplane designs up to the present day.

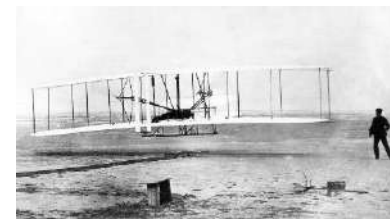
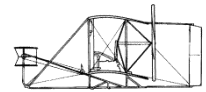
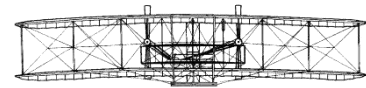
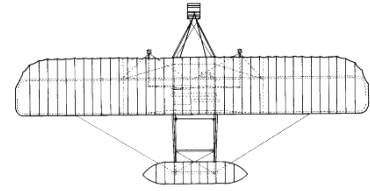



## Aerodynamics: Classification and Objectives

- The word *fluid* is used to denote either a liquid or a gas.
- The liquid and gas will change its shape to conform to that of the container...
- The most fundamental distinction between solids, liquids, and gases is at the atomic and molecular level.

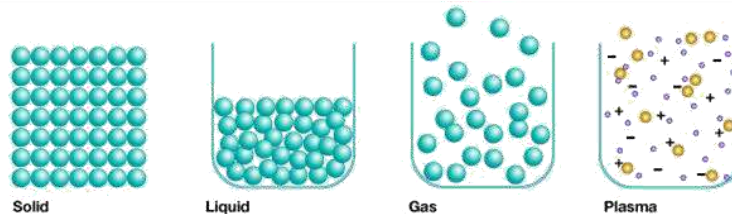

- Fluid dynamics is subdivided into three areas:

Hydrodynamics — flow of liquids

Gas dynamics — flow of gases

Aerodynamics — flow of air





## Aerodynamics: Classification and Objectives

- Aerodynamics is an applied science with many practical applications in engineering.
- It is aimed at one or more of the following practical objectives:

### *external aerodynamics*

1. The prediction of forces and moments on, and heat transfer to, bodies moving through a fluid (usually air).

lift, drag, and moments on airfoils, wings, fuselages, engine nacelles, and most importantly, whole airplane configurations...

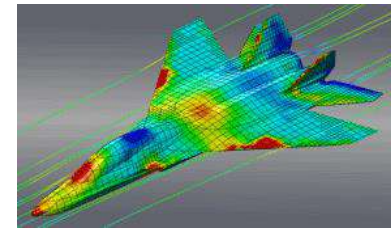

### *internal aerodynamics*

2. Determination of flows moving internally through ducts.

the flow properties inside rocket and air-breathing jet engines and to calculate the engine thrust

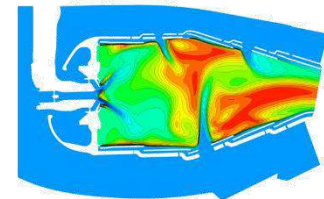





## Some Fundamental Aerodynamic Variables

- The four of the most frequently used words in aerodynamics: *pressure*, *density*, *temperature*, and *flow velocity*.

*Pressure* is the normal force per unit area exerted on a surface due to the time rate of change of momentum of the liquid/gas molecules impacting on (or crossing) that surface.

$$p = \lim \left( \frac{dF}{dA} \right) \quad dA \rightarrow 0$$

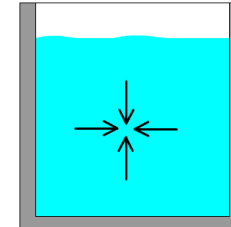

- *Pressure* is a *point property* and can have a different value from one point to another in the fluid.
- It is a scalar quantity, not a vector,
- It is perpendicular to the surface,
- It acts inward, is toward the surface





## Some Fundamental Aerodynamic Variables

- Another important aerodynamic variable is *density*, defined as the mass per unit volume.
- It is a *point property*, scalar quantity, that can vary from point to point in the fluid.

$$\rho = \lim_{dv \rightarrow 0} \frac{dm}{dv}$$

$dv$  = elemental volume around  $B$   
 $dm$  = mass of fluid inside  $dv$

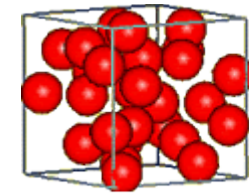

High density

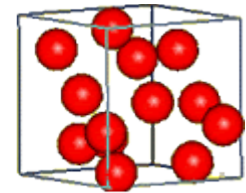

Low density

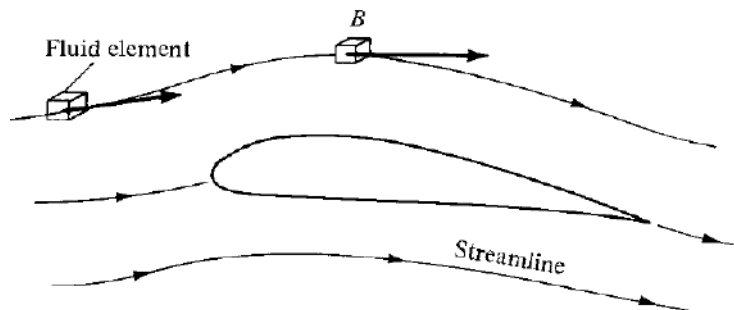



## Some Fundamental Aerodynamic Variables

- *Temperature* takes on an important role in high-speed aerodynamics.
- The temperature  $T$  of a gas is directly proportional to the average kinetic energy of the molecules of the fluid.

$$KE = \frac{3}{2}kT, \quad k = \text{Boltzmann constant}$$

- We can qualitatively visualize a high-temperature gas as one in which the molecules and atoms are randomly rattling about at high speeds.
- Temperature is also a point property, scalar quantity, which can vary from point to point in the gas.





## Some Fundamental Aerodynamic Variables

- The principal focus of aerodynamics is fluids in motion. Hence, flow **velocity** is an extremely important consideration.
- Velocity is the time rate of change of displacement.
- In contrast to solid, a fluid is a “squishy” substance.
- For a fluid in motion, one part of the fluid may be traveling at a different velocity from another part.

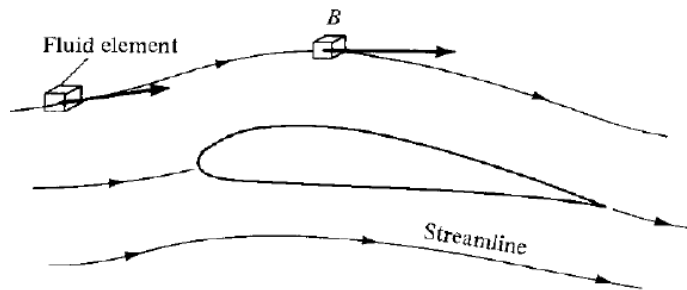

**Flow velocity:** The velocity of a flowing gas at any fixed point  $B$  in space is the velocity of an infinitesimally small fluid element as it sweeps through  $B$ .

- The flow velocity  $\mathbf{V}$  has both magnitude and direction; hence, it is a vector quantity, and it is a point property.





## Some Fundamental Aerodynamic Variables

- we note that friction can play a role internally in a flow. The shear stress  $\tau$  is the limiting form of the magnitude of the frictional force per unit area
- Consider two adjacent fluid layers, streamlines. Due to different velocity values, there will be shear stress on the fluid surfaces.
- It is directly proportional to velocity difference, and inversely proportional to vertical distance.
- The constant of proportionality is defined as the *viscosity coefficient*,  $\mu$ ;

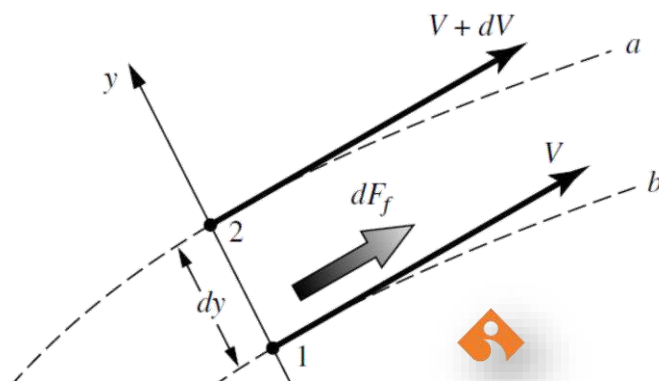

$$\tau \propto dV/dy$$

$$\tau = \mu \frac{dV}{dy}$$

it is a function of the temperature of the fluid.



## Units

- Two consistent sets of units will be used throughout this course, SI units (Système International d'Unités) and the English engineering system of units.
- The basic units of force, mass, length, time, and absolute temperature in these two systems are given in Table 1.1.

**Table 1.1**

	Force	Mass	Length	Time	Temp.
SI Units	Newton (N)	kilogram (kg)	meter (m)	second (s)	Kelvin (K)
English Engineering Units	pounds (lb)	slug	feet (ft)	second (s)	deg. Rankine (°R)

Force:  $\text{kg}\cdot\text{m}/\text{s}^2$

Pressure:  $\text{N}/\text{m}^2$

Density:  $\text{kg}/\text{m}^3$

Velocity :  $\text{m}/\text{s}$

Stress :  $\text{N}/\text{m}^2$





## Aerodynamic forces and moments

- At first glance, the generation of the aerodynamic force may seem complex...
- However, in all cases, the aerodynamic forces and moments on the body are due to only two basic sources:
  1. **Pressure** distribution,
  2. **Shear stress** distribution over the body surface

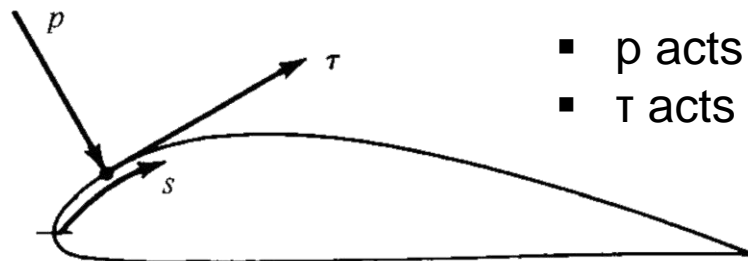

- $p$  acts normal to the surface,
- $\tau$  acts tangential to the surface.

$p = p(s)$  = surface pressure distribution  
 $\tau = \tau(s)$  = surface shear stress distribution





## Aerodynamic forces and moments

- The net effect of the  $p$  and  $\tau$  distributions integrated over the complete body surface is a resultant aerodynamic force  $R$  and moment  $M$  on the body.

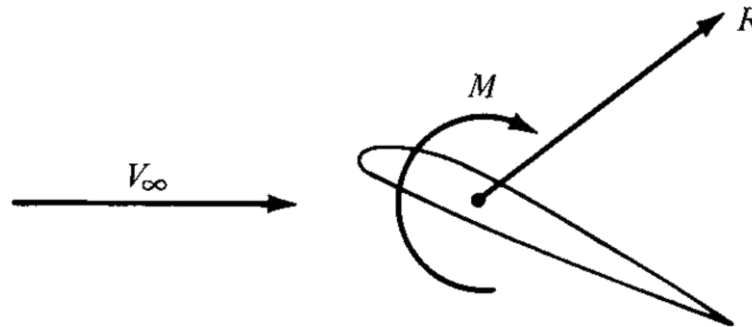

- The resultant  $R$  can be split into components, Normal & Axial or Lift & Drag forces.

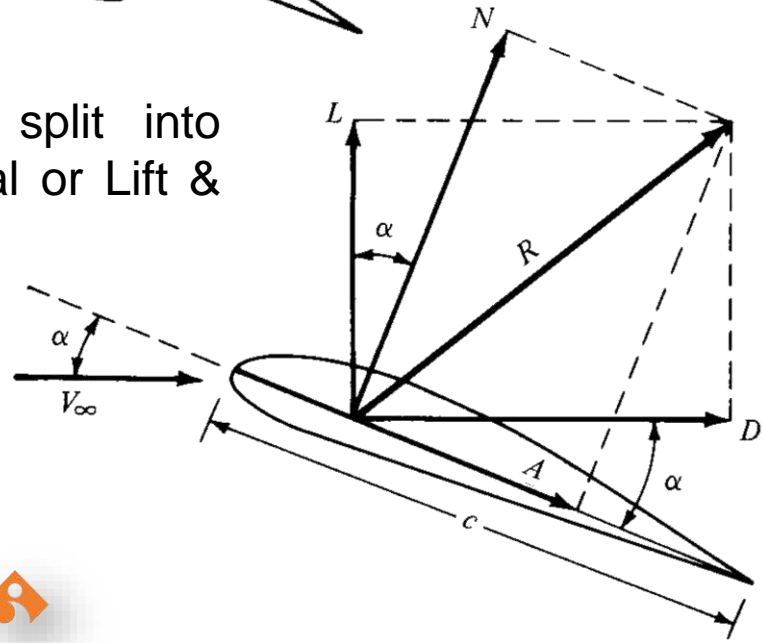





## Aerodynamic forces and moments

- The flow far away from the body is called the *freestream*, and hence  $V_\infty$  is also called the freestream velocity.
- The chord  $c$  is the linear distance from the leading edge to the trailing edge of the body.
- The angle of attack  $\alpha$  is defined as the angle between  $c$  and  $V_\infty$ .
- The geometrical relation between these two sets of components is,

$$L = N \cos \alpha - A \sin \alpha$$

$$D = N \sin \alpha + A \cos \alpha$$

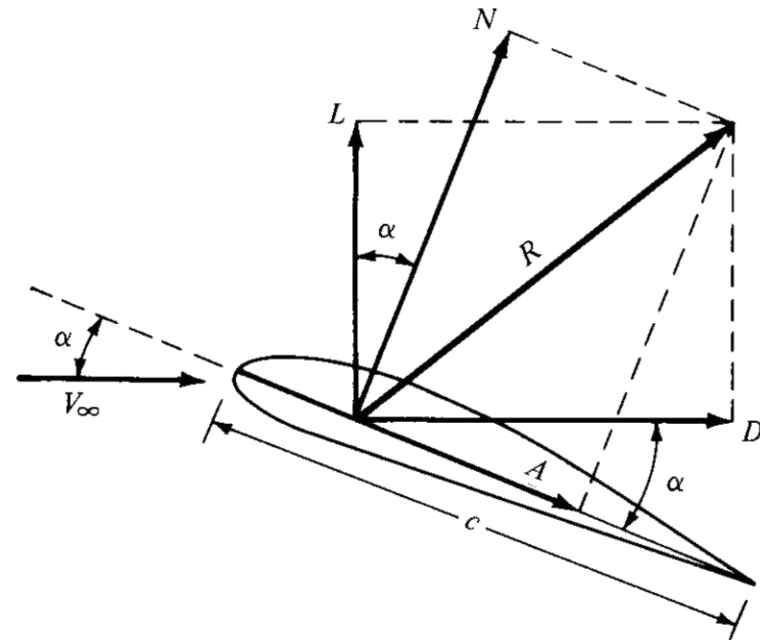

$L$ ; component of  $R$  perpendicular to  $V_\infty$   
 $D$ ; component of  $R$  parallel to  $V_\infty$





## Aerodynamic forces and moments

- We can examine in more detail the integration of the pressure and shear stress distributions to obtain the aerodynamic forces and moments.

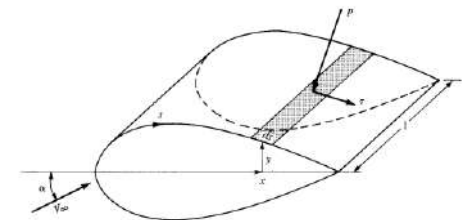
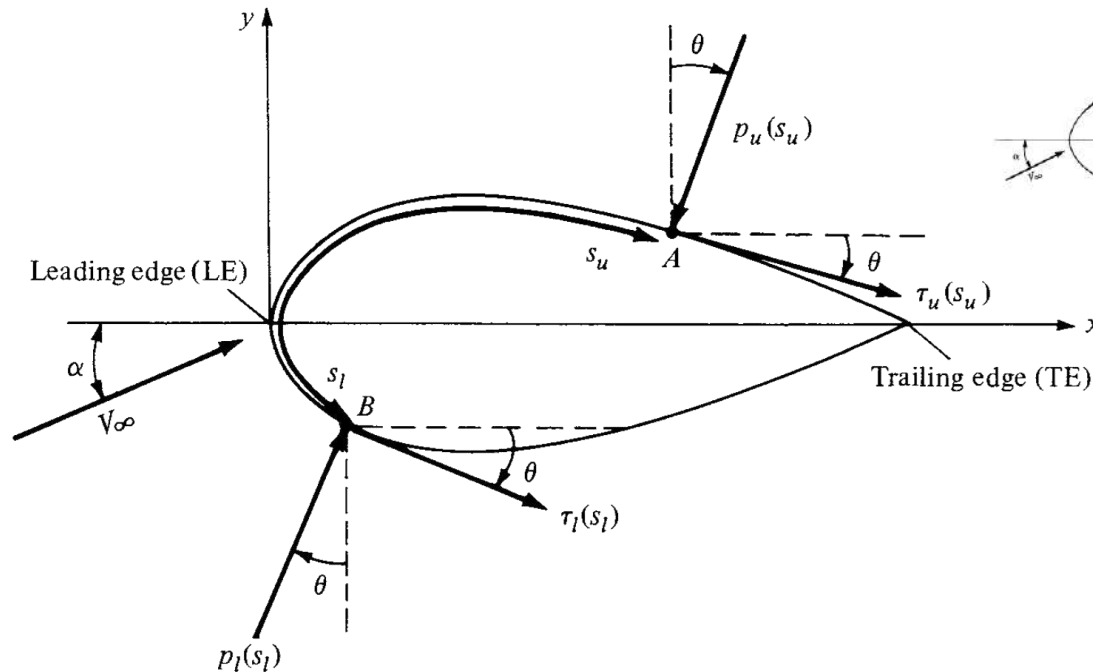

$$dS = (ds)(1)$$

For the upper body surface,  
 $dN'_u = -p_u ds_u \cos \theta - \tau_u ds_u \sin \theta$   
 $dA'_u = -p_u ds_u \sin \theta + \tau_u ds_u \cos \theta$

For the lower body surface,  
 $dN'_l = p_l ds_l \cos \theta - \tau_l ds_l \sin \theta$   
 $dA'_l = p_l ds_l \sin \theta + \tau_l ds_l \cos \theta$





## Aerodynamic forces and moments

- The total normal and axial forces *per unit span* are obtained by integrating equations from the leading edge (LE) to the trailing edge (TE):

$$N' = - \int_{LE}^{TE} (p_u \cos \theta + \tau_u \sin \theta) ds_u + \int_{LE}^{TE} (p_l \cos \theta - \tau_l \sin \theta) ds_l$$

$$A' = \int_{LE}^{TE} (-p_u \sin \theta + \tau_u \cos \theta) ds_u + \int_{LE}^{TE} (p_l \sin \theta + \tau_l \cos \theta) ds_l$$

- We can get lift and drag forces based on the previous equations;

$$L = N \cos \alpha - A \sin \alpha$$

$$D = N \sin \alpha + A \cos \alpha$$





## Aerodynamic forces and moments

- The aerodynamic moment exerted on the body depends on the point about which moments are taken.
- Lets consider moments taken about the leading edge.
- The moment per unit span about the leading edge due to  $p$  and  $\tau$  on the elemental area  $dS$  on the upper and lower surface are

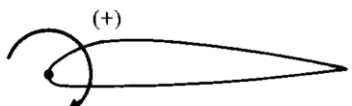

(+)

$$dM'_u = (p_u \cos \theta + \tau_u \sin \theta)x ds_u + (-p_u \sin \theta + \tau_u \cos \theta)y ds_u$$
$$dM'_l = (-p_l \cos \theta + \tau_l \sin \theta)x ds_l + (p_l \sin \theta + \tau_l \cos \theta)y ds_l$$

- By integrating from the leading to the trailing edges, we obtain the pitching moment about the leading edge per unit span

$$M'_{LE} = \int_{LE}^{TE} [(p_u \cos \theta + \tau_u \sin \theta)x - (p_u \sin \theta - \tau_u \cos \theta)y] ds_u$$
$$+ \int_{LE}^{TE} [(-p_l \cos \theta + \tau_l \sin \theta)x + (p_l \sin \theta + \tau_l \cos \theta)y] ds_l$$





## Aerodynamic forces and moments

- In Equations;  $\theta$ ,  $x$ , and  $y$  are known functions of  $s$  for a given body shape.
- A major goal of theoretical or experimental aerodynamics is to calculate  $p(s)$  and  $\tau(s)$  for a given body shape and freestream conditions.
- We get the aerodynamic forces and moments based on them.
- In aerodynamics, shape is probably the most important factor.
- We may eliminate the scale of the shape by defining some dimensionless coefficients.

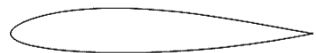



## Aerodynamic forces and moments

- Let  $\rho_\infty$  and  $V_\infty$  be the density and velocity, respectively, in the freestream, far ahead of the body.
- We define a dimensional quantity called the freestream *dynamic pressure* as

$$q_\infty \equiv \frac{1}{2} \rho_\infty V_\infty^2$$

- In addition, let  $S$  be a reference area and  $l$  be a reference length.
- The dimensionless force and moment coefficients are defined as follows:

$$C_L \equiv \frac{L}{q_\infty S} \quad \text{Lift coefficient}$$

$$C_D \equiv \frac{D}{q_\infty S} \quad \text{Drag coefficient}$$

$$C_M \equiv \frac{M}{q_\infty S l} \quad \text{Moment coefficient}$$

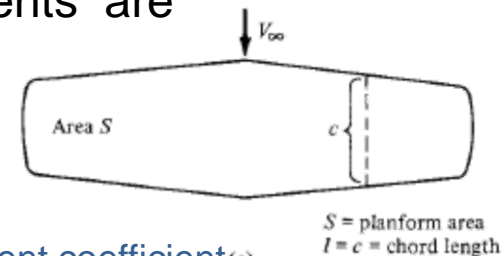



## Aerodynamic forces and moments

- For two-dimensional bodies, it is conventional to denote the aerodynamic coefficients by lowercase letters; for example,

$$c_l \equiv \frac{L'}{q_\infty c} \quad c_d \equiv \frac{D'}{q_\infty c} \quad c_m \equiv \frac{M'}{q_\infty c^2}$$

- Two additional dimensionless quantities of immediate use are

Pressure coefficient  $C_p \equiv \frac{p - p_\infty}{q_\infty}$

Skin friction coefficient  $c_f \equiv \frac{\tau}{q_\infty}$

$p$  local static pressure

$p_\infty$  static free stream pressure

$q_\infty$  dynamic free stream pressure

- From the geometry

$$dx = ds \cos \theta$$

$$dy = -(ds \sin \theta)$$

$$S = c(1)$$

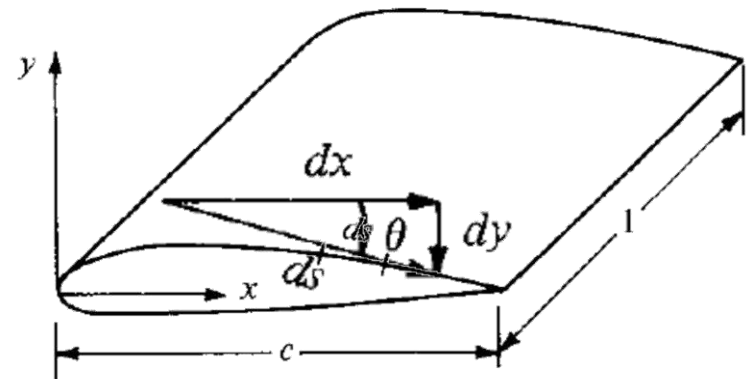



## Aerodynamic forces and moments

- We obtain the following integral forms for the force and moment coefficients

$$c_n = \frac{1}{c} \left[ \int_0^c (C_{p,l} - C_{p,u}) dx + \int_0^c \left( c_{f,u} \frac{dy_u}{dx} + c_{f,l} \frac{dy_l}{dx} \right) dx \right]$$

$$c_a = \frac{1}{c} \left[ \int_0^c \left( C_{p,u} \frac{dy_u}{dx} - C_{p,l} \frac{dy_l}{dx} \right) dx + \int_0^c (c_{f,u} + c_{f,l}) dx \right]$$

$$c_{m_{LE}} = \frac{1}{c^2} \left[ \int_0^c (C_{p,u} - C_{p,l}) x dx - \int_0^c \left( c_{f,u} \frac{dy_u}{dx} + c_{f,l} \frac{dy_l}{dx} \right) x dx \right. \\ \left. + \int_0^c \left( C_{p,u} \frac{dy_u}{dx} + c_{f,u} \right) y_u dx + \int_0^c \left( -C_{p,l} \frac{dy_l}{dx} + c_{f,l} \right) y_l dx \right]$$

- The lift and drag coefficients can also be obtained:

$$c_l = c_n \cos \alpha - c_a \sin \alpha$$

$$c_d = c_n \sin \alpha + c_a \cos \alpha$$

$$C_N \equiv \frac{N}{q_\infty S}$$

$$C_A \equiv \frac{A}{q_\infty S}$$







## Example 1.1

- Consider the supersonic flow over a  $5^\circ$  half-angle wedge at zero angle of attack, as sketched in figure.
- The freestream Mach number ahead of the wedge is 2.0, and the freestream pressure and density are  $1.01 \times 10^5 \text{ N/m}^2$  and  $1.23 \text{ kg/m}^3$ , respectively.
- The pressures on the upper and lower surfaces of the wedge are constant with distance  $s$  and equal to each other, namely,  $p_u = p_l = 1.31 \times 10^5 \text{ N/m}^2$ .
- The pressure exerted on the base of the wedge is equal to  $p_\infty$ .
- The shear stress varies over both the upper and lower surfaces as  $\tau_w = 431 s^{-0.2}$
- The chord length,  $c$ , of the wedge is 2 m. Calculate the drag coefficient for the wedge.





# Example 1.1

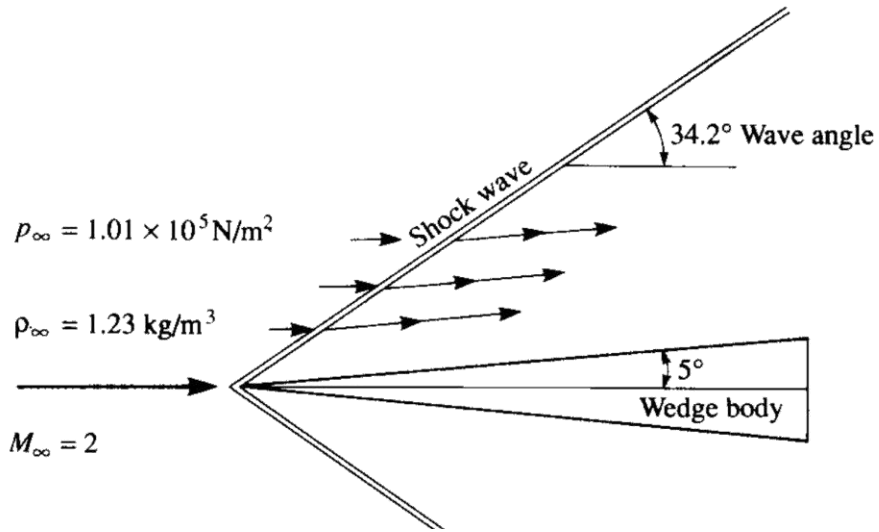

Flow field picture

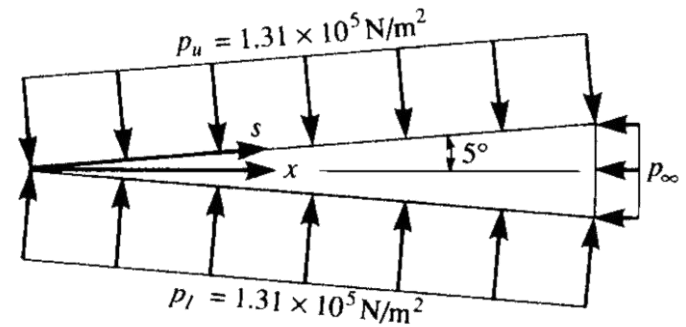

Pressure distribution

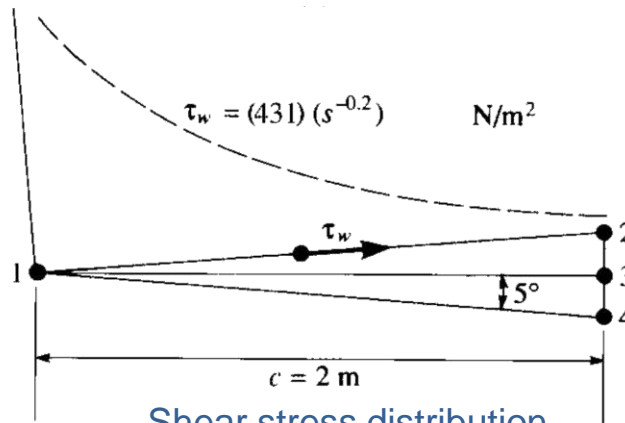

Shear stress distribution





## Example 1.1

- We can calculate the drag and then obtain the drag coefficient.
- The drag can be obtained from

$$D' = \int_{LE}^{TE} (-p_u \sin \theta + \tau_u \cos \theta) ds_u + \int_{LE}^{TE} (p_l \sin \theta + \tau_l \cos \theta) ds_l$$

$$\begin{aligned} \int_{LE}^{TE} -p_u \sin \theta ds_u &= \int_{s_1}^{s_2} -(1.31 \times 10^5) \sin(-5^\circ) ds_u \\ &\quad + \int_{s_2}^{s_3} -(1.01 \times 10^5) \sin 90^\circ ds_u \end{aligned}$$

$$= 1.142 \times 10^4 (s_2 - s_1) - 1.01 \times 10^5 (s_3 - s_2)$$

$$= 1.142 \times 10^4 \left( \frac{c}{\cos 5^\circ} \right) - 1.01 \times 10^5 (c)(\tan 5^\circ)$$

$$= 1.142 \times 10^4 (2.008) - 1.01 \times 10^5 (0.175) = 5260 \text{ N}$$





## Example 1.1

$$\begin{aligned}\int_{LE}^{TE} p_l \sin \theta ds_l &= \int_{s_1}^{s_4} (1.31 \times 10^5) \sin(5^\circ) ds_l + \int_{s_4}^{s_3} (1.01 \times 10^5) \sin(-90^\circ) ds_l \\ &= 1.142 \times 10^4 (s_4 - s_1) + 1.01 \times 10^5 (-1)(s_3 - s_4) \\ &= 1.142 \times 10^4 \left( \frac{c}{\cos 5^\circ} \right) - 1.01 \times 10^5 (c)(\tan 5^\circ) \\ &= 2.293 \times 10^4 - 1.767 \times 10^4 = 5260 \text{ N}\end{aligned}$$

$$\begin{aligned}\int_{LE}^{TE} \tau_u \cos \theta ds_u &= \int_{s_1}^{s_2} 431s^{-0.2} \cos(-5^\circ) ds_u & \int_{LE}^{TE} \tau_l \cos \theta ds_l &= \int_{s_1}^{s_4} 431s^{-0.2} \cos(-5^\circ) ds_l \\ &= 429 \left( \frac{s_2^{0.8} - s_1^{0.8}}{0.8} \right) & &= 429 \left( \frac{s_4^{0.8} - s_1^{0.8}}{0.8} \right) \\ &= 429 \left( \frac{c}{\cos 5^\circ} \right)^{0.8} \frac{1}{0.8} = 936.5 \text{ N} & &= 429 \left( \frac{c}{\cos 5^\circ} \right)^{0.8} \frac{1}{0.8} = 936.5 \text{ N}\end{aligned}$$

- Adding the pressure integrals, and then adding the shear stress integrals, we have for total drag

$$D' = \underbrace{1.052 \times 10^4}_{\text{pressure drag}} + \underbrace{0.1873 \times 10^4}_{\text{skin friction drag}} = \boxed{1.24 \times 10^4 \text{ N}}$$





## Example 1.1

- Note that, for this rather slender body, but at a supersonic speed, most of the drag is pressure drag.
- This is typical of the drag of slender supersonic bodies.

- The drag coefficient is obtained as follows.

- The velocity of the freestream is twice the sonic speed, which is given by

$$a_{\infty} = \sqrt{\gamma RT_{\infty}} = \sqrt{(1.4)(287)(288)} = 340.2 \text{ m/s}$$

- Mach Number =  $V / a$       $V_{\infty} = 2(340.2) = 680.4 \text{ m/s}$ .

$$q_{\infty} = \frac{1}{2} \rho_{\infty} V_{\infty}^2 = (0.5)(1.23)(680.4)^2 = 2.847 \times 10^5 \text{ N/m}^2$$

$$S = c(1) = 2.0 \text{ m}^2$$

$$c_d = \frac{D'}{q_{\infty} S} = \frac{1.24 \times 10^4}{(2.847 \times 10^5)(2)} = \boxed{0.022}$$





## Center of pressure

- We see that the normal and axial forces on the body are due to the *distributed* loads imposed by the pressure and shear stress distributions.
- Moreover, these distributed loads generate a moment about the leading edge.
- *Question:* If the aerodynamic force on a body is specified in terms of a resultant single force  $R$ , or its components such as  $N$  and  $A$ , *where* on the body should this resultant be placed?
- The answer is that the resultant force should be located on the body such that it produces the same effect as the distributed loads.





## Center of pressure

- The components of the resulted aerodynamic force  $R$ ;  $N$  and  $A$  must be placed on the airfoil at such a location to generate the same moment about the leading edge.
- If  $A$  is placed on the chord line, then  $N$  must be located a distance  $x_{cp}$  downstream of the leading edge such that

$$M'_{LE} = -(x_{cp})N'$$

$$x_{cp} = -\frac{M'_{LE}}{N'}$$

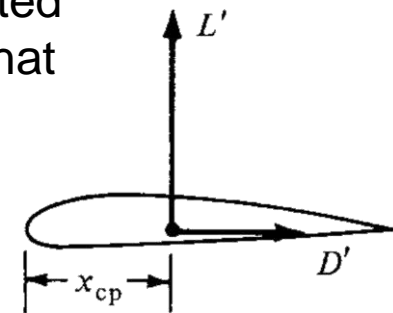

Resultant force at center of pressure

- In cases where the angle of attack of the body is small,  $\sin \alpha \approx 0$  and  $\cos \alpha \approx 1$ ; hence,  $L \approx N$ . Thus, Equation becomes

$$x_{cp} \approx -\frac{M'_{LE}}{L'}$$





## Center of pressure

- Note that if moments were taken about the center of pressure, the integrated effect of the distributed loads would be zero.
- Hence, an alternate definition of the center of pressure is that point on the body about which the aerodynamic moment is zero.

$$\sum M_{cp} = 0$$

- To define the force-and-moment system, the resultant force can be placed at *any* point on the body, as long as the value of the moment about that point is also given.

$$M'_{LE} = -\frac{c}{4}L' + M'_{c/4} = -x_{cp}L'$$

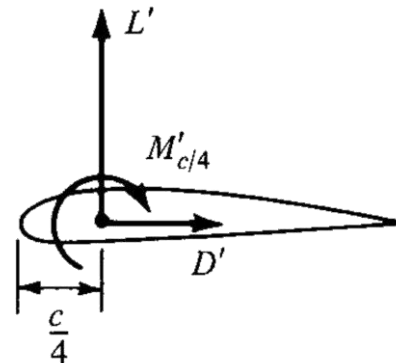





## Example 1.4

- Consider the DC-3 A/C. Just outboard of the engine nacelle, the airfoil chord length is 15.4 ft.
- At cruising velocity (188 mi/h) at sea level, the moments per unit span at this airfoil location are  $M_{c4} = -1071$  ft lb/ft and  $M_{LE} = -3213.9$  ft lb/ft.
- Calculate the lift per unit span and the location of the center of pressure on the airfoil.

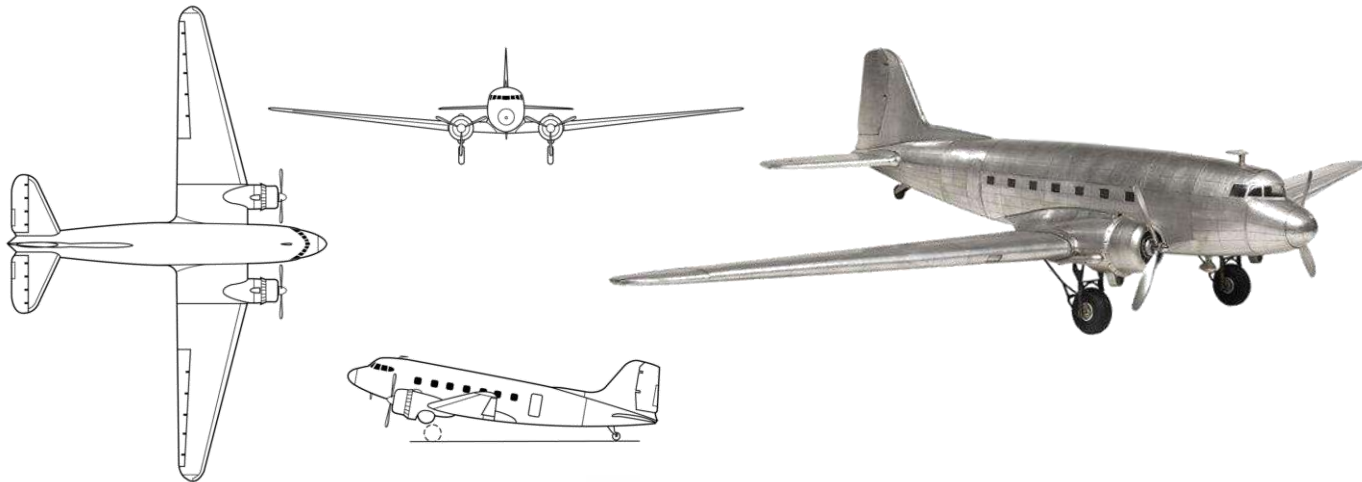



## Example 1.4

- From given equations;

$$\frac{c}{4}L' = M'_{c/4} - M'_{LE} = -1071 - (-3213.9) = 2142.9$$

$$\frac{c}{4} = \frac{15.4}{4} = 3.85 \text{ ft.}$$

$$L' = \frac{2142.9}{3.85} = \boxed{556.6 \text{ lb/ft}}$$

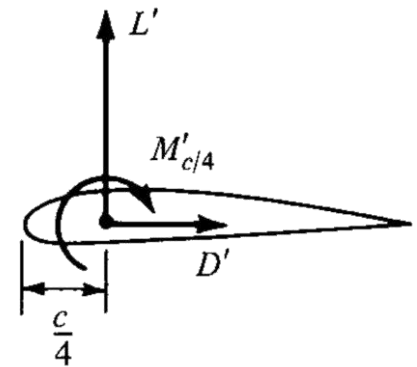

- We know that

$$-x_{cp}L' = M'_{LE}$$

$$-x_{cp} = -\frac{M'_{LE}}{L'} = -\frac{(-3213.9)}{556.6} = \boxed{5.774 \text{ ft}}$$

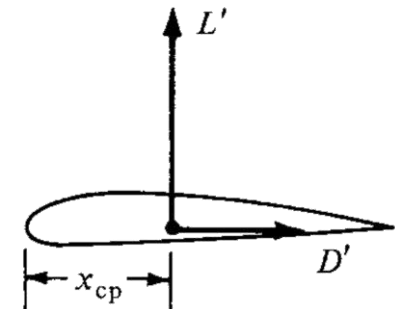



## Dimensional analysis: the Buckingham Pi theorem

- What physical quantities determine the variation of these forces and moments? The answer can be found from the powerful method of dimensional analysis.
- Dimensional analysis is based on the obvious fact that in an equation dealing with the real physical world, each term must have the same dimensions.
- For example, if  $\psi + \eta + \zeta = \phi$   
is a physical relation, then  $\psi$ ,  $\eta$ ,  $\zeta$ , and  $\phi$  must have the same dimensions. Otherwise we would be adding apples and oranges.
- The above equation can be made dimensionless by dividing by any one of the terms, say,  $\phi$ :

$$\frac{\psi}{\phi} + \frac{\eta}{\phi} + \frac{\zeta}{\phi} = 1$$





## Dimensional analysis: the Buckingham Pi theorem

- These ideas are formally embodied in the Buckingham pi theorem, stated below without derivation.
- Let  $K$  equal the number of fundamental dimensions required to describe the physical variables.
- Let  $P_1, P_2, \dots, P_N$  represent  $N$  physical variables in the physical relation;

$$f_1(P_1, P_2, \dots, P_N) = 0$$

- Then, the physical relation may be re-expressed as a relation of  $(N - K)$  dimensionless products (called  $\pi$  products),

$$f_2(\Pi_1, \Pi_2, \dots, \Pi_{N-K}) = 0$$





## Dimensional analysis: the Buckingham Pi theorem

- Each product is a dimensionless product of a set of  $K$  physical variables plus one other physical variable.
- Let  $P_1, P_2, \dots, P_K$  be the selected set of  $K$  physical variables. Then

$$\Pi_1 = f_3(P_1, P_2, \dots, P_K, P_{K+1})$$

$$\Pi_2 = f_4(P_1, P_2, \dots, P_K, P_{K+2})$$

.....

$$\Pi_{N-K} = f_5(P_1, P_2, \dots, P_K, P_N)$$



- The choice of the repeating variables,  $P_1, P_2, \dots, P_K$  should be such that they include all the  $K$  dimensions with the minimum number used in the problem.
- Also, the dependent variable should appear in only one of the  $\pi$  products.





## Dimensional analysis: the Buckingham Pi theorem

- Consider a body of given shape at a given angle of attack. The resultant aerodynamic force is  $R$ .

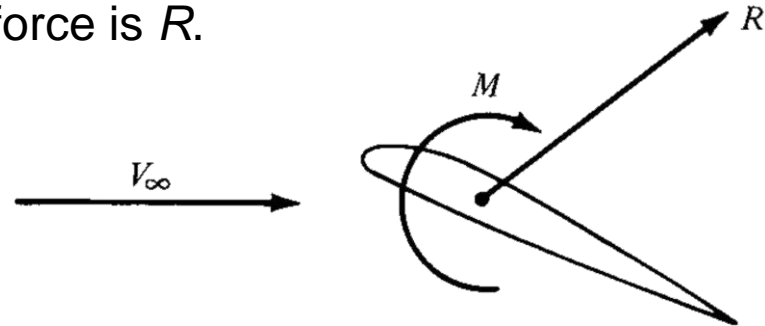

- On a physical, intuitive basis, we expect  $R$  to depend on:
  1. Freestream velocity  $V_\infty$ .
  2. Freestream density  $\rho_\infty$ .
  3. Viscosity of the fluid, by the freestream viscosity coefficient  $\mu_\infty$ .
  4. The size of the body,  $c$
  5. The compressibility of the fluid, by the freestream speed of sound,  $a_\infty$ .
- In light of the above, we can use common sense to write

$$R = f(\rho_\infty, V_\infty, c, \mu_\infty, a_\infty)$$





## Dimensional analysis: the Buckingham Pi theorem

- Equation can be written in the form of

$$g(R, \rho_{\infty}, V_{\infty}, c, \mu_{\infty}, a_{\infty}) = 0$$

- Following the Buckingham pi theorem, The physical variables and their dimensions are

$$[R] = mlt^{-2}$$

$$[\rho_{\infty}] = ml^{-3}$$

$$[V_{\infty}] = lt^{-1}$$

$$[c] = l$$

$$[\mu_{\infty}] = ml^{-1}t^{-1}$$

$$[a_{\infty}] = lt^{-1}$$

- So, the fundamental dimensions are;  $m, l, t$
- Physical factors;  $N = 6$ , and the required dimensions  $K = 3$





## Dimensional analysis: the Buckingham Pi theorem

- Then Equation can be re-expressed in terms of  $N - K = 6 - 3 = 3$  dimensionless  $\pi$  products in the form of

$$f_2(\Pi_1, \Pi_2, \Pi_3) = 0$$

- These products are

$$\Pi_1 = f_3(\rho_\infty, V_\infty, c, R)$$

$$\Pi_2 = f_4(\rho_\infty, V_\infty, c, \mu_\infty)$$

$$\Pi_3 = f_5(\rho_\infty, V_\infty, c, a_\infty)$$

- We choose  $V_\infty, \rho_\infty, c$  such that they include all the  $K$  dimensions ( $l, t, m$ ) with the minimum number used.
- Lets assume that

$$\Pi_1 = \rho_\infty^d V_\infty^b c^e R$$

where  $d, b,$  and  $e$  are exponents to be found.







## Dimensional analysis: the Buckingham Pi theorem

- In dimensional terms, equation is

$$[\Pi_1] = (ml^{-3})^d (lt^{-1})^b (l)^e (mlt^{-2})$$

- Because  $\pi_1$  is dimensionless, the right side of equation must also be dimensionless.
- This means that the exponents of  $m$  must add to zero, and similarly for the exponents of  $l$  and  $t$ . Hence,

$$\text{For } m: \quad d + 1 = 0$$

$$\text{For } l: \quad -3d + b + e + 1 = 0$$

$$\text{For } t: \quad -b - 2 = 0$$

- Solving the above equations, we find that  $d = -1$ ,  $b = -2$ , and  $e = -2$ .





## Dimensional analysis: the Buckingham Pi theorem

- Substituting these values into equation, we have

$$\begin{aligned}\Pi_1 &= R\rho_\infty^{-1}V_\infty^{-2}c^{-2} \\ &= \frac{R}{\rho_\infty V_\infty^2 c^2}\end{aligned}$$

- We can replace  $c^2$  with any reference area such as the planform area of a wing  $S$ .
- Moreover, we can multiply  $\pi_1$  by a pure number, and it will still be dimensionless. Thus

$$\Pi_1 = \frac{R}{\frac{1}{2}\rho_\infty V_\infty^2 S} = \frac{R}{q_\infty S}$$





## Homework

**HOMÉ-WORK** : find  $\pi_2$  and  $\pi_3$





## Dimensional analysis: the Buckingham Pi theorem

- Based on similar approach, we can find

$$\Pi_2 = \frac{\rho_\infty V_\infty c}{\mu_\infty} \quad \Pi_3 = \frac{V_\infty}{a_\infty}$$

- The dimensionless combination of  $\pi_2$  is defined as the freestream *Reynolds number*.

$$Re = \rho_\infty V_\infty c / \mu_\infty$$

- The Reynolds number is physically a measure of the ratio of inertia forces to viscous forces in a flow and is one of the most powerful parameters in fluid dynamics.

- The dimensionless combination of  $\pi_3$  is defined as the freestream *Mach number*.

$$M = V_\infty / a_\infty$$

- It is a powerful parameter in the study of gas dynamics.





## Dimensional analysis: the Buckingham Pi theorem

- The results of our dimensional analysis may be organized as follows;

$$f_2 \left( \frac{R}{\frac{1}{2} \rho_{\infty} V_{\infty}^2 S}, \frac{\rho_{\infty} V_{\infty} c}{\mu_{\infty}}, \frac{V_{\infty}}{a_{\infty}} \right) = 0$$

$$f_2(C_R, \text{Re}, M_{\infty}) = 0$$

$$C_R = f_6(\text{Re}, M_{\infty})$$

- Since the lift and drag are components of the resultant force, corollaries to equation are

$$C_L = f_7(\text{Re}, M_{\infty})$$

$$C_D = f_8(\text{Re}, M_{\infty})$$

$$C_M = f_9(\text{Re}, M_{\infty})$$





## Dimensional analysis: the Buckingham Pi theorem

- Keep in mind that the analysis was for a given body shape at a given angle of attack  $\alpha$ .
- If  $\alpha$  is allowed to vary, then  $C_L$ ,  $C_D$ , and  $C_M$  will in general depend on the value of  $\alpha$ .
- Hence, Equations can be generalized to

$$C_L = f_{10}(\text{Re}, M_\infty, \alpha)$$

$$C_D = f_{11}(\text{Re}, M_\infty, \alpha)$$

$$C_M = f_{12}(\text{Re}, M_\infty, \alpha)$$

- Which means if the dimensionless parameters are the same, the lift coefficient will be the same for the same geometry, independent from the scale...

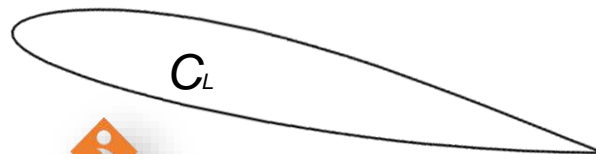



## Flow similarity

- Consider two different flow fields over two different bodies.
- By definition, different flows are *dynamically similar* if:
  1. The streamline patterns are geometrically similar.
  2. The distributions of  $V/V_\infty$ ,  $p/p_\infty$ ,  $T/T_\infty$ , and the force coefficients are the same.

**Question:** What are the *criteria* to ensure that two flows are dynamically similar?

- The **answer** comes from the results of the dimensional analysis. Two flows will be dynamically similar if:
  1. The bodies and any other solid boundaries are geometrically similar for both flows.
  2. The similarity parameters are the same for both flows.





## Flow similarity



- So far, we have emphasized two parameters,  $Re$  and  $M_\infty$ .
- Applicable to many problems, we can say that flows over geometrically similar bodies at the same Mach and Reynolds numbers are dynamically similar.
- Hence the lift, drag, and moment coefficients will be identical for the bodies.
- This is a key point in the validity of wind-tunnel testing.
- If a scale model of a flight vehicle is tested in a wind tunnel, the measured lift, drag, and moment coefficients will be the same as for free flight as long as the Mach and Reynolds numbers of the wind-tunnel test-section flow are the same as for the free-flight case.







## Example 1.6

- Consider a Boeing 747 airliner cruising at a velocity of 550 mi/h at a standard altitude of 38,000 ft.
- The freestream pressure and temperature are 432.6 lb/ft<sup>2</sup> and 390°R, respectively.
- A one-fiftieth scale model of the 747 is tested in a wind tunnel where the temperature is 430°R.
- Calculate the required velocity and pressure of the test airstream in the wind tunnel such that the lift and drag coefficients measured for the wind-tunnel model are the same as for free flight.
- Assume that both  $\mu$  and  $a$  are proportional to  $T^{1/2}$ .





## Example 1.6

- Let subscripts 1 and 2 denote the free-flight and wind tunnel conditions, respectively.
- For  $C_{L,1} = C_{L,2}$  and  $C_{D,1} = C_{D,2}$ , the wind tunnel flow must be dynamically similar to free flight.
- For this to hold,  $M_1 = M_2$  and  $Re_1 = Re_2$ :

$$M_1 = \frac{V_1}{a_1} \propto \frac{V_1}{\sqrt{T_1}}$$

$$M_2 = \frac{V_2}{a_2} \propto \frac{V_2}{\sqrt{T_2}}$$

- Hence, 
$$\frac{V_2}{\sqrt{T_2}} = \frac{V_1}{\sqrt{T_1}}$$

$$V_2 = V_1 \sqrt{\frac{T_2}{T_1}} = 550 \sqrt{\frac{430}{390}} = \boxed{577.5 \text{ mi/h}}$$





## Example 1.6

- We have

$$\text{Re}_1 = \frac{\rho_1 V_1 c_1}{\mu_1} \propto \frac{\rho_1 V_1 c_1}{\sqrt{T_1}} \quad \frac{\rho_1 V_1 c_1}{\sqrt{T_1}} = \frac{\rho_2 V_2 c_2}{\sqrt{T_2}}$$

$$\text{Re}_2 = \frac{\rho_2 V_2 c_2}{\mu_2} \propto \frac{\rho_2 V_2 c_2}{\sqrt{T_2}} \quad \frac{\rho_2}{\rho_1} = \left(\frac{V_1}{V_2}\right) \left(\frac{c_1}{c_2}\right) \sqrt{\frac{T_2}{T_1}}$$

- We know that  $M_1 = M_2$ ,  $\frac{V_1}{V_2} = \sqrt{\frac{T_1}{T_2}}$

- So,  $\frac{\rho_2}{\rho_1} = \frac{c_1}{c_2} = 50$

- The equation of state for a perfect gas is  $p = \rho RT$ , where  $R$  is the specific gas constant. Thus,

$$\frac{p_2}{p_1} = \frac{\rho_2}{\rho_1} \frac{T_2}{T_1} = (50) \left(\frac{430}{390}\right) = 55.1 \quad p_2 = 55.1 p_1 = (55.1)(432.6) = \boxed{23,836 \text{ lb/ft}^2}$$

$$1 \text{ atm} = 2116 \text{ lb/ft}^2, \text{ then } p_2 = 23,836/2116 = \boxed{11.26 \text{ atm}}$$





## Flow similarity

- In Example 1.6, the wind-tunnel test stream must be pressurized far above atmospheric pressure in order to simulate the proper free-flight Reynolds number.
- However, most standard subsonic wind tunnels are not pressurized as such, because of the large extra financial cost involved.
- Today, for the most part, we do not attempt to simulate all the parameters simultaneously.
- Mach number simulation is achieved in one wind tunnel, and Reynolds number simulation in another tunnel.
- The results from both tunnels are then analyzed and correlated to obtain reasonable values for  $C_L$  and  $C_D$  appropriate for free flight.

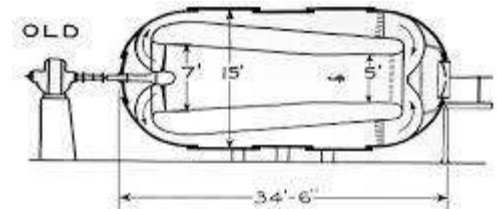
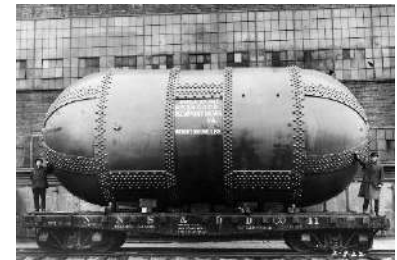



## Example 1.7

- Consider an executive jet transport Cessna 560 Citation V.
- The airplane is cruising at a velocity of 492 mph at an altitude of 33,000 ft, where the ambient air density is  $7.9656 \times 10^{-4}$  slug/ft<sup>3</sup>.
- The weight and wing planform areas of the airplane are 15,000 lb and 342.6 ft<sup>2</sup>, respectively.
- The drag coefficient at cruise is 0.015. Calculate the lift coefficient and the lift-to-drag ratio at cruise.





## Example 1.7

- If it has a stalling speed at sea level of 100 mph at the maximum take-off weight of 15,900 lb.
- The ambient air density at standard sea level is 0.002377 slug/ft<sup>3</sup>.
- Calculate the value of the maximum lift coefficient for the airplane.

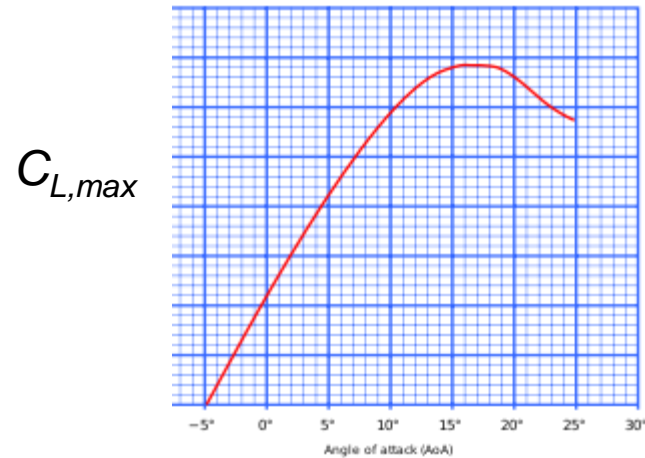



## Example 1.7

- To convert between mph and ft/s, it is useful to remember that  $88 \text{ ft/s} = 60 \text{ mph}$ .

$$V_{\infty} = 492 \left( \frac{88}{60} \right) = 721.6 \text{ ft/s}$$

- We can say that lift must be equal to weight for level flight;  $L = W$ . So,

$$C_L = \frac{2W}{\rho_{\infty} V_{\infty}^2 S} = \frac{2(15,000)}{(7.9659 \times 10^{-4})(721.6)^2(342.6)} = 0.21$$

- The lift-to-drag ratio (fines)

$$\frac{L}{D} = \frac{C_L}{C_D} = \frac{0.21}{0.015} = 14$$





## Example 1.7

- Once again we have to use consistent units, so

$$V_{\text{stall}} = 100 \frac{88}{60} = 146.7 \text{ ft/s}$$

$$C_{L,\text{max}} = \frac{2W}{\rho_{\infty} V_{\text{stall}}^2 S} = \frac{2(15,900)}{(0.002377)(146.7)^2(342.6)} = 1.81$$







## Fluid statics

- In aerodynamics, we are concerned about fluids in motion, and the resulting forces and moments on bodies due to such motion.
- However, in this section, we consider the special case of *no* fluid motion (i.e., *fluid statics*).
- A body immersed in a fluid will still experience a force even if there is no relative motion between the body and the fluid.
- Let us see why.





## Fluid statics

- Consider a stagnant fluid above the  $xz$  plane. The vertical direction is given by  $y$ .
- Consider an infinitesimally small fluid element with sides of length  $dx$ ,  $dy$ , and  $dz$ .
- There are two types of forces acting on this fluid element: pressure forces and the gravity force.
- Consider forces in the  $y$  direction.

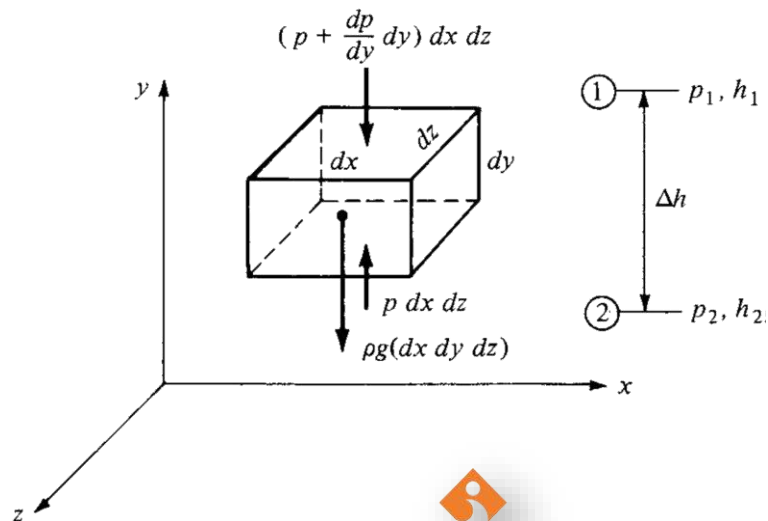



## Fluid statics

- Letting upward force be positive, we have

$$\begin{aligned}\text{Net pressure force} &= p(dx dz) - \left( p + \frac{dp}{dy} dy \right) (dx dz) \\ &= -\frac{dp}{dy} (dx dy dz)\end{aligned}$$

$$\text{Gravity force} = -\rho(dx dy dz)g$$

- Since the fluid element is stationary (in equilibrium), the sum of the forces exerted on it must be zero:

$$\begin{aligned}-\frac{dp}{dy} (dx dy dz) - g\rho(dx dy dz) &= 0 \\ dp &= -g\rho dy\end{aligned}$$

- It is called the *Hydrostatic equation*.
- It is a differential equation which relates the change in pressure  $dp$  in a fluid with a change in vertical height  $dy$ .





## Fluid statics

- Equation governs the variation of atmospheric properties as a function of altitude in the air above us.
- It is also used to estimate the properties of other planetary atmospheres such as for Venus, Mars, and Jupiter.
- Let the fluid be a liquid, for which we can assume  $\rho$  is constant.

- We have

$$\int_{p_1}^{p_2} dp = -\rho g \int_{h_1}^{h_2} dy$$

$$p_2 - p_1 = -\rho g(h_2 - h_1) = \rho g \Delta h \quad \Delta h = h_1 - h_2$$

$$p_2 + \rho g h_2 = p_1 + \rho g h_1$$

$$p + \rho g h = \text{constant}$$





## Fluid statics

- A simple application is the calculation of the pressure distribution on the walls of a container holding a liquid, and open to the atmosphere at the top.

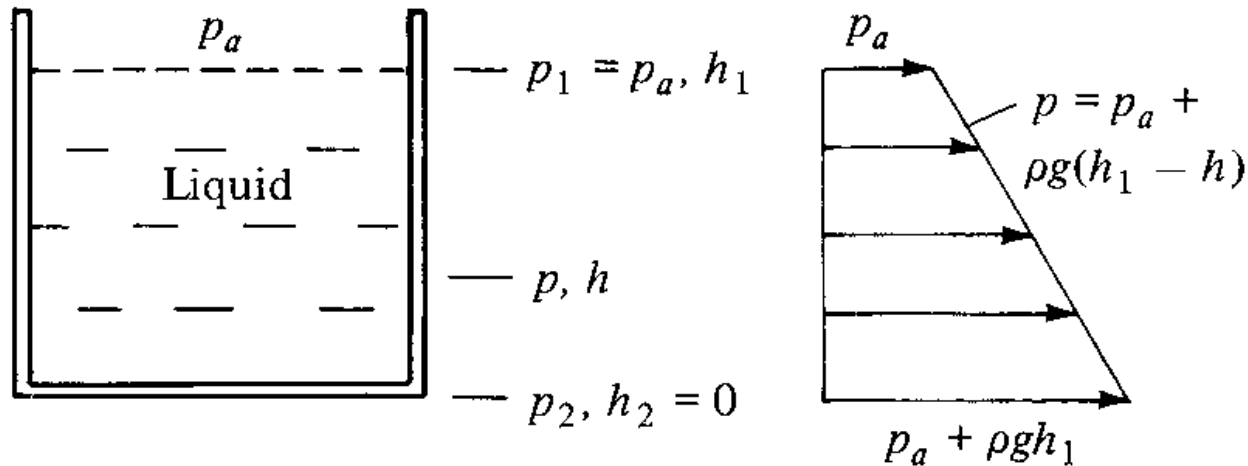

$$p + \rho gh = p_1 + \rho gh_1 = p_a + \rho gh_1$$

$$p = p_a + \rho g(h_1 - h)$$

- Note that the pressure is a *linear* function of  $h$  and that  $p$  increases with depth below the surface.





## Fluid statics

- Another simple and very common application is the liquid filled U-tube manometer used for measuring pressure differences.

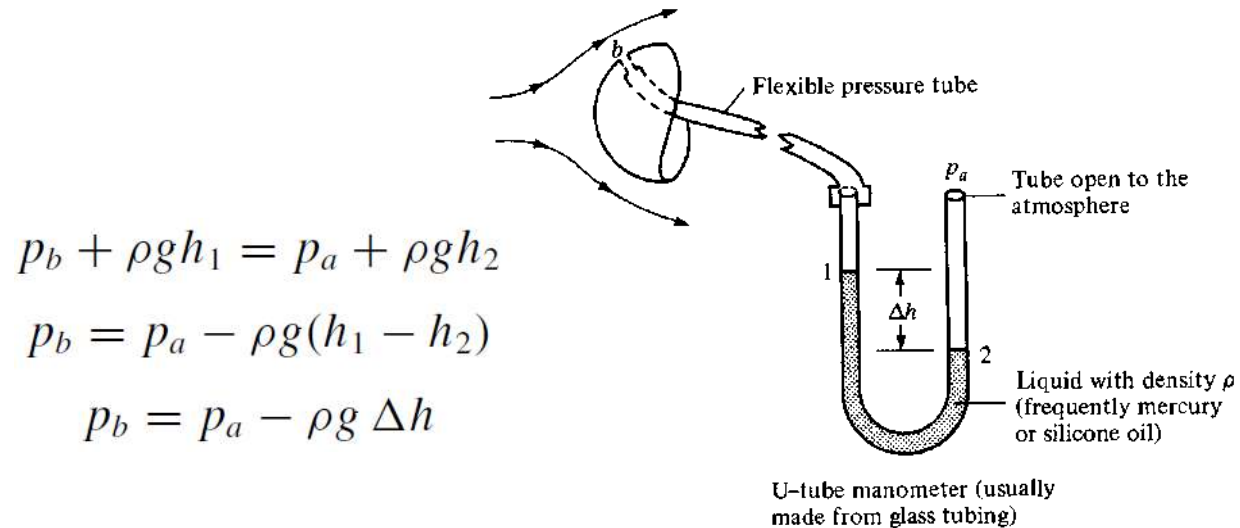

- Note that the pressure on the same level will be the same in fluid.





## Fluid statics

- We stated that a solid body immersed in a fluid will experience a force even if there is no relative motion between the body and the fluid.
- We are now in a position to derive an expression for this force, henceforth called the *buoyancy force*.
- For simplicity, consider a rectangular body of unit width (1), length  $l$ , and height ( $h_1 - h_2$ ).
- We see that the vertical force  $F$  on the body due to the pressure distribution over the surface is

$$F = (p_2 - p_1)l(1)$$
$$p_2 - p_1 = \int_{p_1}^{p_2} dp = - \int_{h_1}^{h_2} \rho g dy = \int_{h_2}^{h_1} \rho g dy$$
$$F = l(1) \int_{h_2}^{h_1} \rho g dy$$

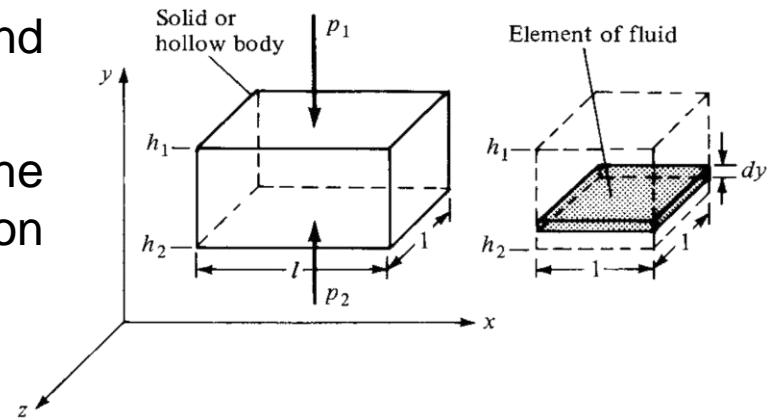

- we obtain the buoyancy force.





## Fluid statics

- Consider the physical meaning of the integral in Equation.

- It is the weight of total volume of fluid;  $l \int_{h_2}^{h_1} \rho g dy$

- Therefore, we can state in words that

$$\text{Buoyancy force on body} = \text{weight of fluid displaced by body}$$

*the well-known Archimedes principle*

- The density of liquids is usually several orders of magnitude larger than the density of gases.
- For water  $\rho = 10^3 \text{ kg/m}^3$ , for air  $\rho = 1.23 \text{ kg/m}^3$ .
- Therefore, a given body will experience a buoyancy force a thousand times greater in water than in air.







## Example 1.9

- A hot-air balloon with an inflated diameter of 30 ft is carrying a weight of 800 lb, which includes the weight of the hot air inside the balloon.
- Calculate;
  - its upward acceleration at sea level the instant the restraining ropes are released.
  - the maximum altitude it can achieve.
  - Assume that the variation of density in the standard atmosphere is given by

$$\rho = 0.002377(1 - 7 \times 10^{-6}h)^{4.21}$$

where  $h$  is the altitude in feet and  $\rho$  is in slug/ft<sup>3</sup>.





## Example 1.9

Buoyancy force = weight of displaced air

$$= g\rho\mathcal{V} \quad h = 0, \rho = 0.002377 \text{ slug/ft}^3$$
$$\frac{4}{3}\pi(15)^3 = 14,137 \text{ ft}^3$$

$$B = (32.2)(0.002377)(14,137) = 1082 \text{ lb}$$

- The net upward force at sea level is  $F = B - W = ma$

- Mass value ( $W/g$ );  $m = \frac{800}{32.2} = 24.8 \text{ slug}$

- Hence 
$$a = \frac{B - W}{m} = \frac{1082 - 800}{24.8} = 11.4 \text{ ft/s}^2$$

- The maximum altitude occurs when  $B = W$

$$B = g\rho\mathcal{V}$$

$$\rho = \frac{B}{g\mathcal{V}} = \frac{800}{(32.2)(14,137)} = 0.00176 \text{ slug/ft}^3$$





## Example 1.9

- From the given variation of  $\rho$  with altitude,  $h$ ,

$$\rho = 0.002377(1 - 7 \times 10^{-6}h)^{4.21} = 0.00176$$

$$h = \frac{1}{7 \times 10^{-6}} \left[ 1 - \left( \frac{0.00176}{0.002377} \right)^{1/4.21} \right] = 9842 \text{ ft}$$





## Example 1.11



- Consider a U-tube mercury manometer oriented vertically.
- One end is completely sealed with a total vacuum above the column of mercury.
- The other end is open to the atmosphere where the atmospheric pressure is that for standard sea level.
- What is the displacement height of the mercury in centimeters, and in which end is the mercury column the highest?
- The density of mercury is  $1.36 \times 10^4 \text{ kg/m}^3$ .

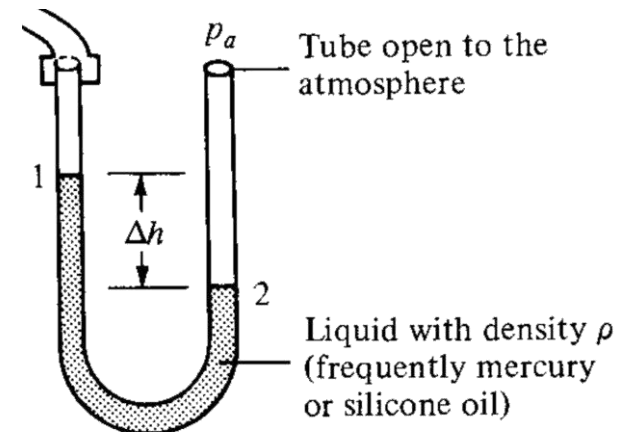



## Example 1.11

- Consider the sealed end with the total vacuum to be on the left, where  $p_b = 0$ .

- We have 
$$p_b = p_a - \rho g \Delta h$$

$$\Delta h = \frac{p_a}{\rho g} \quad \text{at sea level } p_a = 1.013 \times 10^5 \text{ N/m}^2$$

$$\Delta h = \frac{p_a}{\rho g} = \frac{1.013 \times 10^5}{(1.36 \times 10^4)(9.8)} = 0.76 \text{ m}$$

760 mm mercury





## Example 1.10

- Show how the standard altitude tables are constructed with the use of the Hydrostatic equation.
- We know that  $dp = -g\rho dy = -g\rho dh$
- Also we have the equation of state for a perfect gas  $p = \rho RT$

- Lets divide them 
$$\frac{dp}{p} = -\frac{g}{R} \frac{dh}{T}$$

- We know the relationship between altitude and temperature:

- Therefore; 
$$\frac{dp}{p} = -\frac{g}{aR} \frac{dT}{T}$$

- From sea level to an altitude of 11 km, the standard altitude is based on a linear variation of temperature with altitude,  $h$ , where  $T$  decreases at a rate of  $-6.5$  K per kilometer (the lapse rate).



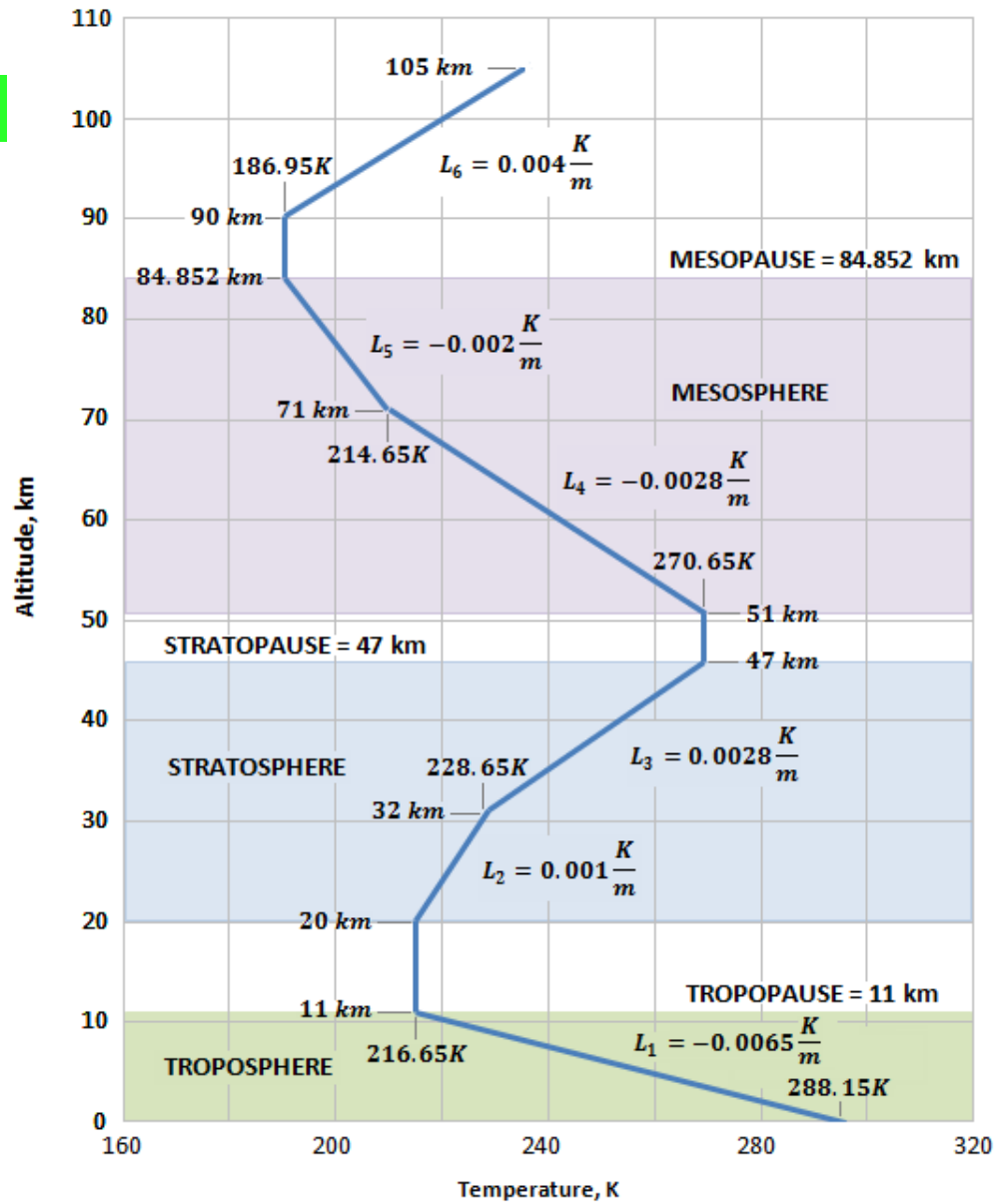



## Example 1.10

- Let's integrate the equation from sea level where the standard values of pressure and temperature are denoted by  $p_s$  and  $T_s$ , respectively,

$$\int_{p_s}^p \frac{dp}{p} = - \int_{T_s}^T \frac{g}{aR} \frac{dT}{T}$$

$$\ln \frac{p}{p_s} = - \frac{g_s}{aR} \ln \frac{T}{T_s}$$

$$\frac{p}{p_s} = \left( \frac{T}{T_s} \right)^{-g_s/aR}$$

- At sea level, the standard pressure, density, and temperature are  $1.01325 \times 10^5 \text{ N/m}^2$ ,  $1.2250 \text{ kg/m}^3$ , and  $288.16 \text{ K}$ , respectively.

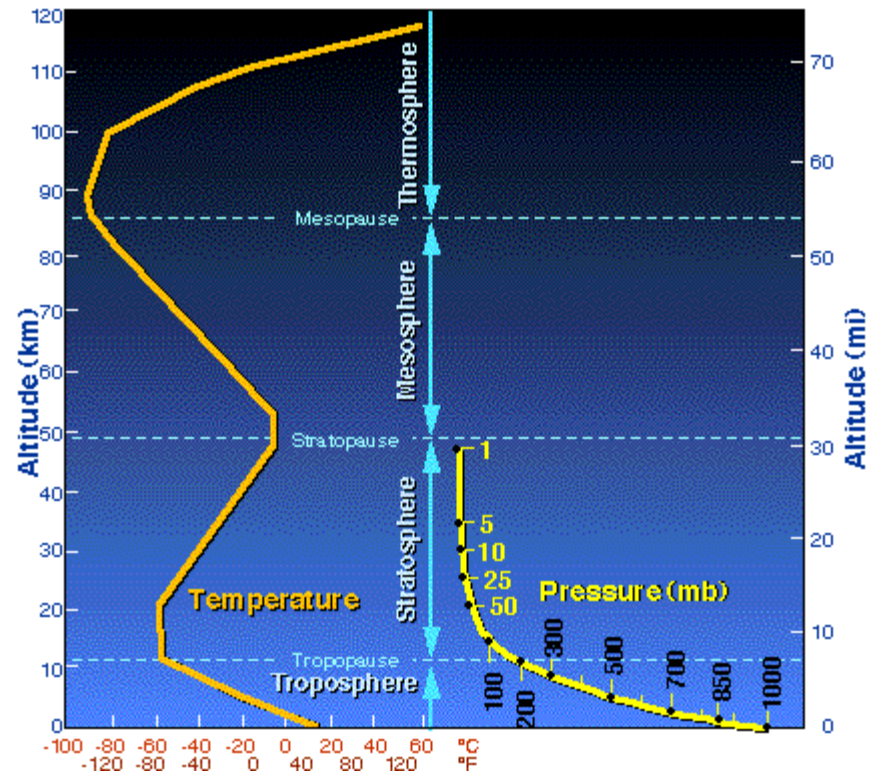





## Types of flow

- An understanding of aerodynamics, like that of any other physical science, is obtained through a “building-block” approach.
- An example of this process is the way that different types of aerodynamic flows are categorized and visualized.
- As a result, a study of aerodynamics has evolved into a study of numerous and distinct types of flow; from the simplest flow to the most complex one...





## Types of flow

### Continuum Versus Free Molecule Flow

- Consider the flow over a body, say, for example, a circular cylinder of diameter  $d$ .
- Also, consider the fluid to consist of individual molecules, which are moving about in random motion.
- The mean distance that a molecule travels between collisions with neighboring molecules is defined as the *mean-free path*  $\lambda$ .
- If  $\lambda$  is orders of magnitude smaller than the scale of the body measured by  $d$ , then the flow appears to the body as a continuous substance.
- Such flow is called *continuum flow*. **Knudsen number:**  $Kn = \frac{\lambda}{d} < 0.01$





## Types of flow

### Continuum Versus Free Molecule Flow

- The other extreme is where  $\lambda$  is on the same order as the body scale.
- The gas molecules are spaced so far apart (relative to  $d$ ) that collisions with the body surface occur only infrequently.
- The body surface can feel distinctly each molecular impact.
- Such flow is called *free molecular flow*.
- For manned flight, vehicles such as the space shuttle encounter free molecular flow at the extreme outer edge of the atmosphere.
- The air density is so low that  $\lambda$  becomes on the order of the shuttle size. **Knudsen number**:  $Kn = \frac{\lambda}{d} \sim 1$





## Types of flow

### Inviscid Versus Viscous Flow

- A flow that is assumed to involve no friction, thermal conduction, or diffusion is called an *inviscid flow*.
- In contrast, a flow that is assumed to involve friction, thermal conduction, or diffusion is called *viscous flows*
- Inviscid flows do not truly exist in nature.
- However, there are many practical aerodynamic flows where the influence of transport phenomena is small, and we can *model* the flow as being inviscid.

! no viscosity !

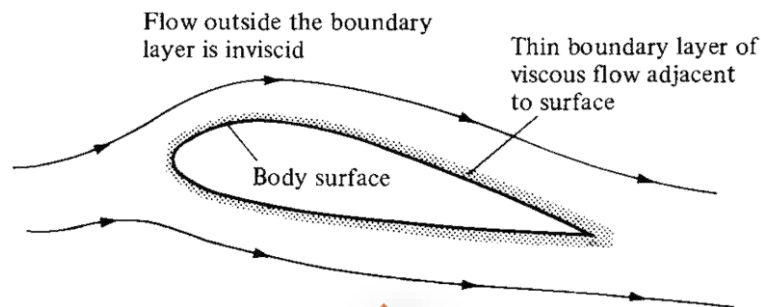



## Types of flow

### Incompressible Versus Compressible Flows

- A flow in which the density  $\rho$  is constant is called *incompressible*.
- In contrast, a flow where the density is variable is called *compressible*.
- All flows are compressible in nature.
- However, there are a number of aerodynamic problems that can be modeled as being incompressible.
- For example, the flow of homogeneous liquids is treated as incompressible.
- Also, the flow of gases at a low Mach number is essentially incompressible; for  $M < 0.3$ .





## Types of flow

### Mach Number Regimes

- If  $M$  is the local Mach number at an arbitrary point in a flow field, then by definition the flow is locally:

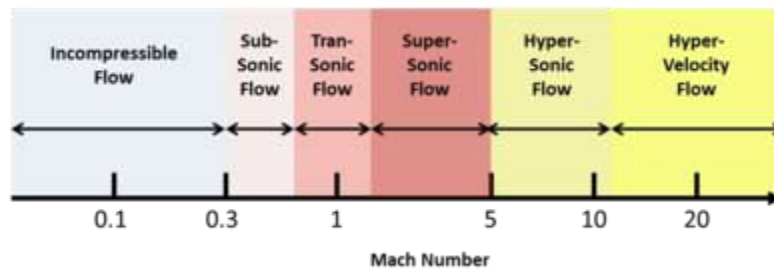

*Subsonic* if  $M < 1$

*Sonic* if  $M \sim 1$

*Supersonic* if  $M > 1$

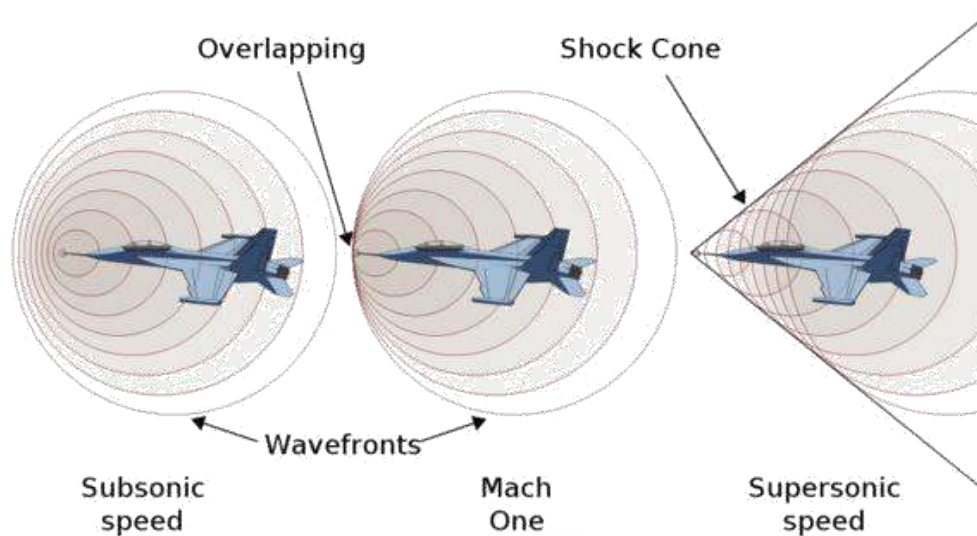



## Types of flow

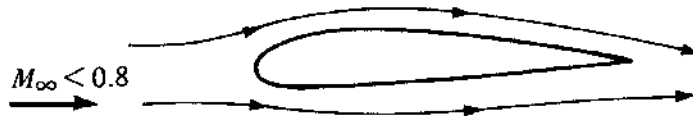

(a) Subsonic flow

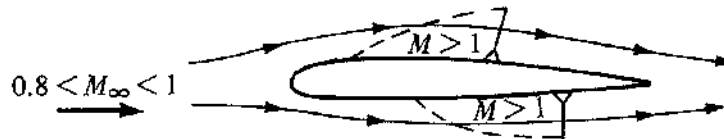

(b) Transonic flow  
with  $M_\infty < 1$

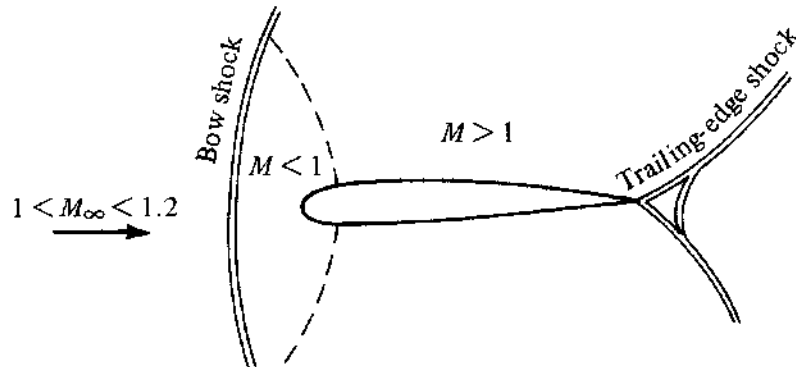

(c) Transonic flow  
with  $M_\infty > 1$

- if  $M_\infty$  is subsonic but is near unity, the flow can become locally supersonic ( $M > 1$ ).
- The flow fields are characterized by mixed subsonic-supersonic flows. Hence, such flow fields are called *transonic flows*.





## Types of flow

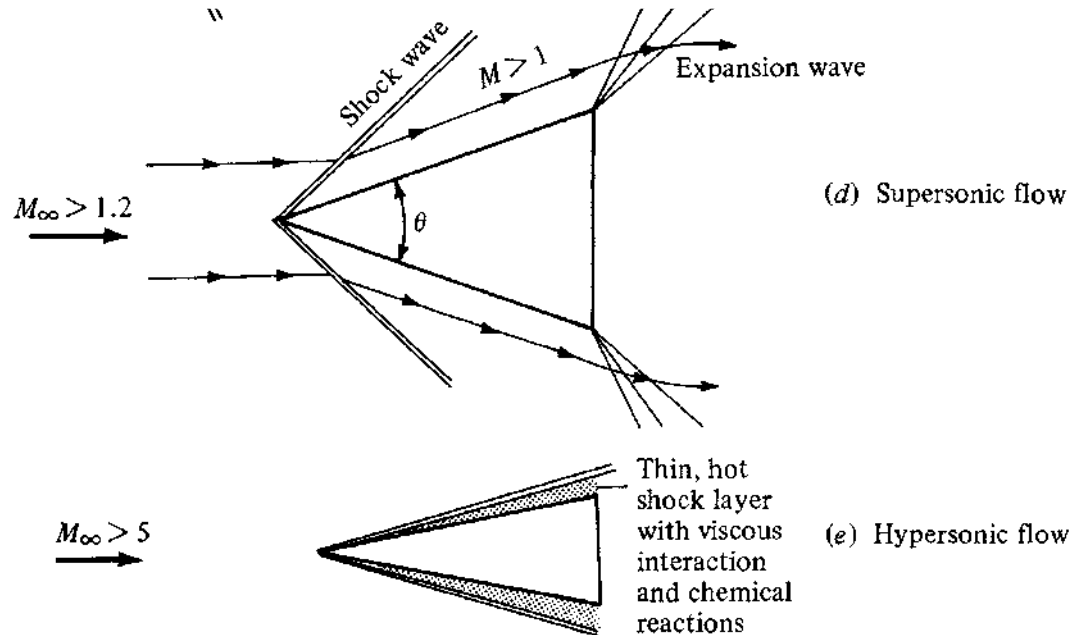

- Hypersonic aerodynamics received a great deal of attention during the period 1955–1970.
- Because atmospheric entry vehicles encounter the atmosphere at Mach numbers between 25 (ICBMs) and 36 (the Apollo lunar return vehicle).







## Types of flow

- The flow features including velocity, pressure and other properties of fluid flow can be functions of space and time.

$$p = f(x, y, z, t)$$

where  $p$  is any property like pressure, velocity or density.

- If a flow is such that the properties at every point in the flow do not depend upon time, it is called a steady flow.
- Mathematically speaking for steady flows,

$$\frac{\partial P}{\partial t} = 0$$

- Unsteady or non-steady flow is one where the properties do depend on time.

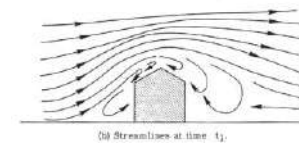
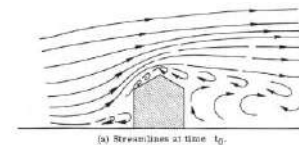

unsteady

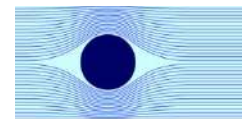
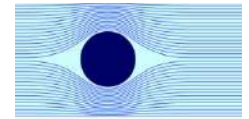

steady





## Types of flow

- A flow field is best characterized by its velocity distribution.
- A flow is said to be one-, two-, or three-dimensional if the flow velocity varies in one, two, or three dimensions, respectively.
- In nature, every flow is 3D.
- However, the variation of velocity in certain directions can be small relative to the variation in other directions and can be ignored.

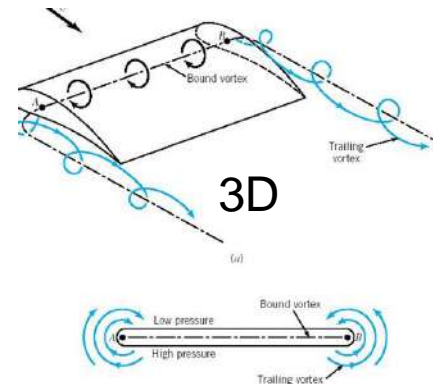
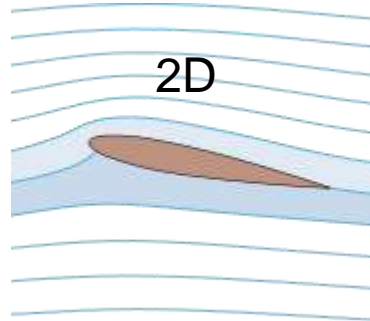



## Types of flow

- A flow field can also be characterized by its flow pattern.
- *Laminar flow*, in which the streamlines are smooth and regular and a fluid element moves smoothly along a streamline.
- *Turbulent* flow, in which the streamlines break up and a fluid element moves in a random, irregular, and tortuous fashion.

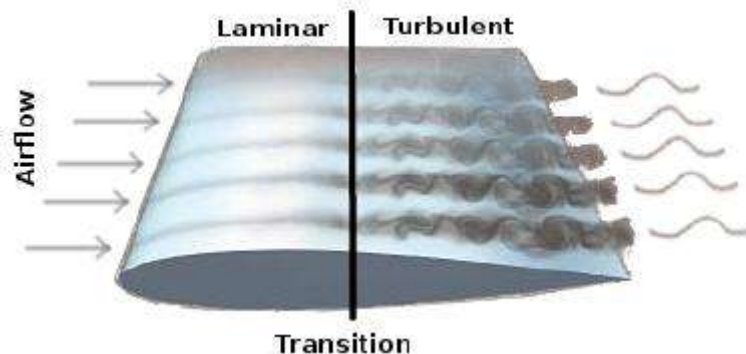



## Applied aerodynamics

- The main purpose is to present knowledge and to show its applications in practice.

**Question:** What are some typical drag coefficients for various aerodynamic configurations?

- Some basic values are shown in Figure.
- The dimensional analysis proved that  $C_D = f(M, Re)$ .
- The drag-coefficient values are for low speeds, essentially incompressible flow; therefore, the Mach number does not come into the picture.





# Applied aerodynamics

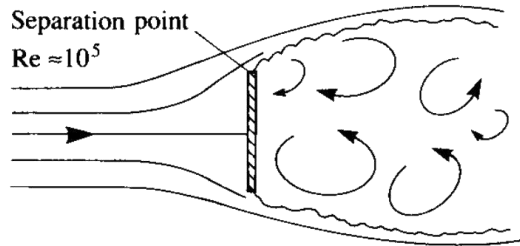

Flat plate  
(Broadside) length =  $d$   $C_D = 2.0$

(a)

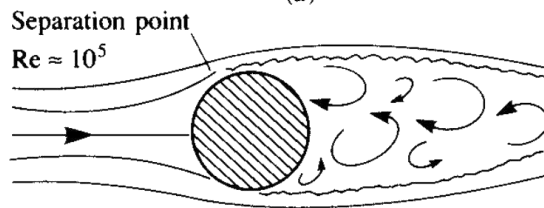

Cylinder diameter =  $d$   $C_D = 1.2$

(b)

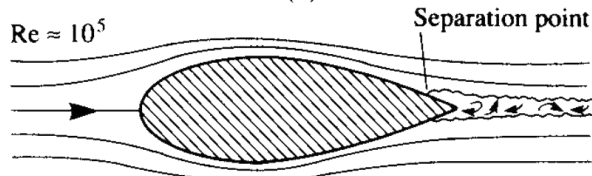

Streamline  
body  
thickness =  $d$   $C_D = 0.12$

(c)

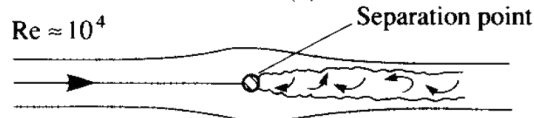

Cylinder  
diameter =  $\frac{1}{10} d$   $C_D = 1.2$

(d)

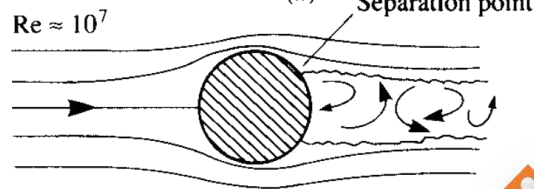

Cylinder  
diameter =  $d$   $C_D = 0.6$

(e)





# Applied aerodynamics

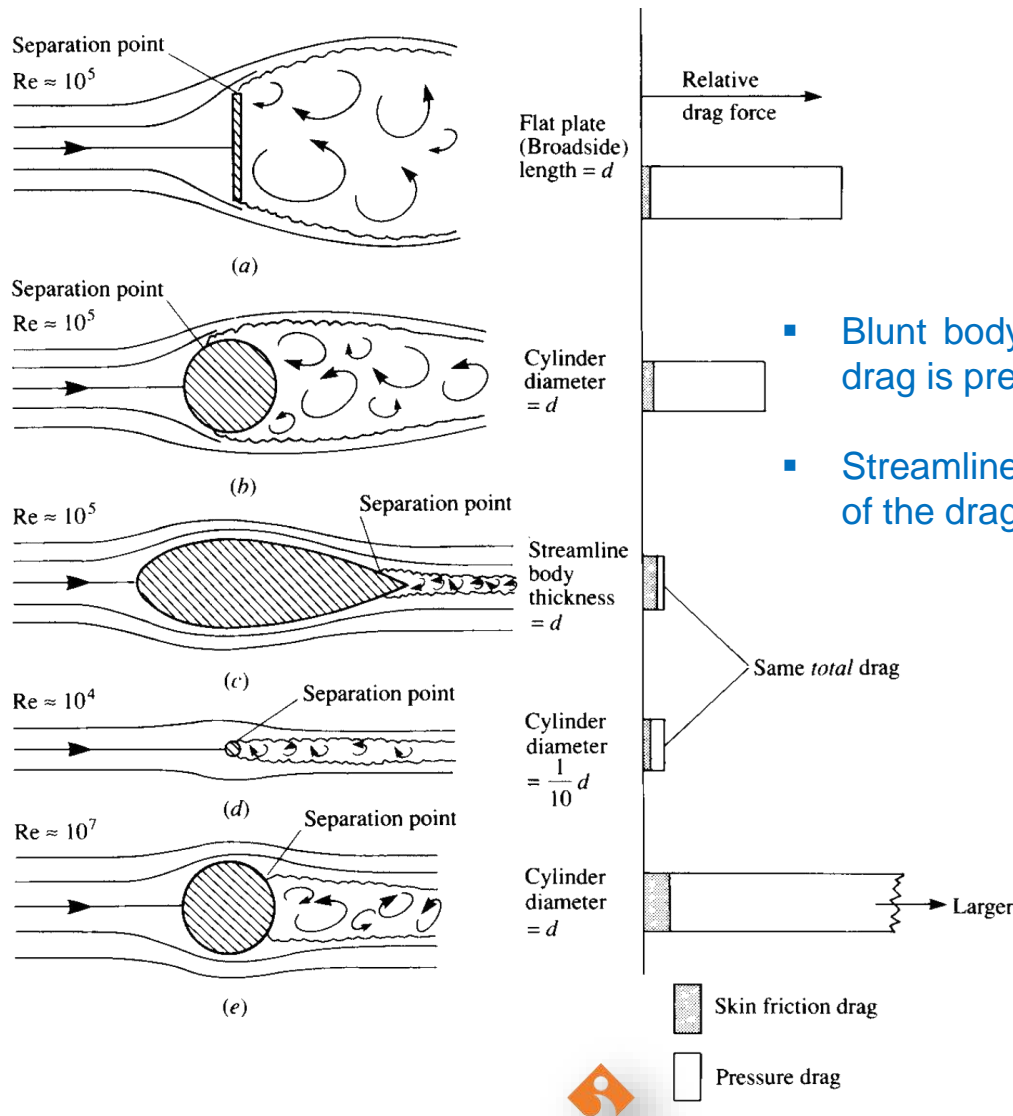

- Blunt body = a body where most of the drag is pressure drag (form drag)
- Streamlined body = a body where most of the drag is skin friction drag





## Applied aerodynamics

Airplane condition

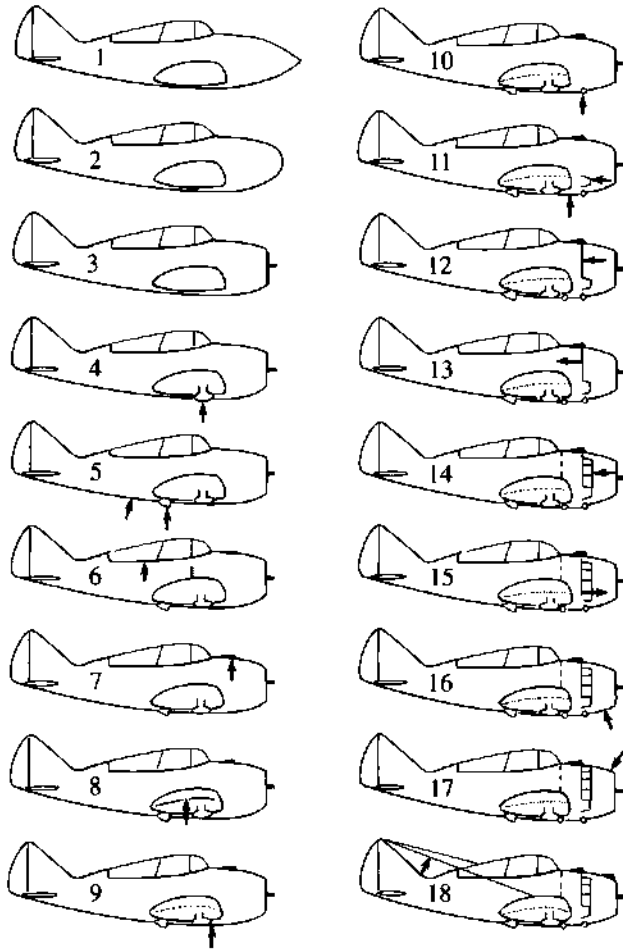

Condition number	Description	$C_D$ ( $C_L = 0.15$ )	$\Delta C_D$	$\Delta C_D$ , % <sup>a</sup>
1	Completely faired condition, long nose fairing	0.0166		
2	Completely faired condition, blunt nose fairing	0.0169		
3	Original cowling added, no airflow through cowling	0.0186	0.0020	12.0
4	Landing-gear seals and fairing removed	0.0188	0.0002	1.2
5	Oil cooler installed	0.0205	0.0017	10.2
6	Canopy fairing removed	0.0203	-0.0002	-1.2
7	Carburetor air scoop added	0.0209	0.0006	3.6
8	Sanded walkway added	0.0216	0.0007	4.2
9	Ejector chute added	0.0219	0.0003	1.8
10	Exhaust stacks added	0.0225	0.0006	3.6
11	Intercooler added	0.0236	0.0011	6.6
12	Cowling exit opened	0.0247	0.0011	6.6
13	Accessory exit opened	0.0252	0.0005	3.0
14	Cowling fairing and seals removed	0.0261	0.0009	5.4
15	Cockpit ventilator opened	0.0262	0.0001	0.6
16	Cowling venturi installed	0.0264	0.0002	1.2
17	Blast tubes added	0.0267	0.0003	1.8
18	Antenna installed	0.0275	0.0008	4.8
Total			0.0109	

<sup>a</sup>Percentages based on completely faired condition with long nose fairing.

- The breakdown of various sources of drag on a late 1930s airplane, the Seversky XP-41





## Applied aerodynamics

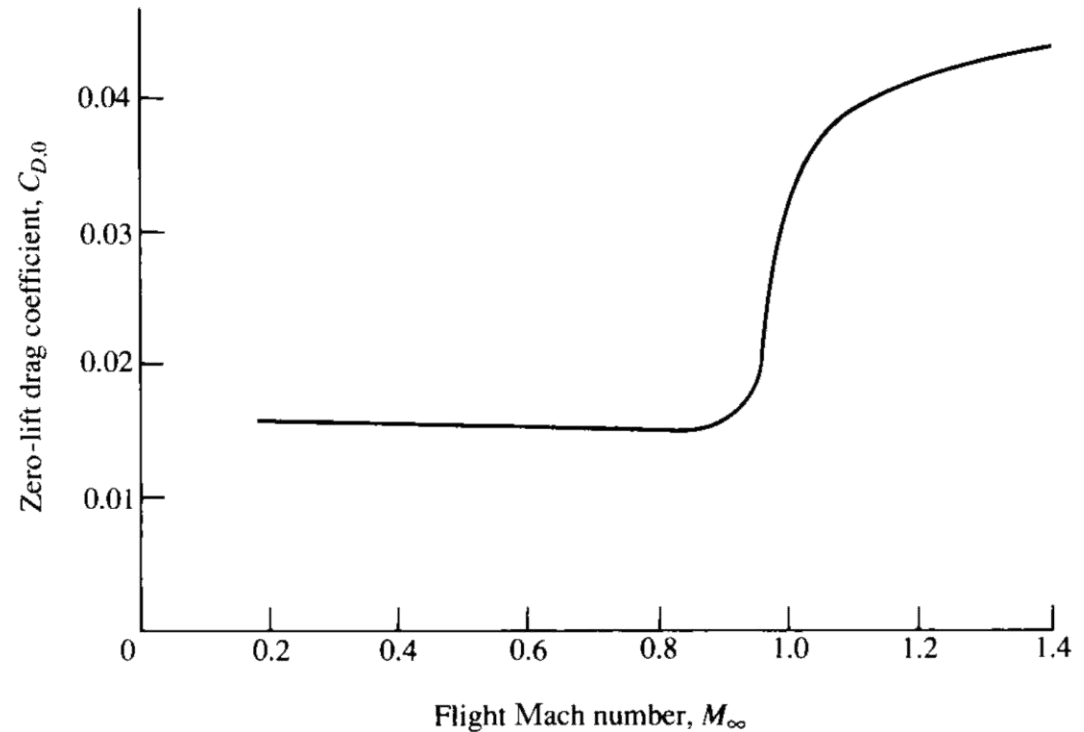
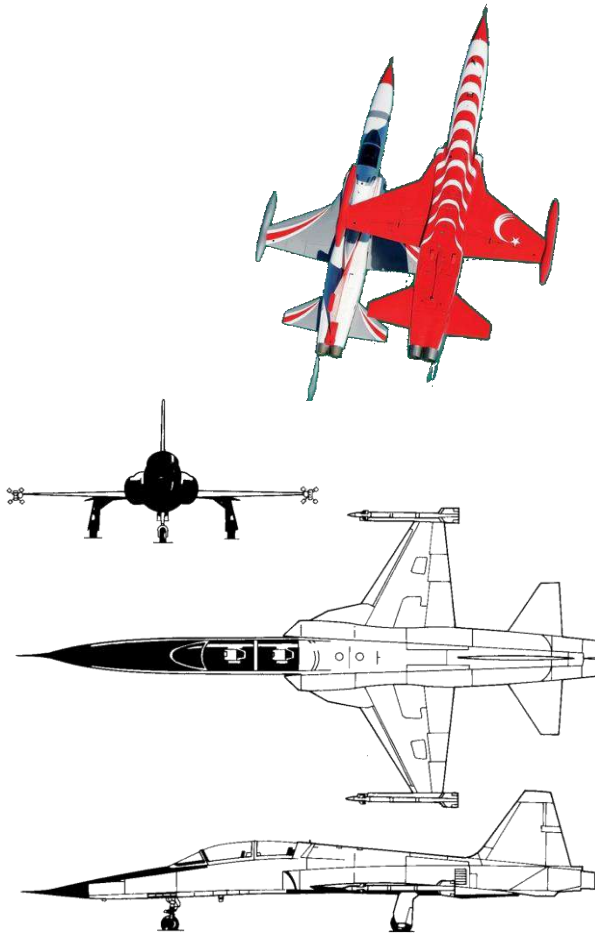

- The aircraft T38 is at a small negative angle of attack such that the lift is zero, hence the  $C_D$  in Figure is called the *zero-lift drag coefficient*.
- Note that the value of  $C_D$  is relatively constant from  $M = 0.1$  to about 0.86. Why?







## Applied aerodynamics

- Variation of section lift coefficient for a NACA 63-210 airfoil.
- $Re = 3 \times 10^6$ .
- No flap deflection.

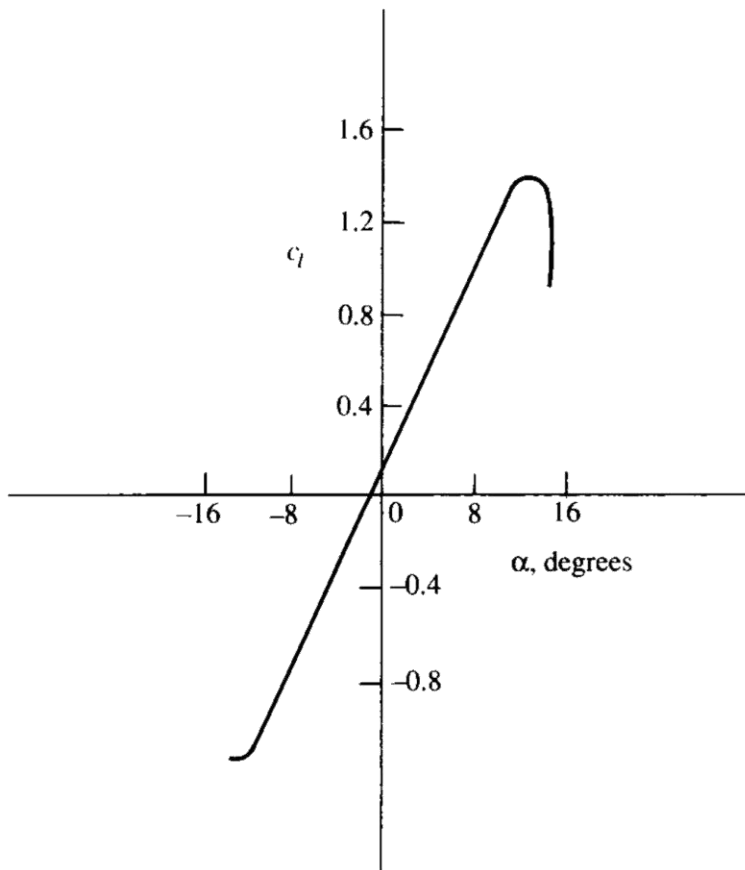

- Variation of lift coefficient with angle of attack for the T-38.
- Three curves are shown corresponding to three different flap deflections. Freestream Mach number is 0.4.

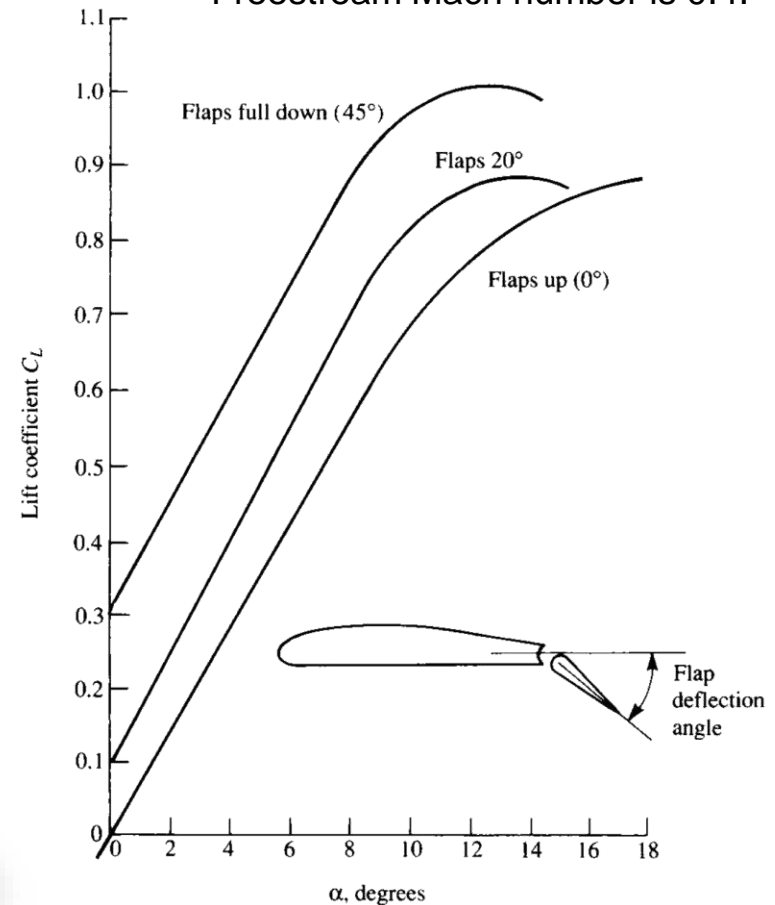



## Example 1.12

- Consider the Seversky P-35 shown in Figure.
- Assume that the drag breakdown given for the XP-41 applies also to the P-35.
- Note that the data given in Figure apply for the specific condition where  $C_L = 0.15$ .
- The wing planform area and the gross weight of the P-35 are 220 ft<sup>2</sup> and 5599 lb, respectively.
- Calculate the horsepower required for the P-35 to fly in steady level flight with  $C_L = 0.15$  at standard sea level.





## Example 1.12

- From basic mechanics, if  $\mathbf{F}$  is a force exerted on a body moving with a velocity  $\mathbf{V}$ , the power generated by this system is  $P = \mathbf{F} \cdot \mathbf{V}$ .
- When  $\mathbf{F}$  and  $\mathbf{V}$  are in the same direction, then the dot product becomes  $P = FV$  where  $F$  and  $V$  are the scalar magnitudes of force and velocity, respectively.
- When the airplane is in steady level flight (no acceleration) the thrust obtained from the engine exactly counteracts the drag, i.e.,  $T = D$ .
- Hence the power required for the airplane to fly at a given velocity  $V_\infty$  is

$$P = TV_\infty = DV_\infty$$





## Example 1.12

- To obtain  $V_\infty$ , we note that in steady level flight the weight is exactly balanced by the aerodynamic lift,

$$W = L$$

- we have

$$W = L = q_\infty S C_L = 1/2 \rho_\infty V_\infty^2 S C_L$$

- Solving Eq. for  $V_\infty$ , we have 
$$V_\infty = \sqrt{\frac{2W}{\rho_\infty S C_L}}$$

- At standard sea level,  $\rho_\infty = 0.002377$  slug/ft<sup>3</sup>. Also,  $S=220$  ft<sup>2</sup>,  $W = 5599$  lb, and  $C_L = 0.15$ .

- Hence, from Eq. we have

$$V_\infty = \sqrt{\frac{2(5599)}{(0.002377)(220)(0.15)}} = 377.8 \text{ ft/s}$$





## Example 1.12

- To complete the calculation of power required, we need the value of  $D$ .

$$C_D = 0.0275 \quad \text{from the table}$$

$$q_\infty = 1/2\rho_\infty V_\infty^2 = 1/2(0.002377)(377.8)^2 = 169.6 \text{ lb/ft}^2$$

- The drag,

$$D = q_\infty S C_D = (169.6)(220)(0.0275) = 1026 \text{ lb}$$

- The required power

$$P = D V_\infty = (1026)(377.8) = 3.876 \times 10^5 \text{ ft lb/s}$$

- Note that 1 horsepower is 550 ft lb/s. Thus, in horsepower,

$$P = \frac{3.876 \times 10^5}{550} = 704 \text{ hp}$$





## Historical notes

- The first person to define and use aerodynamic force coefficients was Otto Lilienthal, the famous German aviation pioneer at the end of the nineteenth century.
- By the end of World War I, Ludwig Prandtl at Gottingen University in Germany established the nomenclature for the aerodynamic force that is accepted as standard today;

$$W = cFq$$

where  $W$  is the force,  $F$  is the area of the surface,  $q$  is the dynamic pressure, and  $c$  is a “pure number”

$$L = q_{\infty} S C_L$$

$$D = q_{\infty} S C_D$$





## Questions

- 1.6** Consider an NACA 2412 airfoil (the meaning of the number designations for standard NACA airfoil shapes is discussed in Chapter 4). The following is a tabulation of the lift, drag, and moment coefficients about the quarter chord for this airfoil, as a function of angle of attack.

$\alpha$ (degrees)	$c_l$	$c_d$	$c_{m,c/4}$
-2.0	0.05	0.006	-0.042
0	0.25	0.006	-0.040
2.0	0.44	0.006	-0.038
4.0	0.64	0.007	-0.036
6.0	0.85	0.0075	-0.036
8.0	1.08	0.0092	-0.036
10.0	1.26	0.0115	-0.034
12.0	1.43	0.0150	-0.030
14.0	1.56	0.0186	-0.025

From this table, plot on graph paper the variation of  $x_{cp}/c$  as a function of  $\alpha$ .





## Questions

- 1.7** The drag on the hull of a ship depends in part on the height of the water waves produced by the hull. The potential energy associated with these waves therefore depends on the acceleration of gravity  $g$ . Hence, we can state that the wave drag on the hull is  $D = f(\rho_\infty, V_\infty, c, g)$  where  $c$  is a length scale associated with the hull, say, the maximum width of the hull. Define the drag coefficient as  $C_D \equiv D/q_\infty c^2$ . Also, define a similarity parameter called the *Froude number*,  $Fr = V/\sqrt{gc}$ . Using Buckingham's pi theorem, prove that  $C_D = f(Fr)$ .
- 1.10** Consider a Lear jet flying at a velocity of 250 m/s at an altitude of 10 km, where the density and temperature are  $0.414 \text{ kg/m}^3$  and 223 K, respectively. Consider also a one-fifth scale model of the Lear jet being tested in a wind tunnel in the laboratory. The pressure in the test section of the wind tunnel is  $1 \text{ atm} = 1.01 \times 10^5 \text{ N/m}^2$ . Calculate the necessary velocity, temperature, and density of the airflow in the wind-tunnel test section such that the lift and drag coefficients are the same for the wind-tunnel model and the actual airplane in flight. *Note:* The relation among pressure, density, and temperature is given by the equation of state described in Problem 1.1.







# *Aerodynamics*

## *AE 301*

Assoc. Prof. Dr. Y . Volkan PEHLİVANOĞLU  
volkan.pehlivanoglu@ieu.edu.tr





## Contents;

- a. Review of vector relations,
- b. Models of fluid,
- c. Continuity equation,
- d. Momentum equation,
- e. Energy equation,
- f. Substantial derivative,
- g. Flow patterns,
- h. Velocity, vorticity, strain,
- i. Circulation,
- j. Flow functions,
- k. How do we solve the equations?

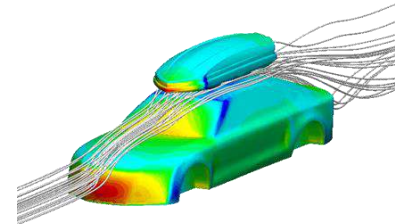
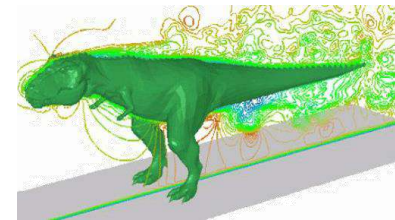
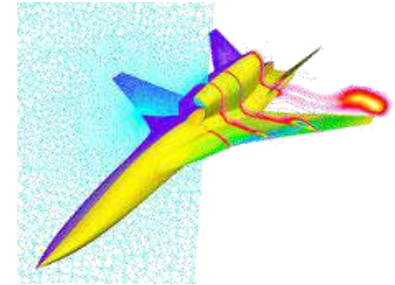
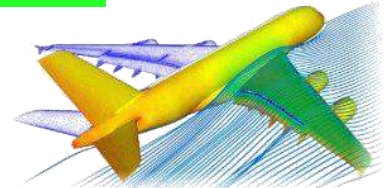



## Introductions

- *The principle is most important, not the detail.*

**Theodore von Karman, 1954**

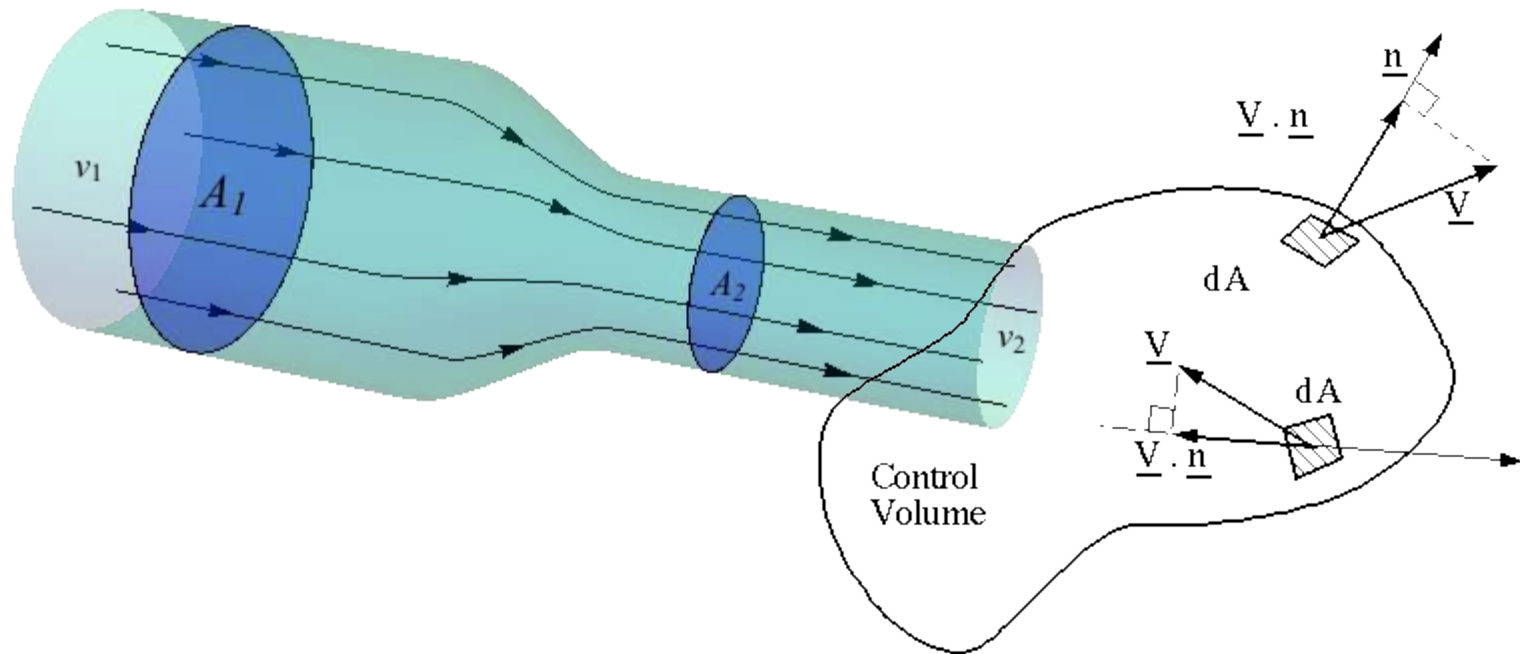



## Introductions

- Central to this chapter is the derivation and discussion of the three most important and fundamental equations in aerodynamics:
  - the continuity,
  - momentum,
  - and energy equations.
- The continuity equation is a mathematical statement of the fundamental principle that mass is conserved.
- The momentum equation is a mathematical statement of Newton's second law.
- The energy equation is a mathematical statement of energy conservation.
  - Nothing in aerodynamics is more fundamental than these three physical principles in aerodynamics.

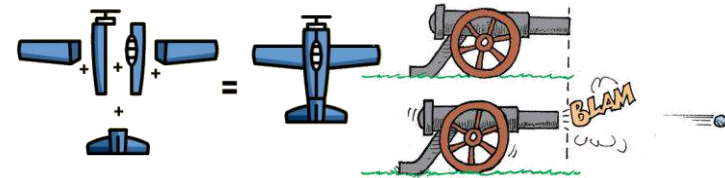



## Some Vector Algebra

- Consider a vector quantity  $\mathbf{A}$ .
- The absolute magnitude of  $\mathbf{A}$  is  $|\mathbf{A}|$ , and is a scalar quantity.
- The *unit vector*  $\mathbf{n}$ , defined by  $\mathbf{n} = \mathbf{A}/|\mathbf{A}|$ , has a magnitude of unity and a direction equal to that of  $\mathbf{A}$ .
- Let  $\mathbf{B}$  represent another vector.

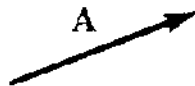

Vector

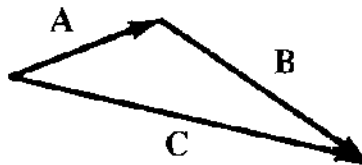

Vector addition

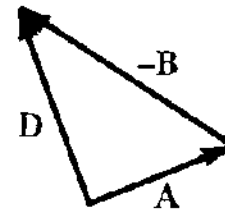

Vector subtraction

Tail-to-tip approach





## Some Vector Algebra

- There are two forms of vector multiplication.
- The *scalar product* (dot product) of the two vectors **A** and **B** is defined as 
$$\mathbf{A} \cdot \mathbf{B} \equiv |\mathbf{A}||\mathbf{B}| \cos \theta$$
- Note that the scalar product of two vectors is a scalar.
- In contrast, the *vector product* (cross product) of the two vectors **A** and **B** is defined as 
$$\mathbf{A} \times \mathbf{B} \equiv (|\mathbf{A}||\mathbf{B}| \sin \theta)\mathbf{e} = \mathbf{G}$$

where **G** is perpendicular to the plane of **A** and **B** and in a direction which obeys the “right-hand rule.”

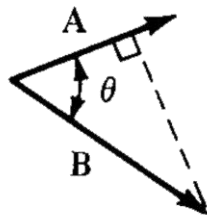

Scalar product

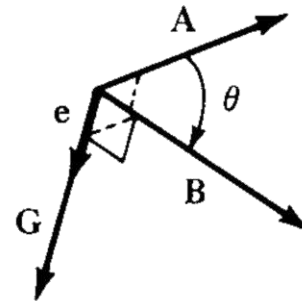

Vector product





## Typical Orthogonal Coordinate Systems

- To describe mathematically the flow of fluid through three-dimensional space, we have to prescribe a three-dimensional coordinate system.
- The geometry of some aerodynamic problems best fits a rectangular space, whereas others are mainly cylindrical in nature, and yet others may have spherical properties.
- Therefore, we have interest in the three most common orthogonal coordinate systems:
  - cartesian,
  - cylindrical,
  - and spherical.
- An orthogonal coordinate system is one where all three coordinate directions are mutually perpendicular.





## Typical Orthogonal Coordinate Systems

- A cartesian coordinate system

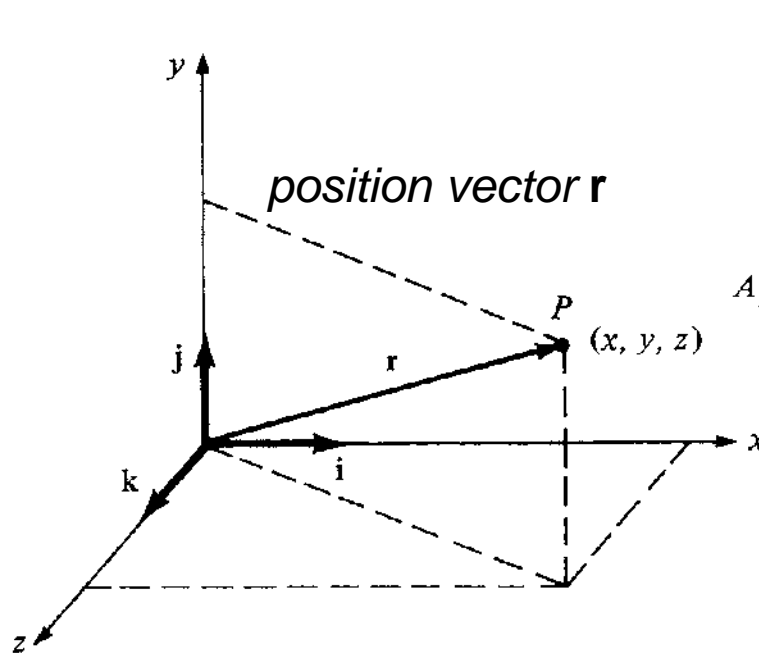

$$\mathbf{r} = x\mathbf{i} + y\mathbf{j} + z\mathbf{k}$$

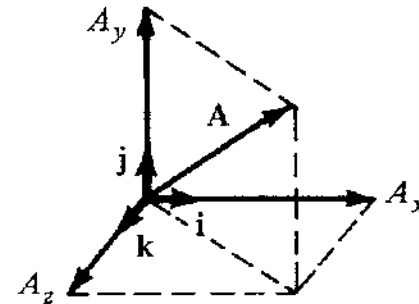

$$\mathbf{A} = A_x\mathbf{i} + A_y\mathbf{j} + A_z\mathbf{k}$$







## Typical Orthogonal Coordinate Systems

- A cylindrical coordinate system

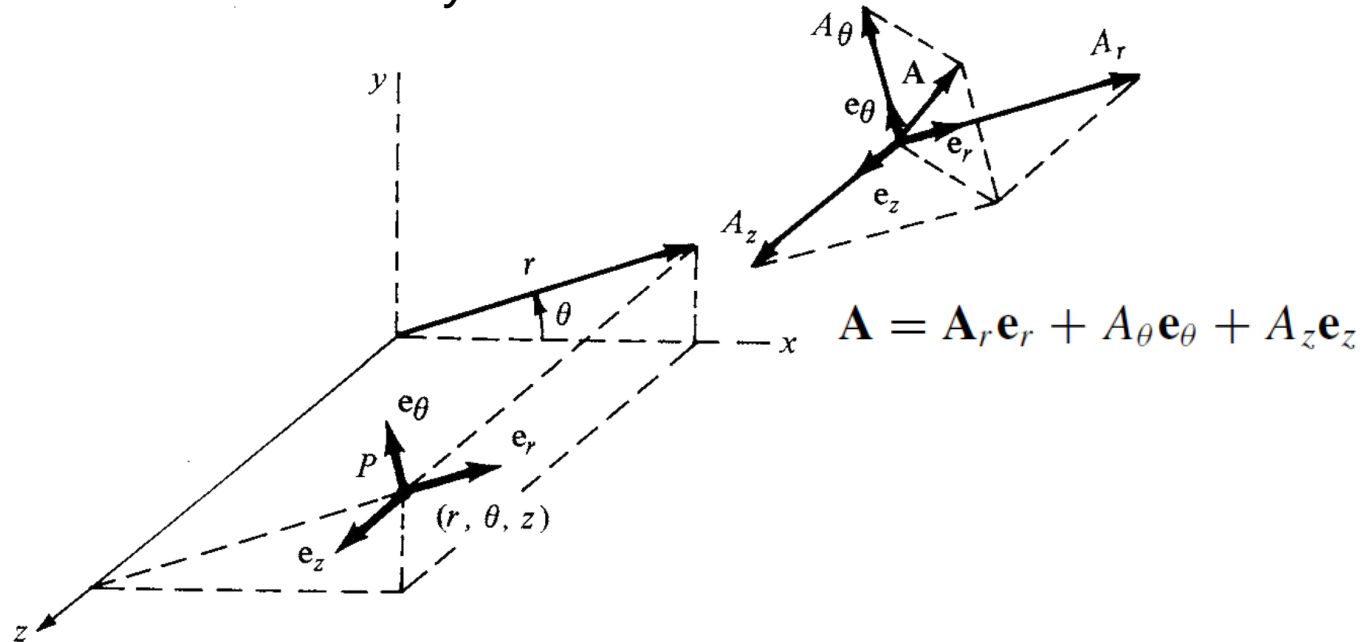

- The relationship, or *transformation*, between cartesian and cylindrical coordinates;

$$x = r \cos \theta \quad r = \sqrt{x^2 + y^2}$$

$$y = r \sin \theta \quad \theta = \arctan \frac{y}{x}$$

$$z = z \quad z = z$$





## Typical Orthogonal Coordinate Systems

- A spherical coordinate system

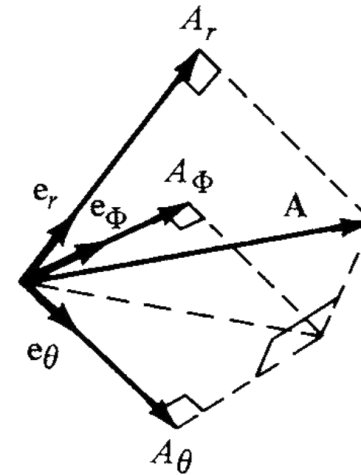
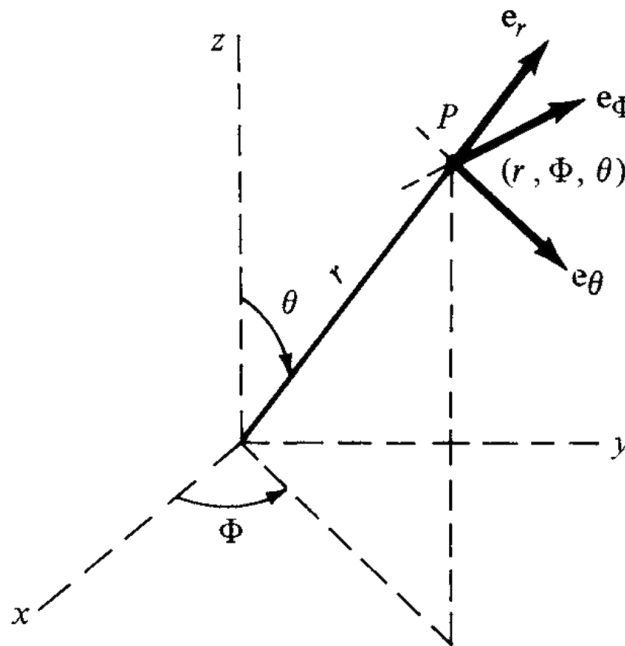

$$\mathbf{A} = A_r \mathbf{e}_r + A_\theta \mathbf{e}_\theta + A_\phi \mathbf{e}_\phi$$

- The transformation between cartesian and spherical coordinates

$$x = r \sin \theta \cos \Phi$$

$$y = r \sin \theta \sin \Phi$$

$$z = r \cos \theta$$

$$r = \sqrt{x^2 + y^2 + z^2}$$

$$\theta = \arccos \frac{z}{r} = \arccos \frac{z}{\sqrt{x^2 + y^2 + z^2}}$$

$$\Phi = \arccos \frac{x}{\sqrt{x^2 + y^2}}$$





## Scalar and Vector Fields

- A scalar quantity given as a function of coordinate space and time  $t$  is called a *scalar field*.
- For example, pressure, density, and temperature are scalar quantities.

$$p = p_1(x, y, z, t) = p_2(r, \theta, z, t) = p_3(r, \theta, \Phi, t)$$

$$\rho = \rho_1(x, y, z, t) = \rho_2(r, \theta, z, t) = \rho_3(r, \theta, \Phi, t)$$

$$T = T_1(x, y, z, t) = T_2(r, \theta, z, t) = T_3(r, \theta, \Phi, t)$$

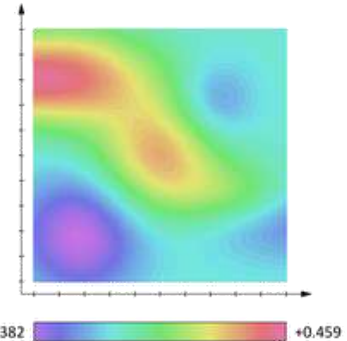

- A vector quantity given as a function of coordinate space and time is called a *vector field*. For example, velocity is a vector quantity.

$$\mathbf{V} = V_x \mathbf{i} + V_y \mathbf{j} + V_z \mathbf{k}$$

$$V_x = V_x(x, y, z, t)$$

$$V_y = V_y(x, y, z, t)$$

$$V_z = V_z(x, y, z, t)$$

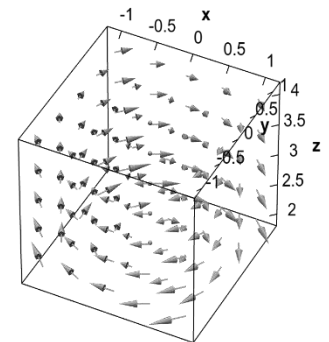



## Scalar and Vector Products

### ▪ Cartesian Coordinates

$$\mathbf{A} = A_x \mathbf{i} + A_y \mathbf{j} + A_z \mathbf{k}$$

$$\mathbf{B} = B_x \mathbf{i} + B_y \mathbf{j} + B_z \mathbf{k}$$

$$\mathbf{A} \cdot \mathbf{B} = A_x B_x + A_y B_y + A_z B_z$$

The scalar product

$$\mathbf{A} \times \mathbf{B} = \begin{bmatrix} \mathbf{i} & \mathbf{j} & \mathbf{k} \\ A_x & A_y & A_z \\ B_x & B_y & B_z \end{bmatrix} = \mathbf{i}(A_y B_z - A_z B_y) + \mathbf{j}(A_z B_x - A_x B_z) + \mathbf{k}(A_x B_y - A_y B_x)$$

The vector product

### ▪ Cylindrical Coordinates

$$\mathbf{A} = A_r \mathbf{e}_r + A_\theta \mathbf{e}_\theta + A_z \mathbf{e}_z$$

$$\mathbf{B} = B_r \mathbf{e}_r + B_\theta \mathbf{e}_\theta + B_z \mathbf{e}_z$$

$$\mathbf{A} \cdot \mathbf{B} = A_r B_r + A_\theta B_\theta + A_z B_z$$

The scalar product

$$\mathbf{A} \times \mathbf{B} = \begin{vmatrix} \mathbf{e}_r & \mathbf{e}_\theta & \mathbf{e}_z \\ A_r & A_\theta & A_z \\ B_r & B_\theta & B_z \end{vmatrix}$$

The vector product

### ▪ Spherical Coordinates

$$\mathbf{A} = A_r \mathbf{e}_r + A_\theta \mathbf{e}_\theta + A_z \mathbf{e}_z$$

$$\mathbf{B} = B_r \mathbf{e}_r + B_\theta \mathbf{e}_\theta + B_z \mathbf{e}_z$$

$$\mathbf{A} \cdot \mathbf{B} = A_r B_r + A_\theta B_\theta + A_z B_z$$

$$\mathbf{A} \times \mathbf{B} = \begin{vmatrix} \mathbf{e}_r & \mathbf{e}_\theta & \mathbf{e}_\phi \\ A_r & A_\theta & A_\phi \\ B_r & B_\theta & B_\phi \end{vmatrix}$$





## Gradient of a Scalar Field

- Consider a scalar field  $p(x, y, z)$ .
- Consider an arbitrary point  $(x, y)$ . If we move away from this point in an arbitrary direction,  $p$  will, in general, change because we are moving to another location in space.
- Moreover, there will be some direction from this point along which  $p$  changes *the most* over a unit length in that direction.
- This defines the *direction of the gradient* of  $p$ .
- The magnitude of  $\nabla p$  is the rate of change of  $p$  per unit length in that direction.

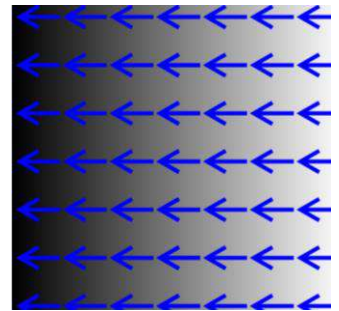
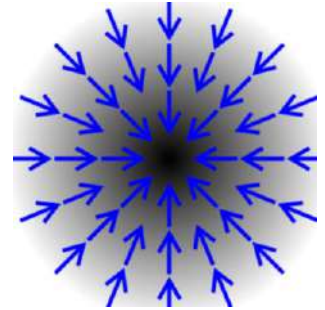



## Gradient of a Scalar Field

- Expressions for  $\nabla p$  in the different coordinate systems

$p = p(x, y, z)$

$\text{grad } p \quad \nabla p = \frac{\partial p}{\partial x} \mathbf{i} + \frac{\partial p}{\partial y} \mathbf{j} + \frac{\partial p}{\partial z} \mathbf{k}$

$\left( \nabla \equiv \mathbf{i} \frac{\partial}{\partial x} + \mathbf{j} \frac{\partial}{\partial y} + \mathbf{k} \frac{\partial}{\partial z} \right)$

Nabla operator

$p = p(r, \theta, z)$

$$\nabla p = \frac{\partial p}{\partial r} \mathbf{e}_r + \frac{1}{r} \frac{\partial p}{\partial \theta} \mathbf{e}_\theta + \frac{\partial p}{\partial z} \mathbf{e}_z$$

$p = p(r, \theta, \Phi)$

$$\nabla p = \frac{\partial p}{\partial r} \mathbf{e}_r + \frac{1}{r} \frac{\partial p}{\partial \theta} \mathbf{e}_\theta + \frac{1}{r \sin \theta} \frac{\partial p}{\partial \Phi} \mathbf{e}_\Phi$$

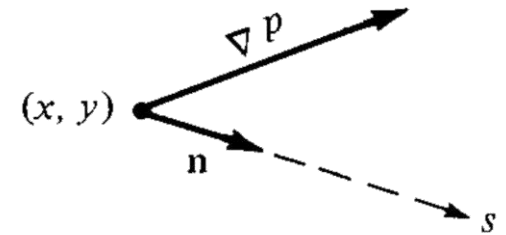

- Consider  $\nabla p$  at a given point  $(x, y)$ . Choose some arbitrary direction  $s$  away from the point. Let  $\mathbf{n}$  be a unit vector in the  $s$  direction.
- The rate of change of  $p$  per unit length in the  $s$  direction is;

$$\frac{dp}{ds} = \nabla p \cdot \mathbf{n}$$





## Divergence of a Vector Field

- Consider a vector field

$$\mathbf{V} = \mathbf{V}(x, y, z) = \mathbf{V}(r, \theta, z) = \mathbf{V}(r, \theta, \Phi)$$

- expansion rate of change of ...

- The *divergence* of  $\mathbf{V}$  is denoted by  $\text{div } \mathbf{V}$  or  $\nabla \cdot \mathbf{V}$ .

- Cartesian

$$\mathbf{V} = \mathbf{V}(x, y, z) = V_x \mathbf{i} + V_y \mathbf{j} + V_z \mathbf{k} \quad \nabla \cdot \mathbf{V} = \frac{\partial V_x}{\partial x} + \frac{\partial V_y}{\partial y} + \frac{\partial V_z}{\partial z}$$

- Cylindrical

$$\mathbf{V} = \mathbf{V}(r, \theta, z) = V_r \mathbf{e}_r + V_\theta \mathbf{e}_\theta + V_z \mathbf{e}_z \quad \nabla \cdot \mathbf{V} = \frac{1}{r} \frac{\partial}{\partial r} (r V_r) + \frac{1}{r} \frac{\partial V_\theta}{\partial \theta} + \frac{\partial V_z}{\partial z}$$

- Spherical

$$\mathbf{V} = \mathbf{V}(r, \theta, \Phi) = V_r \mathbf{e}_r + V_\theta \mathbf{e}_\theta + V_\Phi \mathbf{e}_\Phi$$

$$\nabla \cdot \mathbf{V} = \frac{1}{r^2} \frac{\partial}{\partial r} (r^2 V_r) + \frac{1}{r \sin \theta} \frac{\partial}{\partial \theta} (V_\theta \sin \theta) + \frac{1}{r \sin \theta} \frac{\partial V_\Phi}{\partial \Phi}$$

- $\nabla \cdot \mathbf{V}$  has physical meaning in flow field...





## Curl of a Vector Field

- Consider a vector field

$$\mathbf{V} = \mathbf{V}(x, y, z) = \mathbf{V}(r, \theta, z) = \mathbf{V}(r, \theta, \Phi)$$

- The curl of  $\mathbf{V}$  is denoted by  $\text{curl } \mathbf{V}$ ,  $\text{rot } \mathbf{V}$  or  $\nabla \times \mathbf{V}$ 
  - Rotational rate of change of ...
- Cartesian  $\mathbf{V} = V_x \mathbf{i} + V_y \mathbf{j} + V_z \mathbf{k}$

$$\nabla \times \mathbf{V} = \begin{vmatrix} \mathbf{i} & \mathbf{j} & \mathbf{k} \\ \frac{\partial}{\partial x} & \frac{\partial}{\partial y} & \frac{\partial}{\partial z} \\ V_x & V_y & V_z \end{vmatrix} = \mathbf{i} \left( \frac{\partial V_z}{\partial y} - \frac{\partial V_y}{\partial z} \right) + \mathbf{j} \left( \frac{\partial V_x}{\partial z} - \frac{\partial V_z}{\partial x} \right) + \mathbf{k} \left( \frac{\partial V_y}{\partial x} - \frac{\partial V_x}{\partial y} \right)$$







## Curl of a Vector Field

- Cylindrical  $\mathbf{V} = V_r \mathbf{e}_r + V_\theta \mathbf{e}_\theta + V_z \mathbf{e}_z$

$$\nabla \times \mathbf{V} = \frac{1}{r} \begin{vmatrix} \mathbf{e}_r & r\mathbf{e}_\theta & \mathbf{e}_z \\ \frac{\partial}{\partial r} & \frac{\partial}{\partial \theta} & \frac{\partial}{\partial z} \\ V_r & rV_\theta & V_z \end{vmatrix}$$

- Spherical  $\mathbf{V} = V_r \mathbf{e}_r + V_\theta \mathbf{e}_\theta + V_\Phi \mathbf{e}_\Phi$

$$\nabla \times \mathbf{V} = \frac{1}{r^2 \sin \theta} \begin{vmatrix} \mathbf{e}_r & r\mathbf{e}_\theta & (r \sin \theta)\mathbf{e}_\Phi \\ \frac{\partial}{\partial r} & \frac{\partial}{\partial \theta} & \frac{\partial}{\partial \Phi} \\ V_r & rV_\theta & (r \sin \theta)V_\Phi \end{vmatrix}$$

- $\nabla \times \mathbf{V}$  has physical meaning in flow field...





## Line Integrals

- Consider a vector field

$$\mathbf{A} = \mathbf{A}(x, y, z)$$

- Also, consider a curve  $C$  in space connecting two points  $a$  and  $b$ .

- Let  $ds$  be an elemental length of the curve, and  $\mathbf{n}$  be a unit vector tangent to the curve.

- Define the vector  $d\mathbf{s} = \mathbf{n} ds$ .

- Then, the *line integral* of  $\mathbf{A}$  along curve  $C$  from point  $a$  to point  $b$  is

$$\int_a^b \mathbf{A} \cdot d\mathbf{s}$$

- If the curve  $C$  is closed

$$\oint_C \mathbf{A} \cdot d\mathbf{s}$$

counterclockwise direction around  $C$  is considered positive

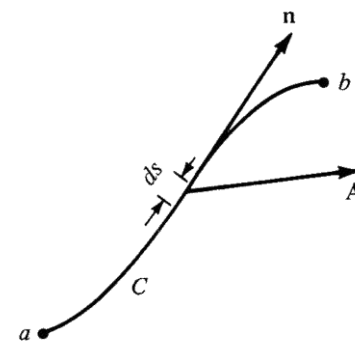

open

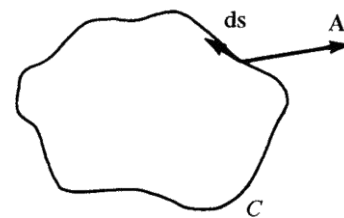

close





## Surface Integrals

- Consider an open surface  $S$  bounded by the closed curve  $C$ .
- At point  $P$  on the surface, let  $dS$  be an elemental area of the surface and  $\mathbf{n}$  be a unit vector normal to the surface.
- Define a vector elemental area as  $\mathbf{dS} = \mathbf{n} dS$ .
- In terms of  $\mathbf{dS}$ , the *surface integral* over the surface  $S$  can be defined in three ways:

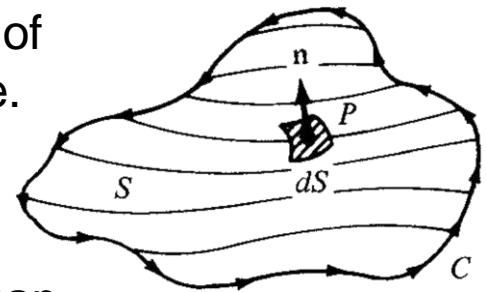

$$\iint_S p \, \mathbf{dS} \quad \iint_S \mathbf{A} \cdot \mathbf{dS} \quad \iint_S \mathbf{A} \times \mathbf{dS}$$

- If the surface  $S$  is *closed*

$$\oiint_S p \, \mathbf{dS} \quad \oiint_S \mathbf{A} \cdot \mathbf{dS} \quad \oiint_S \mathbf{A} \times \mathbf{dS}$$

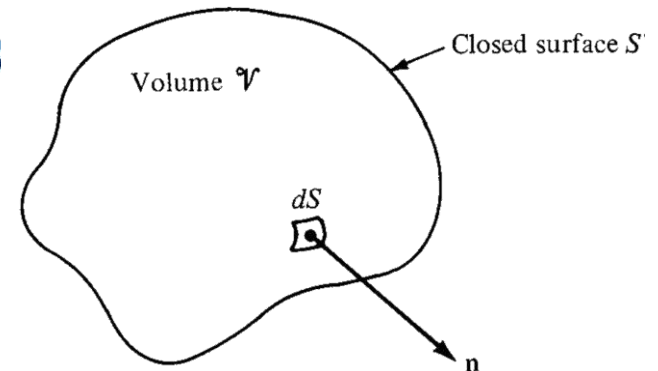



## Volume Integrals

- Consider a volume  $V$  in space. Let  $\rho$  be a scalar field in this space.
- The *volume integral* over the volume  $V$  of the quantity  $\rho$  is written as

$$\iiint_V \rho dV$$

- The result is a scalar
- Let  $\mathbf{A}$  be a vector field in space. The volume integral over the volume  $V$  of the quantity  $\mathbf{A}$  is written as

$$\iiint_V \mathbf{A} dV$$

- The result is a vector





## Relations Between Line, Surface, and Volume Integrals

- Consider again the open area  $S$  bounded by the closed curve  $C$ .
- Let  $\mathbf{A}$  be a vector field. The line integral of  $\mathbf{A}$  over  $C$  is related to the surface integral of  $\mathbf{A}$  over  $S$  by *Stokes' theorem*:

$$\oint_C \mathbf{A} \cdot d\mathbf{s} = \iint_S (\nabla \times \mathbf{A}) \cdot d\mathbf{S}$$

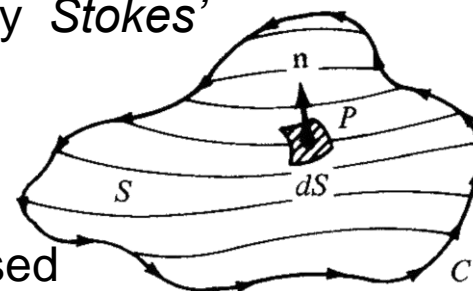

- Consider again the volume  $V$  enclosed by the closed surface  $S$ .
- The surface and volume integrals of the vector field  $\mathbf{A}$  are related through the *divergence theorem*:

$$\oiint_S \mathbf{A} \cdot d\mathbf{S} = \iiint_V (\nabla \cdot \mathbf{A}) dV$$

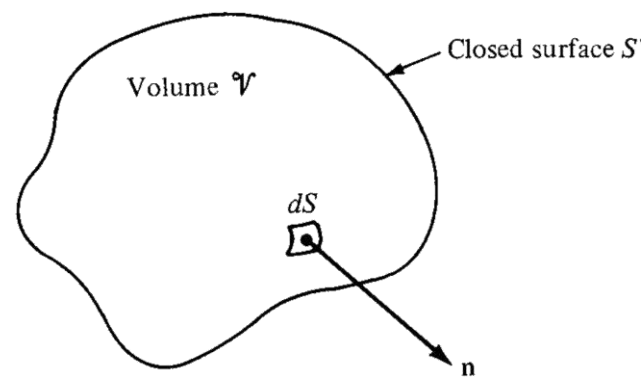



## Relations Between Line, Surface, and Volume Integrals

- If  $p$  represents a scalar field, a relationship analogous to previous equation is given by the *gradient theorem*;

$$\oiint_S p \, d\mathbf{S} = \iiint_V \nabla p \, dV$$

- We will use these relations in conservation laws...





## Models of fluids

- What is a suitable model of the fluid?
- How do we visualize this squishy substance in order to apply the three fundamental physical principles to it?
- There are three different models. They are
  - finite control volume,
  - infinitesimal fluid element,
  - and molecular model.





## Finite Control Volume Approach

- Consider a general flow field as represented by the streamlines.
- Let us imagine a closed volume drawn within a *finite* region of the flow.
- This volume defines a *control volume*  $V$ , and a *control surface*  $S$  is defined as the closed surface which bounds the control volume.
- The control volume may be fixed in space with the fluid moving through it.
- Alternatively, the control volume may be moving with the fluid such that the same fluid particles are always inside it

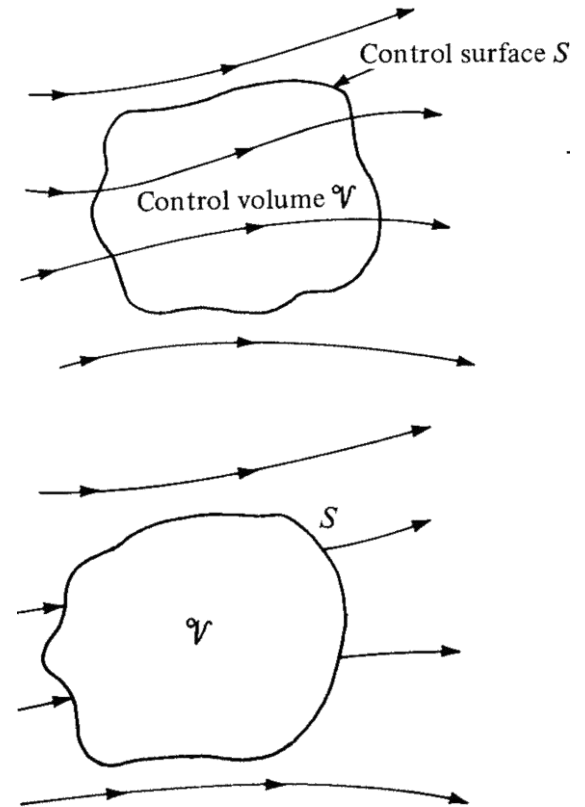

We get equations in integral form...







## Infinitesimal Fluid Element Approach

- Consider a general flow field as represented by the streamlines.
- Let us imagine an infinitesimally small fluid element in the flow, with a differential volume  $dV$ .
- The fluid element may be fixed in space with the fluid moving through it.
- Alternatively, it may be moving along a streamline with velocity  $\mathbf{V}$  equal to the flow velocity at each point.

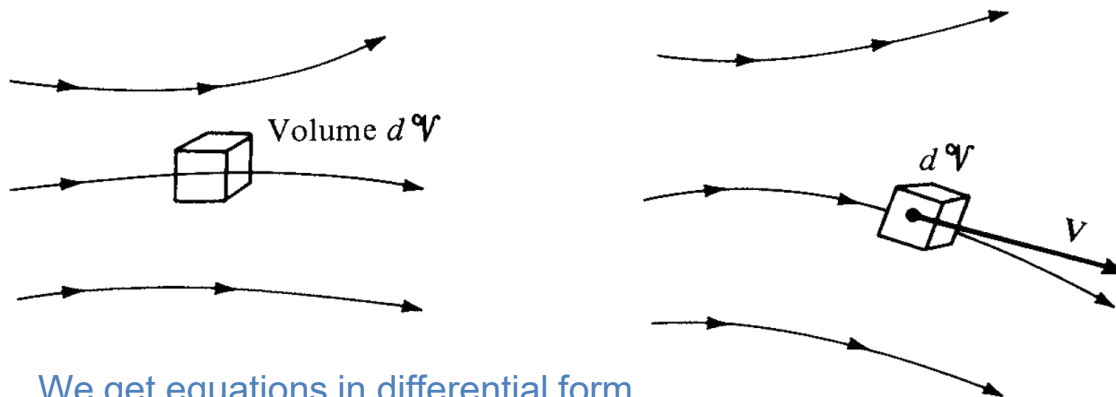

We get equations in differential form...





## Molecular Approach

- In actuality, of course, the motion of a fluid is a ramification of the mean motion of its atoms and molecules.
- Therefore, a third model of the flow can be a microscopic approach.
- The fundamental laws of nature are applied directly to the atoms and molecules, using suitable statistical averaging to define the resulting fluid properties.
- This approach is in the purview of *kinetic theory*.

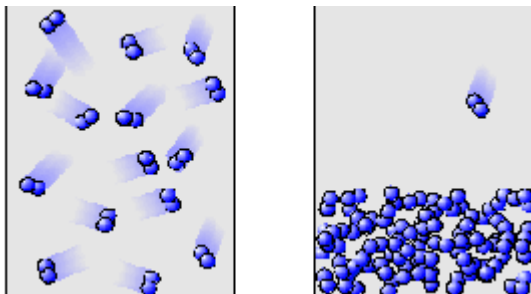



## Specification of the Flow Field

- Aerodynamic properties are function of space and time.
- For example, in cartesian coordinates the equations are

$$p = p(x, y, z, t)$$

$$\rho = \rho(x, y, z, t)$$

$$T = T(x, y, z, t)$$

$$\mathbf{V} = u\mathbf{i} + v\mathbf{j} + w\mathbf{k}$$

$$u = u(x, y, z, t)$$

$$v = v(x, y, z, t)$$

$$w = w(x, y, z, t)$$

- They represent the *flow field*. We have **6 unknowns**, we need **6 equations** to solve the flow field features...

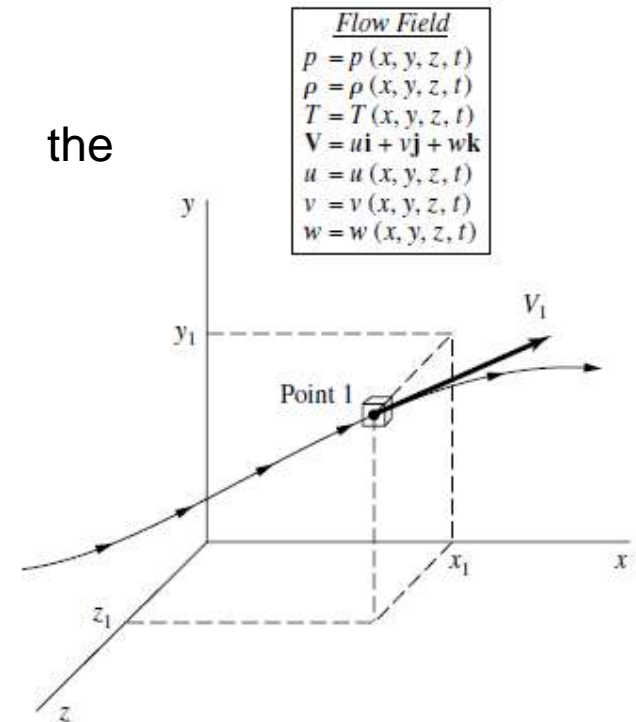



## Continuity Equation

- We now apply the fundamental physical principles to fluid models.
- we will employ the model of a *fixed* finite control volume.
- Here, the control volume is fixed in space, with the flow moving through it.
- The volume  $V$  and control surface  $\mathbf{S}$  are constant with time, and the mass of fluid contained within the control volume can change as a function of time.

**The first physical principle** Mass can be neither created nor destroyed.





## Continuity Equation

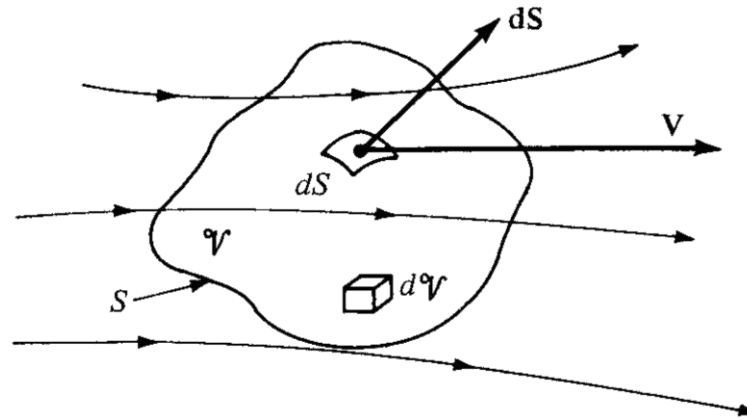

Net mass flow *out* of control volume through surface  $S$  = time rate of decrease of mass inside control volume  $\mathcal{V}$

$$B = C$$

where  $B$  and  $C$  are just convenient symbols for the left and right sides, respectively.

- First, let us obtain an expression for  $B$  in terms of the quantities shown in Figure.
- The elemental mass flow across the area  $dS$  is



$$\rho V_n dS = \rho \mathbf{V} \cdot d\mathbf{S}$$



## Continuity Equation

- By definition, the *mass flow* through  $A$  is the mass crossing  $A$  per second (kilograms per second),  $\dot{m}$ .
- The *net mass flow out* of the entire control surface  $S$  is the summation over  $S$  of the elemental mass flows.
- In the limit, this becomes a surface integral,

$$B = \oiint_S \rho \mathbf{V} \cdot d\mathbf{S}$$

- Now consider the right side of Equation. The mass contained within the elemental volume is
- Hence, the total mass inside the control volume is
- The time rate of *increase* of mass inside control *volume* is then

$$\rho dV$$

$$\iiint_V \rho dV$$

$$\frac{\partial}{\partial t} \iiint_V \rho dV$$





## Continuity Equation

- In turn, the time rate of *decrease* of mass inside *the volume* is the negative of the above;

$$-\frac{\partial}{\partial t} \iiint_V \rho dV = C$$

- Lets combine the resulted equations;  $\iint_S \rho \mathbf{V} \cdot d\mathbf{S} = -\frac{\partial}{\partial t} \iiint_V \rho dV$

$$\frac{\partial}{\partial t} \iiint_V \rho dV + \iint_S \rho \mathbf{V} \cdot d\mathbf{S} = 0$$

- Equation is called the *continuity equation* in integral form.
- It is one of the most fundamental equations of fluid dynamics.





## Continuity Equation

- We can get the differential form that does relate flow properties at a given point, as follows.
- The time derivative can be placed inside the volume integral and Equation can be written as

$$\iiint_V \frac{\partial \rho}{\partial t} dV + \iint_S \rho \mathbf{V} \cdot d\mathbf{S} = 0$$

- Note that the control volume is fixed in time.
- Applying the divergence theorem, we can express the right-hand term of Equation as

$$\iint_S (\rho \mathbf{V}) \cdot d\mathbf{S} = \iiint_V \nabla \cdot (\rho \mathbf{V}) dV$$







## Continuity Equation

- Substituting this Equation into continuity equation, we obtain

$$\iiint_{\mathcal{V}} \frac{\partial \rho}{\partial t} d\mathcal{V} + \iiint_{\mathcal{V}} \nabla \cdot (\rho \mathbf{V}) d\mathcal{V} = 0$$

$$\iiint_{\mathcal{V}} \left[ \frac{\partial \rho}{\partial t} + \nabla \cdot (\rho \mathbf{V}) \right] d\mathcal{V} = 0$$

- The only way for the integral to be zero for an arbitrary control volume is for the integrand to be zero at all points within the control volume.
- Thus, we have  $\frac{\partial \rho}{\partial t} + \nabla \cdot (\rho \mathbf{V}) = 0$
- Equation is the continuity equation in the form of a partial differential equation.
- This equation relates the flow field variables at a point in the flow.





## Continuity Equation

- If the flow is steady, the equation becomes  $\partial/\partial t = 0$ ,

$$\oiint_S \rho \mathbf{V} \cdot d\mathbf{S} = 0$$

- or

$$\nabla \cdot (\rho \mathbf{V}) = 0$$





## Momentum Equation

- Newton's second law is  $\mathbf{F} = \frac{d}{dt}(m\mathbf{V})$

**Physical principle** Force = time rate of change of momentum

- We will apply this principle to the model of a finite control volume fixed in space.
- Our objective is to obtain expressions for both the left and right sides of Equation in terms of the familiar flow-field variables  $p$ ,  $\rho$ ,  $\mathbf{V}$ , etc.
- First, let us concentrate on the left side of Equation. This force comes from two sources:
  1. *Body forces*: gravity, electromagnetic forces, or any other forces which “act at a distance” on the fluid inside  $V$ .
  2. *Surface forces*: pressure and shear stress acting on the control surface  $S$ .





## Momentum Equation

- Let  $\mathbf{f}$  represent the net body force per unit mass exerted on the fluid inside *volume*.
- The body force on the elemental volume is therefore  $\rho \mathbf{f} dV$

- The total body force exerted on the fluid in the control volume is

$$\text{Body force} = \iiint_V \rho \mathbf{f} dV$$

- The elemental surface force due to pressure acting on the element of surface area is

$$-p dS$$

negative sign indicates that the force is in the direction opposite of  $\mathbf{dS}$ .

- The complete pressure force is the summation of the elemental forces over the entire control surface

$$\text{Pressure force} = -\iint_S p dS$$





## Momentum Equation

- In a viscous flow, the shear and normal viscous stresses also exert a surface force.
- Let us simply recognize this effect by letting  $\mathbf{F}_{\text{viscous}}$  denote the total viscous force exerted on the control surface.
- We are now ready to write an expression for the left-hand side of Equation:

$$\mathbf{F} = \iiint_{\mathcal{V}} \rho \mathbf{f} d\mathcal{V} - \iint_S p \mathbf{dS} + \mathbf{F}_{\text{viscous}}$$





## Momentum Equation

- Now consider the right side of Equation.
- The time rate of change of momentum of the fluid as it sweeps through the fixed control volume is the sum of two terms:

Net flow of momentum *out*  
of control volume across surface  $S \equiv \mathbf{G}$

- and

Time rate of change of momentum due to  
unsteady fluctuations of flow properties inside  $\mathcal{V} \equiv \mathbf{H}$

- Consider the term denoted by  $\mathbf{G}$  in Equation. To obtain an expression for  $\mathbf{G}$ , recall that the mass flow across the elemental area  $dS$  is  $(\rho \mathbf{V} \cdot d\mathbf{S})$ ;
- Hence, the flow of momentum per second across  $dS$  is

$$(\rho \mathbf{V} \cdot d\mathbf{S}) \mathbf{V}$$





## Momentum Equation

- The net flow of momentum out of the control volume through  $S$  is the summation of the above elemental contributions,

$$\mathbf{G} = \oiint_S (\rho \mathbf{V} \cdot d\mathbf{S}) \mathbf{V}$$

- Now consider  $\mathbf{H}$ . The momentum of the fluid in the elemental volume is

$$(\rho dV) \mathbf{V}$$

- The momentum contained at any instant inside the control volume is

$$\iiint_V \rho \mathbf{V} dV$$

- and its time rate of change due to unsteady flow fluctuations is

$$\mathbf{H} = \frac{\partial}{\partial t} \iiint_V \rho \mathbf{V} dV$$





## Momentum Equation

- Combining them, we obtain an expression for the total time rate of change of momentum of the fluid as it sweeps through the fixed control volume,

$$\frac{d}{dt}(m\mathbf{V}) = \mathbf{G} + \mathbf{H} = \iint_S (\rho \mathbf{V} \cdot d\mathbf{S}) \mathbf{V} + \frac{\partial}{\partial t} \iiint_V \rho \mathbf{V} dV$$

- Newton's second law, applied to a fluid flow is

$$\frac{d}{dt}(m\mathbf{V}) = \mathbf{F}$$

$$\frac{\partial}{\partial t} \iiint_V \rho \mathbf{V} dV + \iint_S (\rho \mathbf{V} \cdot d\mathbf{S}) \mathbf{V} = - \iint_S p d\mathbf{S} + \iiint_V \rho \mathbf{f} dV + \mathbf{F}_{\text{viscous}}$$

- Equation is the momentum equation in integral form.
- Note that it is a vector equation.







## Momentum Equation

- We now proceed to a partial differential equation which relates flow-field properties at a point in space.
- Lets apply the gradient theorem to the first term on the right side of Equation,

$$-\oint_S p \, d\mathbf{S} = -\iiint_V \nabla p \, dV$$

- Also, because the control volume is fixed, the time derivative in Equation can be placed inside the integral. Hence,

$$\iiint_V \frac{\partial(\rho \mathbf{V})}{\partial t} dV + \oint_S (\rho \mathbf{V} \cdot d\mathbf{S}) \mathbf{V} = -\iiint_V \nabla p \, dV + \iiint_V \rho \mathbf{f} \, dV + \mathbf{F}_{\text{viscous}}$$

- Recall that Equation is a vector equation. It is convenient to write this equation as three scalar equations.





## Momentum Equation

- Using cartesian coordinates, where

$$\mathbf{V} = u\mathbf{i} + v\mathbf{j} + w\mathbf{k}$$

- The x component of Equation is

$$\iiint_{\mathcal{V}} \frac{\partial(\rho u)}{\partial t} d\mathcal{V} + \iint_S (\rho \mathbf{V} \cdot \mathbf{dS})u = - \iiint_{\mathcal{V}} \frac{\partial p}{\partial x} d\mathcal{V} + \iiint_{\mathcal{V}} \rho f_x d\mathcal{V} + (F_x)_{\text{viscous}}$$

- Apply the divergence theorem to the surface integral on the left side of Equation

$$\iint_S (\rho \mathbf{V} \cdot \mathbf{dS})u = \iint_S (\rho u \mathbf{V}) \cdot \mathbf{dS} = \iiint_{\mathcal{V}} \nabla \cdot (\rho u \mathbf{V}) d\mathcal{V}$$

- Substituting it into main Equation, we have

$$\iiint_{\mathcal{V}} \left[ \frac{\partial(\rho u)}{\partial t} + \nabla \cdot (\rho u \mathbf{V}) + \frac{\partial p}{\partial x} - \rho f_x - (\mathcal{F}_x)_{\text{viscous}} \right] d\mathcal{V} = 0$$





## Momentum Equation

- The integrand in Equation is identically zero at all points in the flow; hence,

$$\frac{\partial(\rho u)}{\partial t} + \nabla \cdot (\rho u \mathbf{V}) = -\frac{\partial p}{\partial x} + \rho f_x + (\mathcal{F}_x)_{\text{viscous}}$$

- We can write the y and z components, we obtain in a similar fashion

$$\frac{\partial(\rho v)}{\partial t} + \nabla \cdot (\rho v \mathbf{V}) = -\frac{\partial p}{\partial y} + \rho f_y + (\mathcal{F}_y)_{\text{viscous}}$$

$$\frac{\partial(\rho w)}{\partial t} + \nabla \cdot (\rho w \mathbf{V}) = -\frac{\partial p}{\partial z} + \rho f_z + (\mathcal{F}_z)_{\text{viscous}}$$

*Navier-Stokes*





## Momentum Equation

- Specialized to a steady, inviscid flow with no body forces, these equations become

$$\oiint_S (\rho \mathbf{V} \cdot d\mathbf{S}) \mathbf{V} = - \oiint_S p d\mathbf{S}$$

- and

$$\nabla \cdot (\rho u \mathbf{V}) = - \frac{\partial p}{\partial x}$$

$$\nabla \cdot (\rho v \mathbf{V}) = - \frac{\partial p}{\partial y}$$

$$\nabla \cdot (\rho w \mathbf{V}) = - \frac{\partial p}{\partial z}$$

*Euler*



- The momentum equations for an inviscid flow are called the *Euler equations*.
- The momentum equations for a viscous flow are called the *Navier-Stokes equations*.





## Momentum Equation

An application of the momentum equation: drag of a two-dimensional body

- Consider a two-dimensional body in a flow, as sketched in Figure.
- A control volume is drawn around this body, as given by the dashed lines in figure.

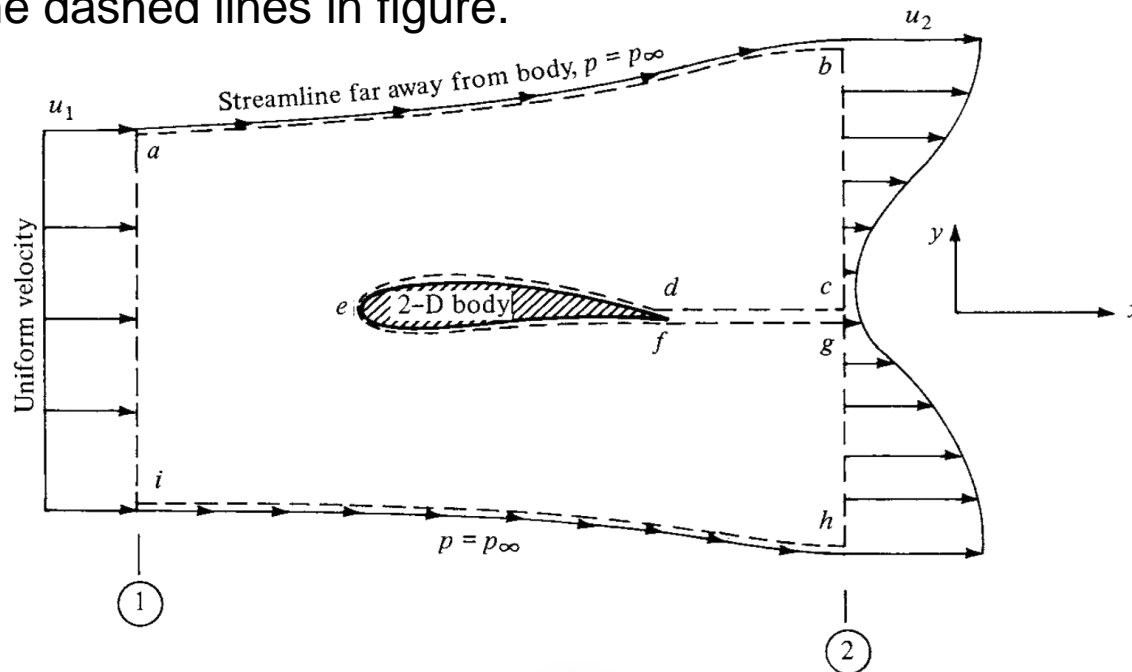



## Momentum Equation

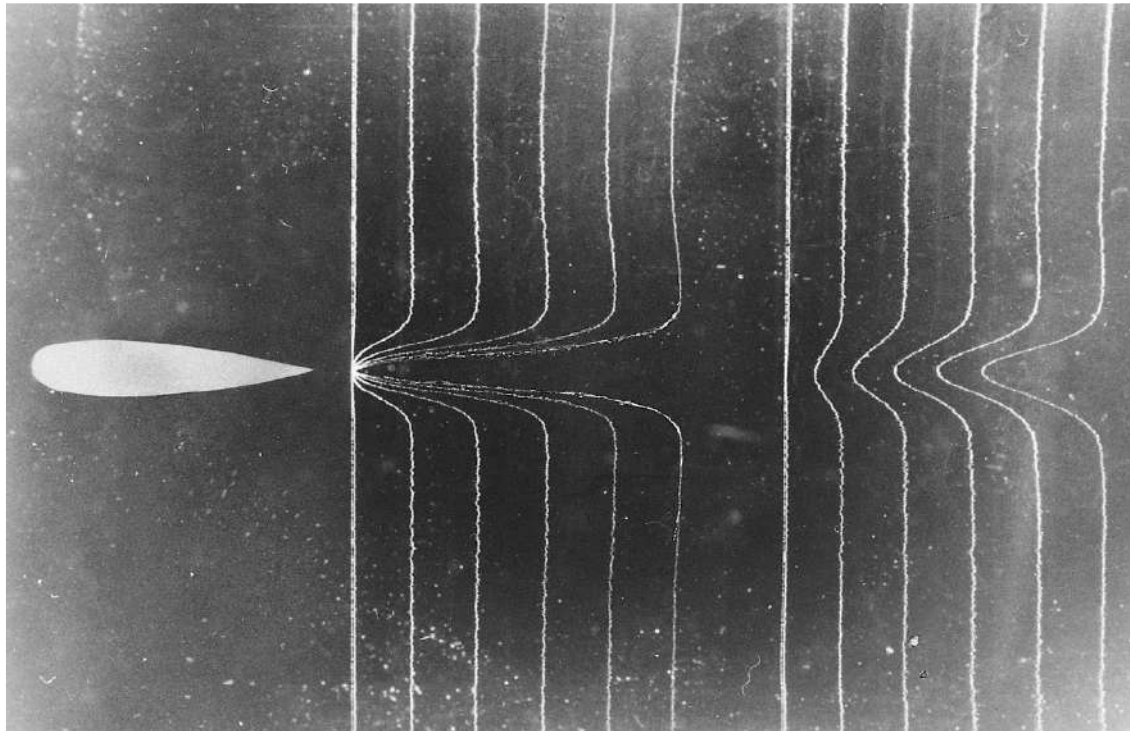

- Photograph of the velocity profiles downstream of an airfoil.





## Momentum Equation

- The control volume is bounded by  $abcdefghia$ .
- The width of the control volume in the  $z$  direction (perpendicular to the page) is unity.
- Stations 1 and 2 are inflow and outflow stations, respectively.
- Assume that the contour  $abhi$  is far enough from the body such that the pressure is everywhere the same on  $abhi$  and equal to the freestream pressure  $p = p^\infty$ .
- Also, assume that both  $u_1$  and  $u_2$  are in the  $x$  direction; hence,  $u_1 = \text{constant}$  and  $u_2 = f(y)$ .





## Momentum Equation

- We know that

$$\iiint_{\mathcal{V}} \frac{\partial(\rho u)}{\partial t} d\mathcal{V} + \iint_S (\rho \mathbf{V} \cdot d\mathbf{S})u = - \iiint_{\mathcal{V}} \frac{\partial p}{\partial x} d\mathcal{V} + \iiint_{\mathcal{V}} \rho f_x d\mathcal{V} + (F_x)_{\text{viscous}}$$

- Lets assume that the flow is steady and does not have body force.
- Additionally, the viscous force can be expressed as  $-\mathbf{R}'$  due to action-reaction principle.

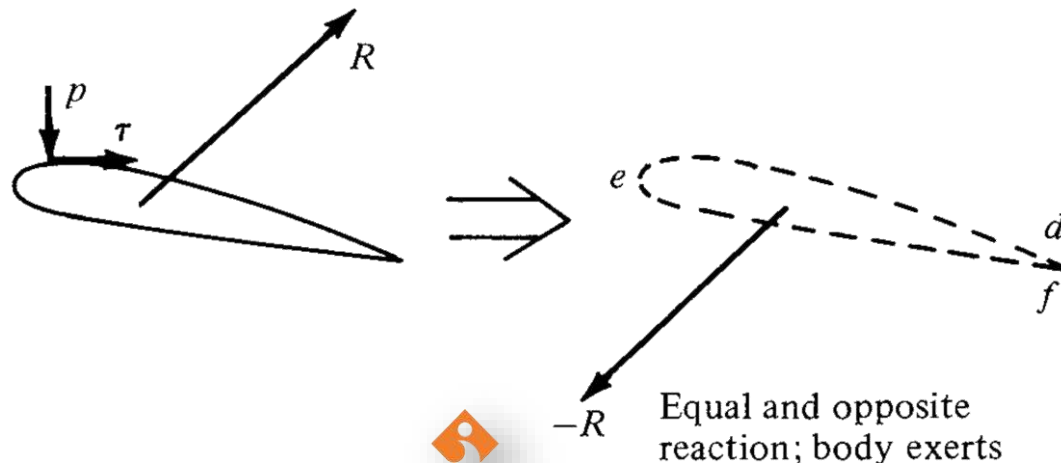





## Momentum Equation

- Based on assumptions, we have

$$\mathbf{R}' = - \oiint_S (\rho \mathbf{V} \cdot d\mathbf{S}) \mathbf{V} - \iint_{abhi} p d\mathbf{S}$$

- Equation is a vector equation.
- Consider again inflow and outflow velocities  $u_1$  and  $u_2$  are in the  $x$  direction and the  $x$  component of  $\mathbf{R}$  is the aerodynamic drag per unit span  $D'$ .

$$D' = - \oiint_S (\rho \mathbf{V} \cdot d\mathbf{S}) u - \iint_{abhi} (p dS)_x$$

- Recall that the boundaries of the control volume  $abhi$  are chosen far enough from the body such that  $p$  is constant along these boundaries.

$$\iint_{abhi} (p dS)_x = 0$$





## Momentum Equation

- Therefore, we obtain

$$D' = - \oiint (\rho \mathbf{V} \cdot d\mathbf{S}) u$$



- The only contributions to the integral in Equation come from sections *ai* and *bh*.  $\mathbf{V} \cdot d\mathbf{S} = 0$
- These sections are oriented in the *y* direction.
- Also, the control volume has unit depth in the *z* direction (perpendicular to the page).
- Hence, for these sections,  $dS = dy(1)$ .
- The integral becomes

$$\oiint_S (\rho \mathbf{V} \cdot d\mathbf{S}) u = - \int_i^a \rho_i u_1^2 dy + \int_h^b \rho_2 u_2^2 dy$$





## Momentum Equation

- Note that the signs are due to  $\mathbf{V} \cdot d\mathbf{S}$
- Lets remember the integral form of the continuity equation for steady flow. Applied to the control volume in Figure, Equation becomes

$$-\int_i^a \rho_1 u_1 dy + \int_h^b \rho_2 u_2 dy = 0 \quad \oiint_S \rho \mathbf{V} \cdot d\mathbf{S} = 0$$

$$\int_i^a \rho_1 u_1 dy = \int_h^b \rho_2 u_2 dy$$

- Multiplying Equation by  $u_1$ , which is a constant, we obtain

$$\int_i^a \rho_1 u_1^2 dy = \int_h^b \rho_2 u_2 u_1 dy$$

- Substituting it into Equation, we have

$$\oiint_S (\rho \mathbf{V} \cdot d\mathbf{S}) u = - \int_h^b \rho_2 u_2 (u_1 - u_2) dy$$





## Momentum Equation

- Therefore, we obtain

$$D' = \int_h^b \rho_2 u_2 (u_1 - u_2) dy$$

- For incompressible flow,  $\rho = \text{constant}$  and is known. For this case, Equation becomes

$$D' = \rho \int_h^b u_2 (u_1 - u_2) dy$$

- It shows how a measurement of the velocity distribution across the wake of a body can yield the drag.
- These velocity distributions are conventionally measured with a Pitot rake, such as shown in Figure.

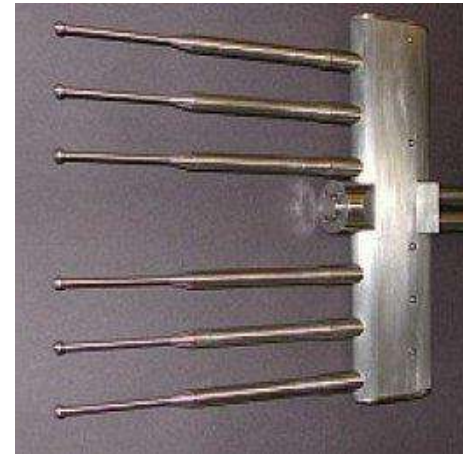



## Energy Equation

**Physical principle** Energy can be neither created nor destroyed; it can only change in form.

- This physical principle is embodied in the first law of thermodynamics.
- Consider a fixed amount of matter contained within a closed boundary.
- This matter defines the *system*.
- Because the molecules and atoms within the system are constantly in motion, the system contains a certain amount of energy.
- For simplicity, let the system contain a unit mass; in turn, denote the internal energy per unit mass by  $e$ .

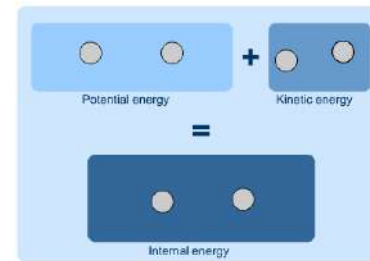



## Energy Equation

- The region outside the system defines the *surroundings*.
- Let an incremental amount of heat  $\delta q$  be added to the system from the surroundings.
- Also, let  $\delta w$  be the work done on the system by the surroundings.
- Both heat and work are forms of energy, and when added to the system, they change the amount of internal energy in the system.
- Denote this change of internal energy by  $de$ . From our physical principle that energy is conserved, we have for the system

$$\delta q + \delta w = de$$

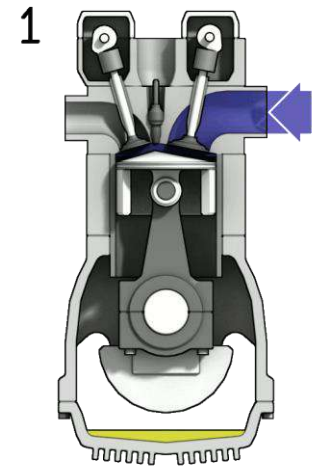



## Energy Equation

- Let us apply the first law to the fluid flowing through the fixed control volume.
- Let
  - $B_1$  = rate of heat added to fluid inside control volume from surroundings,
  - $B_2$  = rate of work done on fluid inside control volume,
  - $B_3$  = rate of change of energy of fluid as it flows through control volume.

- From the first law,

$$B_1 + B_2 = B_3$$

- Note that each term involves the *time rate* of energy change; hence, Equation, strictly speaking, a *power* equation...





## Energy Equation

- Consider the rate of heat transferred to or from the fluid.
- Let volumetric rate of heat addition per unit mass be denoted by  $\dot{q}$ . Typical units for are J/s.
- The mass contained within an elemental volume is;  $\rho dV$  hence, the rate of heat addition to this mass is,

$$\dot{q}(\rho dV).$$

- Summing over the complete control volume, we obtain

$$\iiint_V \dot{q} \rho dV$$

- In addition, if the flow is viscous, additional heat can be transferred into the control volume. The total rate of heat addition is

$$B_1 = \iiint_V \dot{q} \rho dV + \dot{Q}_{\text{viscous}}$$







## Energy Equation

- Lets focus on work. We can state that the rate of doing work on moving body is

$$\mathbf{F} \cdot \mathbf{V}$$

- The rate of work done on fluid inside volume due to **pressure** force on  $S$  is

$$-\oint_S (p \, d\mathbf{S}) \cdot \mathbf{V}$$

- The rate of work done on fluid inside volume due to **body** force is

$$\iiint_V (\rho \mathbf{f} \, dV) \cdot \mathbf{V}$$

- If the flow is viscous, the **shear stress** on the control surface will also perform work on the fluid as it passes across the surface.

$$\dot{W}_{\text{viscous}}$$





## Energy Equation

- Then the total rate of work done on the fluid inside the control volume is the sum of them

$$B_2 = - \oint_S p \mathbf{V} \cdot d\mathbf{S} + \iiint_V \rho (\mathbf{f} \cdot \mathbf{V}) dV + \dot{W}_{\text{viscous}}$$

- Recall that the internal energy  $e$  is due to the random motion of the atoms and molecules inside the system.
- However, the fluid inside the control volume is not stationary; it is moving at the local velocity  $\mathbf{V}$  with a consequent kinetic energy per unit mass of  $V^2/2$ .
- Hence, the energy per unit mass of the moving fluid is the sum of both internal and kinetic energies  $e + V^2/2$ .
- This sum is called the *total energy* per unit mass.





## Energy Equation

- We are now ready to obtain an expression for  $B_3$ , the rate of change of total energy of the fluid as it flows through the control volume.

- Based on the elemental mass flow across  $dS$   $\rho \mathbf{V} \cdot d\mathbf{S}$ ,

$$\iint_S (\rho \mathbf{V} \cdot d\mathbf{S}) \left( e + \frac{V^2}{2} \right) \quad (\rho \mathbf{V} \cdot d\mathbf{S})(e + V^2/2)$$

- In addition, if the flow is unsteady, there is a time rate of change of total energy inside the control volume due to the transient fluctuations of the flow-field variables.

- The total energy contained in the elemental volume  $\iiint_V \rho \left( e + \frac{V^2}{2} \right) dV$

- Time rate of change of total energy inside  $V$  due to transient variations of flow-field variables

$$\frac{\partial}{\partial t} \iiint_V \rho \left( e + \frac{V^2}{2} \right) dV$$





## Energy Equation

- In turn,  $B_3$  is the sum of them

$$B_3 = \frac{\partial}{\partial t} \iiint_{\mathcal{V}} \rho \left( e + \frac{V^2}{2} \right) d\mathcal{V} + \iint_S (\rho \mathbf{V} \cdot \mathbf{dS}) \left( e + \frac{V^2}{2} \right)$$

- Repeating the physical principle that the rate of heat added to the fluid plus the rate of work done on the fluid is equal to the rate of change of total energy of the fluid.
- In turn, these words can be directly translated into an equation by combining Equations

$$\begin{aligned} \iint_{\mathcal{V}} \dot{q} \rho d\mathcal{V} + \dot{Q}_{\text{viscous}} - \iint_S p \mathbf{V} \cdot \mathbf{dS} + \iint_{\mathcal{V}} \rho (\mathbf{f} \cdot \mathbf{V}) d\mathcal{V} + \dot{W}_{\text{viscous}} \\ = \frac{\partial}{\partial t} \iiint_{\mathcal{V}} \rho \left( e + \frac{V^2}{2} \right) d\mathcal{V} + \iint_S \rho \left( e + \frac{V^2}{2} \right) \mathbf{V} \cdot \mathbf{dS} \end{aligned}$$





## Energy Equation

- We can obtain a partial differential equation for total energy from the integral form.
- Applying the divergence theorem to the surface integrals, collecting all terms inside the same volume integral, and setting the integrand equal to zero, we obtain

$$\frac{\partial}{\partial t} \left[ \rho \left( e + \frac{V^2}{2} \right) \right] + \nabla \cdot \left[ \rho \left( e + \frac{V^2}{2} \right) \mathbf{V} \right] = \rho \dot{q} - \nabla \cdot (p\mathbf{V}) + \rho(\mathbf{f} \cdot \mathbf{V}) + \dot{Q}'_{\text{viscous}} + \dot{W}'_{\text{viscous}}$$

- If the flow is steady, inviscid, adiabatic, without body forces, then Equations reduce to

$$\oiint_S \rho \left( e + \frac{V^2}{2} \right) \mathbf{v} \cdot d\mathbf{S} = - \oiint_S p \mathbf{V} \cdot d\mathbf{S} \quad \text{integral form}$$

$$\text{differential form} \quad \nabla \cdot \left[ \rho \left( e + \frac{V^2}{2} \right) \mathbf{V} \right] = -\nabla \cdot (p\mathbf{V})$$





## Energy Equation

- With the energy equation, we have five equations, but six unknowns.
- The additional equation comes from the perfect gas equation of state;

$$e = c_v T$$
$$p = \rho R T$$





## Substantial derivative

- Consider a small fluid element moving through a flow field, as shown in figure. We have

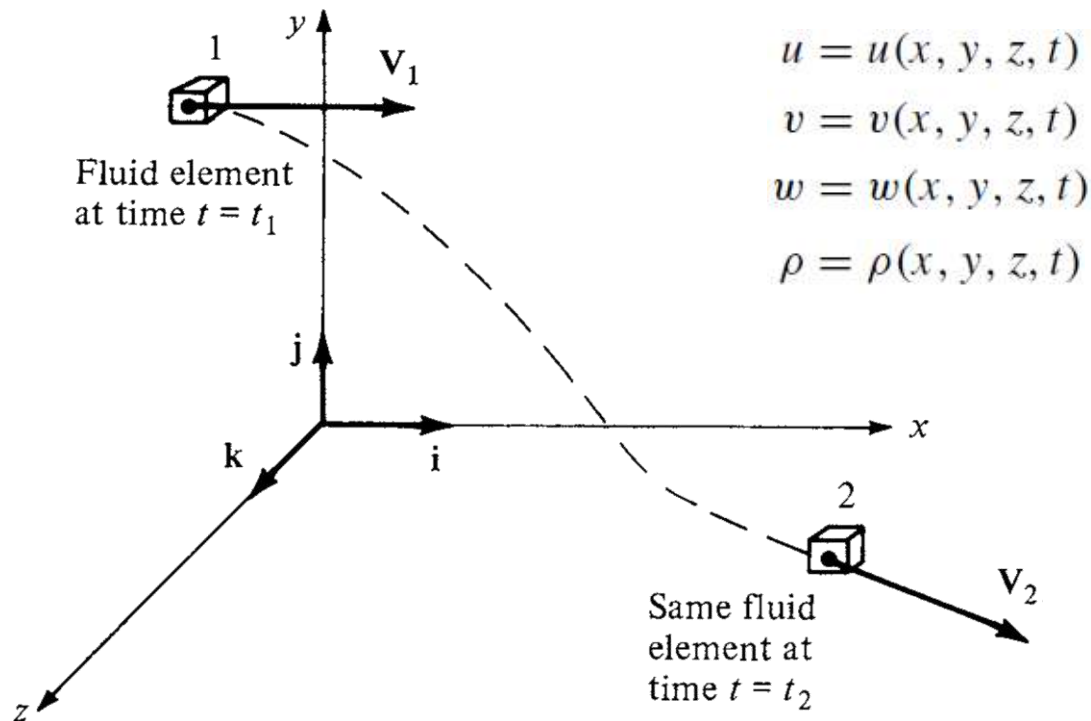

- At time  $t_1$ , the fluid element is located at point 1 in the flow and its density is  $\rho_1 = \rho(x_1, y_1, z_1, t_1)$





## Substantial derivative

- At a later time  $t_2$  the same fluid element has moved to a different location in the flow field, such as point 2.
- At this new time and location, the density of the fluid element is

$$\rho_2 = \rho(x_2, y_2, z_2, t_2)$$

- Since  $\rho = \rho(x, y, z, t)$ , we can expand this function in a Taylor series about point 1 as follows:

$$\begin{aligned} \rho_2 = \rho_1 &+ \left( \frac{\partial \rho}{\partial x} \right)_1 (x_2 - x_1) + \left( \frac{\partial \rho}{\partial y} \right)_1 (y_2 - y_1) + \left( \frac{\partial \rho}{\partial z} \right)_1 (z_2 - z_1) \\ &+ \left( \frac{\partial \rho}{\partial t} \right)_1 (t_2 - t_1) + \end{aligned}$$

- Dividing by  $t_2 - t_1$ , and ignoring the higher-order terms, we have

$$\frac{\rho_2 - \rho_1}{t_2 - t_1} = \left( \frac{\partial \rho}{\partial x} \right)_1 \frac{x_2 - x_1}{t_2 - t_1} + \left( \frac{\partial \rho}{\partial y} \right)_1 \left( \frac{y_2 - y_1}{t_2 - t_1} \right) + \left( \frac{\partial \rho}{\partial z} \right)_1 \frac{z_2 - z_1}{t_2 - t_1} + \left( \frac{\partial \rho}{\partial t} \right)_1$$







## Substantial derivative

- Consider the physical meaning of the left side of Equation.
- The term  $(\rho_2 - \rho_1)/(t_2 - t_1)$  is the *average* time rate of change in density of the fluid element as it moves from point 1 to point 2.
- In the limit, as  $t_2$  approaches  $t_1$ , this term becomes  $\lim_{t_2 \rightarrow t_1} \frac{\rho_2 - \rho_1}{t_2 - t_1} = \frac{D\rho}{Dt}$
- By definition, this symbol is called the *substantial derivative*  $D/Dt$ .
- Note that  $D\rho/Dt$  is the *instantaneous* time rate of change of density of a *given fluid element* as it moves through space.
- This is different from  $(\partial\rho/\partial t)_1$ , which is physically the time rate of change of density at the *fixed* point 1.





## Substantial derivative

- Note that  $\lim_{t_2 \rightarrow t_1} \frac{x_2 - x_1}{t_2 - t_1} \equiv u$

$$\lim_{t_2 \rightarrow t_1} \frac{y_2 - y_1}{t_2 - t_1} \equiv v$$

$$\lim_{t_2 \rightarrow t_1} \frac{z_2 - z_1}{t_2 - t_1} \equiv w$$

- Thus, we obtain

$$\frac{D\rho}{Dt} = u \frac{\partial \rho}{\partial x} + v \frac{\partial \rho}{\partial y} + w \frac{\partial \rho}{\partial z} + \frac{\partial \rho}{\partial t}$$

- From it, we can obtain an expression for the substantial derivative in cartesian coordinates:

$$\frac{D}{Dt} \equiv \frac{\partial}{\partial t} + u \frac{\partial}{\partial x} + v \frac{\partial}{\partial y} + w \frac{\partial}{\partial z}$$

- If we recall Nabla operator, it can be written as  $\frac{D}{Dt} \equiv \frac{\partial}{\partial t} + (\mathbf{V} \cdot \nabla)$





## Substantial derivative

- $D/Dt$  is the substantial derivative, which is physically the time rate of change following a moving fluid element.
- $\partial/\partial t$  is called the *local derivative*, which is physically the time rate of change at a fixed point.
- $\mathbf{V} \cdot \nabla$  is called the *convective derivative*, which is physically the time rate of change due to the movement of the fluid element from one location to another.
- The substantial derivative applies to any flow-field variable. For example,

$$\frac{DT}{Dt} \equiv \underbrace{\frac{\partial T}{\partial t}}_{\text{local derivative}} + \underbrace{(\mathbf{V} \cdot \nabla)T}_{\text{convective derivative}}$$

$$\frac{\partial T}{\partial t} + u \frac{\partial T}{\partial x} + v \frac{\partial T}{\partial y} + w \frac{\partial T}{\partial z}$$





## Substantial derivative

- We can express the continuity, momentum, and energy equations in terms of the substantial derivative.
- In the process, we make use of the following vector identity:

$$\nabla \cdot (\rho \mathbf{V}) \equiv \rho \nabla \cdot \mathbf{V} + \mathbf{V} \cdot \nabla \rho$$

- First, consider the continuity equation given in the form of equation

$$\frac{\partial \rho}{\partial t} + \nabla \cdot (\rho \mathbf{V}) = 0$$

$$\frac{\partial \rho}{\partial t} + \mathbf{V} \cdot \nabla \rho + \rho \nabla \cdot \mathbf{V} = 0$$

- The continuity equation written in terms of the substantial derivative.

$$\frac{D\rho}{Dt} + \rho \nabla \cdot \mathbf{V} = 0$$





## Substantial derivative

- Next, consider the  $x$  component of the momentum equation given in the form of equation

$$\frac{\partial(\rho u)}{\partial t} + \nabla \cdot (\rho u \mathbf{V}) = -\frac{\partial p}{\partial x} + \rho f_x + (\mathcal{F}_x)_{\text{viscous}}$$

$$\frac{\partial(\rho u)}{\partial t} = \rho \frac{\partial u}{\partial t} + u \frac{\partial \rho}{\partial t}$$

$$\nabla \cdot (\rho u \mathbf{V}) \equiv \nabla \cdot [u(\rho \mathbf{V})] = u \nabla \cdot (\rho \mathbf{V}) + (\rho \mathbf{V}) \cdot \nabla u$$

$$\rho \frac{\partial u}{\partial t} + u \frac{\partial \rho}{\partial t} + u \nabla \cdot (\rho \mathbf{V}) + (\rho \mathbf{V}) \cdot \nabla u = -\frac{\partial p}{\partial x} + \rho f_x + (\mathcal{F}_x)_{\text{viscous}}$$

$$\rho \frac{\partial u}{\partial t} + u \left[ \frac{\partial \rho}{\partial t} + \nabla \cdot (\rho \mathbf{V}) \right] + (\rho \mathbf{V}) \cdot \nabla u = -\frac{\partial p}{\partial x} + \rho f_x + (\mathcal{F}_x)_{\text{viscous}}$$

the continuity equation ! the sum inside the square brackets is zero.

$$\rho \frac{\partial u}{\partial t} + \rho \mathbf{V} \cdot \nabla u = -\frac{\partial p}{\partial x} + \rho f_x + (\mathcal{F}_x)_{\text{viscous}}$$





## Substantial derivative

$$\rho \left( \frac{\partial u}{\partial t} + \mathbf{V} \cdot \nabla u \right) = -\frac{\partial p}{\partial x} + \rho f_x + (\mathcal{F}_x)_{\text{viscous}}$$

$$\rho \frac{Du}{Dt} = -\frac{\partial p}{\partial x} + \rho f_x + (\mathcal{F}_x)_{\text{viscous}}$$

- In a similar manner,

$$\rho \frac{Dv}{Dt} = -\frac{\partial p}{\partial y} + \rho f_y + (\mathcal{F}_y)_{\text{viscous}}$$

$$\rho \frac{Dw}{Dt} = -\frac{\partial p}{\partial z} + \rho f_z + (\mathcal{F}_z)_{\text{viscous}}$$

- In an analogous fashion, the energy equation can be expressed in terms of the substantial derivative.
- The derivation is left as a **homework** problem; the result is

$$\rho \frac{D(e + V^2/2)}{Dt} = \rho \dot{q} - \nabla \cdot (p\mathbf{V}) + \rho(\mathbf{f} \cdot \mathbf{V}) + \dot{Q}'_{\text{viscous}} + \dot{W}'_{\text{viscous}}$$





## Flow patterns

- In addition to knowing the density, pressure, temperature, and velocity fields, in aerodynamics we like to draw pictures of “where the flow is going.”
- Consider an unsteady flow with a velocity field.
- Also, consider an infinitesimal fluid element moving through the flow field, say, element  $A$ .
- Element  $A$  passes through point 1. Let us trace the path of element  $A$  as it moves downstream from point 1.
- Such a path is defined as the *pathline* for element  $A$ .

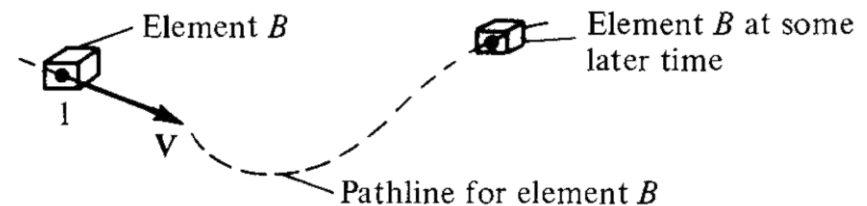
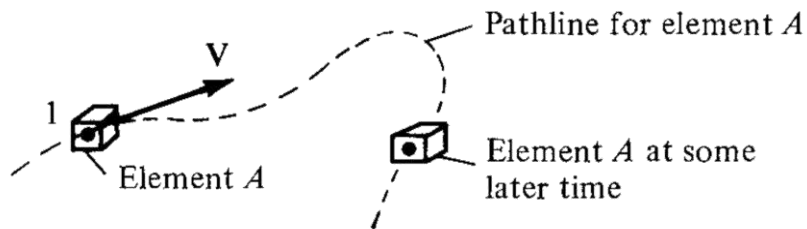



## Flow patterns

- By definition, a *streamline* is a curve whose tangent at any point is in the direction of the velocity vector at that point.
- In general, streamlines are different from pathlines.
- In an unsteady flow, the streamline pattern changes; hence, each “frame” of the motion picture is different.

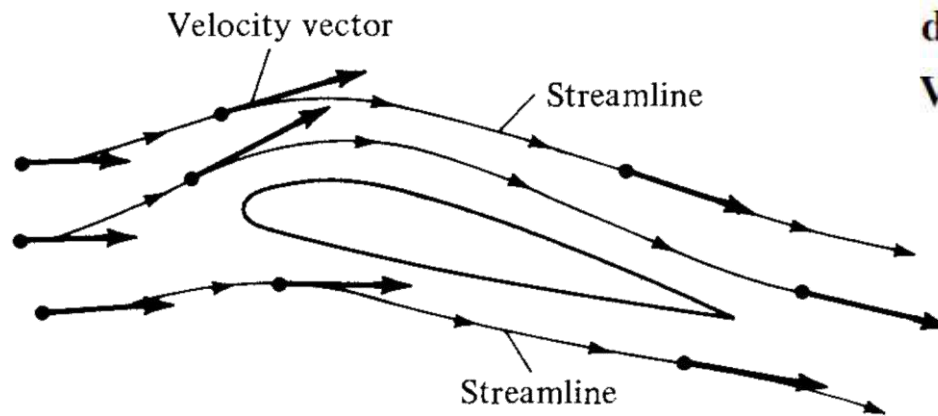

$$\mathbf{ds} = dx\mathbf{i} + dy\mathbf{j} + dz\mathbf{k}$$
$$\mathbf{V} = u\mathbf{i} + v\mathbf{j} + w\mathbf{k}$$

$$w dy - v dz = 0$$

$$u dz - w dx = 0$$

$$v dx - u dy = 0$$

- By definition of a streamline,  $\mathbf{V}$  is parallel to  $\mathbf{ds}$ . Hence,  $\mathbf{ds} \times \mathbf{V} = 0$







## Flow patterns

- We can concisely define a *streakline* as the locus of fluid elements that have earlier passed through a prescribed point.
- To help further visualize the concept of a streakline, imagine that we are constantly injecting dye into the flow field at point 1.
- The dye will flow downstream from point 1, forming a curve in the  $x, y, z$  space in Figure.
- This curve *is* the streakline that the line that connects all fluid elements passed through point 1.

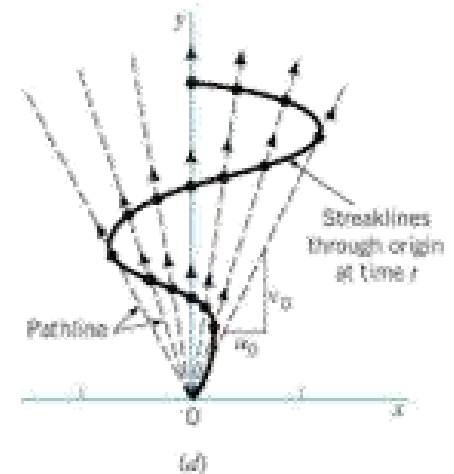



## Angular velocity, vorticity, and strain

- In this section, we pay particular attention to the orientation of the element and its change in shape as it moves along a streamline.

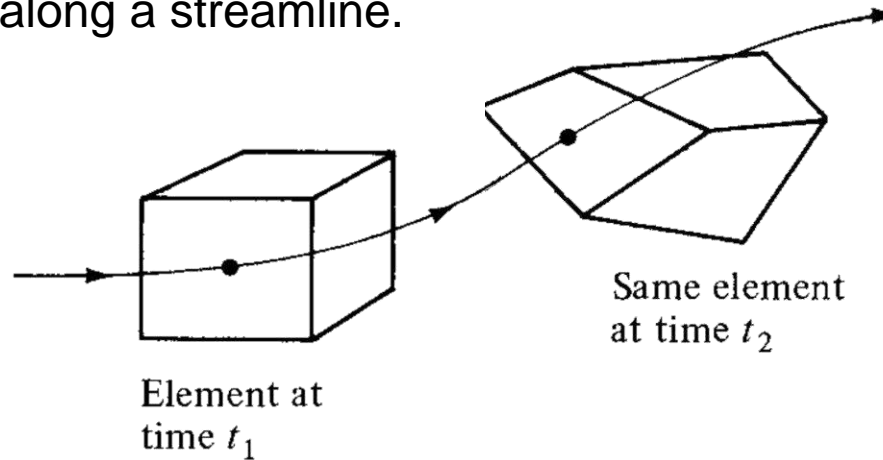

- In the process, we introduce the concept of vorticity, one of the most powerful quantities in theoretical aerodynamics.
- The motion of a fluid element along a streamline is a combination of translation and rotation.
- In addition, the shape of the element can become distorted.





## Angular velocity, vorticity, and strain

- The amount of rotation and distortion depends on the velocity field; the purpose of this section is to quantify this dependency.

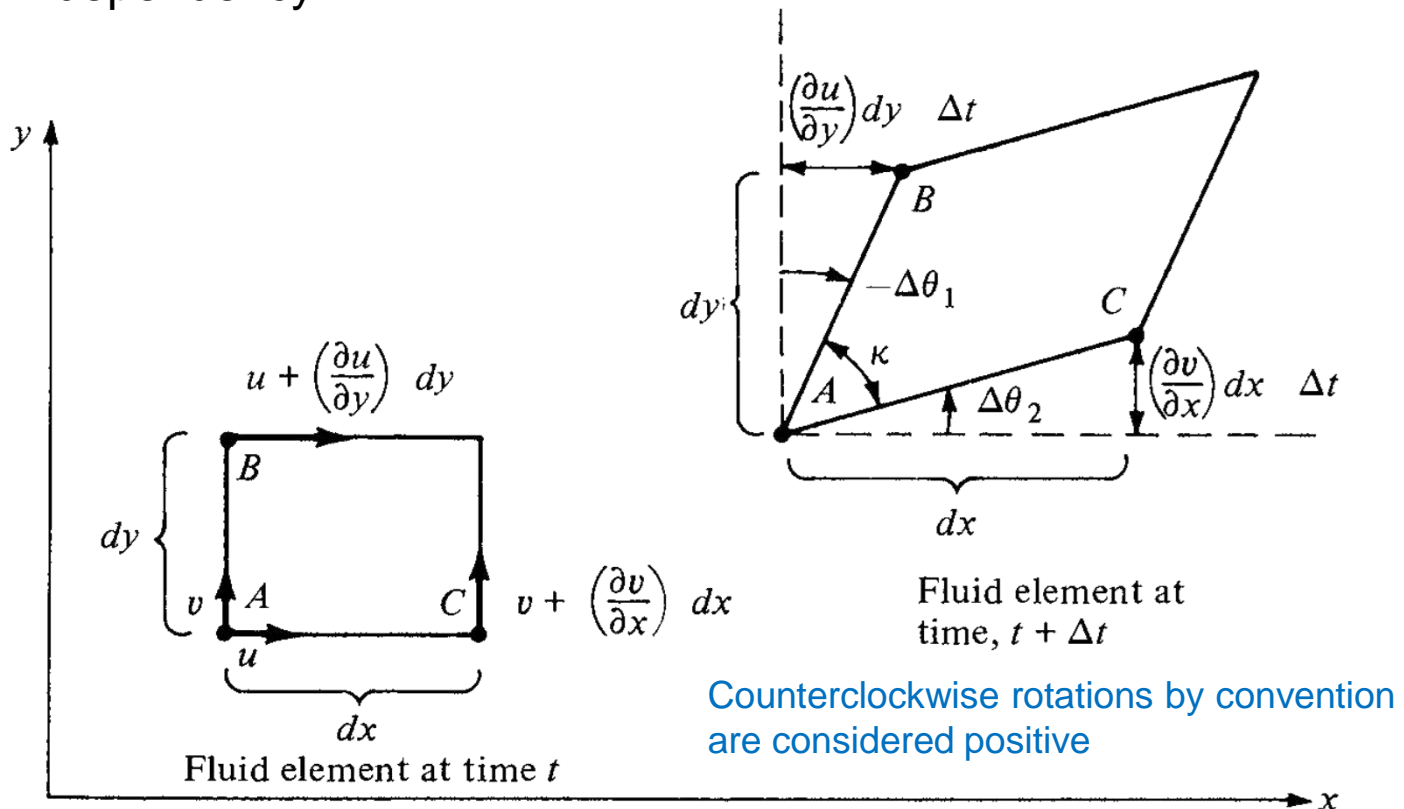



## Angular velocity, vorticity, and strain

- From the geometry

$$\tan \Delta\theta_2 = \frac{[(\partial v/\partial x) dx] \Delta t}{dx} = \frac{\partial v}{\partial x} \Delta t$$

- Since  $\theta_2$  is a small angle,  $\tan \theta_2 \approx \theta_2$ . Hence, Equation reduces to

$$\Delta\theta_2 = \frac{\partial v}{\partial x} \Delta t$$

- From the geometry

$$\tan(-\Delta\theta_1) = \frac{[(\partial u/\partial y) dy] \Delta t}{dy} = \frac{\partial u}{\partial y} \Delta t$$

- Since  $\theta_1$  is a small angle,  $\tan \theta_1 \approx \theta_1$ , Equation reduces to

$$\Delta\theta_1 = -\frac{\partial u}{\partial y} \Delta t$$

- Consider the angular velocities of lines  $AB$  and  $AC$ , defined as  $d\theta_1/dt$  and  $d\theta_2/dt$ , respectively. From Equation, we have

$$\frac{d\theta_1}{dt} = \lim_{\Delta t \rightarrow 0} \frac{\Delta\theta_1}{\Delta t} = -\frac{\partial u}{\partial y} \quad \frac{d\theta_2}{dt} = \lim_{\Delta t \rightarrow 0} \frac{\Delta\theta_2}{\Delta t} = \frac{\partial v}{\partial x}$$





## Angular velocity, vorticity, and strain

- By definition, the angular velocity of the fluid element is the average of the angular velocities of lines  $AB$  and  $AC$ .
- Let  $\omega_z$  denote this angular velocity. Therefore, by definition,

$$\omega_z = \frac{1}{2} \left( \frac{d\theta_1}{dt} + \frac{d\theta_2}{dt} \right) \quad \omega_z = \frac{1}{2} \left( \frac{\partial v}{\partial x} - \frac{\partial u}{\partial y} \right)$$

- The  $x$  and  $y$  components of  $\omega$  can be obtained in a similar fashion.
- The resulting angular velocity of the fluid element in three-dimensional space is

$$\omega = \omega_x \mathbf{i} + \omega_y \mathbf{j} + \omega_z \mathbf{k}$$

$$\omega = \frac{1}{2} \left[ \left( \frac{\partial w}{\partial y} - \frac{\partial v}{\partial z} \right) \mathbf{i} + \left( \frac{\partial u}{\partial z} - \frac{\partial w}{\partial x} \right) \mathbf{j} + \left( \frac{\partial v}{\partial x} - \frac{\partial u}{\partial y} \right) \mathbf{k} \right]$$





## Angular velocity, vorticity, and strain

- We define a new quantity, *vorticity*, which is simply twice the angular velocity. Denote vorticity by the vector  $\xi$ :

$$\xi \equiv 2\omega$$

$$\xi = \left( \frac{\partial w}{\partial y} - \frac{\partial v}{\partial z} \right) \mathbf{i} + \left( \frac{\partial u}{\partial z} - \frac{\partial w}{\partial x} \right) \mathbf{j} + \left( \frac{\partial v}{\partial x} - \frac{\partial u}{\partial y} \right) \mathbf{k}$$

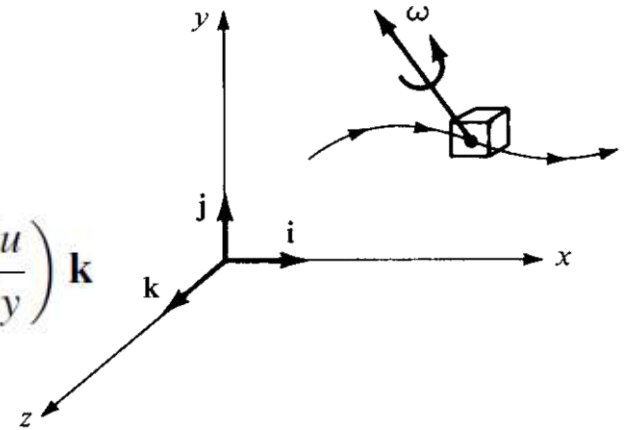

- Recall Equation for  $\nabla \times \mathbf{V}$  in cartesian coordinates. Hence, we have the important result that

$$\xi = \nabla \times \mathbf{V}$$

- In a velocity field, the curl of the velocity is equal to the vorticity.

$$\nabla \times \mathbf{V} \neq 0 \quad \text{Rotational flow}$$

$$\nabla \times \mathbf{V} = 0 \quad \text{Irrotational flow}$$





## Angular velocity, vorticity, and strain

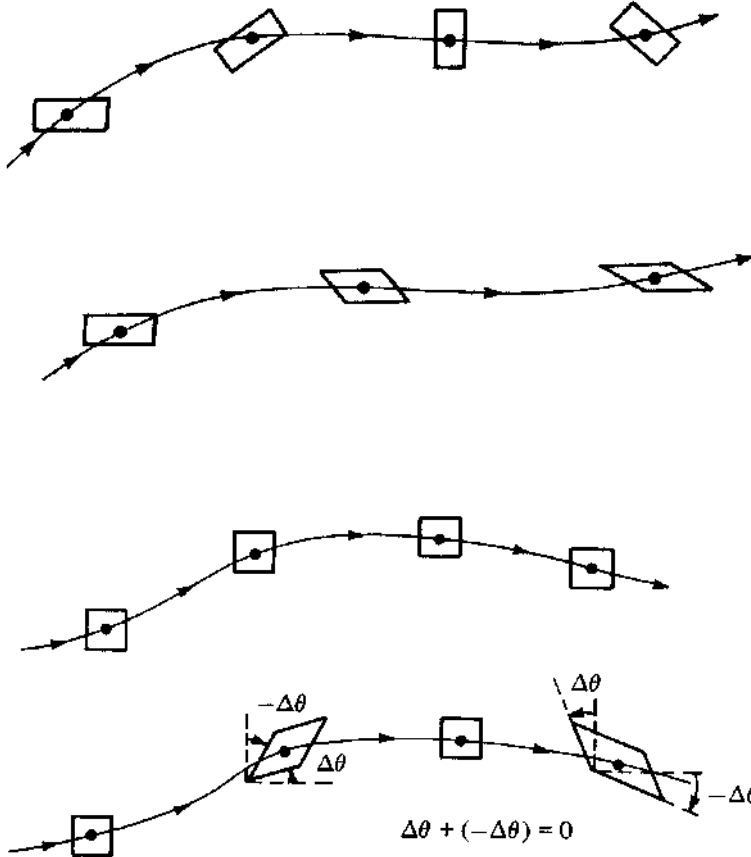

- Fluid elements in a rotational flow.

- Fluid elements in an irrotational flow.





## Angular velocity, vorticity, and strain

- Let the angle between sides  $AB$  and  $AC$  be denoted by  $\kappa$ .
- As the fluid element moves through the flow field,  $\kappa$  will change.
- In Figure, at time  $t$ ,  $\kappa$  is initially  $90^\circ$ . At time  $t + t$ ,  $\kappa$  has changed by the amount  $\kappa$ , where

$$\Delta\kappa = -\Delta\theta_2 - (-\Delta\theta_1)$$

- By definition, the *strain* of the fluid element is the change in  $\kappa$ , where positive strain corresponds to a *decreasing*  $\kappa$ . Hence,

$$\text{Strain} = -\Delta\kappa = \Delta\theta_2 - \Delta\theta_1$$

- In viscous flows, the time rate of strain is an important quantity.

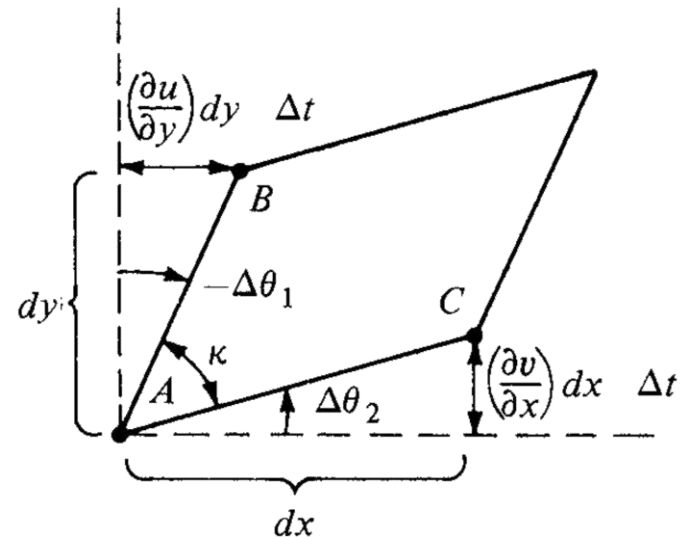





## Angular velocity, vorticity, and strain

- Denote the time rate of strain by  $\varepsilon_{xy}$ ,

$$\varepsilon_{xy} \equiv -\frac{d\kappa}{dt} = \frac{d\theta_2}{dt} - \frac{d\theta_1}{dt}$$

- By using the angular velocity definitions, we get

$$\varepsilon_{xy} = \frac{\partial v}{\partial x} + \frac{\partial u}{\partial y}$$

- In the  $yz$  and  $zx$  planes, by a similar derivation the strain is, respectively,

$$\varepsilon_{yz} = \frac{\partial w}{\partial y} + \frac{\partial v}{\partial z}$$

$$\varepsilon_{zx} = \frac{\partial u}{\partial z} + \frac{\partial w}{\partial x}$$





## Example 2.5

- Consider the velocity field given by  $u = y/(x^2 + y^2)$  and  $v = -x/(x^2 + y^2)$ .
- Calculate the equation of the streamline passing through the point  $(0, 5)$ .

- Calculate the vorticity.

$$w dy - v dz = 0$$

- We know that  $\mathbf{ds} \times \mathbf{V} = 0$   $u dz - w dx = 0$

$$v dx - u dy = 0$$

- The flow is 2D, so  $w=0$ . Hence,  $\frac{dy}{dx} = \frac{v}{u}$

$$dy/dx = v/u = -x/y, \quad y dy = -x dx$$

- Integrating, we obtain  $y^2 = -x^2 + c$

- We have the point  $(0, 5)$ , so  $5^2 = 0 + c$  or  $c = 25$   
 $x^2 + y^2 = 25$





## Example 2.5

- We know that  $\xi = \nabla \times \mathbf{V}$

$$\begin{vmatrix} \mathbf{i} & \mathbf{j} & \mathbf{k} \\ \frac{\partial}{\partial x} & \frac{\partial}{\partial y} & \frac{\partial}{\partial z} \\ u & v & w \end{vmatrix} = \begin{vmatrix} \mathbf{i} & \mathbf{j} & \mathbf{k} \\ \frac{\partial}{\partial x} & \frac{\partial}{\partial y} & \frac{\partial}{\partial z} \\ \frac{y}{x^2 + y^2} & \frac{-x}{x^2 + y^2} & 0 \end{vmatrix}$$

$$= \mathbf{i}[0 - 0] - \mathbf{j}[0 - 0] + \mathbf{k} \left[ \frac{(x^2 + y^2)(-1) + x(2x)}{(x^2 + y^2)^2} - \frac{(x^2 + y^2) - y(2y)}{(x^2 + y^2)^2} \right]$$

$$= 0\mathbf{i} + 0\mathbf{j} + 0\mathbf{k} = \mathbf{0}$$

- The flow field is irrotational.





## Circulation

- In this section, we introduce a tool that is fundamental to the calculation of aerodynamic lift, namely, *circulation*.
- This tool was used independently
  - by Frederick Lanchester (1878–1946) in England,
  - Wilhelm Kutta (1867–1944) in Germany, and
  - Nikolai Joukowski (1847–1921) in Russia

to create a breakthrough in the theory of aerodynamic lift at the turn of the twentieth century.

- Consider a closed curve  $C$  in a flow field.
- Let  $\mathbf{V}$  and  $d\mathbf{s}$  be the velocity and directed line segment, respectively, at a point on  $C$ .
- The circulation, denoted by  $\Gamma$ , is defined as

$$\Gamma \equiv - \oint_C \mathbf{V} \cdot d\mathbf{s}$$

(m<sup>2</sup>/s)





## Circulation

- The circulation is simply the negative of the line integral of velocity around a closed curve in the flow.
- It is a kinematic property depending only on the velocity field and the choice of the curve  $C$ .
- By mathematical convention the positive sense of the line integral is counterclockwise.
- However, in aerodynamics, it is convenient to consider a positive circulation as being clockwise.
- Hence, a minus sign appears in the definition

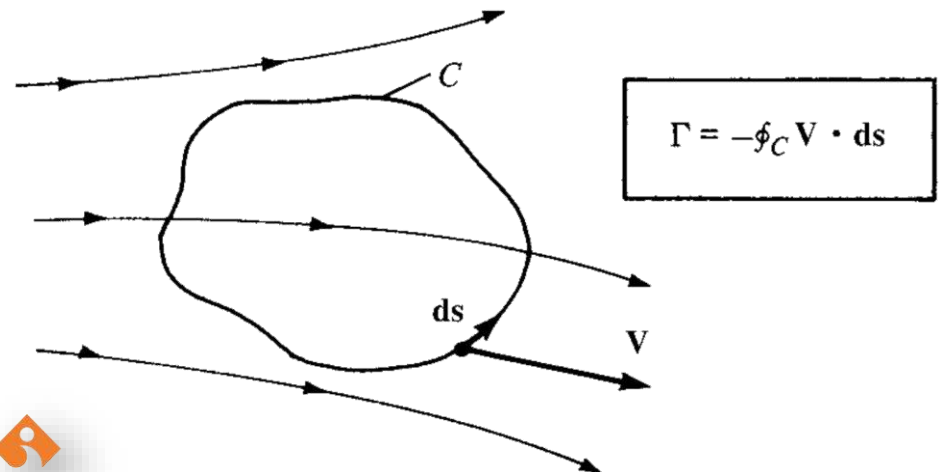



## Circulation

- Circulation is also related to vorticity. From Stokes' theorem;

$$\Gamma \equiv - \oint_C \mathbf{V} \cdot d\mathbf{s} = - \iint_S (\nabla \times \mathbf{V}) \cdot d\mathbf{S}$$

- Hence, the circulation about a curve  $C$  is equal to the vorticity integrated over any open surface bounded by  $C$ .
- if the flow is *irrotational* ( $\nabla \times \mathbf{V} = 0$  over any surface bounded by  $C$ ), then  $\Gamma = 0$ .
- We can also write

$$d\Gamma = -(\nabla \times \mathbf{V}) \cdot d\mathbf{S} = -(\nabla \times \mathbf{V}) \cdot \mathbf{n} dS$$

$$(\nabla \times \mathbf{V}) \cdot \mathbf{n} = -\frac{d\Gamma}{dS}$$

Let  $\mathbf{A}$  be a vector field. The line integral of  $\mathbf{A}$  over  $C$  is related to the surface integral of  $\mathbf{A}$  over  $S$  by *Stokes' theorem*:

$$\oint_C \mathbf{A} \cdot d\mathbf{s} = \iint_S (\nabla \times \mathbf{A}) \cdot d\mathbf{S}$$

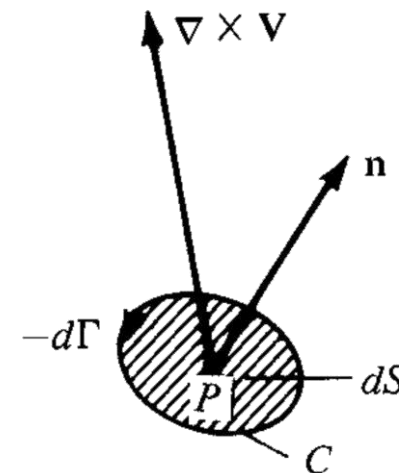
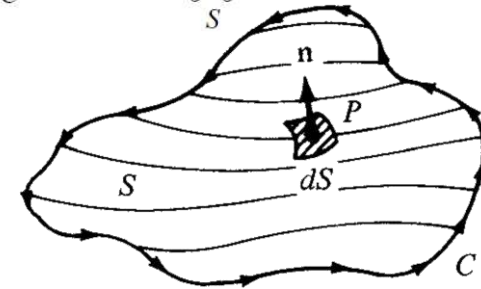



## Example 2.8

- For the velocity field given below, calculate the circulation around a circular path of radius 5 m.

$$u = \frac{y}{x^2 + y^2} \quad v = -\frac{x}{x^2 + y^2}$$

- Assume that  $u$  and  $v$  are in units of meters per second.
- Since we are dealing with a circular path, it is easier to work this problem in polar coordinates, where

$$x = r \cos \theta, \quad y = r \sin \theta, \quad V_r = u \cos \theta + v \sin \theta, \quad V_\theta = -u \sin \theta + v \cos \theta$$

- Therefore,

$$u = \frac{y}{x^2 + y^2} = \frac{r \sin \theta}{r^2} = \frac{\sin \theta}{r} \quad v = -\frac{x}{x^2 + y^2} = -\frac{r \cos \theta}{r^2} = -\frac{\cos \theta}{r}$$

$$V_r = \frac{\sin \theta}{r} \cos \theta + \left(-\frac{\cos \theta}{r}\right) \sin \theta = 0 \quad V_\theta = -\frac{\sin \theta}{r} \sin \theta + \left(-\frac{\cos \theta}{r}\right) \cos \theta = -\frac{1}{r}$$





## Example 2.8

$$\begin{aligned}\mathbf{V} \cdot d\mathbf{s} &= (V_r \mathbf{e}_r + V_\theta \mathbf{e}_\theta) \cdot (dr \mathbf{e}_r + r d\theta \mathbf{e}_\theta) \\ &= V_r dr + r V_\theta d\theta = 0 + r \left( -\frac{1}{r} \right) d\theta = -d\theta\end{aligned}$$

$$\Gamma = - \oint_C \mathbf{V} \cdot d\mathbf{s} = - \int_0^{2\pi} -d\theta = 2\pi \text{ m}^2/\text{s}$$







## Stream function

- We consider two-dimensional steady flow. We know that

$$d\mathbf{s} \times \mathbf{V} = 0$$

on the streamline.

- For 2D case, we get  $\frac{dy}{dx} = \frac{v}{u}$
- If  $u$  and  $v$  are known functions of  $x$  and  $y$ , then Equation can be integrated to yield the algebraic equation for a streamline:

$$\bar{\psi}(x, y) = c$$

where  $c$  is an arbitrary constant of integration, with different values for different streamlines.

- The function  $\bar{\Psi}$  is called the *stream function*.





## Stream function

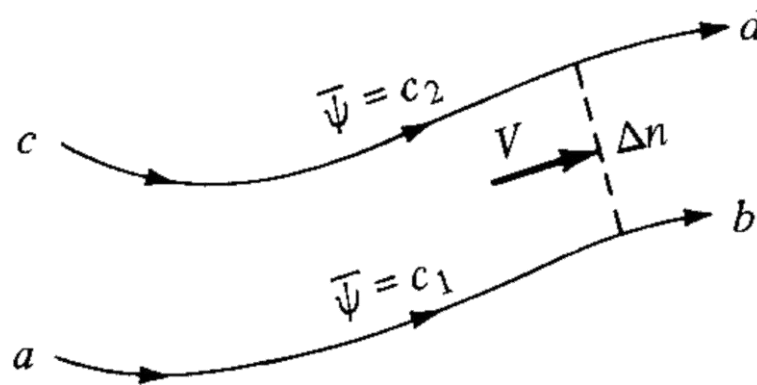

- Lets assume that the difference in stream function lines is equal to the mass flow between the two streamlines.
- The mass flow through the streamtube per unit depth perpendicular to the page is

$$\Delta\bar{\psi} \equiv \rho V \Delta n(1)$$

- Here,  $n$  is the normal distance between two adjacent stream lines.

$$\frac{\Delta\bar{\psi}}{\Delta n} = \rho V \quad \rho V = \lim_{\Delta n \rightarrow 0} \frac{\Delta\bar{\psi}}{\Delta n} \equiv \frac{\partial\bar{\psi}}{\partial n}$$





## Stream function

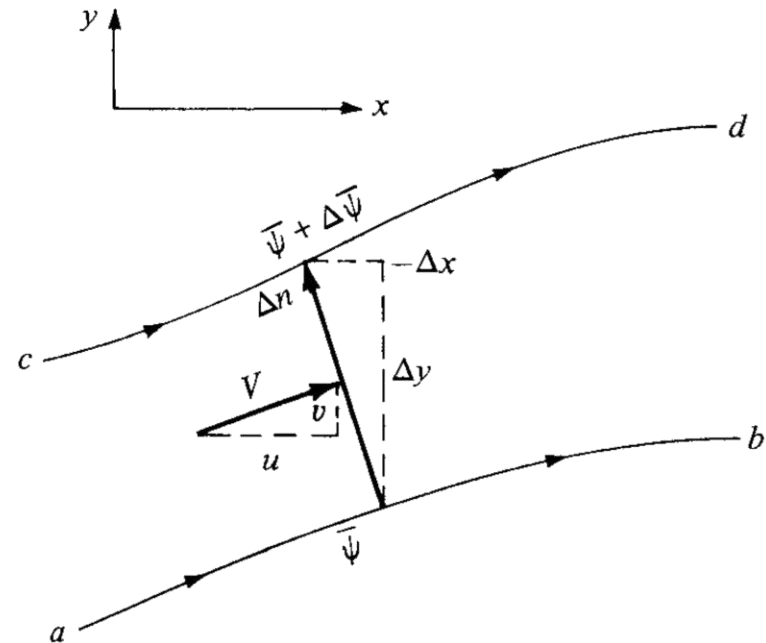

- Notice that the directed normal distance  $\Delta n$  is equivalent first to moving upward in the  $y$  direction by the amount  $\Delta y$  and then to the left in the negative  $x$  direction by the amount  $-\Delta x$ .
- Due to conservation of mass, the mass flow through  $n$  (per unit depth) is equal to the sum of the mass flows through  $y$  and  $-x$  (per unit depth):

$$\Delta \bar{\psi} = \rho V \Delta n = \rho u \Delta y + \rho v (-\Delta x)$$

$$d\bar{\psi} = \rho u dy - \rho v dx$$

- However, since  $\bar{\Psi} = \bar{\Psi}(x, y)$ , the chain rule of calculus states

$$d\bar{\psi} = \frac{\partial \bar{\psi}}{\partial x} dx + \frac{\partial \bar{\psi}}{\partial y} dy$$

- So,  $\rho u = \frac{\partial \bar{\psi}}{\partial y}$   $\rho v = -\frac{\partial \bar{\psi}}{\partial x}$





## Stream function

- In terms of polar coordinates,

$$\rho V_r = \frac{1}{r} \frac{\partial \bar{\psi}}{\partial \theta} \quad \rho V_\theta = -\frac{\partial \bar{\psi}}{\partial r}$$

- The stream function  $\bar{\psi}$  applies to both compressible and incompressible flow.
- Now consider the case of incompressible flow only, where  $\rho = \text{constant}$ .

- Equations can be written as  $V = \frac{\partial(\bar{\psi}/\rho)}{\partial n}$

- We define a new stream function, for incompressible flow only, as

$$\begin{aligned} \psi &\equiv \bar{\psi}/\rho & u &= \frac{\partial \psi}{\partial y} & V_r &= \frac{1}{r} \frac{\partial \psi}{\partial \theta} \\ V &= \frac{\partial \psi}{\partial n} & v &= -\frac{\partial \psi}{\partial x} & V_\theta &= -\frac{\partial \psi}{\partial r} \end{aligned}$$





## Velocity potential

- Recall that an irrotational flow is defined as a flow where the vorticity is zero at every point.

$$\xi = \nabla \times \mathbf{V} = 0$$

- We can describe a scalar function  $\Phi$  that  $\nabla \times (\nabla\phi) = 0$

that is, the curl of the gradient of a scalar function is identically zero.

- Comparing Equations, we see that

$$\mathbf{V} = \nabla\phi$$

- Equation states that for an *irrotational* flow, there exists a scalar function  $\Phi$  such that the velocity is given by the gradient of  $\Phi$ .
- We denote  $\Phi$  as the *velocity potential*.





## Velocity potential

$$\mathbf{V} = \nabla\phi$$

- In cartesian coordinates,

$$u\mathbf{i} + v\mathbf{j} + w\mathbf{k} = \frac{\partial\phi}{\partial x}\mathbf{i} + \frac{\partial\phi}{\partial y}\mathbf{j} + \frac{\partial\phi}{\partial z}\mathbf{k}$$

$$u = \frac{\partial\phi}{\partial x} \quad v = \frac{\partial\phi}{\partial y} \quad w = \frac{\partial\phi}{\partial z}$$

- In cylindrical coordinates,

$$V_r = \frac{\partial\phi}{\partial r} \quad V_\theta = \frac{1}{r} \frac{\partial\phi}{\partial\theta} \quad V_z = \frac{\partial\phi}{\partial z}$$

- In spherical coordinates,

$$V_r = \frac{\partial\phi}{\partial r} \quad V_\theta = \frac{1}{r} \frac{\partial\phi}{\partial\theta} \quad V_\Phi = \frac{1}{r \sin\theta} \frac{\partial\phi}{\partial\Phi}$$





## Velocity potential

- The velocity potential is analogous to the stream function. However, there are distinct differences between  $\Phi$  and  $\psi$ :
  1. The flow-field velocities are obtained by differentiating  $\Phi$  in the same direction as the velocities, whereas  $\psi$  is differentiated normal to the velocity direction.
  2. The velocity potential is defined for irrotational flow only. In contrast, the stream function can be used in either rotational or irrotational flows.
  3. The velocity potential applies to three-dimensional flows, whereas the stream function is defined for two-dimensional flows only.
- Because irrotational flows can be described by the velocity potential  $\phi$ , such flows are called *potential flows*.

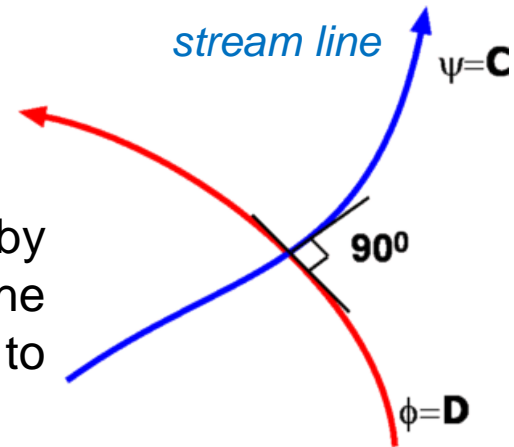

*equipotential line*

$$\xi = \nabla \times \mathbf{V} = 0$$





## Relationship between flow functions

- Because gradient lines and isolines are perpendicular, then equipotential lines ( $\Phi = \text{constant}$ ) and streamlines ( $\psi = \text{constant}$ ) are mutually perpendicular.
- We know that

$$d\psi = \frac{\partial\psi}{\partial x}dx + \frac{\partial\psi}{\partial y}dy = 0 \quad d\psi = -v dx + u dy = 0 \quad \left(\frac{dy}{dx}\right)_{\psi=\text{const}} = \frac{v}{u}$$

- We also have

$$d\phi = \frac{\partial\phi}{\partial x}dx + \frac{\partial\phi}{\partial y}dy = 0 \quad d\phi = u dx + v dy = 0 \quad \left(\frac{dy}{dx}\right)_{\phi=\text{const}} = -\frac{u}{v}$$

- Combining Equations, we have

$$\left(\frac{dy}{dx}\right)_{\psi=\text{const}} = -\frac{1}{(dy/dx)_{\phi=\text{const}}}$$







## How do we solve the equations?

- This chapter is full of mathematical equations that dictate the characteristics of aerodynamic flow fields.
- For the most part, the equations are either in partial differential form or integral form.
- They must be *solved* in order to obtain the actual flow fields over specific body shapes with specific flow conditions.
- For example, the flow field around a Boeing 777 jet transport flying at a velocity of 800 ft/s at an altitude of 30,000 ft. We have to obtain a *solution* of the governing equations for this case.
- A solution that will give us the results for the dependent flow-field variables  $p$ ,  $\rho$ ,  $\mathbf{V}$ , etc., as a function of the independent variables of spatial location and time.





## How do we solve the equations?

- Then we have to squeeze this solution for extra practical information, such as lift, drag, and moments exerted on the vehicle.
- How do we do this?
- There are two types of philosophical approaches;
  - Theoretical (analytical) solutions,
  - Numerical solutions—computational fluid dynamics (CFD)
- The governing equations of aerodynamics, such as the continuity, momentum, and energy equations are highly nonlinear, partial differential, or integral equations.
- To date, no general analytical solution to these equations has been obtained.





## How do we solve the equations?

- However, based on some simplifications and approximations, we can get some simple but basic solutions.
- Classical aerodynamic theory is built on this approach and, as such, is discussed at some length in this course.
- The other general approach to the solution of the governing equations is numerical.
- The high-speed digital computer in the last third of the twentieth century has revolutionized the solution of aerodynamic problems.
- It has given rise to a whole new discipline:  
**computational fluid dynamics**





# How do we solve the equations?

- Analytical approach
  - If flow is 2D, steady and incompressible;
- Numerical approach
  - the governing flow equations are *discretized*,

$$\frac{\partial \rho}{\partial t} + \nabla \cdot (\rho \mathbf{V}) = 0$$

$$\frac{\partial u}{\partial x} + \frac{\partial v}{\partial y} = 0$$

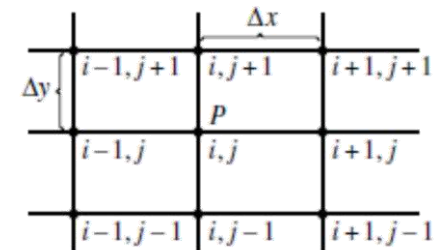
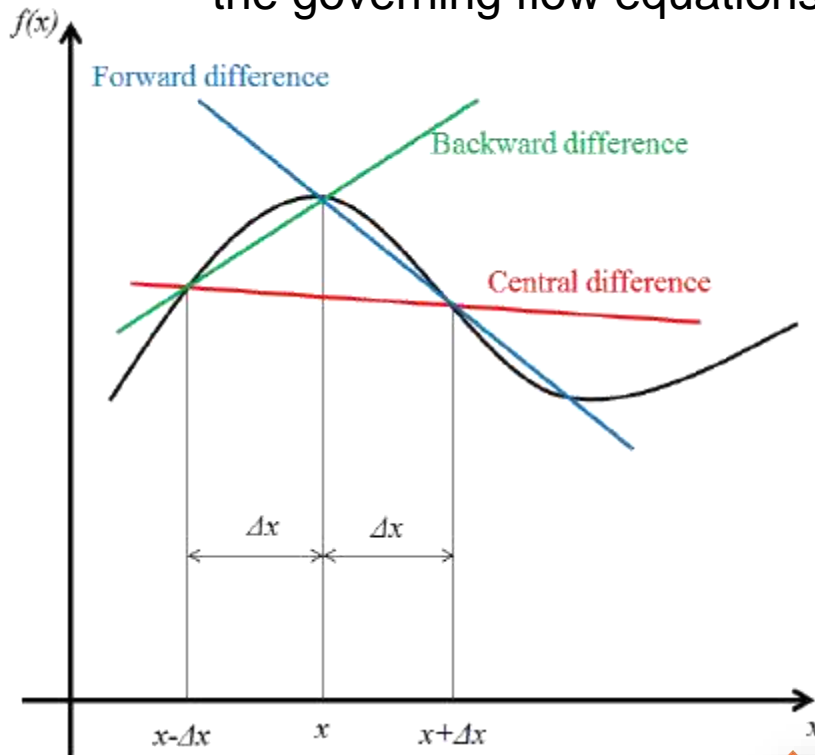

$$\left( \frac{\partial u}{\partial x} \right)$$

$$\left( \frac{\partial u}{\partial x} \right)_{i,j} = \frac{u_{i+1,j} - u_{i,j}}{\Delta x}$$

$$\left( \frac{\partial u}{\partial x} \right)_{i,j} = \frac{u_{i,j} - u_{i-1,j}}{\Delta x}$$

$$\left( \frac{\partial u}{\partial x} \right)_{i,j} = \frac{u_{i+1,j} - u_{i-1,j}}{2\Delta x}$$





## Example 2.10

- Consider a one-dimensional, unsteady flow, where the flow-field variables such as  $\rho$ ,  $u$ , etc. are functions of distance  $x$  and time  $t$ .
- Consider the grid shown in Figure, where grid points arrayed in the  $x$  direction are denoted by the index  $i$ .
- Two rows of grid points are shown, one at time  $t$  and the other at the later time  $t + \Delta t$ .
- In particular, we are interested in calculating the unknown density at grid point  $i$  at time  $t + \Delta t$ , denoted by  $\rho_i^{t+\Delta t}$ .
- Set up the calculation of this unknown density.





## Example 2.10

- From the continuity equation,  $\frac{\partial \rho}{\partial t} + \nabla \cdot (\rho \mathbf{V}) = 0$
  - For unsteady, one-dimensional flow, we have  $\frac{\partial \rho}{\partial t} + \frac{\partial(\rho u)}{\partial x} = 0$
- $$\frac{\partial \rho}{\partial t} = -\frac{\partial(\rho u)}{\partial x} \quad \frac{\partial \rho}{\partial t} = -\rho \frac{\partial u}{\partial x} - u \frac{\partial \rho}{\partial x} \quad \text{Analytical equation}$$

- Replace  $\partial \rho / \partial t$  with a forward difference in time, and  $\partial u / \partial x$  and  $\partial \rho / \partial x$  with central differences in space, centered around grid point  $i$

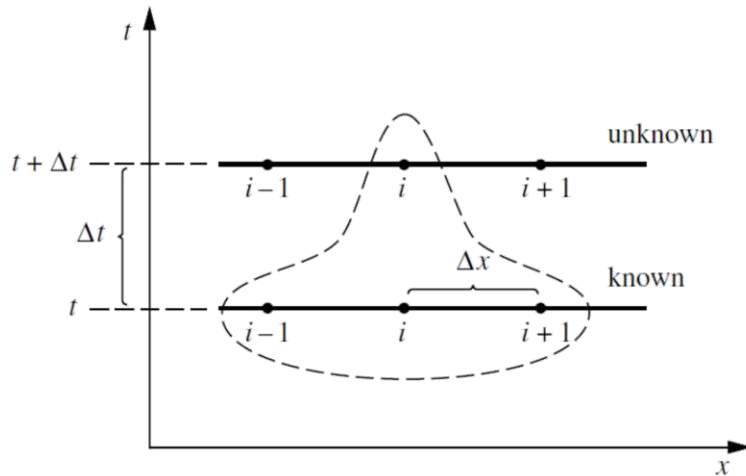

$$\frac{\rho_i^{t+\Delta t} - \rho_i^t}{\Delta t} = -\rho_i^t \left( \frac{u_{i+1}^t - u_{i-1}^t}{2\Delta x} \right) - u_i^t \left( \frac{\rho_{i+1}^t - \rho_{i-1}^t}{2\Delta x} \right)$$

Numerical equation

$$\rho_i^{t+\Delta t} = \rho_i^t - \frac{\Delta t}{2\Delta x} (\rho_i^t u_{i+1}^t - \rho_i^t u_{i-1}^t + u_i^t \rho_{i+1}^t - u_i^t \rho_{i-1}^t)$$





## Homework

- 2.2** Consider an airfoil in a wind tunnel (i.e., a wing that spans the entire test section). Prove that the lift per unit span can be obtained from the pressure distributions on the top and bottom walls of the wind tunnel (i.e., from the pressure distributions on the walls above and below the airfoil).
- 2.6** Consider a velocity field where the  $x$  and  $y$  components of velocity are given by  $u = cx$  and  $v = -cy$ , where  $c$  is a constant. Obtain the equations of the streamlines.
- 2.13** Consider the subsonic compressible flow over the wavy wall treated in Example 2.1. Derive the equation for the velocity potential for this flow as a function of  $x$  and  $y$ .





# *Aerodynamics*

## *AE 301*

Assoc. Prof. Dr. Y . Volkan PEHLİVANOĞLU  
volkan.pehlivanoglu@ieu.edu.tr







## Contents; Inviscid, Incompressible Flow

- Bernoulli's Equation,
- Incompressible Flow in a Duct,
- Pitot Tube: Measurement of Airspeed,
- Pressure Coefficient,
- Condition on Velocity,
- Governing Equation: Laplace's Equation,
- Uniform Flow,
- Source Flow,
- Doublet Flow,
- Vortex Flow,
- The Kutta-Joukowski Theorem,
- Applied Aerodynamics,
- Historical Note...

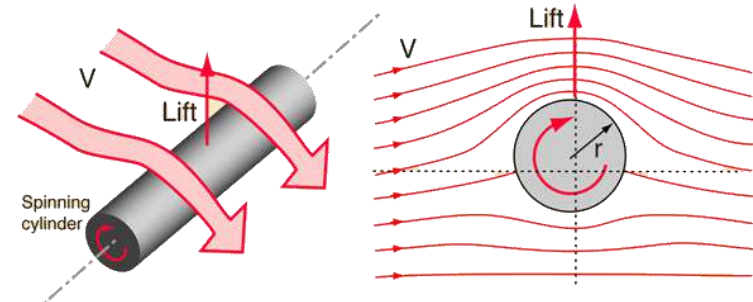
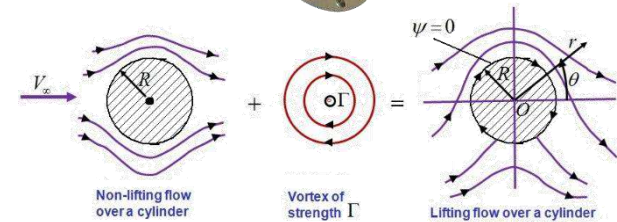



## Introduction

*Theoretical fluid dynamics, being a difficult subject, is for convenience, commonly divided into two branches, one treating of frictionless or perfect fluids, the other treating of viscous or imperfect fluids. The frictionless fluid has no existence in nature, but is hypothesized by mathematicians in order to facilitate the investigation of important laws and principles that may be approximately true of viscous or natural fluids.*

**Albert F. Zahm, 1912**

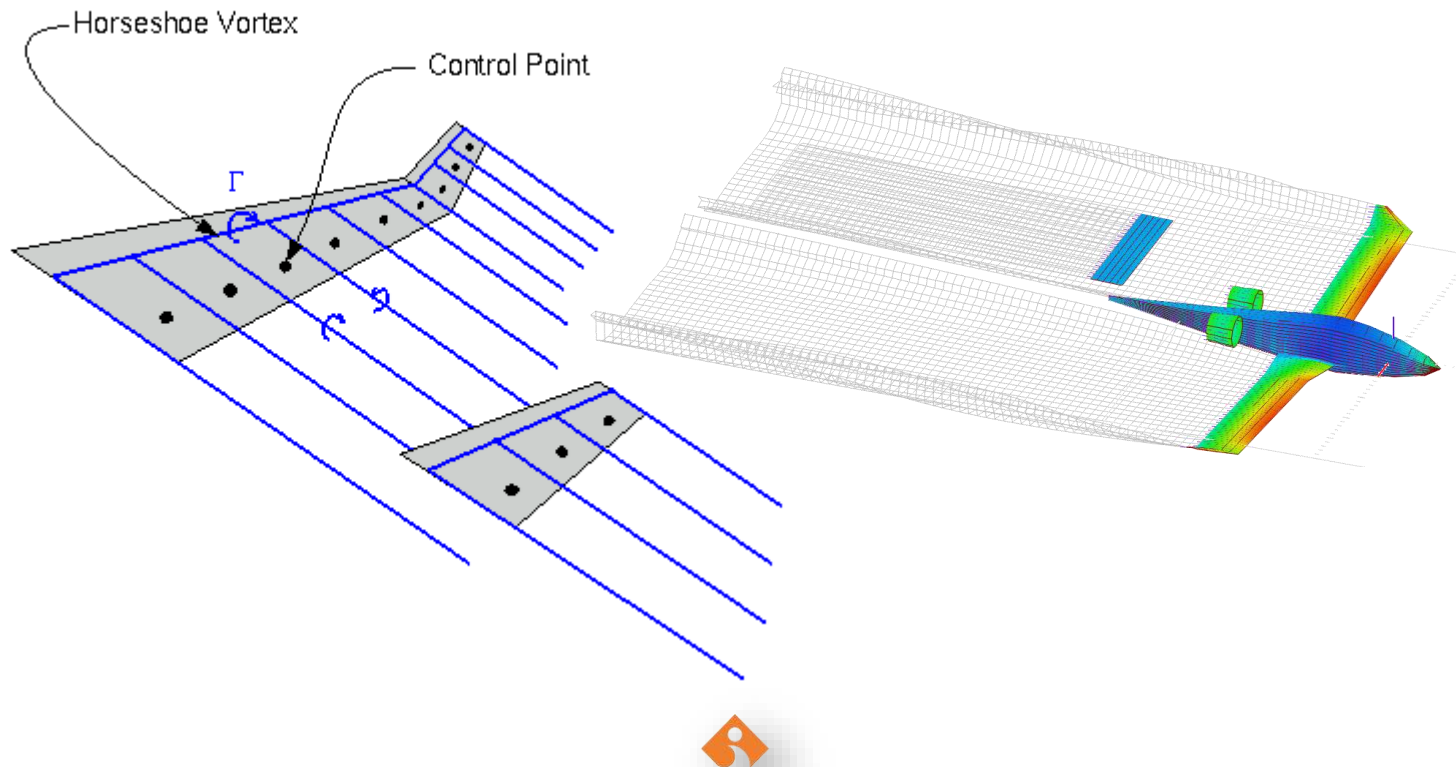



## Introduction

### nomenclature

$\partial$  Partial

$\nabla$  Del – gradient - Nabla

$\times$  Cross

$\cdot$  Dot

$\Gamma$  Gamma

$\Phi$  Phi

$\Psi$  Psi

$\infty$  Infinity

$\Lambda$  lambda





## Introduction

- Inviscid, incompressible flow... Actually, such flow is a myth on two accounts.
- First, in real life there is always friction. In nature there is, strictly speaking, no inviscid flow.
- Second, every flow is compressible. In nature there is, strictly speaking, no incompressible flow.
- There are a whole host of aerodynamic applications that are so *close* to being inviscid and incompressible.
- By making that assumption and we obtain amazingly accurate results.

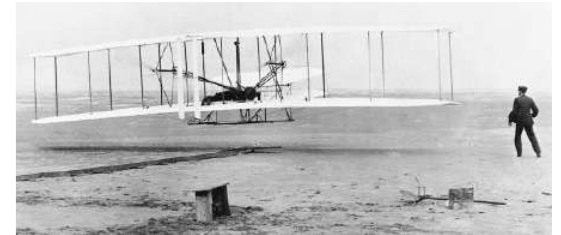

[Wright](#) brothers on December 17, 1903.





## Introduction

- From an aerodynamic point of view, at air velocities between 0 and 300 mi/h the air density remains essentially constant, varying by only a few percent.
- Hence, the aerodynamics of the family of airplanes spanning the period between 1903 and 1940 could be described by *incompressible flow*.

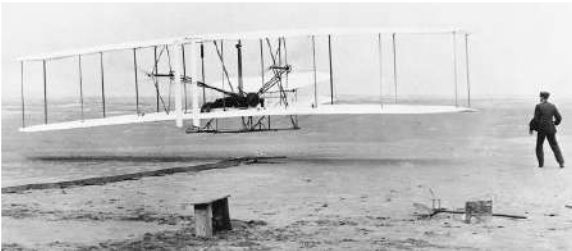

1903



1940



1985

- Today, we are still very interested in incompressible aerodynamics because most modern general aviation aircraft still fly at speeds below 300 mi/h.





## Bernoulli's equation

- The early part of the eighteenth century... It was at this time that the relation between pressure and velocity in an inviscid, incompressible flow was first understood.
- Bernoulli's equation relates velocity and pressure from one point to another in an inviscid, incompressible flow.
- Consider the  $x$  component of the momentum equation and continuity equation;

$$\frac{\partial(\rho u)}{\partial t} + \nabla \cdot (\rho u \mathbf{V}) = -\frac{\partial p}{\partial x} + \rho f_x + (\mathcal{F}_x)_{\text{viscous}}$$

- For an inviscid flow with no body forces, this equation becomes

$$\rho \frac{\partial u}{\partial t} + \rho u \frac{\partial u}{\partial x} + \rho v \frac{\partial u}{\partial y} + \rho w \frac{\partial u}{\partial z} = -\frac{\partial p}{\partial x}$$

- For steady flow,  $\partial u / \partial t = 0$ ,  $u \frac{\partial u}{\partial x} + v \frac{\partial u}{\partial y} + w \frac{\partial u}{\partial z} = -\frac{1}{\rho} \frac{\partial p}{\partial x}$





## Bernoulli's equation

- Multiply Equation by  $dx$

$$u \frac{\partial u}{\partial x} dx + v \frac{\partial u}{\partial y} dx + w \frac{\partial u}{\partial z} dx = -\frac{1}{\rho} \frac{\partial p}{\partial x} dx$$

- Consider the flow along a streamline in three-dimensional space. The equation of a streamline is given by Equations

$$u dz - w dx = 0$$

$$v dx - u dy = 0$$

- Substituting them into previous equation,

$$u \frac{\partial u}{\partial x} dx + u \frac{\partial u}{\partial y} dy + u \frac{\partial u}{\partial z} dz = -\frac{1}{\rho} \frac{\partial p}{\partial x} dx$$

$$u \left( \frac{\partial u}{\partial x} dx + \frac{\partial u}{\partial y} dy + \frac{\partial u}{\partial z} dz \right) = -\frac{1}{\rho} \frac{\partial p}{\partial x} dx$$

- The differential of  $u$  is  $u = u(x, y, z)$ ,  $du = \frac{\partial u}{\partial x} dx + \frac{\partial u}{\partial y} dy + \frac{\partial u}{\partial z} dz$





## Bernoulli's equation

- This is exactly the term in parentheses in Equation. Hence,

$$u \, du = -\frac{1}{\rho} \frac{\partial p}{\partial x} dx$$

- or

$$\frac{1}{2} d(u^2) = -\frac{1}{\rho} \frac{\partial p}{\partial x} dx$$

- In a similar fashion, starting from the  $y$  and  $z$  components of the momentum equation, we have

$$\frac{1}{2} d(v^2) = -\frac{1}{\rho} \frac{\partial p}{\partial y} dy$$

$$\frac{1}{2} d(w^2) = -\frac{1}{\rho} \frac{\partial p}{\partial z} dz$$

- Adding Equations yields

$$\frac{1}{2} d(u^2 + v^2 + w^2) = -\frac{1}{\rho} \left( \frac{\partial p}{\partial x} dx + \frac{\partial p}{\partial y} dy + \frac{\partial p}{\partial z} dz \right)$$







## Bernoulli's equation

- However,

$$u^2 + v^2 + w^2 = V^2$$

- and

$$\frac{\partial p}{\partial x} dx + \frac{\partial p}{\partial y} dy + \frac{\partial p}{\partial z} dz = dp$$

- Substituting them into previous one, we have  $\frac{1}{2}d(V^2) = -\frac{dp}{\rho}$

$$dp = -\rho V dV$$

- Equation is called *Euler's equation*.
- It relates the change in velocity along a streamline  $dV$  to the change in pressure  $dp$  along the same streamline.





## Bernoulli's equation

- In such a case,  $\rho = \text{constant}$ , and can be easily integrated between any two points 1 and 2 along a streamline.

$$\int_{p_1}^{p_2} dp = -\rho \int_{V_1}^{V_2} V dV$$

$$p_2 - p_1 = -\rho \left( \frac{V_2^2}{2} - \frac{V_1^2}{2} \right)$$

$$p_1 + \frac{1}{2}\rho V_1^2 = p_2 + \frac{1}{2}\rho V_2^2$$

- Equation is *Bernoulli's equation*, can also be written as

$$p + \frac{1}{2}\rho V^2 = \text{const} \quad \text{along a streamline}$$

*Johann Bernoulli, father...*



*Daniel Bernoulli, son...*





## Bernoulli's equation

- The physical significance of Bernoulli's equation is obvious from Equations.
- Namely, *when the velocity increases, the pressure decreases, and when the velocity decreases, the pressure increases.*
- Bernoulli's equation is also a relation for mechanical energy in an incompressible flow.
- It states that the work done on a fluid by pressure forces is equal to the change in kinetic energy of the flow.
- Indeed, Bernoulli's equation can be derived from the general energy equation...





## Bernoulli's equation

- The strategy for solving most problems in inviscid, incompressible flow is as follows:
  - Obtain the velocity field from the governing equations appropriate for an inviscid, incompressible flow.
  - Once the velocity field is known, obtain the corresponding pressure field from Bernoulli's equation.

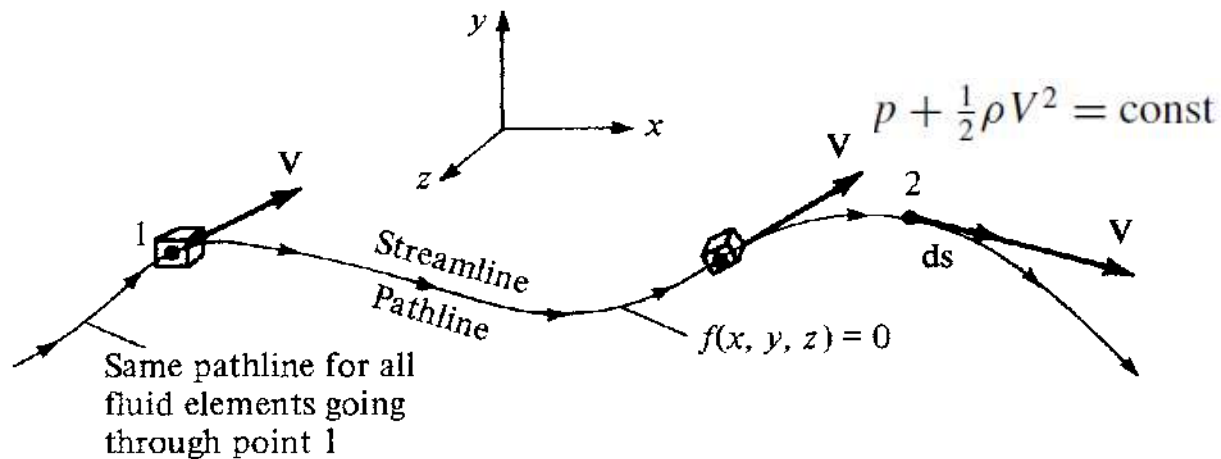



### Example 3.1

- Consider an airfoil in a flow at standard sea level conditions with a freestream velocity of 50 m/s.
- At a given point on the airfoil, the pressure is  $0.9 \times 10^5$  N/m<sup>2</sup>. Calculate the velocity at this point.
- At standard sea level conditions,

$$\rho_{\infty} = 1.23 \text{ kg/m}^3$$
$$p_{\infty} = 1.01 \times 10^5 \text{ N/m}^2$$

$$p_{\infty} + \frac{1}{2}\rho V_{\infty}^2 = p + \frac{1}{2}\rho V^2$$

$$V = \sqrt{\frac{2(p_{\infty} - p)}{\rho} + V_{\infty}^2} = \sqrt{\frac{2(1.01 - 0.9) \times 10^5}{1.23} + (50)^2}$$

$$V = 142.8 \text{ m/s}$$





### Example 3.2

- Consider the inviscid, incompressible flow of air along a streamline.
- The air density along the streamline is  $0.002377$  slug/ft<sup>3</sup>, which is standard atmospheric density at sea level.
- At point 1 on the streamline, the pressure and velocity are  $2116$  lb/ft<sup>2</sup> and  $10$  ft/s, respectively.
- Further downstream, at point 2 on the streamline, the velocity is  $190$  ft/s.
- Calculate the pressure at point 2.
- What can you say about the relative change in pressure from point 1 to point 2 compared to the corresponding change in velocity?





## Example 3.2

- From Equation

$$p_1 + \frac{1}{2}\rho V_1^2 = p_2 + \frac{1}{2}\rho V_2^2$$

$$p_2 = p_1 + \frac{1}{2}\rho(V_1^2 - V_2^2)$$

$$\begin{aligned} p_2 &= 2116 + \frac{1}{2}(0.002377)[(10)^2 - (190)^2] \\ &= 2116 + \frac{1}{2}(0.002377)(100 - 36100) \\ &= 2116 - 42.8 = 2073.2 \text{ lb/ft}^2 \end{aligned}$$

- Only a 2 percent decrease in the pressure creates a 1900 percent increase in the flow velocity.
- This is an example of a general characteristic of low-speed flows.
- Only a small barometric change from one location to another can create a strong wind.





## Incompressible flow in a duct: the Venturi and low-speed wind tunnel

- Consider the flow through a duct. In general, the flow through such a duct is three-dimensional.
- However, in many applications, the variation of area  $A=A(x)$  is moderate.
- For such cases it is reasonable to assume that the flow-field properties are uniform across any cross section, and hence vary only in the  $x$  direction.

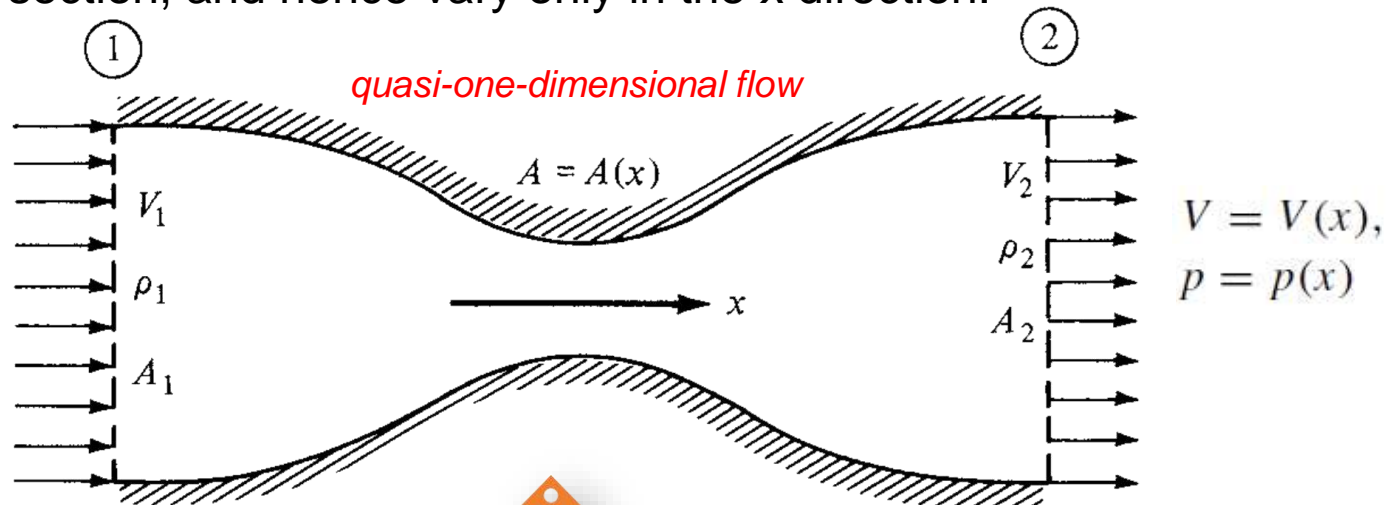





## Incompressible flow in a duct

- Consider the integral form of the continuity equation

$$\frac{\partial}{\partial t} \iiint_V \rho dV + \iint_S \rho \mathbf{V} \cdot d\mathbf{S} = 0$$

- For steady flow, this becomes

$$\iint_S \rho \mathbf{V} \cdot d\mathbf{S} = 0$$

- Apply Equation to the duct, where the control volume is bounded by  $A_1$  on the left,  $A_2$  on the right, and the upper and lower walls of the duct. Hence,

$$\iint_{A_1} \rho \mathbf{V} \cdot d\mathbf{S} + \iint_{A_2} \rho \mathbf{V} \cdot d\mathbf{S} + \iint_{\text{wall}} \rho \mathbf{V} \cdot d\mathbf{S} = 0$$

- Along the walls, the flow velocity is tangent to the wall, and  $d\mathbf{S}$  is perpendicular to the wall,

$$\mathbf{V} \cdot d\mathbf{S} = 0 \quad \iint_{\text{wall}} \rho \mathbf{V} \cdot d\mathbf{S} = 0$$





## Incompressible flow in a duct

- We have

$$\iint_{A_1} p \mathbf{V} \cdot d\mathbf{S} = -\rho_1 A_1 V_1 \quad \iint_{A_2} \rho \mathbf{V} \cdot d\mathbf{S} = \rho_2 A_2 V_2$$

- Substituting Equations into main equation, we obtain

$$-\rho_1 A_1 V_1 + \rho_2 A_2 V_2 + 0 = 0$$

$$\rho_1 A_1 V_1 = \rho_2 A_2 V_2$$

- Equation is the quasi-one-dimensional continuity equation.
- It applies to both compressible and incompressible flow.





## Incompressible flow in a duct

- Consider *incompressible* flow only, where  $\rho = \text{constant}$ .

$$A_1 V_1 = A_2 V_2$$

- It states that the volume flow (cubic meters per second) through the duct is constant.
- We see that if the area decreases along the flow (convergent duct), the velocity increases.
- Conversely, if the area increases (divergent duct), the velocity decreases.

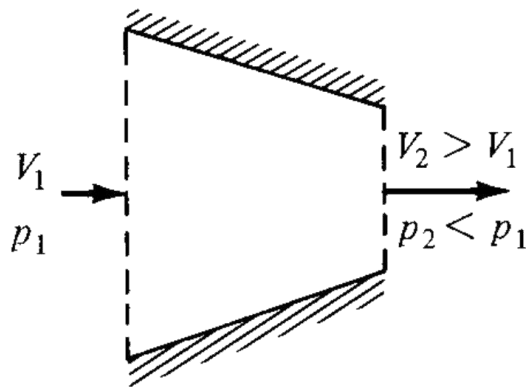

Convergent duct

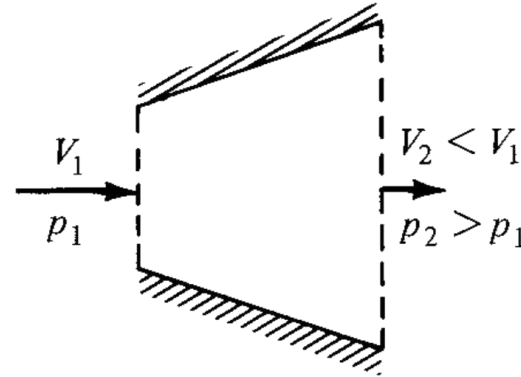

Divergent duct





## Incompressible flow in a duct

- Moreover, from Bernoulli's equation we see that when the velocity increases in a convergent duct, the pressure decreases.
- Conversely, when the velocity decreases in a divergent duct, the pressure increases.
- The velocity increases in the convergent portion of the duct, reaching a maximum value  $V_2$  at the minimum area of the duct.
- This minimum area is called the throat.
- At the throat, the pressure reaches a minimum value  $p_2$ .
- In an application closer to aerodynamics, a venturi can be used to measure airspeeds.

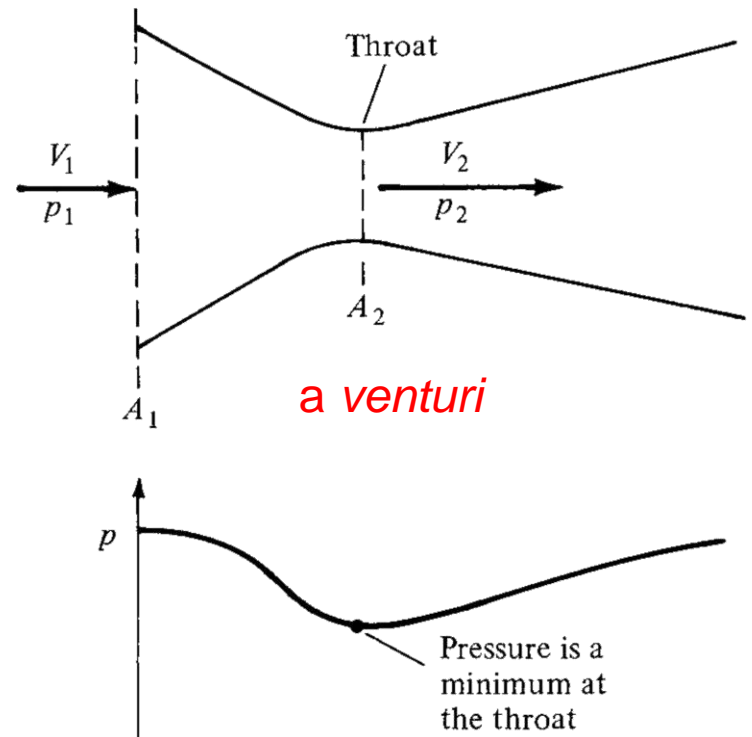



## Incompressible flow in a duct

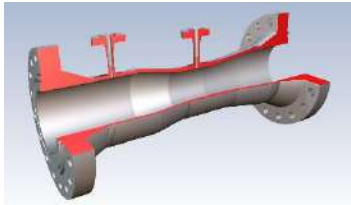

- From Bernoulli's equation,  $V_1^2 = \frac{2}{\rho}(p_2 - p_1) + V_2^2$
- From the continuity equation  $V_2 = \frac{A_1}{A_2} V_1$
- we obtain  $V_1^2 = \frac{2}{\rho}(p_2 - p_1) + \left(\frac{A_1}{A_2}\right)^2 V_1^2$

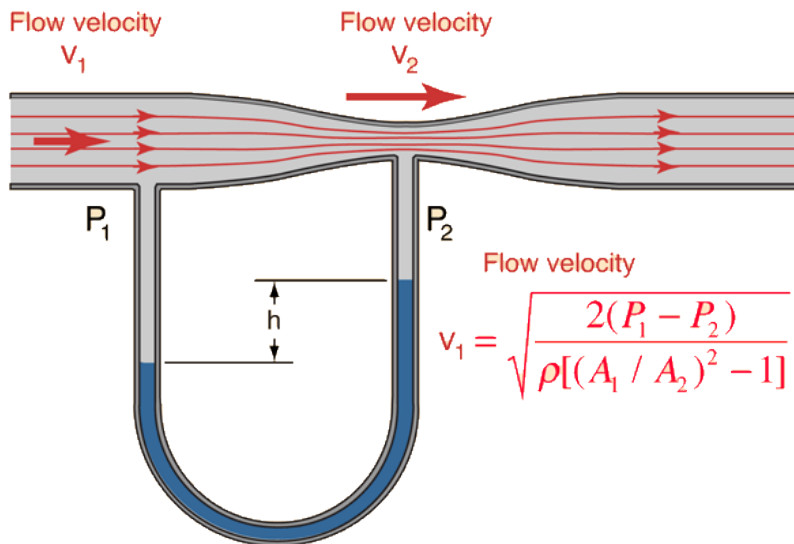

$$V_1 = \sqrt{\frac{2(p_1 - p_2)}{\rho[(A_1/A_2)^2 - 1]}}$$

- Historically the first practical airspeed indicator on an airplane was a venturi used by the French Captain A. Eteve in January 1911





## Incompressible flow in a duct

- Another application of incompressible flow in a duct is the low-speed wind tunnel.
- To simulate actual flight in the atmosphere dates back to 1871, when Francis Wenham in England built and used the first wind tunnel in history.
- In essence, a low-speed wind tunnel is a large venturi where the airflow is driven by a fan connected to some type of motor drive.
- The wind-tunnel fan blades are similar to airplane propellers and are designed to draw the airflow through the tunnel circuit.
- The wind tunnel may be open circuit, or the wind tunnel may be closed circuit.



*F. W. Wenham  
in 1866*





## Incompressible flow in a duct

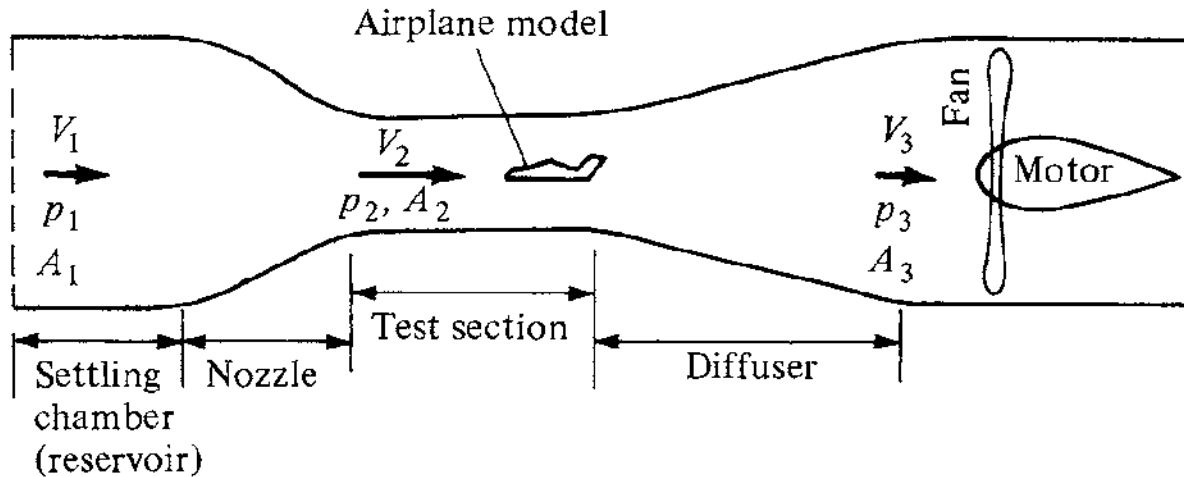

(a) Open-circuit tunnel

- The air is drawn in the front directly from the atmosphere and exhausted out the back, again directly to the atmosphere.

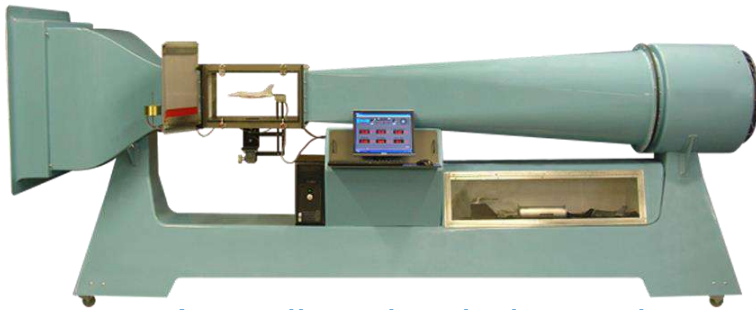

A small-scale wind tunnel



A full-scale wind tunnel, Langley-VA





## Incompressible flow in a duct



[NASA](#) Ames Research Center, Mountain View, California-USA

Built in the early 1980's, the 80- by 120-foot is an open circuit tunnel. Air is drawn from the huge 360-foot wide, 130-foot high air intake, passes through the 120-foot wide, 80-foot high test section and then is expelled to the atmosphere. The maximum airspeed through the test section is 115 mph. Power is derived from six 40-foot diameter fan blades, each motor rated at 23,500 hp. The 80-by 120-foot tunnel is capable of testing aircraft as large as a Boeing 737. The wind tunnel began regular operations in 1987.



The largest wind tunnel in the World.







## Incompressible flow in a duct

NASA Ames Research Center, Mountain View, California-USA





## Incompressible flow in a duct

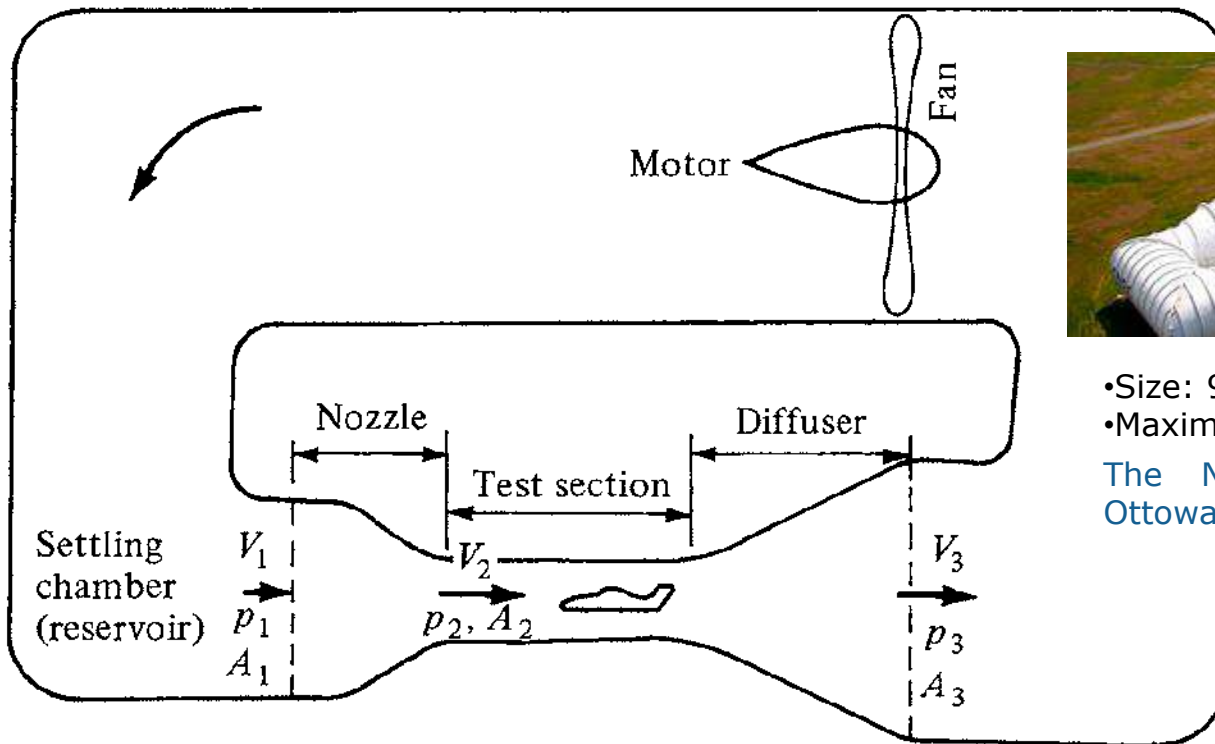

- Size: 9.1 m high x 9.1 m wide x 24 m long
- Maximum wind speed: 55 m/s (200 km/h)

The National Research Council (NRC),  
Ottawa, Canada

(b) Closed-circuit tunnel

- The air from the exhaust is returned directly to the front of the tunnel via a closed duct forming a loop





## Incompressible flow in a duct

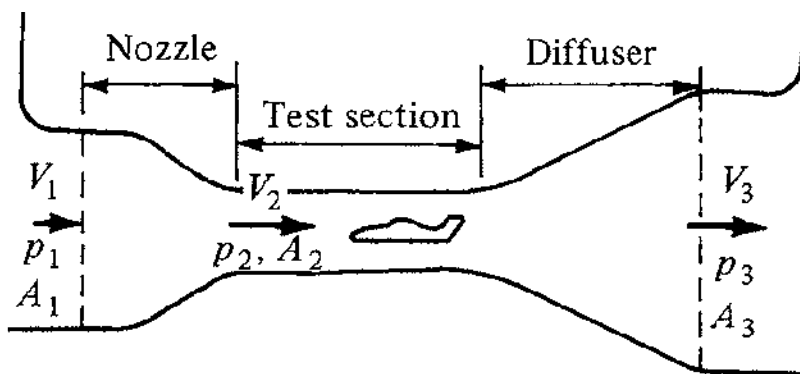

- From the continuity equation, the test-section air velocity is

$$V_2 = \frac{A_1}{A_2} V_1$$

- The velocity at the exit of the diffuser is

$$V_3 = \frac{A_2}{A_3} V_2$$

- The pressure at various locations in the wind tunnel is

$$p_1 + \frac{1}{2}\rho V_1^2 = p_2 + \frac{1}{2}\rho V_2^2 = p_3 + \frac{1}{2}\rho V_3^2$$

- The basic factor that controls the air velocity in the test section of a given low-speed wind tunnel is the pressure difference  $p_1 - p_2$ .

$$V_2^2 = \frac{2}{\rho}(p_1 - p_2) + V_1^2 \quad V_2^2 = \frac{2}{\rho}(p_1 - p_2) + \left(\frac{A_2}{A_1}\right)^2 V_1^2 \quad V_2 = \sqrt{\frac{2(p_1 - p_2)}{\rho[1 - (A_2/A_1)^2]}}$$





## Incompressible flow in a duct

- The test-section velocity  $V_2$  is governed by the pressure difference  $p_1 - p_2$ .
- The fan driving the wind-tunnel flow creates this pressure difference by doing work on the air.
- In low-speed wind tunnels, a method of measuring the pressure difference  $p_1 - p_2$  is by means of a manometer.

$dp = -g\rho dy$  Denote the weight per unit volume by  $w$

$$p_1 - p_2 = w\Delta h$$

$$V_2 = \sqrt{\frac{2w\Delta h}{\rho[1 - (A_2/A_1)^2]}}$$





### Example 3.3

- Consider a venturi with a throat-to-inlet area ratio of 0.8 mounted in a flow at standard sea level conditions.
- If the pressure difference between the inlet and the throat is 7 lb/ft<sup>2</sup>, calculate the velocity of the flow at the inlet.
- At standard sea level conditions,  $\rho = 0.002377$  slug/ft<sup>3</sup>. Hence,

$$V_1 = \sqrt{\frac{2(p_1 - p_2)}{\rho[(A_1/A_2)^2 - 1]}} = \sqrt{\frac{2(7)}{(0.002377)[(\frac{1}{0.8})^2 - 1]}} = 102.3 \text{ ft/s}$$





### Example 3.4

- Consider a low-speed subsonic wind tunnel with a 12/1 contraction ratio for the nozzle.
- The flow in the test section is at standard sea level conditions with a velocity of 50 m/s.
- Calculate the height difference in a U-tube mercury manometer with one side connected to the nozzle inlet and the other to the test section.
- At standard sea level,  $\rho = 1.23 \text{ kg/m}^3$ . From Equation

$$p_1 - p_2 = \frac{1}{2} \rho V_2^2 \left[ 1 - \left( \frac{A_2}{A_1} \right)^2 \right] = \frac{1}{2} (50)^2 (1.23) \left[ 1 - \left( \frac{1}{12} \right)^2 \right] = 1527 \text{ N/m}^2$$

- The density of liquid mercury is  $1.36 \times 10^4 \text{ kg/m}^3$ . Hence,

$$p_1 - p_2 = w \Delta h$$

$$w = (1.36 \times 10^4 \text{ kg/m}^3)(9.8 \text{ m/s}^2) = 1.33 \times 10^5 \text{ N/m}^2 \quad \Delta h = \frac{p_1 - p_2}{w} = \frac{1527}{1.33 \times 10^5} = 0.01148 \text{ m}$$





### Example 3.4

- Consider a model of an airplane mounted in a subsonic wind tunnel. The wind-tunnel nozzle has a 12-to-1 contraction ratio.
- The maximum lift coefficient of the airplane model is 1.3. The wing planform area of the model is 6 ft<sup>2</sup>.
- The lift is measured with a mechanical balance that is rated at a maximum force of 1000 lb.
- Calculate the maximum pressure difference allowable between the wind-tunnel settling chamber and the test section.
- Standard sea level density in the test section,  $\rho_\infty = 0.002377$  slug/ft<sup>3</sup>.





### Example 3.4

- Maximum lift occurs when the model is at its maximum lift coefficient.
- The freestream velocity at which this occurs is obtained from



$$L_{\max} = \frac{1}{2} \rho_{\infty} V_{\infty}^2 S C_{L,\max}$$

$$V_{\infty} = \sqrt{\frac{2L_{\max}}{\rho_{\infty} S C_{L,\max}}} = \sqrt{\frac{(2)(1000)}{(0.002377)(6)(1.3)}} = 328.4 \text{ ft/s}$$

- From Equation

$$p_1 - p_2 = \frac{1}{2} \rho_{\infty} V_{\infty}^2 \left[ 1 - \left( \frac{A_2}{A_1} \right)^2 \right] = \frac{1}{2} (0.002377) (328.4)^2 \left[ 1 - \left( \frac{1}{12} \right)^2 \right] = 127.3 \text{ lb/ft}^2$$







## Pitot tube

- In 1732, the Frenchman Henri Pitot was busy trying to measure the flow velocity of the Seine River in Paris.
- He used his own invention, *Pitot tube*, the most common device for measuring flight velocities of airplanes.
- Consider a flow with pressure  $p_1$  moving with velocity  $V_1$ .
- Pressure is clearly related to the motion of the molecules, random but in all directions.





## Pitot tube

- Now imagine that you hop on a fluid element of the flow and ride with it at the velocity  $V_1$ .
- The gas molecules, because of their random motion, will still bump into you, and you will feel the pressure  $p_1$  of the gas.
- We now give this pressure a specific name: the *static* pressure.
- **Static pressure** is a measure of the purely random motion of molecules in the gas.
- It is the pressure you feel when you ride along with the gas at the local flow velocity.





## Pitot tube

- Furthermore, consider a boundary of the flow, such as a wall, where a small hole is drilled perpendicular to the surface.
  - The plane of the hole is parallel to the flow.
  - Because the flow moves over the opening, the pressure felt at point *A* is due only to the random motion of the molecules.
- 
- That is, at point *A*, the static pressure is measured.
  - Such a small hole in the surface is called a *static pressure orifice*, or a *static pressure tap*.

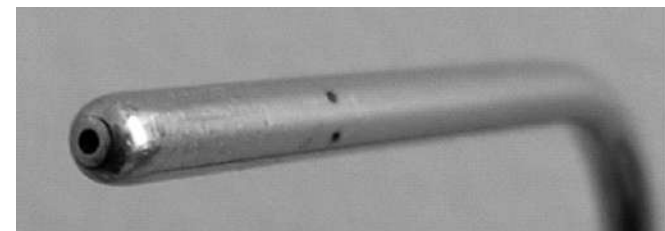
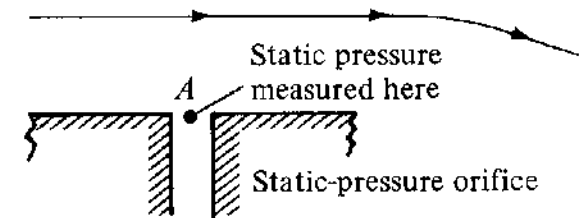



## Pitot tube

- In contrast, consider that a Pitot tube is now inserted into the flow, with an open end facing directly into the flow.
- That is, the plane of the opening of the tube is perpendicular to the flow.
- The other end of the Pitot tube is connected to a pressure gage, such as point C.
- The Pitot tube is closed at point C.

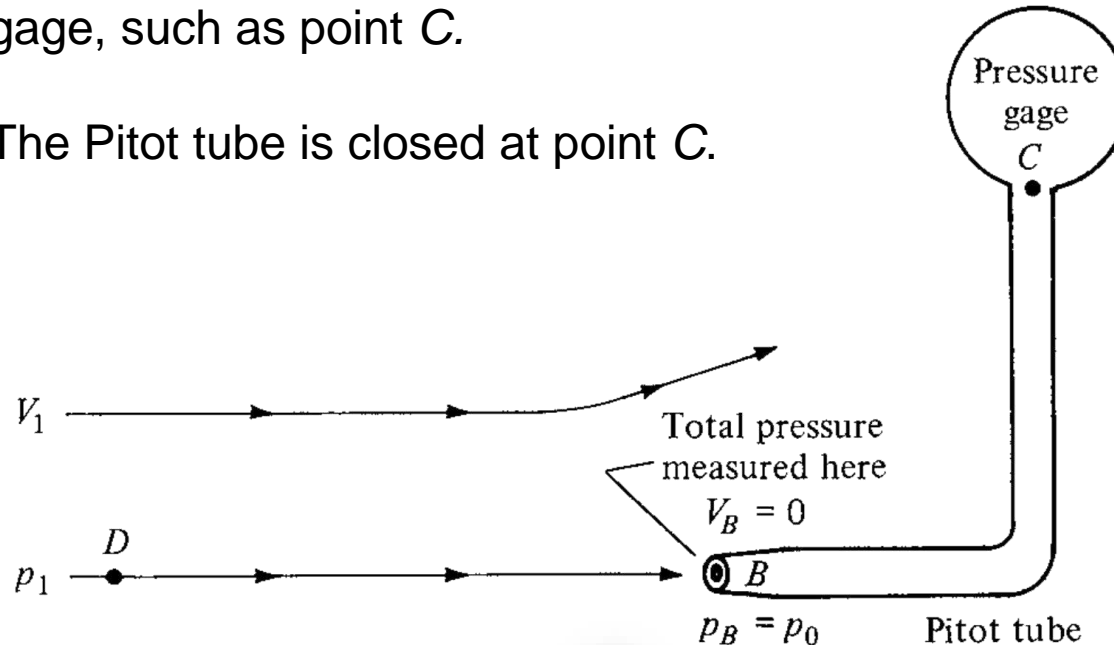



## Pitot tube

- For the first few milliseconds after the Pitot tube is inserted into the flow, the gas will rush into the open end and will fill the tube.
- However, the tube is closed at point *C*; there is no place for the gas to go.
- Hence after a brief period of adjustment, the gas inside the tube will stagnate; that is, the gas velocity inside the tube will go to zero.
- Indeed, the gas will eventually pile up and stagnate *everywhere* inside the tube, including at the open mouth at point *B*.
- Hence, point *B* at the open face of the Pitot tube is a stagnation point, where  $V_B = 0$ .





## Pitot tube

- From Bernoulli's equation we know the pressure increases as the velocity decreases. Hence,  $p_B > p_1$ .
  - The pressure at a stagnation point is called the *stagnation* pressure, or *total* pressure, denoted by  $p_0$ . Hence, at point  $B$ ,  $p_B = p_0$ .
  - The pressure gage at point  $C$  reads  $p_0$ .
  - This measurement, in conjunction with a measurement of the static pressure  $p_1$  at point  $A$ , yields the difference between total and static pressure,  $p_0 - p_1$ .
  - This pressure *difference* that allows the calculation of  $V_1$  via Bernoulli's equation.
- It is possible to combine the measurement of both total and static pressure in one instrument, a *Pitot-static probe*,

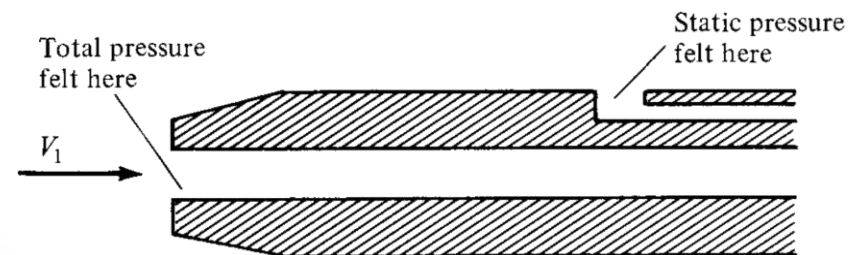



## Pitot tube

- Via Bernoulli's equation.

$$V_1 = \sqrt{\frac{2(p_0 - p_1)}{\rho}}$$

$$p_A + \frac{1}{2}\rho V_A^2 = p_B + \frac{1}{2}\rho V_B^2$$

$$p_1 + \frac{1}{2}\rho V_1^2 = p_0 + 0$$



- Equation allows the calculation of velocity simply from the measured difference between total and static pressure.



dynamic pressure

$$q \equiv \frac{1}{2}\rho V^2$$

$$p_1 + \frac{1}{2}\rho V_1^2 = p_0$$

static pressure      dynamic pressure      total pressure

- It is important to repeat that Bernoulli's equation holds for incompressible flow only.





## Pitot tube

### DESIGN BOX

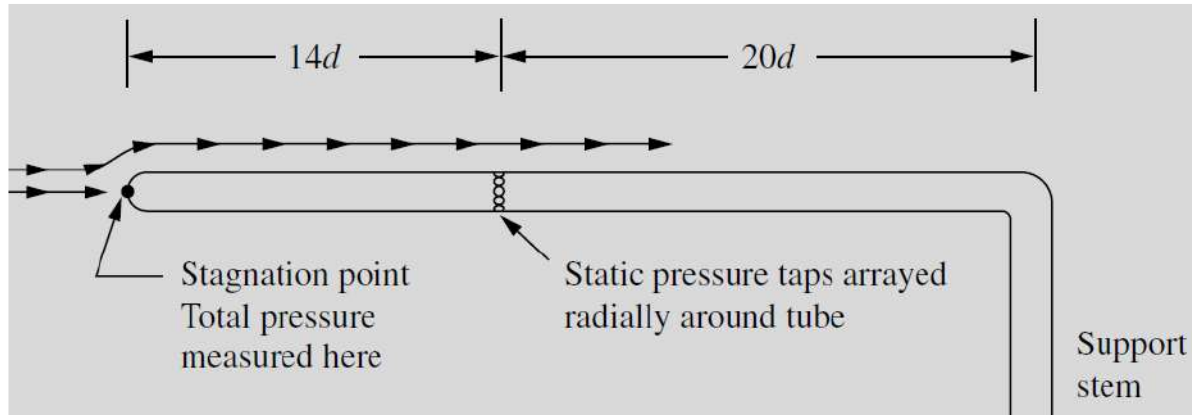

- The diameter of the tube is denoted by  $d$ .
- A number of static pressure taps are arrayed radially around the circumference of the tube.
- The location should be from  $8d$  to  $16d$  downstream of the nose, and at least  $16d$  ahead of the downstream support stem.







### Example 3.9

- Consider the P-35 aircraft cruising at a standard altitude of 4 km.
- The pressure sensed by the Pitot tube on its right wing is  $6.7 \times 10^4 \text{ N/m}^2$ .

- At what velocity is the P-35 flying?



- At a standard altitude of 4 km, the freestream static pressure and density are  $6.166 \times 10^4 \text{ N/m}^2$  and  $0.81935 \text{ kg/m}^3$ , respectively.
- The Pitot tube measures the total pressure of  $6.7 \times 10^4 \text{ N/m}^2$ . From Equation

$$V_1 = \sqrt{\frac{2(p_0 - p_1)}{\rho}} = \sqrt{\frac{2(6.7 - 6.166) \times 10^4}{0.81935}} = 114.2 \text{ m/s}$$





## Pressure coefficient

- Pressure, by itself, is a dimensional quantity
- However, we established the usefulness of certain dimensionless parameters such as  $M$ ,  $Re$ ,  $C_L$ .
- It makes sense, therefore, that a dimensionless pressure would also find use in aerodynamics.
- Such a quantity is the *pressure coefficient*  $C_p$ , and defined as

$$C_p \equiv \frac{p - p_\infty}{q_\infty} \quad q_\infty = \frac{1}{2} \rho_\infty V_\infty^2$$

- The pressure coefficient is another similarity parameter.





## Pressure coefficient

- For *incompressible flow*,  $C_p$  can be expressed in terms of velocity only.

- From Bernoulli's equation,  $p_\infty + \frac{1}{2}\rho V_\infty^2 = p + \frac{1}{2}\rho V^2$

$$p - p_\infty = \frac{1}{2}\rho (V_\infty^2 - V^2)$$

$$C_p = \frac{p - p_\infty}{q_\infty} = \frac{\frac{1}{2}\rho (V_\infty^2 - V^2)}{\frac{1}{2}\rho V_\infty^2}$$

- Finally,

$$C_p = 1 - \left(\frac{V}{V_\infty}\right)^2 \quad p = p_\infty + q_\infty C_p$$

- The pressure coefficient at a stagnation point (where  $V=0$ ) in an incompressible flow is always equal to 1.0.
- Also, keep in mind that in regions of the flow where  $V > V_\infty$  or  $p < p_\infty$ ,  $C_p$  will be a negative value.





### Example 3.12

- Consider the airplane model in wind tunnel.
- The pressure coefficient which occurs at a certain point on the airfoil surface is  $-5.3$ .
- Assuming inviscid, incompressible flow, calculate the velocity at this point when
  - (a)  $V_\infty = 80$  ft/s,
  - (b)  $V_\infty = 300$  ft/s.

$$C_p = 1 - \left( \frac{V}{V_\infty} \right)^2$$

$$V = \sqrt{V_\infty^2(1 - C_p)} = \sqrt{(80)^2[1 - (-5.3)]} = 200.8 \text{ ft/s}$$

$$V = \sqrt{V_\infty^2(1 - C_p)} = \sqrt{(300)^2[1 - (-5.3)]} = 753 \text{ ft/s}$$

- The answer given in part (b) of Example 3.12 is not correct.
- Why? The speed of sound at standard sea level is 1117 ft/s...





## Condition on velocity for Incompressible flow

- From the continuity equation,  $\frac{\partial \rho}{\partial t} + \nabla \cdot \rho \mathbf{V} = 0$
- For incompressible flow,  $\rho = \text{constant}$ . Hence,  $\partial \rho / \partial t = 0$

$$\nabla \cdot (\rho \mathbf{V}) = \rho \nabla \cdot \mathbf{V}$$

$$0 + \rho \nabla \cdot \mathbf{V} = 0$$

$$\nabla \cdot \mathbf{V} = 0$$

- Recall that  $\nabla \cdot \mathbf{V}$  is physically the time rate of change of the volume of a moving fluid element per unit volume.





## Governing equation for irrotational, incompressible flow: Laplace's equation

- For an incompressible flow  $\nabla \cdot \mathbf{V} = 0$
- For an irrotational flow we have seen that a velocity potential  $\phi$  can be defined such that

$$\mathbf{V} = \nabla \phi$$

- for a flow that is both incompressible and irrotational,

$$\nabla \cdot (\nabla \phi) = 0$$

$$\nabla^2 \phi = 0$$

- Equation is *Laplace's equation* and one of the most famous and extensively studied equations in mathematical physics.
- Laplace's equation is a second-order partial differential equation named after Pierre-Simon Laplace who first studied its properties.





## Laplace's equation

- Laplace's equation is written below in terms of the three common orthogonal coordinate systems

Cartesian coordinates  $\phi = \phi(x, y, z) \quad \nabla^2\phi = \frac{\partial^2\phi}{\partial x^2} + \frac{\partial^2\phi}{\partial y^2} + \frac{\partial^2\phi}{\partial z^2} = 0$

Cylindrical coordinates  $\phi = \phi(r, \theta, z) \quad \nabla^2\phi = \frac{1}{r} \frac{\partial}{\partial r} \left( r \frac{\partial\phi}{\partial r} \right) + \frac{1}{r^2} \frac{\partial^2\phi}{\partial\theta^2} + \frac{\partial^2\phi}{\partial z^2} = 0$

Spherical coordinates  $\phi = \phi(r, \theta, \Phi)$

$$\nabla^2\phi = \frac{1}{r^2 \sin\theta} \left[ \frac{\partial}{\partial r} \left( r^2 \sin\theta \frac{\partial\phi}{\partial r} \right) + \frac{\partial}{\partial\theta} \left( \sin\theta \frac{\partial\phi}{\partial\theta} \right) + \frac{\partial}{\partial\Phi} \left( \frac{1}{\sin\theta} \frac{\partial\phi}{\partial\Phi} \right) \right] = 0$$





## Laplace's equation

- We can show that the stream function also satisfies the Laplace's equation.
- Recall that, for a two-dimensional incompressible flow, a stream function  $\psi$  can be defined such that,

$$u = \frac{\partial \psi}{\partial y} \quad v = -\frac{\partial \psi}{\partial x}$$

- From the irrotationality condition  $\frac{\partial v}{\partial x} - \frac{\partial u}{\partial y} = 0$

$$\frac{\partial}{\partial x} \left( -\frac{\partial \psi}{\partial x} \right) - \frac{\partial}{\partial y} \left( \frac{\partial \psi}{\partial y} \right) = 0$$

$$\frac{\partial^2 \psi}{\partial x^2} + \frac{\partial^2 \psi}{\partial y^2} = 0$$







## Laplace's equation

- Note that Laplace's equation is a second-order linear partial differential equation.
- The fact that it is *linear* is particularly important.
- Because the sum of any particular solutions of a linear differential equation is also a solution of the equation.
- For example, if  $\phi_1, \phi_2, \phi_3, \dots, \phi_n$  represent  $n$  separate solutions of Equation, then the sum

$$\phi = \phi_1 + \phi_2 + \dots + \phi_n$$

Superposition  
principle

is also a solution of Equation.

- We conclude that a complicated flow pattern can be synthesized by adding together a number of elementary flows that are irrotational and incompressible.





## Laplace's equation

- By the same equation, namely,  $\nabla^2\Phi = 0$ , how, then, do we obtain different flows for the different bodies?
- The answer is found in the *boundary conditions*.
- Although the governing equation for the different flows is the same, the boundary conditions for the equation must conform to the different geometric shapes  
and hence yield different flow-field solutions.
- Boundary conditions are therefore of vital concern in aerodynamic analysis.





# Laplace's equation

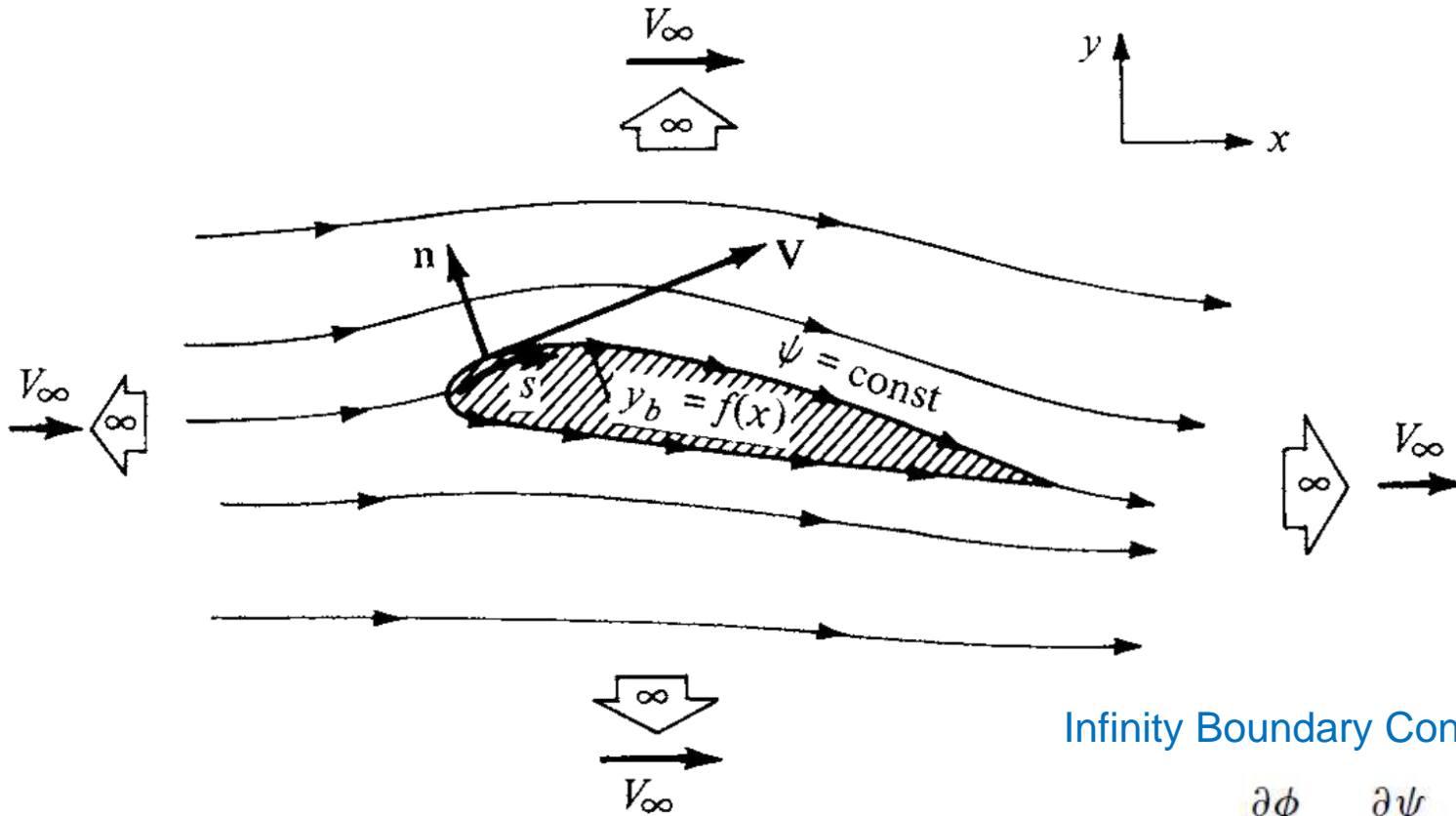

## Infinity Boundary Conditions

$$u = \frac{\partial \phi}{\partial x} = \frac{\partial \psi}{\partial y} = V_\infty$$

$$v = \frac{\partial \phi}{\partial y} = \frac{\partial \psi}{\partial x} = 0$$

- Therefore, two sets of boundary conditions apply as follows.





## Laplace's equation

Wall Boundary Conditions  $\mathbf{V} \cdot \mathbf{n} = (\nabla\phi) \cdot \mathbf{n} = 0$

$$\frac{\partial\phi}{\partial n} = 0$$

- The velocity vector must be *tangent* to the surface.
- If we are dealing with  $\psi$  rather than  $\phi$ , then the wall boundary condition is

$$\frac{\partial\psi}{\partial s} = 0 \quad \psi_{\text{surface}} = \psi_{y=y_b} = \text{const}$$

- The body surface is a streamline of the flow.  $\frac{dy_b}{dx} = \left(\frac{v}{u}\right)_{\text{surface}}$





## Laplace's equation

- The general approach to the solution of irrotational, incompressible flows can be summarized as follows:
  - Solve Laplace's equation for  $\Phi$  or  $\psi$  along with the proper boundary conditions.
  - Obtain the flow velocity from  $\mathbf{V} = \nabla\Phi$  or  $u = \partial\psi/\partial y$  and  $v = -\partial\psi/\partial x$ .
  - Obtain the pressure from Bernoulli's equation...



1749-1827





## Uniform flow

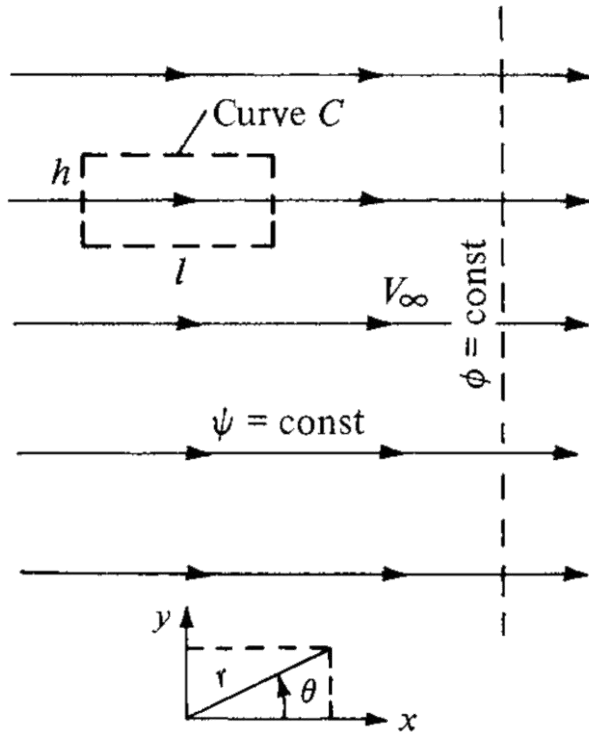

- Consider a uniform flow with velocity  $V_\infty$  oriented in the positive  $x$  direction.

$$\nabla\phi = \mathbf{V}.$$

$$\frac{\partial\phi}{\partial x} = u = V_\infty \quad \frac{\partial\phi}{\partial y} = v = 0$$

- Integrating 1st Equation with respect to  $x$ , we have

$$\phi = V_\infty x + f(y)$$

- Integrating 2nd Equation with respect to  $y$ , we have

$$\phi = \text{const} + g(x)$$

- By comparing these equations,

$$\phi = V_\infty x + \text{const}$$

the velocity potential for a uniform flow

$$g(x) = V_\infty x$$

$$f(y) = \text{const}$$

$$\phi = V_\infty x$$





## Uniform flow

- Consider the incompressible stream function  $\psi$ . We have

$$\frac{\partial \psi}{\partial y} = u = V_{\infty}$$

$$\frac{\partial \psi}{\partial x} = -v = 0$$

- Integrating Equations with respect to  $x$ ,  $y$  and comparing the results, we obtain

$$\psi = V_{\infty}y \quad \text{the stream function for a uniform flow}$$

- Equations can be expressed in terms of polar coordinates,

$$x = r \cos \theta$$

$$y = r \sin \theta$$

$$\phi = V_{\infty}r \cos \theta$$

$$\psi = V_{\infty}r \sin \theta$$





## Uniform flow

- Consider the circulation in a uniform flow.

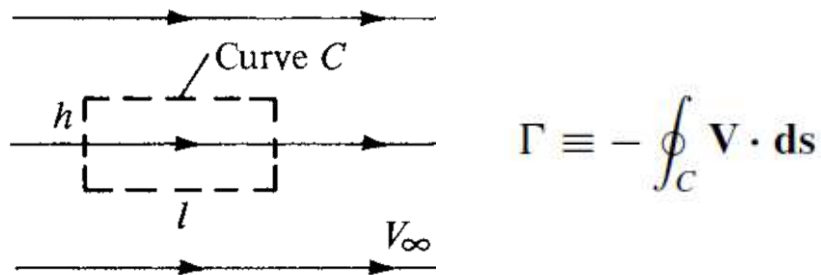

$$\oint_C \mathbf{V} \cdot d\mathbf{s} = -V_\infty l - 0(h) + V_\infty l + 0(h) = 0$$

$$\Gamma = 0$$

- Equation is true for any arbitrary closed curve in the uniform flow.

$$\Gamma = - \oint_C \mathbf{V} \cdot d\mathbf{s} = -\mathbf{V}_\infty \cdot \oint_C d\mathbf{s} = \mathbf{V}_\infty \cdot \mathbf{0} = 0$$







## Source flow

- Consider a two-dimensional, incompressible flow where all the streamlines are straight lines emanating from a central point  $O$ .

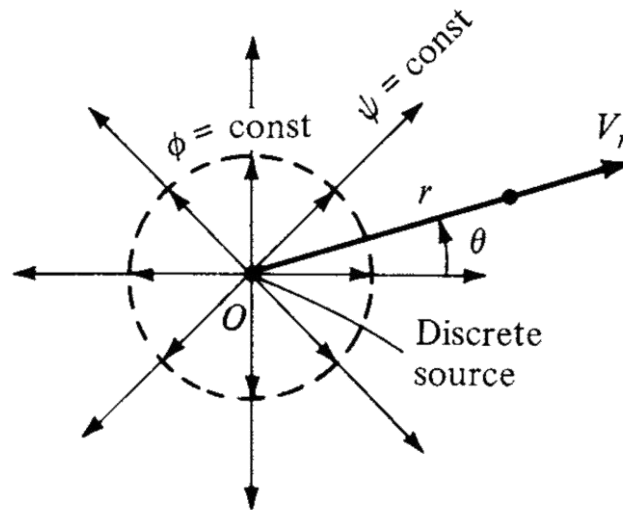

Source flow

- Let the velocity along each of the streamlines vary inversely with distance from point  $O$ .
- Such a flow is called a *source flow*.





## Source flow

- Consider a two-dimensional, incompressible flow where all the streamlines are directed *toward* the origin point  $O$ .

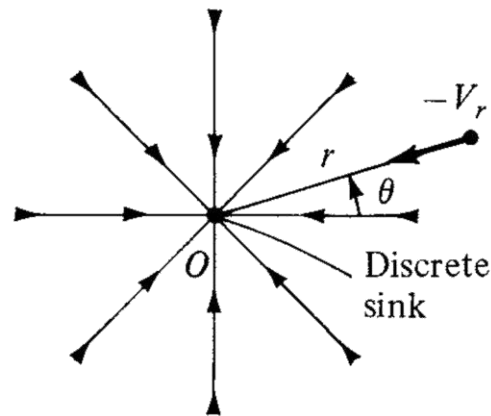

Sink flow

- the origin is a *singular point*

- The flow velocity varies inversely with distance from point  $O$ .
- Indeed, a sink flow is simply a negative source flow.





## Source flow

- By definition,

$$V_r = \frac{c}{r}$$

$$V_\theta = 0$$

where  $c$  is constant.

- The value of the constant is related to the volume flow from the source

$$\dot{v} = \frac{\dot{m}}{\rho}$$

$$\dot{m} = \int_0^{2\pi} \rho \mathbf{V} \cdot d\mathbf{S} = \int_0^{2\pi} \rho V_r (r d\theta) l = \rho r l V_r \int_0^{2\pi} d\theta = 2\pi r l \rho V_r$$

$$\dot{v} = \frac{\dot{m}}{\rho} = 2\pi r l V_r$$

- Denote this volume flow rate per unit length as  $\Lambda$

$$\Lambda = \frac{\dot{v}}{l} = 2\pi r V_r$$

- So, the radial velocity,  $V_r = \frac{\Lambda}{2\pi r}$

$\Lambda$  defines the source strength,

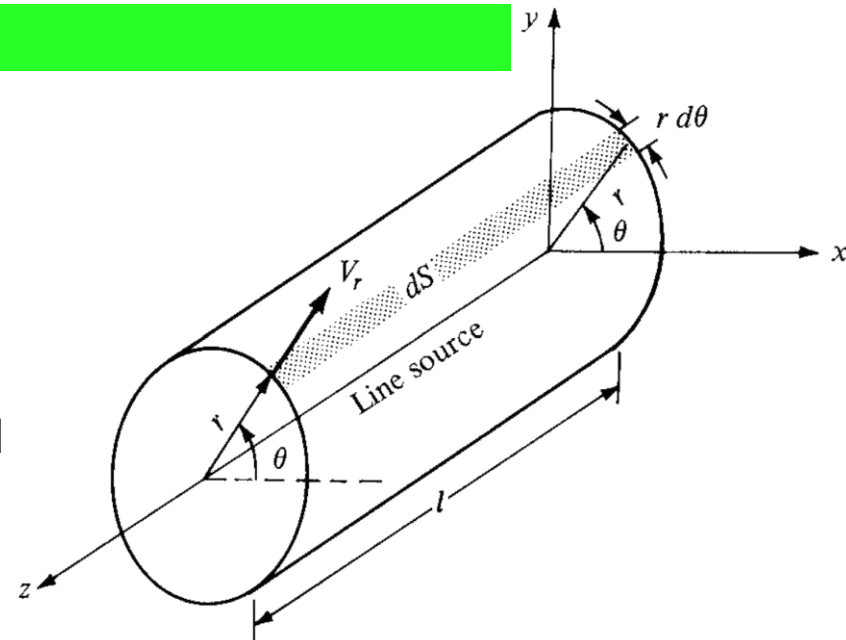



## Source flow

- The velocity potential for a source can be obtained as follows.

$$\frac{\partial \phi}{\partial r} = V_r = \frac{\Lambda}{2\pi r} \quad \frac{1}{r} \frac{\partial \phi}{\partial \theta} = V_\theta = 0$$

- Integrating Equation with respect to  $r$ , we have

$$\phi = \frac{\Lambda}{2\pi} \ln r + f(\theta)$$

- Integrating Equation with respect to  $\theta$ , we have

$$\phi = \text{const} + f(r)$$

- Comparing Equations, we see that  $\phi = \frac{\Lambda}{2\pi} \ln r$





## Source flow

- The stream function can be obtained as follows.

$$\frac{1}{r} \frac{\partial \psi}{\partial \theta} = V_r = \frac{\Lambda}{2\pi r} \quad -\frac{\partial \psi}{\partial r} = V_\theta = 0$$

$$\psi = \frac{\Lambda}{2\pi} \theta + f(r) \quad \psi = \text{const} + f(\theta)$$

$$\psi = \frac{\Lambda}{2\pi} \theta$$

- To evaluate the circulation for source flow, recall the  $\nabla \times \mathbf{V} = 0$  everywhere.

$$\Gamma = - \iint_S (\nabla \times \mathbf{V}) \cdot d\mathbf{S} = 0$$





## Combination of a uniform flow with a source and sink

- Consider a polar coordinate system with a source of strength  $\Lambda$  located at the origin.
- Superimpose on this flow a uniform stream with velocity  $V_\infty$  moving from left to right,
- The stream function for the resulting [flow](#) is the sum of Equations

$$\psi = V_\infty r \sin \theta + \frac{\Lambda}{2\pi} \theta$$

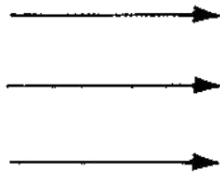

Uniform stream

$$\psi = V_\infty r \sin \theta$$

+

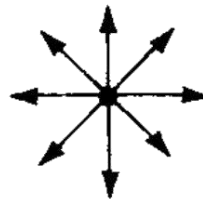

Source

$$\psi = \frac{\Lambda}{2\pi} \theta$$

=

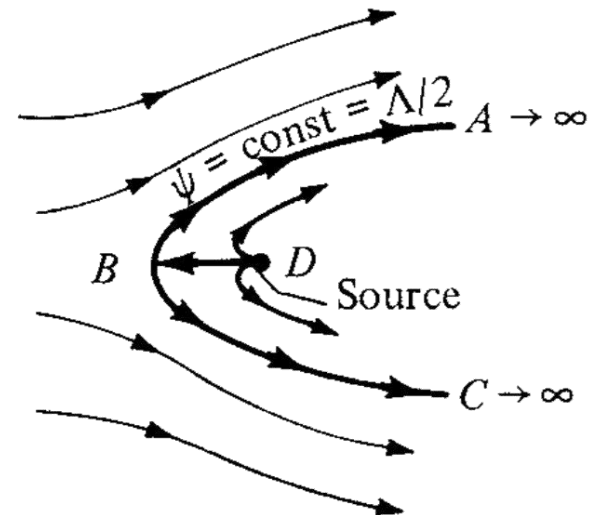

$$\psi = V_\infty r \sin \theta + \frac{\Lambda}{2\pi} \theta$$





## Combination of a uniform flow with a source and sink

- The velocity field is obtained by differentiating Equation

$$V_r = \frac{1}{r} \frac{\partial \psi}{\partial \theta} = V_\infty \cos \theta + \frac{\Lambda}{2\pi r} \quad V_\theta = -\frac{\partial \psi}{\partial r} = -V_\infty \sin \theta$$

- Note that, consistent with the linear nature of Laplace's equation,
  - not only can we add the values of  $\phi$  or  $\psi$  to obtain more complex solutions,
  - we can add their derivatives, that is, the velocities, as well.
- The stagnation points in the flow can be obtained by setting Equations equal to zero

$$V_\infty \cos \theta + \frac{\Lambda}{2\pi r} = 0 \quad V_\infty \sin \theta = 0$$

one stagnation point exists  $(r, \theta) = (\Lambda/2\pi V_\infty, \pi)$





## Combination of a uniform flow with a source and sink

- If the coordinates of the stagnation point at  $B$  are substituted into Equation, we obtain

$$\psi = V_{\infty} \frac{\Lambda}{2\pi V_{\infty}} \sin \pi + \frac{\Lambda}{2\pi} \pi = \text{const} \quad \psi = \frac{\Lambda}{2}$$

- This is a half-body that stretches to infinity in the downstream direction (i.e., the body is not closed).
- However, if we take a sink of equal strength as the source and add it to the flow downstream of point  $D$ , then the resulting body shape will be closed.
- Let us examine this flow in more detail.







## Combination of a uniform flow with a source and sink

- Consider a polar coordinate system with a source and sink placed a distance  $b$  to the left and right of the origin, respectively.
- The strengths of the source and sink are  $\Lambda$  and  $-\Lambda$ , respectively (equal and opposite).
- In addition, superimpose a uniform stream with velocity  $V_\infty$ , as shown in Figure.

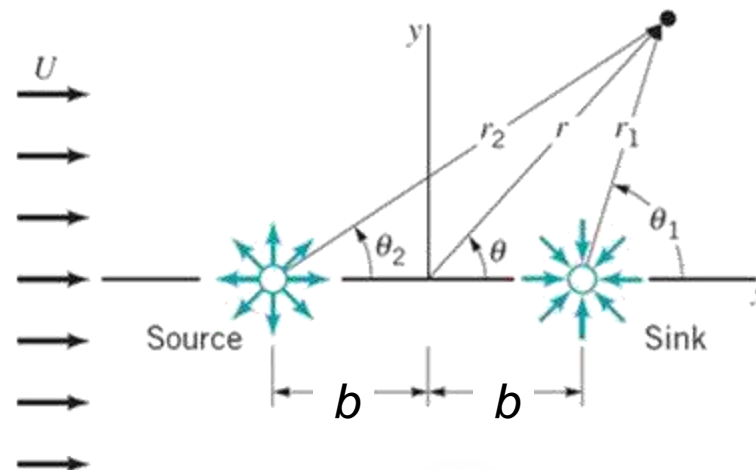



## Combination of a uniform flow with a source and sink

- The stream function for the combined flow at any point  $P$  with coordinates  $(r, \theta)$  is obtained from Equations

$$\psi = V_{\infty} r \sin \theta + \frac{\Lambda}{2\pi} \theta_1 - \frac{\Lambda}{2\pi} \theta_2 \qquad \psi = V_{\infty} r \sin \theta + \frac{\Lambda}{2\pi} (\theta_1 - \theta_2)$$

- Note from the geometry that  $\theta_1$  and  $\theta_2$  are functions of  $r$ ,  $\theta$ , and  $b$ .

$$\psi = \psi_{\text{uniform}} + \psi_{\text{source}} + \psi_{\text{sink}} = V_{\infty} r \sin \theta + \frac{\Lambda}{2\pi} (\theta_1 - \theta_2)$$

$$\text{or, } \psi = V_{\infty} r \sin \theta - \frac{\Lambda}{2\pi} \tan^{-1} \left( \frac{2br \sin \theta}{r^2 - b^2} \right)$$

$$\text{or, } \psi = V_{\infty} y - \frac{\Lambda}{2\pi} \tan^{-1} \left( \frac{2by}{x^2 + y^2 - b^2} \right)$$

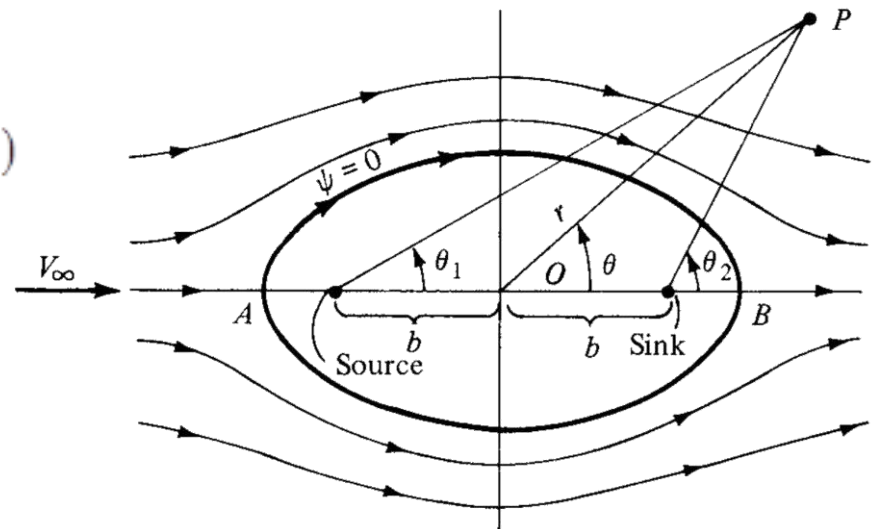

Scottish engineer W. J. M. Rankine.  
a Rankine oval.





## Combination of a uniform flow with a source and sink

- By setting  $V = 0$ , two stagnation points are found, namely, points  $A$  and  $B$ ,

$$\theta = \theta_1 = \theta_2 = \pi \text{ at point } A$$
$$\theta = \theta_1 = \theta_2 = 0 \text{ at point } B$$
$$OA = OB = \sqrt{b^2 + \frac{\Lambda b}{\pi V_\infty}}$$

- The stagnation streamline is given by  $\psi = 0$ , that is,

$$V_\infty r \sin \theta + \frac{\Lambda}{2\pi} (\theta_1 - \theta_2) = 0$$

- The region inside the oval can be replaced by a solid body with the shape given by  $\psi = 0$ .
- The region outside the oval can be interpreted as the inviscid, potential (irrotational), incompressible flow over the solid body.





## Combination of a uniform flow with a source and sink

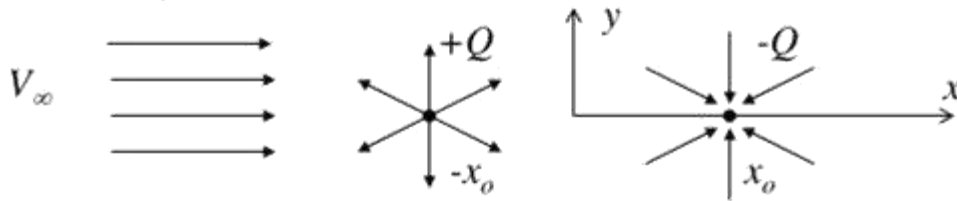

apply:

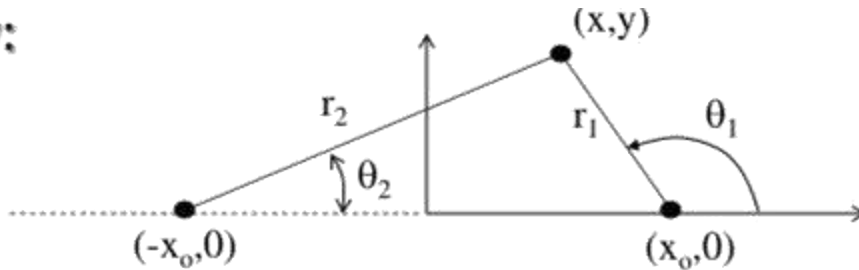

$$r_2 = \sqrt{(x+x_0)^2 + y^2}$$

$$\theta_2 = \text{atan} \frac{y}{x+x_0}$$

$$r_1 = \sqrt{(x-x_0)^2 + y^2}$$

$$\theta_1 = \text{atan} \frac{y}{x-x_0}$$

$$u = V_\infty + \frac{Q}{2\pi} \left[ \frac{(x+x_0)}{(x+x_0)^2 + y^2} - \frac{(x-x_0)}{(x-x_0)^2 + y^2} \right]$$

$$v = \frac{Qy}{2\pi} \left[ \frac{1}{(x+x_0)^2 + y^2} - \frac{1}{(x-x_0)^2 + y^2} \right]$$

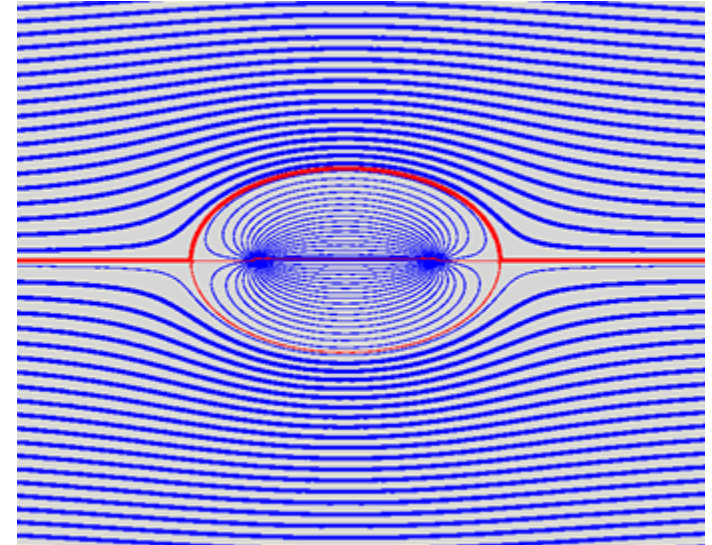



## Doublet flow

- There is a special case of a source-sink pair that leads to a singularity called a *doublet*.
- Consider a source of strength  $\Lambda$  and a sink of equal strength  $-\Lambda$  separated by a distance  $l$ , the stream function is

$$\psi = \frac{\Lambda}{2\pi}(\theta_1 - \theta_2) = -\frac{\Lambda}{2\pi} \Delta\theta \quad \Delta\theta = \theta_2 - \theta_1$$

- The geometry yields

$$a = l \sin \theta$$

$$b = r - l \cos \theta$$

$$d\theta = \frac{a}{b}$$

$$d\theta = \frac{a}{b} = \frac{l \sin \theta}{r - l \cos \theta}$$

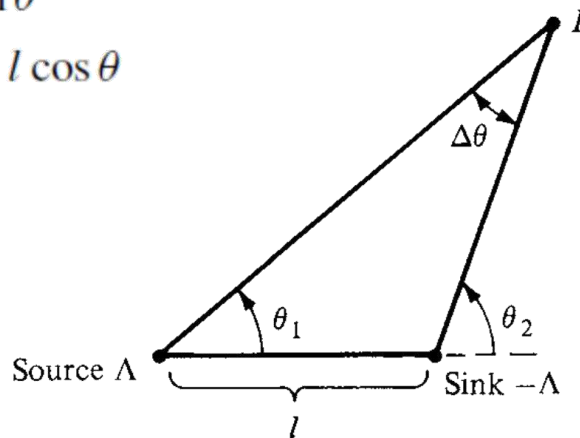

(a) Source-sink pair

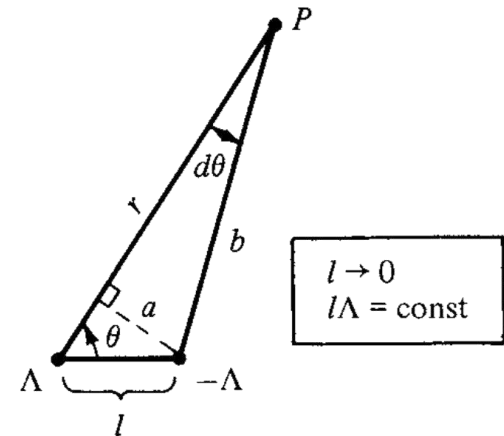

(b) Limiting case for a doublet





## Doublet flow

- Let the distance  $l$  approach zero while the absolute magnitudes of the strengths of the source and sink increase in such a fashion that the product  $l\Lambda$  remains constant.

$$\psi = \lim_{\substack{l \rightarrow 0 \\ \kappa = l\Lambda = \text{const}}} \left( -\frac{\Lambda}{2\pi} d\theta \right)$$

- Substituting  $d\theta$  equation, we have  $\psi = \lim_{\substack{l \rightarrow 0 \\ \kappa = \text{const}}} \left( -\frac{\Lambda}{2\pi} \frac{l \sin \theta}{r - l \cos \theta} \right)$

$$\psi = \lim_{\substack{l \rightarrow 0 \\ \kappa = \text{const}}} \left( -\frac{\kappa}{2\pi} \frac{\sin \theta}{r - l \cos \theta} \right)$$

$$\psi = -\frac{\kappa}{2\pi} \frac{\sin \theta}{r} \quad \kappa \equiv l\Lambda$$

- The strength of the doublet is denoted by  $\kappa$
- Velocity potential for a doublet is given by  $\phi = \frac{\kappa}{2\pi} \frac{\cos \theta}{r}$





## Doublet flow

- The streamlines of a doublet flow are obtained from

$$\psi = -\frac{\kappa}{2\pi} \frac{\sin \theta}{r} = \text{const} = c$$

$$r = -\frac{\kappa}{2\pi c} \sin \theta$$

$$r = d \sin \theta$$

- A circle with a diameter  $d$  on the vertical axis and with the center located  $d/2$  directly above the origin.
- The direction of flow is out of the origin to the left and back into the origin from the right.
- By convention, we designate the direction of the doublet by an arrow drawn from the sink to the source.

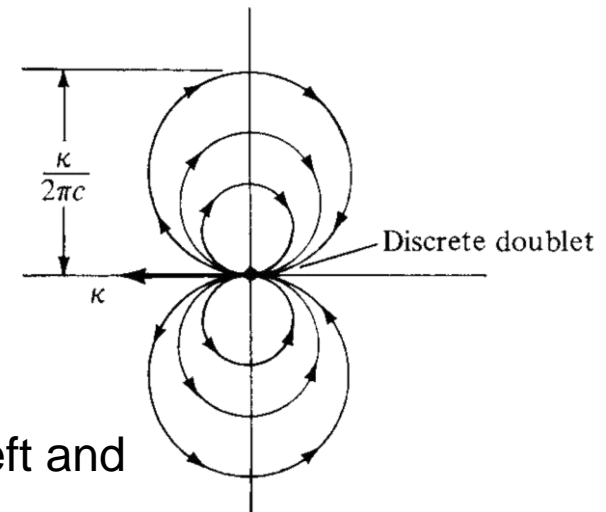



## Nonlifting flow over A circular cylinder

- Consider the addition of a uniform flow with velocity  $V_\infty$  and a doublet of strength  $\kappa$ , as shown in Figure
- The stream function for the combined flow is 
$$\psi = V_\infty r \sin \theta \left( 1 - \frac{\kappa}{2\pi V_\infty r^2} \right)$$



Uniform flow

$$\psi = V_\infty r \sin \theta$$

+

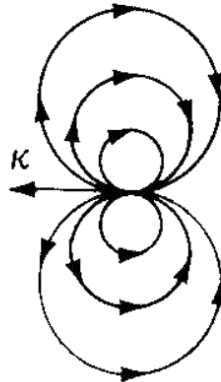

Doublet

$$\psi = \frac{-\kappa}{2\pi} \frac{\sin \theta}{r}$$

=

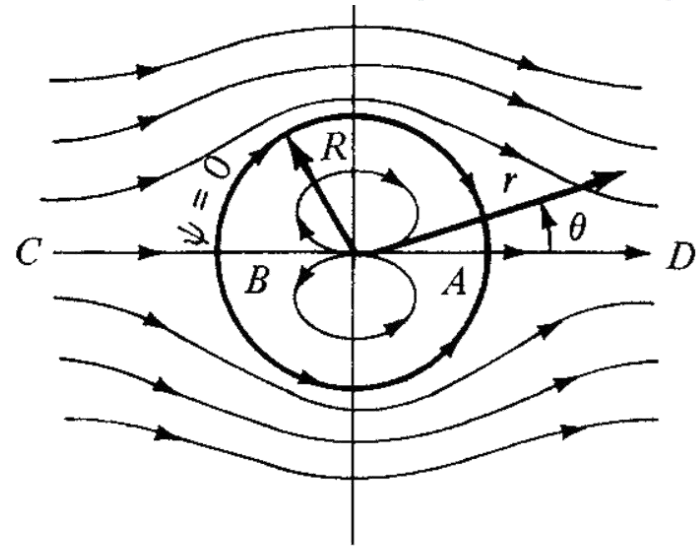

Flow over a cylinder

$$\psi = V_\infty r \sin \theta - \frac{\kappa}{2\pi} \frac{\sin \theta}{r}$$







## Nonlifting flow over A circular cylinder

- Let  $R^2 \equiv \kappa/2\pi V_\infty$
- Then Equation can be written as  $\psi = (V_\infty r \sin \theta) \left(1 - \frac{R^2}{r^2}\right)$
- Equation is the stream function for a uniform flow-doublet combination.
- It is also the stream function for the flow over a circular cylinder of radius  $R$ .

- The velocity field is obtained by

$$V_r = \frac{1}{r} \frac{\partial \psi}{\partial \theta} = \left(1 - \frac{R^2}{r^2}\right) V_\infty \cos \theta$$

$$V_\theta = -\frac{\partial \psi}{\partial r} = -\left(1 + \frac{R^2}{r^2}\right) V_\infty \sin \theta$$

- The stagnation points,  
 $(r, \theta) = (R, 0)$  and  $(R, \pi)$

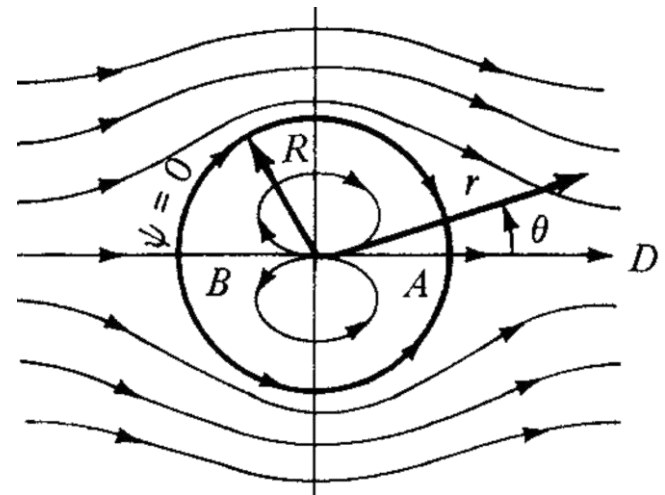



## Nonlifting flow over A circular cylinder

- The equation of this streamline where it goes through the stagnation points

$$\psi = (V_{\infty} r \sin \theta) \left( 1 - \frac{R^2}{r^2} \right) = 0$$

- Consequently, the inviscid irrotational, incompressible flow over a circular cylinder of radius  $R$  can be synthesized by a uniform flow and a doublet;

$$R = \sqrt{\frac{\kappa}{2\pi V_{\infty}}}$$

- The velocity distribution on the surface of the cylinder is given by

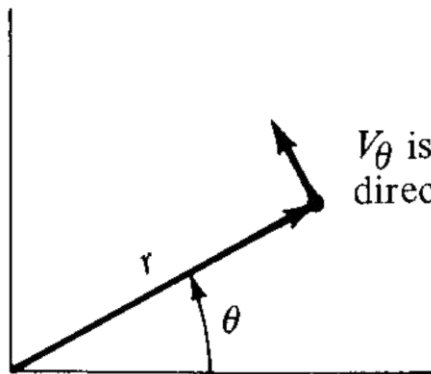

$V_{\theta}$  is positive in the direction of increasing  $\theta$

$$r = R, \quad \begin{aligned} V_r &= 0 \\ V_{\theta} &= -2V_{\infty} \sin \theta \end{aligned}$$

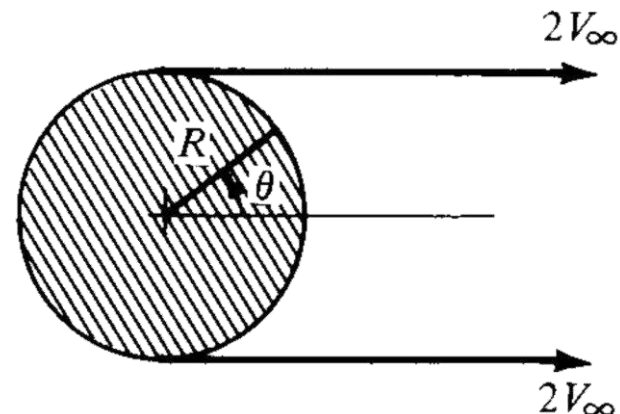
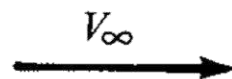



## Nonlifting flow over A circular cylinder

- The pressure coefficient is given by  $C_p = 1 - \left(\frac{V}{V_\infty}\right)^2$   
$$C_p = 1 - 4 \sin^2 \theta$$
- The pressure coefficient distribution over the surface is sketched

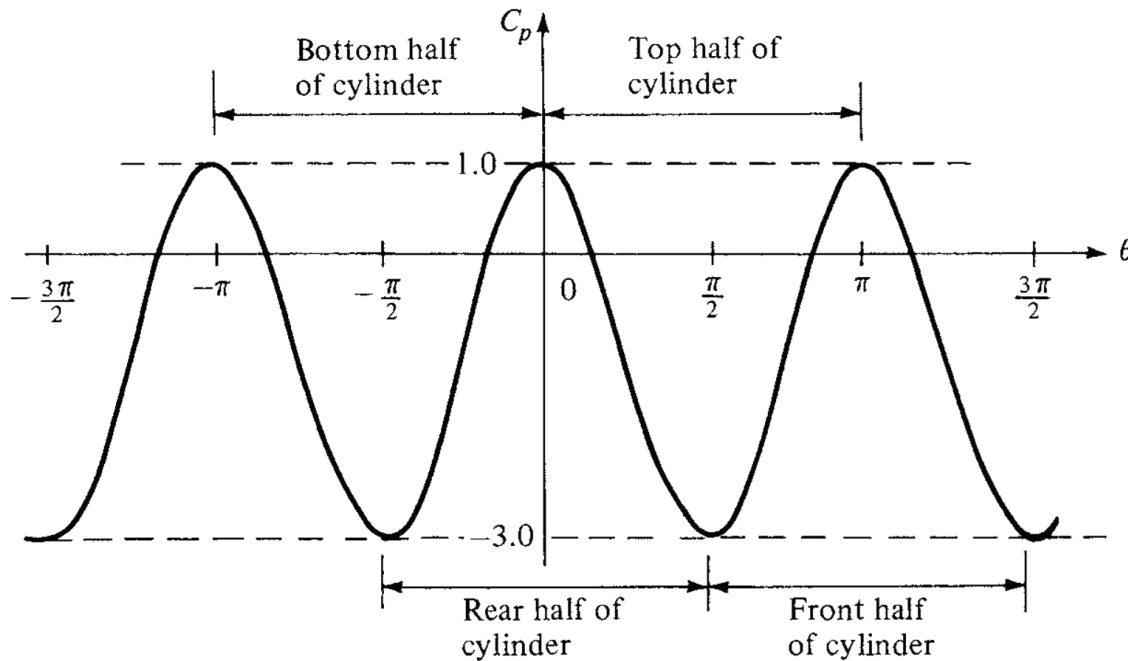



## Nonlifting flow over A circular cylinder

- Clearly, the pressure distribution over the top half of the cylinder is equal to the pressure distribution over the bottom half.
- Hence the lift must be zero.
- Clearly, the pressure distributions over the front and rear halves are the same.
- Hence the drag is theoretically zero.





## Example 3.13

- Consider the nonlifting flow over a circular cylinder.
- Calculate** the locations on the surface of the cylinder where the surface pressure equals the freestream pressure.

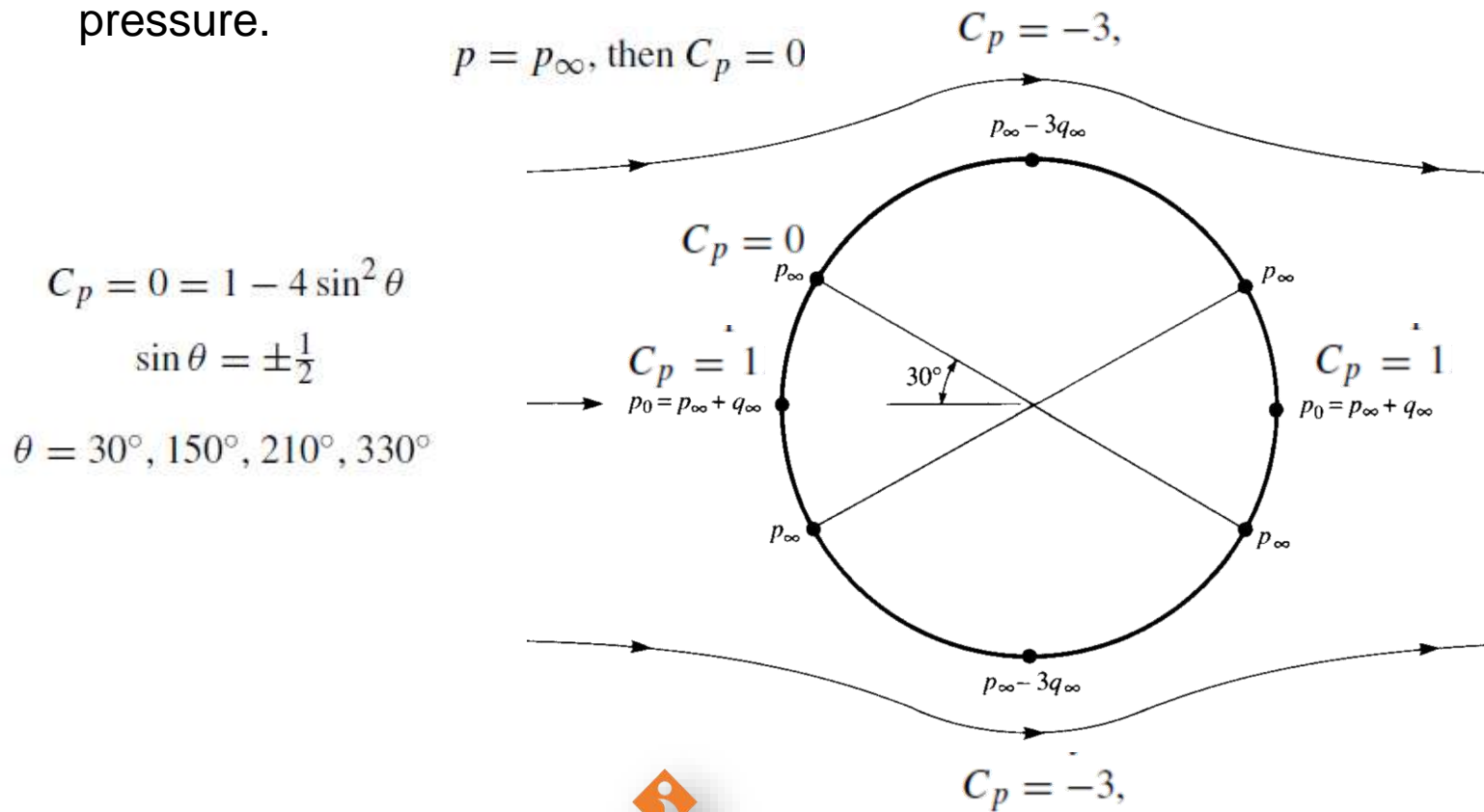



## Example 3.14

- In the nonlifting flow over a circular cylinder, consider the infinitesimally small fluid elements moving along the surface of the cylinder.
- **Calculate** the angular locations over the surface where the acceleration of the fluid elements are a local maximum and minimum.
- The radius of the cylinder is 1 m and the freestream flow velocity is 50 m/s, calculate the values of the local maximum and minimum accelerations.

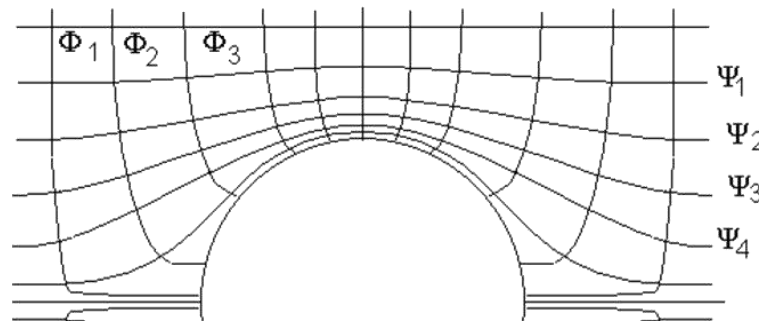



### Example 3.14

- The local velocity of the fluid elements on the surface

$$V_{\theta} = -2V_{\infty} \sin \theta$$

- The acceleration of the fluid elements is  $dV_{\theta}/dt$

$$\frac{dV_{\theta}}{dt} = -2V_{\infty}(\cos \theta) \frac{d\theta}{dt}$$

- Incremental distance on the cylinder surface subtended by  $d\theta$  is  $ds$

$$ds = R d\theta$$

$$\frac{d\theta}{dt} = \frac{1}{R} \frac{ds}{dt} \quad V_{\theta} \equiv ds/dt$$

$$\frac{dV_{\theta}}{dt} = -2V_{\infty}(\cos \theta) \left( \frac{V_{\theta}}{R} \right) \quad \frac{dV_{\theta}}{dt} = \frac{4V_{\infty}^2}{R} \sin \theta \cos \theta \quad \frac{dV_{\theta}}{dt} = \frac{2V_{\infty}^2}{R} \sin 2\theta$$

$$\sin 2\theta \equiv 2 \sin \theta \cos \theta$$





## Example 3.14

- To find the  $\theta$  locations at which the acceleration is a maximum or minimum, differentiate Equation with respect to  $\theta$ , and set the result equal to zero.

$$\frac{d}{d\theta} \left( \frac{dV_\theta}{dt} \right) = \frac{4V_\infty^2}{R} \cos 2\theta = 0 \quad \theta = 45^\circ, 135^\circ, 225^\circ, 315^\circ$$

- The values of the local flow acceleration at each one of these locations are respectively

$$\frac{dV_\theta}{dt} = \frac{2V_\infty^2}{R} \sin 2\theta \quad \frac{2V_\infty^2}{R}, -\frac{2V_\infty^2}{R}, \frac{2V_\infty^2}{R}, -\frac{2V_\infty^2}{R}$$

$\theta = 45^\circ$  minimum acceleration

$\theta = 135^\circ$  maximum *acceleration*.

for  $R = 1$  m and  $V_\infty = 50$  m/s  $\frac{2V_\infty^2}{R} = \frac{2(50)^2}{(1)} = 5000$  m/s<sup>2</sup>

$$\frac{5000}{9.8} = 510.2 \text{ g}$$

Tremendously  
large accelerations







## Vortex flow

- Consider a flow where all the streamlines are concentric circles about a given point, as sketched in Figure;
- Let the velocity along any given circular streamline be constant.
- But let it vary from one streamline to another inversely with distance from the common center.
- Such a flow is called a *vortex flow*.

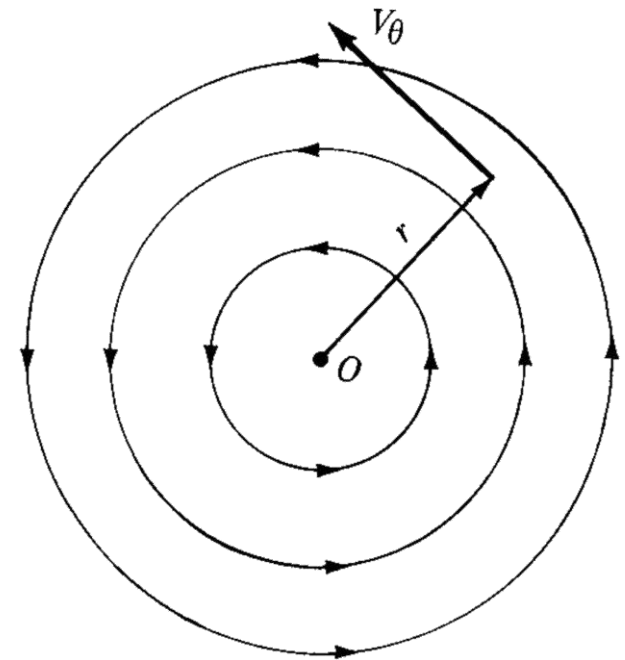

$$V_r = 0$$

$$V_\theta = \frac{\text{const}}{r} = \frac{C}{r}$$





## Vortex flow

- To evaluate the constant  $C$ , take the circulation around a given circular streamline of radius  $r$

$$\Gamma = - \oint_C \mathbf{V} \cdot d\mathbf{s} = -V_\theta(2\pi r)$$
$$V_\theta = -\frac{\Gamma}{2\pi r} \qquad C = -\frac{\Gamma}{2\pi}$$

- Therefore, for vortex flow, Equation demonstrates that the circulation taken about all streamlines is the same value, namely,

$$\Gamma = -2\pi C$$

- $\Gamma$  is called the *strength* of the vortex flow.
- We stated earlier that vortex flow is irrotational except at the origin.
- The origin,  $r = 0$ , is a singular point in the flow field.





## Vortex flow

- The velocity potential for vortex flow

$$\frac{\partial \phi}{\partial r} = V_r = 0$$

$$\frac{1}{r} \frac{\partial \phi}{\partial \theta} = V_\theta = -\frac{\Gamma}{2\pi r}$$

$$\phi = -\frac{\Gamma}{2\pi} \theta$$

- The stream function is determined in a similar manner

$$\frac{1}{r} \frac{\partial \psi}{\partial \theta} = V_r = 0$$

$$-\frac{\partial \psi}{\partial r} = V_\theta = -\frac{\Gamma}{2\pi r}$$

$$\psi = \frac{\Gamma}{2\pi} \ln r$$





## Summary for elementary flows

Type of flow	Velocity	$\phi$	$\psi$
Uniform flow in $x$ direction	$u = V_\infty$	$V_\infty x$	$V_\infty y$
Source	$V_r = \frac{\Lambda}{2\pi r}$	$\frac{\Lambda}{2\pi} \ln r$	$\frac{\Lambda}{2\pi} \theta$
Vortex	$V_\theta = -\frac{\Gamma}{2\pi r}$	$-\frac{\Gamma}{2\pi} \theta$	$\frac{\Gamma}{2\pi} \ln r$
Doublet	$V_r = -\frac{\kappa \cos \theta}{2\pi r^2}$ $V_\theta = -\frac{\kappa \sin \theta}{2\pi r^2}$	$\frac{\kappa \cos \theta}{2\pi r}$	$-\frac{\kappa \sin \theta}{2\pi r}$





## Lifting over a cylinder

- Consider the flow synthesized by the addition of the nonlifting flow over a cylinder and a vortex of strength  $\Gamma$ , as shown in Figure

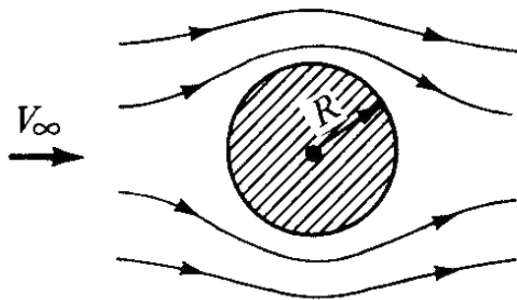

Nonlifting flow  
over a cylinder

$$\psi_1 = (V_\infty r \sin \theta) \left( 1 - \frac{R^2}{r^2} \right)$$

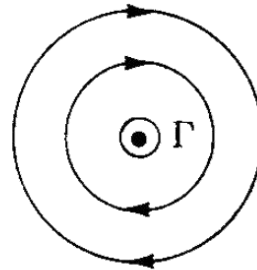

Vortex of  
strength  $\Gamma$

$$\psi_2 = \frac{\Gamma}{2\pi} \ln r + \text{const}$$

$$\text{Const} = -\frac{\Gamma}{2\pi} \ln R$$

$$\psi_2 = \frac{\Gamma}{2\pi} \ln \frac{r}{R}$$

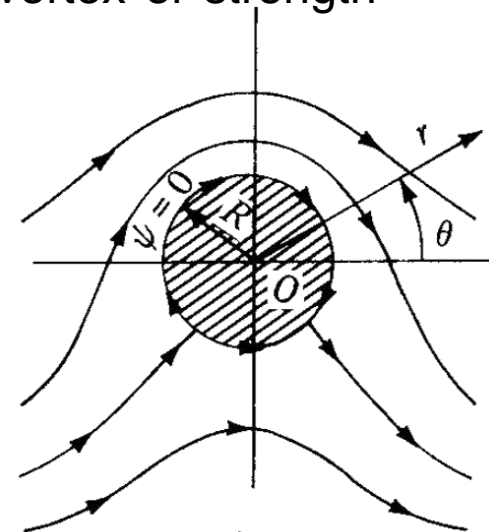

Lifting flow over  
a cylinder

$$\psi = \psi_1 + \psi_2$$

$$\psi = (V_\infty r \sin \theta) \left( 1 - \frac{R^2}{r^2} \right) + \frac{\Gamma}{2\pi} \ln \frac{r}{R}$$





## Lifting over a cylinder

- Note that the streamlines are no longer symmetrical about the horizontal axis through point  $O$ .
- That the cylinder will experience a resulting finite normal force.
- However, the streamlines are symmetrical about the vertical axis through  $O$ .
- As a result the drag will be zero.
- The velocity field can be obtained by

$$V_r = \left(1 - \frac{R^2}{r^2}\right) V_\infty \cos \theta$$

$$V_\theta = - \left(1 + \frac{R^2}{r^2}\right) V_\infty \sin \theta - \frac{\Gamma}{2\pi r}$$





## Lifting over a cylinder

- To locate the stagnation points in the flow, set  $V_r = V_\theta = 0$

$$V_r = \left(1 - \frac{R^2}{r^2}\right) V_\infty \cos \theta = 0$$

$$V_\theta = -\left(1 + \frac{R^2}{r^2}\right) V_\infty \sin \theta - \frac{\Gamma}{2\pi r} = 0$$

$$r = R$$

$$\theta = \arcsin\left(-\frac{\Gamma}{4\pi V_\infty R}\right)$$

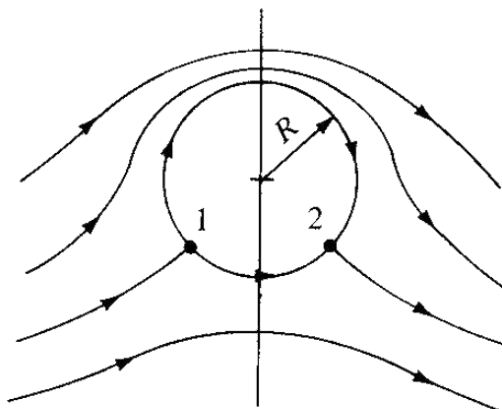

(a)  $\Gamma < 4\pi V_\infty R$

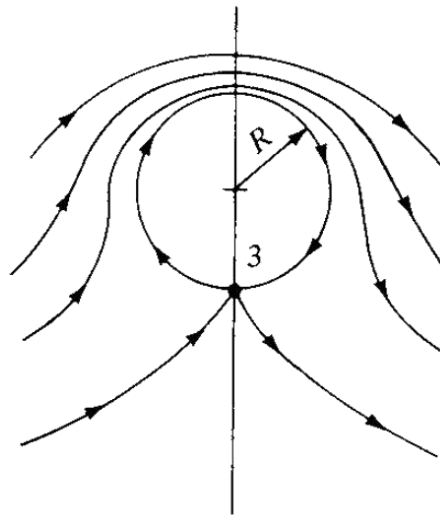

(b)  $\Gamma = 4\pi V_\infty R$

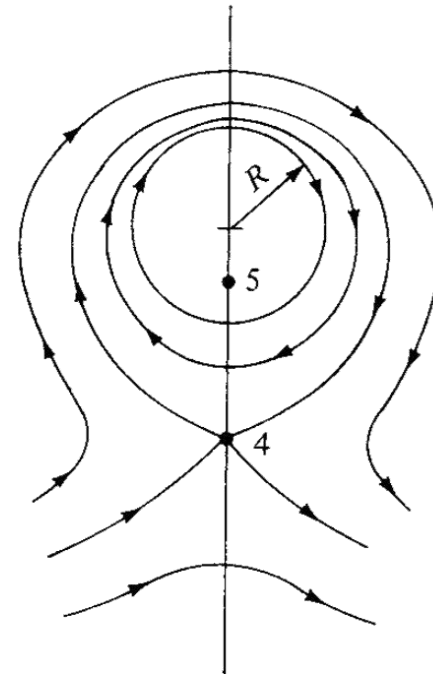

(c)  $\Gamma > 4\pi V_\infty R$





## Lifting over a cylinder

- From the above discussion,  $\Gamma$  is clearly a parameter that can be chosen freely.
- There is no single value of  $\Gamma$  that “solves” the flow over a circular cylinder; rather, the circulation can be any value.
- Therefore, for the incompressible flow over a circular cylinder, there are an infinite number of possible potential flow solutions, corresponding to the infinite choices for values of  $\Gamma$ .
- This statement is not limited to flow over circular cylinders, but rather, it is a general statement that holds for the incompressible potential flow over all smooth two-dimensional bodies.







## Lifting over a cylinder

- The velocity on the surface of the cylinder is given by ( $r=R$ ),

$$V = V_\theta = -2V_\infty \sin \theta - \frac{\Gamma}{2\pi R}$$

- The pressure coefficient is

$$C_p = 1 - \left(\frac{V}{V_\infty}\right)^2 = 1 - \left(-2 \sin \theta - \frac{\Gamma}{2\pi R V_\infty}\right)^2$$

$$C_p = 1 - \left[4 \sin^2 \theta + \frac{2\Gamma \sin \theta}{\pi R V_\infty} + \left(\frac{\Gamma}{2\pi R V_\infty}\right)^2\right]$$

- The drag coefficient  $c_d$  is given by  $c_d = c_a = \frac{1}{c} \int_{LE}^{TE} (C_{p,u} - C_{p,l}) dy$

$$y = R \sin \theta \quad dy = R \cos \theta d\theta$$

$$c = 2R,$$

$$c_d = \frac{1}{2} \int_{\pi}^0 C_{p,u} \cos \theta d\theta - \frac{1}{2} \int_{\pi}^{2\pi} C_{p,l} \cos \theta d\theta \quad c_d = -\frac{1}{2} \int_0^{2\pi} C_p \cos \theta d\theta$$





## Lifting over a cylinder

- Noting that  $\int_0^{2\pi} \cos \theta d\theta = 0$  we immediately obtain

$$c_d = 0$$

$$\int_0^{2\pi} \sin^2 \theta \cos \theta d\theta = 0$$

$$\int_0^{2\pi} \sin \theta \cos \theta d\theta = 0$$

- The lift on the cylinder can be evaluated in a similar manner

$$c_l = c_n = \frac{1}{c} \int_0^c C_{p,l} dx - \frac{1}{c} \int_0^c C_{p,u} dx$$

$$x = R \cos \theta \quad dx = -R \sin \theta d\theta \\ c = 2R,$$

$$c_l = -\frac{1}{2} \int_{\pi}^{2\pi} C_{p,l} \sin \theta d\theta + \frac{1}{2} \int_{\pi}^0 C_{p,u} \sin \theta d\theta$$

$$c_l = -\frac{1}{2} \int_0^{2\pi} C_p \sin \theta d\theta$$





## Lifting over a cylinder

- Noting that  $\int_0^{2\pi} \sin \theta d\theta = 0$  we immediately obtain

$$\int_0^{2\pi} \sin^3 \theta d\theta = 0$$

$$\int_0^{2\pi} \sin^2 \theta d\theta = \pi$$

$$c_l = \frac{\Gamma}{RV_\infty}$$

- From the definition of  $c_l$ , the lift per unit span  $L$  can be obtained from

$$L' = q_\infty S c_l = \frac{1}{2} \rho_\infty V_\infty^2 S c_l$$

$$S = 2R(1)$$

$$L' = \frac{1}{2} \rho_\infty V_\infty^2 2R \frac{\Gamma}{RV_\infty}$$

$$L' = \rho_\infty V_\infty \Gamma$$

It is called  
the Kutta-Joukowski theorem

- It states that the lift per unit span is directly proportional to circulation.





## Lifting over a cylinder

No rotation

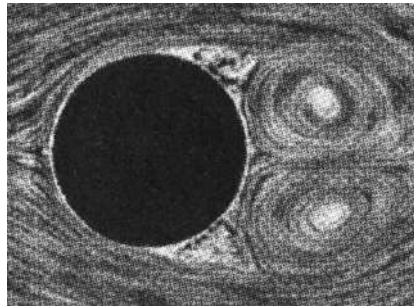

Rotation

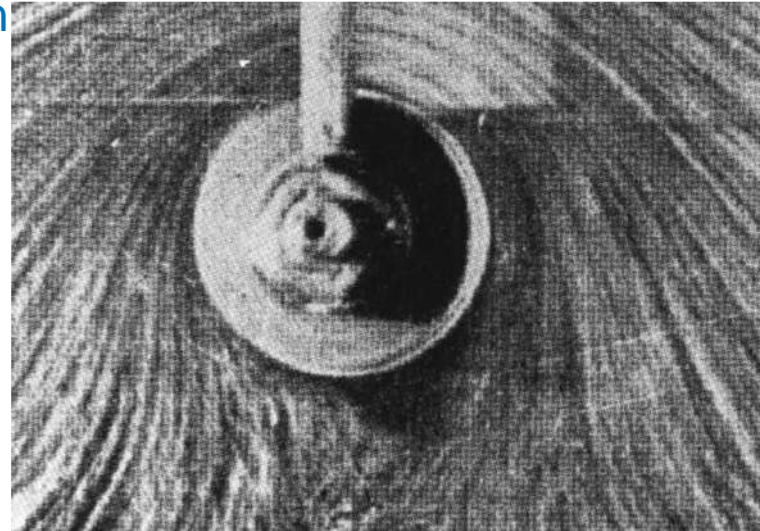

Rotation

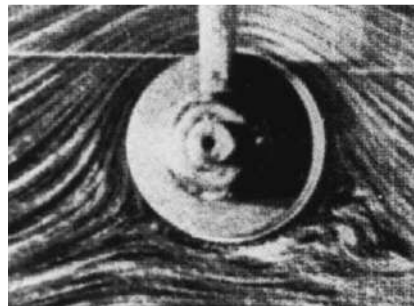

- This pressure imbalance creates a net upward force, that is, a finite lift.

the Magnus effect

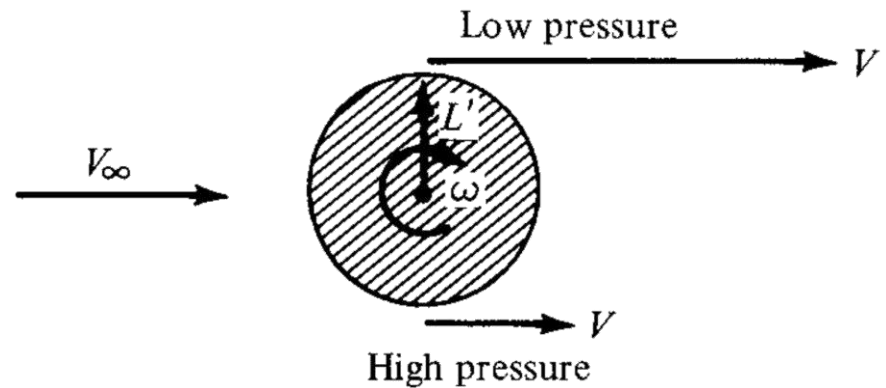



### Example 3.18

- Consider the lifting flow over a circular cylinder with a diameter of 0.5 m.
- The freestream velocity is 25 m/s, and the maximum velocity on the surface of the cylinder is 75 m/s.
- The freestream conditions are those for a standard altitude of 3 km.
- **Calculate** the lift per unit span on the cylinder.
- From Appendix, at an altitude of 3 km,  $\rho = 0.90926$  kg/m<sup>3</sup>.
- The maximum velocity occurs at the top of the cylinder, where  $\theta = 90^\circ$ ,





### Example 3.18

- From Equation

$$V_{\theta} = -2V_{\infty} \sin \theta - \frac{\Gamma}{2\pi R} \quad \theta = 90^{\circ}$$

$$\Gamma = -2\pi R(V_{\theta} + 2V_{\infty})$$

- Recalling our sign convention that  $\Gamma$  is positive in the clockwise direction, and  $V_{\theta}$  is negative in the clockwise direction

$$V_{\theta} = -75 \text{ m/s}$$

$$\Gamma = -2\pi R(V_{\theta} + 2V_{\infty}) = -2\pi(0.25)[-75 + 2(25)]$$

$$\Gamma = -2\pi(0.25)(-25) = 39.27 \text{ m}^2/\text{s}$$

- From Equation, the lift per unit span is

$$L' = \rho_{\infty} V_{\infty} \Gamma$$

$$L' = (0.90926)(25)(39.27) = 892.7 \text{ N/m}$$





## The Kutta-Joukowski theorem and the generation of lift

- Consider the incompressible flow over an airfoil section, as sketched in Figure.

- Let curve  $A$  be any curve in the flow enclosing the airfoil.
- If the airfoil is producing lift, the velocity field around the airfoil will be such that the line integral of velocity around  $A$  will be finite, that is, the circulation

$$\Gamma \equiv \oint_A \mathbf{V} \cdot d\mathbf{s}$$

- In turn, the lift per unit span  $L$  on the airfoil will be given by the *Kutta-Joukowski theorem*,

$$L' = \rho_\infty V_\infty \Gamma$$

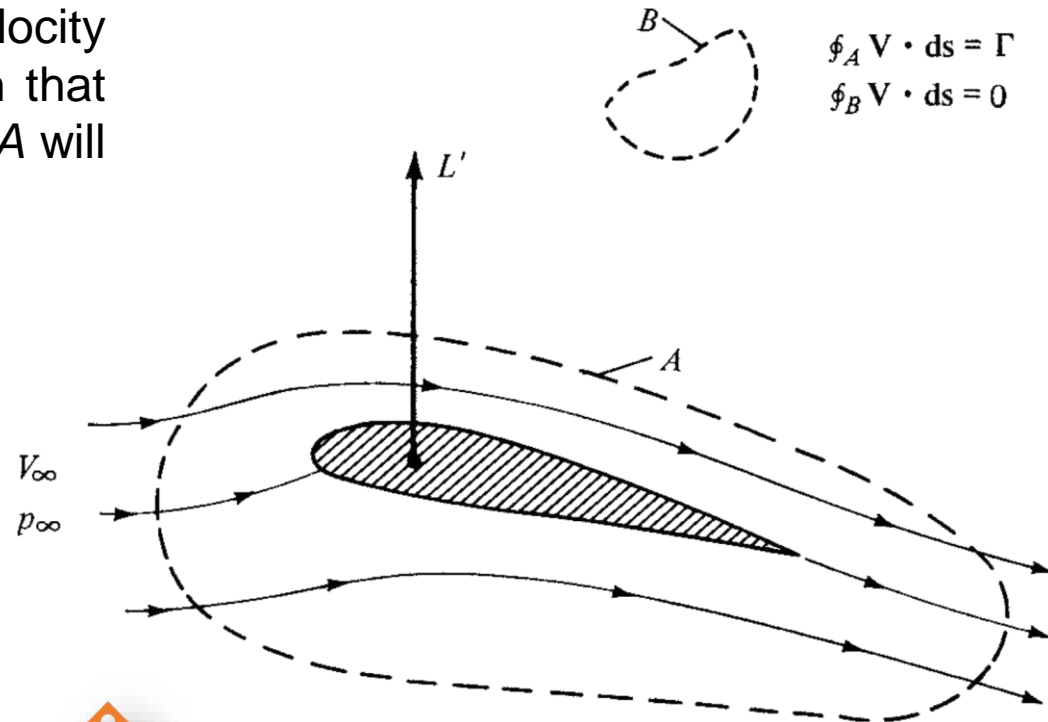



## The Kutta-Joukowski theorem and the generation of lift

- The theoretical analysis of lift on two-dimensional bodies in incompressible, inviscid flow focuses on the calculation of the circulation about the body.
- Once  $\Gamma$  is obtained, then the lift per unit span follows directly from the Kutta-Joukowski theorem.







## **Nonlifting flows over arbitrary bodies: the numerical source panel method**

- Recall that we have already dealt with the nonlifting flows: a Rankine oval and both the nonlifting and the lifting flows over a circular cylinder.
- We added our elementary flows in certain ways and discovered that the dividing streamlines turned out to fit the shapes of such special bodies.
- However, this indirect method can hardly be used in a practical sense for bodies of arbitrary shape.
- For example, consider the airfoil. Do we know in advance the correct combination of elementary flows to synthesize the flow over this specified body?

**No**





## Nonlifting flows over arbitrary bodies: the numerical source panel method

- What we want is a direct method.
- That is, let us *specify* the shape of an arbitrary body and *solve* for the distribution of singularities which produce the flow over the given body.
- The purpose of this section is to present such a direct method, limited for the present to nonlifting flows.

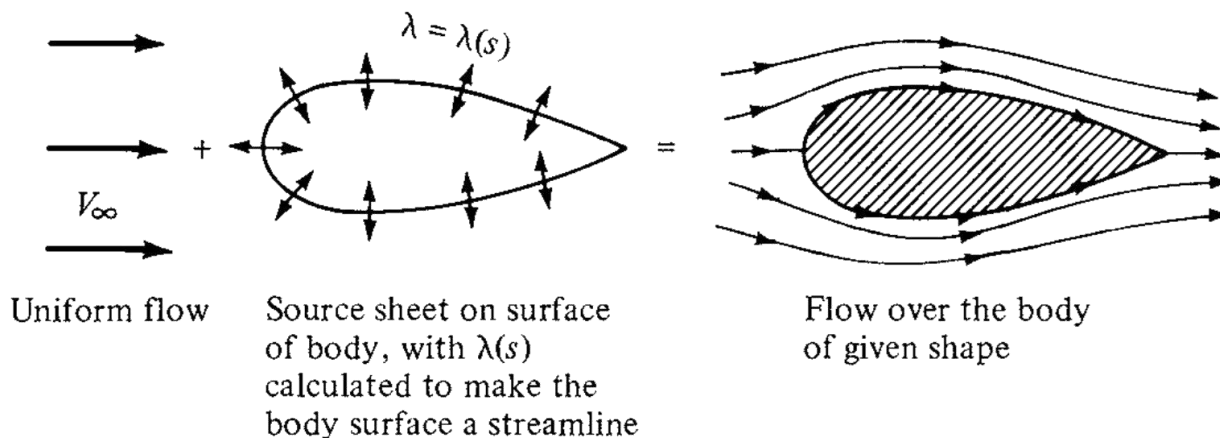



## Nonlifting flows over arbitrary bodies: the numerical source panel method

- The present technique is called the source panel method.
- Now imagine that we have an infinite number of such line sources side by side, where the strength of each line source is infinitesimally small.
- These side-by-side line sources form a *source sheet*.
- Let  $s$  be the distance measured along the source sheet in the edge view.

- Define  $\lambda = \lambda(s)$  to be the *source strength per unit length along  $s$* .
- The small section of the source sheet can be treated as a distinct source of strength  $\lambda ds$

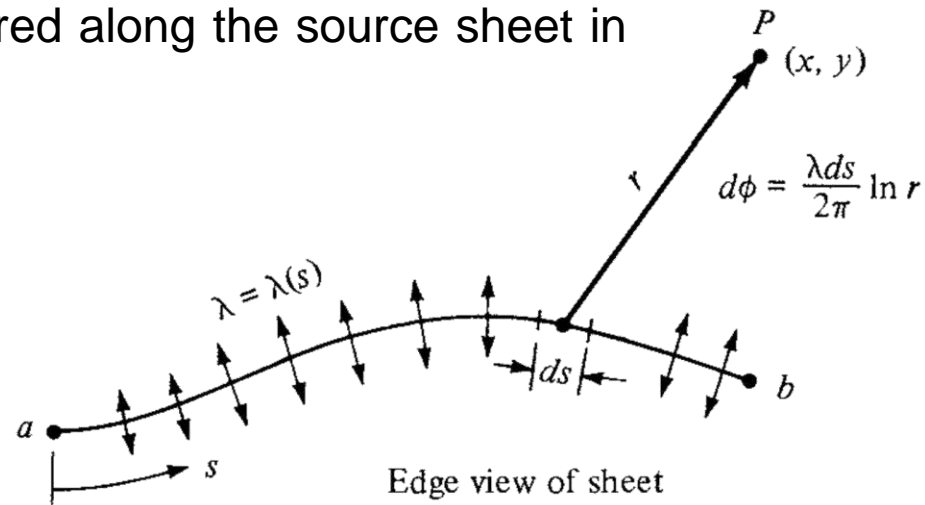



## Nonlifting flows over arbitrary bodies: the numerical source panel method

- Now consider point  $P$  in the flow, located a distance  $r$  from  $ds$ .
- The cartesian coordinates of  $P$  are  $(x, y)$ .
- The small section of the source sheet of strength  $\lambda ds$  induces an infinitesimally small potential  $d\phi$  at point  $P$ .
- From Equation,  $d\phi$  is given by

$$\frac{\lambda}{2\pi} \ln r$$

$$d\phi = \frac{\lambda ds}{2\pi} \ln r$$

- The complete velocity potential at point  $P$ , induced by the entire source sheet from  $a$  to  $b$ , is obtained by integrating Equation

$$\phi(x, y) = \int_a^b \frac{\lambda ds}{2\pi} \ln r$$





## Nonlifting flows over arbitrary bodies: the numerical source panel method

- Note that, in general,  $\lambda(s)$  can change from positive to negative along the sheet.
- That is, the “source” sheet is really a combination of line sources and line sinks.
- Next, consider a given body of arbitrary shape in a flow with freestream velocity  $V_\infty$ , as shown in Figure.
- The combined action of the uniform flow and the source sheet makes the airfoil surface a streamline of the flow.

- Our problem now becomes one of finding the appropriate  $\lambda(s)$ .

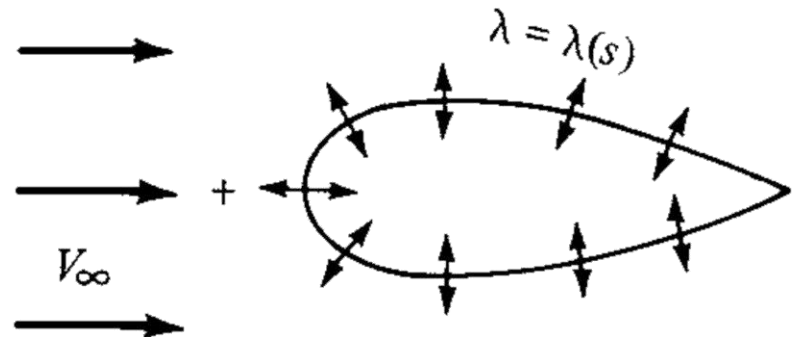



## Nonlifting flows over arbitrary bodies: the numerical source panel method

- The solution of this problem is carried out numerically, as follows.
- Let us approximate the source sheet by a series of straight panels,

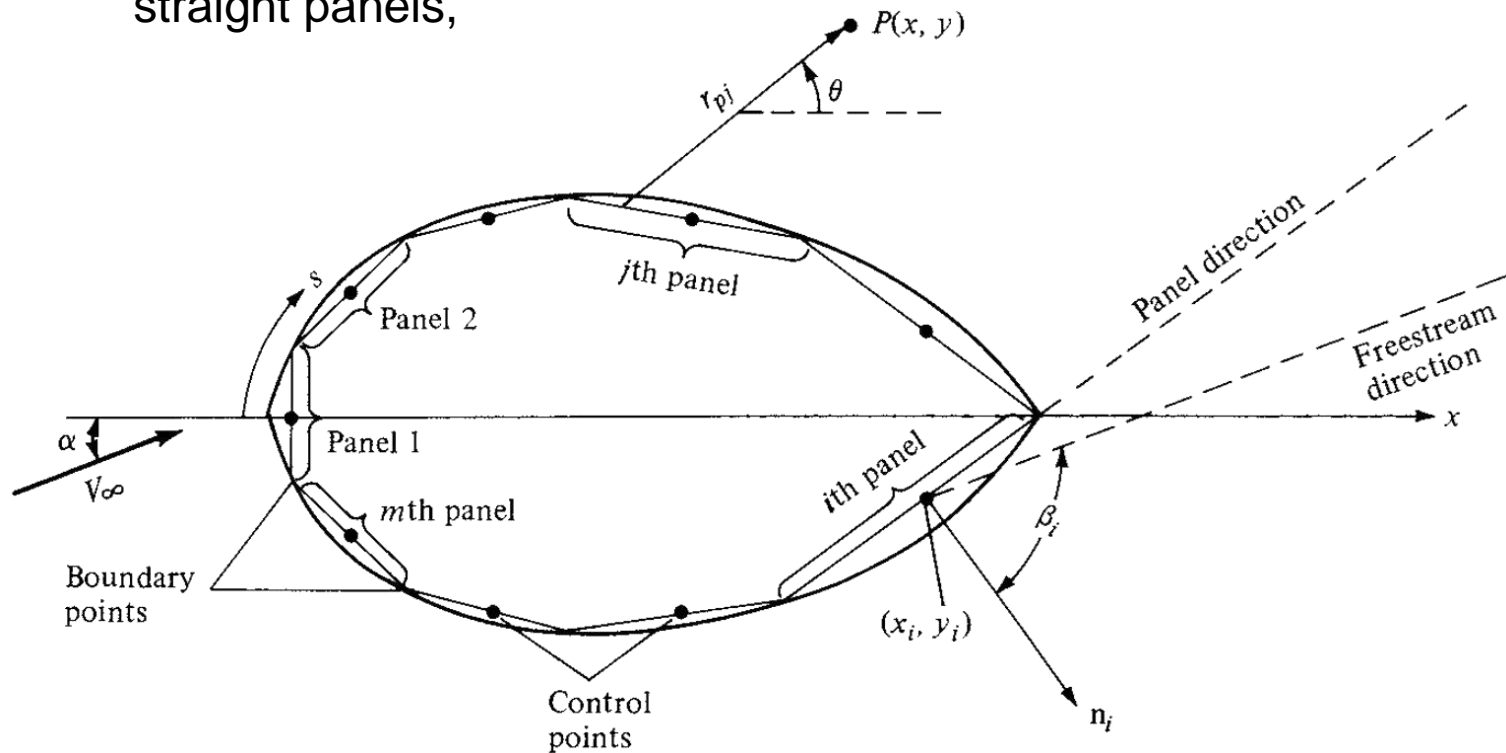



## Nonlifting flows over arbitrary bodies: the numerical source panel method

- Moreover, let the source strength  $\lambda$  per unit length be constant over a given panel, but allow it to vary from one panel to the next.

- If there are a total of  $n$  panels,  $\lambda_j, j = 1 \text{ to } n,$   
 $\lambda_1, \lambda_2, \dots, \lambda_j, \dots, \lambda_n.$

- These panel strengths are unknown.

- Let  $P$  be a point located at  $(x, y)$  in the flow, and let  $r_{pj}$  be the distance from any point on the  $j$ th panel to  $P$ ,

- The velocity potential induced at  $P$  due to the  $j$ th panel  $\Delta\Phi_j$  is,

$$\Delta\phi_j = \frac{\lambda_j}{2\pi} \int_j \ln r_{pj} ds_j$$





## Nonlifting flows over arbitrary bodies: the numerical source panel method

- In turn, the *potential at P* due to *all* the panels is Equation summed over all the panels:

$$\phi(P) = \sum_{j=1}^n \Delta\phi_j$$
$$\phi(P) = \sum_{j=1}^n \frac{\lambda_j}{2\pi} \int_j \ln r_{pj} ds_j$$
$$r_{pj} = \sqrt{(x - x_j)^2 + (y - y_j)^2}$$

where  $(x_j, y_j)$  are coordinates along the surface of the  $j$ th panel.

- Since point  $P$  is just an arbitrary point in the flow, let us put  $P$  at the control point of the  $i$ th panel and the coordinates of this control point be given by  $(x_i, y_i)$ ,

$$\phi(x_i, y_i) = \sum_{j=1}^n \frac{\lambda_j}{2\pi} \int_j \ln r_{ij} ds_j$$
$$r_{ij} = \sqrt{(x_i - x_j)^2 + (y_i - y_j)^2}$$

the contribution of all the panels to  
the potential at the  $i$ th panel.







## Nonlifting flows over arbitrary bodies: the numerical source panel method

- Recall that the boundary condition is applied at the control points.
- That is, the normal component of the flow velocity is zero at the control points.

$$V_{\infty,n} + V_n = 0$$

- First consider the component of freestream velocity perpendicular to the panel.

$$V_{\infty,n} = \mathbf{V}_{\infty} \cdot \mathbf{n}_i = V_{\infty} \cos \beta_i$$

- The normal component of velocity induced at  $(x_i, y_i)$  by the source panels is,

$$V_n = \frac{\partial}{\partial n_i} [\phi(x_i, y_i)]$$





## Nonlifting flows over arbitrary bodies: the numerical source panel method

- A singular point arises on the  $i$ th panel because when  $j=i$ , at the control point itself  $r_{ij}=0$ .
- It can be shown that when  $j = i$ , the contribution to the derivative is simply  $\lambda_i/2$ .

$$V_n = \frac{\lambda_i}{2} + \sum_{\substack{j=1 \\ (j \neq i)}}^n \frac{\lambda_j}{2\pi} \int_j \frac{\partial}{\partial n_i} (\ln r_{ij}) ds_j$$

- We obtain

$$\frac{\lambda_i}{2} + \sum_{\substack{j=1 \\ (j \neq i)}}^n \frac{\lambda_j}{2\pi} \int_j \frac{\partial}{\partial n_i} (\ln r_{ij}) ds_j + V_\infty \cos \beta_i = 0$$

- The values of the integrals in Equation depend simply on the panel geometry; they are not properties of the flow.

- Let  $I_{i,j}$  is  $\int_j \frac{\partial}{\partial n_i} (\ln r_{ij}) ds_j$





## Nonlifting flows over arbitrary bodies: the numerical source panel method

- Then Equation can be written as

$$\frac{\lambda_i}{2} + \sum_{\substack{j=1 \\ (j \neq i)}}^n \frac{\lambda_j}{2\pi} I_{i,j} + V_\infty \cos \beta_i = 0$$

- Equation is a linear *algebraic* equation with  $n$  unknowns  $\lambda_1, \lambda_2, \dots, \lambda_n$ .
- It represents the flow boundary condition evaluated at the control point of the  $i$ th panel.
- Now apply the boundary condition to the control points of *all* the panels;  $i = 1, 2, \dots, n$ .
- The results will be a system of  $n$  linear algebraic equations with  $n$  unknowns  $(\lambda_1, \lambda_2, \dots, \lambda_n)$ , which can be solved simultaneously by conventional numerical methods.





## Nonlifting flows over arbitrary bodies: the numerical source panel method

- We now have the distribution of source panel strengths which cause the body surface to be a streamline of the flow.
- This approximation can be made more accurate by increasing the number of panels.
- A circular cylinder can be accurately represented by as few as 8 panels.
- And most airfoil shapes, by 50 to 100 panels.
- In general, all the panels can be different lengths.

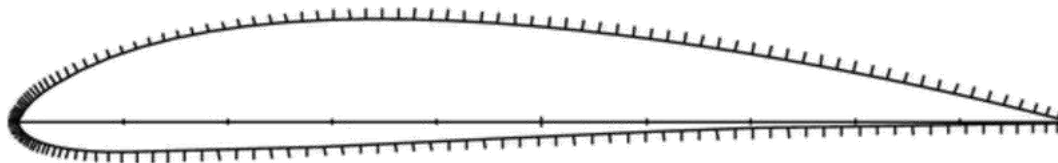



## Nonlifting flows over arbitrary bodies: the numerical source panel method

- Once the  $\lambda_i$ 's ( $i = 1, 2, \dots, n$ ) are obtained, the velocity *tangent* to the surface at each control point can be calculated.

$$V_i = V_{\infty,s} + V_s$$

- The component of freestream velocity tangent to the surface is

$$V_{\infty,s} = V_{\infty} \sin \beta_i$$

- The tangential velocity  $V_s$  at the control point of the  $i$ th panel induced by all the panels is obtained by differentiating

$$V_s = \frac{\partial \phi}{\partial s} = \sum_{j=1}^n \frac{\lambda_j}{2\pi} \int_j \frac{\partial}{\partial s} (\ln r_{ij}) ds_j$$

$j = i$  The tangential velocity on a flat source panel induced by the panel itself is zero





## Nonlifting flows over arbitrary bodies: the numerical source panel method

- The total surface velocity at the  $i$ th control point  $V_i$  is the sum of the contribution from the freestream and from the source panels

$$V_i = V_{\infty,s} + V_s = V_{\infty} \sin \beta_i + \sum_{j=1}^n \frac{\lambda_j}{2\pi} \int_j \frac{\partial}{\partial s} (\ln r_{ij}) ds_j$$

- The pressure coefficient at the  $i$ th control point is obtained from

$$C_{p,i} = 1 - \left( \frac{V_i}{V_{\infty}} \right)^2$$





## Nonlifting flows over arbitrary bodies: the numerical source panel method

- When you carry out a source panel solution as described above, the accuracy of your results can be tested.
- Recall that  $\lambda_j$  is the strength of the  $j$  th panel *per unit length*.
- Hence, the strength of the  $j$  th panel itself is  $\lambda_j S_j$ . For a closed body,

$$\sum_{j=1}^n \lambda_j S_j = 0$$

- Equation provides an independent check on the accuracy of the numerical results.





## Example 3.19

- Calculate the pressure coefficient distribution around a circular cylinder using the source panel technique.
  - We choose to cover the body with eight panels of equal length.
  - The panels are numbered from 1 to 8, and the control points are shown by the dots in the center of each panel.
- Let us evaluate the integrals  $I_{i,j}$  which appear in Equation.

$$\int_j \frac{\partial}{\partial n_i} (\ln r_{ij}) ds_j$$

- Recall that the integral  $I_{i,j}$  is evaluated at the  $i$ th control point and the integral is taken over the complete  $j$ th panel.

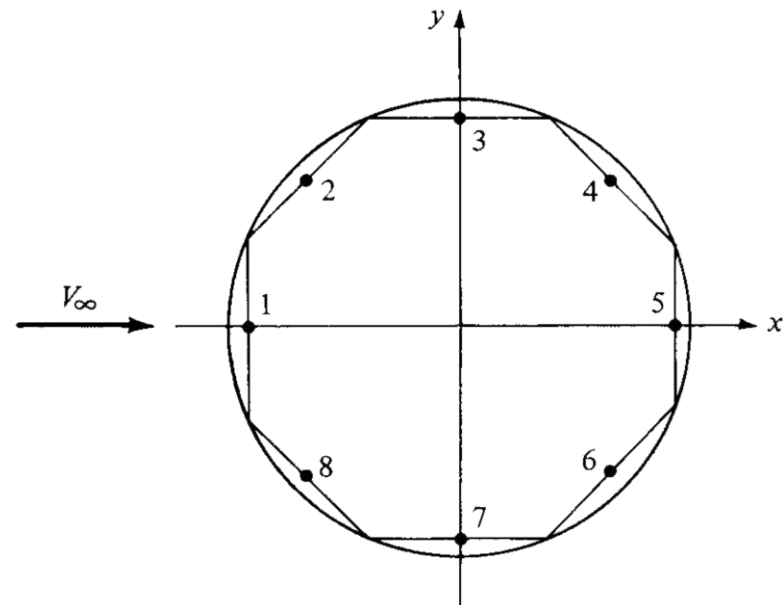





## Example 3.19

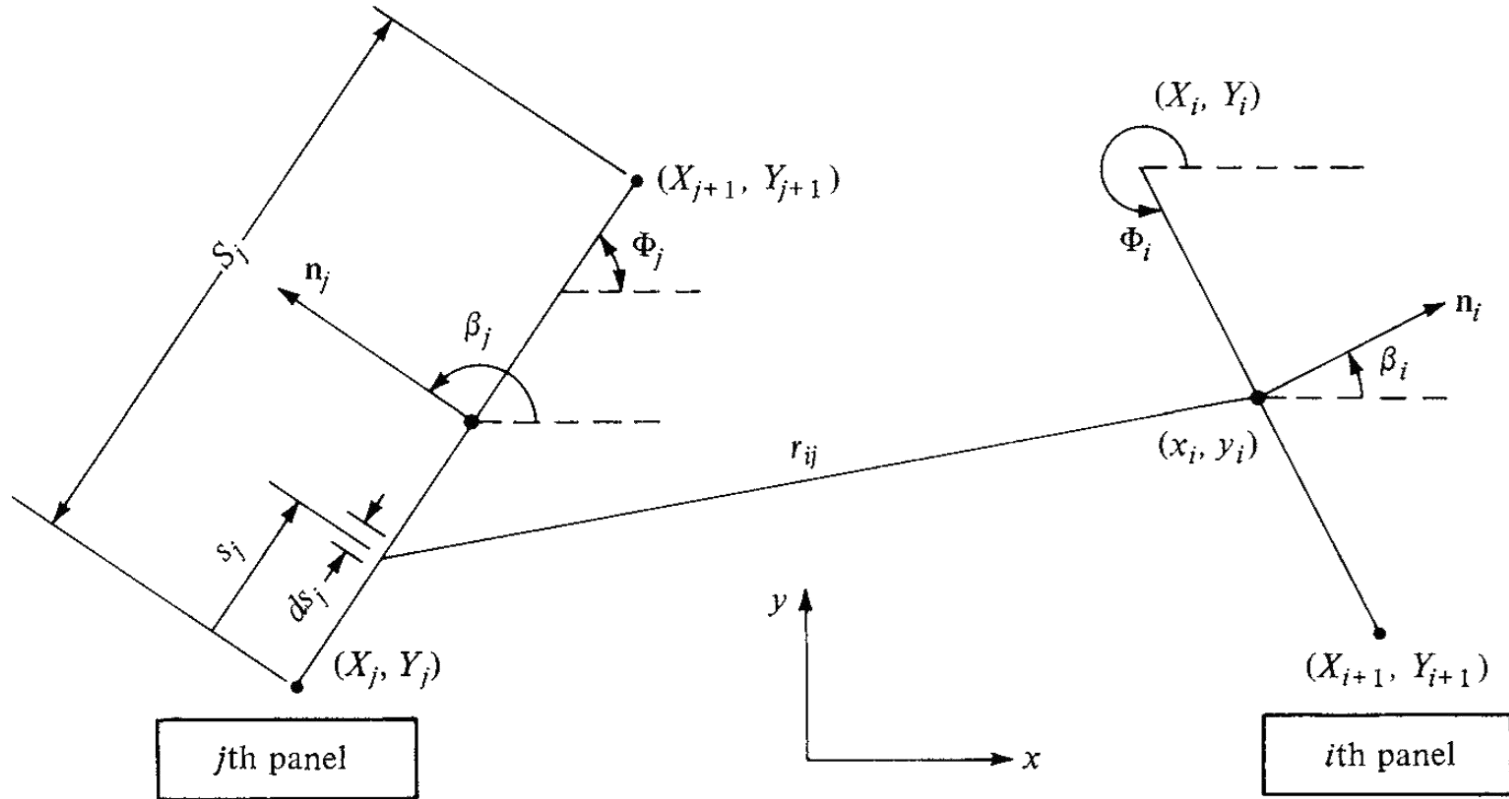

$$I_{i,j} = \int_j \frac{\partial}{\partial n_i} (\ln r_{ij}) ds_j$$





## Example 3.19

▪ Since  $r_{ij} = \sqrt{(x_i - x_j)^2 + (y_i - y_j)^2}$

▪ Then  $\frac{\partial}{\partial n_i}(\ln r_{ij}) = \frac{1}{r_{ij}} \frac{\partial r_{ij}}{\partial n_i}$

$$\frac{dx_i}{dn_i} = \cos \beta_i$$

$$\frac{dy_i}{dn_i} = \sin \beta_i$$

$$= \frac{1}{r_{ij}} \frac{1}{2} [(x_i - x_j)^2 + (y_i - y_j)^2]^{-1/2} \times \left[ 2(x_i - x_j) \frac{dx_i}{dn_i} + 2(y_i - y_j) \frac{dy_i}{dn_i} \right]$$

$$\frac{\partial}{\partial n_i}(\ln r_{ij}) = \frac{(x_i - x_j) \cos \beta_i + (y_i - y_j) \sin \beta_i}{(x_i - x_j)^2 + (y_i - y_j)^2}$$

▪ From this geometry,

▪ Also, from the geometry, we have

$$\beta_i = \Phi_i + \frac{\pi}{2}$$

$$\sin \beta_i = \cos \Phi_i$$

$$\cos \beta_i = -\sin \Phi_i$$

$$x_j = X_j + s_j \cos \Phi_j$$

$$y_j = Y_j + s_j \sin \Phi_j$$





## Example 3.19

- Substituting Equations, we obtain 
$$I_{i,j} = \int_0^{S_j} \frac{Cs_j + D}{s_j^2 + 2As_j + B} ds_j$$

where

$$A = -(x_i - X_j) \cos \Phi_j - (y_i - Y_j) \sin \Phi_j$$

$$B = (x_i - X_j)^2 + (y_i - Y_j)^2$$

$$C = \sin(\Phi_i - \Phi_j)$$

$$D = (y_i - Y_j) \cos \Phi_i - (x_i - X_j) \sin \Phi_i$$

$$S_j = \sqrt{(X_{j+1} - X_j)^2 + (Y_{j+1} - Y_j)^2}$$

- We obtain an expression for Equation from standard table of integrals:

$$\int \frac{1}{ax^2 + bx + c} dx = \frac{2}{\sqrt{4ac - b^2}} \tan^{-1} \frac{2ax + b}{\sqrt{4ac - b^2}}$$

$$\int \frac{x}{ax^2 + bx + c} dx = \frac{1}{2a} \ln |ax^2 + bx + c| - \frac{b}{a\sqrt{4ac - b^2}} \tan^{-1} \frac{2ax + b}{\sqrt{4ac - b^2}}$$





## Example 3.19

$$I_{i,j} = \frac{C}{2} \ln \left( \frac{S_j^2 + 2AS_j + B}{B} \right) + \frac{D - AC}{E} \left( \tan^{-1} \frac{S_j + A}{E} - \tan^{-1} \frac{A}{E} \right)$$

Letting  $E = \sqrt{B - A^2} = (x_i - X_j) \sin \Phi_j - (y_i - Y_j) \cos \Phi_j$

- Equation is a general expression for two arbitrarily oriented panels.
- It is not restricted to the case of a circular cylinder.
- We now apply Equation to the circular cylinder.
- For purposes of illustration, let us choose panel 4 as the  $i$ th panel and panel 2 as the  $j$ th panel.
- That is, let us calculate  $I_{4,2}$ .





### Example 3.19

- From the geometry, assuming a unit radius for the cylinder, we see that

$$\begin{array}{llll} X_j = -0.9239 & X_{j+1} = -0.3827 & Y_j = 0.3827 & Y_{j+1} = 0.9239 \\ \Phi_i = 315^\circ & \Phi_j = 45^\circ & x_i = 0.6533 & y_i = 0.6533 \end{array}$$

- Hence, substituting these numbers into the above formulas, we obtain

$$\begin{array}{llll} A = -1.3065 & B = 2.5607 & C = -1 & D = 1.3065 \\ S_j = 0.7654 & E = 0.9239 & & \end{array}$$

- Inserting the above values into Equation, we obtain  $I_{4,2} = 0.4018$

- We obtain, by means of a similar calculation,

$$I_{4,1} = 0.4074 \quad I_{4,3} = 0.3528, \quad I_{4,5} = 0.3528, \quad I_{4,6} = 0.4018, \quad I_{4,7} = 0.4074, \quad \text{and} \quad I_{4,8} = 0.4084.$$





### Example 3.19

- Written for panel 4, Equation becomes (after multiplying each term by  $2\pi$  and noting that  $\beta_i = 45^\circ$  for panel 4)

$$\frac{\lambda_i}{2} + \sum_{\substack{j=1 \\ (j \neq i)}}^n \frac{\lambda_j}{2\pi} I_{i,j} + V_\infty \cos \beta_i = 0$$

$$0.4074\lambda_1 + 0.4018\lambda_2 + 0.3528\lambda_3 + \pi\lambda_4 + 0.3528\lambda_5 + 0.4018\lambda_6 + 0.4074\lambda_7 + 0.4084\lambda_8 = -0.7071 2\pi V_\infty$$

- Equation is a linear algebraic equation in terms of the eight unknowns,  $\lambda_1, \lambda_2, \dots, \lambda_8$ .
- If we now construct similar equations for each of the seven other panels, we obtain a total of eight equations.
- They can be solved simultaneously for the eight unknown  $\lambda$ 's.





## Example 3.19

- The results are

$$\begin{aligned}\lambda_1/2\pi V_\infty &= 0.3765 & \lambda_2/2\pi V_\infty &= 0.2662 & \lambda_3/2\pi V_\infty &= 0 \\ \lambda_4/2\pi V_\infty &= -0.2662 & \lambda_5/2\pi V_\infty &= -0.3765 & \lambda_6/2\pi V_\infty &= -0.2662 \\ \lambda_7/2\pi V_\infty &= 0 & \lambda_8/2\pi V_\infty &= 0.2662 & & \end{aligned}$$

- Note the symmetrical distribution of the  $\lambda$ 's, which is to be expected for the nonlifting circular cylinder.

- Also, as a check on the above solution,  $\sum_{j=1}^n \lambda_j = 0$

- The velocity at the control point of the  $i$ th panel can be obtained from,

$$V_i = V_{\infty,s} + V_s = V_\infty \sin \beta_i + \sum_{j=1}^n \frac{\lambda_j}{2\pi} \int_j \frac{\partial}{\partial s} (\ln r_{ij}) ds_j$$

- In that equation, the integral over the  $j$ th panel is a geometric quantity that is evaluated in a similar manner as before.





## Example 3.19

- The result is

$$\int_j \frac{\partial}{\partial s} (\ln r_{ij}) ds_j = \frac{D - AC}{2E} \ln \frac{S_j^2 + 2AS_j + B}{B} - C \left( \tan^{-1} \frac{S_j + A}{E} - \tan^{-1} \frac{A}{E} \right)$$

- With the integrals and with the values for  $\lambda_1, \lambda_2, \dots, \lambda_8$  obtained above, we obtain the velocities  $V_1, V_2, \dots, V_8$ .
- In turn, the pressure coefficients  $C_{p,1}, C_{p,2}, \dots, C_{p,8}$  are obtained directly from

$$C_{p,i} = 1 - \left( \frac{V_i}{V_\infty} \right)^2$$







## Example 3.19

- Results for the pressure coefficients obtained from this calculation are compared with the exact analytical result,

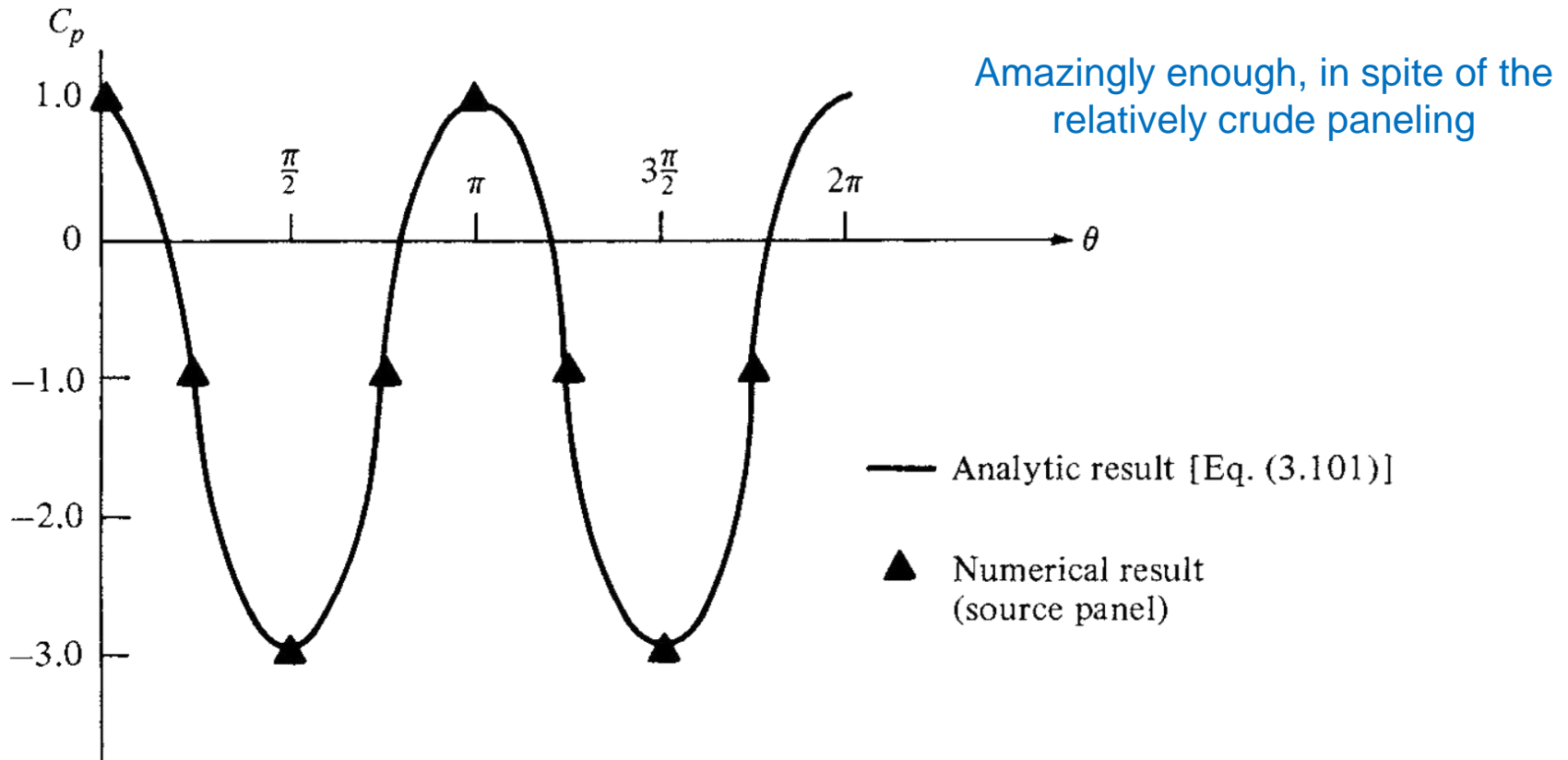



## Applied aerodynamics: the flow over a circular cylinder—the real case

$0 < Re < 4$ ,  
Stokes flow

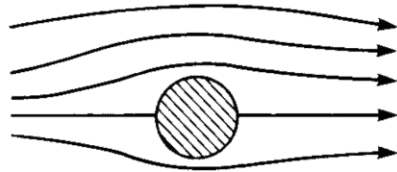

(a)

$10^4 < Re < 3 \times 10^5$   
turbulent and a  
wake flow

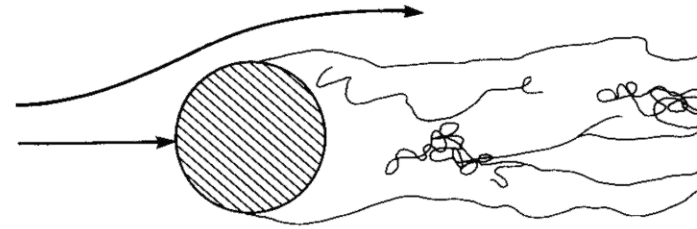

(d)

$4 < Re < 40$   
Separated flow

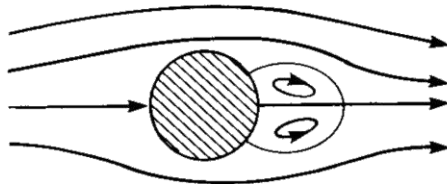

(b)

$3 \times 10^5 < Re < 3 \times 10^6$

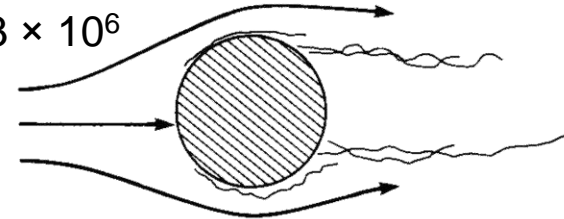

(e)

$40 < Re < 10^4$

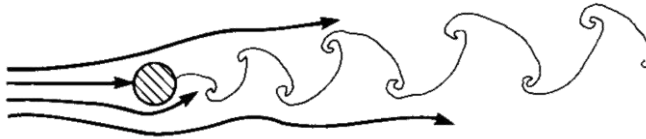

(c)

a Karman vortex street





## Historical note

### D'Alembert and his paradox

- We demonstrate that the combination of a uniform flow and a doublet produces the flow over a circular cylinder.
- Note that the entire flow field is symmetrical about both the horizontal and vertical axes through the center of the cylinder.
- Hence, the pressure distribution is also symmetrical about both axes.
- As a result, *there is no net lift*.
- In real life, the result of zero lift is easy to accept, but the result of zero drag makes no sense.

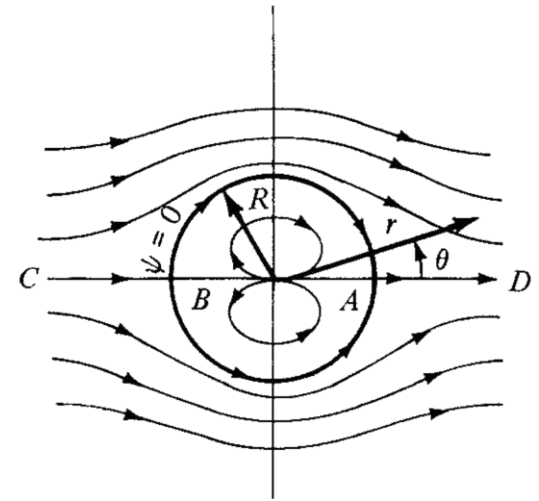

Flow over a cylinder

$$\psi = V_{\infty} r \sin \theta - \frac{\kappa}{2\pi} \frac{\sin \theta}{r}$$





## Historical note

### D'Alembert and his paradox

- This paradox between the theoretical result of zero drag, and the knowledge that in real life the drag is finite, was encountered in the year 1744 by the Frenchman Jean Le Rond d'Alembert.
- It has been known as *d'Alembert's paradox* ever since.
  - For d'Alembert and other fluid dynamic researchers during the eighteenth and nineteenth centuries, this paradox was unexplained.

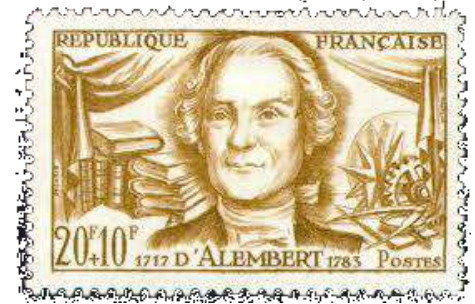



## Historical note

### D'Alembert and his paradox

- Of course, today we know that the drag is due to viscous effects which generate frictional shear stress at the body surface.
- It cause the flow to separate from the surface on the back of the body, thus;
  - creating a large wake downstream of the body,
  - destroying the symmetry of the flow about the vertical axis through the cylinder.

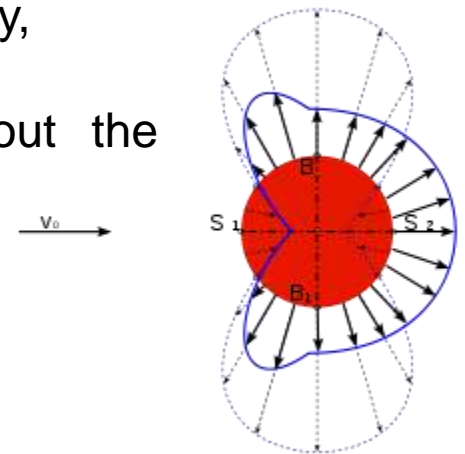



## Questions

**Note:** All the following problems assume an inviscid, incompressible flow. Also, standard sea level density and pressure are  $1.23 \text{ kg/m}^3$  ( $0.002377 \text{ slug/ft}^3$ ) and  $1.01 \times 10^5 \text{ N/m}^2$  ( $2116 \text{ lb/ft}^2$ ), respectively.

- 3.1** For an irrotational flow, show that Bernoulli's equation holds between *any* points in the flow, not just along a streamline.
- 3.4** Consider a low-speed open-circuit subsonic wind tunnel with an inlet-to-throat area ratio of 12. The tunnel is turned on, and the pressure difference between the inlet (the settling chamber) and the test section is read as a height difference of 10 cm on a U-tube mercury manometer. (The density of liquid mercury is  $1.36 \times 10^4 \text{ kg/m}^3$ .) Calculate the velocity of the air in the test section.





## Questions

- 3.12** Consider the flow over a semi-infinite body as discussed in Section 3.11. If  $V_\infty$  is the velocity of the uniform stream, and the stagnation point is 1 ft upstream of the source:
- Draw the resulting semi-infinite body to scale on graph paper.
  - Plot the pressure coefficient distribution over the body; that is, plot  $C_p$  versus distance along the centerline of the body.





## Questions

- Calculate the pressure coefficient distribution around a circular cylinder using the source panel technique.
- Choose to cover the body with 12 panels of equal length.
- Compare results for the pressure coefficients obtained from this calculation with the exact analytical result.







# *Aerodynamics*

## *AE 301*

Assoc. Prof. Dr. Y . Volkan PEHLİVANOĞLU  
volkan.pehlivanoglu@ieu.edu.tr





## Contents; Incompressible Flow over Airfoils



- a. Airfoil Nomenclature,
- b. Airfoil Characteristics,
- c. The Vortex Sheet,
- d. The Kutta Condition,
- e. Kelvin's Circulation Theorem,
- f. The Symmetric Airfoil,
- g. The Cambered Airfoil,
- h. The Aerodynamic Center,
- i. Lifting Flows over Arbitrary Bodies,
- j. Viscous Flow: Airfoil Drag,
- k. Applied Aerodynamics,
- l. Historical Note...

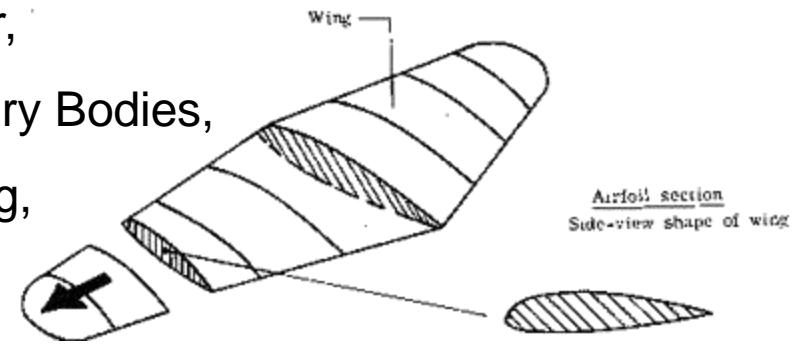
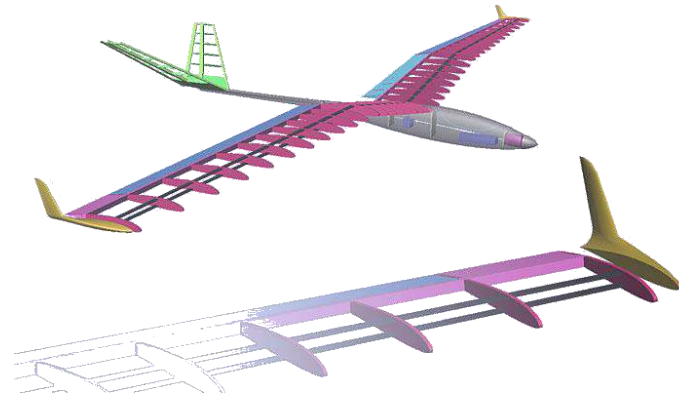



## Nomenclature

$\Xi$  (sai)  $\xi$





## Introduction

*Of the many problems now engaging attention, the following are considered of immediate importance and will be considered by the committee as rapidly as funds can be secured for the purpose. . . . The evolution of more efficient wing sections of practical form, embodying suitable dimensions for an economical structure, with moderate travel of the center-of-pressure and still affording a large range of angle-of-attack combined with efficient action.*

Designation	Date	Diagram
Wright	1908	
Bleriot	1909	
R.A.F. 6	1912	
R.A.F. 15	1915	
U.S.A. 27	1919	
Joukowski (Göttingen 430)	1912	
Göttingen 398	1919	
Göttingen 387	1919	
Clark Y	1922	

**From the first Annual Report of the  
NACA, 1915**

the National Advisory Committee for Aeronautics  
(NACA)

National Aeronautics and Space Administration  
(NASA)





## Introduction

- Figure shows an airplane in flight, sustained in the air by the aerodynamic action of its wing.
- Airplane wings are made up of airfoil shapes.



- The first step in understanding the aerodynamics of wings is to understand the aerodynamics of airfoils.
- Airfoil aerodynamics is important stuff—it is the stuff of this chapter.





## Introduction

- In the period 1912–1918, the analysis of airplane wings took a giant step forward.
- When Ludwig Prandtl and his colleagues at Göttingen, Germany, showed that the aerodynamic consideration of wings could be split into two parts:
  - The study of the *section* of a wing—an airfoil—
  - The modification of such airfoil properties to account for the complete, finite wing.



1875–1953

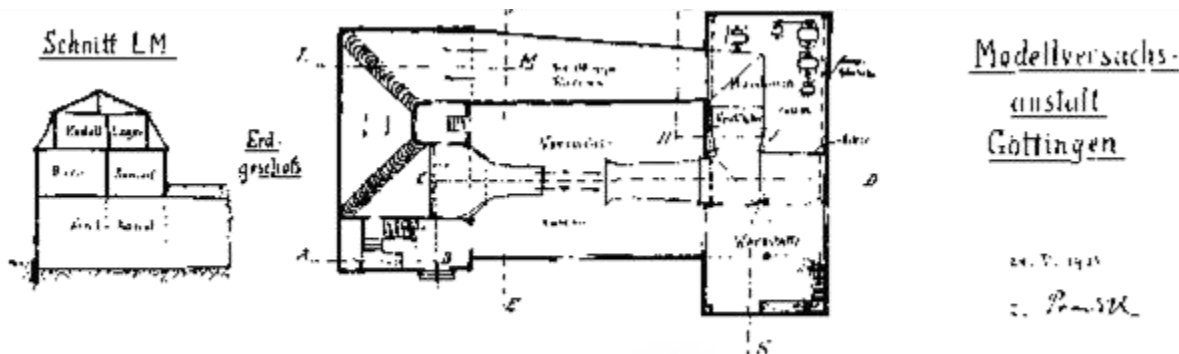



## Introduction

- Consider a wing as drawn in perspective in Figure.
  - The wing extends in the  $y$  direction (the span direction).
  - The freestream velocity  $V_\infty$  is parallel to the  $xz$  plane.
  - Any section of the wing cut by a plane parallel to the  $xz$  plane is called an *airfoil*.
- 
- We will deal with inviscid flow, which does not lead to predictions of airfoil drag.
  - However, the lift and moments on the airfoil are due mainly to the pressure distribution, which is dictated by inviscid flow.

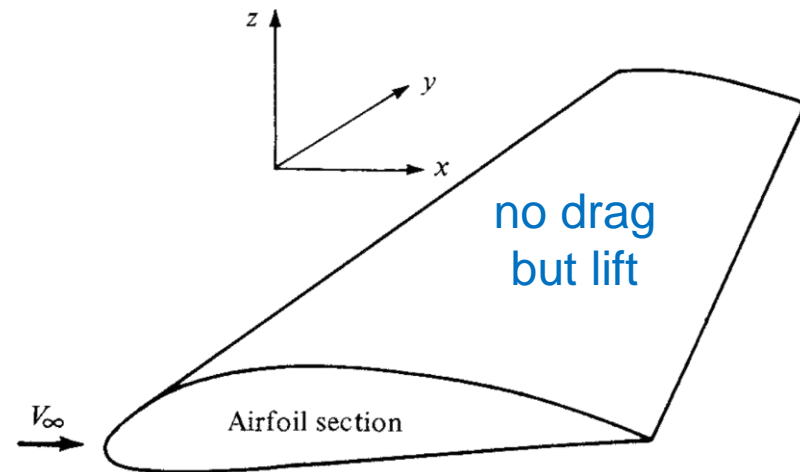



## Airfoil nomenclature

- The first patented airfoil shapes were developed by Horatio F. Phillips in 1884.
- In the early 1930s, NACA embarked on a series of definitive airfoil experiments using airfoil shapes that were constructed rationally and systematically.
- Many of these NACA airfoils are in common use today. Therefore, we follow the nomenclature established by the NACA.
  - The NACA identified different airfoil shapes with a logical numbering system.
    - “four-digit” series, such as the NACA 2412 airfoil.
    - “five-digit” series, such as the NACA 23012 airfoil.
    - “6-series”, such as the NACA 65-218 airfoil.
  - Many of the large aircraft companies today design their own special purpose airfoils; for example, the Boeing...

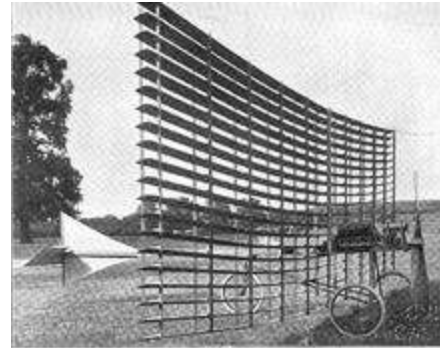





## Airfoil nomenclature

Airplane	Airfoil
Beechcraft Sundowner	NACA 63A415
Beechcraft Bonanza	NACA 23016.5 (at root) NACA 23012 (at tip)
Cessna 150	NACA 2412
Fairchild A-10	NACA 6716 (at root) NACA 6713 (at tip)
Gates Learjet 24D	NACA 64A109
General Dynamics F-16	NACA 64A204
Lockheed C-5 Galaxy	NACA 0012 (modified)





## Airfoil nomenclature

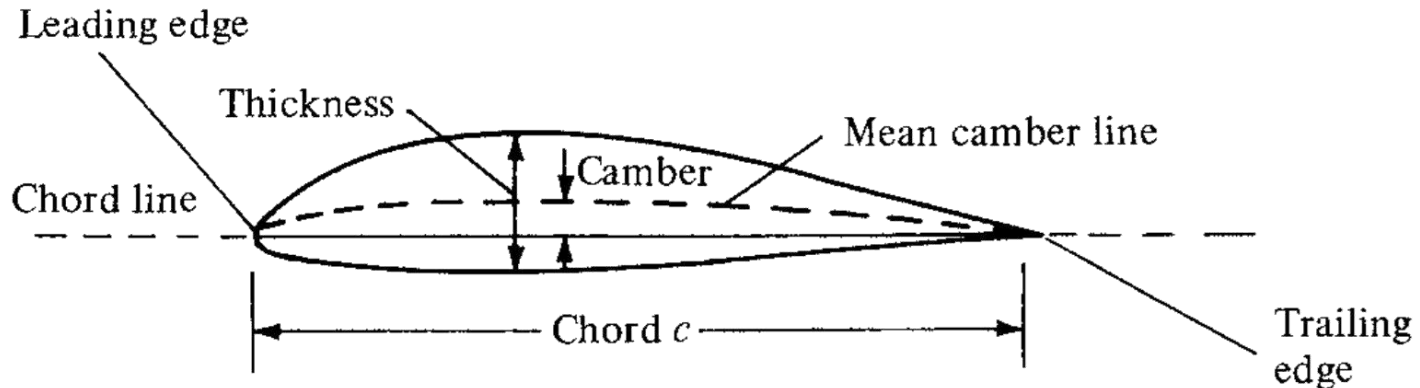

- The *mean camber line* is the locus of points halfway between the upper and lower surfaces as measured perpendicular to the mean camber line itself.
- The most forward and rearward points of the mean camber line are the *leading and trailing edges*, respectively.
- The straight line connecting the leading and trailing edges is the *chord line* of the airfoil,  $c$ .





## Airfoil nomenclature

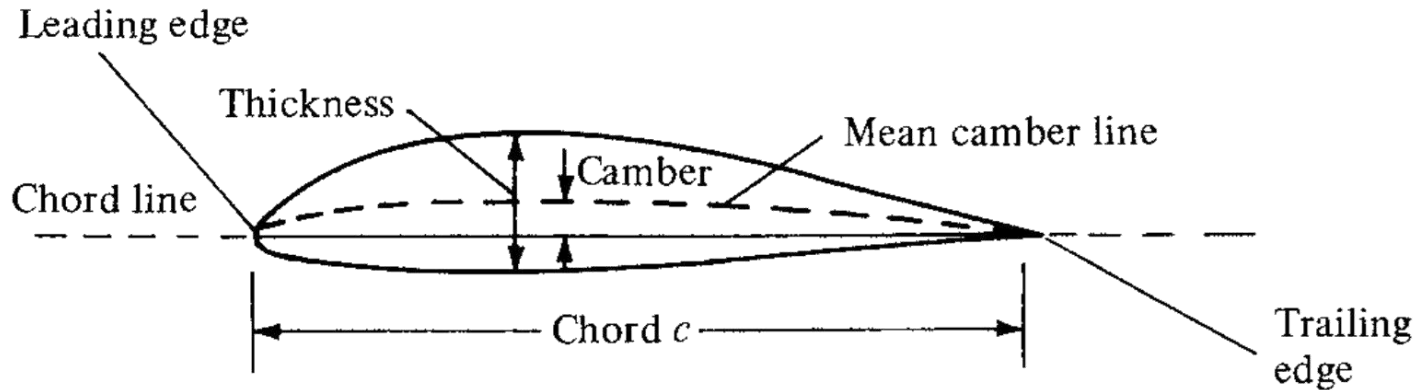

- The *camber* is the maximum distance between the mean camber line and the chord line, measured perpendicular to the chord line.
- The *thickness* is the distance between the upper and lower surfaces, also measured perpendicular to the chord line.
- The shape of the airfoil at the leading edge is usually circular, with a leading-edge radius of approximately  $0.02c$ .





## Airfoil nomenclature

- The shapes of all standard NACA airfoils are generated by
  - specifying the shape of the mean camber line,
  - and then wrapping a specified symmetrical thickness distribution around the mean camber line.

- “four-digit” series, such as the NACA 2412 airfoil.

### NACA 2412

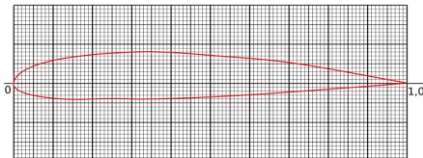

- the maximum camber length is  $0.02c$
- located at  $0.4c$  from the leading edge,
- the maximum thickness is  $0.12c$ .

- NACA 0012 airfoil is a symmetric airfoil with no camber, a maximum thickness of 12 percent.

### NACA 0012

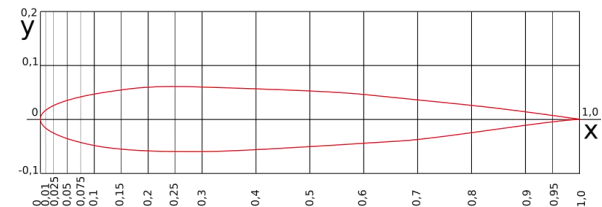



## Airfoil nomenclature

- “five-digit” series, such as the NACA 23012 airfoil.

multiplied by 3/2, in tenths

the next two digits when divided by 2

- the design lift coefficient is 0.3,
- the location of maximum camber is at  $0.15c$ ,
- the airfoil has 12 percent maximum thickness.



- “6-series”, such as the NACA 65-218 airfoil.

NACA 65-218 Wing Section (Continued)

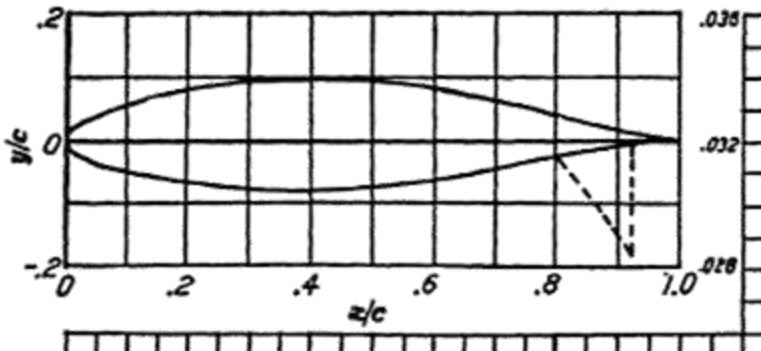

- the 6 is the series designation,
- the minimum pressure occurs at  $0.5c$ ,
- the design lift coefficient is 0.2, in tenths
- the airfoil is 18 percent thick,  $0.18c$ .





## Airfoil characteristics

- The typical variation of lift coefficient with angle of attack for an airfoil is sketched in Figure.
- At low-to-moderate angles of attack,  $c_l$  varies linearly with  $\alpha$ .

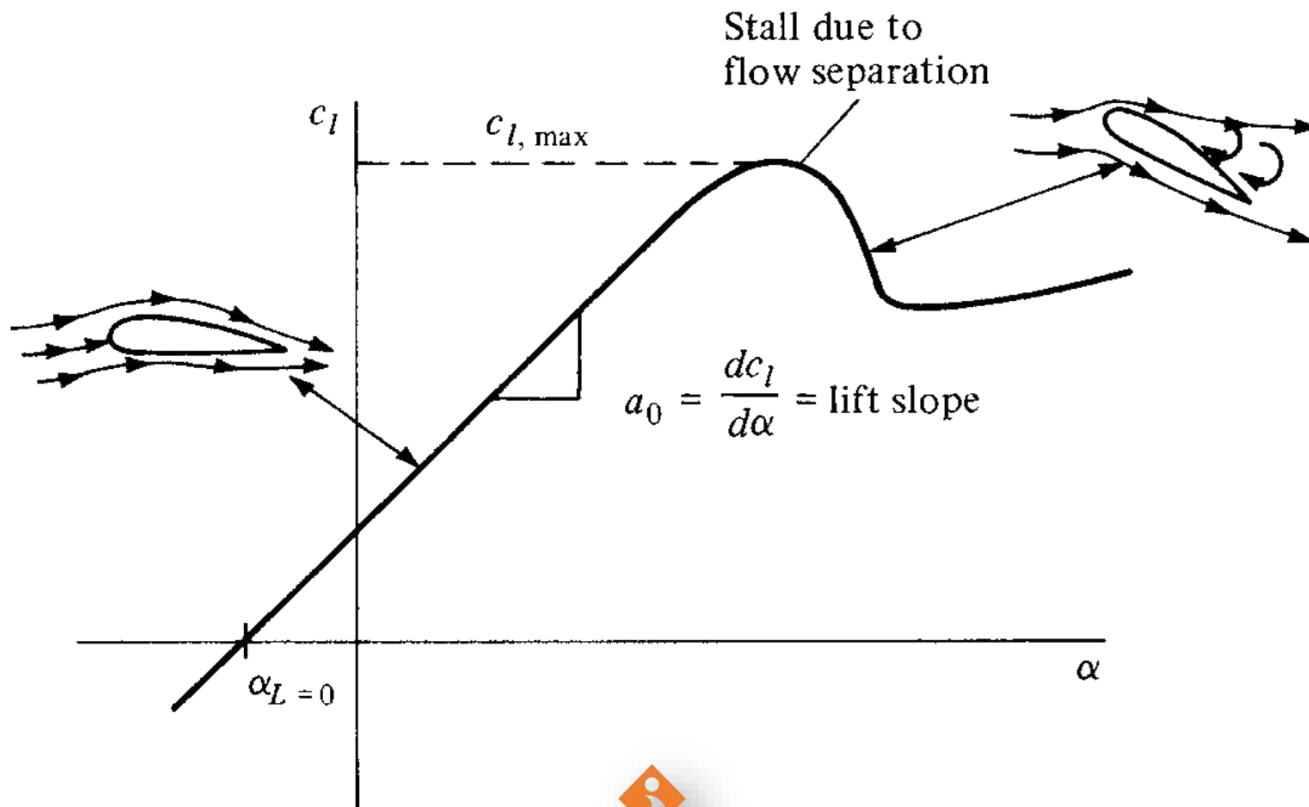



## Airfoil characteristics

- In this region, the flow moves smoothly over the airfoil and is attached over most of the surface.
- However, as  $\alpha$  becomes large, the flow tends to separate from the top surface of the airfoil, creating a large wake of relatively “dead air” behind the airfoil.
- Part of the flow is actually moving in a direction opposite to the freestream—so-called reversed flow.
- We see decrease in lift and a large increase in drag.

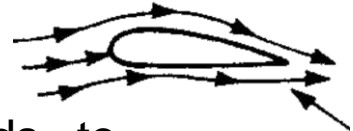

- Under such conditions the airfoil is said to be stalled.

- The maximum value of  $c_l$ , which occurs just prior to the stall, is denoted by  $c_{l,max}$ .

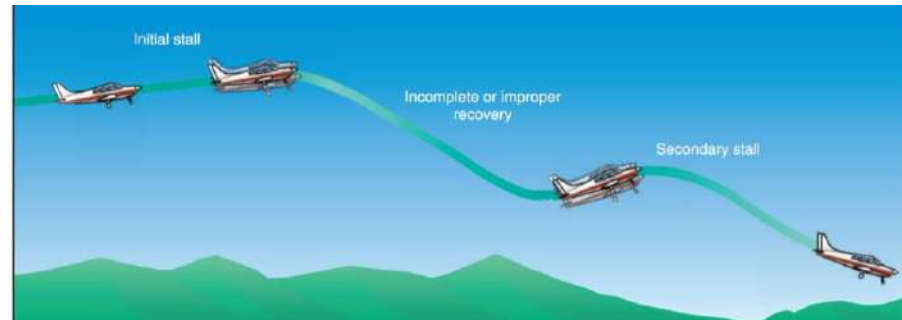



## Airfoil characteristics

- The higher is  $c_{l,max}$ , the lower is the stalling speed.
- A great deal of modern airfoil research has been directed toward increasing  $c_{l,max}$ .
- The NACA 2412 airfoil is given example.
- Note from Figure that
  - $\alpha_{L=0} = -2.1^\circ$ ,
  - $C_{l,max} \approx 1.6$ ,
  - the stall at  $\alpha \approx 16^\circ$ .

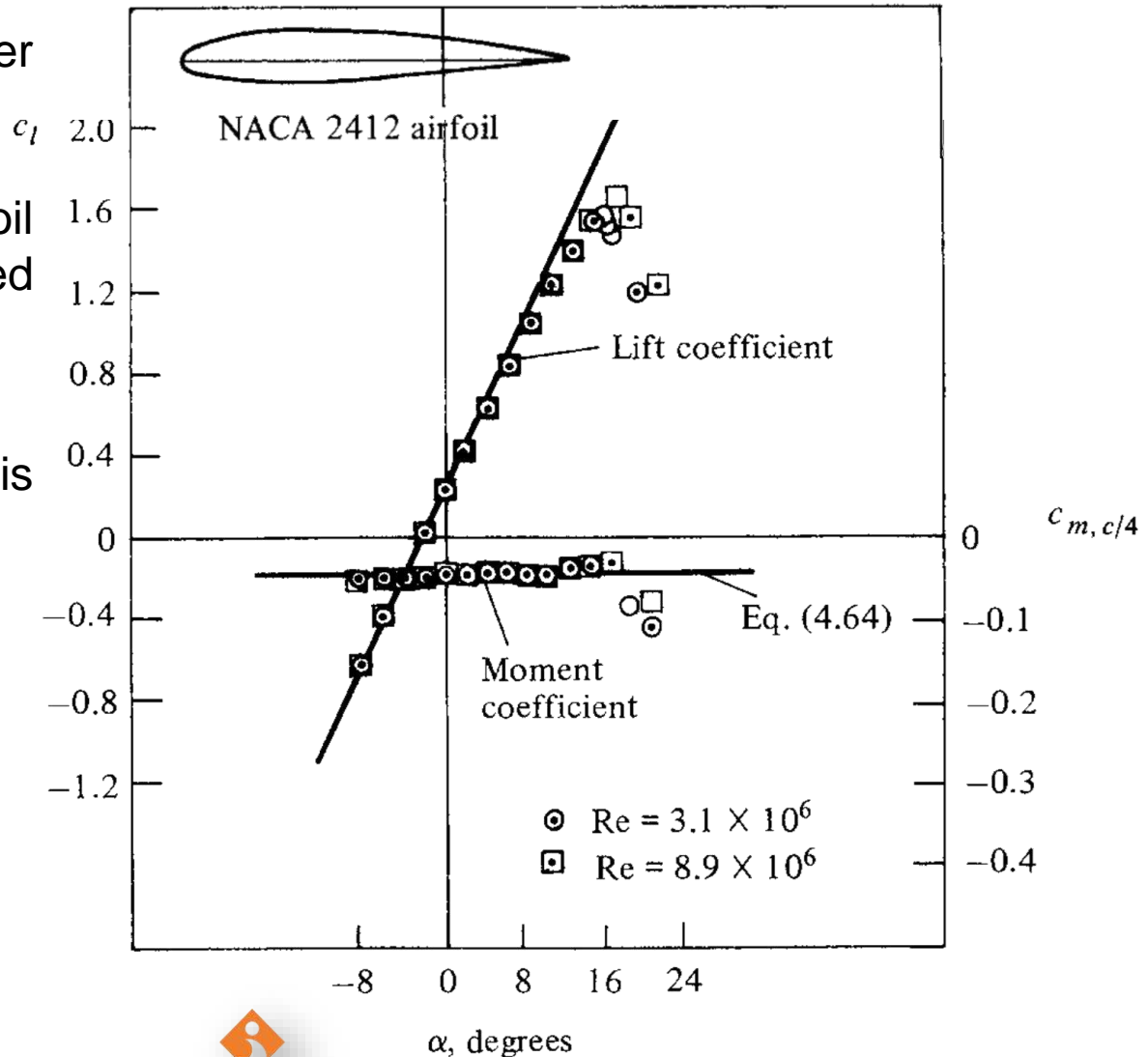





## Airfoil characteristics

- The physical source of drag coefficient is both skin friction drag and pressure drag due to flow separation (so-called form drag).
- The sum of these two effects yields the *profile* drag coefficient  $c_d$  for the airfoil.
- The NACA 2412 airfoil is given example.
- Also plotted in Figure is the moment coefficient about the aerodynamic center  $C_{m,ac}$ .
- In general, moments on an airfoil are a function of  $\alpha$ .

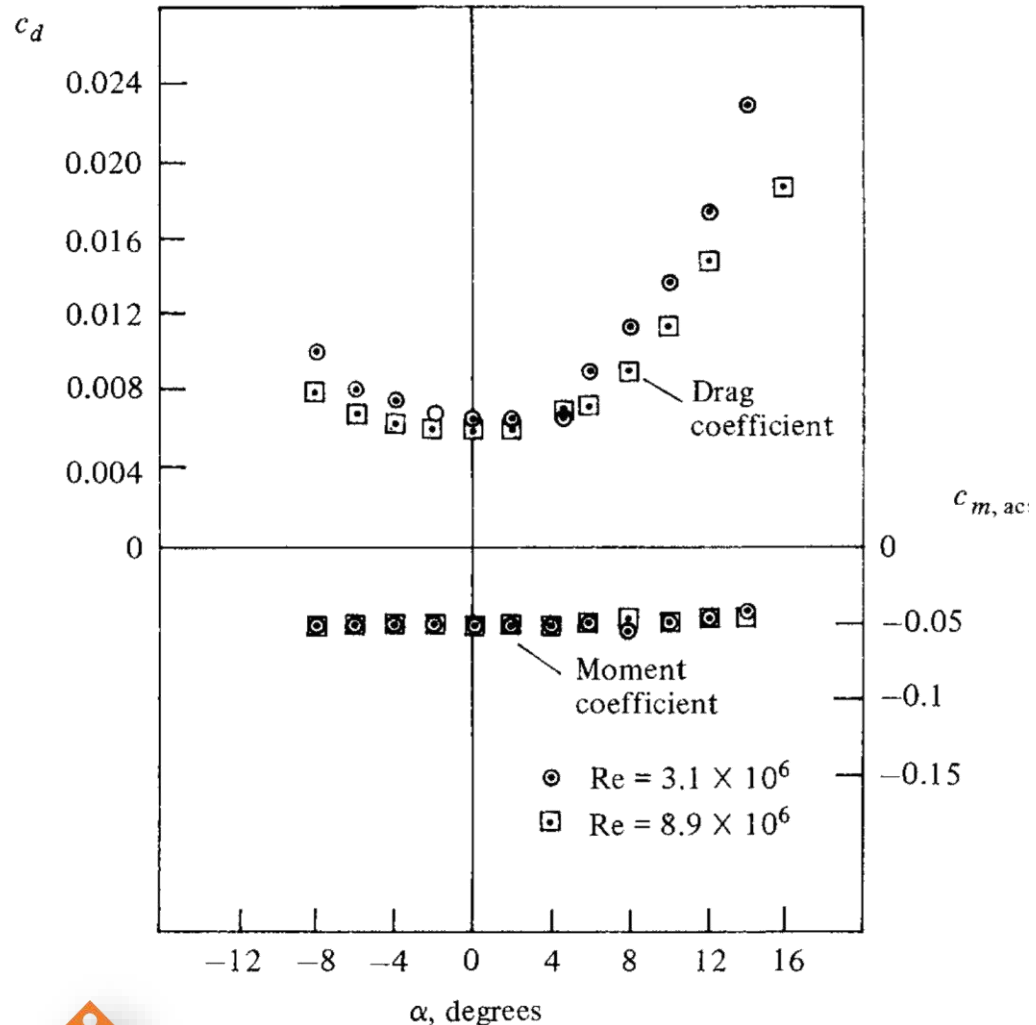



## Airfoil characteristics

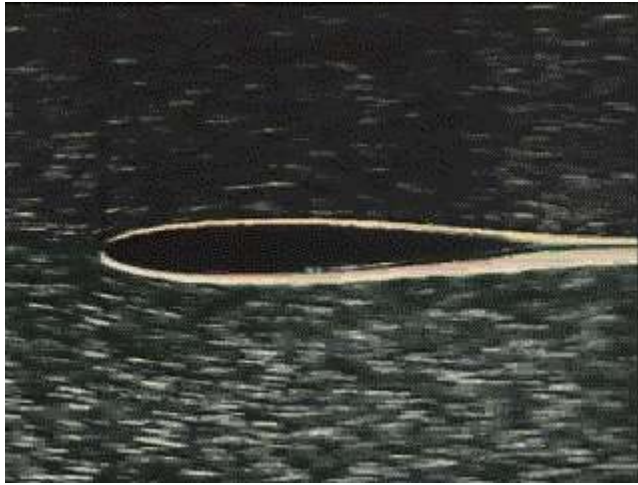

- Foil in viscous flow at varying angles of attack.

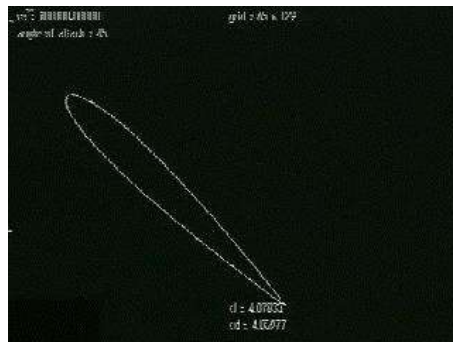

- Circulation around an airfoil.

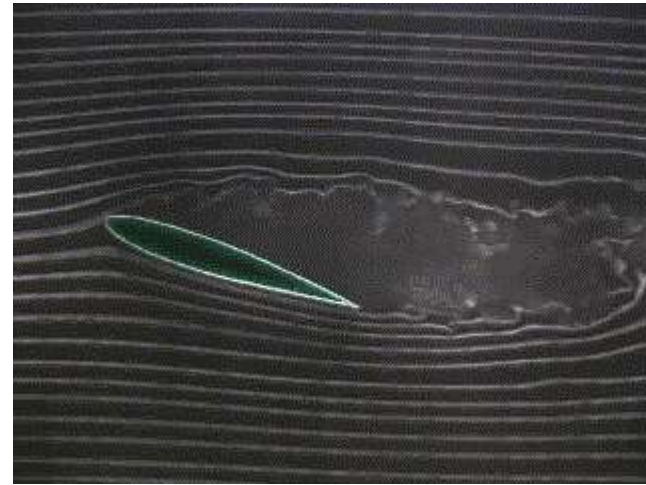

Viscous Flow ( $\alpha = 22$  degrees)

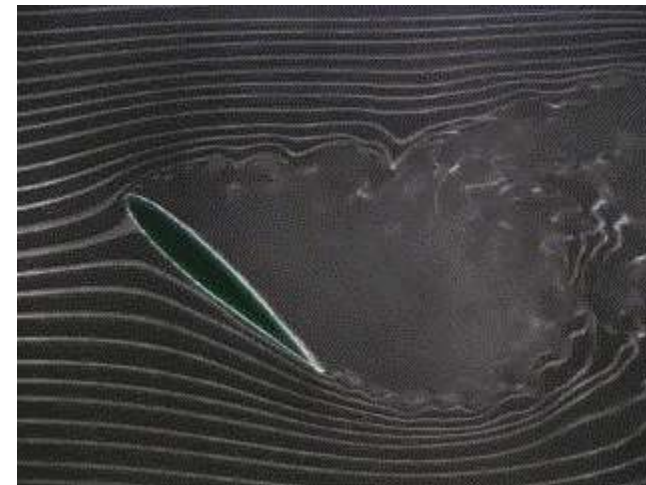

Viscous Flow ( $\alpha = 45$  degrees)





## Airfoil characteristics

- However, there is one point on the airfoil about which the moment is independent of angle of attack.
- Such a point is defined as the *aerodynamic center*.
- Clearly, the data in Figure illustrate a constant value for  $C_{m,ac}$  over a wide range of  $\alpha$ .

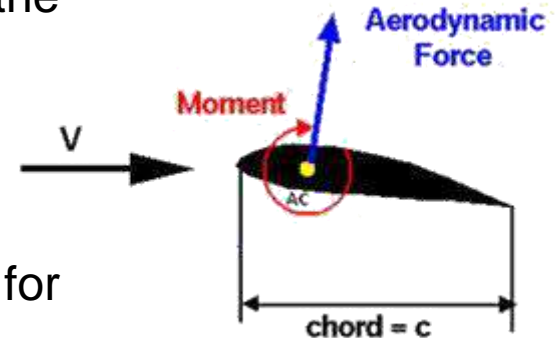

- Aerodynamic center;  $\frac{dC_M}{d\alpha} = 0 \quad M_{c.a.} = c$

- Center of pressure;  $\sum M_{c.p} = 0$

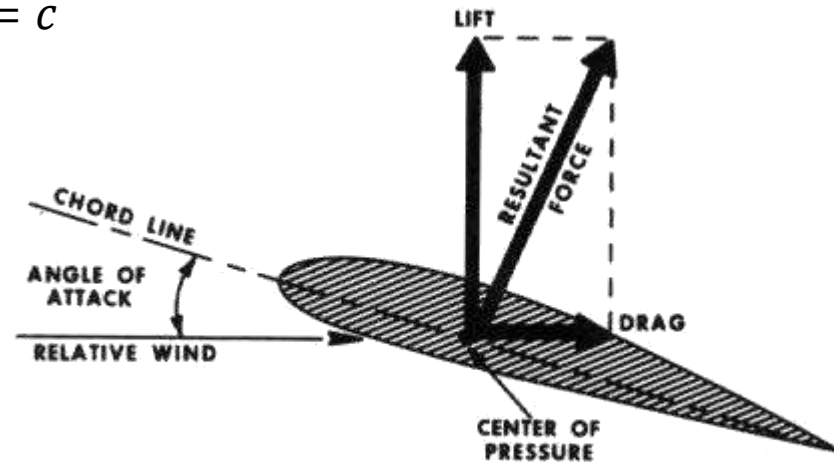



## Example 4.1

- Consider an NACA 2412 airfoil with a chord of 0.64 m in an airstream at standard sea level conditions.
- The freestream velocity is 70 m/s. The lift per unit span is 1254 N/m.
- **Calculate** the angle of attack and the drag per unit span.
- At standard sea level  $\rho = 1.23 \text{ kg/m}^3$ :

$$q_{\infty} = \frac{1}{2} \rho_{\infty} V_{\infty}^2 = \frac{1}{2} (1.23) (70)^2 = 3013.5 \text{ N/m}^2$$

$$c_l = \frac{L'}{q_{\infty} S} = \frac{L'}{q_{\infty} c(1)} = \frac{1254}{3013.5(0.64)} = 0.65$$

- From Figure  $c_l = 0.65$ ,  $\alpha = 4^{\circ}$





## Example 4.1

- Since  $c_d = f(\text{Re})$ , let us calculate  $\text{Re}$ . At standard sea level,

$$\mu = 1.789 \times 10^{-5} \text{ kg/(m} \cdot \text{s)}$$

$$\text{Re} = \frac{\rho_\infty V_\infty c}{\mu_\infty} = \frac{1.23(70)(0.64)}{1.789 \times 10^{-5}} = 3.08 \times 10^6$$

- Therefore, using the data for  $\text{Re} = 3.1 \times 10^6$  in Figure, we find

$$c_d = 0.0068$$

$$D' = q_\infty S c_d = q_\infty c(1) c_d = 3013.5(0.64)(0.0068) = 13.1 \text{ N/m}$$





## Example 4.2

- For the airfoil and flow conditions given in Example 4.1, **calculate** the moment per unit span about the aerodynamic center.
- **Calculate** and compare the lift-to-drag ratios at angles of attack of 0, 4, 8, and 12 degrees.
- The Reynolds number is  $3.1 \times 10^6$ .
- From Figure,  $c_{m,ac}$ , which is independent of angle of attack, is  $-0.05$ .
- The moment per unit span about the aerodynamic center is

$$\begin{aligned}M'_{ac} &= q_{\infty} S c c_{m,ac} \\ &= (3013.5)(0.64)(0.64)(-0.05) = -61.7 \text{ Nm}\end{aligned}$$

- A negative moment, as obtained here, is a pitch-down moment, tending to reduce the angle of attack.





## Example 4.2

- The lift-to-drag ratio,  $L/D$ , is given by 
$$\frac{L}{D} = \frac{q_{\infty} S c_{\ell}}{q_{\infty} S c_d} = \frac{c_{\ell}}{c_d}$$

- From Figures, we have

$\alpha$	$C_{\ell}$	$C_d$	$C_{\ell}/C_d$
0	0.25	0.0065	38.5
4	0.65	0.0070	93
8	1.08	0.0112	96
12	1.44	0.017	85

- As the angle of attack increases, the lift-to-drag ratio increases, reaches a maximum, and then decreases.
- The maximum lift-to-drag ratio,  $(L/D)_{\max}$ , is a direct measure of aerodynamic efficiency.
- The higher the value of  $(L/D)_{\max}$ , the more efficient is the airfoil.
- The values of  $(L/D)_{\max}$  for real airplanes are on the order of 10 to 20.





## The vortex sheet

- Imagine a straight line perpendicular to the page, extending to infinity both out of and into the page.
- This line is a straight *vortex filament* of strength  $\Gamma$ .
- Imagine an infinite number of straight vortex filaments side by side.
- These side-by-side vortex filaments form a *vortex sheet*,

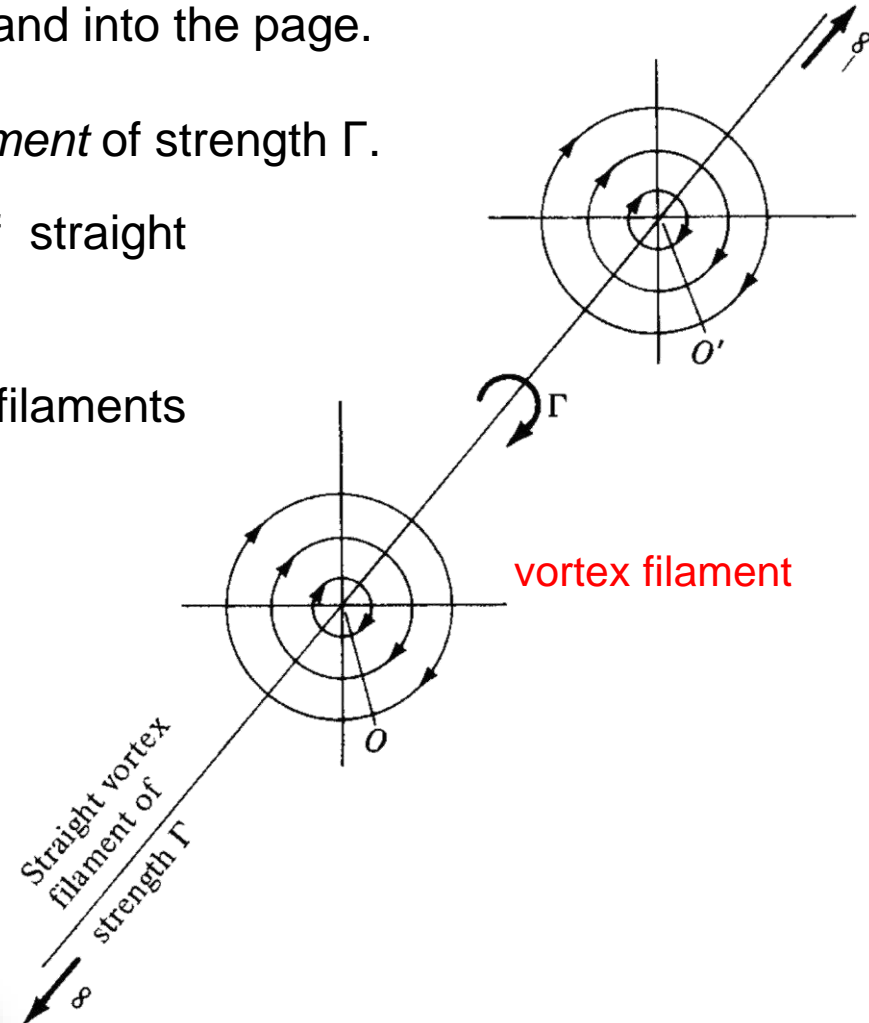
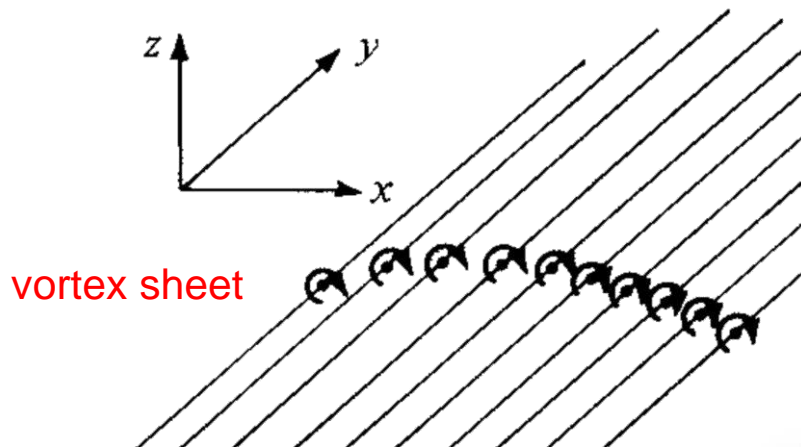





## The vortex sheet

- Here, we are looking at an edge view of the sheet; the vortex filaments are all perpendicular to the page.
- Let  $s$  be the distance measured along the vortex sheet in the edge view.
- Define  $\gamma = \gamma(s)$  as the strength of the vortex sheet, per unit length along  $s$ .
- Thus, the strength of an infinitesimal portion  $ds$  of the sheet is  $\gamma ds$ .
- Now consider point  $P$  in the flow, located a distance  $r$  from  $ds$ .
- The small section of the vortex sheet of strength  $\gamma ds$  induces an infinitesimally small velocity  $dV$  at point  $P$ .

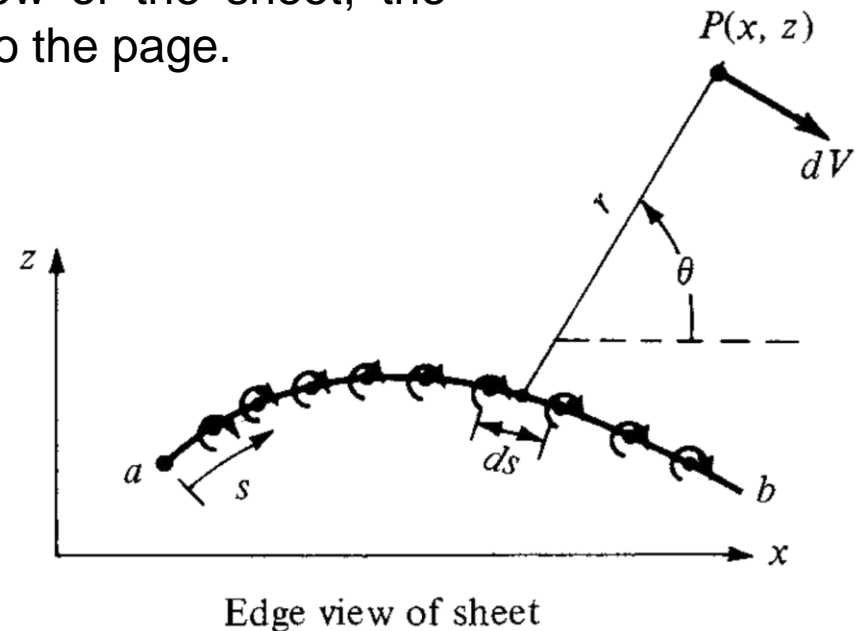

- $dV$  is given by 
$$dV = -\frac{\gamma ds}{2\pi r}$$
 in a direction perpendicular to  $r$





## The vortex sheet

- The increment in velocity potential  $d\phi$  induced at point  $P$  by the elemental vortex  $\gamma ds$  is,

$$d\phi = -\frac{\gamma ds}{2\pi}\theta$$

- The velocity potential at  $P$  due to the entire vortex sheet from  $a$  to  $b$  is

$$\phi(x, z) = -\frac{1}{2\pi} \int_a^b \theta \gamma ds$$

- The circulation around the vortex sheet is the sum of the strengths of the elemental vortices; that is

$$\Gamma = \int_a^b \gamma ds$$





## The vortex sheet

- The change in tangential velocity across the vortex sheet is related to the strength of the sheet as follows.
- Consider a vortex sheet as sketched,

$$\Gamma \equiv - \oint_C \mathbf{V} \cdot d\mathbf{s}$$

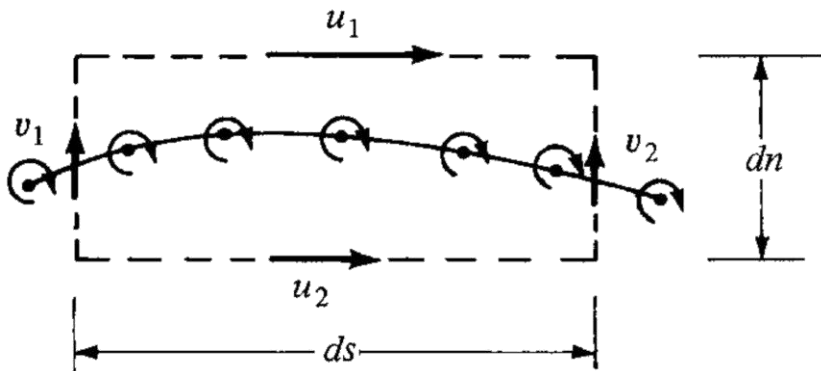

- From the definition of circulation, the circulation around the dashed path is

$$\Gamma = -(v_2 dn - u_1 ds - v_1 dn + u_2 ds)$$

$$\Gamma = (u_1 - u_2) ds + (v_1 - v_2) dn$$

- we also have  $\Gamma = \gamma ds$

- Therefore,  $\gamma ds = (u_1 - u_2) ds + (v_1 - v_2) dn$

- Let  $dn \rightarrow 0$   $\gamma ds = (u_1 - u_2) ds$

$$\gamma = u_1 - u_2$$

- *The local jump in tangential velocity across the vortex sheet is equal to the local sheet strength.*





## The vortex sheet

- A philosophy of airfoil theory of inviscid, incompressible flow is as follows.
- Consider an airfoil of arbitrary shape and thickness in a freestream with velocity  $V_\infty$ , as sketched in Figure.
- Replace the airfoil surface with a vortex sheet of variable strength  $\gamma$  ( $s$ ).
- Calculate the variation of  $\gamma$  as a function of  $s$ .
- Such that the induced velocity field from the vortex sheet when added to the  $V_\infty$  will make the vortex sheet (hence the airfoil surface) a *streamline of the flow*.





## The vortex sheet

- In turn, the circulation around the airfoil will be given by

$$\Gamma = \int \gamma ds$$

where the integral is taken around the complete surface of the airfoil.

- Finally, the resulting lift is given by the Kutta-Joukowski theorem

$$L' = \rho_{\infty} V_{\infty} \Gamma$$

- However, no general analytical solution for  $\gamma = \gamma(s)$  exists for an airfoil of arbitrary shape and thickness.
- Rather, the strength of the vortex sheet must be found numerically.





## The vortex sheet

- However, imagine that the airfoil in Figure is made very thin.
- So, the portions of the vortex sheet on the top and bottom surface of the airfoil would almost coincide.

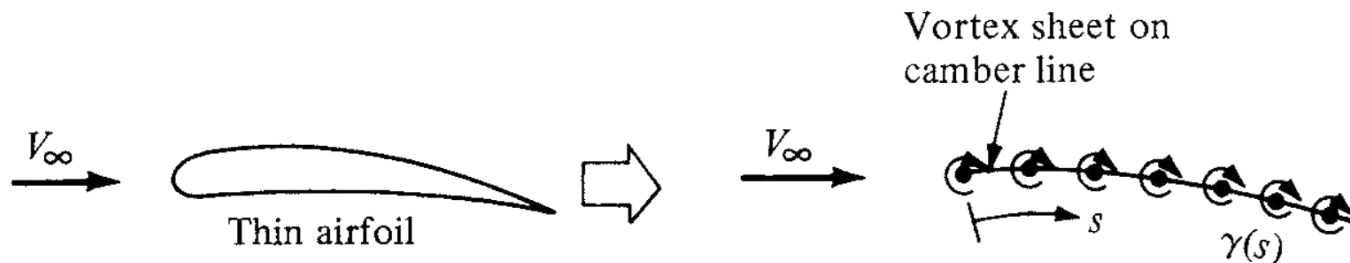

- This gives rise to a method of approximating a thin airfoil by replacing it with a single vortex sheet distributed over the camber line of the airfoil.
- Although it is an approximation, it has the advantage of yielding a closed-form analytical solution.





## The Kutta condition

- The lifting flow over a circular cylinder was discussed in Section 3.15.
- We observed that an infinite number of potential flow solutions were possible, corresponding to the infinite choice of  $\Gamma$ .
- The same situation applies to the potential flow over an airfoil.
- For a given airfoil at a given angle of attack, there are an infinite number of valid theoretical solutions, corresponding to an infinite choice of  $\Gamma$ .

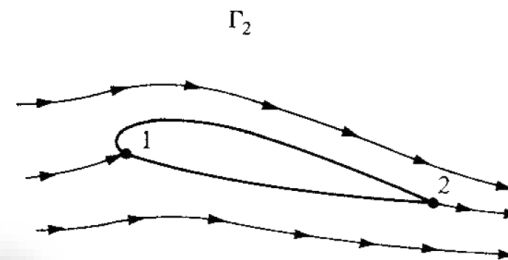
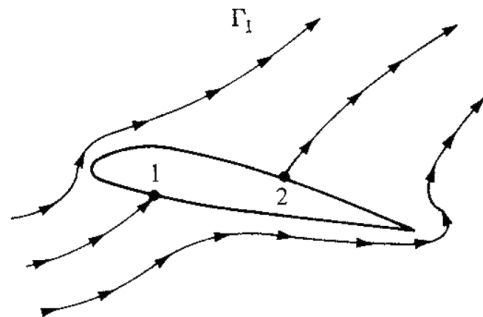



## The Kutta condition

- But, we know from experience that a given airfoil at a given angle of attack produces a single value of lift.
- So, although there is an infinite number of possible potential flow solutions, nature knows how to pick a particular solution.
- Clearly, we need an additional condition that *fixes*  $\Gamma$  for a given airfoil at a given  $\alpha$ .







## The Kutta condition

At the beginning

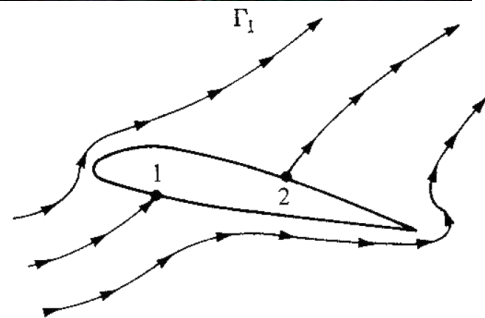

Later...

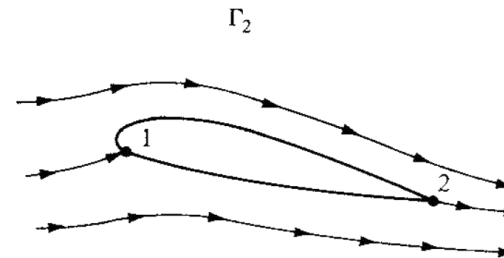

- According to the experiments, the flow is *smoothly leaving the top and the bottom surfaces of the airfoil at the trailing edge.*
- This flow pattern is sketched in Figure and represents the type of pattern to be expected for the steady flow over an airfoil.





## The Kutta condition

- In establishing the steady flow over a given airfoil at a given angle of attack, nature adopts that particular value of circulation.
- This certain circulation results in the flow leaving smoothly at the trailing edge.
- That observation was first made and used in a theoretical analysis by the German mathematician M. Wilhelm Kutta in 1902.
- Therefore, it has become known as the *Kutta condition*.





## The Kutta condition

- We need to be more precise about the nature of the flow at the trailing edge.
- We can summarize the statement of the Kutta condition as follows:
  - For a given airfoil at a given angle of attack, the value of  $\Gamma$  around the airfoil is such that the flow leaves the trailing edge smoothly.
  - If the trailing-edge angle is finite, then the trailing edge is a stagnation point.
  - If the trailing edge is cusped, then the velocities leaving the top and bottom surfaces at the trailing edge are finite and equal in magnitude and direction.

Finite angle



At point  $a$ :  $V_1 = V_2 = 0$

Cusp

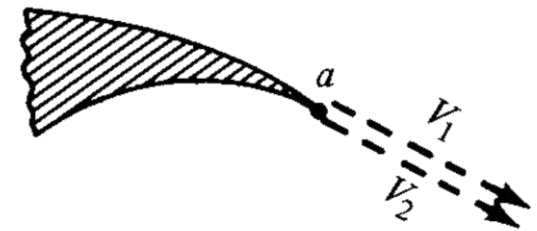

At point  $a$ :  $V_1 = V_2 \neq 0$





## The Kutta condition

- The statement of the Kutta condition in terms of the vortex sheet is as follows.

- At the trailing edge (TE), we have  $\gamma(\text{TE}) = \gamma(a) = V_1 - V_2$

$$V_1 = V_2 = 0; \quad \gamma(\text{TE}) = 0.$$

$$V_1 = V_2 \neq 0; \quad \gamma(\text{TE}) = 0.$$

- At the trailing edge (TE), the strength of the vortex sheet is '0'.
- *Nature enforces the Kutta condition by means of friction.*
- If there were no boundary layer (i.e., no friction), there would be no physical mechanism in the real world to achieve the Kutta condition.
- We can say that without friction we could not have lift.





## Kelvin's circulation theorem

- Specifically, the Kutta condition states that the circulation around an airfoil is just the right value to ensure that the flow smoothly leaves the trailing edge.
- *Question*: How does nature generate this circulation?
- Does it come from nowhere, or is circulation somehow conserved over the whole flow field?
- Consider an arbitrary inviscid, incompressible flow.
- Assume that all body forces  $\mathbf{f}$  are zero.





## Kelvin's circulation theorem

- we can state that circulation around a closed curve formed by a set of contiguous fluid elements remains constant as the fluid elements move throughout the flow.
- Hence, a mathematical statement of the above discussion

is simply 
$$\frac{D\Gamma}{Dt} = 0$$

$$\Gamma_1 = - \int_{C_1} \mathbf{V} \cdot d\mathbf{s}$$

$$\Gamma_2 = - \int_{C_2} \mathbf{V} \cdot d\mathbf{s}$$

Equation is called  
Kelvin's circulation theorem

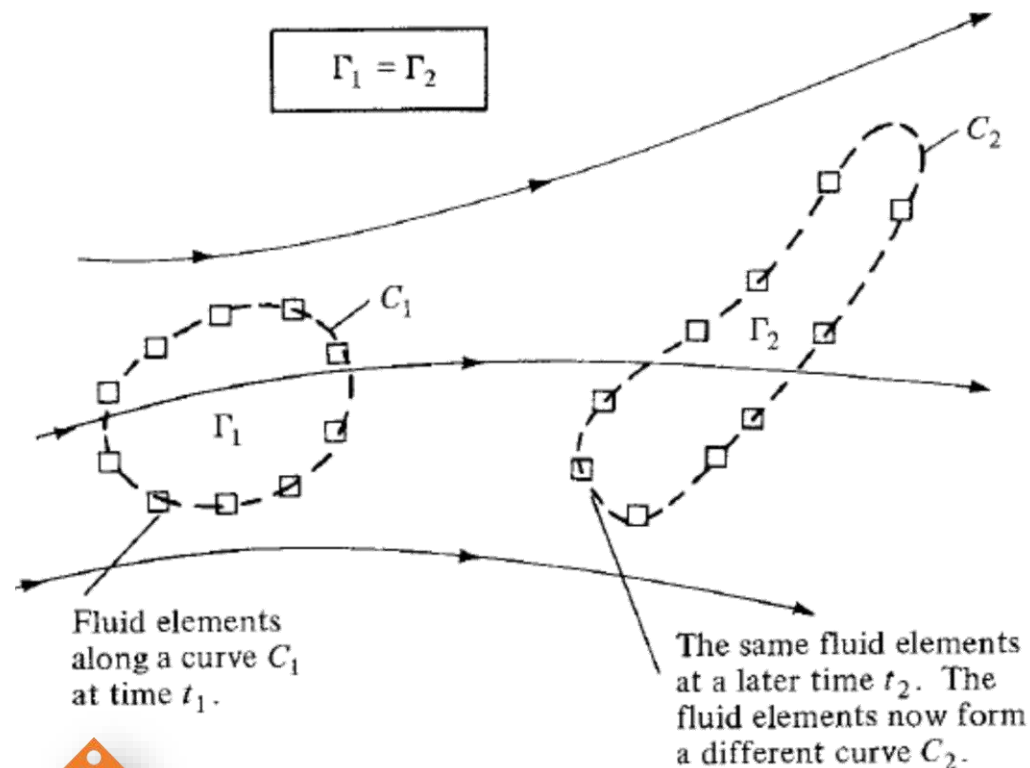



## Kelvin's circulation theorem

- Kelvin's theorem helps to explain the generation of circulation around an airfoil, as follows.
- Consider an airfoil in a fluid at rest.
- Because  $\mathbf{V} = 0$  everywhere, the circulation around curve  $C_1$  is zero.
- Now start the flow in motion over the airfoil.
- Initially, the flow will tend to curl around the trailing edge.
- Consequently, during the very first moments after the flow is started, a thin region of very large velocity gradients (and therefore high vorticity) is formed at the trailing edge.





## Kelvin's circulation theorem

- This high vorticity region is fixed to the same fluid elements.
- Consequently it is flushed downstream as the fluid elements begin to move downstream from the trailing edge.
- As it moves downstream, this thin sheet of intense vorticity is unstable, and it tends to roll up and form a picture similar to a point vortex.
- This vortex is called the *starting vortex*.







# Kelvin's circulation theorem

- After the flow around the airfoil has come to a steady state where the flow leaves the trailing edge smoothly (the Kutta condition), the high velocity gradients at the trailing edge disappear.
- Vorticity is no longer produced at that point.
- However, the starting vortex has already been formed during the starting process.
- It moves steadily downstream with the flow forever after.

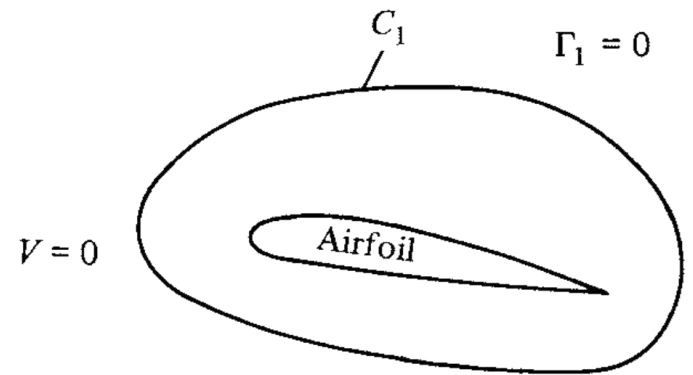

(a) Fluid at rest relative to the airfoil

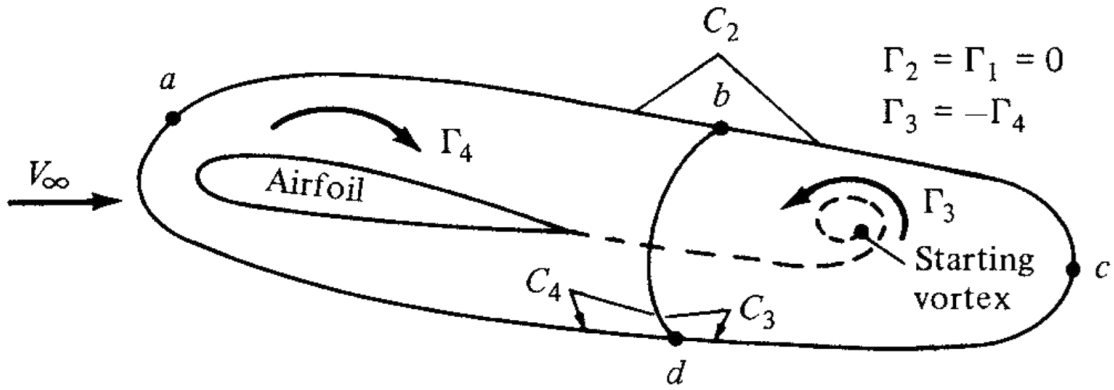

(b) Picture some moments after the start of the flow

$$\Gamma_2 = \Gamma_1 = 0 \quad \Gamma_4 = -\Gamma_3$$

$$\Gamma_3 + \Gamma_4 = \Gamma_2$$





## Kelvin's circulation theorem

- The circulation around the airfoil is equal and opposite to the circulation around the [starting vortex](#).

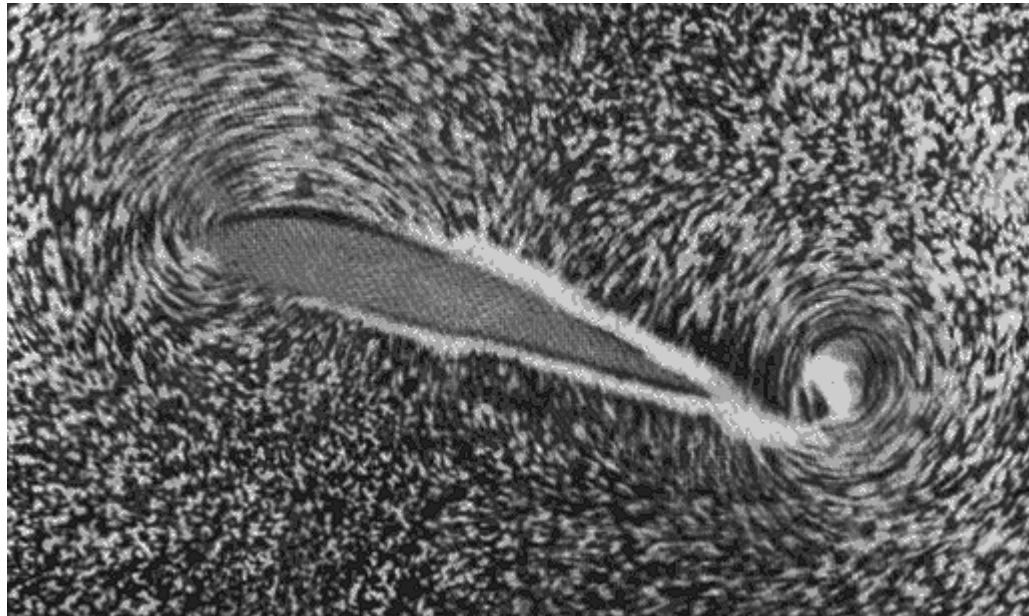



## Example 4.4

- For the NACA 2412 airfoil at the conditions given, **calculate** the strength of the steady-state starting vortex.

$$L' = 1254 \text{ N/m}$$

$$V_\infty = 70 \text{ m/s}$$

$$\rho_\infty = 1.23 \text{ kg/m}^3$$

- From the Kutta-Joukowski theorem,  $L' = \rho_\infty V_\infty \Gamma$

The circulation associated with the flow over the airfoil with  $\Gamma = \frac{L'}{\rho_\infty V_\infty} = \frac{1254}{(1.23)(70)} = 14.56 \frac{\text{m}^2}{\text{s}}$

- The steady-state starting vortex has strength equal and opposite to the circulation around the airfoil. Hence,

$$\text{Strength of starting vortex} = -14.56 \frac{\text{m}^2}{\text{s}}$$

- For practical calculations in aerodynamics, an actual number for circulation is rarely needed.
- Circulation is a mathematical quantity, the starting vortex is simply a theoretical construct.





## Classical thin airfoil theory: the symmetric airfoil

- We deal with *thin* airfoils; for such a case, the airfoil can be simulated by a vortex sheet placed along the camber line.
- Our purpose is to calculate the variation of  $\gamma (s)$ .
- Such that the camber line becomes a streamline of the flow and the Kutta condition is satisfied at the trailing edge; that is,  $\gamma (TE) = 0$ .
- Then the total circulation around the airfoil is found by integrating  $\gamma (s)$  from the leading edge to the trailing edge.
- In turn, the lift is calculated from via the Kutta-Joukowski theorem.





## Classical thin airfoil theory: the symmetric airfoil

- Consider a vortex sheet placed on the camber line of an airfoil,  $z = z(x)$
- $w$  is the component of velocity normal to the camber line induced by the vortex sheet.  $w' = w'(s)$

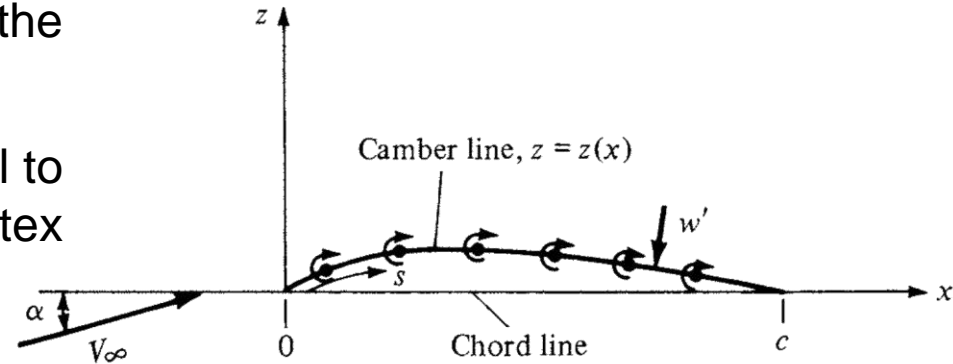

(a) Vortex sheet on the camber line

- If the airfoil is thin, the camber line is close to the chord line, the vortex sheet appears to fall approximately on the chord line.
- Therefore, let us place the vortex sheet on the chord line.  $\gamma = \gamma(x)$

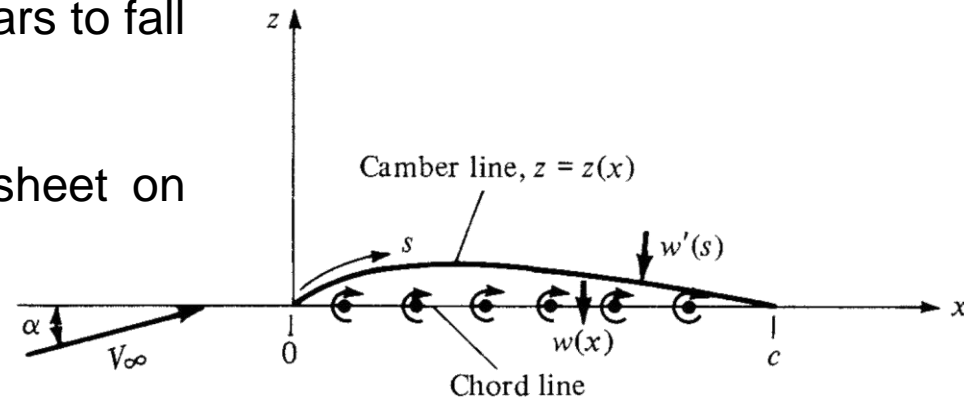

(b) Vortex sheet on the chord line

- The strength of the vortex sheet on the chord line is determined such that the camber line is a streamline &  $\gamma(c) = 0$ .





## Classical thin airfoil theory: the symmetric airfoil

- For the camber line to be a streamline, the component of velocity normal to the camber line must be zero at all points along the camber line.

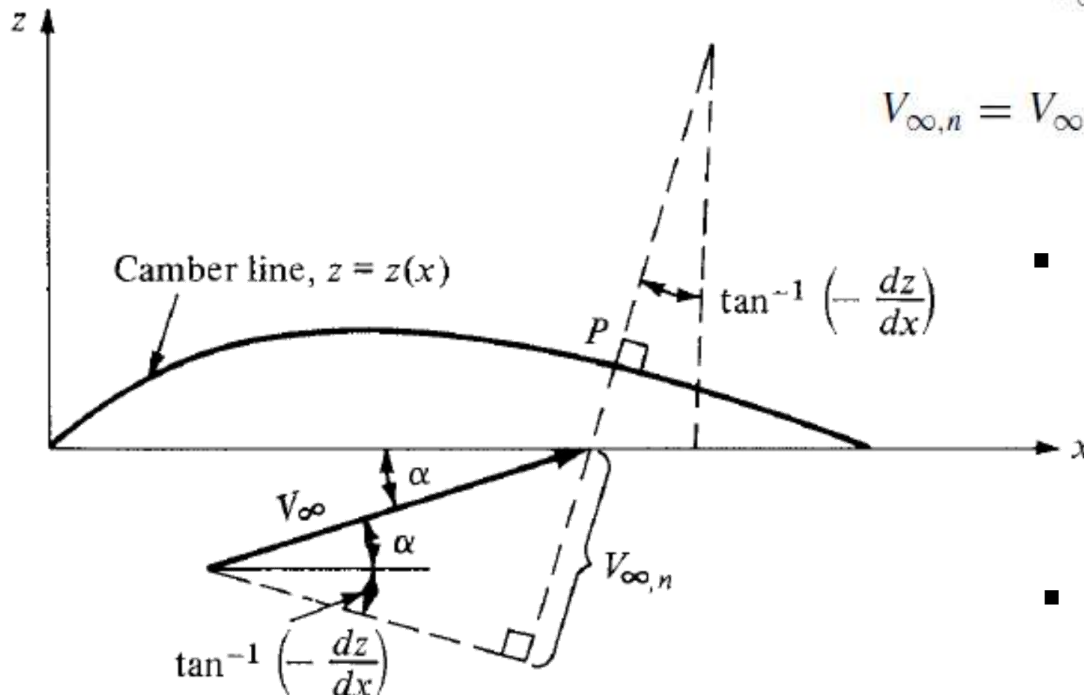

$$V_{\infty,n} + w'(s) = 0$$

$$V_{\infty,n} = V_{\infty} \sin \left[ \alpha + \tan^{-1} \left( -\frac{dz}{dx} \right) \right]$$

- For a thin airfoil at small angle of attack,  $\sin \theta \approx \tan \theta \approx \theta$

$$V_{\infty,n} = V_{\infty} \left( \alpha - \frac{dz}{dx} \right)$$

- Keep in mind that  $\alpha$  is in radians.





## Classical thin airfoil theory: the symmetric airfoil

- Let us develop an expression for  $w'(s)$  in terms of the strength of the vortex sheet.
- Let  $w(x)$  denote the component of velocity normal to the *chord line* induced by the vortex sheet.
- If the airfoil is thin,  $w'(s) \approx w(x)$
- Remember that;  $dV = -\frac{\gamma ds}{2\pi r}$
- We wish to calculate the value of  $w(x)$  at the location  $x$ .

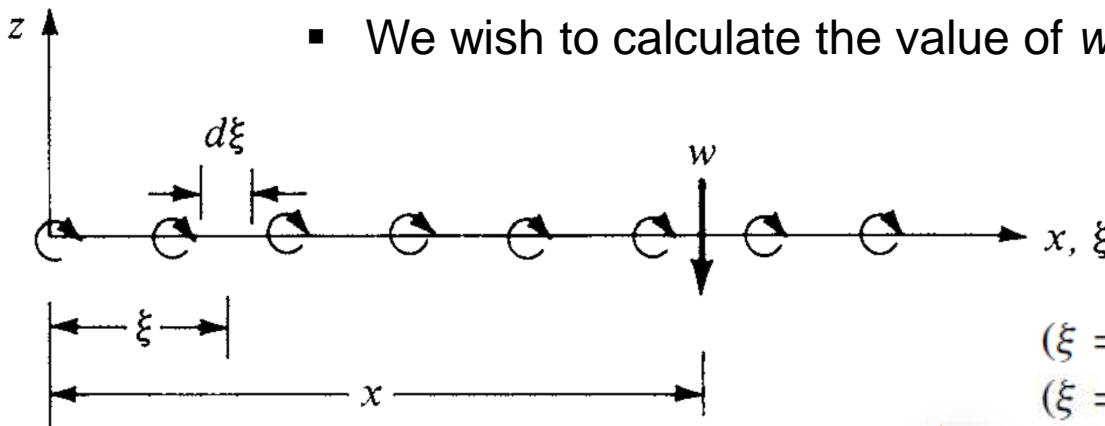

$$dw = -\frac{\gamma(\xi) d\xi}{2\pi(x - \xi)}$$

$$w(x) = -\int_0^c \frac{\gamma(\xi) d\xi}{2\pi(x - \xi)}$$





## Classical thin airfoil theory: the symmetric airfoil

- Recall the boundary condition necessary for the camber line to be a streamline. Substituting Equations, we obtain

$$V_{\infty} \left( \alpha - \frac{dz}{dx} \right) - \int_0^c \frac{\gamma(\xi) d\xi}{2\pi(x - \xi)} = 0$$
$$\frac{1}{2\pi} \int_0^c \frac{\gamma(\xi) d\xi}{x - \xi} = V_{\infty} \left( \alpha - \frac{dz}{dx} \right)$$

- The *fundamental equation of thin airfoil theory*; it is simply a statement that the camber line is a streamline of the flow.
- In this section, we treat the case of a symmetric airfoil;  $dz/dx = 0$ ,

$$\frac{1}{2\pi} \int_0^c \frac{\gamma(\xi) d\xi}{x - \xi} = V_{\infty} \alpha$$







## Classical thin airfoil theory: the symmetric airfoil

- To help deal with the integral, let us transform  $\xi$  into  $\theta$  via the following transformation:

$$\xi = \frac{c}{2}(1 - \cos \theta)$$

- Since  $x$  is a fixed point in Equations, it corresponds to a particular value of  $\theta$ , namely,  $\theta_0$ , such that

$$x = \frac{c}{2}(1 - \cos \theta_0)$$

- Also, from Equation

$$d\xi = \frac{c}{2} \sin \theta d\theta$$

- Substituting them and noting that the limits of integration become  $\theta = 0$  at the leading edge (where  $\xi = 0$ ) and  $\theta = \pi$  at the trailing edge (where  $\xi = c$ ), we obtain

$$\frac{1}{2\pi} \int_0^\pi \frac{\gamma(\theta) \sin \theta d\theta}{\cos \theta - \cos \theta_0} = V_\infty \alpha$$





## Classical thin airfoil theory: the symmetric airfoil

- A rigorous solution of Equation for  $\gamma(\theta)$  can be obtained from the mathematical theory of integral equations.

- We simply state that the solution is 
$$\gamma(\theta) = 2\alpha V_\infty \frac{(1 + \cos \theta)}{\sin \theta}$$

- Note that at the trailing edge, where  $\theta = \pi$ , Equation yields

$$\gamma(\pi) = 2\alpha V_\infty \frac{0}{0}$$

- However, using L'Hospital's rule

$$\gamma(\pi) = 2\alpha V_\infty \frac{-\sin \pi}{\cos \pi} = 0$$

- Thus, Equation also satisfies the Kutta condition.

L'Hospital's Rule tells us that if we have an indeterminate form 0/0 or all we need to do is differentiate the numerator and differentiate the denominator and then take the limit.





## Classical thin airfoil theory: the symmetric airfoil

- We are now in a position to calculate the lift coefficient for a thin, symmetric airfoil. The total circulation around the airfoil is

$$\Gamma = \int_0^c \gamma(\xi) d\xi \qquad d\xi = \frac{c}{2} \sin \theta d\theta$$

$$\Gamma = \frac{c}{2} \int_0^\pi \gamma(\theta) \sin \theta d\theta \qquad \gamma(\theta) = 2\alpha V_\infty \frac{(1 + \cos \theta)}{\sin \theta}$$

$$\Gamma = \alpha c V_\infty \int_0^\pi (1 + \cos \theta) d\theta = \pi \alpha c V_\infty$$

- Substituting Equation into the Kutta-Joukowski theorem, we find that the lift per unit span is

$$L' = \rho_\infty V_\infty \Gamma = \pi \alpha c \rho_\infty V_\infty^2$$





## Classical thin airfoil theory: the symmetric airfoil

- The lift coefficient is  $c_l = \frac{L'}{q_\infty S}$       $c_l = \frac{\pi \alpha c \rho_\infty V_\infty^2}{\frac{1}{2} \rho_\infty V_\infty^2 c(1)}$   
 $S = c(1)$   
 $c_l = 2\pi\alpha$      Lift slope =  $\frac{dc_l}{d\alpha} = 2\pi$
- They state the theoretical result that the lift coefficient is *linearly proportional to angle of attack*, which is supported by the experimental results.
- The experimental lift coefficient data for an NACA 0012 symmetric airfoil are given in Figure.
- Note that Equation accurately predicts  $c_l$  over a large range of angle of attack.





## Classical thin airfoil theory: the symmetric airfoil

$$c_l = 2\pi\alpha$$

$$\alpha = 4^\circ$$

$$C_l = 2\pi\alpha = 2 \times \pi \times 4 \times \frac{2\pi}{360}$$

$$C_l = 0,4386$$

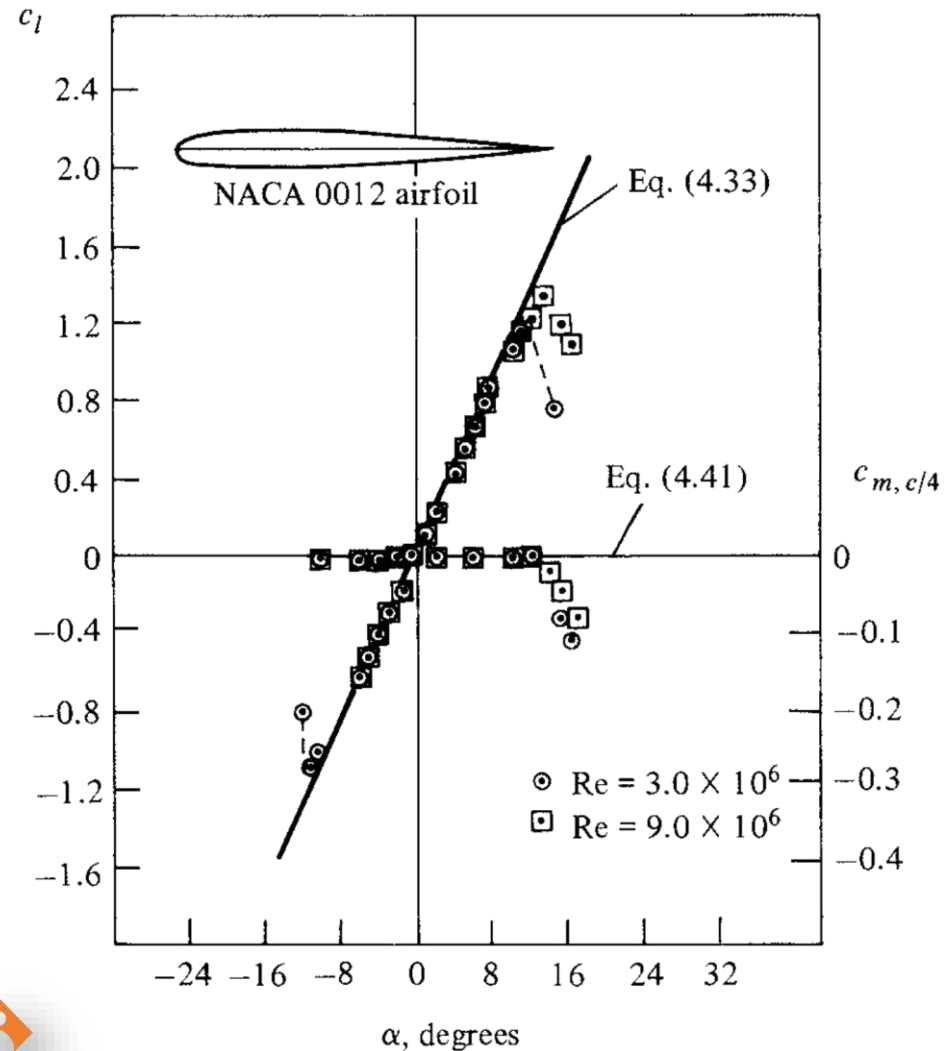



## Classical thin airfoil theory: the symmetric airfoil

- The moment about the leading edge can be calculated as follows.
- The increment of lift  $dL$  contributed by the elemental vortex is

$$dL = \rho_{\infty} V_{\infty} d\Gamma \quad d\Gamma = \gamma(\xi) d\xi$$

- This increment of lift creates a moment about the leading edge

$$dM = -\xi(dL)$$

$$M'_{LE} = - \int_0^c \xi(dL) = -\rho_{\infty} V_{\infty} \int_0^c \xi \gamma(\xi) d\xi$$

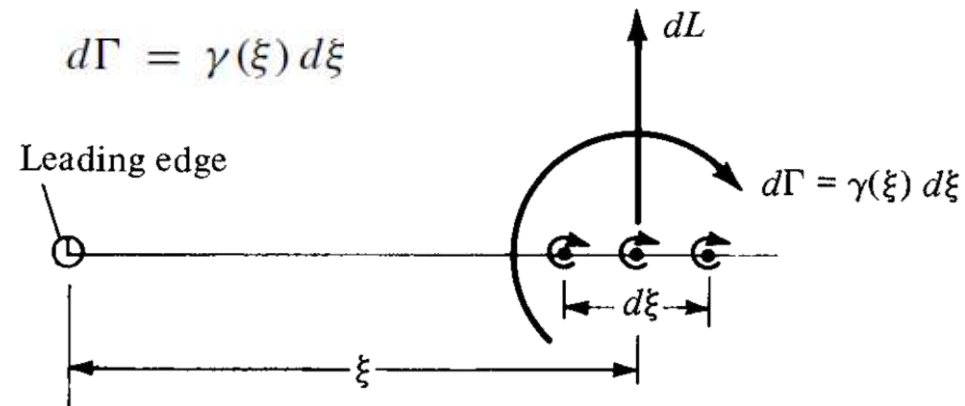

Transforming Equation and performing the integration, we obtain

$$\int \sin^2 ax dx = \frac{x}{2} - \frac{\sin 2ax}{4a}$$

$$M'_{LE} = -q_{\infty} c^2 \frac{\pi \alpha}{2}$$





## Classical thin airfoil theory: the symmetric airfoil

- The moment coefficient is  $c_{m,le} = \frac{M'_{LE}}{q_{\infty} S c} \quad S = c(1)$

$$c_{m,le} = \frac{M'_{LE}}{q_{\infty} c^2} = -\frac{\pi \alpha}{2} \quad \pi \alpha = \frac{c_l}{2}$$

$$c_{m,le} = -\frac{c_l}{4}$$

- From previous Equation, the moment coefficient about the quarter-chord point is

$$c_{m,c/4} = c_{m,le} + \frac{c_l}{4}$$

- Combining Equations, we have  $c_{m,c/4} = 0$

Clearly, Equation demonstrates the theoretical result that the *center of pressure is at the quarter-chord point for a symmetric airfoil.*





## Classical thin airfoil theory: the symmetric airfoil

- By the definition, that point on an airfoil where moments are independent of angle of attack is called the aerodynamic center.
- From Equation, the moment about the quarter chord is zero for all values of  $\alpha$ .
- Hence, for a symmetric airfoil, we have the theoretical result that the *quarter-chord point is both the center of pressure and the aerodynamic center*.
- The theoretical result is supported by the experimental data.

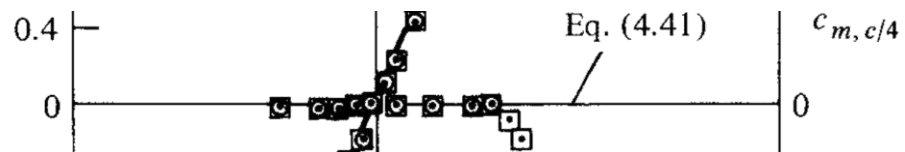





## Questions

- 4.1** Consider the data for the NACA 2412 airfoil given in Figure 4.10. Calculate the lift and moment about the quarter chord (per unit span) for this airfoil when the angle of attack is  $4^\circ$  and the freestream is at standard sea level conditions with a velocity of 50 ft/s. The chord of the airfoil is 2 ft.
- 4.2** Consider an NACA 2412 airfoil with a 2-m chord in an airstream with a velocity of 50 m/s at standard sea level conditions. If the lift per unit span is 1353 N, what is the angle of attack?

- 4.3** Starting with the definition of circulation, derive Kelvin's circulation theorem,

$$\boxed{\frac{D\Gamma}{Dt} = 0}$$

- 4.4** Starting with Equation  $M'_{LE} = - \int_0^c \xi(dL) = -\rho_\infty V_\infty \int_0^c \xi \gamma(\xi) d\xi$

derive Equation  $M'_{LE} = -q_\infty c^2 \frac{\pi \alpha}{2}$





## The cambered airfoil

- To treat the cambered airfoil, return to Equation:

$$\frac{1}{2\pi} \int_0^c \frac{\gamma(\xi) d\xi}{x - \xi} = V_\infty \left( \alpha - \frac{dz}{dx} \right)$$

- Once again, let us transform Equation, obtaining

$$\frac{1}{2\pi} \int_0^\pi \frac{\gamma(\theta) \sin \theta d\theta}{\cos \theta - \cos \theta_0} = V_\infty \left( \alpha - \frac{dz}{dx} \right)$$

- We wish to obtain a solution for  $\gamma(\theta)$  from Equation, subject to the Kutta condition

$$\gamma(\pi) = 0$$





## The cambered airfoil

- The result is  $\gamma(\theta) = 2V_\infty \left( A_0 \frac{1 + \cos \theta}{\sin \theta} + \sum_{n=1}^{\infty} A_n \sin n\theta \right)$
- The coefficients  $A_0$  and  $A_n (n = 1, 2, 3, \dots)$  in Equation must be specific values in order that the camber line be a streamline of the flow.
- To find these specific values, substitute Equation:

$$\frac{1}{\pi} \int_0^\pi \frac{A_0(1 + \cos \theta) d\theta}{\cos \theta - \cos \theta_0} + \frac{1}{\pi} \sum_{n=1}^{\infty} \int_0^\pi \frac{A_n \sin n\theta \sin \theta d\theta}{\cos \theta - \cos \theta_0} = \alpha - \frac{dz}{dx}$$

$$\int_0^\pi \frac{\cos n\theta d\theta}{\cos \theta - \cos \theta_0} = \frac{\pi \sin n\theta_0}{\sin \theta_0}$$

$$\int_0^\pi \frac{\sin n\theta \sin \theta d\theta}{\cos \theta - \cos \theta_0} = -\pi \cos n\theta_0$$

- Hence, using integral definitions, we can reduce Equation to

$$A_0 - \sum_{n=1}^{\infty} A_n \cos n\theta_0 = \alpha - \frac{dz}{dx}$$

$$\frac{dz}{dx} = (\alpha - A_0) + \sum_{n=1}^{\infty} A_n \cos n\theta_0$$





## The cambered airfoil

- By using the form of a Fourier cosine series expansion for the function of  $dz/dx$

$$\frac{dz}{dx} = (\alpha - A_0) + \sum_{n=1}^{\infty} A_n \cos n\theta_0$$

$$f(\theta) = B_0 + \sum_{n=1}^{\infty} B_n \cos n\theta$$

$$B_0 = \frac{1}{\pi} \int_0^{\pi} f(\theta) d\theta$$

$$B_n = \frac{2}{\pi} \int_0^{\pi} f(\theta) \cos n\theta d\theta$$

- The coefficients in Equation are given by

$$\alpha - A_0 = \frac{1}{\pi} \int_0^{\pi} \frac{dz}{dx} d\theta_0 \quad A_0 = \alpha - \frac{1}{\pi} \int_0^{\pi} \frac{dz}{dx} d\theta_0$$

$$A_n = \frac{2}{\pi} \int_0^{\pi} \frac{dz}{dx} \cos n\theta_0 d\theta_0$$





## The cambered airfoil

- Let us now obtain expressions for the aerodynamic coefficients for a cambered airfoil.
- The total circulation due to the entire vortex sheet from the leading edge to the trailing edge is

$$\Gamma = \int_0^c \gamma(\xi) d\xi = \frac{c}{2} \int_0^\pi \gamma(\theta) \sin \theta d\theta$$

- Substituting Equation for  $\gamma(\theta)$ , we obtain

$$\Gamma = cV_\infty \left[ A_0 \int_0^\pi (1 + \cos \theta) d\theta + \sum_{n=1}^{\infty} A_n \int_0^\pi \sin n\theta \sin \theta d\theta \right]$$

- From any standard table of integrals,

$$\int_0^\pi (1 + \cos \theta) d\theta = \pi$$

$$\Gamma = cV_\infty \left( \pi A_0 + \frac{\pi}{2} A_1 \right)$$

$$\int_0^\pi \sin n\theta \sin \theta d\theta = \begin{cases} \pi/2 & \text{for } n = 1 \\ 0 & \text{for } n \neq 1 \end{cases}$$





## The cambered airfoil

- The lift per unit span is  $L' = \rho_\infty V_\infty \Gamma = \rho_\infty V_\infty^2 c \left( \pi A_0 + \frac{\pi}{2} A_1 \right)$

- The lift coefficient  $c_l = \frac{L'}{\frac{1}{2} \rho_\infty V_\infty^2 c(1)} = \pi(2A_0 + A_1)$

- Recall the coefficients  $c_l = 2\pi \left[ \alpha + \frac{1}{\pi} \int_0^\pi \frac{dz}{dx} (\cos \theta_0 - 1) d\theta_0 \right]$

$$A_0 = \alpha - \frac{1}{\pi} \int_0^\pi \frac{dz}{dx} d\theta_0$$

$$A_n = \frac{2}{\pi} \int_0^\pi \frac{dz}{dx} \cos n\theta_0 d\theta_0$$

$$\text{Lift slope} \equiv \frac{dc_l}{d\alpha} = 2\pi$$

- The expression for  $c_l$  itself differs between a symmetric and a cambered airfoil.
- The difference has physical significance.





## The cambered airfoil

- From the geometry

$$c_l = \frac{dc_l}{d\alpha}(\alpha - \alpha_{L=0})$$

- Substituting Equation, we have

$$c_l = 2\pi(\alpha - \alpha_{L=0})$$

- Comparing Equations, we see that the integral term is simply the negative of the zero-lift angle; that is

$$\alpha_{L=0} = -\frac{1}{\pi} \int_0^\pi \frac{dz}{dx} (\cos \theta_0 - 1) d\theta_0$$

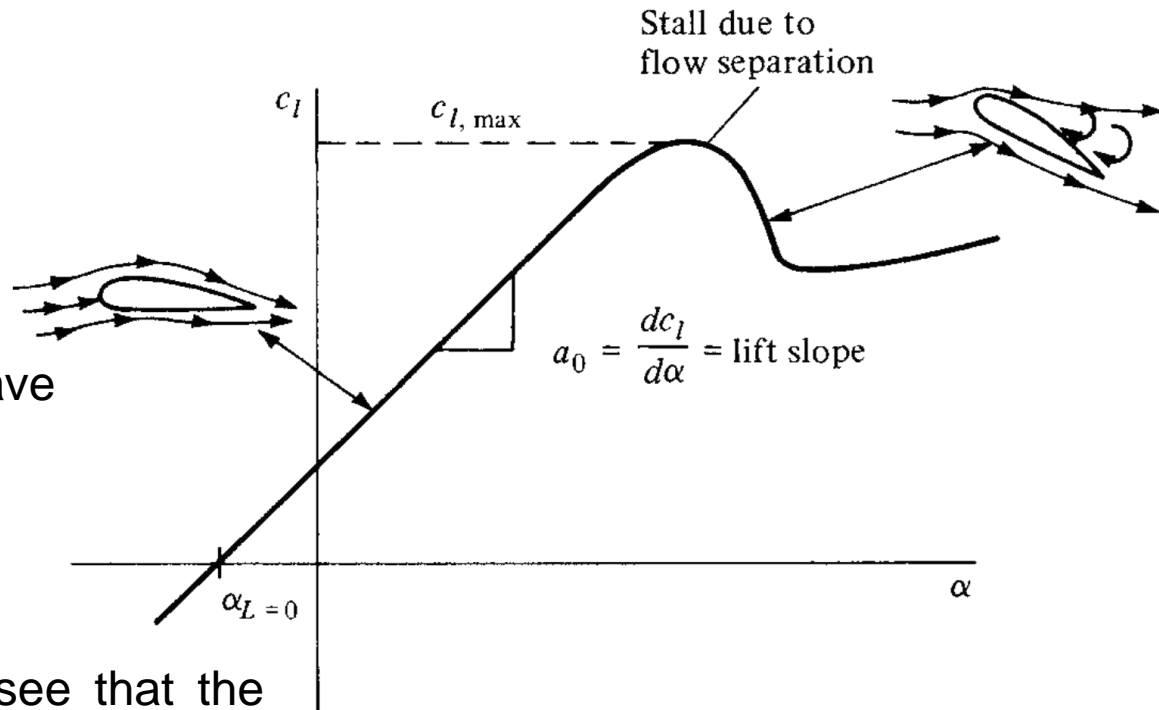



## The cambered airfoil

- The moment about the leading edge can be obtained by substituting  $\gamma(\theta)$  into the transformed version of Equation;

$$\gamma(\theta) = 2V_\infty \left( A_0 \frac{1 + \cos \theta}{\sin \theta} + \sum_{n=1}^{\infty} A_n \sin n\theta \right)$$

$$M'_{LE} = - \int_0^c \xi (dL) = -\rho_\infty V_\infty \int_0^c \xi \gamma(\xi) d\xi$$

- The moment coefficient is

$$c_{m,le} = -\frac{\pi}{2} \left( A_0 + A_1 - \frac{A_2}{2} \right) \quad c_l = \pi(2A_0 + A_1)$$

$$c_{m,le} = - \left[ \frac{c_l}{4} + \frac{\pi}{4} (A_1 - A_2) \right]$$

- The moment coefficient about the quarter chord

$$c_{m,c/4} = c_{m,le} + \frac{c_l}{4} \quad c_{m,c/4} = \frac{\pi}{4} (A_2 - A_1)$$







## The cambered airfoil

- It is independent of  $\alpha$ .
- Thus, the quarter-chord point is the theoretical location of the aerodynamic center for a cambered airfoil.
- The location of the center of pressure can be obtained from

$$x_{cp} = -\frac{M'_{LE}}{L'} = -\frac{c_{m,le}c}{c_l}$$
$$x_{cp} = \frac{c}{4} \left[ 1 + \frac{\pi}{c_l} (A_1 - A_2) \right]$$





## Example 4.6

- Consider an NACA 23012 airfoil. The mean camber line for this airfoil is given by

$$\frac{z}{c} = 2.6595 \left[ \left( \frac{x}{c} \right)^3 - 0.6075 \left( \frac{x}{c} \right)^2 + 0.1147 \left( \frac{x}{c} \right) \right] \quad \text{for } 0 \leq \frac{x}{c} \leq 0.2025$$

$$\frac{z}{c} = 0.02208 \left( 1 - \frac{x}{c} \right) \quad \text{for } 0.2025 \leq \frac{x}{c} \leq 1.0$$

- Calculate**
  - the angle of attack at zero lift,
  - the lift coefficient when  $\alpha = 4^\circ$ ,
  - The moment coefficient about the quarter chord,
  - the location of the center of pressure in terms of  $x_{cp}/c$ , when  $\alpha = 4^\circ$ .
- Compare the results with experimental data.





## Example 4.6

- We will need  $dz/dx$ . From the given shape of the mean camber line, this is

$$\frac{dz}{dx} = 2.6595 \left[ 3 \left( \frac{x}{c} \right)^2 - 1.215 \left( \frac{x}{c} \right) + 0.1147 \right] \quad \text{for } 0 \leq \frac{x}{c} \leq 0.2025$$

$$\frac{dz}{dx} = -0.02208 \quad \text{for } 0.2025 \leq \frac{x}{c} \leq 1.0$$

- Transforming from  $x$  to  $\theta$   $x = (c/2)(1 - \cos\theta)$ ,

$$\begin{aligned} \frac{dz}{dx} &= 2.6595 \left[ \frac{3}{4}(1 - 2\cos\theta + \cos^2\theta) - 0.6075(1 - \cos\theta) + 0.1147 \right] \\ &= 0.6840 - 2.3736\cos\theta + 1.995\cos^2\theta \quad \text{for } 0 \leq \theta \leq 0.9335 \text{ rad} \end{aligned}$$

$$\frac{dz}{dx} = -0.02208 \quad \text{for } 0.9335 \leq \theta \leq \pi$$





## Example 4.6

(a) From Equation

$$\alpha_{L=0} = -\frac{1}{\pi} \int_0^\pi \frac{dz}{dx} (\cos \theta - 1) d\theta$$

For simplicity, we have dropped the subscript zero from  $\theta$ ; in Equation,  $\theta_0$  is the variable of integration

- Substituting the equation for  $dz/dx$  into Equation, we have

$$\alpha_{L=0} = -\frac{1}{\pi} \int_0^{0.9335} (-0.6840 + 3.0576 \cos \theta - 4.3686 \cos^2 \theta + 1.995 \cos^3 \theta) d\theta$$

$$-\frac{1}{\pi} \int_{0.9335}^\pi (0.02208 - 0.02208 \cos \theta) d\theta$$

- From a table of integrals, we see that

$$\int \cos \theta d\theta = \sin \theta$$

$$\int \cos^2 \theta d\theta = \frac{1}{2} \sin \theta \cos \theta + \frac{1}{2} \theta$$

$$\int \cos^3 \theta d\theta = \frac{1}{3} \sin \theta (\cos^2 \theta + 2)$$





## Example 4.6

- Hence, Equation becomes

$$\alpha_{L=0} = -\frac{1}{\pi}[-2.8683\theta + 3.0576 \sin \theta - 2.1843 \sin \theta \cos \theta + 0.665 \sin \theta (\cos^2 \theta + 2)]_0^{0.9335}$$
$$-\frac{1}{\pi}[0.02208\theta - 0.02208 \sin \theta]_{0.9335}^{\pi}$$

$$\alpha_{L=0} = -\frac{1}{\pi}(-0.0065 + 0.0665) = -0.0191 \text{ rad}$$

$$\alpha_{L=0} = -1.09^\circ$$

(b)  $\alpha = 4^\circ = 0.0698 \text{ rad}$

- From Equation  $c_l = 2\pi(\alpha - \alpha_{L=0}) = 2\pi(0.0698 + 0.0191) = 0.559$





## Example 4.6

(c) The value of  $c_{m,c/4}$  is obtained.

- For this, we need the two Fourier coefficients  $A_1$  and  $A_2$ .  
From Equation,

$$A_1 = \frac{2}{\pi} \int_0^\pi \frac{dz}{dx} \cos \theta d\theta$$

$$A_1 = \frac{2}{\pi} \int_0^{0.9335} (0.6840 \cos \theta - 2.3736 \cos^2 \theta + 1.995 \cos^3 \theta) d\theta + \frac{2}{\pi} \int_{0.9335}^\pi (-0.02208 \cos \theta) d\theta$$

$$= \frac{2}{\pi} [0.6840 \sin \theta - 1.1868 \sin \theta \cos \theta - 1.1868 \theta + 0.665 \sin \theta (\cos^2 \theta + 2)]_0^{0.9335} + \frac{2}{\pi} [-0.02208 \sin \theta]_{0.9335}^\pi$$

$$A_1 = \frac{2}{\pi} (0.1322 + 0.0177) = 0.0954$$

$$A_2 = \frac{2}{\pi} \int_0^\pi \frac{dz}{dx} \cos 2\theta d\theta$$

$$= \frac{2}{\pi} \int_0^\pi \frac{dz}{dx} (2 \cos^2 \theta - 1) d\theta = \frac{2}{\pi} \int_0^{0.9335} (-0.6840 + 2.3736 \cos \theta - 0.627 \cos^2 \theta - 4.747 \cos^3 \theta + 3.99 \cos^4 \theta) d\theta + \frac{2}{\pi} \int_{0.9335}^\pi (0.02208 - 0.0446 \cos^2 \theta) d\theta$$





## Example 4.6

- Note:  $\int \cos^4 \theta d\theta = \frac{1}{4} \cos^3 \theta \sin \theta + \frac{3}{8}(\sin \theta \cos \theta + \theta)$
- Thus, 
$$A_2 = \frac{2}{\pi} \left\{ -0.6840\theta + 2.3736 \sin \theta - 0.628 \left( \frac{1}{2} \right) (\sin \theta \cos \theta + \theta) \right. \\ \left. - 4.747 \left( \frac{1}{3} \right) \sin \theta (\cos^2 \theta + 2) + 3.99 \left[ \frac{1}{4} \cos^3 \sin \theta + \frac{3}{8} (\sin \theta \cos \theta + \theta) \right] \right\}_{0.9335} \\ + \frac{2}{\pi} \left[ 0.02208\theta - 0.0446 \left( \frac{1}{2} \right) (\sin \theta \cos \theta + \theta) \right]_{0.9335}^{\pi} \\ = \frac{2}{\pi} (0.11384 + 0.01056) = 0.0792$$
- From Equation  $c_{m,c/4} = \frac{\pi}{4}(A_2 - A_1) = \frac{\pi}{4}(0.0792 - 0.0954)$   
$$c_{m,c/4} = -0.0127$$





## Example 4.6

(d) From Equation

$$x_{cp} = \frac{c}{4} \left[ 1 + \frac{\pi}{c_l} (A_1 - A_2) \right]$$

$$\frac{x_{cp}}{c} = \frac{1}{4} \left[ 1 + \frac{\pi}{0.559} (0.0954 - 0.0792) \right] = 0.273$$

- The data for the NACA 23012 airfoil are shown in Figure.
- From this, we make the following tabulation

	Calculated	Experiment
$\alpha_{L=0}$	$-1.09^\circ$	$-1.1^\circ$
$c_l$ (at $\alpha = 4^\circ$ )	0.559	0.55
$c_{m,c/4}$	-0.0127	-0.01

Wonderful !!!

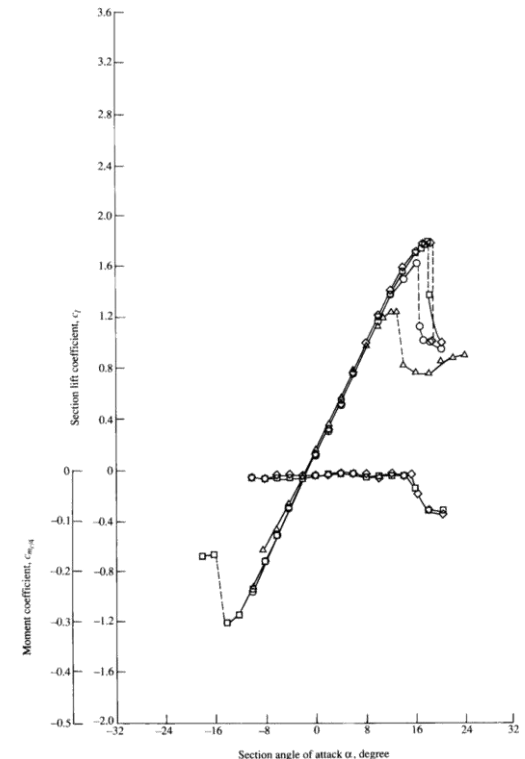





## The aerodynamic center: additional considerations

- Based on experimental and theoretical results, it seems that the aerodynamic center exists.
- For most conventional airfoils, the aerodynamic center is close to, but not necessarily exactly at, the quarter-chord point.
- If that center is different, we can calculate the location of the aerodynamic center as follows.
- We designate the location of the aerodynamic center by  $c x_{ac}$  measured from the leading edge.
- Here,  $x_{ac}$  is the location of the aerodynamic center as a fraction of the chord length  $c$ .

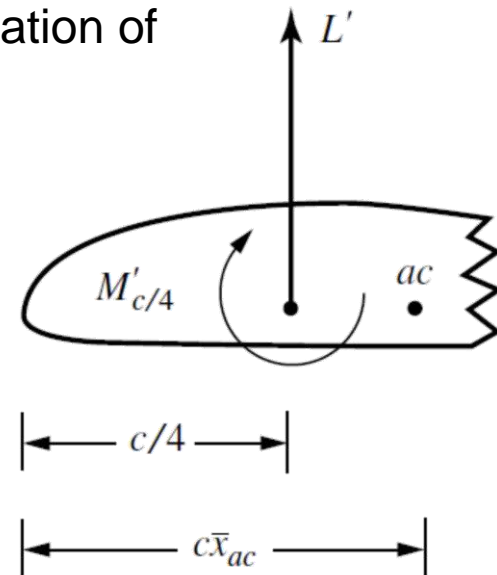



## The aerodynamic center

- Taking moments about the aerodynamic center, we have

$$M'_{ac} = L'(c\bar{x}_{ac} - c/4) + M'_{c/4}$$

- Dividing Equation by  $q_{\infty}Sc$ , we have

$$\frac{M'_{ac}}{q_{\infty}Sc} = \frac{L'}{q_{\infty}S}(\bar{x}_{ac} - 0.25) + \frac{M'_{c/4}}{q_{\infty}Sc}$$

$$c_{m,ac} = c_l(\bar{x}_{ac} - 0.25) + c_{m,c/4}$$

- Differentiating Equation with respect to angle of attack  $\alpha$ , we have

$$\frac{dc_{m,ac}}{d\alpha} = \frac{dc_l}{d\alpha}(\bar{x}_{ac} - 0.25) + \frac{dc_{m,c/4}}{d\alpha}$$

$$\frac{dC_M}{d\alpha} = 0$$

$$0 = \frac{dc_l}{d\alpha}(\bar{x}_{ac} - 0.25) + \frac{dc_{m,c/4}}{d\alpha}$$





## The aerodynamic center

- For airfoils below the stalling angle of attack, the slopes of the lift coefficient and moment coefficient curves are constant.

- Designating these slopes by  $\frac{dc_l}{d\alpha} \equiv a_0$ ;  $\frac{dc_{m,c/4}}{d\alpha} \equiv m_0$

$$0 = a_0(\bar{x}_{ac} - 0.25) + m_0$$

$$\bar{x}_{ac} = -\frac{m_0}{a_0} + 0.25$$

- Equation proves that the aerodynamic center exists as a fixed point on the airfoil.





## Example 4.7

- Consider the NACA 23012 airfoil;  $\alpha = 4^\circ$ ,  $c_l = 0.55$  and  $c_{m,c/4} = -0.005$   
The zero-lift angle of attack is  $-1.1^\circ$   
 $\alpha = -4^\circ$ ,  $c_{m,c/4} = -0.0125$

- From the given information, **calculate** the location of the aerodynamic center for the NACA 23012 airfoil.

- The lift slope is 
$$a_0 = \frac{0.55 - 0}{4 - (-1.1)} = 0.1078$$

- The slope of the moment coefficient curve is

$$m_0 = \frac{-0.005 - (-0.0125)}{4 - (-4)} = 9.375 \times 10^{-4}$$

- From Equation

$$\bar{x}_{ac} = -\frac{m_0}{a_0} + 0.25 = -\frac{9.375 \times 10^{-4}}{0.1078} + 0.25 = 0.241$$





## The aerodynamic center

- For some airfoil family (NACA 230XX & NACA 64-2XX), the location of the aerodynamic center depends on the airfoil thickness,

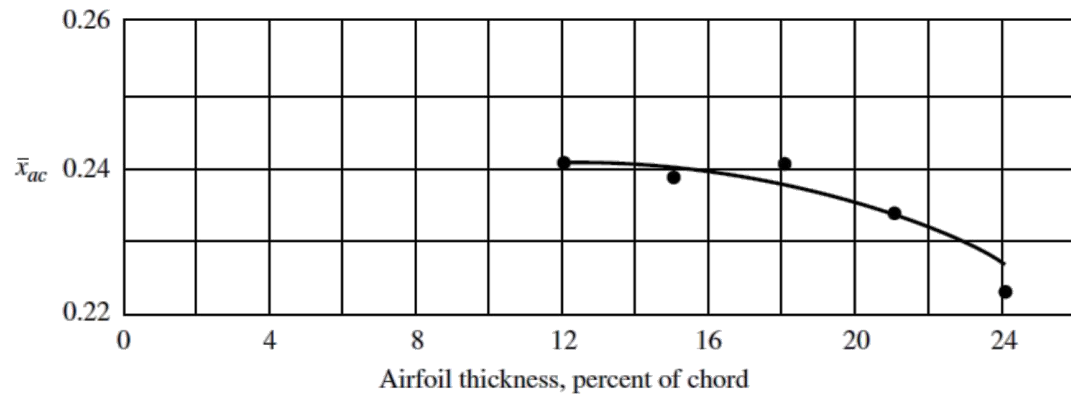

(a) NACA 230XX Airfoil

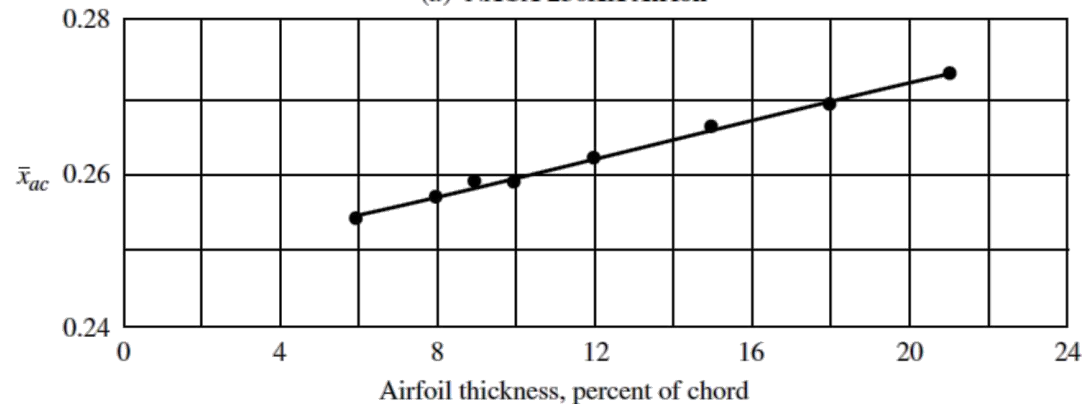

(b) NACA 64-2XX Airfoil





## The aerodynamic center

- The fact that  $M_{ac}$  for a flight vehicle is independent of angle of attack simplifies the analysis of the stability and control characteristics.
- The use of the aerodynamic center therefore becomes important in airplane design.
- For example: the design of tail...

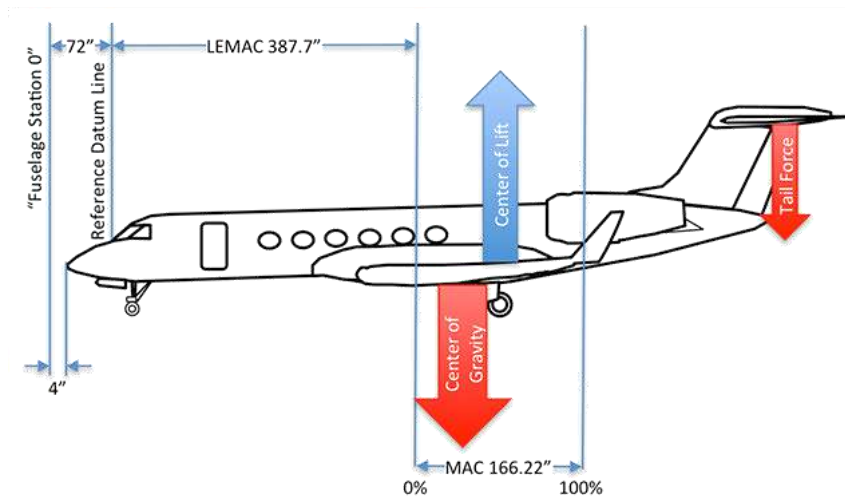



## **Lifting flows over arbitrary bodies: the vortex panel numerical method**

- The thin airfoil theory applies only to thin airfoils at small angles of attack.
- The results compare favorably with experimental data for airfoils of about 12 percent thickness or less.
- However, the airfoils on many low-speed airplanes are thicker than 12 percent.
- Moreover, we are frequently interested in high angles of attack, such as occur during takeoff and landing.
- Finally, we are sometimes concerned with the generation of aerodynamic lift on other body shapes, such as automobiles or submarines.





## Lifting flows over arbitrary bodies: the vortex panel numerical method

- We need a method that allows us to calculate the aerodynamic characteristics of bodies of arbitrary shape, thickness, and orientation.
- Specifically, we treat the vortex panel method, which is a numerical technique that has come into widespread use since the early 1970s.
- We now return to the original idea of wrapping the vortex sheet over the complete surface of the body.

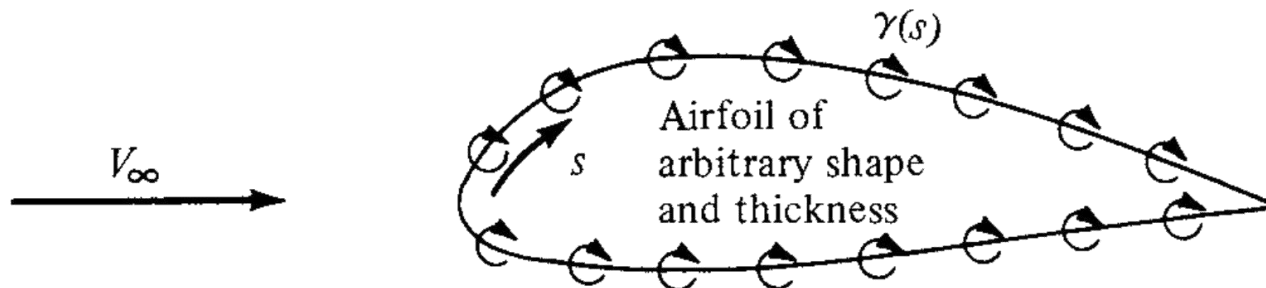





## Lifting flows over arbitrary bodies: the vortex panel numerical method

- We wish to find  $\gamma(s)$  such that the body surface becomes a streamline of the flow.
- There exists no closed-form analytical solution for  $\gamma(s)$ ; rather, the solution must be obtained numerically.
- This is the purpose of the vortex panel method.
- Let the vortex strength  $\gamma(s)$  per unit length be constant over a given panel, but allow it to vary from one panel to the next.  
 $n$  panels  $\gamma_1, \gamma_2, \dots, \gamma_j, \dots, \gamma_n$
- These panel strengths are unknowns.
- The main thrust of the panel technique is to solve for  $\gamma_j$  such that the body surface becomes a streamline of the flow and such that the Kutta condition is satisfied.





## Lifting flows over arbitrary bodies: the vortex panel numerical method

- The midpoint of each panel is a control point at which the boundary condition is applied.
- That is, at each control point, the normal component of the flow velocity is zero.

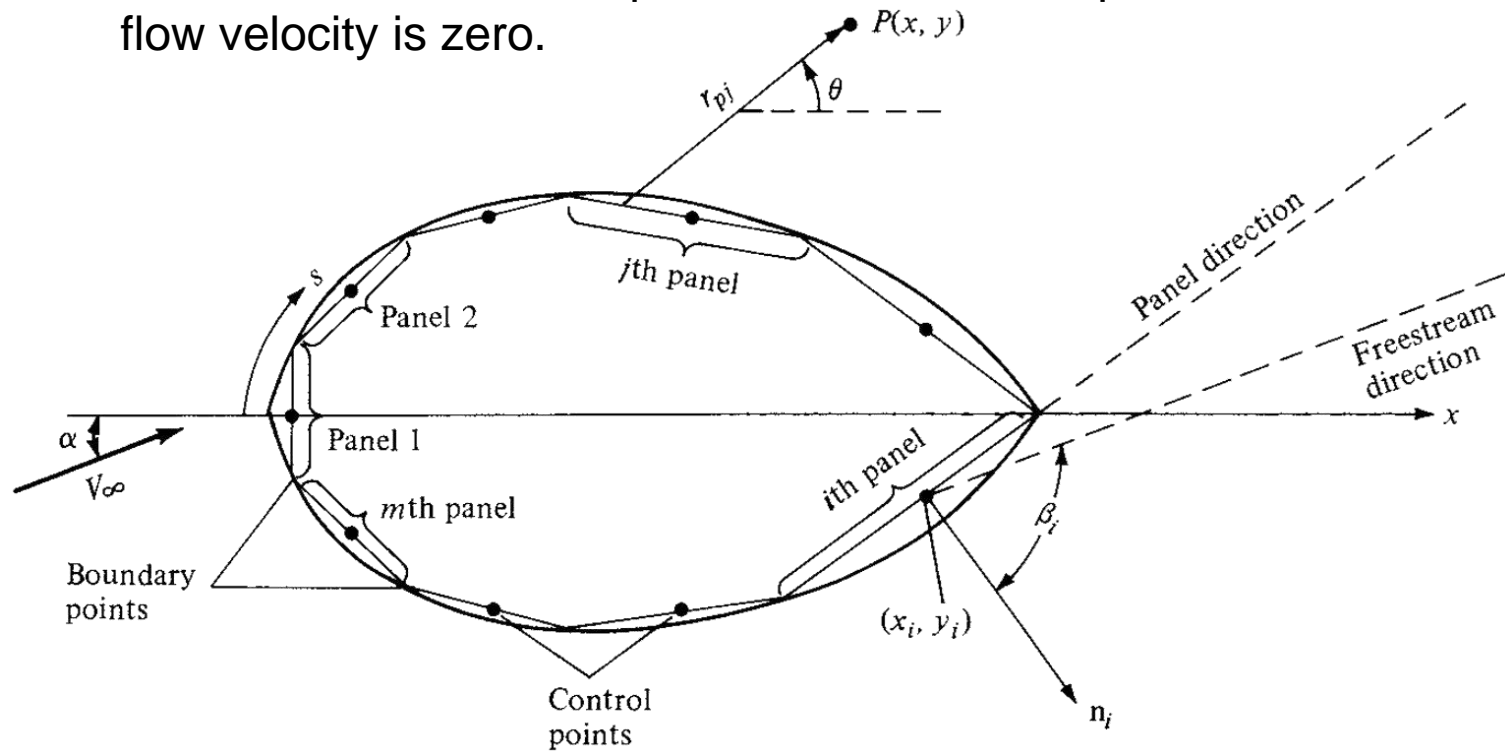



## Lifting flows over arbitrary bodies: the vortex panel numerical method

- The velocity potential induced at  $P$  due to the  $j$  th panel,  $\Delta\phi_j$ , is,

$$\Delta\phi_j = -\frac{1}{2\pi} \int_j \theta_{pj} \gamma_j ds_j$$

$$\phi = -\frac{\Gamma}{2\pi} \theta$$

- $\gamma_j$  is constant over the  $j$  th panel.
- The angle  $\theta_{pj}$  is given by  $\theta_{pj} = \tan^{-1} \frac{y - y_j}{x - x_j}$

- The potential at  $P$  due to *all* the panels is

$$\phi(P) = \sum_{j=1}^n \phi_j = -\sum_{j=1}^n \frac{\gamma_j}{2\pi} \int_j \theta_{pj} ds_j$$

- Since point  $P$  is just an arbitrary point in the flow, let us put  $P$  at the control point of the  $i$ th panel.





## Lifting flows over arbitrary bodies: the vortex panel numerical method

- The coordinates of this control point are  $(x_i, y_i)$ .

- Then Equations become  $\theta_{ij} = \tan^{-1} \frac{y_i - y_j}{x_i - x_j}$

$$\phi(x_i, y_i) = - \sum_{j=1}^n \frac{\gamma_j}{2\pi} \int_j \theta_{ij} ds_j$$

- Equation is physically the contribution of *all* the panels to the potential at the control point of the *i*th panel.
- At the control points, the normal component of the velocity is zero.
- This velocity is the superposition of the uniform flow velocity and the velocity induced by all the vortex panels.





## Lifting flows over arbitrary bodies: the vortex panel numerical method

- The component of  $V_\infty$  normal to the  $i$ th panel is given by

$$V_{\infty,n} = V_\infty \cos \beta_i$$

- The normal component of velocity induced at  $(x_i, y_i)$  by the vortex panels is

$$V_n = \frac{\partial}{\partial n_i} [\phi(x_i, y_i)]$$

$$V_n = - \sum_{j=1}^n \frac{\gamma_j}{2\pi} \int_j \frac{\partial \theta_{ij}}{\partial n_i} ds_j$$

- The boundary condition states that  $V_{\infty,n} + V_n = 0$

$$V_\infty \cos \beta_i - \sum_{j=1}^n \frac{\gamma_j}{2\pi} \int_j \frac{\partial \theta_{ij}}{\partial n_i} ds_j = 0$$





## Lifting flows over arbitrary bodies: the vortex panel numerical method

- Let  $J_{i,j}$  be the value of this integral when the control point is on the  $i$ th panel.

- Then Equation can be written as 
$$V_\infty \cos \beta_i - \sum_{j=1}^n \frac{\gamma_j}{2\pi} J_{i,j} = 0$$

- If Equation is applied to the control points of *all* the panels, we obtain a system of  $n$  linear equations with  $n$  unknowns.
- For the lifting case with vortex panels, in addition to the  $n$  equations applied at all the panels, we must also satisfy the Kutta condition.
- The Kutta condition is applied *precisely* at the trailing edge and is given by  $\gamma(\text{TE}) = 0$ .





## Lifting flows over arbitrary bodies: the vortex panel numerical method

- To approximate this numerically, if points  $i$  and  $i - 1$  are close enough to the trailing edge, we can write

$$\gamma_i = -\gamma_{i-1}$$

- Such that the strengths of the two vortex panels  $i$  and  $i - 1$  exactly cancel at the point where they touch at the trailing edge.
  - Thus, in order to impose the Kutta condition on the solution of the flow, Equation (or an equivalent expression) must be included.
  - to obtain a determined system, velocity Equation is not evaluated at one of the control points on the body.
  - We choose to ignore one of the control points, and we evaluate velocity Equation at the other  $n - 1$  control points.

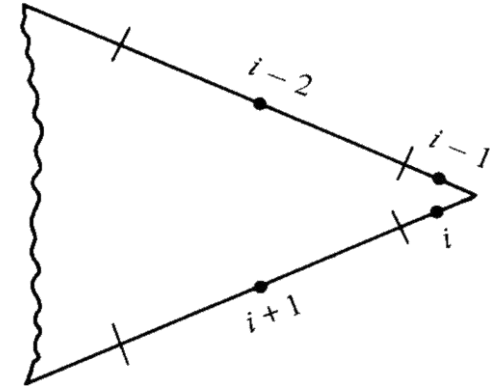



## Lifting flows over arbitrary bodies: the vortex panel numerical method

- This, in combination with Kutta condition, now gives a system of  $n$  linear algebraic equations with  $n$  unknowns, which can be solved by standard techniques.
- The flow velocity tangent to the surface can be obtained directly from  $\gamma$ .

- From Equation

$$\gamma = u_1 - u_2 = u_1 - 0 = u_1$$
$$V_a = \gamma_a$$

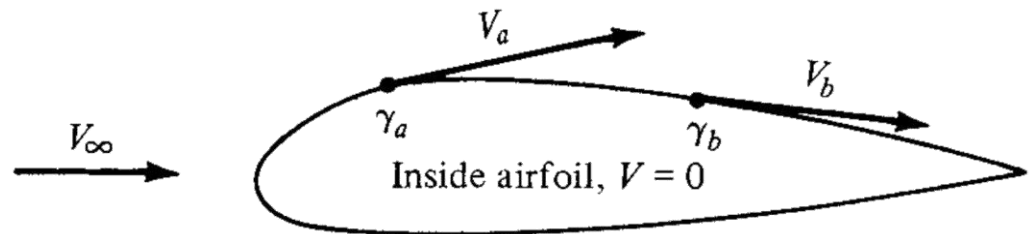

- Therefore, *the local velocities tangential to the airfoil surface are equal to the local values of  $\gamma$ .*
- In turn, the local pressure distribution can be obtained from Bernoulli's equation.







## Lifting flows over arbitrary bodies: the vortex panel numerical method

- The total circulation due to all the panels is

$$\Gamma = \sum_{j=1}^n \gamma_j S_j$$

- The lift per unit span is obtained from

$$L' = \rho_{\infty} V_{\infty} \sum_{j=1}^n \gamma_j S_j$$

- Such accuracy problems have also encouraged the development of higher order panel techniques.
- For example, a “second-order” panel method assumes a *linear* variation of  $\gamma$  over a given panel.





## Lifting flows over arbitrary bodies:

- An approach is frequently called the *direct problem*, wherein the shape of the body is given, and the surface pressure distribution is calculated.
- It is desirable to specify the surface pressure distribution and calculate the shape of the airfoil that will produce the specified pressure distribution.
- This approach is called the *inverse problem*.
- Today the power of computational fluid dynamics (CFD) is revolutionizing airfoil design and analysis.
- The inverse problem is being made tractable by CFD.





## Viscous flow: airfoil drag

- The lift on an airfoil is primarily due to the pressure distribution exerted on its surface.
- The shear stress distribution acting on the airfoil, when integrated in the lift direction, is usually negligible.
- The lift, therefore, can be accurately calculated assuming inviscid flow in conjunction with the Kutta condition at the trailing edge.
- When used to predict drag, however, this same approach yields zero drag, *d'Alembert's paradox*.
- The paradox is immediately removed when viscosity (friction) is included in the flow.





## Viscous flow: airfoil drag

- Viscosity in the flow is totally responsible for the aerodynamic drag on an airfoil.
- It acts through two mechanisms:
  - *Skin-friction drag*, due to the shear stress acting on the surface,
  - *Pressure drag due to flow separation*, sometimes called *form drag*.
- As a first approximation, we assume that skin-friction drag on an airfoil is essentially the same as the skin-friction drag on a flat plate at zero angle of attack.

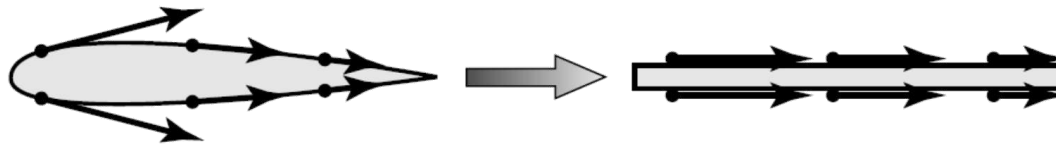



## Viscous flow: airfoil drag

- We first deal with the case of completely laminar flow over the airfoil (and hence the flat plate).
- There is an exact analytical solution for the laminar boundary-layer flow over a flat plate.

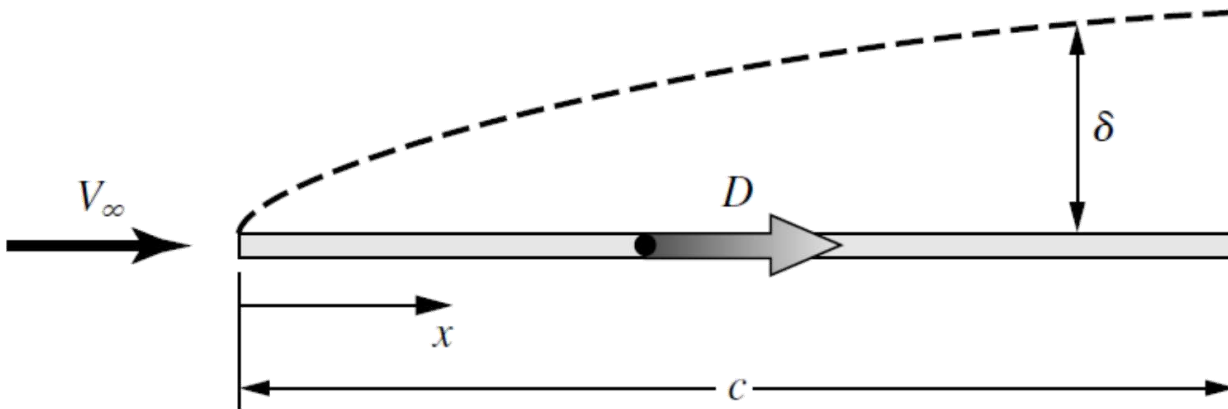

- The boundary-layer thickness for incompressible laminar flow over a flat plate at zero angle of attack is given by

$$\delta = \frac{5.0x}{\sqrt{\text{Re}_x}}$$

$$\text{Re}_x = \frac{\rho_e V_\infty x}{\mu_\infty}$$





## Viscous flow: airfoil drag

- The skin-friction drag coefficient is a function of the Reynolds number, and is given by

$$D_f = 2D_{f,top} = 2D_{f,bottom} \quad C_f \equiv \frac{D_{f,top}}{q_\infty S} = \frac{D_{f,bottom}}{q_\infty S} \quad C_f = \frac{1.328}{\sqrt{Re_c}}$$

- In contrast to the situation for laminar flow, there are no exact analytical solutions for turbulent flow.
- All analyses of turbulent flow are approximate.
- The boundary-layer thickness for turbulent flow over a flat plate at zero angle of attack is given by

$$\delta = \frac{0.37x}{Re_x^{1/5}}$$

- The skin-friction drag coefficient is

$$C_f = \frac{0.074}{Re_c^{1/5}}$$





## Viscous flow: airfoil drag

- In reality, the flow *always* starts out from the leading edge as laminar.
- Then at some point downstream of the leading edge, the laminar boundary layer becomes unstable.
- Small “bursts” of turbulence begin to grow in the flow.
- Finally, over a certain region called the *transition region*, the boundary layer becomes completely turbulent.

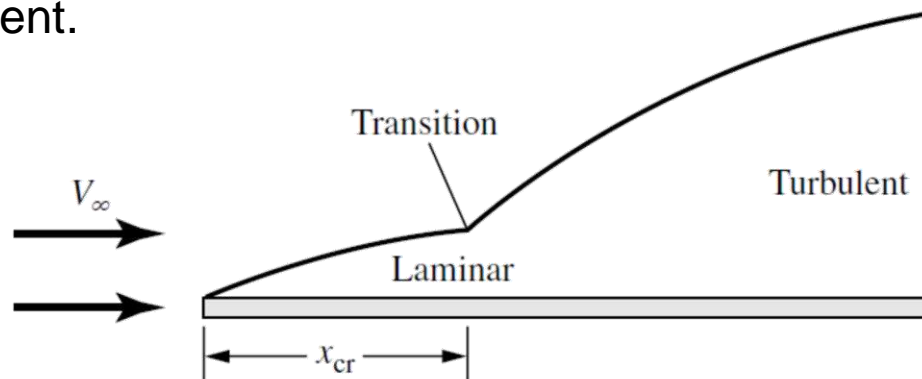



## Viscous flow: airfoil drag

- The value of  $x$  where transition is said to take place is the *critical* value  $x_{cr}$ .
- In turn,  $x_{cr}$  allows the definition of a *critical Reynolds number* for transition as

$$Re_{x_{cr}} = \frac{\rho_{\infty} V_{\infty} x_{cr}}{\mu_{\infty}}$$

- An accurate value for  $Re_{x_{cr}}$  applicable to your problem must come from somewhere—experiment, free flight, or some semi empirical theory.
- This may be difficult to obtain.







## Example 4.10

- For the NACA 2412 airfoil and the conditions  $Re_c = 3.1 \times 10^6$
- Calculate the net skin friction drag coefficient assuming that the critical Reynolds number is 500,000.

$$Re_{x_{cr}} = \frac{\rho_{\infty} V_{\infty} x_{cr}}{\mu_{\infty}} = 5 \times 10^5 \quad Re_c = \frac{\rho_{\infty} V_{\infty} c}{\mu_{\infty}} = 3.1 \times 10^6$$

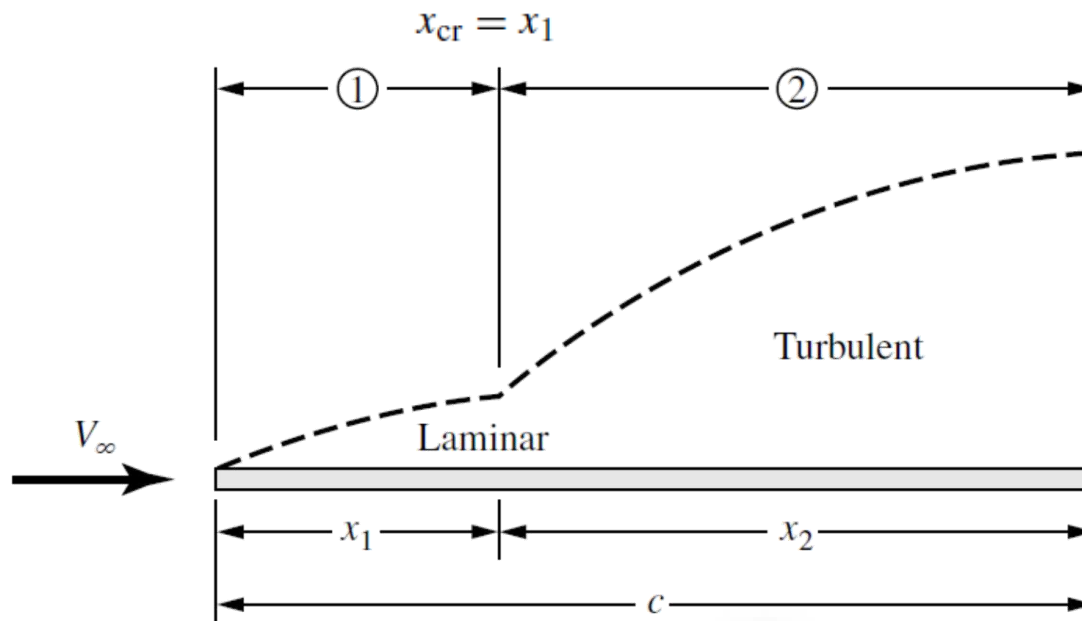

$$\frac{Re_{x_{cr}}}{Re_c} = \frac{5 \times 10^5}{3.1 \times 10^6} = 0.1613$$

$$\frac{(\rho_{\infty} V_{\infty} x_1 / \mu_{\infty})}{(\rho_{\infty} V_{\infty} c / \mu_{\infty})} = \frac{x_1}{c}$$

$$\frac{x_1}{c} = 0.1613$$





## Example 4.10

- The Reynolds number in the equations for skin friction drag coefficient is always based on length measured *from the leading edge*.
- We can not simply calculate the turbulent skin friction drag coefficient for region 2 by using Equation:

$$C_f = \frac{0.074}{\text{Re}_c^{1/5}}$$

- Assuming all turbulent flow over the entire length of the plate, the drag (on one side of the plate) is  $(D_{f,c})_{\text{turbulent}}$ , where

$$(D_{f,c})_{\text{turbulent}} = q_{\infty} S (C_{f,c})_{\text{turbulent}}$$

$$S = c(1)$$

$$(D_{f,c})_{\text{turbulent}} = q_{\infty} c (C_{f,c})_{\text{turbulent}}$$

- The turbulent drag on just region 1 is  $(D_{f,1})_{\text{turbulent}}$ :

$$(D_{f,1})_{\text{turbulent}} = q_{\infty} S (C_{f,1})_{\text{turbulent}} \quad (D_{f,1})_{\text{turbulent}} = q_{\infty} x_1 (C_{f,1})_{\text{turbulent}}$$

$$S = (x_1)(1)$$





### Example 4.10

- Thus, the turbulent drag just on region 2,  $(D_{f,2})_{\text{turbulent}}$ , is

$$(D_{f,2})_{\text{turbulent}} = (D_{f,c})_{\text{turbulent}} - (D_{f,1})_{\text{turbulent}}$$

$$(D_{f,2})_{\text{turbulent}} = q_{\infty} c (C_{f,c})_{\text{turbulent}} - q_{\infty} x_1 (C_{f,1})_{\text{turbulent}}$$

- The *laminar drag on region 1* is  $(D_{f,1})_{\text{laminar}}$

$$(D_{f,1})_{\text{laminar}} = q_{\infty} S (C_{f,1})_{\text{laminar}} = q_{\infty} x_1 (C_{f,1})_{\text{laminar}}$$

- The total skin-friction drag on the plate,  $D_f$ , is then

$$D_f = (D_{f,1})_{\text{laminar}} + (D_{f,2})_{\text{turbulent}}$$

$$D_f = q_{\infty} x_1 (C_{f,1})_{\text{laminar}} + q_{\infty} c (C_{f,c})_{\text{turbulent}} - q_{\infty} x_1 (C_{f,1})_{\text{turbulent}}$$

- The total skin-friction drag coefficient is

$$C_f = \frac{D_f}{q_{\infty} S} = \frac{D_f}{q_{\infty} c}$$





## Example 4.10

$$C_f = \frac{x_1}{c}(C_{f,1})_{\text{laminar}} + (C_{f,c})_{\text{turbulent}} - \frac{x_1}{c}(C_{f,1})_{\text{turbulent}}$$

$$x_1/c = 0.1613,$$

$$C_f = 0.1613(C_{f,1})_{\text{laminar}} + (C_{f,c})_{\text{turbulent}} - 0.1613(C_{f,1})_{\text{turbulent}}$$

$$(C_{f,1})_{\text{laminar}} = \frac{1.328}{\sqrt{\text{Re}_{x_1}}} = \frac{1.328}{\sqrt{5 \times 10^5}} = 0.00188$$

$$(C_{f,1})_{\text{turbulent}} = \frac{0.074}{\text{Re}_{x_1}^{1/5}} = \frac{0.074}{(5 \times 10^5)^{0.2}} = 0.00536$$

$$C_f = \frac{0.074}{\text{Re}_c^{1/5}} = \frac{0.074}{(3.1 \times 10^6)^{1/5}} = 0.00372$$

$$C_f = 0.1613(0.00188) + 0.00372$$

$$- 0.1613(0.00536) = 0.003158$$

- Taking into account both sides of the flat plate,

$$\text{Net } C_f = 2(0.003158) = 0.0063$$





## Viscous flow: airfoil drag

### Flow Separation

- Pressure drag on an airfoil is caused by the flow separation.

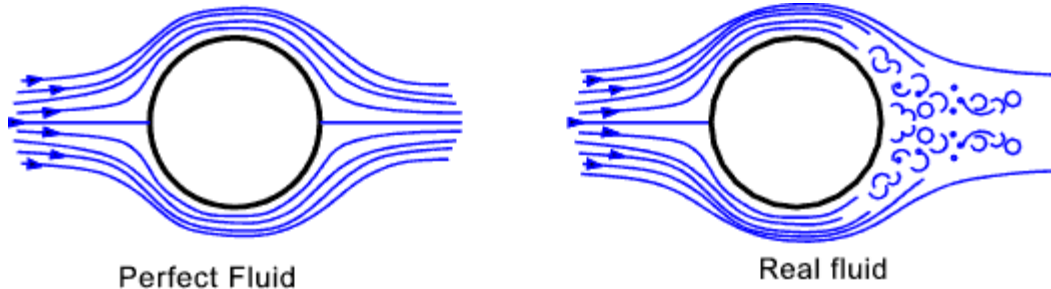

- If the flow is partially separated over the rear surface, the pressure on the rear surface pushing forward will be smaller than the fully attached case.
- The pressure acting on the front surface pushing backwards will not be fully counteracted, giving rise to a net pressure drag on the airfoil





## Viscous flow: airfoil drag

### Flow Separation

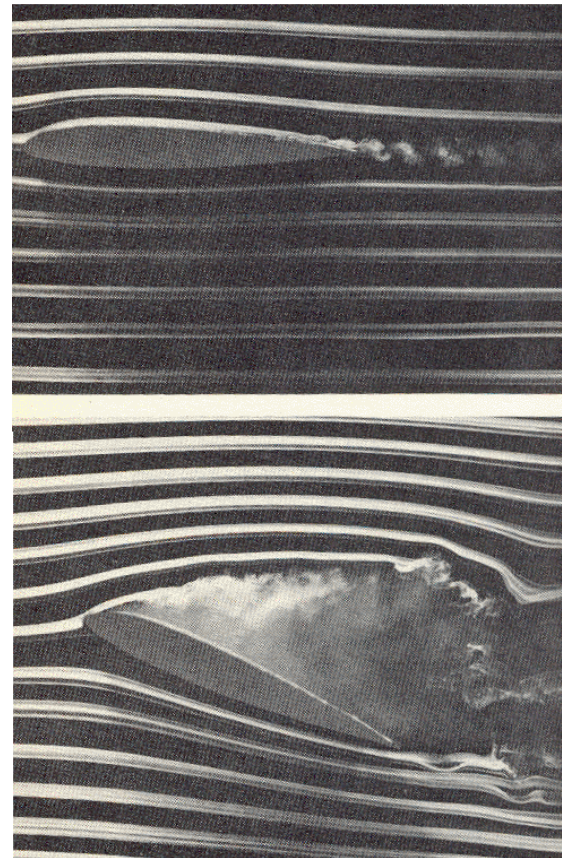
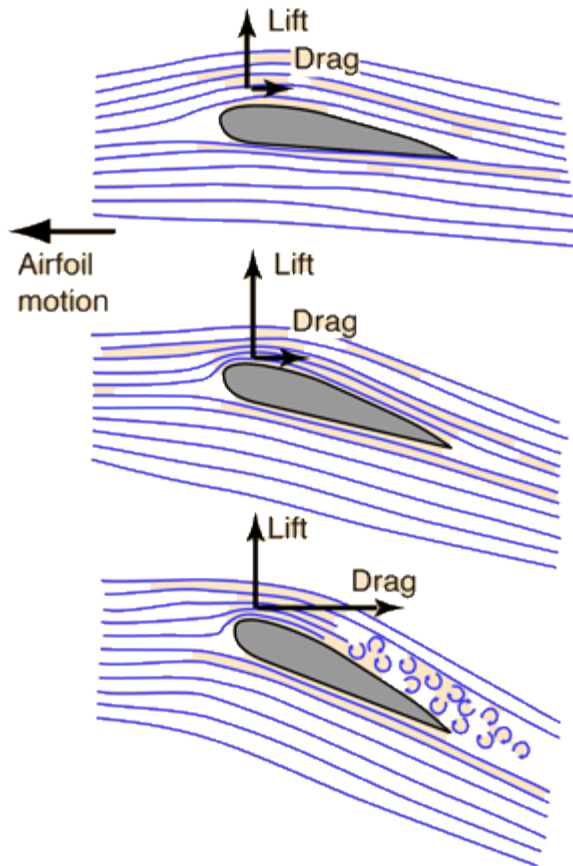



## Viscous flow: airfoil drag

### Flow Separation

- What flow conditions are conducive / possible to flow separation?
- The main reason is the pressure gradients:  $dp/dx$
- Due to viscosity, the fluid particles inside the boundary layer get slower.
- This deceleration cause pressure increase in the flow direction.
- That is, the region where  $dp/dx$  is *positive*.
- In such a case, the *real* viscous flow tends to separate from the surface.

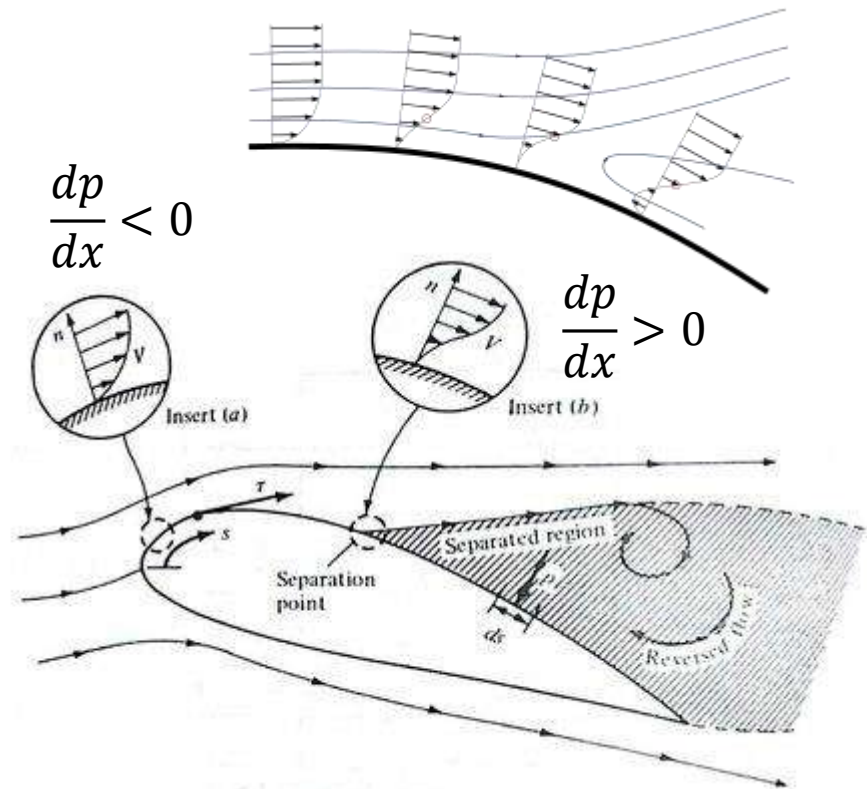

Flow from high pressure to low pressure

$$\frac{dp}{dx} > 0$$





## Viscous flow: airfoil drag

### Flow Separation

- Two major consequences of the flow separating over an airfoil are:
  - A drastic loss of lift (stalling).
  - A major increase in drag, caused by pressure drag due to flow separation.
- In the real case, flow separation occurs over the top surface of the airfoil when the angle of attack exceeds a certain value—the “stalling” angle of attack.







# Applied aerodynamics: the flow over an airfoil—the real case

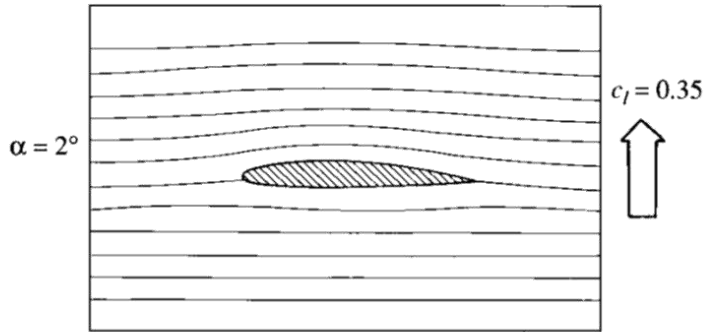

(a)

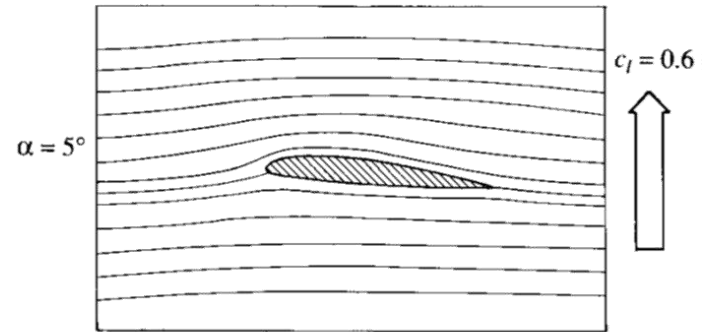

(b)

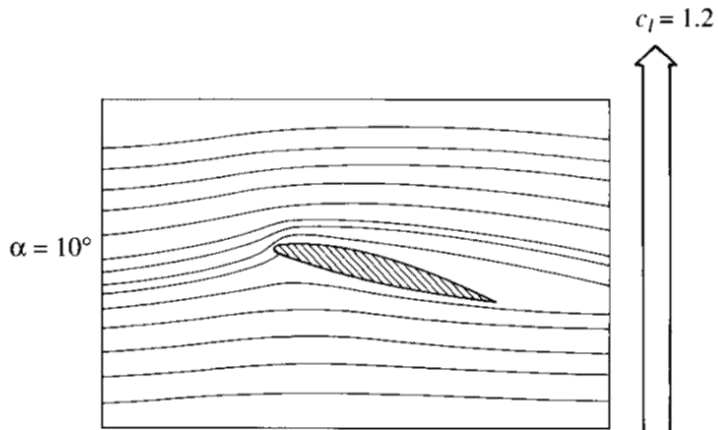

(c)

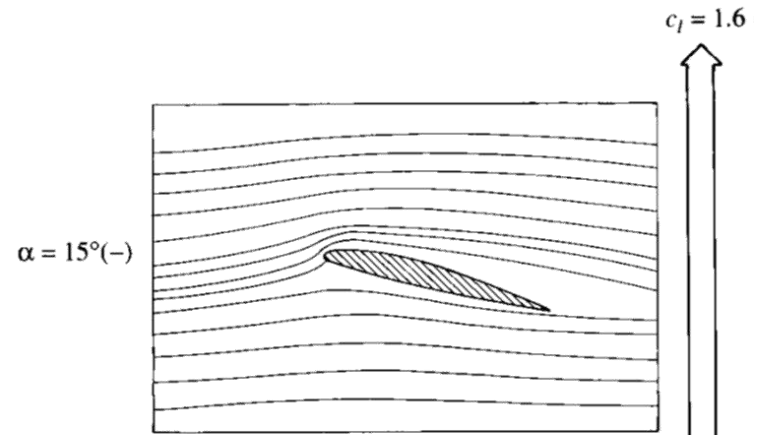

(d)

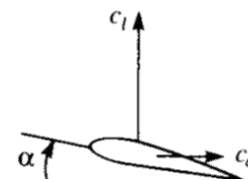



## Applied aerodynamics: the flow over an airfoil—the real case

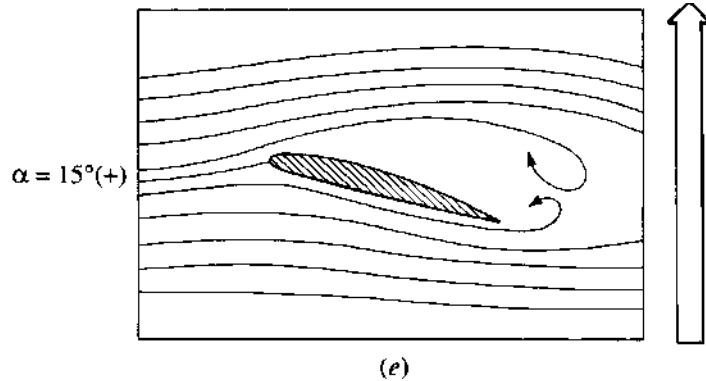

for an NACA 4412 airfoil  
 $Re = 2.1 \times 10^5$  and  $V_\infty = 8$  m/s

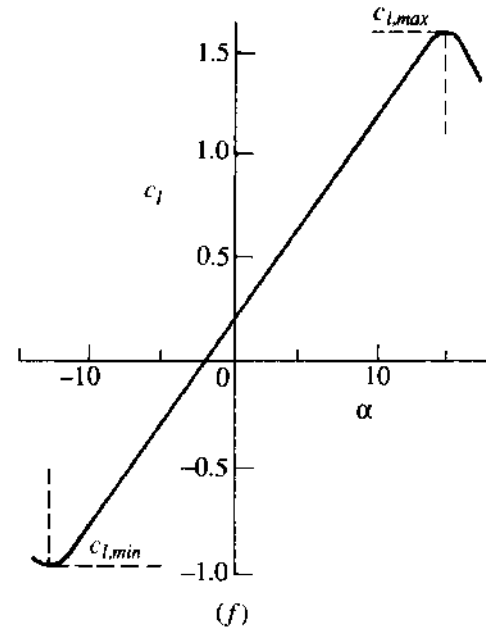

- The type of stalling phenomenon is called *leading-edge stall*.
- Flow separation takes place rather suddenly and abruptly over the entire top surface of the airfoil, with the origin of this separation occurring at the leading edge.





## Applied aerodynamics: the flow over an airfoil—the real case

- A second category of stall is the *trailing-edge stall*.
- This behavior is characteristic of thicker airfoils such as the NACA 4421.
- Here, we see a progressive and gradual movement of separation from the trailing edge toward the leading edge as  $\alpha$  is increased.

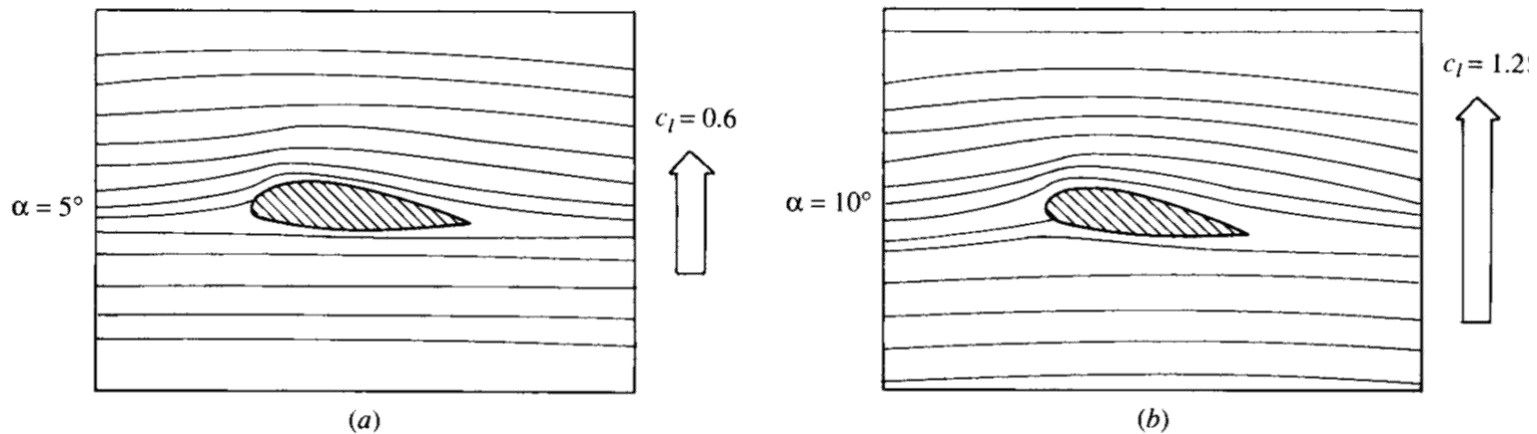



# Applied aerodynamics: the flow over an airfoil—the real case

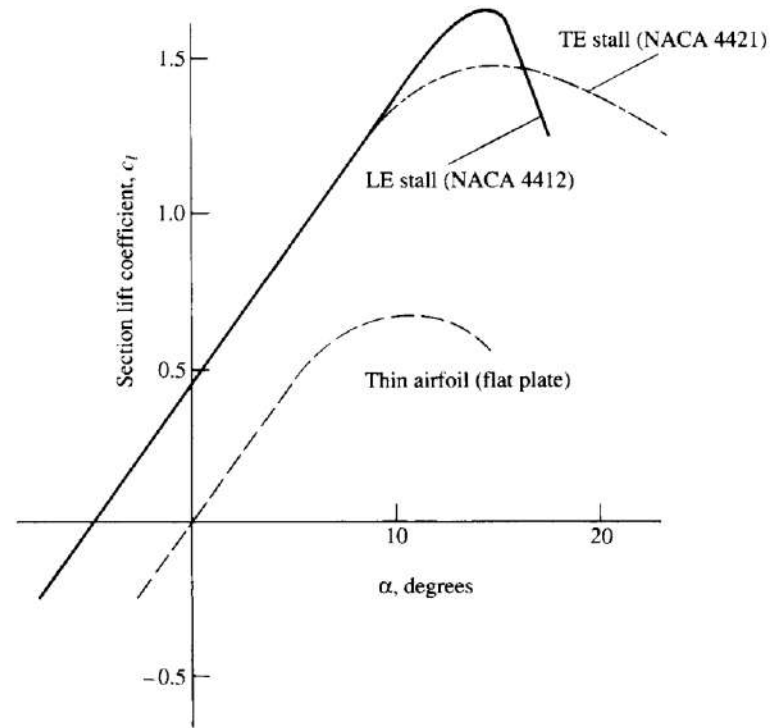
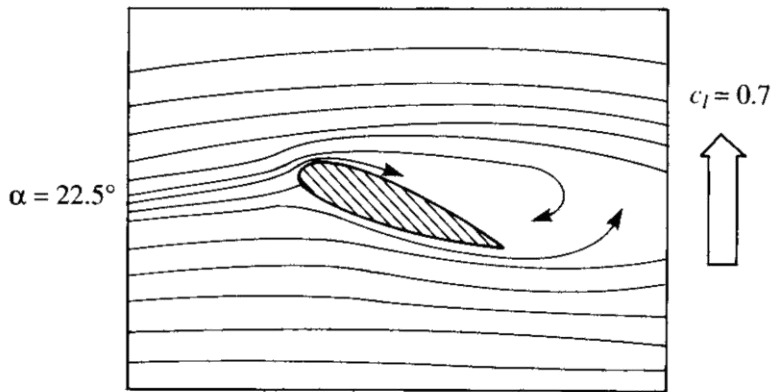
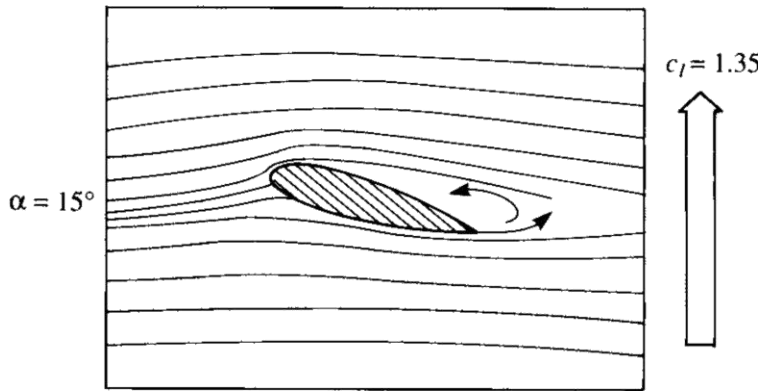



## Applied aerodynamics: the flow over an airfoil—the real case

- There is a third type of stall behavior, namely, behavior associated with the extreme thinness of an airfoil.
- This is sometimes labeled as “thin airfoil stall.”

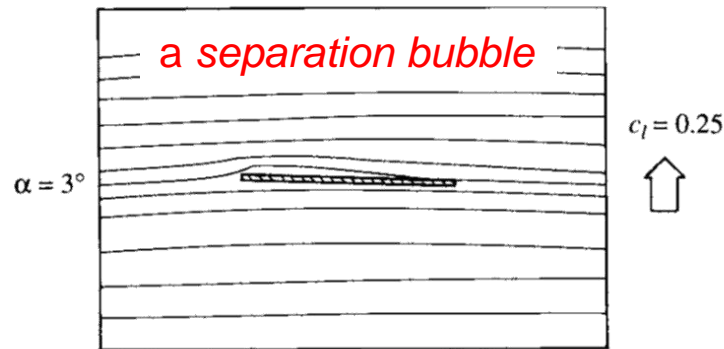

(a)

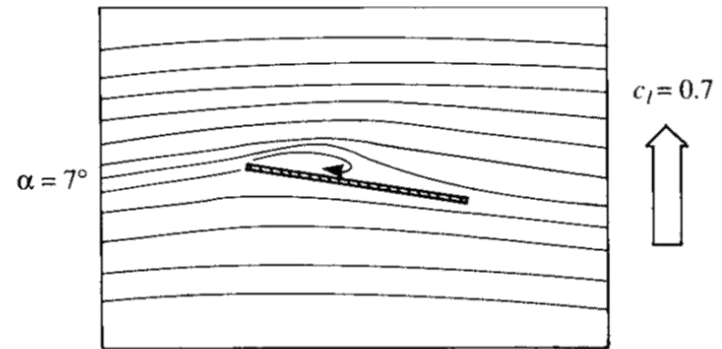

- The separation bubble extends over almost the complete flat plate.

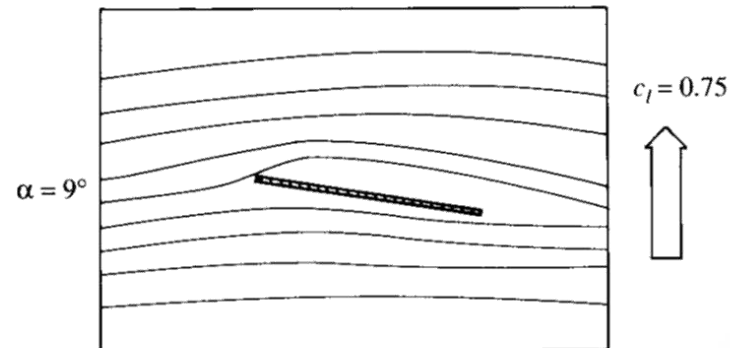

(c)

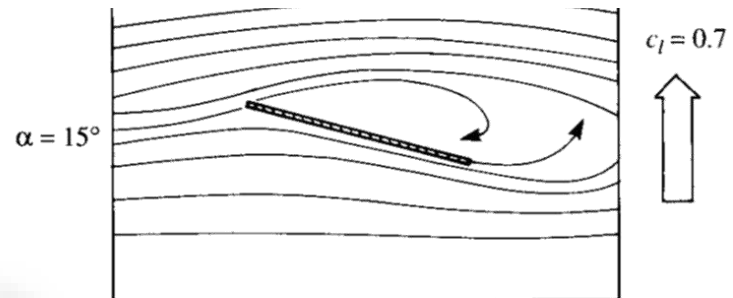

(d)





## Applied aerodynamics: the flow over an airfoil—the real case

- The amount of thickness will influence the type of stall (leading-edge versus trailing-edge) and  $C_{l,max}$ .

Re

◇  $9.0 \times 10^6$

□ 6.0

○ 3.0

△ Standard roughness  $6 \times 10^6$

- Here, experimental data for  $c_{l,max}$  for the NACA 63-2XX series of airfoils is shown as a function of the thickness ratio.

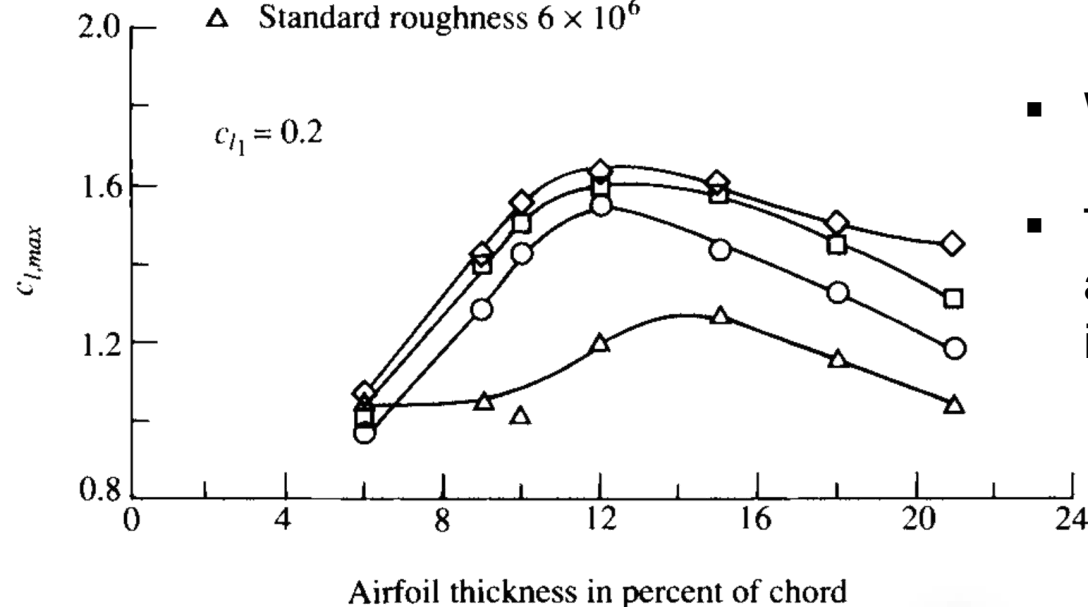

- We see a local maximum.
- The simple generation of lift by an airfoil is not the prime consideration in its design





## Applied aerodynamics: the flow over an airfoil—the real case

- There are two figures of merit that are primarily used to judge the quality of a given airfoil;
  - *The lift-to-drag ratio,  $L/D$*
  - *The maximum lift coefficient  $c_{l,max}$*  determines the stalling speed of the aircraft

$$V_{\text{stall}} = \sqrt{\frac{2W}{\rho_{\infty} S C_{L,\text{max}}}}$$

- To increase  $c_{l,max}$  beyond such a value, we must carry out some special measures.
- Such special measures include the use of flaps and/or leading-edge slats.





# Applied aerodynamics: the flow over an airfoil—the real case

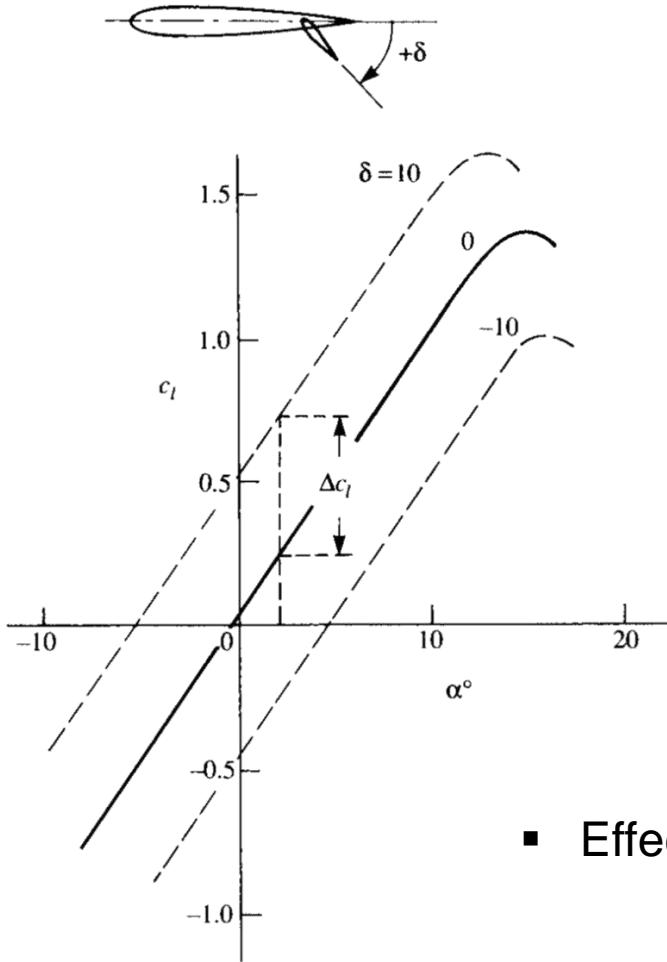

(a)

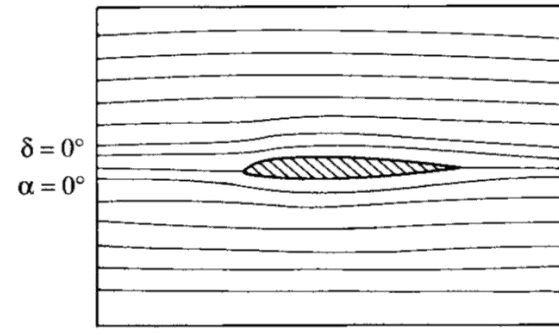

(b)

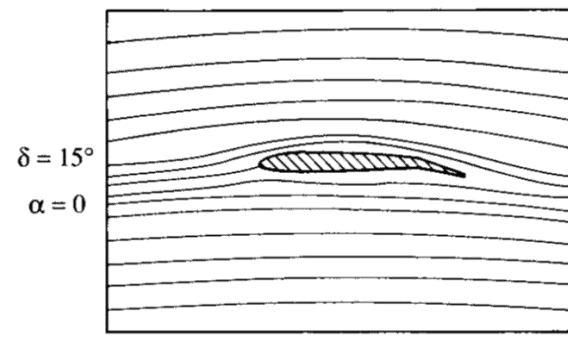

(c)

- Effect of flap deflection







# Applied aerodynamics: the flow over an airfoil—the real case

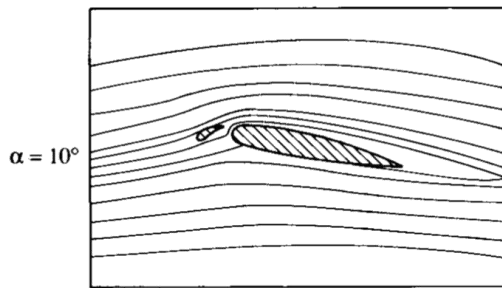

(a)

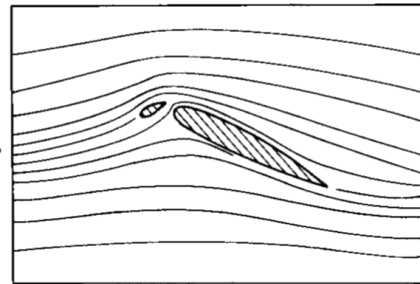

(b)

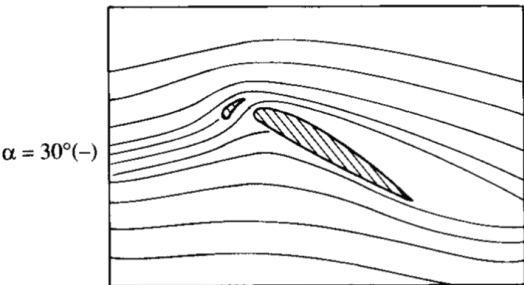

(c)

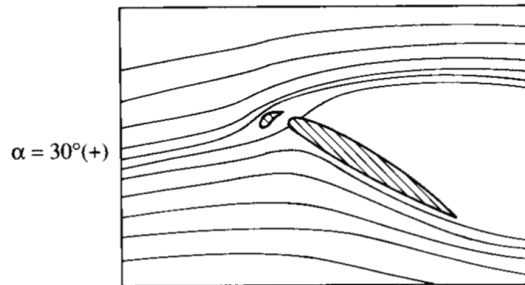

(d)

LE slat

LE droop

Kruger flap

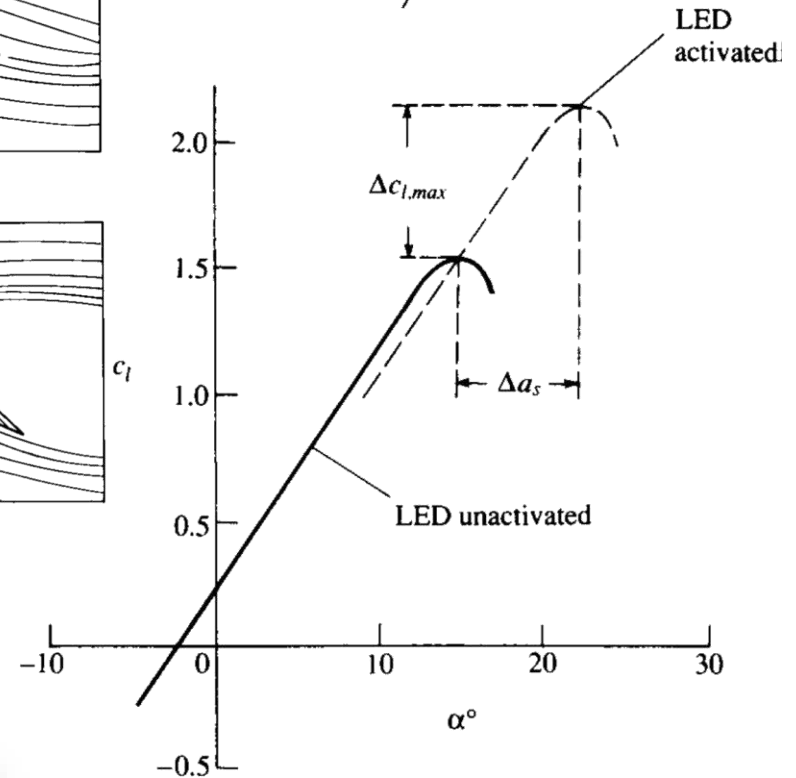



## Applied aerodynamics: the flow over an airfoil—the real case

- The high-lift devices used on modern, high-performance aircraft are usually a combination of leading-edge slats (or flaps) and multi-element trailing-edge flaps.



$\alpha = 25^\circ$

Effect of leading-edge and multi-element trailing-edge flaps on the streamline pattern around an airfoil

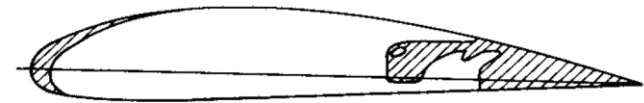

A: Cruise configuration

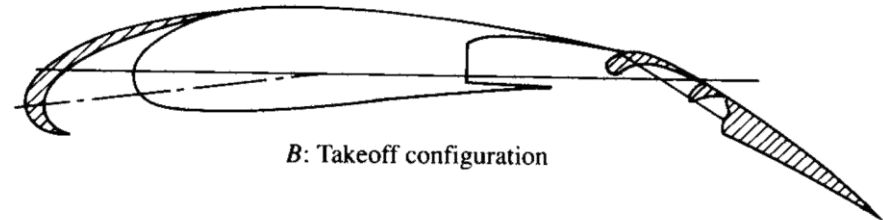

B: Takeoff configuration

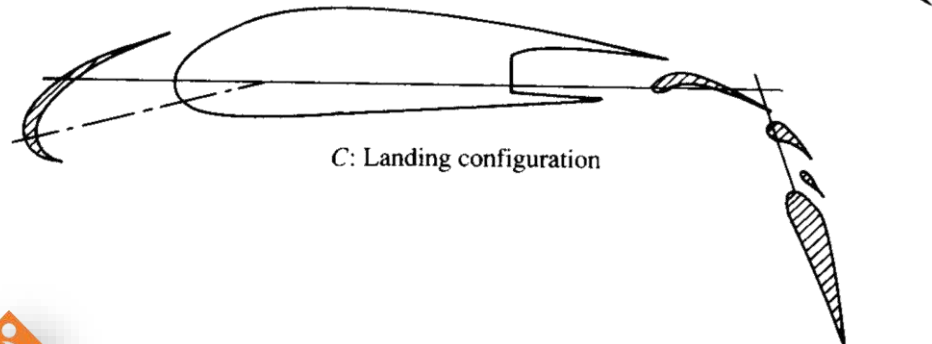

C: Landing configuration





# Applied aerodynamics: the flow over an airfoil—the real case

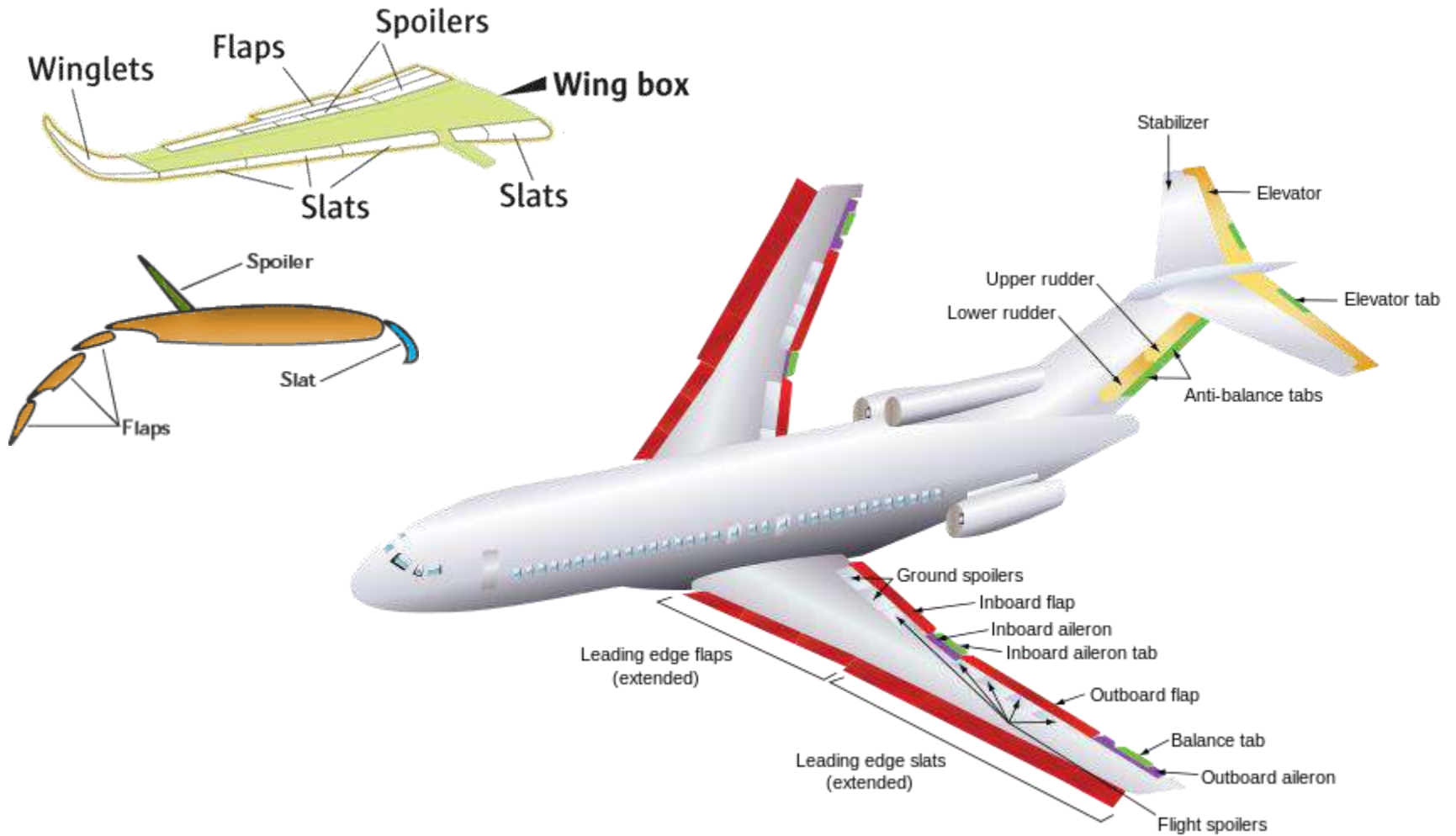



## Applied aerodynamics: the flow over an airfoil—the real case

flaps



leading-edge slats



spoiler



multi-element trailing-edge flaps





## Applied aerodynamics: the flow over an airfoil—the real case

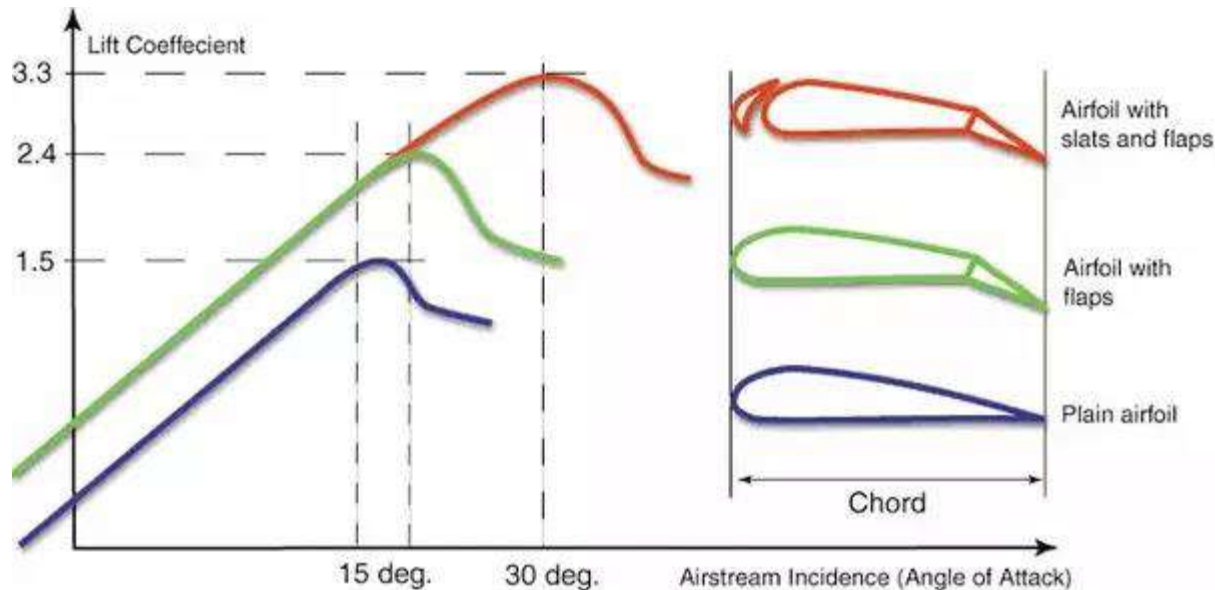

### flaps

- Increased area
- increased wing camber

### leading-edge slats

- increased wing camber
- improved wing upper surface boundary layer by means of the slat-wing slot





## Historical note: Kutta, Joukowski, and the circulation theory of lift

- Frederick W. Lanchester (1868–1946), an English engineer, automobile manufacturer, and self-styled aerodynamicist, was the first to connect the idea of circulation with lift, 1894.
- He published two books, entitled *Aerodynamics* and *Aerodnetics*, where his thoughts on circulation and lift were described in detail, 1907.
- M. Wilhelm Kutta (1867–1944), born in Pitschen, Germany, developed the idea that lift and circulation are related.
- Kutta attempted theoretically to calculate the lift on the curved wing surfaces used by Lilienthal.
- In the process, he realized from experimental data that the flow left the trailing edge of a sharp-edged body smoothly.
- That this condition fixed the circulation around the body (the Kutta condition, 1902).





## Historical note: Kutta, Joukowski, and the circulation theory of lift

- Joukowski was born in Orekhovo in central Russia on January 5, 1847.
- The son of an engineer, he became an excellent student of mathematics and physics.
- Joukowski was deeply interested in aeronautics, and he combined a rare gift for both experimental and theoretical work in the field.
- Much of Joukowski's fame was derived from a paper published in 1906, wherein he gives, for the first time in history, the relation

$$L' = \rho_{\infty} V_{\infty} \Gamma$$

- Joukowski was unaware of Kutta's 1902 note.





## Questions

**4.6** The NACA 4412 airfoil has a mean camber line given by

$$\frac{z}{c} = \begin{cases} 0.25 \left[ 0.8 \frac{x}{c} - \left( \frac{x}{c} \right)^2 \right] & \text{for } 0 \leq \frac{x}{c} \leq 0.4 \\ 0.111 \left[ 0.2 + 0.8 \frac{x}{c} - \left( \frac{x}{c} \right)^2 \right] & \text{for } 0.4 \leq \frac{x}{c} \leq 1 \end{cases}$$

Using thin airfoil theory, calculate

(a)  $\alpha_{L=0}$  (b)  $c_l$  when  $\alpha = 3^\circ$

**4.7** For the airfoil given in Problem 4.6, calculate  $c_{m,c/4}$  and  $x_{cp}/c$  when  $\alpha = 3^\circ$ .







# *Aerodynamics*

## *AE 301*

Assoc. Prof. Dr. Y . Volkan PEHLIVANOĞLU  
volkan.pehlivanoglu@ieu.edu.tr





## Contents; Incompressible Flow over Finite Wings

- Downwash and induced drag,
- The Biot-Savart law and Helmholtz's theorem,
- Lifting line theory,
- A numerical lifting line method,
- The lifting surface theory,
- Applied Aerodynamics,
- Historical Note...

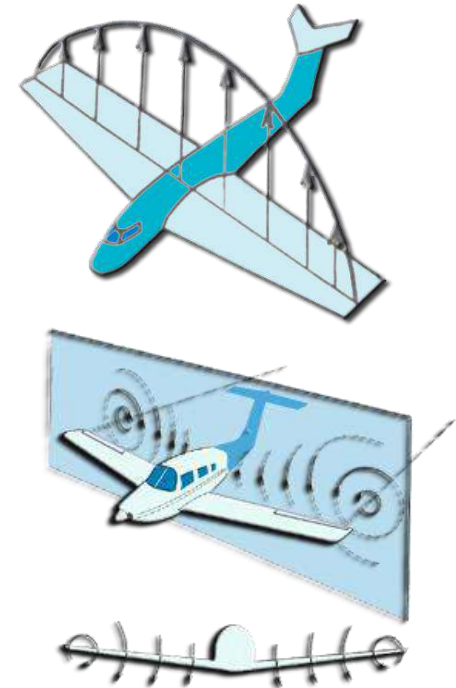
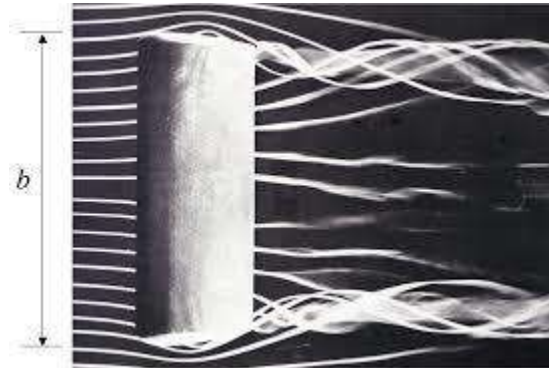
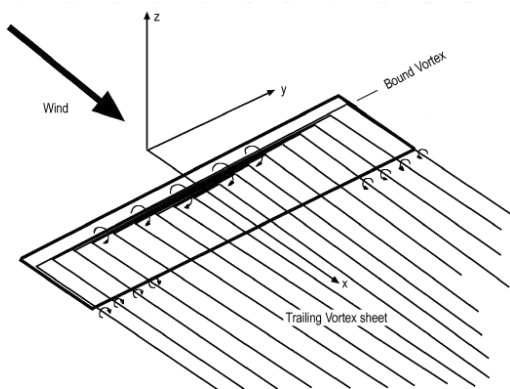



# Nomenclature





## Introduction

- We pose the question: Are  $C_L$  and  $C_D$  for the wing the same as those for the airfoil ( $c_l$  and  $c_d$ )?
- The answer is NO!
- Surprised? How can this be? Why are the aerodynamic coefficients of the wing *not* the same as those for the airfoil shape from which the wing is made?
- Surely, the aerodynamic properties of the airfoil must have something to do with the aerodynamic properties of the finite wing.
- This chapter is focused on the aerodynamic properties of real, finite wings.





## Downwash and induced drag

- Airfoil data are frequently denoted as “infinite wing” data.
- However, all real airplanes have wings of finite span.
- The flow over an airfoil is two-dimensional.
- In contrast, a finite wing is a three-dimensional body, and consequently the flow over the finite wing is three-dimensional.
- That is, there is a component of flow in the spanwise direction.





## Downwash and induced drag

- The physical mechanism for generating lift on the wing is the existence of a high pressure on the bottom surface and a low pressure on the top surface.
- By-product of this pressure imbalance, the flow near the wing tips tends to curl around the tips.

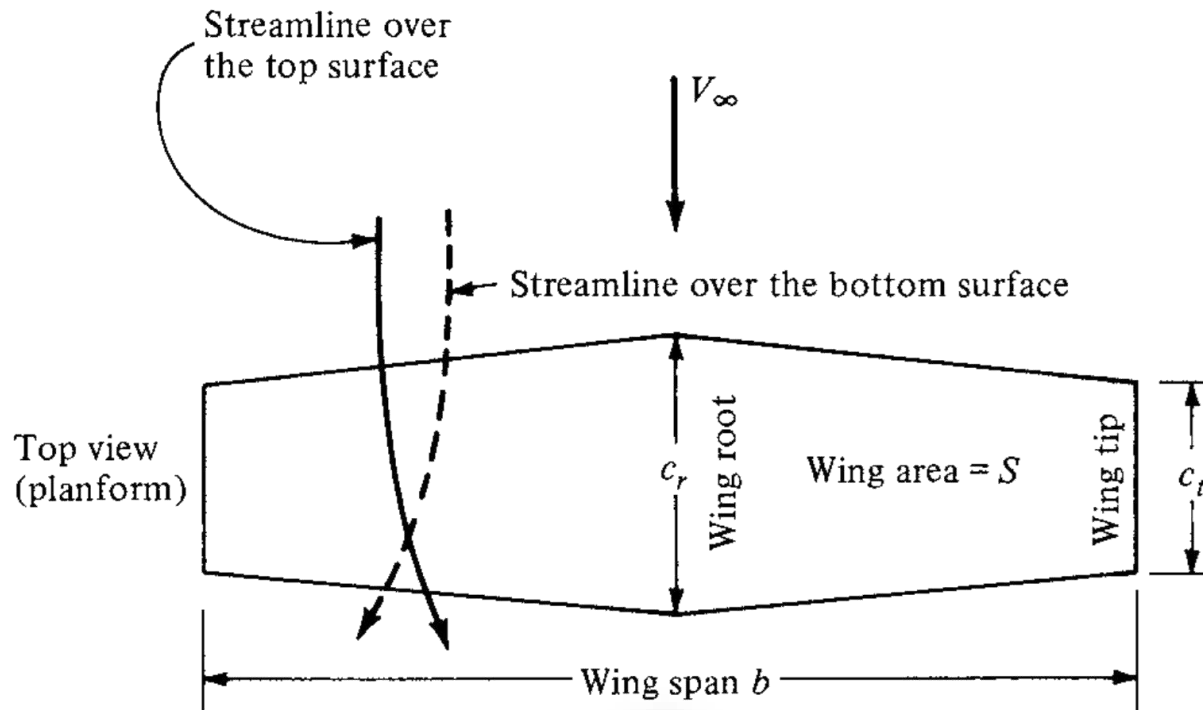



## Downwash and induced drag

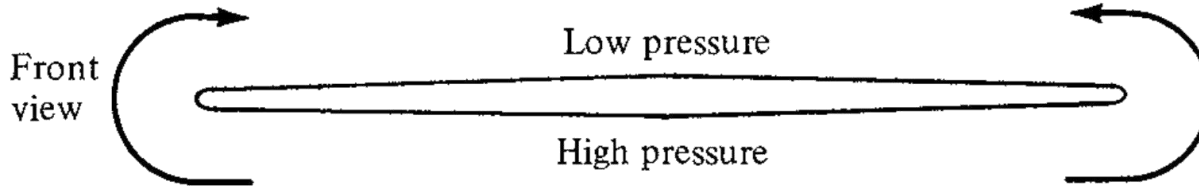

- The tendency for the flow to “leak” around the wing tips has another important effect on the aerodynamics of the wing.
- This flow establishes a circulatory motion that trails downstream of the wing; that is, a trailing *vortex* is created at each wing tip.

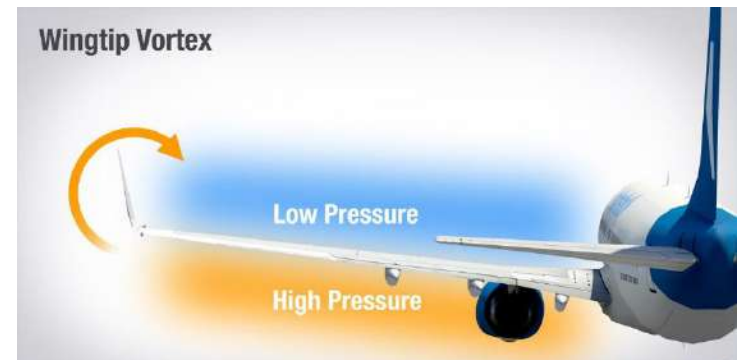
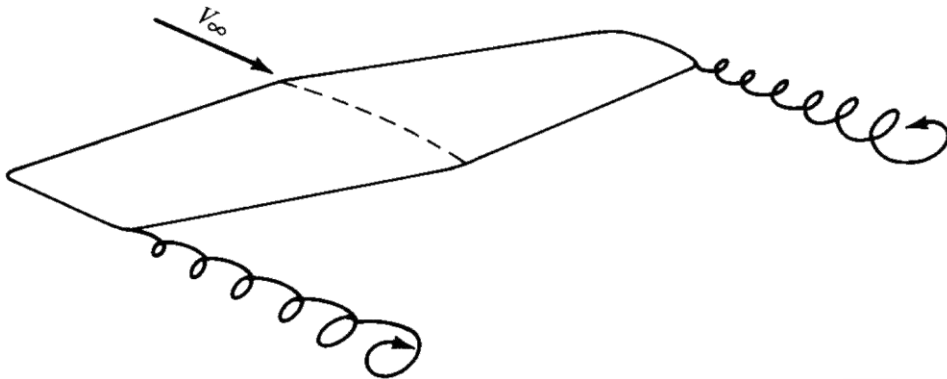



## Downwash and induced drag

- The tip [vortices](#) are essentially weak “[tornadoes](#)” that trail downstream of the finite wing.
- For large airplanes such as a Boeing 747, these tip vortices can be powerful enough to cause light airplanes following too closely to go out of control.
- Such accidents have occurred, and this is one reason for large spacing between aircraft landing or [taking](#) off consecutively at airports.







# Downwash and induced drag

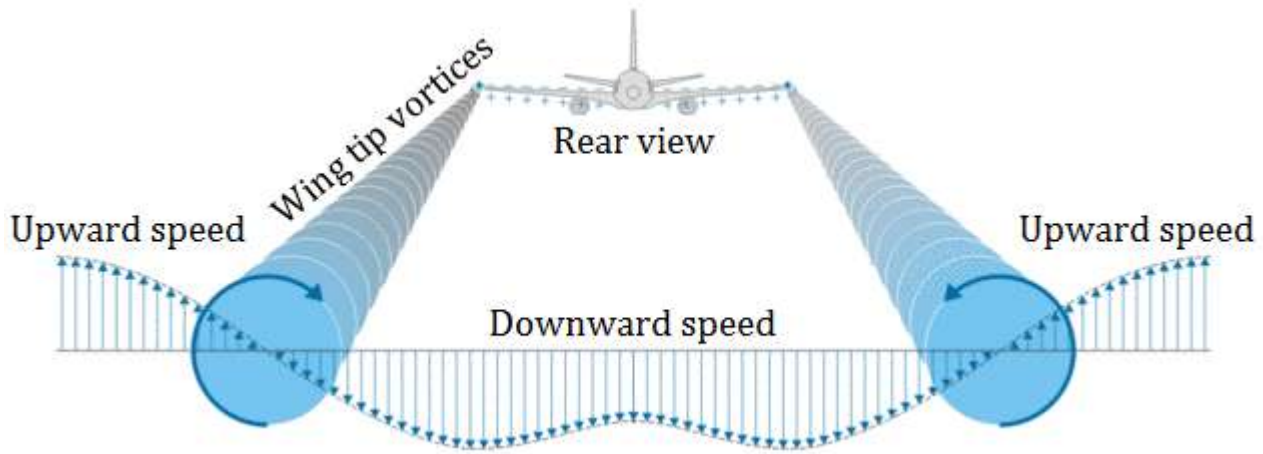



## Downwash and induced drag

- These wing-tip vortices downstream of the wing induce a small downward component of air velocity in the neighborhood of the wing itself.
- This downward component is called *downwash*, denoted by the symbol  $w$ .
- In turn, the downwash combines with the freestream velocity  $V^\infty$  to produce a *local* relative wind.





## Downwash and induced drag





## Downwash and induced drag

$L \equiv$  lift  $\equiv$  component of  $R$  perpendicular to  $V_\infty$

$D \equiv$  drag  $\equiv$  component of  $R$  parallel to  $V_\infty$

$$\alpha_{\text{eff}} = \alpha - \alpha_i$$

$\alpha$  — Geometric angle of attack  
 $\alpha_i$  — Induced angle of attack  
 $\alpha_{\text{eff}}$  — Effective angle of attack  
 $\alpha_{\text{eff}} = \alpha - \alpha_i$

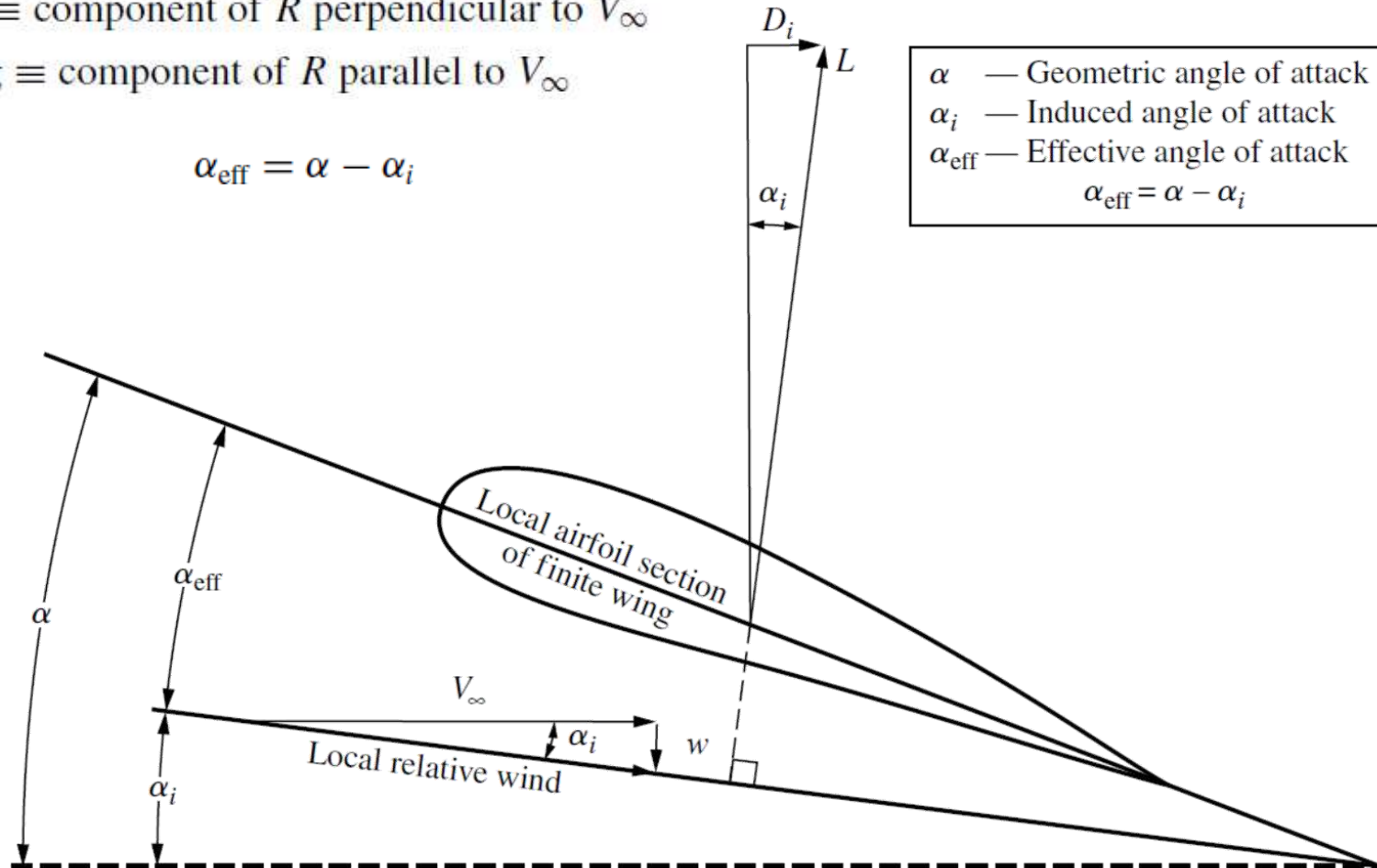



## Downwash and induced drag

- The presence of downwash, and its effect on inclining the local relative wind in the downward direction, has two important effects on the local airfoil section, as follows:
- Although the wing is at a geometric angle of attack  $\alpha$ , the local airfoil section is seeing a smaller angle, namely, the effective angle of attack  $\alpha_{\text{eff}} = \alpha - \alpha_i$
- The local lift vector is aligned perpendicular to the local relative wind, and hence is inclined behind the vertical by the angle  $\alpha_i$
- Consequently, there is a component of the local lift vector in the direction of  $V^\infty$ .
- That is, there is a *drag* created by the presence of downwash. This drag is defined as *induced drag*, denoted by  $D_i$ .





## Downwash and induced drag

- Keep in mind that we are still dealing with an inviscid, incompressible flow, where there is no skin friction or flow separation.
- For such a flow, there is a *finite* drag - the induced drag - on a finite wing.
- D'Alembert's paradox does *not* occur for a finite wing.





## Downwash and induced drag

Roadmap for the analysis

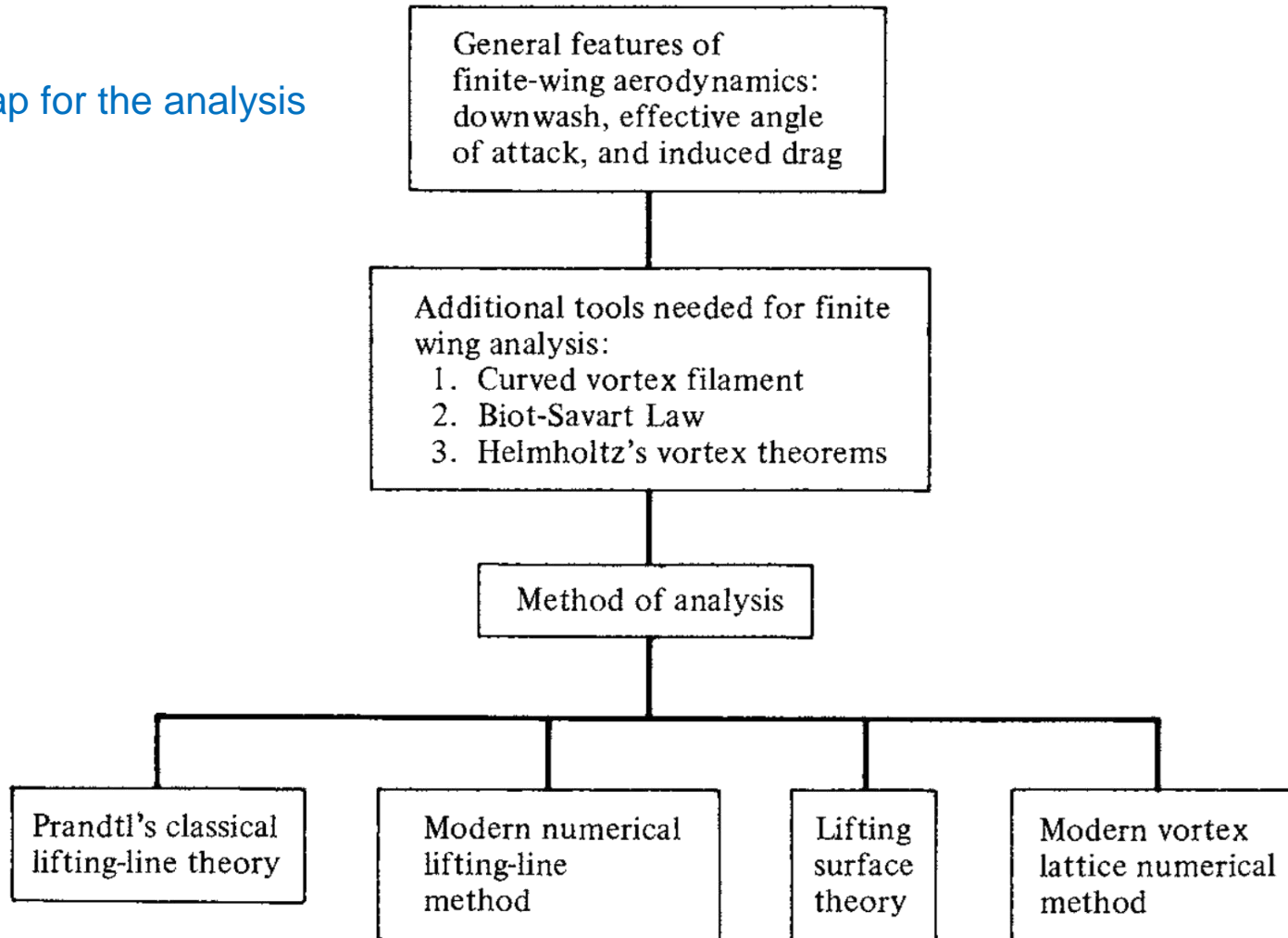



## Downwash and induced drag

- For the two-dimensional bodies  $L'$ ,  $\bar{D}'$ , and  $M'$ ,  
 $c_l$ ,  $c_d$ , and  $c_m$ .

- On a complete three-dimensional body such as a finite wing

$$L, D, \text{ and } M,$$

$$C_L, C_D, \text{ and } C_M.$$

- The total drag coefficient for the finite wing  $C_D$  is given by

$$C_D = c_d + C_{D,i}$$

$\left[ \begin{array}{l} D_f, \text{ the skin friction drag} \\ D_p \text{ the pressure drag} \end{array} \right]$  profile drag

$D_i$ , the induced drag

$$c_d = \frac{D_f + D_p}{q_\infty S}$$

$$C_{D,i} = \frac{D_i}{q_\infty S}$$

- The parasite drag is the sum of the drag due to skin friction and pressure drag due to flow separation associated with the complete airplane, including the wing.







## The vortex filament, the Biot-Savart law, and Helmholtz's theorems

- We discussed a *straight* vortex filament extending to  $\pm\infty$ .
- In general, a vortex filament can be *curved*.
- The strength of the vortex filament is defined as  $\Gamma$ .
- Consider a directed segment of the filament  $d\mathbf{l}$ .
- The radius vector from  $d\mathbf{l}$  to an arbitrary point  $P$  in space is  $\mathbf{r}$ .
- The segment  $d\mathbf{l}$  induces a velocity at  $P$  equal to

$$d\mathbf{V} = \frac{\Gamma}{4\pi} \frac{d\mathbf{l} \times \mathbf{r}}{|\mathbf{r}|^3}$$

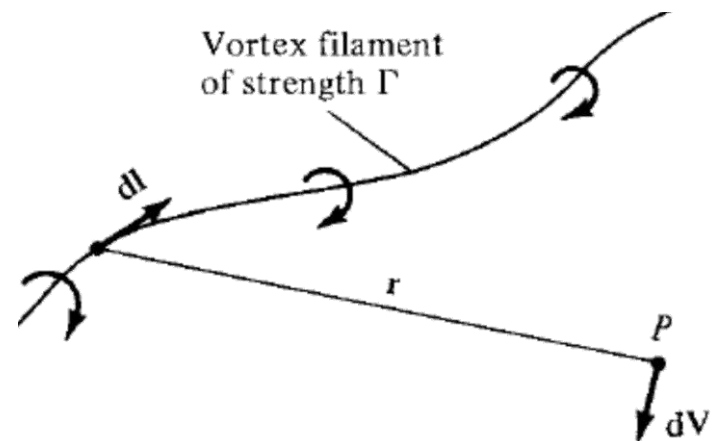
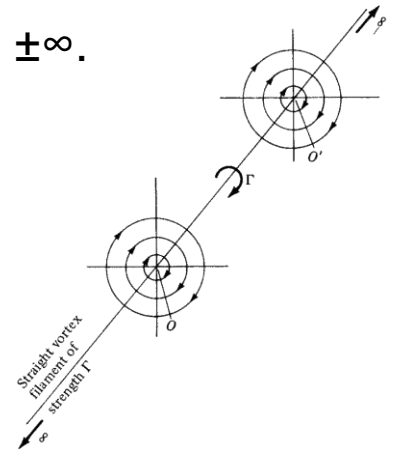



## The vortex filament, the Biot-Savart law, and Helmholtz's theorems

- Equation is called the *Biot-Savart law* and is one of the most fundamental relations in the theory of inviscid, incompressible flow.
- It resembles an analogy with electromagnetic theory, a general result of potential theory.
- Let us apply the Biot-Savart law to a straight vortex filament of infinite length,

$$\mathbf{V} = \int_{-\infty}^{\infty} \frac{\Gamma}{4\pi} \frac{d\mathbf{l} \times \mathbf{r}}{|\mathbf{r}|^3}$$

- The magnitude of the velocity,  $V = |\mathbf{V}|$ , is given by

$$V = \frac{\Gamma}{4\pi} \int_{-\infty}^{\infty} \frac{\sin \theta}{r^2} dl$$





## The vortex filament, the Biot-Savart law, and Helmholtz's theorems

- From the geometry

$$r = \frac{h}{\sin \theta}$$

$$l = \frac{h}{\tan \theta}$$

$$dl = -\frac{h}{\sin^2 \theta} d\theta$$

- Substituting Equations

$$V = \frac{\Gamma}{4\pi} \int_{-\infty}^{\infty} \frac{\sin \theta}{r^2} dl = -\frac{\Gamma}{4\pi h} \int_{\pi}^0 \sin \theta d\theta$$

$$V = \frac{\Gamma}{2\pi h}$$

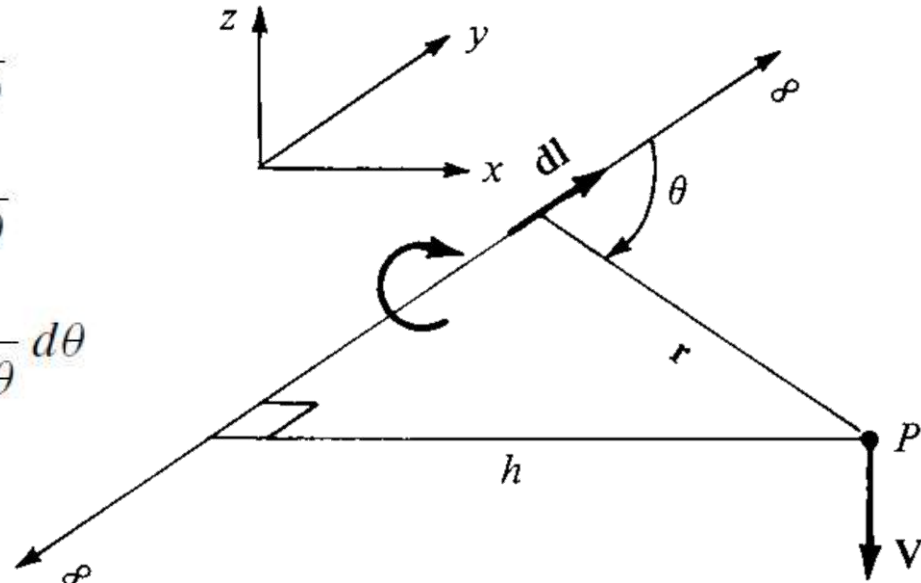



## The vortex filament, the Biot-Savart law, and Helmholtz's theorems

- Consider the *semi*-infinite vortex filament

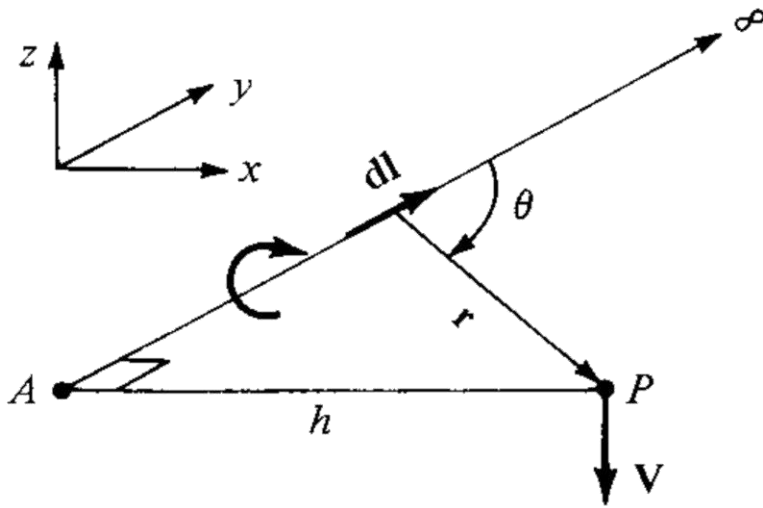

- The filament extends from point  $A$  to  $\infty$ .
- Point  $A$  can be considered a boundary of the flow, ( $\theta = \pi/2$ ).
- The velocity induced at  $P$  by the semi-infinite vortex filament is

$$V = \frac{\Gamma}{4\pi h}$$

- The German mathematician and physician Hermann von Helmholtz (1821–1894) was the first to make use of the vortex filament concept in the analysis of inviscid, incompressible flow.





## The vortex filament, the Biot-Savart law, and Helmholtz's theorems

- He established several basic principles of vortex behavior which have become known as Helmholtz's vortex theorems:
  - The strength of a vortex filament is constant along its length.
  - A vortex filament cannot end in a fluid;
  - It must extend to the boundaries of the fluid (which can be  $\pm\infty$ ) or form a closed path.
- We make use of these theorems in the following sections.

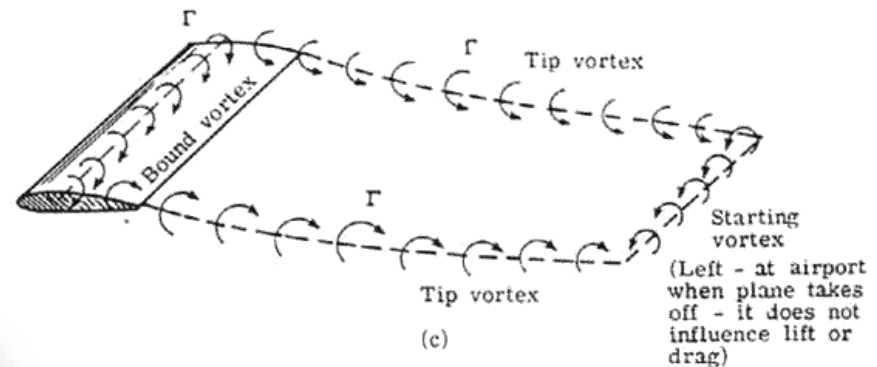
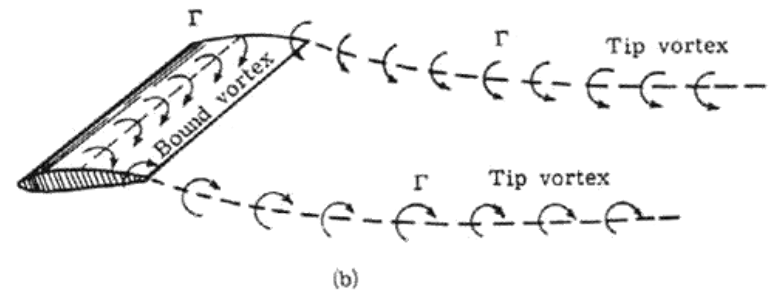
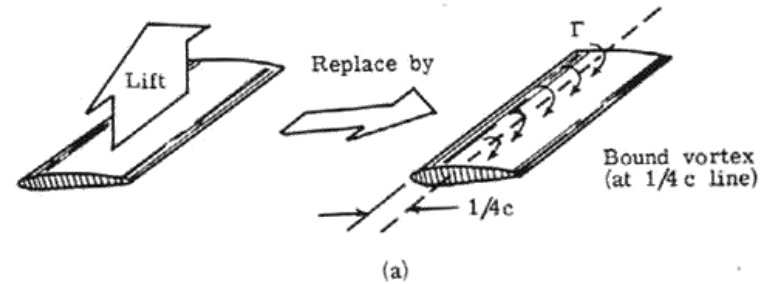



## The vortex filament, the Biot-Savart law, and Helmholtz's theorems

- Let us introduce the concept of *lift distribution* along the span of a finite wing.

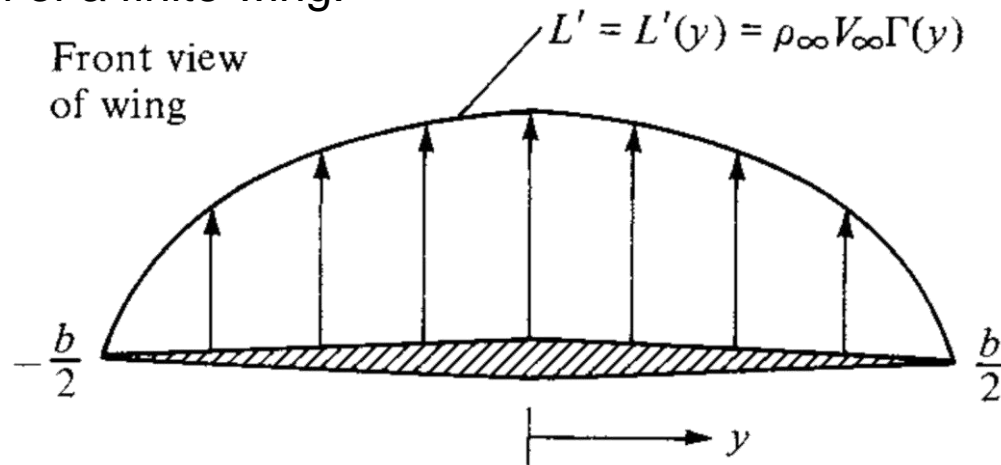

- The lift distribution goes to zero at the tips; there is a pressure equalization from the bottom to the top of the wing, and hence no lift is generated at these points.
- The calculation of the lift distribution  $L(y)$  [or the circulation distribution  $\Gamma(y)$ ] is one of the central problems of finite-wing theory.





## Prandtl's classical lifting-line theory

- Prandtl reasoned as follows. A vortex filament of strength that is somehow bound to a fixed location in a flow—a so-called bound vortex.
- Let us replace a finite wing of span  $b$  with a bound vortex, extending from  $y = -b/2$  to  $y = b/2$ .
- However, due to Helmholtz's theorem, a vortex filament cannot end in the fluid.
- Therefore, assume the vortex filament continues as two free vortices trailing downstream from the wing tips to infinity.
- This vortex (the bound plus the two free) is in the shape of a horseshoe, and therefore is called a *horseshoe vortex*.





## Prandtl's classical lifting-line theory

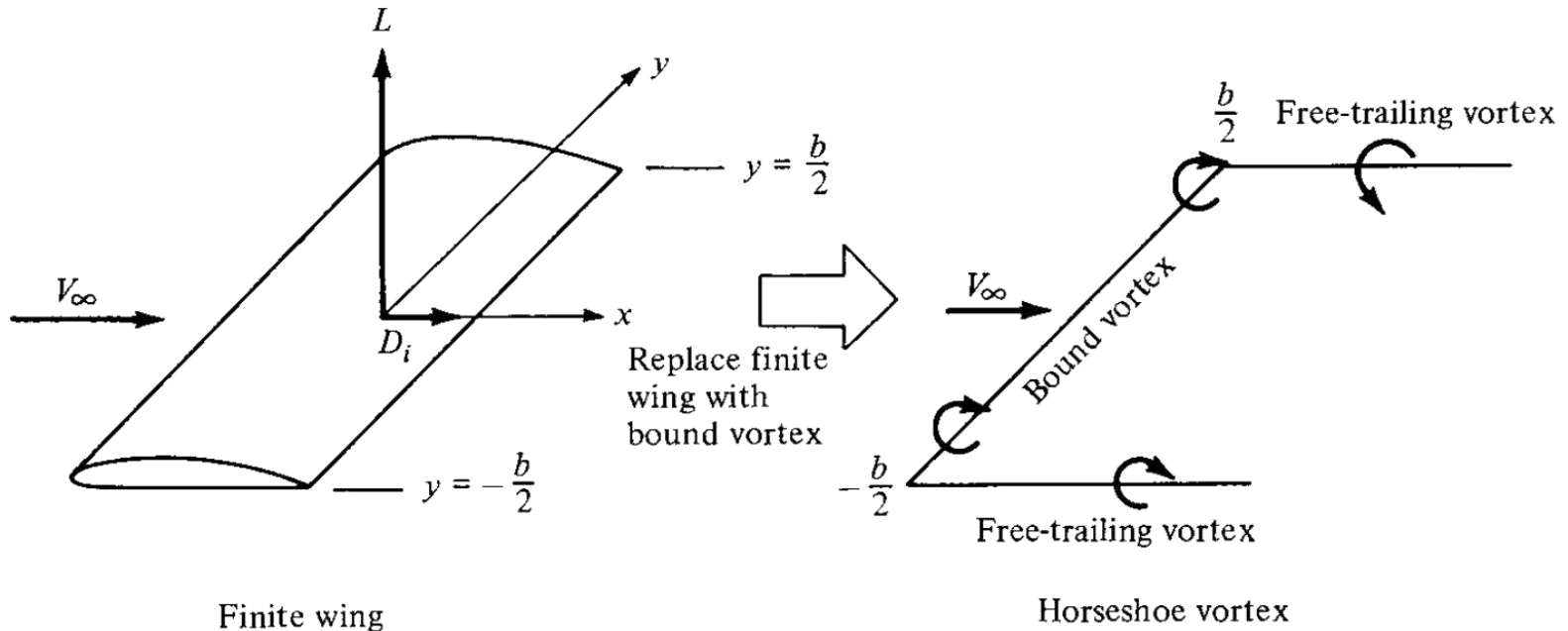

- Consider the downwash  $w$  induced along the bound vortex from  $-b/2$  to  $b/2$  by the horseshoe vortex.
- we see that the bound vortex induces no velocity along itself; however, the two trailing vortices both contribute to the induced velocity.







## Prandtl's classical lifting-line theory

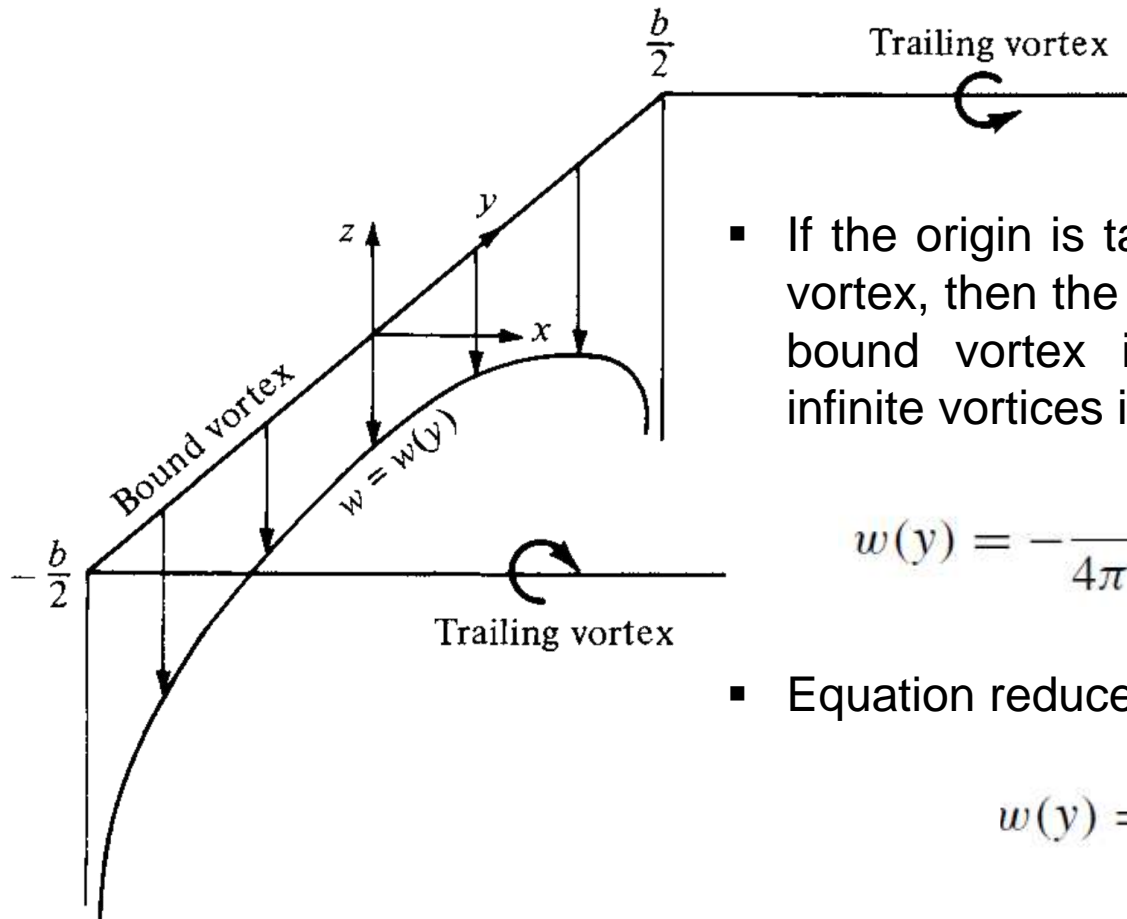

- If the origin is taken at the center of the bound vortex, then the velocity at any point  $y$  along the bound vortex induced by the trailing semi-infinite vortices is,

$$w(y) = -\frac{\Gamma}{4\pi(b/2 + y)} - \frac{\Gamma}{4\pi(b/2 - y)}$$

- Equation reduces to

$$w(y) = -\frac{\Gamma}{4\pi} \frac{b}{(b/2)^2 - y^2}$$

- Note that  $w$  approaches  $-\infty$  as  $y$  approaches  $-b/2$  or  $b/2$ .





## Prandtl's classical lifting-line theory

- The downwash distribution due to the single horseshoe vortex does not realistically simulate that of a finite wing.
- The downwash approaching an infinite value at the tips is especially disconcerting.
- Instead of representing the wing by a single horseshoe vortex, let us superimpose a large number of horseshoe vortices.
- Each with a different length of the bound vortex, but with all the bound vortices coincident along a single line, called the *lifting line*.





## Prandtl's classical lifting-line theory

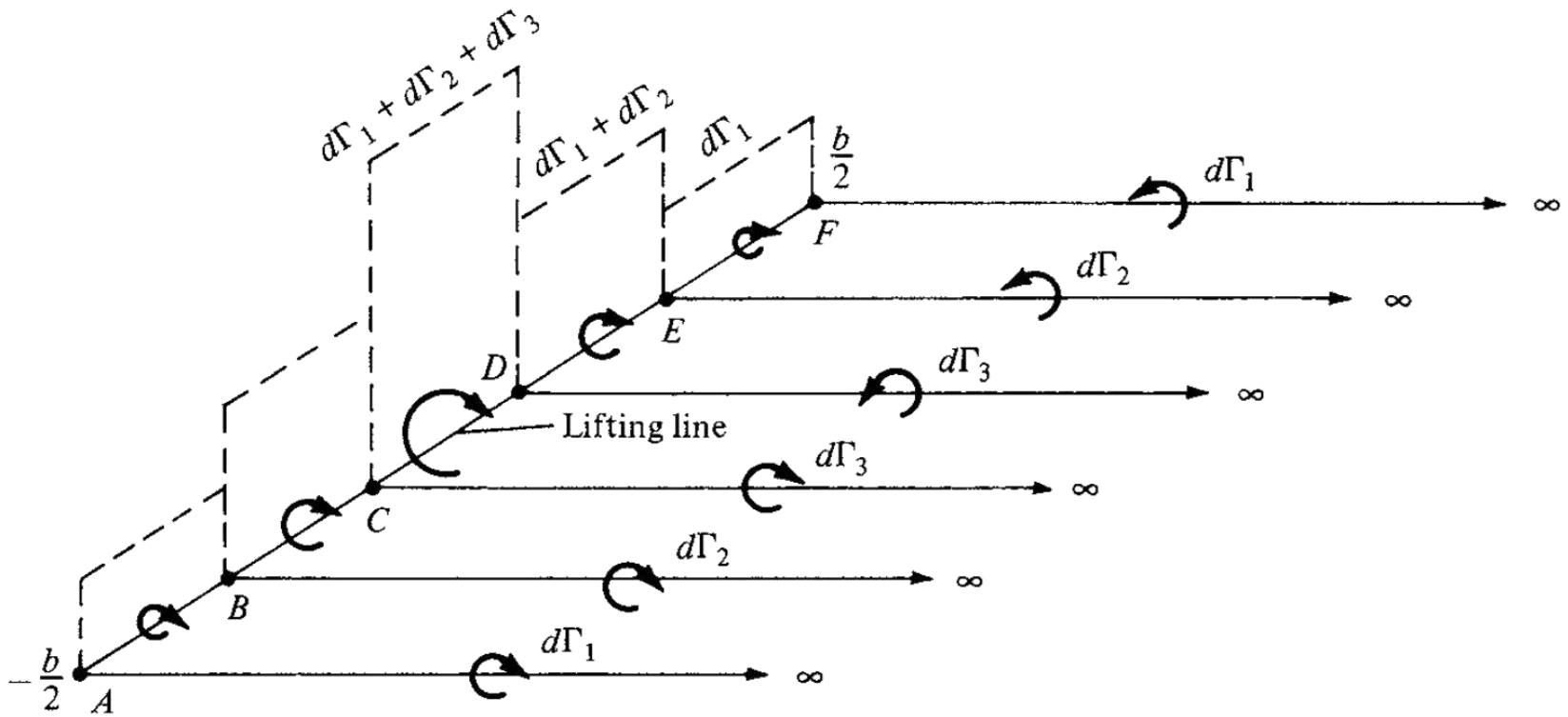

- The circulation varies along the line of bound vortices - the lifting line defined above.





## Prandtl's classical lifting-line theory

- Let us extrapolate Figure to the case where an *infinite number* of horseshoe vortices are superimposed along the lifting line.
- Each with a vanishingly small strength  $d\Gamma$ .

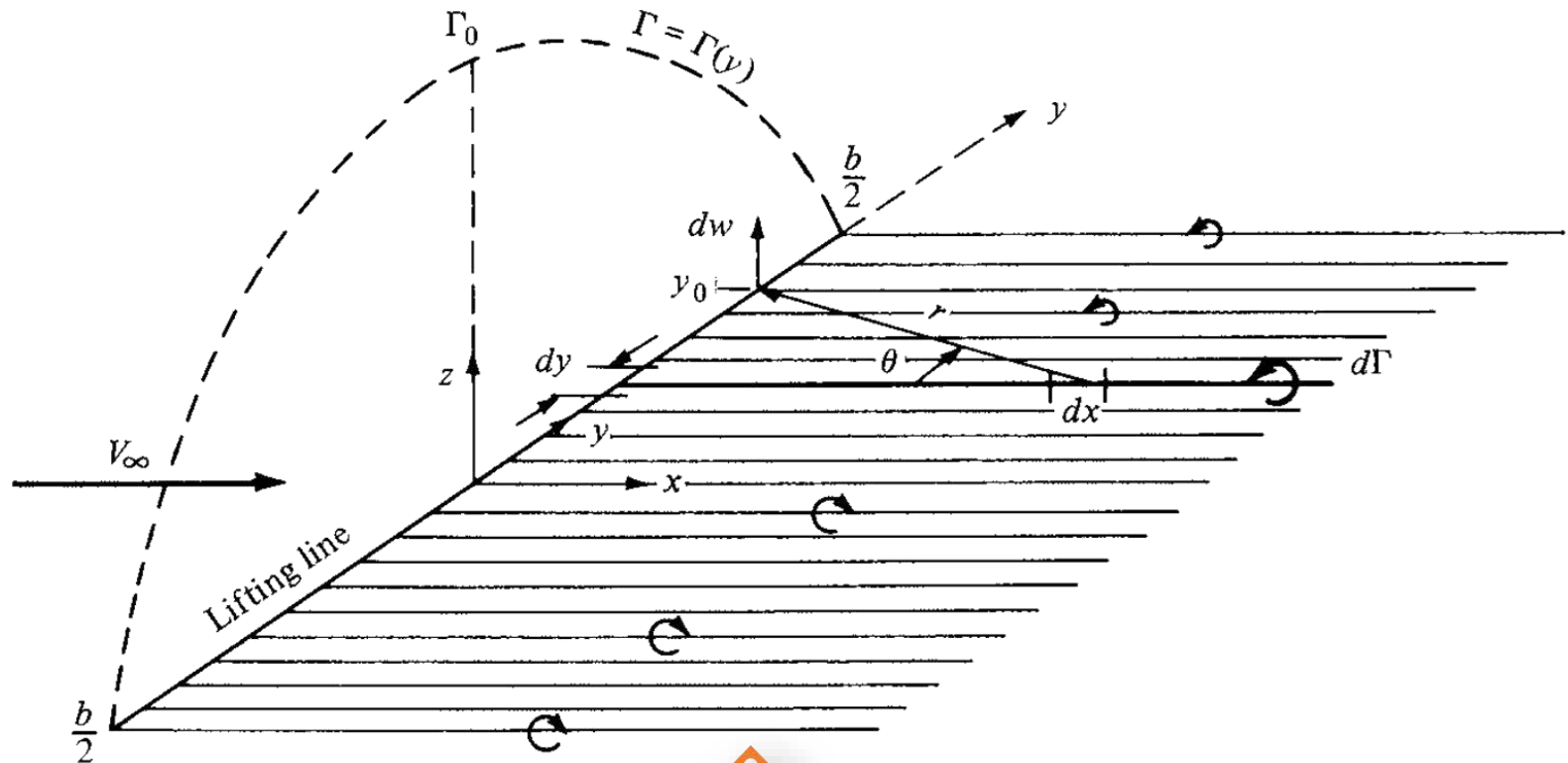



## Prandtl's classical lifting-line theory

- Note that the vertical bars in Figure have now become a continuous distribution of  $\Gamma(y)$  along the lifting line.
- The value of the circulation at the origin is  $\Gamma_0$ .
- The total strength of the sheet integrated across the span of the wing is zero.
- Because it consists of pairs of trailing vortices of equal strength but in opposite directions.
- The velocity  $dw$  at  $y_0$  induced by the entire semi-infinite trailing vortex located at  $y$  is given by

$$dw = -\frac{(d\Gamma/dy) dy}{4\pi(y_0 - y)}$$





## Prandtl's classical lifting-line theory

- The total velocity  $w$  induced at  $y_0$  by the entire trailing vortex sheet is

$$w(y_0) = -\frac{1}{4\pi} \int_{-b/2}^{b/2} \frac{(d\Gamma/dy) dy}{y_0 - y}$$

- By the way, the induced angle of attack  $\alpha_i$  is given by

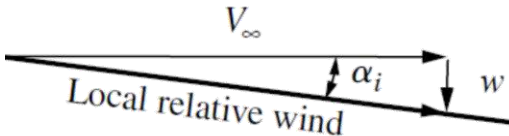
$$\alpha_i(y_0) = \tan^{-1} \left( \frac{-w(y_0)}{V_\infty} \right)$$

- Generally,  $w$  is much smaller than  $V_\infty$ , and hence  $\alpha_i$  is a small angle,

$$\alpha_i(y_0) = -\frac{w(y_0)}{V_\infty} \quad \alpha_i(y_0) = \frac{1}{4\pi V_\infty} \int_{-b/2}^{b/2} \frac{(d\Gamma/dy) dy}{y_0 - y}$$





## Prandtl's classical lifting-line theory

- Consider again the effective angle of attack  $\alpha_{\text{eff}}$ .
- $\alpha_{\text{eff}}$  is the angle of attack actually seen by the local airfoil section.
- Since the downwash varies across the span, then  $\alpha_{\text{eff}}$  is also variable. 
$$\alpha_{\text{eff}} = \alpha_{\text{eff}}(y_0)$$

- The lift coefficient for the airfoil section located at  $y = y_0$  is

$$c_l = a_0[\alpha_{\text{eff}}(y_0) - \alpha_{L=0}] = 2\pi[\alpha_{\text{eff}}(y_0) - \alpha_{L=0}]$$

- The local section lift slope  $a_0$  has been replaced by the thin airfoil theoretical value of  $2\pi$ .





## Prandtl's classical lifting-line theory

- From the definition of lift coefficient and from the Kutta-Joukowski theorem, we have, for the local airfoil section located at  $y_0$ ,

$$L' = \frac{1}{2} \rho_{\infty} V_{\infty}^2 c(y_0) c_l = \rho_{\infty} V_{\infty} \Gamma(y_0)$$

$$c_l = \frac{2\Gamma(y_0)}{V_{\infty} c(y_0)}$$

$$c_l = a_0 [\alpha_{\text{eff}}(y_0) - \alpha_{L=0}] = 2\pi [\alpha_{\text{eff}}(y_0) - \alpha_{L=0}]$$

- Solving for  $\alpha_{\text{eff}}$ , we have

$$\alpha_{\text{eff}} = \frac{\Gamma(y_0)}{\pi V_{\infty} c(y_0)} + \alpha_{L=0} \quad \alpha_{\text{eff}} = \alpha - \alpha_i$$

- We obtain

$$\alpha(y_0) = \frac{\Gamma(y_0)}{\pi V_{\infty} c(y_0)} + \alpha_{L=0}(y_0) + \frac{1}{4\pi V_{\infty}} \int_{-b/2}^{b/2} \frac{(d\Gamma/dy) dy}{y_0 - y}$$







## Prandtl's classical lifting-line theory

- That is the *fundamental equation of Prandtl's lifting-line theory*.
- The only unknown is  $\Gamma$ .
- All the other quantities,  $\alpha$ ,  $c$ ,  $V^\infty$ , and  $\alpha_{L=0}$ , are known for a finite wing of given design at a given geometric angle of attack in a freestream with given velocity.
- Based on  $\Gamma(y)$  solution we have;

- The lift for an airfoil

$$L'(y_0) = \rho_\infty V_\infty \Gamma(y_0)$$

- The total lift for a wing

$$L = \int_{-b/2}^{b/2} L'(y) dy \quad L = \rho_\infty V_\infty \int_{-b/2}^{b/2} \Gamma(y) dy$$

- The lift coefficient for a wing

$$C_L = \frac{L}{q_\infty S} = \frac{2}{V_\infty S} \int_{-b/2}^{b/2} \Gamma(y) dy$$





## Prandtl's classical lifting-line theory

- The induced drag, an airfoil

$$D'_i = L'_i \sin \alpha_i$$

$$D'_i = L'_i \alpha_i$$

- The total induced drag, a wing

$$D_i = \int_{-b/2}^{b/2} L'(y) \alpha_i(y) dy$$

$$D_i = \rho_\infty V_\infty \int_{-b/2}^{b/2} \Gamma(y) \alpha_i(y) dy$$

- The induced drag coefficient, a wing

$$C_{D,i} = \frac{D_i}{q_\infty S} = \frac{2}{V_\infty S} \int_{-b/2}^{b/2} \Gamma(y) \alpha_i(y) dy$$

- $\Gamma(y)$  is clearly the key to obtaining the aerodynamic characteristics of a finite wing.
- Before discussing the general solution of this equation, let us consider a special case.





## Prandtl's classical lifting-line theory

- Consider/assume that a circulation distribution given by

$$\Gamma(y) = \Gamma_0 \sqrt{1 - \left(\frac{2y}{b}\right)^2}$$

- $\Gamma_0$  is the circulation at the origin.
- The circulation varies elliptically with distance  $y$  along the span; hence, it is designated as an elliptical *circulation distribution*.
- Since  $L'(y) = \rho_\infty V_\infty \Gamma(y)$ ,

$$L'(y) = \rho_\infty V_\infty \Gamma_0 \sqrt{1 - \left(\frac{2y}{b}\right)^2}$$

- We now ask the question, 'What are the aerodynamic properties of a finite wing with such an elliptic lift distribution?'

Ellipse type 1:

$$\frac{(x-h)^2}{a^2} + \frac{(y-k)^2}{b^2} = 1$$

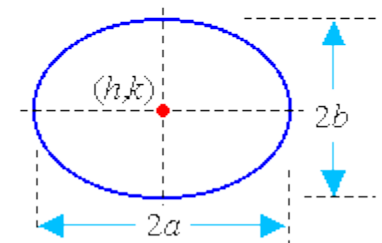



## Prandtl's classical lifting-line theory

- First, let us calculate the downwash. Differentiating Equation, we obtain

$$\frac{d\Gamma}{dy} = -\frac{4\Gamma_0}{b^2} \frac{y}{(1 - 4y^2/b^2)^{1/2}}$$

- Substituting it, we have the total velocity

$$w(y_0) = \frac{\Gamma_0}{\pi b^2} \int_{-b/2}^{b/2} \frac{y}{(1 - 4y^2/b^2)^{1/2}(y_0 - y)} dy$$

- The integral can be evaluated easily by making the substitution

$$y = \frac{b}{2} \cos \theta \quad dy = -\frac{b}{2} \sin \theta d\theta$$

- Hence, Equation becomes

$$w(\theta_0) = -\frac{\Gamma_0}{2\pi b} \int_0^\pi \frac{\cos \theta}{\cos \theta - \cos \theta_0} d\theta$$





## Prandtl's classical lifting-line theory

- The solution becomes

$$w(\theta_0) = -\frac{\Gamma_0}{2b}$$

which states the interesting and important result that the *downwash is constant over the span for an elliptical lift distribution.*

- In turn, from Equation, we obtain, for the induced angle of attack,

$$\alpha_i = -\frac{w}{V_\infty} = \frac{\Gamma_0}{2bV_\infty}$$

- The induced angle of attack is also constant along the span.





## Prandtl's classical lifting-line theory

- For lift, we have

$$L = \rho_{\infty} V_{\infty} \Gamma_0 \int_{-b/2}^{b/2} \left(1 - \frac{4y^2}{b^2}\right)^{1/2} dy$$
$$y = \frac{b}{2} \cos \theta \quad dy = -\frac{b}{2} \sin \theta d\theta$$

$$L = \rho_{\infty} V_{\infty} \Gamma_0 \frac{b}{2} \int_0^{\pi} \sin^2 \theta d\theta = \rho_{\infty} V_{\infty} \Gamma_0 \frac{b}{4} \pi$$

- For  $\Gamma_0$ , we have  $\Gamma_0 = \frac{4L}{\rho_{\infty} V_{\infty} b \pi}$

$$L = \frac{1}{2} \rho_{\infty} V_{\infty}^2 S C_L$$

$$\Gamma_0 = \frac{2V_{\infty} S C_L}{b \pi}$$

- Substituting Equation, we obtain

$$\alpha_i = \frac{2V_{\infty} S C_L}{b \pi} \frac{1}{2bV_{\infty}} = \frac{S C_L}{\pi b^2}$$

- An important geometric property of a finite wing is the *aspect ratio*, denoted by AR and defined as

$$AR \equiv \frac{b^2}{S}$$





## Prandtl's classical lifting-line theory

- Hence, Equation becomes  $\alpha_i = \frac{C_L}{\pi AR}$

- The induced drag coefficient, a wing  $C_{D,i} = \frac{D_i}{q_\infty S} = \frac{2}{V_\infty S} \int_{-b/2}^{b/2} \Gamma(y) \alpha_i(y) dy$

- The induced drag coefficient is

$$C_{D,i} = \frac{2\alpha_i}{V_\infty S} \int_{-b/2}^{b/2} \Gamma(y) dy = \frac{2\alpha_i \Gamma_0 b}{V_\infty S} \int_0^\pi \sin^2 \theta d\theta = \frac{\pi \alpha_i \Gamma_0 b}{2V_\infty S}$$

$$C_{D,i} = \frac{\pi b}{2V_\infty S} \left( \frac{C_L}{\pi AR} \right) \frac{2V_\infty S C_L}{b\pi}$$

- We obtain

$$C_{D,i} = \frac{C_L^2}{\pi AR}$$

- The dependence of induced drag on the lift is not surprising,
- Even at relatively high cruising speeds, induced drag is typically 25 percent of the total drag.





## Prandtl's classical lifting-line theory

- Another important aspect of induced drag is that,  $C_{D,i}$  is *inversely proportional to aspect ratio*.
- Hence, to reduce the induced drag, we want a finite wing with the highest possible aspect ratio.
- Unfortunately, the design of very high aspect ratio wings with sufficient structural strength is difficult.
- Therefore, the aspect ratio of a conventional aircraft is a compromise between conflicting aerodynamic and structural requirements.

Today the aspect ratios of conventional subsonic aircraft range typically from 6 to 8.

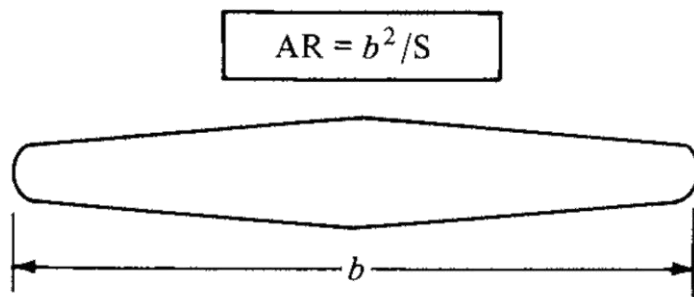

High AR (low induced drag)

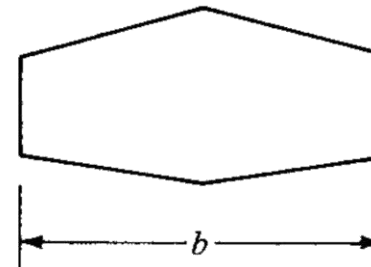

Low AR (high induced drag)







## Prandtl's classical lifting-line theory

- Another property of the elliptical lift distribution is related to the geometry.
- We have seen that  $\alpha_i$  is constant along the span, (with no geometric twist and no aerodynamic twist).

- Since the local section lift coefficient  $c_l$  is given by

$$c_l = a_0(\alpha_{\text{eff}} - \alpha_{L=0}) \quad \text{constant along the span}$$

$$L'(y) = q_\infty c c_l$$

- Solving Equation for the chord, we have  $c(y) = \frac{L'(y)}{q_\infty c_l}$
- Thus, Equation dictates that for such an elliptic lift distribution, the *chord must vary elliptically along the span*.
- That is, for the conditions given above, the *wing planform is elliptical*.





## Prandtl's classical lifting-line theory

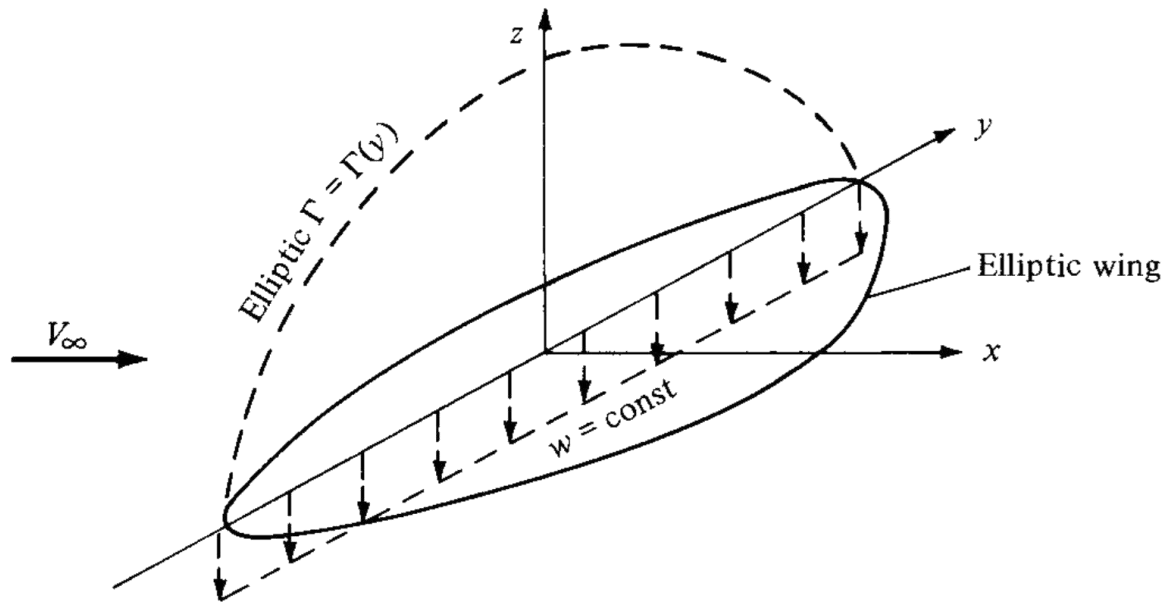

- Illustration of the related quantities: an elliptic circulation/lift distribution, elliptic planform, and constant downwash.





## Prandtl's classical lifting-line theory

### General Lift Distribution

- Consider the transformation  $y = -\frac{b}{2} \cos \theta$   $0 \leq \theta \leq \pi$
- In terms of  $\theta$ , the elliptic lift distribution is  $\Gamma(\theta) = \Gamma_0 \sin \theta$   
 $\Gamma(y) = \Gamma_0 \sqrt{1 - \left(\frac{2y}{b}\right)^2}$
- Equation hints that a Fourier sine series would be an appropriate expression for the general circulation distribution along an arbitrary finite wing.
- Hence, **assume** for the general case that  $\Gamma(\theta) = 2bV_\infty \sum_1^N A_n \sin n\theta$
- The coefficients  $A_n$  (where  $n = 1, \dots, N$ ) are unknowns.
- However, they must satisfy the fundamental equation of Prandtl's lifting-line theory.





## Prandtl's classical lifting-line theory

- The fundamental equation of Prandtl's lifting-line theory; it simply states that the geometric angle of attack is equal to the sum of the effective angle plus the induced angle of attack.

$$\alpha(y_0) = \frac{\Gamma(y_0)}{\pi V_\infty c(y_0)} + \alpha_{L=0}(y_0) + \frac{1}{4\pi V_\infty} \int_{-b/2}^{b/2} \frac{(d\Gamma/dy) dy}{y_0 - y}$$

- Differentiating the general circulation Equation, we obtain

$$\frac{d\Gamma}{dy} = \frac{d\Gamma}{d\theta} \frac{d\theta}{dy} = 2bV_\infty \sum_1^N n A_n \cos n\theta \frac{d\theta}{dy}$$

- Substituting Equations, we obtain

$$\alpha(\theta_0) = \frac{2b}{\pi c(\theta_0)} \sum_1^N A_n \sin n\theta_0 + \alpha_{L=0}(\theta_0) + \frac{1}{\pi} \int_0^\pi \frac{\sum_1^N n A_n \cos n\theta}{\cos \theta - \cos \theta_0} d\theta$$





## Prandtl's classical lifting-line theory

- The integral in Equation becomes

$$\int_0^\pi \frac{\cos n\theta \, d\theta}{\cos \theta - \cos \theta_0} = \frac{\pi \sin n\theta_0}{\sin \theta_0}$$

$$\alpha(\theta_0) = \frac{2b}{\pi c(\theta_0)} \sum_1^N A_n \sin n\theta_0 + \alpha_{L=0}(\theta_0) + \sum_1^N n A_n \frac{\sin n\theta_0}{\sin \theta_0}$$

- Examine Equation closely.
- It is evaluated at a given spanwise location; hence,  $\theta_0$  is specified.
- In turn,  $b$ ,  $c(\theta_0)$ , and  $\alpha_{L=0}(\theta_0)$  are known quantities from the geometry and airfoil section of the finite wing.
- The only unknowns in Equation are the  $A_n$ 's.





## Prandtl's classical lifting-line theory

- However, let us choose  $N$  different spanwise stations, and let us evaluate Equation at each of these  $N$  stations.
- We then obtain a system of  $N$  independent algebraic equations with  $N$  unknowns.
- In this fashion, actual numerical values are obtained for the  $A_n$ 's.
- Now that  $\Gamma(\theta)$  is known, the lift coefficient for the finite wing follows

$$\Gamma(\theta) = 2bV_\infty \sum_1^N A_n \sin n\theta$$

$$C_L = \frac{2}{V_\infty S} \int_{-b/2}^{b/2} \Gamma(y) dy = \frac{2b^2}{S} \sum_1^N A_n \int_0^\pi \sin n\theta \sin \theta d\theta$$

- Hence, Equation becomes

$$C_L = A_1 \pi \frac{b^2}{S} = A_1 \pi AR$$

$$\int_0^\pi \sin n\theta \sin \theta d\theta = \begin{cases} \pi/2 & \text{for } n = 1 \\ 0 & \text{for } n \neq 1 \end{cases}$$





## Prandtl's classical lifting-line theory

- The induced drag coefficient is obtained from

$$\begin{aligned} C_{D,i} &= \frac{2}{V_\infty S} \int_{-b/2}^{b/2} \Gamma(y) \alpha_i(y) dy \\ &= \frac{2b^2}{S} \int_0^\pi \left( \sum_1^N A_n \sin n\theta \right) \alpha_i(\theta) \sin \theta d\theta \end{aligned}$$

- We know that

$$\alpha_i(y_0) = \frac{1}{4\pi V_\infty} \int_{-b/2}^{b/2} \frac{(d\Gamma/dy) dy}{y_0 - y}$$

$$\frac{d\Gamma}{dy} = \frac{d\Gamma}{d\theta} \frac{d\theta}{dy} = 2bV_\infty \sum_1^N n A_n \cos n\theta \frac{d\theta}{dy}$$

$$y = -\frac{b}{2} \cos \theta \quad 0 \leq \theta \leq \pi$$

- Therefore,

$$\alpha_i(y_0) = \frac{1}{\pi} \sum_1^N n A_n \int_0^\pi \frac{\cos n\theta}{\cos \theta - \cos \theta_0} d\theta = \sum_1^N n A_n \frac{\sin n\theta_0}{\sin \theta_0}$$





## Prandtl's classical lifting-line theory

- $\theta_0$  is simply a dummy variable which ranges from 0 to  $\pi$  across the span of the wing; it can therefore be replaced by  $\theta$ ,

$$\alpha_i(\theta) = \sum_1^N n A_n \frac{\sin n\theta}{\sin \theta}$$

- Substituting Equation, we have

$$C_{D,i} = \frac{2b^2}{S} \int_0^\pi \left( \sum_1^N A_n \sin n\theta \right) \left( \sum_1^N n A_n \sin n\theta \right) d\theta$$

- From the standard integral,  $\int_0^\pi \sin m\theta \sin k\theta = \begin{cases} 0 & \text{for } m \neq k \\ \pi/2 & \text{for } m = k \end{cases}$

- Hence, Equation becomes

$$C_{D,i} = \frac{2b^2}{S} \left( \sum_1^N n A_n^2 \right) \frac{\pi}{2} = \pi AR \sum_1^N n A_n^2 = \pi AR \left( A_1^2 + \sum_2^N n A_n^2 \right)$$

$$C_{D,i} = \pi AR A_1^2 \left[ 1 + \sum_2^N n \left( \frac{A_n}{A_1} \right)^2 \right]$$







## Prandtl's classical lifting-line theory

- We know that  $C_L = A_1 \pi \frac{b^2}{S} = A_1 \pi AR$
- Substituting Equation, we obtain  $C_{D,i} = \frac{C_L^2}{\pi AR} (1 + \delta)$   
$$\delta = \sum_2^N n(A_n/A_1)^2 \quad \delta \geq 0;$$
- Let us define a span efficiency factor,  $e$ , as  $e = (1 + \delta)^{-1}$   
 $e$ : span efficiency factor
- Then Equation can be written as  $C_{D,i} = \frac{C_L^2}{\pi e AR} \quad e \leq 1$
- Note that  $\delta = 0$  and  $e = 1$  for the elliptical lift distribution.
- Hence, the lift distribution which yields minimum induced drag is the *elliptical lift distribution*.





## Prandtl's classical lifting-line theory

- However, elliptic planforms are more expensive to manufacture.
- On the other hand, a simple rectangular wing generates a lift distribution far from optimum.
- A compromise is the tapered wing.
- The tapered wing can be designed with a taper ratio, that is, tip chord/root chord  $\equiv c_t/c_r$  such that the lift distribution closely approximates the elliptic case.



Elliptic wing

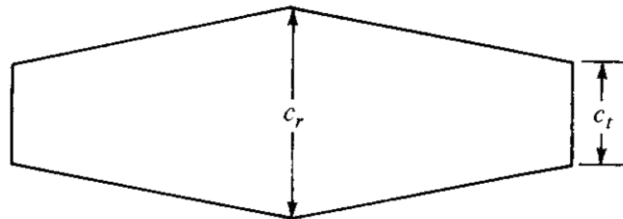

Tapered wing



Rectangular wing





## Prandtl's classical lifting-line theory

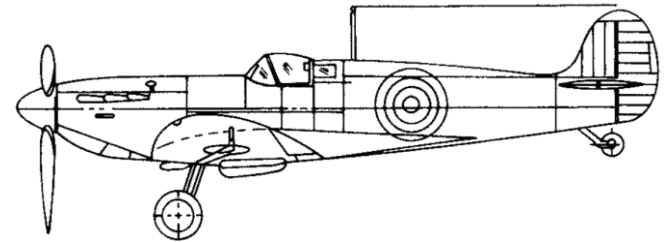
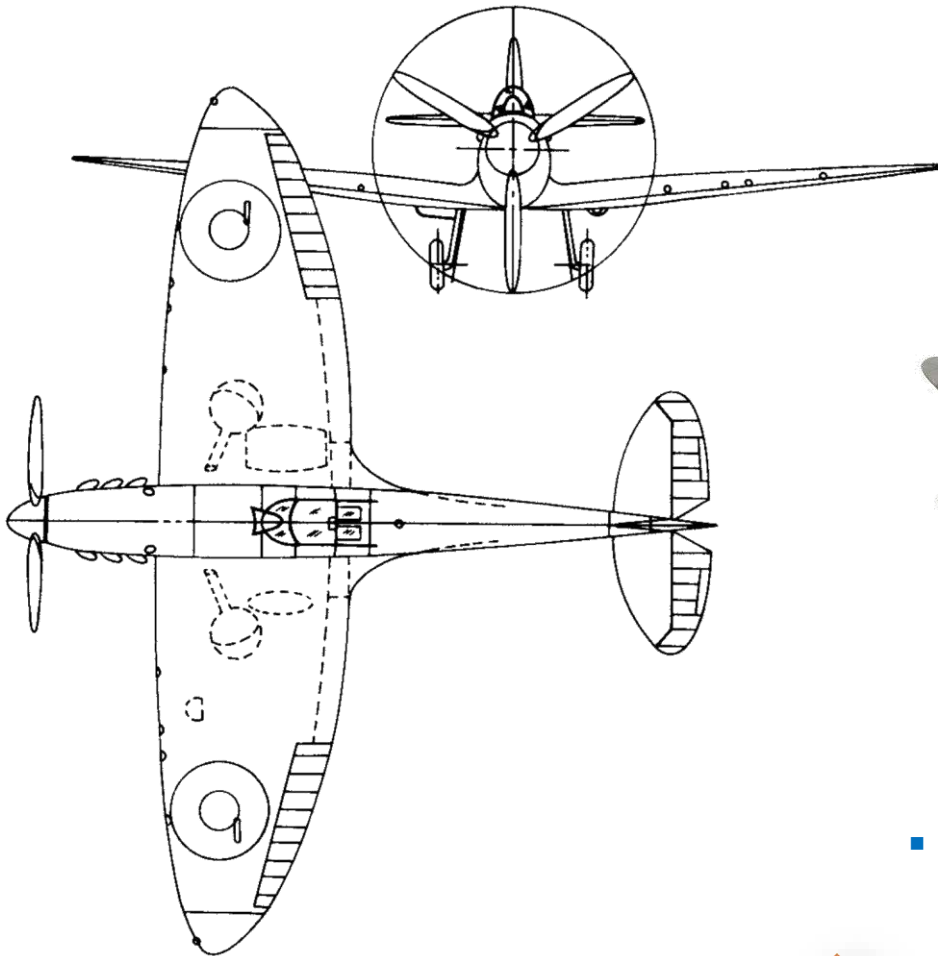

- The views of the Supermarine Spitfire, a famous British World War II fighter.





## Prandtl's classical lifting-line theory

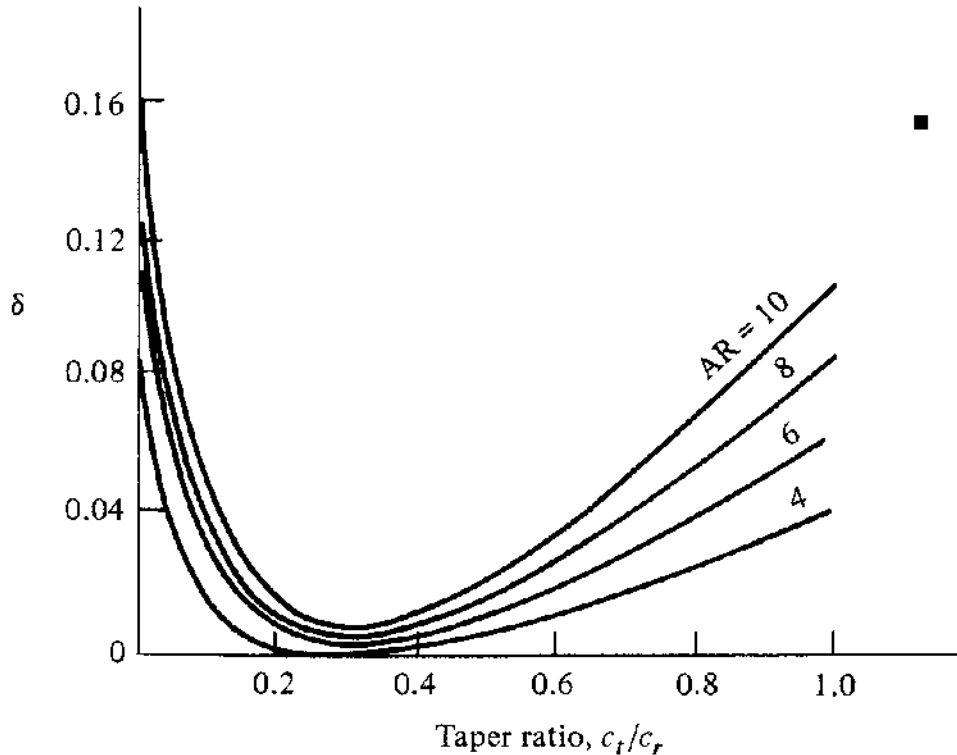

- For a specific aspect ratio, we have the optimal taper ratio which provides the minimum induced drag.

$$C_{D,i} = \frac{C_L^2}{\pi AR} (1 + \delta)$$

- Induced drag factor  $\delta$  as a function of taper ratio.





## Prandtl's classical lifting-line theory

### Effect of Aspect Ratio

- Note that the induced drag coefficient for a finite wing with a general lift distribution is inversely proportional to the aspect ratio.
- AR, which typically varies from 6 to 22 for standard subsonic airplanes and sailplanes, has a much stronger effect on  $C_{D,i}$  than the value of  $\delta$ .
- Hence, the primary design factor for minimizing induced drag is the ability to make the aspect ratio as large as possible.
- Recall from Equation that the total drag of a finite wing is given by

$$C_D = c_d + \frac{C_L^2}{\pi e AR}$$





## Prandtl's classical lifting-line theory

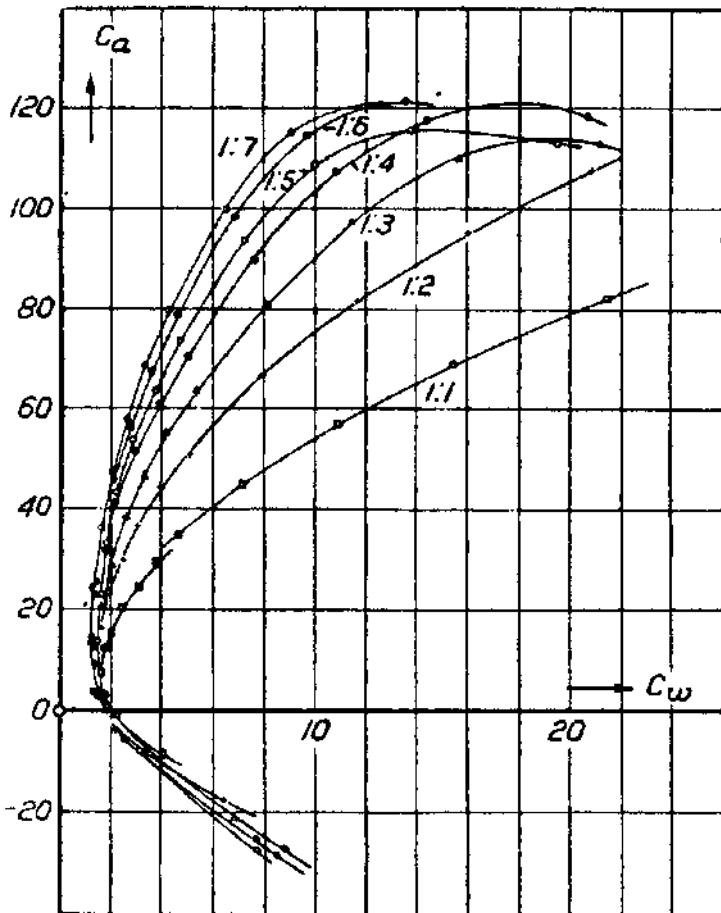

- This is a plot of lift coefficient versus drag coefficient, and is called a *drag polar*.

$$C_D = c_d + \frac{C_L^2}{\pi e AR}$$

- Prandtl's classic rectangular wing data for seven different aspect ratios from 1 to 7; variation of lift coefficient versus drag coefficient.
- Note that, in his nomenclature,  $C_a$  = lift coefficient and  $C_w$  = drag coefficient.
- Also, the numbers on both the ordinate and abscissa are 100 times the actual values of the coefficients.





## Prandtl's classical lifting-line theory

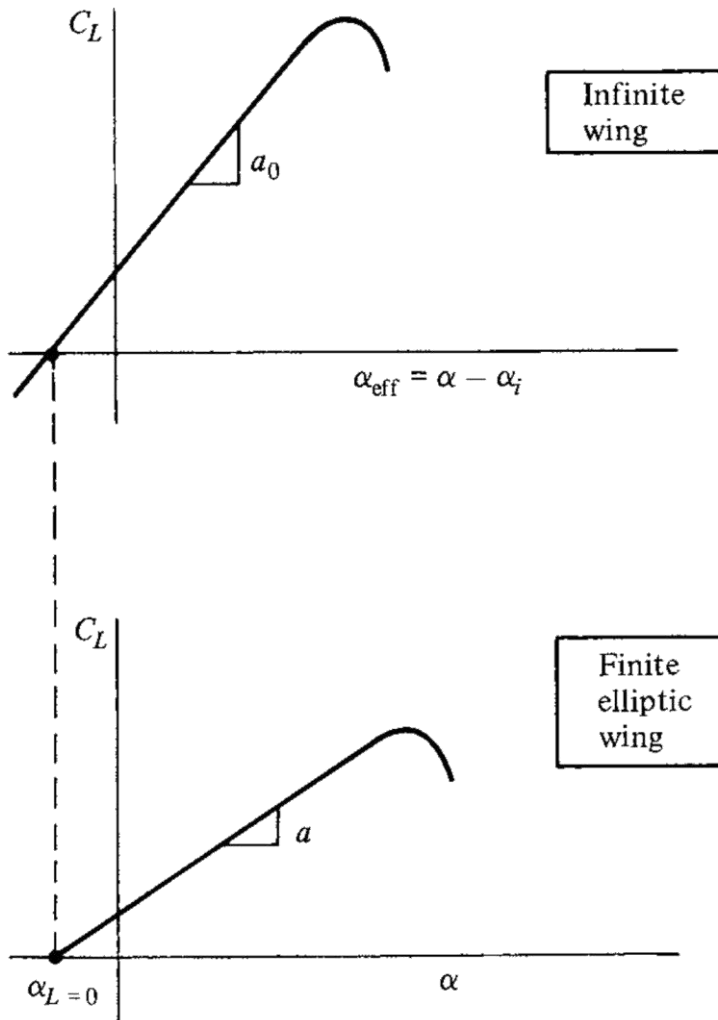

- Also, recall that at zero lift, there are no induced effects.
- Thus, when  $C_L = 0$ ,  $\alpha = \alpha_{\text{eff}}$ .
- As a result,  $\alpha_{L=0}$  is the same for the finite and the infinite wings,

$$C_D = c_d + \frac{C_L^2}{\pi eAR}$$

- The values of  $a_0$  and  $a$  are related as follows.

$$\frac{dC_L}{d(\alpha - \alpha_i)} = a_0$$

$$C_L = a_0(\alpha - \alpha_i) + \text{const}$$





## Prandtl's classical lifting-line theory

- Recall that  $\alpha_i = \frac{C_L}{\pi AR}$  for an elliptic finite wing.
- Substituting Equation, we obtain  $C_L = a_0 \left( \alpha - \frac{C_L}{\pi AR} \right) + \text{const}$
- Differentiating Equation with respect to  $\alpha$ , and solving for  $dC_L/d\alpha$ , we obtain

$$\frac{dC_L}{d\alpha} = a = \frac{a_0}{1 + a_0/\pi AR}$$

- For a finite wing of general planform,

$$a = \frac{a_0}{1 + (a_0/\pi AR)(1 + \tau)} \quad AR \rightarrow \infty, a \rightarrow a_0$$

- $\tau$  is a function of the Fourier coefficients  $A_n$ .
- Values of  $\tau$  typically range between 0.05 and 0.25.







## Prandtl's classical lifting-line theory

- The effect of aspect ratio on the lift curve is shown in Figure;

$$C_L = A_1 \pi \frac{b^2}{S} = A_1 \pi AR$$

### Physical Significance

- Prandtl's lifting-line model with its trailing-vortex sheet is physically consistent with the actual flow downstream of a finite wing.

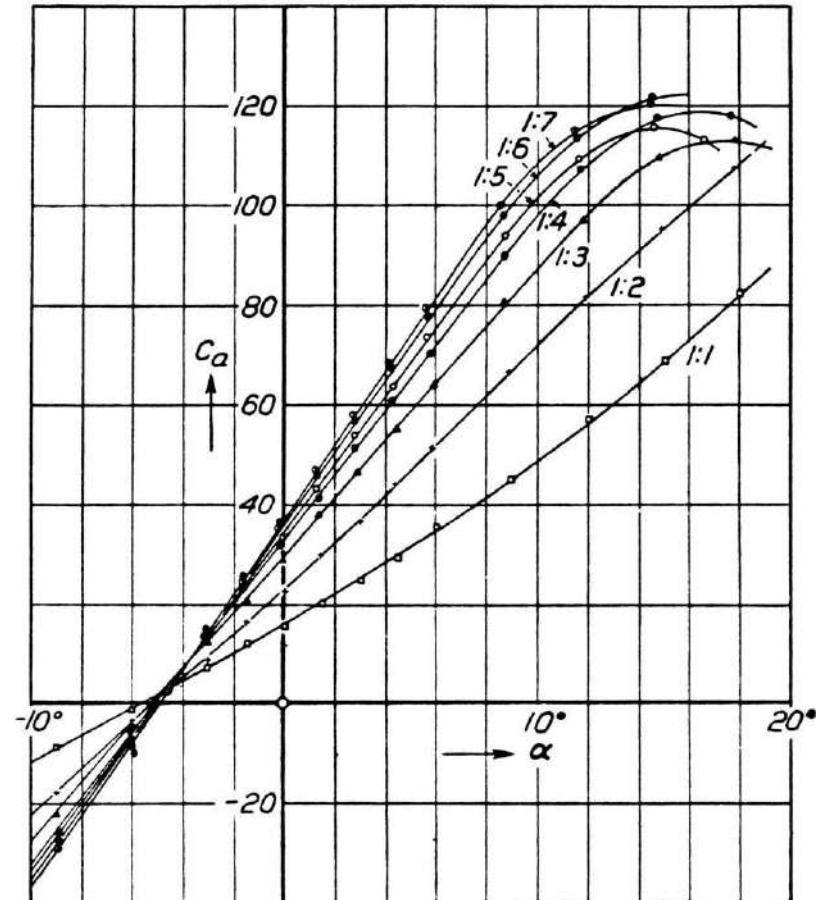



## Example 5.4

- Consider the wing of the Beechcraft Baron 58 at a 4-degree angle of attack.
- The wing has an aspect ratio of 7.61 and a taper ratio of 0.45.
- Calculate**  $C_L$  and  $C_D$  for the wing.
- From Figure, the zero-lift angle of attack of the airfoil, which is the same for the finite wing, is

$$\alpha_{L=0} = -1^\circ$$

- We arbitrarily pick two points on this curve:  $\alpha = 7^\circ$  where  $c_l = 0.9$ , and  $\alpha = -1^\circ$  where  $c_l = 0$ . Thus

$$a_0 = \frac{0.9 - 0}{7 - (-1)} = \frac{0.9}{8} = 0.113 \text{ per degree}$$

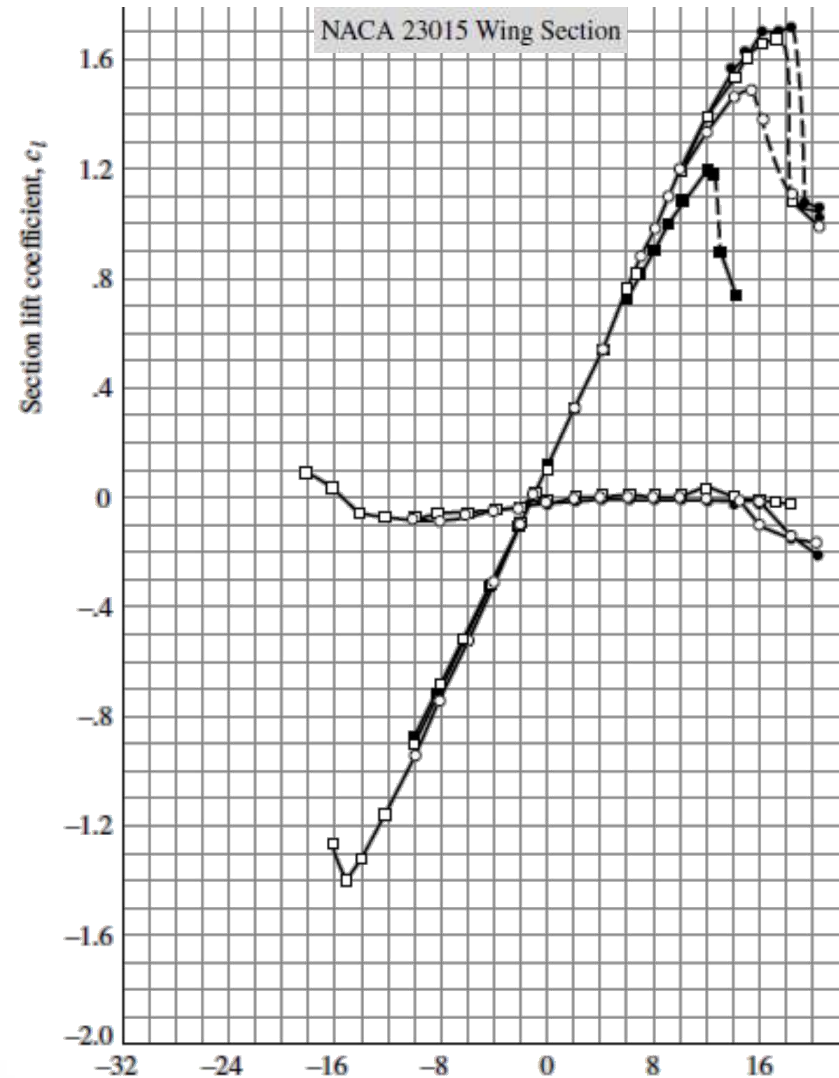



## Example 5.4

- The lift slope in radians is:  $a_0 = 0.113(57.3) = 6.47$  per rad
- From Figure, for  $AR = 7.61$  and taper ratio = 0.45;  $\delta = 0.01$

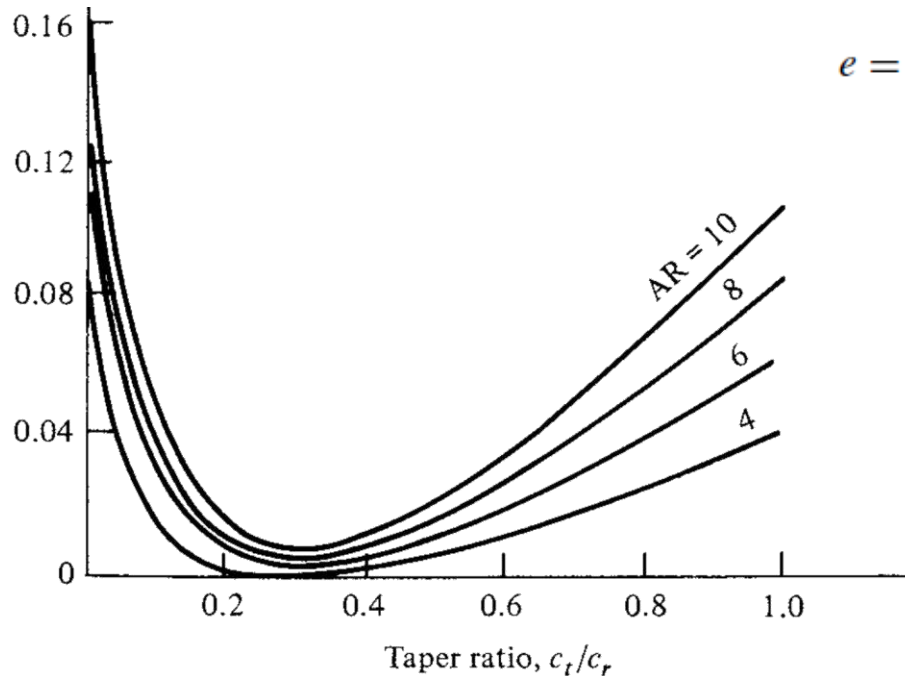

$$e = \frac{1}{1 + \delta} = \frac{1}{1 + 0.01} = 0.99$$

- Assuming  $\tau = \delta$ ,

$$a = \frac{a_0}{1 + \left(\frac{a_0}{\pi AR}\right)(1 + \tau)} = 5.08 \text{ per rad} \\ 0.0887 \text{ per degree}$$

- For the linear lift curve for the finite wing

$$C_L = a(\alpha - \alpha_{L=0})$$

- For  $\alpha = 4^\circ$ , we have

$$C_L = 0.0887[4 - (-1)] = 0.0887(5)$$

$$C_L = 0.443$$





## Example 5.4

- The drag coefficient is given by  $C_D = c_d + \frac{C_L^2}{\pi eAR}$
- We need  $c_l$  for  $c_d$ .
- We need  $\alpha_i$  for  $c_l$ .

- we will assume an elliptical lift distribution over the wing.

$$\alpha_i = \frac{C_L}{\pi AR} = \frac{(0.443)}{\pi(7.61)} = 0.0185 \text{ rad} \\ = 1.06^\circ$$

$$\alpha_{\text{eff}} = \alpha - \alpha_i = 4^\circ - 1.06^\circ = 2.94^\circ \approx 3^\circ$$

$$c_l = a_0(\alpha_{\text{eff}} - \alpha_{L=0}) \\ = 0.113[3 - (-1)] = 0.113(4) = 0.452$$

- Taking the data at the highest Reynolds number shown, for  $c_l = 0.452$ , we have  $c_d = 0.0065$

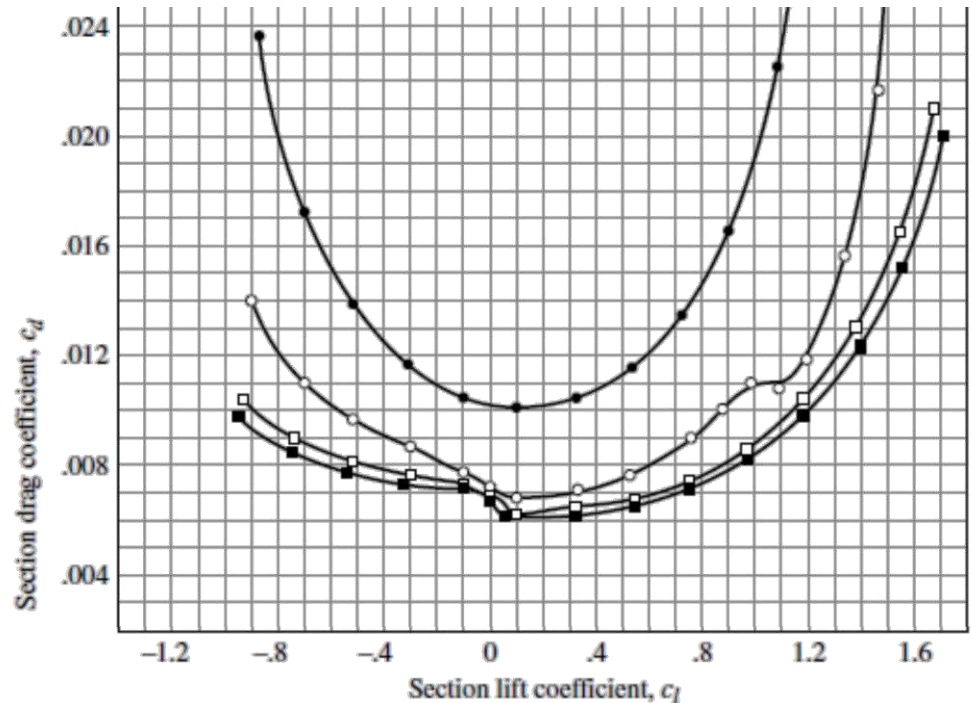



## Example 5.4

- Returning to Equation

$$C_D = c_d + \frac{C_L^2}{\pi eAR}$$
$$= 0.0065 + \frac{(0.443)^2}{\pi(0.99)(7.61)} = 0.0148$$

- The lift coefficient for the finite wing is 0.443 compared to the airfoil value of 0.54.
- 18% lower than the airfoil value - **a substantial difference.**
- The drag coefficient for the finite wing is 0.0148 compared to the airfoil value of 0.0068.
- More than a factor of two larger - **a dramatic difference.**





## A numerical nonlinear lifting-line method

- The classical theory is essentially closed form; that is, the results are analytical equations.
- However, the elements of the lifting-line theory lend themselves to a straightforward purely numerical solution which allows the treatment of nonlinear effects.
- Consider the most general case of a finite wing of given planform and geometric twist, with different airfoil sections at different spanwise stations.
- Assume that we have experimental data for the lift curves of the airfoil sections, including the nonlinear regime
- A numerical iterative solution for the finite-wing properties can be obtained as follows:





## A numerical nonlinear lifting-line method

1. Divide the wing into a number of spanwise stations, here  $k + 1$  stations are shown, with  $n$  designating any specific station.

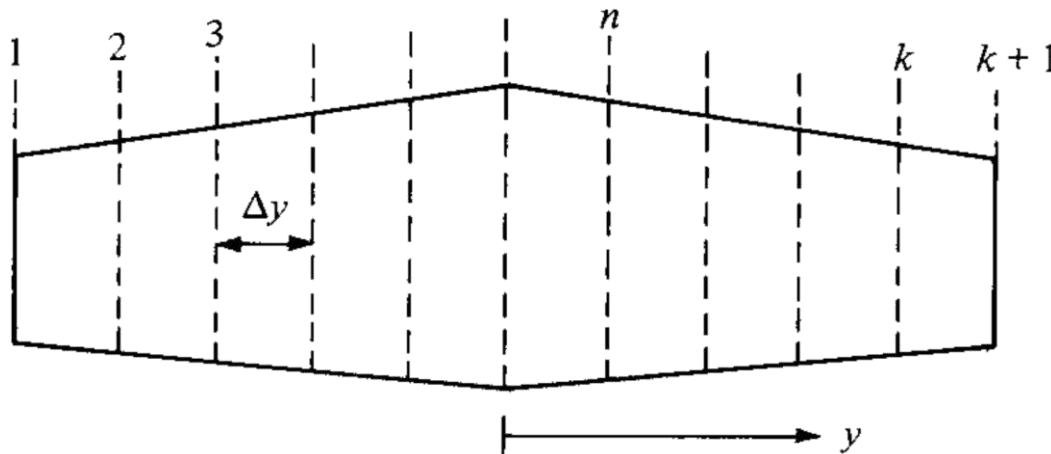

2. For the given wing at a given  $\alpha$ , *assume* the lift distribution along the span; that is, assume values for at all the stations  $1, 2, \dots, n, \dots, k+1$ .

An elliptical lift distribution is satisfactory for such an assumed distribution.





## A numerical nonlinear lifting-line method

3. With this assumed variation of  $\Gamma$ , calculate the induced angle of attack  $\alpha_i$  at each of the stations:

$$\alpha_i(y_n) = \frac{1}{4\pi V_\infty} \int_{-b/2}^{b/2} \frac{(d\Gamma/dy) dy}{y_n - y} \quad \text{Simpson's rule}$$

$$\alpha_i(y_n) = \frac{1}{4\pi V_\infty} \frac{\Delta y}{3} \sum_{j=2,4,6}^k \frac{(d\Gamma/dy)_{j-1}}{(y_n - y_{j-1})} + 4 \frac{(d\Gamma/dy)_j}{y_n - y_j} + \frac{(d\Gamma/dy)_{j+1}}{y_n - y_{j+1}}$$

4. Using  $\alpha_i$  from step 3, obtain the effective angle of attack  $\alpha_{\text{eff}}$  at each station from

$$\alpha_{\text{eff}}(y_n) = \alpha - \alpha_i(y_n)$$

5. With the distribution of  $\alpha_{\text{eff}}$  calculated from step 4, obtain the section lift coefficient  $(c_l)_n$  at each station. These values are read from the known lift curve (experimental data) for the airfoil.







## A numerical nonlinear lifting-line method

6. From  $(c_l)_n$  obtained in step 5, a *new* circulation distribution is calculated from the Kutta-Joukowski theorem and the definition of lift coefficient:

$$L'(y_n) = \rho_\infty V_\infty \Gamma(y_n) = \frac{1}{2} \rho_\infty V_\infty^2 c_n (c_l)_n$$

$$\Gamma(y_n) = \frac{1}{2} V_\infty c_n (c_l)_n$$

where  $c_n$  is the local section chord. Keep in mind that in all the above steps,  $n$  ranges from 1 to  $k + 1$ .

7. The new distribution of  $\Gamma$  obtained in step 6 is compared with the values that were initially fed into step 3.

If the results from step 6 do not agree with the input to step 3, then a new input is generated.

If the previous input to step 3 is designated as  $\Gamma_{\text{old}}$  and the result of step 6 is designated as  $\Gamma_{\text{new}}$ ,





## A numerical nonlinear lifting-line method

$$\Gamma_{\text{input}} = \Gamma_{\text{old}} + D(\Gamma_{\text{new}} - \Gamma_{\text{old}})$$

where  $D$  is a damping factor for the iterations.

Experience has found that the iterative procedure requires heavy damping, with typical values of  $D$  on the order of 0.05.

8. Steps 3 to 7 are repeated a sufficient number of cycles until  $\Gamma_{\text{new}}$  and  $\Gamma_{\text{old}}$  agree at each spanwise station to within acceptable accuracy.
9. From the converged  $\Gamma(y)$ , the lift and induced drag coefficients are obtained. The integrations in these equations can again be carried out by Simpson's rule.





## The lifting-surface theory and the vortex-lattice numerical method

- Prandtl's classical lifting-line theory gives reasonable results for straight wings at moderate to high aspect ratio.
- However, for low-aspect-ratio straight wings, swept wings, and delta wings, classical lifting-line theory is inappropriate.
- For such planforms, a more sophisticated model must be used.

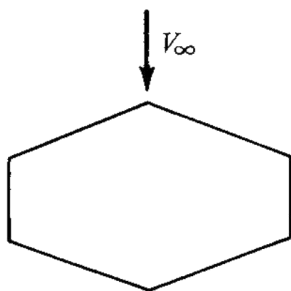

Low aspect ratio  
straight wing

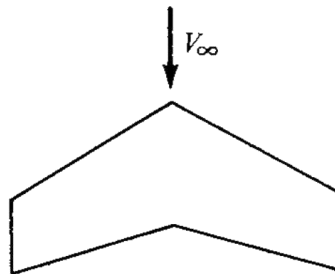

Swept wing

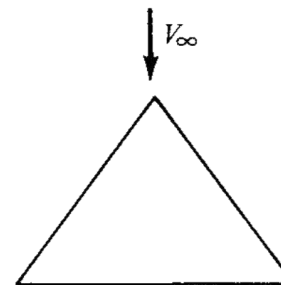

Delta wing





## The lifting-surface theory and the vortex-lattice numerical method

- Let us place a *series* of lifting lines on the plane of the wing, at different chordwise stations.
- That is, consider a large number of lifting lines all parallel to the  $y$  axis, located at different values of  $x$ .
- In the limit of an infinite number of lines of infinitesimal strength, we obtain a vortex sheet, where the vortex lines run parallel to the  $y$  axis.
- The strength of this sheet (per unit length in the  $x$  direction) is denoted by  $\gamma = \gamma(x, y)$ .

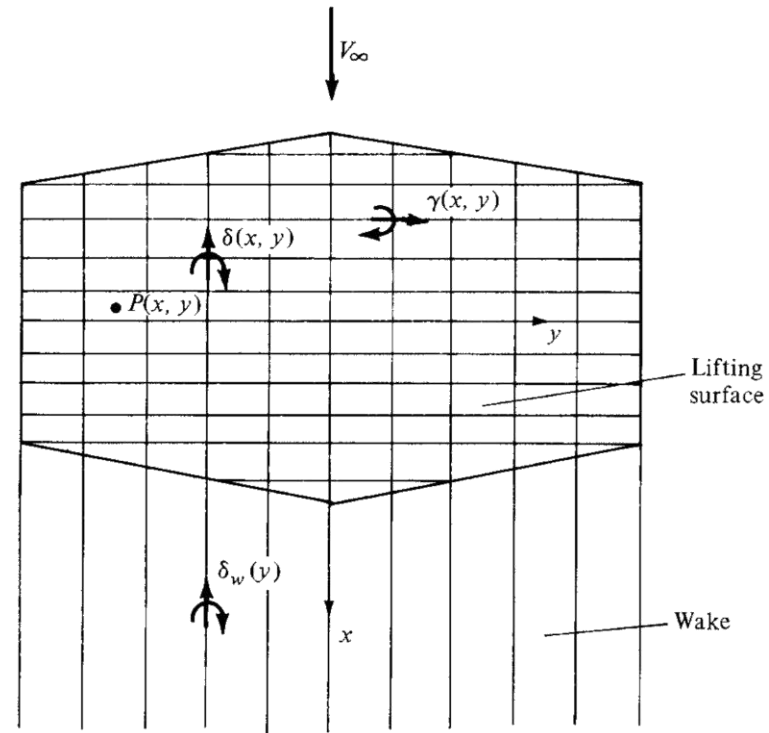



## The lifting-surface theory and the vortex-lattice numerical method

- In addition, recall that each lifting line has a system of trailing vortices.
- Hence, the series of lifting lines is crossed by a series of superimposed trailing vortices parallel to the  $x$  axis.
- In the limit of an infinite number of infinitesimally weak vortices, these trailing vortices form another vortex sheet of strength  $\delta$  (per unit length in the  $y$  direction),  $\delta = \delta(x, y)$ .
- The two vortex sheets—the one with vortex lines running parallel to  $y$  with strength  $\gamma$  and the other with vortex lines running parallel to  $x$  with strength  $\delta$  result in a *lifting surface* distributed over the entire planform of the wing,





## The lifting-surface theory and the vortex-lattice numerical method

- Note that downstream of the trailing edge we have no spanwise vortex lines, only trailing vortices.
- Hence, the wake consists of only chordwise vortices.
- The strength of this wake vortex sheet is given by  $\delta_w = \delta_w(y)$ .

- Consider point  $P$  located at  $(x, y)$  on the wing. The lifting surface and the wake vortex sheet both induce a normal component of velocity at point  $P$ .
- Denote this normal velocity by  $w(x, y)$ .
- Keep in mind that we are treating the wing as a flat surface in this discussion.

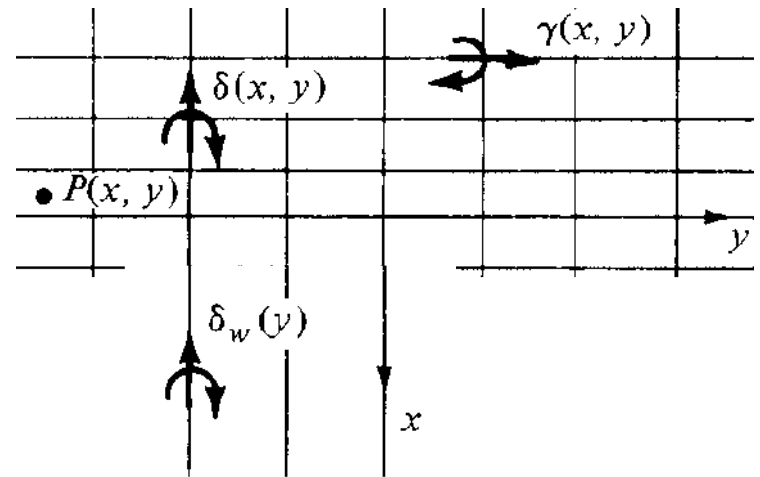



## The lifting-surface theory and the vortex-lattice numerical method

- We want the wing planform to be a stream surface of the flow.
- That is, we want the sum of the induced  $w(x, y)$  and the normal component of the freestream velocity to be zero at point  $P$  and for all points on the wing.
- This is the flow-tangency condition on the wing surface.
- The central theme of lifting-surface theory is to find  $\gamma(x, y)$  and  $\delta(x, y)$  such that the flow-tangency condition is satisfied at all points on the wing.
- Let us obtain an expression for the induced normal velocity  $w(x, y)$  in terms of  $\gamma$ ,  $\delta$ , and  $\delta_w$ .





## The lifting-surface theory and the vortex-lattice numerical method

- Consider the sketch given in Figure.
- Consider the point given by the coordinates  $(\xi, \eta)$ . At this point, the spanwise vortex strength is  $\gamma(\xi, \eta)$ .
- Consider a thin ribbon, or filament, of the spanwise vortex sheet of incremental lengths.
- From the Biot-Savart law, the incremental velocity induced at  $P$  due to  $\gamma$

$$|d\mathbf{V}| = \left| \frac{\Gamma}{4\pi} \frac{d\mathbf{l} \times \mathbf{x}}{|\mathbf{r}|^3} \right| = \frac{\gamma d\xi}{4\pi} \frac{(d\eta)r \sin\theta}{r^3}$$

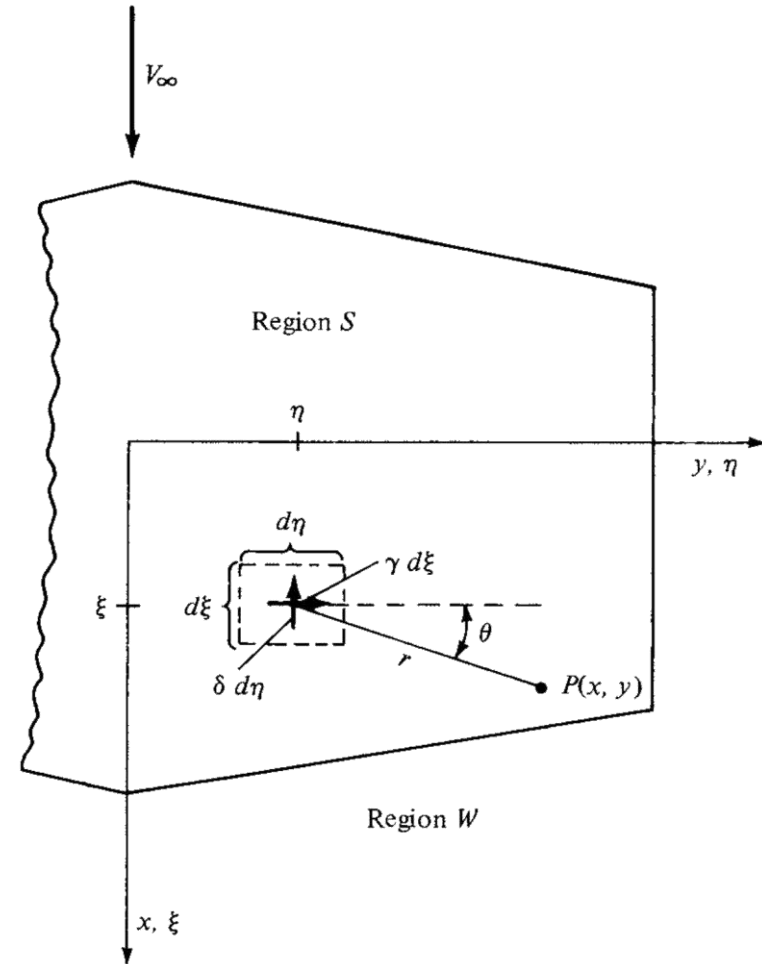





## The lifting-surface theory and the vortex-lattice numerical method

- The induced velocity  $w$  as  $(dw)_\gamma = -|\mathbf{dV}| \sin \theta = (x - \xi)/r$

$$(dw)_\gamma = -\frac{\gamma}{4\pi} \frac{(x - \xi) d\xi d\eta}{r^3}$$

- The incremental velocity induced at  $P$  due to  $\delta$

$$(dw)_\delta = -\frac{\delta}{4\pi} \frac{(y - \eta) d\xi d\eta}{r^3}$$

- The incremental velocity induced at  $P$  due to  $\delta_w$

$$(dw)_\delta = -\frac{\delta_w}{4\pi} \frac{(y - \eta) d\xi d\eta}{r^3}$$

- the normal velocity induced at  $P$  by both the lifting surface and the wake is

$$w(x, y) = -\frac{1}{4\pi} \iint_S \frac{(x - \xi)\gamma(\xi, \eta) + (y - \eta)\delta(\xi, \eta)}{[(x - \xi)^2 + (y - \eta)^2]^{3/2}} d\xi d\eta$$
$$r = \sqrt{(x - \xi)^2 + (y - \eta)^2}$$
$$-\frac{1}{4\pi} \iint_W \frac{(y - \eta)\delta_w(\xi, \eta)}{[(x - \xi)^2 + (y - \eta)^2]^{3/2}} d\xi d\eta$$





## The lifting-surface theory and the vortex-lattice numerical method

- The advent of the high-speed digital computer/[codes](#) has made possible the implementation of numerical solutions based on the lifting-surface concept.

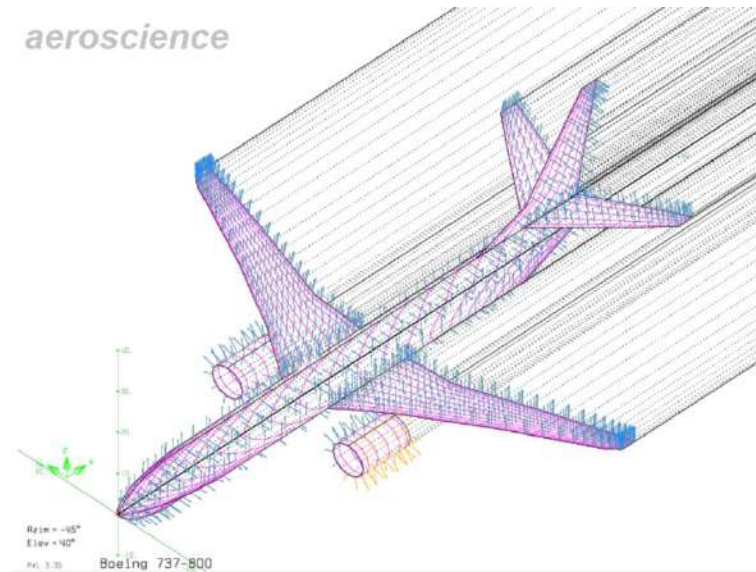



## Design box

- The lift slope for a high-aspect-ratio straight wing with an elliptical lift distribution is predicted by Prandtl's lifting-line theory and is given by

$$a = \frac{a_0}{1 + a_0/\pi AR} \quad AR > 4,$$

- The German aerodynamicist H. B. Helmbold in 1942 modified Equation to obtain the following form applicable to low-aspect-ratio straight wings:

$$a = \frac{a_0}{\sqrt{1 + (a_0/\pi AR)^2} + a_0/(\pi AR)} \quad AR < 4$$

- For swept wings, Kuchemann suggests the following modification to Helmbold's equation:

$$a = \frac{a_0 \cos \Lambda}{\sqrt{1 + [(a_0 \cos \Lambda)/(\pi AR)]^2} + (a_0 \cos \Lambda)/(\pi AR)}$$

where  $\Lambda$  is the sweep angle of the wing, referenced to the half-chord line





## Applied aerodynamics: the delta wing

- A special case of swept wings is those aircraft with a triangular planform, called delta wings.
- Indeed, there are several variants of the basic delta wing used on modern aircraft;

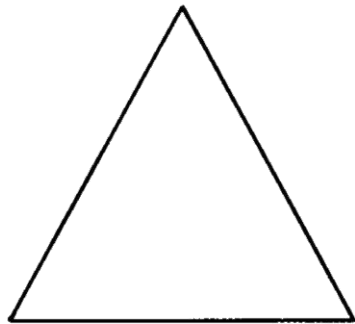

(a) Simple delta

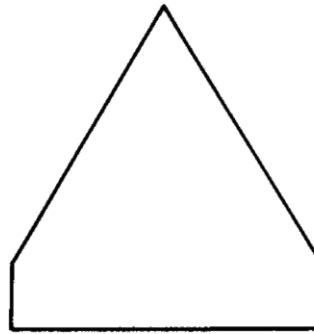

(b) Cropped delta

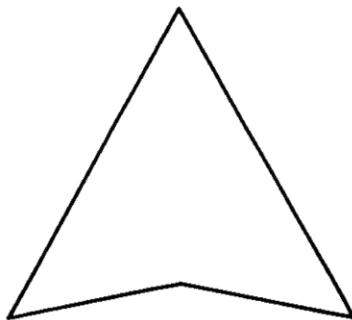

(c) Notched delta

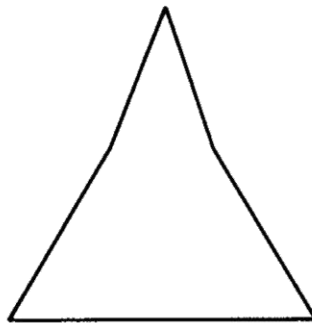

(d) Double delta



The Convair F-102A

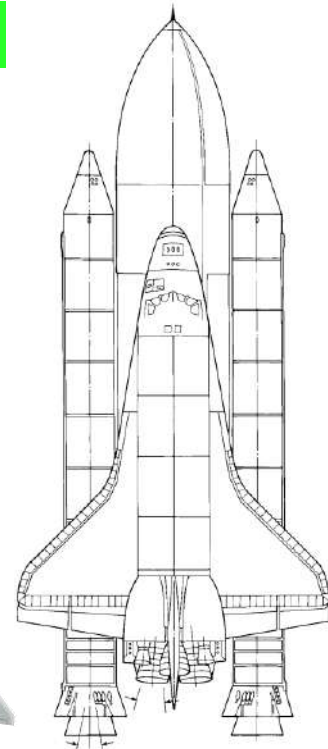

The space shuttle

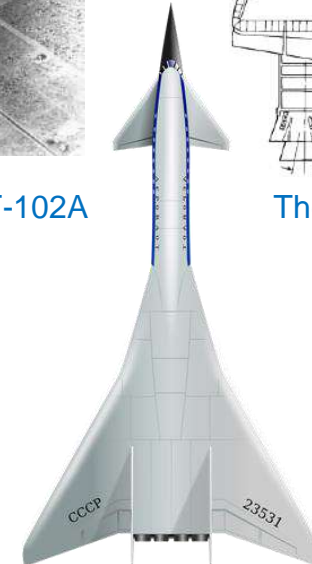



## Applied aerodynamics: the delta wing

- The subsonic flow pattern over the top of a delta wing at angle of attack is sketched in Figure.
- The vortex formation is because of pressure difference between upper and lower surface of wing.

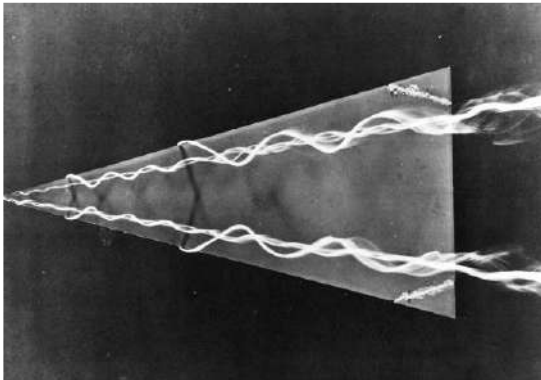

Flow [visualization](#)

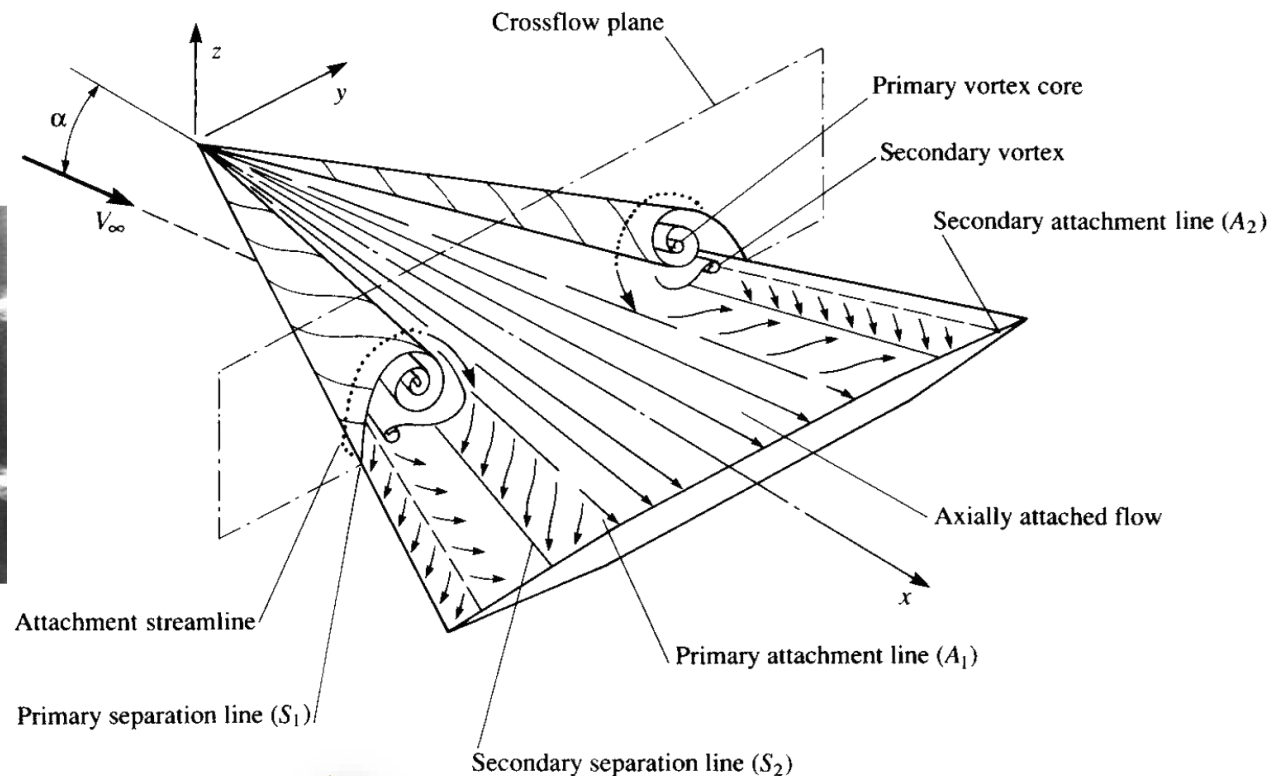



## Applied aerodynamics: the delta wing

- Vortex formation generates pressure drop on the upper surface, especially near the leading edge and reasonably constant over the middle of the wing..

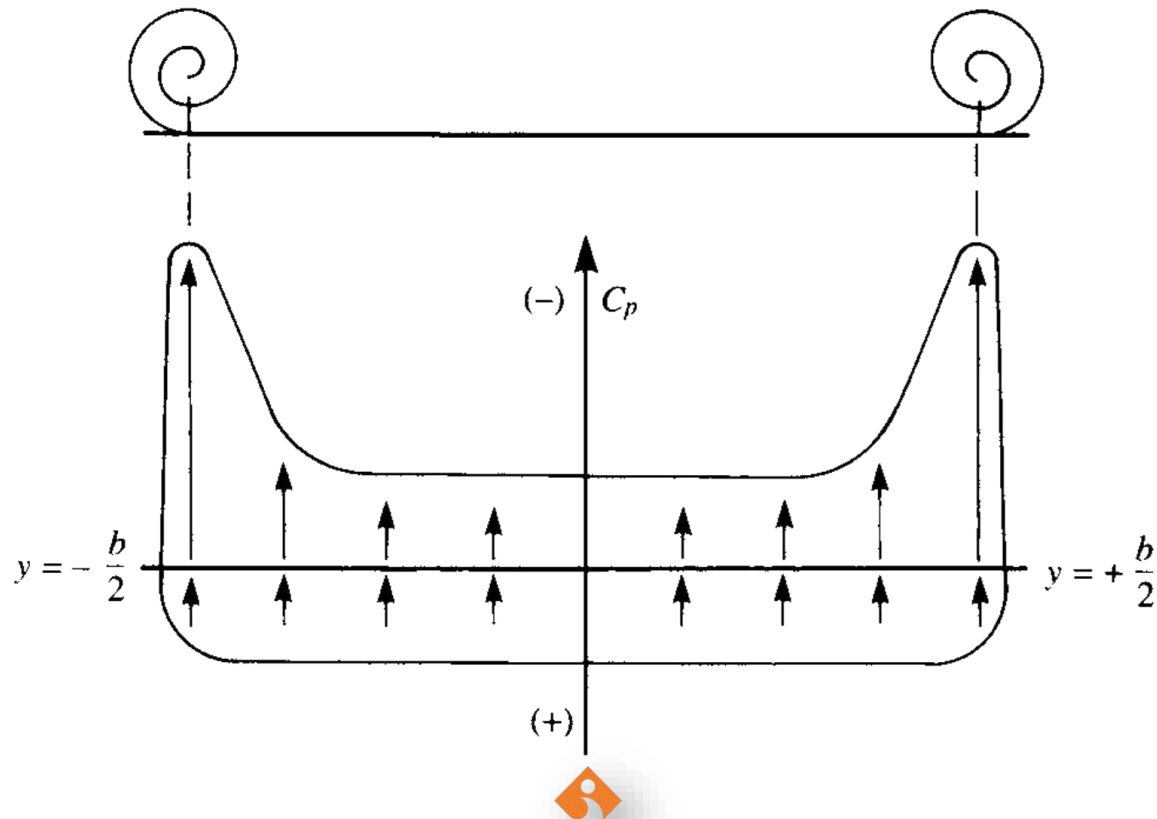



## Applied aerodynamics: the delta wing

- The suction effect of the leading-edge vortices enhances the lift.
- For this reason, the lift coefficient curve for a delta wing exhibits an increase in  $C_L$  for values of  $\alpha$  at which conventional wing planforms would be stalled.
- A typical variation of  $C_L$  with  $\alpha$  for a  $60^\circ$  delta wing is shown in Figure.
- The lift slope is small, the stalling angle of attack is on the order of  $35^\circ$ .
- However, the aerodynamic effect of these vortices is not necessarily advantageous.
- In fact, the lift-to-drag ratio  $L/D$  for a delta planform is not so high as conventional wings.

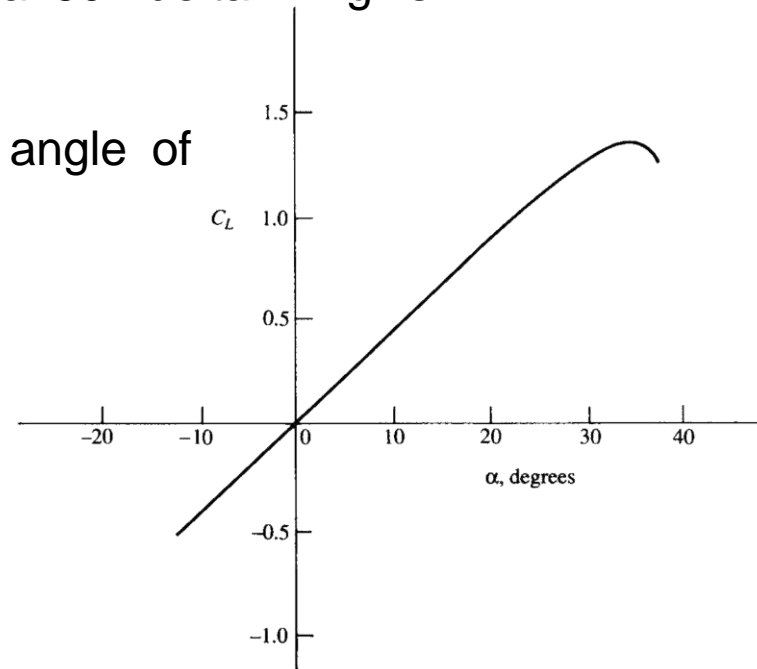



## Historical note: Ludwig Prandtl - the man

- Ludwig Prandtl was born on February 4, 1874, in Freising, Bavaria/Germany.
- In his childhood, his father, a great lover of nature, induced Ludwig to observe natural phenomena and to reflect on them.



Ludwig: 4 years



6 years

- His Ph.D. thesis at Munich was in solid mechanics, dealing with unstable elastic equilibrium in which bending and distortion acted together.
- Prandtl's contributions in fluid mechanics had begun as an engineer in the Maschinenfabrick Augsburg.
- In 1904, Prandtl delivered his famous paper on the concept of the boundary layer to the Third Congress on Mathematicians at Heidelberg.

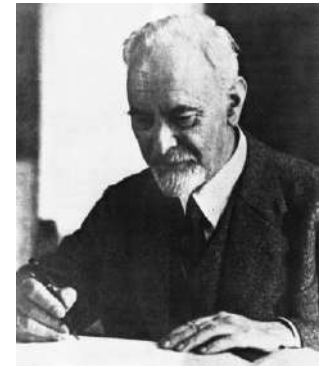





## Historical note: Ludwig Prandtl - the man

- Prandtl's Heidelberg paper established the basis for most modern calculations of skin friction, heat transfer, and flow separation.
- Later that year, he moved to the prestigious University of Göttingen to become Director of the Institute for Technical Physics, (1904-1953).



Prandtl's water tunnel, 1902.

- Prandtl spent the remainder of his life at Göttingen, building his laboratory into the world's greatest aerodynamic research center of the 1904–1930 time period.
- At Göttingen, during 1905–1908 Prandtl carried out numerous experiments on supersonic flow through nozzles and developed oblique shock- and expansion wave theory.





## Historical note: Ludwig Prandtl - the man

- From 1910 to 1920, he devoted most of his efforts to low-speed aerodynamics, principally airfoil and wing theory, developing the famous lifting line theory for finite wings.
- Prandtl remained at Göttingen throughout the turmoil of World War II, engrossed in his work and seemingly insulated from the intense political and physical disruptions.



Prandtl with his *Institut* -personnel

- Prandtl died in 1953 in Göttingen. He was clearly the father of modern aerodynamics - a monumental figure in fluid dynamics. His impact will be felt for centuries to come.



▸ Hsin Cheng, with her husband, and Johanna Vogel-Pra  
Prandtl's grave





## Questions

- 5.1** Consider a vortex filament of strength  $\Gamma$  in the shape of a closed circular loop of radius  $R$ . Obtain an expression for the velocity induced at the center of the loop in terms of  $\Gamma$  and  $R$ .
- 5.2** Consider the same vortex filament as in Problem 5.1. Consider also a straight line through the center of the loop, perpendicular to the plane of the loop. Let  $A$  be the distance along this line, measured from the plane of the loop. Obtain an expression for the velocity at distance  $A$  on the line, as induced by the vortex filament.
- 5.3** The measured lift slope for the NACA 23012 airfoil is  $0.1080 \text{ degree}^{-1}$ , and  $\alpha_{L=0} = -1.3^\circ$ . Consider a finite wing using this airfoil, with  $AR = 8$  and taper ratio = 0.8. Assume that  $\delta = \tau$ . Calculate the lift and induced drag coefficients for this wing at a geometric angle of attack =  $7^\circ$ .





## Questions

- 5.4** The Piper Cherokee (a light, single-engine general aviation aircraft) has a wing area of  $170 \text{ ft}^2$  and a wing span of 32 ft. Its maximum gross weight is 2450 lb. The wing uses an NACA 65-415 airfoil, which has a lift slope of  $0.1033 \text{ degree}^{-1}$  and  $\alpha_{L=0} = -3^\circ$ . Assume  $\tau = 0.12$ . If the airplane is cruising at 120 mi/h at standard sea level at its maximum gross weight and is in straight-and-level flight, calculate the geometric angle of attack of the wing.
- 5.6** Consider a finite wing with an aspect ratio of 6. Assume an elliptical lift distribution. The lift slope for the airfoil section is 0.1/degree. Calculate and compare the lift slopes for (a) a straight wing, and (b) a swept wing, with a half-chord line sweep of 45 degrees.





# *Aerodynamics*

## *AE 301*

Assoc. Prof. Dr. Y . Volkan PEHLİVANOĞLU  
volkan.pehlivanoglu@ieu.edu.tr





## Contents; Three-Dimensional Incompressible Flow

- a. Three-Dimensional Source,
- b. Three-Dimensional Doublet,
- c. Flow over a Sphere,
- d. General Three-Dimensional Flows: Panel Techniques,
- e. Applied Aerodynamics.

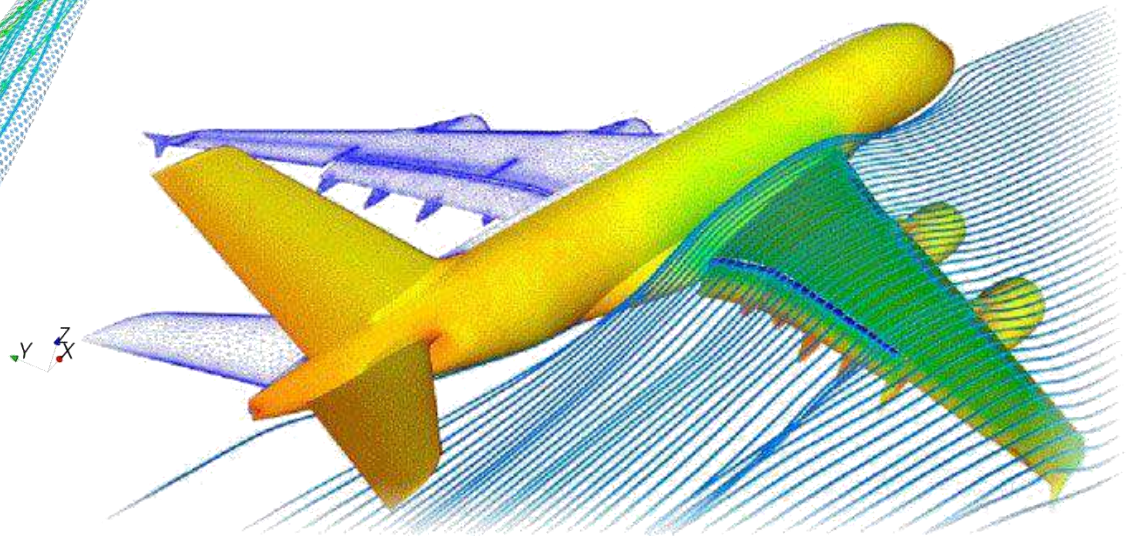
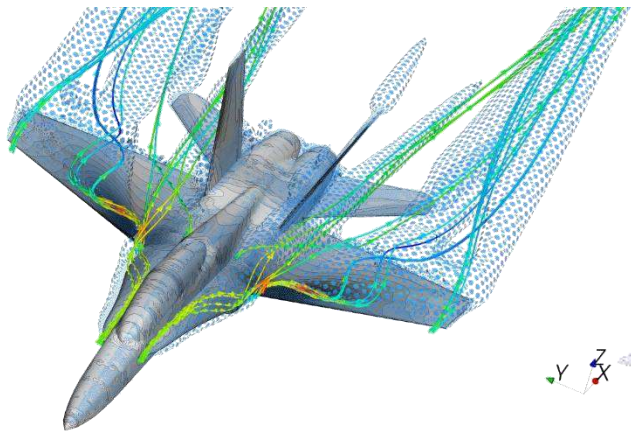



# Nomenclature





## Introduction

- To this point in our aerodynamic discussions, we have been working mainly in a two-dimensional world; so-called planar flows.
- The real world of aerodynamic applications is three-dimensional.
- However, because of the addition of one more independent variable, the analyses generally become more complex.
- The accurate calculation of three-dimensional flow fields has been, and still is, one of the most active areas of aerodynamic research.







## Introduction

- The purpose of this chapter is to introduce some very basic considerations of three-dimensional incompressible flow.
- The governing fluid flow equations have already been developed in three dimensions.
- In particular, if the flow is irrotational,

$$\mathbf{V} = \nabla\phi$$

- If the flow is also incompressible, the velocity potential is given by Laplace's equation:

$$\nabla^2\phi = 0$$

- Solutions of Equation for flow over a body must satisfy the flow-tangency boundary condition on the body, that is,

$$\mathbf{V} \cdot \mathbf{n} = 0$$





## Introduction

- $\mathbf{n}$  is a unit vector normal to the body surface.
- In all of the above equations,  $\phi$  is, in general, a function of three-dimensional space.
- For example, in spherical coordinates  $\phi = \phi(r, \theta, \Phi)$ .
- Let us use these equations to treat some elementary three-dimensional incompressible flows.





## Three-dimensional uniform flow

$$\mathbf{V} = \mathbf{V}_\infty = \text{const.}$$

- Consider the velocity potential given by

$$\phi = \mathbf{V}_\infty \cdot \mathbf{r} = (u_\infty \mathbf{i} + v_\infty \mathbf{j} + w_\infty \mathbf{k}) \cdot (x\mathbf{i} + y\mathbf{j} + z\mathbf{k})$$

- We obtain

$$\begin{aligned}\mathbf{V} &= \nabla \phi \\ &= \nabla (u_\infty x + v_\infty y + w_\infty z) \\ &= u_\infty \mathbf{i} + v_\infty \mathbf{j} + w_\infty \mathbf{k} \\ &= \mathbf{V}_\infty\end{aligned}$$

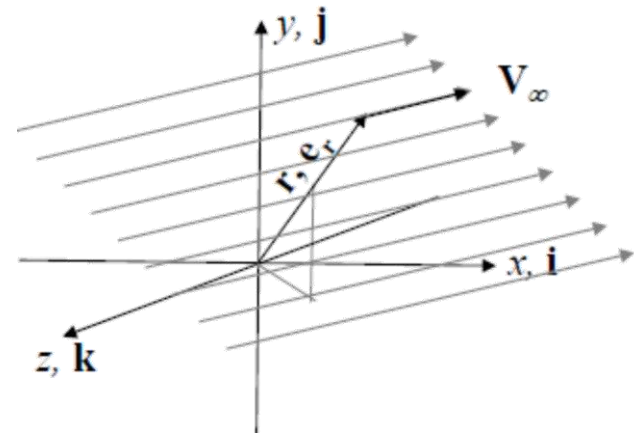



## Three-dimensional source

- Consider the velocity potential given by

$$\phi = -\frac{C}{r}$$

where  $C$  is a constant and  $r$  is the radial coordinate from the origin.

- We obtain  $\mathbf{V} = \nabla\phi = \frac{C}{r^2}\mathbf{e}_r$

- In terms of the velocity components, we have

$$V_r = \frac{C}{r^2}$$

$$V_\theta = 0$$

$$V_\phi = 0$$

- Such a flow is defined as a *three-dimensional source*. Sometimes it is called simply a *point source*

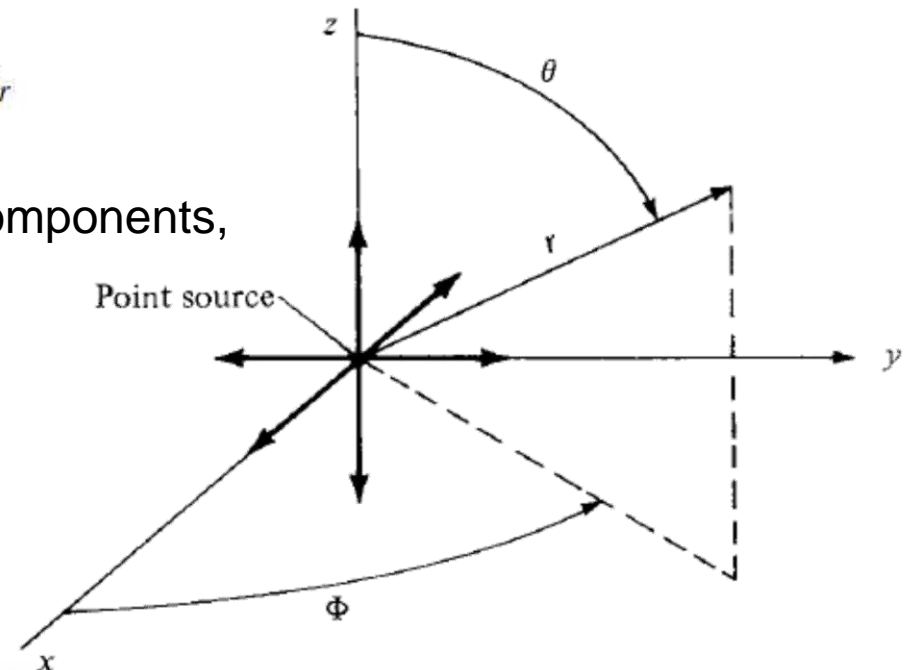



## Three-dimensional source

- To evaluate the constant  $C$ , consider a sphere of radius  $r$  and surface  $S$  centered at the origin.
- The mass flow across the surface of this sphere is

$$\oiint_S \rho \mathbf{V} \cdot d\mathbf{S}$$

- Hence, the *volume* flow, denoted by  $\lambda$ , is  $\lambda = \oiint_S \mathbf{V} \cdot d\mathbf{S}$
- On the surface of the sphere, the velocity is a constant value

$$V_r = C/r^2$$

$$\lambda = \frac{C}{r^2} 4\pi r^2 = 4\pi C$$

- Hence,

$$C = \frac{\lambda}{4\pi}$$

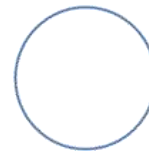

$$2\pi r$$



$$\pi r^2$$

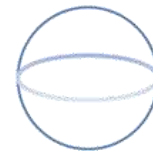

$$4\pi r^2$$



$$\frac{4}{3}\pi r^3$$





## Three-dimensional source

- Substituting Equation, we find

$$V_r = \frac{\lambda}{4\pi r^2}$$

$$\phi = -\frac{\lambda}{4\pi r}$$

- In the above equations,  $\lambda$  is defined as the *strength* of the source.
- When  $\lambda$  is a negative quantity, we have a point sink.





## Three-dimensional doublet

- Consider a sink and source of equal but opposite strength located at points  $O$  and  $A$ .
- The distance between the source and sink is  $l$ .
- Consider an arbitrary point  $P$  located a distance  $r$  from the sink and a distance  $r_1$  from the source.

- The velocity potential at  $P$  is  $\phi = -\frac{\lambda}{4\pi} \left( \frac{1}{r_1} - \frac{1}{r} \right)$

$$\phi = -\frac{\lambda}{4\pi} \frac{r - r_1}{rr_1}$$

- Let  $l \rightarrow 0$  as  $\lambda \rightarrow \infty$

$$l \rightarrow 0, r - r_1 \rightarrow OB = l \cos \theta, \\ rr_1 \rightarrow r^2$$

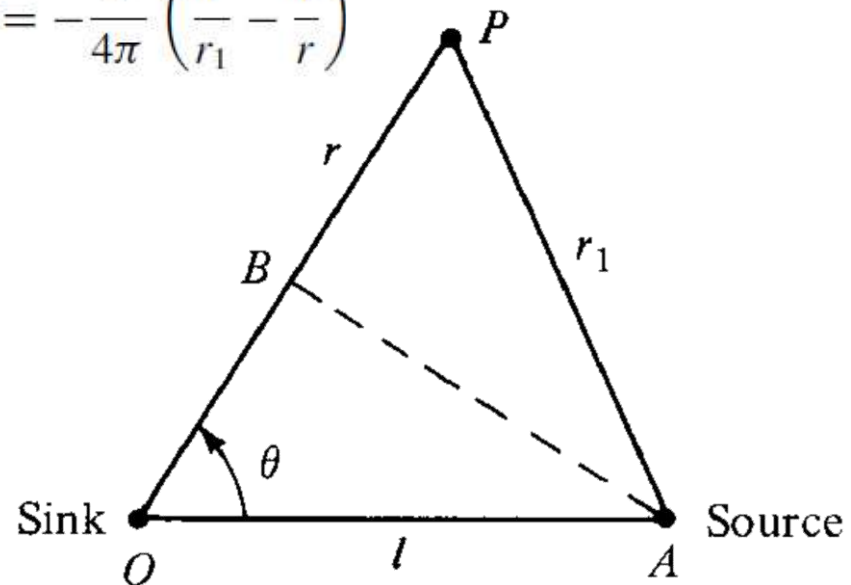



## Three-dimensional doublet

$$\phi = - \lim_{\substack{l \rightarrow 0 \\ \lambda \rightarrow \infty}} \frac{\lambda}{4\pi} \frac{r - r_1}{rr_1} = - \frac{\lambda l \cos \theta}{4\pi r^2} = - \frac{\mu \cos \theta}{4\pi r^2}$$

$$\mu = \Lambda l$$

- The flow field produced by Equation is a *three-dimensional doublet*.
- $\mu$  is defined as the strength of the doublet.
- We find

$$\mathbf{V} = \nabla \phi = \frac{\mu \cos \theta}{2\pi r^3} \mathbf{e}_r + \frac{\mu \sin \theta}{4\pi r^3} \mathbf{e}_\theta + 0 \mathbf{e}_\phi$$

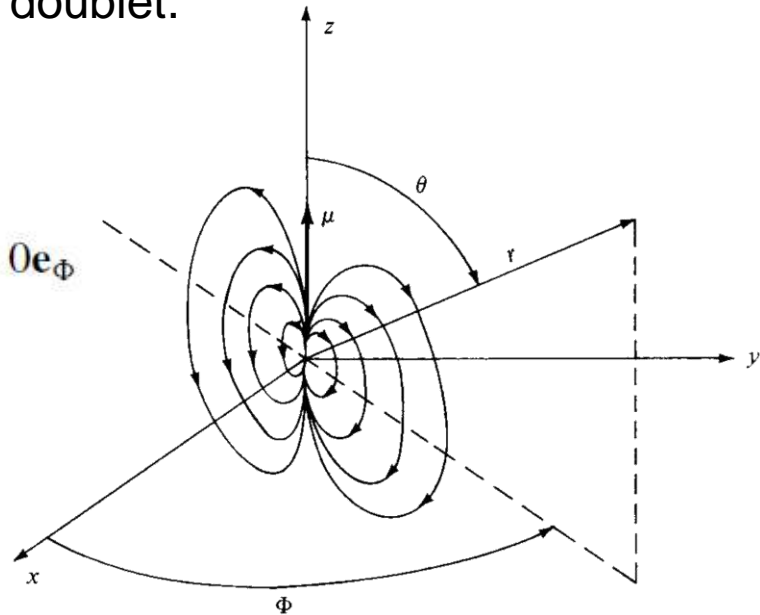





## Flow over a sphere

- Consider again the flow induced by the three-dimensional doublet.
- Superimpose on this flow a uniform velocity field of magnitude  $V_\infty$  in the negative  $z$  direction.
- The spherical coordinates of the freestream are

$$V_r = -V_\infty \cos \theta$$

$$V_\theta = V_\infty \sin \theta$$

$$V_\phi = 0$$

- We obtain, for the combined flow, 
$$V_r = -V_\infty \cos \theta + \frac{\mu \cos \theta}{2\pi r^3} = -\left(V_\infty - \frac{\mu}{2\pi r^3}\right) \cos \theta$$

$$V_\theta = V_\infty \sin \theta + \frac{\mu \sin \theta}{4\pi r^3} = \left(V_\infty + \frac{\mu}{4\pi r^3}\right) \sin \theta$$

$$V_\phi = 0$$

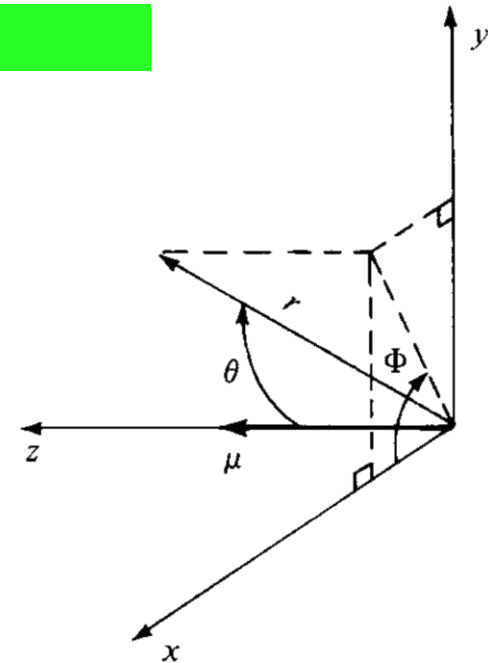
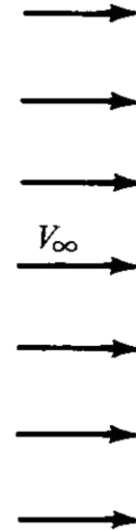



## Flow over a sphere

- To find the stagnation points in the flow, set  $V_r = V_\theta = 0$

$$\sin \theta = 0; \pi.$$

$$V_\infty - \frac{\mu}{2\pi R^3} = 0$$

- We obtain

$$R = \left( \frac{\mu}{2\pi V_\infty} \right)^{1/3}$$

- There are two stagnation points, both on the z axis, with  $(r, \theta)$  coordinates

$$\left[ \left( \frac{\mu}{2\pi V_\infty} \right)^{1/3}, 0 \right] \quad \left[ \left( \frac{\mu}{2\pi V_\infty} \right)^{1/3}, \pi \right]$$





## Flow over a sphere

- Insert the value of  $r = R$  from Equation into the expression for  $V_r$ . We obtain

$$V_r = -(V_\infty - V_\infty) \cos \theta = 0$$

$$R = \left( \frac{\mu}{2\pi V_\infty} \right)^{1/3}$$

$$V_r = - \left( V_\infty - \frac{\mu}{2\pi r^3} \right) \cos \theta$$

- Thus,  $V_r = 0$  when  $r = R$  for *all values* of  $\theta$  and  $\Phi$ .
- This is precisely the flow-tangency condition for flow over a sphere of radius  $R$ .
- Hence, the velocity field is the *incompressible flow over a sphere of radius  $R$* .

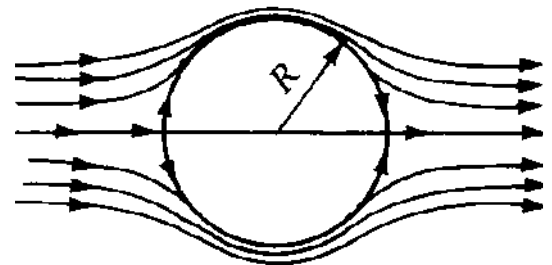
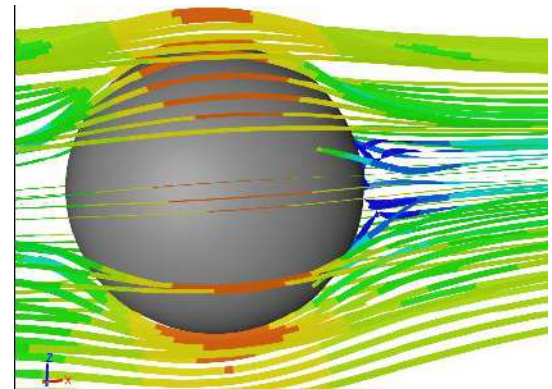



## Flow over a sphere

- On the surface of the sphere, where  $r = R$ , the tangential velocity is obtained from

$$V_{\theta} = \left( V_{\infty} + \frac{\mu}{4\pi R^3} \right) \sin \theta$$

$$R = \left( \frac{\mu}{2\pi V_{\infty}} \right)^{1/3}$$

$$V_{\theta} = \left( V_{\infty} + \frac{1}{4\pi} \frac{2\pi R^3 V_{\infty}}{R^3} \right) \sin \theta$$

$$\mu = 2\pi R^3 V_{\infty}$$

$$V_{\theta} = \frac{3}{2} V_{\infty} \sin \theta$$

- The maximum velocity occurs at the top and bottom points of the sphere, and its magnitude is  $\frac{3}{2} V_{\infty}$
- For the two-dimensional flow, the maximum velocity is  $2V_{\infty}$





## Flow over a sphere

- Hence, for the same  $V_\infty$ , the maximum surface velocity on a sphere is *less* than that for a cylinder.
- The flow over a sphere is somewhat “relieved” in comparison with the flow over a cylinder.
- The flow over a sphere has an extra dimension in which to move out of the way of the solid body.
- The flow can move sideways as well as up and down.
- This is an example of the *three-dimensional relieving effect*, which is a general phenomenon for all types of three-dimensional flows.





## Flow over a sphere

- The pressure distribution on the surface of the sphere is given by

$$C_p = 1 - \left(\frac{V}{V_\infty}\right)^2 = 1 - \left(\frac{3}{2} \sin \theta\right)^2$$

$$C_p = 1 - \frac{9}{4} \sin^2 \theta$$

- The pressure distributions over a sphere and a cylinder are compared in Figure.
- It dramatically illustrates the three-dimensional relieving effect.

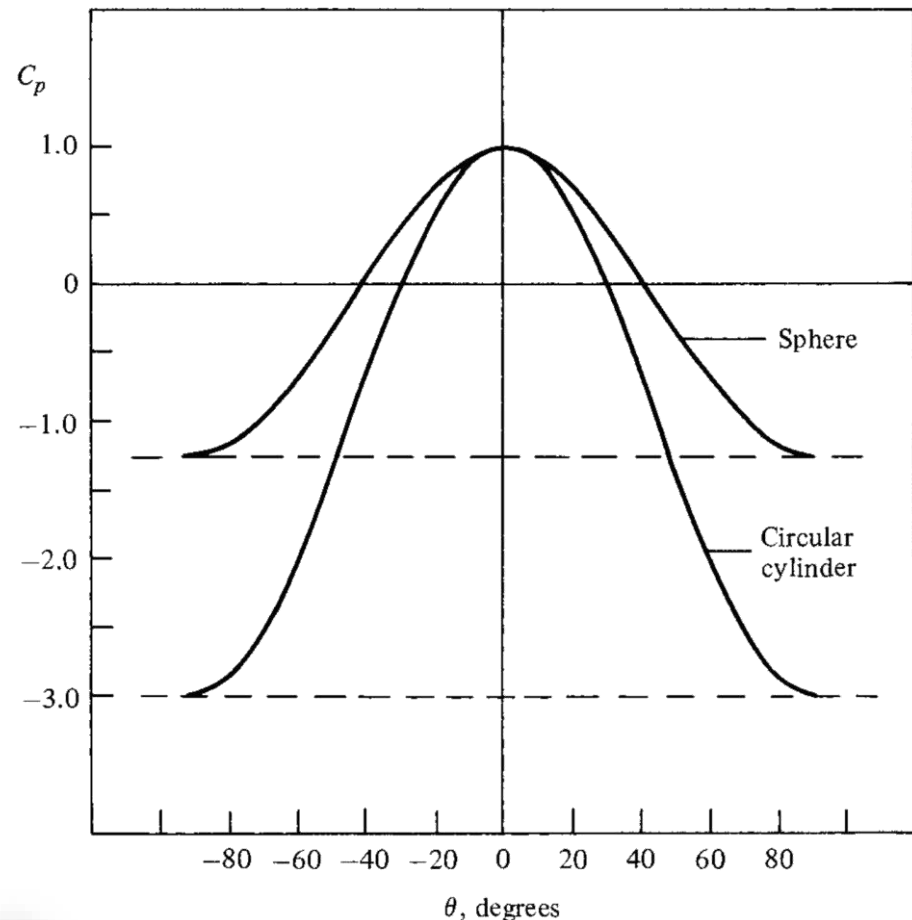



## General three-dimensional flows: panel techniques

- In modern aerodynamic applications, three-dimensional, inviscid, incompressible flows are almost always calculated by means of numerical panel techniques.
- The general idea behind all such panel programs is to cover the three-dimensional body with panels.

- There is an unknown distribution of singularities (such as point sources, doublets, or vortices).
- These unknowns are solved
  - through a system of simultaneous linear algebraic equations,
  - generated by calculating the induced velocity at control points on the panels and applying the flow-tangency condition.

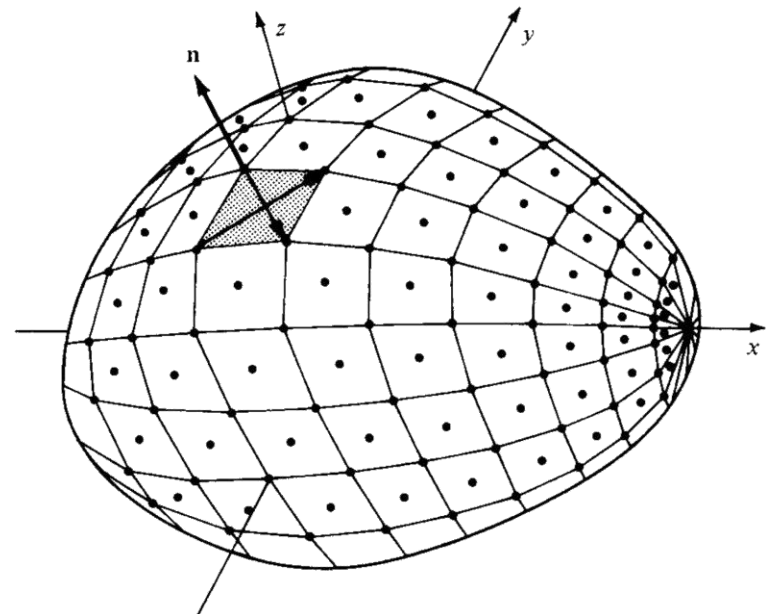



## General three-dimensional flows: panel techniques

- For a nonlifting body, a distribution of source panels is sufficient.
- However, for a lifting body, both source and vortex panels are necessary.

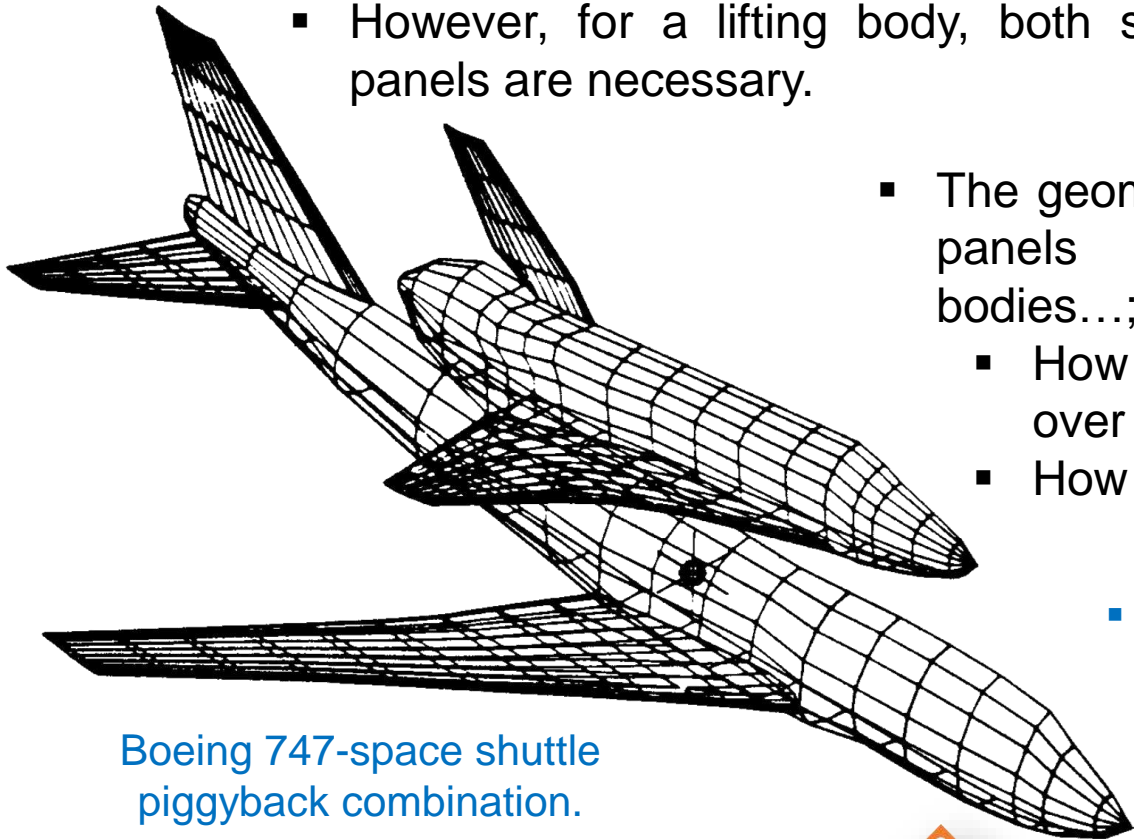

Boeing 747-space shuttle  
piggyback combination.

- The geometric complexity of distributing panels over the three-dimensional bodies...;
  - How do you distribute the panels over the body?
  - How many panels do you use?

- A few months determining the best geometric distribution of panels over a complex body...







## Applied aerodynamics: airplane lift and drag

- A three-dimensional object of primary interest to aerospace engineers is a whole airplane.
- We emphasized that the aerodynamic force on any body moving through the air is due only to two basic sources, the pressure and shear stress distributions exerted over the body surface.
- Lift is primarily created by the pressure distribution; shear stress has only a minor effect on lift.
- Inviscid flow has given us reasonable predictions of the lift on airfoils, and finite wings.
- Drag, on the other hand, is created by both the pressure and shear stress distributions, and analyses based on just inviscid flow are not sufficient for the prediction of drag.





## Applied aerodynamics: airplane lift and drag

### Airplane Lift

- Lift is produced by the fuselage of an airplane as well as the wing.
- Of course, other components of the airplane such as a horizontal tail, canard surfaces, and wing strakes can contribute to the lift, either in a positive or negative sense.
- We emphasize that reasonably accurate predictions of lift on a complete airplane can come only from
  - wind tunnel tests,
  - detailed computational fluid dynamic calculations (such as the panel calculations),
  - and, of course, from actual flight tests of the airplane.





## Applied aerodynamics: airplane lift and drag

### Airplane Lift

- For subsonic speeds, however, data obtained using different fuselage thicknesses,  $d$ , mounted on wings with different spans,  $b$ , show that the total lift for a wing-body combination is essentially constant for  $d/b$  ranging from 0 to 6.
- Hence, the lift of the wing-body combination can be treated as simply the lift on the complete wing by itself, including that portion of the wing that is masked by the fuselage.

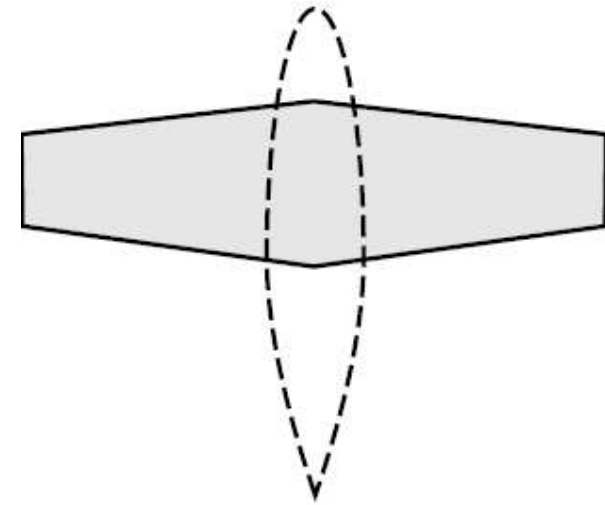

About the same as the lift on the wing of planform area  $S$ , which includes that part of the wing masked by the fuselage





## Applied aerodynamics: airplane lift and drag

### Airplane Drag

- It is important to produce this lift as *efficiently as possible*, that is, with as little drag as possible.
- The ratio of lift to drag,  $L/D$ , is a good measure of aerodynamic efficiency.
- As in the case of lift, the drag of an airplane can *not* be obtained as the simple sum of the drag on each component.
- For example, for a wing-body combination, the drag is usually higher than the sum of the separate drag forces on the wing and the body, giving rise to an extra drag component called interference drag.





## Applied aerodynamics: airplane lift and drag

### Airplane Drag

- For a finite wing; 
$$C_D = c_d + \frac{C_L^2}{\pi e AR}$$
- $C_D$  is the total drag coefficient for a finite wing,
- $c_d$  is the profile drag coefficient caused by skin friction and pressure drag due to flow separation,
- and the induced drag coefficient with the span efficiency factor  $e$ .





## Applied aerodynamics: airplane lift and drag

### Airplane Drag

- For the whole airplane,  $C_D = C_{D,e} + \frac{C_L^2}{\pi eAR}$
- $C_D$  is the total drag coefficient for the airplane.
- $C_{D,e}$  is defined as the *parasite drag coefficient*.
- It contains not only the profile drag of the wing [ $c_d$ ] but also the friction and pressure drag of the other surfaces.
- Such as tail surfaces, fuselage, engine nacelles, landing gear, and any other component of the airplane that is exposed to the airflow.





## Applied aerodynamics: airplane lift and drag

### Airplane Drag

- We think that as the angle of attack is varied,  $C_{D,e}$  will change with angle of attack.
- Because the lift coefficient,  $C_L$ , is a specific function of angle of attack, we can consider that  $C_{D,e}$  is a function of  $C_L$ .
- A reasonable approximation for this function is

$$C_{D,e} = C_{D,o} + rC_L^2$$

where  $r$  is an empirically determined constant.

- Since at zero lift,  $C_L = 0$ , then Equation defines  $C_{D,o}$  as the parasite drag coefficient at zero lift, or more commonly, the *zero-lift drag coefficient*.





## Applied aerodynamics: airplane lift and drag

### Airplane Drag

- We can rewrite Equation as  $C_D = C_{D,o} + \left(r + \frac{1}{\pi e AR}\right) C_L^2$
- It is similar to a finite wing drag expression.
- We can redefine  $e$  as Oswald efficiency factor ( $e$  is span efficiency factor) and rewrite the equation

the drag polar for  
the airplane

$$C_D = C_{D,o} + \frac{C_L^2}{\pi e AR} \quad e = \left(r\pi AR + \frac{1}{e}\right)$$

- $e$  the Oswald efficiency factor is for a complete airplane.
- the Oswald efficiency factor for different airplanes typically varies between 0.7 and 0.85 whereas the span efficiency factor typically varies between 0.9 and at most 1.0.







## Applied aerodynamics: airplane lift and drag

### Airplane Drag

- Daniel Raymer gives the following empirical expression for the Oswald efficiency factor for straight-wing aircraft, based on data obtained from actual airplanes:

$$e = 1.78 (1 - 0.045 AR^{0.68}) - 0.64 \quad AR < 25$$





## Applied aerodynamics: airplane lift and drag

### Airplane Lift-to-Drag Ratio

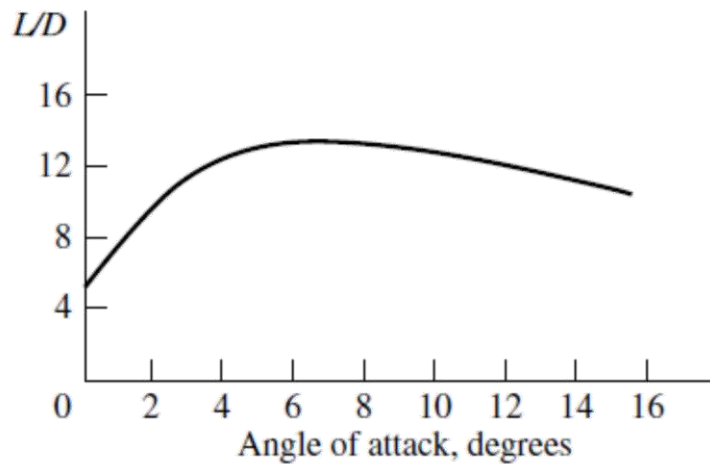

- Note that  $C_L / C_D$  first increases as  $\alpha$  increases, reaches a maximum value at a certain value of  $\alpha$ , and then subsequently decreases as  $\alpha$  increases further.

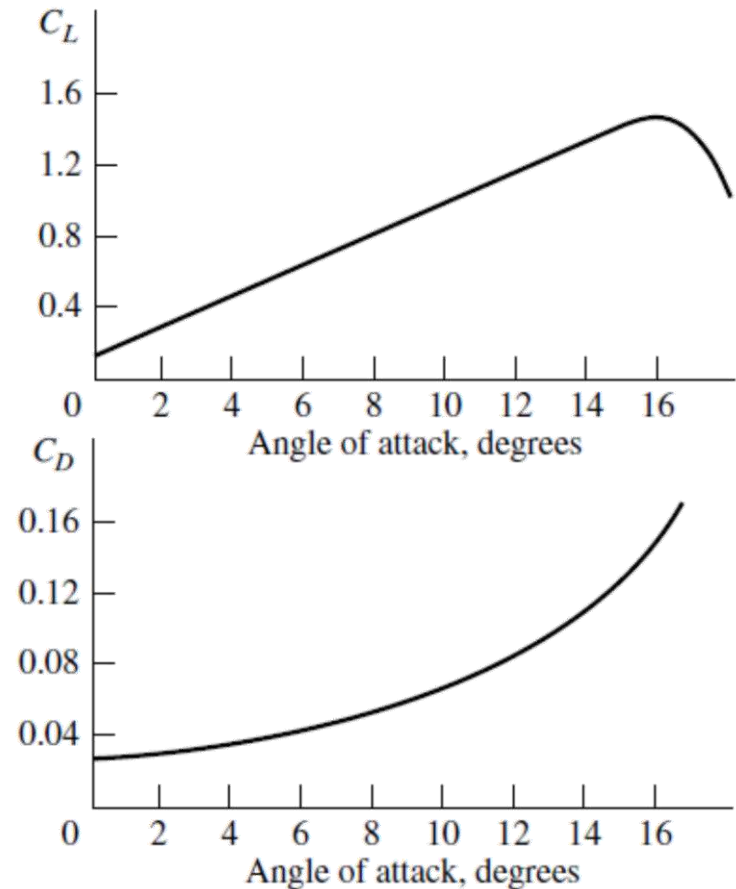



## Applied aerodynamics: airplane lift and drag

### Airplane Lift-to-Drag Ratio

- The maximum lift-to-drag ratio,  $(L/D)_{\max} = (C_L/C_D)_{\max}$ , is a direct measure of the aerodynamic efficiency of the airplane.
- Therefore, its value is of great importance in airplane design.

- Let us see (extremum point) 
$$\frac{C_L}{C_D} = \frac{C_L}{C_{D,o} + C_L^2/(\pi eAR)}$$
$$\frac{d(C_L/C_D)}{dC_L} = \frac{C_{D,o} + \frac{C_L^2}{\pi eAR} - C_L[2C_L/(\pi eAR)]}{[C_{D,o} + C_L^2/(\pi eAR)]^2} = 0$$

$$C_{D,o} + \frac{C_L^2}{\pi eAR} - \frac{2C_L^2}{\pi eAR} = 0 \quad C_{D,o} = \frac{C_L^2}{\pi eAR}$$





## Applied aerodynamics: airplane lift and drag

### Airplane Lift-to-Drag Ratio

$$C_{D,o} = \frac{C_L^2}{\pi eAR}$$

- Equation is an interesting intermediate result.
- It states that when the airplane is flying at the specific angle of attack where the lift-to-drag ratio is maximum, the zero-lift drag and the drag due to lift are precisely equal.
- Solving Equation for  $C_L$ , we have  $C_L = \sqrt{\pi eAR C_{D,o}}$
- We obtain for the maximum lift-to-drag ratio

$$\left(\frac{C_L}{C_D}\right)_{\max} = \frac{(\pi eAR C_{D,o})^{1/2}}{C_{D,o} + \frac{\pi eAR C_{D,o}}{\pi eAR}} \quad \text{or,} \quad \left(\frac{C_L}{C_D}\right)_{\max} = \frac{(\pi eAR C_{D,o})^{1/2}}{2C_{D,o}}$$





## Questions

- 6.1** Prove that three-dimensional source flow is irrotational.
- 6.2** Prove that three-dimensional source flow is a physically possible incompressible flow.
- 6.3** A sphere and a circular cylinder (with its axis perpendicular to the flow) are mounted in the same freestream. A pressure tap exists at the top of the sphere, and this is connected via a tube to one side of a manometer. The other side of the manometer is connected to a pressure tap on the surface of the cylinder. This tap is located on the cylindrical surface such that no deflection of the manometer fluid takes place. Calculate the location of this tap.

