

See discussions, stats, and author profiles for this publication at: <https://www.researchgate.net/publication/363410495>

Industrial Fluid Power (Hydraulics and Pneumatics) Part 1

Presentation · September 2022

CITATIONS

0

READS

3,063

1 author:



[Abhishek D. Patange](#)

College of Engineering, Pune

99 PUBLICATIONS 466 CITATIONS

[SEE PROFILE](#)

Some of the authors of this publication are also working on these related projects:



Machine Health Monitoring using Wavelet Feature Extraction : A Machine Learning Approach [View project](#)



Covid-19 Data Analysis at regional level (India) [View project](#)

Introduction

In the industry we use three methods for transmitting power from one point to another. Mechanical transmission is through shafts, gears, chains, belts, etc. Electrical transmission is through wires, transformers, etc. Fluid power is through liquids or gas in a confined space. In this chapter, we shall discuss a structure of hydraulic systems and pneumatic systems. We will also discuss the advantages and disadvantages and compare hydraulic, pneumatic, electrical and mechanical systems.

Fluid Power and Its Scope

Fluid power is the technology that deals with the generation, control and transmission of forces and movement of mechanical element or system with the use of pressurized fluids in a confined system. Both liquids and gases are considered fluids. Fluid power system includes a hydraulic system (*hydra* meaning water in Greek) and a pneumatic system (*pneuma* meaning air in Greek). Oil hydraulic employs pressurized liquid petroleum oils and synthetic oils, and pneumatic employs compressed air that is released to the atmosphere after performing the work.

Perhaps it would be in order that we clarify our thinking on one point. By the term “fluid” we refer to air or oil, for it has been shown that water has certain drawbacks in the transmission of hydraulic power in machine operation and control. Commercially, pure water contains various chemicals (some deliberately included) and also foreign matter, and unless special precautions are taken when it is used, it is nearly impossible to maintain valves and working surfaces in satisfactory condition. In the cases where the hydraulic system is closed (i.e., the one with a self-contained unit that serves one machine or one small group of machines), oil is commonly used, thus providing, in addition to power transmission, benefits of lubrication not afforded by water as well as increased life and efficiency of packings and valves. It should be mentioned that in some special cases, soluble oil diluted with water is used for safety reasons. The application of fluid power is limited only by the ingenuity of the designer, production engineer or plant engineer. If the application pertains to lifting, pushing, pulling, clamping, tilting, forcing, pressing or any other straight line (and many rotary) motions, it is possible that fluid power will meet the requirement.

Fluid power applications can be classified into two major segments:

Stationary hydraulics: Stationary hydraulic systems remain firmly fixed in one position. The characteristic feature of stationary hydraulics is that valves are mainly solenoid operated.

The applications of stationary hydraulics are as follows:

- Production and assembly of vehicles of all types
- Machine tools and transfer lines
- Lifting and conveying devices
- Metal-forming presses
- Plastic machinery such as injection-moulding machines

- Rolling machines
- Lifts
- Food processing machinery
- Automatic handling equipment and robots

Mobile hydraulics: Mobile hydraulic systems move on wheels or tracks such as a tower crane or excavator truck to operate in many different locations or while moving. A characteristic feature of mobile hydraulics is that the valves are frequently manually operated. The applications of mobile hydraulics are as follows:

- Automobiles, tractors, aeroplanes, missile, boats, etc
- Construction machinery
- Tippers, excavators and elevating platforms
- Lifting and conveying devices
- Agricultural machinery

Hydraulics and pneumatics have almost unlimited application in the production of goods and services in nearly all sectors of the country. Several industries are dependent on the capabilities that fluid power affords. Table 1.1 summarizes few applications of fluid power.

Table 1.1 More applications of fluid power

Agriculture	Tractors; farm equipment such as mowers, ploughs, chemical and water sprayers, fertilizer spreaders, harvesters
Automation	Automated transfer lines, robotics
Automobiles	Power steering, power brakes, suspension systems, hydrostatic transmission
Aviation	Fluid power equipment such as landing wheels in aircraft. Helicopters, aircraft trolleys, aircraft test beds, luggage loading and unloading systems, ailerons, aircraft servicing, flight simulators
Construction industry/equipment	For metering and mixing of concrete rudders, excavators, lifts, bucket loaders, crawlers, post-hole diggers, road graders, road cleaners, road maintenance vehicles, tippers
Defence	Missile-launching systems, navigation controls
Entertainment	Amusement park entertainment rides such as roller coasters
Fabrication industry	Hand tools such as pneumatic drills, grinders, borers, riveting machines, nut runners
Food and beverage	All types of food processing equipment, wrapping, bottling,
Foundry	Full and semi-automatic moulding machines, tilting of furnaces, die-casting machines
Glass industry	Vacuum suction cups for handling

Hazardous gaseous areas	Hydraulic fracturing technologies: It involves pumping large volumes of water and sand into a well at high pressure to fracture shale and other tight formations, allowing hazardous oil and gas to flow into the well. However, hydraulic fracturing has serious environmental and water pollution related issues.
Instrumentation	Used to create/operate complex instruments in space rockets, gas turbines, nuclear power plants, industrial labs
Jigs and fixtures	Work holding devices, clamps, stoppers, indexers
Machine tools	Automated machine tools, numerically controlled(NC) machine tools
Materials handling	Jacks, hoists, cranes, forklifts, conveyor systems
Medical	Medical equipment such as breathing assistors, heart assist devices, cardiac compression machines, dental drives and human patient simulator
Movies	Special-effect equipment use fluid power; movies such as Jurassic park, Jaws, Anaconda, Titanic
Mining	Rock drills, excavating equipment, ore conveyors, loaders
Newspapers and periodicals	Edge trimming, stapling, pressing, bundle wrapping
Oil industry	Off-shore oil rigs
Paper and packaging	Process control systems, special-purpose machines for rolling and packing
Pharmaceuticals	Process control systems such as bottle filling, tablet placement, packaging
Plastic industry	Automatic injection moulding machines, raw material feeding, jaw closing, movement of slides of blow moulder
Press tools	Heavy duty presses for bulk metal formation such as sheet metal, forging, bending, punching, etc.
Printing industry	For paper feeding, packaging
Robots	Fluid power operated robots, pneumatic systems
Ships	Stabilizing systems, unloading and loading unit, gyroscopic instruments, movement of flat forms, lifters, subsea inspection equipment
Textiles	Web tensioning devices, trolleys, process controllers
Transportation	Hydraulic elevators, winches, overhead trams
Under sea	Submarines, under sea research vehicles, marine drives and control of ships
Wood working	Tree shearers, handling huge logs, feed, clamp, sawing

The following are the two types of hydraulic systems:

- **Fluid transport systems:** Their sole objective is the delivery of a fluid from one location to another to accomplish some useful purpose. Examples include pumping stations for pumping water to homes, cross-country gas lines, etc.
- **Fluid power systems:** These are designed to perform work. In fluid power systems, work is obtained by pressurized fluid acting directly on a fluid cylinder or a fluid motor. A cylinder produces a force resulting in linear motion, whereas a fluid motor produces a torque resulting in rotary motion.

Classification of Fluid Power Systems

The fluid power system can be categorized as follows:

- **Based on the control system**

Open-loop system: There is no feedback in the open system and performance is based on the characteristics of the individual components of the system. The open-loop system is not accurate and error can be reduced by proper calibration and control.

Closed-loop system: This system uses feedback. The output of the system is fed back to a comparator by a measuring element. The comparator compares the actual output to the desired output and gives an error signal to the control element. The error is used to change the actual output and bring it closer to the desired value. A simple closed-loop system uses servo valves and an advanced system uses digital electronics.

- **Based on the type of control**

Fluid logic control: This type of system is controlled by hydraulic oil or air. The system employs fluid logic devices such as AND, NAND, OR, NOR, etc. Two types of fluid logic systems are available:

(a) Moving part logic (MPL): These devices are miniature fluid elements using moving parts such as diaphragms, disks and poppets to implement various logic gates.

(b) Fluidics: Fluid devices contain no moving parts and depend solely on interacting fluid jets to implement various logic gates.

Electrical control: This type of system is controlled by electrical devices. Four basic electrical devices are used for controlling the fluid power systems: switches, relays, timers and solenoids. These devices help to control the starting, stopping, sequencing, speed, positioning, timing and reversing of actuating cylinders and fluid motors. Electrical control and fluid power work well together where remote control is essential.

Electronic control: This type of system is controlled by microelectronic devices. The electronic brain is used to control the fluid power muscles for doing work. This system uses the most advanced type of electronic hardware including programmable logic control (PLC) or microprocessor (μ P). In the electrical control, a change in system operation results in a cumbersome process of redoing hardware connections.

The difficulty is overcome by programmable electronic control. The program can be modified or a new program can be fed to meet the change of operations. A number of such programs can be stored in these devices, which makes the systems more flexible.

Hydrostatic and Hydrodynamic Systems

A hydrostatic system uses fluid pressure to transmit power. Hydrostatics deals with the mechanics of still fluids and uses the theory of equilibrium conditions in fluid. The system creates high pressure, and through a transmission line and a control element, this pressure drives an actuator (linear or rotational). The pump used in hydrostatic systems is a positive displacement pump. The relative spatial position of this pump is arbitrary but should not be very large due to losses (must be less than 50 m). An example of pure hydrostatics is the transfer of force in hydraulics.

Hydrodynamic systems use fluid motion to transmit power. Power is transmitted by the kinetic energy of the fluid. Hydrodynamics deals with the mechanics of moving fluid and uses flow theory. The pump used in hydrodynamic systems is a non-positive displacement pump. The relative spatial position of the prime mover (e.g., turbine) is fixed. An example of pure hydrodynamics is the conversion of flow energy in turbines in hydroelectric power plants.

In oil hydraulics, we deal mostly with the fluid working in a confined system, that is, a hydrostatic system.

History of Fluid Power

Fluid power is as old as our civilization itself. Water was used for centuries to produce power by means of water wheels and air was used to turn windmills and to propel ships. Chinese used wooden valves to control water flow through bamboo pipes in 4000 BC. Ancient Egyptians have built a masonry dam across Nile, 14 miles south to present Cairo, for the control of irrigation water by canals, sluices, brick conduits and ceramic pipes. During the Roman empire, extensive water systems using aqueducts, reservoirs and valves were constructed to carry water to cities. However, these early uses of fluid power required the movement of huge quantities of fluid because of the relatively low pressures provided by nature.

Fluid power technology actually began in 1650 with the discovery of Pascal's law. Simply stated, this law says that *pressure in a fluid at rest is transmitted undiminished equally in all directions in a confined body of fluid*. Pascal found that when he rammed a cork down into a jug completely full of wine, the bottom of the jug broke and fell out. However, in order for Pascal's law to be made effective for practical use, it was necessary to make a piston that would fit exactly. Not until over 100 years later was this accomplished. It was in 1795 that Joseph Bramah invented the cup packing that led to the development of a workable hydraulic press. Bramah's hydraulic press consisted of a plunger pump piped to a large

cylinder and a ram. This new hydraulic press found wide use in England because it provided a more effective and economical means of applying large force to industrial applications.

In 1750, Bernoulli developed his law of conservation of energy for a fluid flowing in a pipeline. Both Pascal's and Bernoulli's laws operate at the heart of all fluid power applications and are used for analytical purposes. However, it was not until the Industrial Revolution of 1850 in Great Britain that these laws were actually applied to the industry.

The first use of a large hydraulic press for foregoing work was made in 1860 by Whitworth. In the next 20 years, many attempts were made to reduce the waste and excessive maintenance costs of the original type of accumulator. In 1872, Rigg patented a three-cylinder hydraulic engine in which provision was made to change the stroke of plungers to vary its displacement without a throttle valve. In 1873, the Brotherhood three-cylinder, constant-stroke hydraulic engine was patented and was widely used for cranes, winches, etc. Both the above-mentioned engines were driven by fluid from an accumulator.

Up to this time, electrical energy was not developed to power the machines of industry. Instead, fluid power was being used to drive hydraulic equipment such as cranes, presses, shearing machines, etc. With electricity emerging dominantly in the 19th century, it was soon found superior to fluid power for transmitting power over great distances.

The modern era in fluid power began around the turn of the century. Fluid applications were made to such installations as the main armament system of USS Virginia in 1906. In these applications, a variable-speed hydrostatic transmission was installed to drive the main guns. Since that time, marine industry has applied fluid power to cargo-handling systems, controllable pitch controllers, submarine control system, aircraft elevators, aircraft- and missile-launching system and radar/sonar-driven systems. In 1926, the United States developed the first unitized, packaged hydraulic system consisting of a pump, controls and an actuator.

Today fluid power is used extensively in practically every branch of industry. The innovative use of modern technology such as electrohydraulic closed loops, microprocessors and improved materials for component construction continues to advance the performance of fluid power systems. The military requirements kept fluid power applications and developments going at a good pace. Aviation and aerospace industry provided the impetus for many advances in fluid power technology.

Advantages of a Fluid Power System

Oil hydraulics stands out as the prime moving force in machinery and equipment designed to handle medium to heavy loads. In the early stages of industrial development, mechanical linkages were used along with prime movers such as electrical motors and engines for handling loads. But the mechanical efficiency of linkages was very low and the linkages often failed under critical loading conditions. With the advent of fluid power technology and associated electronics and control, it is used in every industry now.

The advantages of a fluid power system are as follows:

1. Fluid power systems are simple, easy to operate and can be controlled accurately:

Fluid power gives flexibility to equipment without requiring a complex mechanism. Using fluid power, we can start, stop, accelerate, decelerate, reverse or position large forces/components with great accuracy using simple levers and push buttons. For example, in Earth-moving equipment, bucket carrying load can be raised or lowered by an operator using a lever. The landing gear of aircraft can be retrieved to home position by push button.

2. Multiplication and variation of forces: Linear or rotary force can be multiplied by a fraction of a kilogram to several hundreds of tons.

3. Multifunction control: A single hydraulic pump or air compressor can provide power and control for numerous machines using valve manifolds and distribution systems. The fluid power controls can be placed at a central station so that the operator has, at all times, a complete control of the entire production line, whether it be a multiple operation machine or a group of machines. Such a setup is more or less standard in the steel mill industry.

4. Low-speed torque: Unlike electric motors, air or hydraulic motors can produce a large amount of torque while operating at low speeds. Some hydraulic and pneumatic motors can even maintain torque at a very slow speed without overheating.

5. Constant force or torque: Fluid power systems can deliver constant torque or force regardless of speed changes.

6. Economical: Not only reduction in required manpower but also the production or elimination of operator fatigue, as a production factor, is an important element in the use of fluid power.

7. Low weight to power ratio: The hydraulic system has a low weight to power ratio compared to electromechanical systems. Fluid power systems are compact.

8. Fluid power systems can be used where safety is of vital importance: Safety is of vital importance in air and space travel, in the production and operation of motor vehicles, in mining and manufacture of delicate products. For example, hydraulic systems are responsible for the safety of takeoff, landing and flight of aeroplanes and space craft. Rapid advances in mining and tunneling are the results of the application of modern hydraulic and pneumatic systems.

Basic Components of a Hydraulic System

Hydraulic systems are power-transmitting assemblies employing pressurized liquid as a fluid for transmitting energy from an energy-generating source to an energy-using point to accomplish useful work. Figure 1.1 shows hydraulic system with basic components.

Functions of the components shown in Fig. 1.1 are as follows:

- The hydraulic actuator is a device used to convert the fluid power into mechanical power to do useful work. The actuator may be of the linear type (e.g., hydraulic cylinder) or rotary type (e.g., hydraulic motor) to provide linear or rotary motion.

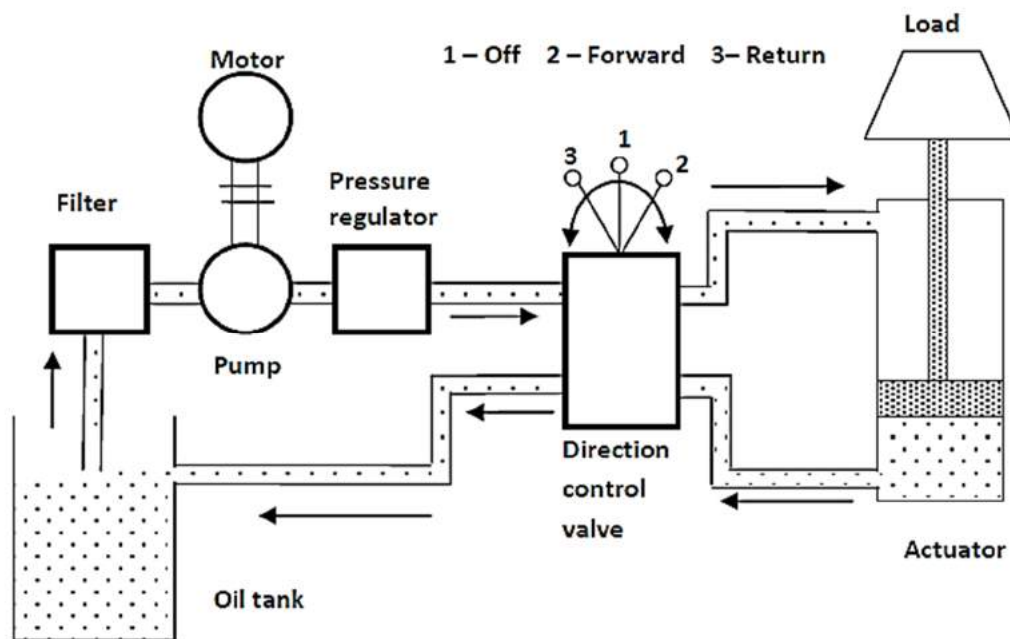

Figure 1.1 Components of a hydraulic system

- The hydraulic pump is used to force the fluid from the reservoir to rest of the hydraulic circuit by converting mechanical energy into hydraulic energy.
- Valves are used to control the direction, pressure and flow rate of a fluid flowing through the circuit.
- External power supply (motor) is required to drive the pump.
- Reservoir is used to hold the hydraulic liquid, usually hydraulic oil.
- Piping system carries the hydraulic oil from one place to another.
- Filters are used to remove any foreign particles so as keep the fluid system clean and efficient, as well as avoid damage to the actuator and valves.
- Pressure regulator regulates (i.e., maintains) the required level of pressure in the hydraulic fluid.

The piping shown in Fig. 1.1 is of closed-loop type with fluid transferred from the storage tank to one side of the piston and returned back from the other side of the piston to the tank. Fluid is drawn from the tank by a pump that produces fluid flow at the required level of pressure. If the fluid pressure exceeds the required level, then the excess fluid returns back to the reservoir and remains there until the pressure acquires the required level.

Cylinder movement is controlled by a three-position change over a control valve.

- When the piston of the valve is changed to upper position, the pipe pressure line is connected to port A and thus the load is raised.
- When the position of the valve is changed to lower position, the pipe pressure line is connected to port B and thus the load is lowered.
- When the valve is at center position, it locks the fluid into the cylinder (thereby holding it in position) and dead-ends the fluid line (causing all the pump output fluid to return to tank via the pressure relief).

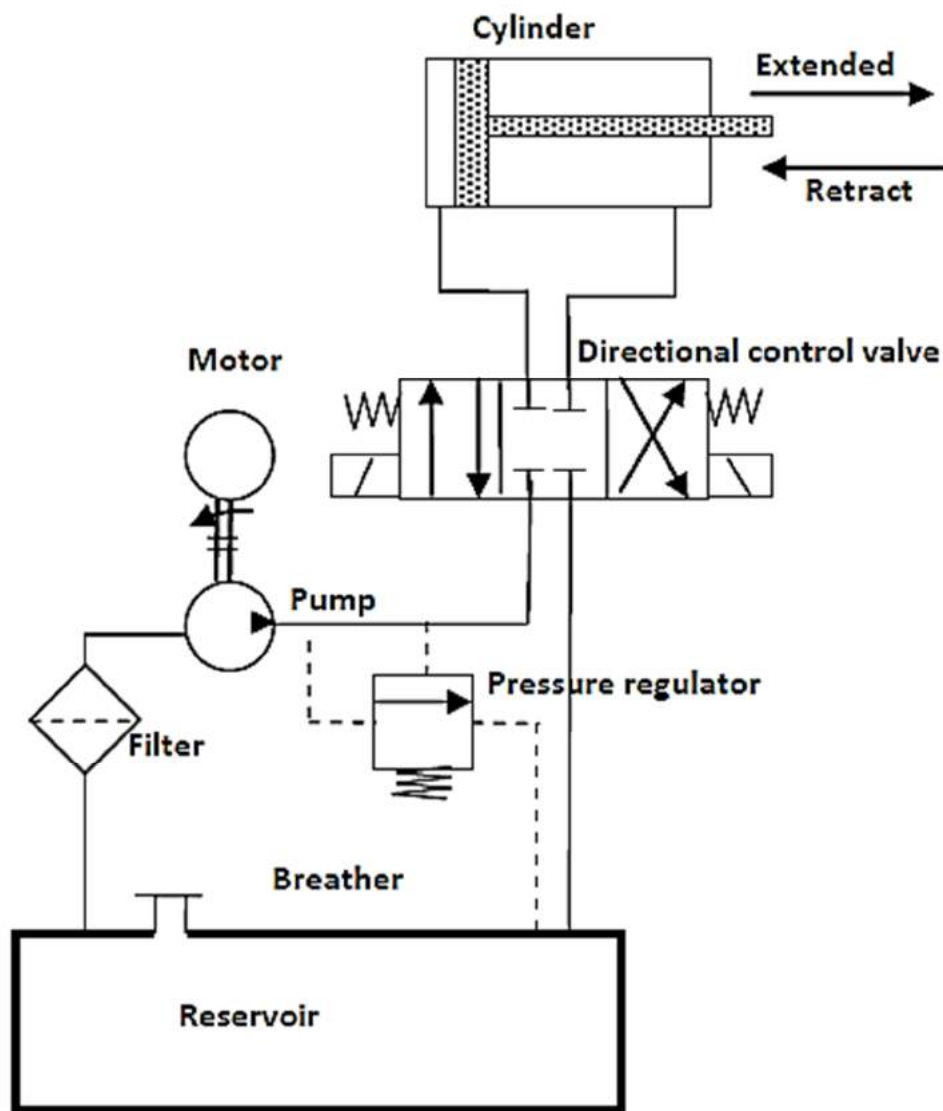

Figure 1.2 Components of a hydraulic system (shown using symbols)

In industry, a machine designer conveys the design of hydraulic systems using a circuit diagram. Figure 1.2 shows the components of the hydraulic system using symbols. The working fluid, which is the hydraulic oil, is stored in a reservoir. When the electric motor is switched ON, it runs a positive displacement pump that draws hydraulic oil through a filter and delivers at high pressure. The pressurized oil passes through the regulating valve and does work on actuator. Oil from the other end of the actuator goes back to the tank via return line. To and fro motion of the cylinder is controlled using directional control valve.

The hydraulic system discussed above can be broken down into four main divisions that are analogous to the four main divisions in an electrical system.

- The power device parallels the electrical generating station.
- The control valves parallel the switches, resistors, timers, pressure switches, relays, etc.
- The lines in which the fluid power flows parallel the electrical lines.
- The fluid power motor (whether it is a rotating or a non-rotating cylinder or a fluid power motor) parallels the solenoids and electrical motors.

Basic Components of a Pneumatic System

A pneumatic system carries power by employing compressed gas, generally air, as a fluid for transmitting energy from an energy-generating source to an energy-using point to accomplish useful work. Figure 1.3 shows a simple circuit of a pneumatic system with basic components.

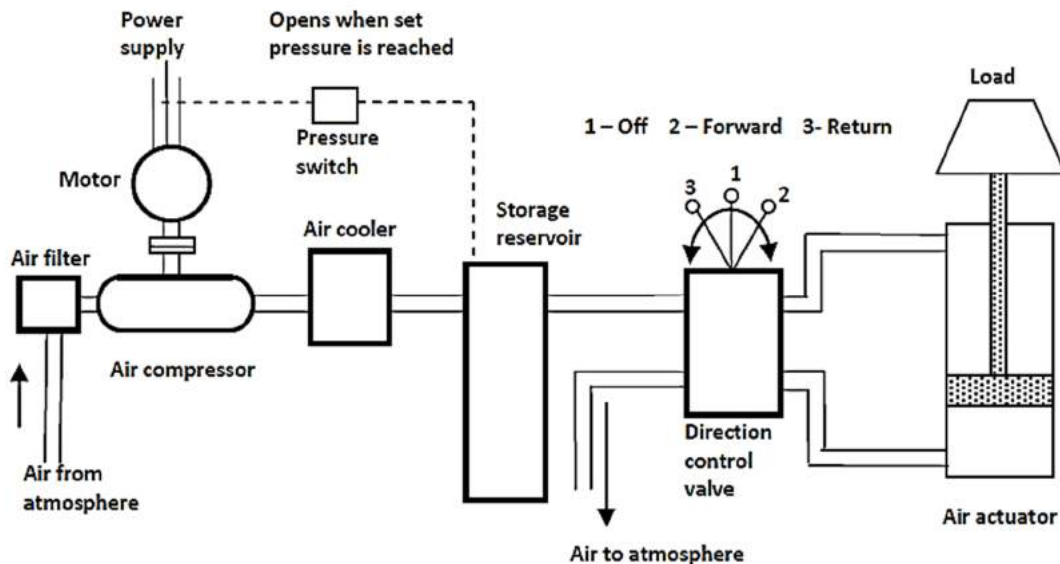

Figure 1.3 Components of a pneumatic system.

The functions of various components shown in Fig. 1.3 are as follows:

- The pneumatic actuator converts the fluid power into mechanical power to perform useful work.
- The compressor is used to compress the fresh air drawn from the atmosphere.
- The storage reservoir is used to store a given volume of compressed air.
- The valves are used to control the direction, flow rate and pressure of compressed air.
- External power supply (motor) is used to drive the compressor.
- The piping system carries the pressurized air from one location to another.

Air is drawn from the atmosphere through an air filter and raised to required pressure by an air compressor. As the pressure rises, the temperature also rises; hence, an air cooler is provided to cool the air with some preliminary treatment to remove the moisture. The treated pressurized air then needs to get stored to maintain the pressure. With the storage reservoir, a pressure switch is fitted to start and stop the electric motor when pressure falls and reaches the required level, respectively.

The three-position change over the valve delivering air to the cylinder operates in a way similar to its hydraulic circuit.

Comparison between Hydraulic and Pneumatic Systems

Usually hydraulic and pneumatic systems and equipment do not compete. They are so dissimilar that there are few problems in selecting any of them that cannot be readily

resolved. Certainly, availability is one of the important factors of selection but this may be outweighed by other factors. In numerous instances, for example, air is preferred to meet certain unalterable conditions, that is, in “hot spots” where there is an open furnace or other potential ignition hazard or in operations where motion is required at extremely high speeds. It is often found more efficient to use a combined circuit in which oil is used in one part and air in another on the same machine or process. Table 1.2 shows a brief comparison of hydraulic and pneumatic systems.

Table 1.2 Comparison between a hydraulic and a pneumatic system

S. No.	Hydraulic System	Pneumatic System
1.	It employs a pressurized liquid as a fluid	It employs a compressed gas, usually air, as a fluid
2.	An oil hydraulic system operates at pressures up to 700 bar	A pneumatic system usually operates at 5–10 bar
3.	Generally designed as closed system	Usually designed as open system
4.	The system slows down when leakage Occurs	Leakage does not affect the system Much
5.	Valve operations are difficult	Valve operations are easy
6.	Heavier in weight	Lighter in weight
7.	Pumps are used to provide pressurized liquids	Compressors are used to provide compressed gases
8.	The system is unsafe to fire hazards	The system is free from fire hazards
9.	Automatic lubrication is provided	Special arrangements for lubrication are needed

Future of Fluid Power Industry in India

The automation market in India is estimated to be 1/10th that of China. If India has to become one of the leading economies in the world, based on manufacturing, it will have to attain higher technological standards and higher level of automation in manufacturing. In the past 30 years, fluid power technology rose as an important industry. With increasing emphasis on automation, quality control, safety and more efficient and green energy systems, fluid power technology should continue to expand in India. Fluid power industry is gaining a lot of importance in Indian industry. According to a recent survey, it has shown a growth of 20% over the last 10 years and the size of market is estimated to be close to 5000 crores per annum. This makes it a sizable industry segment in India. The growth rate of this industry in India is typically about twice the growth of economy.

The reasons for this are three-fold:

1. As the economy grows, this industry grows.
2. There is a lot of automation and conversion into more sophisticated manufacturing methods which increases the rate.

3. One of the interesting things happening in this industry is that India is becoming an attractive destination for manufacturing and outsourcing of some of the products.

So these three aspects together create a situation where the growth of this industry is twice the growth of GDP in India. The fluid power sector in India consists of many sophisticated Indian industries and partnership with number of global fluid power technology leaders that include Festo, Rexroth, Vickers, Eaton, Parker Hannifin, Norgren, , Saucer Donfos, Yuken, Siemens, Shamban, Pall and Gates, , Rotex, , Janatics, Maxwell, Wipro Dynamic Technologies and many more. One of the major segments for hydraulic industry in India is mobile hydraulics. Because of massive programs on road construction, there is a major expansion of construction machinery industry as well. In addition to this, a trend toward the usage of more sophisticated hydraulics in tractors and farm equipment is witnessed. The manufacturing industry in India is working toward higher automation and quality of output. As Indian industry moves toward: Modernization to meet the productivity and to compete in the global market, an excellent potential for the pneumatic industry is expected in India. Another area of interest for fluid power industry would be the opportunities in defence equipment. Defence is a major market segment in Indian fluid power industry and contributes to over 40% of the market demand. There is also a move toward products with miniature pneumatics, process valves, servo drives, hydraulic power steering with new controls and sophisticated PLC, microprocessor controls. However, the key input required for the effective utilization of fluid power is education and training of users. So there is a big need for education and training in design application and maintenance of fluid power systems. Rexroth recently opened many competence centers in India to train the manpower and to create awareness about the use of fluid power in Indian industry.

Introduction to basic laws

Fluid power systems are designed using all the principles learned in fluid mechanics. It is appropriate to briefly review these principles before proceeding with our study of the applications. One of underlying postulates of fluid mechanics is that, for a particular position within a fluid at rest, the pressure is the same in all directions. This follows directly from Pascal's Law. Other postulate states that fluids can support shear forces only when in motion. Two postulates define the features of fluids used to transmit power & control motion.

Pascal's Law

Pascal's law states that the pressure exerted on a confined fluid is

- transmitted undiminished in all directions
- acts with equal force on equal areas
- acts at right angles to the containing surfaces

In Fig. 1.1, a force is being applied to a piston, which in turn exerts a pressure on the confined fluid. The pressure is equal everywhere and acts at right angles to the containing

surfaces. Pressure is defined as the force acting per unit area and is expressed as $\text{Pressure} = F/A$, where F is the force acting on the piston, A is the area of the piston and P is the pressure on the fluid.

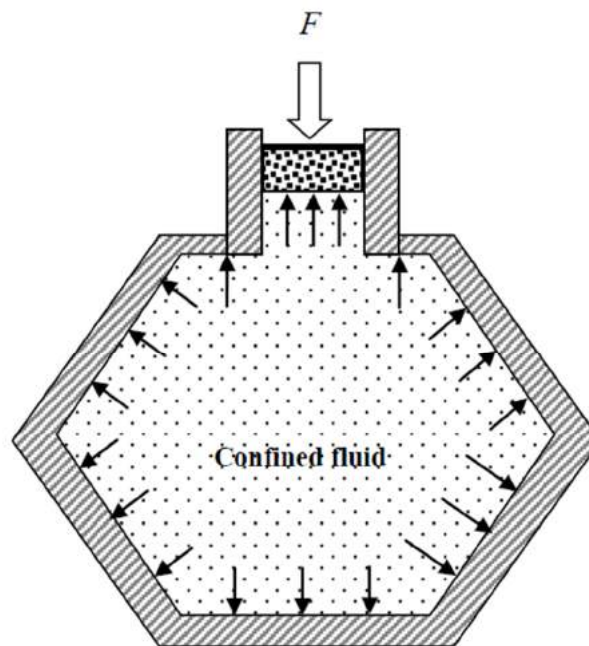

Figure 1.1 Illustration of Pascal's law

Multiplication of Force

The most useful feature of fluid power is the ease with which it is able to multiply force. This is accomplished by using an output piston that is larger than the input piston. Such a system is shown in Fig. 1.2.

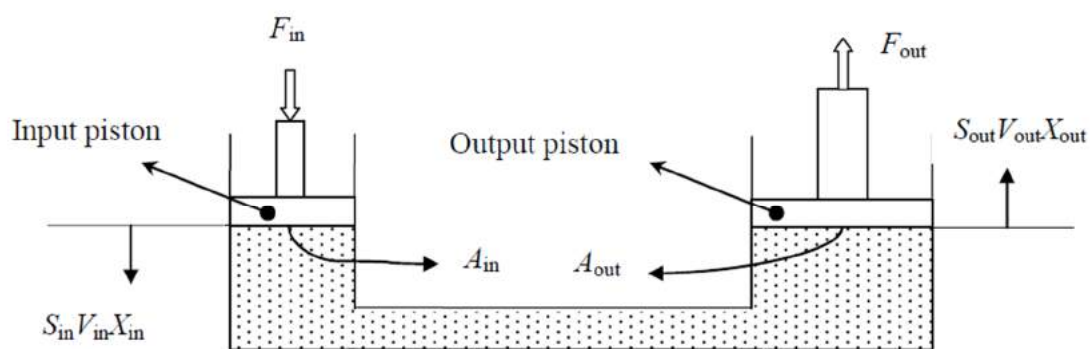

Figure 1.2 Multiplication of force

This system consists of an input cylinder on the left and an output cylinder on the right that is filled with oil. When the input force is F_{in} on the input piston, the pressure in the system is given by

$$P = \frac{F_{out}}{A_{out}}$$

$$\Rightarrow F_{out} = PA_{out} = \frac{F_{in}}{A_{in}} A_{out} = \frac{A_{out}}{A_{in}} F_{in}$$

Here to obtain the output force, the input force is multiplied by a factor that is equal to the ratio of the output piston area to the input piston area. If the output piston area is x times the input piston area, then the output force is x times the input force. Generally, the cross-sectional area of the piston is circular. The area is given by

$$A = \pi d^2 / 4$$

Hence, the above equation can be written as

$$F_{\text{out}} = \frac{d_{\text{out}}^2}{d_{\text{in}}^2} F_{\text{in}}$$

$$\Rightarrow \frac{F_{\text{out}}}{F_{\text{in}}} = \frac{d_{\text{out}}^2}{d_{\text{in}}^2}$$

The conservation of energy is very fundamental principle. It states that energy can neither be created nor destroyed. At first sight, multiplication of force as depicted in Fig.1.2 may give the impression that something small is turned into something big. But this is wrong, since the large piston on the right is only moved by the fluid displaced by the small piston on left. Therefore, what has been gained in force must be sacrificed in piston travel displacement. Now we shall mathematically derive force displacement relation and force power relation.

Force displacement relation: Hydraulic oil is assumed to be incompressible; hence, the volume displaced by the piston is equal to the volume displaced at the output piston:

$$V_{\text{in}} = V_{\text{out}}$$

Since the volume of a cylinder equals the product of its cross-sectional area and its height, we have

$$A_{\text{in}} S_{\text{in}} = A_{\text{out}} S_{\text{out}}$$

Where S_{in} is the downward displacement of the input piston and S_{out} is the upward displacement of the output piston:

$$\frac{S_{\text{in}}}{S_{\text{out}}} = \frac{A_{\text{out}}}{A_{\text{in}}}$$

Comparing

$$\frac{F_{\text{out}}}{F_{\text{in}}} = \frac{A_{\text{out}}}{A_{\text{in}}} = \frac{S_{\text{in}}}{S_{\text{out}}}$$

Force power relation: Hydraulic oil is assumed to be incompressible; hence, the quantity of oil displaced by the input piston is equal to the quantity of oil gained and displaced at the output piston:

Flow rate is the product of area and volume of fluid displaced in a specified time

$$\begin{aligned}
 Q_{in} &= Q_{out} \\
 \Rightarrow A_{in} V_{in} &= A_{out} V_{out} \\
 \Rightarrow \frac{A_{out}}{A_{in}} &= \frac{V_{in}}{V_{out}}
 \end{aligned}$$

Comparing Equations. (1.1) and (1.2) we get

$$\frac{A_{out}}{A_{in}} = \frac{V_{in}}{V_{out}} = \frac{F_{out}}{F_{in}} = \frac{S_{in}}{S_{out}}$$

From the above equation, we get

$$\begin{aligned}
 F_{in} S_{in} &= F_{out} S_{out} \\
 (\text{Work done})_{in} &= (\text{Work done})_{out}
 \end{aligned}$$

or

We know that

Power = Force x Velocity

$$\begin{aligned}
 \Rightarrow F_{in} v_{in} &= F_{out} v_{out} \\
 (\text{Power})_{in} &= (\text{Power})_{out}
 \end{aligned}$$

Example 1

A pressure of 2000 Pa is transmitted throughout a liquid column due to a force being applied on a piston. If the piston has an area of 0.1 m², what force is applied?

This can be calculated using Pascal's Law formula,

$$F = PA$$

Here,

$$P = 2000 \text{ Pa} = \text{N/m}^2$$

$$A = 0.1 \text{ m}^2$$

Substituting values, we arrive at $F = 200 \text{ N}$

Example 2

An input cylinder with a diameter of 30 mm is connected to an output cylinder with a diameter of 80 mm (Fig. 1.3). A force of 1000 N is applied to the input cylinder.

(a) What is the output force?

(b) How far do we need to move the input cylinder to move the output cylinder 100 mm?

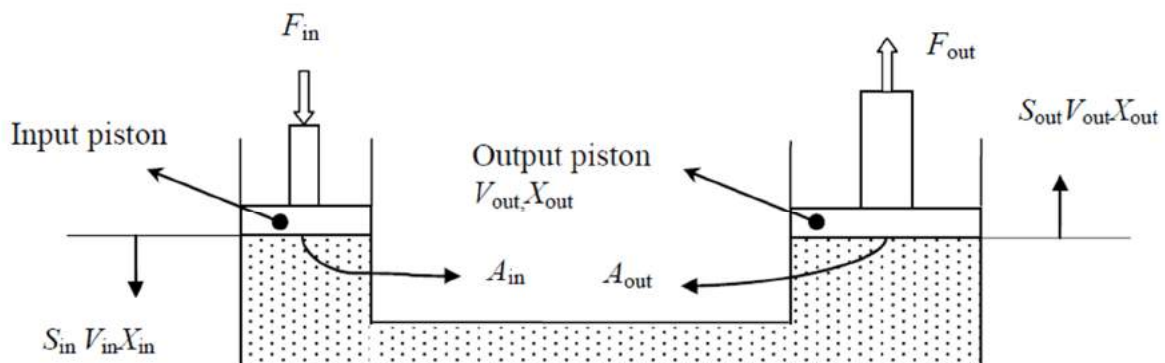

Figure 1.3

Solution: Since the volume of a cylinder equals the product of its cross-sectional area and its height, we have

$$A_{\text{in}} X_{\text{in}} = A_{\text{out}} X_{\text{out}}$$

where X_{in} is the downward movement of the input piston and X_{out} is the upward movement of the output piston. Hence we get

$$\frac{X_{\text{out}}}{X_{\text{in}}} = \frac{A_{\text{in}}}{A_{\text{out}}}$$

The piston stroke ratio $X_{\text{out}} / X_{\text{in}}$ equals the piston area ratio $A_{\text{in}} / A_{\text{out}}$. For a piston area of 10, the output force F_{out} increases by a factor of 10, but the output motion decreases by a factor of 10.

Thus, the output force is greater than the input force, but the output movement is less than the input force and the output movement is less than the input movement. Hence, we can write by combining equations

$$A_{\text{in}} X_{\text{in}} = A_{\text{out}} X_{\text{out}} \text{ and } \frac{X_{\text{out}}}{X_{\text{in}}} = \frac{A_{\text{in}}}{A_{\text{out}}}$$

that

$$\begin{aligned} \frac{F_{\text{out}}}{F_{\text{in}}} &= \frac{X_{\text{in}}}{X_{\text{out}}} \\ \Rightarrow W_{\text{in}} &= W_{\text{out}} \end{aligned}$$

Hence, the input work equals the output work.

Given $F_{\text{in}} = 1000 \text{ N}$, $A_1 = 0.7854 \times 30^2 \text{ mm}^2$ and $A_2 = 0.7854 \times 80^2 \text{ mm}^2$, $S_{\text{out}} = 1000 \text{ mm}$.

To calculate S_{in} and F_2 .

(a) **Force on the large piston F_2 :** By Pascal's law, we have

$$\begin{aligned} \frac{F_1}{F_2} &= \frac{A_1}{A_2} \\ \Rightarrow F_2 &= \frac{A_2 \times F_1}{A_1} = \frac{1000 \text{ N}}{0.7854 \times 30^2} \times 0.7854 \times 80^2 \\ \Rightarrow F_2 &= 7111.1 \text{ N} \end{aligned}$$

(b) **Distance moved by the large piston S_{out} :** We also know by the conservation of energy that

$$\begin{aligned} \frac{F_1}{F_2} &= \frac{S_{\text{out}}}{S_{\text{in}}} \\ \Rightarrow S_{\text{in}} &= \frac{S_{\text{out}} \times F_2}{F_1} = \frac{1000 \times 7111.1}{1000} \\ \Rightarrow S_{\text{in}} &= 7111.11 \text{ mm} \end{aligned}$$

Practical Applications of Pascal's Law

The practical applications of Pascal's law are numerous. In this section, two applications of Pascal's law are presented: (a) The hand-operated hydraulic jack and (b) the air-to-hydraulic pressure booster.

Hand-Operated Hydraulic Jack

This system uses a piston-type hand pump to power a hydraulic load cylinder for lifting loads, as illustrated in Fig. 1.12. The operation is as follows:

1. A hand force is applied at point A of handle ABC which is pivoted at point C. The piston rod of the pump cylinder is pinned to the input handle of the pump piston at point B.

2. The pump cylinder contains a small-diameter piston that is free to move up and down. The piston and rod are rigidly connected together. When the handle is pulled up, the piston rises and creates a vacuum in the space below it. As a result, the atmospheric pressure forces the oil to leave the oil tank and flow through check valve 1 to fill the void created below the pump piston. This is the suction process.
3. A check valve allows flow to pass in only one direction, as indicated by the arrow. When the handle is pushed down, oil is ejected from the small-diameter pump cylinder and it flows through check valve 2 and enters the bottom end of the large-diameter load cylinder.
4. The load cylinder is similar in construction to the pump cylinder and contains a piston connected to a rod. Pressure builds up below the load piston and equals the pressure generated by the pump piston. The pressure generated by the pump piston equals the force applied to the pump piston rod divided by the area of the pump piston.
5. The load that can be lifted equals the product of the pressure and the area of the load piston. Also, each time when the input handle is cycled up and down, a specified volume of oil is ejected from the pump to raise the load cylinder a given distance.
6. The bleed valve is a hand-operated valve, which, when opened, allows the load to be lowered by bleeding oil from the load cylinder back to the oil tank.

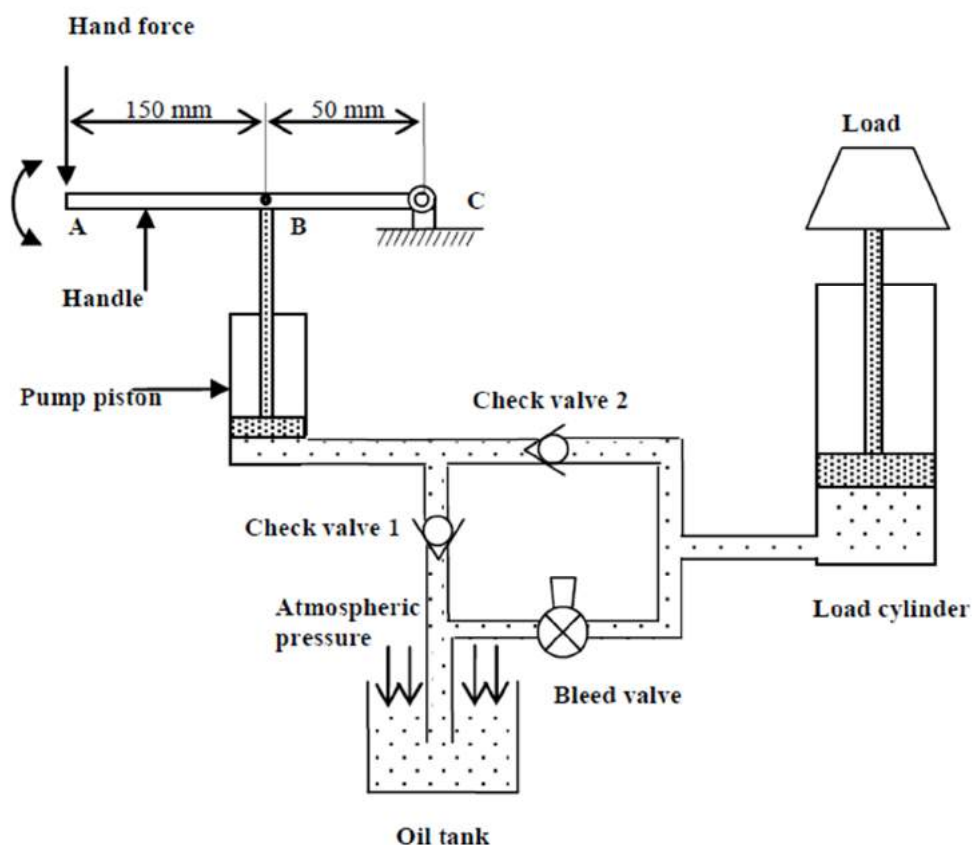

Figure 1.12 Application of Pascal's law: Hand-operated hydraulic jack

Air-to-Hydraulic Pressure Booster

This device is used for converting shop air into higher hydraulic pressure needed for operating hydraulic cylinders requiring small to medium volumes of higher pressure oil. It

consists of a cylinder containing a large-diameter air piston driving a small-diameter hydraulic piston that is actually a long rod connected to the piston. Any shop equipped with an airline can obtain smooth, efficient hydraulic power from an air-to-hydraulic pressure booster hooked into the air line. The alternative would be a complete hydraulic system including expensive pumps and high-pressure valves. Other benefits include space savings and low operating and maintenance costs.

Figure 1.13 shows an application where an air-to-hydraulic pressure booster supplies high-pressure oil to a hydraulic cylinder whose short stroke piston is used to clamp a work piece to a machine tool table. Since shop air pressure normally operates at 100 psi, a pneumatically operated clamp would require an excessively large cylinder to rigidly hold the workpiece while it is being machined.

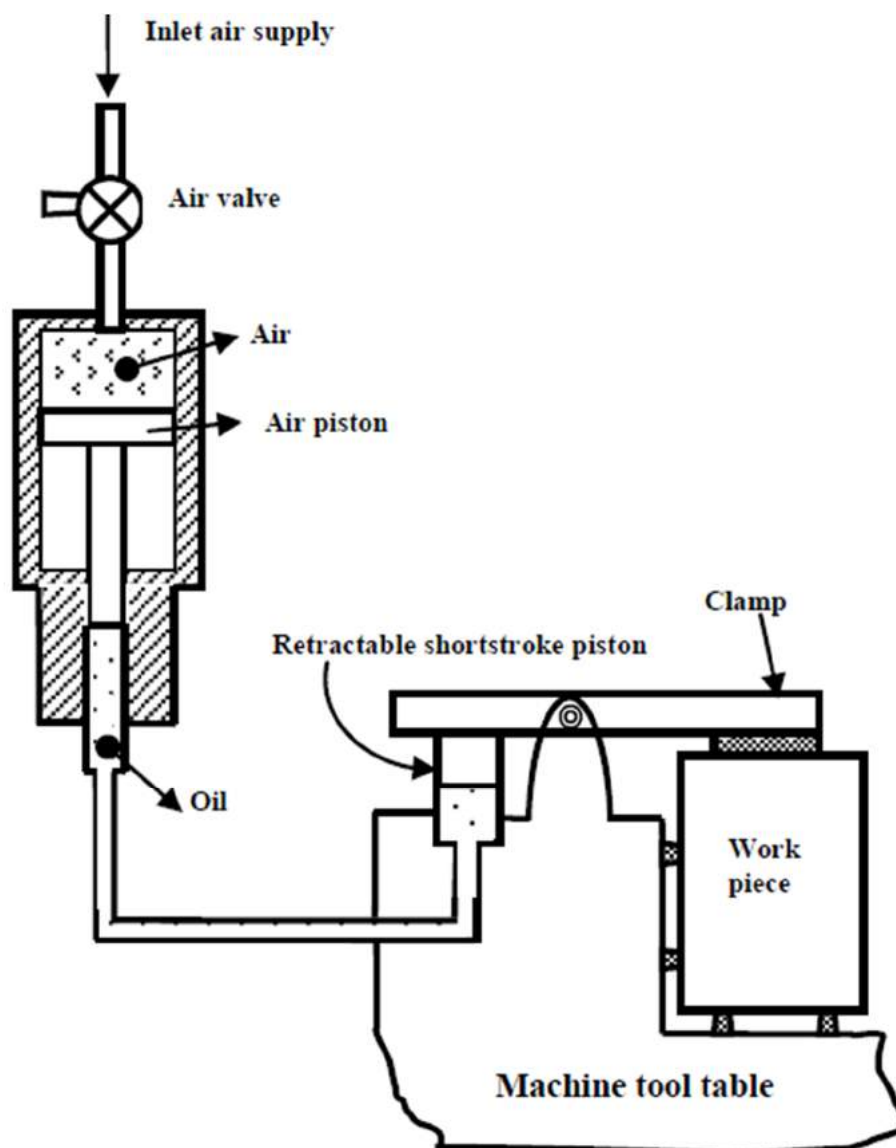

The air-to-hydraulic pressure booster operates as follows. Let us assume that the air piston has 10 cm^2 area and is subjected to a 10 bar air pressure. This produces a 1000 N force on the booster's hydraulic piston. Thus, if the area of the booster's hydraulic piston is 1 cm^2 , the hydraulic oil pressure is 100 bar. As per Pascal's law, this produces 100 bar oil at the short stroke piston of the hydraulic clamping cylinder mounted on the machine tool table.

The pressure ratio of an air-to-hydraulic pressure booster can be found by using the following equation:

$$\begin{aligned} \text{Pressure ratio} &= \frac{\text{Output oil pressure}}{\text{Input oil pressure}} \\ &= \frac{\text{Area of air piston}}{\text{Area of hydraulic piston}} \end{aligned}$$

Substituting into the above equation for the earlier mentioned pressure booster, we have

$$\text{Pressure ratio} = \frac{10000 \text{ kPa}}{1000 \text{ kPa}} = \frac{10 \text{ cm}^2}{1 \text{ cm}^2}$$

For a clamping cylinder piston area of 0.5 cm^2 , the clamping force equals $1000 \text{ N/cm}^2 \times 0.5 \text{ cm}^2$ or 500 N . To provide the same clamping force of 500 N without booster requires a clamping cylinder piston area of 5 cm^2 , assuming 10 bar air pressure. Air-to-hydraulic pressure boosters are available in a wide range of pressure ratios and can provide hydraulic pressures up to 1000 bar using approximately 7 bar shop air.

Example 3

An operator makes 15 complete cycles in 15 s interval using the hand pump shown in Fig. 1.14. Each complete cycle consists of two pump strokes (intake and power). The pump has a piston of diameter 30 mm and the load cylinder has a piston of diameter 150 mm . The average hand force is 100 N during each power stroke.

- How much load can be lifted?
- How many cycles are required to lift the load by 500 mm , assuming no oil leakage? The pump piston has 20 mm stroke.
- What is the output power assuming 80% efficiency?

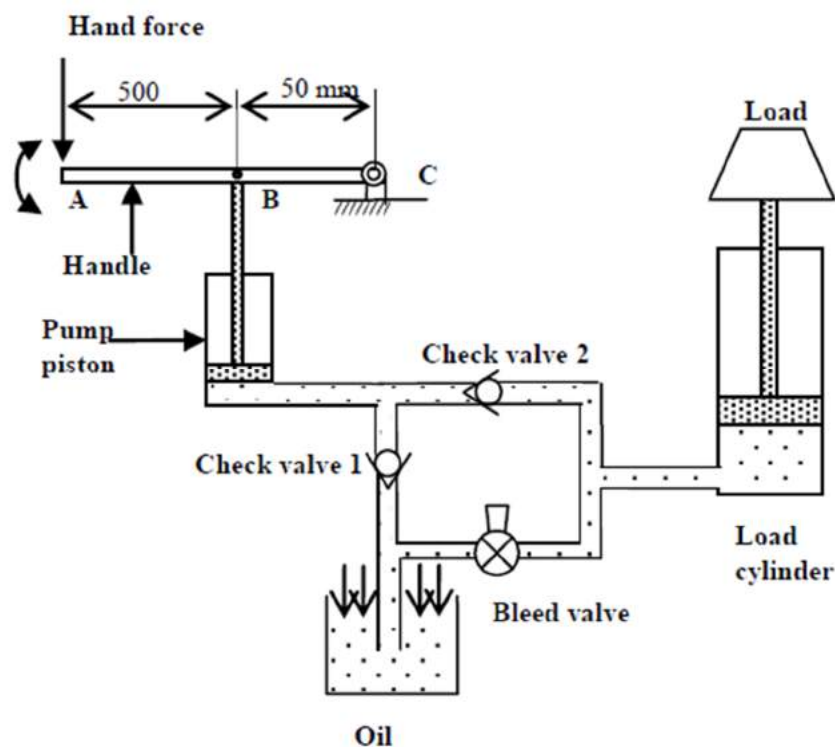

Solution: Given: pump diameter $d = 30\text{mm}$, load cylinder diameter $D = 150\text{mm}$, hand force $f = 100\text{N}$, number of cycles $n = 15$ strokes/s, pump piston force

$$F_1 = \frac{100 \times 550}{50} = 1100\text{ N}$$

(a) **Load capacity:** Now since the pressure remains undiminished throughout, we have $p_1 = p_2$. Therefore,

$$\frac{F_1}{A_1} = \frac{F_2}{A_2}$$

$$\Rightarrow F_2 = \frac{\pi D^2 / 4}{\pi d^2 / 4} F_1 = \frac{150^2}{30^2} \times 1100 = 27500\text{ N} = 27.5\text{ kN}$$

(b) **Number of cycles:** Stroke length $l = 20\text{ mm}$. Let the number of strokes be N . Then assuming no leakage, we get

$$Q_1 = Q_2$$

where

$$Q_1 = \text{Total volume of fluid displaced by pump piston} \\ = (\text{Area} \times \text{Stroke}) \times \text{Number of strokes} = N \times A_1 l$$

$$Q_2 = \text{Flow rate of load cylinder} = (\text{Area} \times \text{Stroke of load cylinder}) \\ = A_2 \times 500$$

So we get

$$N \times A_1 l = A_2 \times 500$$

$$\Rightarrow N = \frac{150^2}{20 \times 30^2} \times 500 = 625$$

Hence, the number of cycles required is 625.

(c) **Output power:**

$$\text{Input power} = F_1 \times l \times n$$

$$\text{Output power} = \eta \times F_1 \times l \times n = 0.8 \times 1100 \times 0.02 \times 15 = 264\text{ W}$$

Differential hydraulic cylinders

Differential hydraulic cylinder will have a piston within its cylindrical housing. Area of piston, where hydraulic pressure force will be applied by pressurized hydraulic fluid, will not be equal at both ends.

If we will look the internal construction of differential hydraulic cylinder, we will come to know that at cap end side there will be complete piston area where pressure force will be applied by the pressurized hydraulic fluid. While at rod end side, hydraulic pressure force will be applied over annular area of piston.

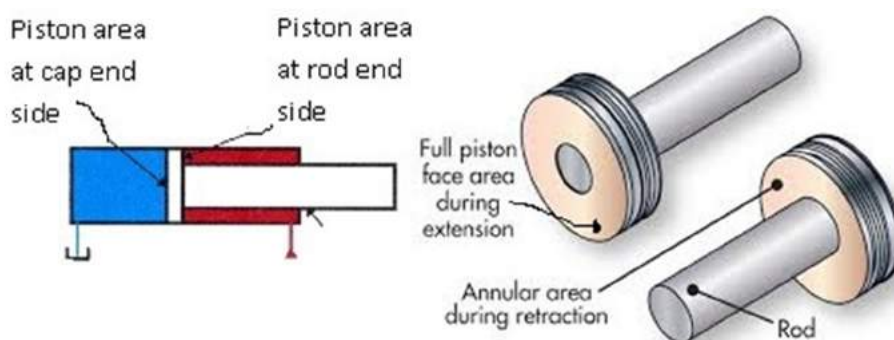

Above picture indicates the differential hydraulic cylinder, where we may see that area of piston is not equal at its both ends.

During extension of cylinder, hydraulic pressure force will be applied over the complete area of piston from cap end side, while during retraction hydraulic pressure force will be applied over the annular area of piston. Complete face area of piston and annular area of piston are also displayed in above figure.

Non-differential hydraulic cylinders

Image displayed here indicates the non-differential hydraulic cylinder. As we can see here, there will be piston rod extended at both end in such type of hydraulic cylinder and hence speed as well as thrust will be equal in each direction.

Such type of hydraulic cylinders could be used in an application where job could be done by each end of the hydraulic cylinder.

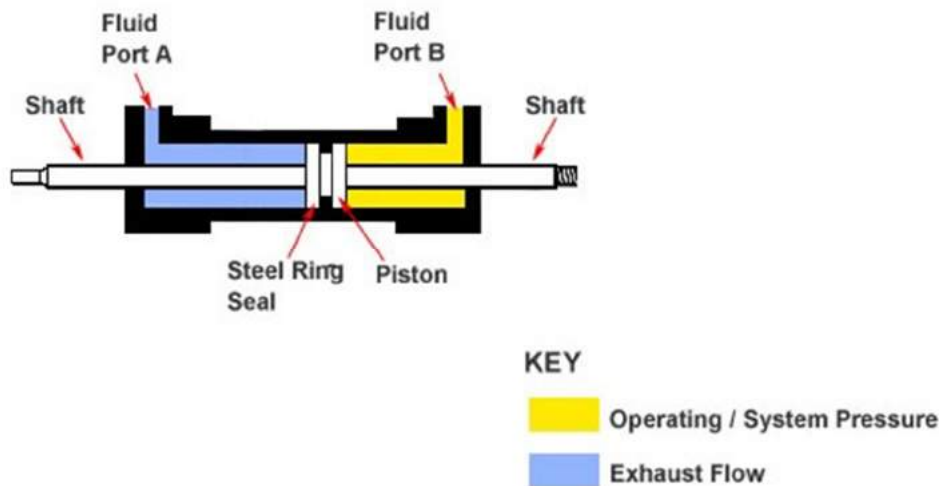

Actuation of double acting hydraulic cylinder

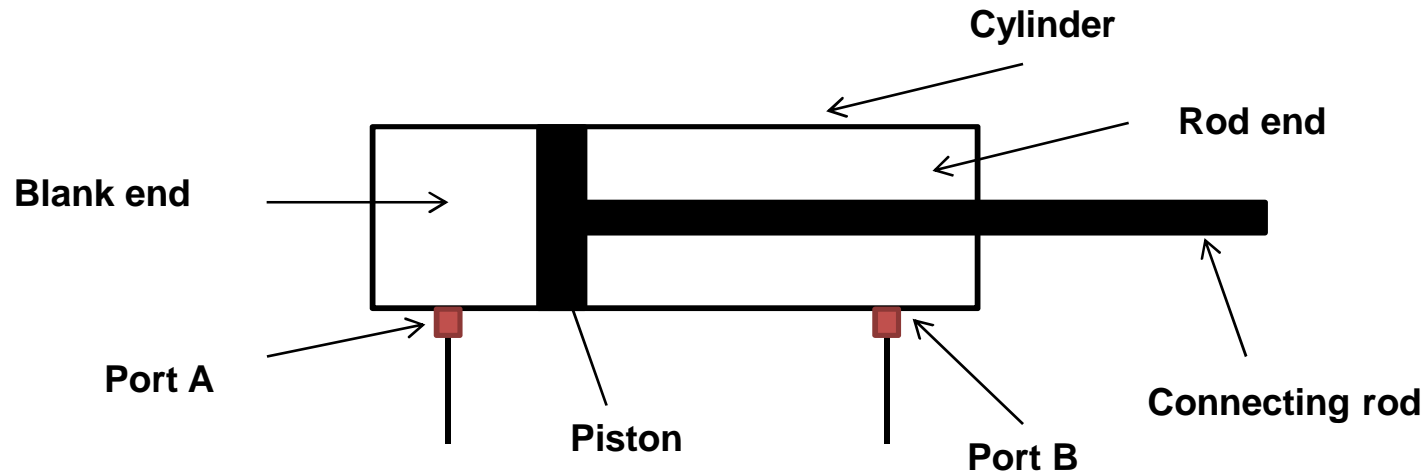

Mode of operation: Linear actuation/displacement

1. Extension / forward stroke (How to visualize?)

Connecting rod is *coming out* from cylinder or
piston is moving from *left to right*

2. Retraction / reverse stroke (How to visualize?)

Connecting rod is *moving inside* the cylinder or
piston is moving from *right to left*

How to achieve **Extension / forward stroke?**

To move connecting rod *out* of the cylinder or to move piston from *left to right*,
 Add oil to the blank end from port A and remove oil from rod end from port B

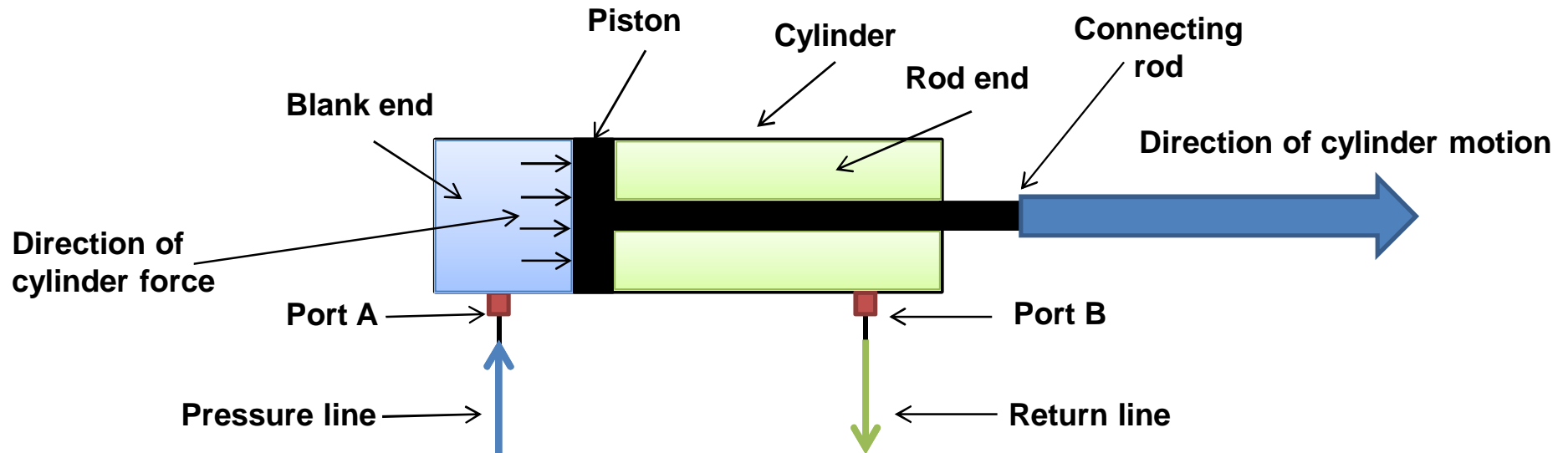

Blue color indicates working pressure & must be connected to pump

Green color indicates return line pressure & must be connected to reservoir/tank

Look at the direction of actuation of cylinder and entry/exit of oil...!!!

How to achieve Retraction / reverse stroke?

To move connecting rod *inside* of the cylinder or to move piston from *right to left*,
 Add oil to the rod end from port B and remove oil from blank end from port A

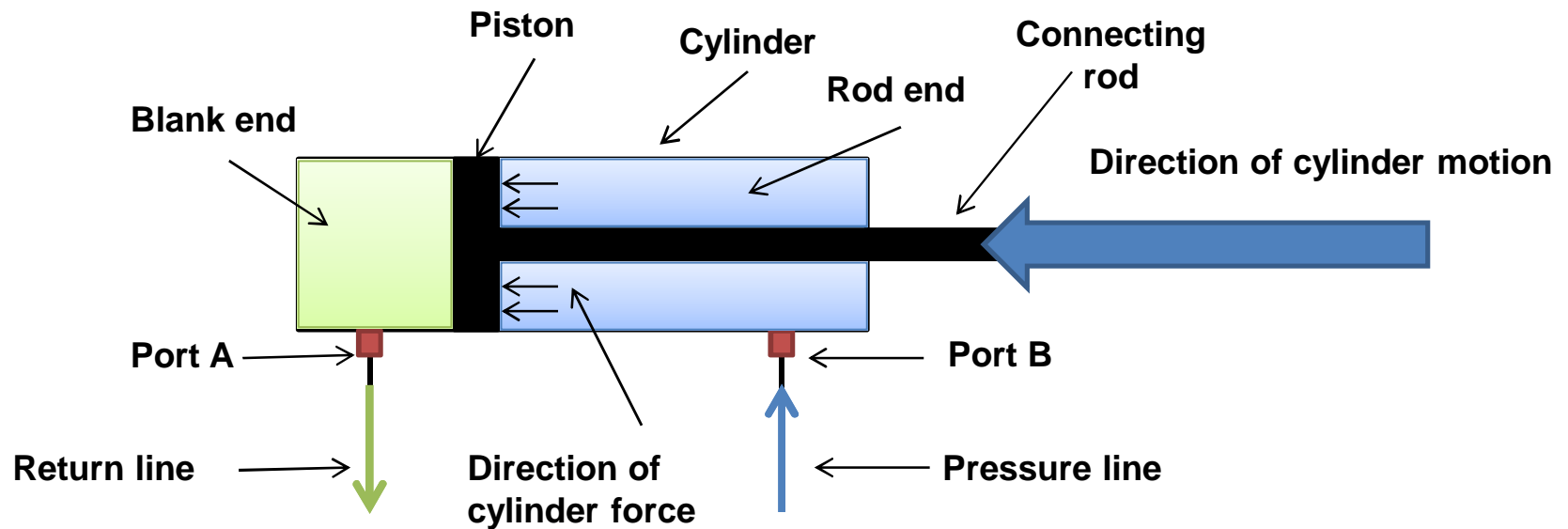

Green color indicates return line pressure & must be connected to reservoir/tank

Blue color indicates working pressure & must be connected to pump

Look at the direction of actuation of cylinder and entry/exit of oil...!!!

How to achieve **direction control** for **extension**?

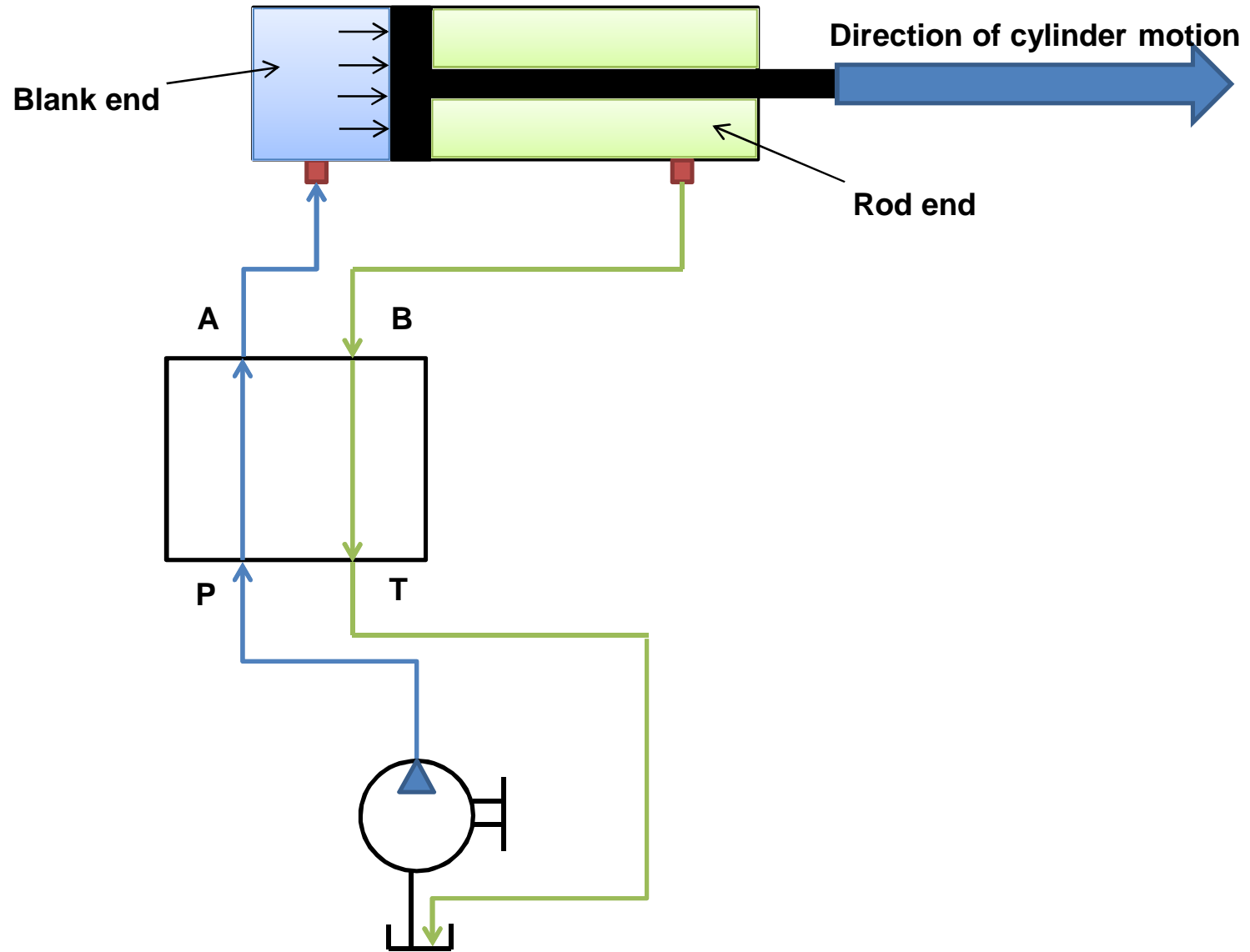

How to achieve **direction control** for **retraction**?

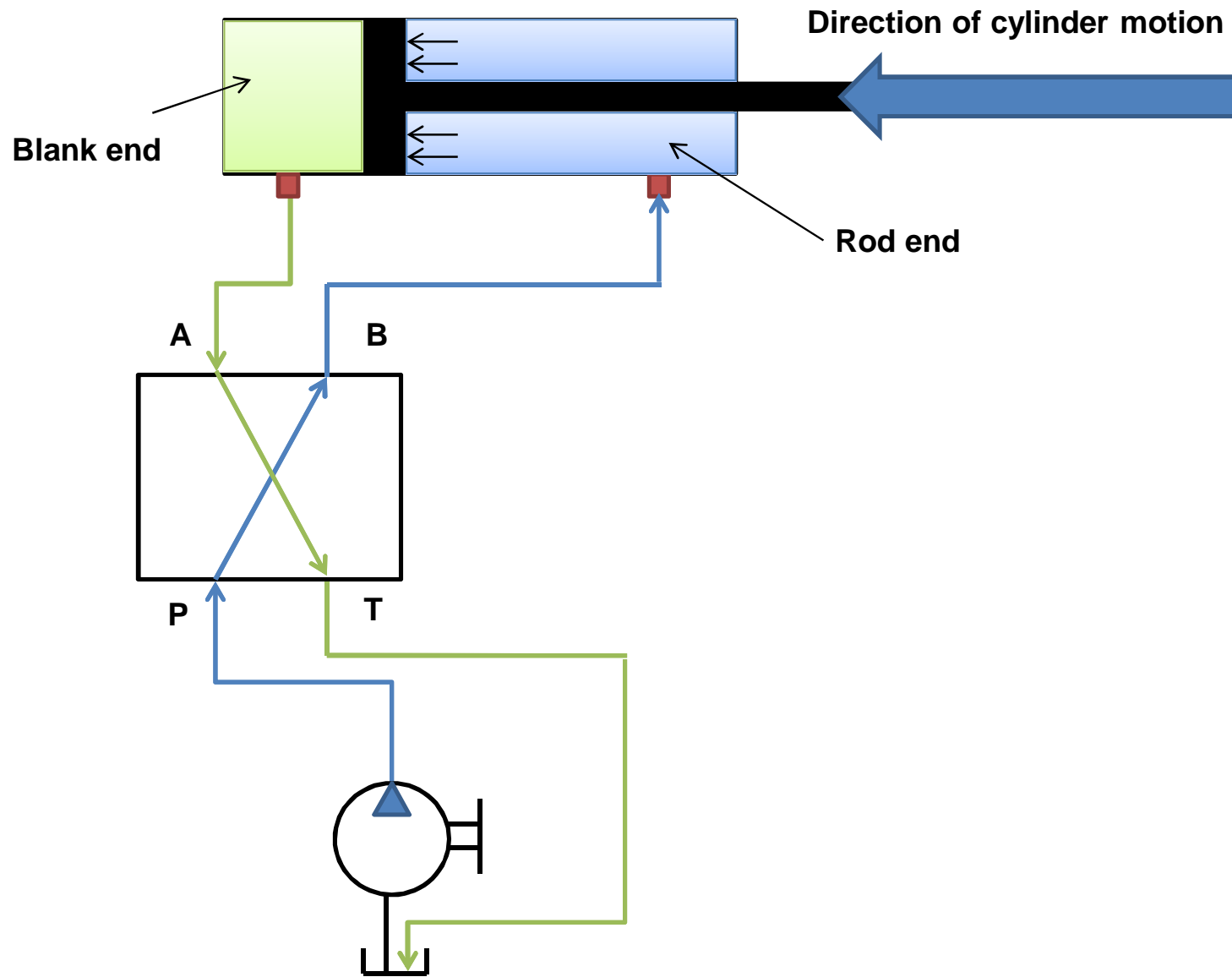

How to achieve **direction control** for **locking of cylinder**?

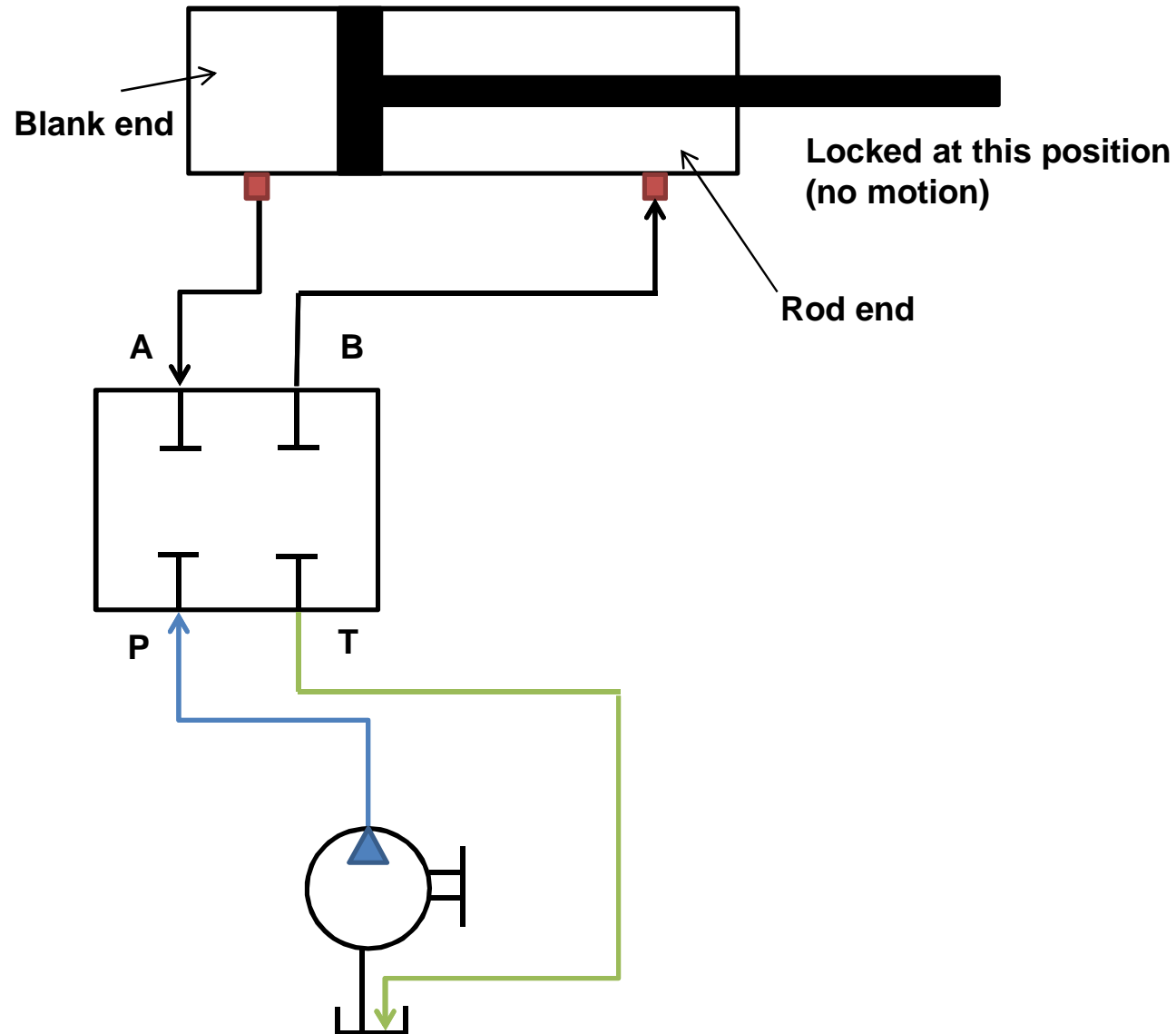

How to achieve direction control?

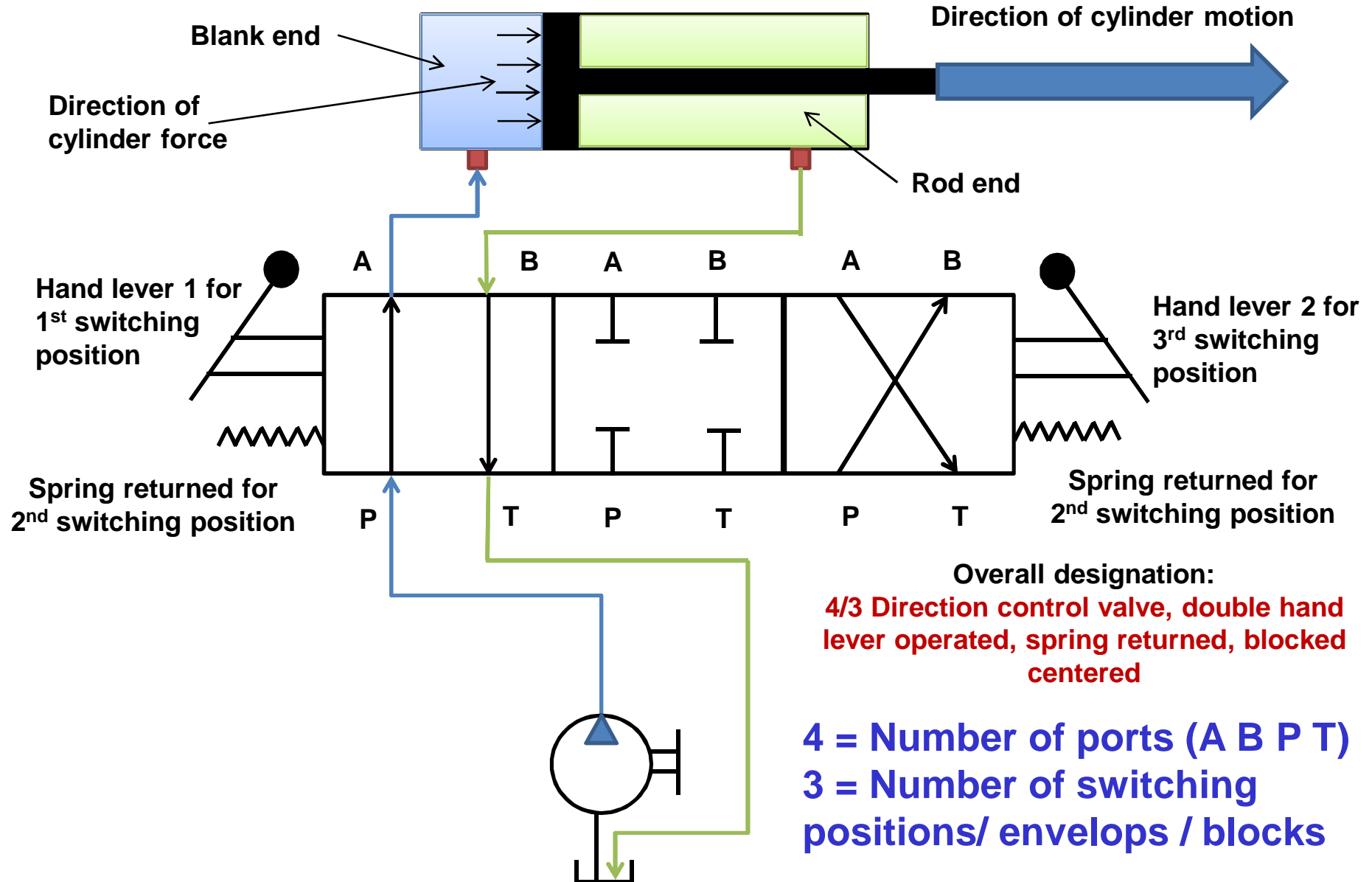

What is **back pressure**? When it arise? How to avoid it?

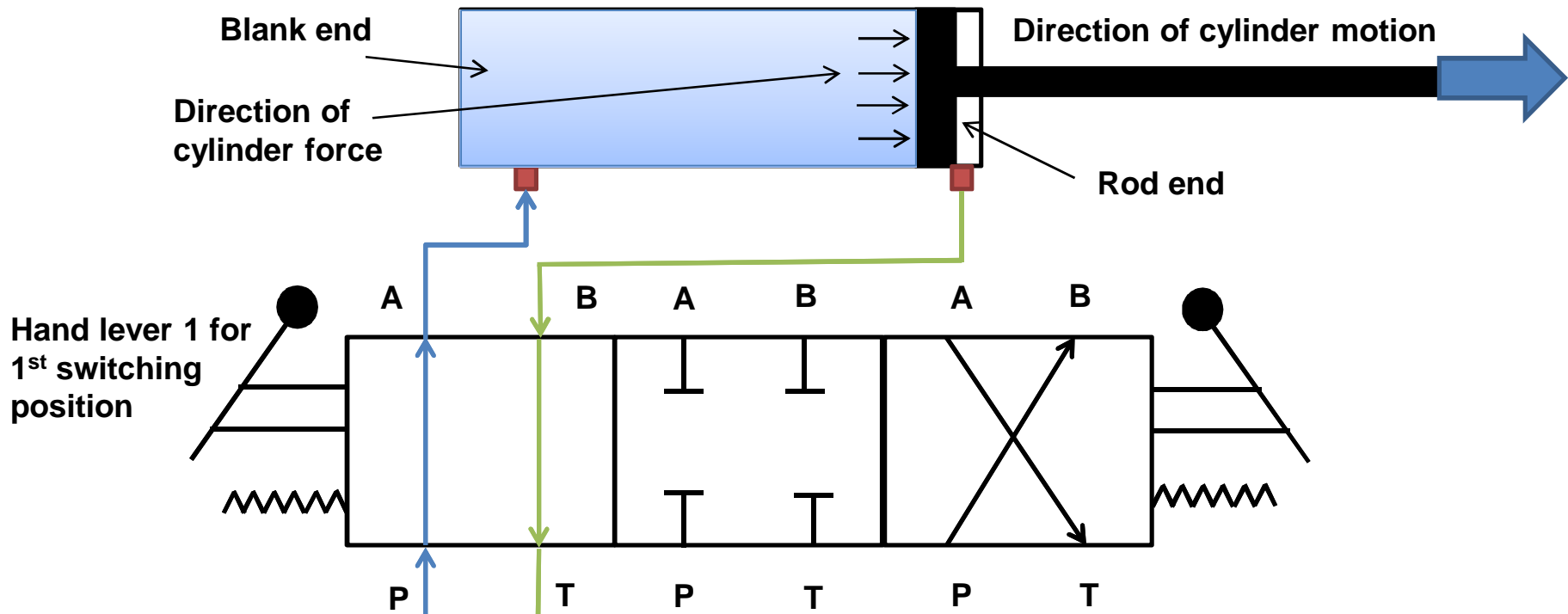

For extension

Back pressure is a **resistance or force opposing the desired flow of fluid**. **At the end of the extension**, blank end side and pressure line will be **full of oil** and there is no space for oil which is coming from pump. This creates a **back pressure** and thus it **needs to be relieved**. For this a **pressure relief valve** must be added in pressure line (**After a pump and before direction control valve**).

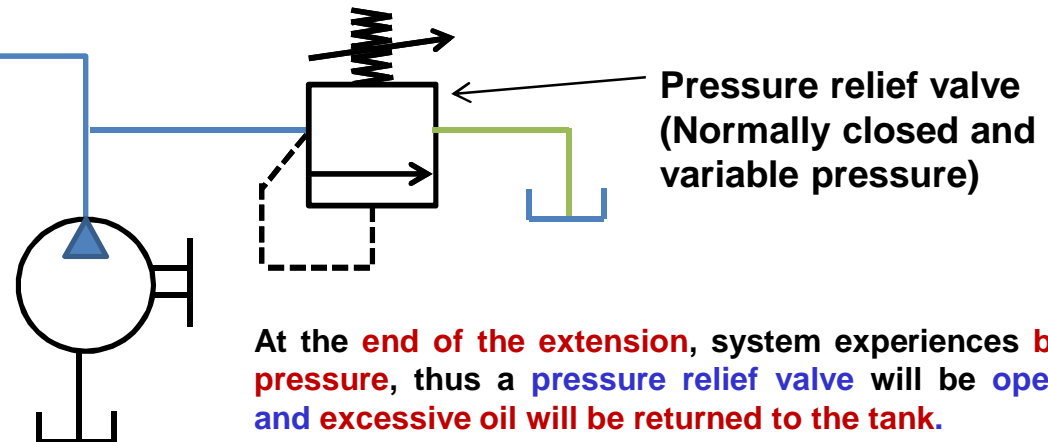

At the **end of the extension**, system experiences **back pressure**, thus a **pressure relief valve** will be **opened** and **excessive oil** will be **returned to the tank**.

What is **back pressure**? When it arise? How to avoid it?

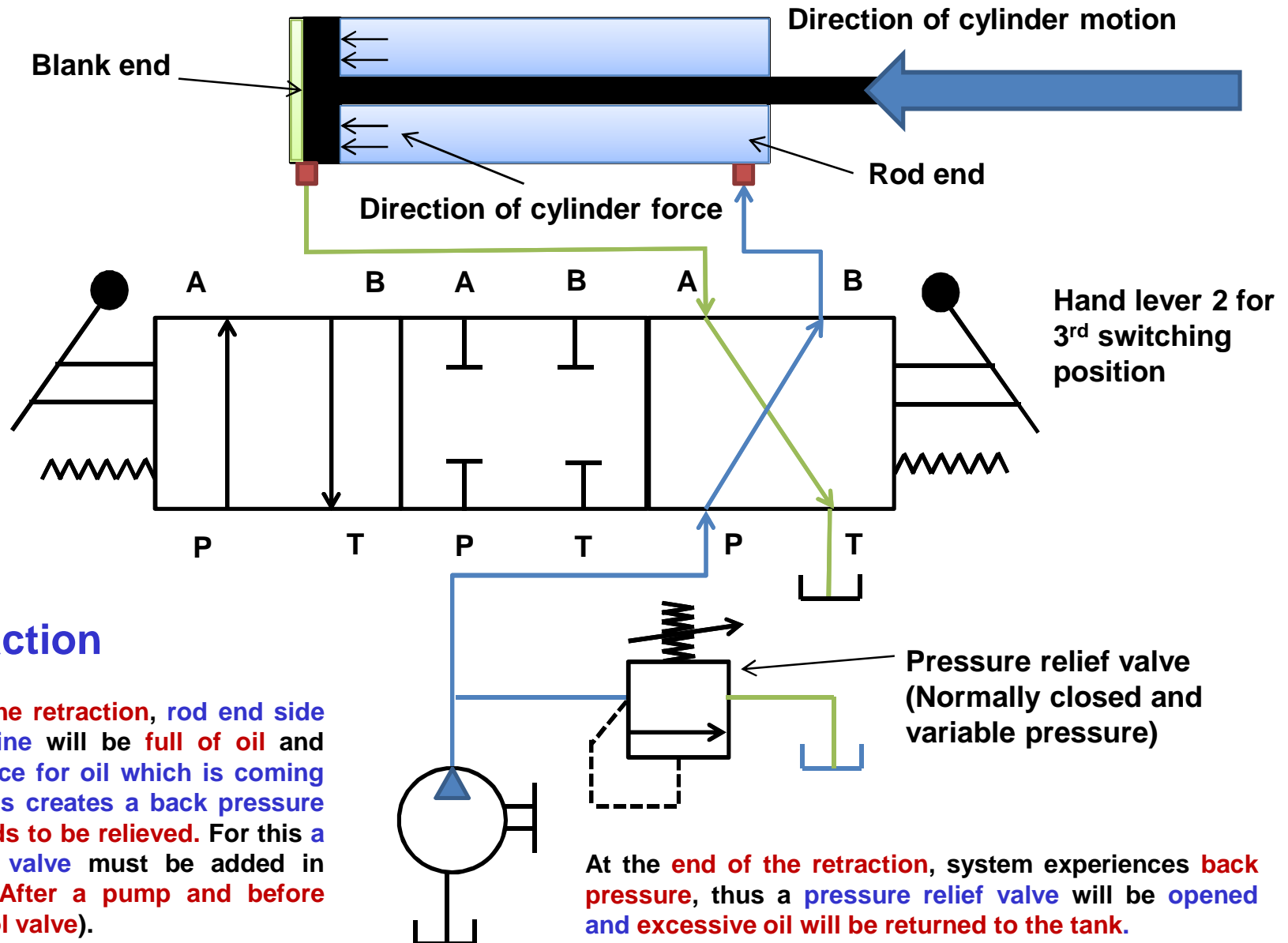

For Retraction

At the end of the retraction, rod end side and pressure line will be full of oil and there is no space for oil which is coming from pump. This creates a back pressure and thus it needs to be relieved. For this a pressure relief valve must be added in pressure line (After a pump and before direction control valve).

At the end of the retraction, system experiences back pressure, thus a pressure relief valve will be opened and excessive oil will be returned to the tank.

Calculation of pressure, velocity, power during extension of a double acting cylinder

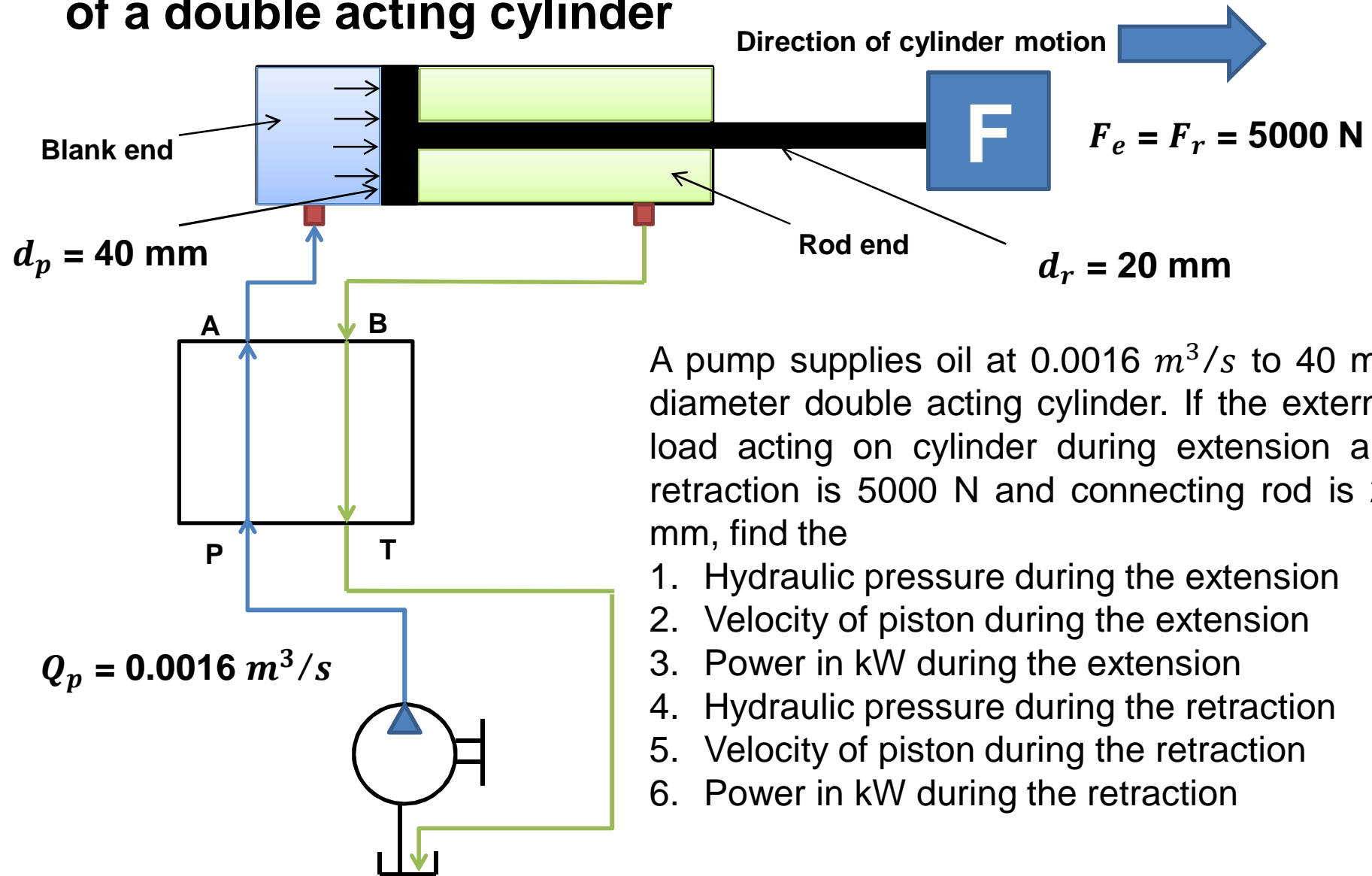

A pump supplies oil at $0.0016 \text{ m}^3/\text{s}$ to 40 mm diameter double acting cylinder. If the external load acting on cylinder during extension and retraction is 5000 N and connecting rod is 20 mm, find the

1. Hydraulic pressure during the extension
2. Velocity of piston during the extension
3. Power in kW during the extension
4. Hydraulic pressure during the retraction
5. Velocity of piston during the retraction
6. Power in kW during the retraction

Calculation of pressure during extension

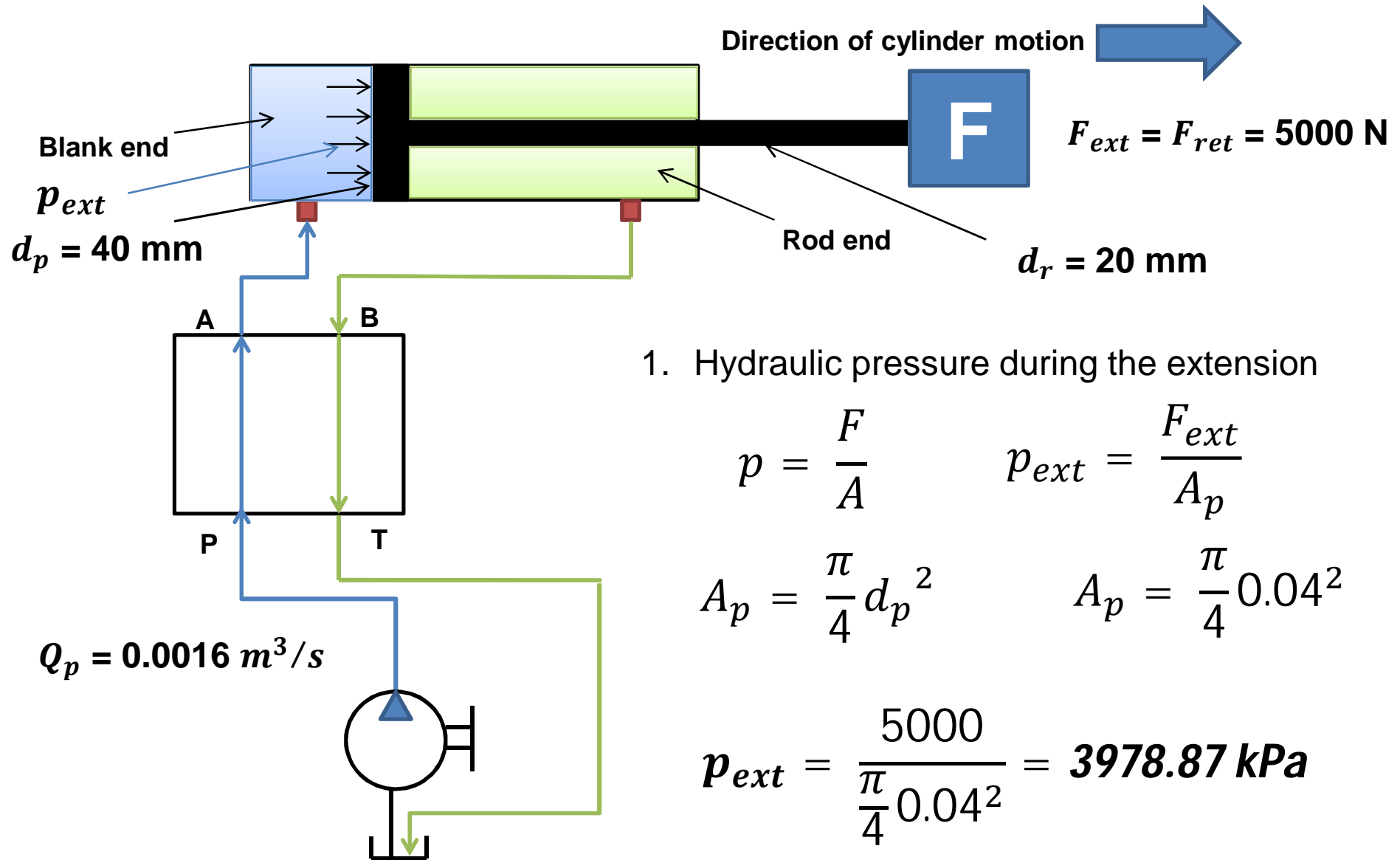

Calculation of velocity during extension

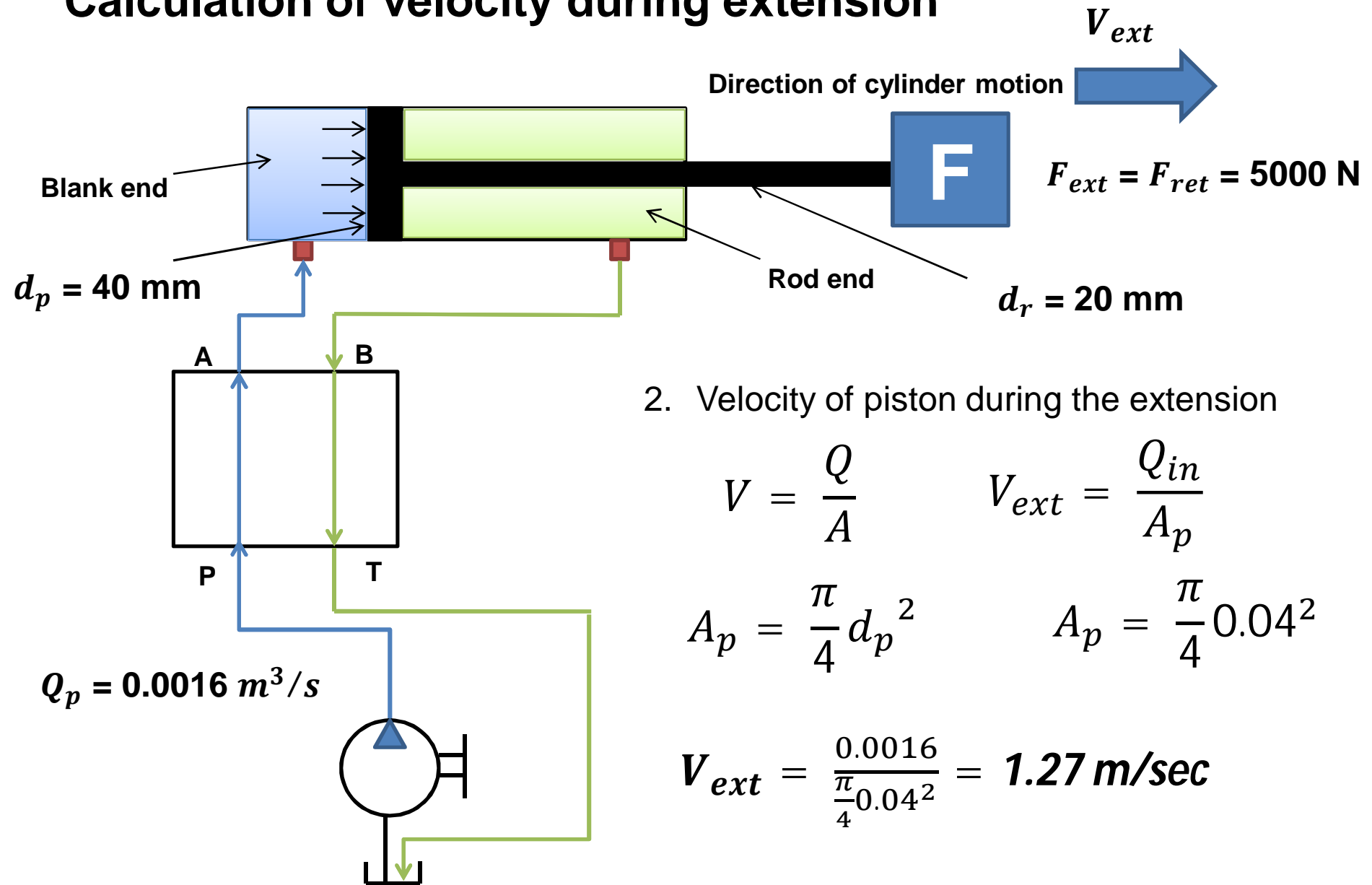

Calculation of power during extension

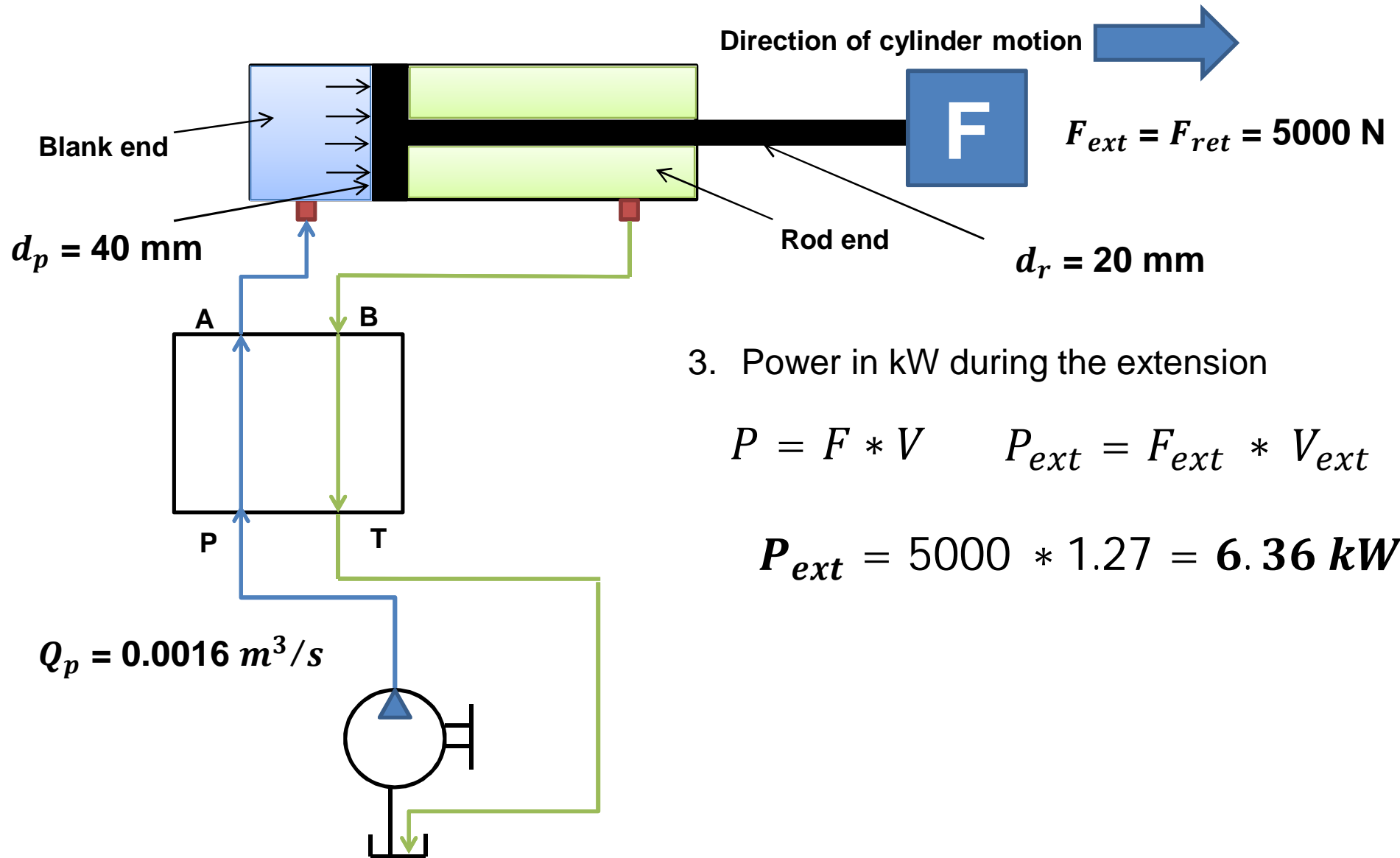

3. Power in kW during the extension

$$P = F * V \quad P_{ext} = F_{ext} * V_{ext}$$

$$P_{ext} = 5000 * 1.27 = 6.36 \text{ kW}$$

Calculation of pressure during retraction

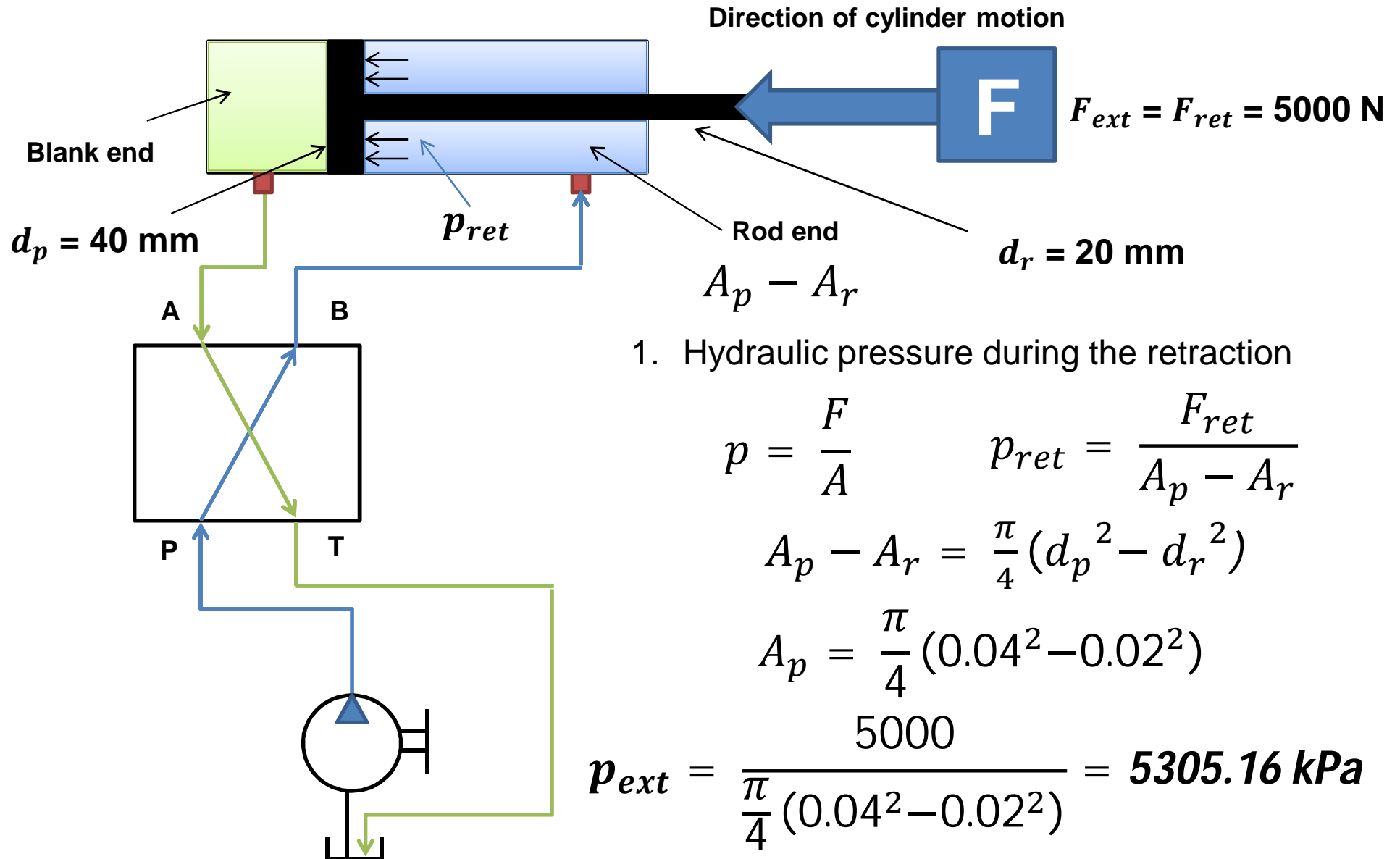

Calculation of velocity during retraction

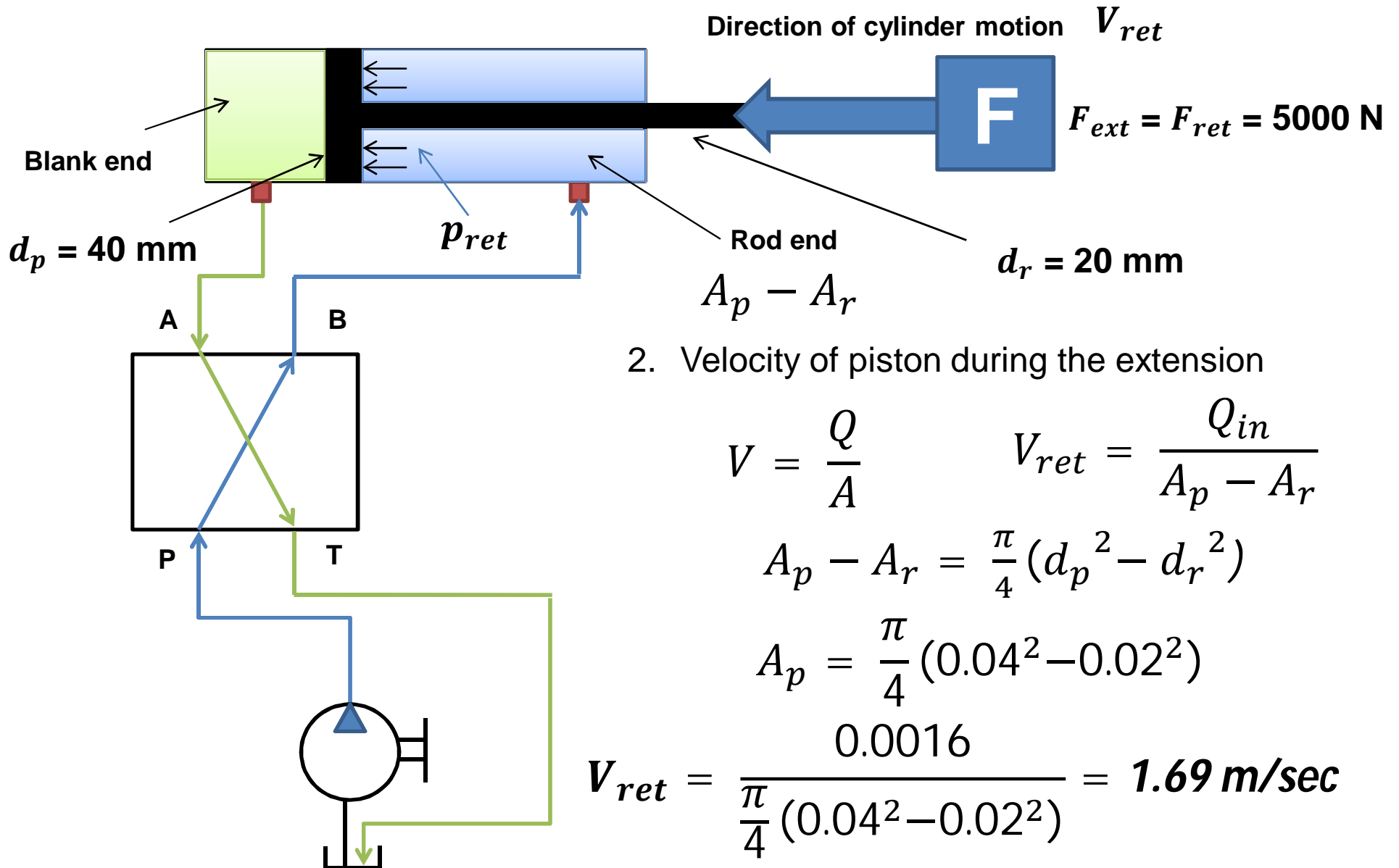

Calculation of power during retraction

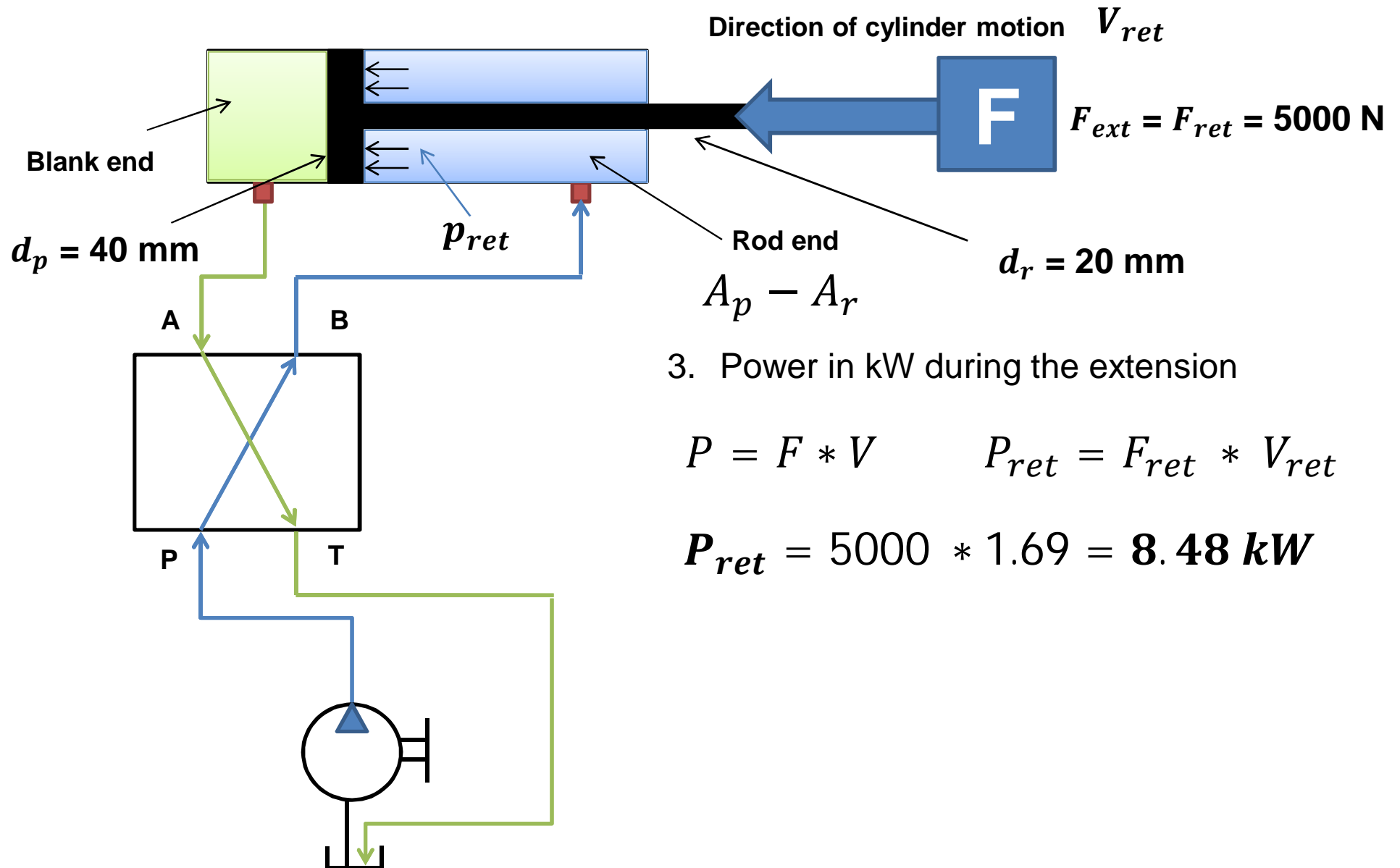

	Extension		Retraction
Pressure	$p_{ext} = \frac{F_{ext}}{A_p}$ <p>3978.87 kPa</p>	<	$p_{ret} = \frac{F_{ret}}{A_p - A_r}$ <p>5305.16 kPa</p>
Velocity	$V_{ext} = \frac{Q_{in}}{A_p}$ <p>1.27 m/sec</p>	<	$V_{ret} = \frac{Q_{in}}{A_p - A_r}$ <p>1.69 m/sec</p>
Power	$P_{ext} = F_{ext} * V_{ext}$ <p>6.36 kW</p>	<	$P_{ret} = F_{ret} * V_{ret}$ <p>8.48 kW</p>

Regenerative circuit (fast extension)

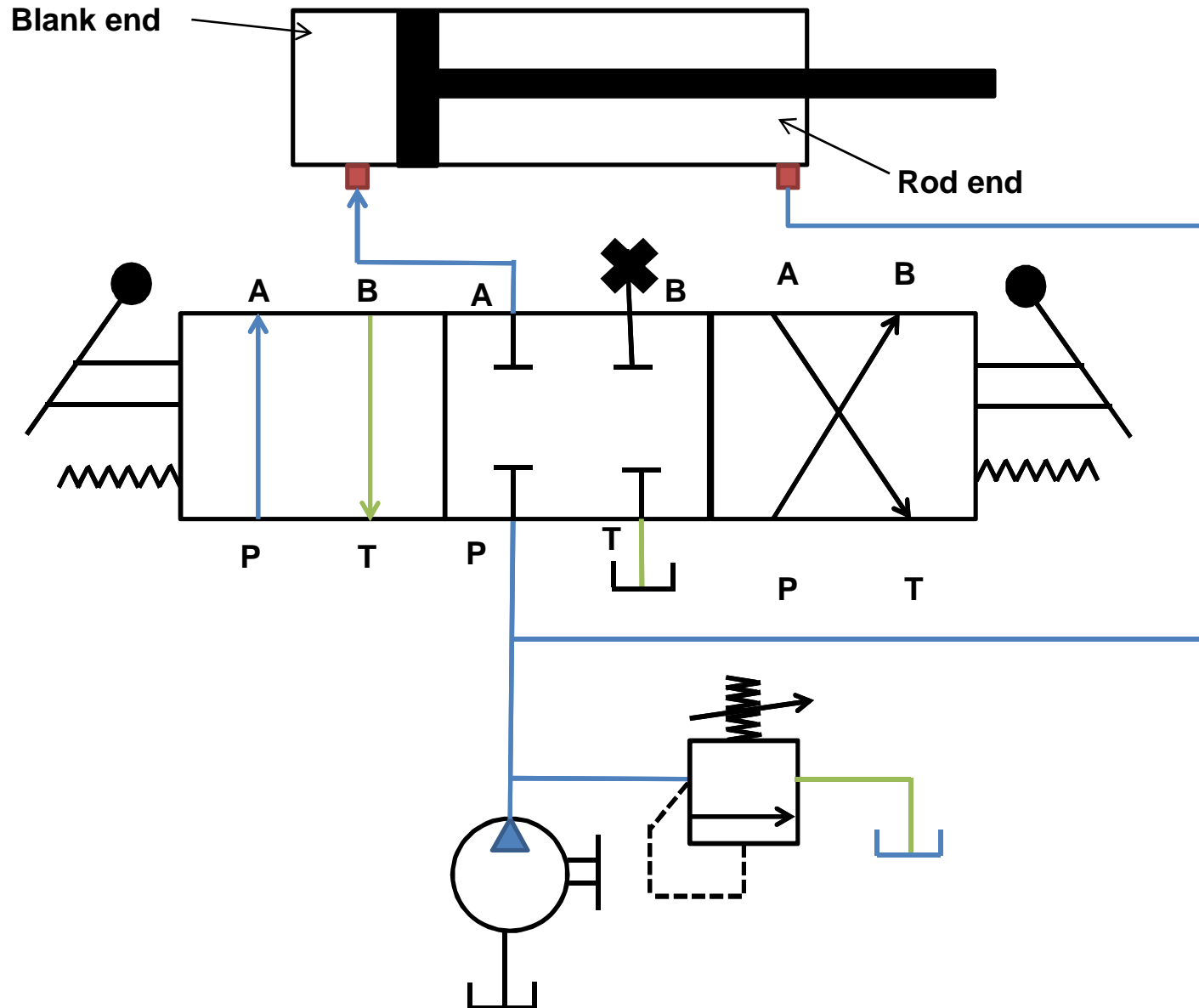

Regenerative circuit (fast extension)

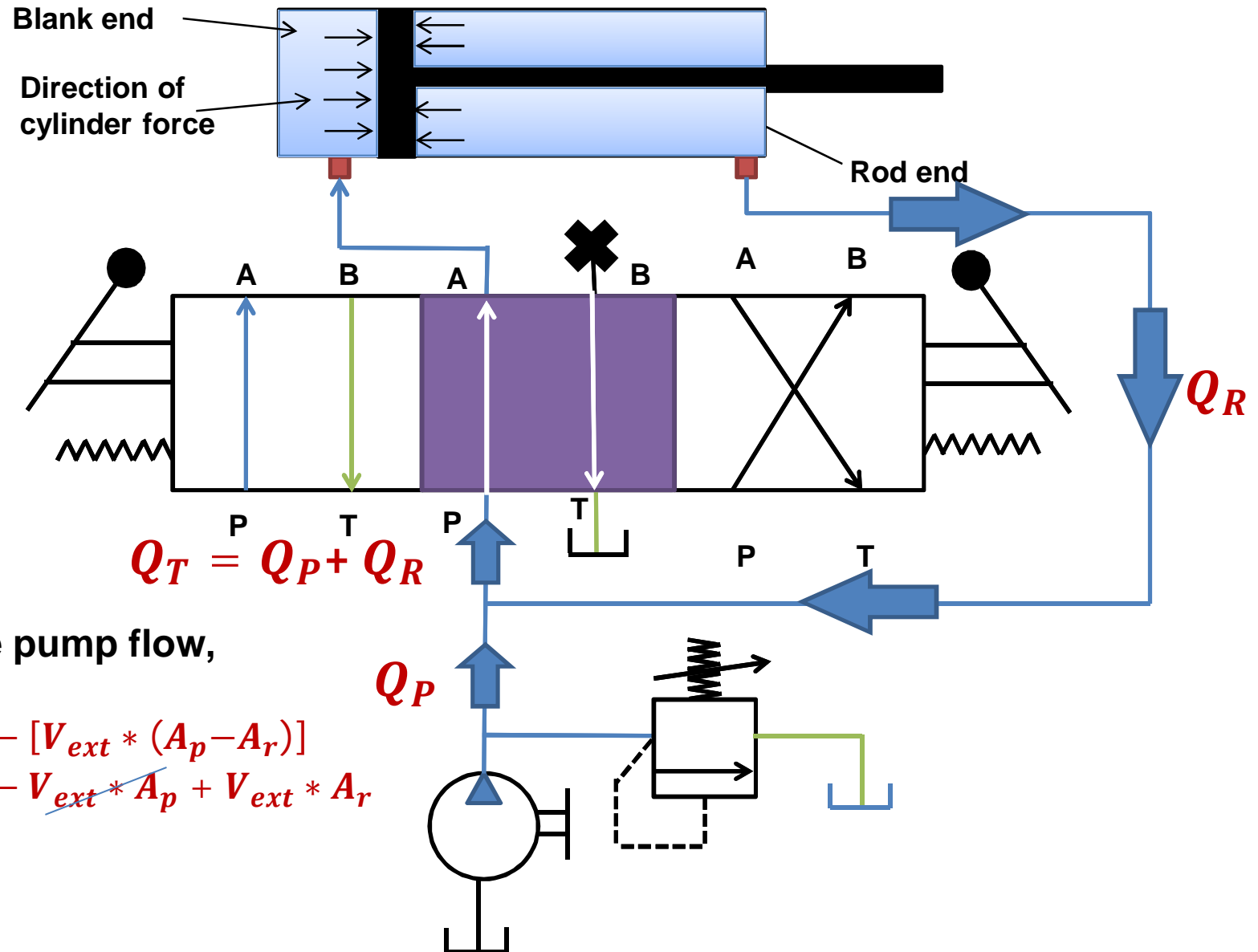

Solving for the pump flow,

$$Q_P = Q_T - Q_R$$

$$Q_P = V_{ext} * A_p - [V_{ext} * (A_p - A_r)]$$

$$Q_P = \cancel{V_{ext} * A_p} - \cancel{V_{ext} * A_p} + V_{ext} * A_r$$

$$Q_P = V_{ext} * A_r$$

$$V_{ext} = Q_P / A_r$$

Regenerative circuit (fast extension)

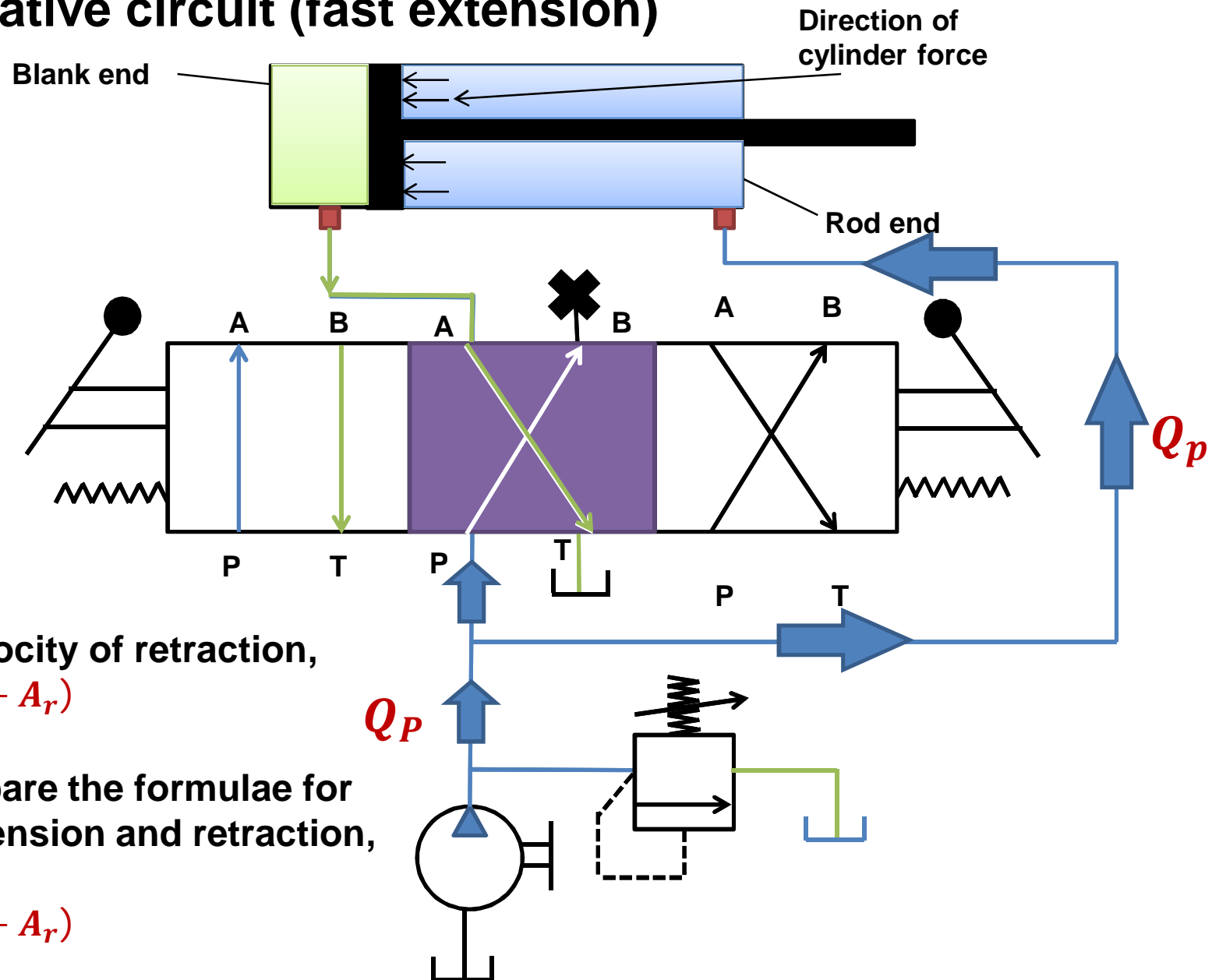

Solving for velocity of retraction,

$$V_{ret} = Q_P / (A_p - A_r)$$

So if you compare the formulae for Velocity of extension and retraction,

$$V_{ext} = Q_P / A_r$$

$$V_{ret} = Q_P / (A_p - A_r)$$

Regenerative circuit (fast extension)

Dividing velocity of extension by velocity of retraction,

$$\frac{V_{ext}}{V_{ret}} = \frac{Q_P / A_r}{Q_P / (A_p - A_r)}$$

$$\frac{V_{ext}}{V_{ret}} = \frac{A_p - A_r}{A_r}$$

$$\frac{V_{ext}}{V_{ret}} = \frac{A_p}{A_r} - 1$$

From Eq. (9-3), we see that when the piston area equals two times the rod area, the extension and retraction speeds are equal. In general, the greater the ratio of piston area to rod area, the greater the ratio of extending speed to retracting speed.

Regenerative circuit (fast extension)

It should be kept in mind that the load-carrying capacity of a regenerative cylinder during extension is less than that obtained from a regular double-acting cylinder. The load-carrying capacity (F_{load}) for a regenerative cylinder equals the pressure times the piston rod area rather than the pressure times piston area. This is due to the same system pressure acting on both sides of the piston during the extending stroke of the regenerative cylinder. This is in accordance with Pascal's law.

$$F_{\text{load}} = PA_r \quad (9-4)$$

Thus, we are not obtaining more power from the regenerative cylinder because the extending speed is increased at the expense of load-carrying capacity.

Regenerative circuit (fast extension)

		Extension	Retraction
Pressure	Simple	$p_{ext} = \frac{F_{ext}}{A_p}$	$p_{ret} = \frac{F_{ret}}{A_p - A_r}$
	Regenerative	$p_{ext} = \frac{F_{ext}}{A_r}$	$p_{ret} = \frac{F_{ret}}{A_p - A_r}$
Velocity	Simple	$V_{ext} = \frac{Q_{in}}{A_p}$	$V_{ret} = \frac{Q_{in}}{A_p - A_r}$
	Regenerative	$V_{ext} = \frac{Q_{in}}{A_r}$	$V_{ret} = \frac{Q_{in}}{A_p - A_r}$
Power	Simple	$P_{ext} = F_{ext} * V_{ext}$	$P_{ret} = F_{ret} * V_{ret}$
	Regenerative	$P_{ext} = F_{ext} * V_{ext}$	$P_{ret} = F_{ret} * V_{ret}$

Fluid Machinery & Fluid Power

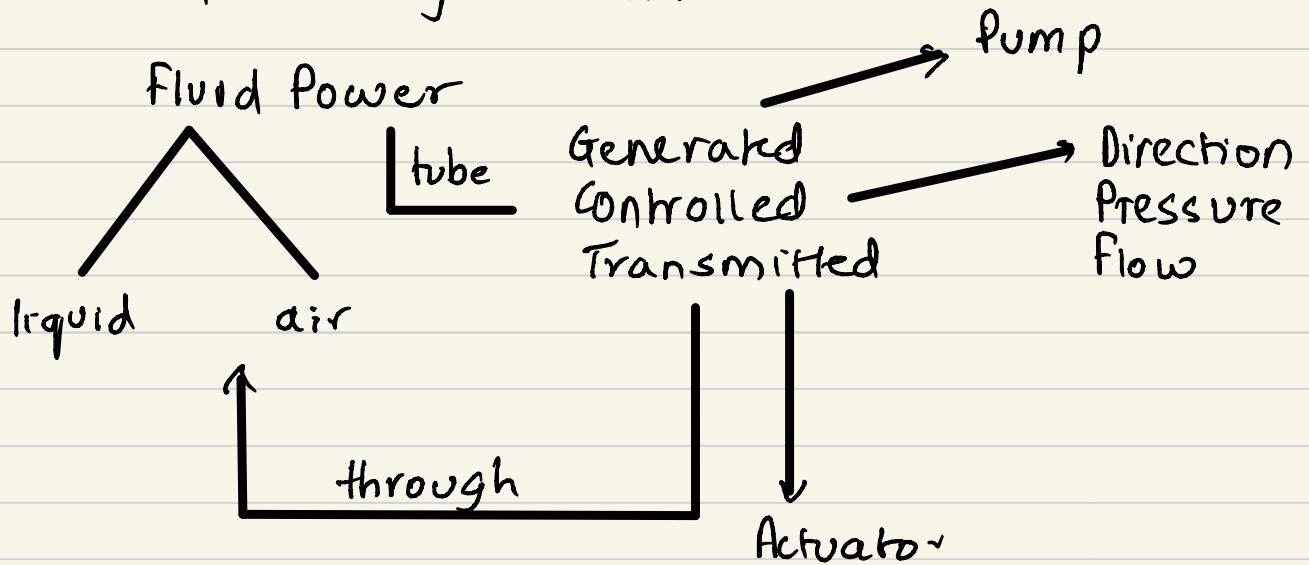

Activation of a double acting cylinder.

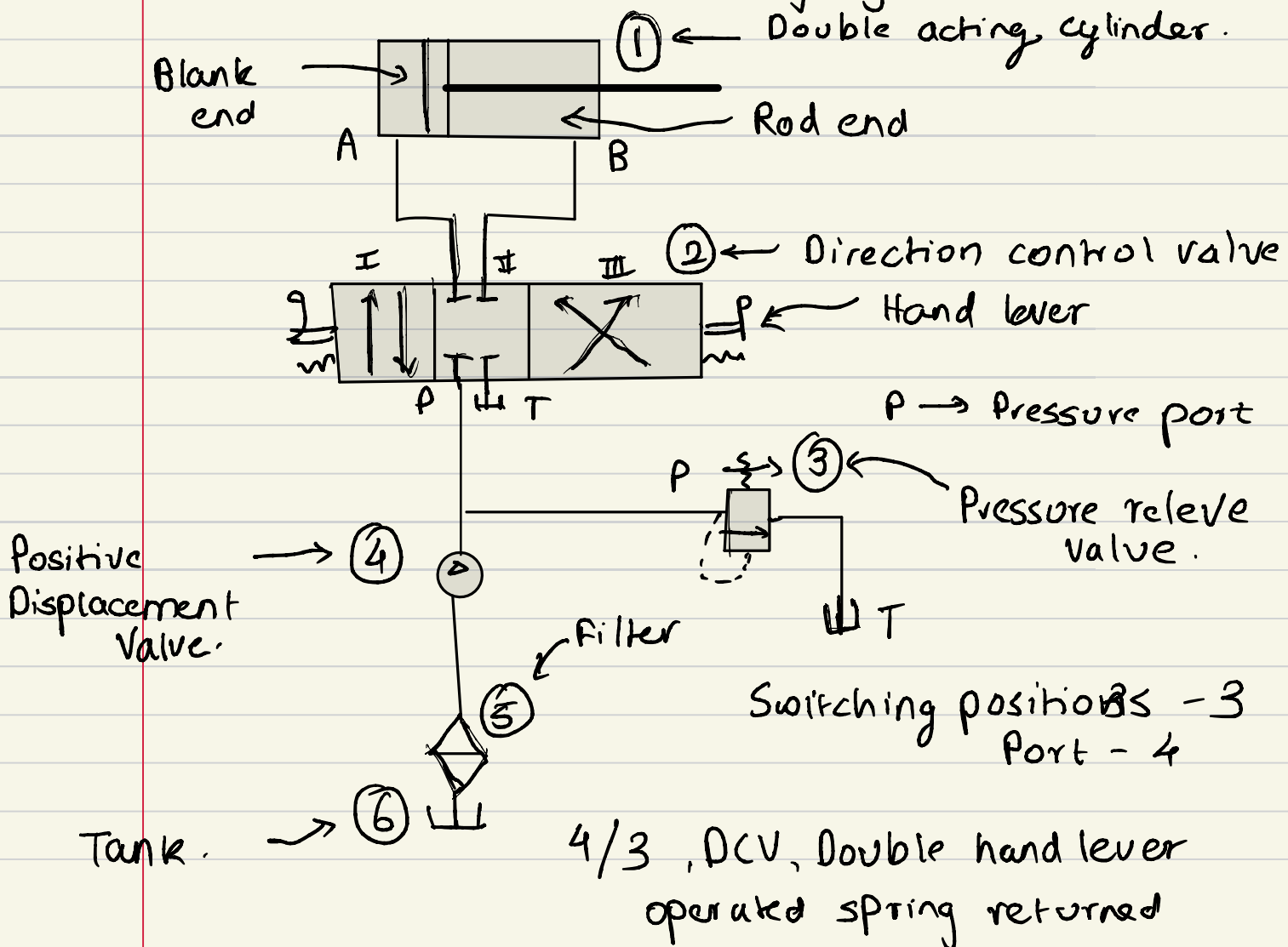

connecting rod / Piston comes out - Extension stroke
Connecting Rod goes in - Retraction stroke.

* Write working after going home.

These cylinders are used for power transmission

Cylinders can also be replaced by fans

Actuators are of 2 types

Cylinder - Linear motion

Fans - Rotational motion.

Func of pump is to convert mech to hydraulic energy.

Pumps are used to generate flow & not pressure.

Filter is used for fluid conditioning.

Working → The water from tank is filtered through the filter (5) and is pumped through the positive displacement valve. I.

In the initial phase i.e. (II), there is no connection of ports. Hence the fluid cannot reach the cylinder. Due to this back pressure is created which lifts the pressure relieve valve (3) and ~~the~~ fluid goes back in the tank.

In phase (I) P port is connected to A and T port to B. The fluid enters the cylinder through the Blank end and exerts pressure on the piston to the right side.

Due to this the connecting rod moves outwards and the stroke is called extension stroke. The fluid which is already present in the Rod end of cylinder comes through B port and goes to port T.

In **phase CIII** - from fig. the port A & T are connected and B & P are connected. Hence fluid enters through the rod end & pressure is exerted on piston & as a result piston moves inward. This is called as Retraction stroke.

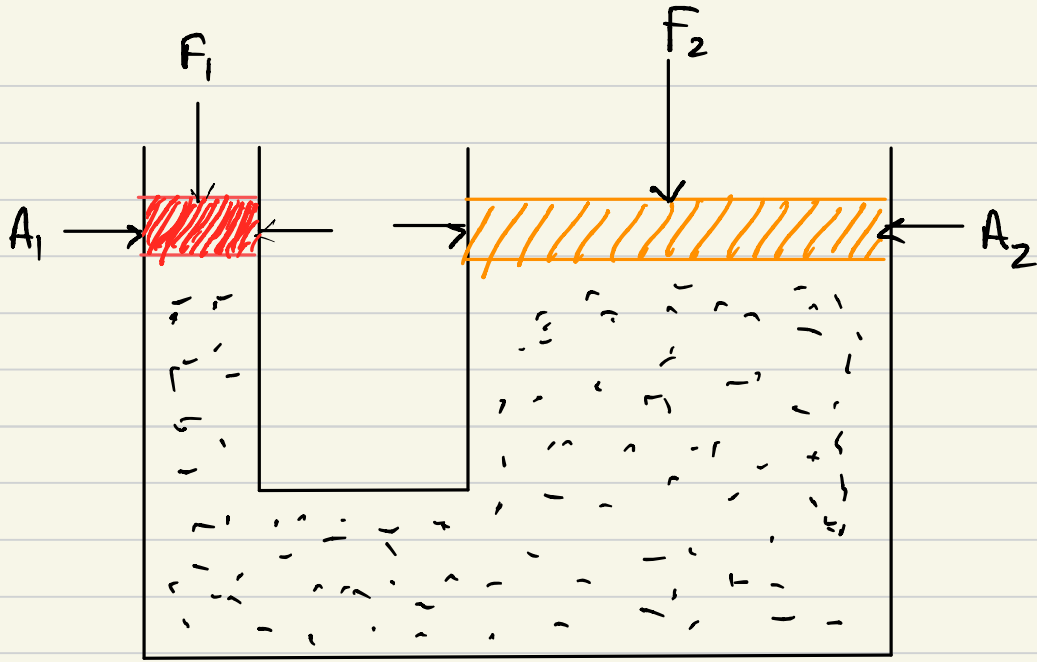

Pascals law

$$P_1 = F_1/A_1 \quad , \quad P_2 = F_2/A_2$$

$$P_1 = P_2 \quad \therefore \quad F_2 = P_1 A_2$$

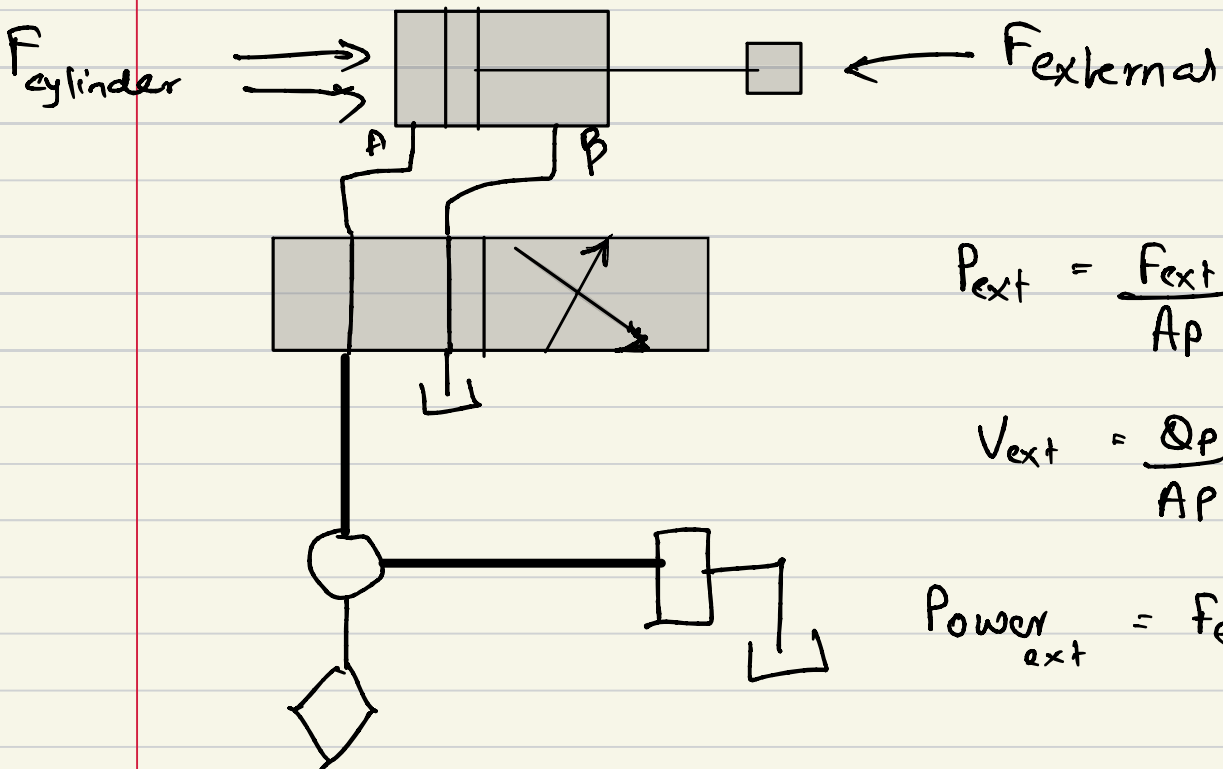

$$P_{ext} = \frac{F_{ext}}{A_p}$$

$$V_{ext} = \frac{Q_p}{A_p}$$

$$Power_{ext} = F_{ext} \times V_{ext}$$

Thus hydraulic power can be obtained using pressure & discharge or force & velocity.

* While Retraction, the area of connecting rod is also considered along with area of piston

$$\therefore P_{ret} = \frac{F_{ret}}{A_p - A_r}$$

$$V_{ret} = \frac{Q_p}{A_p - A_r}$$

\therefore Pressure during retraction $>$ Pressure during extension
 $V_{el} (Retraction) > V_{el} (Extension)$
 $P_{ret} > P_{ext}$.

Cylinders mounted in vertical direction

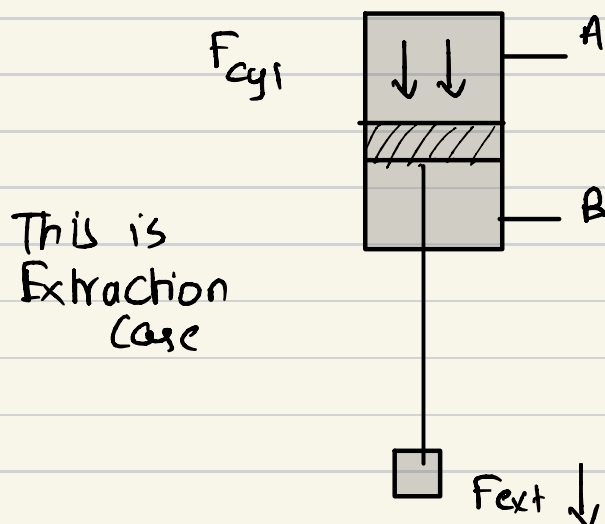

This is
Extraction
Case

Running loads

For retraction, the load will be pushed upwards however load always acts downwards

Case-1 Piston is located above C.R

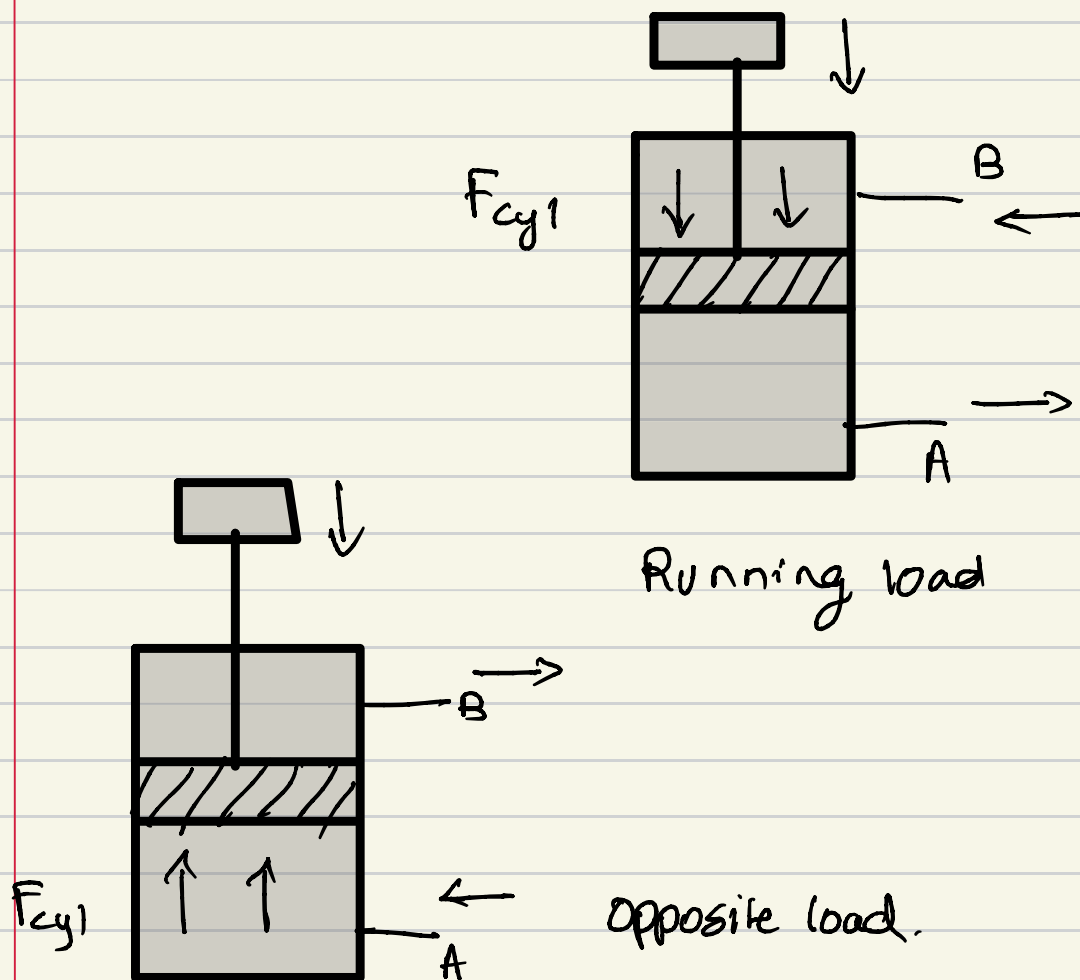

- * In the circuit which is drawn, if the return line is again connected to pressure line, instead of tank, the velocity of extension can be increased. This is called as Regeneration.

Designation of different letters used in hydraulic system :-

- 1) P : Pressure port
- 2) T or R : Return port
- 3) A and B : Cylinder ports
- 4) X, Y, Z : Pilot ports

Multiple cylinders such as C_1, C_2 and so on.

$C_1 +$ = Extension of cylinder 1

$C_1 -$ = Retraction of cylinder 1

$C_2 +$ = Extension of cylinder 2

$C_2 -$ = Retraction of cylinder 2

5) E : Exhaust port

Hydraulic lines

1)  : Working hydraulic line

2)  : Pilot line (Dash line)

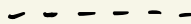
3)  : Drain line (Dotted line)

4)  : Flexible line

Line joints or joining lines

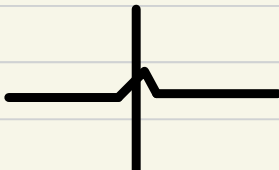
 : Line passing

 : Flow direction (Hydraulic)

 : Pneumatic

Hydraulic reservoir or hydraulic tank: 

- * Continuous non-flowing line is represented by black colour
- Continuous pump flow: Red colour
- Continuous tank flow: Blue colour.
- Continuous suction flow: Green colour
- Continuous metered flow: Yellow colour
- Continuous Reduced pressure: Orange colour
- Continuous Intensified fluid: Purple colour

Hydraulic Pumps

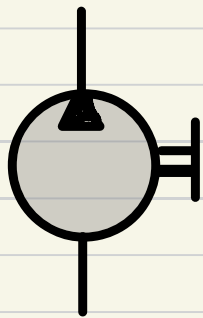

- Fixed displacement unidirectional pump.
Displacement of pump is amount of liquid delivered per cycle.

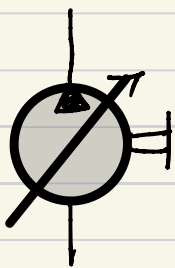

- Variable displacement unidirectional pump.
Displacement can be varied by varying the speed of pump.

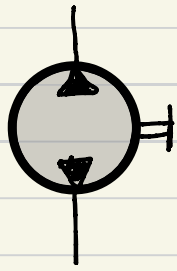

- Fixed displacement bidirectional pump.

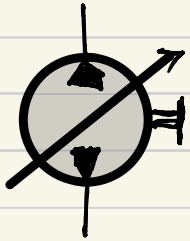

- Variable displacement bidirectional pump.

* Actuators

i) Motors: In motors, hydraulic energy is converted into mechanical energy.

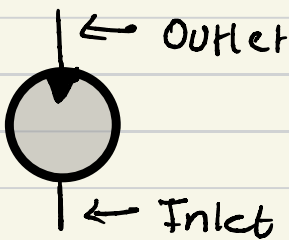

- Fixed displacement unidirectional hydraulic motor

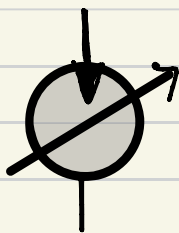

- Variable displacement unidirectional hydraulic motor.



- Fixed displacement unidirectional

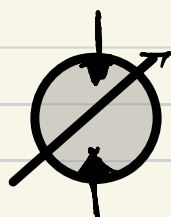

- Variable displacement unidirectional

2) Hydraulic cylinders:

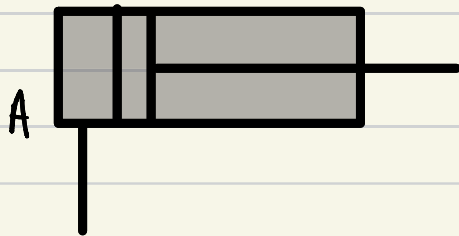

- Single acting cylinder
(only one port at blank end)

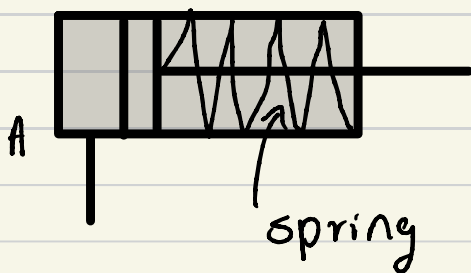

- Single acting cylinder
spring return.

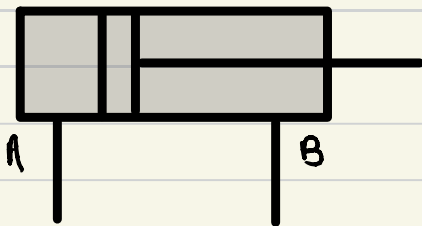

- Double acting cylinder

Pillow

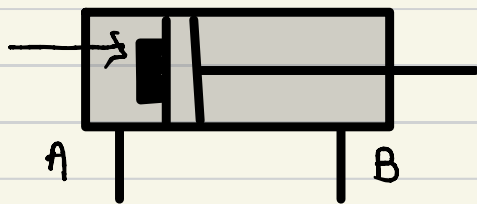

- Cushioned cylinder on blank end side.

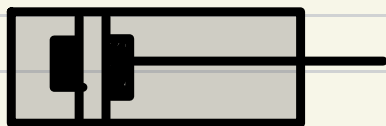

- Cushioned cylinder on both sides

Double acting hydraulic cylinder with piston rods at both ends

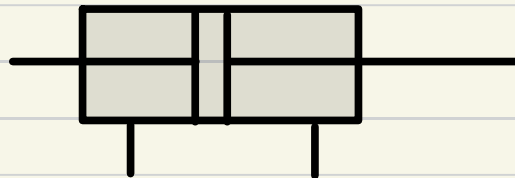

For this cylinder, the velocity & pressure of extension & retraction is same as the areas on both sides of piston is same.

Tandem cylinder

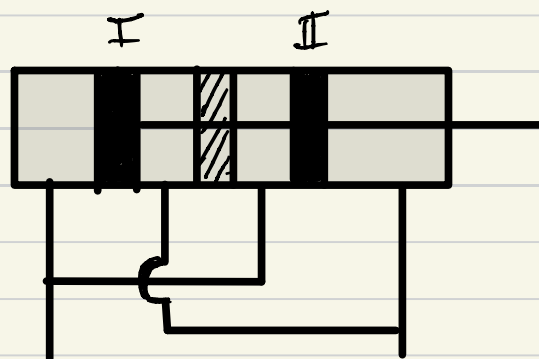

In this cylinder, as there is more area, the force acting on the cylinder will be more.

For case - I

$$P_{ext} = \frac{F_{ext}}{A_p}$$

For case - II

$$P_{ext} = \frac{F_{ext}}{A_p - A_r}$$

For retraction

$$P_{ret} = \frac{F_{ret}}{A_p - A_r}$$

... For both cases

∴ We can observe that cylindrical force for extension is greater than cylindrical force during retraction.

Telescopic cylinder - They are used to achieve greater stroke length for a given piston area.

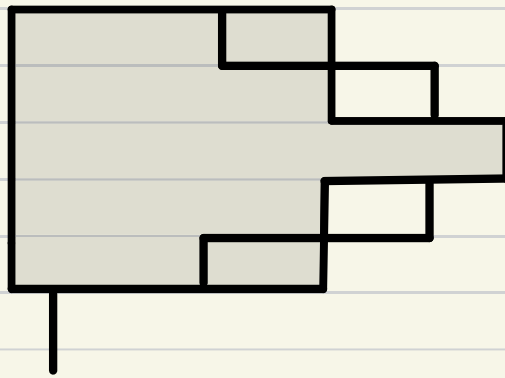

* Control valves:

1) Direction control valves

a) Simple non-return valve / check valve / one way valve

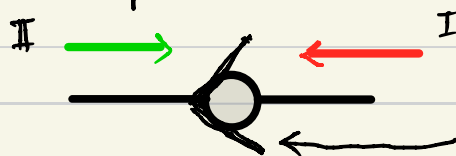

Indicate seat of valve.

To join the two pipelines, there shouldn't be any connection betⁿ the ball and the seat. So, in case I, if the water flows in the given direction, it tends to push the ball further on the seat.

In case II, if the water flows as shown, the ball tends to move away from the seat. Hence flow in only one direction can be allowed.

b) Pilot operated check valve:

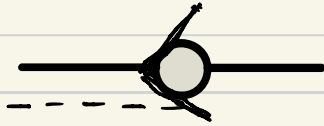

1] DCV with 2 ports — In the first case, the two ports are connected, so there is a possibility of flow in both direction.

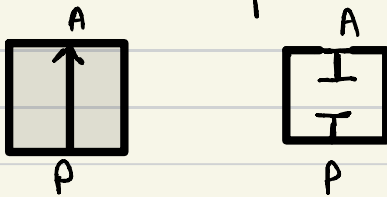

2] 2/2 DCV (Normally open)

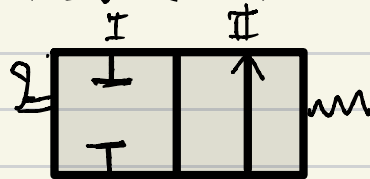

3] 2/2 DCV (Normally closed)

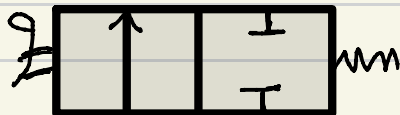

In 2] If hand lever is pressed, 'I' is brought into working condition and as soon as the lever is released 'II' comes into working due to spring. It is called normally open because only when the hand lever is pressed, the valve remains open.

- 1) DCV with 3 ports - Used to activate single acting cylinder or two auxiliary valves & also in 2 hand safety circuit.

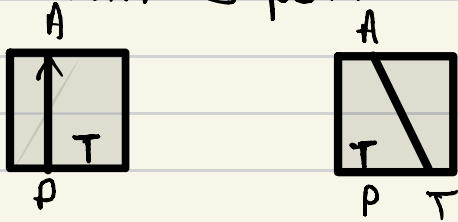

- 2) 3/2 DCV (Normally open) - Used for extension

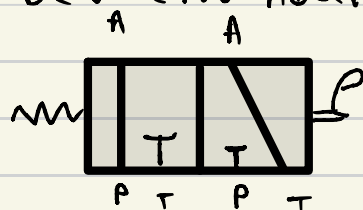

- 3) 3/2 DCV (Normally closed) - Used for retraction

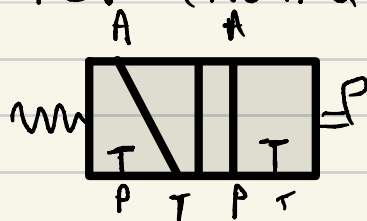

- 4) DCV with 4 ports

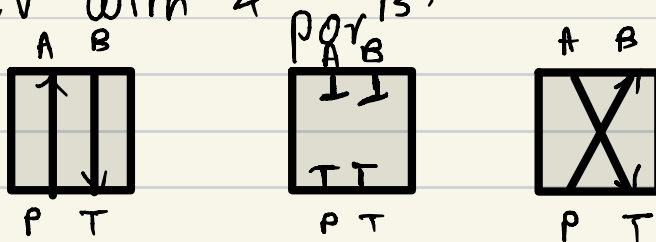

4/2

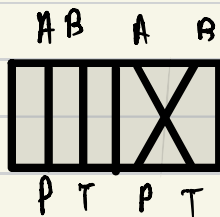

4/3

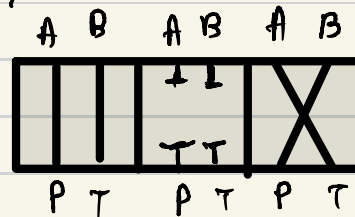

- * For a double acting cylinder only one 3/2 valve can't be used, two 3/2 valves are required.

→ Flow control valves

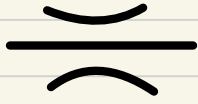

- Fixed throttle valve.



- Variable throttle valve.

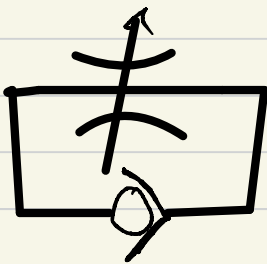

- This valve allows controlled flow of liquid in one direction & free flow in other direction, can be used to monitor extraction.

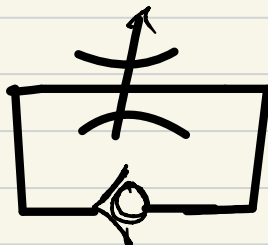
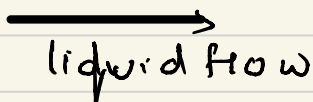

- Can be used to monitor retraction

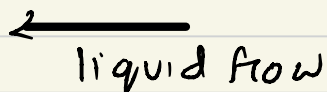

Regenerative circuits

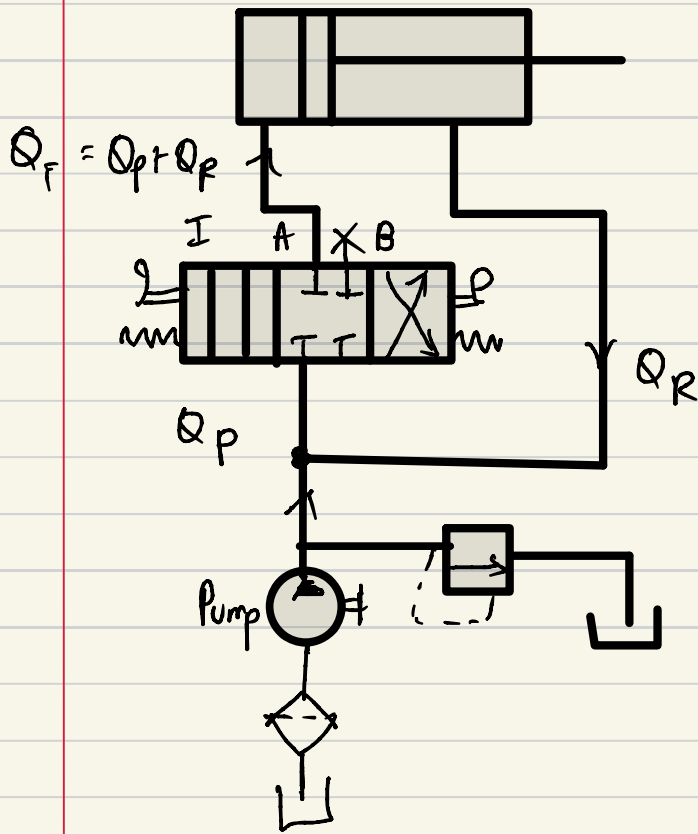

Simple DAC circuit.

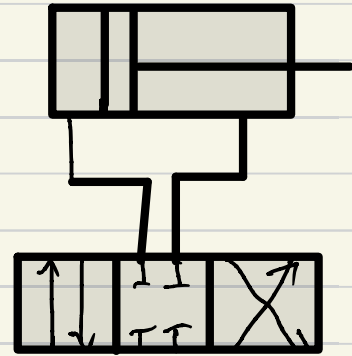

Use of Regenerative circuit is to achieve faster velocity of extension where return line is connected to pressure line parallelly.

Now for Ist section.

$$Q_T = Q_p + Q_R \quad \therefore Q_p = Q_T - Q_R$$

$$A_p \times V_e \quad \rightarrow \quad (A_p - A_r) V_e$$

$V_e \rightarrow$ extension vel.

$$\therefore Q_p = A_p \cdot V_e - A_r \cdot V_e + A_r \cdot V_e$$

$$\therefore Q_p = A_r \cdot V_e \quad \therefore V_{ext} = \frac{Q_p}{A_r}$$

In the exp, denominator is A_r which is smaller than A_p , (which is the case for simple circuit). Hence V_{ext} is more.

First justification was that added discharge from return line results in higher velocity.

For \square section

$$V_{ret} = \frac{Q_p}{A_p - A_r}$$

Now

$$\frac{V_{ext}}{V_{ret}} = \frac{Q_p / A_r}{Q_p / (A_p - A_r)} = \frac{A_p - A_r}{A_r} = \frac{A_p}{A_r} - 1$$

Now if $\frac{V_{ext}}{V_{ret}} = D$.. it means V_{ext} is D small

If $A_p = 2A_r$ then $V_{ext} = V_{ret}$
 $\therefore \frac{A_p}{A_r} = 2 \therefore \frac{V_{ext}}{V_{ret}} = 1$

Now consider

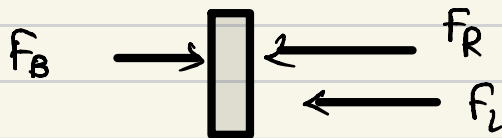

F_R → force on Rod end
 F_L → External force
 F_B → force on Blank end

$$\begin{aligned} \therefore F_B &= F_R + F_L \\ \therefore F_L &= F_B - F_R = PA_p - P(A_p - A_r) \\ &= PA_p - PA_p + PA_r \\ \therefore F_L &= PA_r \end{aligned}$$

Regenerative circuit for drilling application

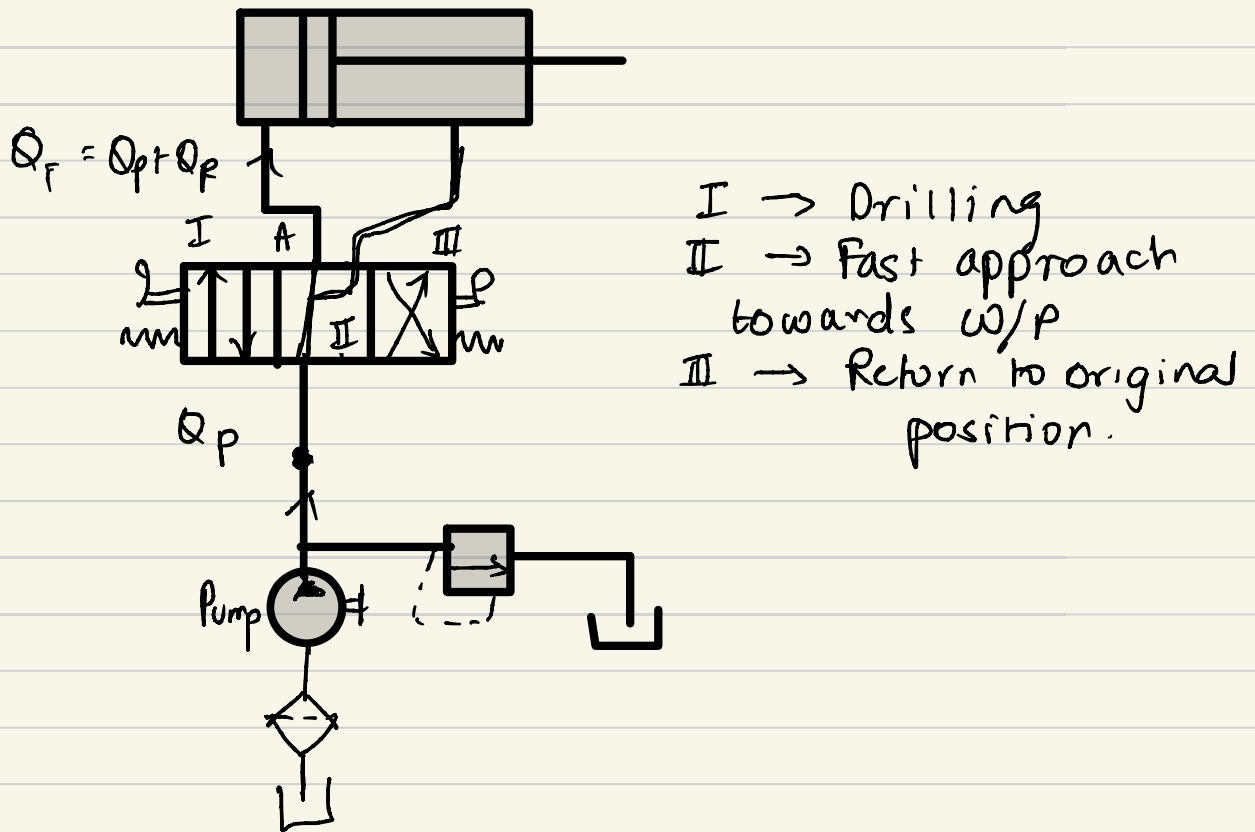

Regenerative circuit using 3/2 DCV

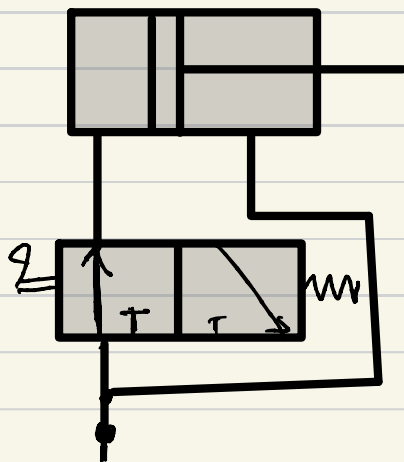

Q A pump supplies $0.0016 \text{ m}^3/\text{s}$ oil to an actuator of 40 mm dia & C.R dia is 20 mm . Ext load acting on cylinder is 5000 N for extension & retraction. Find V_{ext} , V_{ret} , Pressure during extension & retraction & Power during ext & ret for

- 1) Actuating DAC in normal way
- 2) Actuating DAC in regeneration for extension only

Now

$$P_{\text{ext}} = \frac{F_{\text{ext}}}{A_p} = \frac{5000}{\frac{\pi \times (0.04)^2}{4}} = 3.978 \text{ MPa.}$$

Now

$$P_{\text{ret}} = \frac{5000}{\frac{\pi ((0.04)^2 - (0.02)^2)}{4}} = 5.305 \text{ MPa.}$$

Now

$$V_{\text{ext}} = \frac{Q_p}{A_p} = \frac{0.0016}{1.2566 \times 10^{-3}} = 1.273 \text{ m/s}$$

$$V_{\text{ret}} = \frac{Q_p}{A_p - A_v} = \frac{0.0016}{9.424 \times 10^{-4}} = 1.6976 \text{ m/s}$$

Now

$$\text{Power}_{\text{ext}} = F_{\text{ext}} \times V_{\text{ext}} = 6.365 \text{ kW}$$

$$\text{Power}_{\text{ret}} = 5000 \times 1.6976 = 8.488 \text{ kW}$$

Now for regenerative circuit -

$$P = \frac{F_{\text{external}}}{A_1} = \frac{5000}{\frac{\pi \times (0.02)^2}{4}} = 15.915 \text{ MPa}$$

Now

$$v_{\text{ext}} = \frac{0.0016}{A_1} = \frac{0.0016}{3.141 \times 10^{-4}} = 5.092 \text{ m/s}$$

v_{ret} will be same as 1st case

Now

$$\text{Power}_{\text{ext}} = 5000 \times 5.092 = 25.464 \text{ kW}$$

In regeneration circuit, greater velocity of extension is achieved in expense of reduced load carrying capacity of cylinder during extension.

This can be proved by observing power required for moving load of 5000 N. Considering both cases for first case, to move load of 5 kN, power is 6.36 kW whereas in 2nd case, to move same load, power is 25.46 kW.