

Soil Mechanics

20

AL-MUSTANSIRIYAH UNIVERSITY

FACULTY OF ENGINEERING

ENVIRONMENTAL DEPT.



SOIL MECHANICS

LECTURES

ميكانيك التربة

2016-2017

Second *Year*

*Students*

By

DR. KHITAM ABDULHUSSEIN SAEED

*CHAPTER ONE*

**SOIL BEHAVIOUR &  
SOIL FORMATION**

## SOIL BEHAVIOUR AND SOIL FORMATION

### 1. INTRODUCTION

*Civil* and *environmental* engineering includes the **conception, analysis, design, construction, operation, and maintenance** of a diversity of structures, **facilities, and systems**. All are built on, in, or with **soil or rock**. The properties and behavior of these materials have major **influences** on the **success, economy, and safety** of the work.

**Soils** and their **interactions** with the **environment** are major considerations. **Furthermore**, detailed understanding of the behavior of **earth materials** is essential for mining, for energy resources development and recovery, and for scientific studies in virtually all the geosciences. To deal properly with the earth materials associated with any problem and project **requires knowledge, understanding, and appreciation** of the importance of geology, materials science, materials testing, and mechanics. **Geotechnical engineering** is concerned with all of these. **Environmental concerns**—especially those related to **groundwater, the safe disposal and containment of wastes, and the cleanup of contaminated sites**.

#### 1.1 The Earth's Crust

The continental crust covers 29 percent of Earth's surface. The elemental compositions of the whole Earth and the crust are indicated in Fig. 1. There are more than 100 elements, but 90 percent of Earth consists of **iron, oxygen, silicon, and magnesium**. Less iron is found in the **crust** than in the **core** because its **higher density causes it to sink**. **Silicon, aluminum, calcium, potassium, and sodium** are *more abundant* in the **crust** than in the **core** because they are *lighter elements*. **Oxygen** is the only anion that has an abundance of more than 1 percent by weight; however, it is very abundant by volume.

**Silicon, aluminum, magnesium, and oxygen** are the most commonly observed elements in soils.

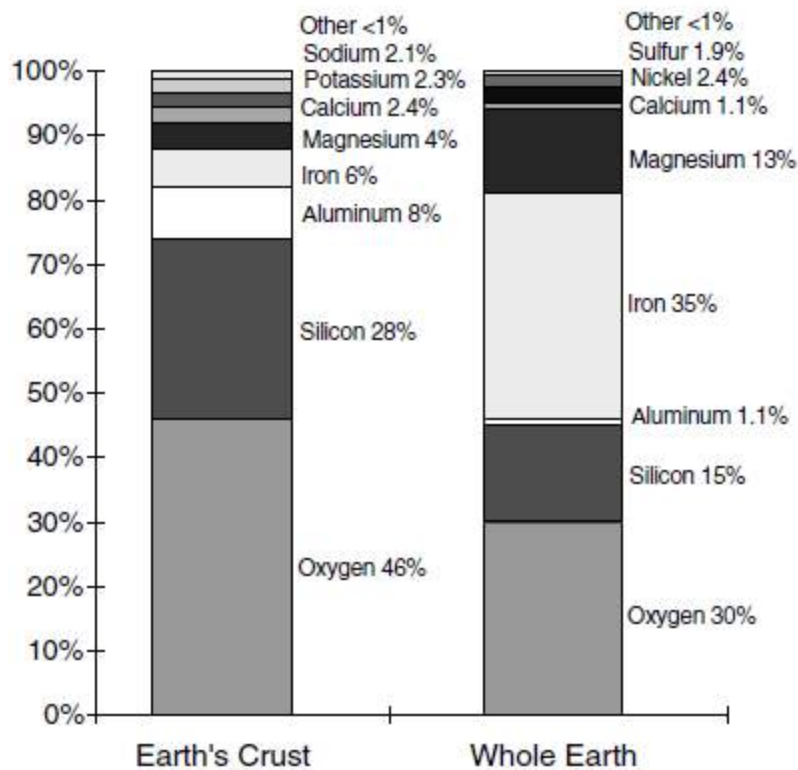

**Fig.1** Elemental composition of the whole Earth and the crust (percent by weight)

## 1.2 Geologic Cycle and Geological

The surface of Earth is acted on by four basic processes that proceed in a never-ending cycle, as indicated in Fig. 2. **Denudation** includes all of those processes that act to wear down land masses. These include landslides, debris flows, avalanche transport, wind abrasion, and overland flows such as rivers and streams. **Weathering** includes all of the destructive mechanical and chemical processes that break down existing rock masses in situ. Erosion initiates the

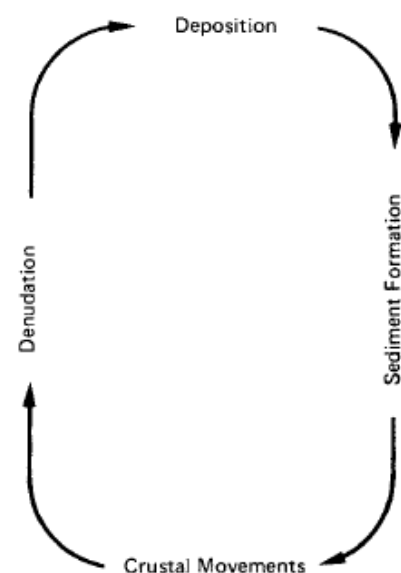

**Fig. 2: Geological Cycle**

transportation of weathering products by various agents from one region to another—generally from high areas to low. Weathering and erosion convert rocks into sediment and form soil.

*Deposition* involves the accumulation of sediments transported previously from some other area.

### **1.3 Soil Formation**

Soil is defined as sediments or other accumulation of mineral particles produced by the physical or chemical disintegration of rock, plus the air, water, organic matter, and other substances that may be included. Soil is typically a non-homogeneous, porous, and earthen material whose engineering behavior is influenced by changes in moisture content and density. To understand and appreciate the characteristics of any soil deposit require an understanding of what the material is and how it reached its present state. This requires consideration of rock and soil weathering, the erosion and transportation of soil materials, depositional processes, and postdepositional changes in sediments.

#### **1.3.1 Weathering**

In situ, weathering processes lead to a sequence of horizons within soil. Weathering of rocks and soils is a destructive process whereby debris of various sizes, compositions, and shapes is formed. The new compositions are usually more stable than the old and involve a decrease in the internal energy of the materials.

A variety of physical, chemical, and biological processes act to break down rock masses. Physical processes reduce particle size, increase surface area, and increase bulk volume. Chemical and biological processes can cause complete changes in both physical and chemical properties.

### 1.3.1.1 Physical Processes of Weathering

Physical weathering processes cause in situ breakdown without chemical change. All type of actions that cause a disintegration of the parent rocks by physical means such as, gravity, wind and water. The product of this type is rounded, sub rounded or granular, its products called coarse grained soil e.g. (gravel and sand ) they present in nature in a single grain structure(which are cohesion less and they have the same properties of the parent rock) .

### 1.3.1. 2 Chemical Processes of Weathering

All types of chemical reactions that occur between the minerals of the rock and the environment (air, water ---et.) and will end up by disintegration of parent rock into fine grain particles; these products have different properties from the parent rock. Chemical weathering transforms one mineral to another or completely dissolves the mineral. Practically all chemical weathering processes depend on the presence of water. Hydration, that is, the surface adsorption of water, is the forerunner of all the more complex chemical reactions, many of which proceed simultaneously. Its products called coarse grained soil e.g. (silt and clay), which are cohesive materials, and its properties do not reflect the same properties of the parent rocks.

## 1.4 Soil Origin

The origin of soil can be broken down to two basic types: **residual, and transported**. The properties of each of one as follow:

### Residual soil

1- Is caused by the weathering (decomposition) of rock by chemical or physical action.

- 2- Residual soils may be very thick in areas of intense weathering such as the tropics, or they may be thin or absent in areas of rapid erosion such as steep slopes.
- 3- They are usually clayey, and their properties are related to climate and other factors prevalent at the location of the soil.
- 4- Residual soils are usually preferred to support foundations, as they tend to have better, more predictable engineering properties.

### **Transported or deposited soils**

- 1- They are derived by the movement of soil from one location to the other by natural means such as wind, water, ice, and gravity.
- 2- The character of the resulting deposit often reflects the modes of transportation and deposition and the source material for example deposits by water include alluvial floodplains, coastal plains, and beaches, deposits by wind include sand dunes and loess, and deposits by melting ice include glacial till and outwash.
- 3- Each of these materials has behavioral characteristics dependent on geological origin, and the geological name, such as loess, conveys much useful information.
- 4- Transported soils – particularly by wind or water – are often of poor quality in terms of engineering properties.

## **2. SOIL MINERALOGY**

Soil is composed of solid particles, liquid, and gas and ranges from very soft, organic deposits through less compressible clays and sands to soft rock. The solid particles vary in size from large boulders to minute particles that are visible only with the aid of the electron microscope. A soil may contain virtually any element contained in Earth's crust; however, by far the most abundant are oxygen, silicon,

hydrogen, and aluminum. These elements, along with calcium, sodium, potassium, magnesium, and carbon, comprise over 99 percent of the solid mass of soils worldwide.

**Mineralogy** is the primary factor controlling the size, shape, and properties of soil particles. These same factors determine the possible ranges of physical and chemical properties of any given soil; therefore, a priori knowledge of what minerals are in a soil provides intuitive insight as to its behavior.

Commonly defined particle size ranges are shown in Fig. 3. The divisions between gravel, sand, silt, and clay sizes are convenient. Particles smaller than about 200 mesh sieve size (0.074 mm), which is the boundary between sand and silt sizes, cannot be seen by the naked eye. **Clay** can refer both to a size and to a class of minerals. **As a size term**, it refers to all constituents of a soil smaller than a particular size, usually 0.002 mm ( $2\mu\text{m}$ ) in engineering classifications.

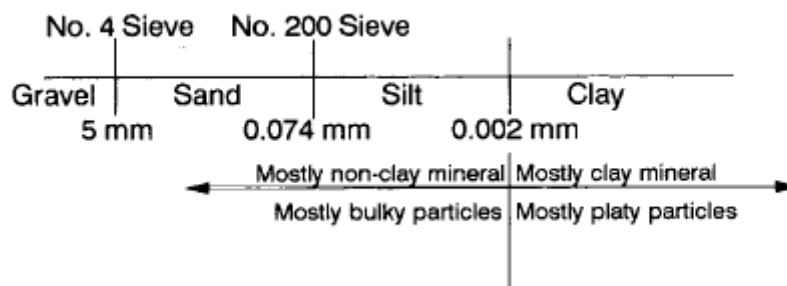

Figure 3: Particle size ranges in soils

#### 4. Soil Composition and Engineering Properties

The engineering properties of a soil depend on the composite effects of several interacting factors. These factors may be divided into two groups: **compositional factors and environmental factors**. Compositional factors determine the potential range of values for any property. They include:



1. Types of minerals
2. Amount of each mineral
3. Types of adsorbed cations
4. Shapes and size distribution of particles
5. Pore water composition
6. Type and amount of other constituents, such as organic matter, silica, alumina, and iron oxide

While, Environmental factors determine the actual value of any property. They include:

1. Water content
2. Density
3. Confining pressure
4. Temperature
5. Fabric
6. Availability of water

Soils are classified as **coarse grained**, granular, and **cohesionless** if the amount of gravel and sand exceeds 50 percent by weight or **fine grained** and **cohesive** if the amount of fines (silt and clay-size material) exceeds 50 percent.

### **5. Clay Behavior**

In geotechnical and environmental fields, an engineer will work with soil, which consists of the entire thickness of the earth's crust. From the geotechnical engineering viewpoint, clay is a kind of cohesive soil, which is very weak, and its strength will decrease by influence of climate or the water content in the soil. Clay can refer both to a size and to a class of minerals. **As a size term**, it refers to all constituents of a soil smaller than a particular size, usually 0.002 mm (2 $\mu$ m) in

engineering classifications. **As a mineral term**, it refers to specific clay minerals that are distinguished by

- (1) small particle size
- (2) a net negative electrical charge
- (3) plasticity when mixed with water
- (4) high weathering resistance.

**Clay minerals** are primarily hydrous aluminum silicates. Not all clay particles are smaller than 2  $\mu\text{m}$ , and not all **non-clay** particles are coarser than 2 $\mu\text{m}$ ; however, the amount of clay mineral in a soil is often closely approximated by the amount of material finer than 2  $\mu\text{m}$ . Thus, it is useful to use the terms clay size and clay mineral content to avoid confusion. A further important difference between clay and nonclay minerals is that the non-clays are composed primarily of bulky particles; whereas, the particles of most of the clay minerals are platy, and in a few cases they are needle shaped or tubular.

### **5.1 Classification of Clay Mineral**

Clay minerals which are found in soils related to the mineral family called **phyllosilicate** that their structures are formed from groupings of two basic units, the **silicon tetrahedron** and **the alumina octahedron**. The tetrahedral and octahedral sheets are the main structural components of these minerals. In a sheet of silica, each silicon atom with a positive charge of four is connected to four oxygen atoms with negative charge total of eight. Each oxygen atom at the base of the tetrahedron accompanies two silicon atoms as depicted in Figures ( 5 & 6).

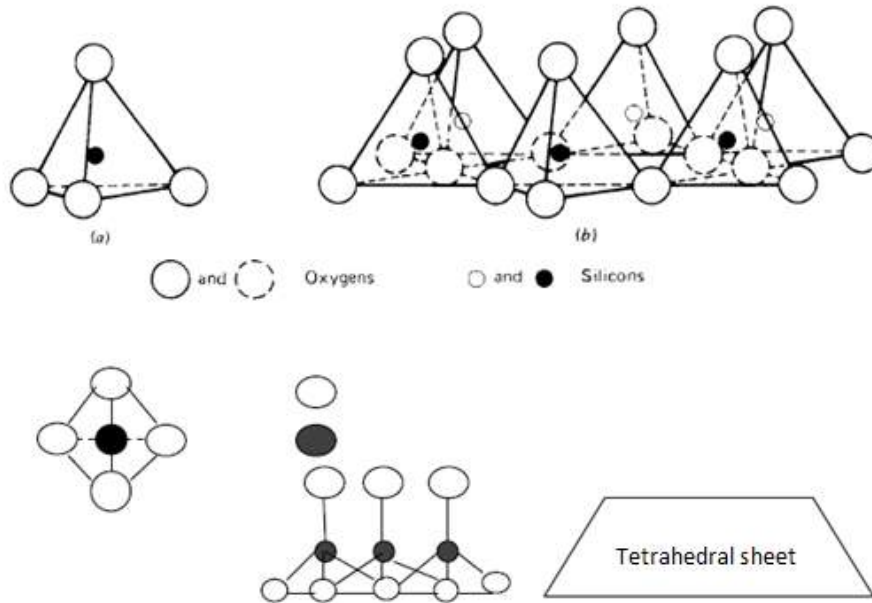

Figure 5: **Tetrahedral Unit**: Consists of four oxygen atoms (or hydroxyls, if needed to balance the structure) and one silicon atom

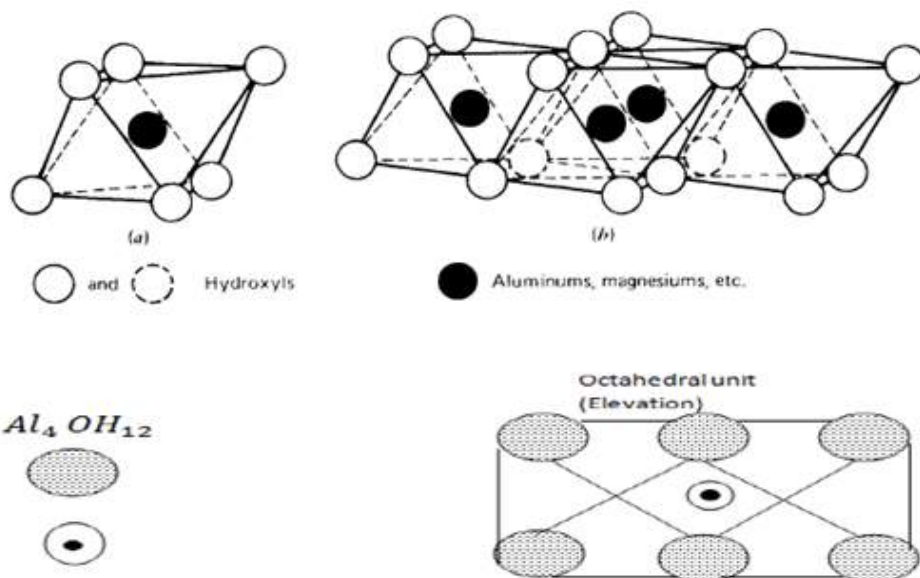
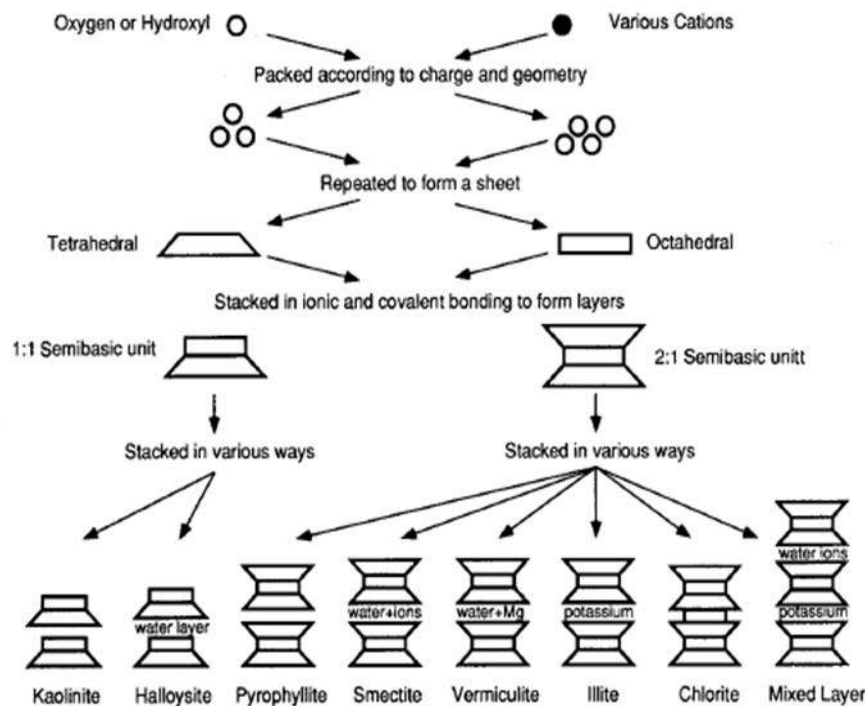

Figure 6: **Octahedral Unit** (consist of six hydroxyl ion at apices of an octahedron enclosing an aluminum ion at the center)

Therefore, different clay mineral may be formed by the scheme of stacking of the sheets of these units and the format in which two or three successive layers are held together as shown in Figure (7).



**Figure 7:** Synthesis pattern for the clay minerals.

## 5.2 Mineralogical Composition of Clays

The mineralogy of soil is the most important factor can influence the physical and chemical properties of any soil. Clay soils have a wide variety of mineralogical composition. They may include many proportions of different types of clay minerals, particularly **kaolinite, illite and montmorillonite** and non-clay minerals, especially **quartz, orthoclase feldspar, muscovite mica, calcite, dolomite, gypsum, pyrite and / or organic matter.**

Based on these, the clay minerals are categorized into two different groups, i.e., 1:1 and 2:1 type minerals. However, the structure and the detailed characterization of the clay minerals are commonly found in soil deposits described briefly in this section.

### 1- Kaolinite (1:1 Minerals)

Kaolinite is the most important member of the kaolin group. The structure is composed of a single tetrahedral sheet and a single alumina octahedral sheet as shown in figure (8) below: These layers are bond to other impending layers by hydrogen bonding. Thus, cations and water do not come in between the structural layers of kaolinite

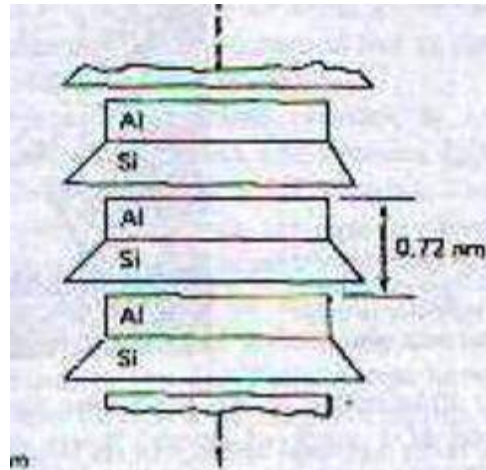

**Fig. 8:** Diagrammatic sketch of the kaolinite structure

As you can see each particle, kaolinite is constituted by a series of layers of hexagonal shape much like the pages of a book, as shown in Figure (9).

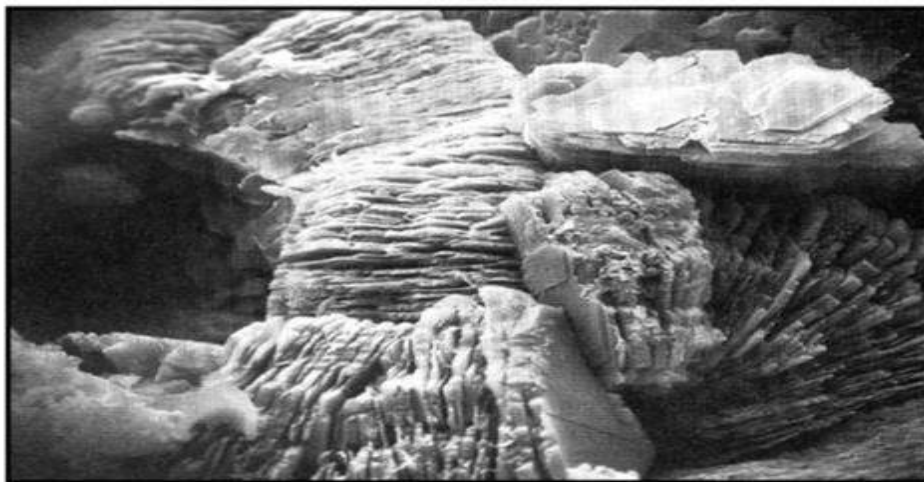

**Fig. 9:** Photomicrograph of well-crystallized kaolinite

2. **Illite (2:1 Smectite Minerals):** It is another important constituent of clay soils which have a crystal structure similar to the mica minerals but with less potassium; thus they are chemically much more active than other mica. The crystalline layers of these minerals are classified by a gibbsite octahedral sheet sandwiched between two tetrahedral layers of silica—one at the top and another at the bottom as shown in Figure (10).

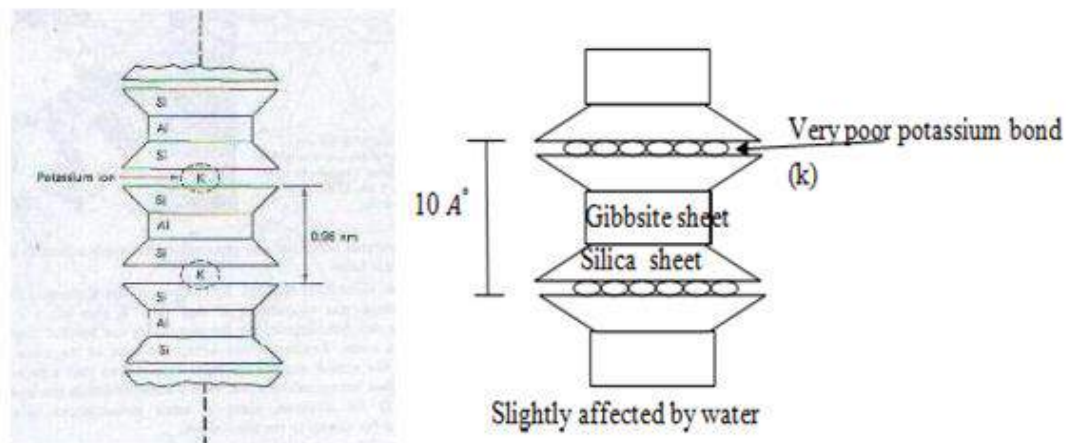

**Fig. 10:** Diagrammatic sketch of the structure of Illite

It has a basic structure consisting of two silica sheets with a central alumina sheet. There is a potassium bond between the layers. The morphology of these particles is often flaky and thin on the edges as note in the Figure 11.

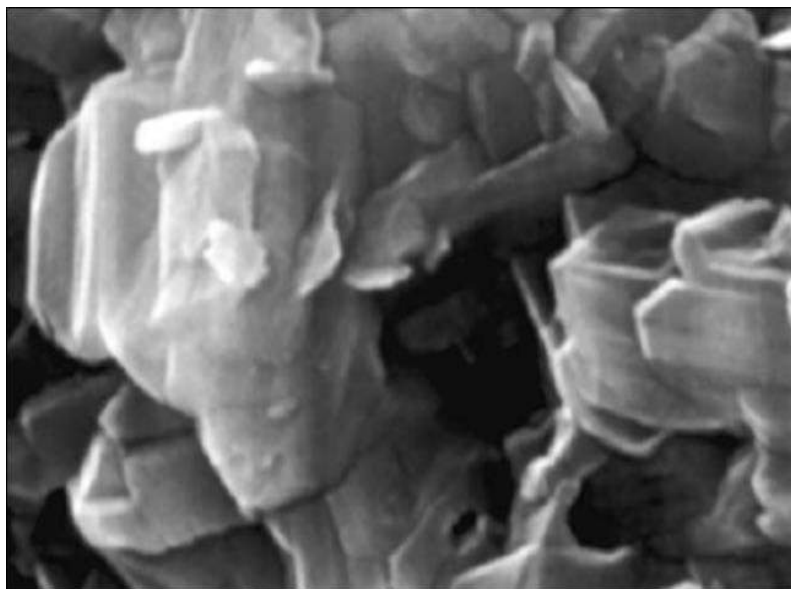

**Fig. 11:** Electron photomicrograph of Illite



3. **Montmorillonite (2:1 Smectite Minerals):** it is composed of two silica sheets and one alumina sheet, thus it is called a 2:1 mineral. The structure of montmorillonite is alike to the illite, which is an octahedral sheet gibbsite sandwiched between two silica tetrahedral sheets as shown in Figure (12).

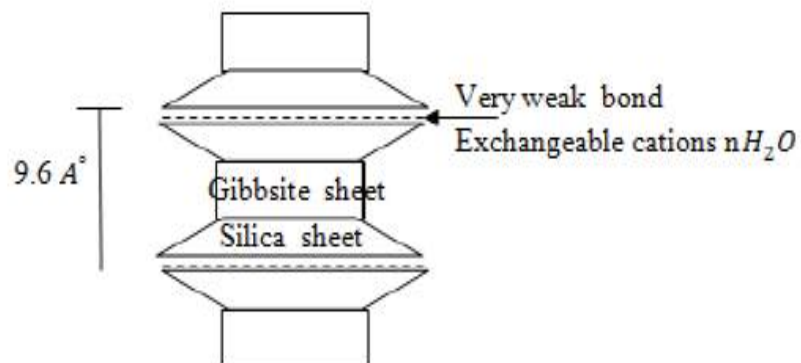

Highly affected by water

**Fig. 12:** Schematic diagrams of the structures of Montmorillonite

The small, very thin, and very thin particles of this mineral are shown in Figure 13

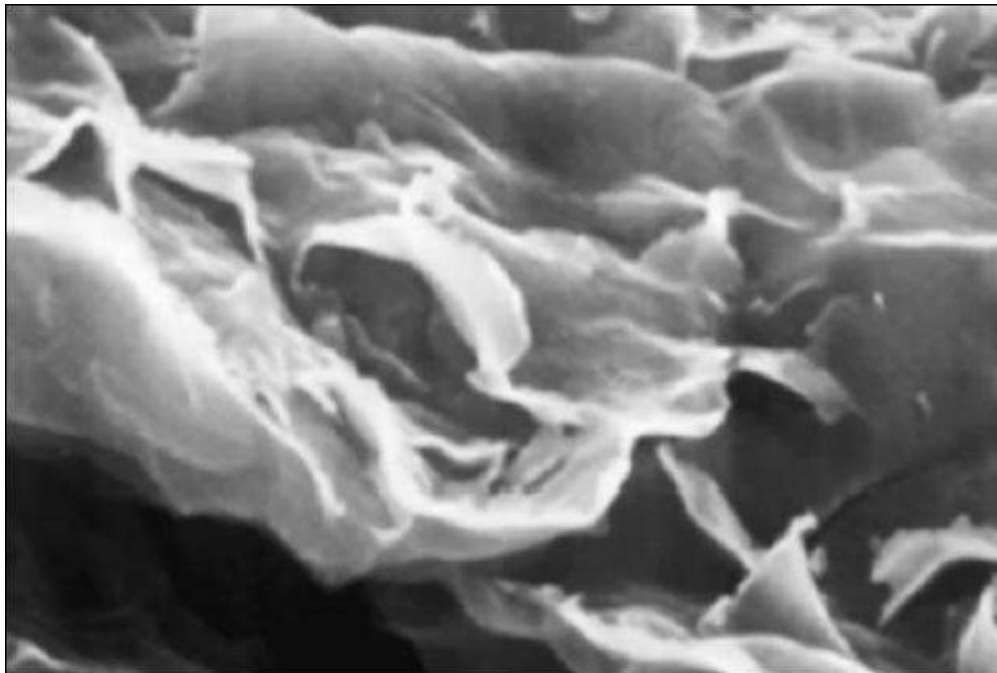

**Fig. 13:** Electron photomicrograph of Montmorillonite

### 5.3 Clay-Water Interaction

The clay particles have a high ability for polar liquids and adsorb cations such as water. Since the centers of positive and negative charges of water molecules do not coincide, the molecules behave like dipoles. The negative charge on the surface of the soil particle therefore attracts the positive (hydrogen) end of the water molecules. More than one layer of water molecules sticks on surface with considerable force decrease with increase in the distance of the water molecule from the surface. The electrically attracted water surrounds the clay particle is known as the diffused double-layer of water. The water located within the zone of influence is known as the adsorbed layer as shown in figure 14.

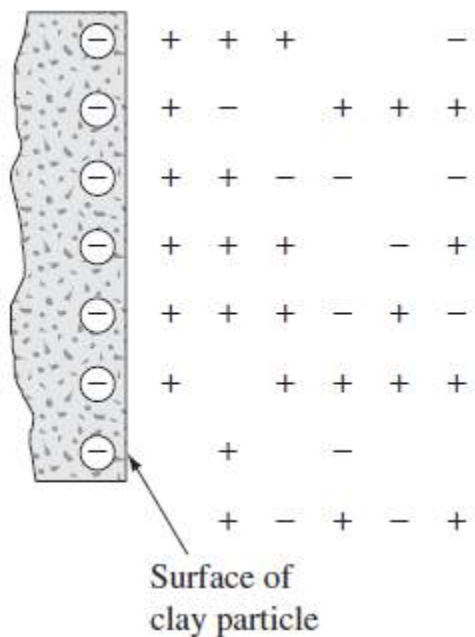

**Fig. 14:** mechanisms of water adsorption by clay surfaces (hydrogen bonding)

#### 5.3.1 Diffuse double layer

Adsorbed water layer surrounding a soil particle



**6- Clay structures**

Dispersed structure

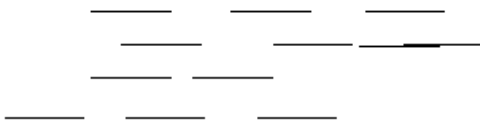

Lower strength

Permeability is higher permeability is less

Low compressibility higher compressibility

Flocculated structure



More strength Lower strength

Permeability is higher permeability is less

Low compressibility

**7. Soil Volume & Density Relationships**

A soil mass is a porous material containing solid particles interspersed with pores or voids. These voids may be filled with air, water, or both as shown in Figure 15. Figure 16 shows a conceptual diagram of relative volumes of air, water, and soil solids in a given volume of soil.

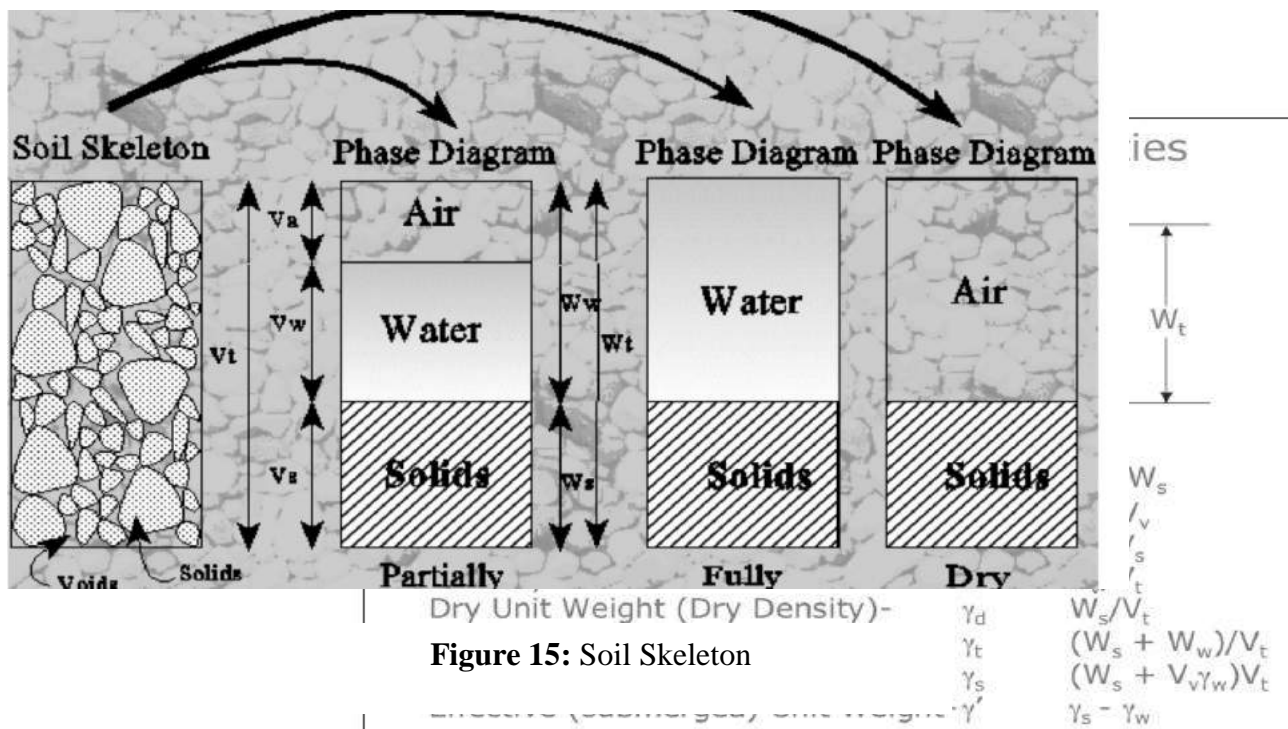

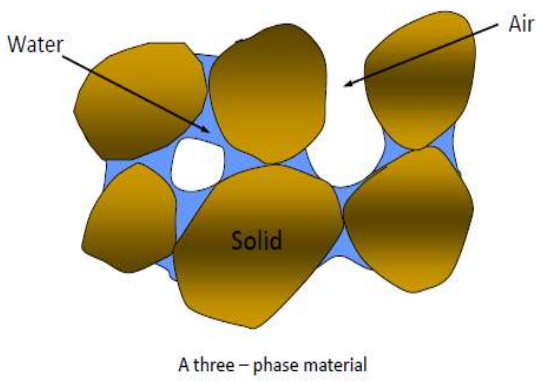

### The Mineral Skeleton

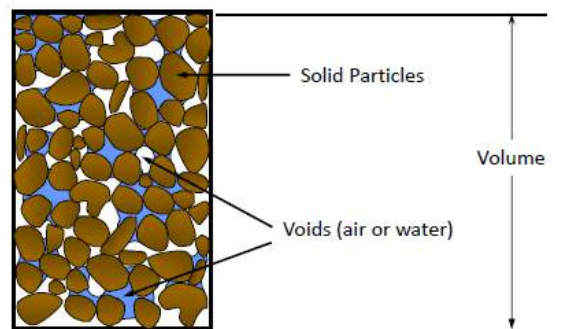

### Three-Phase Diagram

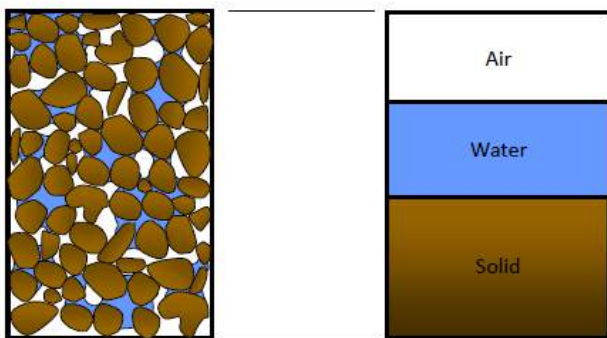

Idealization:  
Three Phase Diagram

### Full Saturated Soils

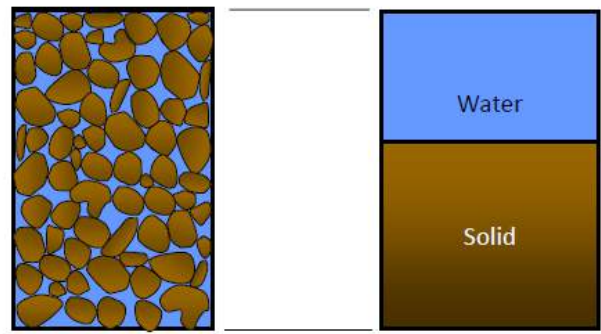

Fully Saturated

## Dry Soils

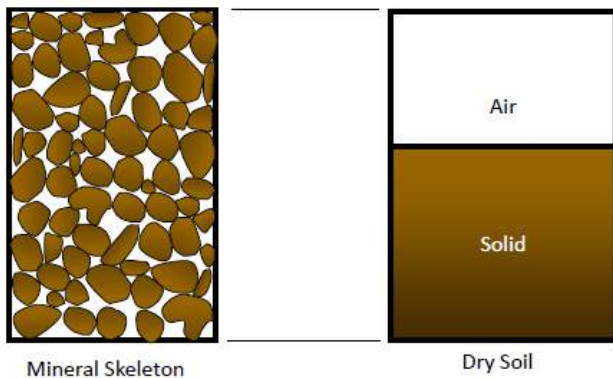

## Partly Saturated Soils

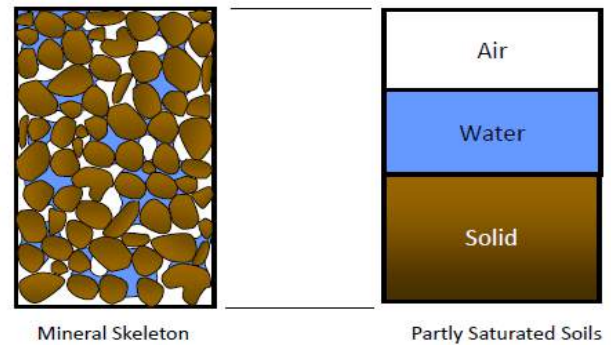

**Density** : is the weight of a unit volume of soil. It is more correctly termed the unit weight. Density may be expressed either as a **wet density** (including both soil and water) or as a **dry density** (soil only).

**Moisture Content**: is the ratio of the weight of water to the weight of soil

**Porosity**: is the ratio of the volume of voids to the total volume of the soil mass regardless of the amount of air or water contained in the voids.

**Void ratio**: is the ratio of the volume of voids to the volume of soil particles.

**Permeability or hydraulic conductivity** :is the property of soil allowing it to transmit water. Its value depends largely on the size and number of the void spaces, which in turn depends on the size, shape, and state of packing of the soil grains.

### **Basic Relationships**

$$\text{Weight } W_t = W_w + W_s$$

**Where:**

$W_t$ : total weight of soil

$W_s$ : Weight of solid

$W_w$ : Weight of water

$W_a$ : Weight of air  $\approx 0$

$$\text{Volume } V_t = V_v + V_s = V_a + V_w + V_s$$

$V_t$ : Total Volume

$V_v$ : Volume of Void

$V_a$ : Volume of Air

$V_w$ : Volume of water

$V_s$ : Volume of Solid

**1- Unit Weight – Density**

$$\gamma_{soil} = \frac{\text{Total weight}}{\text{Total volume}} = \frac{w_t}{V_t}$$

**2- Water content %**

$$\omega_c \% = \frac{w_w}{w_s} \cdot 100 \quad \text{or} \quad \omega_c = \frac{m_w}{m_s} \cdot 100$$

**3- Void ratio, e**

$$e = \frac{V_v}{V_s}$$

**4- Porosity (n %)**

$$n \% = \frac{V_v}{V_t} \cdot 100$$

**5- Air content A %**

$$A \% = \frac{V_a}{V_t} \cdot 100$$

**6- Bulk Density (total density),  $\rho_t$** 

$$\rho_t = \frac{m_t}{V_t}$$

**7- Dry density ,**

$$\rho_{dry} = \frac{m_s}{V_t} \quad (gm/cm^3) \quad \text{or} \quad \left(\frac{kg}{m^3}\right)$$

**8- Dry unit weight ( $\gamma_{dry}$ )**

$$\gamma_{dry} = \frac{W_s}{V_t} \quad (kN/m^3)$$

**9- Specific gravity,  $G_s$**

$$G_s = \frac{\rho_s}{\rho_w} = \frac{m_s/v_s}{\rho_w} = \frac{m_s}{v_s \rho_w}$$

$$G_s = \frac{\gamma_s}{\gamma_w} = \frac{w_s/v_s}{\gamma_w} = \frac{w_s}{v_s \gamma_w} \quad (\text{its value range between 2.6- 2.85})$$

#### 10- Solid Density, $\rho_s$

$$\rho_s = \frac{m_s}{v_s}, \quad \gamma_s = \frac{w_s}{v_s}$$

#### Some Useful Correlation:

$$1- S.e = G_s \cdot \omega_c$$

$$2- n = \frac{e}{1+e}$$

$$3- e = \frac{n}{1-n}$$

$$4- A = n(1 - s)$$

$$5- A = \frac{e - \omega \cdot G_s}{1+e}$$

$$6- \rho_t = \frac{G_s(1+\omega)}{1+e} \rho_w \quad \text{or} \quad \gamma_t = \frac{G_s(1+\omega)}{1+e} \gamma_w$$

$$7- \rho_t = \frac{G_s + s \cdot e}{1+e} \rho_w \quad \text{or} \quad \gamma_t = \frac{G_s + s \cdot e}{1+e} \gamma_w$$

$$8- \rho_s = \frac{G_s + e}{1+e} \rho_w \quad \text{or} \quad \gamma_s = \frac{G_s + e}{1+e} \gamma_w$$

$$9- \rho_{dry} = \frac{G_s}{1+e} \rho_w \quad \text{or} \quad \gamma_d = \frac{G_s}{1+e} \gamma_w$$

$$10- \rho_{eff.} = \dot{\rho} = \rho_{sat} - \rho_w$$

$$11- \gamma_{eff} = \dot{\gamma} = \frac{G_s - 1}{1+e} \gamma_w$$

Some typical values of void ratio, moisture content in a saturated condition, and dry unit weight for soils in a natural state are given in the following table:

Table 1- Void ratio, Moisture Content, and Dry Unit Weight for some Typical Soils in a Natural State.

Type of Soil	Void ratio	Natural moisture content in a saturated state (%)	Dry unit weight, $\gamma_d$ ( $kN/m^3$ )
Loose uniform sand	0.8	30	14.5
Dense uniform sand	0.45	16	18
Loose angular-grained silty sand	0.65	25	16
Dense angular-grained silty sand	0.4	15	19
Stiff clay	0.6	21	17
Soft clay	0.9-1.4	30-50	11.5-14.5

Note: the weight of one kilogram mass is 9.806 Newton

1 kg = 9.806 N



**Example- 1:** In its condition a soil sample has a mass of 2290 g and a volume of  $1.15 \times 10^{-3} \text{ m}^3$ . After being completely dried in an oven the mass of the sample is 2035g. The value of  $G_s$  for the soil is 2.68. Determine the bulk density, unit weight, water content, void ratio, porosity, degree of saturation and air content.

**Solution:**

$$\rho_t = \frac{M}{V} = \frac{2.290}{1.15 \times 10^{-3}} = 1990 \text{ kg/m}^3 = 1.99 \frac{\text{Mg}}{\text{m}^3}$$

$$\text{Unit weight } \gamma = \frac{Mg}{V} = 1990 \times 9.8 = 19500 \text{ N/m}^3 = 19.5 \text{ kN/m}^3$$

$$\text{Water content } \omega = \frac{M_w}{M_s} = \frac{2290 - 2035}{2035} = 0.125 \text{ or } 12.5\%$$

$$\gamma_t = \frac{G_s(1 + \omega_c)}{1 + e} \gamma_w$$

$$19.5 = \frac{2.68(1 + .125)}{1 + e} \times 10$$

$$e = 0.538$$

$$\text{Porosity, } n = \frac{e}{1 + e} = \frac{0.538}{1.538} = 0.3490 \sim 0.35$$

$$S \cdot e = G_s \cdot \omega_c$$

$$\text{Degree of saturation } S = \frac{0.125 \times 2.68}{0.538} = 62.267\%$$

$$\text{Air content, } A = n(1 - S) = 0.35(1 - .62) = 0.132$$

**Example 3:** In the natural state, a moist soil has a volume of  $0.0093 \text{ m}^3$  and weighs 177.6 N. The oven dry weight of the soil is 153.6 N. If  $G_s = 2.71$ . Calculate the moisture content, moist unit weight, dry unit weight, void ratio, porosity and degree of saturation.

$$\text{Solution: } \omega_c = \frac{w_w}{w_s} = \frac{177.6 - 153.6}{153.6} = 15.6\%$$

$$\gamma_t = \frac{W}{V} = \frac{177.6}{0.0093} = 19096 \frac{\text{N}}{\text{m}^3} = 19.1 \text{ kN/m}^3$$

$$\gamma_d = \frac{W_s}{V} = \frac{153.6}{0.0093} = 16516 \frac{\text{N}}{\text{m}^3} \sim 16.52 \text{ kN/m}^3$$

$$e = \frac{V_v}{V_s}, \quad V_s = \frac{W_s}{G_s \gamma_w} = \frac{0.1536}{2.71 \times 10} = 0.0058 \text{ m}^3$$

$$\therefore V_v = 0.0093 - 0.0058 = 0.0035 \text{ m}^3$$

$$e = \frac{0.0035}{0.0058} = 0.6 \longrightarrow n = \frac{e}{1 + e} = \frac{0.6}{1 + 0.6} = 0.375$$

$$S \cdot e = G_s \cdot \omega \longrightarrow S \cdot 0.6 = 2.71 \times 0.156 \longrightarrow S = 70.46\%$$

**CHAPTER TWO**  
*Soil Consistency*

### 1. Soil Consistency (Atterberg limits)

Most of soils include a fine fraction of silt, clay or a combination. The consistency of these soils can range from a dry solid condition to a liquid form with successive addition of water and mixing as necessary to expand pore space for acceptance of water. **The Atterberg limits** are a basic measure of the critical water contents of a fine-grained soil: **its shrinkage limit, plastic limit, and liquid limit** as shown in the Figure(1). As a dry, clayey soil takes on increasing amounts of water, it undergoes distinct changes in behavior and consistency. Depending on the water content of the soil, it may appear in four states: solid, semi-solid, plastic and liquid. In each state, the consistency and behavior of a soil is different and consequently so are its engineering properties.

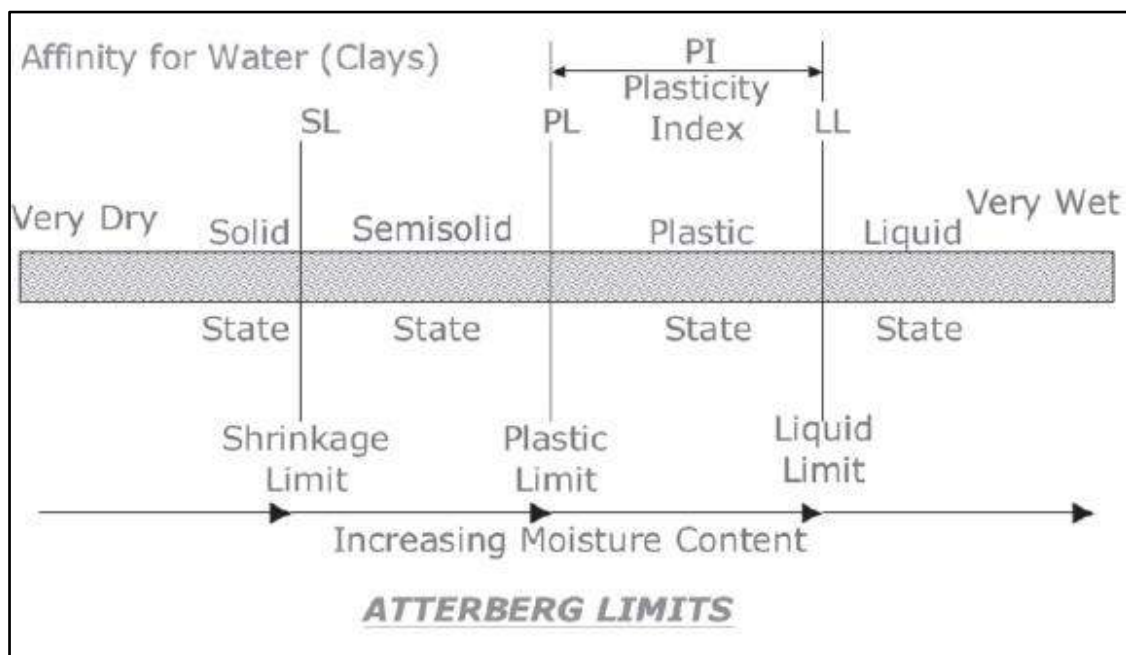

**Figure 1:** The Consistency Limits (atterberg limit)



## 1.2 Plasticity Limits

**Liquid limit (L.L.):** is defined as the moisture content in percent at which the soil changes from liquid to plastic state.

**Plastic Limit (P.L.):** The moisture contents in % at which the soil changes from plastic to semi solid state.

**Shrinkage Limit (S.L.):** The moisture contents in % at which the soil changes from semi solid to solid state.

**Plasticity Index (P.I.):** it is the range in moisture content when the soil exhibited its plastic behavior:

$$P.I = L.L - P.L$$

**Liquidity Index (L.I. or IL) :** a relation between the natural moisture contents ( $c^a$ ) and (L.L.) and (P.L.) in form:

If  $LI > 1$  Then the soil at Liquid state

If  $LI = 1$  then the soil at L.L.

If  $LI < 1$  then the soil below L.L.

### Plasticity Index - Definition

**Plasticity Index is the difference between the liquid limit and plastic limit of a soil.**

$$PI = LL - PL$$

PI	Description
0	Nonplastic
1-5	Slightly plastic
5-10	Low plasticity
10-20	Medium plasticity
20-40	High plasticity
>40	Very high plasticity

## Plasticity Characteristics Of Soils

The plasticity of a soil is its ability to undergo deformation without cracking. It is an important index property of fine grained soil, especially for clayey soils. The adsorbed water in clayey soils leads to the plasticity of soil. Adsorbed water in the clay particles allow the particles to slip over one another. The particles do not return to its original position following the deformation of soil. The soil becomes plastic only when it has clay minerals.

### **ATTERBERG LIMITS**

In 1911, A Swedish agriculture engineer Atterberg mentioned that a fine grained soil can exist in four states, namely, liquid, plastic, semi-solid or solid. The water content at which the soil changes from one state to other are known as Atterberg limits or Consistency limits.

It is very important properties of fine grained soils.

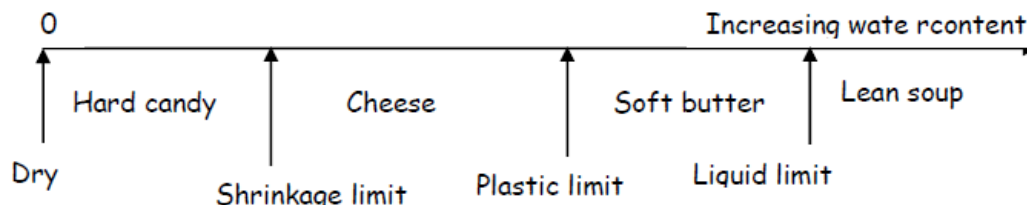

Figure 4-1 : Atterberg Limits

LL and SL can be understood from the study of clay water system. Adsorbed water layer is considered as an integral part of clay particle. As shown in Figure 4.2, when clay particles contain enough water, adsorbed water layers are not at all in contact with each other, and thus, there is no frictional resistance. It is at a liquid stage (lean soup). Now, if water is removed to a certain level at which all the adsorbed water layers are just in contact, frictional resistance will be developed at

the contact points. This is considered to be the stage of LL. When it is further dried, overlapping of adsorbed water layer will take place. The limiting stage of this overlapping is the level at which all particles themselves touch each other and no further overlapping possible. This stage is considered as the SL (cheese). PL may have some degree of overlapping of adsorbed water layers (soft butter)

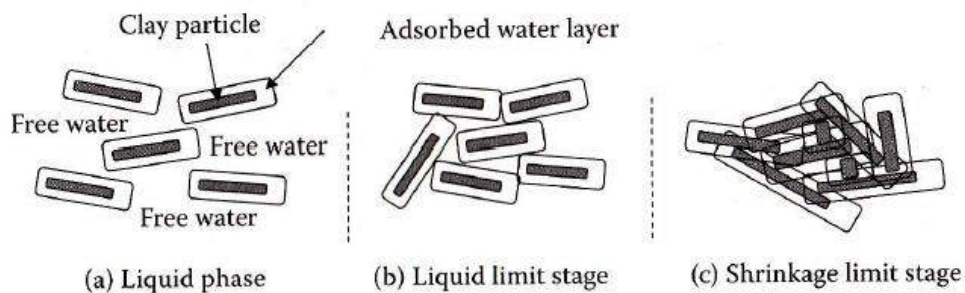

Figure 4.2: Clay particles with adsorbed water layers in water

### Determination of Shrinkage Limit

Shrinkage limit is the smallest water content at which the soil is saturated. It is also define as the maximum water content at which a reduction of water content will not cause a decrease in the volume of the soil mass.

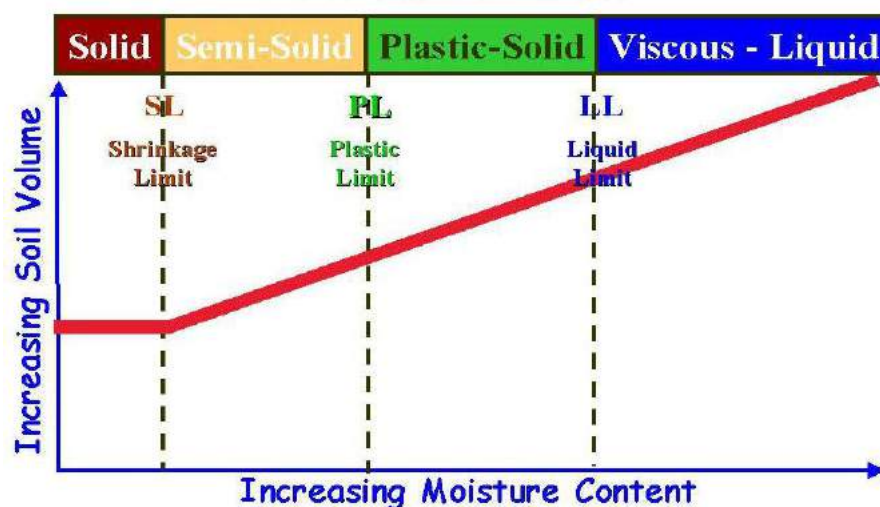

Figure 4.3: Definition of shrinkage limit

Figure 4.4(Stage(I)) shows the block diagram of a soil sample when it is fully saturated and has the water content greater than expected shrinkage limit, Figure 4.4 (Stage (II)) shows the sample at shrinkage limit and Figure 4.4 (Stage (III)) depicts the condition at oven dry state.

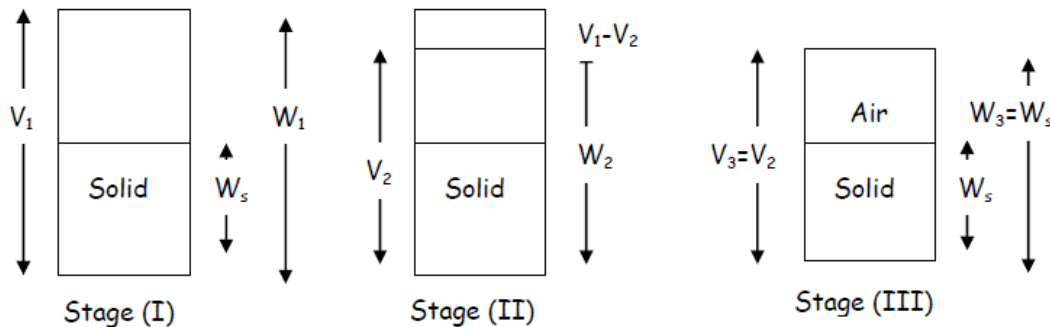

Figure 4.4: Stages for derivation of shrinkage limit

Weight of water in stage (I), =  $W_a - W_s$

Loss of weight of water from stage (I) to stage (II), =  $(V_1 - V_2)\gamma_w$

Weight of water in stage (II), =  $(W_1 - W_s) - (V_1 - V_2)\gamma_w$

From definition, shrinkage limit = water content in stage (II),

$$SL = \frac{(W_1 - W_s) - (V_1 - V_2)\gamma_w}{W_s}$$

$$SL = w_1 - \frac{(V_1 - V_2)}{M_s} \gamma_w$$

Where,  $w_1$  is the water content in stage (I).

### Plasticity, Liquidity, and Consistency Indexes

**Plasticity index:** Plasticity index (PI) is the range of water content over which the soil remains in the plastic state and mathematically defined as,  $PI=LL-PL$

**Liquidity index:** Liquidity index indicates the nearness of its water content to its

**liquid limit:** When the soil is at its liquid limit, its liquidity index is 100% and it behaves as a liquid. When the soil is at the plastic limit, its liquidity index is zero.

Negative values of the liquidity index indicate water content smaller than the plastic limit. The liquidity index is also known as Water-Plasticity ratio.

Mathematically,

$$LI = \frac{w - w_p}{PI} \times 100$$

**Consistency index:** the consistency index indicates the consistency of a soil. It shows the nearness of the water content of the soil to its plastic limit. A soil with a consistency index of zero is at the liquid limit. It is extremely soft and has negligible shear strength. On the other hand, a soil at a water content equal to the plastic limit has a consistency index of 100%, indicating that the soil is relatively firm. A consistency index of greater than 100% shows that the soil is relatively strong.

$$CI = \frac{LL - w}{PI} \times 100$$

### ACTIVITY OF SOILS

Activity of soil is the ratio of the plasticity index and the percentage of clay fraction (finer than  $2\mu$ ).

$$A = \frac{PI}{F}$$

$$\text{Activity} = \frac{PI}{\% \text{ of clay size particles}}$$

### Some useful notes:

$v_s$  : Constant at all stages

Degree of saturation (S %) at S.L. and up to = 100%

Degree of Saturation in the region from S.L. and below < 100%

$$v_{t \text{ dry}} = v_{t \text{ at S.L}}$$

$$v_{v \text{ dry}} = v_{v \text{ at S.L}}$$

$$e_{\text{dry}} = e_{\text{S.L}}$$

**Relative Density:** is the ration of the actual density to the maximum possible density of the soil it is expressed in terms of void ratio.

$$RD(\%) = \frac{e_{max} - e_n}{e_{max} - e_{min}} * 100$$

Or 
$$RD(\%) = \frac{\gamma_{dmax}}{\gamma_{dn}} * \frac{\gamma_{dn} - \gamma_{dmin}}{\gamma_{dmax} - \gamma_{dmin}} * 100$$

$e_{max}$ : The void ratio of the soil in its loosest condition

$e_{min}$ : The void ratio of the soil in its densest condition

$e_n$ : The void ratio of the soil in its natural condition

$\gamma_{dmax}$ : Maximum dry unit weight (at  $e_{min}$ )

$\gamma_{dmin}$ : Minimum dry unit weight (at  $e_{max}$ )

$\gamma_{dn}$ : Natural dry unit weight (at  $e_n$ )

RD	Description
$0 - \frac{1}{3}$	loose
$\frac{1}{3} - \frac{2}{3}$	medium
$\frac{2}{3} - 1$	Dense

Example 1: for a granular soil, given,  $\gamma_{dry} = 17.3 \frac{kN}{m^3}$ , relative density = 82%,  $\omega = 8\%$  and  $G_s = 2.65$ . If  $e_{min} = 0.44$ . what would be  $e_{max}$ ? what would be the dry unit weight in the loosest state?

Solution:

$$\gamma_{dry} = \frac{G_s}{1+e_n} * 10 \quad \Rightarrow \quad 17.3 = \frac{2.65}{1+e_n} * 10$$

$$\therefore e_n = 0.53 \quad \Rightarrow \quad RD = \frac{e_{max} - e_n}{e_{max} - e_{min}} * 100$$

$$0.82 = \frac{e_{max} - 0.53}{e_{max} - 0.44} \quad \Rightarrow \quad \therefore e_{max} = 0.94$$

$$\begin{aligned} \therefore \gamma_{dry} (\text{at loosest}) &= \frac{G_s}{1 + e_{max}} \gamma_w = \frac{2.65}{1 + 0.94} * 10 \\ &= 13.65 \text{ kN/m}^3 \end{aligned}$$



Example 2: a granular soil is compacted to moist unit weight of  $20.45 \text{ kN/m}^3$  at moisture content of 18%. What is relative density of the compacted soil? Given,  $e_{max} = 0.85$ ,  $e_{min} = 0.42$  and  $G_s = 2.65$ ?

Solution:

$$\gamma = \frac{G_s(1+\omega_c)}{1+e_n} \gamma_w \quad \Longrightarrow \quad 20.45 = \frac{2.65(1+0.18)}{1+e} * 10$$

$$\therefore e_n = 0.52 \quad \Longrightarrow \quad RD = \frac{e_{max} - e_n}{e_{max} - e_{min}} =$$

$$RD = \frac{0.85 - 0.52}{0.85 - 0.42} * 100 = 76.74\%$$

Example 3: A dry sample of soil having the following properties, L.L. = 52%, P.L. = 30%,  $G_s = 2.7$ ,  $e = 0.53$ . Find: Shrinkage limit, dry density, dry unit weight, and air content at dry state.

Solution

$$\text{Dry sample} \quad \Longrightarrow \quad e_{dry} = e_{shrinkage} = 0.53$$

$$\therefore S \cdot e_{s,l} = G_s \cdot \omega_{c,s,l} \quad \Longrightarrow \quad 1 * 0.53 = 2.7 * \text{S.L.}$$

$$\text{S.L.} = 19.6\%$$

$$\rho_{dry} = \frac{G_s}{1+e} \rho_w \quad \Longrightarrow \quad \rho_{dry} = \frac{2.7}{1+0.53} * 1 = 1.764 \frac{\text{gm}}{\text{cm}^3}$$

$$\therefore \gamma_{dry} = \rho_{dry} * g = 1.764 * 10 = 17.64 \text{ kN/m}^3$$

$$\text{Case is dry} \quad \Longrightarrow \quad s=0$$

$$\therefore A = n = \frac{e}{1+e} = \frac{0.53}{1+0.53} = 0.346$$

$$\therefore A = 34.6\%$$

# **CHAPTER THREE**



# ***SOIL COMPACTION***

## **1. Introduction**

Soil compaction is one of the most critical components in the construction of roads, airfield, embankments and foundations. The durability and stability of a structure are related to the achievement of proper soil compaction. Structural failure of roads, airfield and the damage caused by foundation settlement can often be traced back to the failure to achieve proper soil compaction.

## **2. What is Soil Compaction?**

**Soil compaction** is the compression of soil particles. Compaction reduces total pore space of a soil. More importantly it significantly reduces the amount of large pore space, restricting air and water movement into and through the soil. Low soil oxygen levels caused by soil compaction are the primary factor limiting plant growth in landscape soils. Soil conditions, primarily soil compaction, contribute to a large portion of plant disorders in the landscape setting. Figure 1 illustrates

Figure 1. Comparison of large pore space in non-compacted soil (left) and compacted soil (right).

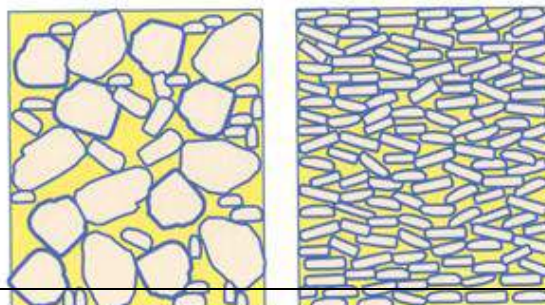

comparison of large pore spaces in a non-compacted versus a compacted soil.

### 3. Soil Compaction

Compaction is the process of increasing the density of a soil by packing the particles closer together with a reduction in the volume of air only. However, compaction increases the dry density and decreases the void ratio. Soil compaction is defined as the method of mechanically increasing the density of soil. In construction, this is a significant part of the building process.

If performed improperly, settlement of the soil could occur and result in unnecessary maintenance costs or structure failure. Almost all types of building sites and construction projects utilize mechanical compaction

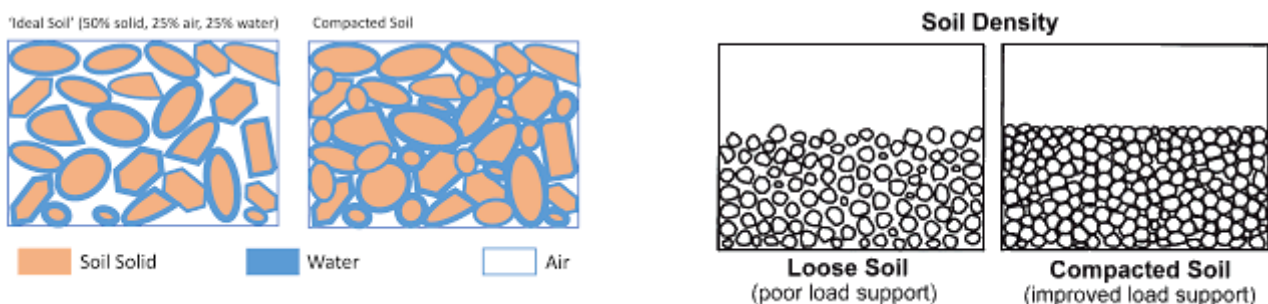
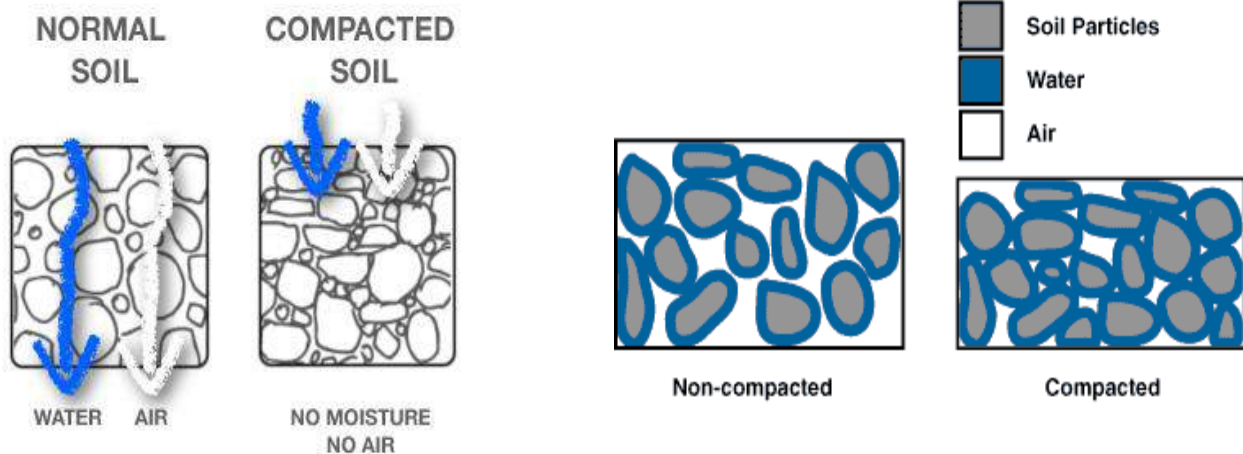

Figure 1. Soil compaction causes a reduction in available space for soil air and water, and limits pathways for crop roots.



#### 4. Why compact?

There are five principle reasons to compact soil:

- Increases load-bearing capacity
- Increase shear strength of soil
- Prevents soil settlement and frost damage
- Provides stability
- Reduces water seepage, swelling and contraction
- Reduces settling of soil
  - Reduce void ratio thus reduce permeability
  - Controlling the swell-shrinkage movement
  - Reduce settlement under working load

#### 5. Types of compaction

There are four types of compaction effort on soil or asphalt:

- Vibration
- Impact
- Kneading
- Pressure

#### 6. Factors affecting compaction:

- Water content

- Type of soil
- Compaction energy or effort

All these factors are shown in the following figures:

### 7. Soil density tests

To determine if proper soil compaction is achieved for any specific construction application, several methods were developed. The most prominent by far is soil density

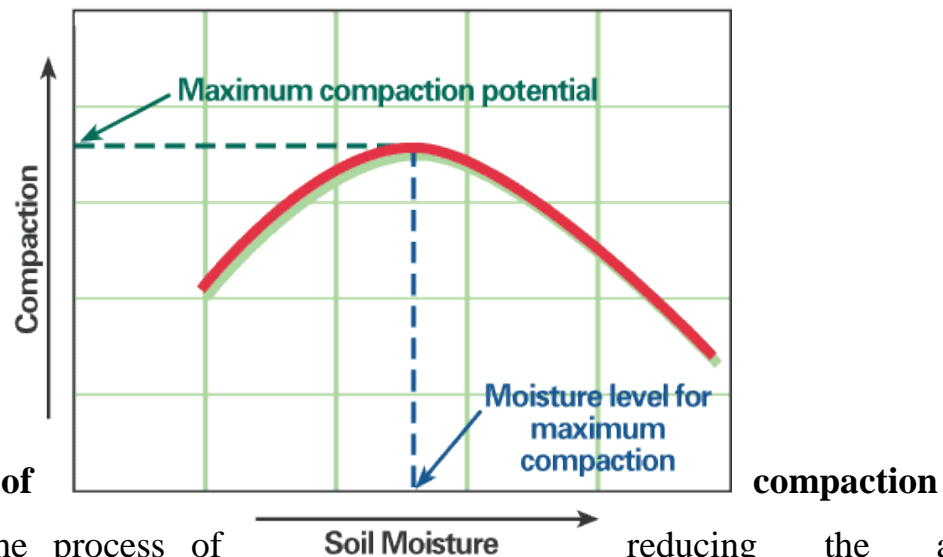

### 8. Theory

Compaction is the process of reducing the air content by the application of energy

to the moist soil. From compaction test we can find:

- 1- There is a unique relationship between the water content and the dry density for specific compaction energy.
- 2- There is one water content (O.M.C.) (Optimum moisture content) at which the max dry density is achieved

The two above points can be clearly shown through the following Figure

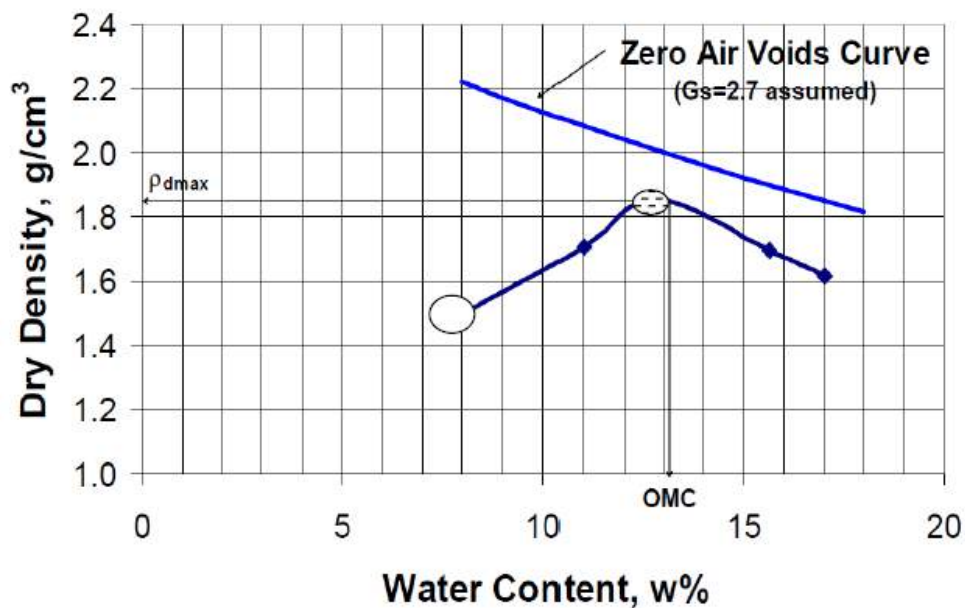

### MOISTURE-DENSITY RELATION (*COMPACTION TEST*)

This laboratory test is performed to determine the relationship between the moisture content and the dry density of a soil for a specified compactive effort. The compactive effort is the amount of mechanical energy that is applied to the soil mass. Several different methods are used to compact soil in the field, and some examples include tamping, kneading, vibration, and static load compaction. This laboratory will employ the tamping or impact compaction method using the type of equipment and methodology developed by R. R. Proctor in 1933, therefore, the test is also known as the Proctor test.

Two types of compaction tests are routinely performed: (1) The standard Proctor and (2) The modified Proctor test.

Type of test	No. of layer	No. of blows per layer	Volume of mold ( $\text{cm}^3$ )	Weight of hammer (kg)	Height of drops cm
Standard Proctor	3	25	1000	2.5	30
Modified Proctor	5	25	1000	4.5	45

$$\text{Compaction Effort} = \frac{\text{wt of hammer} \cdot \text{drops height} \cdot \text{No. of blows} \cdot \text{No. of layer}}{\text{Volume of mold}}$$

**Test Procedure :**

- 1- a sufficient quantity of air-dried soil in large mixing pan (say 3 kg)
- 2- Determine the weight of the compaction mold with its base (without the collar).
- 3- Start with initial water such (3% of Soil weight)
- 4- Add the water to the soil and mix it thoroughly into the soil until the soil gets uniform color (see figure B and C).
- 5- Assemble the compaction mold to the base, place soil in the mold and compact the soil in the number of equal layers specified by the type of compaction method (see photo D and E).  
The number of drops per layer is dependent upon the type of compaction.  
The drops should be applied at a uniform rate not exceeding around 1.5 seconds per drops, and the rammer should provide uniform coverage of the specimen surface.
- 6- The soil should completely fill the cylinder and the last compacted layer must extend slightly above the collar joint. If the soil below the collar joint at the completion of the drops, the test point must be repeated.
- 7- Carefully remove the collar and trim off the compacted soil so that it is completely even with the top of the mold.(see photo F).
- 8- Weigh the compacted soil while it's in the mold and to the base, and record the mass (see Photo G). Determine the wet mass of the soil by subtracting the weight of the mold and base.
- 9- Remove the soil from the mold using a mechanical extruder (see Photo H) and take the soil moisture content samples from the top and bottom of the specimen (see Photo i). Determine the water content.

10- Place the soil specimen in the large tray and break up the soil until it appears visually as if it will pass through the #4 sieve, add 3% more water on the soil and remix as in step 4. Repeat step 5 through 9 until a peak value is reached followed by two slightly lesser compacted

Analysis:

- 1- Calculate the moisture content of each compacted soil specimen.
- 2- Compute the wet density in grams per cm<sup>3</sup> of the compacted soil by dividing the wet mass by the volume of the mold used.
- 3- Compute the dry density using the weight density and the water content determined in step 1. Use the following formula:

$$\rho_{dry} = \frac{\rho_{wet}}{1 + \omega_c}$$

4- Plot the dry density values on the y-axis and the moisture contents on the x-axis.

Draw a smooth curve connecting the plotted points.

5- On the same graph draw a curve of Saturation line ( Zero air void line ) using the following Equation :

$$\rho_{dry} = \frac{G_s}{1+e} \rho_w$$

$$S \cdot e = G_s \cdot \omega_c \implies \text{For } S=1 \quad \therefore e = G_s \omega_c$$

Assume values of water content and find dry density, then plot the zero air void line which must be parallel to the moist side of compaction curve and never intersect it , If so that mean there is some error.

To plot Air content line (A%) use the following equation:



$$\rho_{dry} = \frac{G_s(1 - A)}{1 + \omega_c G_s} \rho_w$$

The following Figures give the steps used in the test:

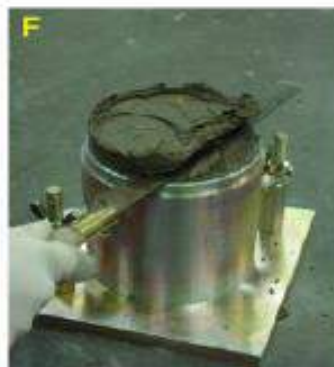
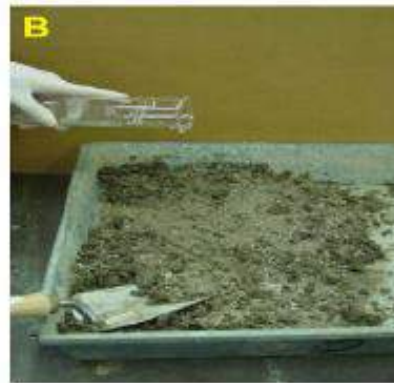
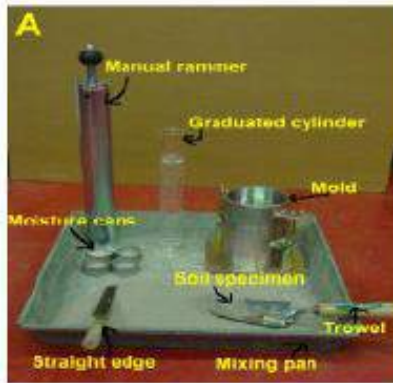

**Compaction Equipments:**

- 1- Sheep's foot roller (for cohesive soil)
- 2- Pneumatic roller (many different soils)
- 3- Vibratory rollers (mainly for granular material)
- 4- Grid rollers
- 5- Power Rammer
- 6- Vibratory plates.

**Compaction Of cohesion less soil:**

Moisture content has little or no influence on the granular soils (except when the soil is fully saturated) .

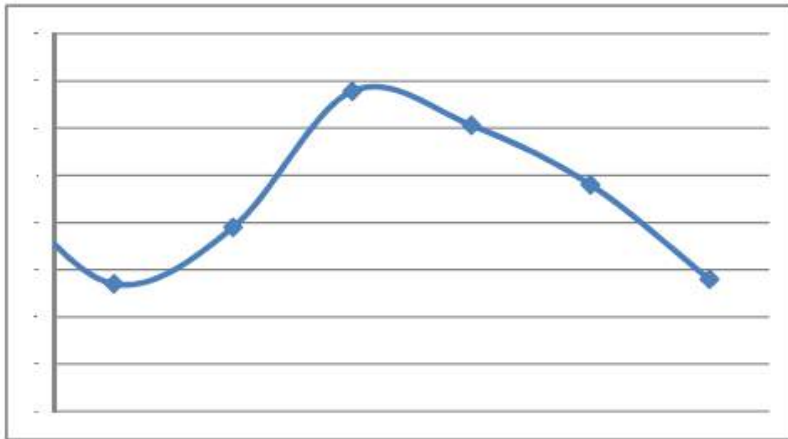

Their state of compaction can be obtained by relating dry density to the minimum and maximum dry densities and as in the following equation:

$$RD = \frac{e_{max} - e_{natural}}{e_{max} - e_{min}} = \left( \frac{\gamma_{dmax}}{\gamma_d} \right) \frac{\gamma_d - \gamma_{min}}{\gamma_{max} - \gamma_{min}}$$

Where RD : Relative density

### Compaction in the field:

The results of laboratory tests are not directly applicable to the field compaction, because

- 1- The Laboratory tests are carried out on material smaller than 20 mm size.
- 2- Compactive efforts are different and apply in different method.

### Relative compaction:

Relative compaction or degree of compaction is a means of comparing the field density with Laboratory results and is defined as the ratio of the dry density in the field to the maximum dry density in the Laboratory and in most construction works, the degree of compaction is specified as 95 % or more.

$$\text{Relative Compaction R.C} = \frac{\gamma_{dry \text{ field}}}{\gamma_{max \text{ at lab.}}} \geq 95\% \text{ or as specify in the works}$$

So by using sand replacement method, find dry density at field then check the R.C

**The Optimum moisture content can be useful in field as follows :**

If  $\omega_{c\ field} < \omega_{opt}$  then add water and compact the soil

If  $\omega_{c\ field} = \omega_{opt}$  then compact the soil directly

If  $\omega_{c\ field} > \omega_{opt}$  then either postponed the compaction to other time or add some additive (such as cement or lime) to accelerate evaporation of extra water.

**Measurement of field Density**

- 1- Core cutter
- 2- Sand Replacement method
- 3- Air-Ball on method
- 4- Penetrating Needle
- 5- Radiation Technique.

**Example 1 :**

The following results were obtained from a standard compaction test. Determine the Optimum moisture content and maximum dry density. Plot the curves of 0%, 5% and 10% air content and gives the value of air content at the maximum dry density. Given the volume of standard mold is  $1000 \text{ cm}^3$  and  $G_s = 2.7$ .

Mass (gm)	1768	1929	2074	2178	2106	2052	2007
Water content (%)	4	6	8	10	12	14	16

**Solution :**

Calculate dry density for each test and tabulate the results.

$\omega(\%)$	4	6	8	10	12	14	16
$\rho_{wet}$	1.768	1.929	2.074	2.178	2.106	2.052	2.007
$\rho_{dry} \text{ gm/cm}^3$	1.7	1.82	1.92	1.98	1.88	1.8	1.73

$\omega(\%)$	A %	4	6	8	10	12	14	16
$\rho_{dry} \text{ gm/cm}^3$	0	2.44	2.32	2.22	2.13	2.04	1.96	1.88
$\rho_{dry} \text{ gm/cm}^3$	5	2.32	2.2	2.11	2.02	1.94	1.86	1.79
$\rho_{dry} \text{ gm/cm}^3$	10	2.20	2.09	2.00	1.92	1.84	1.76	1.69

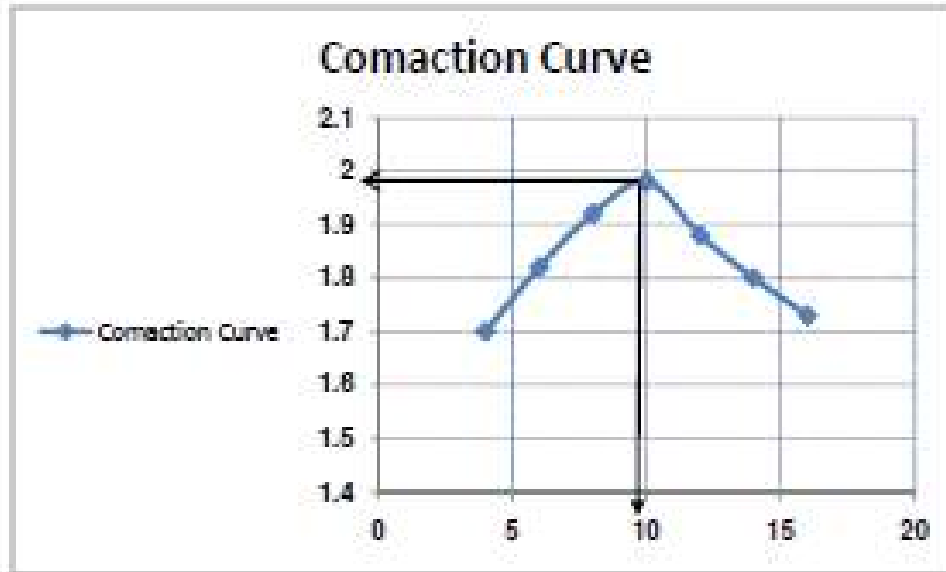

From Figure: The  $\gamma_{dry\ max} = 1.98\ kN/m^3$ ,

and the Optimum Moisture content = 10%.

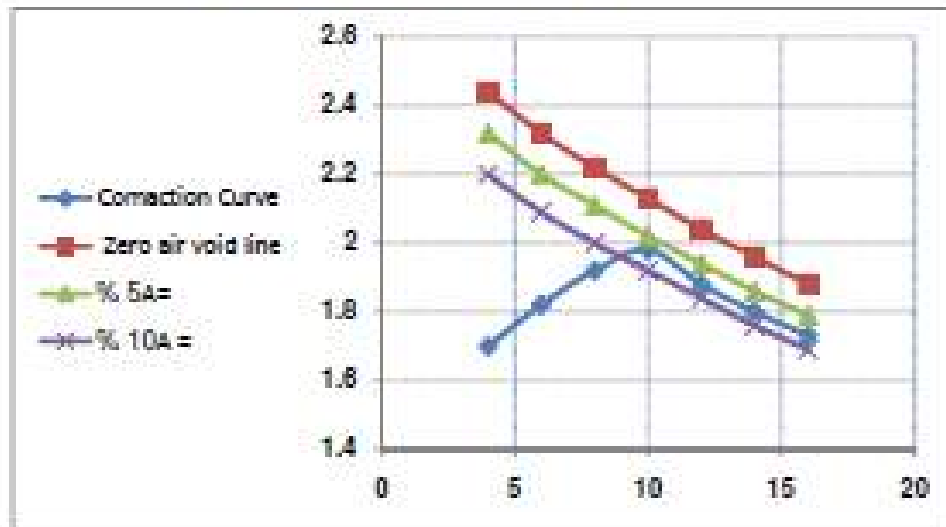

Figure show the Zero air void line and a line of 5 and 10% air content





# *CHAPTER FOUR*

# **SOIL CLASSIFICATION**

## **1. Classification System**

Soils in nature rarely exist separately as gravel, sand, silt, clay or organic matter, but are usually found as mixtures with varying proportions of these components.

Classifying soils into **groups** with similar behavior in terms of **simple** indices can provide geotechnical engineer a general guidance about engineering properties of the soils through the accumulated experience.

Two commonly used systems for classifying soils based on particle distribution and Atterberg limits:

- 1- **USCS**: United Soil Classification System (preferred by geotechnical engineer).
- 2- **AASHTO**: System: American Association of State Highway and Transportation Officials (preferred by Transportation engineers).

## 1. Unified Soil Classification System (USCS)

### i. Definition of Grain Size

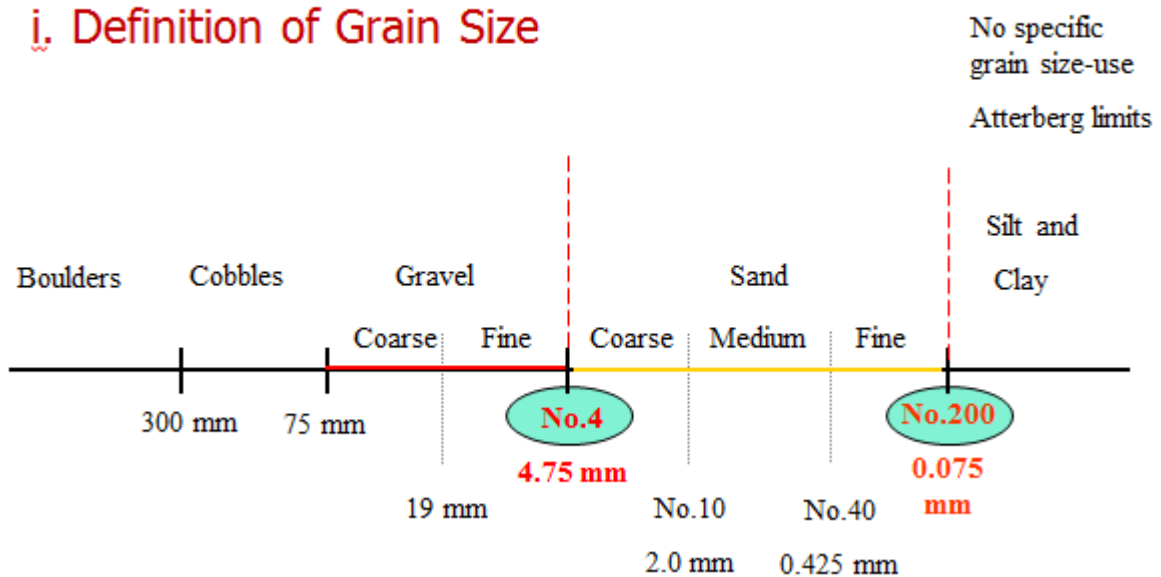

Used for Fine grained soils to determine whether silt (M) or clay (C)

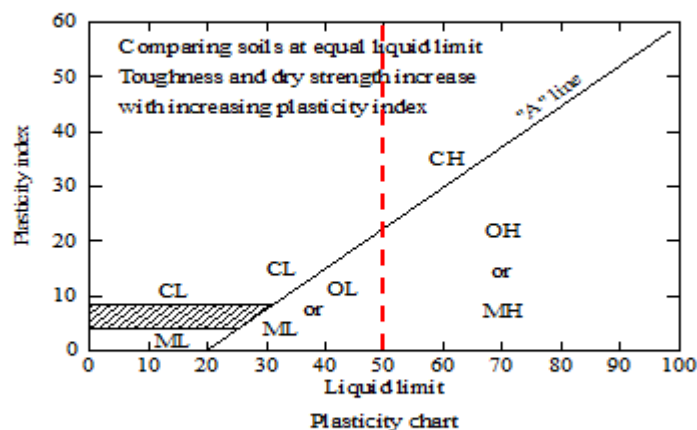

Below A-line is silt – use symbol M    LL > 50 → High plasticity

Above A-line is clay – use symbol C    LL < 50 → low plasticity

## **2. Soil Classification**

Classification of soil is the separation of soil into classes or groups each having similar characteristics and potentially similar behaviour. A classification for engineering purposes should be based mainly on mechanical properties: permeability, stiffness, strength. The class to which a soil belongs can be used in its description.

The aim of a classification system is to establish a set of conditions which will allow useful comparisons to be made between different soils. The system must be simple. The relevant criteria for classifying soils are the size distribution of particles and the plasticity of the soil. Particle Size Distribution for measuring the distribution of particle sizes in a soil sample, it is necessary to conduct different particle-size tests. Wet sieving is carried out for separating fine grains from coarse grains by washing the soil specimen on a 75 micron sieve mesh.

**2.1 Dry sieve analysis** is carried out on particles coarser than 75 micron. Samples (with fines removed) are dried and shaken through a set of sieves of descending size. The weight retained in each sieve is measured. The cumulative percentage quantities finer than the sieve sizes (passing each given sieve size) are then determined. The resulting data is presented as a distribution curve with grain size along x-axis (log scale) and percentage passing along y-axis (arithmetic scale).

**U.S. Standard sieve sizes**

Sieve no.	Opening (mm)
4	4.750
6	3.350
8	2.360
10	2.000
16	1.180
20	0.850
30	0.600
40	0.425
50	0.300
60	0.250
80	0.180
100	0.150
140	0.106
170	0.088
200	0.075
270	0.053



A set of sieves for a test in the laboratory

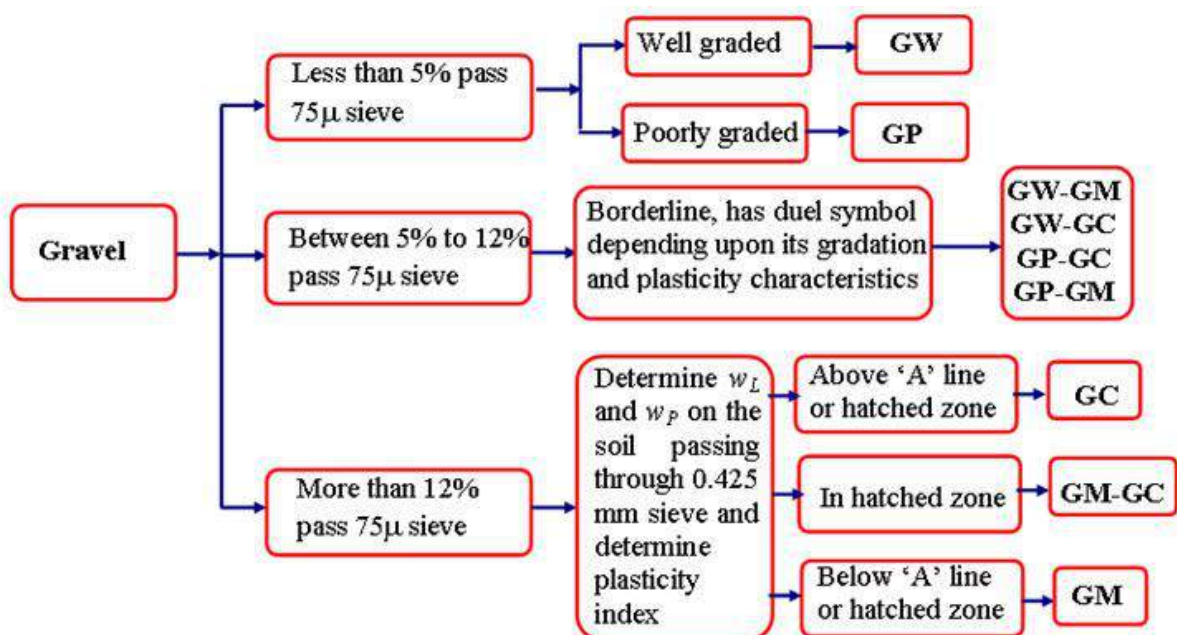

## Soil Classification Systems

- Group symbols:
  - G - gravel
  - S - sand
  - M - silt
  - C - clay
  - O - organic silts and clay
  - Pt - peat and highly organic soils
  - H - high plasticity
  - L - low plasticity
  - W - well graded
  - P - poorly graded
  
- Group names:
  - several descriptions

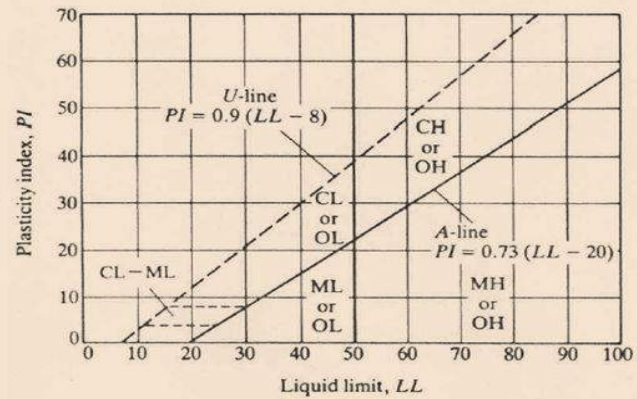

Plasticity Chart

Trial pit	Liquid limit (%)	Plasticity index	Symbol	Classification
1	29.23	17.7	CL	Inorganic clays, silty clays, sandy clays.
2	38.7	12.2	CL	Inorganic clays, silty clays, sandy clays.
3	43.0	33.5	CH	Inorganic clays of high plasticity, fatty clays
4	32.7	16.7	CL	Inorganic clays, silty clays, sandy clays.
5	34.0	17.0	CL	Inorganic clays, silty clays, sandy clays.

To determine if well graded (W) or poorly graded (P), calculate  $C_u$  and  $C_c$

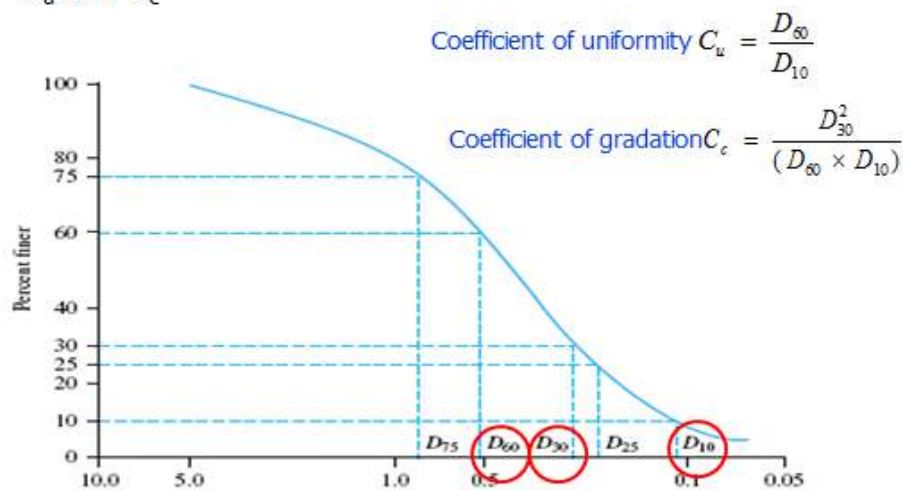

Coefficient of uniformity  $C_u = \frac{D_{60}}{D_{10}}$

Coefficient of gradation  $C_c = \frac{D_{30}^2}{(D_{60} \times D_{10})}$

Conditions for Well-graded soils

For gravels  $\rightarrow C_u > 4$  **and**  $C_c$  is between 1 and 3

For Sand  $\rightarrow W$  if  $C_u > 6$  **and**  $C_c$  is between 1 and 3

**2.2 Hydrometer (Sedimentation) analysis** is based on the principle of sedimentation of soil grains in water. When a soil specimen is dispersed in water, the particles settle at different velocities, depending on their shape, size, and weight. For simplicity, it is assumed that all the soil particles are spheres, and the velocity of soil particles can be expressed by Stokes' law, according to which:



$$v = \frac{\rho_s - \rho_w}{18\eta} D^2$$

where

$v$  = velocity

$\rho_s$  = density of soil particles

$\rho_w$  = density of water

$\eta$  = viscosity of water

$D$  = diameter of soil particles

$$D = \sqrt{\frac{18\eta v}{\rho_s - \rho_w}} = \sqrt{\frac{18\eta}{\rho_s - \rho_w}} \sqrt{\frac{L}{t}}$$

where  $v = \frac{\text{distance}}{\text{time}} = \frac{L}{t}$

Note that

$$\rho_s = G_s \rho_w$$

If the units of  $\eta$  are (g · sec)/cm<sup>2</sup>,  $\rho_w$  is in g/cm<sup>3</sup>,  $L$  is in cm,  $t$  is in min, and  $D$  is in mm, then

$$\frac{D (\text{mm})}{10} = \sqrt{\frac{18\eta [(g \cdot \text{sec})/\text{cm}^2]}{(G_s - 1)\rho_w (\text{g}/\text{cm}^3)}} \sqrt{\frac{L (\text{cm})}{t (\text{min}) \times 60}}$$

or

$$D = \sqrt{\frac{30\eta}{(G_s - 1)\rho_w}} \sqrt{\frac{L}{t}}$$

Assuming  $\rho_w$  to be approximately equal to 1 g/cm<sup>3</sup>, we have

$$D (\text{mm}) = K \sqrt{\frac{L (\text{cm})}{t (\text{min})}}$$

In this method, the soil is placed as a suspension in a jar filled with distilled water to which a deflocculating agent is added. The soil particles are then allowed to settle down. The concentration of particles remaining in the suspension at a particular level can be determined by using a hydrometer. Specific gravity readings of the solution at that same level at different time intervals provide information about the size of particles that have settled down and the mass of soil remaining in solution. The results are then plotted between % finer (passing) and log size. Grain-Size Distribution Curve the size distribution curves, as obtained from coarse and fine grained portions, can be combined to form one complete grain-size distribution curve (also known as grading curve). A typical grading curve is shown.

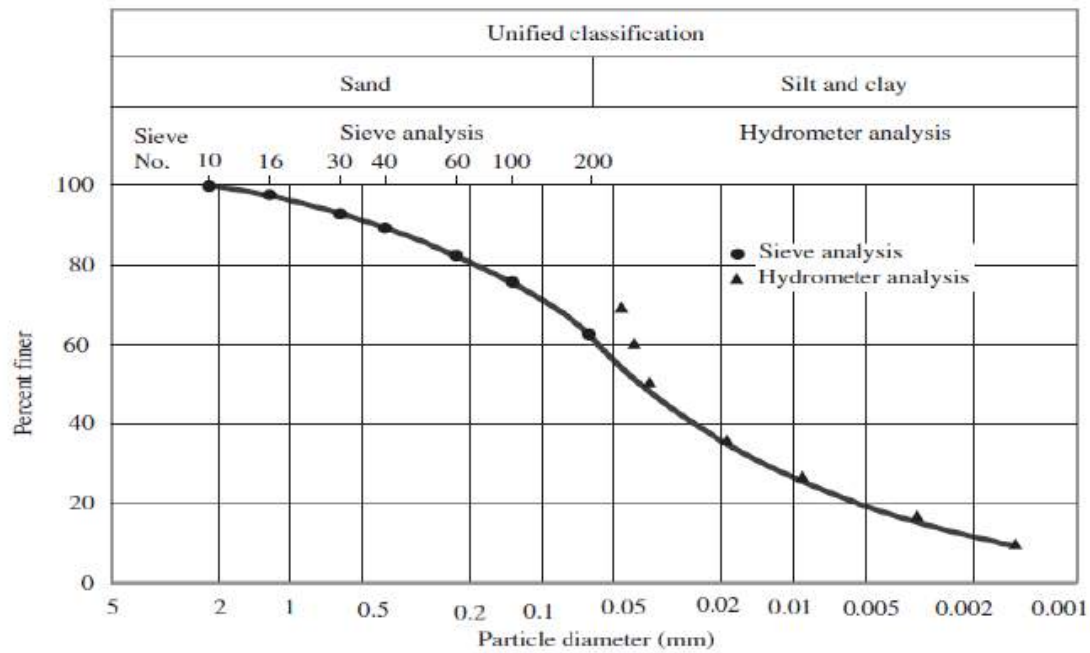

- 3.
- 4.
- 5.
- 6.
- 7.

### 3. Grain-size distribution curve

From the complete grain-size distribution curve, useful information can be obtained

such as: **1. Grading characteristics**, which indicate the uniformity and range in grain-size distribution. **2. Percentages (or fractions)** of gravel, sand, silt and clay size. Grading Characteristics A grading curve is a useful aid to soil description. The geometric properties of a grading curve are called grading characteristics.

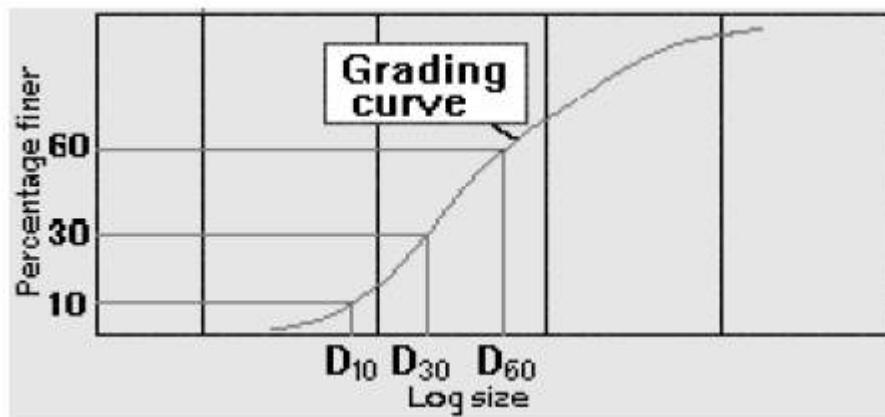

To obtain the grading characteristics, three points are located first on the grading curve. D60 = size at 60% passing, D30 = size at 30% passing, D10 = size at 10% passing.

The grading characteristics are:

1. Effective size
2. Uniformity coefficient
3. Curvature coefficient

If  $C_u > 4$  for gravelly soils, it is well-graded soil. The distribution of particle sizes is

The consistency of a fine-grained soil refers to its firmness, and it varies with the water content of the soil.

A gradual increase in water content changes the soil from one state to another (solid to plastic to liquid limits). The three limits are shrinkage limit (SL) and liquid limit (WL) as determined by laboratory tests. (as explained below)

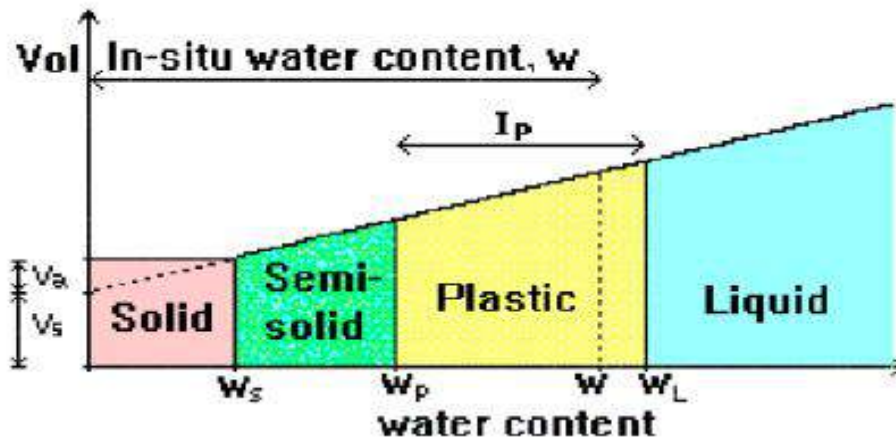

**Classification Based on Grain Size** The range of particle sizes encountered in soils is very large: from boulders with dimension of over 300 mm down to clay particles that are less than 0.002 mm. Some clay contains particles less than 0.001 mm in size which behave as colloids, i.e. do not settle in water.

According to grain Size analysis:

Coarse soils	Gravel size (G)	Coarse	20 - 80 mm
		Fine	4.75 - 20 mm
	Sand size (S)	Coarse	2 - 4.75 mm
		Medium	0.425 - 2 mm
Fine soils		Fine	0.075 - 0.425 mm
	Silt size (M)		0.002 - 0.075 mm
	Clay size (C)		< 0.002 mm

Gravel, sand, silt, and clay are represented by group symbols G, S, M, and C respectively. Physical weathering produces very coarse and coarse soils. Chemical weathering produces generally fine soils.

**Coarse-grained soils** are those for which more than 50% of the soil material by weight has particle sizes greater than 0.075 mm. They are basically divided into either gravels (G) or sands (S). According to gradation, they are further grouped as well-graded (W) or poorly graded (P). If fine soils are present, they are grouped as containing silt fines (M) or as containing clay fines (C). For example, the combined symbol SW refers to well-graded sand with no fines. Both the position

and the shape of the grading curve for a soil can aid in establishing its identity and description. Some typical grading curves are shown.

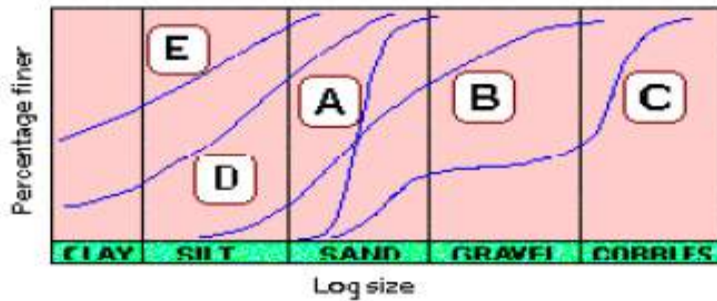

**Curve A - poorly-graded SAND**

**Curve B - a well-graded GRAVEL-SAND (i.e. having equal amounts of gravel and sand)**

**Fine-grained soils** are those for which more than 50% of the material has particle sizes less than 0.075 mm. Clay particles have a **flaky** shape to which water adheres, thus imparting the property of **plasticity**.

A **plasticity chart**, based on the values of liquid limit (WL) and plasticity index (IP),

The 'A' line in this chart is expressed as  $IP = 0.73 (WL - 20)$ .

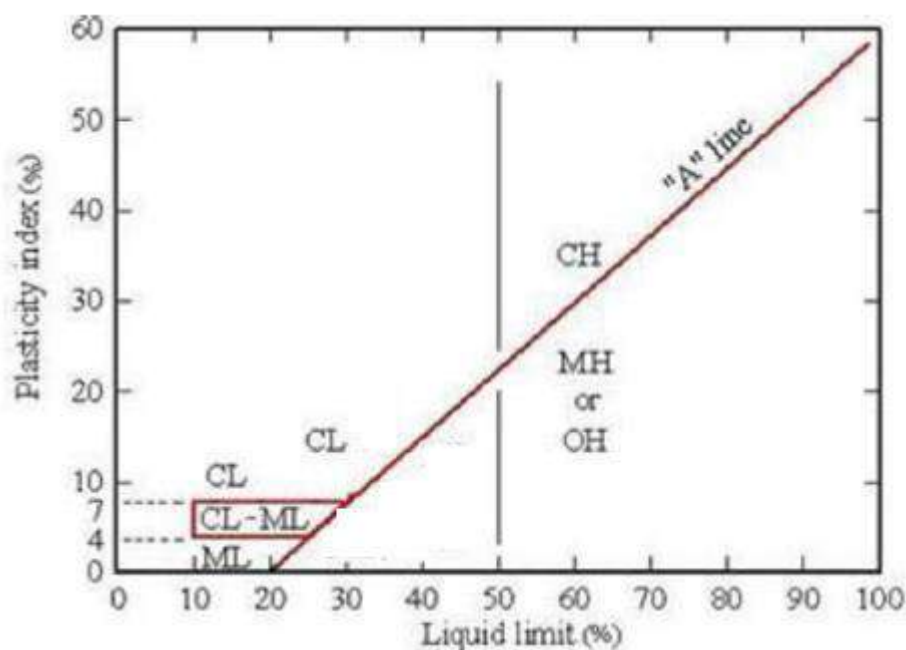



Depending on the point in the chart, fine soils are divided into clays (C), silts (M) or organic soils (O). The organic content is expressed as a percentage of the mass of organic matter in a given mass of soil to the mass of the dry soil solids.

Soil classification using group symbols is as follows:

Group Symbol	Classification
<i>Coarse soils</i>	
<b>GW</b>	Well-graded GRAVEL
<b>GP</b>	Poorly-graded GRAVEL
<b>GM</b>	Silty GRAVEL
<b>GC</b>	Clayey GRAVEL
<b>SW</b>	Well-graded SAND
<b>SP</b>	Poorly-graded SAND
<b>SM</b>	Silty SAND
<b>SC</b>	Clayey SAND

<i>Fine soils</i>	
<b>ML</b>	SILT of low plasticity
<b>MH</b>	SILT of high plasticity
<b>CL</b>	CLAY of low plasticity
<b>OH</b>	Organic soil of high plasticity
<b>CH</b>	CLAY of high plasticity
<b>OL</b>	Organic soil of low plasticity



Activity "Clayey soils" necessarily do not consist of 100% clay size particles. The proportion of clay mineral flakes (< 0.002 mm size) in a fine soil increases its tendency to swell and shrink with changes in water content. This is called the activity of the clayey soil, and it represents the degree of plasticity related to the clay content.

$$A = \frac{PI}{\% \text{ clay fraction (weight)}}$$

Where PI is plasticity index =  $L_L - P_L$

Liquidity Index In fine soils, especially with clay size content, the existing state is dependent on the current water content ( $w$ ) with respect to the consistency limits) or Atterberg limits). The liquidity index (LI) provides a quantitative measure of the present state.

$$L_I = \frac{\omega - P_L}{L_L - P_L}$$

### Example 1:

Following are the results of a sieve analysis. Make the necessary calculations and draw a particle –size distribution curve.

U.S.sieve size	Mass of soil retained on each sieve (g)
4	0
10	40
20	60
40	89
60	140
80	122
100	210
200	56
Pan	12

**Solution:**

**Solution**

The following table can now be prepared.

U.S. sieve (1)	Opening (mm) (2)	Mass retained on each sieve (g) (3)	Cumulative mass retained above each sieve (g) (4)	Percent finer <sup>a</sup> (5)
4	4.75	0	0	100
10	2.00	40	0 + 40 = 40	94.5
20	0.850	60	40 + 60 = 100	86.3
40	0.425	89	100 + 89 = 189	74.1
60	0.250	140	189 + 140 = 329	54.9
80	0.180	122	329 + 122 = 451	38.1
100	0.150	210	451 + 210 = 661	9.3
200	0.075	56	661 + 56 = 717	1.7
Pan	—	12	717 + 12 = 729 = $\Sigma M$	0

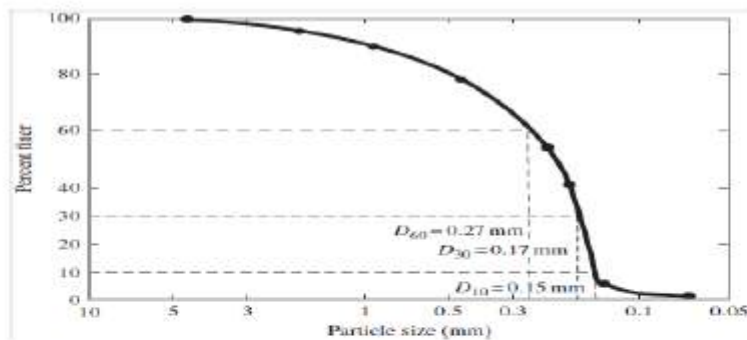

Find  $C_u$ ,  $C_c$

$$C_u = \frac{D_{60}}{D_{10}} = \frac{0.27}{0.15} = 1.8$$

$$C_c = \frac{(D_{30})^2}{D_{60}D_{10}} = \frac{(0.17)^2}{0.27 \cdot 0.15} = 0.71$$

% passing # 200 less than 50% so the soil is coarse, and since % passing # 4 = 100 so the soil is sand and since  $C_u$  less than 6, so the soil is SP.

Home work :1- Following are the results of a sieve analysis:

U.S. Sieve No.	Mass of soil retained on each sieve (g)
4	0
10	21.6
20	49.5
40	102.6
60	89.1
100	95.6
200	60.4
pan	31.2

- I- Plote the grain –size distribution curve.
- II- Calculate the uniformity coefficient , $C_U$ , and cofficient of gradation ,  $C_C$ 
  - A)-For a soil given:
    - $D_{10} = 0.1$  mm
    - $D_{30} = 0.41$  mm
    - $D_{60} = 0.62$  mm
  - B)-for a soil given:
    - $D_{10} = 0.082$  mm

### Home work 1:

2- *Classify the following soil according to USCS*

U.S. Sieve No.	Mass of soil retained on the sieve in g
4	0
6	0
10	0
20	9.1
40	249.4
60	179.8
100	22.7
200	15.5
Pan	23.5

*CHAPTER FIVE*

**SOIL PERMEABILITY AND  
FLOW**

## 1. The Permeability

A material is permeable if it contains continuous voids. All materials such as rocks, concrete, soils etc. are permeable. The flow of water through all of them obeys approximately the same laws. Hence, the difference between the flow of water through rock or concrete is one of degree. The permeability of soils has a decisive effect on the stability of foundations, seepage loss through embankments of reservoirs, drainage of sub grades, excavation of open cuts in water bearing sand, rate of flow of water into wells and many others.

## 2. Soil permeability

The soil permeability is a measure indicating the capacity of the soil or rock to allow fluids to pass through it. It is often represented by the permeability coefficient (k) through the Darcy's equation:

$$V=ki$$

## 3. Flow of Water Through Soils

### 3.1 Fluid Mechanics(Hydraulic Gradient)

When water flows through a saturated soil mass there is certain resistance for the flow because of the presence of solid matter. However, the laws of fluid mechanics which are applicable for the flow of fluids through pipes are also applicable to flow of water through soils. As per Bernoulli's equation, the total head at any point in water under steady flow condition may be expressed as

Total head = pressure head + velocity head + elevation head

$h = \frac{P}{\gamma_w} + \frac{v^2}{2g} + z$	<p><b>h = total head, <math>\frac{P}{\gamma_w}</math> = pressure head</b></p> <p><b><math>\frac{v^2}{2g}</math> = velocity head, <math>z</math> = elevation head</b></p>
---	--

For most soils the velocity of water flow is very small therefore the velocity head term can be neglected

The flow of water through a sample of soil of

$$h = \frac{u}{\gamma_w} + Z = h_p + h_e$$

*h = Pressure head + Elevation head*

length L and cross area A as shown in

$$H_c = Z_c + \frac{P_c}{\gamma_w} + \frac{v_c^2}{2g}$$

sectional area figure1:

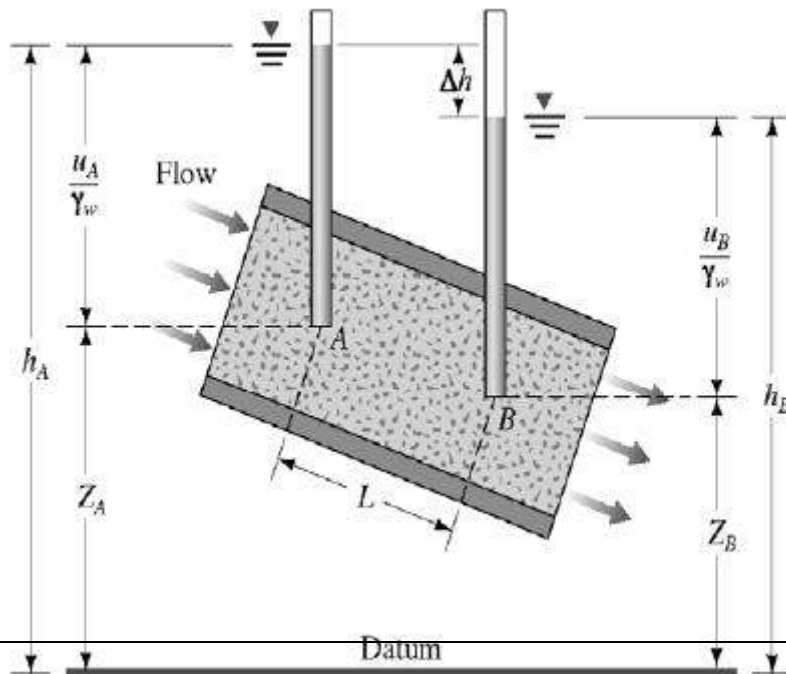

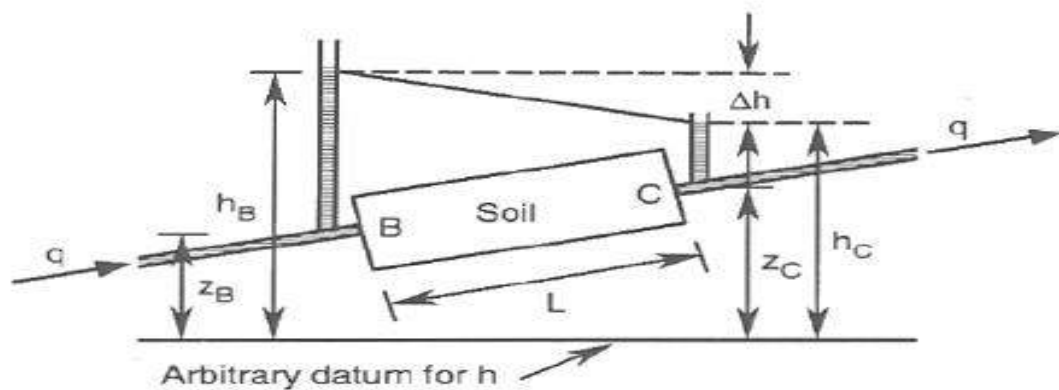
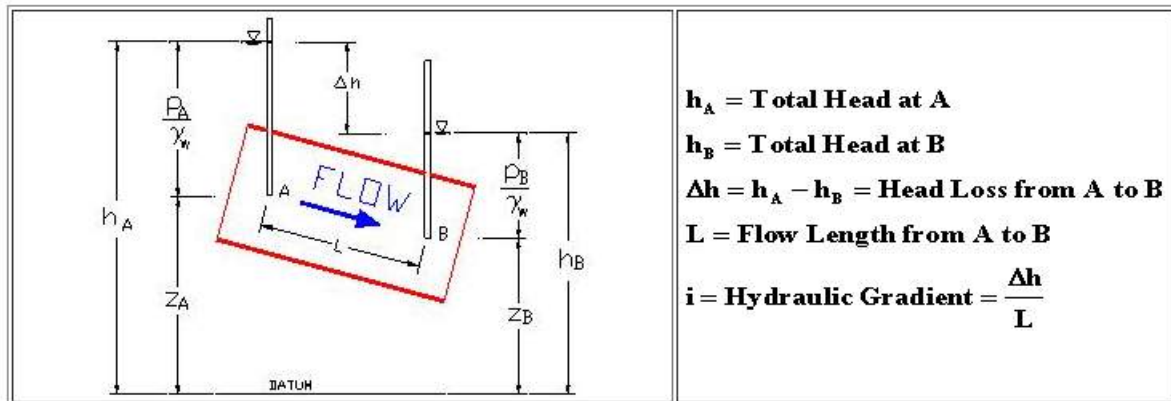

(1) flow of water through a soil sample

For all practical purposes the velocity head is a small quantity and may be neglected.

The water flows from the higher total head to lower total head. So the water will flow from point B to C.

$$H_B - H_C = \left( Z_B + \frac{P_B}{\gamma_w} \right) - \left( Z_C + \frac{P_C}{\gamma_w} \right)$$

Where,  $Z_B$  and  $Z_C = \text{Elevation head}$ ,  $P_B$  and  $P_C = \text{Pressure Head}$ .  
The loss of head per unit length of flow may be expressed as :

$$i = \frac{h}{L}$$

Where  $i$  is the hydraulic gradient.



Which is define as the potential drop between two adjacent equipotentials divided by the distance between them is known as the

## Hydraulic Gradient ( $i$ )

- Head loss per unit length is:

$$i = \frac{\Delta h}{L}$$

where:

$i$  = hydraulic gradient

$\Delta h$  = head loss between points of interest

$L$  = distance between points of interest

hydraulic gradient

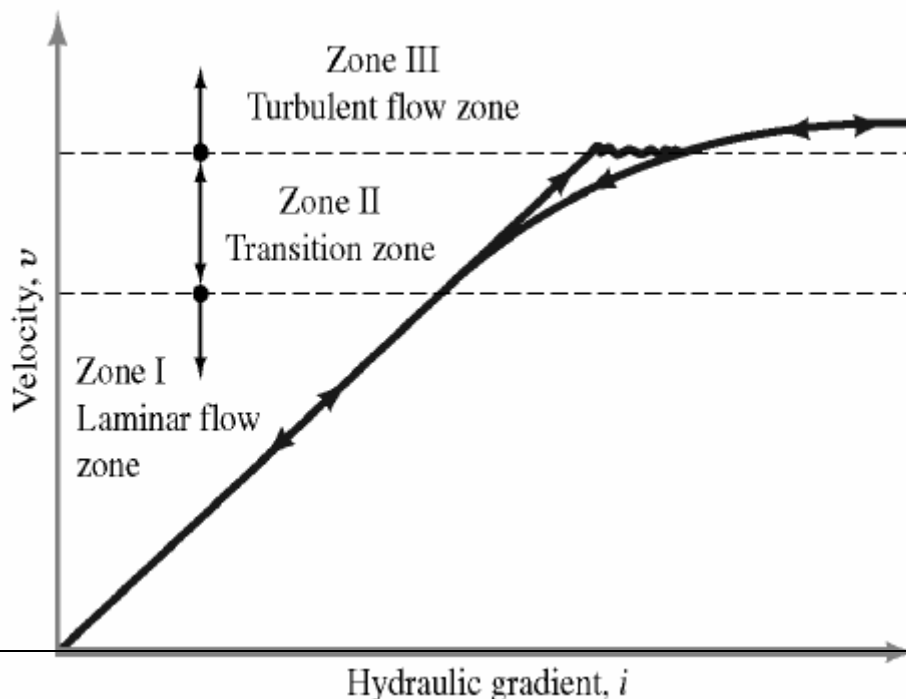

### In Most Soils

Flow through most soils can be considered to be laminar. Therefore a linear relationship between velocity and hydraulic gradient  $v \propto i$

Flow conditions may be turbulent in fractured rock, stones, gravel, and very coarse sands

### 4. Darcy's Law and Other Principles

Darcy's law is a constitutive equation that describes the flow of a fluid through a porous medium. The law was formulated by Henry Darcy based on the results of experiments on the flow of water through beds of sand, forming the basis of hydrogeology, a branch of earth sciences.

Darcy in 1856 derived an empirical formula for the behavior of flow through saturated soils. He found that the quantity of water  $q$  per sec flowing through a cross-sectional area of soil under hydraulic gradient  $i$  can be expressed by the formula

$$q = kiA$$

or the velocity of flow can be written as

$$V = \frac{q}{A}$$

Where  $k$  is termed the hydraulic conductivity (or coefficient of permeability) with

units of velocity. The coefficient of permeability is inversely proportional to the viscosity of water which decreases with increasing temperature; therefore, permeability measurement at laboratory temperatures should be corrected to the values at standard temperature of 20°C using the following equation.

$$k_{20} = \frac{\mu_T}{\mu_{20}} k_T$$

Where  $k_{20}$  : Coefficient of permeability at 20°C

$k_T$  : Coefficient of permeability at Lab. Temperature°C

$\mu_T$  Viscosity of water at lab. Temperature

$\mu_{20}$  Viscosity of water at 20°C

### A. Darcy's Equation

<b>v = ki</b>	<b>v = average velocity, ft / s or m / s</b>
	<b>k = coefficient of permeability, ft / s or m / s</b>
	<b>i = hydraulic gradient</b>

Temperature T(°C)	$\mu_T/\mu_{20}$	Temperature T(°C)	$\mu_T/\mu_{20}$
10	1.298	21	0.975
11	1.263	22	0.952
12	1.228	23	0.930
13	1.195	24	0.908
14	1.165	25	0.887
15	1.135	26	0.867
16	1.106	27	0.847
17	1.078	28	0.829
18	1.051	29	0.811
19	1.025	30	0.793
20	1.000		

Table (1) :The of  $\frac{\mu_T}{\mu_{20}}$  at different temperature.

## Discharge Velocity

Quantity of water flowing in unit time through a unit gross cross sectional area of soil at right angles to the direction of flow . Does not account for flow through soil voids.

## Seepage Velocity

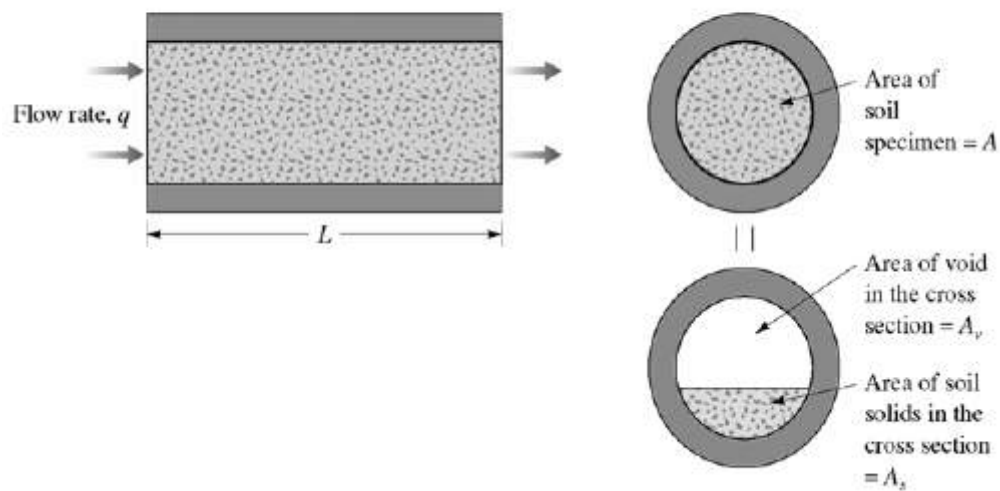

## DISCHARGE AND SEEPAGE VELOCITIES

Figure below shows a soil sample of length  $L$  and cross-sectional area  $A$ . The sample is placed in a cylindrical horizontal tube between screens. The tube is connected to two reservoirs  $R_1$  and  $R_2$  in which the water levels are maintained constant. The difference in head between  $R_1$  and  $R_2$  is  $h$ . This difference in head is responsible for the flow of water. Since Darcy's law assumes no change in the volume of voids and the soil is saturated, the quantity of flow past sections  $AA$ ,  $BB$  and  $CC$  should remain the same for steady flow conditions. We may express the equation of continuity as follows

$$q_{aa} = q_{bb} = q_{cc}$$

If the soil be represented as divided into solid matter and void space, then the area available for the passage of water is only  $A_v$ . If  $v_s$  is the velocity of flow in the voids, and  $v$ , the average velocity across the section then, we have

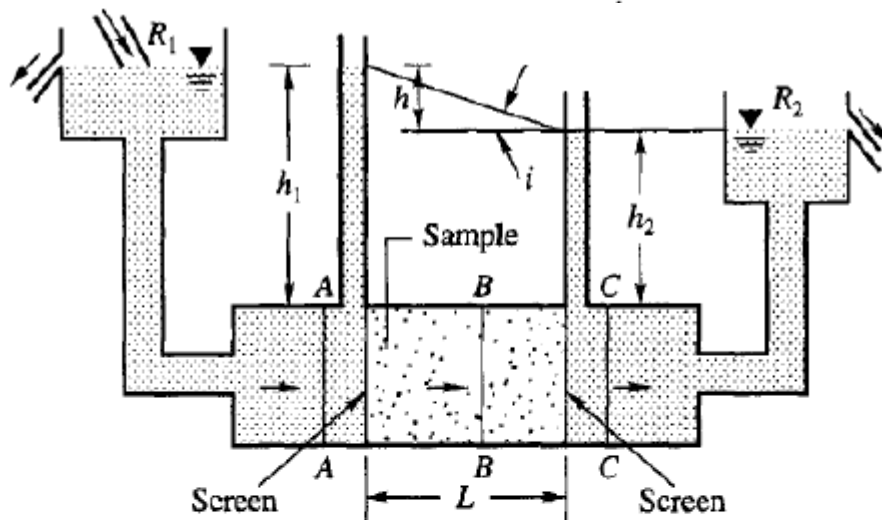

Where  $A_v$  is the area of the void,

$v_s$  is the seepage velocity,

$v$  is the approach velocity

$A$ : is the cross sectional area of the sample

$$v_s = \frac{A * L}{A_v * L} \quad v = \frac{v_t}{v_v} \quad v = \frac{v}{n}$$

Where  $n$  : is the porosity of the soil

## Seepage Velocity

$$q = vA = A_v v_s$$

Where:

q= quantity of water flowing per unit time

v= discharge velocity

A= area of soil specimen perpendicular to flow

$A_v$ = area of voids in soil section

$v_s$ = seepage velocity

## Seepage Velocity

$$\frac{A_v}{A} = \frac{V_v}{V} = n$$

$$v_s = \frac{v}{n} = v \left( \frac{e}{e+1} \right)^{-1}$$

where:

n= porosity

e= void ratio

See derivation DAS page 159

## Seepage Velocity

Note:

- Seepage velocity is significantly greater than the Darcy's discharge velocity
- Seepage velocity is an average velocity through the pore voids
  - Higher velocities will occur in small pore throats
  - Low velocities in large pore throats

See derivation DAS page 159

## HYDRULIC CONDUCTIVITY

### (Coefficient of permeability)

The hydraulic conductivity of a soil is a measure of the soil's ability to transmit water when submitted to a hydraulic gradient. Hydraulic conductivity is defined by Darcy's law, which, for one-dimensional vertical flow.

It depends on:

- Type of fluid (water vs molasses-Viscosity, density)
- Pore size distribution
- Grain size distribution
- Void ratio
- Particle shape

- Degree of saturation
- Size of double layer (clay type)

## Hydraulic Conductivity

$$k = \frac{K\rho g}{\eta} = \frac{K\gamma_w}{\eta}$$

where:

K = absolute permeability (L<sup>2</sup>)

ρ = density of fluid

g = gravitational constant

η = viscosity of fluid

γ<sub>w</sub> = Unit weight of fluid

Table shows the typical values of hydraulic conductivity for saturated soils

	k	k
Soil Type	cm/sec	ft/min
Clean Gravel	1.0 to 100	2.0 to 200
Coarse Sand	0.01 to 1.0	0.02 to 2.0
Fine Sand	0.001 to 0.01	0.002 to 0.02
Silty Clay	0.00001 to 0.001	0.00002 to 0.002
Clay	Less Than 0.000001	Less Than 0.000002

A - Laboratory

## Measurement of Hydraulic Conductivity

Cohesionless soils (sand and gravel)

- Constant head test
- Falling head test

Cohesive soils (silt and clay)

- Triaxial cell



**B- Field methods:**

- 1- Pumping test
- 2- Bore hole tests

**Laboratory methods****1- Constant head permeability test**

The coefficient of permeability for coarse soils can be determined by means of the constant-head permeability test (as shown in figures): A steady vertical flow of water, under a constant total head, is maintained through the soil and the volume of water flowing per unit time ( $q$ ):

A series of tests should be run, each at different rate of flow. Prior to running the test a vacuum is applied to the specimen to ensure that the degree of saturation under

flow

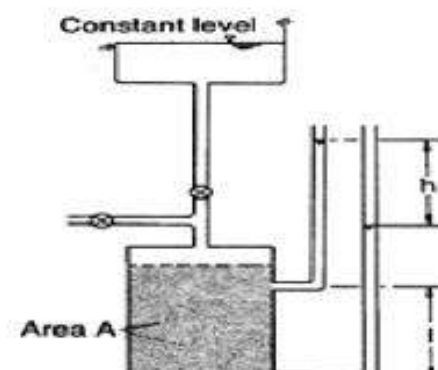
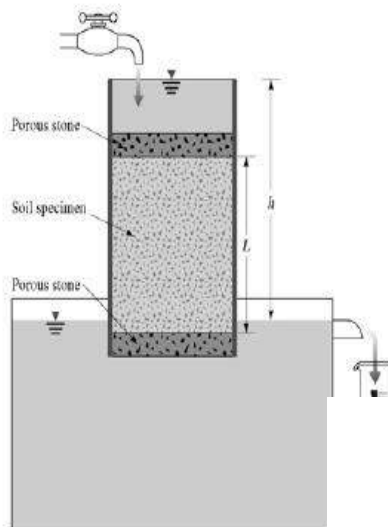
**Constant Head Test****Constant Head Test**

$$Q = vAt = kiAt = k(h/L)At$$

where:

$Q$  = quantity of flow ( $L^3$ )

$A$  = cross section area of column ( $L^2$ )

$t$  = duration of water collection (T)

Solve for  $k$ :

$$k = \frac{QL}{Aht}$$

## 2- Falling head permeability test:

For fine soils the falling-head test (Figure below) should be used. In the case of fine soils, undisturbed specimens are normally tested. The length of the specimen is  $l$  and the cross-sectional area  $A$ . The standpipe is filled with water and a measurement is made of the time ( $t_1$ ) for water level (relative to the water level in the reservoir) to fall from  $h_0$  to  $h_1$ . At any intermediate time  $t$  the water level in the standpipe is given by  $h$  and its rate of change by  $-\frac{dh}{dt}$ . At time  $t$  the difference in total head between the top and bottom of the specimen is  $h$ . then applying Darcy's law:

$$-a \frac{dh}{dt} = AK \frac{h}{l}$$

$$-a \int_{h_0}^{h_1} \frac{dh}{h} = \frac{AK}{l} \int_0^{t_1} dt$$

$$\therefore K = \frac{al}{At_1} \ln \frac{h_0}{h_1} = 2.3 \frac{al}{At_1} \log \frac{h_0}{h_1}$$

Ensure that the degree of saturation remains close to 100%. A series of tests should

be run using different values of  $h_0$  and  $h_1$

# Falling Head Test

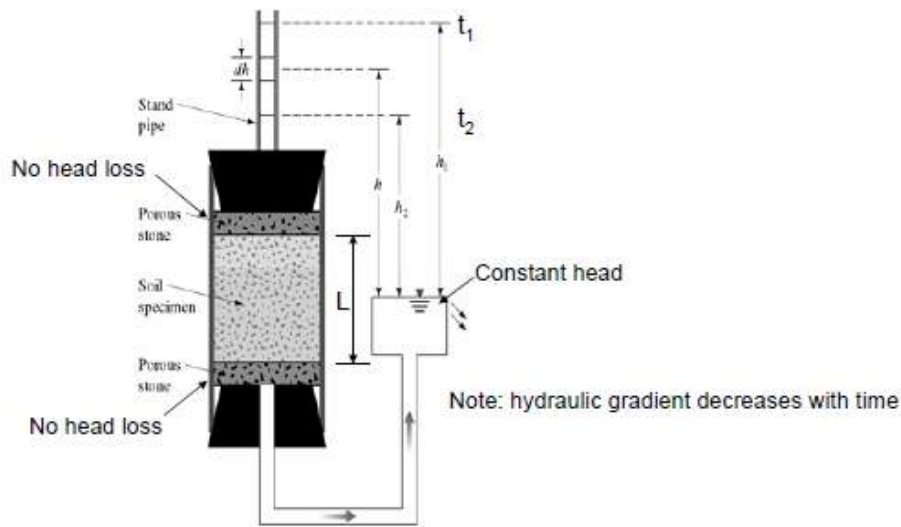

# Falling Head Test

- Record level  $h_1$  at  $t_1=0$
- Head is allowed to flow such that the final head difference is at time  $t = t_2$  is  $h_2$

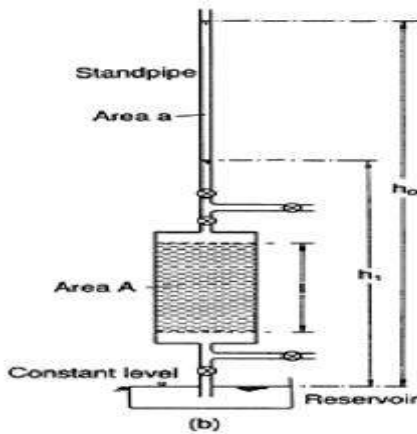

# Falling Head Test

- Record level  $h_1$  at  $t_1=0$
- Head is allowed to flow such that the final head difference is at time  $t = t_2$  is  $h_2$

$$q_{\text{standpipe}} = -a \frac{dh}{dt} = q_{\text{into soil column}}$$

where:

a = cross sectional area of stand pipe

$dh/dt$  = change in head in change in time = velocity of water falling

## Example 1:

Minus sign is used to indicate falling head (decreasing head)

# Falling Head Test

$$q_{\text{soil}} = k \frac{h}{L} A$$

where:

k = soil hydraulic conductivity

h = total head loss

L = length of soil column resulting in head loss

A = soil column cross sectional area

Continuity:

$$q_{\text{in}} = q_{\text{soil}}$$

A constant head permeability test was carried out on a cylindrical of sand 4 in. in diameter and 6 in. in height.  $10 \text{ in}^3$  Of water was collected in 1.75 min, under a head of 12 in. Compute the hydraulic conductivity in ft/year and the velocity of flow in ft/sec.

Solution:

$$k = \frac{Q}{A i t}$$

$$Q = 10 \text{ in}^3, A = 3.14 * \frac{4^2}{4} = 12.56 \text{ in}^2$$

$$i = \frac{h}{L} = \frac{12}{6} = 2, t = 105 \text{ sec}$$

$$\text{Therefore } k = \frac{10}{12.56 * 2 * 105} = 3.79 * \frac{10^{-3} \text{ in}}{\text{sec}} = 31.58 * 10^{-5} \text{ ft/sec}$$

$$\text{Velocity of flow } = ki = 31.58 * 10^{-5} * 2 = 6.316 * 10^{-4} \text{ ft/sec}$$

### Example 2

A sand sample of 35 yP cross sectional area and 20 cm long was tested in a constant head permeameter. Under a head of 60 cm, the discharge was 120 ml in 6 min. The dry weight of sand used for the test was 1120 g. and  $G_s = 2.68$ . Determine (a) the hydraulic conductivity in cm/sec. (b) the discharge velocity, and (c) the seepage velocity.

Solution:

$$k = \frac{QL}{\Delta hAt}$$

$Q = 120 \text{ ml}$ ,  $t = 6 \text{ min}$ ,  $A = 35 \text{ cm}^2$ ,  $L = 20 \text{ cm}$ , and  $h = 60 \text{ cm}$

$$k = \frac{120 \times 20}{60 \times 35 \times 6 \times 60} = 3.174 \times 10^{-3} \text{ cm/sec}$$

Discharge velocity,  $v = ki = 3.174 \times 10^{-3} \times \frac{60}{20} = 9.52 \times 10^{-3} \text{ cm/sec}$

Seepage velocity  $v_s$

$$\gamma_d = \frac{w_s}{v} = \frac{1120}{35 \times 20} = 1.6 \text{ gm/cm}^3$$

$$\gamma_d = \frac{\gamma_w G_s}{1 + e} \text{ or } e = \frac{G_s}{\gamma_d} - 1$$

$$e = \frac{2.68}{1.6} - 1 = 0.675$$

$$n = \frac{e}{1 + e} = 0.403$$

$$v_s = \frac{v}{n} = \frac{9.52 \times 10^{-3}}{0.403} = 2.36 \times 10^{-2} \text{ cm/sec}$$

## DIRECT DETERMINATION OF K OF SOILS IN FIELD:

### 1- Field test in unconfined aquifer

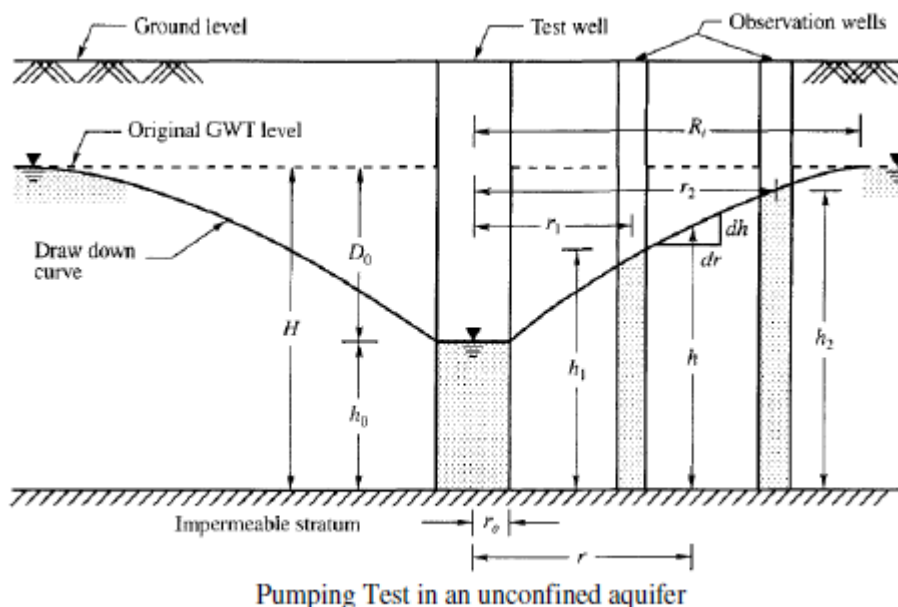

$$k = \frac{2.3q}{\pi(h_2^2 - h_1^2)} \log \frac{r_2}{r_1}$$

## 2- Field test in Confined aquifer

There are two cases :

Case 1- when  $h_0 > H_0$

$$k = \frac{2.3q}{2\pi H_0 (h_2 - h_1)} \log \frac{r_2}{r_1}$$

Case 2-when  $h_0 < H_0$

$$k = \frac{2.3q}{\pi(2HH_0 - H_0^2 - h_0^2)} \log \frac{R_i}{r_0}$$

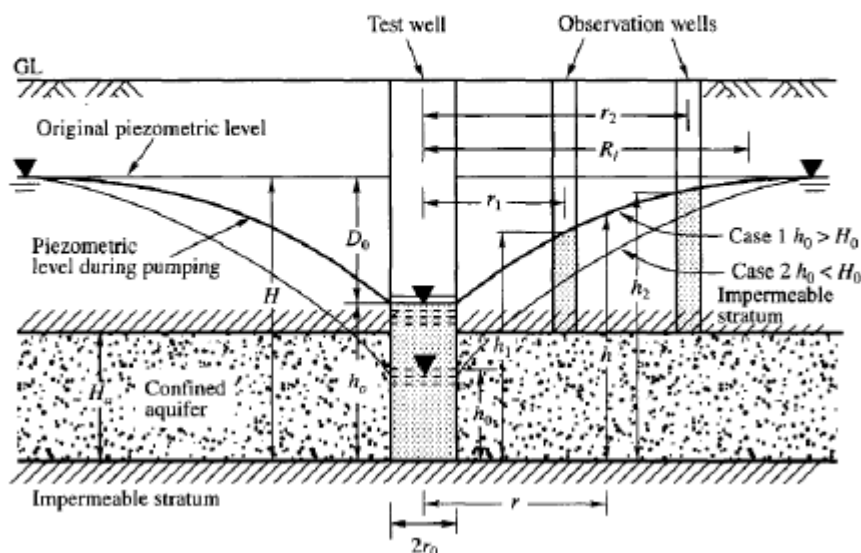

## Empirical Relations for Hydraulic Conductivity

Several empirical equations for estimating hydraulic conductivity have been proposed over the years.

### K Relationships for Granular Soils

#### Hazen Equation

$$k(\text{cm/s}) = cD_{10}^2$$

where:

$c$  = a constant that varies from 1.0 to 1.5

$D_{10}$  = effective particle size for 10 percent passing (mm)

Equation works OK for clean loose sand.

The above equation is based primarily on Hazen's observations of loose, clean, filter sands. A small quantity of silts and clays, when present in a sandy soil, may change the hydraulic conductivity substantially.

The accuracy of the values of  $k$  determined in the laboratory depends on the following factors:

- 1- Temperature of the fluid
- 2- Viscosity of fluid
- 3- Trapped air bubbles present in the specimen
- 4- Degree of saturation
- 5- Migration of fines during testing
- 6- Duplication of field conditions in the laboratory.

The coefficient of consolidation of saturated cohesive soils can be determined by laboratory consolidation tests. This will be listed in details in "consolidation of soil"

Table -1 Typical Values of Hydraulic Conductivity of Saturated Soils

***Typical values of permeability***

Gravel	$> 10^{-1}$ m/s
Sands	$10^{-1}$ to $10^{-5}$ m/s
Fine sands, coarse silts	$10^{-5}$ to $10^{-7}$ m/s
Silts	$10^{-7}$ to $10^{-9}$ m/s
Clays	$< 10^{-9}$ m/s



Exercise:

1-

In a constant-head permeability test in the laboratory, the following are given:  $L = 300 \text{ mm}$  and  $A = 110 \text{ cm}^2$ . If the value of  $k = 0.02 \text{ cm/sec}$  and a flow rate of  $140 \text{ cm}^3/\text{min}$  must be maintained through the soil, what is the head difference,  $h$ , across the specimen? Also, determine the discharge velocity under the test conditions.

2-

For a variable-head permeability test, the following are given:

- Length of the soil specimen = 20 in.
  - Area of the soil specimen =  $2.5 \text{ in.}^2$
  - Area of the standpipe =  $0.15 \text{ in.}^2$
  - Head difference at time  $t = 0$  is 30 in.
  - Head difference at time  $t = 8 \text{ min}$  is 16 in.
- a. Determine the hydraulic conductivity of the soil (in./min)
  - b. What is the head difference at time  $t = 6 \text{ min}$ ?

## HEADS AND ONE-DIMENSIONAL FLOW

There are three heads which must be considered in problem involving fluid flow in soil as shown in the figure below:

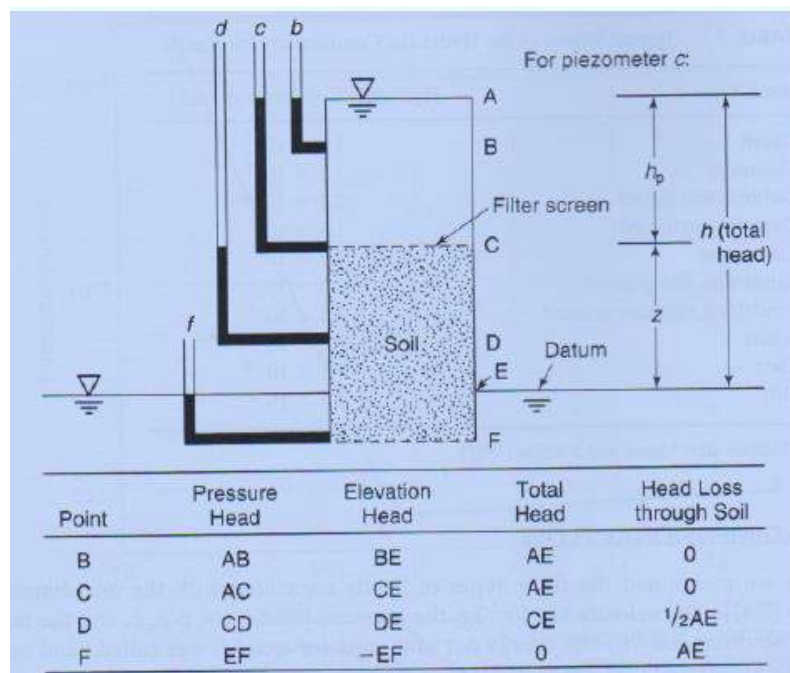
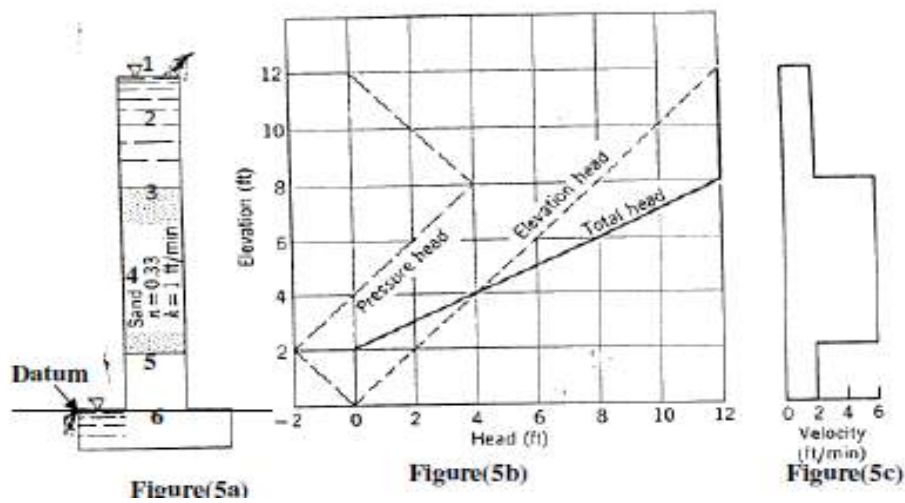

Figure : illustration of types of head(after Taylor, 1948).

- 1- Pressure head ( $h_p$ ) is the pizometer reading = pore water pressure /unit weight of water
- 2- Elevation head at any point ( $h_e$ ) is the vertical distance above or below some reference elevation or datum plane.
- 3- Total head,  $h = h_p + h_e$

Example 1: For the Setup shown (Figure 5a), plot,  $h_t$ ,  $h_e$ ,  $h_p$  and the velocity of flow?



Points	$h_t$ (ft) (Figure 5b)	$h_e$ (ft) (Figure 5b)	$h_p = h_t - h_e$ (ft) (Figure 5b)	$V$ (ft/min) <sup>n</sup> = $Ki$ (Figure 5c)
1	12	12	0	2
2	12	10	2	2
3	12	8	4	6
4	$\frac{12+0}{2} = 6$	5	1	6
5	0	2	-2	6
6	0	0	0	2

Example 2

For the setup shown(Figure 6a) , Draw,  $h_t$ ,  $h_e$  ,  $h_p$  and velocity of flow ?

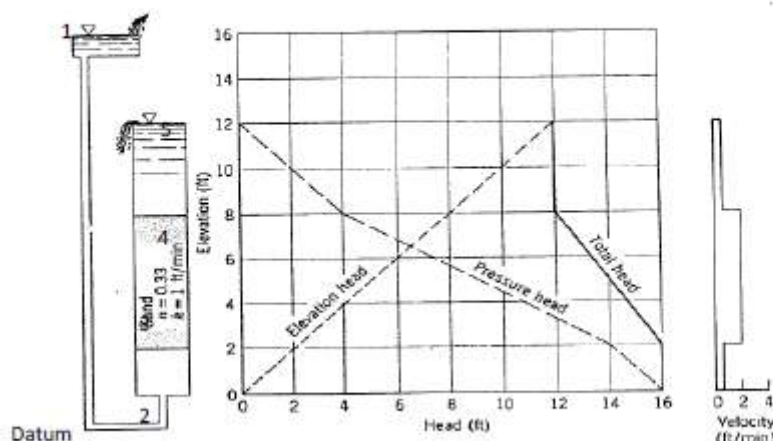

Figure (6)

- 1- Direction of flow is upward flow (look to the water's symbol usually water flow from higher one to lower one)
- 2- List all point with direction of flow
- 3- Construct a table to solve the problem

Points	ht(ft) (Figure 6b)	he(ft) (Figure 6b)	hp=ht- he(ft) (Figure 6b)	V(ft/min)*=Ki (Figure 6c)
1	16	16	0	
2	16	2	14	
3	$\frac{16 + 12}{2} = 14$	5	9	
4	12	8	4	
5	12	12	0	

$$*i = \frac{h_{t \text{ at } 2} - h_{t \text{ at } 4}}{L_{2-4}} = \frac{16-12}{6} = 0.667$$

Example 3: For the setup shown(Figure below) , Draw, ht, he , hp and velocity of flow ?

Figure (7a)

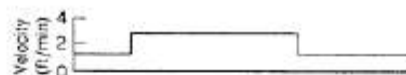

Figure (7c)

Solution:

- 1- Assume any arbitrary line representing the datum and let it at elevation =0(Figure 7a).
- 2- The flow will be in horizontal direction (elevation head is constant)
- 3- Construct the table

Since pressure =3.4 psi=3.4\*144= 489.6 lb/ft<sup>2</sup>

$$hp = \frac{\text{pressure}}{\text{unit weight of water}} = \frac{489.6}{62.4} = 7.84 \text{ ft}$$

Points	ht(ft)	he(ft)	hp(ft)
1	7.84	0	8

2	7.84	3	5.84
3	3.92	3	0.92
4	0	3	-3
5	0	0	0

$$i = \frac{h_t \text{ at } 2 - h_t \text{ at } 4}{L_{2-4}} = \frac{7.84 - 0}{6} = 1.3$$

Approch velocity =  $ki = 1 \times 1.3 = 1.3 \text{ ft/min}$

Seepage velocity =  $v = \frac{1.3}{3} = 0.43 \text{ ft/sec}$

Example 4

For the setup shown in figure 8:a) - Calculate the pressure head, elevation head, total head and head loss at points B, C,D and F in centimeter of water. b)-Plot the heads versus the elevation.

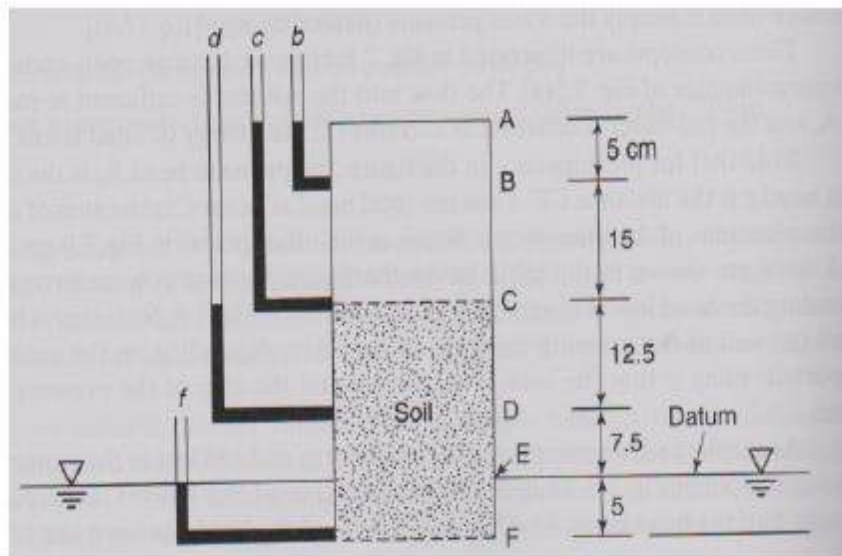

Figure shows the Set up of example 4

Solution (1):

points	ht(cm)	he(cm)	hp(cm)	Head loss
B	40	35	5	0

C	40	20	20	0
D	20	7.5	12.5	20
F	0	-5	5	40

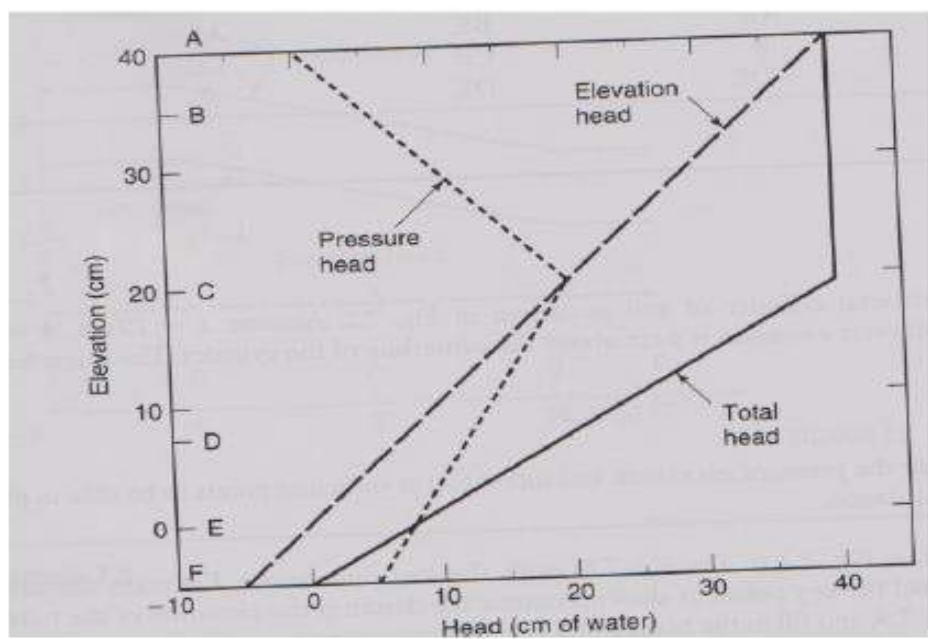
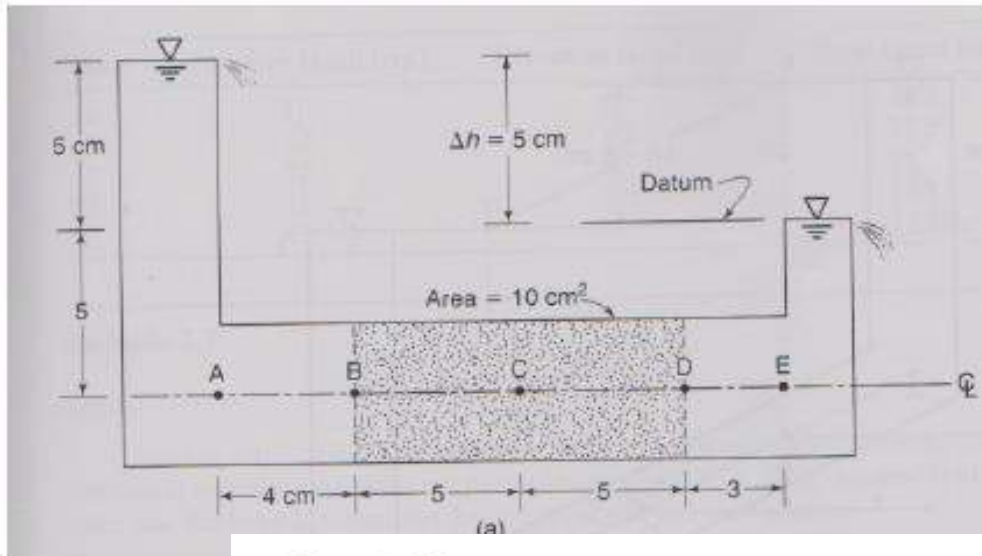

Figure (8)Example 4

Example (5): for the setup shown Calculate and plot total head, elevation head and pressure head.





Example 5

Solution example 5:

Points	Ht(cm)	He(cm)	Hp(cm)	Head loss
A	5	-5	10	0
B	5	-5	10	0
C	2.5	-5	7.5	2.5
D	0	-5	5	5

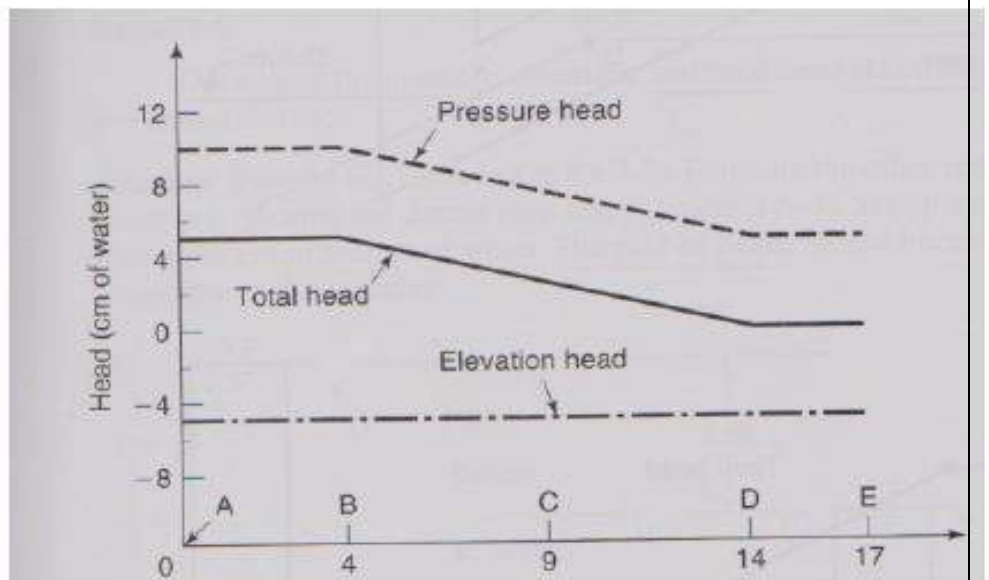

Solution Example 5

Example 9: For the setup shown draw  $h_t$ ,  $h_e$ ,  $h_p$  and find the seepage force .

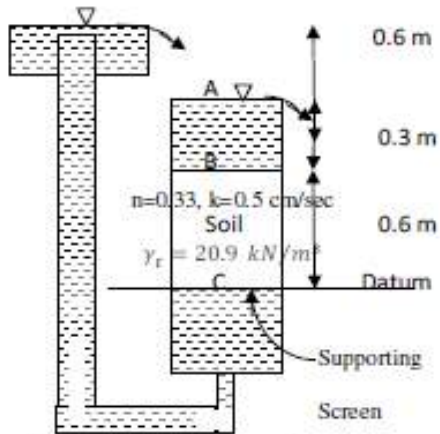

Points	$h_t$ (cm)	$h_e$ (cm)	$h_p$ (cm)
A	0.9	0.9	0
B	0.9	0.6	0.3
C	1.5	0.0	1.5

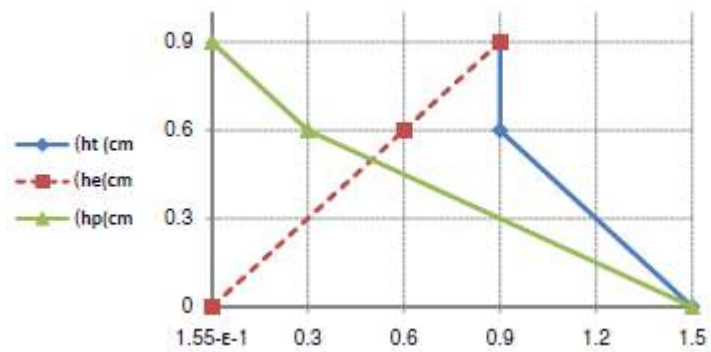

Elevation (cm)	$\Delta\sigma_v$ ( $kN/m^2$ )	$\sigma_v$ ( $\frac{kN}{m^2}$ )	$u$ ( $\frac{kN}{m^2}$ )	
0.9		0	0	0
	0.3 *10=3kN/m <sup>2</sup>			
0.6		3	0.3*10=3	0
	0.6*20.9 = 12.54			
0		15.54	1.5*10=15	0.54

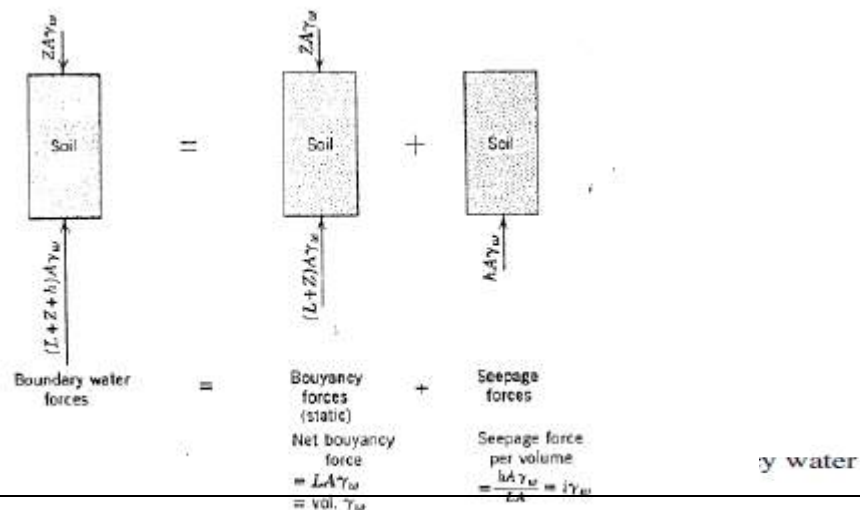



Water Force on Soil:

$$j = \frac{\text{Seepage force}}{\text{Volume of soil}} = \frac{hA\gamma_w}{LA} = i \gamma_w$$

Seepage forces usually act with direction of flow.

Quick Condition:

The shear strength of cohesionless soil is directly proportional to the effective stress. When a cohesionless soil is subjected to a water condition that results in zero effective stress, the strength of the soil becomes zero and quick condition exists.

Quick condition: occurs in upward flow( for cohesionless soil) and when the total stress equals to pore water pressure .

$$\sigma_{effect} = 0 = LA\gamma_w - hA\gamma_w = 0$$

$$\frac{h}{L} = i = \frac{\gamma_b}{\gamma_w} = i_c$$

Example 10: Excavation is been carried out as shown in the figure. Find: 1- the depth Z that could caused boiling at the bottom of clay layer.

2-The depth ( Z) for the factor of safety against boiling equal to 2 at the

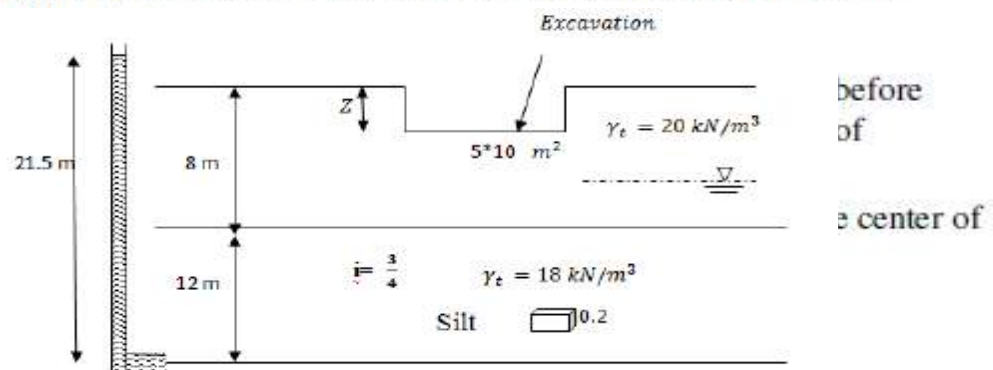

Solution:

$$ht_1 = 21.5$$

$$1- i = \frac{3}{4} = \frac{\Delta h_{1-2}}{10 \text{ m}} = \frac{21.5 - ht_2}{10} \dots \therefore ht_2 = 14 \text{ m}$$

$$\therefore hp_2 = ht_2 - he_2 = 14 - 10 = 4 \text{ m}$$

To find Z

F. down = F. upward

$$A(8-z) * 20 = 4.0 * 10 * A \longrightarrow z = 6 \text{ m}$$

2-

$$F.S = \frac{\text{down ward force}}{\text{up ward force}}$$

$$2 = \frac{(8-z) * 20 * A}{4 * 10 * A}$$

$$\therefore Z = 4 \text{ m}$$

3- F down ward = F upward

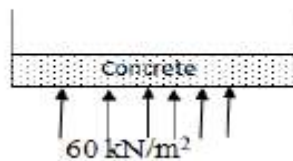

$$t * 5 * 10 * 25 = 60 * 5 * 10$$

$$\therefore t = \frac{60}{25} = 2.4 \text{ m (thickness of concrete)}$$

4- Seepage force =  $i\gamma_w \text{ volume}$

$$= \frac{3}{4} * 10 * (0.2)^3 = 0.06 \text{ kN}$$

Summary of Main Points:

- 1- In soils  $v = ki$
- 2- There are three heads of importance to flow through porous media: elevation head ( $h_e$ ), pressure head ( $h_p$ ) and total head ( $h_t$ ).
- 3- Flow depends on difference in total head.
- 4- The seepage force per a volume of soil is  $i\gamma_w$  and acts in the direction of flow.
- 5- "Quick", refers to a condition where in a cohesion less soil loses its strength because the upward flow of water makes the effective stress become zero.

## TWO DIMENSIONAL FLUIDS FLOW

Most problems of flow are two dimensional flows, e.g. are shown in Fig. below

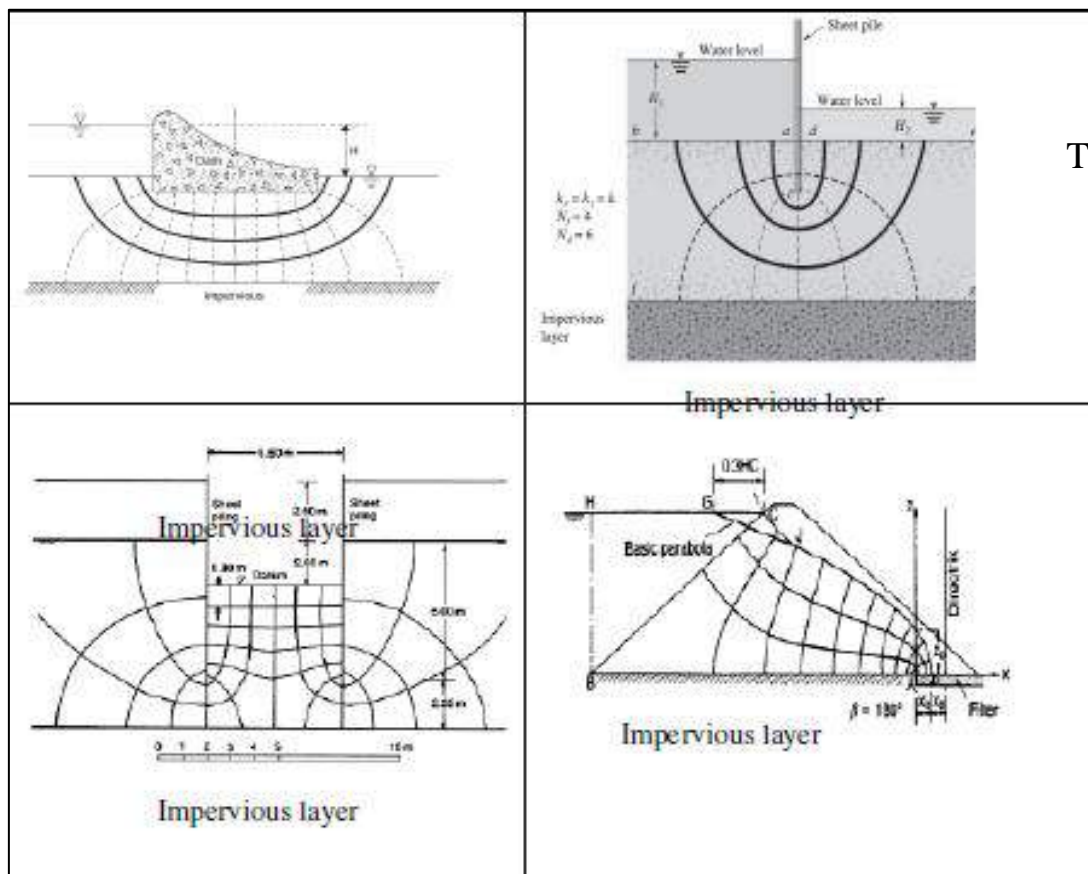

The

purpose of studying the flow in two Dimension are :

- 1- To find the amount of seepage per meter length (i.e. rate of flow).
- 2- Pressure distribution (pore water pressure)
- 3- Stability against piping or boiling.
- 4- Pizometer levels of selected point required.

**SEEPAGE THEORY:**

The general case of seepage in two dimensions will now be considered.

In same principle used in one dimensional problem applied (Darcy's law & Continuity flow state.) (Consider the two dimensional steady state flows in the

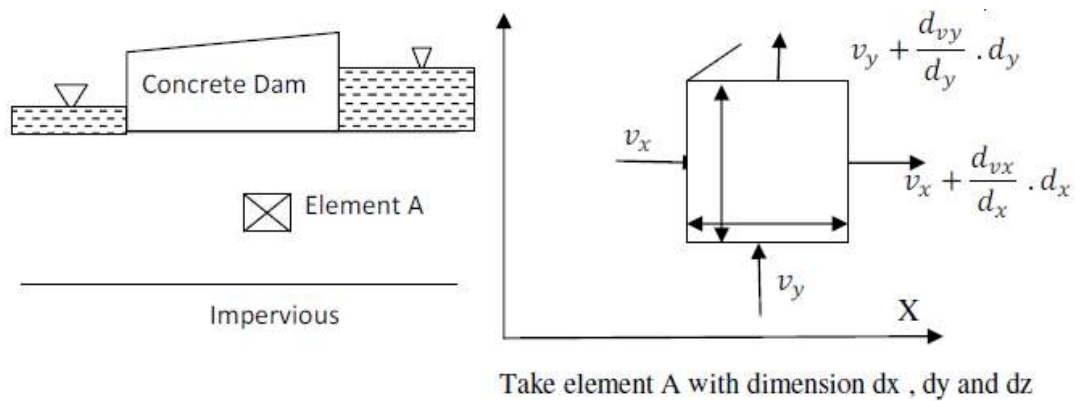

fig.

Rate of flow ( $q_{in}$ ) the flow entering the element

$$(v_x + \frac{dv_x}{dx} dx)dydz + (v_y + \frac{dv_y}{dy} dy)dxdz$$

Since the

$$v_y = -k \frac{dh}{dy}$$

$v_x dy dz + v_y dx dz$

$$\therefore \frac{dv_y}{dy} = -k \frac{d^2h}{dy^2}$$

By simplif

Sub. In equation (1)

$$-k \frac{d^2h}{dx^2} + (-k \frac{d^2h}{dy^2}) = 0$$

Darcy's la

$$\frac{d^2h}{dx^2} + \frac{d^2h}{dy^2} = 0$$

Laplace equation

$$\therefore \frac{dv_x}{dx} = -k \frac{d^2h}{dx^2}$$

Consider a function  $\phi(x, y)$  so that

$$v_x = \frac{d\phi}{dx}$$

$$v_y = \frac{d\phi}{dy}$$

$$v_x = \frac{d\phi}{dx} = -k \frac{dh}{dx}$$

$$v_y = \frac{d\phi}{dy} = -k \frac{dh}{dy}$$

$$\phi(x, y) = -kh(x, y) + c$$

Where  $c$  is a constant

Thus if the function  $\phi(x, y)$  is given a constant value equal to  $\phi_1$  & it will represent a curve along which the value of total head ( $h_1$ ) is constant. If the function  $\phi(x, y)$  is given a series of constant value  $\phi_1, \phi_2, \phi_3$  etc a family of curves, such curves are called equipotentials and this will correspond to total head  $h_1, h_2, h_3, \dots, h_n$  from the total difference.

$$d\phi = \frac{d\phi}{dx} \cdot dx + \frac{d\phi}{dy} dy$$

$$0 = v_x dx + v_y dy$$

$$-v_x dx = v_y dy$$

The second function  $\psi(x, y)$  called the flow line

$$v_x = -\frac{d\psi}{dy}$$

$$v_y = \frac{d\psi}{dx}$$

$$\frac{dv_x}{dx} = -\frac{d^2\psi}{dx dy}$$

$$\frac{dv_y}{dy} = -\frac{d^2\psi}{dydx}$$

$$\frac{dv_x}{dx} + \frac{dv_y}{dy} = 0$$

$$\frac{d^2\psi}{dx dy} - \frac{d^2\psi}{dy dx} = 0$$

$\therefore \psi(x, y)$  Satisfy the Laplace equation

A gain a series of  $\psi$  using  $\psi_1, \psi_2, \psi_3 \dots \psi_n$

Is selected and this function

$$\psi = \frac{d\psi}{dx} dx + \frac{d\psi}{dy} dy$$

$$0 = v_y dx + (-v_x) dy$$

$$v_y dx = v_x dy$$

$$\frac{dy}{dx} = \frac{v_y}{v_x}$$

### Flow net:

The graphical representation of the Laplace equation is represented by the two families of curve:

1-Equipotential lines: A series of lines of equal total head e.g.

$$h_1, h_2, h_3 \dots h_n$$

2-Flow lines: A family of the rate of flow between any two adjacent flow lines is constant.

**For isotropic soil:**



The flow net is formed by a mesh of the intersection of two lines with the following limitation

1- Each element is a curvilinear square  $\psi_1$

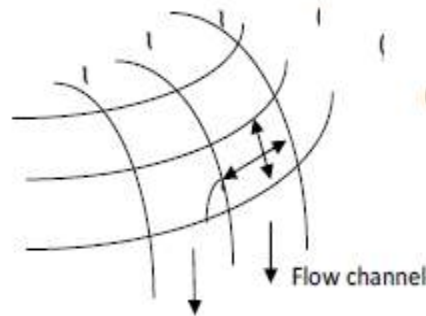

$$\frac{b}{l} \cong 1$$

Summary of the main points:

- 1- Laplace equation governs the steady state flow in two dimensions
- 2- The solution is represented by two families of curve

Example:

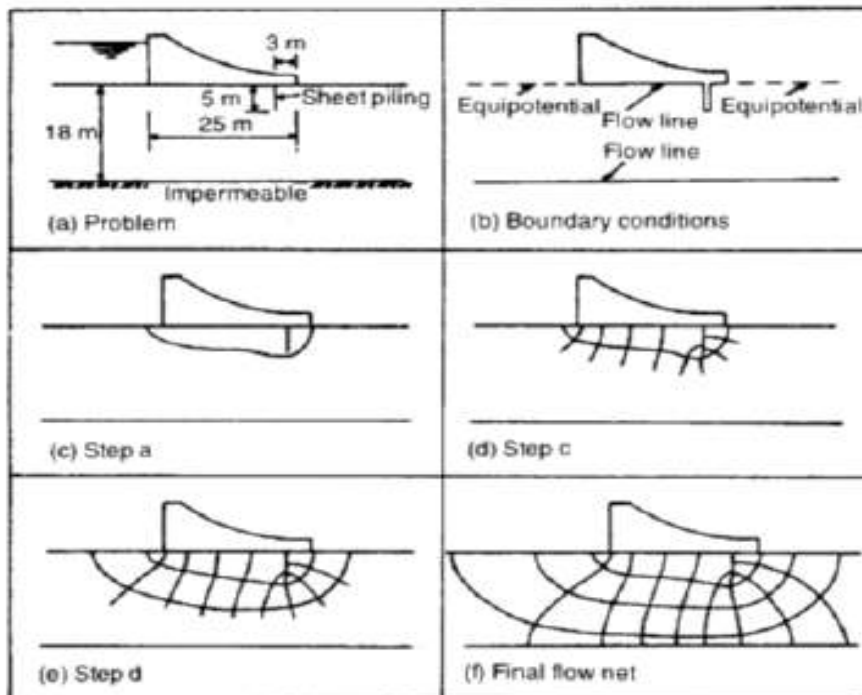

Figure example for flow net construction

Rate of flow

$$q = kiA$$

$$\Delta q = b * 1 * k * \frac{\Delta h_t}{L}$$

this is for one flow channel



$$\Delta h t = \frac{H}{n d}$$

$$\Delta q = \frac{b}{L} * k * \frac{H}{N d} \quad (b \cong L)$$

$$\Delta q = k \frac{H}{N d} \quad \text{this is for one channel}$$

Assume No. of channel = Nf

$$\therefore q = \Delta q N f = K H \frac{N f}{N d}$$

Where H= difference in water level (upstream and downstream).

Example 1:

$Nf$ : Number of flow channel = 4  
 $Nd$ : No. of drop = 12  
 $\therefore \Delta d = \frac{H}{Nd}$   
 $q = k H \frac{Nf}{Nd}$  (m<sup>3</sup>/sec/m)  
 $H \rightarrow \frac{q}{k} \rightarrow \frac{q}{k}$   
 $F.S. = \frac{10}{10} = \frac{8 \text{ out} - 24}{\frac{10}{10} \frac{\Delta h}{L}}$

NOTE  
 outlet is permeable (F.S) into permeable  
 istana cipta ipu air  $\frac{\Delta h}{L}$  per di  
 Dan di outlet] per di  
 utti

### Example 9

A deposit of cohesion less soil with a permeability of  $3 \times 10^{-2}$  cm/sec has a depth of 10 m with an impervious ledge below. A sheet pile wall is driven into deposit to a depth of 7.5 m. The wall extends above the surface of the soil and 2.5 m depth of water acts on one side. Determine the seepage quantity per meter length of the wall.

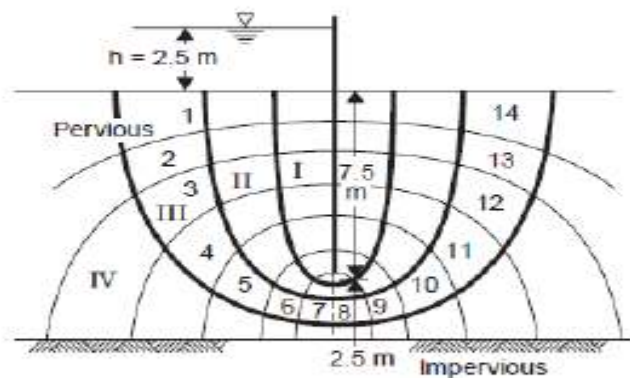
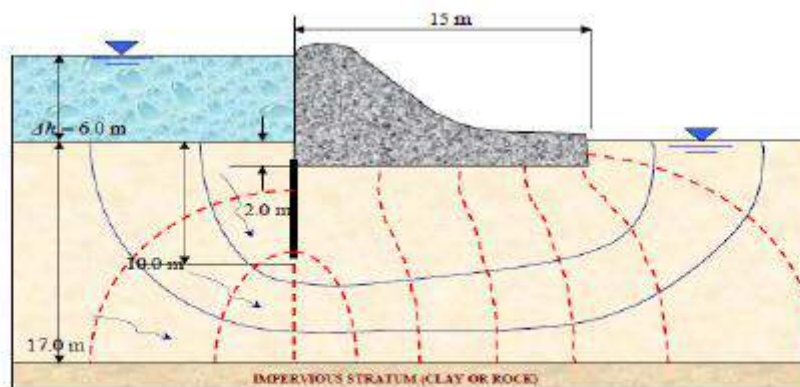

Fig. 6.28 Sheet pile wall (Example 6.6)

$$\begin{aligned}
 &= 3 \times 10^{-4} \times 2.5 \times \frac{4}{14} \text{ m}^3/\text{sec}/\text{metre run} \\
 &= 2.143 \times 10^{-4} \text{ m}^3/\text{sec}/\text{meter run} \\
 &= \mathbf{214.8 \text{ ml}/\text{sec}/\text{metre run.}}
 \end{aligned}$$

### Example 10-

For the flow net shown below includes sheet-pile cutoff wall located at the head water side of the dam in order to reduce the seepage loss. The dam is half kilometer in width and the permeability of the silty sand stratum is  $3.5 \times 10^{-4}$  cm/sec. Find (a) the total seepage loss under the dam in liters per year, and (b) would the dam be more stable if the cutoff wall was placed under its tail-water side?



Solution:

a) Notice that  $\Delta h = 6.0 \text{ m}$ , the number of flow channels  $N_f =$

3 and  $N_d = 10$  by using  $q = k\Delta h \frac{N_f}{N_d}$

$$q = (3.5 \times 10^{-4} \frac{\text{cm}}{\text{sec}}) \left( \frac{\text{m}}{100 \text{ cm}} \right) (6.0 \text{ m}) \left( \frac{3}{10} \right)$$

$$= 6.3 \times 10^{-6} \text{ m}^3/\text{sec}/\text{m}$$

Since the dam is 500 meters wide, the total Q under the dam is

$$Q = Lq = 500 \text{ m} (6.3 \times 10^{-6} \text{ m}^3/\text{sec}) \left( \frac{10^3 \text{ liters}}{1 \text{ m}^3} \right) \left( 31.5 \times 10^6 \frac{\text{sec}}{\text{year}} \right) =$$

$$100 \frac{\text{million liters}}{\text{year}}$$

b) - No: Placing the cutoff wall at the toe would allow higher uplift hydrostatic pressure to develop beneath the dam.

*CHAPTER SIX*

**STRESSES WITHIN THE  
SOIL**

## *Stresses in a Soil Mass*

### Topics

- Normal and Shear Stresses on a Plane
- Stress distribution in soils
- Stress Caused by a Point Load
- Vertical Stress Caused by a Line Load
- Vertical Stress Caused by a Strip Load
- Vertical Stress Due to Embankment Loading
- Vertical Stress below the Center of a uniformly Loaded Circular Area
- Vertical Stress at any Point below a uniformly Loaded Circular Area
- Vertical Stress Caused by a Rectangularly Loaded Area
- Influence Chart for Vertical Pressure (Newmark Chart)
- Approximate methods

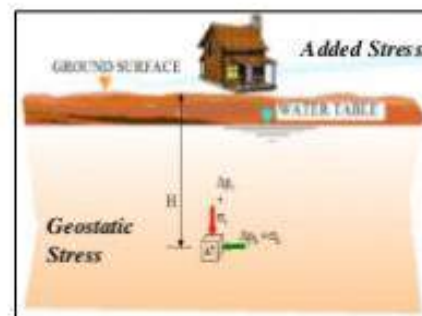

### 1- Stress within the Soil

Stresses within the soil:

Types of stresses:

1- Geostatic stress: Sub Surface Stresses cause by mass of soil

a- Vertical stress  $\sigma_v = \sum \gamma h$

b- Horizontal Stress  $\sigma_H = K_0 \sigma_v$

Note : Geostatic stresses increased lineraly with depth.

2- Stresses due to surface loading :

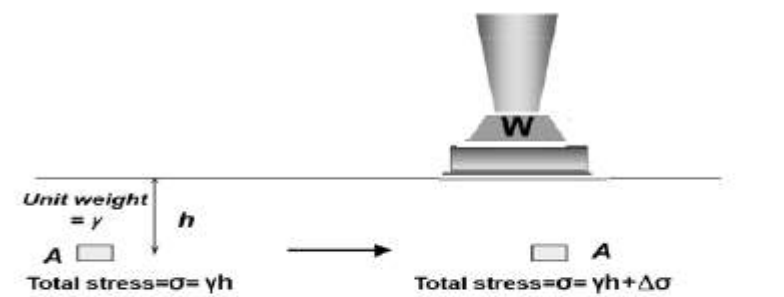

1-

stresses due Geostatic soil mass

$$\sigma_v = \gamma h \text{ (Geostatic stress)}$$

$$\sigma_h = k_0 \sigma_v, \quad \text{where } k_0 : \text{ is the coefficient of earth pressure at}$$

rest.



## 2-Effective Stress Concept

### *Effective Stress Concept*

#### **Topics**

- Effective Stress Concept
- Effective Stress in Saturated Soil with no Seepage
- Effective Stress in Saturated Soil with Seepage
- Seepage Force
- Filter Requirements and Selection of Filter Material
- Capillary Rise in Soil
- Effective Stress in Capillary Zone

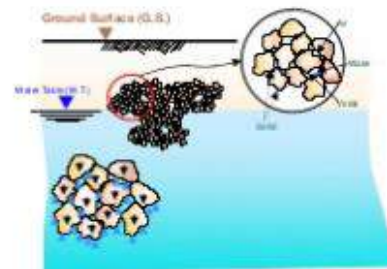

The effective stress equation is a simple, but very important equation in geotechnical engineering.

$\sigma = \sigma' + u$	$\sigma = \text{Total Stress}$
	$u = \text{Neutral Stress}$
	$\sigma' = \text{Effective Stress}$

The total stress in a soil is divided into two parts: (1) the neutral stress, which is the pressure in the water and air in the voids, and (2) the effective stress, which is the stress in the solid portion of the soil. Neutral stresses may be determined from the principles of fluid mechanics. Effective stresses may be determined from the principles of mechanics of materials.

**B. Calculation of Stresses at Point A for the Soil Profile Above**

The total stress at A is equal to the weight of all the material above the point, and may be calculated from the sum of the depths of the layers multiplied by the soil unit weights for the respective layers. The neutral stress is equal to the depth below the water table multiplied by the unit weight of water.

$$\sigma = \text{Total Stress} = z_1\gamma_1 + z_2\gamma_2$$

$$u = \text{Neutral Stress} = z_2\gamma_w$$

The effective stress may be calculated from the effective stress equation.

$$\sigma' = \text{Effective Stress} = \sigma - u$$

$$\sigma' = z_1\gamma_1 + z_2\gamma_2 - z_2\gamma_w$$

$$\sigma' = z_1\gamma_1 + z_2(\gamma_2 - \gamma_w)$$

**C. Submerged Unit Weight**

The submerged unit weight of a soil is the apparent unit weight of a soil below the water table, and may be determined by subtracting the unit weight of water from the saturated unit weight of the soil.

$$\gamma' = \text{Submerged Unit Weight} = \gamma_{sat} - \gamma_w$$

Thus, for situations with no flow of water, the effective stress may be determined by the sum of the layer depths multiplied by the respective soil unit weights, using moist unit weights above the water table, and submerged unit weights below the water table.

$$\sigma' = z_1\gamma_1 + z_2\gamma'_2$$

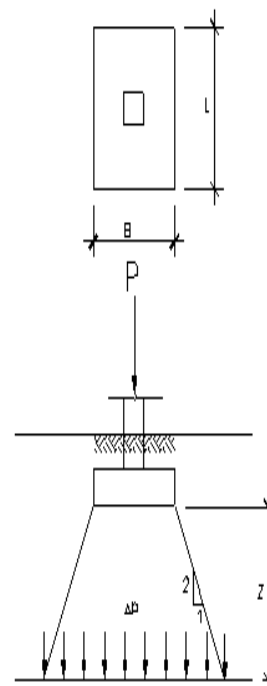
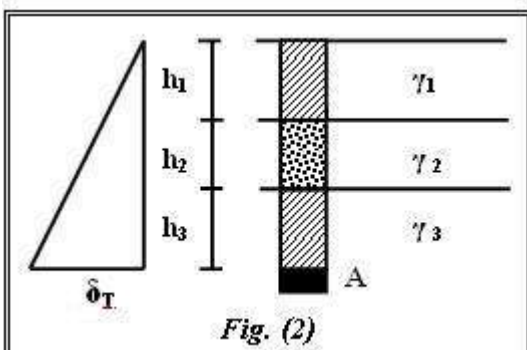
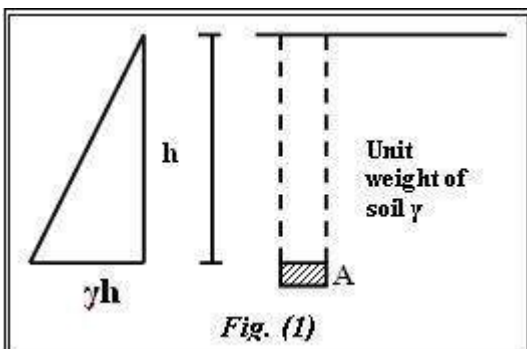



Example: Plot the variation of total and effective vertical stresses, and pore water pressure with depth for the soil profile shown below:

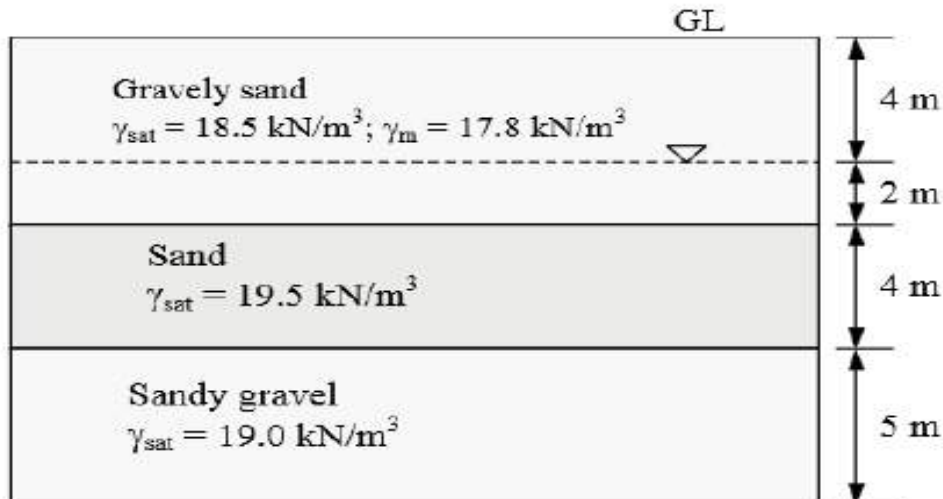

Solution:

Within a soil layer, the unit weight is constant, and therefore the stresses vary linearly. Therefore, it is adequate if we compute the values at the layer interfaces and water table location, and join them by straight lines. At the ground level,

$\sigma_v = 0$  ;  $\sigma'_v = 0$ ; and  $u = 0$  At 4 m depth,

$\sigma_v = (4)(17.8) = 71.2 \text{ kPa}$ ;  $u = 0$

$\therefore \sigma'_v = 71.2 \text{ kPa}$

At 6 m depth,  $\sigma_v = (4)(17.8) + (2)(18.5) = 108.2 \text{ kPa}$

$u = (2)(9.81) = 19.6 \text{ kPa}$

$\therefore \sigma'_v = 108.2 - 19.6 = 88.6 \text{ kPa}$

At 10 m depth,

$\sigma_v = (4)(17.8) + (2)(18.5) + (4)(19.5) = 186.2 \text{ kPa}$

$u = (6)(9.81) = 58.9 \text{ kPa}$

$\therefore \sigma'_v = 186.2 - 58.9 = 127.3 \text{ kPa}$

At 15 m depth,

$\sigma_v = (4)(17.8) + (2)(18.5) + (4)(19.5) + (5)(19.0) = 281.2 \text{ kPa}$

$u = (11)(9.81) = 107.9 \text{ kPa}$

$$\therefore \sigma'_v = 281.2 - 107.9 = 173.3 \text{ kPa}$$

The values of  $\sigma_v$ ,  $u$  and

$\sigma'_v$  Computed above are summarized in Table 6.1.

depth (m)	$\sigma_v$ (kPa)	$u$ (kPa)	$\sigma'_v$ (kPa)
0	0	0	0
4	71.2	0	71.2
6	108.2	19.6	88.6
10	186.2	58.9	127.3
15	281.2	107.9	173.3

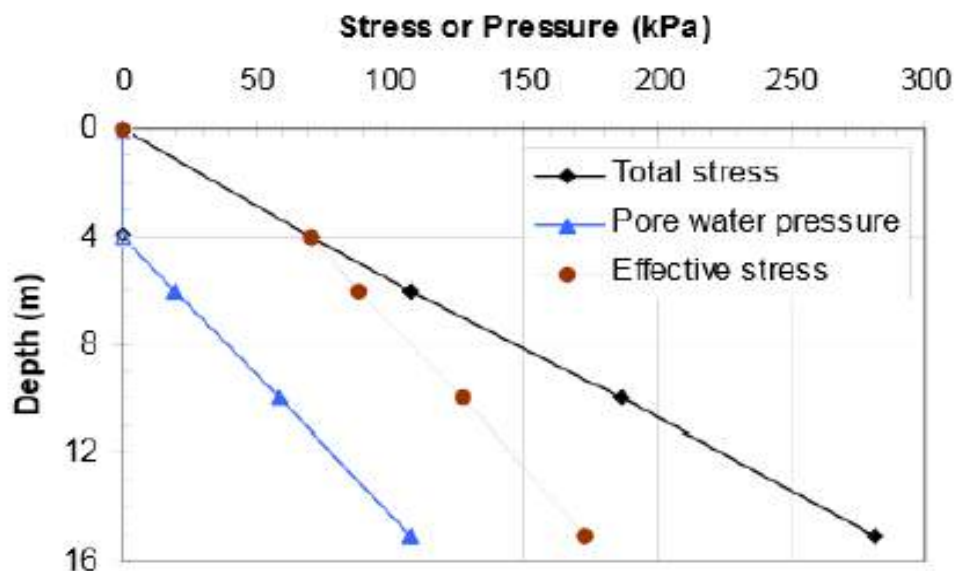

### 3- Negative pore pressure (suction):

Below the water table, pore pressure are positive. In dry soil, the pore pressure are positive. In dry soil, the pore pressure is zero. Above the water table, when the soil is saturated, pore pressure will be negative.

$$u = -h_w \gamma_w$$

The height above the water table to which the soil is saturated is called the capillary rise, and this depends on the grain size and type (and thus the size of pores):

- In coarse soils capillary rise is very small
- In silts it may be up to 2m
- In clays it can be over 20m

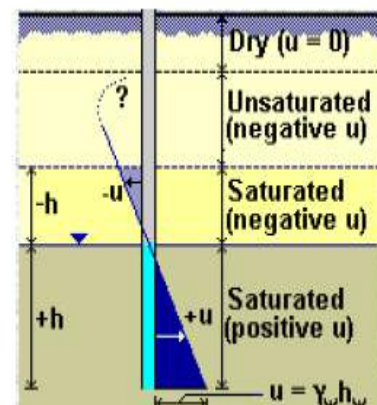

### Stresses in Saturated Soils with Upward Seepage

Variations of effective stress upward seep

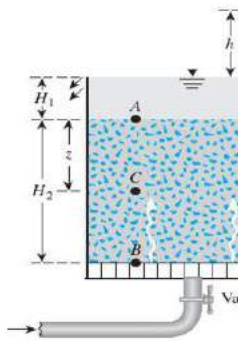

Example :

For the soil profile shown find the total, effective and pore water pressure:?

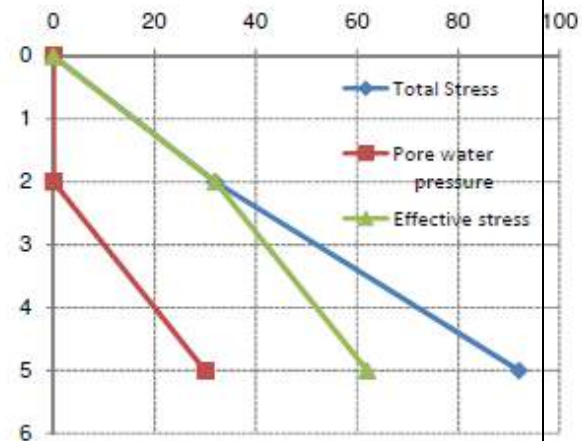
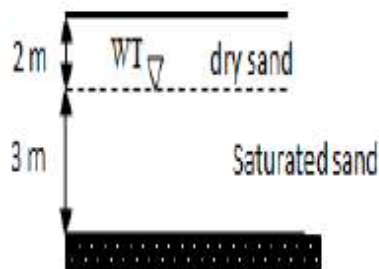

Given:

$$\gamma_{dry} = 16 \frac{kN}{m^3}, \gamma_{sat} = 20 \frac{kN}{m^3}$$

Solution:

At depth

$$z=0, \sigma_{total} = 0, u = 0, \sigma'_{eff} = 0$$

At depth

$$z= 2m \quad \sigma_{total} = 2 * 16 = 32 \frac{kN}{m^2}, u = 0, \sigma'_{eff} = 32 \frac{kN}{m^2}$$

At depth

$$Z= 5m \quad \sigma_{total} = 2 * 16 + 3 * 20 = 92 \frac{kN}{m^2}, u = 3 * 10 = 30 \frac{kN}{m^2}, \sigma'_{eff} = 32 \frac{kN}{m^2}$$

Example:

For the soil profile shown: Determine , total, effective and pore water pressure for the following conditions: 1- water table 3 m above the ground level, 2- water table at the ground level 3- 1.0 m below the surface, 4- 2 m below the surface?

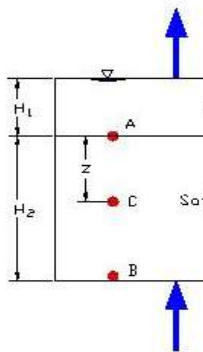

#### B. Effective Stress

The equation for eff

$$\sigma' = \sigma - i \gamma_w z$$

$\sigma =$  Depth Below  
 $i =$  Hydraulic G  
 $\gamma' = \gamma_{SAT} - \gamma_w$

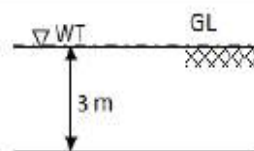

$$\gamma_{dry} = 16 \frac{kN}{m^3}$$

$$\gamma_{sat} = 20 \frac{kN}{m^3}$$

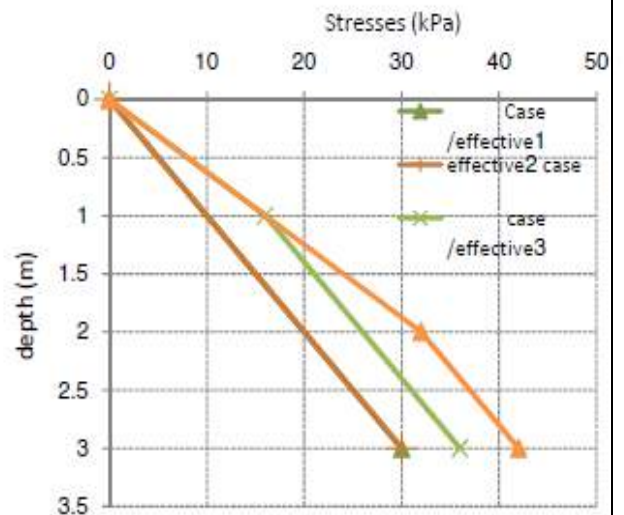



Depth (m)	WT	Total stress(kPa)	u(kPa)	$\sigma'_{eff}(kPa)$
0	Case 1	30	30	0
3		$30+3*20=90$	$6*10=60$	30
0	Case 2	0	0	0
3		$3*20=60$	$3*10=30$	30
0	Case 3	0	0	
1		$1*16=16$	0	16
3		$16+20*2=56$	20	36
0	Case 4	0	0	0
2		$2*16=32$	0	32
3		$32+1*20=52$	$1*10=10$	42

Example :

A building 20 m \* 20m results in a uniform surface contact pressure of 150 kPa. Determine the increase in vertical pressure at depth of 10 m below a) the center of the building b) the corner of the building. Estimate the additional pressure at both locations of a tower 5m \*5m placed at the center of the building imposing 300 kPa uniform additional pressures.

At the corner:

$nz=10 \rightarrow n*10=20, n=2$   
 $mz=10 \rightarrow m*10=20, m=2$   
 $F(1,1)=0.2325$   
 $\Delta\sigma$  at the corner due to surface load =  $0.2325 * 150 = 34.875kPa$

At the center :

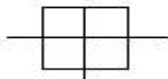
$N*10=10 \rightarrow$    
 $n=m=1$   
 From figure (rectangular)  $f(1, 1)= 0.085$   
 $\Delta\sigma$  at the center =  $4*0.176*150= 105.6 kPa$   
 $\Delta\sigma$  due to tower =

at the center:

$n*10=2.5$   
 $n=m= 0.25$   
 $f(0.25,0.25)= 0.0261$

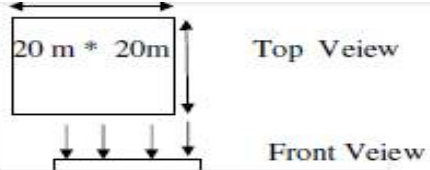

$\Delta\sigma$  due to tower below the center  
 $\Delta\sigma = 4*0.0261*300=31.32 kPa$

$\Delta\sigma$  at the corner due to tower for e1:

$n*10=12.5$   
 $n=m= 1.25$   
 $f(1.25,1.25)= 0.211$   
 For e2=e3  
 $n*10=7.5$   
 $n=0.75$   
 $m*10=12.5$   
 $m=1.25$   
 $f(0.75,1.25)= 0.165$   
 for e3:  
 $n*10=7.5,$   
 $n=m=0.75$   
 $f(0.75,0.75)=0.136$   
 $= (0.211 - (0.165*2) - 0.136)*300=5.1 kPa$

Example: A distributed load of  $50 \text{ kN/m}^2$  is acting on the flexible rectangular area  $6 \times 3 \text{ m}$ , as shown in figure. Determine the vertical stress at point A which is located at depth of  $3 \text{ m}$  below the ground surface. ( $\gamma = 18.5 \text{ kN/m}^3$ ).

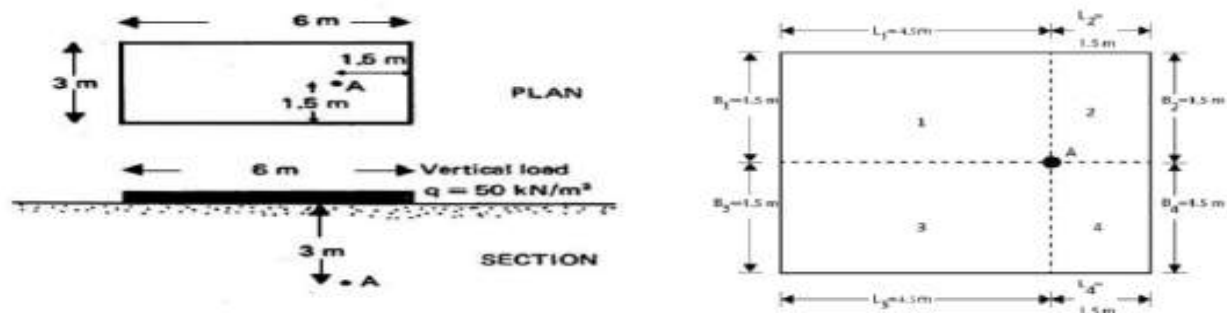

Solution:

$$e1=e3, \quad n^*3=4.5 \quad \text{-----} \quad n=1.5, \quad m^*3=1.5, \quad m=0.5$$

$$f(1.5,0.5)=0.131$$

$$e2=e4, \quad n^*3=1.5, \quad n=0.5, \quad m^*3=1.5, \quad m=0.5$$

$$f(0.5,0.5)=0.085$$

$$\Delta\sigma = 50 * (0.131 * 2 + 2 * 0.085) = 21.6 \text{ kN/m}^2$$

Total stresses = Geostatic stress +  $\Delta\sigma$

$$\text{Total Stresses} = 18 * 3 + 21.6 = 75.6 \text{ kPa}$$

Example : For the same example .If the foundation at  $0.5 \text{ m}$  below ground surface:

$$q_{\text{net}} = 50 - 0.5 * 18 = 41 \text{ kN/m}^2$$

$$e1=e3, \quad n^*2.5=4.5, \quad n=1.8, \quad m^*2.5=1.5, \quad m=0.6$$

$$f(1.8,0.6)=0.155$$

$$e2=e4, \quad n^*2.5=1.5, \quad n=0.6, \quad m^*2.5=1.5, \quad m=0.6$$

$$f(0.6,0.6)=0.109$$

$$\Delta\sigma = 41 * (0.155 * 2 + 2 * 0.109) = 21.648 \text{ kN/m}^2$$

$$\text{Total stresses} = 18 * 2.5 + 21.648 = 66.648 \text{ kN/m}^2$$

## Principal Stresses and Mohr Circle

### Principal Stresses

There are exist at any stressed point in three orthogonal (i.e. naturally perpendicular) planes on which there are zero shear stresses. These planes are called the principal stress planes. The normal stresses that acts on these three planes are principal stresses. The largest of these three stresses is called the major principal stress  $\sigma_1$ , the smallest is called the minor principal stress  $\sigma_3$ , and the third is called the intermediate stress  $\sigma_2$ . When the stresses in the ground are geostatic, the horizontal plane through a point is a principal plane and so too are all vertical planes through the point. When ( $k = \frac{\sigma_v}{\sigma_h}$ )  $k < 1$ ,  $\sigma_v = \sigma_1$  and  $\sigma_h = \sigma_3 = \sigma_2$ . when  $k > 1$ , the situation is reversed. The shear stresses on any orthogonal planes (planes meeting at right angles) must be numerically equal ( $\tau_h = \tau_v$ ).

Mohr circle: it is concerned only with the stresses existing in two dimensions, the state of stress in plane that contains the major and minor principal stresses  $\sigma_1, \sigma_3$ . The stresses will be considered positive when compressive.

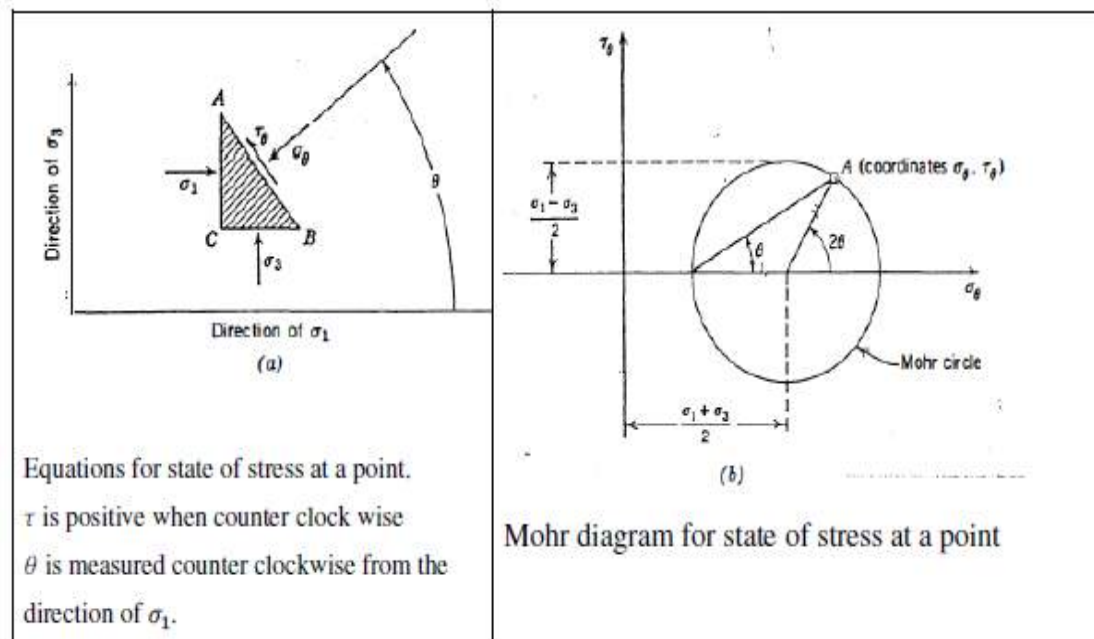



$$\sigma_{\theta} = \frac{\sigma_1 + \sigma_3}{2} + \frac{\sigma_1 - \sigma_3}{2} \cos 2\theta$$

$$\tau = \frac{(\sigma_1 - \sigma_3)}{2} \sin 2\theta$$

Where  $\sigma_{\theta}$  and  $\tau$  are the stresses acts on any planes, the direction and magnitude of principal stresses can be found.

**Origin of planes:** is a point on the Mohr circle, denoted by Op, with following property:

- 1- A line through Op and any points (A) of the Mohr circle will be parallel to the plane on which the stresses given by point A act.
- 2- If the plane and Op are known then the line parallel to the plane passes through Op and intersect Mohr circle, the intersect point represent the point which acts on that plane.

To find the stresses, there are two method:

- 1- By drawing (prefer)
- 2- By using equations
  - 1- By drawing

To determine the normal and shear stresses on any plane, we have to do the following:

- 1- Draw the stress- state on Mohr circle (compression (+) and ( $\downarrow$ )). ✓
- 2- Find the point denoted by Op origin of planes by either select  $\sigma_1$  and draws a line parallel to the plane on which  $\sigma_1$  is acting until it intersects Mohr Circle & the point of intersection is OP, or use  $\sigma_3$  (the same principal is apply to  $\sigma_3$ ).
- 3- From OP draw a line parallel to the plane you want to find stress on it. The point of intersection with Mohr Circle represents the stress & shear stress you need.



هناك ( 3 ) عوامل رئيسية مرتبطة مع بعضها هي

- 1- الاجهاد stress
- 2- مستوي Plane
- 3- نقطة اصل المستوي OP

OP : هي نقطة وهمية وحيدة لكل دائرة ووحيدة فقط وتعين من اجهاد ومستوي.  
اي خط يمر في OP ويقطع دائرة مور فان هذا الخط يمثل المستوي الذي تعمل عليه ذلك الاجهاد.

### Principle Stress:

Stresses acting normal on mutually orthogonal planes with no shear stresses.

### Principle Planes:

The planes on which there is zero shear stresses.

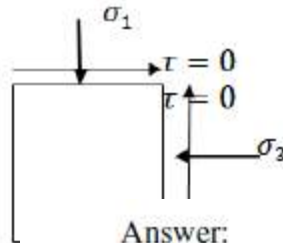

Answer:

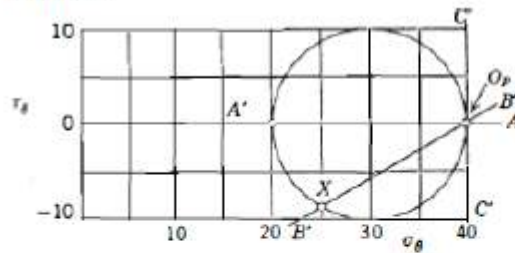

### Case one: Given $\sigma$

Exa

$$\sigma_1 = 40 \text{ kN/m}^2$$

$$\sigma_3 = 20 \text{ kN/m}^2$$

$$C = \frac{\sigma_1 + \sigma_3}{2} = \frac{40 + 20}{2} = 30 \text{ kN/m}^2$$

$$R = \frac{\sigma_1 - \sigma_3}{2} = \frac{40 - 20}{2} = 10 \text{ kN/m}^2$$

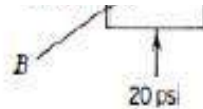

Find stresses on plane B-B?

By drawing:

- 1- Locate points (40,0) and (20,0).
- 2- Draw circle, using these points to define diameter.
- 3- Draw line  $\hat{A}\hat{A}$  through point (20,0) and parallel to plane on which stress (20,0) acts.
- 4- Intersection of  $\hat{A}\hat{A}$  with Mohr circle at point (40,0) is the origin Of planes.
- 5- Draw Line  $\hat{B}\hat{B}$  through OP and parallel to B-B
- 6- Read coordinates of X where  $\hat{B}\hat{B}$  intersect Mohr circle.

So on B-B  $\begin{cases} \sigma = 25 \text{ psi} \\ \tau = -8.7 \text{ psi} \end{cases}$

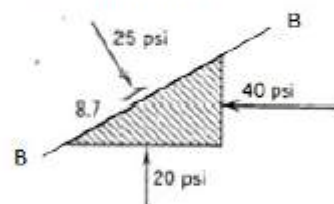

Method 2 using Equations :

$$\sigma_{\theta} = \frac{\sigma_1 + \sigma_3}{2} + \frac{\sigma_1 - \sigma_3}{2} \cos 2\theta$$

$$\sigma_{\theta} = \frac{40+20}{2} + \frac{40-20}{2} \cos(2 * 120) = 30 + (-5) = 25 \quad \downarrow$$

We usually take the largest couple.

$$\sigma_1 = \frac{\sigma_1 + \sigma_3}{2} + \frac{\sigma_1 - \sigma_3}{2}$$

$$\sigma_3 = \frac{\sigma_1 + \sigma_3}{2} - \frac{\sigma_1 - \sigma_3}{2}$$

$$\sin 2\theta = \frac{\tau_{\theta}}{\frac{\sigma_1 - \sigma_3}{2}} = \frac{2\tau_{\theta}}{\sigma_1 - \sigma_3}$$

Ca

Usi

Example 2 : Find the stresses on Horizontal plane D-D?

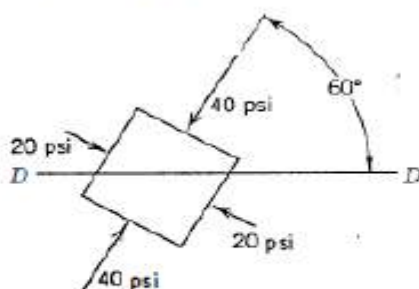

1- Draw point 1(40,0), point (20,0)

- 2- From point (20,0) draw a line through point (20,0), parallel to the plane that the force (20,0) acts .
- 3- The point of intersection with Mohr –circle represent the OP.
- 4- From the op draw a horizontal line (line parallel to horizontal plane) the point of intersection with Mohr circle represent the stresses on horizontal plane. ( 35, 8.7).

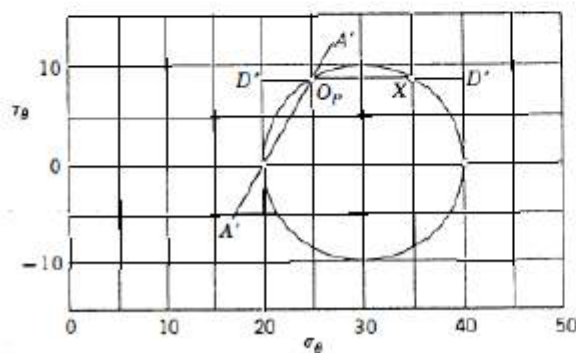

Example 3 :

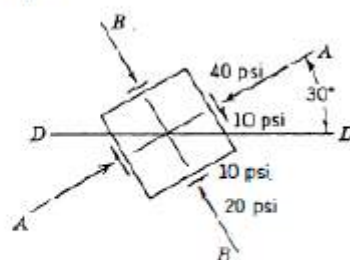

Find the Magnitude and direction of principle stresses.

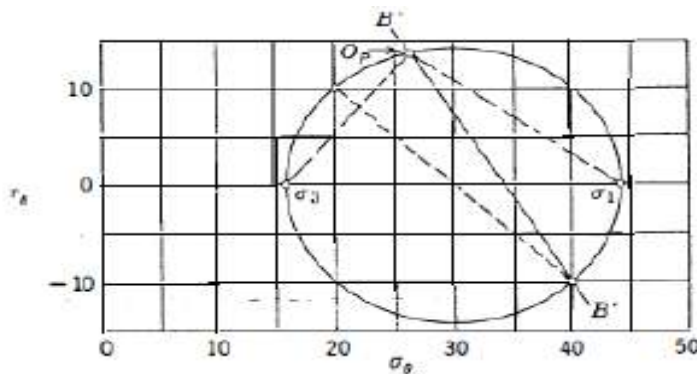

- 1- Locate points (40,-10) and (20,10)
- 2- Erect diameter and draw Mohr circle.
- 3- Draw  $\hat{B}\hat{B}$  through (40,-10) parallel to BB
- 4- Intersection of  $\hat{B}\hat{B}$  with circle gives  $O_p$ .
- 5- Read  $\sigma_1$  and  $\sigma_3$  from graph.
- 6- Line through  $O_p$  and  $\sigma_1$  give plane on which  $\sigma_1$  acts.

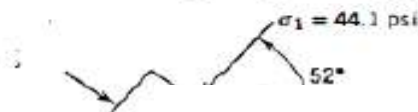

Solution t  
1- Make u

$$2\theta = -45^\circ$$

$$\theta = -22.5^\circ$$

5- Angle from horizontal to major principle stress direction = 52.5°

2- Use th

Examples : to be added

$$\left(\frac{\sigma_1 - \sigma_3}{2}\right) =$$

3-  $\sigma_1 = \left(\frac{\sigma_1 + \sigma_3}{2}\right) + \left(\frac{\sigma_1 - \sigma_3}{2}\right)$  Stress Path (p-q diagram):

$$\sigma_3 = \left(\frac{\sigma_1 + \sigma_3}{2}\right) - \left(\frac{\sigma_1 - \sigma_3}{2}\right) = 15.86 \text{ psi}$$

4- Use stress pair in which  $\sigma_\theta$  is largest ; (40, -10)

$$\sin 2\theta = \frac{2\tau_\theta}{\sigma_1 - \sigma_3} = \frac{-20}{28.28} = -0.707$$



*CHAPTER SEVEN*

**SOIL  
CONSOLIDATION**

**INTRODUCTION:**

A stress increase caused by the construction of foundations or other loads compresses the soil layers. The compression is caused by (a) deformation of soil particles, (b)



relocations of soil particles, and (c) expulsion of water or air from the void spaces. In general, the soil settlement caused by load may be divided into three broad categories:

1- Immediate settlement, which is caused by the elastic deformation of dry soil and of moist and saturated soils without any change in the moisture content. Immediate settlement calculations are generally based on equations derived from the theory of elasticity.

2- Primary consolidation settlement, which is the result of a volume change in saturated cohesive soils because of the expulsion of water that occupies the void spaces.

3- Secondary consolidation settlement, which is observed in saturated cohesive soils and is the result of the plastic adjustment of soil fabrics. It follows the primary consolidation settlement under a constant effective stress.

This chapter presents the fundamental principles for estimating the consolidation settlement:

**Consolidation** : is the gradual reduction in volume of a fully saturated soil of low permeability due to drainage of some of the pore water, the process continuing until the excess pore water pressure set up by an increase in total stress has completely dissipated.

### Soil consolidation

consolidation occurs when the weight of a structure or newly-placed fill soils compress lower, weak clayey soils. The applied load forces water out of the clay soils, allowing the individual soil particles to become more densely spaced.

Consolidation results in downward movement or settlement of overlying structures. Settlement caused by consolidation of foundation soils may take weeks, months, or years to be considered "complete."

As this occurs, the foundation will experience downward movement -- sometimes at an uneven rate. This leads to cracks and structural damage.



## What is Consolidation?

When a saturated clay is loaded externally,

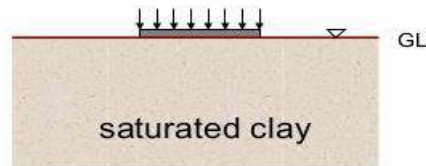

the water is squeezed out of the clay over a long time (due to low permeability of the clay).

## Concept of Consolidation

\* As the time passes the water comes out of the soil voids and so the volume of soil decreases, this is the cause of the settlement.

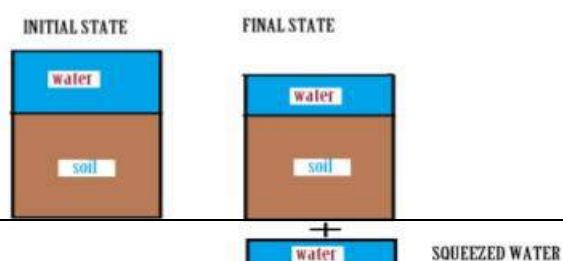

The settlement is directly proportional to the decrease in volume of soil = The volume of squeezed out water

## Types of Consolidation

- There are three types of consolidation:
  - **Immediate consolidation**; caused by **elastic deformation** of dry soil or moist and saturated soil without change in moisture content
  - **Primary consolidation**; caused as a result of **volume change** in saturated cohesive soils due to **exclusion of water** occupied the void spaces
  - **Secondary consolidation**; occurs in saturated cohesive soils as a result of the **plastic adjustment** of soil fabrics

## FUNDAMENTALS OF CONSOLIDATION

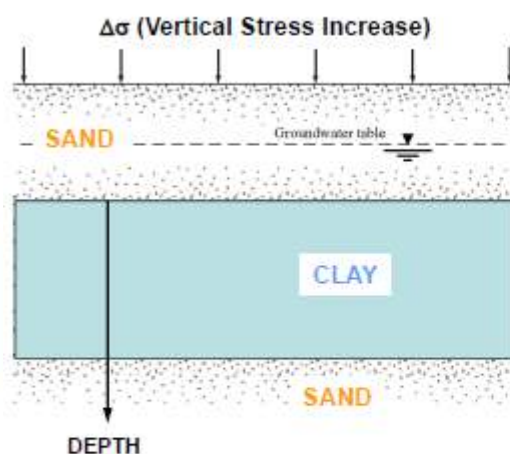

after Figure 7.1a. Das FGE (2005).

### At Time of Initial Loading ( $t = 0$ )

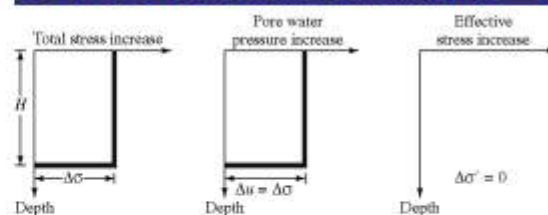

Variation in Total, Pore water, and Effective Stresses in Clay Layer

Figure 7.1b. Das FGE (2005)

Pore water takes initial change in vertical loading ( $\Delta\sigma = \Delta u$ ) since water is incompressible

Soil skeleton does not see initial loading

# FUNDAMENTALS OF CONSOLIDATION

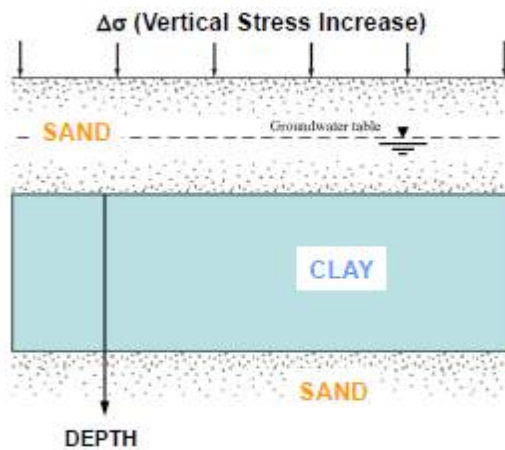

after Figure 7.1a. Das FGE (2005).

Between time  $t = 0$  to  $t = \infty$

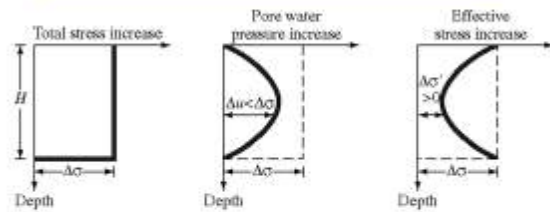

Variation in Total, Pore water, and Effective Stresses in Clay Layer  
Figure 7.1c. Das FGE (2005)

Pore water increase due to initial loading dissipates

Soil skeleton takes loading as pore pressure decreases



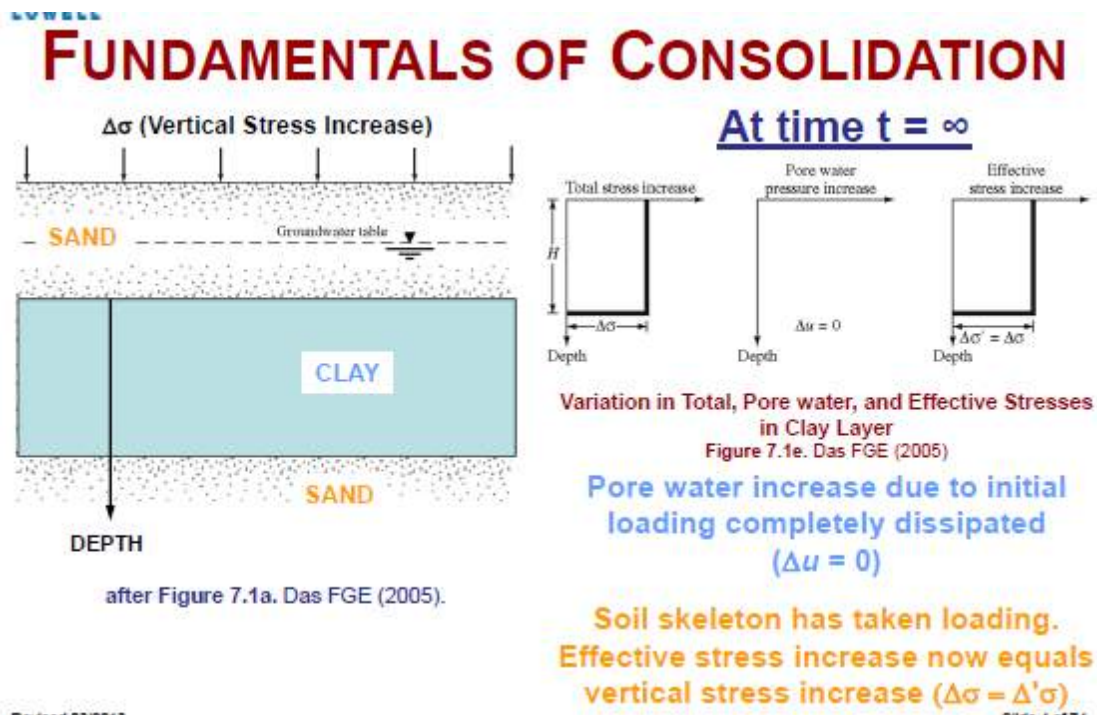

The simplest case is that of **one – dimensional consolidation** in which condition of zero lateral strain.

**Swelling**: is the reverse of consolidation, is the gradual increase in volume of a soil under negative excess pore water pressure.

**Consolidation settlement**: is the vertical displacement of the surface corresponding to the volume change at any stage of the consolidation process.

Consolidation settlement will result, for example, if a structure is built over a layer of saturated clay or if the water table is lowered permanently in a stratum overlying a clay layer on the other hand, if an excavation is made in a saturated clay, heaving (the

**Fundamentals of Consolidation**: When a saturated clayey soil layer is subjected to a stress increase, the pore water pressure suddenly increases. So at time  $t=0$   $\Delta u = \Delta\sigma$  while  $\Delta\sigma' = 0$  (Figure 1-b), but after a time  $t$   $\Delta u < \Delta\sigma$  while  $\Delta\sigma' > 0$  (Figure 1-c) and after very long time ( $t \approx \infty$ )  $\Delta u = 0$  while  $\Delta\sigma' = \Delta\sigma$  (Figure 1-d).

reverse of settlement) will result in the bottom of the excavation due to swelling of the clay.

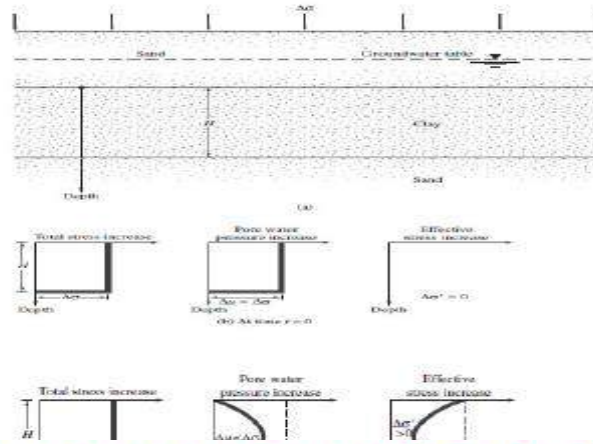

# FUNDAMENTALS OF CONSOLIDATION

## THE SPRING ANALOGY

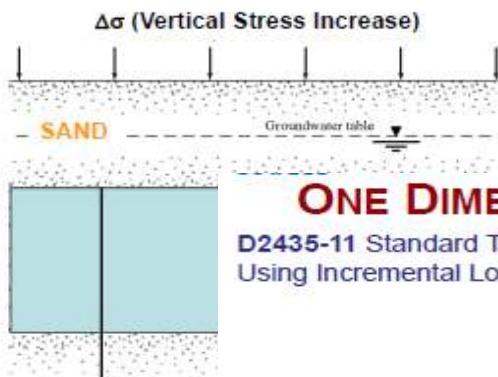

## ONE DIMENSIONAL (1D) CONSOLIDATION TEST

D2435-11 Standard Test Methods for One-Dimensional Consolidation Properties of Soils Using Incremental Loading

IS

DEPTH  
after Figure

Revised 03/2013

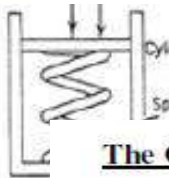

The

Before

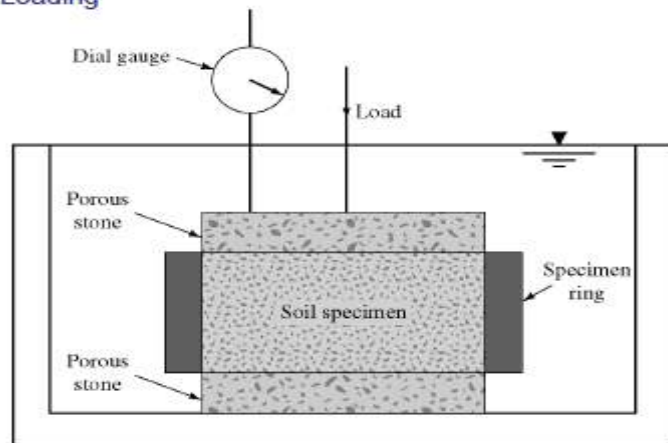

Consolidometer  
Figure 7.2. Das FGE (2005)

Revised 03/2013

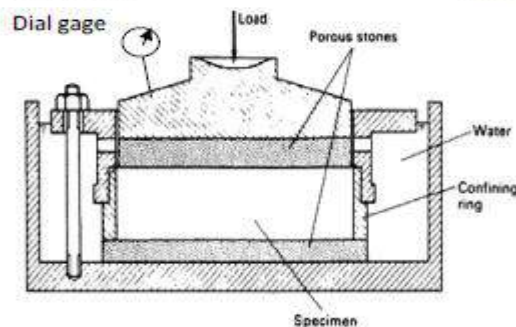

Figure (7-2) Consolidation Cell





- And record the dial gage reading for 24 hrs at similar times to those of step 2.
- 4- Repeat step 3 by doubling the applied stress and recording the dial gage reading. This process is repeated till we reach a stress of 1600 kPa (some times we reach 3200 kPa). This process last 7 days and it called loading stage.
  - 5- Unload (3/4) the applied stress (i.e. remove 1200 kPa and leave 400 kPa) and record the dial gage reading for (24 hrs).
  - 6- After 24 hrs , unload (3/4) the remaining stress (remove 300 kPa and keep 100 kPa)and record dial reading for 24 hrs. then remove all the applied stress and record dial readings.
  - 7- Determine the final water content of the soil sample.

Example : The results of an odometer test is given below:-

Time (min)	Dial gage readings									
	25 kPa	50 kPa	100 kPa	200 kPa	400 kPa	800 kPa	1600 kPa	400 kPa	100 kPa	0
0	0	127.5	218	320	443	598	841	1038	1028	597
0.25	95	164	250	366	510	695	904	1038	937	
0.5	101	168	255	373	515	704	910	1038	924	
1	104	172	262	381	528	725	920	1036	904	
2	110	179	268	391	544	739	932	1035	880	
4	115	185	278	402	560	763	946	1033	835	
8	115	189	284	413	570	783	963	1031	800	
15	121	195	291	421	582	802	977	1030	765	
30	124	198	300	428	591	805	979	1029	680	
60	125.5	204	303	430	596	822	1000	1028	655	
120	126	205	306	435	597	831	1012	1028	622	
1440	127.5	218	320	443	598	841	1038	1028	597	420

Mass of empty ring = 99.18 gm

Mass or ring +wet soil = 266.4 gm

Mass of ring + dry soil = 226.68 gm

Dia. Of ring = 75 mm

Ht of ring = 19 mm

Dial gage Coeff. = 0.0001"

Initial water content = 31.14%

Specific Gravity of soil solids ( $G_s$ ) = 2.76

Initial Degree of saturation = 100%

Required: void ratio at each load increment.

Solution :

1- find  $e_0$  using  $S.e = G_s * \omega$

$$e_0 = 2.76 * 0.3114$$

$$e_0 = 0.8595$$

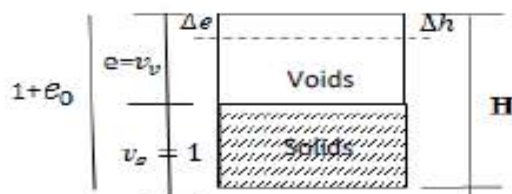

2- Since the volume of solid particles not change (incompressible)

So Assume  $v_s = 1$ .

So  $e_0 = v_v$

So the Total volume ( $v_t = 1 + e_0$ )

So any change in the volume due to apply load is due to change in void so

$$\Delta e = e_0 - e_f$$

$$\epsilon_v = \frac{\Delta e}{1 + e_0}$$

Since the consolidation in one dimension, and there is no lateral strain so the axial strain ( $\epsilon_a = \frac{\Delta h}{H}$ ) will be equal to volumetric strain ( $\epsilon_v$ ).

$$\frac{\Delta h}{H} = \frac{\Delta e}{1 + e_0}$$

Applied Pressure (kPa)	Final Dial gage reading	Dial change *0.0001*25.4 mm $\Delta h(mm)$	Thickness of sample at the end of (24 hrs) mm	Change in void ratio $\Delta e = \frac{\Delta h}{H} (1 + e_0)$	Void ratio at the end of 24 hrs $e = e_0 - \Delta e$
0	0		19		0.8595
25	127.5	0.32385	18.676	0.0317	0.8278
50	218	0.22987	18.446	0.0225	0.8053
100	320	0.25908	18.187	0.0254	0.7799
200	443	0.31242	18.187	0.0306	0.7799
400	598	0.3937	17.875	0.0385	0.7493
800	841	0.61722	17.481	0.0604	0.07108
1600	1038	0.5	16.864	0.0489	0.6504
400	1028	0.0254	16.364	-0.0025	0.6015
100	1028	-1.09474	16.389	-0.10714	0.604
0	597	-0.4496	17.484	-0.044	0.7111
0	420		17.934		0.755

From consolidation test the following result we can get :

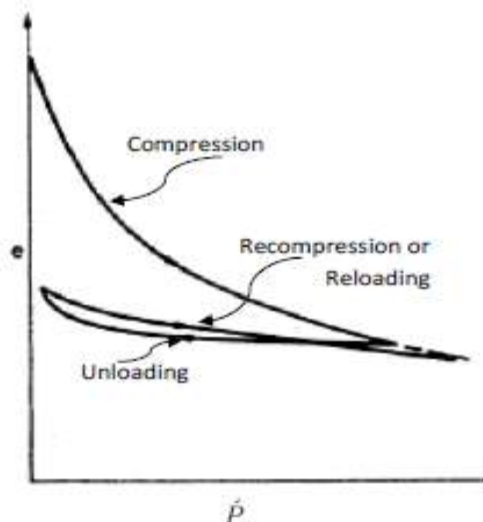

Figure e-  $\dot{p}$  (results from oedometer test)

The slop of this curve at any stress range can be defined as :

$$a_v = \frac{\Delta e}{\Delta \dot{p}}$$

$a_v$  : Coeff. Of compressibility

$\Delta \dot{p}$  : change in effective stress

$\Delta e$  : corresponding change in void ratio

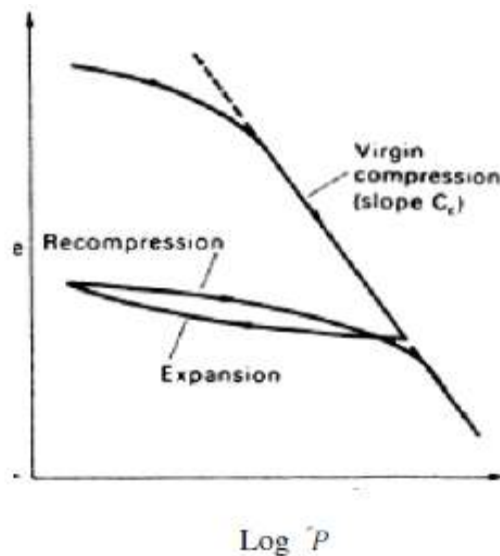

$$m_v = \frac{a_v}{1 + e_0}$$

$m_v$ : Coeff. Of volume change  
 $a_v$ : Coeff. Of Compressibility  
 $e_0$ : Initial void ratio

Plot the  
 $\text{Log } \dot{P}$  versus void ratio ( $e$ )

\* the slope of first portion of the loading curve is defined

$$C_r = \frac{\Delta e}{\Delta \log \dot{P}}$$

Which is equal to the slope of the unloading curve, and the first portion of the reloading curve

$$\therefore C_r = C_e = \frac{\Delta e}{\Delta \log \dot{P}}$$

$C_r$ : Reloading index

$C_e$ : Expansion index

The slope of the last portion of the loading curves is defined as :

$$C_c = \frac{\Delta e}{\Delta \log \dot{P}}$$

$C_c$ : Compression index

Note : \*  $C_c$  can be obtained using empirical correlation from Liquid Limit (L.L)

$$C_c = 0.009 (L.L - 10)$$

An empirical correlation between  $C_c$  and  $C_r$  is given by:

$$C_r \cong 0.1 C_c$$



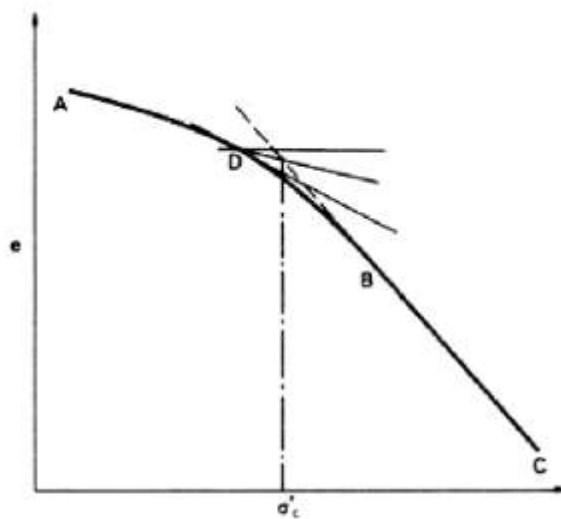

Figure e-  $\log p'$  (find  $\hat{P}_c$ )

#### Pre-Consolidation

#### Pressure ( $\hat{P}_c$ )

: The max. Effective stress that has been experienced by the soil in the past or at the present.

#### How to find $\hat{P}_c$

- 1- Produce back the straight line (BC) of the curve
- 2- Draw the tangent to the curve at D and bisect the angle between the tangent and the horizontal through D
- 3- The vertical through the point of the bisector and CB gives the approximate value of the pre consolidation

### Normally and Over consolidation Clays:

According to the stress history, the clay can be:

#### 1- Normally Consolidated clay(N.C.C.)

Which represent the clay at which the existing effective overburden pressure ( $\hat{P}_0 = \sigma'_v$ ) is the largest stress experienced by the soil at the present time and in the past thus :

For N.C.C.  $\hat{P}_c = \hat{P}_0$

#### 2- Over Consolidated Clay(O.C.C.)

Represent the clay which has experienced a stress in the past larger than the existing effective overburden pressure ( $\hat{P}_0$ ) acting at the present time.

For O.C.C.  $\hat{P}_c > \hat{P}_0$

#### Over Consolidation Ratio: (O.C.R.)

$$\text{O.C.R.} = \frac{\hat{P}_c}{\hat{P}_0}$$

If O.C.R. = 1

$$\therefore \hat{P}_c = \hat{P}_0 \quad \therefore \text{N.C.C.}$$

If O.C.R. > 1

$$\therefore \hat{P}_c > \hat{P}_0 \quad \therefore \text{O.C.C.}$$

# VOID RATIO-PRESSURE PLOTS

Final  $e - \log \sigma'$  plots consist of results of numerous

Two Definitions based on

**Normally Consolidated**  
The present overburden effective in-situ stress has never seen.

**Overconsolidated**  
The present overburden stress is greater than the soil has ever experienced. The maximum effective stress is called the preconsolidation stress or *Maximum Past*

Revised 03/2013

Revised 03/2013

## NC Clay

Settlement ( $S_p$ ) using Void Ratio

$$S_p = \frac{C_c H}{1 + e_0} \log \left( \frac{\sigma'_o + \Delta \sigma'}{\sigma'_o} \right)$$

Where:

- $S_p$  = Settlement
- $H$  = Height of Soil Layer
- $\sigma'_{vm}$  = Final Vertical Effective Stress
- $\sigma'_o$  = Current Vertical Effective Stress
- $\Delta \sigma'$  = Change in Vertical Effective Stress
- $\sigma'_f$  = Final Vertical Effective Stress
- $e_f$  = Final Void Ratio

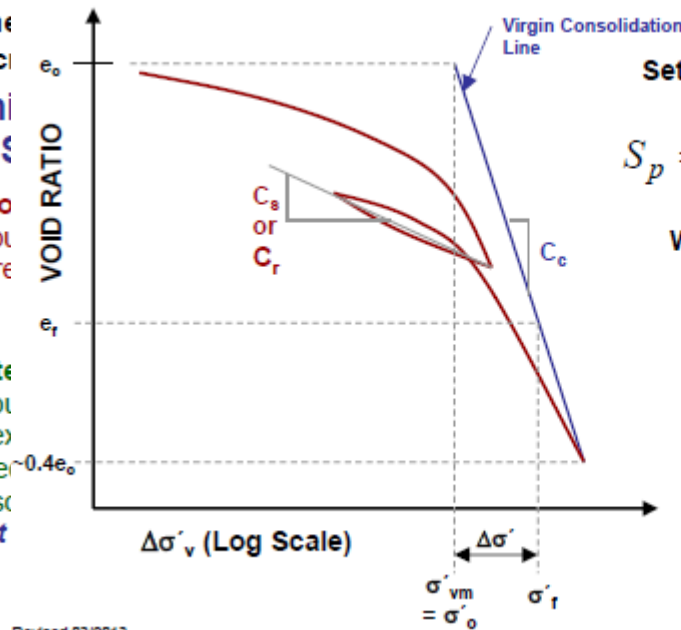

Slide 23 of 74

## OC Clay

Where:

- $C_c$  = Slope of Field Virgin Consolidation Curve - Compression Index

## OC Clay

Settlement ( $S_p$ ) using Void Ratio

$$S_p = \frac{C_r H}{1 + e_0} \log \left( \frac{\sigma'_{vm}}{\sigma'_o} \right) + \frac{C_c H}{1 + e_0} \log \left( \frac{\sigma'_o + \Delta \sigma'}{\sigma'_o} \right)$$

Where:

- $S_p$  = Settlement
- $H$  = Height of Soil Layer
- $\Delta \sigma'$  = Change in Vertical Effective Stress
- $\sigma'_o$  = Initial Vertical Effective Stress
- $\sigma'_f$  = Final Vertical Effective Stress
- $e_f$  = Final Void Ratio

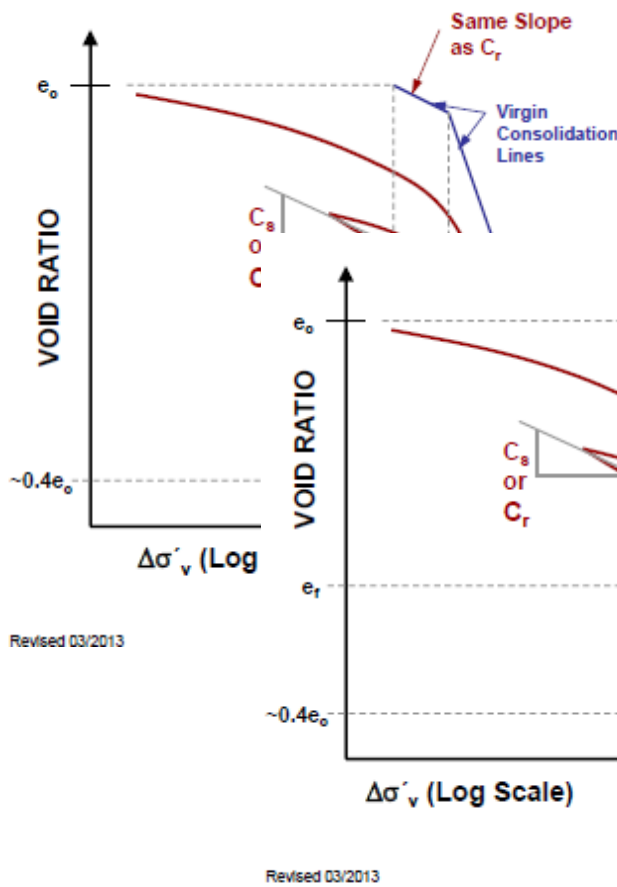

Revised 03/2013

Revised 03/2013

Slide 25 of 74



**Consolidation Settlement:**

To calculate the final consolidation settlement ( at  $t = \infty$  ) use one of the following :

$$1- Scf = \frac{\Delta e}{1+e_0} H$$

$$2- Scf = m_v \Delta \sigma H$$

$$3- Scf = \frac{C_c}{1+e_0} H \log \frac{P_0 + \Delta P}{P_0}$$

4- For O.C.C. we have to Check:

a- If  $P_0 + \Delta P \leq P_c$  then use :

$$Scf = \frac{C_r}{1+e_0} H \log \frac{P_0 + \Delta P}{P_0}$$

b- If  $P_0 + \Delta P > P_c$  then use :

$$Scf = \frac{C_r}{1+e_0} H \log \frac{P_c}{P_0} + \frac{C_c}{1+e_0} H \log \frac{P_0 + \Delta P}{P_c}$$

Where Scf : Final consolidation settlement

$e_0$ : Initial void ratio

$\Delta e$ : Change in void ratio =  $e_0 - e_f$

H : thickness of compressed clay layer

$m_v$  : Coefficient of volume compressibility for the stress range

$\Delta P$  : change in effective stress between initial and final conditions

$C_c$  : Compression index

Note About settlement Calculation:

- 1- Scf : usually find at the middle of compressed clay layer (represent the worse case).
- 2- Calculate the increase in vertical stress at the middle of clay layer by either using 2:1 method or using Chart (figures 8.6 and 8.4).
- 3- Check whether the clay is N.C.C. or O.C.C., and use proper equation mention above.
- 4- For more accurate result you can divide the clay layer into sub layers (i.e not more than 2 m). Then find the total settlement by summing the settlement for each layer.

Example:

For the soil Profile shown find the final consolidation settlement?

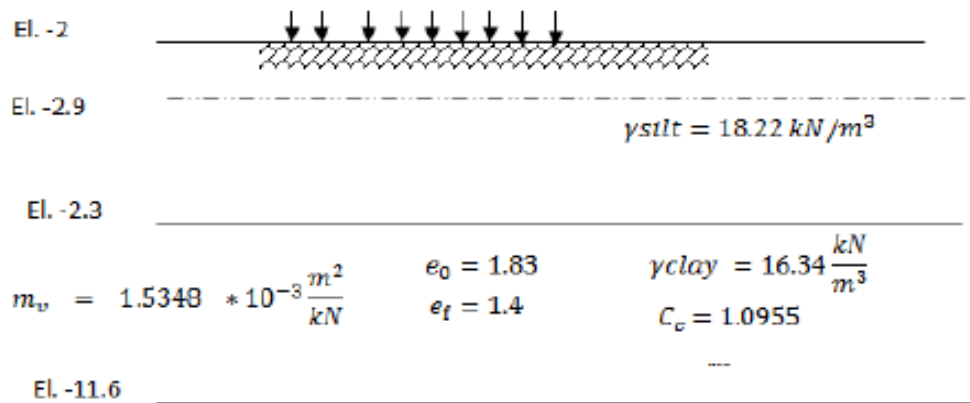

### Sand

$$1- Scf = \frac{\Delta e}{1+e_0} H = \frac{e_0 - e_f}{1+e_0} H = \frac{1.83-1.4}{1+1.83} (11.6 - 7.3) = 0.653 \text{ m}$$

$$2- Scf = m_v \Delta \dot{P} H = h_{fill} * \gamma_{fill} = 22 * 4.5 = 99 \text{ kN/m}^2$$

$$3- Scf = \frac{C_c}{1+e_0} H \log \frac{\dot{P}_0 + \Delta \dot{P}}{\dot{P}_0}$$

$\dot{P}_0 = \dot{\sigma} = \sigma - u$  at the middle of the clay layer before fill application

$$\therefore \sigma = (7.3 - 2) * 18.22 * \left( \frac{11.6 - 7.3}{2} \right) * 16.34 = 131.7 \frac{\text{kN}}{\text{m}^2}$$

$$U = \left[ (7.3 - 2.9) + \left( \frac{11.6 - 7.3}{2} \right) \right] * 9.807 = 64.236 \frac{\text{kN}}{\text{m}^2}$$

$$\dot{P}_0 = \dot{\sigma} = 131.7 - 64.236 = 67.46 \frac{\text{kN}}{\text{m}^2}$$

$$Scf = \frac{1.0955}{1+1.83} (11.6 - 7.3) \log \frac{67.46+99}{67.46} = 0.653 \text{ m}$$

LOWELL

### EXAMPLE: SETTLEMENT FROM VIRGIN CONSOLIDATION CURVES

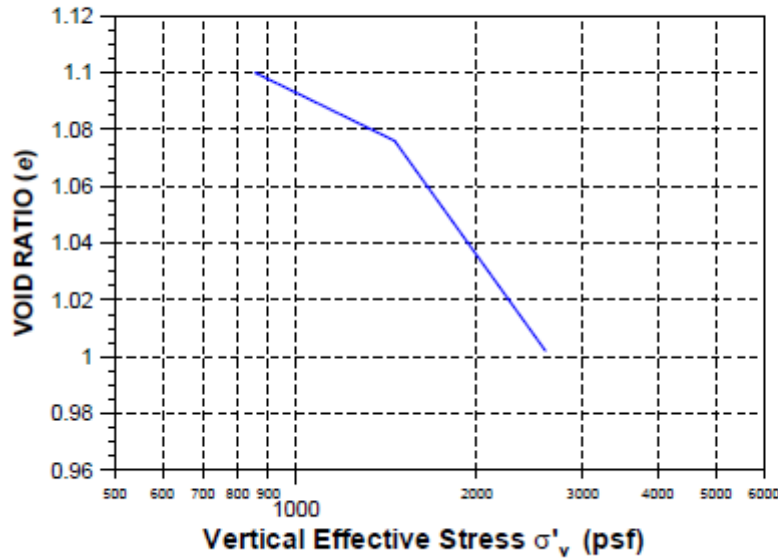

GIVEN:

OC CH layer

$$\sigma'_o = 855 \text{ psf}$$

$$\sigma'_{vm} = 1460 \text{ psf}$$

$$\Delta\sigma' = 1005 \text{ psf}$$

$$e_o = 1.1$$

Height of CH Layer = 10 ft

revised 03/2013

Figure 1. Example of Virgin Consolidation Curves.

Slide 29 of 74

### EXAMPLE: SETTLEMENT FROM VIRGIN CONSOLIDATION CURVES

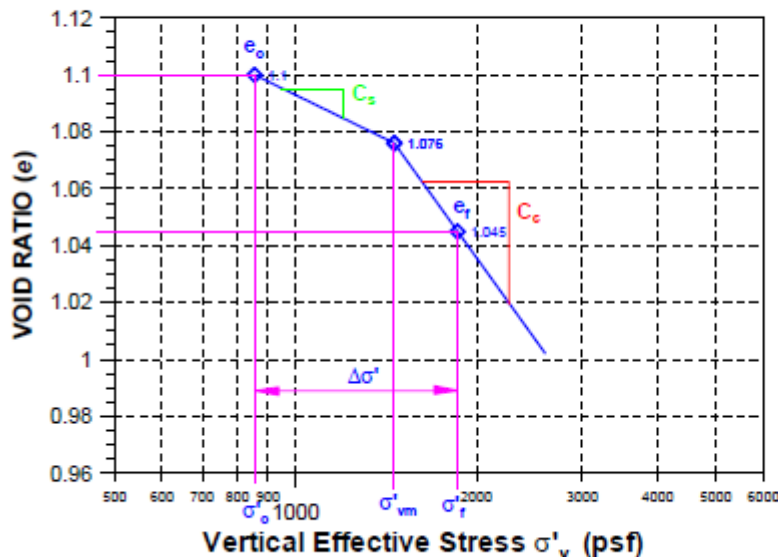

$$S_p = H \frac{\Delta e}{1 + e_o}$$

$$\Delta e = 1.1 - 1.045 = 0.055$$

$$e_o = 1.1$$

$$S_p = (10 \text{ ft}) \left( \frac{0.055}{1 + 1.1} \right)$$

$$S_p = 0.262 \text{ ft}$$

$$S_p = 3.14 \text{ in} = 3 \frac{1}{4} \text{ in}$$

vised 03/2013

Figure 1. Example of Virgin Consolidation Curves.

Slide 30 of 74

Degree of Consolidation ( $U\%$  )

For an element of soil at a particular depth  $z$  in a clay layer the progress of the consolidation process under a particular total stress increment can be expressed in terms of void ratio as follows:

$$U_z = \frac{e_0 - e}{e_0 - e_1}$$

where  $U_z$  is defined as the degree of consolidation, at a particular instant of time, at depth  $z$  ( $0 \leq U_z \leq 1$ ), and  $e_0$ =void ratio before the start of consolidation,  $e_1$ =void ratio at the end of consolidation and  $e$ =void ratio, at the time in question, during consolidation.

Degree of consolidation can be finding by

$$U_z = \frac{\sigma' - \sigma'_0}{\sigma'_1 - \sigma'_0}$$

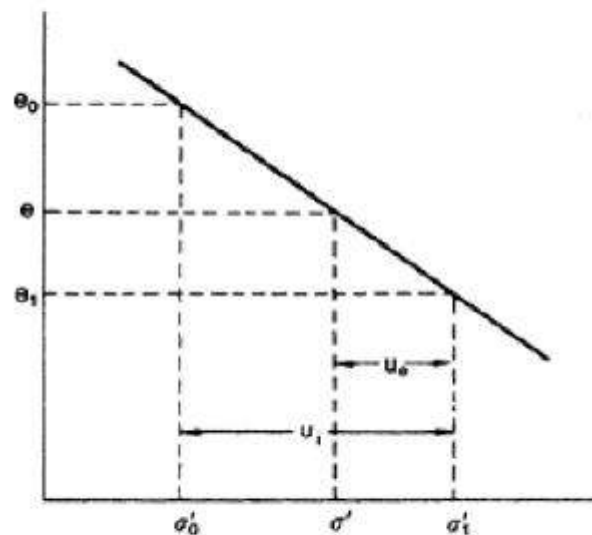

Figure: Assumed linear  $e-\sigma'$  relation

The degree of consolidation can then be expressed as

$$U_z = \frac{u_i - u_e}{u_i} = 1 - \frac{u_e}{u_i}$$

Terzaghi's theory of one-dimensional consolidation:

The assumptions made in the theory are:

- 1- The soil is homogenous.
- 2- The soil is fully saturated.
- 3- The solid particles and water are incompressible.
- 4- Compression and flow is one-dimensional (vertical).
- 5- Strains are small.
- 6- Darcy's law is valid at all hydraulic GRADIENTS.
- 7- The coefficient of permeability and the coefficient of volume compressibility remain constant throughout the process.
- 8- There is a unique relationship, independent of time, between void ratio and effective stress.

There are three variable in the consolidation equation:

$$\frac{\partial u}{\partial t} = C_v \frac{\partial^2 u}{\partial z^2} \quad (\text{Consolidation equation})$$

- 1- Depth of the soil element in the layer (z).
- 2- The excess pore water pressure (U)
- 3- The time elapsed since application of the loading (t)

Where u: is the excess pore water pressure.

$C_v$ : is the coefficient of consolidation.

$$C_v = \frac{K}{m_v \gamma_w}$$

Where  $m_v$  : is the coefficient of volume changes ( $m^2/year$ ).

$$T_v = \frac{C_v t}{h_{dr}^2}$$

Where  $T_v$  : Time factor



$t$ : the time

$h_{dr}$ : is the drainage path

$h_{dr} = H/2$  (clay layer Between two permeable layers).

$h_{dr} = H$  (for clay layer between one permeable and one impermeable layer).



The variation of total consolidation with time is most conveniently plotted in the form of the average degree of consolidation ( $U$ ) for the entire stratum versus dimensionless time  $T_v$ , and this is illustrated below:

$U_z$ : Degree

There is a relation

- 1- Degree of consolidation
- So the graph equation

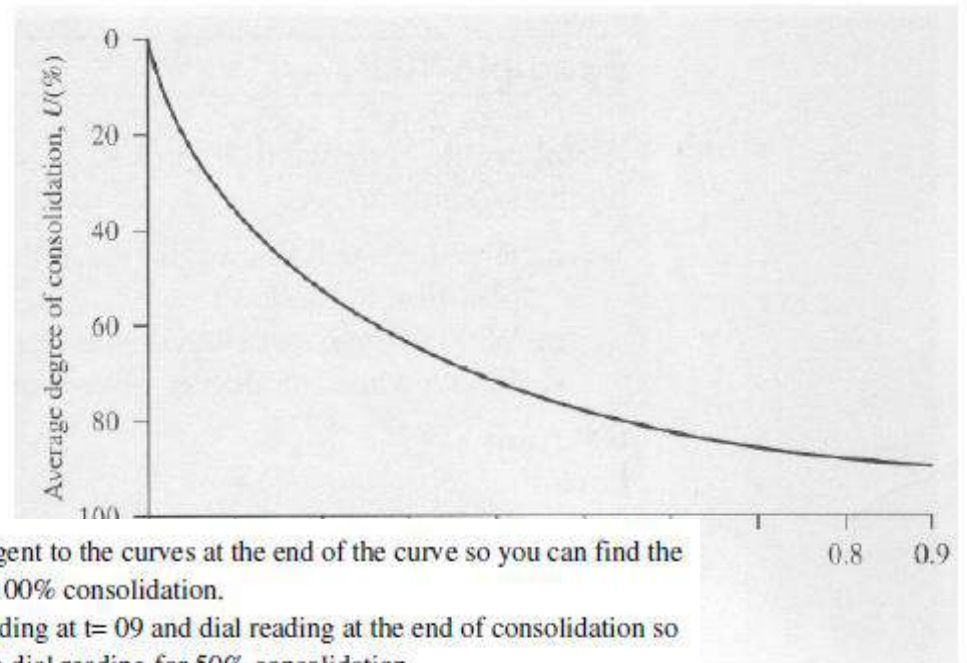

b)- Take the tangent to the curves at the end of the curve so you can find the dial reading at 100% consolidation.

c)- Now dial reading at  $t = 0.9$  and dial reading at the end of consolidation so you can find the dial reading for 50% consolidation.

e)- So the coefficient of consolidation  $c_v$  can be found by the following equation.

$$c_v = \frac{0.196 t^2}{t_{50}}$$

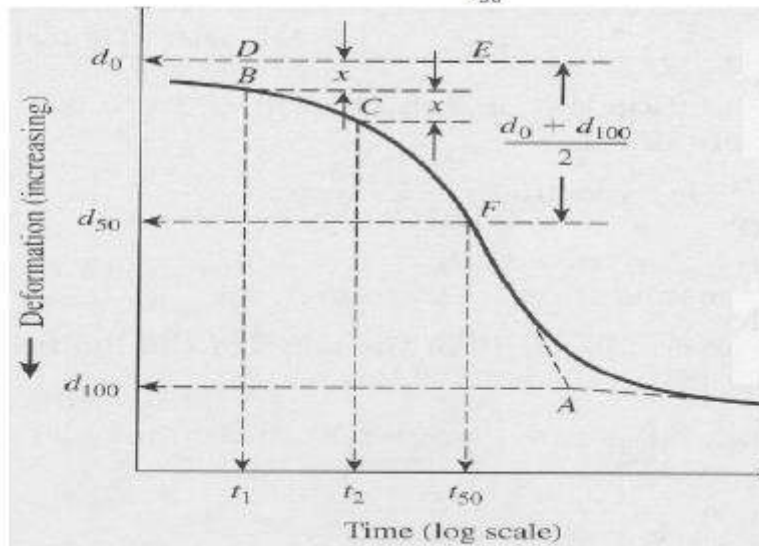

factor

consolidation and the time

dial reading at  $4t$  then move you can find the dial



2- The root time method (Taylor)

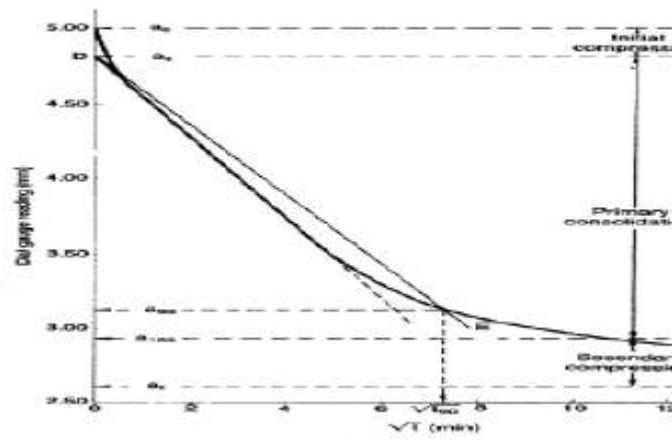

$$C_v = \frac{0.848 h_{dr}^2}{t_{90}}$$

### Consolidation Settlement Time:

To estimate the amount of consolidation which occur and the time, it is necessary to know:

- 1- The boundary drainage conditions
- 2- The loading condition
- 3- The soil parameters including initial void ratio, coefficient of compressibility, compressibility index and coefficient of consolidation. All these are obtained from consolidation test on representative sample.

So to plot the variation of settlement versus time curve:

- 1- Find the time required to complete the consolidation ( $T_v = 1$ ).
- 2- Assume different value of time start from ( $t=0$ ) to time ( $t$ ) find in step 1
- 3- For each value of time  $t$ , find the  $T_v$  using ( $T_v = \frac{C_v t}{h_{dr}^2}$ ).
- 4- For each value of  $T_v$  (from step 3) find ( $U_{av}$ ).
- 5- Find the final consolidation ( $S_{cf}$ ) using any proper equations.
- 6- Find the settlement at time  $t$  ( $S_{ct} = U_{av} * S_{cf}$ ).
- 7- Plot the settlement-Time curve.

Time (t)	$T_v = \frac{C_v t}{h_{dr}^2}$	$U_{av}$	$S_{cf}$	$S_{ct} = U_{av} * S_{cf}$

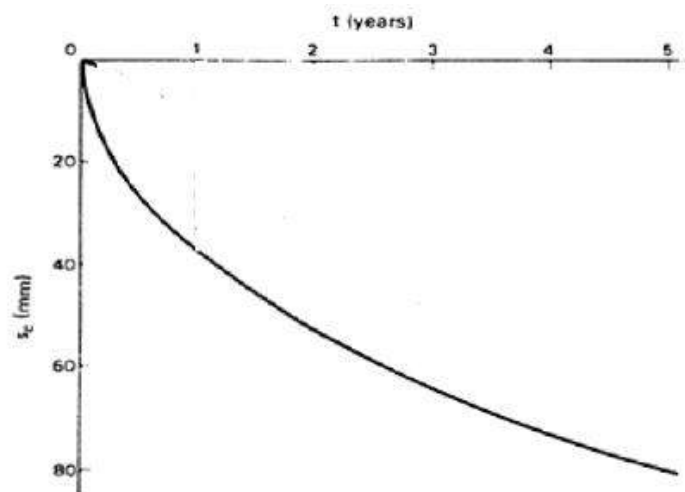
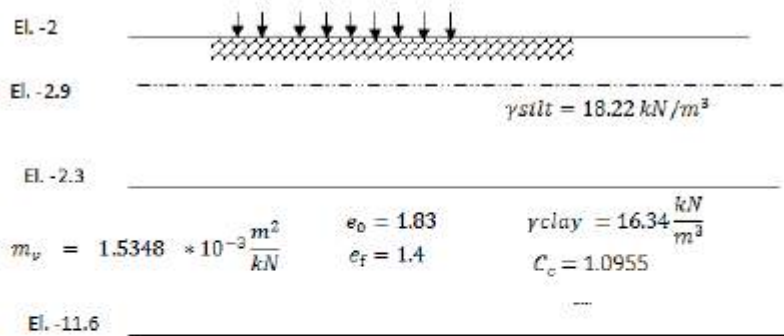

Figure Variation of settlement with time

Example: For the soil Profile shown find the final consolidation settlement?



Sand

$$1- Scf = \frac{\Delta e}{1+e_0} H = \frac{e_0 - e_f}{1+e_0} H = \frac{1.83-1.4}{1+1.83} (11.6 - 7.3) = 0.653 \text{ m}$$

$$2- Scf = m_v \Delta \dot{p} H = h_{fill} * \gamma_{fill} = 22 * 4.5 = 99 \text{ kN/m}^2$$

$$3- Scf = \frac{C_c}{1+e_0} H \log \frac{\dot{p}_0 + \Delta \dot{p}}{\dot{p}_0}$$

$\dot{p}_0 = \dot{\sigma} = \sigma - u$  at the middle of the clay layer before fill application

$$\therefore \sigma = (7.3 - 2) * 18.22 + \left( \frac{11.6 - 7.3}{2} \right) * 16.34 = 131.7 \frac{\text{kN}}{\text{m}^2}$$

$$U = \left[ (7.3 - 2.9) + \left( \frac{11.6 - 7.3}{2} \right) \right] * 9.807 = 64.236 \frac{\text{kN}}{\text{m}^2}$$

$$\dot{p}_0 = \dot{\sigma} = 131.7 - 64.236 = 67.46 \frac{\text{kN}}{\text{m}^2}$$

$$Scf = \frac{1.0955}{1+1.83} (11.6 - 7.3) \log \frac{67.46+99}{67.46} = 0.653 \text{ m}$$

Example :

Astrata of consolidated clay of thickness 10 ft drained on one side only. The hydraulic conductivity of  $k = 1.863 \times 10^{-8}$  in /sec. and coefficient of volume compressibility  $m_v = 8.6 \times 10^{-4} \frac{\text{in}^2}{\text{lb}}$ . Determine the ultimate value of the compression of the stratum by assuming a uniformly distributed load of 5250  $\text{lb}/\text{ft}^2$  and also determine the time required for 20 percent and 80 percent consolidation.

Solution : Total compression

$$S_c = m_v H \Delta P = 8.6 \times 10^{-4} \times 10 \times 12 \times 5250 \times \frac{1}{144} = 3.763 \text{ in.}$$

For determining the relationship between U% and T for 20% consolidation use the equation

$$T = \frac{\pi U\%}{4 \cdot 100} \text{ or } T = \frac{3.14}{4} \times \frac{20^2}{100} = 0.0314$$

For 80% consolidation use the equation

$$T = 1.781 - 0.933 \log(100 - 80)$$

Therefore  $T = 1.781 - 0.933 \log(100 - 80) = 0.567$

The coefficient of consolidation is

$$c_v = \frac{k}{\gamma_w m_v} = \frac{1.863 \times 10^{-8}}{3.61 \times 10^{-2} \times 8.6 \times 10^{-4}} = 6 \times 10^{-4} \text{ in}^2 / \text{sec}$$

The times required for 20% and 80% consolidation are

$$t_{20} = \frac{H_{dr}^2 T}{c_v} = \frac{(10 \times 12)^2 \times 0.0314}{6 \times 10^{-4} \times 60 \times 60 \times 24} = 8.72 \text{ days}$$

$$t_{80} = \frac{H_{dr}^2 T}{c_v} = \frac{(10 \times 12)^2 \times 0.567}{6 \times 10^{-4} \times 60 \times 60 \times 24} = 157.5 \text{ days}$$

Example : The loading period for a new building extended from may 1995 to may 1997. In May 2000, the average measured settlement was found to be 11.43 cm. it is known that the ultimate settlement will be about 35.56 cm. Estimate the settlement in may 2005. Assume double drainage to occur.

Solution:

For the majority of practical cases in which loading is applied over a period, acceptable accuracy is obtained when calculating time-settlement relationships by assuming the time datum to be midway through the loading or construction period.

$$s_t = 11.43 \text{ cm when } t = 4 \text{ years and } S = 35.56 \text{ cm}$$

The settlement is required for  $t=9$  years, that is up to may 2005. Assuming as a starting point that at  $t = 9$  years, the degree of consolidation will be  $= 0.60$ . under these conditions.  $U = 1.13 \sqrt{T}$ .

Is  $S_{t_1} = \text{Settlement at time } t_1$ ,  $S_{t_2} = \text{Settlement at time } t_2$

$$\frac{S_{t_1}}{S_{t_2}} = \frac{U_1}{U_2} = \sqrt{\frac{T_1}{T_2}} = \sqrt{\frac{t_1}{t_2}} \quad \text{Since } T = \frac{C_v t}{H_{dr}^2}$$

Where  $\frac{C_v}{H_{dr}^2}$  is a constant. Therefore  $\frac{11.43}{S_{t_2}} = \sqrt{\frac{4}{9}}$  or  $S_{t_2} = 17.15 \text{ cm}$

E Example :

tl Two points on a curve for a normally consolidated clay have the following coordinates.

Point 1:  $e_1 = 0.7$ ,  $p_1 = 2089 \text{ lb/ft}^2$

Point 2:  $e_2 = 0.6$ ,  $p_2 = 6266 \text{ lb/ft}^2$

If the average overburden pressure on a 20 ft thick clay layer is  $3133 \text{ lb/ft}^2$ , how much settlement will the clay layer experience due to an induced stress of  $3340 \text{ lb/ft}^2$  at its middepth.

**Solution**

From Eq. (7.4) we have

$$C_c = \frac{e_1 - e_2}{\log \frac{p_2}{p_1}} = \frac{0.7 - 0.6}{\log \frac{6266}{2089}} = 0.21$$

$$\text{Settlement, } S = \frac{C_c}{1 + e_0} H \log \frac{p_0 + \Delta p}{p_0}$$

Substituting the known values, with  $\Delta p = 3340 \text{ lb/ft}^2$

$$S = \frac{0.21 \times 20 \times 12}{1.663} \log \frac{3133 + 3340}{3133} = 9.55 \text{ in}$$

**Example :**

A strata of normally consolidated clay of thickness 10 ft is drained on one side only. It has a hydraulic conductivity of  $k = 1.863 \times 10^{-8}$  in/sec and a coefficient of volume compressibility  $m_v = 8.6 \times 10^{-4}$  in<sup>2</sup>/lb. Determine the ultimate value of the compression of the stratum by assuming a uniformly distributed load of 5250 lb/ft<sup>2</sup> and also determine the time required for 20 percent and 80 percent consolidation.

**Solution**

Total compression,

$$S_c = m_v H \Delta p = 8.6 \times 10^{-4} \times 10 \times 12 \times 5250 \times \frac{1}{144} = 3.763 \text{ in.}$$

For determining the relationship between  $U\%$  and  $T$  for 20% consolidation use the equation

$$T = \frac{\pi}{4} \frac{U\%}{100}^2 \quad \text{or} \quad T = \frac{3.14}{4} \times \frac{20}{100}^2 = 0.0314$$

$$T = 1.781 - 0.933 \log_{10} (100 - U\%)$$

$$\text{Therefore } T = 1.781 - 0.933 \log_{10} (100 - 80) = 0.567.$$

**The coefficient of consolidation is**

$$c_v = \frac{k}{\gamma_w m_v} = \frac{1.863 \times 10^{-8}}{3.61 \times 10^{-2} \times 8.6 \times 10^{-4}} = 6 \times 10^{-4} \text{ in}^2 / \text{sec}$$

**The times required for 20% and 80% consolidation are**

$$t_{20} = \frac{H_{dr}^2 T}{c_v} = \frac{(10 \times 12)^2 \times 0.0314}{6 \times 10^{-4} \times 60 \times 60 \times 24} = 8.72 \text{ days}$$

$$t_{80} = \frac{H_{dr}^2 T}{c_v} = \frac{(10 \times 12)^2 \times 0.567}{6 \times 10^{-4} \times 60 \times 60 \times 24} = 157.5 \text{ days}$$