

# Louisiana State Police Crime Laboratory Forensic Services Guide



Louisiana Department of Public Safety and Corrections

## MESSAGE FROM THE LABORATORY DIRECTOR

This guide was created to aid you as our customer, with the ultimate goal of providing quality forensic analysis in a timely manner. Our commitment to this goal is paramount and unwavering. Our crime laboratory employees represent some of the best analysts in the industry. They not only meet, but also exceed the uppermost forensic standards and work tirelessly to maintain the highest expectations from requesting agencies.

In 2019, our public laboratory was accredited by the ANSI National Accreditation Board (ANAB) in the following disciplines: Bloodstain Pattern Analysis, Crime Scene Investigation, DNA, Firearms and Toolmarks, Fire Debris and Explosives, Footwear/Tire, Friction Ridge (Latents), Trace Materials, Drugs, Toxicology, and Alcohol Content.

Our staff consists of men and women who have committed themselves to this profession. They represent some of the most intelligent, dedicated, and ethical individuals I could hope to assemble. I am truly honored to work with them as their Laboratory Director.

The future is bright for our laboratory as we are on the cutting edge of new technologies including providing quantitative analysis for toxicology requests. We are on the fringe of beginning Rapid DNA and other DNA analyses that will only improve our ability to evaluate complex profiles.

We will continue to foster mutually respectful working relationships with you, our partners in the criminal justice community. Please take a few moments to complete the [Louisiana State Police Crime Laboratory Customer Satisfaction Survey](#) located on our website so we may better serve you.

-Captain Kevin Marcel

“JUSTICE, TRUTH, SCIENCE”

## Louisiana State Police Crime Laboratory Core Values

*LSPCL's Core Values are fundamental qualities that each employee of the Crime Lab should strive to possess and exhibit on a daily basis. LSPCL's management is committed to complying with these core values and encouraging all employees to do the same.*

**LEADERSHIP-** Guide and facilitate others to be a positive influence in their careers. Take the time to invest in others in the lab, have patience with trainees and new employees, and assist others without being asked. Contribute to the lab's goals.

**SERVICE-** Serve the citizens of Louisiana by providing accurate and timely reports, non-biased testimony/opinions based on your work, and professionalism when dealing with the public, agencies, and criminal justice partners.

**POSITIVITY-** Have an optimistic attitude and invoke a work environment where others will be inspired by you to take on challenging situations with confidence. Project an enthusiastic demeanor that is contagious to those working around you.

**CREDIBILITY-** Be trustworthy by being truthful and transparent with coworkers and the public. Be reliable and dependable to your unit and to the lab.

**RESPECT-** Treat others the way you want to be treated, consider others' opinions and ideas with an open mind, and always be kind and courteous.

**INITIATIVE-** Be proactive; identify solutions to problems and solve them without being prompted. Have the ability to assess an issue and become a problem solver. Go above and beyond what is expected because it benefits the case, the unit, or the lab. Always continuously improve.

**TEAMWORK-** Collaborate with coworkers and management to achieve efficient work flow, timely case reviews, and administrative duties. Complete tasks with a positive, considerate, and professional attitude. Volunteer to conduct tours, be on the audit team or crime scene response, and assist other units when they ask for help, etc.

**INTEGRITY-** Be honest with others, be true to the core values, make the right decision for the right reasons, and follow through with commitments.

**PROFESSIONALISM-** Communicate effectively and appropriately. Always find a way to be productive. Take on new challenges, new technology, and new procedures without complaint. Be thorough in your work and take strides to improve your skill set. Be active in and contribute to the profession.

**ACCOUNTABILITY-** Justify your actions and decisions without excuses, be responsible for your assigned duties and other actions, complete tasks and assignments in a timely manner, and be detail-oriented.

**BALANCE-** Create a work environment that is pleasant and fun to work in. Participate in work related functions to increase morale and camaraderie. Avoid workplace tension and conflict.

"Wherever he steps, wherever he touches, whatever he leaves, even without consciousness, will serve as a silent witness against him. Not only his fingerprints or his footprints, but his hair, the fibers from his clothes, the glass he breaks, the tool mark he leaves, the paint he scratches, the blood or semen he deposits or collects. All of these and more bear mute witness against him. This is evidence that does not forget. It is not confused by the excitement of the moment. It is not absent because human witnesses are. It is factual evidence. Physical evidence cannot be wrong, it cannot perjure itself, it cannot be wholly absent. Only human failure to find it, study, and understand it can diminish its value."

-Dr. Edmond Locard

## Table of contents

<a href="#">Introduction</a> .....	6
<a href="#">Important information and contacts</a> .....	7
<a href="#">Objectives</a> .....	9
<a href="#">Overview of laboratory services</a> .....	10
<a href="#">Sections of LSP Crime Laboratory</a> .....	11
<a href="#">Chain of custody</a> .....	13
<a href="#">General evidence handling</a> .....	15
<a href="#">Specific evidence handling</a> .....	23
<a href="#">Controlled substances</a> .....	24
<a href="#">Toxicology</a> .....	30
<a href="#">DNA</a> .....	36
<a href="#">CODIS</a> .....	40
<a href="#">Crime scene</a> .....	41
<a href="#">Physical evidence</a> .....	44
<a href="#">Collecting evidence by type</a> .....	45
<a href="#">Firearms</a> .....	53
<a href="#">Latent prints and impression</a> .....	65
<a href="#">Fire debris</a> .....	72

## Introduction

The rapidly evolving and expansive field of Forensic Science commands a need for constant attention by the various individuals who have devoted themselves to this career path. New technology, techniques, and procedures are continually developed, providing new capabilities or refinements to existing capabilities, allowing cases to be worked in ways the law enforcement community never would have imagined were possible. We strongly urge investigators to use this as a guide for their crime scene examinations and investigations, as the ultimate goal in its creation is to provide a valuable reference guide for evidence collection and submittal for analysis.

With that in mind, the Louisiana State Police Crime Laboratory Forensic Services Guide has been compiled to assist law enforcement personnel with the basic procedures of proper evidence handling and the importance of doing so for their investigation. Recognition, collection, and preservation of physical evidence is the most vital aspect of solving crimes. Thus, accuracy and attention to detail cannot be overemphasized when handling evidence.

This handbook should give officers the necessary tools to develop their ability to recognize the numerous types of evidence that may be encountered. This handbook is enabled with hyperlinks to various sections in this document, laboratory forms, and websites that will assist you in locating forms and information necessary for submitting evidence to the laboratory.

All agencies are encouraged to keep regular contact with the Louisiana State Police Crime Laboratory to remain informed about any changes or modifications to existing lab techniques, procedures, or capabilities.

While this guide gives a wide variety of specific information, many conditions are out of your control. In a perfect environment, these recommendations should be followed, however there may be instances where the situation you are experiencing is not described in this guide.

***Please do not hesitate to contact properly trained personnel at the Crime Laboratory if you feel this manual lacks information crucial to your investigation or to clarify anything outlined herein that seems unclear. This guide is not intended to supersede any specific agency and/or department protocols.***

## Important information and contacts

Hours of Operation: 8:00am-4:30pm (Monday-Friday)

Note: The Crime Laboratory is closed every year on state holidays observed in Louisiana. Please contact Troop A (or your nearest troop) if your agency requires assistance with a crime scene investigation outside the laboratory's regular hours of operation.

Contact numbers:

- Main Office: (225) 925-6216 ext. 200
- Main Office Fax: (225) 925-6217
- Evidence Receiving: (225) 925-6223
- Troop A: (225) 754-8500
- Crime Laboratory on-call mobile number: (225) 252-6269

Mailing Address:

Louisiana State Police Crime Laboratory  
376 East Airport Avenue  
Baton Rouge, Louisiana 70806

Email address: [CrimeLab@la.gov](mailto:CrimeLab@la.gov)

Website: <http://www.lsp.org/crimelab.html> (Note: our customer satisfaction survey, this guide, submittal forms and other info can be found here)

Questions for individual departments can be addressed by trained laboratory personnel:

- DNA: (225) 925-7791
- CODIS/DNA Accessioning: (225) 925-7070
- Controlled Substances (Drug Unit): (225) 925-6257
- Toxicology: (225) 925-6256
- Firearms: (225) 925-1774
- Crime Scene: (225) 925-4549
- Latent Prints/Fire Debris/Shoeprints: (225) 925-6098

Other Useful Contacts:

- Haz Mat Unit (Right to Know hotline): Telephone (877) 925-6595 (When hazardous materials are suspected or have been encountered, then Louisiana State Police TESS Unit should be contacted.)
- Department of Child & Family Services (to be contacted if children or vulnerable adults are in need of assistance at a scene): Telephone: (888) 524-3578
- Department of Public Safety Central Supply Warehouse (to obtain Blood Alcohol/Toxicology Kits and evidence envelopes for your agency): 290 East Airport Avenue Baton Rouge, LA 70806. Telephone: (225) 925-6152
- Louisiana State Fire Marshal for arson investigations: Telephone: (225) 925-3647
- FBI Criminal Justice Information Services (CJIS) (to order fingerprint cards or NGI issues): Telephone: (304) 625-3983 or <https://www.fbi.gov/services/cjis/fingerprints-and-other-biometrics/ordering-fingerprint-cards-and-training-aids>
- LSP Bureau of Identification/Criminal Records. Telephone: (225) 925-6095



## Objectives

The laboratory's objectives in providing this guide are as follows:

- To explain and highlight the most important aspects of physical evidence in criminal investigations.
- To explain the proper methods officers should utilize for the identification, collection, and preservation of physical evidence.
- To outline the various services provided by the Louisiana State Police Crime Laboratory for law enforcement agencies throughout our state.
- To instruct officers regarding the proper way to submit evidence for analysis to the laboratory.
- To demonstrate the usefulness of expert witness testimony as a valuable tool for attorneys within the judicial process.

## Overview of Crime Laboratory Services

Analysis is performed for official criminal investigations only. The Louisiana State Police Crime Laboratory does not conduct evidence examination services for private individuals or corporations. The only time the Crime Lab is involved in civil litigation is when criminal cases become civil in nature.

Additionally, the Crime Laboratory's forensic services include, but are not limited to, assistance with crime scene investigations. When requested by an authorized law enforcement agency, scientific analyses in several forensic disciplines and court appearances that require expert testimony, are available at no charge. The only exception is a criminal case for which the court orders lab services when a defendant has shown cause.

The procedures contained herein conform to LRS 15:41, 32:1700 et seq., and 40:4601 et seq., and shall form the basis for the confiscation, storage, transfer, release, disposal of evidence or contraband, and property seized.

Laboratory Services are to provide:

- Assistance to any Louisiana law enforcement agency, upon request, in criminal matters ONLY; these services are furnished at no cost to agencies requesting such help
- Assistance to Louisiana law enforcement agencies includes crime scene processing, where specialized scientific knowledge is needed
- Examination, analysis, and comparison of numerous types of physical evidence. This is explained with more specificity throughout this guide
- Expert witness testimony in courtroom proceedings
- Instruction, both basic and specialized, to law enforcement personnel within the state. Requests for in-person instruction should be directed to the Laboratory Director or appropriate Manager

## Sections of the LSP Crime Laboratory

The Louisiana State Police Crime Laboratory is comprised of three main analytical units or sections: Chemistry, Physical Evidence, and DNA.

### CHEMISTRY UNIT

#### Drug Chemistry

- Analyze pharmaceuticals, powders, liquids, crystalline substances, illicitly made tablets, and vegetable material for the presence or absence of controlled dangerous substances, as prohibited by LRS 40, Schedules I-V
- Provide information on processing of clandestine labs and large seizures of illegal drugs
- Disseminates current drug trend information and safe handling practices to law enforcement agencies

#### Toxicology

- Analyze blood and urine for drugs that may cause impairment
- Quantify certain drugs in blood
- Analyze blood samples to determine ethyl alcohol levels for impairment cases
- Permit laboratories to perform Blood Alcohol and Toxicology analyses in Louisiana

### DNA UNIT

#### Forensic DNA

- Analyze biological samples taken from crime scenes, victims, suspects, etc. (swabs, cuttings)
- Screen items of evidence for possible recovery of DNA (blood, semen and contact DNA)
- STR and Y-STR analysis
- CODIS DNA database searches (for eligible DNA profiles)

#### CODIS DNA / Accessioning

- Receive DNA collection kits taken from arrestees, convicted offenders, and sex offenders
- DNA samples are processed and profiles are uploaded into CODIS database
- Agency training / re-training on proper data collection and use of DNA collection kits

### PHYSICAL EVIDENCE UNIT

### Firearms

- NIBIN database entry of evidence firearms and cartridge cases
- Obliterated serial number restoration
- Gunshot residue analysis for distance determination
- Firearms examination
- Toolmark examination
- Fracture comparison

### Crime Scene

- Assist law enforcement agencies with processing crime scenes (including vehicles) and recovering evidence
- Provide blood stain pattern analysis
- Provide trajectory analysis

### Latent Prints/Impressions/Fire Debris

- Process evidence for fingerprints
- Latent print comparison
- AFIS / NGI database entry
- Impression comparison (shoeprints, tire tracks)
- Fire debris analysis
- Indented writing

## Chain of Custody

The chain of custody is a record that documents custody and evidence items collected during criminal investigations; this record is chronicled from the moment of its collection until its final disposition. It is date and time stamped to determine the timeline of events. It can be comprised of digital and/or paper documents. It allows the courts to question all persons who possessed an item regarding their handling procedures and actions.

The importance of a properly documented chain of custody cannot be overemphasized. The chain of custody is often closely scrutinized, and admission of evidence in trial is challenged and sometimes rejected because of improper handling or documentation. Therefore, it is extremely important that proper methods be used in collecting, preserving, and documenting physical evidence.

### Avoiding Weak Links:

The chain of custody can be challenged in an attempt to expose weak links. To avoid weak links, it is important to keep the following in mind:

- A. Keep the chain as short as possible: evidence should be handled by a minimal number of people. A chronological log should be maintained, or records to construct this chronology should be easily retrievable. This includes the dates and times of transfer and the name of person(s) to whom evidence was transferred.
- B. Documentation may be maintained in several ways:
  1. A special form for all evidence in the case
  2. On each individual container of evidence
  3. Electronically, using secure passwords and/or PINs (personal identification numbers)
- C. The same person who recovered the evidence should seal and place evidence labels on each container.
- D. NEVER store evidence in a vehicle at any time of the year. Exposure to the heat, moisture, light, etc. may destroy an item's evidentiary value.
- E. Evidence delivery to the Louisiana State Police Crime Laboratory should be made in accordance with both your agency's policies and the policies set forth in this guide.
- F. All evidence submitted to the Crime Lab must be properly packaged and sealed, using tamper evident evidence tape. All seals must be initialed on and off the tape ([as illustrated on page 22](#)). Contact the Crime Lab for instructions on maintaining evidence integrity for those items that are too large to be packaged. Also, the "[General Evidence Packaging](#)" section will provide more information on this topic, or you may reference the evidence type you are packaging within the "[Specific Evidence Handling](#)" section.

Legal Requirements:

To maintain the judicial admissibility and value of the evidence, the investigator should be able to:

- A. Identify each piece of evidence when asked to do so
- B. Describe the exact location of the item at the time it was collected
- C. Prove that the chain of custody has been properly maintained
- D. Describe changes that may have occurred in or to the evidence between the time of its collection and its introduction in court

## General Evidence Handling

Physical evidence is any object that can provide a link between a crime victim(s) or suspect(s). The proper handling of evidence is crucial in any investigation, often determining whether or not a case can be solved or successfully adjudicated. In any investigation, the validity of information derived from examination of the physical evidence depends upon the care with which evidence has been handled. If evidence has been improperly collected, handled, documented, or stored, its value may be destroyed and no amount of laboratory work will be of assistance. If handled properly, the likelihood that useful information can be obtained from the evidence is increased.

Stages of Processing a Crime Scene (The following assumes control has been established, lifesaving efforts have ended and the area is considered a secure crime scene.)

- A. Protection: The first officer at the scene has the initial responsibility of protecting the scene. Upon arriving at a crime scene, officers may not be sure what evidence is most valuable. Therefore, all items should be treated with equal significance.
1. Take note of persons and vehicles in the general area. Document any first responders that are/were present and the general actions they took. Support personnel (e.g. detectives, wrecker service, search & rescue canines, chase teams, traffic/crowd control, etc.) should be contacted immediately, if needed.
  2. Guard all entrances/exits to the crime scene.
  3. Limit crime scene access to essential personnel ONLY. This includes limiting access to other law enforcement or auxiliary personnel not actively processing the crime scene. An inner and outer crime scene perimeter may be needed, and should be clearly marked with barrier tape.
  4. Note your route through the scene. Do not use victim/suspect suspected points of entry or exit, if possible.
  5. Remove persons present from the scene—victims or witnesses—so that they do not purposely or inadvertently alter or destroy evidence. Instruct them not to discuss the events. Document if they have disturbed anything in or around the scene.
  6. Maintain a crime scene log in which the name, department, arrival, and departure of each person at the crime scene is recorded. Note who has been inside the scene perimeter (EMS, fire department, etc.).
  7. Use a camera, video camera, or other means to document the scene as it was initially found.
  8. Record any changes to the scene by your actions or those of emergency personnel.
  9. Make note of the following but do not move or pick up anything:
    - a. Doors and Windows: opened, closed, or locked?
    - b. Lights, TVs, or Radios: On or off? Which ones?
    - c. Odors in the air? (Cleaning solutions, cigarette smoke, perfume, etc.)
    - d. Items out of place?
    - e. Condition of body? (if applicable)
  10. Attempt to “freeze” the scene as closely as possible to the condition in which it was found to minimize the destruction of evidence.

- a. Protect suspected routes of entry and exit. If possible, use another entrance to the scene to avoid destroying possible latent footwear and fingerprint impressions.
  - b. Protect evidence (such as footwear and tire impressions, biological and trace evidence) from inclement weather.
  - c. Wear gloves and, if necessary, mask and shoe covers when entering the scene. (Shoe covers should be worn at scenes where biological and trace evidence and latent footwear impressions may be important.) These types of items are known as Personal Protective Equipment (PPE).
11. Collect victim/suspect clothing, including footwear. If the victim's clothing is removed at the scene by emergency personnel, advise them not to cut through the bullet holes and pattern impressions in the clothing.
  12. Record any observations of the suspect or victim. Any injuries? Any bloodstains on hands or clothing? Condition?
  13. If first responders are turning the scene over to other detectives, fully brief those assuming command

B. Recognition:

1. Evidence recognition is an acquired skill, improved and refined over the course of an officer's career. Education and experience will improve this skill.
2. By making themselves aware of the functions of the Crime Lab and what analyses the Crime Lab or other labs can perform, officers can determine what items at a scene hold the best evidentiary value.
3. Understanding all types of evidence and what questions they may potentially answer will aid tremendously in the reconstruction of a crime.

C. Documentation: Documentation of the crime scene has a two-fold basis of significance:

1. Legally: If evidence associated with a crime scene is not properly collected or documented, this may present complications when tried in court.
2. Scientifically: Incorrect or incomplete crime scene documentation can impede the forensic analysis process, resulting in little or no assistance in solving your case.

**IMPORTANT: Nothing at the crime scene should be altered until a detailed record of scene and item condition, location, etc. has been made, unless inaction will immediately cause loss or deterioration of the item.** Utilize the following methods as necessary:

- Written notes
- Sketches
- Photographs
- Audio and/or Video tapes

D. Collection & Preservation:

- The general rule is to submit the evidence in the same condition as when collected. Exceptions are noted throughout this manual. (E.g. some evidence must be dried, refrigerated, or frozen).
- Care should be exercised when collecting all evidence. This section provides general guidelines for handling evidence during collection.



- Evidence should not be collected until the whole crime scene has been documented (unless transient evidence will potentially be lost if not immediately collected). First responders should ensure the scene remains secure until trained crime scene response personnel arrive.

**If any uncertainties arise regarding how to collect, package, or preserve evidence, please call Crime Lab personnel for instructions or on-site assistance. *Louisiana State Police crime scene investigators are on call\* 24 hours a day, 7 days a week for this purpose.***

\*Contact numbers for LSPCL crime scene personnel are listed on pages [7](#) and [41](#) of this manual.\*

1. Use personal protective equipment (PPE) to prevent contamination of both personnel and the scene.
2. Remain aware of your and others' movements in and around the crime scene. Even slight changes could impede or alter forensic analysis.
3. With some types of evidence, known comparison samples (references) are necessary.
4. **Labeling evidence accurately is of the utmost importance.** Labeling errors, inconsistencies, and oversights tend to be one of the most frequently encountered, yet avoidable, challenges for forensic analysts.
5. Identify and protect fragile and/or perishable evidence (e.g. consider climatic conditions, crowds/hostile environments). Ensure that all evidence that may be compromised is immediately documented, photographed, and collected.
6. Some items must be thoroughly dried before packaging (DNA swabs, bloody clothing, plants, etc.) After drying, these types of evidence are best stored in clean paper containers. Plastic containers should NEVER be used for long-term storage of biological fluids or fresh vegetable material, except urine collected in the approved BU or PM kit.

E. Packaging: Use appropriately sized containers to package your evidence securely and properly. Avoid folding or stuffing larger items into smaller containers or packaging smaller items in very large packages (unless secured to the package).

1. Paper Containers: Paper is appropriate packaging for most types of evidence. Paper is porous—it allows water and other vapor to escape. Clothing and other cloth items which are to be examined for DNA evidence should always be packaged in paper; moisture can lead to the destruction of DNA evidence. Items collected for fire debris analysis should NEVER be stored in paper containers, even for short periods of time (this allows the ignitable liquid vapors to escape, or could contaminate the sample. Plant materials, such as marijuana or mushrooms which are confiscated fresh, should be dried before submittal to the laboratory or packaged in paper. (More specificity about packaging evidence of this type can be found in the “Specific Evidence Handling” section, within the categories entitled [Fire Debris](#), [DNA](#) & [Controlled Substances](#).)

Paper packets can also be used to package paint chips, hairs, fibers, or other very small items. Ensure that the paper is folded and sealed so that the sample cannot



escape. Paper packets should then be enclosed in an outer evidence envelope. An illustration, showing the best way to make a paper fold to enclose evidence in this manner will be shown later in this guide.

- a. Bags: Paper bags are widely used and very effective in packaging most types of evidence. Evidence should fit inside the paper bag comfortably, while allowing sufficient room to fold the top over and apply evidence tape for proper sealing.
- b. Envelopes: Like paper bags, envelopes may leak at the seams and may not be suitable for powder evidence unless the seams are taped.
  - i. Heavy-gauge paper envelopes of various sizes are best for packaging narcotics evidence or moderately heavy evidence items.
  - ii. Paper evidence packets are widely used for enclosing very small, easily lost pieces of evidence (paint chips, small pieces of glass, etc.) \*See below for illustrations on making paper folds can be found on the following pages.\*
  - iii. Manila “coin” envelopes are very useful for packaging evidence that is not as easily lost as much smaller items, like cigarette butts or cartridge cases.

# HOW TO MAKE A PAPERFOLD

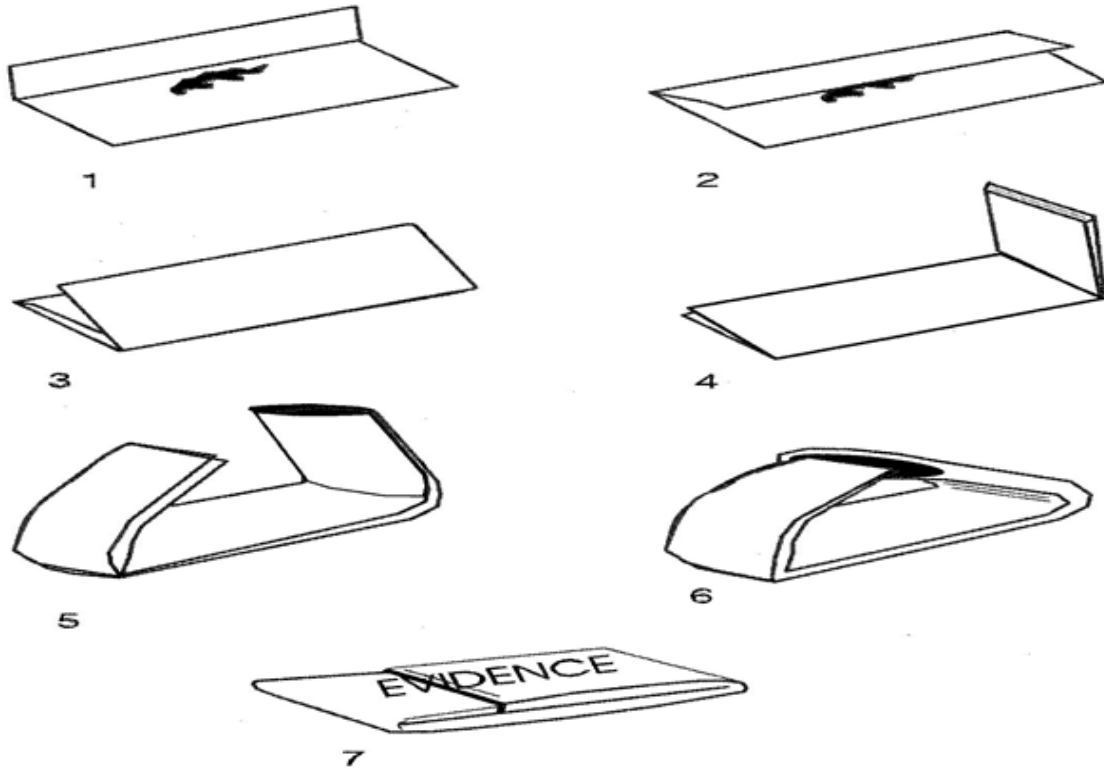

\*The above and below figures illustrate two popular ways of making paper folds.\*

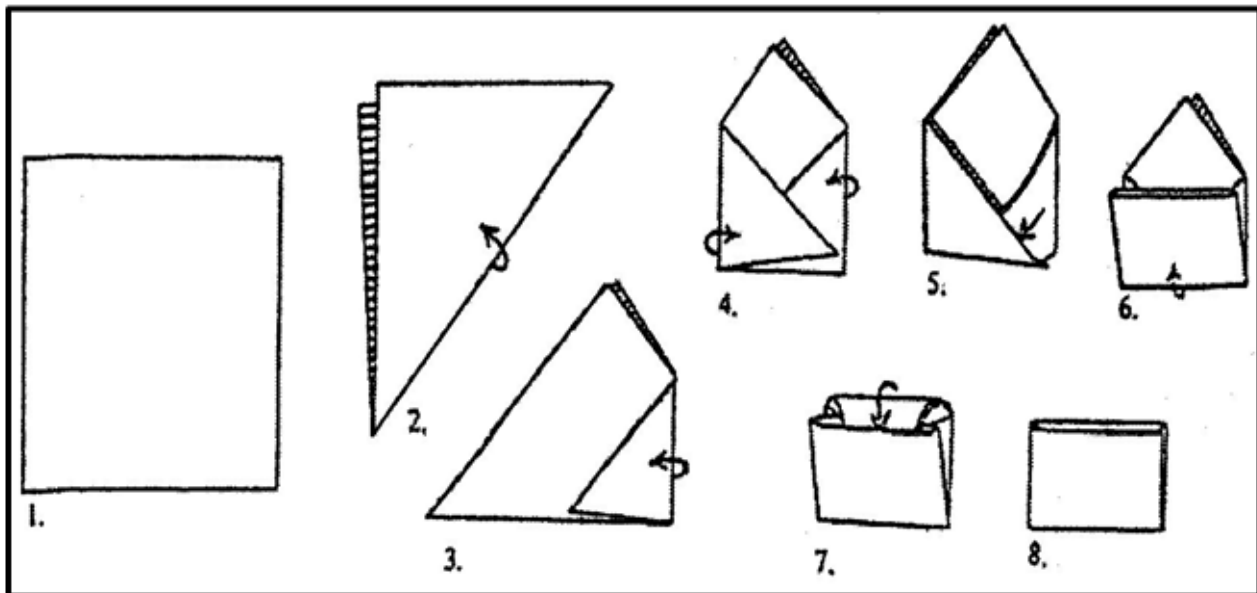

2. Boxes: Cardboard boxes will routinely be used to create a durable enclosure for items that could possibly be broken, crushed, abraded, eroded, or damaged in any way and for heavy, bulky items. Unless they have a waxy finish, cardboard shares paper's porous nature and is a good choice for items that may contain residual moisture and for DNA samples. Cardboard boxes should not be used for trace evidence (or when the item being packaged is to be examined for trace evidence.)

Cardboard boxes (i.e. copy paper boxes or similar): Many forensic supply companies carry boxes designed for packaging weapons, including knives, long guns, and hand guns.

Please submit reasonably sized boxes that are not overfilled, too heavy, awkward, or bulky.

3. Metal Containers: New, clean, lined paint cans are ideal for storing non-biological samples that could evaporate and that contain volatile smell/fumes. The most common example is fire debris containing ignitable liquids. A previously used can is not acceptable due to contamination risk.
4. Glass Vials or Jars:
  - a. These are useful for collection of liquid evidence, such as urine or blood. They may also be used for packaging liquid fire debris evidence (e.g. gasoline, charcoal lighter fluid, etc).
  - b. Please do not submit glass jars or tubes without packaging them securely within boxes, or similar enclosures, to prevent breakage.
  - c. Appropriately identify biological fluids with biohazard labels, for the safety of all persons who will handle this evidence.
5. Plastic: Plastic has several obvious advantages: it has great strength for its weight and transparent plastic allows inspection of the enclosed contents. However, there are several disadvantages: Water vapor does not freely pass through plastic. Most evidence is adversely affected by prolonged exposure to water: steel will rust, cardboard or paper may decompose, biological materials (e.g. blood stains) are destroyed, and natural clothing materials (leather, wool, cotton) can mold and degrade. Some vapors other than water can pass through plastic, and, therefore, may allow sought-after samples to escape. Plastic is acceptable, however, for items that you are certain are dry.
  - a. Plastic Bags: These are available in a variety of sizes and can be used to package a few types of evidence. Plastic bags are seldom recommended for packaging evidence, except in the case of certain types of drug evidence.  
\*Refer to the [Controlled Substances](#) subsection under "Specific Evidence Handling" for more information regarding the use of plastic bags\*
  - b. Plastic Sharps Containers: These are available in a variety of sizes. Hypodermic needles and/or knives can be placed in sharps containers. However, consideration should be taken when deciding what packaging to use for sharp objects. If questions arise about this topic, please contact crime lab personnel.

- c. Heat Sealed Bags: The heat sealing method partially melts the plastic packaging and fuses it together. Some sealers emboss an identifiable mark on the seal. Use an indelible marker to write your initials across the seal, if this method is utilized. This demonstrates that the package was not opened and then resealed.

- F. Sealing and Labeling Evidence: Evidence is considered properly sealed when the evidence inside is protected from loss, contamination, or deleterious change and any attempt to remove the items would be noticed. Throughout this handbook, the phrase, “please use proper evidence sealing techniques” refers to all of the guidelines listed here.

Tamper evident tapes are commonly used so that any attempt to remove them will result in destruction of the tape. Traditionally, the security feature is created by a combination of a tenacious adhesive and a low tensile strength backing. Some tapes change color, have words that develop when disturbed, or fluoresce under alternate light. These tapes are available in long rolls and individual strips; they can be purchased through any forensic supply company.

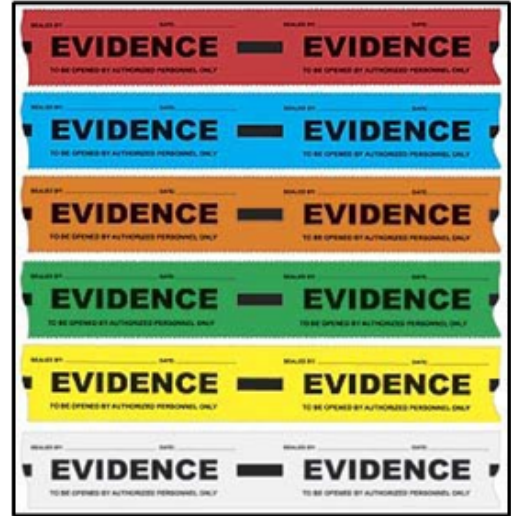

1. Basic Techniques for Proper Evidence Sealing:
  - a. Use tamper evident evidence tape to seal all evidence containers.
  - b. Staples, clear tape, paper clips, or anything other than evidence tape does not constitute proper sealing.
  - c. The open flaps of envelopes must be sealed with evidence tape, and each strip of tape must be initialed. The collector must initial or sign across the junction of the tape and the container as illustrated above using an indelible pen/marker. Intact manufacturer seals do not need to be resealed with evidence tape.
  - d. Bottles and jars must be capped tightly to avoid leakage, and then sealed with evidence tape. The tape must extend across the container/lid junction in at least one area.
  - e. Package all containers securely to avoid leakage, tearing, or the sifting of evidence through cracks or small openings. Consider a double packaging process to protect trace evidence from being lost in a larger outer container.
  - f. Containerization and sealing are unnecessary for large items such as furniture, doors, windows, and automotive components which cannot be packaged and sealed in a practical manner. In such cases, the area of the item that has forensic importance should be covered and clearly marked.
2. Other Information to Consider:
  - a. Tamper evident tapes provide a seal that when breached it obvious that the seal has been tampered with. Always perform a quality check before using a new roll of tape. Each brand of tape used should also be tested in this manner.
  - b. Some evidence tapes will not adhere under cold conditions.

- c. Evidence tape should not be placed on top of packaging tape in a manner that only covers such tape, but should be placed in such a way that creates a tamper evident seal.
3. Basic Techniques for Proper Evidence Labeling: Be sure to include as much information as possible about each item collected; below is the minimum amount of information needed for each piece of evidence.
- \*An indelible pen/marker should be used when entering this information on the outside of properly sealed evidence\***
- a. Name or initials of collector, written across the junction of the tape and envelope (see photo below)
  - b. Date/Time of collection
  - c. Where in the crime scene the evidence was found.
  - d. Source of item/name of subject: If collected from a person, label using the person's name and whether they are the suspect or victim, rather than only "suspect" or "victim"
  - e. Brief description of the item (i.e. identifying features like color, license plate number, vehicle make and model)

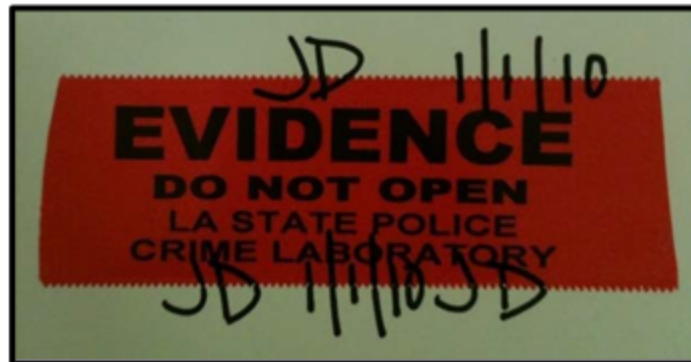

A properly completed [Laboratory Submittal Form \(DPSSP 4606\)](http://www.lsp.org/crimelab_forms.html) must accompany all evidence submitted to the LSP Crime Laboratory! This form is located at [http://www.lsp.org/crimelab\\_forms.html](http://www.lsp.org/crimelab_forms.html) under the FORMS tab and labeled Lab Evidence Submittal Form.

### Specific Evidence Handling:

The following sections will offer specific details regarding the handling of various evidence types. These are organized in the same manner as the Louisiana State Police Crime Laboratory Units.

Subsequent segments of this manual will discuss certain types of analysis not performed by the Crime Lab, but such evidence is worthy of mention for informational purposes. If questions arise, please contact the laboratory for clarification or additional information.

### A Short Introduction to Forensic Evidence Handling:

It would be impossible to list all the objects that could conceivably be useful in solving a crime. Every crime scene should be treated on an individual basis, with its own history, conditions, and complexities. Below is a list of items whose scientific examination is likely to yield significant results in ascertaining the nature and circumstances of a crime.

Being familiar with the recognition, collection, and analysis of physical evidence, as well as the LSP Crime Laboratory's capabilities to process this evidence, will allow you to make the best decisions when determining what to collect from the scene and what to submit for analysis.

## CONTROLLED SUBSTANCES

Many substances are analyzed by forensic scientists at the Crime Lab to determine the presence of controlled dangerous substances in plant materials, powders, liquids, capsules, and tablets. A controlled dangerous substance is a drug, substance, or immediate precursor in Schedules I-V of R.S. 40:964 of the Louisiana Criminal Code. For a current list of controlled dangerous substances, consult an updated copy of Title 40 or visit the Louisiana State Legislature website (<http://www.legis.la.gov/Legis/Law.aspx?d=98877>). Forensic Scientists may also advise law enforcement personnel in assessing, processing, and collecting evidence at clandestine drug laboratories. Additionally, analysts, with specialized training in this area, will alert law enforcement personnel to the most current drug trends.

Federal, state, and local agencies share responsibility for enforcing the Nation's drug laws, although most arrests are made by state and local authorities. In 2012 the Federal Bureau of Investigation's Uniform Crime Reports (UCR) estimated that there were about 1,552,432 state and local arrests for drug abuse violations in the United States.

According to the UCR, drug abuse violations are defined as state and/or local offenses relating to the unlawful possession, sale, use, growing, manufacturing, and making of narcotic drugs including opium or cocaine and their derivatives, marijuana, synthetic narcotics, and dangerous non-narcotic drugs such as barbiturates. More than four-fifths of drug violation arrests are for possession.

### Cautionary Rules When Collecting Suspected Drug Substances:

*These precautions may be mentioned several times throughout this section; however, because of their importance to the health and safety of the investigating officer(s), these points cannot be overemphasized.*

- Never taste any material suspected of containing drugs, chemicals, or poisons. Treat all powders, pills and crystalline substances as if they are fentanyl. Have Narcan (aka naloxone) available, and wear a protective eye shield, lab coat, & a particulate filtering mask if available. Open evidence in a ductless fume hood, if possible. K9 officers are not immune to exposure, therefore use Narcan and call their vet immediately.
- Never smell materials suspected of containing drugs, chemicals, or poisons. Fentanyl compounds are extremely dangerous if inhaled, and may cause loss of consciousness and even death.
- Do not handle drug evidence more than is absolutely necessary. After drugs have been handled, wash hands thoroughly and as soon as possible. Wear nitrile gloves (latex will not prevent an accidental exposure) as many compounds are absorbed through the skin, such as LSD and fentanyl.



- Handle all chemical materials with care. They may be highly flammable, poisonous, caustic, or explosive.
- Use particular care in searching a person who is suspected of having drugs, an automobile suspected of containing drugs, or any area where it is possible that hypodermic syringes or makeshift needles may be hidden. Even slight pricks in the skin from such needles can be dangerous if the drug user has a communicable disease, such as infectious hepatitis or HIV. If the skin is punctured, wash the area with soap and water and seek appropriate medical attention. Wear puncture resistant gloves under your nitrile gloves for sharps or syringes.

A. **Evidence Analysis:** Qualitative tests are performed to determine the presence of controlled substances. The following are the most common types of samples sent to the laboratory for forensic analysis:

1. Powders, Crystalline and Rock-like substances
2. Pharmaceutical Items (Tablets, Capsules, Patches, Sublingual Film)
3. Vegetable Material
4. Illicit/Counterfeit Tablets
5. Liquids

B. **Collection of Drug Evidence:** Proper collection, packaging, storage, and submission of drug evidence help ensure the integrity of the evidence for forensic analysis. Each type of evidence requires specific handling precautions that need to be followed before submitting to the laboratory for analysis.

For faster and more efficient analysis:

- Minimize the layers of evidence packaging
- Combine like drugs in the same envelopes
- Use approximate counts and weights on the submittal form or packaging
- Submit only one packet of each brand of suspected synthetic cannabinoids.

**DO NOT SUBMIT FOR CONTROLLED SUBSTANCE ANALYSIS:**

- Field test kits (including those with broken ampules) and field test wipes (aka NIK wipes)
- Empty plastic bags, bottles, and containers
- Factory Rolled cigarettes and cigars
- Paraphernalia such as scales, rolling papers, rolling machines, roach clips, cigarette lighters, etc.
- Currency including coins and paper money
- Over the counter (OTC) drugs that are not controlled such as
- Aspirin (acetylsalicylic acid), Tylenol (acetaminophen), Advil (ibuprofen), Aleve (naproxen), Guaifenesin, Phenylephrine, Vivarin (caffeine), cough and cold medicines.\*
- Prescription medicines that are not controlled such as antibiotics, heart medications, Viagra, etc.\*

*The above section refers only to narcotics testing of these items. These items may be submitted for other types of testing (ex. prints, DNA).*

*\* These items may be submitted on a case-by-case basis if case details warrant their testing. Call the Narcotics Unit supervisor for inquiries.*

1. Powders & Crystalline/Rock-Like Material: Cocaine, cocaine base (crack), methamphetamine, and heroin are controlled substances usually seen in a powdered or chunky/rock-like form. These drugs are commonly encountered in colors ranging from white to tan to brown. Cocaine is sometimes seen as compressed bricks of white to off-white powder (kilo bricks), with logo marking and multiple layers of tape and plastic packaging.
2. Pharmaceuticals: Pharmaceutical tablets, capsules, and patches can frequently be identified through their markings (imprint codes). An officer may consult references such as the Physicians' Desk Reference, the Drug Identification Bible, or [www.drugs.com](http://www.drugs.com).
  - a. This type of evidence should not be removed from the original containers in which they are found. Preserve any bottle, cans, boxes, envelopes, or wrappers connected with the evidence (information found on any outside labels may be helpful to lab analysts).
  - b. Each package should be itemized, counted (approximate tablet counts are acceptable), and listed on the submittal form.
3. Marijuana and other Vegetable Material: The most common drug submitted to the laboratory is marijuana. Marijuana contains the controlled substance tetrahydrocannabinol, commonly known as THC. Synthetic cannabinoids are also present in vegetable material form that is submitted for analysis, and are controlled in Schedule I.
  - a. Marijuana, in any form, should be air-dried thoroughly before it is submitted to the Crime Lab. Large amounts of fresh or wet plant material can ferment and become moldy, which will destroy the evidence.
  - b. Dry, loose vegetable material should be placed in sealed paper or plastic bags.
  - c. Partially burned vegetable material should be packaged in either sealed envelopes or plastic bags.
  - d. Live plants should be removed from the container with the roots intact. Plants must be submitted with leaves, stems, and roots intact and still connected. Package the plants in paper bags or boxes. **NEVER PUT FRESH PLANTS INTO PLASTIC BAGS.**
  - e. Seeds should be placed in a small envelope. Care should be taken to prevent crushing, as seeds must be grown into a plant before analysis can be performed. Seeds will only be grown at the discretion of the Crime Laboratory and submitting agency.
  - f. Mushrooms must be removed from the original container, stored in paper and delivered to LSPCL as soon as possible. Mushrooms should be dried if possible. The controlled substance in mushrooms (psilocin and/or psilocybin) cannot be detected until the mushrooms are fully grown. Therefore, suspected mushroom spores should not be submitted.

4. Illicit Tablets: Illicit tablets often contain many types of controlled substances and these appear in many colors with various logos. These tablets are commonly referred to as “ecstasy.” Ecstasy tablets have traditionally contained methylenedioxymethamphetamine (MDMA), however more recently they commonly contain methamphetamine. Laboratory analysis has found other controlled substances such as 3, 4-methylenedioxymethamphetamine (MDA), benzypiperazine (BZP), cathinones, ketamine, PCP, and GHB, often in combination with MDMA and other adulterants. Laboratory analysis can determine the specific controlled substance(s) present.
5. Liquids: Phencyclidine (PCP), gamma-hydroxybutyric acid (GHB), codeine cough syrup, and anabolic steroids are controlled substances usually seen in liquid form. Steroids usually are available in pharmaceutical preparations with labels often in a foreign language.
  - a. Liquids should be placed in clean glass or plastic bottles with screw caps.
  - b. Submit the liquids in a plastic bag to prevent leaking.
  - c. Place in a box, seal, and mark “FRAGILE” if in a glass container.
6. Fentanyl and Fentanyl Analogs: Working with controlled substances and unknown materials presents officers with a certain level of hazards and risks. Evidence may be encountered that increases this level of hazard and risk, such as fentanyl and fentanyl analogs. Officers should be aware of these hazards and use the appropriate PPE when necessary. This should include the use of fume hoods, gloves, face shields, and other PPE while working with the material. A supply of NARCAN® (naloxone HCl) should be available in the event of an accidental exposure. 911 must be called when naloxone is administered because the victim may need additional doses. Naloxone is available for FREE through the AG’s office <https://www.ag.state.la.us/Article/2408>.
  - a. When to use NARCAN® (naloxone HCl) Nasal Spray:
    - i. Suspect opioid exposure
    - ii. Individual is unresponsive to voice or touch
    - iii. Breathing is slow or stopped
    - iv. Individual is making gasping or snoring sounds
    - v. Fingertips or lips are blue or purple
    - vi. Respiratory and central nervous system depressant
  - b. How to use NARCAN®:
    - i. Lay individual on their back
    - ii. Retrieve NARCAN® (naloxone HCl) Nasal Spray
    - iii. Hold container with thumb under the plunger
    - iv. Tilt the individual’s head back slightly
    - v. Insert tip in nostril
    - vi. Press the plunger one time
    - vii. Turn the individual on their side, put hands under head, bend upper leg forward
    - viii. Call 911 and stay with the individual
    - ix. If the individual is not responsive after 2-3 minutes, repeat NARCAN® administration with a new dispenser in the other nostril
    - x. Visit [www.narcan.com](http://www.narcan.com) for additional information and instructions

7. Drug Paraphernalia: The term “drug paraphernalia” means anything primarily intended or designed for use in manufacturing, concealing, ingesting, or otherwise introducing into the human body a controlled substance. Possession of these items is unlawful under Louisiana law. **DO NOT SUBMIT** paraphernalia for controlled substance analysis unless it is the **ONLY** item in the case.
  - a. Syringes - Due to safety concerns, syringes **SHALL** be addressed in the following manner:
    - i. For a living suspect: the syringe must be the only item in the case being submitted for controlled dangerous substance analysis, have a court date (letter from prosecuting DA’s office), have prior approval by Drug Unit Supervisor, Chemistry Manager or designee, and be properly packaged in a biohazard sharps tube.
    - ii. For a deceased subject: the syringe must be the only item in the case being submitted for controlled dangerous substance analysis, have prior approval by Drug Unit Supervisor, Chemistry Manager or designee, and be properly packaged in a biohazard sharps tube.
    - iii. All cases with other items in addition to syringes being submitted for controlled dangerous substance analysis will not be allowed to be submitted, and will be rejected. The syringe(s) must be removed by the submitting agency prior to submission.
    - iv. Approval requires the initials of the approver, the word “approved”, and the date on the original submittal form. Any deviation from this policy requires approval from the Drug Unit Supervisor or Chemistry Manager.

C. Latent Prints/DNA on Drug Packaging Materials: When it is anticipated that latent print examination or DNA testing will be needed on drug packaging materials, these items should be handled as little as possible. Indicate on the lab submittal form, at the time of submittal, that latent prints and/or DNA analysis is requested in addition to drug analysis.

D. Large Drug Seizures:

1. Determine if a crime scene team is needed for assistance in fingerprinting, photographing, and sampling large seizure of drugs at the scene.
2. If large amounts of drugs are seized (i.e. large marijuana or cocaine bundles, several hundred packets of suspected bath salts or synthetic cannabinoids), contact the Narcotics Unit supervisor so that an appointment may be made for a drug analyst to obtain a total weight and to sample the evidence.

E. Clandestine Laboratories: A clandestine lab is defined by the DEA as an illicit operation consisting of a sufficient combination of apparatus and chemicals that either has been or could be used in the manufacture or synthesis of controlled substances. Such labs range from makeshift operations to highly sophisticated and technologically advanced facilities, some of which are mobile. The health and environmental safety concerns will vary with the type of drug being manufactured and production method being utilized.

Because of the danger of explosions, fire, and toxic chemical exposure, a clandestine lab must never be processed or dismantled without the aid of a member of a Hazardous Material team or a DEA chemist who has been trained and certified in this area. Visit the Louisiana State Police Hazardous Material and Explosives Control Unit (HAZMAT) website at <http://www.lsp.org/hazmat.html> for more information.

General Information & Safety Precautions: Clandestine labs can be set up anywhere, even in vehicles. These laboratories are often hidden in remote areas, may contain sophisticated surveillance equipment, and may be booby-trapped to prevent intruders and law enforcement personnel from entering as well as to destroy any evidence should the facility be discovered. Operations also vary in degrees of sophistication from individual operators to organized groups.

According to the DEA, more clandestine drug labs are being seized than ever before; this increase is attributed to the availability of chemicals and information about manufacturing processes, as well as the ease of the manufacturing processes, low production costs, and high profits from the drugs.

Extreme care and caution should be used whenever investigating or processing a clandestine lab site. The substances used in the production of controlled substances may be caustic, carcinogenic, explosive, or flammable. Personnel engaged in clandestine drug laboratory investigations and seizures should have specialized training and personal protective equipment. Clandestine drug labs may also involve the removal and proper destruction of large quantities of hazardous toxic chemicals. The disposal of these chemicals is strictly regulated by state and federal environmental protection agencies.

F. Miscellaneous Drug Information:

1. Drugs are categorized both legally and pharmacologically. Legally, drugs are listed and classified based on their medical use and potential for abuse and dependency. The “highest” schedule is Schedule I, indicating drugs that have no accepted medical use and a high potential for abuse and dependency. The “lowest” schedule of drugs is Schedule V, indicating drugs that require a prescription but have a very low potential for abuse.
2. The LSPCL Drug Unit has the right of refusal, meaning that if a case is improperly packaged or if the evidence is compromised, decayed, or consumed the case can be returned unanalyzed. The evidence may be resubmitted at a later date if the situation can be resolved.

## TOXICOLOGY:

Forensic Toxicology is the scientific area which identifies alcohol and/or other drugs in biological specimens which may cause impairment. The most commonly submitted cases to the LSP Crime Lab toxicology unit are beverage alcohol content (AC), blood alcohol concentration (BAC), identification and/or quantification of drugs other than alcohol in blood (TOX), and identification of drugs other than alcohol in urine (TOX). For confirmatory lists of all substances tested for, contact the LSP Crime Lab toxicology unit.

The Toxicology Unit routinely analyzes blood/urine relating to DWI (impaired driving), drug facilitated sexual assault, death investigations, and officer involved shootings.

The LSP Crime Laboratory toxicology unit oversees the blood alcohol and toxicology program within the state, with the responsibility of permitting laboratories that analyze blood/urine samples for use in Louisiana Courts of Law. Individual labs must attain ISO/IEC 17025 accreditation AND apply for a permit to the LSP Crime Laboratory. For a list of permitted laboratories, contact the LSP Crime Lab toxicology unit.

The LSP Crime Laboratory toxicology unit is responsible for approving and providing blood/urine collection kits for live individuals (BU-0LA) and blood/urine collection kits for deceased individuals (PM-0LA). Kits are available to all Louisiana law enforcement agencies free of charge and are available at the DPS warehouse (225-385-6008). For a list of approved kits, contact the LSP Crime Lab toxicology unit.

Louisiana state law currently allows for two types of tests to determine ethyl alcohol levels in the human body, breath and blood. Louisiana's breath testing program is overseen by the LSP Applied Technology section (225-925-6128). Please contact LSP Applied Technology with questions regarding breath testing equipment such as the Breathalyzer 9000. Blood can be submitted to the LSPCL toxicology unit to quantify the amount of ethyl alcohol in that sample.

Blood alcohol and/or toxicology requests:

- A. A request for any toxicological analysis should include:
  1. In a DWI investigation, the officer should include the individual's physical state and results of any tests conducted to determine impairment. Information that may narrow the drug possibilities may also be helpful.
  2. A list of all drugs found in possession of subject.
- B. Specimens needed:
  1. DWI Investigation: Even if an individual has submitted to a breath test, blood and/or urine samples may be collected. **Blood is considered the Gold Standard for toxicology testing.**
  2. Death Investigation: Blood and urine.
  3. Sexual Assault: Blood and urine.
- C. The approved BA/TOX kit **must** be used for preserving blood for blood alcohol analysis and/or for preserving blood and urine for toxicological analysis.

**Make sure the kit you are using is not expired!**

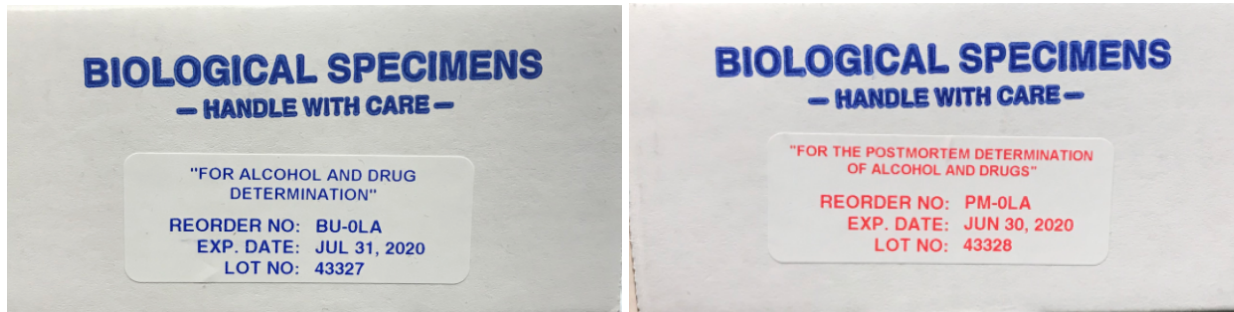

- D. Minimum sample volumes:
1. The minimum amount of urine needed for analysis is approximately 10mL.
  2. The minimum amount of blood needed for analysis is approximately 20mL (2 full tubes)
- E. All samples **must** be collected in the appropriate containers provided in the blood alcohol kit and only from that one kit using **ONLY** the contents of that kit.
- F. Guidelines that **MUST** be adhered to when collecting blood or urine specimens for submittal to the Crime Lab for forensic toxicological analysis:
1. Kit numbers found on the outside of kits, urine collection container and both blood vials **MUST** match. Additional stickers are provided in the kit to label all related documents.
  2. If inconsistencies are detected by an officer before a sample is collected, discard the entire kit.
  3. If such inconsistencies are detected once the specimen is submitted to the lab, analysis may not be able to be conducted and/or a discrepancy will be reported to the case officer.
  4. Kits **MUST** be used **BEFORE** their expiration date.
  5. Evidence tape or opaque labels, tapes of any kind **MUST NOT** be placed over a kit's expiration date. Please be aware of kit expiration dates' locations so that labels or opaque tape are not inadvertently placed in a manner that prevents the expiration date from being seen once the kits has been utilized.
- G. Blood collection precautions and guidelines:
1. Precautions when collecting blood for blood alcohol concentration and/or toxicology:
    - a. Labeling accuracy is of the utmost importance. Labeling errors are very common but very avoidable, so please check and re-check your specimen collections to ensure all information is accurate and as detailed as necessary before submittal.
    - b. Make sure that vials/tubes of blood and the paperwork inside your evidence envelope are labeled with the **EXACT** same information: e.g. kit numbers, name of subject (first and last), date of blood draw, etc.
    - c. Ensure to use biohazard labels in appropriate places to indicate the enclosed evidence is biological in nature.
    - d. BU-0LA kits are for **LIVE** persons only.

- e. PM-0LA kits are for **DECEASED** persons only. **DO NOT USE** a PM-0LA kit on a live person.
2. Blood collection guidelines:
- a. The proper collection and submission of specimens for toxicological analyses is of great importance if analytical results are to be accurate and their subsequent interpretation is to be scientifically sound and useful in court. These guidelines can apply equally to investigations by Medical Examiners / Coroners and to investigations by law enforcement agencies.
  - b. For the purposes of blood alcohol analysis for potential DWI prosecution, only those blood alcohol kits approved by the Louisiana Department of Public Safety and Corrections may be utilized for such collections.
  - c. BA/TOX kits are provided free of charge, by LSP, for all state law enforcement agencies. Substituting any portion of these kits or use of another kit may invalidate the test results for legal purposes.
  - d. Blood may only be drawn by a physician, registered nurse, or qualified technician. Each qualified technician must be certified by an accredited licensing agency as a certified phlebotomist.
  - e. Read the instructions found inside the BA/TOX kit.
  - f. All information from the blood collection should be recorded on the investigating officer's report, found inside the kits, along with the signature of the subject, in the allotted space on the consent form.
  - g. The blood draw **MUST** be witnessed by a police officer, whose name must be entered on the Investigating Officer's Report.
  - h. Immediately following the collection, the blood vials **MUST** be slowly inverted several times; this is done so that the blood will completely mix with the chemicals in the vial that prevent coagulation of blood and inhibits the growth of microorganisms capable of destroying alcohol.
  - i. The "Investigating Officer's Report" should be as complete as possible. Remember to include the name and the title of the person taking the samples.
  - j. The chain of possession section should be completed if the samples change hands at any time. This will ensure the evidence's integrity is preserved at all times.
  - k. Adhesive seals found in the kit must be filled in with appropriate information. Seals are to be used to secure the stoppers to each vial and the sample box.
  - l. Syringes must **NOT** be included and/or returned in the kit. Dispose of these properly at the medical facility or where the blood sample is collected.
  - m. If delivery to the Crime Lab is not immediate, the kit must be placed in a secured location (i.e. locked storage area) within twenty-four (24) hours of the collection. Room temperature is allowed for blood samples, however refrigerated temperature is highly recommended. **NEVER EXPOSE KITS TO HIGH TEMPERATURE. DO NOT LEAVE KITS IN YOUR UNIT FOR ANY LENGTH OF TIME.**
  - n. Kit(s) must be submitted to the Crime Laboratory within ten (10) days after their initial collection. A completed [Laboratory Submittal Form \(DPSSP 4606\)](#) must accompany the kit(s).
  - o. In addition to the items indicated on the forms to be filled in, also include the driver's license number of the subject, the state the driver's license was issued in, date of



- birth, and the state computer number found on the accident report. Also, indicate if the subject is deceased.
- p. Sealed BA/TOX Kits may be submitted to the LSPCL via Registered Mail (USPS), FedEx, UPS, etc. When mailing, please make sure the absorbent pad is placed in the box holding the sample blood vials, and place that box inside the plastic bag. This can then be placed inside the cardboard shipping container.
  - q. The completed submittal form should also be placed in the cardboard box. Another alternative is to place both the cardboard box and the form in a large mailing envelope.
  - r. When BA/TOX kits are received at the Crime Lab, they are handled in the standard procedure of evidence submitted to the lab.
  - s. **LSP Kits**-In accordance with the rules and regulations for blood alcohol and toxicological analysis, kits may be destroyed after one (1) year after analysis. Photocopies of the inner kit box along with the specimen containers (labels showing) should be made. The original of the consent form and blood collector's report may be retained. LSP kits associated with fatal injury crashes are kept for five (5) years post analysis then destroyed unless a court order prevents destruction.
  - t. **Non-LSP Kits**- All non LSP kits are returned to the agency post analysis unless a court order mandates their retention at the LSPCL.

#### H. Urine collection precautions and guidelines:

1. Precautions when collecting blood for blood alcohol concentration and/or toxicology:
  - a. Labeling accuracy is of the utmost importance. Labeling errors are very common but very avoidable, so please check and re-check your specimen collections to ensure all information is accurate and as detailed as necessary before submittal.
  - b. Make sure that container of urine and the paperwork inside your evidence envelope are labeled with the EXACT same information: e.g. kit numbers, name of subject (first and last), date of collection, etc.
  - c. Ensure to use biohazard labels in appropriate places to indicate the enclosed evidence is biological in nature.
  - d. Completely remove the safety seal from the urine collection bottle and **THROW IT AWAY**. If you leave it on the container, urine will leak out.
2. Urine collection guidelines:
  - a. The proper collection and submission of specimens for toxicological analyses is of great importance if analytical results are to be accurate and their subsequent interpretation is to be scientifically sound and, therefore, useful in court. These guidelines can apply equally to investigations by Medical Examiners / Coroners and to investigation by law enforcement agencies.
  - b. For the purposes of urine analysis for potential DWI prosecution, only those blood/urine collection kits approved by the Louisiana Department of Public Safety and Corrections may be utilized for such collections.
  - c. BA/TOX kits are provided free of charge, by LSP, for all state law enforcement agencies. Substituting any portion of these kits or use of another kit may invalidate the test results for legal purposes.
  - d. Urine collection **MUST** be witnessed by a law enforcement officer. Female/male officers may be needed to facilitate a proper witnessing.

- e. Read the instructions found inside the BA/TOX kit.
- f. All information from the specimen collection should be recorded on the investigating officer's report, found inside the kits, along with the signature of the subject, in the allotted space on the consent form.
- g. The urine collection **MUST** be witnessed by a police officer, whose name must be entered on the Investigating Officer's Report.
- h. Immediately following the collection, secure the lid on the container to finger tight.
- i. The "Investigating Officer's Report" should be as complete as possible. Remember to include the name and the title of the person taking the samples.
- j. The chain of possession section should be completed if the samples changes hands at any time. This will ensure the evidence's integrity is preserved at all times.
- k. Adhesive seals found in the kit must be filled in with appropriate information. Seals are to be used to secure the top of the container.
- l. Syringes must **NOT** be included and/or returned in the kit. Dispose of these properly at the medical facility or where the urine sample is collected.
- m. If delivery to the Crime Lab is not immediate, the kit must be placed in a secured location (i.e. locked storage area) within twenty-four (24) hours of the collection. The urine containers do not contain a preservative, refrigerated temperature required. **NEVER EXPOSE KITS TO HIGH TEMPERATURE. DO NOT LEAVE KITS IN YOUR UNIT FOR ANY LENGTH OF TIME.**
- n. Kit(s) must be submitted to the Crime Laboratory within ten (10) days after their initial collection. A completed laboratory submittal form (DPSSP 4606) must accompany the kit(s).
- o. In addition to the items indicated on the forms to be filled in, also include the driver's license number of the subject, the state the driver's license was issued in, date of birth, and the state computer number found on the accident report. Also, indicate if the subject is deceased.
- p. Sealed BA/TOX Kits may be submitted to the LSPCL via Registered Mail (USPS), FedEx, UPS, etc. When mailing urine place the plastic bag around the urine container before sealing. This can then be placed inside the cardboard shipping container.
- q. The completed submittal form should be placed in the cardboard box. Another alternative is to place both the cardboard box and the form in a large mailing envelope.
- r. When BA/TOX kits are received at the Crime Lab, they are handled in the standard procedure of evidence submitted to the lab.
- s. **LSP Kits**-In accordance with the rules and regulations for blood alcohol and toxicological analysis, kits may be destroyed after one (1) year after analysis. Photocopies of the inner kit box along with the specimen containers (labels showing) should be made. The original of the consent form and blood collector's report may be retained. LSP kits associated with fatal injury crashes are kept for five (5) years post analysis then destroyed unless a court order prevents destruction.
- t. **Non-LSP Kits**- All non-LSP kits are returned to the agency post analysis unless a court order mandates their retention at LSPCL.

Alcohol Content Requests: Alcohol content analysis quantifies the amount of ethyl alcohol present in a sample suspected to be an alcoholic beverage. R.S. 32:300 defines alcoholic beverage as any beverage containing 0.5% or more alcohol by volume. There are many other laws regarding the consumption of alcoholic beverages in motor vehicles, in public areas, and possessing an open container in a motor vehicle. Requirements for submitting samples of suspected alcoholic beverages for analysis are as follows:

- A. The minimum amount of sample needed for analysis is 1.0 mL.
- B. The sample must be contained in a leak resistant plastic container such as a Nalgene, Fisher, VWR or equivalent brand of liquid storage container.
- C. Glass or plastic beverage containers are not recommended due to high propensity for leaking.
- D. The container with the liquid must be placed into a properly labeled and sealed plastic or paper evidence bag or envelope.

## DNA:

DNA is the genetic material that determines the characteristics of all living organisms. While the majority of human DNA is very similar, enough variation exists that forensic DNA analysis can distinguish one individual from another, except for identical twins. This extremely sensitive and specific type of analysis is allowing more criminal cases to be solved than in decades past.

The Louisiana State Police Crime Laboratory currently performs nuclear DNA and Y-STR analysis. Nuclear DNA is found in the nucleus of the cells and is the type of DNA testing generally utilized in crime laboratories. Y-STR analysis examines the Y Chromosome and identifies DNA from all males in a family lineage.

Despite the various ways that DNA testing has advanced the field of forensic science, there are still some limitations to be aware of:

- Casual contact may not transfer enough DNA for analysis
- DNA can be removed by washing, bleaching or other activities
- DNA analysis cannot be performed in a few hours
- DNA analysis cannot determine when/how the DNA was deposited on an item
- Certain environmental factors such as mold, heat, humidity, bacteria, and sunlight can destroy DNA very quickly

### PLEASE NOTE:

- Plastic bags should **NEVER** be used to package evidence containing biological fluids.
- DNA collections should **ALWAYS** be air-dried and packaged in a paper container.
- **NEVER** use heat to dry.
- Packages that contain items with biological fluids should have biohazard labels.
- **ALL DNA** evidence items **MUST** have the following forms in addition to the completed [laboratory submittal form \(DPSSP 4606\)](#):
  - [DNA Consumption Letter](#)
  - [DNA Supplemental Information Sheet \(DNA Submittal Form\)](#)

- A. Blood: This is the most often encountered biological fluid at scenes. It can be found on a wide range of items, and in several states; the most common are listed below along with basic instructions for collection.

*DO NOT dry DNA evidence with a heat source, direct sunlight, dryer, or any other heat-producing appliance. Heat, light, and moisture can destroy DNA.*

1. Blood found at a Crime Scene, (i.e. pool of blood that is not staining an object):
  - a. Saturate two sterile swabs with the blood. After doing so, AIR-DRY the sample.
  - b. If the suspected blood sample is extremely small (i.e. size of a letter on this page), use only one swab to collect and submit the sample.

- c. Enclose swabs inside a clean envelope (ex. coin envelope) or an appropriately sized paper bag.
    - d. Transport samples to the Crime Lab.
  2. Moveable Items Stained with Blood (i.e. bedding, clothing, or any type of evidence that can be transported to the lab with relative ease):
    - a. Air-dry the entire area of the sample where blood is present.
    - b. Each blood-stained item should be packaged separately and securely to avoid contamination.
    - c. Transport such items to the Crime Lab.
  3. Immoveable /Large Items Stained with Blood (i.e. items that cannot be transported to or moved from their location):
    - a. If the blood is wet, use two sterile swabs to collect it, as described above.
    - b. If the blood has already dried, use sterile water and two sterile swabs to collect a sample (for very small samples use one swab).
- B. Saliva: Saliva contains water, mucous, proteins, salts, and enzymes, in addition to suspended skin cells from inside the mouth. An individual's DNA is present in these cells.
1. Cigarette Butts: Do not touch the filter end, where possible saliva may have been deposited.
  2. From skin (i.e. bite marks)
    - a. Dampen a sterile cotton swab with sterile water.
    - b. Swab the area to remove suspected saliva.
    - c. Air-dry the sample.
    - d. Place in a clean paper swab box or envelope.
  3. Liquid Saliva (large volume):
    - a. Soak two sterile cotton swabs in the liquid.
    - b. Air-dry the sample.
    - c. Place in a clean paper swab box or envelope.
  4. Reference Samples: (Note: The Crime Lab will accept blood or saliva to use as reference DNA samples.)
    - a. Collect known reference samples from all parties involved (i.e., home owners, vehicle owners and /or other elimination samples).
    - b. Swab the inside of the cheek and along the gum line.
    - c. Air-dry the sample.
    - d. Place in a clean paper swab box or envelope.
- C. Semen: The presence of semen is most commonly associated with but not limited to sex crimes. Semen is composed of seminal fluid and sperm cells. Seminal fluid acts as the liquid carrier for sperm, the male reproductive cell where DNA is found.
1. Collection of Biological Evidence:
    - a. Objects stained with semen:
      - i. Air-dry the stain in a manner similar to that for blood.
      - ii. Place the item in a clean paper bag.
    - b. Liquid Semen:
      - i. Soak a cotton swab in liquid semen

- ii. Air-dry the sample
  - iii. Place in a clean paper swab box or envelope
- c. Sexual Assault Kit:
  - i. The attending physician, SANE or coroner should obtain the samples specified in the sexual assault kit, including vaginal washings and swabs from the suspected assault victim.
  - ii. Seal, label, and initial the sexual assault kit.
  - iii. Store in a secure, refrigerated location until transport to the Crime Lab.
- b. Reference Samples:
  - i. Collect reference DNA samples (blood or saliva) from victim, suspect, and any known consensual partners.
- 2. Samples Collected for Suspected Sexual Assault:
  - a. Vaginal Samples:
    - i. Vaginal samples (air-dried); a cervical swab may also be collected.
    - ii. Vaginal washings should be as concentrated as possible with 1-2 mL of sterile saline solution.
    - iii. Pubic hair combings for the identification of foreign hair.
  - b. Rectal Samples (if anal intercourse is indicated):
    - i. Rectal swabs
  - c. Oral (mouth) Swabs (if oral intercourse is indicated):
    - i. Oral swabs
  - d. Other Swabs: Based on the case synopsis, collect the appropriate swabs (bite mark swabs, breast swabs, etc.)
  - e. Reference Materials from Victim:
    - i. Buccal swabs may be collected instead of blood, if no oral assault is reported.

*Always collect reference material; it may be needed for comparisons with evidence from the scene. Package and label each reference sample separately.*

- D. Contact DNA: Contact DNA is also referred to as “touch DNA.” It is a small amount of DNA that is recovered from skin/epithelial cells that are left behind when a person touches or comes into contact with items.
  - 1. Swabs from or items left at a crime scene by suspect.
  - 2. Swabs from or items touched by suspect.
  - 3. Whenever possible collect one contact type swab from each item to be tested. If not, then submit the item to be swabbed to the crime lab.
  - 4. Items submitted that may have been touched or belonged to the victim(s). These require the collection and submission of reference samples to the crime lab for comparison purposes from individuals that have touched the item (i.e., home owners, vehicle owners and/or other elimination samples).
- E. Reference (Known) Sample(s): Collect reference samples from victim(s), suspect(s) or others who may have come into contact with or contaminated the object to be tested (buccal, or mouth swabs, should be used for reference DNA). If collecting a liquid blood sample, it should be placed in a tube containing a preservative and anticoagulant, such as the tubes in the BU-OLA kits available at the DPS warehouse for DWI blood collection.

Kits used for arrestee and convicted offender collections should not be used to collect evidence at a crime scene.

Each sample should be labeled with the person's name and transported to the Crime Lab as soon as possible. Collect and label samples one at a time.

- F. Contamination Prevention/Preservation During Collection: Contamination prevention is vital to ensure that future analysis of your evidence will be possible, or will produce meaningful results.
1. Wear proper protective clothing, including gloves, mask/face shield, disposable lab jacket, or other disposable items that cover clothing/shoes.
  2. **Do not handle any items without gloves.**
  3. **Change gloves after handling each item.**
  4. Avoid handling any item directly where DNA may be deposited— you will likely wipe it off, even with gloves (ex. mouth area of water bottle).
  5. Beware of personal habits: Do NOT talk, cough, smoke, dip, chew gum, spit or sneeze, etc. on or near DNA evidence.
  6. Each item of evidence should be packaged and labeled separately; one item should be placed in each envelope/bag. (The only exception would be for multiple swabs from the same person/item.)

**When collecting DNA evidence from an object, document from where the sample was obtained. Such documentation may consist of notes, a diagram and/or photograph detailing the sample's location before collection.**

- G. Packaging:
1. Each item, including each article of clothing, should be packaged separately to avoid transfer of materials/DNA between items.
  2. Use clean paper bags, envelopes, or boxes to package evidence. Evidence must be completely dry before packaging.
  3. Plastic is acceptable storage for transporting wet items from the scene, but evidence must be removed and dried immediately upon return to your office.
  4. Do not package objects tightly into bags; leave room so the packages can be resealed after examination. Comforters, blankets, pillows, coats, and other large items should be packaged in a way that allows them to be re-packaged at the end of the forensic examination. Contact the DNA unit before submitting large items such as bedding, couch cushions, etc.

## **CODIS:**

The Louisiana State Police Crime Laboratory participates in the **Combined DNA Indexing System (CODIS)**, which is maintained by the **Federal Bureau of Investigation (FBI)**. This allows for searching of qualifying samples within the **State DNA Indexing System (SDIS)**, as well as across the nation via the **National DNA Indexing System (NDIS)**. These databases allow the searching of forensic samples against each other in an attempt to link cases. Forensic samples are also searched against offenders' samples in an attempt to link an offender to a crime scene evidence. When cases are linked to one another, this is termed a "hit."

Offender DNA samples should be submitted to the LSPCL for CODIS database entry and maintenance. Offender samples maintained in the database are not intended for court purposes but only for searching and supplying investigative leads. These DNA samples, submitted for the purposes of entry into the LA arrestee and convicted offender cataloguing system, are **NOT** considered evidence samples and do not take the place of a suspect reference sample in forensic cases. Offender DNA Collection kits should **NOT** be used for forensic case reference samples, the collection of DNA at a crime scene, or in any other manner. If reference samples are submitted using these kits, they may be rejected by the Crime Lab.

The following pages include information regarding agency responsibility in collecting arrestee and convicted offender DNA samples. Please consult someone within the DNA Administrative Unit of the Crime Lab if you have questions.

### A. Arrestee and Convicted Offender (CO) DNA Collection Kits:

1. Provided upon request to law enforcement agencies, collection kits are shipped in sets of 50, and each kit possesses a unique barcode identification number.
2. Each arrestee DNA collection kit contains instructions for use, gloves for the collector's protection, two collection swabs, an evidence envelope to enclose subject's DNA swabs, and two small barcode stickers, all marked with duplicated identifying numbers, along with one postage paid manila envelope, used for returning the collected DNA sample and all necessary paperwork.

***\*The collector should ensure EXACT matches on the above noted barcode numbers.***

Instructions for the collection of Arrestee and Convicted Offender samples are included in each collection kit. If questions arise, please contact an LSP Crime Lab CODIS Unit Supervisor for assistance.



## CRIME SCENE UNIT:

The Louisiana State Police Crime Lab Crime Scene Team responds to major crime scenes statewide and has at least three crime scene personnel on call 24/7. Areas of processing include *documentation (photography/video), evidence collection, fingerprint processing, trajectory analysis (structures/vehicles), latent blood enhancement and bloodstain pattern analysis*. Below are instructions for requesting a CSI Team response to a scene or vehicle exam.

### Requesting the LSP CSI Team for a Scene:

- When requesting the assistance of the LSP Crime Scene Unit, please call the *Louisiana State Police Troop A – 225.925.6536 - or the LSP CSI Phone – 225.252.6269* - for the on call person.
- Let the CSI Primary know as many details regarding the scene as possible to ensure that they bring the proper resources to adequately process the scene.
- Ensure that any search warrants necessary to process/collect evidence are in place prior to the LSP CSI's arrival on scene.
- Crime Lab personnel typically have to meet at the lab prior to heading to the scene to attain the necessary reagents, so scene response time may be delayed.

### Requesting the LSP CSI Team for a Vehicle Exam:

- If requesting to submit a vehicle to the Crime Lab for processing, please call the *main crime lab number – 225.925.6216 – or the CSI Supervisor – 225.925.4272* - to set up bringing the vehicle in.
- If requesting for the CSI Team to come process a vehicle a facility, please call the *CSI Supervisor – 225.925.4272* - to set up a date and time to process the vehicle.
- Let the CSI Supervisor know as many details regarding the vehicle as possible.
- Ensure that any search warrants necessary to process the vehicle and collect evidence from the vehicle are in place *prior* to the LSP CSI's arrival.

*If you need immediate assistance with a crime scene or vehicle examination, please call the Crime Scene Supervisor: Michele Smith – 225.603.8917 / 225.925.4272.*

**Below are general crime scene processing and evidence handling guidelines.**

## Crime Scene Processing/Documentation/Evidence Collection

### **General Evidence Handling:**

- Physical evidence is any object which can provide a link between a crime victim(s) or suspect(s). The proper handling of evidence is crucial in any investigation, often determining whether or not a case can be solved or successfully adjudicated.
- In any investigation, the validity of information derived from examination of the physical evidence depends upon the care with which evidence has been handled. If evidence has

been improperly collected, handled, documented, or stored, its value may be destroyed and no amount of laboratory work will be of assistance.

- If handled properly, the likelihood that useful information can be obtained from the evidence is increased.

### **Scene Processing/Documentation:**

- Evidence recognition is an acquired skill, improved and refined over the course of an officer's career. Education and experience will improve this skill.
- By making themselves aware of the functions of the Crime Lab and what analyses the Crime Lab or other labs can perform, officers can determine what items at a scene hold the best evidentiary value.
- Understanding all types of evidence and what questions they may potentially answer will aid tremendously in the reconstruction of a crime.
- Legally: If evidence associated with a crime scene is not properly collected or documented, this may present complications when tried in court.
- Scientifically: Incorrect or incomplete crime scene documentation can impede the forensic analysis process, resulting in little or no assistance in solving your case.

### **Collection/Preservation of Scene Evidence:**

- The general rule is to submit the evidence in the same condition as when collected. Exceptions are noted throughout this manual. (E.g. some evidence must be dried, refrigerated, or frozen).
- Care should be exercised when collecting all evidence. This section provides general guidelines for handling evidence during collection.
- Evidence should not be collected until the whole crime scene has been documented (unless transient evidence will potentially be lost if not immediately collected). First responders should ensure the scene remains secure until trained crime scene response personnel arrive.

***If any uncertainties arise regarding how to collect, package, or preserve evidence, please call Crime Lab personnel for instructions or on-site assistance.***

**LA State Police crime scene investigators are on call\* 24 hours a day, 7 days a week for this purpose.**

- A. Use personal protective equipment (PPE) to prevent contamination of both personnel and the scene.
- B. Remain aware of your and others' movements in and around the crime scene. Even slight changes could impede forensic analysis.
- C. With some types of evidence, known comparison samples (references) are necessary.

- D. ***Labeling evidence accurately is of the utmost importance.*** Labeling errors, inconsistencies, and oversights tend to be one of the most frequently encountered, yet avoidable, challenges for forensic analysts.
- E. Identify and protect fragile and/or perishable evidence (e.g. consider climatic conditions, crowds/hostile environments). Ensure that all evidence that may be compromised is immediately documented, photographed, and collected.
- F. Some items must be thoroughly dried before packaging (DNA swabs, bloody clothing, plants, etc.) After drying, these types of evidence are best stored in clean paper containers. Plastic containers should NEVER be used for long-term storage of biological fluids or fresh vegetable material.
- G. Packaging: Use appropriately sized containers to package your evidence securely and properly. Avoid folding or stuffing larger items into smaller containers or packaging smaller items in very large packages (unless secured to the package). For more information on specific packaging, please see the sections for [General Evidence Handling](#) and/or [Specific Evidence Handling](#).

## PHYSICAL EVIDENCE:

Items of physical evidence encompass any items related to a crime scene that can assist in solving the crime that occurred. The Physical Evidence Unit of the Crime Lab is divided into three sections—Latent Prints, Firearms, and Crime Scene—and performs forensic analysis in the following disciplines:

### **Firearms Unit**

Firearm Analysis  
Serial Number Restoration  
Distance Determination  
Test fire / Function Check  
NIBIN Database Entry  
Tool Mark Analysis

### **Crime Scene Unit**

Crime Scene Processing  
Vehicle Examination  
Fracture Comparison

Bloodstain Pattern Analysis  
Trajectory Analysis

### **Latents Unit**

Print Processing  
Print Comparison  
AFIS/NGI Database Entry  
Fire Debris Analysis  
Shoeprint/Tire Track Analysis  
Indented Writing Analysis

## **Probative Evidence at a Crime Scene:**

- DNA Evidence:
  - Blood, Contact, Semen, Saliva, Urine, Bodily Fluids
- Physical Evidence:
  - Items touched by suspect or victim can be processed for fingerprints
  - Weapons/Tools (cartridge cases, bullets, crowbar, hammer, etc.)
  - Fractured/Broken Items (hit and run vehicle debris, broken glass/door from point of entry)
- Controlled Substance Evidence:
  - Drugs (tablets, powder, crystalline substance, rock-like substance, etc.)
  - Drug Paraphernalia (pipes, syringes, scales, packaging materials, etc.)
  - Plants and vegetable material
- Toxicology Evidence:
  - Blood and Urine Kits (DWI, hit and runs)

There are two types of evidence that can be examined: individualizing evidence and class evidence. Individualizing evidence is evidence that can be identified to a specific person, a specific gun, or a specific item. Class evidence is evidence that can be categorized by classes and similarity of characteristics, not identified to a specific entity or item. Below are examples of each type of evidence:

## **Individualizing Evidence** **FINGERPRINTS (AFIS)**

FIREARMS (NIBIN)  
DNA (CODIS)  
FRACTURE MATCHES  
SHOEPRINTS  
FINGERNAILS – torn

Class Evidence

PAINT  
FIBERS  
HAIR (no root)  
GLASS

Photographing Evidence: (Note: a crime scene photography class is highly recommended; for more information on photography training, please contact the crime laboratory crime scene unit.)

- Composition of the frame
- General over-all photos of the scene
- Evidence Establishing/Mid-Range photos (relationship of a piece of evidence to other evidence items and/or location in the scene)
- Close-up photos (filling the frame with that one piece of evidence or specific area)
- Photos should “flow” together if possible (leading into one another to tell a story)

Collecting evidence:

Following are the disciplines in which testing is performed, with descriptions, collection guidelines, etc. For more specific information about any of these topics, please contact the Physical Evidence Unit Supervisors or Manager.

Collecting Firearms Evidence:

A firearm is defined as any weapon (including a starter gun) which will expel a projectile by means of an explosive, or which is designed or may be readily converted to do so. This includes the frame or receiver of any such weapon, any firearm muffler or silencer, or any destructive device.

Criminal incidents and investigations involving firearms are widespread and numerous. It is important, when applicable to your case, that firearms or any related evidence be properly collected for preservation of any elements left behind (e.g. fingerprints, DNA, gunshot residue). Firearm examiners can identify bullets and cartridge cases as having been fired in a specific weapon. Even bullets fired from consecutively manufactured barrels possess sufficient differences to distinguish between them. Many other examinations within the firearms section routinely assist the law enforcement community.

Precautions relating to collecting firearms evidence:

- A. Do not stick any object in the barrel of the firearm for any reason.
- B. Handle each firearm with an abundance of caution, even if all initial appearances indicate the gun is unloaded or the safety switch is active/on. The safety may be faulty or the trigger pull may be very light (“hair trigger”). Place the firearm into a box (preferred), paper bag, or envelope for transporting.
- C. Carefully render the firearm SAFE\* while still preserving any potential print or DNA evidence on the firearm.
- D. Place any bullets/cartridges/cartridge cases in envelopes or bags. Bullets and cartridge cases should be packaged individually.
- E. You can leave the cartridges in the magazine of the firearm; you do not have to package them separately. The firearm, magazine (removed from the firearm), and cartridges (still in the magazine) can all be packaged together inside a single gun box.

Collecting Latent Prints:

All prints are unique and persistent throughout an individual’s lifetime. They are formed in the womb at around 12 weeks gestation, and are persistent even through death until decomposition of the friction ridge skin. Each individual finger, joint, palm, toe, and foot sole is unique. Even identical twins have different prints.

Items can be submitted to the lab and processed for prints. There are two types of prints that can be obtained from items: patent prints and latent prints. **Patent prints** are prints can be seen with the “naked” eye, while **latent prints** are prints that are developed using reagents and other development mediums (example: powders, fluorescent dye stains, etc.). Items submitted for print processing can also be submitted for DNA analysis, and the collection methods can be done simultaneously.

***\*Be sure to request BOTH print processing and DNA analysis on the submittal form at the time of submission if both are needed. It may be too late once the processing has begun to go back and request additional analysis.***

Collecting items for prints:

- A. Wear personal protective equipment (PPE)
  - 1. Gloves
  - 2. Masks (for items with a DNA request)
- B. Handle the evidence with care
  - 1. Prints are fragile and can easily be wiped off or damaged, even if gloves are worn
  - 2. Try to only touch the evidence in areas where prints would most likely not be developed (ex: edges or rough surfaces)
- C. Use appropriate packaging for the specific item
  - 1. Ensure items do not move around too much in the packaging and potentially rub off any prints or packed too tightly together
  - 2. Ensure items aren’t too tightly packed-rubbing against the packaging or each other

3. Too small or too large of an evidence package is not the best for preserving the prints and/or DNA on the item
  4. Paper packages (envelopes or bags) are usually best
- D. Photographing patent or latent prints:
1. ALWAYS have a ruler in the picture for comparison purposes
  2. Be sure to have the proper lighting (side lighting or ALS)
  3. Be sure the camera lens is parallel to surface of the print
  4. Be sure the print is as clear in the picture as possible (suggested best practice is to use the manual focus setting)
- E. If collecting wads of used tape:
1. Do NOT place in paper bags (the adhesive side adheres to the bag and cannot be removed easily)
  2. Try to adhere to acetate sheets or place plastic lift backs on exposed adhesive areas and package in a box or container where it can be anchored down and not move around

#### Collecting Shoe and Tire Impressions:

Also referred to as Track Evidence. Track evidence is a mark or series of marks left by a person, animal, or thing that has passed, such as a footprint, tire track, etc., and the identification of these marks and prints as they relate to a criminal investigation.

Footwear evidence (shoe impressions) can reveal the type of shoe, make of shoe, the path or direction of movement, the approximate or precise size of the shoe, and approximately how many people were traveling in an area. Tire Track Evidence (tire impressions) can reveal the type of tire, the make of tire, the possible size of the tire, the path or direction of movement, and approximately how many tires or vehicles were traveling in an area.

#### Collection of track evidence:

- A. When photographing track evidence:
1. ALWAYS have a ruler in the photo
  2. Be sure camera is at a 90° angle from the surface of the track evidence
  3. Use an ALS and side light from all four sides (top, bottom, left, right) and photograph each (best suggested practice is to use a tripod the manual setting on the camera)
- B. When lifting track evidence:
1. If using an Electrostatic Dust Lifter : Place the static sheet over the track evidence, attach the negative clamp to the sheet first then the positive, turn on the apparatus to create the static charge, turn off the apparatus then remove the clamps in the reverse order and lift the sheet
  2. If using a Gelatin/Adhesive Lifter : Remove the backer and anchor the adhesive side down BEFORE the track evidence, then using a roller apply pressure and roll the lifter over the track evidence, then slowly remove the lifter from the surface and place a clear backer over it to preserve
- C. When casting track evidence:
1. Using 2 lbs of Dental Stone and 10\* fl oz of water, mix to a pancake batter consistency
  2. Start pouring mixture BEFORE the track evidence, and using the volume of the mixture to “push” the remaining mixture over the evidence to avoid any gaps or bubbles

### Collecting Fire Debris Evidence:

The analysis of debris samples from fire scenes to determine whether an **ignitable liquid residue (ILR)** is present. Most labs, like ours, identify only classes of samples and do not “match” samples to each other. This is done with the use of GC-MS: Gas chromatography–mass spectrometry (GC-MS) is an analytical method that combines the features of gas-chromatography and mass spectrometry to identify different substances within a test sample.

- A. For all Fire Scenes: Contact the State Fire Marshal’s Office at (225) 925-3647
- B. For packaging solid evidence:
  1. Clean, lined, metal paint cans
  2. Additionally, the cans could be placed in heat-sealed evidence packaging (Kapak bag and/or Nylon bag)
- C. For packing liquid evidence:
  1. Clean, glass container (evidence vial or glass jar)
  2. Seal the vial or glass jar with evidence tape
  3. Package the glass container inside a padded envelope or paint can
- D. Preserving soil samples:
  1. Clean, lined, metal paint can
  2. IMMEDIATELY be stored in the freezer to minimize bacterial degradation of ignitable liquids in the soil
  3. If freezer is unavailable, then store sample in the refrigerator
- E. ALL samples should be stored in a climate controlled storage
- F. If collecting evidence for Print and DNA analysis as well, be sure to wear PPE and be mindful of cross-contamination when handling the evidence

### Collecting Indented Writing Evidence:

Indented writing analysis attempts to develop marks (indentions) which are left on a surface (usually paper) underneath the one on which visible writing was placed. Such indentions are caused by pressure exerted on the paper by the writing instrument. Indented writing has proven to be a very valuable type of evidence which can remain long after the original document has been lost or destroyed.

- A. The best ways to handle evidence of this type are as follows:
  1. Remember the possibility of latent prints and handle accordingly.
  2. Handle as little as possible and only on the edges.
  3. This examination must be done before the surface is processed for latent prints.
  4. If the indented writing is on a paper surface, do not fold. Place document unfolded in a manila envelope.
  5. Be sure to initial and date the evidence label BEFORE the document is placed inside the envelope.
  6. Take care that nothing is place on the envelope that will either make new indentions or destroy the existing ones.



7. The type of analysis request for these cases is “Indented Writing.” Please specify this, so that latent print processing will not be administered first.

#### Collecting Fracture Comparison Evidence:

These examinations/comparisons are conducted in an attempt to establish a common origin between two or more pieces of evidence. For example: A broken turn signal lens fragment from a hit and run scene may be positively matched to piece remaining on the suspect vehicle, placing that vehicle at the crime scene. The examination may be conducted in a fashion similar to putting together a jigsaw puzzle or may require tedious examination under a microscope.

- A. A few types of evidence encountered in this category are:
  1. Glass fragments (headlights, mirror pieces, etc.)
  2. Plastic fragments (vehicle lens or grill pieces, packaging materials)
  3. Tape (masking, duct, electrical)
  4. Fiberglass (especially in vehicle front and rear ends)
  5. Cloth (torn sheets, garment pieces)
  6. Wire (cut, broken, pulled apart)
  7. Metal (chrome trim on auto/broken chain links)
  8. Paper
  9. Fingernails
- B. Many times a fracture comparison is incidental to the original request for analysis. However, since a fracture match is just as unique as a fingerprint match, the investigator should always collect evidence with this in mind.
- C. When adequately sized fragments of plastic lenses are recovered from a vehicle or crime scene, attempts should be made to have them identified by local auto dismantlers or new vehicle parts department employees.
- D. In the case of cut wire (or similar material), mark the end of the wire material which was cut by an agency representative during evidence collection, indicating that this is a cut produced by a known tool. This provides information to the Crime Lab as to which end of the material is to be compared.

#### Other Physical Evidence Information:

Many items of evidence at a scene can be collected for types of analysis not performed by LSP Crime Lab. Below are some types of analysis that may be performed on evidence items from crime scenes, and general information on proper collection/documentation methods.

#### Collecting Glass Evidence:

Glass is encountered in several types of crime scenes. Some common instances are windows broken in vehicle or home / business burglaries, or headlights in hit and run. Also, bottles or

other glass objects may break and leave fragments in pockets or on garments or shoes of suspects in these types of crimes. Glass taken from a broken window at a burglary may be compared with glass fragments found on a suspect's body or clothing; glass from a broken windshield may be compared with pieces of glass found on a hit-and-run victim's body or to glass found at the scene. These types of cases involve comparison of the glass samples to determine if they could have a common origin. With larger pieces of glass, it may be possible to physically fit the pieces together (fracture match). These examinations require the collection of all glass pieces found.

#### A. Collection & Packaging of Glass Evidence:

1. The shoes and clothing of suspects, as well as other objects which may have been contaminated with glass should be collected, marked and packaged separately to avoid cross-contamination. Package each item in paper bags or boxes.
2. All glass at hit and run scenes should be recovered because more than one type may be present. In addition, if just a few representative samples are saved, individual pieces that could be physically matched may be overlooked. The search should not be limited to just the point of impact since other pieces may drop off at some distance away as the car or individual leaves the crime scene. Glass from different locations should be kept in separate containers.
3. Place small glass fragments in folded white paper; seal and mark the container. Refer to the section entitled "General Evidence Handling" for paper fold instructions.
4. Place large glass fragments in paper bags or boxes. Separate individual pieces with paper or tissue to prevent breakage or damage to edges during shipment. Large fragments can be marked with grease pencil, adhesive tape, or other labels, but this is usually not necessary if all are sealed together in a single marked container. When breakage direction determination is requested, it will be necessary to mark each glass piece prior to its removal from the window to designate inside and outside surfaces.

#### B. Standards for Comparison:

1. **Windows:** If the evidence glass is large enough for physical matching of broken edges or comparing the fracture lines, surface abrasions, hackle marks, or contamination, the whole broken window is necessary. When physical matching does not appear possible and a broken window is large, the recovery of several samples of the window is usually satisfactory. Heat hardened or tempered glass is commonly encountered in glass doors and automobile side and rear windows. The well-known diced breakage of this kind of glass into typically small, rectangular beads makes physical matching impractical in most cases. Several pieces should be collected for comparison of physical properties with evidence glass.
2. **Other Glass:** When bottles or other glass objects are broken, recover all remaining glass. For example, glass on shoes of suspects may be compared with broken bottles at crime scenes, or glass found on a murder victim may be compared with a broken bottle used as a weapon.

- C. **Value of Glass Comparison:** Glass will have the greatest value as evidence only when fragments from two sources can be physically matched together. When this is possible, a common origin can be conclusively established even when the fragments are quite small. In the case of powdered glass and minute fragments, it can be established that the material is glass and limited comparisons can be conducted. However, conclusive identifications as to common origin usually are not possible. Nevertheless, the latter type of comparisons will establish similarities or differences in samples and thus may prove significant.
- D. **Other Glass Studies:** Other studies of glass are sometimes of importance. In the case of broken windows or other glass sheets, it often is possible to determine the side to which the force was applied which resulted in breakage. When multiple fractures are present in glass, it also may be possible in some instances to prove the sequence of shots through glass when consecutive bullets penetrate glass from one or both sides. In all such instances, it is essential to have all remaining glass in a window, as well as fragments which broke and fell to the ground, available for study/examination.

#### Collecting Fibers:

Fiber comparisons are a sub discipline of fracture matches. Results of fiber comparisons are used as circumstantial evidence to corroborate testimony or other evidence.

- A. Types of Fibers:
1. Animal (Wool)
  2. Vegetable (Cotton)
  3. Synthetics (Nylon, etc.)
  4. Mineral (Fiberglass, etc.)
- B. Determinations can be made as to whether unknown fibers are of the same type, color, blend, along with any other unique, microscopic characteristics.
- C. Collection may involve preserving a single thread to cutting a 6- inch section from a carpet, rug, etc. Samples must have been collected and packaged in separate packages in a manner which will prevent contamination.
- D. Known or reference samples for comparison must be obtained and packaged to prevent contamination.
- E. Samples may be collected by physically “picking” them off a surface, vacuuming, or adhesive lifting.

#### Collecting Explosives Residue:

Residues of explosives are materials left at the scene of an explosion. This may include unexploded devices or small particles left in soil, wood, glass, etc.

- A. When explosives are found: Call the Bomb Squad from your agency or the LA State Police HAZ MAT Unit in Baton Rouge. (The LA State Police troop nearest to you can be contacted for assistance in contacting the HAZ MAT Unit). Army EOD teams are also available for deactivation of bombs, but they should be used as a last resort. 225-925-6113 or 1-877-925-6595 (TESS/Right to Know hotline)

B. Collecting Explosives Residue:

1. Before any evidence is collected, photographs of the scene should be taken. All evidence should be collected by a person wearing gloves so as not to destroy any fingerprint evidence.
2. The first objective in the collection of explosives residues is to locate the area of the origin of the blast. At this site, swab samples should be taken. Each swab is packaged individually in a tube, sealed, and labeled with location, date, time, and name of collector.
3. Loose soil and debris should be collected for examination for explosives residue. This should be placed in metal paint cans, sealed, labeled, and taped closed. Do not use paper bags. Collect approximately two full cans of soil from the crater area.
4. The total area to be searched is determined by establishing the origin of the blast and the farthest point from that origin where debris may be found. This entire area must be searched. Be sure to search not only the ground but also rooftops, trees, and anywhere that fragments could possibly be lodged. You will be searching for components of the device

***For specific evidence packaging and submission requirements for the individual sections of the Physical Evidence Unit, see below.***

## Firearms Unit

### A. General Information on Firearm/Tool Mark Section

The Firearms Unit is responsible for the examination of firearms, fired ammunition components, ammunition, tools, and related evidence. The Section utilizes forensic microscopes to examine evidence and make comparisons. The Firearms unit maintains a firing tank that is used for test firing and related purposes. The Firearms unit is located in the Louisiana State Police Crime Lab (LSPCL).

The Firearms Unit maintains the BRASSTrax system, which is linked to the National Integrated Ballistics Information Network (NIBIN). NIBIN is a searchable computerized national forensic database of images for the potential association of individual characteristics found on fired cartridge cases. NIBIN is an evidence screening tool that provides possible links between fired specimens (from various crime scenes), therefore providing possible links between crimes not previously known by law enforcement to be connected.

The following describes the examinations commonly performed, the evidence you should submit, some information you may see in our reports, and/or some of the information we may need from you to conduct our examinations.

### B. Case Acceptance Policy

Please note that exceptions to these policies may be made on a case-by-case basis, at the discretion of the discipline manager, laboratory director and/or section supervisor.

- “RUSH” CASES - Requests for “RUSH” examinations of evidence must have a demonstrable need, such as, needing results for warrants, making an imminent arrest, or similar circumstances. In cases where a “RUSH” request is made to examine evidence for imminent court proceedings, the firearms unit requests to have a minimum of fifteen (15) working days to complete such cases.
- CROSS REFERENCE CASES - Firearms submitted for comparison to evidence in other cases will not be compared unless there is some demonstrable investigative link between the firearm and the evidence in the other case. If such a link is not present, firearms meeting the guidelines for NIBIN entry will be examined, test fired, and “entered” into NIBIN. Non-NIBIN firearms such as revolvers may be compared if a link is present. Non-NIBIN caliber firearms will not be routinely compared if no link is present.
- FIRED CARTRIDGE CASES FOUND IN FIREARM - Fired cartridge cases found in and/or removed from the cylinder of a revolver or from the chamber of other types of firearms will not be routinely examined or compared microscopically.
- TOOL MARKS/FRACTURE MATCH - Before any case involving a tool mark and/or fracture (physical comparison) request is accepted, there must be a suspect tool/known sample (fracture) available that can be linked to a suspect via possession, latent prints, DNA, and/or demonstrable investigative information. If no such tool or link is available, the case will not be accepted. Property crime cases involving tool mark and/or fracture (physical comparison) requests will not be routinely accepted. Such cases with crimes against persons usually will be accepted.

- HUNTING/WILDLIFE related firearm cases will not be routinely accepted unless personal injury is involved.
- ANIMALS - Firearm cases involving crimes against animals will not be routinely accepted.
- SUICIDES - Firearm cases involving suicides, attempted suicides, or murder-suicides will not be routinely accepted.
- NIBIN - Firearms submitted for NIBIN entry only, which do not meet the guidelines for NIBIN entry, will be returned without examination. Firearms and/or fired specimens submitted for NIBIN entry must have been found property, seized or collected in reference to a criminal act. Badly rusted, corroded, or non-functional firearms submitted for NIBIN entry only, will not be restored to a functional condition for test firing unless this can be easily accomplished.
- BB GUNS - Pellet guns, BB guns, and/or non-firearm replicas of firearms will not be routinely examined.
- EVIDENCE NOT REQUIRING EXAMINATION - Contributors should only submit evidence that requires examination. Extraneous items that do not require examination but are being submitted merely for the purpose of simplifying the chain of custody should not be submitted. Contributors also should strive to submit all of the evidence that requires examination at one time, if possible.
- RETURN OF EVIDENCE WITHOUT EXAM - Unexamined or partially examined firearm and/or tool mark evidence that is present in the Firearms unit may be returned to the submitter if authorized by the Discipline Manager or Section Supervisor and written correspondence is received from the contributor.
- NON-STANDARD EXAMINATIONS - Cases with requests for any unusual or non-standard examinations will not be routinely accepted and must accompany a request to the firearm section supervisor. Please note that the Firearms unit does not conduct firearm e-traces and/or registration checks.

### C. Firearms Examination

Firearms are a tool that produces tool marks when the tool (firearm) comes into contact with a cartridge case or bullet. Physical contact between a tool and the surface of an object produces marks not only characteristic of the type of tool used, but marks that may be individual to a single tool. Examples of these types of tool marks are a bullet passing through the barrel of a firearm and/or a cartridge case in contact with the breech face/firing pin of a firearm. In each instance, the working surfaces of the tool can leave their individual characteristics upon the damaged surface of an object. The laboratory can perform the following tests:

- comparison of the questioned bullets or cartridge cases to each other to determine if they were fired in the same firearm
- comparison of test fire samples from a firearm to questioned bullets or cartridge cases
- bullet caliber classification (General Rifling Characteristics)
- shotgun component analysis (shot/pellet size, gauge determination of waddings)
- barrel length determination (altered barrel length)
- trigger pull analysis

- drop test analysis (determine if firearm will discharge if dropped)
- serial number restoration
- distance determination (muzzle to object) Note: no analysis performed on shooter clothing or hands
- Firearms Database (SEE BELOW NIBIN SECTION)

Collection and Packaging: Recommendation of suitable Packaging Materials:

- Manila envelopes (bullets, cartridge cases, etc.)
- Cardboard box (firearms and sharps)



1. Fired Bullets, Fragments, Pellets, and Wadding:
  - a. Do not use forceps or other sharp instruments to remove bullets as they may further damage the evidence. Bullets from bodies should not be packaged before rinsing off blood and tissue since body fluids will be corrosive to the bullet. Gently rinse the bullets/fragments/pellets/wadding under running water and air-dry them prior to packaging.
  - a. Use a separate container for each bullet. Pellets from the same area may be packaged in the same container. If a projectile is embedded in wood or some other material, remove it exercising extreme care. If it cannot be removed without damaging it, then carefully cut out the whole area around it and submit it to the laboratory with the projectile in place. Do not clean or change the condition of items recovered from the scene. Investigators should not mark fired bullets, fragments, pellets, and wadding for identification due to the danger of damaging individual characteristics used for comparison. Package each item separately in an appropriate-sized container and label the container and seal. Pellets may be packaged together if they were found in the same location. Do not seal wet exhibits in plastic before they are thoroughly air-dried. Do not use glass containers for the packaging of exhibits due to potential injury to personnel from breakage.

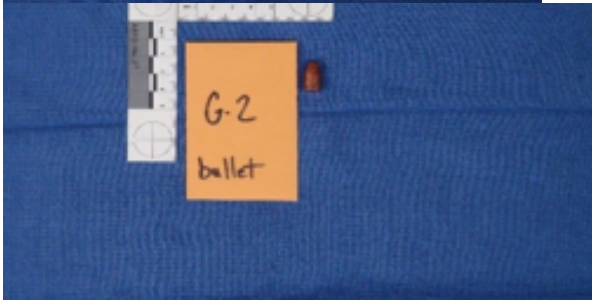

2. Fired Cartridge Cases and Shotshells:

- a. Do not mark the cartridge cases and shotshells. Place each exhibit in a suitable container, mark the container, and seal it. All exhibits may be placed inside a single outer package for ease of submission.

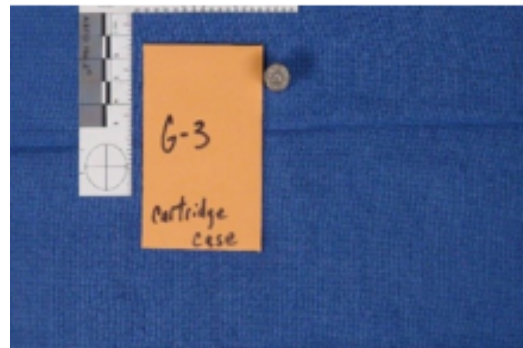

3. Unfired Cartridges or Shotshells:

- a. Collect from the crime scene any cartridges/shotshells of the same brand and type in case the laboratory requests them for testing and distance determinations. Only submit these upon the request of the laboratory. Do not mark the unfired cartridges or shotshells. Seal them all in appropriate containers and mark the containers. Contributors may routinely submit less than five (5) unless requesting distance determination.

4. Firearms:

- a. Record the condition of the firearm before you handle it, i.e., position of hammer, safety, slide, cylinder, jammed, etc. The primary concerns when packaging a firearm is rendering it safe and the preservation of the evidence including blood, trace evidence, and latent prints that may be present. Handle the firearm carefully to avoid loss of trace evidence or latent prints. Additionally, if DNA analysis is being requested, a facial mask and gloves should be worn while handling to prevent contamination. DNA and fingerprint analysis must be completed prior to submission



to the Firearms unit. Do not clean, dry fire, test fire, take apart, or work the action, except to unload. Never place any object in the barrel (plastic tie straps used to demonstrate that the firearm is unloaded are the exception). Unload carefully and record the position of the cartridge cases and unfired cartridges/shotshells as you remove them. Any evidence firearm with possible blood or body fluids should be air-dried, then packaged in a cardboard box labeled with a "BIOHAZARD" label.

- i. Revolvers: A firearm with a cylinder having several chambers arranged to rotate around an axis; it can be discharged successively by the same firing mechanism.

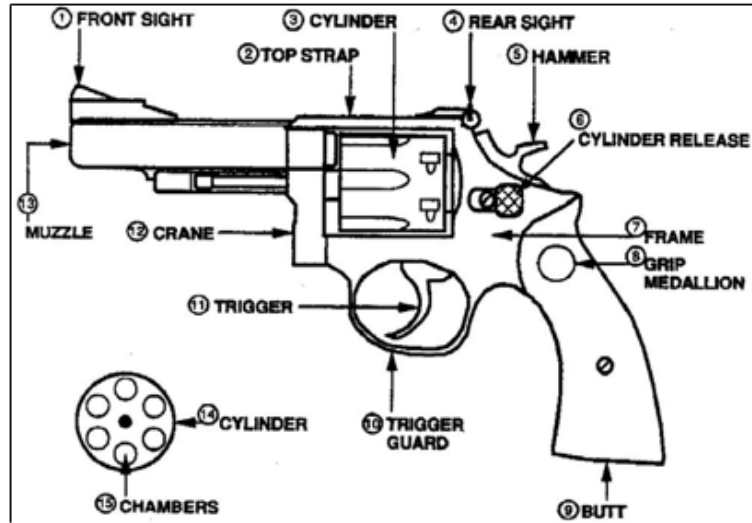

- (a) Before opening the cylinder, mark each side of the cylinder at the top strap with a sharpie pen, being careful not to destroy latent prints or trace evidence. Open the cylinder and draw a diagram or photograph the back view indicating which chamber was under the hammer. On the diagram, number each chamber and identify the cartridge/cartridge case in it by the head stamp and whether or not there is a firing pin impression. Remove each cartridge/cartridge case and place it in a manila envelope numbered to correspond with the chamber from which the cartridge/cartridge case was removed. Fired cartridge cases found in and/or removed from the cylinder of a revolver will not be routinely examined or compared microscopically.

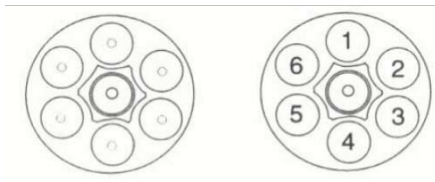

- ii. Pistols or Rifles with Detachable Magazines:

- (a) A repeating firearm requiring a separate pull of the trigger for each shot fired, and which uses the energy of discharge to perform a portion of the operating or firing cycle.
- (b) Magazine: A container for cartridges which has a spring and follower. The magazine serves to provide a new cartridge for loading into the chamber of a pistol during the firing cycle.
- (c) Clip: A detachable metal frame or box, which contains cartridges and serves to facilitate the loading of an internal magazine.
- (d) Remove the magazine and leave the cartridges in it. Place in manila envelope or other container. Remove the cartridge/cartridge case from the chamber, if present and place it in an envelope or other container and mark the container. ALWAYS submit the magazine and the cartridges/cartridge cases that have been removed from the firearm's chamber and/or magazine.

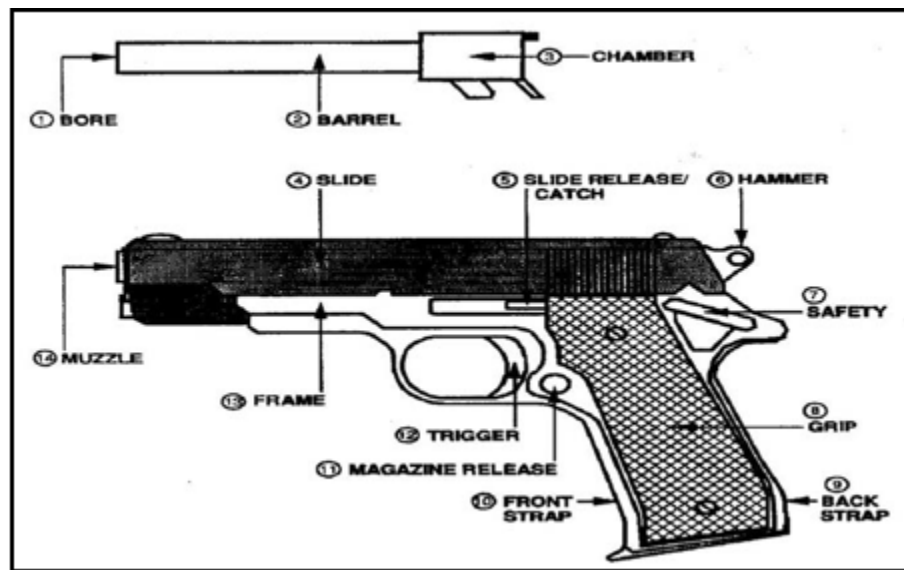

iii. Derringers:

- (a) Note which barrel each cartridge/cartridge case came from. Remove each cartridge/cartridge case and place in an appropriately marked container.

iv. Rifles and Shotguns with Fixed Magazines:

- (a) Do not cycle the cartridges/shotshells through the action if you can avoid it. Unload the firearm the same way it is loaded. Remove the cartridge/shotshell from the chamber, package separately, and mark the package. Remove the remaining cartridges/shotshells which can be packaged together.

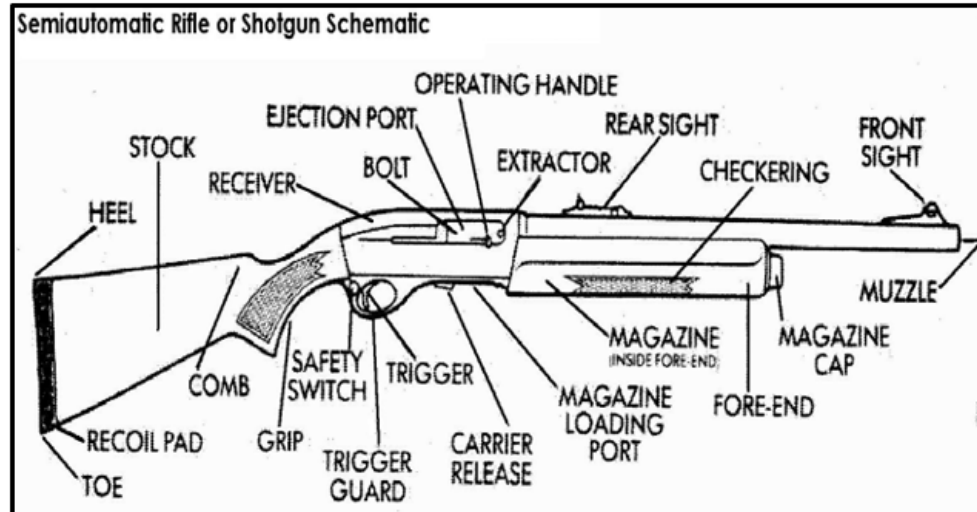

#### D. Special Requirements

1. If a firearm cannot be unloaded or there are special circumstances, call the laboratory and have a firearm examiner tell you how to proceed. Call the firearms unit prior to your arrival if you must bring a loaded gun into the laboratory. Boldly mark the package with the words: **WARNING: LOADED FIREARM.**
2. If the firearm is found in freshwater, immediately immerse it in the same water in a suitable container such as a Rubbermaid container. Caution: Corrosion may occur if a wet firearm remains exposed to air for even a short period of time. If the firearm is found in saltwater, immediately submerge in vegetable oil or other water displacing lubricant. Submit the firearm to the laboratory as soon as possible.

#### E. Distance Determination (Clothing for Gunpowder Residue)

When fired, a mixture of burned and unburned gunpowder and vaporized primer material is expelled out the firearm's muzzle along with the bullet or shot pellets and wad(s). This gunshot residue may indicate how far away the muzzle of a firearm was from the entry site at the moment of discharge.

1. Note the sequence and condition of the clothing, i.e., T-shirt under flannel shirt, shirt unbuttoned, etc. Collect all clothing containing suspected bullet holes. Submit only outermost garment. Handle carefully so as not to displace or remove any gunshot residue. Air dry clothing on a clean piece of paper. When dry, place another piece of paper on top and fold for placement in a paper bag and seal. Mark the paper bag for identification. Package each item of clothing separately to avoid cross-contamination. Provide information as to the number and location of bullet holes in the body. If possible, collect and submit ammunition of the same type used in the crime (e.g. ammunition from the firearm's magazine, unused ammunition from a box at the scene, etc.).



*NOTE:* The suspect's clothing will not be routinely accepted for gunshot residue analysis. Approval of the Firearm Section Supervisor is necessary. Call the laboratory for information when submitting other types of items with a suspected bullet hole.

#### F. Serial Number Restoration

The obliteration of serial numbers and manufacturer's marks is often done to prevent tracing ownership of articles. The laboratory uses mechanical and chemical processes that may restore the original marking in whole or in part.

1. Package the evidence in a manner that will protect the area where the serial number has been obliterated. Contact the laboratory prior to delivering large items or have a question of item to restore.
2. NO attempt should be made to restore the serial number prior to submitting it to the laboratory for serial number restoration.

#### G. NIBIN (National Integrated Ballistics Information Network)

In the past, firearm examiners were greatly limited in their ability to associate fired components from separate incidents unless an investigative lead was developed to warrant a comparison of the evidence. NIBIN is a database-driven multimedia imaging system designed for imaging the markings made by the firearm on fired components to increase the effectiveness of the forensic firearm examiner. Using NIBIN, examiners are able to search unsolved case files, store classification data and images, and simulate a comparison microscope for comparing fired cartridge cases and shotshells. This technology enables the firearm examiner to connect otherwise unrelated shooting events in the same city and/or between two different cities. In addition, by comparing test-fired cartridge cases and shotshells from confiscated firearms, an

examiner can establish a connection to a specific firearm that may also tie it to a specific suspect resulting in the complete resolution of an unsolved shooting event.

1. Capabilities include:
  - a. Digital image capturing of fired cartridge cases and shotshells that meet imaging criteria through a software program known as “BRASSTrax”
  - b. Sharing database information with other crime laboratories, both state and nationwide, if requested
  - c. Automated search and retrieval of unsolved case images and fired standards
2. AGENCY TEST FIRE PROGRAM
  - a. the agency test fires the firearm and submits test fires for entry into NIBIN
  - b. large submitters of test fires may contact the Firearms Section Supervisor for training to have their agency representative enter into NIBIN
3. NIBIN ELIGIBLE CALIBERS: (NOTE: Exceptions can be made by the firearms supervisor.)
  - 380 Auto
  - 9mm
  - 357 Sig
  - 40 S&W
  - 45 Auto
  - 223 Rem/5.56 NATO (5.56x45mm)
  - 7.62x39mm
4. WHAT IS NOT IMAGED IN NIBIN: The following guns/evidence are not suitable for entry into the NIBIN database and are not accepted:
  - No bullets/projectiles of any caliber
  - single shot/break open shotguns
  - derringers
  - antique firearms
  - black powder firearms
  - “BB” guns
  - weapons purchased in a “Buy-Back” or “Guns for Cash” program

#### H. Tool Marks (TM)

Tool Marks are impressions or marks produced when a tool comes into contact with an object; the tool is generally the harder of the two objects. Physical contact between a tool and the surface of an object produces marks not only characteristic of the type of tool used, but marks that may be unique to a single tool. Examples would include a screwdriver used to pry open a cash box, a crowbar used on a steel door frame, a pair of bolt cutters used on a chain link fence, or a pair of wire cutters or pruning shears used on copper power lines. In each instance, the working edges of the tools can leave their individual characteristics upon the damaged surface of an object. The laboratory can perform the following tests:

Comparison of the questioned tool mark to a suspect tool to determine if the tool did, could have, or did not make the questioned tool mark

1. Collection and Packaging: (Recommendation of suitable Packaging Materials)
  - a. Manila envelopes (casts and/or small objects)
  - b. Cardboard box (large tools and sharps)
  
2. Tool mark from the Crime Scene
  - a. Do not try to “fit” anything into the tool mark, as this will damage the individual characteristics that may be present.
  - b. Take an overall photograph of the item containing the tool mark and the item’s surroundings. Whenever possible, submit the item containing the tool mark. Place your identifying mark in an area away from the tool mark. If the object is too small to mark, i.e., a broken screwdriver tip, or if you have casts, put them in an appropriate-sized container and label the container.
  - c. Package the tool mark in such a way that they will not be damaged or contaminated. Package and seal the whole item, when possible, and package each item separately. If the item is too large, cover the tool mark area with cardboard to protect it. Never tape directly over the tool mark.
  - d. For items that are too large or otherwise impractical to submit, two (2) casts of each tool mark should be collected and may be submitted. Call the laboratory for assistance on casting tool marks.
  
3. Suspect Tool
  - a. Handle carefully to avoid damage and loss or contamination of trace evidence. Do not attempt to determine if a found tool “fits” in the tool mark. This may alter or obliterate the tool mark and trace evidence may be lost or added.
  - b. Do not clean the suspect tool. Put your identifying marks in an area away from the working edges of the tool or on the packaging.
  - c. Package the tool to prevent the loss of trace evidence and to protect the working edges from damage. The working edges may be wrapped with paper and the paper secured to the shaft of the tool with tape. Do not put tape directly on the working edges.
  - d. Package each tool separately. Do not put the tool in the same container as the objects displaying the tool mark.
  - e. When possible, submit only the tool that exhibits class characteristics similar to those of the questioned tool mark. If in doubt, call the lab for assistance.

#### I. Laboratory Submission Form

Each request for forensic examination must include a [Louisiana State Police Crime Lab Evidence Submission Form](#).

- Please include the description of evidence being submitted and number of items (Example: five (5) Cartridge cases, one (1) Ruger pistol, two (2) bullets)
- Select FA/TM from Service Requested section
- Additional Examination Requested section should include a category
  - FIREARMS EXAMINATION

- GENERAL COMAPARISON
- BARREL LENGTH
- TRIGGER PULL ANALYSIS
- DROP TEST ANALYSIS\*\*\*
- NIBIN
- SERIAL NUMBER RESTORATION
- DISTANCE DETERMINATION\*\*\*
- TOOL MARKS\*\*\*
- FRACTURE COMPAIRSON\*\*\*

\*\*\*Note: Examinations that are not routinely performed may require additional information.

## J. DO's and DON'Ts Appendix

### 1. Firearms

- a. DO record the serial number, make, and caliber of the firearm for identification before sending. DO place the firearm in a sturdy box and secure or package it to prevent shifting, mark UNLOADED on box.
- b. DO place any unfired cartridges/shotshells that have been removed from the firearm in a separate sealed container. This container may be packaged in with the firearm. Boxes must be used for packaging firearms. Paper bags tend to rip and firearms should never be tightly wrapped in paper. (NOTE: unfired cartridges are not necessary for NIBIN only requests)
- c. DO call the laboratory ahead of time if a loaded firearm must be submitted. Mark the packaging with: **WARNING: LOADED FIREARM.**
- d. Do label evidence containing suspected blood with a BIOHAZARD sticker or warning label.
- e. DO submit the cartridge magazines with the pistols and rifles.
- f. DON'T place any object in the barrel (plastic tie straps used to show that the firearm is unloaded are the exception).
- g. DON'T clean the bore, chamber, or cylinder before submitting the firearm.
- h. DON'T take the firearm apart or test-fire before submitting to the laboratory.
- i. DON'T submit cases involving crimes against animals unless a gun is submitted and approved by the Firearm Section Supervisor.
- j. DON'T submit replica guns, BB guns and pellet guns unless the submission is approved by the Firearm Section Supervisor.
- k. DON'T attempt to restore the serial number of a firearm prior to submitting it to the laboratory.

### 3. Fired Bullets

- a. DO place bullets in manila envelope after wrapping in wax paper to prevent movement in package. Place only one bullet in each envelope. Pellets from the same area may be placed in the same envelope. Mark the packaging for identification.
- b. DO submit all fired bullets and fragments recovered.
- c. DO gently rinse and air dry projectiles removed from victims.
- d. DON'T clean fired bullets from crime scenes.
- e. DON'T wrap fired bullets, fragments, etc., in cotton or tissue paper.

- f. DON'T place identification marks on bullets as this could destroy marks made by the firearm.
  - g. DON'T put bullets in glass containers.
  - h. DON'T touch fired bullets without examination gloves.
4. Fired Cartridge Cases/Shot shells
- a. DO mark the envelope for identification.
  - b. DO place each fired cartridge case/shotshell in a separate envelope.
  - c. DON'T mark fired cartridge cases/shotshells.
  - d. DON'T place marks of identification on the primer end of fired cartridge cases/shotshells.
5. Unfired Ammunition
- a. DO try to recover any ammunition of the same brand and type for test firing and comparison purposes (not necessary for NIBIN only cases).
  - b. DO mark the envelope for identification.
  - c. DON'T mark ammunition unless removing from magazine or chamber.
6. Serial Number Restoration
- a. DO protect the area where the serial number has been obliterated. DO contact the laboratory prior to submitting any large items.
  - b. DON'T attempt to restore any serial number prior to submitting to the laboratory.
7. Clothing Analysis for Gunpowder
- a. DO note the sequence of the clothing, i.e. T-shirt under open flannel shirt.
  - b. DO only submit the outermost garment worn, i.e. no boxer shorts if jeans are outer garment.
  - c. DO handle carefully to preserve any gunshot residue around suspected bullet holes.
  - d. DO contact Firearm Section Supervisor if multiple bullet holes in garment.
  - e. DO completely air dry clothing prior to submission.
  - f. DO package in white butcher paper and brown paper bag. DO mark the paper bag for identification.
  - g. DON'T package clothing in plastic even after air drying.
  - h. DON'T submit suspect's clothing for Gunpowder analysis without prior approval from the Firearm Section Supervisor.
8. Tool Marks
- a. DO protect all areas of tools that may contain trace evidence with plastic bags or other wrappings. DO submit the entire object with the tool mark to the laboratory if possible. If not, photograph the mark in its location, and then remove the damaged area for submission to the laboratory.
  - b. DO for items that are too large or otherwise impractical to submit, two (2) casts of each tool mark should be collected and may be submitted. Call the laboratory for assistance on casting tool marks.



- c. DON'T attempt to "fit" a tool into the evidence damaged tool mark.
- d. DON'T use the suspect tool for any reason.
- e. DON'T submit tool mark involving property crimes without prior approval from the Firearm Section Supervisor.

## Latent Prints and Impressions Unit

### Fingerprints:

The Crime Lab processes evidence for prints in the lab and at crime scenes. There are many reagents available for processing evidence at a scene, but the most common is fingerprint powder. Items can be processed by officers at a scene, or collected and submitted to the Crime Lab for lab analysis. When prints are recovered, they are forwarded to print comparison analysts for examination.

Friction ridge impressions can be organized into two categories—latent and patent prints. Latent prints require some method of physical or chemical enhancement to be seen. The processes used to recover latent prints are determined by the surface of the object upon which the prints have been deposited and the condition of the surface. Patent prints are those that can be seen without any enhancement, such as a greasy or a bloody print, or three dimensional prints, such as those found in gum, putty, or paint.

There are a few important considerations for making processing and collection decisions about evidence at a scene. However, the most important thing to remember is that prints are very fragile, so all items should be examined, processed, and packaged with utmost care. Careful evaluation of the scene and knowledge of your processing capabilities will determine the course of action taken at each scene.

### Print Processing:

- A. Identify what objects may be suitable for print processing
  1. Disturbed or out of place items—which items were likely to have been handled?
  2. Items not belonging to victim (or suspect)
  3. Points of entry/exit at a scene (doors, door frames, windows, window screens, door knobs, tools used to gain entry, etc.)
  4. Points of attack (areas where items have been disturbed, damaged, or removed)
  5. Other items that may be of evidentiary value—will prints on the object be probative to the investigation?
  6. Once it is determined what items are to be processed for prints, any fragile or transient evidence should be handled first.
- B. Handling of Objects
  1. Handle objects (with gloved hands) by touching edges, corners, or other surfaces that are too small for prints or unsuitable for prints (such as textured surfaces of gun grips).
  2. Gloves should be utilized with care. Any surface that has a print on it can easily have the print wiped off when handled, even if handled with gloves.
  3. Extreme care should be exercised when handling tape or other items with exposed sticky surfaces.
    - a. Prevent handling loose ends or other exposed sticky surfaces.
    - b. Leave the tape intact on the item, whenever possible. If it is necessary to remove from a person, cut the tape in an area that is away from the end of the tape and do not separate layers. You may stick the adhesive side to a clean page protector. The tape can be placed in a suitably sized box for transport.

- C. Decide which processing method will work best:
  - 1. Porous vs nonporous items
  - 2. Bloody vs non-bloody items
  - c. Light vs dark colored items
  - d. Large vs small items
- D. Decide which items should be processed at scene, and which items should be processed at lab
  - 1. Do you have the reagents and equipment necessary to best process items at the scene?
  - 2. Will processing for prints likely destroy other evidence that may be present? Does the item need more than one type of analysis (prints, drugs, DNA, etc.)?
  - 3. Do you have the evidence collection and packaging equipment needed to properly preserve the item for lab analysis?
    - a. Ensure that your vehicle is stocked with proper evidence collection/documentation equipment
      - i. Multiple sizes of envelopes, bags, sharps containers, etc.
      - ii. Labeling utensils, rulers, evidence markers, etc.
    - b. Some items may be too large to collect (couch, bed, wall, etc.) and should be processed at scene, or a sample of the item may be collected for analysis (example: area of a floor with bloody shoeprints)

As noted above, the majority of scene processing by officers will likely be with fingerprint powder. Basic dusting and lifting techniques are described below. The most important thing to do for developing good evidence handling, dusting, and preservation techniques is PRACTICE!!!

- E. Dusting techniques
  - 1. Use fiberglass or feather brushes for all non-magnetic powders—any other type of brush may damage fragile prints.
  - 2. Magnetic brushes must be used for magnetic powder.
  - 3. On large surfaces, use broad, sweeping strokes to apply powder and locate ridge detail in prints.
  - 4. Follow up with smaller circular strokes to work powder onto all sides of the developing print and get rid of excess powder.
  - 5. Shining a flashlight at an oblique angle will aid in locating prints after dusting.
  - 6. When dusting, you should not “spin” the brush, “poke” at the surface, or brush too hard—this will damage or completely erase prints that are very faint or fragile.
- F. Print preservation techniques
  - 1. Photograph before doing anything else to the print!!
  - 2. Use a ruler in the photos. Make sure the ruler is in the same plane (position and height) as the print being photographed.
  - 3. Get as close-up a shot as you can—fill the frame with the print being captured
  - 4. Make sure the photo is in focus before lifting the print
  - 5. Ensure the camera is parallel to the surface/print being photographed. Otherwise, the print may be distorted.
- G. Lifting techniques
  - 1. Can use hinge lifters, lift tape and lift backs (preferably clear backs), or gel lifters
    - a. Clear lift backs are preferred to allow for additional contrast if needed
  - 2. Wear gloves and avoid unnecessary handling, as even gloved hands can destroy prints.
  - 3. When lifting on curved surfaces, remember that the tape will only bend in one plane at a time.

4. Hold the tape or lifter in such a way that it doesn't flop over and stick to itself or other items.
5. Eliminate bubbles and creases in the tape when lifting and when adhering to lift backs.
  - a. Large bubbles may be eliminated by pricking (not slicing) the bubble with a scalpel or other sharp point and then "squeezing" the air out of the bubble.
6. Adhering tape to lift backs
  - a. Do not stick tape to index cards, evidence envelopes, or other coarse-grained paper.
  - b. Adhere the lift to a (preferably clear) lift back—do not fold the tape back onto itself as a backing
  - c. DO NOT lift prints that have been processed with superglue only—the adhesive on the lift tape will dissolve the print

#### Print Comparisons:

Analysts in the print comparison discipline receive prints from outside agencies, as well as prints recovered from cases processed by the Crime Lab. Direct comparison is made between the unidentified print and reference prints from victims, suspects, officers, or other individuals who may have touched the evidence on which prints were developed.

When submitting evidence for print processing or print comparison, the following information must be included on the submittal form (or in other submitted paperwork):

- A. Name, race, sex, date of birth, and State Identification Number (SID #, if applicable) of all victims, suspects, and elimination individuals
- B. Reference finger AND palm prints for any victims, suspects, or other individuals who may have touched the evidence
  1. A SID number may be submitted in lieu of reference prints if officers have verified that both finger and palm prints of an individual are in AFIS.
  2. If the evidence is from a business burglary, high-traffic area, etc., reference prints may not be necessary. This information should be stated on the submittal form.
  3. Both inked and live scan prints are sufficient for comparison purposes, as long as the prints are clear.

**Submission criteria may be waived on a case-by-case basis by the Latents Unit Supervisor or Manager.**

- C. Guidelines for taking good reference prints:
  1. Roll the finger "nail to nail". The resulting fingerprint should be square-like in shape with no smears. Palms should be rolled from the wrist bracelet (crease at bottom of hand) to fingertips, ensuring that all ridge detail is present and there are no voids in the print.
  2. Maintain constant, even pressure throughout the roll.
  3. Inked prints: Do not use too much ink. Excess ink makes the prints blotchy, smudged, and unclear.
  4. Livescan prints: make sure to clean the glass before rolling each finger.
  5. Label all reference prints with the individual's name, and label each finger (right index, left thumb, etc.).

- D. Tips for taking good reference prints on individuals with “difficult” prints:
1. Sweaty hands—wipe each finger with an alcohol swab before inking and rolling. This should remove excess sweat and allow ink to stick to the finger.
  2. Poor ridge detail—construction workers, some office workers, and elderly individuals may have very poor ridge detail or flat ridges. Have them hold an ice cube for approximately 1 minute, or use a purchased “ridge builder” to plump up ridges before rolling.
  3. Dry hands—apply a small amount of lotion to the hands and rub in completely. The added moisture should rehydrate ridges enough to take legible prints.
  4. Deceased prints—reference finger and palm prints should be taken from all deceased individuals involved in a case, as their prints may be needed for future comparison requests.
    - a. Clean the individual’s hands using alcohol swabs.
    - b. Use disposable ink strips to ink the hands.
    - c. Cut individual strips from a roll of latex tape (1-2” wide), press onto the finger, remove, and adhere the tape lift to a clear acetate sheet, page protector, etc. Pressing down on the finger joints may assist in straightening the fingers for easier printing.

#### AFIS & NGI Databases:

Unidentified prints are routinely searched through AFIS, and NGI, if they are of sufficient quality. If suspects or victims are from another state, this should be stated on the submittal form so that prints can be searched through NGI.

- A. AFIS (Automated Fingerprint Identification System) is the state Fingerprint / palm print database. Arrestees, applicants (nurses, concealed carry permits, etc.), law enforcement, and unidentified prints are all housed in this database.
1. Unidentified prints are searched through this database and may remain in the system if all reference prints have been submitted in a case, and if the print is of sufficient quality.
- B. NGI (Next Generation Identification) is the federal fingerprint / palm print database. Criminal, civil, military, applicant, and unidentified finger and palm prints are housed in this database, which is maintained by the FBI.
1. Unidentified prints may be searched through NGI. They are typically not retained in this system for continued searching.

#### Shoe & Tire Impression Evidence:

Wherever a crime has been committed, someone has had to enter and exit the scene. In the process, shoeprints, footprints, and tire tracks can be left. These types of impressions are encountered on a wide variety of surfaces and different collection techniques may be utilized. Proper processing of each surface type may result in collection of impressions which can, in some cases, be positively matched to a specific shoe or tire.

Footwear and tire track comparisons are typically conducted between a questioned impression and known shoe or tire impression. **It is necessary to submit to the LSP Crime Lab both the questioned impression and the known shoe or tire to conduct a comparison.**

A questioned impression does not need to contain the entire length of the shoe or tire for a comparison analysis to be performed. The most important factor is the quality of the photo/cast/lift, which is dependent on the officer using proper collection/documentation techniques. Additionally, some impressions such as shoeprints in blood can be enhanced using physical methods. Please contact the Crime Lab for assistance with this.

A. Shoe Prints:

1. Locating:
  - a. Soil, mostly free of vegetation, may retain a good quality three-dimensional impression unless it is too loose, firm, dry, or wet.
  - b. A dirty shoe sole may leave a two-dimensional (flat) impression. A faint shoe impression may need additional illumination to be seen. Using oblique lighting techniques will aid in locating faint impressions on many surfaces.
2. Processing the Shoeprint:
  - a. Measurements: A scale must be used when photographing or electronically documenting an impression. It is necessary for the scale to be on the same plane (height, ruler angle, etc.) as the bottom of the impression. If the ruler is above or below the impression, accurate measurements cannot be made. In addition, discrepancies in shoe size could be made.
  - b. Photography: Close up photos should be taken with an L- ruler. Camera should be positioned so that it is exactly parallel to the impression. Use of a tripod is highly recommended. Side lighting from several different angles with electronic flash or other high intensity light should be utilized. Vary the position of the light source with the camera in the same position, taking a photo in each of the light positions. This will ensure that all details are recorded rather than partially obscured by shadows. Fill the frame with the shoe impression, making sure the bottom of the impression is in focus.
3. Casting: Casting may be used to capture three-dimensional impressions, such as those left in soil. The most common type of casting material is dental stone, which is easily obtained from dental supply companies.
  - a. Approximately two pounds of dental stone and 8-12 ounces of water is enough to cast a medium-sized shoe impression. Casting material should be the consistency of pancake batter when pouring, and should be free of clumps.
  - b. Casting material should never be poured directly onto the impression. It should be poured next to the impression so that the dental stone flows, or gets “pushed” into the adjacent impression. Pour to approximately 1” thickness and label the cast as it begins to dry
  - c. Never clean the dirt or debris from the bottom of the cast; dig slightly below the depth of the cast and remove and package the soil and cast together. Once the cast has dried, it should be packaged in a box or paper bag. Casts should be allowed to fully dry for 48 hours before cleaning, and should never be packaged in plastic.



## B. Tire Impressions:

Several measurements can be determined from tire tracks which may aid in an investigation. These include: tire width, front wheel stance, rear wheel stance, and wheel base. This data, when coupled with the tread design, can aid in locating or greatly reducing the number of vehicles which may have left the impressions.

1. Vehicles may have more than one brand of tire on the wheels. Ensure that all four tires are photographed and that each tire's information (brand, model, etc.) is documented if a comparison is to be done.
2. Wheelbase measurements can assist in determining vehicle type. At the scene, look for where the vehicle turned, stopped, or changed directions. The tracks that make sharp turns will be the front tire tracks. Wheelbase measurement is made from the leading edge of the front tire to the leading edge of the rear tire. Turns and direction changes will be the best locations for measuring the front and rear stance as well.
3. Photographs of the impression should include no more than 12-14 inches of the tire track. Multiple photographs should be taken along the length of the tire track to ensure that the full rotation of the tire has been captured.



4. Casting can be done as described in the shoe impression section above. Do not cast more than ~1 foot of track as the cast will become heavy and more susceptible to breaking. Several casts can be taken from a single tire track.



## Fire Debris Unit:

The Crime Lab can furnish the arson investigator with information relating to the presence and classification of an ignitable liquid at a fire scene. Fire debris analysis cannot determine whether a fire was intentionally set, and cannot identify a specific source of the ignitable liquid residue. The presence and classification of an ignitable liquid, which may be used to start or accelerate the spread of a fire, is determined by analysts using a gas chromatograph/mass spectrometer (GC/MS).

Latent print or DNA examinations may be incorporated in arson cases. Unburned or partially burned items may yield identifiable latent prints or DNA profiles if collected properly and submitted for analysis immediately.

Proper collection and packaging of evidence for fire debris analysis is critical; such debris may contain volatile ignitable liquid residues which can evaporate quickly if packaged improperly.

The State Fire Marshal is an excellent resource for investigating and collecting evidence from fire scenes. An arson investigator should be consulted when processing complex fire scenes or those involving fatalities / serious injury.

**ALL fire debris** evidence items **MUST** have the [Fire Debris Case Information Sheet](#) filled out in addition to the completed [Laboratory Submittal Form \(DPSSP 4606\)](#).

- A. Collection: All equipment used to process fire scenes and collect evidence should be cleaned before each use. This includes tools (shovels, rakes, screens, etc.), clothing (especially shoes), and other items that may come into contact with scene debris.
  - 1. The lab's analysis equipment is extremely sensitive and may detect ignitable liquid residues carried over from another scene if items are not properly cleaned. Do not use citrus or lemon scented soap for cleaning.
  - 2. Whenever possible, use disposable items (such as gloves). Do NOT include gloves used to collect evidence inside of your evidence container, as they can interfere with the lab's analysis.
- B. Packaging: It is strongly recommended that all fire debris evidence that comes into the laboratory be packaged in one of the following ways:
  - 1. Heavy Duty KAPAK or Nylon bag –used for packaging solids and soils. The bags can be cut to size, and should be filled no more than 2/3 full. Liquids should never be placed directly inside these bags.
  - 2. Clean, lined, metal paint cans—used for packaging solids and soils. The cans can be placed inside rust more easily than lined cans, and could result in sample loss or contamination. Cans should be filled no more than 2/3 full. Liquids should never be placed directly inside a metal paint can.
  - 3. Clean, glass containers – used for packaging liquids. Appropriate glass containers include evidence vials or glass jars. To prevent breakage, the glass container may be placed inside of another clean container with padding. Only a small amount of liquid is needed (generally 2-20ml). An alternative is to absorb some of the liquid onto clean gauze or similar material, and then package the gauze inside a clean, metal paint can or KAPAK or Nylon bag.

- C. Storage: Samples should be stored in a climate controlled storage facility. Heat will cause ignitable liquid residues in samples to vaporize, expand, and move around inside the container. If the containers are not sealed properly, leak, or fail in some other way, contamination or sample loss may occur.
1. Soil samples should be immediately stored in the freezer to minimize bacterial degradation of ignitable liquids in the soil.
  2. Large, bulky items such as gas cans, flooring, lumber, etc. may be difficult to package in the recommended containers. It is acceptable to place these items inside paper or plastic bags, provided the agency can get these items to the laboratory quickly so they can be properly packaged as soon as possible.
  3. Comparison samples (same material as test sample, but believed to be free of ignitable liquid) may provide an abundance of information about the test sample, and therefore can be collected when possible. Comparison samples should be stored in the same manner as test samples.

**NOTE: Regardless of the packaging method used, all containers must be thoroughly sealed so that any ignitable liquids present are not allowed to escape from the sample**

**Published by Louisiana Department of Public Safety & Corrections –  
Louisiana State Police Crime Laboratory**