



Try the rabbit: a practical guide

Source	Technical Centre for Agricultural and Rural Cooperation (CTA)
Keywords	Rabbit keeping, rabbits, livestock production
Country of first practice	Nigeria
ID and publishing year	6951 and 2010
Sustainable Development Goals	No poverty, zero hunger, good health and well-being decent work and economic growth, and life on land

Summary

Through proper guidelines, rabbit rearing not only requires minimal capital investment but also provides increased livelihood income and yield. This step-by-step guide details rabbit breeds, behaviour, and handling. It instructs how to construct rabbit hutches, kindling boxes, weaner cages and where to place the rabbits. Information on breeding management is also provided which includes the process of controlled mating, what to do during the heat period, the process of doe servicing as well as how to take care of does during pregnancy and what to do after delivery. What to do in the event of death litters, how to sex and sell weaners, and specifications on feeding methods, feed transportation and what food types to feed the rabbits are also given. The guide additional details the process of breeding stock selection, highlighting the issues of inbreeding as well as giving information on rabbit diseases and pests. Record keeping was also advised.

Description

1. Introduction

One of the main advantages of small-scale rabbit farming (rabbitry) is that, it requires minimal capital investment. Young people can easily afford to start keeping rabbits with virtually no financial risk. The venture could

begin as a backyard or garden enterprise, requiring very little space.

Rabbits are prolific breeders, producing large quantities of tasty meat for home consumption. Their rate of production is faster than that of pigs, goats or sheep. If properly raised and cared for, a female rabbit (doe) can produce more than 15 times her own weight in offspring in a year. Under natural conditions, she delivers a litter every 31 days. In controlled conditions, however, she should produce only four or five litters a year. The number in each litter is usually between 4 and 12.

Rabbits grow rapidly because they are efficient at converting food into meat. A baby rabbit weighs about 57 g when born. In six days it doubles its weight, and after 30 days its weight will have increased eightfold or more. By the end of the second month, the breed known as Californian or New Zealand White will, if well looked after, weigh over 2 kg. A young rabbit reaches maturity at five months but can be slaughtered at the end of the third month; at this stage, a Californian White would probably weigh about 3 kg.

In Europe and elsewhere, it is common practice to slaughter rabbits at the age of two months but this is rarely done

TECA

TECHNOLOGIES
and PRACTICES
for SMALL
AGRICULTURAL
PRODUCERS



in West Africa, where the slaughter houses generally prefer mature animals.

1.1 Breeds

In Europe, rabbits are raised for both meat and pelt production. Because white pelts are preferred, the standard commercial breeds are the white - furred varieties. In West Africa, the farmer is concerned with producing a meaty type, not with the color of the pelt. Care is usually taken to select strains which are both prolific breeders and efficient converters of food. They should have a high ratio of meat to bone.

The local African rabbits are usually the easiest to manage. Although they are smaller than the imported breeds, they suffer less from disease. Also, the does have more teats than the breeds from other regions (exotic breeds), enabling them to nurse more offspring. If a good local doe is mated with a good exotic male (buck), the female offspring will not only be stronger, healthier and meatier but will possess 10 teats.

There are several varieties of cross-bred rabbits available. Some are hybrid offspring (the offspring of two different breeds), generally of the New Zealand White, the American Albino and the Checkered Giant.

Figure 1 shows a cross-bred Californian doe, a common breed in the Kumasi area of Ghana; an adult weighs between 4.5 and 5.3 kg.

1.2 Behaviour

Rabbits are relatively quiet animals and do not like to be disturbed by noise. They rest during the day, while at night they wander about, eating both green and dry leaves. Their main feeding time is generally between 4 and 5 am, when they eat green leaves in large quantities.

Figure 1. A Californian cross-bred doe, showing the typical black nose and dark hairs around the ears

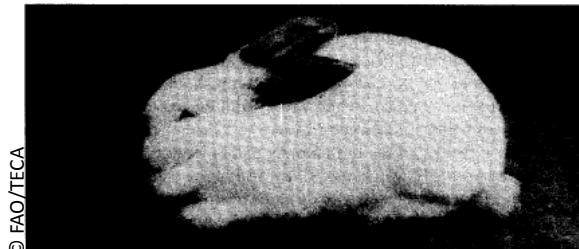

In the wild, the rabbit's main enemies are wild cats and jackals. It does not, as is generally believed, live in holes as rats do. However, it does keep its young in such bunows should danger threaten it will dash into a hole it has prepared. When the doe is about to give birth, she bunows a hole to create a safe place for her young. She lines it with dry grass and soft materials, such as kapok. To this she adds some of her own fur which she pulls from her mane and from the area around her teats. After the birth, the doe leaves the litter and sets off to the entrance of the bunow, where she gathers earth and other materials to seal it off.

While she is busily working, the buck waits nearby. He invites the new mother to become impregnated again. At this stage, the doe is on heat and therefore submits to the buck. She usually falls pregnant from this mating. Then she continues her work of sealing off the entrance to the bunow. The male waits nearby and further mating takes place when the doe has completed sealing the bunow entrance. The young rabbits are fed on milk once a day, usually early in the morning or late in the evening. They are born blind and deaf. After 11 days their eyes open and their fur begins to grow. After 14 days they venture out of the bunow, and between 16 and 21 days they start to eat green leaves. If the doe is pregnant again, she begins to wean them after 23 days. On the 31st day she produces another litter.



2. Handling rabbits

Rabbits should not be disturbed too often. They should be handled only when there is a valid reason for doing so. When catching a rabbit, use both hands, one to hold the folds of the skin on the shoulders and the other to support the rump, as shown in Figure 2. If the rabbit starts to show signs of aggression or if it struggles to get down, lower it slowly into the cage and attempt another hold. Do not pick it up only by the legs or by the ears. Another technique is to hold both ears and the folds of the skin on the shoulders together. This is necessary when the animal is so meaty that there is not enough loose skin on the shoulders to get a good grip.

Figure 2. Picking up a rabbit by the folds of the skin on the shoulders



Catching a strayed rabbit requires some skill. The native variety is a fast runner, its speed exceeding that of a dog. The exotic breeds are less of a problem. To catch an escaped rabbit, try to manoeuvre yourself so that you stand in front of it. When in this position, crouch down and spread the fingers of both hands widely near the rabbit's face. The rabbit will stop and lower its ears in readiness for a nest, as shown in Figure 3.

Do not attempt to chase the rabbit from behind as this will prove unsuccessful.

Figure 3. Catching a rabbit that has escaped from its hutch



3 Constructing rabbit hutches

There are a number of important factors which rabbit breeders must take into account if they are to be successful. They have to consider the rabbits' accommodation, feeding and safety requirements. They must also establish ways of controlling the rabbits' prolific rate of reproduction.

The rabbit is almost defenseless and thus has many predators. It should therefore be provided with safe and sturdy shelter. For the same reason, it cannot be allowed to forage for itself, so it must be well supplied with a balanced ration of greens and grains. Careful management of such factors as these will ensure a steady production of healthy and vigorous young rabbits.

3.1 Hutches

Unlike other domestic animals such as goats, sheep and fowls, rabbits cannot be kept under free-range conditions. Apart from the fact that they can easily be stolen, they are always in danger of being attacked by enemies such as dogs and cats. They need, therefore, to be provided with good shelter, such as outdoor hutches divided into cages (see Figure 4). If large-scale commercial production is being considered, breeders will have to build large wooden or



concrete buildings which can house a series of wired cages.

A single hutch can be divided into two, three or four cages and should be easily transportable should the need arise. The hutch must be well ventilated and constructed from cheap, locally available material such as bamboo strips and wire netting. The design must aim at excluding predators, such as dogs, cats and snakes, as well as mice and other vermin.

The hutch should be about 30 cm from the ground. If it is an outdoor hutch, the roof should slope to allow rainwater to trickle downwards. The floor should consist of wire mesh in which the holes are large to allow the droppings to fall through to the ground. Large-scale commercial rabbit keepers in urban centers benefit from such amenities as electricity and a piped water supply. In these circumstances, a durable building with good drainage should be erected, electric light should be installed and water piped in. The building should include a shelter for attendants and one or two rooms for storage and other purposes.

Figure 4. Rabbit hutches on the author's farm

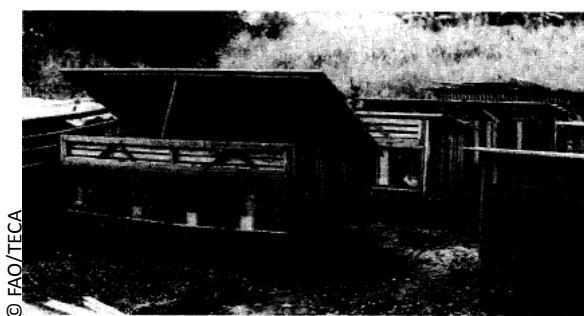

3.3 Cages or bucks and does

If mating is not strictly controlled, does will produce 12 litters a year. As a result, they will become lean and unhealthy. To prevent this, each breeding doe should have her own cage so that the buck cannot have

constant access to her. The cage should have the following minimum dimensions: 107 cm long x 60 cm wide x 56 - 76 cm deep (see Figure 5).

The cage for a buck must be slightly larger than that for a doe. It should preferably occupy an area of about 90 cm x 90 cm. This should be large enough to contain a buck and a doe when the doe is placed in the cage for mating.

Figure 5. Hutch for breeding does

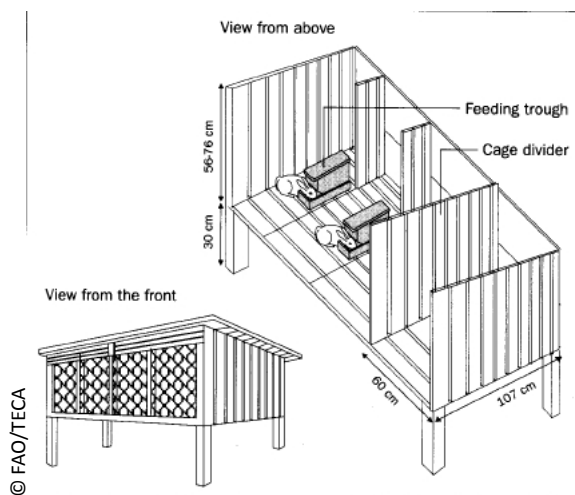

3.4. Kindling box

A kindling box must be placed on the floor of a doe's cage at least a week before delivery is expected. This will allow her plenty of time to line it before the birth. The box should be easily removable because the young rabbits will use it for only the first 12 to 14 days. They will then need more space in the cage in which to roam about. Figure 6 provides an indication of the ideal size of a kindling box. Dry rags and leaves must be provided for the doe to use in lining the kindling box. Stringy material such as weaving yarns or spongy synthetics should, on no account, be put into these boxes. Such materials will probably entangle the young rabbits and can cause great harm.



Figure 6. Hutch for breeding does 2

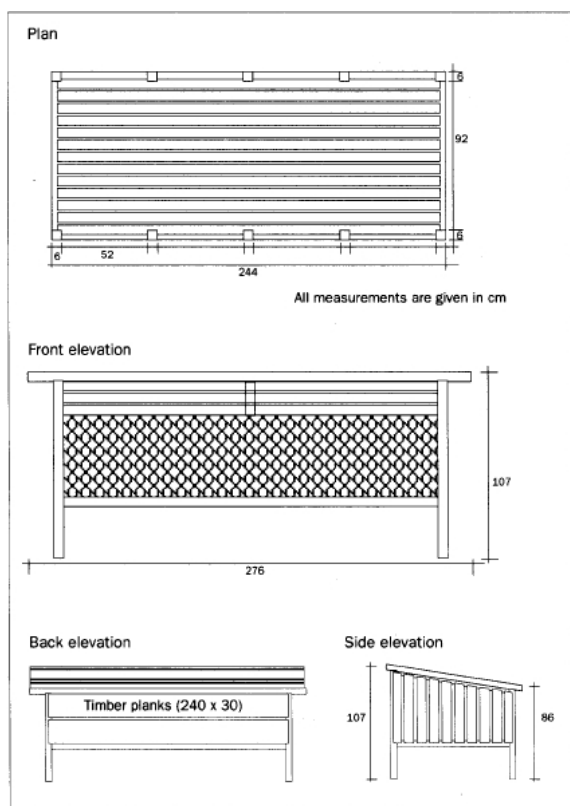

3.5 Cage for weaners

Several weaners intended for the market or for other purposes can be sexed and reared together in one large cage. The construction of a cage suitable for weaners is shown in Figure 7. To prevent weaners from fighting each other, it is important that those placed in the same cage are the same age. When they are three or three and a half months old, they must be separated and each one placed in its own cage. If this is not done, does will begin to ride one another, causing 'false pregnancies'. The bucks will begin to castrate one another, which will lead to fighting and the possible death of some of the rabbits.

4 Breeding management

For efficient production, the rabbit breeder should plan the mating program of the rabbits so that three or more does give

birth within a day or so of each other. This arrangement is known as 'synchronization'. One of the advantages of synchronization is that it enables the owner to provide adequate care for his or her rabbits. For example, if a doe with only eight teats produces an unusually large litter of, say, ten rabbits she will have more than she can nurse. To reduce the numbers she has to nurse, two or three young rabbits can be transferred to a doe who has just produced a smaller than usual litter.

If a doe produces an exceptionally small litter, the whole litter can be given to other does to nurse so that she is then ready for immediate impregnation or breeding. In such instances, it is advisable to allow this doe to be mated without delay. Extra young rabbits are readily accepted by foster mothers if they are of the same age, within two or three days, as their own litter. Rabbit breeders should manage such situations to their advantage.

Figure 7. Kindling box

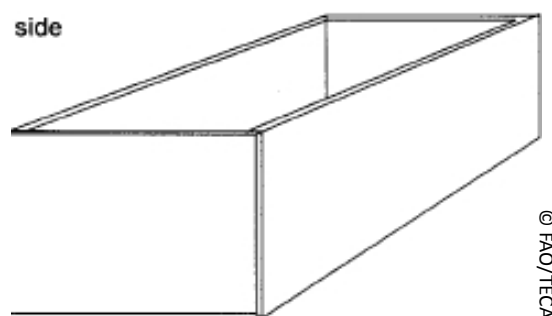

4.1 Controlled mating

A good buck has the stamina to cover a female 10 to 12 times a day. Indeed, if a doe is left with a buck overnight it is likely that the buck will tire himself out in repeated and useless attempts to mate her. A buck should not be allowed to strain himself in this way. The ideal course is to allow the buck only one mating chance per doe. After a doe is serviced for the first time,



she should be removed from the buck's cage and, shortly afterwards, another doe should be placed in the cage. In this way, a buck can service three to five does in one day, with no harm to himself. If he is then allowed to rest for a few days, he can service another three or four does. In theory, controlled mating would allow a buck to mate with any number of does. However, the conscientious rabbit breeder would never repeatedly cross all his does with the same buck for fear of inbreeding (breeding between animals which are closely related). Inbred rabbits are usually smaller and weaker than normal rabbits; any such inferior rabbits should be culled.

Does are ready for impregnation when they are more than five months old. If they are more than three years old they usually give birth to smaller litters. Any doe consistently producing less than eight in a litter should be eliminated.

Depending on the number of does which are present in a rabbit farm, two or more bucks are usually required for breeding purposes. If, however, the rabbit fanner does not want to maintain his own bucks, he can manage to have his does serviced by the bucks from another farm. When raising rabbits, it is important to select only the best animals for breeding stock and to keep accurate records of their servicing and kindling. An example of a servicing and kindling record is given in Figure 8.

4.2 The heat period

Does are impregnated during their heat period. This lasts for 15 to 16 days. When a doe is on heat, she becomes restless and aggressive. Her genital area becomes swollen, pinkish red and moist and she begins to jump about, always trying to get into the cage of the rabbit next to her. As

soon as a doe is seen to be on heat, she must be serviced.

Figure 8. A servicing and kindling record sheet

Figure 8: A servicing and kindling record sheet

First year	Date crossed	Name of buck	Date of birth	Number at birth	Mortality record	Survival at weaning
1990	1	Bill	20/10	8	H1	5
	2					
	3					
	4					
	5					
1991	1					
	2					
	3					
	4					
	5					
1992	1					
	2					
	3					
	4					
	5					
General remarks						
1990			1991		1992	
1			1		1	
2			2		2	
3			3		3	
4			4		4	
5			5		5	

© FAO/TECA

If two does are in the same cage, the doe on heat will attempt to ride the other doe. If the rabbit farmer ignores this behaviour, it can lead to a 'false pregnancy'. This term is used when a doe thinks she is about to give birth and prepares a kindling box by collecting rubbish and pulling out her fur to line the box. Does exhibiting this behaviour should be serviced immediately, just as does which are seen to be on heat must be serviced immediately to avoid developing a false pregnancy.

The main heat period occurs 15 to 17 weeks after birth. However, this is too soon for a young doe to be serviced. She should not be allowed to mate until she is five to six months old. A doe will also come on heat if she loses her whole litter at birth, and



may be serviced immediately. Sometimes, nursing mothers may show signs of being on heat on the 28th day after delivery. These does can be serviced one to two weeks later.

In the conditions which prevail in West Africa, does should have only four or five litters a year if they and their offspring are to be healthy. In the USA and Europe, where the infrastructure supporting commercial meat production is good, rabbit farmers can allow does to have up to seven litters a year. This means that the young rabbits are weaned when they are less than 28 days old but, with the availability of prepared pellets which contain all the rabbit's nutritional requirements, infant mortality is very low.

For rabbit farming in West Africa, the following timetable is suggested.

Four times per annum

- Wean the young rabbits.
- Service the doe 50 to 60.
- The doe will produce the next litter 80 to 91 days.

Five times per annum

- Wean the young rabbits 45 to 49 days after birth 40 days after birth.
- Service the doe 42 days after the birth after birth.
- The doe will produce the next litter 73 days after the last birth after the last birth.

It must be stressed that these timetables will work only if the rabbit farmer adopts the feeding and management practices suggested further; poor management can result in miscarriages.

4.3 Servicing the doe

As suggested above, it is useful for several does to be impregnated on the same day

or within three days of one another. This requires careful planning. Recently matured does should be fed on special rations such as fish meal and grain, in addition to the usual greens. They should be given more than they can eat to ensure that they are well fed. If this regime is followed they should come on heat within three to five days.

When the doe shows signs of being on heat, she should be removed from her cage and placed in a buck's cage. The buck will ride the doe while she raises her tail to expose her genital area. After the buck has penetrated her, they will move away from each other. At this point the female should be caught and inspected to discover whether successful mating has occurred. If a white jelly-like liquid is found on the outside skin of the swollen vagina and on the fur immediately around it, no further mating is required and the doe can be put back into her cubicle.

4.4 The pregnant doe

Six hours after a doe has been impregnated, she will reject any buck if she is put back into the buck's cage. The symptoms of being on heat will have gone completely by the next morning; the swollen vagina will have shrunk and the red, moist appearance will have changed to pale pink. The doe will begin to grow more fur and gain weight rapidly. At 14 days after servicing, her teats will become pinkish-red, her vagina will begin to swell and she will start growing more fur in her mane.

The rabbit fanner will also notice that a pregnant doe will try to tip over any container put into her cage. For example, she will tip over her drinking bowl after taking some water. She will also make strange noises should a buck approach her.



A reliable technique for determining pregnancy is the palpitation method. This involves feeling the growing embryos in the horns of the uterus. An experienced person can determine pregnancy between the 9th and 10th day; the inexperienced person should try on the 15th day or a bit later. The developing embryos can be felt, between the thumb and fingers, under the doe's stomach between the hind legs and in front of the pelvis. This technique must be practiced with care. If not done properly, it could cause the death of the embryo or the doe, or both.

At about five days before the doe is due to give birth, she begins to prepare the kindling box, collecting dry grass and soft materials with which to line it. On the day she is due to deliver, she will pull fur from her mane and from around her teats to complete the lining. Given the slightest opportunity, she will also pull fur from other rabbits (see Figure 9). At this time she must be provided with fresh water because she will drink large quantities of water during and after delivery.

Figure 9. A doe with fur pulled from her body to line the kindling box



© FAO/TECA

4.5 After delivery

After the doe has given birth to the litter, it is necessary to check several aspects.

- All the newly born rabbits are in the kindling box. If they are scattered about in

the cage, collect them for safekeeping in the box.

- The size of each of the young is normal (see Figure 10). If any are abnormally small, remove and destroy them. If they are allowed to remain, they will die later. This could happen at any time between the 2nd and 60th day, during which time the rabbit will have wasted precious milk and food supplies.
- The newly born have taken some milk by looking at the size of their bellies. If none has taken any milk, this shows there is something wrong with the mother and her young will die of starvation. Remove them from the hutch and place them with healthy does.
- She does not have too many young to care for. If she has, the extra ones should be given to a doe able to care for more rabbits.
- They are all still alive. This must be done every morning.

Note that if the newly born rabbits need to be given to another doe, this doe must have given birth at almost the same time as the original doe.

Figure 10. A litter just after birth

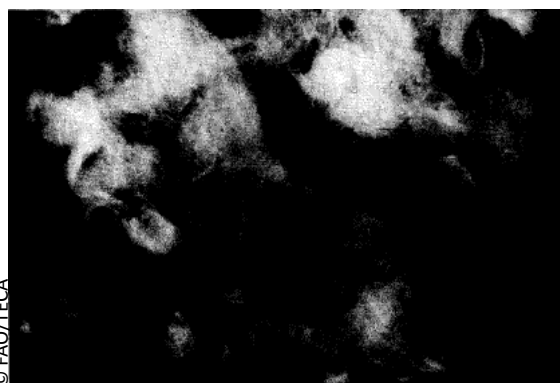

© FAO/TECA

The mother feeds her young once a day. Exceptionally good mothers feed their young twice a day, but such rabbits are rare. On the 11th day the eyes open (see



Figure 11). The young may begin to eat green leaves as early as the 15th day, but at this stage give them only fairly dry grass.

Figure 11. Rabbits at 11 days old, when the eyes have just opened



4.6 Death in the litter

Chilling because of lack of care by the mother or the rabbit farmer may lead to the death of young rabbits. If textile materials are placed in the kindling box, the threads can entangle and deform or kill a young rabbit. Rabbits should be kept out of the rain completely. Strong young rabbits will generate heat for themselves when the weather is cold by forming a cluster. A sick young rabbit is usually isolated. When it dies the mother will bury it in the kindling bed. It is important to inspect the bed every day to ensure that any dead rabbits are removed immediately so that the decomposition does not affect the others.

Many factors cause high infant mortality rates.

- Negligence (by the mother or the farmer).
- Unhealthy or weak parents.
- Inbreeding
- The mother being allowed to breed too early and too often.
- Feeding mothers and young rabbits on succulents or on too many immature greens.
- Insufficient food supply.

- Exposure to rain.
- Cold, if the mother has not provided enough fur or bedding material.

4.7 Sexing and selling the weaners

Wean young rabbits at six to eight weeks. This means separating them from the mother. The mother is then fed on extra rations to make her come on heat within a short space of time, ready for breeding again. The weaners can be sold between two and four weeks after they have been weaned. The waiting period is to ensure that they will survive in their new home. Experience shows that the mortality rate among rabbits which have just been weaned can be high. Deaths at this stage usually stem from inbreeding.

A customer approaching a rabbit farmer for breeding stock will ask for a specific number of does and/or bucks, and thus the farmer must be able to sex the weaned rabbits. It is essential to keep the sexes in separate hutches.

It is easier to determine the sex of adults than of weaners.

4.7.1 Sexing the adults

The study of the sex organs of the adult must be undertaken as a first step before learning how to identify the weaner's sex organs. The male organ is easy to identify. The testicles and penis of a good buck can easily be seen. The female's vagina is also easy to find, a 'V-shaped opening a few centimeters above the anus.

4.7.2 Sexing the weaners

The rabbit should be held on its back, with its hind legs pointing outwards. Press gently on each side of the sexual organ, exposing it. The female organ is slit-like and is situated near the anus, while the male organ appears as a rounded



protrusion and is further away from the anus. Experienced farmers are able to sex the young as early as the day of birth.

5. Feeding rabbits

Rabbits feed on fresh and dry leaves and grasses, and occasionally on roots. They are one of the few animals that do not compete with humans for food. Unlike the poultry farmer, the small-scale rabbit fanner should not face problems with food supplies at any time of the year. Even when the grasses have withered, the leaves from tall trees and shrubs are available for food. However, care must be taken as to what is given to young rabbits and pregnant and nursing does, as they are particularly sensitive to some plants.

In general, rabbits will eat about 80 percent of available plants. However, they have their favourites, including the leaves below the crown of cabbages (*Brassica aleracea*), groundnut leaves, juice plant (*Euphorbia heterophylla*), *Centrosema pubescens* and wild marigold (*Melanthera scandens*). They eat all types of grass. Although freshly cut and dried greens, together with food wastes from the house, are suitable for small-scale enterprises, this would not be practical for commercial-scale projects, where quick growth of the animals is required.

Unfortunately, the unavailability of pellets in West Africa restricts the development of rabbit farming on a commercial scale. It is possible, however, for rabbit farmers to mix their own feeds which will meet the requirements of a balanced diet and ensure fast growth, good milk production and good health. Although the rabbit is regarded as a herbivorous animal, many rabbit fanners feed their animals with poultry feed, which often contains dried fish. Rabbits will consume dried but not fresh fish.

For rabbit farmers who wish to prepare their own rabbit feed pellets, a specific formula is suggested.

- Greens and grasses; 70 percent.
- Carbohydrate; 15 percent.
- Protein or fish meal; 10 percent.
- Other ingredients, including minerals; 5 percent.

It is important that rabbit farmers avoid overfeeding rabbits. If the quantities of greens supplied are too large, this will encourage young rabbits and weaners to eat more than they really need. As a result, they will develop rotund bellies and their growth will be considerably retarded. A hungry rabbit will rise and come to meet the farmer when he is approaching the hutch. A well-fed rabbit will take no notice of the fanner when he is passing the cage.

5.1 Greens

These constitute the largest percentage of the required food. Marigolds and many creeping leguminous plants and greens provide essential nutrients for all rabbits, both young and old.

Table 1 lists some useful greens; where known, local names are given. The list of plants in the table is in the order of the rabbits' preference, as observed by the author. Rabbit farmers will no doubt find suitable plants in their locality which are not listed in Table 1. They should observe what the local domestic and other herbivorous animals in the area eat and then try feeding the same plant material to their rabbits.

5.1.1 Cabbage

Cabbage is the rabbit's most favorite food but when the leaves contain too much water they can be dangerous. Feed the rabbit with matured, ripe cabbage only.



Cabbage reaches maturity after it develops a crown. If the crown has not developed, the leaf can be dangerous for all age groups. Note that rabbits do not like eating the crown. The parts they do like are the unwanted, overgrown leaves found below the crown. Once the crown has been

cut, the cabbage plant develops several shoots through the buds on the stem. Again, these shoots must not be fed to the rabbits until they have reached maturity. Rabbits also enjoy other plants in the same family as the cabbage, such as cauliflower.

Table 1: Some suitable greens for rabbits

Scientific name	Common name	Country	Local name
<i>Bidens spinosa</i>	Bur mar gold	Ghana	Twi: gyimantwi
<i>Sida acuta</i>	Black jack	Nigeria Sierra leone Liberia Ghana Nigeria	Akwapim: anase mpaane Eve: dzanai pipi Krepi: adzrokpaii Krobo: dsethi Yoruba: abrekdoko Mende: tombolo Mano: zikilli wissi Twi: abrane atu ata Ga: schwuoblo Krepi: didinglome Eve: afidemii, ade-meamea Yoruba: oshe potu
<i>Amaranthus</i>		Ghana	Twi: nantwi nkese
<i>Spinosa</i> <i>Lonchocarpus</i>	Indigo plant	Nigeria Sierra Leone Ghana	Ga: sraganmei Krepi: amma Eve: matonui Ibo: inene ugu, nnu-no aku Yoruba: tete elegun Mende: tahondi Ti: kanunkuna Twi: dwira
	Asanlewa nkasee		
<i>Cyenescons</i> <i>Ficus spp.</i>	Sandpaper leaf	Nigeria Sierra Leone Ghana	Ga: akese Eve: adzudzu Yoruba: elu Hausa: talaki Twi: nyankyerene
<i>Mangifera indica</i>	Mango	Ghana	Mango

Source: FAO 2010



5.1.2 Groundnuts and maize plants

Although these plants provide some of the best greens for rabbits they should not be used if there are other, cheaper greens available. The reason for this is that the rabbit farmer should avoid a situation where man and animal compete for the same resources.

Groundnuts, for example, provide good edible nuts for man and should therefore not be used for rabbits until the crop is harvested. The waste leaves left over after the harvest can then be used as feed. This

also applies to the by-products of other edible crops, such as plantain leaves and bean leaves.

5.1.3 *Tridax procumbens*

This plant grows wild and is a good source of cheap rabbit food. The problem is that it is difficult to gather because, when it is picked, it collects a considerable amount of dirt from the ground. Rabbits will never eat anything dirty. Care must therefore be taken when gathering this plant. During the wet season, it is advisable that rabbit farmers dry the plant for several hours

Table 1: Suitable greens for rabbits continued

Scientific name	Common name	Country	Local name
<i>Euphorbia heterophylla</i>	Juice plant	Ghana Liberia Senegal Sierra Leone	Twɛ: ahinkogyɛ, adankomilk Eve: notsigne Nzema: akubaa Mano: to a gbono wolot: homguelem Ti: ebit, yonkaraebit
<i>Melanthera soandens</i>	Wild marigold	Ghana Nigeria	Twɛ: mfofo Yoruba: iyawa
<i>Synedrella nodiflora</i>		Ghana Nigeria Sierra Leone	Twɛ: ntewadupo tutu mirika, kohwe epo, aguakro Yoruba: zanaposa, aluganbi Balkeyan: karuni
<i>Desmodium scopiurus</i>		Ghana	Twɛ: adowobo
<i>Vernonia cinerea</i>		Ghana	Eve: hosikonu
<i>Setaria spp.</i>		Ghana	Twɛ: awaha Eve: ebe
<i>Centrosema pubescens</i>	Centrosema	Ghana	Twɛ: anase nturumunhoma
<i>Aspilia africana</i>	Wild marigold	Ghana	Twɛ: mfofo-nini

Source: FAO 2010



before they feed it to rabbits. In the dry season, however, there is no need to do this and it can be fed to them straight away.

5.2 Succulents

Leaves or greens which contain large quantities of water are termed succulents. Young rabbits and pregnant and nursing does should not be fed such plants unless a careful study of the effects of the plants has been made. After eating certain succulents, rabbits are liable to develop diarrhea and young rabbits, especially weaners, will soon die. Pregnant does are liable to have miscarriages. These rabbits should therefore be fed on dry leaves.

5.2.1 Sweet potato

Many rabbit farmers in West Africa supply their rabbits with the leaves of sweet potato (*Ipomoea batatas*), but this can be disastrous. Rabbits fed on immature sweet potato leaves usually do not produce well. Often, the females cannot have offspring and the few young that are born are subject to a high mortality rate. As with cabbage, sweet potato leaves can safely be fed to rabbits when the plant is mature but it is difficult to determine when it has reached maturity. Because of the adverse effects which result from eating immature leaves, this plant should not be included on the list of recommended foods.

5.2.2 *Talinum triangulare*

This is a good succulent plant for chickens. Although it is not popular with rabbits, it is believed that when rabbits are fed on it for an extended period, they sometimes develop a taste for it. Before feeding it to rabbits, the abundant juice in the plant should be reduced by spreading it to dry in the sun for a few hours. It should be fed to adult rabbits only.

5.2.3 *Commelina*

There are several varieties of this succulent plant. Generally, they are not good for rabbits. Whenever greens are gathered, the rabbit farmer should ensure that no *Commelina* species are included in the harvest.

5.3 Butterfly larvae

The cocoons or larvae of many species of butterflies and moths can be dangerous to rabbits. When greens are gathered, any leaves which bear these should be discarded. Normally, when rabbits are eating, they smell the foreign body and avoid eating that particular part of the leaf. Occasionally, however, they fail to detect the presence of foreign matter. Cocoons or larvae can be eliminated from leaves in the hutch by sprinkling water containing salt on the leaves.

5.4 Planting fodder

For farmers operating large-scale enterprises, collecting green grass and creeping plants from the wild for large-scale rabbit farming is tedious work. It often involves covering considerable distances before enough suitable edible material is found. In addition, greens collected in this manner are easily soiled in the process. One way of overcoming the problem is for the farmer to grow suitable plants which are easy to harvest. Some leguminous shrubs and trees, such as *Desmodium tortuosum*, *Gliricidia sepium* and several varieties of *Prosopis* are excellent for rabbit feed. Although planting fodder on a large scale to feed domestic animals is not a traditional practice in much of West Africa, there is no reason why it should not be adopted. In America, Australia, Europe and Asia it is a common practice to grow alfalfa, clover and other plants specifically as animal fodder.



5.4.1 *Desmodium tortuosum*

This plant is now becoming fairly abundant but it still is not found in sufficient quantity for raising animals. It is highly recommended for planting on a large scale. The leaf contains some juice. When it was tested with a refractometer to determine its sugar content, this was found to be 13 to 14 percent. The twigs, as well as the leaves, are eaten by many animals. As far as the rabbit is concerned, it is second only to the cabbage in the order of preference. All the *Desmodium* species are palatable and can be grown from seed.

5.4.2 *Caloponium mucunoides*

This plant is regarded as one of the best rabbit foods. It is a creeper and looks like *Centrosema pubescens*. The main feature which distinguishes the two plants is that *C. mucunoides* has a hairy stalk whereas the stalk of *C. pubescens* lacks hair. *Caloponium mucunoides* propagated from seed and will grow prolifically if it is properly managed.

5.4.3 *Melanthera scandens*

Many people confuse this plant with *Aspilia africana*. In Ghana, the Akan people call *Melanthera scandens* 'mfofo bere' and *A. africana* 'mfofonini'. *M. scandens* resembles the wild plant *Chromolaena odorata* and until recently it provided large quantities of greens for rabbits. The introduction of *C. odorata*, however, has threatened the growth of many other plants. Much of the area that was previously occupied by *M. scandens* now given over to *C. odorata* which is of no use as animal food. *M. scandens* easily cultivated in moist areas around towns and villages, especially near garbage disposal areas. It can be grown from seed

or from cuttings. If a fodder farm is being developed, it is important that it should be located near the rabbit rearing area; otherwise, the farmer will need a vehicle to transport the feed.

5.5 Solids and grains

In addition to greens, rabbits should be given grains and foods containing carbohydrates and oil to ensure a balanced diet. Rabbit farmers should also remember that salt is an essential part of the rabbit's diet; if a rabbit is seen gnawing at the wood in a cage, this is a sign that the animal is lacking salt. Salt should be put into the water to taste. Some grains should be given with about 0.05 percent salt added.

5.5.1 Carbohydrates

Carbohydrates are energy-giving foods and are an essential component of a balanced diet. The dried pulp of sugar cane, if ground and mixed with grains and dried leaves and then formed into pellets, is a useful feed.

The cassava plant also provides a good meal. The cassava should be cooked and salt added to taste. Surplus food from the house, such as peels, should be collected and salt added to taste. The mixture can then be dried and formed into biscuits. Other items which can form a good meal are bread (especially the crust), banku, kenkey, rice, plantain and cocoyam (boiled or raw).

5.5.2 Oil

Never waste palm fruit and the chaff. Collect the chaff from places where palm soup has been prepared for the day and soak it in salt (to taste). It should then be ready to feed to rabbits. Not only is this a good meal for rabbits but they enjoy the palm soup as well.



5.5.3 Grains

Rabbits enjoy all grain foods. The part of the grain which should be given to them is the husk (the outer covering of rice, maize, millet, etc). The spent grain from brewers' malt is also good food. It is worth visiting a local brewery, collecting the spent grain and drying it. It is high in nutrients for rabbits. Some breweries sell excellent dry spent grain to farmers rearing poultry, pigs and other livestock. Maize and rice husks can be collected, sometimes free of charge, from corn mills. Always keep grain products in feeding troughs which are designed in such a way as to prevent rabbits from scattering their droppings into them (see Figure 12).

Figure 12. Trough

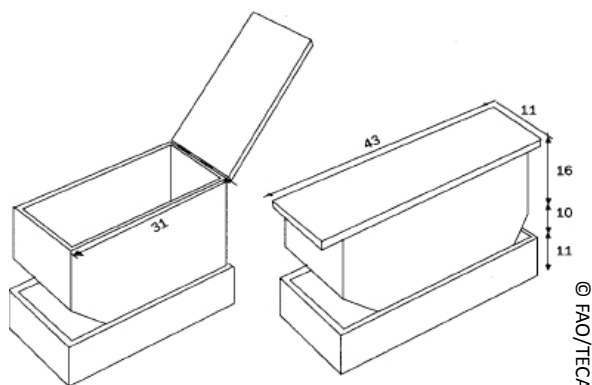

Young rabbits have the habit of soiling their dry food in this manner; they will then reject it, even when they are very hungry. It is important that feed troughs are properly designed to allow food to be kept for a few days at a stretch, depending on the number of rabbits that are in the hutch. If troughs intended for storing only dry grain are well designed, there is no need to clean or wash them frequently.

5.6 Water

A reliable supply of clean water is essential. A restricted supply of water will inhibit

food intake, restrict growth and reduce the supply of milk. Fresh leaves contain some water but not enough to meet the rabbit's needs. If rabbits consume large quantities of dried foods, an abundant supply of water will be required. A doe about to give birth must have large quantities of good drinking water. After delivery, she will drink large quantities to fill her stomach. In the absence of automatic watering devices, the rabbit farmer must provide a suitable heavy bowl inside the cage.

Light drinking containers will be tipped over. Special earthenware bowls, about 15 cm in diameter with a wide base, are suitable, easy to clean and are not easily tipped over. For medium - to - large-scale rabbit farms, the automatic watering device depicted in Figure 12 is very useful. It was previously imported from Europe and America but it is now made locally.

5.7 Feeding methods

Fresh leaves and any other type of food scattered in the rabbit cages will be turned into bedding material and also into a place for fouling. The farmer will think there is enough food in the cage for the animal but rabbits will not eat soiled food. Green leaves should always be suspended off the ground in a hanging position. Rabbits will also reject greens which have been collected from the roadside, especially those which smell smoky or oily from motor vehicle engines.

Always ensure that greens are collected from clean places. Farmers should make sure there is always enough food in the cage, remembering that rabbits need food during the night. Grains must be placed in a trough or a heavy bowl which the rabbits cannot tip over.



5.8 Transporting a rabbit feed

The smaller a rabbit farming operation, the easier it is to provide food for it. But once the enterprise starts growing, the problem of acquiring adequate supplies of greens and other food arises.

Most areas of West Africa are fortunate in that there is no lack of greens and other appropriate foods for rabbits, but what they do lack is an appropriate vehicle for transporting food supplies.

6. Selecting breeding stock

Breeding stock must be selected from among the best that is available to ensure that only desirable traits are passed on to the offspring. There are several qualities to look for in breeding stock.

- The animals must be prolific breeders.
- They should have a good growth rate.
- They must be good converters of food.
- They should have a high meat to bone ratio.

Small, lean and unhealthy rabbits as well as old, sterile, castrated and deformed animals must be disposed of. They can be used as a source of meat and but should not be used for breeding purposes.

6.1 Selecting a good doe

A doe which is to be used for breeding purposes should have reached adulthood (five months old or more). She should be strong and able to protect her young from attacks. She should have at least eight teats, all visible and normal.

A doe which scatters her young rabbits around the cage should be watched; if she does this more than once she is not a good mother and should be culled for meat. A doe can deliver any number of young ones, up to a maximum of 16, but she should be

allowed to care for a maximum of only eight or for as many as she has teats.

6.2 Selecting a good buck

It is the buck who largely determines the quality of the breeding operation. His size, his colouring and most of his other features will be inherited by his offspring. His influence is therefore usually much greater than that of the female. Care must therefore be taken to select only the best specimens.

The buck should be well built and have a round head, sound feet, a broad and meaty body and a good undercoat of fur. He should have short claws. The testicles must be visible and well developed. There should be no bite marks. If young bucks of about 14 weeks old are left together in one cage they usually fight and try to castrate one another. The buck must show no sign of discharge from its nose or other symptoms of disease. He must be well fed to ensure virility.

6.3 Inbreeding

The main reason why many animal breeders, including rabbit farmers, have remained small-scale operators is that the death toll of their animals is high. Often, no cause can be found. Farmers who have experienced this problem should check the degree of inbreeding that has taken place. It is a common practice to keep male offspring in the same barn. It is a common sight, for example, to see a young goat having sex with his mother or sisters. If this goat matures in the place where he was born, he will continue to cover his relatives.

A farm where this is allowed to happen is doomed because the offspring will become weaker and weaker and the infant mortality rate greater and greater.



An experiment involving ten female rabbits was conducted in 1984. Brothers were selected to mate with mothers and, in some cases, with sisters. The young rabbits produced by some of the sisters all died before they reached the weaning stage. When the females which had been used in this experiment were next on heat, they were sent away to be covered by another farmer's bucks. The researcher established that the males used for mating were in no way related to the does. Seventy-two young were produced. None of them died and all were sold at the age of four months.

In another case, in 1989, a rabbit forced himself into a cage containing three of his sisters whom a researcher had kept for breeding purposes. In less than 30 minutes the rabbit managed to cover all three sisters. They were allowed to litter and they gave birth to 21 young. All the young died in less than a week.

These examples illustrate the results of inbreeding. How can the problem be solved?

Rabbit farmers should make certain that they obtain their breeding stock from parents who are not related to one another in any way. To ensure that this is so, it is advisable to buy all the does from one farm and the bucks from another farm, situated as far away as possible from the farm where the does came from. Another suggestion is that it is possible for a breeder to maintain two or more streams of different bloodstock (that is, stock deriving from different parents), making it possible for a single farm to supply all the breeding stock required by someone who is establishing a rabbit farm.

Inbreeding will be prevented if farmers follow certain guidelines.

- Make sure that members of their breeding stock are not closely related.
- Sell, castrate or remove any males born to ensure that they do not mature and mate with their sisters, mothers or other close relatives.
- If the animals are kept on a free-range basis, make sure that the males are changed at least every year.
- If some of the best males from the farm are to be kept for breeding purposes, make sure they do not cover any close relatives.
- When purchasing breeding stock always ask the farmer whether it is possible to buy females and males which have no blood relationship.
- Never obtain breeding stock from a farmer who appears to be dishonest in any way.

6.5 Age of breeding stock at purchase

Young rabbits are weaned between six and eight weeks. These rabbits are only worth purchasing if they come from a well-organised farm where inbreeding cannot occur. However, if farmers are not certain whether there has been inbreeding, they should buy rabbits which are older than eight weeks (some inbred rabbits die within a few weeks of weaning). On some farms pregnant does are sold, but it is important to obtain information on when the does were covered so that the expected delivery dates can be calculated.

7. Record keeping

Record keeping is an essential part of the breeding operation. A family history and breeding record must be kept for every breeding doe and buck. The seller must be ready to provide accurate information about every animal, young or old, whenever a buyer requests it.



Figure 8 in section four provides an example of a record sheet.

8. Disease and pests

Rabbits that are properly cared for (well fed and watered and kept clean and dry) will avoid most diseases. Diseases reduce the weight of the animals, resulting in the loss of meat and in deaths. Curing rabbit diseases is very difficult if there is not a good veterinary officer in the locality. For example, it is difficult to force a rabbit to take any drugs. It is advisable, therefore, to wash the cages weekly with a strong disinfectant and, generally, to maintain strict standards of hygiene. Avoid insecticides because these preparations may be dangerous if ingested by the animals. There are some insecticides, such as Opigal 50 and Asuntol 50, which are known to be harmless to animals.

Nature has endowed most animals with the instinct to eat certain leaves which have curative properties. Some of the illnesses which afflict them can be cured if they eat the appropriate leaves. If the animals are allowed to move about freely they can cure themselves. Rabbits kept in hutches, however, are unable to do this. It is essential, therefore, that the breeder provides a variety of leaves for the rabbits so that a sick rabbit might, by chance, eat the particular leaf required to cure itself. Rabbits that die from an unknown cause should be removed and burnt, and the cages they occupied should be thoroughly cleaned and disinfected.

8.1 Signs of sickness

A sick rabbit becomes dull and inactive. Its eyes turn pale, it loses weight and it sometimes produces a watery discharge from the anus, nose and eyes. The feces of a rabbit can sometimes give a clue that the animal is sick.

8.2 Diseases

8.2.1 Diarrhea

The commonest disease the rabbit farmer will come across is diarrhea. This is usually caused by the rabbit consuming the wrong food, such as sweet potatoes or the larvae of certain species of butterfly. When rabbits have diarrhea, they become dull and begin to discharge watery green droppings. Some forms of diarrhea can kill a rabbit within 24 hours. Diarrhea can be prevented by providing the rabbits with freshly cut and dried greens.

8.2.2 Coccidiosis

This is caused by the rabbit consuming tiny parasitic creatures which crawl around in feeding troughs and watering bowls or on the hutch walls. It can result in diarrhea. The affected rabbits will sit hunched up and extend their hind legs forward. They will also lose weight. To prevent this disease, it is important to keep the cages very clean. If the disease persists for a long time, call in a veterinary doctor.

8.2.3 Ear canker

Small mites may burrow under the rabbit's skin, especially in the ears. The scabs must be removed with warm water and palm oil or vaseline applied to the affected area. Also, pour some palm oil into the affected ear.

8.2.4 Warbles

If dirt is allowed to build up in and around rabbit hutches, the rabbits might develop warbles. Warbles is the result of eggs being laid in the fur of the rabbit, usually on its legs or feet, on the nose and around the eyes or on the fringes of the ear. When the eggs hatch, tiny maggots burrow under the skin to form a small lump under the fur of the rabbit. The rabbit may scratch the



spot and this in turn might cause infection. Warbles have developed on the nose of the rabbit in Figure 18. A knife may be used to open or remove the lump. Then dilute a small quantity of Opigal 50 powder and apply it to the affected area, repeating this treatment after a week if necessary. Warbles may also be effectively treated with palm oil.

8.2.5 Colds

When a rabbit has a cold, it will sneeze and mucous will be discharged from its nostrils. Rabbits with colds should be isolated because the cold might develop into another illness which could spread to other rabbits and kill them.

8.2.6 Worms

Rabbits may have worms. These are white and sometimes coiled. To de-worm a rabbit, feed it pawpaw if available. The pawpaw plant is a natural de-wormer. The best remedy is to give the rabbit, every four weeks or so, dry pawpaw leaves or a mixture of a few mashed dried pawpaw seeds and grain. This will remove most of the worms.

8.2.7 Wry neck

Rabbits are sometimes afflicted by a disease known as wry neck. Their necks become twisted and they lose their sense of balance. Some farmers prescribe total destruction as the cure and to prevent the ailment being transferred to other rabbits. Our experience, however, is that wry neck can be completely cured in about 6 weeks without the use of any medication, and that the disease is not transferable.

One case reported to us is worth quoting here:

“My rabbit had a terrible twist of the neck for more than two months. Friends

advised me to destroy the animal but I decided to leave it alone to see what would happen without any treatment. At the end of the second month the neck started turning to its original position, and two weeks later the animal was completely healed. The disease was not transferred to another rabbit although the affected rabbit was paired with a young buck in the same cage”.

8.2.8 Head banging

A strong rabbit which shows no symptom of any disease or illness may, without warning, run at tremendous speed into any obstacle in front of it, banging its head in the process. It will continue doing this until it dies. It is not known what causes this, or what the cure might be. Usually, by the time a veterinary officer gets to the farm the rabbit will have died.

8.3 Pests

8.3.1 Dogs

Dogs are the worst enemies of rabbits. If they get the slightest chance, they will, in a short space of time, kill all the rabbits found in any one place. Always safeguard rabbits from dogs by keeping the dogs indoors or away from the hutch area and making sure that the rabbit hutches are strong enough to give the animals the protection they need.

8.3.2 Cats

Wild cats and some domestic cats will molest rabbits. They will catch a young rabbit and eat only its nose, leaving the rest of the carcass in the coop. If properly made, hutches will keep cats out.

8.3.3 Mice and shrews

Some nursing does are unable to drive away mice and shrews which enter the hutches and kindling boxes and eat the



young rabbits. If mice and shrews are not destroyed, they will eventually eat all the young rabbits. To prevent this from happening, traps can be placed outside the hutch. Alternatively, poison can be used (rat poison is effective). When poison is being used, the farmer must provide water; after consuming the poison and drinking water, the mice or shrews die before they reach the rabbits. Always keep poisons on the ground near the hutches.

8.3.4 Snakes

It is always possible that dangerous snakes such as cobras and puff adders may approach the hutches. If there are young rabbits, they are likely to be visited by a black cobra every three to four days. The snakes may swallow the rabbits whole. There are several effective ways of dealing with snakes. The first is to kill them, using hard-boiled eggs as bait. The snake swallows the egg whole but its stomach cannot digest it, and the snake dies in the bush, away from the hutch. The second is to use 2 cm wire mesh when constructing the hutches. The third is to grow shallots or onions around or close to the hutches. The scent of shallots or onions will keep all types of snakes away.

8.3.5 Fleas and lice

Some of the fleas that infest rabbits are similar to those found on dogs. They jump quickly from one spot to another. They

suck blood and cause rabbits to lose fur. Fleas should be destroyed with Opigal 50 or Asuntol 50, or similar drug powders. One tablespoonful of either of these solutions will destroy fleas and lice on rabbits within a few hours. The rabbit is dipped into the solution or lightly washed with the liquid. There is no need to remove food when applying Opigal or Asuntol, any quantity ingested by the animal will not be harmful. The new Chinese 'miraculous' insecticide chalk is good to apply. Eamatox is also good for fighting fleas and lice.

9. Validation of the practice

The practice was tested and validated by farmers in Nigeria

10. Minimum requirements for the successful implementation of the practice

- Capital to start the venture

11. Agro-ecological zones

- Tropics, warm

12. Objectives fulfilled by the project

12.1 Women-friendly

Rabbit rearing is not a drudgery task and can be done by women

12.2 Pro-poor technology

It does not need a lot of capital to start rabbit farming