



MRCET CAMPUS

MALLA REDDY COLLEGE OF ENGINEERING & TECHNOLOGY **(AUTONOMOUS INSTITUTION - UGC, GOVT. OF INDIA)**

Affiliated to JNTUH; Approved by AICTE, NBA-Tier 1 & NAAC with A-GRADE | ISO 9001:2015
Maisammaguda, Dhulapally, Komapally, Secunderabad - 500100, Telangana State, India

LECTURE NOTES

ENGINEERING PHYSICS

2021-22 (R20)



PREFACE

Physics is a fundamental aspect of science on which all engineering sciences are made. The fundamental concepts of physics have given the way for the development of engineering branch and technologies. All modern technological advances from laser micro surgery to television, from computers to mobile phones, from remote controlled toys to space vehicles, directly work on the principles of physics. Accordingly, the syllabus of engineering courses includes physics as an essential subject. The physics syllabus in engineering course is primarily divided into two parts i.e. applied physics & Engineering physics as per curriculum requirement in universities & engineering colleges in India. Engineering physics is also known as Technical physics related to both science & technology. Engineering physics is more focussed on research/development/improvement of the industry & technology. The scope of engineering physics is extended to various fields of Engineering & Technology. An engineer needs to think in a creative manner to solve the real times problems of world by using the weapon of technology. Thus a study of engineering physics gives the students an opportunity to develop their skills & creativity. The present hand-book/material of engineering physics is divided into five units i.e. Unit-1 deals with Harmonic oscillations, Unit-2 deals with wave optics, Unit-3 deals with Introduction to solids, Unit-4 deals with Dielectric and Magnetic properties of materials, Unit-5 deals with lasers and fiber-optics.

Unit-1 deals with Simple harmonic oscillation & simple harmonic oscillator, equation of motion and its solution, damped harmonic oscillator, equation of motion and its solution, types of damping effects i.e. over, critical and under damped motion, energy decay in damped oscillator, Quality factor, forced harmonic oscillator, equation of motion and its solution. Students able to know the working principles of various oscillating mechanical & electrical systems subjected to damping forces in real time experience in practical's or experiments in lab. Students know the importance of oscillations and waves which are prime types of motion & responsible for communication i.e. seeing, speaking & hearing with the outside world. Harmonic oscillations can arise from isolated or coupled oscillator in the system.

Unit-2 covers Wave-Optics deals with Interference, superposition of waves, interference of light by division of wave front-interference of reflected light in thin films, interference of amplitude-Newton's rings, Diffraction-Diffraction- difference between Fresnel and Fraunhofer diffraction, Fraunhofer diffraction due to single slit, Diffraction grating- Grating spectrum and resolving power. Students will be familiar with interference and diffraction concepts by performing expts in optics lab such as Newton's rings, dispersive power of prism, diffraction grating expt with the help of optical devices (Microscopes & Telescopes) & different light sources and know the significance of wave optics in science & engineering technology.

Unit-3 covers Introduction to solids which deals with free electronic theory (Classical & Quantum), Fermi level, and density of energy states, periodic potential, Bloch's theorem, Kronig-Penny model, E-K diagram & effective mass of an electron, Origin of energy bands & classification of materials into metals, insulators & semiconductors. Students will be to think and judge the electric response of materials/solids largely stems from the dynamics of electrons, and their interplay with atoms and molecules. Students will be familiar with Fermi level and classification of materials based on band –gap of solids.

Unit-4 covers Dielectric & Magnetic properties of materials. The dielectric materials deals with introduction & basic definitions of dielectric materials, types of polarizations(Electronic & Ionic) and calculation of their polarizabilities, internal fields in a solid , Clausius-Mossotti relation. Magnetic materials with introduction & basic definitions, Origin of magnetic moment(Bohr magneton), classification of dia, para & ferro magnetic materials, properties of anti-ferro and ferri magnetic materials, Hysteresis curve based on domain theory, soft and hard magnetic materials. Dielectric materials finds useful in capacitor, power transformer, cables, spark generators, transducers. A magnetic material finds application in making of permanent magnets, core materials for inductance coils & transformers, relays & heavy current engineering.

Unit-5 deals with Lasers & Fibreoptics first chapter of unit-5 deals with lasers where students were able to study the laser principles and features, absorption and emission(spontaneous & stimulated mechanisms), Population inversion and various pumping schemes of laser systems, laser mechanism and types of laser systems such as Ruby, He-Ne & Semiconductor lasers & its applications.

The second chapter of unit-5 deals with fiber-optics where students were able to know about principle & construction of optical fibers, Acceptance angle & N.A. relations, modes of propagation of light through step-index and graded index fibers(Single & Multi-mode fibers),optical communication system & applications of fibers. Students were able to know the importance of optical fiber & lasers in photonics and fiber-optics industry. Optical fibers finds application in communication and broadcasting the information from place to place.

The concepts in this material are explained in very lucid manner & the contents are optimised so that student will follow & digest the content. Language is simple & self explanatory. Authors express their happiness on the encouraging welcome given to hand book/material made by physics faculty all over. We are thankful to all physics faculty in taking pain in preparation of the digital content/hand-book. Comments and feedback for the improvement of hand book is welcome & appreciated. I hope this material will be beneficial to both students for preparation of internal & final semester exams.

AUTHORS

CONTENTS

UNIT	NAME OF THE UNIT
1	HARMONIC OSCILLATIONS
2	WAVE OPTICS
3	INTRODUCTION TO SOLIDS
4	DIELECTRICS AND MAGNETIC PROPERTIES OF MATERIALS
5	LASERS AND FIBEROPTICS

MALLA REDDY COLLEGE OF ENGINEERING & TECHNOLOGY

B. TECH- I- YEAR- I-SEM

L	T	P	C
3	-	-	3

(R20A0012) ENGINEERING PHYSICS

COURSE OBJECTIVES:

1. To gain the knowledge on the basic concepts of oscillations exhibited by various systems in nature.
2. To Study the basic concepts of light through interference and diffraction.
3. To explore band structure of the solids and classification of materials.
4. To Compare dielectric and magnetic properties of the materials and enable them to design and apply in different fields.
5. To analyze the ordinary light with a laser light and realize the transfer of light through optical fibers.

UNIT – I

HARMONIC OSCILLATIONS

(10Hours)

Introduction to harmonic oscillators, simple harmonic oscillator: equation of motion and its solution (complex exponential method), damped harmonic oscillator: equation of motion and its solution, over, critical and lightly-damped oscillators; energy decay in damped harmonic oscillator, Quality factor (qualitative), forced damped harmonic oscillator: equation of motion and its solution.

UNIT – II

WAVEOPTICS

(10Hours)

Interference- Introduction, Superposition of waves, interference of light by division of wave front-interference of reflected light in thin films, interference of light by division of amplitude- Newton's rings, Diffraction- difference between Fresnel and Fraunhofer diffraction, Fraunhofer diffraction due to single slit, Diffraction grating- Grating spectrum and resolving power.

UNIT- III

INTRODUCTION TO SOLIDS

(7 Hours)

Free electron theory (Classical & Quantum): Assumptions, Merits and drawbacks, Fermi level, Density of states, Periodic potential, Bloch's theorem, Kronig – Penny modal , E – K diagram, Effective mass, Origin of energy bands in solids, Classification of materials : Metals, semi conductors and insulators.

UNIT – IV

DIELECTRICS AND MAGNETIC PROPERTIES OF MATERIALS

(10 Hours)

Dielectrics: Introduction, Types of polarizations (Electronic and Ionic) and calculation of their polarizabilities, internal fields in a solid, Clausius-Mossotti relation.

Magnetism: Introduction, Bohr magneton, classification of dia, para and ferro magnetic materials on the basis of magnetic moment, Properties of anti-ferro and ferri magnetic materials, Hysteresis curve based on Domain theory of ferro magnetism, Soft and hard magnetic materials.

UNIT-V

LASERS

(10 Hours)

Characteristics of lasers, Absorption, Spontaneous and Stimulated emissions, Einstein's Coefficients, population inversion, meta stable state, types of pumping, lasing action, construction and working of Ruby Laser, Helium-Neon Laser, CO₂ Laser, Applications of lasers.

Fiber Optics: Introduction to optical fiber, Construction and working principle of an Optical Fiber, Acceptance angle and Numerical aperture, Types of Optical fibers - Mode and Propagation through step and graded index fibers, Attenuation in optical fiber, Optical Fiber in Communication System, Applications of optical fibers

TEXT BOOKS:

1. Engineering Physics by Arumugam, Anuradha publications.
2. Engineering Physics- B.K. Pandey, S. Chaturvedi, Cengage Learning.

REFERENCES:

1. Engineering Physics – R.K. Gaur and S.L. Gupta, DhanpatRai Publishers.
2. Engineering Physics, S Mani Naidu- Pearson Publishers.
3. Engineering physics 2nd edition –H.K. Malik and A.K. Singh.
4. Engineering Physics – P.K. Palaniswamy, Scitech publications.
5. Physics by Resnick and Haliday.

COURSE OUTCOMES: After completion of studying Engineering Physics the student is able to,

1. Analyze the various oscillations made by different oscillating bodies in nature.
2. Design different devices to go to maximum accuracy in measuring the dimensions optically.
3. Find the importance of band structure of solids and their applications in various electronic devices.
4. Examine dielectric, magnetic properties of the materials and apply them in material technology.
5. Observe the properties of light and its engineering applications of laser in fiber optic communication systems.

UNIT I HARMONIC OSCILLATIONS

Introduction to harmonic oscillators

To and fro motion of a particle about the equilibrium position is known as oscillations.

Any motion which repeats itself after equal intervals of time is called a periodic motion or harmonic motion.

Ex: Spin of earth, the motion of a satellite around a planet, moon around the earth etc.

There are two types of oscillators

- i) Mechanical oscillators
- ii) Electrical oscillators

The oscillations which are due to change in mechanical quantities such as displacement, velocity, acceleration are known as mechanical oscillations. These oscillations belong to mechanical oscillator.

Ex: Spin of earth, moon around the earth etc..

The oscillations which are due to electrical and magnetic field vectors in visible light, radio waves etc are known as electrical oscillations. These oscillations belong to electrical oscillators.

Ex: A tuned circuit and closed metal cavity oscillate electro magnetically.

Simple harmonic motion

The oscillatory motion in which the force is directly proportional to the displacement is called simple harmonic motion (S.H.M). The particle or body executing S.H.M is called a simple oscillator. Since force is proportional to the displacement, the acceleration is not constant but varies with time.

Simple harmonic oscillator:

When a particle or body moves such that its acceleration is always directed towards a fixed point and varies directly as its distance from that point, the particle or body is said to execute S.H.M. The particle or body executing simple harmonic motion is called a simple oscillator.

Equation of motion of a simple oscillator:

Equation of motion of a simple oscillator

Consider a particle p of mass 'm' executing S.H.M about equilibrium position 'o' along X-axis. Let x be the displacement of p from o at any instant, then the restoring force F acting upon p is given by

$$F \propto -x$$

$$F = -kx \text{ ----- (1)}$$

Where 'k' is proportionality factor which represents the force per unit displacement, -ve sign indicates force F is opposite to the displacement.

According to Newton second law of motion

$$F = \text{mass} \times \text{acceleration}$$

$$F = m \frac{d^2x}{dt^2} \text{ ----- (2)}$$

From equation (1) and (2)

$$m \frac{d^2x}{dt^2} = -kx$$

$$\frac{d^2x}{dt^2} = -\frac{k}{m}x$$

$$\frac{d^2x}{dt^2} = -\frac{k}{m}x$$

$$\frac{d^2x}{dt^2} = -\frac{k}{m}x$$

$$\frac{d^2x}{dt^2} + \frac{k}{m}x = 0$$

$$\frac{d^2x}{dt^2} + \omega^2x = 0$$

This is known as the differential equation of simple harmonic oscillation.

Solution using complex exponential method

The simple harmonic oscillator is

$$\frac{d^2x}{dt^2} + \omega^2x = 0 \text{ ----- (1)}$$

$$\text{Where } \omega^2 = \frac{k}{m}$$

Let us assume a trial solution of the form

$$x = Ce^{\alpha t} \text{ ----- (2)}$$

Where 'C' and 'α' are arbitrary constants.

By differentiating we get

$$\frac{dx}{dt} = C\alpha e^{\alpha t}$$

$$\frac{d^2x}{dt^2} = C\alpha^2 e^{\alpha t} \text{ ----- (3)}$$

Sub (2),(3) in (1), we get

$$C\alpha^2 e^{\alpha t} + \omega^2 C e^{\alpha t} = 0$$

$$C e^{\alpha t} (\alpha^2 + \omega^2) = 0$$

$$(\alpha^2 + \omega^2) = 0$$

$$\alpha^2 = -\omega^2$$

$$\alpha = \pm i\omega$$

From eq(2)

$$x = C_1 e^{+i\omega t} + C_2 e^{-i\omega t}$$

Where C_1 and C_2 are arbitrary constants

$$x = C_1 [\cos \omega t + i \sin \omega t] + C_2 [\cos \omega t - i \sin \omega t]$$

$$x = (C_1 + C_2) \cos \omega t + i(C_1 - C_2) \sin \omega t$$

Let us put $C_1 + C_2 = a \sin \phi$ and $C_1 - C_2 = a \cos \phi$

Where a and ϕ are constants

$$x = a \sin \phi \cos \omega t + i a \cos \phi \sin \omega t$$

$$x = a \sin(\omega t + \phi) \text{ ----- (4)}$$

Equation (4) is the solution of simple harmonic motion.

Damped harmonic oscillator:

Definition: Damped harmonic motion is defined as decay or decrease of amplitude of motion with respect to time in presence of air or other medium. The oscillator which performs such type of motion is known as damped harmonic oscillator.

Ex: Motion of tuning fork, Motion of simple pendulum. etc.

Equation for damped harmonic oscillator:

The damped system is subjected to:

- i) A **restoring force** which is proportional to displacement but oppositely directed. This is written as $-kx$ where k is force constant.
- ii) **Frictional force:** Frictional force is proportional to velocity but oppositely directed, given by

$$f_2 \propto -\frac{dx}{dt}$$

$$f_2 = -r \left(\frac{dx}{dt} \right) \text{ ----- (2)} \quad \text{Where 'r' is frictional force per unit velocity.}$$

Since, $\text{force} = \text{mass} \times \text{acceleration} = m \frac{d^2x}{dt^2}$

Therefore, the equation of the motion of particle is given by

$$m \frac{d^2x}{dt^2} = -kx - r \left(\frac{dx}{dt} \right) \quad \text{or} \quad \frac{d^2x}{dt^2} + \frac{r}{m} \frac{dx}{dt} + \frac{k}{m} x = 0$$

Or

$$\frac{d^2x}{dt^2} + 2b \frac{dx}{dt} + w^2 x = 0 \quad \dots \dots \dots (1)$$

Where

$$\frac{r}{m} = 2b \quad \text{and} \quad \frac{k}{m} = w^2$$

Here b is damping constant, and this is a differential equation of damped harmonic motion.

Solution of the equation:

Equation (1) is a differential equation of second degree .Let its solution be $x = Ae^{\alpha t} \dots \dots \dots (2)$ where A and α arbitrary constants.

Differentiating equation 2 with respect to t, we get

$$\frac{dx}{dt} = A\alpha e^{\alpha t} \quad \text{and} \quad \frac{d^2x}{dt^2} = A\alpha^2 e^{\alpha t}$$

Substituting these values in eq.(1), we have

$$A\alpha^2 e^{\alpha t} + 2b A\alpha e^{\alpha t} + w^2 A e^{\alpha t} = 0$$

$$A e^{\alpha t} (\alpha^2 + 2b \alpha + w^2) = 0$$

As

$$A e^{\alpha t} \neq 0 \quad \therefore (\alpha^2 + 2b \alpha + w^2) = 0$$

This gives

$$\alpha = -b \pm \sqrt{b^2 - w^2}$$

The general solution of eq. (1) is given by

$$x = A_1 e^{[-b + \sqrt{b^2 - w^2}]t} + A_2 e^{[-b - \sqrt{b^2 - w^2}]t} \dots \dots \dots (3)$$

Where A_1 and A_2 are arbitrary constants.

Different damping conditions:**Case – I, Over damped motion:**

When $b^2 > \omega^2$. In this case $\sqrt{b^2 - \omega^2}$ is real & less than b. Now the powers in eq. (3) are both negative. Thus this displacement x consists of two terms, both dying off exponentially to zero without performing any oscillations as shown in figure.

The rate of decrease of displacement is governed by the term $[-b + \sqrt{b^2 - w^2}]t$ as the other term reduced to zero.

In this case, the body once displaced returns to its equilibrium position quite slowly without performing any oscillation. This type of motion is called as **over damped** or **dead beat**.

Ex: Motion of simple pendulum moving in thick oil
a dead beat moving coil galvanometer.

Case II. Critical damping:

When $b^2 = \omega^2$, if we put $b^2 = \omega^2$ in equation (3), this solution does not satisfy the differential equation(1).

Let us consider $\sqrt{b^2 - \omega^2}$ is not zero, but this is equal to a very small quantity 'h'.
i.e. $\sqrt{b^2 - \omega^2} = h \rightarrow 0$

Now equation (3) reduces to

$$x = A_1 e^{(-b+h)t} + A_2 e^{-(b-h)t}$$

$$= e^{-bt} [A_1 e^{ht} + A_2 e^{-ht}]$$

$$= e^{-bt} [A_1(1 + ht + \dots) + A_2(1 - ht + \dots)]$$

$$= e^{-bt} [(A_1 + A_2) + ht(A_1 - A_2) + \dots \dots]$$

$$x = e^{-bt}(p + qt) \dots \dots (4)$$

Where $p = (A_1 + A_2)$ and $q = (A_1 - A_2)$

Eq.(4) represents a possible form of solution .

In this equation as 't' increases, e^{-bt} decreases and $[p + q t]$ increases and the damping is said to be critical.

Thus in the case of critical damping, the motion just becomes a periodic or non oscillatory.

Ex: This type of motion is exhibited by many pointer instruments such as Ammeter, **voltmeter**, etc, in which the pointer moves to the correct position and comes to rest much rapidly without any oscillations.

Case III. Under –damped motion:

When $b^2 < w^2$. In this case $\sqrt{b^2 - w^2}$ is imaginary. Let us write $\sqrt{b^2 - w^2} = i\sqrt{w^2 - b^2} = i\beta$ where $\beta = \sqrt{w^2 - b^2}$ and $i = \sqrt{-1}$

now eq.(3) becomes $x = A_1 e^{(-b+i\beta)t} + A_2 e^{(-b-i\beta)t}$

$$\begin{aligned} &= e^{-bt} (A_1 e^{i\beta t} + A_2 e^{-i\beta t}) \\ &= e^{-bt} ((A_1 \cos \beta t + i \sin \beta t) + A_2 (\cos \beta t - i \sin \beta t)) \\ &= e^{-bt} ((A_1 + A_2) \cos \beta t + i(A_1 - A_2) \sin \beta t) \\ &= e^{-bt} (a \sin \phi \cos \beta t + a \cos \phi \sin \beta t) \end{aligned}$$

Where $a \sin \phi = (A_1 + A_2)$ and $a \cos \phi = i (A_1 - A_2)$

$$= e^{-bt} a \sin(\beta t + \phi)$$

$$x = a e^{-bt} \sin(\sqrt{(w^2 - b^2)}t + \phi)$$

The above expression is the equation of motion of damped harmonic oscillator.

The amplitude of the motion continuously decreasing owing to the factor e^{-bt} which is called damping factor.

The factor $\sin(\sqrt{(w^2 - b^2)}t + \phi)$ varies between +1 to -1, therefore the amplitude also varies between $+a e^{-bt}$ and $-a e^{-bt}$. It is called under damped motion, b is called damping coefficient.

Ex: Motion of a pendulum in air, the electric oscillations of LCR circuit.

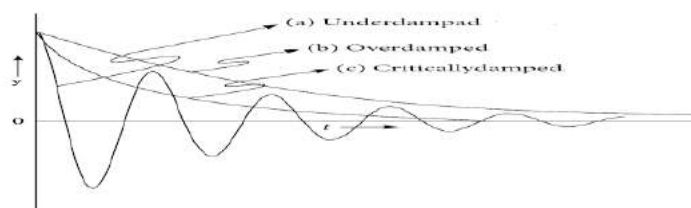

Return of a harmonic oscillator to equilibrium position. (a) Under damped (b) Over damped (c) Critically damped

Energy decay in damped harmonic oscillator (Energy dissipation):

Whenever the system is set into oscillations, its motion is opposed by frictional (damping) forces due to air resistance. The work done against these forces is dissipated out in the form of heat. So the mechanical energy of the system continuously decreases with time and amplitude of oscillation gradually decays to zero.

The displacement of a damped harmonic oscillator at any time is given by

$$x = ae^{-bt} \sin(\sqrt{(w^2 - b^2)} t + \phi) \\ = ae^{-bt} \sin(w't + \phi) \dots \dots \dots (1)$$

$$\text{where } w' = \sqrt{w^2 - b^2}$$

Then velocity, $\left(\frac{dx}{dt}\right) = -abe^{-bt} \sin(w't + \phi) + aw'e^{-bt} \cos(w't + \phi) \dots \dots \dots (2)$

If damping is very small i.e. $b \ll w$. Hence the term $-abe^{-bt} \sin(w't + \phi)$ can be neglected in comparison with the term $aw'e^{-bt} \cos(w't + \phi)$.

Then $\frac{dx}{dt} = aw'e^{-bt} \cos(w't + \phi) \dots \dots \dots (3)$

The mechanical energy E of oscillator is given by

$$E = \text{Kinetic energy} + \text{Potential energy} \\ = \frac{1}{2} m \left(\frac{dx}{dt}\right)^2 + \frac{1}{2} \mu x^2 \dots \dots \dots (4)$$

Substituting the value of $\frac{dx}{dt}$ and x from equations (3) and (1) in eq.n (4),

$$E = \frac{1}{2} ma^2 w'^2 e^{-2bt} \cos^2(w't + \phi) + \frac{1}{2} \mu a^2 w'^2 e^{-2bt} \sin^2(w't + \phi) \\ = \frac{1}{2} ma^2 \frac{\mu}{m} e^{-2bt} \cos^2(w't + \phi) + \frac{1}{2} \mu a^2 e^{-2bt} \sin^2(w't + \phi)$$

$$\therefore w' = \sqrt{w^2 - b^2} \approx w = \sqrt{\left(\frac{\mu}{m}\right)}$$

$$= \frac{1}{2} a^2 \mu e^{-2bt} (\cos^2(w't + \phi) + \sin^2(w't + \phi))$$

$$= \frac{1}{2} a^2 \mu e^{-2bt}$$

$$= \frac{1}{2} a^2 m w^2 e^{-2bt}$$

$$E = \frac{1}{2} a^2 \mu e^{-2bt}$$

This shows that the energy of oscillator decreases with time.

Quality factor(qualitative):

The quality factor is defined as 2π times the ratio of the energy stored in the system to the energy lost per period.

$$Q = 2\pi \frac{\text{energy stored in system}}{\text{energy lost per period}} = 2\pi \frac{E}{PT}$$

Where P is power dissipated and T is periodic time. We know that $P = \frac{E}{\tau}$, where τ is relaxation time. So

$$Q = 2\pi \frac{E}{\frac{E}{T}} = \frac{2\pi\tau}{T} = w\tau$$

Where $w = \frac{2\pi}{T}$ = angular frequency.

Forced damped harmonic vibrations

Forced vibrations can be defined as the vibrations in which the body vibrates with a frequency other than its natural frequency under the action of an external periodic force. Ex: consider the vibrations of bridge under the influence of marching solders, vibrations of a tuning fork when exposed to the periodic force of sound waves.

Equation of motion of forced harmonic oscillator

The forces acted upon the particle are:

- i) A restoring force

Restoring force is proportional to the displacement but oppositely directed, given by

$$f_1 \propto -x$$

$$f_1 = -kx \text{ ----- (1)}$$

Where 'k' is known as the force constant.

- ii) Frictional force

Frictional force is proportional to velocity but oppositely directed, given by

$$f_2 \propto -\frac{dx}{dt}$$

$$f_2 = -r \left(\frac{dx}{dt} \right) \text{ ----- (2)}$$

Where 'r' is frictional force per unit velocity.

- iii) The external periodic force

$$\text{It is represented by } f_3 = F \sin pt \text{ ----- (3)}$$

Where F is the maximum value of this force

So the total force acting on the particle is given by

$$\text{Total force} = f_1 + f_2 + f_3$$

From (1),(2) and (3)

$$\text{Force}(F) = -kx + -r \left(\frac{dx}{dt} \right) + F \sin pt$$

According to Newton second law of motion

F= mass × acceleration

$$F = m \frac{d^2x}{dt^2}$$

Hence

$$m \frac{d^2x}{dt^2} = -kx - r \left(\frac{dx}{dt} \right) + F \sin pt$$

$$m \frac{d^2x}{dt^2} + kx + r \left(\frac{dx}{dt} \right) = F \sin pt$$

$$\frac{d^2x}{dt^2} + \frac{k}{m}x + \frac{r}{m}\left(\frac{dx}{dt}\right) = \frac{F}{m}\sin pt$$

$$\frac{d^2x}{dt^2} + 2b\left(\frac{dx}{dt}\right) + \omega^2x = f \sin pt \text{ ----- (4)}$$

$$\text{Where } \frac{r}{m} = 2b \text{ and } \frac{k}{m} = \omega^2 \frac{F}{m} = f$$

Equation (4) is the differential equation of motion of the particle.

Solution of equation of forced oscillations

In this case, when the steady state is setup, the particle vibrates with the frequency of applied force and not with its own natural frequency.

The solution of differential equation (4) must be of the type

$$x = A \sin(pt - \theta) \text{ ----- (5)}$$

Where A is the steady amplitude of vibration and θ is the angle by which the displacement x lags behind the applied force $F \sin pt$. A and θ are arbitrary constants.

Differentiating equation (5) we get

$$\frac{dx}{dt} = Ap \cos(pt - \theta) \text{ ----- (6)}$$

$$\text{And } \frac{d^2x}{dt^2} = -Ap^2 \sin(pt - \theta) \text{ ----- (7)}$$

Sub (5),(6),(7) in (4), we get

$$-Ap^2 \sin(pt - \theta) + 2bAp \cos(pt - \theta) + \omega^2 A \sin(pt - \theta) = f \sin pt$$

$$A \sin(pt - \theta) (\omega^2 - p^2) + 2bAp \cos(pt - \theta) = f \sin(pt - \theta + \theta)$$

$$A \sin(pt - \theta) (\omega^2 - p^2) + 2bAp \cos(pt - \theta) = f \sin\{(pt - \theta) + \theta\}$$

$$A \sin(pt - \theta) (\omega^2 - p^2) + 2bAp \cos(pt - \theta) = f \sin(pt - \theta) \cos \theta + f \cos(pt - \theta) \sin \theta$$

Comparing the coefficients of $\sin(pt - \theta)$ and $\cos(pt - \theta)$ on b/s we get

$$A(\omega^2 - p^2) = f \cos \theta \text{ ----- (8)}$$

$$2bAp = f \sin \theta \text{ ----- (9)}$$

Square and add equations (8) and (9), we get

$$A^2(\omega^2 - p^2)^2 + 4b^2A^2p^2 = f^2$$

$$A = \frac{f}{\sqrt{(\omega^2 - p^2)^2 + 4b^2A^2p^2}} \text{ ----- (10)}$$

Where A is amplitude of forced vibrations.

Divide (9) by (8), we get

$$\frac{f \sin \theta}{f \cos \theta} = \frac{2bAp}{A(\omega^2 - p^2)}$$

$$\tan \theta = \frac{2bp}{(\omega^2 - p^2)}$$

$$\theta = \tan^{-1} \left(\frac{2bp}{(\omega^2 - p^2)} \right)$$

This is called phase of vibrations.

MRCET

UNIT II

WAVE OPTICS

Introduction:

Optics is a branch of physics which deals with the “Theory of light and its propagation in a given medium”. The branch of optics is divided into two parts

1. Ray or Geometrical optics and
2. Physical or Wave optics

Ray optics: Ray optics deals with image formation by optical systems. It was supported by Newton’s corpuscular theory. It deals with the particles propagating in a medium called “light-photons with energy $E_n = nh\nu$ in a medium”

Physical optics: Physical optics deals with nature of light. Huygens proposed the wave theory of light. According to this, a luminous body is a source of disturbance in a hypothetical medium called “ether”

Superposition Principle: According to superposition principle “The resultant or total displacement of the medium acted upon by two or more waves simultaneously equal to sum or difference of displacements of individual waves”.

$$R \text{ or } Y = y_1 \pm y_2 \pm \dots \pm y_n$$

Interference of light:

It is defined as “Modification of Resultant Intensity of light obtained by the superposition of two or more light waves”. This theory of interference of light was developed by Thomas young in his experimental study of light. The resultant intensity consists of series of bright & dark fringes that appear on the screen which are known as interference pattern or interference fringes which correspond to maximum & minimum intensities of light.

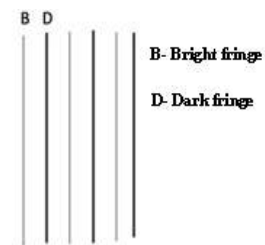

Fig: Interference fringe pattern

Interference pattern may be either straight or circular or parabolic (Arc) fringes

Coherent Sources: If the phase difference between two light waves emitted from two sources is zero or has a constant value then the sources are said to be coherent.

Incoherent- sources: If the phase difference between two light waves coming from two sources changes with time, the sources are called as “In-coherent Sources”.

Types of interference: Interference of light based upon young’s double slit experiment is divided into two types.

1. Constructive interference
2. Destructive interference

Constructive interference: When the two light waves reach a point in phase the resultant displacement (R_{Max} or Y_{Max}) is always equal to algebraic sum of individual displacements of the light waves. It is known as constructive interference.

$$R_{Max} \text{ or } Y_{Max} = y_1 + y_2 + \dots + y_n$$

Destructive interference: When the two light waves reach a point i.e. out of phase. The resultant displacement (R_{Min} or Y_{Min}) is always equal to the difference of displacements of the light waves. It is known as destructive interference.

$$R_{Min} \text{ or } Y_{Min} = y_1 - y_2 - \dots - y_n$$

Conditions for interference of light:

- 1) The two light sources emitting light waves should be coherent.
- 2) The separation between the two sources should be small.
- 3) The distance between the two sources and the screen should be large.
- 4) To view interference fringes, the back-ground (good-contrast) should be dark.
- 5) Amplitudes of two light waves are nearly equal.
- 6) The source should be mono-chromatic.
- 7) The sources should be narrow i.e. they must be small.

Interference of reflected light in thin films:

When light is incident on a (plane parallel) thin film, some portion gets reflected from the upper surface and the remaining portion is transmitted into the film. Again, some portion of the transmitted light is reflected back into the film by lower surface and emerges through the upper surface. These reflected light beams superimpose with each other, producing interference and forming interference patterns.

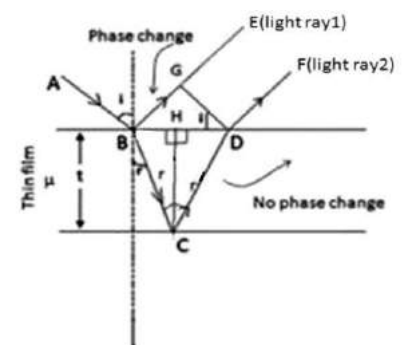

Fig-1: Interference in thin films due to reflection

Consider a thin film of thickness 't' and refractive index μ . Let a monochromatic light ray AB be incident at an angle of incidence of 'i' on the upper surface of the film. BE and BC are the reflected and transmitted light rays. Let the angle of refraction is 'r'. The ray BC will be reflected into the film and emerge through the film in the form of the light ray DF.

These two light rays superimpose depending upon path difference between them producing interference patterns. To know the path difference, let us draw the normal DG to BE. From D and G onwards, the light rays travel equal distances. By the time the light ray travels from B to G, the transmitted light ray has to travel from B to C and C to D.

The path difference between light rays (1) and (2) is

$$\Delta = \mu (BC+CD) \text{ (in film)} - BG \text{ (in air)} \quad \text{----- (1)}$$

$$\text{From triangle BCH, } BC = \frac{HC}{\cos r} = \frac{t}{\cos r}$$

$$\therefore BC = \frac{HC}{\cos r} = \frac{t}{\cos r}$$

$$\text{From triangle DCH, } \cos r = \frac{HC}{CD}$$

$$\Rightarrow \cos r = \frac{t}{CD}$$

$$CD = \frac{t}{\cos r}$$

$$BC = CD = \frac{t}{\cos r}$$

$$\Rightarrow (BC + CD) = \frac{2t}{\cos r} \quad \text{----- (2)}$$

To calculate BG, $BD = BH + HD$

$$\text{Triangle BHC, } \tan r = \frac{BH}{CH} = \frac{BH}{t}$$

$$\therefore BH = t \tan r$$

$$\text{Similarly } HD = t \tan r$$

$$BD = BH + HD = 2t \tan r \quad (\because BH = HD)$$

$$\text{From triangle BGD, } \sin i = \frac{BG}{BD}$$

$$\Rightarrow BG = BD \sin i$$

$$\therefore BG = 2t \tan r \sin i$$

$$\text{From Snell's law, } \mu = \frac{\sin i}{\sin r}$$

$$\sin i = \mu \sin r$$

$$BG = 2\mu t \tan r \sin r$$

Substituting the above values in equation-(1)

$$\begin{aligned} \text{pathdifference} &= \mu \left(\frac{2t}{\cos r} \right) - 2\mu t (\tan r) \sin r \\ &= \frac{2\mu t}{\cos r} (1 - \sin^2 r) \\ &= \frac{2\mu t}{\cos r} (\cos^2 r) \end{aligned}$$

$$\boxed{\text{pathdifference} = 2\mu t \cos r}$$

In the above case, the ray BE is reflected at the surface of a denser medium and hence it suffers an additional pathdifference equal to $\frac{\lambda}{2}$.

The ray BC suffers reflection at C, at the surface of a rarer medium and hence on emerging out at D, it suffers no additional path change.

Hence the net pathdifference between the two reflected rays DF and BE

$$\text{Total pathdifference} = 2\mu t \cos r + \frac{\lambda}{2}$$

When the pathdifference is an integral multiple of λ then the rays (1) and (2) will be in phase and appear as constructive interference.

$$\text{i.e., } 2\mu t \cos r + \frac{\lambda}{2} = n\lambda \quad (\text{Condition for the bright fringe})$$

$$2\mu t \cos r = n\lambda - \frac{\lambda}{2}$$

$$2\mu t \cos r = (2n - 1) \frac{\lambda}{2} \quad \text{where } n=0, 1, 2, \dots$$

When the pathdifference is half integral multiple of λ , the rays (1) and (2) meet in out of phase and undergo destructive interference.

$$\text{i.e., } 2\mu t \cos r + \frac{\lambda}{2} = (2n - 1) \frac{\lambda}{2} \quad (\text{Condition for the dark fringe})$$

$$2\mu t \cos r = (2n - 1) \frac{\lambda}{2} + \frac{\lambda}{2}$$

$$2\mu t \cos r = n\lambda \text{ where } n=0, 1, 2, \dots$$

Depending on the conditions the interference pattern consists of bright and dark fringes.

Newton's Rings:

Newton's rings are one of the best examples for the interference in a non uniform thin film. When a plano convex lens with its convex surface is placed on a plane glass plate, an air film of increasing thickness is formed between the two. The thickness of the film at the point of contact is zero.

If monochromatic light is allowed to fall normally and the film is viewed in the reflected light, alternate dark and bright rings concentric around the point of contact between the lens and glass plate are seen. These circular rings were discovered by Newton and are called as Newton's rings.

The plano-convex lens (L) of large radius of curvature is placed with its convex surface on a plane glass plate (P). The lens makes the contact with the plate at 'O'. The monochromatic light falls on a glass plate G held at an angle of 45° with the vertical. The glass plate G reflects normally a part of the incident light towards the air film enclosed by the lens L and the glass plate P. A part of the light is reflected by the curved surface of the lens L and a part is transmitted which is reflected back from the plane surface of the plate. These reflected rays interfere and give rise to an interference pattern in the form of circular rings. These rings are seen near the upper surface of the air film through the microscope.

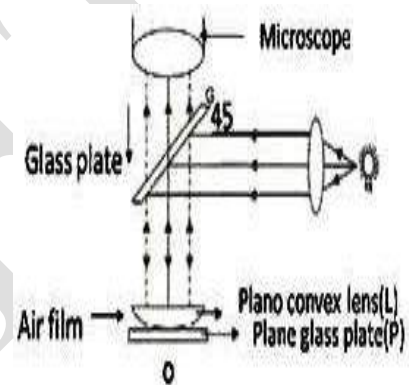

Fig 2 Newton's rings experiment

Explanation:

Newton's rings are formed due to interference between the light rays reflected from the top and bottom surfaces of air film between the plate and the lens. A part of the incident light is reflected at a point in the form of the ray (1) with any additional phase change. The other part is refracted and again reflected in the form of the ray (2) with additional phase change of π or path change of $\lambda/2$.

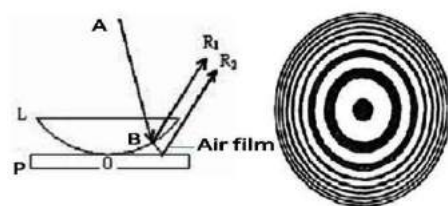

Fig: formation of Newton's rings

As the rings are observed in the reflected light, the path difference between the rays is

$$\text{path difference} = 2\mu t \cos r + \frac{\lambda}{2}$$

For air film $\mu = 1$ and for normal incidence $r = 0$,

then, $path\ difference = 2t + \frac{\lambda}{2}$

At the point of contact $t = 0$ the path difference is $\lambda/2$, i.e., the reflected light at the point of contact suffers phase change of π . Then the incident and reflected rays are out of phase and interfere destructively. Hence the central spot is dark.

The condition for the bright ring is $2t + \frac{\lambda}{2} = n\lambda$

$$2t = (2n - 1) \frac{\lambda}{2} \text{ where } n=1, 2, 3, \dots$$

The condition for dark ring is $2t + \frac{\lambda}{2} = (2n + 1) \frac{\lambda}{2}$

$$2t = n\lambda \text{ where } n=0, 1, 2, 3, \dots$$

Theory:

To find the diameters of dark and bright rings, let 'L' be the lens placed on a glass plate P. The convex surface of the lens is the part of spherical surface with centre at 'C'. Let R be the radius of curvature and r be the radius of Newton's ring corresponding to the film thickness 't'.

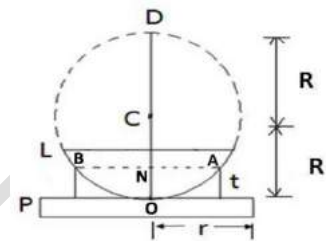

From the property of a circle,

$$NA \times NB = NO \times ND$$

$$r \times r = t \times (2R - t)$$

$$r^2 = 2Rt - t^2$$

where R is the radius of curvature of plano lens and 't' is the maximum thickness of air film

As 't' is small, r^2 will be negligible, $r^2 = 2Rt$

$$t = \frac{r^2}{2R}$$

Condition for bright ring is, $2t = (2n - 1) \frac{\lambda}{2}$

$$2 \frac{r^2}{2R} = (2n - 1) \frac{\lambda}{2}$$

$$r^2 = \frac{(2n - 1) \lambda R}{2}$$

Replacing r by $D/2$ the diameter of n^{th} bright ring will be

$$\frac{D_n^2}{4R} = \frac{(2n-1)\lambda}{2}$$

$$\therefore D \propto \sqrt{\text{odd natural number}} \quad (\text{for bright ring})$$

$$D \propto \sqrt{\text{natural number}} \quad (\text{for dark ring})$$

Thus, the diameters of dark rings are proportional to the square root of natural numbers and diameters of bright rings are proportional to odd natural numbers.

Determination of wavelength of a light source:

Let R be the radius of curvature of a Plano convex lens, λ be the wavelength of light used. Let D_m and D_n are the diameters of m^{th} and n^{th} dark rings are respectively.

$$D_m^2 = 4m\lambda R$$

$$D_n^2 = 4n\lambda R$$

$$D_m^2 - D_n^2 = 4(m-n)\lambda R$$

$$\lambda = \frac{D_m^2 - D_n^2}{4(m-n)R}$$

$$R = \frac{D_m^2 - D_n^2}{4(m-n)\lambda}$$

From the graph, $\frac{AB}{CD} = \frac{D_m^2 - D_n^2}{(m-n)}$

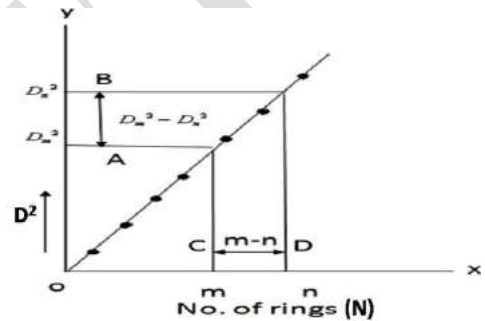

Fig: Plot of D^2 w.r.t. no. of rings

The radius R of the Plano convex lens can be obtained with the help of a spherometer. λ can be calculated by substituting all the above values.

DIFFRACTION:

Introduction:

The bending of light around the edges of an obstacle is called diffraction.

When light falls on an obstacle then the corresponding geometrical shadow on the screen should be completely dark. Practically the

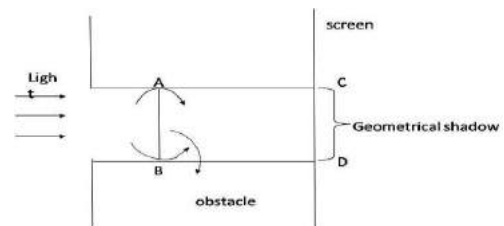

Fig: Diffraction

geometrical shadow consists of bright and dark fringes. These fringes are due to the superposition of bended light waves around the corners of an obstacle. The amount of bending depends upon the size of an obstacle and wavelength of light.

When light falls on an obstacle whose size is comparable with the wavelength of light then light bends around the edges or corners of an obstacle and enters into the geometrical shadow. This bending of light is known as **diffraction**.

Types of Diffraction:

The diffraction phenomena are broadly classified into two types.

1. Fresnel's Diffraction:

In this type of diffraction, the source of light and the screen are placed at finite distance. In this, lenses are not necessary to study the diffraction. This diffraction can be studied in the direction of propagation of light. The incident wave fronts are either spherical or cylindrical.

2. Fraunhofer's Diffraction:

In this type of diffraction, the source and screen are placed at infinite distances. Here we need lenses to study the diffraction. This diffraction can be studied in any direction. In this, the incident wavefront is plane.

Difference between Fresnel diffraction and Fraunhofer diffraction:

S. No.	Fresnel diffraction	Fraunhofer Diffraction
1	Source and screen are placed at finite distances.	Source and screen are at placed at infinite distances.
2	No lenses are used.	Lenses are used.
3.	The incident wave front is spherical or cylindrical.	The incident wave front is plane wave front.
4.	The diffraction can be studied in the direction of propagation of light.	The diffraction can be studied in any of propagation of light.

Fraunhofer's diffraction at single slit:

Consider a slit AB of width 'e'. Let a plane wavefront WW' of monochromatic light of wavelength λ propagating normally towards the slit is incident on it. The diffracted light

through the slit be focused by means of a convex lens on a screen placed in the focal plane of the lens.

According to Huygens-Fresnel, every point on the wavefront in the plane of the slit is a source of secondary wavelets, which spread out to the right in all directions. These wavelets travelling normal to the slit i.e., along the direction OP_0 are brought to focus at P_0 by the lens. Thus, P_0 is a bright central image.

The secondary wavelets travelling at an angle θ with the normal are focused at a point P_1 on the screen. Depending on the path difference, the point P_1 may have maximum or minimum intensities. In order to find out intensity at P_1 , let us draw a parallel AC from A to the light ray at B .

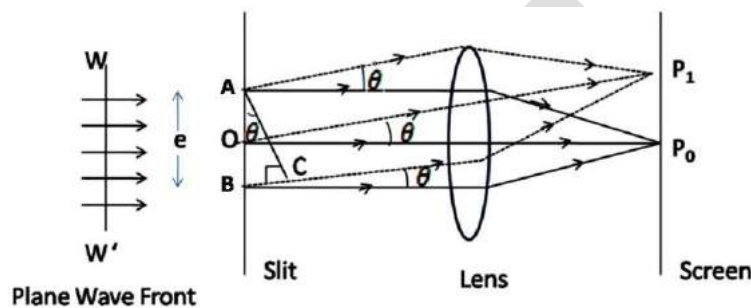

Fig: Fraunhofer Diffraction–Single Slit

The path difference between secondary wavelets from A and B in direction θ , is given by

$$\Delta = BC = AB \sin \theta = e \sin \theta$$

The relationship between phase difference and path difference is given by

$$\begin{aligned} \text{Phase difference} &= \frac{2\pi}{\lambda} \times \text{path difference} \\ &= \frac{2\pi}{\lambda} \times e \sin \theta \end{aligned}$$

Let the width of the slit is divided into 'n' equal parts and the amplitude of the wave from each part is 'a'. Then the phase difference between any two successive waves is

$$\frac{1}{n}(\text{Total phase}) = \frac{1}{n} \left(\frac{2\pi}{\lambda} e \sin \theta \right) = d \quad (\text{say})$$

Using the method of vector addition of amplitudes the resultant amplitude R is given by

$$R = \frac{a \sin\left(\frac{nd}{2}\right)}{\sin\left(\frac{d}{2}\right)} = \frac{a \sin\left(\frac{\pi e \sin \theta}{\lambda}\right)}{\sin\left(\frac{\pi e \sin \theta}{n\lambda}\right)}$$

$$= \frac{a \sin \alpha}{\sin\left(\frac{\alpha}{n}\right)} \quad \text{Where } \alpha = \frac{\pi e \sin \theta}{\lambda}$$

$$= a \frac{\sin \alpha}{\frac{\alpha}{n}} \left(\because \frac{\alpha}{n} \text{ is very small} \right)$$

$$= \frac{na \sin \alpha}{\alpha}$$

Let $na = A$,

$$R = \frac{A \sin \alpha}{\alpha}$$

Resultant intensity (I) is proportional to square of amplitude (R). Therefore, the intensity is given by

$$I = R^2 = A^2 \left(\frac{\sin \alpha}{\alpha} \right)^2$$

Intensity distribution:

The diffraction pattern consists of central principal maximum for $\alpha=0$. There are subsidiary or secondary maxima of decreasing intensity on either sides of it at positions $\alpha = \pm \frac{3\pi}{2}, \pm \frac{5\pi}{2}$. Between secondary maxima, there are minima at positions $\alpha = \pm\pi, \pm 2\pi$.

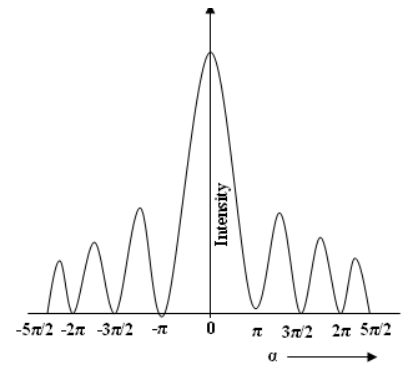

Fig: Intensity Distribution

Condition for principal maximum:

It is clear that intensity to be maximum means $\frac{\sin \alpha}{\alpha}$ should also be maximum.

$$\text{i.e. } \lim_{\alpha \rightarrow 0} \frac{\sin \alpha}{\alpha} = 1 \text{ means } R = \frac{A}{\alpha} \left[\alpha - \frac{\alpha^3}{3!} + \frac{\alpha^5}{5!} - \frac{\alpha^7}{7!} + \dots \right]$$

$$= A \left[1 - \frac{\alpha^2}{3!} + \frac{\alpha^4}{5!} - \frac{\alpha^6}{7!} + \dots \right]$$

R maximum means –ve values must vanish and all α terms on right hand side should be equal to zero. it is possible

$$\text{if } \sin\theta=0 \quad \left[\text{where } \alpha = \frac{\pi e \sin\theta}{\lambda} \right]$$

then $\theta = 0$ is the condition for principal maximum with high intensity.

$$R=A \quad I_{max} = R^2 = A^2$$

Condition for minimum intensity:

I will be minimum when $\sin\alpha = 0$

$$\alpha = \pm\pi, \pm2\pi, \pm3\pi, \dots$$

$$\alpha = \pm m\pi$$

$$\frac{\pi e \sin\theta}{\lambda} = \pm m\pi$$

$$e \sin\theta = \pm m\lambda$$

where $m = 1, 2, 3, \dots$

Thus, we obtain the points of minimum intensity on either side of principal maximum.

Diffraction grating:

Diffraction grating is closed placed multiple slits. It consists of very large number of narrow slits side by side separated by opaque spaces. The incident light is transmitted through the slits and blocked by opaque spaces. Such a grating is called transmission grating.

When light passes through the grating, each one of the slit diffracts the waves. All the diffracted waves combine one another producing sharp and intense maxima on the screen.

A plane transmission grating is a plane sheet of transparent material on which opaque lines are made with a diamond point. The space between the rulings is equal and transparent and consists of parallel slits. The combined width of a ruling and a slit is called grating element.

Let 'e' be the width of the line and 'd' be the width of the slit. Then (e + d) is known as grating element. If 'N' is the no. of lines per inch on the grating then

$$N(e+d) = 1" = 2.54cm$$

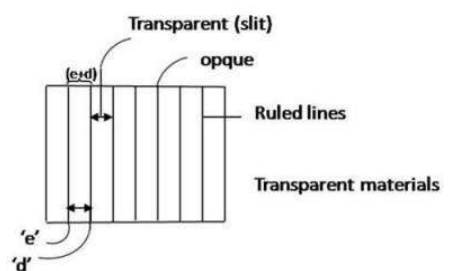

Fig: Diffraction grating

$$e + d = \frac{2.54}{N} \text{ cm}$$

When light falls on the grating, the light gets diffracted through each slit. As a result, both diffraction and interference of diffracted light gets enhanced and forms a diffraction pattern. This pattern is known as diffraction spectrum.

Grating spectrum:

The condition to form the principal maxima in a grating is given by

$$(e + d) \sin \theta = n\lambda \text{ is called grating equation.}$$

where $(e + d)$ is the grating element and $n=1, 2, \dots$

Instead of monochromatic source of light such as sodium vapour lamp, if white light source such as mercury is used then each diffracted order will have different colours at different angles.

For $n=1$

$$(e + d) \sin \theta_v = \lambda_v \text{ (for violet ray)}$$

$$(e + d) \sin \theta_r = \lambda_r \text{ (for red ray)}$$

Thus in the spectrum for a grating, there is no overlapping or mixing of colours unlike the spectrum for a prism where different colours overlap. For a grating the angle of diffraction (i.e., angular dispersion) depends on λ and $(e + d)$. Hence if two different gratings of same $(e + d)$ values are chosen, they will produce same dispersion and hence they will be identical.

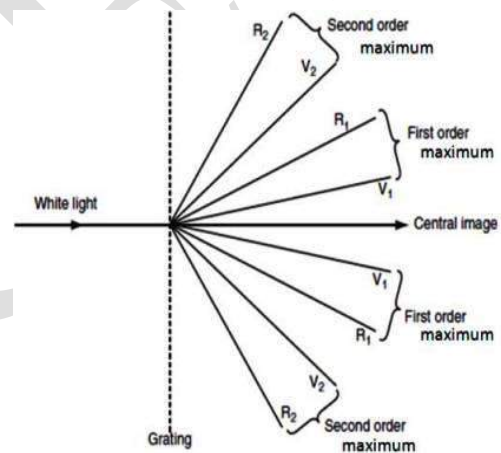

Fig: Grating spectrum for monochromatic source

Maximum no. of orders available with a grating:

The principal maxima in a grating

$$(e + d) \sin \theta = n\lambda$$

$$\frac{1}{e + d} = N$$

$$\text{Hence } r_1 < r_2, \mu_0 > \mu_e$$

For $\theta=90^\circ$, the maximum possible value of $\sin \theta$ is 1.

$$nN\lambda \leq 1 \text{ or } n \leq \frac{1}{N\lambda}$$

This gives the maximum number of orders possible and n is a integer.

Resolving power of a grating:

The resolving power of a grating represents its ability to form separate spectral lines for wavelengths very close together. It is measured by $\frac{\lambda}{d\lambda}$, where $d\lambda$ is the smallest wavelength difference that can just be resolved at wavelength λ .

Analysis:

Let a parallel beam of light of two wavelengths λ and $\lambda + d\lambda$ be incident normally on the grating. If the n th principal maximum of λ is formed in the direction θ_n , we will have $(e + d) \sin \theta_n = n\lambda$ where $(e+d)$ is the grating element.

Now the grating equation for the minima is $N(e + d) \sin \theta = m\lambda$ where N is the total number of rulings on the grating and m can take all integral values except $0, N, 2N, \dots, Nn$, because these values of m give respective principal maxima. It is clear from figure that the first minimum of λ adjacent to n th principal maximum of $(\lambda + d\lambda)$ in the direction of increasing θ will be obtained for $m = Nn + 1$. Therefore, for this minimum we have

$$N(e + d) \sin (\theta_n + d\theta_n) = (nN + 1)\lambda$$

$$(e + d) \sin (\theta_n + d\theta_n) = \left(\frac{nN + 1}{N}\right)\lambda$$

According to Rayleigh criterion, the wavelengths λ and $\lambda + d\lambda$ are just resolved by the grating when the n th maximum of $\lambda + d\lambda$ is also obtained in direction $\theta_n + d\theta_n$ i.e

$$(e+d)\sin(\theta_n + d\theta_n) = n(\lambda + d\lambda) \dots \dots \dots (4)$$

Figure shows the overlapping of principal maxima of two patterns

Comparing eqs (3) and (4), we get

$$\left(\frac{nN+1}{N}\right)\lambda = n(\lambda + d\lambda)$$

$$nN\lambda + \lambda = nN\lambda + nNd\lambda$$

$$\lambda / d\lambda = nN$$

But $\left(\frac{\lambda}{d\lambda}\right)$ is the resolving power R of the grating. Therefore ,

$$R = nN$$

$$R = \frac{N(e+d) \sin \theta_n}{\lambda}$$

As expected, the resolving power is zero for the central principal maximum ($n=0$), all wavelengths being undiffracted in this order.

Unit III**INTRODUCTION TO SOLIDS****Free electron theory:**

In solids, electrons in outer most orbits of atoms determine its electrical properties. Electron theory is applicable to all solids, both metals and non metals. In addition, it explains the electrical, thermal and magnetic properties of solids. The structure and properties of solids are explained employing their electronic structure by the electron theory of solids.

It has been developed in three main stages:

1. Classical free electron theory
 2. Quantum Free Electron Theory.
 3. Zone Theory.
- **Classical free electron theory:** The first theory was developed by Drude & Lorentz in 1900. According to this theory, metal contains free electrons which are responsible for the electrical conductivity and metals obey the laws of classical mechanics.
 - **Quantum Free Electron Theory:** In 1928 Sommerfeld developed the quantum free electron theory. According to Sommerfeld, the free electrons move with a constant potential. This theory obeys quantum laws.
 - **Zone Theory:** Bloch introduced the band theory in 1928. According to this theory, free electrons move in a periodic potential provided by the lattice. This theory is also called “Band Theory of Solids”. It gives complete informational study of electrons.

Classical free electron theory:

Even though the classical free electron theory is the first theory developed to explain the electrical conduction of metals, it has many practical applications. The advantages and disadvantages of the classical free electron theory are as follows:

Advantages:

1. It explains the electrical conductivity and thermal conductivity of metals.
2. It verifies ohm's law.
3. It is used to explain the optical properties of metals.
4. The valence electrons are freely moving about the whole volume of the metals like the molecules of perfect gas in a container
5. The free electrons moves in random directions and collide with either positive ions or other free electrons. Collision is independent of charges and is elastic in nature
6. The movements of free electrons obey the laws of classical kinetic theory of gases
7. Potential field remains constant throughout the lattice.

Drawbacks:

1. The classical free electron model predicts the incorrect temperature dependence of σ . According to the classical free electron theory, $\sigma \propto T^{-1}$.
2. It fails to explain superconducting properties of metals.
3. It fails to explain new phenomena like photoelectric effect, Compton effect, black – body radiation, etc.

4. It fails to explain Electrical conductivity (perfectly) of semiconductors or insulators.
5. It fails to give a correct mathematical expression for thermal conductivity.
6. Ferromagnetism couldn't be explained by this theory.
7. Susceptibility has greater theoretical value than the experimental value.

Quantum free electron theory of metals:

Advantages:

1. All the electrons are not present in the ground state at 0 K, but the distribution obeys Pauli's exclusion principle. At 0 K, the highest energy level filled is called Fermi-level.
2. The potential remains constant throughout the lattice.
3. Collision of electrons with positive ion cores or other free electrons is independent of charges and is elastic in nature.
4. Energy levels are discrete.
5. It was successful to explain not only conductivity, but also thermionic emission paramagnetism, specific heat.

Drawbacks:

1. It fails to explain classification of solids as conductors, semiconductors and insulators.

Fermi level and Fermi energy:

The distribution of energy states in a semiconductor is explained by Fermi-Dirac statistics since it deals with the particles having half integral spin like electrons. Consider that the assembly of electrons as electron gas which behaves like a system of Fermi particles or fermions. The Fermions obeying Fermi-Dirac statistics i.e., Pauli's exclusion principle.

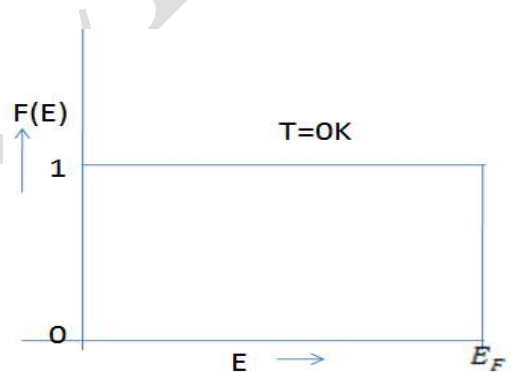

Fermi energy: It is the energy of state at which the

probability of electron occupation is $1/2$ at any temperature above 0K. It separates filled energy states and unfilled energy states. The highest energy level that can be occupied by an electron at 0 K is called Fermi energy level

Fermi level: It is a level at which the electron probability is $1/2$ at any temp above 0K (or) always it is 1 or 0 at 0K.

Therefore, the probability function $F(E)$ of an electron occupying an energy level E is given by,

$$F(E) = \frac{1}{1 + \exp\left(\frac{E-E_F}{KT}\right)} \dots \dots \dots (1)$$

Where E_F known as Fermi energy and it is constant for a system,

K is the Boltzmann constant and T is the absolute temperature.

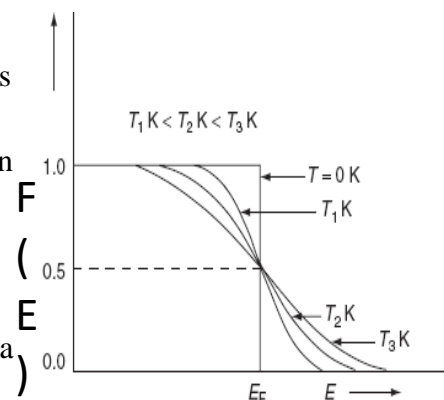

Case I : Probability of occupation at $T= 0K$, and $E < E_F$

$$F(E) = \frac{1}{1 + \exp\left(\frac{-1}{0}\right)} = \frac{1}{1 + 0} = 1$$

Therefore $F(E) = 1$, as per above, clearly indicates that at $T=0K$, the energy level below the Fermi energy level E_F is fully occupied by electrons leaving the upper level vacant. Therefore, there is 100% probability that the electrons to occupy energy level below Fermi level.

Case II: Probability of occupation at $T= 0K$, and $E > E_F$

Then

$$F(E) = \frac{1}{1 + e^{\frac{1}{0}}} = \frac{1}{1 + e^{\infty}} = \frac{1}{1 + \infty} = \frac{1}{\infty} = 0$$

i.e., all levels below E_F are completely filled and all levels above E_F are completely empty. As the temperature rises $F(E)$.

Case III: Probability of occupation at $T= 0K$, and $E = E_F$

$$F(E) = \frac{1}{1 + e^0} = \frac{1}{1 + 1} = \frac{1}{2} = 0.5$$

The above condition states that, $T=0K$, there is a 50% probability for the electrons to occupy Fermi energy.

The probability function $F(E)$ lies between 0 and 1.

Hence there are three possible probabilities namely

$F(E) = 1$ 100% probability to occupy the energy level by electrons.

$F(E) = 0$ No probability to occupy the energy levels by electrons and hence, it is empty.

$F(E) = 0.5$ 50% probability of finding the electron in the energy level.

Density of States (DOS):

The number of electrons per unit volume in an energy level at a given temperature is equal to the product of density of states (number of energy levels per unit volume) and Fermi Dirac distribution function (the probability to find an electron).

$$n_c = \int g(E) \times f(E) dE \dots \dots \dots (1)$$

where n_c is the concentration of electrons, $g(E)$ is the density of states & $F(E)$ is the occupancy probability.

The number of energy states with a particular energy value E is depending on how many combinations of quantum numbers resulting in the same value n .

To calculate the number of energy states with all possible energies, we construct a sphere in 3D- space with 'n' as radius and every point (n_x, n_y and n_z) in the sphere represents an energy state.

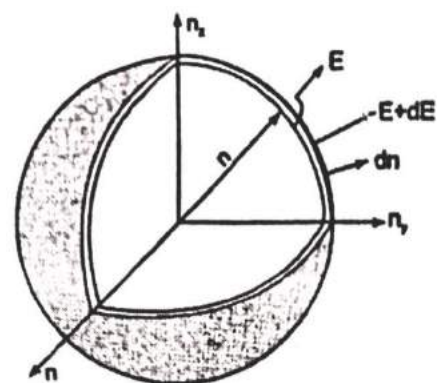

As every integer represents one energy state, unit volume of this space contains exactly one state .Hence; the number of states in any volume is equal to the volume expressed in units of cubes of lattice parameters).Also $n^2 = n_x^2 + n_y^2 + n_z^2$ Consider a sphere of radius n and another sphere of radius $n+dn$ with the energy values are E and $(E+dE)$ respectively.

Therefore, the number of energy states available in the sphere of radius ‘ n ’ is

$$\frac{1}{8} \left(\frac{4\pi n^3}{3} \right)$$

by considering one octant of the sphere

(Here, the number of states in a shell of thickness dn at a distance ‘ n ’ in coordinate system formed by n_x, n_y and n_z and will take only positive values ,in that sphere $\frac{1}{8}$ of the volume will satisfy this condition).

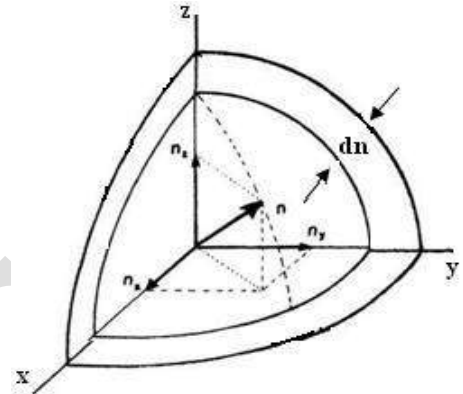

The number of energy states within a sphere of radius $(n+dn)$ is

$$\frac{1}{8} \left(\frac{4\pi}{3} \right) (n + dn)^3$$

Thus the number of energy states having energy values between E and $E+dE$ is given by

$$g(E)dE = \frac{1}{8} \left(\frac{4\pi}{3} \right) (n + dn)^3 - \frac{1}{8} \left(\frac{4\pi}{3} \right) n^3$$

$$= \frac{1}{8} \left(\frac{4\pi}{3} \right) [(n + dn)^3 - n^3] = \frac{\pi}{6} (3n^2 dn) = \frac{\pi}{2} n^2 dn$$

compared to ‘ dn ’, dn^2 and dn^3 are very small .

Neglecting higher powers of dn

$$g(E)dE = \frac{\pi}{2} n^2 dn \dots \dots (2)$$

The expression for n^{th} energy level can be written as ,

$$E = \frac{n^2 h^2}{8mL^2} \text{ or, } n^2 = \frac{8mL^2 E}{h^2} \dots \dots (3)$$

$$\Rightarrow n = \left(\frac{8mL^2 E}{h^2} \right)^{\frac{1}{2}} \dots \dots (4)$$

Differentiating eq. (3):

$$2ndn = \frac{8mL^2}{h^2} dE \Rightarrow dn = \frac{1}{2n} \left(\frac{8mL^2}{h^2} \right) dE$$

∴ by substituting $1/n$ value in dn ,

$$n = \frac{1}{2} \left(\frac{8mL^2}{h^2} \right)^{\frac{1}{2}} \frac{dE}{E^{\frac{1}{2}}} \dots \dots (5)$$

Substitute n^2 and dn from eq. (3) and (5), we get

$$g(E)dE = \frac{\pi}{2} \left(\frac{8mL^2}{h^2}\right) E dE \times \frac{1}{2} \left(\frac{8mL^2}{h^2}\right)^{\frac{3}{2}} \frac{dE}{E^{1/2}}$$

$$g(E)dE = \frac{\pi}{4} \left(\frac{8mL^2}{h^2}\right)^{\frac{3}{2}} E^{\frac{1}{2}} dE \dots \dots \dots (6)$$

According to Pauli’s Exclusion Principle, two electrons of opposite spin can occupy each energy state

Equation (6) should be multiplied by 2

$$g(E)dE = 2 \times \frac{\pi}{4} \left(\frac{8mL^2}{h^2}\right)^{\frac{3}{2}} E^{\frac{1}{2}} dE$$

After mathematical simplification, we get g

$$g(E)dE = \frac{4\pi}{h^3} (2m)^{\frac{3}{2}} E^{\frac{1}{2}} L^3 dE$$

The density of energy states $g(E) dE$ per unit volume is given by,

$$g(E)dE = \frac{4\pi}{h^3} (2m)^{\frac{3}{2}} E^{\frac{1}{2}} dE \quad \because L^3 = 1$$

Bloch Theorem:

According to free electron model, a conduction electron in metal experiences constant potential. But in real crystal, there exists a periodic arrangement of positively charged ions through which the electrons move. As a consequence, the potential experienced by electrons is not constant but it varies with the periodicity of the lattice. In zone theory, as per Bloch, potential energy of electrons considered as varying potential with respect to lattice ‘a’.

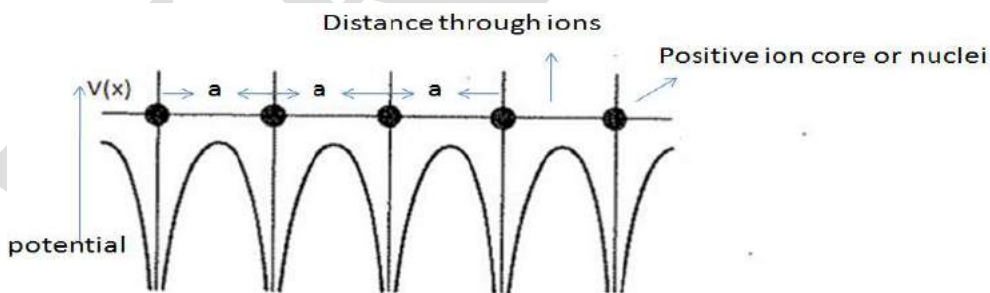

Fig: Variation of potential energy in a periodic lattice.

Let us examine one dimensional lattice as shown in figure. It consists of array of ionic cores along X-axis. A plot of potential V as a function of its position is shown in figure.

From graph:

At nuclei or positive ion cores, the potential energy of electron is minimum and in-between nuclei, the P.E.is considered as maximum w.r.to. Lattice constant ‘a’.

This periodic potential $V(x)$ changes with the help of lattice constant a, $V(x) = V(x + a)$ (‘a’ is the periodicity of the lattice)

To solve, by considering Schrodinger's time independent wave equation in one dimension,

$$\frac{d^2\psi}{dx^2} + \frac{8\pi^2m}{h^2} [E - V(x)]\psi = 0 \dots \dots (1)$$

Bloch's 1D solution for Schrodinger wave equation (1) $\psi_k(x) = u_k(x)exp(ikx) \dots \dots \dots (2)$

where $u_k(x) = u_k(x + a)$

Here $u_k(x)$ -periodicity of crystal lattice, modulating function, k- propagation vector $= \frac{2\pi}{\lambda} e^{ikx}$ is plane wave.

By applying eq.n (2) to eq.n (1), it is not easy to solve Schrodinger wave equation and Bloch cannot explain complete physical information about an e^- in periodic potential field. Then Kronig Penny model was adopted to explain the electrical properties of an e^- .

Kronig-Penney model:

Kronig -penny approximated the potentials of an e^- s inside the crystal in terms of the shapes of rectangular steps as shown, i.e. square wells is known as Kronig Penny model. i.e. The periodic potential is taken in the form of rectangular one dimensional array of square well potentials and it is the best suited to solve Schrodinger wave equation.

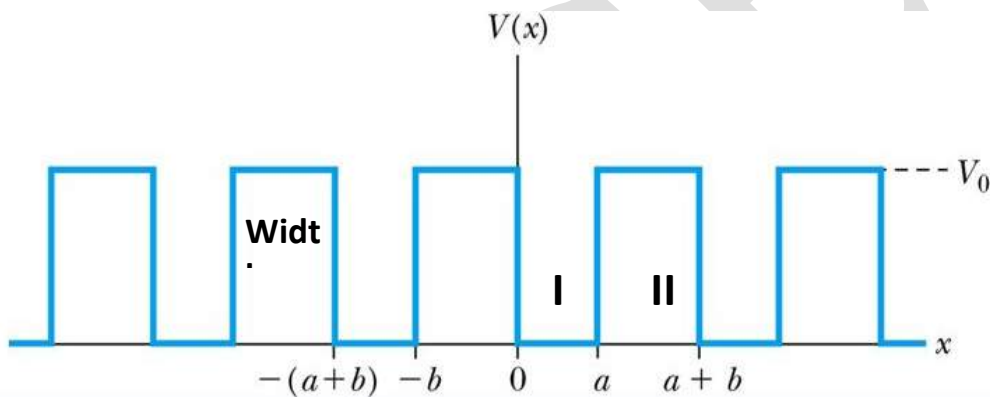

It is assumed that the potential energy is zero when x lies between 0 and a, and is considered as I region. Potential energy is V_0 , when x lies between -b and 0. And considered as II region.

Boundary conditions:

$$V(x) = 0, \text{ where } x \text{ lies between } 0 < x < a - \text{I region}$$

$$= V_0, \text{ where } x \text{ lies between } -b < x < 0 - \text{II region}$$

This model explains many of the characteristic features of the behavior of electrons in a periodic lattice.

The wave function related to this model may be obtained by solving Schrodinger equations for the two regions,

$$\frac{d^2\psi}{dx^2} + \frac{2m}{\hbar^2} E\psi = 0, \text{ for } 0 < x < a \text{ with } V(x) = 0 \dots \dots \dots (1)$$

$$\frac{d^2\psi}{dx^2} + \frac{2m}{\hbar^2} (E - V_0)\psi = 0, \text{ for } -b < x < 0 \text{ with } V(x) = V_0 \dots \dots \dots (2)$$

Again,

$$\frac{d^2\psi}{dx^2} + \alpha^2\psi = 0 \dots \dots (3) \quad \text{where } \alpha^2 = \frac{2mE}{\hbar^2} \text{ and } \alpha = \frac{2\pi}{h} \sqrt{2mE}$$

$$\frac{d^2\psi}{dx^2} - \beta^2\psi = 0 \dots \dots (4) \quad \text{where } \beta^2 = \frac{2m}{\hbar^2} (V_0 - E)$$

The solution of these equations from Bloch theorem, $\psi_k(x) = u_k(x)exp(ikx)$. From figure, square well potentials, if V_0 increases, the width of barrier 'w' decreases, if V_0 decreases the width of barrier w increases. But the (product) barrier strength V_0w remains constant.

To get this, differentiating above Schrodinger wave equations 3 & 4 w.r.to x, and by applying boundary conditions of x (w.r.to their corresponding Ψ), to know the values of constants A, B of region -I, C,D-for reg-II, we get mathematical expression (by simplification)

$$\boxed{\cos ka = P \frac{\sin \alpha a}{\alpha a} + \cos \alpha a}$$

where,

$$P = \frac{4\pi^2 ma}{\hbar^2} V_0 w \quad \text{and} \quad \alpha = \frac{2\pi}{h} \sqrt{2mE}$$

P-varying term, known as scattering power.

And 'v₀ b' is known as barrier strength.

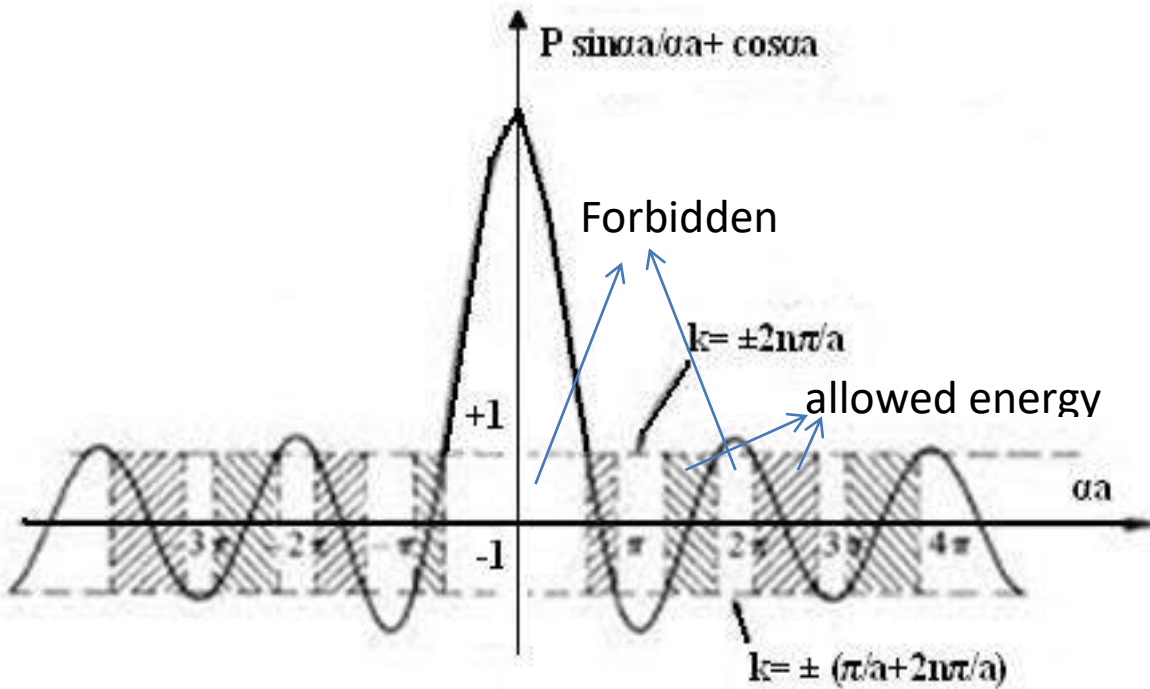

Conclusions:

1. The L.H.S is a cosine term which varies between the limits -1 and +1, and hence the R.H.S also varies between these limits. It means energy is restricted within -1 to +1 only.
2. If the energy of e^- lies between -1 to +1, are called **allowed energy bands** and it is shown by shaded portion in energy spectrum. This means that ' αa ' can take only certain range of values belonging to allowed energy band.
3. As the value of αa increases, the width of the allowed energy bands also increases.
4. If energy of e^- s not lies between -1 to +1 are known as **forbidden energy bands** and it decreases w.r.to increment of αa .
5. Thus, motion of e^- s. in a periodic lattice is characterized by the bands of allowed & forbidden energy levels.

Case 1:

1. $P \rightarrow \infty$

If $P \rightarrow \infty$, the allowed band reduces to a single (line) energy level, gives us steeper lines.

We have

$$\cos ka \left(\frac{\alpha a}{p} \right) = \sin \alpha a + \cos \alpha a \left(\frac{\alpha a}{p} \right)$$

$$P \rightarrow \infty, \frac{1}{\infty} = 0 \quad \text{then} \quad \sin \alpha a = 0$$

$$\sin \alpha a = \sin n\pi$$

$$\alpha a = n\pi$$

$$\alpha^2 a^2 = n^2 \pi^2$$

$$\alpha^2 = \frac{n^2 \pi^2}{a^2}$$

$$\frac{2mE}{\hbar^2} = \frac{n^2 \pi^2}{a^2}$$

$$E = \frac{n^2 \pi^2 \hbar^2}{2ma^2} = \frac{n^2 \pi^2 \hbar^2}{2ma^2 4\pi^2}$$

$$E = \frac{n^2 \hbar^2}{8ma^2}, \text{ here } a \text{ is lattice constant}$$

It means, it (zone theory) supports quantum free electron theory.

Case 2:

$P \rightarrow 0$, We have

$$\cos ka = P \frac{\sin \alpha a}{\alpha a} + \cos \alpha a$$

$$\alpha a = ka$$

$$\alpha = k$$

$$\alpha^2 = k^2$$

$$\frac{2mE}{\hbar^2} = \left(\frac{2\pi}{\lambda} \right)^2 = \frac{4\pi^2}{\lambda^2}$$

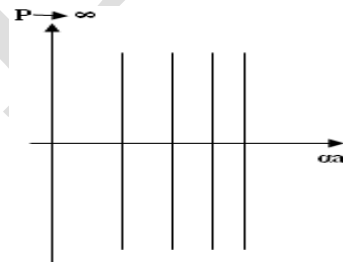

$$E = \frac{4\pi^2 \hbar^2}{2m\lambda^2}$$

$$E = \frac{4\pi^2 \hbar^2}{2m\lambda^2 4\pi^2}$$

$$E = \frac{1}{2} m v^2$$

It gives us kinetic energy of an electron. It means zone theory supports classical free electron theory at this situation electron completely free electron not bounded with allowed and forbidden gaps (and no energy level exists).

Thus by varying P from 0 to ∞, we find that the completely free electron(s) becomes completely bound to Brillouin Zone.

Brillouin Zone OR E-K diagram:

The Brillouin zone are the boundaries that are marked by the values of wave vector k, in which electrons can have allowed energy values. These represent the allowed values of k of the electrons in 1D, 2D, & 3D.

We have, the energy of the electron in a constant potential box is,

$$E = \frac{n^2 \hbar^2}{8ma^2} \dots (1) \text{ where } a = \text{length of the box.}$$

But,

$$k = \frac{n\pi}{a} \Rightarrow k^2 = \frac{n^2 \pi^2}{a^2}$$

$$\frac{n^2}{a^2} = \frac{k^2}{\pi^2} \dots \dots (2)$$

Substitute eqn (2) in (1), we get

$$E = \frac{k^2 \hbar^2}{8m\pi^2}; E \propto k^2$$

*k*². It represents parabolic equation.

A graph is drawn between the total energy (E) and the wave vector k, for various values of k.

i.e. $k = \frac{n\pi}{a}; n = \pm 1, \pm 2, \pm 3, \dots$

It is the energy spectrum of an electron moving in presence of a periodic potential field and is divided into allowed energy regions (allowed zones) or forbidden energy gaps (forbidden zones).

Allowed energy values lie in the region $k = -\pi/a$ to $+\pi/a$. This zone is called the first Brillouin zone. After a break in the energy values, called forbidden energy band, we have another allowed zone spread from $k = -\pi/a$ to $-2\pi/a$ and $+\pi/a$ to $+2\pi/a$. This zone is called the second Brillouin zone. Similarly, higher Brillouin zones are formed

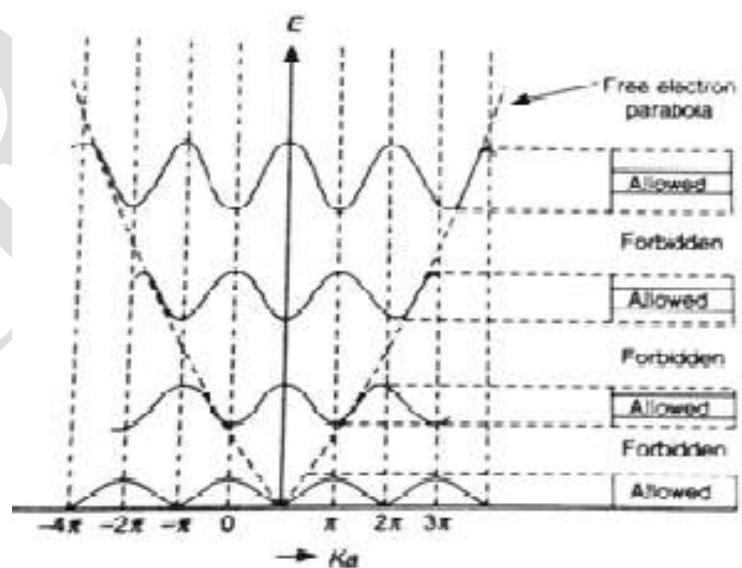

Concept of effective mass of electron:

When an electron in a periodic potential of lattice is accelerated by an known electric field or magnetic field, then the mass of the electron is called effective mass and is represented by m^* . To explain, let us consider an electron of charge 'e' and mass 'm' moving inside a crystal lattice of electric field E.

Then by taking known expression $F=ma$, can be considered here as $F = m^* a \dots\dots (1)$

The acceleration $a = \frac{eE}{m}$ is not constant in the periodic lattice but varies due to the change in electronic mass.

If free electron under wave packet, the group velocity V_g corresponding to the particle's velocity can be written as

$$v_g = \frac{d\omega}{dk} = 2\pi \frac{dv}{dk} = \frac{2\pi}{h} \frac{dE}{dk} = \frac{1}{\hbar} \frac{dE}{dk} \dots\dots (2) \text{ where } E = \hbar v$$

The rate of change of velocity is known as

$$\text{Acceleration, } a = \frac{dv_g}{dt} = \frac{1}{\hbar} \frac{d^2E}{dk dt}$$

$$a = \frac{1}{\hbar} \frac{dE}{dt} \frac{dk}{dk} = \frac{1}{\hbar} \frac{d^2E}{dk^2} \frac{dk}{dt} \dots\dots (3)$$

From quantum mechanics relation, $p = \hbar k \dots (4)$

$$\text{and } F = \frac{dp}{dt} \dots\dots (5)$$

By differentiating eq (4) w.r.to t, and by substituting eq(5)

$$\hbar \frac{dk}{dt} = \frac{dp}{dt} = F \Rightarrow \frac{dk}{dt} = \frac{F}{\hbar} \dots\dots (6)$$

by substituting eq.(6) in eq (3),

$$\therefore a = \frac{1}{\hbar} \frac{d^2E}{dk^2} \frac{F}{\hbar}$$

By rearranging the above term and by comparing with eq.(1)

$$F = \left[\frac{\hbar^2}{(d^2E/dk^2)} \right] a$$

$$\therefore m^* = \frac{\hbar^2}{(d^2E/dk^2)}$$

Is known as expression for m^* and it is depends on E and K.

Origin of energy band formation in Solids:

The band theory of solids explains the formation of energy bands and determines whether a solid is a conductor, semiconductor or insulator.

The existence of continuous bands of allowed energies can be understood starting with the atomic scale. The electrons of a single isolated atom occupy atomic orbitals, which form a discrete set of energy levels.

When two identical atoms are brought closer, the outermost orbits of these atoms overlap and interact. When the wave functions of the electrons of different atoms begin to overlap considerably, the energy levels corresponding to those wave functions split.

If more atoms are brought together more levels are formed and for a solid of N atoms, each of the energy levels of an atom splits into N energy levels. These energy levels are so close that they form an almost continuous band. The width of the band depends upon the degree of overlap of electrons of adjacent atoms and is largest for the outermost atomic electrons.

As a result of the finite width of the energy bands, gaps are essentially leftover between the bands called forbidden energy gap.

The electrons first occupy the lower energy levels (and are of no importance) then the electrons in the higher energy levels are of important to explain electrical properties of solids and these are called valence band and conduction band.

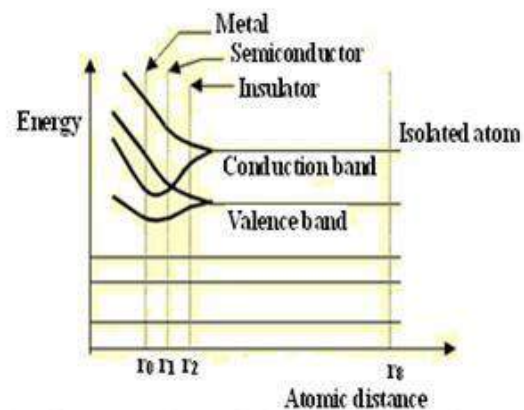
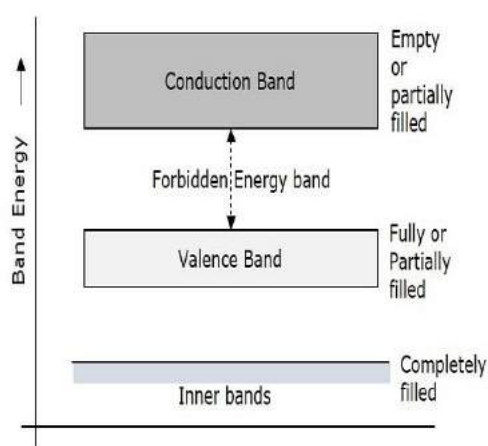

Fig: Formation of energy bands when atoms are closer

Valence band: A band occupied by valence electrons and is responsible for electrical, thermal and optical properties of solids and it is filled at 0K.

Conduction band: A band corresponding to outer most orbit is called conduction band and is the highest energy band and it is completely empty at 0K.

The forbidden energy gap between valence band conduction band is known as the energy band gap. By this solids are classified in to conductors, semiconductors and insulators.

Classification of solids into conductors , Semiconductors & Insulators:

Based on the energy band diagram materials or solids are classified as follows:

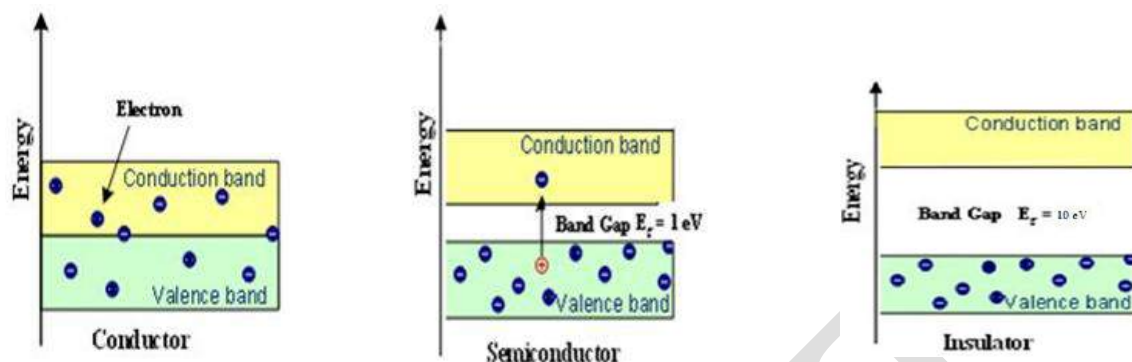

Conductors: In this kind of materials, there is no forbidden gap between the valence band and conduction band. It is observed that the valence band overlaps with the conduction band in metals as shown in figure. There are sufficient numbers of free electrons, available for electrical conduction and due to the overlapping of the two bands there is an easy transition of electrons from one band to another band takes place, and there no chance for the presence of holes. Resistivity of conductors is very small and it is very few milli ohm meters. ($\Omega \text{ m}$).

Examples: All metals (Na, Mg, Al, Cu, Ni Cu, Ag, Li, Ar etc)

Semiconductors:

In semiconductors, there is a band gap exists between the valence band and conduction band and it is very less and it is the order of -1 to 2 eV are known as semiconductors. It will conduct electricity partially at normal conditions. The electrical resistivity values are 0.5 to 10^3 ohm meter. Due to thermal vibrations within the solid, some electrons gain enough energy to overcome the band gap (or barrier) and behave as conduction electrons. Conductivity exists here due to electronics and holes.

Examples: Silicon, Germanium, Ga As.

Insulators:

In insulators, the width of forbidden energy gap between the valence band and conduction band is very large. Due to large energy gap, electrons cannot jump from V.B to C.B. Energy gap is of the order of $\sim 10 \text{ eV}$ and higher than semiconductors. Resistivity values of insulators are 10^7 to 10^{12} ohm-m. Electrons are tightly bound to the nucleus, no valence electrons are available.

Examples: Wood, rubber, glass.

Introduction:

All dielectric materials are insulators but all insulators are not perfect dielectric materials. There are no free charges available for conduction in a dielectric. All the electrons are tightly bound to their nucleus of the atoms. When the dielectric is placed in an electric field, then separation of positive and negative charges takes place in a dielectric, causing polarization of dielectric. Dielectrics are characterized by polarization & dielectric constant. Dielectrics materials store large amounts of electro-static fields.

There are two principal methods by which a dielectric can be polarized: stretching and rotation. Stretching an atom or molecule results in an induced dipole moment added to every atom or molecule. Rotation occurs only in polar molecules — those with a permanent dipole moment like the water molecule shown in the diagram below.

Basic Definitions:

(i) Electric Dipole: Two opposite charges of equal magnitude separated by a finite distance constitutes an electric dipole.

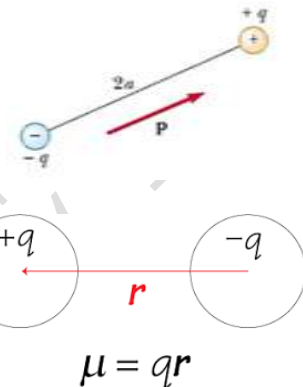

(ii) Dipole moment(μ): Electric dipole moment is defined as the product of one of the charges and the charge separating distance.

Units: coulomb meter or Debye, 1 Debye = 3.3×10^{-30} c-m

(iii) Permittivity (ϵ): Permittivity represents the easily polar sable nature of the dielectric or medium.

$$\epsilon_0 = \text{permittivity of free space} = 8.854 \times 10^{-12} \text{ F/m}$$

(iv) Dielectric constant(ϵ_r): Dielectric constant is the ratio between the permittivity of the medium and the permittivity of free space.

Let us take a parallel plate capacitor. Suppose the separation distance between the plates is d. Use air or vacuum as a medium for this experiment.

Suppose +Q is the charge on one plate and -Q is charge on the second plate. Bring a rectangular slab made up of conducting material between the plates of the capacitor. The thickness of the slab must be less than the distance between the plates of the capacitor.

When the electric field will be applied then polarization of molecules will be started. The polarization will take place in the direction same as that of electric field. Consider a vector that must be polarized, name it as P. The polarization vector must be in the direction of electric field E_0 . Then this vector will start its functioning and will produce an electric field E_p in the opposite direction to that of E_0 . The net electric field in the circuit is shown by the figure.

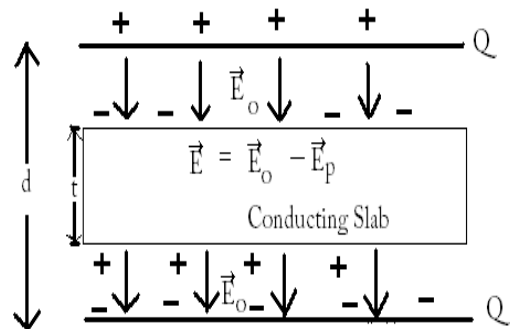

$$\epsilon_r = \epsilon / \epsilon_0$$

$$E = E_0 - E_p$$

Dielectric constant, property of an electrical insulating material (a dielectric) equal to the ratio of the capacitance of a capacitor filled with the given material(c) to the capacitance of an identical capacitor(c_0)(in a vacuum without the dielectric material).

$$\epsilon_r = c/c_0$$

(v) **Dielectric polarization (p):** Dielectric polarization or Electric polarization is the induced dipole moment (μ) per unit volume (v) of the dielectric in the presence of an electric field.

Electric polarization, slight relative shift of positive and negative electric charge in opposite directions within an insulator, or dielectric, induced by an external electrical field.

$$P = \mu/v$$

Units: $C\cdot m^{-2}$

If " μ " is the average dipole moment per molecule and " N " is the number of molecules per unit volume then

$$P = N \mu$$

(vi) **Dielectric polarisability (α):**

Di-electric polarisability is the net dipole moment induced per unit applied electric field.

$$P = N \mu = N \alpha E$$

Units: $F\cdot m^2$

(vii) **Electric susceptibility (χ):**

It measures the amount of polarization in a given electric field produced in a dielectric. Polarization proportional to the product of ' ϵ_0 ' and applied electric field.

$$\chi = P / \epsilon_0 E$$

(viii) **Electric flux density or Electric displacement (D):**

It is defined as the total number of electric lines of force passing through the dielectric material is known as electric flux density (D).

Mathematically it is represented by the following equation

$$D = \epsilon E + p$$

$$\epsilon E = \epsilon_0 E + p$$

$$\epsilon = \epsilon_0 \epsilon_r$$

$$\epsilon_0 \epsilon_r E = \epsilon_0 E + p$$

$$p = \epsilon_0 E (\epsilon_r - 1)$$

Types of polarization in dielectrics:

There are four types of polarization processes in dielectric.

1. Electronic –polarization(p_e)
2. Ionic – polarization(p_i)
3. Orientation-polarization or di-polar polarization(p_o)
4. Space-charge polarization(p_s)

1. Electronic –polarization(p_e) or Atomic Polarization:

It is defined as polarization of rare-gas atoms in the presence of a static electric field or polarization due to displacement of an electron-cloud from positive charge of nucleus in an atom in the presence of an electric field in a dielectric material is known as electronic-

polarization(p_e). This involves the separation of the centre of the electron cloud around an atom with respect to the centre of its nucleus under the application of electric field.

- It occurs in monoatomic gases like He, Ne, Ar, Xe, Kr
- It occurs at optical frequencies (10^{15} Hz)
- It is independent of temperature.

Expression for Electronic polarization of a dielectric material:

The displacement of the positively charged nucleus and the (negative) electron of an atom in opposite directions, on application of an electric field, result in electronic polarization.

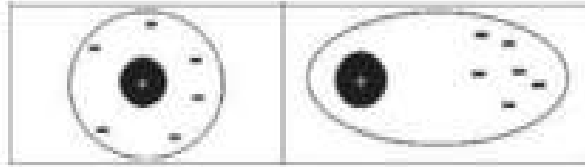

Dielectric Polarization in Nonpolar Molecules. The electric field causes the shifting of charges.

On application of external electric field E , the electron cloud around the nucleus readily shifts towards the positive end of the field. Because of this, dipole moment is created, within each atom due to the separation of positive and negative charges. This separation or shift is proportional to field strength (E).

∴ Dipole moment is the product of charge and the separation between the charges.

∴ Induced dipole moment $\mu \propto E$

$$\mu = \alpha_e E$$

α_e is constant of proportionality or electronic polarizability and it is independent of temperature.

Calculation of Electronic polarizability:

By taking classical model of an atom, the nucleus of charge Ze is surrounded by an electron cloud of charge $-Ze$ distributed in a sphere of radius R .

Then the charge density (Z – atomic number) is given by

$$\rho = \frac{-Ze}{\frac{4}{3}\pi R^3} = -\frac{3}{4}\left(\frac{Ze}{\pi R^3}\right) \rightarrow (1)$$

When an external electric field E is applied, the nucleus and electrons experience Lorentz forces of magnitude ZeE in opposite direction. Because of this, the nucleus and electron cloud are pulled apart. If separation is there in between nucleus and electron cloud, a coulomb force develops which is attractive.

When Lorentz and Coulomb force are equal and opposite, equilibrium is reached.

Let 'x' be the displacement under this condition. Here, nucleus is much heavier than the electron cloud; it is assumed that only the electron cloud is displaced when the external field is applied.

Lorentz force = $-ZeE$

$$\begin{aligned} \text{Coulomb force} &= Ze \times \frac{\text{charge enclosed in the sphere of radius } x}{4\pi\epsilon_0 x^2} \quad \text{The charge enclosed} \\ &= \frac{4}{3}\pi x^3 \rho \end{aligned}$$

$$= \frac{4}{3} \pi x^3 \left(\frac{-Ze}{\frac{4}{3} \pi R^3} \right) = \frac{4}{3} \pi x^3 \left(\frac{-3}{4} \right) \frac{Ze}{\pi R^3} = \frac{-Zex^3}{R^3}$$

$$\text{Coulomb force} = Ze \times \left(\frac{-Zex^3}{R^3} \right) \times \frac{1}{4\pi\epsilon_0 x^2} = \frac{-Z^2 e^2 x}{4\pi\epsilon_0 R^3}$$

$$\text{In the equilibrium position, } -ZeE = \frac{-Z^2 e^2 x}{4\pi\epsilon_0 R^3}$$

$$\text{or } x = \frac{4\pi\epsilon_0 R^3 E}{Ze}$$

Thus, displacement of electron cloud is proportional to applied field

$$x \propto E$$

∴ The electric charges $+Ze$ and $-Ze$ are separated by a distance x under the influence of E constituting induced dipoles (moment).

Induced electric dipole moment,

$$\begin{aligned} \mu_e &= Zex \\ &= Ze \cdot \frac{4\pi\epsilon_0 R^3 E}{Ze} = 4\pi\epsilon_0 R^3 E \end{aligned}$$

$$\text{i.e. } \mu_e = \alpha_e E$$

where $\alpha_e = 4\pi\epsilon_0 R^3$ is called electronic polarizability

It is the dipole moment per unit volume & is independent of temperature.

$$P_e = N\mu_e$$

$= N\alpha_e E$ (where, N is the no. of atom/ m^3)

$$P_e = \epsilon_0 E (\epsilon_r - 1) = N\alpha_e \epsilon_r - 1 = \frac{N\alpha_e}{\epsilon_0}$$

Hence

$$\alpha_e = \frac{\epsilon_0 (\epsilon_r - 1)}{N}$$

2. Ionic – polarization (p_i):

The polarization that occurs due to relative displacement of ions of the molecules in the presence of an external electrical field. This happens in solids with ionic bonding which automatically have dipoles but which get cancelled due to symmetry of the crystals. Here, external field leads to small displacement of ions from their equilibrium positions and hence inducing a net dipole moment.

- Ex: NaCl, KCl or KBr molecules.
- It occurs at a frequency of around 10^{13} Hz.
- It is a slower process when compared to electronic polarization.
- It is independent of temperature.

Expression for Ionic polarization of a molecule:

The ionic polarization is due to the displacement of cation and anions in opposite direction and occurs in an ionic solid.

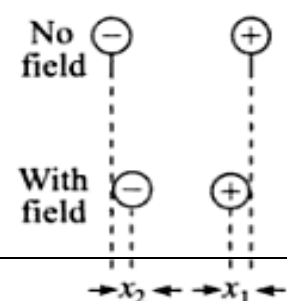

Consider an electric field is applied in the positive x direction then the positive ions move to the right by x_1 and the negative ions move to left by x_2 . If we assume, each unit cell has one cation and one anion.

The resultant dipole moment per unit cell due to ionic displacement is

$$\mu = e(x_1 + x_2)$$

If β_1 and β_2 are restoring force constants of cation and anion, Newton is the force due to applied field. Then

$$F = \beta_1 x_1 = \beta_2 x_2$$

$$\text{Hence, } x_1 = \frac{F}{\beta_1}$$

Restoring force constants depends upon the mass of the ion and angular frequency of the molecule in which the ions are present.

$$x_1 = \frac{eE}{m\omega_0^2} \text{ \& } x_2 = \frac{eE}{M\omega_0^2}$$

where m- mass of the positive ion & M-mass of the negative ion

$$x_1 + x_2 = \frac{eE}{\omega_0^2} \left(\frac{1}{M} + \frac{1}{m} \right) \mu = e(x_1 + x_2) = \frac{e^2}{\omega_0^2} \left(\frac{1}{M} + \frac{1}{m} \right) \alpha_i = \frac{\mu}{E} = \frac{e^2}{\omega_0^2} \left(\frac{1}{M} + \frac{1}{m} \right)$$

The polarizability α_i is inversely proportional to the square of natural frequency of the ionic molecule and to its reduced mass which is equal to

$$\left(\frac{1}{m} + \frac{1}{M} \right)^{-1}$$

Internal fields in solids [Lorentz Method]:

Now a dielectric material is placed between the two parallel plate capacitor and there be an imaginary spherical cavity around the atom 'A' inside the dielectric. By taking that the radius of the cavity is large compared to the radius of the atom. Now, the internal field at the atom site 'A' can be considered to be made up of four components namely E_1 , E_2 , E_3 and E_4

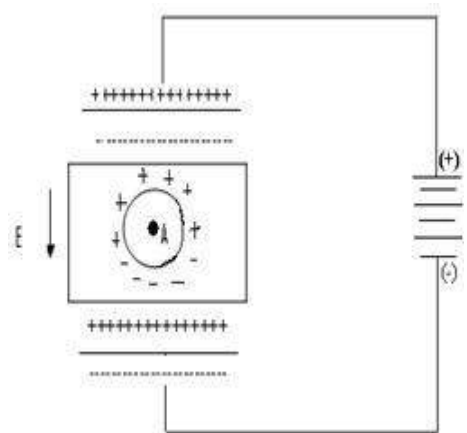

Field E_1 : -

E_1 is the field intensity at A due to the charge density on the plates. From the field theory.

$$D = P + E\epsilon_0$$

$$\therefore E_1 = \frac{P + \epsilon_0 E}{\epsilon_0} \Rightarrow E_1 = E + \frac{P}{\epsilon_0} \rightarrow (1)$$

Field E_2 : -

E_2 is the field intensity at A due to charge density induced on the two sides of the dielectric. Therefore,

$$E_2 = \frac{-P}{\epsilon_0} \rightarrow (2)$$

Field E_3 :-

E_3 is the field intensity at A due to other atoms contained in the cavity. If we assume a cubic structure then $E_3=0$ because of symmetry.

Field E_4 :-

E_4 is the field density due to polarization charges on the surface of the cavity and it is calculated by Lorentz. The enlarged view of the cavity is shown.

If dA is the surface area of the sphere of radius r lying between θ and $\theta+d\theta$ (where θ is the direction with reference to the direction of the applied force) Then $dA = 2\pi(PQ)(QR)$

$$\sin\theta = \frac{PQ}{r} \Rightarrow PQ = r\sin\theta$$

$$\text{and } d\theta = \frac{QR}{r} \Rightarrow QR = rd\theta$$

Hence,

The charge dq on the surface dA is equal to the normal component of the polarization multiplied by the surface area.

$$\therefore dq = p\cos\theta dA = P(2\pi r^2 \sin\theta \cos\theta d\theta)$$

Field due to this charge at the centre 'A' is denoted by dE_4 and is obtained by imagining a unit charge at point 'A'

$$dE_4 = \frac{dq \times l \times \cos\theta}{4\pi\epsilon_0 r^2} = \frac{P(2\pi r^2 \sin\theta \cos\theta d\theta) \cos\theta}{4\pi\epsilon_0 r^2} dE_4$$

$$= \frac{P}{2\epsilon_0} \cos^2\theta \sin\theta d\theta \rightarrow (3)$$

Thus, the total field E_4 due to the charges on the surface of the entire cavity is obtained by integrating. $\therefore \int dE_4 = \frac{P}{2\epsilon_0} \int_0^\pi \cos^2\theta \sin\theta d\theta$

$$= \frac{P}{2\epsilon_0} \int_0^\pi \cos^2\theta d(-\cos\theta) = -\frac{P}{2\epsilon_0} \left(\frac{\cos^3\theta}{3} \right)_0^\pi = -\frac{P}{6\epsilon_0} (-1 - 1) = \frac{P}{3\epsilon_0}$$

i.e. $E_i = E + \frac{P}{3\epsilon_0} \rightarrow (4)$

where E_i is the internal field (or) Lorentz field.

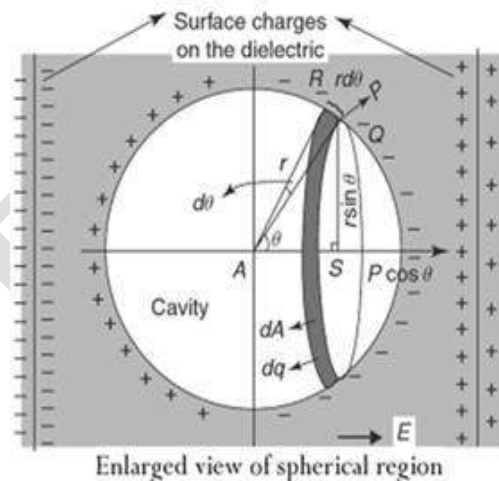

Clausius – Mosotti relation: -

The relation between the dielectric constant and the polarizability of a polarized dielectric is known as Clausius – Mosotti equation. Consider the dielectric having cubic structure, here there are no ions and permanent dipoles in these materials, the ionic polarizability α_i and orientational polarizability α_0 are zero.

i.e. $\alpha_i = \alpha_0 = 0$

Polarization $P = N\alpha_e E_i$

$$= N\alpha_e \left(E + \frac{P}{3\epsilon_0} \right)$$

$$P \left(1 - \frac{N\alpha_e}{3\epsilon_0} \right) = N\alpha_e E \text{ (or) } P = \frac{N\alpha_e E}{\left(1 - \frac{N\alpha_e}{3\epsilon_0} \right)} \rightarrow (1)$$

We have, $D = P + \epsilon_0 E$

$$P = D - \epsilon_0 E$$

$$\frac{P}{E} = \frac{D}{E} - \epsilon_0$$

$$= \epsilon - \epsilon_0$$

$$= \epsilon_0 \epsilon_r - \epsilon_0$$

$$\therefore \boxed{P = E\epsilon_0(\epsilon_r - 1)} \rightarrow (2)$$

Using (1) and (2):

$$P = E\epsilon_0(\epsilon_r - 1) = \frac{N\alpha_e E}{\left(1 - \frac{N\alpha_e}{3\epsilon_0} \right)}$$

$$1 - \frac{N\alpha_e}{3\epsilon_0} = \frac{N\alpha_e}{\epsilon_0(\epsilon_r - 1)}$$

$$1 = \frac{N\alpha_e}{3\epsilon_0} \left(1 + \frac{3}{\epsilon_r - 1} \right)$$

$$\Rightarrow \frac{N\alpha_e}{3\epsilon_0} = \frac{1}{\left(1 + \frac{3}{\epsilon_r - 1} \right)}$$

$$= \frac{\epsilon_r - 1}{\epsilon_r + 2}$$

N is the no. of atoms,

By knowing ϵ_r , we can determine α_e

MAGNETIC MATERIALS

Introduction:

Magnetism has its own application in the field of physics. Magnetic properties have been the subject of special interest because of the information they yield about the constitution of matter. Magnetics have wide range of application in electrical machinery and in magnetic tapes in computers. Magnetic materials are classified into three, namely diamagnetic, paramagnetic and ferromagnetic materials.

Magnetic field: The 3D region around a magnet in which it's magnetic force is felt is called magnetic field of that magnet. It is a scalar quantity.

Magnetic dipole: It's a system consisting of two equal and opposite magnetic poles separated by a small distance of $2lm$

Or

Two poles of equal strength separated by a very small distance is called a magnetic dipole.

Pole strength (m): The ability of a pole of magnet to attract or repel another magnetic pole is called it's pole strength.

Magnetic dipole moment (μ): It can define in three ways depending on situation.

1. In case of bar magnet it is defined as the product of pole strength and distance between them.

$$\mu = 2lm$$

2. In case of current carrying conductor, it is the product of current (i) and cross section area (A) of the conductor.

$$\mu = iA$$

3. In case of atom, it is the product of current (i) developed by orbital motion of electron and the area covered by the orbital.

$$\mu = iA$$

It is a vector quantity. Its direction is from south pole to the north pole.

Its SI unit is ampere/m².

Magnetic flux(ϕ): The total number of magnetic lines of force passing normal to a surface in a magnetic field is called magnetic flux.

Or

The number of magnetic lines of force passing through a point is called magnetic flux.

Its SI unit is weber/tesla – m²

Magnetic field induction or magnetic flux density (B): The magnetic flux passing through a unit normal area of substance is defined as magnetic flux density and is denoted by B. It is commonly known as magnetic induction. Let ϕ be the flux passing through a substance of

area A , then flux density is

$$B = \frac{\phi}{A} = \frac{F}{m} \text{ or } \phi = \mathbf{B} \cdot \mathbf{A} = BA \cos \theta.$$

It is a vector quantity.

Its SI unit is weber/m² or tesla and CGS unit is Gauss (= maxwell/cm²).

1 Tesla = 10⁴ Gauss.

Magnetising field (force) or Magnetic intensity (H): The force acting on a unit north pole placed at the point. It is independent of the medium.

$$B = \mu H$$

It is vector quantity. Its SI unit is ampere/m.

Permeability: It's ability to allow the magnetic lines of force to pass through it or to allow itself to be influenced by magnetic field (μ).

Relative magnetic permeability (μ_r): The ratio of its absolute magnetic permeability (μ) of the material to the magnetic permeability of free space (μ_0).

$$\mu_r = \frac{\mu}{\mu_0}$$

It is purely a number, it has no units.

The permeability of free space or vacuum is $\mu_0 = 4\pi \times 10^{-7}$ H/m.

Magnetization: The ability of a material to get magnetized when placed in an external magnetic field is called magnetization.

It is measured by a quantity called intensity of magnetization (I).

The net magnetic dipole moment acquired by a substance per unit volume is defined as intensity of magnetization (I).

$$I = \frac{\text{net magnetic dipole moment of material}}{\text{Volume of the material}} \text{ A/m}$$

It is vector quantity. Its SI unit is A/m.

Relation between B, H and I:

The flux density B in a material due to magnetizing force H , as the sum of the flux density B_0 in vacuum produced by magnetizing force and flux density B_m due to magnetization of material.

Therefore $B = B_0 + B_m$

Also we know that $B_0 = \mu_0 H$ and $B_m = \mu_0 I$

Therefore, $B = \mu_0 H + \mu_0 I$

$$B = \mu_0(H + I)$$

It is the relation in SI unit

Magnetic Susceptibility(χ):The ratio of magnetization to the magnetic intensity.

$$\chi = \frac{I}{H}$$

It has no units when a material has high susceptibility then it can be easily magnetized.

Relation between Permeability and Susceptibility:

We know that $B \propto (H+I)$

$$B = \mu_0 (H+I)$$

$$\text{In vacuum } B = \mu_0 H + \mu_0 I$$

$$\frac{B}{H} = \mu_0 + \mu_0 \frac{I}{H}$$

Also,

$$\frac{B}{H} = \mu \text{ (permeability of the material) and}$$

$$\chi = \frac{I}{H} \text{ (Susceptibility)} \therefore \mu = \mu_0 + \mu_0 \chi \text{ or } \mu = \mu_0(1 + \chi)$$

$$\frac{\mu}{\mu_0} = (1 + \chi)$$

$$\mu_r = (1 + \chi)$$

$$\mu_r - 1 = \chi$$

$$\boxed{\mu_r = \chi + 1}$$

Origin of magnetic moment:

Materials are made up of atoms. These atoms consist of positively charged nucleus, surrounded by cloud of electrons. In all atoms electrons are revolving around the nucleus in different orbits and also spin about their own axis. These revolving electrons constitute an electrical current in the orbits. These revolving electrons produces its own orbital magnetic dipole moment, measured in Bohr magneton(μ_B) and there is also a spin magnetic moment associated with it (spin of orbital electrons and spin of nucleus). In most materials there is no resultant magnetic moments, due to the electrons being grouped in pairs causing the magnetic moment to be cancelled by its neighbour. Under external applied magnetic field these dipoles experience torque in the direction of applied field and the atom acquires certain magnetism.

So, the magnetic moment of an atom is due to

1. Orbital magnetic moment of the electrons.
2. Spin magnetic moment of the electrons.
3. Spin magnetic moment of the nucleus.

The orbital magnetic moment of the electrons(BohrMagneton):

The magnetic moment contributed by a single electron is known as Bohr Magneton. Mathematically it can express as

$$\mu_B = \frac{e\hbar}{2m}$$

Proof:

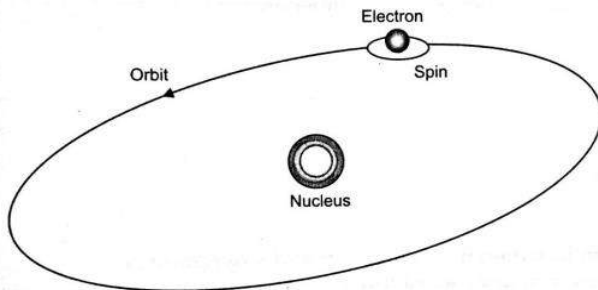

The orbit of a spinning electron about the nucleus of an atom

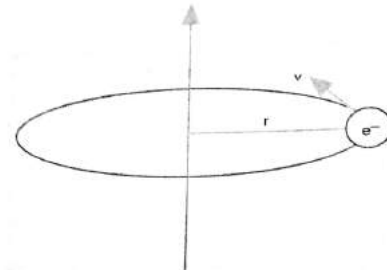

Motion of electron in a orbital

Let us consider an electron revolving in a circular orbit of radius r with a speed v . Consider a

point p on the circle. The electron crosses this point once in every revolution. In one revolution the electron travels $2\pi r$ distance.

The current i due to the electron motion in the circular loop (orbit) is

$$i = \frac{\text{charge of electron}(q)}{\text{time}(T)} = \frac{-e}{T}$$

Where, T is time for one revolution of electron about the nucleus.

$$T = \frac{\text{distance travelled by an electron}}{\text{speed of an electron}} = \frac{2\pi r}{v}$$

$$i = \frac{-e}{\left[\frac{2\pi r}{v}\right]} =$$

$$\frac{-ev}{2\pi r}$$

The magnetic moment μ_l associated with the orbit due to orbital motion of electron is

$$\mu_l = iA$$

Where, ' i ' is current produced by the orbital motion of the electron and A is area covered by the orbital (πr^2).

$$\mu_l = \frac{-ev}{2\pi r} \times \pi r^2$$

Dividing and multiplying above eq. by the mass of the electron

$$\mu_l = \frac{-evr}{2} \times \frac{m}{m} = \left(\frac{-e}{2m}\right) [mvr] = \left(\frac{-e}{2m}\right) [L]$$

w.k.t the angular momentum of an electron revolving in circular orbit is equal to integral multiple of $\frac{h}{2\pi}$

$$L = mvr = \frac{lh}{2\pi}$$

$$\mu_l = \left(\frac{-eh}{4\pi m}\right) l$$

$$\mu_l = \mu_B l \quad \text{where } l = 0, 1, 2, \dots$$

Where, l = orbital quantum number.

$$\mu_B = \frac{-eh}{4\pi m}$$

Bhormagneton

$$= \frac{1.6 \times 10^{-19} \times 6.626 \times 10^{-34}}{4 \times 3.14 \times 9.1 \times 10^{-31}} = 9.27 \times 10^{-34} \text{A - m}$$

Here – sign indicates that magnetic moment is anti-parallel to the angular momentum L.

CLASSIFICATION OF MAGNETIC MATERIAL:

Depending on the direction and magnitude of magnetization and also the effect of temperature on magnetic properties, all magnetic materials are classified into dia ,para and ferro materials. Depending upon the spin orientation of the electrons, ferro magnetic materials are classified into two types. They are

a. Antiferro magnetic material.

b.

Ferrimagnetic materials.

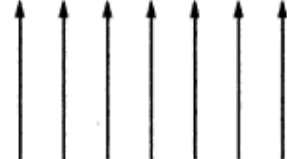
PROPERTY	DIA MAGNETIC SUBSTANCES	PARA MAGNETIC SUBSTANCES	FERRO MAGNETIC SUBSTANCES
Defination	The substance in which the resultant magnetic moment of individual atoms is zero.	The substance in which the resultant magnetic moment of individual atoms is not zero.	The substance in which the resultant magnetic moments of individual atoms align themselves in parallel by giving rise to spontaneous magnetization
Cause	Orbital motion of electrons.	Spin motion of electrons.	Formation of domains.
Susceptibility (χ)	Low and negative	Low and positive.	High and positive.
χ depend on T	Does not depend on T. except Bi at low T.	$\chi = \frac{c}{T}$ (curie law) c is curie constant.	$\chi = \frac{c}{T-T_c} : T > T_c$ (curie wises law) T_c is curie temperature.
Relative permeability (μ_r)	<1	>1	>> 1
spin alignment	No spin alignment is present.	All spins or magnetic moments are randomly oriented. 	All spins or magnetic moments are orderly oriented. 

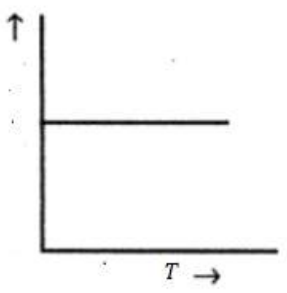
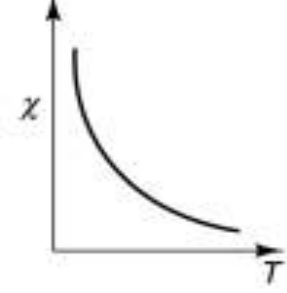
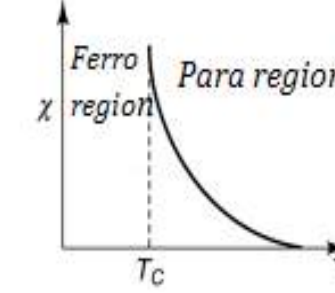
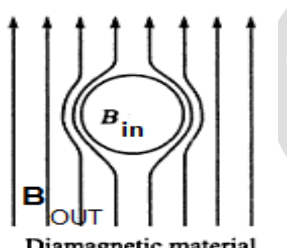
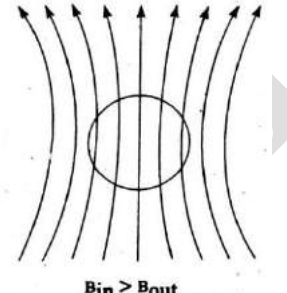
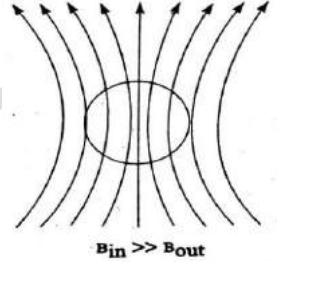
<p>$\chi - T$ curve</p>			
<p>Transition of material at T_c</p>	<p>Do not change.</p>	<p>On cooling these are converted into ferromagnetic material.</p>	<p>Converted into para magnetic material above T_c.</p>
<p>In the presence of magnetic field.</p>	<p>The magnetic lines of force are pulled out from the material. Hence, magnetic flux density is greater, outside the material than inside.</p> 	<p>The magnetic lines of force are attracted towards the centre of the material and hence the B_{in} material is greater than the B_{out}.</p> 	<p>The magnetic lines of force are highly attracted towards the centre of the material and hence the B_{in} material is very greater than the B_{out}.</p> 
<p>Example:</p>	<p>Bi, Zn, H₂O, Gold.....</p>	<p>Al, Pt, Mn, CuCl₂.....</p>	<p>Fe, Ni, Co, MnO, Fe₂O₃.....</p>

Antiferro magnetic materials:

These are the ferromagnetic materials in which the magnetic interaction between any two dipoles aligns themselves anti parallel to each other. All the dipoles are equal in magnitude. Therefore the resultant magnetization is zero.

Properties:

1. Susceptibility is small and positive for these materials.
2. Spin alignment is systematic, but in anti parallel manner.
3. Initially, the susceptibility increases slightly as the temperature increases, and beyond a particular temperature known as Neel temperature the susceptibility decreases with temperature.
4. The temperature at which anti ferromagnetic material converts into paramagnetic material is known as Neel's temperature.
5. Susceptibility is inversely proportional to the temperature. The variation of susceptibility with temperature is expressed as

$$\chi = \frac{C}{T + T_N} \quad \text{When } T > T_N$$

$$\chi \propto T \quad \text{When } T < T_N$$

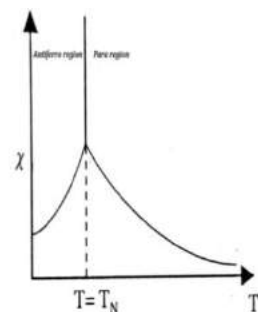

Where 'c' is the curie constant and the T_N is Neel temperature.

Ex: FeO, MnO, Cr₂O₃

Ferrimagnetic materials:

These are the ferromagnetic materials in which the magnetic interaction between any two dipoles aligns themselves anti parallel to each other. But the magnitudes of any two adjacent dipoles are not equal. Therefore, if we apply a small value of magnetic field, it will produce a large value of magnetization.

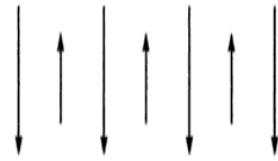

Properties:

1. Susceptibility is positive and very large for these materials.
2. Spin alignment is systematic, but in anti parallel of different magnitudes.
3. Ferrimagnetic materials possess net magnetic moment.
4. Above curie temperature becomes paramagnetic while below it behaves as ferrimagnetic material.
5. Ferrimagnetic domains become magnetic bubbles to act as memory elements.
6. Susceptibility is inversely proportional to the temperature. The variation of susceptibility with temperature is

$$\chi = \frac{c}{T \pm T_N} \text{ for } T > T_N$$

Where, C is curie constant and T_N is Neel temperature.

7. Ferrites are the best examples of ferromagnetic materials.
8. General formula of ferrites are $\text{Me}^{2+}\text{OFe}_2\text{O}_3$ or $\text{Me}^{2+}\text{Fe}_2\text{O}_4$
Examples: $\text{Zn}^{2+}\text{Fe}_2\text{O}_4$, CuFe_2O_4



DOMAIN THEORY OF FERROMAGNETISM:

The concept of domains was proposed by Weiss in order to explain the properties of ferromagnetic materials and their hysteresis effects.

Magnetic Domains: Every ferromagnetic material is made of a very large number of miniature (very small) regions which are known as domains. The boundaries separating the domains are called domain walls, also known as Bloch walls.

In each domain the magnetic dipoles align parallel to each other and produce spontaneous magnetization. The direction of spontaneous magnetization varies from domain to domain.

Process of Domain magnetization:

When the external field is applied there are two possible ways of alignment of random domains.

1. By the motion of domain walls.
2. By rotation of domains.

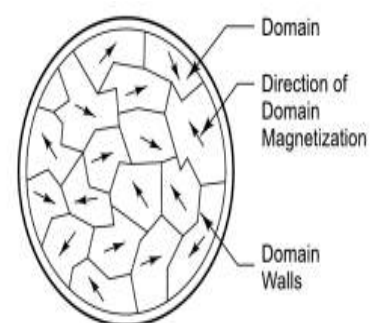

Motion of Domain walls: When a small amount of magnetic field is applied on a ferromagnetic material then the domains of the material whose magnetic moments are parallel or nearly parallel to the direction of applied field can grow in size whereas the domains are not parallel to field can diminish in size. This change produces large magnetization for the bulk material.

Rotation of Domains:

When the magnetic field is increased further to a large value (i.e., near saturation), further domains growth becomes impossible and hence fully grown domains can rotate into the field direction and specimen is said to be saturated.

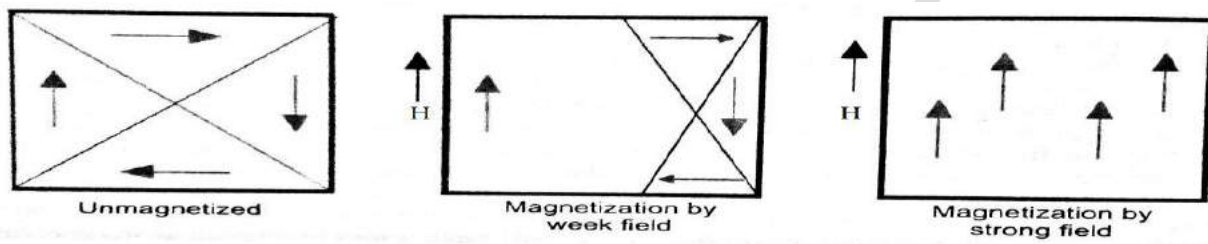

Magnetization of a ferro magnetic material

HYSTERESIS CURVE:

It means retardation. [or] Lagging of an effect behind the cause of the effect [or] The phenomenon of B lagging H . [or] It is also defined as a phenomenon of flux density (B) with the change in magnetic field strength (H) in a ferromagnetic material.

Explanation: When the magnetic field H is applied on an unmagnetized ferromagnetic material the magnetic induction increases first rapidly and then slowly from o to a . The increase is non linear, after that the rate of induction slows down and attaining a saturation value B_{sat} , with further increase in H , there is no increase in B . If applied magnetic field H on the material is decreased at this stage, naturally B decreases and B will not travel in that initial path, creates a new path.

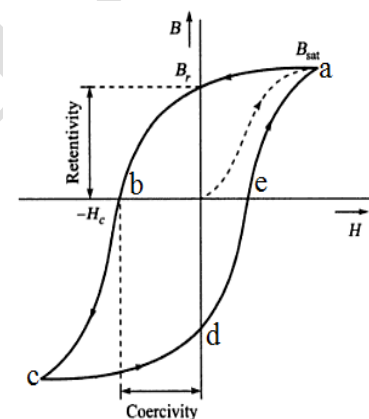

When H is reduced to zero, B does not vanish, the value of B that remains in the material is called as retentivity B_r or reduce magnetisation. To remove retentivity in the material sufficient negative magnetic field $-H_c$ or H_c is applied in opposite direction then the retentivity B_r becomes zero. This is (field) known as coercive field. On increasing H further B reaches saturation in the opposite direction denoted by 'c'. Then reducing H to zero B reaches 'd' and then increasing H in the positive direction B reaches again to B_{sat} and a curve is obtained. This completes a closed loop called hysteresis loop. It includes some area. This area indicates the amount of energy wasted in one cycle of operation.

SOFT AND HARD MAGNETIC MATERIALS:

Ferromagnetic materials are classified into two types based on the characteristic parameters such as hysteresis and magnetisation. They are

1. Hard magnetic materials
2. Soft magnetic materials

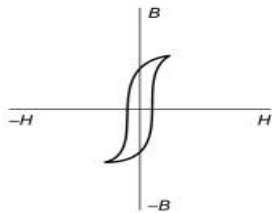
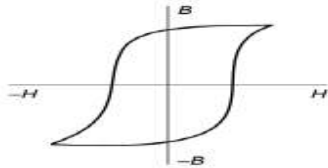
S.NO	SOFT MAGNETIC MATERIAL	HARD MAGNETIC MATERIAL
1	Materials which can be easily magnetized and demagnetized are called Soft magnetic materials.	Materials which can't be easily magnetized and demagnetized are called hard magnetic materials.
2	The nature of hysteresis loop is very steep 	The nature of hysteresis loop is very large. 
3	They are prepared by annealing process.	They are prepared by quenching process.
4	Due to small hysteresis loop area, they have small hysteresis loss.	Due to large hysteresis loop area, they have large hysteresis loss.
5	They have large value of permeability and susceptibility.	They have low value of permeability and susceptibility.
6	The coercivity and retentivity are small.	The coercivity and retentivity are large.
7	They are free from irregularities.	They have large amount of impurities and lattice defects.
8	They are used <ul style="list-style-type: none"> • To produce temporary magnets. • In the preparation of magnetic core materials used in transformers, electric motors, magnetic amplifiers, magnetic switching circuits, etc., 	They are used <ul style="list-style-type: none"> • To produce permanent magnets. • In loud speakers, toys, in measuring meters, microphones, magnetic detectors, magnetic separators, etc.,
9	<i>Ex:</i> Iron and silicon alloys, Nickel – Iron alloy, Iron – Cobalt alloy.	<i>Ex:</i> High carbon steel, Cobalt steel, Barium ferrite .

UNIT V

LASERS

INTRODUCTION:

LASER stands for Light Amplification by Stimulated Emission of Radiation. Laser technology started with Albert Einstein in 1917, he has given theoretical basis for the development of Laser. The technology further evolved in 1960 when the very first laser called Ruby Laser was built at Hughes Research Laboratories by T.H. Mainmann.

CHARACTERISTIC OF LASER RADIATION:

The laser beam has the properties given below which distinguish it from an ordinary beam of light. Those are

1. Highly directional
2. Highly monochromatic
3. Highly intense
4. Highly coherence

1. Highly directional:

A conventional light source emits light in all directions. On the other hand, Laser emits light only in one direction. The width of Laser beam is extremely narrow and hence a laser beam can travel to long distances without spreading.

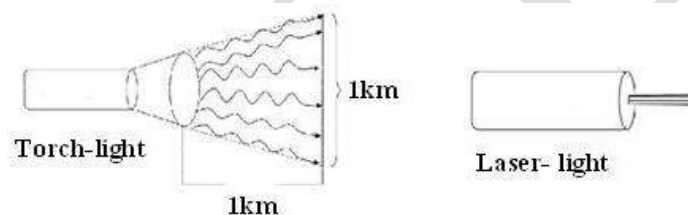

The directionality of laser beam is expressed in terms of divergence

$$\Delta\theta = \frac{r_2 - r_1}{d_2 - d_1}$$

Where r_1 and r_2 are the radii of laser beam spots at distances of d_1 and d_2 respectively from laser source.

2. Highly monochromatic:

A monochromatic source is a single frequency or single wavelength source of light. The laser light is more monochromatic than that of a conventional light source. This may be due to the stimulated characteristic of laser light. The band width of conventional monochromatic light source is 1000\AA . But the band width of ordinary light source is 10\AA . For high sensitive laser source is 10^{-8}\AA .

3. Highly intense:

Laser light is highly intense than the conventional light. A one milli-Watt He-Ne laser is highly intense than the sun intensity. This is because of coherence and directionality of laser.

Suppose when two photons each of amplitude 'A' are in phase with other, then young's principle of superposition, the resultant amplitude of two photons is $2A$ and the intensity is $4a^2$. Since in laser many numbers of photons are in phase with each other, the amplitude of the resulting wave becomes ' nA ' and hence the intensity of laser is proportional to n^2A^2 . So 1mw He-Ne laser is highly intense than the sun.

4. Highly coherence

A predictable correlation of the amplitude and phase at any one point with other point is called coherence. In case of conventional light, the property of coherence exhibits between a source and its virtual source where as in case of laser the property coherence exists between any two sources of same phase.

There are two types of coherence

- i) Temporal coherence
- ii) Spatial coherence.

Temporal coherence (or longitudinal coherence):

The predictable correlation of amplitude and phase at one point on the wave train w.r.t another point on the same wave train, then the wave is said to be temporal coherence.



Spatial coherence (or transverse coherence):

The predictable correlation of amplitude and phase at one point on the wave train w.r.t another point on a second wave, then the waves are said to be spatial coherence (or transverse coherence). Two waves are said to be coherent when the waves must have same phase & amplitude.

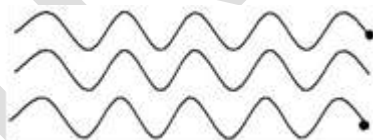

INTERACTION OF LIGHT WITH MATTER AND THE THREE QUANTUM PROCESSES:

When the radiation interacts with matter, results in the following three important phenomena. They are

- (i) Induced or Stimulated Absorption
- (ii) Spontaneous Emission
- (iii) Stimulated Emission

STIMULATED ABSORPTION (OR) INDUCED ABSORPTION (OR) ABSORPTION:

An atom in the lower energy level or ground state energy level (E_1) absorbs the incident photon and goes to excited state (E_2) as shown in figure below. This process is called induced or stimulated absorption.

Let E_1 and E_2 be the energies of ground and excited states of an atom. Suppose, if a photon of energy $E_2 - E_1 = h\nu$ interacts with an atom present in the ground state, the atom gets excitation from ground state E_1 to excited state E_2 . This process is called stimulated absorption.



Stimulated absorption rate depends upon the number of atoms available in the lowest energy state as well as the energy density of photons.

SPONTANEOUS EMISSION:

The atom in the excited state returns to ground state emitting a photon of energy ($E = E_2 - E_1 = h\nu$), without applying an external energy spontaneously is known as spontaneous emission.

Let E_1 and E_2 be the energies of ground and excited states of an atom. Suppose, if photon of energy $E_2 - E_1 = h\nu$ interacts with an atom present in the ground state, the atom gets excitation from ground state E_1 to excited state E_2 .

The excited atom does not stay for a long time in the excited state. The excited atom gets de-excitation after its life time by emitting a photon of energy $E_2 - E_1 = h\nu$. This process is called spontaneous emission.

The spontaneous emission rate depends up on the number of atoms present in the excited state.

The probability of spontaneous emission (P_{21}) is independent of $u(\nu)$.

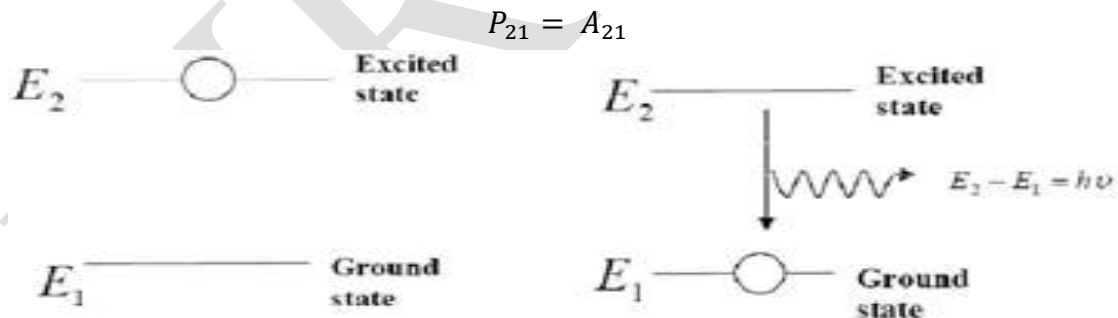

STIMULATED-EMISSION:

The atom in the excited state can also returns to the ground state by applying external energy or inducement of photon thereby emitting two photons which are having same energy as that of incident photon. This process is called as stimulated emission.

Stimulated emission was postulated by Einstein. Let E_1 and E_2 be the energies of ground and excited states of an atom. Let a Photon of energy $E_2 - E_1 = h\nu$ interacts with the excited atom with in their life time The atom gets de-excitation to ground state by emitting of another photon.

These photons have same phase and it follows coherence. This phenomenon is called stimulated emission

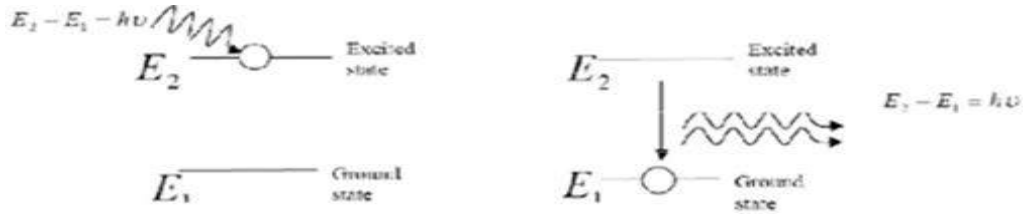

Stimulated emission rate depends upon the number of atoms available in the excited state as well as the energy density of photons.

Comparison between Spontaneous and Stimulated emission:

Spontaneous emission	Stimulated emission
1. The spontaneous emission was Postulated by Bohr.	1. The stimulated emission was Postulated by Einstein.
2. Additional photons are not required in spontaneous emission.	2. Additional photons are required in Stimulated emission.
3. One Photon is emitted in spontaneous emission.	3. Two photons are emitted in stimulated emission.
4. The emitted radiation is incoherent.	5. The emitted radiation is coherent.
5. The emitted radiation is less intense.	6. The emitted radiation is high intense.

Light Amplification:

Light amplification requires stimulated emission exclusively. In practice, absorption and spontaneous emission always occur together with stimulated emission. The laser operation is achieved when stimulated emission exceeds the other two processes due to its higher transitions rates of atomic energy levels.

EINSTEIN COEFFICIENTS & THEIR RELATIONS

Einstein coefficients:

Einstein mathematically expressed the statistical nature of the three possible radiative transition routes (spontaneous emission, stimulated emission, and absorption) with the so-called Einstein coefficients and quantified the relations between the three processes.

Let N_1 be the number of atoms per unit volume with energy E_1 and N_2 be the number of atoms per unit volume with energy E_2 . Let ' n ' be the number of photons per unit volume at frequency ' ν ' such that $E_2 - E_1 = h\nu$. Then, the energy density of photons $E = h\nu$.

- **Stimulated absorption:** When the photons interact with the atoms it leads to absorption transition which is called as stimulated absorption. Stimulated absorption rate depends upon the number of atoms available in the lowest energy state as well as the energy density photons.

$$\begin{aligned} \text{Stimulated absorption rate} &\propto N_1 \\ &\propto u(\nu) \\ &= B_{12} N_1 u(\nu) \end{aligned}$$

Where B_{12} is the Einstein coefficient of stimulated absorption.

- **Spontaneous emission:** The atom in the excited state returns to ground state emitting a photon of energy $(E) = E_2 - E_1 = h\nu$, without applying an external energy spontaneously is known as spontaneous emission. The spontaneous emission rate depends up on the number of atoms present in the excited state.

$$\begin{aligned} \text{Spontaneous emission rate} &\propto N_2 \\ &= A_{21} N_2 \end{aligned}$$

Where A_{21} is the Einstein coefficient of spontaneous emission.

- **Stimulated emission:** The atom in the excited state can also returns to the ground state by applying external energy or inducement of photon thereby emitting two photons which are having same energy as that of incident photon. This process is called as stimulated emission. Stimulated emission rate depends upon the number of atoms available in the excited state as well as the energy density of incident photons.

$$\begin{aligned} \text{Stimulated emission rate} &\propto N_2 \\ &\propto u(\nu) \\ &= B_{21} N_2 u(\nu) \end{aligned}$$

Where B_{21} is the Einstein coefficient of stimulated emission.

If the system is in equilibrium, the rates of absorption transitions (Stimulated absorption) are equal to emission transitions (The rate of Spontaneous + Stimulated emission).

The rate of Absorption = The rate of Spontaneous + Stimulated emission

$$B_{12} N_1 u(\nu) = A_{21} N_2 + B_{21} N_2 u(\nu)$$

$$B_{12} N_1 u(\nu) - B_{21} N_2 u(\nu) = A_{21} N_2$$

$$u(\nu)(B_{12} N_1 - B_{21} N_2) = A_{21} N_2$$

$$u(\nu) = \frac{A_{21}N_2}{B_{12}N_1 - B_{21}N_2}$$

$$u(\nu) = \left(\frac{A_{21}}{B_{21}} \times \frac{1}{\left[\frac{N_1}{N_2} \times \frac{B_{12}}{B_{21}} - 1 \right]} \right)$$

According to Boltzmann distribution law

$$N = N_0 e^{-\frac{E}{k_B T}}$$

$$N_1 = N_0 e^{-\frac{E_1}{k_B T}}$$

$$N_2 = N_0 e^{-\frac{E_2}{k_B T}}$$

$$\frac{N_1}{N_2} = \frac{N_0 e^{-\frac{E_1}{k_B T}}}{N_0 e^{-\frac{E_2}{k_B T}}} = e^{\frac{E_2 - E_1}{k_B T}} = e^{\frac{h\nu}{k_B T}}$$

$$u(\nu) = \frac{A_{21}}{B_{21}} \times \frac{1}{\left[e^{\frac{h\nu}{k_B T}} \left(\frac{B_{12}}{B_{21}} \right) - 1 \right]} \quad \text{---(1)}$$

According to Planck's radiation formula the energy density of photon is given by,

$$u(\nu) = \frac{8\pi h\nu^3}{c^3} \times \left(\frac{1}{\left[e^{\frac{h\nu}{k_B T}} - 1 \right]} \right) \quad \text{---(2)}$$

Comparing eq.(1) & eq.(2), we get

$$(i) \quad \frac{A_{21}}{B_{21}} = \frac{8\pi h\nu^3}{c^3} \quad \text{or} \quad \frac{A_{21}}{B_{21}} \propto \nu^3$$

$$(ii) \quad \frac{B_{12}}{B_{21}} = 1 \quad \text{or,} \quad B_{12} = B_{21}$$

POPULATION INVERSION:

The number of atoms present in the excited (or higher) state is greater than the number of atoms present in the ground energy state (or lower state) is called population inversion.

Let us consider two level energy systems of energies E_1 and E_2 as shown in figure. Let N_1 and N_2 be the population (means number of atoms per unit volume) of E_1 and E_2 respectively.

According to Boltzmann's distribution the population of an energy level E_i , at temperature T is given by

$$N_i = N_0 e^{-\left(\frac{E_i}{k_B T}\right)} \quad \text{where } i = 1, 2, 3, \dots, N_i$$

where 'N₀' is the number of atoms in ground or lower energy states & k is the Boltzmann constant.

From the above equation the population of energy levels E₁ & E₂ are given by

$$N_1 = N_0 e^{\left(-\frac{E_1}{k_B T}\right)}$$

$$N_2 = N_0 e^{\left(-\frac{E_2}{k_B T}\right)}$$

At ordinary conditions N₁ > N₂ i.e., the population in the ground or lower state is always greater than the population in the excited or higher states. The stage of making, population of higher energy level greater than the population of lower energy level is called population inversion i.e., N₂ > N₁.

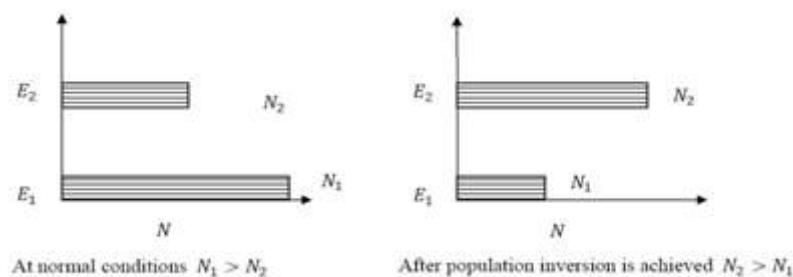

METASTABLE STATE: In general the number of excited particles in a system is smaller than the non excited particles. The time during which a particle can exist in the ground state is unlimited. On the other hand, the particle can remain in the excited state for a limited time known as life time.

The life time of the excited hydrogen atom is of the order of 10⁻⁸sec. However there exist such excited states in which the life time is greater than 10⁻⁸sec. These states are called as Meta stable states.

PUMPING MECHANISMS (OR TECHNIQUES):

Pumping:

The process of rising more no of atoms to the excited state by artificial means is called pumping.

A system in which population inversion is achieved is called as an active system. The method of raising the particles from lower energy state to higher energy state is called pumping. (or the process of achieving of population inversion is called pumping). This can be done by number of ways. The most commonly used pumping methods are

- Optical pumping
- Electrical discharge pumping
- Chemical pumping
- Injection current pumping

Optical pumping:

Optical pumping is used in solid laser. Xenon flash tubes are used for optical pumping. Since these materials have very broad band absorption, sufficient amount of energy is absorbed from the emission band of flash lamp and population inversion is created. Examples of optically pumped lasers are ruby, Nd: YAG Laser ($Y_3Al_5G_{12}$) (Neodymium: Yttrium Aluminum Garnet), Nd: Glass Laser

Electrical discharge pumping:

Electrical discharge pumping is used in gas lasers. Since gas lasers have very narrow absorption band pumping them any flash lamp is not possible. Examples of Electrical discharge pumped lasers are He-Ne laser, CO₂ laser, argon-ion laser, etc

Chemical pumping:

Chemical reaction may also result in excitation and hence creation of population inversion in few systems. Examples of such systems are HF and DF lasers.

Injection current pumping:

In semiconductors, injection of current through the junction results in creates of population inversion among the minority charge carriers. Examples of such systems are InP and GaAs.

PRINCIPLE OF LASER/LASING ACTION:

Let us consider many no of atoms in the excited state. Now the stimulating photon interacts with any one of the atoms in the excited state, the stimulated emission will occur. It emits two photons, having same energy & same frequency move in the same direction. These two photons will interact with another two atoms in excited state & emit 8-photons. In a similar way chain reaction is produced this phenomenon is called “Principle of lasing –action”. We get a monochromatic, coherent, directional & intense beam is obtained. This is called laser beam. This is the principle of working of a laser.

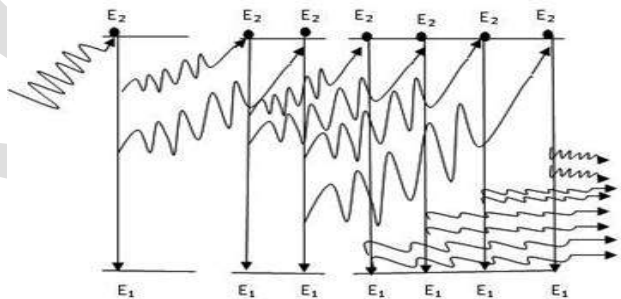
**Components of a LASER:**

Any laser system consists of 3-important components. They are

- (i) Source of energy or pumping source
- (ii) Active-medium (Laser Material)
- (iii) Optical cavity or resonator

(i) Energy Source : It supply energies & pumps the atoms or molecules in the active medium to excited states. As a result we get population inversion in the active medium which emits laser.

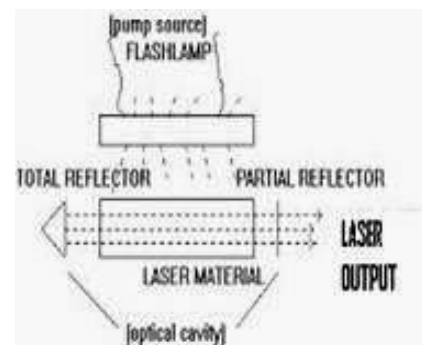

Ex: Xenon flash lamp, electric field.

(ii) Active medium: The medium in which the population inversion takes place is called as active medium.

Active-centre: The material in which the atoms are raised to excited state to achieve population inversion is called as active center.

(iii) Optical-cavity or resonator: The active medium is enclosed between a fully reflected mirror & a partially reflective mirror. This arrangement is called as cavity or resonator. As a result, we get highly intense monochromatic, coherence laser light through the non-reflecting portion of the mirror.

DIFFERENT TYPES OF LASERS

On the basis of active medium used in the laser systems, lasers are classified into several types

- | | |
|-------------------------|--|
| I. Solid lasers | : Ruby laser, Nd:YAG laser, Nd:Glass |
| II. Liquid lasers | : Europium Chelate laser, SeOCl ₂ |
| III. Gas lasers | : CO ₂ , He-Ne, Argon-Ion Laser |
| IV. Dye lasers | : Rhodamine 6G |
| V. Semiconductor lasers | : InP, GaAs. |

RUBY LASER

Ruby laser is a three level solid state laser and was developed by Mainmann in 1960. Ruby ($\text{Al}_2\text{O}_3 + \text{Cr}_2\text{O}_3$) is a crystal of Aluminium oxide, in which 0.05% of Al^{+3} ions are replaced by the Cr^{+3} ions. The colour of the ruby rod is pink. The active medium in the ruby rod is Cr^{+3} ions.

Principle or Characteristics of a ruby laser:

Due to optical pumping, the chromium atoms are raised to excited states then the atoms come to metastable state by non-radiative transition. Due to stimulated emission the transition of atoms takes place from metastable state to ground state and gives a laser beam.

Construction:

- In ruby laser 4cm length and 5mm diameter rod is generally used.
- Both the ends of the rods are highly polished and made strictly parallel.
- The ends are silvered in such a way, one becomes partially reflected and the other end fully reflected.
- The ruby rod is surrounded by xenon flash tube, which provides the pumping light to excite the chromium ions in to upper energy levels.

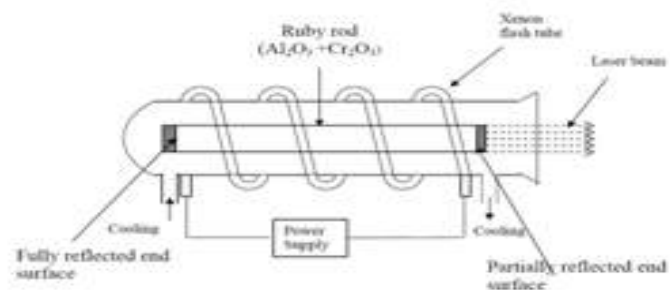

- Xenon flash tube emits thousands joules of energy in few milli seconds, but only a part of that energy is utilized by the chromium ions while the rest energy heats up the apparatus.
- A cooling arrangement is provided to keep the experimental set up at normal temperatures.

Working:

- The energy level diagram of chromium ions is shown in figure.
- The chromium ions get excitation into higher energy levels by absorbing of 5600Å of wave length radiation.
- The excited chromium ions stay in the level H for short interval of time (10^{-8} Sec).
- After their life time most of the chromium ions are de-excited from H to G and a few chromium ions are de-excited from H to M.

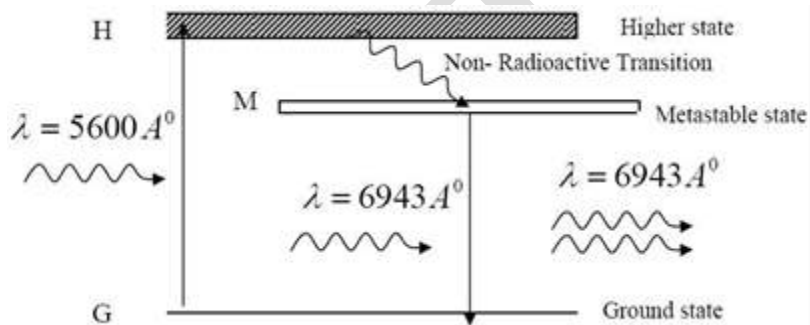

- The transition between H and M is non-radioactive transition i.e. the chromium ions give their energy to the lattice in the form of heat.
- In the Metastable state the life time of chromium ions is 10^{-3} sec.
- Due to the continuous working of flash lamp, the chromium ions are excited to higher state H and returned to M level.
- After few milli seconds the level M is more populated than the level G and hence the desired population inversion is achieved.
- The state of population inversion is not a stable one.
- The process of spontaneous transition is very high.
- When the excited chromium ion passes spontaneously from H to M it emits one photon of wave length 6943Å .
- The photon reflects back and forth by the silver ends and until it stimulates an excited chromium ion in M state and it emits fresh photon in phase with the earlier photon.
- The process is repeated again and again until the laser beam intensity is reached to a sufficient value.
- When the photon beam becomes sufficient intense, it emerges through the partially silvered end of the rod.
- The wave length 6943Å is in the red region of the visible spectrum on returning to ground state (G).

Uses of Ruby laser:

- Used in distance measurement using 'pulse echo technique'
- Used for measurement of plasma properties such as electron density and temperature.
- Used to remove the melanin of the skin.
- Used for recording pulsed holograms.
- Used as target designators and range finders in military.

Draw backs of Ruby laser:

- It requires high pumping power.
- The efficiency of ruby laser is very small. It is a pulse laser.

He-Ne LASER

It was discovered by A. Javan & his co-workers in 1960. It is a continuous wave gas laser. It consists of mixture of He & Ne in 10:1 ratio as a active medium.

Principle/Characteristics of He-Ne laser:

This laser is based on the principle of stimulated emission, produced in the He & Ne. The population inversion is achieved due to the interaction between He & Ne gases. Using gas lasers, we can achieve highly coherent, directional and high monochromatic beam.

Construction:

- In He-Ne gas laser, the He and Ne gases are taken in the ratio 10:1 in the discharge tube.
- Two reflecting mirrors are fixed on either ends of the discharge tube, in that, one is partially reflecting and the other is fully reflecting.
- In He-Ne laser 80cm length and 1cm diameter discharge tube is generally used.
- The output power of these lasers depends on the length of the discharge tube and pressure of the gas mixture.
- Energy source of laser is provided by an electrical discharge of around 1000V through an anode and cathode at each end of the glass tube.

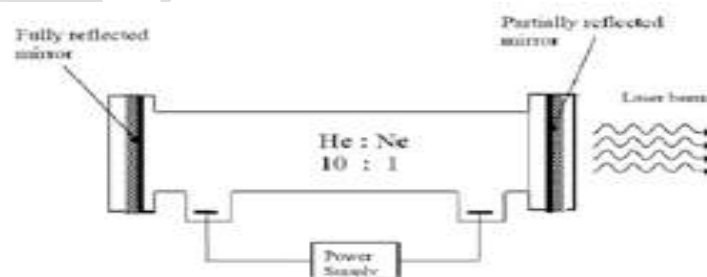

Working:

- When the electric discharge is passing through the gas mixture, the electrons accelerated towards the positive electrode.
- During their passage, they collide with He atoms and excite them into higher levels.
- F_2 and F_3 form F_1 . In higher levels F_2 and F_3 , the life time of He atoms is more.
- So there is a maximum possibility of energy transfer between He and Ne atoms through atomic collisions.
- When He atoms present in the levels F_2 and F_3 collide with Ne atoms present ground state E_1 , the Ne atoms gets excitation into higher levels E_4 and E_6 .

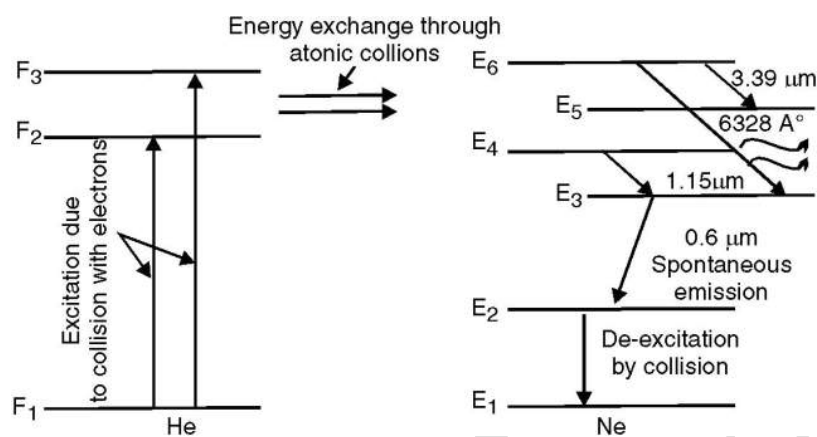

- Due to the continuous excitation of Ne atoms, we can achieve the population inversion between the higher levels E_4 (E_6) and lower levels E_3 (E_5).
- The various transitions $E_6 \rightarrow E_5$, $E_4 \rightarrow E_3$ and $E_6 \rightarrow E_3$ leads to the emission of wavelengths 3.39 μm , 1.15 μm and 6328 \AA .
- The first two corresponding to the infrared region while the last wavelength is corresponding to the visible region.
- The Ne atoms present in the E_3 level are de-excited into E_2 level, by spontaneously emission of photon.
- When a narrow discharge tube is used, the Ne atoms present in the level E_2 collide with the walls of the tube and get de-excited to ground level E_1 .

Uses of He-Ne laser:

- Used in laboratories for all interferometric experiments.
- Used widely in metrology in surveying, alignment etc.
- Used to read barcodes and He-Ne laser scanners also used for optical character recognition.
- Used in holography.

CO₂ laser :

The CO₂ laser was one of the gas laser, these are the highest power continuous wave lasers that are currently available, they are also quite efficient. The ratio of output power to pump power can be as large as 20%.

The CO₂ laser produces a beam of infrared light with the principle wavelength bands centering around 9.6 and 10.6 μm.

Principle: The principle of carbon di oxide laser is transition between vibrational states of the same electronic states by achieving population inversion between these states.

For the laser action two points are important ,one is the population inversion between the two levels and second increased density of the incident radiation.

Vibrational states in co2 molecules:

A carbon dioxide molecule has a carbon atom at the centre with two oxygen atoms attached, one at both sides. Such a molecule exhibits three independent modes of vibrations. They are

- a) Symmetric stretching mode.
- b) Bending mode
- c) Asymmetric stretching mode.

a) Symmetric stretching mode :In this mode of vibration, carbon atoms are at rest and both oxygen atoms vibrate simultaneously along the axis of the molecule departing or approaching the fixed carbon atoms

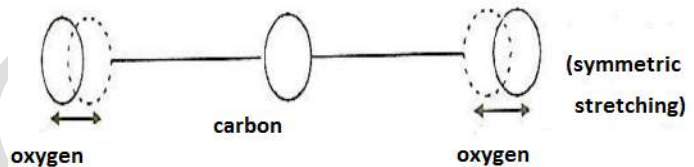

b) Bending mode:

In this mode of vibration, oxygen atoms and carbon atoms vibrate perpendicular to molecular axis.

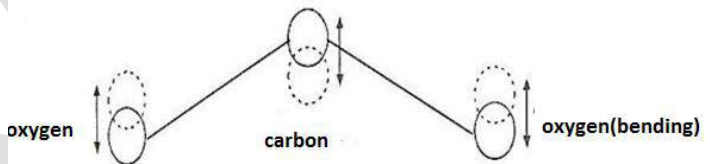

c) Asymmetric Stretching Mode :

In this mode of vibration, oxygen atoms and carbon atoms vibrate asymmetrically, i.e., oxygen atoms move in one direction while carbon atoms in the other direction

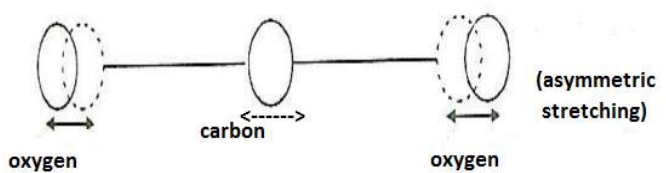

Consturction:

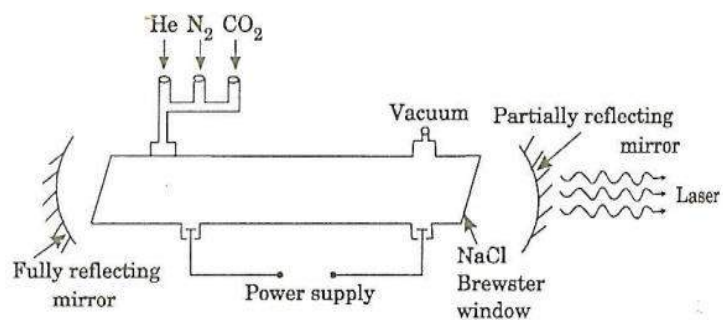

- It consists of a quartz tube 5 m long and 2.5 cm in the diameter.
- This discharge tube is filled with gaseous mixture of CO₂ (active medium), helium and nitrogen with suitable partial pressures.
- The terminals of the discharge tubes are connected to a D.C power supply.
- The ends of the discharge tube are fitted with NaCl Brewster windows so that the laser light generated will be polarized.
- Two concave mirrors one fully reflecting and the other partially form an optical resonator.

Working :

Figure shows energy levels of nitrogen and carbon dioxide molecules.

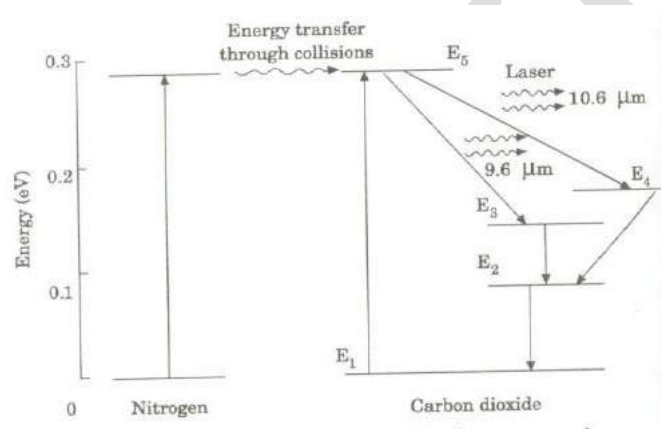

- A mixture of CO₂, N₂ and helium or water vapour is used as active medium here.
- When an electric discharge occurs in the gas, the electrons collide with nitrogen molecules and they are raised to excited states. This process is represented by the equation.

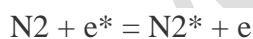

N₂ = Nitrogen molecule in ground state e* = electron with kinetic energy

N₂* = nitrogen molecule in excited state e = same electron with lesser energy

- Now N₂* molecules in the excited state collide with CO₂ atoms in ground state and excite to higher electronic, vibrational and rotational levels. This process is represented by the equation

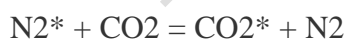

N₂* = Nitrogen molecule in excited state.

CO₂ = Carbon dioxide atoms in ground state

CO₂* = Carbon dioxide atoms in excited state

N₂ = Nitrogen molecule in ground state.

- Since the excited level of nitrogen is very close to the E5 level of CO₂ atom, population in E5 level increases.
- As soon as population inversion is reached, any of the spontaneously emitted photon will trigger laser action in the tube. There are two types of laser transition possible.
- **1. Transition E5 to E4** : This will produce far IR radiation of laser beam at the wavelength 10.6 μ m
- **2. Transition E5 to E3**: This laser transition will produce a laser beam of wavelength 9.6 μ m in IR region. Normally 10.6 μ m transition is more intense than 9.6 μ m transition. The power output from this laser is 10kW.

E3 and E4 levels also metastable states and the CO₂ molecules at these levels fall to the lower level E2 through inelastic collisions with unexcited CO₂ molecules, then again tends to closer ground state through thermal excitations. The nature of output may be continuous wave or pulsed wave.

Advantages:

1. The construction of CO₂ laser is simple and the output of this laser is continuous.
2. It has high efficiency
3. It has very high output power.
4. The output power can be increased by extending the length of the gas tube.

Disadvantages:

1. The contamination of oxygen by carbon monoxide will have some effect on laser action
2. The operating temperature plays an important role in determining the output power of laser.
3. The corrosion may occur at the reflecting plates.
4. Accidental exposure may damage our eyes, since it is invisible (infrared region) to our eyes.

Applications:

1. High power CO₂ laser finds applications in material processing, welding, drilling, cutting soldering etc.
2. The low atmospheric attenuation (10.6 μ m makes CO₂ laser suitable for open air communication.
3. It is used for remote sensing.
4. It is used for treatment of liver and lung diseases.
5. It is mostly used in neuro surgery and general surgery.
6. It is used to perform microsurgery and bloodless operations.

APPLICATIONS OF LASERS

Due to high intensity, high mono-chromaticity and high directionality of lasers, they are widely used in various fields like

1. communication
2. computers
3. chemistry
4. photography
5. industry
6. medicine
7. military
8. scientific research

1. Communication:

- In case of optical communication, semiconductor laser diodes are used as optical sources.
- More channels can be sent simultaneously. Signal cannot be tapped as the bandwidth is large, more data can be sent.
- A laser is highly directional and has less divergence, hence it has greater potential use in space crafts and submarines.

2. Computers :

- In LAN (local area network), data can be transferred from memory storage of one computer to other computer using laser for short time.
- Lasers are used in CD-ROMS during recording and reading the data.

3. Chemistry :

- Lasers are used in molecular structure identification.
- Lasers are also used to accelerate some chemical reactions.
- Using lasers, new chemical compounds can be created by breaking bonds between atoms or molecules.

4. Photography :

- Lasers can be used to get 3-D lensless photography.
- Lasers are also used in the construction of holograms.

5. Industry :

- Lasers can be used to blast holes in diamonds and hard steel.
- Lasers are also used as a source of intense heat.
- Carbon dioxide laser is used for cutting drilling of metals and nonmetals, such as ceramics, plastics, glass etc.
- High power lasers are used to weld or melt any material.
- Lasers are also used to cut teeth in saws and test the quality of fabric.

6. Medicine :

- Pulsed neodymium laser is employed in the treatment of liver cancer.
- Argon and carbon dioxide lasers are used in the treatment of liver and lungs.
- Lasers used in the treatment of Glaucoma.

7. Military :

- Lasers can be used as a war weapon.
- High energy lasers are used to destroy the enemy air-crafts and missiles.
- Lasers can be used in the detection and ranging like RADAR.

8. Scientific research:

- Lasers are used in the field of 3D-photography.
- Lasers used in Recording and reconstruction of hologram.
- Lasers are employed to create plasma.
- Lasers used to produce certain chemical reactions.
- Lasers are used in Raman spectroscopy to identify the structure of the molecule.
- Lasers are used in the Michelson- Morley experiment.
- A laser beam is used to confirm Doppler shifts in frequency for moving objects.

MRCET

FIBER-OPTICS

INTRODUCTION TO OPTICAL FIBER:

Fiber optics is a branch of physics which deals with the transmission & reception of light waves using optical fibers which acts as a guiding media. The transmission of light waves by fiber optics was first demonstrated by John Tyndall in 1870.

Optical Fiber:

Optical fiber is a thin & transparent guiding medium or material which guides the information carrying light waves. It is a cylindrical wave-guide system which propagates the data & speech signals in the optical frequency range.

A light beam acting as a carrier wave is capable of carrying more information than radio waves & microwaves because of its high frequency as shown below.

Radio waves - 10^4 Hz , Micro waves - 10^{10} Hz, Light waves - 10^{15} Hz

Construction:

An optical fiber is a very thin, flexible transparent made with plastic or glass.

It has cylindrical shape consisting of three layers or sections

- 1) The Core
- 2) The Cladding
- 3) The Outer jacket or Buffer jacket

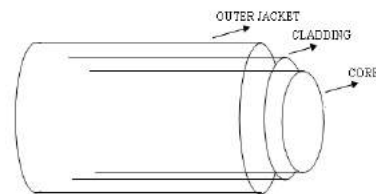

1)The Core:It is the central layer surrounded by another layer called cladding. Light is transmitted within the core which has refractive index (n_1). It is a denser medium. Core is made of silica (SiO_2).

2)The Cladding:It is the second layer, surrounded by a third layer called the outer jacket. It has refractive index n_2 which is less than the refractive index of core i.e ($n_1 > n_2$). It acts as a rarer medium. It keeps the light within the core because $n_1 > n_2$. To lower the refractive index of cladding the silica is doped with phosphorous or bismuth material.

3)The Outer or Buffer Jacket:It is the third layer it protects the fiber from moisture & abrasion. To provide necessary toughness & tensile strength, a layer of strength member is arranged surrounding buffer jacket. It is made of polyurethane material.

Working Principle of Optical Fiber:

Total Internal Reflection: The principle of optical fiber is total internal reflection.

Condition for Total Internal Reflection:

- 1) The light ray should move from denser to rarer medium.
- 2) The refractive index of core must be greater than cladding i.e. $n_1 > n_2$
- 3) The angle of incidence (i) must be greater than the critical angle(θ_c) i.e. $i > \theta_c$.
- 4) The critical angle $\theta_c = \sin^{-1} \frac{n_2}{n_1}$.

Explanation:

Let us consider a denser medium & rarer medium of refractive indices n_1 & n_2 respectively and $n_1 > n_2$. Let a light ray move from denser to rarer medium with 'i' as the angle of incidence & 'r' as angle of refraction. The refracted ray bends away from the normal as it travels from denser to rarer medium with increase of angle of incidence 'i'.

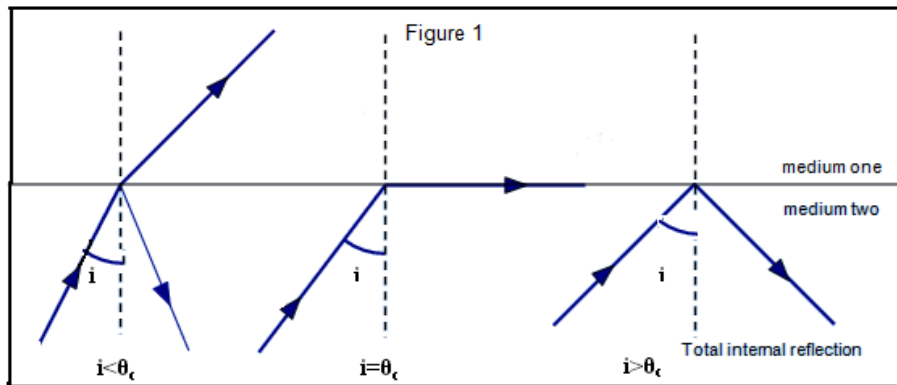

In this we get three cases

Case-1: When $i < \theta_c$, Then the light ray refracts into rarer medium as shown in figure.

Case-2: When $i = \theta_c$, then the light ray traverses along the two media as shown in figure.

For the two media, applying Snell's law

$$n_1 \sin i = n_2 \sin r$$

$$(\because i = \theta_c \text{ \& } r = 90^\circ)$$

$$n_1 \sin \theta_c = n_2 \sin 90$$

$$n_1 \sin \theta_c = n_2$$

$$\sin \theta_c = \frac{n_2}{n_1}$$

Where $n_1 > n_2$

For air, $n_2 = 1$,

$$\theta_c = \sin^{-1} \frac{1}{n_1}$$

Case-3: When $i > \theta_c$, then the light ray reflected back into the medium as shown in figure

ACCEPTANCE ANGLE & ACCEPTANCE CONE:

Def: Acceptance angle is the maximum angle of incidence at the core of an optical fiber so that the light can be guided through the fiber by total internal reflection. This angle is called as acceptance angle. It is denoted by ' α_i '.

- Consider a cross-sectional view of an optical fiber having core & cladding of refractive indices n_1 and n_2 .
- Let the fiber be in air medium (n_o). The incident light while entering into the core at 'A' makes an incident angle of ' α_i ' with the fiber-axis.
- In core it travels along AB & is incident at part B on cladding interface.
- Let α_r be the angle of refraction at part 'A' & ' θ ' be the angle of incidence at 'B'.
- When ' θ ' is greater than the critical angle ' θ_c ', then total internal reflection takes place into the core & light takes the path BD.
- Due to multiple total internal reflections the propagation of light ray takes place through the fiber.
- Applying Snell's law at AC core-air interface :-

$$\frac{\sin \alpha_i}{\sin \alpha_r} = \frac{n_1}{n_o}$$

$$n_o \sin \alpha_i = n_1 \sin \alpha_r \rightarrow (1)$$

- Let a normal 'BC' be drawn from the point 'B' to the fiber axis. Then from ΔABC , we get

$$\alpha_r = 90^\circ - \theta \rightarrow (2)$$

Substitute eq - (2) in eq - (1)

$$n_o \sin \alpha_i = n_1 \sin(90^\circ - \theta)$$

$$n_o \sin \alpha_i = n_1 \cos \theta \rightarrow (3)$$

- To get total internal reflection at point B

(Core-Cladding Interface) i.e. $\theta > \theta_c$

- Let the maximum angle of incidence at point A be $\alpha_i(\max)$ for which $\theta > \theta_c$.

From eqn (3), we get

$$n_o \sin \alpha_i = n_1 \cos \theta \rightarrow (4)$$

$$\alpha_i(\max) = \alpha_i, \text{ when } \theta = \theta_c$$

$$\sin \alpha_i(\max) = \frac{n_1}{n_o} \cos \theta_c \rightarrow (5)$$

We know that $\sin \theta_c = \frac{n_2}{n_1}$

$$\cos \theta_c = \sqrt{1 - \sin^2 \theta_c} = \sqrt{1 - \frac{n_2^2}{n_1^2}} \Rightarrow \sqrt{\frac{n_1^2 - n_2^2}{n_1^2}} = \frac{\sqrt{(n_1^2 - n_2^2)}}{n_1} \therefore \cos \theta_c = \frac{\sqrt{(n_1^2 - n_2^2)}}{n_1}$$

→ (6)

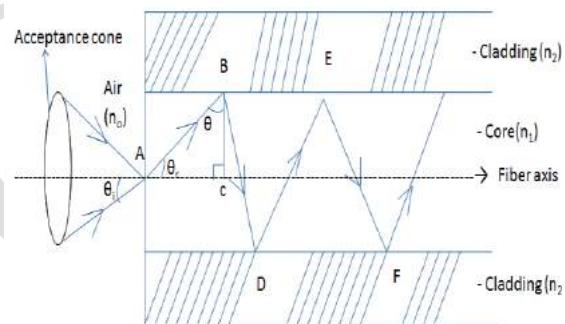

Substitute the eq(6) in eq(5) , we get

$$\sin \alpha_i(\max) = \frac{n_1}{n_0} \sqrt{\frac{n_1^2 - n_2^2}{n_1}}$$

$$\sin \alpha_i(\max) = \sqrt{\frac{n_1^2 - n_2^2}{n_0}}$$

(OR)

$$\alpha_i(\max) = \sin^{-1} \sqrt{\frac{n_1^2 - n_2^2}{n_0}} \rightarrow (7)$$

For air medium, $n_0=1$ $\alpha_i(\max) = \sin^{-1} \sqrt{n_1^2 - n_2^2} \rightarrow (8)$

Fractional Index Change (Δ):

It is the ratio of refractive index difference in core & cladding to the refractive index of core.

$$\Delta = \frac{n_1 - n_2}{n_1}$$

$$n_1 - n_2 = \Delta n_1 \rightarrow (1)$$

NUMERICAL APERTURE (N.A.):

Def:It is defined as light accepting efficiency of the fiber and is equal to sine of the acceptance angle of the fiber i.e. $N.A. = \sin \alpha_i(\max)$

$$N.A. = \sin \alpha_i(\max) = \sqrt{\frac{n_1^2 - n_2^2}{n_0}}$$

We know that $\Delta = \frac{n_1 - n_2}{n_1}$

$$n_1 - n_2 = \Delta n_1 \rightarrow (2)$$

We know, $N.A. = \sin \alpha_i(\max) = \sqrt{n_2^2 - n_1^2}$ for air $n_0=1$

$$N.A. = \sqrt{(n_1 + n_2)(n_1 - n_2)}$$

If $n_1 = n_2$, then $N.A. = \sqrt{2n_1} \times \Delta n_1$

$$N.A. = n_1 \sqrt{2\Delta} \rightarrow (3)$$

TYPES OF OPTICAL FIBERS:

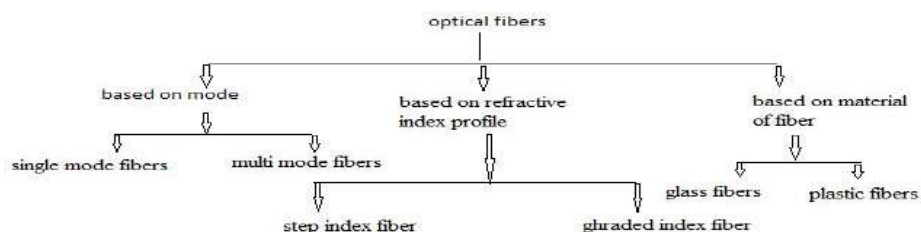

Optical fibers can be classified based on either the mode they support or the refractive index profile of the fiber. They can also be classified based on the material of the fiber.

Based on Mode:

The rays travelling in the fiber by total internal reflection are called modes.

1) Single mode fibers:

- If the thickness of the fiber is so small that it supports only one mode then the fiber is called **single mode fiber** or mono mode fiber.
- The core diameter of this fiber is about 8 to 10 μm and the outer diameter of cladding is 60 to 70 μm .

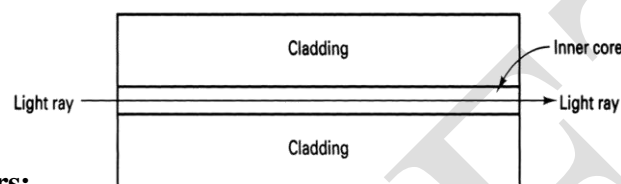

2) Multi mode fibers:

- If the thickness of the fiber is very large that it supports more than one mode then the fiber is called **multi mode fiber**.
- The core diameter of this fiber is about 50 to 200 μm and the outer diameter of cladding is 100 to 250 μm .

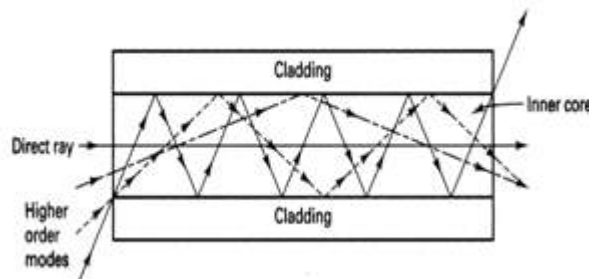

Based on refractive index profile:

1) Step-Index Optical fiber:

- In a step-index optical fiber, the entire core has uniform refractive index n_1 slightly greater than the refractive index of the cladding n_2 .
- Since the index profile is in the form of a step, these fibers are called step-index fibers.
- The transmission of information will be in the form of signals or pulses.
- These are extensively used because distortion and transmission losses are very less.
- Step-index optical fibers are of two types.

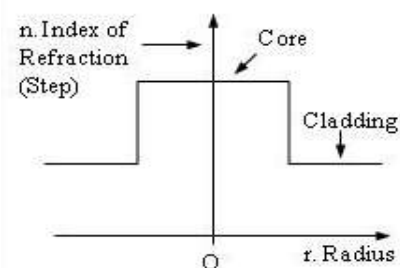

They are

- (i) Single mode step-index fiber
- (ii) Multi-mode step-index fiber

Transmission / propagation of signal in Step-index fibers:

- Generally the signal is sent through the fiber in digital form i.e. in the form of pulses.
- The same pulsed signal travels in different paths.
- Let us now consider a signal pulse travelling through step index fiber in two different paths (1) and (2).
- The pulse (1) travelling along the axis of the fiber and pulse (2) travelling away from the axis.
- At the receiving end only the pulse (1) which travels along the fiber axis reaches first while the pulse (2) reaches after some time delay.
- Hence the pulsed signal received at the other end is broadened. This is called internal dispersion.
- This reduces transmission rate capacity of the signal.
- This difficulty is overcome by graded index fibers.

2) Graded index optical fiber:

- In this fiber, the refractive index of the core varies radially.
- It has maximum refractive index at its centre, which gradually falls with increase of radius and at the core-cladding interface matches with refractive index of cladding.
- Variation of refractive index of the core with radius is given by

$$n(x) = n_1 \left[1 - 2\Delta \left(\frac{x}{a} \right)^p \right]^2$$

Where n_1 -> refractive index at the centre of the core

a-> radius of the core

Δ -> Fractional index change, $\Delta = \frac{n_1 - n_2}{n_1}$

p-> grading profile index number

- This fiber divided into two types.

- (i) Single-mode graded index fiber
- (ii) Multi-mode graded index fiber

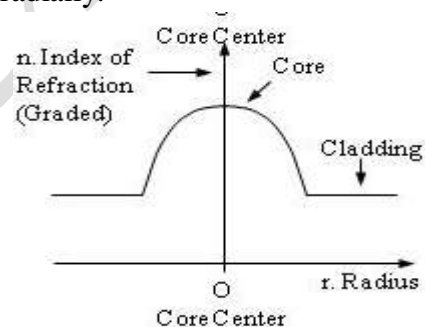

Transmission / propagation of signal in Step-index fibers:

- Let us now consider a signal pulse travelling through graded index fiber in two different paths (1) and (2).
- The pulse (1) travelling along the axis of the fiber though travels along shorter route it travels through higher refractive index.
- The pulse (2) travelling away from the axis undergo refraction and bend as shown in fig. though it travels longer distance, it travels along lesser refractive index medium.
- Hence both the pulses reach the other end simultaneously.
- Thus the problem of inter modal dispersion can be overcome by using graded index fibers.

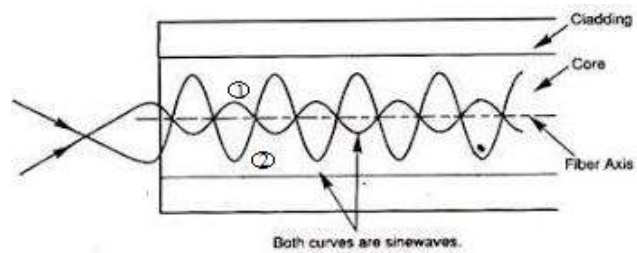
**Based on types of materials:**

- 1) glass-glass optical fiber
- 2) glass-plastic optical fiber
- 3) plastic-plastic optical fiber

ATTENUATION (POWER-LOSS) IN OPTICAL FIBERS

When light propagates through an optical fiber, then the power of the light at the output end is found to be always less than the power launched at the input end. The loss of power is called Attenuation. It is measured in terms of decibels per kilometer.

Attenuation: It is defined as the ratio of the optical power output (P_{out}) from a fiber of length 'L' to the power input (P_{in}).

$$Attenuation(\alpha) = -\frac{10}{L} \left(\frac{P_{in}}{P_{out}} \right) dB/km$$

Attenuation occurs because of the following reasons

- (1) Absorption (2) Scattering loss (3) Bending loss

(1) Absorption:

- It occurs in two ways, i) Absorption by impurity or impurity absorption
- ii) Intrinsic absorption or internal absorption
- **Impurity absorption:** The impurities present in the fiber are transition metal ions, such as iron, chromium, cobalt & copper. During signal propagation when photons interact with these impurity atoms, then the photons are absorbed by atoms. Hence loss occurs in light power.

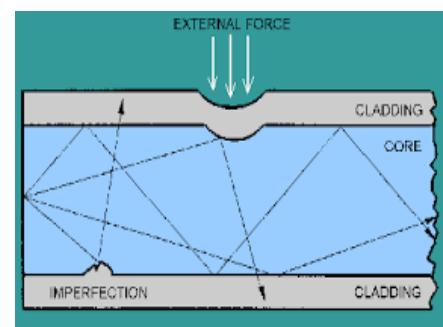

- **Intrinsic absorption or internal absorption:** The fiber itself as a material has a tendency to absorb light energy however small it may be. The absorption that takes place in fiber material assuming that there are no impurities in it, is called intrinsic absorption.

(II) Scattering loss:

- When the signals travels in the fiber, the photons may be scattered due to variations in the refractive index inside the fiber. This scattering is called as Rayleigh scattering. It is also a wavelength dependent loss. $\text{Rayleigh scattering loss} \propto \frac{1}{\lambda^4}$

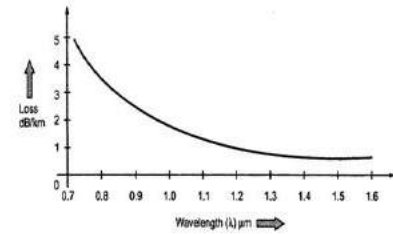
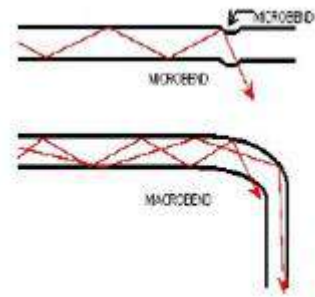

Fig. 1 Scattering loss

(III) Bending losses:

- These losses occur due to (a) Macroscopic bending (b) Microscopic bending
- **Macroscopic bending:** If the radius of core is large compared to fiber diameter causes large curvature at the bends. At these bends, the light will not satisfy the condition for total internal reflection & light escapes out from the fiber. It is called as macroscopic bending.
- **Microscopic bending:** These are caused due to non-uniform pressures created during the cabling of the fiber or during the manufacturing the fiber. It causes irregular reflections. This lead to loss of light by leakage through the fiber.



OPTICAL FIBER IN COMMUNICATION SYSTEM

The most important application of optical fibers occurs in the field of communication.

Fiber optic communication systems comprise of the following units.

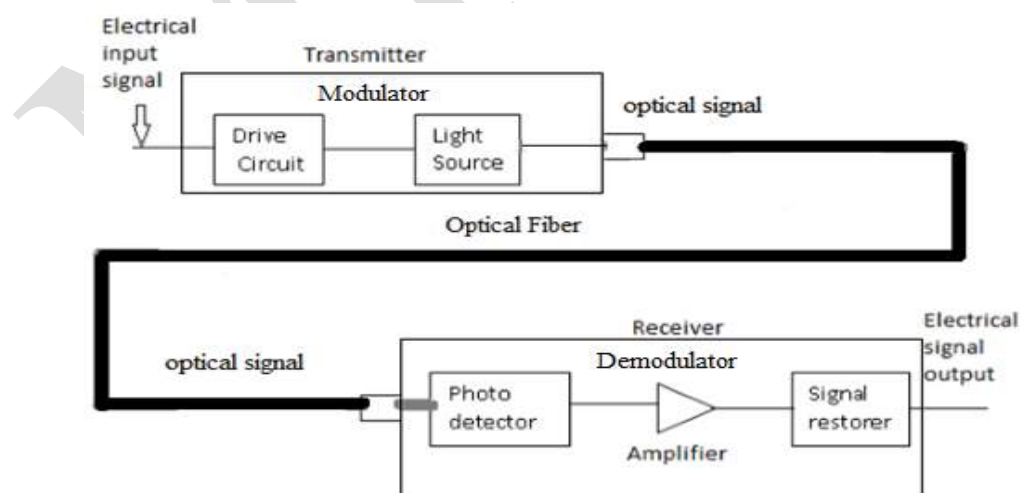

Information signal source:

- The information signal to be transmitted may be voice, video or computer data (analog signals).
- In order to communicate through optical fiber, the analog signals are converted into electrical signals.(by Analog to Digital converter)
- The converted electrical signals are passed through the transmitter.

Transmitter:

- The transmitter is a modulator device used to receive electrical input signal, and then modulate it into digital pulses for propagation into an optical fiber.
- The modulator consists of a driver and a light source as shown in fig.
- The driver receives the electrical signals and then converts into the digital pulses.
- These digital pulses are converted into optical signals after passing through a light source, generally either light emitting diodes (LED's) or a semi conductor laser is used as light source.
- The optical signals are then focused into the optical fiber as shown in fig.

Optical Fiber (or) Transmission medium:

- The optical fiber is used as transmission medium between the transmitter and the receiver.
- The optical signals are then fed into an optical fiber cable where they are transmitted over long distances using the principle of total internal reflection.

Receiver:

- The receiver is a demodulator device used to receive the optical signals from the optical fiber and then convert into electrical signals.
- The demodulator consists of a photodetector, an amplifier and a signal restorer.
- The optical signals which are emerging from the optical fiber are received by photo detector.
- The photodetector converts the optical signals into electrical signals.
- The electrical signals are then amplified by the amplifier and the amplified electrical signals are converted into digital form.
- The amplified electrical signals are fed to a signal restorer where the original voice is recovered.

Advantages of Optical Fibers in communication system:

- High data transmission rates and bandwidth.
- Low losses.
- Small cable size and weight.
- Immunity to EM radiations.
- Safety due to lack of sparks.
- Data security.

APPLICATIONS OF OPTICAL FIBERS:

- 1) Due to high band-width, light can transmit at a higher rate up to 10^{14} to 10^{15} Hz. Than radio or micro-frequencies.
- 2) Long distance signal transmission.
- 3) They are used for exchange of information in cable television, space vehicles, sub-marines
- 4) Optical fibers are used in industry in security alarm systems, process control & industrial automation.
- 5) They are used in pressure sensors in biomedical & engine control applications.

MRCET