

For any enquiries email [Colin Mitchell](mailto:Colin.Mitchell@talkingelectronics.com)

## **BASIC ELECTRONICS**

(this is the Basic Electronics section i.e. Page 1)  
(Chapters 1 and 3 are available as .pdf )

[Quick Quiz](#) - to see how much you know  
[Encyclopedia of Components](#) - this is excellent !!!

Page 1: [Basic Electronics](#) (this page) - [.pdf](#) (1.2MB) or [.zip](#)

[The capacitor](#) - how it works

[The Diode](#) - how the diode works

[Circuit Symbols](#) - EVERY Circuit Symbol

[Soldering](#) - videos

Page 2: [The Transistor](#)

- [PNP or NPN](#) [Transistor TEST](#)

Page 2a: [The 555 IC](#)

The [555 - 1](#)

The [555 - 2](#)

The [555 - 3](#)

The [555 TEST](#)

Page 3: [The Power Supply](#) [download as .pdf](#) (900kB)

3a: - [Constant Current](#)

3b: - [Voltage Regulator](#)

3c: - [Capacitor-fed Power Supply](#)

Page 4: [Digital Electronics](#)

4a: - [Gates](#) [Touch Switch](#) [Gating](#)

4b: - The DELAY CIRCUIT

Page 5: [Oscillators](#)

Page 6: [Test](#) - Basic Electronics (50 Questions)

Page 7: [The Multimeter](#) - using the Multimeter

Page 8: Constructing a Project

**Remember:** the animations do not work in .pdf  
the site is being constantly updated

## INDEX

[Active HIGH](#)

[AND Gate](#)

[Battery](#)

[Battery](#) - Internal Resistance

[Battery Boost](#)

[Battery Booster](#) - for a flat battery

[Battery Current](#)

[Blocking Diode](#)

[Breadboard](#)

[Bypass Diode](#)

[Capacitors](#)

[Capacitors in Parallel](#)

[Capacitors in Series](#)

[Cell](#)

[Charging A Capacitor](#)

[Capacitor Charging](#)

[Capacitor Charging](#) - more details

[Capacitors on Volume Control](#)

[Capacitor](#) - values

[Characteristic Voltage drop](#) - LED

[Chassis](#)

[Circuit](#)

[Circuit](#) - Drawing

[Component](#) - Symbols [more](#)

[Current](#) - milliamp

[Current Divider Circuit](#)

[Cutoff and Saturation](#)

[Damage A LED](#)

[DC Current](#)

[DC Voltage](#)

[Digital States](#)

[Diode](#)

[Diode](#) - how a diode works

[Drawing A Circuit](#)

[Earth Rail](#) [Earth Rail](#)

[Earth Return](#)

[Electret Microphone](#)

[Electrolytics](#)

[Energy in a cell](#)

[Flashing LED](#) [Flashing LED](#)

[Forward Voltage Drop](#)

[Gates with Diodes](#)

[Globe](#)

[Ground](#)

[NAND Gate](#)

[Negative Voltage](#)

[NOR Gate](#)

[NOT Gate](#)

[Ohm's Law](#)

[Passive Components](#)

[Piezo](#)

[Plant Watering Circuit](#)

[PNP Transistor](#)

[Power and Energy](#)

[Power Rail](#)

[Potentiometer](#)

[Protection Diode](#)

[Questions](#)

[Regeneration](#)

[Resistance](#) - Multimeter

[Resistor Colours](#)

[Resistors In Parallel](#)

[Resistors in Series](#)

[Resistor Wattage](#)

[Robot Man](#)

[Robot Man Animation](#)

[Schematic](#)

[Slide Switch](#)

[Short Circuit](#)

[Soldering](#)

[Soldering Iron](#)

[Speaker](#)

[Supply Rail](#)

[Switch](#)

[Symbols](#) [more](#) - components

[Tap A Piezo](#)

[Test A Cell](#)

[Testing A LED](#)

[Time Delay](#)

[Time Delay Animation](#)

[Toggle Switch](#)

[Tolerance](#) - resistors

[Transformer Feedback](#)

[3 - Transistor Circuit](#)

[Transistor](#) NPN and PNP

[Transistor](#) - how it works

[Transistor Tester](#)

[Turning ON a Transistor](#)

[How a Transistor turns ON](#)

[How to Solder](#)

[LED](#)

[LED flat spot \(cathode\)](#)

[LEDs in Parallel](#)

[LEDs in Series](#)

[LED Resistors](#)

[LED Voltages](#)

[Light Dependent Resistor](#)

[Load Resistor](#)

[Memory Cell](#)

[Microphone - Electret](#)

[Milliamp - current](#)

[Multimeters](#)

[Variable Capacitors](#)

[Variable resistor - potentiometer](#)

[Voltage](#)

[Voltage - Analogue Multimeter](#)

[Voltage - Digital Multimeter](#)

[Voltage Divider Circuit](#)

[Wattage of a Resistor](#)

[White LED Voltage](#)

[Wire](#)

[50 Questions](#)

## KIT OF PARTS

Talking Electronics supplies a kit of parts that can be used to build the majority of the circuits in this eBook.

The [kit costs \\$15.00](#) plus postage.

**BUY NOW**

**Kit for Transistor Circuits -  
\$15.00**

A kit of components to make many of the circuits described in this eBook is available for \$15.00 plus \$7.00 post.

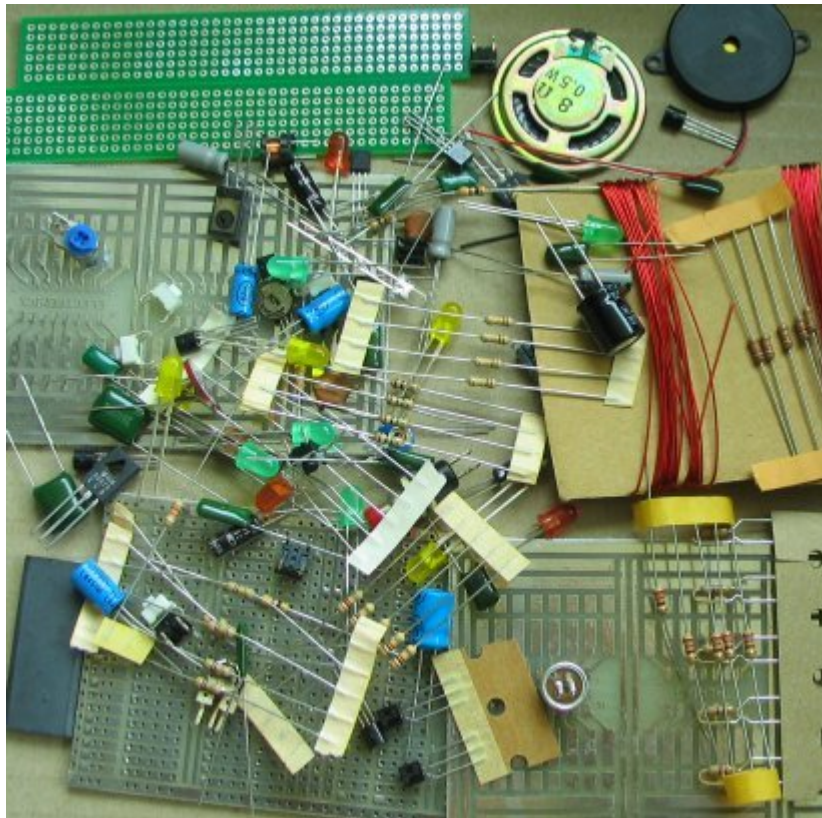
Or email Colin Mitchell: [talking@tpg.com.au](mailto:talking@tpg.com.au)

The kit contains the following components:  
(plus **extra** 30 resistors and 10 capacitors for experimenting), plus:

3 - 47R  
5 - 220R  
5 - 470R  
5 - 1k  
5 - 4k7  
5 - 10k  
2 - 33k  
4 - 100k  
4 - 1M  
1 - 10k mini pot  
1 - 100k mini pot  
2 - 10n  
2 - 100n  
5 - 10u electrolytics  
5 - 100u electrolytics

- 5 - 1N4148 signal diodes
- 6 - BC547 transistors - NPN - 100mA
- 2 - BC557 transistors - PNP - 100mA
- 1 - BC338 transistor - NPN - 800mA
- 3 - BD679 Darlington transistors - NPN - 4amp
- 5 - red LEDs
- 5 - green LEDs
- 5 - orange LEDs
- 2 - super-bright WHITE LEDs - 20,000mcd
- 1 - 3mm flashing LED
- 1 - mini 8R speaker
- 1 - mini piezo
- 1 - LDR (Light Dependent Resistor)
- 1 - electret microphone
- 1m - 0.25mm wire
- 1m - 0.5mm wire
- 1 - 10mH inductor
- 1 - push button
- 5 - tactile push buttons
- 1 - Experimenter Board (will take 8, 14 and 16 pin chips)
- 5 - mini Matrix Boards: 7 x 11 hole,  
11 x 15 hole, 6 x 40 hole, surface-mount 6 x 40 hole board and others.

**Photo of kit of components.  
Each batch is slightly different:**



There are more components than you think. . . plus an extra bag of approx 30 components. The 8 little components are switches and the LDR and flashing LED is hiding.

In many cases, a resistor or capacitor not in the kit, can be created by putting two resistors or capacitors in series or parallel or the next higher or lower value can be used.

# BEFORE WE START

Too many text books start with the physics of the atom and have equations and mathematics to show how smart the author is.

Don't worry, we won't have any physics or equations.

The reason . . .

This is not a physics course. It is a practical electronics course to teach the basics as quickly as possible. There are no equations because most transistor circuits cannot be worked out mathematically as the gain of a transistor changes according to the current-flow and these gain-values are never provided. So the mathematics is worthless.

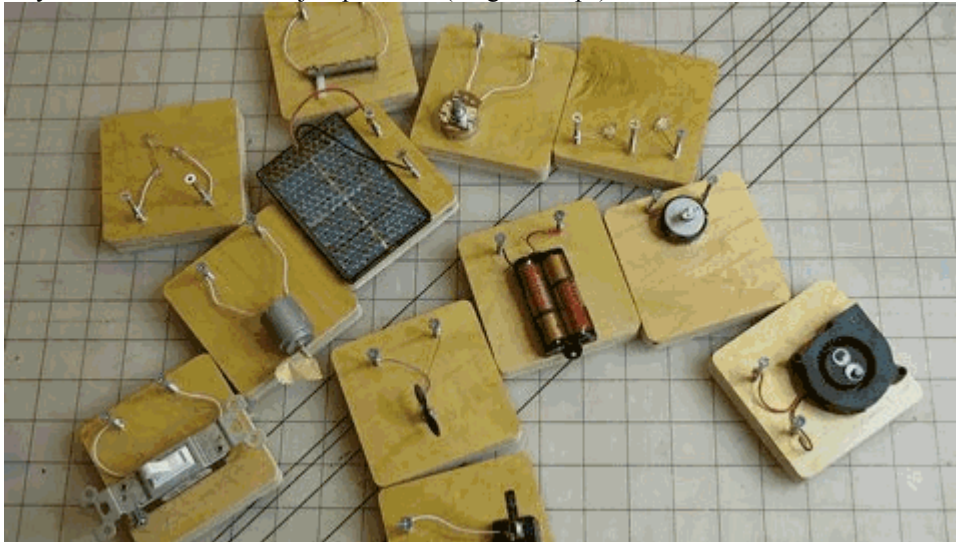
To get an answer, all you have to do is build the circuit and measure the values with a multimeter.

Also lots of discussions in text books will never be used in your next 40 years of electronics, so this course doesn't have any unnecessary material and is much-more concentrated than anything you have read before.

Every frame contains important points - especially the animations - as they show you how a circuit works in slow-motion - something that has NEVER been done before.

# ELECTRONICS BLOCKS

Here is an idea from Instructables to produce blocks with screws, containing a single component and they can be connected with jumper leads (alligator clips).



SLOTTED HEAD



PHILIPS HEAD

Use a slotted head for the negative screw and a philips head for the positive screw.

Learn electronics from the beginning . . .

## START HERE:

All electrical and electronic components need wire to connect them to the circuit.

In a diagram called a **CIRCUIT DIAGRAM**, the wires are drawn as lines.

When the wires (or lines) cross, they may be joined or just passing.

It is **VERY IMPORTANT** to show the difference between lines that are **JOINED** and lines that are **NOT JOINED**.

When the lines are joined, it is best to place a dot on the connection to **PROVE** the lines are joined.

When the lines are just crossing, a gap should be made so it is obvious that one wire goes under the other and does not touch.

Lines should be "across the page" or "up and down." Very few lines should be at 45°.

You can make a line thicker to indicate a power rail or a wire that will be thick in reality.

**Fig 1** The wire in a circuit diagram

[to Index](#)

Next we need a **battery**. A battery consists of two or more cells. The positive terminal of a battery is the long line in the diagram and you must add the voltage (of the cell or battery) to the symbol as a single cells can be 1.2v, 1.5v, 2.2v or up to 3.6v. The symbol does not let you know the voltage. The positive is always at the top and is the longest line on the battery symbol.

**Fig 2** A single Cell and many Cells

[to Index](#)

**globe**

Next we need a globe. A globe has two connections (a fine wire inside a glass bulb glows when the globe is connected to a battery).

**Fig 3:** A Globe

[to Index](#)

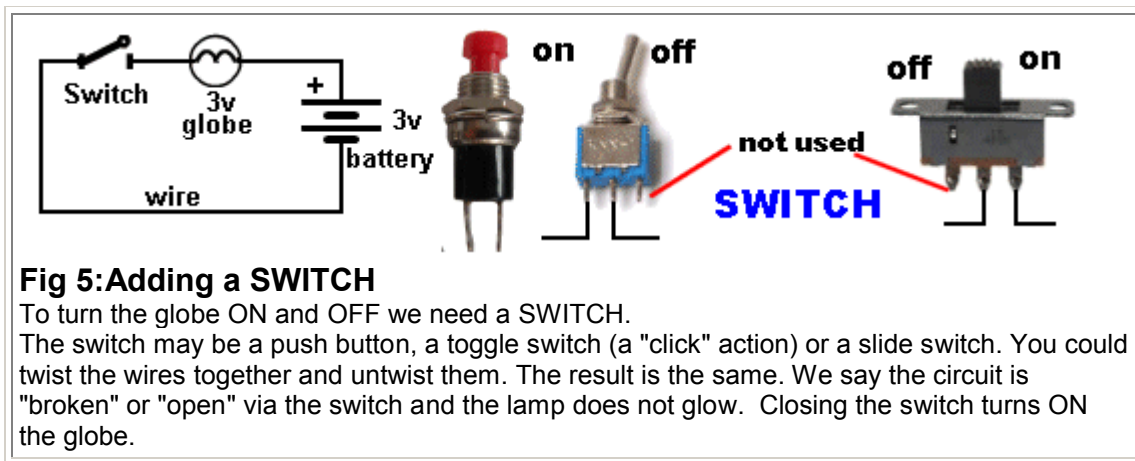
With a globe, battery and wire we have produced a **CIRCUIT**. A **CIRCUIT** is a complete path and we say the "electricity" the **CURRENT** emerges from the positive of the battery, moves through the globe and returns to the battery via the wire. If the globe is a "3v GLOBE" it will glow when connected to a 3v battery.

The globe can be connected either way around.

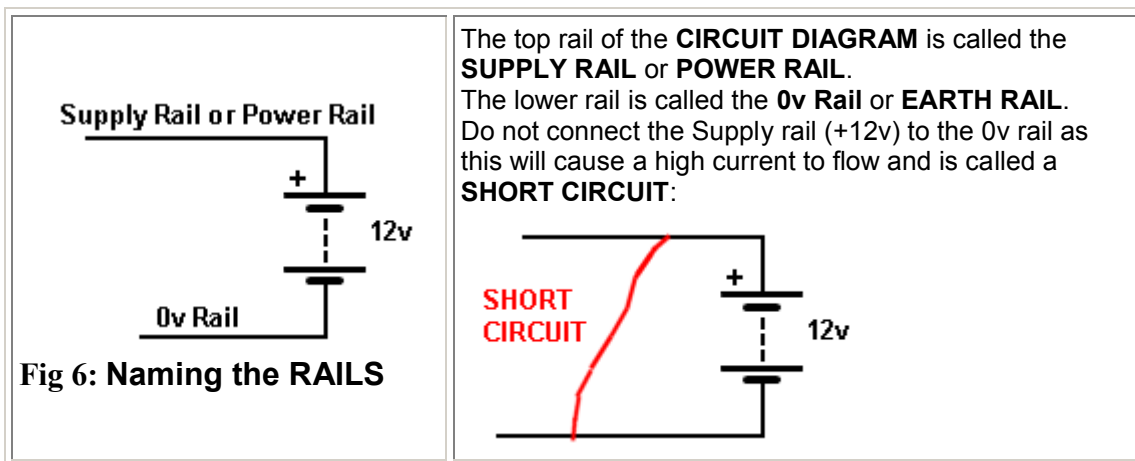
The circuit we have shown is called a **SCHEMATIC** and consists of symbols: a globe symbol and a battery symbol. The line connecting the two components is called **WIRE**.

**Fig 4:** A Circuit

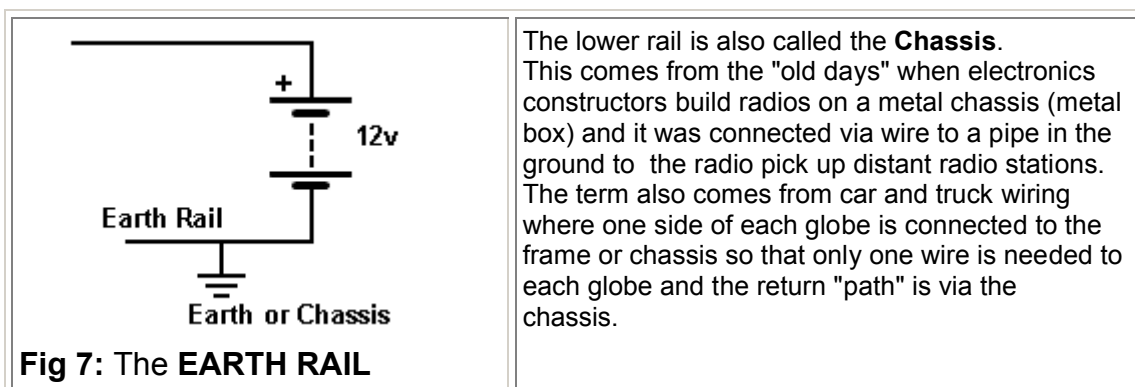
[to Index](#)



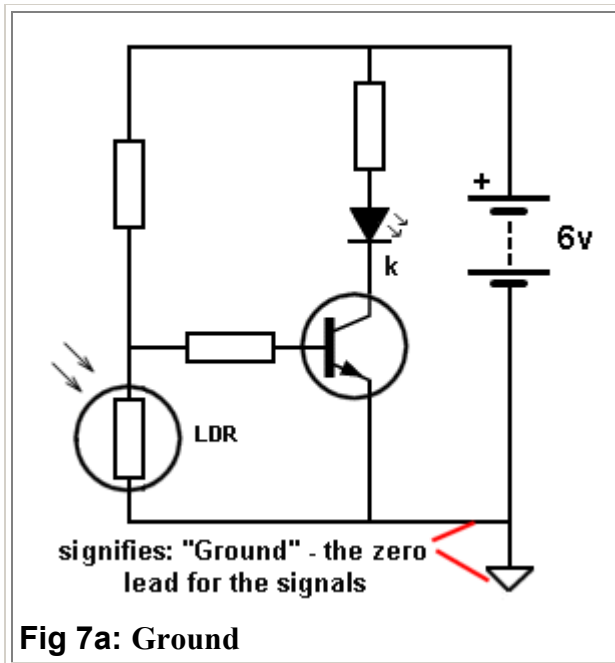
[to Index](#)



[to Index](#)



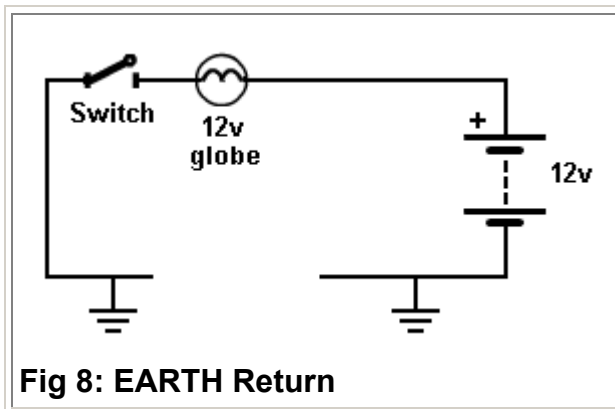
[to Index](#)



**Fig 7a: Ground**

Some circuits identify the "**Ground Lead**" or "**Ground Wire**" of a project to show where all the **signals** have been "referenced to." In other words, all the signals rise and fall above and below this "Ground wire" or "Ground Lead." This lead may not be at **earth potential** as the project may be in a plastic box but it identifies where the earth lead of a Cathode Ray Oscilloscope or the negative lead of a multimeter is connected. On some printed circuit boards, the negative terminal of the battery (the 0v wire or terminal) is connected to a very large area of copper and this is called the **EARTH PLANE** or **GROUND PLANE**. It is designed to prevent signals travelling along the tracks (called traces) being radiated and also prevents outside interference upsetting the project. It also "tightens-up" the earth rail.

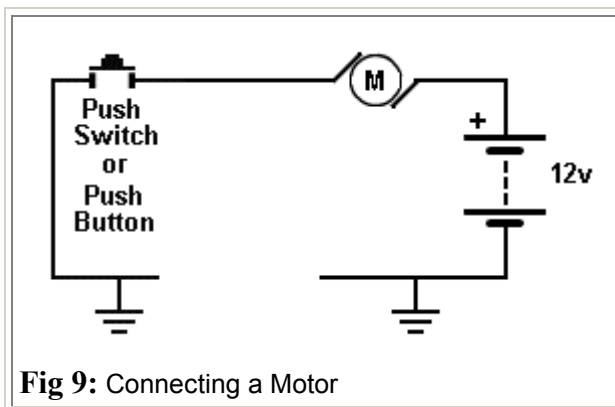
[to Index](#)



**Fig 8: EARTH Return**

The circuit shows a 12v globe connected to a 12v battery and the circuit appears to be "broken" (not continuous). But the **current returns** via the earth connection. We talk about the **CURRENT RETURNING**. We don't say: the voltage returning. The voltage of the globe must be the same as the battery voltage, otherwise it will not glow fully or it will **burn out** if it is say a 6v globe.

[to Index](#)

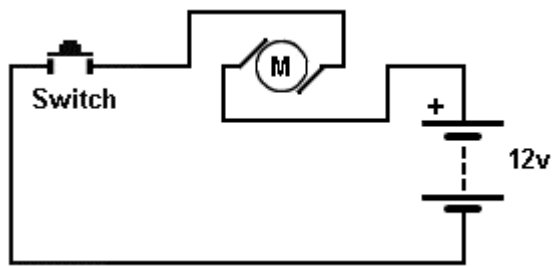


**Fig 9: Connecting a Motor**

The circuit shows a 12v **Motor**. It is turned ON when the push-switch is pressed.

[to Index](#)





**Fig 10:** Reversing a Motor

If the wires are connected to the motor "around the other way," the motor will reverse direction.

[to Index](#)

## VOLTAGE AND CURRENT

What is voltage and what is current?

Here is a very simple description.

A battery produces a voltage called DC. (This is a very confusing name because the letter actually refer to Direct Current, so we just say **DC Voltage**).

A battery also produces current called DC - Direct Current. We say **DC current**.

### VOLTAGE

Voltage is a value produced by an electrical component called a battery or cell.

A single cell produces one and a half volts. (1.5v) and although this is not a high voltage, when cells are connected together we get higher voltages.

If 6 cells are connected in series we get 9v.

Here is a 9v battery:



Touch the two terminals with your tongue. You get a tingle. This is a 9v tingle. Now you have "felt" electricity. This is a 9v tingle.

### CURRENT

You cannot feel current with your tongue so we have to carry out another experiment:



Place a 22 ohm or 47 ohm resistor across the terminals of the battery and hold your fingers on the resistor. It will get hot. This is the result of current flowing through the resistor and heating it up. The current will be about half an amp and the voltage is 9v, so the wattage will be about 2 to 4 watts. Feel the heat produced.

**Milli** - milli means 1/1,000th (one thousandth) - such as one milliamp or one millivolt.

In other words one thousand milliamps is equal to 1 amp.

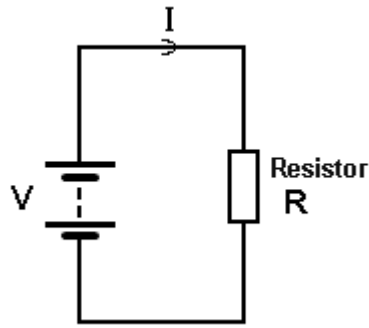
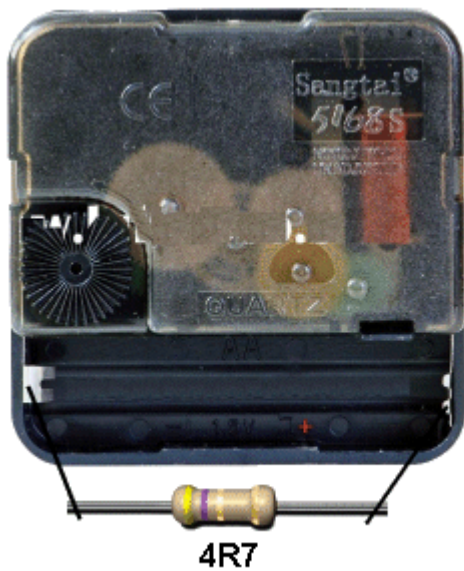
One volts is not a very large value as a battery produces 9v and a cell produces 1.5v to 3.6v (depending on the type of cell).

But 1 amp is a large quantity when talking about electronic circuits involving LEDs, motors and transistors.

The globe used in the experiments above requires about 300mA. (1,000mA = 1 amp)

The 3v motor used in the experiments requires about 250mA

The LEDs used in the experiments require about 20mA.



Transistor  
s can  
pass  
about  
100mA to  
800mA via  
the  
collector-  
emitter.  
In most  
cases  
current-  
flow in the

circuits we will be discussing will be less than 1 amp and will be shown as 25mA, 100mA, 350mA etc.

## WATTAGE and CAPACITY

A 9v battery has 6 very small cells and they will not last very long.

A "AAA" cell is larger and a "D" cell is much larger.

A large cell is said to have a **LARGE CAPACITY**. This means it will deliver a larger current for a longer period of time.

The **WATTAGE** of a cell is the multiplication of the voltage x current. The answer is milliwatts or watts.

The **CAPACITY** of a cell is the wattage x hours. The answer is milliwatt-hours or watt-hours. This is also called watt-hours.

You can determine the capacity of a cell (such as a rechargeable cell) by connecting it to a clock-mechanism that has a 4R7 connected across the terminals. The resistor will take a considerable current and deplete the cell in a few hours. The clock will let you know exactly how long the cell delivered the current. You can then compare other cells.

The simplest electrical circuit consists of a battery and resistor. The current flowing through the circuit will depend on the voltage of the battery and the resistance of the resistor R. The formula connecting these three quantities is:

$$I = \frac{V}{R}$$

**Ohm's Law**

$$I = \frac{12}{3}$$

$$I = 4 \text{ amps}$$

This is called **Ohm's Law**. Suppose you have a 12v battery and the resistor is 3 ohms. The current flowing through the resistor will be 4 amps.

Increasing the resistance will decrease the current if the voltage remains fixed.

All the above circuits are called **ELECTRICAL CIRCUITS** because they contain electrical components (such as a motor, globe, relay, switch).

When the circuit contains an **ELECTRONIC** component such as a diode, transistor, LED, it is called an **ELECTRONIC CIRCUIT** or **ELECTRONIC SCHEMATIC**.

[to Index](#)

## POWER and ENERGY

Here's an easy way to remember the difference between **POWER** and **ENERGY**:

A 9v alkaline battery has enough **ENERGY** to start a car. But it does not have enough **POWER** (strength).

Energy is effectively the strength of the battery (and this is the voltage and the current it can deliver) multiplied by the time it can deliver this energy. When the answer is obtained, it consists of three factors ((3 quantities) VOLTS, AMPS and TIME.

This results in an answer called xxxx WATT-HOURS.

For a 9v battery the quantities are: 9 volts, 500mA and the battery will deliver this  $9 \times 0.5 = 4.5$  watts for about 1 hour. This is equal to  $4.5 \times 60 \times 60 = 16,200$  watt-seconds.

To start a car requires 250 amps from a 12v battery for 5 seconds.

This is:  $12 \times 250 \times 5 = 15,000$  watt-seconds.

This means the energy stored in a 9v battery could start a car if all the energy could be delivered in 5 seconds.

This is not possible however the FACT is this: A 9v battery has enough stored energy to START A CAR.

[to Index](#)



## BATTERY BOOSTER

One of the simplest things we can do is start a car with a flat battery with the assistance of a BATTERY BOOSTER.

This consists of a 12v rechargeable battery in a handy case with leads to connect to the flat battery in your car.

This simple operation puts two 12v batteries in parallel, but no-one has actually described what happens and why.

That's because the explanation is very complex. We have included it here to show that a simple explanation involves a lot of technical terms and you will understand more after reading the course.

The flat battery in the car is not fully charged but it has some percentage of charge and when it sits for a

period of time in a non-fully charged condition, the voltage drops from 12.6v to less than 12v as the battery gradually self-discharges due to the potential at the top of the cell being different to that at the bottom of the cell and the specific gravity of the electrolyte being different at the top and bottom. This causes an internal current to flow within the cell and slowly discharge the cell. But if you try to start the car, the voltage drops to less than 7v because the electrolyte cannot carry the high current and a slight potential is developed across the liquid. The result is the starter-motor does not crank the car.

The reason is this: When the battery is fully charged, the current taken by the starter motor is about 300 amps. This is about  $11\text{v} \times 300\text{ amps} = 3300\text{ watts} = 4.4\text{Horsepower}$ .

But when the voltage drops to 7v, the current will drop to 190 amps to deliver  $1336\text{ watts} = 1.8\text{HP}$ .

This is only 40% of normal and that's why the car does not start. The engine needs 4HP to overcome the pressure in the cylinders due to the compression of the air during the "firing stroke."

Let's put it this way. If we have a brand new 7v battery, the car will not start. The starter-motor will only accept 190 amps when the supply is 7v.

So, we have to increase the voltage.

We do this by placing a 12v battery across the flat battery. The voltage of the flat battery will immediately rise to 12.6v. It might take 2 minutes but the flat battery will take a small current (1 to 10amps) from the battery in the "booster" and the output of the combination will be 12.6v. The current-carrying capacity of the electrolyte will improve very quickly and you have effectively given the "flat battery" a very quick charge.

The starter-motor will now accept 300 amps from the combination and **SURPRISINGLY** the cells of the "flat battery" will deliver about 200 amps and the booster battery will deliver about 100 amps. The actual sharing of current will depend on the two batteries but the secret behind the success is the increase in voltage we call **TERMINAL VOLTAGE**. The voltage on the terminals (the alligator clips).

The capacity of the booster battery is not important. It can be from 7Ahr to 40Ahr. We are just using a very small amount of its capacity to start the car and nearly all batteries will provide 200 Amps for a short period of time.

The voltage of the car battery is very important. The Horsepower taken by the starter-motor is defined by the formula:  $P_{\text{watts}} = V^2/R$ . Since the resistance remains constant, a voltage of 7 volts will produce  $7 \times 7 = 49$  units and a voltage of 11v will produce 121 units. This gives the ratio of 40% to 100% as explained above.

[to Index](#)



## BATTERY BOOST

Continuing from the previous frame where we showed the effect of placing a weak battery in parallel with a good battery, we can show what happens when a weak cell is placed IN SERIES with a good cell.

This also applies when you have 5 good cells and one weak cell.

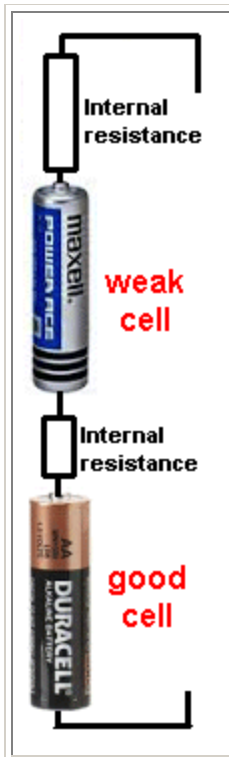
Basically, the weak cell will reduce the current. In other words, if the 5 cells are driving a motor and supplying 250mA, the 5 cells and 1 weak cell will deliver 200mA or less, depending if it is weak or very weak. The current flowing through the weak cell will have the effect of giving it a small charge - in other words, you will be charging the weak cell from the good cells when the motor is operating.

### **BUT . . . .**

There is a way to use weak cells. If you have say 6 weak cells driving a motor and the RPM is reducing, you can add 2 more weak cells to increase the RPM.

The effect is this: The voltage from the 8 cells will be higher than from 6 cells and this will allow a higher current to flow. Sometimes the cells will provide this higher current and thus more of the energy will be delivered and you will get the last of the energy from the cells.

[to Index](#)



## INTERNAL RESISTANCE

All batteries and also all individual cells have a "secret, hidden" value of resistance inside each cell due to the resistance of the chemicals. This resistance is very small when the cell is new but it increases as the cell gets older.

It is very easy to measure this value. Simply put an ammeter directly across the cell and measure the current. Use Ohm's law to work out the resistance.

But this not always a wise thing to do as some cells will deliver 10 amps and some will deliver 100 amps and damage the meter.

The diagram opposite shows a large internal resistance for the weak cell and a small internal resistance for the good cell.

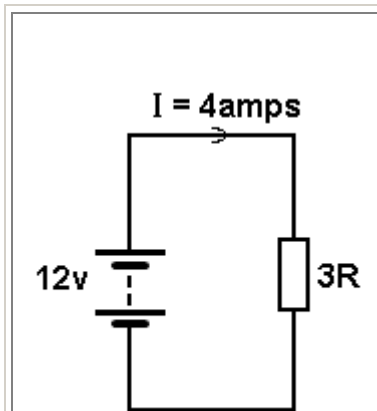
If a cell did not have any INTERNAL RESISTANCE it would deliver thousands of amps. It's the Internal Resistance that limits the current.

In most cases we neglect (do not consider) the value of internal resistance when making tests and when using a battery in a project.

But when a battery gets old, it cannot deliver a high current and the internal resistance gets so high that the output voltage drops from say 9v to 7v, even when the battery is not connected to a circuit.

This is the result of the INTERNAL RESISTANCE of the chemicals increasing to a point where they become noticeable and what we call "poisoning" of the chemicals due to the cell "aging" and new chemicals being produced in the cell that have a high resistance. Some of the terms we use are: "drying out and sulphating. Some cells produce spikes or needles that completely short-circuit the cell and make it totally useless.

[to Index](#)



This resistor is dissipating 48 watts.

As a comparison, a soldering iron is dissipating about 10 to 20 watts.

## RESISTOR WATTAGE

**Resistor Wattage** means two things.

1. The physical size of a resistor tells you number of watts it is capable of dissipating. This is called RESISTOR WATTAGE. It is really RESISTOR-SIZE or RESISTOR-CAPABILITY.

2. The multiplication of the voltage across a resistor and the current flowing though it will produce a value called WATTAGE.

This is also called RESISTOR-WATTAGE or RESISTOR-LOSS or RESISTOR-DISSIPATION or HEAT-LOSS.

In the circuit shown, the wattage being lost in the resistor is:  
 $12 \times 4 = 48$  watts.

Most of the resistors we will be using in our projects are 0.25watts. This means they will dissipate 250milliwatts, however the actual wattage being dissipated may be only 70 milliwatts and the resistor will not get hot.

0.25watts is the maximum wattage it can dissipate without overheating.

If it is dissipating 400milliwatts, it will be VERY HOT.

The wattage it is dissipating (the heat it is getting rid of) will depend on the supply voltage and the value of the surrounding components.

[to Index](#)

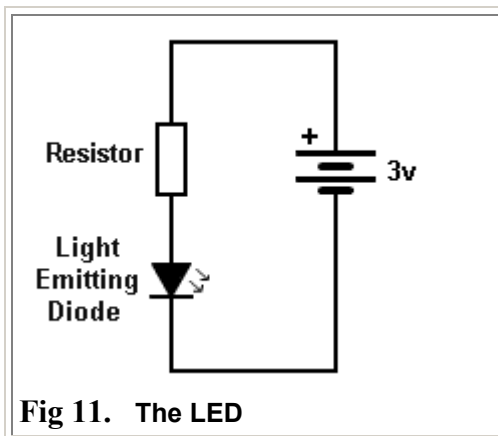


Fig 11. The LED

This simple **ELECTRONIC CIRCUIT** contains a **LIGHT EMITTING DIODE (LED)**, **RESISTOR** and battery.

The circuit is classified as electronic because the LED is not an electrical item (such as a globe) but more-complex, as it produces light when current flows through a crystal and the crystal produces the colour.

[to Index](#)

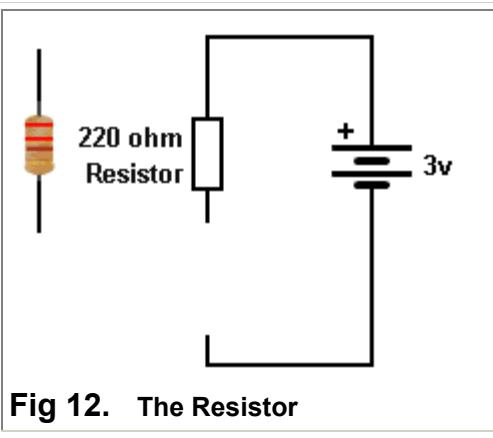


Fig 12. The Resistor

A **RESISTOR** must be included in the circuit to prevent the LED being damaged. The resistor in this circuit must be 220 ohms. This is shown by the colours on the resistor. The colours for 220 ohms: **red - red - brown**. The 4th band is gold - indicating a tolerance of 5%. A resistor has **RESISTANCE**. It reduces the current from the battery to a required amount to prevent the LED glowing too bright. A resistor is just like putting your foot on a hose. The water trickles out the end. The resistor "resists" the high current-flow that the battery is able to deliver.

[to Index](#)



Fig 12a. The Resistor Colours

There are hundreds of different resistors because the resistance-values need to cover the range one ohm to 10 million ohms. There are also small, medium and large resistors. The resistors on the left are just a few in the range. (See the full range below). They show colour bands for 1 ohm to 8.2 ohms and 1 million ohms to 8.2 million ohms. All the other values are shown below. An electronics engineer does not have the room to store 10 million different resistors so they make each resistor 5% or 10% higher than the previous. This reduces the number to about 100 to 200.

### TOLERANCE

The first 3 bands indicate the value of the resistor and the 4th band indicates either 5% or 10% tolerance. All modern resistors are 5% or 2% or 1%. The "old" 10% resistors are no longer made. Gold = 5%  
Silver = 10%

[to Index](#)

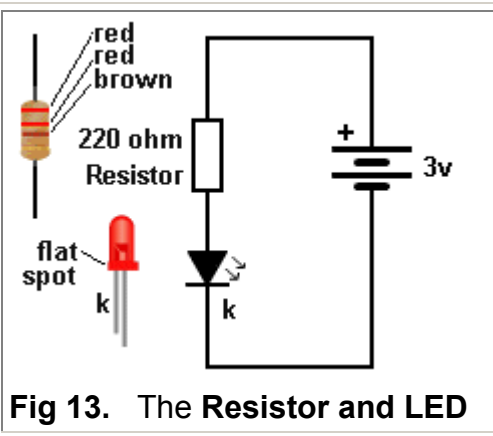
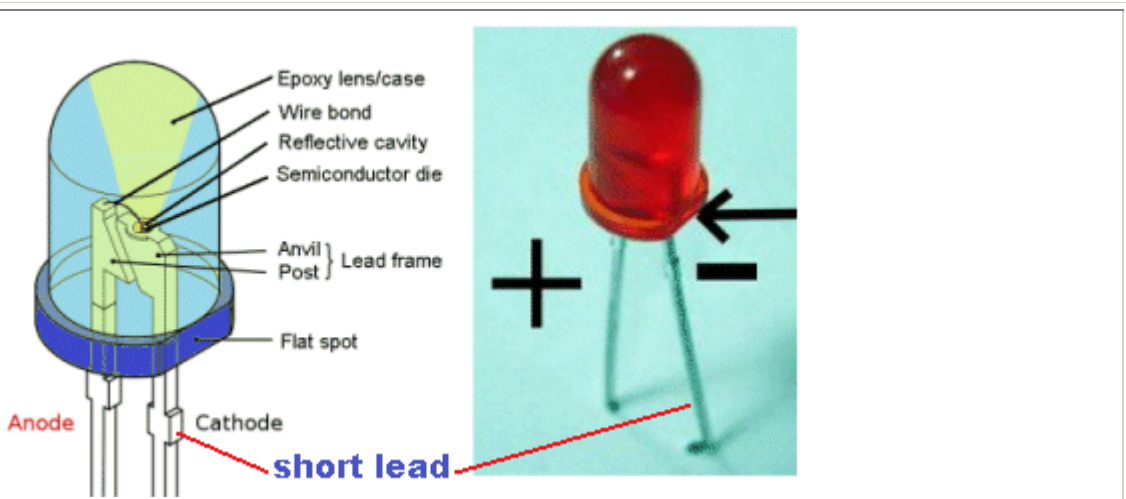


Fig 13. The Resistor and LED

The **LIGHT EMITTING DIODE** is called an electronic component (mainly because it is more complex than a globe and it produces light by a more-complex means than heating a wire). A **LED** must be connected around the correct way. It will not illuminate if connected around the wrong way. All **LEDs** have one lead longer than the other. The **SHORT** lead is called the **CATHODE (k)**. All **LEDs** have a flat on one side and this is the **CATHODE** lead. The arrows on the diagram indicate light is "given off" (emitted - produced).

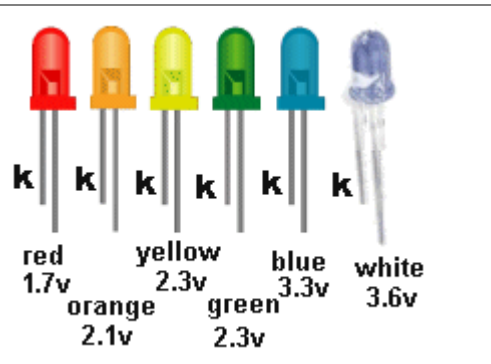
[to Index](#)



**Fig 14. The LED - showing the flat spot**

A close-up of a red LED. The cathode lead is the short lead and next to a flat side on the LED. DO NOT show "+" or "-" on a diagram. Only show the letter "k" to indicate cathode. The symbols "+" and "-" are used when a component produces a voltage or is connected directly to "+" and "-" A LED is connected via a resistor.

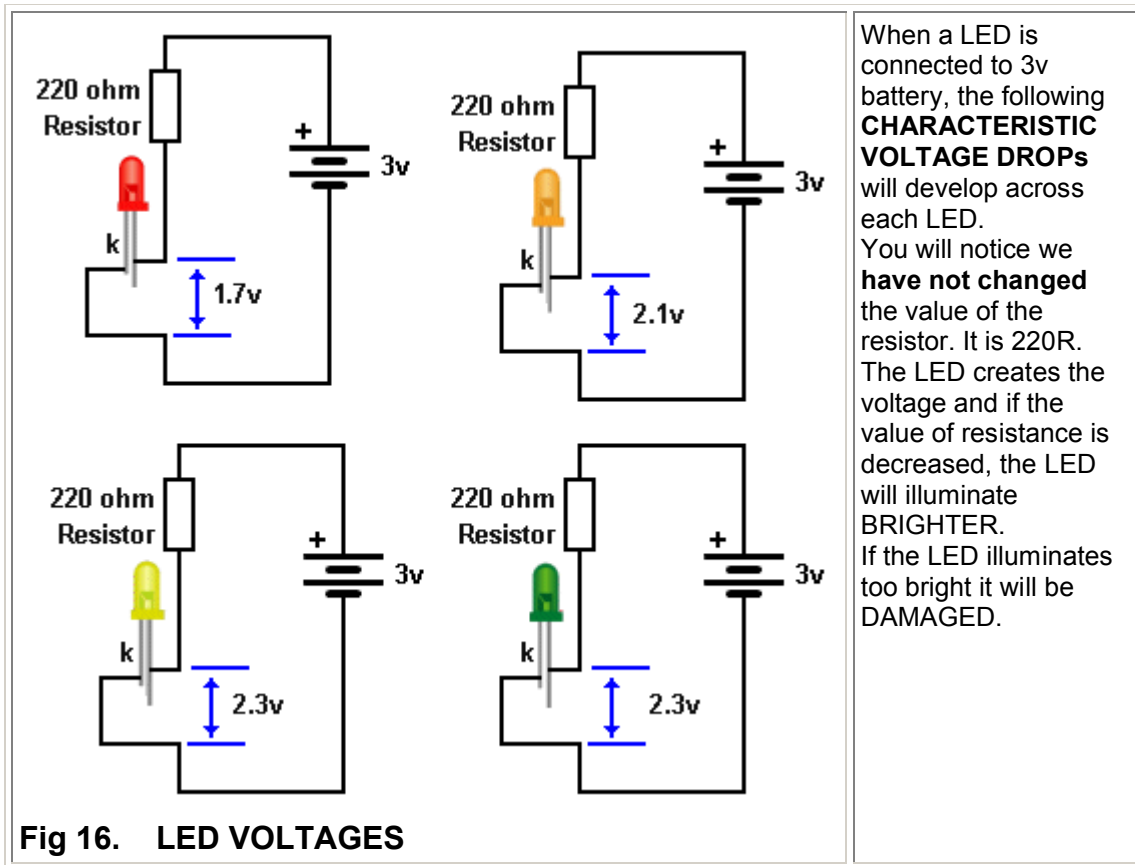
[to Index](#)



**Fig 15. LED VOLTAGES**

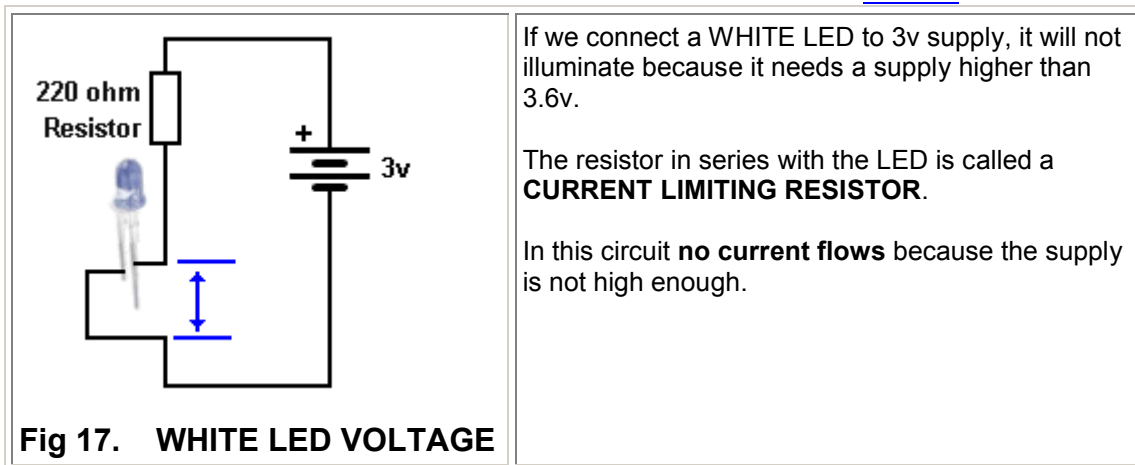
When a LED is connected to a circuit, (and the correct-value resistor is included), a voltage will be develop across the LED called the **CHARACTERISTIC VOLTAGE DROP**. This voltage is due to the colour of the LED and the crystal inside the LED that produces the colour. The diagram on the left shows the approximate voltage developed for each LED. The voltage **does not change** for small, medium, surface-mount, or large LEDs.

[to Index](#)



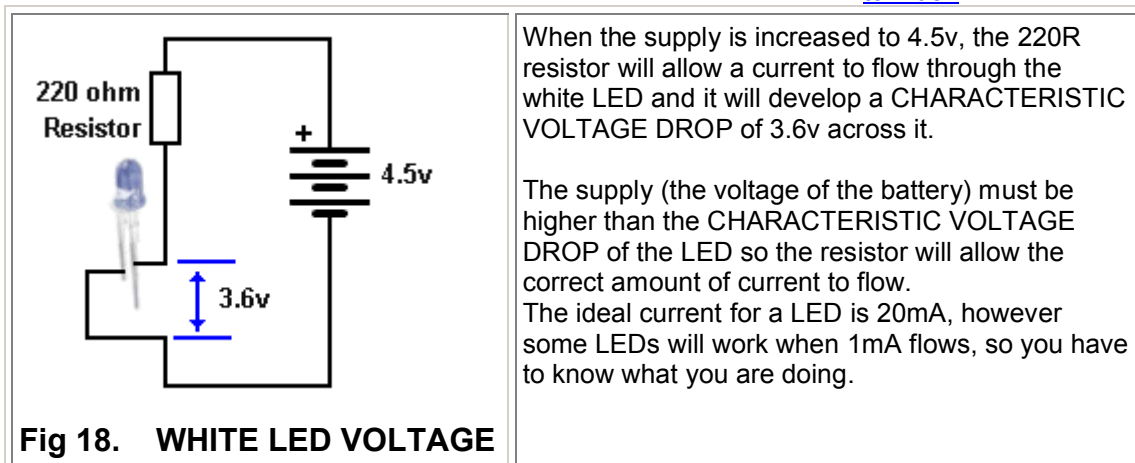
**Fig 16. LED VOLTAGES**

[to Index](#)



**Fig 17. WHITE LED VOLTAGE**

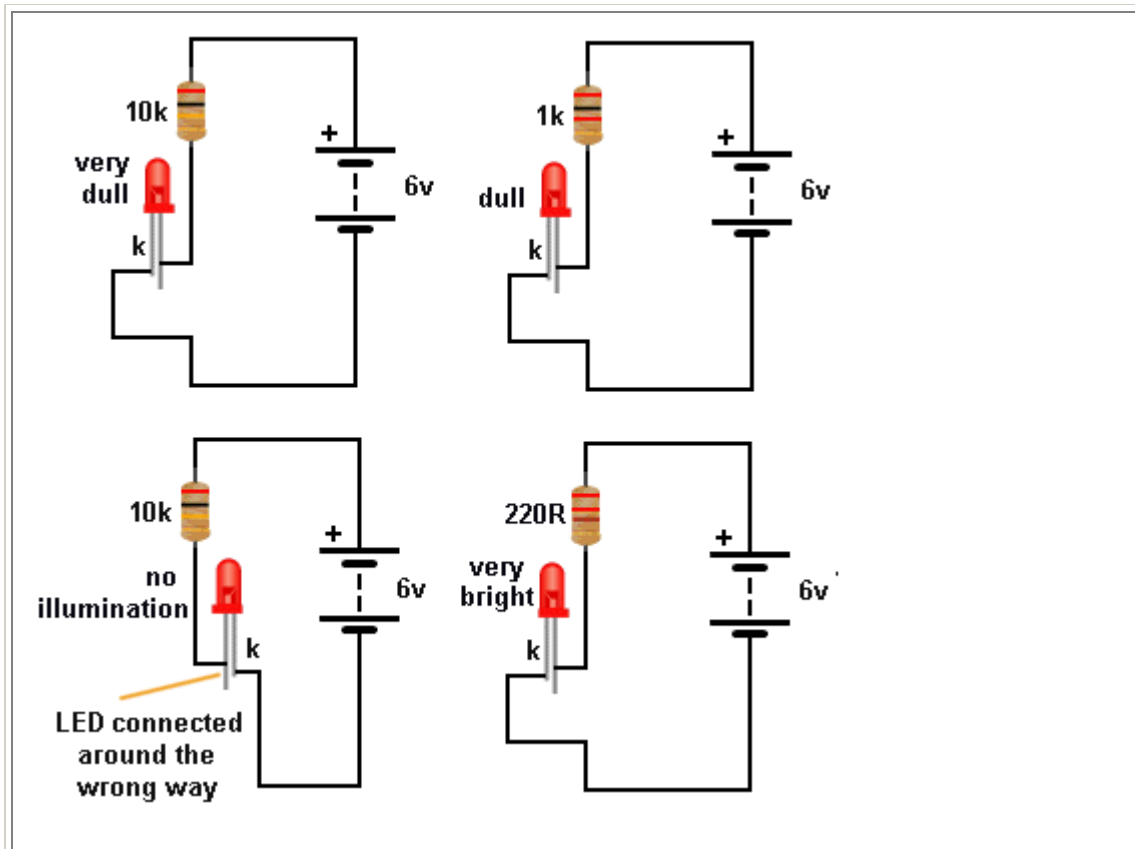
[to Index](#)



**Fig 18. WHITE LED VOLTAGE**

[to Index](#)





**Fig 19. Testing A LED**

Now connect either the 1k, 470R or 220R and determine the brightness you need. As the brightness increases, the current will be higher. You can use 3v supply for all LEDs except blue and white.

**HOW TO TEST A LED**

Some clear LEDs produce red or orange and some LEDs do not have the cathode lead clearly identified.

Here's how to find the colour, cathode lead and the current.

You need a 6v battery, 10k resistor, 1k resistor, 470R resistor and 220R resistor.

Connect the 6v battery and 10k resistor to the LED and it will only illuminate when the cathode is connected to the negative of the battery. This is the short lead.

[to Index](#)

<p>The diagram shows a 3V battery connected directly across an LED. The LED is shown with jagged lines around it, indicating it is damaged. The cathode lead is labeled 'k'.</p>	<p>Do not connect a 3v battery directly across a LED. It will be DAMAGED. You MUST include a resistor.</p>
--	--

**Fig 20. Damage a LED**

[to Index](#)

**A LED IS CURRENT DRIVEN**

You may have seen this statement and tried to work out what it means.

Basically it means an increase in current will make the LED brighter.

But a LED needs 2 things:

It needs a voltage that is EXACTLY the voltage required to produce illumination. And this voltage depends on the colour of the LED.

As soon as you supply the exact voltage, the crystal will begin to glow and as you increase the current, the illumination will increase.

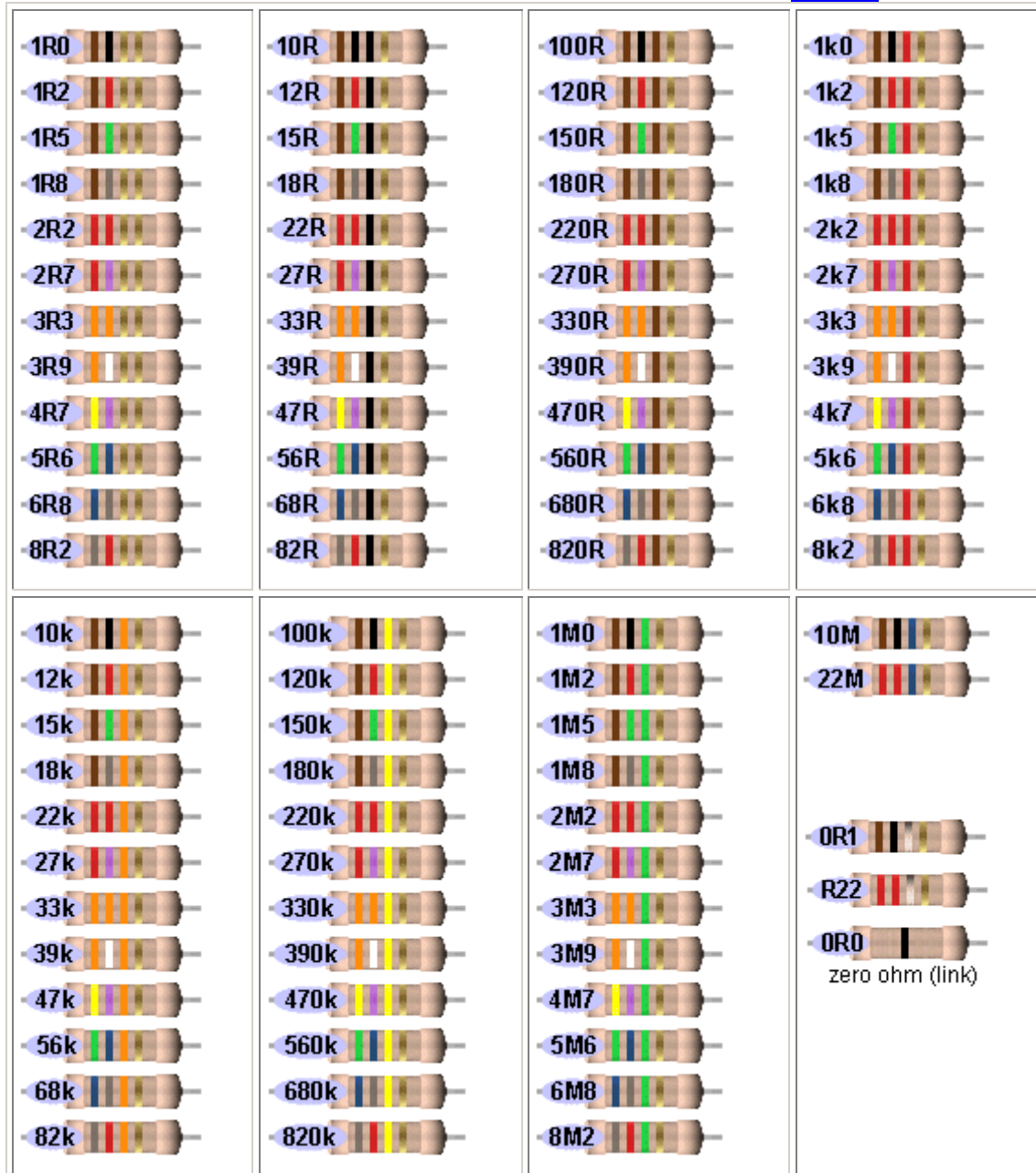
But doing this is VERY VERY difficult.

It is very easy to supply an exact voltage such as 1.7v or 3.4v, but delivering a current such as 10mA or 20mA at the same time is very difficult. You cannot get a 1.7v battery and deliver 10mA to a LED.

As we have shown above, you need a simple components such as a resistor between the battery and LED to achieve the desired result.

A LED is CURRENT DRIVEN but firstly you need to provide a VOLTAGE that is exactly the connect value for the colour of the LED and then the current can be increased.

[to Index](#)



**Fig 21. All the resistor values**

Here are all the colours and values for the resistors you will using in this course. Just match-up the colours on your resistor with the resistors above and you will find the value.

[to Index](#)

Resistor values are always OHM values. One ohm is a small value. It might be the resistance of a length of wire 3 metres long.

When a switch is open the resistance is infinite - millions and millions of ohms.

The resistance of your body from one hand to the other will be about 70,000 ohms.

The resistance between two wires dipped in water will be about 1,000 to 100,000 ohms (depending on the dissolved-salts in the water - pure water has a very high resistance)

The resistance of the filament of a 3v globe will be about 30 ohms.

The resistance of the winding of a 3v motor will be about 3 ohms.

Resistors are made with values from less than one ohm to more than 10 million ohms by adding carbon to the mixture inside the resistor (and cutting a track around the outside of the resistor) then connecting a lead to each end. Adding more carbon reduces the value of resistance. Carbon has a low resistance.

Resistance-values are measured with the RESISTANCE settings on a MULTIMETER.

This is called the "Ohms Range." Sometimes with the symbol:  $\Omega$

A Multimeter will have 2, 3 4 or more scales to cover the range one ohm to 10 million ohms.

Low value resistors (from 1 ohm to 999 ohms) are written as 1R, 220R, 470R, 999R. with the letter "R" indicating Resistance (ohms). You can also use the symbol "omega" ( $\Omega$ )

For values above 1,000 ohms to 99,999 ohms, they are written as: 1k, 2k2, 4k7, 10k, 100k, 220k, 470k, with the letter "k" indicating "kilo" (thousand).

1M = 1,000,000 - one million ohms 1M2, 2M2, 4M7, 10M.

The letters "R, k and M" are placed so they take the place of the decimal point. This prevents any mistake, as a decimal point can be missing in a poor photocopy.

[to Index](#)



## MULTIMETERS

There are two types of **MULTIMETER**. The top two are called **DIGITAL MULTIMETERS** (DMM) and show numbers on a display.

The lower two meters are called **ANALOGUE MULTIMETERS** and have a pointer and scale.

All meters come with a set of red and black leads.

The **red lead** is always connected to the positive of the battery or the positive on a project and the **black lead** is connected to the negative or earth or chassis.

When making a resistance measurement, the leads can be around either way.

Resistance measurements are always made with the power removed from a circuit. Any voltage on a circuit will upset the resistance reading.

[to Index](#)



**Fig 22. Resistance Measurement with Analogue Multimeter**

The resistance of a resistor is measured by placing the leads of the multimeter on the ends of a resistor and turning the dial on the analogue multimeter to the resistance scale to make the pointer move to about the centre of the scale.

The resistance scale is marked with a high value on the left and 0 ohm on the right. This is opposite to all the other scales. You must get the pointer to move to the middle of the scale as it is not accurate at left-end.

Analogue multimeters are only suitable for reading values from 1 ohm to 100,000 ohms. The scale is too hard to read above 100k.

To find the value of a resistor, you can compare the colours with the table above.

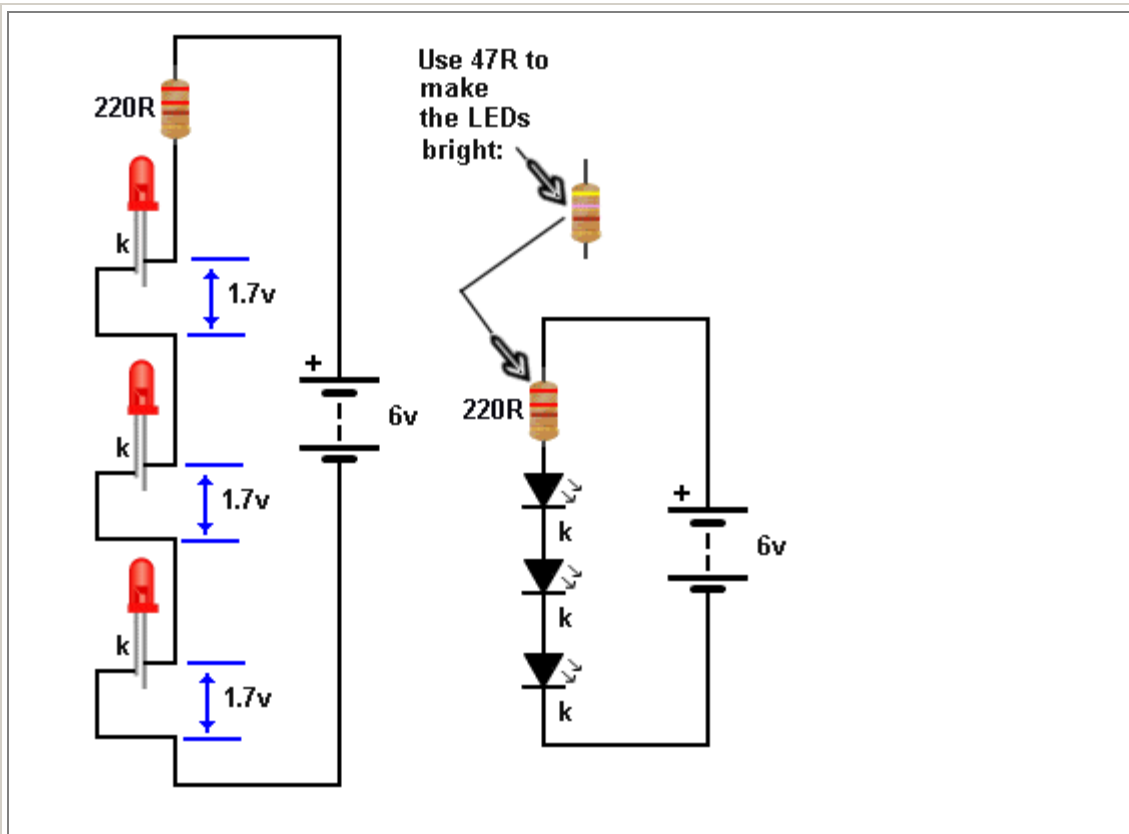
[to Index](#)



**Fig 23. Resistance Measurement with a DMM**

A digital multimeter produces a more-accurate reading of resistance. It is accurate from 1 ohm to 10M ohms. Select the scale that provides a reading.

[to Index](#)



**Fig 24.** Connecting LEDs in series

LEDs can be placed in series provided the total **CHARACTERISTIC VOLTAGE DROP** across the LEDs is LESS than the supply voltage.

In this case the voltage across the LEDs is  $1.7\text{v} + 1.7\text{v} + 1.7\text{v} = 5.1\text{v}$

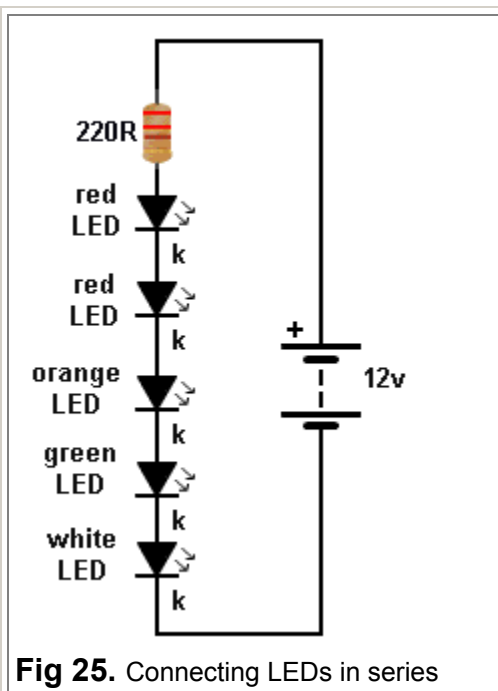
The supply is 6v and this allows 0.9v for the **CURRENT LIMITING RESISTOR**.

The LEDs will not be very bright with 220R.

Change the resistor to 47R

If you connect 4 LEDs in series, the total **CHARACTERISTIC VOLTAGE DROP** will be 6.8v and no LEDs will illuminate because the total is higher than the 6v supply.

[to Index](#)

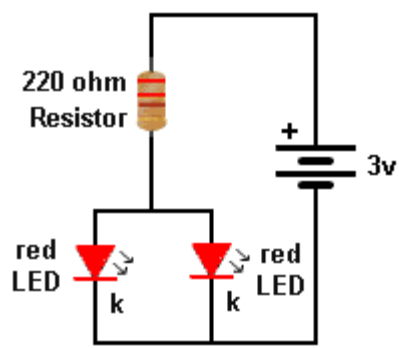


**Fig 25.** Connecting LEDs in series

Different-colour LEDs can be connected in series. Add up the total Characteristic Voltage for the 5 LEDs and see if it is less than 12v.

The 220R resistor will have to be reduced to 47R to make the LEDs bright.

[to Index](#)



**Fig 26.** Connecting LEDs in parallel

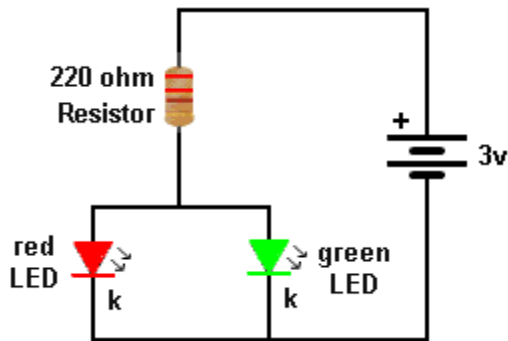
LEDs can be connected in parallel if they are the same colour.

In the diagram a red LED drops a CHARACTERISTIC VOLTAGE of 1.7v and if they are from the same manufacturer or the same batch, they will work ok.

Although we say the characteristic voltage for a red LED is 1.7v, this can change slightly from different manufacturers and one LED may glow brightly while the other is dull.

You have to build the circuit and see the result.

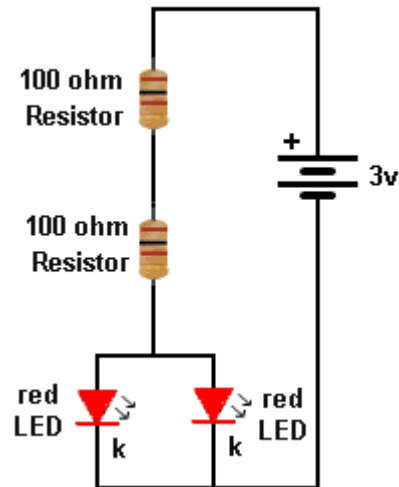
[to Index](#)



**Fig 27.** Connecting LEDs in parallel

Different colour LEDs cannot be connected in parallel. The voltage across a red LED is 1.7v. This becomes the "Supply Voltage" for the green LED and it is too low. The green LED needs a supply of 2.1v to 2.3v. Only the red LED will illuminate.

[to Index](#)



**Fig 28.** Connecting Resistors in Series

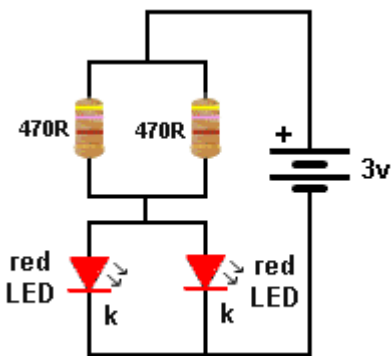
Suppose you don't have a 220 ohm resistor. You can make a 220 ohm resistor with two resistors in series. The total resistance will be 200 ohms, but resistors are not accurate and the result will be very close to 220R.

Electronic circuits are not very critical. You will not be able to see the difference in brightness between 200 ohms and 220 ohms.

**When resistors are connected in series, the total resistance is found by adding the resistance of each resistor.**

$$R_{\text{total}} = R_1 + R_2 + R_3 + \dots$$

[to Index](#)



**Fig 29.** Connecting Resistors in Parallel

You can create a 220 ohm resistor by connecting two resistors in Parallel.

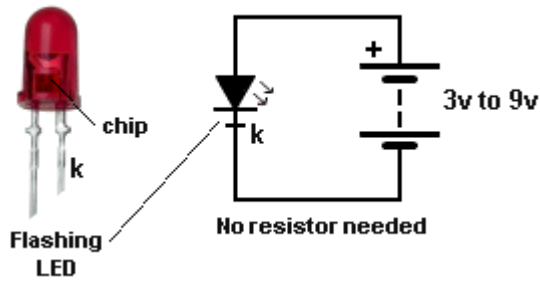
When two equal-value resistors are connected in Parallel, the total resistance across the combination is HALF.

470R in parallel with 470R produces 235R. This is very close to 220R.

We are not going into the formula as it is very complex.

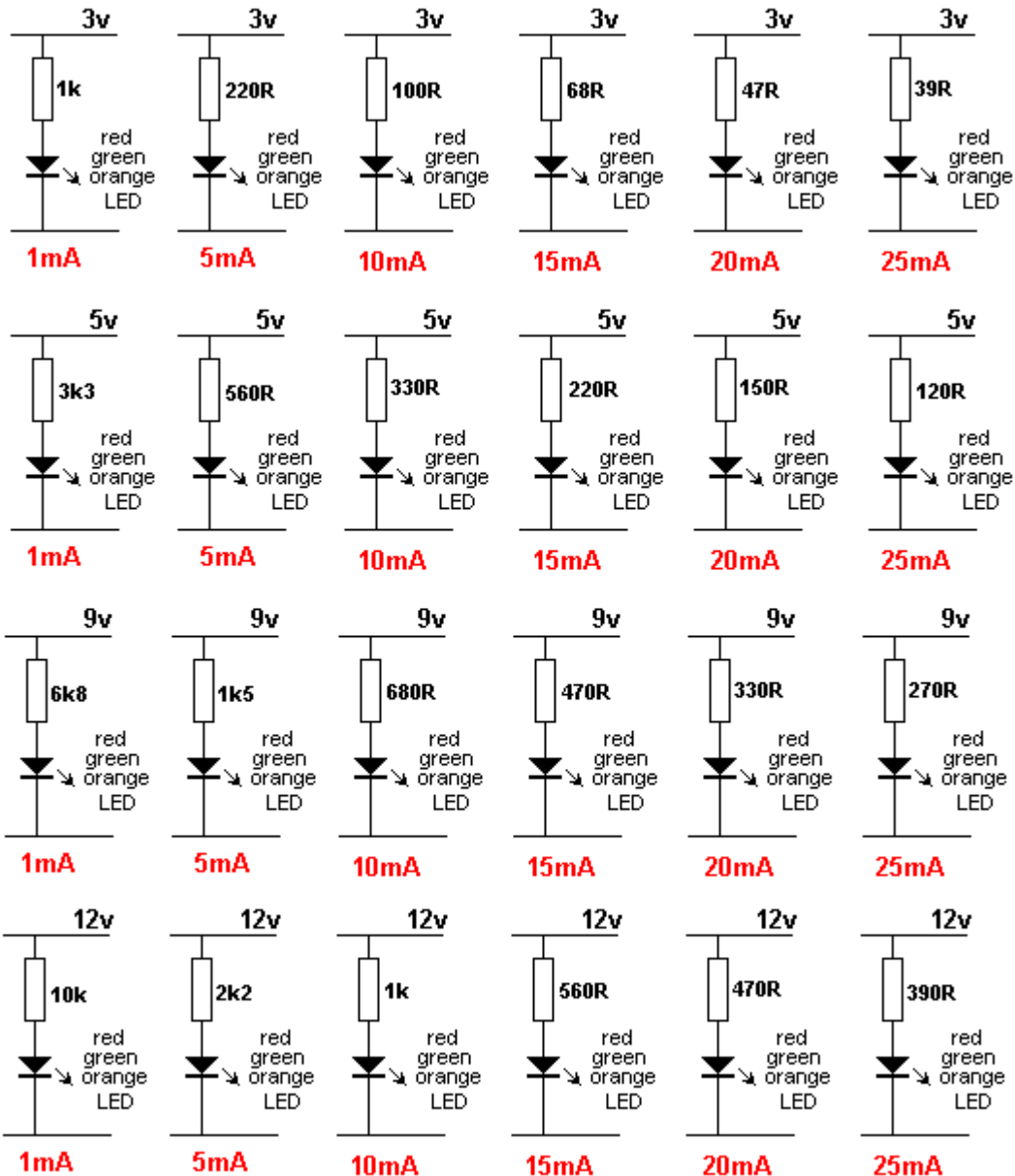
Three equal-value resistors in parallel produce a total of **one-third**.

Simply get two resistors and connect them in parallel and measure them with a multimeter.

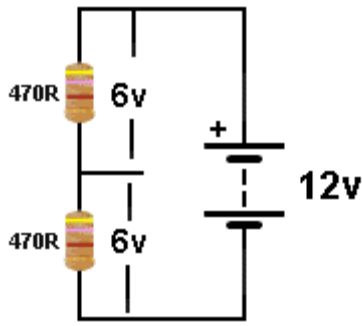


There are some special LEDs that can be connected to 3v to 9v and they flash or produce a range of colours. These LEDs have a chip and resistor inside the body of the LED to produce the effect and allow the LED to operate on a voltage without the need for a current limiting resistor.

**Fig 30.** Flashing LED



**Fig 31.** These diagrams show the resistor needed to produce 1mA to 25mA current through a single LED on 3v, 5v, 9v and 12v supply.



**Fig 31a. Voltage Divider Circuit.**

### THE VOLTAGE DIVIDER

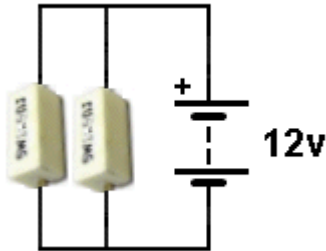
In the circuits above, the resistor and LED are forming a **VOLTAGE DIVIDER**.

A red LED is dropping 1.7v across it and the resistor is dropping the remaining voltage.

Whenever two (or more) components are placed across a battery, they form a **VOLTAGE DIVIDER**. Sometimes we want a 6v supply and only have 12v. We can produce the 6v supply by putting two equal-value resistors across the 12v as shown in the circuit opposite.

We are not going into the mathematics because the selection of the correct value is very complex and the circuit is very wasteful.

[to Index](#)



**Fig 31b. Current Divider Circuit.**

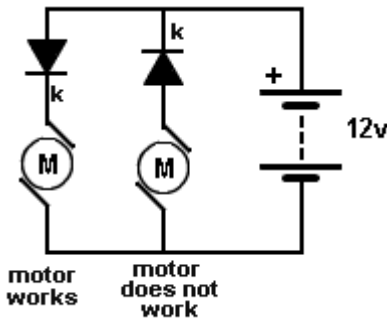
### THE CURRENT DIVIDER

The **CURRENT DIVIDER CIRCUIT** is actually a **LOAD SHARING CIRCUIT**.

Suppose you are testing a Power Supply and need a 10 watt LOAD. But you only have 5 watt resistors.

Placing two 5watt resistors in parallel across the output of the power supply will allow half the current to flow through each resistor. This is called **CURRENT SHARING** or **LOAD SHARING** and the current is divided (or passed) through each resistor according to the value of resistance.

[to Index](#)



**Fig 32. The DIODE**

### THE DIODE

The next simple electronic component is the **DIODE**.

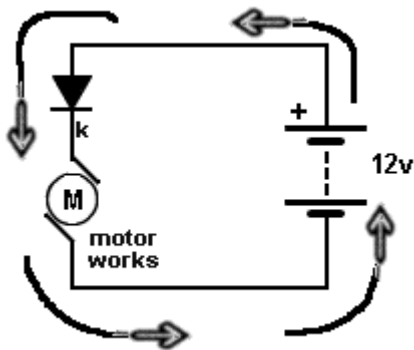
It only works when connected correctly.

A **DIODE** allows current to flow through it when it is connected as shown in the diagram.

A Diode is similar to a one-way water valve.

When the diode is "facing down," the motor spins.

When it is "facing up" the motor does not spin.



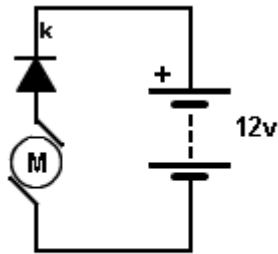
The diagram shows the "current path" around the circuit. The current is measured in **AMPS** and we discuss current as **CONVENTIONAL CURRENT**.

This is the way current was thought to flow when electricity was born and they said it flows out the **POSITIVE TERMINAL** of the battery, around the circuit and into the **NEGATIVE TERMINAL**.

The arrow on the diode shows the current will flow through the diode and allow the motor to spin.

The diode is said to be **FORWARD BIASED**.





motor does not work

There is no flow of current because the diode prevents any current-flow when connected as shown.

The motor DOES NOT WORK.

The diode is said to be **REVERSE BIASED**.

[to Index](#)

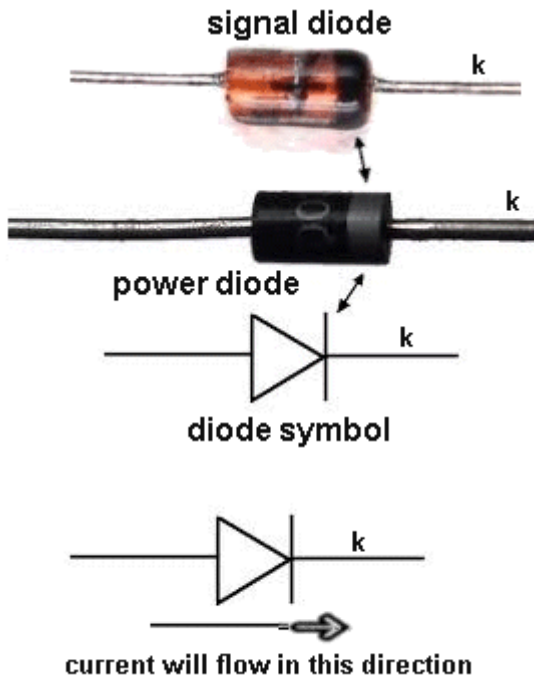


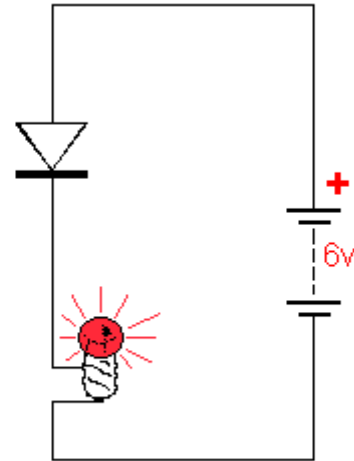
Fig 33. A Signal diode and a Power diode

There are hundreds of different types of diodes.

Power diodes, signal diodes, low voltage diodes, high voltage diodes, high-speed diodes and many other types.

They all do one thing.

They pass current in one direction and if turned around, they **do not pass** any current.



**How a diode works**

[to Index](#)

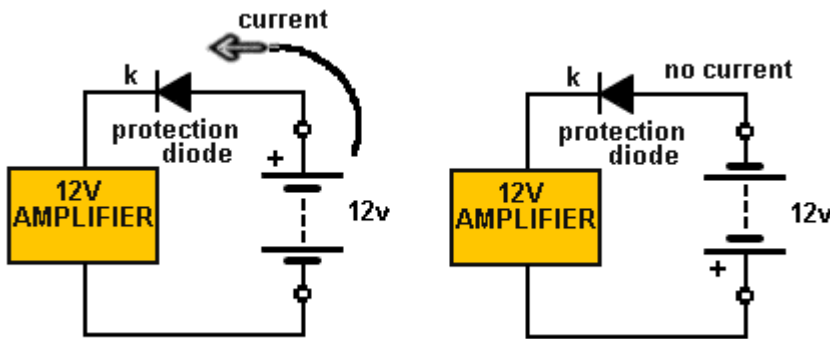


Fig 34. A Protection diode

Diodes perform many function in electrical and electronic circuits. Here is an application as a **PROTECTION DIODE**.

It protects the amplifier. If the 12v battery is connected around the wrong way, no current will flow.

[to Index](#)

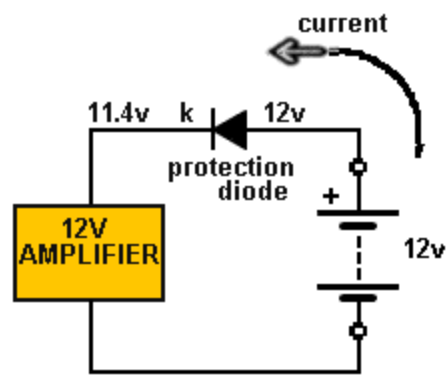


Fig 35. Diode "Voltage Drop"

When a diode is placed in a circuit (and current is flowing), a small voltage develops across the diode. This voltage is called the **FORWARD VOLTAGE DROP**.

This voltage is approximately 0.6v.

This is due to a junction inside the diode where two different materials are joined.

Normally, this voltage is not important because it is only small, but sometimes you need to take it into account.

For the circuit above, the amplifier only gets 11.4v

[to Index](#)

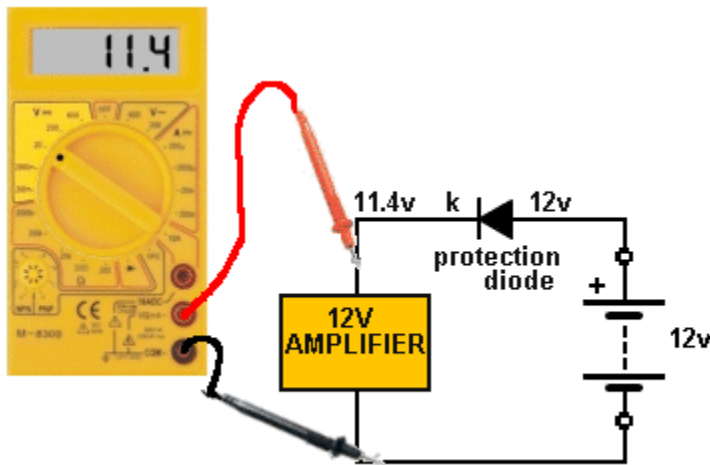


Fig 36. Measuring Voltage with a Digital Multimeter

Voltage is measured with a **VOLTMETER**.

Multimeters have 2 or 3 voltage ranges so you can measure low voltage (0v to 20v), medium voltages (0v to 200v and high voltages (0v to 500v).

A voltmeter is placed across the component being tested, as shown in the diagram.

The Digital Multimeter is detecting 11.4v across the amplifier.

[to Index](#)

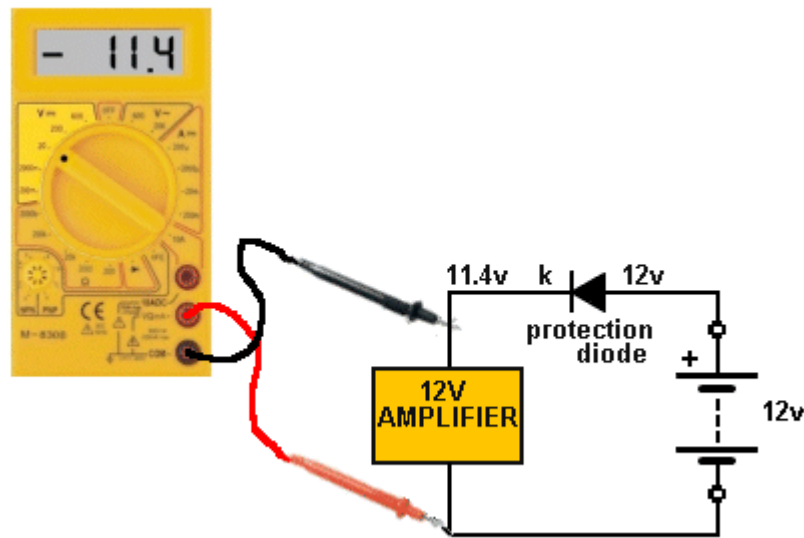
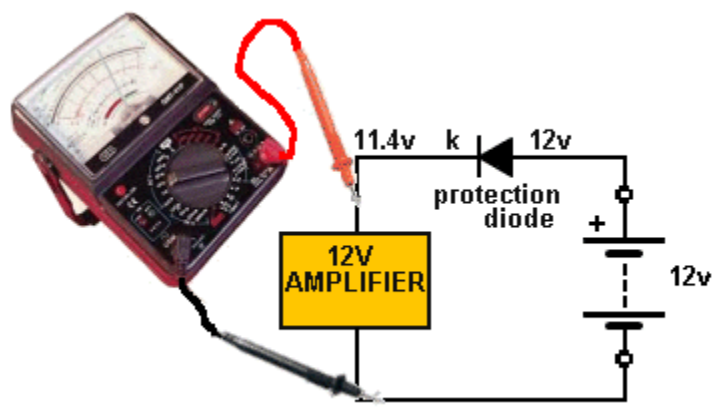


Fig 37. Measuring Voltage with a Digital Multimeter

If you place the probes of a digital multimeter around the wrong way on a component, the display will show a "-". The meter will not be damaged.

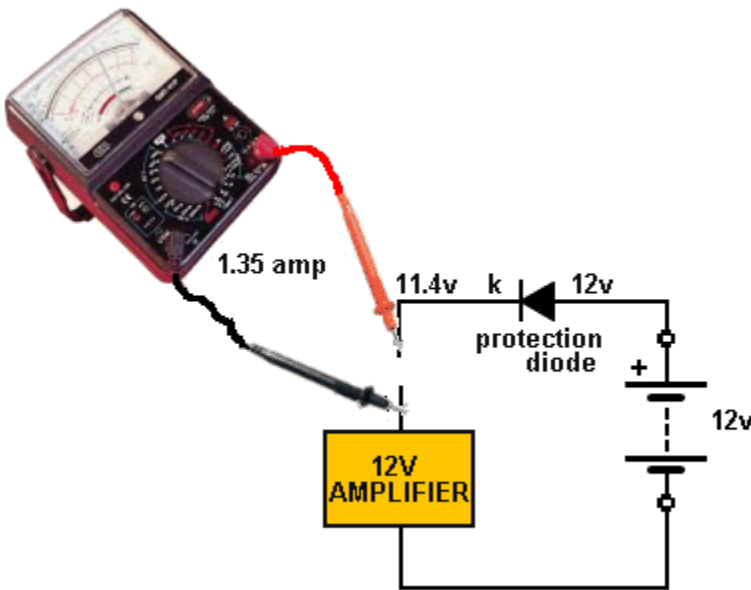
[to Index](#)



**Fig 38. Measuring Voltage with an Analogue Multimeter**

An analogue Multimeter must be connected around the correct way to make the pointer move "up scale." Select the range that will allow the pointer to show somewhere in the middle of the scale.

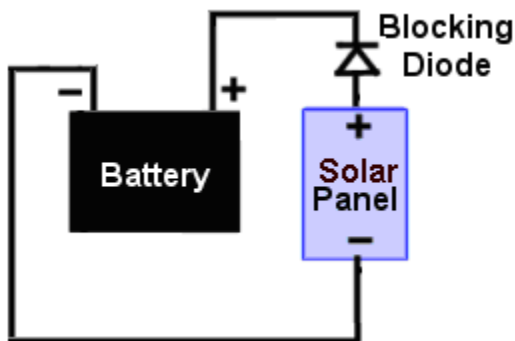
[to Index](#)



**Fig 39. Measuring Current with an Analogue Multimeter**

Current is measured by "breaking into the circuit" and inserting the leads so the positive probe is closest to the positive of the battery. If you connect the leads around the other way, the needle will not move but it will hit the "end stop" and you may have to "bump" the meter to get the pointer to move from its jammed position.

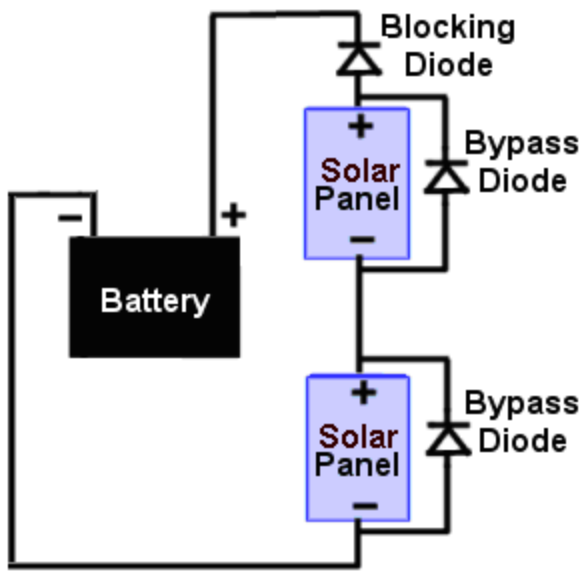
[to Index](#)



**Fig 39a. The Solar Panel and the Blocking Diode**

A DIODE is also used with a solar panel to prevent the battery discharging into the solar panel when the sun is not shining. When the solar panel is not receiving any light it becomes a resistor with a large value and a small current can flow through it from the battery. The diode prevents this current-flow. The diode is called a **BLOCKING DIODE**.

[to Index](#)



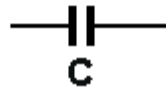
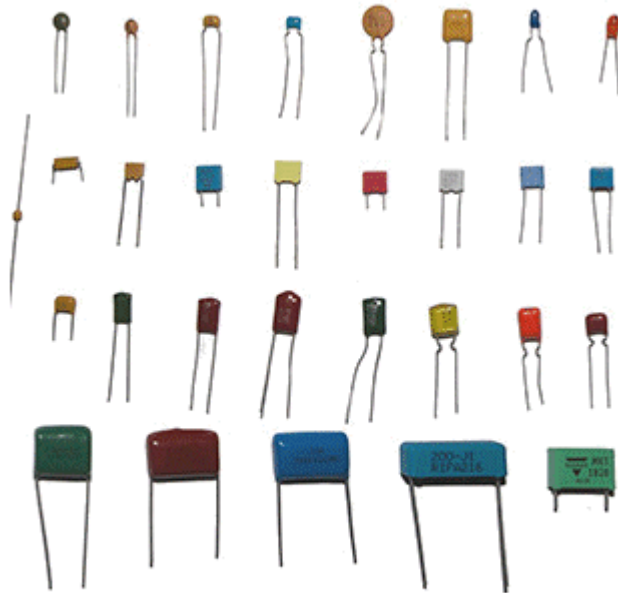
**Fig 39b. The Solar Panel with diodes called BLOCKING DIODES and BYPASS DIODES.**

Diodes are given different names, according to their function. They all perform the same job by passing current in one direction and prevent current-flow in the opposite direction.

When the top solar panel is shaded by a cloud, it generates less current and this will reduce the current into the battery. By placing a diode across the panel, the diode will pass the current produced by the lower panel to the battery.

These diodes are called **BYPASS DIODES**.

[to Index](#)



**Fig 40. Capacitors and symbol**

The next component we cover is the **CAPACITOR**.

There are thousands of different types of capacitor.

Each value of capacitor can have a low voltage rating, medium voltage or high voltage.

Capacitors can be very small in size and shape or very stable with temperature-rise or simply very cheap to make.

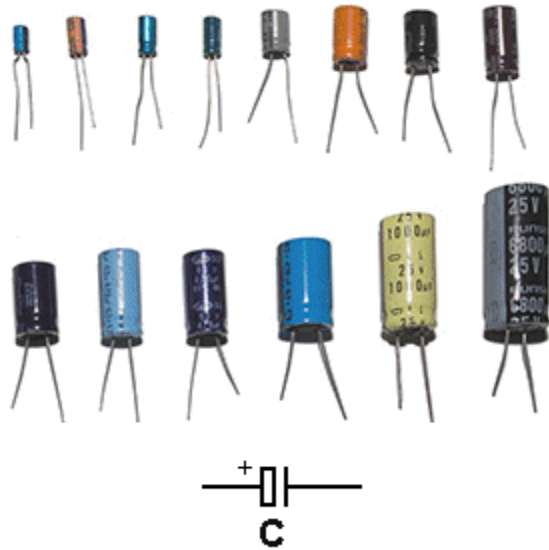
A capacitor consists of two thin sheets of metal such as aluminium with a thin sheet of plastic between.

The sheets may be rolled up in a cylinder or laid on top of each other.

The fact is this: the top sheet of metal does not touch the bottom sheet. This is shown in the symbol. The resistance between the two terminals is INFINITE.

The 6th capacitor in the top row is called a **MONOBLOCK**.

[to Index](#)



**Fig 41. Electrolytic Capacitor**

A capacitor gets bigger as its value increases.  
 It also gets bigger when the voltage-rating increases.  
 The basic unit of capacitance is the FARAD. A one-farad capacitor would be the size of a house. To make the capacitor smaller the sheets are etched to increase the surface-area and different insulating materials are used between the sheets.  
 The result is a capacitor called an **ELECTROLYTIC**. It is a bit like a rechargeable battery. It stores a lot of energy in a small space.  
 The negative lead is shorter and has a black stripe on the side of the electrolytic.

[to Index](#)

One FARAD is too big to handle. We use smaller values.  
 The middle of the range is one microfarad. This is written as 1u. (sometimes you see uF)  
 This is one-millionth of a FARAD.  
 The smallest value of capacitance is one picofarad. This is one millionth of a microfarad.  
 It is written as 1p.  
 Capacitors are broadly separated into two groups. 1p to 1u and 1u to 100,000u  
 Capacitors 1p to 1u are ceramic, polyester, air, styrofoam, monoblock and other names.  
 Capacitors 1u to 100,000u are electrolytic or tantalum. A tantalum is the same as an electrolytic - for testing purposes - it is a more-compact electrolytic.

1 microfarad is one millionth of 1 farad.  
 1 microfarad is divided into smaller parts called nanofarad.  
 1,000 nanofarad = 1 microfarad  
 Nanofarad is divided into small parts called picofarad  
 1,000 picofarad = 1 nanofarad.

Recapping:  
 1p = 1 picofarad.    1,000p = 1n ( 1 nanofarad)    1,000,000p = 1u  
 1,000n = 1u (1 microfarad)  
 1,000u = 1millifarad  
 1,000,000u = 1 FARAD.

Examples:  
 All ceramic capacitors are marked in "p" (puff)  
 A ceramic with 22 is 22p = 22 picofarad  
 A ceramic with 47 is 47p = 47 picofarad  
 A ceramic with 470 is 470p = 470 picofarad  
 A ceramic with 471 is 470p = 470 picofarad  
 A ceramic with 101 is 100p (it can also be 100)  
 A ceramic with 102 is 1,000p = 1n  
 A ceramic with 223 is 22,000p = 22n  
 A ceramic with 104 is 100,000p = 100n = 0.1u    A common 100n is called a **MONOBLOCK**.  
 A ceramic with 105 is 1u

### TYPES OF CAPACITOR

For testing purposes, there are two types of capacitor.  
 Capacitors from 1p to 100n are non-polar and can be inserted into a circuit around either way.  
 Capacitors from 1u to 100,000u are electrolytics (or tantalum) and are polarised. They must be fitted so the positive lead goes to the supply voltage and the negative lead goes to ground (or earth).

[to Index](#)

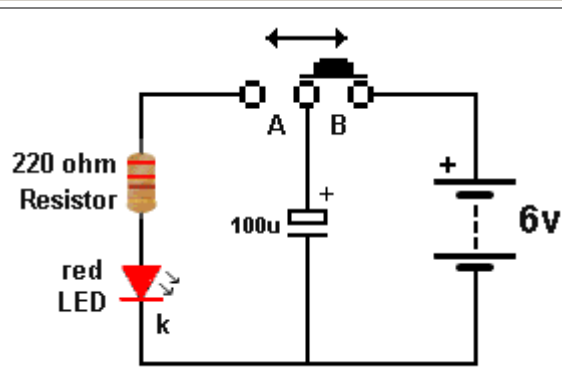


Fig 42. Charging a Capacitor

Here is an experiment to show how much (little) energy is stored in a 100uF electrolytic. When the slide-switch is in position "B", the 100uF is charged by the 6V battery. When the slide switch is moved to position "A" the electrolytic supplies energy to illuminate the red LED via the 220R resistor. It will illuminate for a short period of time. By moving the switch back and forth, you can keep the LED illuminated.

[to Index](#)

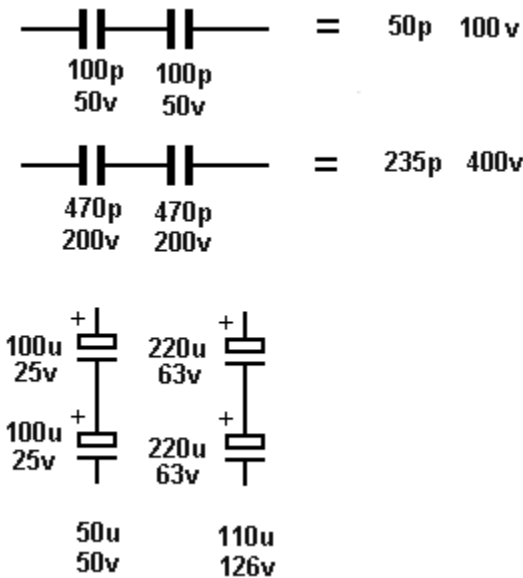


Fig 43. Capacitors in Series

Capacitors can be connected in **Series or Parallel** to obtain a value of capacitance you may not have available. They are also connected in series to increase the effective **VOLTAGE RATING**. However when two equal-value capacitors are connected in series, the final value is **HALF**, and thus you need two with double the final-value to get a value with an increased voltage-rating. When two equal-value capacitors are connected in series, the result is **HALF**. (This is the opposite to connecting resistors)

[to Index](#)

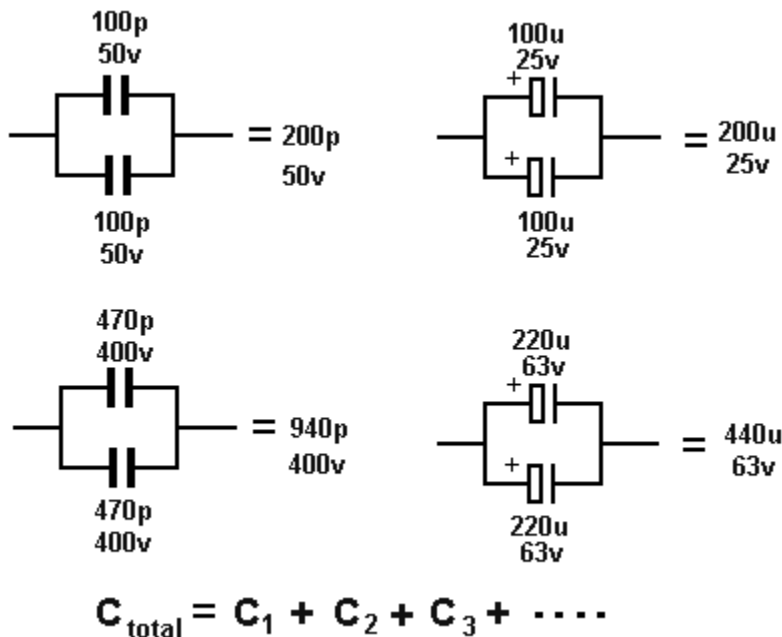
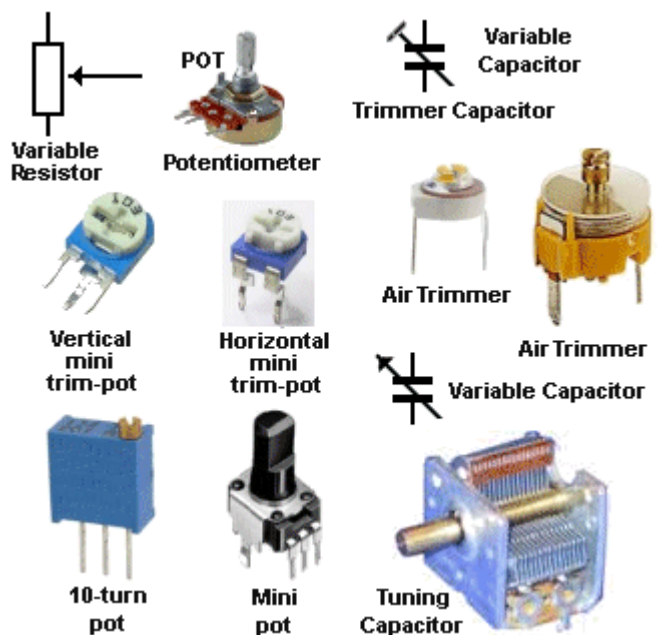


Fig 44. Capacitors in Parallel

Capacitors can be connected in **Parallel** to obtain a value of capacitance you may not have available. (This does not change the **VOLTAGE RATING**.) When two equal-value capacitors are connected in parallel, the result is **DOUBLE**. (This is the opposite to connecting resistors). If one electrolytic is 25V and the other 63V, the answer is the **LOWER VOLTAGE = 25V**.



**Fig 45. Variable Capacitors and Resistors**

The value of a capacitor or resistor may need to be increased or decreased in a circuit to tune in radio stations or increase and decrease the volume of a speaker. The symbol for these components have an arrow to show they can be adjusted.

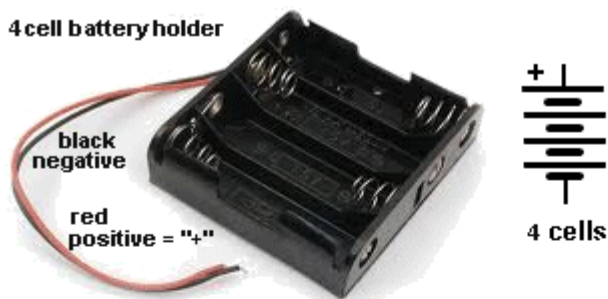
The resistance of a potentiometer can be from 1 ohm to 5M

They come in many different shapes and sizes to suit the PC board or front-panel layout.

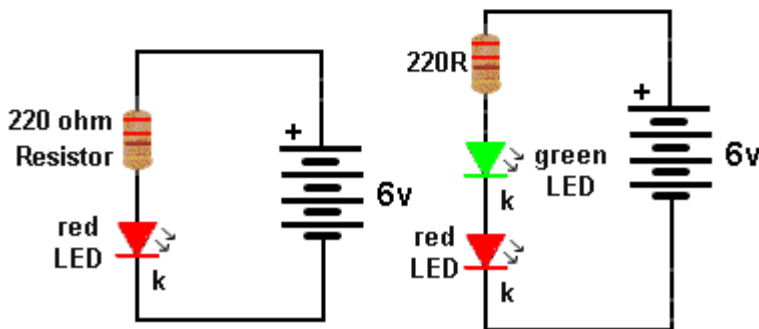
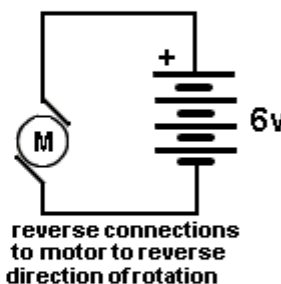
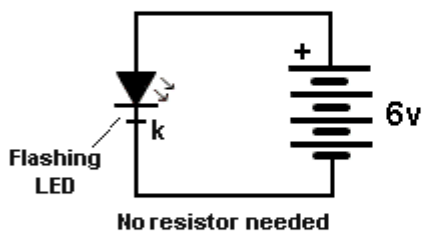
The "T" represents a trimmer capacitor and this can be from 1p to about 120p.

A variable capacitor will be from about 10p to 415p.

**4 cell battery holder**



**4 cells connected in SERIES to produce 1.5v x 4 = 6v**



**Fig 46. Simple Circuits**

**Simple CIRCUITS**

We have covered enough symbols and components to create a number of simple circuits.

These circuits will show how to connect a motor, a LED, (how to make it bright or dull) and how to connect 4 cells to make a battery.

Note: The flashing LED does not need a resistor because a resistor and chip are inside the LED, to make it flash and control the current.

Connect all the components around the correct way and then connect them around the wrong way to see what happens.

Connect the flashing LED in series with a red LED and see what happens.

**QUESTIONS**

1. Explain why the Flashing LED circuit has no external resistor.

2. How many 1.5v cells are needed to produce a 6v battery
3. Explain what happens when you reverse the leads to a motor.
4. Identify the positive terminal:



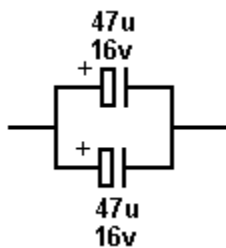
5. Can 3 green LEDs be connected in series to a 6v supply?
6. A variable resistor is also called: \_\_\_\_\_
7. The combined resistance of two 1k resistors in series is: \_\_\_\_\_
8. The combined resistance of two 1k resistors in parallel is: \_\_\_\_\_
9. Name the short lead on a LED
10. Name the type of multimeter with a pointer and scale: \_\_\_\_\_
11. The total capacitance of two 100u electrolytics in series is: \_\_\_\_\_
12. The total capacitance of two 100u electrolytics in series is: \_\_\_\_\_
13. Write these values in words:

**22R** \_\_\_\_\_  
**4k7** \_\_\_\_\_  
**1n** \_\_\_\_\_  
**100u** \_\_\_\_\_

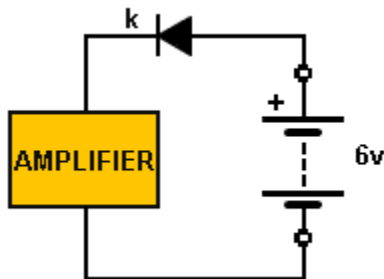
14. How many 1.5v cells in a 9v battery?
15. The red probe is: \_\_\_\_\_ (positive/negative)
16. Conventional current flows from: \_\_\_\_\_ (positive to negative / negative to positive)
17. Make a 470u electrolytic with two electrolytics:
18. What is the voltage drop across a diode?
19. Name the component that only allows current to flow in one direction: \_\_\_\_\_
20. Name this symbol:



21. When resistors are connected in series, the resistance of the combination: \_\_\_\_\_ (increases / decreases)
22. When two capacitors are connected in parallel, the voltage-rating of the combination: \_\_\_\_\_ (increases / equal to the capacitor with the lowest voltage-rating)
23. Draw two 2k2 resistors in parallel.
24. Which is larger: 470R or 22k
25. What is the value of this combination:

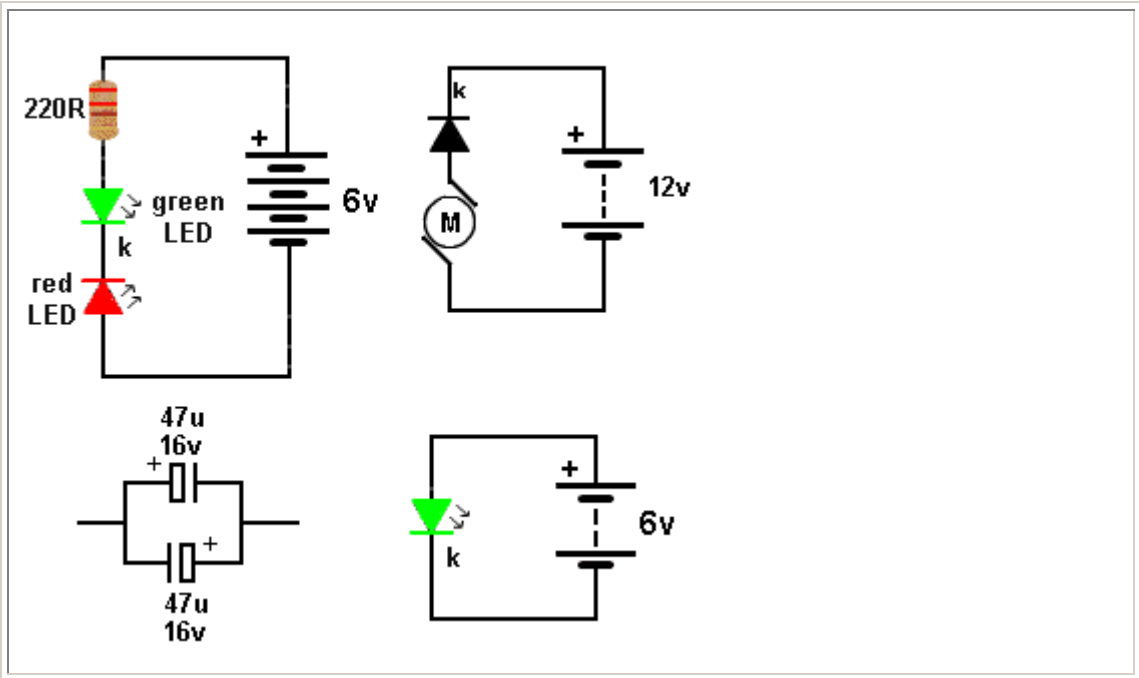


26. What is the name of the resistor in series with a LED: \_\_\_\_\_
27. What is the voltage across the amplifier: \_\_\_\_\_



28. Identify the fault with these circuits:





[to Index](#)

<b>Name these components:</b>					<p><b>Passive Components</b>          All the components shown on the left are called <b>PASSIVE COMPONENTS</b>. This means they do not amplify. Write the name beside each symbol.</p>
_____	_____	_____	_____	_____	
_____	_____	_____	_____	_____	
_____	_____	_____	_____	_____	

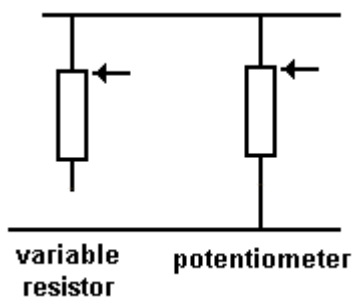
**Fig 47. Passive Components**

[to Index](#)

	<p><b>The Potentiometer</b> is a variable resistor.</p> <p>It consists of a curved carbon track with a wiper that touches the track and can be turned via a screwdriver or knob.</p> <p>The wiper is the middle wire on the circuit symbol and it moves up and down as shown in the animation.</p> <p>When the three leads are connected the symbol is called a potentiometer. When two leads are connected it is a variable resistor.</p> <p>When the resistance increases, less current flows through the pot.</p>
--	--

**Fig 47a. The Potentiometer in action**

[to Index](#)



**Fig 47b. The Variable Resistor and Potentiometer**

There is a difference in operation between a **Variable Resistor** and a **Potentiometer**. Both will increase or decrease the sound level as a volume control or the speed of a motor or the brightness of a globe, but a Potentiometer will guarantee zero volume or zero brightness when the pot is turned fully anticlockwise (as shown in the animation). This is because the output will be zero volts, but the variable resistor may still deliver some "energy" (voltage and current) to the circuit when turned fully anticlockwise.

[to Index](#)

**Potentiometers** come in values from 100 ohms to 5 Meg ohms (500R, 1k, 2k, 5k, 10k, 50k, 100k, 200k, 250k, 500k, 1M are most popular).

They come as linear, or logarithmic where the resistance of the track (per mm) is higher at one end. Because our hearing is not linear, these pots can be used as volume controls to produce a gradual (very nearly linear) increase in volume.

Selecting the correct value of resistance for a circuit is VERY complex. If the value is not correct, the volume will not be loud or it will drop to zero before the pot is turned fully anticlockwise. Or the motor will drop to zero at mid-turn of the pot or it will not reduce in RPM to the desired amount.

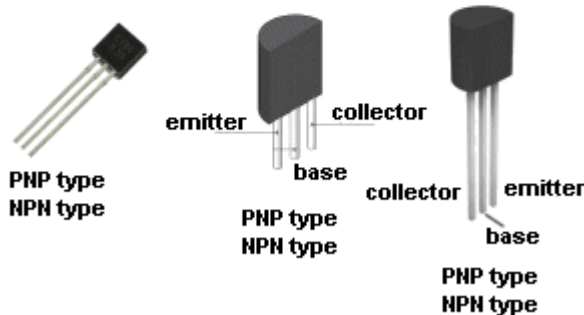
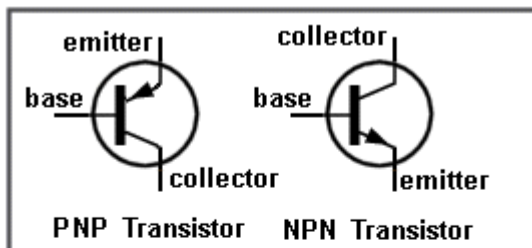
The simple answer is to copy a circuit.

Or you can try the whole range of pots and you will find one value is the best.

A Potentiometer can be used in hundreds of different circuits to produce hundreds of different effects, but the actual "thing" that flows between the input and output is a percentage of the voltage. At the same time the current will also be passed to the output at a reduced value. A pot actually delivers BOTH reduced values at the same time and the receiving circuit will be designed to "look for" the change in voltage or current. If the supply voltage is not rising or falling, the "values" are called DC values.

The voltage can also be in the form of a signal (volume). This is called an AC signal.

[to Indexx](#)



**Fig 48. The TRANSISTOR**

### The TRANSISTOR

A TRANSISTOR is an ACTIVE device. It AMPLIFIES.

There are many types of transistor (over 20,000 different types) from hundreds of manufacturers and they have many different names.

We are going to study the simplest. It has the technical name

**BIPOLAR JUNCTION TRANSISTOR (BJT)** but we are going to call it a **TRANSISTOR**.

There are two types in this group: **PNP** and **NPN**.

The type we will study is also called a **SMALL-SIGNAL TRANSISTOR**.

You cannot tell an **NPN** transistor from **PNP** by looking at it. You must test it in a circuit.

In **Fig 65** you will make a **Transistor Tester** project, but first some basic facts:

[to Index](#)

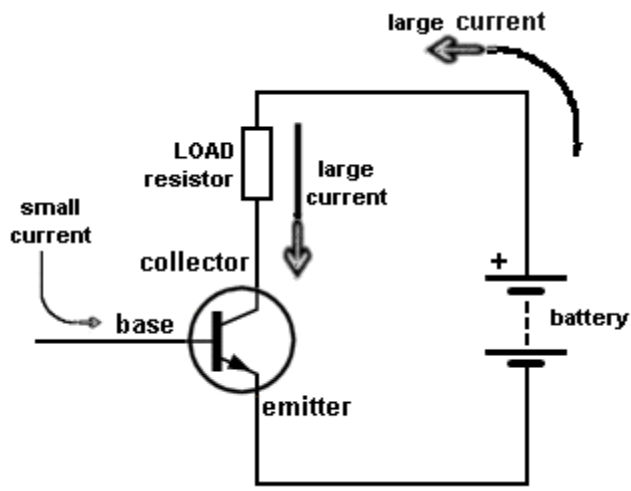


Fig 49. The NPN TRANSISTOR in a Circuit

The first type of transistor we are going to study is the **NPN**.  
 A transistor has three leads:  
**BASE, COLLECTOR** and **EMITTER**  
 Basically, a small current enters the base and a large current flows through the collector-emitter leads as shown in the diagram.  
 The resistor in the collector lead is called the LOAD Resistor.  
 Sometimes the load is a speaker.

[to Index](#)

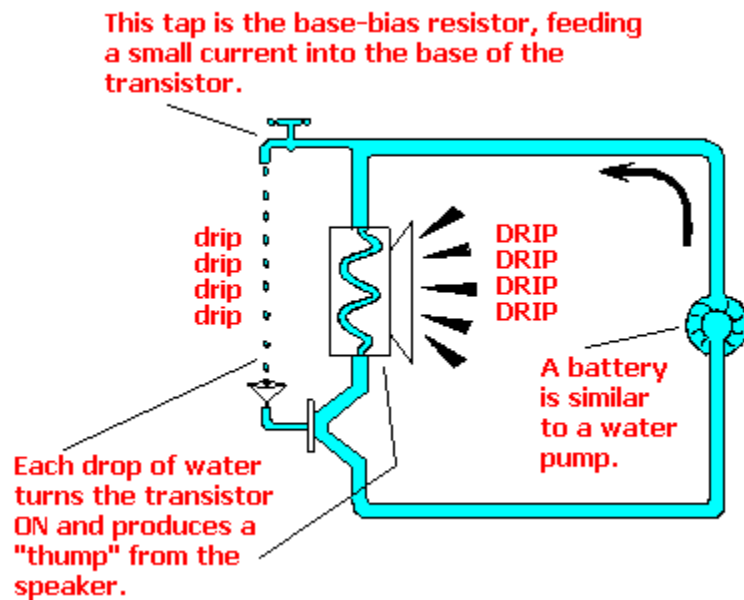
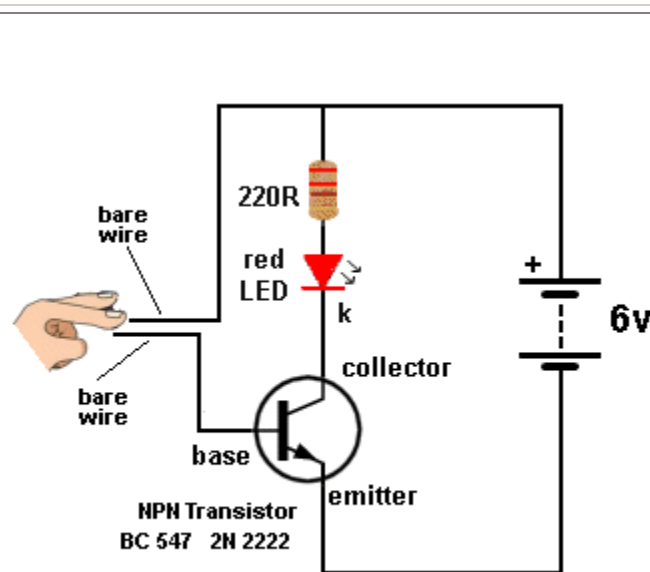


Fig 50. The Water TRANSISTOR

The transistor is similar to the diagram opposite. A small drop of water entering the base is amplified to produce a loud DRIP from the speaker.

[to Index](#)

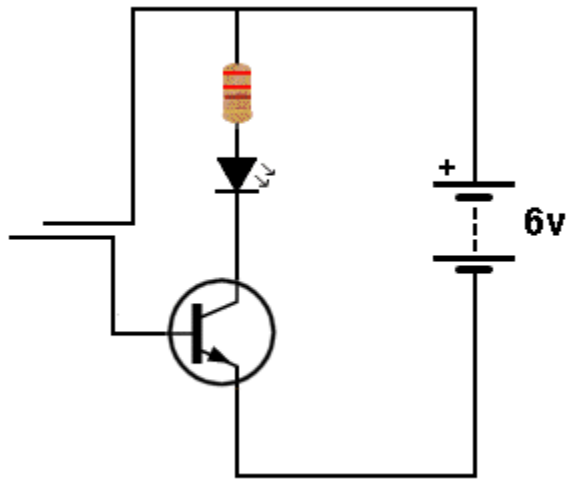


In this experiment we will construct a ONE TRANSISTOR circuit similar to the WATER TRANSISTOR above and observe the results.  
 Make sure the two leads DO NOT TOUCH. If they touch, the transistor will be DESTROYED.

The transistor is amplifying the current through your finger via the two leads and it will be very dim.

**ANIMATION**

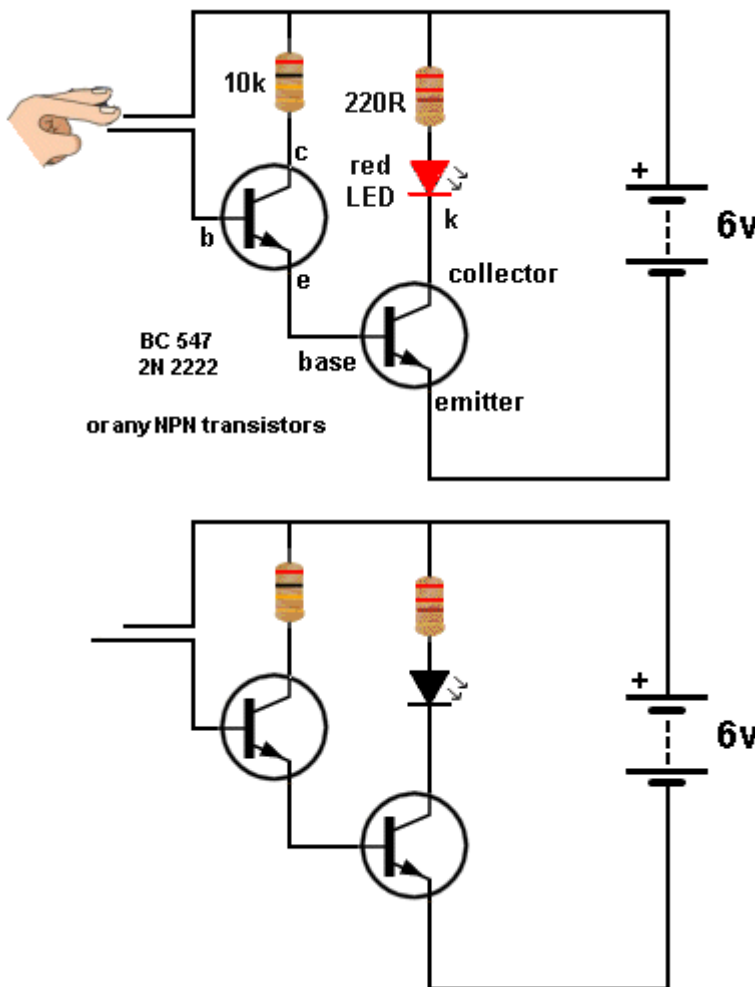
The lower diagram shows the transistor turning ON when a finger is pressed against the two wires.



**Fig 51. One Transistor Circuit**

The finger produces a resistance that turns the transistor ON and this turns the transistor into a smaller and smaller resistor. That's how more and more current flows through the LED and it gets brighter and brighter.

[to Index](#)



**Fig 52. Two Transistor Circuit**

By adding another transistor we amplify the current through the finger about 200 times and now the LED will glow bright.

Make sure the bare wires do not touch each other as this will destroy BOTH transistors.

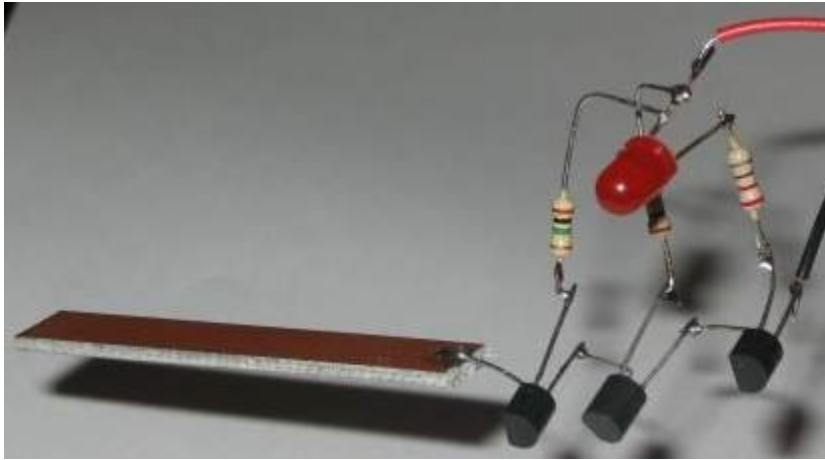
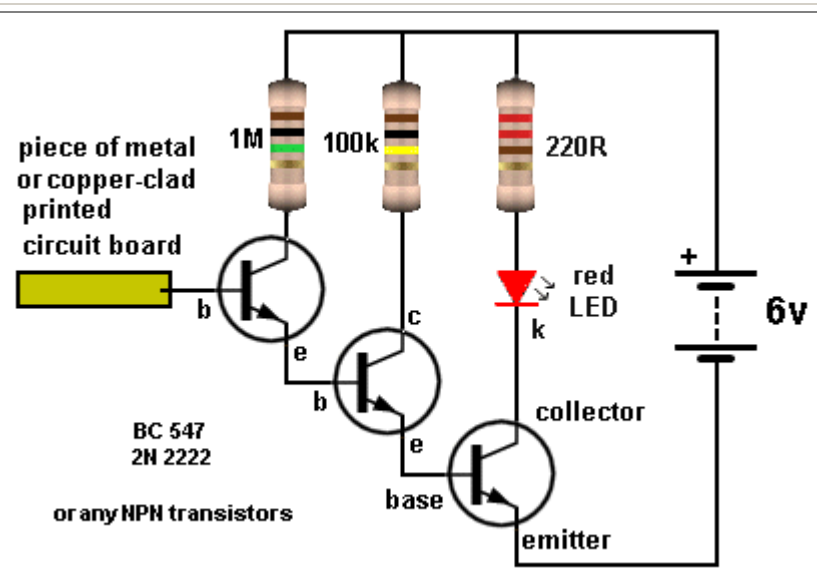
### ANIMATION

The lower diagram shows both transistors turning **ON** when a finger is pressed against the two wires.

**They both becomes smaller and smaller resistors.**

The first transistor allows more current to flow into the base of the second transistor and this is how the second transistor turns on more and more. This allows more current to flow through the LED and it gets brighter and brighter.

[to Index](#)



**Fig 53. Three Transistors**

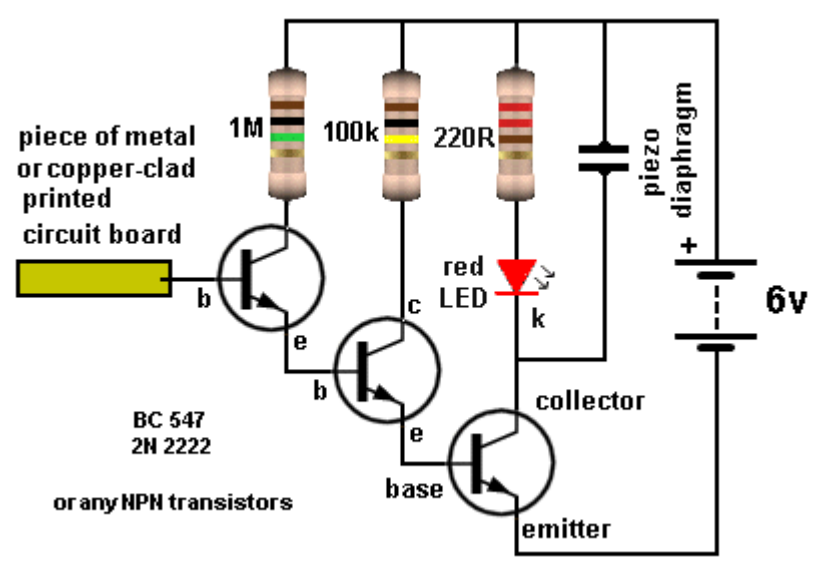
This circuit has enormous gain. Each transistor has a gain or more than 200 and the final gain will be more than:  
 $200 \times 200 \times 200 = 8,000,000$   
**8 MILLION!**

The circuit is very sensitive to static voltages in the air or electrical waves such as the waveform produced by the electrical wiring in a house. Move the project around a room and detect all the electrical signals.

[to Index](#)

You can see the effect of one transistor. It does not do much. The two transistor circuit allows the resistance of your finger to deliver current into the base of the first transistor and this transistor delivers more current into the base of the second transistor. The result is more collector-emitter current and the LED illuminates. The three transistor circuit produce an ENORMOUS effect. It will pick up STATIC ELECTRICITY and all forms of electro-magnetic energy (radiation) and illuminate the LED.

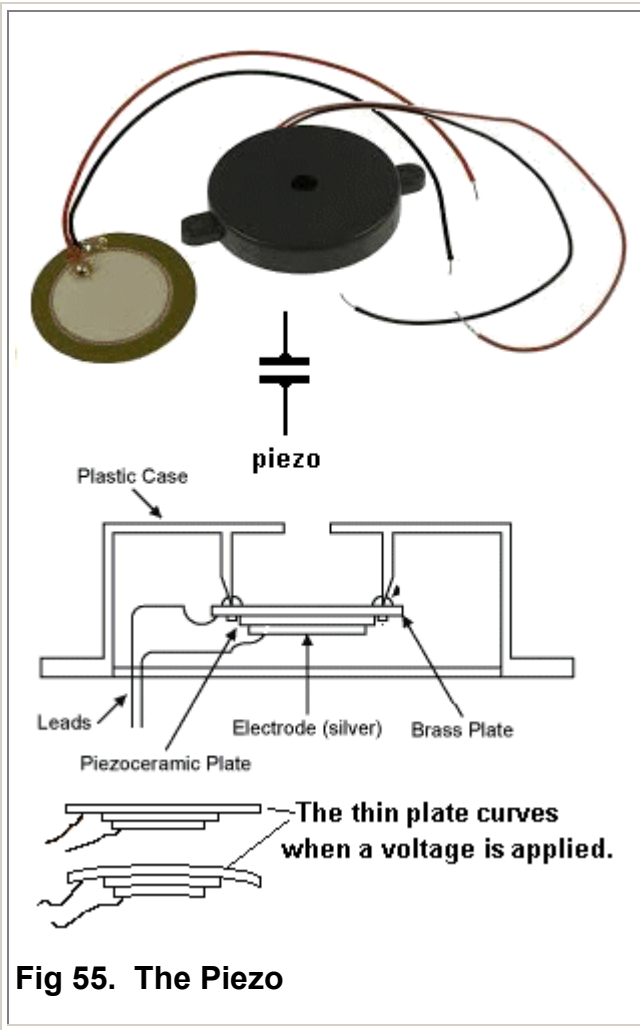
[to Index](#)



By adding a piezo diaphragm to the output you will be able to hear the hum of the mains. This is the frequency of the supply into your house. It will be either 50 cycles per second or 60 cycles per second. The term: "cycles per second" is given the name HERTZ after **Heinrich Rudolf Hertz**, who was the first to prove the existence of electromagnetic

**Fig 54. Adding a PIEZO**

[to Index](#)



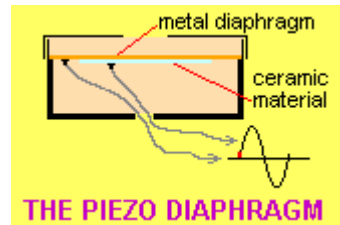
The Piezo diaphragm is held around the outer edge inside a plastic case and when a voltage is applied to the two leads, the thin plate curves very slightly. When the voltage is removed, the plate returns to its flat shape. If the voltage is reversed, the plate curves in the opposite direction.

The curving is due to a thin layer of ceramic material under the plate and then a film of metal is deposited onto the ceramic so a lead can be soldered.

There is infinite resistance between the two leads as the ceramic material is an INSULATOR.

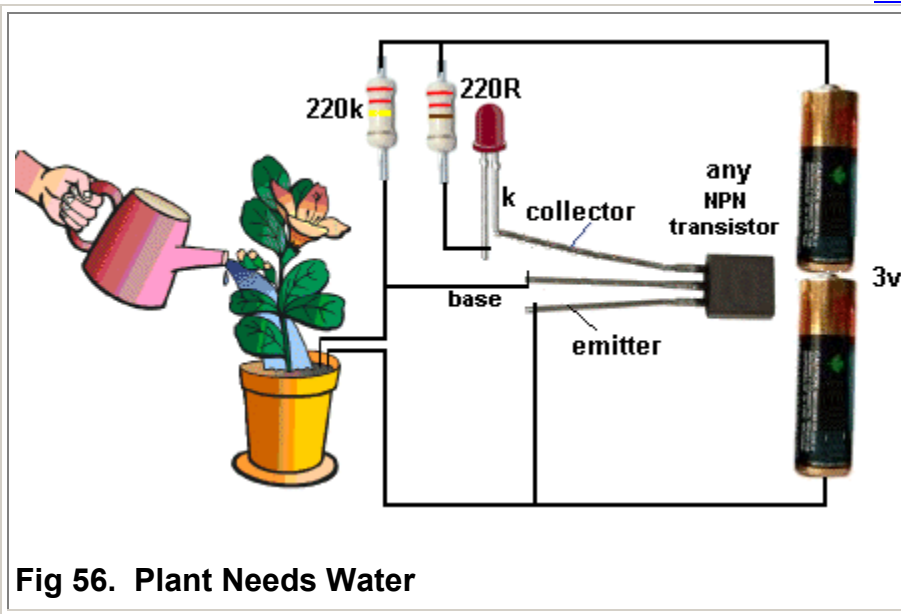
The capacitance between the two leads is approx 22n.

The Piezo is a passive device. It needs a pulse or frequency for it to produce an output.



**Fig 55. The Piezo**

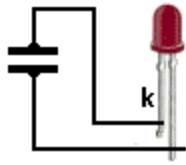
[to Index](#)



**Fig 56. Plant Needs Water**

The **ONE TRANSISTOR CIRCUIT** above can be turned into a detector to show when a plant needs water. Place the two probes into the soil and water the plant. The LED will turn off. As the water evaporates the LED will turn **ON** to let you know the plant needs watering.

[to Index](#)



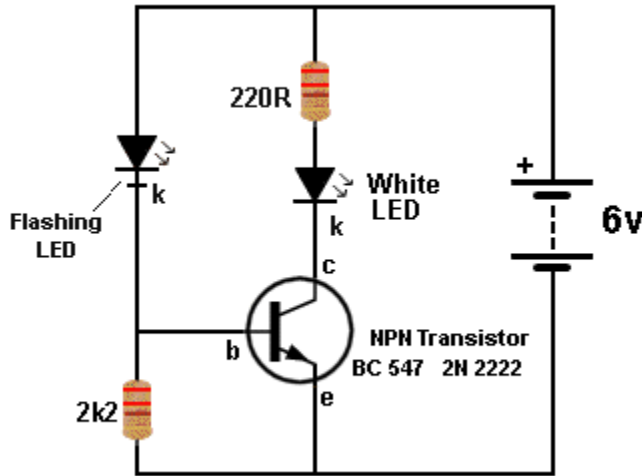
**Fig 57. Tap the Piezo**

This experiment produces a pulse from the piezo when it is tapped and the LED illuminates briefly.

The LED can be connected either way around.

This proves the diaphragm flexes when a voltage is applied and also in the reverse situation. A voltage is produced when the diaphragm is tapped.

[to Index](#)



**Fig 58. Flashing LED and White LED**

A flashing LED is not very bright. It can be connected to a transistor and the transistor will drive a very bright white LED.

The transistor is an amplifier. It is amplifying the current flowing through the flashing LED and supplying a higher current for the white LED.

We cannot discuss any further details of the circuit at the moment because the actual operation of the circuit is quite complex.

At the moment we just need to experiment with simple transistor circuits.

[to Index](#)



**Fig 59. Soldering Iron**

We now come to the point of **ING YOU WITH CONSTRUCTION.**

We have already shown you 6 different circuits and there are many ways to build them.

You can:

1. Solder them.
2. Build them on an Experimenter Board
3. Connect the components with clips or twist the leads together.

It does not matter how you build the circuits.

The fact is this: **YOU MUST START BUILDING.**

The best soldering iron for a beginner is a **CONSTANT TEMPERATURE** soldering iron.

It has a dial that can be turned to set the desired temperature.

An ordinary soldering iron **GETS TOO HOT.** It is not suitable for soldering electronic circuits.

This is something that no-one has mentioned before. An ordinary soldering iron will melt the solder **TOO QUICKLY** and burn the resin inside the solder and make soldering very difficult for a beginner.

Soldering must be done slowly so the resin in the middle of the solder gets hot and cleans the leads of the components so the solder will "stick."

That's why you must apply the solder to the leads you are soldering and allow the resin to

"attack" the leads and clean them.

The cheapest TEMPERATURE CONTROLLED soldering Iron is available on eBay for less than \$10.00 (post FREE).

You will also need a small roll of solder (0.9mm) and a soldering Iron stand.

Email [Colin Mitchell](mailto:Colin Mitchell) for links to eBay. ([talking@tpg.com.au](mailto:talking@tpg.com.au))

A whole book could be written on the ART OF SOLDERING.

Look on the web for articles and videos on SOLDERING.

[to Index](#)

## SOLDERING

1. Soldering is very easy and very simple. You just need a **Temperature Controlled Soldering Iron**, **Fine solder** and clean components.
2. Remember this: It is **NOT** the solder you need for a joint, but the **FLUX**. And the flux lasts for only 2 seconds. When the flux is **HOT** it attacks and cleans the joint so that the solder will stick.
3. Turn ON the Temperature Controlled Soldering Iron to a low temperature. Put solder on the tip. It will not melt. Turn up the temperature slightly. Try more solder. As soon as the solder starts to melt, this is your starting point. Turn up the temperature slightly MORE and this is the correct temperature for **small, delicate, fine soldering**.

4. Place a component through a hole and bend the lead slightly so the component does not move. Turn the board over and touch the iron on the component and bring the solder **FROM THE OTHER SIDE** so the solder melts and flows towards the iron.

From start-to-finish, count one-two-three and remove the solder. Count four-five and remove the iron. You will have a perfect joint.

If you are soldering thick leads or large pads on a circuit board, you will need to turn the temperature UP slightly.

You must add enough solder to make the joint "bulge" slightly.

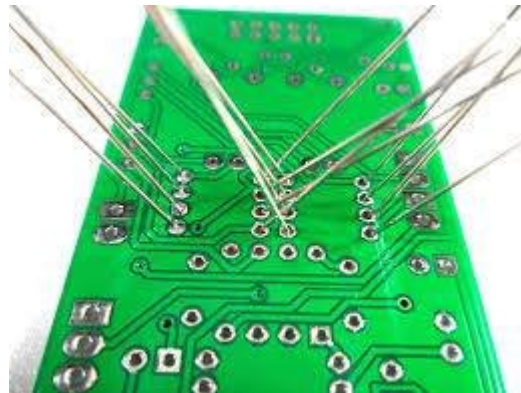
Fine solder (1mm or 0.9mm or 0.8mm) makes the best joint because it is easier to use.

Use a wet sponge to clean the tip or a ball of "Steel Wool." Steel wool is the best.

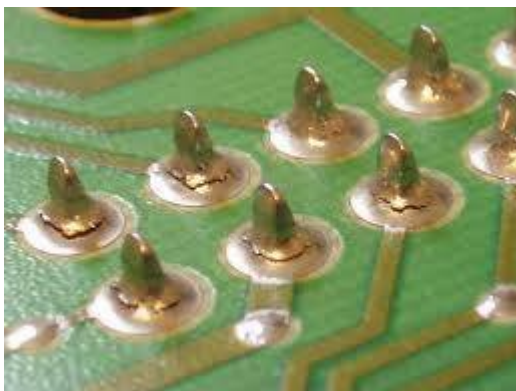
Here is the steel wool, bending the leads and some examples of poor joints due to insufficient solder:



**Steel wool cleans the tip beautifully**



**Bend the leads before soldering**



**The joints do not have enough solder and that's why they fractured. Called a DRY JOINT.**



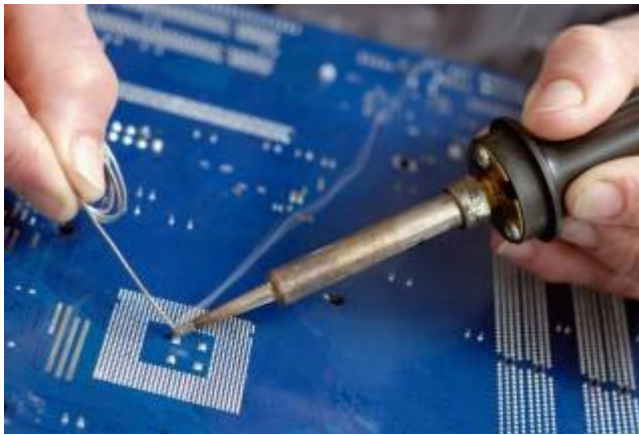
**More "Dry Joints."**





This is the cheapest and simplest soldering iron stand.

This stand is very messy as the spring grabs the iron and makes it difficult to remove from the stand. Test the stand before buying. You will see why not to buy this type of soldering stand. Get one with a "wide mouth" and a heavy stand is best as it does not move.

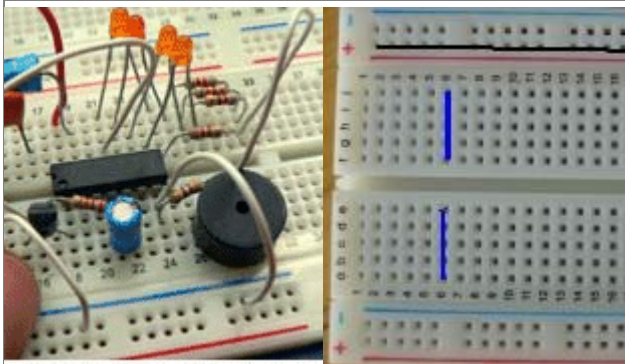


This photo clearly shows how to hold a soldering iron and solder.

This is NOT a temperature-controlled soldering iron and you can see it is too hot as it is burning off the flux too quickly.

**Temperature Controlled Soldering Irons** are now cheaper than the JUNK soldering iron shown in the photo. See eBay for prices.

[to Index](#)



**Photo shows a number of components fitted to the breadboard.**

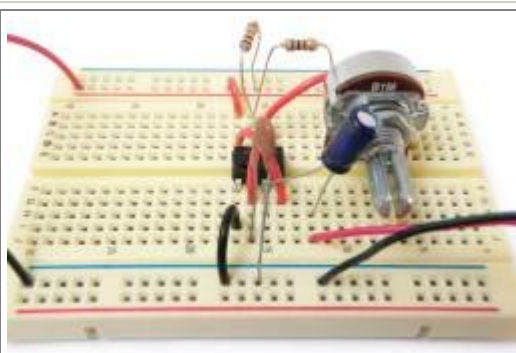
## BREADBOARD

The term BREADBOARD refers to any piece of wood or plastic containing pins or pegs or clips or holes where you can build a circuit.

The components can be soldered, twisted clipped or fitted into holes. Breadboard also means the circuit can be easily pulled apart.

Some breadboards do not have two rows for the positive and negative rails. Connections under the board for the positive rail is shown with a black line in the photo. Connections on the main section of the board are shown with blue lines. Your breadboard MUST look exactly like the photo opposite.

Other breadboards are quite useless. The breadboard in the photo can be purchased on eBay for less than \$5.00 (post FREE).



**Fig 60. BREADBOARD and Components**

[to Index](#)



**Fig 61. Jumpers**

The components on the BREADBOARD are fitted down the holes and metal strips under the board join each column of 5 holes. If you want to join one hole with another, you can use 0.5mm tinned copper wire or JUMPERS. See photo opposite. Jumpers can be purchased on eBay for less than \$3.00 posted.

Email [Colin Mitchell](mailto:Colin Mitchell) for links to eBay. ([talking@tpg.com.au](mailto:talking@tpg.com.au))

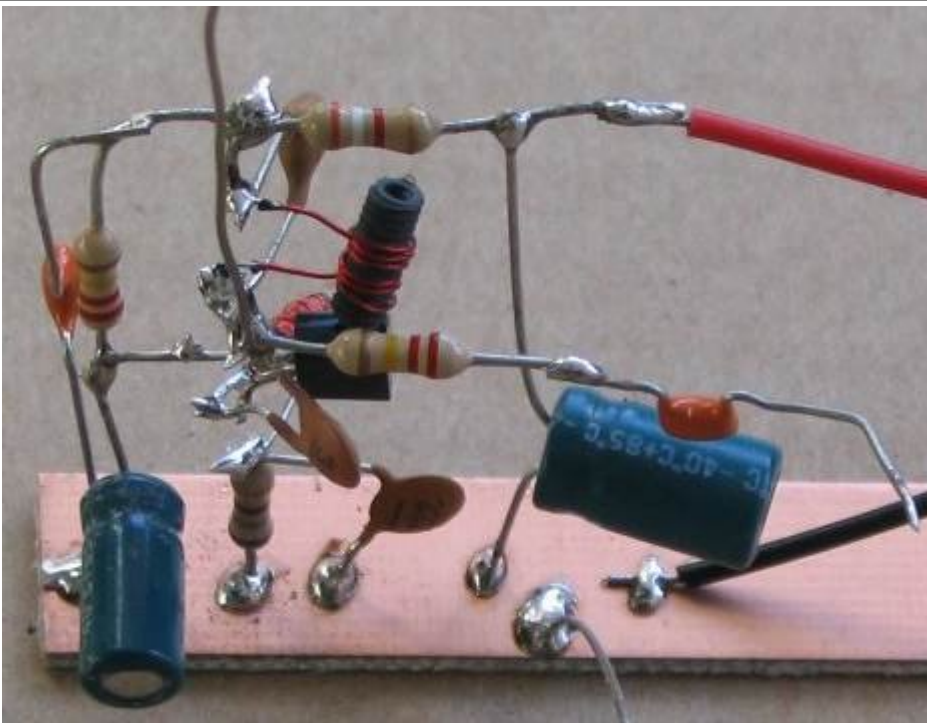
[to Index](#)



**Fig 62. Breadboard with Nails**

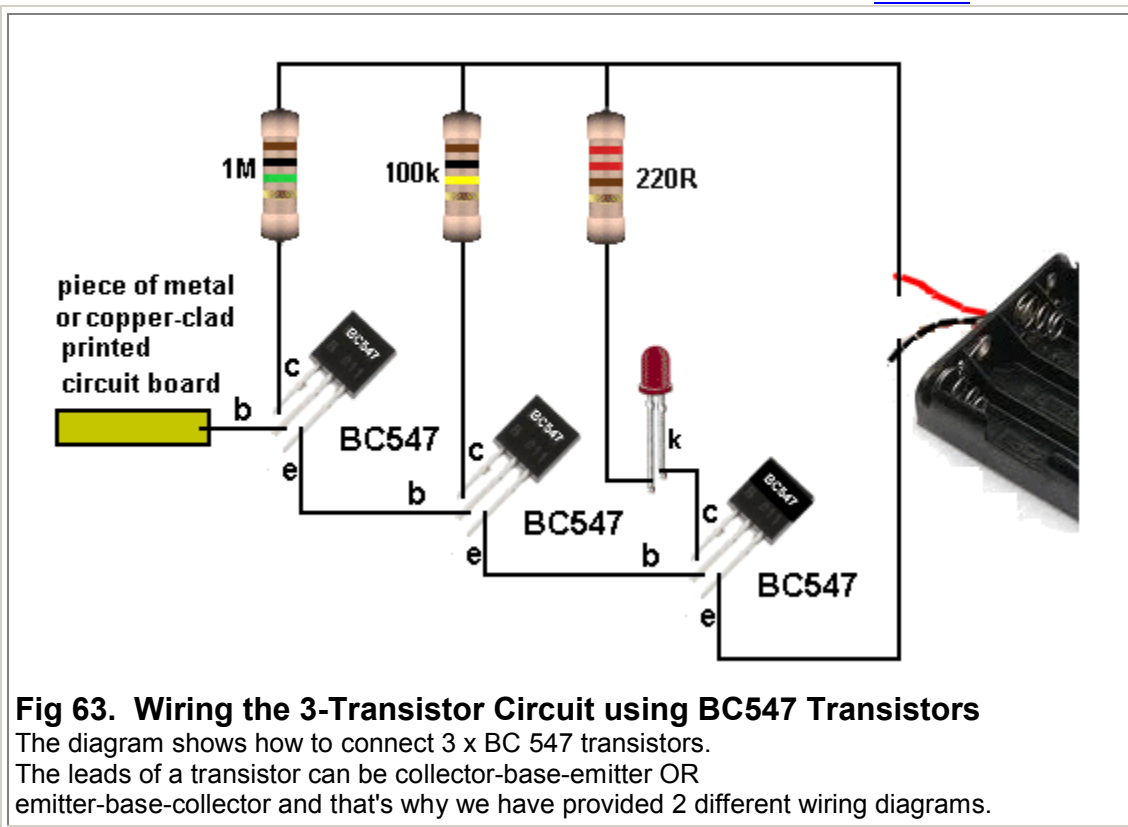
If you don't have a soldering iron or experimental breadboard, you can make your own board with nails. See the photo above. It is a multivibrator circuit and we will be presenting this circuit in a moment. The components can be twisted around the nails and bare wire used to join some of the nails to complete the circuit.

Another method of connecting the components is called BIRD-NESTING. This involves soldering the components "in the air" as shown in the 27MHz transmitter circuit below:



Another way to connect the component( if you don't have a soldering iron), is to wind 6 turns of bare wire around each connection and leaving all the components "in the air." The bare wire can be obtained from hook-up flex. This is plastic coated "wire" containing up to 15 fine strands of wire. Use a single strand for the connections. None of the components will touch each other BY MISTAKE and the circuit will work perfectly. Bird-nesting is a good way to build a quick circuit and test its performance. It might look messy but you can easily change any component.

[to Index](#)

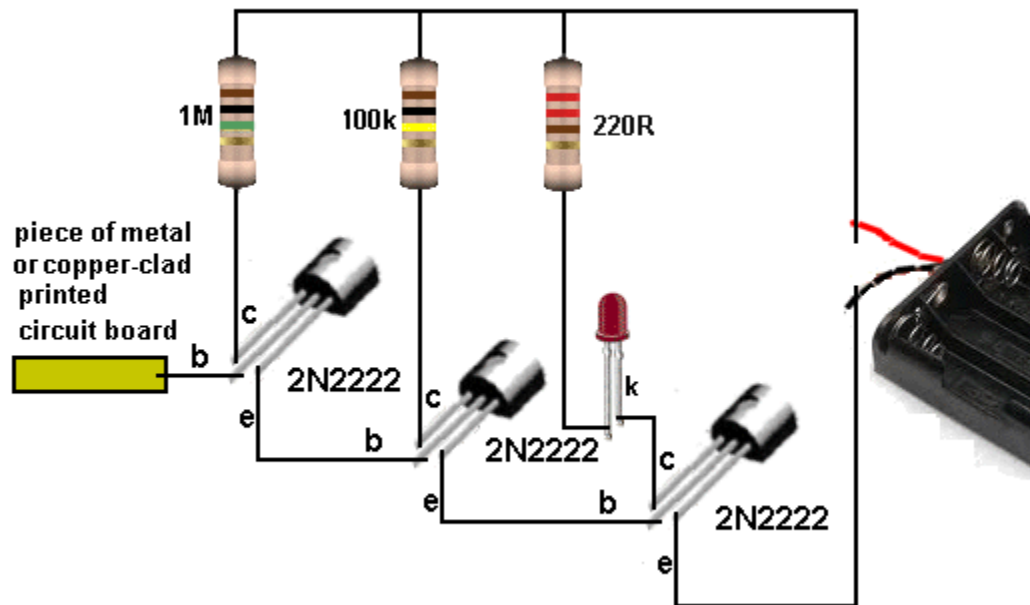


**Fig 63. Wiring the 3-Transistor Circuit using BC547 Transistors**

The diagram shows how to connect 3 x BC 547 transistors.

The leads of a transistor can be collector-base-emitter OR emitter-base-collector and that's why we have provided 2 different wiring diagrams.

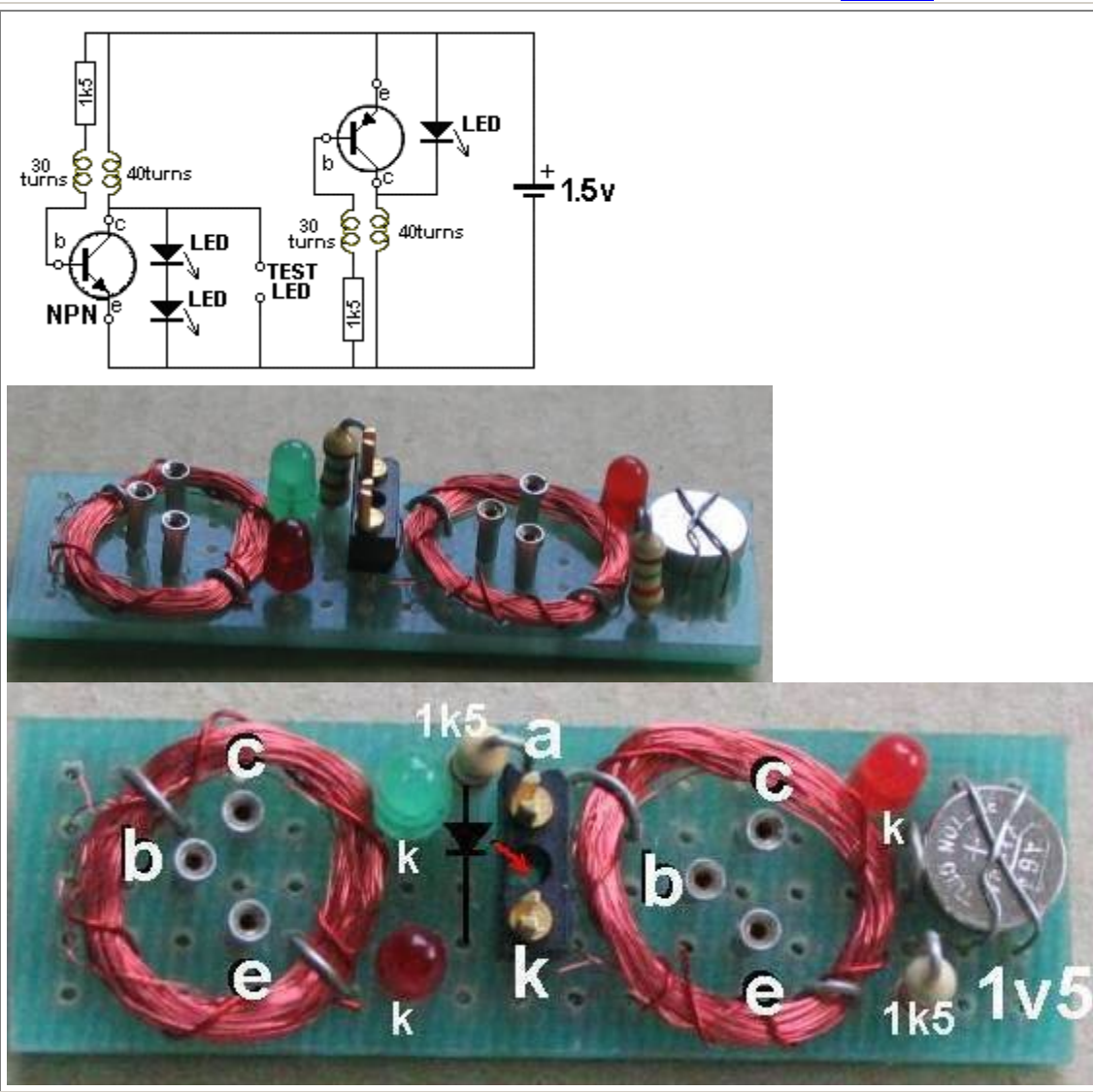
[to Index](#)

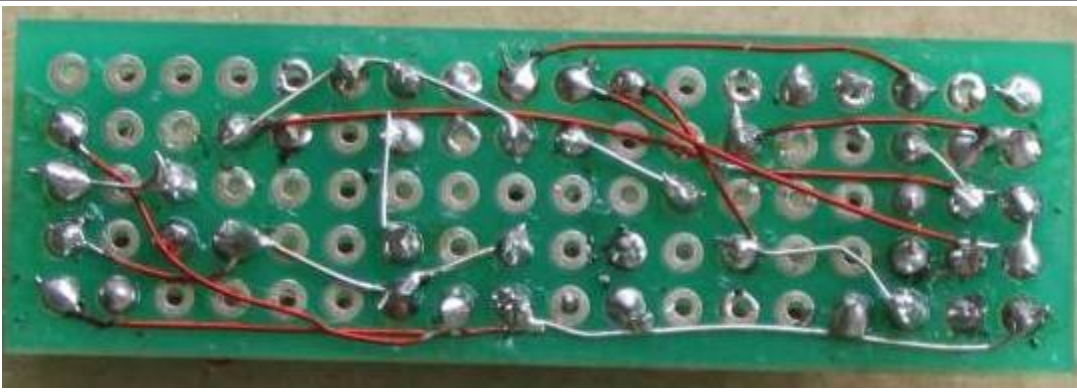


**Fig 64. Wiring the 3-Transistor Circuit using 2N2222 Transistors**

The diagram shows how to connect 3 x 2N2222 transistors.

[to Index](#)





**Fig 65. Transistor Tester**

This handy transistor and LED tester can be built to test LEDs and both PNP and NPN transistors.

The project consists of two identical circuits, one for NPN and one for PNP. You can build just the NPN section and then build the PNP section later.

### LED VOLTAGE

We have shown a LED needs at least 1.7v supply for it to operate.

This circuit works on 1.5v and thus the action of the transistor and coil (called a Transformer) MUST be increasing the voltage for the LED to illuminate.

This circuit works on two "actions."

1. Transistor ACTION - this is the action of a transistor providing gain to make the circuit oscillate.
2. Transformer ACTION - this is the action of a coil of wire producing a voltage higher than the supply voltage when it is turned off.

This circuit is very technical and very complex.

We will be explaining it in a very simple way because this is a **Basic Electronics Course**.

**THE TRANSFORMER** - the two coils of wire on the left and the two coils of wire on the right.

When the voltage (actually the current) is switched off, the 40 turn coil in either of the circuits in this project; the voltage across the coil rises to more than the 1.5v supply and is in the opposite direction to the voltage of the supply.

The circuit looks to be very simple but it uses an air-cored transformer to produce the voltage needed to illuminate the LED indicators and the circuit only works when the transistor is connected correctly. There are two separate circuits, one for NPN transistors and one for PNP transistors. We will cover the NPN section:

The circuit turns ON when the NPN transistor is fitted and the current through the 30 turn coil and 1k5 resistor turns ON the transistor and produces expanding flux in the 40 turn coil. This flux cuts the turns of the 30 turn coil and produces a voltage in the coil that adds to the supply voltage and increases the current into the base. This turns the NPN transistor ON more. This action continues until the transistor is fully turned ON. At this point the current in the 40 turn coil is a maximum but it is not expanding flux and the 30 turn coil ceases to see the extra voltage. Thus the current into the base reduces and this turns the transistor OFF slightly. The flux produced by the 40 turn coil now becomes collapsing (or reducing ) flux and it produces a voltage in the opposite direction to greatly reduce the current into the base. In a very short period of time the transistor becomes TURNED OFF and it is effectively removed from the circuit. The flux in the 40 turn coil collapses quickly and it produces a voltage in the 40 turn coil that is higher than the supply voltage and is in the opposite direction. This means the voltage produced by the 40 turns ADDS to the supply voltage and is delivered to the LEDs to illuminate them.

The NPN circuit has two LEDs in series so that a LED of any colour (including white) can be connected to the TEST LED terminals and it will illuminate. You can use any colour LED for any of the LEDs, however it is best to use either green or yellow or white for the single LED. The two "coils" are wound on a 10mm dia pen with 0.1mm wire (very fine wire). The loops of tinned copper wire holding the coils on the board are connected to separate lands under the board and MUST NOT produce a complete loop as this will create a "Shorted Turn" and the circuit WILL NOT WORK.

If the LEDs do not illuminate, simply reverse the wires to the 30 turn coil.

The circuit does not need an ON/OFF switch because the LEDs require a voltage of over 2v to illuminate (the orange LED) and the supply is only 1.5v. A red LED needs about 1.5v to 1.7v to

operate but when it is in series with a green LED, this voltage is over 3.5v. All the components fit on a small matrix board 5 holes x 18 holes. A kit of parts for the project is available for \$4.00 plus \$3.00 postage and ordering details can be obtained by emailing [Colin Mitchell](mailto:Colin Mitchell). ([talking@tpg.com.au](mailto:talking@tpg.com.au))

Build the circuit and test your transistors and LEDs.

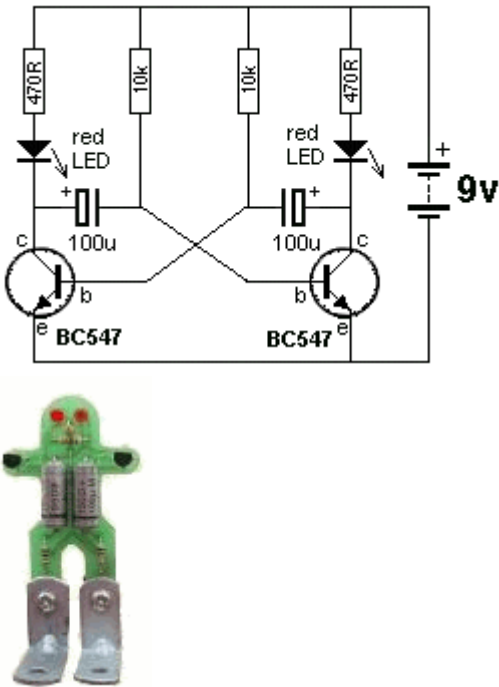
We will be covering more on the action of a transistor and the action of a transformer in the discussion below, but it is important to build the circuit and see it working.

It is your first piece of **TEST EQUIPMENT**.

### Questions

1. Identify the letters "c" "b" and "e"
2. What type of transistor is tested in the first set of hollow pins?
3. Put a PNP transistor into the first set of hollow pins and try all positions. Does the red and green LEDs illuminate?
4. When both the red and green LEDs illuminate, what is the approximate voltage across the pair?
5. When you fit a red LED to the test-socket, what is the approximate voltage across it?
6. When you fit a red LED to the test-socket, why does the red LED and green LED on the PC board turn off?
7. Why doesn't the project need an on/off switch?
8. The two coils for the circuit on the left is called a TRANSFORMER. Do the connections of the windings have to be connected to the circuit around a particular way?

[to Index](#)



The diagram shows two BC547 NPN transistors in a cross-coupled configuration. Each transistor's emitter is connected to ground. The collector of one transistor is connected to the base of the other through a 10k resistor. The base of each transistor is connected to ground through a 100uF capacitor. The collector of each transistor is also connected to a 470R resistor, which is in series with a red LED. A 9V battery provides power to the circuit. Below the diagram is a photograph of a green plastic robot figure with two red LEDs for eyes, which are connected to the circuit.

### ROBOT MAN

This multivibrator circuit will flash the Robot Man's eyes as shown in the photo. The kit of components is available from Talking Electronics for \$8.50 plus postage. Send an email to find out the cost of postage: [talking@tpg.com.au](mailto:talking@tpg.com.au)

The photo shows the LEDs flashing.

The circuit is called an **ASTABLE MULTIVIBRATOR** and this means it is not stable but keeps switching from one transistor to the other.

It is also called a **FLIP FLOP** circuit.

[to Index](#)

**Fig 66. ROBOT MAN**  
The **ASTABLE MULTIVIBRATOR** or "free-running" multivibrator.

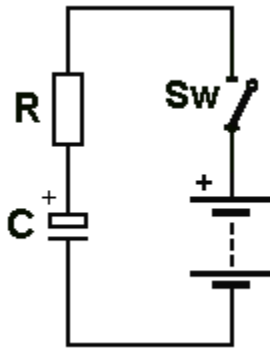


Fig 67. The TIME DELAY

The **TIME DELAY** circuit consists of a Resistor **R** and Capacitor **C** in **SERIES**.

When the switch is closed, the electrolytic (called the CAPACITOR) charges slowly because the resistor only allows a small amount of current to flow.

It's just like charging your mobile phone. The battery takes time to charge because there is a resistor in the circuit to limit the current. If we remove the resistor in the mobile phone, the battery will get too hot when it is being charged but in the **TIME DELAY** circuit, we want the capacitor to charge slowly, because we want a **TIME DELAY**.

[to Index](#)



Fig 68. The charging of a capacitor is the same as building a brick wall.

### CHARGING A CAPACITOR

The capacitor in **Fig 67** charges via the resistor **R**. But the voltage on the capacitor does not rise at a constant rate.

It starts off charging very quickly and as the voltage across it get higher, the voltage increases at a slower and slower rate.

In the photo I am building a brick wall.

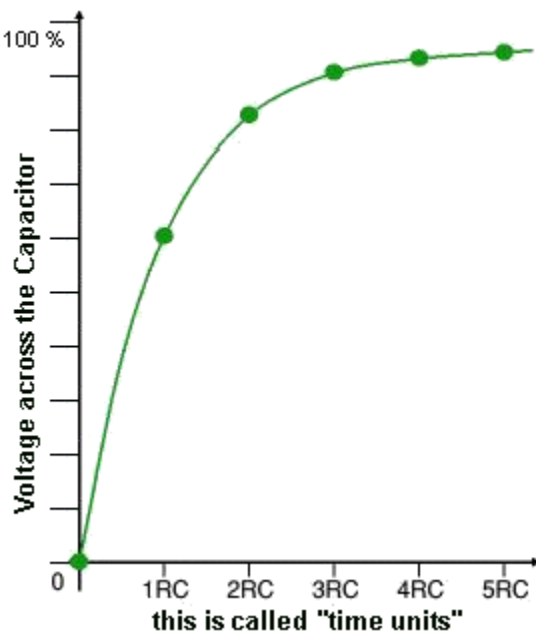
I am working at a constant rate.

When I started building the brick wall, I laid 5 rows of bricks (5 courses) in the first hour.

As the wall increased in height, I had to climb the ladder and I could only lay 3 courses an hour and finally the wall was so high I could only lay 1 course per hour.

This is exactly the same as a capacitor charging. When the capacitor is uncharged, the supply voltage allows a high current to pass through the resistor **R** and the energy quickly fills the capacitor. This results in a rapidly increasing voltage on the capacitor. But as the voltage on the capacitor increases, the difference in voltage between that on the capacitor and the supply is very small and only a small current will pass through the resistor. This means the voltage on the capacitor increases at a slower rate.

[to Index](#)



It really does not matter how fast or slow or uneven a capacitor charges because most circuits detect a voltage on a capacitor and the time taken to reach this voltage is called the **TIME DELAY**.

But to prevent you thinking the capacitor charges "smoothly" we have to explain what actually happens.

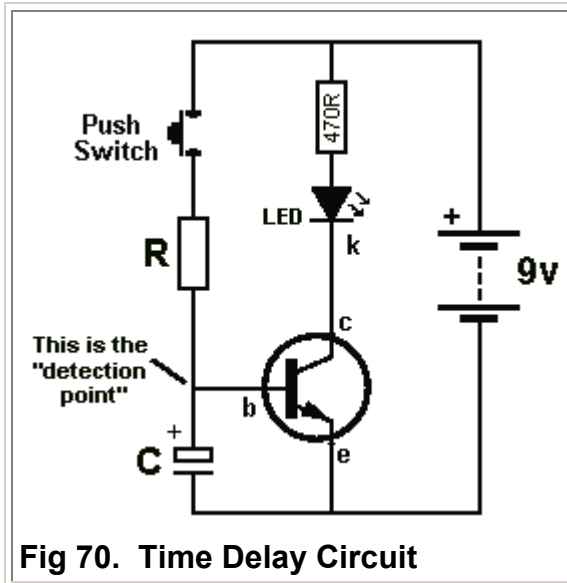
The graph on the left shows the capacitor charging. You can see it charges quickly at the beginning and then charges slowly and then very slowly.

You can see the first part of the graph is fairly "straight" (constant charging) - NOT "straight up and down" but a straight line - and this applies to a voltage of about 63%. The time taken to reach this voltage is called **ONE TIME UNIT** - also called **ONE TIME CONSTANT**. The graph continues for another 4 "time units" (time-constants) and the final voltage is very nearly 100%.

(It never reaches 100%.)

**Fig 69. Time Units**

[to Index](#)



**Fig 70. Time Delay Circuit**

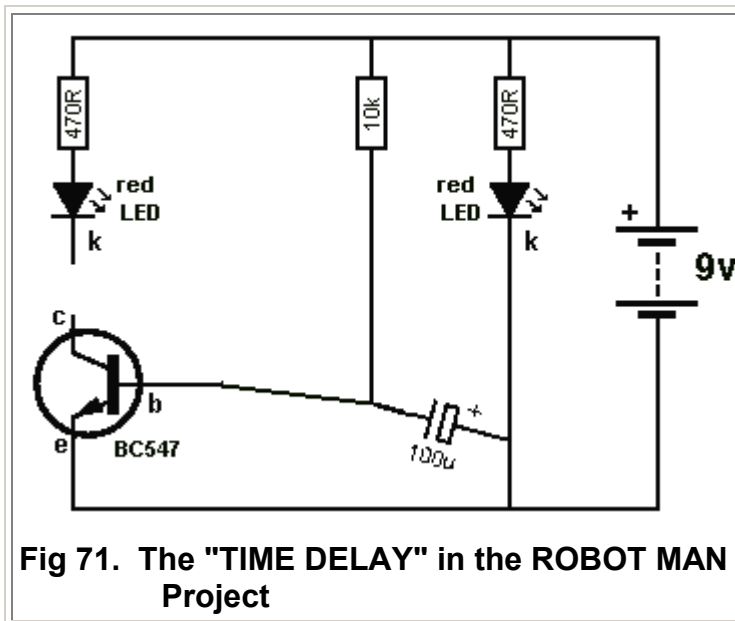
A **TIME DELAY** circuit needs three things:

1. A Resistor (R)
2. A Capacitor (C)
3. A "Detection Point."

When the switch is pressed, capacitor (C) takes time to charge via resistor (R) and after a short period of time the voltage at the **DETECTION POINT** is 0.6v and the transistor is **TURNUED ON**. The LED illuminates.

Build the circuit with 100u and 100k and see how long it takes before the LED illuminates.

[to Index](#)

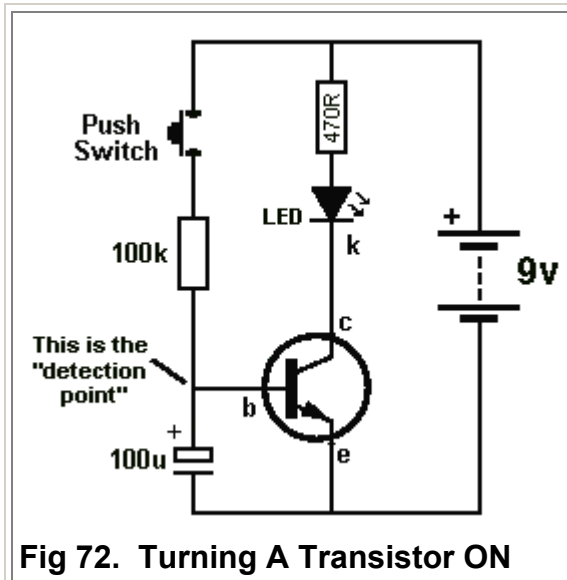


**Fig 71. The "TIME DELAY" in the ROBOT MAN Project**

In the **ROBOT MAN** project you can see the "**TIME DELAY**" circuit made up of the 100u, 10k resistor and the base of the transistor.

This is one of the most important **BUILDING BLOCKS** in electronics. It is the basis of all oscillators and will be discussed below, after we explain a few more details.

[to Index](#)



**Fig 72. Turning A Transistor ON**

We will use the **TIME DELAY** circuit to turn the transistor **ON**.

Make sure the 100u is uncharged by touching both leads (both ends of the capacitor) at the same time with a **JUMPER** - this is a piece of wire shown in Fig 61.

Push the switch and noting happens. After a short period of time the LED starts to glow and then comes on fully.

This shows two things:

1. The transistor is not turned **ON** when the base voltage is zero.
2. The base voltage must be 0.6v for the transistor to start to turn **ON** and when the voltage is 0.65v the transistor is turned **ON FULLY**.

[to Index](#)



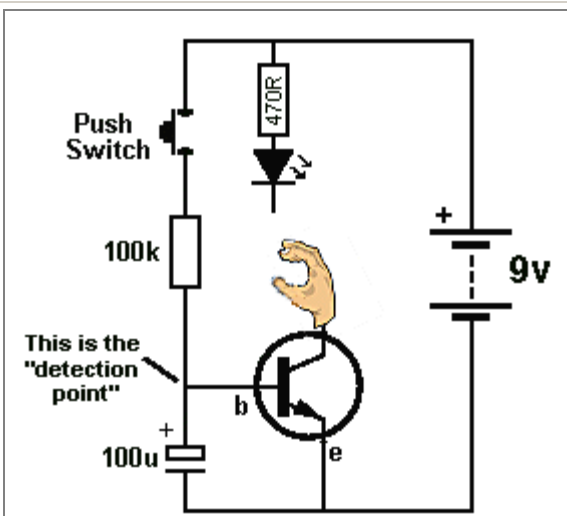


Fig 73. How the LED turns ON

Here is an explanation of how the LED turns ON.

When the circuit is first assembled and the switch is not pressed, the transistor is not turned on and it is just like the diagram opposite. The LED is not connected to the transistor.

[to Index](#)

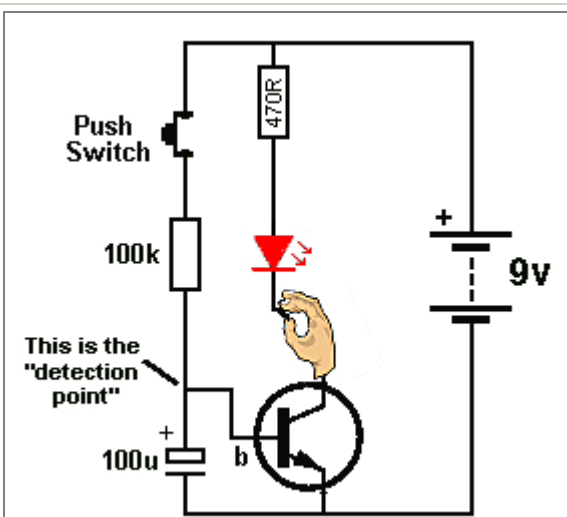


Fig 74. The LED turned ON

When the switch is pushed, the transistor turns **ON** (after a few seconds) and it pulls the lower lead of the LED down towards the 0v rail and this action turns the LED **ON**.

[to Index](#)

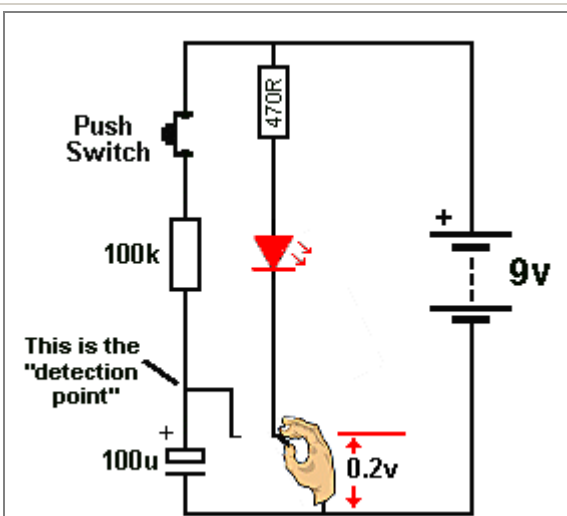


Fig 75. The LED fully turned ON

When the LED is **fully turned ON**, the lower lead of the LED is almost directly connected to the 0v rail.

In other words:

When the transistor is **FULLY TURNED ON**, the lower lead of the LED is almost directly connected to the 0v rail.

The voltage between the lead of the LED and 0v rail is 0.2v. This is the characteristic voltage across the collector-emitter terminals of a transistor when it is **TURNED ON**.

[to Index](#)

In the three diagrams above you can see the LED is changed from an **OFF** condition to an **ON** condition by the action of the transistor.

The transistor is acting **LIKE A SWITCH**.

**This action is one of the most important actions in electronics.**

It is called: **"The Transistor as a SWITCH"**

**It is the basis to ALL Digital Circuits.**

It is the basis because of these two facts:

1. When the transistor is **OFF**, the circuit is taking **no current** and no power is being lost or wasted.
2. When the transistor is **ON**, the LED is almost at 0v and no resistor is in the lower lead to waste any power.

Thus we can turn things **ON** and **OFF** without wasting and power.

This is the basis to **DIGITAL ELECTRONICS**.

[to Index](#)

**DIGITAL ELECTRONICS** revolves around circuits that are either **FULLY ON** or **FULLY OFF**. This means they take almost no power and we can combine lots of circuits and still take almost no power.

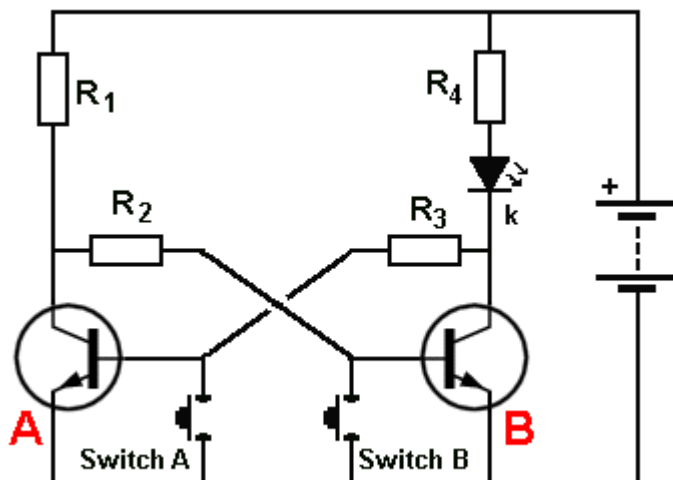
This means they do not get hot and it also means they will last a long time.

You may not think turning a transistor **ON** and **OFF** will achieve any worthwhile outcome but a circuit can be designed to use two transistors (similar to the **ROBOT MAN** above). The circuit does not Flip-Flop but requires a switch and when the switch is pressed, the circuit changes state. The two transistors are connected together and it takes two presses of the switch to make the output of the second transistor change state **ONCE**.

The circuit is a divider. It is called a: **divide-by-two** and is the basis of all counting in a computer.

By adding more **"divide-by-two"** circuits we can get **"divide by 4, divide by 8"** etc. Two transistors don't do much but when you combine millions of transistors we have a **COMPUTER**.

[to Index](#)



**Fig 76. The "MEMORY CELL"**

When Switch **A** is pressed, the voltage on the base is removed and transistor **A** turns OFF.

Transistor **B** turns ON via resistors  $R_1$  and  $R_2$  and the LED is turned **ON**.

When the switch is released, the voltage on the collector of transistor **B** is less than 0.6v and the two transistors remain in this state.

Pressing switch **B** turns the LED **OFF**. (transistor **A** turns ON via  $R_3$ ,  $R_4$  and the LED - very little current flows through the LED and you can hardly see it glowing). The voltage on the collector of transistor **A** is less than 0.6v and the two transistors remain in this state.

Two transistors can do one more thing. They can **"REMEMBER."**

Here is a manual circuit. Pressing Switch **A** turns the LED **ON** and pressing switch **B** turns the LED **OFF**.

The circuit "remembers" or remains in each state called a stable state.

The technical name for this circuit is:

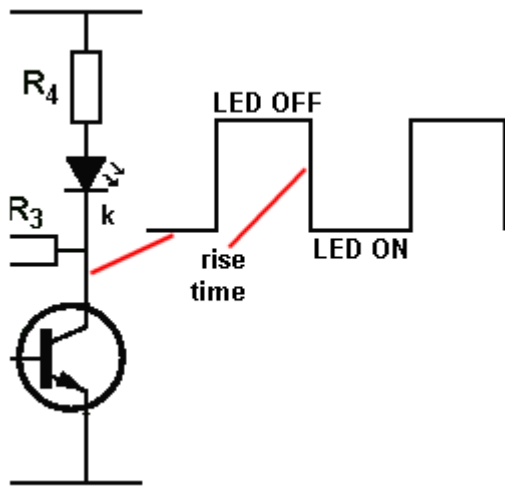
**BISTABLE MULTIVIBRATOR**  
or **BISTABLE SWITCH** or  
**BISTABLE LATCH**.

This is the basis to all the memory in a computer.

[to Index](#)

In electronics, we talk about the **DIGITAL TRANSISTOR** and **ANALOGUE TRANSISTOR**. This is just an ordinary transistor (called a Bipolar Junction Transistor) in a **DIGITAL CIRCUIT** or **ANALOGUE CIRCUIT**.

We are now discussing the **DIGITAL CIRCUIT** - The Multivibrator - Astable Multivibrator and



Bistable Multivibrator (Memory Circuit).  
 The **DIGITAL CIRCUIT** has **2 STATES**.  
 The **ON STATE** and the **OFF STATE**.  
 It is conducting in the ON STATE and the LED is illuminated.  
 In the OFF STATE, the LED is not illuminated.  
 In the ON STATE the transistor is said to be **CONDUCTING** or **BOTTOMED**.  
 In the OFF STATE the transistor is said to be **"CUT OFF"** or **"OFF"**.  
 These two states are reliable and guaranteed.  
 They are not "half on" or "quarter on" or "75% off."  
 These states are easy to transmit "down a wire."  
 The ON STATE is transmitted as "1" (voltage present) and the OFF STATE is transmitted as "0" (voltage not present).

These are the two **DIGITAL STATES**.

The **ROBOT MAN** is a **DIGITAL CIRCUIT**.

Each LED is ON or OFF.

The waveform on the output of each transistor is called a **DIGITAL SIGNAL**.

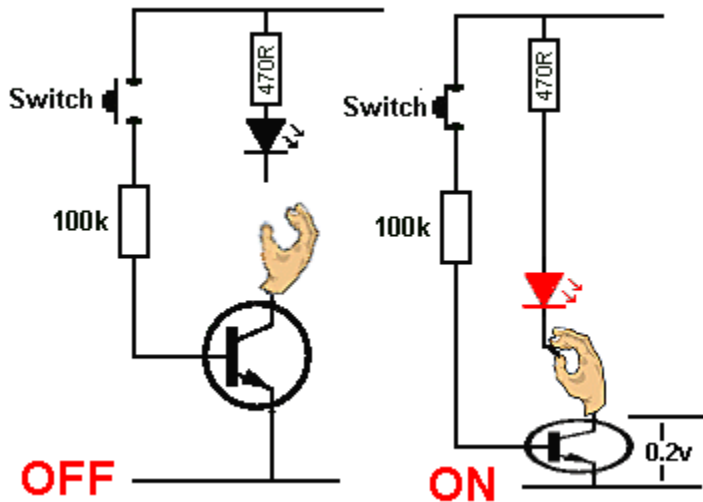
The waveform is said to be **DIGITAL** or **SQUARE WAVE**.

The top line of the graph represents the LED OFF.

The bottom line of the graph represents the LED ON. The LED is ON when the collector voltage is LOW because we are pulling the lead of the LED to the 0v rail as shown above.

The circuit changes from one state to the other very quickly and this is called the **RISE TIME**.

[to Index](#)



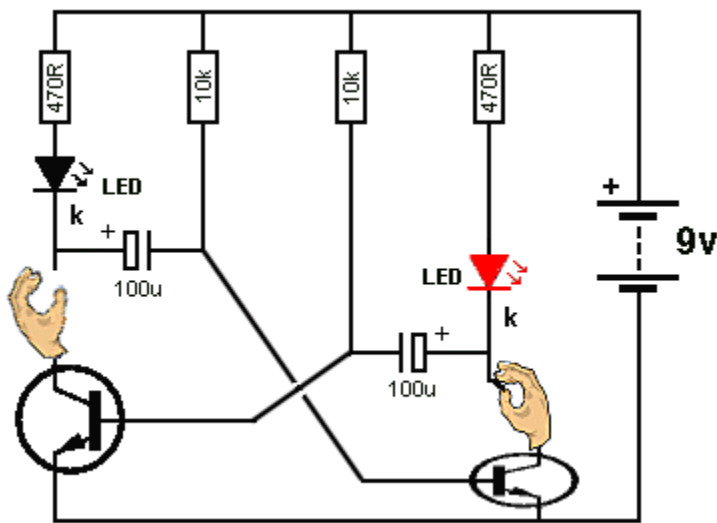
**Fig 77. The two Digital States**

Going over the two **DIGITAL STATES** for a transistor.

In the first diagram the switch is not pressed and the base does not see a voltage to turn the transistor on. The transistor is **"OFF"** (not conducting) and it is not "grabbing" the LED. The LED is not illuminated.

In the second diagram the base of the transistor sees a voltage via the switch and it is **TURNE**d on. The LED is illuminated.

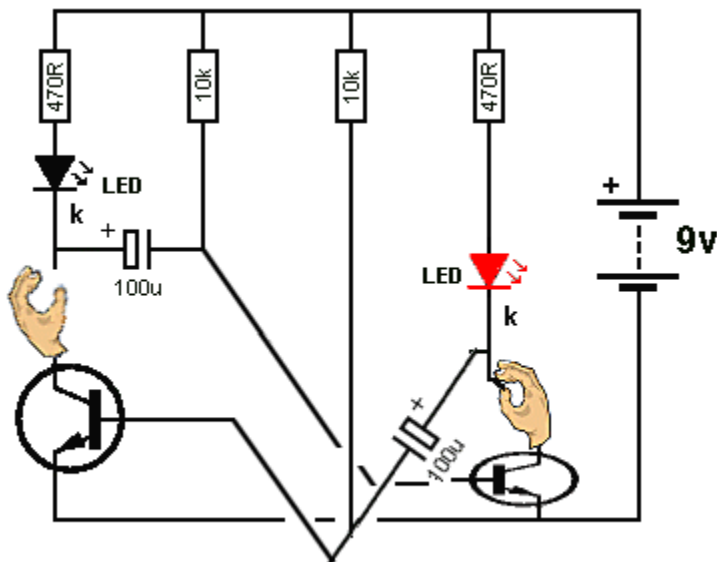
[to Index](#)



**Fig 78. ROBOT MAN Animation**

This animation shows how a transistor grabs a LED and pulls it towards the 0v rail to turn it ON.

[to Index](#)



**Fig 79. TIME DELAY Animation**

The animation in Fig 78 shows the two transistors turning the LEDs **ON** and **OFF** in a **FLIP FLOP** circuit.

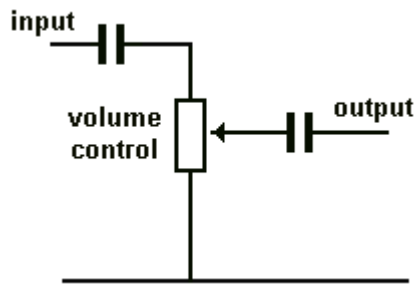
We know the 10k and 100u components form a **TIME DELAY** to create the time for each LED to be illuminated. The timing for one LED plus the other LED creates a **CYCLE** and this is the **FREQUENCY OF OPERATION** for the circuit. It is measured in cycles per second - Hertz - Hz.

We will now go into more detail of how the **TIMING COMPONENTS** create the **TIME DELAY** for each LED.

The circuit is more-complex than you think.

The 100u is already charged from a previous cycle and we show how it gets discharged via the 10k and charged in the opposite direction by the 10k to create a **TIME DELAY**.

[to Index](#)



## THE CAPACITOR

The capacitor can perform many different functions and produce many different effects, depending on its value and the surrounding components. In this circuit the capacitors on the input and output prevent DC on the volume control creating "scratchy sounds" when the volume is altered. This is called "DC blocking." The AC (the signal) passes through the capacitors but the DC voltage on the input is blocked.

[to Index](#)

## CHARGING A CAPACITOR Part II

It is easy to see how a capacitor charges via a resistor in the **TIMING CIRCUIT** ([Delay Circuit](#)) above but many capacitors are not connected to the 0v rail.

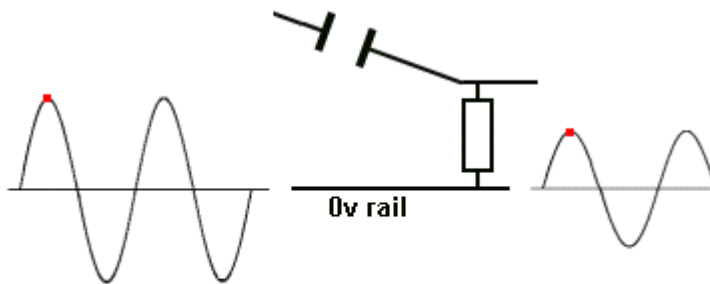
They are connected as show in the animation below and their "job" is to pass a waveform.

When they pass the waveform they **CHARGE** and **DISCHARGE**.

The waveform is called an **AC SIGNAL** and the output is smaller than the input.

The circuit is taken from the circuit above, but the same effect applies to all capacitors that "pass a signal."

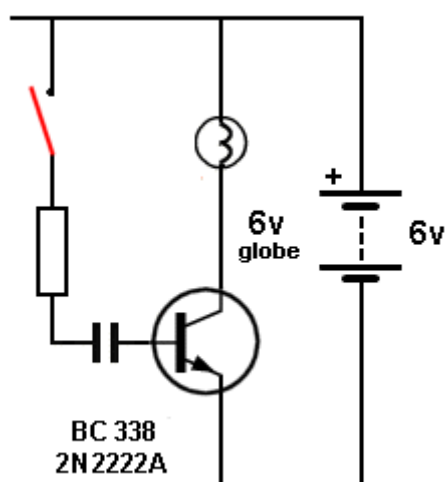
Here's why:



The capacitor charges slightly during the rise of the signal and the right-plate of the capacitor does not rise as high as the left-plate. That's why the output signal is not as large as the input signal.

If the capacitor did not charge, the output would be as large as the input. If you use a capacitor with a large value, it will not charge and thus the output will be as large as the input. That's why you use a large capacitor !!!!

[to Index](#)



## CHARGING A CAPACITOR Part III

Here is another CAPACITOR in action.

The animation shows a capacitor charging (via a resistor). The initial current is LARGE and this turns the transistor FULLY ON and the globe illuminates. As the capacitor charges, the base current reduces and the transistor starts to turn OFF. Eventually the capacitor is fully charged and the voltage on the base falls to 0v, turning the transistor OFF.

This animation shows three features:

1. The initial charging current is HIGH.
2. It gradually falls to zero.
3. The voltage on the base drops below 0.6v and the

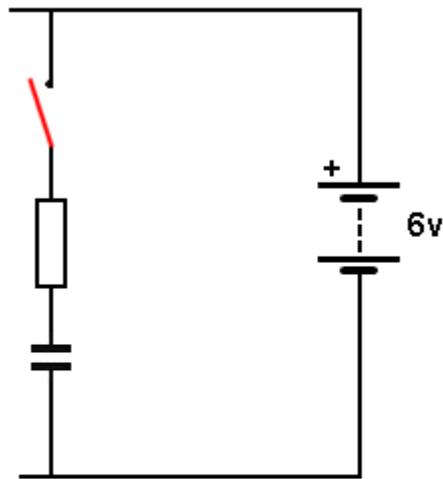
transistor turns OFF.

[to Index](#)

# NEGATIVE VOLTAGE

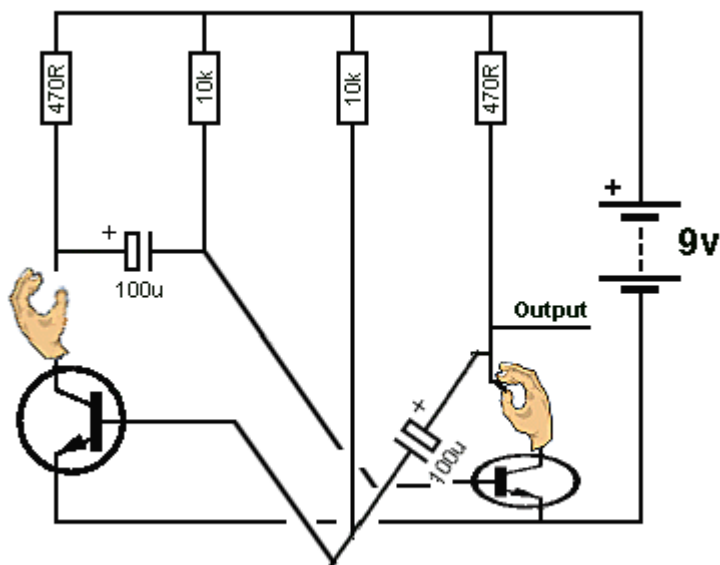
You will be surprised to learn that many circuits produce a negative voltage or negative spike at some point (when doing circuit-analysis, each location or point or join of components is called a NODE) on the circuit. In other words the voltage will be LESS than the 0v rail of the circuit.

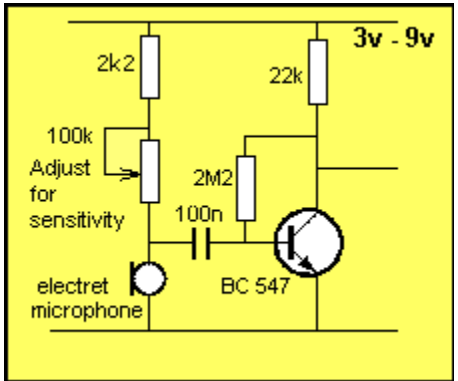
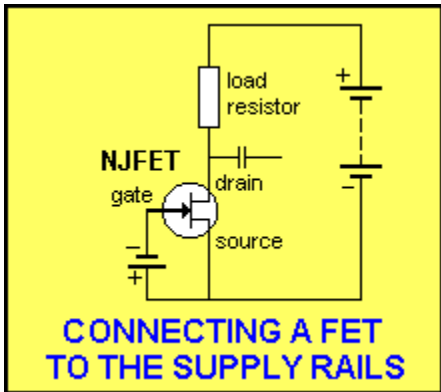
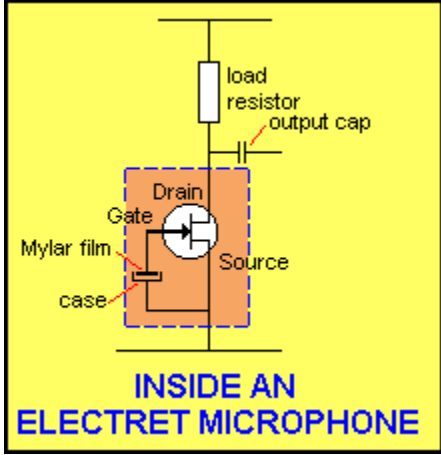
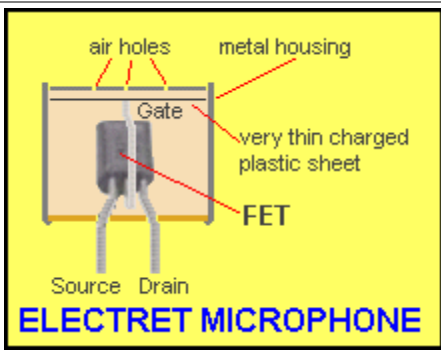
This is due to the presence of a capacitor and the animation shows how a capacitor can produce a negative voltage:



When a charged capacitor is "lowered from one position in a circuit" the positive lead may be lowered by say 3v. This means the other lead will be lowered by 3v. We are assuming the capacitor can be lowered and is not directly connected to the 0v rail.

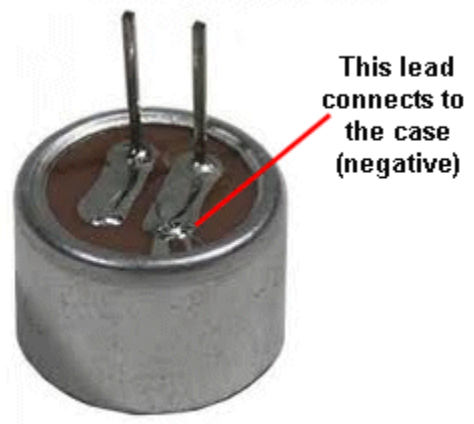
You can see the electrolytic produces a NEGATIVE VOLTAGE on the base in the following animation, when the two transistors change states:



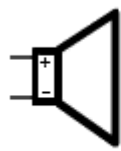


# The Electret Microphone

The most common type of microphone is the ELECTRET MICROPHONE. It is incorrectly termed the "Capacitor Microphone" or "Condenser Microphone." "Capacitor Microphone" descriptions make no mention of a FET as the amplifying device and a polarized diaphragm to detect the audio, so they are something different. The electret microphone consists of a FET (transistor) inside an aluminium case with a very thin Mylar film at the front. This is charged and when it moves (due to the audio it receives via a small hole in the front of the case), it vibrates and sends a very small voltage to the GATE lead of the Field Effect Transistor. This transistor amplifies the signal and produces a waveform of about 2mV to 20mV at the output. The electret microphone requires about 0.5mA and will operate from 1.5v supply with 4k7 LOAD RESISTOR. For 3v supply, the Load Resistor can be 22k to 47k. For higher supply voltages the resistor will be 68k or higher. Electret microphones are extremely sensitive and will detect a pin-drop at 3 metres.



Most electret microphones have two leads. One lead is connected to the case and this lead goes to the 0v rail. The other lead goes to a LOAD RESISTOR (4k7 to 68k - depending on the voltage of the project). Reducing the value of the load resistor will increase the sensitivity until the background noise is very noticeable. They are used in Hearing Aids and are more-sensitive than the human ear. They are very small, low-cost and very sensitive.



## The Speaker

The most common speaker is about 30mm to 60mm diameter and 8 ohm impedance. This means the voice coil is about 8 ohms resistance.

The two leads can be connected either

way to a circuit.

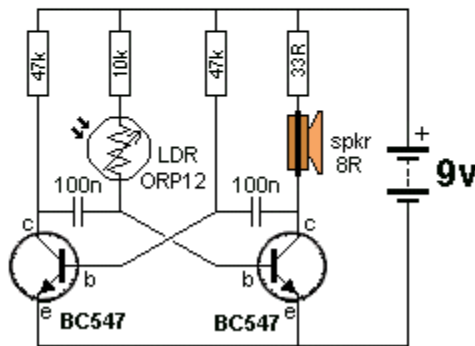
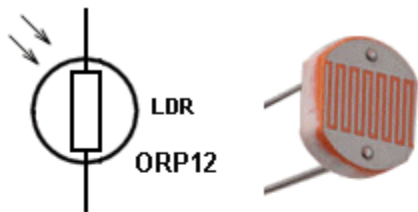
The speaker shown is 32mm diameter and has a realistic wattage of 100mW (NOT 1watt).

These speakers have a Mylar cone and the magnet is a "super magnet" and very small. That's why it is so flat.

A speaker can be used as a microphone (called a Dynamic Microphone) and a circuit to connect the speaker (mic) to an amplifier can be found on Talking Electronics website. It is not as sensitive as an electret microphone and does not

**Speaker Symbol** produce the same output amplitude, but it is an emergency microphone.

[to Index](#)



**LDR and Light Alarm Circuit**

## Light Dependent Resistor

(LDR)

Also called **PHOTOCELL** or **PHOTO RESISTOR**

A **Light Dependent Resistor** is a 2-leaded component containing a layer of semiconductor material.

The top contains two interleaving combs of conducting wires with a path of semiconductor material between. When light falls on the component, the resistance of the semiconductor material decreases.

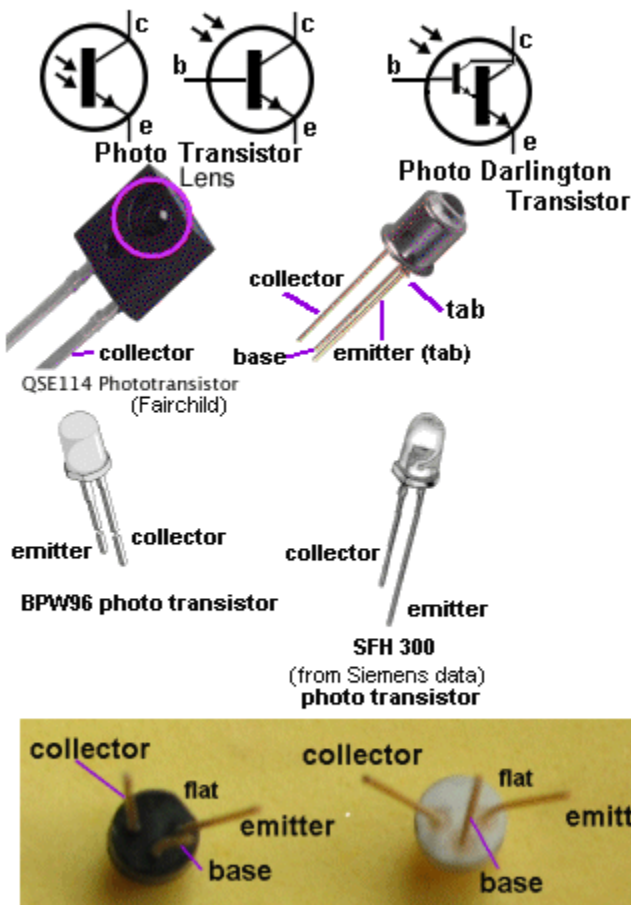
In darkness the LDR will be about 300k. In very bright light the resistance will be about 200 ohms.

But if the light changes only a very small amount, the resistance **CHANGE** is **VERY SMALL**. For a large change, see **Photo Transistor**.

The **Light Alarm** circuit will produce a squeal when light falls on the LDR.

[to Index](#)





**FPT100 Photo Darlington Transistor**

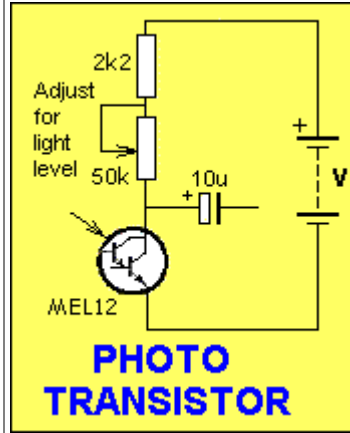
The FPT-100 Darlington Photo Transistor is available from [Talking Electronics](http://TalkingElectronics.com) for \$1.00 each plus postage.

## Photo Transistor

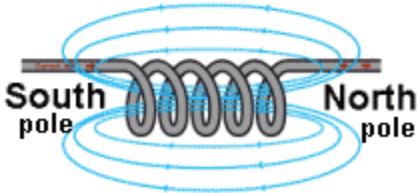
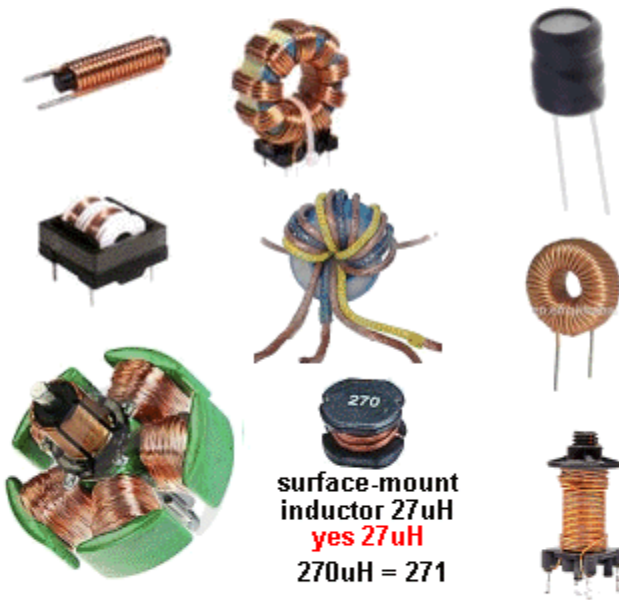
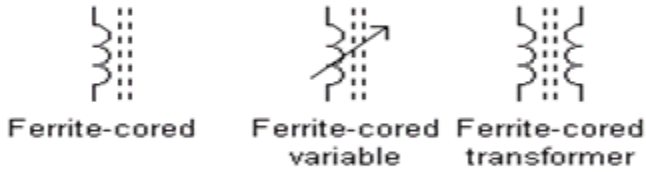
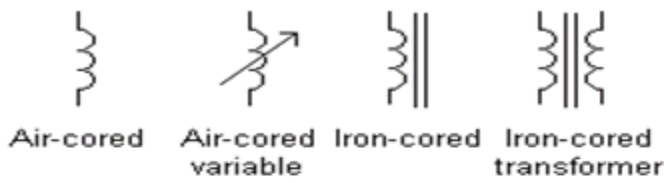
The **Photo Transistor** is very sensitive to changes in illumination. It is about 100 times more sensitive than the **LDR**.

The **Photo Transistor** is also available as a **DARLINGTON**. The **Darlington Photo-transistor** is 100 x 100 times (10,000) more sensitive than the LDR.

The **Photo Transistor** and **Photo Darlington Transistor** are connected just like a normal transistor but the base lead is not connected. If the value of the **LOAD RESISTOR** is large, the transistor will not be very sensitive.



[to Index](#)



The emerging **magnetic lines of force** from an inductor produce the NORTH POLE - this is just "convention," a simple way to explain things - to get the explanation started.

When two or more coils are wound near each other, the inductor is called a **TRANSFORMER** (but not the armature above).

## The Inductor

Also called "**coil**," or "**Choke**."

An **Inductor** consists of one to many turns of wire wrapped around a former (tube of cardboard). The wire can be jumble-wound or wound in layers. The result is the same. This is called an **air-cored coil** or **air-cored inductor**.

The centre can be filled with a metal such as iron or laminations (thin sheets of metal) or a ferrite material.

Different cores operate at higher frequencies.

The core can be circular (doughnut) or rectangular and it is called a **MAGNETIC CIRCUIT** (when it is a closed loop).

Additional turns or increasing the diameter of the turns will increase the inductance.

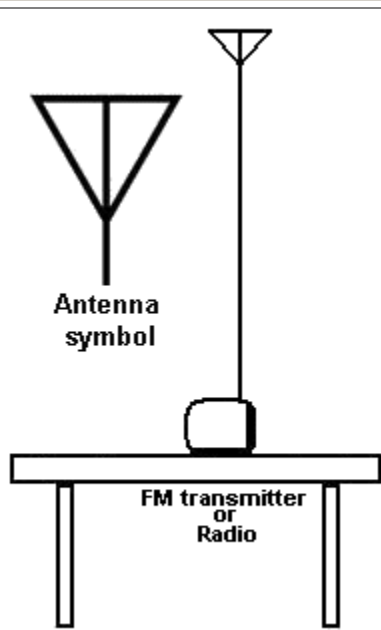
A coil with a magnetic core can be used to pick up nails and metal items. It is called an **electromagnet**. It can be operated on AC or DC.

When the metal core is loose and gets pulled into the coil it is called a **SOLENOID** or **ACTUATOR** or **LINEAR ACTUATOR**. It can be operated on AC or DC.

The way an inductor works is very complex but we can say it resists any rise or fall in voltage by turning the rise or fall into magnetic flux.

If the applied voltage is suddenly turned off, the inductor produces a **very high voltage** of **opposite polarity** (these are the **two** most important things for you to remember).

[to Index](#)



## The Antenna

The first time you will need an antenna is when making an FM transmitter.

The antenna is usually a length of wire equal to half the wavelength of the transmitter. The frequency is about 100MHz and the wavelength is 3 metres.

A half-wave antenna is 1.5metres.

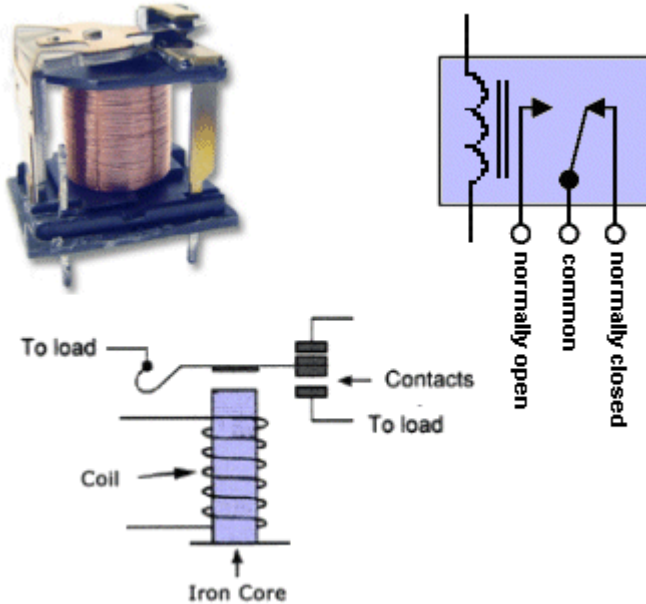
The length is important but the height is more important. The wire should be as high as possible and "up-and-down" if the antenna on the radio is vertical, to get the maximum range.

This is called an **end-fed half-wave antenna** or **half-wave Monopole**.

The transmitting circuit should have a good ground-plane such as connection to large batteries so the signal can be pushed and pulled into and out of the antenna.

This signal is then radiated as electromagnetic radiation to the surroundings.

[to Index](#)

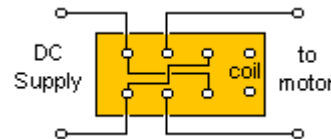


## The RELAY

The word **Relay** comes from the days of Morse Code where a coil of wire (an electromagnet) closed a switch to allow the Morse code to travel further down the telegraph line. It would "relay" or "pass-on" the information.

A relay allows a "weak circuit" (one with low current) to operate a LOAD that needs a large current. It also separates the two circuits electrically and prevents a voltage such as 240v connecting to a 12v circuit. The coil is separated from the contacts and this gives the two circuits isolation.

A double-pole double-throw relay can be used to reverse a motor as shown here:



A single contact consists of 2 pins -called SPST (single-pole single-throw).

Or a single pair of contacts can consist of 3 pins - called change-over or SPDT (single-pole double-throw).

A double set of contacts consists of 6 pins, called DPDT (double-pole, double-throw). This is also called a **CHANGE-OVER RELAY** or **REVERSING RELAY** (when connected to a motor).

[to Index](#)

## Driving A Relay

### (Powering A Relay)

The first thing you must decide is the voltage of the relay.

This will depend on the voltage(s) available.

The relay will be driven (activated) by a transistor and the base of the transistor only needs a signal (less than about 1v). This means the project can be operated on a voltage from 3v to 12v and the relay can be connected to a 5v to 12v supply.

Next you need to know the current-rating of the contacts. This will depend on the current taken by the LOAD. The rating of most relays is: 1 amp, 5 amp or 10 amp.

Finally you need to know how many contacts are required.

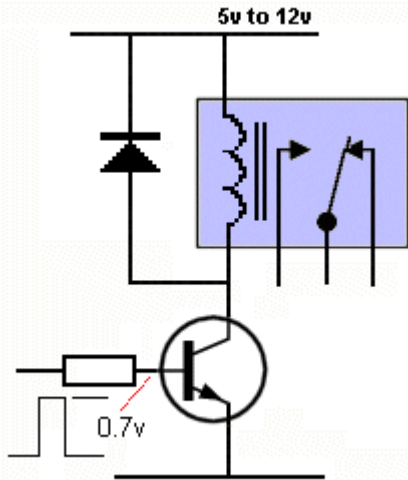
For a single circuit you will need 2 pins and for two circuits you will need 4 pins (but relays only come with 6 pins).

You can get relays that need a very small current for activation. These are called CMOS relays. But most relays need about 100mA.

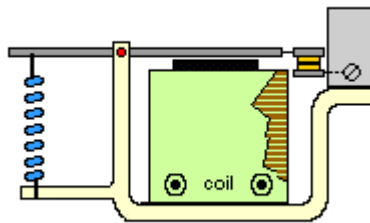
To protect the driving-transistor from spikes when the relay is turned off, you will need a diode across the coil.

The top animation shows a "single set of change-over contacts."

The lower animation shows the ARMATURE being drawn to the electromagnet. The electromagnet is the coil with a core of magnetic material that becomes a magnet (an electromagnet) when a current flows through the coil.

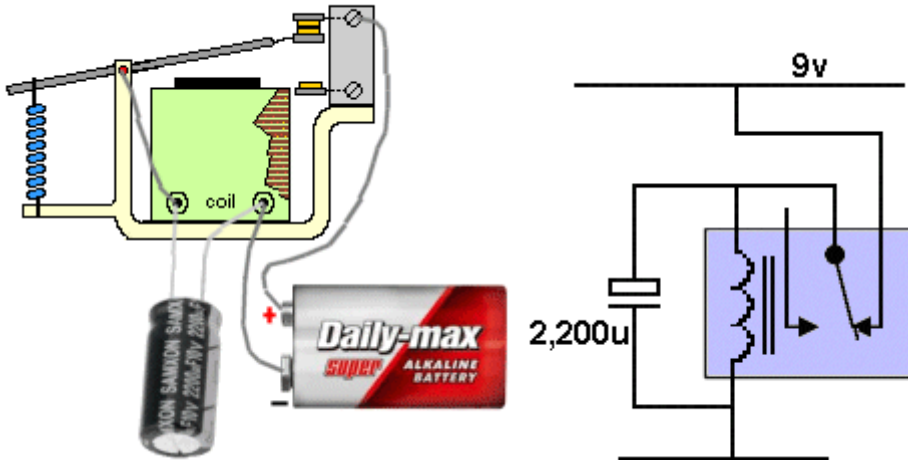


Driving A



### Relay

The armature is drawn towards the coil when a current flows through the coil.



When the circuit is turned ON, the voltage across the 2,200uF electrolytic is zero and it gradually charges. When the voltage is about 8v, the coil has enough voltage across it to pull the armature and open the contacts. The electrolytic supplies voltage to the coil for about 1 second and then the electromagnet does not have sufficient magnetism to hold the armature and it returns to close the contacts.

# GATES

Animations of **GATES** and more details of their operation is covered in [DIGITAL ELECTRONICS](#) chapter.

[to Index](#)

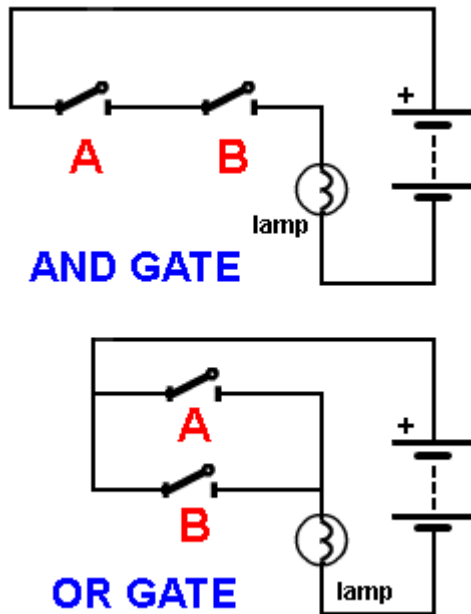


Fig 80. The "AND" GATE and "OR" GATE with switches

The next **BUILDING BLOCK** we will cover is called the **GATE**.

In its simplest form it is an electrical circuit consisting of switches.

Its just two or more switches connected in series or parallel.

We give each circuit a name so we can talk about it and explain its action with a single word.

Later we will cover the electronic version and show how diodes and a transistor are needed to perform a **GATING FUNCTION**.

The **type of GATE** we are talking about is a **LOGIC GATE**.

The circuit performs an operation called a **LOGICAL OPERATION** on an input or a number of inputs and creates a single output - called a **LOGICAL OUTPUT**.

**LOGICAL** means "understandable" or "correct" and in this case it means **DIGITAL** - the signal will rise to full rail voltage or fall to zero voltage. The output will not be half rail or quarter-rail voltage. The diagram show an "**AND**" **GATE** and "**OR**" **GATE** with switches.

For the **AND GATE** close switch **A AND** switch **B** for the lamp to illuminate.

For the **OR GATE** close switch **A OR** switch **B** for the lamp to illuminate.

[to Index](#)

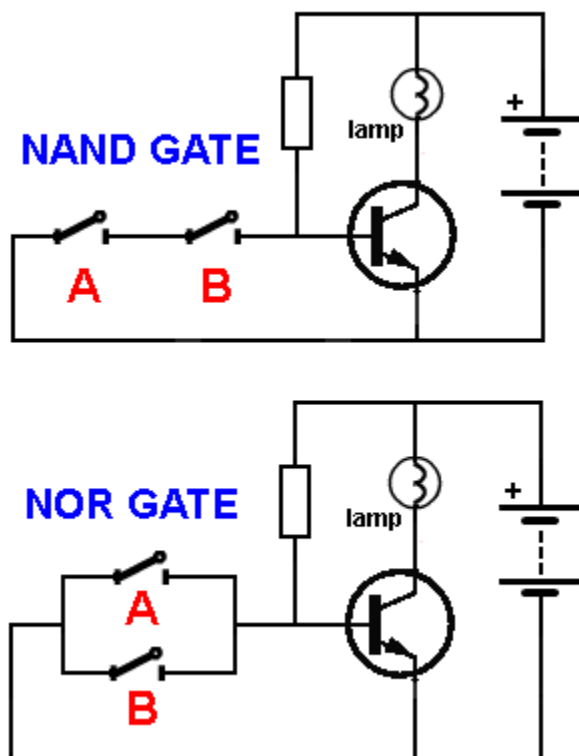


Fig 81. The "NAND" GATE and "NOR" GATE with switches and a transistor

## INVERSION

Inversion produces the opposite effect to the results above.

Suppose we want to turn OFF a lamp when one or two switches are pressed.

We need a transistor.

The technical word for Inversion is **NOT**.

It is simplified to the letter "**N**."

For the **NAND GATE** close switch **A PLUS** switch **B** for the lamp to turn OFF.

For the **NOR GATE** close switch **A OR** switch **B** for the lamp to turn OFF.

These gates are only **demonstration-gates** to show how one or two switches will turn a lamp OFF.

[to Index](#)

## NOT GATE

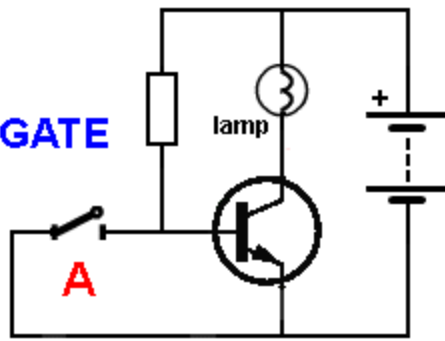


Fig 82. The "NOT" GATE

## NOT GATE

A single switch and transistor produces a **NOT GATE**.

This is simply an **INVERSION**.

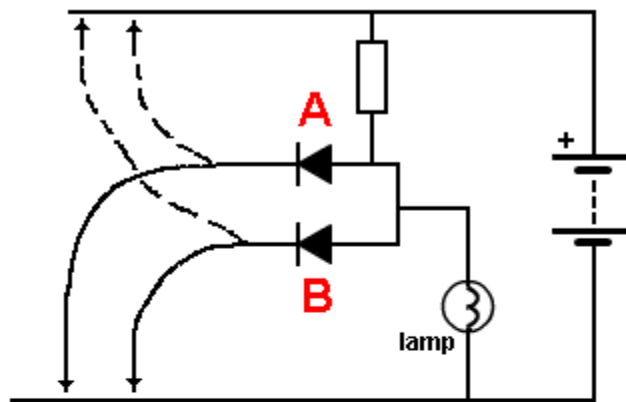
The resistor turns the transistor **ON** and the lamp illuminates. The switch removes the voltage on the base and the transistor turns **OFF**.

This is only a demonstration circuit to show how a switch can turn a lamp OFF.

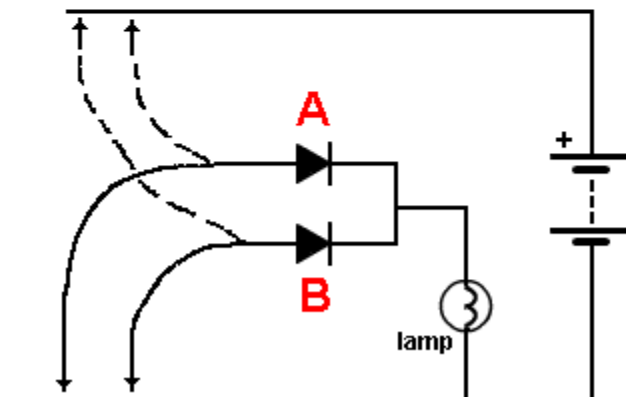
[to Index](#)

The 5 gates above form the basis to turning a circuit **ON** and **OFF**. We will discuss these gates later in the digital section.

[to Index](#)



## AND GATE with DIODES



## OR GATE with DIODES

Fig 83. "AND and "OR" gate with diodes

The next building block is the **GATING DIODE**.

We have shown a diode allows current to flow when the diode is correctly placed in a circuit and blocks current when it is reversed.

The 5 gates above are electrical circuits but an electronic circuit works in a slightly different way.

The electronic circuit will be covered later in the DIGITAL section.

For the moment we will explain how a diode can be used to create a **GATE**.

In other words it creates a **ONE-WAY PATH** to allows signals to pass from one stage to another and prevents signals passing in the opposite direction.

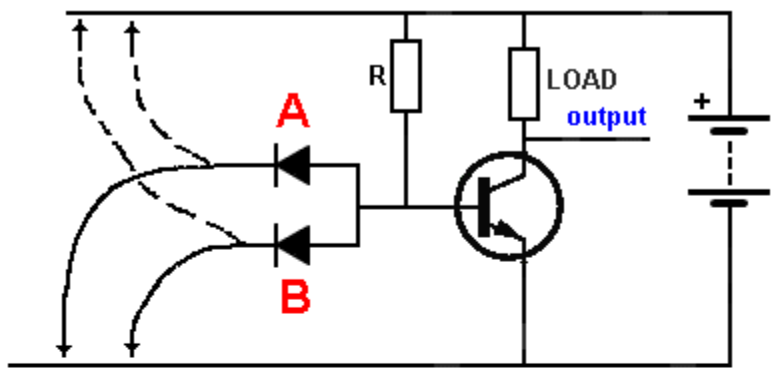
In the **AND GATE** circuit, both inputs are **LOW** and current flows through the resistor (it will get **HOT**). When one input is taken **HIGH**, current still flows through the other diode and the lamp does not illuminate.

When **BOTH** inputs are **HIGH**, current flows through the resistor to illuminate the lamp. No current flows through the diodes.

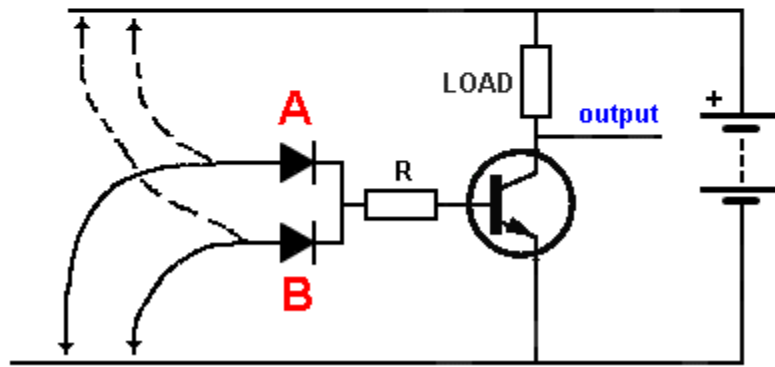
In the **OR GATE**, when one input is taken **HIGH**, current flows through the diode to illuminate the lamp.

This can be done with **EITHER** input.

[to Index](#)



NAND GATE with DIODES and Transistor



NOR GATE with DIODES and Transistor

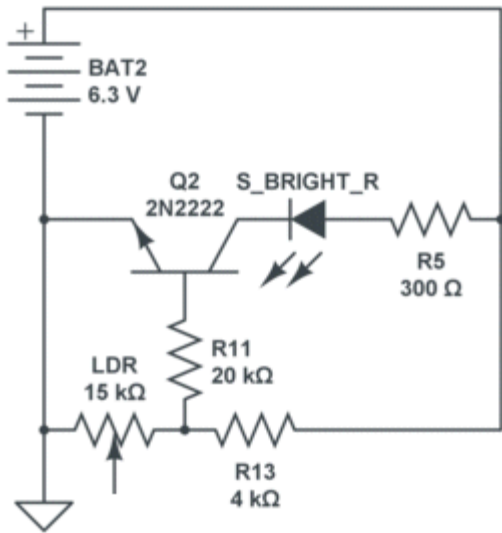
Fig 84. "NAND" and "NOR" gate with diodes and a transistor.

A **NAND** and **NOR** gate can be made with diodes and a transistor. This time we the output is either HIGH or LOW. We are gradually producing circuits that are electronic, rather than electrical circuits. In the **NAND GATE** circuit, taking one of the inputs HIGH will still allow the other input to prevent the transistor turning ON.

When BOTH inputs are HIGH, the transistor turns on via resistor R and the output is LOW.

In the **NOR GATE** circuit, taking one of the inputs HIGH will turn the transistor ON and the output will be LOW.

[to Index](#)



## Drawing A Circuit

A circuit must be drawn according to simple rules so it can be instantly recognised.

An electronics engineer can "**see a circuit working**" when it is drawn correctly and can see if it is drawn correctly; if the parts-values are correct and can use the circuit to assist in diagnosing a problem with a faulty circuit.

The top circuit on is very difficult to visualise because it is not drawn in the normal way.

All the components have to be "**turned around in your mind,**" to see what the circuit is doing.

# QUICK QUIZ - to see how much you know

**Answer the following 50 questions . . . JavaScript is required!**  
This test will see how much you have learnt.

**1. What does LED stand for?**

- Light Emitting Display
- Low Energy Display
- Light Emitting Diode
- Light Emitting Detector

**2. Name the three leads of a common transistor**

- Collector Bias Omitter
- Base Collector Case
- Emitter Collector Bias
- Collector Base Emitter

**3. Connecting a lead from the negative to the positive of a battery will produce:**

- A high resistance circuit
- A short circuit
- A low current path
- An open circuit

**4. What is the approximate characteristic voltage that develops across a red LED?**

- 1.7v
- 3.4v
- 0.6v
- 5v

**5. If two resistors are placed in series, is the final resistance:**

- Higher
- Lower
- The same
- Cannot be determined

**6. Which is not a "common" value of resistance:**

- 2k7
- 1M8



- 330R
- 4k4

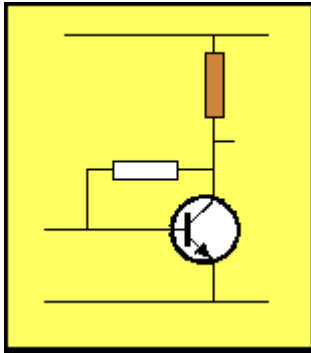
7. Which value of resistance, placed across a 9v battery will get hot:

- 22k
- 22R
- 220k

8. If the voltage on the base of a transistor increases, does it:

- Turn on
- Turn off
- Not enough information
- Remain the same

9. The resistor identified in brown is called the:



- Base Bias Resistor
- Load Resistor
- Emitter Feedback Resistor
- Bypass Resistor

10. The first three colour bands on a resistor are:  
yellow - purple - orange

- 47k
- 4k7
- 470k
- 4R7

11. A resistor with colour bands: red-red-red-gold, has the value:

- 22k 5%
- 2k2 5%
- 220R 5%
- 22R 5%

12. The lead marked with the arrow is:



- The Collector
- The Base
- The Emitter
- The case

13. A 10k resistor in parallel with 10k produces:

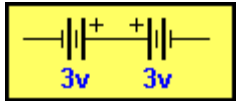
- 10k
- 5k
- 20k
- Cannot be determined

14. The symbol is:



- NPN Transistor
- PNP Transistor
- Photo Transistor
- Field Effect Transistor

15. Two 3v batteries are connected as shown.  
The output voltage is:

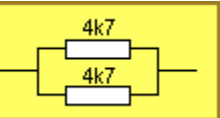


- 3v
- 0v
- 6v

16. 4 resistors in ascending order are:

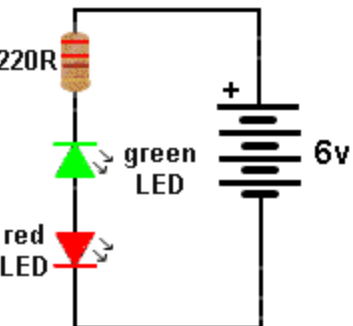
- 22R 270k 2k2 1M
- 4k7 10k 47R 330k
- 3R3 4R7 22R 5k6
- 100R 10k 1M 3k3

17. The closest value for this combination is:



- 4k7
- 2k3
- 9k4

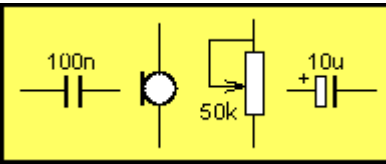
18. Which LED will illuminate:



- Green
- Both

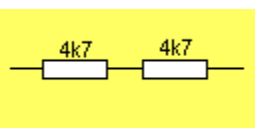
- RED
- None

19. The four symbols are:



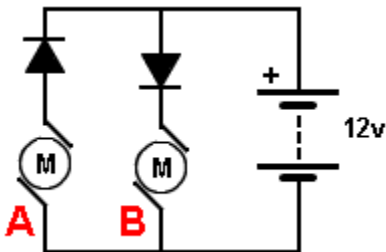
- Capacitor, Microphone, Potentiometer, Electrolytic
- Electrolytic, Microphone, Resistor, Capacitor
- Capacitor, Piezo, Resistor, Electrolytic
- Electrolytic, Coil, Resistor, Capacitor

20. The closest value of the combination is:



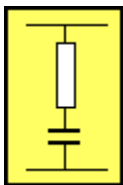
- 10k
- 2k3
- 2k5

21. Which motor will work:



- A
- B
- A and B

22. A resistor and capacitor in series is called a:



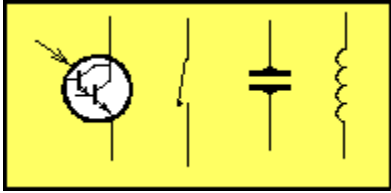
- Pulse Circuit
- Timing Circuit/Time Delay Circuit
- Oscillator Circuit/Frequency Circuit
- Schmitt Circuit

23. A red-red-red-gold resistor in series with an orange-orange-orange-gold resistor produces:

- 5k5
- 35,200 ohms

- 55k
- None of the above

24. Name the 4 components:

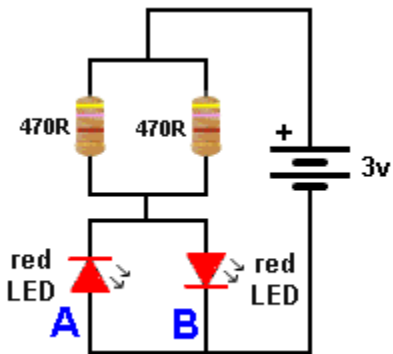


- Photo transistor, switch, capacitor, coil
- Transistor, mercury switch, piezo, inductor
- Photo transistor, reed switch, piezo, coil
- Photo Darlington transistor, switch, piezo, inductor

25. To obtain a higher value of resistance, resistors are connected in:

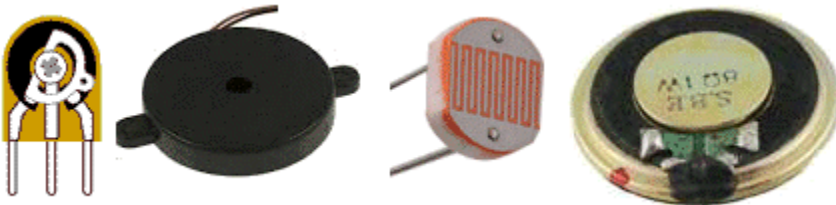
- Reverse
- Forward
- Parallel
- Series

26. Which LED will illuminate:



- A
- B
- Both
- None

27. Name the component that detects light:



- mini trim pot
- Light Dependent Resistor

- piezo
- speaker

**28. What is 1,000p?**

- 0.01n
- 0.0001u
- 0.1n
- 1n

**29. The current in a circuit is 45mA. This is:**

- 0.045Amp
- 0.00045A
- 0.0045A
- 0.45A

**30. A 100n capacitor can be expressed as:**

- 0.1u u = microfarad
- 0.01u
- 0.001u
- none of the above

**31. 1mA is equal to:**

- 0.001A
- 0.00001A
- 0.01A
- 0.1A

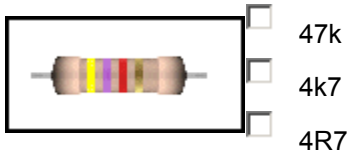
**32. 1,200mV is equal to:**

- 12v
- 1.2v
- 0.12v
- 0.0012v

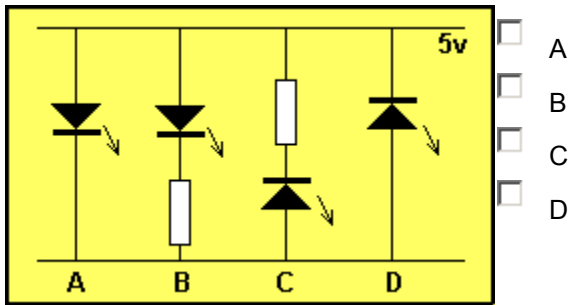
**33. The approximate current for a toy 3v motor is:**

- 10mA
- 100mA to 300mA
- 1 amp

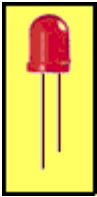
**34. What is the resistance of this resistor:**



35. Identify the correctly connected LED:



36. Identify the correct statement:

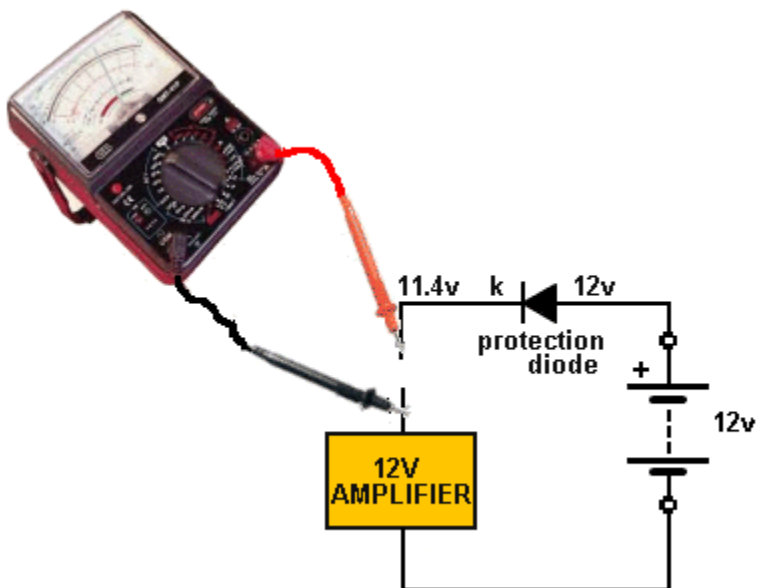


- The cathode lead is longer. It goes to the negative rail
- The cathode lead is shorter. It goes to the negative rail
- The cathode lead is shorter. It goes to the positive rail
- The cathode lead is longer. It goes to the positive rail

37. The current requirement of a LED is:

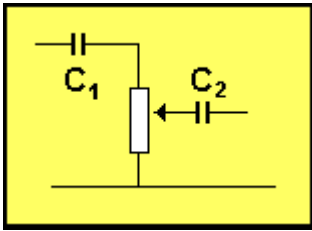
- 1.7mA
- 25mA
- Between 3 and 35mA
- 65mA

38. The multimeter is measuring . . .



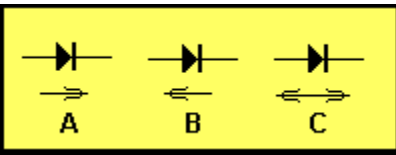
- Voltage
- Current
- Resistance

39. The purpose of the two capacitors:



- To pass AC from the input to the output
- To allow the signal to oscillate
- To pass DC from the input to the output
- To amplify the signal

40. The direction of conduction for a diode is:



- A
- B
- C

41. A DC voltage . . .

- rises and falls
- is a sinewave
- remains constant
- is an audio waveform

42. Arrange these in ascending order: k, R, M  
(as applied to resistor values)

- R, k, M
- M, R, k
- k, M, R
- M, k, R

43. A battery produces AC current:

- true
- false

44. The tolerance bands: gold, silver, represent:

- 5%, 10%
- 10%, 5%

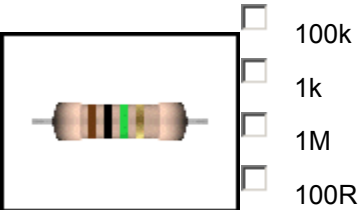
45. 223 on a capacitor represents:

- 0.022u u = microfarad
- 22n n = nanofarad
- 22,000p p = picofarad
- All of the above

**46. Arrange these in ascending order: n, p, u  
(as applied to capacitor values)**

- p, u, n,
- n, u, p
- p, n, u

**47. What is the resistance of this resistor:**



**48. The number "104" on a capacitor indicates:**

- 0.1u
- 100n
- 1n
- 10n

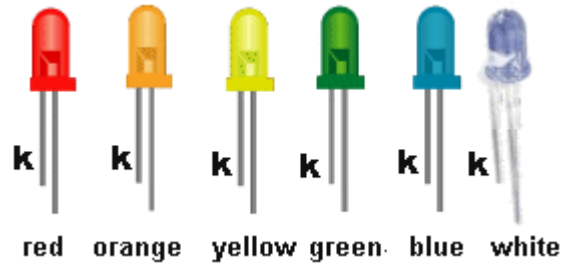
**49. What is the multimeter detecting:**

- Voltage
- Current
- Resistance





50. For the LEDs, what is the characteristic voltage for the red and white LEDs:



- 3.6v, 1.7v
- 2.4v, 3.3v
- 1.7v, 3.6v
- Cannot be determined

[to Index](#)