





# Basic English Syntax with Exercises

Mark Newson

Dániel Pap  
Gabriella Tóth  
Krisztina Szécsényi  
Marianna Hordós  
Veronika Vincze



# Preface

Linguists, it has to be admitted, are strange animals. They get very excited about things that the rest of the species seem almost blind to and fail to see what all the fuss is about. This wouldn't be so bad if linguists were an isolated group. But they are not, and what's more they have to teach non-linguists about their subject. One mistake that linguists often make is to assume that to teach linguistics, students should be instilled with the kind of enthusiasm for the subject that linguists themselves have. But not everybody wants to be a linguist and, as a friend of mine once said, not everybody *can* be a linguist.

What the dedicated language student wants, however, is not the ability to analyse complex data from languages in exotic regions of the world, or to produce coherent theories that explain why you can't say *his being running* in a more elegant way than anyone else can. What they want from linguistics is to see what the subject can offer them in coming to some understanding of how the language that they are studying works. It is for these students that this book has been written.

This is not to say that this is not a linguistics text. It is, and linguistics permeates every single page. But the difference is that it is not trying to tell you how to become a linguist – and what things to get excited about – but what linguistic theory has to offer for the understanding of the English language. Many introductory text books in syntax use language data as a way of justifying the theory, so what they are about is the linguistic theory rather than the language data itself. A book which was about language would do things differently; it would use the theory to justify a certain view of the language under study. We have attempted to write such a book.

As part consequence of this, we have adopted a number of strategies. The first is what we call the 'No U-turn' strategy. If you have ever read an introductory book on a linguistic topic you may have found pages and pages of long and complicated arguments as to why a certain phenomena must be analysed in such and such a way, only to find in the next chapter that there is actually a better way of doing things by making certain other assumptions. This is the sort of thing that linguist find fun. But students often find it confusing and frustrating. So we have attempted to write this book without using this strategy. As far as possible, concepts and analyses that are introduced at some point in the book are not altered at some later point in the book. Obviously, pictures have to be painted a bit at a time to make them understandable and so it isn't possible to 'tell the whole truth' right from the start. But an attempt has been made to build up the picture piece by piece, without having to go back and rub out earlier parts of the sketch.

Another strategy adopted in the book is to avoid unnecessary formalisms. These are very useful if you want to understand the workings of a theory to the extent needed to see where its weaknesses are and how it needs to be developed to overcome these. But as this is not our aim, it is not necessary to make students fully aware of how to formalise grammatical principles. All they need is an understanding of how the principles work and what they predict about the language and this can be put over in a less formal way.

## Preface

---

The target audience for the book is BA students, covering the introductory syntax level and going through to more advanced BA level material. For this reason, the book starts from the beginning and tries to make as few assumptions as possible about linguistic notions. The first two chapters are a fairly substantial introduction to grammatical concepts both from a descriptive and a theoretical point of view. This material alone, along with the exercises, could form the basis of an introduction to a syntax course. The latter chapters then address specific aspects of the English language and how the concepts and grammatical mechanisms introduced in the first two chapters can be applied to these to enable an understanding of why they are as they are. As the book relies on a 'building' process, starting out at basic concepts and adding to these to enable the adequate description of some quite complex and subtle phenomena, we have also provided an extensive glossary, so that if you happen to forget a concept that was introduced in one part of the book and made use of in another, then it is easy to keep yourself reminded as you read.

Obviously, another feature that we hope is more student-friendly is the exercises, of which we have a substantial amount. These range in type and level, from those which you can use to check your understanding of the text, to those which get you to think about things which follow from the text, but which are not necessarily discussed there. Some are easy and some will make you think. A fairly unique aspect of the book is that it also provides model answers to the exercises so that you can check to see whether you were on the right track with your answer and also for you to learn from: making mistakes is one of the best ways to learn. But if you never know what mistakes you made, you can't learn from them. Obviously, the best way to use the exercises and model answers is to have a go at the exercises by yourself first and then go and read the model answers. While you may be able to learn something by reading the model answers without having a go at the exercises, it is doubtful that you will get as much out of them.

Finally, a brief word about the team of writers is in order. Although we very much opted for a division of labour approach to the writing of this book, it has been no less of a team effort. The text was written by Mark Newson and the exercises prepared by Hordós Marianna, Szécsényi Krisztina, Pap Dániel, Tóth Gabriella and Vincze Veronika. Szécsényi Krisztina prepared the glossary. Most of the editing was carried out by Hordós Marianna, Nádasdi Péter, Szécsényi Krisztina and Szécsényi Tibor. Szécsényi Tibor also has had the responsibility for the electronic version of the book and managing the forum set up to help us keep in touch. Thanks go to Kenesei István for his help in setting up the project and for valuable comments on the text and also to Marosán Lajos for equally valuable comments. We are also grateful for the conscientious work and useful remarks of our reviewer, Pelyvás Péter. Marianna and Krisztina are responsible for everything. Without them, nothing would have happened.

# Table of Contents

Preface	v
Table of Contents	vii
<b>Chapter 1 Grammatical Foundations: Words</b>	<b>1</b>
1 Language, Grammar and Linguistic Theory	1
2 Word Categories	4
2.1 The Lexicon	4
2.2 Categories	5
2.3 Morphological criteria for determining category	6
2.4 Distribution	8
3 A Typology of Word Categories	10
3.1 Categorial features	11
3.2 Predicates and arguments	15
3.3 Grammatical aspects of meaning	17
3.4 The Thematic categories	18
3.5 Functional Categories	37
3.6 Functionally underspecified categories	47
Check Questions	51
Test your knowledge	51
<b>Chapter 2 Grammatical Foundations: Structure</b>	<b>57</b>
1 Structure	57
1.1 The building blocks of sentences	57
1.2 Phrases	59
1.3 Sentences within phrases	61
1.4 Structural positions	64
1.5 Structural terminology	65
1.6 Labels	66
1.7 Rules	67
2 Grammatical Functions	68
2.1 The subject	68
2.2 The object	72
2.3 Indirect object	74
3 Testing for Structure	75
3.1 Substitution	75
3.2 Movement	79
3.3 Coordination	82
3.4 Single-word phrases	83
Check Questions	84
Test your knowledge	85

## Table of Contents

---

Chapter 3 Basic Concepts of Syntactic Theory	87
1 X-bar Theory	87
1.1 Rewrite rules and some terminology	87
1.2 Endocentricity	89
1.3 Heads and Complements	92
1.4 Specifiers	95
1.5 Adjuncts	96
1.6 Summary	100
2 Theoretical Aspects of Movement	101
2.1 Move $\alpha$	102
2.2 D-structure and S-structure	104
2.3 Traces	113
2.4 Locality Restrictions on movement	118
3 Conclusion	120
Check Questions	120
Test your knowledge	121
Chapter 4 The Determiner Phrase	129
1 Why the Noun is not the Head of the DP	129
2 The Internal Structure of the DP	137
2.1 Determiners and Complements	137
2.2 The Specifier of the DP	138
2.3 Adjunction within the DP	142
3 Multiple Determiners	143
4 Conclusion	148
Check Questions	148
Test your knowledge	149
Chapter 5 Verb Phrases	153
1 Event Structure and Aspect	153
2 Verb Types	156
2.1 Unaccusative verbs	156
2.2 Light verbs	159
2.3 Ergative verbs	162
2.4 Transitive verbs	172
2.5 Intransitive verbs	182
2.6 Multiple complement verbs	184
2.7 Phrasal verbs	188
2.8 Verbs with clausal complements	193
2.9 Summary	197
3 Aspectual Auxiliary Verbs	197
3.1 The auxiliary as a dummy	198
3.2 The nature of the aspectual morpheme	201
4 Adverbs, PPs and Clausal modifiers	203
4.1 Adverbs	203
4.2 PP modifiers	206
4.3 Clausal modifiers	207
5 Conclusion	209
Check Questions	210
Test your knowledge	210



## Table of Contents

---

Chapter 6 Inflectional Phrases	213
1 The structure of IP	213
2 The syntax of inflection	218
2.1 Inserting auxiliaries into I	220
2.2 <i>Do</i> -insertion	221
2.3 Tense and Agreement	225
2.4 Movement to tense and I	230
3 Movement to Spec IP	233
4 Adjunction within IP	238
5 Conclusion	239
Check Questions	239
Test your knowledge	240
Chapter 7 Complementiser Phrases	243
1 The structure of CP	243
2 The Clause as CP	246
3 Interrogative CPs	248
3.1 Basic positions within the CP	248
3.2 <i>Wh</i> -movement	250
3.3 Inversion	253
3.4 The interaction between <i>wh</i> -movement and inversion	254
3.5 Subject questions	261
4 Relative Clauses	263
4.1 The position of the relative clause inside the NP	263
4.2 A comparison between relative and interrogative clauses	265
5 Other fronting movements	270
5.1 Topicalisation	270
5.2 Focus fronting	272
5.3 Negative fronting	273
6 Conclusion	277
Check Questions	277
Test your knowledge	278
Chapter 8 The Syntax of Non-Finite Clauses	281
1 Exceptional and Small Clauses	281
1.1 Clauses without CP	281
1.2 Clauses without IP	288
2 Raising and Control	290
2.1 Raising	294
2.2 Control	298
3 The Gerund	303
4 Conclusion	307
Check questions	308
Test your knowledge	308

## Table of Contents

---

Suggested Answers and Hints	313
Chapter 1	313
Chapter 2	327
Chapter 3	329
Chapter 4	346
Chapter 5	364
Chapter 6	376
Chapter 7	396
Chapter 8	413
Glossary	431
Bibliography	455
Index	456

# Chapter 1

---

## Grammatical Foundations: Words

### 1 *Language, Grammar and Linguistic Theory*

This book attempts to describe some of the basic grammatical characteristics of the English language in a way accessible to most students of English. For this reason we start at the beginning and take as little as possible for granted. Definitions are given for grammatical concepts when they are first used and there is a glossary at the back of the book to remind the reader of these as he or she works through it. At the end of each chapter there are an extensive set of exercises which the student is encouraged to consider and work through either in class or alone. For those students working alone, we have also provided model answers for the exercises. These are for the student to check their understanding of the material supported by the exercises and to offer observations that the student may have missed.

The uninitiated student might be surprised to find that there are many ways to describe language, not all compatible with each other. In this book we make use of a particular system of grammatical description based mainly on Government and Binding theory, though it is not our aim to teach this theory and we will very rarely refer to it directly. We use the theory to offer a description of English, rather than using English to demonstrate the theory. We will spend a short amount of time at the beginning of the book to state our reasons for choosing this theory, as opposed to any other, to base our descriptions.

Whatever else language might be (e.g. a method of communicating, something to aid thought, a form of entertainment or of aesthetic appreciation) it is first and foremost a system that enables people who speak it to produce and understand linguistic expressions. The nature of this system is what linguistics aims to discover. But where do we look for this system? It is a common sense point of view that language exists in people's heads. After all, we talk of *knowing* and *learning* languages. This also happens to be the belief of the kind of linguistics that this book aims to introduce: in a nutshell, the linguistic system that enables us to 'speak' and 'understand' a language is a body of knowledge which all speakers of a particular language have come to acquire.

If this is true, then our means for investigating language are fairly limited – we cannot, for instance, subject it to direct investigation, as delving around in someone's brain is not only an ethical minefield, but unlikely to tell us very much given our current level of understanding of how the mind is instantiated in the brain. We are left, therefore, with only indirect ways of investigating language. Usually this works in the following way: we study what the linguistic system produces (grammatical sentences which have certain meanings) and we try to guess what it is that must be going on in

## Chapter 1 - Grammatical Foundations: Words

---

the speaker's head to enable them to do this. As you can imagine, this is not always easy and there is a lot of room for differences of opinion. Some of us might tell you that that is exactly what makes linguistics interesting.

There are however some things we can assume from the outset about the linguistic system without even looking too closely at the details of language. First, it seems that speakers of a language are able to produce and understand a limitless number of expressions. Language simply is not a confined set of squeaks and grunts that have fixed meanings. It is an everyday occurrence that we produce and understand utterances that probably have never been produced before (when was the last time you heard someone say *the bishop was wearing a flowing red dress with matching high heeled shoes and singing the Columbian national anthem?* – yet you understood it!). But if language exists in our heads, how is this possible? The human head is not big enough to contain this amount of knowledge. Even if we look at things like brain cells and synapse connections, etc., of which there is a very large number possible inside the head, there still is not the room for an **infinite** amount of linguistic knowledge. The answer must be that this is not how to characterise linguistic knowledge: we do not store all the possible linguistic expressions in our heads, but something else which enables us to produce and understand these expressions. As a brief example to show how this is possible, consider the set of numbers. This set is infinite, and yet I could write down any one of them and you would be able to tell that what I had written was a number. This is possible, not because you or I have all of the set of numbers in our heads, but because we know a small number of simple rules that tell us how to write numbers down. We know that numbers are formed by putting together instances of the ten digits 0,1,2,3, etc. These digits can be put together in almost any order (as long as numbers bigger than or equal to 1 do not begin with a 0) and in any quantities. Therefore, 4 is a number and so is 1234355, etc. But 0234 is not a number and neither is *qewd*. What these examples show is that it is possible to have knowledge of an infinite set of things without actually storing them in our heads. It seems likely that this is how language works.

So, presumably, what we have in our heads is a (finite) set of rules which tell us how to recognise the infinite number of expressions that constitute the language that we speak. We might refer to this set of rules as a **grammar**, though there are some linguists who would like to separate the actual set of rules existing inside a speaker's head from the linguist's guess of what these rules are. To these linguists a grammar is a linguistic hypothesis (to use a more impressive term than 'guess') and what is inside the speaker's head IS language, i.e. the object of study for linguistics. We can distinguish two notions of language from this perspective: the language which is internal to the mind, call it **I-language**, which consists of a finite system and is what linguists try to model with grammars; and the language which is external to the speaker, **E-language**, which is the infinite set of expressions defined by the I-language that linguists take data from when formulating their grammars. We can envisage this as the following:

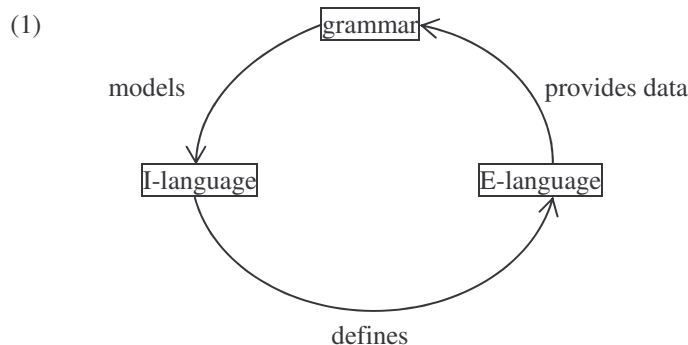

So, a linguist goes out amongst language speakers and listens to what they produce and perhaps tests what they can understand and formulates a grammar based on these observations.

It is the way of the universe that no truths are given before we start our investigations of it. But until we have some way of separating what is relevant to our investigations from what is irrelevant there is no way to proceed: do we need to test the acidity of soil before investigating language? It seems highly unlikely that we should, but if we know nothing from the outset, how can we decide? It is necessary therefore, before we even begin our investigations, to make some assumptions about what we are going to study. Usually, these assumptions are based on common sense, like those I have been making so far. But it is important to realise that they are untested assumptions which may prove to be wrong once our investigations get under way. These assumptions, plus anything we add to them as we start finding out about the world, we call a **theory**.

Linguistic theories are no different from any other theory in this respect. All linguists base themselves on one theory or another. One group of linguists, known as **generativists**, claim that in order to do things properly we need to make our theories explicit. This can be seen as a reaction to a more traditional approach to linguistics which typically claims to operate atheoretically, but, in fact, makes many implicit assumptions about language which are themselves never open to investigation or challenge. Generative linguists point out that progress is unlikely to be made like this, as if these assumptions turn out to be wrong we will never find out, as they are never questioned. In order to find out if our assumptions are correct, they need to be constantly questioned and the only way to do this is to make them explicit.

Because of this, it is my opinion that the generative perspective is the one that is most likely to provide the best framework for a description of language. We will therefore adopt this perspective and so certain aspects of the theory will form part of the content of the book, but only in so far as they help to achieve the main goal of explaining why English is as it is. In true generative style, I will take the rest of this chapter to try to make explicit some of the basic assumptions that we will be making in the rest of the book.

## 2 Word Categories

### 2.1 The Lexicon

The first assumption we will make is that one of the things that a speaker of a language knows is facts about words. We know, for instance, how a given word is pronounced, what it means and where we can put it in a sentence with respect to other words. To take an example, the English word *cat* is known to be pronounced [kæt], is known to mean ‘a small, domesticated animal of meagre intelligence that says meow’ and is known to be able to fit into the marked slots in sentences (2), but not in those marked in (3):

- (2) a the cat slept  
b he fed Pete’s cat  
c I tripped over a cat
- (3) a \*the dog cat the mouse  
b \*cat dog howled  
c \*the dog slept cat a kennel

Note!

An asterisk at the beginning of a sentence indicates that the sentence is ungrammatical.

It is obvious that this knowledge is not predictable from anything. There is no reason why the object that we call a cat should be called a cat, as witnessed by the fact that other languages do not use this word to refer to the same object (e.g. *macska* (Hungarian), *chat* (French), *Katze* (German), *gato* (Spanish), *quatus* (Maltese) *kot* (Russian), *kissa* (Finnish), *neko* (Japanese), *mao* (Chinese), *paka* (Swahili)). Moreover, there is nothing about the pronunciation [kæt] that means that it must refer to this object: one can imagine a language in which the word pronounced [kæt] is used for almost anything else. This kind of linguistic knowledge is not ‘rule governed’, but is just arbitrary facts about particular languages.

Part of linguistic knowledge, therefore, is a matter of knowing brute fact. For each and every word of the language we speak it must be the case that we know how they are pronounced and what they mean. But this is different from our knowledge of sentences. For one thing, there are only a finite number of words in any given language and each speaker will normally operate with only a proportion of the total set of words that may be considered to belong to the language. Therefore, it is not problematic to assume that knowledge of words is just simply stored in our heads. Moreover, although it is possible, indeed it is fairly common, for new words to enter a language, it is usually impossible to know what a new word might mean without explicitly being told. For example, unless you had been told, it is not possible to know that the word *wuthering* found in the title of the novel by Emily Brontë is a Yorkshire word referring to the noise that a strong wind makes. With sentences, on the other hand, we know what they mean on first hearing without prior explanation. Thus, knowledge of words and knowledge of sentences seem to be two different things: knowledge of words is brute knowledge while knowledge of sentences involves knowing a system that enables us to produce and understand an infinite number of them (an I-language). Clearly, part of knowing what a sentence means involves knowing what the words that constitute it mean, but this is not everything: the meanings of the words *three*, *two*, *dogs*, *cats*, and *bit* simply do not add up to the meaning of the sentence *three dogs bit*

## Word Categories

---

*two cats* (if you think about it this sentence might mean that anything between two and six cats got bitten, which is not predictable from the meaning of the words).

Let us assume that these different types of linguistic knowledge are separate. We can call the part of I-language which is to do with words the **Lexicon**. This might be imagined as a kind of mental dictionary in which we store specific information about all the words that we use: how they are pronounced, what they mean, etc.

### 2.2 Categories

Lexical knowledge concerns more than the meaning and pronunciation of words, however. Consider the examples in (2) and (3) again. The word *cat* is not the only one that could possibly go in the positions in (2), so could the words *dog*, *mouse* and *budgerigar*:

- (4) a the *dog* slept  
b he fed Pete's *mouse*  
c I tripped over a *budgerigar*

This is perhaps not so surprising as all these words have a similar meaning as they refer to pets. However, compare the following sets of sentences:

- (5) a the *hairbrush* slept  
b he fed Pete's *algebra*  
c I tripped over a *storm*

- (6) a the *if* slept  
b he fed Pete's *multiply*  
c I tripped over a *stormy*

There is something odd about both these set of sentences, but note that they do not have the same status. The sentences in (5), while it is difficult to envisage how they could be used, are not as weird as those in (6). Given that neither sets of sentences make much sense, this does not seem to be a fact about the meanings of the words involved. There is something else involved. It seems that some words have something in common with each other and that they differ from other words in the same way. Hence, the set of words in a language is not one big homogenous set, but consists of groupings of words that cluster together. We call these groups **word categories**. Some well known categories are listed below:

- (7) nouns  
verbs  
adjectives  
prepositions

The obvious question to ask is: on what basis are words categorised? As pointed out above, it is not straightforward to categorise words in terms of their meaning, though traditionally this is a very popular idea. Part of the problem is that when one looks at the range of meanings associated with the words of one category, we need to resort to some very general concept that they might share. For example, a well known definition for the category **noun** is that these are words that name people, places or

## Chapter 1 - Grammatical Foundations: Words

---

things. While this may give us a useful rule of thumb to identifying the category of a lot of words, we often run into trouble as the notion is not particularly precise: in what way do nouns 'name' and what counts as a *thing*, for example? While it may be obvious that the word *Bartók* names a particular person, because that is what we call the thing that this word refers to, it is not clear why, therefore, the word *think* is not considered a name, because that is what we call the thing that this refers to. Moreover, the fact that the words:

- (8) idea
- weather
- cold
- friendliness
- diplomacy

are all nouns means that the concept *thing* must extend to them, but how do we therefore stop the concept from extending to:

- (9) conceptualise
- atmospheric
- warm
- friendly
- negotiate

which are not nouns?

Fortunately, there are other ways of determining the category of words, which we will turn to below. But it is important to note that there are two independent issues here. On the one hand is the issue of how the notion of word category is instantiated in the linguistic system and on the other hand is the issue of how we, as linguists, tell the category of any particular word. As to the first issue, word categories are simply properties of lexical elements, listed in the lexical entry for each word, and, as we have pointed out, lexical information is arbitrary. Therefore, word categories are whatever the linguistic system determines them to be. While there may be some link between meaning and category established by the linguistic system, for now it is not important that we establish what this link is or to speculate on its nature (does meaning influence category or does category influence meaning, for example?). More pressing at the moment is the issue of how we determine the category of any given word. Before looking at specific categories, let us consider some general ways for determining categories.

### 2.3 Morphological criteria for determining category

Consider the set of words in (8) again. Alongside these we also have the related words:

- (10) ideas
- weathers
- colds
- friendlinesses
- diplomacies



## Word Categories

---

Although some of these may sound strange concepts, they are perfectly acceptable forms. The *idea-ideas* case is the most straightforward. The distinction between these two words is that while the first refers to a single thing, the second refers to more than one of them. This is the distinction between singular and plural and in general this distinction can apply to virtually all nouns. Consider a more strange case: *friendliness-friendlinesses*. What is strange here is not the grammatical concepts of singular or plural, but that the semantic distinction is not one typically made. However, it is perfectly possible to conceptualise different types of friendliness: one can be friendly by saying good morning to someone as you pass in the street, without necessarily entering into a deeper relationship with them; other forms of friendliness may demand more of an emotional commitment. Therefore we can talk about different *friendlinesses*. By contrast, consider the following, based on the words in (9):

- (11)    conceptualises  
          atmospherics  
          warms  
          friendlies  
          negotiates

While not all of these words are ill formed by themselves, none of them can be considered to be the plural versions of the words in (9). These words simply do not have a plural form. Plural forms are restricted to the category noun and other categories do not have them.

What we have been looking at in the above paragraph is the **morphological** properties of words: the various forms we find for different words. Often morphemes constitute different pieces of words: the form *ideas* can be broken down into ‘idea’ and ‘s’, where the second piece represents the plural aspect of the word and is called the plural morpheme. The point is that only words of certain categories can host morphemes of certain types. Consider *warms* from (11). This, too, breaks down into two pieces, ‘warm’ and ‘s’. But the ‘s’ here is not the plural morpheme but another one which expresses something entirely different. This is the morpheme we get on words like *hits*, *sees*, *kisses* and *imagines* and it represents **present tense**, which has a number of meanings in English ranging from the description of what is taking place at the present moment to something that habitually happens:

- (12) a the groom kisses the bride (commentary on a video of a wedding)  
      b John hits pedestrians only when he’s not paying attention

Note that this morpheme cannot go in any of the words in (8) (except for *weather*, a fact that we will return to): *ideas* is not the present tense form of the word *idea*. Essentially then, different categories of words have different morphological properties and therefore one can distinguish between categories in terms of what morphemes they take: if it has a plural form, it is a noun and if it has a present tense form it is a verb.

It should be noted however, that there are a number of complications to the simple picture given above. First, it should be pointed out that morphological forms are not always uniformly produced. For example, compare the following singular and plural forms:

## Chapter 1 - Grammatical Foundations: Words

---

(13)	idea	ideas
	cat	cats
	man	men
	sheep	sheep
	hippopotamus	hippopotami

The first two cases in (13) represent the regular plural form in English, as we have been discussing. But even here there are differences. In the first case the morpheme is pronounced [z] whereas in the second it is pronounced [s]. This is a fact about English morpho-phonemics, that certain morphemes are unvoiced following an unvoiced consonant, that we will not go into in this book. However, this does show that what we are dealing with is something more abstract than simply pronunciations. This point is made even more forcefully by the third and fourth cases. The plural form *men* differs from the singular *man* in terms of the quality of the vowel and the plural form *sheep* is phonetically identical to the singular form *sheep*. From our point of view, however, the important point is not the question of how morphological forms are realised (that is a matter for phonologists), but that the morphological forms exist. *Sheep* IS the plural form of *sheep* and so there is a morphological plural for this word, which we know therefore is a noun. There is no plural form for the word *warm*, even abstractly, and so we know that this is not a noun.

What about cases like *weather*, where the form *weathers* can either be taken to be a plural form or a present tense form, as demonstrated by the following:

- (14) a the weathers in Europe and Australasia differ greatly  
b heavy rain weathers concrete

This is not an unusual situation and neither is it particularly problematic. Clearly, the word *weather* can function as either a noun or a verb. As a noun it can take the plural morpheme and as a verb it can take the present tense morpheme. There may be issues here to do with how we handle this situation: are there two entries in the lexicon for these cases, one for the noun *weather* and one for the verb, or is there one entry which can be categorised as either a noun or a verb? Again, however, we will not concern ourselves with these issues as they have little bearing on syntactic issues.

### 2.4 Distribution

Let us turn now to the observations made in (2) and (3). There we observed that there are certain positions in a sentence that some words can occupy and other words cannot. Clearly, this is determined by category. This is perhaps the most basic point of word categories as far as syntax is concerned. The grammar of a language determines how we construct the expressions of the language. The grammar, however, does not refer to the individual words of the lexicon, telling us, for example, that the word *cat* goes in position X in expression Y. Such a system would not be able to produce an indefinite number of sentences as there would have to be such a rule for every expression of the language. Instead, the grammar defines the set of possible positions for word categories, hence allowing the construction of numerous expressions from a small number of grammatical principles. The question of how these positions are defined is mostly what this book is about, but for now, for illustrative purposes only, let us pretend that English has a rule that says that a sentence can be formed by putting a

## Word Categories

---

noun in front of a verb. This rule then tells us that the expressions in (15) are grammatical and those in (16) are not:

- (15) a John smiled  
b cats sleep  
c dogs fly  
d etc.
- (16) a \*ran Arnold  
b \*emerged solutions  
c \*crash dogs  
d \*etc.

This is not meant to be a demonstration of how English grammar works, but how a rule which makes reference to word categories can produce a whole class of grammatical expressions.

We call the set of positions that the grammar determines to be possible for a given category the **distribution** of that category. If the grammar determines the distribution of categories, it follows that we can determine what categories the grammar works with by observing distributional patterns: words that distribute in the same way will belong to the same categories and words that distribute differently will belong to different categories.

The notion of distribution, however, needs refining before it can be made use of. To start with, as we will see, sentences are not organised as their standard written representations might suggest: one word placed after another in a line. We can see this by the following example:

- (17) dogs chase cats

If distribution were simply a matter of linear order, we could define the first position as a position for nouns, the second position for verbs and the third position for nouns again based on (17). Sure enough, this would give us quite a few grammatical sentences:

- (18) a dogs chase birds  
b birds hate cats  
c hippopotami eat apples  
d etc.

However, this would also predict the following sentences to be ungrammatical as in these we have nouns in the second position and verbs in the third:

- (19) a obviously dogs chase cats  
b rarely dogs chase birds  
c today birds hate cats  
d daintily hippopotami eat apples

It is fairly obvious that the sentences in (19) are not only grammatical, but they are grammatical for exactly the same reason that the sentences in (17) and (18) are: the nouns and verbs are sitting in exactly the same positions regardless of whether the

## Chapter 1 - Grammatical Foundations: Words

---

sentence starts with a word like *obviously* or not. It follows, then, that distributional positions are not defined in terms of linear order. Just how distributional positions are defined is something to which we will return when we have introduced the relevant concepts.

A further complication is indicated by the following observation:

- (20) a Knut hates sea  
b \*Knut smiles sea

The morphological forms *hates* and *smiles* are both present tense, indicating that the words are of the same category, i.e. verbs. However, as demonstrated by (20), these words appear to have different distributions and thus they belong to different categories. How can this apparent contradiction be reconciled? We will see that part of the solution to this problem follows from the way in which distributions are defined, which we have yet to discuss. However, another aspect of distribution can be discussed at this point. Note that a sentence in which the verb *smiles* would be grammatical, would be ungrammatical with the word *hates*:

- (21) a Knut smiles  
b \*Knut hates

Obviously there are words which cannot go in either of these positions:

- (22) a \*Knut cats sea  
b \*Knut cats

What (22) indicates is that the positions we are considering here are both verb positions, and hence a noun cannot occupy them. Yet some verbs can occupy one of these positions and other verbs can occupy the other. This suggests that there are different types of verb, what we might call **subcategories** of the category verb. If this is right, we would expect that the set of possible verbal positions would be divided up between the different verbal subcategories so that the positions in which one can appear in are those in which the others cannot. In other words, different subcategories will have **complementary distributions**. This indeed seems to be true, as (20) and (21) indicate.

### 3 A Typology of Word Categories

Having introduced some of the basic concepts, let us now turn to look at what categories we need to refer to in the description of a language like English. In generative linguistics it is often seen as a positive aim to keep basic theoretical equipment to a bare minimum and not to expand these unnecessarily. This can be seen in the standard approach to word categories in terms of the attempt to keep these to as small a number as possible. In the present book we will mainly be concerned with eight basic categories. These come in two general types: **thematic** categories and **functional** categories. In the thematic categories we have verbs (V), nouns (N), adjectives (A) and prepositions (P) and in the functional categories there are inflections (I), determiners (D), degree adverbs (Deg) and complementisers (C). Thus we have the following classification system:

## A Typology of Word Categories

---

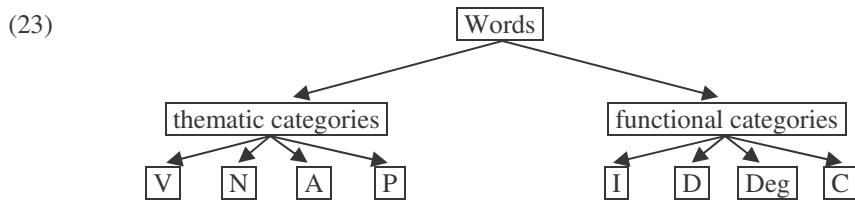

We will introduce these categories individually in the following sections.

### 3.1 Categorical features

Before we start to look at the properties of individual categories, we will make the typology of categories described in (23) a little more systematic. One might wonder why there are these categories and why their division is so regular: four thematic categories and four functional ones. Moreover, we may have the feeling that the categories given in (23) are not completely unrelated to each other. For example, it is often felt that nouns and verbs are somehow opposites of each other or that adjectives have some things in common with nouns and other things in common with verbs. Even across the thematic/functional divide, we may see similarities. For example, words like *the*, *these* and *some* are determiners and these seem more related to nouns, which they usually accompany, than to verbs. Modal auxiliary verbs, such as *may*, *can* and *must*, which as we will see are classified as belonging to the inflections, are obviously more closely related to verbs than nouns.

But how can we explain these perceived relationships? It is certain that if we define word categories in individual terms, say by just listing possible categories, then any explanation of the categories themselves or their relationships will be impossible. An analogy might serve to make the point clearer. Suppose that biologists had never thought of categorising living things into taxonomic groups and instead simply identified individual sub-species such as ladybirds, field mice, pythons, etc. From this perspective it would be impossible to answer questions such as why do ladybirds and bluebottles both have six legs and wings? At best, biologists would only be able to claim that this was an accidental chance happening. Once there is a taxonomic system, such questions are easily answered: ladybirds and bluebottles are both insects and all insects have six legs and wings. The same is true for word categories. If we merely identify categories such as nouns, verbs and determiners, we cannot explain relationships between the categories.

One way to impose a system on elements is to use a set of features to distinguish between them. Each category can then be defined in terms of a unique collection of these features, but they may share some of the features with other categories, accounting for similarities between them. In linguistics, binary features, i.e. those which can be valued in one of two ways (plus or minus), have been found useful for producing systems of categorisation. For example, we might propose a feature  $[\pm F]$  ('F' to indicate functional) to distinguish between the thematic and functional categories. All thematic categories would possess the  $[-F]$  feature and all functional categories would possess the  $[+F]$  feature. In this way we can immediately distinguish between the two groups and account for why certain categories are similar to others in terms of which feature they possess.

## Chapter 1 - Grammatical Foundations: Words

---

Other features that have been proposed include  $[\pm N]$  and  $[\pm V]$ , first suggested by Chomsky (1970). The ‘N’ and ‘V’ used in these features obviously do not stand for noun and verb as these categories are to be defined by these features. However, the fact that nouns are categorised as being  $[+N]$  and verbs as  $[+V]$  indicates that these features are meant to have something to do with these categories. To some extent, it is irrelevant what the features ‘mean’. The important point is which categories share which features and hence have something in common and which have different features and hence are distinguished. From this perspective we could have used features such as  $[\pm 1]$  and  $[\pm 2]$ .

Consider now the intuition that nouns and verbs are diametrically opposed categories. We can account for this if we assume that they have exactly the opposite features to each other. We have said that nouns are categorised as a  $[+N]$  category and so verbs must be  $[-N]$  if we are to maintain that they oppose nouns. Similarly, as verbs are  $[+V]$ , nouns must be  $[-V]$ . We therefore categorise nouns and verbs as the following:

$$(24) \begin{array}{l} \text{nouns} = [-F, +N, -V] \\ \text{verbs} = [-F, -N, +V] \end{array}$$

Note, both nouns and verbs are thematic categories and hence they share the  $[-F]$  feature, but in every other way they differ.

How can we capture the sense that determiners have something in common with nouns and modal auxiliary verbs have something in common with verbs, even though one of these pairs of elements is functional and the other is thematic? The answer is fairly easy. The pairs may differ in terms of the  $[\pm F]$  feature, but they are similar in terms of the  $[\pm N]$  and  $[\pm V]$  features:

$$(25) \begin{array}{l} \text{determiners} = [+F, +N, -V] \\ \text{modals} = [+F, -N, +V] \end{array}$$

In other words, determiners are the functional equivalents to nouns and modals are functional verbs.

To develop the system a little further, consider the intuitions that adjectives seem to have something in common with nouns, as they are typically used to modify nouns, as in *crazy kid* or *thoughtful suggestion*, but they also seem to have something in common with verbs, as they have certain distributional properties in common:

$$(26) \begin{array}{l} \text{a Rick is } \left\{ \begin{array}{l} \text{rich} \\ \text{running} \end{array} \right\} \\ \text{b the } \left\{ \begin{array}{l} \text{rich} \\ \text{running} \end{array} \right\} \text{ robber} \end{array}$$

In this example, *rich* is an adjective and *running* is a verb and obviously they can both appear in similar environments. But if nouns and verbs are diametrically opposed to each other, how can adjectives be similar to both? The answer is that adjectives share different features with both nouns and verbs. Thus, we may categorise both nouns and adjectives as  $[+N]$  and both verbs and adjectives as  $[+V]$  and in this way adjectives will share features with both nouns and verbs. Of course, they will also have features different from nouns and verbs, but as we do not want to categorise adjectives as the

## A Typology of Word Categories

---

same as the other categories, this is a positive aspect of this proposal. Adjectives can therefore be categorised as:

(27) adjectives = [-F, +N, +V]

Having demonstrated that we can capture similarities and differences between word categories using binary features, let us turn to the issue of what categories there are. We will start this discussion by considering the two binary features [ $\pm$ N] and [ $\pm$ V]. So far we have shown how combinations of these features can be used to define nouns, verbs and adjectives. The two binary features can be combined in four possible ways, however, and hence there is one possible combination that we have yet to associate with a category. This is demonstrated by the following table:

(28)

		N	
		+	-
V	+	adjective	verb
	-	noun	?

This is fortunate as there is one more thematic category left to be included into the system: the prepositions. Thus we can claim that prepositions fill this slot:

(29) prepositions = [-F, -N, -V]

However, this cannot be put down to good fortune. After all, categorising elements in terms of these features has consequences concerning what other categories are related to or different from these elements. Note that the feature combination in (29) predicts that while prepositions differ from nouns in that they are [-N], they are similar to nouns in that they are [-V]. Similarly, prepositions differ from verbs in being [-V], but they share the [-N] feature with them. Thus prepositions are predicted to be similar to nouns and verbs, but in a different way to how adjectives are similar to these categories. Indeed, while prepositions do not have similar distribution patterns as verbs, as do adjectives, they share another property with verbs. Consider the following observations:

- (30)
- a see him
  - b to him
  - c \*portrait him (portrait of him)
  - d \*mindful him (mindful of him)

In (30), we see that both verbs (*see*) and prepositions (*to*) can be followed by a word such as *him*, which is a pronoun. Nouns (*portrait*) and adjectives (*mindful*) cannot. We might claim therefore that the ability to be followed by a pronoun is restricted to the [-N] categories. Now consider the following:

- (31)
- a it was Sally that Sam saw
  - b it was underneath that I found the treasure
  - c \*it was stupid that Steve seemed
  - d \*it was fishing that Fred went

As shown in (31), a noun like *Sally* and a preposition such as *underneath* can sit in the position between the words *was* and *that* in this English construction, known as a cleft

## Chapter 1 - Grammatical Foundations: Words

---

construction. However, an adjective (*stupid*) and a verb (*fishing*) cannot occupy this position. We might claim therefore that this position can only be occupied by [-V] categories.

We see from the discussion above the predictive power of the system that we have set up: the system predicted that there should be a fourth thematic category that has certain properties and these fit the category of prepositions very well. We can take this as evidence in favour of this system of features. What else does the system predict? It is clearly predicted that if we add a third binary feature to the two we have just been discussing, then a further four categories will be defined. This again matches perfectly with the description of categories we started this section with, as seen in (23). With the third feature, [ $\pm F$ ], there should be four functional categories which match the four thematic categories in terms of their feature settings for [ $\pm N$ ] and [ $\pm V$ ]. We have already seen how determiners and modals can be analysed as functional nouns and functional verbs, respectively. The expectation is that degree adverbs, such as *so* and *too*, and complementisers, such as *that* and *if*, should be related to adjectives and prepositions in the same way. As degree adverbs modify adjectives in a very similar way to how determiners modify nouns, it is not difficult to conclude that degree adverbs are functional adjectives. This leaves complementisers to fill the final place as functional prepositions. There is evidence in favour of this assumption, but it rests on notions not yet introduced, so we will have to wait until later to demonstrate it.

We can re-draw the typology given in (23) using the three features in the following way:

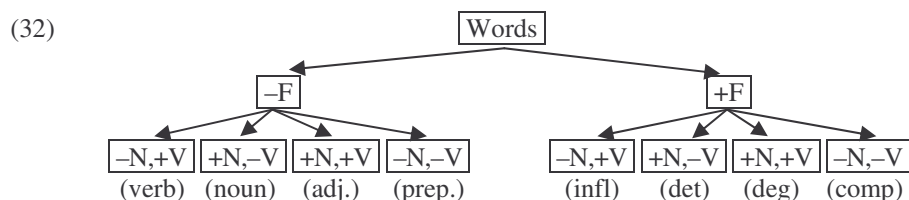

A further advantage of this system is that it places restrictions on what categories we can suppose to exist, hence increasing its explanatory power. For example, we would not be entitled to come up with an extra category without destroying the system developed. One way to add extra possible categories within the system would be to declare another binary feature. But this would not allow the addition of one extra category, but a further eight! Moreover, these extra categories would have to be shown to be related and opposed to the existing categories in the same way that these are related and opposed to each other.

Another way to extend the system, which we will be making some use of, relies on the notion of **underspecification** of features. All the categories discussed above are fully specified for all the features, so each is associated with a plus or minus value for all three features. Underspecification is a situation in which one or more features is not specified for its value. Thus, we might propose a new category [+N, -V] which is not specified for the [ $\pm F$ ] feature. This category would then be a noun which is neither functional, nor thematic. We will see that there is evidence that the [ $\pm F$ ] feature can be left underspecified and hence there are a further four ‘non-functional’ categories. We will introduce these categories in the following sections. The important point for the moment is that the system of features restricts our ability to invent new categories ‘willy-nilly’.



### 3.2 Predicates and arguments

To understand the difference between thematic and functional categories we first need to introduce concepts to do with how the elements of a sentence can be related to each other. Take a simple sentence:

(33) Peter chased Mary

This sentence describes an event which can be described as ‘chasing’ involving two individuals, Peter and Mary, related in a particular way. Specifically, Peter is the one doing the chasing and Mary is the one getting chased. The verb describes the character of the event and the two nouns refer to the participants in it. A word which functions as the verb does here, we call a **predicate** and words which function as the nouns do are called **arguments**. Here are some other predicates and arguments:

- (34) a Selena slept  
argument predicate  
b Tom is tall  
argument predicate  
c Percy placed the penguin on the podium  
argument predicate argument argument

In (34a) we have a ‘sleeping’ event referred to involving one person, *Selena*, who was doing the sleeping. In (34b) the predicate describes a state of affairs, that of ‘being tall’ and again there is one argument involved, *Tom*, of whom the state is said to hold. Finally, in (34c) there is a ‘placing’ event described, involving three things: someone doing the placing, *Percy*, something that gets placed, *the penguin*, and a place where it gets placed, *on the podium*.

What arguments are involved in any situation is determined by the meaning of the predicate. Sleeping can only involve one argument, whereas placing naturally involves three. We can distinguish predicates in terms of how many arguments they involve: *sleep* is a **one-place predicate**, *see* is a **two-place predicate** involving two arguments and *place* is a **three-place predicate**.

Moreover, the nature of the arguments is also largely determined by the meaning of the predicate. Compare the following:

- (35) a Harold hit Henry  
b Sam saw Simon

In the first case, *Harold* is the one doing the hitting and *Henry* is the one getting hit whereas in the second *Sam* does the seeing and *Simon* gets seen. However, these arguments play very different roles in the two events. With *hit* the one doing the hitting consciously performs an action and the one who gets hit is affected in some way by this. We call an argument who deliberately performs an action an *agent* and one who or which is acted upon a *patient*. With *see*, the arguments are not interpreted as agent and patient however: *Sam* is not performing any action and *Simon* is not getting acted upon in (35b). Instead, we call these arguments *experiencer*, for the one who does the seeing, and *theme*, for the one who gets seen. Collectively, we call terms such as agent and patient, **thematic roles**, or **Θ-roles** for short. I will not provide a definitive list of possible theta roles and their definitions here as such a list does not

## Chapter 1 - Grammatical Foundations: Words

---

exist. Different linguists tend to make use of different  $\Theta$ -roles and there is very little agreement amongst them. Fortunately, the identity of  $\Theta$ -roles has very little bearing on most syntactic processes and we can get a long way without precise definitions (exercise 3 introduces a wider list of  $\Theta$ -roles than given here).

Given that the meaning of a predicate which determines the nature of the arguments is a lexical property, the  $\Theta$ -roles that it determines must also be part of its lexical entry. We call the part of a predicate's lexical entry which informs us about which  $\Theta$ -roles the predicate has its **theta-grid**, and this may be represented as follows:

- (36) *sleep*  **$\Theta$ -grid:** <agent>  
*hit*  **$\Theta$ -grid:** <agent, patient>  
*see*  **$\Theta$ -grid:** <experiencer, theme>  
*place*  **$\Theta$ -grid:** <agent, patient, location>

(36) clearly represents that *sleep* is a one-place predicate, *hit* and *see* are two-place predicates and *place* is a three-place predicate.

So far we have mostly spoken of predicates that happen to be verbs, but it is not the case that all predicates are verbs. We have seen one case where this was not so, in (34b). Here we said the predicate was *is tall*. However considering the meaning of *Tom is tall*, we can see that the main semantic relations exist between *Tom* and *tall* and the *is* part simply expresses that Tom's being tall is true at the present time (compare this with *Tom was tall*). Thus, we might claim that *tall*, which is an adjective also has a  $\Theta$ -role as part of its lexical entry:

- (37) *tall*  **$\Theta$ -grid:** <theme>

Just like verbs, some adjectives express a relationship between two arguments:

- (38) a Fred is fond of Fiona  
b Kevin is keen on karate

In these examples we see two arguments being related by an adjective: *Fred* is the one who is 'fond' and *Fiona* is the one who he is 'fond of', etc. Thus we have the following lexical entries:

- (39) *fond*  **$\Theta$ -grid:** <experiencer, theme>  
*keen*  **$\Theta$ -grid:** <experiencer, theme>

Nouns, too, can be used as predicates:

- (40) Peter is a postman

And again, nouns can be used to express relationships between two or more arguments:

- (41) Picasso's painting of petunias

In this example, *Picasso* may be interpreted either as the possessor of the painting, or the agent who did the painting, while *petunias* constitutes the subject matter of the painting. We will consider the thematic status of the possessor in a subsequent section, but for now we will ignore the issue and suppose a lexical entry as follows:

- (42) *painting*  **$\Theta$ -grid:** <agent, theme>

## A Typology of Word Categories

---

It should be pointed out, however, that nouns tend not to have such a strong relationship to their arguments as verbs do. Often a noun can be used without any mention of its arguments:

- (43) a this is Picasso's painting of petunias  
b this is Picasso's painting  
c this is a painting of petunias  
d this is a painting

We might therefore state that the arguments of nouns are optionally represented in an expression and indicate their optionality in the lexical entry by placing the elements of the  $\Theta$ -grid in brackets:

- (44) *painting*  $\Theta$ -grid: <(agent), (theme)>

Note: Round brackets around an element means that that element is optional.

To complete the picture, it should also be pointed out that Prepositions too can act as predicates:

- (45) the house is on the hill

In this example, the arguments *the house* and *the hill* are related by a relation expressed by the preposition *on*. Thus we can propose the following lexical entry for this preposition:

- (46) *on*  $\Theta$ -grid: <theme, location>

With reference to the categorial features introduced in the preceding section, note that it is the [-F] categories that can have  $\Theta$ -grids. [+F] categories, as we will see below, are not specified in their lexical entries for these.

### 3.3 Grammatical aspects of meaning

Consider the following bracketed sentence:

- (47) I think [that Mary may marry Martin]

The predicate here is the verb *marry* and the arguments are *Mary* and *Martin*. Let us call the part of meaning expressed by a predicate and its arguments the **basic proposition**. But what role do the other words, *may* and *that*, have in the sentence? Clearly, they have no role in the basic proposition, being neither predicates nor arguments. But they do carry some meaning. *May* is a **modal auxiliary verb** and in this sentence it either expresses that the event described by the predicate and its arguments (Mary marrying Martin) is a possibility or that permission has been given for it to take place:

- (48) a Mary may marry Martin – but it's not sure that she will.  
b Mary may marry Martin – his mum will allow it.

The kind of meaning we are talking of here is known as the **modality** of the sentence and thus auxiliary verbs like *may*, *can*, *should*, etc. express modality.

*That* is a **complementiser** and its meaning is a little more difficult to determine. We can see its meaning if we compare (47) to (49):

(49) I asked [if Mary may marry Martin]

In the bracketed sentence here, the complementiser is *if* and we can see that the difference between this and the previous case is that here the sentence is interpreted as a question, not a statement as previously. The sentence beginning with *that* is **declarative** and the one beginning with *if* is **interrogative**. Given that the only difference between the two is the complementiser, it seems reasonable to assume that this is what the complementiser contributes to the meaning of the sentence. The distinction between declarative and interrogative is known as the **force** of the sentence and hence complementisers contribute to this aspect of sentence meaning.

Functional categories, such as modal auxiliaries and complementisers are specified for the [+F] and a distinguishing property of these categories is that they are not involved with the assignment of  $\Theta$ -roles. They therefore lack  $\Theta$ -grids in their lexical entries.

Having established this major division we will now proceed to investigate the individual categories.

### 3.4 The Thematic categories

Let us focus our attention first on the thematic ([-F]) categories, returning to the functional ([+F]) categories towards the end of the chapter. Much of our discussion so far has concerned verbs. This perhaps reflects their centrality in many sentences, being typical predicates. It also seems that notions such as predicate and argument are more obviously expressed in relation to verbs. So it is right to start our discussion of categories with them.

#### 3.4.1 Verbs

Verbs, as discussed above, are categorised as [-F, -N, +V] elements. In this section we will introduce a number of properties peculiar to this category.

We have already seen that verbs take morphemes which express tense:

(50) smiled/smiles  
reached/reaches  
required/requires  
etc.

The different forms of a word are known as its **inflections** and we say that verbs inflect for tense in that different forms represent tense distinctions. As discussed earlier, not all inflectional forms are regular and, especially in the past tense, we have irregular forms:

(51) sink – sank  
think – thought  
hit – hit  
etc.

We are not so much concerned with morphological or phonetic form in this book, so we can think of these past tense verbs as abstractly being a **stem**, i.e. the lexical verb, plus a past tense morpheme which we will represent as *-ed* though obviously this is not supposed to indicate a pronunciation:

## A Typology of Word Categories

---

- (52) sink+ed (= sank)  
think+ed (= thought)  
hit+ed (= hit)

Virtually all verbs have a past tense form, with only a handful of very exceptional cases, such as *lightening* used as a verb, which can only appear in this *ing* form:

- (53) a it is lightening  
b \*it lightens  
c \*it lightened

The present tense inflection is slightly different to the past tense one. Compare the examples in the following:

- (54) a Charlie chopped the cheese  
b I chopped the cheese  
c you chopped the cheese  
d they chopped the cheese  
e etc.

- (55) a Charlie chops the cheese  
b I chop $\emptyset$  the cheese  
c you chop $\emptyset$  the cheese  
d they chop $\emptyset$  the cheese  
e etc.

In (54) the verb has the same past tense inflection in all permutations of the sentence, but in (55) there is a difference between the first example and all the others. This corresponds to the fact that the argument which precedes the verb in the first case is third person and singular and in all other cases this argument is either plural or first or second person (I or you). This argument is called the **subject** and we will discuss its nature and properties in the next chapter. For now we will simply use the term to refer to the argument in front of the verb without further discussion. The morphological phenomenon shown in (55) is known as **agreement**. We say that the verb agrees with certain features (number and person) of the subject (later on, we will see that it is the inflection that agrees with the subject and that this is independent of the verb). English does not demonstrate much in the way of agreement inflection. For the vast majority of verbs it is only in the present tense and with a third person singular argument that the verb has an agreement form. The exception is the verb *to be*, for which there are three present tense forms (first person singular, third person singular and the rest) and two past tense forms (first and third person singular and the rest):

- (56) a I *am* ready  
b he *is* ready  
c you/*we*/they *are* ready

## Chapter 1 - Grammatical Foundations: Words

---

- (57) a I *was* ready  
c he *was* ready  
d you *were* ready  
e they *were* ready

Some languages show a good deal more agreement phenomena than English. Consider the Hungarian paradigm:

- (58) a én vá**gom** a sajtot  
I cut the cheese  
b te vá**god** a sajtot  
you ...  
c ő vá**gja** a sajtot  
he/she ...  
d mi vá**gjuk** a sajtot  
we ...  
e ti vá**játok** a sajtot  
you (pl.) ...  
f ő**k** vá**gják** a sajtot  
they ...
- (59) a én vá**gtam** a sajtot  
b te vá**gtad** a sajtot  
c ő vá**gta** a sajtot  
d mi vá**gtuk** a sajtot  
e ti vá**gtátok** a sajtot  
f ő**k** vá**gták** a sajtot

The English verb has other inflectional forms expressing things other than tense. For example there are perfect and progressive aspectual forms:

(60)	<b>past</b>	<b>perfect</b>	<b>progressive</b>
	went	has gone	is going
	drove	has driven	is driving
	hoped	has hoped	is hoping
	put	has put	is putting

While tense typically places an event in time, aspect refers to the process of the event itself: whether it has stopped or is still going on, for example. Perfect aspect often denotes that an event has finished while progressive denotes that it is still continuing:

- (61) a I have read the book (but I'm not doing it now)  
b I am reading the book (it's still going on)

As we can see from the 'perfect' column in (51), there is also a good deal of irregularity with this inflectional form. As before, we will envisage this as an abstract process in which a verbal stem and a morpheme are combined:

## A Typology of Word Categories

---

- (62) go+en (= gone)  
 drive+en (= driven)  
 hope+en (= hoped)  
 put+en (= put)

The progressive aspect is fortunately more regular and, in fact, it is always formed by adding *ing* to the stem. Finally, verbs have a passive form as well. This is always identical to the perfective however:

- (63) a he had driven the car            the car was driven down the road  
 b he had hoped to leave            it was hoped that he would leave  
 c he had put his trousers on        his trousers were put on

To summarise, there are five forms in which an English verb can appear: the base form (uninflected), the past tense form, the third person singular present form, the perfective (and passive) form and the progressive form.

(64)	base	past	3.s.present	perfective/ passive	progressive
	see	saw	sees	seen	seeing
	say	said	says	said	saying
	stop	stopped	stops	stopped	stopping
	strew	strewed	strews	strewn	strewing

Any word which inflects in this way will be a verb.

We cannot properly address the issue of the distribution of word categories until we have introduced the organising principles of English sentences, to which we turn in the following chapter. However, the issue of the subcategorisation of verbs, which has a role in determining verb distribution patterns, can be discussed here. Recall from above that we pointed out that different verbs seem to be able to be followed by different things:

- (65) a the villain laughed  
 b the hero defeated the villain

- (66) a \*the villain laughed the city  
 b \*the hero defeated

To some extent, this is connected to the properties of the verb as a predicate: *laugh* is a one-place predicate and its only argument, an agent, tends to precede it, while *defeat* is a two-place predicate and takes its agent to the left and the patient to the right. If we consider a three-place predicate, a pattern begins to emerge:

- (67) the mayor gave the hero a reward

In this case, one of the arguments appears to the left and the others are on the right. It seems that there is always one argument on the left and any other argument must follow the verb. We call the arguments which follow the verb the verb's **complements**. It appears that there is a special relationship that holds between a verb and its complements. Consider the following:

## Chapter 1 - Grammatical Foundations: Words

---

- (68) a the villain awaited his trial  
b the villain waited for his trial

- (69) a \*the villain awaited for his trial  
b \*the villain waited his trial

What we see by these examples is that different verbs are followed by different complements. The verb *await* must be followed by a nominal complement (i.e. one expressed with a noun: his *trial*) whereas the verb *wait* must be followed by a prepositional complement (expressed with a preposition: *for* his trial). Although there is often a connection between the thematic interpretation of the complement argument and its category, patients tend to be nominal and locations tend to be expressed by prepositional complements for example, it is not always possible to predict the category of the complement from its thematic role. In (68) for example, the two complements seem to be interpreted fairly similarly, but still they are expressed by complements of different categorial statuses. It follows that the category of the complement should be stated as a separate piece of information in a verb's lexical entry:

- (70) *await* **category:** [-F, -N, +V]  
**Θ-grid:** <agent, goal>  
**subcat:** [nominal]  
*wait* **category:** [-F, -N, +V]  
**Θ-grid:** <agent, goal>  
**subcat:** [prepositional]

What is represented in these lexical entries is that the two verbs are both two-place predicates taking agent and goal (something that an action is directed towards) arguments, but that the goal of *await* must be nominal while that of *wait* must be prepositional. The part of the lexical entry that states the categorial status of the complement is known as a **subcategorisation frame**. Thus a lexical entry for a typical verb will consist of a theta-grid and a subcategorisation frame in addition to phonological and semantic information.

Traditionally, verbs which have nominal complements are called **transitive** and those without **intransitive**. The verb *await* is a transitive verb and *wait* is intransitive. However, another kind of intransitive verb has no complement at all:

- (71) a the villain laughed  
b the dragon flew  
c Susan slept

These verbs are one-place predicates with their arguments on the left. Their lexical entries might be represented as follows:

- (72) *laugh* **category:** [-F, -N, +V]  
**Θ-grid:** <agent>  
**subcat:** [∅]



## A Typology of Word Categories

---

*fly*     **category:** [-F, -N, +V]  
           **Θ-grid:** <agent>  
           **subcat:**        [∅]

*sleep*   **category:** [-F, -N, +V]  
           **Θ-grid:** <agent>  
           **subcat:**        [∅]

Because these verbs have no complements, their subcategorisation frames are empty (as indicated by the ‘null symbol’ ∅, which typically stands for the absence of content). These verbs obviously differ from those such as *wait* which have non-null subcategorisation frames. We might distinguish between the two types by referring to those in (72) as true intransitives and those such as *wait* as being **prepositional** verbs.

Various types of transitive verbs can also be distinguished. For example there are those which take one nominal complement and those which take two:

- (73) a the hero fought the dragon  
       b the king gave the hero half the kingdom

The traditional term for verbs with two nominal complements is **ditransitive**. We can represent the lexical entries for these verbs as follows:

(74) *fight*   **category:** [-F, -N, +V]  
               **Θ-grid:** <agent, patient>  
               **subcat:**        [nominal]

*give*        **category:** [-F, -N, +V]  
               **Θ-grid:** <agent, goal, theme>  
               **subcat:**        [nominal, nominal]

A further type takes both a nominal and a prepositional complement, known as **complex transitive** verbs:

- (75) a Percy placed the penguin on the podium  
       b *place*   **category:** [-F, -N, +V]  
                   **Θ-grid:** <agent, theme, location>  
                   **subcat:**        [nominal, prepositional]

Other verbs take adjectival or adverbial complements:

- (76) a the judge looked mean  
       b *look*    **category:** [-F, -N, +V]  
                   **Θ-grid:** <theme, attribute>  
                   **subcat:**        [adjectival]
- (77) a the pianist performed passionately  
       b *perform* **category:** [-F, -N, +V]  
                   **Θ-grid:** <agent, manner>  
                   **subcat:**        [adverbial]

Finally, there are verbs which are often traditionally called transitives, but which do not have a nominal complement at all. These verbs take sentences as their complements.

## Chapter 1 - Grammatical Foundations: Words

---

- (78) a Larry left = sentence  
b Theodore thinks Larry left

From a semantic point of view, these verbs take a proposition as their complement and this obviously is expressed as a sentence. We might therefore suppose a lexical entry such as the following:

- (79) *think* **category:** [-F, -N, +V]  
**Θ-grid:** <experiencer, proposition>  
**subcat:** [sentence]

There is no traditional term specifically for predicates with sentential complements, but generative grammar has not felt the need to invent one as the subcategorisation frame serves to distinguish between the different subcategories of verbs.

### 3.4.2 Nouns

The next category we will discuss is the noun, which we categorised as bearing the features [-F, +N, -V] above. With verbs, they share the property that they have Θ-grids as part of their lexical entries, being [-F] categories. But they are distinguished from verbs on the other two features and hence do not share many other properties.

From a morphological point of view, nouns are less varied than verbs, having just two forms, singular and plural:

- (80) dog dogs  
pass passes  
mouse mice  
buffalo buffalo  
cherub cherubim

Like verbs there is a fair amount of deviation from the regular morphological representation of the plural [s]. Again, we will ignore the morphological irregularities and treat these forms as being syntactically *stem + plural*:

- (81) dog + s = dogs  
pass + s = passes  
mouse + s = mice  
buffalo + s = buffalo  
cherub + s = cherubim

Besides morphological irregularity, there are also a number of problematic cases. Some nouns express concepts for which number distinctions are not normally made. For example, *sand* refers to stuff that naturally comes in a quantity for which the division into 'one' (singular) and 'more than one' (plural) is not particularly natural. Nouns which naturally accommodate this distinction are known as **count nouns** and those that do not are called **mass nouns**. If we wish to individuate mass nouns, we usually do this in terms of another noun which names a unit of what the mass noun refers to and put this into a more complicated construction, known as the **partitive**:

- (82) a three grains of sand  
b seven loaves of bread  
c two cups of tea

## A Typology of Word Categories

---

Thus, it is not typical to find plural forms of mass nouns, though, of course, this does not mean that they should not be considered as nouns. As a matter of fact, plural forms of mass nouns do exist, though their uses tend to be rather specialised:

- (83) a the sands of time  
b the seven seas  
c the breads that we bake

Typically, the plural forms of mass nouns tend to refer to different collections of what the nouns refer to. Take (83c) for example. Here the plural noun *breads* refers to various types of bread: cottage loaves, whole meal bread, rye bread, baguettes, etc.

Another class of nouns for which the plural form is not entirely natural is the **proper nouns**, i.e. names. Again, there is probably a semantic reason for this: names name individuals and individuals come in ones. Once again it is possible to find proper nouns used in the plural with the right semantic context:

- (84) a the two Ronnies (British comedy series of the 1970s)  
b the Smiths will be visiting next week  
c there are no Einsteins in this class

In the first case, the plural proper noun is used because it refers to two individuals who happen to have the same name (Ronny Corbet and Ronny Barker in this instance). In the second, the family name *Smith* is used in the plural to refer to the collective set of individuals of that family and in the third case the name *Einstein* is not used as a name at all, but as a word to describe an individual with certain properties (high intelligence in this case).

Exactly the opposite problem is caused by examples such as *scissors* and *trousers*, which appear to be nouns which lack a singular form (*\*scissor*, *\*trouser*). This might be more of a semantic problem rather than a grammatical one however, as the objects to which these words refer are inherently plural in some respect: scissors have two blades and trousers have two legs. Moreover, without this plural aspect to the meaning, the object ceases to be describable in the same way: something with one blade cannot be described as scissors (or scissor for that matter) and something with one leg is not trousers (nor trouser). Again, it is possible to find the singular form of such words used, though in very limited contexts. When two nouns are put together to form a single **compound noun**, the preceding noun must be in its singular form:

- (85) armchair           \*armschair  
doorframe           \*doorsframe  
schoolboy           \*schoolsboy

(There are some exceptions, e.g. *dogsbody*.) Note this restriction holds whether or not the plural form would be more appropriate semantically, as is the case with *armchair* which tend to have more than one arm! When an inherently plural noun is used as the first noun in a compound, it too appears in its singular form:

- (86) scissor-kick       \*scissors-kick  
trouser-press       \*trousers-press  
spectacle-case       \*spectacles-case

## Chapter 1 - Grammatical Foundations: Words

---

In general then, it seems that nouns are a fairly well behaved category and that even for the more problematic cases morphologically distinct forms for singular and plural can be found.

Turning to the distribution of nouns, as with verbs a proper treatment of this will be possible later in this chapter, though we can once again talk about subcategories of noun. Nouns subcategorise in exactly the same way that verbs do, in terms of restrictions placed on the possible categories of their complements. Just as with verbs, the complement of the noun follows it. The similarity between noun complements and verb complements can best be seen by comparing the behaviour of nouns that have been derived from verbs with these verbs:

- (87)
- |   |                                 |                                |
|---|---------------------------------|--------------------------------|
| a | he waited for the letter        | his wait for the letter        |
| b | he believed in Father Christmas | his belief in Father Christmas |
| c | he fought with the dragon       | his fight with the dragon      |
| d | I expect that he left           | my expectation that he left    |
| e | they detonated the bomb         | their detonation of the bomb   |

As seems clear, most nouns that are formed from verbs take exactly the same complements as the original verb does. The one difference can be seen in (87e) where the verb takes a nominal complement while the noun takes a prepositional one. Note that the verb and its complement express exactly the same relationship as the noun and its complement: in both cases it is 'the bomb' that gets detonated. Thus, the preposition *of* in the case of the noun complement does not seem to add anything of a semantic nature. Moreover, this is an entirely regular process – any verb that has a nominal complement will take a prepositional complement (with *of*) when it is formed into a noun:

- (88)
- |                        |                                      |
|------------------------|--------------------------------------|
| construct a house      | construction <b>of</b> a house       |
| destroy his confidence | destruction <b>of</b> his confidence |
| observe the reaction   | observation <b>of</b> the reaction   |
| peruse the index       | perusal <b>of</b> the index          |

Indeed, there are no nouns that take following nominal complements, even ones that are not formed from verbs:

- (89)
- |                         |                       |
|-------------------------|-----------------------|
| a book of magic         | *a book magic         |
| a plague of flies       | *a plague flies       |
| a case of mismanagement | *a case mismanagement |
| a cup of tea            | *a cup tea            |

For some reason then, it seems that the whole class of nouns fails to have nominal complements and thus they differ from verbs in this way (we will see later on in this book there is an explanation for this observation). However, other than this, nouns can take any other kind of complement and as such we can propose that they subcategorise in the same way as verbs do, by the inclusion of a subcategorisation frame in their lexical entries.

This inability to take nominal complements is something nouns share with adjectives, as we shall see. Verbs pattern with prepositions in this respect. Thus we can claim that whatever property it is that allows verbs and prepositions to take nominal

## A Typology of Word Categories

---

complements, it is connected to the [-N] feature that they both share. The [+N] categories (nouns and adjectives) obviously lack this property.

It is clear from the examples given above that nouns formed from verbs have arguments in the same way that those verbs do: the noun *wait* may express the relationship between someone who is waiting and what they are waiting for. The argument that comes to the left of the verb is typically expressed by the possessor of the derived noun (*his* and *my* and *their* in (87)). In other instances, however, the possessor simply names the one who possesses the noun. The difference is made clear in the two interpretations of the following:

(90) Ken's construction of a kite

This can be interpreted either as something that *Ken* did (he constructed a kite) or something that he possesses (the kite is his). Obviously the possessive interpretation is only available for the case of the noun, the related verb cannot have a possessive argument:

(91) Ken constructed a kite

In this example, *Ken* can only be interpreted as agent. The question arises as to whether the possessor is another thematic argument which nouns can have, in addition to agents, patients, themes, goals, etc., or whether it is something of a different nature. There is reason to believe that the possessor is not the same kind of element as a thematic argument. One thing that differentiates possessors from other arguments is that the possessor may appear with almost any noun and does not appear to be determined by the noun's meaning:

- (92) a my music                      (e.g. the CDs that I own)  
      b your drawing                (the one on your wall)  
      c his organisation            (the one that belongs to him)  
      d our plans                    (the bits of paper that we have)

Of course there are things named by nouns that cannot be possessed in this way:

(93) Emily's embarrassment

In this example, *Emily* has to be interpreted as the one who experiences the embarrassment rather than someone who possesses it outside of their emotions. But this is a general semantic fact: some things can be possessed and other things cannot. The fact remains, however, that of those things that are able to be possessed, the relationship between them and the possessor is uniform and is not affected by the meaning of the noun. This is very different from other argument-predicate relationships:

- (94) a he wriggled                    (he = agent)  
      b he arrived                    (he = theme)  
      c he embarrasses easily      (he = experiencer)  
      d he attracts criticism        (he = goal)

## Chapter 1 - Grammatical Foundations: Words

---

Another difference between the possessor and arguments is that the semantic relationship that possessors express is rather vague in relation to those expressed by arguments. Consider the following:

(95) Shufflebotham's sheep

The relationship between Shufflebotham and the sheep could be almost anything, ranging from ownership to something far more distant such as the sheep that Shufflebotham selected in a sheep of the year contest. Thematic arguments, on the other hand, have very definite interpretations: an agent is someone who consciously performs an action and cannot be interpreted as anything else.

A final difference between possessors and arguments is that the possessor relationship is restricted to nouns whereas thematic relationships seem to be available to all thematic categories: we can find themes, experiencers, etc. for verbs, nouns or adjectives.

For these reasons, therefore, we will not consider the possessor to be a thematic role included in the lexical entry of the nouns, but something that can be added to any compatible noun. Below we can see some example lexical entries for nouns:

(96)	<i>wait</i>	<b>category:</b> [-F, +N, -V] <b>Θ-grid:</b> <agent, goal> <b>subcat:</b> [prepositional]
	<i>belief</i>	<b>category:</b> [-F, +N, -V] <b>Θ-grid:</b> <experiencer, theme> <b>subcat:</b> [prepositional]
	<i>fight</i>	<b>category:</b> [-F, +N, -V] <b>Θ-grid:</b> <agent, theme> <b>subcat:</b> [prepositional]
	<i>expectation</i>	<b>category:</b> [-F, +N, -V] <b>Θ-grid:</b> <experiencer, proposition> <b>subcat:</b> [sentential]
	<i>plague</i>	<b>category:</b> [-F, +N, -V] <b>Θ-grid:</b> <theme> <b>subcat:</b> [prepositional]
	<i>cat</i>	<b>category:</b> [-F, +N, -V] <b>Θ-grid:</b> <∅> <b>subcat:</b> [∅]

### 3.4.3 Adjectives

We now turn to the [-F, +N, +V] category: adjectives. As their categorial features suggest they share properties with both nouns and verbs, though obviously differ from both.

Adjectives tend to describe states, properties or attributes of things, though as usual, one needs to be careful with semantic definitions of syntactic categories. This category tends to be used in one of two ways; either as a modifier of a noun or as a predicate in a sentence:

- (97) a a stupid man  
b the man was stupid

## A Typology of Word Categories

---

This observation, however, will also require modification once we start to consider adverbs and their relationship to adjectives.

The morphology of adjectives is an interesting area, though slightly more complex than that of verbs and nouns. There are three main adjectival morphemes which we might use to identify members of the category. First, many adjectives have three distinct forms relating to the straightforward adjective (traditionally called the **positive form**), the situation in which two elements are compared with respect to the property expressed by the adjective (the **comparative form**) and the situation in which more than two elements are compared (the **superlative form**):

(98)	positive:	tall	sure	clever
	comparative	taller	surer	cleverer
	superlative	tallest	surest	cleverest

Although there are few irregular adjectival inflections for comparative and superlative (*many – more – most, good – better – best, far – further – furthest* being obvious examples), there are a number of adjectives which do not take part in this morphological paradigm at all. One class of adjectives that do not have comparative or superlative forms are those which cannot be used for the basis of comparison from a semantic point of view. Obviously, the notion of comparison involves properties that can be graded into more or less: the property *long*, for example, covers a whole range of lengths, some longer some shorter. A long piece of string could be anything between, say 1 metre and infinitely long. We can therefore compare two elements in terms of their lengths and determine that one is longer than the other. Some adjectives however, do not express properties that can form the basis of comparison: some states such as being *dead* or being *married* are absolute or **ungradable**, so someone cannot be more dead or more married than someone else. Clearly ungradable adjectives are not going to have comparative or superlative forms:

(99)	dead	set	married	frozen	plural
	*deader	*setter	*marrieder	*frozenner	*pluraler
	*deadeast	*settest	*marriedest	*frozenest	*plurallest

In the above cases there is a semantic explanation for the lacking forms. In other cases however, there are other explanations. Quite a few adjectives are morphologically complex, being derived from nouns or verbs. It seems that morphologically complex adjectives cannot bear the comparative and superlative morphemes:

(100)	*beautifuler	*beautifullest
	*Americaner	*Americanest
	*fortunater	*fortunatest
	*edibler	*ediblest
	*sunkener	*sunkenest
	*smilinger	*smilingest

There are, however, certain exceptions to this:

(101)	smoke – smoky – smokier – smokiest
	stretch – stretchy – stretchier – stretchiest
	friend – friendly – friendlier – friendliest

## Chapter 1 - Grammatical Foundations: Words

---

It seems that adjectives formed with either ‘-y’ or ‘-ly’ are able to take ‘-er’ and ‘-est’.

However, unlike the case of the ungradable adjectives, we can express comparative and superlative notions with morphologically complex adjectives using degree adverbs *more* and *most*:

- (102)    more beautiful    most beautiful  
          more American    most American  
          more fortunate    most fortunate  
          more edible        most edible  
          more sunken        most sunken  
          more smiling      most smiling

These are known as the **periphrastic** comparative and superlative constructions as opposed to the inflectional ones. Often it is the case that adjectives participate in either one or the other of these constructions, though there are some adjectives that can appear with both:

- (103)    bigger            \*more big  
          \*reliabler    more reliable  
          wiser            more wise

We need not go into this any further. The main point that concerns us here is that the less productive nature of these adjectival morphemes makes them less reliable as a test for adjectival status than we have seen in the case of verbs and nouns. Obviously, if a word can appear in a comparative or superlative form, it is an adjective, but failure to do so cannot automatically lead us to a negative conclusion.

Another morpheme closely associated with adjectives is *-ly*. This is used with a large number of adjectives to form adverbs:

- (104)    nice            nicely  
          brave        bravely  
          black        blackly  
          erroneous    erroneously

There is some debate about the status of this morpheme which revolves around the central issue of our present discussion. On the one hand, *-ly* might be taken as a **derivational morpheme** which is applied to a lexical item of one category to derive another lexical item of another category. This would be similar to morphemes such as *-er* in *cook-er*, *-ic* as in *scen(e)-ic* or *-ment* in *govern-ment*. We have not been concerned with such morphemes so far as they tend to be rather restricted, applying to certain lexical items of a given category rather than to the category as a whole. There are, for example, no forms *\*exister* (someone who exists), *\*viewic* (the property of resembling a nice view) or *\*rulement* (the collective body of people who rule). As we have been concerned in using morphological observations for identifying categories, the derivational morphemes would have been only of limited use to us. The important point about derivational morphology is that it takes place in the lexicon, forming new lexical elements from others, prior to any grammatical operation. If *-ly* is a derivational morpheme, then adverbs are a different category from the adjectives they are derived from. However, we have no feature analysis for adverbs using the  $[\pm F]$ ,  $[\pm N]$  and  $[\pm V]$



## A Typology of Word Categories

---

features and as we have pointed out we cannot just introduce a new category into the system without there being some fairly substantial consequences. If we introduce a new feature to try to accommodate adverbs, we predict the existence of a further seven more categories for which we have very little evidence.

However, *-ly* is strangely productive for a derivational morpheme, applying to many adjectives, though there are exceptions:

- (105) \*bigly  
      \*redly  
      \*fastly

Yet we can explain many of these absent forms. For example, while the form *fastly* does not exist, the form *fast* can be used as both an adjective and an adverb:

- (106) a he rode a fast horse (adjective)  
      b the horse ran fast (adverb)

In many ways, then, this is like the missing plural *\*sheeps* or the missing past tense *\*putted* (as past tense of *put*, not *putt*, which is *putted*). As such *fast* is just an irregular adverb. In general, colour adjectives do not tend to form adverbs and the fact that this is a semantically well-defined class of adjectives indicates that there might be semantic reasons for it. This is further supported by the fact that colour adjectives that do form *-ly* adverbs, such as *blackly*, do so only if they have meanings that go beyond reference to the colour: *blackly* means ‘in a sinister or evil way’ and *greenly* can mean either *innocently* or *enviously*. Admittedly, the absence of size adverbs like *\*bigly* and *\*smallly* is problematic given the existence of *hugely* and *minutely*. But putting this small number of problematic cases to one side, we can see that the *-ly* morpheme is a very productive one, applying to most adjectives. As pointed out above, most derivational morphemes, being lexical in nature, are not productive and apply only to selected lexical items.

The alternative to viewing *-ly* as a derivational morpheme is to see it as an **inflectional morpheme**. These are morphemes like the ones we have been mainly concerned with so far. These apply to a lexical word to give back another form of the same word. So *see*, *sees*, *saw*, *seen* and *seeing* are all forms of the same word, not different words created from a single source as are *depart*, *department*, *departmental*, *departmentalisation*. Inflectional morphemes on the whole are a lot more productive than derivational morphemes (though we have seen a certain degree of irregularity and exceptions in most of the morphemes we have investigated) and this would seem to fit better the productive nature of *-ly*. However, in what sense can an adjective and its related adverb be considered different forms of the same word, especially if they belong to different categories? If *-ly* is an inflectional morpheme, it seems that we would have to consider adjectives and adverbs to be the same category. There is a certain amount of evidence in support of this view however. First, note that both adjectives and adverbs have similar distributions, if we consider their immediate environment:

- (107) a very fond  
      b as quick as lightning  
      c too happy to notice  
      d so foolish that he believed me

## Chapter 1 - Grammatical Foundations: Words

---

- (108) a very fondly  
b as quickly as lightning  
c too happily to notice  
d so foolishly that he believed me

We see from these examples that the same kinds of words (*very, as, too, so, etc.* – known as **degree adverbs**) are used to modify both adjectives and adverbs. Such things cannot be used to modify words of other categories:

- (109) a \*very smiled  
b \*too disaster to think about

Thus, it seems that adjectives and adverbs are closely related categories if they are not the same category. Of course, over a larger domain adjectives and adverbs do not distribute the same: adjectives tend to modify nouns and adverbs modify verbs or whole sentences:

- (110) a a hot cup of tea            \*a hotly cup of tea  
b it was debated hotly        \*it was debated hot

Yet, if we consider the total set of possible positions for adjectives and adverbs, we notice that where an adverb can appear an adjective cannot and vice versa. In other words, the two are in complementary distribution, just like transitive and intransitive verbs. In the case of verbs we took their complementary distributions to be evidence that they are of the same category and, therefore, there is no reason why we should not argue the same here in relation to adjectives and adverbs.

As a further observation, adverbs, like adjectives, can appear in contexts of comparison and hence in comparative and superlative constructions:

- (111) more beautifully            most beautifully  
more fortunately                most fortunately  
more smilingly                  most smilingly

Adverbs, however, tend not to have comparative or superlative forms:

- (112) cleverer/cleverest            \*cleverlier/cleverliest  
nicer/nicest                        \*nicelier/niceliest  
smarter/smarterest                \*smartlier/smartliest

The reason for this is probably because these adverbs are morphologically complex and as we have seen morphologically complex adjectives tend not to have such forms. This is supported by the fact that adverbs not formed with the *-ly* morpheme can have morphological comparative and superlative forms:

- (113) a his horse was running **faster** than mine    his horse ran **fastest**  
b I arrived **sooner** than I'd expected            I came the **soonest** that I could

Interestingly, for adjectives the derivational morpheme *-ly* does not block the comparative and superlative morphemes, as we have seen:

## A Typology of Word Categories

---

- (114) friendly    friendlier    friendliest  
lovely        lovelier        loveliest  
manly         manlier         manliest

This would seem to suggest that the two morphemes have different statuses and as the adjectival *-ly* is clearly a derivational morpheme, we might use this to argue that the adverb *-ly* is inflectional.

A final argument for seeing adjectives and adverbs as being of the same category has to do with the system of categorisation introduced in the preceding section. Above we pointed out that while verbs are able to take nominal complements, nouns are not. Adjectives are like nouns in this respect. For example, when we derive an adjective from a transitive verb, the adjective must take a prepositional complement, not a nominal one:

- (115) a observe the results  
      b \*observant the results        observant of the results

All adjectives are like this, even those not derived from verbs:

- (116) a \*fond his sister                fond of his sister  
      b \*keen crossword puzzles      keen on crossword puzzles  
      c \*certain the answer            certain of the answer

If we assume that this property is related to the [+N] feature, then we can account for why nouns and adjectives pattern alike in this respect, as both are [+N] categories. Note that prepositions and verbs, the [-N] categories, can have nominal complements. Adverbs behave like nouns and adjectives in not being able to have nominal complements:

- (117) a Mary minds her manners  
      b \*Mary carried out her duties, mindfully her manners  
      c Mary carried out her duties, mindfully of her manners

We shall see a little later that the question of what complements adverbs can take (and when) is a complex issue. However, as they never take nominal complements under any circumstances it is safe to assume that they are, like adjectives and nouns, a [+N] category. As adverbs are thematic categories they are also [-F] and thus they have either of the following feature specifications:

- (118) a [-F, +N, -V]  
      b [-F, +N, +V]

The feature set in (118a) is that of nouns and we have no reason to believe that adverbs are a type of noun. We are therefore left with the feature set (118b), which is that of adjectives. Hence it seems we are forced to accept that adverbs and adjectives are of the same category by the system we have devised.

The difference between adjectives and adverbs is in how they are used: a [-F, +N, +V] category that is used to modify a noun is called an adjective and one that is used to modify a verb or a sentence is called an adverb. That they often have different forms is not by itself a problem, as there are certain nominal elements, for example, that have different forms depending on how they are used:

## Chapter 1 - Grammatical Foundations: Words

---

- (119) a I know him  
 b he knows me

When a pronoun follows a verb, it has one form and this differs from the form it has before the verb. We will return to this in more detail in subsequent chapters, but for now all that is important to note is that these elements have different forms in different positions, but we do not therefore conclude that they belong to different categories. We will assume something similar is going on with the [-F, +N, +V] categories and that adjectival and adverbial forms are different forms of the same category determined by its use.

Though we will maintain the traditional terms for adjectives and adverbs, as there has not been a common term developed for them (Radford 1988 has suggested *Adverb* or *Adjective*, but surprisingly they did not catch on!). However, we will use the general category label *A* to stand for this whole category.

Finally in this section, we turn to the subcategorisation of adjectives and adverbs. We start with adjectives as these are the most straightforward. We have already seen that adjectives, like nouns, cannot take nominal complements. However, all other possibilities are open to them:

- |                                       |                                       |
|---------------------------------------|---------------------------------------|
| (120) a Reginald regrets the decision | Reginald is regretful of the decision |
| b Harry hopes that it will snow       | Harry is hopeful that it will snow    |
| c Rick responded to the treatment     | Rick is responsive to the treatment   |
| d Rebecca rested                      | Rebecca felt ill                      |

The lexical entries for these adjectives might therefore be:

- |                        |                  |              |                |                               |
|------------------------|------------------|--------------|----------------|-------------------------------|
| (121) <i>regretful</i> | <b>category:</b> | [-F, +N, +V] | <b>Θ-grid:</b> | <(experiencer) (theme)>       |
|                        | <b>subcat:</b>   |              |                | [prepositional]               |
| <i>hopeful</i>         | <b>category:</b> | [-F, +N, +V] | <b>Θ-grid:</b> | <(experiencer) (proposition)> |
|                        | <b>subcat:</b>   |              |                | [sentential]                  |
| <i>responsive</i>      | <b>category:</b> | [-F, +N, +V] | <b>Θ-grid:</b> | <(agent) (theme)>             |
|                        | <b>subcat:</b>   |              |                | [prepositional]               |
| <i>ill</i>             | <b>category:</b> | [-F, +N, +V] | <b>Θ-grid:</b> | <(experiencer)>               |
|                        | <b>subcat:</b>   |              |                | [∅]                           |

The arguments of the adjectives are included as optional to allow for their non-predicative use. When an adjective is used to modify a noun, it does not typically appear with its arguments:

- (122) a a regretful decision  
 b a hopeful football supporter  
 c a responsive audience  
 d an ill wind

The subcategorisation of adverbs is a rather more tricky issue. One would have thought that if adverbs are formal variants of the relevant adjective, then they would

## A Typology of Word Categories

---

subcategorise in the same way as these adjectives – like the present tense verb subcategorises in the same way as the past tense verb. There are some cases where this might well be true:

- (123) a the newspapers were independent of the government  
b the newspapers operated independently of the government

In this example, both the adjective (*independent*) and the adverb (*independently*) take the same prepositional complement. In other cases, however, this does not seem to work:

- (124) a he was very fond of his sister  
b we were all anxious that the plan should succeed

- (125) a \*he thought about his visit fondly of his sister  
b \*we met at the arranged time anxiously that the plan should succeed

These observations raise a number of perplexing questions. Why, for example, do adjectives and adverbs differ in this way? And why are some cases of adverbs with complements ok? Comparing (124) with (125) we can see a difference in the functions of the adjectives and adverbs: whereas the adjectives are functioning as the predicate of the sentence, the adverb plays a modifying role, modifying the verb in these cases. It turns out that when adjectives function as modifiers, they also cannot take the complements that they usually can:

- (126) a \*a very fond of his sister boy  
b \*an anxious that the plan should succeed band of pirates

Thus, it turns out that this is not a difference which divides adjectives and adverbs, but a property that unifies them. Under what circumstance can an adverb have a complement then? If what we said above is correct, we predict that adverbs can only take a complement when they do not function as modifiers. This is indeed true in (123b) where the adverb functions as a complement of the verb. It is quite unusual to find an adverb in a non-modifying role and, therefore, it is not at all usual to find adverb with complements.

### 3.4.4 Prepositions

The last thematic category we will consider is prepositions. The pattern with nouns in being [-V] and with verbs in being [-N] and therefore do not share any feature with adjectives, apart from [-F] as they are both thematic.

Morphologically there is very little to say about this category as they tend to be morphologically simple and do not have inflectional forms. However, this is a property that we may use to identify an instance of the category: they are the category that do not have plural, tensed, comparative or superlative forms:

- (127) with    \*withs    \*withed    \*wither    \*withest  
by        \*bys        \*byed        \*byer        \*byest  
to        \*tos        \*toed        \*toer        \*toest

There are a small number of exceptions to these observations. For example *inner* might be claimed to be a comparative form of *in*, *ins* is a possible plural (as in *ins and outs*) and *toing* is a progressive based on the preposition *to* (as in *toing and froing*).

## Chapter 1 - Grammatical Foundations: Words

---

But it is obvious that in such cases the stem is not used as a preposition, but as a member of the appropriate category: *in* in *ins* is a noun, not a preposition.

In terms of the subcategorisation of prepositions, they can appear with most types of complements, including nominal ones:

- (128) a it disappeared under the bridge  
 b it came from under the bridge  
 c he went out

In (128a) the preposition *under* takes a nominal complement, demonstrating its [-N] property, in (128b) *from* takes a prepositional complement and in (128c) *out* has no complement and hence is used ‘intransitively’.

The one complement that prepositions fail to have is clausal. While verbs, nouns and adjectives can all take clausal complements beginning with the word *that*, it seems that this is not possible for prepositions:

- (129) a we said [that we didn’t see the sign]  
 b our knowledge [that we were right]  
 c we were anxious [that you should be told]  
 d \*we spoke about [that you left]

It is quite mysterious why this should be, especially given the fact that all other categories seem to have no trouble in taking such complements. It is even more mysterious when we notice that prepositions can take certain clausal complements:

- (130) a I thought about [whether I should leave a note]  
 b I haven’t seen him since [we had the argument]

In (130a) the clause is **interrogative**, functioning as a question, and it seems that interrogative clauses can be the complements of certain prepositions. (130b) is even more puzzling as here we have a preposition with a clausal complement without a *that*. Typically this word is either optional or obligatory with clausal complements:

Note:  
 \*(xxx) means that xxx is obligatory

- (131) a Theodore thinks [(that) Linda left]  
 b my observation [\* (that) he had a missing shoe]  
 c I was certain [(that) no one knew about the body under the bed]

It is possible that, given the complementary distribution between words like *that* and *since*, they are of the same category and hence since is not used as a preposition in (130b). Indeed, we will see, words like *that*, being complementisers, are analysed as ‘functional prepositions’, given their feature specification [+F, -N, -V]. However, we will not pursue the issue here.

The following are some examples of the lexical entries of prepositions:

- |       |             |                  |              |                         |
|-------|-------------|------------------|--------------|-------------------------|
| (132) | <i>with</i> | <b>category:</b> | [-F, -N, -V] |                         |
|       |             | <b>Θ-grid:</b>   | <(theme)     | (location)>             |
|       |             | <b>subcat:</b>   |              | [nominal]               |
|       | <i>from</i> | <b>category:</b> | [-F, -N, -V] |                         |
|       |             | <b>Θ-grid:</b>   | <(theme)     | (location)>             |
|       |             | <b>subcat:</b>   |              | [nominal/prepositional] |

### 3.5 Functional Categories

It is now time we turned our attention to the second main subdivision of word categories, the functional categories.

#### 3.5.1 Inflections

The feature bundle [+F, -N, +V] defines a 'functional verb'. Such an element would have verbal properties, but no thematic content: it would not be specified for taking arguments in its lexical entry and hence would have no theta-grid. The most obvious thing that fits this bill is the class of auxiliary verbs:

- (133) a they **have** gone  
b he **is** shaving  
c she **can** swim

We need to distinguish between two groups of auxiliary verb, however. (133a) and (133b) involve aspectual auxiliaries (perfective and progressive respectively). (133c) concerns a modal auxiliary. These two types of auxiliaries differ not only in their semantic content, but also in their syntactic behaviour. For example, while modal auxiliaries are in complementary distribution with one another (there can only ever be one per clause), they are not in complementary distribution with the aspectuals. The aspectual auxiliaries are also not in complementary distribution with each other:

- (134) a \*he can will fly  
b he may have fallen  
c he must be hiding  
d he has been drinking

This distribution pattern would argue that modals occupy a different position to aspectuals. This position, note, is always in front of all other verbal elements.

Modal auxiliaries are also in complementary distribution with other elements of the clause. But before we can discuss this, we need to distinguish between two types of clause. Consider the clauses in brackets in the following:

- (135) a I think [that Sam saw me]  
b I was anxious [for Sam to see me]

These two clauses express the same thematic content: a seeing relationship holding between *Sam* and *me*. However, they differ in a number of ways. In (135a) the verb is inflected for tense (past in this case) whereas in (135b) the verb is uninflected and cannot display tense distinctions:

- (136) \*I was anxious [for no one to saw/sees me]

We call sentences with verbs inflected for tense **finite clauses** and those without, **non-finite clauses**. In finite clauses, the nominal element that is in front of the verb, if it is expressed as a pronoun, has a certain form, but it has another form in non-finite clauses:

- (137) a I think [that **he** saw me]  
b I was anxious [for **him** to see me]

## Chapter 1 - Grammatical Foundations: Words

---

This distinction is traditionally called a **Case** distinction, which has to do with the forms that certain nominal arguments appear in. In English there are not many Case distinctions to be seen as it is only the pronouns which have Case forms, but in other languages there can be more such distinctions made (think of Hungarian *János, Jánost, Jánosnak*, etc.). The *he* form of the pronoun (similarly, *she, I, we, they*) is called the **nominative case** form, while the *him* form (*her, me, us, them*) is the **accusative case** form. Note, finite clauses must have nominative elements in the relevant position, whereas, if the position is filled at all in non-finite clauses, it must be by an accusative element:

- (138) a \*I think [that **him** saw me]  
b \*I was anxious [for **he** to see me]

We can also see a difference between the clause types in terms of the word that introduces them, the complementiser. For the finite clause, the complementiser must be *that* and for this kind of non-finite clause, the complementiser must be *for*:

- (139) a \*I think [for he saw me]  
b \*I was anxious [that him to see me]

Finally, finite clauses can stand as the main sentence, in which other **embedded** sentences can appear. A non-finite clause is always an embedded clause:

- (140) a he saw me  
b \*him to see me

Returning to the modal auxiliaries, note that these can only appear in finite clauses:

- (141) a I think [that he could see me]  
b \*I was anxious [for him to could see me]

There are two points of interest. First, when a modal does appear in a finite clause, the verb does not appear in its finite (tensed) form:

- (142) \*I think [that he could saw me]

Second, the non-finite clause contains an element not found in finite clauses which appears to occupy the same position as the modal in finite clauses:

- (143) a I think [that he **could** see me]  
b I was anxious [for him **to** see me]

Putting these together, we find that there are three elements here which are in complementary distribution: modals, the non-finite element *to* and the finite inflections on verbs. In any clause, wherever one of these appears, the others cannot:

- (144) a I think [that he may leave/\*leaves/\*to leave]  
b I think [that he left/\*can left/\*to left]  
c I was anxious [for him to leave/\*must leave/\*leaves]

We have spoken about complementary distribution patterns before, concluding that elements that are in complementary distribution should be analysed as instances of the same category. If this argument applies here, then modals, finite inflections and the



## A Typology of Word Categories

---

non-finite element *to* are to be analysed as of the same category. While this makes perfect sense for modals and *to*, as these are words which appear to occupy the same position in the clause, it seems somewhat odd to claim that the finite inflections belong to this category. For a start, finite inflections are inflections that appear on the verb, not independent words themselves. However, there are things which seem to form part of other things in sentences, but which we might want to claim that at some deeper level of analysis are independent from them. Consider the status of *n't* in negated auxiliaries such as *can't*, *won't*, *couldn't*, etc. In one sense this element is part of the auxiliary, but in another sense it is an independent element expressing negation in exactly the same way that its non-contracted counterpart *not* does. It would seem reasonable to suggest that the contracted negative is an independent lexical item, with its own lexical entry (perhaps even the same one as the non-contracted negation) and that as such it enters the sentence as a word. Then there are syntactic processes which combine the auxiliary and negation into a single element:

(145) he will n't listen → he – won't – listen

It could be argued that the same thing is true of finite inflections: they enter a sentence as an independent word, but are joined with the verb by some syntactic process. If this is true, then there would be nothing wrong with treating finite inflections as the same kind of thing as modal auxiliaries as they could occupy the same underlying position:

(146) he –d smile → he – smile-d –

One argument in support of this treatment of finite inflections concerns the difference between inflectional morphemes and derivational morphemes, discussed above. A derivational morpheme forms a new word from an existent one in the lexicon. This new word has lexical properties of its own and may even differ in its meaning from the original word. Furthermore, the process tends to be limited, applying to a selection of lexical elements rather than to whole classes. Inflectional morphology, on the other hand, does not change the lexical element, it just provides another form of that word. Often, it adds some element of meaning (such as tense or plural) to the meaning of the original word rather than changing the meaning to something else. This all suggests that the two processes are very different and that derivational morphology is something that goes on in the lexicon to expand the number of available words. Inflectional morphology is, on the other hand, too regular to be a lexical process, applying to whole categories. This would seem to be the hallmark of a syntactic process not a lexical one. We will assume therefore that verbal morphemes expressing tense and agreement are independent words inserted into a sentence in their own position and undergo a subsequent syntactic process which combines them with the verb that they are attached to.

We, therefore, have a functional category with three main members: modal auxiliaries, the non-finite *to* and finite inflections. This category has been called **inflection**, sometimes abbreviated to INFL or more usually these days I.

## Chapter 1 - Grammatical Foundations: Words

---

Given that inflection is a functional category and takes no part in thematic structure, members of this category do not have theta grids as part of their lexical entry. Furthermore, their subcategorisation seems to be much simpler than any thematic category: all inflections are always followed by a verbal element and hence we might suppose that they all subcategorise for verbal complements:

- (147) *will*     **category:** [+F, -N, +V]  
                  **subcat:** [verbal]  
*can*         **category:** [+F, -N, +V]  
                  **subcat:** [verbal]  
*-ed*         **category:** [+F, -N, +V]  
                  **subcat:** [verbal]  
*to*          **category:** [+F, -N, +V]  
                  **subcat:** [verbal]

### 3.5.2 Determiners

The functional category that is most closely associated with nouns are the **determiners** which always precede nominal elements:

- (148) a **the** party  
       b **a** snake  
       c **this** idea of yours  
       d **which** friend of mine

Determiners may contribute to the interpretation of the nominal in terms of the notion of **definiteness**. This has a number of roles to play in interpreting a sentence. One of these has to do with how we introduce new items into a discourse and how we maintain a discourse topic. Consider the short monologue below:

- (149) A man walked into a shop. The shopkeeper greeted the man.

In the first sentence, we introduce the main aspects of the story: the man and the 'shop' situation. In this sentence the two nouns *man* and *shop* are preceded by the determiner *a*. This is the **indefinite article** and one of its functions is to signal new information that has not been mentioned previously. In the next sentence we have two more nouns *shopkeeper* and *man* (again). This time they are preceded by the determiner *the*, which is the **definite article**. Its function is to indicate information which has already been given and, therefore, to connect a series of sentences as being about the same thing. Thus, *the shopkeeper* is assumed to be the shopkeeper of the shop mentioned in the previous sentence, not another one round the corner, and *the man* is assumed to be the one who we have just been informed has walked into the shop, not one who was already in the shop, for example.

Determiners are also involved in the interpretation of nouns with respect to **specificity**. Compare the following:

- (150) a I was looking for the cat  
       b I was looking for a cat

In the first sentence there is a specific cat that I am looking for, and the speaker obviously assumes the person who is addressed knows which specific cat he is talking

## A Typology of Word Categories

---

about. The second sentence is, however, ambiguous. It could either mean that the speaker was looking for a specific cat, but assumed that the addressee does not know which cat is referred to, or it could mean that the speaker is looking for some non-specified cat and that any cat would satisfy the conditions of his search.

In English there are a number of syntactic phenomena that seem to be determined by the notion of definiteness. For example, only indefinite nominals can go in the post-verbal position in sentences which start with *there*:

- (151) a there once lived an old woodcutter  
b \*there once lived the old woodcutter

Determiners are often marked for number. So, *a*, *this* and *that* are singular whilst *these* and *those* are plural, only introducing nouns with the relevant number:

- (152) a a boy/\*boys  
b these girls/\*girl

With mass nouns, for which number is not applicable, we can have neither singular nor plural determiners (unless we treat the mass noun as a count noun, referring to types or groups of the material that the noun refers to – see the discussion in section 2.1.3.):

- (153) a \*a sand  
b \*these sand

The definite determiner *the* can be used in either singular or plural contexts and even those unmarked for number, when used with mass nouns:

- (154) a the boy  
b the boys  
c the water

A related concept to number is quantity and determiners often act as **quantifiers** for the nouns they introduce:

- (155) a some people  
b all newspapers  
c both parties  
d every student

These quantificational determiners are also often marked for number, introducing only certain types of noun:

- |       |       |                 |               |             |
|-------|-------|-----------------|---------------|-------------|
| (156) |       | <i>singular</i> | <i>plural</i> | <i>mass</i> |
| a     | both  | *house          | houses        | *bread      |
| b     | every | book            | *books        | *water      |
| c     | all   | *cat            | cats          | sand        |
| d     | some  | man             | men           | oil         |

They are also marked for definiteness and so may or may not introduce nouns sitting in the post-verbal position in *there* sentences:

## Chapter 1 - Grammatical Foundations: Words

---

- (157) a there arrived some letters  
b there appeared many djinn  
c \*there sat all footballers

Not all quantificational elements are determiners, however. Some quantifiers might at first appear to be determiners, but the observation that they are not in complementary distribution with determiners challenges this assumption:

- (158) a many problems (the many problems)  
b few ideas (these few ideas)  
c several inaccuracies (the several inaccuracies)

Traditionally this group of quantifiers are known as **post-determiners** as they always follow other determiners (which are sometimes called **central determiners**). This terminology gives the impression that post-determiners are a subclass of determiner, which is likely to be inaccurate. These elements often have many adjectival qualities, including being able to be modified by degree adverbs and having comparative and superlative forms:

- (159) a very many buildings    more buildings    most buildings  
b so few typos    fewer typos    fewest typos  
c ?very less money    ?the lesser money    the least money

For these reasons we will consider these elements as adjectival and will put off their discussion until a later section.

Pronouns might also be argued to be determiners. Certain determiners can be used straightforwardly as pronouns:

- (160) a I like this hat    I like this  
b I'd like some cake    I'd like some

Moreover, some pronouns can be used as determiners:

- (161) a we three kings  
b you fool  
c them dandelions (dialectal)

Also, pronouns and determiners are in total complementary distribution:

- (162) a the man  
b him  
c \*the him

While certain nouns tend not to appear with determiners either, suggesting that pronouns might be analysed as one of these kinds of noun, the fact is that all nouns *can* appear with determiners under the right circumstances:

- (163) a he's not the Peter she married  
b I met a Peter the other day

However, there are no circumstances that a pronoun can appear with a determiner:

## A Typology of Word Categories

---

- (164) a \*he's not the him she married  
b \*I met a him the other day

Like the inflections, the lexical properties of determiners are relatively simple. They have no theta grid and they subcategorise only for nominal complements. If pronouns are determiners, then in their pronominal use they can be considered as 'intransitive', taking no complement:

(165)	<i>the</i>	<b>category:</b>	[+F, +N, -V]
		<b>subcat:</b>	[nominal]
	<i>a</i>	<b>category:</b>	[+F, +N, -V]
		<b>subcat:</b>	[nominal]
	<i>this</i>	<b>category:</b>	[+F, +N, -V]
		<b>subcat:</b>	[(nominal)]
	<i>he</i>	<b>category:</b>	[+F, +N, -V]
		<b>subcat:</b>	[(∅)]

In these lexical entries, *the* and *a* are indicated to be determiners that have an obligatory nominal complement, while *this* has an optional complement and *he* has no complement. Thus *this* may be used as a pronoun (i.e. a determiner used without a nominal complement) and *he* is always used as a pronoun.

### 3.5.3 Degree Adverbs

So far we have looked at auxiliary verbs, which accompany verbs, and determiners, which accompany nouns, classifying these as functional equivalents of the categories they accompany. The obvious choice for functional adjectives, therefore, are the degree adverbs that accompany them:

- (166) a so light  
b too heavy  
c as thick (as a brick)

Thus we might categorise these elements as [+F, +N, +V].

It is a complex, but interesting question as to what counts as a degree adverb. Firstly, these elements are used primarily to indicate the degree to which the state or property expressed by an adjective holds of something. But there are a number of elements that do this, not all of which seem to behave the same:

- (167) a too strong  
b very fast  
c quite real  
d extremely tiring

Some of these degree modifiers are in complementary distribution with each other, indicating that they belong to the same category:

- (168) a \*too so tall  
b \*so as wide  
c \*as too long

However, others are not in complementary distribution:

## Chapter 1 - Grammatical Foundations: Words

---

- (169) a so very boring  
b quite as fragile  
c as extremely frustrating

This would suggest that not all of these words should be categorised as degree adverbs, that is, as words with [+F, +N, +V] categorial features. Given that normal adverbs can be used to modify adjectives, some of the cases in (167) can simply be taken as adverbs, especially those that are formed from adjectives by the *-ly* morpheme:

- (170) a he obviously left                      obviously tired  
b they certainly met                      certainly irregular  
c we wanted it extremely                      extremely tough

Others however are more difficult to categorise. Words like *very* do not appear to be able to be used as typical adverbs, modifying verbs or sentences, but are restricted to modifying adjectives as are the degree adverbs:

- (171) \*he flexed his muscles very

Besides distributional properties, degree adverbs also have other properties that unify them. For example, it is typical for a degree adverb to appear alongside a clausal element which follows the adjective being modified:

- (172) a so fat [that he couldn't do up the buttons]  
b too far [to walk]  
c as stupid [as they come]

This clause specifies the bounds to which the degree of the property expressed by the modified adjective is given. Note that plain adverb modifiers of adjectives do not appear with such limiting clauses:

- (173) a \*very tired [that he had to rest]  
b \*extremely big [to get through the door]  
c \*quite famous [as I am]

There is an interpretation in which these kind of constructions are not ungrammatical. However, this is where the following clauses are associated with the adjectives or even the whole clause rather than the degree modifiers:

- (174) a he was tired, [(so) that he had to rest]  
b the sofa was big [to get through the door]  
c he is famous, [as I am]                      (in formal English: as am I)

This is another reason to consider these words to belong to different categories.

Other words which behave as degree adverbs both distributionally and in that they can be accompanied by a limiting clause are the comparative and superlative adverbs *more* and *most*:

- (175) a so fanatical                      more fanatical                      \*so more fanatical  
b as wonderful                      most wonderful                      \*as most wonderful  
c more predictable [than I am]  
d most regrettable [of all]



## A Typology of Word Categories

---

Although the accompanying element to *most* does not look much like a clause, its interpretation is *of all the things that are regrettable*, which is more clause like. These observations also lead us to consider the inflectional comparative and superlative:

- (176) a so nice                      nicer                      \*so nicer  
 b as tall                              tallest                      \*as tallest  
 c cuter [than I am]  
 d strongest [of all]

Clearly, these behave exactly like the periphrastic constructions, and hence would seem to involve a degree adverb. The obvious choice would be the comparative and superlative morphemes themselves, which would suggest an analysis similar to what was proposed for verbal inflections: the comparative and superlative are independent lexical elements which are inserted into an expression separately into the degree adverb position and then by a syntactic process become attached to the adjective:

- (177) a -er tight →   
 b -est black → 

Below, we can see a selection of lexical entries for degree adverbs:

- (178) *so*            **category:** [+F, +N, +V]  
                       **subcat:** [adjectival]  
*more*            **category:** [+F, +N, +V]  
                       **subcat:** [adjectival]  
*-er*              **category:** [+F, +N, +V]  
                       **subcat:** [adjectival]

### 3.5.4 Complementisers

The final word category we will consider in this section is the complementiser. This category is used to introduce clauses of one type or another. For now, we can take a clause as a coherent part of an expression that contains an inflection, though this will be made more precise later in the book. Examples of complementisers are:

- (179) a I know [**that** I am right]  
 b I was hoping [**for** you to phone]  
 c I wonder [**if** you would lend me the money]

The remaining set of categorial features that has not been assigned to a category is [+F, -N, -V], that is 'functional prepositions'. One argument for treating complementisers as functional prepositions is the fact that at least one of them, *for*, has certain prepositional properties (it is sometimes called the **prepositional complementiser**). Note that prepositions take nominal complements that are always in the accusative Case, and never in the nominative:

- (180) a to/with/for/by/etc. him  
 b \*to/with/for/by/etc. he

## Chapter 1 - Grammatical Foundations: Words

---

Although the complement of complementisers (the part of the expression that follows it) seems to be clausal rather than nominal, the nominal element that follows the complementiser *for* is always accusative and indeed seems to depend on the complementiser to its presence in that if the complementiser is absent, then so must the nominal be:

- (181) a [for him to stay] would be unwise  
b \*[for he to stay] would be unwise  
c [to stay] would be unwise  
d \*[him to stay] would be unwise

We will be examining these observations in more detail later on in the book, but for now we can take the observations as support for the categorisation of complementisers as types of preposition. Indeed, we may even take this as evidence that complementisers should be [-N] elements as it is this feature that is responsible for the accusative nature of the following nominal, as discussed above.

Another argument in favour of categorising complementisers as functional prepositions is that both prepositional elements and clauses introduced by a complementiser undergo a syntactic process known as post-posing, where they appear to be moved to the end of the main clause:

- (182) a lies [about Larry] were circulated →  
lies were circulated [about Larry]  
b a book [that no one had read] was awarded first prize →  
a book was awarded first prize [that no one had read]

We saw above how inflectional elements determine the finiteness of the clause, with modal auxiliaries and tense appearing in finite clauses and the non-finite *to* appearing in non-finite clauses. Complementisers are also sensitive to finiteness. *That* and *if* always introduce finite clauses, while *for* always introduces non-finite clauses:

- (183) a that he may speak      \*that him to speak  
b if she is staying      \*if she to stay  
c for you to know      \*for you must know

A second property of complementisers concerns what might be termed the **force** of the clause that they introduce. This concerns the interpretation of the clause as either a statement or a question:

- (184) a I said [that I have the money]  
b I asked [if you are free at the weekend]

The complementisers *that* and *for* introduce **declarative** clauses, i.e. ones that make statements, while *if* introduces **interrogative** clauses, ones that ask questions. We can view this in terms of a set of non-categorial features which distinguish between the complementisers. These features are [ $\pm$ Wh] for the force of the clause and [ $\pm$ Fin] for the finiteness of the clause. The [+Wh] feature (pronounced ‘double-u aitch’) indicates interrogative, based on the fact that interrogative pronouns such as *who*, *what*, *where*, etc. are written with an initial ‘wh’ and the [-Wh] feature indicates declarative. [+Fin]



## A Typology of Word Categories

---

stands for finite and [-Fin] for non-finite. Thus, we have the following classification of complementisers:

(185)

		Wh	
		+	-
Fin	+	<i>if</i>	<i>that</i>
	-		<i>for</i>

Obviously, there is one missing complementiser, the [+Wh, -Fin] one. We will put this apparent gap in the system to one side until we are in a better position to deal with it.

The lexical entries for complementisers can be given as follows:

- (186)
- |             |   |
|-------------|---|
| <i>that</i> | <b>category:</b> [+F, -N, -V]<br><b>subcat:</b> [clausal]<br><b>features:</b> [-Wh, +Fin] |
| <i>for</i>  | <b>category:</b> [+F, -N, -V]<br><b>subcat:</b> [clausal]<br><b>features:</b> [-Wh, -Fin] |
| <i>if</i>   | <b>category:</b> [+F, -N, -V]<br><b>subcat:</b> [clausal]<br><b>features:</b> [+Wh, +Fin] |

### 3.6 Functionally underspecified categories

We have now discussed all eight of the categories that we listed at the start of this section. However, there are some categories that we have not yet discussed and some members of the categories that we have which do not seem to fit well in them. In this section we will briefly discuss the possibility of four extra categories which differ from the previous ones in that they are not specified for the [ $\pm$ F] feature. This means that they differ from each other in terms of the specification of the [ $\pm$ N] and [ $\pm$ V] features, but they differ from the other categories in that they are neither functional nor thematic.

We will start with the aspectual auxiliaries. We have pointed out that these auxiliary verbs do not behave like modals as they are not in complementary distribution with them. In fact, aspectual auxiliaries are not in complementary distribution with any I element:

- (187) a he **may** have been shopping  
 b ... for him **to** have been shopping  
 c he **had** been shopping

This would suggest that they are not categorised in the same way as inflections. They appear to be verbal elements as they inflect for almost the same set of things that verbs do (perfective *have* inflects for tense (*has/had*), progressive *be* inflects for tense (*is/was*) and perfect aspect (*been*) and passive *be* inflects for tense (*is/was*), perfect aspect (*been*) and progressive aspect (*being*)). However, they are clearly not thematic elements in that they play no role in the thematic interpretation of the sentence. Aspectual auxiliaries therefore share properties with verbs and inflections, but they cannot be categorised as either. We can capture this situation if, like verbs and

## Chapter 1 - Grammatical Foundations: Words

---

inflections, we categorise aspectuals as  $[-N, +V]$  elements, but simply leave the  $[\pm F]$  feature undefined. In common with inflections, aspectual auxiliaries also take only verbal complements and they never precede any other category. However, they may precede either verbs or other aspectual auxiliaries:

- (188) a he has [eaten the sandwich]  
b he has [been eating the sandwich]

Given that verbs are categorised as  $[-F, -N, +V]$ , we cannot claim that this is the category that aspectual auxiliaries subcategorise for as this would exclude them from taking non-thematic verbal complements (i.e. other aspectual auxiliaries). On the other hand, if we claim that they select complements of the category  $[-N, +V]$  they would only be able to select for auxiliary complements and not main verbs. The solution to the problem is stating that the category they select as their complement is optionally specified for the  $[-F]$  feature, which correctly predicts that they cannot have an inflectional complement.

Thus aspectual auxiliaries might have lexical entries such as the following:

- |       |             |                  |                  |
|-------|-------------|------------------|------------------|
| (189) | <i>have</i> | <b>category:</b> | $[-N, +V]$       |
|       |             | <b>subcat:</b>   | $[(-F), -N, +V]$ |
|       | <i>be</i>   | <b>category:</b> | $[-N, +V]$       |
|       | (prog)      | <b>subcat:</b>   | $[(-F), -N, +V]$ |
|       | <i>be</i>   | <b>category:</b> | $[-N, +V]$       |
|       | (pass)      | <b>subcat:</b>   | $[(-F), -N, +V]$ |

If there is a non-functional non-thematic verb, then it is predicted that there must be non-functional non-thematic nouns, adjectives and prepositions. To what extent is this prediction fulfilled? There are nouns which do not appear to behave like thematic nouns and yet are clearly not categorised as determiners either. Consider the following examples:

- (190) a a *bottle* of wine  
b a *cup* of tea  
c a *group* of tourists

The italicised items in these examples appear to be nouns and yet they do not behave like other nouns. If we compare these examples to the following we can see some obvious differences:

- (191) a a *picture* of the president  
b the *disposal* of the evidence  
c the *door* of the house

The nouns in (190) do not function as the main semantic element of the expression as do those in (191). Note that the expressions in (191) refer to a picture, a disposal and a door respectively, but the referents of the expressions in (190) are wine, tea and tourists respectively. One can pour a bottle of wine and drink a cup of tea, but what is poured and drunk is not the bottle or the cup but the wine and the tea. On the other hand, if one breaks a picture of the president or deplores the disposal of the evidence, it is not the president that gets broken nor the evidence that is deplored. The kind of

## A Typology of Word Categories

---

nouns in (190) are called **measure or group nouns** and they differ from other nouns in terms of their relationship to their complements. The complements of the nouns in (191) are arguments of those nouns and as such stand in a thematic relationship to them. In other words, these nouns are thematic elements which have  $\Theta$ -grids in their lexical entries. Measure nouns do not stand in the same relationship to their complements at all and in fact they appear to have a similar relationship to their complements as quantifying determiners do to their nominal complements. This is not a thematic relationship and hence it appears that these nouns are not thematic nouns. Clearly they are not determiners either and hence they seem to be prime candidates to be analysed as non-thematic non-functional nouns.

The complements of measure nouns are always prepositional, though specifically the preposition *of* is always involved. We are not yet in a position to clearly see the details of what this implies, so we will not pursue the issue at this point. The following lexical entries are an approximation of what is necessary to more precisely capture their true nature:

(192)	<i>bottle</i>	<b>category:</b>	[+N, -V]
		<b>subcat:</b>	[prepositional]
	<i>cup</i>	<b>category:</b>	[+N, -V]
		<b>subcat:</b>	[prepositional]
	<i>group</i>	<b>category:</b>	[+N, -V]
		<b>subcat:</b>	[prepositional]

Next, let us consider possible non-thematic non-functional adjectives. Recall that post-determiners are elements which seem to have adjectival properties in that they have comparative and superlative forms and may be modified by adverbs:

- (193) a the many/more/most people  
 b these extremely few advantages

It is clear that these elements are not thematic and hence should not be analysed as adjectives such as *pink*, *certain* or *keen*, for example. For one thing, they cannot be used predicatively as adjectives can, making them more like degree adverbs:

- (194) a the outcome was certain/irrelevant/stupid/etc.  
 b \*the people were more/most/several/etc.  
 c \*the idea was so/too/as

However, degree adverbs do not have comparative and superlative forms and so it would be inaccurate to categorise the post-determiners as functional adjectives (i.e. as [+F, +N, +V]). Therefore we propose that these elements be categorised as [+N, +V] elements. It seems that post-determiners always select nominal complements, which is why they have been confused with determiners and hence they have the following lexical entries:

(195)	<i>many</i>	<b>category:</b>	[+N, +V]
		<b>subcat:</b>	[nominal]
	<i>few</i>	<b>category:</b>	[+N, +V]
		<b>subcat:</b>	[nominal]
	<i>several</i>	<b>category:</b>	[+N, +V]
		<b>subcat:</b>	[nominal]

## Chapter 1 - Grammatical Foundations: Words

---

Finally, we turn to non-thematic non-functional prepositions. There are elements which appear to be prepositions, but which do not play a role in the thematic structure of the clause. For example, we have introduced the use of the preposition *of* in situations such as the following:

- (196) a a picture of Mary  
      b fond of his grandmother

As we pointed out, nouns and adjectives seem not to be able to take nominal complements and hence the preposition *of* is inserted so that the complement is prepositional instead. This preposition plays no role in the thematic interpretation of these constructions however, the thematic relations hold between the noun or the adjective and the following nominal element. Another such preposition is the *by* which is found in passive clauses:

- (197) a Peter hit the policeman      the policeman was hit by Peter  
      b Lucy received a letter        a letter was received by Lucy

Note that in the passive structures the nominal following *by* is interpreted the same as the nominal preceding the verb in the active. It is, of course, the verb which determines how to interpret this nominal, agent in (197a) and recipient in (197b), and hence, presumably, the verb which determines it in the passive examples. If this is so, then *by* plays no role in the thematic interpretation as this is entirely determined by the verb.

However, these prepositional elements, though apparently non-thematic, are not complementisers, as they do not introduce clauses. We therefore categorise them as prepositions which are unmarked for the F feature. Thus, they are non-thematic, but also non-functional prepositions, categorised as [-N, -V]. Like most prepositional elements they take nominal complements:

- (198) *of*            **category:**    [-N, -V]  
                      **subcat:**        [nominal]  
*by*                **category:**    [-N, -V]  
                      **subcat:**        [nominal]

This concludes our typology of word categories. Although it has not been exhaustive, as there are one or two categories that we have not discussed (conjunctions such as *and* and *or* for example), we have covered all of the categories that we will be concerned with in the rest of this book and nearly all of those made use of in the English language. How to include those we have not dealt with within the system we have developed is not something we will touch on in this book.

## Check Questions

---

### Check Questions

- 1 Discuss how it is possible to conceive of linguistic knowledge and what is meant by the 'grammar' of a language.
- 2 Define the terms 'arbitrariness', 'lexicon', 'word category' and explain how they are related.
- 3 Discuss some general ways of determining word categories and potential problems that may arise in connection with them.
- 4 Explain how the properties of a predicate determine argument structure.
- 5 What is meant by argument structure and subcategorisation frame? Show how it is possible to establish different subtypes of verbs. Support your answer with examples.
- 6 What subtypes of nouns can be established using notions like 'countable' and 'uncountable' and how may members of the latter be made countable?
- 7 Can the possessor be conceptualised as an argument? Justify your answer: if yes, why; if not, why not
- 8 How is categorial information stored in the lexicon?
- 9 What evidence is available for collapsing the categories Adjective – Adverb? Discuss the behaviour of the *-ly* morpheme and list some irregularities. In what respect do the categories Adjective – Adverb differ?
- 10 Compare the complementation of N, V, A and P.

### Test your knowledge

#### ▪ Exercise 1

Given the two main parts of a sentence *subject and predicate*, chop up the sentences below into their parts. With the help of the grammatical functions *subject, direct object, indirect object, adverbial*, divide the sentences into even smaller units.

- (1)
  - a Peter met Mary in the park yesterday.
  - b He gave Mary flowers when she greeted him.
  - c Mary put the flowers into a vase at home.
  - d The man who lives next door saw that they met.
  - e That Peter and Mary met surprised everyone.
  - f The curtains extended to the floor.
  - g He hasn't finished reading the book she lent him.
  - h Mary has become a teacher.
  - i Peter lives in Paris.
  - j Mary is in Paris at the moment.

## Chapter 1 - Grammatical Foundations: Words

---

### ▪ Exercise 2

Identify the arguments in the following sentences.

- (1) a Peter left his family.
- b Peter left after dinner.
- c Peter and Mary met in the park.
- d Mary suddenly noticed that her purse was missing.
- e Before leaving the house she checked her bag.
- f The purse was on the kitchen table.
- g Peter considers Mary beautiful.
- h John knew that Peter and Mary met in the park in the afternoon.
- i John knows Mary.
- j Peter wanted John out of the room.
- k They treated their guests kindly during their stay.
- l Peter wrote a letter to Mary the other day.
- m He sent her a box of chocolate, too.
- n Peter called Mary yesterday.
- o John called Peter a liar.

### ▪ Exercise 3

Here is a list of definitions of theta roles. Given the definitions, label the arguments in the sentences below.

**Agent:** the participant who deliberately initiates the action denoted by the verb (usually animate).

**Theme:** the participant (animate or inanimate) moved by the action.

**Patient:** an affected participant (animate or inanimate) undergoing the action (the roles 'theme' and 'patient' are often collapsed).

**Experiencer:** the participant (animate or inanimate) that experiences some (psychological, emotional, etc.) state.

**Beneficiary/Benefactive:** the participant that gains by the action denoted by the verb.

**Goal:** the participant towards which the activity is directed.

**Source:** the place from which something is moved as a result of the action.

**Location:** the place in which the action or state denoted by the verb is situated.

**Propositional:** clausal arguments have the propositional theta role.

- (1) a Peter loves Mary.
- b Peter knows Mary well.
- c The door opened.
- d The purse was stolen.
- e Mary wrote a letter to John the following day.
- f John received a letter from Mary.
- g Mary cut the cake with a knife.
- i There arrived some visitors.
- j Mary was cooking dinner when they entered.
- k Peter has broken his leg.

### Test your knowledge

---

- l Peter has broken a vase.
- m It surprised everyone that the visitors arrived.
- n They wondered what to do.
- o Mary is beautiful.
- p John is in Paris.
- q That the purse was stolen shocked everyone.

▪ **Exercise 4**

Give sentences according to the following patterns:

- (1)
- a N+V
  - b N+V+N
  - c D+N+V+V+P+D+N
  - d D+N+V+D+N+P+D+N
  - e D+V+NEG+V+C+D+V+V+D+N
  - f D+Adv+V
  - g Adv+N+V+D+N
  - h N+Adv+V+D+N
  - i N+V+D+N+Adv
  - j V+D+Adv+V+P+N
  - k N+V+P+D+N+P+D+A+N
  - l D+A+N+P+D+N+V+Adv+A
  - m N+P+N+V+A+N
  - n N+V+D+C+D+V+Adv+V+P+N
  - o D+A+N+V+D+A+N
  - p D+N+V+V+A
  - q D+Adv+V+P+A+N
  - r D+N+V+A

▪ **Exercise 5**

Give two examples for a one-place predicate, two-place predicate and three-place predicate.

▪ **Exercise 6**

Identify the thematic and the functional categories in the following sentence and give the feature matrix of each item by making use of the following features [ $\pm F$ ], [ $\pm N$ ] and [ $\pm V$ ]:

The boy in the neighbourhood may have made a big mistake.

## Chapter 1 - Grammatical Foundations: Words

---

### ▪ Exercise 7

Mark the morphological boundaries and state whether the underlined morphemes are inflectional or derivational in the following words.

- (1) a easier
- b grandfather<sub>s</sub>
- c unhappiest
- d failed
- e unemployment
- f wants
- g eatable
- h quickly

### ▪ Exercise 8

Identify the part of speech of each word in the sentences below.

- (1) a John likes eating nice food.
- b The workers must have built the bridge near Boston.
- c A friend of mine gave a book to John's brother.

### ▪ Exercise 9

The following word forms can have more than one grammatical category. State which these categories are and create sentences in order to show their different distribution.

- (1) a leaves
- b lead
- c costs
- d fly
- e rings
- f tears
- g water
- h rules
- i present
- j mine
- k left
- l long
- m fast



### Test your knowledge

---

#### ▪ Exercise 10

Identify the word categories in the following sentences and give the lexical entries of the verbs, auxiliaries and degree adverbs as well.

- (1) a The pretty girl will surely go for a luxury holiday in Haiti with a very tall young man.  
b His excellent idea about trade reform can probably change the economic situation of African countries.  
c A very big picture of old buildings has been sent to the former president of the electric company in Southern France.  
d The spokesman announced that the most modern houses may have been built in the centre of London for a year.  
f The ancient ruins might have been destroyed by the biggest earthquake of the century.

#### ▪ Exercise 11

Identify the embedded clauses in the following sentences. Classify them according to whether they are finite (F) clauses or non-finite clauses (N).

- (1) a I think that John saw Hugh.  
b John was anxious for Hugh to see him.  
c They are anxious for they got bad news from their daughter today.  
d My father asked me to go the shop and get him tobacco.  
e You will not get any tobacco from me for you only a child.  
f The buyer wanted me to buy the horse from the seller.  
g The horse I bought yesterday belonged to my brother's best man.  
h The landlady will go upstairs to clean the rooms.  
i We saw John & Hugh going into their friend's house a while ago.  
j Did you see the woman that I was talking about?  
k That Mary has a headache every day does not surprise anyone.  
l I asked you to go.  
m For him to stay would be unwise.  
n To leave the party was very smart.

#### ▪ Exercise 12

Sentences (1a–h) below are all grammatical. On the basis of the examples, provide the lexical entry for each underlined predicate.

- (1) a My brother ate a lot of chocolate.  
b John is keen on wild animals.  
c John gave a book to his friend.  
d He always parks his car near a nice old hotel.  
e I love Vermeer's painting of the young girl.  
f Jane broke the vase.  
g The vase broke.  
h Everybody got a letter from the Prime Minister.

▪ **Exercise 13**

Give the lexical entries of each predicate of the following sentences.

- (1) a The inspector realised that the key could not open the box.  
b The baby crawled from her mother to her father.  
c Jack thought that the storm broke the window.  
d Shannon travelled from Paris to Rome.  
e Lucy cut the bread with a knife.  
f My friend wrote to me that John loved Eve.  
g John told a story to Peter.  
h John told her that his mother was afraid of spiders.  
i Sarah is proud of her sons.  
j Young people are often keen on sciences.  
k Mrs Smith is always angry at her neighbours.  
l Some astrologists have always held the belief that the Sun moves around the Earth.

# Chapter 2

---

## Grammatical Foundations: Structure

### 1 Structure

#### 1.1 The building blocks of sentences

So far we have been discussing the properties of words and have said hardly anything about larger units of language such as sentences. A sentence is obviously made up of a number of words, but as we pointed out in the previous chapter, it is not true that sentences are formed simply by putting a row of words together. If this were so then we might expect positions in a sentence to be identifiable numerically, but this is not so:

- (1) a Sid saw Wendy  
b yesterday Sid saw Wendy

In (a) we have the verb in the second position, with one of its arguments (the experiencer) to the left, in first position, and another of its arguments to the right in the third position. In (b) however, everything moves one step to the right to accommodate the word *yesterday* which now occupies first position. The point we made previously is that the ordinal placement of a word in a sentence is unimportant as it is clear that the words *Sid*, *saw* and *Wendy* are in the same grammatical positions in both sentences, even though they are in different ordinal positions in the string of words.

This then raises the question of how grammatical positions are defined, if not linearly. To answer this question we must first acknowledge the existence of units in a sentence which are bigger than words. Let us start with an observation that we have already noted, without much discussion, that a sentence might contain another sentence. Consider the following sentences:

- (2) a Geoff jeopardised the expedition  
b Kate claimed [Geoff jeopardised the expedition]

It is fairly clear that the bracketed part of the sentence in (2b) is the exact same sentence as stands alone in (2a) and that the elements that they contain are in the same positions in both cases. It therefore follows that (2b) is not simply a string of words, but has a **structure** whereby it is made up of things which themselves are made up of other things. We can represent this situation in the following way:

## Chapter 2 - Grammatical Foundations: Structure

---

(3)

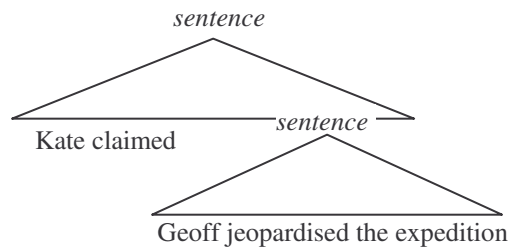

If it is grammatical for one sentence to contain another, then it follows that the contained sentence can contain another sentence and indeed that that sentence can contain another, etc. In fact there should be no limit to how many sentences can be contained one within the other. That this is so is exemplified by nursery rhymes of the following kind:

- (4)
- a this is the house [that Jack built]
  - b this is the malt [that lay in the house [that Jack built]]
  - c this is the mouse [that ate the malt [that lay in the house [that Jack built]]]
  - d this is the cat [that chased the mouse [that ate the malt [that lay in the house [that Jack built]]]]
  - e etc.

Potentially, this rhyme might go on forever, limited only by the parent's imagination and the fact that their children will one day grow up and want to listen to pop music instead. One might argue that no one could ever produce an infinitely long sentence as they would forget what they were saying after a relatively short time, and for the same reason no one would be able to understand it. Furthermore, they would die before they got to the end of it. Admittedly it would be a fairly pointless thing to do, but that is not the issue. Facts about people's imagination, their likes and dislikes, their attention spans and even their mortality have nothing to do with the language system. This is, as we have pointed out, a set of rules that enables us to produce and understand the linguistic expressions that make up an E-language.

Now, if those rules tell us that sentences can contain sentences then it follows that infinitely long sentences are grammatical regardless of whether or not anyone could ever produce or understand such a sentence due to external considerations.

Indeed, there would be no point in adding limitations to the grammar to make it fit with these other limitations. For example, suppose we determined that sentences with more than 9 other sentences embedded in them go beyond the human mental capacity to process (it is clear that it would be virtually impossible to come up with a definite number which was applicable to all humans on all occasions – when I get up in the morning, for example, my capacity to process sentences seems to be limited to one! – but for the sake of the argument let us assume this number). Let us pretend, nonetheless, that the grammar is limited to producing only 9 or less embedded sentences. This would be an extra complication to the grammatical system as it adds a limitation to it. Yet the situation would be exactly the same if we did not add the limitation: humans would still be able to process sentences with 9 or fewer embedded sentences, because of their mental restrictions, no matter what the grammar was capable of defining as grammatical. So the extra complication to the grammar would

## Structure

---

achieve nothing and we would be better off not adding it and keeping things simpler. Moreover, why would we want to make the grammar explain facts that had nothing to do with it: it would be like trying to get the laws of gravity to explain why red balls fall to the ground at the same speed as blue ones do.

Let us therefore assume the grammar to contain a rule which informally might be stated as follows:

(5) a sentence can be made up of (at least) words and sentences

This rule defines sentences in terms of sentences and so the definition refers to what is being defined. A rule that does this is known as **recursive**, and recursive rules have exactly the property that we want to be able to define human languages. Recall from the discussion in Chapter 1, human languages are limitless and yet they must be defined by a finite set of rules as the human head can only store a finite amount of information. If I-languages are made up of recursive rules, then a finite set of these will be capable of defining an infinite number of expressions that make up an E-language.

The rule in (5) can be stated a little more formally in the following way:

(6) sentence  $\rightarrow$  word\*, sentence\*

This rule introduces a number of symbols to replace words used in (5). The point of this is to make properties of the rules more obvious. Recall that generative linguists insist on making their grammars explicit so that we are able to test and question the assumptions being made and it is easier to see properties of rules when stated as a formula than it is if they are given as a set of linguistic instructions, especially as the rules become more complex.

We can read the rule in (6) as follows. The arrow indicates that the element on the left (*sentence*) is defined as being made up of the elements on the right (*word\**, *sentence\**). The asterisk after *word* and *sentence* indicates there can be any number of these elements. Thus the rule states that a sentence can be made up of a sequence of words and a sequence of sentences.

At the moment, this is not a particularly accurate rule as it is not the case that English sentences are simply made up of sequences of words and sentences without further restrictions. We have introduced it purely for expository purposes. To make things more accurate we need to introduce another concept.

### 1.2 Phrases

We have said that a sentence can consist of a predicate and its arguments. So in a sentence such as (7):

(7) Prudence pestered Dennis

we have the verb *pestered* as the predicate which relates the two arguments *Prudence*, the agent and *Dennis*, the patient. Now consider a slightly more complex case:

(8) the postwoman pestered the doctor

This could mean exactly the same thing as (7), on the assumption that Prudence is a postwoman and Dennis is a doctor. In this case the arguments seem to be *the postwoman* and *the doctor*, a sequence of words made up of a determiner followed by

## Chapter 2 - Grammatical Foundations: Structure

---

a noun. But what status do these sequences of words have in the sentence? It seems as though they function as single words do in (7), inasmuch as they constitute the same arguments as *Prudence* and *Dennis* do. Thus these two words seem to go together to make up a unit which is the functional equivalent of the proper nouns in the original sentence. This unit is called a **phrase**. We can represent this as follows:

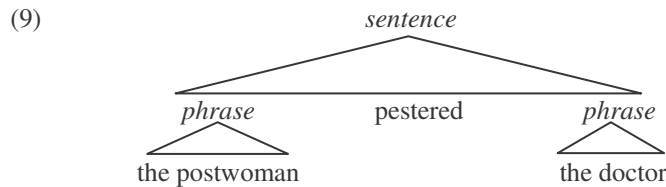

Thus, a sentence has more internal structure to it than we have so far been assuming. Not only can sentences contain words and other sentences, they can also contain phrases.

To make the drawing of the structures clearer in what follows we will use the symbol *S* to stand for sentences and the symbol *P* to stand for phrases. Though it should be made clear that these symbols have no place in the system we will eventually develop and are used now as mnemonics which stand for something we have yet to properly introduce.

Two questions arise immediately: do sentences contain any more phrases than those indicated in (9), and what can phrases contain? To be able to answer these questions, we must first look a little more closely at the properties of phrases in general. The first thing to note is that just as words have distributions in a sentence, so do phrases. This is obvious from the above example, as the phrases *the postwoman* and *the doctor* distribute in the same way that the nouns *Prudence* and *Dennis* do: wherever it is grammatical to have *Prudence* it will be grammatical to have *the postwoman* and where it is ungrammatical to have *Prudence* it will be ungrammatical to have *the postwoman*:

- (10)
- |   |                         |                              |
|---|-------------------------|------------------------------|
| a | Prudence is considerate | the postwoman is considerate |
| b | I saw Prudence          | I saw the postwoman          |
| c | they spoke to Prudence  | they spoke to the postwoman  |
| d | *we Prudence Dennis     | *we the postwoman Dennis     |

With this in mind, consider the following:

- (11)
- |   |                                       |
|---|---------------------------------------|
| a | Prudence pestered Dennis on Wednesday |
| b | Prudence persisted on Wednesday       |

It seems that in the position where we have *pestered Dennis* we can have the verb *persisted*. This is not surprising as the verb *pestered* is used transitively in (11a), with a nominal complement (*Dennis*) whereas *persisted* is used intransitively in (11b), without a complement. However, if intransitive verbs distribute the same as transitive verbs plus their complements, this means that transitive verbs and their complements form a phrase that has a distribution in the same way that a determiner with its nominal complement distributed like certain nouns. Thus a more accurate description of the sentence than (9) would be:

## Structure

---

(12)

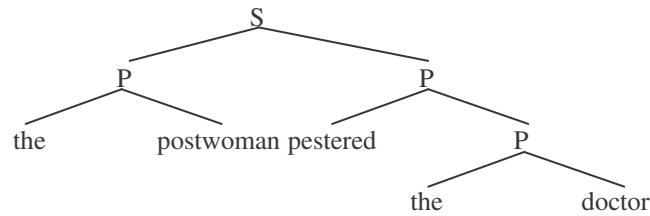

We see here that the sentence has even more internal structure as a phrase may also contain another phrase.

Indeed, once we recognise the notion of a phrase, we can see them in many positions. For example, a string consisting of the preposition *on* and its nominal complement *Wednesday* can be replaced by the noun *yesterday* demonstrating that they have the same distribution. Thus, *on Wednesday* is also a phrase in the sentence:

(13) the postwoman pestered the doctor [on Wednesday]/yesterday

This suggests we have the following structure for this particular sentence:

(14)

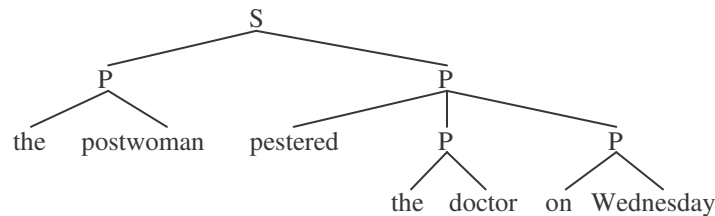

Moreover, in the phrase *on Wednesday*, the noun *Wednesday* can be replaced by the words *his birthday*, indicating that this is also a phrasal position:

(15) the postwoman pestered the doctor on Wednesday/[his birthday]

(16)

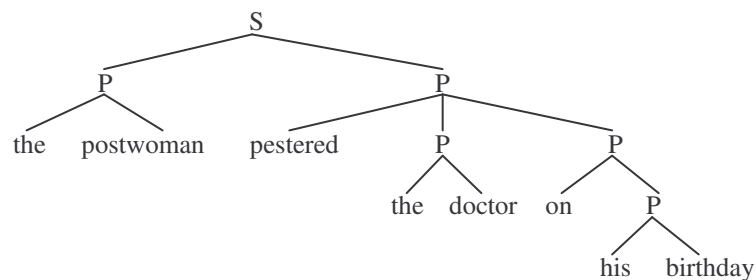

### 1.3 Sentences within phrases

From what we have said so far we might think that English expressions are organised with sentences at the top, phrases in the middle and words at the bottom. Unfortunately things are not quite so regular. As we have seen, sentences can appear within sentences. A typical way for this to happen is to have a sentence as part of a phrase which itself is part of the bigger sentence. For example, instead of the phrase *pestered the doctor* in (12) we might have another phrase:

## Chapter 2 - Grammatical Foundations: Structure

---

- (17) a the postwoman [pestered the doctor]  
b the postwoman [thinks the doctor is cute]

The fact that we can substitute one phrase for another is an indication that they both are phrases as they both have the same distribution. But note, the new phrase in (17b) contains something that could stand alone as a sentence:

- (18) the doctor is cute

Hence we have a phrase which contains a sentence. We can represent this situation easily enough, as in the following structure:

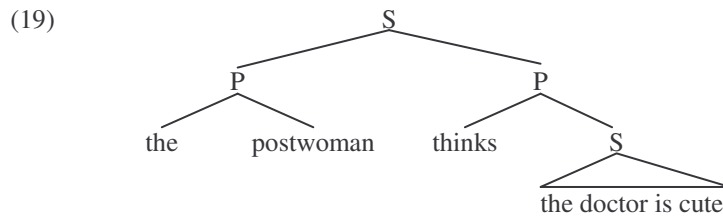

Of course, this embedded sentence (traditionally called a **clause** – though some linguists do not use the terms *sentence* and *clause* with such a distinction these days) has its own internal structure made up of phrases and words and so the structure can be fully specified as follows:

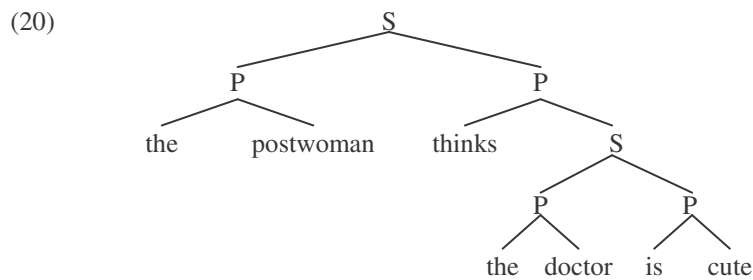

As we have mentioned, there is recursion in structure and so as sentences can contain phrases which themselves contain sentences, then these sentences can contain phrases which contain sentences – and so on, indefinitely. We will provide an example here with just one more level of embedding to give you some idea of how it works:



## Structure

---

(21)

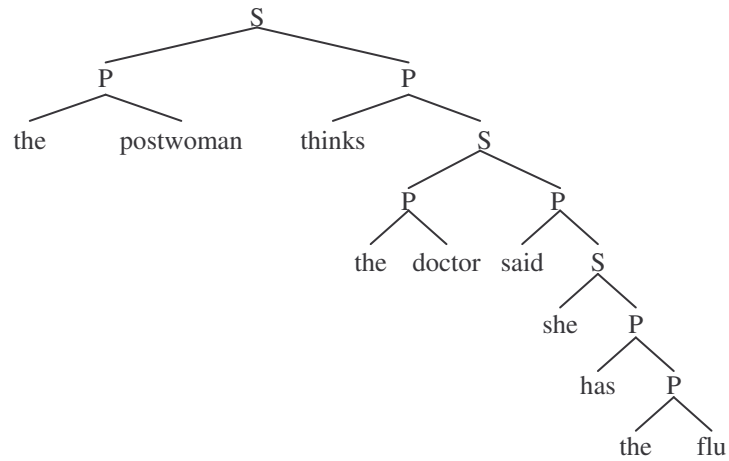

So far we have looked at sentences which appear inside the second phrase of the main sentence, but this is not the only position we can find an embedded sentence. For example, we can find a sentence as the first element of another sentence:

- (22) a [the doctor] worried the postwoman  
 b [that she had a sore throat] worried the postwoman

In (22b) we have a sentence *she had a sore throat* introduced by the complementiser *that*. This sentence sits in a similar position to the phrase *the doctor* in (22a), in front of the verb. Thus, instead of this phrase, we can have a sentence, as in the following diagram:

(23)

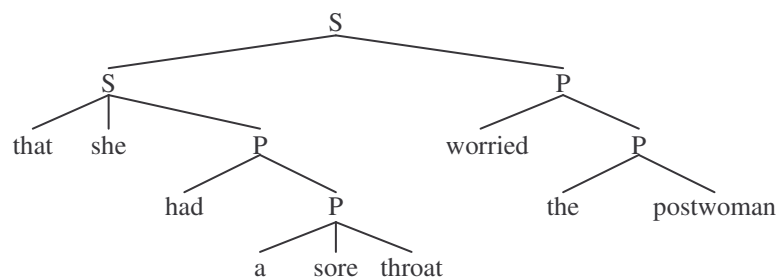

Furthermore, we can have a sentence inside the first phrase of a sentence:

- (24) [the diagnosis that she had the flu] worried the postwoman

Here, *the diagnosis that she had the flu*, is a phrase which contains the embedded sentence *she had the flu*, introduced by a complementiser *that*. The structure looks as follows:

(25)

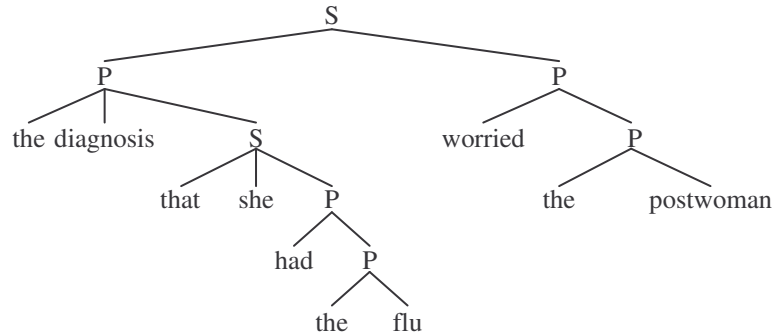

Of course, this sentence could contain phrases that contain sentences and there could be other phrases elsewhere in the sentence that contain sentences. Hence very complex structures can be produced, though we will not exemplify these here for reasons of space.

#### 1.4 Structural positions

The notion of structure helps us to define grammatical positions more easily. As we saw previously grammatical positions cannot be defined in terms of linear order. The verb, for example, might be the second, the third or indeed the  $n^{\text{th}}$  element in a sentence, and yet there is still a definite position for the verb which no other element can occupy. Once we have introduced the notion of structure, however, we can see that the verb occupies the same structural position no matter what else is present in the clause.

Consider the following structures:

(26)

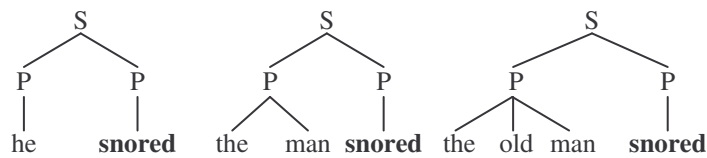

Notice that in all these structures the verb occupies the same position inside the second phrase of the sentence. It would not matter how many words or other phrases the first phrase contained, the verb would still be in the same position with respect to its own phrase, and hence grammatical position defined in terms of structure is much more satisfactory than in terms of linear order. Moreover, if we consider the structure of the phrase that the verb appears in, we can identify its position within this phrase more easily than by counting its position in a linear string:

(27)

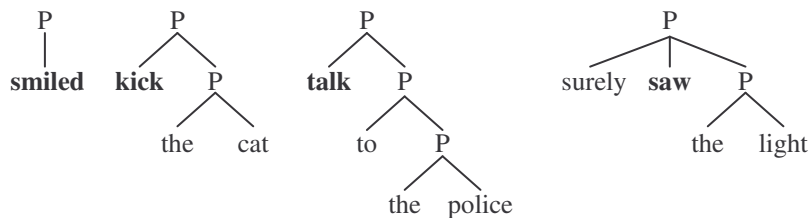

## Structure

---

Again, we cannot identify the position of the verb within the phrase in terms of linear order, but in terms of the structure it is clear that the verb always comes directly underneath this phrase, precedes its phrasal complements and may follow adverbial modifiers. As we proceed it will become even clearer that there is a unique structural position that verbs and verbs alone can occupy.

### 1.5 Structural terminology

Now that we have introduced the notion of structure, we need some terms to use to refer to aspects of structures and the way we can represent them. The notion of structure entails that there are elements of a sentence that themselves are made up of other elements and indeed that these other elements may be made up of yet more elements, and so on and so on. The elements that make up a larger part of the structure are called its **constituents** and the constituents that directly make up a part of structure are called its **immediate constituents**. Thus, in a phrase such as the following, the verb and its complement phrase are its immediate constituents. Everything inside the complement phrase is a constituent of the whole phrase, though not an immediate constituent:

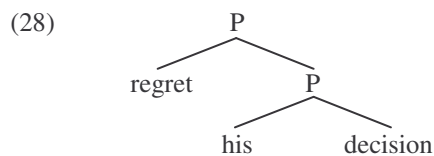

This kind of representation of grammatical structure is called a **tree diagram**, though unlike real trees, grammatical trees tend to grow downwards. The elements that make up the tree, the words and phrases etc. are called **nodes** and the lines that join the nodes are **branches**.

Finally, it is often useful to talk about two or more nodes in a tree and their relationships to each other. For this purpose a syntactic tree is seen like a family tree with the nodes representing different family members. For some reason however, these families are made up of women only. A node which has immediate constituents is called the **mother** of those constituents and the constituents are its **daughters**. Two nodes which have the same mother are **sisters**.

So to refer to the tree in (28) again, the top P node is the mother of the verb and the P node which represents the verb's complement. The verb and the complement P node are therefore sisters. The complement P node is also a mother to the pronoun *his* and the noun *decision* and again these two nodes are sisters.

It would of course be possible to define the relationships 'grandmother', 'aunt', 'cousin' etc. for any given tree diagram. However these relationships tend not to be very important for syntactic processes and so we will not consider them.

There is another popular way of representing structure, which we have made some use of above without comment. This is the use of **brackets** to represent constituents. For example, the sentence we discussed above *the postwoman pestered the doctor on his birthday* can be represented as follows:

(29) [[the postwoman] [pestered [the doctor] [on [his birthday]]]]

## Chapter 2 - Grammatical Foundations: Structure

---

The way this works is that each constituent is surrounded by square brackets and so a constituent can be determined by finding an open bracket '[' to its left and the corresponding close bracket ']' to the right. Thus, *the postwoman* in (29) is defined as a constituent as it has an open bracket immediately to its left and a close bracket immediately to its right.

Admittedly, it is harder to see the structure of a sentence when represented with brackets than with a tree, as it takes some working out which open brackets go along with which close bracket. However, bracketings are a lot more convenient to use, especially if we only want to concentrate on certain aspects of a structure. So, for example, above we represented an embedded sentence using brackets:

(30) Kate claimed [Geoff jeopardised the expedition]

This partial bracketing demonstrates at a glance how the main sentence contains an embedded one and so bracketing can be a very useful way of describing simple structures.

The bracketing in (29) is not entirely equivalent to the tree diagram in (16) as in the tree the nodes have labels that tell us what they represent, phrases or sentences. We can add labels to brackets to make the two representations equivalent. With bracketing, the label is usually placed on the open bracket of the constituent:

(31) [<sub>S</sub> [<sub>P</sub> the postwoman] [<sub>P</sub> pestered [<sub>P</sub> the doctor] [<sub>P</sub> on [<sub>P</sub> his birthday]]]]

Again, this adds to the complexity of the representation and so it is not as clear as the tree diagram. But providing it is not too complex, it is still a useful way to represent structural details.

### 1.6 Labels

Although we have been labelling phrases with the symbol P, not all phrases are equivalent to each other. This is best seen in terms of the distributions of phrases. Take, for example the two phrases in (16) *the postwoman* and *the doctor*. These look very similar, both consisting of a determiner followed by a noun. They also have the same distribution patterns, as shown by the fact that wherever we can put one of them we will also be able to put the other:

(32) a [the doctor] pestered [the postwoman]  
b I saw [the doctor]/[the postwoman]  
c they hid from [the doctor]/[the postwoman]

As these phrases have the same distributions, we can assume that they are phrases of the same kind. However, not all phrases distribute in the same way. Consider the phrase *on his birthday*. This cannot go in the same places as those in (32):

(33) a \*[on his birthday] pestered [the postwoman]  
b \*I saw [on his birthday]  
c \*they hid from [on his birthday]

Clearly this phrase must be different from the previous two. We will see in the next chapter that the identity of a phrase is determined by one of the words it contains. This word is known as the **head** of the phrase. It will be argued later on in this book that the

## Structure

---

head of phrases such as *the postwoman* is the determiner and the head of phrases such as *on his birthday* is the preposition. Thus, we distinguish between **determiner phrases** (DPs) and **preposition phrases** (PPs).

There are also other phrases associated with the verb (VPs), with adjectives (APs) and indeed with every kind of word category that we have discussed (noun phrases – NPs, inflectional phrases – IPs, CPs and degree adverb phrases – DegPs).

For now, the main point is that there are different kinds of phrases and these have different positions within the structure of the sentence and hence different distributions. We might therefore represent the sentence in (31) more fully as:

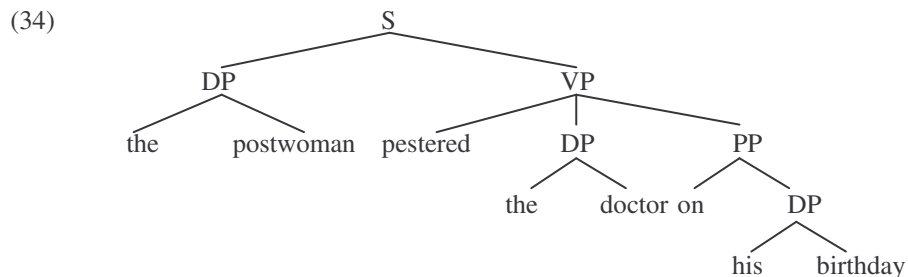

We will not develop this any further at this point, and we will see that certain aspects of this structure are in need of revision. But the arguments for these developments will be given in subsequent chapters.

### 1.7 Rules

The last thing we will mention in this section concerns the kinds of grammatical rules that could be responsible for producing structures such as in (34). Recall from the start of this section we introduced a formal rule which stated that sentences can be made up of words and other sentences:

(35) sentence  $\rightarrow$  word\*, sentence\*

The rule states that a sentence is made up of some words and some sentences. Although this rule is not particularly accurate, we can see that this kind of rule is ideal for describing the kinds of structures we have been discussing, as they state what the immediate constituents of a structure are: in other words, this rule describes mother–daughter relationships.

From the structure in (34) it is possible to formulate the following rules:

(36)  $S \rightarrow DP VP$   
 $VP \rightarrow V DP PP$   
 $PP \rightarrow P DP$   
 $DP \rightarrow D N$

Such rules are known as **rewrite rules** as they describe how to draw a tree by ‘re-writing’ the symbol on the left of the arrow for the symbols on the right. Thus, if we start with the S at the top of the tree diagram we can rewrite this as a DP and a VP. The VP can be re-written as a verb, a DP and a PP and the PP as a preposition and a DP. The DPs can then be re-written as determiners followed by nouns.

Although the system of rules in (36) is capable of describing the structures of a good number of English sentences, it is clear that we would need many more rules to attempt to describe the structures of all English sentences. For example, not every DP is made up of a determiner followed by a noun. Some may contain just a determiner, such as *this* for example, or a determiner, an adjective and a noun, such as *a rusty kettle*. A DP may indeed contain, amongst other things another sentence, such as *the diagnosis that she had flu*. It is clear that we would need many rewrite rules to capture all the possibilities for English DPs.

This fact does not invalidate this kind of rule for linguistic descriptive purposes. As long as there is only a finite number of rules, a legitimate grammar could be formulated even with a very large number of them. However, if human grammars are constructed of a large number of rules the question is raised of how children could ever learn their grammatical systems. This consideration has led some linguists to assume that what is needed is a far more restricted set of rules. We will introduce the theory of phrase structure that follows this line of thought in the next chapter.

## 2 Grammatical Functions

### 2.1 The subject

In all the sentences we have looked at so far, there has been an argument of the verb which appears to its left. All of the other arguments have appeared after the verb. As we see by the following sentences, this is an essential fact about grammatical English sentences:

- (37) a Garry gave Victor a radio  
 b \*gave Garry Victor a radio  
 c \*Victor Gary gave a radio  
 d \*a radio Victor Gary gave

While there is a special way to pronounce these words in the order in (37c) that would make it grammatical (with a pause after *Victor*), this would have a special interpretation in which *Victor* is singled out from a set of possible referents and the rest of the sentence is taken to be something said particularly about him. However, without this special intonation and meaning the sentence is just as ungrammatical as the others: the ‘normal’ word order of English is as in (37a). Thus the basic word order of English has one and only one argument of the verb to its left and all the others to its right.

From a structural point of view, the argument that precedes the verb also differs from the other arguments. This argument is an immediate constituent of the sentence, whereas all other arguments are inside the verb phrase:

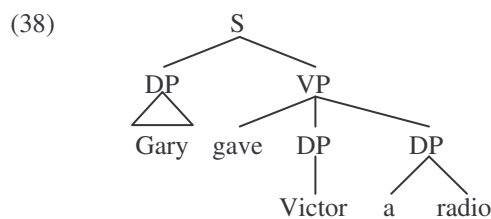

**Note:**

A triangle is used in a tree diagram when we do not want to represent the details of the internal structure of the phrase.

## Grammatical Functions

---

We call the argument that precedes the VP in the sentence the **subject**. Besides its privileged position in the sentence, the subject also plays an important role in a number of different phenomena. In a finite sentence, the verb may have a different form depending on properties of the subject:

- (39) a I/you eat breakfast at 6.30  
b we/they eat breakfast at 8  
c he/she/Ernie eats breakfast at 9.15

When the subject refers to either the speaker or the addressee, what we call first and second **person**, the finite verb in present tense shows no overt morphology. The same is true when the subject is plural. However, when the subject is **third person** (referring neither to the speaker nor the addressee) and singular the present tense verb inflects with an 's'. This morpheme not only shows the tense therefore, but also the nature of the subject: that it is third person singular. This phenomenon is known as **agreement**: we say that the verb agrees with the subject.

Clearly English does not have much in the way of agreement morphology, usually distinguishing just the two cases given above, though the verb *be* has three agreement forms in the present tense and two in the past tense:

- (40) a I **am** ready  
b you/we/they **are** ready  
c he/she/Itgy **is** ready  
d I/he/she/Wanda **was** ready  
e you/we/they **were** ready

Other languages, however, show a good deal more, as the following Hungarian examples show:

- (41) a (én) 6-kor reggeliz**ek** (I eat breakfast at 6)  
b (te) 6-kor reggeliz**el** (you eat breakfast at 6)  
c (ő) 6-kor reggeliz**ik** (he/she eats breakfast at 6)  
d (mi) 6-kor reggeliz**ünk** (we eat breakfast at 6)  
e (ti) 6-kor reggeliz**tek** (you(plural) eat breakfast at 6)  
f (ők) 6-kor reggeliz**nek** (they eat breakfast at 6)

Hungarian verbal morphology is a good deal more complex than this, though it is not my intention to go into it here. The point is that although English has less agreement morphology than Hungarian, the phenomenon is the same in that the form of the verb reflects person and number properties of the subject. In English, the other arguments have no effect on the form of the verb:

- (42) TV bores me/you/him/...

Thus agreement is a relationship that holds between the subject and the finite verb.

Another aspect of the subject that shows up in finite clauses concerns the form of the subject itself. Previously we introduced the notion of Case, which is morphologically apparent only on pronouns in English. The subject of the finite clause is the only position where a nominative pronoun (*I, he, she, we, they*) can appear. In all

## Chapter 2 - Grammatical Foundations: Structure

---

other positions English pronouns have the accusative form (*me, him, her, us, them – you* and *it* are the same in nominative and accusative):

- (43) a I/he/she/we/they will consider the problem  
b Robert recognised me/him/her/us/them  
c Lester never listens to me/him/her/us/them  
d Conrad considers me/him/her/us/them to be dangerous

In (43a) the pronouns are the subject of the finite clause and are in their nominative forms, in (43b) they act as the complement of the verb (a position which we will return to), in (43c), complement of a preposition and in (43d) subject of a non-finite clause containing the infinitive marker *to*, and they are in their accusative forms.

A further grammatical fact about the subject of the finite clause is that it is always present. That this is a grammatical fact is most clearly shown by the fact that if there is no need for a subject semantically, a grammatical subject which has no meaning has to appear:

- (44) it seems [that Roger ran away]

The verb *seem* has just one argument, the clause *that Roger ran away*, which acts as its complement. Thus from a semantic point of view there is no subject argument here. Yet there is a subject, the pronoun *it*, which in this case has no meaning. Note that this *it* is not the same as the one that refers to a third person non-human, as in the following:

- (45) it bit me!

With (45) one could question the pronoun subject and expect to get an answer:

- (46) Q: what bit you? – A: that newt!

With (44) however, this is not possible because the pronoun does not refer to anything:

- (47) Q: what seems [that Roger ran away]? – A: ???

These meaningless subjects are often called **expletive** or **pleonastic** subjects, both terms meaning *meaningless*.

The appearance of an expletive element is restricted to the subject position. We do not get an expletive in a complement position of intransitive verbs, which do not subcategorise for a complement:

- (48) a \*Sam smiled it (Sam smiled)  
b \*Sue sat it (Sue sat)

The subject of non-finite clauses is a little more complex as there are occasions where they are necessary and hence an expletive must appear if there is no semantic subject, and there are other cases where the position must be left empty, even though there is semantic interpretation for it:

- (49) a I consider [it to be obvious who the murderer is]  
b \*I consider [- to be obvious who the murderer is]

- (50) a Terry tried [- to escape]  
b \*Terry tried [himself to escape]



## Grammatical Functions

---

In (49) the situation is exactly like the subject of the finite clause and the expletive subject must be present. In (50) however, the subject is obligatorily absent, though it is clear that the clause is interpreted as though *Terry* is the subject: the one who is escaping. We will investigate these observations later in this book. For now, however, what all this shows is that subjects are treated rather differently from other arguments from a grammatical point of view.

Semantically, the treatment of subjects is not quite so clear-cut. It is a traditional point of view that the subject names what the sentence is about, with the rest of the sentence (traditionally called the **predicate**) saying something about the subject. So it is claimed that a sentence such as (51) is about *Simon* and what is said about him is that he *ate the sandwich*:

(51) Simon ate the sandwich

However, although this may be true for a lot of sentences, there are many occasions when it is not so. For example, sentences with expletive subjects could hardly be claimed to be about the subject as otherwise they would not be about anything at all. Moreover, other sentences can just as easily be said to be about arguments other than the subject:

(52) a as for your claim that you are Superman, I don't believe it  
b Q: what's up with Amanda?  
A: the teacher just failed her

In (52a) the subject is *I*, but it is clear that the sentence is not about *me* but the dubious claim. The answer given in (52b) has *the teacher* as the subject, but given the context of the question, we see that the sentence is about *Amanda*, the referent of *her*, which is a complement. Therefore the traditional approach to the subject is highly problematic and will not be adopted here.

The other semantic aspect of the subject concerns its interpretation as an argument of the verb. This is also very complex, but less doubtful than the claim that the subject is what the sentence is about. When there is a meaningful subject of a verb with two or more arguments, the subject is interpreted as a specific argument, and we do not just interpret it as any one of the possible arguments:

(53) Henry hit Thomas

The verb *hit* has two arguments: the one who does the hitting, the agent, and the one who gets hit, the patient. But (53) is unambiguous: it must be interpreted with *Henry* as the agent and *Thomas* as the patient. Indeed, agent is a very typical  $\Theta$ -role for a subject to have. Experiencer is also a typical subject  $\Theta$ -role:

(54) Simone sensed a problem

This does not mean to say that we never have any other kind of subject however, as it is possible to have patient and theme subjects:

(55) a the letter arrived late  
b a problem was sensed

## Chapter 2 - Grammatical Foundations: Structure

---

However, it might be claimed that these are special cases (the nature of their status will be discussed in a later chapter) and that the typical position for such arguments is not the subject.

Further problems for a simple relationship between subjects and thematic interpretation can be seen in examples such as the following:

- (56) a Fred fears heights  
b heights frighten Fred

In both these cases, the argument *Fred* is interpreted as experiencer and in (56a) the experiencer is the subject, as would be expected. However, this is not the case in (56b). We see then that the relationship between thematic interpretation and grammatical position is a complex business. We will not go into the matter here as we lack the means to do so. We will return to the issue in a subsequent chapter.

One last point to mention about subjects is that although all the cases we have so far dealt with have involved a DP subject, it is possible to find other kinds of phrases and even clauses in subject positions:

- (57) a [<sub>PP</sub> down there] would be a good place to hide  
b [<sub>S</sub> that I don't know the answer] should not be surprising  
c [<sub>AP</sub> ill] was how I was feeling at the time  
d [<sub>VP</sub> run away] is what I advise you to do

Clearly some of these sentences have a special status in one sense or another and it is certainly not typical to find AP or VP subjects. They are included here however to provide a fuller picture of the set of possibilities.

### 2.2 The object

So far we have concentrated on the subject, but what about any other argument: do they have special statuses? One other argument, known as the **object**, might be claimed to have special features with regard to all other types of complement.

The object is a DP complement and like other complements it follows the verb:

- (58) a Peter put [<sub>DP</sub> the bike] [<sub>PP</sub> in the shed]  
c Gary gave [<sub>DP</sub> the voucher] [<sub>PP</sub> to the attendant]

Note that the object has a privileged position in relation to the other complements in that it must immediately follow the verb:

- (59) a \*Peter put [<sub>PP</sub> in the shed] [<sub>DP</sub> the bike]  
c \*Gary gave [<sub>PP</sub> to the attendant] [<sub>DP</sub> the voucher]

Another fact about objects is that they are arguments which may undergo certain syntactic processes and so seem to be singled out by these. For example, in a passive sentence, the subject may go missing (it may be present inside a *by*-phrase, but we will not deal with this at the moment). In this case, the argument which would normally be interpreted as the object appears in the subject position. We may interpret this as a process which 'moves' the object into subject position:

## Grammatical Functions

---

- (60) a we all saw Wendy  
b Wendy was seen –  
    └──────────┘  
    ^

This process is restricted to object and does not happen to other kinds of complements:

- (61) a [DP the bike] was put [PP in the shed]  
b [DP the voucher] was given [PP to the attendant]  
a \*[PP in the shed] was put [DP the bike]  
c \*[PP to the attendant] was given [DP the voucher]

We have also seen that the object is a more limited complement in some ways. For example, Verbs and Prepositions have objects, but nouns and adjectives do not:

- (62) a see [DP the sights]  
b to [DP the castle]  
c \*a picture [DP his mother]  
d \*regretful [DP his deeds]

The object following the preposition is called a **prepositional object**.

In the same way that subjects tend to have a Case form associated with them, so too do objects. The object, when it sits in object position and is not moved to the subject position as in (60), always appears in its accusative Case:

- (63) a I saw him/her/them/etc.  
b \*I saw he/she/they/etc.

The prepositional object also must appear in the accusative form:

- (64) a I looked at him/her/them/etc.  
b \* I looked at he/she/they/etc.

Prepositional objects also sometimes undergo the same movements that verbal objects do, for example in passive structures:

- (65) a the doctor looked at her  
b she was looked at – by the doctor  
    └──────────┘  
    ^

However, this phenomenon is complex and not all objects of prepositions can undergo this movement:

- (66) \*the doctor was stood near by the patient  
    (cf. the patient stood near the doctor)

Quite what determines when a prepositional object may undergo this movement and when it may not is not well understood. It seems to have something to do with the relationship between the verb that is passivised and the preposition whose object moves: the closer the relationship, the more likely the object will be able to move. Thus the *at* preposition in (65) is closely related to the verb, heading the PP complement of this verb. The *near* preposition in (66) does not head a PP complement, but a PP that modifies the verb. Modification is not such a close relationship as it is not indicated in a head's lexical entry, but can be fairly freely be added to any appropriate head.

## Chapter 2 - Grammatical Foundations: Structure

---

The clausal complement of certain verbs have some properties in common with objects. For example, these clauses can undergo movement in passive structures:

- (67) a everyone believed [that Bill belly-dances]  
b [that Bill belly-dances] was believed – by everyone
- 

Presumably this is one of the reasons why verbs which have clausal complements have traditionally been considered as transitive verbs. There are, however, a number of differences between clausal and DP complements. One is that clauses obviously do not appear in accusative Case. However, given that it is only the pronouns in English that demonstrate Case distinctions, this is not surprising. Another difference is that not all clausal complements can undergo passive movement:

- (68) a \* [that Charley cheated] was considered by everyone  
b \* [if Kevin likes coffee] was wondered by Wendy

Moreover, even in those cases where it can take place, the movement is an optional one:

- (69) a [that students attend exams] is expected by the university  
b it is expected [that students attend exams] by the university

DP objects always move in passive structures:

- (70) a Fiona was found by the search party  
b \* it was found Fiona by the search party

Given the differences between clausal and DP objects, we will, in this book, reserve the term object for DP complements alone and will not extend it to clausal complements as is sometimes done.

Overall, we see that the object receives a special treatment in the grammar, though it is treated very differently to subjects.

### 2.3 Indirect object

Some verbs can have more than one object:

- (71) Lucy lent Larry a lasso

This construction is known as the **double object construction**, for obvious reasons.

Interestingly, the two objects do not have the same properties. For one thing, their orders are fixed in Standard English, though there are dialectal differences, especially if either or both objects are expressed by a pronoun:

- (72) a Lucy lent a lasso Larry (ungrammatical in Standard English)  
b Lucy lent him it/it him (both grammatical in non-Standard English)

We call the object that immediately follows the verb in Standard English the **indirect object** and the one that follows this, the **direct object**. The indirect object is more often than not assigned the *goal* or *beneficiary*  $\Theta$ -role by the verb while the direct object bears the theme  $\Theta$ -role.

## Testing for Structure

---

Restricting ourselves to the discussion of the standard dialect, we find the two objects also differ in terms of passive movement. Only the indirect object can undergo this movement:

- (73) a Larry was lent a lasso  
b \* a lasso was lent Larry

The direct object can only undergo passive movement if the goal argument is expressed as a PP, in what is often called the **dative alternate** or the **dativ construction**:

- (74) a Lucy lent a lasso to Larry  
b a lasso was lent to Larry

The notions of subject, direct object and indirect object are known as **grammatical functions**. It is fairly clear that they are defined as positions in the English sentence, in that any element which sits in those positions will be interpreted as subject and object respectively, no matter if this makes sense or not:

- (75) a Eddy ate his dinner  
b ?his dinner ate Eddy

The fact that people eat dinners and that dinners do not usually eat people is irrelevant as far as the interpretation of these sentences is concerned. What is important is which position each argument occupies and hence which grammatical function each argument has, and this alone is what determines how to interpret the sentence.

### 3 Testing for Structure

#### 3.1 Substitution

In the previous sections we have presented the sentence as structured into a subject DP followed by a VP, and the VP as structured into the verb and its complements:

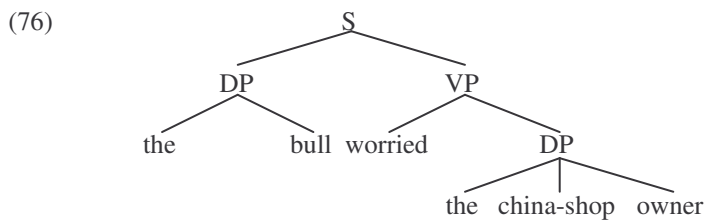

We developed this structure by noting certain distributional patterns, such as the subject *the bull* could be replaced by the pronoun *it* and the VP *worried the china-shop owner* could be replaced by the verb *charged*:

- (77) it charged

As we claimed, the distribution of an element shows us that it has a certain status in the sentence and all elements which have the same distribution will have the same status. This is why we could use observations about distribution to demonstrate the structure of the sentence: the fact that *the bull* has the same distribution as *it* shows that

## Chapter 2 - Grammatical Foundations: Structure

---

*the bull* is a constituent, specifically a DP as, as argued above, pronouns are determiners. Furthermore, the fact that *worried the china-shop owner* has the same distribution as *charged* shows that the former is also a constituent, specifically a VP as *charge* is a verb. In other words, we can use distributional observations such as these to test the structure of any sentence: for any part of the sentence, if we find it distributes like some element that we know what its categorial status is, then we can assume that that part of the sentence has the same status as that element.

Let us consider another sentence to show how this might work:

(78) the bishop that just left was hiding a gun under his mitre

At first glance, you might be tempted to claim that the subject of this sentence is *the bishop*. But note that this cannot be replaced by a pronoun, though the whole string *the bishop that just left* can be:

(79) a \*he that just left was hiding a gun under his mitre  
 b he was hiding a gun under his mitre

Thus we conclude that the subject of this sentence is *the bishop that just left*, not just *the bishop*.

The rest of the sentence *was hiding a gun under his mitre* can be replaced by a single verb:

(80) [the bishop that just left] disappeared

Hence we may assume that this part of the sentence constitutes the VP:

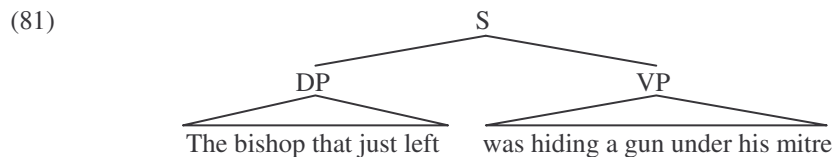

Turning to the VP, we note that the word *a gun* can also be replaced by a pronoun *it* and hence this is also a DP – this time it is a DP complement, i.e. the object:

(82) [<sub>DP</sub> the bishop that just left] was hiding **it** under his mitre

Furthermore, the part of the sentence *his mitre* can also be replaced by a pronoun and so this must be a DP too:

(83) a [<sub>DP</sub> the bishop that just left] [<sub>VP</sub> was hiding [<sub>DP</sub> a gun] under *it*]  
 b [<sub>DP</sub> the bishop that just left] [<sub>VP</sub> was hiding [<sub>DP</sub> a gun] under [<sub>DP</sub> his mitre]]

Next, we note that *under his mitre* can be replaced by the word *there*:

(84) [<sub>DP</sub> the bishop that just left] [<sub>VP</sub> was hiding [<sub>DP</sub> a gun] *there*]

This shows us that the string of words, *under his mitre* forms a constituent of the sentence, but the category of this constituent is not so easy to determine from the category of its replacement. We might suppose that *there* is a pronoun and therefore it replaces DPs, but this constituent is made up of a preposition (*under*) followed by a DP (*his mitre*) which does not distribute like a DP:

## Testing for Structure

---

- (85) a \**[under his mitre] disappeared*  
 b \**the bishop was hiding [under his mitre]*

(85b) is ungrammatical if we take *under his mitre* to name what it is that is being hidden, equivalent to *a gun* in (78) (though it is grammatical with the interpretation that it names the place where the bishop was hiding! In this case it does not function as the object and hence is not distributing like one). We called this kind of constituent a prepositional phrase above and we will continue to assume this and therefore we can conclude that *there* is in fact a pronominal preposition phrase as this is what it seems to replace.

Turning to the structural position of the auxiliary verb *was* note also that the part of the VP that follows this can also be replaced by a verb:

- (86) [<sub>DP</sub> the bishop that just left] was *smiling*

We concluded above that if something can be replaced by a verb it has the status of a VP and hence we have one VP inside another in this case, which tallies with our description of auxiliary verbs that they take verbal complements.

Putting this together, we have now derived the structure:

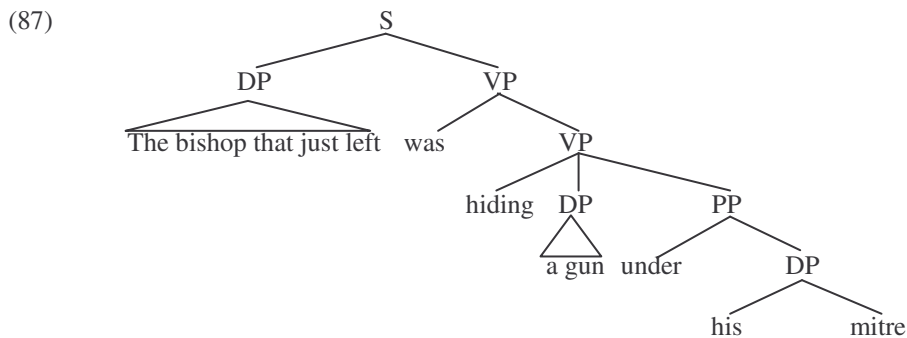

Turning to the subject, we note that the part of this DP *bishop that just left* can be replaced by a single noun:

- (88) [<sub>DP</sub> the *impostor*] [<sub>VP</sub> was [<sub>VP</sub> hiding [<sub>DP</sub> a gun] [<sub>PP</sub> under [<sub>DP</sub> his mitre]]]]

We may conclude, therefore that this part of the structure is also a phrase, presumably a noun phrase, as the word *impostor* is a noun. This NP is constructed of a noun followed by *that just left*, which as it is introduced by a complementiser we can conclude is some kind of a clause, though admittedly it doesn't look much like a clause and a lot more needs to be said to show that it is. For now, let us just accept that it is a clause and stop our analysis at this point. What we have therefore is the following structure:

(89)

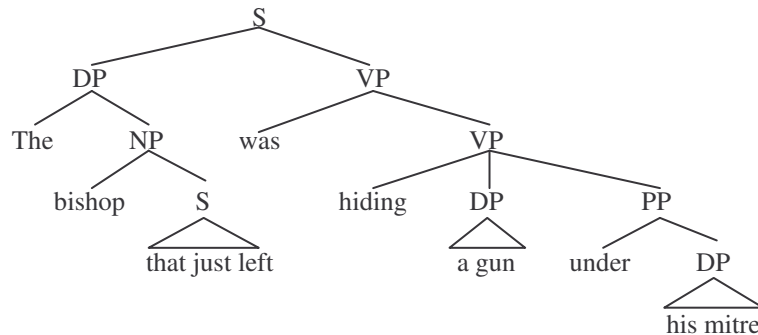

In our discussion so far we have shown that whole DPs can be replaced by a pronoun and, indeed, that a PP can be replaced by the prepositional ‘pronoun’ *there*. But for VP we have used intransitive verb to demonstrate the distributional properties of the phrase. Is there a ‘pronoun’ for a VP? I may be that the words *do so* function as a kind of pronominal replacement for VPs, though its use is a little more restricted than other pronouns:

(90) the bishop hid his gun and the verger *did so* too

In this example, we have two sentences: the bishop hid his gun; the verger did so too. These two sentences are made into one sentence by placing them either side of the word *and*. The phenomena is known as **coordination**, about which we will have more to say in a little while. Given that the words *did so* in (90) are interpreted as meaning *hid his gun*, we can see that they replace the VP in the second sentence, forcing this VP to be interpreted the same as the VP of the first sentence. This is similar to the use of the pronoun in the following:

(91) the bishop hid his gun and *he* jumped into the getaway car

Given this similarity, we might take the words *do so* to be a pronoun which replaces VPs and hence we can test whether a constituent is a VP by seeing if it can be replaced by *do so*.

The NP inside the DP may also have a pronominal replacement. Consider the following:

(92) this robbery of a bank was more successful than that *one*

In this sentence the word *one* replaces *robbery of a bank*, which is an NP. Note that it does not replace the whole DP, as do pronouns such as *it*, *that*, *him*, etc. We can therefore claim that *one* is a pronoun which replaces NPs and hence anything that can be replaced by *one* is an NP.

Pronominalising adjective phrases is more restricted than the other phrases we have considered. It appears that only APs functioning as predicates can be pronominalised and not those which are modifiers:

(93) a the bishop was guilty and *so* was the verger  
 b \*the guilty bishop and the *so* verger



## Testing for Structure

---

As we can see the pronoun for APs is *so*, though as it is restricted to predicative APs and it also plays a role in Pronominalising VPs, we might consider it as a general pronoun for replacing predicates. Nevertheless it can still be used as a constituent test as anything that functions as a predicate is a constituent of one type or another.

Finally in this section, let us consider pronouns which replace clauses. In some cases, the pronoun *it* can be used for this purpose:

(94) they said the bishop robbed the bank, but I don't believe *it*

Given that the *it* stands for *the bishop robbed the bank* and that this is a clause, this word can be claimed to be a clausal pronoun (as well as a DP pronoun).

The word *so* can also replace whole clauses:

(95) they said the bishop is dangerous, but I don't think *so*

Thus, besides being a general predicative pronoun, *so* can also be a clausal pronoun. Like other pronouns, then, it can provide us with evidence as to what counts as a constituent in a sentence.

### 3.2 Movement

There are other aspects of distribution we might use to support a structural analysis of a clause. For example, the distribution of an element refers to the *set* of positions that that element may occupy. Sometimes we can identify a number of positions that an element might be able to occupy in related sentences:

(96) a the policeman searched the bishop  
b the bishop, the policeman searched

Both of these sentences are grammatical in English, though the second one seems to have a special status and the first is more 'normal' in this respect. To start with, the second sentence seems to give a special interpretation to *the bishop*. The meaning can be understood in a context in which there are a group of people being searched, including the bishop, and these are being searched by various people. We might therefore have an extended context:

(97) the policewoman searched the nun, the chief constable searched the vicar and the bishop, the policeman searched.

We call the element in front of the subject that has this interpretation the **topic**.

Note that in this case the topic is also interpreted as the object: the one being searched. This is why this structure seems to be special with respect to the one in (96a), where the object has no extra aspects to its interpretation. From a syntactic point of view, the interesting observation is that the topic is a separate position, somewhere in front of the subject. We might account for why the element which sits in this position is interpreted as both the object and the topic by proposing that the object is moved into the topic position:

(98) the bishop, the policeman searched —  
↑

## Chapter 2 - Grammatical Foundations: Structure

---

Obviously, such movement processes determine aspects of the distribution of an element: an element which can be moved from one position to another must be able to occupy both positions. Turning this the other way round, something which moves has a certain distribution and we know that anything that has a distribution is a constituent.

It therefore follows that anything that moves is a constituent, and we can use movement phenomena to test assumptions about the structure of a sentence. For example, the movement involved in topicalising the object in (98) can be taken as support that the object is a constituent of this sentence.

In the following sentence we see that the VP can also undergo a similar movement, supporting the claim that the verb and its object form a constituent:

(99) I thought the policeman would search the bishop, and  
       [search the bishop], he did –  
       └──────────────────┘

Thus these movement facts support the following analysis of the structure of this sentence:

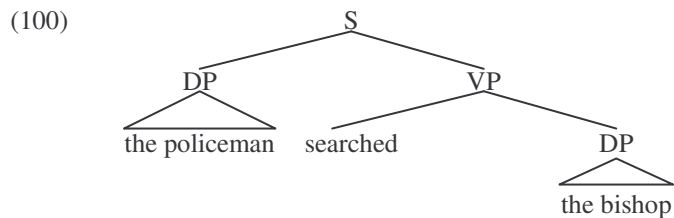

There are many instances of movements to be found in language. One of the most obvious is found in certain questions. Many English questions involve a word like *which*, *what*, *where*, *why*, etc. at the beginning of the sentence. However, these words have a dual function, being associated with some function within the clause as well as indicating the interrogative status of the clause by appearing at its beginning. For example, in the following the word *what* is interpreted not only as an interrogative but also as the object of the sentence:

(101) what did they find

One way to account for this interpretation is to claim that the *wh*-element does not start in the clause-initial position, but is moved to this position from the object position. In this way we can claim that *what* IS the object and hence account for its interpretation. The movement may be indicated thus:

(102) what did they find –  
       └──────────────────┘

These interrogative elements are called *wh*-elements as they tend to be spelled with the letters *w* and *h* at the beginning, though this does not reflect the current pronunciation of these words. In the above example, the *wh*-element can be categorised as a DP, originating from object position, which is a DP position. We can also find *wh*-APs and PPs:

## Testing for Structure

---

- (103) a where did they find the gun (A = under the bishops mitre)  
 b how did the judge find the bishop (A= guilty!)

The fact that the answer to (103a) is a preposition phrase and that to (103b) is an adjective phrase is an indication that these *wh*-elements are prepositional and adjectival respectively.

Not every kind of phrase can be questioned in this way, however. For example, there is no *wh*-element that corresponds to a VP, nor one for an NP. However the fact remains that only constituents can undergo this movement and so it can act as a fairly reliable test for the constituent structure of most parts of a sentence.

It is important to note that only one constituent can undergo any particular movement and that two constituents cannot move together. To demonstrate this, consider the following sentence:

- (104) the bishop killed the bank manager with the gun

This sentence can be interpreted in one of two ways depending on who is seen as having the gun. If it is the bank manager who has the gun, then the PP *with the gun* acts as a modifier within the DP *the bank manager with the gun*. If, on the other hand, the bishop has the gun, then the PP is interpreted as modifying the VP *killed the bank manager with the gun*. In the first interpretation the PP is a kind of locative modifier, locating the gun with the bank manager and in the second it is an instrumental modifier saying what was used to kill the bank manager. The important point to note is that in the first case the PP forms a single constituent with the DP, whereas in the second it is a separate constituent from this. Thus we have the two structures:

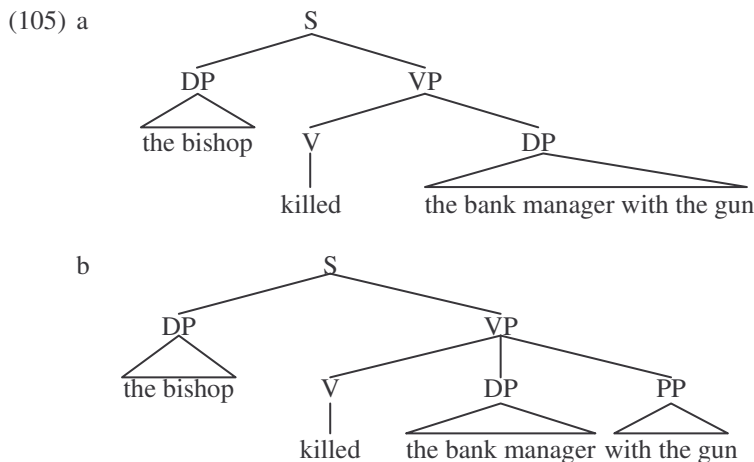

Suppose we topicalise the object in (105a), moving the DP to the front of the clause. As the PP is part of the DP it will be carried along with the rest of it and we will derive the following sentence:

- (106) the bank manager with the gun, the bishop killed \_
-

## Chapter 2 - Grammatical Foundations: Structure

---

This sentence is no longer ambiguous between the two meanings. This is because we must interpret the moved element as a single constituent and not as two separate constituents that have been moved together. The same point can be made with the movement of *wh*-elements, as shown by the following:

(107) which bank manager with a gun did the bishop kill –  
↑ └───┬───┘

Again this sentence is unambiguous and the PP must be interpreted as modifying the DP and not the VP. An overall conclusion about movement is therefore that anything that can be moved is a single constituent and hence movement provides a relatively robust and useful test for constituent structure.

### 3.3 Coordination

There are other phenomena besides distribution that can also be used to support structural analyses. One of these involves **coordination**. This is a device used in language to take two elements and put them together to form a single element. This coordinated element then acts like the two coordinated elements would have individually. For example, we can take two nouns, say *Bill* and *Ben*, and we can coordinate them into a single element *Bill and Ben*. This coordinated element behaves exactly like each of the nouns in that it can appear as subject, object, object of a preposition or topic in a sentence:

- (108) a Bill and Ben went down the pub  
       b I know Bill and Ben  
       c they sent a letter to Bill and Ben  
       d Bill and Ben, everyone avoids

The point is that as the coordinated element behaves in the same way as its coordinated parts would individually, we cannot coordinate two conflicting things. So while two nouns can be coordinated, and two verbs can be coordinated, a noun and a verb cannot:

- (109) a the [boys and girls]  
       b have [sung and danced]  
       c \*the [boys and danced] have [sung and girls]

Not just words can be coordinated however; we can also coordinate phrases and sentences. As long as the phrases and sentences are sufficiently the same, the result will be a phrase or a sentence which behaves in the same way as its coordinated parts:

- (110) a [these boys] and [those girls]  
       b [have sung] and [are now dancing]  
       c [the boys have sung] and [the girls are now dancing]

Just like in the case of movement, only constituents may be coordinated and two independent constituents cannot act as one single conjunction which is coordinated with another. To demonstrate this, recall the ambiguous sentence in (104) where the PP was either associated with the object DP or with the VP. Now, if we coordinate the

## Testing for Structure

---

string of words, *the bank manager with the gun* with the DP *the security guard*, the ambiguity is resolved:

(111) the bishop killed the bank manager with the gun and the security guard

In this example two DP objects are coordinated, one *the bank manager with the gun* and the other *the security guard*. The first conjunct cannot be interpreted as a separate DP with following PP modifying the VP as this would not constitute a single constituent which could be coordinated with the second DP.

Again we can turn these observations round to provide a test for structural analyses. If we claim that a certain part of a sentence constitutes a phrase, then to test this claim we could take another similar element and see if the two things can be coordinated. Thus, to go back to the structure proposed in (100), there are three constituents proposed: the subject DP, the VP and the object DP inside the VP. If this is accurate, we should be able to find an element to coordinate with these constituents to form grammatical sentences:

(112) a [[the policeman] and [the chief constable]] searched the bishop  
b the policeman [[searched the bishop] and [confiscated his crosier]]  
c the policeman searched [[the bishop] and [the verger]]

The prediction seems to be supported and hence we can feel reasonably confident about the structure proposed in (100).

The coordination test, however, needs to be carefully applied. Recall that the way coordination works is to take two elements and form them into a single element that has the same function as the two elements would have individually. It therefore follows that two elements cannot be coordinated if they do not have the same function, even though they may be constituents of the same category. For example, if we tried to coordinate a PP that was a locative modifier of a DP with one which was an instrumental modifier of a VP the result would be ungrammatical:

(113) \*the bishop shot the bank manager with a moustache and with a gun

By the same token, two constituents with the same function can be coordinated, even if they do not have the same categorial status:

(114) you should take the medicine regularly and under proper medical supervision

In this example the adverb *regularly* and the PP *under medical supervision* have the same modifying function in the VP and hence can be coordinated.

Still, despite these few complications, it remains a fact that only constituents can be coordinated and hence the coordination test is also a fairly reliable one for constituent structure.

### 3.4 Single-word phrases

There is an important point we should make before finishing this chapter. We have claimed that elements which have the same distribution have the same categorial status. We have also seen cases where phrases can be replaced by a single word. This leads us to the conclusion that these words have the status of the phrases they replace.

## Chapter 2 - Grammatical Foundations: Structure

---

This might sound contradictory, but it is not. The fact is that phrases can consist of one or more words. Thus, while *smile* is a verb, it is also a VP in the following sentence:

(115) the Cheshire cat [<sub>VP</sub> smiled]

Furthermore, while a pronoun is a determiner, it is also a DP in the following sentence:

(116) I never knew [<sub>DP</sub> that]

We have also seen that the word *there* can replace prepositional phrases, and so not only is it a word, it is also a PP:

(117) we don't go [<sub>PP</sub> there]

The situation is easy enough to represent in terms of a tree diagram:



In such trees the dual status of these elements as both word and phrasal categories is clearly represented.

### Check Questions

- 1 What are phrases?
- 2 What are rewrite rules?
- 3 Define what a recursive rule looks like and comment on its importance in the grammar.
- 4 Compare characteristics of subjects in finite and non-finite clauses.
- 5 What is an direct object, an indirect object and a prepositional object?
- 6 Compare the dative construction with the double-object construction.
- 7 What tests can you use to define whether a string of words forms a constituent or not?

### Test your knowledge

▪ **Exercise 1**

List the rewrite rules used in generating the following structure:

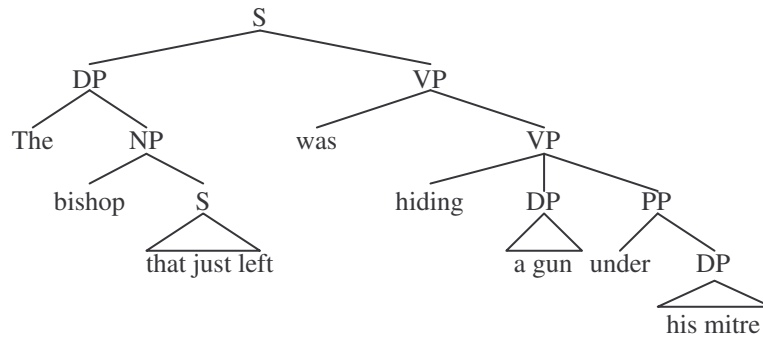

▪ **Exercise 2**

Identify the constituents in the following sentences.

- a The postman lost his key yesterday.
- b The student who has just passed the exam is very happy.
- c This theory of language acquisition is easy for students who understand mathematics.

▪ **Exercise 3**

Account for why the following sentences are ungrammatical.

- a \*Yesterday I met Paul and with Peter.
- b \*Whose did you see favourite film?
- c \*Mike invited the woman with long hair, Jamie invited the she with short hair.
- d \*The student, I haven't seen of Physics lately.
- e \*She can paint with her mouth and with pleasure.





# Chapter 3

---

## Basic Concepts of Syntactic Theory

### 1 *X-bar Theory*

#### 1.1 Rewrite rules and some terminology

We will start by looking at some general principles that determine the basic structure of phrases and sentences. The perspective we will present claims that these principles are simple because there are a very small number of them that apply to all structures. In fact this theory claims there to be at most three different rules which determine the nature of all structures in a language. These can be stated as follows:

- (1) a  $X' \rightarrow X YP$   
b  $XP \rightarrow YP X'$   
c  $X^n \rightarrow X^n, Y/YP$

Recall from chapter 2, rewrite rules which tell us how structures of various kinds decompose into their constituent parts. The rules in (1) are like these, only far more general. The generality is achieved through the use of **category variables**, X and Y, which stand for any possible category (nouns, verbs, prepositions, determiners, etc.). Thus these rules tell us how phrases in general are structured, not how particular VPs, PPs or DPs are.

The third rule in (1) introduces a position into the phrase called the **adjunct**. Given that we have yet to introduce these elements we will put off discussion of this rule until section 1.3, where we will give a fuller account of both adjuncts and the adjunction rule.

The first rule (1a) is called the **complement rule**, as it introduces the structural position for the complement (the *YP* of this rule). The structure it defines is given below:

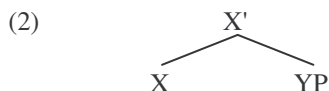

There are several things to note about this structure. First there are two immediate constituents of the  $X'$  (pronounced “X bar”): X, which is called the **head** of the phrase and the complement YP. The complement, which, as its label suggests is a phrase of any possible category, follows the head. This is a fact about English and in other languages the complement may precede the head.

### Chapter 3 - Basic Concepts of Syntactic Theory

---

Whether it precedes or follows the complement, the head is the central element of the phrase and is a word of the same category as the X'. Thus, if the head is an adjective, the X' will be an A' and if the head is a complementiser the X' will be a C'.

Here are some structures that conform to this pattern:

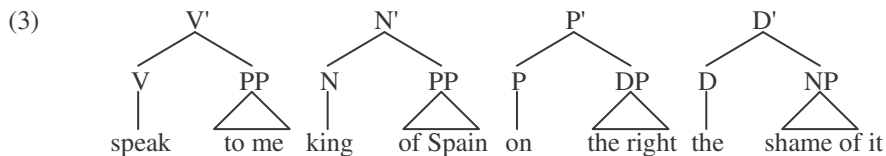

Note that, although these are constituents of different types, they all have a very similar pattern: the head is on the left and the complement is on the right. This is exactly what the X-bar rules were proposed to account for. It is clearly the case that there are cross-categorical generalisations to be made and if constituents were described by the rewrite rules of the kind given in chapter 2, where for each type of constituent there is a specific rule, it would be impossible to capture obvious similarities between phrases.

The rule in (1b) is the **specifier** rule, as it introduces a structural position called the specifier (the YP of this rule). The structure it defines is as below:

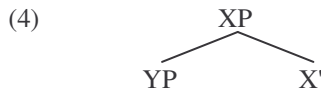

Again there are several things to note about this structure. Once more, there are two immediate constituents of the phrase. The specifier, a phrase of any category, precedes the X', the constituent just discussed containing the head and the complement. Again the ordering of these two constituents is language dependent: specifiers precede X's in English, but this is not necessarily so in all languages. Specifiers are a little more difficult to exemplify than complements due to complications that we have yet to discuss. However, the following are fairly straightforward cases:

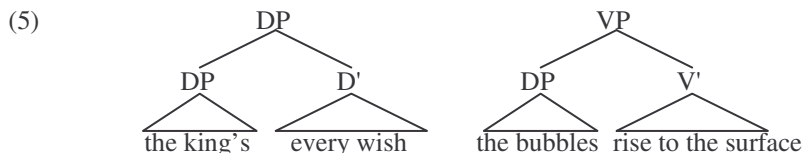

The specifier of the DP is the possessor and this precedes the D' constituted of the determiner and its complement. The VP in (5) is exemplified in the following sentence:

(6) we watched [the bubbles rise to the surface]

This VP has many things in common with a clause and indeed it looks very much like one. We will discuss the difference between the two in a subsequent chapter. The important point to note is that the theme argument of the verb (the argument undergoing the process described by the verb – in this case, *the bubbles*) occupies the specifier position of the VP as defined by the rule in (1b).

## X-bar Theory

---

Note that the X' and the phrase share the same categorial status (X) and so if X' is P' XP will be PP, etc. As X' is the same category as the head, it follows that the whole phrase will be of the same category as the head. In this way, the head of the phrase determines the phrase's category.

The property of sharing category between the head, the X' and the phrase is called **projection**. We say that the head projects its categorial status to the X' and ultimately to the XP. If we put the two parts of the structure together, we can more clearly see how projection works:

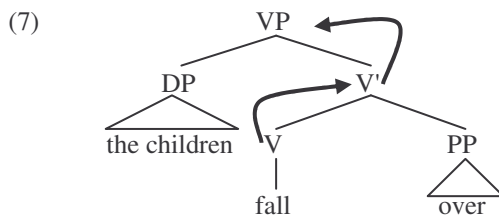

The line of projection proceeds from the head, via the X' to the phrase thus ensuring that phrases and heads match.

The meaning of the 'bar' can be seen in terms of the notion of projection. We can imagine a phrase as a three-floored building, with a ground floor, a first floor and a top floor. On the ground floor we have the head, which is not built on top of anything – it is an unprojected element. Often heads are called **zero level projections**, to indicate that they are not projected from anything. This can be represented as X<sup>0</sup>.

Above the head, we have the X', the first projection of the head. The bar then indicates the projection level of the constituent: X' is one projection level above X<sup>0</sup>.

On the top floor we have the phrase, XP. This is the highest level projected from the head and hence it is called the **maximal projection**. Another way of representing the maximal projection is X'', an X with two bars (pronounced 'X double bar'), with the bars again representing the projection level. It seems that all phrases project to two levels and so we will not entertain the possibility of X''', or X''''', etc. Typically we will maintain the custom of representing the maximal projection as XP.

### 1.2 Endocentricity

An obvious consequence of the notion of projection is that we will never get a phrase of one category with a head of another. While this might seem a slightly perverse situation to want to prevent in the first place (why would verb phrases be headed by anything other than a verb?), it is certainly a logical possibility that there could be phrases of category X which do not contain a word of category X. For example the traditional view that preposition phrases can function adverbially could be captured under the following assumption:

(8)  $AP \rightarrow P DP$

In other words, a preposition phrase which behaves as an adverbial phrase is an adverb phrase headed by the preposition. Clearly this is something that would not be allowed by the X-bar rules in (1). Evidence favours the X-bar perspective and there is no reason to believe that just because something *functions* adverbially it is categorially the

### Chapter 3 - Basic Concepts of Syntactic Theory

---

same as an adverb. For example, even when PPs are used adverbially, they still have different distributions to AP:

- (9) a we met [<sub>AP</sub> secretly]      we met [<sub>PP</sub> in secret]  
b we [<sub>AP</sub> secretly] met      \*we [<sub>PP</sub> in secret] met

As we see in (9), a PP modifier of a verb must follow it, while an AP modifier may precede or follow it, even if the two modifiers have virtually the same interpretation. Thus a phrase headed by a preposition has a different categorial status to one headed by an adverb, supporting the X-bar claim that phrases have heads of the appropriate kind.

Moreover, the X-bar rules in (1) rule out another possibility if we assume that these are the only rules determining structure. While it might not make much sense to have a phrase with a head of a different category, the idea of a phrase that simply lacks a head is not so absurd. There is a traditional distinction made between **endocentric** and **exocentric** language elements. An endocentric phrase gets its properties from an element that it contains and hence this element can function by itself as the whole phrase. For example:

- (10) a I saw [three blind mice]  
b I saw [mice]

An exocentric phrase on the other hand contains no element that can have the same function as the whole phrase and so appears to have properties that are independent from the elements it contains. A standard example is:

- (11) a we saw him [in the park]  
b \*we saw him [in]  
c \*we saw him [the park]

The issue is rather complex. The traditional view mixes category and function in a way that is perhaps not helpful. The point is, however, that the X-bar rules in (1) claim that, categorially, all phrases are endocentric: in other words, all phrases have heads which determine their categorial nature.

There is one grammatical construction that seems at first to stand outside the X-bar system precisely in that it lacks a head: the clause. Certainly from a functional perspective the clause contains no element that could replace the whole construction: neither the subject nor the VP can function as clauses by themselves:

- (12) a [Susan] [shot Sam]  
b [Susan]  
c [shot Sam]

The examples in (12) all have very different natures, even categorially.

It might be argued that sometimes VPs can act as clauses:

- (13) get out!

However, such expressions have a special status and there is more to them than appears at the surface. The sentence in (13) is an **imperative** construction in which there appears to be no subject. However it is fairly clear that there is a definite subject

## X-bar Theory

---

understood in this sentence: *you!* An imperative cannot be interpreted as a command given to some third person and must be interpreted as directed towards the addressee. The question is then, what is the status of the subject of such sentences: are they only ‘understood’, present at some semantic level or are they merely ‘unpronounced’ though present at the grammatical level?

There is reason to believe that language makes much use of unpronounced elements that are nonetheless present grammatically and we will see many examples of such things in the following pages. One argument to support the assumption of an unpronounced subject in (13) comes from observations concerning the behaviour of **reflexive pronouns** such as *himself*. Unlike other pronouns, reflexives must refer to something else in the same sentence:

- (14) a Sue said Fred fancies himself  
b Sue said Fred fancies her

In (14a) *himself* can only be interpreted as referring to *Fred* and cannot, for example, be taken to mean someone else not mentioned in the sentence. Compare this to the behaviour of *her* in (14b). In this case the pronoun may either be taken as referring to *Sue* or to some other woman. We can say therefore that reflexive pronouns must have grammatical **antecedents**: some element present in the sentence which provides the reflexive with its reference. With this in mind, consider the following observations

- (15) a Pete ate the pie by himself  
b Pete ate the pie by itself
- (16) a eat the pie by yourself!  
b Pete ate  
c \*Pete ate by itself

As we see from (15), a *by* phrase containing a reflexive is interpreted to mean ‘unaccompanied’. In (15a), the reflexive refers to *Pete* and so it means that he was unaccompanied in eating the pie. In contrast, in (15b) the reflexive refers to *the pie* and so it means that the pie was unaccompanied (by ice cream for example) when Pete ate it. (16a) is grammatical even though there is no apparent antecedent for the reflexive. It is not surprising that the reflexive should be *yourself* however, as, as we have said, the understood subject of an imperative is *you*. Yet we cannot simply say that the antecedent ‘being understood’ is enough to satisfy the requirements of the reflexive as (16c) is ungrammatical. In this case the object is absent, though it is clearly understood that something was eaten in (16b). But this understanding is not enough to license the use of the reflexive in this case. So we conclude that the missing subject in (16a) is different from the missing object in (16c) and in particular that the missing subject has a more definite presence than the missing object. This would be so if the missing subject were present as an unpronounced grammatical entity while the missing object is absent grammatically and present only at the semantic level. In conclusion then, while imperatives might look like VP clauses which lack subjects, they are in fact full clauses with unpronounced subjects.

### Chapter 3 - Basic Concepts of Syntactic Theory

---

If the VP cannot be argued to function as a clause, one might try to argue that clauses and subjects have certain things in common. For example, a clause can act as a subject:

(17) [that ice cream production has again slumped] is bad news for the jelly industry

But this does not show that subjects are functional equivalent to clauses but quite the opposite: clauses may be functionally equivalent to subjects under certain circumstances.

Therefore it would appear that clauses are exocentric constructions, having no heads, and as such stand outside of the X-bar system. Later in this book, we will challenge this traditional conclusion and claim that clauses do indeed have heads, though the head is neither the subject nor the VP. From this perspective, X-bar theory is a completely general theory applying to all constructions of the language and given that X-bar theory consists of just three rules it does indeed seem that I-language principles are a lot simpler than observation of E-language phenomena would tend to suggest.

#### 1.3 Heads and Complements

But if the structural rules of the grammar are themselves so general as to not make reference to categories how do categorial features come to be in structures? One would have thought that if all the grammar is constructed from are rules that tell us how phrases are shaped in general, then there should only be one kind of phrase: an XP.

To see how categorial information gets into structure we must look more closely at heads and the notion of projection. We have seen how heads project their properties to the X' and thence to XP, the question we must ask therefore is where do heads get their properties from? The main point to realise is that the head is a word position and words are inserted into head positions from the lexicon. In chapter 1 we spent quite some time reviewing the lexical properties of words, including their categorial properties. These, we concluded, are specified for every lexical item in terms of categorial features ([±F, ±N, ±V]). If we now propose that a head's categorial features are projected from the lexical element that occupies the head position we can see that phrases of different categories are the result of different lexical elements being inserted into head positions.

One way to envisage this is to think of X-bar rules as building a general X-bar structure devoid of categorial properties. So we might start with the following:

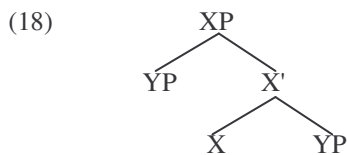

We then populate this structure by inserting words into it from the lexicon and these bring along with them their categorial features. Suppose we insert the verb *fall* into the head position, as this is categorised [-F, -N, +V] (i.e. verb) these will project to the head position:

## X-bar Theory

---

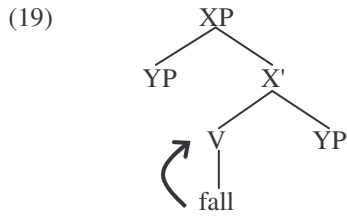

These features then project to the X':

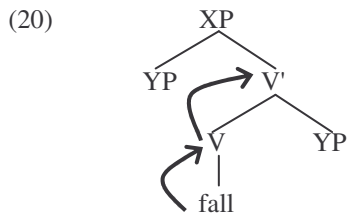

And finally they end up on the maximal projection:

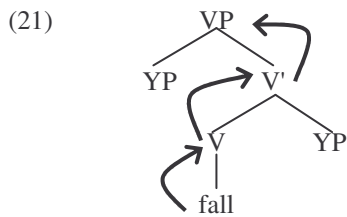

In this way we can see that categorial features are actually projected into structures from the lexicon. This makes a lot of sense given that categorial properties are to a large extent idiosyncratic to the words involved in an expression and are not easily predicted without knowing what words a sentence is constructed from. Things which are predictable, such as that all phrases have heads which may be flanked by a specifier to its left and a complement to its right, are what are expressed by the X-bar rules. Thus we have a major split between idiosyncratic properties, which rightly belong in the lexicon, and general and predictable properties which rightly belong in the grammar.

The structure in (21) is still incomplete however and we must now consider how to complete it. Let us concentrate firstly on the complement position. At the moment this is expressed by the general phrase symbol YP. This tells us that only a phrasal element can sit here, but it does not tell us what category that phrase must be. Yet, it is clear that we cannot insert a complement of just any category into this position:

- (22)
- a fell [<sub>PP</sub> off the shelf]
  - b \*fell [<sub>DP</sub> the cliff]
  - c \*fell [<sub>VP</sub> jumped over the cliff]

This restriction clearly does not come from the X-bar rules as these state that complements can be of any category, which in general is absolutely true. But in specific cases, there must be specific complements. Again it is properties of heads

### Chapter 3 - Basic Concepts of Syntactic Theory

---

which determine this. Recall that part of the lexical entry for a word concerns its subcategorisation. The subcategorisation frame of a lexical element tells us what kind of complement there can be. For *fall*, for instance, it is specified that the complement is prepositional:

- (23) *fall*     **category:** [-F, -N +V]  
                   **Θ-grid:** <theme, path>  
                   **subcat:** prepositional

Thus through the notion of subcategorisation, the head imposes restrictions on the complement position, allowing only elements of a certain category to occupy this position:

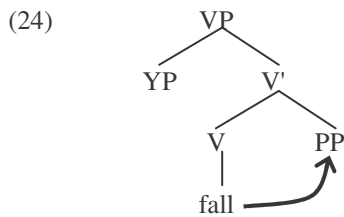

As we know that the complement must be prepositional, we also know by the general principles of X-bar theory that only a preposition could be inserted into the head position of this phrase and the lexical properties of this head will, in turn, impose restrictions on what can appear in its complement position:

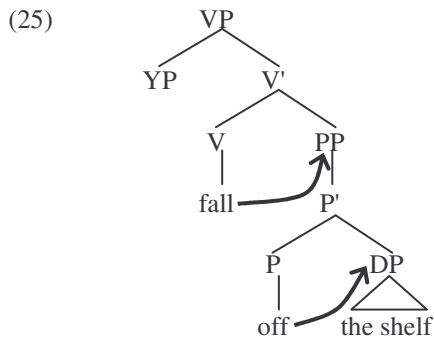

In this structure, *off* is inserted into the head position of the PP complement of the verb and as this preposition selects for a DP complement (as most of them do), only a determiner could be inserted into the head position of this phrase. The determiner would then impose restrictions on its complement, ensuring this to be an NP and hence only a noun could be inserted into the head of the determiner's complement. Obviously, this could continue indefinitely, but in this case the process stops at this point as the noun subcategorises for no complement.



### 1.4 Specifiers

So far we have been concerned with heads and their complements. In this section we turn to specifiers. As we said above the specifier position is a little more complex than the complement for reasons which we will turn to in section 2.

In general we will find that specifiers are occupied by certain arguments of a predicate or by elements with a certain specified property which relates to the head. This second class of specifiers can only be discussed after a good deal more of the grammar has been established, so we will put these to one side for the moment.

The argument specifiers tend to be subjects, though again this statement will need much qualification as we proceed. One class of verb for which this is most straightforward are those which have theme subjects:

- (26) a a letter arrived  
       b the ship sank  
       c Garry is in the garden

Simplifying somewhat, we might claim that these arguments sit in the specifier of the VP:

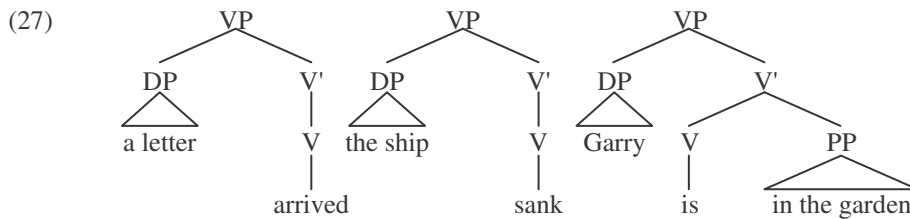

These arguments are nearly always DPs and so, unlike the complement they do not seem to be restricted differently by different heads in terms of their category. This is reflected in the lexical entries of the relevant heads in the fact that subcategorised elements are always complements and subjects are never subcategorised for. Of course, there are restrictions placed on these specifier arguments from the predicate, but of a more semantic nature. The verb assigns a  $\Theta$ -role to these arguments and so the argument must be semantically compatible with the  $\Theta$ -role it has to bear. For example:

- (28) the complete works of Shakespeare arrived

The most natural interpretation for this sentence would be to interpret the subject *the complete works of Shakespeare* as a book or set of manuscripts, i.e. something concrete rather than the artistic pieces of work themselves. Only if one was speaking about arriving in a metaphorical sense could one claim that one of Shakespeare's plays had 'arrived' after he had written it.

This is different from the situation facing complements where there are both semantic and categorial restrictions placed on them. For example consider the following difference:

- (29) a Arthur asked what the time was  
       Arthur asked the time  
       b Wonder woman wondered what the time was  
       \*Wonder woman wondered the time

## Chapter 3 - Basic Concepts of Syntactic Theory

---

The verbs *ask* and *wonder* both have questions as their complements, but only with *ask* can this question be expressed by a DP like *the time*. Thus there are extra restrictions imposed on complements which go beyond the requirement that they be compatible with the  $\Theta$ -role that is assigned to them. In short, specifiers are more generally restricted than complements as they tend to be a uniform category for different heads and merely have to be compatible with the meaning of the head.

### 1.5 Adjuncts

It is now time to turn to the third rule in (1), which we repeat here:

$$(30) \quad X^n \rightarrow X^n, Y/YP$$

This is different from the previous two rules in a number of ways. First, the previous rules specified the possible constituents of the various specific projections of the head: complements are immediate constituents of  $X'$  and specifiers are immediate constituents of  $XP$ . The adjunction rule in (30) is more general as it states the possible constituents of an  $X^n$ , that is, an  $X$  with any number of bars. In other words,  $X^n$  stands for  $XP (=X^n)$ ,  $X'$  or  $X (=X^0)$ . The adjunct itself is defined either as a word ( $Y$ ) or as a phrase ( $YP$ ) and we will see that which of these is relevant depends on the status of  $X^n$ : if  $X^n$  is a word, then the adjunct is a word, if not then the adjunct is a phrase.

Note that the two elements on the right of the rewrite arrow are separated by a comma. This is missing from the complement and specifier rule. The significance of the comma is to indicate that the order between the adjunct and the  $X^n$  is not determined by the rule. We have seen that in English the complement follows the head and the specifier precedes it. Adjuncts, on the other hand, it will be seen, may precede or follow the head depending on other conditions, which we will detail when looking at specific instances of adjunction.

The final thing to note is that the adjunction rule is recursive: the same symbol appears on the left and the right of the rewrite arrow. Thus the rule tells us that an element of type  $X^n$  can be made up of two elements, one of which is an adjunct and the other is another  $X^n$ . Of course, this  $X^n$  may also contain another  $X^n$ , and so on indefinitely. In this way, any number of adjuncts may be added to a structure.

#### 1.5.1 Adjunction to $X$ -bar

Let us take an example to demonstrate how this might work. We know that an adjectival phrase can be used to modify a noun, as in:

- (31) a smart student  
b vicious dog  
c serious mistake

It is clear that the noun is the head of this construction as it can act as the complement of a determiner and determiners take nominal complements, not adjectival ones:

- (32) a the [<sub>NP</sub> serious error]  
b the [<sub>NP</sub> error]  
c \*the [<sub>AP</sub> serious]

The bracketed elements in (32a) and (b) have the same distribution and hence we can conclude they have the same categorial status. As this phrase in (32b) contains only a

## X-bar Theory

---

noun, we conclude that it is an NP. In (32c) however, the phrase following the determiner contains only an adjective and is ungrammatical. This clearly has a different distribution to the other two phrases, indicating that the adjective in (32a) is not the head of this phrase.

It is also possible to conclude that the adjective is not a complement of the head noun as it does not follow the noun and as we have seen, in English, all complements follow their heads.

The other possibility is that the adjective functions as a specifier within the NP and as specifiers precede their heads, this seems more likely. Yet there are properties of the adjective that make it an unlikely specifier. As we saw, specifiers of thematic heads tend to be arguments of those heads. The adjective is obviously not an argument of the noun as it does not bear a thematic role assigned by the noun. Furthermore, specifiers are limited to a single occurrence and there cannot be more than one of them:

- (33) a the letter arrived  
b the postman arrived  
c \*the letter the postman arrived

However, there can be more than one adjectival modifier of a noun:

- (34) a popular smart student  
b big evil vicious dog  
c solitary disastrous unforgivable serious mistake

Thus, the adjectival modifier is an adjunct of the noun. We will argue in a later chapter that adjectival modifiers follow the specifier of the NP and hence adjectival phrases are attached in a position between the specifier and the head. As we see in the following, this puts them as adjuncts to the N':

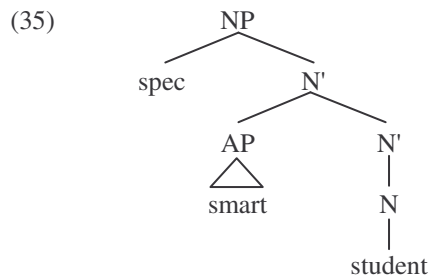

The part of the structure containing the AP is recursive with an N' as the mother and an N' as one of the daughters. This means that there is room for more APs, as demonstrated by (36):

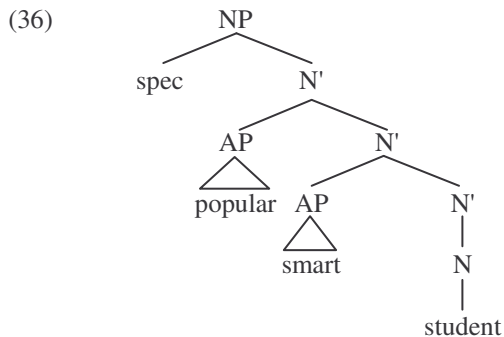

This could go on indefinitely with each adjunct introducing an N' which itself contains an adjunct and another N' and hence any number of adjuncts could be added to the structure, which appears to be the correct treatment of adjuncts.

**1.5.2 Adjunction to phrase**

We can exemplify adjunction to a phrase with a certain type of relative clause. Relative clauses are clauses which are used to modify nouns:

- (37) a the queen, [who was Henry VIII's daughter]
- b the sun, [which is 93 million miles from the earth]
- c my mother, [who was a successful racing driver]

These clauses are not complements of the nouns, the nouns in (37) all being intransitive, and cannot be specifiers as they follow the head. Like AP adjuncts, they are recursive, demonstrating a clear property of an adjunct:

- (38) book, [which I was telling you about], [which I haven't read]

We will see in a later chapter that there is reason to believe that these types of relative clause are adjoined to the NP rather than the N':

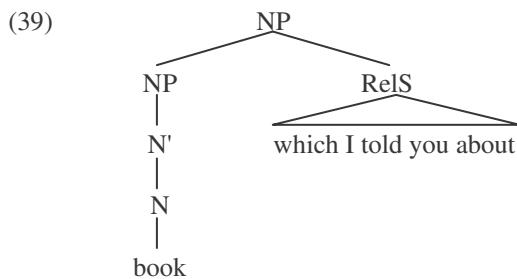

In this case it is the NP that is recursive, the top NP node contains the relative clause and another NP. This means that there is room for further relative clauses:

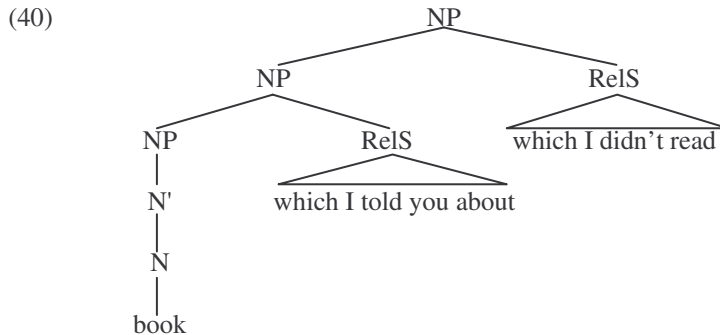

Again, we could keep adding NPs and relative clauses indefinitely, each relative clause adjoined to a successively higher NP. Incidentally, note that here we see that adjuncts may appear on different sides of the element that they modify. While an AP adjunct precedes the N', the relative clause follows the P.

### 1.5.3 Adjunction to head

Finally, we will consider the case of adjunction to a head, using compound nouns for an example. There are a number of complexities which we will not go into here, sticking to more straightforward cases. Compound nouns are formed by putting two otherwise independent elements, usually an adjective and a noun or two nouns, together and use the resulting unit as a single noun:

- (41) a armchair  
 b breastplate  
 c luncheon meat  
 d blackbird  
 e tallboy

Sometimes the spelling indicates that the two parts of the noun are put together to form one word, but other times it does not. We will not delve into the mysteries of English spelling here. Note that when compounds are formed from an adjective and a noun, the noun is second. Moreover, if there is a main semantic element of the two parts of the compound, this is also the second element: an *armchair* is a kind of chair not a kind of arm. We might claim therefore that the second element is the head and the first is a modifier of the head. The structures we get are:

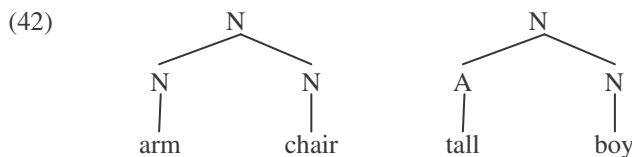

Given that the second noun is the head, it follows that the first element is an adjunct to the head. In principle, we should be able to get multiple head adjuncts by the same recursive process as we have noted with other adjuncts. However in practice it is not so common to find multiple compound nouns of this type. It is more common

### Chapter 3 - Basic Concepts of Syntactic Theory

---

to find the adjunct itself being made up of a compound, which has a very different structure. Compare the following:

- (43) a computer hard disk  
b ballpoint pen

In both cases the last noun is the head, but the adjuncts are related in different ways. In (43a), the adjective *hard* modifies the head to form a compound *hard disk*. We then add the second adjunct which modifies this. Thus we have the structure:

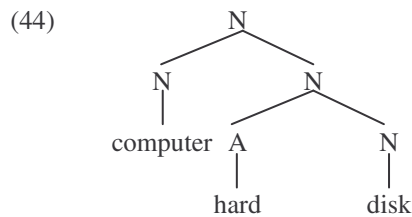

In (43b) on the other hand, we have a compound made up of *ball* and *point*, with the latter as the head. This compound is then used as an adjunct in the compound *ballpoint pen*, giving the following structure:

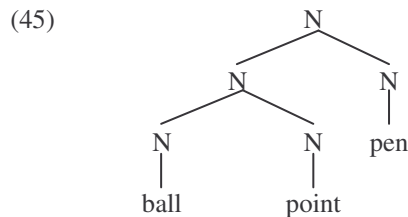

An interesting point to note is that the adjunct to a head is always a head itself, which differs from the previous cases of adjunction we looked at above. Adjuncts adjoined to X' or XP are always phrases. It has been suggested that this is due to a restriction on adjunction such that only like elements can adjoin: heads to heads, phrases to phrases. If this is true, then X' adjunction should not be possible as the adjunct differs in its X-bar status to the X', being a phrase. We will not accept this point of view however and assume that while only heads can adjoin to heads, phrases can adjoin to any constituent larger than a head.

#### 1.6 Summary

Before moving on to look at other aspects of syntactic processes, let us consolidate what we have said in this section. X-bar theory is a theory of basic structure comprising of just three rules. These rules are generally applicable to all structures and substructures, no matter what their category: they are category neutral. The categorial status of a specific structure depends on the lexical elements it contains, in particular one word acts as the head of each phrase and this determines the category of the phrase by projecting its own categorial properties, established in the lexicon, to the X' node above it and ultimately to the XP.

The three X-bar rules introduce three elements besides the head. The complement is introduced as the sister of the head. It always follows the head and is restricted by the head's subcategorisation requirements. Thus, if a head selects for a PP complement, the complement must be a PP. The specifier is introduced as the sister to X' and daughter of XP. Specifiers precede the head and are restricted to one per phrase. The last element of the phrase, the adjunct, can be introduced at any X-bar level: X, X' and XP. This element expands what it is adjoined to into another element of the same type. Therefore the process is recursive and in principle any number of adjuncts can be added to a structure.

We will have far more to say about X-bar structures as we proceed through this book and many more examples of heads, complements, specifiers and adjuncts will be provided. However, all of these will conform to the basic principles set out here and as such the theory of structure provided by X-bar principles is an extremely general and explanatory one.

## 2 Theoretical Aspects of Movement

Consider a sentence such as the following:

(46) who does Harry hate?

The verb *hate* typically has two arguments, experiencer and theme, and is transitive with the theme as its object:

(47) Harry hates him

But in (46) the object appears to be missing. This is not a case of an 'understood' object, where the argument is present at a semantic level, as it is fairly obvious that the interrogative pronoun *who* has the grammatical function of the object. Yet, this pronoun is not sitting in the canonical object position, the complement of the verb, directly after it. Indeed, the interrogative pronoun is occupying a position that no other object can occupy:

(48) \*him does Harry hate

The obvious questions to ask are: why is the object sitting at the front of the sentence in (46)?; and how is the interrogative pronoun interpreted as an object when it is not sitting in an object position? As to the first question the obvious answer is that it has something to do with the interrogative nature of the clause: the clause is a question and interrogative clauses of this kind start with an interrogative phrase such as *who*.

The second question is a little more difficult to answer. In English, an element typically is interpreted as object depending on the position it occupies:

(49) a Harry hates him  
b He hates Harry

In (49a), the pronoun *him* is interpreted as the object as it is sitting in the complement position. *Harry* on the other hand is the subject and is sitting in a specifier position. In (49b) it is the other way round: *He* is the subject, sitting in the specifier position, and *Harry* is the object, sitting in the complement position. If *who* in (46) is interpreted as

### Chapter 3 - Basic Concepts of Syntactic Theory

---

object, we should expect it to occupy the object position. The grammar that we will be adopting in this book assumes that this is exactly the case: the interrogative pronoun does indeed sit in the object position at some level of description of this sentence. However, at another level of description, the interrogative pronoun is in another position, one at the beginning of the clause. The assumption then is that this element undergoes a **movement** which takes it from the object position into the sentence initial position.

Movement processes turn out to be a central aspect of grammar in many languages and we will see many instances of it in this book. In this section we will introduce the main theoretical considerations relating to movement processes and which play a role in the description of virtually all English sentences.

#### 2.1 Move $\alpha$

Once the idea has been put forward that things can move about within a sentence, we can see that it can be applied to a lot of linguistic phenomena:

- (50) a the water was wasted  
b is this the end?  
c this conclusion, virtually no one has ever come to  
d the plans were released for the new car park

In the first case in (50) we have a **passive** sentence in which the subject is interpreted as the object: *the water* was what was wasted, not what did the wasting. We might claim that in this case the object moves from object position into subject position:

- (51) a - was wasted the water  
          ↓  
b the water was wasted -

In (50b) we have what is termed a **yes–no question**, as it may be answered with a simple “yes” or “no”. These questions typically involve **subject–auxiliary inversion**, in which the auxiliary verb and the subject appear to switch places. A more current view of the inversion process is that the auxiliary moves to a position to the left of the subject:

- (52) a - this is the end  
          ↓  
b is this - the end

(50c) involves **topicalisation**, a process which moves an element interpreted as a topic to the front of the sentence. A topic is typically something that has already been mentioned before in a conversation, or can be interpreted as easily accessible in a conversation due to the context. Consider the sentence in (50c), it is obvious that *the conclusion* mentioned must have been a part of the preceding discussion and that it has not just been newly introduced. We may analyse this sentence as:

- (53) a - virtually no one has ever come to this conclusion  
          ↓  
b this conclusion, virtually no one has ever come to -



## Theoretical Aspects of Movement

---

Finally in (50d) we see another kind of movement which appears to split a constituent across the structure. The preposition phrase *for the new car park*, is clearly related to the noun *plans*. Indeed, this PP is the complement of the noun:

(54) the plans for the new car park

However, the PP appears to have been moved out of the subject DP into the sentence final position. This process is known as **extraposition**:

(55) a the plans for the new car park were released –  
 b the plans – were released for the new car park

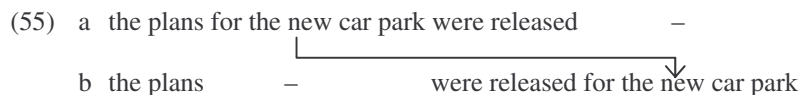

As we saw in the previous section grammatical processes should be stated as simply and generally as possible if we are to provide a theory that can cover the basic fact of language learnability. This would argue against an approach to movement in which we provide many movement rules designed to capture the specific facts about individual movements. Instead we should follow the example of the previous section and provide a small number of general rules which have a wide applicability.

In fact the general assumption is that there is just one movement rule, usually called **Move  $\alpha$**  which can be stated as:

(56) Move  $\alpha$   
 Move anything anywhere.

This might not seem a very wise kind of rule to allow in a grammar as it would seem to sanction complete chaos and English does not appear to be anything near chaotic in its grammatical organisation.

The rule in (56) indeed would sanction chaos if this were all there was to say about movement. However there is a good deal more to be said. Let us take X-bar structures into consideration. When an object moves to subject position in a passive construction it is moving from one DP position to another: complement of the verb to specifier position. Simplifying somewhat, we might suppose the following analysis:

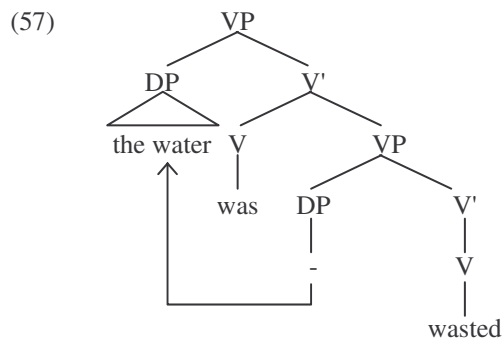

Here the main verb *wasted* takes its argument in the specifier position of its own phrase. This phrase is in turn the complement of the auxiliary verb *was*. The argument moves from the specifier of the lower verb to that of the higher one.

### Chapter 3 - Basic Concepts of Syntactic Theory

---

The structure we end up with is one that is perfectly compatible with X-bar principles. In other words, the movement seems not to have radically altered the structure. Suppose we assume a restriction on all movements, that they cannot alter structures in a way that would violate basic X-bar principles:

- (58) Structure Preservation Principle  
no movement can alter the basic X-bar nature of structure

This would rule out immediately a very large class of movements possible under the assumption of (56).

The important point to recognise is that the assumption of (56) and the imposition of a restriction such as (58) offer a far simpler and general theory of what can move where than would a theory that was made up of lots of specific rules telling us what can move where and under what conditions in particular cases. Of course, (56) and (58) together still do not constitute a particularly accurate theory of movement and there are still many movements allowed under these assumptions that do not actually occur. However, even if we add five or ten more restrictions of the kind in (58) we would still have a more general theory of movement than the literally hundreds of movement rules that would be required to describe specific cases of movements. We will see that the number of restrictions required to capture the majority of facts about movement is surprisingly small.

#### 2.2 D-structure and S-structure

An immediate consequence of accepting movements as a part of grammatical description is that there are at least two levels that we can describe the structure of any sentence: a level before movement takes place and a level after movement has taken place.

- (59) structure  
    ↓  
    movement  
    ↓  
    structure

The difference between the two levels of structural description will simply be the positions that the moved elements occupy, given the above assumption that movements do not actually alter the structure. For example, consider the following two sentences:

- (60) a Mary met Mark in the park  
      b in the park, Mary met Mark

In (60a) the PP *in the park* is an adjunct to the VP, modifying the VP by adding information about where the meeting took place. In (60b) the PP has moved to the front of the sentence, in a similar way to that in which topics are moved to the front. We can call this movement **preposing**. Before the preposing takes place, the PP is in its VP adjoined position:

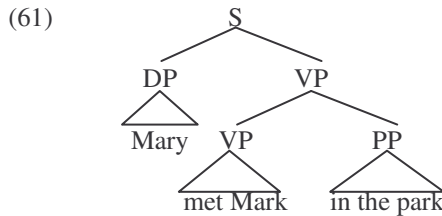

After the movement, the structure will look like this:

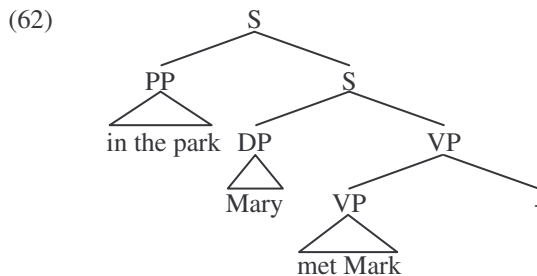

We call the structure before movement takes place, a **D-structure** and the post-movement structure an **S-structure**. The ‘D’ and the ‘S’ originally stood for *deep* and *surface*, reflecting the fact that S-structures represent an ordering of the elements which is closer to that which holds in the externalisation of the sentence (its pronunciation, or whatever) while D-structures represent an abstract level of description more deeply embedded in the analysis. However, the words *deep* and *surface* have unfortunate connotations which may lead to misunderstanding. *Deep*, for example, can be taken to mean ‘meaningful’ or ‘ponderous’, while *surface* can mean ‘superficial’ or ‘apparent’. It would be wrong however to come to the conclusion that deep-structure is somehow more important or that surface-structure is irrelevant. These terms should be taken simply as referring to the two levels of the description of a sentence and neither one nor the other is any more important than the other. This is why the more neutral terms D-structure and S-structure are used and we will follow this tradition.

### 2.2.1 D-structure and Theta Theory

Let us consider the nature of D- and S-structure a little more closely. An obvious question is why it is that some elements start off in one position and then move to another. To answer this question we have to ask about why elements occupy the positions they do at any level of description. This is a matter of distribution: there are grammatical principles which determine the range of possible positions of categories of certain types. X-bar principles obviously have a large role to play in this, determining head, complement, specifier and adjunction positions. But as both D- and S-structures conform to X-bar principles, this clearly is not what differentiates the two. Obviously there must be other grammatical principles holding at D-structure which are not applicable at S-structure and vice versa.

A D-structure principle may then require a constituent X to occupy a certain position and an S-structure principle may require X to occupy a certain position, and if

### Chapter 3 - Basic Concepts of Syntactic Theory

---

these two positions are not the same then X will have to move from its D-structure position to the required S-structure position. Thus, explaining movement is a matter of finding out the principles which determine the distribution of elements at D- and S-structure.

Turning to D-structure first, an important consideration which has been present in all developments of this concept, first proposed by Noam Chomsky in the 1950s, is that D-structure positions are somehow basic. For example, in a passive sentence, what sits in the subject position at S-structure is interpreted as the object of the verb and hence is assumed to occupy the object position at D-structure:

- (63) S-structure: Ken was confused  
 D-structure: was confused Ken

The idea is that the way an element is interpreted in terms of its thematic status indicates its D-structure position and thus if something is interpreted as an object it will be in an object position at D-structure. Moreover, an element that is interpreted as the subject or object of a predicate will be in the relevant subject or object position of that predicate at D-structure:

- (64) S-structure: Ken was considered to be confused  
 D-structure: was considered to be confused Ken

In this example, although *Ken* is sitting in the subject position of the verb *consider*, this element is interpreted as the object of *confused* and thus is in the object position of this predicate at D-structure.

D-structure then is a pure representation of thematic relations. Anything which is interpreted as the subject or object of a given predicate will be in the subject or object position of that predicate at D-structure no matter where it is found at S-structure.

The principles that determine D-structure positions must therefore have something to do with thematic relationships. We saw in chapter 1 how  $\Theta$ -roles are encoded in the lexical entry of predicates. Yet in a sentence it is the arguments that are interpreted as bearing these  $\Theta$ -roles. It must be the case therefore that these  $\Theta$ -roles are given from the predicate to the argument. We can refer to this process as  **$\Theta$ -role assignment**. For example:

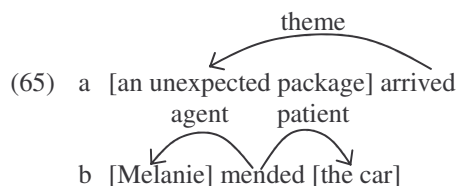

The verb *arrive* is a one-place predicate, having one  $\Theta$ -role to assign which it assigns to the argument *an unexpected package* in (65a). The verb *mend* is a two-place predicate. It assigns the agent role to its subject and the patient role to its object.

Where can a predicate assign its  $\Theta$ -roles to? If there were no restrictions on this then arguments would not have distributions at D-structure as they could appear anywhere. We are assuming that this is not so and hence there must be conditions which determine where  $\Theta$ -roles can be assigned. One fairly clear condition on  $\Theta$ -role

## Theoretical Aspects of Movement

---

assignment that can be seen in (64) is that  $\Theta$ -roles are not assigned over long distances. For an argument to receive a  $\Theta$ -role from a predicate it must be close to it. We can see this from the fact that the following sentence has just one interpretation:

(66) Sophie suspects that Linda loves Dwain

We can only interpret this sentence with *Sophie* doing the suspecting, *Linda* doing the loving and *Dwain* getting loved and there is no way to get *Sophie* associated with *love* or *Linda* and *Dwain* with *suspect*. This is simply because *Sophie* is structurally closer to *suspect* and *Linda* and *Dwain* are close to *love*. If *love* could assign its  $\Theta$ -roles over long distances, *Sophie* might be able to be interpreted as one of its arguments.

We will adopt the following restrictive condition on  $\Theta$ -role assignment:

(67) the Locality Restriction on Theta-role Assignment  
a predicate assigns its  $\Theta$ -roles to either its complement or its specifier

According to (67), the structural configuration for all  $\Theta$ -role assignment is as follows:

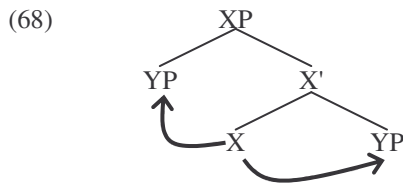

It is a long standing assumption that there is a uniformity in  $\Theta$ -role assignment which links certain  $\Theta$ -roles to certain positions. The reason why the object is assumed to move in a passive sentence is precisely because of this assumption. In an active sentence the object occupies the object position, following the verb, and so it is assumed that in the passive sentence the argument that is interpreted identically to the object in the active originates from the same position that we see it in in the active:

(69) a Monika munched the sandwich = active  
b was munched the sandwich = D-structure of passive  
c the sandwich was munched = S-structure of passive

Thus it is assumed that there is a uniform position to which the patient  $\Theta$ -role is assigned across different structures. We will actually adopt a very rigid form of this idea which was first proposed by Baker (1988), called the **Uniform Theta-role Assignment Hypothesis** (UTAH):

(70) the Uniform Theta-role Assignment Hypothesis  
a  $\Theta$ -role  $P$  is assigned in the same structural configuration in all structures in which it is present

Thus, if we propose that the theme argument is assigned to the specifier of the verb it is related to in a structure such as:

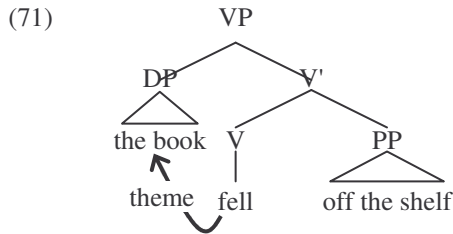

Then it follows from the UTAH that all themes in all structures will be assigned to the specifier of the verb that they are related to. We will see that this is a very restrictive theory of  $\Theta$ -role assignment that will force certain analyses of structures which, while not at first obvious, turn out to have a number of positive features which go to support them and in turn this supports the assumption of the UTAH in the first place.

There are other aspects of the assignment of  $\Theta$ -roles than those to do with *where* they are assigned. We saw in chapter 1 that for some predicates an argument that they select as a lexical property does not have to be realised as a syntactic entity but may be present only at a semantic level. Such an argument would be understood, but unable to play any role in a sentence such as licensing a reflexive pronoun:

- (72) a Paul ate the pie by itself  
 b \*Paul ate by itself

This means that certain  $\Theta$ -roles do not have to be assigned within a structure. However, the same is not true for other predicates:

- (73) a Fiona found the book  
 b \*Fiona found  
 c \*found the book

It is not well understood what determines when a  $\Theta$ -role may be left understood, but it seems to be an idiosyncratic property of certain predicates. It is generally the case that  $\Theta$ -roles must be assigned. The  $\Theta$ -role assigned to the subject, for example, cannot be left as understood. Therefore we might propose that there is a general grammatical condition ensuring the assignment of  $\Theta$ -roles, unless they are marked in the lexical entry of a predicate as being able to be understood. Moreover, a theta role can only be assigned to one argument and cannot be 'shared out' between more than one:

- (74) \*Fiona found the book the pen
- 

We might propose the following condition on  $\Theta$ -role assignment:

- (75) a  $\Theta$ -role must be assigned to one and only one argument

Now if we turn our attention to the arguments themselves we note that it is not possible to have an argument that is not assigned a  $\Theta$ -role:

- (76) a Sam smiled  
 b \*Sam smiled the cat

## Theoretical Aspects of Movement

---

The verb *smile* is intransitive and therefore does not have a  $\Theta$ -role to assign to an object. If we provide this verb with an object, we therefore have an argument that receives no  $\Theta$ -role, which as we see from (76) is ungrammatical. Moreover, an argument cannot receive more than one  $\Theta$ -role. So if a predicate must assign more than one  $\Theta$ -role, it cannot assign them both to the same argument:

- (77) a Fred fancies himself  
  
 b \*Fred fancies  

If it were possible for one argument to bear both  $\Theta$ -roles of a predicate, (77b) would mean the same thing as (77a) which has a reflexive pronoun in one argument position taking its reference from the other argument. The unacceptability of (77b) can therefore not be a semantic fact.

It is also not possible for an argument to bear two  $\Theta$ -roles assigned from different predicates. Consider the following:

- (78) Knut knows Dennis danced

This sentence is grammatical, but only with the interpretation that what Knut knows is that Dennis danced. In other words, the arguments of *know* are *Knut*, a DP, and *Dennis danced*, a sentence in which *Dennis* is the argument of *danced*:

- (79) Knut knows [Dennis danced]  

What is not possible is to interpret *Dennis* as being the one who is known and the one who dances:

- (80) \*Knut knows [Dennis] danced  

Again this would involve one argument bearing more than one  $\Theta$ -role, which appears to be impossible.

In addition to (75) therefore, we might propose the following restriction:

- (81) an argument must bear one and only one  $\Theta$ -role

Together the conditions in (75) and (81) are called the **Theta Criterion**:

- (82) The Theta Criterion  
 a  $\Theta$ -role must be assigned to one and only one argument  
 an argument must bear one and only one  $\Theta$ -role

We have now reviewed three simple and basic principles which regulate the assignment of  $\Theta$ -roles within a structure: the Locality Condition on Theta-role Assignment, the UTAH and the Theta Criterion. All of these apply to D-structures, restricting the distribution of arguments at this level of representation. Collectively, the principles which govern  $\Theta$ -role assignment are often referred to as Theta Theory and this can be considered as a part of the grammar, similar to the principles of X-bar theory which regulate the general formation of structures. A final important contributor to the well-

formedness conditions of D-structure is the lexicon which provides structures with categorial information and Theta theory with the  $\Theta$ -roles to be assigned. We might represent this in the following way:

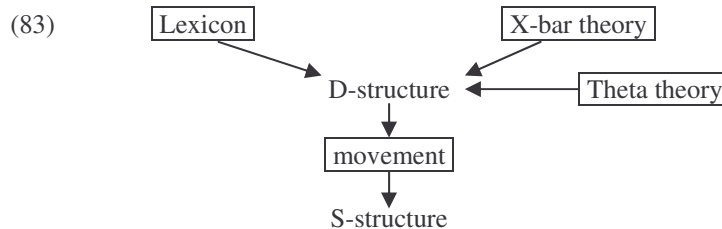

### 2.2.2 S-structure and Case Theory

So far we have looked at some of the principles governing the distribution of arguments at D-structure. In order to understand movement we must now consider some of the principles that apply at S-structure which determine the distribution of arguments at this level.

In chapter 2 we mentioned the grammatical notion of Case, pointing out that certain pronouns in English have different Case forms. Nominative pronouns include *he, she, I* and *we* while accusative pronouns are *him, her, me* and *us*. What determines which form the pronoun appears in is apparently its S-structure position. If a pronoun is the subject of a finite clause it will be nominative, anywhere else it is accusative (we ignore the possessor position inside the DP which is associated with **genitive** Case: *his, her, my* and *our*):

- (84) a *he* has helped *her*  
 b *I* consider [*him* to be unkind to *us*]

In (84a) the clause is finite as tense is marked on the auxiliary verb. The subject *he* is in the nominative form, not the accusative *him*. However, the object of the verb *help*, *her*, is in the accusative not the nominative *she*. In (84b), while the main clause is finite and has a nominative subject, *I*, the embedded clause is non-finite. This clause has an accusative subject *him*. The object of the preposition in this clause is also accusative, *us*.

Now consider the following example:

- (85) he was helped

The pronoun is in the subject of a finite clause and so naturally is in the nominative. However, as this clause is passive, the pronoun originates from the object position at D-structure. But this fact does not seem to have any bearing on the case of the pronoun: the pronoun is nominative not accusative as a non-moved object would be. Clearly, then, it is the position that a pronoun sits in at S-structure that determines its case. We might claim therefore that there are positions which are Case positions, specifically nominative positions and accusative positions, and there are positions which are not Case positions.

But if there are nominative and accusative case positions, what are we to say about the non-pronominal DPs that sit in these positions as no other DP demonstrates



## Theoretical Aspects of Movement

---

morphological Case distinctions? There are two things that we might say. One is that Case positions are only Case positions when occupied by a pronominal DP. This would be rather difficult to arrange however, as it appears that apart from the fact that Cases are only visible on pronominals, what defines Case positions is fairly general: the subject of a finite clause is nominative, the object position of a verb or preposition is accusative and the subject position of a non-finite clause is accusative. It is not clear how to include the presence of the pronominal into the definition of a case position.

The alternative is to claim that there are general case positions that are occupied by any DP, but only some DPs show any morphological reflex of this. Obviously this is the more general and simplest position and hence it is preferable unless there can be demonstrated to be advantages of accepting that case positions are only defined in the presence of a pronoun.

One reason to believe that case positions are generally defined but just morphologically distinguished on certain elements is the fact that case is not distinguished on all English pronouns. For example there is no distinction between nominative and accusative for the pronoun *it*:

- (86) a he eats it  
b it eats him

The third person singular masculine pronoun demonstrates a Case distinction between subject and object position in (86), but not the pronoun *it*. It would be extremely difficult to account for why Case positions are only defined in the presence of pronouns, except for *it* and would be much better to say that the Case position is defined in the presence of *it* but this pronoun does not realise the distinction overtly. In other words, *it* is the nominative form of this pronoun and *it* is the accusative form. But once we have accepted this as a possibility it is reasonable to accept it for all other nominal elements as well.

One way to view this situation is to separate two notions of Case. One notion of Case, relating to the traditional view, is that Case has to do with the form a nominal element takes dependent on its position or, in some languages, its function in a sentence. We can call this phenomenon **Morphological case**. The other view of Case is that this is something a DP gets simply by occupying a certain structural position, whether or not it is realised overtly. We call this **Abstract Case**, or just Case (spelled with a capital). From this perspective then, any DP that occupies the subject position of a finite clause has nominative Case irrespective of whether that DP looks different from what it would if it were sitting in an object position and bearing accusative Case.

One piece of support for this distinction comes from observations such as the following:

- (87) a for her to be ready on time would be a miracle  
b \*for she to be ready on time would be a miracle  
c \*her to be ready on time would be a miracle  
d \*she to be ready on time would be a miracle

In (87) we have a series of pronominal subjects of non-finite clauses. In the one grammatical case the subject is accusative, demonstrating that this is an accusative position. The ungrammaticality of the nominative pronoun in (87b) is therefore

### Chapter 3 - Basic Concepts of Syntactic Theory

---

understandable. That (87c) should be ungrammatical is interesting as here we have an accusative pronoun. In this case the complementiser *for* is absent, indicating that this element is in some way responsible for the accusative case in (87a) in which it is present. This is understandable as this complementiser is similar to a preposition, and in fact is often called the **prepositional complementiser**, and as we know, the complement of prepositions is in the accusative. To account for this let us assume that Case is rather like  $\Theta$ -roles and is assigned by certain elements to certain positions. The prepositional complementiser therefore assigns accusative Case to the subject of the non-finite clause that it introduces:

(88)  $\begin{array}{c} \text{acc} \\ \swarrow \searrow \\ [\text{CP } \text{for } [\text{IP } \text{her to be ready } \dots]] \end{array}$

Although this might explain why the subject has accusative Case in (87a) and cannot have nominative Case in (87b), by itself it does not account for why (87c) and (d) are ungrammatical. To understand what is going on here we must attend more closely to the facts. Firstly the element that we have assumed to assign accusative Case to this position is absent and so we might assume that no accusative Case is assigned in these circumstances. Presumably whatever it is that assigns nominative Case is not present in a non-finite clause. Therefore in this situation it seems that neither accusative nor nominative case are assigned to the subject position.

But why would any of this mean that the sentence should be ungrammatical? Only with an extra assumption can we account for this properly: the pronoun subject needs a Case. One might think that this is fairly obvious as there is no Case neutral form of the pronoun: what form would it take if it occupied a Caseless position? However, the following observations seriously question the assumption that the ungrammaticalities in (87) have anything to do with Morphological case:

- (89) a for Rebecca to be ready on time would be a miracle  
b \*Rebecca to be ready on time would be a miracle

What we see here is that even a nominal element that does not display morphological case distinctions cannot occupy a position to which no Case is assigned. Thus the requirement that a nominal element have Case is nothing to do with the impossibility of the choice of morphological form when no Case is assigned. Instead, it appears to be a general requirement that all DPs must occupy a Case position. We call this requirement the **Case Filter**:

- (90) the Case Filter  
All DPs must be assigned Case

The fact that the Case Filter applies to all DPs and not just those that demonstrate morphological case is strong evidence in favour of the assumption of Abstract Case.

Let us review what we have said so far. We started with the observation that the position that a DP occupies at S-structure determines its Case. We then claimed that Case is something applicable to all DPs and finally we proposed a general condition to the effect that all DPs must receive Case. But putting all this together it is obvious that the Case Filter can only operate at S-structure as, as we have seen, D-structure positions are in general irrelevant for determining the Case of an element. Consider the

## Theoretical Aspects of Movement

---

possibility that all the grammatical principles involved with Case and its assignment are bundled together in a single Case theory, paralleling Theta Theory discussed above. Case theory then applies to S-structure:

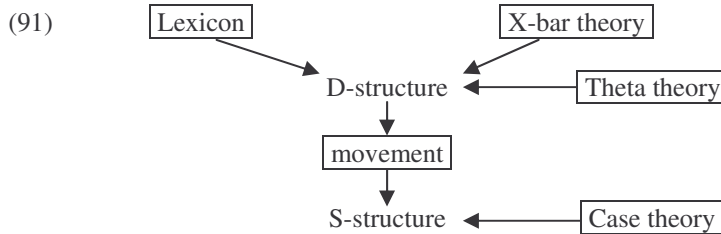

While Theta theory accounts for the distribution of arguments at D-structure, it is the principles of Case theory that account for the distribution of DP arguments at S-structure.

We are now in a position to be able to understand at least certain aspects of movement. Suppose that the principles of Theta theory determine that a DP argument must sit in position X. Suppose further that position X is not a position to which Case is assigned. If the DP remains in this position at S-structure, then the Case filter will be violated and the structure will be deemed ungrammatical. If on the other hand the DP can move to a position to which Case is assigned, then the movement will enable the Case Filter to be satisfied and the structure to be grammatical. This kind of movement might be said to be Case motivated and as we shall see, there are quite a few movements which follow this pattern. This is not the only motivation for movements, however, though we will not go into others at this point. The purpose of this section has been mainly to demonstrate how the interaction of grammatical principles applying at D-structure and S-structure can provide us with an understanding of movement phenomena.

### 2.3 Traces

In the previous sections of this chapter we have concerned ourselves with the positions in which elements originate at D-structure and the positions they move to at S-structure. We might term these positions the **Extraction site** and the **Landing site** of a moved element. What is the status of the landing site at D-structure and the extraction site at S-structure? In (58) we introduced a restriction on movement called the Structure Preservation principle, which states that movements are not allowed to alter the basic X-bar nature of a structure. The result of this restriction is that the structure cannot be much different between D- and S-structure. In particular, we would not expect landing and extraction sites to appear at one level of representation but be absent at another. Thus, if we consider a passive structure in which the object moves to subject position, we can expect the object and subject positions to be present at both D- and S-structure:

- (92)
- |  |   |                              |           |                              |             |
|--|---|------------------------------|-----------|------------------------------|-------------|
|  | a | [ <sub>DP</sub> e]           | was found | [ <sub>DP</sub> the hideout] | D-structure |
|  | b | [ <sub>DP</sub> the hideout] | was found | [ <sub>DP</sub> e]           | S-structure |

### Chapter 3 - Basic Concepts of Syntactic Theory

---

These representations indicate that the positions marked [<sub>DP</sub> e] are present in the structure, but empty and thus the movement does not change the structure but merely moves things about within the framework it provides.

There is reason to believe however, that the two empty positions in (92) are not the same as they display different properties. Consider the empty subject position in (92a). As this is a position to which something moves it would not be reasonable to think of it as being filled by some other element before the movement takes place. If there were something in this position at D-structure, presumably it would have to be deleted to allow the object to move into the position as general principles of structure do not allow two elements to occupy the same structural position. But if this element is always deleted, how could we ever be aware of its existence, let alone its nature. Moreover, if it were possible to delete elements in a structure to allow others to move into the vacated positions, we would expect far more movement possibilities that we actually observe. We would be able to move an object into a subject position of any verb, not just the passive ones:

- (93) a [<sub>DP</sub> the FBI] found [<sub>DP</sub> the hideout]  
b \* [<sub>DP</sub> the hideout] found [<sub>DP</sub> e]

Obviously, this is a situation we want to avoid and so we need to strengthen the Structure Preservation principle to prevent things in a structure from being deleted willy-nilly. Suppose we assume that lexical material that enters a structure cannot be altered by a movement. This maintains the Structure Preservation principle given that the lexical items that are inserted into a structure determine that structure to a great extent through notions of projection and selection, but it also prevents the deletion of lexical information once it has been inserted into a structure. This principle is called the **Projection Principle**:

- (94) the Projection Principle  
structures are projected from the lexicon at all levels

What this means is that anything that is inserted into a structure from the lexicon cannot change from one level of representation to another. If a verb is put into a structure, nothing can delete or alter this verb, turning it into a noun, for example. Also no movement can alter a verb's selectional properties: a transitive verb will remain transitive at D-structure and S-structure even if the object is moved.

Under these assumptions, it must be that a passive verb loses its subject before it enters into a structure. There are numerous ways in which we might suppose that this can happen, but we will put the matter aside until we are in a better position to understand it. The general point is that as a result of being passivised, a verb fails to assign a  $\Theta$ -role to its subject and hence this position is absolutely vacant at D-structure. So with regard to the empty subject position in (92a) we can say that this position, whilst being present in the structure, is simply devoid of any contentful element and hence is vacant to be moved into.

Now consider the nature of the empty object in (92b): the extraction site of the moved object. By the Projection Principle, this object position must remain in the structure and cannot be deleted otherwise the transitive verb would find itself without an object and hence would be sitting in the structural position of an intransitive verb.

### Theoretical Aspects of Movement

---

As this would alter the lexical nature of the verb, we conclude that it would be impossible. Yet if this position were simply vacant, like the subject position is at D-structure, we might expect that it could be the landing site for some other moved element. This, it turns out, is not true at all. Consider the following analysis which indicates several movements step by step:

- (95) a [DP e] Susan said [[DP who] helped [DP Fred]] D-structure  
       ↓  
       b who (did) Susan say [[DP e] helped [DP Fred]] after 1 movement  
           ↓  
       c who (did) Susan say [[DP Fred] helped [DP e]] after 2 movements

Both of these derived structures seem to be grammatical, but importantly they do not mean the same thing. In (95b) *Fred* is interpreted as the one who is helped and the interrogative pronoun *who* is the one doing the helping, as is indicated by the D-structure in (95a). But in (95c), *Fred* is the one doing the helping and *who* is the one helped. Under the assumption that  $\Theta$ -roles are assigned at D-structure, it cannot be the case that (95c) was formed from the D-structure (95a), but must be related to another D-structure, i.e. (96a):

- (96) a [DP e] Susan said [[DP Fred] helped [DP who]]  
       ↓  
       b who (did) Susan say [[DP Fred] helped [DP e]]

The fact that (95c) cannot be interpreted in the same way as (95b) leads us to conclude that the movement indicated in the former is impossible and that the object cannot move into the vacated subject position.

The overall conclusion of this discussion then is that the empty positions that are present at D-structure are of a different nature to the empty positions present at S-structure which are created by movements: D-structure empty positions are vacant to be moved into, S-structure empty positions are not. Obviously this demands an explanation.

One possible account of the nature of empty extraction sites is that they cannot act as landing sites for subsequent movements because they are occupied. As two elements cannot occupy the same position and as we are not allowed to delete material, this would block movement into this position. There are two problems that this assumption faces: what element occupies the extraction site and why cannot we see it? Given the above discussion, there is no choice as to the identity of the element that occupies this position: it must be the moved element itself. No other element could either be moved into this position or be inserted into it from elsewhere without drastically changing the lexical information represented by the D-structure and this would violate the Projection Principle. But then we seem to be forced to accept that one element can occupy two positions.

We can get some understanding of this situation if we make the following assumption: when an element moves, it leaves behind a copy of itself in the extraction site. This copy is called a **trace** and is envisaged to be identical to the moved element in terms of its grammatical and semantic properties. Thus the category of the trace, its role in the thematic structure of the sentence and its referential properties are the same

### Chapter 3 - Basic Concepts of Syntactic Theory

---

as the moved element. The main way in which the trace differs from the moved element is that the trace has no phonological content and hence is unpronounced. We have already considered the possibility of phonologically empty but grammatically active elements when we discussed imperatives at the beginning of this chapter. A trace is another such element.

Traces are typically represented by a *t*, which bears an index which it shares with the moved element, both to link the trace and the moved element and to demonstrate that they have the same reference:

- (97) a *who*<sub>1</sub> did Susan say [Fred helped *t*<sub>1</sub>]  
b *who*<sub>1</sub> did Susan say [*t*<sub>1</sub> helped Fred]

The S-structure representations here demonstrate the movement of an interrogative pronoun from two different D-structure positions, marked by the trace. In (97a) *who* moved from object position and hence the sentence is interpreted as a question about the one who was helped. In (97b) on the other hand *who* moves from the subject position and hence the question is about the one who does the helping.

There are two views concerning the nature of traces. One is that a trace is related to but independent of the moved element. From this point of view a trace is a little like a pronoun referring to the moved element:

- (98) a Charles<sub>1</sub> was cheated *t*<sub>1</sub>  
b Harry<sub>1</sub> helped himself<sub>1</sub>

In these examples, the trace and the pronoun sit in object positions and refer to the subject in much the same way. From this perspective, the trace can be seen as having properties of its own independent of the moved element. We will see that there is some truth to this idea. However, traces are not like pronouns in one important way. As we see in (98b), the pronoun and its antecedent represent two different arguments, though they both refer to the same individual. Thus *Harry* is interpreted as the one who does the helping and *himself* is interpreted as the one who gets helped. With the trace in (98b) however, there is only one argument interpreted here: the one who was cheated. Because the verb is passivised, the subject's  $\Theta$ -role is not present and so no element is interpreted as agent. Thus, it is as though the trace and the moved element share the same  $\Theta$ -role, which strictly speaking should not be possible due to the Theta Criterion. From this perspective, the trace and the moved element seem to be interpreted as a single element, capable of bearing a single  $\Theta$ -role. This single element is, however, spread out across a number of positions in a structure.

The notion of a **chain** might be useful here. We can see a moved element and its associated traces as a single object made up of several parts: like a single chain is made up from different links. Extending this analogy further, we can then refer to the different parts of a movement chain as the links of the chain. Thus, the movement in (99a) can be said to contain the chain represented in (99b):

- (99) a *this sentence*<sub>1</sub>, you might not have seen *t*<sub>1</sub> before  
b [*this sentence*<sub>1</sub>, *t*<sub>1</sub>]

This chain has two links: *this sentence* and the trace. We say that the moved element is at the **head of the chain**, while the trace is at its **foot**.

## Theoretical Aspects of Movement

---

There is one more point we need to make in connection with positions involved in movement. Above we said that the landing site for a moved object in a passive structure is an empty position: the subject. This seems to make sense given that the subject position is an integral part of the sentence, without which we would not have a complete sentence. However, it is not always easy to identify a landing site as something that exists before the movement takes place. For example, consider the case of PP preposing, in which a PP is moved to the front of the clause:

- (100) a Petra put the book [PP on the shelf]  
**↑**  
b [PP on the shelf]<sub>1</sub>, Petra put the book t<sub>1</sub>

This PP does not move to the subject position, which is already occupied by *Petra*. The position it moves to is to the left of the subject and it is not really a position that we easily claim to be integral to all sentences given that in many it is not filled at all.

Furthermore, this position has a number of things in common with an adjunct, in that an unlimited number of elements can undergo preposing:

- (101) a Petra put the book [on the shelf] [without telling me] [yesterday]  
b [yesterday]<sub>1</sub>, [without telling me]<sub>2</sub>, [on the shelf]<sub>3</sub>, Petra put the book t<sub>3</sub> t<sub>2</sub> t<sub>1</sub>

If we were to propose that these movements put the moved elements into empty positions, we would have to suppose the existence of an indefinite number of empty positions at the front of the clause which sit there waiting for something to move into them. This does not seem a reasonable assumption.

Moreover, there are instances that we might want to analyse as a case of movement where an element moves to a position that is blatantly not empty. For example:

- (102) a we will not be moved  
b we won't be moved

In (102b) it might be claimed that the negative element moves to the position occupied by the modal auxiliary and the two somehow join together to become a single word. Again there is something like an adjunction formed in this case with a word being created from two independent words, like a compound noun (in this case the 'compound' is a verb).

Because of examples such as these it has been proposed that there are two types of movement. One, known as **substitution**, moves an element into a vacant position. The other, called **adjunction**, creates an adjunction structure by the movement. Thus, PP preposing might be argued to move the PP to a position adjoined to the left of the clause:

(103)

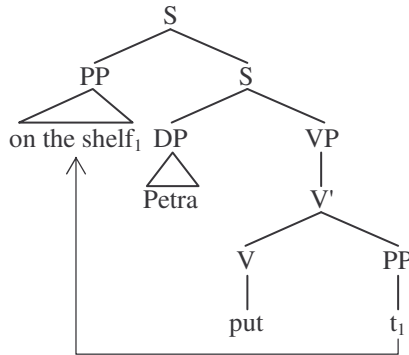

Similarly we might propose that some movements can move words to adjoin to other words, as is the case of the contracted negation:

(104)

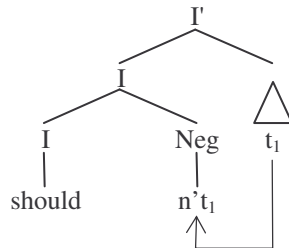

The irrelevant aspects of the analysis, such as the extraction site of the negative, need not detain us here. The important point is that the negative is moved from one position to a site adjoined to the modal.

One might wonder if adjunction conforms to structure preservation as it does seem to alter the structure from its D-structure condition. However, it should be noted that adjunction does not alter lexically determined aspects of structure and so is perfectly compliant with the Projection Principle which supersedes structural preservation. Moreover, adjunction is something which X-bar theory allows for and hence to create an adjunction structure is not to create something that violates the possible X-bar nature of the structure. In this way, adjunction movement does not radically alter structure and can be seen as structure preserving.

#### 2.4 Locality Restrictions on movement

The restrictions on movement we have mentioned so far have concerned its structure preserving nature. Not all structures which conform to these restrictions are grammatical, however, indicating that other restrictions are in operation. Most of the movements we have looked at have involved something moving within a single clause. Passivisation, for example, moves the object of a predicate to the subject of that predicate and obviously both the extraction site and the landing site are within the same clause. There are movements however, that move elements from one clause to another. Consider the following:



## Theoretical Aspects of Movement

---

- (105) a it seems [Fiona favours dancing]  
b Fiona seems [to favour dancing]

Given the near synonymy of these two sentences and the fact that the subject of *seem* in (105b) does not appear to be semantically related to this verb (*Fiona* is not the one who ‘seems’) we might assume that the latter is formed by a movement of the lower clause subject into the higher clause subject position:

- (106) a [e] seems [Fiona to favour dancing]  
          ↓  
b Fiona<sub>1</sub> seems [ t<sub>1</sub> to favour dancing]

This movement is known as **raising** as the subject of the lower clause raises to the subject of a higher clause.

Raising can apparently happen out of a number of clauses:

- (107) a it seems [it is believed [it is unlikely [that Stan will steal diamonds]]]  
b [e] seems [to be believed [to be unlikely [Stan to steal diamonds]]]  
          ↓  
c Stan<sub>1</sub> seems [to be believed [to be unlikely [ t<sub>1</sub> to steal diamonds]]]

Thus, at first sight it would seem that movement is unrestricted in terms of how far an element can be moved. But on closer inspection this might not be an accurate description of what is going on here. For example, note that in (107b) and (c) all the clauses that the subject is raised out of are non-finite and none of them seem to have subjects.

Suppose we try to move out of a finite clause instead:

- (108) a \*Stan<sub>1</sub> seems [it is unlikely [t<sub>1</sub> to steal diamonds]]  
b it seems [Stan<sub>1</sub> is unlikely [t<sub>1</sub> to steal diamonds]]

As we can see, a subject can be raised out of a non-finite clause into the subject position of a finite clause, but it cannot be raised out of a finite clause. Note that the finite clause in (108a) has a subject of its own: *it*. It is a fact about English finite clauses that they must have subjects and hence the sentence would be ungrammatical if the subject were missing for independent reasons. So this case differs from the grammatical movement in (107c) in two ways: the moved subject is moved out of a finite clause and it is moved out of a clause with a subject.

To control for these variables, let us consider a case where the movement is out of a non-finite clause with a subject:

- (109) a it is unusual [for Eric to hope [Stan will steal diamonds]]  
b \*Stan<sub>1</sub> is unusual [for Eric to hope [t<sub>1</sub> to steal diamonds]]

Again the result is ungrammatical, demonstrating that movement over a subject is itself enough to cause an ungrammaticality. But why would moving over a subject be a problem? If long distance movements are possible, it is hard to understand why the presence or absence of a subject should make any difference at all. However, if we suppose that long distance movements are not possible, though an element can move a long way via a series of short movements, we can come to an understanding of these observations. Consider the grammatical case of (107). As each subject position is

### Chapter 3 - Basic Concepts of Syntactic Theory

---

empty it is possible for the moved subject to move into each one in turn, moving from one clause to the next each time:

- (110) a [e] seems [[e] to be believed [[e] to be unlikely [Stan to steal diamonds]]]  
          ↓          ↓          ↓          ↓  
      b Stan<sub>1</sub> seems [t<sub>1</sub> to be believed [t<sub>1</sub> to be unlikely [t<sub>1</sub> to steal diamonds]]]

If there is a subject in one of these positions the moving subject would be forced to make a longer movement and if long movements are not allowed, we predict the result to be ungrammatical, which it is:

- (111) a [e] is unusual [for Eric to hope [Stan to steal diamonds]]  
          ↓          ×          ↓  
      b Stan<sub>1</sub> is unusual [for Eric to hope [t<sub>1</sub> to steal diamonds]]

We call this phenomenon, the **boundedness** of movement. For now it is enough to note that movement is bounded. We will look in more detail at the phenomenon in a subsequent chapter.

### 3 Conclusion

In this chapter we have briefly set down many of the theoretical mechanisms which we will be using in the rest of the book to describe syntactic phenomena in English. There is a lot more to say on theoretical issues and many differences of opinion as to how they should be formulated. However, as it is not our intention to teach all the details of the theory, but merely to use it, we will not go into these issues and the interested reader is directed to other text books, such as Haegeman (1994), Webelhuth (1995) or Radford (2004) for more detailed discussion on theoretical issues.

### Check Questions

- 1 Discuss rewrite rules: use the terms ‘category variables’, ‘head’, ‘complement’, ‘specifier’, ‘adjunct’, ‘recursion’, ‘category neutral’.
- 2 Exemplify adjunction (i) to a head, (ii) to a bar-level projection, (iii) to a maximal projection, and state the corresponding rewrite rule.
- 3 Explain the notion ‘projection’ and the way heads project their properties using expressions like ‘zero-level projection’, ‘bar-level constituent’, ‘maximal projection’.
- 4 What is the difference between endocentric versus exocentric phrases?
- 5 Which of the following properties of heads and/or phrases are predictable?
  - a endocentricity
  - b category
  - c argument structure
  - d subcategorisation frame
  - e pronunciation
  - f meaning

### Test your knowledge

---

- 6 Explain the difference between restrictions imposed by a head on complements and those imposed on specifiers.
- 7 Discuss implications of the rule Move  $\alpha$  and the Structure Preservation Principle.
- 8 What levels of structural description are assumed and how are they linked? How can D-Structure be characterised?
- 9 Discuss theta role assignment and the locality constraint imposed on it.
- 10 Show the distribution of nominative versus accusative case in English.
- 11 What bearing does the observation that clauses must have subjects have on the movement types passive and raising?

### ***Test your knowledge***

▪ **Exercise 1**

Identify those tree diagrams that exemplify possible configurations. State what the problem is with those that contain impossible configurations.

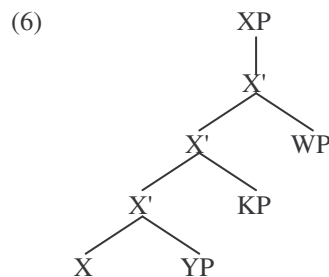
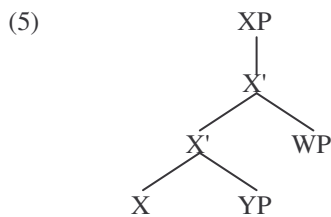
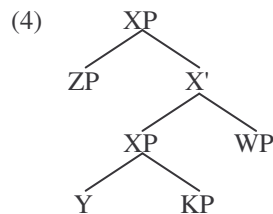
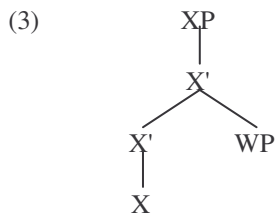
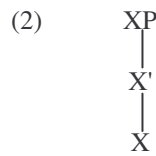
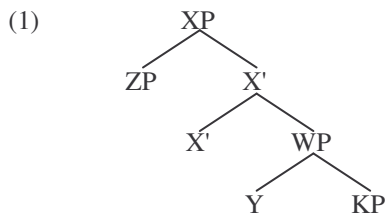

**Chapter 3 - Basic Concepts of Syntactic Theory**

---

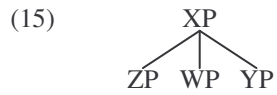
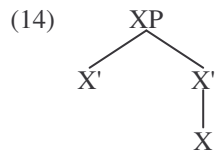
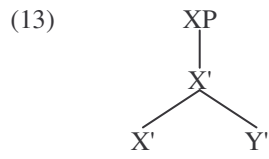
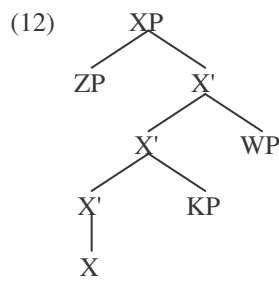
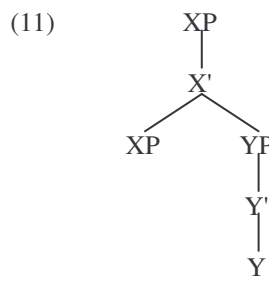
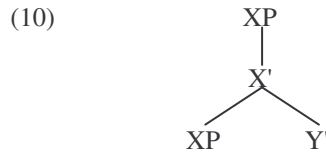
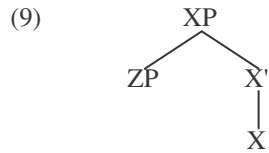
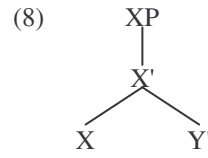
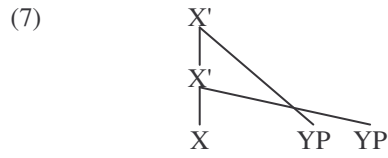

▪ **Exercise 2**

Fill in the well-formed tree diagrams in Exercise 1 with lexical items. Pay attention to category: if there happen to be two XPs in a diagram, make sure that the category of the lexical items chosen is identical.

### Test your knowledge

---

#### ▪ Exercise 3

Decide what the syntactic head of the following compounds is and where it is in the structure. Comment on whether the meaning of the compounds may be composed of the meanings of its elements.

- |     |                    |                          |
|-----|--------------------|--------------------------|
| (1) | a passer-by        | f catwalk                |
|     | b greenhouse       | g brother-in-law         |
|     | c redneck          | h day job                |
|     | d coffee table     | i double sheepshead knot |
|     | e attorney general | j mousetrap              |

#### ▪ Exercise 4

Comment on how the Theta Criterion can account for the grammaticality or ungrammaticality of the sentences below.

- (1)
- a Peter drinks.
  - b \*Peter Mary met John.
  - c \*Peter met.
  - d \*Peter gave Mary.
  - e \*Peter gave flowers.
  - f \*John put the book.
  - g \*John put on the table.
  - h Peter wrote a letter to Mary.
  - i Peter wrote a letter.
  - j Mary washed.
  - k Mary wondered what the time was.
  - l That they stole the diamonds surprised the police.

#### ▪ Exercise 5

Compare the grammatical functions and theta roles of the DPs in the pairs of sentences below. Comment on changes in either.

- (1)
- a Peter gave Mary flowers.
  - b Peter gave flowers to Mary.
- (2)
- a The postman delivered the letters.
  - b The letters were delivered.
- (3)
- a That he left surprised us.
  - b It surprised us that he left.
- (4)
- a Peter noticed the scar on her ankle.
  - b The scar on her ankle appeared small.
- (5)
- a Mary is easy to please.
  - b Mary tries to please everybody.

### Chapter 3 - Basic Concepts of Syntactic Theory

---

- (6) a Who do you want to meet?  
b Who do you want to help?
- (7) a He took a shower.  
b He showered.
- (8) a He made the ball roll down the hill.  
b He rolled the ball down the hill.

▪ **Exercise 6**

Below you can find an abstract sentence where small letters symbolize the words of the sentence while capital letters stand for larger units. Construct a tree diagram equivalent to the bracketed structure.

[I [H a b] [J c [K d [L e f]]]]

▪ **Exercise 7**

Below you will find the tree structure of an abstract sentence. Small letters represent words while capitals stand for larger units. Give an equivalent bracketed structure.

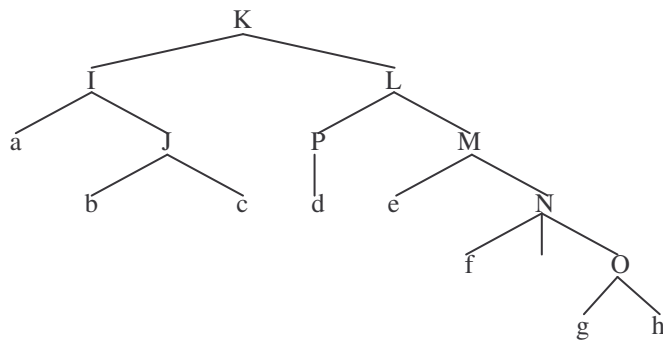

▪ **Exercise 8**

Give the lexical entry of each word in the following sentence.

The little boy may think that he will get a very expensive present for his birthday.

### Test your knowledge

---

#### ▪ Exercise 9

Identify the arguments in the following sentences and state what thematic role they are assigned to by what items.

- (1) Jack thought that he knew the right answer.
- (2) One of the big parties seems to be unlikely to be believed to win the elections.
- (3) John gave three red roses to Jane.
- (4) The teacher wanted the students to pass the exam.
- (5) It was believed that John was taken to hospital.
- (6) There is a man at the entrance door.
- (7) The exam sheets were believed to have been corrected by the teacher.

#### ▪ Exercise 10

Identify the adjuncts in the sentences below.

- (1) a The little boy gave a nice drawing to his mother for her birthday.  
b The teacher wanted to know whether the new students would know what to do when they arrive.  
c Why do you ask me whether I want to buy a new computer next year?  
d The new guest professor of Mathematics from Germany will probably arrive at the recently renovated railway station at 2:15.  
e How can you decide whether a loaf of bread on the shelf is fresh or not?  
f Jack and Jane saw a very interesting new film at the cinema in the city centre.  
g Sometimes it is difficult for students to find the adjuncts in sentences like this.  
h The mayor of the city said that the river is unlikely to flood the city.  
i The workers didn't believe that they don't have to work on the following week.

#### ▪ Exercise 11

Decide whether the phrases in italics in (1) are adjuncts or complements of the verb. Try to prove your statement by applying an appropriate constituency test.

- (1) a. David wrote a letter *on the desk*.  
b. David put a letter *on the desk*.  
c. Mary slept *in the bed*.  
d. Mary stayed *in the bed*.  
e. Jill arrived *at the station*.  
f. Jill waited *at the station*.

### Chapter 3 - Basic Concepts of Syntactic Theory

---

#### ▪ Exercise 12

Observe the contrast between the sentences in each pair. Explain why sentences (a) are correct while sentences (b) are incorrect.

- (1) a. Julie met the student of Physics from France and I met the one from Spain  
b. \*John knows the student of Physics from France and I know the one of English from Spain.
- (2) a. Julie met a student of Physics of considerable intelligence.  
b. \*Julie met a student of considerable intelligence of Physics.
- (3) a. Julie met a student of Physics and of Mathematics.  
b. \*Julie met a student of Physics and of considerable intelligence.

#### ▪ Exercise 13

Give the X-bar structure of each of the following phrases in italics.

- (1) a. John solved the problem *independently of me*.  
b. My professor lives *right in the middle of nowhere*.  
c. I am *very afraid of wild animals*.  
d. John read a *book about Britain*.

#### ▪ Exercise 14

The X-bar theory predicts that in English the following sentences are ungrammatical. Explain how the X-bar theory can account for the ungrammaticality of the sentences below. Notice that the phrases in italics are responsible for the ungrammaticality of the sentences.

- (1) a. \*The *teacher from France of English* likes going to open lectures.  
b. \*Mary often *drives too fast her car*.  
c. \*Every *student in Cambridge of Physics* gets an excellent job.

#### ▪ Exercise 15

Give the tree diagram of the following phrases.

- (1) a. a big house  
b. little brown jug  
c. this incredible story  
d. a tall handsome student of physics  
e. funny little thing  
f. those pretty women from Europe

#### ▪ Exercise 16

Give the internal structure of the following compound nouns.

- (1) a. car park  
b. floppy disk  
c. bicycle race winner  
d. micro wave oven  
e. pettycoat  
f. second hand shop  
g. orange juice cocktail  
h. hot water heater  
i. season ticket holder  
j. petrol station owner  
k. heavy metal band



### Test your knowledge

---

▪ **Exercise 17**

Why are these sentences ill-formed?

- (1) a \*Penny promised.  
b \*The boy slept a car.  
c \*Garry gave Greg.  
d \*Gave a cent to Marion.  
e \*Adam ate an apple for Anne.  
f \*Daniel danced Dora.

▪ **Exercise 18**

Identify the thematic roles assigned by each predicate and identify the Cases of the DPs as well.

- (1) a Who do you think Izzy will invite?  
b Terry thinks that the car has been stolen.  
c Frank will fly from New York to Amsterdam.  
d Sally seems to be selected by the committee.  
e I expect this girl to rewrite her essay.  
f For Chuck to choose from these chicks will be hard.

▪ **Exercise 19**

- (i) Find examples from languages other than English for reversed orders of head–complement, specifier–head, specifier–head–complement, head–adjunct, etc.  
(ii) Work out possibilities for adjunction the adjunct rule allows. Which constituent can never occur as an adjunct? Why?  
(iii) Attempt to think about constructions that may potentially go against the idea that all phrases are endocentric (either because they seem exocentric or because they seem to exhibit properties of more than one head).  
(iv) Given the distribution of nominative and accusative forms in English, what problem is raised by the following examples?
- (1) a He being the owner, we were all given a free drink.  
b Who wants ice cream? Me.  
c Her cheat on him? Never.



# Chapter 4

---

## The Determiner Phrase

The time has come to start applying what we have introduced in the previous three chapters to the analysis of English structures. We will start with the Determiner Phrase as it is one which appears in many of the other phrases we shall investigate. Also there are a number of recurrent themes which will crop up from time to time throughout this book and the DP is a good place to introduce these.

### 1 *Why the Noun is not the Head of the DP*

The following all have the same distributions and hence can all be considered determiner phrases:

- (1) a that man
- b he
- c Henry
- d men

The first consists of a determiner and a noun, which we have so far been describing as a head followed by its complement, in the usual English pattern. The second a pronoun, and we have claimed that pronouns are ‘intransitive’ determiners, i.e. determiners without an NP complement. The third consists of just a proper noun and the last just a plural count noun. These last two examples are puzzling: how can they be considered as DPs when they contain no determiner? Perhaps these are not DPs at all, but simply NPs. But if this is true, as all the examples in (1) have the same distribution, they must all be considered NPs. Thus, the pronoun should be categorised as a noun and the determiner in (1a) is not the head of the phrase, but some other element within the NP, perhaps an adjunct or a specifier (it is on the wrong side to be considered a complement).

This proposal might be supported by two further observations. First, note that even when a determiner is present, the noun seems to be the most semantically salient element, suggesting its greater importance:

- (2) a these socks
- b an idea
- c each portrait of the Queen

(2a) refers to something of a ‘socky’ nature and (2b) to an *idea*. In (2c) we are talking about instances of *portraits*, not instances of *each*. The determiners obviously do contribute a meaning, but this seems secondary to the meaning of the noun. From this point of view, then we might claim that the noun should be seen as the more important syntactic element, i.e. the head.

## Chapter 4 - The Determiner Phrase

---

This is not a good argument, however, as it is not wise to conclude about the syntactic properties of an element on the basis of its semantic properties. There are many elements which might be considered to be the syntactic head of a phrase which are not the semantically most important word. For example, consider the following:

- (3) cups of tea

Semantically, the noun *tea* is the most important element in this phrase: it refers to something which can be described as *tea* and not a *cup*. When one drinks a cup of tea, it is the tea that gets drunk, not the cup! Yet, syntactically it seems that *cup* should be considered as the head and the phrase containing *tea* as its complement. This provides us with a straightforward structure:

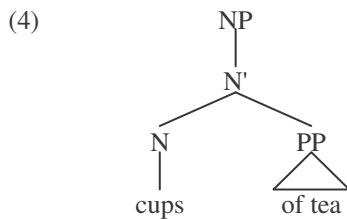

If, on the other hand, we wanted to claim that the noun *tea* is the syntactic head of the phrase we would have difficulty fitting in the preposition and the other noun:

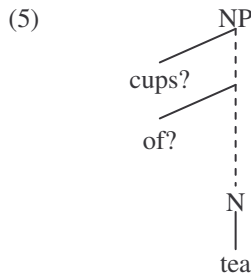

Neither of these elements appears to behave like either a specifier or an adjunct and so the analysis is highly problematic.

Another case where it might be argued that the syntactic head of a phrase is not the most important semantic element within it concerns preposition phrases:

- (6) a go [to London]  
 b look [through the tunnel]

In these cases, as in those above, the preposition does contribute something to the meaning of the phrase, though it is not clear that this should be seen as the most important aspect of the meaning of the whole phrase. Indeed *London* and *tunnel* seem to contribute just as important, if not more important information. However, it would not make sense to claim that the nouns are the heads of these phrases as they are clearly not NPs, not having the distribution of NPs:

- (7) a \*go [London]  
 b \*look [the tunnel]

## Why the Noun is not the Head of the DP

---

There are syntactic reasons, then, for considering these phrases to be headed by the preposition and thus it seems better to assume that the most important semantic word is not always the syntactic head.

A second observation that might support the assumption that the noun and not the determiner is the head of the phrase is the fact that the noun contributes features which play a role in interpreting the meaning of the whole phrase:

- (8) a the mouse  
b the mice

In (8a) the whole phrase is considered to be singular and in (8b) the phrase is plural, as can be observed from facts concerning verb agreement:

- (9) a the mouse *is* eating the cheese  
b the mice *are* eating the cheese

As *is* is the form of the verb 'to be' that agrees with a third person singular subject and *are* is the form agreeing with a third person plural one, we can conclude that the phrases sitting in subject positions have these properties. Thus it would seem that the noun *projects* its number features to the whole phrase. We have said that projection is something that concerns heads and so this might be taken as evidence that the noun is the head.

Again, however, this is not an entirely unproblematic assumption. Many determiners carry number features of their own:

- |      |                     |                     |                        |
|------|---------------------|---------------------|------------------------|
| (10) | a these people      | *these person       | } plural determiners   |
|      | b all answers       | *all answer         |                        |
|      | c each prescription | *each prescriptions | } singular determiners |
|      | c an occasion       | *an occasions       |                        |

In these cases both the nouns and the determiners are marked for number and so it is difficult to say where the number feature of the whole phrase is projected from. Indeed, even in those cases such as (8a) and (8b) where it looks as though the number is projected from the noun, we could argue that the determiner *the* is ambiguously marked for singular or plural and, like the other determiners, when it is singular it can only accompany a singular noun and when it is plural it can only accompany a plural noun. The issue therefore rests on which we take to be the head: the determiner or the noun. For this reason, we cannot use these observations to argue in favour of one or the other having head status but we must look elsewhere to resolve the issue.

The assumption that the determiner is not the head leads to further problems for the analysis of determiners and pronouns themselves. First consider the determiner. If this is not the head then it is presumably an adjunct or a specifier within the NP. We should therefore expect it to behave as such. Determiners do not appear to be adjoined within the NP as they do not behave like adjectival modifiers, which we have analysed as N' adjuncts in the previous chapter. Adjectives are recursive modifiers of nouns and can normally be arranged in any order, as we might expect of an adjunct:

Chapter 4 - The Determiner Phrase

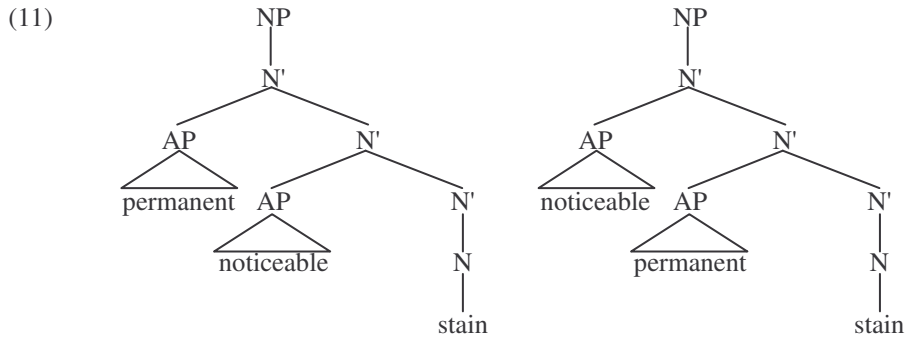

Determiners, on the other hand, are not recursive and have a very fixed position at the beginning of the phrase:

- (12) a \*the this book           cf. the book/this book  
       b \*some a property       cf. some property/a property  
       c \*boring these lectures cf. these boring lectures

Even if we claimed the determiner to be adjoined to the NP rather than the N', so that it would always precede AP adjuncts, which are adjoined to the N', as in (13), the non-recursive nature of determiners would remain a problem:

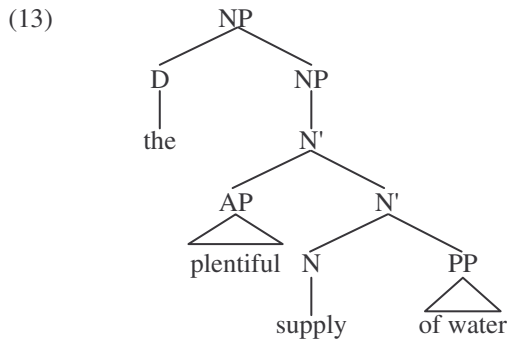

A further problem with this analysis is that adjuncts adjoined to XP or X' are phrasal. Only adjuncts adjoined to a head are X<sup>0</sup> categories. But the determiner looks suspiciously like a word and to analyse it as a phrase by itself begs the question of why determiners never have complements, specifiers or adjuncts of their own:

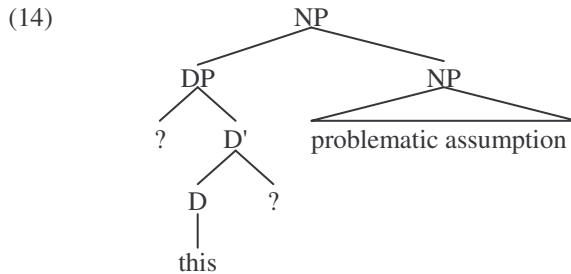

### Why the Noun is not the Head of the DP

This same problem dogs the assumption that determiners are specifiers: the specifier position is a phrasal one, but a determiner does not appear to be more than a word.

The assumption that the determiner is the head of the phrase, on the other hand, captures its position perfectly: it precedes the noun because the noun heads its complement and heads precede their complements in English. Comparing the two options, then, it seems that the one in which the determiner is the head is the more straightforward:

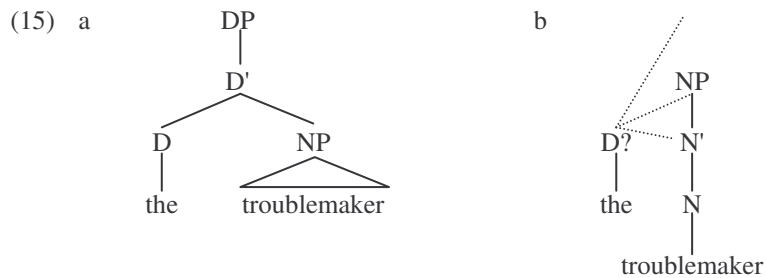

Another problem that arises if we assume that determiners are not heads of phrases is that they do make a contribution to the whole phrase. In chapter 1 we spent some time discussing properties of determiners (section 3.5.2), pointing out that a major contribution determiners make to the phrases that contain them is the definiteness–indefiniteness distinction:

- (16) a a house  
b the house

The phrase in (16a) is indefinite while that in (16b) is definite, obviously as a consequence of the determiner. The noun is the same in both cases and therefore does not seem to contribute to this distinction. But if the determiner is not the head of the phrase, how does it project this property to it? Projection, we showed in the previous chapter, is a property of heads, not adjuncts or specifiers so the fact that determiners do project properties to the phrase is an argument in favour of treating them as heads.

Next, consider the status of the pronoun. If this is a determiner heading a DP, its status is quite straightforward; it is simply a head which is the solitary element in the phrase:

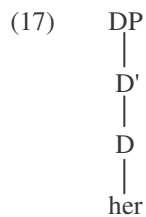

This is nothing unusual and we find similar things elsewhere:

## Chapter 4 - The Determiner Phrase

---

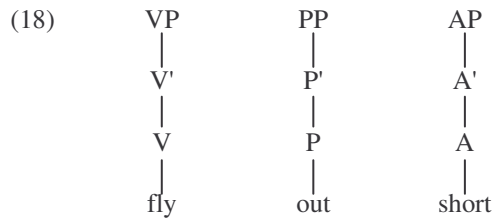

These phrases can be found in sentences such as:

- (19) a birds [fly]  
 b the manager is [out]  
 c the trousers were [short]

Of course, if we analyse pronouns as nouns, then we get a similar situation with them heading an NP:

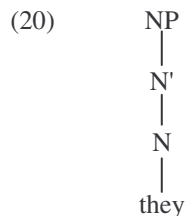

However, the analysis in (17) accounts for the absolute complementary distribution between pronouns and determiners:

- (21) a \*the he  
 b \*a her  
 c \*every they

If pronouns are determiners, this observation is accounted for. But if pronouns are nouns something else must be said to account for why they cannot appear with determiners. Some nouns do not sit well with determiners. In English, proper nouns are not usually accompanied by a determiner:

- (22) a \*a Linda left                      cf. Linda left  
 b \*I spoke to the Thomas    cf. I spoke to Thomas

Yet, in some circumstances we can use determiners with proper nouns:

- (23) a a Linda that I used to know telephoned me yesterday  
 b the Thomas you are thinking of is not the one I am

Interestingly, even in these situations a pronoun is ungrammatical accompanied by a determiner:

- (24) a \*a she/her that I used to know telephoned me yesterday  
 b \*the he/him you are thinking of is not the one I am

It seems that the evidence all points to the assumption that pronouns are determiners. But, if the noun is the head of the phrase and not the determiner, how are



## Why the Noun is not the Head of the DP

---

we to analyse a phrase consisting of just a pronoun as this would appear to be an NP that lacks a noun. This brings us full circle to the observations we started with. Under the proposal that the determiner is the head, there appear to be DPs that lack determiners:

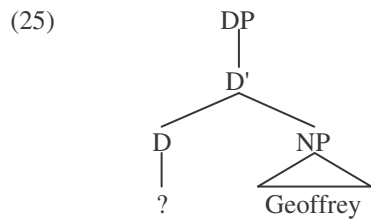

And under the proposal that nouns are the head of the phrase, there appear to be NPs that lack nouns:

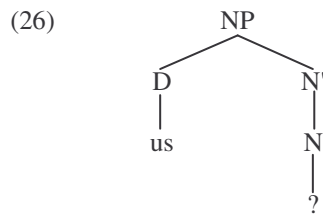

It seems that whatever option we take we face a problem.

There is a way to solve the problem, either way, which involves a slightly more abstract analysis. Suppose the phrases in question do have heads, but they are unpronounced. The idea of an unpronounced, phonologically 'empty' element has been made use of several times already in this book. For example as the understood subject of an imperative or as the trace left behind by a movement. So the idea is not without precedence. Making use of this idea, we have two opposing analyses:

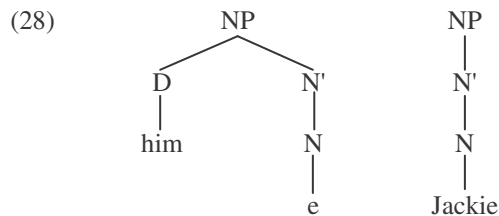
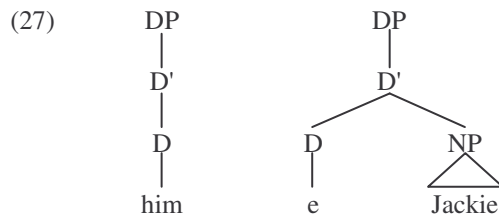

## Chapter 4 - The Determiner Phrase

Of course, the assumption of an empty category must have other motivations than just their necessity to make the analysis work. With the empty subject of an imperative we pointed out that this could act as the antecedent of a reflexive pronoun and with the trace we demonstrated how this prevents other elements from moving into a position vacated by another moved element. Is there any independent justification for either of the empty heads in (27) or (28)? If we consider the empty noun in (28), the only justification this has is to provide a head for the NP. The entire semantic content and the grammatical features of the phrase are contributed by the pronoun itself: the NP is third person singular because the pronoun is third person singular and the NP has a reference which is determined by the pronoun. Thus there is no independent support for the existence of this empty noun.

Now let us consider the empty determiner in (27). At first, we might think that we are facing the same situation here. However, this is not so. Certainly, the main semantic content of the whole phrase is provided by the noun. But this is typical: nouns are the main semantic element in such constructions, even if the determiner is visible. Determiners contribute other semantic aspects, as discussed above. The phrase *Jackie* is definite, as can be seen by the fact that it cannot sit in the post-verbal position in *there* sentences (see chapter 1 section 3.5.2 for discussion):

(29) \**there* arrived Jackie

This then can be taken as a reason to think that there is a determiner accompanying this noun which is responsible for the definiteness interpretation on the assumption that it is determiners and not nouns which contribute this property:

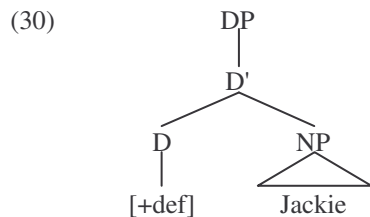

This might be extended to other cases of nouns that appear without apparent determiners, as with plural nouns, for example:

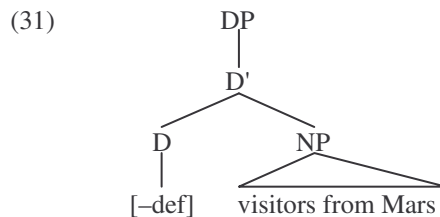

Note that in this case the phrase is indefinite, as shown by the fact that it can appear in the post-verbal position of a *there* sentence:

(32) *there* arrived visitors from Mars

This suggests that there are two different empty determiners: one which is definite and the other indefinite. The interesting thing is that these empty determiners differ in other ways. The empty definite determiner takes only NP complements headed by proper nouns whereas the empty indefinite determiner takes only NP complements headed by plural nouns. This is perfectly normal behaviour for a head, as heads do place restrictions on their complements.

To conclude the present discussion, while it seems that there is no independent evidence that pronouns are accompanied by an empty noun, there is much evidence that proper and plural nouns may be accompanied by empty determiners. This conclusion itself lends support for the claim that the determiner is the head of the phrase and that the noun is not. From this perspective, the noun is the head of its own phrase which sits in the complement position of the determiner.

## 2 The Internal Structure of the DP

Having established the status of the determiner as a head, let us now look at how the DP is arranged.

### 2.1 Determiners and Complements

We have already seen two subcategories of determiner: those which take NP complements and those which take no complement. There are also determiners which take optional NP complements:

- (33) a the proposal      \*the  
      b \*him proposal    him  
      c that proposal    that

Determiners are rather boring in this respect and it seems that there are no other possibilities. This, as it turns out is very typical of functional categories as a whole, as they all have very limited complement taking abilities. However, even if the range of complements of the determiner is very limited, the arrangement of the determiner and its NP complement still conforms to the general pattern of head–complement relationships in English with the head preceding the complement:

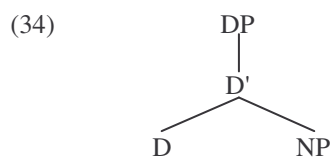

As we have seen, the determiner may impose restrictions on its NP complement, particularly in terms of number: singular determiners take singular NP complements and plural determiners take plural NP complements. Some determiners take mass NP complements, and we have seen that the empty definite determiner takes a proper NP complement:

## Chapter 4 - The Determiner Phrase

---

(35)	<b>singular complement</b>	<b>plural complement</b>	<b>mass complement</b>	<b>proper complement</b>
	a man	*a men	*a sand	?a Jim
	*both man	both men	*both sand	*both Jim
	some man	some men	some sand	?some Jim
	*e <sub>[+def]</sub> man	*e <sub>[+def]</sub> men	*e <sub>[+def]</sub> sand	e <sub>[+def]</sub> Jim
	*e <sub>[-def]</sub> man	e <sub>[-def]</sub> men	e <sub>[-def]</sub> sand	*e <sub>[-def]</sub> Jim

As heads, determiners also project their properties to the phrase and so a plural indefinite determiner will head a plural indefinite DP. We can see this from the following observations:

- (36)
- a there are some men in the garden
  - b there is a man in the garden
  - c \*there is/are the man/men in the garden
  - d the man is in the garden
  - e the men are in the garden

As we have pointed out, only indefinite DPs can appear in the post-verbal position in *there* sentences. Interestingly, in this construction the verb appears to agree with the post-verbal element. So in (36a) the post-verbal DP is indefinite, the sentence being grammatical, and the verb is in the plural form. The determiner *some* is an indefinite plural determiner and these properties are projected to the whole phrase. The determiner *a* is indefinite and singular and hence the DP that it heads can go in the post-verbal position of a *there* sentence and the verb will be in its singular form, as in (36b). The determiner *the* is definite, but unmarked for number. Therefore it cannot head a DP in the post-verbal position of a *there* sentence (36c), but it can trigger either singular or plural agreement on the verb when it sits in the canonical subject position, (36d) and (36e), depending on what NP it takes as a complement.

We can represent these relationships in the following way:

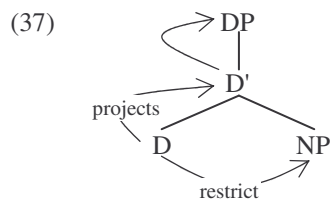

All this is very typical of the behaviour of a head.

### 2.2 The Specifier of the DP

Let us now turn to the specifier of the DP. Like all specifiers this should be a single phrasal element which comes before the head. The most obvious choice would be the possessor:

- (38) John's book

### The Internal Structure of the DP

---

However, the problem in viewing the possessor as the specifier of the DP is that this would predict that possessors can appear in front of a determiner, when in actual fact possessors and determiners seem to be in complementary distribution:

- (39) a the book  
b John's book  
c \*John's the book

If X-bar theory is correct however, this observation cannot be taken to show what it seems to: i.e. that the specifier and the determiner sit in the same structural position. Words and phrases cannot be in complementary distribution as they cannot appear in the same positions in a phrase. Some other element must appear in complementary distribution with the determiner in (39c), not the possessor. But what?

To answer this question we first have to consider another property of the possessor. Pre-nominally, possessors are marked by the element 's'. What is this morpheme? Some have suggested that it is the marker of genitive Case born by the possessor. However, if this is a Case marker, it is a very strange one for at least two reasons. First it is a Case marker in a language which does not usually mark Case on its nominal elements. English only normally marks Case on its pronouns and noun forms are typically invariant no matter what Case position they occupy. Yet if we take 's' to be a marker of genitive Case we have to assume that nominals are marked for this Case. The other strange thing about this morpheme seen as a marker of Case is that it does not behave anything like a Case morpheme in any other language. Note that it does not attach itself to the noun, but to the last element in the whole DP:

- (40) a John's book  
b that man's book  
c the man that I told you about's book  
d the man that you met's book

This behaviour is consistent with the claim that this morpheme does not attach itself to any word, but to the whole phrase. Note this is not the way that Case morphemes behave in other languages. In Hungarian, for example, the accusative case morpheme –*t* is attached to the noun inside the DP, not to the last element in the DP:

- (41) a egy képet Mariról  
b \*egy kép Marirólt

There is another morpheme in English however that behaves like the possessive 's':

- (42) a the man's going  
b the man that I told you about's going  
c the man that you met's going
- (43) a the man'll do it  
b the man that I told you about'll do it  
c the man that you met'll do it

## Chapter 4 - The Determiner Phrase

---

The contracted auxiliary attaches itself to the end of the subject in much the same way that the possessive morpheme attaches itself to the end of the possessor. The difference is, however, that with the contracted auxiliary there is an uncontracted form:

- (44) a the man **is** going  
 b the man that I told you about **is** going  
 c the man that you met **is** going
- (45) a the man **will** do it  
 b the man that I told you about **will** do it  
 c the man that you met **will** do it

Presumably, what happens when the auxiliary verb contracts is that it undergoes some process which attaches it to the subject. Very likely this is not a syntactic movement, but a phonological process which takes place after the structure has been constructed.

Evidence in favour of this comes from the comparison of auxiliary contraction and negative contraction, which does involve a syntactic movement. When the negative element *not* contracts, it sticks itself onto the auxiliary verb in front of it:

- (46) a I will not talk  
 b I wo-n't talk

If the auxiliary then moves, the contracted negative is taken along. Thus when the auxiliary inverts with the subject in certain questions, the negative also inverts and cannot be left stranded behind the subject:

- (47) a could<sub>1</sub>-n't you t<sub>1</sub> be more precise?  
 ↑ \_\_\_\_\_  
 b \*could<sub>1</sub> you t<sub>1</sub> -n't be more precise?  
 ↑ \_\_\_\_\_

In contrast to this, a contracted auxiliary never moves along with a subject that it is attached to:

- (48) a D-structure: Theodore thinks [who -'ll win]  
 b S-structure \*who<sub>1</sub>'ll does Theodore think [t<sub>1</sub> win]  
 ↑ \_\_\_\_\_

Indeed, auxiliaries can contract onto a subject that has moved to the position in front of the auxiliary, suggesting that this contraction takes place after movement:

- (49) a D-structure: [DP e] will seem [this man to disappear]  
 b S-structure: this man<sub>1</sub>'ll seem [t<sub>1</sub> to disappear]  
 ↑ \_\_\_\_\_

The point is, however, that there is a process which takes an independent word and sticks it to the phrase immediately in front of it. If this is what is going on with the possessive construction in English, then the 's' morpheme must originate as an independent word which sits in a position immediately following the possessor. Given that the word position immediately following the possessor is the determiner, we conclude that the morpheme 's' must be a determiner. Unlike auxiliaries, this

## The Internal Structure of the DP

---

determiner has no uncontracted form and so we never see it occupying the D position. We thus have the following analysis:

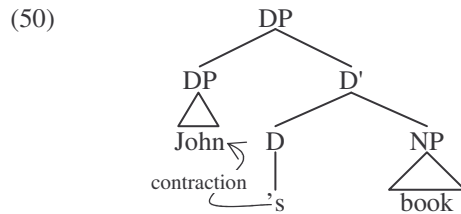

If this analysis can be maintained, we now know why possessors and determiners are in complementary distribution; in fact they are not in complementary distribution but the possessive determiner 's' is in complementary distribution with other determiners, as we would expect.

There is one drawback to this analysis however, which concerns pronoun possessors:

- (51) a his idea  
b my mother

Presumably as these pronouns have the same function as possessors, they sit in the same position: specifier of the DP:

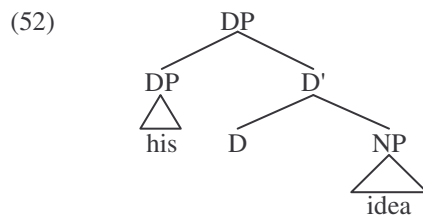

Note that these pronouns have a special genitive form, which demonstrates that this position is one to which genitive Case is assigned. Thus, even if the 's' morpheme is not the marker of genitive Case, DPs which sit in the specifier of a DP have this Case. The problem is that with pronoun possessors the possessive determiner (the 's' morpheme) does not appear. This is rather puzzling, especially if this morpheme is nothing to do with genitive Case.

There are a number of possible solutions we might suppose. One is to assume that the possessive determiner is present with pronoun possessors, but remains unpronounced. This is supported by the fact that, as with all other possessors, no other determiner can appear with a pronoun possessor:

- (53) a \*my the house  
b \*her a travel permit

If nothing is in the determiner position, these observations would be hard to account for. We then have to assume that for some reason when the possessor is a pronoun, the possessive determiner is unpronounced and when it is a non-pronoun it gets

## Chapter 4 - The Determiner Phrase

pronounced as ‘s’. As far as I know there is no explanation as to why this should be and so it remains as a descriptive statement at present.

An alternative would be to claim that the possessive determiner is always unpronounced and hence that the ‘s’ morpheme is not a realisation of this determiner at all. Instead it is a marker of possession, which pronouns do not need as they have a genitive form to demonstrate their status as possessors. The problem with this is that it is tantamount to claiming that the ‘s’ morpheme really is a Case morpheme after all, despite it not behaving like one.

A third possibility would be to claim that the reason why pronoun possessors are in complementary distribution with all other determiners, including the possessive determiner, is because they are determiners sitting in the head position. From this perspective, the structure of the DP with a possessive pronoun would be:

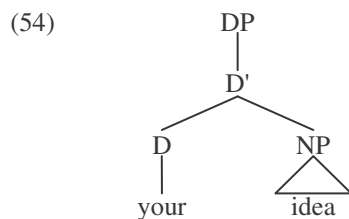

This solves all the previous distribution problems, but places the pronominal possessor in a different structural position to all other possessors, which makes their similar interpretations difficult to account for. Moreover, (54) is not likely to be the correct analysis for semantic reasons. The reference of the possessor is obviously different to the reference of the whole DP: the pronoun refers to a person (i.e. you) whereas the DP refers to a mistake. But if the pronoun is the head of the DP, how could it have a reference that differed from the DP? It seems that there is no perfect solution to these problems from our present understanding of the internal organisation of the DP and we will therefore have to wait for further developments to make progress in this matter.

### 2.3 Adjunction within the DP

Adjunction within the DP itself is a rather limited phenomenon. We know that APs and PPs act as modifiers of nouns and adjoin within the NP, but these do not adjoin within the DP ever as can be seen by the fact that they never precede determiners or never modify pronouns:

- (55) a \*tall the building (the tall building)  
b \*he in the smart suit (the man in the smart suit)

Certain adverbs may precede determiners and hence might be analysed as DP adjuncts:

- (56) a not the right answer  
b only a fool

However, it is not at all clear that these elements form part of the DP at all as their distribution is more limited than we would expect if they were inside the DP:



## Multiple Determiners

---

- (57) a this is not the right answer  
b \*not the right answer is 42
- (58) a only a fool would think that  
b \*I met only a fool

These observations would be consistent with the idea that these modifiers are not part of the DP at all, but occupy separate positions in the sentence.

There are some cases of modification by an adverb, however, that do seem to behave as though the adverb is part of the DP. This mainly takes place with quantificational determiners, the meaning of which is modified by the adverb:

- (59) a almost all men have two legs and one head  
b I like almost all Renaissance paintings

It seems that such adverbs are adjoined at the DP level, rather than at the D' level as can be seen from the fact that they precede possessives:

- (60) a almost John's whole life was spent avoiding work  
b \*his almost whole life ...

Thus, we propose the following analysis for these structures:

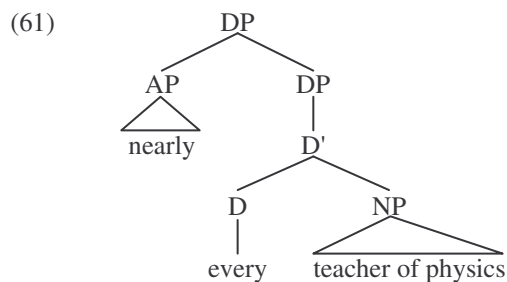

### 3 Multiple Determiners

In the last part of this chapter we will consider structures which appear to have more than one determiner. In fact English seems to allow for up to three determiners:

- (62) all the many disappointments

Traditionally, the determiner which appears in the middle is called a **Central Determiner**, the one in front a **Pre-determiner** and the one following a **Post-determiner**. One might think that an appropriate analysis for this kind of structure would be as follows:

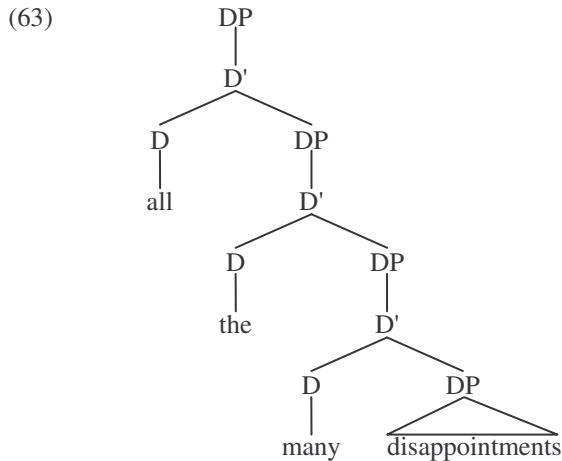

Unfortunately however this fails to capture some rather basic facts about multiple determiners and it also complicates the theory of heads to some extent. The first problem is obvious: if a determiner like *the* can take a DP as its complement, why can it not take any DP complement? The only 'DP' that can follow this determiner is one headed by a post-determiner:

- (64) a the few good ideas  
 b \*the all men  
 c \*the this mistake

In general then, the structure in (63) predicts that determiners can come in any order within the DP and moreover there can be any number of them. Neither of these expectations is true. The second problem lies in the fact that this suggestion forces us to accept that determiners do not just take NP complements; they can take DP complements as well. We will see in later chapters that it is very typical of functional heads to take just one kind of complement, and no functional head takes a DP complement. DP complements seem to be restricted to thematic heads and so it is unlikely that a determiner should be able to take one.

So what is the proper analysis of multiple determiners? The easiest case to deal with is the post-determiner. We argued in chapter 1 that these are adjectival elements which are undefined for the F feature and hence are neither functional nor thematic adjectives. The fact that they may be modified in the same way as thematic adjectives, however, indicates that they head APs:

- (65) a his [<sub>AP</sub> very few] good ideas  
 b my [<sub>AP</sub> not so many] disastrous parties

We can see from this that the traditional term 'post-determiner' is a rather misleading one as they are not determiners, nor even heads but whole adjectival phrases. Where is this AP situated? Clearly it follows the determiner and what follows the head is its complement. But determiners do not take AP, but NP complements. It must therefore be the case that post-determiners occupy a position within the NP complement of the

## Multiple Determiners

---

determiner, the specifier position of the NP complement. Thus, we have the following structure:

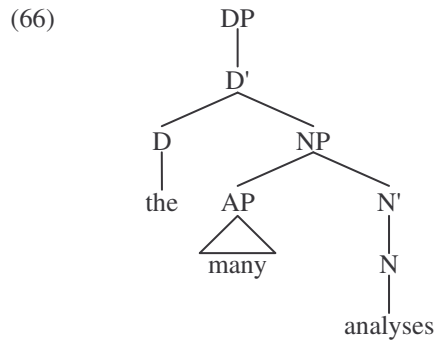

This leaves the pre-determiners to accommodate. These are more problematic. However, it turns out that pre-determiners are not such a special class of determiner after all, once one considers the following:

- (67) a all (of) the people  
 b those of his students who knew him  
 c few of his enemies

The only difference between pre-determiners and other determiners is that when they appear in front of a DP the pre-determiner has an optional *of* whereas this is obligatory with other types of determiner. The fact that we can have a post-determiner in this position is interesting. We have stated that these come in specifier of NP, but where is the NP in (67c) that the post-determiner is in the specifier of? If there is an NP in this structure the head of which cannot be seen, it seems that we are forced to assume that this head is an unpronounced empty category and therefore the structure must be something like the following:

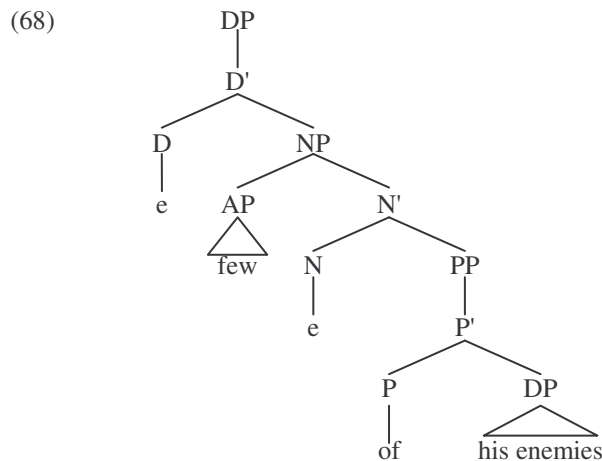

## Chapter 4 - The Determiner Phrase

---

Of course, as we saw previously, caution must be exercised in proposing such empty heads to ensure that they are independently motivated and not just assumed to make the analysis work. It turns out that there is a good deal of independent evidence for the existence of this empty noun.

First, consider the presence of the preposition *of* which is obligatory in nearly all structures of this type, with the exception of the ‘pre-determiners’. This is the preposition we find when there is a noun which takes a DP complement:

- (69) a an illustration **of** [<sub>DP</sub> the technique]  
b a publication **of** [<sub>DP</sub> names and addresses]  
c the theory **of** [<sub>DP</sub> relativity]  
d the record **of** [<sub>DP</sub> his birth]

This preposition has no meaning in these structures and it is fairly obvious that the semantic relationships hold between the noun and the following DPs. This can be most obviously seen from the fact that the verbs from which some of these nouns are formed are transitive and have no need of the preposition to express their relationship with the DP complement:

- (70) a to illustrate [<sub>DP</sub> the technique]  
b to publish [<sub>DP</sub> names and addresses]  
c to record [<sub>DP</sub> his birth]

The object of the verb is associated with accusative Case and hence must be in a Case position. But the object of the noun is not associated with any Case; indeed nouns in general cannot take bare object. We can account for these observations if we simply assume that the complement position of a noun is a Caseless position. Given the Case Filter introduced in the previous chapter, it follows that DPs are not allowed to occupy such a position at S-structure. There is nothing to prevent a noun from taking a DP complement at D-structure, however, and thematically it seems to be the case that many nouns do have DP arguments which all surface as PPs headed by the meaningless preposition *of*. We might therefore assume that this preposition is inserted into the structure at S-structure so that the Case Filter may be satisfied.

Note that the object of a preposition is an accusative position and hence that prepositions are Case assigners. Inserting *of* then allows an otherwise Caseless DP to be assigned Case. *Of*-insertion is however a very limited phenomenon. It happens with the DP complements of nouns and adjectives and nowhere else which might be argued to be a Caseless position:

- (71) a a knowledge of karate  
b fed up of fish fingers  
c \*of him to pay his debts

It seems therefore that the appearance of the meaningless *of* is a good indication of the presence of a noun or an adjective. In the structure we are considering concerning the pre-determiner, the appearance of the *of* can be taken as strong evidence in favour of the presence of a noun even though one is not visible.

Another argument for the existence of the empty noun in pre-determiner constructions comes from their interpretation. Compare the following examples:

## Multiple Determiners

---

- (72) a some of the dancers  
b a group of the dancers

These two constructions are interpreted in very similar ways. (72b) involves a measure or group noun, which we have argued are non-thematic nouns lacking a specification for the F feature. Semantically these work in a very uniform way: the complement of the group noun identifies a set of individuals (in this case *the dancers*) and the group noun focuses on a part of this set by dividing the set up into natural quantities (groups of individuals, bottles of wine, cups of tea, etc.). This is exactly how the structure with the pre-determiner is interpreted: the set is identified by the inner DP (*the dancers*) and this set is partitioned into natural quantities (individual dancers in this case) and the pre-determiner quantifies these.

One possible way to account for this similarity is to assume that the empty noun in the pre-determiner structure works like a group or measure noun. Thus, if this can be maintained, there is semantic evidence for the presence of the empty noun. We can take this further by the following observation. Group nouns allow their DP complements to be fronted:

- (73) a of the dancers, a group were selected to perform  
b of the wine, ten bottles remained unopened  
c of the tea, three cups were set aside

Other nouns do not allow their complements to be fronted like this:

- (74) a \*of Bugsy, a photograph was distributed  
b \*of relativity, a theory was proposed  
c \*of linguistics, a student was examined

With pre-determiner structures, the fronting of the *of*-phrase is also possible:

- (75) a of the dancers, some were sent home  
b of my family, all were famous cuckoo clock engineers

As this phenomenon is restricted to structures involving group nouns, it seems that this is strong evidence in favour of the assumption that pre-determiner constructions involve a group noun in the position we have proposed an empty category.

If this analysis can be maintained, then we can claim that pre-determiners are no different to other determiners (apart from the optionality of *of*) in that they may introduce a DP that has an NP complement with an empty head:

(76)

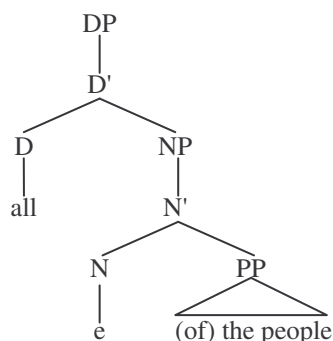

With this analysis then we are able to accommodate all the ‘determiners’ found in English in the appropriate number and order.

#### 4 Conclusion

In this chapter we have introduced the structure of the DP, the projection of a functional category. We will contrast this in the next chapter with the VP, which is obviously the projection of a thematic category. As far as the X-bar structure is concerned, the two are very similar. But, as we know, lexical properties have a very strong influence on structure and hence we might expect that the phrases headed by functional and thematic heads will differ to some extent.

As far as the DP is concerned, an important observation that we have made in this chapter is that the possibilities for its complementation are very limited. Determiners take NP complements or no complements. This is typical of functional heads and contrasts strongly with thematic heads. In the next chapter this difference will be made clear.

#### Check Questions

- 1 How can it be argued that proper nouns and plural count nouns are also DPs?
- 2 What evidence is available to support the assumption that pronouns are determiners heading a DP?
- 3 How can the complementation of a D head be characterised?
- 4 Given the assumption that the ‘s morpheme occupies the D head position, what can appear as [Spec, DP]?
- 5 What may function as adjuncts in a DP?

## Test your knowledge

### Exercise 1

Determine the internal structure of the following DPs by giving their tree diagram.

- (1) a all the small things
- b few of the blond boys
- c nearly every clever student of American history
- d almost all of these young animals
- e any of you
- f any possible solution for this exercise in English syntax

### Exercise 2

Which of the following trees represent the structure of the DP in *italics* in the sentence below correctly? Try to find a test which can prove your statement.

- (1) I know *the new students of Mathematics from London*.
- (2)

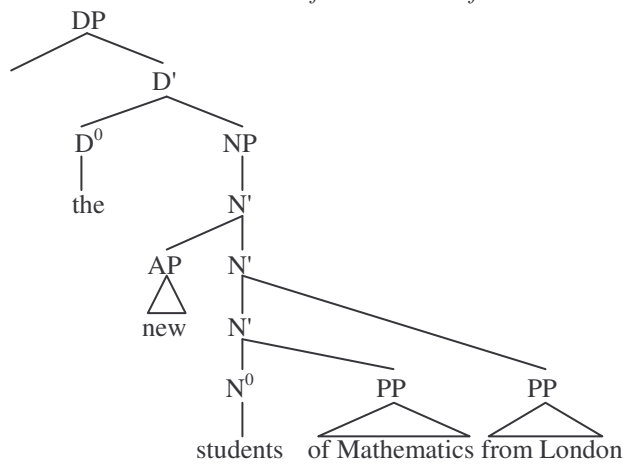

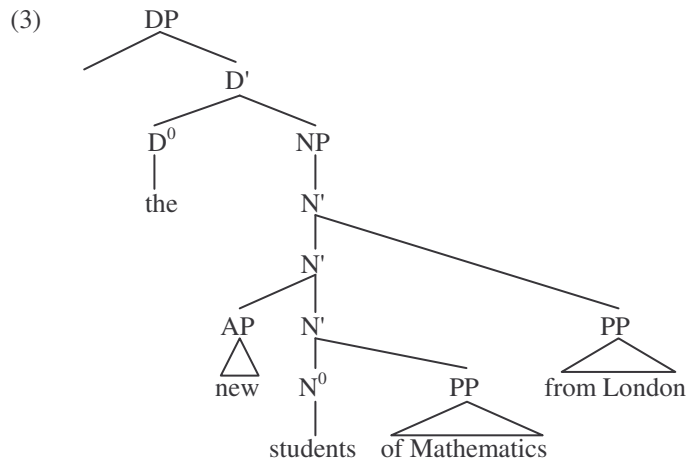

▪ **Exercise 3**

Identify all the DPs in the following examples, bearing in mind that one DP may have another DP as a constituent (usually a non-immediate constituent).

- (1) My colleagues like the idea that the researchers invented the most dangerous weapon ever been made.
- (2) Some students who study Linguistics hate parasitic gaps.
- (3) One very good reason for giving her a second chance is that she did a very good job two years ago in Paris.

▪ **Exercise 4**

Give the X-bar representation of the following nominal constructions

- (1) the President's speech in the Congress
- (2) some of the most recent assumptions about life
- (3) the most interesting books on Physics
- (4) all essays on the theory
- (5) magnificent Gothic building

▪ **Exercise 5**

What problems does the grammaticality of the Italian DP *il mio libro* raise for the analysis of determiners and possessive pronouns?

▪ **Exercise 6**

Discuss the structure of the DPs *a few too many parking tickets*, *many a pleasant day*, and *this very moment*.



### Test your knowledge

---

▪ **Exercise 7**

An important difference between natural languages and artificial languages is that natural language is full of ambiguous structures (which, of course, would be devastating in an artificial language used e.g. for computer programming). The source of ambiguity may be (a) lexical, when a given lexical item has more than one meaning in the lexicon, e.g. *bank*, *chip* or *light*, or (b) structural, when the same set of strings can be analysed in different ways, e.g. in *I saw the girl with the telescope*. In this case either I had the telescope and saw the girl with the help of it, or I saw a girl having a telescope. In the first interpretation *with the telescope* is the adjunct of the verb phrase, in the second interpretation it is the adjunct of the noun phrase. Of course, taking into consideration the great number of potentially ambiguous structures it seems to be surprising that misunderstanding happens relatively infrequently. This can be explained by the support of the context itself which very often rules out one (or more) of the potential interpretations.

Provide a tree-structure analysis for the following ambiguous nominal expression:

- (1) an analysis of sentences with several mistakes

▪ **Exercise 8**

The following DP is ambiguous:

- (1) [<sub>DP</sub> one of the children's book's]

Disambiguate the above DP by using it in two sentences and give the tree structure of the DP with both meanings.

▪ **Exercise 9**

The following sentence has ambiguous syntactic structure. Determine the ambiguities using an appropriate constituency test for each meaning.

- (1) Jane wanted to try on a pair of jeans in the shop window.



# Chapter 5

---

## Verb Phrases

In this chapter we are going to take a detailed look at the structure of the phrase that is in some ways the core of the clause. In this phrase the basic **argument structure** of the clause is formed which is made up of the verb, acting as the predicate, its arguments and adjoined modifiers. Thus, it is within the VP that  $\Theta$ -role assignment takes place. We will also see that it is within the VP that other aspects of semantic interpretation are represented, such as **event structure** and **aspect**. Other aspects of clausal interpretation, such as tense, modality and force are introduced in structures built on top of the VP and we will deal with these in the following chapters.

The principles of Theta Theory introduced in chapter 2 will play a large part in determining the structure of the VP, alongside those of X-bar theory. In particular we will be guided by the Uniform Theta-role Assignment Hypothesis (UTAH), which as we explained in chapter 2 assumes that specific  $\Theta$ -roles are assigned to similar positions in all structures. Thus, if we find evidence that a particular  $\Theta$ -role, *theme* for example, is assigned to a particular position in one structure, then by the UTAH we should assume that it is assigned to this position in all structures where it is found. In many ways this is a very simple theory, but it does lead to the assumption of somewhat more abstract structures than might have been guessed at prior to analysis. However, we will demonstrate that the more abstract structures have quite a few advantages over what might at first seem to be more straightforward analyses and these advantages can be used to independently motivate the analyses and thus support the assumption of the UTAH. We will start our discussion with the simpler cases and work our way to the more complex ones, though this order of presentation might not be the usual one we find in grammar books.

The notions of event structure and aspect are new and we will spend a little time introducing them in the next section.

### 1 *Event Structure and Aspect*

As we have seen in chapter 1, the traditional idea that verbs are ‘doing words’, inasmuch as what they refer to is actions, is not very accurate. Some verbs refer to emotions or states of mind in which nothing can really be said to be done:

- (1) a Lucy loves silent movies
- b Fred fears commitment
- c Sam saw the possibilities

Yet obviously these verbs have meaning and they can be said to refer to something. Let us call what it is that a verb describes in a sentence an **event** and this can either be an action, a state or whatever.

Some events described by a verb are simple, consisting of a single part. For example:

## Chapter 5 - Verb Phrases

---

- (2) a the plane arrived at Heathrow  
b Lorraine lives in London  
c the rock eroded

In each of these sentences there is a single event consisting of the state of some element or the relationship between two elements. In (2a), for example, the plane has achieved a state in which it can be said to be located in some place, i.e. at Heathrow.

Other verbs describe a more complex event:

- (3) a the wind eroded the rock  
b Peter put the eggs in a bowl  
c Gus gave Sam a sandwich

In (3a) an event is described which includes the event described in (2c) but also involves the wind doing something that results in this. We might see this as a series of 'sub-events' connected in one way or another to make up a complex event. Thus, one event involves the wind doing something involving the rock (blowing at it or something) and the other event involves the rock being in a state of erosion. Moreover, the first event has a causal relationship with the second. We might represent this situation thus:

- (4)  $e = e_1 \rightarrow e_2$

Here,  $e$  represents the complex event associated with the sentence *the wind eroded the rock* and the equals sign indicates that this is constituted of a series of other events, in this case  $e_1$  and  $e_2$ . The first of these is the event involving the wind's action and the second is the event of the rock being in the state of erosion. The arrow between the two indicates the causal relationship between the two sub-events in that  $e_1$  causes  $e_2$ .

The events described in (3b) and (c) are even more complex. In (3b) we have *Peter* doing something to the eggs which causes the eggs to undergo a process of movement which results in them being situated in a location (in the bowl):

- (5)  $e = e_1 \rightarrow e_2 \rightarrow e_3$

In this,  $e_1$  represents the action of Peter,  $e_2$  the movement of the eggs and  $e_3$  the state achieved by the eggs of being located in the bowl. Note that  $e_1$  results in  $e_2$  and  $e_2$  results in  $e_3$  as represented by the arrows. (3c) has a similar event structure involving Gus doing something that causes the sandwich to undergo a process the end result of which is that it ends up in Sam's possession. Thus,  $e_1$  is Gus's action,  $e_2$  is the process of movement or 'change of ownership' that the sandwich undergoes and  $e_3$  is the state achieved by the sandwich of being possessed by Sam.

Just like thematic structure, we will demonstrate below that event structure also has an effect on the syntactic organisation of elements within the VP. The main claim is that there is an isomorphism between event structure and the structure of the VP, so that just as a complex event may be broken up into a series of sub-events, then the VP also breaks up into 'sub-VPs' in a one-to-one correspondence with the sub-events. This will become clearer as we progress.

Turning now to aspect. Again this is a semantic property of verbs which has to do with the process involved and its relationship to the progression of time. This is not *tense*, however, which situates an event at a particular place in time with respect to

## Event Structure and Aspect

---

some other point, the time at which a sentence is uttered, for example. With aspect time is important with respect to the internal aspects of the event itself. For example, the end point of the event seen with respect to its starting point and what goes on between the two. It is important to distinguish between two types of aspect, one which is internal to the meaning of the verb, which we might refer to as **lexical aspect**, and one which is to do with the interpretation of a particular event described by a sentence, which we call **grammatical aspect**. Lexical aspect is also sometimes called **aktionsart**.

With lexical aspect we can distinguish between those verbs which describe events which have a natural end point and those which do not. Consider the difference between *eat* and *sit*. Eating involves a process which if it continues long enough must come to a natural end determined by the extent of the thing being eaten: one can only eat an apple until it is all gone! Sitting, on the other hand, can continue indefinitely and will only come to an end when something else happens to stop it, the person stands up or the chair breaks, for example. By contrast, grammatical aspect looks at end points of an event from the perspective of the situation being described. Compare:

- (6) a the Queen of England is sitting on this chair  
b the Queen of England has sat on this chair

In (6a) the situation described involves the Queen of England being on the chair when the sentence is uttered. The sitting event started at some point before the utterance and continued for some undetermined time after it. In (6b), the Queen of England is no longer on the chair when the sentence is uttered – she has stopped sitting and has gone somewhere else. Thus the sitting event is complete. Note that in (6a) the auxiliary verb *be* is used in conjunction with the *ing* form of the verb and in contrast (6b) involves the auxiliary *have* with the ‘*en*’ form of the verb (irregularly expressed as *sat* in this case).

Although the encoding of grammatical aspect in English is complex, the forms *be* + *Ving* and *have* + *Ven* are often called the *progressive* and *perfective* forms to reflect the kind of distinction made in (6). That things are not so simple, however, can be seen from the following:

- (7) a I was living in Paris (until 1985)  
b I have lived in Paris (for 12 years)

Although (7a) has the verb in its progressive form, the event described is clearly completed and the person has stopped living in Paris. (7b) on the other hand is in the perfective form, but the event is not complete: the person is still living in Paris at the time the sentence is uttered.

While this is a very interesting and complex part of the description of the semantics of English verbal complexes, we will not have very much to say about it in this book, as we are mainly interested in syntax and in semantics only inasmuch as it has an effect on the syntactic organisation of an expression. For us, the main interest in grammatical aspect is to do with the appearance of the auxiliary verbs and their syntactic distributions and properties.

Having introduced these notions, we can now turn to the analysis of English verbs and the constructions we find them in.

## 2 Verb Types

Obviously, the Verb Phrase revolves around the head verb, the head being the central element of any phrase. Not only does the head project its categorial properties to the phrase, but also by restrictive selection it determines the categorial nature of its complements. Thematic heads also impose restrictions on arguments by assigning  $\Theta$ -roles to them. The arguments of a thematic head, such as a verb, will appear either in complement or specifier positions according to the principles of  $\Theta$ -role assignment detailed in chapter 2. It follows therefore that the lexical properties of individual verbs will play a large role in determining the structure of particular VPs. We will organise this central section of this chapter by focussing on different subcategories of verbs, starting with those that have the simplest lexical specifications.

### 2.1 Unaccusative verbs

Perhaps the simplest verb type, seen from a lexical perspective, is a group known as **unaccusative** verbs. At first sight, these look like simple intransitive verbs, though we shall see that they are in fact simpler than intransitives (or at least, intransitives are more complex!). Unaccusatives take one DP argument to which they assign a theme  $\Theta$ -role. They may also, optionally in most cases, take a location or path argument expressed by a PP:

- (8) a a letter *arrived* (in the mail box) (from the tax office)  
b the train *departed* (from the station) (to Helsinki)  
c the disease *spread* (to other towns)  
d the table *sat* in the corner  
e the heater *stood* against the wall  
f the gas *appeared* (from nowhere)  
g the snow *settled* (on the roof)  
h the Picts *lived* in Scotland  
i the water ran (down the wall)

These verbs are typically verbs of movement or location. Some of them are ambiguous, having an unaccusative sense and an agentive sense. For example, the verb *sit* can simply mean ‘be situated in a particular location’ (perhaps with a particular orientation), as in (8d), or it can mean ‘to adopt a posture in which most weight is supported by the rear end’ as in (9):

- (9) Sam sat on the sofa

In this usage, the verb is not unaccusative as it involves an agent argument: only something which is capable of volitional action can ‘sit’ in this sense, but virtually anything that is capable of being located can ‘sit’ in the unaccusative sense.

Unaccusative verbs have a certain range of properties by which we can identify them. One is that they may appear in *there* sentences, which we have mentioned several times in the previous chapters. These have a *there* subject and the theme argument sits behind the verb (and must be indefinite):

## Verb Types

---

- (10) a there arrived a letter  
b there departed a train  
c there spread a disease  
d there sat a table in the corner  
e etc.

We will have more to say about the analysis of this structure later, but for now we will simply note it for its diagnostic use.

Note that agentive verbs cannot be used in this construction:

- (11) there sat a man on the chair

This sentence can only be interpreted as having the man situated on the chair and not with him performing the action of sitting. Compare the following:

- (12) a a man deliberately sat on the chair  
b \*there deliberately sat a man on the chair

Another structure in which we find unaccusatives is known as the locative inversion construction. This involves the PP locative argument apparently sitting in subject position, while the DP theme again sits behind the verb:

- (13) a [from platform 9] departed a train to Minsk  
b [in the corner] sat a shadowy figure  
c [down the walls] ran some muddy water

Like the *there* construction, locative inversion seems to be available only for unaccusative verbs and cannot be used with other verbs which have locative arguments or adjuncts:

- (14) a \*[on the table] put he the book  
b \*[in the garden] smiled a boy  
c \*[on the chair] deliberately sat a man

It is not entirely clear that the PP in these structures occupies the subject position as it can be combined with a *there* subject:

- (15) a [from platform 9] there departed a train to Minsk  
b [in the corner] there sat a shadowy figure  
c [down the walls] there ran some muddy water

For the time being, however, we will not worry about the complexities of the analysis of this particular structure, but again use its presence as a diagnostic for unaccusative verbs.

Another distinguishing fact about unaccusatives is that they do not take objects of any kind. You might wonder how this fact distinguishes unaccusatives from intransitives which also do not have objects, but the fact is that intransitives may appear with a limited set of objects:

- (16) a he smiled a rueful smile  
b she laughed an evil laugh  
c they died a mysterious death

## Chapter 5 - Verb Phrases

---

These objects are clearly strongly related to the verb themselves and are called **cognate objects**. Unaccusative verbs, however, do not take cognate objects:

- (17) a \*the letter arrived an arrival  
 b \*the magician appeared an appearance  
 c \*the kettle sat a sit on the stove

Apparent exceptions to this can probably be accounted for in terms of the ambiguity of the verb. For example:

- (18) she lived an eventful life

The verb *to live* can mean something similar to *reside* as in (19):

- (19) she lived in Paris

But it is clear that this is not what is meant in (18) and indeed it cannot have this meaning in the presence of a cognate object. Thus, when it has the meaning *reside* the verb cannot take a cognate object and this is precisely the meaning it has as an unaccusative:

- (20) a there lived Picts in the Highlands  
 b \*there lived a woman an eventful life

Again, for the moment, we will not be concerned about why unaccusative verbs do not take cognate objects, but will use this as a diagnostic for determining whether a verb is unaccusative or not.

In the most straightforward case, ignoring the complexities of the *there* construction for the moment, the theme argument is always the subject. If there is a prepositional argument, this always appears behind the verb, presumably in complement position. Thus the simplest assumption we could make for the structure of a VP involving an unaccusative verb is:

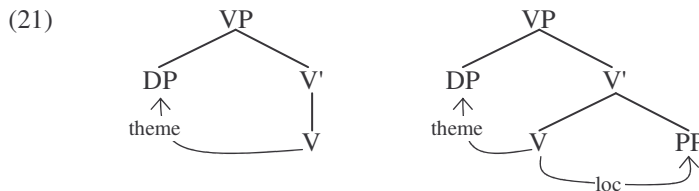

Following the UTAH we might now claim to have discovered the position to which the theme  $\Theta$ -role is assigned: the specifier of the VP.

It is important to point out at this stage that what we are looking at here is the VP at D-structure, i.e. prior to any movement process and not the complete analysis of a full sentence. We will see that this is more complex, involving more structure and a greater number of syntactic processes. In particular, it is common for the subject not to remain in the VP, but to move out into a higher position in the clause:

- (22) the letter<sub>1</sub> may not have [t<sub>1</sub> arrived]  
 ↑



## Verb Types

---

The position to which the subject moves is typically a nominative position and so we might assume that the movement has something to do with placing this argument in a Case position. The reason why these verbs are called ‘unaccusative’ is because unlike with transitive verbs, which share the possibility of having theme arguments, the theme of the unaccusative cannot normally remain inside the VP to receive accusative Case.

As far as the event structure is concerned, unaccusative verbs have a very simple interpretation involving a simple state or relationship between the theme argument and the location. To see this, compare the unaccusative and agentive use of *sit* again:

- (23) a the water sat on the work surface  
      b the old man sat (himself) on the chair

In (23a) the event expressed simply involves the relationship between the water and the work surface, i.e. that the water was on the work surface. In (23b) on the other hand, the event involves the old man doing something which results in him being situated on the chair. Thus the two can be analysed in the following way:

- (24) a  $e = e_1$                    :  $e_1 =$  ‘the water was on the work surface’  
      b  $e = e_1 \rightarrow e_2$           :  $e_1 =$  ‘the old man did something’  
                                       $e_2 =$  ‘the old man was on the chair’

The simple event structure corresponds with the simple VP structure of the unaccusative. We will see that more complex event structures lead to more complex VPs.

### 2.2 Light verbs

The next class of verbs we will consider is rather small and seemingly insignificant, though we will see that they enable us to understand other VP structures in a more illuminating way. Jespersen (1965) first coined the term *light verb* to refer to verbs which, though they may have a fuller semantic usage in other contexts, can be used in combination with some other element, typically a noun or verb, where their contribution to the meaning of the whole construction is reduced in some way.

For example, consider the following:

- (25) a we *had* a walk                 = we walked  
      b they *did* a dance             = they danced  
      c I *took* a look                 = I looked  
      e she *made* a comment         = she commented  
      f you should *give* it a kick = you should kick it

In each of these examples, the italicised verb clearly contributes less of a meaning to the whole sentence than verbs usually do, the main predicative content coming from the deverbal noun in the complement position. However, it is not that these verbs contribute no semantic content to the whole construction as the two sides of the equals sign in (25) are not identical. This is made clear by the following examples:

- (26) a I took a bath                 = I bathed (myself)  
      b I gave him a bath         = I bathed him

What light verbs actually contribute to the meaning of an expression is a complex and subtle issue. For example, it seems from (26) that they do have something to do with

## Chapter 5 - Verb Phrases

argument structure as the main difference here is to do with the number of arguments. The other examples in (25) demonstrate that the contribution of the light verb can affect aspect (*do a dance* versus *dance*) and duration (*take a look* versus *look*) of an event.

It seems that these verbs lie somewhere between thematic verbs with a full descriptive content and functional verbs which play no role in the thematic structure of the sentence. This is why they are called *light* verbs as they make a contribution to thematic and other aspects of semantic structure, though a 'lighter' one than fully thematic main verbs.

In the following cases, the light verbs take verbal complements, but function in a similar way to the above:

- (27) a I made the glass shatter = I shattered the glass  
 b they got the door shut = they shut the door  
 c we let the water run = we ran the water

Again in these cases the light verbs do make a contribution to the meaning of the construction and so the sentences on either side of the equation are not identical. Interestingly, there seems to be different degrees to which these verbs contribute a meaning, with *make* in (27a) contributing very little and *let* in (27c) far more. Compare:

- (28) a I made the door close  
 b I let the door close

Only in (28a) could it be said that *I closed the door*, though in both cases I did something that resulted in the door becoming closed.

It has become standard in recent years to represent light verbs with a lower case 'v' rather than an upper case 'V', which is used for fully thematic verbs. We will adopt this practice here.

What is the structure of the VP containing a light verb? Let us concentrate on the cases in (27). In these we have the light verb itself with a subject to its left. To the right we appear to have a VP containing the main verb and its arguments. Suppose we assume that the main VP is a complement of the light verb. This would give us the structure:

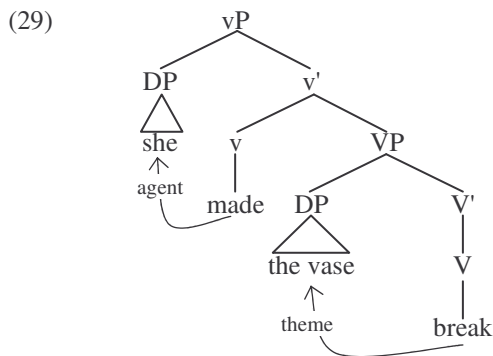

## Verb Types

---

The thematic relationships are straightforward. In the lower VP we have a situation fairly similar to the VP in the previous section. The theme argument, *the vase*, is in the specifier of the VP as we discovered previously. The verb *break* therefore looks fairly similar to an unaccusative verb (we will investigate the properties of this type of verb more fully in the next section). The specifier of the vP is interpreted as an agent and therefore the light verb is clearly not unaccusative. This is not surprising as unaccusative verbs either have no complement or prepositional ones, and here the light verb has a VP complement. In terms of the UTAH, we might therefore propose that the agent  $\Theta$ -role is assigned to the specifier of a (light) verb which has a VP complement.

If we include this complex VP in a sentence, we note that it is the agent that moves to the clausal subject position and the theme appears to remain inside the VP:

(30)  $she_1$  may have [<sub>VP</sub>  $t_1$  made [<sub>VP</sub> the window open]]

As the theme does not move, we can conclude that it gets Case in its original position. Interestingly, there is no Case assigned when there is no light verb forcing the theme to move out of the VP:

(31) the window<sub>1</sub> could have [<sub>VP</sub>  $t_1$  opened]

This is identical to what happens with unaccusative verbs (compare (31) with (22)): the theme subject receives no Case in its original VP internal position and hence has to move to the nominative subject position. So how does the theme get Case in (30)? The obvious difference is the presence of the light verb and therefore we might assume that it is this verb that is responsible for assigning accusative Case to the theme:

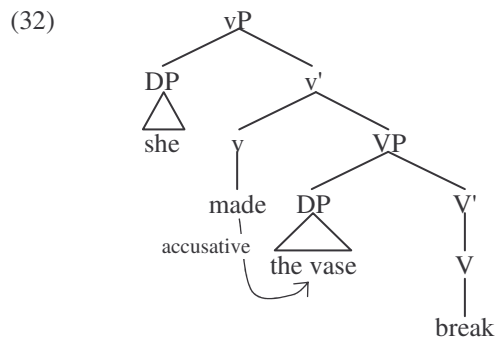

Consider the event structure expressed by this verbal complex. It is fairly clear that there is one (complex) event described by the light verb and thematic verb complex: there is just one clause here with one subject. The event, however, is made up of two sub-events: she does something and this causes the vase to break:

(33)  $e = e_1 \rightarrow e_2$  :  $e_1 =$  'she did something'  
 $e_2 =$  'the vase broke'

## Chapter 5 - Verb Phrases

---

Note that the complex event structure is mirrored by the complex VP structure. There are two sub-events and two parts to the VP, an upper vP and a lower VP. Moreover, the vP corresponds to the first sub-event and the causative connection between the sub-events. The VP corresponds to the sub-event that results from the first. This indicates that there is a connection between event structure and syntactic structure, specifically the more complex the event structure, the more complex the syntactic structure used to represent it.

### 2.3 Ergative verbs

We have just seen that a verb like *break* can appear in a VP with a single theme argument which in the absence of a light verb will be the subject of the clause. This looks exactly like an unaccusative verb, yet there are differences between this class of verb and the unaccusatives. For one thing, these verbs are not movement or locative verbs, but typically involve a change of state:

- (34) a the window broke  
b the door closed  
c the glass shattered  
d the ship sank  
e the bomb exploded  
f the tree grew

Furthermore, these verbs do not appear in *there* sentences or locative inversion structures:

- (35) a \*there broke a window  
b \*there sank a ship
- (36) a \*in the house opened a door  
b \*in the cupboard shattered a glass

Apparent exceptions to these observations may again be accounted for by assuming an ambiguous status of the verb involved. For example, the verb *grow* can apparently behave like an unaccusative:

- (37) a there grew a tree in the garden  
b in the garden grew a tree

In these examples, however, it might be that the verb has a locative interpretation rather than a change of state interpretation. If we force the change of state interpretation, the verb ceases to behave like an unaccusative:

- (38) a the tree grew bigger  
b \*there grew a tree bigger  
c \*in the garden grew a tree bigger

Another major difference between this group of verbs and unaccusatives is that this group can apparently appear in a transitive context:

## Verb Types

---

- (39) a I broke the window  
b she closed the door  
c he shattered the glass  
d they sank the ship  
e the police exploded the bomb  
f the gardener grew the tree

Most unaccusatives cannot appear transitively:

- (40) a \*he arrived the letter  
b \*they departed the train  
c \*the magician appeared a rabbit  
d \*the Romans lived the Picts in Scotland

Some can, however:

- (41) a we sat the guests at the table  
b he stood the ladder against the wall  
c the rats spread the disease  
d they ran a pipeline under the sea

In these cases, these verbs are unable to appear in *there* or locative inversion structures and so again this may be another case of ambiguity:

- (42) a \*there sat the host some guests at the table  
b \*there spread the rats a disease
- (43) a \*against the wall stood the builder a ladder  
b \*under the sea ran the engineers a pipeline

These verbs that have a transitive and an unaccusative use are sometimes called **ergative verbs** as the subject of the unaccusative version is interpreted the same as the object of the transitive version:

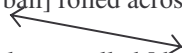
- (44) a [the ball] rolled across the pitch  
b the players rolled [the ball] across the pitch
- 

Languages which relate the subject of the intransitive verb with the object of a transitive verb in terms of a shared case form, for example, are called Ergative languages and while it is doubtful whether the phenomenon demonstrated in (44) has anything to do with the ergativity we find in languages like Basque or Eskimo languages such as Yupik, the term is a convenient one.

The transitive version of ergative verbs all have agentive subjects and theme objects. A first attempt at representing the structure of a VP headed by an ergative might be:

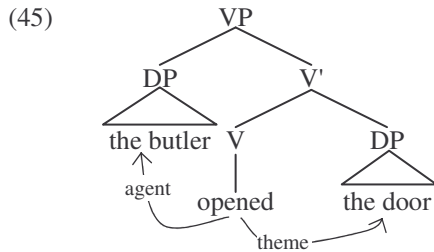

Unfortunately this is an entirely different set of  $\Theta$ -role assignments to what we have previously found. We concluded above that the theme  $\Theta$ -role is assigned to the specifier of a thematic verb, not its complement position. The agent, on the other hand, was assigned to the specifier of a light verb taking a VP complement. If we are to maintain the UTAH, either the structure in (45) is inaccurate, or our analyses of unaccusative and light verbs is.

Moreover, the structure of the VP in (45) is simple, in comparison to that of verbal complexes involving light verbs, as in (32), for example. Yet the event structure expressed here is not simple. In *the butler opened the door*, there is an event involving the butler doing something and an event involving the door being open and clearly the first event causes the second. Hence the event structure is:

$$(46) \quad e = e_1 \rightarrow e_2 \quad : \quad e_1 = \text{'the butler did something'}$$

$$\quad \quad \quad \quad \quad \quad \quad \quad \quad \quad e_2 = \text{'the door opened'}$$

If (45) is the correct analysis, then there is a mismatch here between event structure and syntactic structure whereas in other cases we have seen there has been an isomorphism between the two.

### 2.3.1 Potential problems

If we accept (45), a number of puzzles arise. First consider the alternation between the transitive and unaccusative uses of ergative verbs. Why does the subject go missing in this alternation and not the object and why does the object become the subject? A possible answer to the latter question is that the unaccusative verb is unable to assign Case and hence the object must move to subject position to satisfy the Case Filter:

$$(47) \quad \text{the ship}_1 \text{ may have } [_{VP} \text{ sunk } t_1]$$

There is a fairly robust generalisation, named after the linguist who first noted it, Luigi Burzio, that verbs which assign no  $\Theta$ -role to their subjects, do not assign accusative Case to their objects. While **Burzio's Generalisation** may offer a description of what is going on in these cases, it is an unfortunate fact that the generalisation has little in the way of explanatory content: why it should be that verbs that have no subjects cannot assign accusative Case is entirely mysterious from this perspective.

A second set of questions concerns the relationship between the transitive alternate and the structure with a light verb and the unaccusative alternate:

- (48) a Mike made the ball bounce  
 b Mike bounced the ball

How come these structures mean virtually the same thing, especially as, as we have seen, light verbs are not without meaning? Note that the subject of the ergative verb in (48b) is interpreted as the causer of the ball's bouncing, which is exactly the same interpretation given to the subject of *make*, a causative verb. The event structure of both examples is also the same:

- (49)  $e = e_i \rightarrow e_j$  :  $e_i =$  'Mike did something'  
 $e_j =$  'the ball bounced'

But while the syntactic structure of (48a) is isomorphic with the event structure in (49), if we analyse the sentence in (48b) as having a structure like (45) then the syntactic isomorphism with the event structure is completely lost.

### 2.3.2 Light verbs and ergatives

One way to solve all these problems in one go would be to assume that the structure of the transitive alternate of an ergative verb is as follows:

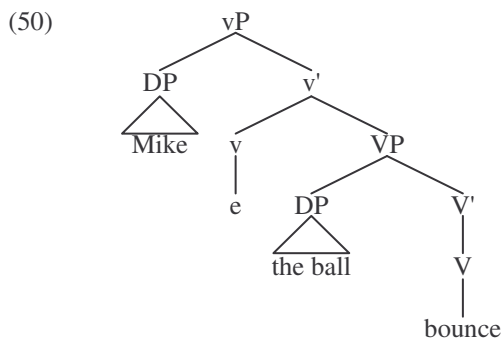

Under this analysis, the UTAH can be maintained as each argument sits in exactly the position it should according to our previous analyses: the theme is the specifier of the main verb and the agent is the specifier of the abstract light verb. Moreover the event structure is represented in an isomorphic way with there being two parts to the syntactic structure each of which relate to the relevant sub-event.

The disadvantages of this analysis are: i) there is an empty light verb and ii) the wrong word order is predicted. The supposition of the empty verb is, of course, not a problem in itself. We have seen a number of instances of empty categories that are well justified and enable us to provide accounts for phenomena that would otherwise be mysterious. As long as we can independently justify the assumption of an empty element, given that language apparently makes use of such things, there is no problem in the assumption itself. There is both semantic and syntactic evidence of the existence of the empty light verb. We will return to the latter, but the semantic evidence is fairly obvious: the structure is interpreted as a causative and the presence of this meaning justifies the assumption of a light verb which provides it. Similarly, the presence of a 'causer' argument justifies the assumption of a predicate which assigns the relevant  $\Theta$ -

## Chapter 5 - Verb Phrases

role. As there is no such visible predicate which can do such things in (48b) our conclusion is that this predicate is 'invisible'.

But how can we even consider (50) as a possible analysis when it obviously gets the word order wrong? The thing to remember is that what we are discussing here is the organisation of the VP at D-structure and we know that things tend to move about before we get to S-structure. Thus, if there is a plausible movement analysis which will re-arrange things so that the right word order is achieved at S-structure, then this objection will have been answered. The obvious way to achieve the correct word order would be to have the verb move to the light verb position:

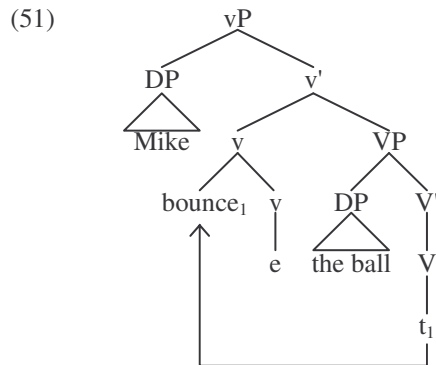

The analysis claims that the main verb moves to adjoin to the empty light verb. This is a perfectly possible movement given what we know about other movements. The movement is neither too far, violating bounding conditions, nor in violation of the Projection principle by changing lexically stated information. The movement is also structurally preserving in the way that adjunction is structurally preserving.

Of course, showing something to be a possible movement and showing it to be an actual movement are two different things. In order to justify the movement analysis in (51) we might consider a similar construction in Hungarian. Consider the following:

- (52) a legurította a labdát  
 down-rolled-3.s the ball-acc  
 'he rolled the ball down'  
 b a labda legurult  
 the ball down-rolled

- (53) a építette a házat  
 built-3.s. the house  
 'he built the house'  
 b a ház felépült  
 'the house (became) built'



## Verb Types

---

- (54) a elmozdította a dobozt  
 away-moved-3.s. the box-acc  
 'he moved the box'  
 b a doboz elmozdult  
 'the box moved'
- (55) a gépesítette a mezőgazdaságot  
 mechanised-3.s. the farmland  
 'he mechanised the farmland'  
 b a mezőgazdaság gépesült  
 'the farmland (became) mechanised'

As we see in these examples, Hungarian has a similar alternation with a set of 'change of state' verbs. Moreover, the transitive versions all have a causative reading, just like the English examples we have been looking at. The interesting point is that the Hungarian causative verbs have a special form with the morpheme *ít* indicating causative:

(56)	pre-verb	stem	causative	tense	agreement
	le-	gur	-ít	-ot	-ta
	(fel-)	ép	-ít	-et	-te
	el-	mozd	-ít	-ot	-ta
		gépes	-ít	-et	-te

Putting aside the issue of tense and agreement inflections, it is possible to give a very similar analysis of the Hungarian causative verbs to the one we proposed for English causatives, with a causative light verb introducing the causative interpretation and the agent subject:

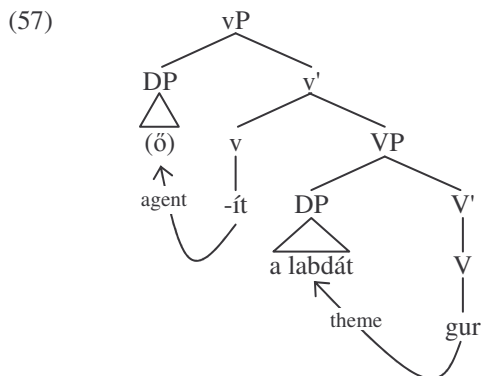

The difference between English and Hungarian, however, is that the causative element is not phonologically empty in Hungarian. The *ít* morpheme, however, is a **bound** morpheme, which means that it must attach to some appropriate stem, i.e. a verb, and this is the trigger for the movement:

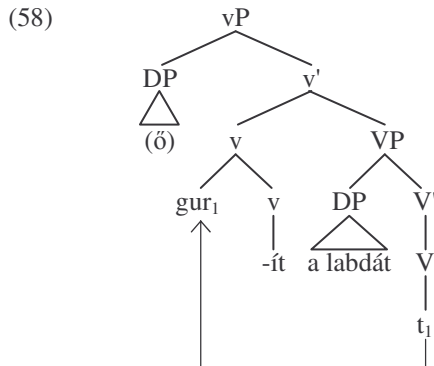

Thus the main verb stem moves to the causative light verb morpheme in order to bind it. The product of the movement would obviously have to undergo further morphological processes in order to show the appropriate tense and agreement forms, but this is unimportant for the point being made here. Suppose English works in exactly the same way as this. The English causative light verb is a bound morpheme, though a phonologically null one, and differs only in this way from the non-null causative *make*. Thus it must be attached to the main verb and this happens by the main verb moving to adjoin to it. This would then give us an independent motivation for the movement of the verb.

### 2.3.3 Unaccusatives and ergatives

Let us consider further aspects of the analysis of the ergative verbs. In the causative construction, the agent is the subject and moves to the nominative position in finite clauses. However the theme stays put inside the VP. In the non-causative, unaccusative form, however, the theme is the subject and moves to the nominative position. Thus in the causative construction the theme must be assigned Case in its original position and this position must be Caseless in the absence of the causative light verb. This clearly points to the light verbs as being responsible for the accusative Case of the theme, just as we claimed for the overt causative structure:

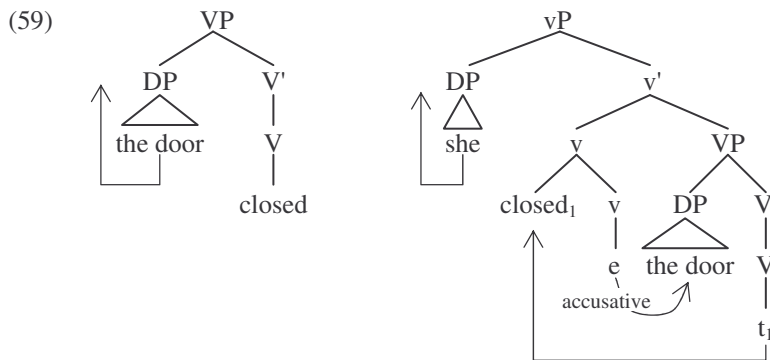

All of this demonstrates that ergative verbs can be analysed in exactly the same way as unaccusatives, in their 'intransitive' use, and as being part of a causative

## Verb Types

---

construction in their ‘transitive’ use. Indeed, ergative verbs themselves are identical to unaccusatives, even in causative constructions as it is the causative light verb which supplies the extra agent argument and the causative interpretation. For this reason, many linguists refer to these kinds of verbs as unaccusatives. However, it still remains that there are differences between the unaccusative verbs we reviewed above and the ergative verbs reviewed in this section. For a start, ergatives cannot appear in the *there* constructions and unaccusatives cannot appear in causative constructions:

- (60) a \*there rolled a ball across the pitch  
b \*there broke a glass in the cupboard
- (61) a \*Andrew arrived the letter  
b \*Lucy lived Ian in Scotland

It seems then that there is a complementary distribution between these verb types. How are we to explain this? Complementary distribution patterns appear when two elements of the same type try to occupy the same position: we can have one or the other, but not both. In the causative construction, we know that there is a light verb above the VP headed by the ergative. Could there possibly be a light verb above the unaccusative VP in the *there* construction?

In order to evaluate this suggestion, let us consider the properties of the *there* construction. The most obvious property is the fact that in this construction the subject position is taken by *there*. This is a meaningless subject that bears no thematic role. Such things are often called **pleonastic** or **expletive** subjects and their function seems to be to act as a ‘place holder’ for the subject when no thematic element will occupy this position. For example, consider the following:

- (62) a Tim<sub>1</sub> seems [t<sub>1</sub> to be tall]  
b it seems [that Tim is tall]

This is a case of raising, as introduced in chapter 3. In (62a) the subject of the lower clause is raised into the subject position of the raising verb *seem*, demonstrating that this position must have been empty at D-structure. In (62b), however, the thematic subject of the lower clause does not move out of this clause. In this case the subject position is filled by another expletive element *it*. It would be ungrammatical for this position to be left empty, an indication that all English sentences must have subjects regardless of whether one is semantically demanded or not. We will return to this observation in the next chapter. Note however that this expletive subject differs from the one used in *there* constructions, though their function (to fill a vacant subject position) seems to be similar. It would be ungrammatical to use a *there* in raising structures and *it* in *there* constructions:

- (63) a \*there seems [that Tim is tall]  
b \*it arrived a letter

This observation clearly calls out for an explanation. Another thing in need of explanation is the fact the post-verbal theme obviously receives Case in this position and does not have to move to subject position. It seems that this fact goes hand in hand with the presence of the *there* subject as, in its absence, the theme must move to the

subject position to get Case. This has led some to the conclusion that the *there* somehow has a role in the assignment of Case to the theme. One possibility is that the difference between an expletive *there* and an expletive *it* is that the former has the ability to **transmit** the Case that it receives by occupying the subject position. If this is so, then the post-verbal theme should get nominative Case as this is the Case that the expletive gets:

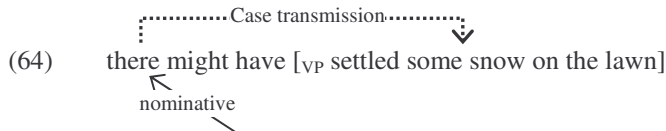

It is unfortunately impossible to check this in English as we can only see visible Case morphemes on personal pronouns and these are excluded from the post-verbal position in the *there* construction as they are definite and only indefinite DPs can occupy this position:

- (65) a \*there departed him  
       b \*there lived he

A second problem with this assumption is that if *there* is able to transmit Case to otherwise Caseless positions, it is not entirely clear why it is not used more often to overcome similar problems when we find DPs sitting in Caseless positions.

The observation that the post-verbal DP is limited to indefinites has led to the claim that neither nominative nor accusative Case is assigned to this position, but a special Case which can only be born by indefinite DPs. Belletti (1988) proposed that **partitive** Case is incompatible with definite DPs for semantic reasons and therefore only indefinites can bear it. Thus if we assume that partitive Case is assigned to the post-verbal position in *there* constructions, we can account for why only indefinite DPs can appear in this position. The problem with this is that under these assumptions it is not entirely clear why we have a *there* expletive and not an *it*. It would seem then that the key to the proper analysis of this construction is the link between the *there* subject and the Case marked indefinite DP in the post-verbal position.

Of course, we also need to explain why the theme argument, that we have claimed to be generated in the specifier of the VP, sits behind the verb, not in front of it, in the *there* construction:

- (66) a there arrived a letter  
       b \*there a letter arrived

Some of the properties of the *there* construction are similar to the causative construction: a Case marked theme which follows the surface position of the verb and some other element in the subject position:

- (67) a there    lived    a dragon    (in the hills)  
       b they    opened the window

These similarities can be captured if we assume that the post-verbal position of the theme is achieved by movement of the verb in front of it and this necessitates the

## Verb Types

---

assumption of a position to which the verb moves. If we assume that this is indeed a light verb, we can account for the Case assignment to the object as well:

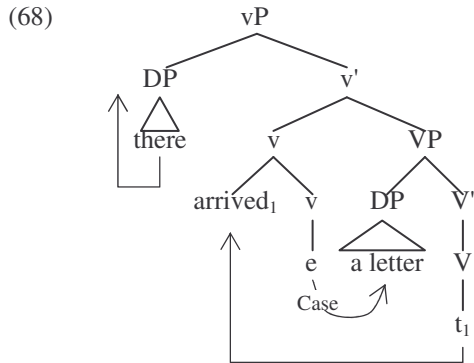

Obviously, this light verb is not the same as the one we get in the causative construction as there is no causative interpretation here and no agent  $\Theta$ -role assigned. In fact, this verb does not appear to have much of a meaning at all. But this might be an advantage in accounting for the other properties of the *there* construction. Recall Burzio's generalisation: only a verb which assigns a  $\Theta$ -role to its subject assigns an accusative Case. The causative light verb fits this restriction well: it assigns an agent  $\Theta$ -role to its subject and an accusative Case to the theme in the specifier of the VP. If the abstract light verb in the *there* construction is restricted by this, then the fact that it assigns no  $\Theta$ -role to the *there* subject, accounts for why we do not find simple accusative DPs in the theme position.

However, we do not want to say that there is absolutely no connection between the abstract light verb and its subject, as there are restrictions placed on it: the subject must be *there* and not *it*. Thus, suppose that *there* is a special argument of this predicate, which receives no actual  $\Theta$ -role from it but is restricted by it. A similar notion of 'quasi-argument' has been proposed for cases such as:

- (69) a it rained  
 b it snowed  
 c it's windy

The *it* subjects that accompany weather predicates are clearly not arguments as they have no referential content, but they are somehow not quite as empty as the expletive *it* in examples like (62b).

One indication of the difference between the quasi-argument *it* and the expletive *it* is that only with the former is a **purpose clause** licensed, i.e. a clause that acts to modify a predicate by providing a purpose for the described event:

- (70) a it rains [to feed the plants]  
 b \*it seems [that Rob is rich] [to impress the neighbours]  
 c Rob seems [to be rich] [to impress the neighbours]

The intended interpretation of (70b) is that Rob pretends to be rich in order to impress the neighbours, and thus it is the 'seeming' rather than the 'being rich' that is being

modified by the purpose clause. The ungrammaticality of this sentence with this interpretation demonstrates that expletive *it* is unable to license this kind of modifier. When the thematic subject is raised, however, the purpose clause is grammatical. The quasi-argument weather predicate *it* appears to behave like a thematic argument in this respect as it does license a purpose clause. Obviously I do not want to claim that the *there* subject in *there* constructions is the same thing as a weather predicate's quasi-argument subject.

But I have discussed this phenomenon to demonstrate that there are different degrees of argumenthood and the claim I want to make is that *there* is somewhere between a thematic argument and an expletive, which is supported by the fact that purpose clauses can appear with *there* subjects:

- (71) a water ran down the cliff face [to hide the mouth of the cave]  
b there ran water down the cliff face [to hide the mouth of the cave]

Now let us suppose that this connection between the light verb and its restricted subject, although it is not enough to license accusative Case, is strong enough to license a Case that can be born by indefinites (perhaps partitive). We then have an explanation for why the post-verbal theme is restricted to indefinite DPs. All in all then, the supposition of a (very) light verb in the *there* construction leads to quite an explanatory account of many of its properties.

### 2.4 Transitive verbs

It is time we turned our attention to those verbs that traditional grammars seem to consider more central: transitive and intransitive verbs. What we have said so far has far reaching repercussions for the analysis of these verbal subcategories. We will start discussing these with respect to the transitives.

A transitive verb is one that has an object, i.e. a DP complement, and a subject. The subject may be agent and the object patient, or the subject could be an experiencer and the object theme. Patient and theme, from this perspective, differ in terms of a notion of **affectedness**: a patient is affected by the action described by the verb while a theme is unaffected by it:

- (72) a Sam sawed the wood (to pieces)  
b Sam saw the wood (\*to pieces)

In (72a) we have the past tense form of the verb *to saw*, *Sam* is an agent and *the wood* is patient. In this cases a resultative modifier like *to pieces* can be used to describe the state of the object after being acted upon. In (72b) we have the past tense form of the verb *to see*, *Sam* is an experiencer and *the wood* is an unaffected theme. Obviously in these cases the resultative is inappropriate because nothing directly happens to the object as a result of being seen. We will put the case of the experiencer–theme type transitives to one side for the moment and start our discussion with the agent–patient type.

Above we found that the agent  $\Theta$ -role was assigned by a light verb which takes a VP complement. If we assume that the patient is a kind of theme, we might expect that it is assigned to the specifier of a main verb:

## Verb Types

---

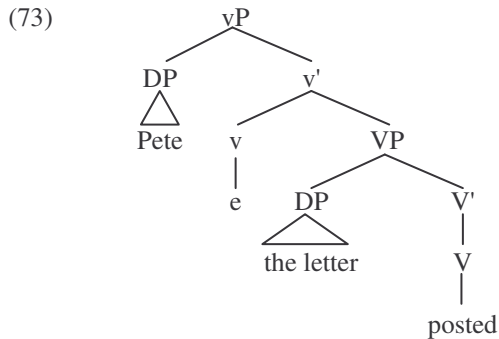

Again, if this were the final analysis of the construction we would derive the wrong order with the verb following its object. Once again, however, we might assume that the main verb raises to the light verb, presumably because of its bound morpheme status:

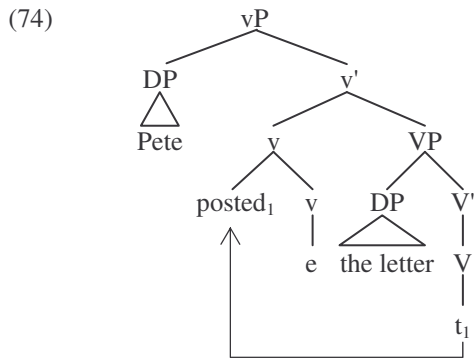

Thus the transitive receives the same analysis as the causative construction, which is not surprising as causatives are the transitive use of ergative verbs.

What is the light verb in this case and how is the main verb related to the subject? We might try the assumption that the empty light verb in this case is the same as the one in causative constructions. From this point of view we would have the following correspondence:

- (75)
- |   |                          |   |                                    |
|---|--------------------------|---|------------------------------------|
| a | Mark made the bed        | = | Mark made the bed be made          |
| b | Harry hit Bill           | = | Harry made Bill be hit             |
| c | Richard wrote the letter | = | Richard made the letter be written |

But while the transitive statements in (75) do entail the relevant causative, in that if *Mark makes the bed*, then *the bed* comes to be made and *Mark* had a hand in causing this to come about, the two are not exactly the same. Particularly, it is not only the case that subjects in (75) caused the event described by the verb to take place, but that the subjects are the ones who actually did it! In other words, these subjects are not just agents, they are agents of the relevant predicates. This might therefore argue that the relevant structure should be:

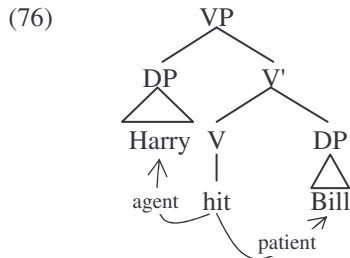

But then the  $\Theta$ -roles are assigned to different structural positions and the UTAH cannot be maintained.

#### 2.4.1 Evidence from passives

There is some evidence that the correct structure should be something like (74) however. This comes from the fact that transitive verbs can undergo passivisation. When a verb is passivised, it loses its agent and the object becomes the subject:

- (77) a Mark made the bed – the bed was made  
 b Harry hit Bill – Bill was hit  
 c Richard write the letter – the letter was written

Even under a less strict view of the UTAH than we are attempting to keep to here, one would like to assume that the object is generated in the same place in active sentences and their passive counterparts. This has been the assumption since the beginning of generative grammar in the 1950s. Thus, the object is generated in object position in the passive, but moves to the subject position. Presumably the only reason it would do this is to get Case. Thus while in the active structure the object gets Case in object position, this ceases to be a Case position in the passive and hence not only does a passive verb lose its subject, it also loses the accusative Case assigned to its object. Again, these are fairly standard assumptions about the analysis of the passive which have been proposed since the 1980s.

Interestingly, the passive is a construction which conforms to Burzio's generalisation: the verb stops assigning a  $\Theta$ -role to its subject and loses the ability to assign accusative to its object. But Burzio's generalisation is a description of a state of affairs, it is not an explanation of that state of affairs. What we need is something that links the two properties. In previous examples we have seen a way to link the  $\Theta$ -role assignment to the subject and the accusative Case assignment to the object: through the light verb which is assumed to do both:



## Verb Types

---

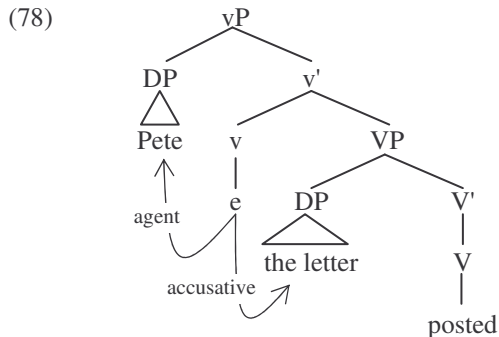

If the light verb ceased to be there, both the agent  $\Theta$ -role and the accusative Case would be lost in one step. What would be left is the main verb with its patient argument which would lack Case and hence have to move to subject position:

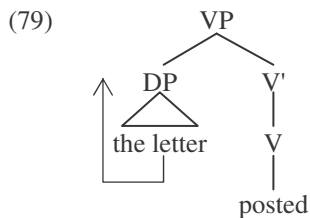

Thus, if we analyse the passive construction as involving the loss of the light verb, we readily account for its two most salient properties.

We might extend this analysis to take into consideration other aspects of the passive construction. It has been argued that one of the central aspects of the passive is the appearance of the passive morpheme. The passive morpheme appears in all English passives, no matter what else happens. Thus, not all passives involve an object moving to subject position (80a), and while some passives contain a *by* phrase reintroducing the missing subject, not all do (80b). Furthermore, most passive constructions involve a passive auxiliary *be*, but not all (80c):

- (80) a it is expected that Pete will post the letter  
 b the letter will be posted (by Pete)  
 c I will expect [the letter posted by noon at the latest]

In all these examples however, the passive verb has the passive morpheme. We can incorporate this into our analysis of the passive making use of an idea presented above, that certain bound morphemes can be analysed as light verbs. Suppose we assume that the passive morpheme is a light verb which replaces the agentive light verb of the active. As the passive light verb does not assign a  $\Theta$ -role to its subject, it will not be able to assign a Case to the theme in the specifier of the VP and hence this argument will have to move to subject position. Moreover, the bound morpheme status of the passive light verb will force the main verb to move in order to support it:

(81)

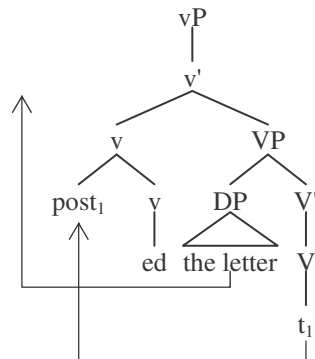

From this perspective, then, the analysis of the passive involves replacing the agentive light verb with a non-agentive passive light verb, most of the other aspects of the passive construction follow straightforwardly from this.

A crucial point to make at this point is that this analysis of the passive would simply be unavailable if we supposed that the structure of the active were to be (76) and not (74). Inasmuch as this analysis helps us to understand the passivisation process any better, then, it can be used as evidence in favour of the assumption of (74).

#### 2.4.2 Extended projections

Yet if this is so, we still face the problem that the subject of an active transitive verb is interpreted as the subject of that verb and not of some independent abstract light verb. To understand this, it is essential to understand the relationship between light verbs and thematic verbs in general. Recall that the semantic contribution of a light verb to a construction is somewhat reduced from its full thematic usage:

- (82) a I gave Charlotte chocolates  
 b I gave Kevin a kick in the pants  
 c I kicked Kevin in the pants

In (82a) the verb *give* is used fully thematically and it contributes its full descriptive content to the whole sentence: the agent is in possession of the chocolates, and does something (i.e. *gives*) that results in the recipient in possession of the chocolates. But in (82b), where *give* is used as a light verb, it does not contribute its whole semantic content. For example, it cannot be claimed that anything has been given here and certainly *Kevin* does not end up in possession of *a kick!* Instead the main descriptive content comes from the deverbal noun and hence the similarity of meaning of (82b) and (c). It seems that semantically speaking, the complement of the light verb is the main contributor to the construction and although light verbs do contribute something, their contribution is often subtle and always dependent on the thematic complement. This shows a very different relationship between a light verb and its complement and a thematic verb and its complement. In the latter case, the thematic verb selects and imposes restrictions on its complement whereas in the former, the light verb is in some ways selected for and restricted by its complement: recall that unaccusative verbs do not appear with the abstract causative light verb, but ergatives do. Suppose then that the main semantic aspects of a light verb are determined by its thematic complement

and that these are passed up to it by a process similar to projection – something which has been called **extended projection**, in fact. It would then depend on the thematic verb how the argument of the light verb was to be interpreted, as a causer, not directly seen as the agent of the thematic verb, or as a direct agent of that verb. We might visualise this in the following way:

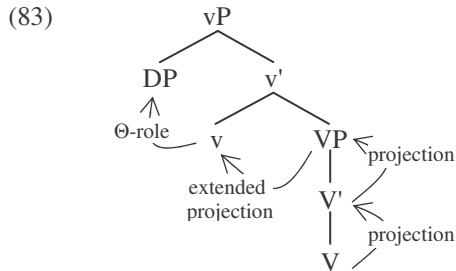

If this is right, then the agent subject of the light verb involved with transitive verbs will receive its  $\Theta$ -role indirectly from the main verb, via the light verb, and hence will be interpreted as the argument of the thematic verb. Of course the actual assignment of the  $\Theta$ -role will be dependent on the presence of the light verb, as by the UTAH roles such as agent can only be assigned to the specifier of a light verb.

#### 2.4.3 Agent and experiencer subjects

What about the event structure of a transitive construction? Above we argued for an isomorphism between the structure of the VP and the structure of the event it describes such that each part of the VP corresponds to a separate sub-event. If transitive verbs involve an agentive light verb, and hence there are two parts to the verbal complex, we should expect that the event described by a transitive verb should consist of two sub-events. But we have just seen that transitives are not causative: *Harry hit Ron* does not mean that Harry does something that causes Ron to get hit. However, there is not necessarily a direct relationship between what the subject does and the object getting hit. Consider the following:

- (84) a Harry hit Ron with his hand  
       b Harry hit Ron with a stick  
       c Harry hit Ron with a stone

We can see from these examples there is a sense in which there are two parts to a hitting event: somebody does something and somebody or something gets hit as a more or less direct result of this. There is obviously a very subtle difference between this interpretation and a causative one, which we will not attempt to describe here. The point is that the event structure of the transitive can be represented in a similar way to that of a causative:

- (85)  $e = e_1 \rightarrow e_2$  :  $e_1 =$  'Harry did something'  
                                    $e_2 =$  'Ron got hit'

Now let us turn our attention to verbs of perception which take experiencer subjects.

**Chapter 5 - Verb Phrases**

---

- (86) a Sally saw a ghost  
 b Harry heard the news  
 c Fred fears the dark

The obvious question that needs to be asked is whether the experiencer subject occupies a similar position to an agent subject or a different one. The choices would seem to be to place the experiencer in the specifier of an abstract light verb, or to place it in the specifier of the thematic verb:

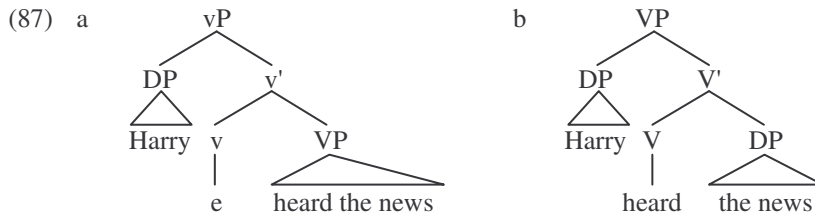

One observation that might be relevant here is that there are some verbs which take both agent and experiencer arguments. With these verbs, the agent always precedes the experiencer:

- (88) a Freddy frightened me  
 b Ursula upset the waiter  
 c Dennis disappointed his parents

Assuming that the agent is in the specifier of a light verb, these observations suggest that the experiencer is in the specifier of the thematic verb, like theme arguments:

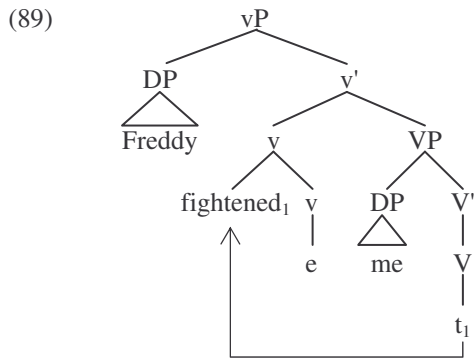

This would support the structure in (87b) which has the experiencer in the specifier of the thematic VP, as in (89).

A second observation that seems to support (87b) concerns the event structure of transitive verbs with experiencer subjects. Certainly there does not appear to be a causative relationship between what the subject is interpreted as doing and what happens to the object. (86c), for example, does not appear to be interpretable as Fred doing something that results in the dark being feared. Instead it seems that these sentences express a simple state of affairs with no sub-events:

## Verb Types

---

(90)  $e = e_1$  :  $e_1 =$  'Fred fears the dark'

If there is an isomorphism between event structure and VP structure and (90) is the correct analysis of the event structure involving an experiencer subject transitive verb, then (87b) appears to be the correct structure of the VP.

However, an obvious disadvantage of (87b) is that the theme is placed in the complement position which is counter to what we have previously discovered. If the theme goes in the specifier of the thematic verb, then there is no alternative than to include the experiencer in a higher position which would mean adding an abstract light verb. A further disadvantage of (87b) is that transitive verbs with experiencer subjects can be passivised. We have analysed passivisation as a process which removes the light verb responsible for the assignment of the  $\Theta$ -role to the subject and the Case to the object, replacing it with the passive morpheme. If there is no light verb responsible for assigning the experiencer  $\Theta$ -role, it is not at all clear how these verbs could undergo passivisation: what would the passive morpheme replace and why would the experiencer  $\Theta$ -role and accusative Case go missing? Moreover, the passivisation of these verbs casts doubt on the assumption that they have a simple event structure. Passivisation of agentive verbs by getting rid of the agentive light verb turns a verb with a complex event structure into one with a simple one:

(91) a Harry hit Ron  
 $e = e_1 \rightarrow e_2$  :  $e_1 =$  'Harry did something'  
 $e_2 =$  'Ron was hit'  
b Ron was hit  
 $e = e_1$  :  $e_1 =$  'Ron was hit'

But if experiencer transitive verbs have a simple event structure and we remove the experiencer, what are we left with? Surely we cannot be left with half an event! This would argue that the event structure of experiencer transitives is similar to that of agentive transitives:

(92) a Fred fears the dark  
 $e = e_1 \rightarrow e_2$  :  $e_1 =$  'Fred experiences something'  
 $e_2 =$  'the dark is feared'  
b the dark is feared  
 $e = e_1$  :  $e_1 =$  'the dark is feared'

To argue for this in any depth, however, would take us beyond the scope of this book and into areas such as psychology and philosophy. Therefore we will assume this to be the case, based on the linguistic arguments so far presented.

### 2.4.4 Multiple light verbs

If we assume that experiencers are assigned their  $\Theta$ -roles in the specifier position of a light verb, we face a problem in analysing verbs with agent and experiencer arguments as in (88). What is puzzling about these verbs is how they can exist at all, given our assumption that agent and experiencer receive their  $\Theta$ -roles in the same position. The only analysis available to us, if we wish to maintain the UTAH, is to assume that there are two light verbs in these constructions, one for the agent and one for the experiencer:

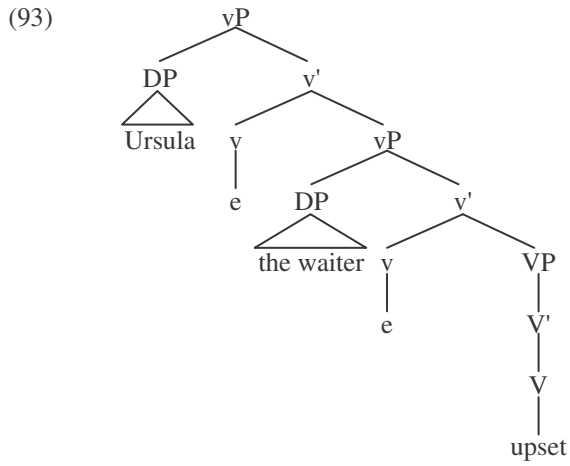

The event structure of these verbs seems to support this analysis as it does seem rather complex:

- (94)  $e = e_1 \rightarrow e_2 \rightarrow e_3$  :  $e_1 =$  'Fred did something'  
 $e_2 =$  'I experience something'  
 $e_3 =$  'I am frightened'

To get the right word order we will have to assume that the verb moves to the highest light verb and in fact, the verb will have to move to them both, one after the other, if abstract light verbs are bound morphemes:

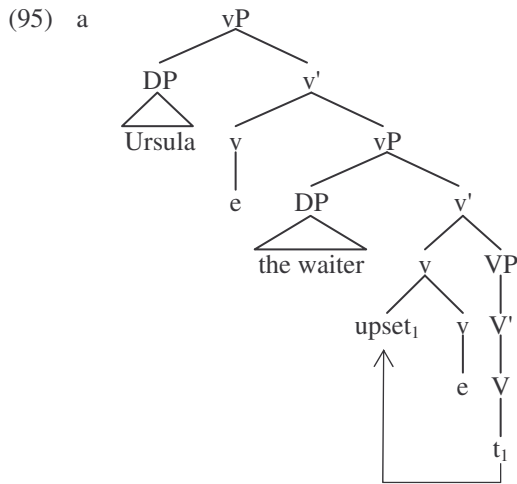

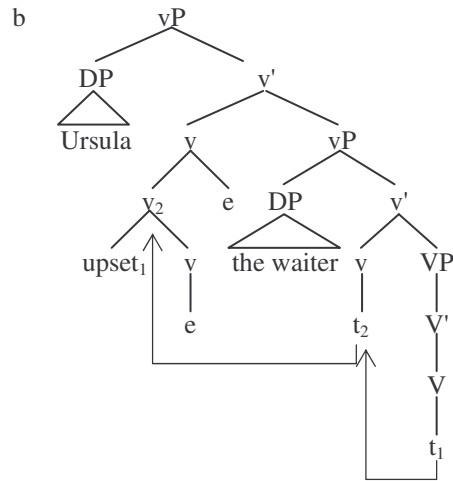

The first step, represented in (95a), involves the verb moving to the lower light verb and adjoining to it. The next step in (95b), takes the light verb with the thematic verb adjoined to it and moves this to adjoin to the upper light verb. The result is a multiple head adjunction structure of the type discussed in chapter 2.

Multiple light verbs are not unheard of in languages which make more of an overt use of them than English. Consider the following Urdu example:

- (96) nadyane saddafko xat lik lene diya  
 Nadya-erg. Saddaf-dat. letter write take-inf. give-perf.Masc.s  
 'Nadya let Saddaf write a letter (completely)'

The verbal complex at the end of this single clause consists of a thematic verb (*write*) and two light verbs (*take* and *give*) where the inner one (*take*) adds some aspectual meaning of perfection and the outer one (*give*) seems to add a modal meaning of permission. Even in English we can have a series of light verbs stacked one on top of another:

- (97) I made him let her take a look

But while this seems a possible analysis for these structures therefore, it does raise the question of why the light verbs are ordered as they are: why is the agentive one always higher than the experiencer one? The answer may have to do with the notion of extended projection. The essence of this is that the thematic verb to some extent controls the  $\Theta$ -roles assigned by the light verbs. It has been proposed in several places that there is a hierarchy of  $\Theta$ -roles which plays a part in the order in which they are assigned. For example, we might suppose that agents are higher in the hierarchy than experiencers and these in turn are higher than themes:

- (98) agent > experiencer > theme

The  $\Theta$ -roles lower on the hierarchy have to be discharged on to an argument before those higher up. The UTAH ensures that  $\Theta$ -roles can only be discharged in certain positions and in combination with (98) we get the following pattern. The first  $\Theta$ -role to

be assigned is the theme, if there is one. As this can be assigned to the specifier of the thematic verb it will be. Next the experiencer  $\Theta$ -role must be assigned, providing there is one. This can only be assigned to the specifier of a light verb so the thematic verb will extend its projection to include a light verb and the experiencer  $\Theta$ -role will be assigned to its specifier. Finally, if there is an agent, again this can only be assigned to the specifier of a light verb and hence will force the verb to extend its projection. If there already is an extended projection, a second light verb will be added to accommodate the agent. Thus, the agent will always be higher in the structure than the experiencer and theme.

### 2.5 Intransitive verbs

Intransitive verbs are verbs with one argument, but unlike unaccusatives this argument is either an agent or an experiencer, i.e. one of the  $\Theta$ -roles assigned to the specifier of a light verb. Accordingly then, we may analyse them as involving the following structure:

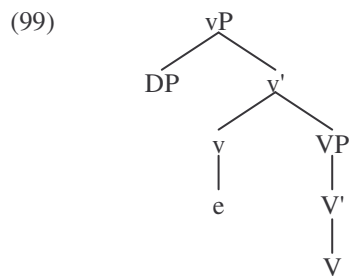

The one argument will move to the subject position in order to get Case and presumably the verb will move to support the light verb.

Examples of intransitives are as follows:

- (100) a Sam smiled  
 b Jerry danced  
 c Richard died  
 d Stan slept

Recall that one mark of an intransitive verb, as opposed to an unaccusative, is its ability to take a cognate object:

- (101) a Sam smiled an evil smile  
 b Jerry danced a merry dance  
 c Richard died a tragic death  
 d Stan slept a restless sleep

Given the structure in (101) a number of possible analyses of cognate objects suggest themselves. One is to assume that these are like theme arguments, though obviously highly restricted by the thematic verb and hence they appear in the specifier of the VP and end up behind the verb when it raises to the light verb position:



## Verb Types

---

(102)

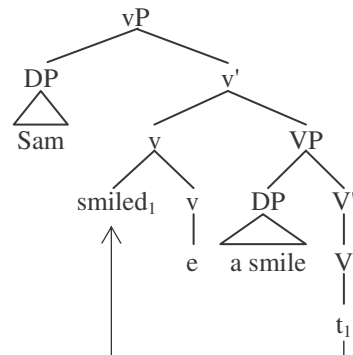

From this perspective, the only difference between a cognate object and a normal object is the restricted semantic relationship that holds between the cognate object and the intransitive verb. Another possible analysis suggests itself through the similarity between intransitive verbs with cognate objects and light verbs with deverbal noun complements:

- (103) a he smiled a smile = he smiled  
 b he took a peep = he peeped

Perhaps then what a cognate object is, is not a virtually meaningless repetition of the verb as is standardly assumed, but the main predicative element in the sentence and it is the verb which has a reduced 'light' meaning. This analysis has possibilities, but we will not follow it up further.

If we analyse intransitives as involving a light verb, the question arises as to why we cannot passivise an intransitive:

- (104) a \*it was smiled by Sam  
 b \*it was died by Richard

This is quite mysterious given our previous analysis of the passive. However, it should be noted that the inability to passivise intransitives is a language particular fact and not a universal truth about intransitives. German intransitive verbs, for example, can passivise:

- (105) Es wurde getanzt  
 it was danced  
 'there was dancing'

This at least shows that in principle passivisation is not incompatible with intransitives and that the reason why intransitives cannot passivise in English must therefore be due to some other particular property of the language. Note that unaccusatives do not passivise in any language:

- (106) \*it was arrived (by the letter)

- (107) a In de zomer wordt er hier vaak gezwommen.  
 In the summer is it here frequently swum  
 ‘In the summer, there is frequently swimming here’  
 b \*In de zomer wordt er hier vaak verdronken.  
 In the summer is it here frequently drowned  
 ‘In the summer, there is frequently drowning here’

This is to be expected given our analysis of the passive and the fact that unaccusatives do not involve light verbs.

The event structure of intransitives is also a little problematic as we predict it to be complex if intransitives involve light verbs, but a sentence like *Sam smiled* does not obviously express a complex event structure. However, it is not impossible to think of this as involving a situation in which Sam does something which results in a smile, which is made more plausible by comparison with the overt light verb construction:

- (108) a Sam smiled  
 b Sam did a smile

If intransitives are in fact formed from an underlying structure involving a ‘cognate object’ and a light verb as suggested above, then the parallel between (108a) and (b) is even stronger. We might therefore propose the following analysis of the event structure:

- (109)  $e = e_1 \rightarrow e_2$  :  $e_1 =$  ‘Sam did something’  
 $e_2 =$  ‘there was a smile’

In all then the analysis of intransitives is relatively unproblematic.

## 2.6 Multiple complement verbs

So far we have been concerned with verbs that have either one or two arguments, but there are cases of verbs with more. In this section we will look at a number of verbs which have three arguments, again trying to maintain the UTAH and using this as a guide for the analysis of the VP’s structure.

Within the standard X-bar structure there are two positions in which we find arguments: specifier and complement:

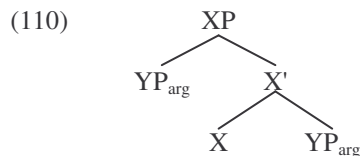

Verbs with more than two arguments have therefore been considered as problematic. However, once we consider the role of light verbs as assigners of  $\Theta$ -roles regulated by the thematic verb, we can see that it is possible to extend the  $\Theta$ -roles assigning domain of a thematic verb to more than two positions. This is essentially the approach we will adopt here.

As a first case of a multiple complement verb, consider verbs of placement:

## Verb Types

---

- (111) a Porter put the book on the shelf  
 b Prudence placed the penguin on the podium  
 c Steve stored the potatoes in the cellar  
 d Karen kept the hamster in a cage

Each of these predicates involves an agent, a theme and a locative. It is fairly obvious what the structure should be from what we have discussed so far. The agent is introduced as the specifier of a light verb, the theme is the specifier of the thematic VP and the locative PP is in the complement position:

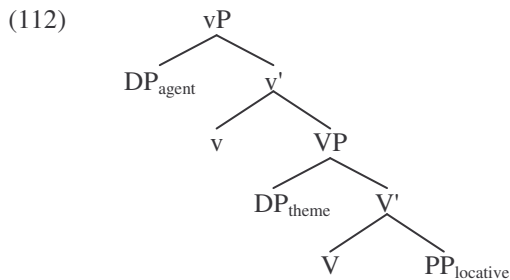

Of course, the verb moves to the light verb position and the word order is as predicted. That the complement position of the thematic verb is the position to which the locative  $\Theta$ -role is assigned is supported by the fact that this seems to be where we find locative PPs with unaccusative verbs, which we have argued do not involve a light verb:

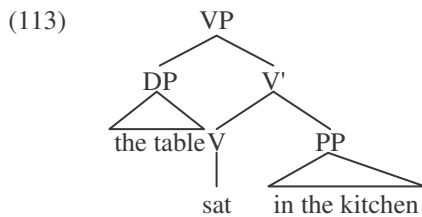

The event structures of these verbs however indicate that the analysis might be a little more complex than we have indicated in (112). For example, consider what is involved in 'putting'. There is an agent who performs some action and there is a theme which undergoes a change of position and there is a location where the theme ends up. Thus the event structure seems to be:

- (114) Porter put the book on the shelf  
 $e = e_1 \rightarrow e_2 \rightarrow e_3$  :  $e_1$  = 'Porter did something'  
 $e_2$  = 'the book changes location'  
 $e_3$  = 'the book is on the shelf'

An isomorphic analysis of the VP would have an extra light verb than indicated in (112). We will see that perhaps there is evidence for this.

Another similar set of verbs involves a PP denoting a goal or beneficiary:

## Chapter 5 - Verb Phrases

---

- (115) a Gary gave a present to Petunia  
 b Sonia sent the letter to Larry  
 c Knut knitted a sweater for Susan  
 d Barry baked a cake for Karen

Again, the arguments are similar, involving an agent, a theme and a PP complement expressing the goal or beneficiary and so we can expect the structure to be similar. This structure is sometimes called the **dative construction**. The interesting thing about these verbs is that they can often enter into another construction which means virtually the same thing as the dative, only involving two DP complements:

- (116) a Gary gave Petunia a present  
 b Sonia sent Larry the letter  
 c Knut knitted Susan a sweater  
 d Barry baked Karen a cake

This is known as the **double object construction** as the verb has two objects, traditionally referred to as the **indirect** and the **direct** objects respectively.

But the analysis of this construction is problematic:

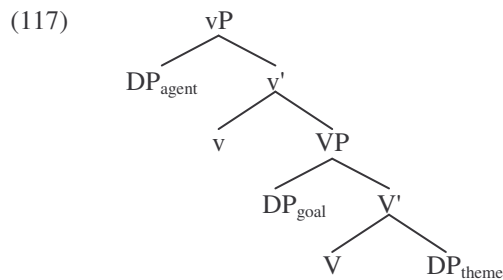

In this structure the theme is sitting in the complement position of the thematic verb, not the specifier, and the goal is in the specifier. The indirect object is obviously interpreted in the same way as the PP is in the dative construction and so we should expect it to appear in the complement position if the UTAH holds. We might try to account for the properties of the double object construction via a movement analysis, using the dative construction as the underlying arrangement as this seems relatively unproblematic. The question is, what moves and where does it move to? A minimal assumption is that besides the verb moving to the light verb position, one of the arguments moves to change their order. Thus, either the theme moves backwards or the goal moves forwards. If the theme moves backwards, it isn't clear what position it would move to and moreover it isn't clear why it would move, given that the position it occupies seems to be a Case position in virtually all other cases we have looked at. The goal argument is slightly different however. In the dative construction there is a preposition and this we might assume is what is responsible for providing the argument with its Case. In the double object construction, however, this preposition is not present and hence the argument cannot be assigned Case in the same way. This would then provide the motivation for the argument to move to a position in which it could get case. Considering the problem more closely the goal must move to a phrasal position between the specifier of the VP, occupied by the theme, and the light verb to

## Verb Types

---

which the main verb moves. The only possibility is that there is another specifier position between the two:

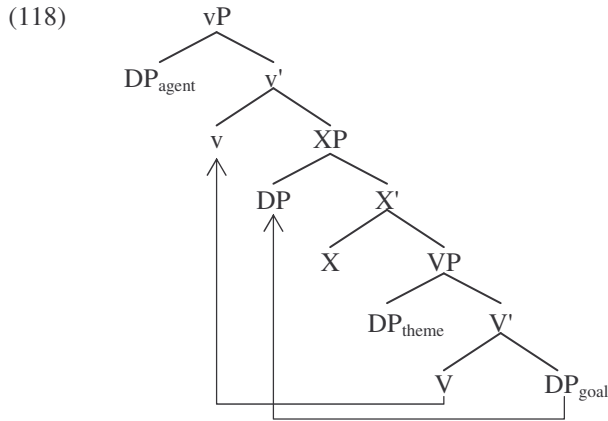

The remaining problems to solve are the identity of X and how the theme argument gets Case if the goal argument gets the Case assigned by the light verb. The obvious answer to the latter is that X provides the theme with its Case, which in turn suggests that X is a Case assigning head, i.e. a verb or a preposition. If X is a verb, we have a structure which is identical to those involving multiple light verbs:

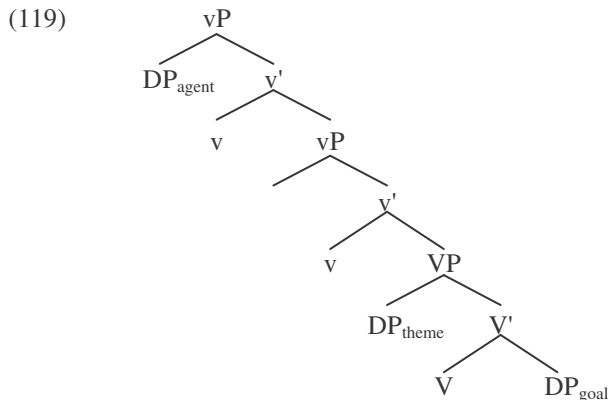

Can this analysis be justified? If one thinks of the event structure involved in the meaning of these verbs they all seem to work as follows:

- (120)  $e = e_1 \rightarrow e_2 \rightarrow e_3$  :  $e_1 =$  'X does something'  
 $e_2 =$  'Y changes location or possession'  
 $e_3 =$  'Y is in a certain location or possession'

In other words, if Gary gives Pete a present, Gary does something which causes the book to undergo a movement or change of possession, the result of which it ends up with Pete. The middle event, involving a change of position or possession is what provides us with the position for the moved goal:

(121)

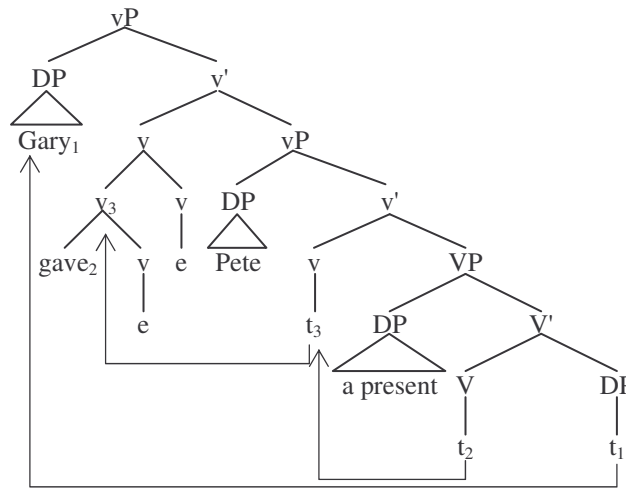

The verb movement is as we have seen before. As both light verbs are bound morphemes, both will need supporting and so the verb will move from one to the other forming a complex head adjunction structure in the top head position. As far as Case relationships are concerned, the subject DP is in a Caseless position and hence will move to the clause subject position to get nominative Case. The indirect object gets accusative from the upper light verb in the position it moves to and the direct object gets Case from the lower light verb without moving. The word order is as predicted with the verb preceding both the objects and the indirect object moved in front of the direct object.

### 2.7 Phrasal verbs

A set of verbs which demonstrate some unique properties are known as **phrasal verbs**. These appear with what looks to be a preposition, traditionally referred to as a **particle**, following them:

- (122) a the plane took off
- b the patient came to
- c time ran out

One obvious fact about these verbs is that their meaning is usually idiomatic in that it is not straightforwardly computed from the meaning of the verb and the meaning of the preposition combined. To *take off*, for example, means ‘to become airborne’ and to *come to* means ‘to become conscious’.

These verbs do not behave like those which take a PP complement and the two types of verb can be distinguished in a number of ways:

- (123) a he took off his hat    he took his hat off
- b he lived in a hut        \*he lived a hut in

- (124) a in this hut, he lived for ten years
- b \*off this hat, he took in an instant

## Verb Types

---

- (125) a he lived right near a mountain  
 b \*he took right off his hat

- (126) a he lived near the forest and next to a river  
 b \*he took off his hat and off his coat

Much of this evidence seems to suggest that the preposition does not act as the head of a preposition phrase, but forms a unit with the verb. For example, while (124a) shows that the PP complement of a verb can be moved to the front of the clause, it seems that the particle plus the following DP cannot be moved (124b), indicating that it is perhaps not a constituent. Moreover, as we have seen in (125a) a PP can be modified by an adverb like *right*, but this is not possible for the particle followed by a DP (125b). Finally, we can coordinate a PP complement with another PP (126a), but we cannot coordinate the particle plus the following DP with a PP, indicating that the particle does not form a PP with the following DP. For this reason, it is often claimed that the particle forms a syntactic unit with the verb, perhaps being adjoined to it:

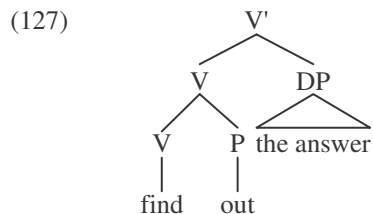

However, it should also be observed that the verb and the particle do not seem to behave like a complex verb and in a number of ways, the verb is still independent of the particle, which would not be expected if (127) were the correct analysis. For one thing, the verb bears all inflections, and these are not stuck onto the end of the phrasal verb itself:

- (128) a faded out      \*fade outed  
 b fading out      \*fade outing  
 c fades out      \*fade outs

From the other side of things, the particle seems independent of the verb, in that it can move separately from the verb, as already pointed out in (123), but demonstrated again here:

- (129) a he looked up the word      he looked the word up  
 b she held up the bank      she held the bank up  
 c they put off the meeting      they put the meeting off

A final problem for (127) is that it tends to go against the general pattern of compounding in English. When a complex head is formed from two heads by adjoining one to the other, it is generally the case that the head of the compound is the leftmost element. This is true in compound nouns and adjectives, but also with verbs:

- (130) a armchair, milk jug, family film, white lie, etc.  
 b dark brown, ice cold, rock hard, squeaky clean, etc.  
 c outdo, undercut, overspend, over wrap, dry clean, etc.

## Chapter 5 - Verb Phrases

---

In all these cases of compounding, the rightmost element provides the compound with its syntactic and semantic properties. So an *armchair* is a kind of chair not a kind of arm and a *white lie* is a noun not an adjective.

We might assume that these compounds are formed by adjoining the modifying element to the left of the head:

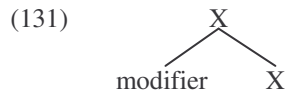

This is clearly the opposite of the phrasal verb, with the preceding verb being taken as the head:

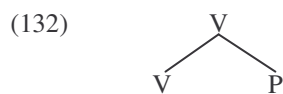

When the particle is separated from the verb by an object, it seems to have properties that it cannot have when it precedes the object. For example, we have seen that, unlike a preposition, the particle cannot be modified by an adverb in (125b). However, in the post-object position it can be modified by an adverb:

- (133) a \*he took right off his hat  
 b he took his hat right off

Moreover, when the particle is behind the object, it cannot have an object of its own, but it can when it follows the object:

- (134) a \*enough to put off his food the dog  
 b enough to put the dog off his food

Obviously, this is a very unique kind of construction with many mysterious properties. Let us see if we can solve at least some of these mysteries. When a phrasal verb has an object, this object is often a theme and hence we would expect it to go in a specifier position of the thematic verb. This verb should follow its specifier, leaving the complement position available for a PP complement. This works fine for an example such as (134b):

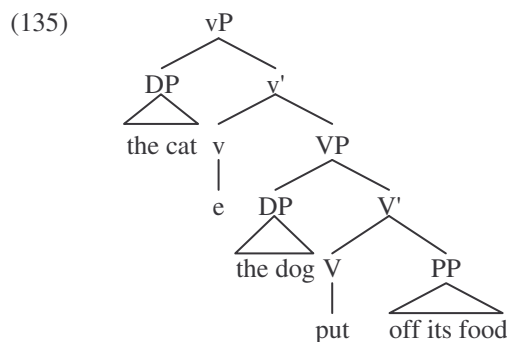



## Verb Types

---

In this structure, presumably the main verb will move to support the light verb and the right word order will be achieved. It would seem reasonable to assume that the particle construction with the particle following the object is derived in exactly the same way, with the preposition heading a PP which has no other content:

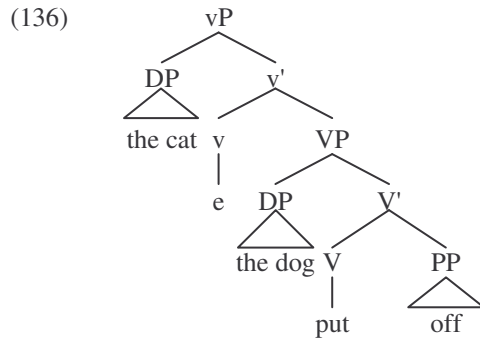

Again the verb will move to the light verb position and the word order is predicted. The fact that the particle heads a PP accounts for its ability to be modified by an adverb, as in (133b).

The tricky part is to account for the pre-object particle. If we assume that (136) is the basic structure of the construction, then we might analyse the pre-object particle construction as derived by a movement of the preposition head to the verb, so that when the verb moves to the light verb position, the preposition is taken along with it:

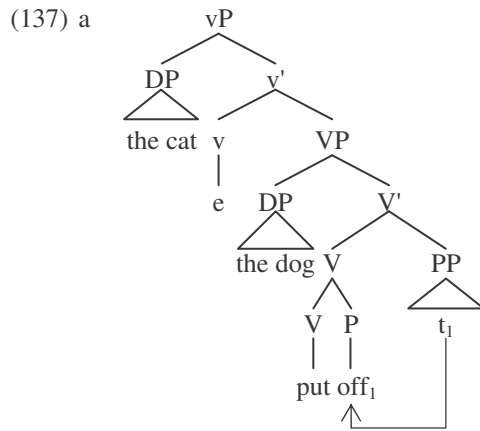

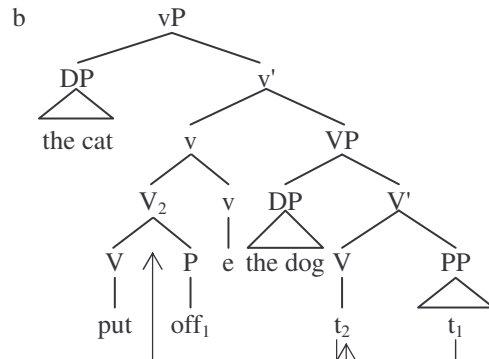

Note that the structure that is formed by the movement of the particle is the same as the one that is traditionally assumed to be the basic structure for a phrasal verb, with the preposition adjoined to the verb. Of course this means that the preposition does not form a PP with the following DP in the specifier of the lower VP and hence we account for why it does not behave like a PP complement, which would have an entirely different structure (see (136) for example).

The question needs to be addressed as to why the movement of the preposition is allowed and when it is not. Obviously not every verb that has a PP complement allows this movement, and indeed those verbs which do allow it do not allow it in all circumstances:

- (138) a they put the meeting off            they put off the meeting  
       b he put the book on the shelf        \*he put on the book the shelf  
       c they put the meeting right off      \*they put off the meeting right

It seems that it is only when the verb has a PP complement which consists only of a prepositional head that the preposition is allowed to move out of the PP. If the preposition itself has a complement, or if it is modified, then it is not allowed to move. It is not entirely clear why this should be, as other heads can move out of their own phrases when there are other elements in other positions within them. For example, we have seen many cases of a verb moving out of the VP when its specifier or complement are filled by its arguments. Another observation from (138) might help to shed some light on the problem. Note that when the verb has a simple PP complement, it has a different interpretation: to *put something off* does not mean the same as to *put something somewhere*. Similarly, *put down*, *put on*, *put back*, *put over*, etc. all have somewhat idiosyncratic meanings that are not simply related to the meaning of *put* as a verb of placement. So, *put down* can mean ‘to kill’ (of animals), *put on* ‘to fake’, *put back* ‘to delay’ and *put over* ‘to convey’. This might suggest that it is not the same verb we are looking at in all these cases and especially they are not the same verb as in (138b). If this is true then it could be that the ability of the preposition to move might be lexically restricted by the verb: some verbs allow it, others do not. Of course, this still does not explain why those that do allow the preposition to move only take ‘simple’ PP complements, which contain just the preposition and so we cannot be said to have solved all the mysteries of phrasal verbs here. In fact we have probably only just scratched the surface and it has to be admitted that phrasal verbs present many

very difficult problems for analysis under any set of assumptions. We will therefore leave this topic at this point and be content with the meagre understanding of them that we have gained.

### 2.8 Verbs with clausal complements

A class of verbs which are often traditionally lumped together with transitive verbs are verbs which have clausal complements:

- (139) a Theo thinks [Sally is smart]  
b Wanda wants [Larry to leave]  
c Bob believes [Tim to be tall]  
d Harry hopes [for Fiona to fall in love with him]  
e Tony tried [to look innocent]  
f Albert asked [why Wendy went]

As can be seen from the limited data in (139), there are a wide range of possibilities for clausal complements. Some verbs take finite clause complements (139a), while others take non-finite complements of various kinds (139b–e). Some complements are declarative (139a–e) while others are interrogative (139f). The possibilities are determined by the verb, as we would expect.

An obvious question to ask is where the clausal complement sits with respect to the verb. There are a number of possibilities. In some ways the clausal complement is rather like an object, which is what leads traditional grammars to conclude that these verbs are transitives. For instance, many of these verbs can appear with an object, sometimes with a similar meaning to the clausal complement:

- (140) a Sam said something      Sam said [that Tim is tall]  
b Albert asked the time      Albert asked [what the time was]

Moreover, some of these verbs can undergo passivisation, and as we have seen, in English, only the transitive verbs can passivise:

- (141) a it was believed [that Tim is tall]  
b Chris was considered [to be clever]

This might lead us to the conclusion that they should be treated like objects and be placed in the specifier of the VP, with the verb moving to a light verb position to precede it:

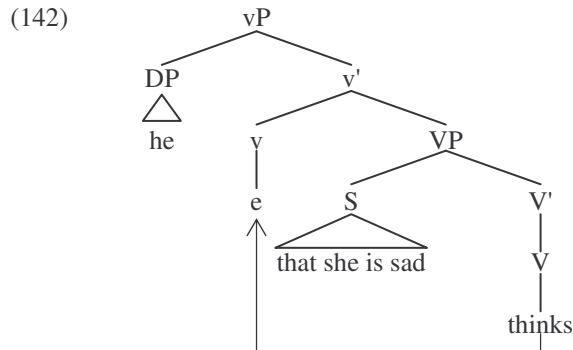

There are however, a number of problems facing this analysis. First, when a verb takes both a DP and a clausal complement, invariably the DP precedes the clause:

- (143) a I asked [him] [where to get off]  
 b I told [him] [that I would write a letter]  
 c I persuaded [him] [that the moon was made of cheese]  
 d I promised [him] [to be good]

In each case of the above, if the DP followed the clause it would be ungrammatical. Moreover, if there is a PP complement and a clause, the PP tends to precede the clause:

- (144) a it seems [to me] [that the gudgeon pin is broken]  
 b I shouted [at him] [to get out of the bath]  
 b we demand [of you] [that you tell the truth]

If we consider the thematic roles assigned to these arguments, typically the DP arguments receive a goal  $\Theta$ -role: the one to whom the event described by the verb is directed. The clause has a theme  $\Theta$ -role. We saw with dative/double object verbs, the goal argument sits in the complement position of the thematic verb, but may move in order to get Case. If this is what is going on here, then the structure should be:

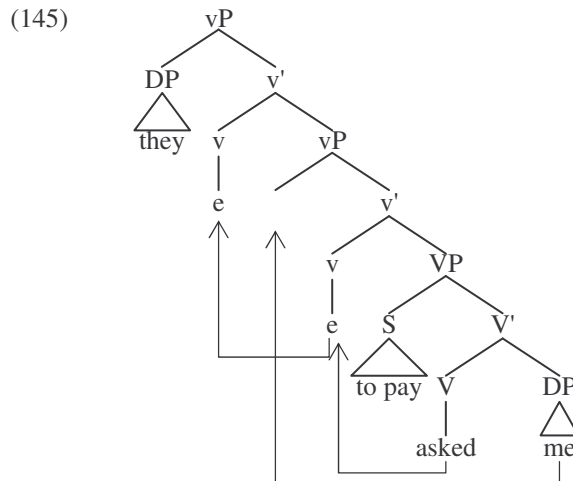

## Verb Types

---

In this, the verb moves from light verb to light verb and the DP moves to the specifier of the first light verb to get Case from the higher one. A similar structure would have to be supposed for the PP arguments. However, this structure does not seem to reflect the event structure of such verbs, which seem to consist of just two events:

- (146)  $e = e_1 \rightarrow e_2$  :  $e_1 =$  they did something  
 $e_2 =$  I was asked to pay

A second problem is why the PP argument would undergo the same movement as the DP as PPs do not need Case and do not normally undergo this kind of movement. Hence it appears that there is not much to recommend this analysis.

If we want to maintain the UTAH we cannot just assume that the arguments start off in different positions, however. So we want to keep the basic structure of the VP as it is in (145). We need to simplify the light verb structure, getting rid of one of these to match with the event structure and finally we need to find a way of getting the PP in front of the clause that does not assume that it undergoes a similar movement to DPs. The structure is as follows:

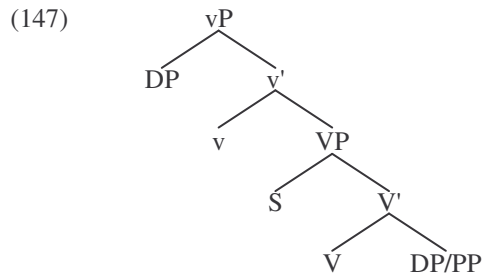

One way to get the PP in front of the clause without moving the PP would be to move the clause backwards, perhaps to adjoin to the VP or v':

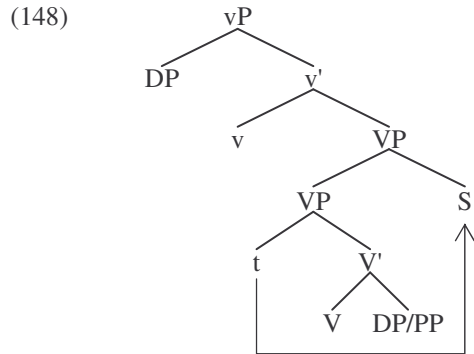

Do we have any evidence that clauses can undergo the supposed movement and any motivation for it to take place in this instance? Actually, there is some evidence that certain clauses can undergo a backward movement:

## Chapter 5 - Verb Phrases

---

- (149) a the announcement [that the prime minister had resigned] was broadcast on the radio  
b the announcement was broadcast on the radio [that the prime minister had resigned]

In this example, the bracketed clause is the complement of the noun *announcement* and hence is part of the DP subject, as is clearly the case in (149a). In (149b) this clause not only does not appear to be part of the subject, but it is right over the other side of the clause from the subject. It seems therefore that the clause moves towards the back of the clause and therefore that backward movement of clauses is a possibility.

But why would the clause have to move backwards in a structure like (148)? Note that the clause occupies a position to which Case is assigned: the light verb assigns accusative Case to the specifier of the VP. There is an old idea, dating back to Stowell (1981), that clauses avoid Case positions. While it might seem that clauses occupy similar positions to DPs, there are a number of reasons to think that this is not so. For example, we do not get clauses in the complement position of prepositions, a position to which Case is assigned:

- (150) a she spoke about [her theory]  
b \*she spoke about [that brontosaurus are thin at both ends and fat in the middle]

Moreover, while it might look as though clauses can occupy subject positions (to which Case is assigned), there are observations which indicate that sentence subjects are not in the same position as DP subjects:

- (151) a did [Ursula] upset you?  
b \*did [that Ursula got drunk] upset you

- (152) a this theory, [I] just can't accept  
b \*this theory, [that the space probe found no pizzerias on Mars] disproves

The data demonstrate that certain things which are possible when there is a DP subject, are not possible with a clausal 'subject'. For instance, the auxiliary can move to the front of the clause to form a question in (151a), but not in (151b) where there is a clausal subject. In (152a) we can see that an object can be moved to the front of the clause in what are called **topicalisation structures**, but not when the subject is clausal (152b). These observations might suggest that the clausal subjects are in a position which prevents the relevant movements and that DP subjects sit in a different position which does not interfere with them. Obviously the DP subjects sit in Case positions, as required by the Case filter and therefore our conclusion is that clausal subjects do not sit in the Case position that the DP subject sits in. All this might be accounted for if we assume that clauses avoid Case positions and this would warrant the clause moving out of its D-structure position in (147) into a position that is Caseless. We therefore assume the following principle:

- (153) the Case avoidance principle  
clauses avoid Case positions

## 2.9 Summary

To summarise this fairly long discussion of the structure of the VP, we can conclude that strict adherence to the UTAH and the assumption that there is isomorphism between event structure and VP structure leads us to sometime quite surprising but enlightening analyses of the central part of the clause. The VP itself seems a hive of activity, with verbs and arguments moving about from position to position which obviously complicates its description. However, the reasons for the movements themselves are fairly straightforward. The verb moves to support the abstract light verbs which have a bound morpheme status, DP arguments move to Case positions and clausal arguments move away from Case positions. Once such things are understood, some rather mysterious properties of VPs become demystified. Phenomena such as passivisation, double object alternation, the *there* construction, cognate objects and phrasal verb constructions are given a fairly satisfying analysis which we can take as encouraging for this approach.

## 3 Aspectual Auxiliary Verbs

We now move a little away from the thematic verb phrase to look at the aspectual auxiliaries of English, *have* and *be*. As introduced in section 2 of this chapter, aspect is a semantic phenomenon concerning the events described by verbs in terms of their internal timing. We also pointed out that this is a rather complex issue which we will not be investigating in this book. Instead, we will concentrate on the syntactic aspects of the auxiliaries and associated elements trying to determine their structural positions and syntactic nature.

In chapter 1, we established that the aspectual auxiliaries are non-thematic, non-functional verbal elements, which are therefore categorially distinct from modal auxiliaries which are functional verbs. We might assume that they are associated with a phrase which they head and this phrase contains the thematic VP complex. A first attempt to represent the structure is as in (154):

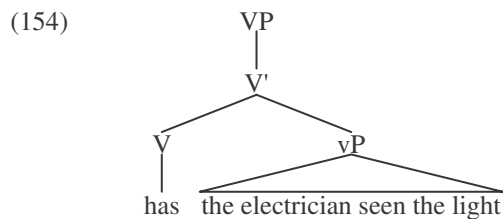

Remember, that what we are looking at there is the D-structure, before movement takes place. Thus this structure is that of a declarative VP, not an interrogative one. At S-structure the subject will move out of the vP to the clausal subject position, where it will get Case:

(155) the electrician<sub>1</sub> [<sub>VP</sub> has [<sub>vP</sub> t<sub>1</sub> seen the light]]

We will discuss this issue in the next chapter.

### 3.1 The auxiliary as a dummy

One very interesting fact about aspectual auxiliaries is that each auxiliary is accompanied by a specific morpheme which is always realised on the verbal element which follows the auxiliary:

- (156) a **has seen** the light  
 b **has been** seeing the light  
 c **is see**ing the light  
 d **is be**ing seen

The first two examples in (156) show that the auxiliary *have* is always followed by a verbal element in the ‘*en*’ form (though there is irregularity here and the morpheme is not always represented like this – see chapter 1). This element may be a main verb, as in (156a) or the auxiliary *be* as in (156b). The auxiliary *be* is followed by a verbal element in its ‘*ing*’ form and again this can either be a main verb (156c) or another auxiliary, as in (156d), where we have the passive auxiliary *be*. We have already seen that the passive morpheme is another instance of *en*. This attaches only to main verbs, a fact which follows from the analysis given above where the morpheme was treated as a light verb immediately above the thematic VP to which the main verb will move.

What is the nature of the two parts of each aspectual elements, the auxiliary and its associated morpheme? A classic analysis dating back to Chomsky (1957) is that the auxiliary and its morpheme are inserted into a structure as one element and then the morpheme is ‘hopped’ backwards onto the following verbal element:

- (157) a have+en see = has seen  
 b be+ing see = be seeing  
 c have+en be+ing see = have been seeing
- 

However some of the details of this analysis were never fully worked out. What is the lexical status of the auxiliary plus morpheme element, for example? If it is to be considered a single lexical item, how is it possible that a syntactic rule can break it apart? But if it is not a single element, what is the relationship between the two parts and how do we ensure that they are always inserted into a structure together?

A related issue concerns the meaning that aspectual elements bring to the sentence. Of the two elements, which is the meaningful one? There are at least three possibilities. Perhaps the most intuitive one is that the aspectual meaning is contributed by the auxiliary and the morpheme has no semantic input. However, it is possible that the meaning contribution is made by the morpheme and the auxiliary is meaningless, or that both elements have a contribution to make. One relevant observation is that the use of meaningless auxiliaries is not unheard of in English. The classic example is the auxiliary *do* which seems to have a variety of uses, mainly to do with providing an element to fulfil a purpose that the main verb is not suited for. For example:



### Aspectual Auxiliary Verbs

---

- (158) a did you see that?  
b I didn't see that  
c you DID see that!  
d you saw that, didn't you?

In these examples, the auxiliary *do* adds very little to the meaning of the sentence, apart from the fact that it carries tense. However, given that main verbs can do this, this is clearly not the main function of the auxiliary in these examples. Instead the auxiliary is used to do something that main verbs cannot do. In (158a), the auxiliary is moved to the front of the clause to form a question, in (158b) it is used to bear the contracted negative, in (158c) it bears stress in order to assert something that had previously been denied and in (158d) it is used to form a **tag question**, the main function of which is to lessen the force of a statement. As the following show, these are all things that we cannot use a main verb to do:

- (159) a \*saw you that?  
b \*you sawn't that  
c you SAW that  
d \*you saw that, sawn't you?

The ungrammaticality of most of the sentences in (159) shows that the main verb cannot be used in this way. That (159c) is not ungrammatical does not indicate that it is an exception, however, as this has a different meaning to (158c). In (159c), the emphasised verb is used to question or contradict a previous statement in terms of the content of the verb itself. So, for example, if someone claimed to have seen something that was invisible to others, (159c) might be an appropriate response. Importantly, (159c) could not be used to contradict someone's claim that they did not see something, i.e. contradicting the truth of their statement. The point is, then, that the auxiliary *do* is inserted into a sentence to do something that is impossible for a main verb to do and hence it has a purely syntactic role rather than a semantic one. For this reason it is often called the **dummy auxiliary**. Perhaps its main function is to support the tense morpheme *when*, for whatever reason, this cannot appear on the main verb and hence the phenomenon is also called **do-support**.

Another instance of the use of a meaningless element might be the use of the copula *be* in examples such as the following:

- (160) a Tim is tall  
b Ferdinand is a fake  
c Gertrude is in the garden

Considering the semantic relationships that exist in these sentences, we notice that they are established between the subject and the predicative element after the verb: *Tim* and *tall*, *Ferdinand* and *a fake* and *Gertrude* and *in the garden*. Again, the main function of the verb here appears to be to support the tense morpheme and it seems to make very little contribution of its own. Indeed, in circumstances where there is no need to express the tense morpheme, the verb is not used:

## Chapter 5 - Verb Phrases

---

- (161) a I consider [Tim tall] = I consider [that Tim **is** tall]  
b I deem [Ferdinand a fake] = I deem [that Ferdinand **is** a fake]  
c I wanted [Gertrude in the garden] = I wanted [Gertrude to **be** in the garden]

The bracketed part of the sentences on the left in (161) express the same predication relationships as those on the right and the only difference between the two is the expression of tense in the latter. Thus it looks as though the copula is used to support the tense morpheme when predication relationships are established between a subject and a non-verbal element. It is interesting that the verb *be* is used in this case, not the verb *do* as it is in cases of *do*-support. Even though both elements seem to contribute little to the interpretation of the sentence, it seems that their use is specialised to certain contexts: *do* for cases where the main verb fails to be able to support tense and *be* for cases where there is no verb present to support tense. I know of no explanation for this fact.

One more possible use of a meaningless verbal element which follows from an analysis developed above is the use of the auxiliary *be* in the passive. We analysed the passive construction as involving the replacement of an agentive light verb with a non-agentive one, realised as the passive morpheme. From this perspective then, the passive morpheme is the defining element of the passive construction. Of course, most passives also make use of the passive auxiliary *be*:

- (162) a Sam **was** seen  
b Harry was **being** hit  
c Barry **was** believed to have **been** murdered

What is the function of the auxiliary in these sentences? Note that the auxiliary bears some morpheme: in (162a) the tense, in (162b) the *ing* associated with the progressive auxiliary and in (162c) the tense on the first passive auxiliary and the *en* associated with the perfective *have* on the second. In these examples, the main verb cannot bear these morphemes for the simple reason that it is already bearing the passive morpheme and it seems a basic principle of English morphology that no word can bear more than one overt inflectional morpheme:

- (163) a \*it seened/sawen = it was seen  
b \*she fallend/fellen = she had fallen  
c \*Ron runnined/ranning = Ron was running

Thus, again, we might say that the passive auxiliary is used to support a morpheme that the verb is unable to due to restrictions on the morphological structure of English.

Again note that the form of the auxiliary used is restricted to context: the auxiliary must be *be* in this case, not *do*. Support for this approach can be gained from observing contexts in which there is no other morpheme to be supported, in such cases the passive morpheme is not present:

- (164) a I saw [the treaty signed]  
b they heard [the charges read out]  
c we felt [the earth moved]

In these cases, there is an ambiguity that must be checked for. For example, what was seen in (164a) could either be taken to be an object (the treaty that was signed) or an

event (the treaty being signed). It is the latter interpretation that is relevant here as this clearly involves a predication-like structure that simply lacks tense, similar to the examples in (161). Of course, the important observation is that here we have a passive construction involving a passive morpheme, but no passive auxiliary. This indicates that the function of the passive auxiliary is to bear an inflection rather than to add any semantic content.

Given the similarity between the passive construction and those constructions involving aspectual elements, it seems likely that they should receive a similar analysis. From this perspective, it is the aspectual morpheme that carries the semantic content and the associated auxiliary is merely a dummy inserted to bear another morpheme that the verb is prevented from bearing by the aspectual morpheme itself.

### 3.2 The nature of the aspectual morpheme

Taking the similarity of the passive morpheme and aspectual morphemes one step further, we might argue that aspectual morphemes are another kind of light verb, which is not surprising as light verbs can affect the aspectual interpretation of the structure they are included in. The Urdu example given above and repeated here for convenience, uses a light verb *lene* ‘take’ to indicate the perfective status of the event described:

- (165) nadyane saddafko xat lik lene diya  
 Nadya-erg. Saddam-dat. letter write take-inf. give-perf.Masc.s  
 ‘Nadya let Saddam write a letter (completely)’

The analysis of the aspectual structure of English might therefore be as follows:

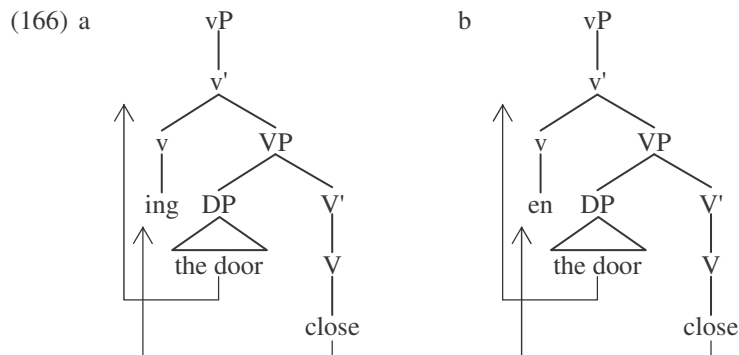

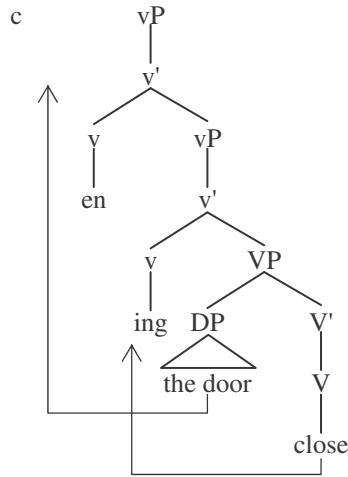

In all these cases, the main verb will move to support the lowest aspectual morpheme at which point it cannot move any further as its morphological structure is complete and cannot be added to. As the aspectual morphemes do not play a role in assigning  $\Theta$ -roles, they also do not have the ability to assign Case as some light verbs do. Thus, the theme will have to move to subject position to get Case.

Finally, presuming the clause to be finite, some element will have to bear the tense morpheme. As the verb cannot do this, the relevant dummy auxiliary will be inserted into the tense position: *have* in the presence of *en* and *be* in the presence of *ing*. In (167c) there is the extra complication that there are two aspectual morphemes as well as the tense morpheme. In this case the verb moves to the lowest aspectual morpheme, *ing*, and an inserted auxiliary will bear the other morphemes, *be* for the perfective and *have* for the tense:

- (167) a - ed [en [the door close]]  
 = the door<sub>1</sub> had [closed<sub>2</sub> [t<sub>1</sub> t<sub>2</sub>]]  
 have
- b - ed [ing [the door close]]  
 = the door<sub>1</sub> was [closing<sub>2</sub> [t<sub>1</sub> t<sub>2</sub>]]  
 be
- c - ed [en [ing [the door close]]]  
 = the door<sub>1</sub> had [been [closing<sub>2</sub> [t<sub>1</sub> t<sub>2</sub>]]]  
 have be

With these assumptions then we can successfully account for the distribution of the aspectual elements in the English clause. We will provide more detail of the upper part of the clause structure including the tense and clausal subject position in the next chapter.

## 4 Adverbs, PPs and Clausal modifiers

To complete this chapter, we will briefly mention modification in the VP. Modifiers may generally be associated with adjuncts and so the modifiers of the VP can be assumed to be adjoined somewhere within the VP structure we have introduced above. There are restrictions however, which partly depend on general conditions and partly depend on the nature of the modifier itself. We will briefly look at each type of modifier in turn.

### 4.1 Adverbs

Adverbs are the classic verbal modifiers. We should be careful, however, to distinguish between them, as some do not modify within the verbal domain of the clause, but have a wider domain of operation, modifying clausal elements. Roughly we can separate **VP adverbs** from **sentential adverbs**. Consider the following examples:

- (168) a he certainly will find out  
b he will quickly find out

The adverb in (168a) modifies the meaning of the whole clause: what is *certain* is *that he will find out*. In contrast, the adverb in (168b) modifies the verb, stating that it will be done in a certain manner (i.e. quickly). Note the different positions of these two adverbs: the sentential adverb precedes the modal auxiliary while the VP adverb follows it and is therefore closer to the VP. Indeed, placing the VP adverb further from the VP often produces an ungrammaticality:

- (169) a \*he quickly will find out  
b \*she suddenly has realised her mistake  
c \*the doctor thoroughly may examine the patient

These sentences can be made more acceptable if heavy stress is placed on the finite element, but with neutral stress they are ungrammatical, indicating that something special has to happen to get the adverb away from the VP it modifies.

It seems a reasonable conclusion therefore that VP adverbs are adjoined to the VP itself. But the VP is a fairly complex structure, as we have seen. Where in the VP can the adverb adjoin? Consider the possible range of positions we can find the adverb in:

- (170) a will accurately have been making notes  
b will have accurately been making notes  
c will have been accurately making notes  
d \*will have been making accurately notes  
e will have been making notes accurately

There looks to be a good deal of freedom in determining the position of the adverb and thus it appears to be able to adjoin to virtually any part of the VP. The one exception is that the adverb may not intervene between the verb and its object. However, the adjacency requirement between the verb and its object is not so straightforward to account for under the assumptions we have been making. Other accounts of this restriction have made different assumptions. For example, Radford (1988) assumes that the object is in the complement position of the verb and that the adjacency

## Chapter 5 - Verb Phrases

---

requirement between the two is a reflex of X-bar theory itself: the head must be adjacent to its complement otherwise an ill formed structure results:

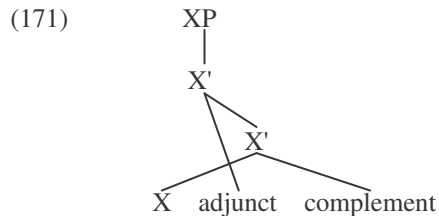

If an adjunct is placed between the head and its sister, i.e. the complement, the branches of the structure cross and this is not a possible configuration. The problem with this account, however, besides its reliance on the assumption that complements are all sisters to the head, is that it is not at all clear why various movement phenomena would not separate the head from its complement. Another account, due to Stowell (1981) assumes that the verb is responsible for assigning Case to the object and that there is an **adjacency** requirement on Case assigners and assignees. As we have assumed that the theme gets its Case from the light verb, we cannot use Case adjacency to account for why the verb and its theme argument cannot be separated. Even if we assume that Case assigners must be adjacent to the element they Case mark, this will not prevent the verb moving to a higher light verb position allowing an adverb to come between the two:

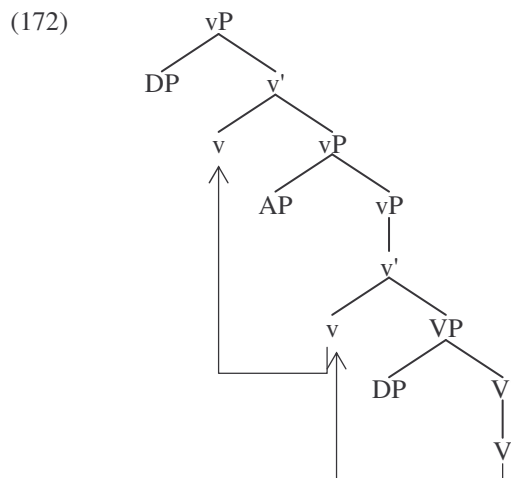

This structure has the adverb phrase adjoined to the lower vP and the verb moving to the higher light verb. Such a structure would be possible either when there is both an agent and an experiencer argument, or if the top light verb is an aspectual morpheme. The structure that would be produced however would be ungrammatical as the adverb would appear between the verb and its theme argument.

We might try to account for this restriction by limiting the kinds of structure that the adverb can adjoin to. But this seems unlikely as under certain conditions adverbs appear to be able to adjoin to virtually any part of the VP:

### Adverbs, PPs and Clausal modifiers

---

- (173) a the letter<sub>1</sub> might [<sub>VP</sub> eventually [<sub>VP</sub> t<sub>1</sub> arrive]]  
b Peter<sub>2</sub> might [<sub>VP</sub> suddenly [<sub>VP</sub> t<sub>2</sub> punch<sub>1-v</sub> [<sub>VP</sub> Paul t<sub>1</sub>]]]  
c water<sub>2</sub> is [<sub>VP</sub> steadily [<sub>VP</sub> pour<sub>1-ing</sub> [<sub>VP</sub> t<sub>2</sub> t<sub>1</sub> out of the bath]]]  
d Betty<sub>2</sub> has [<sub>VP</sub> annoyingly [<sub>VP</sub> beat<sub>1-en</sub> [<sub>VP</sub> t<sub>2</sub> t<sub>1</sub> [<sub>VP</sub> me t<sub>1</sub> again]]]]]

In (173a), given that there is no light verb with an unaccusative verb, the adverb must be adjoined to the VP. In (173b) the adverb is adjoined to a vP headed by an agentive light verb and in (173c) and (d) it is adjoined to a vP headed by aspectual morphemes. Thus there seems to be no limit in principle on what the adverb can adjoin to. In each of these cases however, the adverb is adjoined to a higher position than the verb moves to. When there is no light verb, as in (173a), the verb is not forced to move out of the VP and in this case the adverb can adjoin to the VP. If the verb moves out of the VP, however, the adverb cannot adjoin to it. Indeed, anything that the verb moves out of is out of bounds for an adjunction site for the adverb. This suggests that the adverb interacts with the movement of the verb and it is this interaction that determines the possible adjunction sites for the adverb. Specifically, it seems that the verb never moves over the top of the adverb. Hence, we may assume that in principle an adverb can adjoin to any part of the extended VP, including any light verb projection, as long as the verb remains lower than it at S-structure and does not move over its adjunction position. There are a number of ways in which we might attempt to account for this fact, but at present we will be satisfied at leaving it as a descriptive generalisation.

Another observation that can be made from the data in (170) is that adverbs may appear behind all verbal elements. There are a number of possible ways to capture this fact. One is to assume that adjunction is free from ordering restrictions. Indeed it does seem that different adjuncts can come on different sides of whatever they modify: the PP modifier, as we shall see, typically follows the verbal complex. Thus, adjunction in general is not restricted to a particular side as are complements and specifiers. Adverbs therefore may simply take advantage of this freedom and be adjoined either to the left or the right of the VP. The alternative would be to have adverbs generated on one side of the VP and then achieve the other position via a movement. Jackendoff (1977), for example, argued for this position on the basis of the similarity between adverbs and adjectives. Recall that in chapter 1 we analysed adverbs and adjectives as belonging to the same general category, so one might expect grammatical principles to apply to both in a similar way. Jackendoff's observation was that adjectives typically precede the nouns that they modify:

- (174) a stupid fool                   \*fool stupid  
b heavy book                   \*book heavy  
c precocious child           \*child precocious

If we assume therefore that the basic position of the adjective is before the noun that it modifies, we might take this to indicate that the basic position of the adverb is before the verb that it modifies and therefore that its post-verbal position is a derived one. We are not really in much of a position to be able to evaluate either of these positions and therefore we will leave the matter unresolved.

#### 4.2 PP modifiers

The other main modifier in the VP is the PP. This differs from the AP modifier in its distribution in that it always follows the verb. Thus a PP modifier has a far more restricted distribution than an adverbial one:

- (175) a \*may in the lake have been swimming  
b \*may have in the lake been swimming  
c \*may have been in the lake swimming  
d may have been swimming in the lake

Understandably, we cannot get a PP modifier between a verb and its complement, just like Adverbs, however we can separate a verb from its PP complements:

- (176) a \*flowed under the bridge the river  
b live with his mother in Paris

The only way for (176a) to have been generated would be to adjoin the PP to the left of the lower VP. However, PPs never adjoin to the left, only to the right, and moreover this would necessitate the verb moving over the PP adjunct. As this is impossible for AP modifiers, we can assume that it is impossible for PP modifiers as well. In (176b), assuming the locative PP to be the complement of the verb, the only way for this to get behind the PP adjunct would be for it to move. And hence we can assume that there is a backwards movement that PP arguments may undergo which is similar to the movement that clausal complements undergo, as discussed in section 3.8. That PP complements may undergo such a movement is supported by the following data:

- (177) a a book about penguins was published last week  
b a book was published last week about penguins

In this example, the PP is part of the subject DP and yet it may appear on the opposite side of the clause to the subject, indicating that it can undergo this kind of movement.

DP complements, however, cannot move backwards past a PP adjunct as can be seen by (176a). We might assume that this is because the DP must occupy a Case position and hence cannot move away from its specifier position in the VP. However, this is not so straightforward as DPs can be moved out of Case positions in some instances and moreover some DPs can undergo backward movement:

- (178) a this exercise<sub>1</sub>, I don't think anyone can [do t<sub>1</sub>]  
b which book<sub>1</sub> were you [reading t<sub>1</sub>]  
c you should complete t<sub>1</sub> in ink [every form with a blue cross at the top]<sub>1</sub>

In (178a) and (b) the object has undergone a movement to the front of the clause, out of its Case position. But if this is an allowable movement, why should it not be allowed to move to the back of the clause? In (178c) the object has moved backwards behind the PP adjunct *with ink*. In this case, the DP is very long and complex involving quantification and post head modification. A simpler DP would not be allowed to do the same thing:

- (179) \*you should complete t<sub>1</sub> in ink [the form]<sub>1</sub>



We can call the phenomena noted in (178c) **heavy DP shift** (leaving undefined just what counts as a ‘heavy DP’). It is common to find the attitude that heavy DP shift is a slightly odd phenomenon. However, given that other elements can undergo backward movement and given the fact that DPs of any weight can undergo certain forward movements, what is odd is the refusal of ‘light’ DPs to undergo backward movement. Obviously there are mysteries here that we cannot yet approach and so again we will set the issue aside.

#### 4.3 Clausal modifiers

Finally in this chapter we will note the possibility of modifying a VP with a clause. As we have seen with adverb modifiers the most straightforward VP modifiers are those that modify the manner of the verb. It is not possible to use a clause in this way however, and so it is not easy to tell whether a clause is a VP or a sentential modifier. However, there are certain reasons to think that some clausal modifiers are situated inside the VP.

Without going too much into the details of clause structure itself, a task we will undertake over the next chapters, certain non-finite clauses appear to have a missing subject:

- (180) a Bert bought a Ferrari [to impress his friends]  
b they set fire to the building [to collect the insurance]

Although these clauses seem to lack a subject, it is immediately obvious that a subject is interpreted: in (180a) it is *Bert* who will be doing the impressing and in (180b) it is *they* who will collect the insurance. We call this phenomenon **control**. There is an element in the main clause who is interpreted as, or who ‘controls’ the missing subject of the modifying clause. There are restrictions, however, on which argument can act as the controller:

- (181) Fred phoned the plumber [driving to the office]

In this case, only *Fred* can be interpreted as the one who was driving. It seems that the object is too far down inside the clause to act as controller. This is supported by the following observation:

- (182) the witness claimed the defendant paid a lot of money [to attract attention to himself]

The reflexive pronoun *himself* can either refer to *the witness* or *the defendant*. But note, this depends on what the purpose clause is thought to modify. In one case it is the defendant’s paying money that attracts the attention and in the other case it is the witness’s claim that attracts the attention. In the first case, *himself* refers to the defendant and in the second it refers to the witness. What is not possible is to interpret the purpose clause as modifying the claiming event and for the reflexive to refer to the defendant or for the purpose clause to modify the paying event and the reflexive to refer to the witness. In other words, neither of the following are possible interpretations of (182):

**Chapter 5 - Verb Phrases**

---

- (183) a the purpose of the witnesses claim that the defendant paid a lot of money was to attract attention to the defendant  
 b the witness claimed the purpose of the defendant paying a lot of money was to attract attention to the witness

We can account for this in the following way. We know from chapter 3 that reflexive pronouns must refer to something within their own clause and in (182) the only thing that could be the referent of the reflexive is the missing subject. The missing subject is in turn controlled by some other element in the clause and hence limitations on the reference of the reflexive indicate limitations on the control of the subject. When the purpose clause modifies the higher verb, only the subject of this verb can act as the controller and hence be the ultimate referent of the reflexive. It seems that the subject of the other clause is ‘too low down’ in the clause to act as controller. On the other hand, this subject can act as controller when the purpose clause modifies the lower verb.

Having established that there are structural conditions on what can act as a controller, consider the following examples:

- (184) a Harry hired Freda [to fire the security guard]  
 b Harry fired Freda [to hire the security guard]

(184a) is ambiguous in terms of who is doing the firing: it could be *Harry* or *Freda*. (184b) is not ambiguous however as here only *Harry* can do the hiring. What can account for this difference? We have seen that the structural position of the purpose clause affects what can be the controller and so it might be that there are different possible positions for the purpose clause within the structure. The structure of the main VP in (184a) is as follows:

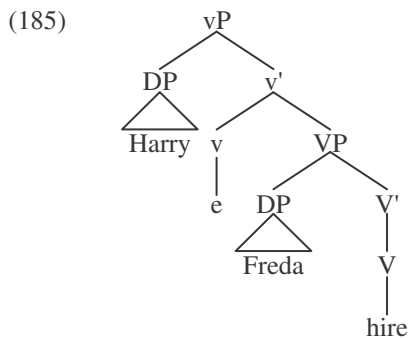

As agent, *Harry* is the specifier of an agentive light verb and as theme *Freda* is the specifier of the main verb. The verb will move to support the light verb as usual. We know in this case, the purpose clause can either be controlled by the subject or the object and so it must be able to attach to the structure high enough to allow subject control and low enough to allow object control. Suppose we assume that the purpose clause can adjoin either to the v' or to the V':

## Conclusion

---

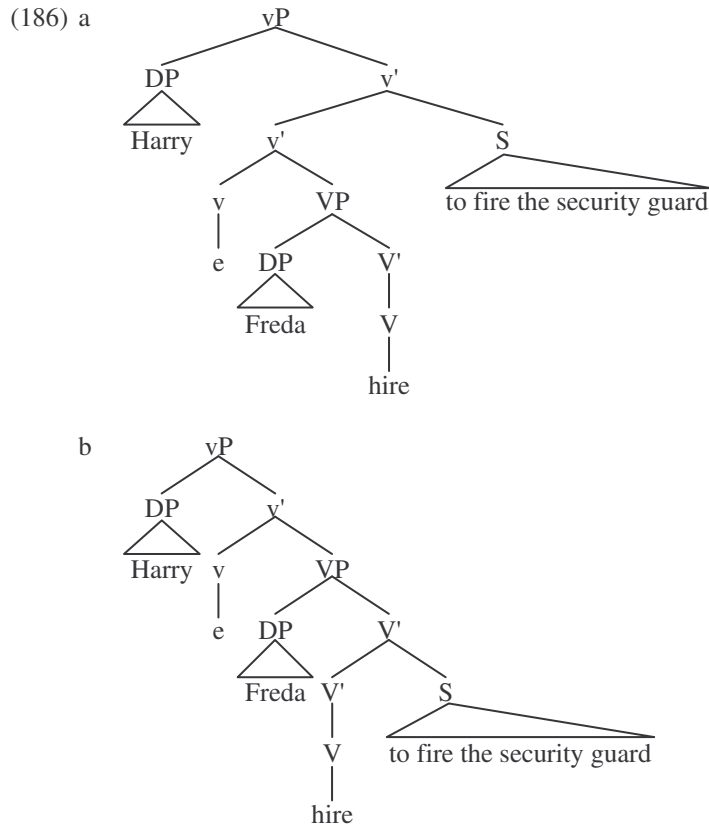

The two structures relate to the two possible meanings. When the purpose clause is adjoined to the v', as in (186a), then the agent can control the missing subject, and when it is adjoined to the V', as in (186b), then the theme can control the missing subject. For some reason, when *fire* is the head of the VP, the purpose clause can only be adjoined to the v' and hence only the agent can be the controller. Hence there will be no ambiguity. Note that the facts as such demonstrate that the purpose clauses must be able to attach within the VP so that objects can act as controllers. If this were never the case, we would only be able to get subject control.

## 5 Conclusion

In this chapter we have taken a detailed look into various aspects of the structure of the VP. We have seen how the semantics of the verb, particularly in its argument and event structures, influence the way the VP is built. The argument structure to a large extent determines the complementation of the verb and the event structure plays a role in determining the extension of the VP into various vPs built on top of it.

In numerous places we have mentioned the sentence, which the VP is a major part, but have so far refrained from discussing, using the symbol 'S' to stand instead of a proper analysis. One important aspect of clausal structure for the VP is the position of

the subject, which as we have maintained throughout this chapter starts off inside the VP, but moves to the nominative position somewhere higher in the clause. We will consider issues such as this in the following two chapters when we discuss clause structure in more detail.

### ***Check Questions***

- 1 Explain the notions 'event structure' and 'aspect'.
- 2 Compare unaccusatives with ergative and intransitive verbs. Consider the event structure of the verbs, their complementation, the position and theta roles assigned to the complements, the ability to appear in causative and/or passive contexts, diagnostics for telling them apart, and further properties.
- 3 Consider the specifier position in a projection headed by a light verb and a thematic verb. How can it be argued that the two specifier positions are assigned different theta roles?
- 4 What evidence is available to support the assumption that there is an empty light verb in the transitive counterpart of a light verb+unaccusative verb structure?
- 5 How is passive conceptualised in the text?
- 6 What assumption(s) provides a way out of the problem(s) that both agent and experiencer arguments occupy [Spec, vP] at D-Structure? What other evidence is available to support the existence of multiple light verb constructions?
- 7 What is the analysis proposed for multiple complement constructions developed in the text?
- 8 What arguments are put forward against the assumption that clausal complements occupy the [Spec, VP] position?
- 9 On the basis of the text make a list of verb-types identified.

### ***Test your knowledge***

▪ **Exercise 1**

Identify instances of a semantically contentless 'there' and 'it' in the sentences below.

- (1) a There was a man at the door.  
b He put the book there.  
c The apples are there.  
d There is no reason to fight.  
e It took them two hours to get there.  
f It appears to be out of order.  
g It appears that he got lost.  
h I take it that the answer is 'no'.  
i There are no policemen there.  
j He had a hard time of it in the army.

### Test your knowledge

---

▪ **Exercise 2**

Determine the subcategory of the verbs in the following sentences. Justify your choice with the help of different distributional tests. Finally, give their syntactic structure as well.

- (1) a A face appeared behind the window.  
 b Susan sang.  
 c Michael moved my map from the middle.  
 d The bomb blew up.  
 e Larry laughed.  
 f Kevin killed Karen.  
 g Ben brought a bulldog for Betty.  
 h Norah knows Nick.  
 i The boat sank.  
 j The letter lay on the table.  
 k The window opened.  
 l A train arrived at the station.  
 m Walt watered the flowers.  
 n Dick died.  
 o Gary gave Greg a gift.

▪ **Exercise 3**

Provide the given forms of verbs.

Verb	Tense	Aspect	Person & number	Voice	Form
see	past	perfect	3Sg	passive	
saw	present	progressive	1Pl	active	
bring	future	perfect	2Sg	passive	
come	present	perfect	3Pl	active	
think	past	progressive	2Sg	active	
sing	future	perfect	3Sg	passive	
read	present	progressive	3Pl	passive	
write	past	perfect	3Sg	passive	
eat	future	progressive	1Sg	active	
fall	past	perfect	3Sg	passive	
buy	present	perfect	2Sg	active	
tell	past	progressive	3Pl	passive	
pull	future	progressive	2Pl	active	
go	past	perfect	3Sg	active	
send	future	perfect	3Pl	passive	

## Chapter 5 - Verb Phrases

---

### ▪ Exercise 4

Some events can be described in two ways: with or without the usage of a light verb. Give the other possible versions of the following events, that is, transform the sentences. (Aspectual differences are irrelevant here.)

- (1) a The boy walked.  
b I gave an answer to the question.  
c The professor commented my essay.  
d She never takes a look at him.  
e We had a drink together.  
f The professor spoke about the economic situation of China.  
g Everyone involved in the project made their contribution to the exercises.  
h She has finally decided.

### ▪ Exercise 5

Determine whether the following sentences contain a phrasal verb with the help of appropriate tests.

- (1) a Lawrence lived in Liverpool.  
b My neighbour takes after my uncle.  
c We must make up this list.  
d He ran up the hill.  
e We have done up the buttons on our coats.  
f He came out of his office.  
g Suddenly she broke into tears.  
h The prisoner did in his mate.  
i Guards broke up the fight.  
j The workers pulled down the old building.

### ▪ Exercise 6

How can the following ambiguous sentence support the v'-V' analysis?

- (1) John closed the window again.

### ▪ Exercise 7

Group the subjects in the sentences below according to whether they are associated with an agent, theme or experiencer theta role.

- (1) a The man laughed heartily.                      f The bag was empty.  
b The bell rang.    g It feels cold today.  
c Peter loves Mary.                                        h Peter heard some noise downstairs.  
d She lay in his arms.                                    i Peter cooked dinner.  
e They found the bag empty.                         j Dinner was cooking.

# Chapter 6

---

## Inflectional Phrases

In the previous chapter we detailed the structure of the central part of the clause, the VP and its extensions into light verb and aspectual morpheme structures. In this chapter we will look at the further extension of the structure so far built into what we can conceive of as 'clause structure', though as we shall see, what is traditionally thought of as a clause is actually a number of hierarchically organised extensions of the basic VP, each of which adds a specific level of semantic and grammatical interpretation. In connection with these extra levels we will see there are specific syntactic phenomena, most of which involves the movement of elements.

In chapter 1 we introduced the category of inflection, consisting of modal auxiliaries, the marker of the infinitival clause *to* and tense morphemes. It is with this category that we will be concerned in the present chapter. We will show that providing a standard X-bar treatment of this element solves a number of problems that we have noted in previous chapters.

### 1 The structure of IP

Inflectional elements are word level categories such as *will*, *can*, *may*, *must*, etc. as well as *to*, *-ed* (and its numerous irregular manifestations) and *-s*. In chapter 1 we argued that these all belong to one category, 'Inflection' (I) because of their complementary distribution:

- (1) a \*Mike might will see the doctor  
b \*Bill will to go to work  
c \*Cathy can watches TV.

In all of the sentences in (1) there are two inflectional elements and each time this produces an ungrammaticality. Therefore not only can we conclude that each of these elements belongs to the same category, but that there is only one position for this category in each clause.

We also suggested in chapter 1 that inflectional elements take verbal complements on the observation that they are always followed by a VP (or perhaps a vP, depending on the properties of the verb). From an X-bar point of view, this suggests that inflections are to be treated as heads as only a head takes a complement. If this is right, then we predict that there will be a phrase that the inflection heads; an IP:

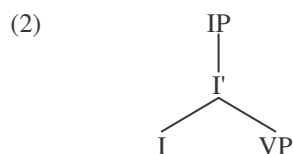

## Chapter 6 - Inflectional Phrases

Note that this is a fundamentally different type of structure than the VP that we investigated in the previous chapter. In the VP, apart from the main verb itself, light verbs, both  $\Theta$ -assigning and aspectual types, select verbal complements and project a verbal phrase. Hence one light verb can take a complement headed by another and a complex VP can be built. Inflections, however, take verbal complements but project an IP. This accounts straightforwardly for why there can only be one inflection per clause as there can only be one IP per clause.

What is the nature of the IP and what else does it contain? Just as inflections are always followed by the VP, they are also typically preceded by the subject in its surface position, though as we pointed out the subject originates inside the VP (vP) at D-structure and moves to get Case:

- (3) a Maggie<sub>1</sub> might [<sub>vP</sub> t<sub>1</sub> mend the lawn mower]  
 b for Tony<sub>1</sub> to [type the letter] (would be helpful)  
 c Harry<sub>1</sub> had [<sub>vP</sub> t<sub>1</sub> helped the police]

A phrasal position to the left of a head could be taken to be its specifier. Clearly the subject is a phrase and it always precedes the inflection at S-structure and hence we might assume that the position to which the subject moves, when it leaves the VP, is the specifier of the IP:

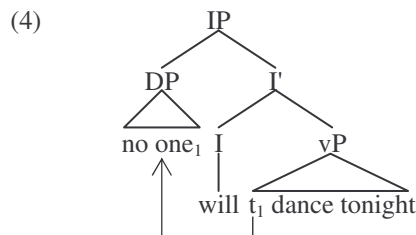

Note that apart from complementisers, which we will discuss in the next chapter, and adverbials, which we will discuss at the end of the present chapter, this structure accounts for all elements of the clause. Specifically we have a subject position, an inflection and a VP predicate: the three obligatory parts of the clause. It seems reasonable to claim therefore that the IP **IS** the clause. This point of view addresses an issue raised in chapter 3 concerning the exocentric nature of the clause. There we discussed reasons for not considering the subject or the VP as the heads of the sentence as they do not seem to have the right properties of a head. Traditionally therefore it has been assumed that clauses are headless.

However, the traditional assumption is challenged by the analysis in (4), where it is claimed that clauses most definitely do have heads. There is much evidence to support this. Firstly consider the relationship between the inflection and the clause. The inflections come in two basic types: finite and non-finite. The finite inflections consist of the modal auxiliaries and tense morphemes. The infinitival marker *to* is non-finite, but we also get clauses, traditionally called **participles**, in which the inflection on the highest verbal element is either *ing* or *en* (or one of its irregular versions):

- (5) a we are anxious [for Sam **to** succeed]  
 b the crowd watched [the fire brigade **rescu**ing the cat]  
 c I saw [the cat **rescu**ed by the fire brigade]



## The structure of IP

---

In the previous chapter, we analysed the morphemes in (5b) and (c) as light verbs heading a vP and so the status of the embedded 'clauses' in these examples is unclear at the moment: they may be clauses (i.e. IPs) or they may be simple vPs. We will not attempt to deal with this issue here, returning to it in a later chapter. But there are some similarities between these clauses and the infinitival clause in (5a) which are useful to consider. Traditionally, those clauses containing a finite inflection are called finite clauses and those containing a non-finite inflection are non-finite clauses. Thus the relationship between the inflection and the clauses has been long acknowledged. I suspect that the relative semantic unimportance of inflections and the lack of recognition of their syntactic importance have contributed to the fact that traditional grammars have failed to recognise them as heads.

It is important to realise that there are differences between clauses headed by finite inflections and those headed by non-finite inflections to see that inflections really do have a contribution to make to the clause. To start, clauses headed by a finite inflection can be main clauses and do not have to be embedded, though they may be:

- (6) a Will won't stop the car  
b I suppose [Will won't stop the car]

In contrast, clauses headed by non-finite inflections are always embedded:

- (7) a \*Tim to stop the car – I want [Tim to stop the car]  
b \*Tim stopping the car – I watched [Tim stopping the car]  
c \*the car stolen – I saw [the car stolen]

In embedded contexts, we see another difference between finite and non-finite clauses in that a finite clause can act as the complement of the complementiser *that*, while only infinitival clauses can act as the complement of the complementiser *for*:

- (8) a ... that [Karen could cook the dinner]  
b ... that [Karen cooked the dinner]  
c \*... that [Karen to cook the dinner]  
d \*... that [Karen cooking the dinner]  
e \*... that [the dinner eaten]
- (9) a ... for [Tracy to teach English]  
b \*... for [Tracy teaching English]  
c \*... for [English taught]  
d \*... for [Tracy can teach English]  
e \*... for [Tracy taught English]

These data not only suggest that there is a difference between finite and non-finite clauses, but also that the infinitive and the participles have a different status, perhaps indicating that while the infinitive has an IP status, the participles are really vPs. The main point is, however, that different clauses distribute differently and this correlates with which inflectional element they contain. All this adds up to the conclusion that the inflection does behave like a head in that it projects its properties to the whole construction and as we saw in chapter 2 it is heads that do this.

## Chapter 6 - Inflectional Phrases

---

So far we have taken the rather simple (perhaps simplistic) view that the VP is the complement of the inflection because the VP follows it. Indeed, if we assume that the VP is the complement of the inflection, this is exactly what we would expect to find as in English all complements follow the head. So this assumption accounts for certain word order facts of English that without it would simply have to be stipulated. Exactly the same is true for the subject. If we assume that this is the specifier of the inflection we account for why the subject precedes both the inflection and the VP, as this is exactly the position in which we find English specifiers.

To see the advantage of this analysis, consider what happens if we do not assume that the inflectional element is the head of the clause. English is often described as an SVO language, based on a way of classifying languages in accordance with the 'typical' ordering of the major elements of the sentence (subject, verb and object). Without X-bar theory and the notions of head, complement and specifier, however, this is just a description of the facts which tells us nothing beyond what can already be observed. Assuming X-bar theory we have a way of accounting for word order patterns by using general statements about the relationships between elements in an X-bar structure and so this is a step in the right direction. However, if we do not assume that the inflection is a head, it is not easy to think of how we can use X-bar generalisations to account for the basic word order of English. This is especially so if we take the traditional view that sentences are exocentric and therefore stand outside of the set of facts that X-bar theory can account for. Only if we assume that sentences are endocentric can X-bar generalisations be used to account for word order facts concerning sentences.

Thus we seem to be inevitably drawn to the conclusion that sentences have heads and that the elements of the sentence are organised in terms of X-bar relationships to the head. The only question that remains is 'what is the head of the clause?' and there seem to be very few options available. The only two real contenders are the inflection and the verb and of these only the inflection really satisfies all the conditions with the minimal number of assumptions.

More supporting evidence for the head status of the inflection comes from its relationships to the other clausal elements. As a head we should expect the inflection to impose restrictions on its complement and specifier positions. Of course, we would not expect these to be based on  $\Theta$ -roles as the inflection is a functional element and plays no role in  $\Theta$ -role assignment. Instead we would expect these restrictions to be similar to those found within the DP discussed in chapter 3. Recall that determiners always take NP complements and no other phrase can appear in this position. The complement of an inflection is always a verbal phrase, be it vP or VP and again no other phrase can appear in this position. We can make this more precise if we use categorial features to describe the situation. The phrase that sits in the complement position of the inflection must be headed by an element with the categorial features  $[(-F), -N, +V]$ , that is, by a non-functional verb including V and v. We can therefore suggest a very restrictive template for the lexical entries of all inflections:

- (10) **category:**  $[+F, -N, +V]$   
**subcat:**  $[(-F), -N, +V]$

## The structure of IP

---

Inflections also impose restrictions on their subjects. Again these restrictions are not thematic in nature but similar to those imposed by determiners on their specifiers. Recall that only a certain kind of determiner allows a specifier: the possessive determiners. The possessive position is restricted to genitive elements, as shown below:

- (11) a [DP his  $\emptyset$  [NP car]]  
b \*[DP he  $\emptyset$  [NP car]]  
c \*[DP him  $\emptyset$  [NP car]]

Inflections similarly impose Case restrictions on their subjects. For example, when there is a finite inflection, the subject is always nominative though this is not so with non-finite clauses:

- (12) a ... that he will hew the rock – \*... that him will hew the rock  
b ... that he hewed the rock – \*... that him hewed the rock  
c ... for him to hew the rock – \*... for he to hew the rock  
d ... him hewing the rock – \*... he hewing the rock  
e ... him hewn – \*... he hewn

As we can see in (12) the subject of the non-finite clause appears in the accusative. There is a further possibility with non-finite clauses which is not available with finite clauses and that is to have a missing subject:

- (13) a Peter prefers [- to be dressed]  
b Lucy likes [- being dressed]  
c the artist painted the model [- dressed]  
d \*they think that [- dressed the model]  
e \*they hope that [- will dress the model]

We will discuss the nature of these restrictions in a later section. For now the important observation is that the inflection imposes these restrictions and hence is demonstrated to have head-like properties.

A final head-like property of the inflection can be seen in the following:

- (14) a Larry dislikes citrus fruits  
b we like $\emptyset$  them

The form of the inflection in (14) depends on properties of the subject. This phenomenon is known as **agreement** (see chapter 1). In English, agreement is very restricted, visible only in the case of the present tense morpheme and the present and past tense forms of *be*. We saw in chapter 4 that the possessive determiner also shows a similar pattern, having one form for pronominal possessors and another for non-pronominal possessors:

- (15) a [DP Carl 's [NP car]]  
b [DP his  $\emptyset$  [NP car]]

For inflections what determines the agreement form of the inflection is the person and number properties of the subject. With a third person and singular subject the inflection is realised as *(e)s* and with any other subject it has a null realisation:

- (16) a [IP Carl does [VP not have a car]]  
 b [IP we do∅ [VP not have a car]]

If we take agreement to be a relationship established between a head (perhaps limited to functional ones) and its specifier, these observations again lead us to the conclusion that the inflection is a head.

## 2 The syntax of inflection

Let us now focus attention on the inflectional element itself to see some of the syntactic processes that concern it. Here we will be concerned with certain movement phenomena involving the inflection and the process of auxiliary insertion discussed in the last chapter.

When the inflection is represented by a free morpheme, such as a modal auxiliary or the infinitival *to*, nothing much happens to it. As a free morpheme it can stand by itself and hence we see it sitting in the head position:

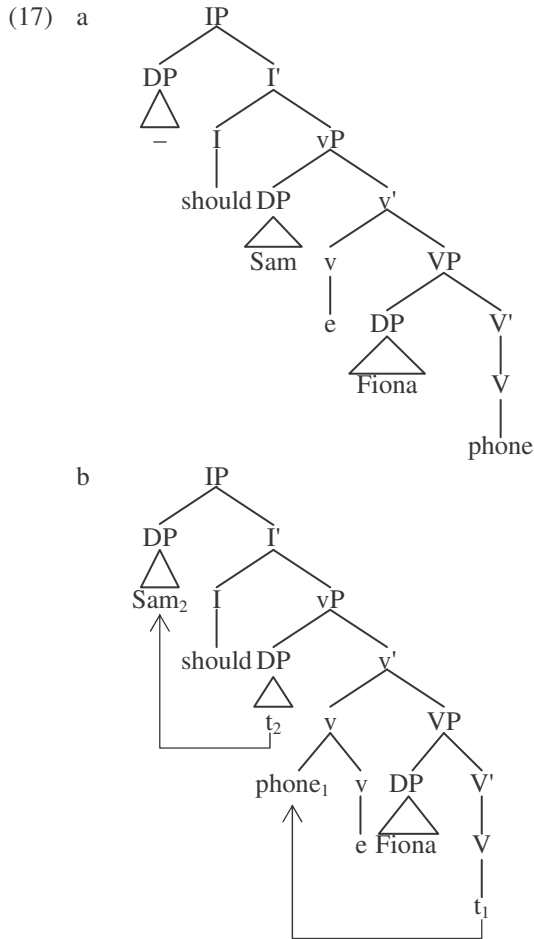

**The syntax of inflection**

---

(17) represents the D- and S-structures of the sentence *Sam should phone Fiona*. As discussed in the previous chapter, the agent originates in the specifier of a light verb, the position to which this  $\Theta$ -role is assigned. It moves to the specifier of the IP, a process we will discuss in the next section. The verb heads the lower VP and moves to support the light verb. The inflectional element is unaffected by any process. Exactly the same is true for an infinitival clause:

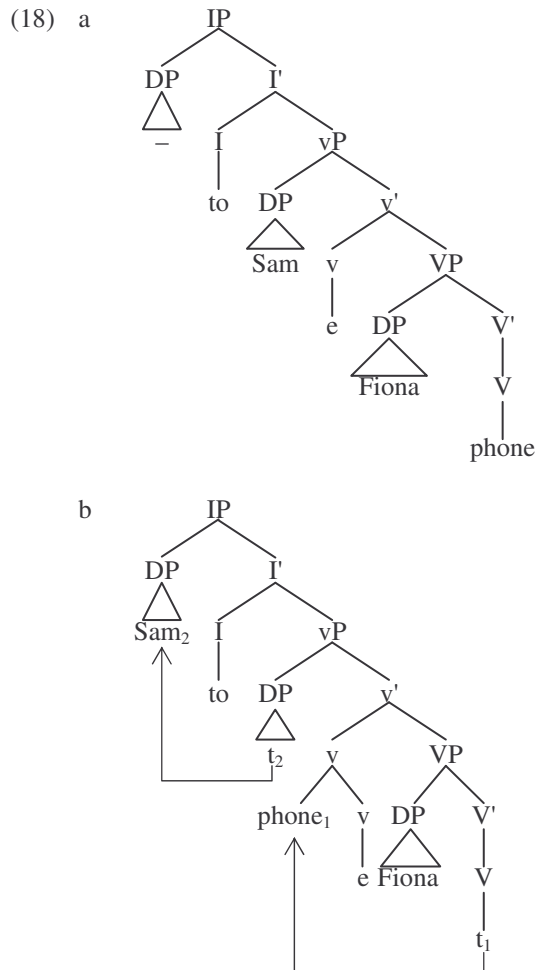

Here (18) provides the D- and S-structures for the infinitival IP in a sentence like *I want [Sam to phone Fiona]*. Again, the same movement processes are observable and again none of these involves the inflection itself.

2.1 Inserting auxiliaries into I

In the previous chapter, we introduced the idea that dummy auxiliaries are inserted into a structure when the verb is unable to support a bound morpheme. Consider what happens with regard to a bound inflectional element such as the present tense morpheme *s*:

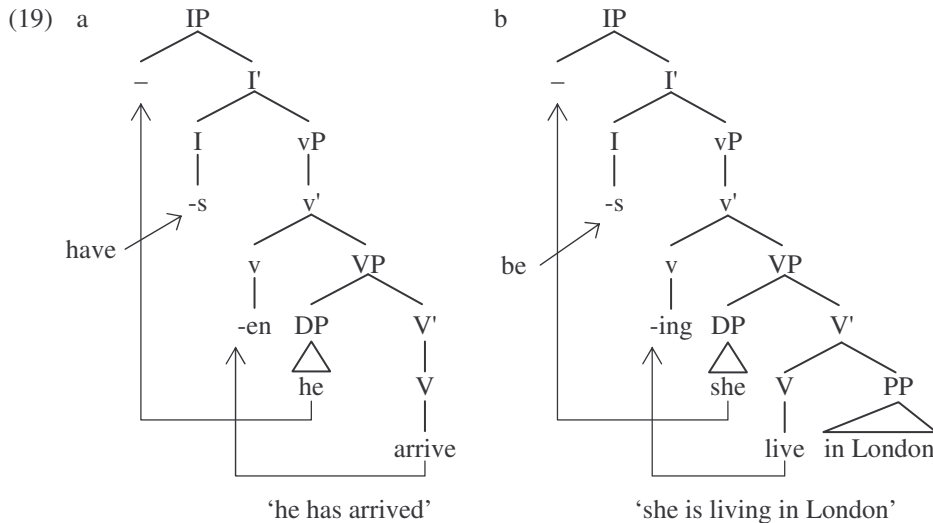

In both of these examples, the verb moves from the V position to support the aspectual morphemes. As a consequence of English stems being unable to support more than one overt morpheme, the verb cannot move further. As the inflection is a bound morpheme it needs supporting and in this case the auxiliaries are inserted directly into the inflectional slot. Note that which auxiliary is used depends on the aspectual element heading the vP complement of the inflectional element. A perfective aspectual morpheme determines the supporting auxiliary to be *have* while the progressive morpheme determines the supporting auxiliary to be *be*. With a slightly more complex example, we see that this is a very general process:

(20)

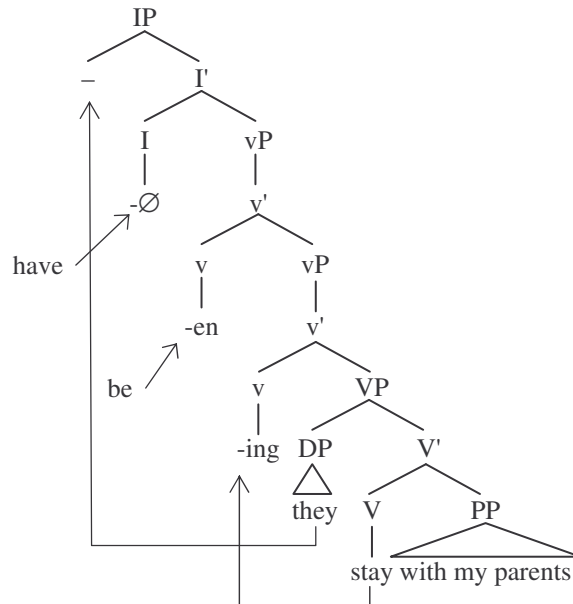

'they have been staying with my parents'

In this case there are two aspectual morphemes as well as the inflection to be supported. The verb moves to the lowest one and cannot move further. Therefore two auxiliaries are inserted: *be*, determined by the progressive, is inserted onto the perfective morpheme which takes the phrase headed by *ing* as its complement, and *have*, determined by the perfective, is inserted onto the tense morpheme (in this case null) which takes the phrase headed by the perfective morpheme as its complement.

## 2.2 Do-insertion

The use of *have* and *be* as supporting auxiliaries is therefore associated with the appearance of the aspectual morphemes whose presence necessitates the use of the auxiliary by 'tying-up' the verb so that it cannot support any other morpheme. The use of the dummy auxiliary *do* however, is a little different as it is not associated with the appearance of any aspectual morpheme and indeed cannot be used in the presence of one:

- (21) a he did not arrive  
 b he had not arrived  
 c \*he did not have arrived

What determines the use of the auxiliary here? Obviously the verb is unable to support the inflection in this case, but this does not seem to be because it already supports another morpheme. In fact the verb is in its base form and there is no reason to think that there is any other verbal morpheme present. (21a) is simply the negative version of *he arrived*. Apparently it is the negative that blocks the verb from moving to support the inflection. To gain some understanding of what is going on here we need to briefly examine another kind of head movement which we will more thoroughly

## Chapter 6 - Inflectional Phrases

---

discuss in the next chapter. In the formation of certain questions an auxiliary verb is moved to the other side of the subject:

- (22) a Denise will dance            will Denise dance?  
       b Tim is tall                    is Tim tall?

As we can see, both modal and aspectual auxiliaries can undergo this movement process. The observation of interest to us is what happens when there are more than one auxiliary:

- (23) a Graham could be gardening  
       b could Graham be gardening?  
       c \*be Graham could gardening?

Apparently, when there are more than one auxiliary, the first one is chosen to move. The reason for this seems to be that moving the first auxiliary involves a shorter movement than moving the second:

- (24) a could<sub>1</sub> Graham t<sub>1</sub> be gardening?  
           ↑  
       b be<sub>1</sub> Graham could t<sub>1</sub> gardening?  
           ↑

Travis (1984) proposed that this phenomenon can be explained by a restriction on head movement which prevents one head from moving over the top of another:

- (25)     the Head Movement Constraint (HMC)  
           a head must move to the next head position

The reason why (23c) is ungrammatical, then, is that if the aspectual auxiliary moves in front of the subject, it has to move over the modal. Whereas if the modal moves, it crosses over no other head. Now consider the case of verb movement in the presence of *not*:

- (26) a he -ed ring the bell     = he rang the bell  
       b he -ed not ring the bell = \*he rang not the bell

The movement represented in (26a) appears to be grammatical whereas that in (26b) is ungrammatical. Again the difference between the two is that the grammatical movement is shorter. But if we want to use the HMC to account for the phenomena, it must be the case that the negative is a head as it is moving over this element that causes the problem. But, what kind of a head is the negative? It is situated between the inflectional element and the v/VP:



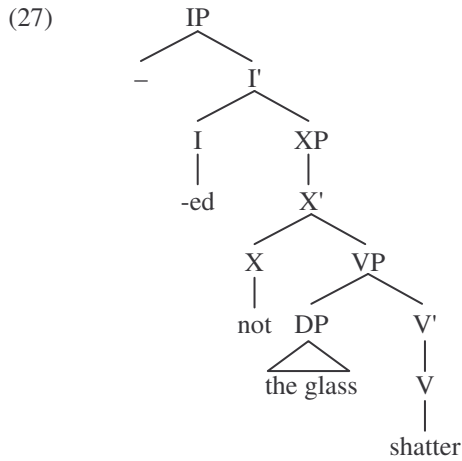

We know that the inflectional element takes a v/VP complement and therefore that the negative must be either V or v. As the complement of the negation is a v/VP it follows that the negative must be v, a light verb, as main verbs do not have verbal complements. Thus the analysis is:

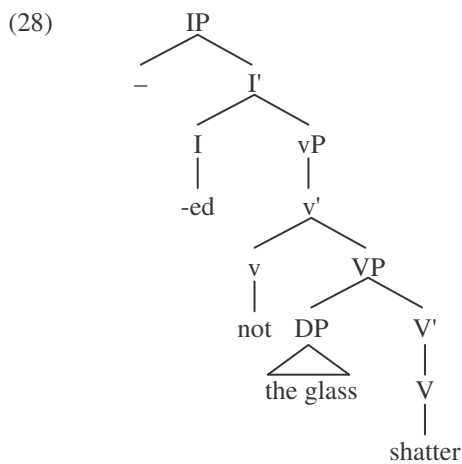

Accepting this, we can account for the insertion of dummy *do*. The verb will not be able to move to inflection without violating the HMC. Apparently in English, the negative is not the sort of verbal element that can support tense and hence the only option available is to insert an auxiliary. As there is no aspectual morpheme to deem otherwise, the inserted auxiliary will be *do*:

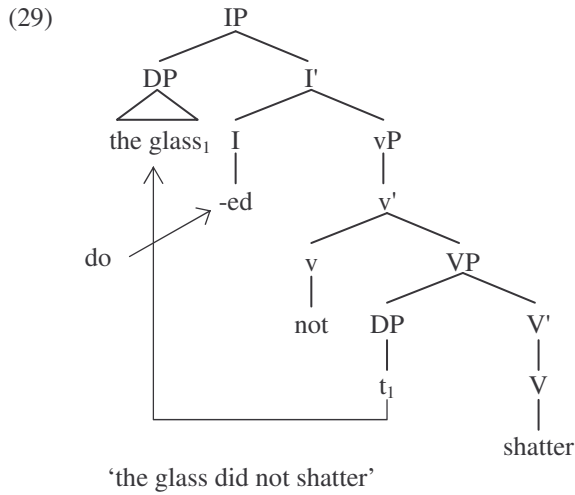

Note that the inability of the negative to support the inflections is a language specific property and there are languages where this is exactly what happens. For example, Finnish negation shows the same agreement morphemes as its verbs do and in the presence of negation the verb does not inflect for agreement:

(30)	menen	–	en	mene	
	go1.s.		not1.s. go		‘I go/I don’t go’
	menet	–	et	mene	
	go2.s		not2.s. go		‘you go/you don’t go’
	menee	–	ei	mene	
	go3.s		not3.s. go		‘he/she goes/he/she doesn’t go’
	menemme	–	emme	mene	
	go1.pl.		not1.pl. go		‘we go/we don’t go’
	menette	–	ette	mene	
	go2.pl		not2.pl. go		‘you (lot) go/you (lot) don’t go’
	menevät	–	eivät	mene	
	go3.pl		not3.pl go		‘they go/they don’t go’

Because of its behaviour, the Finnish negative element is often called the *negative auxiliary* or even a *negative verb*. Moreover, in other languages the negative element surfaces as a bound morpheme on the verb, a situation very similar to the analysis we have given the aspectual markers in English. This is exemplified by the following Choctaw and Japanese sentences:

- (31) ak-Ø-pi-so-tok  
 1s-3s-see-not-past  
 ‘I didn’t see it’
- (32) watashi-wa yom-anakat-ta  
 I read-not-past  
 ‘I didn’t read’

Besides the bound morpheme status of the negative, these languages differ from English in that verbal stems are allowed to support more than one bound morpheme and hence there is **agglutination**: complex words being formed from a series of inflectional morphemes. The point is that in these languages the negative element behaves like we have seen certain English light verbs do and hence they offer support for the suggestion that the negative can be analysed as a light verb.

Note that the presence of the negative will not affect the use of aspectual auxiliaries as these are inserted into the inflection position rather than moving to it:

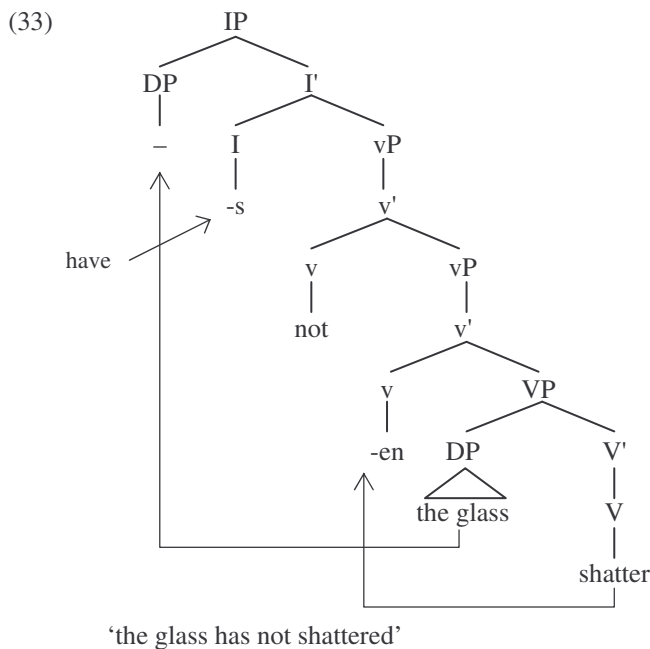

### 2.3 Tense and Agreement

From what has been said so far, we would expect that when there is no aspectual morpheme to be supported and no negation, there will be no need to insert an auxiliary as the main verb can move to support the inflection. Indeed this seems to be true as there is no inserted auxiliary in such cases and the tense morpheme appears on the verb:

(34) he arrive-ed

There is a problem however with the assumption that it is the verb that undergoes the movement in this case. This can be seen clearly when there is a VP adjunct. In the previous chapter, we argued that VP adverbs are adjoined to a v/VP higher than the position to which the verb moves. However, in the absence of any aspectual morphemes, it seems that the inflection appears on the verb inside the v/VP:

(35) he [<sub>vP</sub> quickly [<sub>vP</sub> count-ed his fingers]]

Thus, under these conditions it does not seem that the verb moves to the inflection, but rather that the inflection moves to the verb:

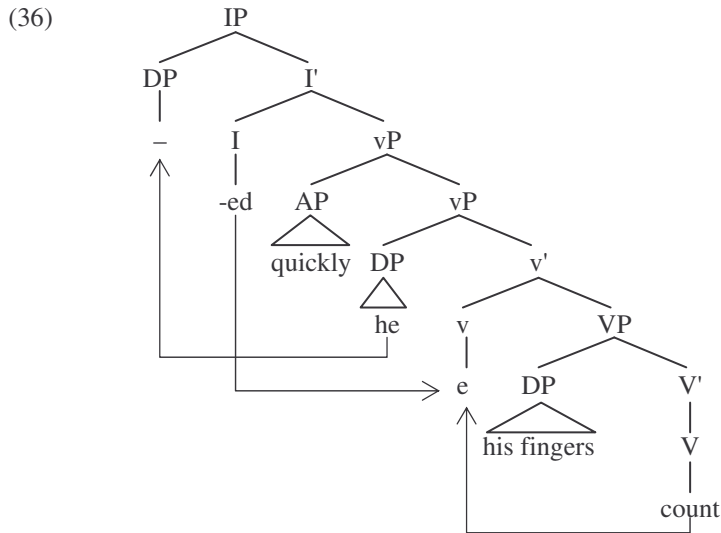

'he quickly counted his fingers'

This analysis suggests that elements can move around in a structure quite freely and in particular both upward and downward movements are possible. But all the movements we have seen so far have been in an upward direction, including all the verb movements and the movement of the subject out of its original VP-internal position. It is possible that this might just be a bias of the small number of movement processes we happen to have reviewed so far. But it turns out, once one starts to investigate movements on a greater scale that the vast majority of them have an upward orientation, which might lead us to the conclusion that perhaps it is our analysis of the small number of apparent cases of downward movements that is at fault. One reason to believe that downward movements are not possible is that it is ungrammatical for certain things to move downwards, which is difficult to explain if such movements are allowable. For example, the verb always moves to the light verb positions and light verbs never move to the verb:

- (37) a [VP he -v [VP the ball hit]] he hit<sub>1</sub> the ball t<sub>1</sub>  
           ↑  
       b [VP he -v [VP the ball hit]] \*he t<sub>1</sub>the ball hit<sub>1</sub>  
           ↑

If downward movements are a possible grammatical process, we have no explanation for why (37b) is ungrammatical in English and can only resort to stipulation that English verbs move upwards in this case. For such reasons, during the 1990s the idea of downward movement was abandoned and all seemingly downward movements were reanalysed as involving upward movements instead.

A further problem with the analysis in (36) is the explanation of why the verb cannot move to the I position. We have seen that verbs are perfectly capable of moving, so why this is not possible to the inflection position is quite mysterious. Some, who accepted the 'I-lowering' (affix lowering) analysis, have suggested that the

## The syntax of inflection

---

verb cannot escape the VP because of its  $\Theta$ -assigning properties, pointing to the fact that aspectual auxiliaries and copular *be*, which do not assign  $\Theta$ -roles, can appear in I (Pollock 1989).

But from our perspective, these elements appear in I by being inserted there and do not undergo movement at all and so there may be other reasons for the fact that they behave differently to main verbs. It is also not entirely clear why the verb can move within the vP, sometimes through as many as three light verb positions and not have any trouble with its  $\Theta$ -assigning properties. Something rather stipulative and ultimately circular has to be claimed to try to account for this fact. For example, we might assume that the inflection has some property, which light verbs lack, that means that if a thematic verb moves to I it cannot assign its  $\Theta$ -roles. Often it is claimed that the inflection is 'too weak' to support the verb's  $\Theta$ -assigning requirements. But the weakness of an element only correlates with the ability of the verb to move to that element, which is the very reason for proposing the notion in the first place!

Before trying to solve these puzzles, one more mystery should be introduced. Our assumptions have been that auxiliaries are inserted into a structure to support bound morphemes when the verb is unable for one reason or another to do so. Obviously a free morpheme does not need supporting either by the verb or an auxiliary. This would predict that when the inflection appears as a free morpheme, i.e. a tense or the infinitival marker, there will be no need for an inserted auxiliary to accompany an aspectual morpheme. But this prediction seems to be false:

- (38) a he will **have** gone  
b she might **be** worrying  
c for you to **be** seen here would be disastrous

The obvious question is what are these auxiliaries supporting? Note that any element that appears after a free inflectional element is always in its base form. Thus, either the auxiliaries are supporting nothing, which throws doubt on their treatment as inserted empty elements, or they are supporting a null morpheme. The latter assumption allows us to maintain our approach but it raises the subsequent question of what this morpheme is.

The facts concerning this morpheme are that it is only present when there is a free inflectional element and the morpheme always follows the inflection.

- (39) a he will leave- $\emptyset$   
b they must have- $\emptyset$  left  
c we might be- $\emptyset$  leaving  
d to be- $\emptyset$  seen

When there is a bound inflectional element, i.e. a tense morpheme, the null morpheme is not present:

- (40) a \*we did have- $\emptyset$  gone      we had gone  
b \*they did be- $\emptyset$  going      they were going  
c \*I did leave- $\emptyset$               I left

**Chapter 6 - Inflectional Phrases**

---

(40c) is of course grammatical, but only with special stress on *did* and used to assert something that has previously been denied. Thus, it does not mean the same thing as *I left* and in fact cannot be used to mean this.

These observations show that this zero morpheme is in complementary distribution with tense and thus the straightforward conclusion is that it IS tense. But how can this be if tense is an inflectional element and the zero morpheme is not in complementary distribution with modal auxiliaries, which are also inflectional elements? What the data show is that it is not modals that tense is in complementary distribution with, but the zero tense morpheme that accompanies the modal and hence the conclusion is that if modals are of the category ‘inflection’, then tense is not of this category. Given that tense is situated in front of the VP, we can assume that it is a head that selects a verbal complement and given that it follows the inflectional elements (i.e. modals) it must project a verbal phrase. In other words, tense is yet another light verb:

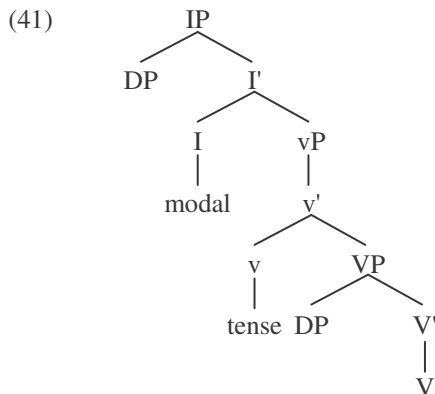

This analysis raises the question of what category ‘inflection’ is if it excludes the tense morpheme, and specifically what occupies this position when there is no modal? To answer this, consider the properties of modal auxiliaries. It is a traditional idea that they are not actually in complementary distribution with tense, as in some sense they display a kind of tense inflection:

- (42)
- |        |        |
|--------|--------|
| may    | might  |
| can    | could  |
| shall  | should |
| will   | would  |
| (must) |        |

Virtually all modals come in pairs, which might be claimed to represent a distinction between past and present. The use of these forms supports this view:

- (43)
- a I think I am going
  - b I thought I was going
  - c \*I thought I am going

## The syntax of inflection

---

- (44) a I think I can go  
b I thought I could go  
c \*I thought I can go

Although I am very much simplifying things here, we can see in (43) that there is some requirement that embedded clauses have a matching tense specification to the main clause and hence the ungrammaticality when the main clause is in the past tense and the embedded clause is in the present. (44) demonstrates something very similar happens with certain modals and hence that modals seem to be specified for tense (or at least they are not themselves in complementary distribution with a tense specification wherever in the clause that specification is made). However, what modals are in complementary distribution with is agreement: modals do not have forms that are dependent on the properties of the subject:

- (45) a he/she/I/you/we/etc. may/will/would/can/etc.  
b \*he/she wills/cans/woulds/etc.

Perhaps, then, what ‘inflection’ is, is agreement and this is expressed either as a morpheme dependent on properties of the subject, or a modal. Of course in English the visible tense and agreement morphemes are expressed as a single form, *s*. But in many languages tense and agreement are expressed as separate morphemes, as they are in Hungarian:

- (46) elmen-t-em      I left  
elmen-t-él      you left  
elmen-t-∅      he/she left  
elmen-t-ünk      we left  
elmen-t-etek      you (lot) left  
elmen-t-ek      they left

In this paradigm, the past tense is represented uniformly as an independent morpheme *t* and the agreement morphemes differ depending on the person and number of the subject.

The inflectional head has a very important role in determining the nature of the following tense head. As we have seen, modals determine that tense will appear as a null morpheme, but note that its content, i.e. past or present, can be recovered from the modal itself, which inflects for tense. When the inflectional element is a null agreement morpheme, the form of the tense will be partly determined by the agreement morpheme and partly by the tense itself. So if the tense is past then it will be realised as *ed* (or one of its irregular forms) no matter what the agreement is. But if the tense is present, it will be realised as *s* when the agreement is third person and singular and as a zero morpheme when the agreement is something else:

- (47) a [IP - can [VP - ∅ ...]]  
b [IP - ∅<sub>3,s.</sub> [VP - -s/-ed ...]]  
c [IP - ∅<sub>-3,s.</sub> [VP - ∅/-ed ...]]

We have not yet mentioned the infinitival marker *to*. What is its status? Is it a non-finite agreement morpheme, similar to a modal, or is it a non-finite tense morpheme

## Chapter 6 - Inflectional Phrases

---

that is accompanied by null agreement? For now I will assume that it is a tense element and demonstrate later that this seems to be correct.

### 2.4 Movement to tense and I

Having separated tense and agreement (=inflection), let us consider their properties separately. Tense is obviously a bound morpheme triggering movement of the verb or insertion of an auxiliary when the verb is unable to move. But what about the null agreement morpheme, is this a bound morpheme or not? If it is, it will need supporting and we would expect verbs and auxiliaries to appear as high as the I node as we do not want to claim that the inflection lowers onto the tense. On the other hand, agreement might be like the modals and be a free morpheme, in which case we would expect nothing to move to I. The data are complex and often depend on other assumptions as to how to interpret them. Basically there appears to be a difference in how verbs and auxiliaries behave. Auxiliaries appear to be able to achieve a higher position than the main verb, indicating that while the verb can move to tense it cannot move to I, whereas auxiliaries can be in I.

As we have seen, adverbs and the negative head can appear in a number of positions within the v/VP, with adverbs being able to adjoin to most phrases above the verb and negation taking most phrases above the verb as its complement:

- (48) a will (quickly) have (quickly) been (quickly) being (quickly) hidden  
b will (not) have (not) been (not) being (not) cooked

Both negation and VP adverbs can also precede the non-finite marker, indicating that this is a tense element that stays inside the vP:

- (49) a for him quickly to have left was a relief  
b for him not to have said anything was strange

However, neither VP adverbs nor negation can precede modals:

- (50) a \*quickly will leave  
b \*not will leave

And neither of them can appear adjoined to a phrase that the verb has moved out from:

- (51) a \*he will have seen<sub>I</sub> quickly [<sub>VP</sub> the papers t<sub>I</sub>]  
b \*he will have seen<sub>I</sub> not [<sub>VP</sub> the papers t<sub>I</sub>]

It thus seems that these elements appear anywhere inside the vP as long as they are below the I and above the surface position of the verb.

Now, when there is no modal, an auxiliary inserted to bear tense behaves as though it is in I as no adverb or negation can precede it:

- (52) a I have quickly marked the essays – \*I quickly have marked the essays  
b I have not graded the papers – \*I not have graded the papers

This supports the assumption that the inflection is a bound morpheme that needs supporting by a verbal element. With main verbs, however, we find that the tensed verb appears below the adverb and the verb cannot support tense in the presence of negation:



**The syntax of inflection**

---

- (53) a I quickly assessed the students – \*I assessed quickly the students  
 b I did not fail his paper – \*I failed not his paper

We already have an account for the behaviour of the main verb in the presence of the negative. The negative is a head that blocks the movement of the verb over it. If negation is situated below the I position, then the verb will not be able to move to support the inflection and hence *do*-support is necessary, as demonstrated in (53b). This will not affect the process of auxiliary insertion however, as this does not involve movement. Yet, an inserted auxiliary bears both tense and agreement and so it seems to be inserted into tense and moved to I, suggesting that the position of the negation is lower than the tensed element, contradicting (49b) where negation is above the non-finite tense. It seems then that negation must be below a finite tense, but above the verb.

The only real problem we face is accounting for the grammaticality of (53a), where the adverb appears in front of the tensed verb. It is this observation which has lead people to the assumption that the inflection must lower to the verb or that the analysis must be more abstract to account for what looks like a downward movement in terms of an upward one.

However, these approaches are based on the assumption that the position of the adverb is rigidly fixed and so if the verb follows the adverb it must be inside the vP. But we have seen that adverbial placement is not so rigid, although it is subject to some restrictions. It would seem to me to be more straightforward to assume that in the case of a finite main verb, the verb does occupy the inflection position and what needs accounting for is the position of the adverb.

Suppose that, like the negative element, the adverb likes to follow the finite tense and precede the verb. However, unlike the negative it is not rigid about this. Specifically, when the verb and the inflection are in one place, it is impossible for the adverb to be between them. Thus a choice must be made: put the adverb above the tense, or put it below the verb. It seems that the restriction on adverbs preceding verbs is the stronger, so the adverb will be adjoined higher than the I position. The position it is actually adjoined to is the I', which we will see is a position where the sentential adverb may appear:

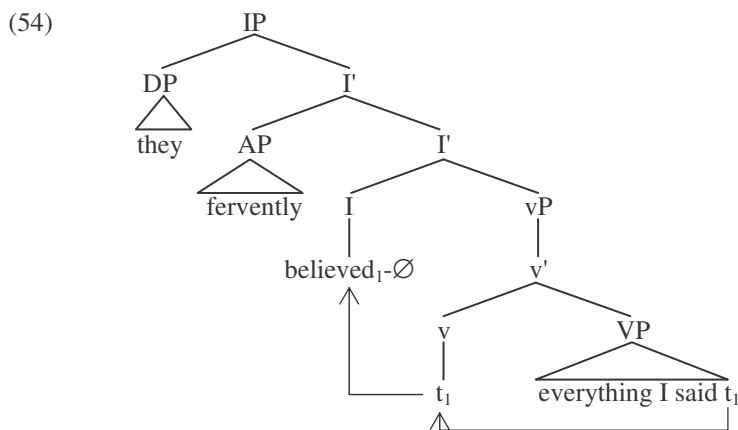

## Chapter 6 - Inflectional Phrases

As we mentioned previously, the negative element is not so accommodating and it refuses to give up its place below the finite inflection and above the verb. Thus in this case the verb cannot support the inflection and the dummy auxiliary has to be inserted:

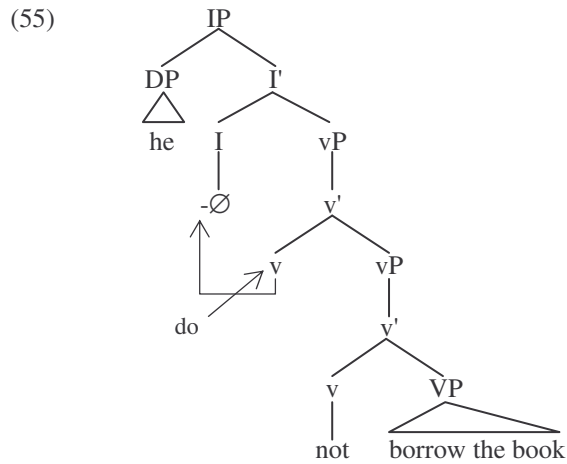

The final structure of the clause we end up with is as follows:

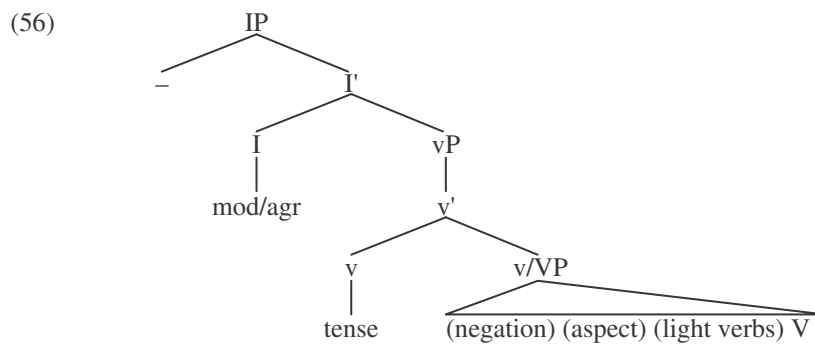

In what follows, we may sometimes for convenience abbreviate this to:

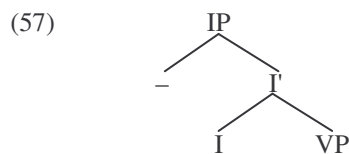

However, the more articulated structure in (56) will be assumed to be correct and indeed will be essential for accounting for certain phenomena which will be introduced in the next chapter.

### 3 Movement to Spec IP

Up to this point we have been assuming that the subject of the clause originates fairly low in the clause, inside the VP or a vP just above it. We have said this DP will move from its original position to the specifier of IP to get Case and thus avoid a Case Filter violation which would render the sentence ungrammatical. Two aspects of this analysis are in need of elaboration. First it must be accounted for that the subject's original position is a Caseless one and second it must be established exactly where in the complex clause structure we have been arguing for the subject moves to and why this is a Case position.

Let us start with the case of a simple transitive verb so that we can compare the situation of the subject and object:

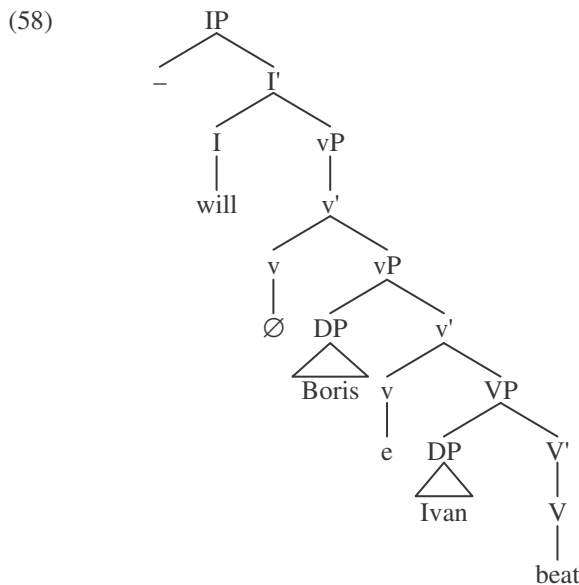

We have said that the light verb which is responsible for assigning the  $\Theta$ -role to the subject is responsible for assigning Case to the object. This seems to be the locus of Burzio's generalisation that verbs which assign a subject  $\Theta$ -role assign an accusative Case. Hence the object is in a Case marked position and need not move away in order to get Case. Consider the subject: why is it not in a Case position? Note that the verbal element above the subject, the tense in this case, does not assign any  $\Theta$ -roles and hence its specifier position is empty at D-structure. Clearly this is unlike the light verb. We may propose therefore that tense is not an accusative Case assigning head. But why doesn't the light verb assign Case to its subject? One might attempt to answer this by claiming that the light verb has to assign Case to the object and assuming that accusative Case can only be assigned to one place. While this seems reasonable, it doesn't explain why the light verb taking an intransitive verb does not assign Case to its subject:

(59)

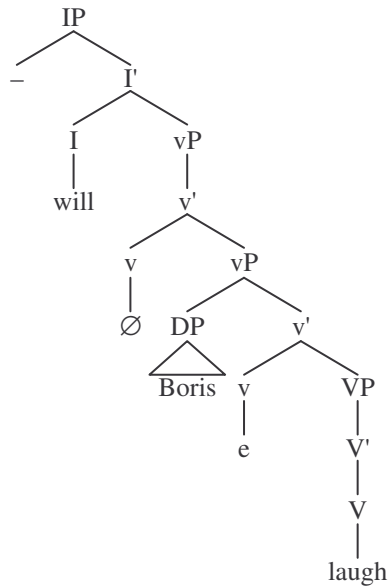

In this case, the light verb assigns agent  $\Theta$ -role to its specifier and so should be capable of assigning Case and in fact the possible appearance of a cognate object seems to confirm this assumption. But when there is no object, the subject still undergoes the movement, suggesting that it does not get Case from the light verb.

There are a number of possible ways to account for these observations. The simplest is to assume that Case assignment is directional and that accusative Case in English is assigned to the right. Thus, the light verb will be able to assign Case to the object as the object appears to the right. However the light verb will not be able to assign Case to the subject as the subject is in the specifier position and specifiers are to the left of the head.

This is too simple, however, as it is not the case that a light verb can assign Case to any element on its right. Consider a more complicated case in which we have a verb with a clausal complement. The light verb of this verb will be to the left of the complement clause and hence to the left of the subject of that clause. But it cannot assign accusative Case to this subject, allowing it to stay inside its own subject position:

**Movement to Spec IP**

---

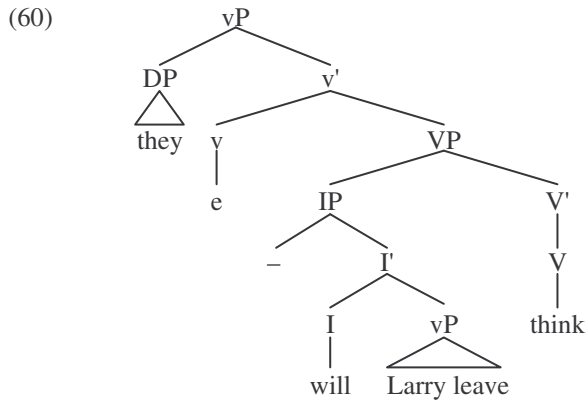

- (61) a \*they think<sub>1-e</sub> [VP [IP - will Larry leave] t<sub>1</sub>]  
 b they think<sub>1-e</sub> [VP [IP Larry<sub>2</sub> will t<sub>2</sub> leave] t<sub>1</sub>]

The word order within the embedded clause shows that the subject does not get Case in its original position and that like any other subject, it has to move to get Case in the subject position of the IP. Considering where a light verb can assign Case to, i.e. the specifier of its own VP complement, and where it cannot assign Case to, i.e. the specifier of a VP inside another clause, it is obvious that there is some locality restriction on Case assignment in addition to the directional one. We are not yet in a position to be able to determine the exact nature of this locality condition and so for now we will just assume that a light verb can only Case mark elements within its own clause.

Having put this in place, we can see that the subject will not be able to be case marked in its original position as it is on the wrong side of the local light verb and too far from any other light verb that might have a Case to assign.

Let us now turn to the landing site of the movement. The subject moves to a position to the left of a modal and so the obvious place to assume as its landing site is the specifier of IP:

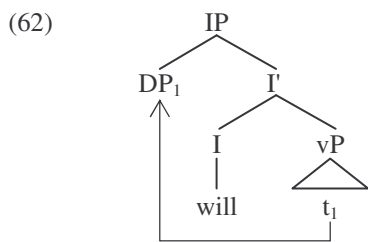

This must be a Case position as the sentence is grammatical with the subject sitting in it and therefore the Case Filter must be satisfied. If we assume that it is the inflection which is responsible for assigning the Case we account for why this is the landing site for this movement. Moreover, we also account for the difference between the subjects of finite and infinite clauses. Recall that while the subject of the finite clause has nominative Case, the typical Case for the subject of the non-finite clause is accusative:

**Chapter 6 - Inflectional Phrases**

---

- (63) a **she** can sing  
 b for **him** to dance

Presumably the agreement element is different in both these cases. For one thing, modal auxiliaries can appear in the agreement position of finite clauses, but not of non-finite clauses. Moreover, finite inflection selects for a finite tense headed phrase as its complement while the one in (63b) clearly selects for a non-finite complement. I will not have anything to say about the accusative Case of the subject of the non-finite clause at present, leaving this for future discussion. Instead, we will concentrate on the finite inflection, which assigns nominative to the subject.

The Case assigned by the finite agreement element is very different from that assigned to the object. Obviously the former is a nominative Case while the latter is accusative, but the differences extend further than this. For one thing assuming that it is the agreement element which is responsible for nominative Case, this Case must be assigned in a leftward direction:

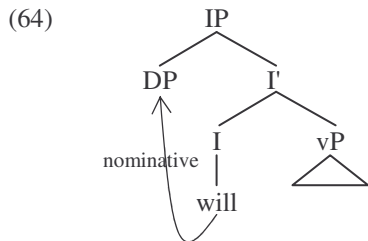

Furthermore, this case is assigned by a functional element, something that is not involved in  $\Theta$ -role assignment. For accusative Case the Case assigner necessarily  $\Theta$ -marks its subject in order to be able to assign accusative Case. But the same is not true for the inflectional assigner of nominative Case.

There are two basic positions linguists take with respect to these observations. One is to assume that nominative and accusative Case are similar and the other assumes that they are fundamentally different. From the first perspective the challenge is to come up with restrictions which define the conditions under which Case can be assigned generally. For example, there are three positions to which we have seen a Case assigned: the specifier of the inflection; the specifier of the complement, and the complement position itself:

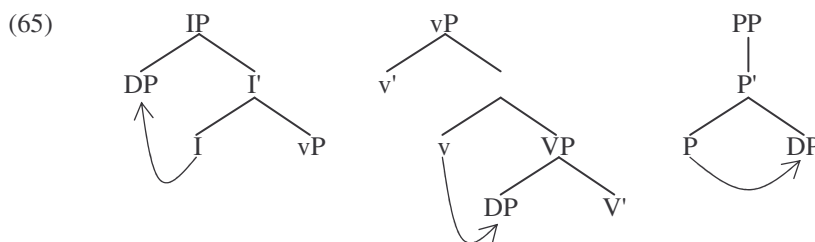

The unified relationship that linguists came up with to capture these three cases of Case assignment was called **government**. Informally this may be stated as:

### Movement to Spec IP

---

- (66) an element governs everything within its own phrase, but not past a certain point

The point of the ‘but’ clause in this definition is to impose locality on government. If a head governs everything inside its phrase, then it can govern quite a long way if its phrase happens to be a long one. Yet government is clearly a local relationship if it is restricted to the situations in (65) and there seems to be a point beyond which government cannot hold. How this point is identified and defined is a matter for discussion, with a number of positions possible. But one thing we can conclude at this point is that VP cannot be something that blocks government, otherwise the light verb would not be able to Case-mark the object in the specifier of VP.

The other point of view observes that it does not seem to be mere coincidence that the two instances of rightward Case assignment in (65) happen to involve accusative Case while the leftward Case assignment involves nominative. The assumption is then that there are two different processes at work here. For nominative the relevant relationship is supposed to be specifier–head agreement, something we mentioned in the previous chapter. The idea is that the finite inflectional element can assign nominative Case to whatever it agrees with, and this will be its specifier. For accusative Case however, government is the relevant relationship, though defined in a slightly different way as it is no longer required to extend to the subject. Informally, this version of government can be defined as:

- (67) a head governs its sister and everything inside its sister, up to a point.

Again, the ‘point’ imposes locality restrictions on the government relationships. From the present perspective there is very little between the two views that allow us to favour one or the other and therefore we will leave the matter unresolved at this point.

#### 4 Adjunction within IP

In the last section of this chapter we will briefly consider adjunction within the clause. We have seen in the last chapter that adverbs come in at least two types: sentential adverbs and VP adverbs. The two can be distinguished by what they modify and also in terms of where they attach to a structure.

Sentential modifiers are normally considered to have the whole sentence as their domain of modification, i.e. they add an extra meaning to the sentence as a whole:

- (68) a she will **certainly** be offended  
 b it will **probably** never happen  
 c I had **luckily** saved the envelope

Note that the most natural position for these adverbs is after the modal but before the rest of the sentence, suggesting that it adjoins to the phrase headed by tense:

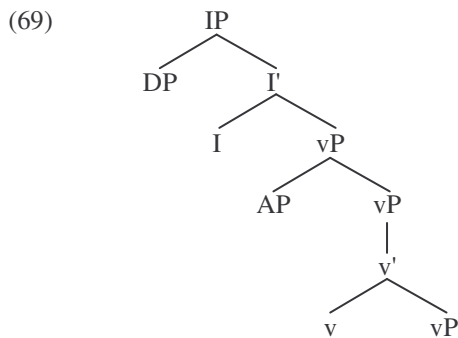

We do however find them following the subject but before the inflection:

- (70) a he naturally could cook  
 b they hopefully might know the way  
 c I regrettably have forgotten your name

The only place that an adverb would be able to attach to, to come between a head and its specifier, is the X'. So unless we assume either that subjects are not necessarily in the specifier of the inflection or that the modals are not necessarily in the inflection position itself, it seems that we must also allow adjuncts to adjoin to the I':



## Conclusion

---

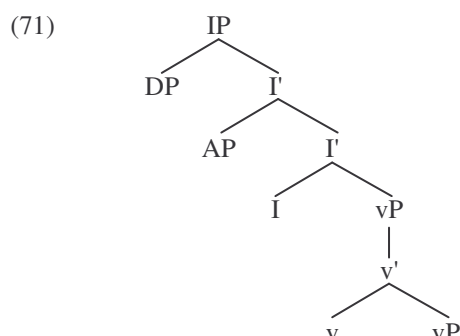

Note that both of these positions are higher than those favoured by the VP adverbs and hence if we have a sentential adverb and a VP adverb, we predict that the sentential adverb will precede, which seems to hold true:

- (72) a I can fortunately quickly send you the money  
b \*I can quickly fortunately send you the money

## 5 Conclusion

In this chapter we have discussed the basic architecture of the clause, claiming that this is headed by the inflectional element. This analysis provides positions for both the subject and the VP as well as the inflectional element itself. However, there are aspects of the syntax of the clause that we have not yet touched upon. We have yet to discuss the position of the complementiser, for example. Furthermore, there are types of clauses that we have not discussed: interrogatives, for example. These will be discussed in the next chapters.

### Check Questions

- 1 How can finite and non-finite clauses be distinguished?
- 2 What evidence is available to assume that clauses are not exocentric constructions, rather, they are headed by the element I'?
- 3 How is the process of attaching bound morpheme inflection heads to their stems analysed?
- 4 What is the analysis of negation and *do*-support?
- 5 What is the position associated with aspect markers and aspectual auxiliaries?
- 6 How is the conceptualisation of the content of Inflection altered in the text?
- 7 What is the distribution of negation and VP adverbs relative to each other?
- 8 What is the difference between light verb vP and tense vP?
- 9 How is Case assignment conceptualised?
- 10 What is the position of sentence adverbs versus VP adverbs?

### ***Test your knowledge***

▪ **Exercise 1**

Consider the examples below. How do the DPs acquire case?

- (1) a John met Mary in the park.  
b For me to survive this week will be quite difficult.  
c Everybody goes to see the painting.  
d John persuaded Bill to go to see a doctor.  
e Mary gave a book to John for Xmas.

▪ **Exercise 2**

Determine the function of *do* in the following sentences.

- (1) a How do you do?  
b He did know the answer although he claimed he did not know it.  
c She does a lot for her parents.  
d He did not tell the truth, did he?  
e When does he get up?  
f I did read this book.  
g They do not go to work today.  
h You sleep too much, don't you?  
i I have quite a lot of things to do.  
j This exercise is almost done now.  
k What are you doing now?  
l I do not know anything.

▪ **Exercise 3**

Identify the DPs in the following sentences and state which Case is assigned to them by which items.

- (1) a Jim sent a bunch of flowers to Jane.  
b For Jim not to buy the house at a lower price wasn't the best decision in his life.  
c The teacher believed that all his students would pass the exam.  
d All the students were believed to pass the exam.  
e John will never trust Jane.  
f Which experiment did the professor mean when he asked whether we were able to do it?  
g John read an interesting book about the cold war.  
h It was raining when I looked out of the window.  
i The children wanted it to be snowing during the whole day.  
j Jane believed Jack to be able to repair the car.

### Test your knowledge

---

▪ **Exercise 4**

Give the X-bar structure of the following sentences and explain how the DPs receive thematic roles and Case.

- (1)
- a John's message arrived.
  - b David made the ball roll to the wall.
  - c David rolled the ball to the wall.
  - d John sank Jim's boat.
  - e Jim's boat sank.
  - f Jim's boat was sunk.
  - g Bill caught a bird.
  - h The bird was caught.
  - i Sam coughed.
  - j John sent a message to Mary.
  - k Mary was sent a message.
  - l Jim took his shoes off.
  - m Jim took off his shoes.
  - n John thinks that Jim knows that Mary gave his book to Jane.



# Chapter 7

---

## Complementiser Phrases

In this chapter we continue to present the parts of the English clause, extending it further upwards. So far we have seen that the clause has a number of layers to it, relating to certain syntactic and semantic properties. The lower layer consists of the thematic part of the VP, including the  $\Theta$ -assigning light verbs, which concern argument and event structure. Above this we have the non-thematic part of the verb phrase where the morphemes of aspect and tense are introduced. Finally above this we have the IP in which agreement and modal auxiliaries are situated. The IP also provides the surface Case position for the grammatical subject.

Above the IP the structure of the clause continues and in particular the complementisers, which a large part of this chapter will be about, are found to reside. We will see that this part of the clause structure also has its semantic impact on the interpretation of the whole sentence, mainly in terms of the notions of **declarative** and **interrogative**, i.e. whether the sentence is supposed to be making a statement or asking a question. This aspect of meaning has been referred to as the **Force** of the sentence.

As with the previous chapter, we start with a general discussion of the general organisation of the super-IP structure. We then turn to look at complementisers themselves and the part they play in certain syntactic processes. We will look at the specifier of the complementiser and its use in various English constructions and finally turn to phenomena that suggest the existence of a certain degree of structure between the complementiser and the IP.

### 1 *The structure of CP*

In embedded contexts we often find that clauses are introduced by a small set of words known as complementisers:

- (1) a Knut knows **that** [water is wet]  
b **for** [Stan to save the world], he needs a red cape  
c I don't remember **if** [I told you about my mother]

These words form a constituent with the following IP, but are not part of its structure. So, the clause can be moved along with its complementiser, the clause and its complementiser can be replaced by a pronoun and the clause and its complementiser can be coordinated with another such string:

- (2) a that water is wet, Knut now knows  
b they told me that Stan saved the world, but I don't believe it  
c I thought that your mother was a racing driver and that she won the Grand Prix

## Chapter 7 - Complementiser Phrases

---

In (2a) the clausal complement of the verb *know* has obviously moved from its normal complement position behind the verb to a position at the front of the sentence. As the complementiser still precedes this clause, it can be assumed to form a constituent with it. In (2b) the pronoun *it* is used to replace the clause *that Stan saved the world*. As this includes both the complementiser and the IP, we conclude that these must form a constituent. Finally, in (2c) two clauses are coordinated. That both clauses begin with a complementiser demonstrates that the complementiser forms a constituent with the following IP.

That the complementiser is not inside the IP itself can be demonstrated by the fact that it is possible to pronominalise the IP without the complementiser and we can coordinate two IPs separate from the complementiser:

- (3) a we expect there to be trouble, but we are not hoping for it  
 b I wondered if there would be trouble and I could be involved

The first case in (3) is fairly straightforward. The *it* replaces the non-finite clause *there to be trouble* and given that the complementiser precedes the *it* the pronoun replaces just the IP. The second case needs a little explanation. What is coordinated here are the two IPs *there would be trouble* and *I could be involved*. In some clauses the complementiser does not have to appear overtly, however:

- (4) I think (that) his eyes were blue

One possible analysis, which we will argue in favour of a little later, is that when there is no overt complementiser, there is an phonologically empty complementiser. This possibility then raises the question of what is being coordinated in (2b): is it just the IP, as we claimed, or an IP with an empty complementiser?:

- (5) a if [there would be trouble] and [I could be involved]  
 b [if there would be trouble] and [e I could be involved]

In the second case, the data obviously do not support the claim that the IP can be coordinated without the complementiser as both sides of the coordination contain complementisers. However, (5b) cannot be the correct analysis as the only complementiser that is allowed to be empty in this kind of situation is *that* and *if* cannot be omitted:

- (6) a I think (that) his eyes were blue  
 b I wondered \*(if) his eyes were blue

Thus, (5b) would only be possible if the empty complementiser were a version of *that*. But this is not possible as, in this case, a clause beginning with *if* cannot coordinate with a clause beginning with *that*:

- (7) \*I wondered [if there would be trouble] and [that I could be involved]

Thus, the only viable analysis is (5a).

The final outcome of this discussion, then, is that the structure of the clause is:

- (8) 
$$\begin{array}{c} \text{XP} \\ \swarrow \quad \searrow \\ \text{C} \quad \quad \text{IP} \end{array}$$

## The structure of CP

---

As the complementiser is a word and the IP is a phrase, we immediately see a potential head–complement relationship between them and if we apply X-bar principles to this situation the structure we expect is:

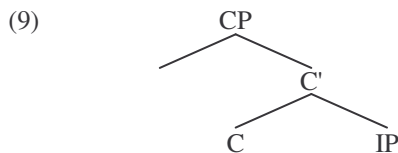

If this is so, we expect the complementiser would demonstrate certain head-like properties and it is fairly easy to show that it does. For example, compare the following sentences:

- (10) a I wonder [if Charles likes chocolate]  
b I think [that Charles likes chocolate]

The embedded clause in (10a) is interrogative as it can act as the complement of the verb *wonder* and this subcategorises for interrogative complements. The clause in (10b) is declarative as it can act as the complement of the verb *think* which subcategorises for declarative clauses. But the only difference between the two clauses lies with the complementisers. The IP in both cases is identical. This would suggest that the interrogative/declarative nature of the clause is fixed by the complementiser and not by anything inside the IP. In other words, it is the complementiser that provides the force of the sentence. As it is heads that provide the properties of the structures they head, this demonstrates that complementisers do have a head-like status within the clause.

Another claim made in (9) is that the IP is the complement of the complementiser. Can this be substantiated? One obvious relevant observation is that the IP follows the complementiser and as we know complements follow heads in English. Thus the claim that the complementiser is the head and the IP its complement accounts for this fact about English word order without resorting to stipulation. Furthermore, we have seen that functional heads such as determiners and inflections have a very limited range of possible complements: determiners always have NP complements and inflections always have v/VP complements. The element which follows a complementiser is always an IP and so this fits the pattern very well. Finally, note that different complementisers introduce different IPs. *If* and *that* both introduce finite IPs, while *for* introduces a non-finite IP. As heads select for their complements, this is again an indication that the complementisers are heads selecting for different types of IP complements. This is very similar to plural determiners selecting for plural NP complements and singular determiners selecting for singular ones.

In what follows, we will be assuming the structure in (9) as essentially correct, though we will see that some extension will be needed for elements that appear between the complementiser and the IP. We will start by discussing facts that do not concern these elements however, and so for the time being (9) provides us with an adequate model of the top part of the English clause.

## 2 The Clause as CP

Not all clauses are introduced by a complementiser. For example, subordinate declarative finite clauses may or may not be introduced by *that* and main clauses never have complementisers:

- (11) a she said [(that) we should make the sandwiches]  
 b (\*that) we should make the sandwiches

What is the status of the clause when there is no complementiser? One possibility is that when there is no complementiser there is no CP and hence a clause without a complementiser has the status of an IP. For embedded clauses this is a problematic conclusion as it means that the verbs which select for such clauses must be able to take IP or CP complements. In other words, they subcategorise for a complement with the features [+F, -N]. But if this is so, we would predict that there should be verbs that select for only CP complements, i.e. complements with [+F, -N, -V] features, and those that select for only IP complements, with [+F, -N, +V] features.

But while there are many verbs which take clausal complements both with or without a complementiser, it is doubtful whether the other predicted verb types exist. It seems that we have to accept a generalisation that if a verb selects for a declarative finite IP complement, it also selects for a declarative finite CP complement. It is not easy to think how we can explain this generalisation when stated in this way. There is another possible view, however. This sees all these complements as being CPs, but sometimes the complementiser is filled with an overt *that* and sometimes it is filled by an unpronounced complementiser:

- (12) a she said [<sub>CP</sub> that she wanted ham and pickle]  
 b she said [<sub>CP</sub> ∅ she wanted ham and pickle]

The generalisation is now that all verbs which select for a finite declarative complement select for a CP. This is fairly easy to capture in terms of the notion of **canonical structural realisation principles**. The idea behind this is quite simple. Basically, certain arguments are canonically realised by certain categories. For example, themes are typically realised as DPs and locations as PPs. This is their 'canonical realisation'. It may be that a certain degree of non-canonical realisation of arguments is possible, for example the nominal *home* can realise a goal argument usually realised by a PP:

- (13) he went [<sub>PP</sub> to London]/[<sub>DP</sub> home]

All we need to say is that something with a propositional meaning is canonically realised as a CP and then it follows that if a verb takes a propositional complement, this will be realised as a CP. It follows from this that all finite declarative complement clauses will be CPs and hence that we must assume that sometimes the complementiser can be abstract, as in (12b). Non-finite complement clauses differ from this pattern quite substantially. Certain verbs take non-finite complements with an obligatory complementiser:

- (14) a we were hoping [for the good weather to arrive soon]  
 b \*we were hoping [the good weather to arrive soon]



## The Clause as CP

---

Verbs such as *wish, prey, plead, demand, indicate, signal*, etc. all seem to behave in this way. Obviously, for these verbs there is no question that they take CP complements.

Others take non-finite clause complements that never have a complementiser:

- (15) a I tried [ - to spread the butter]  
b \*I tried [for - to spread the butter]

Verbs such as *attempt, have* (= be obliged), *promise, wish, prey, plead, demand*, etc. all behave like this.

Note that some of these verbs are in the other category as well. However there is a difference, verbs in the *try* category take non-finite complements with missing subjects and those in the *hope* category take non-finite complements with overt subjects. Thus there seems to be a correlation between when the complement clause has an overt subject and when it has an overt complementiser. We will go into this in more detail in the next chapter, but it can be argued that clauses with covert subjects must be CPs with a covert complementiser position:

- (16) I attempted [<sub>CP</sub> Ø - to cut the tomatoes]

One class of verb takes a non-finite clause complement that has an overt subject:

- (17) he believes [Troy to be trouble]

In the next chapter we will argue that these are exceptional verbs and do not behave like the others in that they take IP non-finite complements. Exceptions aside however, the conclusion is that the majority of non-finite complement clauses seem to be, like the finite ones, CPs. Hence a general conclusion seems to be that complement clauses are always CPs.

This leaves main clauses. As pointed out in (11b), these never have overt complementisers. However, given that covert complementisers seem to be a possibility it is reasonable to ask whether main clauses are CPs which have an obligatory covert complementiser, or whether they are just IPs with no space for a complementiser. The issue is complicated unfortunately. On the one hand, there are some main clauses that have to be argued to be CPs, as we shall see a little later. Thus, on general grounds it seems reasonable to assume that **all** clauses are CPs. Moreover, if the role of the complementiser is to indicate the force of a sentence, and main clauses without complementisers have a force interpretation, then it might be argued that there must be a complementiser to provide this aspect of clausal semantics. On the other hand, most linguists accept that 'exceptional clauses' lack complementisers and these also have a force interpretation and so it seems that there is a way for this to be introduced in the absence of a complementiser, which undermines the argument that main clauses must have complementisers because they have a force interpretation.

If we assume that main clauses are CPs we need an explanation as to why their complementisers are obligatorily covert. But if we assume that main clauses are merely IPs, we must account for why the CP is obligatorily banned. All in all then, it is hard to decide on the issue. In this book, we will take the fairly standard view that all clauses are CP (except for the exceptions) and hence we assume that main clauses have obligatorily covert complementisers by a general principle.

### 3 Interrogative CPs

#### 3.1 Basic positions within the CP

So far we have looked mainly at declarative CPs. In this section we will turn our attention to interrogatives. There are a number of different types of interrogatives and most of them seem to make use of the CP in one way or another. The two most obvious ones are **wh-questions** and **yes–no questions**.

A *wh*-question is formed with the use of an interrogative pronoun, usually called a **wh-element** as in English they mostly begin with the letters ‘wh’, as in *who*, *why*, *which*, *what*, *where*, etc. *How* is an exception to this spelling convention, though from a linguistic point of view, the spelling is uninteresting and it is syntactic and semantic behaviour that are more important. From these points of view, *how* is just like the other ‘wh’-elements. In a *wh*-interrogative, the sentence begins with the *wh*-element:

- (18) a who said that?  
 b what did you say?  
 c why do you say that?

Apart from (18a) where the *wh*-element replaces the subject, all other instances of *wh*-questions involve the *wh*-element being in front of the subject. Given that the subject’s surface position is the specifier of the IP, this indicates that the *wh*-element sits in a position outside the IP. Above the IP is the CP, so we may assume that the *wh*-element is situated in the CP. As *wh*-elements are phrases, probably DPs, though some of them have underlying distributions similar to PPs and therefore are either PPs or perhaps DPs non-canonically realising the prepositional role, they must occupy a phrasal position in the CP and the most obvious choice would be the specifier of the CP:

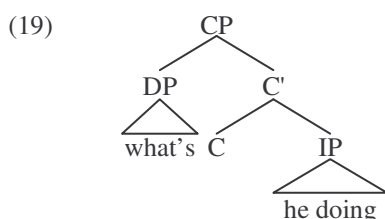

In yes–no questions, there is no interrogative pronoun and the question is interpreted as asking about the truth of the proposition that it expresses. Hence they may be answered by “yes” (that’s true) or “no” (that’s not true):

- (20) a will they ever stop singing?  
 b have you seen my glasses?  
 c did you see that?

Note that these questions are formed by placing an auxiliary verb in front of the subject, a phenomenon traditionally termed **subject–auxiliary inversion**. Again, given that the auxiliary is to the left of the subject, it seems to be outside of the IP and presumably somewhere in the CP. This time, however, the position needed is a word position and the obvious choice is the complementiser position itself:

## Interrogative CPs

---

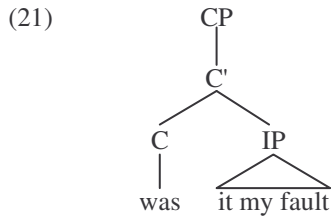

It makes perfect sense that *wh*-questions and yes–no questions involve the complementiser system as complementisers contribute the semantics of force to the sentence, but there is independent evidence for the validity of these analyses. To start, that inverted auxiliaries occupy the C position is supported by the observation that inverted auxiliaries and complementisers are in complementary distribution. The best evidence for this involves not interrogative clauses, though it is also true that we never get inverted auxiliaries and complementisers together in an interrogative, but **conditional** clauses. In English there are two types of conditional clause, one formed with an *if* complementiser and one formed with an inverted auxiliary:

- (22) a [if he’s a government minister] then I’m the Queen of Sheba  
 b [had I known about your allergy] I wouldn’t have sent flowers

That *if* conditionals do not involve auxiliary inversion demonstrates that the complementiser and the inverted auxiliary are in complementary distribution and therefore occupy the same position:

- (23) a \*[if had I known royalty was visiting] I would have combed my hair  
 b \*[had if I been told the deadline] I would have typed the report yesterday

Moreover, with many *wh*-questions we also get auxiliary inversion:

- (24) a what will you do?  
 b when should we meet?  
 c who did you talk to?

As we can see the *wh*-element precedes the inverted auxiliary, supporting the assumption that the *wh*-element is in the specifier of CP and the inverted auxiliary is in the head position:

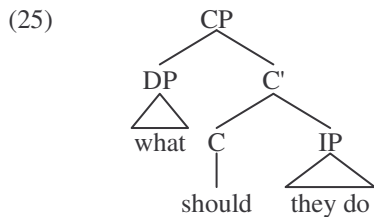

Having established the structure of these interrogatives, let us spend some time discussing the processes involved in their formation.

### 3.2 *Wh*-movement

*Wh*-elements come in a variety of forms and functions. All of them contain some element that has an interrogative interpretation, which may be a pronoun, a determiner or a degree adverb:

- (26) a [DP what] do you think?  
 b [DP which present] did she get you?  
 c [PP to whom] am I talking?  
 d [AP how fast] did they run?

We might assume that all of these phrases share a common ‘interrogative feature’ which determines their interpretation as question elements. Typically this feature is represented as [+wh] and is contrasted with [-wh] which has a declarative interpretation.

The main issue to be discussed is why *wh*-elements move to the specifier of the CP. We have seen that movement of DPs to the specifier of IP is motivated by the need to circumvent the actions of the Case filter. But this cannot be the motivation for *wh*-movements. This can be argued for from a number of perspectives. First note that *wh*-movement does not always involve DPs, unlike movements to spec IP. As the Case filter concerns only the distribution of DPs, it cannot be the motivation for all *wh*-movements and there must be another reason for why non-DP *wh*-elements, at least, undergo the process. Moreover, the Case filter cannot be the motivation for DP *wh*-elements moving to spec CP. This is because DP *wh*-elements move to spec CP from Case positions:

- (27) a what<sub>i</sub> do you know t<sub>i</sub>?  
 b who<sub>i</sub> did you speak to t<sub>i</sub>?  
 c who<sub>i</sub> do you think [t<sub>i</sub> is the thief]?

The *wh*-element in (27a) moves from an object position, from the object of a preposition in (27b) and from a finite clause subject position in (27c). All these are Case positions, so the Case filter cannot explain why the movement took place.

There seem to be two interrelated motivations for *wh*-movement, one concerning the interpretation of the clause, and one concerning the interpretation of the *wh*-element itself. Let’s start with the clause. Obviously clauses are either interpreted as questions or not. Moreover, in embedded contexts the distribution of a clause will depend on its force as some verbs require an interrogative complement while others require a declarative one:

- (28) a Andrew asked [if/\*that the pears were ripe]  
 b they didn’t think [that/\*if the pears were ripe]

In the examples in (28) the force of the embedded clauses is obviously determined by the complementiser, as would be expected. However, in the following, it seems that the force of the clause is determined by the *wh*-element in specifier positions:

- (29) Wendy wondered [when the pears would be ripe]

This is a little puzzling as phrases do not get their properties from their specifiers, but from their heads.

## Interrogative CPs

---

We have seen in a number of previous places that the head and the specifier have a special relationship. In the IP where the subject sits in the specifier and the agreement morpheme sits in the head position, the two elements ‘agree’ with each other in terms of number and person features. Thus if the subject is a third person singular element, then the agreement will be third person singular and determine that the finite morpheme ‘s’ will show up on the verb. In the DP, the possessor sits in the specifier position and this can only be accompanied by a determiner that ‘agrees’ with it in terms of possession. We might assume therefore that the CP will be no different and that the head and its specifier will enter into an agreement relationship, presumably in terms of the [+wh] feature. So, if the specifier has this feature, so will the head. Of course, if the head has the feature, then it will project it to the CP and this will be interpreted as an interrogative clause, and hence the *wh*-specifier can indeed influence the interpretation of the clause in a round-about manner:

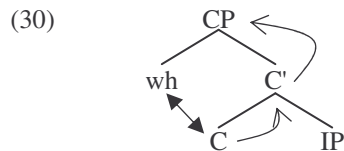

In (30) the double arrow represents the agreement relationship between the head and its specifier and the single headed arrows represent the projection of the head’s features to the CP. By this path then the [+wh] on the *wh*-element ends up on the whole CP and a CP with a *wh*-specifier will be interpreted as interrogative. Thus, one motivation for *wh*-movement might be that there is need to interpret the clause as an interrogative.

This cannot be the whole story however. The following indicates that moving the *wh*-element to the front of the clause is not obligatory:

- (31) A I voted for the Monster Raving Loony Party  
 B you voted for who?

B’s response involves what is known as an **echo question**, in which a previously uttered sentence is more or less repeated and a part of it that was either not heard or not believed replaced by a *wh*-element. The meaning is quite clear: it is a request for someone to repeat or confirm the previous statement. This is very different from the meaning of a *wh*-question which is asking for information about a particular aspect of the sentence. Compare:

- (32) a who did you talk to?  
 b you talked to who?

One major difference in meaning between these two sentences is that the first presupposes the truth of the proposition: the speaker assumes that *you spoke to someone* is true. Thus this kind of question cannot be asked felicitously if the speaker doesn’t think that you spoke to anyone. This is not true of (32b), however. In repeating back the previously made statement, the speaker does not commit himself to either its truth or falsity: judgement about that is postponed until the answer is received. Clearly this difference in meaning has something to do with where the *wh*-element is situated.

## Chapter 7 - Complementiser Phrases

---

If the *wh*-element is moved to the specifier of CP then the result is a *wh*-interrogative interpretation. If not then the sentence is interpreted as an echo question. We might think of this in terms of the interpretation of the *wh*-element itself. A *wh*-element interpreted in an echo question simply has the role of a pointer to the missing information. In a sense it is a ‘place filler’ that does little more than indicate what needs to be repeated. A *wh*-element that is moved into the specifier of the CP is a little more complex in terms of its interpretation. The semantics of a moved *wh*-element is similar to that of a quantifier such as *everyone* or *someone*. These are called **operators** as they indicate a process that is needed to work out the meaning of the sentence that contains them. For example, consider the difference between the following:

- (33) a Tim is tall  
b someone is tall

The truth of (33) is fairly easy to establish. First we find the individual that the name *Tim* refers to and then we see if they have the property of being tall. The truth of the second statement is not quite so easy. For a start, there is no individual to whom the word *someone* refers and so it isn’t just a matter of checking to see if the person has the property of being tall. Instead we must go to the set of things that *someone* could potentially refer to (the set of people relevant to a conversation, perhaps) and go through each of them individually to see if they are tall. If at least one of them is tall, then the sentence in (33) is true. If none of them are tall then the sentence is false. Consider what *who* means in (32a). Like the quantifier *someone* the interrogative pronoun does not refer to a known individual. Instead, the hearer is asked to perform a process of going to the set of potential referents and finding those that if substituted for the *wh*-element would produce a true sentence:

- (34) a who did you talk to?  
b I talked to Tom – false = not the answer  
I talked to Dick – false = not the answer  
I talked to Harry – true = answer

Thus, a fronted *wh*-element is interpreted as an operator. Given that the difference between a *wh*-element that is interpreted as an operator and one that is simply used as an echoic device is that the former is moved to specifier of CP while the latter is not it seems that the movement plays a role in determining the interpretation of the *wh*-element as well as the interpretation of the clause that contains it. Let us assume the following interpretative principle:

- (35) interpret a *wh*-element as an operator if it is in spec CP

There is one exception to the above principle however. Consider the following:

- (36) who does Thelma think likes what

This is known as a multiple *wh*-question as it is a single question that asks for more than one piece of information. Note that both of the *wh*-elements may be interpreted as operators (the second one may be interpreted as an echo given the right intonation), in which case the answer to the question has to be a list of pairs ranging over likers and likees. The interesting point is that the second *wh*-element, although it may be

interpreted as an operator, clearly has not undergone movement and so seems to violate the interpretative principle in (35). One thing is clear, however: the interpretation of this non-moved *wh*-element as an operator is dependent on there being a moved *wh*-element in the same sentence. If this were not a multiple *wh*-question, the *wh*-element would have to move. What we need then is to somehow tie the non-moved *wh*-element to the moved one. One possibility would be to claim that at some level of representation of the sentence which is relevant for semantic interpretation, multiple instances of *wh*-elements are interpreted as a single complex *wh*-element. Let us simply say that we indicate the interpretation of multiple *wh*-elements as a complex operator by coindexing them:

(37)     $\text{who}_i$  does Bill think likes  $\text{what}_i$

We can then alter our statement of the interpretative principle to fit this situation:

(38)    interpret a *wh*-element as an operator if it is in spec CP or is coindexed with a *wh*-element in spec CP

The movement of the *wh*-element to spec CP therefore seems to have an interpretative motivation, which contrasts with the grammatical motivation of the movement to spec IP. There are other differences between the movements, which we will look at in the next chapter. We may, for now, simply identify the kind of Case filter/grammatically motivated movement as A-movement (A stands for ‘argument’ as it is only argument DPs which undergo it) and the kind of semantically motivated movement, such as *wh*-movement, as  $\bar{A}$ -movement ( $\bar{A}$  means ‘not argument’).

### 3.3 Inversion

Looking at inverted auxiliaries, we see that they all have one thing in common: they are all finite. An inverted auxiliary may be a modal, which is inherently finite, or an aspectual auxiliary which bears tense and we never get a non-finite form of the auxiliary in the inverted position:

- (39) a could they be finished?  
       b have they finished?  
       c are they starting again?  
       d \*having him been seen

This suggests that the auxiliary moves to the C position from the inflection position. This is straightforward with modals as they are generated in the inflection position at D-structure. Thus they undergo a movement from I to C in certain interrogative structures:

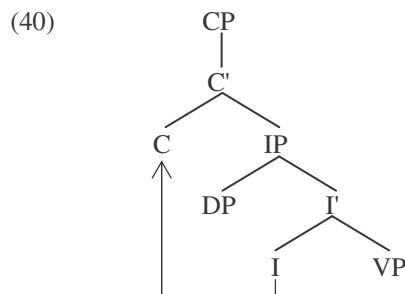

The case of aspectual auxiliaries is similar to the modals. In the previous chapter we claimed that these auxiliaries are inserted elements that may move from the tense position to the I position when there is null agreement in I. Thus, if they are in I, they can also undergo movement from I to C:

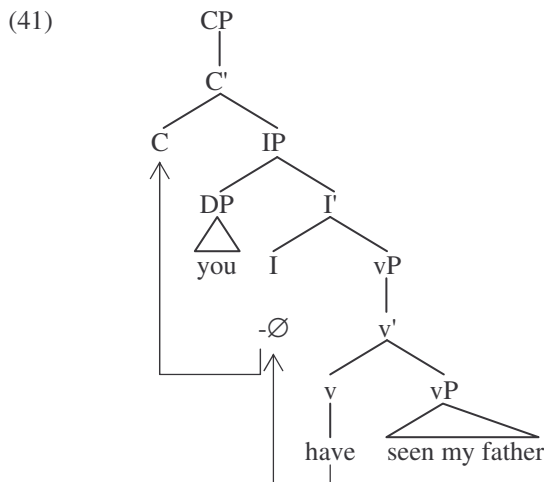

Main verbs are problematic however, as they do not appear to be able to move to the C position:

- (42) a have you read the book?  
 b \*read you the book  
 c did you read the book?

As we can see, a yes–no question involving a main verb moving to the C position is ungrammatical and instead of the main verb moving to C what happens is that the dummy auxiliary *do* is inserted into the tense position, and from there it moves to C, via I. Of course, this is readily accounted for if main verbs do not move to I, as is the standard assumption. If they are never in I they cannot move to C without violating the head movement constraint. But we argued that main verbs can move to I and so it is not readily apparent why they cannot move to C. We will put this issue to one side until we have discussed the facts about I-to-C movement more fully. For the time being, then, we will concentrate on I-to-C movement as it involves auxiliary verbs.

### 3.4 The interaction between *wh*-movement and inversion

The most important issue concerning I-to-C movement is why it happens. There are two main views on this. One is that I-to-C movement happens because there is a bound C morpheme in interrogative clauses and this triggers the movement of the auxiliary to support it in the same way that inflections trigger verbs and auxiliaries to move. The other view is that the movement happens in precisely the cases when there is nothing in C and there is a requirement that there must be. The first is perhaps the most intuitively obvious, but it faces a number of problems which make the other approach more attractive. Let us consider each proposal separately.



## Interrogative CPs

---

We know that the complementiser is the head of the CP and that this provides the relevant features for the force interpretation of the sentence. Some complementisers are interrogative and some are declarative. Thus, when the clause is interrogative, presumably it has an interrogative complementiser and vice versa if the clause is declarative. In yes–no questions, therefore, we might expect the clause to have an interrogative complementiser. As we can see no complementiser in such sentences, we must assume it to be abstract. The assumption of such an element is supported by the fact that in some languages a morpheme with exactly these properties appears overtly. For example, in Japanese, a yes–no question is marked by the appearance of the morpheme *ka* at the end of the clause. Thus, the difference between (43a) and (43b) is that the first is declarative and the second interrogative:

- (43) a Keko-wa sensei desu  
       Keko teacher is  
       ‘Keko is a teacher’  
       b Keko-wa sensei desu ka?  
       ‘is Keko a teacher?’

In Japanese, the complementiser goes in the final position of the clause and so the question particle is suitably analysed as a complementiser. Thus, we might claim that English is similar to this, the main difference being that the question particle is covert in English:

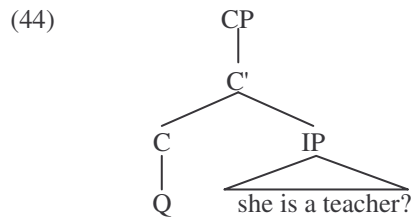

The simple assumption that this interrogative complementiser is a bound morpheme in English is enough to justify the movement of the inflectional element to support it:

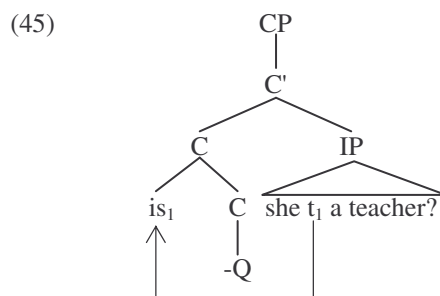

A similar analysis can be provided for inversion that accompanies *wh*-movement to spec CP. As we discussed in the previous section, *wh*-movement to spec CP establishes an agreement relationship between the *wh*-element and the head of CP that

## Chapter 7 - Complementiser Phrases

enables the clause to be interpreted as an interrogative. One way to realise this agreement relationship is in terms of the presence of an interrogative complementiser, i.e. the empty question particle, in the C position:

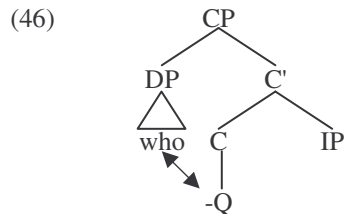

Again, as this particle is a bound morpheme, it will trigger movement to support it:

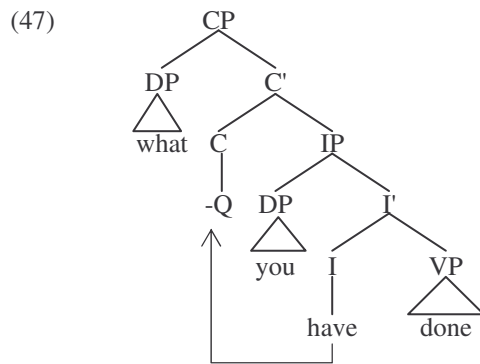

This all seems fairly straightforward. Unfortunately things are a little more complex and it appears that we do not always get inversion in question clauses. One place where we find that inversion doesn't happen is in embedded questions:

- (48) a I didn't know [what he would say]  
 b \*I didn't know [what would he say]

In some embedded contexts, it seems as though inversion is optional:

- (49) a the boarder guard asked [why the tourist didn't have a passport]  
 b the boarder guard asked [why didn't the tourist have a passport]

Note, however, these two sentences have very different meanings. In the first case the embedded question reports on the 'content' of the question that was asked. The question might not have been framed in these exact words, or even in English! In contrast, in the second case the embedded clause reports on the words that were actually used. Thus in the second case, the embedded clause actually echoes a previous sentence that has been uttered. When it was uttered, obviously this sentence was not an embedded clause but a main one, and hence it is not surprising that it follows the pattern of a main clause. Therefore, (49b) isn't really an example of an embedded clause with inversion but it involves something that is a main clause, seemingly being used in an embedded context. The conclusion is that in real embedded clauses we don't get inversion.

## Interrogative CPs

But this is a puzzle. Why do we not get inversion in an embedded interrogative? If the account of why we get inversion in main clauses is as we have so far suggested, then we must conclude that the question complementiser either does not need binding in an embedded clause, or that it is bound by some other element. For example, we might assume that the question complementiser in an embedded clause is not the same complementiser that appears in the main clause. We know that we do not get the kinds of overt complementisers that introduce embedded clauses in main clauses:

- (50) a \*that Rachel is rich  
 b \*if you saw that

However, we have also claimed that main clauses are CPs and so have complementisers introducing them. Therefore there seems to be a distinction between main clause and embedded clause complementisers. If this is so, then we might claim that the main clause interrogative complementiser differs from the embedded interrogative clause complementiser in that the former is a bound morpheme while the latter is not:

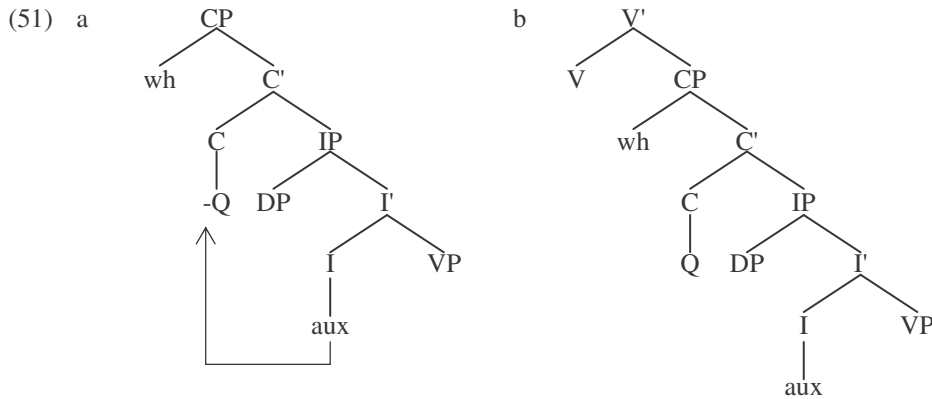

But this is a rather *ad hoc* solution which doesn't really tell us why things are this way and hence does not really have much by way of explanatory content.

A second proposal claims that the difference between main and embedded clauses is that while complementisers are allowed in embedded clauses they are not in main clauses. Thus, a main clause interrogative actually lacks an interrogative in the C position, which is therefore underlyingly empty. An embedded clause on the other hand differs in two ways from a main clause: complementisers are allowed in embedded clauses and the clause itself is selected as a complement by some predicate. We have seen how a predicate imposes selectional restrictions on its clausal complements and those predicates which take an interrogative complement will demand that the CP be marked as interrogative. The way to mark a clause as interrogative is to give it an interrogative head and this can either be overt, i.e. *if* or covert, i.e. *Q*:

- (52) a Robin doesn't remember [<sub>CP</sub> if [<sub>IP</sub> she bought bread]]  
 b Richard doesn't recall [<sub>CP</sub> where Q [<sub>IP</sub> he left his horse]]

## Chapter 7 - Complementiser Phrases

---

If we assume that *Q*, like *if*, is not a bound morpheme, then there will be no reason for inversion. However, in a main clause there can be no complementiser and hence *Q* like all other complementisers will be prevented from appearing. An interrogative CP still needs to be interpreted as interrogative however and hence it will need its head to have the [+wh] feature. We have seen how, when a *wh*-element moves to spec CP, it agrees with the head. If we make the reasonable assumption that nothing can agree with an empty head position, this necessitates something being in the head position of an interrogative clause. Given that complementisers are systematically excluded from this position, the only option is to move the nearest head into the C position and this will be the auxiliary in I:

- (53) a \*<sub>[CP what e <sub>[IP I can do]]</sub>  
b \*<sub>[CP what if/Q <sub>[IP I can do]]</sub>  
c <sub>[CP what can<sub>1</sub> <sub>[IP I t<sub>1</sub> do]]</sub></sub></sub></sub>

(53a) is ruled out because the *wh*-element has nothing to agree with and hence the clause cannot be interpreted as an interrogative. (53b) is ruled out by the general exclusion of complementisers appearing in main clauses. This leaves (53c) as the only grammatical possibility.

While this analysis seems less *ad hoc* than the assumption of different interrogative complementisers in main and embedded clauses, there are still a number of questions left unanswered. For example, how are we to analyse yes–no questions under the assumption that complementisers are not allowed in main clause complementiser positions? What triggers the inversion in this case if there is no *wh*-element to agree with? The answer might be that there is a *wh*-like element in yes–no questions. Although we do not get inversion type yes–no questions in embedded clauses, for obvious reasons, it is still possible to have an embedded yes–no question. These are typically expressed by the element *whether*:

- (54) I asked <sub>[CP whether I should bring some wine]</sub>

If we were to put the content of this embedded clause into a main clause it would be *should I bring some wine*, i.e. a yes–no question. Thus, (54) contains an embedded yes–no question. The *wh*-element *whether* is quite strange. In many ways it looks like a complementiser, being a word that appears at the front of an interrogative clause, rather like *if*. However, there are a number of reasons to believe that *whether* is not a complementiser. For one thing, it can introduce both finite and non-finite clauses:

- (55) a I wonder <sub>[CP whether I should boil the eggs]</sub>  
b I wonder <sub>[CP whether to boil the eggs]</sub>

As we have seen, complementisers generally select for a particular type of CP complement, either finite or non-finite. Moreover, no other complementiser can introduce a non-finite clause with a missing subject:

- (56) \*they hoped <sub>[for – to win]</sub>

*Whether* can be coordinated with operators like the negative and *wh*-pronouns:

- (57) a I'm not sure <sub>[whether or even when I should applaud]</sub>  
b they asked <sub>[whether or not they would be paid]</sub>

## Interrogative CPs

---

No other complementiser can do this:

- (58) a \*I don't know [if and when to stand up]  
 b \*she wondered [if or not to pack the bags]

Finally consider the fact that the word *whether* was used in Old English to introduce yes–no questions in main clauses:

- (59) hwæðer ge nu secan gold on treowum  
 whether you now seek gold in trees  
 'do you now seek gold in trees'

Yet Old English did not have main sentences that started with complementisers, indicating that *whether* never was a complementiser even in former stages of the language.

But if *whether* is not a complementiser, what is it? It differs in one very large way from *wh*-elements and that is while *wh*-elements move out of a clause *whether* does not seem to. *Wh*-elements are all moved to the spec CP from some position inside the IP and therefore they are always associated with a 'gap' in the clause, filled, of course, by a trace:

- (60) a [<sub>CP</sub> who<sub>i</sub> did [<sub>IP</sub> you think I met t<sub>i</sub>]]  
 b [<sub>CP</sub> who<sub>i</sub> did [<sub>IP</sub> he say t<sub>i</sub> likes tennis]]  
 c [<sub>CP</sub> where<sub>i</sub> did [<sub>IP</sub> you put the anti-tank missiles t<sub>i</sub>]]

But *whether* is not linked to any position inside the IP from which it has moved. This, I think, is understandable in terms of the functions of *wh*-elements. Most *wh*-elements are used in *wh*-questions and their function is to mark the clause as an interrogative and to indicate what the focus of the question is. (60a), for example is a question about the object, which is the position from which the *wh*-element derives. As we said, the function of *whether* is to mark a yes–no question and these questions focus on the truth of the sentence rather than on any particular piece of information it may carry. For this reason, then, *whether* does not need to hold a position in the clause, it merely indicates the clause's question status. We may assume therefore that *whether* is a *wh*-element that is generated directly in the specifier of CP as a general interrogative operator. As it appears in embedded contexts, it will be accompanied by an interrogative complementiser *Q* with which it agrees:

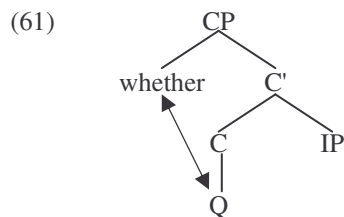

What about main clause yes–no questions? Obviously in Modern English, *whether* is not allowed to appear in main clauses. But we might suppose that something appears in the same position in main clause interrogatives. This is clearly an operator like *whether*, only phonologically null. Standardly, null operators are denoted by *Op*:

**Chapter 7 - Complementiser Phrases**

---

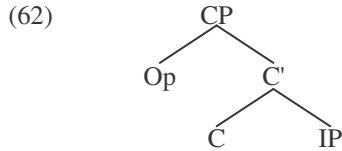

Like other main clauses the complementiser position is empty and yet the null operator must agree with something to ensure the correct interpretation of the clause. This then is the trigger for the auxiliary inversion we see in yes–no main clauses. We end up then with a very uniform analysis of interrogatives in English: they all have an interrogative operator in the specifier position of the CP which agrees with the head. In main clauses the head cannot contain a complementiser, so an auxiliary is moved to C to enter into the agreement relationship. In subordinate clauses however, complementisers can appear and so there is no need for auxiliary inversion:

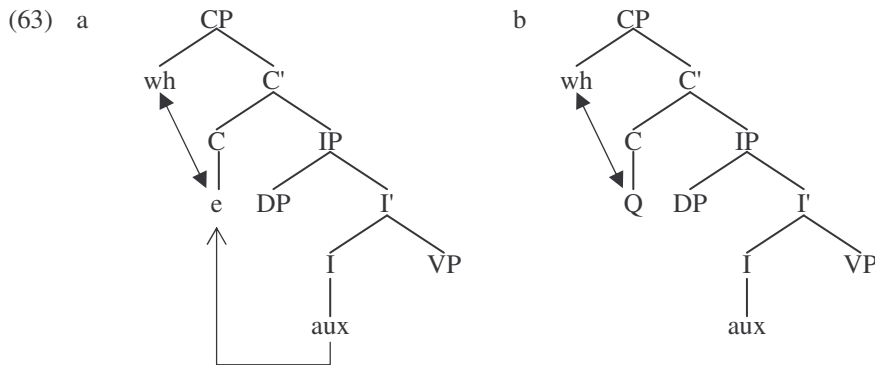

A final issue we might mention in connection with this analysis concerns the embedded clauses. If embedded questions can have complementisers as well as *wh*-elements in their specifier positions, why do we never get them together?:

- (64) a I never heard [Op if [they caught the burglar]]  
 b I never heard [who Q [they caught]]  
 c \*I never heard [who if [they caught]]

This is a puzzle for which I have no real account. Apparently it is a very general condition that a CP can contain either an overt operator or an overt complementiser. We will see that this extends to other clauses too. Moreover, it appears not to be violated by an auxiliary moving to C. The condition has been known as the Doubly Filled COMP Filter since (1977) when it was introduced by Chomsky and Lasnik. However, this stipulatory account has never been superseded by anything more explanatory. I will therefore adopt the Doubly Filled COMP Filter as a condition on the well-formedness of structures in lieu of a proper explanation:

- (65) the Doubly Filled COMP Filter  
 no CP can have both an overt specifier and an overt complementiser generated in C

This will have to suffice until we gain a better understanding of this phenomenon.

### 3.5 Subject questions

The last issue concerning interrogatives we will discuss concerns the difference between *wh*-questions which focus on the main clause subject and all other kinds of *wh*-questions. With most *wh*-questions it is fairly easy to see that movements take place as elements such as objects and adjuncts do not appear in their expected positions, but at the beginning of the clause:

- (66) a *who*<sub>1</sub> did they execute *t*<sub>1</sub>  
 b *when*<sub>1</sub> was the meeting scheduled *t*<sub>1</sub>

Inversion is also possible to detect as the auxiliary and the subject end up on the opposite sides of each other. But when it is the main clause subject that is the focus of the question, things are no longer so clear cut. The word order is consistent with at least three analyses:

- (67) a [<sub>CP</sub> e [<sub>IP</sub> *who* can save the world]]  
 b [<sub>CP</sub> *who*<sub>1</sub> e [<sub>IP</sub> *t*<sub>1</sub> can save the world]]  
 c [<sub>CP</sub> *who*<sub>1</sub> *can*<sub>2</sub> [<sub>IP</sub> *t*<sub>1</sub> *t*<sub>2</sub> save the world]]

In (67a) both the *wh*-subject and the auxiliary are in the IP and do not move to the CP. In (67b) the *wh*-subject moves to the specifier of CP but the auxiliary does not move and in (67c) both the subject and the auxiliary move. But which one is correct and how can we know? From all that we have said above, one might hope that (67c) is accurate as only in this is the CP specifier filled with a *wh*-element and the head filled by something it can agree with. However, doubt is cast on this conclusion from the following phenomena:

- (68) a *who* did you meet  
 b *who* met you

It seems that for some reason, to which we return shortly, main verbs cannot move to C. So when a *wh*-element moves to the specifier of CP and it requires some element in the C position to agree with, the dummy auxiliary is used and hence we get *do*-insertion. However, when the subject is the focus of the question, there is no *do*-insertion indicating that nothing has to move to C. If this is a general condition then it suggests that no element moves from I to C in subject questions and hence that (67c) is not correct. Opinions differ as to the correctness of (67a) or (b), but obviously both are problematic for the straightforward analysis of interrogatives.

Before we consign (67c) to the waste bin however, let us see if it might be salvaged. We have argued that main verbs do not differ in their positions from auxiliary verbs except in the case of negation where the main verb cannot move over the negative head, but as auxiliaries are inserted into tense, the presence of negation does not affect them. Other than this, though, both main verbs and auxiliaries alike can occupy the I position (contra standard wisdom). If this is a general fact, then it is possible that main verbs can raise to C just as auxiliaries do and hence (68b) might be analysed as involving I-to-C movement of the main verb:

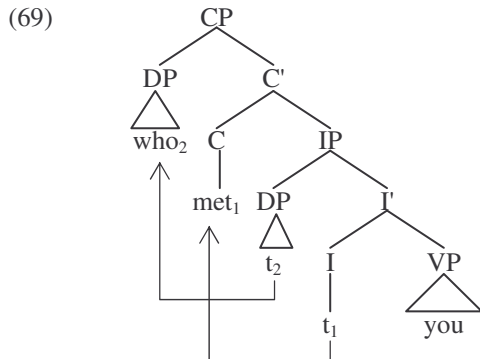

As a structure this is straightforward. It contains a *wh*-element in the specifier of CP so that the whole clause can be interpreted as an interrogative. Moreover it has something in the C position for the *wh*-element to agree with. If we accept this as basically correct, we then have (68a) to account for: why can the verb not move to C when anything but the subject moves to spec CP? The answer would appear to have to do with the subject: when this does not move to spec CP the main verb cannot move past I.

We have seen restrictions like this before. The adverb, for example must be above the verb and the negation must be above the verb but below the tense. It seems that the verb must be below the subject and hence when the subject is in spec IP the verb can be no higher than I. However, when the subject moves to spec CP the verb can move to C and still remain lower than the subject. When the verb cannot move from I to C there is no choice other than to insert the auxiliary *do*. However, it appears that the dummy auxiliary is not enough by itself to provide the *wh*-element with something to agree with, thus the auxiliary must be inserted in to tense and move from there to I and from there to C to provide enough semantic content to support the agreement. The verb stays behind in the VP:

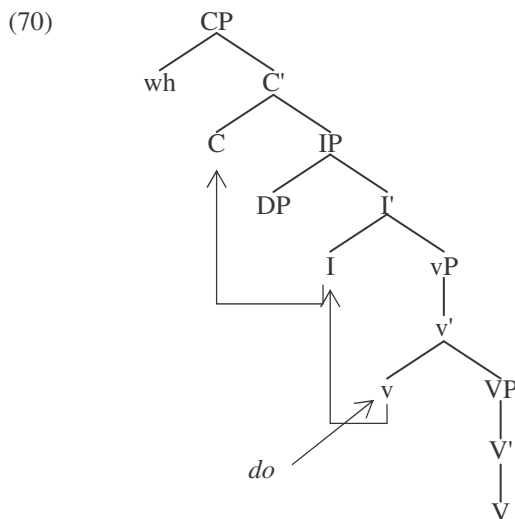



## Relative Clauses

---

To conclude this section. It seems that the distribution of elements in an English sentence is partly due to structural conditions imposed by X-bar theory and the selectional requirements of certain heads, partly due to the morphological properties of certain heads and partly due to general ordering requirements affecting certain elements. Specifically we have seen the effects of the following conditions:

- (71) a verbs follow their subjects  
b negation follows the finite tense and precedes the verb  
c adverbs (follow the finite tense and) precede the verb

The brackets around the condition in (71c) indicate that this seems to be a preference rather than a rigid condition and that if it is impossible for the adverb to both follow the tense and precede the verb, both are in the same place for example, then the condition may be relaxed.

### 4 Relative Clauses

There is another construction in English which looks like an embedded interrogative clause, but which is very different in interpretation. This clause acts as the modifier of the noun inside the DP:

- (72) a I asked [who you met]  
b the man [who you met]

Such noun modifier clauses are called **relative clauses**.

#### 4.1 The position of the relative clause inside the NP

As relative clauses seem to modify nouns we can assume that they occupy a position within the phrase headed by the noun. There is evidence that this is so as the noun and the relative clauses can be pronominalised and coordinated separately from the determiner:

- (73) a the [mistake that I made] was much bigger than that **one**  
b these [components that we make] and [boxes that we pack them in]

There are two possible adjunction sites inside the NP: the N' and the NP itself. There is some evidence that relative clauses are adjoined to the N'. For example, if it is the case that the adjectival phrase is adjoined to the N', then the fact that the relative clause can be adjoined lower still than APs indicates that they must also be adjoined to N' and not to the NP:

- (74) my favourite [places I like to go] and [people I like to visit]

In this example, the AP *favourite* modifies both *places I like to go* and *people I like to visit*, indicating that these are below the adjective:

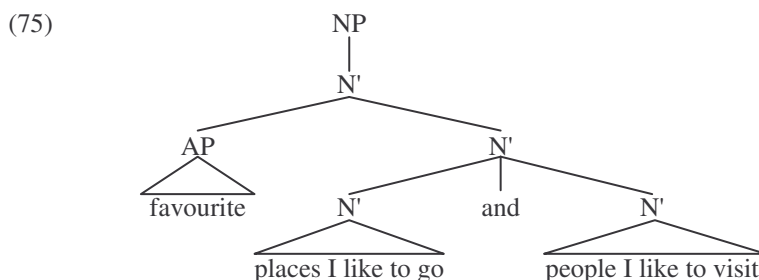

However, there is a slight complication in that there are more than one type of relative clause. Those that we have been looking at so far are known as **restrictive** relative clauses. Semantically these tend to focus on one element out of a set of possible referents. For example, *the components that we make* focuses on a particular set of components out of a larger set of components which are distinguished by the fact that we make them. Thus, the purpose of the relative is to ‘restrict’ our attention to a certain element or elements out of a possible range of elements. By contrast, **non-restrictive** relative clauses simply add extra information about the referent of the noun being modified:

- (76) the earth, which is 93 million miles from the sun

Note here, there is not a range of possible referents for the noun *earth* and the relative clause restricts our attention to one of them. There is just one *earth* being spoken of, and the fact that it is 93 million miles from the sun is given as information about this object.

Restrictive and non-restrictive relative clauses also differ from each other in terms of their internal properties, something which we will discuss more fully in the next section. For now, let us just note that restrictive relative clauses may begin with a *that* whereas non-restrictive relatives never do:

- (77) a the man [that you met] (as opposed to all the other men)  
 b \*the earth [that is next to Mars] (as opposed to all the other earths!)  
 c the earth, [which is next to Mars]

The two kinds of relative also differ in their prosodic properties. In written form the non-restrictive relative is followed by a comma, which indicates a slight pause between the noun and the relative. There is no pause between the noun and its restrictive modifying clause however.

It may be that the two clauses also differ syntactically and indeed it is often assumed that non-restrictive relative clauses are more distant from the noun than are restrictive relatives. This is supported by the following observations:

- (78) a the [man [who you met]] and [woman [who you haven't]]  
 b this [man [who you met]] is taller than that one

- (79) a my [mother [who you met]] and [father [who you didn't]]  
 b \*my [mother [who you met]] is taller than his one

Both kinds of relative clauses can be coordinated with other like constituents showing that they both form a constituent with the noun that they modify. But only the restrictive relative clause and its noun can be pronominalised by *one*. A possible explanation for this is that *one* only pronominalises N's and the string consisting of a noun and a non-restrictive clause is not an N'. This suggests that while restrictive relatives adjoin to the N', non-restrictive relatives adjoin higher up, perhaps to the NP:

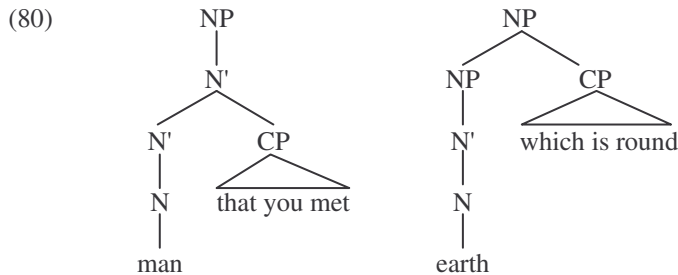

Having established the external distribution of the relative clause, let us move on to look at some of its internal properties.

#### 4.2 A comparison between relative and interrogative clauses

As pointed out, in many ways the relative clause has many properties in common with a *wh*-interrogative. But relative clauses are not interrogative, but declarative. This is clear both from their interpretation and the fact that they may start with the complementiser *that* which as we have seen, introduces declarative clauses. Thus, the *wh*-element which starts relative and interrogative clauses seems to have a different set of features: an interrogative pronoun is [+wh] and a relative pronoun is [-wh]. One might think therefore that they are entirely different lexical elements. This is supported by the fact that in some languages there are differences between relative and interrogative pronouns. In Hungarian for instance, there is a systematic difference with relative pronouns beginning with *a*-:

(81)	Interrogative	Relative
	ki – kit (who nom – acc)	aki – akit
	mi – mit (what nom – acc)	ami – amit
	mikor (when)	amikor
	hol (where)	ahol
	melyik (which)	amelyik

Even so, there is still an obvious relationship between the two and so it probably would not be wise to claim them to be completely separate. It may be that *wh*-pronouns are lexically unmarked for the feature [ $\pm$ wh] and get this through the agreement with the appropriate complementiser, though this suggestion does not entirely square with the claim made earlier that in main clauses there is no complementiser for the interrogative pronoun to agree with.

Whatever the relationship between interrogative and relative pronouns, it still needs to be acknowledged that there are different possibilities in both types. For example, in English although *what* is a perfectly good interrogative pronoun, its use as

## Chapter 7 - Complementiser Phrases

---

a relative pronoun is somewhat stigmatised, being seen as a characteristic of ‘uneducated’ speech. Dialects and sociolects that make use of ‘what relatives’ also do not use the relative pronoun in a way consistent with the interrogative pronoun. While *what* as an interrogative pronoun has a ‘non-human’ aspect to it in any dialect, in that you couldn’t point to a person and ask “what is that” without being offensive (“who is that” would obviously be more appropriate), *what*-relatives are often used to modify nouns with human referents:

- (82) a a man [what I know]  
b this bloke [what I was telling you about]

In standard English, however, *what*-relatives are not accepted even for modifying nouns with non-human referents:

- (83) a \*the book [what I read]  
b \*an idea [what I had]

The only acceptable use of a *what*-relatives in standard English is in relatives which appear to lack a modified noun, what are sometimes called **headless relatives**:

- (84) a [what you should do now] is ...  
b [what I say and what I do] are two totally different things  
c [what I don’t understand] is ...

To conclude on this issue, *what* as an interrogative pronoun and *what* as a relative pronoun are used in very different ways in all dialects.

There is another interesting difference between the use of interrogative and relative pronouns which shows that there is a possibility available for a relative pronoun that is not generally available with interrogatives. The restrictive relative is often noted to come in three different forms. One starts with a *wh*-relative pronoun and is called a ***wh*-relative**. Another starts with the complementiser *that* and is called a ***that*-relative**, and the third has nothing in front of the subject and is called a **zero relative**. These are exemplified below:

- (85) a the man [who I paid]  
b the man [that I paid]  
c the man [I paid]

The *wh*-relative resembles an interrogative in more than just the fact that it is introduced by a *wh*-element, but also in the process which apparently forms the two structures. In both cases, the *wh*-element starts off inside the clause and moves to the specifier of CP. Thus, both types of clauses start with a *wh*-element and have a corresponding ‘gap’ in the position it was moved from. The gap contains the trace of the moved *wh*-element:

- (86) a I wonder [who<sub>i</sub> Sherlock suspects t<sub>i</sub>]  
b the butler [who<sub>i</sub> Sherlock suspects t<sub>i</sub>]

Interestingly, although they do not start with a *wh*-element, both *that*-relatives and zero relatives contain a gap in the same place that they would if they did have a *wh*-element:

## Relative Clauses

---

- (87) a the butler [that Sherlock suspects -]  
b the butler [Sherlock suspects -]

We should first counter a myth about *that*-relatives that prevails from traditional grammars. In these it is common to find *that* at the beginning of the relative clause referred to as a relative pronoun, thus suggesting that it be given the same treatment as *wh*-elements. If this is true, then this element originates inside the clause and moves to the specifier of CP, as do *wh*-elements. But there are many reasons to believe that this word is not a *wh*-element but is, as appearances predict, a simple complementiser. Firstly, note that as would be predicated on the assumption that it is a complementiser, *that* is only ever used in finite clauses and although *wh*-elements can marginally be used in non-finite clauses, *that* never is:

- (88) a the man [who to contact] \*the man [that to contact]  
b a place [where to stay] \*a place [that to live]

Instead, we can get a *for* complementiser in non-finite relatives, as would be expected:

- (89) a a man [for you to contact]  
b a place [for me to stay]

Another argument that *that* is not a relative pronoun in *that*-relatives is that it does not behave like a *wh*-element with respect to prepositions. Note the following two possibilities with a *wh*-relative:

- (90) a the house [which<sub>1</sub> I live in t<sub>1</sub>]  
b the house [in which<sub>1</sub> I live t<sub>1</sub>]

When the *wh*-element is part of a PP it has the option of moving alone, a strategy known as **preposition stranding**, or of taking the whole PP with it, a strategy known as **pied-piping** (after the story of the Pied Piper of Hamelin, who played his pipes and the rats followed him – the connection between prepositions and rats is, however, mysterious). If *that* were a relative pronoun, we might expect the same options to be available in *that*-relatives. But this is not true:

- (91) a the house [that I live in -]  
b \*the house [in that I live -]

One explanation for why we do not get pied piping with a *that*-relatives is that *that* is not a relative pronoun and did not originate in the gapped position and hence the preposition could not be pied-piped by it.

If *that* is a complementiser in the *that*-relatives, then *that*-relatives and zero relatives are alike in that they do not contain a *wh*-element and the difference appears to be the standard ability of the complementiser to be overt or covert in a finite clause:

- (92) a I said [(that) I was reading a book]  
b the book [(that) I was reading -]

The fact remains however, that there is still a gap in these relative clauses. What is the nature of this gap? In many ways it has exactly the same nature as the gap in a *wh*-relative. Consider this a little more closely: in a *wh*-relative, the relative clause acts as

## Chapter 7 - Complementiser Phrases

---

a modifier of the noun by relating the noun to a position in the relative clause itself. Thus in (93a) the noun is modified by being interpreted as the object of the verb in the relative clause, whereas in (93b) the noun is modified by being interpreted as the subject of the relative clause:

- (93) a the team [which we beat t]  
           b the team [which t beat us]
- 

The relationship between the noun and the relevant position is not a direct one, however: it is not the noun which moved out of this position otherwise we would end up with a somewhat circular structure with the noun being part of the relative clause that is part of the NP headed by the noun! The relationship between the noun and the position in the relative clause is mediated by the relative pronoun: it is this element that originates in the relevant position and this pronoun is referentially dependent on the noun:

- (94) a the team [which<sub>i</sub> we beat t<sub>i</sub>]  
           b the team [which<sub>i</sub> t<sub>i</sub> beat us]
- 

We might claim that this is exactly what the function of the relative pronoun is in a relative clause. Indeed, if there is no *wh*-element related to a gap, or if the *wh*-element does not move to create the gap, then the relative clause is ungrammatical:

- (95) a \*the team [we beat Liverpool]  
       b \*the team [we beat which]

If this is true, then the same must be true of all relatives, including *that* and zero ones. The fact that we cannot detect a *wh*-element in these relatives suggests that they should be analysed as containing an empty *wh*-element, similar to the empty operator in yes–no questions, but this time behaving like the type of *wh*-element that originates inside the IP and moves to the spec of CP:

- (96) the team [Op<sub>i</sub> (that) we beat t<sub>i</sub>]
- 

Thus the difference between relative clauses and interrogative clauses in this respect is that relative clauses can use the null operator in ways not possible in an interrogative, i.e. as a referential operator rather than a non-referential one which is associated with the truth of the expression.

Having enumerated several differences between interrogative and relative clauses we can now ponder the question of whether these differences show a fundamental distinction between the constructions, or whether they fall out from other considerations. Let us start with why the *wh*-element undergoes movement in both constructions. We have said that the interrogative *wh*-element undergoes movement

## Relative Clauses

---

because the clause needs to be interpreted as interrogative. This clearly cannot be the reason for the movement of the relative pronoun as relative clauses are not interrogative. The reason why a relative pronoun moves is presumably something to do with its function as a mediator between the modified noun and a position inside the relative clause and again this seems to differ from the *wh*-interrogative as *wh*-elements in interrogatives do not act as mediators.

However, if we take one step back from the details, we can see some striking similarities between the reasons for *wh*-movement in both types of clauses. For one thing, both movements have semantic rather than grammatical motivations. Moreover, the reason why the *wh*-element moves in an interrogative is to enable the CP to be interpreted as a question. The reason why the *wh*-element moves in a relative clause is to enable the CP to be interpreted as a modifier.

Finally by moving to the specifier of the CP, the *wh*-element is interpreted as an operator in both interrogative and relative clauses. The fact that one is interpreted more like a quantificational operator, like quantificational pronouns such as *everyone* or *someone*, while the other is interpreted like an anaphoric operator, which is referentially dependent on some other element in the sentence, like a reflexive pronoun such as *himself*, falls out due to the different functions of questions and relative clauses: one asks a question and the other modifies a noun.

What about the use of empty operators in relatives as compared to their limited use in interrogatives?:

- (97) a the idea [Op<sub>1</sub> (that) I had t<sub>1</sub>]  
b \*I asked [Op<sub>1</sub> (if) you had t<sub>1</sub>]

Again this may be entirely due to differences in the use of these constructions. As a relative clause modifies a noun making use of an anaphoric operator, there must be an antecedent for the operator to take its reference from. This antecedent, i.e. the modified noun, can provide us with the content of the operator and hence this is **recoverable** even if we cannot see the operator itself. With a question, however, as there is no antecedent, the content of the operator has to be visible on the operator itself and hence the null operator cannot be used in this way. The null operator used in yes–no questions is clearly non-referential and hence has no specific content to be recovered. In this situation then the null operator can suffice.

In conclusion then, it seems that the differences between interrogative and relative clauses are mainly to do with their different functions. Syntactic and other differences may be derivable from these. Certainly, given the above discussion, it is not really surprising that they have very similar internal organisations and employ very similar processes in their formation.

## 5 Other fronting movements

So far we have concentrated on movements which seem to specifically involve complementisers and their projections. However, there are movements in English which appear to move an element out of the IP but which do not involve the CP. This indicates that there are positions between the CP and the IP. In this final section of this chapter we will briefly investigate this part of the English clause structure.

### 5.1 Topicalisation

So far we have claimed that AP modifiers of VP and of the clause are adjoined to various places inside the IP. There is another position in which we can find both VP and sentential adverbs which appears to be outside the IP altogether:

- (98) a certainly, no one saw the thieves get away  
b quietly, the robbers made their get-away

In some ways, the initial position for adverbs is similar to the *wh*-position, which is unspecified for the kind of *wh*-element that can occupy it:

- (99) a who did you think [- robbed the Post Office] (subject *wh*)  
b what did you think [Biggs robbed -] (object *wh*)  
c where did you think [Biggs robbed the train -] (adjunct *wh*)

The initial position of the adverb seems also unrestricted in that any kind of adverb can occupy it. The reason why the specifier of CP is so unrestricted is because elements move to this position from positions compatible with their status (e.g. from subject, complement and adjunct positions). Taking this into account, we might therefore claim that the initial adverb position is a position to which various kinds of adverbs move. This is backed up by the observation that this position is not only reserved to adverbs, but a whole range of elements seem to be able to occupy it:

- (100) a [<sub>PP</sub> on the train], I saw Biggs –  
b [<sub>NP</sub> Biggs], I remember seeing – on the train  
c [<sub>VP</sub> see Biggs on the train], I certainly did –

These fronted elements are often referred to as **topics**, as they represent information that is already part of the discourse, or can be assumed to be readily retrieved by the participants in the conversation from the context or from general knowledge (often called ‘old’ information). Note that out of context, these expressions often sound strange, but given a context in which the topicalised element has already been introduced, they greatly improve:

- (101) a considering all the places that I saw the robbers (i.e. on the platform, in the engine and on the train), on the train, I saw Biggs, ...  
b of all the people that I recognised (i.e. Biggs, Smith and Jones), Biggs, I saw on the train, ...  
c I expected to see Biggs on the train and [see Biggs on the train], I certainly did



### Other fronting movements

---

One observation that links all these structures (including those with an initial adverb) is that they are all pronounced with a pause after the initial phrase. This is unlike the *wh*-element in spec CP, which has no pause after it. This might indicate, that they are not in the same positions. Another observation that indicates a difference between topicalisation and *wh*-movement is that there is never inversion with topicalisation:

- (102) a where will the robbers strike next  
 b \*the bank, will the robbers strike next

Moreover, if the fronted topics occupied the same position as fronted *wh*-phrases, then we would expect them to be in complementary distribution, which they are not:

- (103) a on this train, where would you hide the money?  
 b this man, where have I seen before?

These data show us that the topic is not moved to the specifier of the CP, but to a position to its left. The obvious suggestion is that the topic is adjoined to the CP. This is supported by the fact that we can have multiple topics and adjunction is a recursive structure:

- (104) [CP yesterday, [CP on the train, [CP Biggs, [CP I saw]]]]

A complication is added by considering other examples. In embedded contexts, the topic does not precede the CP, but follows both the specifier and the head complementiser:

- (105) a I asked where, in this town, we could hide  
 b I think that, in this town, there's no hiding place

Thus it seems that there are two topic positions in the clause, one adjoined to the CP and one adjoined to the IP. The choice of the two is not free however as it is only in main clauses that the topic can adjoin to the CP and only in embedded clauses that the topic can adjoin to IP:

- (106) a \*where could [in this town], you hide?  
 b \*I asked [in this town] where you could hide?

Thus, the relevant structures for topicalisation in main and embedded clauses is as follows:

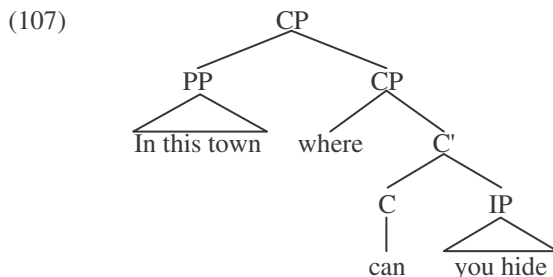

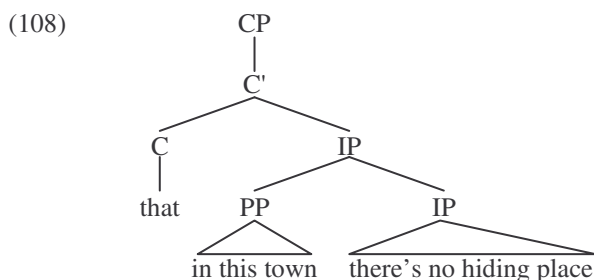

Conditional clauses also have a similar distribution and hence we might claim that they are CP and IP adjuncts:

- (109) a if you had known, what would you have done  
 b I think that, if I had known, I never would have allowed it

However, conditionals, unlike topics, are not restricted to the preceding position:

- (110) a what would you have done, if you had known  
 b I think that I never would have allowed it, if I had known

Moreover, conditional clauses are not associated with any particular position inside the main clause, unlike topics. Therefore we can conclude that conditionals are generated in these positions whereas topics are moved to these positions from various places within the IP.

## 5.2 Focus fronting

Compare the following two sentences:

- (111) a an Arsenal supporter, I wouldn't trust  
 b *an Arsenal supporter* I wouldn't trust

(111a) is a case of topicalisation, whereas (111b) is something different. Note that the comma after the topic indicates an intonational difference between the two sentences: the topic forms an intonational unit by itself, with its own stress, and the following sentence also has its own stress. The other construction, however, has the fronted element within the same intonation unit as the rest of the clause and this element carries the major stress of the sentence. Interpretationally, there is also a large difference between these two sentences. In the first, the conversational situation must be that *an Arsenal supporter* has already been mentioned, probably as one of a number of people being discussed. The sentence then offers some new information about this person: that the speaker wouldn't trust him. Thus we may classify the topic as 'old' information and what follows, usually termed the **comment**, as 'new':

- (112)    an Arsenal supporter,    I wouldn't trust  
                     old                                   new

The other structure is almost the exact opposite of this. The situation here is that it is already known that I wouldn't trust someone and the new information is that *an Arsenal supporter* is that person. A typical use of this construction would be to correct someone asserting that I wouldn't trust *a Liverpool supporter*. The reply might be "no,

### Other fronting movements

---

*an Arsenal supporter* I wouldn't trust". Thus, in terms of the information it contains, the stressed element can be seen as the new stuff and what follows, the old:

- (113)     an Arsenal supporter    I wouldn't trust  
                                new                                  old

We call the stressed element that carries new information the **focus**.

As to the position of the focus, this is a little more difficult to determine. For one thing, foci and questions do not sit happily together:

- (114) a \**men* who would trust  
      b \*who would *men* trust

If we want to have a focus and a *wh*-question in the same clause, we have to indicate the focus by stress alone rather than by movement:

- (115)    who would trust *men*

(115) might be used in response to someone asking 'who would trust women?', with the meaning that it's men who are untrustworthy, not women. However, this complementary distribution between foci and *wh*-elements should not lead us to assume that the focus sits in the specifier of the CP. We can see this from the fact that in embedded clauses the focus, like the topic, follows the complementiser:

- (116)    I said that *men* I wouldn't trust

From this perspective, it seems as though the focus sits in a similar position to the topic, adjoined to the IP in embedded contexts. This assumption is also problematic, as if both the topic and the focus were adjoined to IP, one might expect them to be able to appear in any order. But this is not so:

- (117) a I said that, in this room, *potatoes* I wouldn't store  
      b \*I said that *potatoes*, in this room, I wouldn't store

At the moment it is not obvious how we can accommodate these data and in particular the position of the focus remains a mystery. We will put the issue to one side until after we have looked at one more case of movement to the front of the clause.

### 5.3 Negative fronting

A third movement which places an element at the front of the clause involves negative phrases:

- (118)    never in my life have I been so embarrassed

This kind of movement is even more like *wh*-movement than the other two we have looked at as it is accompanied by an inverted auxiliary, which topicalisation and focus fronting are not. We might be tempted, therefore to propose that negative fronting moves the negative element in to the specifier of CP. Unfortunately, the following datum questions this assumption:

- (119)    I said that never in my life have I been so embarrassed

## Chapter 7 - Complementiser Phrases

---

The fronted negative obviously follows the complementiser and so cannot be in specifier of CP. However, note that the fronted negation is still accompanied by auxiliary inversion and therefore there must be a head position to accommodate the auxiliary. This would suggest the following structure:

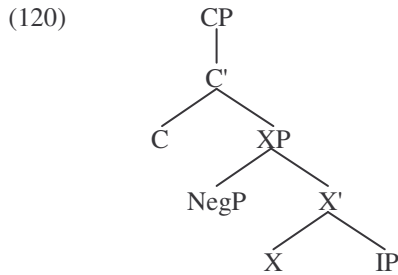

Under these assumptions the negative phrase is fronted to the specifier of some phrase that comes between the complementiser and the IP. The head of this phrase is then where the inverted auxiliary sits.

What is the nature of XP and how does it interact with the other movements we have reviewed? If we are to maintain our view that functional categories select for a very limited selection of complements, then as XP is the complement of a complementiser this argues that it is something like an IP. However, presumably X is a functional element itself and it takes an IP complement, which makes it more like a complementiser. Given that complementisers are categorised as [+F, -N, -V] and inflections are [+F, -N, +V] categories, a category which shares properties of them both would be [+F, -N], with an undefined V feature. Let us refer to this category a little 'i', reflecting the use of 'v' to represent a verbal element with an undefined F feature. This element heads an iP and so the structure can be represented as:

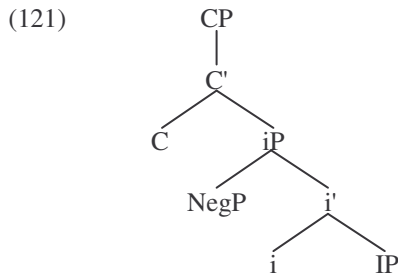

Note that the fronted negative is like the focus in its interaction with the topic: the topic precedes the fronted negative:

- (122) a I said that, in this town, never have I been so embarrassed  
 b \*I said that never have, in this town, I been so embarrassed

We can account for the distribution of the topic if we suggest that it adjoins to the highest phrase that it can. In main clauses the topic can adjoin to the CP and therefore as this is the highest phrase, this is where the topic will adjoin. In embedded contexts, something prevents the topic from adjoining so high up. Perhaps there has to be a

### Other fronting movements

---

relationship between the selecting verb and the head of its complement clause, i.e. the complementiser, that the presence of the topic interferes with. In this case then the topic will have to adjoin lower down: to *iP*, if present, and if not, to *IP*.

The fronted negative is in complementary distribution with the focus:

- (123) a \*I said that under no circumstances would *potatoes* I store in this room  
b \*I said that *potatoes* under no circumstances would I store in this room

Once again, if we want a focus in such a sentence it must be indicated by stress alone without the movement:

- (124) I said that under no circumstances would I store *potatoes* in this room

This complementary distribution seems more significant than that which holds between the focus and the *wh*-element as both the focus and the fronted negative clearly occupy very similar positions. We might therefore claim that both make use of the same landing site: specifier of *iP*.

The difference however, between the fronted focus and the fronted negative is that the latter induces inversion to 'i', while the former does not. Referring back to the difference between *wh*-movement that triggers inversion and *wh*-movement that does not, we proposed that inversion is triggered when there is no head to agree with. In embedded interrogatives the complementiser position could be filled and hence there will be no inversion. If we project these ideas on to the current situation, we conclude that with focus the *i* head is filled by some abstract element but with negative fronting the head position is unfilled. We know that the negative head is a verbal element of the category 'v' and so it cannot be generated directly in *i*. The only way for the negative head to get to *i* is for it to move and yet we know that the negative is not able to move to *I* to support the inflection in English, as it is in Finnish. Thus, there is no way for the negative head to get to *i* and hence when a negative element moves to the specifier of *iP* it will induce inversion to provide a head for it.

With a fronted focus, on the other hand, there must be an abstract head capable of being generated in *i* with which the focus can agree. Let us call this head *Foc*. In other languages this element may appear as a morpheme on the focussed element, supporting the assumption here, as in the following Korean example:

- (125) Mary-ka John-**man**-ul saranghanta  
Mary-nom John-Foc-acc love  
'John Mary loves.'

This head apparently cannot enter into an agreement relationship with the fronted negative and so, presumably, it must be inherently positive. Given that nothing prevents it from appearing when there is a focus, it will be present whenever there is a fronted focus and hence inversion will be unnecessary. The structures we end up with are:

(126) a

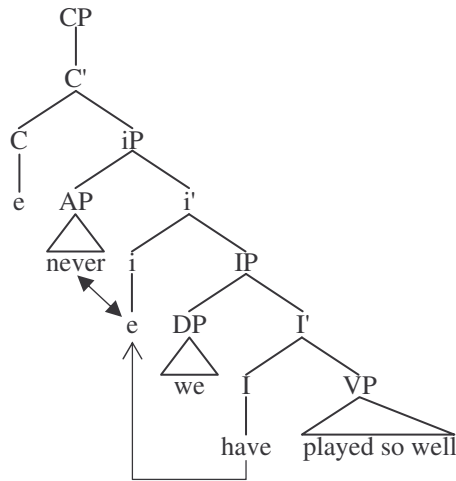

b

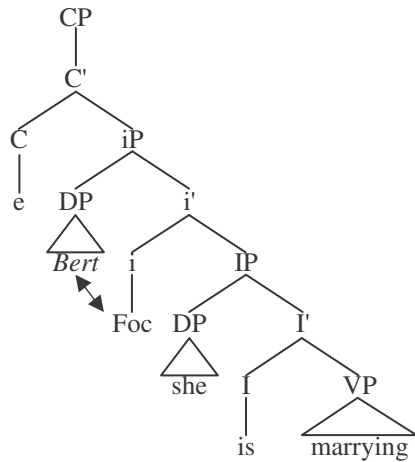

With these structures in place we now have room for all fronted elements in English including *wh*-elements, topics, foci and fronted negatives and the inverted auxiliaries that accompany them. We have not accounted for why there is complementary distribution between elements that move to spec iP and *wh*-elements. This may be a semantic incompatibility rather than a matter of syntactic distribution, as suggested by the fact that this seems more of a universal restriction rather than something restricted to English. Alternatively, it may have something to do with the locality of movement in that if iP is present a *wh*-element is prevented from moving to spec CP. I will not attempt to sort these issues out here.

## 6 Conclusion

In this chapter we have introduced the final part of the clause structure of the English sentence. This part of the structure, built on top of the IP serves a number of purposes, but collectively seems to be to do with the syntactic arrangement of operators of one type or another. With *wh*-movement, both in interrogative clauses and relative clauses, the *wh*-element is an operator with either quantifier-like or anaphoric function. The interpretation of this element is dependent on movement which has a dual role, both to mark the clause as having a special interpretation (as an interrogative or relative) and to establish a relationship between that interpretation and a position in the clause itself. Hence, questions can be seen to be 'about' the subject or the clause, etc. and relatives can relate the modified noun to the object of the clause, etc. Focus and negative fronting may also have a similar function in that their interpretation is quantifier-like. Topicalisation, although not quantificational, may be seen as anaphoric in that the topic refers to some element established in the discourse.

In connection with the movements of these operator-like elements, we also have seen a series of head movements to various positions. These appear to provide the operators with something to agree with and so they play a supporting role in allowing the operators to fulfil their function.

With the end of this chapter we come to the end of the clause, so to speak. In the next chapter we will concentrate on the relationship between elements in different clauses and in particular across non-finite clauses which appear to more readily allow such relationships to be established.

### Check Questions

- 1 What are complementizers in English? How is it possible to argue that complementizers act like heads?
- 2 Which type of clauses must be introduced by a complementizer and which need not, i.e. what is the distribution of overt versus covert complementizers?
- 3 What are canonical structural realisation principles?
- 4 What runs counter to the claim that complementizers determine the force of a clause?
- 5 What does it suggest that complementizers and inverted auxiliaries are in complementary distribution?
- 6 What motivates *wh*-movement?
- 7 What are operators?
- 8 How can A-movement and A-bar movement be distinguished?
- 9 What are the two sets of assumptions proposed to underlie I-to-C movement?
- 10 How can it be shown that 'whether' is not a complementizer?
- 11 What is the Doubly-Filled COMP Filter?

## Chapter 7 - Complementiser Phrases

---

- 12 List some general ordering restrictions affecting certain elements in a clause.
- 13 What are the differences and similarities between restrictive and non-restrictive relative clauses? How are these clauses analysed?
- 14 Discuss the differences between relative and interrogative pronouns.
- 15 How can it be shown that 'that' is not a relative pronoun?
- 16 Define and exemplify pied-piping and preposition stranding.
- 17 What are the different types of relative clauses?
- 18 Define the following terms: topic, focus, comment.
- 19 What is the order of wh-elements and topicalised elements in matrix and embedded contexts?
- 20 What are the three types of movement placing an element to the front of the clause?
- 21 How can it be shown that the negative element in negative fronting does not occupy the [Spec, CP] position?
- 22 What is the distribution of the following elements relative to each other: topic, fronted negative, focus?

### ***Test your knowledge***

#### ▪ **Exercise 1**

What is the case of the DPs in the following sentences? Determine the Case assigner, too.

- (1) a It is time for me to close the door.  
b Jane appears to have stolen the keys.  
c The professor expects me to write an essay for her.  
d Jack has not been to America since January.  
e For Kim to understand this exercise is extremely difficult.  
f I expect Peter to visit his family.  
g The thief seems to be arrested.

#### ▪ **Exercise 2**

What kind of movements can be identified in the following sentences? Identify the traces in the S-structures and give the D-structure of the sentences as well.

- (1) a The letter was sent to the government last night.  
b Interesting books, I often read.  
c Can you lend me your umbrella?  
d In this garden, you can have a rest.  
e Has John ever been caught in the act?  
f A proposal has been handed in for the educational reform.



### Test your knowledge

---

▪ **Exercise 3**

What types of adverbs (i. e. sentential or VP adverb) can be found in the following sentences?

- (1) a Cleverly, Agatha answered the question.  
b Ron hardly goes to the cinema.  
c She suddenly burst into tears.  
d Agatha cleverly answered the question.  
e They certainly went to America for holiday.  
f The student has rewritten her thesis thoroughly.  
g The king often visited the neighbouring countries.

▪ **Exercise 4**

What type of movement is going on in the following sentences? Give their tree diagram as well.

- (1) a Who lives in London?  
b Sam seems to sleep.  
c Who appears to adore Anne?

▪ **Exercise 5**

Thematic role assignment must be local. A  $\Theta$ -role assigning head must be in a local configuration to the DP it assigns  $\Theta$ -role to. Explain how the underlined nominal constituents can get  $\Theta$ -role.

- (1) a Which book did John buy?  
b Short stories, I don't like.  
c Short stories I expect nobody likes.  
d Mary seems to hate big cats.  
e I know the researcher who is believed to have invented cold fusion.

▪ **Exercise 6**

Identify the different types of movement in the following sentences. What moves from which position to which position that is what is the extraction site and what is the landing site for the moved elements?

- (1) a The diamonds were stolen yesterday.  
b Will you meet Mary in Paris?  
c Linguistic textbooks, I never read.  
d I won't trust you.  
e Who does John like?  
f Never have I been treated so rudely.

## Chapter 7 - Complementiser Phrases

---

### ▪ Exercise 7

Identify the head and the foot of each chain in the sentences below.

- (1) a Jane has been taken to hospital.  
b Everybody seems to speak two languages here.  
c Have you ever been to Paris?  
d What did you give to John?  
e In the park, John met Mary.

### ▪ Exercise 8

Consider the contrast between sentences (a) and (b) in the following sentences. How do you account for the differences in grammaticality?

- (1) a. \*Up the letter John tore.  
b. The letter, John tore up.
- (2) a. \*Whose did you meet mother?  
b. Whose mother did you meet?
- (3) a. \*Friends were financially supported of the President.  
b. Friends of the President were financially supported.
- (4) a. \*The fact surprised everybody that he had resigned.  
b. The fact that he had resigned surprised everybody.

### ▪ Exercise 9

Given passivisation, subject–auxiliary inversion, topicalisation, extraposition and preposing, which movement types can be spotted in the sentences below? Classify them according to whether they qualify as substitution or adjunction.

- (1) a It surprised everyone that they left early.  
b What is the meaning and purpose of life?  
c Is there any more coffee?  
d Him, I don't like.  
e In the afternoon, they went fishing.  
f Captain Link was examined by the vet.  
g A man appeared in the doorway with flowers in his hand.  
h Mary, Peter often meets.  
i Mary is said to be beautiful  
j Yesterday, they paid their electricity bill.

# Chapter 8

## The Syntax of Non-Finite Clauses

In this chapter we will concentrate on the non-finite clause and investigate syntactic phenomena that are exclusive to it. There is a surprising amount of this and the non-finite clause is a far more varied structure than its finite counterpart. Much of this variation concerns the subject which in many cases has connections with the verb selecting the non-finite clause as its complement. Thus the boundaries of the clause become blurred at this point. Most of the structures we will look at in this chapter are infinitives, which as they contain both a tensed element and a complementiser have the kind of structure we have been discussing over the previous chapters. Not all of them, however, have identical structures and the amount of functional structure they contain is one of the axes of variation between non-finite clauses. We end the chapter with a look at probably one of the strangest constructions in English, the gerund. This has been claimed to have a status somewhat similar to a mythical beast, being half one creature, half another. The gerund displays certain properties of clauses but also certain properties of DPs. This makes it a very interesting structure to analyse from the X-bar perspective which claims that the properties of a structure come from its head.

### 1 *Exceptional and Small Clauses*

#### 1.1 Clauses without CP

A typical structure for the clause that we have so far argued for, without any elaboration, is:

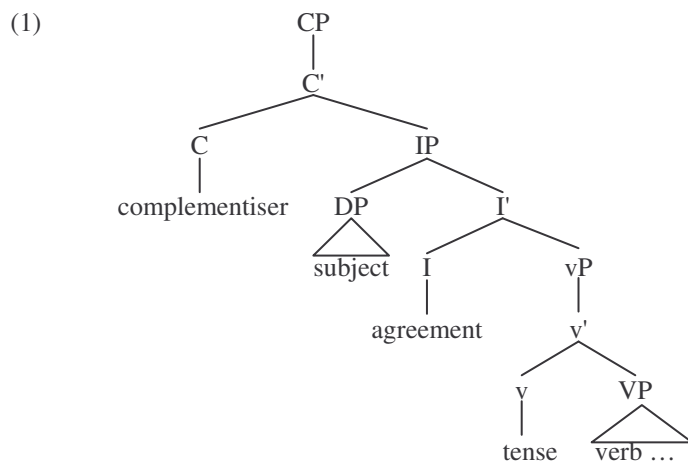

This seems to fit both finite and non-finite types of clause:

## Chapter 8 - The Syntax of Non-Finite Clauses

---

- (2) a [CP that [IP the sheriff will [VP  $\emptyset$  [VP shoot the outlaw]]]]  
b [CP for [IP the sheriff  $\emptyset$  [VP to [VP shoot the outlaw]]]]

But while there certainly are non-finite clauses which fit this pattern, there are others for which bits and pieces of the structure appear to be missing. In some cases the complementiser is not only absent, but obligatorily so, which is very unlike the finite clause which has an optional complementiser:

- (3) a I said [(that) the sheriff's forming a posse]  
b I believe [(*for*) the sheriff to be forming a posse]

In other non-finite clauses the subject appears to be obligatorily absent, again contrasting with the finite clause which always has a subject:

- (4) a the sheriff tried [(*him*) to ride the horse]  
b the sheriff said [(*he*) rode a horse]

There are even some cases of non-finite clause where not only is there no evidence of a complementiser or an inflection, but there isn't even a verb:

- (5) I consider [(*for*) the cowboy (*to*) tough]

What is the best analysis for these clauses with obligatorily missing parts? We will argue in this chapter that the missing elements are mostly not just null, but absent. We will start by considering those clauses with missing complementisers.

Compare the following sentences:

- (6) a the sheriff believes [that they are hiding in the hills]  
b the sheriff believes [them to be hiding in the hills]

One difference between the finite embedded clause and the non-finite one is that the former has a nominative subject and the latter an accusative one. We saw in chapter 5 how the finite inflection is responsible for assigning nominative Case to its specifier. A relevant question is where the accusative Case of the non-finite subject comes from: does the non-finite inflection assign accusative Case? The answer would appear to be no because not all infinitival clauses can have an accusative subject, and if the non-finite inflection were able to assign accusative Case, we would expect an accusative subject to be a permanent possibility, just like the nominative subject is always possible in a finite clause:

- (7) a *the* outlaw attempted [him to escape]  
b *the* cowboy hoped [him to brand the cow]  
c *the* town relied [him to keep law and order]

Moreover, in some non-finite clauses the subject's Case is dependent on the complementiser rather than the inflection. This can be seen by the fact that without the complementiser an accusative subject cannot appear:

- (8) a [for him to shoot the sheriff] would not be wise  
b [to shoot the sheriff] would not be wise  
c *[him to shoot the sheriff] would not be wise*

## Exceptional and Small Clauses

So it appears that the non-finite inflection does not have the capacity to assign Case as if it could, (8c) would be grammatical.

But if this is true, where does the accusative Case on the subject of the non-finite clause in (6b) come from? We know that accusative Case is assigned by light verbs in other situations, could the accusative Case come from a light verb in this structure? Consider the structure in more detail. The verb *believe* has an experiencer subject and hence there is a light verb which assigns this  $\Theta$ -role. The clausal complement of the verb sits in its specifier position and the verb will move to support the light verb:

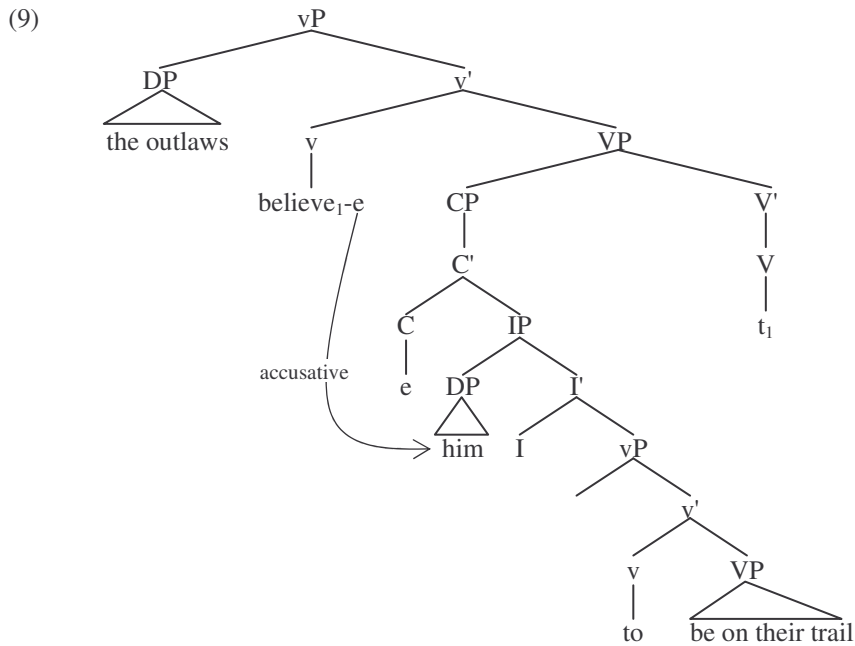

While in principle this might be possible, it does place the Case assigning light verb and the DP to which it assigns Case in rather distant positions. This would not be advisable as on the whole it appears that Case assignment is a local affair and thus there are limitations on how distant the Case assigner and assignee can be. In particular, if the situation pictured in (9) were accurate, we would expect any light verb to be able to assign an accusative case to the subject of a clause appearing in the specifier of its VP complement. But this is not so:

- (10) a \*the outlaws think<sub>I-e</sub> [<sub>VP</sub> [<sub>CP</sub> him is on their trail] t<sub>I</sub>]  
 b \*the outlaws hope<sub>I-e</sub> [<sub>VP</sub> [<sub>CP</sub> him to be on the wrong trail] t<sub>I</sub>]

Note that this has nothing to do with the finiteness of the complement clause, (10b) is just as ungrammatical as (10a) and the latter involves a non-finite clause. There is clearly a difference between verbs like *believe* which can take non-finite complement clauses with accusative subjects and verbs like *hope* which cannot. One observable

## Chapter 8 - The Syntax of Non-Finite Clauses

difference between them is that *hope* can take a non-finite complement clause with a complementiser, but *believe* cannot:

- (11) a the bartender hoped [for the sheriff to stop the fight]  
 b \*the bartender believed [for the sheriff to be a coward]

One assumption that might solve a number of problems might be that with *believe* there is no CP, just an IP. This would account for the missing complementiser with such verbs, it would also place the subject of the non-finite clause a little nearer to the Case assigning light verb:

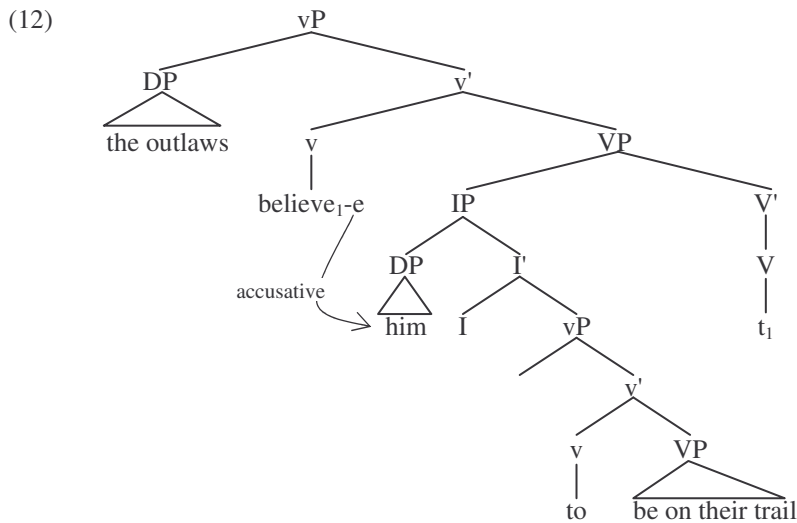

Recall from chapter 6 that the notion of government, which is relevant for Case assignment, imposes a restriction on what can be governed in that an element can govern 'up to a point'. We left undefined what that point was in our previous discussion, but now it is important to be more precise. There are a number of ways that we might think of doing this, but one of the most intuitive is to suppose that certain nodes in a tree form **barriers** to government in that they 'protect' their constituents from government from the outside. Thus a governor may be able to govern up to a barrier, but not through a barrier. We know that a light verb can assign Case to the specifier of the VP, as this is the normal configuration in which accusative Case is assigned:

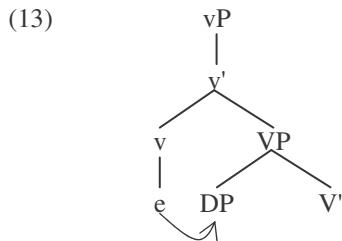

## Exceptional and Small Clauses

---

This means that the VP doesn't act as a barrier to government. From observations given in (8) above, we can conclude that the *for* complementiser assigns Case to the subject of its non-finite clause complement, as the DP subject is only grammatical when the complementiser is present. If this is so, then IP does not count as a barrier either as the complementiser can Case mark the subject through the IP:

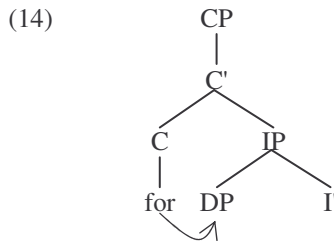

But if neither VP nor IP is a barrier to government, then we expect that the Case marking relationship depicted in (12) should be perfectly possible. There is no reason however to believe that any element can assign Case from outside a CP to any element within the CP and indeed it is a standard assumption that CP does count as a barrier to government. This supports the assumption that the non-finite complement clause of a verb like *believe* has an IP status and is not a full CP.

Given that clauses are normally CPs, a clause which only has an IP status is an exception. Hence, such clauses are known as **exceptional clauses** and the verbs which take exceptional clauses as their complements, i.e. verbs like *believe*, are known as **exceptional verbs**. Finally the process of assigning Case to the subject of an exceptional clause is sometimes called **Exceptional Case Marking**, or ECM for short.

Below are a few examples of exceptional verbs:

- (15)
- a the sheriff *expects* [the outlaws to be in hiding]
  - b the horse *supposed* [the sheriff to be lost]
  - c the deputy *assumed* [his horse to be outside the saloon]
  - d the bartender *understood* [the horse to be brighter than the deputy]
  - e the law *requires* [the sheriff to arrest the outlaws]

In all these cases the complementiser *for* would be ungrammatical if used to introduce the non-finite complement. All of these verbs also may have a finite complement clause, which is obviously a CP as the *that* complementiser can appear:

- (16)
- a the sheriff *expects* [that the outlaws are in hiding]
  - b the horse *supposed* [that the sheriff was lost]
  - c the deputy *assumed* [that his horse was outside the saloon]
  - d the bartender *understood* [that the horse was brighter than the deputy]
  - e the law *requires* [that the sheriff should arrest the outlaws]

Thus it is only the non-finite complement of exceptional verbs that are IPs.

Another observation that supports the claim that the subject of the exceptional clause is Case marked by the light verb of the exceptional verb is that these verbs can undergo passivisation. Recall that in English it is only verbs which have a Case assigning light verb that can undergo the process, which we described as the

**Chapter 8 - The Syntax of Non-Finite Clauses**

---

replacement of the agentive or experiencer light verb with the passive morpheme which neither assigns a  $\Theta$ -role to the subject position nor assigns Case to the specifier of the VP. Consider what happens when an exceptional verb is passivised:

- (17) a the outlaws<sub>1</sub> were expect-ed [t<sub>1</sub> to be in hiding]  
 b the sheriff<sub>1</sub> was suppose-ed [t<sub>1</sub> to be lost]  
 c his horse<sub>1</sub> was assume-ed [t<sub>1</sub> to be outside the saloon]  
 d the horse<sub>1</sub> was understood [t<sub>1</sub> to be brighter than the deputy]  
 e the sheriff<sub>1</sub> was requir-ed [t<sub>1</sub> to arrest the outlaws]

The subject of the non-finite clause moves to the subject position of the passive verb just like the object of a passivised verb does. Given that we argued that the motivation for the object's movement was to get Case, having been robbed of its light verb Case assigner, it is reasonable to assume that this is exactly what is going on with the movement of the subject of the exceptional clause.

Let us take a look at this analysis in more detail. Suppose we take a structure similar to (12) and replace the light verb with the passive morpheme:

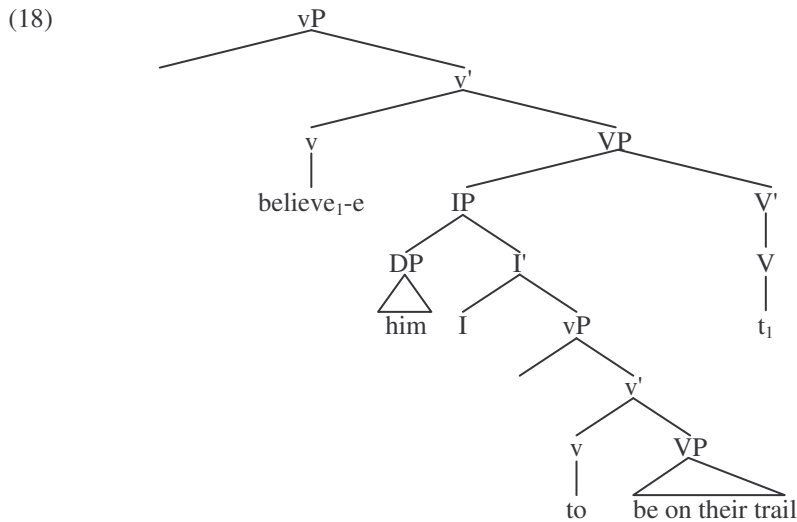

The two immediate consequences of this are that the experiencer  $\Theta$ -role fails to be assigned, leaving the specifier position of the vP empty, and the subject of the exceptional clause is left without Case given our assumption that the passive morpheme is not a Case assigner and neither is the non-finite inflection. Thus if the subject were to stay in this position, it would violate the Case Filter, which demands all DPs to receive Case, and hence the sentence would be ungrammatical, which it is:

- (19) \*it was believed [him to be on their trail]

Note that if the complement clause were finite, there would be no problem:

- (20) it was believed [that he was on their trail]



## Exceptional and Small Clauses

---

In this case the subject of the complement clause gets nominative Case from its own finite inflection and so the replacement of the light verb with the passive morpheme makes no difference.

In conclusion, we can see that there is a class of verbs which subcategorise for exceptional non-finite IP complements. These clauses have subjects which are dependent on the light verb of the governing verb for their Case. Therefore these subjects bear accusative Case. Moreover these subjects are affected by the passivisation of the governing verb which robs them of their Case assigner. Hence they will undergo a movement to the subject position of the higher clause, just like the object of the passive verb does.

Before closing this section, we will point out that there are some verbs which might look like exceptional verbs, but which are probably not. The most notorious of these is the verb *want*. This verb appears in structures that are remarkably similar to those involving exceptional verbs:

(21) the mayor wants [the sheriff to support him]

Here we have a complement clause which is non-finite and has an overt subject. The fact that this subject can be replaced by an accusative pronoun *him* shows that the subject is in an accusative position, just like we get with an exceptional verb. However, unlike exceptional verbs, this verb cannot passivise:

(22) \*the deputy<sub>1</sub> was wanted [t<sub>1</sub> to ride the horse]

If this were an exceptional verb, there would be no problem in passivising it. In this way, *want* behaves like a non-exceptional verb such as *hope*:

(23) \*the outlaws<sub>1</sub> were hoped [t<sub>1</sub> to be caught]

Presumably the reason why the subject cannot move out of the non-finite clause is because this is a CP, not an IP. Besides, passivising the verb would not affect the non-finite clause's subject as this does not get its Case from the light verb, but from the complementiser. But if this is the reason why *want* does not passivise, then we must conclude that it has a CP complement, not an IP, i.e. it is not an exceptional verb. If the complement of *want* is a CP, then its subject must get its Case from a complementiser, but there is no complementiser visible in (21). However, the complementiser can be made visible by separating the clause from the verb by an intervening adjunct:

(24) the mayor wants very much [for the sheriff to support him]

As can be predicted, the same thing does not happen with exceptional verbs, whose complements are not CPs in the first place:

(25) a \*the sheriff believes very much [for the bandits to have robbed the bank]  
b \*the horse expects very much [for the deputy to feed it]

Thus we may conclude that *want* takes a CP complement with a complementiser that may be null. Why the complementiser is null when the clause is adjacent to the verb and why it becomes overt when it is not, is a complete mystery.

### 1.2 Clauses without IP

If some clauses can lack CPs, the question naturally arises as to how small clauses can get. Recall that clauses are structured in various layers, each of which adds something to the interpretation of the whole clause. But the basic proposition is expressed by a predicate and its arguments. As the predicate does not have to be a verb a basic proposition can be expressed with no verbal element at all:

- (26) a Tim tall – Tim *is* tall  
 b Graham in the garden – Graham *is* in the garden  
 c Steven a student – Steven *is* a student

Both expressions on either side of the hyphen state exactly the same relationships between the predicate and its arguments. The difference is that while the expressions on the right are grammatical English sentences, those on the left are not. Or at least, one might think so. But consider the following:

- (27) a I consider [Tim tall]  
 b I require [Graham in the garden]  
 c I believed [Steven a student]

Given that these ‘basic propositions’ can be replaced by a full clause with virtually the same meaning, it seems that we should view them as being clauses of one sort or another:

- (28) a I consider [that Tim is tall]  
 b I require [Graham to be in the garden]  
 c I believed [that Steven is a student]

But what kind of a clause lacks a VP, let alone a CP or an IP? Moreover, what is the categorial status of such clauses?

One of the earliest suggestions, which still has a certain appeal, is that these clauses are simply phrases with subjects (Stowell 1983, who termed these constructions **Small Clauses**):

- (29) a I consider [<sub>AP</sub> Tim [<sub>A'</sub> tall]]  
 b I require [<sub>PP</sub> Graham [<sub>P</sub> in the garden]]  
 c I believed [<sub>DP</sub> Steven [<sub>D'</sub> a student]]

One argument which favours this analysis is that different verbs take different types of small clauses as their complements and what determines the type of the clause is the head of the predicate part of the clause following the subject. The verb *consider*, for example, takes an AP type and a DP type of small clause, but not a PP type:

- (30) a I consider [<sub>DP</sub> him a liar]  
 b I consider [<sub>AP</sub> him untrustworthy]  
 c \*I consider [<sub>PP</sub> him in the garden]

The verb, *order*, on the other hand, takes PP types, but not AP or DP types:

## Exceptional and Small Clauses

---

- (31) a I ordered [PP him out of the room]  
 b \*I ordered [DP him a fool]  
 c \*I ordered [AP him foolish]

The fact that heads subcategorise for their complements in terms of the complement's category would seem to suggest that these clauses do indeed differ in terms of their categorial statuses.

Opponents of this view, however, tend to point to the fact that the predicate part of the small clause seems to have the status of a phrase and if the whole clause is the phrase with the subject in its specifier position, the predicate should have the status of an X':

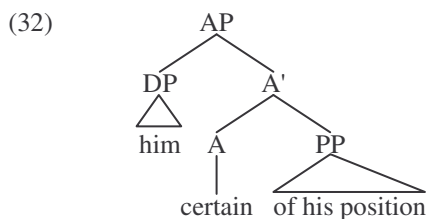

One piece of evidence that the predicate has full phrasal status comes from the fact that they seem to be able to move to phrasal positions, without taking the subject along with them:

- (33) [how certain of his position]<sub>i</sub> do you consider him t<sub>i</sub> ?

Within the confines of X-bar theory, one way to get both the subject and the predicate of the clause to be phrases, is to posit a head between them of which the subject is the specifier and the predicate the complement:

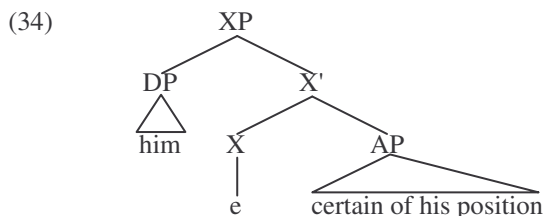

But this proposal claims that the head of the predicate is no longer the head of the whole clause and hence it no longer determines the categorial status of the clause. It would be difficult therefore to account for the observations of (30) and (31) where different verbs subcategorise for different small clauses in terms of the category of the predicate. A separate question concerning (34) is what the status of X is. Haegeman (1994) argues that this head is an agreement element, i.e. what we have been calling I. Thus small clauses, according to Haegeman, are IPs (AgrPs in her terminology):

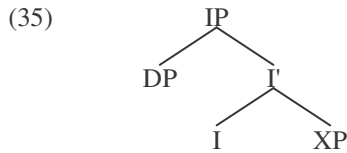

Besides the problem that under this analysis the head of the predicate is not the head of the clause, a major problem facing it is that it forces us to assume that the inflection can subcategorise for a whole set of different complements, ranging from DPs to PPs. But functional heads do not normally display this amount of freedom in their complement taking abilities. In all the cases we have considered so far, the agreement head selects for a v/VP complement, i.e. complements with [-N, +V] features. But if I can select for DP, AP and PP complements as well, i.e. [+F, +N, -V], [-F, +N, +V] and [-F, -N, -V], this must mean that it imposes no categorial conditions on its complement whatsoever. This is not true as bare NPs, non-thematic vPs, IPs and CPs cannot act as predicates inside small clauses:

- (36) a \*I consider him [<sub>NP</sub> student]  
 b \*I thought him [<sub>vP</sub> have gone]  
 c \*I ordered him [<sub>IP</sub> will leave]  
 d \*I consider him [<sub>CP</sub> that he will leave]

Stowell has countered the argument that the predicate part of the small clause is a full phrase by claiming that it only seems to behave like a phrase as the subject moves out of the subject position before the predicate itself moves. Thus the derivation of a sentence like (37) would follow the steps indicated below:

- (37) a you consider [him how intelligent]  
 b you consider him<sub>1</sub> [t<sub>1</sub> how intelligent]  
 c [t<sub>1</sub> how intelligent]<sub>2</sub> do you consider him<sub>1</sub> t<sub>2</sub>
- 

The debate continues and we will not attempt to put an end to it here. Stowell's analysis does seem to be able to address the problematic issue of the selection of small clause complements, but his analysis of how the predicate can appear to behave like a phrase rests on the validity of the suggested subject movement, and it is not at all clear that there is a well motivated position for the subject to move to, even assuming a more articulated structure of the vP.

## 2 Raising and Control

Another aspect of non-finite clauses that we have noted without much comment is their ability to have missing subjects. This is surprising in more sense than one. Finite clauses in English never have missing subjects:

- (38) a \*(this) is a mouse  
 b \*(he) has gone

This is so even in cases where there is no semantic subject:

## Raising and Control

---

(39) evidently \*(it) seems that the electrician found a mouse

The verb *seem* is one which takes a clausal complement but it has no thematic subject. In this case the subject position is filled by a meaningless *it*, known as a **pleonastic** subject. This subject, like all subjects in English finite clauses is obligatory. This suggests that the obligatory nature of the subject is more than a semantic condition that arguments need to be realised. In fact there seems to be a grammatical requirement that clauses have subjects. This condition has been called the **Extended Projection Principle** (EPP). Recall from chapter 3 that the Projection Principle ensures that the lexical properties of heads are projected into the structure at all levels of syntactic representation. Thus if a verb requires an object as a lexical property, it must have an object at D-structure and at S-structure. The Extended Projection Principle claims not only this, but that the subject position must be present at all levels of structural representation and moreover that it must be filled by something at S-structure. Of course, under usual circumstances there will be something in the subject position at S-structure as an argument of the verb will move there for Case reasons. But even if there is no argument inside the VP in need of Case, the subject position must be filled by the insertion of a pleonastic subject:

(40) D-structure: [IP e may appear [that he left]]  
S-structure: [IP it may appear [that he left]]

But non-finite clauses are different as they do not always have subjects:

(41) a he appears [- to have left]  
b they want [- to leave]  
c [- to leave now] would be rude

How are these clauses able to escape the EPP? Note that it would in fact be ungrammatical to fill these positions with a pleonastic subject:

(42) a \*he appears [it to have left]  
b \*they want [it to leave] (with *it* being non-referential)  
c \*[it to leave now] would be rude

Recall also that the  $\Theta$ -Criterion requires that  $\Theta$ -roles be assigned to arguments. While some verbs may take **implicit** arguments which are not actually present in the structure but are 'understood' at a semantic level, these arguments are always complements and never subjects:

(43) a he is eating a sandwich  
b he is eating  
c \*is eating a sandwich

How are the non-finite clauses in (41) able to satisfy the  $\Theta$ -Criterion if there is no subject to assign the  $\Theta$ -role to?

The answer to all these problems is that the non-finite clauses in question do not lack subjects at all, they simply do not have *pronounced* subjects. One argument in favour of this assumption is that in different non-finite clauses there may be different types of unpronounced subjects. The argument is that one absent subject ought to be exactly the same as another absent subject and only if they are present could they

## Chapter 8 - The Syntax of Non-Finite Clauses

---

possibly differ from each other. To see how these subjects differ from each other, consider the following facts:

- (44) a Tim seems [- to be tall]  
b Robin wants [- to be rich]
- (45) a it seems [Tim is tall]  
b \*it wants [Robin is rich]
- (46) a \*Tim seems [Tina is tall]  
b Robin wants [Rupert to be rich]
- (47) a \*[- to be tall] is what Tim seems  
b [- to be rich] is what Robin wants
- (48) a \*it seemed to Larry [- to look after himself]  
b we persuaded Larry [- to look after himself]
- (49) a \*Peter seemed [that [- to be a pilot] would be exciting]  
b Peter thinks [that [- to be a pilot] would be exciting]

Consider the two sentences in (44). They both appear to have missing subjects and in other ways they seem to be similar. However, even at this point we can see that the two missing subjects are not entirely equivalent. In (44a), the missing subject is referentially identical to the subject of the higher clause, *Tim*. This subject is not semantically related to the verb of its own clause: *Tim* is not the one doing the *seeming*. We have already seen that verbs like *seem* do not have a subject of their own and often have pleonastic subjects, as we see in (45a). Thus the missing subject of the non-finite clause and the overt subject of the higher clause share a single  $\Theta$ -role assigned from the lower predicate *tall*. In other words, they represent a single argument. This contrasts starkly with the situation in (44b), where the missing subject and the overt subject of the higher clause bare completely different  $\Theta$ -roles: *Robin* is the thematic subject of *want* and the missing subject is the thematic subject of *rich*. The two subjects are coreferential, but they are independent elements in exactly the same way that a pronoun and its referent are independent elements:

- (50) Henry thinks [he is happy]

In this case, *Henry* is the one doing the *thinking* and *he* is the one who is happy. If the pronoun refers to *Henry* then the interpretation is ultimately that *Henry is happy* (or at least this is what he thinks). But if the pronoun refers to someone else, then the interpretation is not that *Henry is happy*. However, the two elements are independent, regardless of what their referential properties are. The same is true of the overt subject and the missing subject in (44b). (45b) demonstrates that there really are two independent arguments in this construction as the subject of the higher predicate cannot be spelled out as a pleonastic element. In contrast, this is exactly what is possible in (45a), demonstrating that there really is only one argument here. The same point is made the other way round in (46). In this case we see that with a verb like *seem*, a different

argument cannot be realised in the two different subject positions as there is only one  $\Theta$ -role involved. A verb like *want*, on the other hand, can realise arguments overtly in both subject positions as there are two independent  $\Theta$ -roles. So, one kind of missing subject shares a  $\Theta$ -role with another element in the sentence while the other kind of missing subject has a  $\Theta$ -role all of its own. The next three examples demonstrate that the two different kinds of missing subject have different referential properties. The non-independent type of missing subject which shares a  $\Theta$ -role with its antecedent, must be lower in the structure than its antecedent. Hence it cannot be part of a structure which is raised to a higher position and the ungrammaticality of (47a) follows. The independent type of missing subject on the other hand can, under certain circumstances be higher in the structure than its antecedent, hence the grammaticality of (47b). The contrast in (48) again shows a difference in the referential properties of the two missing subjects. In (48a) we see that it is impossible for the dependent missing subject to refer to an object: they are always associated with subjects. In (48b) we have an independent missing subject, it being the one who is doing the *looking after*. As we can see, it is capable of referring to the object as the ultimate meaning is that *Larry* will be the one ‘looking after himself’. Finally, (49) shows that the dependent type of missing subject cannot refer out of the subject clause of another clause, where as the independent missing subject can.

Summarising, the dependent type of missing subject shares a  $\Theta$ -role with its antecedent and is fairly restricted in its referential properties, always being below its antecedent which is a subject in the immediately higher clause. The independent missing subject has its own theta role and demonstrates far more flexible referential properties. Its antecedent can be a subject or object, higher or lower, close by or more distant, given the right circumstances. If the missing subjects in both cases were the result of an absence rather than a presence of something unpronounced, it would be rather difficult to account for these differences. If there really is something in these positions, then the evidence suggests that there they come in different types which have different properties.

Of course, the fact that the dependent missing subject shares a  $\Theta$ -role with its antecedent can lead to only one conclusion, given the theory of  $\Theta$ -role assignment discussed in chapter 2: the missing subject and its antecedent are a single argument. In other words, this kind of phenomenon is the result of movement and the missing subject is a trace:

- (51)     D-structure     e seems [Tim to be tall]  
           S-structure     Tim<sub>1</sub> seems [t<sub>1</sub> to be tall]

In reality then, the subject is not ‘missing’, it has just moved. By the same conditions, we cannot treat the independent missing subject as the result of movement: it bears a  $\Theta$ -role different from its antecedent and so they do not represent a single argument, but two different ones. Moreover, at D-structure these two arguments must also be in different positions as different  $\Theta$ -roles are assigned to different positions at D-structure. Hence we conclude that this kind of missing subject is present at D-structure. As we see in (51), this is not true of the other ‘missing’ subject. Because this element has many properties in common with a pronoun, i.e. it bears an independent  $\Theta$ -role but can be referentially dependent on something else, it is often referred to as PRO.

In the next sections we will look at these two different elements individually.

2.1 Raising

As we have seen, with certain verbs a subject which is generated in one clause can move into the subject position of a higher clause. This movement is known as **raising** as the subject always moves from a lower clause to a higher one and never the other way round. The conditions on raising are that the moved element must originate in a non-finite clause and it must be the subject of that clause. Thus, we do not find raising out of finite clauses or raising directly out of object positions:

- (52) a The electrician<sub>1</sub> seems [t<sub>1</sub> to have found a mouse]
- b \*The electrician<sub>1</sub> seems [t<sub>1</sub> has found a mouse]
- c \*A mouse<sub>1</sub> seems [the electrician to have found t<sub>1</sub>]

In a number of ways this is similar to the kinds of movements we have seen previously which take a DP from one position and move it to a subject position, such as the movement of the subject from the specifier of a VP or the movement of an object of a passive or unaccusative verb. Those kinds of movements, we saw, were motivated by the fact that the DP started off in a Caseless position and hence in order to satisfy the Case filter it had to move into a Case position. The subject of a finite clause is a Case position as this is where nominative Case is assigned to by the finite inflection. In (52a) we see a DP that is moved into the subject of a finite clause, and so it may be that this movement is also Case motivated. If this is so, we expect to find that the position it moves from is a Caseless position. Is this prediction accurate? Consider the relevant structure in a little more detail.

A first issue to decide on is whether the embedded clause has the status of a CP or an IP. We saw in the previous section that some verbs select for IP non-finite complement clauses while others do not. The question we need to answer, then, is whether verbs like *seem* are exceptional verbs or not. There is reason to believe that these verbs are exceptional, as they never take a non-finite complement with a *for* complementiser:

- (53) a \*it seems [for the electrician to have found a mouse]
- b \*it appears [for the mouse to be dead]

A possible explanation for this fact could be that the clause is an IP and hence there is no position for the complementiser. Let us assume this to be correct.

At D-structure the complement clause will sit in the specifier of the verb:

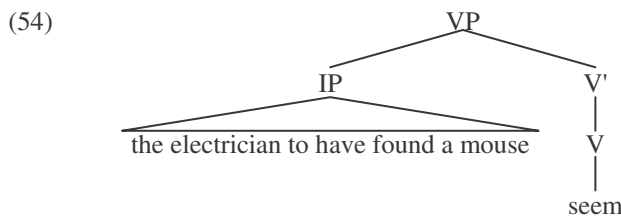

The verb will move from its original position to support some inflection, depending on what is present. If there are aspectual morphemes, the lowest will be supported by the verb, if not the verb will move to either the (null) tense, if there is a modal, or all the way to the I position if there is a bound agreement morpheme as well:



## Raising and Control

- (55) a ... has seem<sub>I</sub>-ed [<sub>VP</sub> [<sub>IP</sub> the electrician to have found a mouse] t<sub>1</sub>]  
 b ... will seem<sub>I</sub>-Ø [<sub>VP</sub> [<sub>IP</sub> the electrician to have found a mouse] t<sub>1</sub>]  
 c ... seem<sub>I</sub>-ed [<sub>VP</sub> [<sub>IP</sub> the electrician to have found a mouse] t<sub>1</sub>]

It is important to realise that, as the verb has no subject of its own, there will be no light verb to assign a  $\Theta$ -role to the subject. As we know, it is the light verb which is responsible for assigning Case and hence as there is no light verb, there will be no Case assigned. The subject of the embedded clause also cannot receive Case from inside this clause as the inflection is non-finite and non-finite I does not assign Case. Thus, we can conclude that, despite the exceptional status of the embedded clause, its subject will not be assigned Case and if it remains in this position it will violate the Case Filter. Raising this subject to the next clause satisfies the Case Filter as it can get Case from the finite I of this clause:

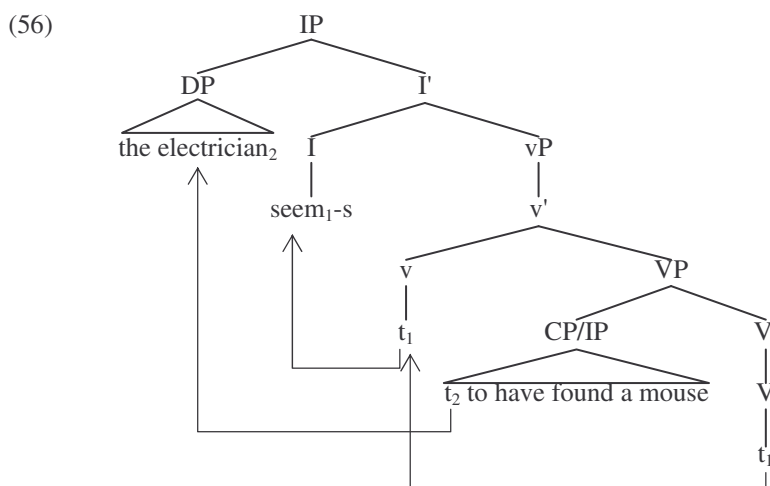

Here, the verb first moves to the tense position, and then into the I to support the bound tense and agreement morphemes. The subject in its D-structure position is Caseless, so it moves into the vacant specifier of the IP where it is assigned nominative Case.

Next, consider the restrictions on the movement shown in (52b) and (c). The subject of the embedded clause cannot undergo raising if it is in a finite clause, or in an object position. In both of these cases, the DP is sitting in a Case position, therefore regardless of any other restriction, there would be little point in it moving to the specifier of the higher clause as once it has satisfied the Case Filter, it does not need to do so again. We might assume a kind of laziness to the system (some call it 'economy') such that if something doesn't need to happen, it will not happen. If the clause is finite and hence the subject gets nominative from the finite inflection, then the higher subject position will be unfilled. It is under these circumstances that the EPP will force the insertion of a pleonastic subject:

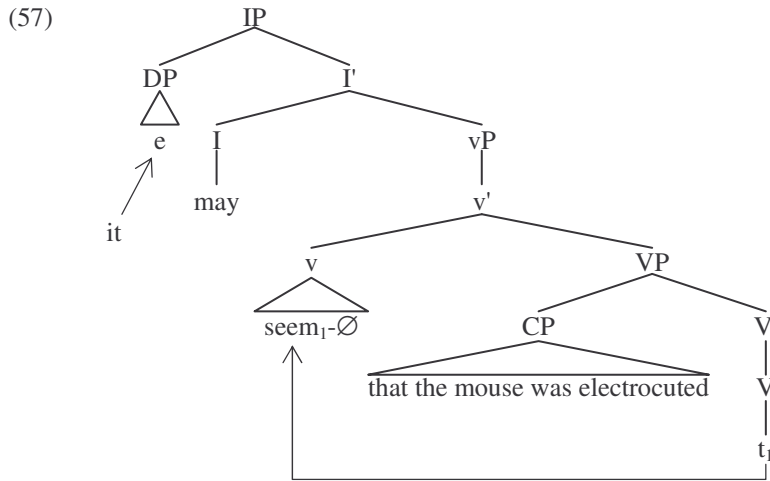

In the case that the clause is non-finite, although the object will not move out of its Case position, the subject will of course need to get its Case by moving to the higher subject position, as we saw in the examples above.

The properties of a verb that allow it to be involved in raising structures are quite specific. First it must lack a light verb which is responsible for assigning a  $\Theta$ -role to the subject and a Case within the VP. Without this light verb the subject position will be vacant and hence available to be moved into. If a verb has such a light verb, it will not be able to take part in raising structures for the simple reason that the subject position will be filled already and moreover, if the lower subject cannot get Case from within its own clause, it will be able to get it from the light verb. Second, it must take a clausal complement. Without the clausal complement, the subject of this clause will not be able to ‘raise’. Moreover, the complement clause must be capable of being non-finite, given that raising only happens from non-finite clause subject position, for reasons we have just discussed. A verb which has no subject of its own, but cannot select for a non-finite clause will always have a pleonastic subject and will never be involved in raising. A possible verb that fits this pattern is *emerge*:

- (58) a it emerged [that the mouse was shocked]  
 b \*the mouse<sub>1</sub> emerged [t<sub>1</sub> to be in shock]

Another structure which bears a remarkable similarity to raising structures concerns the passive exceptional verb. From what we know about the properties of exceptional verbs and the process of passivisation, it can be predicted that they will behave very much like raising verbs. As we know, an exceptional verb can take a non-finite IP complement. Normally there will be an accompanying light verb and this will assign Case to the DP subject of the complement clause. When we passivise a verb, we replace the light verb with the passive morpheme, which neither assigns a  $\Theta$ -role to the subject, nor a Case to the complement. This, then, is the same set of properties that raising verbs have. We can see that such verbs do indeed behave like raising verbs:

## Raising and Control

- (59) a it was believed [<sub>CP</sub> that the electrician was scared of mice]  
 b the electrician<sub>1</sub> was believed [<sub>IP</sub> t<sub>1</sub> to be scared of mice]

When the exceptional verb has a finite complement, the subject of this clause will not move as it gets Case from its own finite inflection, making movement unnecessary. When the clause is non-finite however, its subject will not receive Case from the non-finite I and moreover will not get it from the light verb of the exceptional verb as this will have been exchanged for the passive morpheme. Thus movement will be necessary:

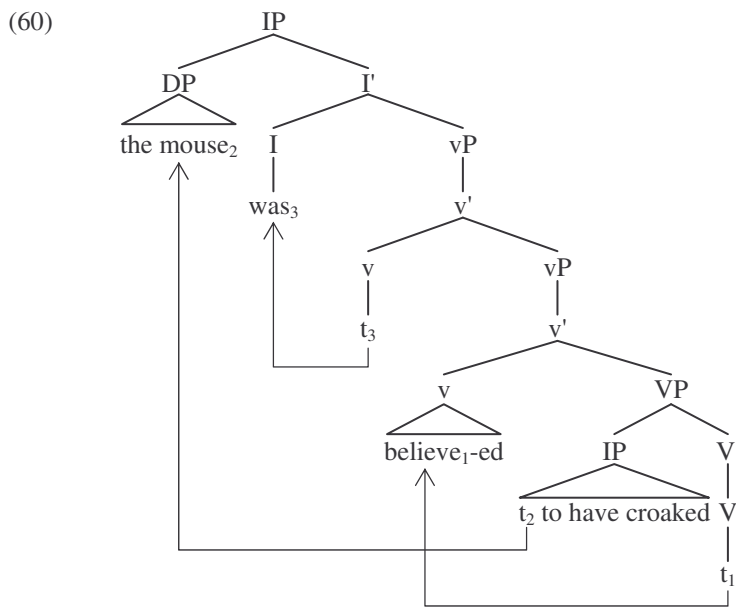

Certain adjectives can also appear in raising structures. As adjectives do not assign Case, if an adjective takes a non-finite complement, the subject of that complement will not get Case and will therefore have to move. Furthermore, if the adjective does not assign a  $\Theta$ -role to its subject, the subject position will be underlyingly vacant and will therefore either need to be filled by a pleonastic element or by a DP moving into it:

- (61) a it is unlikely [that the mouse survived]  
 b the mouse<sub>1</sub> is unlikely [t<sub>1</sub> to have survived]

One more point can be made concerning raising and raising-like structures. As this movement allows a DP to escape the confines of the clause that it originates in, we might wonder how far that DP can move. The following datum seems to suggest that a subject can be raised over quite a distance:

- (62) the builder<sub>1</sub> seemed [to be unlikely [to be considered [t<sub>1</sub> to be very skilled]]]
-

## Chapter 8 - The Syntax of Non-Finite Clauses

---

In this example, the subject starts off in the lowest clause as the subject of the adjective *skilled*. It then moves out of three clauses to the subject position of the raising verb. In principle, then, it might appear that there is no limit to how far a subject may raise. However, it is interesting that in order for this to happen, each predicate between the original clause and the final landing site of the raised subject must be either a raising predicate or a passive verb and moreover each intervening clause must be non-finite and have a vacant subject position. If any of these conditions is not upheld, the sentence is ungrammatical:

(63) \*the builder<sub>1</sub> seemed [that the electrician believed [t<sub>1</sub> to be incompetent]]

The grammatical (62) raises the problem of how it can be grammatical with so many clauses but only one visible subject. The EPP demands that all clauses have subjects and so we might expect that this sentence ought to be ungrammatical. All these problems can be solved if we assume that the subject does not move in one go, but moves from clause to clause, stopping off in each subject position:

(64) the builder<sub>1</sub> seemed [t<sub>1</sub> to be unlikely [t<sub>1</sub> to be considered [t<sub>1</sub> to be very skilled]]]

In this way, each clause is provided with a subject, the trace, and hence the EPP can be satisfied. The ungrammaticality of (63) demonstrates that when a subject raises, it cannot actually be moved too far. Looking at what is possible and what is not possible with such movements, there is something similar about the restriction to the restriction we have noted concerning head movement. Recall that the Head Movement Constraint demands that heads do not move over the top of other heads. It appears that the restriction on subject movement is that it cannot cross over the top of another subject. A general way to express both these restrictions is to claim that a moving element cannot move over the top of a like element. This principle, known as **Relativized Minimality**, was introduced by Rizzi (1990) as a way of accounting for locality conditions on movement. The following diagram might help to make clear how the principle works:

(65) X      Y      Z      where X, Y and Z are of the same type

What this depicts is a situation in which an element Z is moving to a position X over the top of another element Y. Given the structure preserving nature of movement, X and Z will be of the same type, i.e. both phrases or both heads, but if Y is of the same type too, the then movement is not allowed. Thus, a head cannot move over a head and a subject cannot move over a subject.

### 2.2 Control

Let us now turn to the other non-finite clause with an apparently missing subject, in which there is in fact a phonologically empty pronoun. There are a number of interesting points to be made about this element. The first is that although it is obviously a DP, it has a much more limited distribution than normal DPs. The other matters of interest concerning the empty pronoun PRO are the limitations on its

## Raising and Control

---

referential properties, as it does not appear to behave like other pronouns in this respect. We will consider these points separately.

PRO can be found in the subject position of non-finite clauses:

- (66) a we attempted [PRO to work the machine]  
b they tried [PRO turning the wheel]  
c I painted the ceiling [PRO balanced on a chair]

It does not ever appear in the subject position of a finite clause, the object position or the object of a preposition:

- (67) a \*the message said [that PRO would self-destruct in five seconds]  
b \*I congratulated PRO  
c \*the guard spoke to PRO

Note that there is nothing semantically wrong with these sentences. As PRO is a pronoun that refers to some other element in the sentence, the meaning of the sentences in (67), were they grammatical, would be perfectly understandable:

- (68) a the message said [that it would self-destruct in five seconds]  
b I congratulated myself  
c the guard spoke to himself

Why is it that PRO cannot appear in these positions? One relevant observation is that these positions are those to which Case is assigned. The non-finite subject positions, in which PRO is allowed, seem to be Caseless as overt DPs cannot appear there and so presumably they violate the Case Filter:

- (69) a \*we attempted [Sid to work the machine]  
b \*they tried [Tony turning the wheel]  
c \*I painted the ceiling [Bob balanced on a chair]

If PRO must avoid Case positions, we predict that we should not be able to go in the subject position of the non-finite complement of an exceptional verb, as this is a position assigned Case by the light verb of the exceptional verb. This expectation is indeed fulfilled:

- (70) a \*he believes [PRO to be rich]  
b \*I suppose [PRO to drive a Trabant]

Similarly, PRO will not be able to appear with a *for* complementiser, which we have argued assigns Case to the subject position of the non-finite clause that it introduces:

- (71) a \*she hoped [for PRO to be on TV.]  
b \*we were anxious [for PRO not to be late]

In such cases, if the complementiser is absent, the sentence is grammatical:

- (72) a she hoped [PRO to be on TV.]  
b we were anxious [PRO not to be late]

So it seems that PRO cannot appear in Case positions and is therefore in complementary distribution with overt DPs, which of course must sit in Case positions.

## Chapter 8 - The Syntax of Non-Finite Clauses

---

However, this conclusion is problematic both conceptually and empirically. On conceptual grounds, it is odd to say the least that there should be a principle stating that all DPs must have Case and then to find out that there is one DP that not only does this not apply to, but exactly the opposite holds of it and it cannot have Case. The empirical issue is that the assumption does not account completely for the distribution of PRO as there are places which are not Case marked, and so could not support an overt DP, but in which PRO cannot appear either. One such place is the subject position of the non-finite complement clause of a raising verb or a passive verb:

- (73) a \*it seems [PRO to be rich]  
b \*it was believed [PRO to have gone]

One possible solution to both these problems would be to claim that PRO doesn't avoid Case positions *per se*, but has to sit in special Case positions which up to now have been assumed not to be Case-marked, but in fact might be assigned a special Case, applicable only for PRO. Chomsky and Lasnik (1993) proposed that PRO must sit in special Case marked positions. They argue that the subjects of certain non-finite clauses are not Caseless but that what they term 'Null Case' is assigned to them. Only PRO can bear Null Case and Null Case is the only Case that PRO can bear. Thus PRO will not be able to sit where overt DPs go as these will be Case marked with something other than Null Case. Moreover no overt DP can sit in a position in which it would be assigned Null Case as this is not 'strong' enough to satisfy the Case Filter. The good thing about this assumption is that it predicts complementary distribution between overt DPs and PRO but does not force us to assume that PRO can occupy any position in which we cannot find an overt DP. From this perspective, then, PRO cannot sit in a position to which no Case is assigned, as in (73).

So far, I have remained uncommitted about the status of the clause that contains PRO: is it a CP or is it an IP? Under both assumptions that PRO cannot sit in Case positions or that it can only sit in Null Case positions we have to ensure that the place where it can be found is not assigned a full Case from an element outside the clause. We have seen that as PRO cannot be the subject of an exceptional clause it must be assumed that this is not possible. One way to ensure that nothing else can assign Case to the place occupied by PRO is to assume that it is protected by a CP. Recall that a governor can govern up to a CP, but not through it as CP acts as a barrier to government. For this reason then, we will assume that all clauses containing a PRO subject are CPs and not IPs.

Turning to the referential properties of PRO we find that this is quite complex. To see how PRO behaves, we should first consider how other pronouns behave in terms of reference. There are two types of referential pronouns which behave differently with respect to each other. Compare the following:

- (74) a Sue said Lucy likes her  
b Sue said Lucy likes herself

In (74a) the pronoun *her* can either be taken as referring to *Sue* or someone not even mentioned in the sentence. Note that it couldn't possibly refer to *Lucy*. In contrast the pronoun in (74b) can only refer to *Lucy* and cannot refer to someone not mentioned or to *Sue*. We call the first kind of pronoun a **pronominal** and the second kind **anaphors**.

## Raising and Control

---

It seems to work like this. An anaphor must have an antecedent within some domain, say the clause, and cannot refer to anything outside of this, or indeed have no antecedent at all. A pronominal, on the other hand, cannot have its antecedent within the same domain, but may refer freely outside this domain. The situation is a little more complex than this however, as there are restrictions on where the antecedent must be in relation to the pronoun. For example, while an object anaphor can take the subject as its antecedent, a subject anaphor cannot take the object as its antecedent:

- (75) a the doctor healed himself  
b \*himself healed the doctor

In general, the antecedent has to be structurally above the pronoun. Let us call a structurally superior antecedent a **binder**. The principles involved in determining the distribution of pronouns can be stated as follows:

- (76) a An anaphor must have a binder within the binding domain  
b A pronominal cannot have a binder within the binding domain

This is a simplification and things are more complex than this and further complications can be found if we try to define precisely what the binding domain is. However, for our purposes it will suffice to know that there is a domain within which an anaphor must have a binder and a pronominal cannot.

What kind of a pronoun is PRO: an anaphor or a pronominal? Interestingly, this is not such a straightforward question to answer as PRO demonstrates properties of both pronominals and anaphors and a number of properties that are unique to itself. One can find in the literature claims that PRO is a pronominal, an anaphor or even both! One observation is that PRO more than often must have an antecedent, a property that it shares with anaphors. Thus, in the following PRO must be taken as referentially dependent on the subject of the main clause and cannot be taken as referring to someone not mentioned:

- (77) Eddy expects [<sub>CP</sub> PRO to arrive at noon]

In other contexts, however PRO can lack an antecedent altogether. In these cases, it gets what is called **arbitrary reference**, a kind of generic reference similar to that of the pronoun *one*:

- (78) [<sub>CP</sub> PRO to be] or [<sub>CP</sub> PRO not to be], that is the question

While this is similar to the behaviour of a pronominal, it is not entirely equivalent. For one thing when a pronominal has no antecedent it still has a specific referent determined by the discourse conditions (i.e. who or what is the topic of the conversation or who or what is being indicated as the referent in non-linguistic ways such as pointing, etc.). Moreover, pronominals are free to lack antecedents in general whereas PRO can only lack an antecedent under specific circumstances. Basically, PRO can lack an antecedent, and therefore have arbitrary reference when the sentence that PRO is the subject of is itself a subject or when it is the complement of certain predicates:

- (79) a [<sub>IP</sub> [<sub>CP</sub> PRO to leave now] would be rude]  
b it was not known [<sub>CP</sub> how [<sub>IP</sub> PRO to solve the problem]]  
c the audience were hard [<sub>CP</sub> PRO to satisfy]

## Chapter 8 - The Syntax of Non-Finite Clauses

---

However, even describing the conditions under which PRO may have arbitrary reference is a complex business, let alone explaining why the language works like this. Thus we will not delve too deeply into this issue. One point of interest is the fact that in those instances where PRO may have arbitrary reference it seems that it has more referential freedom in general in that it is possible for it to have an antecedent, and therefore a more specific reference, and this antecedent may be in positions which are not normally accessible for pronouns to take their reference from. For example, consider the following:

(80) I think [<sub>CP</sub> that [<sub>IP</sub> [<sub>CP</sub> PRO to leave now] would be difficult for you]]

There are a range of possible ways to interpret this sentence depending on who is taken as the antecedent of PRO. The arbitrary reading is possible with the meaning that if anyone were to leave this would make things difficult for you. On the other hand, the sentence might mean that *I* am the one who could leave, and my leaving would make things difficult for you. Finally, it could mean that *you* are the person considering leaving and if this happens you will experience difficulties. All these cases involve conditions which are not possible for PRO in other contexts. In the first case, PRO has no antecedent, as already discussed. In the second the referent stands three clauses above the clause of which PRO is the subject and PRO typically has to have its antecedent in the next clause above it. Finally in the third possibility the antecedent is not in a structurally superior position and so it does not even count as a binder. Due to these observations, it has been claimed that in these circumstances PRO is free to refer to any element, as long as the conditions for that element are also respected, e.g. PRO would not be able to refer to a pronominal in a lower position in its own clause as this would give the pronominal a binder within its binding domain, which is not allowed for the pronominal.

Turning to those cases where PRO must have an antecedent, we find further distinctions:

(81) a I asked him [<sub>CP</sub> PRO not to mess with the buttons on the flight control panel]  
b I promised him [<sub>CP</sub> PRO to write every week]

In (81a) PRO has to be taken as coreferential with the object *him* and cannot refer to the subject. In contrast (81b) has PRO referring to the subject, not to the object. This is again very different from the referential conditions facing other pronouns, which although they either must or cannot take an antecedent within the binding domain, depending on whether they are an anaphor or a pronominal, are free to take any possible antecedent within these confines:

(82) a the tailor showed the customer himself (in the mirror)  
b Scott told Oats [that he should step outside for a short while]

While there may be more or less ‘natural’ readings for these sentences, which are determined by pragmatic considerations, it is possible to think of contexts in which the pronouns could refer to either the subject or the object in each case: perhaps the tailor in (82a) is modelling a suit for the customer and wants to show the customer a certain effect that can best be seen by looking in the mirror, for example. However there are no contexts in which we could make the subject a possible antecedent for PRO in (81a)



or the object in (81b) as the referential possibilities in this case are grammatically and not pragmatically determined. We call this property of PRO having to take its reference from one place or another **control**. Specifically, (81a) involves **object control** while (81b) involves **subject control**. It seems that what determines the control properties of PRO is the governing verbs: *ask* is an object control verb while *promise* is a subject control verb. Obviously when there is no object, subject control is the only possibility. When there is an object, overwhelmingly verbs tend to be object control and only a very small number of verbs behave like *promise* and have an object and yet control from the subject.

Again, here we have only just scratched the surface of some very complicated phenomena, a lot of which remains mysterious to this day. As I have no contribution to make to this area we will leave the topic at this point.

### 3 The Gerund

Finally in this book, we will touch on what is probably one of the oddest constructions in the English language: the gerund. It is odd because, like some mythical beast it seems to be half one animal and half another. In other respects, it is like another mythical beast, having more than one head! Even from a morphological point of view it is difficult to categorise the morpheme involved: *ing*.

The gerund from one perspective is a kind of non-finite clause inasmuch as it expresses something which is typically related to clauses, i.e. a proposition, and can contain elements such as aspectual morphemes which are related to some portion of the clause while excluding elements of finiteness such as tense and agreement (including modals). From another perspective the gerund is a nominal form and many of its properties are those of standard DPs. Thus, it is something which oscillates between clause and DP status.

Let us consider an example:

(83) the doctors were worried by [the patient's refusing the medicine]

Here we see a verb *refuse* in its *ing* form. This form is used in a number of contexts which should be separated. Obviously it is the form used to express continuous aspect, as in *he is **running***. It may also be used to form an adjective from a verb, as in *his **smiling** face*. Whether or not these are connected or totally distinct morphemes is an issue we will not attempt to fathom and we will concentrate only on the use of this morpheme in the gerund. In the gerund, the *ing* could be taken to be a 'nominalising' morpheme, turning a verb into a noun. Indeed, there are cases where this is exactly what it is:

(84) a the building  
b the painting of a landscape

In this case, the *ing* element behaves exactly like a noun syntactically. For example it heads a phrase which can be the complement of a determiner. As we know determiners take NP complements, so the *ing* element must have the category of a noun. A further fact about nouns is that their DP complements cannot be assigned case, which is why there is an *of* preposition inserted into the structure. With a verb, its light verb will

## Chapter 8 - The Syntax of Non-Finite Clauses

---

assign Case and hence there is no need to insert *of*. This can be clearly seen in the different behaviours of verbs and their derived nominal counterparts:

- (85) a observe the result – \*observe of the result  
b observation of the result – \*observation the result

As the *ing* element in (84b) has an *of* before its DP complement, we can assume that it is a noun not a verb. Finally, these kind of *ing* elements are modified by adjectives rather than adverbs again indicating their nominal status:

- (86) a the enormous/\*enormously building  
b the intricate/\*intricately painting of the landscape

It is usually accepted that such elements are simply derived nominals turned from verb to noun by a lexical process before being entered into a structure.

If we now refer back to (83), we note that some of these features are missing. For a start, there is no preposition before the DP complement. This suggests that this *ing* element is not a noun, but a verb. This is confirmed by the fact that this element is modified by an adverb, not an adjective:

- (87) the patient's obstinately/\*obstinate refusing the medicine

Verbs head VPs not NPs and so presumably the part of the structure headed by the *ing* element is a VP. This is where the problems begin. Although a determiner is not possible with these elements:

- (88) \*the refusing the medicine

As we see in (83) a possessor is allowed. Whatever the status of the possessive marker 's', possessors are elements which are confined to DP specifier position and hence the whole construction would appear to be a DP. This is further confirmed by the distribution facts concerning the construction. Note that the gerund in (83) serves as the complement of a preposition. In general prepositions take DP complements and they certainly do not take VP complements. Prepositions do not even easily take clausal complements:

- (89) \*they were worried about [that the patient refused the medicine]

There are a few prepositions which appear to be able to take IP complements (e.g. *since*, *before*, *after*, etc.), but then it might be that these are kinds of complementisers rather than prepositions.

The distributional evidence therefore favours the analysis of the gerund as a DP. Hence we have the following structure:

## The Gerund

---

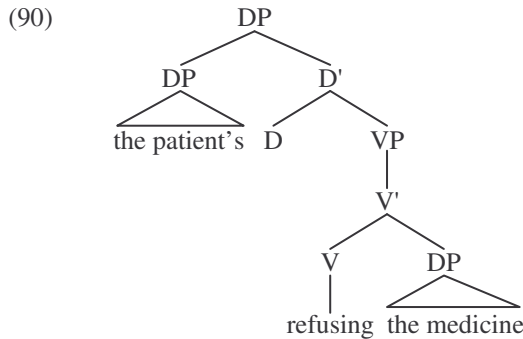

But this cannot be correct as determiners take NP complements not VP ones. It seems that the structure needs to be 'nominalised' at a point above the verb, to allow it to maintain its verbal properties, but below the VP so that the structure can function as the complement of a determiner.

Let us consider the problem in more detail. One type of *ing* element behaves like a pure noun in that it cannot Case mark its DP complement. Verbs Case mark their DP complements via the light verb that accompanies them and thus presumably this light verb is absent in the *ing* structure with the nominal head, but present with the verbal *ing* head. One way to capture this would be to claim that *ing* is a nominal head that takes a verbal complement of the v/VP type. As such it can enter into a structure at various points: directly above the VP or above the VP headed by a light verb:

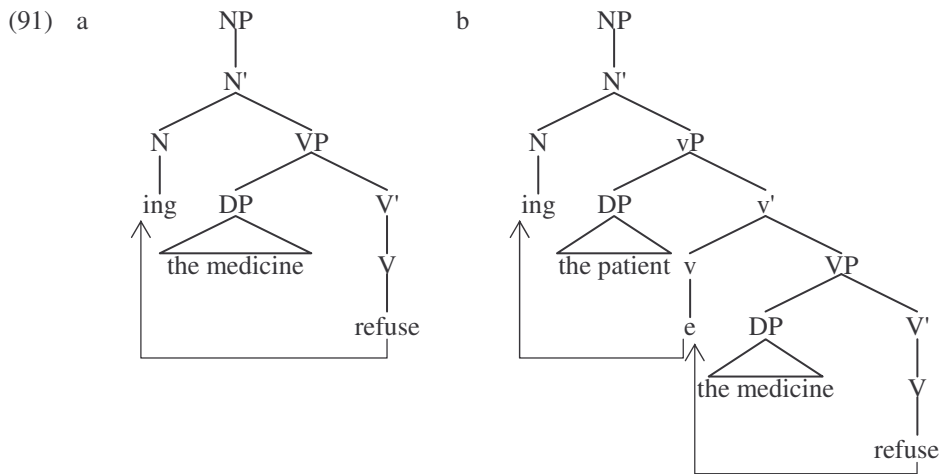

A number of consequences follow from this analysis. First, in (91a) as there is no light verb, the DP in the specifier will be Caseless and hence the preposition *of* will have to be inserted to salvage the structure. The presence of the light verb in (91b) renders this unnecessary as the DP will get Case in the normal way. More interestingly, the subject is present in the structure in (91b) but not in (91a). This does not mean that the subject cannot be introduced in (91a) as it is perfectly possible to have a possessive argument introduced into the NP/DP structure under normal

## Chapter 8 - The Syntax of Non-Finite Clauses

---

circumstances, so there is no reason why it could not happen here. However, the point is that, as is usually the case with nouns, this will be optional and therefore the possessor/agent may or may not appear. When there is no possessor, there can be a determiner and when there is a possessor there can be no determiner, as the two are in complementary distribution:

- (92) a the patient's refusing of the medicine  
b the refusing of the medicine

However, with the presence of the light verb in (91b), the agent is obligatory. As usual, it will have to move to get Case and presumably the place it moves to is the specifier of the DP, i.e. the genitive position. For this reason, a standard determiner will not be possible with this kind of gerund:

- (93) \*the refusing the medicine

The following datum seems to suggest that it is possible for there to be no agent with these gerunds:

- (94) [refusing the medicine] is not a good idea

However, such gerunds are standardly assumed to have PRO subjects and hence the subject position is not empty and we can account for why the determiner is impossible. In such gerunds we might suppose that the *ing* morpheme is added to the structure quite high, perhaps above the tense element. If we further assume that it is a non-finite tense which is responsible for assigning the Null Case borne by PRO we can account for why it is possible to have a PRO subject in a gerund.

Where the subject gets its accusative Case from in examples such as the following is not an issue we will investigate:

- (95) [him refusing the medicine] upset the nurses

One last point will be made. The assumption that the nominalising *ing* can be added to a verbal structure at various points accounts for the fact that gerunds can contain aspectual material as well as verbs. We have argued that aspectual morphemes are light verbs, heading vPs. As the *ing* head can take a vP complement, it is predicted that aspectual morphemes can be included in gerunds. To some extent this seems to be true:

- (96) a [his having refused the medicine] was a problem  
b [the medicine's being refused] annoyed the doctors  
c \*[the patient's being refusing the medicine] upset the other patients

The analysis of (96a) and (b) are fairly straightforward. In both cases the nominalising *ing* is inserted above the relevant aspectual morpheme, taking the vP that it heads as a complement. The verb will move to support the lower morpheme, i.e. the aspectual which will leave *ing* unsupported. As it is a bound morpheme this will trigger the insertion of an auxiliary to bind it. The choice of the auxiliary will, as usual, be determined by the lower aspectual morpheme:

## Conclusion

---

(97)

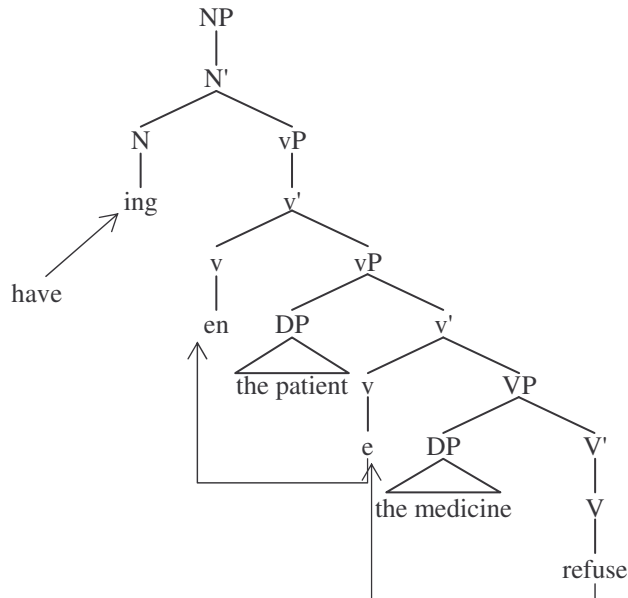

(96c) is a mystery that has been noted for some time: why other aspectual and mood morphemes can appear in the gerund but not the continuous one is something that very few approaches can predict. Some have suggested that that the problem is phonological: having two *ing* forms one following the other for some reason is a problematic sequence. Others disagree and say that the restriction is semantically based. I have nothing to contribute to the discussion and remain as puzzled as ever.

Once again we have scratched a few surfaces, though perhaps a little more substantially this time. There is clearly still a lot more to be said and that could be the subject for a whole new book. However we are at the end of the present book and so this is not the place to embark on this venture.

## 4 Conclusion

In this chapter we have dealt with a number of phenomena concerning non-finite clauses in English. On the whole, the interesting aspect of these constructions concerns their subjects. We have seen various possibilities for empty subjects in non-finite clauses, as with raising and control structures, and also exceptional accusative subjects in other constructions as with exceptional and small clauses. The gerund offers problems for analysis all of its own. By and large, we have offered analyses for all these structures, but have left many issues undiscussed and have ignored many alternative analyses. We might hope that this book has interested the reader sufficiently for them to follow up what has been left out here in further reading and research.

### **Check questions**

- 1 What is the definition of government discussed in the chapter? What counts as a barrier and what does not?
- 2 Explain and exemplify Exceptional Case Marking.
- 3 What are the different existing views on the status (structure) of Small Clauses?
- 4 Discuss the properties of unpronounced subjects.
- 5 What is raising? What motivates raising and what conditions apply to it? What is the landing site of a raised subject? How does it move?
- 6 List case-motivated movement types.
- 7 When does a pleonastic subject appear in a structure?
- 8 What is PRO, how is it distributed and what are its referential properties?
- 9 What is control?
- 10 What is the difference between pronominals and anaphors?
- 11 How can a derived nominal be differentiated from a gerund?

### **Test your knowledge**

▪ **Exercise 1**

Identify the –ing affixed elements in the sentences below as (i) nouns; (ii) adjectives; (iii) participles; (iv) expressing continuous aspect; (v) participles or (vi) gerunds.

- (1) a She was reported missing.  
b They were found working in the garden.  
c We watched them being bundled into the police van.  
d Roughly speaking, all men are liars.  
e After filing a protest she resigned.  
f Having been late for the meeting, he went to a bar instead.  
g Being late for the meeting has changed his prospects for promotion.  
h She suggested waiting till dawn.  
i He didn't envisage there being any danger.  
j Getting the equipment loaded was easy.  
k This time tomorrow they'll be looking at the rising sun.  
l Having finished her lessons, she went home.  
m He was heard talking about having central heating put in.  
n He was pleased with his surroundings.  
o The woman going was in a hurry.  
p Peter saw Mary coming.  
q They caught him stealing.  
r The girl sitting in the corner was reading an interesting book.  
s He insisted on calling a doctor.  
t At the airport one can always see passengers rushing to catch their flights.

## Test your knowledge

---

### ▪ Exercise 2

Determine whether the following verbs have got finite or non-finite clausal complements.

- (1) a Bobby believes Betsy to be beautiful.
- b Terry tried to travel to Toronto.
- c Thomas thinks that Ron runs too fast.
- d Hetty hopes for Hugh to hug her.
- e Alan asked if Sam could stay longer.
- f Sam answered that he had to leave.

Now consider the following data. What conclusions can you draw concerning the types of clausal complements?

- g Bobby believes that Betsy is beautiful.
- h Hetty hopes that Hugh will hug her.

### ▪ Exercise 3

In the following sentences, give the possible referents of the pronouns.

- (2) a John said that he would never kiss Jenny.
- b George believes that Jonathan hates himself.
- c While Mary and Fanny were sleeping, Jack and Bob were making dinner for them.
- d While Mary and Fanny were sleeping, Jack and Bob were making dinner for themselves.
- e Sarah told to Edith that she would never be able to live alone.
- f When Harry and Rita wake up too late, he always gets angry.
- g Mrs Green agreed that her neighbour could give her his keys while he would be away.

### ▪ Exercise 4

To what extent does the Case Filter explain the contrasts in grammaticality in the sentences below?

- (1) a. \*It seems John to have left.
- b. It seems that John has left.
- (2) a. Mary believes him to be a fool.
- b. \*Mary believes he to be a fool.
- (3) a. \*John to prove the theorem would be great.
- b. For John to prove the theorem would be great

## Chapter 8 - The Syntax of Non-Finite Clauses

---

### ▪ Exercise 5

Are the following sentences problematic for the theta theory? If they are, why? If they are not, why not?

- (1) a I want to leave now.  
b John persuaded Bill to leave.  
c I want Mary to leave now.  
d Mary, I really like her.  
e I expected Bill to win the race.

### ▪ Exercise 6

Explain why the following sentences are ungrammatical.

- (1) a \*John<sub>i</sub> seems that it is likely e<sub>i</sub> to have met Mary.  
b \*John<sub>i</sub> seems that Mary hates e<sub>i</sub>.  
c \*I<sub>i</sub> believe e<sub>i</sub> to be clever.  
d \*It is believed John<sub>i</sub> to have been killed e<sub>i</sub> in the accident.

### ▪ Exercise 7

Is the empty category in the sentences below a PRO or the trace of the DP *John*?

- (1) a. John<sub>i</sub> seems e<sub>i</sub> to be clever.  
b. John<sub>i</sub> tries e<sub>i</sub> to be clever.  
c. John<sub>i</sub> appeared e<sub>i</sub> to be clever.  
d. John<sub>i</sub> was believed e<sub>i</sub> to be clever.  
e. John<sub>i</sub> wanted e<sub>i</sub> to come.  
f. John<sub>i</sub> was likely e<sub>i</sub> to come.  
g. John<sub>i</sub> was too tired e<sub>i</sub> to come.  
h. John<sub>i</sub> was unable e<sub>i</sub> to come.  
i. John<sub>i</sub> was certain e<sub>i</sub> to come.  
j. John<sub>i</sub> was happy e<sub>i</sub> to come.

### ▪ Exercise 8

Decide where we have a PRO subject in the following structures and whether the sentences instantiate subject control, object control or arbitrary control.

- (1) a Jack wondered whether to trust Jill.  
b The electrician promised the owner of the flat to do a good job.  
c The teacher told the student to register for the course next semester.  
d It is important to keep your word.  
e I am glad to be back home.  
f To err is human.  
g Mary tried to feed the elephants.  
h The teacher plans to write another study on causatives.



### Test your knowledge

---

▪ **Exercise 9**

Give the tree structure of the following sentences and explain the derivation.

- (1) a John was believed to have stolen the book from the library.
- b Jane was assumed to be taken to the cinema by taxi.
- c The students wanted to pass the exam.
- d Which girl do you think John would like to dance with?



# Suggested Answers and Hints

## Chapter 1

### ▪ Check Questions

Q1 Native speakers of a language have at their disposal a system that enables them to produce and understand an infinite number of utterances in everyday life. They produce and understand sentences never said or heard before; when they know the meaning of a word they also know how to pronounce it and what are the combinations that given word can occur in. In addition, native speakers are capable of explaining why a sentence is ungrammatical ('incorrect') in that particular language without necessarily being able to refer to specific grammar rules. All this constitutes linguistic knowledge and to a large part linguistic knowledge is unconscious. Given that there is no limit on the number of utterances we produce and decode, linguistic knowledge may seem infinite but more plausibly it is possible to devise a system of rules that will generate all and only the possible utterances in a language.

Q2 Given a string of sounds associated with a particular meaning ('roughly' a word), its pronunciation, meaning, combinatorial properties (syntactic properties) are not predictable from its form (arbitrariness). A part of linguistic knowledge is lexical knowledge which is knowledge about words, their pronunciation, meaning, syntactic properties. These types of information are stored in what is called 'the (mental) lexicon', a 'dictionary' of the words a speaker knows. The words stored / contained in the lexicon are grouped according to certain general properties they share – based on these groups a certain limited number of categories may be established.

Q3 Morphological properties, i.e. inflectional endings associated with Ns, Vs, etc.; irregular forms should be mentioned as well. Distributional criteria, i.e. in what position in a sentence may a given word appear; verbs which are not interchangeable should be included. Meaning: in what sense do nouns denote things, verbs actions, events, etc. Thematic categories have conceptual meaning, they carry semantic information, while functional categories encode grammatical information.

Q4 The notion 'predicate' is easy to grasp: there is something we make a statement about. That 'something' is the subject and the statement about it is the predicate. Apart from verbs DPs, APs and PPs may also function as predicates, e.g. *Mary is a teacher*, *Mary is beautiful*, *Mary is at home* or *They elected Mary chairperson*, *They consider Mary beautiful*, *They want Mary in the committee*. The first three sentences show that the verb 'be' (a so-called linking verb or copular verb) does not constitute much to the predication expressed in them. This is further illustrated by the second three sentences where each contains two statements where the second is lacking a verb. Each predicate has a set of elements that minimally have to be included when it is used say, in a sentence, we call these participants minimally involved in expressing the meaning of

## Suggested Answers and Hints - Chapter 1

---

the predicate arguments. Arguments are theta-marked by their predicates, each receives a label that identifies the part it plays in relation to the meaning of the predicate.

Q5 The argument structure includes the subject while the subcategorisation frame does not. The latter contains information on the number and type of complements while the former on theta-roles. Students could be asked to find their own examples for verbs that do not take complements, verbs that take one complement (an NP or a PP or a clause or an AP, etc.), verbs that take two complements, etc.

Q6 Count nouns versus mass nouns, proper nouns and inherently plural nouns; partitive constructions.

Q7 On one hand, nouns formed from verbs retain the verbs arguments structure. However, a possessor may appear with every noun and is not determined by the nouns meaning; the meaning relationship between the noun and the possessor is rather vague; the possessive relationship is unique to nominals.

Q8 Categories should not be defined independently, instead e.g. the fact that thematic relationships (argument structures) are available for all thematic categories should be emphasised. The features  $\pm N$ ,  $\pm V$  enable us to capture cross-categorial generalisations (e.g. the ability to appear with a nominal complement).

Q9 According to the text the *-ly* morpheme may be conceived of as derivational or as inflectional. Irregularities involve adjectives ending in *-ly*, adverbs that are homomorphs of their adjectival pair, adjective–adverb pairs where the *-ly* form of the adverb exists but the two are not in complementary distribution (e.g. ‘deep’ used as an adverb). The difference between them can be explained along the lines that adjectives modify a noun or appear predicatively while adverbs modify a verb or sentence and cannot appear predicatively.

Q10 N: zero, PP, clause; V: zero, NP, PP, clause, AP, or a combination of the last four types; A: zero, PP, clause and P: zero, NP, PP, clause.

### ▪ Exercise 1

The term grammatical function identifies the part a given unit plays in the sentence: we can have subjects, objects, etc. It is not only phrases that may assume a given function but clauses as well, that is to say we can express the subject or object of a sentence with clauses, e.g. *That he left surprised us – What surprised? That he left;* or *Peter saw that Mary climbed up the tree – What did Peter see? That Mary climbed up the tree.* A clause realising a grammatical function is not to be equated with another type of clause, relative clauses, which are used for modification, e.g.: *Peter/The man that lives next door left – Who left? Peter/The man that lives next door/\*The man* (the original sentence contains information about the man)/*\*that lives next door; That Peter left surprised us – What surprised us? That Peter left/\*Peter* (it was not Peter, the person, it was the fact that he left that surprised us).

## Exercise 2

---

### ▪ Exercise 2

A given verb may subcategorise for more than one type of complement.

- (1)
- a [Peter] left [his family].
  - b [Peter] left after dinner.
  - c [Peter and Mary] met in the park.
  - d [Mary] suddenly noticed [that her purse was missing].
  - e Before leaving [the house] [she] checked [her bag].
  - f [The purse] was [on the kitchen table].
  - g [Peter] considers [Mary beautiful].
  - h [John] knew [that [Peter and Mary] met in the park in the afternoon].
  - i [John] knows [Mary].
  - j [Peter] wanted [John out of the room].
  - k [They] treated [their guests] [kindly] during their stay.
  - l [Peter] wrote [a letter] to Mary the other day.
  - m [He] sent [her] [a box of chocolate], too.
  - n [Peter] called [Mary] yesterday.
  - o [John] called [Peter] [a liar].

### ▪ Exercise 3

As clauses can also realise grammatical functions, they can also receive theta-roles but determining the exact label is not always straightforward, especially with clauses. It is only participants which are obligatory to express the meaning of the predicates (arguments) which receive theta-roles, even if they are unexpressed, i.e. left-implicit; optional elements (adjuncts) which add information e.g. about the place or time or manner of some action or event do not receive theta-roles but that is not surprising, they do not need to be included in the sentence for it to be grammatical.

- (1)
- a Peter loves Mary.  
Peter:           Experiencer  
Mary:           Theme
  - b Peter knows Mary well.  
Peter:           Experiencer  
Mary:           Theme
  - c The door opened.  
the door:       Theme/Patient
  - d The purse was stolen.  
the purse:      Theme/Patient
  - e Mary wrote a letter to John the following day.  
Mary:           Agent  
a letter:        Theme  
to John         Goal
  - f John received a letter from Mary.  
John:           Beneficiary  
a letter:        Theme  
from Mary:      Source

### Suggested Answers and Hints - Chapter 1

---

- g Mary cut the cake with a knife.  
Mary: Agent  
the cake: Theme/Patient
- i There arrived some visitors.  
some visitors: Theme
- j Mary was cooking dinner when they entered.  
Mary: Agent  
they: Agent
- k Peter has broken his leg.  
Peter: Experiencer  
his leg: Theme/Patient
- l Peter has broken a vase.  
Peter: Agent  
a vase: Theme/Patient
- m It surprised everyone that the visitors arrived.  
everyone: Experiencer  
that the visitors arrived: Propositional  
the visitors: Theme
- n They wondered what to do.  
they: Experiencer  
what to do: Propositional
- o Mary is beautiful.  
Mary: Theme
- p John is in Paris.  
John: Theme  
in Paris: Location
- q That the purse was stolen shocked everyone.  
that the purse was stolen: Propositional  
everyone: Experiencer  
the purse: Theme/Patient

## Exercise 4

---

▪ **Exercise 4**

- a John sneezed.
- b Dogs hate cats.
- c The boy was waiting for the girl.
- d The president sent a message to the parliament
- e I do not believe that you have won the game.
- f I never smoke.
- g Sometimes John eats a hamburger.
- h John sometimes eats a hamburger.
- i John eats a hamburger sometimes.
- j Have you ever been to England?
- k Joe went to the cinema with a beautiful girl.
- l The old computer in my office is very slow.
- m Students of English like difficult exercises.
- n John told me that he had never been to Paris.
- o The little dog chased a black cat.
- p This exercise is considered easy.
- q I rarely listen to classical music
- r This sentence is short.

▪ **Exercise 5**

Predicates are heads that take arguments. Depending on the number of arguments a predicate has, predicates can be classified into different groups like one-place predicates, two-place predicates, etc. A one-place predicate is a predicate with one argument. It can be a verb (1a), an adjective (1b), a noun (1c) or a preposition (1d). A two-place predicate is a predicate that takes two arguments like the noun in (2a), the verb (2b), the adjective (2c) or the preposition in (2d). A three-place predicate has three arguments. In (3a) the three-place predicate is a noun; in (3b) it is a verb.

- (1)
  - a. John is sleeping.
  - b. John is nice.
  - c. student of Linguistics
  - d. in the room
  
- (2)
  - a. the enemy's destruction of the city
  - b. John hates pets.
  - c. John is afraid of dogs.
  - d. I want you out of my room.
  
- (3)
  - a. Mary's gift of a book to John.
  - b. John gave a book to Mary.

▪ **Exercise 6**

The definite article *the*, the indefinite article *a* and the demonstrative pronoun *this* are functional categories and as such they have [+F] feature. As they are the functional projection of the noun, they share the categorial features associated with the noun. [+N, -V]. Their feature matrix is: [+F, +N, -V].

The words, *boy*, *neighbourhood*, *mistake* and *girl* are nouns. Therefore they are lexical elements that share the same feature matrix. They are specified for the functional feature negatively. As they are nouns, they have [+N, -V] features. Their feature matrix is [-F, +N, -V].

The item *in* is a preposition that is a lexical element. It has neither verbal, nor nominal properties; therefore its feature matrix is [-F, -N, -V].

The modal auxiliary *may* is a functional item as it is in complementary distribution with the tense marker and the *to* infinitival marker that are in  $I^0$ . As IP is a functional projection of the lexical verb, it has also verbal properties. Its feature matrix is: [+F, -N, +V].

The primary auxiliary *have* is not generated in a functional projection, but it heads its own VP, VPs headed by primary auxiliaries have the special property that they can only subcategorise for another VP. As it is not the head of IP in the initial structure, it is not positively specified for [F], but it is not a full lexical verb either, as primary auxiliaries have very limited lexical content. They invariably subcategorise for another VP. Full lexical verbs and primary auxiliaries differ in one feature. While lexical verbs are negatively specified for the [F] feature, primary auxiliaries are not specified for this feature, at all. The feature matrix for *have* is: [-N, +V].

The adjective *big* is a lexical element; therefore its functional feature is specified negatively. As adjectives share lexical features both with nouns and with verbs their feature matrix is [-F, +N, +V].

▪ **Exercise 7**

Easi+er

The stem of the word *easier* is *easy* which is an adjective. Adjectives can be graded. The comparative and superlative forms of *easy* are inflectional that is the suffixes *-er* or *-est* are added to the adjectival stem. The underlined suffix is inflectional, it can be added to the appropriate word class (in this case adjective) productively. Adjectives in comparative form compare two nominal expressions with respect to the property expressed by the adjective.

Grand+father+s

Two simple stems (roots) *grand* and *father* are combined to create the compound stem *grandfather*. The plural marker added to the complex stem is inflectional, as it can co-occur with determiners that require plural nouns e.g. two grandfathers.



## Exercise 7

---

un+happi+est

This word consists of three morphemes. The basic stem is the adjective *happy*. The derivational morpheme *un-* is added to the stem. The newly formed complex stem is still an adjective. Derivational morphemes can change the syntactic category of the basic stem (*happi-ly*), but they do not necessarily do so. In this case no categorical change occurred. However, the meaning of the expression has changed, which is not something inflectional morphemes can do. Inflectional morphemes only have a grammatical function. Hence the prefix is derivational. The superlative suffix, as we have already seen is inflectional.

fail+(e)d

The stem is a verb. Verbs can be marked for tense. Tense is a grammatical category associated with inflection, a functional head. Tense specifies that time of the event encoded in the VP (verb and its arguments), hence interacts with construction outside the word it is attached to. It is an inflectional morpheme.

un+employ+ment

The verbal root is *employ*. The prefix *un-* as we have already seen is derivational and can be combined with adjectives as in (iii) and verbs (*un-do*). *-ment* is a derivational suffix. It converts the verbal stem into a nominal stem. Only derivational morphemes can have this effect.

want+s

The stem is a verb to which the 3<sup>rd</sup>. person singular simple present tense suffix is attached. The agreement marker is inflectional as it indicates that the lexical head of the subject DP is a 3<sup>rd</sup>. person singular noun.

eat+able

The verbal stem *eat* is combined with the derivational suffix *-able*, which converts the verbal stem into an adjective.

quick+ly

*Quick* is an adjective, which is combined with the suffix *-ly*. This process is very productive and the resulting structure is an adverb. According to traditional analyses the *-ly* morpheme is derivational since it changes the grammatical category of the word from adjective to adverb, however, in the present approach it has been argued that adjectives and adverbs belong to the same word class having the features [-F, +N, +V]. This means that the *-ly* morpheme is to be analysed as an inflectional morpheme, which appears when the given word it attaches to occupies a certain position in the structure. E.g. the *-s* ending on verbs appears when the subject is third person singular. The *-ly* morpheme appears on the adjective e.g. when it is used to modify a verb.

## Suggested Answers and Hints - Chapter 1

---

### ▪ Exercise 8

- a John likes eating nice food.

*John* is a proper noun. *Likes* is a verb in 3<sup>rd</sup> person singular simple present tense. *Like* is the verbal stem. '-s' is the 3<sup>rd</sup> person singular present tense inflection. *Eating* is a verb in '-ing' form used as a noun also called the gerund, *nice* is an adjective. *Food* is a common noun.

- b The workers must have built the bridge near Boston.

*The* is the definite article. *Workers* is a common noun in plural. *Must* is a modal auxiliary verb. *Have* is an aspectual auxiliary. *Built* is a lexical verb in its -en form (3<sup>rd</sup> form). *Bridge* is a common noun in singular. *Near* is a preposition. *Boston* is a proper noun.

- c A friend of mine gave a book to John's brother.

*A* is an indefinite article. *Friend* is a common noun in singular. *Of* is a preposition. *Mine* is a possessive pronoun which is used predicatively or in the "of" possessive construction. *Gave* is a lexical verb in past tense. *Book* is a singular common noun. *To* is a preposition. *John* is a proper noun and 's is a determiner. *Brother* is a common noun in singular.

### ▪ Exercise 9

Obviously, as far as the possible sample sentences are concerned, there are a lot of solutions for this exercise. As a guide, a sample set of sentences is given here.

- (1) a The soil of the forest is covered with leaves. (N – plural of leaf)  
b The train leaves immediately. (V – 3Sg form of leave)
- (2) a This behaviour of yours will lead to problems. (V)  
b Lead is considered to be one of the heavy metals. (N)
- (3) a That newspaper costs 2\$. (V – 3Sg form of cost)  
b The costs of the reconstruction must be urgently reduced by the committee. (N – plural of cost)
- (4) a A fly has been found in the guest's soup. (N)  
b Although they are birds, penguins cannot fly. (V)
- (5) a Whenever I go to the bathroom, the telephone rings. (V – 3Sg form of ring)  
b "Three rings for the elven kings under the sky..." (J. R. R. Tolkien) (N – plural of ring)
- (6) a Tears were rolling down on her face while listening to the story. (N – plural of tear)  
b He tears a sheet from the pad. (V – 3Sg form of tear)
- (7) a Our neighbours will water our plants while we travel. (V)  
b Could you please give me a glass of water? (N)
- (8) a Queen Elizabeth II rules the United Kingdom. (V – 3Sg form of rule)  
b All players must follow the rules of this game. (N – plural of ring)

**Exercise 10**

---

- (9) a In the present situation, we cannot but wait. (Adj)  
 b He gave me a fabulous present for my birthday. (N)  
 c The mayor will present the prizes after the competition. (V)
- (10) a Do not dare to touch it, it is mine. (pronoun)  
 b This is the only copper mine of this country. (N)  
 c An Australian company will mine for gold in this village. (V)
- (11) a It is not probable that the left will win the elections. (N)  
 b My uncle writes with his left hand. (Adj)  
 c Turn left at the corner. (Adv)  
 d Her boyfriend left without a word. (V – past tense of leave)
- (12) a It has been a long night. (Adj)  
 b Have you been here long? (Adv)  
 c I long to be with my husband. (V)
- (13) a I do not like fast food very much. (Adj)  
 b You drive too fast. (Adv)  
 c Muslims fast during Ramadan. (V)  
 d In order to lose weight, she went on a fast. (N)

▪ **Exercise 10**

The words are classified according to their category in the following table.

V	N	A (Adj/Adv)	P	I	D	Deg	C
go	girl holiday Haiti man	pretty surely luxury tall young	for in with	will	the a	very	
change	idea trade reform situation countries	excellent probably economic African	about of	can	his the		
sent	picture president buildings company France	big old former electric Southern	to of in	has been	a the	very	
announce built	spokesman houses centre London year	modern	in of for	may have been -ed	the a	most	that
destroyed	ruins earthquake century	ancient big	by of	might have been	the	-est	

## Suggested Answers and Hints - Chapter 1

---

Lexical entries are given here:

### Verbs

a	<i>go</i>	<b>category:</b>	[-F, -N, +V]
		<b>Θ-grid:</b>	<agent, goal>
		<b>subcat:</b>	[prepositional]
b	<i>change</i>	<b>category:</b>	[-F, -N, +V]
		<b>Θ-grid:</b>	<source, patient>
		<b>subcat:</b>	[nominal]
c	<i>send</i>	<b>category:</b>	[-F, -N, +V]
		<b>Θ-grid:</b>	<(agent), theme, goal>
		<b>subcat:</b>	[nominal, prepositional]
d	<i>announce</i>	<b>category:</b>	[-F, -N, +V]
		<b>Θ-grid:</b>	<agent, proposition>
		<b>subcat:</b>	[sentence]
	<i>build</i>	<b>category:</b>	[-F, -N, +V]
		<b>Θ-grid:</b>	<(agent), theme, location>
		<b>subcat:</b>	[nominal, prepositional]
e	<i>destroy</i>	<b>category:</b>	[-F, -N, +V]
		<b>Θ-grid:</b>	<(agent), patient>
		<b>subcat:</b>	[nominal]

### Auxiliaries

a	<i>will</i>	<b>category:</b>	[+F, -N, +V]
		<b>subcat:</b>	[verbal]
b	<i>can</i>	<b>category:</b>	[+F, -N, +V]
		<b>subcat:</b>	[verbal]
c d e	<i>have</i>	<b>category:</b>	[-N, +V]
		<b>subcat:</b>	[verbal]
c d e	<i>be</i>	<b>category:</b>	[-N, +V]
		<b>subcat:</b>	[verbal]
d	<i>may</i>	<b>category:</b>	[+F, -N, +V]
		<b>subcat:</b>	[verbal]
	<i>-ed</i>	<b>category:</b>	[+F, -N, +V]
		<b>subcat:</b>	[verbal]
e	<i>might</i>	<b>category:</b>	[+F, -N, +V]
		<b>subcat:</b>	[verbal]

## Exercise 11

---

Degree adverbs

a c		
	<i>very</i>	<b>category:</b> [+F, +N, +V] <b>subcat:</b> [adjectival]
d		
	<i>most</i>	<b>category:</b> [+F, +N, +V] <b>subcat:</b> [adjectival]
e	<i>-est</i>	<b>category:</b> [+F, +N, +V] <b>subcat:</b> [adjectival]

▪ **Exercise 11**

a) F; b) N; c) F; d) N; e) F; f) N; g) F; h) N; i) N; j) F; k) F; l) N; m) N; n) N;

▪ **Exercise 12**

The lexical entry of a predicate contains a theta-grid that specifies the number and the type of arguments the predicate has and the subcategorisation frame that provides the categorial status of the complements (all the arguments but the subject) of the predicate.

a My brother ate a lot of chocolate.

*Eat* is a two-place predicate that expresses an activity in which an “eater” and an entity which is eaten are involved. The “eater” performs the “eating” activity on the entity that is eaten. The thematic roles associated with the two arguments are the agent role (the “eater” who instigates the activity) and a patient role (the entity that undergoes a change of state caused by the agent). The subcategorisation frame specifies the categorial status of the patient, which is a noun phrase therefore it is categorically nominal.

eat **category:** [-F, -N, +V]  
**Θ-grid:** <agent, patient>  
**subcat:** nominal

b John is keen on wild animals.

*Keen* is a two-place predicate, an adjective that expresses a psychological state of the subject with respect to the object. The subject has experiencer theta role, the object has theme theta role. The subcategorisation frame specifies the categorial status of the complement, which is a preposition phrase therefore it is categorically prepositional.

keen **category:** [-F, +N, +V]  
**Θ-grid:** <experiencer, theme>  
**subcat:** prepositional

## Suggested Answers and Hints - Chapter 1

---

- c John gave a book to his friend.

*give* is a three-place predicate, a verb that describes a situation in which the object (theme) changes its position as the result of the activity of the subject (agent), that instigates the action, that is causes the change of place of the theme. The entity (goal) expressed by the prepositional phrase is the target of the movement of the theme. The subcategorisation frame specifies the categorial status of the two complements, which are a noun phrase and a prepositional phrase.

give    **category:**[-F, -N, +V]  
          **Θ-grid:** <agent, theme,goal>  
          **subcat:** nominal, prepositional

- d He always parks his car near a nice old hotel.

*park* is a verb that has three arguments, an agent *he* that performs the action of parking, theme *his car* that get 'suffers' the result of parking and a location *near a nice old hotel* that specifies the location of the theme as the result of parking. The subcategorisation frame specifies the categorial status of the two complements, which are a noun phrase and a prepositional phrase.

park    **category:**[-F, -N, +V]  
          **Θ-grid:** <agent, theme,location>  
          **subcat:** nominal, prepositional

- e I love Vermeer's painting of the young girl.

*love* is a two-place predicate whose meaning is almost identical with the meaning of the adjective *keen*. It has a subject (experiencer) that is in a psychological state with respect to the object (theme). The differences between the two words are that *love* is a verb and *keen* is an adjective and that *love* takes a nominal complement, while *keen* has a prepositional complement.

love    **category:**[-F, -N, +V]  
          **Θ-grid:** <experiencer, theme>  
          **subcat:** nominal

*painting* is a derived nominal that inherits the argument structure of the verb *paint* it is derived from. *Painting* expresses an activity in which the subject (agent) creates an object (theme) in a certain way. The subcategorisation frame specifies the categorial status of the complement, which is a prepositional phrase.

painting    **category:**[-F, +N, -V]  
              **Θ-grid:** <agent, theme>  
              **subcat:** prepositional

### Exercise 13

---

f Jane broke the vase.

The verb *break* in this sentence is a two-place predicate; the subject (agent) causes the object (theme) to undergo a change of state. Its complement is a nominal phrase.

break **category:**[-F, -N, +V]  
**Θ-grid:** <agent, theme>  
**subcat:** nominal

g The vase broke.

The verb *break* in this sentence is a one-place predicate, whose meaning is very similar to the verb *break* in sentence (1f). The subject (theme) undergoes the same change of state as the object in sentence (1f), but as opposed to sentence (1f), in sentence (1g) the causer is not specified. There is no agent only a theme that is nominal.

break **category:**[-F, -N, +V]  
**Θ-grid:** <theme>  
**subcat:** nominal

h Everybody got a letter from the Prime Minister.

*get* is a three-place predicate, which expresses movement of some entity, the object (theme) of the clause that undergoes some change of place. The source of movement is expressed with prepositional phrase (source). The target of movement is the subject (goal). The verb has two complements, the nominal theme and the prepositional source. The subject argument has the role of beneficiary.

get **category:**[-F, -N, +V]  
**Θ-grid:** <beneficiary, theme, source>  
**subcat:** nominal, prepositional

#### ▪ Exercise 13

- a *realise* **category:** [-N, +V]  
**Θ-grid:** <experiencer, proposition>  
**subcat:** [sentence]
- open* **category:** [-N, +V]  
**Θ-grid:** <instrument, theme>  
**subcat:** [nominal]
- b *crawl* **category:** [-N, +V]  
**Θ-grid:** <agent, source, goal>  
**subcat:** [prepositional, prepositional]
- c *think* **category:** [-N, +V]  
**Θ-grid:** <experiencer, proposition>  
**subcat:** [sentence]
- break* **category:** [-N, +V]  
**Θ-grid:** <source, patient>  
**subcat:** [nominal]

**Suggested Answers and Hints - Chapter 1**

---

d	<i>travel</i>	<b>category:</b> [-N, +V] <b>Θ-grid:</b> <agent, source, goal> <b>subcat:</b> [prepositional, prepositional]
e	<i>cut</i>	<b>category:</b> [-N, +V] <b>Θ-grid:</b> <agent, patient, instrument> <b>subcat:</b> [nominal, prepositional]
f	<i>write</i>	<b>category:</b> [-N, +V] <b>Θ-grid:</b> <agent, goal, proposition> <b>subcat:</b> [prepositional, sentence]
	<i>love</i>	<b>category:</b> [-N, +V] <b>Θ-grid:</b> <experiencer, theme> <b>subcat:</b> [nominal]
g	<i>tell</i>	<b>category:</b> [-N, +V] <b>Θ-grid:</b> <agent, theme, goal> <b>subcat:</b> [nominal, prepositional]
h	<i>tell</i>	<b>category:</b> [-N, +V] <b>Θ-grid:</b> <agent, goal, proposition> <b>subcat:</b> [nominal, sentence]
	<i>afraid</i>	<b>category:</b> [+N, +V] <b>Θ-grid:</b> <(experiencer) (theme)> <b>subcat:</b> prepositional
i	<i>proud</i>	<b>category:</b> [+N, +V] <b>Θ-grid:</b> <(experiencer) (theme)> <b>subcat:</b> prepositional
j	<i>keen</i>	<b>category:</b> [+N, +V] <b>Θ-grid:</b> <(experiencer) (theme)> <b>subcat:</b> prepositional
k	<i>angry</i>	<b>category:</b> [+N, +V] <b>Θ-grid:</b> <(experiencer) (theme)> <b>subcat:</b> prepositional
l	<i>hold</i>	<b>category:</b> [-N, +V] <b>Θ-grid:</b> <experiencer, theme> <b>subcat:</b> [nominal]
	<i>belief</i>	<b>category:</b> [+N, -V] <b>Θ-grid:</b> <experiencer, proposition> <b>subcat:</b> [sentential]
	<i>move</i>	<b>category:</b> [-N, +V] <b>Θ-grid:</b> <agent, location> <b>subcat:</b> [prepositional]



## Chapter 2

### ▪ Check Questions

Q1 Sentences are made up of words but these words are also organised into units which are smaller than the sentence itself. The best way to identify phrases is by having a look at their distribution: sometimes a single word can be substituted by another structure containing several words that cluster together, e.g. in *Mary is dancing* the constituent *Mary* can be substituted by *The girl we met yesterday*. These two structures (*Mary* and *the girl we met yesterday*) have the same function in the sentence and wherever *Mary* is used *the girl we met yesterday* can be used, too. Phrases come in different types, they are always identified by an element contained in the phrase. That central element in *the girl we met yesterday* is *girl*, a noun, so the whole structure is a noun phrase. Phrases can have a rather complex internal structure, they can contain other phrases or even clauses as can be seen in *the girl (that) we met yesterday*, too.

Q2 Rewrite rules describe what constituents a certain structure can be made up of. The rewrite rule  $DP \rightarrow D NP$  means that what is on the left side of the arrow, DP, can be rewritten as a D and an NP. Generative grammar is a set of rewrite rules with the help of which all and only the grammatical expressions of the language can be formed.

Q3 A rewrite rule can be recursive, which means that it can contain the same symbol on both sides, e.g.  $sentence \rightarrow word^*, sentence^*$ . This rule states that a sentence can contain another sentence, an embedded sentence. Recursive rules can be applied again and again. It is the presence of such rules that accounts for how a finite system (remember, the number of rules is finite, and the lexicon, however big, also contains a finite number of elements) can be turned into an infinite one, since human languages are limitless.

Q4 The subject is the argument that precedes the verb. In finite clauses it shows agreement with the verb and appears in nominative Case. Finite clauses always have visible subjects, even if there is no semantic motivation for it. In these cases the subject is an expletive element, e.g. *it* in *It is important to finish with the project today*. Non-finite clauses can have an unpronounced subject, if they have a visible subject it appears in accusative Case.

Q5 direct object (DO): the object that is usually next to the verb, having a theme or patient theta role in the most typical case, e.g. *Botanics* in *I study Botanics*.

indirect object (IO): the object that has the beneficiary theta role in double-object constructions, in such structures it is the that IO appears next to the verb preceding the DO: *I sent him a parcel*. In this structure the IO is *him*. prepositional object: an object that appears after a preposition, e.g. *him* in *I went to the theatre with him*.

Q6 The double-object construction has a dative alternate: *I sent him a parcel* can also be expressed as *I sent a parcel to him* with no particular change in meaning. The order of the theme and goal/beneficiary arguments are different and there are also

## Suggested Answers and Hints - Chapter 2

---

differences in how the structures can be passivised: in the double-object construction only the indirect object can be passivised, if we want to passivise the direct object we have to use the dative structure and express the goal argument in the form of a PP.

Q7 Substitution: if a constituent can be replaced with another constituent they belong to the same constituent-type. E.g. pronouns are DPs and whatever pronouns can substitute will also be DPs in the structure.

Coordination: only identical constituents (with the same function) can be coordinated.

Movement: only constituents can undergo movement. E.g. the sentence *\*The boy was seen with blue eyes by Mary* is ungrammatical as *the boy* is not an independent constituent in this sentence.

### ▪ Exercise 1

S → DP VP  
DP → D NP  
NP → N S  
VP → V VP  
VP → V DP PP  
PP → P DP

### ▪ Exercise 2

- a [S [DP the postman] [VP lost [DP his key] [DP yesterday]]]
- b [S [DP the student [S [DP who] [VP has just passed [DP the exam]]]] [VP is [AP very happy]]]
- c [S [DP this theory [PP of [DP [DP language] acquisition]]] [VP is [AP easy [PP for [DP students [S [DP who] [VP understand [DP mathematics]]]]]]]]]

### ▪ Exercise 3

- a Only identical constituents can be coordinated. Here we have a DP coordinated with a PP.
- b Only constituents can undergo movement. Here *whose* is not a constituent, it forms a constituent together with *film*, so they should move together.
- c Pronouns, in spite of their name substitute full DPs, not only nouns. *She* in the ungrammatical sentence could stand for *the woman with long hair*, it cannot be understood as referring to *woman* only.
- d Again, only constituents can undergo movement. The constituent that could be moved in this sentence is *the student of Physics*.
- e Identical constituents can be coordinated, but only if they have the same function in the sentence. In this sentence the first PP is an instrument, the second expresses manner.

## Chapter 3

▪ **Check questions**

Q1 Rewrite rules establish the nature of structures in languages. They become maximally general via the use of category variables which may stand both for thematic and functional categories. The complement rule ( $X' \rightarrow X YP$ ) introduces the head and the complement; the order of the elements on the right side of the arrow may be swapped, thereby it is possible to achieve cross-linguistic generalisations about the relative order of head + complement. The specifier rule ( $XP \rightarrow YP X'$ ) introduces the structural position associated with specifiers which, in English, appear to the left of the constituent containing the head + complement ( $X'$ ). The adjunct rule differs from the other two in that what is on the left hand side of the arrow may be a head or a bar-level constituent or a maximal projection. In addition, the adjunct may also be of two types: a zero-level category or a maximal projection. Finally, the adjunct rule is recursive, i.e. a constituent appearing on the left hand side of the arrow also appears on the right hand side, thus inclusion of any number of adjuncts in a structure is made possible.

Q2 (i) head to head: compound nouns

$$\begin{array}{l} X \rightarrow X Y \quad (\text{armchair}) \\ X \rightarrow Y X \end{array}$$

(ii) phrase to bar-level constituent: pronominal APs

$$\begin{array}{l} X' \rightarrow X' YP \\ X' \rightarrow YP X' \quad (\text{popular smart student}) \end{array}$$

(iii) phrase to phrase: relative clauses

$$\begin{array}{l} XP \rightarrow XP YP \\ XP \rightarrow YP XP \end{array}$$

It must be noted that the order of the constituents on the right side of the arrow may vary, i.e. adjunction to either side is possible and that in case of adjunction to a head the adjoining element is itself a head, whereas in the other two cases it is a maximal projection.

Q3 The constituent that is not projected in a phrase is called the head (the zero-level projection). A head projects its properties (e.g. its category), thus the maximal projection containing that head will share the category of the head and so will intermediate projections between the two. Projection is sharing category among the three levels of constituents. The properties of a given head which is inserted into a head position are idiosyncratic, in other words, if a word is picked from the lexicon, all the relevant pieces of information about it specified in the lexicon are also automatically available. Thus, depending on what category a given word has, the phrase it heads will acquire the same category.

### Suggested Answers and Hints - Chapter 3

---

Q4 An endocentric phrase has a head that lends its properties to the whole projection, while an exocentric phrase lacks such a head, hence the properties of an exocentric phrase do not necessarily follow from the properties of the elements it contains. It must be pointed out that all phrases are assumed to be endocentric. It is possible to rely on the discussion on imperatives in the text and exemplify a potential candidate for an exocentric construction.

Q5 a) yes; b) no; c) no; d) no; e) no; f) no

Q6 Heads select the number and type of complements they take but there only seem to exist restrictions related to compatibility of meaning with the meaning of the head for specifiers. Specifiers and complements (i) are both arguments of thematic heads, (ii) both receive theta-roles, but (iii) while it is possible for certain verbs to take more than one complement, there can only be a single specifier in a phrase.

Q7 The rule by itself might seem to general and would seemingly allow (generate) ungrammatical sequences. However, given the restriction that movement cannot change basic X-bar configurations (structures), the vast majority of potentially arising ungrammatical structures disappears.

Q8 There are two levels of representation assumed, D-Structure and S-Structure. At D-Structure elements occupy their base-position, i.e. for arguments a position where they can receive a theta role from the predicate. However, a D-Structure position may not be a position where they can receive case from a case assigning element, hence elements may potentially be moved to another position which we call S-Structure position. This is what happens in passive constructions, as we will see in more detail later on in the book. Thus, we can say that the two levels of representation are linked via movement.

Q9 A theta-marking head theta marks arguments in its immediate vicinity, that is, arguments which are associated with the specifier position and the complement position of the phrase headed by the theta-marking head.

Q10 Nominative: subjects of finite clauses; accusative: subjects of non-finite clauses, complements of verbs and prepositions, e.g. *Peter/He loves Mary/her*; *Peter saw John/him climbing up the tree*; *Peter often talks about Mary/her*.

Q11 In both of these constructions there is no argument associated with the subject slot. In addition, the arguments present in them remain Caseless unless they leave the D-Structure position where they receive their respective theta-roles. As the subject position is empty but it can be case-marked, passivisation or raising can occur, depending on whether the structure contains a passive verb or a raising verb or a raising adjective.

## Exercise 1

---

- **Exercise 1**

Possible configurations: 2, 3, 5, 6, 9, 12

1: projection: a Y head cannot project WP, XP has no head, etc.

4: projection (Y as head); X' cannot dominate two maximal projections

7: crossing branches

8: complements must be maximal projections

10: lower XP should be rewritten as X; Y' should be a maximal projection

11: X' cannot dominate two maximal projections; the lower XP should be rewritten as

13: adjuncts must be maximal projections

14: specifiers must be maximal projections

15: ternary branching is not allowed

- **Exercise 3**

The syntactic heads are nouns in each compound. The head is on the left in a) and e). The meanings of b), c) and f) merit discussion as the meanings of the components do not directly relate to the meaning of the whole compound. Perhaps it could be argued that these are exocentric compounds.

- **Exercise 4**

In this exercise the existence of implicit arguments (a, i, j) should be pointed out. One argument cannot receive more than one theta role (c, d, e, f, g). One theta role can only be assigned to one argument (b). Clausal arguments may also receive theta roles (k and l).

- **Exercise 5**

(1) Peter – agent/subject, Mary – beneficiary/indirect object, flowers – theme/direct object: no change in theta-roles or grammatical functions, only word order changes

(2) active: the postman – agent/subject, the letter – theme/direct object; passive: the letter – subject/theme: there is no change in theta-roles but as the subject is unexpressed, the object moves into its position and assumes its grammatical function

(3) he – agent/subject, us – theme/direct object: no change in theta-roles or grammatical functions occurs

(4) Peter – experiencer/subject, the scar – theme/direct object: in the second sentence the scar – theme/subject

(5) Mary – theme/subject: in the second sentence Mary – agent/subject: the meanings of the two sentences differ considerably with respect to who is pleasing who

(6) who – theme/direct object, you – experiencer/subject, the second sentence is ambiguous: who – agent/subject of lower clause, you – experiencer/subject of matrix clause OR who – theme/direct object

(7) he – agent/subject, a shower – theme/(eventive) object: no change in theta roles or grammatical functions

(8) he – agent/subject, the ball – theme/direct object: no change in theta roles or grammatical functions

**Suggested Answers and Hints - Chapter 3**

---

▪ **Exercise 6**

Brackets symbolize the same as nodes do in the tree structure. Each pair of brackets corresponds to a node in the tree with the label given at the left bracket. The first pair of brackets gives the uppermost node, namely I. I is made up from the nodes H and J. Inside J we have a word *c* and the node K. Following this logic, we get the following tree structure:

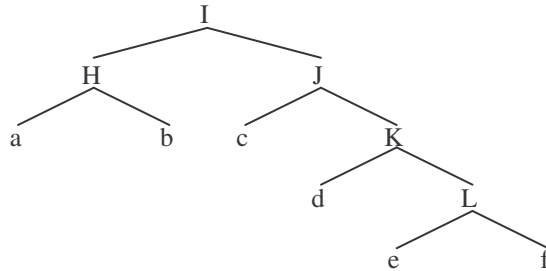

▪ **Exercise 7**

In the bracketed structure each pair of brackets represent a unit, like nodes do in the tree. Thus each node in the tree can have a corresponding pair of brackets in the bracketed structure. The strategy is to take a look at all nodes in the tree and to determine which words of the sentence are dominated by the particular node. To each node we will have a corresponding pair of brackets:

[<sub>K</sub> [<sub>I</sub> a [<sub>J</sub> b c]] [<sub>L</sub> [<sub>P</sub> d] [<sub>M</sub> e [<sub>N</sub> f [<sub>O</sub> g h]]]]]

▪ **Exercise 8**

<i>the</i>	<b>category:</b> [+F, +N, -V] <b>subcat:</b> [nominal]	
<i>little</i>	<b>category:</b> [-F, +N, +V] <b>Θ-grid:</b> <theme>	
<i>boy</i>	<b>category:</b> [-F, +N, -V] <b>Θ-grid:</b> <∅> <b>subcat:</b> [∅]	[∅]
<i>may</i>	<b>category:</b> [+F, -N, +V] <b>subcat:</b> [verbal]	
<i>think</i>	<b>category:</b> [-F, -N, +V] <b>Θ-grid:</b> <experiencer <b>subcat:</b> proposition> sentential	
<i>that</i>	<b>category:</b> [+F, -N, -V] <b>subcat:</b> [clausal] <b>features</b> [-Wh, +Fin]	
<i>he</i>	<b>category:</b> [+F, +N, -V] <b>subcat:</b> [∅]	

### Exercise 9

---

<i>will</i>	<b>category:</b> [+F, -N, +V] <b>subcat:</b> [verbal]	
<i>get</i>	<b>category:</b> [-F, -N, +V] <b>Θ-grid:</b> <beneficiary theme> <b>subcat:</b> [nominal]	
<i>a</i>	<b>category:</b> [+F, +N, -V] <b>subcat:</b> [nominal]	
<i>very</i>	<b>category:</b> [+N, +V] <b>subcat:</b> [adjectival]	
<i>expensive</i>	<b>category:</b> [-F, +N, +V] <b>Θ-grid:</b> <theme> <b>subcat:</b> [Ø]	
<i>present</i>	<b>category:</b> [-F, +N, -V] <b>Θ-grid:</b> <(agent) (beneficiary)> <b>subcat:</b> [prepositional]	
<i>for</i>	<b>category:</b> [+F, -N, -V] <b>subcat:</b> [nominal]	
<i>his</i>	<b>category:</b> [+F, +N, -V] <b>subcat:</b> [Ø]	
<i>birthday</i>	<b>category:</b> [-F, +N, -V] <b>Θ-grid:</b> <Ø> <b>subcat:</b> [Ø]	

▪ **Exercise 9**

exp = experiencer; prop = proposition;

- (1)                    exp     prop            exp     theme  
  
 (2)    prop            prop  
  
 (3)                    prop     agent   theme  
  
 (4)                    agent theme     beneficiary  
  
 (4)                    agent prop                    agent   theme

### Suggested Answers and Hints - Chapter 3

---

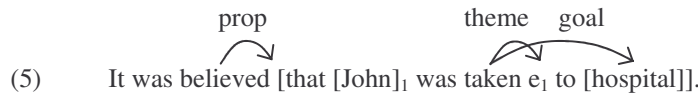
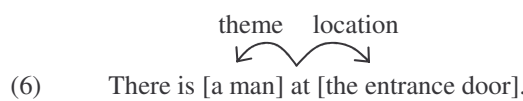
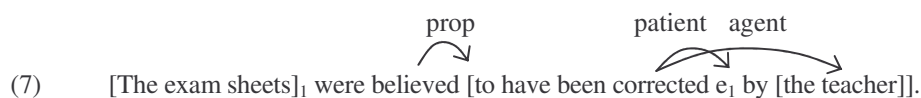
- (5) 
- (6) 
- (7) 

In sentence (2) the DP *one of the big parties* is base-generated as the subject of the verb *win* in the lowest clause, so it is the argument of the verb *win* and receives its theta-role from the verb *win*. In sentence (5) the subject position is filled by an expletive pronoun, which again has no theta-role and thus it is no argument either.

#### ▪ Exercise 10

The adjuncts are given in brackets.

- a The [little] boy gave a [nice] drawing to his mother [for her birthday].
- b The teacher wanted to know whether the [new] students would know what to do [[when] they arrive].
- c [Why] do you ask me whether I want to buy a [new] computer [next year]?
- d The [new] [guest] professor of Mathematics [from Germany] will [probably] arrive at the [[recently] renovated] [railway] station [at 2:15].
- e [How] can you decide whether a loaf of bread [on the shelf] is fresh or not?
- f Jack and Jane saw a [very interesting] [new] film [at the cinema [in the [city] centre]].
- g [Sometimes] it is difficult for students to find the adjuncts [in sentences [like this]].
- h The mayor of the city said that the river is unlikely to flood the city.
- i The workers didn't believe that they didn't have to work [on the following week].

#### ▪ Exercise 11

- (1)
  - a. David wrote a letter *on the desk*.
  - b. David put a letter *on the desk*.
  - c. Mary slept *in the bed*.
  - d. Mary stayed *in the bed*.
  - e. Jill arrived *at the station*.
  - f. Jill waited *at the station*.

Complements are part of the VP while adjuncts are added to the VP, forming another VP node:



Exercise 11

---

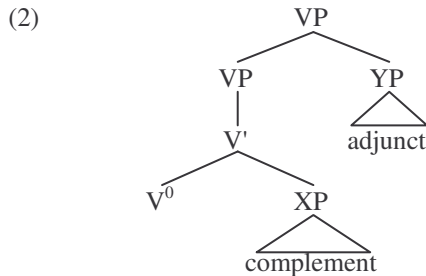

As it can be seen in (2), the verb and its complement forms a phrase without the adjunct, while the verb itself cannot form a phrase without its complement. This fact can be made use of when we would like to decide about the complement or the adjunct status of a particular item. If a phrase can somehow be separated from the verb, then it is an adjunct, while if it cannot be separated, then the phrase is probably a complement of the verb.

Let us apply the so called ‘do so’ test for sentences (1a) and (1b). The string *do so* or *did so* always substitutes for a VP. If the sentence is well-formed, then the phrase which *do so* stands for is a VP. If the sentence is ill-formed, then the string of words which *do so* stands for is not a VP.

- (3) a. Jim wrote a letter on the table and David *wrote a letter* on the desk.  
 b. Jim wrote a letter on the table and David *did so* on the desk.

As we can see in (3a–b), *did so* substitutes for *wrote a letter*. The sentence is well-formed, which means that the string *wrote a letter* is a VP. The PP *on the desk* is outside the VP, so it is an adjunct.

- (4) a. Jim put a letter on the table and David *put a letter* on the desk.  
 b. \*Jim put a letter on the table and David *did so* on the desk.  
 c. Jim put a letter on the desk and so did David.

In (4b) *did so* stands for *put a letter*. Since (4b) is ill-formed, the string *put a letter* cannot be a full VP. The PP *on the desk* is part of the VP, which can be seen in (4c) as well, where *so did* substitutes for *put a letter on the desk*. According to (4b), the PP *on the desk* is a complement of the verb in (1b).

Let us choose a different test for sentences (1c–d). The test used in (5) and (6) is called VP-fronting.

- (5) a. Mary wanted to sleep in the bed and [sleep]<sub>1</sub> she did e<sub>1</sub> in the bed.  
 b. Mary wanted to sleep in the bed and [sleep in the bed]<sub>1</sub> she did e<sub>1</sub>.  
 (6) a. \*Mary wanted to stay in the bed and [stay]<sub>1</sub> she did e<sub>1</sub> in the bed.  
 b. Mary wanted to stay in the bed and [stay in the bed]<sub>1</sub> she did e<sub>1</sub>.

In (5a) *sleep* was moved from behind *did*. The sentence is grammatical, which means that the moved item has to be a full phrase. *sleep* is a VP, thus the PP *in the bed* is an adjunct. Since the VP and the adjunct together form a VP node as well, sentence (5b) will also be grammatical.

### Suggested Answers and Hints - Chapter 3

---

In (6a) only the verb *stay* is moved and the sentence is ill-formed. This means that *stay* alone cannot form a whole VP. The PP *in the bed* is now not an adjunct but a complement of the verb. If we move the verb and the PP together, the sentence is well-formed, as we can see in (6b).

Now let us consider the sentences in (1e–f). The test we are going to use is pseudo-clefting.

- (7) a. \*What Jill did at the station was [arrive].  
b. What Jill did was [arrive at the station].
- (8) a. What Jill did at the station was [wait].  
b. What Jill did was [wait at the station].

In the above pseudo-cleft sentences, if the sentence is well-formed, the string following the auxiliary *was* is a phrase, in these cases a VP. In (7a) the sentence is ill-formed, so the verb *arrive* alone is not a full VP. The PP *at the station* is a complement of the VP, thus it cannot be separated from the verb. (7b) is well-formed because the verb is not separated from its complement. In (8a), similarly to (7a), only the verb follows the auxiliary *was*. The difference is that now the sentence is well formed. This means that the verb *wait* and the PP *at the station* can be separated. The PP *at the station* is an adjunct. Since a VP and an adjunct form another VP node, the sentence in (8b) will be grammatical as well.

#### ▪ Exercise 12

- (1) a. Julie met the student of Physics from France and I met the one from Spain  
b. \*John knows the student of Physics from France and I know the one of English from Spain.
- (2) a. Julie met a student of Physics of considerable intelligence.  
b. \*Julie met a student of considerable intelligence of Physics.
- (3) a. Julie met a student of Physics and of Mathematics.  
b. \*Julie met a student of Physics and of considerable intelligence.

The noun *student* has a PP complement. The PP complement contains a preposition and a DP that is understood as the object of *student*. The prepositional phrase *of considerable intelligence* is interpreted as an adjunct.

(i) In sentences (1) the indefinite pronoun *one* is introduced in the second clause. Pronouns in general have the same distribution as Determiner Phrases (DPs) have. In fact pronouns are analysed as heads of DPs that do not take NP argument. *One* seems to have different distribution as it excludes the definite article as sentence (1a) illustrates and it covers the head and the complement as is shown in (1b). (1b) is ungrammatical as the pronoun is substituted in the position of the noun head and excludes the complement PP between the adjunct PP and the article.

(ii) In sentences (2) the contrast is due to the strict order of the adjunct PP and the complement PP. Complements are always closer to the head than adjuncts in English. In sentence (2a) the complement immediately follows the head, while in (2b) the adjunct follows the head hence the sentence is ungrammatical.

### Exercise 13

---

(iii) In sentence (3a) both PPs can be interpreted as the complement of the head, therefore they can be coordinated and as coordinated PPs, they can be understood as the complement of the head. In sentence (3b) the adjunct PP and the complement PP are coordinated and that renders the sentence ungrammatical. The adjunct and the complement have different statuses in the DP, therefore they cannot be coordinated.

▪ **Exercise 13**

- (1) a John solved the problem *independently of me*.  
 b My professor lives *right in the middle of nowhere*.  
 c I am *very afraid of wild animals*.  
 d John read a *book about Britain*.

(1a) The phrase in this sentence is an adverb phrase (AP) headed by the adverb *independently*. The adverb *independently* has one complement, a prepositional phrase PP *of me*. The head merges with the complement PP to form A'. In accordance with the Specifier Rule A' further projects into AP. The X'-structure of the adverb phrase is in (2):

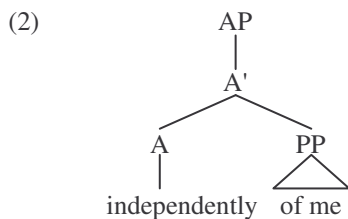

(1b) The phrase in this sentence is a prepositional phrase (PP) whose head is *in*. It is modified by the adverb *right*. The DP *the middle of nowhere* functions as the complement of the prepositional head. The head is merged with the complement. They form the P' level. The adjunct *right* is merged with P' making P' recursive. Finally the P' level is projected into the PP.

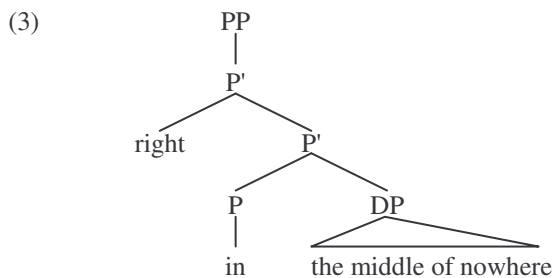

(1c) The structure in italics in sentence (4) is an adjectival phrase whose head is the adjective *afraid*. This adjective is a two-place predicate. It has an experiencer subject and a theme object. The adverb *very* is not in the lexical entry of the adjective. It functions as an adjunct in the structure. The adjectival head is merged with the

**Suggested Answers and Hints - Chapter 3**

---

prepositional complement of *wild animals* to form A'. The adjunct is merged with A' to form another A' level. Adjuncts are added to the X' structure by making one of the levels recursive. Then the higher A' merges with the subject DP to form AP as in (4).

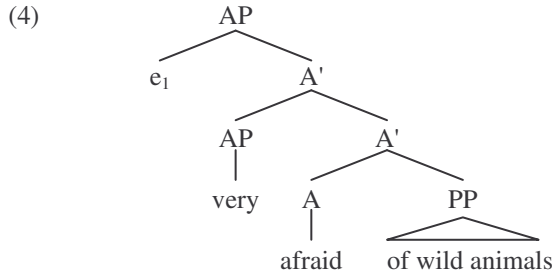

(1d) The phrase in this sentence is a noun phrase headed by the noun *book*. It has a prepositional complement *about Britain*. The noun merges with its complement PP to form N', N' is further projects the NP level as in (5).

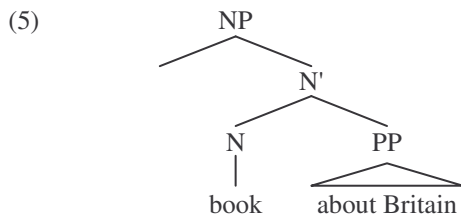

▪ **Exercise 14**

- (1) a \**The teacher from France of English* likes going to open lectures.
- b \**Mary often drives too fast her car*.
- c \**Every student in Cambridge of Physics* gets an excellent job.

(i) The phrase that is responsible for the ungrammaticality of the sentence is the NP *teacher from France of English*. The noun *teacher* is a one-place predicate that takes the PP complement of *English*.

The prepositional phrase *from France* is not in the lexical entry of the noun. It is an optional PP, an adjunct. The problem with the NP is that the adjunct intervenes between the head and the complement. Considering X-bar theory the first rewrite rule, the Complement Rule, is applied (2). The nominal head *teacher* merges with its prepositional complement forming the X' level as rule 1 indicates in (2).

(2) Rule 1: X' → X YP

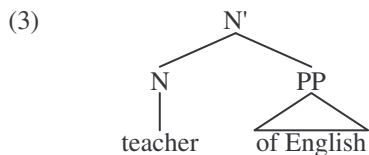

### Exercise 14

---

The adjunct PP is merged with the structure by making the X' level recursive as the result of the application of Adjunct Rule as in (4).

- (4) Adjunct Rule 2:  $X' \rightarrow X' \cdot YP$

After combining the rules in (2) and (4) we get the structure in (5).

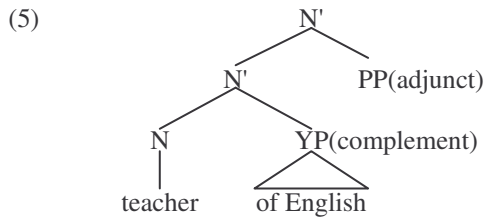

There are two issues at stake here. One is that rule (2) is obligatory while rule (4) is optional. The second is that the application of rules (2) and (4) is ordered. First rule (2) must be applied, and then rule (4). In fact X-bar theory does not allow a head to be combined with an adjunct phrase. Rule 3 as in (5) is unavailable.

- (6)  $*X' \rightarrow X \cdot YP$  (where YP is interpreted as an adjunct)

The other possibility is to allow for the adjunct to be able to intervene between the head and the complement as in the NP in sentence (1a) and still maintain the rules of X-bar theory as in (2) and (4) (excluding (6)) is to allow the branches of the tree to cross. It is again impossible. Therefore X-bar theory predicts that sentence (1a) is ill formed.

- (ii) Sentence (1b) is problematic for the same reason as sentence (1a). The order of the elements in the VP *drives too fast her car* makes the sentence ungrammatical. *drive* is a two-place predicate, it has an agent subject and a patient theme. The lexical entry for the verb *drive*:

- (7) drive **cat**: [-F, -N, +V]  
**Θ-grid**: <agent, patient>  
**subcat**: nominal.

As can be seen in (7) the verb has an object complement specified in its lexical entry, but no adverbial is present in the lexical specification, therefore the adverb phrase functions as an adjunct in the VP. The order of the constituents suggests that first the head and the adjunct are merged as it is in (6), then the complement is merged with the new structure, but as we have seen in (2), this is not possible. As has been shown earlier, X-bar theory does not permit branches to cross, hence the impossibility of VP structure in (1b).

**Suggested Answers and Hints - Chapter 3**

---

(iii) The DP subject in sentence (1c) is headed by the noun *student*, which is a one-place predicate. Its lexical entry is:

- (8) student **cat**: [-F, +N, -V]  
**Θ-grid**: <theme>  
**subcat**: prepositional

The PP *in Cambridge* is not in the lexical entry of the predicate *student*, as it cannot be interpreted as theme; therefore it is interpreted as an adjunct in the DP. The PP *of Physics* can be understood as the theme of the head. In this DP the same problem arises that we had in (i). In this structure the adjunct PP is again closer to the nominal head than the complement PP, which indicates that either the head is first merged with the adjunct, then the resulting structure with the complement or alternatively the branches of the tree should be allowed to cross. Neither of these strategies available in X-bar theory as in (i) and (ii).

▪ **Exercise 15**

a)

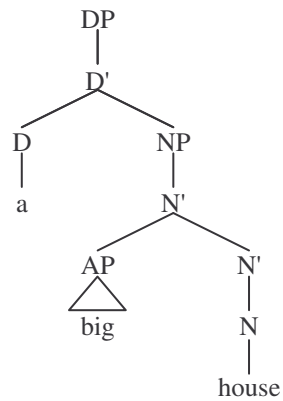

b)

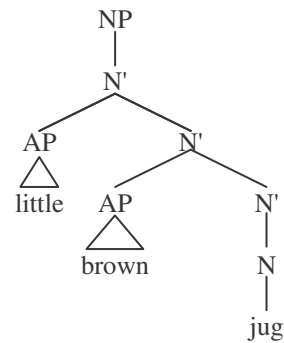

c)

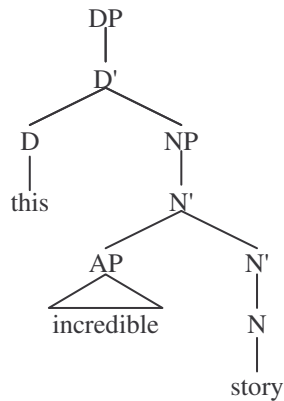

Exercise 15

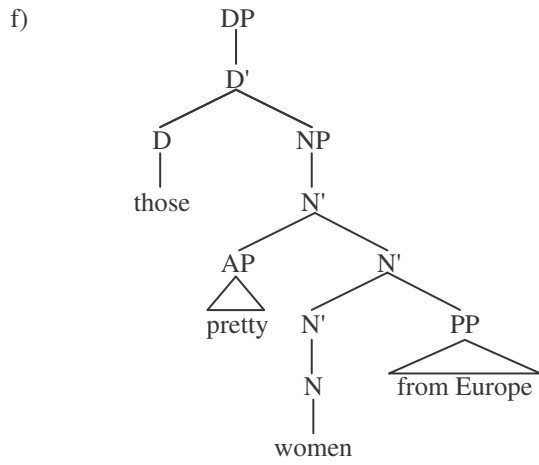
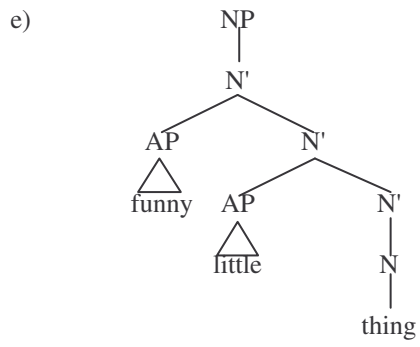
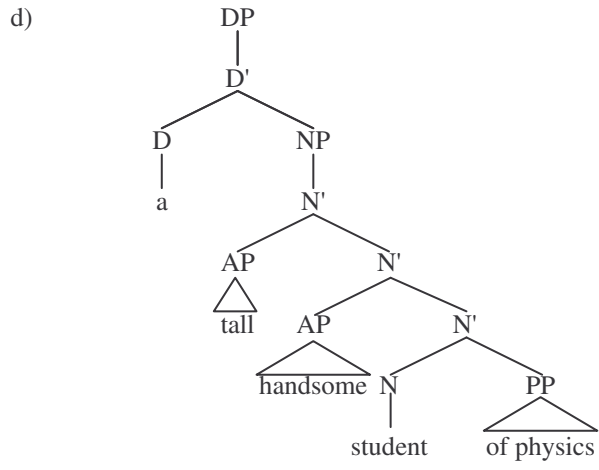

Suggested Answers and Hints - Chapter 3

---

▪ Exercise 16

- a)
- 
- ```
graph TD; N1[N] --- N2[N]; N1 --- N3[N]; N2 --- car[car]; N3 --- park[park];
```
- b)
- 
- ```
graph TD; N1[N] --- A1[A]; N1 --- N2[N]; A1 --- floppy[floppy]; N2 --- disk[disk];
```
- c)
- 
- ```
graph TD; N1[N] --- N2[N]; N1 --- N3[N]; N2 --- N4[N]; N2 --- N5[N]; N4 --- bicycle[bicycle]; N5 --- race[race]; N3 --- winner[winner];
```
- d)
- 
- ```
graph TD; N1[N] --- N2[N]; N1 --- N3[N]; N2 --- A1[A]; N2 --- N4[N]; A1 --- micro[micro]; N4 --- wave[wave]; N3 --- oven[oven];
```
- e)
- 
- ```
graph TD; N1[N] --- A1[A]; N1 --- N2[N]; A1 --- petty[petty]; N2 --- coat[coat];
```
- f)
- 
- ```
graph TD; N1[N] --- N2[N]; N1 --- N3[N]; N2 --- A1[A]; N2 --- N4[N]; A1 --- second[second]; N4 --- hand[hand]; N3 --- shop[shop];
```



Exercise 16

---

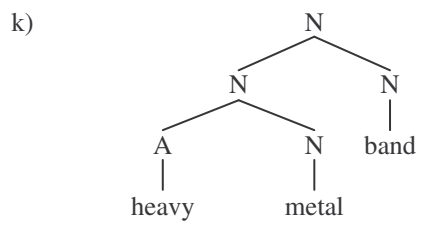
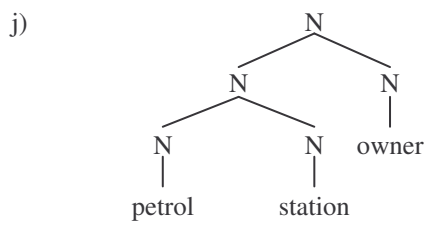
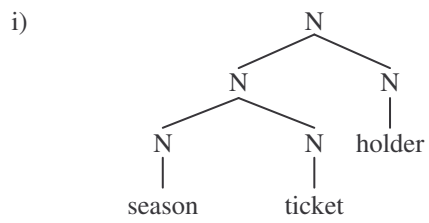
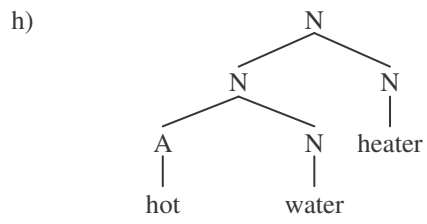
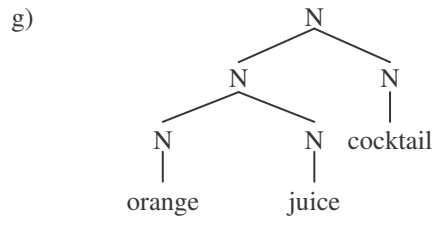

### Suggested Answers and Hints - Chapter 3

---

#### ▪ Exercise 17

The general problem is that the Theta Criterion (a  $\Theta$ -role must be assigned to one and only one argument and an argument must bear one and only one  $\Theta$ -role) is violated for some reason or another.

a) The verb *promise* should have two more arguments to which the theme and the beneficiary thematic roles should be assigned, e.g. *Penny promised a present*.

b) There are too many arguments in the sentence. Since *sleep* is an intransitive verb, there is no need for an object (an extra DP). Thus, *the car* cannot receive a thematic role from the verb, so it cannot occur in the sentence.

c) The verb *give* cannot give its Theme role to any of its arguments because they already have one role and one argument can have only one thematic role in accordance with the Theta Criterion. Thus, one argument with the Theme role should be present, e.g. *Gary gave Greg a guitar*.

d) One argument is missing from the sentence: the verb *give* cannot assign all of its thematic roles to its arguments, more precisely, the Agent role remains unassigned. An acceptable version would be e.g. *Mick gave a cent to Marion*.

e) There are too many arguments in the sentence. The verb *eat* is transitive, thus, it requires the presence of two arguments (DPs) and to them it can assign two thematic roles. It means that the PP (*for Anne*) is superfluous in the sentence because it cannot have a thematic role.

f) Again, there is one more argument in the sentence than necessary. The verb *dance* is intransitive, that is, it can assign one thematic role, to its subject. If another argument (here *Dora*) is present in the sentence, it cannot get a thematic role, and the sentence becomes ungrammatical.

#### ▪ Exercise 18

Thematic roles are always given at the level of D-structure, that is, before movement takes place. However, movements can be motivated by Case. It means that Case is relevant only at the level of S-structure, in other words, DPs usually get their Case in their surface positions.

- a) **Predicate:** think  
**Thematic roles:** experiencer (you)  
                  propositional (Izzy will invite e)  
**DPs:** you               nominative  
**Predicate:** invite  
**Thematic roles:** agent (Izzy)  
                  patient (who)  
**DPs:** Izzy               nominative  
          who               accusative

### Exercise 18

---

- b) **Predicate:** think  
**Thematic roles:** experiencer (Terry)  
 propositional (that the car has been stolen)  
**DPs:** Terry nominative  
**Predicate:** steal  
**Thematic roles:** patient (the car)  
**DPs:** the car nominative
- c) **Predicate:** fly  
**Thematic roles:** agent (Frank)  
 source (New York)  
 goal (Amsterdam)  
**DPs:** Frank nominative  
 New York accusative  
 Amsterdam accusative
- d) **Predicate:** seem  
**Thematic roles:** propositional (Sally to be selected by the committee)  
**DPs:** Sally nominative  
**Predicate:** select  
**Thematic roles:** patient (Sally)  
 agent (the committee)  
**DPs:** Sally nominative  
 the committee accusative
- e) **Predicate:** expect  
**Thematic roles:** experiencer (I)  
**DPs:** I nominative  
 this girl accusative (Exceptional Case marking!)  
**Predicate:** rewrite  
**Thematic roles:** agent (this girl)  
 patient (her essay)  
**DPs:** her essay accusative
- f) **Predicate:** choose  
**Thematic roles:** agent (Chuck)  
 source (these chicks)  
**DPs:** Chuck accusative  
 these chicks accusative

## Suggested Answers and Hints - Chapter 4

---

### ▪ Exercise 19

- (ii)       $XP \rightarrow XP Y;$                        $XP \rightarrow XP YP;$   
             $X' \rightarrow X' Y;$                           $X' \rightarrow X' YP;$   
             $X \rightarrow X Y;$                           $X \rightarrow X YP$

The second member of the first pair, the second member of the second pair and the first member of the third pair are exemplified in the text. Bar-level constituents can never appear as adjuncts.

- (iii)      Adverbial PPs and clauses are discussed in the text as potentially exocentric. Constructions which appear to have more than one head: participles, gerunds.

(iv)

- (1)      a He being the owner, we were all given a free drink.  
            b Who wants ice cream? Me.  
            c Her cheat on him? Never.

The sentence (1a) contains what is traditionally called an absolutive construction, where the subject of the non-finite clause can be in nominative. This construction is also grammatical with an accusative subject in the non-finite clause, though. That is in line with assumptions about the distribution of nominative and accusative forms in English but the nominative form is not, its grammaticality is unexplained – perhaps it is some default form of the pronoun that occurs in situations when no case assigner is present. This is contradicted by the sentence in (1b) where in a structure that contains no case assigner it is the accusative form that appears and not the nominative – perhaps it is the accusative which is the default form in English. The situation is the same in sentence (1c), it is the accusative and not the nominative form that occurs. One can accept the assumption that in English it is the accusative which functions as the default form; the nominative form in (1a) is unexplained.

## Chapter 4

### ▪ Check Questions

Q1      The starting point is that proper nouns and plural count nouns do not contain determiners. However, they have the same distribution as other nominal phrases that do contain determiners. Determiners are marked for number (in languages other than English for gender and even case) and they encode the definite–indefinite distinction (e.g. *a man versus the man*) which is not marked on the noun. Hence it is assumed that determiners are heads taking NP complements. As regards proper nouns, they can in fact appear with determiners even in English and it is normal for a proper noun to appear with a determiner in German (*ich bin der Hans*). Those proper nouns that do not tolerate a determiner appear with a phonologically empty (unpronounced) D head. This is supported by the interpretation of the proper noun as definite – determiners are the locus of the definiteness feature and not nouns. Plural count nouns represent the opposite in that when they appear without a determiner they are interpreted as

## Check Questions

---

indefinite. Again, there is a phonologically empty D head responsible for this interpretation. The empty definite determiner takes only NP complements headed by proper nouns while the empty indefinite determiner takes only NP complements headed by plural nouns.

Q2 Pronouns are in complementary distribution with determiners which suggests that they occupy the same structural slot. A pronoun DP containing a D head takes no NP complement as both the semantic content and the syntactic properties of such a DP are provided by the pronoun itself.

Q3 D heads project the features [ $\pm$ definite], [ $\pm$ plural]. Some D heads obligatorily take an NP complement (e.g. articles), some obligatorily stand without a complement (pronouns) and some take optional NP complements (e.g. demonstrative pronouns).

Q4 When the possessor is a lexical DP in a DP, the morpheme 's is attached to it. This morpheme attaches to phrases rather than heads (e.g. *John's book*, *the man living next door's dog*). However, when the possessor is a pronoun, it is the pronoun itself that bears the possessive feature. Possessors and determiners seem to be in complementary distribution in English (e. g. *\*the his book/\*his the book*) which suggests that they both occupy the D head position. A possessor like *the man living next door's* can be replaced by the possessive pronoun *his*. If possessive pronouns are in the D head position, then *the man living next door's* should likewise occupy that position. However, this is a phrase to which the 's morpheme is attached and phrases cannot occur in head positions. The phrase can be substituted by the possessive pronoun, hence the possessive pronouns should also have the status of a phrase. There is an available phrasal position, however: [Spec, DP]. Furthermore, there is a head position available for the 's morpheme which does not behave like a phrase in any respect: D. Thus, DP possessors occupy the specifier position in a DP, while 's the head position. Although as a bound morpheme it will always attach to the phrase in DP, it is this element that is in complementary distribution with other types of determiners.

Q5 As it is assumed that NPs are inside DPs, APs and PPs occurring inside NPs as modifiers may be conceived of as adjuncts inside DPs. However, these modifying elements are always inside the NP, they never modify pronouns. Some adverbs, on the other hand may be argued to be actual adjuncts of the functional nominal projection and not the lexical one, as they appear preceding a D head, e.g. *only*, *almost*.

▪ Suggested answer for Exercise 1

(1) a

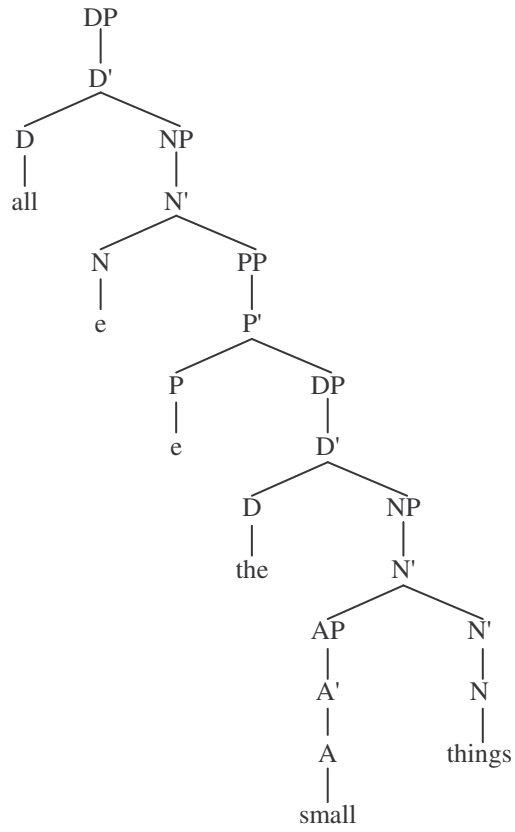

Suggested answer for Exercise 1

---

(1) b

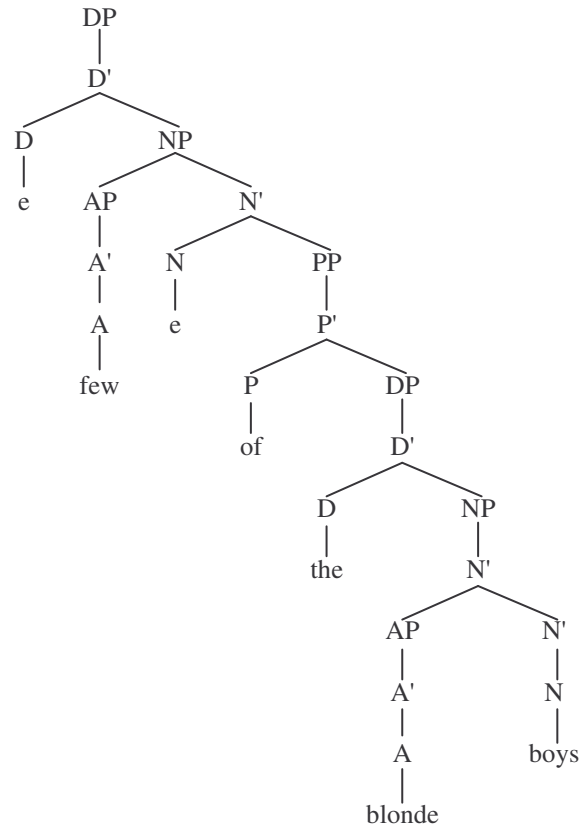

Suggested Answers and Hints - Chapter 4

(1) c

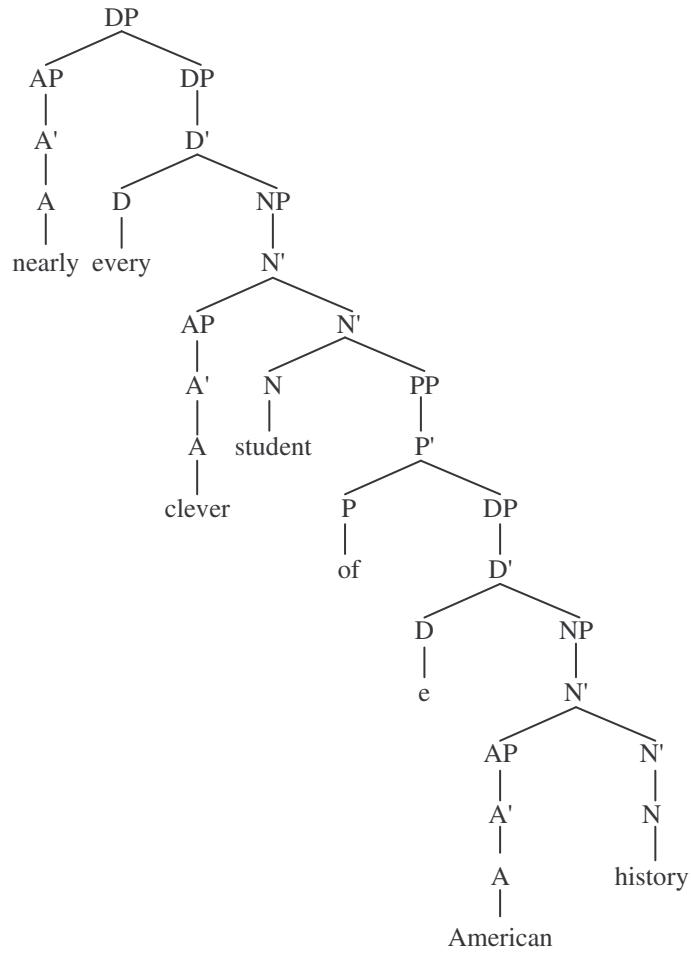



Suggested answer for Exercise 1

---

(1) d

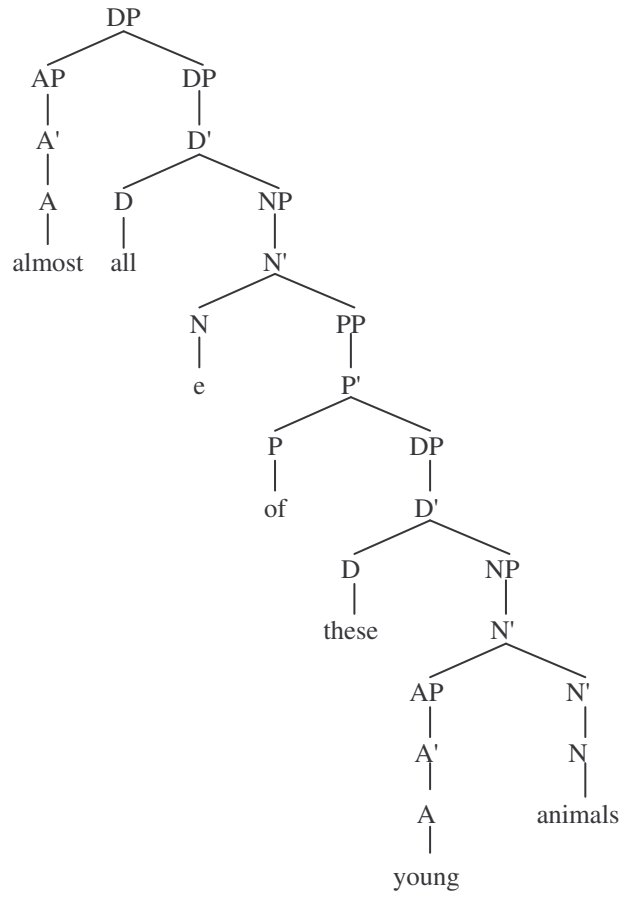

Suggested Answers and Hints - Chapter 4

---

(1) e

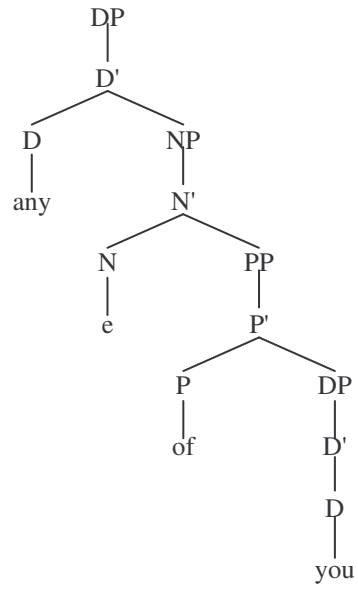

Suggested answer for Exercise 1

(1) f

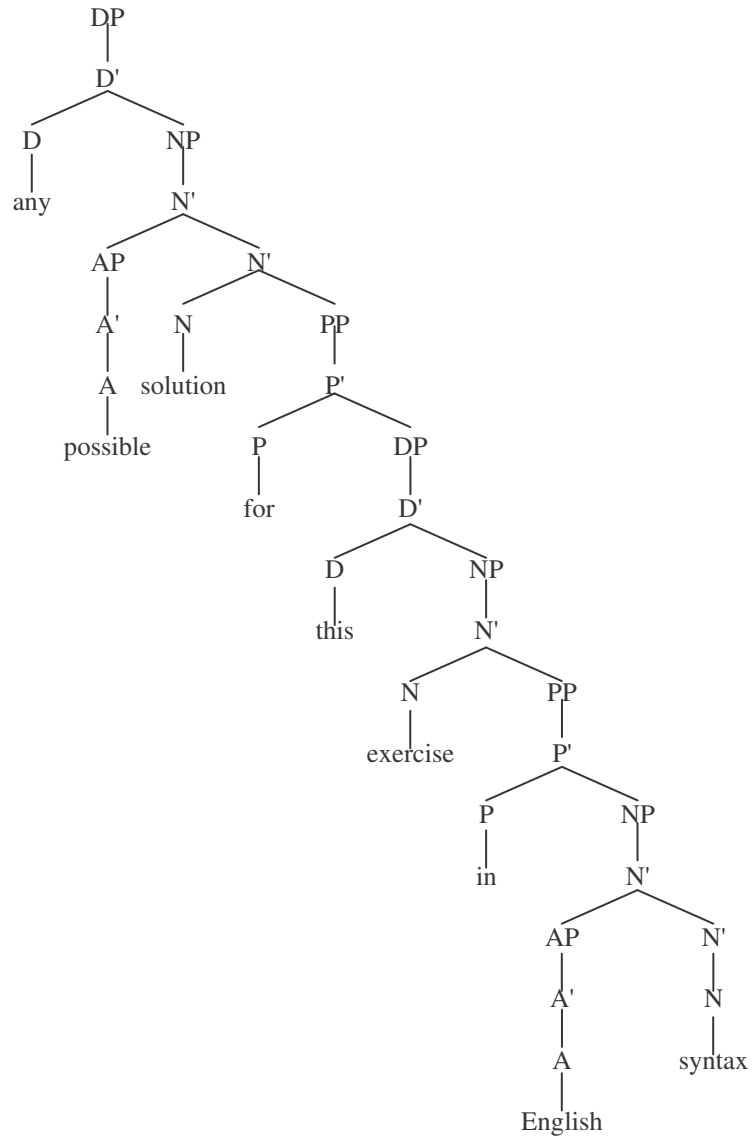

▪ **Exercise 2**

Both tree structures are correct. The sentence can be regarded as an ambiguous sentence with two different meanings and two different structures. However, it is hard to capture the difference in meaning. The sentence with the DP in (2) means that 'I know those students of Mathematics from London who are new'. The other sentence with the DP in (3) means that 'I know those new students of Mathematics who are from London'. The structure can be tested by a substitution test. The N' node can be substituted for by *one/ones*.

- (4) I know the new students of Mathematics from London and Peter knows the old ones.
- (5) I know the new students of Mathematics from London and Peter knows the ones from Paris.

In sentence (4) *one* stands for *students of Mathematics from London*. Thus this string of words has to form one node in the structure. We can find an N' node in structure (2) which exhaustively dominates this string of words while we find no such node in structure ii. This means that the structure in (2) has to be correct.

In sentence (5) *one* stands for *new students of Mathematics*. Thus this string of words has to form one node in the structure as well. Now we can find an N' node in structure (3) which exhaustively dominates this string of words, but we do not find such a node in structure (2). Consequently both structures are correct.

▪ **Exercise 3**

In sentence (1) the verb *likes* takes two DPs, one is the subject DP *my colleagues*, that contains the possessive pronoun *my*, which is analysed as DP. The object DP *the idea that the researchers invented the most dangerous weapon ever been made* contains the noun *idea* that has a sentential complement, a subordinate clause and is preceded by a determiner. The subordinate clause is lexically headed by the verb *invent* whose two arguments are the subject DP *the researchers* and the object DP *the most dangerous weapon ever been made*.

In sentence (2) the verb *hate* is a two-place predicate, that has two DP arguments, the subject *some students who study linguistics* whose lexical head is the noun *student* which is modified by a relative clause and the object DP *parasitic gaps*. The relative clause contains two DPs, the relative pronoun *who* and the object DP *Linguistics* of the lexical head *study* of the clause.

In sentence (3) there is the subject DP *one very good reason for giving her a second chance*, whose lexical head *reason* takes a non-finite sentential complement that contains two DPs, the indirect object pronoun *her* and the direct object DP *a second chance*. The verb *is* links the subject DP to the *that* clause, in which there are four DPs, the subject pronoun *she*, the object DP of the verb *do*, *a very good job* and two DPs in two adjunct PPs, *two years* and *Paris*.

## Exercise 4

---

### ▪ Exercise 4

(1)

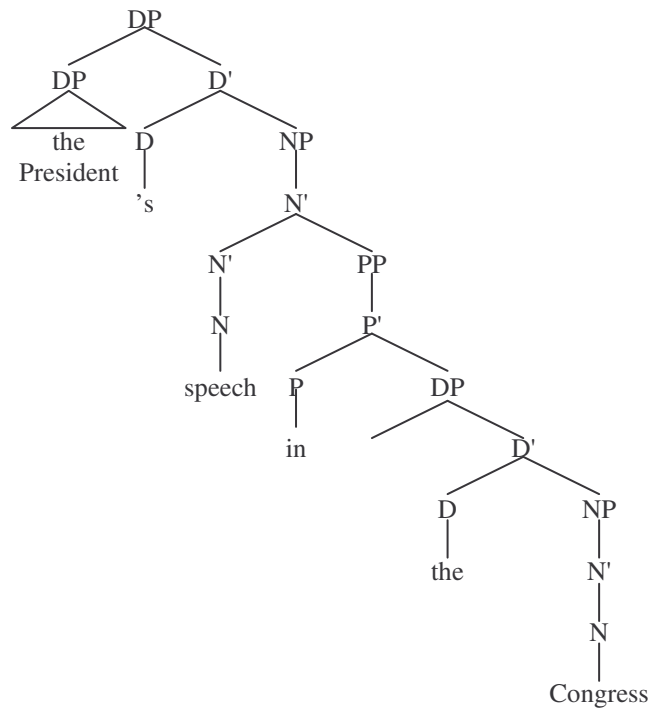

Suggested Answers and Hints - Chapter 4

(2)

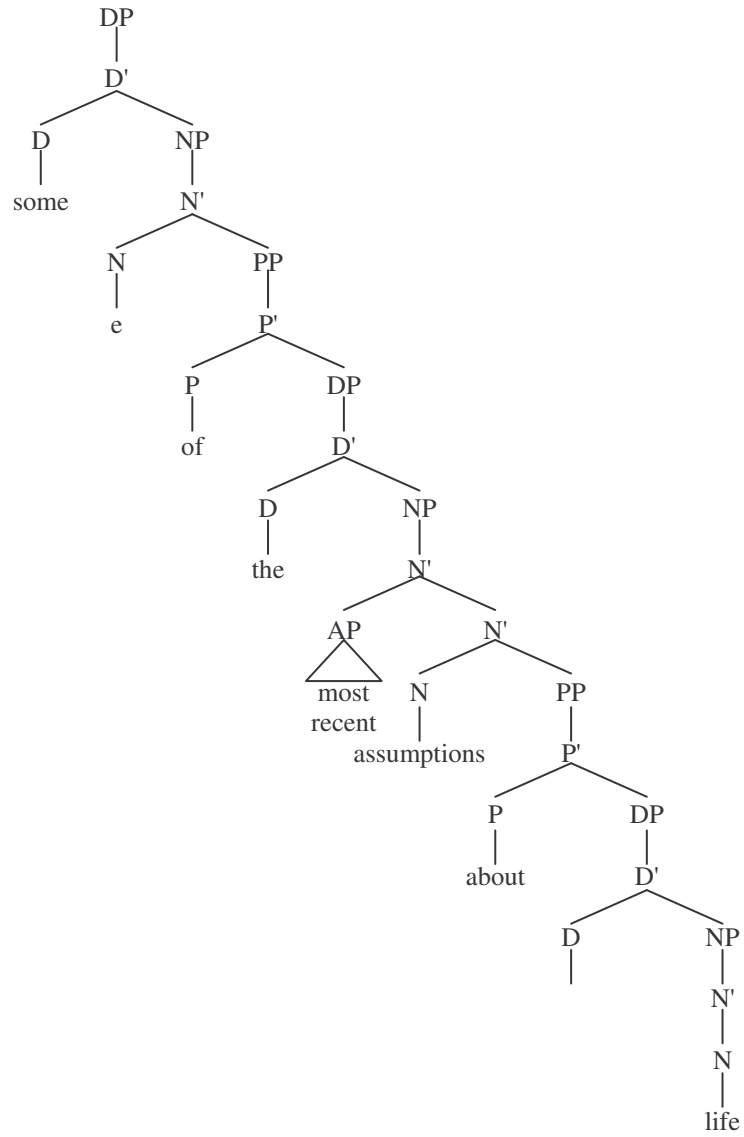

Exercise 4

---

(3)

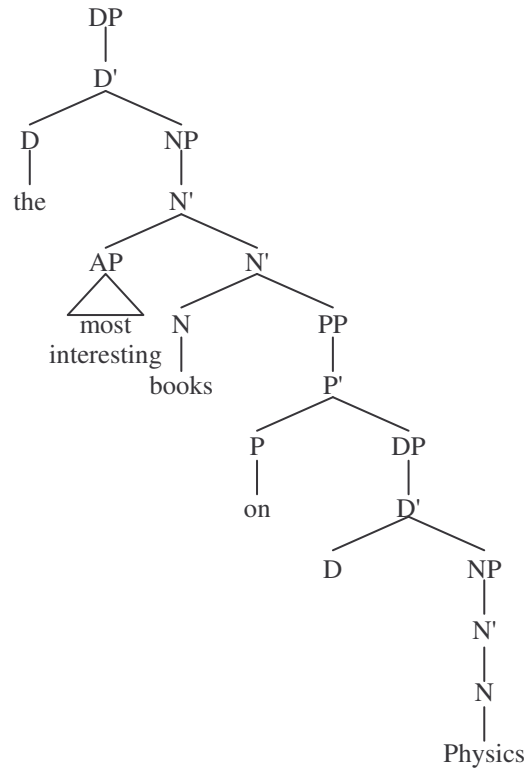

Suggested Answers and Hints - Chapter 4

(4)

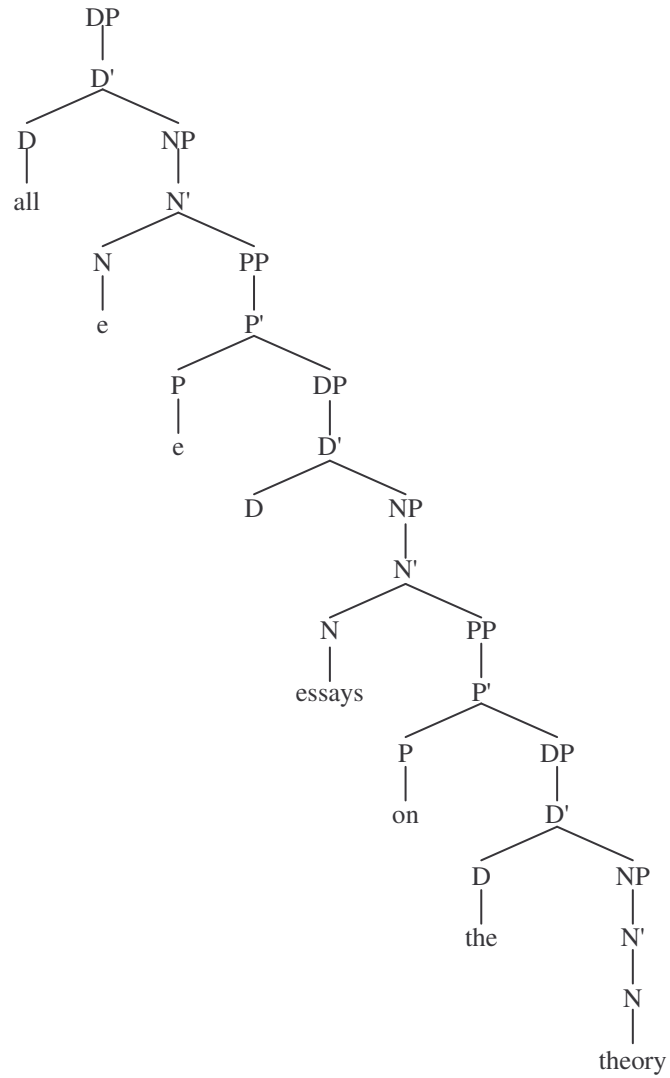

(5)

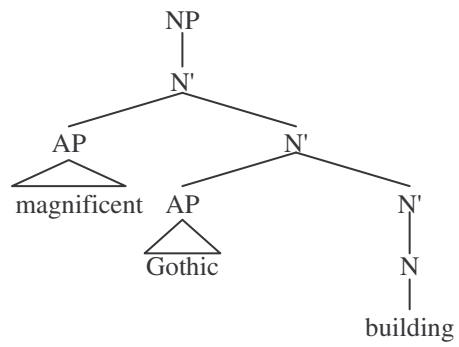



## Exercise 5

---

### ▪ Exercise 5

In the Italian DP *il mio libro* the sequence determiner+possessive pronoun is grammatical. According to the text when there is a possessive pronoun in [Spec, DP], there is an unpronounced D head in D and that element is in complementary distribution with other types of determiners. One problem concerns the order of elements in the Italian example, as the element assumed to be sitting in specifier position follows the element assumed to occupy the head position. Secondly, it is difficult to maintain the idea that there is an unpronounced D head in complementary distribution with the definite determiner as there are languages where the two can co-occur and no ungrammaticality results.

### ▪ Exercise 6

In the DP *a few too many parking tickets* there is a singular indefinite determiner head which clearly cannot be construed with the head of the NP. Thus, it must be assumed that the indefinite determiner is inside the AP. For example, it could be assumed that the indefinite article is the head of a DP occupying the specifier position of the AP but the AP itself should actually contain some nominal element itself. Alternatively, perhaps the structure is something like *a few parking tickets too many parking tickets* where the first instance of *parking tickets* is deleted. This is clearly wrong as there is no number agreement between the determiner and the deleted element, the situation is the same as with the whole phrase. However, this seems to concern more the structure of the AP itself than the DP.

In the DP *many a pleasant day* the first problem concerns number agreement, or rather the lack of it, between the specifier (many) and the head (day). The second problem is raised by the order of elements as [Spec, NP] seems to precede the D head, contrary to assumptions about the structure of DPs.

In the DP *this very moment* there is an adverb between the D head and the N head. The oddity of the example is reflected in that if this adverb is present it is not possible to modify the N head further, e.g. *\*this very beautiful moment/\*this beautiful very moment* (in the first example *very* is not construed with *beautiful* but with *moment*).

### ▪ Exercise 7

What you have to notice first in example (1) is that this structure is ambiguous: *with mistakes* can refer to *sentences* or *an analysis*. This is an instance of structural ambiguity. *With mistakes* cannot be a complement in either of the interpretations, since it is not selected by either *sentences* or *analysis*. In both cases *with mistakes* functions as an adjunct, the ambiguity can be explained by the different positions where the adjunct appears within the tree. In one of the interpretations the Prepositional Phrase is the adjunct of *analysis*, in this case we have the meaning when the analysis itself contains the mistakes. In the other interpretation, when it is the sentences which contain the mistakes (with a potentially good analysis of the bad sentences), the Prepositional Phrase *with mistakes* is the adjunct of sentences.

The whole structure is a DP, since it is the determiner head that defines the definiteness of the nominal expression.

The two trees therefore will look as follows:

Suggested Answers and Hints - Chapter 4

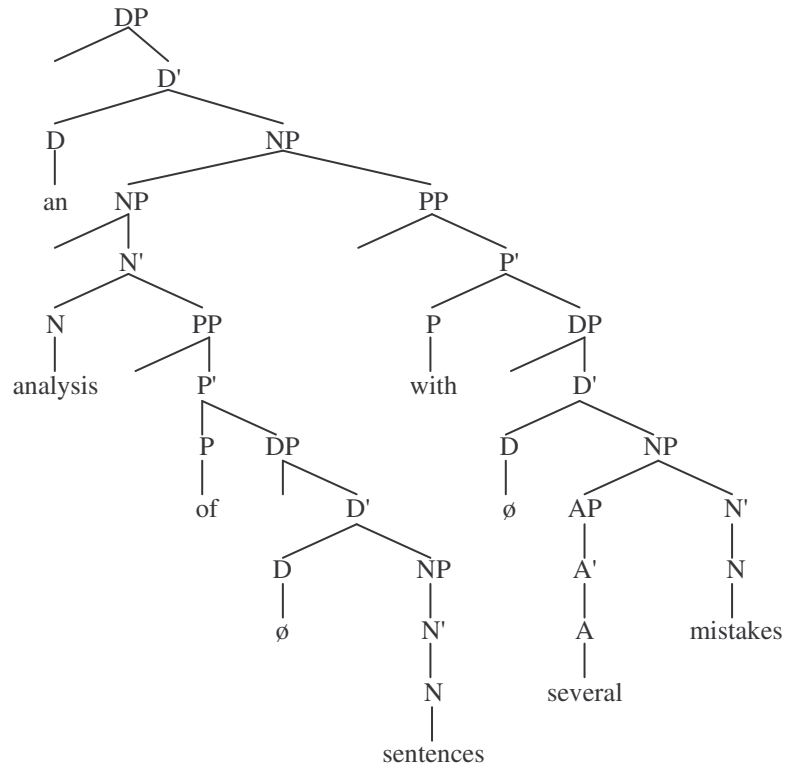

Exercise 8

---

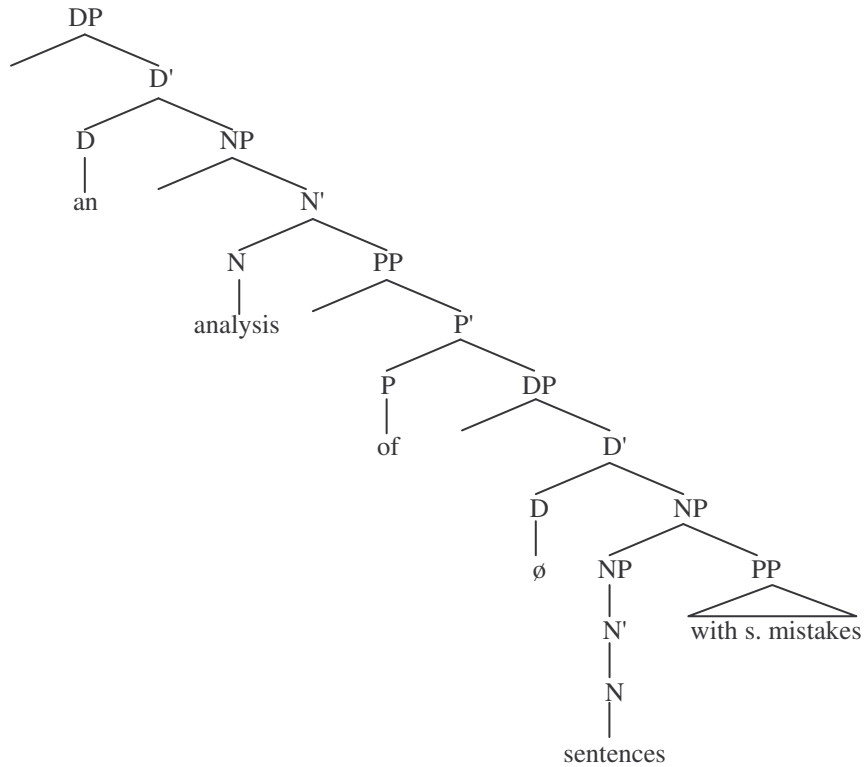

▪ **Exercise 8**

Meaning 1:

One of the children's books were on the desk.

Meaning 2:

One of the children's books was on the desk.

In meaning 1, the string *one of the children* forms one node, which can be proved by substituting a DP for this string of words:

- (1) a [DP one of the children]'s books
- b [DP John]'s books

In meaning 2, the string *the children's books* forms one node, which can again be proved by substituting a DP for this string of words:

- (2) a one of [DP the children's books]
- b one of [DP them]

The tree structure of the DP with meaning 1 is that in (3a) and the structure of the DP with meaning four is under (3b).

Suggested Answers and Hints - Chapter 4

(3) a

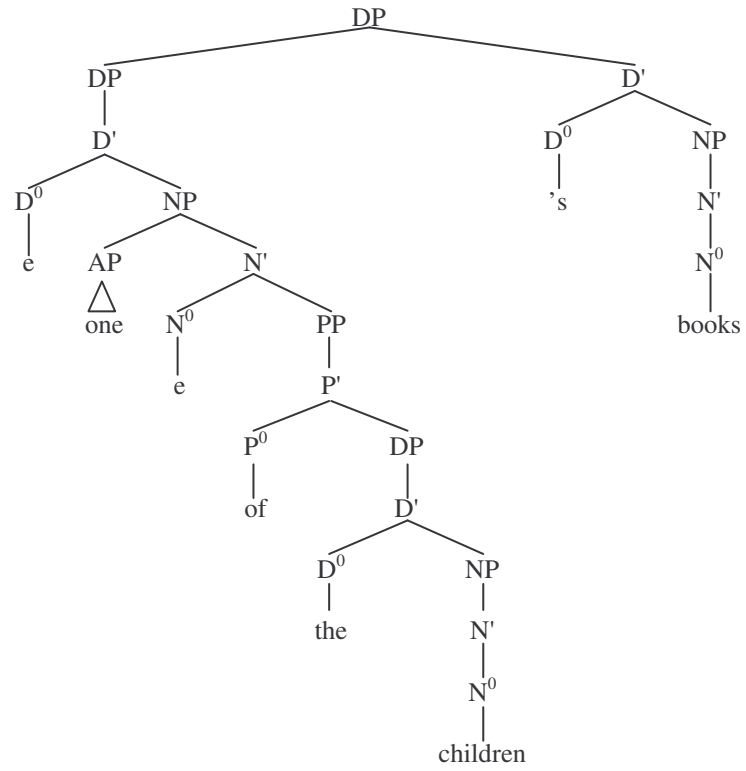

**Exercise 9**

---

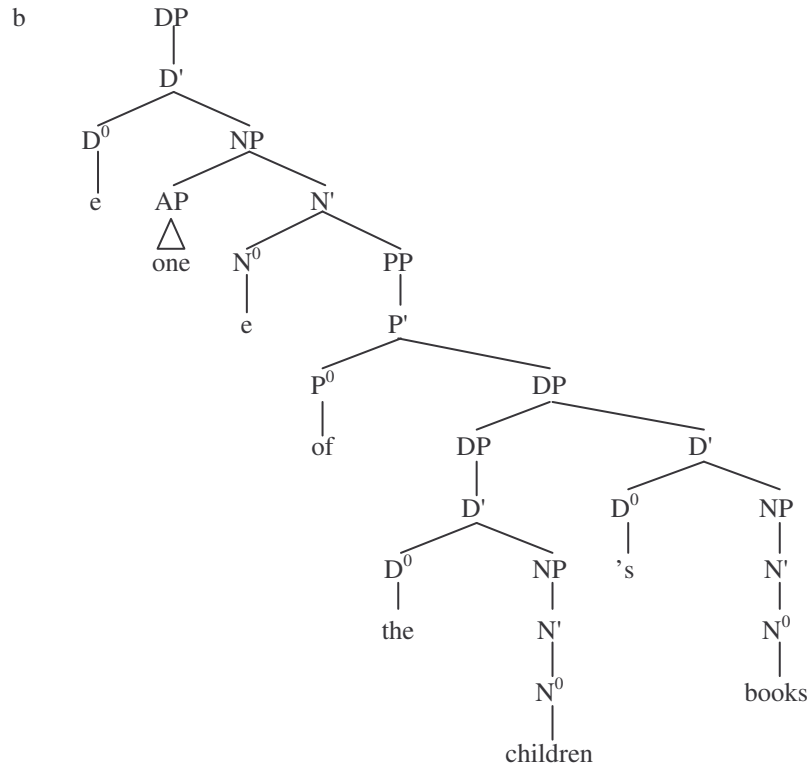

▪ **Exercise 9**

Meaning 1:

Jane wanted to try on a pair of jeans which was in the shop window.

Meaning 2:

Jane wanted to try it on in the shop window.

One of the constituency tests which you can chose from is pseudo-clefting. A pseudo-clefted sentence is like that in (1).

(1) What .... is/was [XP ...].

In (1) the string following the auxiliary is always a phrase. If we apply this test to the sentence *Jane wanted to try on a pair of jeans in the shop window*, we get the following results in meaning 1:

- (2) a. \*What Jane wanted to try on in the shop window was [a pair of jeans].  
 b. What Jane wanted to try on was [a pair of jeans in the shop window].

In meaning 1, the sentence in (2a) is ill-formed. This means that the string *a pair of jeans* is no phrase. (2b) is a well-formed sentence, thus the string of words *a pair of*

## Suggested Answers and Hints - Chapter 5

---

*jeans in the shop window* forms a phrase. It is a DP. Thus the PP *in the shop window* is part of the DP in meaning 1.

In meaning 2 the results of the test are the following:

- (3) a. What Jane wanted to try on in the shop window was [a pair of jeans].  
b. \*What Jane wanted to try on was [a pair of jeans in the shop window].

In meaning 2, (3a) is a well-formed sentence, while (3b) is ill-formed. This means that the string *a pair of jeans* forms a DP, while the PP *in the shop window* is not a part of the DP.

According to the result of the test above, the structure of the sentence can be represented as it can be seen in (4). (4a) represents the structure of the sentence with meaning 1 while (4b) is the structure belonging to meaning 2.

- (4) a. Jane wanted to try on [a pair of jeans] [in the shop window].  
b. Jane wanted to try on [a pair of jeans in the shop window].

The string *a pair of jeans in the shop window* is one phrase in meaning 2 while it is two separate phrases in meaning 1.

## Chapter 5

### ▪ Check Questions

Q1 Given the meanings of verbs, some events appear to involve more than one sub-event, e.g. an action can involve somebody doing something and as a result some object changes position, or gets into some state, or remains in some state, etc. Aspect can be grasped from two different angles: lexical aspect is evident in the meaning of verbs which denote an activity that has a natural beginning and end. Lexical aspect is internal to the meaning of the verb. Grammatical aspect, on the other hand, relates to the interpretation of a given event in a particular sentence depending on whether it is complete or in progress. Furthermore, the two may also be combined.

Q2 Unaccusatives are typically movement or locative verbs, they cannot appear in causative constructions. They can take an expletive 'there' as subject but that does not count as an argument. They take one argument, a theme, but some of them may optionally take a locative PP as an argument. They do not take objects, they cannot be passivised. Intransitives also take one argument but that one argument is either an agent or an experiencer. They cannot appear in a 'there' construction. Some of them can appear with objects which are termed 'cognate objects'. They cannot passivise in English but they can indeed do so in other languages, e.g. in German. Ergatives typically involve a change of state. They cannot appear in 'there' constructions either but they can in a transitive context as well as in causative constructions, in fact, causatives manifest the transitive use of an ergative. When an ergative verb is used in a transitive context, its agent argument is in [Spec, vP] and its theme argument is in [Spec, VP].

Q3 The difference between a light verb and a thematic verb is reflected in notation as well: light verbs head vPs while thematic verbs head VPs. While thematic verbs

## Check Questions

---

contribute to the meaning of the construction they appear in, the contribution to meaning made by light verbs is reduced, they can be used in combination with some noun or verb. [Spec, VP] is associated with the theme argument, [Spec, vP] with the agent or experiencer argument in a structure. Light verbs can take vPs or VPs as complements.

Q4 There is evidence semantic in nature: the structure is interpreted as causative, i.e. there is an agent 'causer' argument present that picks up the theta role assigned by the abstract (empty) light verb head. In languages other than English there may actually be found overt counterparts of this abstract causative verbal head, e.g. in Hungarian there is one such morpheme, *-ít*.

Q5 In passives, a verb loses the ability to assign a theta role to its subject and the ability to case-mark its object. Under the present analysis, a light verb is responsible for theta-marking the subject and assigning case to the theme argument in the specifier position of its thematic VP complement. If there is no light verb in the construction, neither theta-marking of the subject, nor case-marking of the theme occur. Thus, passivisation is seen as a process where the light verb responsible for theta-marking and case-marking is removed and replaced by the passive morpheme. As a result the theme argument of the thematic verb cannot receive case and moves out of the VP to a position which is case-marked.

Q6 In order to be able to maintain the UTAH it is assumed that experiencer transitives contain two light verb projections where both the v head positions contain abstract (non-overt) bound morphemes that are capable of assigning the relevant theta roles (agent and experiencer) to their specifier positions. As there are two light verb projections, one is associated with the agent and the other with the experiencer, hence there is no reason to assume that the two theta-roles compete for the same structural position. In these cases the thematic verb moves to adjoin to the lower v head position (whose specifier is associated with the experiencer role; subsequently, the resulting complex (V + v) move together to adjoin to the higher light verb head (the v associated with the agent role). There are examples of English constructions in which there are light verb layers erected on top of each other. Furthermore, there are languages other than English, where multiple light verbs are regularly overtly represented, e.g. Urdu.

Q7 Multiple complement constructions involve verbs which take three arguments. In one type apart from the subject there is a theme and a locative (verbs of placement) while in the other type apart from the subject there is a theme and a goal/beneficiary double object constructions). In the text theta-marking light verbs are introduced, hence accommodating three arguments into the structure is not a problem. The event structure of these verbs can be broken down into three sub-events. With verbs of placement, the agent (subject) is introduced in the specifier of the light verb position. The theme is introduced in the specifier position of the thematic verb and the locative in the complement position of the thematic verb. With double object constructions, the goal is generated in the complement position of the thematic verb and the theme is in the specifier position of the thematic verb. To be able to derive different word orders, the goal moves into a specifier position between the specifier of the light verb and the specifier of the thematic verb. As the event structure of the double object construction

## Suggested Answers and Hints - Chapter 5

---

involves three sub-events, there are two light verb phrases erected on top of the thematic verb, thus there is a specifier position available for the goal to move into.

Q8 Clausal complements of verbs can be both finite or non-finite, declarative or interrogative. When a verb takes a DP and a clausal complement, the DP always precedes the clause. This is assumed to occur because it receives case from the verb in the light verb position. If so, the clausal complement cannot have occupied that position originally. (Clauses are not subject to the Case Filter anyway.) Furthermore, in some cases the subject of the complement clause depends on the verb in the higher clause, in cases of Exceptional Case Marking.

Q9 Unaccusative verbs, light verbs, ergative verbs, transitive verbs, intransitive verbs, multiple complement verbs, verbs with clausal complements, phrasal verbs.

▪ **Exercise 1**

expletive 'there' and 'it': a, d, e, f, g, h, i (the subject), j

▪ **Exercise 2**

In order to determine the subcategory of the verbs in the sentences, the characteristics of different verb types are listed first.

**Unaccusative verbs:**

One argument  
Theme argument  
There construction possible  
Locative inversion construction possible  
Locative inversion + there construction possible

**Ergative verbs:**

One argument  
Theme/patient argument  
There construction not possible  
Locative inversion construction not possible  
Transitive usage possible

**Transitive verbs:**

Two arguments  
Agent/experiencer and patient/theme arguments  
Passivisation possible

**Intransitive verbs:**

One argument  
Agent/experiencer argument  
Cognate object possible  
No passivisation (at least in English)



## Exercise 2

---

### Multiple complement verbs:

- More than two (usually three) arguments
- Dative alternation possible
- Locative structure

Based on these features and distributional criteria, subcategories of verbs can be determined and their syntactic structure can be also provided.

Since the exercise focuses only on the subcategorisation frames of the verbs they appear in an uninflected form in the trees.

- a A face appeared behind the window.

theme argument

There appeared a face behind the window.

Behind the window a face appeared.

Behind the window there appeared a face.

→ unaccusative

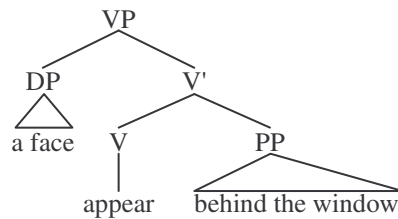

- b Susan sang.

agent argument

Susan sang a song.

→ intransitive

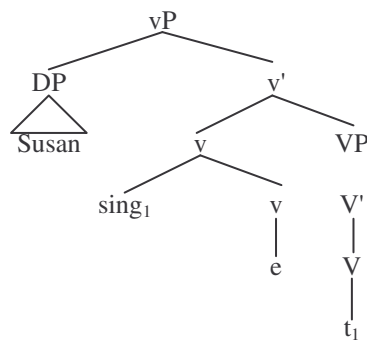

Suggested Answers and Hints - Chapter 5

c Michael moved my map from the middle.

three arguments  
→ multiple complement verb

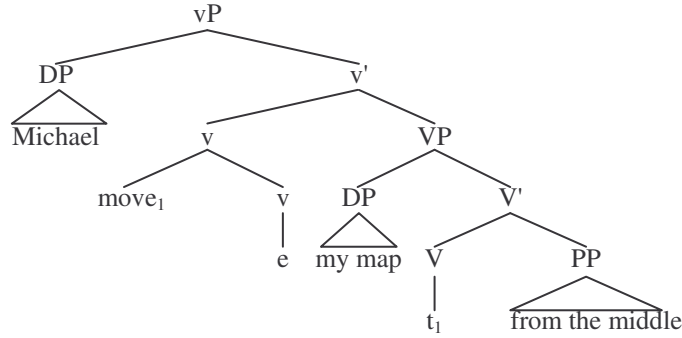

d The bomb blew up.

patient argument  
\*There blew up the bomb.  
\*In the prison blew up the bomb.  
The terrorists blew up the bomb.  
→ ergative verb

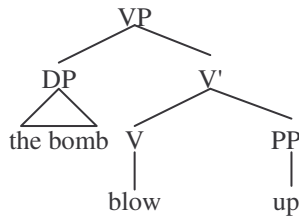

e Larry laughed.

agent argument  
Larry laughed a cruel laugh.  
→ intransitive

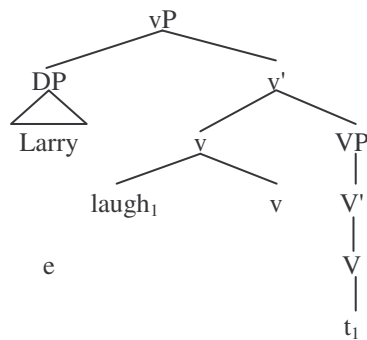

**Exercise 2**

---

f Kevin killed Karen.

agent and patient arguments  
 Karen was killed by Kevin.  
 → transitive

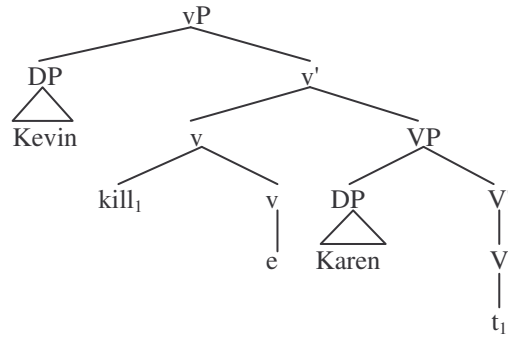

g Ben brought a bulldog for Betty.

three arguments  
 → multiple complement verb

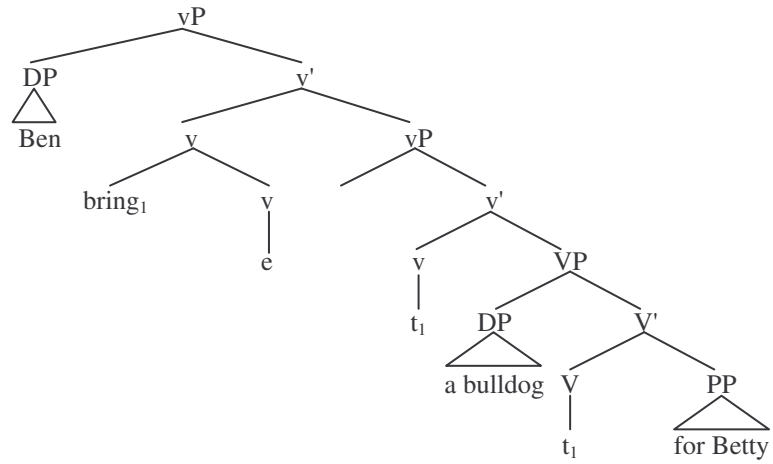

Suggested Answers and Hints - Chapter 5

h Norah knows Nick.

experiencer and theme arguments  
→ transitive

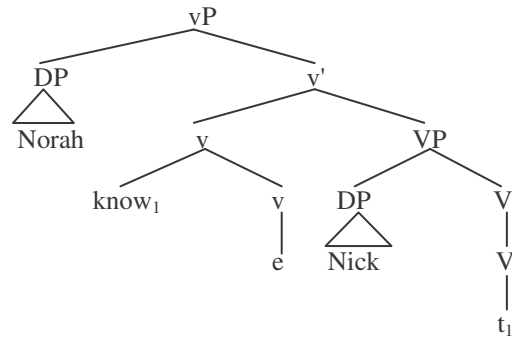

i The boat sank.

patient argument  
\*There sank the boat.  
\*In the Atlantic sank the boat.  
The pirates sank the boat.  
→ ergative verb

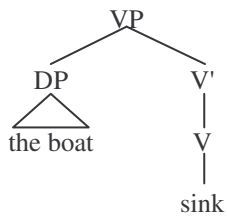

j A letter lay on the table.

theme argument  
There lay a train on the table.  
On the table a letter lay.  
On the table there lay a letter.  
→ unaccusative

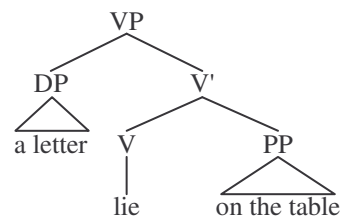

Exercise 2

k The window opened.

theme argument  
 \*There opened the window.  
 \*In the room opened the window.  
 The guests opened the window.  
 → ergative verb

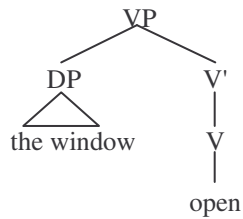

l A train arrived at the station.

theme argument  
 There arrived a train at the station.  
 At the station a train arrived.  
 At the station there arrived a train.  
 → unaccusative

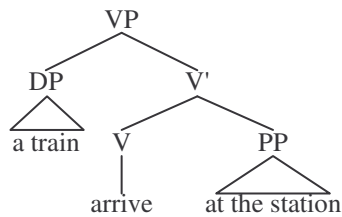

m Walt watered the flowers.

agent and patient arguments  
 The flowers were watered by Walt.  
 → transitive

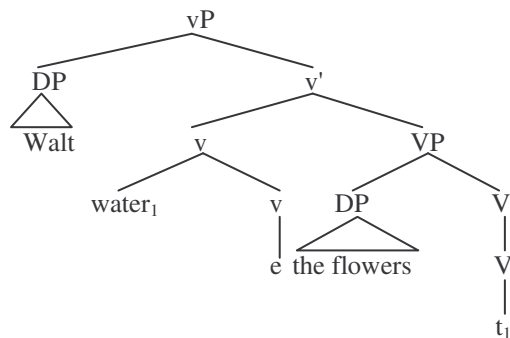

Suggested Answers and Hints - Chapter 5

n Dick died.

experiencer argument  
 Dick died a terrible death.  
 → intransitive

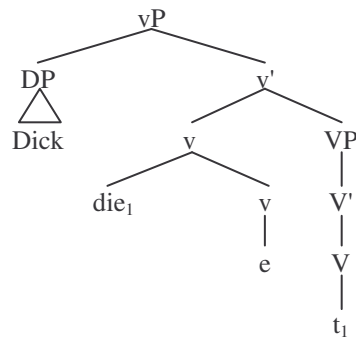

o Gary gave Greg a gift.

three arguments  
 Gary gave a gift to Greg.  
 → multiple complement verb

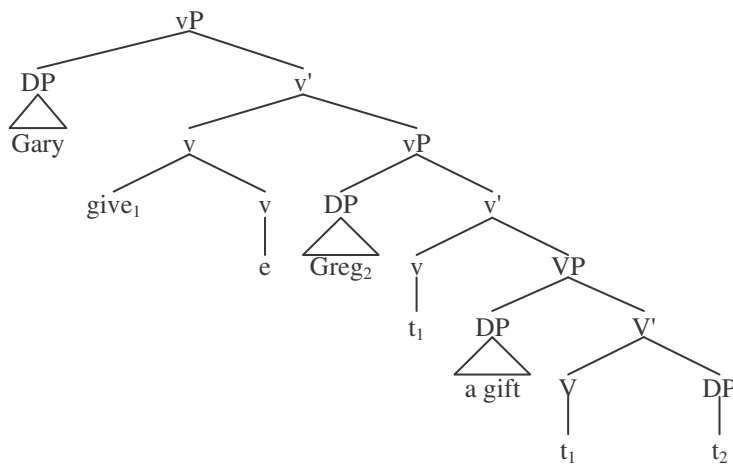

### Exercise 3

---

▪ **Exercise 3**

Verb	Tense	Aspect	Person & number	Voice	Form
see	past	perfect	3Sg	passive	(it) had been seen
saw	present	progressive	1Pl	active	(we) are sawing
bring	future	perfect	2Sg	passive	(you) will have been brought
come	present	perfect	3Pl	active	(they) have come
think	past	progressive	2Sg	active	(you) were thinking
sing	future	perfect	3Sg	passive	(it) will have been sung
read	present	progressive	3Pl	passive	(they) are being read
write	past	perfect	3Sg	passive	(it) had been written
eat	future	progressive	1Sg	active	(I) will be eating
fall	past	perfect	3Sg	passive	(it) had been fallen
buy	present	perfect	2Sg	active	(you) have bought
tell	past	progressive	3Pl	passive	(they) were being told
pull	future	progressive	2Pl	active	(you) will be pulling
go	past	perfect	3Sg	active	(he) had gone
send	future	perfect	3Pl	passive	(they) will have been sent

▪ **Exercise 4**

- (1)
- a The boy had a walk.
  - b I answered the question.
  - c The professor made a comment on my essay.
  - d She never looks at him.
  - e We drank together.
  - f The professor gave a speech on the economic situation of China.
  - g Everyone involved in the project contributed to the exercises.
  - h She has finally made a decision. or She has finally taken a decision.

▪ **Exercise 5**

Phrasal verbs can be distinguished from verbs taking a PP complement in the following ways:

- Reorganisation of arguments is possible for some phrasal verbs but is impossible for verbs with PP complement;
- Topicalisation of PP is possible for verbs with PP complements but is impossible for phrasal verbs;
- Modification of the preposition is possible for verbs with PP complements but is usually impossible for phrasal verbs;
- Coordination is possible for verbs with PP complements but is impossible for phrasal verbs.

## Suggested Answers and Hints - Chapter 5

---

The tests can be applied in the following way.

- (1) a Reorganisation of arguments: \*Lawrence lived Liverpool in.  
Topicalisation: In Liverpool, Lawrence lived.  
Modification: Lawrence lived right in Liverpool.  
Coordination: Lawrence lived in Liverpool and in London.  
→ verb taking a PP complement
  
- (1) b Reorganisation of arguments: \*My neighbour takes my uncle after.  
Topicalisation: \*After my uncle my neighbour takes.  
Modification: \*My neighbour takes right after my uncle.  
Coordination: \*My neighbour takes after my uncle and after his father.  
→ phrasal verb
  
- (1) c Reorganisation of arguments: \*We must make this list up.  
Topicalisation: \*Up this list we must make.  
Modification: \*We must make just up this list.  
Coordination: \*We must make up this list and out that book.  
→ phrasal verb
  
- (1) d Reorganisation of arguments: \*He ran the hill up.  
Topicalisation: Up the hill he ran.  
Modification: He ran right up the hill.  
Coordination: He ran up the hill and down the slope.  
→ verb taking a PP complement
  
- (1) e Reorganisation of arguments: We have done the buttons up on our coats.  
Topicalisation: \*Up the buttons we have done on our coats.  
Modification: \*We have done just up the buttons on our coats.  
Coordination: \*We have done up the buttons and without our passport.  
→ phrasal verb
  
- (1) f Reorganisation of arguments: \*He came of his office out.  
Topicalisation: Out of his office he came.  
Modification: He came right put of his office.  
Coordination: He came out of his office and into the hall.  
→ verb taking a PP complement
  
- (1) g Reorganisation of arguments: \*Suddenly she broke tears into.  
Topicalisation: \*Suddenly into tears she broke.  
Modification: \*Suddenly she broke just into tears.  
Coordination: \*Suddenly she broke into tears and with her friend.  
→ phrasal verb



### Exercise 6

---

- (1) h Reorganisation of arguments: \*The prisoner did his mate in.  
Topicalisation: \*In his mate the prisoner did.  
Modification: \*The prisoner did right his mate.  
Coordination: \*The prisoner did in his mate and over a guard.  
→ phrasal verb
- (1) i Reorganisation of arguments: Guards broke the fight up.  
Topicalisation: \*Up the fight guards broke.  
Modification: \*Guards broke right up the fight.  
Coordination: Guards broke up the fight and with the prisoners.  
→ phrasal verb
- (1) j Reorganisation of arguments: The workers pulled the old building down.  
Topicalisation: \*Down the old building the workers pulled.  
Modification: \*The workers pulled right down the old building.  
Coordination: \*The workers pulled down the old building and apart the walls.  
→ phrasal verb

▪ **Exercise 6**

The event structure of the sentence is represented in (1).

- (1)  $e = e_1 \rightarrow e_2$  :  $e_1 =$  'John did something'  
 $e_2 =$  'the window closed'

The sentence is ambiguous because the adjunct *again* can modify either  $e_1$  or  $e_2$ . If it modifies  $e_1$  then the sentence means that John closed the window then somebody opened it and John closed it again. If  $e_2$  is modified by the adjunct *again* then only  $e_2$  happened again while  $e_1$  happened only once. Thus the sentence means that somebody (but not John) opened the window, then somebody closed it and then John opened it again. So in the first interpretation John opens the window twice while in the second interpretation only once.

The structure representing meaning 1 can be seen in (2) while meaning 2 is represented in (3) showing the verbal projection only.

In meaning 1 *again* modifies  $e_1$ , so it is adjoined to vP. In meaning 2 only  $e_2$  is modified by the adjunct, so *again* is adjoined to VP.

(2)

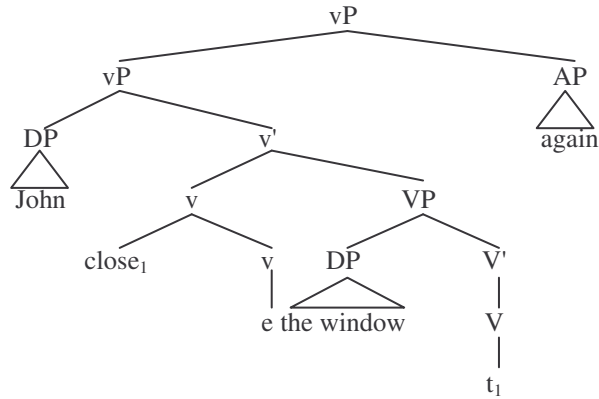

(3)

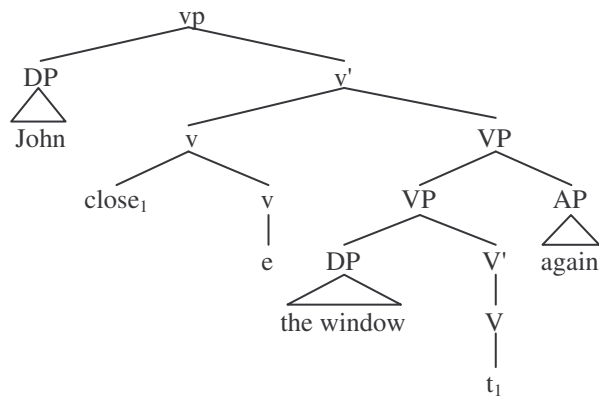

▪ **Exercise 7**

agents: a, d, i; themes: b, f, j; experiencers: c, e, h, the expletive subject in g has no theta-role

**Chapter 6**

▪ **Check Questions**

Q1 As a preliminary assumption it may be assumed that finite clauses contain finite inflection. What this amounts to is that in a finite clause there is agreement with the subject in number and person, and there is some independent tense marking available as well. In a non-finite clause agreement with the subject is not so straightforward, and its tense will depend on the tense of some other finite clause. Less traditionally speaking, another diagnostic to distinguish between the two clause-types is the form of the complementiser introducing them: finite clauses can occur with *that* while non-finite clauses with *for*. This is somewhat unreliable, though, as not all non-finite clauses can occur with *for*, this is only to say that if a clause can, then it is non-finite. Thirdly, finite clauses can occur in isolation or as embedded clauses, while non-finite clauses can only

## Check Questions

---

occur in embedded context. In addition, a further property finite clauses they do not share with non-finite clauses is their ability to contain modals – modals are excluded from non-finite clauses. Lastly, the subject of a finite clause is in nominative Case while the subject of a non-finite clause is in accusative, or phonologically empty.

Q2 It is proposed as a preliminary assumption that the Inflection head contains the bound morphemes *3sg -s*, *past tense -ed*, *modals* and *infinitival to*. As a result, different clauses distribute differently depending on the inflectional element they contain. Secondly, it seems that the inflection behaves like a head in that it restricts its complement to vP or VP. Thirdly, it also behaves like a head in that it influences the Case form of its subject: nominative in finite and accusative in non-finite clauses. In addition, similarly to the other functional head D, the I head also displays agreement with its specifier, the subject.

Q3 There are theoretically two alternatives: either it is the morphemes *-s* and *-ed*, *-ing* and *-en* that move (lower onto the verb) or the verb moves up. It is assumed that English verbal stems cannot host more than one bound morpheme, hence in a clause that contains aspectuals (which head their own vP), the thematic V moves and picks up the lower bound morpheme but as it is unable to host more, an aspectual (*be* or *have* or even both if need be) are inserted to pick up the aspectual morphemes.

Q4 The I head takes a vP or VP complement. When there is negation present in a structure but no other verb apart from the lexical verb, it seems that the presence of the negative particle *not* blocks movement of the verb to pick up the bound morpheme, hence a dummy auxiliary is inserted. That the presence of the negative particle seems to block movement is supported by the fact that when there are more than one auxiliaries in a structure it is always the modal (or the leftmost) that moves to form a question. This observation is formulated as the Head Movement Constraint: a head cannot skip an intervening head position when it moves. In negation the negative element intervenes between the bound morpheme to be picked up and the verb, hence *do* is inserted. In languages other than English where a verb is not restricted to hosting only one bound morpheme, we find paradigms where a bound inflectional morpheme does actually occur attached to the head. For this reason it is also proposed that the negative is in fact a variety on light verb constructions and is best be analysed as one.

Q5 Aspect markers are analysed as morphemes heading their own vP, while aspectual auxiliaries are inserted in the I head position.

Q6 At the beginning of the chapter the implicit assumption about what the Inflection head hosts was that it manifests Tense and Agreement. There is evidence that it only contains agreement. Tense and infinitival *to* are separate from it. One piece of evidence that Tense can be seen as a separate entity is provided by the observation that modals, which are truly Inflectional elements, can inflect for tense in English. Tense is proposed to head its own vP taking another vP as a complement. When there is *-ed* present, there is a phonologically null agreement morpheme in I. In present tense the form of the tense morpheme is realised as *-s* when the agreement is third person singular and as a zero morpheme when the agreement is something else. Thus, what is left for the I head is agreement manifested either as a modal or as *-s* or as a phonologically empty morpheme.

## Suggested Answers and Hints - Chapter 6

---

Q7 Both negation and VP adverbs can precede the tense element but they can never precede the modal in I. Furthermore, neither negation nor VP adverbs can adjoin to a VP whose head has moved out of it. VP adverbs can also adjoin to any vP while negation will have to appear between the tense vP and the rest of the vP or VP. In addition a VP adverb can also be adjoined to I-bar (i.e. it does appear before a tensed verb) when there are only two options available for it in a clause: either it precedes tense or follows the thematic verb. This situation arises in clauses that contain only one verb form (e.g. *They always met in the park*).

Q8 The head of a light verb vP assigns a theta role whereas the head of tense vP does not, thus the specifier position of the latter, but not the former, is always empty.

Q9 Nominative case found on subjects of finite clauses is assumed to be assigned under specifier–head agreement. Accusative case, on the other hand, is assumed to involve a specific relationship between case-assigner and case-assignee: government. Thus, it seems that no unitary configuration exists for case assignment: it can appear both to the left and to the right.

### ▪ Exercise 1

Following the Case Filter, which states that all DPs must have Case, we have to assume that these DPs have case. Case assigners are verbs, prepositions and the finite inflection. Case assigners must be ‘close’ enough to the DP to be able to assign case to it. Finite I can assign nominative Case to its specifier position only, while verbs and prepositions can assign accusative Case to their complement DP or to the DP in the specifier position of their complement.

a) In sentence *John met Mary in the park* there are four DPs. The DP *John* has nominative Case as when it is substituted with a pronoun that displays overt Case marking the pronoun has nominative Case in this position. Nominative Case is assigned by the finite inflection, as nominative Case is available only for subject DPs in finite clauses. The DP ‘*Mary*’ has accusative Case assigned by the verb. The DP ‘*the park*’ gets accusative Case from the preposition ‘*in*’.

b) In sentence *For me to survive this week will be quite difficult* there are two DPs, both in the subject subordinate clause. The subject DP has no nominative Case. As we have seen earlier non-finite I filled with the infinitival marker *to* cannot assign Case, at all. In fact, the DP does not have nominative Case. It has accusative Case assigned by the complementiser *for*. The object DP of the subordinate clause gets Case from the verb *survive*.

c) In sentence *Everybody goes to see the painting* the subject DP *everybody* gets nominative Case from the finite I of the sentence. The object DP is assigned accusative by the verb *see*.

d) Sentence *John persuaded Bill to go to see a doctor* is a complex sentence. Its structure is superficially very similar to sentence (1b), but the structure of the two sentences is not identical. The verb *persuade* has three arguments. It has an agent, a patient and a proposition argument. The agent DP gets nominative Case from the finite

## Exercise 2

---

I. *Bill* gets accusative Case from the verb *persuade*. Notice that while *expect* in sentence (1b) assigns accusative Case to the specifier position of its propositional complement, *persuade* assigns accusative to its complement. Finally the DP *a doctor* is assigned accusative Case by the verb *see*.

e) In sentence *Mary gave a book to John for Xmas* there are four DPs. The agent DP gets nominative Case from the finite I of the sentence. The patient DP *a book* is assigned accusative Case by the verb, the goal argument is assigned Case by the preposition *to* and the DP *Xmas* is assigned Case by the preposition *for*.

▪ **Exercise 2**

- (1) a question-forming + main verb  
 b emphasis + negation  
 c main verb  
 d negation + tag question  
 e question-forming  
 f emphasis  
 g negation  
 h tag question  
 i main verb  
 j main verb  
 k main verb  
 l negation

▪ **Exercise 3**

a [Jim] I<sup>0</sup> sent [a bunch of [flowers]] to [Jane].

b For [Jim] not to buy [the house] at [a lower price] wasn't [the best decision in [his life]].

c [The teacher] I<sup>0</sup> believed that [all his students] would pass [the exam].

d [All the students] were believed to pass [the exam].

**Suggested Answers and Hints - Chapter 6**

---

e [John] will never trust [Jane].



f [Which experiment]<sub>2</sub> did<sub>1</sub> [the professor] e<sub>1</sub> mean e<sub>2</sub> when [he] I<sup>0</sup> asked whether [we] were able to do [it]?

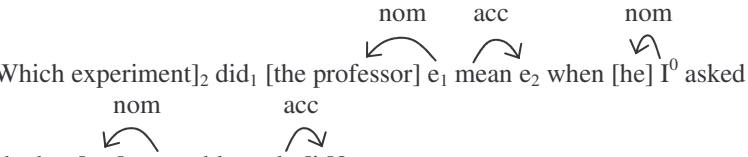

g [John] I<sup>0</sup> read [an interesting book about [the cold war]].

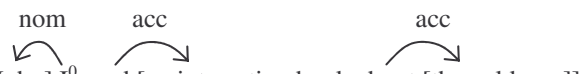

h [It] was raining when [I] I<sup>0</sup> looked out of [the window].

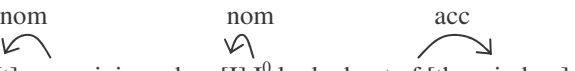

i [The children] I<sup>0</sup> wanted [it] to be snowing during [the whole day].



j [Jane] I<sup>0</sup> believed [Jack] to be able to repair [the car].

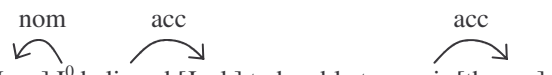

Nominative Case is always assigned by finite inflection. Sometimes the I<sup>0</sup> head is not occupied by any sound material, as in sentences (1a), (1c), (1g), (1h), (1i) and (1j). In other cases it is occupied by a modal auxiliary (modal auxiliaries are inherently finite) or by the verbs *be*, *have* or *do* (in which case it is still the zero inflectional morpheme that assigns case). In some cases like in sentence (1f), the I<sup>0</sup> moves further to a higher position. In this case the Case is assigned by the trace of the auxiliary (it is assigned by the auxiliary before it moves). Sometimes DPs move further after receiving Case like the DP *which experiment* in sentence (1f). Here the chain receives Case only once, only the foot of the chain (the trace of the DP) is in a Case-marked position. Accusative Case is assigned by verbs and prepositions to their complement DPs. Some verbs and the complementiser *for* are able to assign accusative Case to the subject position of their complement IPs, as in sentences (1b), (1i) and (1j). Passive verbs are not able to assign case to their complement DPs, thus these DPs have to move in order to receive Case.

Exercise 4

---

▪ Exercise 4

a) In the sentence *John's message arrived* the verb *arrive* is an unaccusative verb, which takes only one argument, assigning a theme thematic role to it. The argument is in the specifier position of the VP in the D-structure. Since DPs need Case, it has to move to the specifier of the IP, where it gets nominative Case from the finite I head. The higher vP in the structure hosts the tense morpheme *-ed*, which the lexical verb picks up on its way to I.

(1)

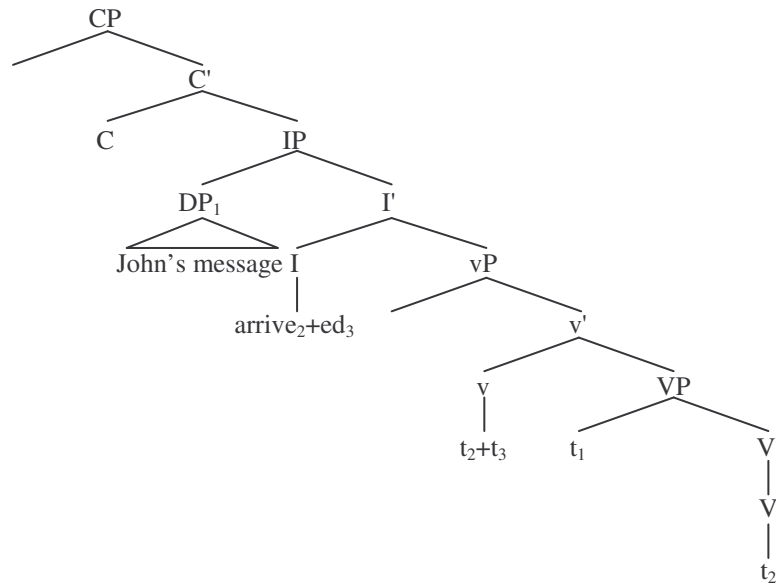

**Suggested Answers and Hints - Chapter 6**

---

b) In the sentence *David made the ball roll to the wall* there are two verbs. *Made* is a light verb while *roll* is a thematic verb. The light verb sits in the v head while the thematic verb occupies the V head. The verb *roll* takes a DP argument, assigning a theme thematic role to it and a PP argument with a goal thematic role. The light verb *made* hosts an argument DP, assigning an agent thematic role to it. The DP *the wall* will be assigned Case by the preposition *to*. The theme argument *the ball* gets its accusative Case from the v. The DP *David* cannot be assigned Case in its base position, so it has to move to the specifier of the IP to get Case from the finite I head. The vP on top of the agentive vP contains the tense morpheme. The verb picks up the *-ed* ending on its way to I.

(2)

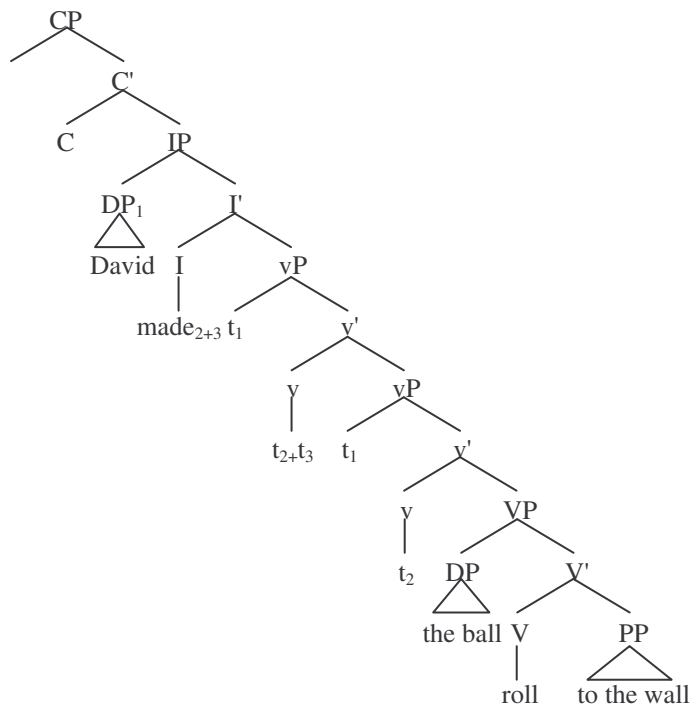



**Exercise 4**

---

c) The sentence *David rolled the ball to the wall* is similar in its structure to that in (b), but here we find no overt light verb in the v head position. Actually, the v head is occupied by an abstract light verb represented by *e* in the structure below. The arguments are the same and Case is assigned to them the same way as described above. The main difference is that the abstract light verb is a bound morpheme, which requires the main verb to move to the v position. The verb *roll* then moves on to the tense vP and I picking up the tense and agreement morphemes.

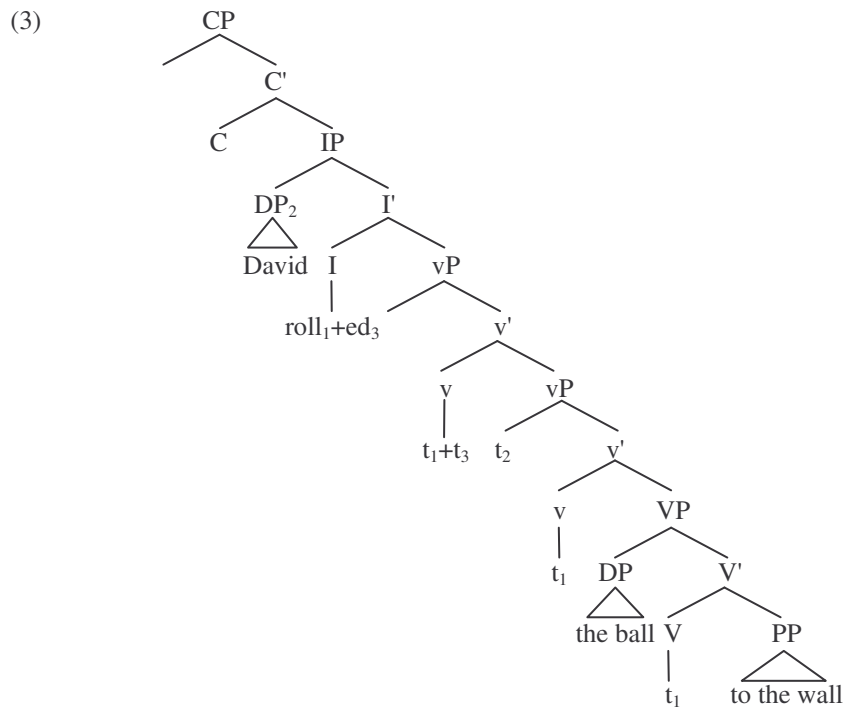

**Suggested Answers and Hints - Chapter 6**

---

d) In the sentence *John sank Jim's boat* the theme argument is in the specifier of the VP, while the agent occupies the specifier of the vP in the D-structure. In the S-structure, the agent DP has to move to a position where Case can be assigned to it. This position is the specifier of IP. The main verb sink has to move as well since the abstract light verb *e* is a bound morpheme, which requires the main verb to move to *v*, tense *v* and then to I.

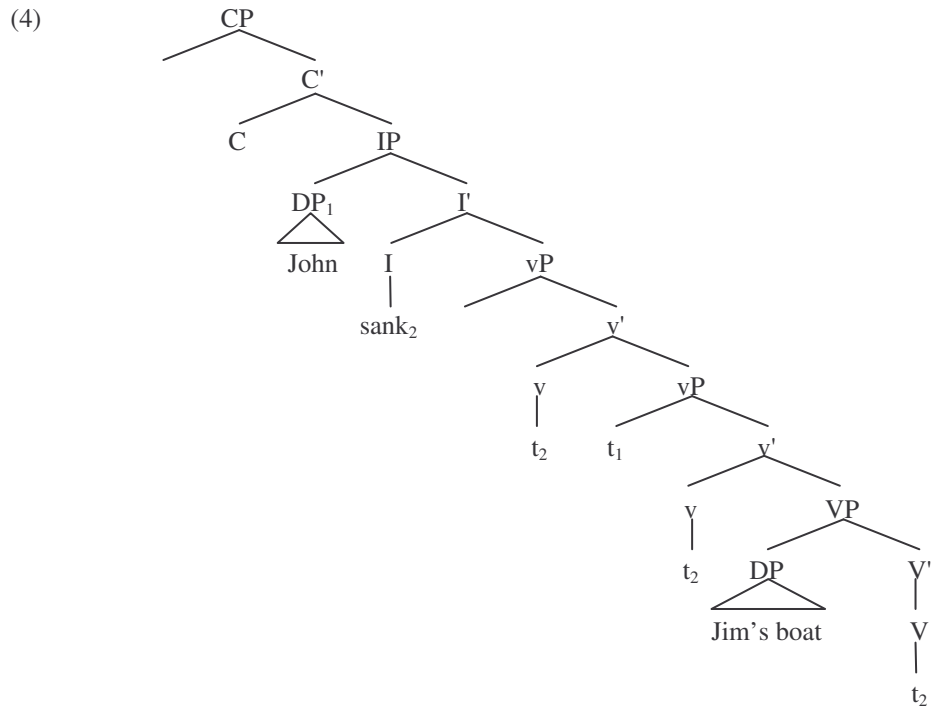

**Exercise 4**

---

e) The verb *sink* is an ergative verb. Ergative verbs are similar to unaccusatives insofar as they take a theme argument, which occupies the specifier of the VP. The difference is that in sentences which contain an ergative verb, an agent can also be present. We could see this in sentence (d), where we had the agent DP *John*. If the agent is not there, the vP will not be projected either. It is actually the abstract light verb in *v* which requires an agent DP in (4). If there is no *v*, no agent argument is required. The only argument of the verb cannot receive Case in its base position as it did in (4) since in this structure there is no *v* head which can assign accusative Case. The I head is not a possible assigner of accusative Case. So the DP *Jim's boat* has to move to the specifier of IP, where the I head assigns nominative Case to it. The thematic verb also moves, first to the tense *v*, then to I to agree with the subject.

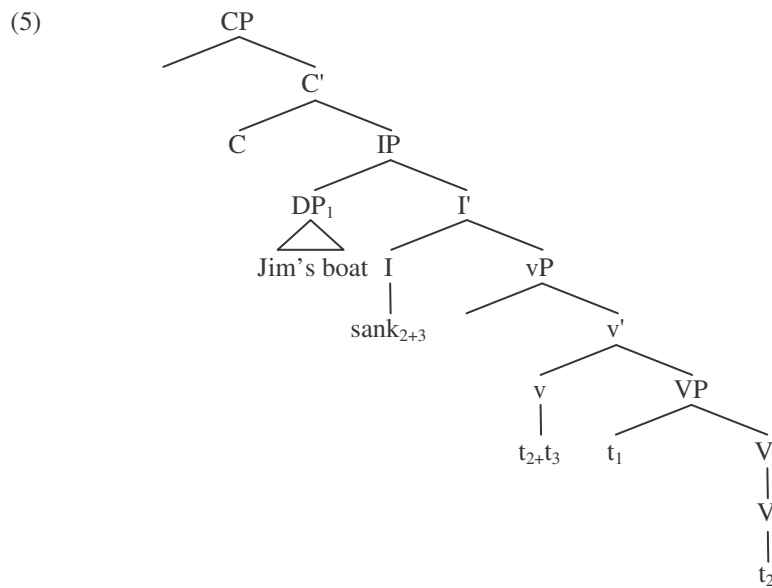

**Suggested Answers and Hints - Chapter 6**

---

f) *Jim's boat was sunk* is a passive sentence. The main verb is *sink*, occupying the V head in the D-structure. Now *v* is not occupied by an abstract light verb as in (4) but by the passive morpheme *-en*. The main difference between a light verb and the passive morpheme is that the passive morpheme does not take an agent argument and it cannot assign Case to the DP occupying the specifier position of the VP. Since the DP has to receive Case, it has to move to the specifier of IP, where the finite I head assigns nominative Case to it. The passive morpheme in *v* is a bound morpheme, so the main verb is required to adjoin to it. The other *vP* in the structure is the tense *vP* where *be* is inserted to support the past tense morpheme (remember, in English a thematic verb is not allowed to have more than one inflectional morpheme, so it cannot move to support a second bound morpheme after having moved to the passive *vP*). Finally, the verb ends up in the I head position.

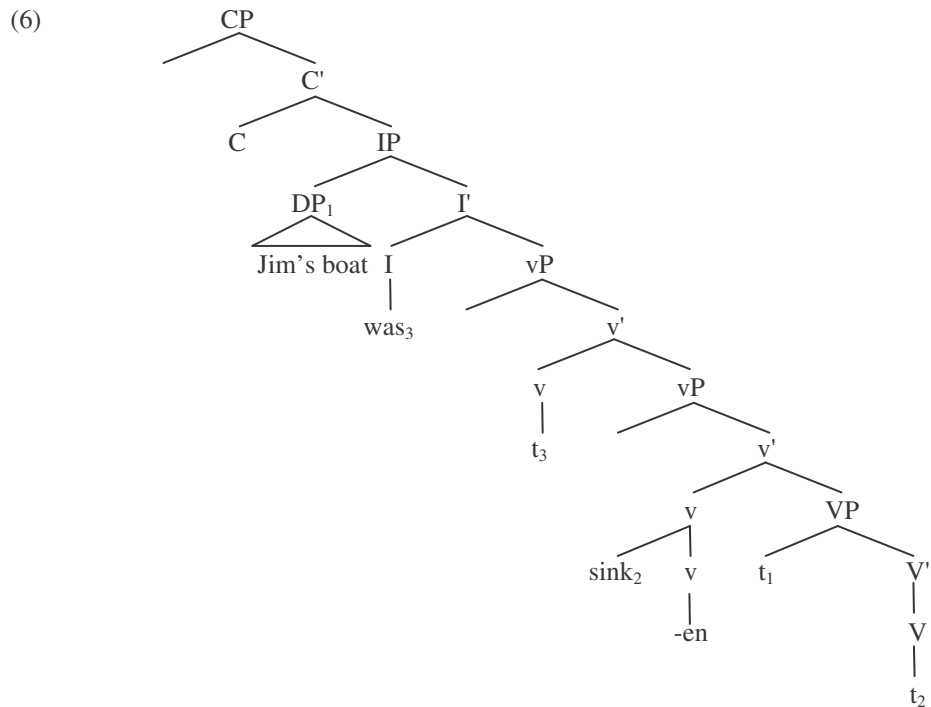

Exercise 4

---

g) In the sentence *Bill caught a bird* the main verb *catch* is a transitive verb. The subject is an agent, the object a patient. Since the vP is the extended projection of V, we can say that the DP in the specifier of the vP receives its thematic role indirectly from the main verb. The abstract light verb is a bound morpheme, which requires the main verb to adjoin to it. The DP in the specifier of the VP is assigned Case by the light verb. The other DP in the specifier of the vP also needs Case. Since that position is not a position to which Case is assigned, it has to move to the specifier of IP, where it receives Case from the finite I. The verb *catch* moves to tense v and then to I.

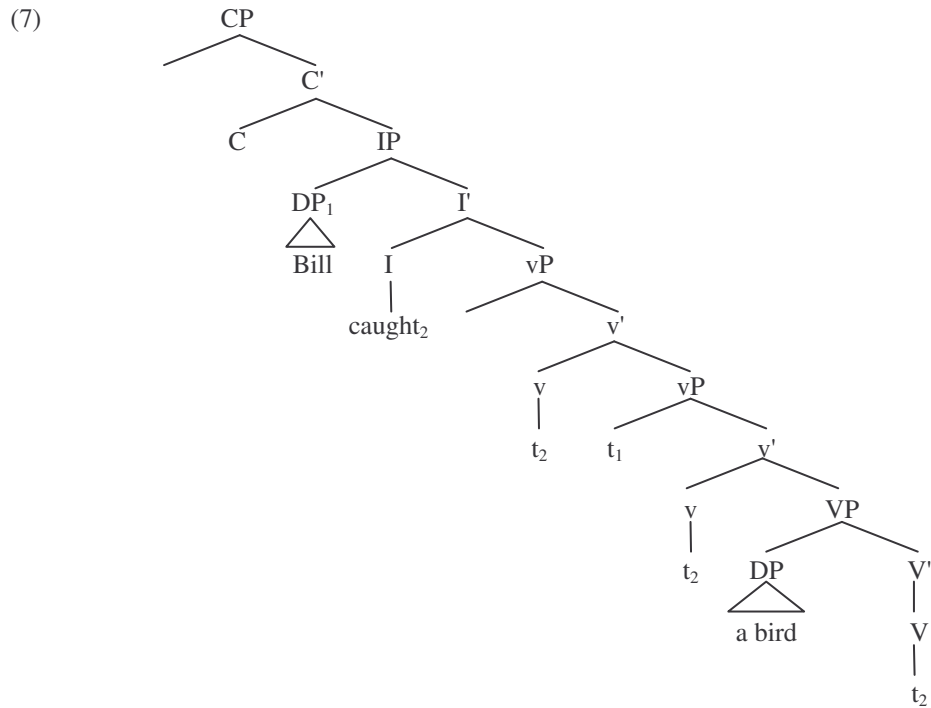

**Suggested Answers and Hints - Chapter 6**

---

h) The sentence in *The bird was caught* is passive. The main verb takes a theme argument. The *v* head is occupied by the passive morpheme *-en*, which does not assign accusative Case to the DP in the specifier of the VP and it does not assign an agent thematic role to its own specifier position either. That is why there is no agent argument in this sentence. Since the passive morpheme is a bound morpheme, the main verb has to move to *v*. The theme DP in the specifier of the VP needs to be assigned Case, so it moves to the specifier of IP in order to receive Case from the finite I. A higher tense vP is also projected where the dummy auxiliary *be* is inserted to support the bound tense morpheme. At the S-structure the auxiliary moves on to the I head.

(8)

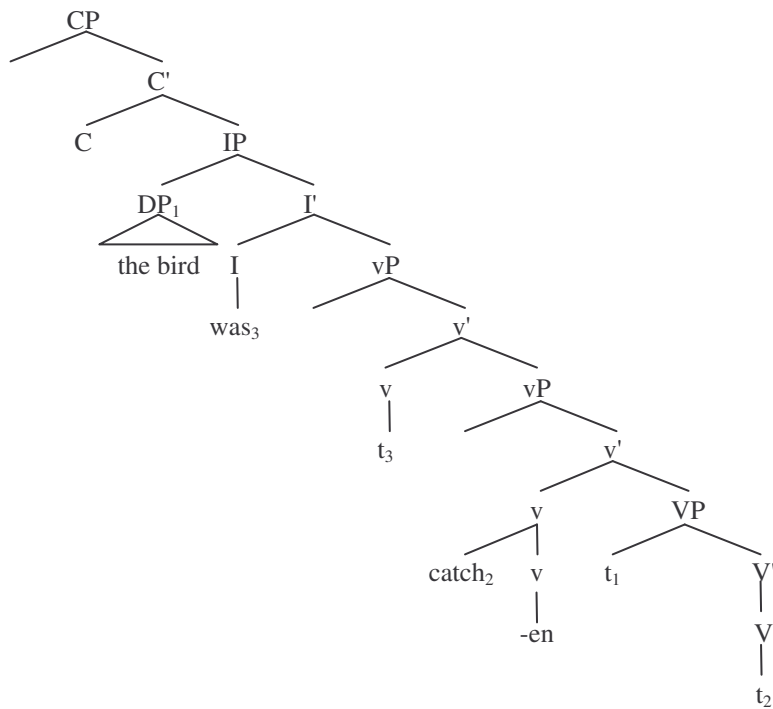

**Exercise 4**

---

i) The verb *cough* in the sentence *Sam coughed* is an intransitive verb. Intransitive verbs take only one argument which is usually an agent. Since the specifier of the VP is the position of the theme argument according to the UTAH, this position is empty in this structure. The agent thematic role is assigned by the light verb to the specifier position of the vP. So the base position of the agent argument is in the specifier of the vP. Since this is no Case position, the DP has to move on to the specifier of the IP in order to receive Case from the finite I head. The thematic verb moves to the tense v and then further on to I.

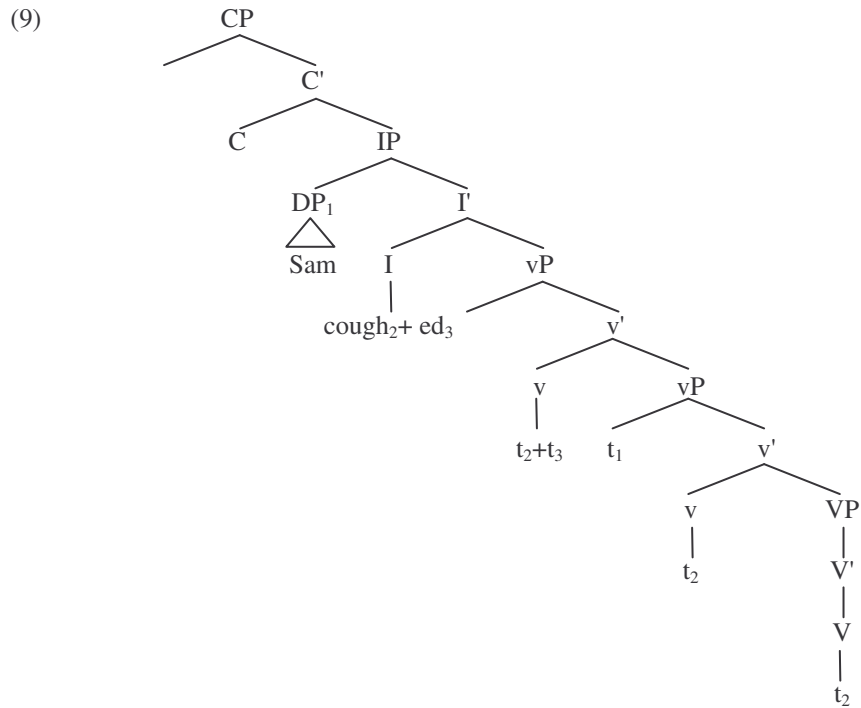

**Suggested Answers and Hints - Chapter 6**

---

j) The sentence in the sentence *John sent a message to Mary* is traditionally called the dative construction. The main verb *send* is in the V head and assigns a theme thematic role to the DP *a message* in the specifier of the VP and a goal thematic role to its complement PP. The vP is an extended projection of the VP, so the main verb assigns an agent thematic role indirectly via the v to the DP in the specifier of the vP. The DP *Mary* receives accusative Case from the preposition *to* while the DP *a message* gets its accusative Case from the v head. Since the light verb is a bound morpheme, the main verb adjoins to the v head and then moves on to the tense v and I to agree with the subject. The DP in the specifier of the vP needs to be assigned Case as well, so it has to move to the specifier of the IP.

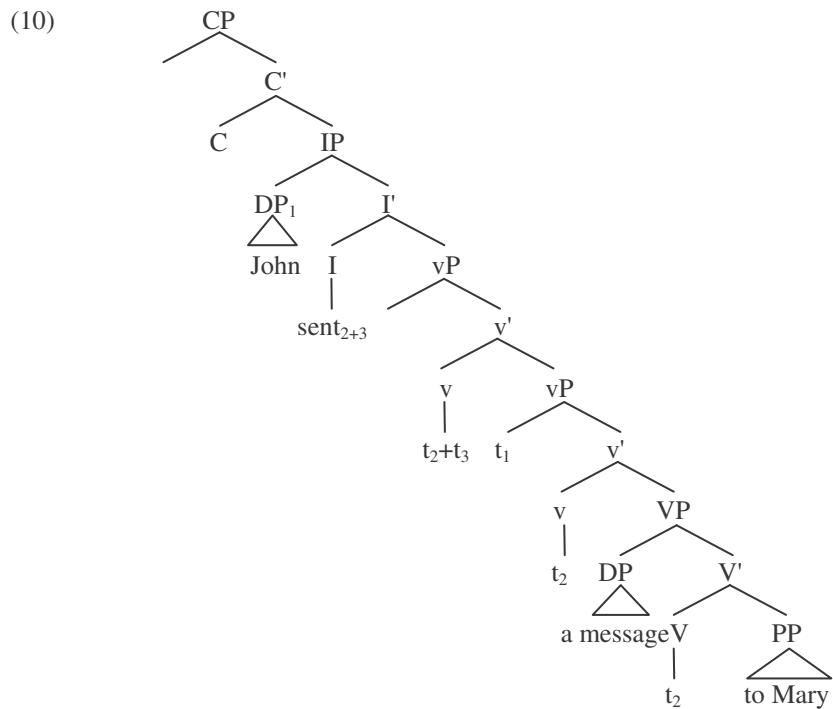

k) The sentence *Mary was sent a message* is a passive sentence with the so called double object construction. The main verb is in V in the D-structure. The theme argument *a message* occupies the specifier of the VP, the agent DP is absent in passive structures, the vP hosting the agentive DP is replaced by the passive vP. The third argument DP is in the complement position of the main verb and it is assigned a goal thematic role by the verb. The DP *a message* receives accusative Case in its base position, so it does not have to move. The DP *Mary*, however, needs to move to a Case position. First it moves to the specifier of the lower vP, which is the position for DPs with a goal thematic role in double-object constructions. In an active sentence, the DP *Mary* can stop in this position, since it can receive Case here as it can be attested in the sentence in (11).

(11) John sent Mary a message.



**Exercise 4**

---

In our sentence, this position cannot be the final position of the DP *Mary* the *v* head of the middle *vP* is occupied by the passive morpheme *-en*, which does not assign accusative Case. So the DP has to move on to the next position where it has a chance to receive Case. This position is the specifier of *IP*, where the finite *I* head assigns nominative Case to it. The main verb has to adjoin to the lower *v*, which is an abstract bound morpheme. This complex head has to move on to the middle *v* head containing the passive morpheme, which is also a bound morpheme. The upper *vP* is the tense *vP* where *be* is inserted as a dummy auxiliary as the thematic verb cannot move further on from the passive *vP*. *Be* together with the tense morpheme moves on to *I* containing the zero agreement morpheme.

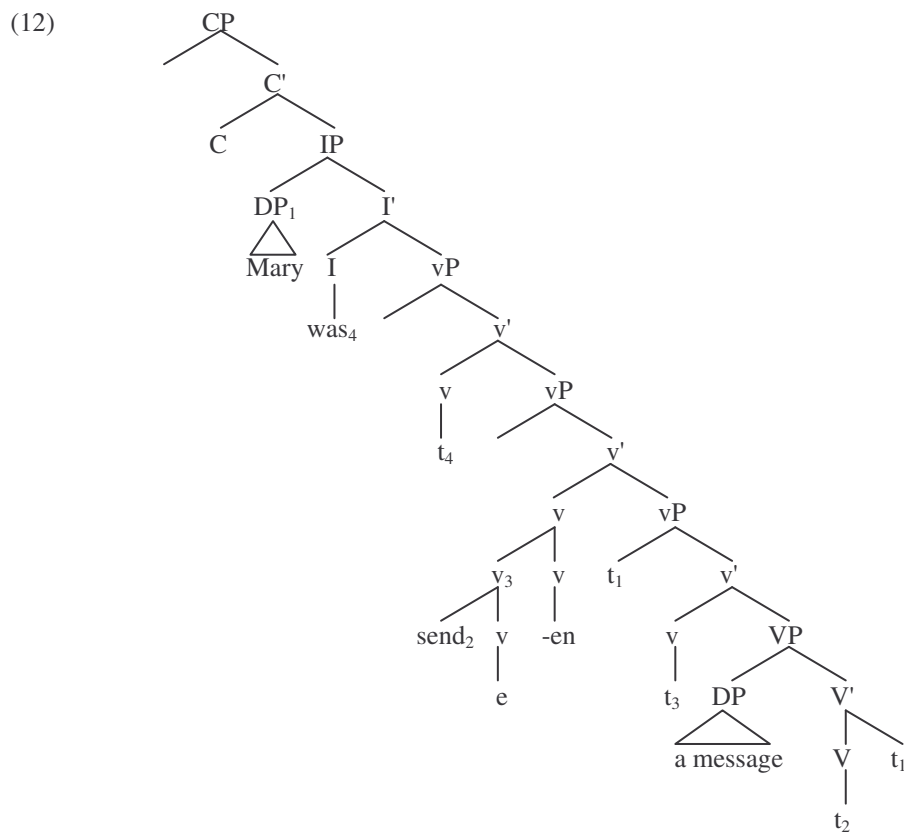

**Suggested Answers and Hints - Chapter 6**

---

1) In the sentence *Jim took his shoes off* we find a phrasal verb *take off*. The main verb *take* occupies the V head, assigning a theme thematic role to the DP in its specifier position and it also takes a PP complement, which consists of a mere head. The agent DP occupies the specifier of the vP. The v head is occupied by an abstract light verb, which is a bound morpheme requiring the main verb to adjoin to it. The agent DP has to move to the specifier of the IP in order to receive nominative Case from the finite I head. From the lower vP the verb moves on to the tense vP and I.

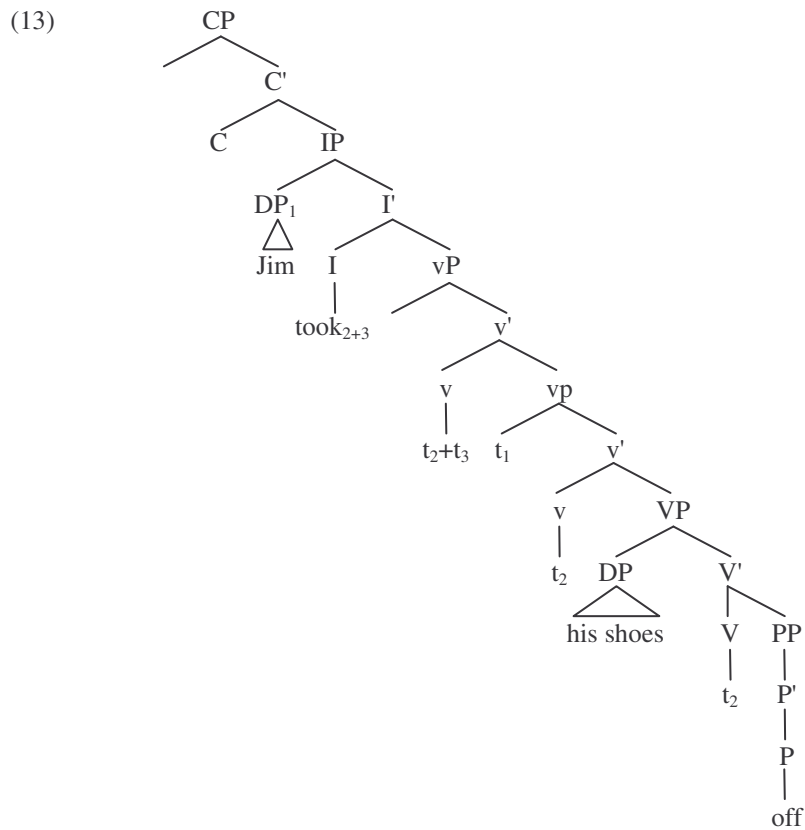

**Exercise 4**

---

m) In the sentence *Jim took off his shoes* we also find the phrasal verb *take off*, but here the preposition *off* precedes the DP *his shoes*. The structure of the sentence can be derived from the structure in (13). The only difference between the two derivations is that the preposition adjoins to the main verb before it moves to the v head. The rest of the derivation is the same as in (13).

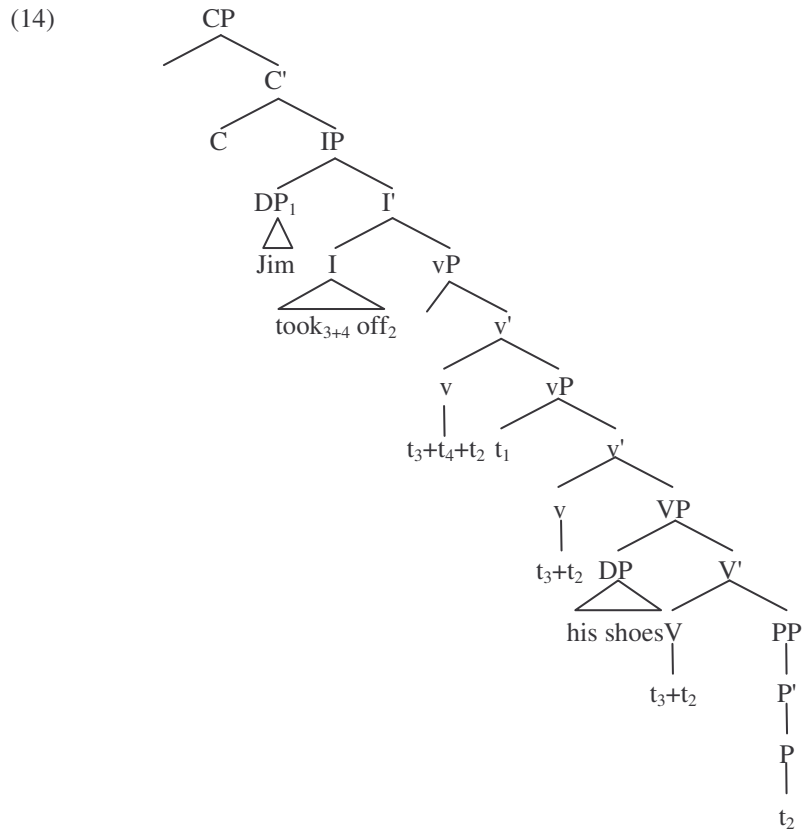

**Suggested Answers and Hints - Chapter 6**

---

n) In the sentence *John thinks that Jim knows that Mary gave his book to Jane* there is a verb *think* which takes a clause as its argument. In this clause there is a verb *know* which again takes a clause as an argument. The verb *think* assigns two thematic roles: an experiencer to the DP *John*, which occupies the specifier of the vP in the D-structure, and a propositional, which is assigned to the CP in the specifier position of the VP. The DP *John* has to move to the specifier position of the IP in order to get Case from the finite I head. There is an abstract light verb in the v head which requires the main verb to adjoin to it. The CP is in a Case position but CPs do not need to be assigned Case, moreover, CPs avoid Case positions, so the CP moves rightwards and adjoins to the VP. Inside this clause the V head is occupied by the verb *know*, which takes two arguments: an experiencer in the specifier of the vP, which moves to the specifier of the IP for Case, and a propositional, which is a CP and occupies the specifier position of the VP. The verb adjoins to the light verb. The CP is again in a Case position, and moves to the right adjoining to the VP. Inside the CP, the V is occupied by the verb *give*. Give takes three arguments: an agent in the specifier of the vP, a theme in the specifier of the VP and a goal PP in the complement position of the verb. The DP *Mary* moves to the specifier of the IP, while the DP *his book* receives Case in its base position from the v head. The DP *Jane* is assigned Case in its base position by the preposition *to*. Besides all this the thematic verbs undergo the usual movements to the tense v and then to I, which appears in a simplified form in the tree to avoid a really disturbing abundance of traces (notice, however, that e.g. *knows* is made up of two morphemes, *know* and *-s*, so there should be two traces in tense v).

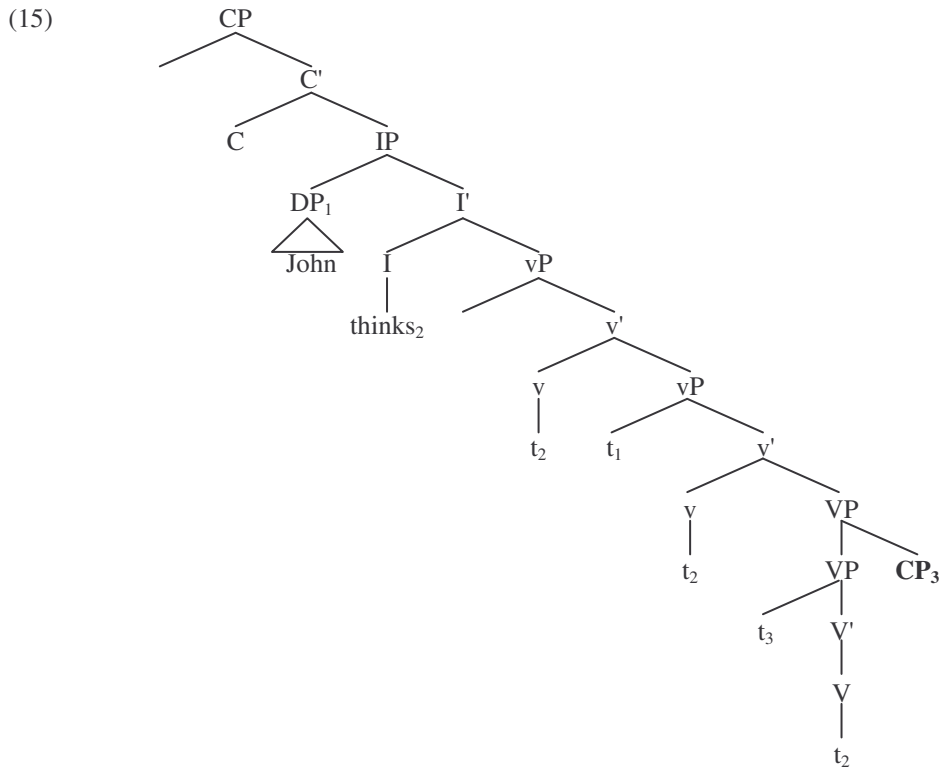

Exercise 4

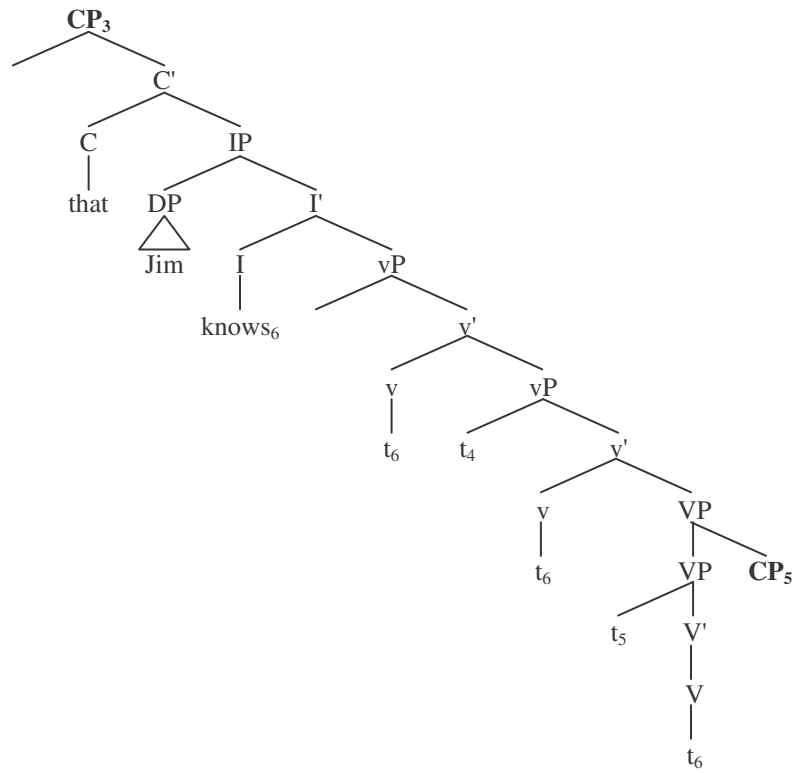

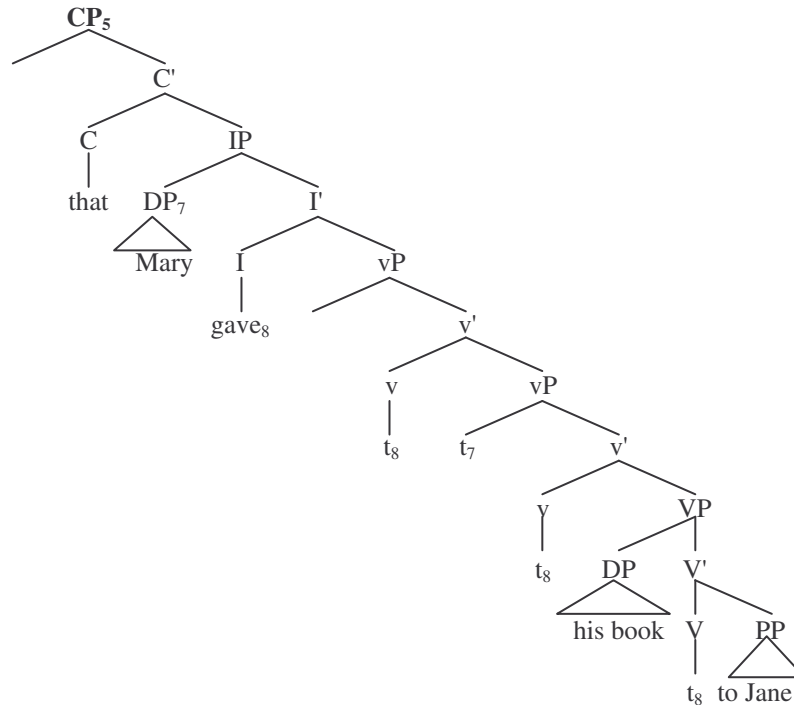

## Chapter 7

- Check Questions

Q1 The set of complementizers in English include the words *if*, *that* and *for* (disregarding any non-overt complementizer for the time being). These elements introduce clauses and determine what is called the 'force' of the clause, i.e. whether the clause is a statement (declarative) or a question (interrogative). Thus, *if* introduces interrogative while *that* and *for* declarative clauses. The latter two differ in terms of whether the clause they introduce is finite (*that*) or non-finite (*for*). Complementizers are not part of basic clause structure (i.e. the IP) but they form a constituent with it. The force, in other words a salient property of a clause is determined by the complementizer, thus it can be argued that they are heads determining the properties of the structure they head (compare *if they should leave* vs *that they should leave* vs *for them to leave*). Heads select their complements and indeed, complementizers select the type of IP they subcategorise for. Another head-like property manifested by complementizers is that they are word-level categories and not phrases, followed by their complement phrase (the IP) which renders them strikingly similar to other functional heads taking only one type of complement.

## Check Questions

---

Q2 Main clauses in English, although it is preferable for them to be conceptualised as CPs, are never introduced by an overt complementizer. Nevertheless, given that the clause is interpreted either as declarative or interrogative, the presence of a non-overt complementizer is justified. Finite declarative object clauses may or may not contain an overt complementizer (*Peter knew (that) Mary left*) in line with the assumption that they are CPs. Subordinate subject clauses, on the other hand, must contain an overt complementizer (*That Mary left surprised everyone*).

Q3 Canonical structural realisation principles underlie the observation that certain arguments are typically realised by certain structures. More specifically, theme arguments are usually realised as DPs, location arguments as PPs and propositional arguments as CPs. This way it may be claimed that verbs which select for a finite declarative complement select for a CP rather than an IP. It must be noted that there are exceptions to canonical structural realisation principles, i.e. there are non-canonical realisations, e.g. when a nominal realises a goal argument which is usually realised by a PP (e.g. *home*).

Q4 On one hand, there are certain verbs that take (non-finite) complement clauses that do not contain complementizers (these also lack overt subjects, e.g. *try, attempt, promise*, etc.), on the other hand, there are finite complement clauses which contain a wh-phrase but not an overt complementizer (e.g. *He didn't know what to do*). It is assumed that in these cases there is a non-overt element in the complementizer position.

Q5 It suggests that these elements occupy the same position, i.e. the C head position.

Q6 In an embedded yes-no question the presence of the interrogative complementizer determines the force of the clause, i.e. that it is interpreted as a question. In an embedded wh-question there is no overt element occupying the C head position and [Spec, CP] is occupied by the wh-element itself. Nevertheless, the clause is interpreted as interrogative. Given assumptions about specifier-head agreement observed elsewhere, it may be assumed that although the element in the C head position is non-overt, it has the [+wh] feature and that is what the wh-element in the [Spec, CP] position agrees with. Thus, it is necessary for the wh-element to appear in the [Spec, CP] position to manifest this specifier-head agreement relationship. For this reason a wh-element is seen as an operator necessary to promote the interpretation of a clause. In echo-questions the wh-element remains in its base position and the structure is not interpreted as a question, instead, it is interpreted as a device to provide missing information. A wh-element is only interpreted as an operator if it has moved into the [Spec, CP] position. In multiple wh-questions only one wh-element moves, the other remains in situ. The interpretation of the non-moved wh-element as an operator depends on the presence or absence of a moved wh-element in the same clause (The interpretative principle: Interpret a wh-element as an operator if it is in [Spec, CP] or is coindexed with a wh-element in [Spec, CP].).

## Suggested Answers and Hints - Chapter 7

---

Q7 Operators are elements that indicate a process necessary in order to be able to work out the meaning of a clause that contains them. For example, fronted wh-elements are operators as they signify that the clause should be interpreted as interrogative, or 'whether' is analysed as a general interrogative operator introducing subordinate yes-no questions similarly to its non-overt counterpart appearing in matrix yes-no questions. (Quantificational pronouns like 'everyone' or 'someone' are also operators).

Q8 A-movement (A=argument) is case-motivated (grammatically motivated), e.g. subject-movement, and the element moving is an argument that ends in an argument position, while A-bar movement (movement of an argument or non-argument to a non-argument position) is semantically motivated, e.g. wh-movement where the interpretation of the clause as interrogative is due to the wh-element moving.

Q9 According to one the motivation behind I-to-C movement is that in interrogative clauses there is a non-overt bound morpheme occupying the C head position and movement of the element in I is necessary to support that bound morpheme. According to the other set of assumptions, I-to-C movement is triggered by the C head position being empty and the requirement that it be filled. The element in I moves to satisfy that requirement. It is assumed that a main clause interrogative, where I-to-C movement occurs, cannot contain an overt complementizer (as opposed to embedded interrogatives). But the clause has to be marked as interrogative, thus the auxiliary moves to the empty head position, thereby providing a head the wh-element in [Spec, CP] position can agree with.

Q10 'Whether' differs from other complementizers in that it can introduce both finite and non-finite clauses. Secondly, as opposed to other complementizers, it can be coordinated with the negative particle *not*. In Old English 'whether' was used to introduce yes-no questions, yet Old English clauses were not introduced by complementizers, so 'whether' is assumed not to be one either. Although 'whether' is similar to wh-elements in that they can also introduce finite and non-finite clauses (e.g. *what he should do – what to do; whether he should go – whether (or not) to go*), it differs from wh-elements in that unlike wh-phrases, it is not associated with a gap inside the clause containing it.

Q11 It is a constraint that bans the co-occurrence of an overt wh-operator and an overt complementizer in a CP. It can contain only either one or the other, even though the two are not generated in the same structural position.

Q12 (i) Subjects precede the verb; (ii) the negative particle follows the finite tense and precedes the verb; (iii) adverbs follow the finite tense and precede the verb.

Q13 Regarding their interpretation, restrictive relative clauses pick and focus on one element out of a set of elements while non-restrictive relatives add extra information about the noun they modify. Structurally, restrictive relative clauses may contain a wh-pronoun or a complementizer or a non-overt element, while non-restrictives can and must contain a wh-pronoun. A further difference between the two types of relative clause is that non-restrictives must be inserted between commas or dashes (in speech there is a pause preceding them). Fourthly, non-restrictives appear to be more distant



## Check Questions

---

structurally from the noun they modify than restrictives as only restrictives can be part of one-pronominalisation together with the noun they modify. Both types can be coordinated with identical constituents, though, and both are analysed as adjuncts with the non-restrictive relative clause being attached further away from the noun head than the restrictive.

Q14 An interrogative pronoun has the feature [+wh] while a relative pronoun has the feature [-wh]. ‘What’ as an interrogative pronoun is associated with non-animate referents, while ‘what’ as a relative pronoun used in dialects is not. ‘What’ as a relative pronoun can only introduce so-called headless relatives in standard English.

Q15 It can only be used in finite clauses while relative pronouns may introduce both finite and non-finite clauses. It does not allow pied-piping, i.e. it must be separated from a preposition it is the complement of (e.g. *the man with whom they talked* – *the man whom they talked with* – \**the man with that they met* – *the man that they talked with*). As ‘that’ is a complementizer, there is no associated gap of the moved element after the preposition.

Q16 If the wh-element is part of a PP, there are two options as to the way it can move: along with the preposition, i.e. the whole PP moves (pied-piping, e.g. *with whom did you leave*) or separate from the preposition (preposition stranding, e.g. *who did you leave with*).

Q17 There are three main types of relative clauses, wh-relatives, that-relatives and zero-relatives. Wh-relatives contain an overt wh-pronoun associated with a trace of the noun head in the nominal structure while that-relatives and zero-relatives contain the non-overt counterpart (a null operator) of the relative pronoun associated with the trace of the noun. Besides, there are the so-called headless relatives that appear to lack a modified noun head, but they also have the distribution of a DP so they should be analysed as such: [*whoever you support*] *will be promoted*

Q18 Topic: it denotes information that is already part of the discourse or is easily identifiable by the participants on the basis of the context or general knowledge (so-called ‘old-information’). Focus: the stressed element that carries new information. Comment: information that follows the topic (so-called ‘new information’).

Q19 Matrix clauses: topicalised elements (potentially more than one) + wh-element. Embedded clauses: wh-element + topicalised elements.

Q20 Topicalisation, focus-fronting and negative-fronting.

Q21 The inverted auxiliary in negative-fronting structures precedes the inverted auxiliary but follows the complementizer.

Q22 The topic precedes the fronted negative. The topic also precedes the focus. The fronted negative is in complementary distribution with the focus.

## Suggested Answers and Hints - Chapter 7

---

### ▪ Exercise 1

Nominative case is given by the finite inflection, that is, an inflection that is tensed. Accusative case can be given by either a transitive verb or a preposition.

DP	Case	Case assigner
it	nominative	is (+tense I on <i>be</i> )
me	accusative	for
the door	accusative	close
Jane	nominative	I + tense
the keys	accusative	stolen
the professor	nominative	I + tense
me	accusative	expects
an essay	accusative	write
her	accusative	for
Jack	nominative	has (+tense I on <i>have</i> )
America	accusative	to
January	accusative	since
Kim	accusative	for
this exercise	accusative	understand
I	nominative	I + tense
Peter	accusative	expect
his family	accusative	visit
the thief	nominative	I + tense

### ▪ Exercise 2

- a The letter was sent to the government last night.  
 passivisation  
 D-structure: [e] was sent [<sub>DP</sub> the letter] to the government last night  
 S-structure: the letter<sub>1</sub> was sent t<sub>1</sub> to the government last night
- b Interesting books, I often read.  
 topicalisation  
 D-structure: [e] I often read [<sub>DP</sub> interesting books]  
 S-structure: interesting books<sub>1</sub> I often read t<sub>1</sub>
- c Can you lend me your umbrella?  
 Subject–auxiliary inversion (yes–no question)  
 D-structure: [e] you can lend me your umbrella  
 S-structure: can<sub>1</sub> you t<sub>1</sub> lend me your umbrella
- d In this garden, you can have a rest.  
 topicalisation  
 D-structure: [e] you can have a rest [<sub>PP</sub> in this garden]  
 S-structure: in this garden<sub>1</sub> you can have a rest t<sub>1</sub>

### Exercise 3

---

- e Has John ever been caught in the act?  
passivisation and subject–auxiliary inversion (yes–no question)  
D-structure before passivisation: [e] has ever been caught [<sub>DP</sub> John] in the act  
D-structure after passivisation but before subject–auxiliary inversion:  
[e] John<sub>1</sub> has ever been caught t<sub>1</sub> in the act  
S-structure: has<sub>2</sub> John<sub>1</sub> t<sub>2</sub> ever been caught t<sub>1</sub> in the act
- f A proposal has been handed in for the educational reform.  
passivisation and extraposition  
D-structure before passivisation:  
[e] has been handed in [<sub>DP</sub> a proposal for the educational reform]  
D-structure after passivisation but before extraposition:  
a proposal for the educational reform<sub>1</sub> has been handed in t<sub>1</sub>  
S-structure: [a proposal t<sub>2</sub>]<sub>1</sub> has been handed in t<sub>1</sub> for the educational reform<sub>2</sub>

▪ **Exercise 3**

If an adverb can be placed between the auxiliary and the main verb, it is a VP adverb.  
If it precedes the modal auxiliary, it is a sentential adverb.

- a The sentence can be reformulated in the following way: It was a clever thing that Agatha answered the question (no matter whether the answer was correct or not).  
→ sentential adverb
- b Ron may hardly go to the cinema.  
\*Ron hardly may go to the cinema.  
→ VP adverb
- c Suddenly, she may burst into tears.  
→ sentential adverb
- d Agatha may cleverly answer the question.  
The sentence can be reformulated in the following way: Agatha's answer to the question was correct. (In fact, with a special intonational pattern, with a pause before and after *cleverly* and also stress on the adverb there is a sentential adverb interpretation available, too. However, in writing this is indicated by commas preceding and following the adverb.)  
→ VP adverb
- e It is certain that they will go to America for holiday.  
→ sentential adverb
- f The student has thoroughly rewritten her thesis.  
\*The student thoroughly has rewritten her thesis.  
→ VP adverb
- g The king should often visit the neighbouring countries.  
\*The king often should visit the neighbouring countries.  
→ VP adverb

▪ Exercise 4

(1) a *WH*-movement

The verb *live* when used in the sense of 'reside' is an unaccusative verb so in this case it would not have an agentive vP above it which introduces the subject. The subject in this sentence has the theta role of theme, so it is base-generated in the specifier position of VP. The vP above VP hosts the tense morpheme *-s* that the lexical verb picks up on its way to C. As discussed in the text movement of the lexical verb to C is possible as long as it appears after the subject, and this is exactly the case in subject questions. So the verb moves from V to v first, then to I, then to C. The movement of the verb is somewhat simplified in the tree, the structure gets more and more complex with each step of movement.

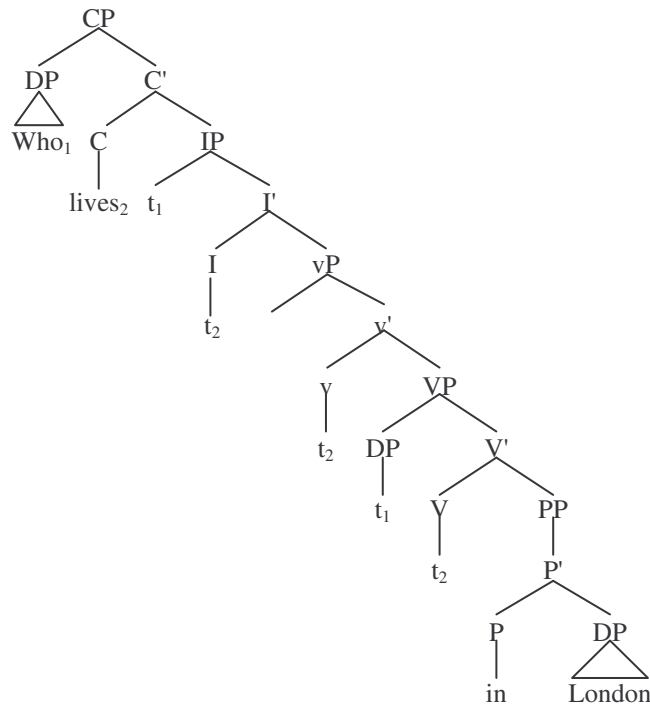

Exercise 4

---

(1) b raising

The verb *seem* is a raising verb, which means that it has only one clausal complement, its subject position is empty. If the clausal complement is an infinitival one, the subject of the embedded clause cannot be assigned Case either by the Inflection of the clause (since it is non-finite) or the verb *seem* (Burzio's generalization). For this reason the movement of the subject of the infinitival clause to a Case position is obligatory. The verb *seem*, as usual, moves from V to tense *v* and from that position further on to I. As discussed in the text *to* is also a tense *v* element as it can be preceded by *not*.

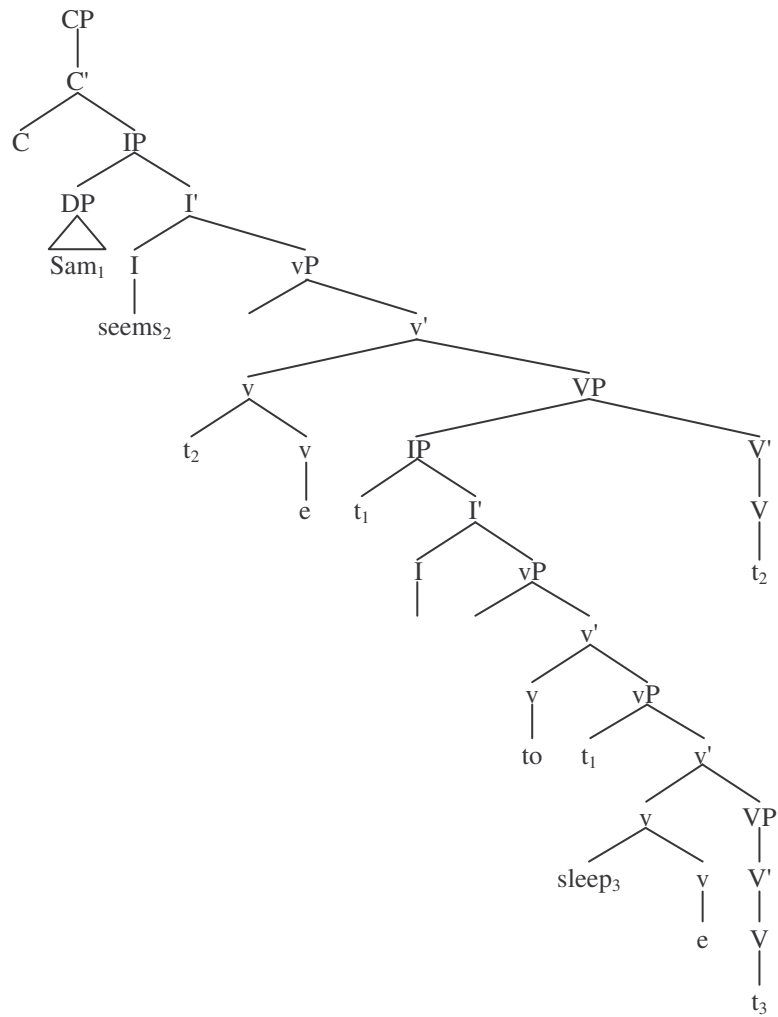

**Suggested Answers and Hints - Chapter 7**

---

(1) c raising + *wh*-movement

In this sentence *wh*-movement and raising are combined. The verb *appear* is also a raising verb selecting a clausal complement. The subject of the embedded infinitival clause is not assigned Case so it moves to the specifier position of the IP of the finite clause. Since it is an instance of subject questions the question word has to move on to the Spec,CP position. The verb *appears* can also undergo movement to C, it will not precede the subject. The verb *adore* in the embedded clause selects an experiencer subject which can appear in the specifier position of a light verb, which is a bound morpheme inducing movement of the lexical verb *adore*. The second vP in the embedded clause hosts the tense morpheme, infinitival *to*.

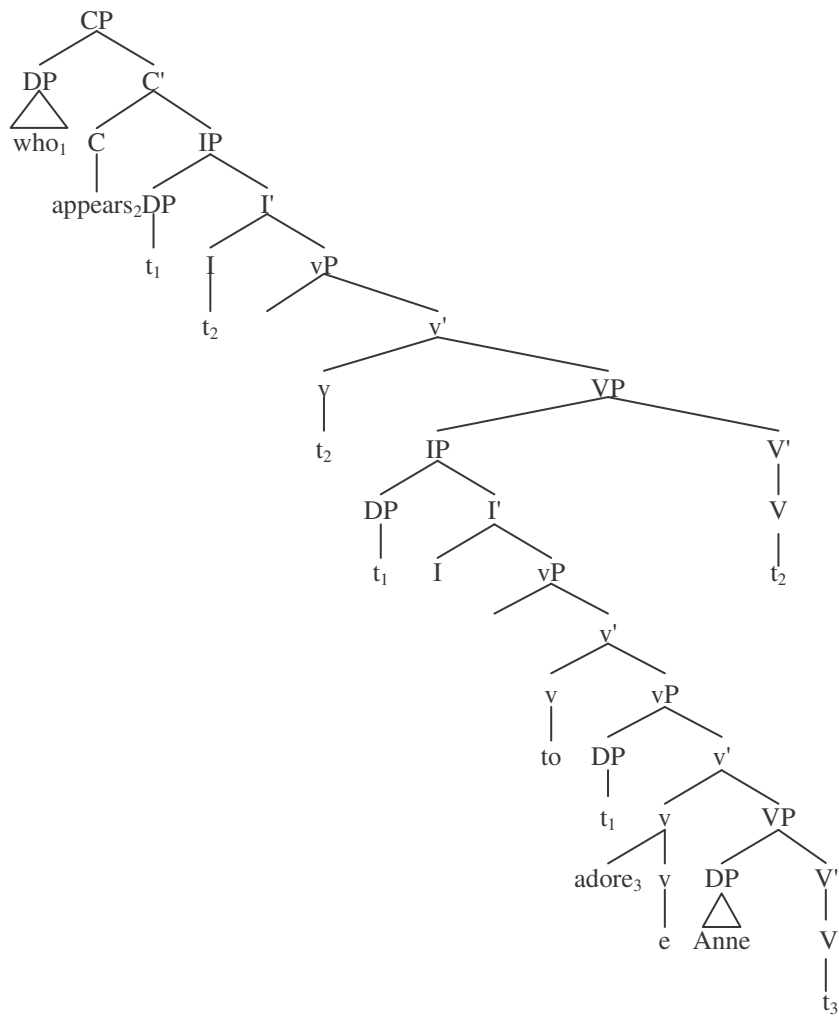

## Exercise 5

---

▪ **Exercise 5**

- (1) a Which book did John buy?  
 b Short stories, I don't like.  
 c Short stories I expect nobody likes.  
 d Mary seems to hate big cats.  
 e I know the researcher who is believed to have invented cold fusion.

Θ-role is assigned by a lexical head in a local configuration. A lexical head can assign Θ-role either to the constituents in its specifier or in its complement position.

Sentence (1a) is problematic as the lexical entry of the verb 'buy' as in (2a) states that it should assign the 'theme' Θ-role to a DP immediately following it as in structure (2b).

- (2) a buy : [-F, -N, +V]  
**Θ-grid:** <agent theme>  
**subcat:** nominal

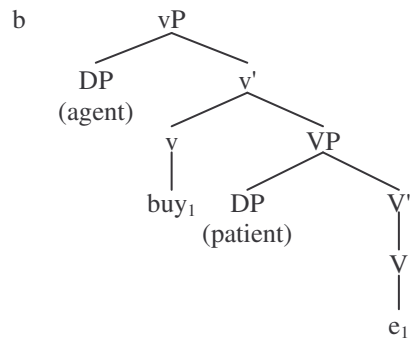

But there is no DP in this position. In fact the object of the verb appears in the initial position in the sentence. Therefore the sentence should be ungrammatical. But it is not. So the assumption is that in the initial structure the *wh*-DP was in Spec,VP, the canonical theme position, where it is assigned the theme theta role, then it moves to the sentence-initial position. Why does it have to move there? Regular theme complements do not undergo this movement (*John bought Ulysses*). However, those DPs that are marked for +*wh* feature have to move to sentence-initial position to fulfil their operator function.

The verb *like* in (1b) is a transitive verb. It has an experiencer and a theme argument as is illustrated in its lexical entry in (3a).

- (3) like :**cat:** [-F, -N, +V]  
**Θ-grid:** <agent theme>  
**subcat:** nominal

As the lexical entry shows there should be a nominal complement in the sister node of the head but this complement seems to be in the initial position of the sentence

**Suggested Answers and Hints - Chapter 7**

---

similarly to sentence (1a). Thematic role assignment can be accounted for in the same manner we did in sentence (1a). The initial position of the object DP was Spec,VP where it got the theme theta role from the main verb. Then it moved to the first position of the sentence. This movement cannot be motivated by the fact that the DP has a +wh feature, as it is not a question word. But it is obvious that the sentence has marked contrastive interpretation (*Short stories I don't like, but I like novels.*). This indicates that the complement has a contrastive interpretation; therefore it is marked as contrastive. DPs marked as contrastive tend to move to the sentence-initial position. This operation is called topicalisation.

In sentence (1c), as in sentence (1b) the DP *short stories* is the theme complement of the verb *like*, as its lexical entry indicates. Sentence (1c) is a complex sentence, the topicalised DP moves to the first position of the main sentence. The theme complement must be in the Spec,VP of the embedded sentence as in (1b) to get thematic role from the lexical verb *like* of the subordinate sentence. Then it moves to the initial position of the main sentence to get the contrastive interpretation.

In the complex sentence (1d) there are two predicates: the verb *seem* and the verb *hate*. The lexical entry of the two verbs is in (4a) and (b).

- (4) a seem **cat:** [-F, -N, +V]      b hate **cat:** [-F, -N, +V]  
**Θ-grid:** <proposition>              **Θ-grid:** <agent theme>  
**subcat:** sentential                      **subcat:** nominal

As the lexical entry of the verb *seem* indicates, it does not have thematic subject, so the subject of the sentence cannot be the thematic subject of the verb *seem*. The verb *hate* has a thematic subject, but there is no DP in the Spec,IP, (the canonical case position of the subject) of the embedded sentence. Still the sentence is grammatical. The DP *Mary* is interpreted as the subject of the verb *hate*, she is the "hater". In the initial structure the DP *Mary* must be in the specifier position of the VP of the subordinate sentence.

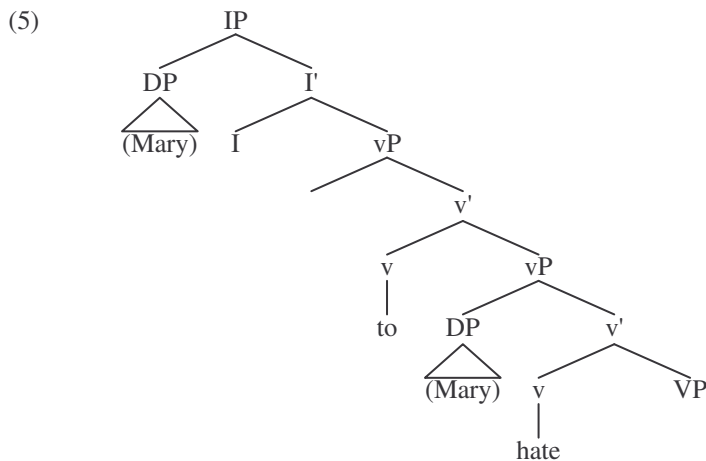



## Exercise 6

---

It is assumed that the subject *Mary* moves from the Spec,VP position of the embedded sentence to the Spec,IP of the main sentence. The motivation for this movement is Case. DPs must have Case. Subject DPs cannot get Case in Spec,VP, they have to move to Spec,IP to get nominative Case. But the infinitival marker, as it is non-finite (present, past, future), cannot assign Case (*\*It seems Mary to hate big cats.*). The subject DP must move to the subject position of the main sentence. As the verb *seem* does not have thematic subject, the subject DP of the embedded sentence can move to the Spec,IP of the main sentence to get nominative Case. As this movement is motivated for Case it is DP-movement.

In sentence (1e) there are three verbs. The lexical entries of the three verbs are in (6a), (6b) and (6c), respectively:

- (6) a know      **cat:** [-F, -N, +V]  
                  **Θ-grid:** <experiencer, theme>  
                  **subcat:** nominal
- b believed    **cat:** [-F, -N, +V]  
                  **Θ-grid:** <proposition>  
                  **subcat:** sentential
- c invent      **cat:** [-F, -N, +V]  
                  **Θ-grid:** <experiencer, propositional>  
                  **subcat:** sentential

The subject DP and the object DP of the verb *know* are in their canonical positions, in Spec,IP and in Spec,VP, respectively. The lexical head of the object DP is modified by a complex relative sentence. The lexical verb *believed* of the main sentence is followed by a sentence as is required by its lexical entry. Notice that the passive form of the verb *believe* has no thematic subject. In the most embedded sentence the verb *invent* has a thematic subject, which should be in Spec,vP in the initial position to get thematic role. Intuitively, we know that the subject of *invent* is the relative pronoun *who*. It has the agent role 'inventor'. It is marked for +wh feature, therefore it moves to the sentence initial position as in (1).

### ▪ Exercise 6

- (1) a The diamonds were stolen yesterday.  
      b Will you meet Mary in Paris?  
      c Linguistic textbooks, I never read.  
      d I won't trust you.  
      e Who does John like?  
      f Never have I been treated so rudely.

In sentence (1a) the DP *the diamonds* is the theme argument of the verb *steal*. It is a passive sentence in which the theme argument moves to the canonical subject position, as it cannot get case in its base position. The common wisdom about passivisation is that the past participial form of the verb cannot assign thematic role to its agent argument and cannot assign accusative case to its theme argument. As the Spec,IP position of the sentence is empty, the theme argument can move there to get

---

**Suggested Answers and Hints - Chapter 7**

---

nominative case. Movement of DPs to Spec,IP to get nominative case is called DP movement. DP movement is substitution as it targets an existing position, in this case, Spec,IP. The initial structure is in (2a), while the derived structure is in (2b).

- (2) a    were stolen the diamonds    yesterday  
       b The diamonds<sub>i</sub> were stolen             t<sub>i</sub>    yesterday

In sentence (1b) a yes–no question is under scrutiny. In yes–no questions in English main clauses the auxiliary precedes the subject. The auxiliary is a head and its base position is in I as is shown in the declarative version of the sentence in (3a). In questions the auxiliary verb moves from I to C to mark C as interrogative, the way we get the interrogative interpretation of the sentence as in (3b). The movement is head-movement and it is substitution as the auxiliary moves to an existing position, to C, which is empty before the movement of the auxiliary.

- (3) a            you will meet Mary in Paris  
       b will<sub>i</sub> you     t<sub>i</sub> meet Mary in Paris

In sentence (1c) the verb *read* is an active transitive verb that has a theme complement. In the initial position the theme argument must be in VP as theta role assignment is performed by the main verb in a very local domain (within the projection of the verb) as in (4a). But the theme DP moves to the front of the sentence (4b). This movement is called Topicalisation and it is an adjunction operation as we can have several topicalised constituents.

- (4) a    I never read    Linguistic textbooks  
       b Linguistic textbooks<sub>i</sub> I never read             t<sub>i</sub>

In sentence (1d) the negative marker is unified with the modal auxiliary in I. As is seen in (5a) the canonical position for the negative head follows I, the D(eep)-structure position of the modal auxiliary. In English negation can be adjoined to the auxiliary in I as in (5b). This movement is adjunction as it is adjoined to a position that is already filled with the modal auxiliary.

- (5) a I will    not trust you  
       b I won't<sub>i</sub> t<sub>i</sub> trust you

Sentence (1e) is an interrogative sentence in which the theme argument of the verb *like* is an interrogative pronoun. Interrogative pronouns in English tend to move to the front of the sentence followed by the movement of the (first) auxiliary to C. As the pronoun is the complement DP of the verb, in D-structure it has to be in VP (6a). But being an interrogative pronoun it has to move to the most initial position in the sentence (6b) to mark the sentence interrogative. This is a substitution operation as interrogative pronouns move to an existing empty position (to Spec,CP). The movement of the auxiliary backs up this movement from I to C in accordance with the Structure Preserving Principle.

### Exercise 7

---

- (6) a                    John -s like who  
       b Who<sub>j</sub> does<sub>i</sub> John t<sub>i</sub> like t<sub>i</sub>

That the movement of the interrogative pronoun is substitution is further supported by the fact that in English only one interrogative pronoun can occur in sentence-initial position, as the contrast between (7a) and (7b) illustrates.

- (7) a Who saw what?  
       b \*Who what saw?

Sentence (1f) contains both negative fronting and passivisation. The negative word *never* moves to iP from its adverbial base position, which is a position adjoined to vP. The auxiliary *have* that has been inserted in the topmost vP, the tense vP to support the bound tense morpheme (remember, the thematic verb cannot move from the passive vP, English is not an agglutinating language where the same verb form can “collect” several inflectional endings) moves to I first and then to C. The subject, which is understood as the theme of the verb *treat* moves from the specifier position of VP to Spec,IP where it can be assigned Case. Finally, the thematic verb itself moves from V to v to support the bound passive morpheme.

▪ **Exercise 7**

In the sentence *Jane has been taken to hospital* there are two chains, a DP chain and a head chain. The DP chain is the result of the movement of the theme argument of the passive verb *taken* to the subject position of the clause, to Spec,IP, the head of the chain is the DP *Mary* in Spec,IP and the foot of the chain is the trace that follows the verb as in (1). The other movement is the movement of the verb *take* to the vP containing the aspectual morpheme *-en*. The aspectual auxiliaries *have* and *be* are inserted as dummy forms to the appropriate positions.

- (1)        [IP Jane<sub>i</sub> has [<sub>vP</sub> been [<sub>VP</sub> take<sub>j</sub> +en t<sub>i</sub> t<sub>j</sub> to hospital]]]]

In the sentence *Everybody seems to speak two languages here* the DP *everybody* is the agent argument of the verb *speak* of the embedded sentence. It moves to Spec,IP of the matrix sentence to get Case as it cannot get Case in the Spec,IP position of the embedded sentence. The Inflection of the embedded sentence is non-finite and non-finite inflection heads cannot assign Case. The head of the chain is the DP in Spec,IP of the matrix sentence and the foot is in the Spec,VP position of the embedded sentence. The V head also moves to vP that assigns the agentive theta role to the subject. The verb *seem* also moves from its base position to tense v and then to I. The derivation is in (2).

- (2)        [IP Everybody<sub>i</sub> seems<sub>k</sub> [<sub>vP</sub> t<sub>k</sub> [<sub>VP</sub> t<sub>k</sub> [IP t<sub>i</sub> [<sub>vP</sub> to [<sub>VP</sub> t<sub>i</sub> speak<sub>j</sub> two languages t<sub>j</sub> here]]]]]]

In the sentence *Have you ever been to Paris?* the primary auxiliary *have* undergoes head movement, as the sentence is a yes–no question. The auxiliary starts out from vP headed by the auxiliary verb *where* it is inserted to support the tense morpheme as the thematic verb cannot move there, then moves through I to C. The head of the chain is

## Suggested Answers and Hints - Chapter 7

---

the copy in C while the foot of the chain is in v as in (3). The thematic verb also moves, to adjoin to the passive morpheme, which is the position it ends up in, as it cannot support another bound morpheme.

- (3) [CP have<sub>j</sub> [IP you t<sub>j</sub> [vP ever [vP t<sub>j</sub> [vP be<sub>k</sub>+en [vP t<sub>k</sub> to Paris]]]]]]

In the sentence *What did you give to John?* we have an interrogative sentence. In interrogative sentences there are usually chains, one formed by the movement of the interrogative pronoun, the other one is the movement of the modal auxiliary verb to the position immediately preceding the subject DP. The interrogative pronoun is interpreted as the object DP of the verb, it is in VP in D-structure. The interrogative pronoun has to move to the initial position of the sentence forming a chain whose head is the pronoun in the first position of the sentence and the foot of the chain is its trace in VP. In this sentence there is no modal auxiliary present, *did* does not move to C but is inserted there as a dummy form, since the verb cannot move to that position. Other movements, however, do happen: the subject DP moves from vP to IP to be assigned Case, and the lexical verb moves to the light verb in vP and then to tense v and I. The derivation is in (4).

- (4) [CP What<sub>j</sub> did [IP you<sub>k</sub> give<sub>i</sub> [vP t<sub>i</sub> [vP t<sub>k</sub> t<sub>i</sub> [vP t<sub>j</sub> t<sub>i</sub> to John]]]]]

In the sentence *In the park, John met Mary* the PP adjunct *in the park* is right-adjoined to VP in D-structure as in declarative sentences the PP follows the verb and its complement(s). In this sentence the PP undergoes movement and gets adjoined to some initial projection of the sentence leaving a trace in the vP-adjoined position as in (5). The head of the chain formed by the movement of the PP is the copy of the PP adjoined to IP. The foot of the chain is the base position of the PP adjoined to vP in D-structure. The lexical verb *meet* moves to v, tense v and I, the subject DP moves to Spec,IP.

- (5) [IP In the park<sub>i</sub> [IP John<sub>k</sub> met<sub>j</sub> [vP t<sub>j</sub> [vP t<sub>k</sub> t<sub>j</sub> Mary t<sub>j</sub> t<sub>i</sub>]]]]

### ▪ Exercise 8

- (1) a. \*Up the letter John tore.  
b. The letter, John tore up.
- (2) a. \*Whose did you meet mother?  
b. Whose mother did you meet?
- (3) a. \*Friends were financially supported of the President.  
b. Friends of the President were financially supported.
- (4) a. \*The fact surprised everybody that he had resigned.  
b. The fact that he had resigned surprised everybody.
- (i) The contrast between sentences (1a) and (1b) suggests that the constructions *up* and *the letter* do not form a constituent. Only those items can be moved as one unit that form a constituent. The DP *the letter* and the particle *up* do not form a PP. Otherwise sentence (1a) would be grammatical but the particle and the DP is part of VP, which includes the verb, as well

### Exercise 8

---

As the grammaticality in sentence (1b) shows the items *the* and *letter* form a constituent, the reason why *the* and *letter* can undergo topicalisation as one unit.

(ii) In sentence (2a) the problem is that the question words *whose* and the noun *mother* are separated by moving the question word to a sentence-initial position and leaving the noun in its original position, in situ. This is obvious as sentence (2b) is grammatical as both the question word and the noun move to the sentence-initial position. The hypothesis is that the question word and the noun form one constituent; therefore they cannot be separated by movement. The common wisdom about the whose-N construction is that the noun is the lexical head of the DP and *whose* is the functional head of the DP as in (5). Wh movement moves a maximal projection, therefore when *whose* moves, it cannot move alone but as a maximal projection, in this case, as the DP containing *whose*. This DP includes the NP whose head is *book*.

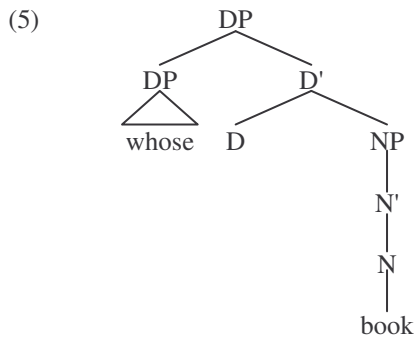

(iii) Sentences (3a) and (3b) are passive sentences in which the object of the active sentence (*They financially supported the friends of the President*) becomes the subject of the passive sentence. In (3a) the object is broken up into two parts: the determiner–noun sequence and the preposition–determiner phrase sequence. The determiner–noun sequence moves to the subject position while the preposition–determiner phrase remains in situ. This is not possible as the sentence proves to be ungrammatical. In sentence (3b) all the elements that constitute the object move to the subject position and the sentence is grammatical. It seems reasonable to assume that all the elements of the object form one constituent; therefore syntactic operations cannot separate them.

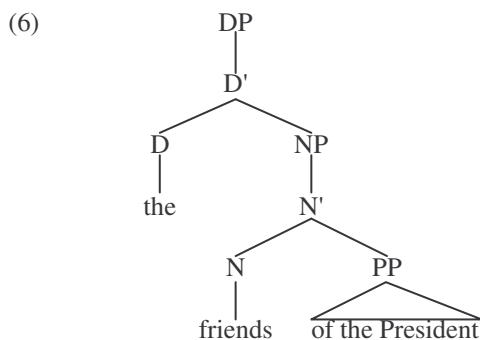

## Suggested Answers and Hints - Chapter 7

---

The sequence *the-friends* cannot move without the PP complement, as the DP that includes the definite article and the noun contains the PP as well. Technically speaking, there is no node that dominates the determiner and the noun head, but does not dominate the PP complement.

(iv) In sentences (4a) and (4b) the subject of the non-finite subordinate clause moves to the subject position of the matrix sentence. In sentence (4a) only a part of the subject moves, the complement clause of the head of the subject DP remains in its original position and this gives us the wrong result. The complement DP cannot be separated from the head and the determiner as they form one constituent.

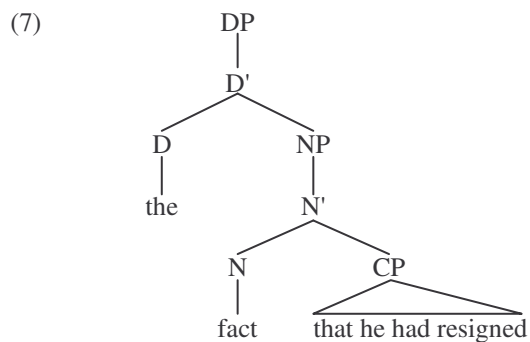

The complement CP is part of the phrases headed by the noun and the determiner, respectively, while there is no common node that dominates D and N but does not dominate the complement clause.

### ▪ Exercise 9

passivisation – substitution: f, i; subject–auxiliary inversion – substitution: b, c; topicalisation – adjunction: d, h; extraposition – adjunction: a, g; preposing – adjunction: e, j

## Chapter 8

### ▪ Check Questions

Q1 Government is a structural configuration under which e.g. case is assigned. A head governs its sister and everything within its sister unless a barrier intervenes. The notion 'barrier' is introduced to prevent certain elements to be governed from outside by a governor (i.e. to allow certain elements to remain ungoverned). VPs are not barriers as the case-assigning light verb can govern into them. Non-finite IPs are not barriers, as the prepositional complementizer *for* can govern into them and case-mark the subject of an infinitival clause. CPs are barriers though, they block government by a governor from outside.

Q2 Exceptional Case Marking occurs with a special group of verbs whose propositional complement, contrary to other types of verbs, is not realised by a CP but an IP, i.e. these verbs subcategorise for non-finite IPs with overt subjects which must be case-marked. The subjects are case-marked by the case-assigning light verb governing into the VP. The case assigned is accusative, the direction of case-assignment being leftward.

Q3 According to one view, clauses which consist of a subject and a predicate not including a verbal element to express a proposition are analysed as 'Small Clauses' which lack a categorial status (thus, these would count as exocentric projections). Another view assumes that these clauses have the categorial status of their predicate and their subjects occupy the specifier position within the projection of the predicate. According to the third view these type of clauses contain an agreement element acting as head (an I head). In this view the head of the predicate does not determine the categorial status of the whole clause, the agreement element does.

Q4 There are two types of unpronounced subjects: the non-independent type and the independent type. The non-independent type of subject has an antecedent with which it shares a theta-role. It has to be lower in the structure than its antecedent. It is always associated with a subject antecedent and it cannot refer outside of the subject clause of another clause. The independent type of unpronounced subject has a theta-role of its own even if it is coreferential with another element. It does not necessarily have to be higher up in the structure than the element it is associated with. It can be coreferential with subjects and objects as well.

Q5 Raising is a type of movement that occurs with certain types of verbs. The subject of the lower clause is moved out to the subject position of the higher clause. The moved element must originate in the subject position of the lower clause which must be a non-finite clause. There is no raising out of finite clauses or object positions. The properties of verbs that may occur in a raising structure include lacking a light verb that can assign a theta-role to the subject and case-mark it. Lacking a light verb implies having a subject position available and vacant. Another property of verbs that can be part of raising structures is that they take a propositional (clausal) complement, which can be finite or non-finite. In raising structures the light verb cannot case-mark

## Suggested Answers and Hints - Chapter 8

---

the subject of the lower clause and when the lower clause is non-finite there is no potential case-assigner within that clause either, hence the subject must move to a position where it can get case. Thus, raising is another type of case-motivated movement. The subject can move across any number of clauses as long as they are non-finite or contain a raising predicate and have an available subject position.

Q6 Case-motivated movements are: subject-movement, movement of objects in passive structures, movement of the internal argument of an unaccusative verb, raising.

Q7 The Extended Projection Principle requires that clauses must have subjects. Pleonastic subjects (*it* and *there*) are made to appear by the EPP when the clausal complement of a raising verb is finite, hence there is no reason for the subject of the lower clause to move since it can get case-marked in its position in the lower clause. In such cases a pleonastic subject (an element that does not require a theta-role) is inserted into the structure to satisfy the EPP.

Q8 PRO is an empty (unpronounced) DP. It can only appear in the subject position of non-finite clauses, not elsewhere (i.e. as subject of a finite clause or object or object of a preposition). The subject positions of non-finite clauses where it can occur are positions to which Null Case is assigned. PRO can have arbitrary reference when it is interpreted as having some generic referent. However, it can also be coreferent with a subject or an object. In some contexts both arbitrary reference and obligatory coreference to an antecedent are allowed at the same time, e.g. *They discussed growing a moustache* – this could be interpreted either as growing a moustache in general or them growing a moustache.

Q9 Control is the property of PRO that when its interpretation is not arbitrary, it can take reference either from a subject or an object. Whether PRO is controlled by the subject or the object is determined by the governing verb, thus there are so-called subject control verbs, e.g. *promise* and object control verbs like *ask* (*They asked him PRO to leave* – it is 'him', the object of the main clause who will leave vs. *They promised him PRO to leave* – it is the subject of the main clause who will leave).

Q10 Anaphors are reflexive pronouns (*myself*, *yourself*, etc.) and reciprocal pronouns (*each other*, *one another*). They must have an antecedent within some unit, e.g. within a clause or DP that contains them and cannot refer outside it. On the other hand a pronominal (*him*, *her*, etc) must refer outside the unit that contains them.

Q11 In derived nominals the *-ing* affix turns the verb into a noun and the unit behaves like a noun syntactically. In gerunds the *-ing* element turns the verb into a unit that has the external distribution of a nominal but the internal structure of it retains verbal properties. With derived nominals the complement it takes is case-marked by the preposition *of* while in gerunds no *of*-insertion is necessary, the complement of the gerund is case-marked in the ordinary fashion verbs case-mark their complement DP. Derived nominals can be pluralised and used with determiners while gerunds cannot be pluralised and only tolerate what looks like a possessive determiner.



## Exercise 1

---

### ▪ Exercise 1

a- adjective, b-participle; c-participle/continuous aspect; d-participle/continuous aspect; e-gerund; f-participle; g-gerund; h-gerund; i-gerund; j-gerund; k-looking: continuous aspect, rising: adjective; l-participle m-talking:participle, having:gerund, heating: noun; n-noun; o-participle; p-participle; q-participle; r-sitting:participle, reading: continuous aspect; s-gerund; t-participle

### ▪ Exercise 2

- (1) a Bobby believes [Betsy to be beautiful]. → non-finite clause  
b Terry tried [to travel to Toronto]. → non-finite clause  
c Thomas thinks [that Ron runs too fast]. → finite clause  
d Hetty hopes [for Hugh to hug her]. → non-finite clause  
e Alan asked [if Sam could stay longer]. → finite clause  
f Sam answered [that he had to leave]. → finite clause  
g Bobby believes [that Betsy is beautiful]. → finite clause  
h Hetty hopes [that Hugh will hug her]. → finite clause

On the basis of the examples, it can be concluded that for some verbs (*believe*, *want* and *hope*, respectively) both finite and non-finite complements are possible. In other words, their clausal complement may or may not express tense: if tense is expressed, the clause is finite, if it is not expressed, the clause is non-finite.

### ▪ Exercise 3

In English, reflexive pronouns must have an antecedent, i.e. a DP that has got the same reference, within the clause they occur. On the other hand, this is not true for personal pronouns: there cannot be an antecedent within the same clause (or DP), however, there is an antecedent outside the clause (or outside the DP). Whenever there are more than one possible antecedent for a pronoun (either for a reflexive or for a personal pronoun), the sentence becomes ambiguous: there are at least two ways of interpretation for the pronoun, thus, for the whole sentence.

- a *he* = John or *he* = another male

*He* is a personal pronoun therefore it does not have an antecedent within the clause [that he would never kiss Jenny]. However, there is a possible antecedent (*John*) in the previous clause [John said], since *he* requires a singular male referent, and *John* fulfils these criteria. On the other hand, *he* can refer to another male, who is not present in this sentence but has previously been mentioned during the discourse.

- b *himself* = Jonathan

*Himself* is a reflexive, that is, it must have an antecedent within the same clause [that Jonathan hates himself]. The antecedent must be male and singular, thus, *Jonathan* is the only available DP that functions as its antecedent.

## Suggested Answers and Hints - Chapter 8

---

c *them* = Mary and Fanny or *them* = other people

*Them* is a personal pronoun therefore there is no need for an antecedent within the clause [Jack and Bob were making dinner for them]. There is a possible antecedent (*Mary and Fanny*) in the subordinate clause [while Mary and Fanny were sleeping], since *them* requires a plural referent, and *Mary and Fanny* refers to two people. However, *them* can have other, previously mentioned people as its antecedent, who are not mentioned in this sentence.

d *themselves* = Jack and Bob

*Themselves* is a reflexive, that is, it must have an antecedent within the clause [Jack and Bob were making dinner for themselves]. The antecedent of *themselves* must be plural, thus, the only possible DP is *Jack and Bob*.

e *she* = Edith or *she* = Sarah or *she* = another female

*She* is a personal pronoun referring to a singular female person. Since it is a personal pronoun, it does not have an antecedent within the clause [that she would never be able to live alone]. Nevertheless, outside the clause there are two possible antecedents: both Edith and Sarah are singular and female. What is more, we should not forget the possibility that the antecedent of *she* is not mentioned in this piece of discourse, that is, *she* refers to a third female person. Thus, the sentence is ambiguous: we cannot decide whether she refers to Sarah or Edith or another female.

f *he* = Harry or *he* = another male

*He* is a personal pronoun referring to a singular male person. It does not have an antecedent within the clause [he always gets angry], however, *Harry* is an available antecedent in the previous clause because it refers to a male person. On the other hand, the possibility for referring to another male not mentioned in this sentence should not be neglected.

g *her* = Mrs Green or *her* = another female

*Her* is a pronoun therefore it can have an antecedent outside its clause or, in the case of *her neighbour*, outside its DP. *Mrs Green* has the properties of being female and singular, so it can be an antecedent for *her*. On the other hand, the antecedent of a pronoun may not be spelled out in the same sentence or DP, thus, *her* can have another female antecedent that has been mentioned earlier in the discourse.

*his* = neighbour or *his* = another male

*His* is a pronoun, therefore it cannot have an antecedent within the DP it occurs. Outside the DP, *her neighbour* is a possible antecedent for *his*, since *his* requires a singular male antecedent and *her neighbour* is singular and is not marked for gender, that is, it can be interpreted as male. However, it can be that *his* refers to another male not present in this sentence.

*he* = neighbour or *he* = another male

*He* is a personal pronoun referring to a singular male person. It does not have an antecedent within the clause [while he would be away], however, *her neighbour* is a

#### Exercise 4

---

possible antecedent in the previous clause because it can refer to a male person as discussed above. On the other hand, the possibility for referring to another male not mentioned in this sentence must be also mentioned here.

#### ▪ Exercise 4

The Case Filter states that all DPs must have case. Sentence (1a) is ungrammatical because the DP *John*, which is the thematic subject of the embedded sentence, does not have case. As the inflection of the embedded sentence is non-finite (infinitival), it cannot assign case to the DP *John*. In sentence (1b) the embedded sentence is finite, the finite inflection can assign nominative case, hence the subject DP 'John' gets nominative case from the finite inflection and the sentence is grammatical.

Sentence (2b) is ungrammatical as the non-finite I cannot assign nominative case to the subject DP of the subordinate sentence. The sentence can be improved when the subject has accusative case, as the ECM verb *believe* can assign accusative case to the DP in the specifier position of its complement.

In (3a) the DP *John* does not have case, as the non-finite I of the subject subordinate clause cannot assign case. In (3b) the preposition *for* saves the sentence as it can assign accusative case to the specifier of its complement.

#### ▪ Exercise 5

The Theta Criterion states that each argument can have only one thematic role and each thematic role can be assigned to only one argument.

- (1) a I want to leave now.  
b John persuaded Bill to leave.  
c I want Mary to leave now.  
d Mary, I really like her.  
e I expected Bill to win the race.

(i) In sentence (1a) the DP *John* seems to have two thematic roles. Intuitively, *John* is the 'wanter' and the 'leaver'. This intuition can be supported by giving the lexical entry of the two predicates of the sentence. *want* and *leave*. The predicate *want* is a two-place predicate whose lexical entry is in (2):

- (2) *want* **category:** [-F, -N, +V]  
**Θ-grid:** <agent proposition>  
**subcat:** clausal

The verb 'leave' is a one-place predicate whose lexical entry is in (3):

- (3) *leave* **category:** [-F, -N, +V]  
**Θ-grid:** <agent>  
**subcat:** 0

The verb *want* assigns an agent theta role to its subject. The verb *leave* has an agent theta role that is assigned to the DP *John*. As the DP has two theta roles the sentence is predicted to be ungrammatical. But the sentence is fully grammatical, therefore problematic for the Theta Criterion.

---

### Suggested Answers and Hints - Chapter 8

---

(ii) In sentence (1b) there are two verbs, *persuade* and *kill*. *Persuade* is a three-place predicate as is indicated in (4a), while *kill* is a two-place predicate as in (4b):

- (4) a *persuade* **category:** [-F, -N, +V]  
**Θ-grid:** <agent, theme, proposition>  
**subcat:** nominal, sentential  
b *kill* **category:** [-F, -N, +V]  
**Θ-grid:** <agent>  
**subcat:** nominal

It seems that the person, who is persuaded, is the theme of the verb *persuade* and the subject of the verb *leave* is the DP *Bill*. The DP *Bill* has a ‘theme’ thematic role assigned by the verb *persuade* and an agent thematic role assigned by the verb *leave* contrary to the Theta Criterion.

(iii) The relevant structure of sentence (in bold letters) (1c) is seemingly identical with sentence (1b) as in (5).

- (5) **DP<sub>nom</sub> – V – DP<sub>acc</sub> – V – (DP)**

But the lexical entries of the verbs suggest that the two sentences have fairly different structures. The lexical entries of the predicates in (i) are repeated here as (2)’ and (3)’.

- (2)’ *want* **category:** [-F, -N, +V]  
**Θ-grid:** <agent proposition>  
**subcat:** clausal  
(3)’ *leave* **category:** [-F, -N, +V]  
**Θ-grid:** <agent>  
**subcat:** 0

The verb *want* is a two-place predicate that has an agent DP argument *I* and a clause, but no object DP. *leave* has one agentive argument. The DP *Mary* is assigned agent theta role by the verb *leave*. The DP *Mary* has only one theta role, therefore the Theta Criterion predicts that the sentence is grammatical.

(iv) In sentence (1d) the verb *like* is a two-place predicate as indicated in its lexical entry in (6).

- (6) *like* **category:** [-F, -N, +V]  
**Θ-grid:** <experiencer, theme>  
**subcat:** nominal

The verb has an experiencer subject *I* and a theme object *her*. The object DP and the sentence-initial DP *Mary* have the same reference. The DP *her* is in the canonical object position, in Spec,VP and gets thematic role from the verb there. But it is not obvious what assigns thematic role to *Mary*. There are two options. One is that the verb assigns the theme theta role both to the DP *Mary* and to the DP *her*. The Theta Criterion does not allow this option. The other option is that the DP *Mary* is not the argument of the verb, but an adjunct. It is adjoined to the highest node in the sentence.

## Exercise 6

---

(v) In sentence (1e) there are two predicates: *expect* and *win*. The surface ordering of the constituents is identical with structure (5) repeated here as (5)'.

(5)'  $DP_{nom} - V - DP_{acc} - V - (DP)$

We have already seen that superficially the relevant part of sentences (1b) and (1c) are identical, but it turned out that it is not. The question is whether the verb *expect* behaves like the verb *want* or the verb *persuade*. To answer this question we need to know the lexical entry of the verbs in the sentence.

- (7) a *expect* **category:** [-F, -N, +V]  
**Θ-grid:** <experiencer, proposition>  
**subcat:** sentential  
b *win* **category:** [-F, -N, +V]  
**Θ-grid:** <agent, theme>  
**subcat:** nominal

### ▪ Exercise 6

DPs undergo DP movement for Case. DP movement can target Spec,IP under the condition that this position is not filled by the thematic (deep) subject of the predicate of the clause. DP movement must be local. DPs move in a cyclic manner. DPs have to move to each Spec,IP on their way to the highest Spec,IP where they can get case. There can be no DP that intervenes between the head and the foot of the chain formed by the movement of the element.

In sentence (1a) the DP *John* is the thematic subject of the verb *meet*. The inflectional head of the most embedded sentence is non-finite, it cannot assign case therefore the subject of the embedded verb has to move to a case position. The predicates *likely* and *seem* are raising predicates. They have no thematic subjects. The Spec,IP positions of the sentences lexically headed by these raising predicates are empty. The DP *John* can move to the Spec,IP position of the matrix sentence. This movement is problematic, as it does not land in each Spec,IP position on its way up to the highest Spec,IP. The expletive *it* occupies the intermediate subject position of the clause lexically headed by the adjective *likely*. The expletive *it* intervenes between the head of the chain formed by the moved DP and the foot of the chain, its trace. Locality is not respected, hence the sentence is ungrammatical.

In sentence (1b) we seem to have the same problem as in sentence (1a). The verb *hate* is a two-place predicate. It has an experiencer subject and a theme object. The matrix sentence contains the raising verb *seem* that does not have a thematic subject, therefore the Spec,IP position of the matrix sentence is available as a landing site for the DP to move there for case. As can be seen the object DP of the embedded sentence moves to the subject position of the matrix sentence. This movement is illegitimate as the subject of the embedded sentence the DP *Mary* intervenes between the moved DP and its trace in the VP of the embedded sentence. Locality is not respected. Also, *John* is assigned Case in its base position, it does not have to undergo Case-motivated movement at all.

In sentence (1c) as the derivation shows the moved DP is the thematic experiencer subject of the predicate *clever*. This DP moves to the subject position of the matrix

## Suggested Answers and Hints - Chapter 8

---

sentence. It is obvious that in this sentence the problem is not that the movement of the DP *I* is not local. *I* moves from the Spec,IP position of the embedded sentence to the Spec,IP position of the matrix sentence. Still the sentence is ungrammatical. Notice though that the verb *believe* is an ECM verb that can assign Case to the subject of its infinitival complement, so no movement is necessary.

In sentence (1d) the DP *John* is the thematic object of the passive verb *killed*. Passive verbs cannot assign case. The object DP must move to a case position where it can get case. It moves to Spec,IP of the embedded sentence where it cannot get nominative case because I is non-finite. Notice that the verb *believe* is an ECM verb, that is it can assign case to the item in the Spec,IP position of its complement clause. The problem is that the verb *believe* is in its passive form therefore it cannot assign accusative case. Hence the DP *John* has no case. The Case Filter is violated.

### ▪ Exercise 7

- (1)
- a. John<sub>i</sub> seems t<sub>i</sub> to be clever.
  - b. John<sub>i</sub> tries PRO<sub>i</sub> to be clever.
  - c. John<sub>i</sub> appeared t<sub>i</sub> to be clever.
  - d. John<sub>i</sub> was believed t<sub>i</sub> to be clever.
  - e. John<sub>i</sub> wanted PRO<sub>i</sub> to come.
  - f. John<sub>i</sub> was likely t<sub>i</sub> to come.
  - g. John<sub>i</sub> was too tired PRO<sub>i</sub> to come.
  - h. John<sub>i</sub> was unable PRO<sub>i</sub> to come.
  - i. John<sub>i</sub> was certain t<sub>i</sub> to come.
  - j. John<sub>i</sub> was happy PRO<sub>i</sub> to come.

### ▪ Exercise 8

- a Jack wondered whether [PRO] to trust Jill.  
subject control
- b. The electrician promised the owner of the flat [PRO] to do a good job.  
subject control
- c The teacher told the student [PRO] to register for the course next semester.  
object control
- d It is important [PRO] to keep your word.  
ambiguous between arbitrary and subject control interpretation: it can mean that it is important for the listener to keep their word or the clause can be understood to have a generic interpretation, it is important for people in general to keep their word.
- e I am glad [PRO] to be back home.  
subject control

## Exercise 9

---

- f [PRO] To err is human.  
arbitrary control
- g Mary tried [PRO] to feed the elephants.  
subject control
- h The teacher plans [PRO] to write another study on causatives.  
subject control

▪ **Exercise 9**

- (1) a John was believed to have stolen the book from the library.  
b Jane was assumed to be taken to the cinema by taxi.  
c The students wanted to pass the exam.  
d Which girl do you think John would like to dance with?

*Believe* is a two-place predicate selecting for an experiencer and a theme or propositional argument. Here the *v* head is occupied by the passive morpheme *-en*, which does not require an experiencer argument. So there will be only one argument, which is a clausal argument occupying the specifier position of the VP. The head of the upper *vP* is the base position for the passive auxiliary *be*. This moves to the I head in the S-structure. The verb *believe* adjoins to the passive morpheme in *v*. In the embedded clause, the main verb takes two arguments: a theme DP in the specifier of the VP and an agent DP in the specifier position of the light verb. The main verb *steal* adjoins to the light verb, and this complex head moves on the aspectual morpheme *-en*, being also a bound morpheme. The perfect auxiliary *have* occupies the head of the upper *vP* projection. The PP *from the library* is an adjunct, since the verb *steal* requires only two arguments: an agent and a theme. The DP *the book* can be assigned Case by the light verb in *v* in its base position. The other argument, however, has to move in order to receive Case. The first position where it has a chance to receive Case is the first subject position in the specifier of the lower IP. If the verb in the upper clause is not passive, then the light verb can assign accusative Case to the DP in the specifier of the lower IP, as can be seen in (2).

- (2) Jane believed John to have stolen the book from the library.

In this sentence, however, the *v* head is occupied by the passive morpheme *-en*, which cannot assign Case. So the DP has to move on to the next position where it can get Case. This position is the subject position in the specifier of the higher IP. Here the finite I head assigns nominative Case to the DP.

Suggested Answers and Hints - Chapter 8

---

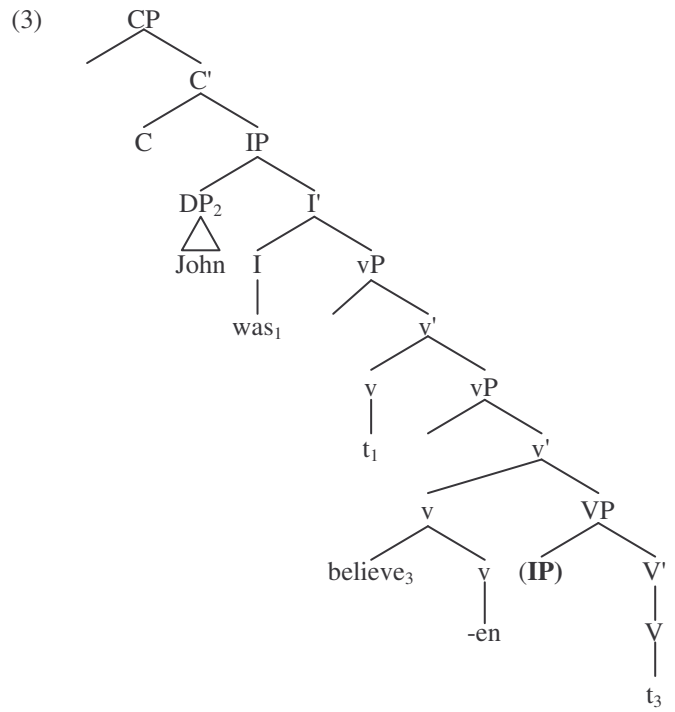



Exercise 9

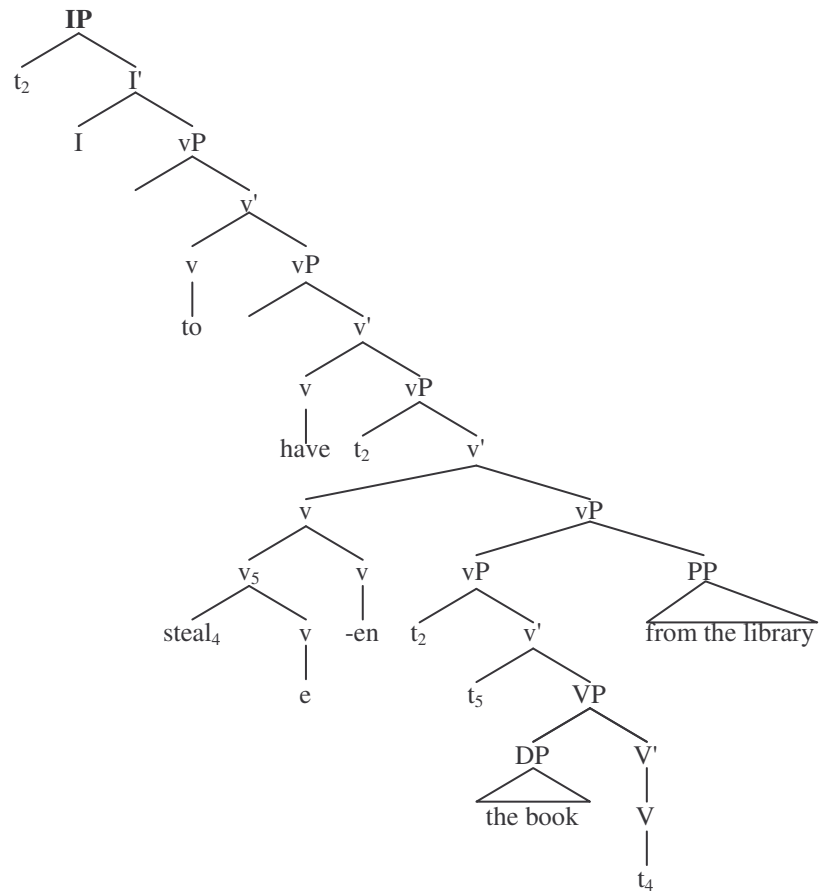

**Suggested Answers and Hints - Chapter 8**

---

The structure of sentence (1b) is quite similar to that in (1a). The main verb *assume*, being a passive verb, takes only one argument, which is a clausal theme argument in the specifier of the VP. The verb *take* in the lower clause is a multiple complement verb, but since it is also passive, it takes only two arguments: a theme DP *Jane*, which occupies the specifier position of the VP in the D-structure, and a goal argument PP, which occupies the complement position of the verb. The main verb adjoins to the passive morpheme in both clauses. The PP *by taxi* is an adjunct, since it is not selected by the verb *take* as a complement. The theme DP *Jane* needs to be assigned Case. The specifier of the vP, its base position, is not a Case position, since the passive morpheme in v is not able to assign accusative Case. The DP moves to the specifier of the IP, which is the first position where the DP has chance for receiving Case. The head of the IP is non-finite, thus it cannot assign nominative Case to the DP in its specifier position. Since the head of the vP dominating the specifier of the IP is a passive morpheme, no accusative Case can be assigned to the DP either. The DP moves on to the next possible Case position, which is the specifier of the next IP. Since the I head is finite, it can assign nominative Case to the DP.

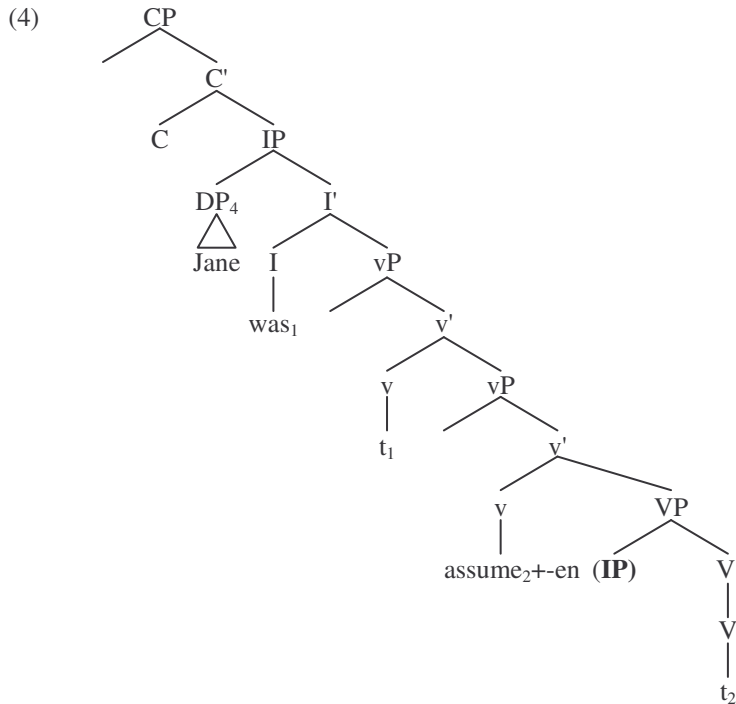

Exercise 9

---

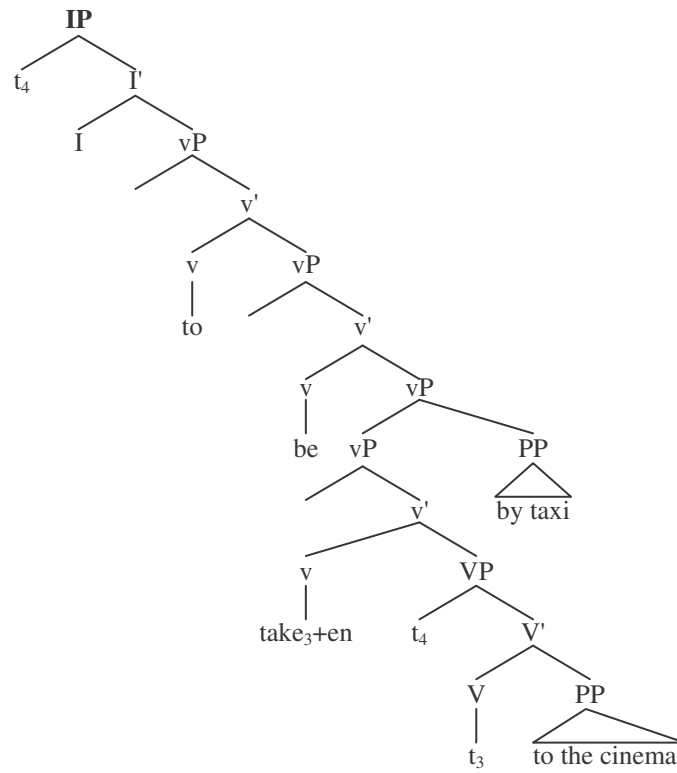

**Suggested Answers and Hints - Chapter 8**

---

In (1c) *want* is a two-place predicate. It takes an agent and a propositional argument. The agent has its base position in the specifier of the vP and it moves to the specifier of the IP in order to get nominative Case from the finite I head. The proposition is a CP, which occupies the specifier of the VP. This is a Case position, the light verb in v can assign accusative Case to this position. Since sentences avoid Case positions, it moves rightwards and adjoins to the VP. The main verb *pass* selects for two arguments: an agent and a theme. The theme DP *the exam* receives Case from the light verb in its base position. The agent DP occupies the specifier of the vP in the D-structure. This DP is coreferential with *the students* but it cannot be the trace of that DP since they both receive a separate thematic role from one of the main verbs. Thus the agent DP in the lower clause is not the trace of *the students* but it is a PRO, taking an independent thematic role.

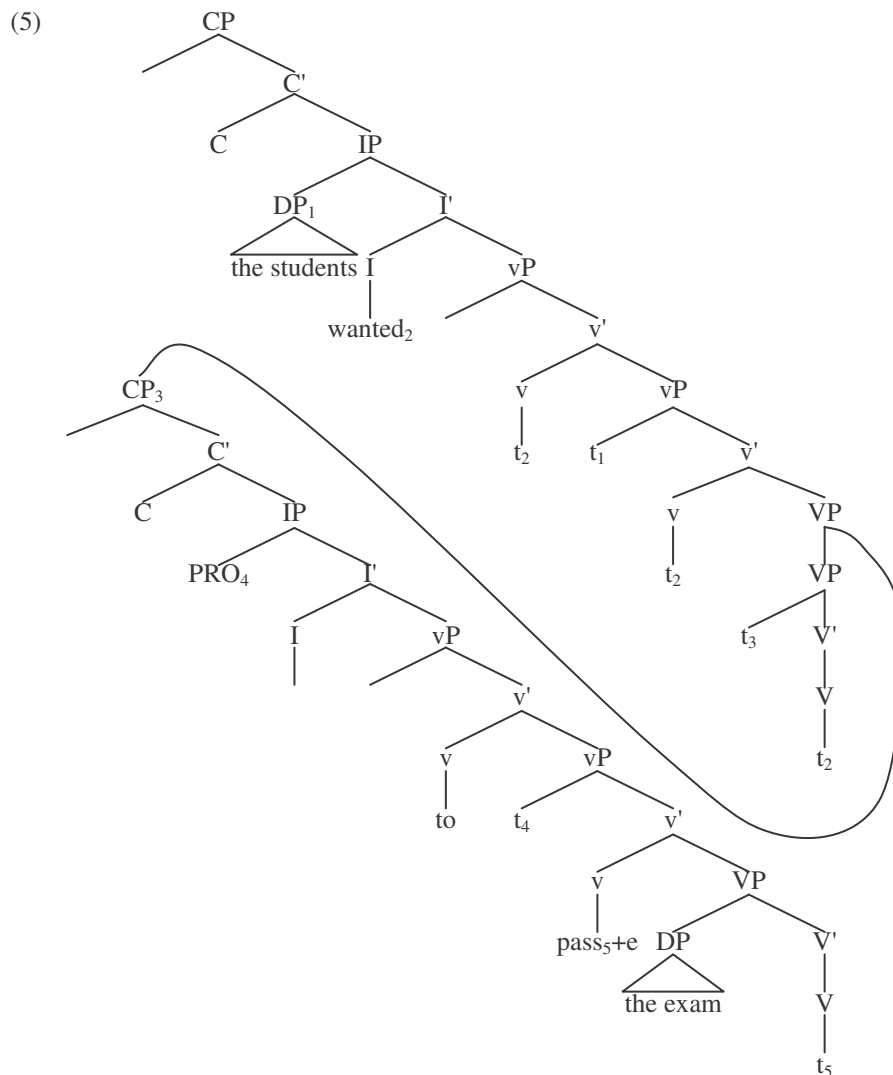

**Exercise 9**

---

In sentence (1d) the main verb *think* takes two arguments: an experiencer, which occupies the specifier of the vP and a theme, which is a CP occupying the specifier of the VP. Since CPs avoid Case positions and the specifier of the VP is a Case position, the CP moves rightwards and adjoins to the VP. In the middle CP, the verb *like* selects for two arguments: an experiencer occupying the specifier of the vP and a theme occupying the specifier of the VP. The CP argument of the verb *like* moves rightwards in order to avoid the Case position. It adjoins to the VP. In the lowest clause, the verb *dance* takes only one argument: an agent in the specifier of the vP. The PP *with which girl* is an adjunct since it is not required by the verb *dance*. The agent argument is a PRO since it is unpronounced but has an independent thematic role. The DP *which girl* is a *wh*-expression which has to move to the specifier of a CP with a [+Wh] feature. So the DP moves first to the specifier of the lowest CP. Since the C head has a [-Wh] feature, it has to move on to the specifier of the next CP. This again has a [-Wh] feature, so the DP cannot stay there. It moves on to the specifier of the upper CP. The head of the upper CP has a [+Wh] feature, so the DP can stay in that position. The [+Wh feature] of the C head attracts the I head as well. Since the thematic verb cannot move above the subject, dummy *do* is inserted into C.

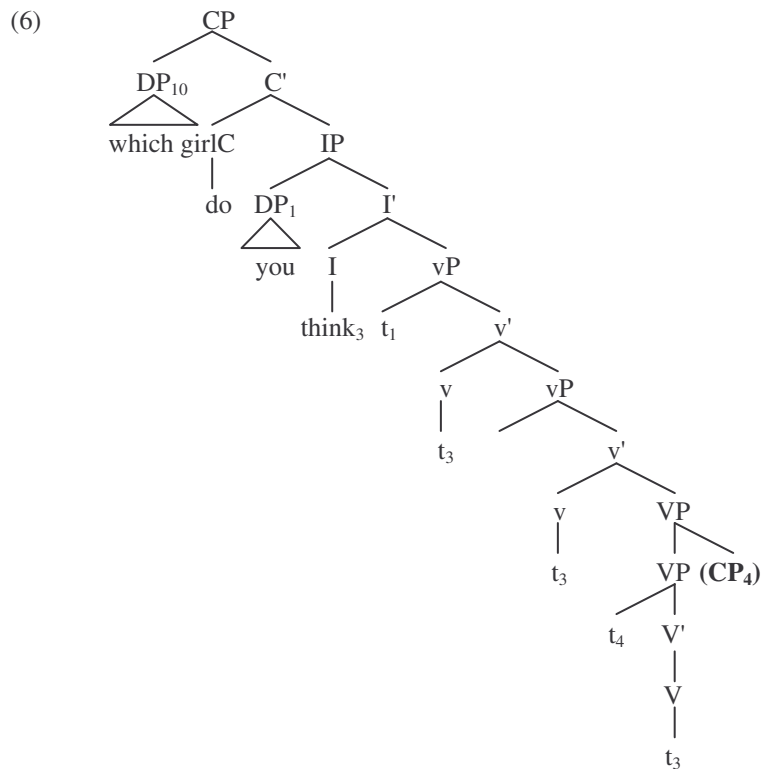

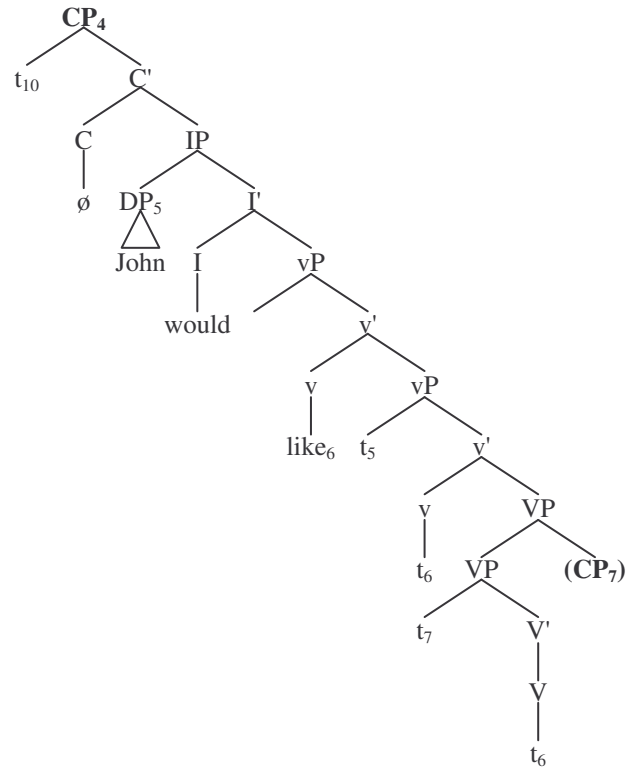

Exercise 9

---

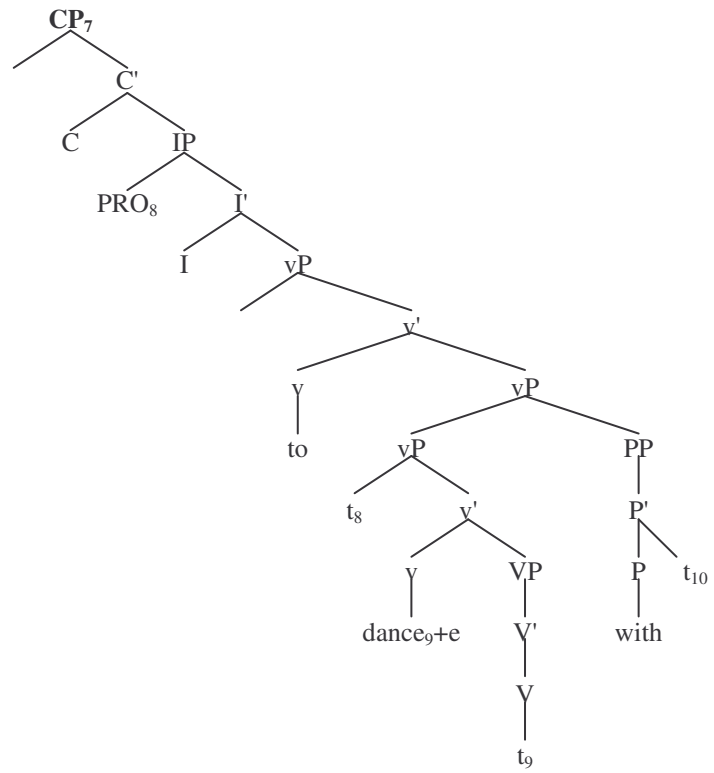





# Glossary

- A-movement:** argument-movement, the syntactically motivated  $\rightarrow$ movement of  $\rightarrow$ arguments from argument positions to argument positions. The  $\rightarrow$ Case-motivated movement of  $\rightarrow$ DPs in  $\rightarrow$ passive and  $\rightarrow$ raising structures is a typical example for this movement type. See also  $\rightarrow$ A'-movement.
- A'-movement:** A-bar movement, non-argument movement, the  $\rightarrow$ movement of  $\rightarrow$ arguments or non-arguments to non-argument positions, e.g.  $\rightarrow$ wh-movement or  $\rightarrow$ focus fronting.
- abstract Case:** being Case-marked is assumed to be a universal property of  $\rightarrow$ overt nominal expressions. Whenever there is no visible marking, we assume there to be invisible Case on the given nominal expression.
- abstract light verb:** the  $\rightarrow$ head position of a  $\rightarrow$ vP can be occupied by a  $\rightarrow$ phonetically empty  $\rightarrow$ light verb.
- accusative Case:** the case of  $\rightarrow$ DPs appearing after verbs,  $\rightarrow$ prepositions and visible subjects of infinitival  $\rightarrow$ clauses. In English it is visible only on certain  $\rightarrow$ pronouns, e.g. *him/her*.
- active voice:** a structure with no  $\rightarrow$ passivisation, where the subject of the  $\rightarrow$ clause does not originate in the  $\rightarrow$ object position but in the  $\rightarrow$ specifier position of the  $\rightarrow$ vP. Compare with  $\rightarrow$ passive voice, see also voice.
- adjacency:** according to traditional analyses  $\rightarrow$ Case assigner and Case assignee must be adjacent, next to each other. This accounts for why the sentence *\*Mary speaks fluently English* is ungrammatical.
- adjective:** a  $\rightarrow$ constituent with the feature composition: [+N, +V, -F] modifying nouns, e.g. *mad* in *mad cow*. These constituents cannot have nominal complements, their semantically nominal complement must appear as a  $\rightarrow$ Prepositional Phrase with the rescue strategy of  $\rightarrow$ of-insertion.
- adjective phrase (AP):** a  $\rightarrow$ phrase headed by an  $\rightarrow$ adjective. In the complement position we can find  $\rightarrow$ PPs and  $\rightarrow$ finite and  $\rightarrow$ non-finite  $\rightarrow$ CPS.  $\rightarrow$ DPs and  $\rightarrow$ exceptional clauses are excluded since adjectives are not  $\rightarrow$ Case assigners. APs are complements of  $\rightarrow$ DegPs.
- adjunct:** a constituent not selected by a  $\rightarrow$ head.
- adjunct rule:** one of the three rules of  $\rightarrow$ X-bar theory, a  $\rightarrow$ recursive rule of the form

$$X^n \rightarrow X^n, Y/YP$$

This rule states that an  $\rightarrow$ adjunct can be  $\rightarrow$ adjoined to the head, the  $\rightarrow$ intermediate projection or the  $\rightarrow$ maximal projection.  $\rightarrow$ Heads can be adjoined to heads,  $\rightarrow$ phrases can be adjoined to the intermediate or maximal projection.

The constituent an adjunct is adjoined to is doubled. The comma in the rule indicates that the order of the two constituents is not fixed.

## Glossary

---

**adjunction:** a type of  $\rightarrow$ movement where a new position is formed as a result of the movement creating an adjunction structure, like the (simplified) movement of the  $\rightarrow$ PP in the following  $\rightarrow$ tree structure representation where the S  $\rightarrow$ node is doubled:

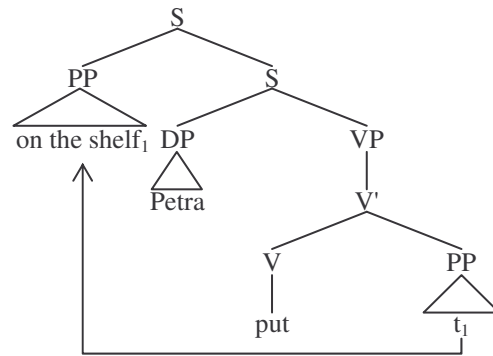

**adverb:** a constituent with the feature composition [+N, +V, -F] used to modify a verb (as in *everything went smoothly*) or a sentence (as in *Unfortunately, I did not pass the first exam*). In this approach adverbs and  $\rightarrow$ adjectives belong to the same category, the difference between them being what they modify.

**affix:** a  $\rightarrow$ bound morpheme added to the beginning or end of a word, a  $\rightarrow$ prefix or a  $\rightarrow$ suffix.

**Affix Lowering:** the downward  $\rightarrow$ movement of the  $\rightarrow$ bound  $\rightarrow$ inflectional morpheme *-s*, *-ed* or the  $\rightarrow$ zero inflectional morpheme onto the verbal head. This is the only movement type where we move a  $\rightarrow$ constituent down. Assuming downward movement to take place is necessary in the traditional framework because it is assumed that  $\rightarrow$ lexical verbs in English cannot leave the  $\rightarrow$ VP and this way we can also account for the order of  $\rightarrow$ sentence medial adverbs relative to the verb: *She often invites her friends*.

**agent:** one of the thematic or  $\rightarrow$ theta-roles, where the  $\rightarrow$ argument deliberately performs an action, as *Jamie* in *Jamie sang a song* or *Robert* in *Robert kicked the cat*. In terms of the  $\rightarrow$ UTAH the agentive theta-role is assigned to the  $\rightarrow$ specifier position of  $\rightarrow$ vP, similarly to  $\rightarrow$ experiencer arguments.

**agglutination:** stems are allowed to support more than one  $\rightarrow$ bound morpheme and hence there are complex words being formed from a series of  $\rightarrow$ inflectional morphemes.

**agreement:** a syntactic process whereby certain  $\rightarrow$ constituents must share certain features, e.g.  $\rightarrow$ subjects must agree with the  $\rightarrow$ inflection on the verb in person and  $\rightarrow$ number.

**aktionsart:** see lexical aspect.

**ambiguity:** a structure is ambiguous if it can be interpreted in more than one way. We differentiate  $\rightarrow$ lexical ambiguity from  $\rightarrow$ structural ambiguity.

**anaphor:** a reflexive (e.g. *himself*) or a reciprocal (e.g. *each other*). A  $\rightarrow$ DP without independent reference needing an  $\rightarrow$ antecedent.

## Glossary

---

- anaphoric operator:** an  $\rightarrow$ operator that behaves like an  $\rightarrow$ anaphor, one that is referentially dependent on another constituent in the sentence, like a  $\rightarrow wh$ -element in  $\rightarrow$ relative clauses.
- antecedent:** a  $\rightarrow$ constituent another constituent without independent reference (such as an  $\rightarrow$ anaphor or a  $\rightarrow$ trace) takes reference from/is  $\rightarrow$ coreferential with. In the sentence '*Mary is enjoying herself*' the antecedent of *herself* is *Mary*. We indicate coreference with  $\rightarrow$ coindexation.
- AP:** see Adjective Phrase
- arbitrariness:** based on the phonological form of a certain word we cannot predict its meaning. The same word can mean different things in different  $\rightarrow$ languages.
- arbitrary reference:** in certain contexts  $\rightarrow$ PRO does not need an  $\rightarrow$ antecedent, it has a generic interpretation similarly to the  $\rightarrow$ pronoun *one*:
- [<sub>CP</sub> PRO to be] or [<sub>CP</sub> PRO not to be], that is the question
- arguments:** the participants minimally involved in an action defined by the  $\rightarrow$ predicate. The complements and the subject, the latter also called an  $\rightarrow$ external argument.
- aspect:** a  $\rightarrow$ semantic property of verbs expressing how a certain event is viewed. See lexical aspect and grammatical aspect.
- aspectual auxiliary verb:** those  $\rightarrow$ dummy auxiliary verbs that participate in forming the  $\rightarrow$ progressive (different forms of *be* as in *They are waiting*.) or the  $\rightarrow$ perfective aspect (different forms of *have* as in *I have read this book*.). They are not generated in the head position of  $\rightarrow$ IPs (as opposed to  $\rightarrow$ modal auxiliaries) but in  $\rightarrow$ vP, and can undergo upward  $\rightarrow$ movement to the head position of IP. Feature composition: [-N, +V]
- aspectual morpheme:** the morphemes *-ing* and *-en* responsible for the  $\rightarrow$ progressive and  $\rightarrow$ perfective aspectual meanings, respectively.
- asterisk:** a) a symbol used to indicate an ungrammatical structure.  
b) in a  $\rightarrow$ rewrite rule it indicates that there can be any number of the  $\rightarrow$ constituent marked with this symbol
- bare infinitive:** an  $\rightarrow$ infinitive without *to*, a  $\rightarrow$ non-finite verb form appearing after auxiliaries, not to be confused with the  $\rightarrow$ base form of the verb which can also be  $\rightarrow$ finite.
- barrier:** certain  $\rightarrow$ nodes in a  $\rightarrow$ tree form barriers to  $\rightarrow$ government, they 'protect' their  $\rightarrow$ constituents from government from the outside. A governor may be able to govern up to a barrier, but not through a barrier.  $\rightarrow$ Case assignment is impossible through a barrier.  $\rightarrow$ CPs are barriers to government.
- base form:** the (at least apparently) uninflected form of the verb. it can be  $\rightarrow$ finite (like in *I like chocolate* where a  $\rightarrow$ zero form of the inflection indicates SG1  $\rightarrow$ agreement) or  $\rightarrow$ non-finite (like in *I may invite Jamie* where a verb form also called the  $\rightarrow$ bare infinitive is used, no inflection whatsoever is present on the verb, the inflectional head position is occupied by the  $\rightarrow$ modal auxiliary *may*).
- base position:** the position where a  $\rightarrow$ constituent first appears in the generative process.

## Glossary

---

- base-generate:** to insert →constituents into a position reflecting the basic →semantic relationships. The →arguments of the verb appear within the →Verb Phrase but they may be forced to leave that position by different principles of →grammar.
- binary features:** abstract representations of a contrasting linguistic unit such as [±Tense]. These units can have one of the two values + or –.
- binder:** a nominal expression that gives reference to another nominal expression without independent reference. In the sentence *Mary knows that she will pass the exam* the constituent *Mary* can be the binder of the →pronoun *she* (mind you, it is not necessarily so, the interpretation of the pronoun can be some other female character determined by the context)
- binding:** an element that can be coreferential with another element (the most typically →pronouns and →anaphors) is bound by that element. This relationship is called binding. In the sentence *Peter and Mary love each other* the constituent *Peter and Mary* binds *each other*.
- binding domain:** the domain within which →anaphors must be, →pronouns cannot be →bound. E.g. in the sentence *Peter knows him* the constituent *Peter* cannot be coreferent with the pronoun *him* since they are in the same domain. In the sentence *Peter knows himself* the anaphor has to be coreferent with *Peter* since it is the only available →antecedent for it in the same domain as required by the →binding principles.
- binding principles:** principles that refer to the interpretation of nominal expressions:
- An →anaphor must have a →binder within the →binding domain
  - A →pronominal cannot have a binder within the binding domain
  - An →R-expression must be free everywhere
- bound morpheme:** a →morpheme that has to attach to another morpheme, it cannot stand on its own, e.g. *-ed, -ment, un-*. See also free morpheme
- bracketed representation:** a representation of grammatical structure by bracketing those →constituents that belong together, an alternative to →tree diagrams.
- branch:** lines connecting the →nodes in →tree-structure representations.
- Burzio's Generalisation:** verbs which assign no →theta-role to their →subjects do not assign →accusative Case to their →objects.
- canonical subject position:** the →specifier position of the →IP. This is the position where subjects are assigned →Case. The canonical subject position, however, is not equivalent with the →base position of the →subject, as was assumed for a long time, see the →VP-Internal Subject Hypothesis.
- Case:** see abstract Case and morphological case.
- Case assigner:** a head that has the ability to assign →Case, like V(erb), →P(reposition) and →finite →I(nflection).
- Case avoidance principle:** →Clauses avoid →Case positions.
- Case Filter:** every →overt →DP must be assigned →abstract Case.
- Case position:** a position where (→nominative or →accusative) →Case can be assigned.
- Case Theory:** one of the →modules of →GB defining Case-assignment to →DPs.

## Glossary

---

- category variable:** in  $\rightarrow$ X-bar theory and the rules of X-bar theory X is a category variable that can be  $\rightarrow$ substituted by any of the  $\rightarrow$ categories. XP can be  $\rightarrow$ NP,  $\rightarrow$ VP,  $\rightarrow$ PP,  $\rightarrow$ DP, etc.
- central determiner:** traditionally these are  $\rightarrow$ determiners following  $\rightarrow$ pre-determiners and preceding  $\rightarrow$ post-determiners. In  $\rightarrow$ GB central determiners occupy the head position of  $\rightarrow$ DP this way defining the  $\rightarrow$ definiteness of the phrase (e.g. *a man/the man*)
- chain:** a moved element and its associated  $\rightarrow$ traces functioning as a single object made up of several parts. See also  $\rightarrow$ head of the chain,  $\rightarrow$ foot of the chain.
- clause:** a structure containing a (visible or invisible) subject and a  $\rightarrow$ predicate.
- cognate object:**  $\rightarrow$ objects that are strongly related to the verb (mostly  $\rightarrow$ intransitive), usually they repeat the meaning of the verb: *smile an evil smile, live a happy life*.
- coindexation:** an indication of  $\rightarrow$ coreference between two  $\rightarrow$ constituents by giving them the same subscript index symbol. In *Peter<sub>i</sub> knows that Mary likes him<sub>i</sub>* the <sub>i</sub> index indicates that in the sentence *him* is to be understood as referring to *Peter*, though in theory it could also be understood as referring to a third party previously mentioned.
- comment:** it forms a full sentence together with a  $\rightarrow$ topic. The comment is the new information in the information structure of the sentence.
- comparative form of adjectives:** this form is used for comparison to a higher (or in the case of *less* lower) degree when two  $\rightarrow$ constituents are compared: *He is taller than I am*. This sentence contains  $\rightarrow$ inflectional comparative, but there is another,  $\rightarrow$ periphrastic way of comparison: *This car is more expensive than that one*.
- complement:** an  $\rightarrow$ argument which follows the  $\rightarrow$ verb, or, more generally, a  $\rightarrow$ phrase selected by a  $\rightarrow$ head.
- complement rule:** one of the three rules of  $\rightarrow$ X-bar theory of the following form:

$$X' \rightarrow X YP$$

which states that the  $\rightarrow$ intermediate category X' can be  $\rightarrow$ rewritten as X (the  $\rightarrow$ head) and YP (the  $\rightarrow$ complement, always a full  $\rightarrow$ phrase of some kind), in this order.

- complementary distribution:** two  $\rightarrow$ constituents are in complementary distribution if one of them never appears in any of the environments where the other appears. If two constituents are in complementary distribution it indicates that they compete for the same structural position. E.g. we cannot have both an  $\rightarrow$ inflectional ending and a  $\rightarrow$ modal auxiliary in the same  $\rightarrow$ clause as these two occupy the head position within an  $\rightarrow$ IP, thus the ungrammaticality of *\*She can dances*.
- complementiser:** a  $\rightarrow$ constituent introducing a sentential complement. The complementisers in English are *that, if, and for*. They occupy the head position of  $\rightarrow$ CP and have selectional restrictions on the  $\rightarrow$ force and  $\rightarrow$ finiteness of the  $\rightarrow$ clause. Feature composition: [+F, -N, -V]
- complementiser phrase (CP):** a phrase headed by one of the three  $\rightarrow$ complementisers *that, if or for* (in structures like *It is important [for Jim to pass this exam]*)

## Glossary

---

where *for* is used not as a  $\rightarrow$ preposition but as a  $\rightarrow$ prepositional complementiser.) The complement of a CP is an  $\rightarrow$ IP, the  $\rightarrow$ specifier position is occupied by moved  $\rightarrow$ *wh*-elements or  $\rightarrow$ *whether*.

**complex transitive verb:** a verb with a nominal and a  $\rightarrow$ prepositional complement, e.g. *put (the newspaper on the desk)*

**compound noun:** two nouns put together to form a single noun, e.g. *homework*.

**constituency test:** a test for deciding whether a certain string of words is a  $\rightarrow$ constituent or not, e.g.  $\rightarrow$ coordination,  $\rightarrow$ preposing,  $\rightarrow$ extraposition,  $\rightarrow$ substitution etc.

**constituent:** a linguistic expression that functions as a unit in grammatical structure. A group of words that undergo syntactic processes together.

**control:** a term related to the interpretation of  $\rightarrow$ PRO. E.g. in the sentence *I promised [PRO to visit her]* the constituent *I* controls PRO, gives reference to it. See also subject control, object control, arbitrary reference.

**coordinating conjunction:** elements connecting  $\rightarrow$ clauses or  $\rightarrow$ phrases on the same level: *and, or* and *but*

**coordination:** one of the  $\rightarrow$ constituency tests where two elements of the same type are put together to form a single element using a  $\rightarrow$ coordinating conjunction. The coordinated element acts like the two coordinated elements would individually.

**coreference:** when two or more  $\rightarrow$ referential phrases pick out the same entity in the world they are said to be coreferential. Coreference is indicated by  $\rightarrow$ coindexation: *Peter<sub>i</sub> thinks that he<sub>i</sub> has every reason to be proud of himself<sub>i</sub>*.

**count noun:** a noun that shows  $\rightarrow$ number distinction, e.g. *one book/two books*.

**covert:** invisible, without  $\rightarrow$ phonological realisation but still having grammatical function

**CP:** see Complementiser Phrase

**dative alternate:** see dative construction.

**dative construction:** an alternative to the verb–indirect object–direct object construction where the indirect object appears in the form of a  $\rightarrow$ PP: *I gave an apple to Peter* as opposed to *I gave Peter an apple*.

**daughter:** an  $\rightarrow$ immediate constituent of a  $\rightarrow$ node which then is the  $\rightarrow$ mother node.

**declarative clause:** a positive or negative statement mainly used to convey information.

**D(eep)-structure:** the structure before  $\rightarrow$ movement takes place, a representation of  $\rightarrow$ thematic relations.

**defining relative clause:** see restrictive relative clause.

**definite determiner:** a  $\rightarrow$ determiner like *the* or *this* that turns a nominal expression into a definite  $\rightarrow$ DP.

**definiteness:** a category expressing whether a nominal expression is identifiable or not. In the sentences *A man was walking in the park with a dog. The man sat on a bench and the dog ran away* first we have indefinite individuals but in the second sentence they can already be identified from the context. Identification can also come from the situation or our knowledge of the world (*the Sun*).

## Glossary

---

- DegP:** the functional projection on top of  $\rightarrow$ APs (similarly to  $\rightarrow$ DPs taking  $\rightarrow$ NP complements) hosting degree modifiers like the superlative and comparative  $\rightarrow$ morpheme.
- degree adverb:** a subclass of  $\rightarrow$ adverbs which specifies the degree to which some property applies, e.g. *very* and *extremely*. Feature composition: [+F, +N, +V]
- derivational morpheme:** it forms a new word from an existing one in the  $\rightarrow$ lexicon with its own lexical properties. The meaning of the new word may differ from the original word. Lexical process
- derived noun:** a noun derived from a word belonging to another  $\rightarrow$ word category. See  $\rightarrow$ deverbal noun.
- determiner:** the  $\rightarrow$ head of a  $\rightarrow$ Determiner Phrase, a closed class item taking an  $\rightarrow$ NP complement defining its  $\rightarrow$ definiteness. Feature composition: [+F, -N, +V]
- determiner phrase (DP):** a phrase headed by a  $\rightarrow$ central determiner or the possessive 's morpheme. The complement of a DP is an  $\rightarrow$ NP, the  $\rightarrow$ specifier the DP the possessive ending attaches to.
- deverbal noun:** a noun  $\rightarrow$ derived from a verb, e.g. *a bite* from the verb *to bite*.
- direct object:** the  $\rightarrow$ DP complement of a verb most often bearing the  $\rightarrow$ theta-role of  $\rightarrow$ patient or  $\rightarrow$ theme.
- distribution:** the set of positions that the  $\rightarrow$ grammar determines to be possible for a given  $\rightarrow$ category. Words that distribute in the same way will belong to the same categories, words that distribute differently will belong to different categories.
- ditransitive verb:** a verb with two nominal complements, e.g. *give*.
- do-insertion:** see *do*-support.
- do-support:** a last resort operation when neither the auxiliary nor the  $\rightarrow$ lexical verb can move. We find it in the following structures:
- (a) the  $\rightarrow$ VP has fronted: [*crash the car*] *he did*
  - (b) the  $\rightarrow$ inflection itself has inverted in a question: *did he – crash the car?*
  - (c) there is a negative between the I and the VP: *he did not use the windscreen wipers*
- double-object construction:** the special construction when the verb *give* selects two  $\rightarrow$ objects, an  $\rightarrow$ indirect object and a  $\rightarrow$ direct object, in this order, like in the sentence *Peter gave Mary a teddy bear*.
- Doubly Filled COMP Filter:** no  $\rightarrow$ CP can have both an  $\rightarrow$ overt  $\rightarrow$ specifier and an overt  $\rightarrow$ complementiser generated in C.
- DP:** see Determiner Phrase.
- DP-movement:** the  $\rightarrow$ movement of  $\rightarrow$ DPs in passive and  $\rightarrow$ raising structures. In both cases the DP is  $\rightarrow$ base-generated in a position where it cannot be assigned  $\rightarrow$ Case. In terms of the  $\rightarrow$ Case Filter it has to move to a position where it can be Case-marked.
- dummy auxiliary:** a certain form of the auxiliary *do*, its main function is to support the  $\rightarrow$ tense morpheme when it cannot appear on the main verb
- echo question:** a question in which a previously uttered sentence is more or less repeated and a part of it that was either not heard or not believed is replaced

## Glossary

---

by a  $\rightarrow wh$ -element. The meaning is quite clear: it is a request for someone to repeat or confirm the previous statement.

A: At the exam, I was asked about Zantedeschia.

B: You were asked about what?

**ECM:** see Exceptional Case-marking.

**E-language:** the language that is external to the speaker – the infinite set of expressions defined by the  $\rightarrow I$ -language – that linguists have access to when formulating their  $\rightarrow$ grammars

**embedded clause:** a  $\rightarrow$ clause that is part of a larger  $\rightarrow$ constituent (*I know [that you like him], the man [that you like].*)

**endocentric structure:** one that gets its properties from an element that it contains, this element can function by itself as a whole  $\rightarrow$ phrase. Such phrases have a head that determines their categorial nature. It is a requirement in  $\rightarrow X$ -bar theory that phrases be endocentric. A noun projects a  $\rightarrow$ noun phrase, a verb a  $\rightarrow$ verb phrase etc.

**ergative language:** a  $\rightarrow$ language where the subject of an  $\rightarrow$ intransitive verb and the  $\rightarrow$ object of a  $\rightarrow$ transitive verb have the same  $\rightarrow$ Case form.

**ergative verb:** a verb that can appear in a  $\rightarrow$ VP either (a) with a single  $\rightarrow$ theme  $\rightarrow$ argument functioning as the subject of the  $\rightarrow$ clause (*The ship sank*), similarly to  $\rightarrow$ unaccusative structures or (b) in the presence of a  $\rightarrow$ light verb together with an  $\rightarrow$ agentive subject (*They sank the ship*), when the structure is similar to the structure of  $\rightarrow$ transitive verbs. As opposed to unaccusative verbs, ergative verbs cannot appear in the  $\rightarrow$ existential *there* construction (unless they are  $\rightarrow$ ambiguous between the two readings), and they are typically verbs expressing a change of state, like *break, explode, grow*.

**event structure:** verbs can express simple or complex events. Event structure describes what sub-events an event expressed by a certain verb is made up of. This has an effect on the syntactic organisation of elements within the  $\rightarrow$ VP. There is supposed to be an isomorphism between event structure and the structure of the VP: a VP breaks up into sub-vPs/VPs in a one-to-one correspondence with the sub-events.

**Exceptional Case-marking (ECM):** in the normal case the  $\rightarrow$ Case assigner and the  $\rightarrow$ constituent which is assigned  $\rightarrow$ Case are in the same  $\rightarrow$ clause. There are structures, however, where it is impossible, e. g. in *I believe him to be disappointed*. The  $\rightarrow$ embedded clause contains non-finite  $\rightarrow$ Inflection, which is not a Case assigner. The only option for the subject  $\rightarrow$ DP to be assigned Case is by an outside  $\rightarrow$ governor, hence the term, ECM. The verb *believe* is a potential Case assigner since it can also take a DP complement to which it assigns  $\rightarrow$ accusative Case: *I believe him*.

**exceptional clause:**  $\rightarrow$ clauses selected by  $\rightarrow$ exceptional verbs such as *believe*. What makes them exceptional is that the clauses introduced by them are not  $\rightarrow$ CPs as clauses in general are, but  $\rightarrow$ IPs. Evidence for this comes from ungrammatical structures like *\*I believe for him to be the best*. It is the insertion of the  $\rightarrow$ prepositional complementiser that makes the sentence ungrammatical indicating that the position to host it (head of CP) is not projected, the clause is not a CP.



## Glossary

---

- exceptional verb:** verbs selecting not a  $\rightarrow$ CP but an  $\rightarrow$ IP complement when their complement is clausal. The most typical representative is *believe*, which is an exceptional verb when it takes an infinitival complement (when its clausal complement is finite, it is a full CP).
- existential *there*-construction:** a structure where *there* is used as an  $\rightarrow$ expletive, introducing a nominal expression as in *There were three girls waiting for me*. In such structures the emphasis is on the existence (or non-existence) of the situation/the participants.
- exocentric structure:** one that contains no element that can have the same function as the whole phrase, it appears to have properties that are independent from the elements it contains. E.g.  $\rightarrow$ small clauses for a long time were assumed to be exocentric structures.
- experiencer:** one of the thematic or  $\rightarrow$ theta-roles where the  $\rightarrow$ argument experiences some physical or mental state, like *Mary* in *Mary was afraid of dogs*. The experiencer theta-role is assigned in the  $\rightarrow$ specifier position of  $\rightarrow$ vP, similarly to the  $\rightarrow$ agent role. If both an agent and an experiencer argument are selected by the verb there are two vPs projected and the experiencer occupies the specifier position of the lower vP.
- expletive subject:** a subject without reference, its presence is merely required by the  $\rightarrow$ EPP. Expletive subjects have no theta-roles but they do receive  $\rightarrow$ Case from finite  $\rightarrow$ Inflection. The expletives in the English language are *there* introducing nominal expressions as in *There lived a cruel dragon in the forest* and *it* introducing  $\rightarrow$ clauses as in *It occurred to me too late that he had not been invited*. Both *there* and *it* have  $\rightarrow$ referential uses too!
- extended projection:** a  $\rightarrow$ Verb Phrase has an extended projection into  $\rightarrow$ IP and  $\rightarrow$ CP in a  $\rightarrow$ clause. Similarly to it a  $\rightarrow$ noun phrase has an extended projection into  $\rightarrow$ DP which may further project into a  $\rightarrow$ PP.
- Extended Projection Principle (EPP):** every  $\rightarrow$ clause must have a (visible or invisible)  $\rightarrow$ subject.
- external argument:** the subject, occupying a position external to the verb, [Spec, IP]
- extraction site:** the position from which elements move.
- extraposition:** a  $\rightarrow$ constituent ( $\rightarrow$ PP,  $\rightarrow$ CP) moved from the phrase where it belongs to a sentence final position: *The rumour t has been circulating [that we will have an oral exam this semester]*.
- [ $\pm$ F]:** one of the three basic  $\rightarrow$ binary features on which all categories can be defined. With the help of these features we can explain why we have the categories that we do and also describe how these categories are related. With the help of the three binary features we can predict what kinds of categories are possible in human language, we can give an exclusive list of them. [ $\pm$ F] is a feature used to distinguish between functional and thematic categories. [-F] categories have thematic content and [+F] categories do not. The categories with [+F] feature are the following:  $\rightarrow$ inflections,  $\rightarrow$ complementisers,  $\rightarrow$ determiners and  $\rightarrow$ degree adverbs. Certain categories are unspecified for the [ $\pm$ F] feature, see underspecification.
- finite clause:** a  $\rightarrow$ clause containing a finite verb.

## Glossary

---

- finite verb form:** a verb form that is inflected for →tense in a visible or invisible form. In English this →inflection is visible only in the past tense or in SG3 in the present tense.
- finiteness:** whether a →constituent (a →clause or a →verb) is understood as →finite or →non-finite.
- focus:** the stressed element in a sentence that carries new information.
- focus fronting:** →focus can be indicated either by stress alone or by →movement in which latter case we speak about focus fronting, as the constituent that bears focus stress moves to the front of the →clause, as in *Peter I wouldn't trust*
- foot of a chain:** the lowest position an element has been moved from containing the →trace of the moved constituent; the →extraction site of the moved element.
- force:** the distinction between a →declarative and an →interrogative interpretation of sentences.
- free morpheme:** a →morpheme that can stand on its own, e.g. *flower, walk*. See also bound morpheme
- functional category:** →categories without lexical content, fulfilling some grammatical function in a given structure: →inflections, →determiners, →degree adverbs and →complementisers.
- gender:** the contrast between masculine and feminine, or (in some →languages) animate and inanimate nominal expressions.
- generative grammar:** a →grammar containing rules with the help of which we can generate all and only the well-formed expressions of a →language (therefore excluding the ungrammatical structures).
- genitive Case:** in traditional terminology the 's ending on a nominal expression (e.g. in *Peter's dog*) is assumed to be the marker of genitive Case.
- gerund:** a →verb form with a noun-like role in the sentence retaining characteristics of both verbs and nouns as in [*The patient's refusing of the medicine*] *worried the doctors*.
- government:** a structural relationship between a head and its complement. Government is a necessary condition for case-assignment.
- Government and Binding Theory (GB):** a version of Noam Chomsky's universal →grammar according to which linguistic expressions, though infinite in number, can be generated with the help of a restricted number of rules. Grammatical expressions are the result of several interacting →modules within this system.
- gradable adjective:** an →adjective that has comparative and superlative forms, e.g. *nice/nicer/nicest*.
- grammar:** (a) a (finite) set of rules which tell us how to recognise the infinite number of expressions that constitute the →language that we speak. (b) a linguistic hypothesis about these rules.
- grammatical aspect:** refers to how the event is viewed as a process: whether it has stopped (→perfect aspect) or is still going on (→progressive aspect).
- head:** a word level or →zero level →category. It projects its properties to the phrase (XP) via the X', so that the category of X is the same as X' and XP. The head defines the properties of the phrase. Heads also impose restrictions on the type of the complement that can follow them.

## Glossary

---

- headless relative:** a  $\rightarrow$ relative clause that does not appear to be a modifier inside a nominal phrase as it appears without a noun, however it can be argued to function as such, like in *I spoke to [whoever I met]*.
- Head Movement Constraint (HMC):** a head must move to the next head position.
- head of a chain:** the position an element moves to, its final  $\rightarrow$ landing site.
- heavy DP-shift:** when the  $\rightarrow$ DP is particularly long and complicated, it may undergo  $\rightarrow$ extraposition: *You can post today [all the letters you have written in the past five days]./\*You can post today them.*
- HMC:** see Head Movement Constraint.
- idiosyncratic:** not predictable. The idiosyncratic properties of e.g. words are those that are specific to that word, such as its phonological form, meaning and  $\rightarrow$ subcategorisation frame. These properties cannot be described with the help of rules, so they must be encoded in the  $\rightarrow$ lexicon.
- I-language:** the  $\rightarrow$ language which is internal to the mind; a finite system that linguists try to model with  $\rightarrow$ grammars.
- immediate constituent:** the immediate constituent of a  $\rightarrow$ node is the node that is lower than the given  $\rightarrow$ constituent and is connected to it by a single  $\rightarrow$ branch. It is the constituent directly below the node it is the immediate constituent of.
- imperative:** a structure used to express a request or command. An imperative sentence usually has no visible subject: *Eat your breakfast, please.*
- implicit argument:** an  $\rightarrow$ argument that is not present in the syntactic structure but understood. In the sentence *I am eating* the  $\rightarrow$ transitive verb *eating* has no visible  $\rightarrow$ object, still, the sentence means that something is eaten.
- indefinite determiner:** a  $\rightarrow$ determiner like *a* or *some* turning a nominal expression into an indefinite  $\rightarrow$ DP.
- indirect object:** one of the  $\rightarrow$ objects of e.g. the verb *give* in the  $\rightarrow$ double object construction assigned the theta-role of beneficiary.
- infinitive:** a  $\rightarrow$ non-finite, uninflected verb form either with or without *to*.
- inflection:** (a) a  $\rightarrow$ morpheme added to the end of words of a given  $\rightarrow$ category in sentence structure as required by the given structure, e.g. *-s* in *Peter like-s his dog* or *-er* in *Peter is clever-er than Tony*.  
(b) the head of an  $\rightarrow$ Inflectional Phrase. It can be realised as a modal auxiliary or a zero agreement morpheme. Information about tense can be found in a separate vP directly under IP.
- inflectional comparison:** the comparative and superlative forms of the  $\rightarrow$ adjective are expressed with the help of the  $\rightarrow$ inflectional endings *-er* and *-est*. E.g. *hungrier/hungriest*. See also periphrastic comparison.
- inflectional morpheme:** it does not change the  $\rightarrow$ category of the lexical element to which it is added, it provides another form of the word, e.g. the past inflectional morpheme *-ed*. The meaning of the original word does not change. Syntactic process.
- inflectional phrase (IP):** in traditional grammars the IP is a phrase headed by an  $\rightarrow$ inflectional element which can be a  $\rightarrow$ modal auxiliary (e.g. *may, should, will*), infinitival *to* or the  $\rightarrow$ bound morphemes expressing  $\rightarrow$ tense (*-ed, -s*) the latter undergoing  $\rightarrow$ Affix Lowering to form a unit with the verb. In the

## Glossary

---

present approach, however, it has been argued that the head position of the IP contains only the modal auxiliaries and the (in English) invisible agreement morpheme, information about Tense can be found in an independent vP hosting infinitival *to*, and the bound morphemes *-ed* and *-s* also appear here. The →specifier position of an IP is occupied by the subject (see →canonical subject position), the complement of an I is usually a →VP or →vP (but see →small clauses for an exception). IPs are complements of →CPs or →ECM verbs.

**intermediate projection:** the X-bar level projection connecting the →zero-level (or word-level) projection X and the →maximal (or phrase-level) projection XP.

**interrogative clause:** a structure mainly used to ask for information, either in the form of a →yes–no question or a →*wh*-question.

**intransitive verb:** a verb without a nominal complement (the →object), e.g. *ski*. Its subject is either an →agent or an →experiencer, i.e. one of the →theta-roles assigned to the →specifier of a →vP. Occasionally intransitive verbs appear with a →cognate object.

**IP:** see Inflectional Phrase.

**irregular:** cannot be described with the help of a rule, exceptional.

**isomorphism:** a one-to-one correspondence between the members of two sets.

**I-to-C movement:** the generative equivalent of the descriptive notion of →subject–auxiliary inversion attested in questions like ‘*Can you swim?*’, where the auxiliary is assumed to move from the head position of →IP to the head position of →CP.

**landing site:** the position elements move to.

**language:** a system that enables people who speak it to produce and understand linguistic expressions.

**lexical ambiguity:** the source of →ambiguity is a lexical constituent which is associated with more than one meaning in the →lexicon, e.g. *bank*, *hot*.

**lexical aspect or aktionsart:** →aspect internal to the meaning of the verb, e.g. some verbs describe events with an endpoint (*eat*), as opposed to others without a natural endpoint (*sit*).

**lexical entry:** a collection of the →idiosyncratic properties of lexical items.

**lexical verb:** a verb with lexical content as opposed to one having grammatical function in the structure.

**lexicon:** a mental dictionary where we store information about all the words we use focusing on the →idiosyncratic properties such as pronunciation, meaning, etc.

**light verb:** a verb occupying the →head of a →vP used in combination with another element, typically a noun or verb, where the light verb’s contribution to the meaning of the whole construction is less than that of a fully thematic main verb, e.g. *to take a shower=to shower*. Certain verbs expressing →aspectual (*be*, *have*) or →modal (*let*) meaning also belong here. According to the proposals in the present book the following constituents can appear within the vP in a visible or abstract form (see also vP-shells):

## Glossary

---

- agentive arguments in the specifier positions
- experiencer arguments in the specifier position
- goal arguments in the double-object construction as specifiers
- the passive *-en* morpheme in the head of vP
- the aspectual morphemes *-en* and *-ing* in the head of vP
- the tense morpheme in the head of vP

**linguistics:** the scientific study of →language.

**Locality Restrictions on Movement:** a →head cannot move over the top of another head, a →subject cannot move over the top of another subject – a →constituent cannot move over the top of a like constituent. See also Relativized Minimality.

**Locality Restriction on Theta-role Assignment:** a →predicate assigns its → $\Theta$ -roles to either its →complement or its →specifier.

**locative inversion:** a structure where a →PP locative →argument apparently sits in →subject position while the →DP →theme sits behind the verb, as in *In the corner sat a shadowy figure*.

**main clause:** a →clause that is not →embedded in another clause. In the sentence *I know that you are clever* the main clause is *I know* selecting an embedded →CP.

**mass noun:** a noun that does not show →number distinction, e.g. *tea/a cup of tea*. See also partitive construction.

**matrix clause:** very often used as a synonym for →main clause. However, in the case of multiple →embeddings there is a difference between the two. In the sentence *I know that she thinks she is hopeless* the main clause is *I know*, which also functions as the matrix clause for the first embedding *that she thinks she is hopeless*. The matrix clause for *she is hopeless* is the →clause selecting it *that she thinks*, but it is not a main clause.

**maximal projection:** the phrase-level projection, XP, where X is a →categorical variable.

**measure noun:** a non-thematic, non-functional noun indicating quantity, e.g. *loaf in a loaf of bread*.

**missing subject:** in terms of the →EPP every →clause must have a subject, so clauses cannot have a missing subject. In certain structures it seems to be the case, however, it can be argued that these clauses only have a missing visible subject, there is an abstract element occupying the →subject position in these clauses as well, either in the form of a →trace or →PRO.

**modal auxiliary verb:** an auxiliary verb expressing modal meanings like necessity, possibility, permission, e.g. *may, should, can, will*, etc.. They are always →finite so they occupy the head position of →IP and take →vP or →VP complements.

**module:** →GB is made up of different but interacting components called modules, e.g. →Theta Theory, →X-bar Theory, →Case Theory. The interaction of these modules generates the grammatical structures of →language.

**morpheme:** the smallest meaningful unit. Words can be made up of one or more morphemes. See also bound morpheme, free morpheme.

## Glossary

---

- morphological case:** there is a morphologically visible indication of →Case on the nominal expression (→DP). In English case is not visible on lexical DPs, only in the →pronoun system with several examples of case syncretism (*he/him, she/her, but it, you*)
- morphology:** the study of words and how words are structured.
- mother:** a →node directly above another node.
- Move  $\alpha$ :** move anything anywhere. Further restrictions on →movement come from factors independent from the formulation of the movement rule.
- movement:** →S-structure →constituents do not always appear in the position where they are →base-generated in →D-structure, they often move from their →base positions to other structural positions. There can be various reasons motivating movement, see *wh*-movement and DP-movement.
- multiple light verb:** the internal structure of the →VP and the →structure of the event expressed by the verb are →isomorphic. If the event structure of the →predicate is complex we have multiple light verbs in the structure. Light verbs can also express →tense and →aspect
- multiple *wh*-question:** a single question that asks for more than one piece of information hence contains more than one →*wh*-element, e.g. *Who did you say said what?*
- [±N]:** one of the three basic →binary features on which all →categories can be defined. With the help of these features we can explain why we have the categories that we do and also describe how these categories are related. With the help of the three binary features we can predict what kinds of categories are possible in human →language, we can give an exclusive list of them. Since we want to define verbs and nouns as polar opposites the abstract binary features [±N] and [±V] were introduced, though obviously they do not mean noun and verb and are used to define other categories besides nouns and verbs. A property linked to the [-N] feature is the ability to have a nominal complement. The categories with [+N] feature are the following: a. →thematic: nouns, →adjectives; b. →functional: →determiners, →degree adverbs; unspecified for the [F] value: post-determiners, measure nouns.
- negative fronting:** a →movement type where a negative element is placed at the beginning of the →clause as in *Never have I met such a talented musician!*
- node:** a symbol defining syntactic units (→heads, →intermediate constituents, →phrases) connected by →branches in a →tree structure representation.
- nominative Case:** the →Case assigned to →DPs in the →subject position of →finite clauses. The →Case assigner is the finite →Inflectional head.
- non-defining relative clause:** see non-restrictive relative clause.
- non-finite clause:** a →clause in which no →finite verb is present.
- non-finite verb form:** a verb form without independent →tense interpretation. In the sentences *I want to walk* and *I wanted to walk* the →embedded clause *to walk* is non-finite, its tense interpretation depends on the →matrix clauses.
- non-referential:** without reference. In the sentence *There are 24 students in the group* the expletive *there* is non-referential as opposed to *there* in *She was standing there*.

## Glossary

---

- non-restrictive relative clause:** this  $\rightarrow$ clause-type is used to add extra information rather than to restrict the application of the noun. They only have the  $\rightarrow wh$ -relative form (as opposed to  $\rightarrow$ restrictive relatives): *Yesterday I met your father, who is a very intelligent man.*
- noun:** a word that names people, places or things that can have a plural form. Feature composition: [+N, -V, -F]
- noun phrase (NP):** a phrase headed by a noun. Noun heads can take  $\rightarrow$ PP or  $\rightarrow$ CP complements,  $\rightarrow$ DP complements are excluded since nouns are not  $\rightarrow$ Case assigners. The  $\rightarrow$ specifier position of an NP is occupied by what are generally called  $\rightarrow$ post-determiners. NPs are complements of DPs.
- NP:** see Noun Phrase.
- NP-movement:** see DP-movement.
- Null Case:** the  $\rightarrow$ Case assigned to  $\rightarrow$ PRO in the  $\rightarrow$ subject position of  $\rightarrow$ non-finite clauses.
- number:** a contrast between singular and plural as in *a shirt/several shirts*. The English regular plural marker is -s.
- object:** a  $\rightarrow$ DP complement immediately following the verb. It can move to the  $\rightarrow$ subject position in  $\rightarrow$ passive sentences. See also direct object, indirect object.
- object control:**  $\rightarrow$ PRO can be coreferent either with the subject or the object of the preceding  $\rightarrow$ clause depending on the main verb. The verb *tell* is an object-control verb, in the sentence *I told him [PRO to go]* PRO is coreferent with the object.
- object position:** the  $\rightarrow$ specifier position of  $\rightarrow$ VP.
- of-insertion:** a rescue strategy to avoid a  $\rightarrow$ Case Filter violation.  $\rightarrow$ APs and  $\rightarrow$ NPs are unable to assign  $\rightarrow$ Case to their complements, so their  $\rightarrow$ semantic  $\rightarrow$ DP  $\rightarrow$ argument is realised as a  $\rightarrow$ PP and the  $\rightarrow$ preposition *of* is inserted: *to be envious of Mary* (compare with *to envy Mary*)
- one-place predicate:** a predicate with one  $\rightarrow$ argument, e.g. *walk*.
- operator:**  $\rightarrow$ constituents affecting the interpretation of the sentence indicating a process that is needed to work out the meaning of the sentence that contains them;  $\rightarrow$ quantifiers and  $\rightarrow wh$ -elements.
- overt:** visible, having  $\rightarrow$ phonological realisation
- participle:** a  $\rightarrow$ non-finite verb form, can be past or present: *Singing* (present participle) *always out of tune, I got on the nerves of my music teacher. I have never met most of the people invited* (past participle) *to the wedding.*
- partitive Case:**  $\rightarrow$ Case that can be born only by indefinites, available in the post-verbal position in  $\rightarrow there$ -constructions.
- partitive construction:** if we want to count  $\rightarrow$ mass nouns we can do so by inserting an appropriate term expressing some unit of the given mass noun which will result in a partitive construction: *two bars of chocolate, a glass of milk.*
- passive structure:** a verb with the *-en* ending often (but not always) preceded by an inflected form of *be*. Passive verbs do not have a  $\rightarrow vP$ -projection similar to *vPs* in active structures. The *vP* in passives is headed by the passive *-en* morpheme which does not assign theta role to the subject and for this reason it is unable to case-mark its nominal complement (see Burzio's

## Glossary

---

Generalisation), so the  $\rightarrow$ DP has to move from its  $\rightarrow$ base-position to a  $\rightarrow$ Case-position.

**passive voice:** the subject of the passive sentence is interpreted as the  $\rightarrow$ object of the verb.

**patient:** one of the  $\rightarrow$ thematic or theta-roles where the  $\rightarrow$ argument is affected by the action described by the verb, e.g. in *Peter stroked the cat* the cat is directly affected by this activity.

**perfect aspect:** an action is viewed as being completed, e.g. in *I have written my homework*.

**periphrastic comparison of adjectives:** the comparative and superlative forms of the  $\rightarrow$ adjective are expressed with the  $\rightarrow$ degree adverbs *more* and *most*. E.g. *more indignant/most indignant*

**phonologically empty:** not having phonological, visible realisation, but still present, syntactically active in an abstract, unpronounced form, e.g.  $\rightarrow$ PRO is a phonologically empty category, similarly to  $\rightarrow$ traces.

**phonology:** the study of the sound patterns of  $\rightarrow$ language.

**phrasal category:** a category of phrases as opposed to words.

**phrasal verb:** see verb–particle construction.

**phrase:** a group of words that can undergo syntactic operations (e.g.  $\rightarrow$ movement) as a unit.

**pied-piping:** one of the strategies of  $\rightarrow$ wh-movement when the  $\rightarrow$ wh-element is part of a  $\rightarrow$ PP. The wh-element does not move alone, it takes the  $\rightarrow$ preposition along with it: [*With who*]<sub>i</sub> *did you go to the cinema t<sub>i</sub> yesterday?* See also preposition stranding.

**pleonastic subject:** see expletive subject.

**plural noun:** a noun denoting more than one entity, e.g. *three teddy bears*.  $\rightarrow$ Count nouns can be used either in the singular or the plural form.

**positive form of adjectives:** the  $\rightarrow$ base form of the  $\rightarrow$ adjective appearing in structures expressing comparison to the same degree, like in *He is as tall as I am*.

**post-determiner:** traditionally it is a  $\rightarrow$ determiner following a  $\rightarrow$ central determiner but within the framework of  $\rightarrow$ Government and Binding Theory it can be claimed that it is actually an  $\rightarrow$ AP that acts to quantify over a noun, and occupies the  $\rightarrow$ specifier position of  $\rightarrow$ NPs, e.g. *many, few*.

**PP:** see Preposition Phrase.

**pragmatics:** a branch of linguistics concerned with the meaning of sentences as they are uttered in a given context. E.g. the sentence *It's very hot in here* can be understood as a request to open a window.

**pre-determiner:** traditionally pre-determiners are those  $\rightarrow$ determiners that appear in front of  $\rightarrow$ central determiners within a nominal expression. These are three in number: *all, both* and *half*. In the present approach, however, they are analysed similarly to central determiners, they also occupy the head position of  $\rightarrow$ DP to account for why they can also be followed by a  $\rightarrow$ PP beginning with *of* as in *all the girls/all of the girls*.



## Glossary

---

- predicate:** the part of the  $\rightarrow$ clause excluding the subject giving information about the subject: *Mary [is clever/likes chocolate/is waiting for Jamie/was in bed/is a university student]*.
- prefix:** a  $\rightarrow$ bound morpheme added to the beginning of a word, e.g. *un-* in *unimportant*.
- preposing:** the  $\rightarrow$ movement of  $\rightarrow$ PPs,  $\rightarrow$ VPs, negative expressions to the beginning of the sentence: *Under no circumstances would I read another novel by him*.
- preposition:** a syntactic unit preceding its complement, the most often a  $\rightarrow$ DP defining a special syntactic and/or  $\rightarrow$ semantic relationship between the complement and another  $\rightarrow$ constituent: *cat in the bag/grapes of wrath/tea without sugar/a reduction of taxes*. Feature composition: [-F, -N, -V].
- preposition phrase (PP):** a  $\rightarrow$ phrase headed by a  $\rightarrow$ preposition. It usually takes a  $\rightarrow$ DP complement but certain types of CPs can also appear in the complement position of PPs. PPs themselves can be complements of different  $\rightarrow$ constituents such as  $\rightarrow$ verbs,  $\rightarrow$ nouns and  $\rightarrow$ adjectives.
- prepositional complementiser:** the  $\rightarrow$ complementiser *for*, introducing non-finite  $\rightarrow$ declarative clauses. Due to its  $\rightarrow$ prepositional origin it can assign  $\rightarrow$ accusative Case to visible subjects of infinitival  $\rightarrow$ clauses, e.g. in *It is important for Jane/her to win the game*. It is very easy to make a difference between *for* used as a preposition and *for* used as a complementiser: when *for* is followed only by a  $\rightarrow$ DP it is a preposition (*I bought a bar of chocolate for my kids on Saturday*.), when it is followed by a DP and a *to*-infinitive it is a prepositional complementiser introducing an  $\rightarrow$ IP. The DP appears in the  $\rightarrow$ specifier position of this IP as subjects in general do (*It is advisable for you to prepare well for the syntax exam*.).
- prepositional object:** the complement  $\rightarrow$ DP of a  $\rightarrow$ preposition.
- prepositional verb:** a verb with a  $\rightarrow$ prepositional complement, e.g. *look at sg*
- preposition stranding:** one of the strategies of  $\rightarrow$ wh-movement when the  $\rightarrow$ wh-element is part of a  $\rightarrow$ PP. The *wh*-element moves alone and leaves the  $\rightarrow$ preposition behind: *Who<sub>i</sub> did you laugh at t<sub>i</sub>?* See also pied-piping. Preposition stranding can also be found in passive structures when a verb taking a PP complement is passivised, in this case preposition stranding is obligatory: *The new student was talked about*.
- PRO:** the  $\rightarrow$ phonologically empty  $\rightarrow$ DP appearing in the  $\rightarrow$ subject position of  $\rightarrow$ non-finite clauses. It bears  $\rightarrow$ Null Case and takes the  $\rightarrow$ theta-role assigned by the non-finite verb to its subject.
- productive morpheme:** a  $\rightarrow$ morpheme that can be attached regularly to any appropriate stem. The formation of the past  $\rightarrow$ tense with the *-ed* ending is a productive process, a new verb that enters the English language will be formed with this morpheme, thus, the *-ed* ending to express past tense is a productive morpheme.
- progressive aspect:** the event is viewed as being in progress, e.g. *I was having a bath when my sister arrived*. Having a bath was an activity in progress when the other past activity happened.
- Projection Principle:** lexical information is syntactically represented.

## Glossary

---

- pronominal:** those  $\rightarrow$ DPs that cannot have a  $\rightarrow$ binder within the  $\rightarrow$ binding domain. See also anaphor.
- pronoun:** a  $\rightarrow$ DP that usually refers to another DP, but contains only the grammatical features ( $\rightarrow$ number, person,  $\rightarrow$ gender) of it (*I, you, he, she*, etc.). Its interpretation depends on linguistic factors or the situation. Within the DP pronouns occupy the D head position, as they cannot be modified by  $\rightarrow$ determiners even on very special readings (as opposed to grammaticality of *the John I met yesterday*)
- proper noun:** a name, e.g. *John, Wendy Smith, the Beatles*. Within the  $\rightarrow$ DP it appears as an  $\rightarrow$ NP (as opposed to  $\rightarrow$ pronouns)
- quantificational operator:** an  $\rightarrow$ operator that is interpreted like quantificational  $\rightarrow$ pronouns like *every, all, some*, e.g.  $\rightarrow$ *wh*-elements in questions. See also anaphoric operator.
- quantifier:** a  $\rightarrow$ determiner that expresses a  $\rightarrow$ definite or  $\rightarrow$ indefinite amount or number of the nominal expression it modifies, e.g. *all, both, some, many, four*.
- quasi-argument:** the subject of weather-verbs (*it* in *It's raining*) and potentially *there* in  $\rightarrow$ existential *there*-constructions.
- raising:** a process whereby the subject of an  $\rightarrow$ embedded infinitival clause moves to the  $\rightarrow$ subject position of the verb selecting the  $\rightarrow$ clause. In such structures the selecting verb is a one- $\rightarrow$ argument verb selecting a clause (like *seem*). If the clause is  $\rightarrow$ non-finite, the subject of the  $\rightarrow$ embedded clause is not assigned  $\rightarrow$ Case within the clause, but since the  $\rightarrow$ subject position of the selecting verb is empty it can move there to be case-marked.
- raising adjective:** an  $\rightarrow$ adjective inducing  $\rightarrow$ raising, e.g. *likely* in *Peter is likely to win*.
- raising verb:** a verb inducing  $\rightarrow$ raising, e.g. *seem, appear*.
- recoverable:** a constituent is recoverable if it can be identified even if it has undergone deletion. Recoverability is a condition on syntactic processes.
- recursive rule:** a rule where the definition refers to what is being defined, e.g. the  $\rightarrow$ adjunct rule. The same symbol appears on the left and on the right of the  $\rightarrow$ rewrite rule, so the rule can be applied indefinitely. The application of such a rule is optional for this reason.
- referential:** something that refers to something. Lexical  $\rightarrow$ DPs are referential, e.g.  $\rightarrow$ anaphors are not, they gain reference by  $\rightarrow$ coindexation with a referential element.
- reflexive pronoun:** a  $\rightarrow$ DP without independent reference, e.g. *himself*. Reflexives always need an  $\rightarrow$ antecedent.
- regular:** can be described with the help of a rule, e.g. the regular plural form of nominal expressions is formed by adding the plural morpheme *-s*.
- relative clause:** relative clauses are  $\rightarrow$ adjoined to  $\rightarrow$ NPs, they give information about the nominal expression. See restrictive and non-restrictive relative clause.
- Relativized Minimality:** a rule expressing the locality conditions on movement, see also  $\rightarrow$ Locality Restrictions on Movement.



## Glossary

---

- restrictive relative clause:** a  $\rightarrow$ clause which modifies a noun by restricting its application to one of a number of possibilities. Restrictive relatives come in three forms:  $\rightarrow$ *that*-relative,  $\rightarrow$ *wh*-relative and  $\rightarrow$ zero relative.
- rewrite rule:** a phrase structure rule defining what the  $\rightarrow$ immediate constituents of e.g. a phrase are. On the left of the rule we find the phrase-type being defined followed by an arrow. On the right side of the arrow we can find the immediate constituents of the given phrase, which may be further rewritten. Bracketed  $\rightarrow$ constituents indicate optionality, the presence of a comma means that the order of the constituents is not restricted to the order found in the rule. See also adjunct rule, specifier rule, complement rule.
- R-expression:**  $\rightarrow$ referential expression, a nominal with independent reference, e.g. *Peter* as opposed to *he* or *himself*.
- semantics:** the study of meaning. It covers both lexical meaning and the meaning of sentences with special emphasis on their truth conditions (under what circumstances a sentence is true/false).
- sentence medial adverb:** an  $\rightarrow$ adverb modifying the meaning of a verb appearing in a position  $\rightarrow$ adjoined to the  $\rightarrow$ VP. In traditional approaches it is used as a diagnostic test to decide whether a  $\rightarrow$ constituent moved upwards or downwards. If the sentence medial adverb precedes the inflected verb the  $\rightarrow$ inflectional head lowered onto the verbal head, e.g. in *She*  $t_i$  *always enjoy-ed<sub>i</sub> going to parties*. If the sentence contains an inflected  $\rightarrow$ aspectual auxiliary this constituent precedes the sentence medial adverb indicating that the verbal head moved up to the inflectional head position: *She is (be<sub>i</sub> +s) always*  $t_i$  *singing./She has (have<sub>i</sub>+s) always*  $t_i$  *enjoyed going to parties*.
- sentential adverb:** an  $\rightarrow$ adverb which modifies the meaning of the sentence, e.g. *fortunately*.
- singular noun:** a noun denoting one entity, e.g. *a teddy bear*.  $\rightarrow$ Count nouns can be singular or  $\rightarrow$ plural.
- sister nodes:** two  $\rightarrow$ nodes that have the same  $\rightarrow$ mother.
- small clause:** a  $\rightarrow$ clause where a subject $\rightarrow$ predicate relationship is established but no  $\rightarrow$ inflectional element is present. The predicate can be expressed by an  $\rightarrow$ AP (*I consider [her reliable]*), a  $\rightarrow$ DP (*I consider [her the best student]*), or a  $\rightarrow$ PP (*I want [these news in press]*). Small clauses are often called verbless  $\rightarrow$ clauses but it is misleading since small clauses can contain  $\rightarrow$ VPs in certain cases like in *I saw [him run away]*. Such clauses are analysed as IPs where the zero agreement morpheme can be found as in several languages we find agreement markers on the subject and the predicate in these structures.
- specificity:** a nominal expression is specific if the speaker knows the identity of its reference. The sentence *I am looking for a pen* is  $\rightarrow$ ambiguous between a specific and a non-specific interpretation: the pen may be a certain pen the speaker has in mind or any pen may do.
- specifier position:** a position defined by  $\rightarrow$ X-bar Theory. The specifier is  $\rightarrow$ sister to X',  $\rightarrow$ daughter of XP. It is a phrasal position, the nature of the phrase depends on what it is the specifier of. E.g. the specifier of  $\rightarrow$ IP is the subject, the specifier of  $\rightarrow$ DP is the possessor in possessive structures.

## Glossary

---

**specifier rule:** one of the three rules of  $\rightarrow$ X-bar Theory of the following form:

$$XP \rightarrow YP X'$$

where the  $\rightarrow$ specifier is the phrase-sized  $\rightarrow$ constituent preceding the  $\rightarrow$ intermediate projection. The order of YP and X' is fixed.

**structural ambiguity:** the source of  $\rightarrow$ ambiguity is not  $\rightarrow$ lexical. The different interpretations can be explained by assigning different structural representations to the ambiguous expression, e.g. in the  $\rightarrow$ DP *an analysis of sentences with mistakes* the  $\rightarrow$ PP *with mistakes* can be interpreted either as referring to the *analysis* or *sentences*. The structural difference between the representations will be the placement of the  $\rightarrow$ adjunct PP: in the former meaning the PP is the adjunct of the  $\rightarrow$ DP *analysis*, in the latter case it is the adjunct of the DP *sentences*.

**Structure Preservation Principle:** no  $\rightarrow$ movement can alter the basic X-bar nature of structure, structures are projected from the  $\rightarrow$ lexicon at all levels.

**subcategorisation frame:** that part of the  $\rightarrow$ lexical entry that states the categorial status of the complement.

**subcategory:** a  $\rightarrow$ category under a main category, e.g. the category of  $\rightarrow$ intransitive verbs is a subcategory of the verbal category.

**subject:** the  $\rightarrow$ argument that precedes the  $\rightarrow$ VP in the sentence. Also called the  $\rightarrow$ external argument since it occupies the  $\rightarrow$ specifier position of  $\rightarrow$ IP, the  $\rightarrow$ canonical subject position.

**subject control:**  $\rightarrow$ PRO can be coreferent either with the subject or the  $\rightarrow$ object of the preceding  $\rightarrow$ clause depending on the  $\rightarrow$ main verb. The verb *promise* is a subject-control verb, in the sentence *I promise [PRO not to destroy my brother's castle again]* PRO is coreferent with the subject.

**subject movement:** the  $\rightarrow$ movement of the  $\rightarrow$ subject from its  $\rightarrow$ base position (Spec,vP or Spec,VP) to a  $\rightarrow$ Case position (Spec,IP).

**subject position:** the position where  $\rightarrow$ subjects appear in the tree. The  $\rightarrow$ base position of the subject depends on its  $\rightarrow$ theta role.  $\rightarrow$ Agents and experiencers are generated in Spec,vP. Theme subjects appear in Spec,VP. These positions are not  $\rightarrow$ Case positions, so the subjects move to the  $\rightarrow$ canonical subject position, Spec, IP.

**subject-auxiliary inversion:** a descriptive cover term for the reverse order of the subject and the auxiliary in questions like *Can you dance?*, see also I-to-C movement.

**substitution:** a) one of the  $\rightarrow$ constituency tests to define whether a certain  $\rightarrow$ constituent is the same type as another. If a constituent can be substituted by another one it is assumed to be of the same type. E.g. lexical nominal expressions can be substituted by  $\rightarrow$ pronoun forms, so they are both assumed to be  $\rightarrow$ DPs: *The girl I met yesterday/She will visit her family tomorrow.*

b) a type of movement where a constituent is moved into an empty position already existing prior to movement, see also adjunction.

**suffix:** a  $\rightarrow$ bound morpheme added to the end of the word, e.g. *-ful* in *mouthful*.

## Glossary

---

- superlative form of adjectives:** comparison to a higher (or in the case of *least* lower) degree when there are more than two →agents involved: *He is the tallest of us*. The →periphrastic way of forming the superlative is with the help of *most*: *He is the most sophisticated man I have ever met*.
- S(urface)-structure:** post-→movement structure containing the →traces of moved →constituents.
- syntax:** the study of sentence structure
- tense:** a syntactic category with the help of which we can locate an event or situation in time. In syntactic representation information about tense can be found within the vP appearing directly under the →IP in the form of *-s*, *-ed* or the zero tense morpheme.
- that-relative:** a →relative clause that is introduced by the →complementiser *that*: *The cat that I found yesterday*.
- thematic category:** →categories with lexical content: →verbs, →nouns, →adjectives, →prepositions.
- thematic hierarchy:** the hierarchy of the assignment of →thematic roles. →Agents are higher than →experiencers, which in turn are higher than →themes. The theta-roles lower on the hierarchy have to be assigned first (if present).
- thematic role:** see theta-role.
- theme:** one of the →thematic roles where the →argument is not affected by the action described by the verb e.g. in *Peter saw John* nothing directly happens to *John* as a result of being seen. In terms of the →UTAH the theme theta-role is assigned to the →specifier position of the →VP.
- there-construction:** see existential *there*-construction.
- Theta Criterion:** – a → $\Theta$ -role must be assigned to one and only one →argument  
– an argument must bear one and only one  $\Theta$ -role.
- theta-grid:** that part of a →predicate's →lexical entry which informs us about what →theta-roles the predicate has.
- theta-marking:** the assignment of →theta-roles.
- theta role:** the →semantic role of the participants as required by the →predicate. E.g. verbs define what kind of semantic relationship is to be established between the verb itself and the →arguments of the verb, and arguments are selected accordingly. The verb *kick* calls for an →agent subject, so its →subject position cannot be occupied by e.g. *my CD-player*.
- Theta Theory:** a →module of →GB accounting for how verbs assign →theta-roles to their →arguments.
- three-place predicate:** a predicate with three →arguments, e.g. *give*.
- to-infinitive:** an infinitive appearing with *to*, a non-finite verb-form.
- topic:** an element appearing in front of the subject with a special interpretation (something like '*as far as topic is concerned*'). Topics have either already been mentioned before in a conversation or can be interpreted as easily accessible due to the context.
- topicalisation:** a process which moves an element interpreted as a →topic to the front of the sentence.

## Glossary

---

- trace:** moved  $\rightarrow$ constituents leave traces in the position where they have been moved from. Once a trace is present in a structure, no other constituent can  $\rightarrow$ land in the position occupied by it.
- transitive verb:** a verb with a nominal complement, e.g. *read, buy*. The  $\rightarrow$ agentive subject occupies the  $\rightarrow$ specifier position of  $\rightarrow$ vP, the  $\rightarrow$ theme  $\rightarrow$ object occupies the specifier position of  $\rightarrow$ VP.
- tree diagram:** a representation of grammatical structure containing  $\rightarrow$ nodes connected by  $\rightarrow$ branches.
- two-place predicate:** a predicate with two  $\rightarrow$ arguments, e.g. *write*.
- unaccusative verb:** a verb taking one  $\rightarrow$ argument to which it assigns a  $\rightarrow$ theme  $\rightarrow$ theta-role in the  $\rightarrow$ specifier position of a  $\rightarrow$ VP. They may also optionally take a location or path argument expressed by a  $\rightarrow$ PP. Some of the unaccusative verbs in English are *arrive, appear, sit*, they are typically verbs of  $\rightarrow$ movement or location. Unaccusative verbs can appear in the  $\rightarrow$ existential *there* construction or  $\rightarrow$ locative inversion structures. They do not take  $\rightarrow$ objects of any kind, see also cognate object.
- underspecification:** a feature can have values which are not determined.  $[\pm F]$  is supposed to be such a feature in the classification of  $\rightarrow$ word categories. The categories with underspecified features are the following:  $\rightarrow$ aspectual auxiliaries  $[-N, +V]$ ,  $\rightarrow$ measure nouns  $[+N, -V]$ ,  $\rightarrow$ post-determiners  $[+N, +V]$ , the non-thematic, non-functional uses of the  $\rightarrow$ prepositions *of* and *by*  $[-N, -V]$
- ungradable adjective:** an  $\rightarrow$ adjective that has no comparative and superlative forms. The absence of these forms is due to  $\rightarrow$ semantic reasons. E.g. *polar, atomic*
- Uniform Theta-role Assignment Hypothesis (UTAH):** a  $\rightarrow\Theta$ -role is assigned in the same structural position in all structures in which it is present.
- unpronounced:** see phonologically empty
- verb:** a word used to describe an event or situation that can appear in one of the five  $\rightarrow$ verb forms. Feature composition:  $[-N, +V, -F]$ .
- verb forms:**  $\rightarrow$ base form, past  $\rightarrow$ tense form, the third person singular present form, the  $\rightarrow$ perfective (same as passive) form and the  $\rightarrow$ progressive form.
- verb phrase (VP):** a  $\rightarrow$ phrase headed by a verb. It is in the VP together with the vp(s) that the basic  $\rightarrow$ argument structure of the  $\rightarrow$ clause is formed, thus,  $\rightarrow$ theta-role assignment takes place here. The  $\rightarrow$ specifier position of the VP is occupied by the constituent bearing the theme/patient  $\rightarrow$ theta role. In passive structures this constituent has to move from the specifier position of the verb to the specifier position of  $\rightarrow$ IP in order to get  $\rightarrow$ Case. A VP can have different types of complements such as a  $\rightarrow$ DP,  $\rightarrow$ CP, IP,  $\rightarrow$ PP.
- verb-particle construction:** a structure where the particle appearing together with the verb does not function as a preposition, which forms a unit with its DP complement. Rather, the particle seems to form a unit with the verb. Several differences between verb-particle constructions and prepositional verb structures follow from this, e.g. a preposition can be moved together with its DP complement, a particle cannot: *in this hut, he lived for ten years/\*off this hat, he took in an instant*.

## Glossary

---

- [±V]:** one of the three basic →binary features on which all →categories can be defined. With the help of these features we can explain why we have the categories that we do and also describe how these categories are related. With the help of the three binary features we can predict what kinds of categories are possible in human →language, we can give an exclusive list of them. Since we want to define verbs and nouns as polar opposites the abstract binary features →[±N] and [±V] were introduced, though obviously they do not mean noun and verb and are used to define other categories besides nouns and verbs. The categories with [±V] feature are the following: a. →thematic: →verbs, →prepositions; b. →functional: →inflections, →degree adverbs, →aspectual auxiliaries; unspecified for the →[F] value: →aspectual auxiliaries, →post-determiners.
- voice:** →a distinction between →active voice and →passive voice. It applies only to sentences containing →transitive verbs.
- voiced sound:** a sound produced with the vibration of the vocal cords, e.g. *d, z, g*.
- voiceless/unvoiced sound:** a sound produced without the vibration of the vocal cords, e.g. *t, s, k*.
- VP adverb:** an →adverb which modifies the meaning of the verb, e.g. *always, already, never*.
- VP-Internal Subject Hypothesis:** the hypothesis according to which subjects are not →base-generated in the →specifier position of →IP but move there from within the vP or →VP where they are selected and →theta-marked by the verb (see also canonical subject position). The →movement of the →DP is case-motivated.
- VP:** see Verb Phrase
- vP (pronounced: little vP):** a →phrase headed by a →light verb taking a →VP complement hosting →agent or →experiencer →arguments in its →specifier position. For a list of elements that can appear in vp see light verb.
- vP-shell:** →vP-projection(s) on →VP: if the →event structure of the verb is complex, the structural representation of the verb will be complex, too. The number of vP-shells surrounding the VP core depends on the →theta-role of the →arguments. If there is an →agent or an →experiencer selected by the verb one vP-projection is needed. If both an agent and an experiencer are present there are two vPs, the lower hosting the experiencer.
- whether:** though in certain cases *whether* is interchangeable with *if*, which is a →complementiser, *whether* cannot be regarded as such since it does not impose selectional restrictions on the finiteness of the →clause following it. Both *I wonder whether to invite him* and *I wonder whether I should invite him* are grammatical. Rather, *whether* is assumed to occupy the →specifier position of →CP similarly to →wh-elements. An argument in favour of this approach is that *whether* also introduces only →interrogative clauses.
- wh-movement:** the →movement of a →wh-element to the beginning of the →clause. This movement is obligatory in English.
- wh-question:** a question containing a →wh-element. It cannot be answered with *yes* or *no*.

## Glossary

---

- wh-relative:** a  $\rightarrow$ relative clause introduced not by a  $\rightarrow$ complementiser but a  $\rightarrow$ wh-element: *The girl [whom I invited].*
- wh-element:** question word. Question words often but not always begin with these letters, e.g. *where, what, when, who, whom*. The question word *how* is also considered a *wh*-element.  $\rightarrow$ *Whether*, although a word beginning with *wh* is not considered to be a *wh*-element in this sense.
- word category:** a set of expressions that share certain linguistic features, a grouping of words that cluster together, e.g. noun, verb. See also functional category, thematic category.
- X-bar theory:** a  $\rightarrow$ module of  $\rightarrow$ GB containing three very simple rules to describe the structure of the expressions of a  $\rightarrow$ language. See also specifier rule, complement rule, adjunct rule.
- yes-no question:** a question that can be answered either with *yes* or *no*, formed either by inverting the auxiliary with the subject as in *Would you like to go to the cinema?* or the insertion of  $\rightarrow$ dummy *do* as in *Did you enjoy the performance?*
- zero inflectional morpheme:** as the  $\rightarrow$ morphology of the English language is rather impoverished very often we have no visible markers of person and  $\rightarrow$ number  $\rightarrow$ agreement on the verb (the exception being the third person singular *-s* morpheme in the present tense). In the other cases the  $\rightarrow$ inflection is assumed to be present in an invisible form. The zero inflectional  $\rightarrow$ morpheme is one without  $\rightarrow$ phonological realisation but it has syntactic functions to fulfil in the structure.
- zero level projection:** the head of a phrase, X in an XP.
- zero relative:** a  $\rightarrow$ relative clause that could be but is not introduced by an  $\rightarrow$ overt  $\rightarrow$ complementiser: *The man [- I told you about yesterday].*
- $\Theta$ -role:** see  $\rightarrow$ theta role.



# Bibliography

- Baker, Mark C. (1988): *Incorporation: A Theory of Grammatical Function Changing*. University of Chicago Press. Chicago, IL.
- Belletti, Adriana (1988): The Case of unaccusatives. *Linguistic Inquiry* **19.1**. 1–35
- Burzio, Luigi (1986): *Italian Syntax*. Reidel. Dordrecht.
- Chomsky, Noam (1957): *Syntactic Structures*. Mouton. the Hague.
- Chomsky, Noam (1970): Remarks on nominalism. In R. Jacobs and P. S. Rosenbaum (eds.): *Readings in English Transformational Grammar*. Ginn and Co. Waltham, Mass.
- Chomsky, Noam (1991): Some notes on economy of derivation and representation. In Robert Freidin (ed.): *Principles and Parameters in Comparative Grammar*. MIT Press. Cambridge, Mass. 417–545. First published in 1989 in *MIT Working Papers in Linguistics* **10**. 43–74.
- Chomsky, Noam and Howard Lasnik (1977): Filters and Control. *Linguistic Inquiry* **8**. 425–504.
- Chomsky, Noam and Howard Lasnik (1993): Principles and parameters theory. In J. Jacobs, AS. von Stechow, W. Sternefeld and T. Vennemann (eds.): *Syntax: An International Handbook of Contemporary Research*. de Gruyter. Berlin. 506–69.
- Haegeman, Liliane (1994) *Introduction to Government and Binding Theory*. 2nd edition. Blackwell. Oxford, England.
- Jackendoff, Raymond (1977): *X-Bar Syntax: A Study of Phrase Structure*. MIT Press. Cambridge, Mass.
- Jespersen, Otto (1965): *A Modern English Grammar on Historical Principles Part IV: Morphology*. George Allen and Unwin Ltd. London.
- Pollock, Jean-Yves (1989): Verb movement, Universal Grammar and the structure of IP. *Linguistic Inquiry* **20**. 365–424.
- Radford, Andrew (1988) *Transformational Grammar*. Cambridge University Press. Cambridge, England.
- Radford, Andrew (2004): *English Syntax: An Introduction*. Cambridge University Press. Cambridge, England.
- Rizzi, Luigi (1990): *Relativized Minimality*. MIT Press. Cambridge, Mass.
- Stowell, Tim (1981): *Origins of Phrase Structure*. PhD. dissertation. MIT. Cambridge, Mass.
- Stowell, Tim (1983): Subjects across categories. *The Linguistic Review* **2**. 285–312.
- Travis, Lisa (1984): *Parameters and Effects of Word Order Variation*. PhD. dissertation. MIT. Cambridge, Mass.
- Webelhuth, Gert (1995) X-bar theory. In Gert Webelhuth (ed.): *Government and Binding Theory and the Minimalist Program*. Blackwell. Oxford.

# Index

## A.

adjacency 221  
adjective 11, 13, 14, 17, 25, 28, **30–38**,  
39, 46–9, 53, 54, 74, 80, 105, 106,  
108, 109, 144, 157, 160, 206, 223,  
329, 330, 336, 337  
comparative form of adjectives **31**,  
32, 34, 35, 38, 46, 49, 54  
positive form of adjectives **31**  
superlative form of adjectives **31**,  
32, 35, 38, 46, 49, 54  
ungradable adjective **31**, 32  
adjective phrase (AP) 73, 79, 86, 88,  
98, 105–108, 144, 155–58, 223,  
224, 289, 297, 319–21  
adjunct **95**, **105–10**, 114, 129, 141–46,  
155, 170, 220–24, 247, 260, 286,  
297, 299, 318  
adjunct rule 95, 105  
adjunction **105–10**, 110, 114, 115,  
129, 130, 144, 145, 165, 179, 181,  
196, 204–206, 208, 212, 220–27,  
247, 252, 253, **260–61**, 289, 290,  
297, 298, 300, 302  
adverb 25, 30–38, 48, 54, 71, 98, 155,  
156, 205–207, **220–23**, 234, 252,  
253, 260, 287, 288, 297, 298, 337  
degree adverb 11, 14, 32, **34**, 46,  
**47–49**, 54, 273  
sentential adverb **220**, 253, 260,  
261, 297  
VP adverb **220**, 221, 247, 252, 260,  
261  
Affix Lowering 248  
agglutination **246**  
agreement **20**, 21, 43, **75**, 76, 143, 150,  
180, 181, **238**, 245, **246–51**, 253,  
258, 259, 265, 274, 277, 280–87,  
291, 302, 303, 305, 320, 321, 326,  
327, 336  
aktionsart *see* lexical aspect

ambiguity 44, 78, 89, 90, 143, 169,  
170, 175, 176, 218, 226  
anaphor 305, **333**, 334, 335  
anaphoric operator 295  
antecedent **99**, 100, 128, 148, 295,  
324, 325, 333–36  
AP *see* Adjective Phrase  
arbitrariness 4, 6, 335  
arbitrary reference **334**, 335  
argument 15–30, 37, 40, 41, 53, 63,  
65, 66, 74–79, 82, 97, 103, 104,  
106, 110, 111, 113–20, 124, 128,  
146, 160, **165**, 168–203, 209–13,  
221–25, 265, 269, 277, 319, 322–  
25, 339  
implicit argument **323**  
quasi-argument 186  
aspect 21, 40, **165–68**, 172, 196, 214,  
215, 218, 220, 241, 245, 336, 340  
grammatical aspect **167**, 168  
lexical aspect **167**  
perfect aspect 21, 22, 40, 52, 167,  
196, 217–19, 241, 242  
progressive aspect 21, 22, 38, 40,  
52, 167, 217, 241, 242  
asterisk 65

## B.

Baker, Mark C. 117  
barrier **315**, 333  
base form 22, 242, 248  
Basque 176  
Belletti, Adriana 184  
binary features 12–15  
binding 181, 281, 340  
binding domain 333–35  
binding principles **334**  
biner **334**, 335  
boundedness of movement **132**  
bracketed representation 18, 40, 63, 72  
branch **71**, 221

- Burzio, Luigi 178  
 Burzio's Generalisation **178**, 185, 189, 255
- C.**  
 canonical structural realisation principles **269**  
 canonical subject position 151  
 Case 123, 257, 326  
     abstract Case **41**, 76, 80, 81, 120–24, 152–55, 159, 174, 177, 182–90, 194, 197, 202–204, 210–14, 219, 221, 234, 237, 254–59, 265, 313–18, 322, 327–33, 337–39  
     accusative Case **41**, 50, 76, 81, 120–23, 152, 159, 171, 174, 178, 182–86, 189, 194, 204, 212, 237, 255, 256, 258, 259, 312–18  
     Case position 121–23, 152, 159, 171, 182, 189, 202, 212–14, 224, 255, 257, 273, 326–28, 332, 333  
     morphological Case **122**, 123  
     nominative Case **41**, 50, 76, 120–23, 171, 174, 181–84, 204, 237, 258, 259, 312, 317, 326, 327  
     partitive Case **184**, 186  
     Case assigner 160, 221, 258, 313–17  
     Case avoidance principle **213**  
     Case Filter **123**, 124, 159, 177, 213, 254, 257, 273, 277, 317, 326, 327, 331, 333  
     Case Theory **120–24**  
     category variable **95**  
     chain **128**  
         foot of a chain **128**  
         head of a chain **128**  
 Chinese 4  
 Choctaw 245  
 Chomsky, Noam 12, 115, 215, 286, 332, 474  
 clause 39–42, 48–51, 54, 55, **68**, 70, 77, 79, 81, 85–89, 97–100, 107, 111, 121, 128–31, 165, 171, 174, 175, 183, 185, 196, 204, 205, 210–13, 216, 219, 220, 224, 225, 228, 233–37, 250, 254–261, 265–67, **268–70**, 274–302, 305, 311–36  
     conditional clause **272**  
     declarative clause **19**, **51**, 209, 214, **265**, 267–70, 273, 274, 279, 291  
     embedded clause **41**, 64, 72, 121, 235, 250, 257, 267, 268, 274, 280–83, 285, 288, 298, 300, 302, 312, 326, 327  
     exceptional clause 270, **311–21**, 333, 341  
     interrogative clause **19**, **39**, **51**, 88, 111, 209, 214, 261, **265**, 267, **270–88**, **291–96**, 303, 305  
     main clause 50, 121, 225, 235, 250, 268, 270, 281–86, 291, 298, 299, 302, 334  
     purpose clause **185**, 186, 225–27, 299  
 coindexation 276, 277  
 comment **300**  
 complement **100–103**, **141–49**  
 complement rule **95**  
 complementary distribution **10**, 34, 39, 40, 42, 45–47, 52, 146, 151, 154, 155, 182, 233, 249, 250, 272, 298, 300, 302, 304, 332, 333, 339  
 complementiser 11, 14, **18**, 19, 39, 41, **47–49**, 55, 85, 96, 122, 234, 235, 261, 265–70, 272, 274, 279–85, 291–93, 297–303, 311–16, 318, 326, 332, 338  
 complementiser phrase (CP) 73, **265–305**, **311–18**, 319, 321, 326, 333  
 constituency test 86, 87, 91  
 constituent **71**, 72, 83, 84, 87, 89–91, 95, 96, 97, 105, 110, 112, 115, 205, 265, 266, 290, 315  
 control **225**, 226, 227, **322–36**, 341  
     object control 226, **336**  
     subject control 226, 227, **336**  
 coordination **86**, **87–90**, 205, 266, 267, 283, 289, 290  
 coreference 324, 335  
 covert 270, 279, 282, 293  
 CP *see* Complementiser Phrase

**D.**

dative alternate *see* dative construction  
 dative construction **82**, **201**, 202  
 daughter **71**, 74, 107, 110  
 Deep-structure **111–14**, 124–27, 130, 159, 171, 179, 183, 213, 214, 234, 240, 255, 277, 322, 325, 326, 327  
 defining relative clause *see* restrictive relative clause  
 definiteness **44**, 45, 145, 148  
 DegP 73  
 derived noun 27, 28, 337  
 determiner 11, 12, 14, **43–47**, 53, 54, 66, 67, 72–74, 83, 92, 95, 96, 103–106, **141–49**, 151, 153–61, 237, 238, 268, 273, 274, 289, 337–40  
     central determiner **45**, **156**  
     definite determiner **44**, 45, 149, 150, 151  
     indefinite determiner **44**, 149, 150, 151  
     post-determiner **45**, 54, **156**, 157, 158  
     pre-determiner **156**, 158–61  
 determiner phrase (DP) **73**, 74, 79, 81, 83, 84, 85, 86, 88, 89, 91, 95, 96, 104, 113, 121–24, **141–61**, 168, 169, 184–86, 201, 204, 205, 208, 210–14, 224, 237, 254, 269, 271, 274, 277, 288, 311, 320–39  
 distribution **8–10**, 13, 14, 22, 27, 34, 40, 48, 66, 67, 72, 73, 83–85, 87, 90, 92, 98, 106, 115, 116, 120, 124, 141, 143, 155, 168, 220, 223, 236, 271, 273, 274, 288, 290, 299, 302, 304, 331–34, 337  
*do*-insertion *see do*-support  
*do*-support **216**, 217, **242–46**, 252, 286  
 double object construction **82**, **201**, 202, 210, 214  
 Doubly Filled COMP Filter **285**  
 DP *see* Determiner Phrase  
 DP-movement 273

**E.**

echo question **275**

ECM *see* Exceptional Case Marking  
 E-language **2**, 64, 65, 100  
 endocentric structure **97–100**, 236  
 ergative language 176  
 event structure **165–68**, 171–79, 192–94, 199, 201, 211, 213, 265  
 Exceptional Case-marking (ECM) **316**  
 existential there-construction 169, 171, 182–86, 214  
 exocentric structure **98**, 100, 234, 236  
 extended projection **191–92**, 196, 197  
 Extended Projection Principle **322**, 327, 330  
 extraction site **124**, 126, 127, 130  
 extraposition **112**

**F.**

[±F] 12, 14, 15, 18, 19, 25, 30, 33, 36, 38, 39, 40, 47, 48, 49, 51, 52, 54, 101, 237, 268, 301, 321  
 finite clause **41**, 42, 50, 75–77, 120–22, 131, 182, 209, 219, 235–38, 258, 268, 273, 293, 312, 322, 325–27, 331  
 finiteness 50, 51, 314  
 Finnish 4, 245, 303  
 focus 300–303  
 focus fronting 299–03, 305  
 force **19**, **51**, 165, 216, **265**, 267, 270, 272, 274, 279  
 French 4  
 functional category **11**, 12, 14, 15, 19, 39, **40–51**, 150, 161, 301

**G.**

GB *see* Government and Binding Theory  
     general ordering requirements 288  
     generative grammar 3, 10, 25, 65, 188  
     genitive Case **121**, 151, 154  
     German 4, 199  
     gerund 311, **336–41**, 341  
     government **259**, 314–17, 333, 336  
     Government and Binding Theory (GB) 1  
     grammar **1–3**, 8, 9, 64, 65, 74, 81, 100–103, 111, 113, 120, 186, 209, 235

**H.**

Haegeman, Liliane 132, 320  
 head 100–103, 108–10, 141–49  
 Head Movement Constraint (HMC)  
   **243**, 244, 278, 330  
 heavy DP shift **224**  
 HMC *see* Head Movement Constraint  
 Hungarian 4, 21, 41, 76, 152, 180,  
   181, 251, 291

**I.**

idiosyncratic 102, 118, 209  
 I-language **2**, 4, 5, 65, 100  
 immediate constituent **71**, 72, 74, 75,  
   95, 96, 105  
 imperative **99**, 100, 127, 148  
 infinitive 236, 311  
 inflection 11, **19**, 20, 31, 32, 35, 38,  
   **40–43**, 46, 49, 52, 180, 205, 218,  
   **223–24**, 233–38, 257–61, 268, 277–  
   79, 301, 312, 313, 317, 321, 326,  
   327, 329  
 inflectional comparison 49  
 inflectional phrase (IP) 73, **233–61**,  
   265–74, 277, 284, 286, 287, 294,  
   297–02, 305, 314–18, **319–21**, 326–  
   28, 333, 338  
 IP *see* Inflectional Phrase  
 irregular 19, 22, 26, 31, 33, 34, 167,  
   215, 233, 235, 251  
 isomorphism 166, 177–79, 192, 193,  
   201, 213  
 I-to-C movement 277, 278, 287

**J.**

Jackendoff, Raymond 223  
 Japanese 4, 245, 279  
 Jespersen, Otto 172

**K.**

Korean 303

**L.**

landing site **124**, 126–28, 130, 257,  
   258, 302, 330

language 1–5, 8, 10, 21, 63–65, 88, 90,  
   95–100, 113, 152, 176, 179, 196,  
   199, 236, 245, 251, 279, 284, 335  
 Lasnik, Howard 286, 332  
 lexical entry 6, 8, 16–19, 23–25, 28,  
   30, 37, 40, 42, 43, 47, 49, 51–54,  
   81, 102, 104, 116, 118, 237  
 lexicon **4–5**, 8, 9, 33, 43, 101, 102,  
   110, 120, 125  
 light verb **172–81**, 182, 184–204, 207,  
   210–12, 215, 217–19, 221, 222,  
   226, 233–35, 239, 244, 246–49,  
   255–57, 259, 265, 313–18, 326,  
   328, 329, 332, 337–40  
   abstract light verb 178, 185, 191,  
     192, 194, 195, 213  
   multiple light verb **194–97**, 203  
 linguistics 1–3, 12  
 Locality Restriction on Theta-role  
   Assignment **117**, 120  
 Locality Restrictions on movement  
   **130–32**, 330  
 locative inversion 169, 175, 176

**M.**

Maltese 4  
 maximal projection **97**, 101  
 mood 341  
 morpheme 7, 8, 20, 22, 31–33, 43, 49,  
   75, 151–55, 181, 183, 190, 194,  
   215–19, 233, 235, 238–42, 245–51,  
   265, 274, 278, 279, 303, 316, 317,  
   327, 329, 336, 340, 341  
   aspectual morpheme 218–**20**, 222,  
     233, 241, 242, 244, 246–48, 265,  
     326, 336, 340, 341  
   bound morpheme **181**, 187, 190,  
     195, 204, 214, 240, 241, 245–52,  
     278–82, 326, 327  
   derivational morpheme **32**, 33, 35,  
     43  
   free morpheme 238, 248, 252  
   inflectional morpheme **33**, 43, 217,  
     246  
   productive morpheme 32–34  
   zero inflectional morpheme 249, 251

morphology 31, 33, 43, 75, 76, 217

mother **71**, 74, 107

Move  $\alpha$  **113**, **111–14**

movement 80–82, **87–90**, **110–32**,  
148, 153, 166, 169, 171, 175, 179,  
181, 184, 202–204, 207, 208, 211–  
14, 221–24, 233, 238, 240, 243,  
247, 248, 273, 276–80, 286, 295,  
**297–304**, 305, 316, 318, 325–31

A movement 277

A' movement 277

multiple wh-question 276

## N.

[ $\pm$ N] 12–15, 19, 25, 28, 30, 33, 36,  
38–40, 47–55, 101, 237, 268, 301,  
321

negative fronting **301–4**, 305

node **71**, 72, 108, 110, 251, 315

non-defining relative clause *see* non-  
restrictive relative clause

non-finite clause **41**, 42, 50, 76, 77,  
121–23, 131, 209, 225, 235–37,  
258, 266, 269, 270, 283, 293, 305,  
**311–41**

non-referential 294, 295

noun 6, 11, **25–30**, **141–49**

compound noun **27**, 108, 109, 129,  
206

count noun **26**, 45, 141

deverbal noun 27, 28, 172, 191, 198

mass noun **26**, 45, 150

measure noun **53**, 160, 161

plural noun 25–27, 143, 149

proper noun **26**, 27, 66, 141, 147,  
149

singular noun 25, 27, 143

noun phrase (NP) 73, 85, 86, 89, 103,  
106–108, 141–51, 155, 157, 158,  
161, 237, 268, **288–96**, 294, 321,  
337–39

NP-movement *see* DP-movement

Null Case 332, 333, 340

number 20, 26, 44, 45, 76, 143, 150,  
151, 238, 251, 274

## O.

object **79–81**, 82, 84, 87–91, 100,  
110–13, 116, 117, 119, 121, 125–  
28, 130, 159, 160, 170, 176–78,  
184–94, 198, 201, 204, 206, 207,  
209, 210, 213, 218, 221, 224, 225,  
227, 236, 255, 256, 258, 259, 284,  
286, 294, 305, 316, 318, 322, 324,  
325, 328, 333, 335, 336

cognate object **170**, 171, 198, 199,  
214, 256

direct object **82**, **201**, 204

indirect object **79–81**, **201**, 202, 204

object position 80, 88, 111, 112,  
116, 117, 121, 122, 126–28, 188,  
273, 325, 327, 331

prepositional object **80**

of-insertion 160

Old English 284

one-place predicate **16**, 17, 22, 24, 116

operator **275**, 276, 277, 283, 284, 285,  
294, 295, 305

overt 75, 122, 182, 196, 199, 217, 241,  
266, 269, 270, 279, 281, 282, 285,  
286, 293, 318, 323, 324, 331–33

## P.

particle **204–208**, 279, 280

partitive construction **26**

passive structure 81, **186–88**

periphrastic comparison of adjectives  
**32**

phonologically empty 99, 100, 127,  
147, 154, 155, 158, 266, 269, 323,  
325, 331

phonology 8, 23, 127, 153, 181, 285,  
341

phrasal category 92

phrasal verb **204–9**, 214, *see also*  
verb–particle construction

phrase **65–74**, **90–93**, 95–113, 142–45

pied-piping **293**

pleonastic subject *see* expletive subject

PP *see* Preposition Phrase

pragmatics 336

- predicate **15–18**, 19, 22, 25, 29, 30, 38, 65, **77**, 86, 103, 104, 116–19, 130, 165, 179, 185, 186, 188, 200, 234, 282, 319–21, 324, 330, 334
- preposing **114**, 128, 129
- preposition 11, 13, 14, 18, 23, 25, 28, 35–37, **38–40**, 49, 50, 53–55, 67, 73, 74, 76, 80, 81, 84, 85, 90, 95, 98, 102, 103, 121, 122, 142, 143, 159, 160, 171, 174, 202–208, 213, 271, 273, 293, 331, 337, 338, 339
- preposition phrase (PP) **73**, 74, 81–85, 88–92, 95, 97, 98, 103, 110, 112, 114, 128, 129, 142, 155, 160, 168–170, 200–12, **223–24**, 269, 271, 293, 319–21
- preposition stranding **293**
- prepositional complementiser **50**, **122**
- prepositional verb **24**
- Projection Principle **125**, 126, 127, 130, 179, 322
- pronominal 46, 84–86, 121, 122, 155, 238, **333**, 334, 335
- pronoun 14, 36, 41, 46, 47, 51, 71, 76, 77, 81–86, 92, 99, 111, 120–23, 127, 128, 141, 144, 146–49, 152, 154, 155, 183, 266, 273, 283, 291, 294, 295, 318, 324, 325, 331, 333, 334, 335, 336
- reflexive pronoun **99**, 118, 119, 148, 225, 295
- Q.**
- quantificational operator 295
- quantifier **45**, 53, 156, 160, 224, 275, 276, 305
- R.**
- Radford, Andrew 36, 132, 221
- raising **130**, 131, 183, **322–36**, 341
- raising verb 183, 328, 330
- recoverable **295**
- recursive rule **65**, 105, 107, 108, 109
- referential 127, 185, 294, 295, 323–25, 331, 333–36
- regular 8, 11, 19, 22, 26, 28, 43, 68
- relative clause 107, 108, **288–96**, 305
- headless relative **292**
- non-restrictive relative clause **289**, 290
- restrictive relative clause **289**, 290
- that*-relative **292**, 293, 294
- wh*-relative 291, 292, 293
- Relativized Minimality **330**
- rewrite rule **74**, **95–97**, 105
- Rizzi, Luigi 330
- Russian 4
- S.**
- semantics 7, 17, 23–33, 40, 53, 76–78, 99, 100, 104, 109, 111, 118, 119, 127, 130, 141–43, 148, 155, 159, 160, 165, 167, 168, 172, 173, 179, 183, 184, 191, 198, 206, 214–18, 227, 233, 235, 265, 270–72, 275–77, 288, 289, 295, 304, 322, 323, 331, 341
- sister node **71**, 110, 221, 259
- small clause **311–21**, 341
- Spanish 4
- specificity **44**
- specifier position 96, 97, **100–103**, 105–107, 110, 111, 113, 115, 117, 118, 141–46, **151–56**, 158, 168, 171, 173, 177, 178, 184, 185, 187, 190–94, 197, 198, 200, 202, 206, 208–12, 223–26, 234–39, **254–59**, 260, 265, 271–76, 284–87, 292, 295, 297–303, 312–17, 320, 325–27, 337, 339
- specifier rule **96**, 105
- Stowell, Tim 212, 221, 319, 321
- Structure Preservation Principle **113**, 124, 125, 130
- subcategorisation frame **23**, 24, 25, 28, 37, 38, 43, 46, 52, 77, 102–104, 110, 267, 268, 317, 320, 321
- subcategory **10**, 22, 25, 27, 28, 150, 168, 186
- subject **74–79**, **192–94**, **286–88**
- expletive subject **77**, 78, 183–86, **322**, 323, 324, 327–29

- missing subject 100, 190, 225, 227, 238, 269, 283, 322–25, 331  
 PRO 325, 331–36, 340  
 subject position 77–80, 112, 113, 116, 121–31, 143, 169, 170, 174, 177, 183, 184, 189, 190, 197, 204, 213, 214, 219, 220, 234, 256, 257, 273, 316–32, 340  
 subject movement 171, 234, 255, 257, 287, 321, 330  
 subject-auxiliary inversion **112, 271**  
 substitution 68, **83–87, 129, 276**  
 Surface-structure 124–127, 159, 179, 214, 223, 234, 239, 240, 322  
 Surface-structure **111–14**  
 Swahili 4  
 syntax 8, 168, 261
- T.**  
**tense** 7, 8, 10, 19–22, 33, 37, 41, 43, 50, 52, 75, 121, 165, 167, 180, 181, 187, 216–20, 233, 235, 238, 240, 242, 244, **246–54, 255, 258, 260, 265, 277, 278, 287, 288, 311, 326, 327, 336, 340**  
 thematic category **11–40, 43, 161**  
 thematic hierarchy 196, 197  
 thematic role *see* theta role  
*there*-construction *see* existential *there*-construction  
 Theta Criterion **120, 128, 323**  
 theta role **16, 17, 19, 23, 30, 78, 82, 104, 106, 116–20, 123, 126, 128, 165, 168, 171, 174, 177–79, 183, 185, 187–90, 192, 194, 196, 197, 200, 210, 219, 237, 239, 248, 255, 256, 258, 313–17, 323–29**  
 agent 16, 17, 22, 23, 29, 30, 55, 65, 78, 116, 169, 171, 173, 174, 177, 178, 180–82, **185–94, 196, 197, 200, 201, 217, 222, 226, 227, 239, 256, 316, 339**  
 experiencer 16, 29, 30, 63, 78, 79, 110, 186, 187, **192–94, 196, 197, 222, 313, 316, 317**  
 patient 16, 23, 29, 65, 78, 116, 117, 186, 187, 189  
 theme 16, 30, 78, 82, 97, 104, 110, 118, 141, 165, 168–78, 182–87, 190, 193–206, 210, 219, 221, 222, 226, 227, 269  
 Theta Theory **115–20, 124, 165**  
 theta-grid **16, 18, 19, 23, 25, 40, 43, 46, 53**  
 theta-marking 258  
 three-place predicate **16, 17, 23**  
 to-infinitive 238, 251  
 topic 44, **87, 90, 112, 114, 209, 297, 298, 299, 300, 302, 305**  
 topicalisation 87, 89, **112, 213, 297–99, 301, 304, 305**  
 trace **120–24, 148, 284, 292, 325, 330**  
 Travis, Lisa 243  
 tree diagram **71, 72, 74, 92, 315**  
 two-place predicate **16, 17, 23, 116**
- U.**  
 underspecification **15, 51–56**  
 Uniform Theta-role Assignment Hypothesis (UTAH) **117, 118, 120, 165, 171, 174, 177, 178, 188, 192, 194, 197, 199, 202, 211, 213**  
 unpronounced *see* phonologically empty  
 Urdu 196, 218
- V.**  
 [±V] 12–15, 19, 25, 30, 33, 36, 38–40, 47–49, 52, 54, 55, 101, 237, 268, 301, 321  
 verb 11, **19–25, 168–214**  
 aspectual auxiliary verb 40, 52, **214–20, 234, 243, 246, 248, 277**  
 complex transitive verb **25**  
 ditransitive verb **24**  
 dummy auxiliary **215–18, 219, 240, 242, 244, 253, 278, 286, 287**  
 ergative verb **175–86, 188, 191**  
 exceptional verb 270, **315, 316, 318, 326, 328, 329, 332**  
 finite verb form 42, 75, 76, 235, 253



## Index

---

- intransitive verb **24**, 34, 39, 46, 66, 77, 85, 107, 119, 126, 141, 168, 170, 176, 182, 186, **197–99**, 255  
lexical verb 20  
modal auxiliary verb 11, 12, **18**, 19, 40, 41, 42, 43, 50, 129, 214, 220, 233, 235, 238, 249, 250, 258, 265  
non-finite verb form 235, 341  
transitive verb **24**, 25, 34, 35, 66, 81, 110, 125, 126, 159, 171, 176, 177, 182, **186–88**, 209, 210, 255  
unaccusative verb **168–72**, 173–78, **181–86**, 191, 197–200, 222, 325  
verb phrase (VP) 73–75, 79, 83–92, 95–100, 104, 114, 161, **165–228**, 233–37, 239, 244, 247–49, 252, 254, 257, 259, 261, 265, 268, 288, 297, 314, 315, 316, 319, 321, 322, 325, 328, 337, 338  
voice  
  active voice 55, 117, 188, 190, 191  
  passive voice **112**  
voiceless sound 8  
vP 173, 175, 214, 222, 228, 233–37, 241, 244, 248, 252–54, 268, 317, 321, 338, 340  
VP *see* Verb Phrase  
VP-Internal Subject Hypothesis 174, 247
- W.**  
Webelhuth, Gert 132  
*wh*-element 88, 90, **271**, 272–77, 280, 282–305  
*whether* 283, 284  
*wh*-movement 90, **273–86**, 295, 298, 301, 302, 305  
*wh*-question **271**, 272, 275, 284, 286, 300  
word category **4–56**, 73, 84, 91, 92, 95–98, 100, 102, 104, 105, 110, 115, 127, 145, 148, 158, 161, 179, 223, 233, 249, 269, 301, 303, 320, 337
- X.**  
X-bar theory **95–110**, 120, 130, 151, 165, 221, 236, 288, 320
- Y.**  
yes-no question **112**, **271**, 272, 278, 279, 283, 284, 294, 295  
Yupik 176
- Z.**  
zero level projection **97**  
zero relative **292**, 293, 294
- Θ.**  
Θ-role *see* theta role



