

BASIC ELECTRICAL AND ELECTRONICS ENGINEERING

DIGITAL NOTES



MALLA REDDY COLLEGE OF ENGINEERING & TECHNOLOGY

(Autonomous Institution – UGC, Govt. of India)

Recognized under 2(f) and 12 (B) of UGC ACT 1956

(Affiliated to JNTUH, Hyderabad, Approved by AICTE-Accredited by NBA & NACC-'A' Grade – ISO 9001:2015 Certified)

Maisammaguda, Dhulapally (Post Via. Hakimpet), Secunderabad -500100, Telangana State, India.

MALLA REDDY COLLEGE OF ENGINEERING & TECHNOLOGY

B.TECH I YEAR - I SEM - MECH/ANE

L T/P/D C
3 -/-/ 3

(R20A0261) BASIC ELECTRICAL AND ELECTRONICS ENGINEERING

Course Objectives:

1. To introduce the concept of electrical circuits and electrical machines.
2. To introduce the concepts of diodes & transistors.
3. To impart the knowledge of various configurations, characteristics and applications.

UNIT –I:

Introduction to Electrical Circuits: Concept of Circuit and Network, Types of elements, R-L-C Parameters, Independent and Dependent sources, Source transformation and Kirchhoff's Laws. (Simple Problems).

UNIT –II:

Network Analysis: Network Reduction Techniques- Series and parallel connections of resistive networks, Star-to-Delta and Delta-to-Star Transformations for Resistive Networks and mesh analysis.

Network Theorems: Thevenin's Theorem, Norton's Theorem and Superposition Theorem.

UNIT-III:

Electrical Machines (Elementary treatment only):

DC Generator: principle of operation, constructional features, emf equation.

DC Motor: principle of operation, Back emf, torque equation.

Single phase transformer: principle of operation, constructional features and emf equation.

UNIT –IV:

Diodes: P-n junction diode, symbol, V-I Characteristics, Diode applications, Zener Diode: characteristics, Rectifiers – Half wave, Full wave and Bridge rectifiers (Simple Problems).

UNIT –V:

Bipolar Junction Transistor (BJT): Construction, Principle of Operation, Amplifying Action, Common Emitter, Common Base and Common Collector configurations. (Elementary treatment only)

Text Books:

1. Basic Electrical and electronics Engineering –M S Sukija, TK Nagasarkar Oxford University.
2. Basic Electrical and electronics Engineering-D P Kothari. I J NagarathMcGraw Hill Education.
3. Electric Circuits - A. Chakrabarhty, Dhanipat Rai & Sons.

Reference Books:

1. Electronic Devices and Circuits – R.L. Boylestad and Louis Nashelsky, PEI/PHI, 9th Ed,2006
2. Millman's Electronic Devices and Circuits – J. Millman and C. C. Halkias, Satyabratajit, TMH, 2/e, 1998. 3. Engineering circuit analysis- by William Hayt and Jack E. Kemmerly, McGraw Hill Company, 6th edition.
3. Linear circuit analysis (time domain phasor and Laplace transform approaches)- 2 nd edition by Raymond A. DeCarlo and Pen-Min-Lin, Oxford University Press-2004.
4. Network Theory by N. C. Jagan& C. Lakshminarayana, B.S. Publications.
5. Network Theory by Sudhakar, Shyam Mohan Palli, TMH.

Course Outcomes: After going through this course, the student will be able to

1. Analyze and solve electrical circuits using network laws and theorems.
2. Identify and characterize diodes and various types of transistors.
3. Understand the principle of operation of DC Machines and Transformers.

UNIT-I

INTRODUCTION TO ELECTRICAL CIRCUITS

- Concept of Circuit and Network
- Types of elements
- R-L-C Parameters
- Independent and Dependent sources
- Source transformation Technique
- Kirchoff's Laws
- Simple Problems

INTRODUCTION TO ELECTRICAL CIRCUITS

Network theory is the study of solving the problems of electric circuits or electric networks. In this introductory chapter, let us first discuss the basic terminology of electric circuits and the types of network elements.

Basic Terminology

In Network Theory, we will frequently come across the following terms –

- Electric Circuit
- Electric Network
- Current
- Voltage
- Power

So, it is imperative that we gather some basic knowledge on these terms before proceeding further. Let's start with Electric Circuit.

Electric Circuit

An electric circuit contains a closed path for providing a flow of electrons from a voltage source or current source. The elements present in an electric circuit will be in series connection, parallel connection, or in any combination of series and parallel connections.

Electric Network

An electric network need not contain a closed path for providing a flow of electrons from a voltage source or current source. Hence, we can conclude that "all electric circuits are electric networks" but the converse need not be true.

Current

The current "**I**" flowing through a conductor is nothing but the time rate of flow of charge. Mathematically, it can be written as

$$I = \frac{dQ}{dt}$$

Where,

- Q is the charge and its unit is Coloumb.
- t is the time and its unit is second.

As an analogy, electric current can be thought of as the flow of water through a pipe. Current is measured in terms of Ampere. In general, Electron current flows from negative terminal of source to positive terminal, whereas, Conventional current flows from positive terminal of source to negative terminal.

Electron current is obtained due to the movement of free electrons, whereas, Conventional current is obtained due to the movement of free positive charges. Both of these are called as electric current.

Voltage

The voltage "V" is nothing but an electromotive force that causes the charge (electrons) to flow. Mathematically, it can be written as

$$V = \frac{dW}{dQ}$$

Where,

- W is the potential energy and its unit is Joule.
- Q is the charge and its unit is Coloumb.

As an analogy, Voltage can be thought of as the pressure of water that causes the water to flow through a pipe. It is measured in terms of Volt.

Power

The power "P" is nothing but the time rate of flow of electrical energy. Mathematically, it can be written as

$$P = \frac{dW}{dt}$$

Where,

- W is the electrical energy and it is measured in terms of Joule.
- t is the time and it is measured in seconds.

We can re-write the above equation as

$$P = \frac{dW}{dt} = \frac{dW}{dQ} * \frac{dQ}{dt}$$

Therefore, power is nothing but the product of voltage V and current I. Its unit is Watt.

Types of Network Elements

We can classify the Network elements into various types based on some parameters.

Following are the types of Network elements –

- Active Elements and Passive Elements
- Linear Elements and Non-linear Elements
- Bilateral Elements and Unilateral Elements
- Lumped Elements and Distributed Elements

Active Elements and Passive Elements

We can classify the Network elements into either active or passive based on the ability of delivering power.

- Active Elements deliver power to other elements, which are present in an electric circuit. Sometimes, they may absorb the power like passive elements. That means active elements have the capability of both delivering and absorbing power.

Examples: Voltage sources and current sources.

- Passive Elements can't deliver power (energy) to other elements, however they can absorb power. That means these elements either dissipate power in the form of heat or store energy in the form of either magnetic field or electric field.

Examples: Resistors, Inductors, and capacitors.

Linear Elements and Non-Linear Elements

We can classify the network elements as linear or non-linear based on their characteristic to obey the property of linearity.

- Linear Elements are the elements that show a linear relationship between voltage and current. Examples: Resistors, Inductors, and capacitors.
- Non-Linear Elements are those that do not show a linear relation between voltage and current. Examples: Voltage sources and current sources.

Bilateral Elements and Unilateral Elements

Network elements can also be classified as either bilateral or unilateral based on the direction of current flows through the network elements.

Bilateral Elements are the elements that allow the current in both directions and offer the same impedance in either direction of current flow. Examples: Resistors, Inductors and capacitors.

The concept of Bilateral elements is illustrated in the following figures.



In the above figure, the current (I) is flowing from terminals A to B through a passive element having impedance of $Z \Omega$. It is the ratio of voltage (V) across that element between terminals A & B and current (I).

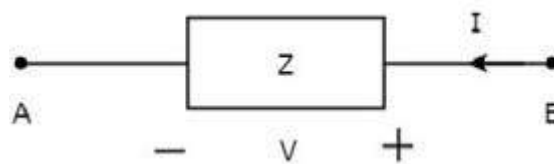

In the above figure, the current (I) is flowing from terminals B to A through a passive element having impedance of $Z \Omega$. That means the current ($-I$) is flowing from terminals A to B. In this case too, we will get the same impedance value, since both the current and voltage having negative signs with respect to terminals A & B.

Unilateral Elements are those that allow the current in only one direction. Hence, they offer different impedances in both directions.

We discussed the types of network elements in the previous chapter. Now, let us identify the nature of network elements from the V-I characteristics given in the following examples.

Example 1

The V-I characteristics of a network element is shown below.

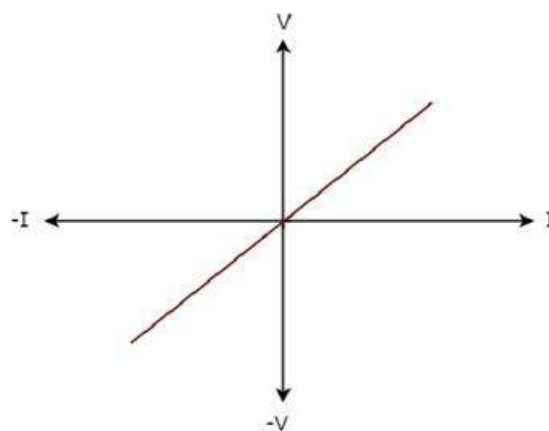

Step 1 – Verifying the network element as linear or non-linear.

From the above figure, the V-I characteristics of a network element is a straight line passing through the origin. Hence, it is linear element.

Step 2 – Verifying the network element as active or passive.

The given V-I characteristics of a network element lies in the first and third quadrants.

- In the first quadrant, the values of both voltage (V) and current (I) are positive. So, the ratios of voltage (V) and current (I) gives positive impedance values.

- Similarly, in the third quadrant, the values of both voltage (V) and current (I) have negative values. So, the ratios of voltage (V) and current (I) produce positive impedance values.

Since, the given V-I characteristics offer positive impedance values, the network element is a Passive element.

Step 3 – Verifying the network element as bilateral or unilateral.

For every point (I, V) on the characteristics, there exists a corresponding point (-I, -V) on the given characteristics. Hence, the network element is a Bilateral element.

Therefore, the given V-I characteristics show that the network element is a Linear, Passive, and Bilateral element.

Example 2

The V-I characteristics of a network element is shown below.

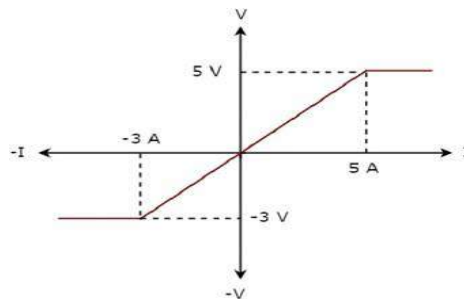

Step 1 – Verifying the network element as linear or non-linear.

From the above figure, the V-I characteristics of a network element is a straight line only between the points (-3A, -3V) and (5A, 5V). Beyond these points, the V-I characteristics are not following the linear relation. Hence, it is a Non-linear element.

Step 2 – Verifying the network element as active or passive.

The given V-I characteristics of a network element lies in the first and third quadrants. In these two quadrants, the ratios of voltage (V) and current (I) produce positive impedance values. Hence, the network element is a Passive element.

Step 3 – Verifying the network element as bilateral or unilateral.

Consider the point (5A, 5V) on the characteristics. The corresponding point (-5A, -3V) exists on the given characteristics instead of (-5A, -5V). Hence, the network element is a Unilateral element.

Therefore, the given V-I characteristics show that the network element is a Non-linear, Passive, and Unilateral element. The circuits containing them are called unilateral circuits.

Lumped and Distributed Elements

Lumped elements are those elements which are very small in size & in which simultaneous actions takes place. Typical lumped elements are capacitors, resistors, inductors.

Distributed elements are those which are not electrically separable for analytical purposes.

For example a transmission line has distributed parameters along its length and may extend for hundreds of miles.

R-L-C Parameters

Resistor

The main functionality of Resistor is either opposes or restricts the flow of electric current. Hence, the resistors are used in order to limit the amount of current flow and / or dividing (sharing) voltage. Let the current flowing through the resistor is I amperes and the voltage across it is V volts. The symbol of resistor along with current, I and voltage, V are shown in the following figure.

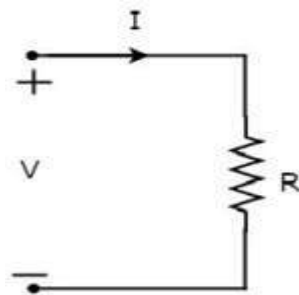

According to Ohm's law, the voltage across resistor is the product of current flowing through it and the resistance of that resistor. Mathematically, it can be represented as

$$V=I*R \quad \text{Equation 1}$$

$$I=V/R \quad \text{Equation 2}$$

Where, **R** is the resistance of a resistor.

From Equation 2, we can conclude that the current flowing through the resistor is directly proportional to the applied voltage across resistor and inversely proportional to the resistance of resistor.

Power in an electric circuit element can be represented as

$$P=V*I \quad \text{Equation 3}$$

Substitute, Equation 1 in Equation 3.

$$P= (IR) I$$

$$P=I^2R \quad \text{Equation 4}$$

Substitute, Equation 2 in Equation 3.

$$P=V*(V/R)$$

$$P=V^2/R \quad \text{Equation 5}$$

So, we can calculate the amount of power dissipated in the resistor by using one of the formulae mentioned in Equations 3 to 5.

Inductor

In general, inductors will have number of turns. Hence, they produce magnetic flux when current flows through it. So, the amount of total magnetic flux produced by an inductor depends on the current, I flowing through it and they have linear relationship.

Mathematically, it can be written as

$$\phi \propto I$$

$$\phi = LI$$

Where,

- Ψ is the total magnetic flux
- L is the inductance of an inductor

Let the current flowing through the inductor is I amperes and the voltage across it is V volts. The symbol of inductor along with current I and voltage V are shown in the following figure.

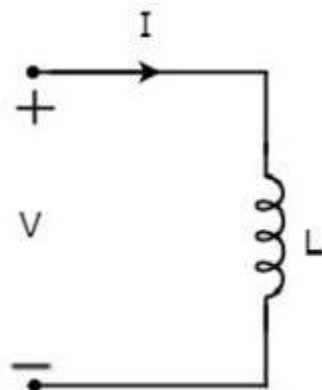

According to Faraday's law, the voltage across the inductor can be written as

$$V = \frac{d\phi}{dt}$$

Substitute $\Psi = LI$ in the above equation.

$$V = \frac{d(LI)}{dt}$$

$$V = L \frac{dI}{dt}$$

$$I = \frac{1}{L} \int V dt$$

From the above equations, we can conclude that there exists a linear relationship between voltage across inductor and current flowing through it.

We know that power in an electric circuit element can be represented as

$$P = V * I$$

Substitute $V = L \frac{dI}{dt}$ in the above equation

$$p = \left(L \frac{dI}{dt} \right) * I$$

$$p = LI \frac{dI}{dt}$$

By integrating the above equation, we will get the energy stored in an inductor as

$$W = \frac{1}{2} LI^2$$

So, the inductor stores the energy in the form of magnetic field.

Capacitor

In general, a capacitor has two conducting plates, separated by a dielectric medium. If positive voltage is applied across the capacitor, then it stores positive charge. Similarly, if negative voltage is applied across the capacitor, then it stores negative charge.

So, the amount of charge stored in the capacitor depends on the applied voltage V across it and they have linear relationship. Mathematically, it can be written as

$$Q \propto V$$

$$Q = CV$$

Where,

- Q is the charge stored in the capacitor.
- C is the capacitance of a capacitor.

Let the current flowing through the capacitor is I amperes and the voltage across it is V volts. The symbol of capacitor along with current I and voltage V are shown in the following figure.

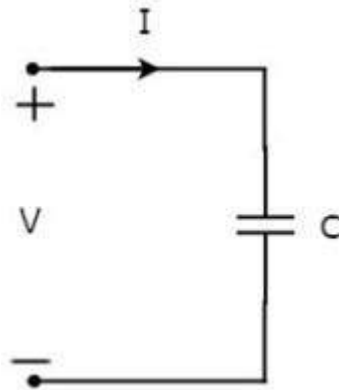

We know that the current is nothing but the time rate of flow of charge. Mathematically, it can be represented as

$$I = \frac{dQ}{dt}$$

Substitute $Q = CV$ in the above equation.

$$I = \frac{d(CV)}{dt}$$

$$I = C \frac{dV}{dt}$$

$$V = \frac{1}{C} \int I dt$$

From the above equations, we can conclude that there exists a linear relationship between voltage across capacitor and current flowing through it.

We know that power in an electric circuit element can be represented as

$$P = V * I$$

Substitute $I = C \frac{dV}{dt}$ in the above equation

$$p = \left(C \frac{dV}{dt} \right) * V$$

$$p = CV \frac{dI}{dt}$$

By integrating the above equation, we will get the energy stored in the capacitor as

$$W = \frac{1}{2} CV^2$$

So, the capacitor stores the energy in the form of electric field.

Passive Sign Convention:

The concept of passive sign convention comes directly from the definition of voltage.

Voltage is a difference of charge between two places in space. Not an absolute quality. You could think of it in terms of depth and height.

Something has an elevation or height only with respect to something else such as sea level. Likewise depth, something is only deep compared to some level, again such as sea level.

There is one difference between depth and height. We consider height to be positive and depth to be negative. One of the reasons why we do this is because we usually deal more with height than depth, and we wish to minimize the amount of subtraction that we perform.

The passive sign convention is the same concept. It is an algorithm to decide what is adding potential energy to the system and what is taking it away.

Here are some basic ground rules:

- All resistors are either positive or negative uniformly. Which means that if you consider one resistor to be positive (which is the common case) then all the resistors are positive.
- At least one source is the opposite sign of the resistors. If only one is present then that is the one.
- Always start by making your loop.

Why do we use this Passive sign convention?

One of the most important ideas of an electric circuit is that there is a source of power and a dissipater of power. As circuit connections become more intricate this basic idea becomes more blurred. In some cases there is more than one power supply at different circuit locations, such that simple addition of their power magnitudes is not possible. We need to know which direction power supply and consumption is. The next examples will illustrate this.

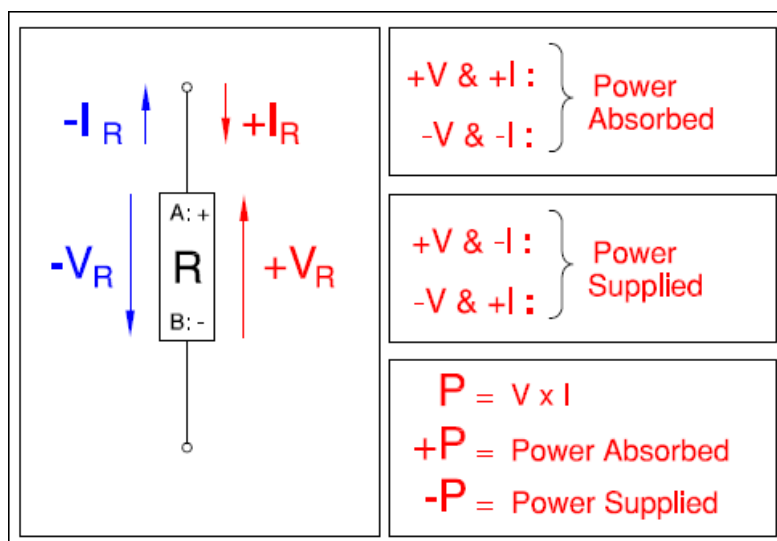

Points A and B physical end points of an element. By convention A (+) has a higher potential than (-) by amount V . If V is negative then B is higher than A. but the signs remain unchanged. The current I enter point A and leaves point B .If I is negative then current is entering point B and existing point A.

Electric charge Q at point A gets moves from a higher potential to a lower potential (i.e from points A to B). Since the charge is leaving at a lower potential the charge has lost potential energy. This is called a **resistor**. If the charge moves from B to A it gains potential energy. This is called a **source**.

If we keep A and B as the (+) and (-) terminals, then there are four possible combinations. The two cases (- V , - I) and (+ V , + I) are ones where the element acts as a resistor, and it uses up energy. The two cases (- V , + I) and (+ V , - I) are ones where the element acts as a source, and it supplies energy.

If we flip A to be (-) and B to be (+) then we have effectively rotated the element by 180 degrees. All of the above cases still hold true.

Being comfortable with the convention and being able to quickly visualize different combinations of +/- I or +/- V from either terminal A or B will help in using the circuit solving methods of **Mesh** and **Nodal Analysis**.

Types of Sources

Active Elements are the network elements that deliver power to other elements present in an electric circuit. So, active elements are also called as sources of voltage or current type. We can classify these sources into the following two categories –

- Independent Sources
- Dependent Sources

Independent Sources

As the name suggests, independent sources produce fixed values of voltage or current and these are not dependent on any other parameter. Independent sources can be further divided into the following two categories –

- Independent Voltage Sources
- Independent Current Sources

Independent Voltage Sources

An independent voltage source produces a constant voltage across its two terminals. This voltage is independent of the amount of current that is flowing through the two terminals of voltage source. Independent ideal voltage source and its V-I characteristics are shown in the following figure.

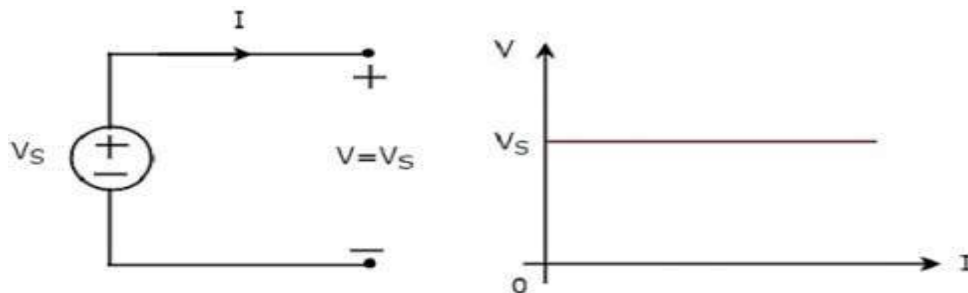

The V-I characteristics of an independent ideal voltage source is a constant line, which is always equal to the source voltage (V_S) irrespective of the current value (I). So, the internal resistance of an independent ideal voltage source is zero Ohms.

Hence, the independent ideal voltage sources do not exist practically, because there will be some internal resistance.

Independent practical voltage source and its V-I characteristics are shown in the following figure.

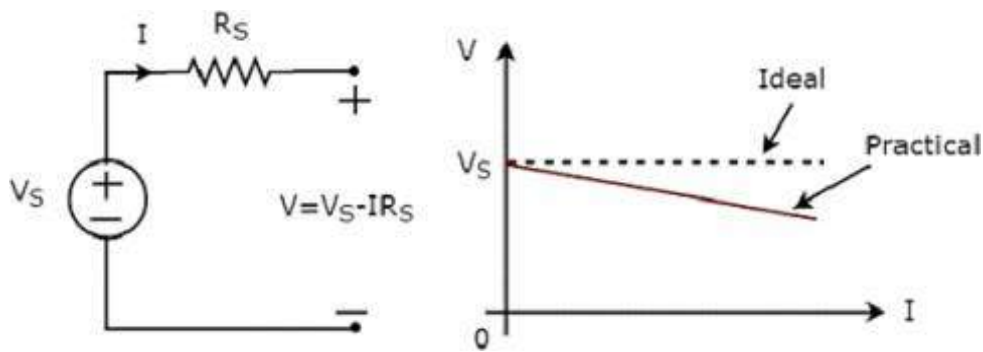

There is a deviation in the V-I characteristics of an independent practical voltage source from the V-I characteristics of an independent ideal voltage source. This is due to the voltage drop across the internal resistance (R_S) of an independent practical voltage source.

Independent Current Sources

An independent current source produces a constant current. This current is independent of the voltage across its two terminals. Independent ideal current source and its V-I characteristics are shown in the following figure.

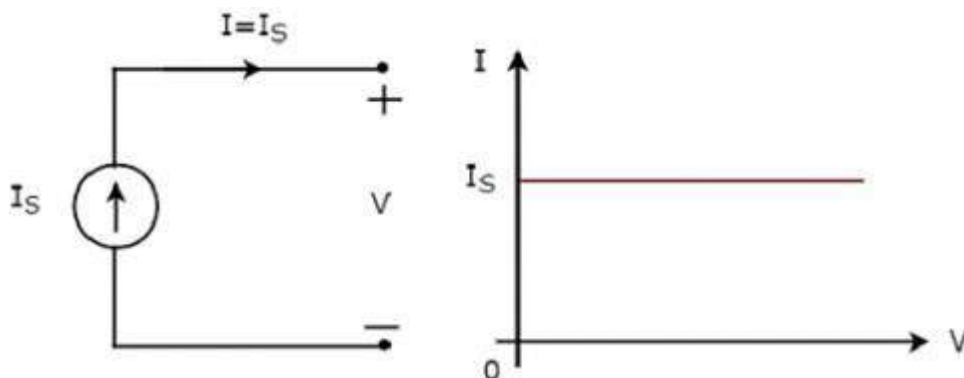

The V-I characteristics of an independent ideal current source is a constant line, which is always equal to the source current (I_S) irrespective of the voltage value (V). So, the internal resistance of an independent ideal current source is infinite ohms.

Hence, the independent ideal current sources do not exist practically, because there will be some internal resistance.

Independent practical current source and its V-I characteristics are shown in the following figure.

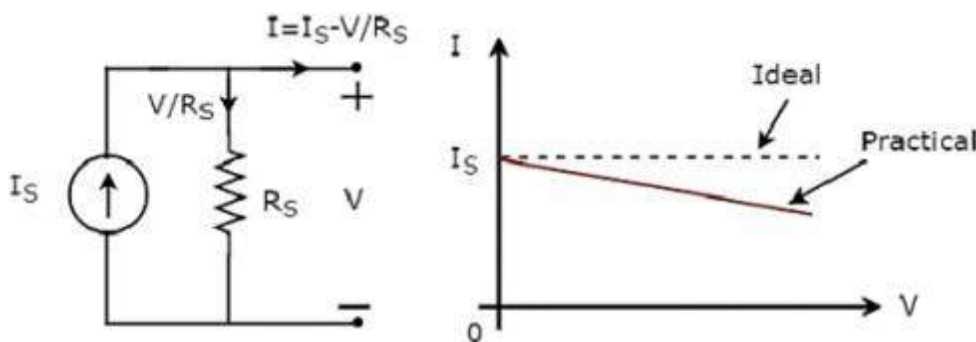

There is a deviation in the V-I characteristics of an independent practical current source from the V-I characteristics of an independent ideal current source. This is due to the amount of current flows through the internal shunt resistance (R_S) of an independent practical current source.

Dependent Sources

As the name suggests, dependent sources produce the amount of voltage or current that is dependent on some other voltage or current. Dependent sources are also called as controlled sources. Dependent sources can be further divided into the following two categories –

- Dependent Voltage Sources
- Dependent Current Sources

Dependent Voltage Sources

A dependent voltage source produces a voltage across its two terminals. The amount of this voltage is dependent on some other voltage or current. Hence, dependent voltage sources can be further classified into the following two categories –

- Voltage Dependent Voltage Source (VDVS)
- Current Dependent Voltage Source (CDVS)

Dependent voltage sources are represented with the signs '+' and '-' inside a diamond shape. The magnitude of the voltage source can be represented outside the diamond shape.

Dependent Current Sources

A dependent current source produces a current. The amount of this current is dependent on some other voltage or current. Hence, dependent current sources can be further classified into the following two categories –

- Voltage Dependent Current Source (VDCCS)
- Current Dependent Current Source (CDCS)

Dependent current sources are represented with an arrow inside a diamond shape. The magnitude of the current source can be represented outside the diamond shape. We can observe these dependent or controlled sources in equivalent models of transistors.

Source Transformation Technique

We know that there are two practical sources, namely, voltage source and current source. We can transform (convert) one source into the other based on the requirement, while solving network problems.

The technique of transforming one source into the other is called as source transformation technique. Following are the two possible source transformations –

- Practical voltage source into a practical current source
- Practical current source into a practical voltage source

Practical voltage source into a practical current source

The transformation of practical voltage source into a practical current source is shown in the following figure

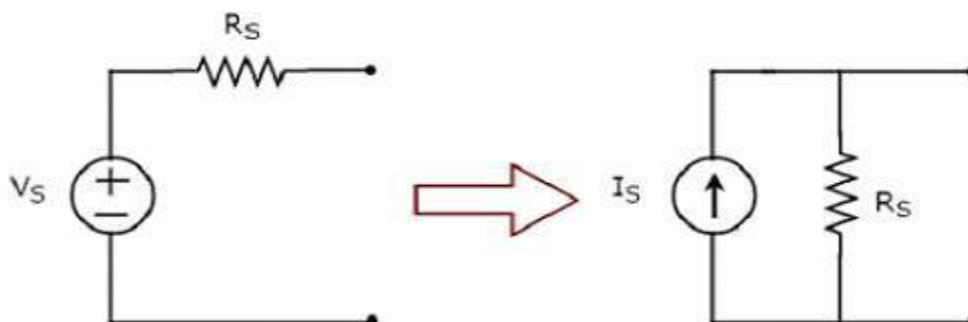

Practical voltage source consists of a voltage source (V_S) in series with a resistor (R_S). This can be converted into a practical current source as shown in the figure. It consists of a current source (I_S) in parallel with a resistor (R_S).

The value of I_S will be equal to the ratio of V_S and R_S . Mathematically, it can be represented as

$$I_S = \frac{V_S}{R_S}$$

Practical current source into a practical voltage source

The transformation of practical current source into a practical voltage source is shown in the following figure.

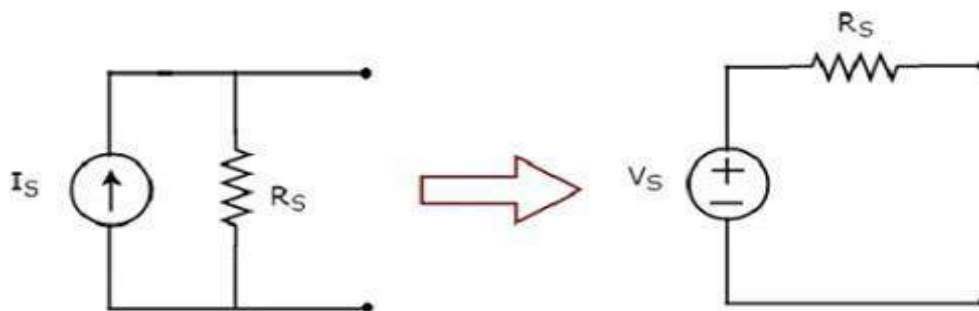

Practical current source consists of a current source (I_s) in parallel with a resistor (R_s). This can be converted into a practical voltage source as shown in the figure. It consists of a voltage source (V_s) in series with a resistor (R_s).

The value of V_s will be equal to the product of I_s and R_s . Mathematically, it can be represented as

$$V_s = I_s \cdot R_s$$

In this chapter, we will discuss in detail about the passive elements such as Resistor, Inductor, and Capacitor. Let us start with Resistors.

Kirchhoff's Laws

Network elements can be either of active or passive type. Any electrical circuit or network contains one of these two types of network elements or a combination of both.

Now, let us discuss about the following two laws, which are popularly known as Kirchhoff's laws.

- Kirchhoff's Current Law
- Kirchhoff's Voltage Law

Kirchhoff's Current Law

Kirchhoff's Current Law (KCL) states that the algebraic sum of currents leaving (or entering) a node is equal to zero.

A Node is a point where two or more circuit elements are connected to it. If only two circuit elements are connected to a node, then it is said to be simple node. If three or more circuit elements are connected to a node, then it is said to be Principal Node.

Mathematically, KCL can be represented as

$$\sum_{m=1}^M I_m = 0$$

Where,

- I_m is the m^{th} branch current leaving the node.

- M is the number of branches that are connected to a node.

The above statement of KCL can also be expressed as "the algebraic sum of currents entering a node is equal to the algebraic sum of currents leaving a node". Let us verify this statement through the following example.

Example

Write KCL equation at node P of the following figure.

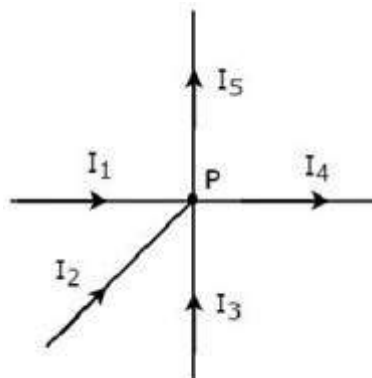

- In the above figure, the branch currents I_1 , I_2 and I_3 are entering at node P. So, consider negative signs for these three currents.
- In the above figure, the branch currents I_4 and I_5 are leaving from node P. So, consider positive signs for these two currents.

The KCL equation at node P will be

$$-I_1 - I_2 - I_3 + I_4 + I_5 = 0$$

$$I_1 + I_2 + I_3 = I_4 + I_5$$

In the above equation, the left-hand side represents the sum of entering currents, whereas the right-hand side represents the sum of leaving currents.

In this tutorial, we will consider positive sign when the current leaves a node and negative sign when it enters a node. Similarly, you can consider negative sign when the current leaves a node and positive sign when it enters a node. In both cases, the result will be same.

Note – KCL is independent of the nature of network elements that are connected to a node.

Kirchhoff's Voltage Law

Kirchhoff's Voltage Law (KVL) states that the algebraic sum of voltages around a loop or mesh is equal to zero.

A Loop is a path that terminates at the same node where it started from. In contrast, a Mesh is a loop that doesn't contain any other loops inside it.

Mathematically, KVL can be represented as

$$\sum_{n=1}^N V_n = 0$$

Where,

- V_n is the n^{th} element's voltage in a loop (mesh).
- N is the number of network elements in the loop (mesh).

The above statement of KVL can also be expressed as "the algebraic sum of voltage sources is equal to the algebraic sum of voltage drops that are present in a loop." Let us verify this statement with the help of the following example.

Example

Write KVL equation around the loop of the following circuit.

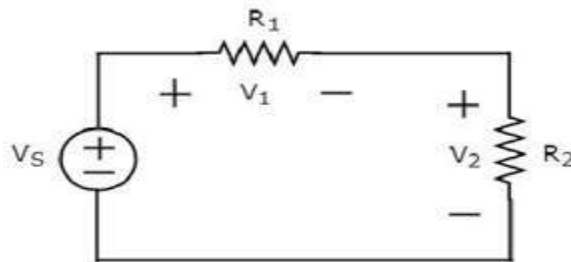

The above circuit diagram consists of a voltage source, V_S in series with two resistors R_1 and R_2 . The voltage drops across the resistors R_1 and R_2 are V_1 and V_2 respectively.

Apply KVL around the loop.

$$V_S - V_1 - V_2 = 0$$

$$V_S = V_1 + V_2$$

In the above equation, the left-hand side term represents single voltage source V_S . Whereas, the right-hand side represents the sum of voltage drops. In this example, we considered only one voltage source. That's why the left-hand side contains only one term. If we consider multiple voltage sources, then the left side contains sum of voltage sources.

In this tutorial, we consider the sign of each element's voltage as the polarity of the second terminal that is present while travelling around the loop. Similarly, you can consider the sign of each voltage as the polarity of the first terminal that is present while travelling around the loop. In both cases, the result will be same.

Note – KVL is independent of the nature of network elements that are present in a loop.

In this chapter, let us discuss about the following two division principles of electrical quantities.

- Current Division Principle
- Voltage Division Principle

Current Division Principle

When two or more passive elements are connected in parallel, the amount of current that flows through each element gets divided (shared) among themselves from the current that is entering the node.

Consider the following circuit diagram.

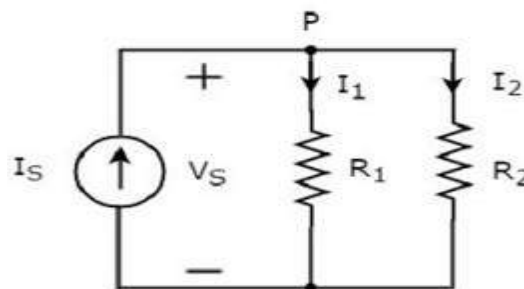

The above circuit diagram consists of an input current source I_S in parallel with two resistors R_1 and R_2 . The voltage across each element is V_S . The currents flowing through the resistors R_1 and R_2 are I_1 and I_2 respectively.

The KCL equation at node P will be

$$I_S = I_1 + I_2$$

- Substitute $I_1 = \frac{V_S}{R_1}$ and $I_2 = \frac{V_S}{R_2}$ in the above equation

$$I_S = \frac{V_S}{R_1} + \frac{V_S}{R_2} = V_S \left(\frac{1}{R_1} + \frac{1}{R_2} \right)$$

$$V_S = I_S \left(\frac{R_1 R_2}{R_1 + R_2} \right)$$

- Substitute the values of V_S in $I_1 = \frac{V_S}{R_1}$

$$I_1 = \frac{I_S}{R_1} \left(\frac{R_1 R_2}{R_1 + R_2} \right)$$

$$I_1 = I_S \left(\frac{R_2}{R_1 + R_2} \right)$$

- Substitute the values of V_S in $I_2 = \frac{V_S}{R_2}$

$$I_2 = \frac{I_S}{R_2} \left(\frac{R_1 R_2}{R_1 + R_2} \right)$$

$$I_2 = I_S \left(\frac{R_1}{R_1 + R_2} \right)$$

From equations of I_1 and I_2 , we can generalize that the current flowing through any passive element can be found by using the following formula.

$$I_N = I_S \frac{Z_1 || Z_2 || \dots || Z_{N-1}}{Z_1 + Z_2 + \dots + Z_N}$$

This is known as current division principle and it is applicable, when two or more passive elements are connected in parallel and only one current enters the node.

Where,

- I_N is the current flowing through the passive element of N^{th} branch.
- I_S is the input current, which enters the node.
- Z_1, Z_2, \dots, Z_N are the impedances of 1st branch, 2nd branch, ..., N^{th} branch respectively.

Voltage Division Principle

When two or more passive elements are connected in series, the amount of voltage present across each element gets divided (shared) among themselves from the voltage that is available across that entire combination.

Consider the following circuit diagram.

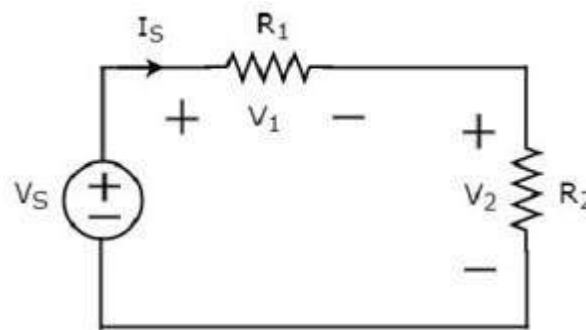

The above circuit diagram consists of a voltage source, V_S in series with two resistors R_1 and R_2 . The current flowing through these elements is I_S . The voltage drops across the resistors R_1 and R_2 are V_1 and V_2 respectively.

The KVL equation around the loop will be

$$V_S = V_1 + V_2$$

- Substitute $V_1 = I_S R_1$ and $V_2 = I_S R_2$ in the above equation

$$V_S = I_S R_1 + I_S R_2 = I_S (R_1 + R_2)$$

$$I_S = \frac{V_S}{R_1 + R_2}$$

- Substitute the value of I_S in $V_1 = I_S R_1$.

$$V_1 = R_1 \left(\frac{V_S}{R_1 + R_2} \right)$$

$$V_1 = V_S \left(\frac{R_1}{R_1 + R_2} \right)$$

- Substitute the value of I_S in $V_2 = I_S R_2$.

$$V_2 = R_2 \left(\frac{V_S}{R_1 + R_2} \right)$$

$$V_2 = V_S \left(\frac{R_2}{R_1 + R_2} \right)$$

From equations of V_1 and V_2 , we can generalize that the voltage across any passive element can be found by using the following formula.

$$V_N = V_S \left(\frac{Z_N}{Z_1 + Z_2 + \dots + Z_N} \right)$$

This is known as voltage division principle and it is applicable, when two or more passive elements are connected in series and only one voltage available across the entire combination.

Where,

- V_N is the voltage across N^{th} passive element.
- V_S is the input voltage, which is present across the entire combination of series passive elements.
- Z_1, Z_2, \dots, Z_N are the impedances of 1st passive element, 2nd passive element, ..., N^{th} passive element respectively.

➤ Find the current flowing through 10 ohms resistor using KVL and KCL.

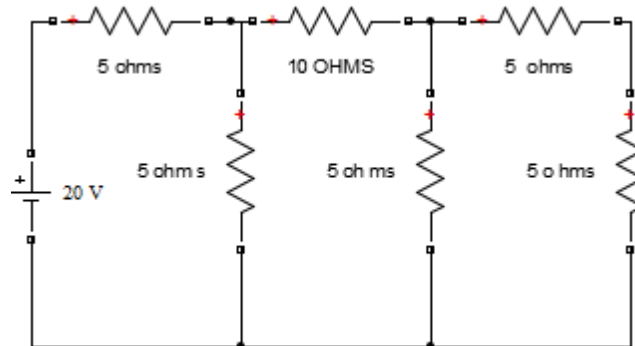

Method 1: LOOP ANALYSIS (BY CONSIDERING BRANCH CURRENTS)
INDICATE CURRENTS IN EACH BRANCH

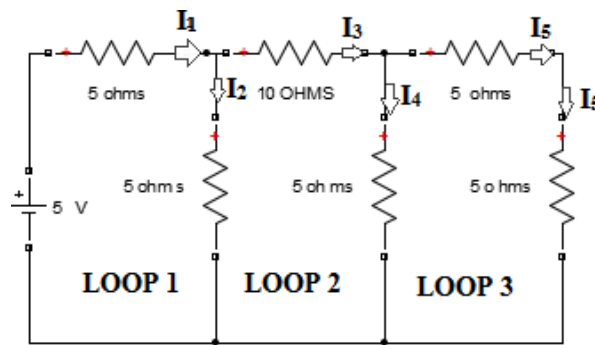

APPLY KVL AT LOOP 1

$$20 - 5I_1 - 5I_2 = 0$$

$$I_1 + I_2 = 4 \dots\dots\dots 1)$$

APPLY KVL AT LOOP 2

$$-10I_3 - 5I_4 + 5I_2 = 0$$

$$I_2 - 2I_3 - I_4 = 0 \dots\dots\dots 2)$$

APPLY KVL AT LOOP 3

$$-5I_5 - 5I_5 + 5I_4 = 0$$

$$I_4 - 2I_5 = 0 \dots\dots\dots 3)$$

FROM KCL $I_1 = I_2 + I_3$, $I_3 = I_4 + I_5$

SUB $I_5 = I_3 - I_4$ IN EQUATION 3, WE GET,

$$I_4 = 2/3 I_3 \dots\dots\dots 4)$$

SUB I_4 VALUE IN EQUATION 2, WE GET,

$$-8I_1 + 11I_2 = 0 \dots\dots\dots 5)$$

SOLVE 5 AND 1, WE WILL GET

$$I_2 = 1.684A$$

FROM EQUATION 1, SUB I_2 VALUE WE GET $I_1 = 2.31A$

FROM KCL $I_3 = I_1 - I_2$

$$I_3 = 2.31 - 1.64 = 0.63A$$

Current flowing through 10 ohm resistor is I_3 and the Value is 0.63 A.

EX: Find the current flowing through R2 resistor

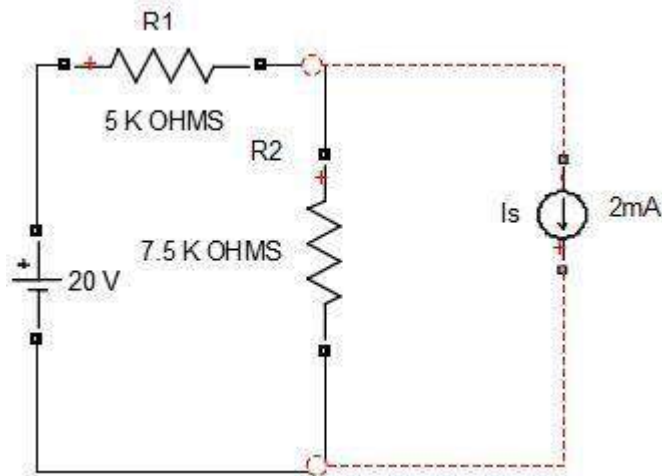

APPLY KCL AT NODE

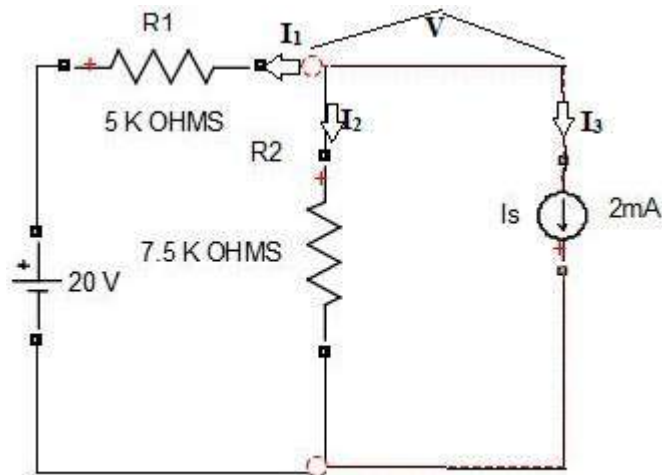

0 REFERENCE NODE

$$I_1 + I_2 + I_3 = 0$$

$$\frac{V - 20}{5K} + \frac{V}{7.5K} + 2mA = 0$$

$$\frac{(V - 20)15}{75K} + \frac{10V}{75K} + 2mA = 0$$

$$\frac{15V - 300 + 10V}{75K} + 2mA = 0$$

$$\frac{25V - 300}{75K} + 2mA = 0$$

$$\frac{25V - 300 + 150}{75K} = 0$$

$$\frac{25V - 150}{75K} = 0$$

$$V = \frac{150}{25} = 6V$$

Current Flowing Through R_2 IS $\frac{V}{7.5K} = \frac{6}{7.5K}$
 $= 0.8mA$

**UNIT-II
NETWORK ANALYSIS**

- Network Reduction Techniques
- Series and Parallel connection of Resistive Networks
- Star-to-Delta and Delta-to-Star Transformations for Resistive Networks
- Mesh Analysis
- Network Theorems: Thevenin's Theorem
- Norton's Theorem
- Superposition Theorem
- Problems

Network Reduction Techniques:

There are two basic methods that are used for solving any electrical network: Nodal analysis and Mesh analysis. In this chapter, let us discuss about the Mesh analysis method.

Series and parallel connections of resistive networks:

If a circuit consists of two or more similar passive elements and are connected in exclusively of series type or parallel type, then we can replace them with a single equivalent passive element. Hence, this circuit is called as an equivalent circuit.

In this chapter, let us discuss about the following two equivalent circuits.

- Series Equivalent Circuit
- Parallel Equivalent Circuit

Series Equivalent Circuit

If similar passive elements are connected in series, then the same current will flow through all these elements. But, the voltage gets divided across each element.

Consider the following circuit diagram.

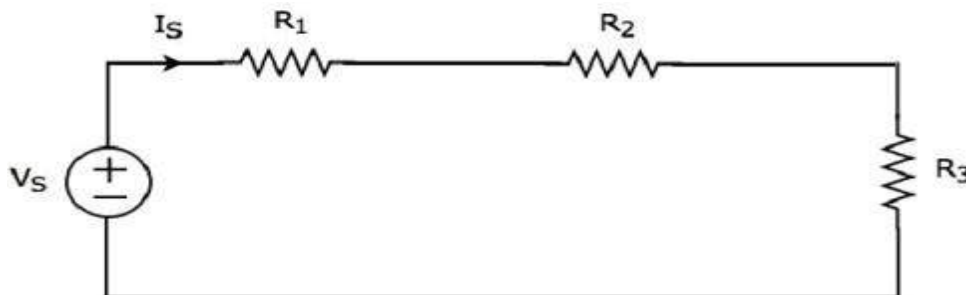

It has a single voltage source (V_s) and three resistors having resistances of R_1 , R_2 and R_3 . All these elements are connected in series. The current I_s flows through all these elements.

The above circuit has only one mesh. The KVL equation around this mesh is

$$V_s = V_1 + V_2 + V_3$$

- Substitute the value of $V_1 = I_s R_1$, $V_2 = I_s R_2$ and $V_3 = I_s R_3$

$$V_s = I_s R_1 + I_s R_2 + I_s R_3$$

$$V_s = I_s (R_1 + R_2 + R_3)$$

The above equation in the form of $V_s = I_s R_{Eq}$ where,

$$R_{Eq} = (R_1 + R_2 + R_3)$$

The equivalent circuit diagram of the given circuit is shown in the following figure.

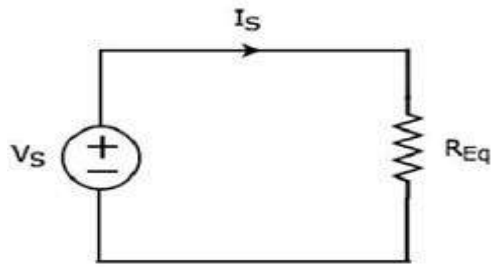

That means, if multiple resistors are connected in series, then we can replace them with an equivalent resistor. The resistance of this equivalent resistor is equal to sum of the resistances of all those multiple resistors.

Note 1 – If ‘N’ inductors having inductances of L_1, L_2, \dots, L_N are connected in series, then the equivalent inductance will be

$$L_{Eq} = L_1 + L_2 + L_3 + \dots + L_N$$

Note 2 – If ‘N’ capacitors having capacitances of C_1, C_2, \dots, C_N are connected in series, then the equivalent capacitance will be

$$\frac{1}{C_{Eq}} = \frac{1}{C_1} + \frac{1}{C_2} + \dots + \frac{1}{C_N}$$

Parallel Equivalent Circuit

If similar passive elements are connected in parallel, then the same voltage will be maintained across each element. But, the current flowing through each element gets divided.

Consider the following circuit diagram.

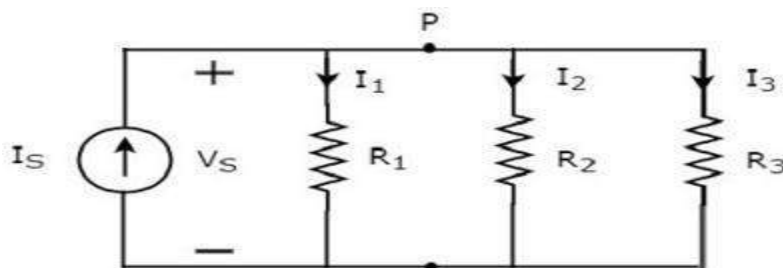

It has a single current source (I_S) and three resistors having resistances of R_1, R_2 , and R_3 . All these elements are connected in parallel. The voltage (V_S) is available across all these elements.

The above circuit has only one principal node (P) except the Ground node. The KCL equation at this principal node (P) is

$$I_S = I_1 + I_2 + I_3$$

- Substitute the value of $I_1 = \frac{V_S}{R_1}$, $I_2 = \frac{V_S}{R_2}$ and $I_3 = \frac{V_S}{R_3}$

$$I_S = \frac{V_S}{R_1} + \frac{V_S}{R_2} + \frac{V_S}{R_3}$$

$$I_S = V_S \left(\frac{1}{R_1} + \frac{1}{R_2} + \frac{1}{R_3} \right)$$

$$V_S = I_S \left(\frac{1}{\frac{1}{R_1} + \frac{1}{R_2} + \frac{1}{R_3}} \right)$$

The above equation in the form of $V_S = I_S R_{Eq}$ where,

$$R_{Eq} = \left(\frac{1}{\frac{1}{R_1} + \frac{1}{R_2} + \frac{1}{R_3}} \right)$$

$$\frac{1}{R_{Eq}} = \frac{1}{R_1} + \frac{1}{R_2} + \frac{1}{R_3}$$

The equivalent circuit diagram of the given circuit is shown in the following figure.

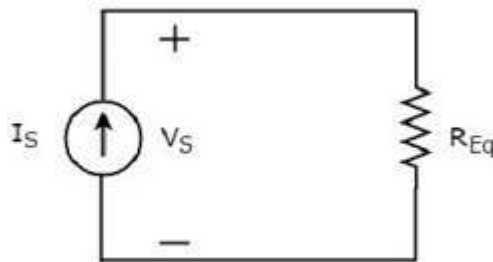

That means, if multiple resistors are connected in parallel, then we can replace them with an equivalent resistor. The resistance of this equivalent resistor is equal to the reciprocal of sum of reciprocal of each resistance of all those multiple resistors.

Note 1 – If ‘N’ inductors having inductances of L_1, L_2, \dots, L_N are connected in parallel, then the equivalent inductance will be

$$\frac{1}{L_{Eq}} = \frac{1}{L_1} + \frac{1}{L_2} + \frac{1}{L_3}$$

Note 2 – If ‘N’ capacitors having capacitances of C_1, C_2, \dots, C_N are connected in parallel, then the equivalent capacitance will be

$$C_{Eq} = C_1 + C_2 + C_3 + \dots + C_N$$

Example Problems:

1) Find the Req for the circuit shown in below figure.

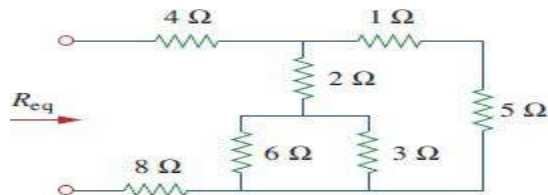

fig(a)

Solution:

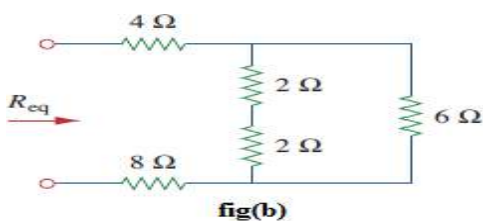

fig(b)

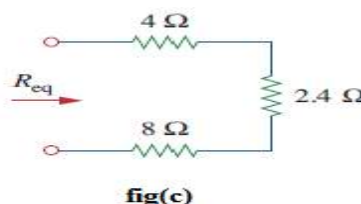

fig(c)

To get Req we combine resistors in series and in parallel. The 6 ohms and 3 ohms resistors are in parallel, so their equivalent resistance is

$$6 \Omega \parallel 3 \Omega = \frac{6 \times 3}{6 + 3} = 2 \Omega$$

Also, the 1 ohm and 5ohms resistors are in series; hence their equivalent resistance is

$$1 \Omega + 5 \Omega = 6 \Omega$$

Thus the circuit in Fig.(b) is reduced to that in Fig. (c). In Fig. (b), we notice that the two 2 ohms resistors are in series, so the equivalent resistance is

$$2 \Omega + 2 \Omega = 4 \Omega$$

This 4 ohms resistor is now in parallel with the 6 ohms resistor in Fig.(b); their equivalent resistance is

$$4 \Omega \parallel 6 \Omega = \frac{4 \times 6}{4 + 6} = 2.4 \Omega$$

The circuit in Fig.(b) is now replaced with that in Fig.(c). In Fig.(c), the three resistors are in series. Hence, the equivalent resistance for the circuit is

$$R_{eq} = 4 \Omega + 2.4 \Omega + 8 \Omega = 14.4 \Omega$$

2) Find the Req for the circuit shown in below figure.

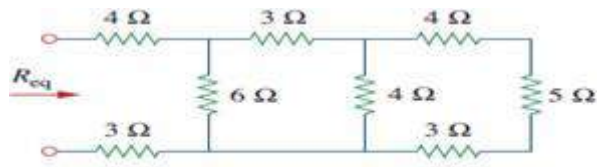

fig(a)

Solution:

In the given network 4 ohms, 5 ohms and 3 ohms comes in series then equivalent resistance is $4+5 + 3 = 12$ ohms

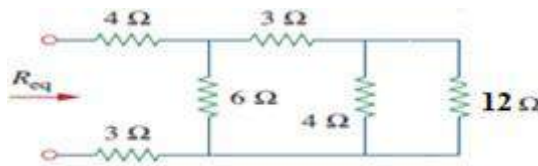

fig(b)

From fig(b), 4 ohms and 12 ohms are in parallel, equivalent is 3 ohms

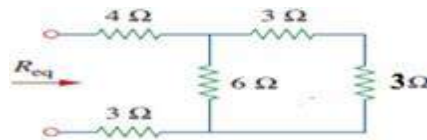

fig(c)

From fig(c), 3 ohms and 3 ohms are in series, equivalent resistance is 6 ohms

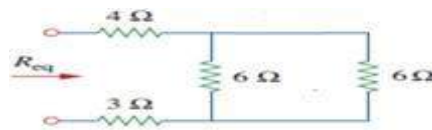

fig(d)

From fig(d), 6 ohms and 6 ohms are in parallel, equivalent resistance is 3 ohms

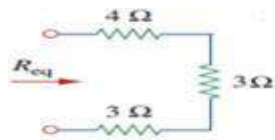

fig(e)

From fig(e), 4 ohms, 3 ohms and 3 ohms are in series .Hence $R_{eq} = 4+ 3+ 3 =10$ ohms

Star-to-Delta and Delta-to-Star Transformations for Resistive Networks:

Delta to Star Transformation

In the previous chapter, we discussed an example problem related equivalent resistance. There, we calculated the equivalent resistance between the terminals A & B of the given electrical network easily. Because, in every step, we got the combination of resistors that are connected in either series form or parallel form.

However, in some situations, it is difficult to simplify the network by following the previous approach. For example, the resistors connected in either delta (δ) form or star form. In such situations, we have to convert the network of one form to the other in order to simplify it further by using series combination or parallel combination. In this chapter, let us discuss about the Delta to Star Conversion.

Delta Network

Consider the following delta network as shown in the following figure.

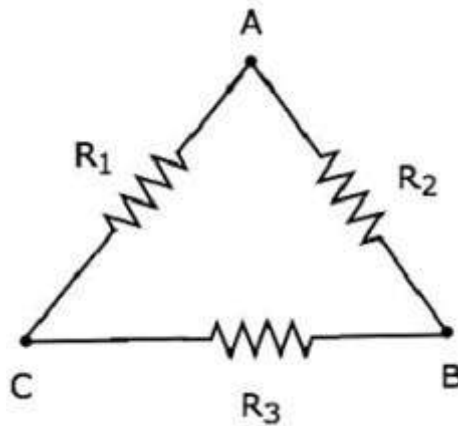

The following equations represent the equivalent resistance between two terminals of delta network, when the third terminal is kept open.

$$R_{AB} = \frac{(R_1 + R_3)R_2}{R_1 + R_2 + R_3}$$

$$R_{BC} = \frac{(R_1 + R_2)R_3}{R_1 + R_2 + R_3}$$

$$R_{CA} = \frac{(R_2 + R_3)R_1}{R_1 + R_2 + R_3}$$

Star Network

The following figure shows the equivalent star network corresponding to the above delta network.

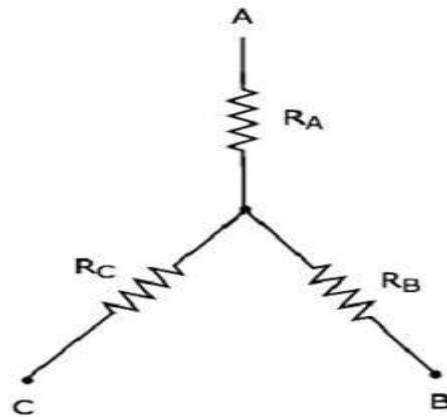

The following equations represent the equivalent resistance between two terminals of star network, when the third terminal is kept open.

$$R_{AB} = R_A + R_B$$

$$R_{BC} = R_B + R_C$$

$$R_{CA} = R_C + R_A$$

Star Network Resistances in terms of Delta Network Resistances

We will get the following equations by equating the right-hand side terms of the above equations for which the left-hand side terms are same.

$$R_A + R_B = \frac{(R_1 + R_3)R_2}{R_1 + R_2 + R_3} \quad \text{Equation 1}$$

$$R_B + R_C = \frac{(R_1 + R_2)R_3}{R_1 + R_2 + R_3} \quad \text{Equation 2}$$

$$R_C + R_A = \frac{(R_2 + R_3)R_1}{R_1 + R_2 + R_3} \quad \text{Equation 3}$$

By adding above **three** equations, we will get

$$2(R_A + R_B + R_C) = \frac{2(R_1R_2 + R_2R_3 + R_3R_1)}{R_1 + R_2 + R_3}$$

$$R_A + R_B + R_C = \frac{R_1R_2 + R_2R_3 + R_3R_1}{R_1 + R_2 + R_3} \quad \text{Equation 4}$$

Subtracting **equation 2** from **equation 4**, we will get

$$R_A + R_C - (R_B + R_C) = \frac{R_1R_2 + R_2R_3 + R_3R_1}{R_1 + R_2 + R_3} - \frac{(R_1 + R_2)R_3}{R_1 + R_2 + R_3}$$

$$R_A = \frac{R_1R_2}{R_1 + R_2 + R_3}$$

Subtracting **equation 3** from **equation 4**, we will get

$$\frac{R_A + R_B + R_C - (R_C + R_A)}{R_1 + R_2 + R_3} = \frac{R_1 R_2 + R_2 R_3 + R_3 R_1}{R_1 + R_2 + R_3} - \frac{(R_2 + R_3)_1}{R_1 + R_2 + R_3}$$

$$R_B = \frac{R_2 R_3}{R_1 + R_2 + R_3}$$

Subtracting equation 1 from equation 4, we will get

$$\frac{R_A + R_B + R_C - (R_A + R_B)}{R_1 + R_2 + R_3} = \frac{R_1 R_2 + R_2 R_3 + R_3 R_1}{R_1 + R_2 + R_3} - \frac{(R_1 + R_3)_2}{R_1 + R_2 + R_3}$$

$$R_C = \frac{R_3 R_1}{R_1 + R_2 + R_3}$$

By using the above relations, we can find the resistances of star network from the resistances of delta network. In this way, we can convert a delta network into a star network.

Star to Delta Transformation

In the previous chapter, we discussed about the conversion of delta network into an equivalent star network. Now, let us discuss about the conversion of star network into an equivalent delta network. This conversion is called as Star to Delta Conversion.

In the previous chapter, we got the resistances of star network from delta network as

$$R_A = \frac{R_1 R_2}{R_1 + R_2 + R_3}$$

$$R_B = \frac{R_2 R_3}{R_1 + R_2 + R_3}$$

$$R_C = \frac{R_3 R_1}{R_1 + R_2 + R_3}$$

Delta Network Resistances in terms of Star Network Resistances

Let us manipulate the above equations in order to get the resistances of delta network in terms of resistances of star network.

- Multiply each set of two equations and then add.

$$R_A R_B + R_B R_C + R_C R_A = \frac{R_1 R_2^2 R_3 + R_2 R_3^2 R_1 + R_3 R_1^2 R_2}{(R_1 + R_2 + R_3)^2}$$

$$\frac{R_A R_B + R_B R_C + R_C R_A}{R_1 + R_2 + R_3} = \frac{R_1 R_2 R_3 (R_1 + R_2 + R_3)}{(R_1 + R_2 + R_3)^2}$$

$$\frac{R_A R_B + R_B R_C + R_C R_A}{R_1 + R_2 + R_3} = \frac{R_1 R_2 R_3}{R_1 + R_2 + R_3}$$

By dividing equation 4 with equation 2, we will get

$$\frac{R_A R_B + R_B R_C + R_C R_A}{R_B} = R_1$$

$$R_1 = R_A + R_C \frac{R_C R_A}{R_B}$$

By dividing equation 4 with equation 3, we will get

$$R_2 = R_A + R_B \frac{R_B R_A}{R_C}$$

By dividing equation 4 with equation 1, we will get

$$R_3 = R_B + R_C \frac{R_B R_C}{R_A}$$

By using the above relations, we can find the resistances of delta network from the resistances of star network. In this way, we can convert star network into delta network.

Example problems:

1) Convert the Delta network in Fig.(a) to an equivalent star network

Solution:

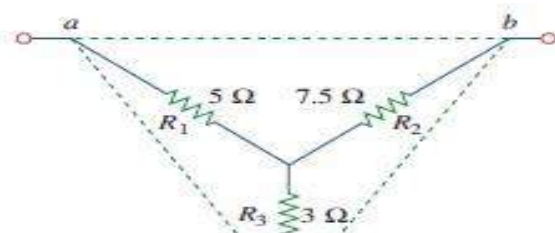
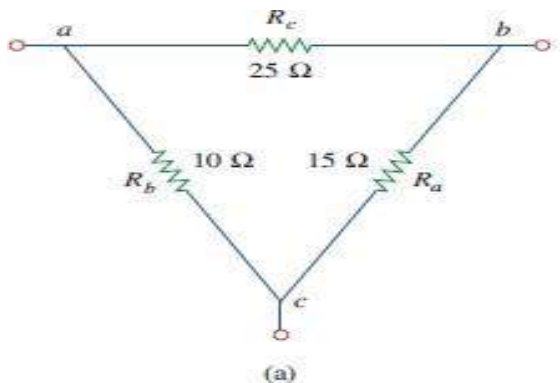

$$R_1 = \frac{R_b R_c}{R_a + R_b + R_c} = \frac{10 \times 25}{15 + 10 + 25} = \frac{250}{50} = 5 \Omega$$

$$R_2 = \frac{R_c R_a}{R_a + R_b + R_c} = \frac{25 \times 15}{50} = 7.5 \Omega$$

$$R_3 = \frac{R_a R_b}{R_a + R_b + R_c} = \frac{15 \times 10}{50} = 3 \Omega$$

2) Convert the star network in fig(a) to delta network

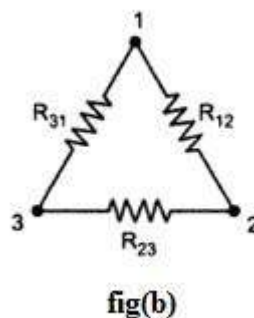
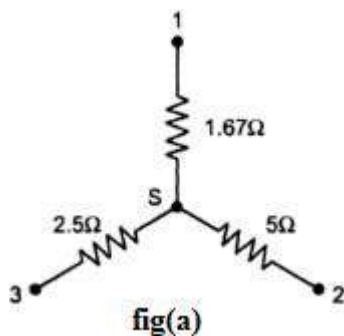

Solution: The equivalent delta for the given star is shown in fig(b), where

$$R_{12} = 1.67 + 5 + \frac{1.67 \times 5}{2.5} = 1.67 + 5 + 3.33 = 10 \Omega$$

$$R_{23} = 5 + 2.5 + \frac{5 \times 2.5}{1.67} = 5 + 2.5 + 7.5 = 15 \Omega$$

$$R_{31} = 2.5 + 1.67 + \frac{2.5 \times 1.67}{5} = 2.5 + 1.67 + 0.833$$
$$= 5 \Omega$$

3) Determine the total current I in the given circuit.

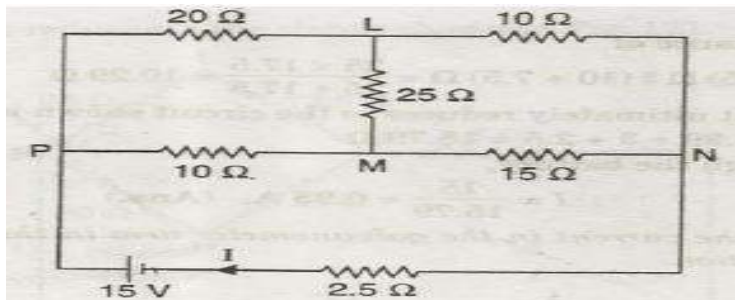

Solution: Delta connected resistors 25 ohms, 10 ohms and 15 ohms are converted in to star as shown in given figure.

$$R_1 = R_{12} R_{31} / R_{12} + R_{23} + R_{31} = 10 \times 25 / 10 + 15 + 25 = 5 \text{ ohms}$$

$$R_2 = R_{23} R_{12} / R_{12} + R_{23} + R_{31} = 15 \times 10 / 10 + 15 + 25 = 3 \text{ ohms}$$

$$R_3 = R_{31} R_{23} / R_{12} + R_{23} + R_{31} = 25 \times 15 / 10 + 15 + 25 = 7.5 \text{ ohms}$$

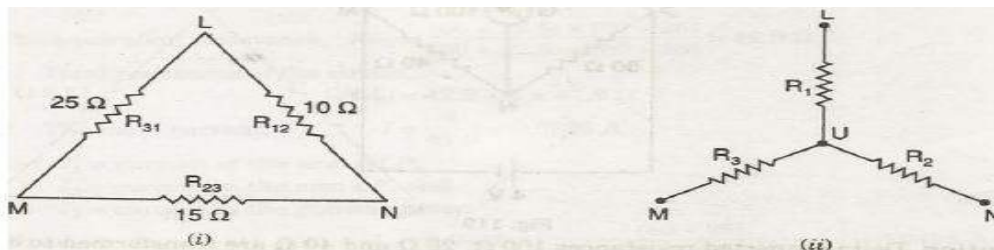

The given circuit thus reduces to the circuit shown in below fig.

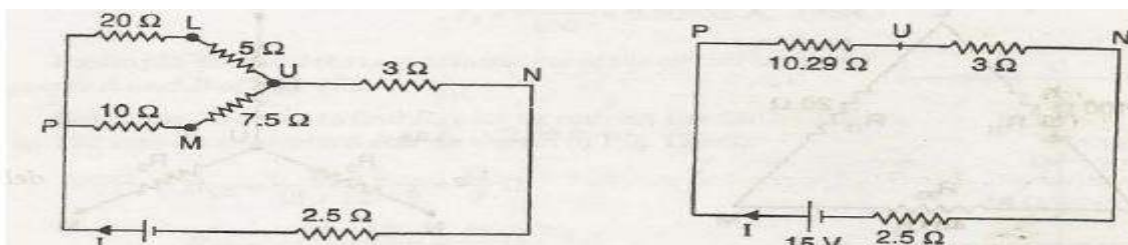

The equivalent resistance of

$$(20 + 5) \text{ ohms} \parallel (10 + 7.5) \text{ ohms} = 25 \times 17.5 / 25 + 17.5 = 10.29 \text{ ohms}$$

$$\text{Total resistance} = 10.29 + 3 + 2.5 = 15.79 \text{ ohms}$$

Hence the total current through the battery,

$$I = 15 / 15.79 = 0.95 \text{ A}$$

Mesh Analysis:

Mesh analysis provides general procedure for analyzing circuits using mesh currents as the circuit variables. Mesh Analysis is applicable only for planar networks. It is preferably useful for the circuits that have many loops. This analysis is done by using KVL and Ohm's law.

In Mesh analysis, we will consider the currents flowing through each mesh. Hence, Mesh analysis is also called as Mesh-current method.

A branch is a path that joins two nodes and it contains a circuit element. If a branch belongs to only one mesh, then the branch current will be equal to mesh current.

If a branch is common to two meshes, then the branch current will be equal to the sum (or difference) of two mesh currents, when they are in same (or opposite) direction.

Procedure of Mesh Analysis

Follow these steps while solving any electrical network or circuit using Mesh analysis.

- **Step 1** – Identify the meshes and label the mesh currents in either clockwise or anti-clockwise direction.
- **Step 2** – Observe the amount of current that flows through each element in terms of mesh currents.
- **Step 3** – Write mesh equations to all meshes. Mesh equation is obtained by applying KVL first and then Ohm's law.
- **Step 4** – Solve the mesh equations obtained in Step 3 in order to get the mesh currents.

Now, we can find the current flowing through any element and the voltage across any element that is present in the given network by using mesh currents.

Example

Find the voltage across $30\ \Omega$ resistor using Mesh analysis.

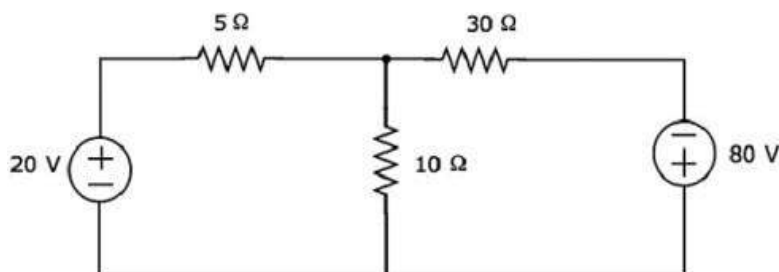

Step 1 – There are two meshes in the above circuit. The mesh currents I_1 and I_2 are considered in clockwise direction. These mesh currents are shown in the following figure.

Step 2 – The mesh current I_1 flows through 20 V voltage source and 5 Ω resistor. Similarly, the mesh current I_2 flows through 30 Ω resistor and -80 V voltage source. But, the difference of two mesh currents, I_1 and I_2 , flows through 10 Ω resistor, since it is the common branch of two meshes.

Step 3 – In this case, we will get two mesh equations since there are two meshes in the given circuit. When we write the mesh equations, assume the mesh current of that particular mesh as greater than all other mesh currents of the circuit. The mesh equation of first mesh is

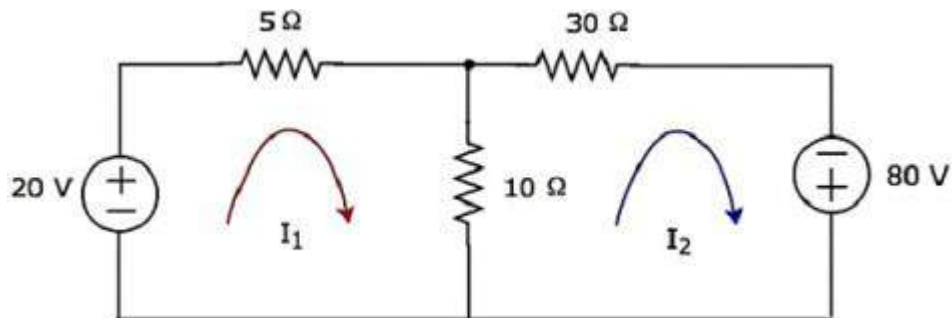

$$20 - 5I_1 - 10(I_1 - I_2) = 0$$

$$\Rightarrow 20 - 15I_1 + 10I_2 = 0$$

$$\Rightarrow 10I_2 = 15I_1 - 20$$

Divide the above equation with 5.

$$2I_2 = 3I_1 - 4$$

Multiply the above equation with 2.

$$4I_2 = 6I_1 - 8 \quad \text{Equation 1}$$

The **mesh equation** of second mesh is

$$-10(I_2 - I_1) - 30I_2 + 80 = 0$$

Divide the above equation with 10.

$$-(I_2 - I_1) - 3I_2 + 8 = 0$$

$$\Rightarrow -4I_2 + I_1 + 8 = 0$$

$$4I_2 = I_1 + 8 \quad \text{Equation 2}$$

Step 4 – Finding mesh currents I_1 and I_2 by solving Equation 1 and Equation 2.

The left-hand side terms of Equation 1 and Equation 2 are the same. Hence, equate the right-hand side terms of Equation 1 and Equation 2 in order find the value of I_1 .

$$6I_1 - 8 = I_1 + 8$$

$$\Rightarrow 5I_1 = 16$$

$$\Rightarrow I_1 = \frac{16}{5} A$$

Substitute I_1 value in Equation 2.

$$4I_2 = \frac{16}{5} + 8$$

$$\Rightarrow 4I_2 = \frac{56}{5}$$

$$\Rightarrow I_2 = \frac{14}{5} A$$

So, we got the mesh currents I_1 and I_2 as $\frac{16}{5} A$ and $\frac{14}{5} A$ respectively.

Step 5 – The current flowing through 30Ω resistor is nothing but the mesh current I_2 and it is equal to $\frac{14}{5} A$. Now, we can find the voltage across 30Ω resistor by using Ohm's law.

$$V_{30\Omega} = I_2 R$$

Substitute the values of I_2 and R in the above equation.

$$V_{30\Omega} = \left(\frac{14}{5}\right)30$$

$$\Rightarrow V_{30\Omega} = 84V$$

Therefore, the voltage across 30Ω resistor of the given circuit is $84 V$.

Note 1 – From the above example, we can conclude that we have to solve 'm' mesh equations, if the electric circuit is having 'm' meshes. That's why we can choose Mesh analysis when the number of meshes is less than the number of principal nodes (except the reference node) of any electrical circuit.

Note 2 – We can choose either Nodal analysis or Mesh analysis, when the number of meshes is equal to the number of principal nodes (except the reference node) in any electric circuit.

Network Theorems:**Introduction:**

Any complicated network i.e. several sources, multiple resistors are present if the single element response is desired then use the network theorems. Network theorems are also can be termed as network reduction techniques. Each and every theorem got its importance of solving network. Let us see some important theorems with DC and AC excitation with detailed procedures.

Thevenin's Theorem and Norton's theorem (Introduction) :

Thevenin's Theorem and Norton's theorem are two important theorems in solving Network problems having many active and passive elements. Using these theorems the networks can be reduced to simple equivalent circuits with one active source and one element. In circuit analysis many a times the current through a branch is required to be found when it's value is changed with all other element values remaining same. In such cases finding out every time the branch current using the conventional mesh and node analysis methods is quite awkward and time consuming. But with the simple equivalent circuits (with one active source and one element) obtained using these two theorems the calculations become very simple. Thevenin's and Norton's theorems are dual theorems.

Thevenin's Theorem Statement:

Any linear, bilateral two terminal network consisting of sources and resistors (Impedance), can be replaced by an equivalent circuit consisting of a voltage source in series with a resistance (Impedance). The equivalent voltage source V_{Th} is the open circuit voltage looking into the terminals (with concerned branch element removed) and the equivalent resistance R_{Th} while all sources are replaced by their internal resistors at ideal condition i.e. voltage source is short circuit and current source is open circuit.

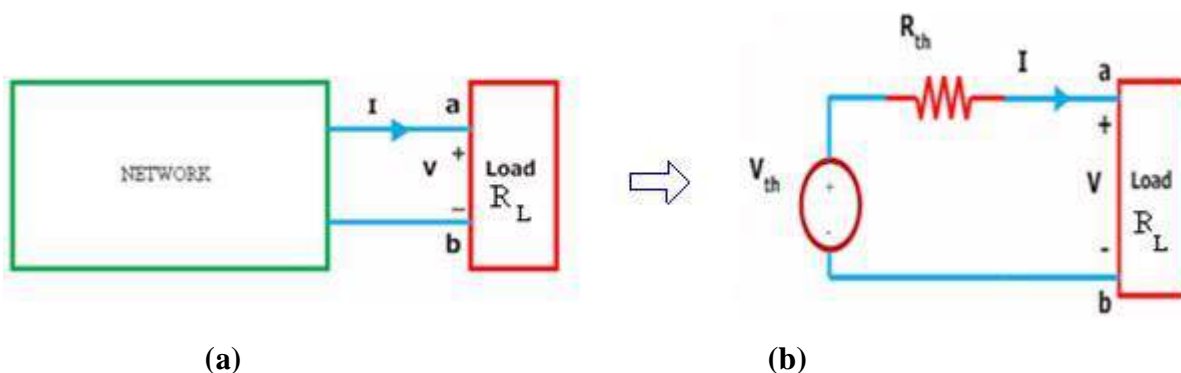

Figure (a) shows a simple block representation of a network with several active / passive elements with the load resistance R_L connected across the terminals 'a & b' and figure (b) shows the Thevenin's equivalent circuit with V_{Th} connected across R_{Th} & R_L .

Main steps to find out V_{Th} and R_{Th} :

1. The terminals of the branch/element through which the current is to be found out are marked as say a & b after removing the concerned branch/element
2. Open circuit voltage V_{OC} across these two terminals is found out using the conventional network mesh/node analysis methods and this would be V_{Th} .
3. Thevenin's resistance R_{Th} is found out by the method depending upon whether the network contains dependent sources or not.
 - a. With dependent sources: $R_{Th} = V_{oc} / I_{sc}$
 - b. Without dependent sources : $R_{Th} =$ Equivalent resistance looking into the concerned terminals with all voltage & current sources replaced by their internal impedances (i.e. ideal voltage sources short circuited and ideal current sources open circuited)
4. Replace the network with V_{Th} in series with R_{Th} and the concerned branch resistance (or) load resistance across the load terminals (A&B) as shown in below fig.

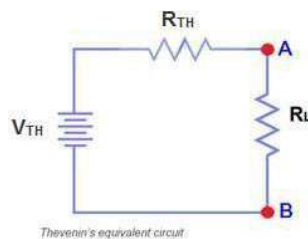
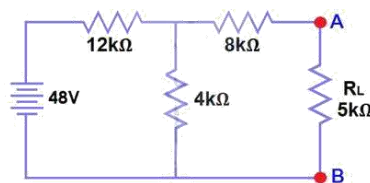

Fig.(a)

Example: Find V_{Th} , R_{Th} and the load current and load voltage flowing through R_L resistor as shown in fig. by using Thevenin's Theorem?



Solution:

The resistance R_L is removed and the terminals of the resistance R_L are marked as A & B as shown in the fig. (1)

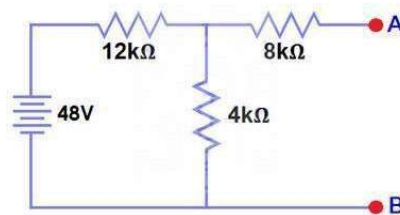

Fig.(1)

Calculate / measure the Open Circuit Voltage. This is the Thevenin Voltage (V_{TH}). We have already removed the load resistor from fig.(a), so the circuit became an open circuit as shown in fig (1). Now we have to calculate the Thevenin's Voltage. Since 3mA Current flows in both 12k Ω and 4k Ω resistors as this is a series circuit because current will not flow in the 8k Ω resistor as it is open. So 12V (3mA x 4k Ω) will appear across the 4k Ω resistor. We also know that current is not flowing through the 8k Ω resistor as it is open circuit, but the 8k Ω resistor is in parallel with 4k resistor. So the same voltage (i.e. 12V) will appear across the 8k Ω resistor as 4k Ω resistor. Therefore 12V will appear across the AB terminals.

So, $V_{TH} = 12V$

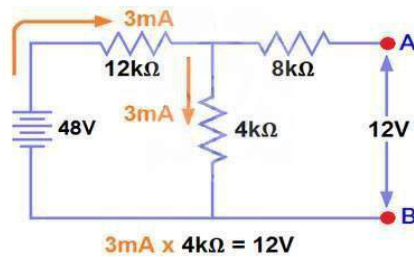
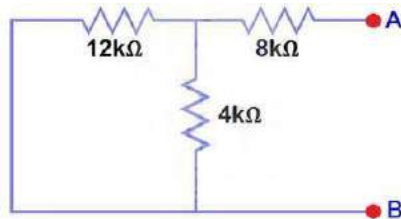

Fig (2)

All voltage & current sources replaced by their internal impedances (i.e. ideal voltage sources short circuited and ideal current sources open circuited) as shown in fig.(3)



Fig(3)

Calculate /measure the Open Circuit Resistance. This is the Thevenin's Resistance (R_{TH}) We have Reduced the 48V DC source to zero is equivalent to replace it with a short circuit as shown in figure (3) We can see that 8k Ω resistor is in series with a parallel connection of 4k Ω resistor and 12k Ω resistor. i.e.:

$$8k\Omega + (4k\Omega \parallel 12k\Omega) \dots (\parallel = \text{in parallel with})$$

$$R_{TH} = 8k\Omega + [(4k\Omega \times 12k\Omega) / (4k\Omega + 12k\Omega)]$$

$$R_{TH} = 8k\Omega + 3k\Omega$$

$$R_{TH} = 11k\Omega$$

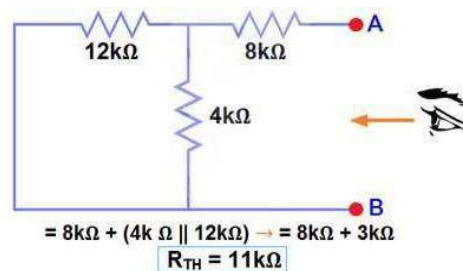

Fig(4)

Connect the R_{TH} in series with Voltage Source V_{TH} and re-connect the load resistor across the load terminals(A&B) as shown in fig (5) i.e. Thevenin's circuit with load resistor. This is the Thevenin's equivalent circuit.

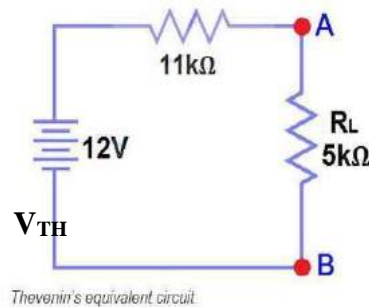

Fig (5)

Now apply Ohm's law and calculate the load current from fig 5.

$$I_L = V_{TH} / (R_{TH} + R_L) = 12V / (11k\Omega + 5k\Omega) = 12/16k\Omega$$

$$I_L = 0.75mA$$

$$\text{And } V_L = I_L \times R_L = 0.75mA \times 5k\Omega$$

$$V_L = 3.75V$$

Norton's Theorem Statement:

Any linear, bilateral two terminal network consisting of sources and resistors(Impedance), can be replaced by an equivalent circuit consisting of a current source in parallel with a resistance (Impedance), the current source being the short circuited current across the load terminals and the resistance being the internal resistance of the source network looking through the open circuited load terminals.

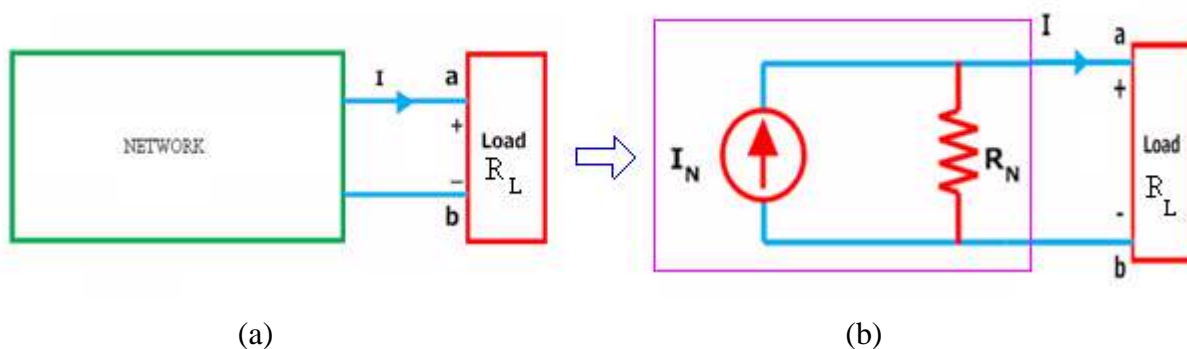
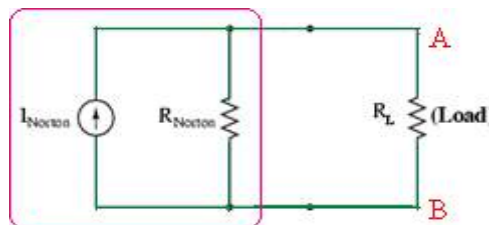

Figure (a) shows a simple block representation of a network with several active / passive elements with the load resistance R_L connected across the terminals 'a & b' and figure (b) shows the **Norton equivalent circuit** with I_N connected across R_N & R_L .

Main steps to find out I_N and R_N :

- The terminals of the branch/element through which the current is to be found out are marked as say **a & b** after removing the concerned branch/element.

- Open circuit voltage V_{OC} across these two terminals and I_{SC} through these two terminals are found out using the conventional network mesh/node analysis methods and they are same as what we obtained in Thevenin's equivalent circuit.
- Next **Norton resistance R_N** is found out depending upon whether the network contains dependent sources or not.
 - a) With dependent sources: $R_N = V_{oc} / I_{sc}$
 - b) Without dependent sources : $R_N =$ Equivalent resistance looking into the concerned terminals with all voltage & current sources replaced by their internal impedances (i.e. ideal voltage sources short circuited and ideal current sources open circuited)
- Replace the network with I_N in parallel with R_N and the concerned branch resistance across the load terminals(A&B) as shown in below fig



Example: Find the current through the resistance R_L (1.5Ω) of the circuit shown in the figure (a) below using Norton's equivalent circuit.

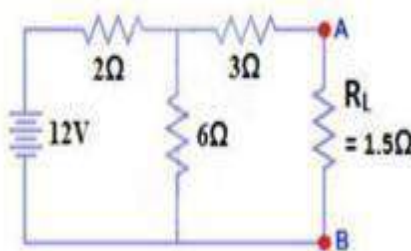

Fig(a)

Solution: To find out the Norton's equivalent ckt we have to find out $I_N = I_{sc}$, $R_N = V_{oc} / I_{sc}$. Short the 1.5Ω load resistor as shown in (Fig 2), and Calculate / measure the Short Circuit Current. This is the Norton Current (I_N).

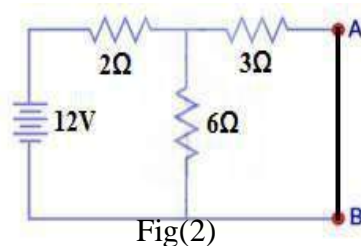

Fig(2)

We have shorted the AB terminals to determine the Norton current, I_N . The 6Ω and 3Ω are then in parallel and this parallel combination of 6Ω and 3Ω are then in series with 2Ω . So the Total Resistance of the circuit to the Source is:-

$$2\Omega + (6\Omega \parallel 3\Omega) \dots \dots (\parallel = \text{in parallel with})$$

$$R_T = 2\Omega + [(3\Omega \times 6\Omega) / (3\Omega + 6\Omega)]$$

$$R_T = 2\Omega + 2\Omega$$

$$R_T = 4\Omega$$

$$I_T = V / R_T$$

$$I_T = 12V / 4\Omega = 3A..$$

Now we have to find $I_{SC} = I_N$... Apply CDR... (Current Divider Rule)...

$$I_{SC} = I_N = 3A \times [(6\Omega / (3\Omega + 6\Omega))] = 2A.$$

$$I_{SC} = I_N = 2A.$$

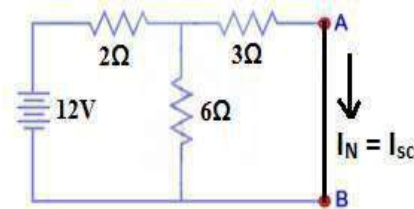

Fig(3)

All voltage & current sources replaced by their internal impedances (i.e. ideal voltage sources short circuited and ideal current sources open circuited) and Open Load Resistor. as shown in fig.(4)

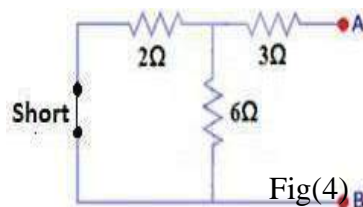

Fig(4)

Calculate /measure the Open Circuit Resistance. This is the Norton Resistance (R_N) We have Reduced the 12V DC source to zero is equivalent to replace it with a short circuit as shown in fig(4), We can see that 3Ω resistor is in series with a parallel combination of 6Ω resistor and 2Ω resistor. i.e.:

$$3\Omega + (6\Omega \parallel 2\Omega) \dots \dots (\parallel = \text{in parallel with})$$

$$R_N = 3\Omega + [(6\Omega \times 2\Omega) / (6\Omega + 2\Omega)]$$

$$R_N = 3\Omega + 1.5\Omega$$

$$R_N = 4.5\Omega$$

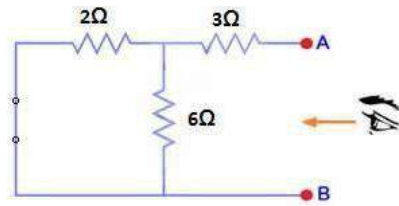

Fig(5)

Connect the R_N in Parallel with Current Source I_N and re-connect the load resistor. This is shown in fig (6) i.e. Norton Equivalent circuit with load resistor.

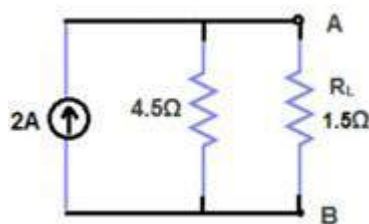

Fig(6)

Now apply the Ohm's Law and calculate the load current through Load resistance across the terminals A&B. Load Current through Load Resistor is

$$I_L = I_N \times [R_N / (R_N + R_L)]$$

$$I_L = 2A \times (4.5\Omega / 4.5\Omega + 1.5k\Omega)$$

$$I_L = 1.5A \quad I_L = 1.5A$$

Superposition Theorem:

The principle of superposition helps us to analyze a linear circuit with more than one current or voltage sources sometimes it is easier to find out the voltage across or current in a branch of the circuit by considering the effect of one source at a time by replacing the other sources with their ideal internal resistances.

Superposition Theorem Statement:

Any linear, bilateral two terminal network consisting of more than one sources, The total current or voltage in any part of a network is equal to the algebraic sum of the currents or voltages in the required branch with each source acting individually while other sources are replaced by their ideal internal resistances. (i.e. Voltage sources by a short circuit and current sources by open circuit)

Steps to Apply Super position Principle:

1. Replace all independent sources with their internal resistances except one source. Find the output (voltage or current) due to that active source using nodal or mesh analysis.

2. Repeat step 1 for each of the other independent sources.
3. Find the total contribution by adding algebraically all the contributions due to the independent sources.

Example: By Using the superposition theorem find I in the circuit shown in figure?

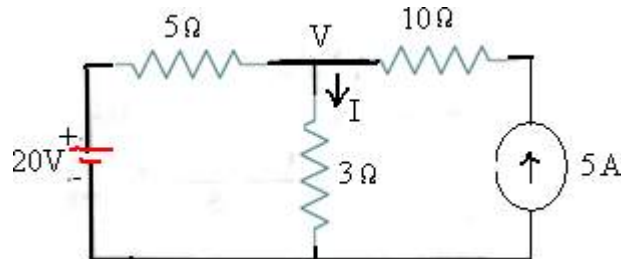

Fig.(a)

Solution: Applying the superposition theorem, the current I_2 in the resistance of $3\ \Omega$ due to the voltage source of 20V alone, with current source of 5A open circuited [as shown in the figure.1 below] is given by :

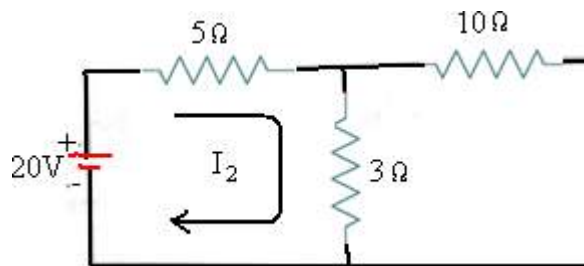

Fig.1

$$I_2 = 20/(5+3) = 2.5\text{A}$$

Similarly the current I_5 in the resistance of $3\ \Omega$ due to the current source of 5A alone with voltage source of 20V short circuited [as shown in the figure.2 below] is given by :

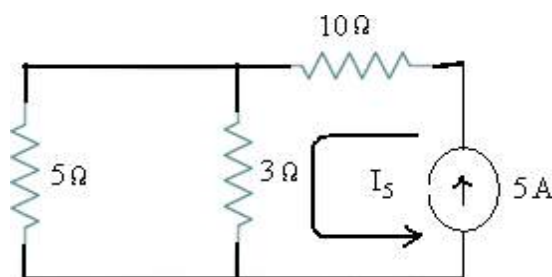

Fig.2

$$I_5 = 5 \times 5/(3+5) = 3.125\text{ A}$$

The total current passing through the resistance of $3\ \Omega$ is then $= I_2 + I_5 = 2.5 + 3.125 = 5.625\text{ A}$

Let us verify the solution using the basic nodal analysis referring to the node marked with V in fig.(a). Then we get :

$$\frac{V - 20}{5} + \frac{V}{3} = 5$$

$$3V - 60 + 5V = 15 \times 5$$

$$8V - 60 = 75$$

$$8V = 135$$

$$V = 16.875$$

The current I passing through the resistance of $3\Omega = V/3 = 16.875/3 = 5.625 \text{ A}$.

EX: Using KCL, KVL Find the currents in all the sources of the circuit of the following figure [10 M]

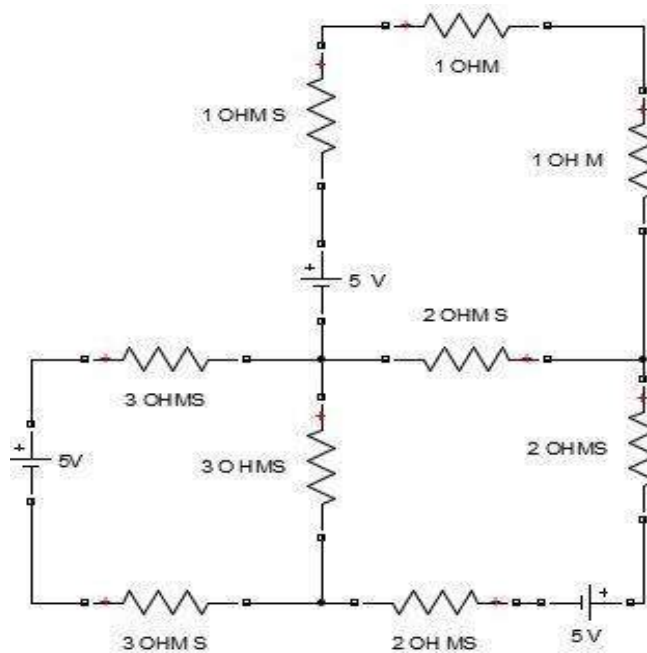

Method 1: LOOP ANALYSIS (BY CONSIDERING BRANCH CURRENTS)
INDICATE CURRENTS IN EACH BRANCH

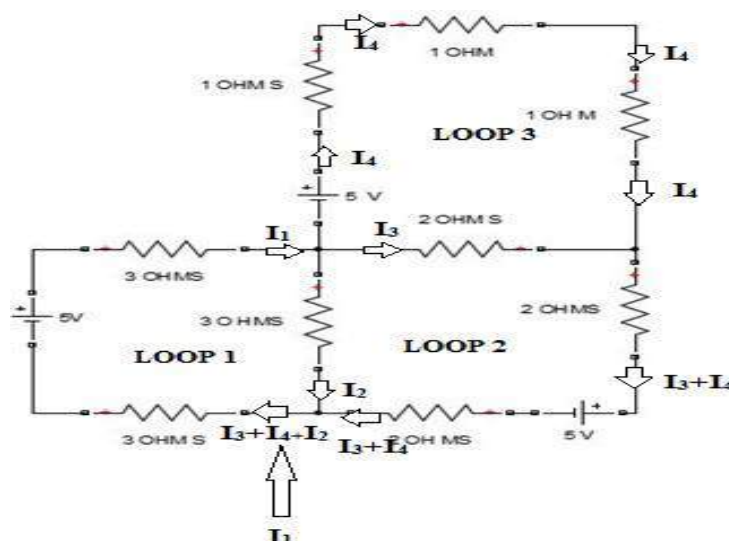

APPLY KVL AT LOOP 1

$$5 - 3I_1 - 3I_2 - 3I_1 = 0$$

$$-6I_1 - 3I_2 - 5 = 0 \dots\dots\dots 1)$$

APPLY KVL AT LOOP 2

$$-2I_3 - 2(I_3 + I_4) - 5 - 2(I_3 + I_4) + 3I_2 = 0$$

$$3I_2 - 6I_3 - 4I_4 - 5 = 0 \dots\dots\dots 2)$$

APPLY KVL AT LOOP 3

$$-I_4 - I_4 - I_4 + 2I_3 + 5 = 0$$

$$2I_3 - 3I_4 + 5 = 0 \dots\dots\dots 3)$$

FROM KCL $I_1 = I_2 + I_3 + I_4 \dots\dots\dots 4)$

SUB EQUATION 4 IN 1, WE WILL GET

$$-6(I_2 + I_3 + I_4) - 3I_2 + 5 = 0$$

$$-9I_2 - 6I_3 - 6I_4 + 5 = 0 \dots\dots\dots 5)$$

SOLVE 5 AND 2, WE WILL GET

$$-6I_2 - I_4 + 5 = 0 \dots\dots\dots 6)$$

SOLVE 5 AND 3, WE WILL GET

$$-9I_2 - 15I_4 + 20 = 0 \dots\dots\dots 7)$$

SOLVE 6 AND 7, WE WILL GET

$$I_4 = \frac{75}{81} = 0.925 \text{ A}$$

Sub I_4 value in equation 6 we will get,

$$I_2 = \frac{5 - 0.925}{6} = 0.679 \text{ A}$$

Sub I_2 value in equation 1 we will get,

$$I_1 = \frac{5 - 3(0.679)}{6} = 0.493 \text{ A}$$

Sub I_4, I_2, I_3 values in equation 4 we will get

$$I_3 = -0.493 - 0.679 - 0.925$$

$$I_3 = -1.11 \text{ A}$$

currents in all the sources are $I_1, I_3 + I_4, \& I_4$

$$I_1 = 0.493 \text{ A}$$

$$I_4 = 0.925 \text{ A}$$

$$I_4 + I_3 = 0.925 + (-1.11) = -0.185 \text{ A}$$

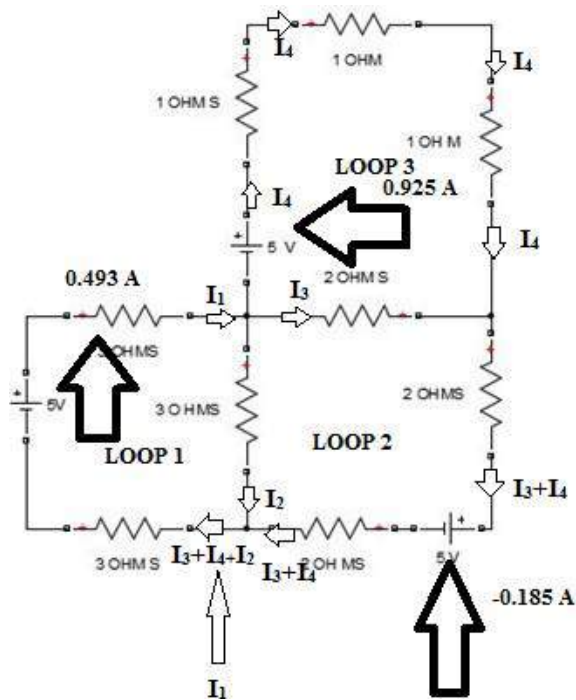

EX: Find the current flowing through R4 resistor

[10 M]

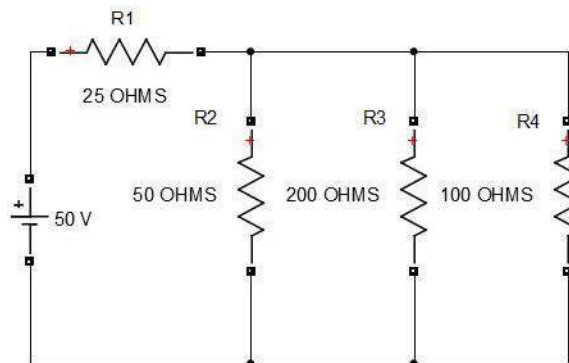

Method 1: NODAL ANALYSIS

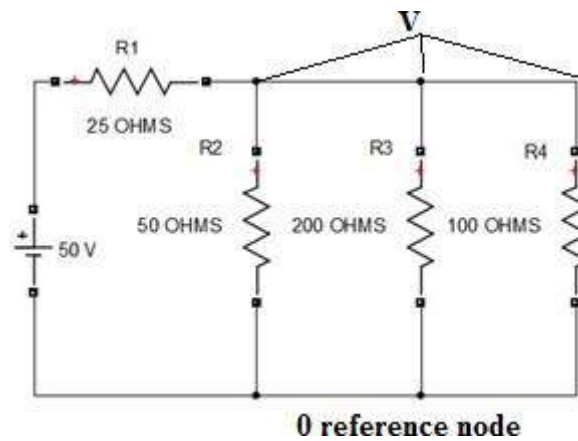

Assume considered node voltage is superior, so all currents are always leaving at node

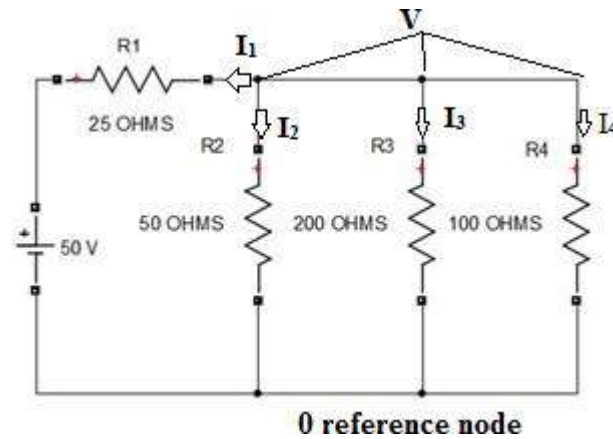

Apply KCL at node

$$I_1 + I_2 + I_3 + I_4 = 0$$

$$\frac{V - 50}{25} + \frac{V}{50} + \frac{V}{200} + \frac{V}{100} = 0$$

$$\frac{8V - 400 + 4V + V + 2V}{200} = 0$$

$$V = 26.6V$$

Current through R4 Resistor is $I_4 = \frac{V}{100}$

$$I_4 = 26.6/100 = 0.266 \text{ A}$$

UNIT-III
ELECTRICAL MACHINES

Dc Generator

- Principle Of Operation
- Constructional Features
- EMF Equation

Dc Motor

- Principle Of Operation
- Back EMF
- Torque Equation

Single Phase Transformer

- Principle Of Operation
- Constructional Features
- EMF Equation
- Simple Problems

DC GENERATOR

Principle of DC Generator:

There are two types of generators, one is ac generator and other is DC generator. Whatever may be the types of generators, it always converts mechanical power to electrical power. An AC generator produces alternating power. A DC generator produces direct power. Both of these generators produce electrical power, based on same fundamental principle of Faraday's law of electromagnetic induction. According to this law, when a conductor moves in a magnetic field it cuts magnetic lines of force, due to which an emf is induced in the conductor. The magnitude of this induced emf depends upon the rate of change of flux (magnetic line force) linkage with the conductor. This emf will cause a current to flow if the conductor circuit is closed.

Hence the most basic two essential parts of a generator are

1. Magnetic field
2. Conductors which move inside that magnetic field.

Now we will go through working principle of DC generator. As, the working principle of ac generator is not in scope of our discussion in this section.

Single Loop DC Generator

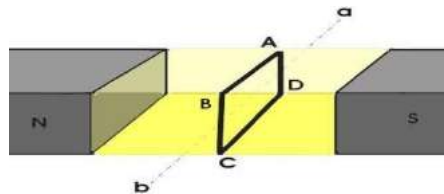

In the figure above, a single loop of conductor of rectangular shape is placed between two opposite poles of magnet.

Let's us consider, the rectangular loop of conductor is ABCD which rotates inside the magnetic field about its own axis ab. When the loop rotates from its vertical position to its horizontal position, it cuts the flux lines of the field. As during this movement two sides, i.e. AB and CD of the loop cut the flux lines there will be an emf induced in these both of the sides (AB and BC) of the loop.

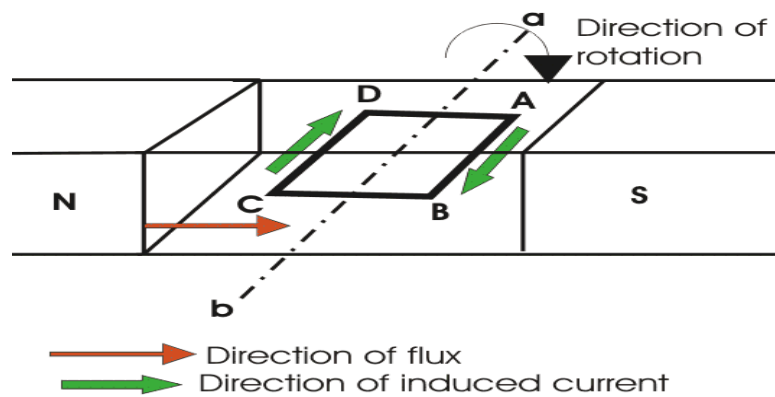

As the loop is closed there will be a current circulating through the loop. The direction of the current can be determined by Fleming's right hand Rule. This rule says that if you stretch thumb, index finger and middle finger of your right hand perpendicular to each other, then thumbs indicates the direction of motion of the conductor, index finger indicates the direction of magnetic field i.e. N - pole to S - pole, and middle finger indicates the direction of flow of current through the conductor. Now if we apply this right hand rule, we will see at this horizontal position of the loop, current will flow from point A to B and on the other side of the loop current will flow from point C to D.

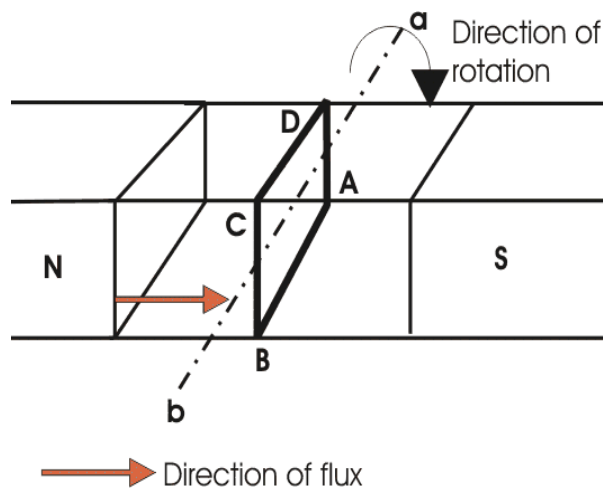

Now if we allow the loop to move further, it will come again to its vertical position, but now upper side of the loop will be CD and lower side will be AB (just opposite of the previous vertical position). At this position the tangential motion of the sides of the loop is parallel to the flux lines of the field. Hence there will be no question of flux cutting and consequently there will be no current in the loop. If the loop rotates further, it comes to again in horizontal position. But now, said AB side of the loop comes in front of N pole and CD comes in front of S pole, i.e. just opposite to the previous horizontal position as shown in the figure beside.

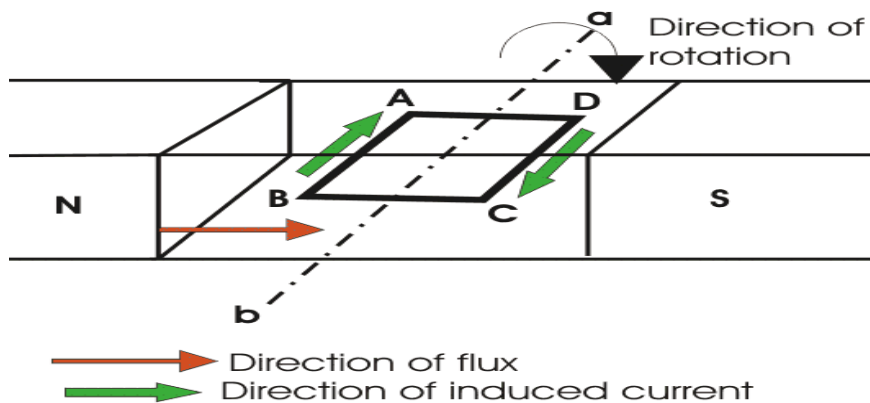

Here the tangential motion of the side of the loop is perpendicular to the flux lines, hence rate of flux cutting is maximum here and according to Fleming’s right hand rule, at this position current flows from B to A and on other side from D to C. Now if the loop is continued to rotate about its axis, every time the side AB comes in front of S pole, the current flows from A to B and when it comes in front of N pole, the current flows from B to A. Similarly, every time the side CD comes in front of S pole the current flows from C to D and when it comes in front of N pole the current flows from D to C.

If we observe this phenomena in different way, it can be concluded, that each side of the loop comes in front of N pole, the current will flow through that side in same direction i.e. downward to the reference plane and similarly each side of the loop comes in front of S pole, current through it flows in same direction i.e. upwards from reference plane. From this, we will come to the topic of principle of DC generator.

Now the loop is opened and connected it with a split ring as shown in the figure below. Split ring are made out of a conducting cylinder which cuts into two halves or segments insulated from each other. The external load terminals are connected with two carbon brushes which are rest on these split slip ring segments.

Working Principle of DC Generator

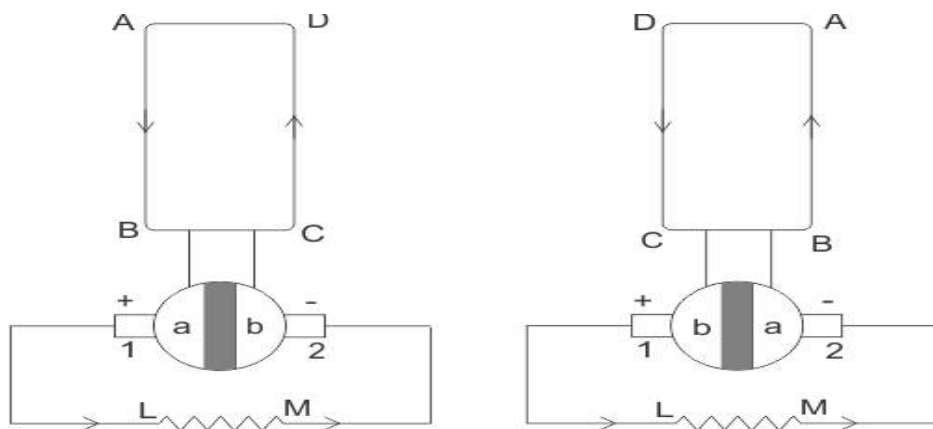

It is seen that in the first half of the revolution current flows always along ABLMCD i.e. brush no 1 in contact with segment a. In the next half revolution, in the figure the direction of the induced current in the coil is reversed. But at the same time the position of the segments a and b are also reversed which results that brush no 1 comes in touch with the segment b. Hence, the current in the load resistance again flows from L to M. The wave form of the current through the load circuit is as shown in the figure. This current is unidirectional.

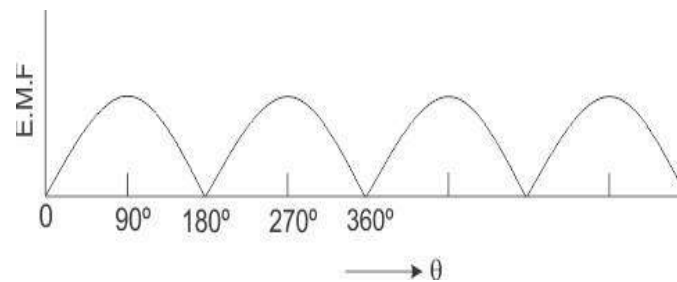

This is basic working principle of DC generator, explained by single loop generator model. The position of the brushes of DC generator is so arranged that the change over of the segments a and b from one brush to other takes place when the plane of rotating coil is at right angle to the plane of the lines of force. It is so become in that position, the induced emf in the coil is zero.

Construction of DC Generator

During explaining working principle of DC Generator, we have used a single loop DC generator. But now we will discuss about practical construction of DC Generator. A DC generator has the following parts

1. Yoke
2. Pole of generator
3. Field winding
4. Armature of DC generator
5. Brushes of generator and Commutator
6. Bearing

Yoke of DC Generator

Yoke or the outer frame of DC generator serves two purposes,

1. It holds the magnetic pole cores of the generator and acts as cover of the generator.
2. It carries the magnetic field flux.

In small generator, yoke are made of cast iron. Cast iron is cheaper in cost but heavier than steel. But for large construction of DC generator, where weight of the machine is concerned, lighter cast steel or rolled

steel is preferable for constructing yoke of DC generator. Normally larger yokes are formed by rounding a rectangular steel slab and the edges are welded together at the bottom. Then feet, terminal box and hangers are welded to the outer periphery of the yoke frame.

Pole Cores and Pole Shoes

Let's first discuss about pole core of DC generator. There are mainly two types of construction available.

One: Solid pole core, where it is made of a solid single piece of cast iron or cast steel.

Two: Laminated pole core, where it made of numbers of thin, limitations of annealed steel which are riveted together. The thickness of the lamination is in the range of 0.04" to 0.01". The pole core is fixed to the inner periphery of the yoke by means of bolts through the yoke and into the pole body. Since the poles project inwards they are called salient poles. The pole shoes are so typically shaped, that, they spread out the magnetic flux in the air gap and reduce the reluctance of the magnetic path. Due to their larger cross-section they hold the pole coil at its position.

Pole Coils: The field coils or pole coils are wound around the pole core. These are a simple coil of insulated copper wire or strip, which placed on the pole which placed between yoke and pole shoes as shown.

Armature Core

The purpose of armature core is to hold the armature winding and provide low reluctance path for the flux through the armature from N pole to S pole. Although a DC generator provides direct current but induced current in the armature is alternating in nature. That is why, cylindrical or drum shaped armature core is build up of circular laminated sheet. In every circular lamination, slots are either die - cut or punched on the outer periphery and the key way is located on the inner periphery as shown. Air ducts are also punched of cut on each lamination for circulation of air through the core for providing better cooling. Up to diameter of 40", the circular stampings are cut out in one piece of lamination sheet. But above 40", diameter, number of suitable sections of a circle is cut. A complete circle of lamination is formed by four or six or even eight such segment.

Armature Winding

Armature winding are generally formed wound. These are first wound in the form of flat rectangular coils and are then pulled into their proper shape in a coil puller. Various conductors of the coils are insulated from each other. The conductors are placed in the armature slots, which are lined with tough insulating material. This slot insulation is folded over above the armature conductors placed in it and secured in place by special hard wooden or fiber wedges. Two types of armature windings are used – Lap winding and Wave winding.

Commutator

The commutator plays a vital role in DC generator. It collects current from armature and sends it to the load as direct current. It actually takes alternating current from armature and converts it to direct current and then send it to external load. It is cylindrical structured and is build up of wedge-shaped segments of high conductivity, hard drawn or drop forged copper. Each segment is insulated from the shaft by means of insulated commutator segment shown below. Each commutator segment is connected with corresponding armature conductor through segment riser or lug.

Brushes

The brushes are made of carbon. These are rectangular block shaped. The only function of these carbon brushes of DC generator is to collect current from commutator segments. The brushes are housed in the rectangular box shaped brush holder or brush box. As shown in figure, the brush face is placed on the commutator segment which is attached to the brush holder.

Bearing

For small machine, ball bearing is used and for heavy duty DC generator, roller bearing is used. The bearing must always be lubricated properly for smooth operation and long life of generator.

Armature winding

Basically armature winding of a DC machine is wound by one of the two methods, lap winding or wave winding. The difference between these two is merely due to the end connections and commutator connections of the conductor. To know how armature winding is done, it is essential to know the following terminologies -

1. Pole pitch: It is defined as number of armature slots per pole. For example, if there are 36 conductors and 4 poles, then the pole pitch is $36/4=9$.
2. Coil span or coil pitch (Y_s): It is the distance between the two sides of a coil measured in terms of armature slots.
3. Front pitch (Y_f): It is the distance, in terms of armature conductors, between the second conductor of one coil and the first conductor of the next coil. OR it is the distance between two coil sides that are connected to the same commutator segment.
4. Back pitch (Y_b): The distance by which a coil advances on the back of the armature is called as back pitch of the coil. It is measured in terms of armature conductors.
5. Resultant pitch (Y_r): The distance, in terms of armature conductor, between the beginning of one coil and the beginning of the next coil is called as resultant pitch of the coil.

Armature winding can be done as single layer or double layer. It may be simplex, duplex or multiplex, and this multiplicity increases the number of parallel paths.

Lap Winding and Wave Winding

In lap winding, the successive coils overlap each other. In a simplex lap winding, the two ends of a coil are connected to adjacent commutator segments. The winding may be progressive or retrogressive. A progressive winding progresses in the direction in which the coil is wound. The opposite way is retrogressive. The following image shows progressive simplex lap winding.

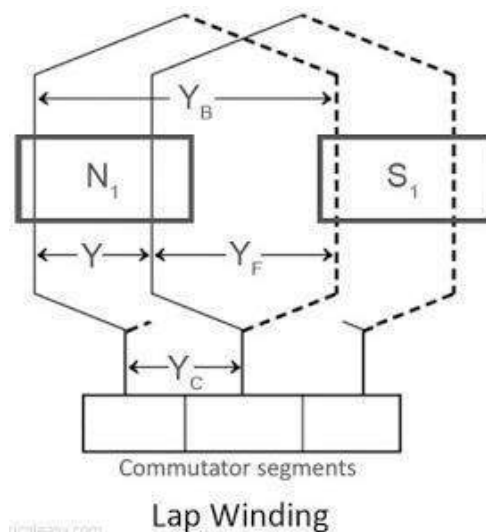

In wave winding, a conductor under one pole is connected at the back to a conductor which occupies an almost corresponding position under the next pole which is of opposite polarity. In other words, all the coils which carry e.m.f in the same direction are connected in series. The following diagram shows a part of simplex wave winding.

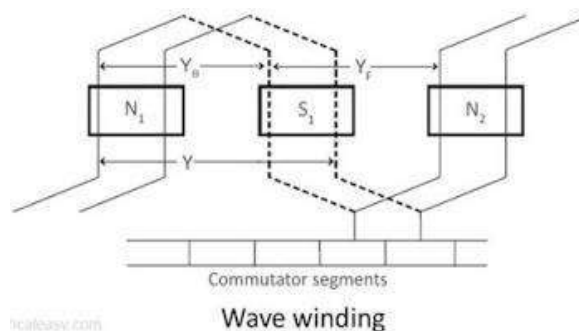

Basis For Comparison	Lap Winding	Wave Winding
Definition	The coil is lap back to the succeeding coil.	The coil of the winding form the wave shape.
Connection	The end of the armature coil is connected to an adjacent segment on the commutators.	The end of the armature coil is connected to commutator segments some distance apart.
Parallel Path	The numbers of parallel path are equal to the total of number poles.	The number of parallel paths is equal to two.
Other Name	Parallel Winding or Multiple Winding	Two-circuit or Series Winding.
EMF	Less	More
Number of Brushes	Equal to the number of parallel paths.	Two
Types	Simplex and Duplex lap winding.	Progressive and Retrogressive wave winding
Efficiency	Less	High
Additional Coil	Equalizer Ring	Dummy coil
Winding Cost	High (because more conductor is required)	Low
Uses	In low voltage, high current machines.	In high voltage, low current machines.

EMF Equation of a DC Generator

Consider a DC generator with the following parameters,

P = number of field poles

Φ = flux produced per pole in Wb (weber)

Z = total no. of armature conductors

A = no. of parallel paths in armature

N = rotational speed of armature in revolutions per min. (rpm)

Now,

- Average emf generated per conductor is given by $d\Phi/dt$ (Volts) ... eq. 1
- Flux cut by one conductor in one revolution = $d\Phi = P\Phi$ (Weber),
- Number of revolutions per second (speed in RPS) = $N/60$
- Therefore, time for one revolution = $dt = 60/N$ (Seconds)
- From eq. 1, emf generated per conductor = $d\Phi/dt = P\Phi N/60$ (Volts)(eq. 2)

Above equation-2 gives the emf generated in one conductor of the generator. The conductors are connected in series per parallel path, and the emf across the generator terminals is equal to the generated emf across any parallel path.

$$\text{Therefore, } E_g = P\Phi N Z / 60A$$

For simplex lap winding, number of parallel paths is equal to the number of poles (i.e. $A=P$),

Therefore, for simplex lap wound dc generator, $E_g = P\Phi N Z / 60P$

For simplex wave winding, number of parallel paths is equal to 2 (i.e. $P=2$),

Therefore, for simplex wave wound dc generator, $E_g = P\Phi N Z / 120$

DC MOTOR

Working or Operating Principle of DC Motor:

A DC motor in simple words is a device that converts electrical energy (direct current system) into mechanical energy. It is of vital importance for the industry today, and is equally important for engineers to look into the working principle of DC motor in details that has been discussed in this article. In order to understand the operating principle of DC motor we need to first look into its constructional feature. The very basic construction of a DC motor contains a current carrying armature which is connected to the supply end through commutator segments and brushes. The armature is placed in between north south poles of a permanent or an electromagnet as shown in the diagram above.

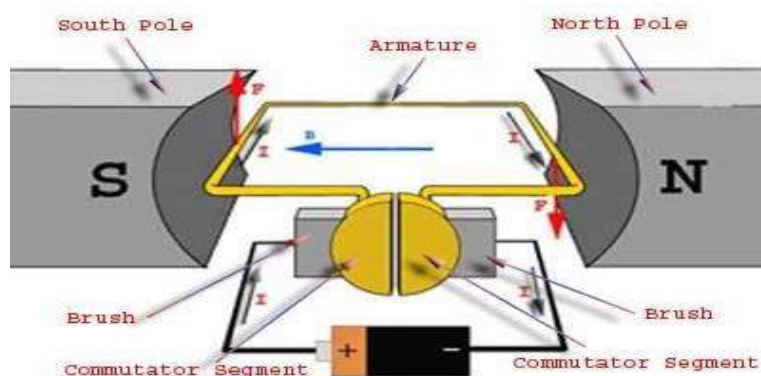

As soon as we supply direct current in the armature, a mechanical force acts on it due to electromagnetic effect of the magnet. Now to go into the details of the operating principle of DC motor its important that we have a clear understanding of Fleming's left hand rule to determine the direction of force acting on the armature conductors of DC motor.

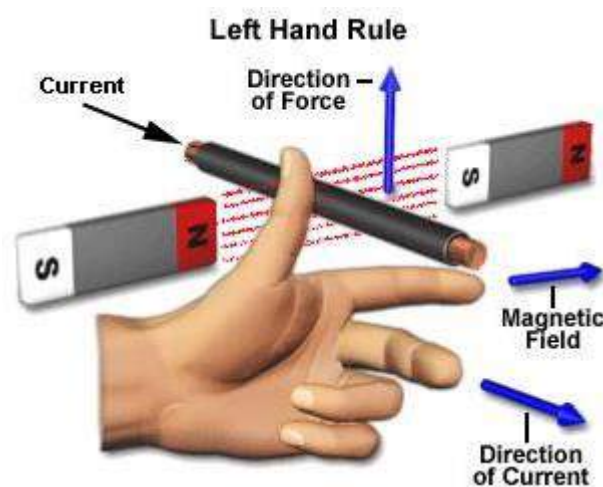

If a current carrying conductor is placed in a magnetic field perpendicularly, then the conductor experiences a force in the direction mutually perpendicular to both the direction of field and the current

carrying conductor. Fleming's left hand rule says that if we extend the index finger, middle finger and thumb of our left hand perpendicular to each other, in such a way that the middle finger is along the direction of current in the conductor, and index finger is along the direction of magnetic field i.e. north to south pole, then thumb indicates the direction of created mechanical force. For clear understanding the principle of DC motor we have to determine the magnitude of the force, by considering the diagram below.

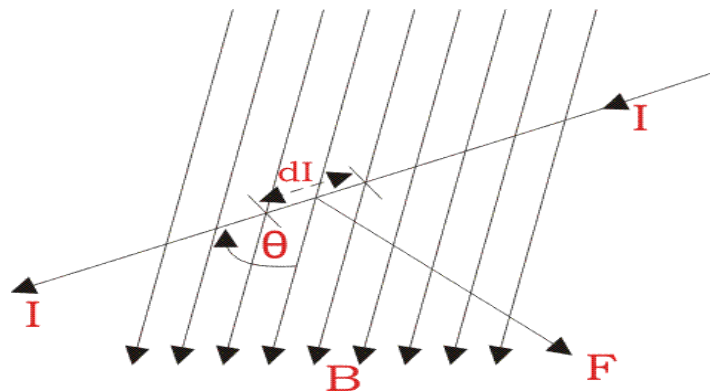

We know that when an infinitely small charge dq is made to flow at a velocity 'v' under the influence of an electric field E , and a magnetic field B , then the Lorentz Force dF experienced by the charge is given by:-

$$dF = dq(E + vB)$$

For the operation of DC motor, considering $E=0$

$$dF = dq \times v \times B$$

I.e. it's the cross product of dq, v and magnetic field B

$$dF = dq \frac{dL}{dt} \times B \quad [V = \frac{dL}{dt}]$$

Where, dL is the length of the conductor carrying charge q

$$dF = dq \frac{dL}{dt} \times B$$

$$\text{or, } dF = IdL \times B \quad [\text{since, current } I = \frac{dq}{dt}]$$

$$\text{or, } F = I L \times B = I L B \sin \phi$$

$$F = B I L \sin \phi$$

From the 1st diagram we can see that the construction of a DC motor is such that the direction of current through the armature conductor at all instance is perpendicular to the field. Hence the force acts on the armature conductor in the direction perpendicular to the both uniform field and current is constant.

$$\text{i.e } \phi = 90^\circ$$

So if we take the current in the left hand side of the armature conductor to be I , and current at right hand side of the armature conductor to be $-I$, because they are flowing in the opposite direction with respect to each other.

Then the force on the left hand side armature conductor,

$$F_l = B I L \sin 90^\circ = BIL$$

Similarly force on the right hand side conductor

$$F_r = (-I) L \sin 90^\circ = -BIL$$

Therefore, we can see that at that position the force on either side is equal in magnitude but opposite in direction. And since the two conductors are separated by some distance $w =$ width of the armature turn, the two opposite forces produces a rotational force or a torque that results in the rotation of the armature conductor.

Now let's examine the expression of torque when the armature turn crate an angle of α (alpha) with its initial position.

The torque produced is given by,

$$\text{Torque} = (\text{Force, tangential to the direction of armature rotation}) \times (\text{distance})$$

$$\text{Or, } \tau = F \cos \alpha \times \omega$$

$$\text{Or, } \tau = BIL \omega \cos \alpha$$

Where, α (alpha) is the angle between the plane of the armature turn and the plane of reference or the initial position of the armature which is here along the direction of magnetic field.

The presence of the term $\cos \alpha$ in the torque equation very well signifies that unlike force the torque at all position is not the same. It in fact varies with the variation of the angle α (alpha). To explain the variation of torque and the principle behind rotation of the motor let us do a step wise analysis.

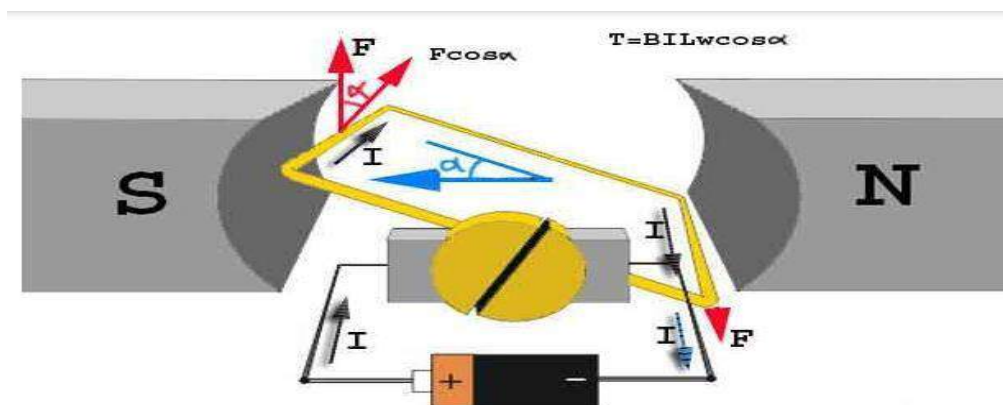

Step 1:

Initially considering the armature is in its starting point or reference position where the angle $\alpha = 0$.

$$\tau = BILw \cos 0^\circ = BILw$$

Since, $\alpha = 0$, the term $\cos \alpha = 1$, or the maximum value, hence torque at this position is maximum given by $\tau = BILw$. This high starting torque helps in overcoming the initial inertia of rest of the armature and sets it into rotation.

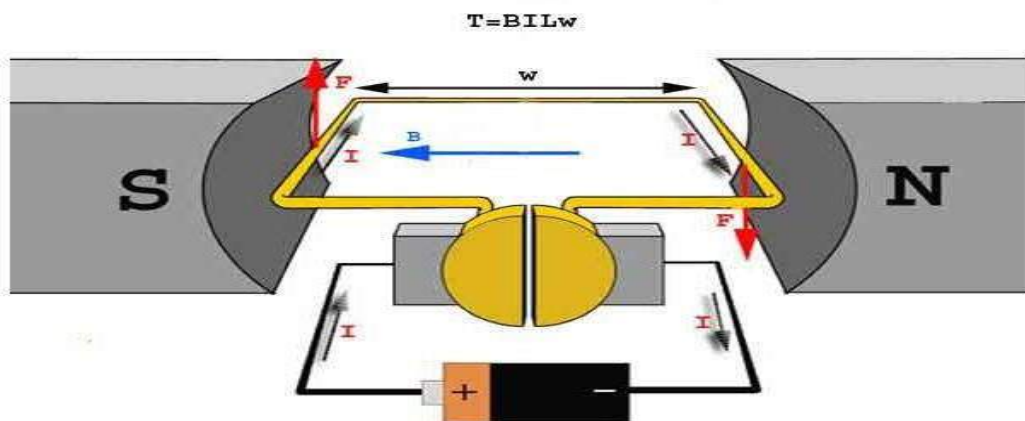

Step 2:

Once the armature is set in motion, the angle α between the actual position of the armature and its reference initial position goes on increasing in the path of its rotation until it becomes 90° from its initial position. Consequently the term $\cos \alpha$ decreases and also the value of torque.

The torque in this case is given by $\tau = BILw \cos \alpha$ which is less than $BILw$ when α is greater than 0° .

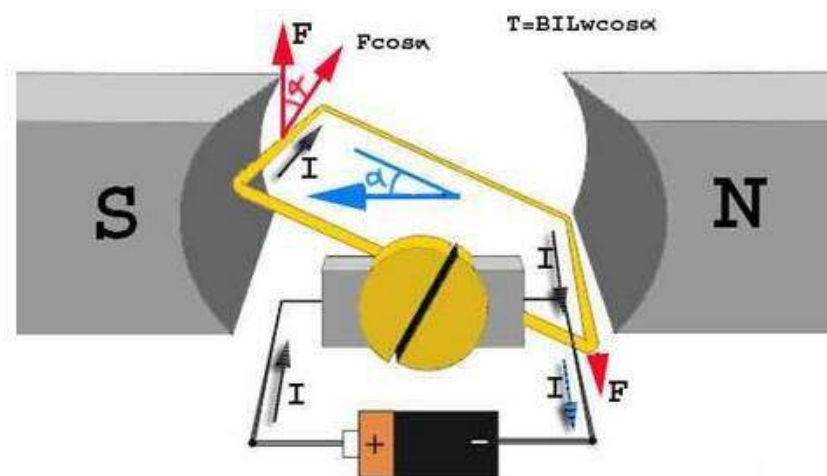

Step 3:

In the path of the rotation of the armature a point is reached where the actual position of the rotor is exactly perpendicular to its initial position, i.e. $\alpha = 90^\circ$, and as a result the term $\cos\alpha = 0$.

The torque acting on the conductor at this position is given by,

$$\tau = BIL\omega \times \cos 90^\circ = 0$$

$$T = BIL\omega \cos 90^\circ = 0$$

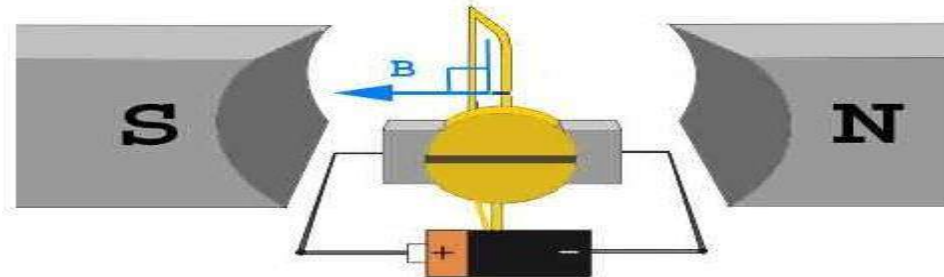

i.e. virtually no rotating torque acts on the armature at this instance. But still the armature does not come to a standstill, this is because of the fact that the operation of DC motor has been engineered in such a way that the inertia of motion at this point is just enough to overcome this point of null torque. Once the rotor crosses over this position the angle between the actual position of the armature and the initial plane again decreases and torque starts acting on it again.

Torque Equation of DC Motor

When a DC machine is loaded either as a motor or as a generator, the rotor conductors carry current. These conductors lie in the magnetic field of the air gap. Thus each conductor experiences a force. The conductors lie near the surface of the rotor at a common radius from its center. Hence torque is produced at the circumference of the rotor and rotor starts rotating. The term torque as best explained by Dr. Huger d Young is the quantitative measure of the tendency of a force to cause a rotational motion, or to bring about a change in rotational motion. It is in fact the moment of a force that produces or changes a rotational motion.

The equation of torque is given by,

$$\tau = FR \sin \theta \dots \dots \dots (1)$$

Where, F is force in linear direction.
 R is radius of the object being rotated,
 and θ is the angle, the force F is making with R vector

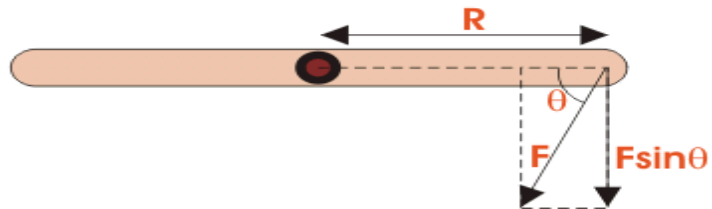

The DC motor as we all know is a rotational machine, and torque of DC motor is a very important parameter in this concern, and it's of utmost importance to understand the torque equation of DC motor for establishing its running characteristics.

To establish the torque equation, let us first consider the basic circuit diagram of a DC motor, and its voltage equation.

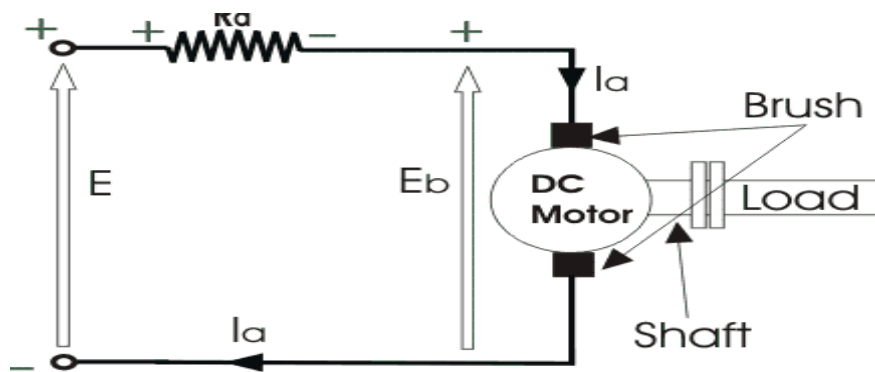

Referring to the diagram beside, we can see, that if E is the supply voltage, Eb is the back emf produced and Ia, Ra are the armature current and armature resistance respectively then the voltage equation is given by,

$$E = E_b + I_a R_a \dots \dots \dots (2)$$

But keeping in mind that our purpose is to derive the torque equation of DC motor we multiply both sides of equation (2) by Ia.

$$E I_a = E_b I_a + I_a^2 R_a \dots \dots \dots (3)$$

Now $I_a^2 \cdot R_a$ is the power loss due to heating of the armature coil, and the true effective mechanical power that is required to produce the desired torque of DC machine is given by,

$$P_m = E_b I_a \dots \dots \dots (4)$$

The mechanical power P_m is related to the electromagnetic torque T_g as,

$$P_m = T_g \omega \dots\dots\dots (5)$$

Where ω is speed in rad/sec.

Now equating equation (4) and (5) we get,

$$E_b I_a = T_g \omega$$

Now for simplifying the torque equation of DC motor we substitute.

$$E_b = \frac{P \phi Z N}{60 A} \dots\dots\dots (6)$$

Where, P is no of poles,
 ϕ is flux per pole,
 Z is no. of conductors,
 A is no. of parallel paths,
 and N is the speed of the DC motor.

$$\text{Hence, } \omega = \frac{2\pi N}{60} \dots\dots\dots (7)$$

Substituting equation (6) and (7) in equation (4), we get:

$$T_g = \frac{P \cdot Z \cdot \phi \cdot I_a}{2\pi A}$$

The torque we so obtain, is known as the electromagnetic torque of DC motor, and subtracting the mechanical and rotational losses from it we get the mechanical torque. Therefore,

$$T_m = T_g - \text{mechanical losses}$$

\This is the torque equation of DC motor. It can be further simplified as:

$$T_g = k_a \phi I_a$$

$$\text{Where, } k_a = \frac{P \cdot Z}{2\pi A}$$

Which is constant for a particular machine and therefore the torque of DC motor varies with only flux ϕ and armature current I_a .

The Torque equation of a DC motor can also be explained considering the figure below.

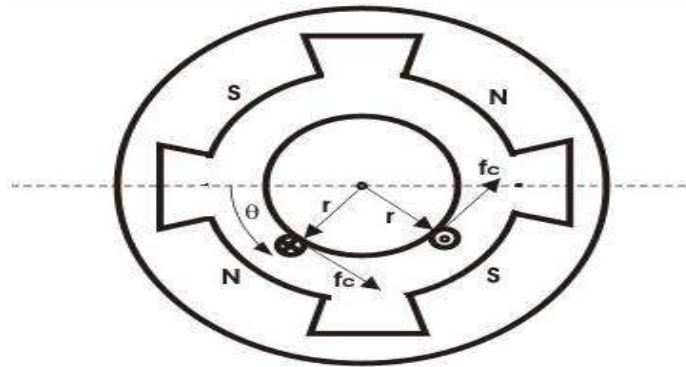

Here we can see Area per pole $A_r = \frac{2\pi \cdot r \cdot L}{P}$

$$B = \frac{\phi}{A_r}$$

Here we can see Area per pole $A_r = \frac{2\pi r L}{P}$

$$B = \frac{\phi}{A_r}$$

$$B = \frac{p\phi}{2\pi r L}$$

Current /conductor $I_c = I_a A$

Therefore, force per conductor $= F_c = B L I_a / A$

Now Torque $T_c = F_c \cdot r = B L I_a \cdot r / A$

$$T_c = \frac{P \cdot \phi \cdot I_a}{2\pi A}$$

Hence, Total torque developed by DC machine is

$$T_g = \frac{P \cdot Z \cdot \phi \cdot I_a}{2\pi A}$$

$$T_g = k_a \phi I_a$$

$$\text{Where, } k_a = \frac{P \cdot Z}{2\pi A}$$

Which is constant for a particular machine and therefore the torque of DC motor varies with only flux ϕ and armature current I_a .

SINGLE PHASE TRANSFORMER

Introduction:

The transformer is a device that transfers electrical energy from one electrical circuit to another electrical circuit. The two circuits may be operating at different voltage levels but always work at the same frequency. Basically transformer is an electro-magnetic energy conversion device. It is commonly used in electrical power system and distribution systems. It can change the magnitude of alternating voltage or current from one value to another. This useful property of transformer is mainly responsible for the widespread use of alternating currents rather than direct currents i.e., electric power is generated, transmitted and distributed in the form of alternating current. Transformers have no moving parts, rugged and durable in construction, thus requiring very little attention. They also have a very high efficiency as high as 99%.

Single Phase Transformer

A transformer is a static device of equipment used either for raising or lowering the voltage of an a.c. supply with a corresponding decrease or increase in current. It essentially consists of two windings, the primary and secondary, wound on a common laminated magnetic core as shown in Fig 1. The winding connected to the a.c. source is called primary winding (or primary) and the one connected to load is called secondary winding (or secondary). The alternating voltage V_1 whose magnitude is to be changed is applied to the primary.

Depending upon the number of turns of the primary (N_1) and secondary (N_2), an alternating e.m.f. E_2 is induced in the secondary. This induced e.m.f. E_2 in the secondary causes a secondary current I_2 . Consequently, terminal voltage V_2 will appear across the load.

If $V_2 > V_1$, it is called a step up-transformer.

If $V_2 < V_1$, it is called a step-down transformer.

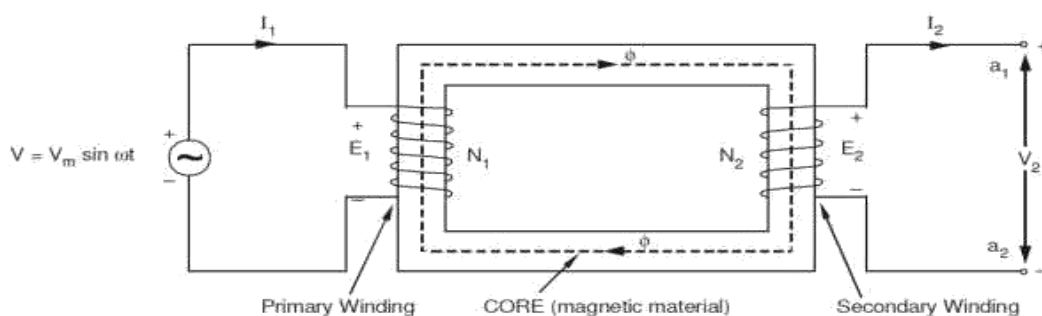

Constructional Details

Depending upon the manner in which the primary and secondary windings are placed on the core, and the shape of the core, there are two types of transformers, called

- (a) Core type
- (b) Shell type.

Core-type and Shell-type Construction

In core type transformers, the windings are placed in the form of concentric cylindrical coils placed around the vertical limbs of the core. The low-voltage (LV) as well as the high-voltage (HV) winding are made in two halves, and placed on the two limbs of core. The LV winding is placed next to the core for economy in insulation cost. Figure 2.1(a) shows the cross-section of the arrangement. In the shell type transformer, the primary and secondary windings are wound over the central limb of a three-limb core as shown in Figure 2.1(b). The HV and LV windings are split into a number of sections, and the sections are interleaved or sandwiched i.e. the sections of the HV and LV windings are placed alternately.

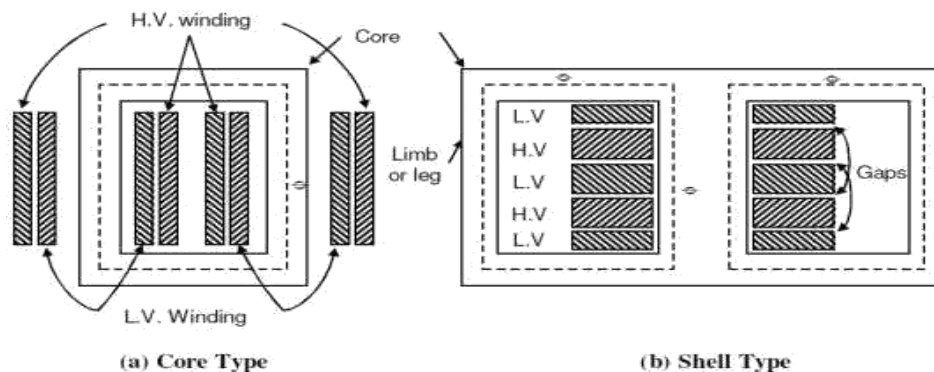

Core

The core is built-up of thin steel laminations insulated from each other. This helps in reducing the eddy current losses in the core, and also helps in construction of the transformer. The steel used for core is of high silicon content, sometimes heat treated to produce a high permeability and low hysteresis loss. The material commonly used for core is CRGO (Cold Rolled Grain Oriented) steel. Conductor material used for windings is mostly copper. However, for small distribution transformer aluminum is also sometimes used. The conductors, core and whole windings are insulated using various insulating materials depending upon the voltage.

Insulating Oil

In oil-immersed transformer, the iron core together with windings is immersed in insulating oil. The insulating oil provides better insulation, protects insulation from moisture and transfers the heat produced in core and windings to the atmosphere.

The transformer oil should possess the following qualities:

- (a) High dielectric strength,
- (b) Low viscosity and high purity,
- (c) High flash point, and
- (d) Free from sludge.

Transformer oil is generally a mineral oil obtained by fractional distillation of crude oil.

Tank and Conservator

The transformer tank contains core wound with windings and the insulating oil. In large transformers small expansion tank is also connected with main tank is known as conservator. Conservator provides space when insulating oil expands due to heating. The transformer tank is provided with tubes on the outside, to permits circulation of oil, which aides in cooling. Some additional devices like breather and Buchholz relay are connected with main tank. Buchholz relay is placed between main tank and conservator. It protect the transformer under extreme heating of transformer winding. Breather protects the insulating oil from moisture when the cool transformer sucks air inside. The silica gel filled breather absorbs moisture when air enters the tank. Some other necessary parts are connected with main tank like, Bushings, Cable Boxes, Temperature gauge, Oil gauge, Tapings, etc.

Principle of Operation

When an alternating voltage V_1 is applied to the primary, an alternating flux ϕ is set up in the core. This alternating flux links both the windings and induces e.m.f.s E_1 and E_2 in them according to Faraday's laws of electromagnetic induction. The e.m.f. E_1 is termed as primary e.m.f. and E_2 is termed as secondary e.m.f.

$$\text{Clearly } E_1 = -N_1 \frac{d\phi}{dt}$$

$$\text{And } E_2 = -N_2 \frac{d\phi}{dt}$$

$$\boxed{\frac{E_2}{E_1} = \frac{N_2}{N_1}}$$

Note that magnitudes of E_2 and E_1 depend upon the number of turns on the secondary and primary respectively.

If $N_2 > N_1$, then $E_2 > E_1$ (or $V_2 > V_1$) and we get a step-up transformer.

If $N_2 < N_1$, then $E_2 < E_1$ (or $V_2 < V_1$) and we get a step-down transformer.

If load is connected across the secondary winding, the secondary e.m.f. E_2 will cause a current I_2 to flow through the load. Thus, a transformer enables us to transfer a.c. power from one circuit to another with a change in voltage level.

The following points may be noted carefully

- (a) The transformer action is based on the laws of electromagnetic induction.
- (b) There is no electrical connection between the primary and secondary.
- (c) The a.c. power is transferred from primary to secondary through magnetic flux.
- (d) There is no change in frequency i.e., output power has the same frequency as the input power.
- (e) The losses that occur in a transformer are:
 - (a) core losses—eddy current and hysteresis losses
 - (b) copper losses—in the resistance of the windings

In practice, these losses are very small so that output power is nearly equal to the input primary power. In other words, a transformer has very high efficiency

E.M.F. Equation of a Transformer

Consider that an alternating voltage V_1 of frequency f is applied to the primary as shown in Fig.2.3. The sinusoidal flux ϕ produced by the primary can be represented as:

$$\phi = \phi_m \sin \omega t$$

When the primary winding is excited by an alternating voltage V_1 , it is circulating alternating current, producing an alternating flux ϕ .

ϕ - Flux

ϕ_m - maximum value of flux ,

N_1 - Number of primary turns ,

N_2 - Number of secondary turns

f - Frequency of the supply voltage

E_1 - R.M.S. value of the primary induced e.m.f , E_2 - R.M.S. value of the secondary induced e.m.f

The instantaneous e.m.f. e_1 induced in the primary is –

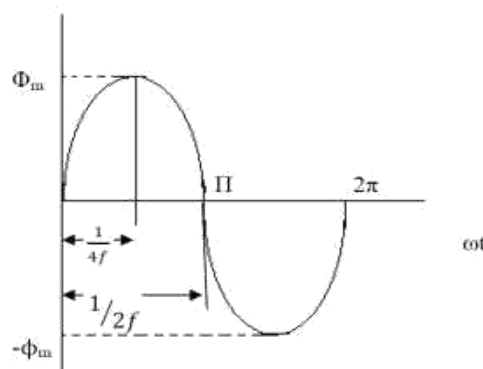

The flux increases from zero value to maximum value ϕ_m in $1/4f$ of the time period that is in $1/4f$ seconds.

The change of flux that takes place in $1/4f$ seconds = $\phi_m - 0 = \phi_m$ webers

Voltage Ratio

$$\frac{d\phi}{dt} = \frac{\phi_m}{1/4f} = 4f\phi_m \text{ Wb/sec}$$

Since flux ϕ varies sinusoidally, the R.M.S value of the induced e.m.f obtained by multiplying the average value with the form factor

$$\text{Form factor of sin wave} = \frac{\text{R.m.s value}}{\text{Average value}} = 1.11$$

$$\begin{aligned} \text{R.M.S value of e.m.f induced in one turn} &= 4\phi_m f \times 1.11 \text{ volts} \\ &= 4.44\phi_m f \text{ volts} \end{aligned}$$

$$\text{R.M.S value of e.m.f induced in primary winding} = 4.44\phi_m f N_1 \text{ volts}$$

$$\text{R.M.S value of e.m.f induced in Secondary winding} = 4.44\phi_m f N_2 \text{ volts}$$

The expression of E_1 and E_2 are called e.m.f equation of a transformer

$$\begin{aligned} V_1 = E_1 &= 4.44\phi_m f N_1 \text{ volts} \\ V_2 = E_2 &= 4.44\phi_m f N_2 \text{ volts} \end{aligned}$$

$$\frac{E_2}{E_1} = \frac{4.44\phi_m f N_2}{4.44\phi_m f N_1}$$

$$\frac{E_2}{E_1} = \frac{N_2}{N_1}$$

Voltage transformation ratio is the ratio of e.m.f induced in the secondary winding to the e.m.f induced in the primary winding.

This ratio of secondary induced e.m.f to primary induced e.m.f is known as voltage transformation ratio

1. If $N_2 > N_1$ i.e. $K > 1$ we get $E_2 > E_1$ then the transformer is called step up transformer.
2. If $N_2 < N_1$ i.e. $K < 1$ we get $E_2 < E_1$ then the transformer is called step down transformer.
3. If $N_2 = N_1$ i.e. $K = 1$ we get $E_2 = E_1$ then the transformer is called isolation transformer or 1:1 Transformer.

$$E_2 = KE_1$$

Current Ratio

Current ratio is the ratio of current flow through the primary winding (I_1) to the current flowing through the secondary winding (I_2). In an ideal transformer -

Apparent input power = Apparent output power.

$$V_1 I_1 = V_2 I_2$$

$$\frac{I_1}{I_2} = \frac{V_2}{V_1} = \frac{N_2}{N_1} = K$$

Volt-Ampere Rating

i) The transformer rating is specified as the products of voltage and current (VA rating).

ii) On both sides, primary and secondary VA rating remains same. This rating is generally expressed in KVA (Kilo Volts Amperes rating)

$$\frac{V_2}{V_1} = \frac{N_2}{N_1} = K$$

$$V_1 I_1 = V_2 I_2$$

$$\text{KVA rating of a transformer} = \frac{V_1 I_1}{1000} = \frac{V_2 I_2}{1000} \quad (\text{1000 is to convert KVA to VA})$$

V_1 and V_2 are the primary and secondary voltages, by using KVA rating we can calculate I_1 and I_2 full load current and it is safe maximum current

$$I_1 \text{ Full load current} = \frac{\text{KVA rating} \times 1000}{V_1}$$

$$I_2 \text{ Full load current} = \frac{\text{KVA rating} \times 1000}{V_2}$$

**UNIT –IV
DIODES AND RECTIFIERS**

- P-N Junction Diode
- Symbol
- V-I Characteristics
- Diode Applications
- Zener Diode: Characteristics
- Rectifiers – Half Wave Rectifier
- Full Wave Rectifier
- Bridge Rectifier
- Simple Problems

PN JUNCTION DIODE

INTRODUCTON

Based on the electrical conductivity all the materials in nature are classified as insulators, semiconductors, and conductors.

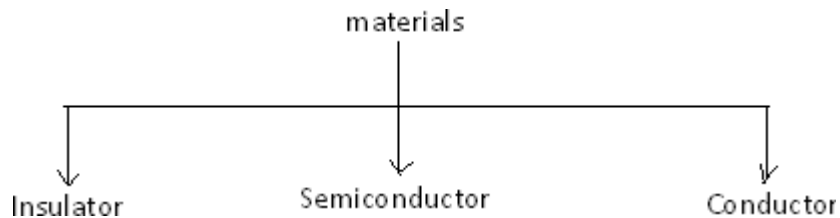

Insulator: An insulator is a material that offers a very low level (or negligible) of conductivity when voltage is applied. Eg: Paper, Mica, glass, quartz. Typical resistivity level of an insulator is of the order of 10^{10} to 10^{12} Ω -cm. The energy band structure of an insulator is shown in the fig.1.1. Band structure of a material defines the band of energy levels that an electron can occupy. Valance band is the range of electron energy where the electron remain bended too the atom and do not contribute to the electric current. Conduction bend is the range of electron energies higher than valance band where electrons are free to accelerate under the influence of external voltage source resulting in the flow of charge.

The energy band between the valance band and conduction band is called as forbidden band gap. It is the energy required by an electron to move from balance band to conduction band i.e. the energy required for a valance electron to become a free electron.

$$1 \text{ eV} = 1.6 \times 10^{-19} \text{ J}$$

For an insulator, as shown in the fig.1.1 there is a large forbidden band gap of greater than 5Ev. Because of this large gap there a very few electrons in the CB and hence the conductivity of insulator is poor. Even an increase in temperature or applied electric field is insufficient to transfer electrons from VB to CB.

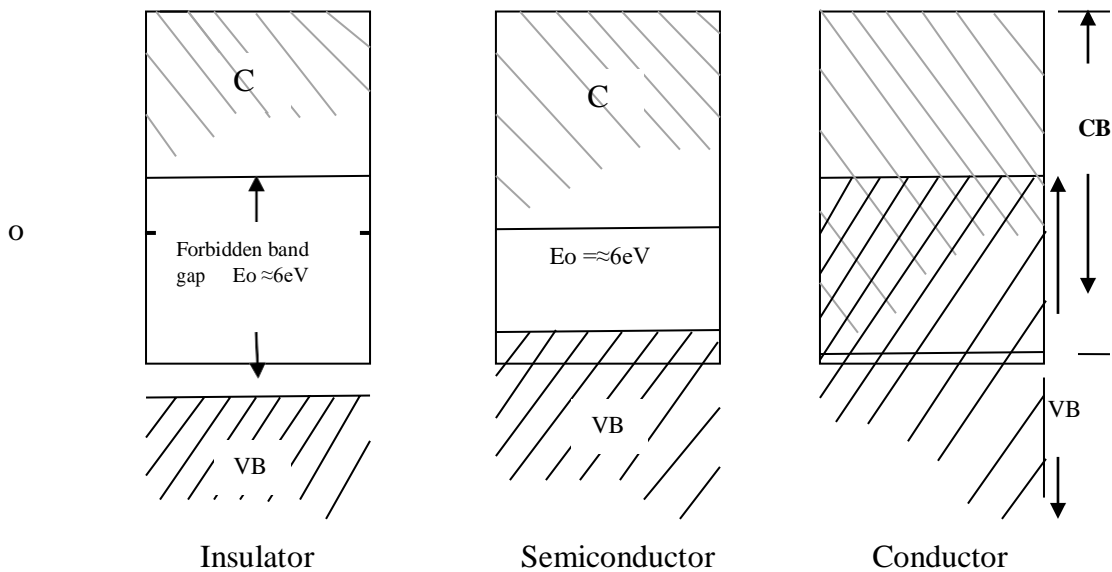

Fig: 1.1 Energy band diagrams insulator, semiconductor and conductor

Conductors: A conductor is a material which supports a generous flow of charge when a voltage is applied across its terminals. i.e. it has very high conductivity. Eg: Copper, Aluminum, Silver, Gold. The resistivity of a conductor is in the order of 10^{-4} and $10^{-6} \Omega\text{-cm}$. The Valance and conduction bands overlap (fig1.1) and there is no energy gap for the electrons to move from valance band to conduction band. This implies that there are free electrons in CB even at absolute zero temperature (0K). Therefore at room temperature when electric field is applied large current flows through the conductor.

Semiconductor: A semiconductor is a material that has its conductivity somewhere between the insulator and conductor. The resistivity level is in the range of 10 and $10^4 \Omega\text{-cm}$. Two of the most commonly used are Silicon (Si=14 atomic no.) and germanium (Ge=32 atomic no.). Both have 4 valance electrons. The forbidden band gap is in the order of 1eV . For eg., the band gap energy for Si, Ge and GaAs is 1.21, 0.785 and 1.42 eV, respectively at absolute zero temperature (0K). At 0K and at low temperatures, the valance band electrons do not have sufficient energy to move from V to CB. Thus semiconductors act a insulators at 0K. as the temperature increases, a large number of valance electrons acquire sufficient energy to leave the VB, cross the forbidden bandgap and reach CB. These are now free electrons as they can move freely under the influence of electric field. At room temperature there are sufficient electrons in the CB and hence the semiconductor is capable of conducting some current at room temperature.

Inversely related to the conductivity of a material is its resistance to the flow of charge or current. Typical resistivity values for various materials' are given as follows.

Insulator	Semiconductor	Conductor
$10^{-6} \Omega\text{-cm}$ (Cu)	$50 \Omega\text{-cm}$ (Ge)	$10^{12} \Omega\text{-cm}$ (mica)
	$50 \times 10^3 \Omega\text{-cm}$ (Si)	

Typical resistivity values

SEMICONDUCTOR TYPES

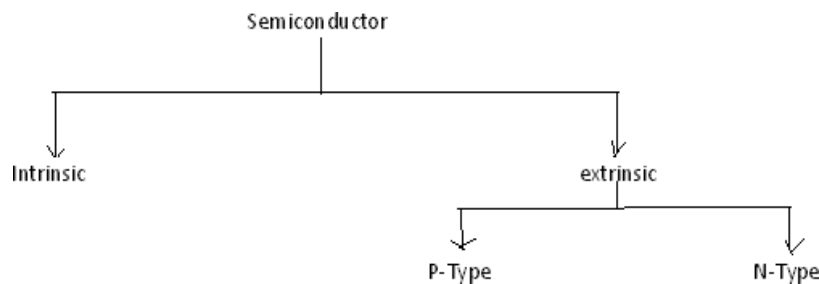

A pure form of semiconductors is called as intrinsic semiconductor. Conduction in intrinsic sc is either due to thermal excitation or crystal defects. Si and Ge are the two most important semiconductors used. Other examples include Gallium arsenide GaAs, Indium Antimonide (InSb) etc.

Let us consider the structure of Si. A Si atomic no. is 14 and it has 4 valance electrons. These 4 electrons are shared by four neighboring atoms in the crystal structure by means of covalent bond. Fig. 1.2a shows the crystal structure of Si at absolute zero temperature (0K). Hence a pure SC acts has poor conductivity (due to lack of free electrons) at low or absolute zero temperature.

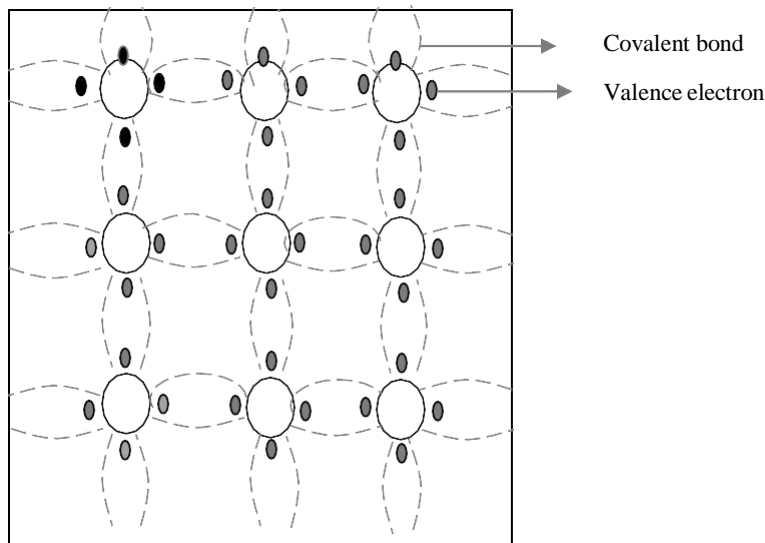

Fig. 1.2a crystal structure of Si at 0K

At room temperature some of the covalent bonds break up to thermal energy as shown in fig 1.2b. The valance electrons that jump into conduction band are called as free electrons that are available for conduction.

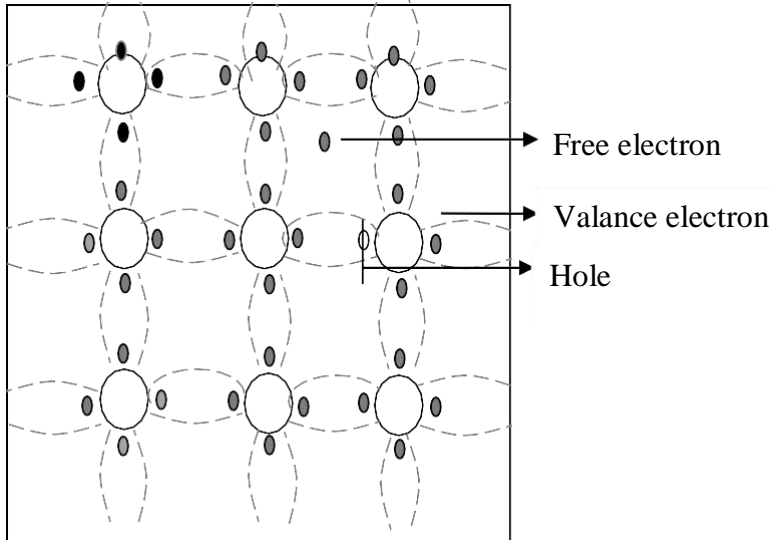
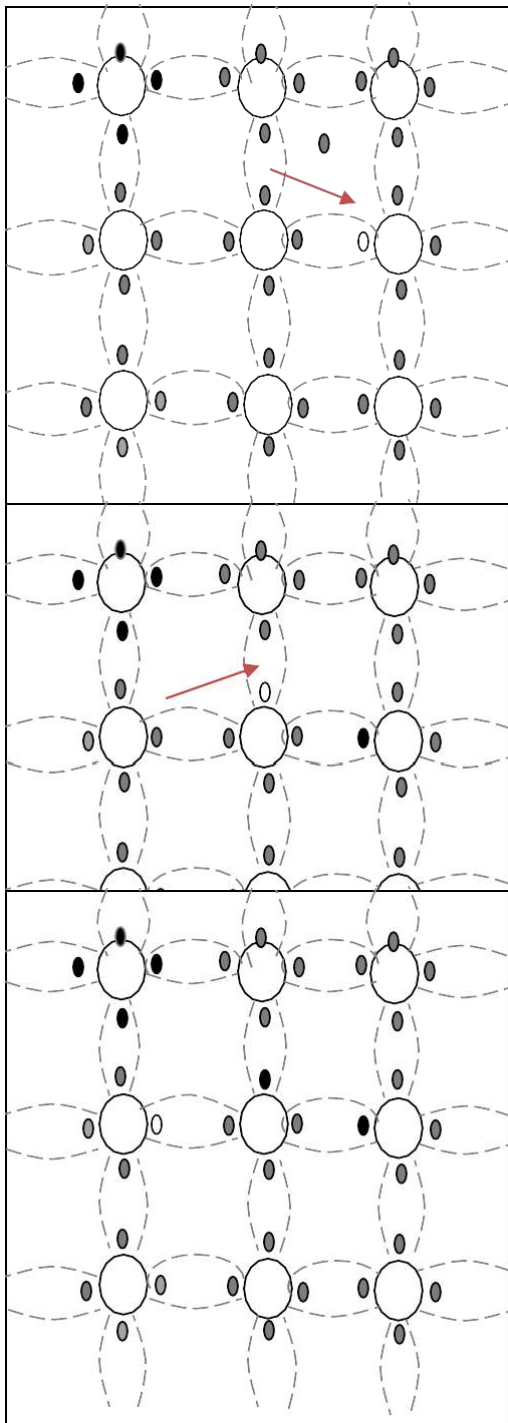

Fig. 1.2b crystal structure of Si at room temperature 0K

The absence of electrons in covalent bond is represented by a small circle usually referred to as hole which is of positive charge. Even a hole serves as carrier of electricity in a manner similar to that of free electron.

The mechanism by which a hole contributes to conductivity is explained as follows:

When a bond is incomplete so that a hole exists, it is relatively easy for a valance electron in the neighboring atom to leave its covalent bond to fill this hole. An electron moving from a bond to fill a hole moves in a direction opposite to that of the electron. This hole, in its new position may now be filled by an electron from another covalent bond and the hole will correspondingly move one more step in the direction opposite to the motion of electron. Here we have a mechanism for conduction of electricity which does not involve free electrons. This phenomenon is illustrated in fig 1.3





 Electron movement
 Hole movement

Fig. 1.3a

Fig. 1.3b

Fig. 1.3c

Fig 1.3a show that there is a hole at ion 6. Imagine that an electron from ion 5 moves into the hole at ion 6 so that the configuration of 1.3b results. If we compare both fig 1.3a & fig 1.3b, it appears as if the hole has moved towards the left from ion 6 to ion 5. Further if we compare fig 1.3b and fig 1.3c, the hole moves from

ion5 to ion 4. This discussion indicates the motion of hole is in a direction opposite to that of motion of electron. Hence we consider holes as physical entities whose movement constitutes flow of current.

In a pure semiconductor, the number of holes is equal to the number of free electrons.

EXTRINSIC SEMICONDUCTOR:

Intrinsic semiconductor has very limited applications as they conduct very small amounts of current at room temperature. The current conduction capability of intrinsic semiconductor can be increased significantly by adding a small amounts impurity to the intrinsic semiconductor. By adding impurities it becomes impure or extrinsic semiconductor. This process of adding impurities is called as doping. The amount of impurity added is 1 part in 10^6 atoms.

N type semiconductor: If the added impurity is a pentavalent atom then the resultant semiconductor is called N-type semiconductor. Examples of pentavalent impurities are Phosphorus, Arsenic, Bismuth, Antimony etc.

A pentavalent impurity has five valance electrons. Fig 1.3a shows the crystal structure of N-type semiconductor material where four out of five valance electrons of the impurity atom(antimony) forms covalent bond with the four intrinsic semiconductor atoms. The fifth electron is loosely bound to the impurity atom. This loosely bound electron can be easily

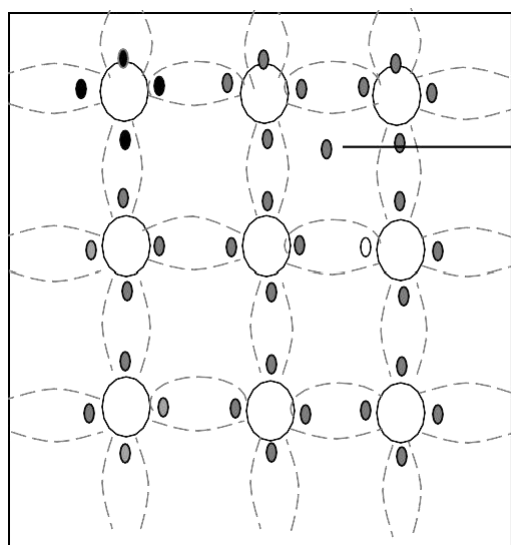

Fig. 1.3a crystal structure of N type

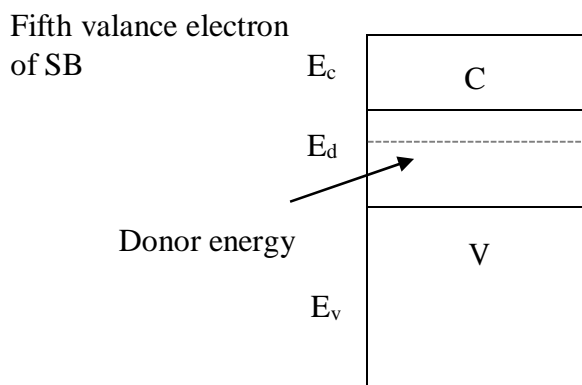

Fig. 1.3b Energy band diagram of N

excited from the valance band to the conduction band by the application of electric field or increasing the thermal energy. The energy required to detach the fifth electron form the impurity atom is very small of the order of 0.01ev for Ge and 0.05 eV for Si.

The effect of doping creates a discrete energy level called donor energy level in the forbidden band gap with energy level E_d slightly less than the conduction band (fig 1.3b). The difference between the energy

levels of the conducting band and the donor energy level is the energy required to free the fifth valence electron (0.01 eV for Ge and 0.05 eV for Si). At room temperature almost all the fifth electrons from the donor impurity atom are raised to conduction band and hence the number of electrons in the conduction band increases significantly. Thus every antimony atom contributes to one conduction electron without creating a hole.

In the N-type sc the no. of electrons increases and the no. of holes decreases compared to those available in an intrinsic sc. The reason for decrease in the no. of holes is that the larger no. of electrons present increases the recombination of electrons with holes. Thus current in N type sc is dominated by electrons which are referred to as majority carriers. Holes are the minority carriers in N type sc

P type semiconductor: If the added impurity is a trivalent atom then the resultant semiconductor is called P-type semiconductor. Examples of trivalent impurities are Boron, Gallium, indium etc.

The crystal structure of p type sc is shown in the fig1.3c. The three valence electrons of the impurity (boron) forms three covalent bonds with the neighboring atoms and a vacancy exists in the fourth bond giving rise to the holes. The hole is ready to accept an electron from the neighboring atoms. Each trivalent atom contributes to one hole generation and thus introduces a large no. of holes in the valence band. At the same time the no. electrons are decreased compared to those available in intrinsic sc because of increased recombination due to creation of additional holes.

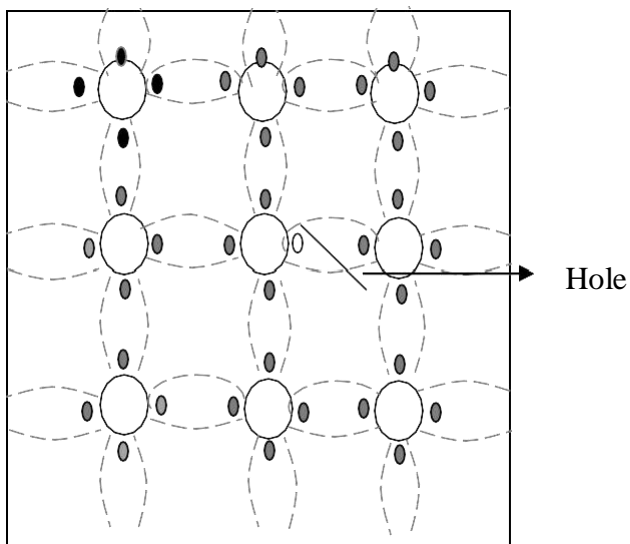

Fig. 1.3c crystal structure of P type

Thus in P type sc, holes are majority carriers and electrons are minority carriers. Since each trivalent impurity atoms are capable accepting an electron, these are called as acceptor atoms. The following fig 1.3d shows the pictorial representation of P type sc

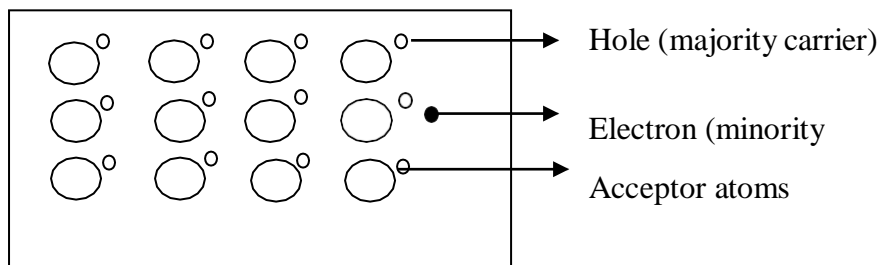

Fig. 1.3d crystal structure of P type

- The conductivity of N type sc is greater than that of P type sc as the mobility of electron is greater than that of hole.
- For the same level of doping in N type sc and P type sc, the conductivity of an Ntype sc is around twice that of a P type sc

THEORY OF PN JUNCTION DIODE:

A p–n junction is formed by joining P-type and N-type semiconductors together in very close contact. The term junction refers to the boundary interface where the two regions of the semiconductor meet. Diode is a two-terminal electronic component that conducts electric current in only one direction. The crystal conducts conventional current in a direction from the p-type side (called the anode) to the n-type side (called the cathode), but not in the opposite direction.

Symbol of PN junction diode

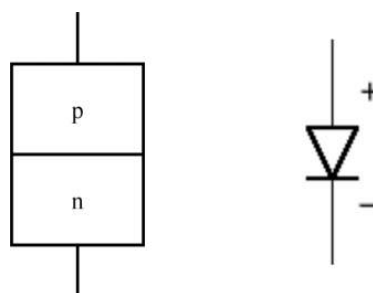

Biasing

“Biasing” is providing minimum external voltage and current to activate the device to study its characteristics.

There are two operating regions and two "biasing" conditions for the standard Junction Diode and they are:

❖ Zero Bias:

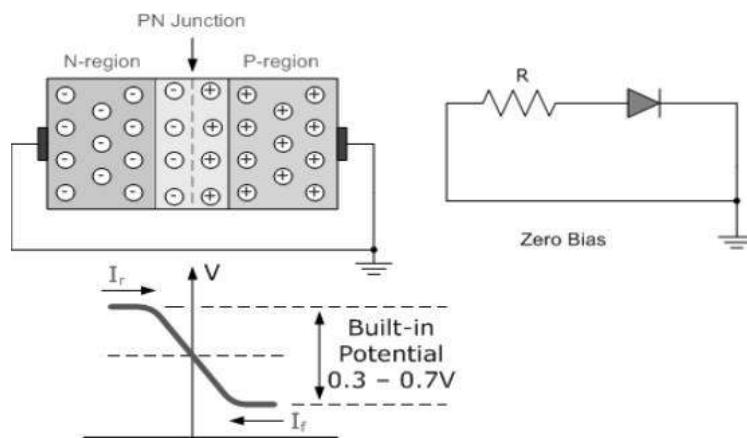

When a diode is **Zero Biased** no external energy source is applied and a natural **Potential Barrier** is developed across a depletion layer.

(i) Forward Bias:

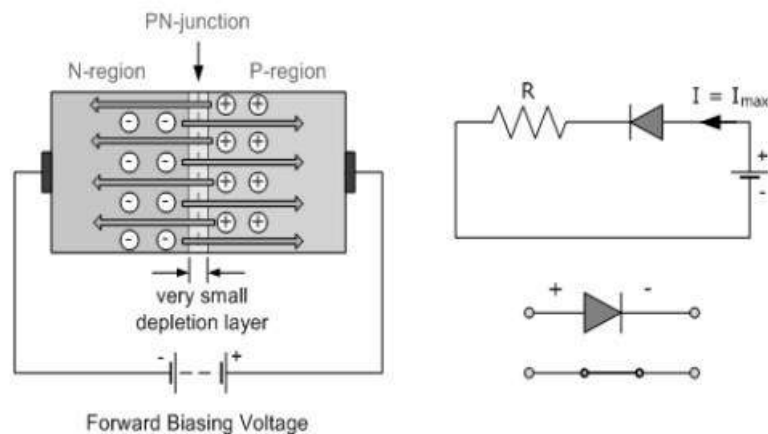

When the positive terminal of a battery is connected to P-type semiconductor and negative terminal to N-type is known as forward bias of PN junction.

➤ The applied forward potential establishes an electric field opposite to the potential barrier. Therefore the potential barrier is reduced at the junction. As the potential barrier is very small (0.3V for Ge and 0.7V for Si), a small forward voltage is sufficient to completely eliminate the barrier potential, thus the junction resistance becomes zero.

➤ In other words, the applied positive potential repels the holes in the 'P' region so that the holes move towards the junction and applied negative potential repels the electrons in the 'N' region towards the junction. Results in the depletion region starting to decrease. When the applied potential is more than the internal barrier potential then the depletion region completely disappears, thus the junction resistance becomes zero.

➤ Once the potential barrier is eliminated by a forward voltage, junction establishes the low resistance path for the entire circuit, thus a current flows in the circuit, it is called as forward current.

Reverse Bias:

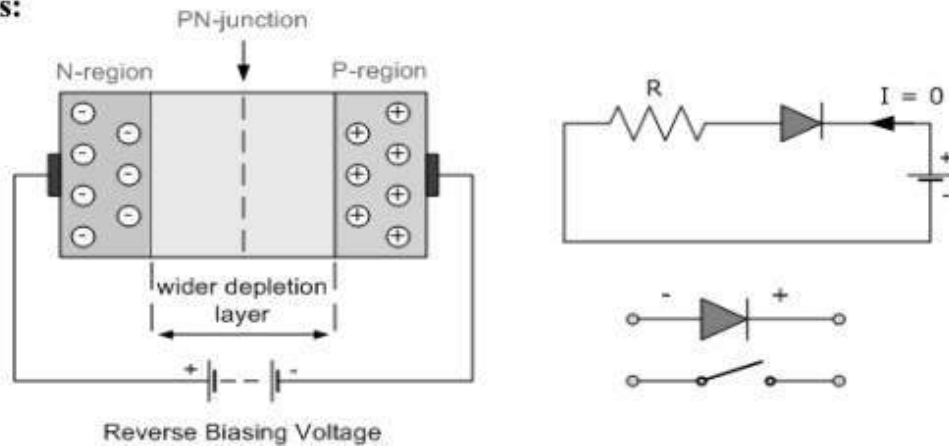

For reverse bias, the negative terminal is connected to P-type semiconductor and positive terminal to N type semiconductor.

- When reverse bias voltage is applied to the junction, all the majority carriers of ‘P’ region are attracted towards the negative terminal of the battery and the majority carriers of the N region attracted towards the positive terminal of the battery, hence the depletion region increases.
- The applied reverse voltage establishes an electric field which acts in the same direction of the potential barrier. Therefore, the resultant field at the junction is strengthened and the barrier width is increased. This increased potential barrier prevents the flow of charge carriers across the junction, results in a high resistance path.
- This process cannot continue indefinitely because after certain extent the junction break down occurs. As a result a small amount of current flows through it due to minority carriers. This current is known as “reverse saturation current”.

V-I characteristics of PN junction diode

Forward Bias:

- The application of a forward biasing voltage on the junction diode results in the depletion layer becoming very thin and narrow which represents a low impedance path through the junction thereby allowing high currents to flow.
- The point at which this sudden increase in current takes place is represented on the static I-V characteristics curve above as the "knee" point.

Reverse Bias:

- In Reverse biasing voltage a high resistance value to the PN junction and practically zero current flows through the junction diode with an increase in bias voltage.
- However, a very small leakage current does flow through the junction which can be measured in microamperes, (μA).
- One final point, if the reverse bias voltage V_r applied to the diode is increased to a sufficiently high enough value, it will cause the PN junction to overheat and fail due to the avalanche effect around the junction.
- This may cause the diode to become shorted and will result in the flow of maximum circuit current, and this shown as a step downward slope in the reverse static characteristics curve below.

V-I CHARACTERISTICS AND THEIR TEMPERATURE DEPENDENCE:

Diode terminal characteristics equation for diode junction current:

$$I_D = I(e^{\frac{V}{\eta V_T}} - 1)$$

Where $V_T = kT/q$;

V_D _ diode terminal voltage, Volts

I_o _ temperature-dependent saturation current, μA

T _ absolute temperature of p-n junction, K

k _ Boltzmann's constant $1.38 \times 10^{-23} \text{J/K}$

q _ electron charge $1.6 \times 10^{-19} \text{C}$

η = empirical constant, 1 for Ge and 2 for Si

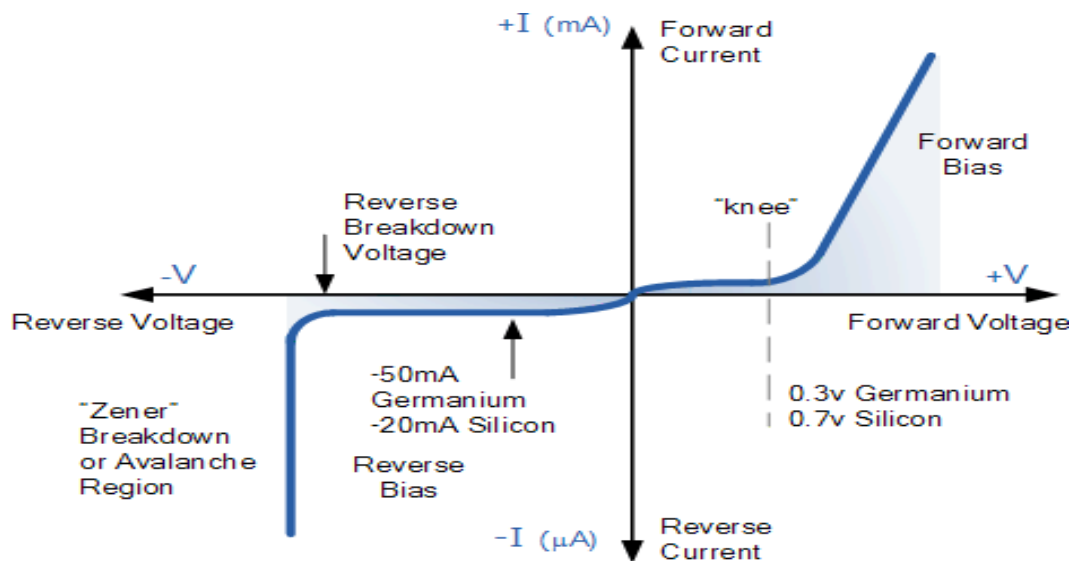

DIFFUSION CAPACITANCE AND SPACE CHARGE CAPACITANCE

Diffusion capacitance

- As a p-n diode is forward biased, the minority carrier distribution in the quasi-neutral region increases dramatically.
- In addition, to preserve quasi-neutrality, the majority carrier density increases by the same amount.
- This effect leads to an additional capacitance called the diffusion capacitance.
- The diffusion capacitance is calculated from the change in charge with voltage:

$$C = \frac{d\Delta Q}{dV_a}$$

Where the charge, ΔQ , is due to the excess carriers.

- Unlike a parallel plate capacitor, the positive and negative charge is not spatially separated. Instead, the electrons and holes are separated by the energy band gap.
- Nevertheless, this voltage dependent charges yield a capacitance just as the one associated with a parallel plate capacitor.
- The excess minority-carrier charge is obtained by integrating the charge density over the quasi-neutral region:

$$\Delta Q_p = \int_{x_n}^{x_p} q(p_n - p_{n0}) dx$$

Space Charge capacitance:

- After joining p-type and n-type semiconductors, electrons near the p–n interface tend to diffuse into the p region.
- As electrons diffuse, they leave positively charged ions (donors) in the n region.
- Similarly, holes near the p–n interface begin to diffuse into the n-type region leaving fixed ions (acceptors) with negative charge.
- The regions nearby the p–n interfaces lose their neutrality and become charged, forming the space charge capacitance.

CLASSIFICATION OF RECTIFIERS:

Using one or more diodes in the circuit, following rectifier circuits can be designed.

- 1) Half - Wave Rectifier
- 2) Full – Wave Rectifier
- 3) Bridge Rectifier

HALF-WAVE RECTIFIER:

A Half – wave rectifier as shown in **fig 2** is one, which converts a.c. voltage into a pulsating voltage using only one half cycle of the applied a.c. voltage.

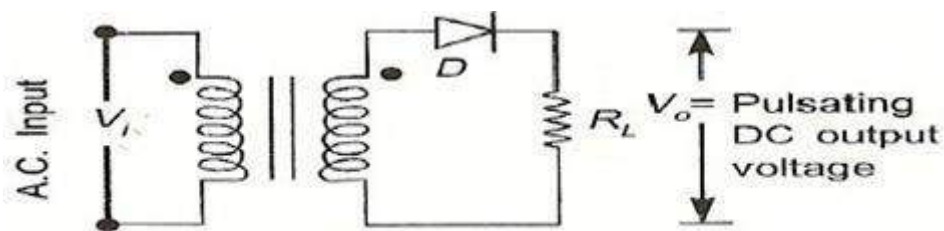

fig 2 Basic structure of Half-Wave Rectifier

The a.c. voltage is applied to the rectifier circuit using step-down transformer-rectifying element i.e., p-n junction diode and the source of a.c. voltage, all connected in series. The a.c. voltage is applied to the rectifier circuit using step-down transformer

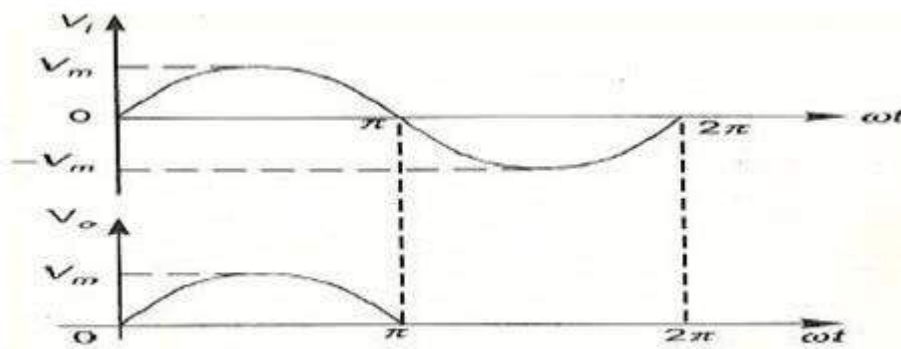

fig 3 Input and output waveforms of a Half wave rectifier

$$V = V_m \sin(\omega t)$$

The input to the rectifier circuit, Where V_m is the peak value of secondary a.c. voltage.

Operation:

For the positive half-cycle of input a.c. voltage, the diode D is forward biased and hence it conducts. Now a current flows in the circuit and there is a voltage drop across RL. The waveform of the diode current (or) load current is shown in **fig 3**.

For the negative half-cycle of input, the diode D is reverse biased and hence it does not conduct. Now no current flows in the circuit i.e., $i=0$ and $V_o=0$. Thus for the negative half-cycle no power is delivered to the load.

Analysis:

In the analysis of a HWR, the following parameters are to be analyzed.

1. DC output current
2. DC Output voltage
3. R.M.S. Current
4. R.M.S. voltage
5. Rectifier Efficiency (η)
6. Ripple factor (γ)
7. Peak Factor
8. % Regulation
9. Transformer Utilization Factor (TUF)
10. form factor
11. o/p frequency

Let a sinusoidal voltage V_i be applied to the input of the rectifier.

Then $V = V_m \sin(\omega t)$ Where V_m is the maximum value of the secondary voltage. Let the diode be idealized to piece-wise linear approximation with resistance R_f in the forward direction i.e., in the ON state and $R_r (= \infty)$

in the reverse direction i.e., in the OFF state. Now the current 'i' in the diode (or) in the load resistance RL is given by $V = V_m \sin(\omega t)$

i) AVERAGE VOLTAGE

$$V_{dc} = \frac{1}{T} \int_0^T V d(\omega t)$$

$$V_{dc} = \frac{1}{T} \int_0^{2\pi} V(\alpha) d\alpha$$

$$V_{dc} = \frac{1}{2\pi} \int_{\pi}^{2\pi} V(\alpha) d\alpha$$

$$V_{dc} = \frac{1}{2\pi} \int_0^{\pi} V_m \sin(\omega t) d(\omega t)$$

$$V_{dc} = \frac{V_m}{\pi}$$

ii) AVERAGE CURRENT:

$$I_{dc} = \frac{I_m}{\pi}$$

iii) RMS VOLTAGE:

$$V_{rms} = \sqrt{\frac{1}{T} \int_0^T V^2 d(\omega t)}$$

$$V_{rms} = \sqrt{\frac{1}{2\pi} \int_0^{2\pi} (V_m \sin(\omega t))^2 d(\omega t)}$$

$$V_{rms} = \frac{V_m}{2}$$

IV) RMS CURRENT

V) PEAK FACTOR

$$\text{Peak factor} = \frac{\text{peakvalue}}{\text{rmsvalue}}$$

$$I_{rms} = \frac{I_m}{\pi}$$

$$\text{Peak Factor} = \frac{V_m}{(V_m / 2)}$$

Peak Factor =2

vi) FORM FACTOR

$$\text{Form factor} = \frac{\text{Rmsvalue}}{\text{averagevalue}}$$

$$\text{Form factor} = \frac{(V_m / 2)}{V_m / \Pi}$$

$$\text{Form Factor} = 1.57$$

vii) Ripple Factor:

$$\Gamma = \frac{V_{ac}}{V_{dc}}$$

$$V_{ac} = \sqrt{V_{rms}^2 - V_{dc}^2}$$

$$\Gamma = \frac{\sqrt{V_{rms}^2 - V_{dc}^2}}{V_{dc}}$$

$$\Gamma = \sqrt{\frac{V_{rms}^2}{V_{dc}^2} - 1}$$

$$\Gamma = 1.21$$

viii) Efficiency (η):

$$\eta = \frac{o / p_{power}}{i / p_{power}} * 100$$

$$\eta = \frac{P_{ac}}{P_{dc}} * 100$$

$$\eta = 40.8$$

ix) Transformer Utilization Factor (TUF):

The d.c. power to be delivered to the load in a rectifier circuit decides the rating of the transformer used in the circuit. Therefore, transformer utilization factor is defined as

$$TUF = \frac{P_{dc}}{P_{ac(rated)}}$$

$$TUF = 0.286.$$

The value of TUF is low which shows that in half-wave circuit, the transformer is not fully utilized.

If the transformer rating is 1 KVA (1000VA) then the half-wave rectifier can deliver

$1000 \times 0.287 = 287$ watts to resistance load.

x) Peak Inverse Voltage (PIV):

It is defined as the maximum reverse voltage that a diode can withstand without destroying the junction. The peak inverse voltage across a diode is the peak of the negative half-cycle. For half-wave rectifier, PIV is V_m .

DISADVANTAGES OF HALF-WAVE RECTIFIER:

1. The ripple factor is high.
2. The efficiency is low.
3. The Transformer Utilization factor is low.

Because of all these disadvantages, the half-wave rectifier circuit is normally not used as a power rectifier circuit.

FULL WAVE RECTIFIER

A full-wave rectifier converts an ac voltage into a pulsating dc voltage using both half cycles of the applied ac voltage. In order to rectify both the half cycles of ac input, two diodes are used in this circuit. The diodes feed a common load R_L with the help of a center-tap transformer. A center-tap transformer is the one, which produces two sinusoidal waveforms of same magnitude and frequency but out of phase with respect to the ground in the secondary winding of the transformer. The full wave rectifier is shown in the **fig 4** below

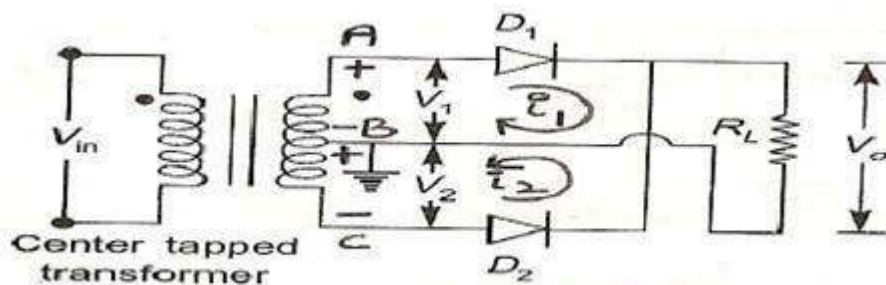

fig 4 Full-Wave Rectifier.

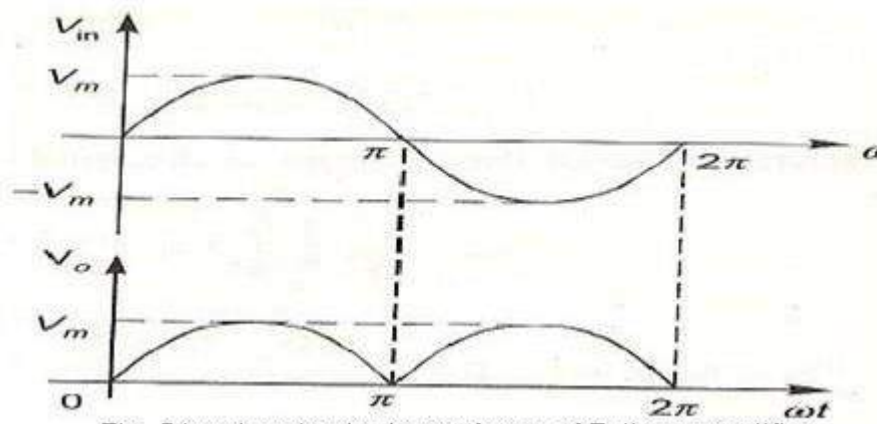

Fig. 5 input and output waveforms of Fullwave rectifier

Fig. 5 shows the input and output wave forms of the ckt.

During positive half of the input signal, anode of diode D1 becomes positive and at the same time the anode of diode D2 becomes negative. Hence D1 conducts and D2 does not conduct. The load current flows through D1 and the voltage drop across RL will be equal to the input voltage.

During the negative half cycle of the input, the anode of D1 becomes negative and the anode of D2 becomes positive. Hence, D1 does not conduct and D2 conducts. The load current flows through D2 and the voltage drop across RL will be equal to the input voltage. It is noted that the load current flows in the both the half cycles of ac voltage and in the same direction through the load resistance.

i) AVERAGE VOLTAGE

$$V_{dc} = I_{dc} \cdot R_L = \frac{2I_m}{\pi} \cdot R_L \quad \text{We know that } I_m = \frac{V_m}{R_S + R_F + R_L}$$

$$V_{dc} = \frac{2V_m R_L}{\pi(R_S + R_F + R_L)}$$

If $(R_S + R_F) \ll R_L$

$$V_{dc} = \frac{2V_m}{\pi} = 0.637V_m$$

ii) AVERAGE CURRENT

$$\begin{aligned} \frac{1}{2\pi} \int_0^{2\pi} Id\theta &= \frac{1}{2\pi} \int_0^{2\pi} I_m \sin \theta dt \\ &= \frac{I_m}{2\pi} \left[\int_0^{\pi} \sin \theta d\theta - \int_{\pi}^{2\pi} \sin \theta d\theta \right] \\ &= \frac{I_m}{2\pi} [(-2) - (-2)] \\ I_{dc} &= \frac{4I_m}{2\pi} = 0.637I_m \end{aligned}$$

$$I_{dc} = 0.637I_m$$

$$I_{DC} \text{ FWR} = 2I_{DC} \text{ HWR}$$

iii) RMS VOLTAGE:

$$V_{rms} = \sqrt{\frac{1}{T} \int_0^T V^2 d(wt)}$$

$$V_{rms} = \sqrt{\frac{1}{2\pi} \int_0^{2\pi} (V_m \sin(wt))^2 d(wt)}$$

$$V_{rms} = \frac{V_m}{\sqrt{2}}$$

IV) RMS CURRENT

$$I_{rms} = I_m / \sqrt{2}$$

V) PEAK FACTOR

$$\text{Peak factor} = \frac{\text{peakvalue}}{\text{rmsvalue}}$$

$$\text{Peak Factor} = \frac{V_m}{(V_m / 2)}$$

$$\text{Peak Factor} = 2$$

vi) **FORM FACTOR**

$$\text{Form factor} = \frac{\text{Rms value}}{\text{average value}}$$

$$\text{Form factor} = \frac{(V_m / \sqrt{2})}{2V_m / \pi}$$

$$\text{Form Factor} = 1.11$$

vii) **Ripple Factor:**

$$\gamma = \sqrt{\left(\frac{I_{rms}}{I_{dc}}\right)^2 - 1}$$

For FWR,

$$I_{RMS} = \frac{I_{rm}}{\sqrt{2}} \quad \& \quad I_{DC} = \frac{2I_m}{\pi}$$

$$\gamma_{FWR} = \sqrt{\left(\frac{\frac{I_m}{\sqrt{2}}}{\frac{2I_m}{\pi}}\right)^2 - 1}$$

$$= \sqrt{\left(\frac{\pi}{2\sqrt{2}}\right)^2 - 1}$$

$$= \sqrt{\left(\frac{3.1416}{2 \times 1.414}\right)^2 - 1}$$

$$= 0.483$$

viii) **Efficiency (η):**

$$\eta = \frac{o / \text{power}}{i / \text{power}} * 100$$

$$\eta = \frac{P_{DC}}{P_{AC}} \times 100\%$$

$$\text{For FWR, } P_{DC} = I_{DC}^2 \cdot R_L = \left(\frac{2I_m}{\pi}\right)^2 \cdot R_L$$

$$P_{AC} = I_{rm}^2 (R_F + R_S + R_L)$$

$$= \left(\frac{I_m}{\sqrt{2}}\right)^2 (R_F + R_S + R_L)$$

$$\eta = \frac{\left(\frac{2I_m}{\pi}\right)^2 \cdot R_L}{\left(\frac{I_m}{\sqrt{2}}\right)^2 (R_F + R_S + R_L)} \times 100\%$$

$$\text{If } (R_S + R_L) \ll R_L$$

$$\eta = \frac{4}{\pi^2} \times \frac{2}{1} = 0.812 \times 100\% = 81.2\%$$

ix) Transformer Utilization Factor (TUF):

The d.c. power to be delivered to the load in a rectifier circuit decides the rating of the transformer used in the circuit. So, transformer utilization factor is defined as

$$TUF = \frac{P_{dc}}{P_{ac(rated)}}$$

$$\text{a) TUF(Secondary)} = \frac{P_{DC \text{ delivered to load}}}{AC \text{ power rating of transformer secondary}}$$

$$\text{b) Since both windings are used } TUF_{FWR} = 2TUF_{HWR} = 2 * 0.287 = 81.2\%$$

$$\text{c) TUF}_{primary} = \text{Rated efficiency} = \frac{P_{DC}}{P_{AC}} \times 100\% = 81.2\%$$

$$\text{d) Average} = \frac{0.812 + 0.574}{2} = 0.693$$

x) Peak Inverse Voltage (PIV):

It is defined as the maximum reverse voltage that a diode can withstand without destroying the junction. The peak inverse voltage across a diode is the peak of the negative half- cycle. For half- wave rectifier, PIV is $2V_m$

xi) % Regulation

$$\text{Voltage Regulation} = \frac{I_{dc}(R_F + R_L)}{\frac{2V_m}{\pi} - I_{dc}(R_F + R_L)}$$

.Advantages

- 1) Ripple factor = 0.482 (against 1.21 for HWR)
- 2) Rectification efficiency is 0.812 (against 0.405 for HWR)
- 3) Better TUF (secondary) is 0.574 (0.287 for HWR)
- 4) No core saturation problem

Disadvantages

- 1) Requires center tapped transformer.

BRIDGE RECTIFIER

Another type of circuit that produces the same output waveform as the full wave rectifier circuit above, is that of the **Full Wave Bridge Rectifier**. This type of single phase rectifier uses four individual rectifying diodes connected in a closed loop "bridge" configuration to produce the desired output. The main advantage of this bridge circuit is that it does not require a special centre tapped transformer, thereby reducing its size and cost. The single secondary winding is connected to one side of the diode bridge network and the load to the other side as shown below.

The Diode Bridge Rectifier

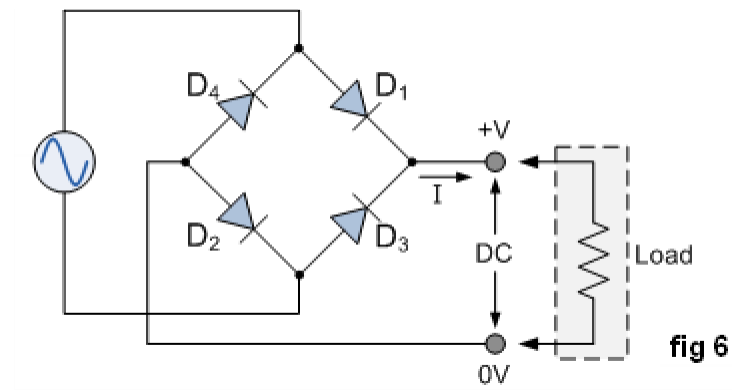

The four diodes labeled D₁ to D₄ are arranged in "series pairs" with only two diodes conducting current during each half cycle. During the positive half cycle of the supply, diodes D₁ and D₂ conduct in series while diodes D₃ and D₄ are reverse biased and the current flows through the load as shown below (fig 7).

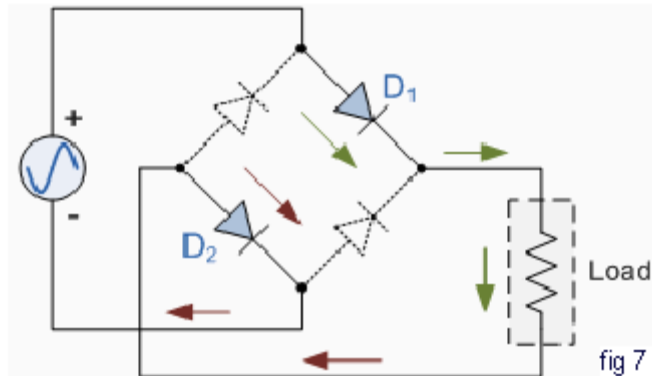
The Positive Half-cycle**The Negative Half-cycle**

During the negative half cycle of the supply, diodes D3 and D4 conduct in series (fig 8), but diodes D1 and D2 switch "OFF" as they are now reverse biased. The current flowing through the load is the same direction as before.

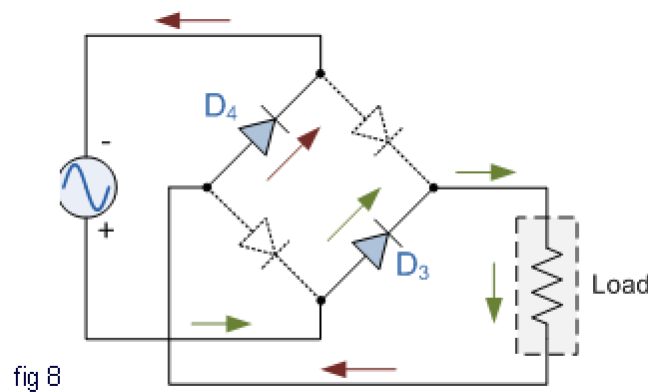

As the current flowing through the load is unidirectional, so the voltage developed across the load is also unidirectional the same as for the previous two diode full-wave rectifier, therefore the average DC voltage across the load is $0.637V_{\max}$. However in reality, during each half cycle the current flows through two diodes instead of just one so the amplitude of the output voltage is two voltage drops ($2 \times 0.7 = 1.4V$) less than the input V_{\max} amplitude. The ripple frequency is now twice the supply frequency (e.g. 100Hz for a 50Hz supply)

Therefore, following Expressions are same as that pf full wave rectifier

- a) Average current = $\frac{2I_m}{\pi}$
- b) RMS current = $\frac{I_m}{\sqrt{2}}$
- c) DC output voltage $V_{dc} = \frac{2V_m}{\pi}$
- d) Ripple factor = 0.482
- e) Rectification Efficiency = 0.812
- f) DC output full load $V_{DCFL} = \frac{2V_m}{\pi} - I_{dc} (2R_F + R_s)$

TUF of both primary and secondary are 0.812 therefore TUF overall is 0.812 (better than FWR with 0.693)

Comparison:

Sl No.	Parameter	HWR	FWR	BR
1	No. of diodes	1	2	4
2	PIV of diodes	V_m	$2V_m$	V_m
3	Secondary voltage (rms)	V	V-0-V	V
4	DC output voltage at no load	$\frac{V_m}{\pi} = 0.318 V_m$	$\frac{2V_m}{\pi} = 0.636 V_m$	$\frac{2V_m}{\pi} = 0.636 V_m$
5	Ripple factor γ	1.21	0.482	0.482
6	Ripple frequency	f	2f	2f
7	Rectification efficiency η	0.406	0.812	0.812
8	TUF	0.287	0.693	0.812

**UNIT –V
BIPOLAR JUNCTION TRANSISTOR (BJT)**

- Bipolar Junction Transistor
- Construction
- Principle of Operation
- Amplifying Action
- Common Emitter configuration
- Common Base configuration
- Common Collector configuration

BIPOLAR JUNCTION TRANSISTOR

INTRODUCTION

A bipolar junction transistor (BJT) is a three terminal device in which operation depends on the interaction of both majority and minority carriers and hence the name bipolar. The BJT is analogous to vacuum triode and is comparatively smaller in size. It is used as amplifier and oscillator circuits, and as a switch in digital circuits. It has wide applications in computers, satellites and other modern communication systems.

CONSTRUCTION OF BJT AND ITS SYMBOLS

The **Bipolar Transistor** basic construction consists of two PN-junctions producing three connecting terminals with each terminal being given a name to identify it from the other two. These three terminals are known and labeled as the Emitter (E), the Base (B) and the Collector (C) respectively. There are two basic types of bipolar transistor construction, PNP and NPN, which basically describes the physical arrangement of the P-type and N-type semiconductor materials from which they are made.

Transistors are three terminal active devices made from different semiconductor materials that can act as either an insulator or a conductor by the application of a small signal voltage. The transistor's ability to change between these two states enables it to have two basic functions: "switching" (digital electronics) or "amplification" (analogue electronics). Then bipolar transistors have the ability to operate within three different regions:

1. Active Region - the transistor operates as an amplifier and $I_c = \beta \cdot I_b$
2. Saturation - the transistor is "fully-ON" operating as a switch and $I_c = I(\text{saturation})$
3. Cut-off - the transistor is "fully-OFF" operating as a switch and $I_c = 0$

Bipolar Transistors are current regulating devices that control the amount of current flowing through them in proportion to the amount of biasing voltage applied to their base terminal acting like a current-controlled switch. The principle of operation of the two transistor types PNP and NPN, is exactly the same the only difference being in their biasing and the polarity of the power supply for each type.

Bipolar Transistor Construction

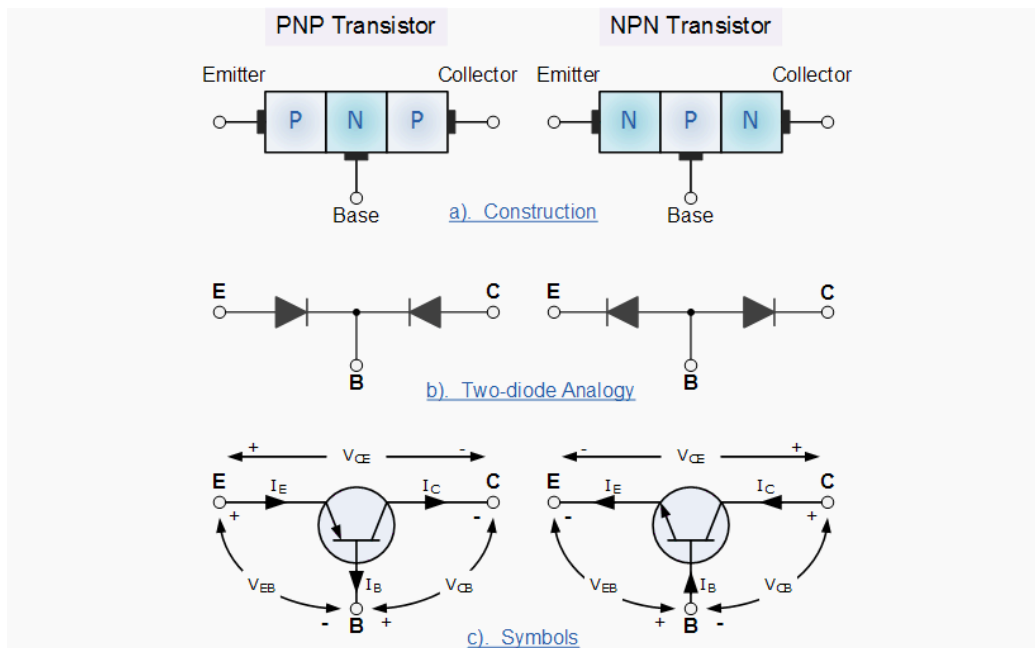

The construction and circuit symbols for both the PNP and NPN bipolar transistor are given above with the arrow in the circuit symbol always showing the direction of "conventional current flow" between the base terminal and its emitter terminal. The direction of the arrow always points from the positive P-type region to the negative N-type region for both transistor types, exactly the same as for the standard diode symbol.

TRANSISTOR CURRENT COMPONENTS:

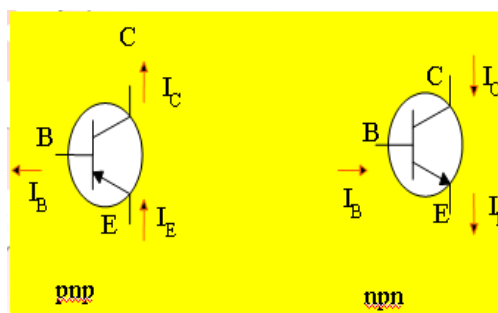

The above fig 2 shows the various current components, which flow across the forward biased emitter junction and reverse- biased collector junction. The emitter current I_E consists of hole current I_{pE} (holes crossing from emitter into base) and electron current I_{nE} (electrons crossing from base into emitter). The ratio of hole to electron currents, I_{pE} / I_{nE}, crossing the emitter junction is proportional to the ratio of the conductivity of the p material to that of the n material. In a transistor, the doping of that of the emitter is made much larger than the doping of the base. This feature ensures (in p-n-p transistor) that the emitter

current consists almost entirely of holes. Such a situation is desired since the current which results from electrons crossing the emitter junction from base to emitter does not contribute carriers, which can reach the collector.

Not all the holes crossing the emitter junction J_E reach the collector junction J_C

Because some of them combine with the electrons in n-type base. If I_{pC} is hole current at junction J_C there must be a bulk recombination current $(I_{pE} - I_{pC})$ leaving the base.

Actually, electrons enter the base region through the base lead to supply those charges, which have been lost by recombination with the holes injected into the base across J_E . If the emitter were open circuited so that $I_E=0$ then I_{pC} would be zero. Under these circumstances, the base and collector current I_C would equal the reverse saturation current I_{CO} . If $I_E \neq 0$ then

$$I_C = I_{CO} - I_{pC}$$

For a p-n-p transistor, I_{CO} consists of holes moving across J_C from left to right (base to collector) and electrons crossing J_C in opposite direction. Assumed referenced direction for I_{CO} i.e. from right to left, then for a p-n-p transistor, I_{CO} is negative. For an n-p-n transistor, I_{CO} is positive. The basic operation will be described using the pnp transistor. The operation of the pnp transistor is exactly the same if the roles played by the electron and hole are interchanged.

One p-n junction of a transistor is reverse-biased, whereas the other is forward-biased.

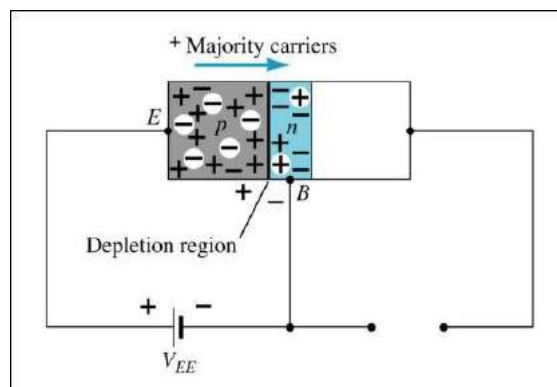

Forward-biased junction of a PNP transistor

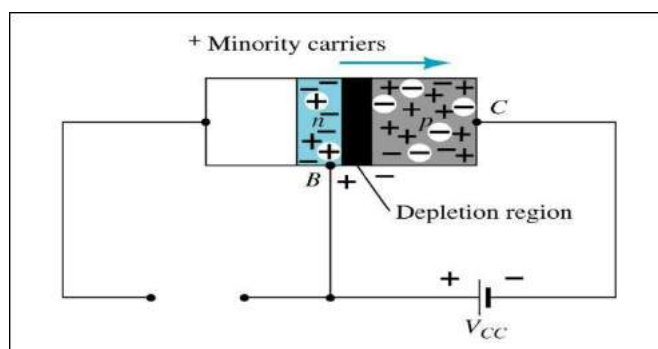

Reverse-biased junction of a PNP transistor

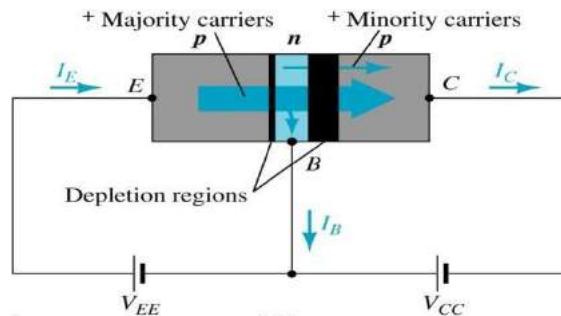

Both biasing potentials have been applied to a pnp transistor and resulting majority and minority carrier flows indicated.

Majority carriers (+) will diffuse across the forward-biased p-n junction into the n-type material.

A very small number of carriers (+) will through n-type material to the base terminal. Resulting I_B is typically in order of microamperes.

The large number of majority carriers will diffuse across the reverse-biased junction into the p-type material connected to the collector terminal

Applying KCL to the transistor:

$$I_E = I_C + I_B$$

The comprises of two components – the majority and minority carriers

$$I_C = I_{C\text{majority}} + I_{CO\text{minority}}$$

I_{CO} – I_C current with emitter terminal open and is called leakage current

Various parameters which relate the current components is given below

Emitter efficiency:

$$\gamma = \frac{\text{current of injected carriers at } J_E}{\text{total emitter current}}$$

$$\gamma = \frac{I_{pE}}{I_{pE} + I_{nE}} = \frac{I_{pE}}{I_{nE}}$$

Transport Factor:

$$\beta^* = \frac{\text{injected carrier current reaching } J_C}{\text{injected carrier current at } J_E}$$

$$\beta^* = \frac{I_{pC}}{I_{nE}}$$

Large signal current gain:

The ratio of the negative of collector current increment to the emitter current change from zero (cut-off) to I_E is the large signal current gain of a common base transistor.

$$\alpha = \frac{-(I_C - I_{CO})}{I_E}$$

Since I_C and I_E have opposite signs, then α , as defined, is always positive. Typically numerical values of α lies in the range of 0.90 to 0.995

$$\alpha = \frac{I_{pC}}{I_E} = \frac{I_{pC}}{I_{nE}} * \frac{I_{pE}}{I_E} \quad \alpha = \beta * \gamma$$

The transistor alpha is the product of the transport factor and the emitter efficiency. This statement assumes that the collector multiplication ratio α^* is unity. α^* is the ratio of total current crossing J_C to hole arriving at the junction.

Bipolar Transistor Configurations

As the **Bipolar Transistor** is a three terminal device, there are basically three possible ways to connect it within an electronic circuit with one terminal being common to both the input and output. Each method of connection responding differently to its input signal within a circuit as the static characteristics of the transistor vary with each circuit arrangement.

1. Common Base Configuration - has Voltage Gain but no Current Gain.
2. Common Emitter Configuration - has both Current and Voltage Gain.
3. Common Collector Configuration - has Current Gain but no Voltage Gain.

COMMON-BASE CONFIGURATION

Common-base terminology is derived from the fact that the: base is common to both input and output of this configuration. base is usually the terminal closest to or at ground potential. Majority carriers can cross the reverse-biased junction because the injected majority carriers will appear as minority carriers in the n-type material. All current directions will refer to conventional (hole) flow and the arrows in all electronic symbols have a direction defined by this convention.

Note that the applied biasing (voltage sources) are such as to establish current in the direction indicated for each branch.

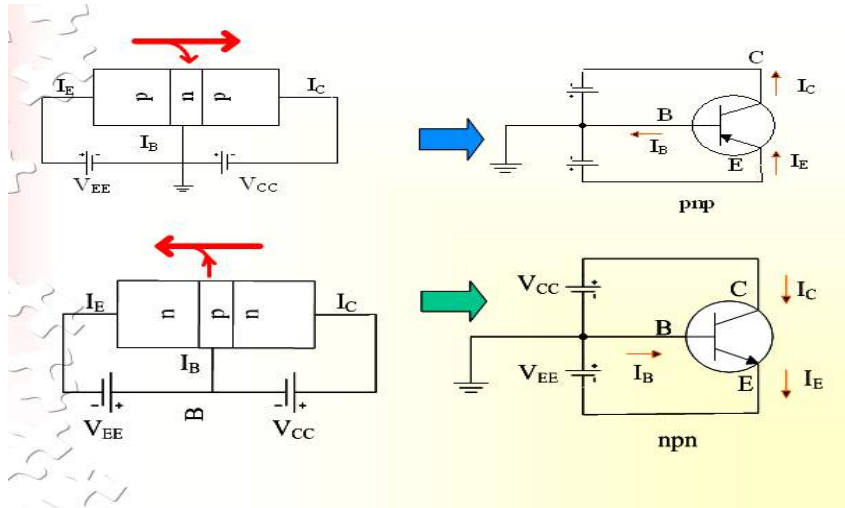

To describe the behavior of common-base amplifiers requires two set of characteristics:

1. Input or driving point characteristics.
2. Output or collector characteristics

The output characteristics have 3 basic regions:

- Active region –defined by the biasing arrangements
- Cutoff region – region where the collector current is 0A
- Saturation region- region of the characteristics to the left of $V_{CB} = 0V$

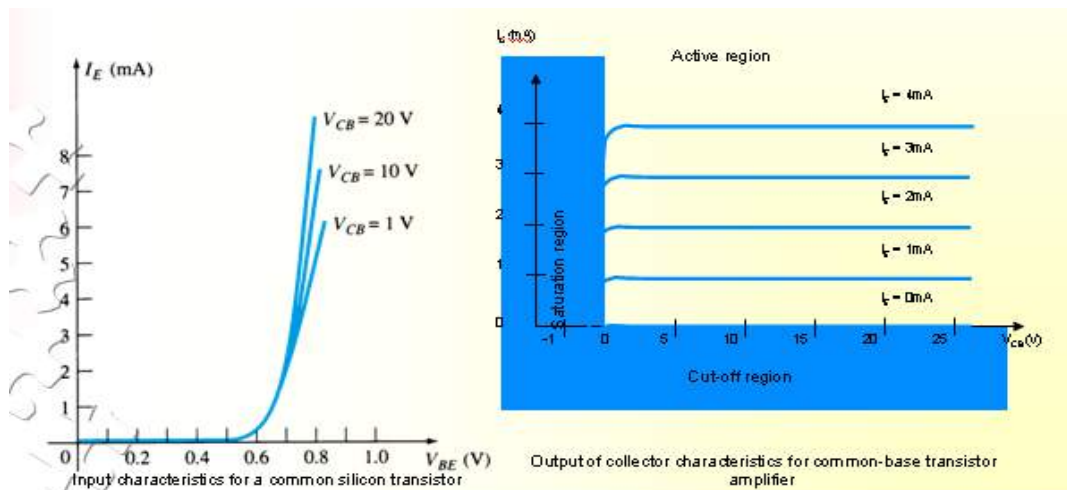

Active region	Saturation region	Cut-off region
<ul style="list-style-type: none"> • I_E increased, I_C increased • BE junction forward bias and CB junction reverse bias • Refer to the graf, $I_C \approx I_E$ • I_C not depends on V_{CB} • Suitable region for the transistor working as amplifier 	<ul style="list-style-type: none"> • BE and CB junction is forward bias • Small changes in V_{CB} will cause big different to I_C • The allocation for this region is to the left of $V_{CB} = 0 V$. 	<ul style="list-style-type: none"> • Region below the line of $I_E = 0 A$ • BE and CB is reverse bias • no current flow at collector, only leakage current

The curves (output characteristics) clearly indicate that a first approximation to the relationship between I_E and I_C in the active region is given by

$I_C \approx I_E$ Once a transistor is in the 'on' state, the base-emitter voltage will be assumed to be $V_{BE} = 0.7V$

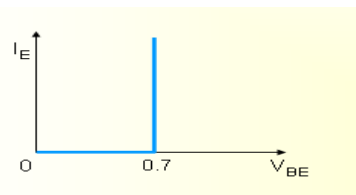

In the dc mode the level of I_C and I_E due to the majority carriers are related by a quantity called alpha $\alpha = \alpha_{dc}$

$$I_C = \alpha I_E + I_{CBO}$$

It can then be summarize to $I_C = \alpha I_E$ (ignore I_{CBO} due to small value)

For ac situations where the point of operation moves on the characteristics curve, an ac alpha defined by α_{ac} Alpha a common base current gain factor that shows the efficiency by calculating the current percent from current flow from emitter to collector. The value of α is typical from 0.9 ~ 0.998.

Biasing: Proper biasing CB configuration in active region by approximation $I_C \approx I_E$ ($I_B \approx 0 \mu A$)

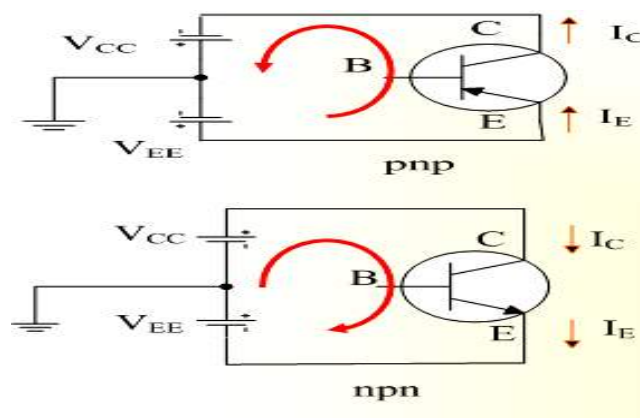

TRANSISTOR AS AN AMPLIFIER

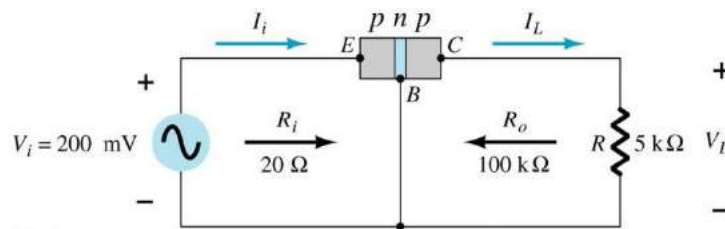

Common-Emitter Configuration

It is called common-emitter configuration since : emitter is common or reference to both input and output terminals. emitter is usually the terminal closest to or at ground potential.

Almost amplifier design is using connection of CE due to the high gain for current and voltage.

Two set of characteristics are necessary to describe the behavior for CE ;input (base terminal) and output (collector terminal) parameters.

Proper Biasing common-emitter configuration in active region

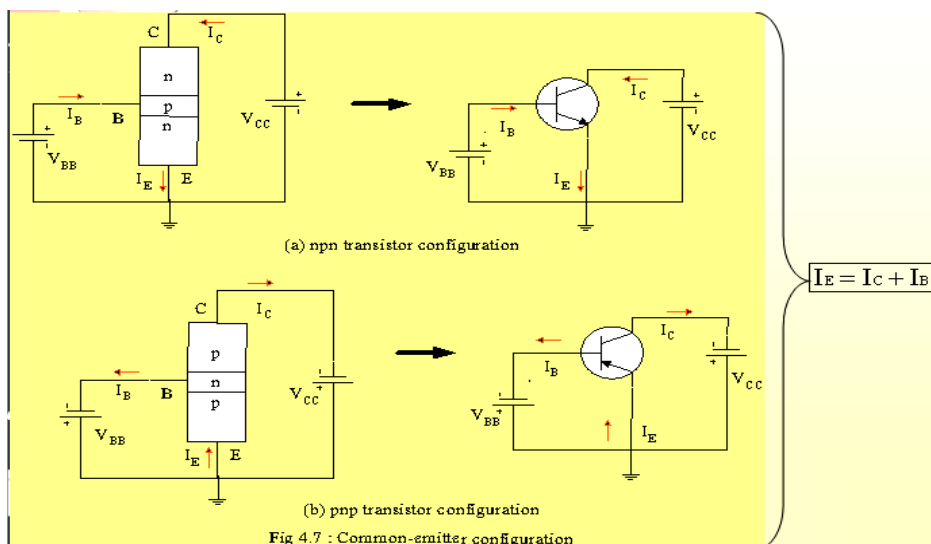

I_B is microamperes compared to milliamperes of I_C .

I_B will flow when $V_{BE} > 0.7V$ for silicon and $0.3V$ for germanium

Before this value I_B is very small and no I_B .

Base-emitter junction is forward bias Increasing V_{CE} will reduce I_B for different values.

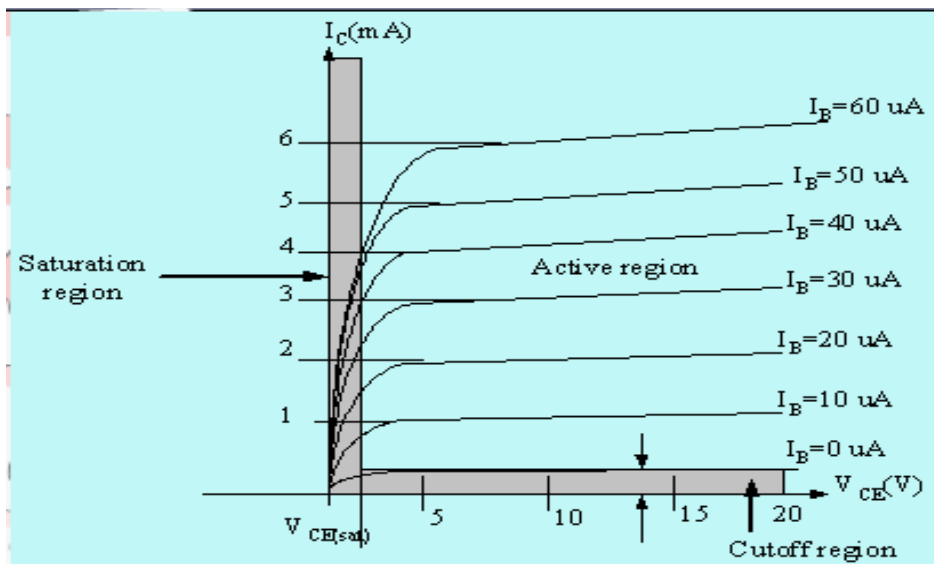
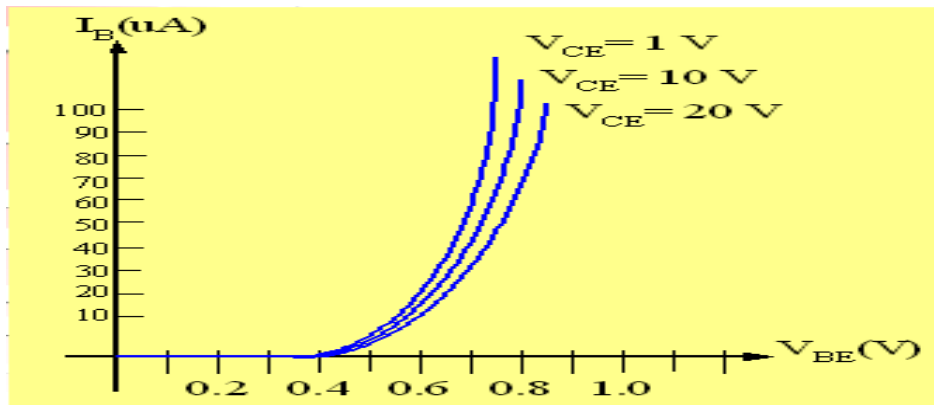

Output characteristics for a common-emitter npn transistor

For small V_{CE} ($V_{CE} < V_{CE(sat)}$, I_C increase linearly with increasing of V_{CE}

$V_{CE} > V_{CE(sat)}$ I_C not totally depends on $V_{CE} \rightarrow$ constant I_C

I_B (μA) is very small compare to I_C (mA). Small increase in I_B cause big increase in I_C

$I_B = 0 A \rightarrow I_{CE0}$ occur.

Noticing the value when $I_C = 0 A$. There is still some value of current flows.

Active region	Saturation region	Cut-off region
<ul style="list-style-type: none"> B-E junction is forward bias C-B junction is reverse bias can be employed for voltage, current and power amplification 	<ul style="list-style-type: none"> B-E and C-B junction is forward bias, thus the values of I_B and I_C is too big. The value of V_{CE} is so small. Suitable region when the transistor as a logic switch. NOT and avoid this region when the transistor as an amplifier. 	<ul style="list-style-type: none"> region below $I_B = 0 \mu A$ is to be avoided if an undistorted o/p signal is required B-E junction and C-B junction is reverse bias $I_B = 0$, I_C not zero, during this condition $I_C = I_{CEO}$ where is this current flow when B-E is reverse bias.

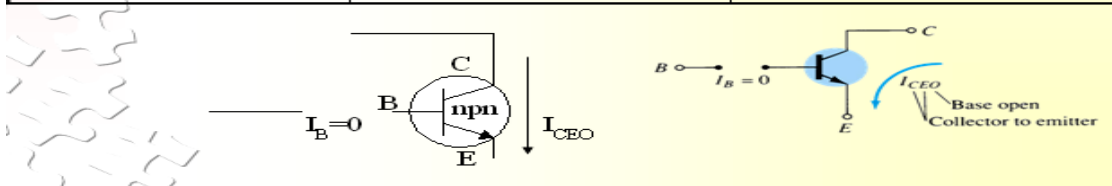

Beta (β) or amplification factor

The ratio of dc collector current (I_C) to the dc base current (I_B) is dc beta (β_{dc}) which is dc current gain where I_C and I_B are determined at a particular operating point, Q-point (quiescent point). It's define by the following equation:

$$30 < \beta_{dc} < 300 \rightarrow 2N3904$$

On data sheet, $\beta_{dc} = h_{fe}$ with h is derived from ac hybrid equivalent cct. FE are derived from forward-current amplification and common-emitter configuration respectively.

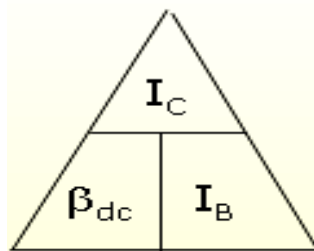

For ac conditions, an ac beta has been defined as the changes of collector current (I_C) compared to the changes of base current (I_B) where I_C and I_B are determined at operating point. On data sheet, $\beta_{ac} = h_{fe}$ It can defined by the following equation:



From output characteristics of common emitter configuration, find β_{ac} and β_{dc} with an

Operating point at $I_B=25 \mu A$ and $V_{CE}=7.5V$

$$\beta_{ac} = \frac{\Delta I_C}{\Delta I_B} \Big|_{V_{CE} = \text{constant}}$$

$$= \frac{I_{C2} - I_{C1}}{I_{B2} - I_{B1}} = \frac{3.2 \text{ m} - 2.2 \text{ m}}{30 \mu - 20 \mu}$$

$$= \frac{1 \text{ m}}{10 \mu} = 100$$

$$\beta_{dc} = \frac{I_C}{I_B}$$

$$= \frac{2.7 \text{ m}}{25 \mu}$$

$$= \underline{\underline{108}}$$

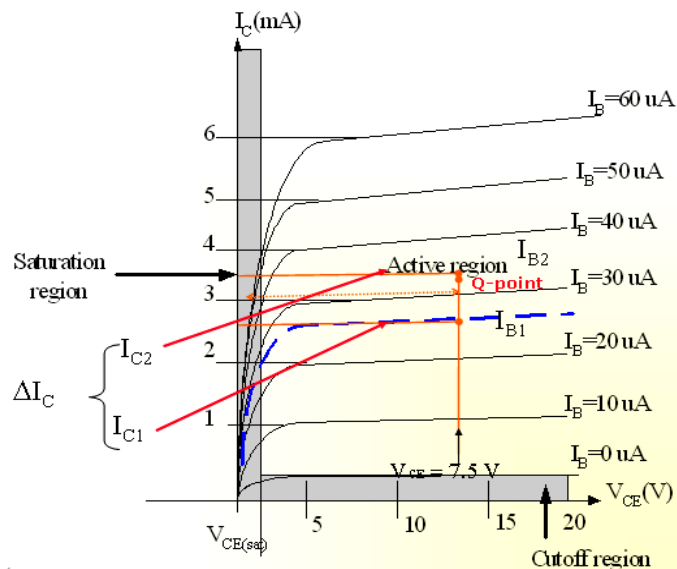

Relationship analysis between α and β

CASE 1

$$I_E = I_C + I_B \quad (1)$$

substitute equ. $I_C = \beta I_B$ into (1) we get

$$I_E = (\beta + 1)I_B$$

CASE 2

known : $\alpha = \frac{I_C}{I_E} \Rightarrow I_E = \frac{I_C}{\alpha} \quad (2)$

known : $\beta = \frac{I_C}{I_B} \Rightarrow I_B = \frac{I_C}{\beta} \quad (3)$

substitute (2) and (3) into (1) we get,

$$\alpha = \frac{\beta}{\beta + 1} \quad \text{and} \quad \beta = \frac{\alpha}{1 - \alpha}$$

COMMON – COLLECTOR CONFIGURATION

Also called emitter-follower (EF). It is called common-emitter configuration since both the signal source and the load share the collector terminal as a common connection point. The output voltage is obtained at emitter terminal. The input characteristic of common-collector configuration is similar with common-emitter. Configuration. Common-collector circuit configuration is provided with the load resistor connected from emitter to ground. It is used primarily for impedance-matching purpose since it has high input impedance and low output impedance.

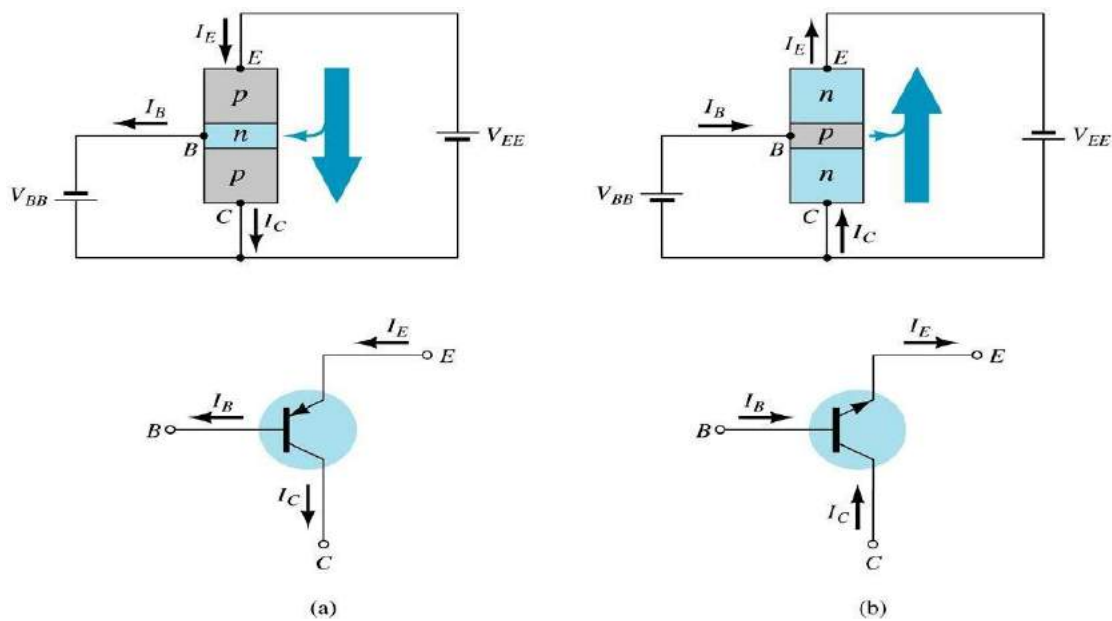

For the common-collector configuration, the output characteristics are a plot of I_E vs V_{CE} for a range of values of I_B .

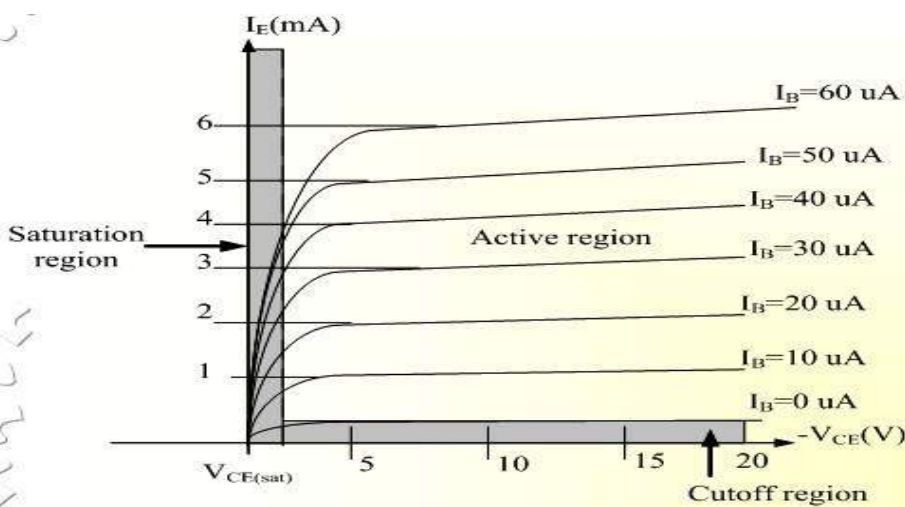

Fig 4.9 : Output characteristic in CC configuration for npn transistor

Limits of operation

Many BJT transistor used as an amplifier. Thus it is important to notice the limits of operations. At least 3 maximum values are mentioned in data sheet.

There are:

- Maximum power dissipation at collector: P_{Cmax} or P_D
- Maximum collector-emitter voltage: V_{CEmax} sometimes named as $V_{BR(CEO)}$ or V_{CEO} .
- Maximum collector current: I_{Cmax}

There are few rules that need to be followed for BJT transistor used as an amplifier. The rules are: transistors need to be operating in active region!

$$I_C < I_{Cmax}$$

$$P_C < P_{Cmax}$$

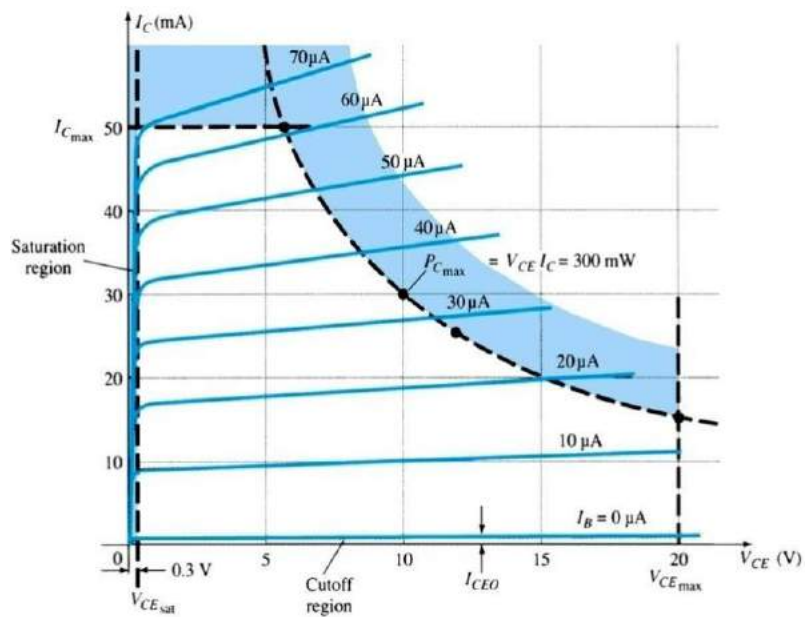

Note: V_{CE} is at maximum and I_C is at minimum ($I_{Cmax}=I_{CEO}$) in the cutoff region. I_C is at maximum and V_{CE} is at minimum ($V_{CE\ max} = V_{cesat} = V_{CEO}$) in the saturation region. The transistor operates in the active region between saturation and cutoff.

Example 1:

P_D : maximum power dissipation line

