

EARTHQUAKE ENGINEERING

DESIGN OF EARTHQUAKE RESISTANT

BUILDINGS

Definition of Structural Components

The main structural system usually consists of frames, shear walls, or a combination of both (a dual system). These elements are connected at the floor level by diaphragms.

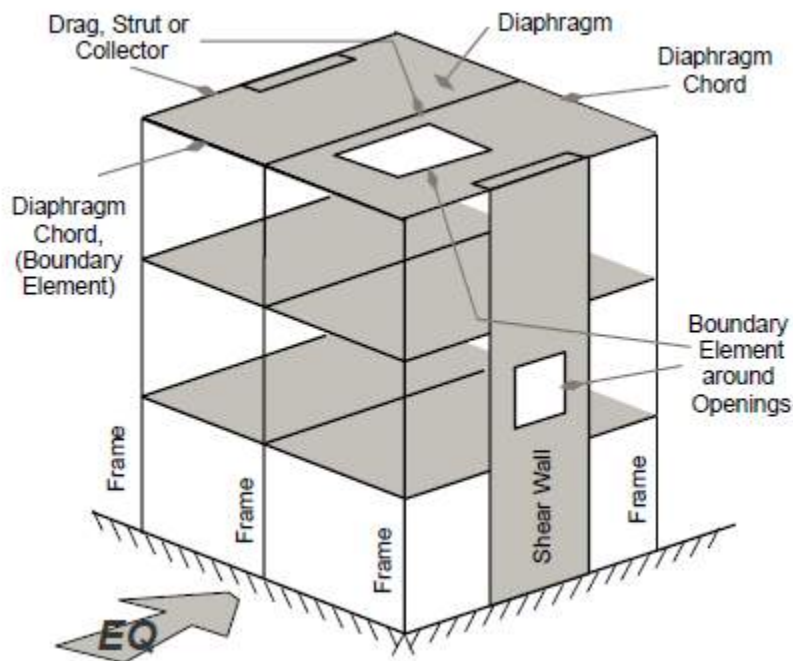

BASIC COMPONENTS OF EARTHQUAKE-RESISTANT BUILDING

Recommended versus Undesirable Structural Systems

In general, seismic design prefers simplicity in structural systems and structural forms. Structures that exhibit good ductility, energy dissipation, and self-centering capacity are recommended. The following systems are recommended:

1. Systems with simplicity in plans. Structures with square and circular shapes are preferred.
2. Systems with compactness in shape. Avoid structures with long extended wings.
3. Systems with symmetry and large torsional resistance.
4. Systems with vertical uniformity and continuity. Avoid structures with sudden changes in mass and stiffness.

Undesirable seismic systems

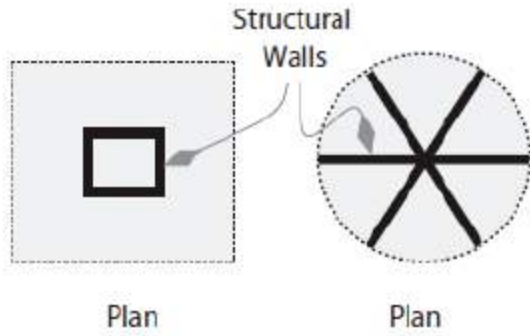

(a) Small Torsional Resistance

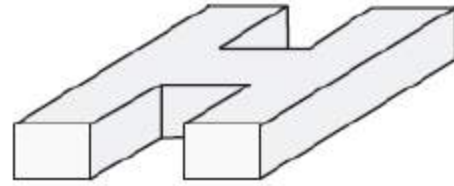

(b) Long Extension Wings

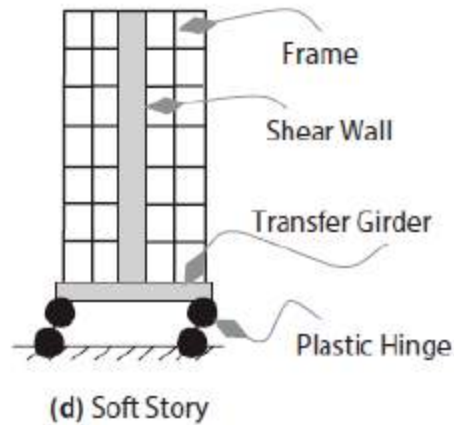
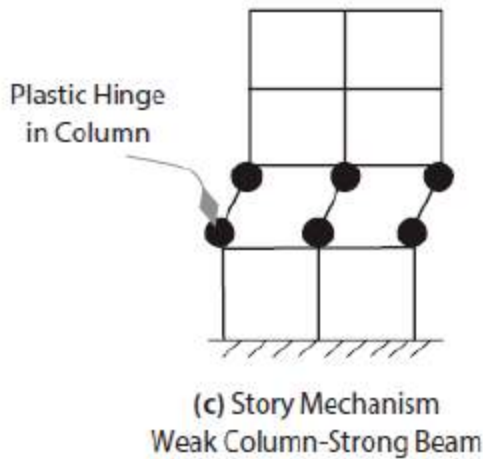

Recommended seismic systems

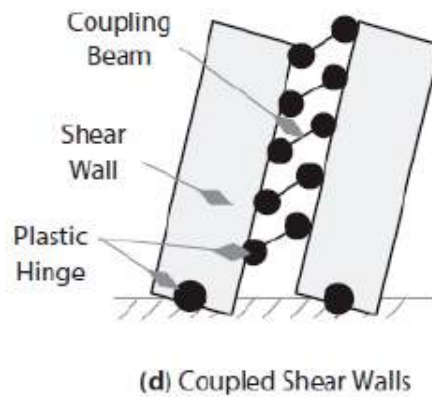
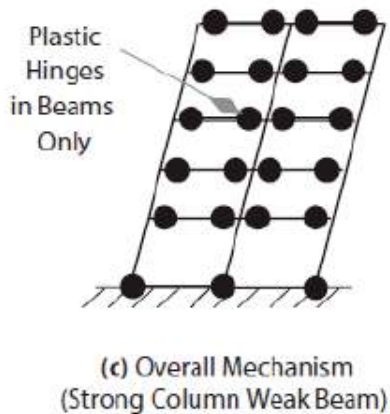
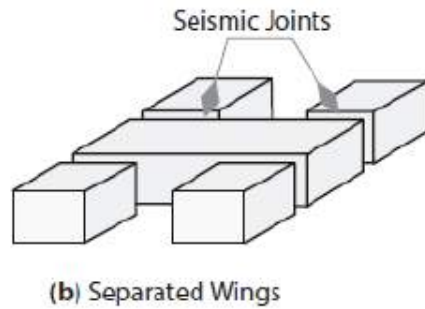
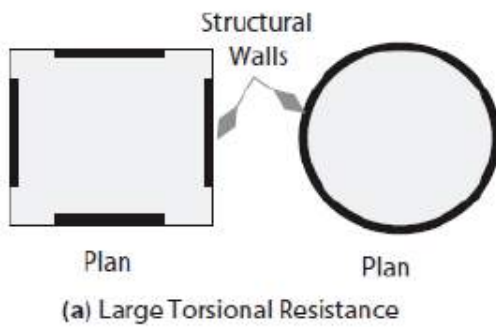

Seismic Load Analysis

Current Model Codes

Provide minimum provisions for design and construction of structures to resist effects of seismic ground motions.

Load Analysis Procedure, (IBC 2018, ASCE 7-16) and It is Similar For ISC-2017

1. Determine building occupancy category
2. Determine design response spectrum
3. Determine seismic design category
4. Determine importance factor
5. Select structural system and system parameters (R , C_d , Ω_o)
6. Examine system for configuration irregularities
7. Determine diaphragm flexibility (flexible, semirigid, and rigid)
8. Determine redundancy factor (ρ)
9. Determine lateral force analysis procedure
10. Compute lateral loads
11. Add torsional loads, as applicable
12. Add orthogonal loads as applicable
13. Perform analysis
14. Combine results
15. Check strength, deflection, and stability

1. Occupancy Category

IBC-2018, TABLE 1604.5, RISK CATEGORY OF BUILDINGS AND OTHER STRUCTURES

ASCE-7-16, Table 1.5-1 Risk Category of Buildings and Other Structures for Flood, Wind, Snow, Earthquake, and Ice Loads

I. Normal Hazard Occupancy:

Except those listed in categories II, III, IV.

II. Substantial Hazard Occupancy:

- High occupancy (more than 300 people in one room) Schools and Universities
Health care more than 50 patient residents.
- Jails and detention facilities.
- Power stations.
- Water treatment plant.
- Waste water treatment plants

III. Essential Facilities:

- Hospitals and emergency facilities with surgery
- Fire, rescue, ambulance, police stations
- Designated emergency shelters
- Aviation control towers
- Critical national defense facilities

IV. Low hazard Occupancy:

- Agricultural facilities
- Temporary facilities
- Minor storage facilities

2. Design Response Spectrum

Recall Lecture 7

3. Seismic Design Category –

➤ S_{DS} , Short Period Acceleration

ASCE-7-16

TABLE 11.6-1 Seismic Design Category Based on Short-Period Response Acceleration Parameter

Value of S_{DS}	Risk Category	
	I or II or III	IV
$S_{DS} < 0.167$	A	A
$0.167 \leq S_{DS} < 0.33$	B	C
$0.33 \leq S_{DS} < 0.50$	C	D
$0.50 \leq S_{DS}$	D	D

➤ S_{D1} , 1-second Period Acceleration

ASCE-7-16

TABLE 11.6-2 Seismic Design Category Based on 1-s Period Response Acceleration Parameter

Value of S_{D1}	Risk Category	
	I or II or III	IV
$S_{D1} < 0.067$	A	A
$0.067 \leq S_{D1} < 0.133$	B	C
$0.133 \leq S_{D1} < 0.20$	C	D
$0.20 \leq S_{D1}$	D	D

S_{DS}	S_{D1}	Risk Category	
		I, II, or III	IV
$S_{DS} < 0.167$	$S_{D1} < 0.067$	A	A
$0.167 \leq S_{DS} < 0.33$	$0.067 \leq S_{D1} < 0.133$	B	C
$0.33 \leq S_{DS} < 0.50$	$0.133 \leq S_{D1} < 0.20$	C	D
$0.50 \leq S_{DS}$	$0.20 \leq S_{D1}$	D	D
$S_1 \geq 0.75$		E	F

5. Importance Factor (Ie)

Table 1.5-2 Importance Factors by Risk Category of Buildings and Other Structures for Snow, Ice, and Earthquake Loads

Risk Category from Table 1.5-1	Snow Importance Factor, I_s	Ice Importance Factor—Thickness, I_i	Ice Importance Factor—Wind, I_w	Seismic Importance Factor, I_e
I	0.80	0.80	1.00	1.00
II	1.00	1.00	1.00	1.00
III	1.10	1.15	1.00	1.25
IV	1.20	1.25	1.00	1.50

Importance Factor

Risk Category		Seismic Importance Factor, I_e
I	Low hazard to humans, such as agricultural facilities	1
II	Other than I, III, and IV	1
III	Hazardous to humans because of large number of occupants, such as schools and public areas	1.25
IV	Essential facilities either important for security or for major services such as rescue operations, health services, transportation, and communications	1.5

5. Structural System and System Parameters (R , C_d , Ω_o)

System Parameters:

R =Response (strength) modification coefficient

Ω_o =System over-strength parameter

C_d =Deflection amplification factor

The design level V_s

This strength level is reduced from the elastic strength demand by the R -factor.

The code also defines a system overstrength factor, Ω_o , which brings the structure to its fracture level, V_m . This level includes any strain-hardening effect of the material that may come early in the structure because of cyclic effect.

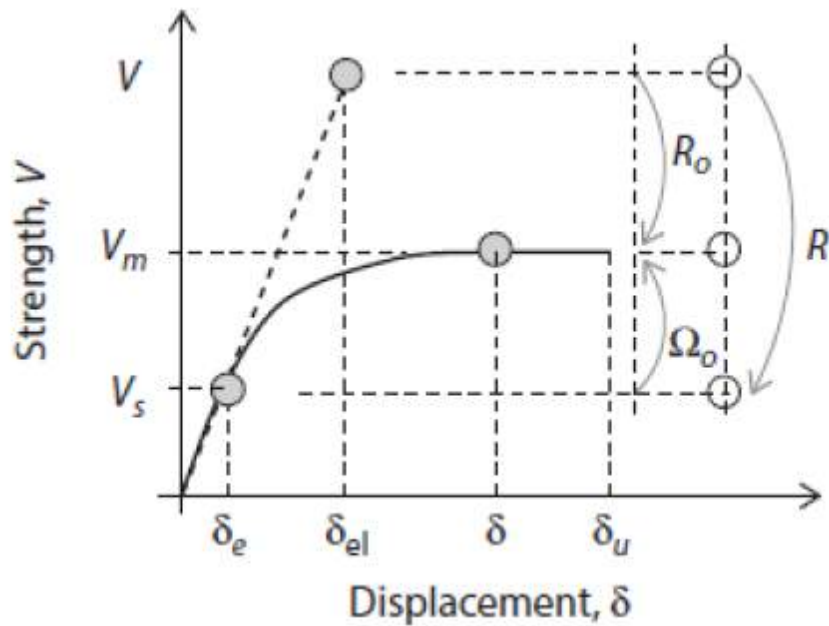
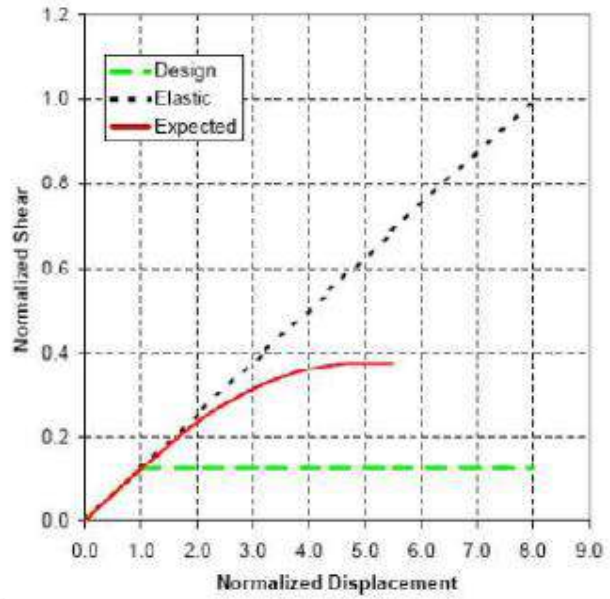
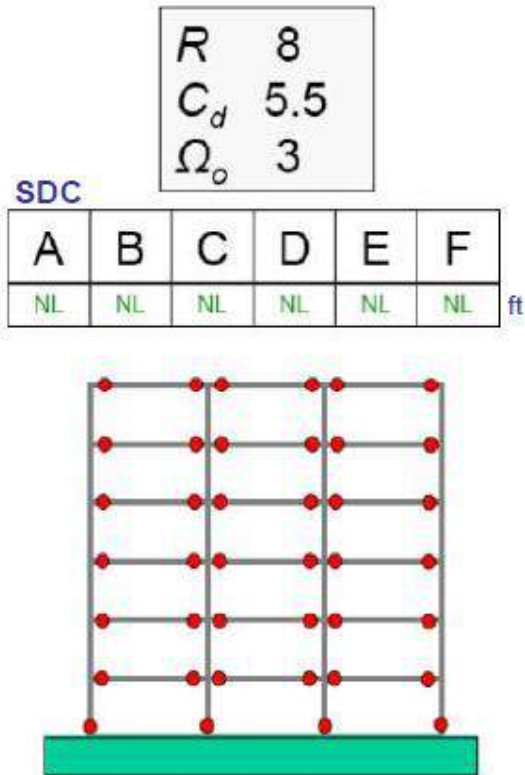

Figure , IBC definition of strength and displacements

Steel special moment frames



<p>Advantages: Architectural simplicity, relatively low base shear</p> <p>Disadvantages: Drift control, connection cost, connection testing</p>

Steel Special Concentrically Braced Frames

R	6
C_d	5
Ω_o	2

SDC

A	B	C	D	E	F	
NL	NL	NL	160	160	100	ft

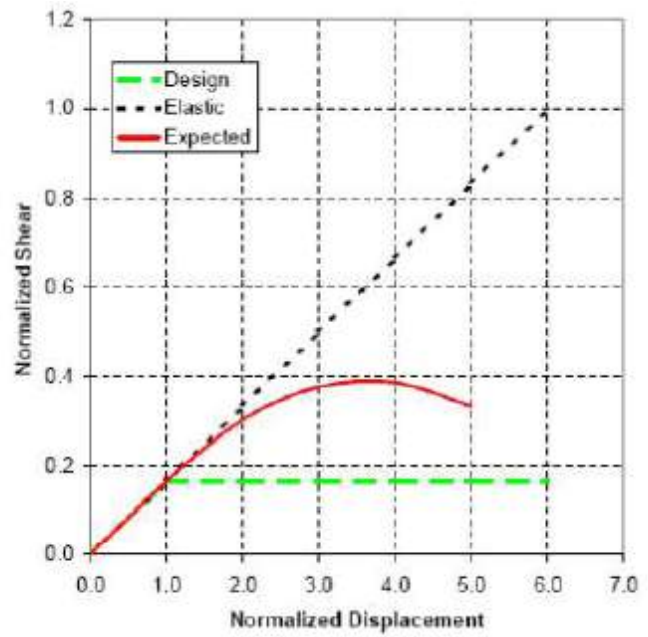
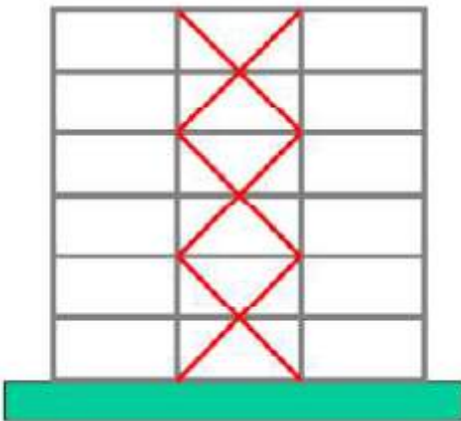

Advantages:

Lower drift, simple field connections

Disadvantages:

Higher base shear, high foundation forces, height limitations, architectural limitations

Special Reinforced Concrete Shear Walls

R	6
C_d	5
Ω_o	2.5

SDC

A	B	C	D	E	F	
NL	NL	NL	160	160	160	ft

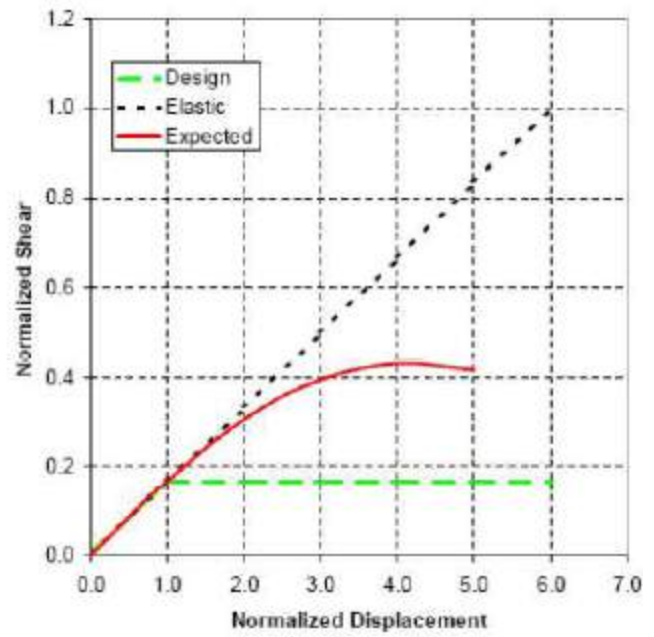
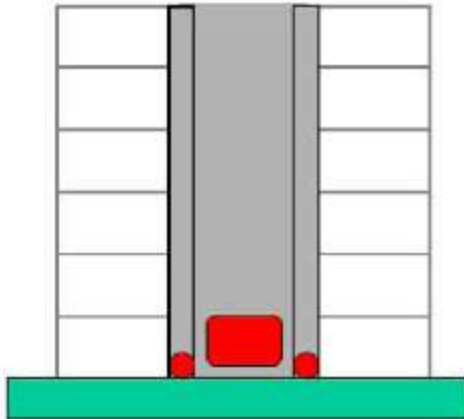

<p>Advantages: Drift control</p> <p>Disadvantages: Lower redundancy (for too few walls)</p>

Response Modification Factor R

- **Account for:**
 - Ductility (inelastic action)
 - Overstrength
 - Redundancy
 - Damping
 - Past behavior
- **Maximum = 8**
- **Minimum = 1.5**

Overstrength Factor Ω_o

- Sequential yielding of critical regions
- Strength enhancement due to strain hardening
- Materials strength greater than specified values
- Capacity reduction (Φ) factors

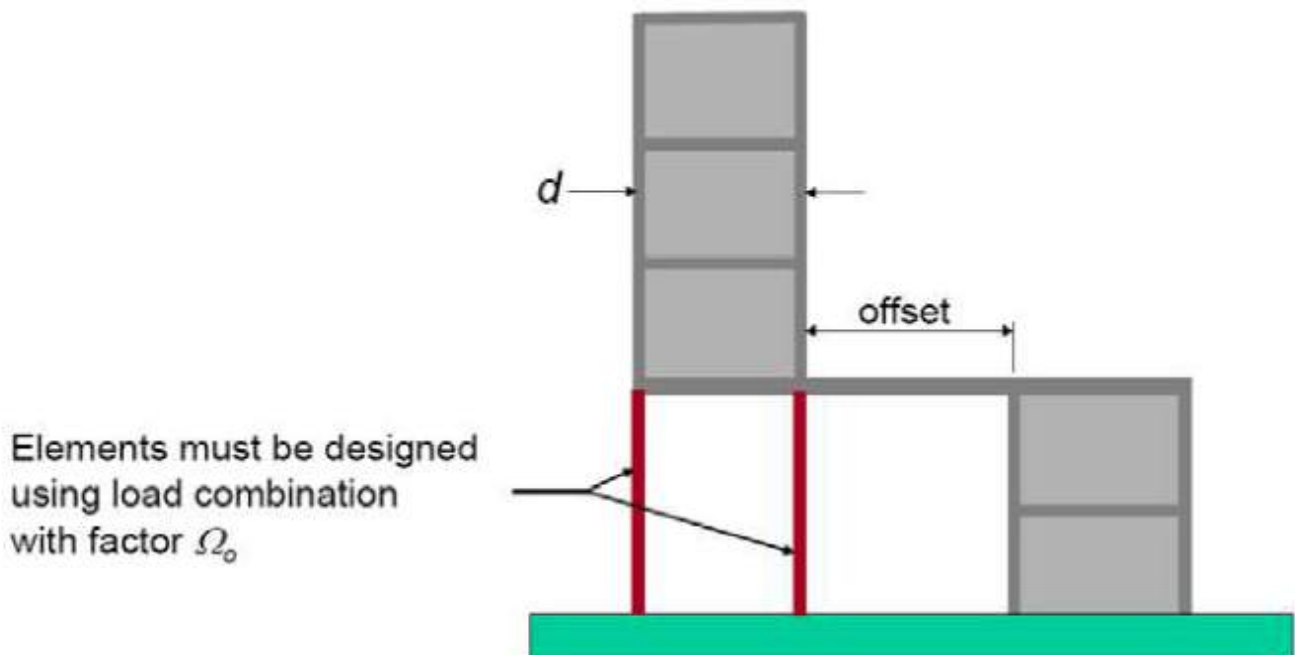

Deflection Amplification Factor C_d

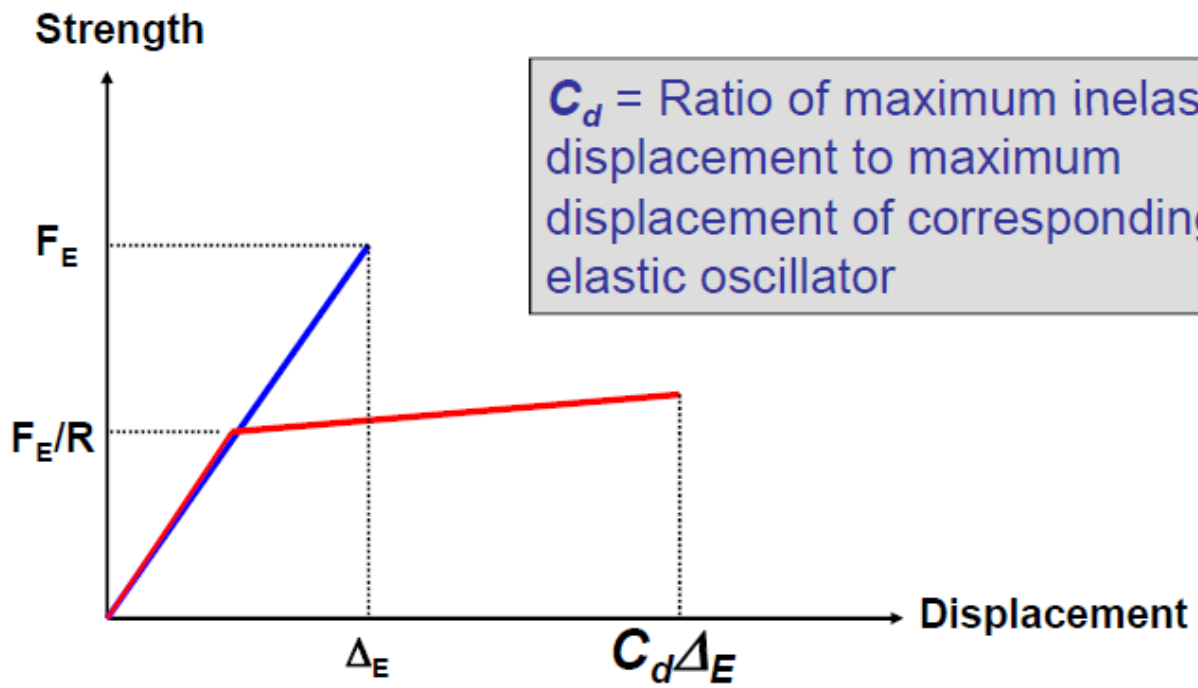

6. Structure Irregularity

- **Horizontal Structural Irregularities:** buildings have one or more of the features listed in Table 12.3-1, ASCE-7-16.
- **Vertical Structural Irregularities:** buildings having one or more of the features listed in Table 12.3-2, ASCE-7-16.

Horizontal Structural Irregularity

1a) and 1b) torsional irregularity

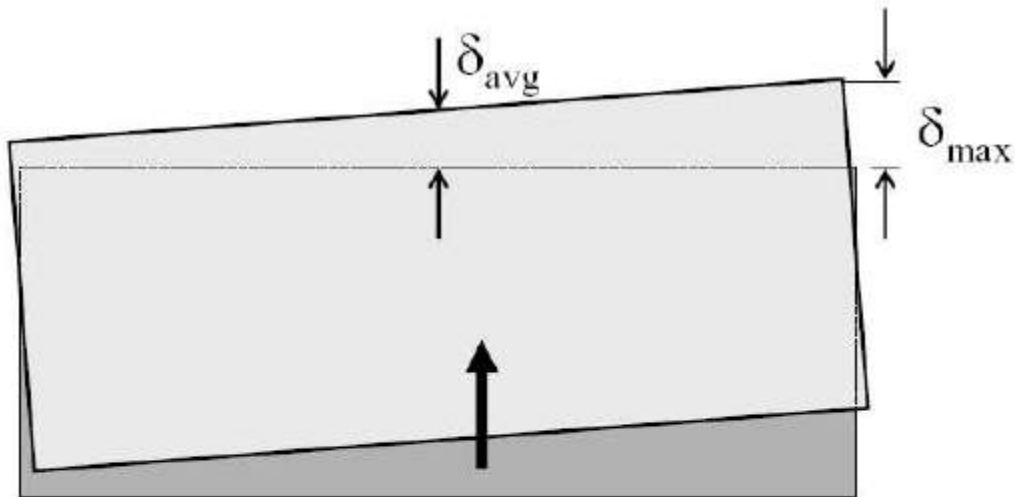

1a) $\delta_{\max} > 1.2 \delta_{\text{avg}}$

Irregular

1b) $\delta_{\max} > 1.4 \delta_{\text{avg}}$

Irregular

Horizontal Structural Irregularity

2) Re-entrant Corner Irregularity

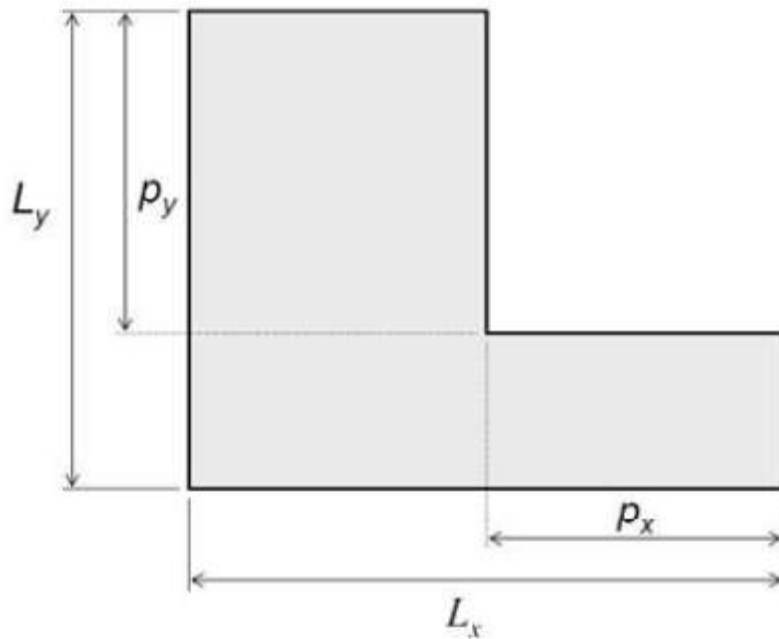

Irregularity exists if $p_x > 0.15L_x$ and $p_y > 0.15L_y$

Horizontal Structural Irregularity

3) Diaphragm Discontinuity Irregularity

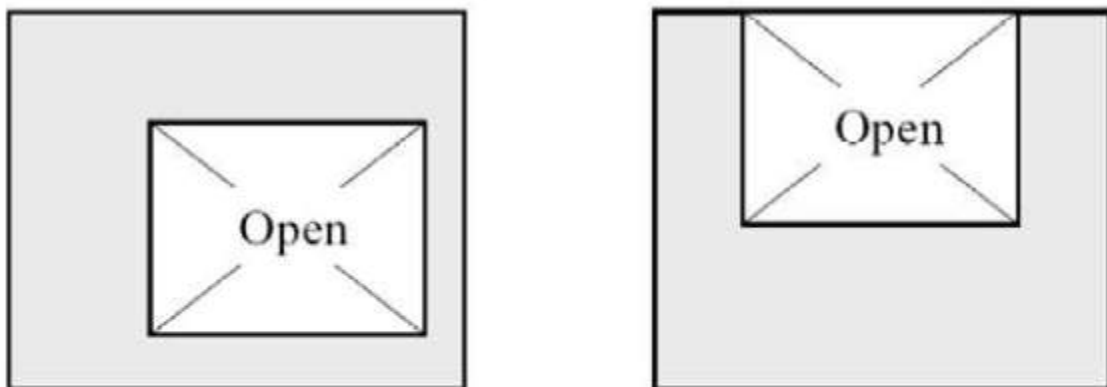

Irregularity exists if open area > 0.5 times floor area OR if effective diaphragm stiffness varies by more than 50% from one story to the next.

Horizontal Structural Irregularity

4) Out of Plane Offsets

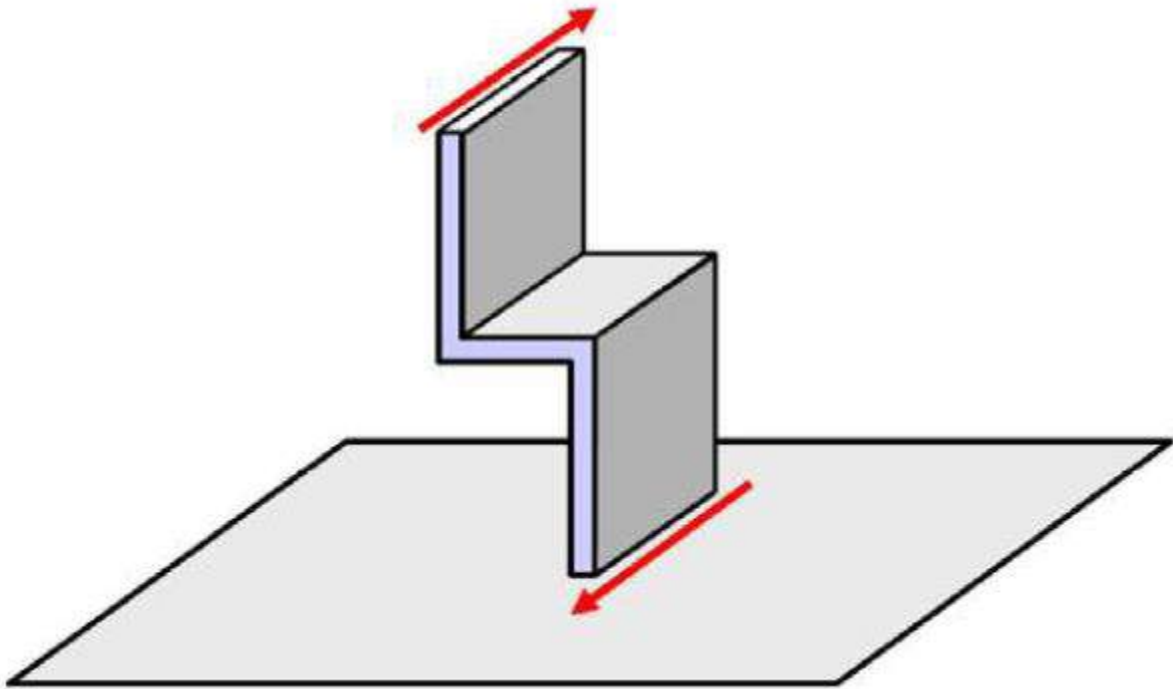

Horizontal Structural Irregularity

5) Non Parallel Systems Irregularity

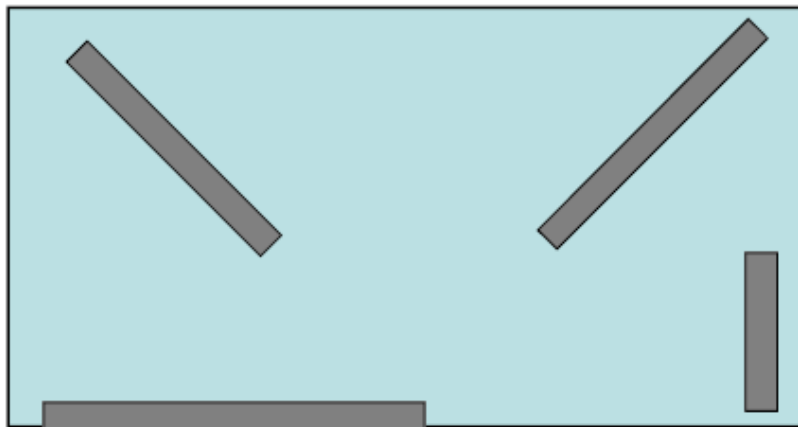

Nonparallel System Irregularity exists when the vertical lateral force resisting elements are not parallel to or symmetric about the major orthogonal axes of the seismic force resisting system.

Vertical Structural Irregularity 1a) & 1b) Stiffness (Soft Storey) Irregularity

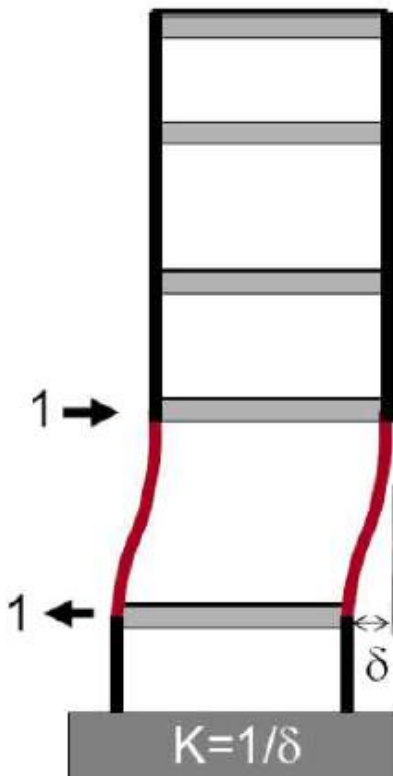

Irregularity (1a) exists if stiffness of any story is less than **70%** of the stiffness of the story above or less than **80%** of the average stiffness of the three stories above.

An extreme irregularity (1b) exists if stiffness of any story is less than **60%** of the stiffness of the story above or less than **70%** of the average stiffness of the three stories above.

Exception: Irregularity does not exist if no story drift ratio is greater than 1.3 times drift ratio of story above.

Irregularity 1b is NOT PERMITTED in SDC E or F.

Vertical Structural Irregularity 2) Weight (Mass) Irregularity

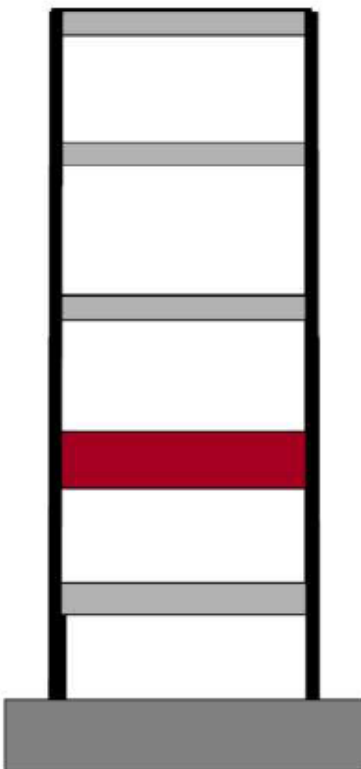

Irregularity exists if the effective mass of any story is more than **150%** of the effective mass of an adjacent story.

A roof that is lighter than the floor before need not be considered.

Exception: Irregularity does not exist if no story drift ratio is greater than 1.3 times drift ratio of story above.

Vertical Structural Irregularity

3) Vertical Geometric Irregularity

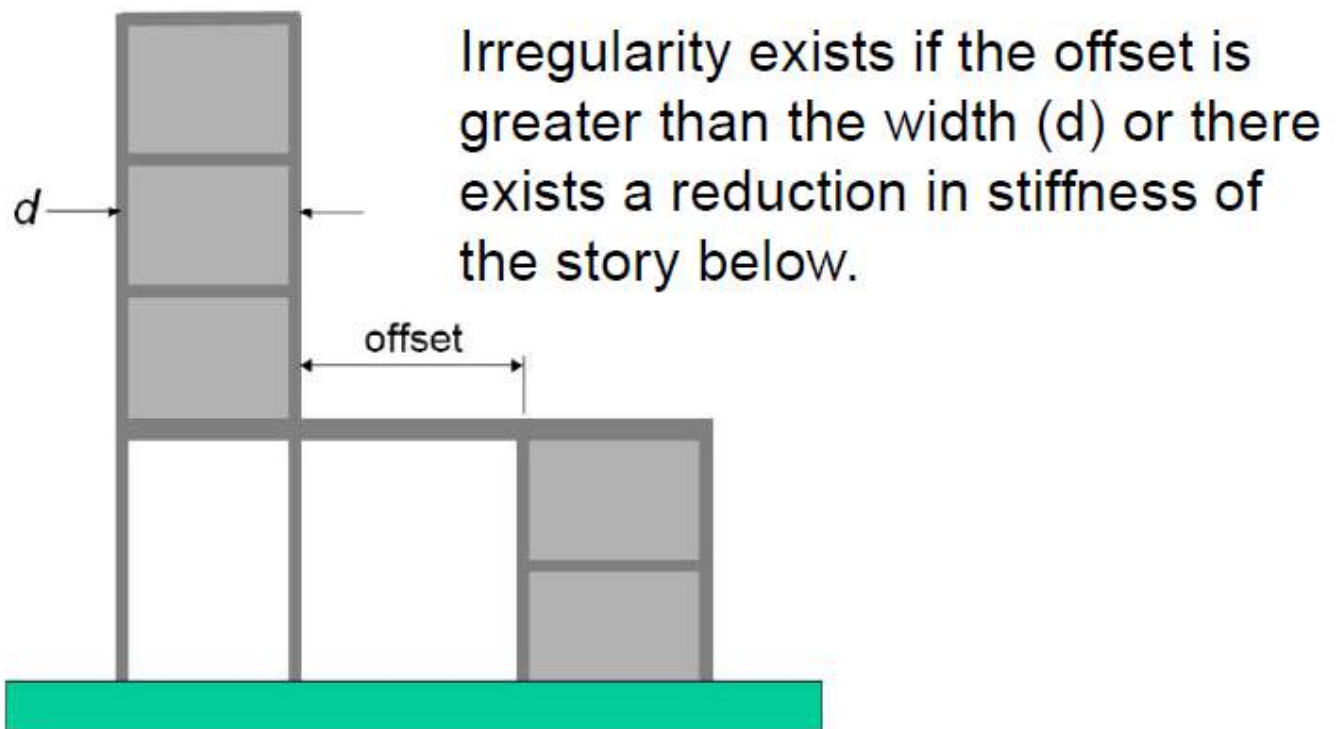

Vertical Structural Irregularity

5) Capacity (Weak-Storey) Irregularity

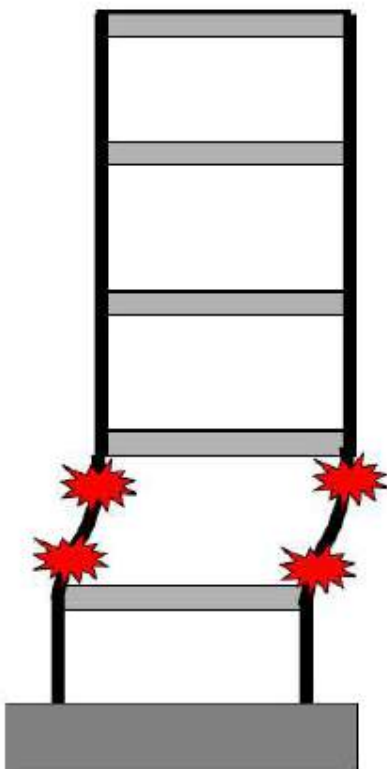

a) Irregularity exists if the lateral strength of any story is less than **80%** of the strength of the story above.

b) An extreme irregularity exists if the lateral strength of any story is less than **65%** of the strength of the story above.
(FEMA 450)

Irregularities (a) and (b) are NOT PERMITTED in SDC E or F. Irregularity (b) not permitted in SDC D.

7. Diaphragm Flexibility

Diaphragms must be considered as semi-rigid unless they can be classified as **FLEXIBLE** or **RIGID**. (ASCE-7-16, 12.3)

- Untopped steel decking and untopped wood structural panels are considered FLEXIBLE if the vertical seismic force resisting systems are steel or composite braced frames or are shear walls.
- Diaphragms in one- and two-family residential buildings may be considered FLEXIBLE.
- Concrete slab or concrete filled metal deck diaphragms are considered RIGID if the width to depth ratio of the diaphragm is less than 3 and if no horizontal irregularities exist.

Rigid versus Flexible Diaphragms

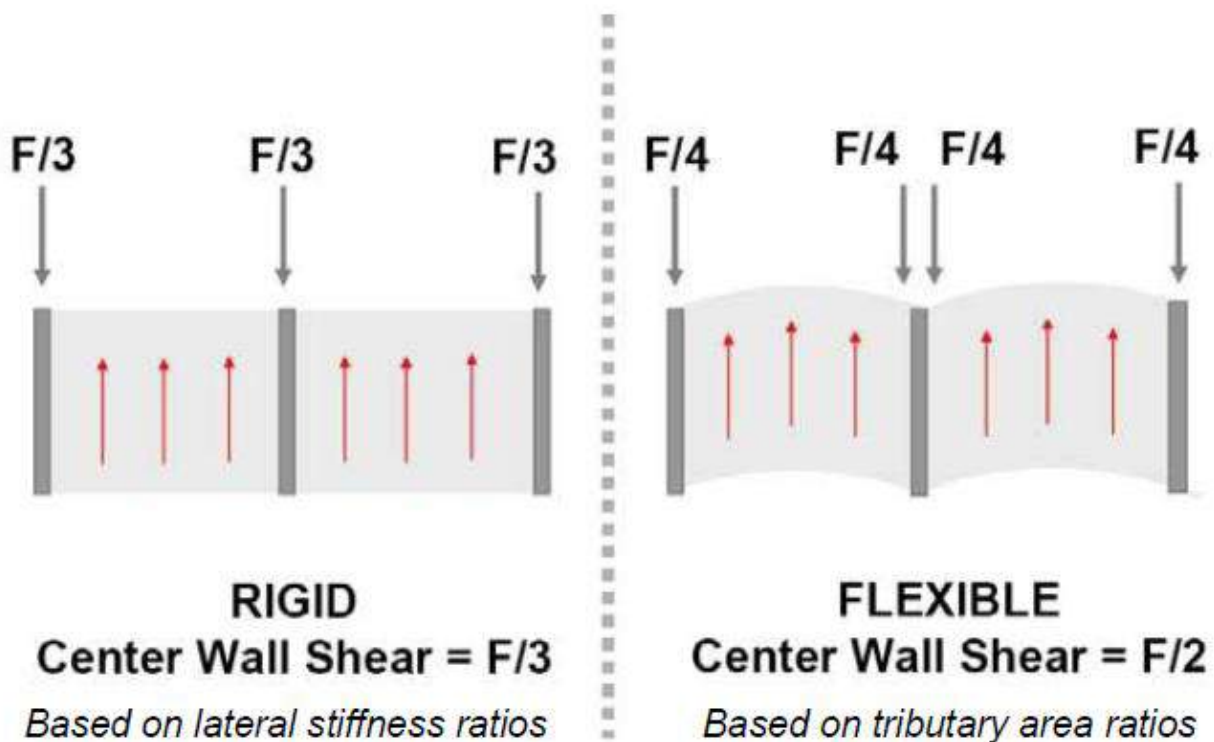

Diaphragm Flexibility

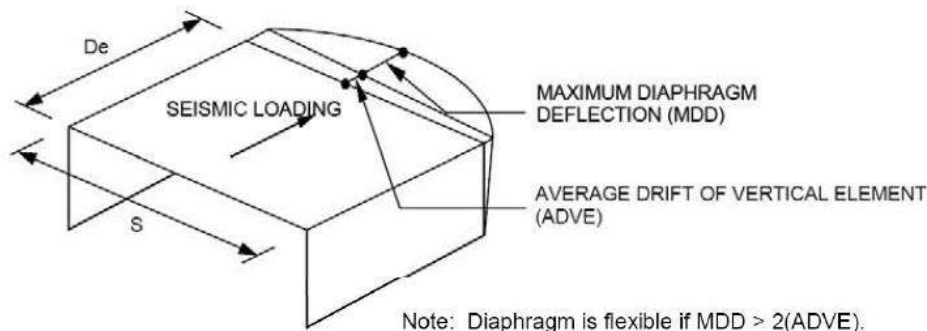

FIGURE 12.3-1 Flexible Diaphragm, ASCE-7-16

8. Redundancy factor (ρ)

The value according 12.3.4

The redundancy factor, ρ , is intended to encourage redundant force paths in the structure, which is inversely proportional to redundancy. In other words, the code requires larger design seismic forces for less redundant systems. The code assigns two values for the redundancy factor that are outlined in the following two cases.

The first approach is a check of the elements outlined in Table 12.3-3 for cases where the seismic design story shear exceeds 35% of the base shear

Case 1: $\rho = 1$, the redundancy factor is permitted to be 1.0 in the following conditions:

1. Structures in SDC B or C
2. Drift calculations and P- Δ effect
3. Design of nonstructural components
4. Design of nonbuilding structures that are not similar to buildings
5. Design of collector elements, splices, and their connections for which load combinations with overstrength factor are used
6. Design of members or connections where the load combinations of overstrength are required for design
7. Diaphragm loads as determined by the following equation

$$F_{px} = \frac{\sum F_i}{\sum w_i} w_{px}$$

(Outlined later on)

8. Structures with damping systems designed in accordance with ASCE 7 standards.
9. Design of structural walls for out-of-plane forces, including their anchorage

Case 2: $\rho = 1.3$, the redundancy factor shall be taken as $\rho = 1.3$ for SDC D, E, or F. However, ρ is permitted to be 1.0 for these seismic design categories if one of the following two conditions is met:

1. Each story resisting more than 35 percent of the base shear in the direction of interest shall comply with Table 12.3-3

Table 12.3-3 Requirements for Each Story Resisting More than 35% of the Base Shear

Lateral Force-Resisting Element	Requirement
Braced frames	Removal of an individual brace, or connection thereto, would not result in more than a 33% reduction in story strength, nor does the resulting system have an extreme torsional irregularity (horizontal structural irregularity Type 1b).
Moment frames	Loss of moment resistance at the beam-to-column connections at both ends of a single beam would not result in more than a 33% reduction in story strength; nor does the resulting system have an extreme torsional irregularity (horizontal structural irregularity Type 1b).
Shear walls or wall piers with a height-to-length ratio greater than 1.0	Removal of a shear wall or wall pier with a height-to-length ratio greater than 1.0 within any story, or collector connections thereto, would not result in more than a 33% reduction in story strength; nor does the resulting system have an extreme torsional irregularity (horizontal structural irregularity Type 1b). The shear wall and wall pier height-to-length ratios are determined as shown in Fig. 12.3-2.
Cantilever columns	Loss of moment resistance at the base connections of any single cantilever column would not result in more than a 33% reduction in story strength; nor does the resulting system have an extreme torsional irregularity (horizontal structural irregularity Type 1b).
Other	No requirements.

2. Structures that are regular in plan at all levels, provided that the seismic force-resisting systems consist of at least two bays of seismic force-resisting perimeter framing on each side of the structure in each orthogonal direction at each story resisting more than 35 percent of the base shear. The number of bays for a shear wall shall be calculated as the length of shear wall divided by the story height or two times the length of shear wall divided by the story height for light-framed construction.

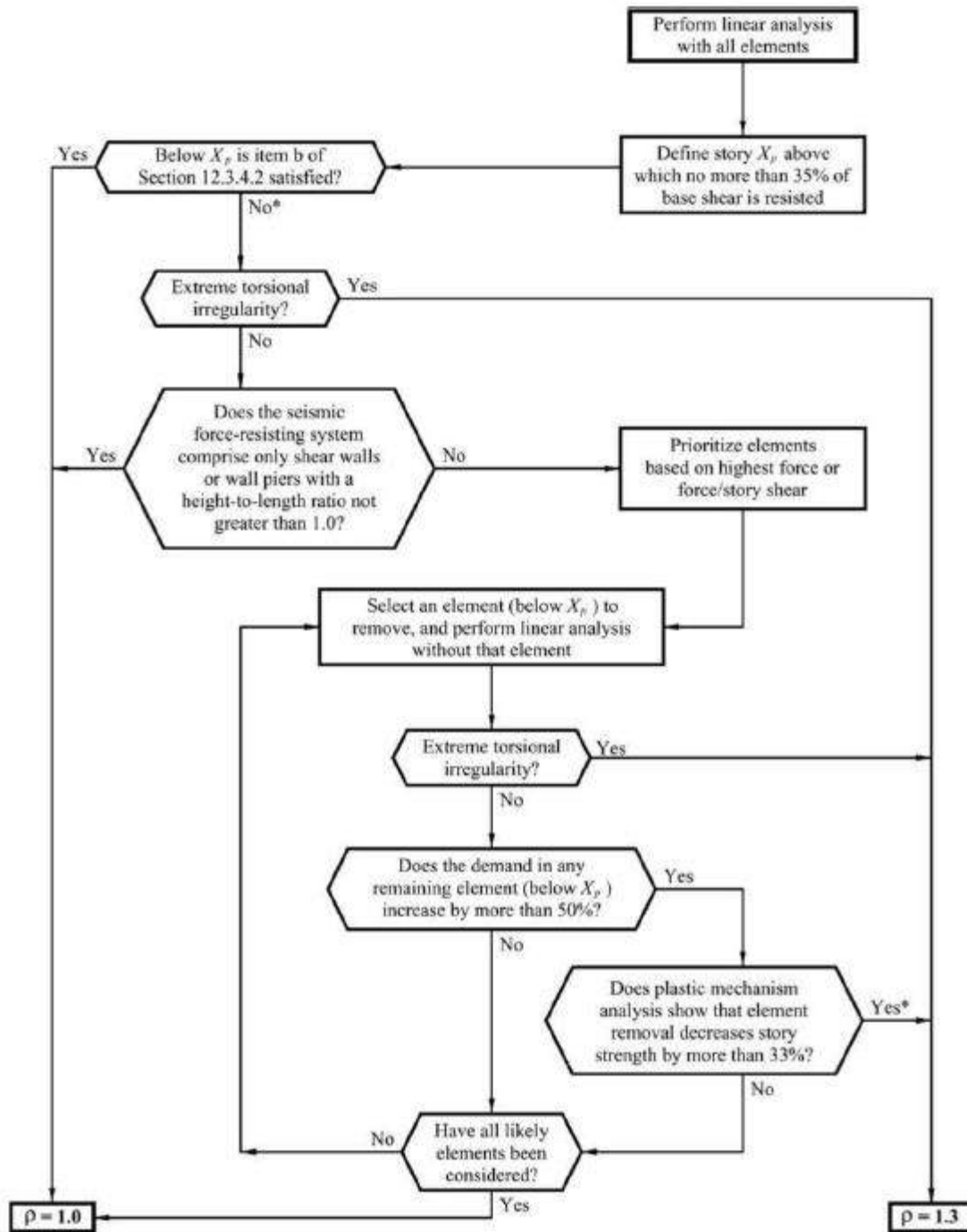

* or not considered

FIGURE C12.3-6 Calculation of the Redundancy Factor, ρ

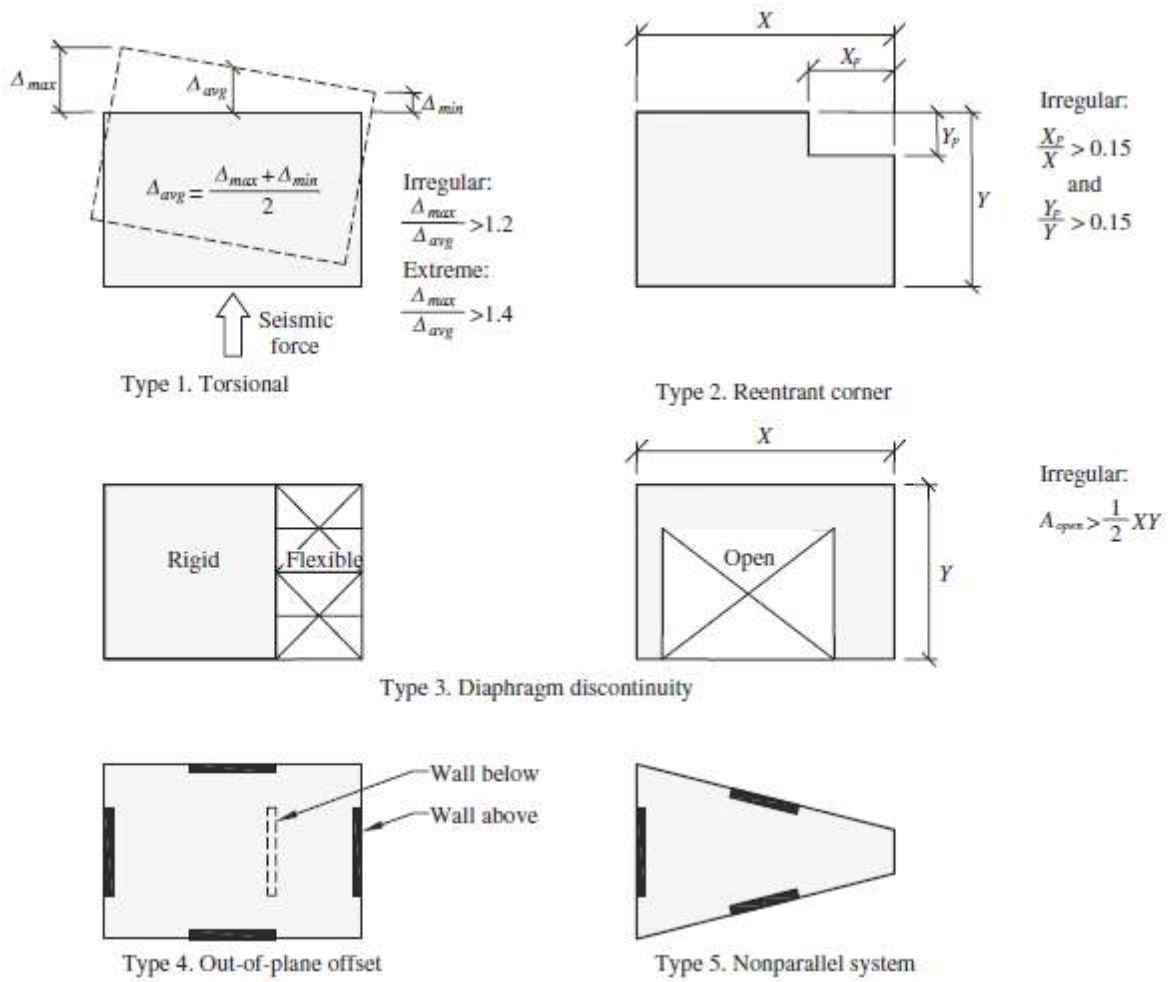
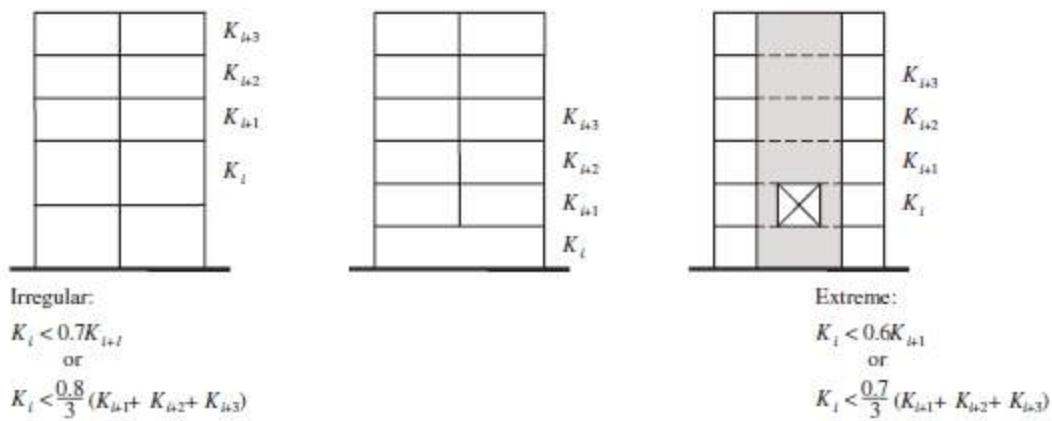
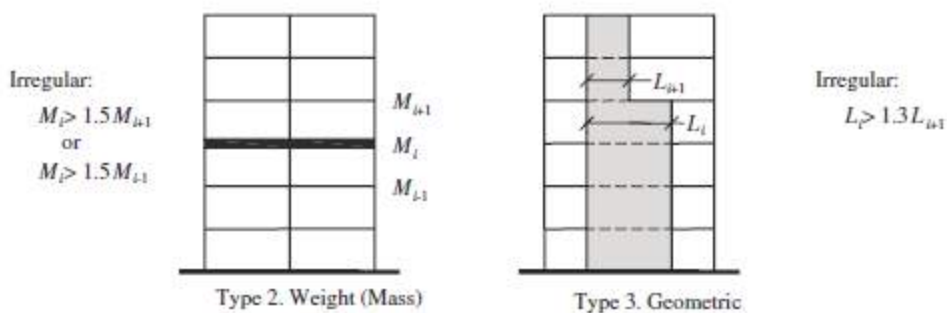

FIGURE C12.3-1 Horizontal Structural Irregularity Examples



Type 1. Stiffness — Soft Story



Type 2. Weight (Mass)

Type 3. Geometric

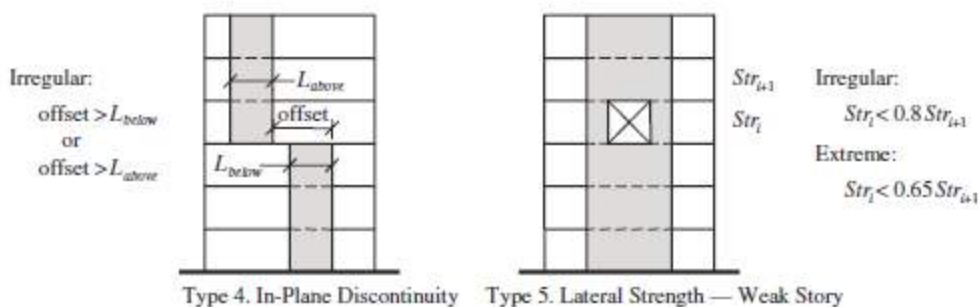

Type 4. In-Plane Discontinuity

Type 5. Lateral Strength — Weak Story

FIGURE C12.3-2 Vertical Structural Irregularities

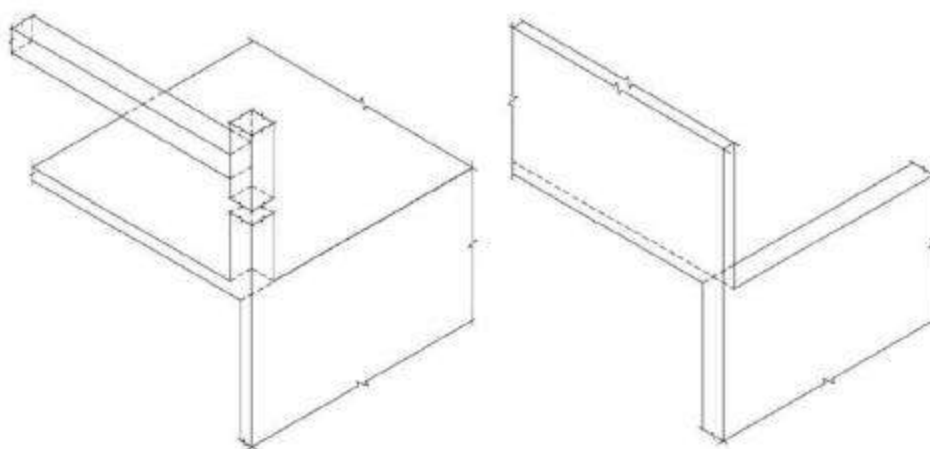

FIGURE C12.3-3 Vertical In-Plane-Discontinuity Irregularity from Columns or Perpendicular Walls (Type 4)

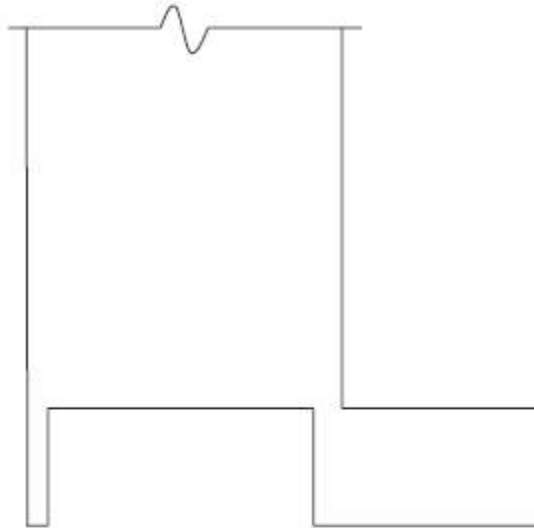

FIGURE C12.3-4 Vertical In-Plane-Discontinuity Irregularity from Walls with Significant Offsets (Type 4)

Effective Seismic Weight, W,(ASCE-7-16, 12.7.2)

The design forces and requirements of structures are given according to their SDC. The effective seismic weight to be considered for seismic force calculations is given as:

1. Total dead load above the base.
2. 25 percent of live load in storage areas and warehouses.
3. Actual partition weight; but shall not be taken less than 0.48 kN/m².
4. 20 percent of the snow load if intensity of the snow exceeds 1.44 kN/m².
5. Weight of landscaping and other material at roof gardens and similar areas
6. Permanent equipment

9. Equivalent Lateral Force (ELF) Procedure

- The equivalent lateral force (ELF) method is allowed for all buildings in SDC B and C.
- It is allowed in all SDC D, E, and F buildings EXCEPT:
 - Any structure with $T > 3.5 T_s$
 - Structures with $T < 3.5 T_s$ and with Plan Irregularity 1a or 1b or Vertical Irregularity 1, 2 or 3. where $T_s = S_{D1}/S_{Ds}$, which is the controlling period in the response spectra

When the ELF procedure is not allowed, analysis must be performed by the response spectrum analysis procedure or by the linear (or nonlinear) response history analysis procedure.

9.1 Minimum Lateral Force

- Allowed for structures in SDC A
- Provide lateral force resisting system design to resist F_i applied at each floor level

$$F_i = 0.01 w_i$$

where;

F_i = design lateral force applied at each floor x

w_i = portion of the total effective seismic gravity load of the structure, W, assigned to level "i"

9.2 Simplified Analysis Procedure (ASCE-7-16,12.14.8)

This method may be applied to simple, three-story buildings with bearing wall or building frame systems, subject to strength and geometry limitations. Some of these limitations may be highlighted as follows:

1. SDC is determined according to S value.
2. Structures shall only be in Risk Categories I and II.
3. Site class shall be a class other than E or F.
4. Structures will have at least two lines of lateral resisting systems in each major direction, provided that at least one line of resistance lies on each side of the center of mass.
5. Story strength shall not be less than 80 percent of the story above.

$$V = \frac{FS_{DS}}{R} W$$

where;

F = 1.0 for one-story buildings

= 1.1 for two-story buildings

= 1.2 for three-story buildings

R = response modification factor as per Table 12.14-1

S_{DS} = design spectral acceleration at short period as defined earlier. In calculating S_{DS} , S_s need not be taken as larger than 1.5

W = the effective seismic weight defined earlier

If three-story buildings:

$$F_i = 1.2 S_{DS} w_i / R$$

$$F_i = \frac{w_i}{W} V$$

w_i = portion of the total effective seismic gravity load of the structure, W, assigned to level "i"

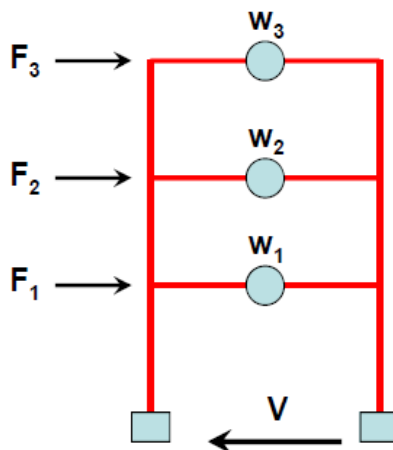

Unless otherwise calculated by more refined methods, the story drift, Δ , in this method may be taken as 1 percent of the story height. The story drift, Δ , given in this section is the relative displacement between stories.

9.3 Equivalent Lateral Force Procedure (ELF),(ASCE-7-16, 12.8)

The total base shear, V , is obtained from the response spectra shown in Fig. 6-3, which may be expressed as follows:

$$V = C_s W$$

where

$$C_s = \frac{S_{DS} I_e}{R} = \left(\begin{array}{l} \leq \frac{S_{D1} I_e}{RT} \quad \text{for } T \leq T_L \\ \leq \frac{S_{D1} T_L I_e}{RT^2} \quad \text{for } T > T_L \\ \geq 0.044 S_{DS} I_e \geq 0.01 \\ \geq \frac{0.5 S_1 I_e}{R} \quad \text{for } S_1 \geq 0.6 \end{array} \right)$$

where C_s = seismic response coefficient

I_e = importance factor as defined earlier

R = response modification factor

S_{D1} = design spectral acceleration at 1-s period

S_{DS} = design spectral acceleration at short period

T = the fundamental period of the structure (12.8.2)

W = the effective seismic weight as defined earlier

Approximate Period of Vibration, T,(12.8.2)

An approximate fundamental period may be calculated using the following expression:

$$T_a = C_t(h_n)^x$$

Where;

h_n = total height of the building above the base in meters

The coefficients C_t and x are determined from Table 12.8-2.

Approximate Period Calculation Coefficients

Structure Type	C _t	x
Steel moment frames free to deflect under seismic forces	0.0724	0.8
Reinforced concrete moment frames free to deflect under seismic forces	0.0466	0.9
Eccentrically braced steel frames	0.0731	0.75
All other structural systems	0.0488	0.75

Buildings ONLY: for concrete and steel moment frames < 12 stories in height, minimum story height of 3 m. N = number of stories.

$$T_a = 0.1 N$$

The fundamental period of the structure, T, may also be calculated by established methods in structural dynamics. However, if the period, T, is calculated by rigorous analysis, the period shall not exceed the following value:

$$T \leq C_u T_a$$

where C_u = coefficient for upper limit on calculated period, which is dependant on the design spectral response acceleration at 1 s; S_{D1} , as given in Table 12.8-1

Coefficient for Upper Limit on Calculated Period

S _{D1}	≥ 0.4	0.3	0.2	0.15	≤ 0.1
C _u	1.4	1.4	1.5	1.6	1.7

10. Vertical Distribution of Base Shear

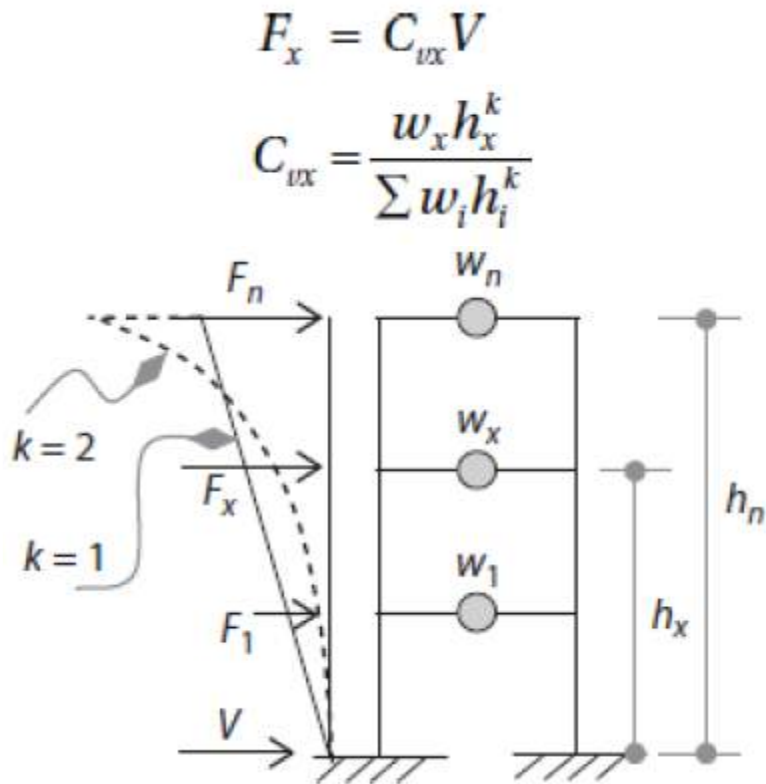

k Account for Higher Mode Effects

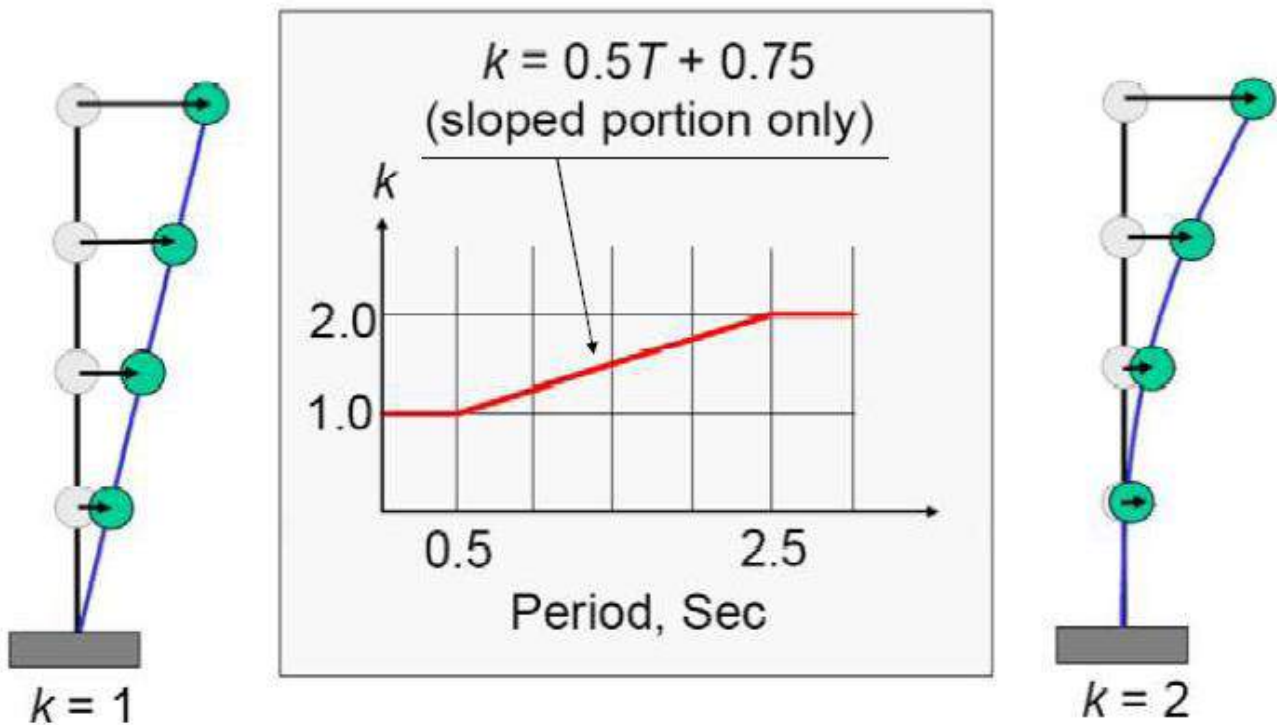

11. Torsional Effects

ALL Induce inherent and accidental torsion effects.

B Ignore torsional amplification.

C, D, E, F Include torsional amplification where Type 1a or 1b irregularity exists

Accidental Torsion

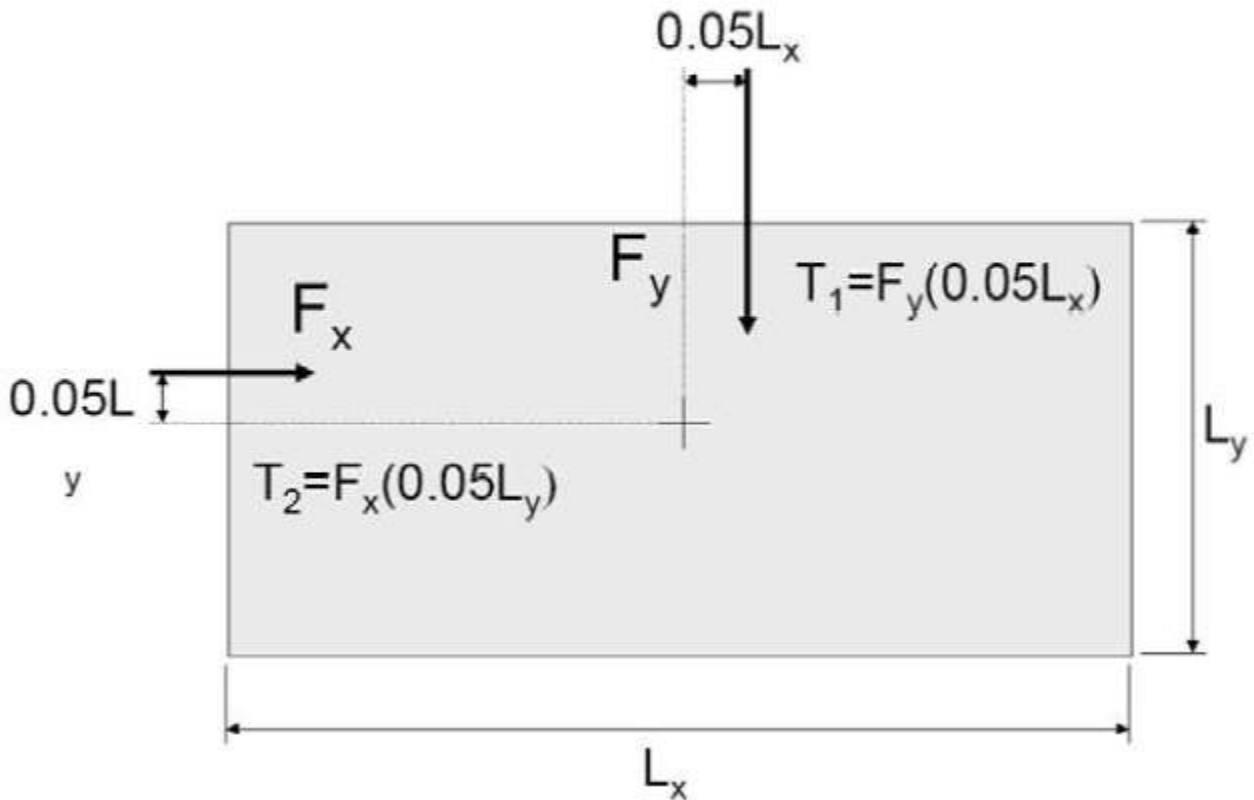

Uncertainty in the location of center of mass and center of rigidity

Amplification to Accidental Torsion

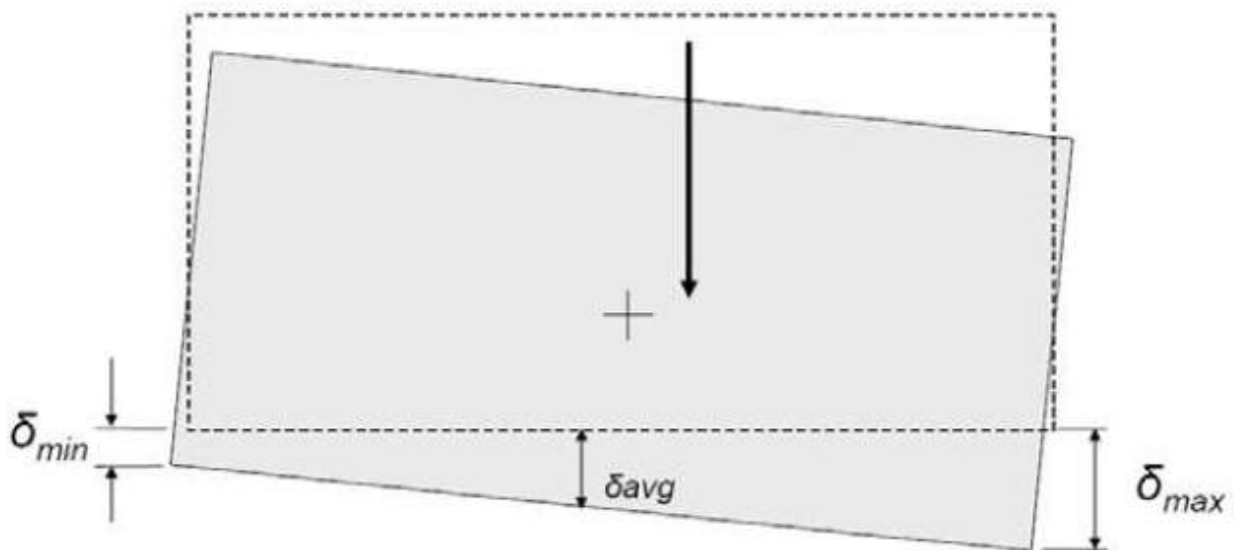

$$A_x = \left(\frac{\delta_{max}}{1.2\delta_{avg}} \right)^2 \leq 3.0$$

Why Amplifying Accidental Torsion?

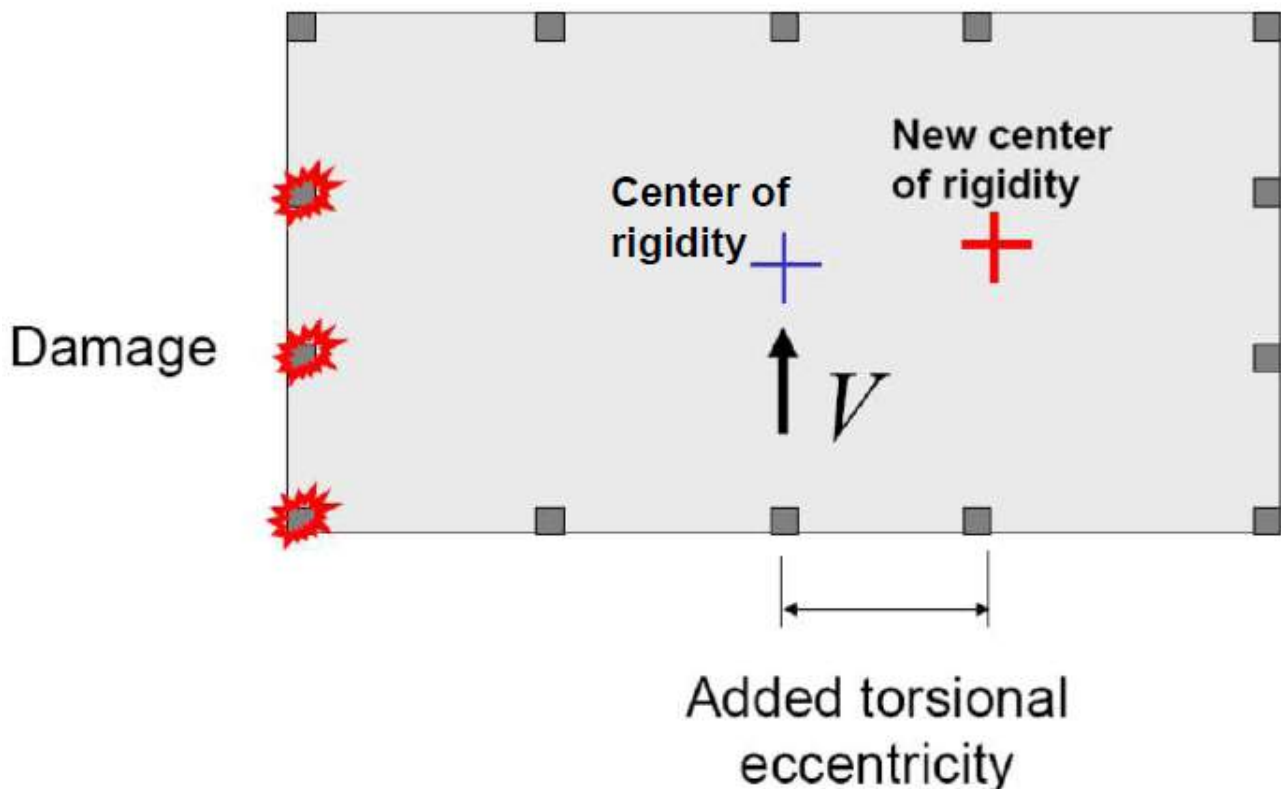

12. Orthogonal Load Effects

- Earthquake can produce inertia forces in any direction
- Structures should be investigated for forces that act in the direction that causes the “critical load effect”
- Since this direction is not easily defined, seismic codes allow loading the structure with 100% of the seismic force in one direction and 30% of the force acting in the orthogonal direction.

Orthogonal Load Effects, Q_E



- Applicable to S.D.C. **C**, **D**, **E**, and **F**
- Affect primarily column, especially corner columns

Nonsymmetrical Building Example

Orthogonal loading effects
and accidental torsion

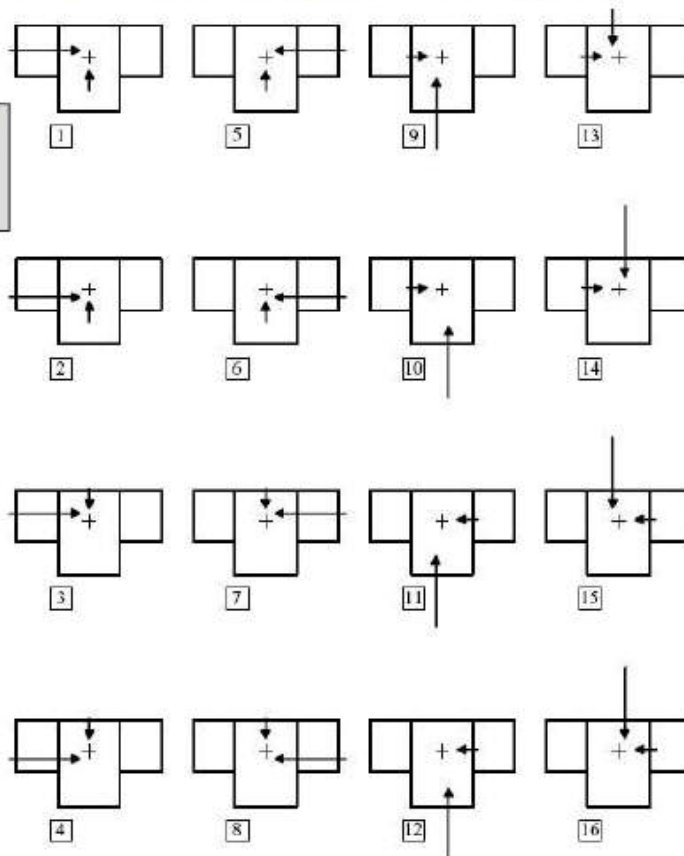

14. Basic Load Combinations

$$U = 1.2D + 1.0E + 0.5L + 0.2S$$

$$U = 0.9D + 1.0E$$

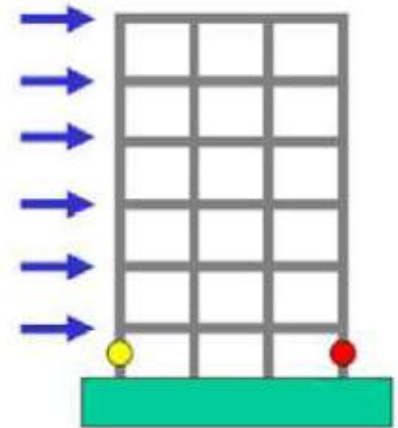

Note: **1.0L** instead of **0.5L** may be used when $L_o \geq 4.79 \text{ kN/m}^2$ or in case of public assembly or parking garages.

Combination of Load Effects

In load combinations, substitute the following for earthquake effect, E:

$$E = E_h \pm E_v$$

$$E_h = \rho Q_E \quad E_v = 0.2S_{DS}D$$

Resulting load combinations:

$$U = (1.2 + 0.2S_{DS})D + \rho Q_E + 0.5L + 0.2S$$

$$U = (0.9 - 0.2S_{DS})D + \rho Q_E$$

Maximum Seismic Load Effect

- Special combination for special members requires by the code:

$$E = E_{mh} \pm E_v$$

$$E_{mh} = \Omega_o Q_E \quad E_v = 0.2S_{DS}D$$

Resulting load combinations:

$$U = (1.2 + 0.2S_{DS})D + \Omega_o Q_E + 0.5L + 0.2S$$

$$U = (0.9 - 0.2S_{DS})D + \Omega_o Q_E$$

15. Storey Drift

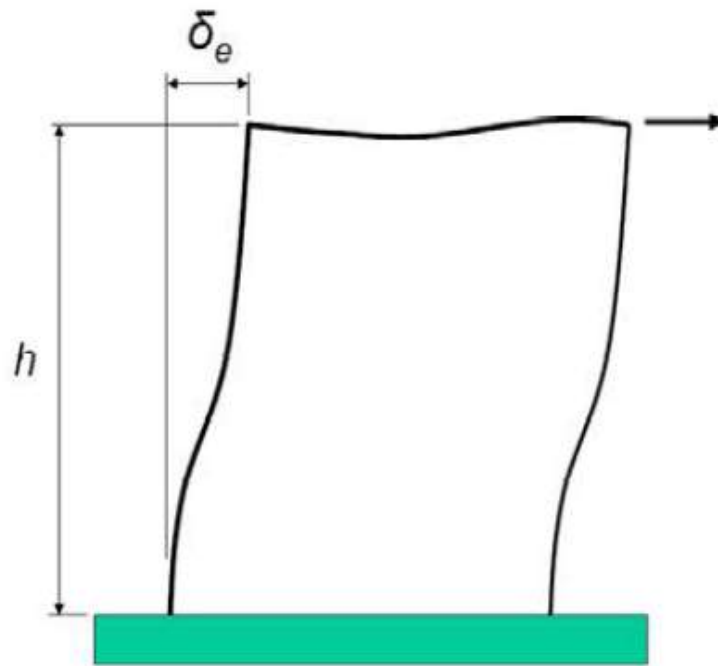

Strength level forces modified by R and I

Drift reported by analysis with strength level forces:

$$\Delta_e = \frac{\delta_e / l}{h}$$

Inelastic Drift (amplified drift):

$$\Delta = C_d \Delta_e$$

$$\Delta_{P-\Delta} = \frac{\Delta}{1 - \theta}$$

Drift computed at center of mass of story

Drift Limits: ASCE-7-16, Table 12.12-1 Allowable Story Drift

Table 12.12-1 Allowable Story Drift, $\Delta_x^{a,b}$

Structure	Risk Category		
	I or II	III	IV
Structures, other than masonry shear wall structures, four stories or less above the base as defined in Section 11.2, with interior walls, partitions, ceilings, and exterior wall systems that have been designed to accommodate the story drifts	$0.025h_{xx}^c$	$0.020h_{xx}$	$0.015h_{xx}$
Masonry cantilever shear wall structures ^d	$0.010h_{xx}$	$0.010h_{xx}$	$0.010h_{xx}$
Other masonry shear wall structures	$0.007h_{xx}$	$0.007h_{xx}$	$0.007h_{xx}$
All other structures	$0.020h_{xx}$	$0.015h_{xx}$	$0.010h_{xx}$

^a h_{xx} is the story height below level x.

Drift Limitation Ratio (Δ/h) According to the ASCE-7-16, Table 12.12-1 Allowable Story Drift

Building	Risk Category		
	I or II	III	IV
Other than masonry shear walls, four stories or less above the base, that have been designed to accommodate drifts	0.025	0.020	0.015
Masonry cantilever shear wall structures	0.010	0.010	0.010
Other masonry shear wall structures	0.007	0.007	0.007
All other buildings	0.020	0.015	0.010

16. Building Separation to Avoid Pounding

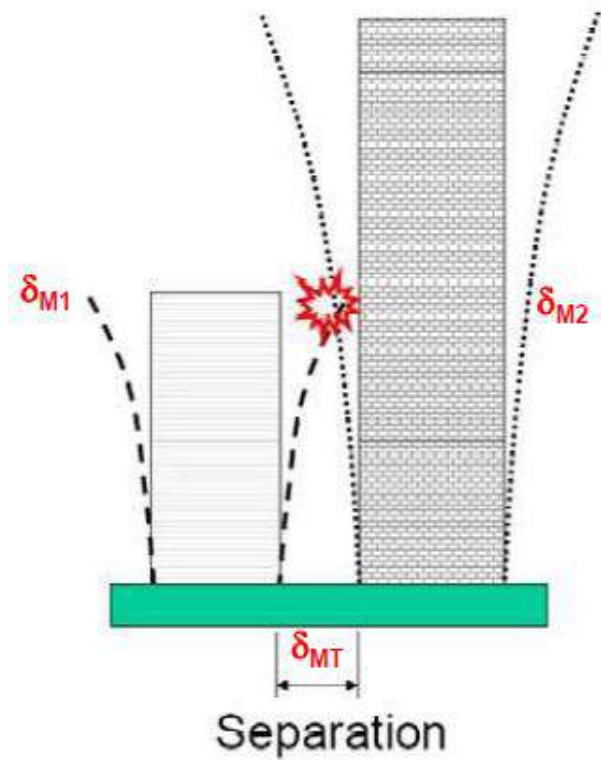

$$\delta_{MT} = \sqrt{(\delta_{M1})^2 + (\delta_{M2})^2}$$



Exterior damage to the back (north side) of Oviatt Library during Northridge Earthquake (attributed to pounding).

Source: <http://library.csun.edu/mfinley/eqexdam1.html>

where δ_{M1} and δ_{M2} are the inelastic displacements of the two adjacent structures

$$\delta_M = \frac{C_d \delta_{\max}}{I_e}$$

17. P-Delta Effects

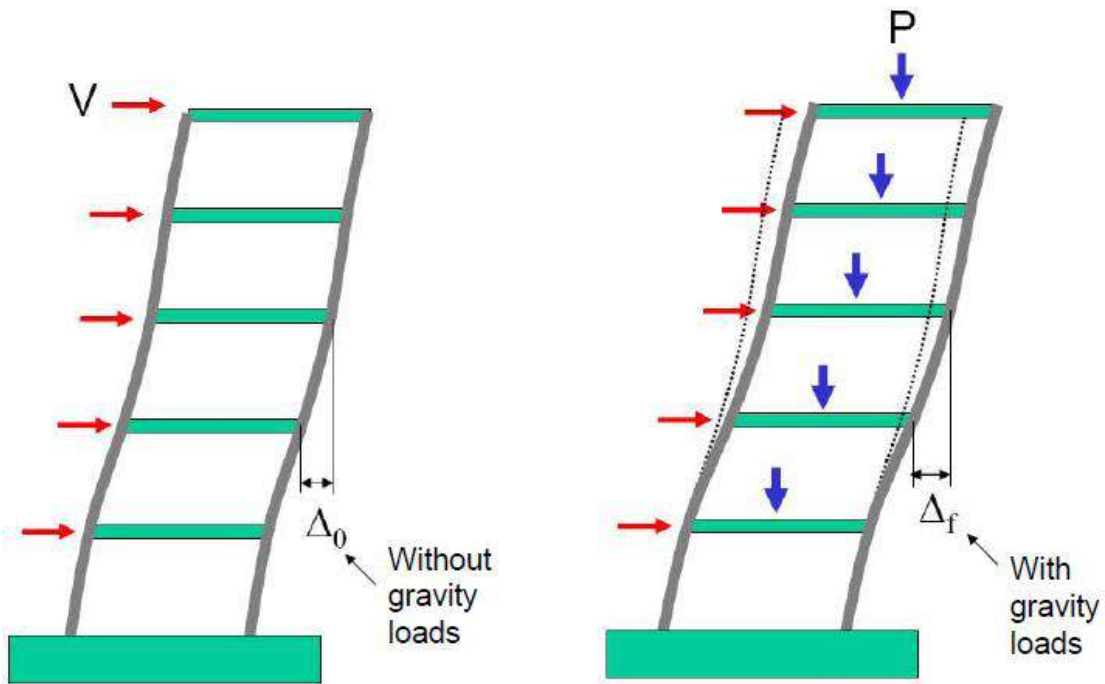

For each story compute :
$$\theta = \frac{P_x \Delta I_e}{V_x h_{sx} C_d}$$

P_x = total vertical design load at story above level x

Δ = computed story design level drift (including C_d)

V_x = total shear in story

h_{sx} = story height

If $\theta < 0.1$, ignore P-delta effects

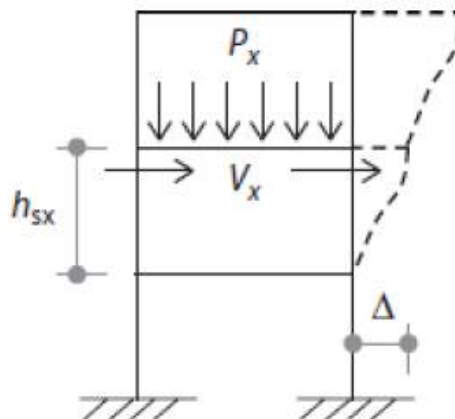

If $\theta > 0.1$ and less than θ_{\max} :

Multiply all computed element forces and displacements by:

$$a = \frac{1}{1 - \theta}$$

- ✓ Check drift limits using amplified drift
- ✓ Design for amplified forces

Note: P-delta effects may also be automatically included in the structural analysis. However, limit on θ still applies.

However, the structure must be redesigned if

$$\theta \geq \theta_{\max}$$

where

$$\theta_{\max} = \frac{0.5}{\beta C_d} \leq 0.25$$

where β is the ratio of shear demand to shear capacity. β may be conservatively taken as equal to 1.0.