

SUB: Fluid Mechanics & Fluid Power Engg.

Subject Code: BME 308

5th Semester, BTech (MS)

Mechanical Engg. Dept

VSSUT Burla

Disclaimer

This document does not claim any originality and cannot be used as a substitute for prescribed textbooks. The information presented here is merely a collection by the committee members for their respective teaching assignments. Various sources as mentioned at the reference of the document as well as freely available material from internet were consulted for preparing this document. The ownership of the information lies with the respective authors or institutions. Further, this document is not intended to be used for commercial purpose and the committee members are not accountable for any issues, legal or otherwise, arising out of use of this document. The committee members make no representations or warranties with respect to the accuracy or completeness of the contents of this document and specifically disclaim any implied warranties of merchantability or fitness for a particular purpose.

SCOPE OF FLUID MECHANICS

Knowledge and understanding of the basic principles and concepts of fluid mechanics are essential to analyze any system in which a fluid is the working medium. The design of almost all means transportation requires application of fluid Mechanics. Air craft for subsonic and supersonic flight, ground effect machines, hovercraft, vertical takeoff and landing requiring minimum runway length, surface ships, submarines and automobiles requires the knowledge of fluid mechanics. In recent years automobile industries have given more importance to aerodynamic design. The collapse of the Tacoma Narrows Bridge in 1940 is evidence of the possible consequences of neglecting the basic principles fluid mechanics.

The design of all types of fluid machinery including pumps, fans, blowers, compressors and turbines clearly require knowledge of basic principles fluid mechanics. Other applications include design of lubricating systems, heating and ventilating of private homes, large office buildings, shopping malls and design of pipeline systems.

The list of applications of principles of fluid mechanics may include many more. The main point is that the fluid mechanics subject is not studied for pure academic interest but requires considerable academic interest.

CHAPTER -1

Definition of a fluid:-

Fluid mechanics deals with the behaviour of fluids at rest and in motion. It is logical to begin with a definition of fluid. Fluid is a substance that deforms continuously under the application of shear (tangential) stress no matter how small the stress may be. Alternatively, we may define a fluid as a substance that cannot sustain a shear stress when at rest.

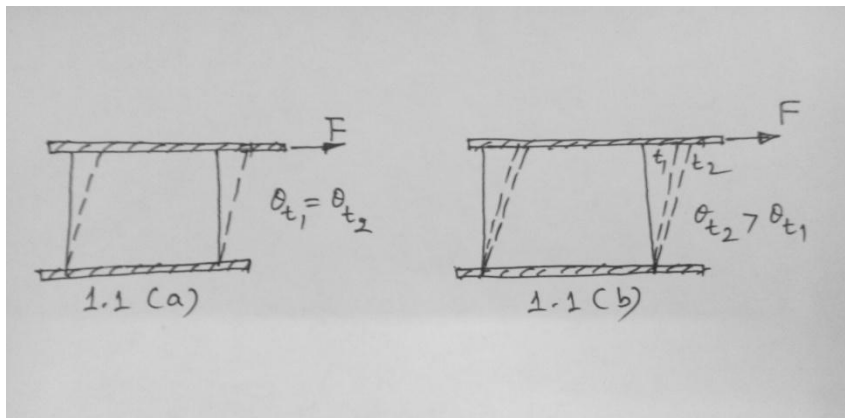

A solid deforms when a shear stress is applied, but its deformation doesn't continue to increase with time.

Fig 1.1(a) shows and 1.1(b) shows the deformation of solid and fluid under the action of constant shear force. The deformation in case of solid doesn't increase with time i.e

$$\theta_{t1} = \theta_{t2} \dots \dots = \theta_{tm} .$$

From solid mechanics we know that the deformation is directly proportional to applied shear stress ($\tau = F/A$), provided the elastic limit of the material is not exceeded.

To repeat the experiment with a fluid between the plates, let us use a dye marker to outline a fluid element. When the shear force 'F', is applied to the upper plate, the deformation of the fluid element continues to increase as long as the force is applied, i.e $\theta_{t2} > \theta_{t1}$.

Fluid as a continuum :-

Fluids are composed of molecules. However, in most engineering applications we are interested in average or macroscopic effect of many molecules. It is the macroscopic effect that we ordinarily perceive and measure. We thus treat a fluid as infinitely divisible substance, i.e continuum and do not concern ourselves with the behaviour of individual molecules.

The concept of continuum is the basis of classical fluid mechanics. The continuum assumption is valid under normal conditions. However it breaks down whenever the mean free path of the molecules becomes the same order of magnitude as the smallest significant characteristic dimension of the problem

.In the problems such as rarefied gas flow (as encountered in flights into the upper reaches of the atmosphere) , we must abandon the concept of a continuum in favour of microscopic and statistical point of view.

As a consequence of the continuum assumption, each fluid property is assumed to have a definite value at every point in the space .Thus fluid properties such as density , temperature , velocity and so on are considered to be continuous functions of position and time .

Consider a region of fluid as shown in fig 1.5. We are interested in determining the density at

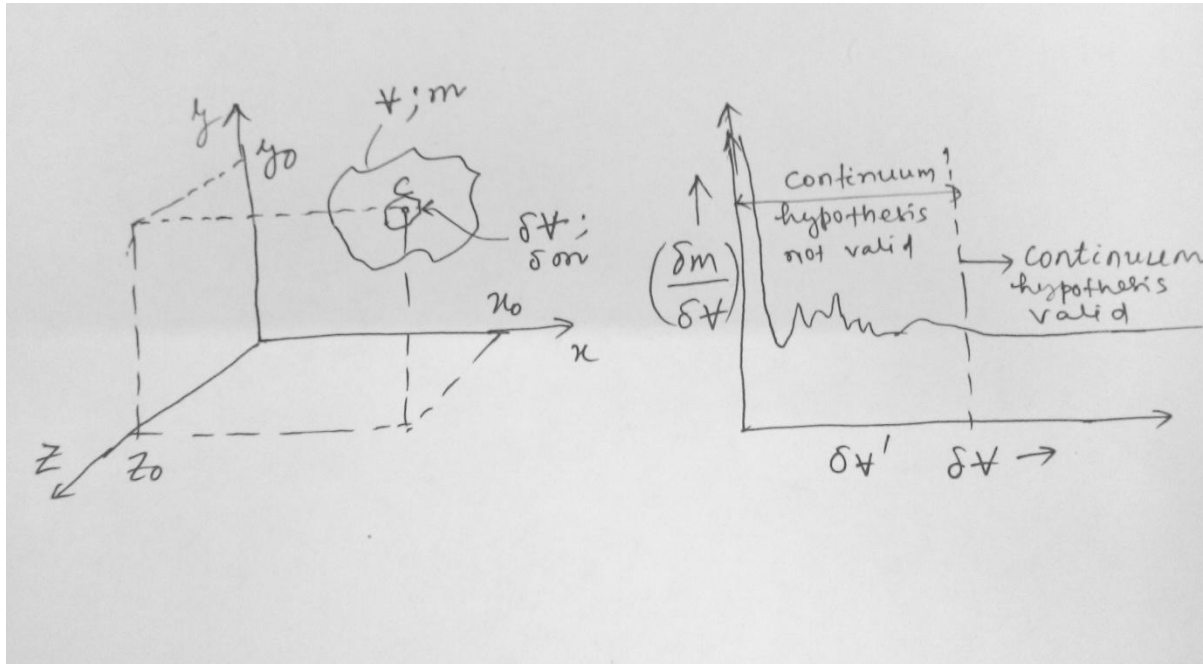

the point 'c', whose

coordinates are x_0, y_0 and z_0 . Thus the mean density V would be given by $\rho = \frac{m}{V}$. In general, this will not be the value of the density at point 'c' . To determine the density at point 'c' , we must select a small volume , δV , surrounding point 'c' and determine the ratio $\frac{\delta m}{\delta V}$ and allowing the volume to shrink continuously in size.

Assuming that volume δV is initially relatively larger (but still small compared with volume , V) a typical plot might appear as shown in fig 1.5 (b) . When δV becomes so small that it contains only a small number of molecules , it becomes impossible to fix a definite value for $\frac{\delta m}{\delta V}$; the value will vary erratically as molecules cross into and out of the volume. Thus there is a lower limiting value of δV , designated $\delta V'$. The density at a point is thus defined as

$$\rho = \lim_{\delta V \rightarrow \delta V'} \frac{\delta m}{\delta V}$$

Since point 'c' was arbitrary , the density at any other point in the fluid could be determined in a like manner. If density determinations were made simultaneously at an infinite number of points in the fluid ,

we would obtain an expression for the density distribution as function of the space co-ordinates , $\rho = \rho(x,y,z)$, at the given instant.

Clearly , the density at a point may vary with time as a result of work done on or by the fluid and /or heat transfer to or from the fluid. Thus , the complete representation(the field representation) is given by

$$\rho = \rho(x,y,z,t)$$

Velocity field:

In a manner similar to the density , the velocity field ; assuming fluid to be a continuum , can be

$$\text{expressed as } \vec{V} = \vec{V}(x,y,z,t)$$

The velocity vector can be written in terms of its three scalar components , i.e

$$\vec{V} = u\hat{i} + v\hat{j} + w\hat{k}$$

In general ; $u = u(x,y,z,t)$, $v = v(x,y,z,t)$ and $w = w(x,y,z,t)$

If properties at any point in the flow field do not change with time , the flow is termed as steady.

Mathematically , the definition of steady flow is $\frac{\partial \eta}{\partial t} = 0$; where η represents any fluid property.

Thus for steady flow is $\frac{\partial \rho}{\partial t} = 0$ or $\rho = \rho(x,y,z)$

$$\frac{\partial \vec{V}}{\partial t} = 0 \text{ or } \vec{V} = \vec{V}(x,y,z)$$

Thus in steady flow ,any property may vary from point to point in the field , but all properties , but all properties remain constant with time at every point.

One, two and three dimensional flows :

A flow is classified as one two or three dimensional based on the number of space coordinates required to specify the velocity field. Although most flow fields are inherently three dimensional, analysis based on fewer dimensions are meaningful.

Consider for example the steady flow through a long pipe of constant cross section (refer Fig1.6a). Far from the entrance of the pipe the velocity distribution for a laminar flow can be described

as: $\frac{u}{u_{max}} = \left[1 - \left(\frac{r}{R}\right)^2\right]$. The velocity field is a function of r only. It is independent of r and θ . Thus the

flow is one dimensional.

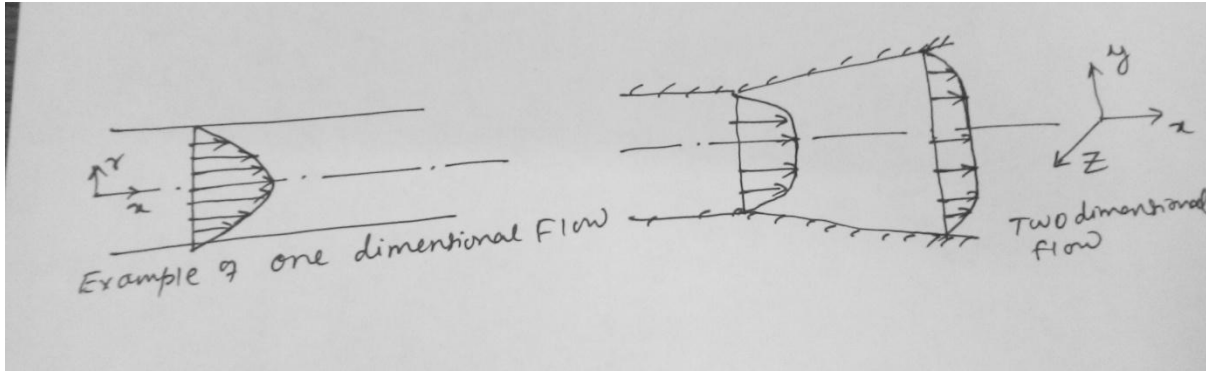
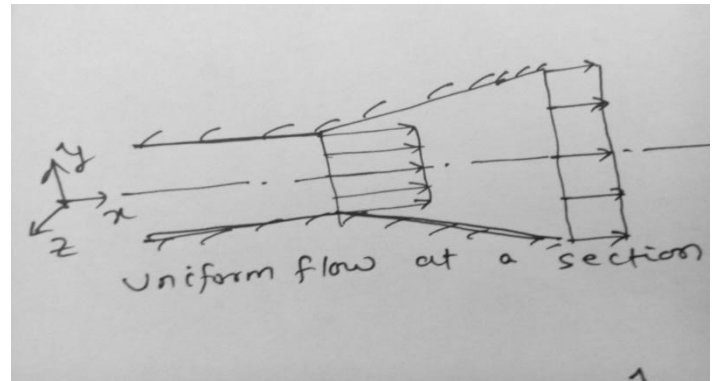

Fig1.6a and Fig1.6b

An example of a two-dimensional flow is illustrated in Fig1.6b. The velocity distribution is depicted for a flow between two diverging straight walls that are infinitely large in z direction. Since the channel is considered to be infinitely large in z the direction, the velocity will be identical in all planes perpendicular to z axis. Thus the velocity field will be only function of x and y and the flow can be classified as two dimensional. Fig 1.7

For the purpose of analysis often it is convenient to introduce the notion of uniform flow at a given cross-section. Under this situation the two dimensional flow of Fig 1.6 b is modelled as one dimensional flow as shown in Fig1.7, i.e. velocity field is a function of x only. However, convenience alone does not justify the assumption such as a uniform flow assumption at a cross section, unless the results of acceptable accuracy are obtained.



Stress Field:

Surface and body forces are encountered in the study of continuum fluid mechanics. Surface forces act on the boundaries of a medium through direct contact. Forces developed without physical contact and distributed over the volume of the fluid, are termed as body forces . Gravitational and electromagnetic forces are examples of body forces .

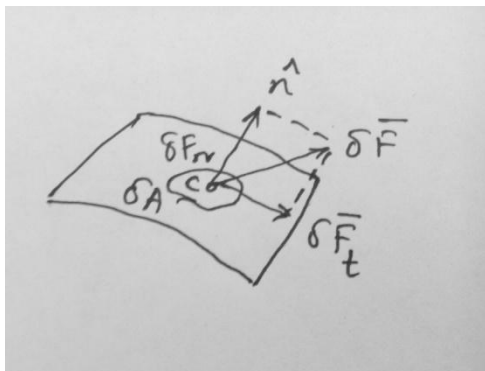

Consider an area $\delta \bar{A}$, that passes through 'c' .Consider a force $\delta \bar{F}$ acting on an area $\delta \bar{A}$ through point 'c' .The normal stress σ_n and shear stress τ_n are then defined as $\sigma_n = \lim_{\delta A_n \rightarrow 0} \frac{\delta F_n}{\delta A_n}$

$\tau_n = \lim_{\delta A_n \rightarrow 0} \frac{\delta F_t}{\delta A_n}$; Subscript 'n' on the stress is included as a reminder that the stresses are associated

with the surface $\delta \bar{A}$, through 'c', having an outward normal in \hat{n} direction. For any other surface through 'c' the values of stresses will be different.

Consider a rectangular co-ordinate system, where stresses act on planes whose normal are in x, y and z directions.

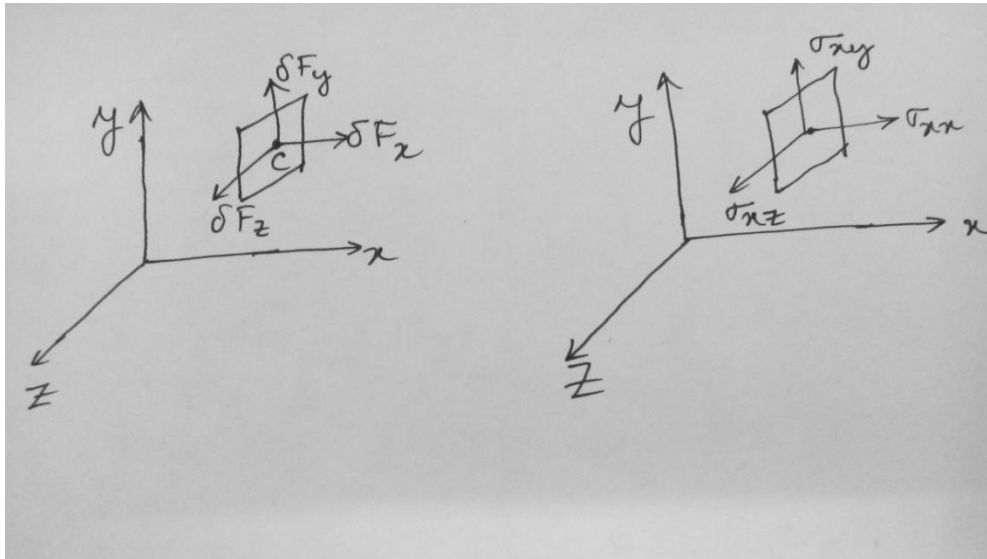

Fig 1.9

Fig 1.9 shows the forces components acting on the area δA_x .

The stress components are defined as ;

$$\sigma_{xx} = \lim_{\delta A_x \rightarrow 0} \frac{\delta F_x}{\delta A_x}$$

$$\sigma_{xy} = \lim_{\delta A_x \rightarrow 0} \frac{\delta F_y}{\delta A_x}$$

$$\sigma_{xz} = \lim_{\delta A_x \rightarrow 0} \frac{\delta F_z}{\delta A_x}$$

A double subscript notation is used to label the stresses. The first subscript indicates the plane on which the stress acts and the second subscript represents the direction in which the stress acts, i.e σ_{xy} represents a stress that acts on x- plane (i.e the normal to the plane is in x direction) and acts in 'y' direction .

Consideration of area element δA_y would lead to the definition of the stresses σ_{yx} , σ_{yy} and σ_{yz} . Use of an area element δA_z would similarly lead to the definition σ_{zx} , σ_{zy} and σ_{zz} .

An infinite number of planes can be passed through point 'c', resulting in an infinite number of stresses associated with planes through that point. Fortunately, the state of stress at a point can be completely described by specifying the stresses acting on three mutually perpendicular planes through the point.

Thus, the stress at a point is specified by nine components and given by :

$$\bar{\sigma} = \begin{bmatrix} \sigma_{xx} & \sigma_{xy} & \sigma_{xz} \\ \sigma_{yx} & \sigma_{yy} & \sigma_{yz} \\ \sigma_{zx} & \sigma_{zy} & \sigma_{zz} \end{bmatrix}$$

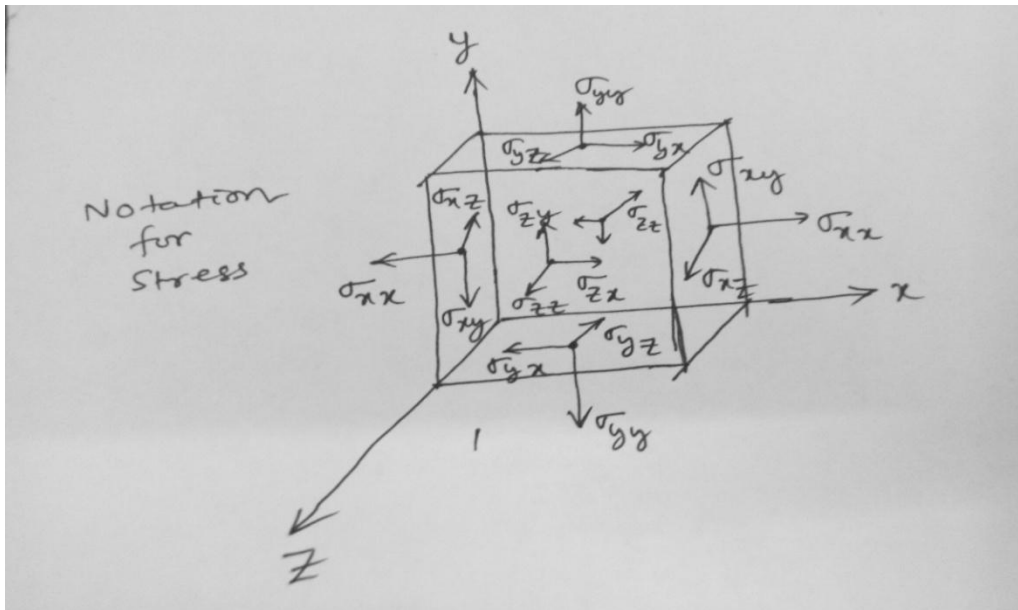

Fig 1.10

Viscosity:

In the absence of a shear stress, there will be no deformation. Fluids may be broadly classified according to the relation between applied shear stress and rate of deformation.

Consider the behaviour of a fluid element between the two infinite plates shown in fig 1.11. The upper plate moves at constant velocity, δu , under the influence of a constant applied force, δF_x .

The shear stress, σ_{yx} , applied to the fluid element is given by :

$$\sigma_{yx} = \lim_{\delta A_y \rightarrow 0} \frac{\delta F_x}{\delta A_y} = \frac{dF_x}{dA_y}$$

Where, δA_y is the area of contact of a fluid element with the plate. During the interval δt , the fluid element is deformed from position $MNOP$ to the position $M'NOP'$. The rate of deformation of the fluid element is given by:

$$\text{Deformation rate} = \lim_{\delta t \rightarrow 0} \frac{\delta \alpha}{\delta t} = \frac{d\alpha}{dt}$$

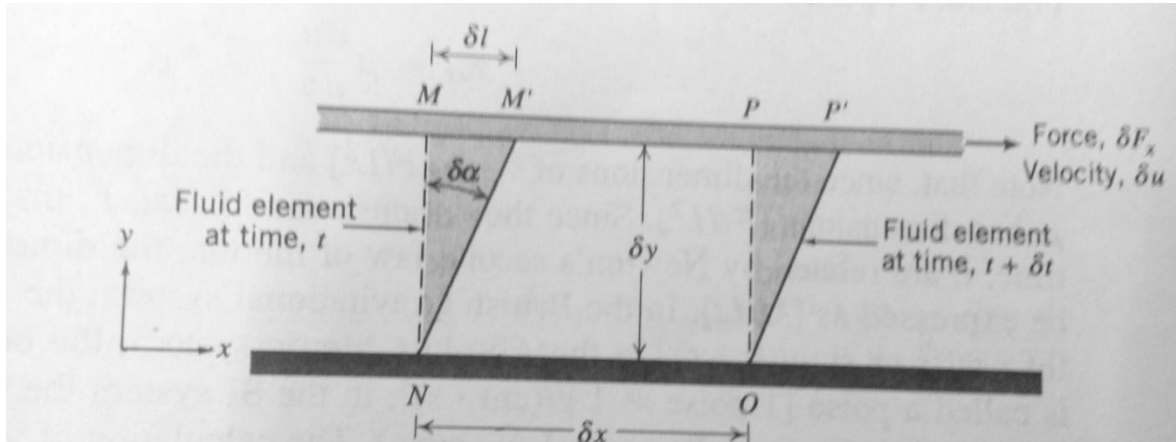

To calculate the shear stress, σ_{yx} , it is desirable to express $\frac{d\alpha}{dt}$ in terms of readily measurable quantity.

$$\delta l = \delta u \delta t$$

Also for small angles, $\delta l = \delta y \delta \alpha$

Equating these two expressions, we have

$$\frac{\delta \alpha}{\delta t} = \frac{\delta u}{\delta y}$$

Taking limit of both sides of the expression, we obtain; $\frac{d\alpha}{dt} = \frac{du}{dy}$

Thus the fluid element when subjected to shear stress, σ_{yx} , experiences a deformation rate, given by $\frac{du}{dy}$.

Fluids in which shear stress is directly proportional to the rate of deformation are "Newtonian fluids".

The term Non-Newtonian is used to classify in which shear stress is not directly proportional to the rate of deformation.

Newtonian Fluids :

Most common fluids i.e Air, water and gasoline are Newtonian fluids under normal conditions. Mathematically for Newtonian fluid we can write :

$$\sigma_{yx} \propto \frac{du}{dy}$$

If one considers the deformation of two different Newtonian fluids , say Glycerin and water ,one recognizes that they will deform at different rates under the action of same applied stress. Glycerin exhibits much more resistance to deformation than water . Thus we say it is more viscous. The constant of proportionality is called , 'μ' .

Thus ,
$$\sigma_{yx} = \mu \frac{du}{dy}$$

Non-Newtonian Fluids :

$$\sigma_{yx} = k \left(\frac{du}{dy} \right)^n$$
 , 'n' is flow behaviour index and 'k' is consistency index .

To ensure that σ_{yx} has the same sign as that of $\left(\frac{du}{dy} \right)$, we can express

$$\sigma_{yx} = k \left| \left(\frac{du}{dy} \right) \right|^{n-1} \left(\frac{du}{dy} \right) = \eta \left(\frac{du}{dy} \right)$$

Where 'η' = $k \left| \left(\frac{du}{dy} \right) \right|^{n-1}$ is referred as apparent viscosity.

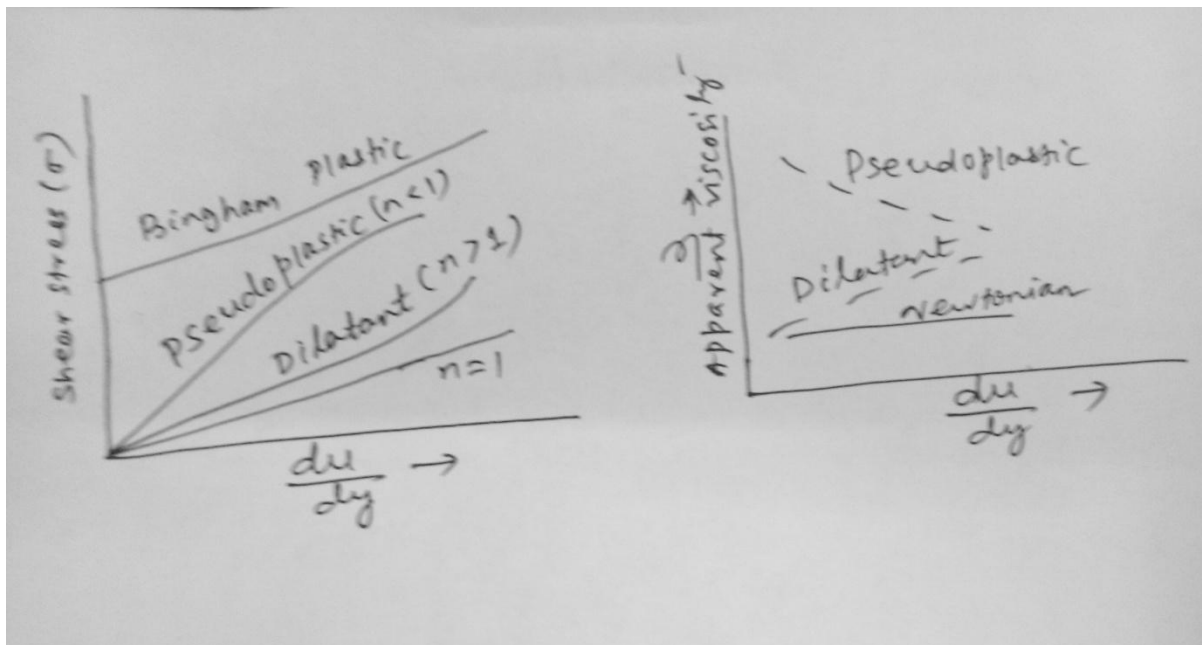

The fluids in which the apparent viscosity decreases with increasing deformation rate ($n < 1$) are called pseudoplastic (shear thinning) fluids . Most Non –Newtonian fluids fall into this category . Examples include : polymer solutions , colloidal suspensions and paper pulp in water.

If the apparent viscosity increases with increasing deformation rate ($n > 1$) the fluid is termed as dilatant(shear thickening). Suspension of starch and sand are examples of dilatant fluids .

A fluid that behaves as a solid until a minimum yield stress is exceeded and subsequently exhibits a linear relation between stress and deformation rate .

$$\sigma_{yx} = \sigma_{yield} + \mu \left(\frac{du}{dy} \right)$$

Examples are : Clay suspension , drilling muds & tooth paste.

Causes of Viscosity:

The causes of viscosity in a fluid are possibly due to two factors (i) intermolecular force of cohesion (ii) molecular momentum exchange.

#Due to strong cohesive forces between the molecules, any layer in a moving fluid tries to drag the adjacent layer to move with an equal speed and thus produces the effect of viscosity.

#The individual molecules of a fluid are continuously in motion and this motion makes a possible process of momentum exchange between layers. Such migration of molecules causes forces of acceleration or deceleration to drag the layers and produces the effect of viscosity.

Although the process of molecular momentum exchange occurs in liquids, the intermolecular cohesion is the dominant cause of viscosity in a liquid. Since cohesion decreases with increase in temperature, the liquid viscosity decreases with increase in temperature.

In gases the intermolecular cohesive forces are very small and the viscosity is dictated by molecular momentum exchange. As the random molecular motion increases with a rise in temperature, the viscosity also increases accordingly.

Example-1 An infinite plate is moved over a second plate on a layer of liquid. For small gap width ,d, a linear velocity distribution is assumed in the liquid . Determine :

- (i) The shear stress on the upper and lower plate .
- (ii) The directions of each shear stresses calculated in (i).

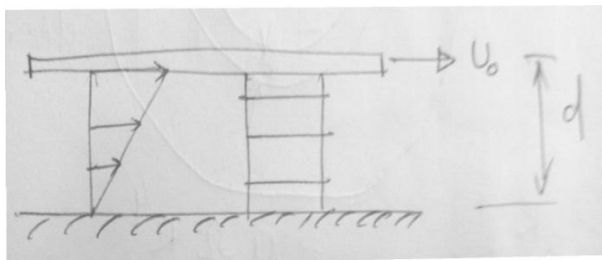

Soln: $\tau_{yx} = \mu \frac{du}{dy}$

Since the velocity profile is linear ;we have

$$\tau_{yx} = \mu \left(\frac{U_0 - 0}{d - 0} \right) = \mu \frac{U_0}{d}$$

$$\text{Hence; } \tau_{yx}|_{y=d} = \tau_{yx}|_{y=0} = \mu \frac{u_0}{d} = \text{constant}$$

Example-2

An oil film of viscosity μ & thickness $h \ll R$ lies between a solid wall and a circular disc as shown in fig E .1.2. The disc is rotated steadily at an angular velocity Ω . Noting that both the velocity and shear stress vary with radius 'r' , derive an expression for the torque 'T' required to rotate the disk.

Soln:

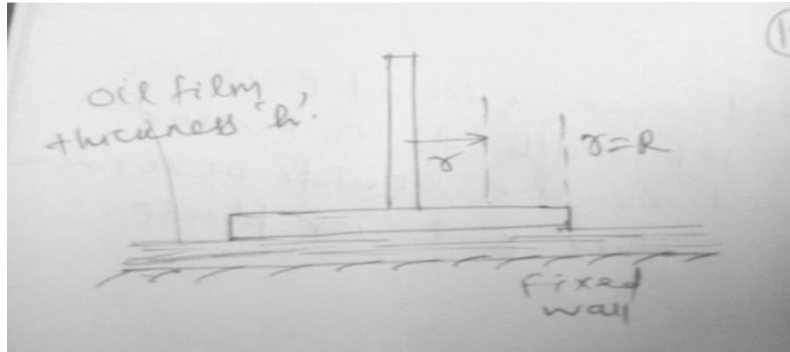

Assumption : linear velocity

laminar flow. $u = \Omega r$; $\tau_{yx} = \mu \frac{du}{dy} = \mu \frac{\Omega r}{h}$; $dF = \tau dA$

$$dF = \mu \left(\frac{\Omega r}{h} \right) 2\pi r dr$$

$$T = \int dT = \int_0^R r dF = \frac{2\pi\mu\Omega}{h} \int_0^R r^3 dr = \frac{\pi\mu\Omega R^4}{2h}$$

Vapor Pressure:

Vapor pressure of a liquid is the partial pressure of the vapour in contact with the saturated liquid at a given temperature. When the pressure in a liquid is reduced to less than vapour pressure, the liquid may change phase suddenly and flash.

Surface Tension:

Surface tension is the apparent interfacial tensile stress (force per unit length of interface) that acts whenever a liquid has a density interface, such as when the liquid contacts a gas, vapour, second liquid, or a solid. The liquid surface appears to act as stretched elastic membrane as seen by nearly spherical shapes of small droplets and soap bubbles. With some care it may be possible to place a needle on the water surface and find it supported by surface tension.

A force balance on a segment of interface shows that there is a pressure jump across the imagined elastic membrane whenever the interface is curved. For a water droplet in air, the pressure in the water is higher than ambient; the same is true for a gas bubble in liquid. Surface tension also leads to

the phenomenon of capillary waves on a liquid surface and capillary rise or depression as shown in the figure below.

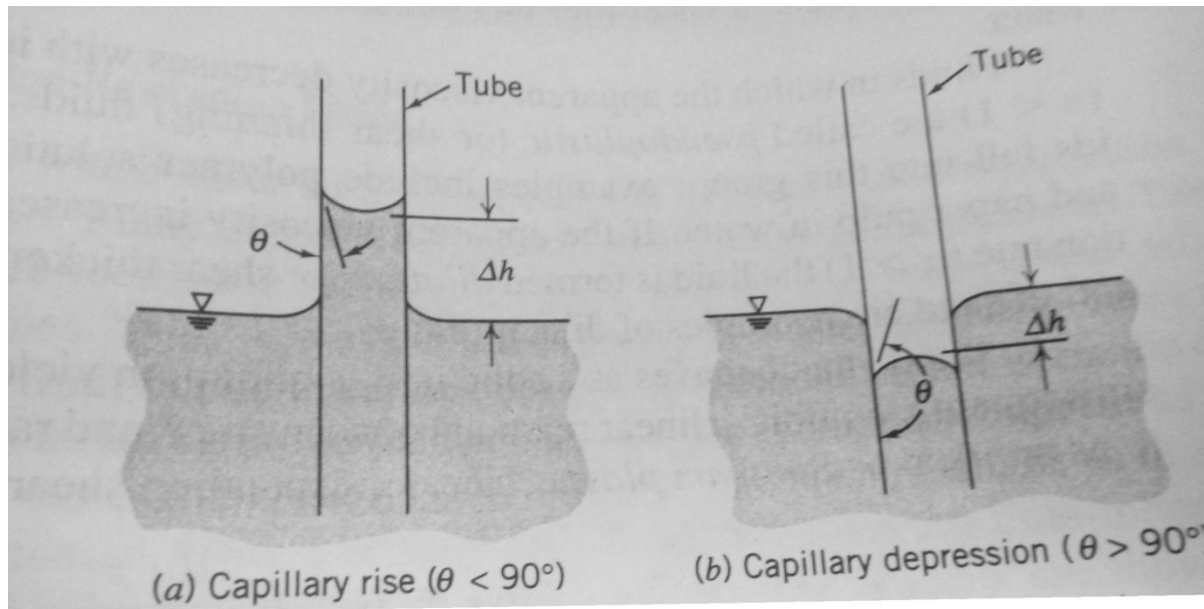

Basic
flow

Analysis Techniques:

There are three basic ways to attack a fluid flow problem. They are equally important for a student learning the subject.

- (1) Control-volume or integral analysis
- (2) Infinitesimal system or differential analysis
- (3) Experimental or dimensional analysis.

In all cases the flow must satisfy three basic laws with a thermodynamic state relation and associated boundary condition.

1. Conservation of mass (Continuity)
2. Balance of momentum (Newton's 2nd law)
3. First law of thermodynamics (Conservation of energy)
4. A state relation like $\rho = \rho(P, T)$
5. Appropriate boundary conditions at solid surface, interfaces, inlets and exits.

Flow patterns:

Fluid mechanics is a highly visual subject. The pattern of flow can be visualized in a dozen of different ways. Four basic type of patterns are :

1. Stream line- A streamline is a line drawn in the flow field so that it is tangent to the line velocity field at a given instant.

2. Path line- Actual path traversed by a fluid particle.

3. Streak line- Streak line is the locus of the particles that have earlier passed through a prescribed point.

4. Time line – Time line is a set of fluid particles that form a line at a given instant .

For stream lines : $d\vec{r} \times \vec{V} = 0$

$$\begin{vmatrix} i & j & k \\ dx & dy & dz \\ u & v & w \end{vmatrix} = 0$$

$$\Rightarrow \hat{i}(w dy - v dz) - \hat{j}(w dx - u dz) + \hat{k}(v dx - u dy) = 0$$

$$\Rightarrow w dy = v dz ; w dx = u dz \quad \& \quad v dx = u dy.$$

$$\text{So ; } \frac{dx}{u} = \frac{dy}{v} = \frac{dz}{w}$$

Ex: A velocity field given by $\vec{V} = A x \hat{i} - A y \hat{j}$. x, y are in meters . units of velocity in m/s.

$$A = 0.3 \text{ s}^{-1}$$

(a) obtain an equation for stream line in the x,y plane.

(b) Stream line plot through (2,8,0)

(c) Velocity of a particle at a point (2,8,0)

(d) Position at t = 6s of particle located at (2,8,0)

(e) Velocity of particle at position found in (d)

(f) Equation of path line of particle located at (2,8,0) at t=0

Soln:

(a) For stream lines ; $\frac{dx}{u} = \frac{dy}{v}$

$$\Rightarrow \frac{dx}{Ax} = \frac{dy}{-Ay}$$

$$\Rightarrow \int \frac{dx}{x} = - \int \frac{dy}{y}$$

$$\Rightarrow \ln x = - \ln y + C$$

$$\Rightarrow \ln xy = C$$

$$\Rightarrow xy = C$$

(b) Stream line plot through (x₀ , y₀ , 0)

$$\Rightarrow x_0 y_0 = C$$

$$\Rightarrow C = 16$$

$$\Rightarrow xy = 16$$

(c) $\vec{V} = 0.6 \hat{i} - 0.6 \hat{j}$

$$(d) u = Ax , \quad \frac{dx}{dt} = Ax \quad , \quad \int_{x_0}^x \frac{dx}{x} = A \int_0^t dt$$

$$\Rightarrow \ln\left(\frac{x}{x_0}\right) = At \quad , \quad \frac{x}{x_0} = e^{At}$$

$$v = - Ay , \quad \frac{dy}{dt} = -Ay \quad , \quad \int_{y_0}^y \frac{dy}{y} = - A \int_0^t dt$$

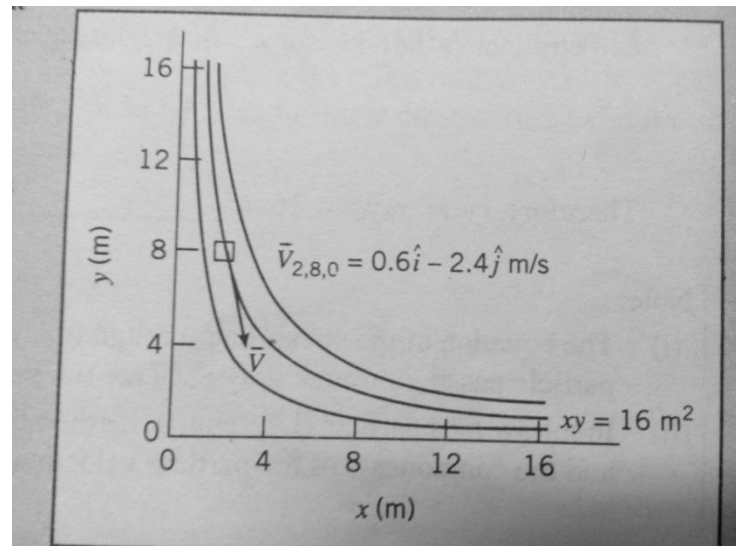

$$\Rightarrow \ln\left(\frac{y}{y_0}\right) = -At, \quad \frac{y}{y_0} = e^{-At}$$

$$\text{At } t = 6\text{ s}; x = 2 e^{0.3 \times 6} = 12.1 \text{ m}$$

$$; y = 8 e^{-0.3 \times 6} = 1.32 \text{ m}$$

$$(e) \vec{V} = 0.3 \times 12.1 \hat{i} - 0.3 \times 1.32 \hat{j} = 3.63 \hat{i} - 0.396 \hat{j}$$

(f) To determine the equation of the path line, we use the parametric equation:

$$x = x_0 e^{At} \quad \text{and} \quad y = y_0 e^{-At} \quad \text{and eliminate 't'}$$

$$\Rightarrow xy = x_0 y_0$$

Remarks:

(a) The equation of stream line through (x_0, y_0) and equation of the path line traced out by particle passing through (x_0, y_0) are same as the flow is steady.

(b) In following a particle (Lagrangian method of description), both the coordinates of the particle (x, y) and the component $(u_p \& v_p)$ are functions of time.

Example -2:

A flow is described by velocity field, $\vec{V} = ay \hat{i} + bt \hat{j}$, where $a = 1 \text{ s}^{-1}$, $b = 0.5 \text{ m/s}^2$. At $t = 2\text{ s}$, what are the coordinates of the particle that passed through $(1, 2)$ at $t = 0$? At $t = 3\text{ s}$, what are the coordinates of the particle that passed through the point $(1, 2)$ at $t = 2\text{ s}$.

Plot the path line and streak line through point $(1, 2)$ and compare with the stream lines through the same point $(1, 2)$ at instant, $t = 0, 1, 2 \& 3 \text{ s}$.

Soln:

Path line and streak line are based on parametric equations for a particle.

$$v = \frac{dy}{dt} = bt, \quad \text{so, } dy = bt \, dt$$

$$\Rightarrow y - y_0 = \frac{b}{2}(t^2 - t_0^2)$$

$$\& u = \frac{dx}{dt} = ay = a \left[y_0 + \frac{b}{2}(t^2 - t_0^2) \right]$$

$$\Rightarrow \int_{x_0}^x dx = \int_{t_0}^t \left\{ a \left[y_0 + \frac{b}{2}(t^2 - t_0^2) \right] \right\} dt$$

$$\Rightarrow (x - x_0) = a y_0 (t - t_0) + \frac{b}{2} \left(\frac{t^3}{3} - t_0^2 t \right)_{t_0}^t$$

$$\Rightarrow x = x_0 + a y_0 (t - t_0) + \frac{ab}{2} \left\{ \left(\frac{t^3 - t_0^3}{3} \right) - t_0^2 (t - t_0) \right\}$$

(a) For $t_0 = 0$ and $(x_0, y_0) = (1, 2)$, at $t = 2\text{ s}$, we have

$$\Rightarrow y - 2 = \frac{b}{2}(4)$$

$$\Rightarrow y = 3 \text{ m}$$

$$\Rightarrow x = 1 + 2(2 - 0) + \frac{0.5}{2} \left[\frac{8}{3} - 0 \right] = 5.67 \text{ m}$$

(b) For $t_0 = 2\text{s}$ and $(x_0, y_0) = (1, 2)$. Thus at $t = 3\text{s}$

$$\text{We have, } y - 2 = \frac{b}{2}(t^2 - t_0^2) = \frac{0.5}{2}(9 - 4) = 1.25$$

$$\Rightarrow y = 3.25 \text{ m}$$

$$\& \quad x = 1 + 2(3 - 2) + \frac{0.5}{2} \left\{ \left(\frac{3^3 - 2^3}{3} \right) - 2^2(3 - 2) \right\}$$

$$\Rightarrow x = 1 + 2(3 - 2) + \frac{0.5}{2} \left\{ \left(\frac{27 - 8}{3} \right) - 4(1) \right\} = 3.58 \text{ m}$$

(c) The streak line at any given 't' may be obtained by varying 't₀'.

part (a) : path line of particle located at (x_0, y_0) at $t_0 = 0\text{ s}$.

$t_0(\text{s})$	t	X(m)	Y(m)
0	0	1	2
0	1	3.08	2.25
0	2	5.67	3.00
0	3	9.25	4.25

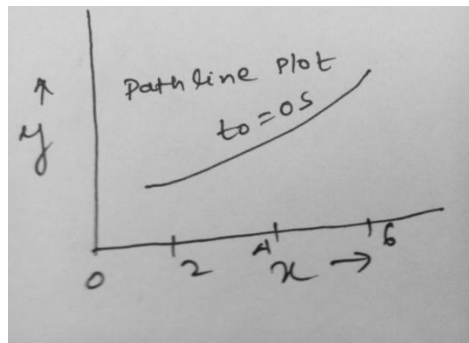

#part (b): path lines of a particle located at (x_0, y_0) at $t_0 = 2\text{s}$

$t_0(\text{s})$	t(s)	X	Y
2	2	1	2
2	3	3.58	3.25
2	4	7.67	5.0

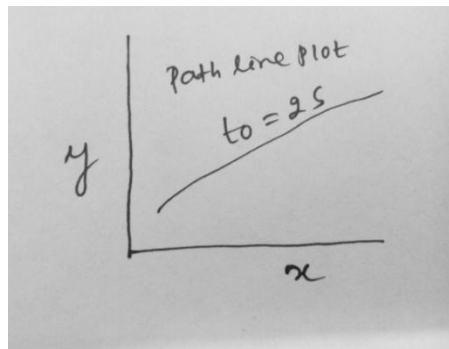

#part (c) : $\frac{dx}{u} = \frac{dy}{v}$

$$\Rightarrow dx = \left(\frac{ay}{bt} \right) dy$$

$$\Rightarrow y dy = \frac{bt}{a} dx$$

$$\Rightarrow y^2 = \left(\frac{2bt}{a} \right) x + c$$

$$\text{Thus, } c = y_0^2 - \left(\frac{2bt}{a} \right) x_0$$

For $(x_0, y_0) = (1, 2)$, for different value of 't'.

$$\text{For } t=0; c = (2)^2 = 4$$

$$t = 1; c = 4 - \left(\frac{1}{1} \right) 1 = 3$$

$$t = 2; c = 4 - \left(\frac{2}{1} \right) 1 = 2$$

$$t=3; c = 4 - \left(\frac{3}{1}\right)1 = 1$$

t(s)	0	1	2	3
C=	4	3	2	1
X	Y	Y	Y	Y
1	2	2	2	2
2	2	2.24	2.45	2.65
3	2	2.45	2.83	3.16
4	2	2.65	3.16	3.61
5	2	2.53	3.46	4.0
6	2	3.0	3.74	4.36
7	2	3.16	4.00	4.69

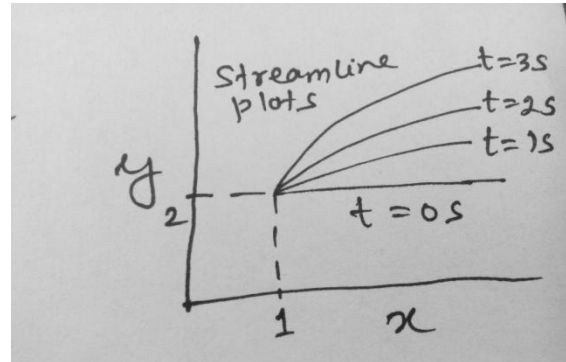

Streak line of particles that passed through point (x_0, y_0) at $t = 3s$.

$t_0(s)$	$t(s)$	X(m)	Y(m)
0	3	9.25	4.25
1	3	6.67	4.00
2	3	3.58	3.25
3	3	1.0	2.0

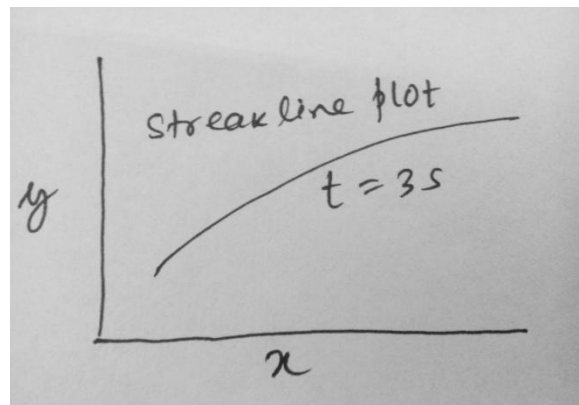

CHAPTER – 2

FLUID STATICS

In the previous chapter , we defined as well as demonstrated that fluid at rest cannot sustain shear stress , how small it may be. The same is true for fluids in “ rigid body” motion. Therefore, fluids either at rest or in “rigid body” motion are able to sustain only normal stresses. Analysis of hydrostatic cases is thus appreciably simpler than that for fluids undergoing angular deformation.

Mere simplicity doesn't justify our study of subject . Normal forces transmitted by fluids are important in many practical situations. Using the principles of hydrostatics we can compute forces on submerged objects, developed instruments for measuring pressure, forces developed by hydraulic systems in applications such as industrial press or automobile brakes.

In a static fluid or in a fluid undergoing rigid-body motion, a fluid particle retains its identity for all time and fluid elements do not deform. Thus we shall apply Newton's second law of motion to evaluate the forces acting on the particle.

The basic equations of fluid statics :

For a differential fluid element , the body force is $d\bar{F}_B = \bar{g} \, dm = \bar{g} \, \rho \, d\forall$

(here , gravity is the only body force considered)where, \bar{g} is the local gravity vector , ρ is the density & $d\forall$ is the volume of the fluid element. In Cartesian coordinates, $d\forall = dx \, dy \, dz$.In a static fluid no shear stress can be present. Thus the only surface force is the pressure force. Pressure is a scalar field, $p = p(x,y,z)$; the pressure varies with position within the fluid.

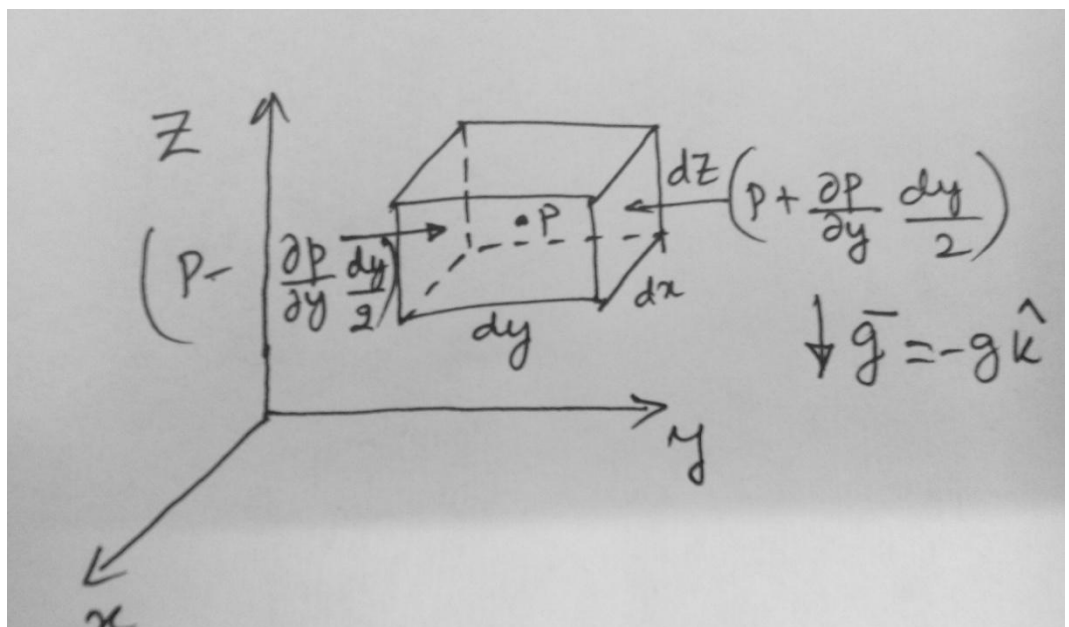

Pressure at the left face : $P_L = (p - \frac{\partial p}{\partial y} \frac{dy}{2})$

Pressure at the right face : $P_R = (p + \frac{\partial p}{\partial y} \frac{dy}{2})$

Pressure force at the left face : $F_L = (p - \frac{\partial p}{\partial y} \frac{dy}{2}) dx dz \hat{j}$

Pressure force at the right face : $F_R = (p + \frac{\partial p}{\partial y} \frac{dy}{2}) dx dz (-\hat{j})$

Similarly writing for all the surfaces , we have

$$\begin{aligned} d\vec{F}_s = & \hat{i} (p - \frac{\partial p}{\partial x} \frac{dx}{2}) dy dz + (p + \frac{\partial p}{\partial x} \frac{dx}{2}) dy dz (-\hat{i}) + (p - \frac{\partial p}{\partial y} \frac{dy}{2}) dx dz \hat{j} \\ & + (p + \frac{\partial p}{\partial y} \frac{dy}{2}) dx dz (-\hat{j}) + (p + \frac{\partial p}{\partial z} \frac{dz}{2}) dx dy (\hat{k}) + (p + \frac{\partial p}{\partial z} \frac{dz}{2}) dx dy (-\hat{k}) \end{aligned}$$

Collecting and concealing terms , we obtain :

$$d\vec{F}_s = - (\hat{i} \frac{\partial p}{\partial x} + \hat{j} \frac{\partial p}{\partial y} + \hat{k} \frac{\partial p}{\partial z}) dx dy dz$$

$$\triangleright d\vec{F}_s = - (\nabla p) dx dy dz$$

Thus

Net force acting on the body:

$$\triangleright d\vec{F} = d\vec{F}_s + d\vec{F}_B = (-\nabla p + \rho \vec{g}) dx dy dz$$

$$\triangleright d\vec{F} = (-\nabla p + \rho \vec{g}) dV$$

or, in a per unit volume basis:

$$\frac{d\vec{F}}{dV} = (-\nabla p + \rho \vec{g}) \quad \rightarrow (2.1)$$

For a fluid particle , Newton's second law can be expressed as : $d\vec{F} = \vec{a} dm = \vec{a} \rho dV$

$$\text{Or } \frac{d\vec{F}}{dV} = \vec{a} \rho \quad \rightarrow (2.2)$$

Comparing 2.1 & 2.2 , we have

$$-\nabla p + \rho \vec{g} = \vec{a} \rho$$

For a static fluid , $\vec{a} = 0$; Thus we obtain ; $-\nabla p + \rho \vec{g} = 0$

The component equations are ;

$$\vec{g} = -g \hat{k}$$

$$-\frac{\partial p}{\partial x} + \rho g_x = 0$$

$$g_x = 0 = g_y$$

$$-\frac{\partial p}{\partial y} + \rho g_y = 0$$

$$\frac{\partial p}{\partial z} + \rho g_z = 0$$

Using the value of g_x, g_y & g_z we have

$$\frac{\partial p}{\partial x} = 0, \frac{\partial p}{\partial y} = 0 \quad \& \quad \frac{\partial p}{\partial z} = -\rho g \quad ; \text{ since } P=P(Z)$$

We can write $\frac{dp}{dz} = -\rho g$

Restrictions: (i) Static fluid

(ii) gravity is the only body force

(iii) z axis is vertical upward

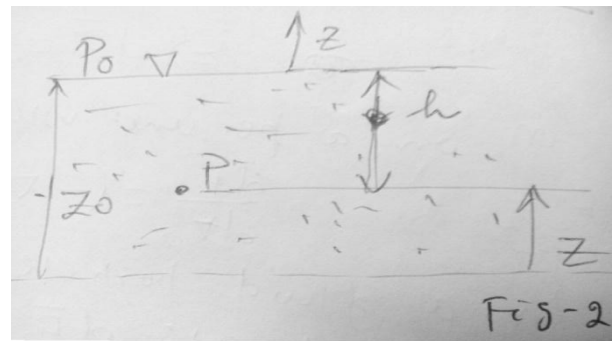
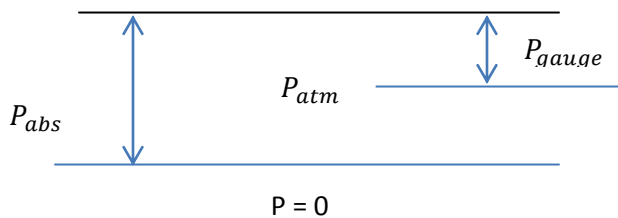

#Pressure variation in a static fluid :

$$\frac{dP}{dz} = -\rho g = \text{constant}$$

- $\int_{P_0}^P dP = -\rho g \int_{Z_0}^Z dZ$
- $P - P_0 = -\rho g(Z - Z_0)$
- $P - P_0 = -\rho g(Z_0 - Z) = \rho gh$

Ex:2.1 A tube of small diameter is dipped into a liquid in an open container. Obtain an expression for the change in the liquid level within the tube caused by the surface tension.

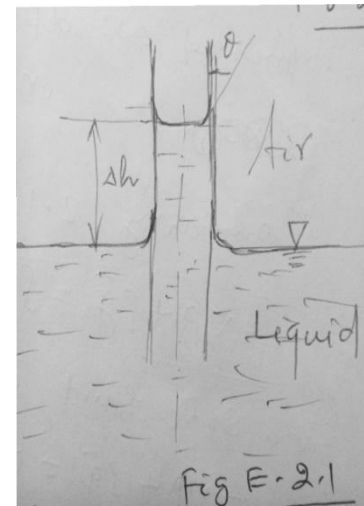
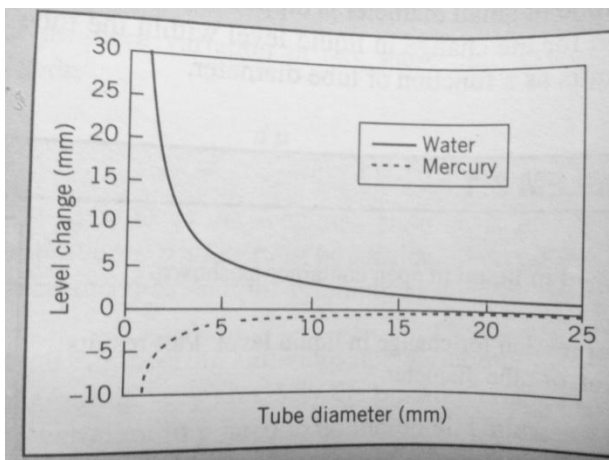

Soln:

$$\Sigma F_z = \sigma \pi D \cos \theta - \rho g \Delta \nabla = 0$$

Neglecting the volume of the liquid above Δh , we obtain

$$\Delta \nabla = \frac{\pi}{4} D^2 \Delta h$$

$$\text{Thus ; } \sigma \pi D \cos \theta - \rho g \frac{\pi}{4} D^2 \Delta h = 0$$

$$\rightarrow \Delta h = \frac{4 \sigma \cos \theta}{\rho g D}$$

Multi Fluid Manometer:

Ex2.2 Find the pressure at 'A'.

$$\text{Soln: } P_A + \rho_a g \times 0.15 - \rho_m g \times 0.15 + \rho_a g \times 0.15 - \rho_w g \times 0.3 = P_0$$

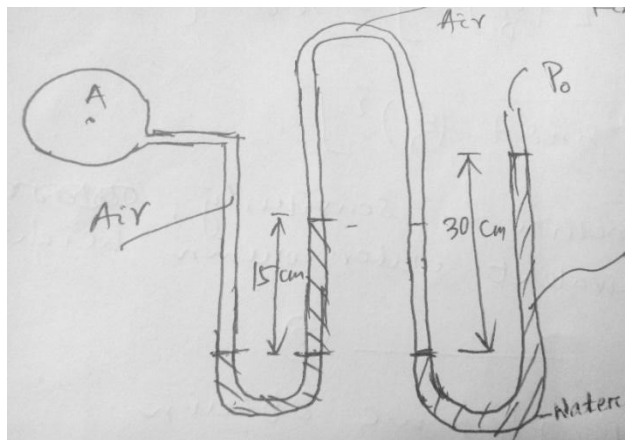

#Inclined Tube manometer:

Ex2.3 Given : Inclined-tube reservoir manometer .

Find : Expression for 'L' in terms of ΔP .

#General expression for manometer sensitivity

#parameter values that give maximum sensitivity

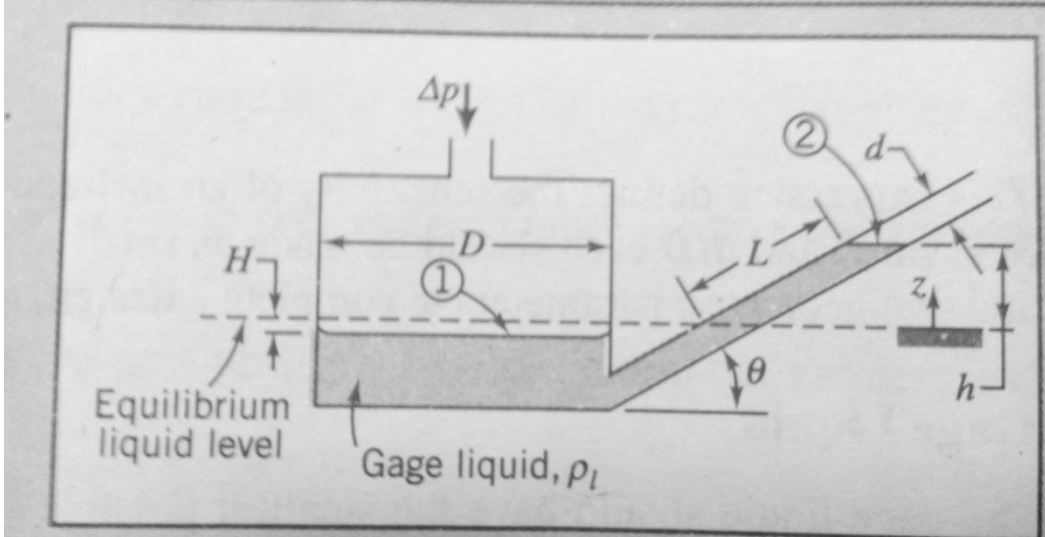

Soln:

Equating pressures on either side of Level -2, we have; $\Delta P = \rho_l g (h+H)$

To eliminate 'H', we recognise that the volume

of manometer liquid remains constant i.e the volume displaced from the reservoir must be equal to the volume rise in the tube.

$$\text{Thus ; } \frac{\pi}{4} D^2 H = \frac{\pi}{4} d^2 L$$

$$\text{➤ } H = L \left(\frac{d}{D}\right)^2$$

$$\text{➤ } \Delta P = \rho_l g [L \sin \theta + L \left(\frac{d}{D}\right)^2] = \rho_l g L \left[\sin \theta + \left(\frac{d}{D}\right)^2 \right]$$

1

$$\text{Thus, } L = \frac{\Delta P}{\rho_l g \left[\sin \theta + \left(\frac{d}{D}\right)^2 \right]}$$

To obtain an expression for sensitivity, express ΔP in terms of an equivalent water column height, h_e

$$\Delta P = \rho_w g h_e$$

2

Combining equation 1 & 2, we have

$$\rho_l g L \left[\sin \theta + \left(\frac{d}{D}\right)^2 \right] = \rho_w g h_e$$

$$\text{Thus, } S = \frac{L}{h_e} = \frac{1}{SG \left[\sin \theta + \left(\frac{d}{D}\right)^2 \right]}$$

$$\text{Where, } SG = \frac{\rho_e}{\rho_w}$$

The expression 'S' for sensitivity shows that to increase sensitivity SG, $\sin \theta$ and $\frac{d}{D}$ should be made as small as possible.

Hydrostatic Force on the plane surface which is inclined at an angle 'θ' to horizontal free surface:

We wish to determine the resultant hydrostatic force on the plane surface which is inclined at angle 'θ' to the horizontal free surface.

Since there can be no shear stresses in a static fluid, the hydrostatic force on any element of the surface must act normal to the surface. The pressure force acting on an element $d\bar{A}$ of the upper surface is given by $d\bar{F} = -p d\bar{A}$.

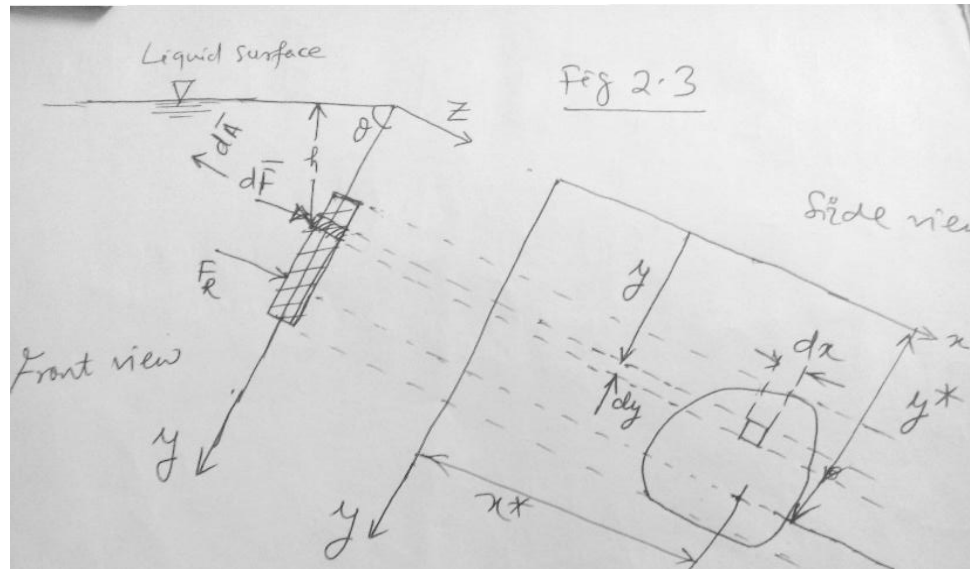

The negative sign indicates that the pressure force acts against the surface i.e in the direction opposite to the area $d\bar{A}$. $\bar{F}_R = \int_A -p d\bar{A}$

If the free surface is at a pressure ($P_0 = P_{atm}$), then, $p = p_0 + \rho gh$

$$|\bar{F}_R| = \int_A (p_0 + \rho gh) dA = p_0 A + \int_A \rho g y \sin\theta dA$$

$$\triangleright |\bar{F}_R| = p_0 A + \rho g \sin\theta \int_A y dA$$

$$\text{But } \int_A y dA = y_c A$$

$$\text{Thus, } |\bar{F}_R| = p_0 A + \rho g y_c A \sin\theta = (p_0 + \rho g y_c \sin\theta) A$$

Where h_c is the vertical distance between free surface and centroid of the area.

To evaluate the centre of pressure (c.p) or the point of application of the resultant force

The point of application of the resultant force must be such that the moment of the resultant force about any axis is equal to the sum of the moments of the distributed force about the same axis.

If \bar{r}^* is the position vector of centre pressure from the arbitrary origin, then

$$\bar{r}^* \times \bar{F}_R = \int \bar{r} \times d\bar{F} = - \int \bar{r} \times p d\bar{A}$$

Referring to fig 2.3, we can express

$$\bar{r}^* = \hat{i} x^* + \hat{j} y^*$$

$$\bar{r} = x\hat{i} + y\hat{j} ; d\bar{A} = -dA \hat{k} \text{ and } \bar{F}_R = F_R \hat{k}$$

Substituting into equation , we obtain

$$(\hat{i} x^* + \hat{j} y^*) \times F_R \hat{k} = \int (x\hat{i} + y\hat{j}) \times d\bar{F} = \int_A (x\hat{i} + y\hat{j}) \times p dA \hat{k}$$

Evaluating the cross product , we get

$$\Rightarrow \hat{j} x^* F_R + \hat{i} y^* F_R = \int_A (-\hat{j} x p + \hat{i} y p) dA$$

Equating the components in each direction ,

$y^* F_R = \int_A y p dA$ and $x^* F_R = \int_A x p dA$ #when the ambient (atmospheric) pressure , p_0 , acts on both sides of the surface , then p_0 makes no contribution to the net hydrostatic force on the surface and it may be dropped . If the free surface is at a different pressure from the ambient, then ‘ p_0' ’ should be stated as gauge pressure , while calculating the net force .

$$y^* = \frac{\int_A p y dA}{F_R} = \frac{\int_A \rho g x^2 \sin \theta dA}{\rho g y_c A \sin \theta}$$

$$\Rightarrow y^* = \frac{\rho g \sin \theta \int y^2 dA}{\rho g y_c A \sin \theta}$$

$$\Rightarrow y^* = \frac{I_{xx}}{A y_c}$$

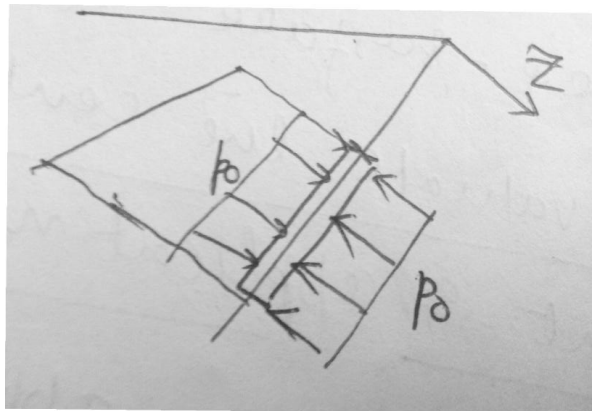

But from parallel axis theorem , $I_{xx} =$

$$I_{\hat{x}\hat{x}} + A y_c^2$$

Where $I_{\hat{x}\hat{x}}$ is the second moment of the area about the centroid al ‘ \hat{x} ’ axis . Thus

$$y^* = y_c + \frac{I_{\hat{x}\hat{x}}}{A y_c}$$

$$\text{Or , } y^* = \left(\frac{h_c}{\sin \theta} \right) + \frac{I_{\hat{x}\hat{x}} \sin \theta}{A h_c}$$

Similarly taking moment about ‘ y ’ axis ;

$$x^* F_R = \int x p dA$$

$$\Rightarrow x^* \rho g \sin \theta y_c A = \int_A x \rho g h dA = \rho g \sin \theta \int_A x y dA$$

$$\Rightarrow x^* = \frac{\int_A x y dA}{A y_c} = \frac{I_{xy}}{A y_c}$$

From the parallel axis theorem , $I_{xx} = I_{\hat{x}\hat{y}} + A x_c y_c$

Where $I_{\hat{x}\hat{y}}$ is the area product of inertia w.r.t centroid al $\hat{x}\hat{y}$ axis.

$$\text{So, } x^* = x_c + \frac{I_{xy}}{Ay_c}$$

For surface that is symmetric about 'y' axis, $x^* = x_c$ and hence usually not asked to evaluate.

Example Problem:

Ex 2.4: Rectangular gate, hinged at 'A', $w=5\text{m}$. Find the resultant force, \bar{F}_R , of the water and the air on the gate. The inclined surface shown, hinged along edge 'A', is 5m wide. Determine the resultant force, \bar{F}_R , of the water and air on the inclined surface.

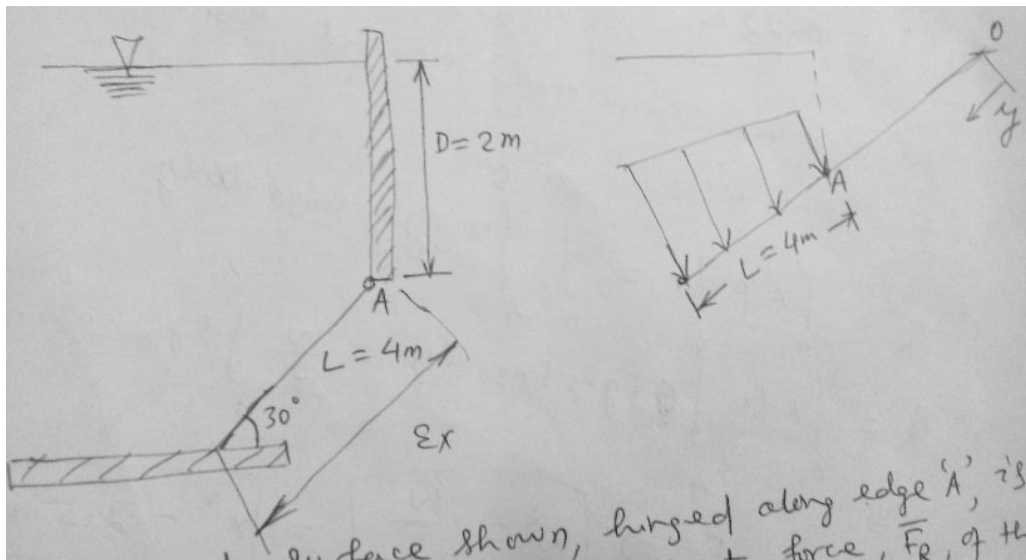

Soln:-

$$\bar{F}_R = \int_A p d\bar{A} = - \int_4^8 \rho g y \sin 30 w dy \hat{k}$$

$$\Rightarrow \bar{F}_R = -\frac{\rho g w}{2} \hat{k} \left[\frac{y^2}{2} \right]_4^8 = -\frac{999 \times 9.81 \times 5}{4} [64 - 16] \hat{k}$$

$$\Rightarrow \bar{F}_R = -588.01 \text{ KN}$$

Force acts in negative 'z' direction.

To find the line of action :

Taking moment about x axis through point 'O' on the free surface, we obtain :

$$y^* F_R = \int_A y p dA = \int_4^8 y \rho g \sin 30 w dy$$

$$\Rightarrow y^* F_R = \left(\frac{\rho g w}{2} \right) \left[\frac{y^3}{3} \right]_4^8 = \frac{5 \times 999 \times 9.81}{6} [8^3 - 4^3]$$

$$\Rightarrow y^* \times (588.01 \times 10^3) = 3658.73 \times 10^3$$

$$\Rightarrow y^* = 6.22 \text{ m}$$

#To find x^* ; we can take moment about y axis through point 'o'.

$$x^* F_R = \int_A x p dA = \int_0^w \int_4^8 x \rho y g \sin 30 dx dy$$

$$\rightarrow x^* F_R = \int_0^w x dx \int_4^8 \rho g y \sin 30 dy = \frac{w}{2} \int_4^8 \rho g y \sin 30 . w dy$$

$$\rightarrow x^* F_R = \frac{w}{2} F_R$$

$$\rightarrow x^* = \frac{w}{2} = 2.5 \text{ m}$$

Alternative way: By directly using equations:

$$F_R = \rho g h_c A = \rho g (2+2\sin 30)$$

$\times 4 \times 5$

$$y^* = y_c + \frac{I_{xx}}{Ay_c} = 6 + \frac{w l^3 / 12}{20 \times 6} = 6.22 \text{ m}$$

$$x^* = x_c + \frac{I_{xy}}{Ay_c}$$

$$I_{xy} = \int_A \hat{x} \hat{y} dA = \int_{-\frac{w}{2}}^{\frac{w}{2}} \int_{-\frac{l}{2}}^{\frac{l}{2}} \hat{x} \hat{y} d\hat{x} d\hat{y} =$$

0

Thus, $x^* = x_c = 2.5 \text{ m}$

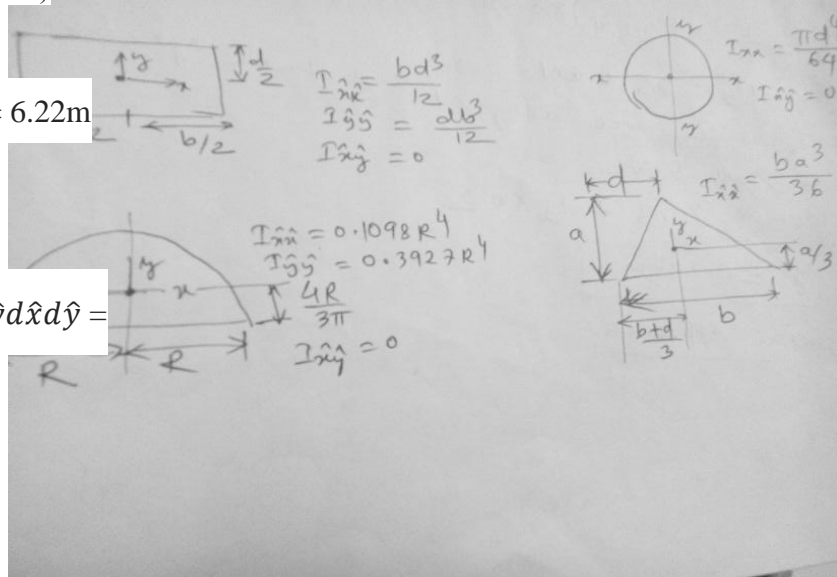

Concept of pressure prism:

$$F_R = \text{volume} = \frac{1}{2} (\rho g h) b h$$

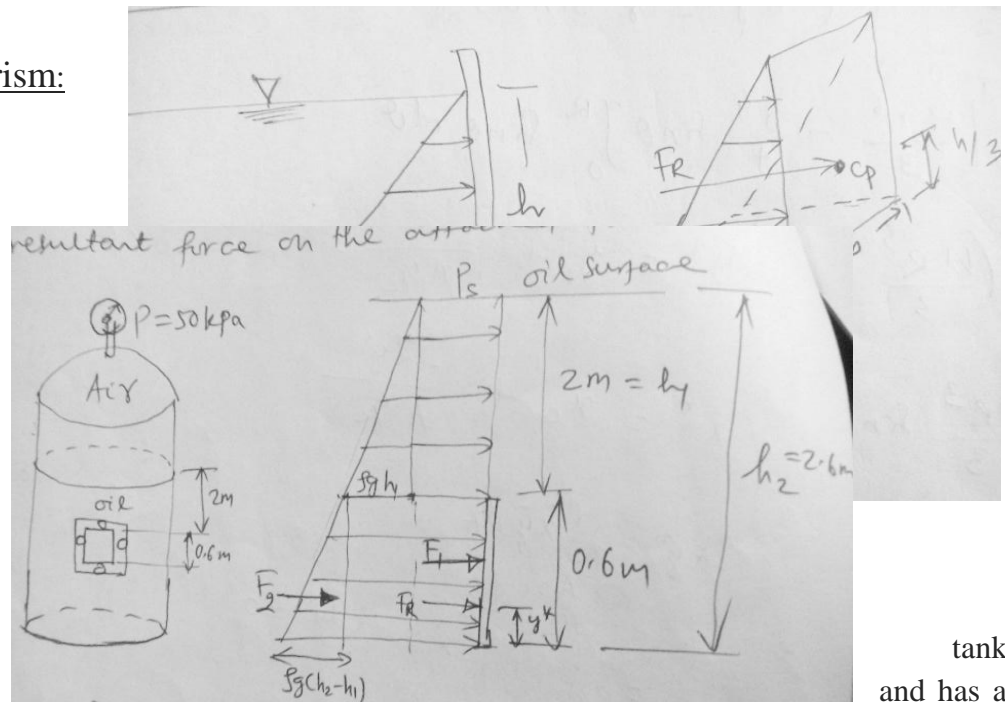

Ex2.5: A pressurised tank contains oil (SG=0.9)

and has a

square, 0.6 m by 0.6 m plate bolted to its side as shown in fig. The pressure gage on the top of the tank reads 50 kPa and the outside tank is at atmospheric pressure. Find the magnitude & location of the resultant force on the attached plate.

$$\text{Soln: } F_1 = (P_s + \rho g h_1) \times 0.36 = 24.4 \text{ kN}$$

$$F_2 = \frac{1}{2} \rho g (h_2 - h_1) \times 0.36 = 0.954 \text{ kN}$$

$$F_R = F_1 + F_2 = 25.4 \text{ kN}$$

If ' F_R ' is the force acting at a distance y^* for

the bottom, we have; $F_R y^* = F_1 \times 0.3 + F_2 \times 0.2$ and $y^* = 0.296 \text{ m}$

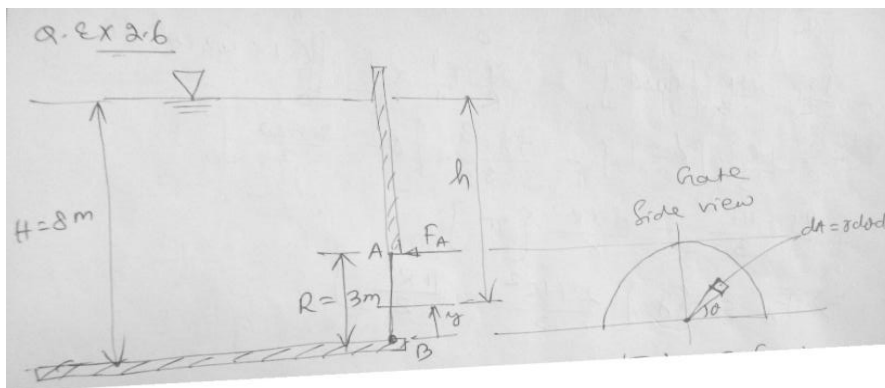

Ex-2.6

Soln: Basic equations :

$$\frac{dp}{dh} = \rho g ; |\overline{F_R}| = \int p dA ;$$

$\sum \overline{M} = 0$; Taking moment about the hinge 'B', we have

$$F_A R = \int y dF = \int \rho g h y dA$$

- $dA = r d\theta dr$;
- $y = r \sin\theta$; $h = H - y$
- $F_A = \frac{1}{R} \int_0^\pi \int_0^R r \sin\theta \rho g (H - r \sin\theta) r dr d\theta$
- $F_A = \frac{\rho g}{R} \int_0^\pi \int_0^R (Hr^2 - r^3 \sin\theta) dr d\theta$

$$= \frac{\rho g}{R} \int_0^\pi \left[\frac{Hr^3}{3} - \frac{r^4}{4} \sin\theta \right]_0^R \sin\theta d\theta$$

$$= \frac{\rho g}{R} \int_0^\pi \left(\frac{HR^3}{3} - \frac{R^4}{4} \sin\theta \right) \sin\theta d\theta$$

$$= \frac{\rho g}{R} \left[\int_0^\pi \frac{HR^3}{3} \sin\theta d\theta - \int_0^\pi \frac{R^4}{4} \sin^2 \theta d\theta \right]$$

$$\begin{aligned}
&= \frac{\rho g}{R} \frac{HR^3}{3} [-\cos\theta]_0^\pi - \frac{\rho g}{R} \frac{R^4}{4} \times \frac{1}{2} \left[\int_0^\pi (1 - \cos 2\theta) d\theta \right] \\
&= -\frac{\rho g}{R} \frac{HR^3}{3} [-1-1] - \frac{\rho g R^3}{8} \left[\theta - \frac{\sin 2\theta}{2} \right]_0^\pi \\
&= \frac{2\rho g HR^2}{3} - \frac{\rho g R^3}{8} [\pi]
\end{aligned}$$

$$\begin{aligned}
\text{➤ } F_A &= \rho g \left[\frac{2HR^2}{3} - \frac{\pi R^3}{8} \right] \\
\text{➤ } F_A &= 366 \text{ kN} \quad . \quad (\text{Ans})
\end{aligned}$$

Ex-2.7 :- Repeat the example problem 2.4 if the C.S area of the inclined surface is circular one , with radius R=2.

Soln: Using integration;

$$F_R = \int_A dF = \int_A \rho g h dA = \iint \rho g y \sin\theta dr r d\phi$$

$$\eta + y = 6\text{m}$$

$$\Rightarrow y = 6 - \eta = 6 - r \sin\phi$$

$$F_R = \rho g \sin 30 \int_0^{2\pi} \int_0^R (6 - r \sin\phi) r dr d\phi$$

$$= \frac{\rho g}{2} \int_0^{2\pi} \int_0^R (6r - r^2 \sin\phi) dr d\phi$$

$$\Rightarrow F_R = \frac{\rho g}{2} \int_0^{2\pi} \left[\left(6 \frac{r^2}{2} - \frac{r^3}{3} \sin\phi \right) \right]_0^R d\phi = \frac{\rho g}{2} \int_0^{2\pi} \left(3R^2 - \frac{R^3}{3} \sin\phi \right) d\phi$$

$$= \frac{\rho g}{2} \left[3R^2 \phi - \frac{R^3}{3} (-\cos\phi) \right]_0^{2\pi}$$

$$= \frac{\rho g}{2} [12 \times 2\pi - 0] = 12\rho g \pi = 369.458 \text{ kN}$$

Similarly for y^* we can write

$$y^* \cdot F_R = \int y dF = \int_0^{2\pi} \int_0^R (6 - r \sin\phi)^2 \rho g \sin\theta dr r d\phi$$

$$\text{By using formula : } F_R = \rho g h_c A = \rho g (2 + 2\sin 30) \pi R^2 = 369.458 \text{ kN}$$

$$y^* = y_c + \frac{I_{\hat{x}\hat{x}}}{A y_c} = 6 + \frac{\left(\frac{\pi 4^4}{64} \right)}{\left(\frac{\pi 4^4}{4} \right)} \times \frac{1}{6}$$

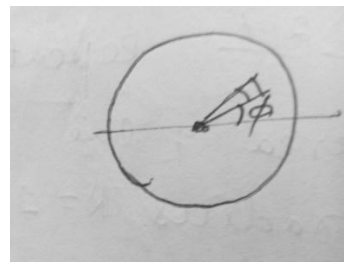
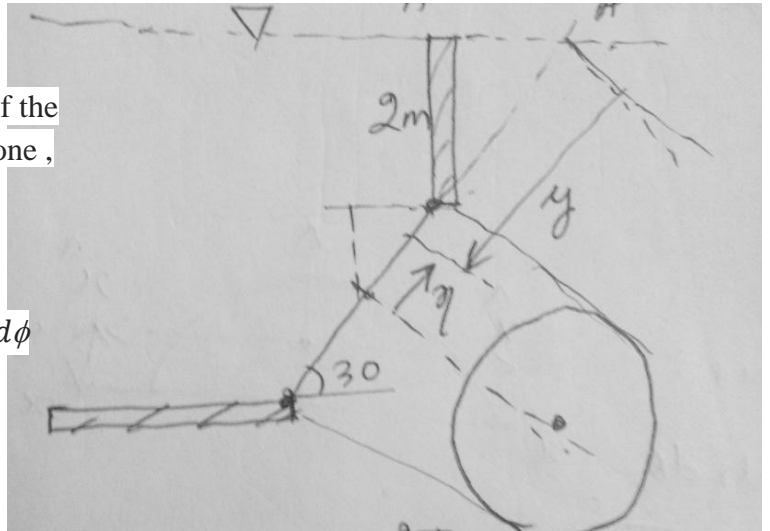

$$y^* = 6.166m$$

Find $I_{\hat{x}\hat{x}}$ for a circular C.S

$$dA = dr r d\phi$$

$$I_{\hat{z}\hat{z}} = \int r^2 dA = \int_0^{2\pi} \int_0^R r^3 dr d\phi$$

$$\Rightarrow I_{\hat{z}\hat{z}} = \frac{R^4}{4} \times 2\pi$$

But, $I_{\hat{x}\hat{x}} + I_{\hat{y}\hat{y}} = I_{\hat{z}\hat{z}}$ (perpendicular axis theorem)

$$\Rightarrow 2I_{\hat{x}\hat{x}} = \frac{2\pi R^4}{4}$$

$$\Rightarrow I_{\hat{x}\hat{x}} = \frac{\pi R^4}{4}$$

Find $I_{\hat{x}\hat{x}}$ for a semi-circle:

$$y_c = \frac{\int y dA}{\int dA} = \frac{\int_0^\pi \int_0^R r \sin\theta r dr d\theta}{\left(\frac{\pi R^2}{2}\right)}$$

$$= \frac{\left(\frac{R^3}{3}\right) [-\cos\theta]_0^\pi}{\left(\frac{\pi R^2}{2}\right)} = \frac{4R}{3\pi}$$

$$I_{xx} = \frac{\pi R^4}{8} \text{ (half of the circle)}$$

$$I_{xx} = I_{\hat{x}\hat{x}} + Ay_c^2$$

$$\Rightarrow \frac{\pi R^4}{8} = I_{\hat{x}\hat{x}} + \frac{\pi R^2}{2} \left(\frac{4R}{3\pi}\right)^2$$

$$\Rightarrow I_{\hat{x}\hat{x}} = 0.1098 R^4$$

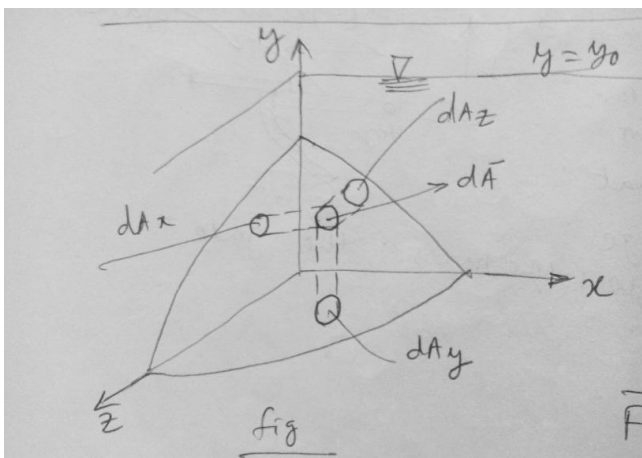
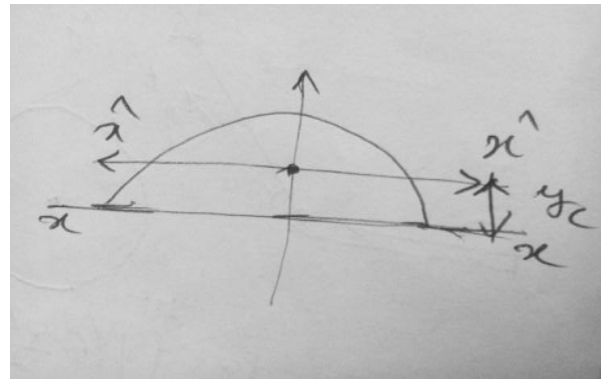

#Hydrostatic Force on a curved submerged surface:

Consider the curved surface as shown in fig. The pressure force acting on the element of area , $d\bar{A}$ is given by

$$d\bar{F} = -pd\bar{A}$$

$$\rightarrow \bar{F} = - \int_A pd\bar{A}$$

We can write; $\bar{F}_R = \hat{i}F_{Rx} + \hat{j}F_{Ry} + \hat{k}F_{Rz}$

Where, F_{Rx} , F_{Ry} & F_{Rz} are the components of \bar{F}_R in x, y & z directly respectively.

$$F_{Rz} = \hat{k} \bar{F}_R = \int d\bar{F} \cdot \hat{k} = - \int_A pd\bar{A} \hat{k} = - \int_{A_z} pdA_z$$

Since the direction of the force component can be found by inspection, the use of vectors is not necessary.

Thus we can write: $F_{Rl} = \int_{A_l} pdA_l$

Where dA_l is the projection of the element dA on a plane perpendicular to the 'l' direction.

With the free surface at atmospheric pressure, the vertical component of the resultant hydrostatic force on a curved submerged surface is equal to the total weight of the liquid above the surface.

$$F_{Ry} = \int pdA_y = \int \rho gh dA_y = \int \rho g dV = \rho gV$$

Ex:2.9: The gate shown is hinged at 'O' and has a constant width $w = 5m$. The equation of the surface is $x = \frac{y^2}{a}$, where $a = 4m$. The depth of water to the right of the gate is $D = 4m$. Find the magnitude of the force

, F_a , applied as shown, required to maintain the gate in equilibrium if the weight of the gate is neglected.

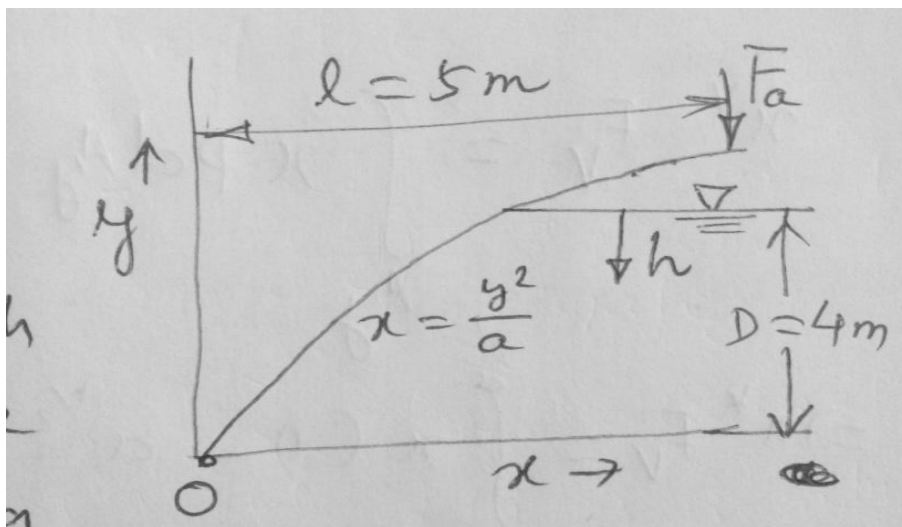

Soln: Horizontal Component of force:-

$$F_{RH} = \rho g h_c (WD) = \rho g (0.5) WD = 392 \text{ kN} h^*$$

$$h^* = h_c + \frac{I_{\bar{x}\bar{x}}}{Ay_c} = 0.5D + \frac{\left(\frac{wD^3}{12}\right)}{(wD \times \frac{D}{2})}$$

$$= 0.5D + \frac{D}{6} = 2.67 \text{ m}$$

Vertical component:

$$F_v = \int_0^{\frac{D^2}{a}} p w dx = \int_0^{\frac{D^2}{a}} \rho g h w dx = \rho g w \int_0^{\frac{D^2}{a}} h dx$$

$$\rightarrow F_v = \rho g w \int_0^{\frac{D^2}{a}} (D - a^{\frac{1}{2}} x^{\frac{1}{2}}) dx \quad , \text{ (where } h+y=D, h = D-y = D-(ax)^{1/2} \text{)}$$

$$\rightarrow F_v = \rho g w \left[Dx - a^{\frac{1}{2}} \frac{2}{3} x^{\frac{3}{2}} \right]_0^{\frac{D^2}{a}} = (\rho g w D^3 / 3a)$$

$$\rightarrow F_v = 261 \text{ kN}$$

$$x^* F_v = \int_{A_y} x p dA_y = \int_0^{\frac{D^2}{a}} x \rho g h w dx$$

$$\rightarrow x^* F_v = \int_0^{\frac{D^2}{a}} x (D - a^{\frac{1}{2}} x^{\frac{1}{2}}) dx = \frac{\rho g w D^5}{10 a^2}$$

$$\rightarrow x^* = \frac{1}{F_v} \left(\frac{\rho g w D^5}{10 a^2} \right) = 1.2 \text{ m}$$

Summing moments about 'O'

$$\sum M_0 = x^* F_v + F_H (D - h^*) - l F_a = 0$$

$$\Rightarrow F_a = 167 \text{ kN.}$$

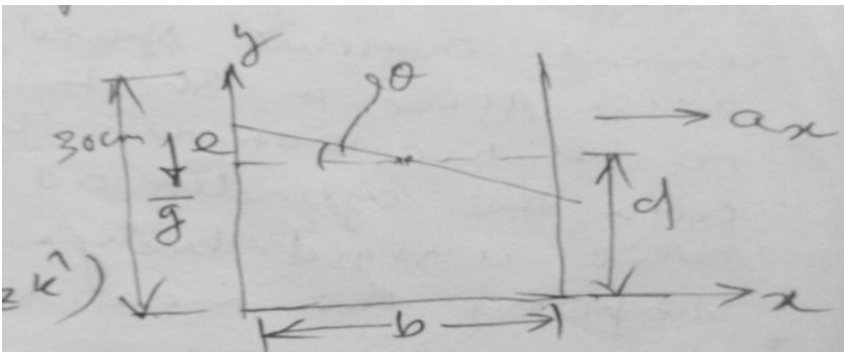

Fluids in Rigid-Body Motion:-

Basic equation: $-\nabla p + \rho \bar{g} = \rho \bar{a}$

A fish tank 30cm×60cm×30cm is partially filled with water to be transported in an automobile. Find allowable depth of water for reasonable assurance that it will not spill during the trip.

Soln: $b=d=30\text{cm}=0.3\text{m}$

$$-\left(\frac{\partial p}{\partial x} \hat{i} + \frac{\partial p}{\partial y} \hat{j} + \frac{\partial p}{\partial z} \hat{k}\right) + \rho (\hat{i}g_x + \hat{j}g_y + \hat{k}g_z) = \rho (\hat{i}a_x + \hat{j}a_y + \hat{k}a_z)$$

But; $g_x = 0 = g_z$ & $a_x = 0 = a_z$

$$\Rightarrow \frac{\partial p}{\partial z} = 0$$

$$\Rightarrow p = p(x, y)$$

$$-\frac{\partial p}{\partial x} = \rho a_x$$

$$-\frac{\partial p}{\partial y} = \rho g \quad (g_y = -g) \quad \bar{g} = -g\hat{j}$$

Now we have to find an expression for $p(x, y)$.

$$dp = \frac{\partial p}{\partial x} dx + \frac{\partial p}{\partial y} dy$$

But since the force surface is at constant pressure, we have to;

$$0 = \frac{\partial p}{\partial x} dx + \frac{\partial p}{\partial y} dy$$

$$\Rightarrow \left(\frac{dy}{dx}\right)_{\text{surface}} = -\frac{a_x}{g} \quad (\text{the free surface is a plane})$$

$$\Rightarrow \tan\theta = \frac{(b/2)}{e} = \frac{b}{2} \left(\frac{a_x}{g}\right)$$

$$\Rightarrow e = \frac{b}{2} \left(\frac{a_x}{g}\right) = 0.15 \left(\frac{a_x}{g}\right) \quad \{\text{as } b=0.3\text{m}\}$$

The minimum allowable value of 'e' = (0.3 - d) m

$$\text{Thus; } 0.3 - d = 0.15 \left(\frac{a_x}{g}\right)$$

$$\text{Hence, } d_{\text{max}} = 0.3 - 0.15 \left(\frac{a_x}{g}\right)$$

#Liquid in rigid body motion with constant angular speed:

A cylindrical container, partially filled with liquid, is rotated at a constant angular speed, ω , about its axis. After a short time there is no relative motion; the liquid rotates with the cylinder as if the system were a rigid body. Determine the shape of the free surface.

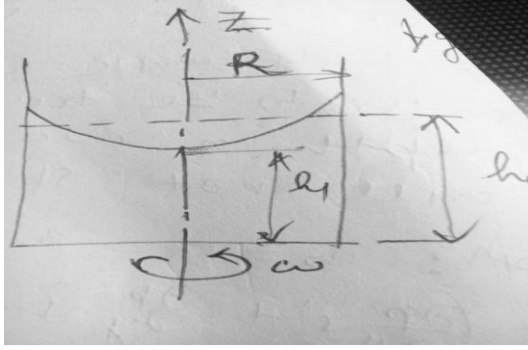

Soln: In cylindrical co-ordinate;

$$\nabla p = e_r \frac{\partial p}{\partial r} + \frac{e_\theta}{r} \frac{\partial p}{\partial \theta} + e_z \frac{\partial p}{\partial z}$$

$$\& -\nabla p + \rho g = \rho \bar{a}$$

$$-(e_r \frac{\partial p}{\partial r} + \frac{e_\theta}{r} \frac{\partial p}{\partial \theta} + e_z \frac{\partial p}{\partial z}) + \rho(e_r g_r + e_\theta g_\theta + e_z g_z) = \rho(e_r a_r + e_\theta a_\theta + e_z a_z)$$

For the given problem ; $g_r = g_\theta = 0$ & $g_z = -g$

and $a_\theta = a_z = 0$ and $a_r = -\omega^2 r$

The component equations are:

$$\frac{\partial p}{\partial r} = \rho \omega^2 r ; \frac{\partial p}{\partial \theta} = 0 \text{ and } \frac{\partial p}{\partial z} = -\rho g$$

Hence , $p(r,z)$ only

$$dp = \frac{\partial p}{\partial r} \Big|_z dr + \frac{\partial p}{\partial z} \Big|_r dz$$

Taking (r_1, z_1) as reference point , where the pressure is p_1 and the arbitrary point (r,z) where the pressure is p , we can obtain the pressure difference as ;

$$\int_{p_1}^p dp = \int_{r_1}^r \frac{\partial p}{\partial r} dr + \int \frac{\partial p}{\partial z} dz$$

$$\Rightarrow p - p_1 = \rho \frac{\omega^2}{2} (r^2 - r_1^2) - \rho g(z - z_1)$$

If we take the reference point at the free surface on the cylinder axis , then;

$$p_1 = p_{atm} ; r_1 = 0 \text{ and } z_1 = h_1$$

$$p - p_{atm} = \rho \frac{\omega^2}{2} r^2 - \rho g(z - h_1)$$

Since the free surface is a surface of constant pressure ($p = p_{atm}$) , the equation of the free surface is given by :

$$0 = \rho \frac{\omega^2}{2} r^2 - \rho g(z - h_1)$$

$$\Rightarrow z = h_1 + \frac{\omega^2}{2g} r^2 = h_1 + \frac{(r\omega)^2}{2g}$$

Volume of the liquid remain constant . Hence $\forall = \Pi R^2 h_0$ (without rotation)

With rotation :

$$\forall = \int_0^R \int_0^z 2\pi r (h_1 + \frac{\omega^2}{2g} r^2) r \cdot dr$$

$$\Rightarrow \forall = \pi [h_1 R^2 + \frac{\omega^2 R^4}{4g}]$$

$$\text{and } h_1 = h_0 - \frac{\omega^2 R^2}{4g}$$

$$\text{Finally: } z = h_0 - \frac{(r\omega)^2}{2g} [\frac{1}{2} - (\frac{r}{R})^2]$$

Note that this expression is valid only for $h_1 > 0$. Hence the maximum value of ω is given by

$$\omega_{max} = \frac{[2gh_0]^{1/2}}{R} .$$

$$\{ (\omega R)^2 = (h_0 - h_1) \times 4g \text{ and } \omega^2 = \frac{1}{R^2} (h_0 - h_1) \times 4g$$

$$\text{For } , \omega_{max} ; h_1 \cong 0 \}$$

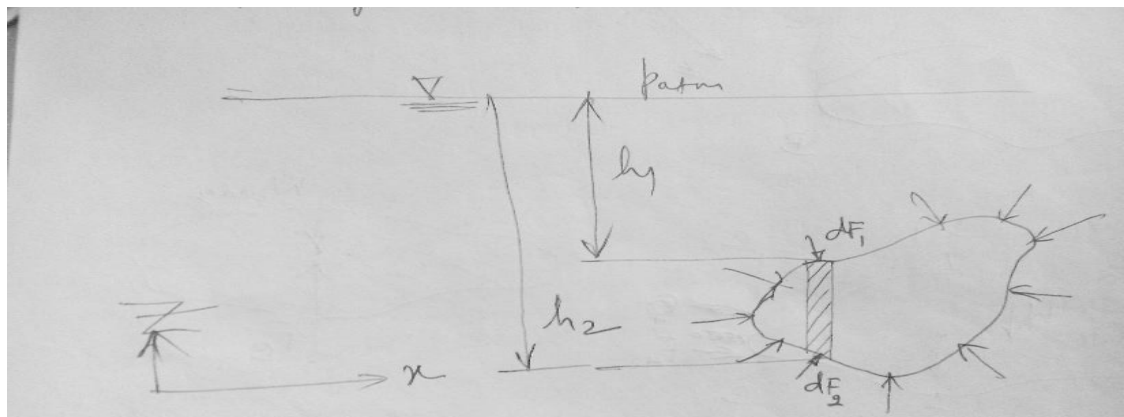

Buoyancy:

When a stationary body is completely submerged in a fluid or partially immersed in a fluid, the resultant fluid force acting on the body is called the 'Buoyancy' force. Consider a solid body of arbitrary shape completely submerged in a homogeneous liquid.

$$d\bar{F}_1 = p d\bar{A}$$

$$dF_{V1} = (p_{atm} + p_1) dA_z = (p_{atm} + \rho g h_1) dA_z$$

$$dF_{V2} = (p_{atm} + p_2) dA_z = (p_{atm} + \rho g h_2) dA_z$$

The buoyant force (the net force acting vertically upward) acting on the elemental prism is

$$dF_B = (dF_{V2} - dF_{V1}) = \rho g (h_2 - h_1) dA_z = \rho g d\forall$$

Where, $d\forall$ = volume of the prism

Hence, the buoyant force F_B on the entire submerged body is obtained as :

$$F_B = \int_{\forall} \rho g d\forall, \quad \text{i.e } F_B = \rho g \forall$$

Consider a body of arbitrary shape, having a volume \forall , is immersed in a fluid. We enclose the body in a parallelepiped and draw a free body diagram of the parallelepiped with the body removed as shown in fig. The forces F_1, F_2, F_3 & F_4 are simply the forces acting on the parallelepiped, w_f is the weight of the fluid volume (dotted region); F_B is the force the body is exerting on the fluid.

Alternate approach:-

The forces on vertical surfaces are equal and opposite in direction and cancel,

$$\text{i.e } F_3 - F_4 = 0.$$

$$F_1 + F_B + w_f = F_2 \quad \text{or } F_B = F_2 - F_1 - w_f$$

$$\text{Also; } F_1 = \rho_f g h_1 A, \quad F_2 = \rho_f g h_2 A \quad \text{and } w_f = \rho_f g [A(h_2 - h_1) - \forall]$$

$$\text{➤ } F_B = \rho_f g h_2 A - \rho_f g h_1 A - \rho_f g [A(h_2 - h_1) - \forall]$$

$$\text{➤ } F_B = \rho_f g \forall, \quad \text{where } \forall \text{ is volume of the body}$$

The direction of the buoyant force, which is the force of the fluid on the body, will be opposite to that of ' F_B ' shown in fig (FBD of fluid). Therefore, the buoyant force has a magnitude equal to the weight of the fluid displaced by the body and is directed vertically upward. The line of action of the buoyant force can be determined by summing moments of the forces w.r.t some convenient axis. Summing the moments about an axis perpendicular to paper through point 'A' we have:

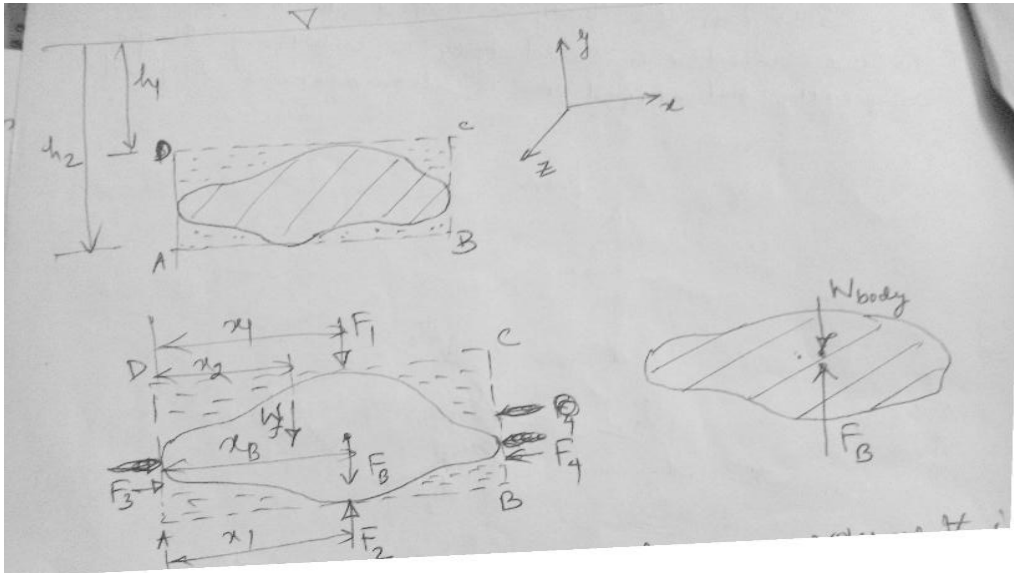

$$F_B x_B = F_2 x_1 - F_1 x_1 - W_f x_2$$

Substituting the forces; we have

$$\nabla x_B = \nabla_T x_1 - (\nabla_T - \nabla) x_2$$

Where $\nabla_T = A(h_2 - h_1)$. The right hand side is the first moment of the displaced volume ∇ and is equal to the centroid of the volume ∇ . Similarly it can be shown that the 'Z' co-ordinate of buoyant force coincides with 'Z' co-ordinate of the centroid.

$$x_B = \frac{\nabla_T x_1 - (\nabla_T - \nabla) x_2}{\nabla}$$

Stability:-

Another interesting and important problem associated with submerged as well as floating body is concerned with the stability of the bodies.

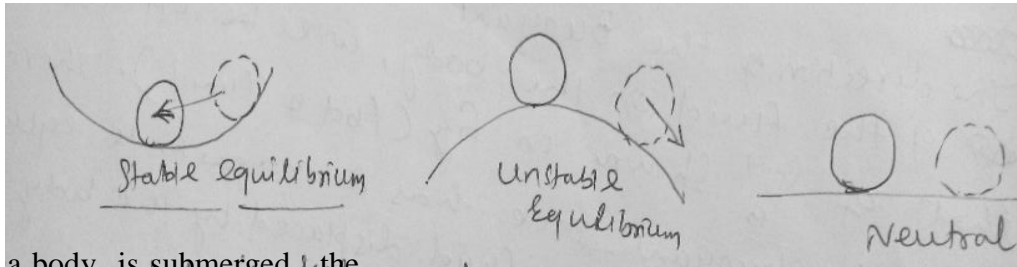

When a body is submerged, the equilibrium requires that the weight of the body acting through its C.G should be collinear with the buoyancy force. However in general, if the body is not homogeneous in distribution of mass over the entire volume, the location of centre of gravity 'G' don't coincide with the centre of volume i.e centre of buoyancy, 'B'. Depending upon the relative location of G & B, a floating or submerged body attains different states of equilibrium, namely (i) Stable equilibrium (ii) Unstable equilibrium (iii) Neutral equilibrium.

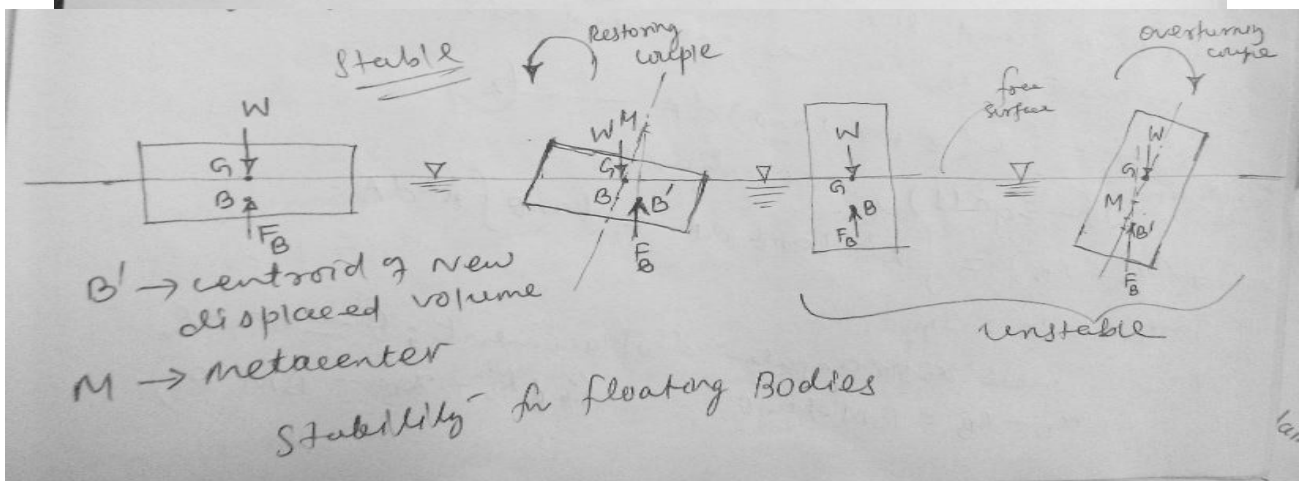
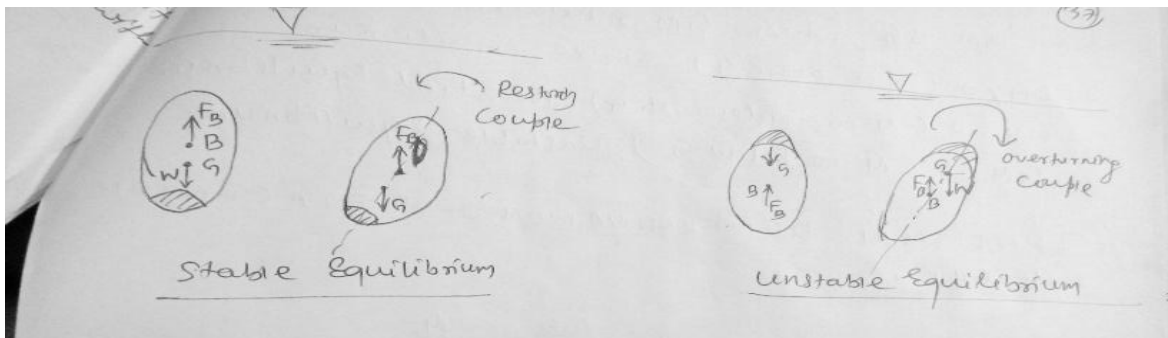

Stability of submerged Bodies

#Stability problem is more complicated for floating bodies, since as the body rotates the location of centre of Buoyancy (centroid of displaced volume) may change.

$GM = BM - BG$, where \rightarrow Metacentric Height

If $GM > 0$ (M is above G) Stable equilibrium

$GM = 0$ (M coincides with G) Neutral Equilibrium

$GM < 0$ (M is below G) Unstable equilibrium

Theoretical Determination of Metacentric Height:

Before Displacement

$$x_B \nabla = \int x dV = \int x(z dA) \rightarrow (1)$$

After Displacement, depth of elemental volume immersed is $(z + x \tan \theta)$ and the new centre of Buoyancy $x_{B'}$ can be expressed as :

$$x_{B'} \nabla = \int x(z + x \tan \theta) dA \rightarrow (2)$$

Subtracting eq.1 from eq.2, we have

$$\nabla(x_{B'} - x_B) = \int x^2 \tan \theta dA = \tan \theta \int x^2 dA$$

$$\text{But } \int x^2 dA = I_{yy}$$

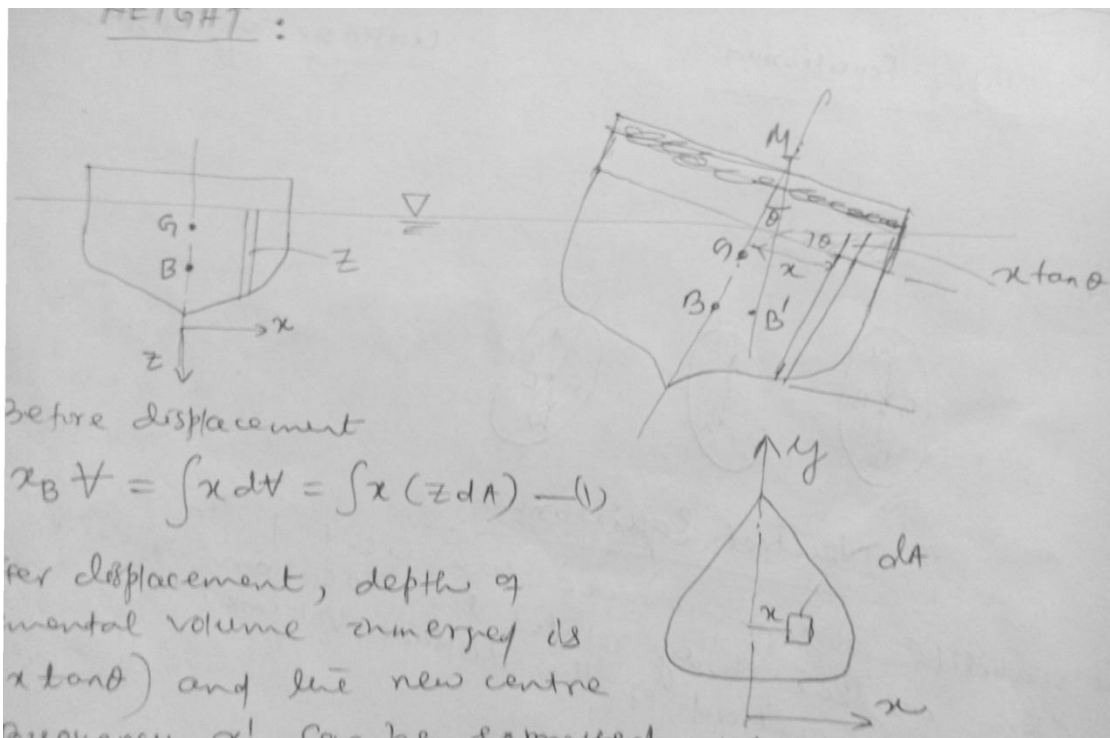

➤ $GM + BG = \frac{I_{yy}}{\nabla}$ #Notice that ∇ is the immersed volume

Also, for small angular displacement ; $\theta = \tan \theta$

$$x_{B'} - x_B = BM \tan \theta \quad (\text{as } x_{B'} - x_B = BM \theta)$$

$$\text{Since, } \nabla BM \tan \theta = \tan \theta I_{yy}$$

$$\text{➤ } BM = \frac{I_{yy}}{\nabla}$$

#Notice that

I_{yy} is the M.I at the p

$$\triangleright GM = \frac{I_{yy}}{V} - BG$$

Fig: Theoretical Determination of Metacentric Height:

#Floating Bodies Containing Liquid:-

If a floating body carrying liquid with free surface undergoes an angular displacement, the liquid will move to keep the free surface horizontal. Thus not only the centre of buoyancy moves, but also the centre of gravity 'G' moves, in the direction of the movement of 'B'.

Thus, the stability of the body is reduced. For this reason, liquid which has to be carried in a ship is put into a number of separate compartments so as to minimize its movement within the ship.

#Period of oscillation:

From previous discussion we know that restoring couple to bring back the body to its original equilibrium position is : $WGM \sin\theta$

Since the torque is equal to mass moment of inertia ; we can write

$WGM \sin\theta = - I_M \left(\frac{d^2\theta}{dt^2} \right)$, where $I_M \rightarrow$ mass M.I of the body about its of rotation.

If ' θ ' is small, $\sin\theta = \theta$, and equation can be written as, $\frac{d^2\theta}{dt^2} + \frac{WGM}{I_M} \theta = 0$
 $\rightarrow(3)$

Eqn (3) represents an SHM.

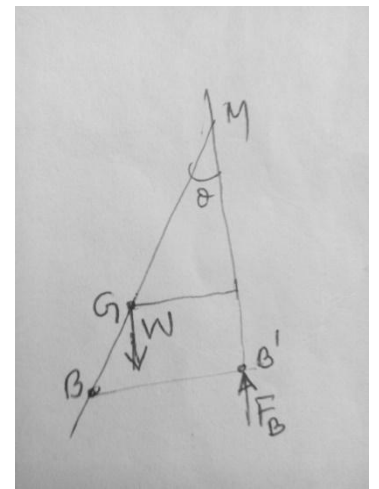

$$\text{The time period, } T = \frac{2\pi}{\omega} = \frac{2\pi}{\left(\frac{W.GM}{I_M}\right)^{\frac{1}{2}}} = 2\pi \left(\frac{I_M}{W.GM}\right)^{\frac{1}{2}}$$

Here time period is the time taken for a complete oscillation from one side to other and back again. The oscillation of the body results in a flow of the liquid around it and this flow has been neglected here.

Ex-1

A rectangular barge of width b and a submerged depth of H has its centre of gravity at its waterline. Find the metacentric height in terms of $\frac{b}{H}$ & hence show that for stable equilibrium of the barge $\frac{b}{H} \geq \sqrt{6}$.

Soln:

Given that $OG = H$

Also from geometry

$$OB = \frac{H}{2}, \quad BG = OG - OB = H - \frac{H}{2} = \frac{H}{2}$$

$$BM = \frac{I}{\nabla} = \frac{LB^3}{12 \times LbH} \quad (\text{Notice that } \nabla \text{ is the immersed volume})$$

$$BM = \frac{b^2}{12H}$$

$$GM = BM - BG = \frac{b^2}{12H} - \frac{H}{2} = \frac{H}{2} \left\{ \frac{1}{6} \left(\frac{b}{H}\right)^2 - 1 \right\}$$

For stable equilibrium of the barge; $MG \geq 0$

$$\frac{H}{2} \left\{ \frac{1}{6} \left(\frac{b}{H}\right)^2 - 1 \right\} \geq 0$$

$$\Rightarrow \left(\frac{b}{H}\right) \geq \sqrt{6} \quad \text{proved.}$$

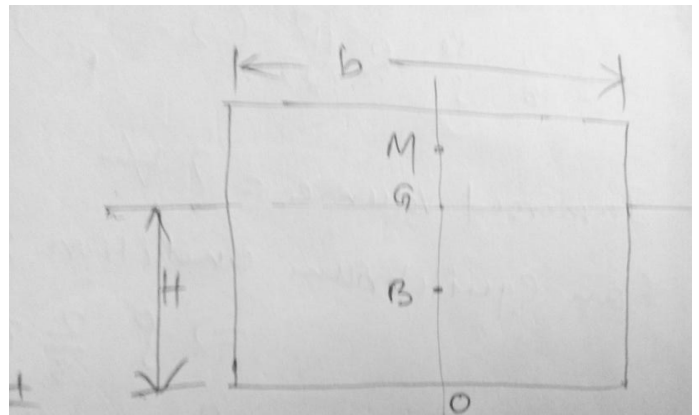

CHAPTER – 3

INTRODUCTION TO DIFFERENTIAL ANALYSIS OF FLUID MOTION

Differential analysis of fluid motion:

Integral equations are useful when we are interested in the gross behaviour of a flow field and its effect on various devices. However the integral approach doesn't enable us to obtain detailed point by point knowledge of flow field.

To obtain this detailed knowledge, we must apply the equations of fluid motion in differential form.

Conservation of mass/continuity equation:

The assumption that a fluid could be treated as a continuous distribution of matter – led directly to a field representation of fluid properties. The property fields are defined by continuous functions of the space coordinates and time. The density and velocity fields are related by conservation of mass.

Continuity equation in rectangular co-ordinate system:-

Let us consider a differential control volume of size Δx , Δy and Δz .

Rate of change of mass inside the control volume = mass flux in – mass flux out ——— (1)

Mass fluxes:

At left face: $\rho u \Delta y \Delta z$

At right face: $\rho u \Delta y \Delta z + \frac{\partial(\rho u \Delta y \Delta z)}{\partial x} \Delta x$

At bottom face: $\rho v \Delta x \Delta z$

At top face: $\rho v \Delta x \Delta z + \frac{\partial(\rho v \Delta x \Delta z)}{\partial y} \Delta y$

At back face: $\rho w \Delta x \Delta y + \frac{\partial(\rho w \Delta x \Delta y)}{\partial z} \Delta z$

Applying equation (1):

$$\frac{\partial(\rho \Delta x \Delta y \Delta z)}{\partial t} = - \frac{\partial(\rho u)}{\partial x} \Delta x \Delta y \Delta z - \frac{\partial(\rho v)}{\partial y} \Delta x \Delta y \Delta z - \frac{\partial(\rho w)}{\partial z} \Delta x \Delta y \Delta z$$

$$\Rightarrow \frac{\partial \rho}{\partial t} + \frac{\partial(\rho u)}{\partial x} + \frac{\partial(\rho v)}{\partial y} + \frac{\partial(\rho w)}{\partial z} = 0$$

$$\Rightarrow \frac{\partial \rho}{\partial t} + \nabla \cdot (\rho \vec{u}) = 0 \quad \text{————— (2)}$$

To find the expression for an incompressible flow:

$$\frac{\partial \rho}{\partial t} + \rho \nabla \cdot \vec{u} + \vec{u} \cdot \nabla \rho = 0$$

$$\Rightarrow \left(\frac{\partial \rho}{\partial t} + \vec{u} \cdot \nabla \rho \right) + \rho \nabla \cdot \vec{u} = 0$$

$$\Rightarrow \frac{D\rho}{Dt} + \rho \nabla \cdot \vec{u} = 0 \quad \text{-----} \quad (3)$$

Let us define; $\vec{u}^* = \frac{\vec{u}}{u_{ref}}$; $x_i^* = \frac{x_i}{L}$

$$\nabla \cdot \vec{u} = \frac{u_{ref}}{L} (\nabla^* \cdot u^*) \quad [\text{Since } \nabla \cdot \vec{u} = \frac{\partial u_i}{\partial x_i} = \frac{u_{ref}}{L} \frac{\partial u_i^*}{\partial x_i^*}]$$

$$\Rightarrow \frac{u_{ref}}{L} (\nabla^* \cdot u^*) = - \frac{1}{\rho} \frac{D\rho}{Dt}$$

$$\Rightarrow (\nabla^* \cdot u^*) = - \frac{1}{\left(\frac{u_{ref}}{L}\right)} \cdot \frac{1}{\rho} \frac{D\rho}{Dt} \quad \text{-----} \quad (4)$$

Eqn (4) may be approximated as $(\nabla^* \cdot u^*) = 0$

$$\text{If } \left[\frac{1}{\left(\frac{u_{ref}}{L}\right)} \cdot \frac{1}{\rho} \frac{D\rho}{Dt} \right] \ll 1 \quad \text{-----} \quad (5)$$

The velocity field is approximately solenoidal if condition (5) is satisfied.

For incompressible flow, $\rho = \text{constant}$ is a wrong statement. (unfortunately such statements appear in standard books).

For example: Sea water or stratified air where density varies from layer to layer but the flow is essentially incompressible as the density of the particles along its path line don't change.

$$\frac{D\rho}{Dt} = 0, \text{ doesn't necessarily mean that } \rho = \text{constant}$$

Hence, for incompressible flow;

$$\nabla \cdot \vec{u} = 0, \text{ doesn't matter whether the flow is steady or unsteady.}$$

If $\rho = \text{constant}$ then the flow is incompressible, but the converse is not true, i.e. Incompressible flow, the density may or may not be constant.

MOMENTUM EQUATION:

A dynamic equation describing fluid motion may be obtained by applying Newton's 2nd law to a particle.

Newton's 2nd law for a finite system is given by:

$$\vec{F} = \left(\frac{d\vec{P}}{dt} \right)_{\text{system}} \quad (1)$$

where the linear momentum 'P' is given by:

$$\vec{P}_{\text{system}} = \int_{\text{mass}} \vec{V} dm \quad (2)$$

Then, for an infinitesimal system of mass 'dm', Newton's 2nd law can be written as:

$$d\vec{F} = dm \left(\frac{d\vec{v}}{dt} \right) \quad (3)$$

The total derivative $\frac{d\vec{v}}{dt}$ in equation (3) can be expressed as:

$$u \frac{\partial \vec{v}}{\partial x} + v \frac{\partial \vec{v}}{\partial y} + w \frac{\partial \vec{v}}{\partial z} + \frac{\partial \vec{v}}{\partial t}$$

Hence;

$$d\vec{F} = dm \left[u \frac{\partial \vec{v}}{\partial x} + v \frac{\partial \vec{v}}{\partial y} + w \frac{\partial \vec{v}}{\partial z} + \frac{\partial \vec{v}}{\partial t} \right] \quad (4)$$

Now the force $d\vec{F}$ acting on the fluid element can be expressed as sum of the surface forces (both Normal forces and tangential forces) and body forces (includes gravity field, electric field or magnetic fields).

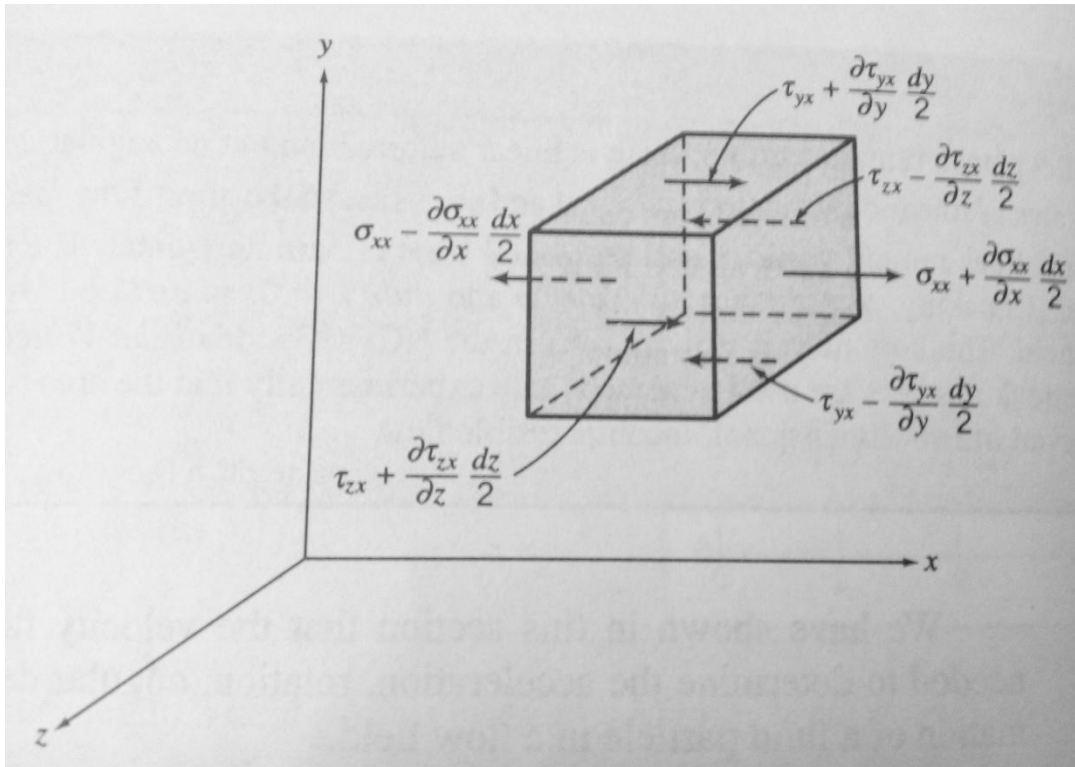

To obtain the surface forces in x - direction we must sum the forces in x direction. Thus,

$$dF_{sx} = (\sigma_{xx} + \frac{\partial \sigma_{xx}}{\partial x} dx) dy dz - \sigma_{xx} dy dz + (\sigma_{yx} + \frac{\partial \sigma_{yx}}{\partial y}) dx dz - \sigma_{yx} dx dz + (\sigma_{zx} + \frac{\partial \sigma_{zx}}{\partial z}) dx dy - \sigma_{zx} dx dy$$

On simplifying , we obtain ;

$$dF_{sx} = \left(\frac{\partial \sigma_{xx}}{\partial x} + \frac{\partial \sigma_{yx}}{\partial y} + \frac{\partial \sigma_{zx}}{\partial z} \right) dx dy dz$$

$$dF_x = dF_{sx} + dF_{bx} = \rho g_x + \left(\frac{\partial \sigma_{xx}}{\partial x} + \frac{\partial \sigma_{yx}}{\partial y} + \frac{\partial \sigma_{zx}}{\partial z} \right) dx dy dz \quad \text{----- (5)}$$

Similar expression for the force components in y & z direction are:

$$dF_y = \rho g_y + \left(\frac{\partial \sigma_{xy}}{\partial x} + \frac{\partial \sigma_{yy}}{\partial y} + \frac{\partial \sigma_{zy}}{\partial z} \right) dx dy dz \quad \text{----- (6)}$$

$$dF_z = \rho g_z + \left(\frac{\partial \sigma_{xz}}{\partial x} + \frac{\partial \sigma_{yz}}{\partial y} + \frac{\partial \sigma_{zz}}{\partial z} \right) dx dy dz \quad \text{----- (7)}$$

Now writing the differential form of equation of motion:

$$\left(\rho g_x + \frac{\partial \sigma_{xx}}{\partial x} + \frac{\partial \sigma_{yx}}{\partial y} + \frac{\partial \sigma_{zx}}{\partial z} \right) = \rho \left(\frac{\partial u}{\partial t} + u \frac{\partial u}{\partial x} + v \frac{\partial u}{\partial y} + w \frac{\partial u}{\partial z} \right) \quad \text{----- (8)}$$

$$\left(\rho g_y + \frac{\partial \sigma_{xy}}{\partial x} + \frac{\partial \sigma_{yy}}{\partial y} + \frac{\partial \sigma_{zy}}{\partial z} \right) = \rho \left(\frac{\partial v}{\partial t} + u \frac{\partial v}{\partial x} + v \frac{\partial v}{\partial y} + w \frac{\partial v}{\partial z} \right) \quad \text{----- (9)}$$

$$\left(\rho g_z + \frac{\partial \sigma_{xz}}{\partial x} + \frac{\partial \sigma_{yz}}{\partial y} + \frac{\partial \sigma_{zz}}{\partial z} \right) = \rho \left(\frac{\partial w}{\partial t} + u \frac{\partial w}{\partial x} + v \frac{\partial w}{\partial y} + w \frac{\partial w}{\partial z} \right) \quad \text{----- (10)}$$

Newtonian fluid :- Navier-stokes equation:

The stresses may be expressed in terms of velocity gradients & fluid properties in rectangular coordinates as follows :

$$\sigma_{xy} = \sigma_{yx} = \mu \left(\frac{\partial v}{\partial x} + \frac{\partial u}{\partial y} \right)$$

$$\sigma_{yz} = \sigma_{zy} = \mu \left(\frac{\partial w}{\partial y} + \frac{\partial v}{\partial z} \right)$$

$$\sigma_{zx} = \sigma_{xz} = \mu \left(\frac{\partial u}{\partial z} + \frac{\partial w}{\partial x} \right)$$

$$\sigma_{xx} = -P - \frac{2}{3} \mu \nabla \cdot \vec{V} + 2 \mu \frac{\partial u}{\partial x}$$

$$\sigma_{yy} = -P - \frac{2}{3} \mu \nabla \cdot \vec{V} + 2 \mu \frac{\partial v}{\partial y}$$

$$\sigma_{zz} = -P - \frac{2}{3} \mu \nabla \cdot \vec{V} + 2 \mu \frac{\partial w}{\partial z}$$

$$\sigma_{av} = \frac{1}{3} (\sigma_{xx} + \sigma_{yy} + \sigma_{zz})$$

$$\sigma_{av} = -P - 2 \mu \nabla \cdot \vec{V} + 2 \mu \nabla \cdot \vec{V}$$

$$P_m = P - \mathcal{X} (\nabla \cdot \vec{V})$$

Where 'P' is the local thermodynamic pressure, and 'X' is co-efficient of bulk viscosity.

Stream function for two dimensional incompressible flow:

It is convenient to have a means of describing mathematically any particular pattern of flow. A mathematical device that serves this purpose is the stream function, ψ . The stream function is formulated as a relation between the streamlines and the statement of conservation of mass. The stream function $\psi(x, y, t)$ is a single mathematical function that replaces two velocity components, $u(x, y, t)$ and $v(x, y, t)$.

For a two dimensional incompressible flow in the xy plane, conservation of mass can be written as :

$$\frac{\partial u}{\partial x} + \frac{\partial v}{\partial y} = 0.$$

If a continuous function $\psi(x, y, t)$ called stream function is defined such that $u = \frac{\partial \psi}{\partial y}$ and $v = -\frac{\partial \psi}{\partial x}$, then the continuity equation is satisfied exactly.

Then $\frac{\partial u}{\partial x} + \frac{\partial v}{\partial y} = \frac{\partial^2 \psi}{\partial x \partial y} - \frac{\partial^2 \psi}{\partial y \partial x} = 0$ and the continuity equation is satisfied exactly.

If \bar{ds} is an element of length along the stream line, the equation of streamline is given by:

$$\bar{V} \times \bar{ds} = 0 = (iu + jv) \times (idx + jdy) = k(udy - vdx)$$

Thus equation of streamline in a two dimensional flow is: $udy - vdx = 0$

Then we can write: $\frac{\partial \psi}{\partial x} dx + \frac{\partial \psi}{\partial y} dy = 0$ ----- (1)

Since $\psi = \psi(x, y, t)$ then at any instant t_0 , $\psi = \psi(x, y, t_0)$. Thus at a given instant a change in ψ may be evaluated as $\psi = \psi(x, y)$.

Thus at any instant, $d\psi = \frac{\partial \psi}{\partial x} dx + \frac{\partial \psi}{\partial y} dy$ ----- (2)

Comparing Eqn.1 and 2, we see that along an instantaneous streamline $d\psi = 0$ or ψ is constant along a streamline. Since differential of ψ is exact, the integral of $d\psi$ between any two points in a flow field depends on the end points only, i.e. $\psi_2 - \psi_1$.

Example problem: Stream Function flow in a corner:

The velocity field for a steady, incompressible flow is given as: $\vec{V} = Ax\mathbf{i} - Ay\mathbf{j}$ with $A=0.3\text{s}^{-1}$

Determine the stream function that will yield this velocity field. Plot and interpret the streamlines in the first quadrant of xy plane:

Solution: $u = Ax = \frac{\partial\psi}{\partial y}$

Integration with respect to y yields:

$$\psi = \int \frac{\partial\psi}{\partial y} dy + f(x) = Axy + f(x) ;$$

where $f(x)$ is an arbitrary function of x.

$f(x)$ can be evaluated using the expression for v. can write,

$$v = -\frac{\partial\psi}{\partial x} = -Ay - \frac{df}{dx} .$$

But from the velocity field description, $v = -Ay$. Hence $\frac{df}{dx} = 0$ or $f(x) = \text{constant}$.

Thus, $\psi = Axy + c$. The c is arbitrary constant and can be chosen as zero without any loss in generality. With $c=0$ and $A=0.3\text{s}^{-1}$, we have, $\psi = Axy$. The streamlines in the 1st quadrant is shown in Fig. Regions of high speed flow occur where the streamlines are close together. Lower-speed flow occurs near the origin, where the streamline spacing is wider. The flow looks like flow in a corner formed by a pair of walls.

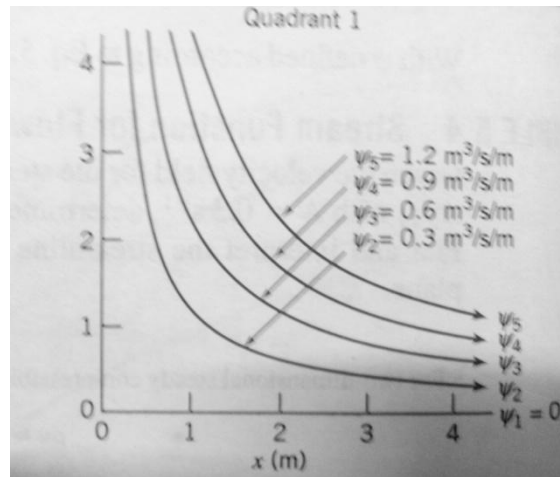

Thus we

Before formulating the effects of force on fluid motion (dynamics), let us consider first the motion (kinematics) of a fluid element on a flow field. For convenience, we follow a infinitesimal element of a fixed identity (mass)

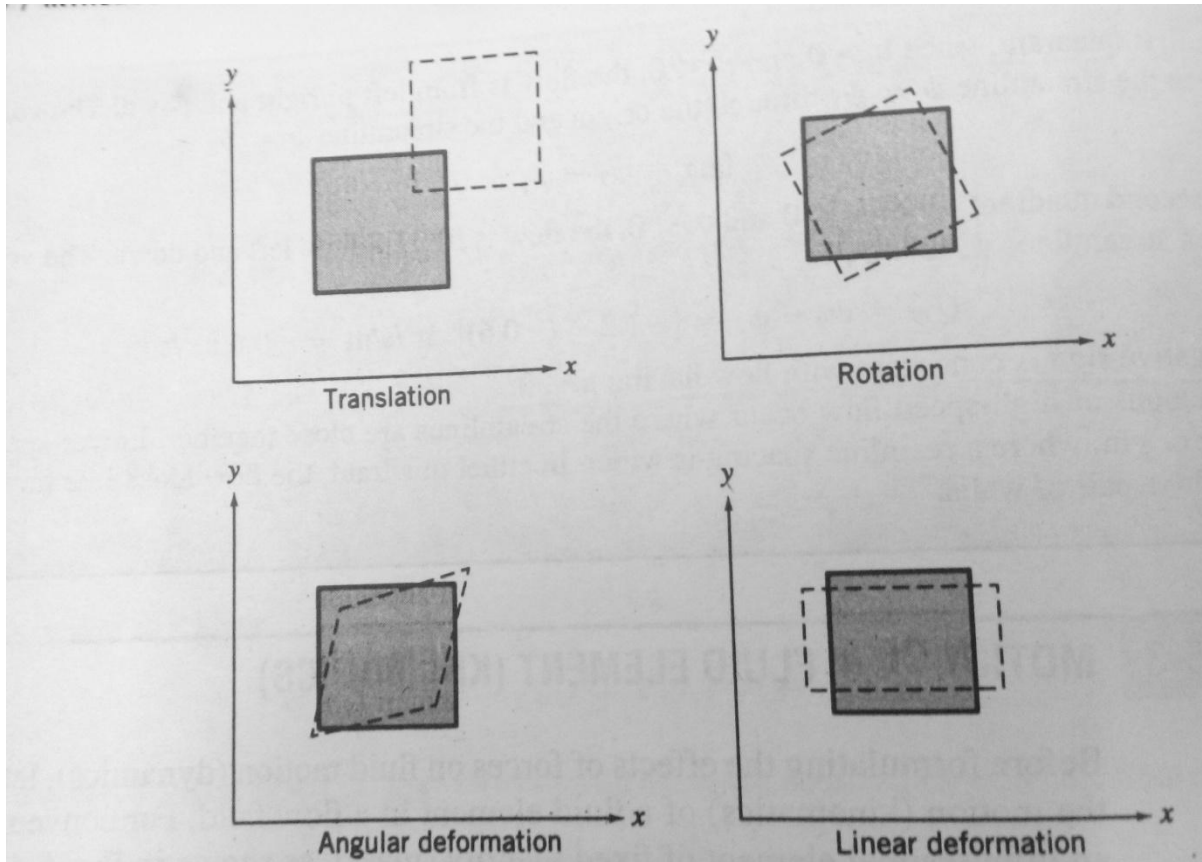

As the

infinitesimal element of mass ' dm ' moves in a flow field, several things may happen to it. Certainly the element translates, it undergoes a linear displacement from x, y, z to x_1, y_1, z_1 . The element may also rotate (no change in the included angle in adjacent sides). In addition the element may deform i.e. it may undergo linear and angular deformation. Linear deformation involves a deformation in which planes of element that were originally perpendicular remain perpendicular. Angular deformation involves a distortion of the element in which planes that were originally perpendicular do not remain perpendicular. In general a fluid element may undergo a combination of translation, rotation, linear deformation and angular deformation during the course of its motion.

For pure translation or rotation, the fluid element retains its shape, there is no deformation. Thus shear stress doesn't arise as a result of pure translation or rotation (since for a Newtonian fluid the shear stress is directly proportional to the rate of angular deformation). We shall consider fluid translation, rotation and deformation in turn.

Fluid translation: Acceleration of a fluid particle in a velocity field. A general description of a particle acceleration can be obtained by considering a particle moving in a velocity field. The basic hypothesis of continuum fluid mechanics has led us to a field description of fluid flow in which the properties of flow field are defined by continuous functions of space and time. In particular, the velocity

field is given by $\vec{V}=\vec{V}(x,y,z,t)$. The field description is very powerful, since information for the entire flow is given by one equation.

The problem, then is to retain the field description for the fluid properties and obtain an expression for acceleration of a fluid particle as it moves in a flow field. Stated simply, the problem is:

Given the velocity field $\vec{V}=\vec{V}(x,y,z,t)$, find the acceleration of a fluid particle, \vec{a}_p .

Consider the particle moving in a velocity field. At time 't', the particle is at the position x,y,z and has velocity corresponding to velocity at that point in space at time 't', i.e. $\vec{V}_p|_t=\vec{V}(x,y,z,t)$.

At 't+dt', the particle has moved to a new position with co-ordinates $x+dx, y+dy, z+dz$ and has a velocity given by: $\vec{V}_p|_{t+dt}=\vec{V}(x+dx,y+dy,z+dz,t+dt)$.

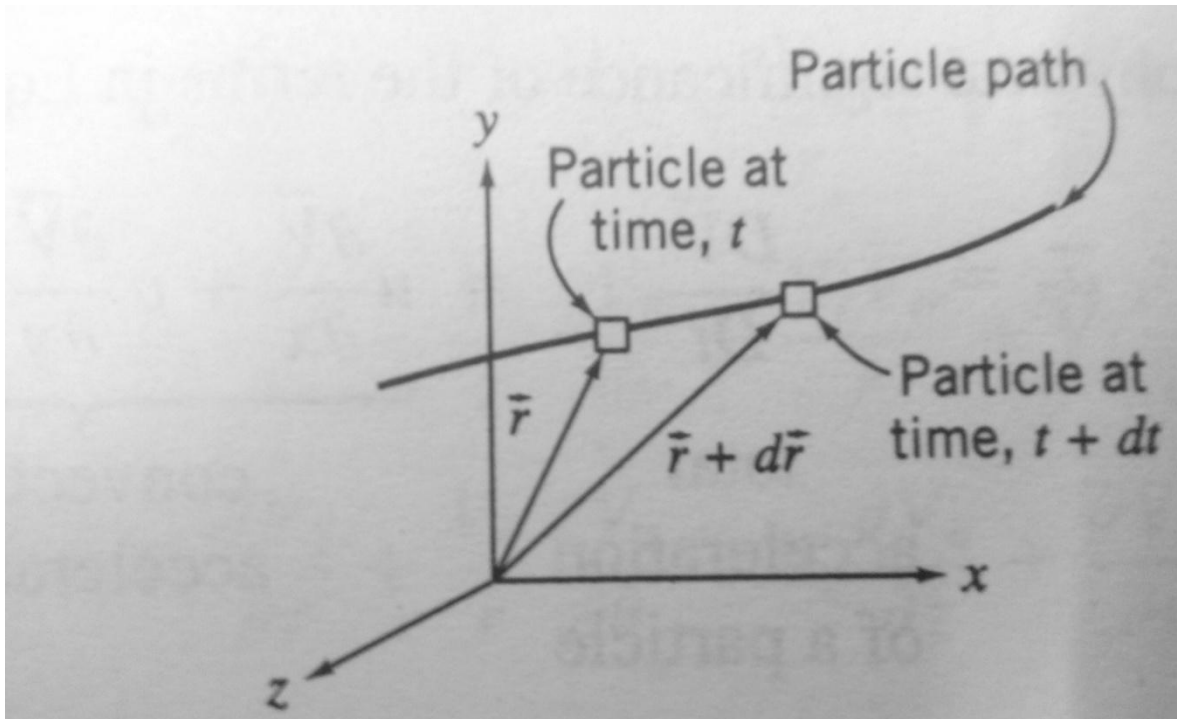

Fig4.1

This is shown in pictorial fig 4.1

$d\vec{V}_p$, the change in velocity of the particle, in moving from location \vec{r} to $\vec{r} + d\vec{r}$, is given by:

$$d\vec{V}_p = \frac{\partial \vec{V}}{\partial x} dx_p + \frac{\partial \vec{V}}{\partial y} dy_p + \frac{\partial \vec{V}}{\partial z} dz_p + \frac{\partial \vec{V}}{\partial t} dt$$

The total acceleration of the particle is given by :

$$\vec{a}_p = \frac{d\vec{V}_p}{dt} = \frac{\partial \vec{V}}{\partial x} \frac{dx_p}{dt} + \frac{\partial \vec{V}}{\partial y} \frac{dy_p}{dt} + \frac{\partial \vec{V}}{\partial z} \frac{dz_p}{dt} + \frac{\partial \vec{V}}{\partial t}$$

Since $\frac{dx_p}{dt} = u$, $\frac{dy_p}{dt} = v$ and $\frac{dz_p}{dt} = w$,

$$\begin{aligned} \overrightarrow{a_p} &= \frac{d\overrightarrow{V_p}}{dt} = u \frac{\partial \overrightarrow{V}}{\partial x} + v \frac{\partial \overrightarrow{V}}{\partial y} + w \frac{\partial \overrightarrow{V}}{\partial z} + \frac{\partial \overrightarrow{V}}{\partial t} \\ \frac{D\overrightarrow{V}}{Dt} &= \overrightarrow{a_p} = \frac{d\overrightarrow{V_p}}{dt} = u \frac{\partial \overrightarrow{V}}{\partial x} + v \frac{\partial \overrightarrow{V}}{\partial y} + w \frac{\partial \overrightarrow{V}}{\partial z} + \frac{\partial \overrightarrow{V}}{\partial t} \end{aligned} \quad (4.1)$$

The derivative $\frac{D\overrightarrow{V}}{Dt}$ is commonly called substantial derivative to remind us that it is computed for a particle of substance. It is often called material derivative or particle derivative.

From equation 4.1 we recognize that a fluid particle moving in a flow field may undergo acceleration for either of the two reasons. It may be accelerated because it is convected into a region of higher (lower) velocity. For example, the steady flow through a nozzle, in which by definition, the velocity field is not a function of time, a fluid particle will accelerate as it moves through the nozzle. The particle is convected into a region of higher velocity. If a flow field is unsteady the fluid particle will undergo an additional “local” acceleration, because the velocity field is a function of time.

The physical significance of the terms in the equation 4.1 is :

$$u \frac{\partial \overrightarrow{V}}{\partial x} + v \frac{\partial \overrightarrow{V}}{\partial y} + w \frac{\partial \overrightarrow{V}}{\partial z} = \text{convective acceleration}$$

$$\frac{\partial \overrightarrow{V}}{\partial t} = \text{local acceleration.}$$

Therefore equation 4.1 can be written as:

$$\overrightarrow{a_p} = \frac{D\overrightarrow{V}}{Dt} = (\overrightarrow{V} \cdot \nabla) \overrightarrow{V} + \frac{\partial \overrightarrow{V}}{\partial t}$$

For a steady and three dimensional flow the equation 4.1 becomes:

$$\frac{D\overrightarrow{V}}{Dt} = u \frac{\partial \overrightarrow{V}}{\partial x} + v \frac{\partial \overrightarrow{V}}{\partial y} + w \frac{\partial \overrightarrow{V}}{\partial z}; \text{ which is not necessarily zero.}$$

Equation 4.1 may be written in scalar component equation as:

$$\boxed{a_{x_p} = \frac{Du}{Dt} = u \frac{\partial u}{\partial x} + v \frac{\partial u}{\partial y} + w \frac{\partial u}{\partial z} + \frac{\partial u}{\partial t}} \quad (4.2 a)$$

$$\boxed{a_{y_p} = \frac{Dv}{Dt} = u \frac{\partial v}{\partial x} + v \frac{\partial v}{\partial y} + w \frac{\partial v}{\partial z} + \frac{\partial v}{\partial t}} \quad (4.2 b)$$

$$\boxed{a_{z_p} = \frac{Dw}{Dt} = u \frac{\partial w}{\partial x} + v \frac{\partial w}{\partial y} + w \frac{\partial w}{\partial z} + \frac{\partial w}{\partial t}} \quad (4.2 c)$$

We have obtained an expression for the acceleration of a particle anywhere in the flow field; this is the Eulerian method of description. One substitutes the coordinates of the point into the field expression for acceleration.

In the Lagrangian method of description, the motion (position, velocity and acceleration) of a fluid particle is described as a function of time.

Fluid rotation: A fluid particle moving in a general three dimensional flow field may rotate about all three coordinate axes. The particle rotation is a vector quantity and in general

$$\vec{\omega} = \hat{i} \omega_x + \hat{j} \omega_y + \hat{k} \omega_z ; \text{ where } \omega_x \text{ is the rotation about } x \text{ axis.}$$

To evaluate the components of particle rotation vector, we define the angular velocity about an axis as the average angular velocity of two initially perpendicular differential line segments in a plane perpendicular to the axis of rotation.

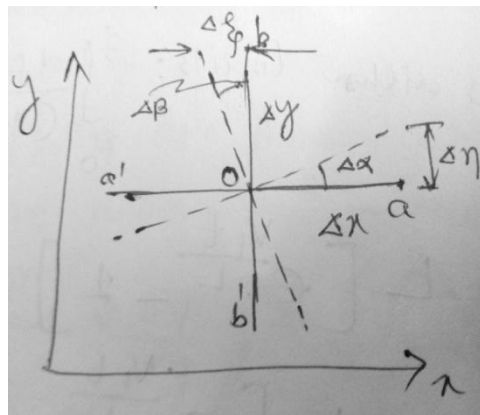
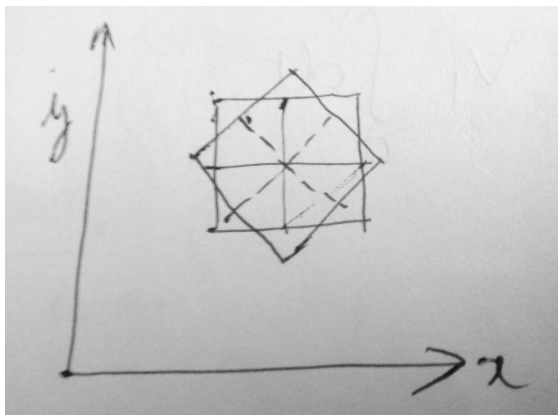

To obtain a mathematical expression for ω_z , the component of fluid rotation about the z axis, consider motion of fluid in x-y plane. The components of velocity at every point in the field are given by $u(x,y)$ and $v(x,y)$. Consider first the rotation of line segment oa of length Δx . Rotation of this line is due to the variation of 'y' component of velocity. If the 'y' component of the velocity at point 'o' is taken as V_o , then the 'y' component velocity at point 'a' can be written using Taylor expansion series as:

$$V = V_o + \frac{\partial V}{\partial x} \Delta x$$

$$\omega_{oa} = \lim_{\Delta t \rightarrow 0} \frac{\Delta \alpha}{\Delta t} = \lim_{\Delta t \rightarrow 0} \frac{\frac{\Delta \eta}{\Delta x}}{\Delta t}$$

$$\text{since } \Delta \eta = (V_a - V_o) \Delta t = \frac{\partial v}{\partial x} \Delta x \Delta t$$

$$\omega_{oa} = \lim_{\Delta t \rightarrow 0} \frac{\left(\frac{\partial v}{\partial x}\right)(\Delta x \Delta t)}{\Delta x \Delta t} = \frac{\partial v}{\partial x}$$

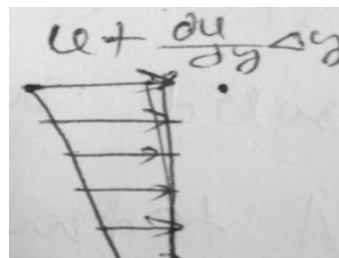

The angular velocity of 'ob' is obtained similarly. If the x - component of velocity at point 'b' is $u_o + \frac{\partial u}{\partial y} \cdot \Delta y$

$$\omega_{ob} = \lim_{\Delta t \rightarrow 0} \frac{\Delta \beta}{\Delta t} = \lim_{\Delta t \rightarrow 0} \frac{\Delta \xi}{\Delta t}$$

$u_b = \frac{\partial u}{\partial y} \Delta y$; which will rotate the fluid element in clock-wise direction, thus -ve sign is multiplied to make it counter clock-wise direction.

$$\text{But } \Delta \xi = - \frac{\partial u}{\partial y} \Delta y \Delta t \quad (\text{-ve sign is used to give +ve value of } \omega_{ob})$$

$$\text{Thus } \omega_{ob} = \lim_{\Delta t \rightarrow 0} \frac{-\left(\frac{\partial u}{\partial y}\right)(\Delta y \Delta t)}{\Delta y \Delta t} = - \frac{\partial u}{\partial y}$$

The rotation of fluid element about z - axis is the average angular velocity of the two mutually perpendicular line segments, oa and ob , in the x - y plane.

$$\text{Thus } \omega_z = \frac{1}{2} \left[\frac{\partial v}{\partial x} - \frac{\partial u}{\partial y} \right]$$

By considering the rotation about other axes :

$$\omega_x = \frac{1}{2} \left[\frac{\partial w}{\partial y} - \frac{\partial v}{\partial z} \right] \quad \text{and} \quad \omega_y = \frac{1}{2} \left[\frac{\partial u}{\partial z} - \frac{\partial w}{\partial x} \right]$$

Then $\vec{\omega} = \frac{1}{2} \left[\left(\frac{\partial w}{\partial y} - \frac{\partial v}{\partial z} \right) \hat{i} + \left(\frac{\partial u}{\partial z} - \frac{\partial w}{\partial x} \right) \hat{j} + \left(\frac{\partial v}{\partial x} - \frac{\partial u}{\partial y} \right) \hat{k} \right]$; which can be written in vector notation as :

$$\boxed{\vec{\omega} = \frac{1}{2} \nabla \times \vec{V}}$$

Under what conditions might we expect to have a flow without rotation (irrotational flow) ?

A fluid particle moving, without any rotation, in a flow field cannot develop rotation under the action of body force or normal surface forces. Development of rotation in fluid particle, initially without rotation, requires the action of shear stresses on the surface of the particle. Since shear stress is proportional to the rate of angular deformation, then a particle that is initially without rotation will not develop a rotation without simultaneous angular deformation. The shear stress is related to the rate of angular deformation through viscosity. The presence of viscous force means the flow is rotation.

The condition of irrotationality may be a valid assumption for those regions of a flow in which viscous forces are negligible. (For example , such a region exists outside the boundary layer in the flow over a solid surface.)

A term vorticity is defined as twice of the rotation as:

$$\vec{\zeta} = 2 \vec{\omega} = \nabla \times \vec{V}$$

The circulation, Γ is defined as the line integral of the tangential velocity component about a closed curve fixed in the flow ; $\Gamma = \oint_c \vec{V} \cdot \vec{dS}$

where \vec{dS} elemental vector tangent to the curve , a positive sense corresponds to a counter clock-wise path of integration around the curve. A relation between circulation and vorticity can be obtained by considering the fluid element as shown:

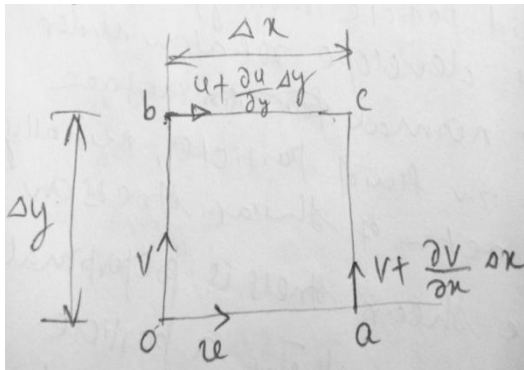

$$\begin{aligned} \Delta\Gamma &= u\Delta x + \left(v + \frac{dv}{dx}\Delta x\right)\Delta - \left(u + \frac{du}{dy}\Delta y\right)\Delta x - v\Delta y \\ &= \left(\frac{dv}{dx} - \frac{du}{dy}\right)\Delta x\Delta y = 2\omega_z \Delta x\Delta y \end{aligned}$$

$$\Gamma = \oint \Delta\Gamma = \oint_c \vec{V} \cdot \vec{dS}$$

$$= \int_A 2\omega_z dA$$

$$\Rightarrow \Gamma = \int_A (\nabla \times \vec{V})_z dA$$

Angular deformation: Angular deformation of a fluid element involves changes in the perpendicular line segments on the fluid.

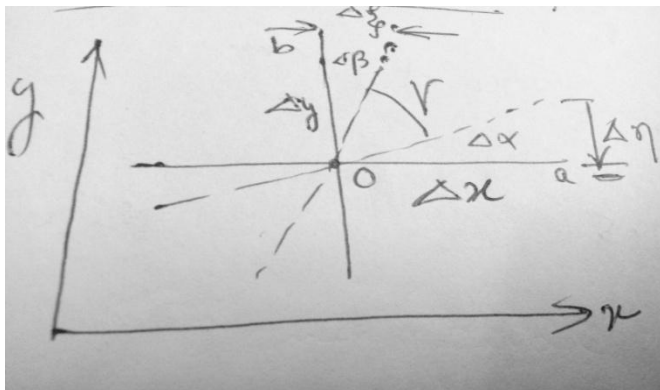

We see that the rate of angular deformation of the fluid element in the xy plane is the rate of decrease of angle “ γ ” between the line oa and ob . Since during interval Δt ,

$$\Delta \gamma = \gamma - 90 = -(\Delta \alpha + \Delta \beta)$$

$$\Rightarrow \frac{d\gamma}{dt} = \frac{d\alpha}{dt} + \frac{d\beta}{dt}$$

Now;

$$\frac{d\alpha}{dt} = \frac{dv}{dx} \quad \text{and} \quad \frac{d\beta}{dt} = \frac{du}{dy}$$

INCOMPRESSIBLE INVISCID FLOW

All real fluids possess viscosity. However, in many flow cases it is reasonable to neglect the effect of viscosity. It is useful to investigate the dynamics of an ideal fluid that is incompressible and has zero viscosity. The analysis of ideal fluid motion is simpler because no shear stresses are present in inviscid flow. Normal stresses are the only stresses that must be considered in the analysis. For a non-viscous fluid in motion, the normal stress at a point is the same in all directions (scalar quantity) and equals to the negative of the thermodynamic pressure, $\sigma_{nn} = -P$.

Momentum equation for frictionless flow: Euler's equations:

The equations of motion for frictionless flow, called Euler's equations, can be obtained from the general equations of motion, by putting $\mu = 0$ and $\sigma_{nn} = -p$.

$$\rho g_x - \frac{\partial P}{\partial x} = \rho \left(\frac{\partial u}{\partial t} + u \frac{\partial u}{\partial x} + v \frac{\partial u}{\partial y} + w \frac{\partial u}{\partial z} \right)$$

$$\rho g_y - \frac{\partial P}{\partial y} = \rho \left(\frac{\partial v}{\partial t} + u \frac{\partial v}{\partial x} + v \frac{\partial v}{\partial y} + w \frac{\partial v}{\partial z} \right)$$

$$\rho g_z - \frac{\partial P}{\partial z} = \rho \left(\frac{\partial w}{\partial t} + u \frac{\partial w}{\partial x} + v \frac{\partial w}{\partial y} + w \frac{\partial w}{\partial z} \right)$$

In vector form it can be written as:

$$\rho \vec{g} - \nabla P = \rho \left(\frac{\partial \vec{V}}{\partial t} + u \frac{\partial \vec{V}}{\partial x} + v \frac{\partial \vec{V}}{\partial y} + w \frac{\partial \vec{V}}{\partial z} \right)$$

$$\Rightarrow \rho \vec{g} - \nabla P = \rho \left(\frac{\partial \vec{V}}{\partial t} + (\vec{V} \cdot \nabla) \vec{V} \right)$$

$$\Rightarrow \boxed{\rho \vec{g} - \nabla P = \rho \frac{D\vec{V}}{Dt}}$$

In cylindrical co-ordinates:

$$r: \rho g_r - \frac{\partial P}{\partial r} = \rho \left(\frac{\partial V_r}{\partial t} + V_r \frac{\partial V_r}{\partial r} + \frac{V_\theta}{r} \frac{\partial V_r}{\partial \theta} + V_z \frac{\partial V_r}{\partial z} - \frac{V_\theta^2}{r} \right)$$

$$\theta: \rho g_\theta - \frac{1}{r} \frac{\partial P}{\partial \theta} = \rho \left(\frac{\partial V_\theta}{\partial t} + V_r \frac{\partial V_\theta}{\partial r} + \frac{V_\theta}{r} \frac{\partial V_\theta}{\partial \theta} + V_z \frac{\partial V_\theta}{\partial z} + \frac{V_\theta V_r}{r} \right)$$

$$z: \rho g_z - \frac{\partial P}{\partial z} = \rho \left(\frac{\partial V_z}{\partial t} + V_r \frac{\partial V_z}{\partial r} + \frac{V_\theta}{r} \frac{\partial V_z}{\partial \theta} + V_z \frac{\partial V_z}{\partial z} \right)$$

Euler's equations in streamline co-ordinates:

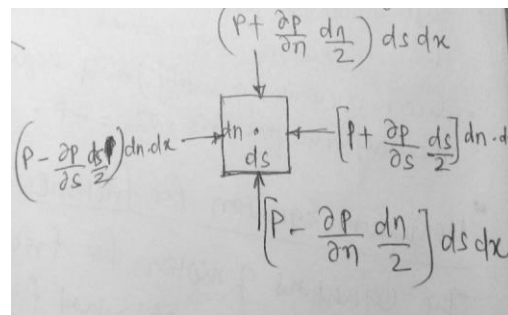
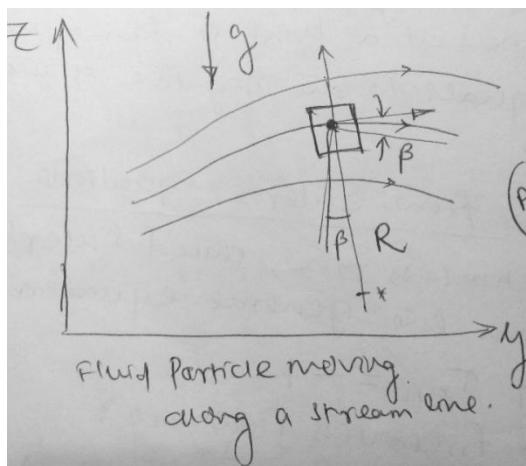

Applying Newton's 2nd law in streamwise (the 's') direction to the fluid element of volume $ds \times dn \times dx$, and neglecting viscous forces we obtain:

$$\left(P - \frac{\partial P}{\partial s} \frac{ds}{2}\right) dn dx - \left(P + \frac{\partial P}{\partial s} \frac{ds}{2}\right) dn dx - \rho g \sin\beta ds dn dx = \rho a_s ds dn dx$$

Simplifying the equation we have:

$$-\frac{\partial P}{\partial s} - \rho g \sin\beta = \rho a_s$$

Since $\sin\beta = \frac{\partial z}{\partial s}$, we can write:

$$-\frac{\partial P}{\partial s} - \rho g \frac{\partial z}{\partial s} = \rho \frac{D\vec{V}}{Dt} = \rho \left(\frac{\partial V}{\partial t} + V \frac{\partial V}{\partial s}\right)$$

$$\Rightarrow \boxed{-\frac{1}{\rho} \frac{\partial P}{\partial s} - g \frac{\partial z}{\partial s} = \frac{\partial V}{\partial t} + V \frac{\partial V}{\partial s}}$$

To obtain Euler's equation in a direction normal to the streamlines, we apply Newton's 2nd law in the 'n' direction to the fluid element. Again, neglecting viscous forces; we obtain:

$$\left(P - \frac{\partial P}{\partial n} \frac{dn}{2}\right) ds dx - \left(P + \frac{\partial P}{\partial n} \frac{dn}{2}\right) ds dx - \rho g \cos\beta dn dx ds = \rho a_n dn dx ds$$

where 'β' is the angle between 'n' direction and vertical and 'a_n' is the acceleration of the fluid particle in 'n' direction.

$$-\frac{\partial P}{\partial n} - \rho g \cos\beta = \rho a_n$$

Since $\cos\beta = \frac{\partial z}{\partial n}$, we can write:

$$-\frac{1}{\rho} \frac{\partial P}{\partial n} - g \frac{\partial z}{\partial n} = a_n$$

The normal acceleration of the fluid element is towards the centre of curvature of the streamline; in the negative 'n' direction. Thus $a_n = -\frac{V^2}{R}$

$$\Rightarrow \boxed{\frac{1}{\rho} \frac{\partial P}{\partial n} + g \frac{\partial z}{\partial n} = \frac{V^2}{R}}$$

For steady flow on a horizontal plane, Euler's equation normal to the streamline can be written as:

$$\Rightarrow \boxed{\frac{1}{\rho} \frac{\partial P}{\partial n} = \frac{V^2}{R}}$$

Above equation indicates that pressure increases in the direction outward from the centre of curvature of streamlines.

Bernoulli's equation: Integration of Euler's equation along a stream line for steady flow(Derivation using stream line co-ordinates):

Euler's equation for steady flow will be:

$$-\frac{1}{\rho} \frac{\partial P}{\partial s} - g \frac{\partial z}{\partial s} = V \frac{\partial V}{\partial s}$$

If a fluid particle moves a distance 'ds' along a streamline, then

$$\frac{\partial P}{\partial s} ds = dp \quad \text{(the change in pressure along 's')}$$

$$\frac{\partial z}{\partial s} ds = dz \quad \text{(the change in elevation along 's')}$$

$$\frac{\partial V}{\partial s} ds = dV \quad \text{(the change in velocity along 's')}$$

$$\text{Thus; } -\frac{dP}{\rho} - g dz = V dV$$

$$\Rightarrow \frac{dP}{\rho} + V dV + g dz = 0$$

$$\Rightarrow \int \frac{dP}{\rho} + \frac{V^2}{2} + gz = \text{constant}(\text{along 's'}) \quad \text{-----} \quad (5.1)$$

For an incompressible flow, i.e. 'P' is not a function of 'ρ'; we can write:

$$\frac{P}{\rho} + \frac{V^2}{2} + gz = \text{constant}(\text{along 's'})$$

Restrictions:

- i. Steady flow
- ii. Incompressible flow
- iii. Inviscid
- iv. Flow along a stream line

* In general the constant has different values along different streamlines.

* For derivation using rectangular co-ordinates, refer page-7.

Unsteady Bernoulli's equation(Integration of Euler's equation along a stream line):

$$-\frac{1}{\rho} \nabla P - \vec{g} = \frac{D\vec{V}}{Dt} \quad \text{or}$$

$$-\frac{1}{\rho} \frac{\partial P}{\partial s} - g \frac{\partial z}{\partial s} = \frac{\partial V}{\partial t} + V \frac{\partial V}{\partial s}$$

Multiplying ds and integrating along a stream line between two points '1' and '2',

$$\int_1^2 \frac{dp}{\rho} + \frac{V_2^2 - V_1^2}{2} + g(z_2 - z_1) + \int_1^2 \frac{\partial V}{\partial t} ds = 0$$

For an incompressible flow, the above equation reduces to :

$$\frac{P_1}{\rho} + \frac{V_1^2}{2} + g z_1 = \frac{P_2}{\rho} + \frac{V_2^2}{2} + g z_2 + \int_1^2 \frac{\partial V}{\partial t} ds$$

Restrictions:

- i. Incompressible flow
- ii. Frictionless flow
- iii. Flow along a stream line

Ex: A long pipe is connected to a large reservoir that initially is filled with water to a depth of 3 m. The pipe is 150 mm in diameter and 6 m long. Determine the flow velocity leaving the pipe as a function of time after a cap is removed from its free end.

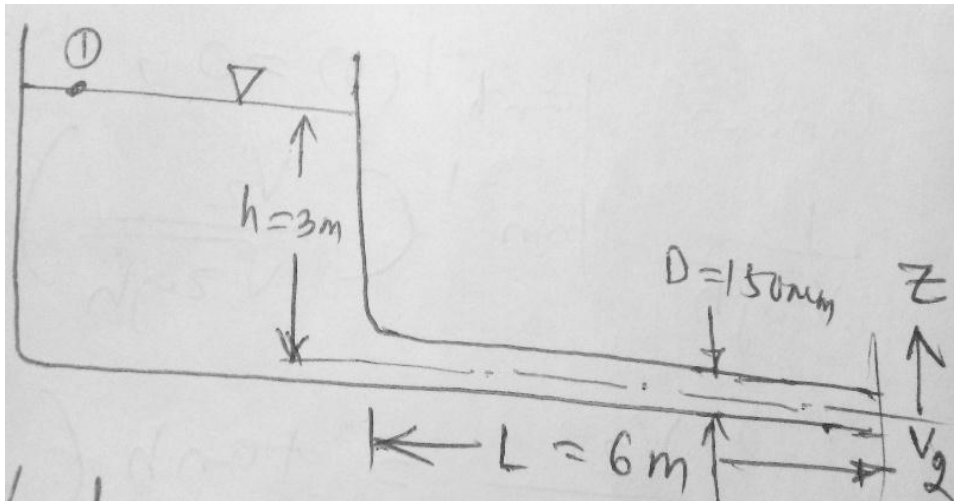

Ans: Applying Bernoulli's equation between 1 and 2 we have:

$$\frac{P_1}{\rho} + \frac{V_1^2}{2} + g z_1 = \frac{P_2}{\rho} + \frac{V_2^2}{2} + g z_2 + \int_1^2 \frac{\partial V}{\partial t} ds$$

Assumptions:

- i. Incompressible flow
- ii. Frictionless flow
- iii. Flow along a stream line for '1' and '2'
- iv. $P_1 = P_2 = P_{\text{atm}}$
- v. $V_1 = 0$
- vi. $Z_2 = 0$
- vii. $Z_1 = h$
- viii. Neglect velocity in reservoir, except for small region near the inlet to the tube.

$$\text{Then; } g z_1 = g h = \frac{V_2^2}{2} + \int_1^2 \frac{\partial V}{\partial t} ds \quad \text{----- (1)}$$

In view of assumption 'viii', the integral becomes

$$\int_1^2 \frac{\partial V}{\partial t} ds \approx \int_0^L \frac{\partial V}{\partial t} ds$$

In the tube, $V = V_2$, everywhere, so that

$$\int_0^L \frac{\partial V}{\partial t} ds = \int_0^L \frac{dV_2}{dt} ds = L \frac{dV_2}{dt}$$

Substituting in the equation (1),

$$g h = \frac{V_2^2}{2} + L \frac{dV_2}{dt}$$

Separating the variables we obtain:

$$\frac{dV_2}{2gh - V_2^2} = \frac{dt}{2L}$$

Integrating between limits $V = 0$ at $t = 0$ and $V = V_2$ at $t = t$,

$$\int_0^{V_2} \frac{dV_2}{2gh - V_2^2} = \int_0^t \frac{dt}{2L}$$

$$= \left[\frac{1}{\sqrt{2gh}} \tanh^{-1} \left(\frac{V}{\sqrt{2gh}} \right) \right]_0^{V_2} = \frac{t}{2L}$$

Since $\tanh^{-1}(0) = 0$, we obtain

$$\frac{1}{\sqrt{2gh}} \tanh^{-1} \left(\frac{V}{\sqrt{2gh}} \right) = \frac{t}{2L}$$

$$\Rightarrow \frac{V_2}{\sqrt{2gh}} = \tanh \left(\frac{t}{2L} \sqrt{2gh} \right)$$

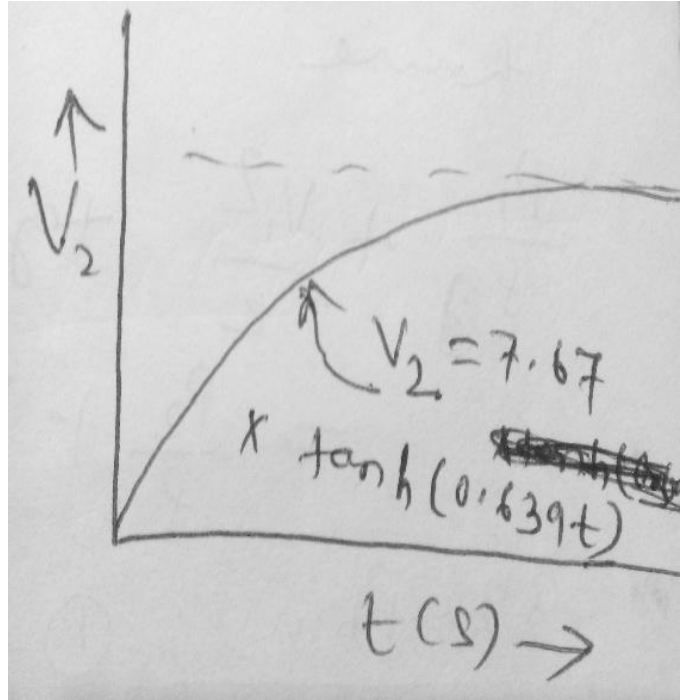

Bernoulli's equation using rectangular coordinates:

$$-\frac{1}{\rho} \nabla P - g \hat{k} = (\vec{V} \cdot \nabla) \vec{V}$$

Using the vector identity:

$$(\vec{V} \cdot \nabla) \vec{V} = \frac{1}{2} \nabla (\vec{V} \cdot \vec{V}) - \vec{V} \times (\nabla \times \vec{V})$$

For irrotational flow: $\nabla \times \vec{V} = 0$

$$\text{So } (\vec{V} \cdot \nabla) \vec{V} = \frac{1}{2} \nabla (\vec{V} \cdot \vec{V})$$

$$-\frac{1}{\rho} \nabla P - g \hat{k} = \frac{1}{2} \nabla (\vec{V} \cdot \vec{V}) = \frac{1}{2} \nabla (V^2)$$

Consider a displacement in the flow field from position ' \vec{r} ' to ' $\vec{r} + d\vec{r}$ ', the displacement ' $d\vec{r}$ ' being an arbitrary infinitesimal displacement in any direction. Taking the dot product of $d\vec{r} = dx \hat{i} + dy \hat{j} + dz \hat{k}$ with each of the terms, we have

$$-\frac{1}{\rho} \nabla P \cdot d\vec{r} - g \hat{k} \cdot d\vec{r} = \frac{1}{2} \nabla (V^2) \cdot d\vec{r}$$

And hence $-\frac{dP}{\rho} - g dz = \frac{1}{2} d(V^2)$

$$\Rightarrow \frac{dP}{\rho} + \frac{1}{2} d(V^2) + g dz = 0$$

$$\Rightarrow \boxed{\frac{P}{\rho} + \frac{V^2}{2} + g z = \text{constant}} \quad \text{----- (5.2)}$$

Since 'd \vec{r} ' was an arbitrary displacement, equation '5.2' is valid between any two points in a steady, incompressible and inviscid flow that is irrotational.

If 'd \vec{r} ' = 'd \vec{s} ' i.e. the integration is to be performed along a stream line, then taking the dot product of $d\vec{s}$, we get:

$$(\vec{V} \cdot \nabla) \vec{V} \cdot d\vec{s} = \frac{1}{2} \nabla (\vec{V} \cdot \vec{V}) \cdot d\vec{s} - \vec{V} \times (\nabla \times \vec{V}) \cdot d\vec{s}$$

Here even though $(\nabla \times \vec{V})$ is not zero, the product $\vec{V} \times (\nabla \times \vec{V}) \cdot d\vec{s}$

will be zero as $\vec{V} \times (\nabla \times \vec{V})$ is perpendicular to V and hence perpendicular to $d\vec{s}$.

A fluid that is initially irrotational may become rotational if:-

1. There are significant viscous forces induced by jets, wakes or solid boundaries. In these cases Bernoulli's equation will not be valid in such viscous regions.
2. There are entropy gradients caused by shock waves.
3. There are density gradients caused by stratification (uneven heating) rather than by pressure gradients.
4. There are significant non inertial effects such as earth's rotation (The Coriolis component).

HGL and EGL:

Hydraulic Grade Line (HGL) corresponds to the pressure head and elevation head i.e. Energy Grade Line(EGL) minus the velocity head.

$$\text{EGL} = \frac{P}{\rho g} + \frac{V^2}{2g} + z = H \quad (\text{Total Bernoulli's constant})$$

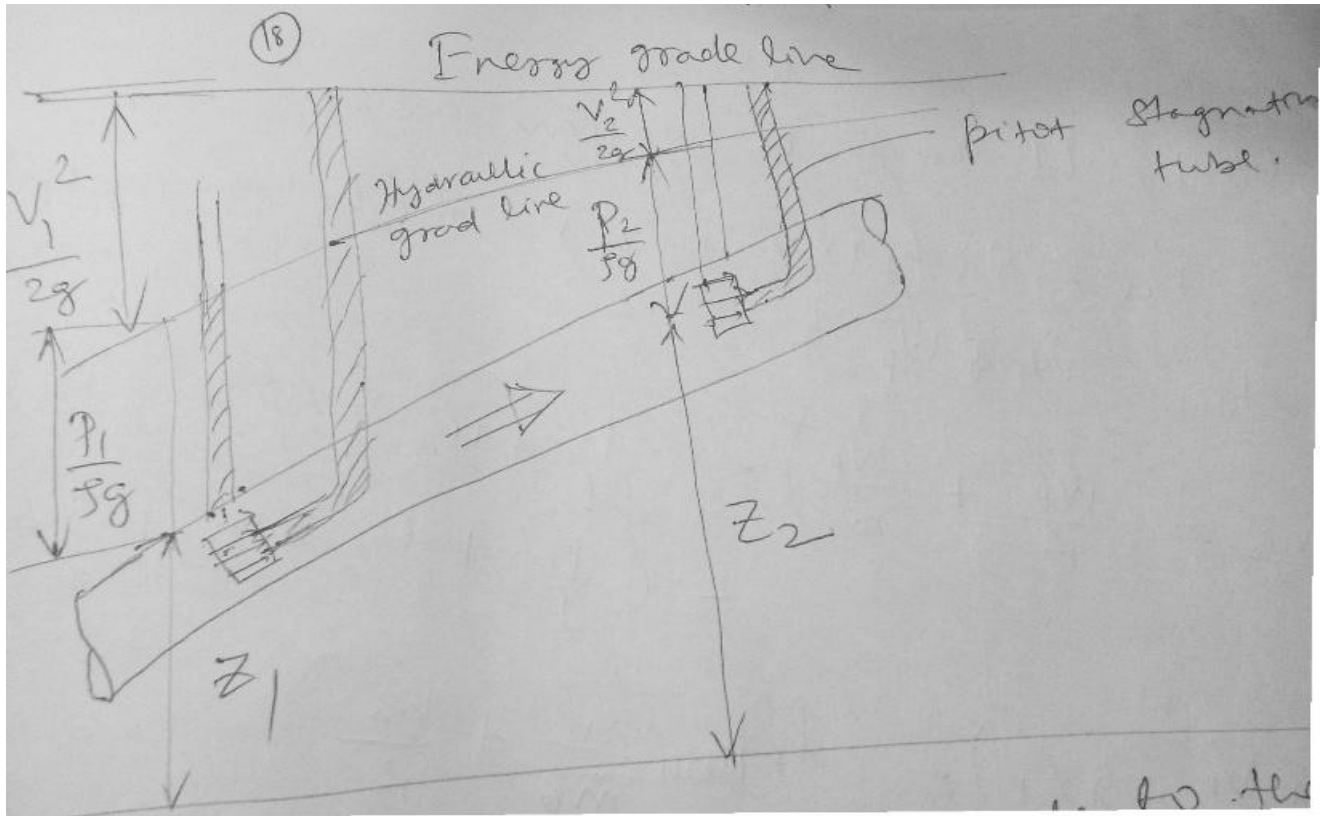

Principles of a hydraulic Siphon: Consider a container T containing some liquid. If one end of the pipe S completely filled with same liquid, is dipped into the container with the other end being open and vertically below the free surface of the liquid in the container T, then liquid will continuously flow from the container T through pipe S and get discharged at the end B. This is known as siphonic action and the justification of flow can be explained by applying the Bernoulli's equation.

Applying the Bernoulli's equation between point A and B, we can write

$$\frac{P_A}{\rho g} + 0 + Z_A = \frac{P_B}{\rho g} + \frac{V_B^2}{2g} + Z_B$$

The pressure at A and B are same and equal to atmospheric pressure. Velocity at A is negligible compared to velocity at B, since the area of the tank T is very large compared to that of the tube S. Hence we get,

$$V_B = \sqrt{2g(Z_A - Z_B)} = \sqrt{2g\Delta Z}$$

The above expression shows that a velocity head at B is created at the expenses of the potential head difference between A and B.

Applying the Bernoulli's equation between point A and B, we can write

$$\frac{P_A}{\rho g} + 0 + Z_A = \frac{P_C}{\rho g} + \frac{V_C^2}{2g} + Z_C$$

Considering the pipe cross section to be uniform, we have, from continuity, $V_B = V_C$

Thus we can write;
$$\frac{P_C}{\rho g} = \frac{P_{atm}}{\rho g} - \frac{V_B^2}{2g} - h$$

Therefore pressure at C is below atmospheric and pressure at D is the lowest as the potential head is maximum here. The pressure at D should not fall below the vapor pressure of the liquid, as this may create vapor pockets and may stop the flow.

CHAPTER-4

Hydraulic Machines-Turbines

A *hydraulic turbine* uses *potential energy* and *kinetic energy* of water and converts it into usable *mechanical energy*. The mechanical energy made available at the turbine shaft is used to run an electric power generator which is directly coupled to the turbine shaft.

The hydraulic turbines are classified according to type of energy available at the inlet of turbine, direction of flow through vanes, head at the inlet of the turbines and specific speed of the turbines.

According to the type of energy at inlet:

Impulse turbine:- In the impulse turbine, the total head of the incoming fluid is converted in to a large velocity head at the exit of the supply nozzle. That is the entire available energy of the water is converted in to kinetic energy. Although there are various types of impulse turbine designs, perhaps the easiest to understand is the *Pelton wheel turbine*. It is most efficient when operated with a large head and lower flow rate.

Reaction turbine :-Reaction turbines on the other hand, are best suited -for higher flow rate and lower head situations. In this type of turbines, the rotation of runner or rotor (rotating part of the turbine) is partly due to impulse action and partly due to change pressure over the runner blades; therefore, it is called as *reaction turbine* . For, a reaction turbine, the penstock pipe feeds water to a row of fixed blades through casing. These fixed blades convert a part of the pressure energy into kinetic energy before water enters the runner. The water entering the runner of a reaction turbine has both pressure energy and kinetic energy. Water leaving the turbine is still left with some energy (pressure energy and kinetic energy). Since, the flow from the inlet to tail race is under pressure, casing is absolutely necessary to enclose the turbine. In general, Reaction turbines are *medium to low-head* , and high *-flow rate devices* . The reaction turbines in use are *Francis* and *Kaplan*.

According to the direction of flow through runner:

Tangential flow turbines : In this type of turbines, the water strikes the runner in the direction of tangent to the wheel. *Example:* Pelton wheel turbine.

Radial flow turbines: In this type of turbines, the water strikes in the radial direction. accordingly, it is further classified as,

Axial flow turbine: The flow of water is in the direction parallel to the axis of the shaft. *Example:* Kaplan turbine and propeller turbine.

Mixed flow turbine: The water enters the runner in the radial direction and leaves in axial direction. *Example:* Modern Francis turbine.

Impulse Hydraulic Turbine : The Pelton Wheel



Figure Typical PELTON WHEEL with 21 Buckets

The only hydraulic turbine of the impulse type in common use, is named after an American engineer Laster A Pelton, who contributed much to its development around the year 1880. Therefore this machine is known as Pelton turbine or Pelton wheel. It is an efficient machine particularly suited to high heads. The rotor consists of a large circular disc or wheel on which a number (seldom less than 15) of spoon shaped buckets are spaced uniformly round its periphery as shown in Figure 1.1. The wheel is driven by jets of water being discharged at atmospheric pressure from pressure nozzles. The nozzles are mounted so that each directs a jet along a tangent to the circle through the centres of the buckets (Figure 1.2). Down the centre of each bucket, there is a splitter ridge which divides the jet into two equal streams which flow round the smooth inner surface of the bucket and leaves the bucket with a relative velocity almost opposite in direction to the original jet.

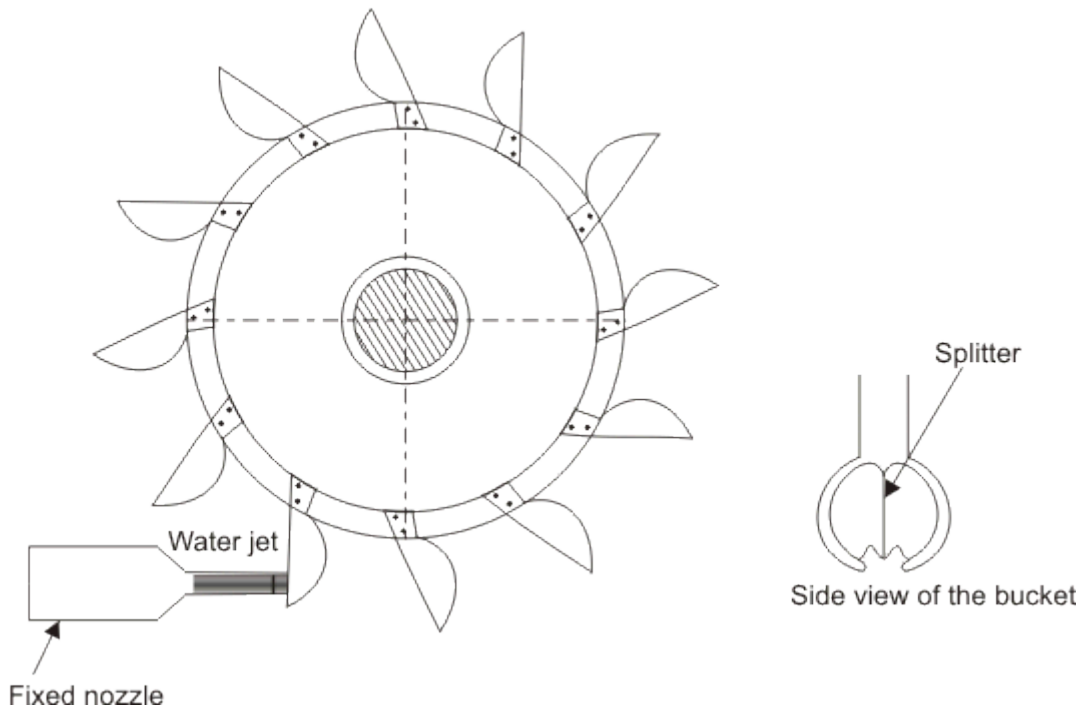

Figure: A Pelton wheel

For maximum change in momentum of the fluid and hence for the maximum driving force on the wheel, the deflection of the water jet should be 180° . In practice, however, the deflection is limited to about 165° so that the water leaving a bucket may not hit the back of the following bucket. Therefore, the camber angle of the buckets is made as 165° ($\theta = 165^\circ$). Figure(1.3a)

The number of jets is not more than two for horizontal shaft turbines and is limited to six for vertical shaft turbines. The flow partly fills the buckets and the fluid remains in contact with the atmosphere. Therefore, once the jet is produced by the nozzle, the static pressure of the fluid remains atmospheric throughout the machine. Because of the symmetry of the buckets, the side thrusts produced by the fluid in each half should balance each other.

Analysis of force on the bucket and power generation

Figure 1.3a shows a section through a bucket which is being acted on by a jet. The plane of section is parallel to the axis of the wheel and contains the axis of the jet. The absolute velocity of the jet V_1 with which it strikes the bucket is given by

$$V_1 = C_v \sqrt{2gH}$$

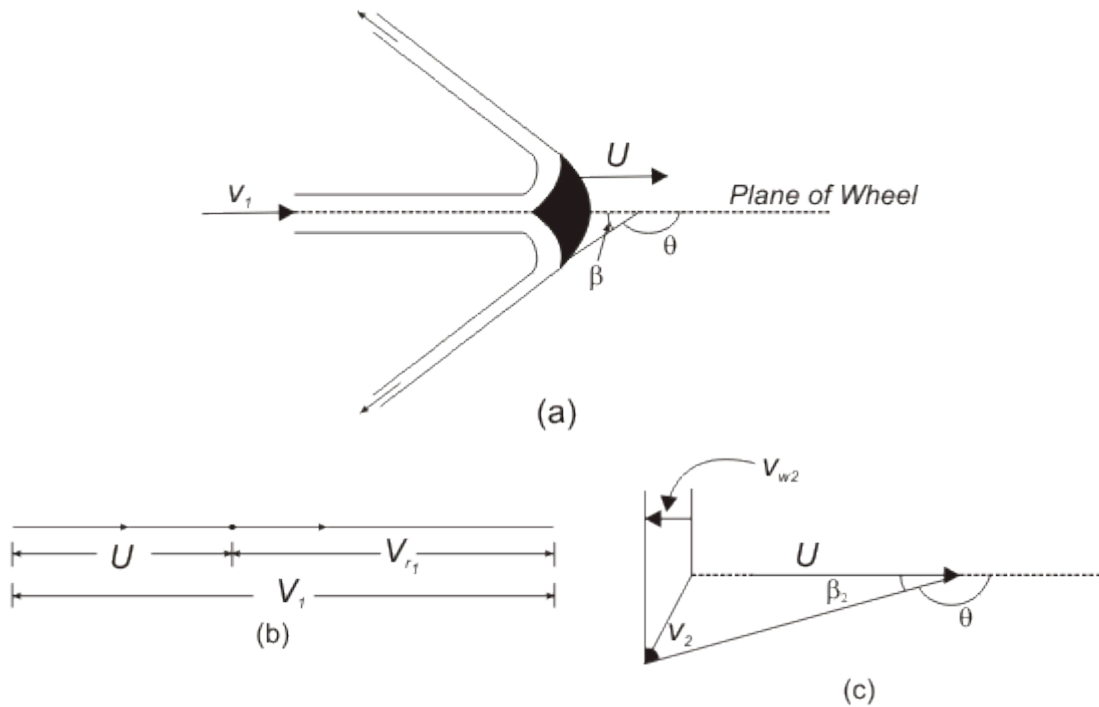

Figure 1.3
 (a) Flow along the bucket of a pelton wheel
 (b) Inlet velocity triangle
 (c) Outlet velocity triangle

where, C_v is the coefficient of velocity which takes care of the friction in the nozzle. H is the head at the entrance to the nozzle which is equal to the total or gross head of water stored at high altitudes minus the head lost due to friction in the long pipeline leading to the nozzle. Let the velocity of the bucket (due to the rotation of the wheel) at its centre where the jet strikes be U . Since the jet velocity V_1 is tangential, i.e. V_1 and U are collinear, the diagram of velocity vector at inlet (Fig 26.3.b) becomes simply a straight line and the relative velocity is given by

$$V_{r1} = V_1 - U$$

It is assumed that the flow of fluid is uniform and it glides the blade all along including the entrance and exit sections to avoid the unnecessary losses due to shock. Therefore the direction of relative velocity at entrance and exit should match the inlet and outlet angles of the buckets respectively. The velocity triangle at the outlet is shown in Figure 1.3c. The bucket velocity U remains the same both at the inlet and outlet. With the direction of U being taken as positive, we can write. The tangential component of inlet velocity (Figure 1.3b)

$$V_{w_1} = V_1 = V_{r_1} + U$$

and the tangential component of outlet velocity (Figure 1.3c)

$$V_{w_2} = -(V_{r_2} \cos \beta_2 - U)$$

where V_{r_1} and V_{r_2} are the velocities of the jet relative to the bucket at its inlet and outlet and β_2 is the outlet angle of the bucket.

From the Eq. (1.2) (the Euler's equation for hydraulic machines), the energy delivered by the fluid per unit mass to the rotor can be written as

$$\begin{aligned} E/m &= [V_{w_1} - V_{w_2}] U \\ &= [V_{r_1} + V_{r_2} \cos \beta_2] U \end{aligned} \quad (1.1)$$

(since, in the present situation, $U_1 = U_2 = U$)

The relative velocity V_{r_2} becomes slightly less than V_{r_1} mainly because of the friction in the bucket. Some additional loss is also inevitable as the fluid strikes the splitter ridge, because the ridge cannot have zero thickness. These losses are however kept to a minimum by making the inner surface of the bucket polished and reducing the thickness of the splitter ridge. The relative velocity at outlet V_{r_2} is usually expressed as $V_{r_2} = KV_{r_1}$ where, K is a factor with a value less than 1. However in an ideal case (in absence of friction between the fluid and blade surface) $K=1$. Therefore, we can write Eq.(1.1)

$$E/m = V_{r_1} [1 + K \cos \beta_2] U \quad (1.2)$$

If Q is the volume flow rate of the jet, then the power transmitted by the fluid to the wheel can be written as

$$\begin{aligned} P &= \rho Q V_{r_1} [1 + K \cos \beta_2] U \\ &= \rho Q [1 + K \cos \beta_2] (V_1 - U) U \end{aligned} \quad (1.3)$$

The power input to the wheel is found from the kinetic energy of the jet arriving at the wheel and is given by $\frac{1}{2} \rho Q V_1^2$. Therefore the wheel efficiency of a pelton turbine can be written as

$$\begin{aligned}\eta_w &= \frac{2\rho Q[1+K \cos \beta_2](V_1 - U)U}{\rho Q V_1^2} \\ &= 2[1+K \cos \beta_2] \left[1 - \frac{U}{V_1}\right] \frac{U}{V_1}\end{aligned}\quad (1.4)$$

It is found that the efficiency η_w depends on K , β_2 and U/V_1 . For a given design of the bucket, i.e. for constant values of β_2 and K , the efficiency η_w becomes a function of U/V_1 only, and we can determine the condition given by U/V_1 at which η_w becomes maximum.

For η_w to be maximum,

$$\begin{aligned}\frac{d\eta_w}{d(U/V_1)} &= 2[1+K \cos \beta_2] \left[1 - 2\frac{U}{V_1}\right] = 0 \\ \text{or,} \quad U/V_1 &= \frac{1}{2}\end{aligned}\quad (1.5)$$

$d^2\eta_w / d(U/V_1)^2$ is always negative.

Therefore, the maximum wheel efficiency can be written after substituting the relation given by eqn.(1.5) in eqn.(1.4) as

$$\eta_{w \max} = 2(1 - K \cos \beta_2)/2 \quad (1.6)$$

The condition given by Eq. (1.5) states that the efficiency of the wheel in converting the kinetic energy of the jet into mechanical energy of rotation becomes maximum when the wheel speed at the centre of the bucket becomes one half of the incoming velocity of the jet. The overall efficiency η_o will be less than η_w because of friction in bearing and windage, i.e. friction between the wheel and the atmosphere in which it rotates. Moreover, as the losses due to bearing friction and windage increase rapidly with speed, the overall efficiency reaches its peak when the ratio U/V_1 is slightly less than the theoretical value of 0.5. The value usually obtained in practice is about 0.46. The Figure 2.1 shows the variation of wheel efficiency η_w with blade to jet speed ratio U/V_1 for assumed values at $k=1$ and 0.8 , and $\beta_2 = 165^\circ$. An overall efficiency of 85-90 percent may usually be obtained in large machines. To obtain high values of wheel efficiency, the buckets should have smooth surface and be properly designed. The length, width, and depth of the buckets are chosen about

2.5.4 and 0.8 times the jet diameter. The buckets are notched for smooth entry of the jet.

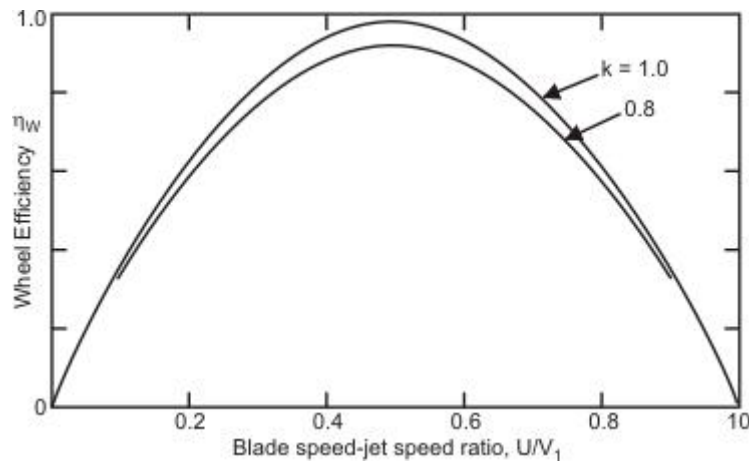

Figure 2.1 Theoretical variation of wheel efficiency for a Pelton turbine with blade speed to jet speed ratio for different values of k

Specific speed and wheel geometry .

The specific speed of a pelton wheel depends on the ratio of jet diameter d and the wheel pitch diameter. D (the diameter at the centre of the bucket). If the hydraulic efficiency of a pelton wheel is defined as the ratio of the power delivered P to the wheel to the head available H at the nozzle entrance, then we can write.

$$P = \rho Q g H \eta_h = \frac{\pi \rho d^2 V_1^3 \eta_h}{4 \times 2 C_v^2} \quad (2.1)$$

$$\text{Since } \left[Q = \frac{\pi d^2}{4} V_1 \text{ and } V_1 = C_v (2gH)^{1/2} \right]$$

The specific speed $N_{sT} = \frac{N P^{1/2}}{H^{5/4}}$

The optimum value of the overall efficiency of a Pelton turbine depends both on the values of the specific speed and the speed ratio. The Pelton wheels with a single jet operate in the specific speed range of 4-16, and therefore the ratio D/d lies between 6 to 26 as given by the Eq. (15.25b). A large value of D/d reduces the rpm as well as the mechanical efficiency of the wheel. It is possible to increase the specific speed by choosing a lower value of D/d , but the efficiency

will decrease because of the close spacing of buckets. The value of D/d is normally kept between 14 and 16 to maintain high efficiency. The number of buckets required to maintain optimum efficiency is usually fixed by the empirical relation.

$$n(\text{number of buckets}) = 15 + \frac{53}{N_{sT}} \quad (2.2)$$

Governing of Pelton Turbine :

First let us discuss what is meant by governing of turbines in general. When a turbine drives an electrical generator or alternator, the primary requirement is that the rotational speed of the shaft and hence that of the turbine rotor has to be kept fixed. Otherwise the frequency of the electrical output will be altered. But when the electrical load changes depending upon the demand, the speed of the turbine changes automatically. This is because the external resisting torque on the shaft is altered while the driving torque due to change of momentum in the flow of fluid through the turbine remains the same. For example, when the load is increased, the speed of the turbine decreases and *vice versa*. A constancy in speed is therefore maintained by adjusting the rate of energy input to the turbine accordingly. This is usually accomplished by changing the rate of fluid flow through the turbine- the flow is increased when the load is increased and the flow is decreased when the load is decreased. This adjustment of flow with the load is known as the governing of turbines.

In case of a Pelton turbine, an additional requirement for its operation at the condition of maximum efficiency is that the ratio of bucket to initial jet velocity U/V_1 has to be kept at its optimum value of about 0.46. Hence, when U is fixed, V_1 has to be fixed. Therefore the control must be made by a variation of the cross-sectional area, A , of the jet so that the flow rate changes in proportion to the change in the flow area keeping the jet velocity V_1 same. This is usually achieved by a spear valve in the nozzle (Figure 2.2a). Movement of the spear and the axis of the nozzle changes the annular area between the spear and the housing. The shape of the spear is such, that the fluid coalesces into a circular jet and then the effect of the spear movement is to vary the diameter of the jet. Deflectors are often used (Figure 2.2b) along with the spear valve to prevent the serious water hammer problem due to a sudden reduction in the rate of flow. These plates temporarily deflect the jet so that the entire flow does not

reach the bucket; the spear valve may then be moved slowly to its new position to reduce the rate of flow in the pipe-line gradually. If the bucket width is too small in relation to the jet diameter, the fluid is not smoothly deflected by the buckets and, in consequence, much energy is dissipated in turbulence and the efficiency drops considerably. On the other hand, if the buckets are unduly large, the effect of friction on the surfaces is unnecessarily high. The optimum value of the ratio of bucket width to jet diameter has been found to vary between 4 and 5.

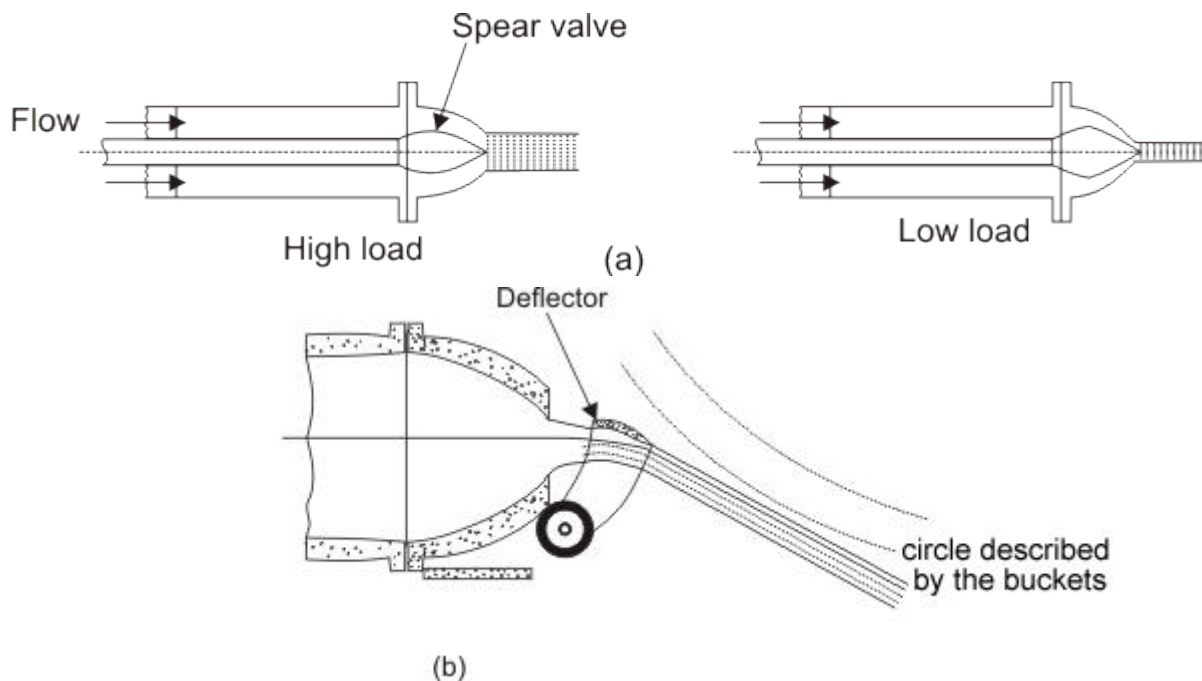

Figure (a) Spear valve to alter jet area in a Pelton wheel
(b) Jet deflected from bucket

Limitation of a Pelton Turbine:

The Pelton wheel is efficient and reliable when operating under large heads. To generate a given output power under a smaller head, the rate of flow through the turbine has to be higher which requires an increase in the jet diameter. The number of jets are usually limited to 4 or 6 per wheel. The increases in jet diameter in turn increases the wheel diameter. Therefore the machine becomes unduly large, bulky and slow-running. In practice, turbines of the reaction type are more suitable for lower heads.

Reaction Turbine Francis Turbine

The principal feature of a reaction turbine that distinguishes it from an impulse turbine is that only a part of the total head available at the inlet to the turbine is converted to velocity head, before the runner is reached. Also in the reaction turbines the working fluid, instead of engaging only one or two blades, completely fills the passages in the runner. The pressure or static head of the fluid changes gradually as it passes through the runner along with the change in its kinetic energy based on absolute velocity due to the impulse action between the fluid and the runner. Therefore the cross-sectional area of flow through the passages of the fluid. A reaction turbine is usually well suited for low heads. A radial flow hydraulic turbine of reaction type was first developed by an American Engineer, James B. Francis (1815-92) and is named after him as the Francis turbine. The schematic diagram of a Francis turbine is shown in Fig. 3.1

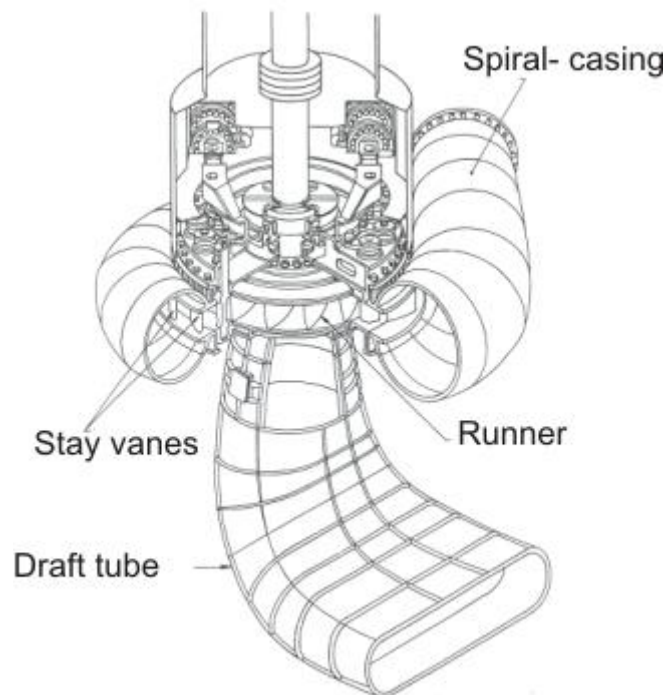

Figure 3.1 A Francis turbine

A Francis turbine comprises mainly the four components:

- (i) spirical casing,
- (ii) guide on stay vanes,

(iii) runner blades,

(iv) draft-tube as shown in Figure 3.1 .

Spiral Casing : Most of these machines have vertical shafts although some smaller machines of this type have horizontal shaft. The fluid enters from the penstock (pipeline leading to the turbine from the reservoir at high altitude) to a spiral casing which completely surrounds the runner. This casing is known as scroll casing or volute. The cross-sectional area of this casing decreases uniformly along the circumference to keep the fluid velocity constant in magnitude along its path towards the guide vane.

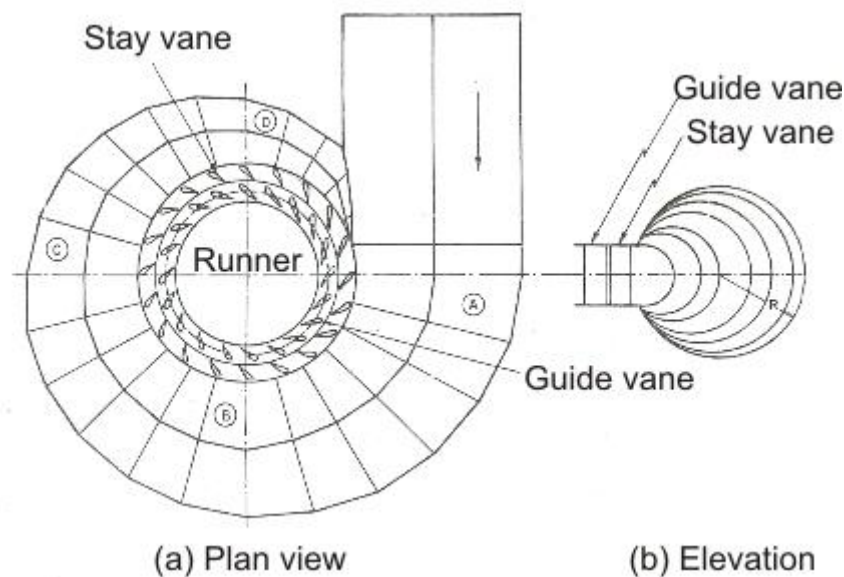

Figure Spiral Casing

This is so because the rate of flow along the fluid path in the volute decreases due to continuous entry of the fluid to the runner through the openings of the guide vanes or stay vanes.

Guide or Stay vane:

The basic purpose of the guide vanes or stay vanes is to convert a part of pressure energy of the fluid at its entrance to the kinetic energy and then to direct the fluid on to the runner blades at the angle appropriate to the design. Moreover, the guide vanes are pivoted and can be turned by a suitable governing mechanism to regulate the flow while the load changes. The guide vanes are also known as wicket gates. The guide vanes impart a tangential velocity and hence an angular momentum to the water before its entry to the runner. The flow in the runner of a Francis turbine is not purely radial but a combination of radial and tangential. The flow is inward, i.e. from the periphery towards the centre. The height of the runner depends upon the

specific speed. The height increases with the increase in the specific speed. The main direction of flow change as water passes through the runner and is finally turned into the axial direction while entering the draft tube.

Draft tube:

The draft tube is a conduit which connects the runner exit to the tail race where the water is being finally discharged from the turbine. The primary function of the draft tube is to reduce the velocity of the discharged water to minimize the loss of kinetic energy at the outlet. This permits the turbine to be set above the tail water without any appreciable drop of available head. A clear understanding of the function of the draft tube in any reaction turbine, in fact, is very important for the purpose of its design. The purpose of providing a draft tube will be better understood if we carefully study the net available head across a reaction turbine.

Net head across a reaction turbine and the purpose to providing a draft tube . The effective head across any turbine is the difference between the head at inlet to the machine and the head at outlet from it. A reaction turbine always runs completely filled with the working fluid. The tube that connects the end of the runner to the tail race is known as a draft tube and should completely to filled with the working fluid flowing through it. The kinetic energy of the fluid finally discharged into the tail race is wasted. A draft tube is made divergent so as to reduce the velocity at outlet to a minimum. Therefore a draft tube is basically a diffuser and should be designed properly with the angle between the walls of the tube to be limited to about 8 degree so as to prevent the flow separation from the wall and to reduce accordingly the loss of energy in the tube. Figure 3.3 shows a flow diagram from the reservoir via a reaction turbine to the tail race.

The total head H_1 at the entrance to the turbine can be found out by applying the Bernoulli's equation between the free surface of the reservoir and the inlet to the turbine as

$$H_0 = \frac{P_1}{\rho g} + \frac{V_1^2}{2g} + z + h_f \quad (3.1)$$

or,
$$H_1 = H_0 - h_f = \frac{P_1}{\rho g} + \frac{V_1^2}{2g} + z \quad (3.2)$$

where h_f is the head lost due to friction in the pipeline connecting the reservoir and the turbine. Since the draft tube is a part of the turbine, the net head across the turbine, for the conversion of mechanical work, is the

difference of total head at inlet to the machine and the total head at discharge from the draft tube at tail race and is shown as H in Figure 3.3

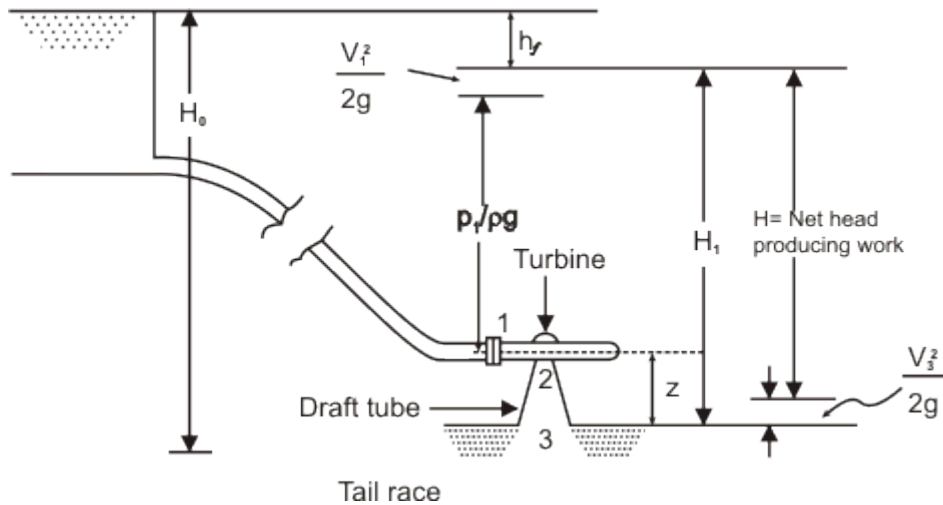

Figure Head across a reaction turbine

Therefore, $H =$ total head at inlet to machine (1) - total head at discharge (3)

$$= \frac{P_1}{\rho g} + \frac{V_1^2}{2g} + z - \frac{V_3^2}{2g} = H_1 - \frac{V_3^2}{2g} \quad (3.3)$$

$$= (H_0 - h_f) - \frac{V_3^2}{2g} \quad (3.4)$$

The pressures are defined in terms of their values above the atmospheric pressure. Section 2 and 3 in Figure 3.3 represent the exits from the runner and the draft tube respectively. If the losses in the draft tube are neglected, then the total head at 2 becomes equal to that at 3. Therefore, the net head across the machine is either $(H_1 - H_3)$ or $(H_1 - H_2)$. Applying the Bernoulli's equation between 2 and 3 in consideration of flow, without losses, through the draft tube, we can write.

$$\frac{P_2}{\rho g} + \frac{V_2^2}{2g} + z = 0 + \frac{V_3^2}{2g} + 0 \quad (3.5)$$

$$\frac{P_2}{\rho g} = - \left[z + \frac{V_2^2 - V_3^2}{2g} \right] \quad (3.6)$$

Since $V_3 < V_2$, both the terms in the bracket are positive and hence $P_2/\rho g$ is always negative, which implies that the static pressure at the outlet of the runner is always below the atmospheric pressure. Equation (3.1) also shows

that the value of the suction pressure at runner outlet depends on z , the height of the runner above the tail race and $(V_2^2 - V_3^2)/2g$, the decrease in kinetic energy of the fluid in the draft tube. The value of this minimum pressure P_2 should never fall below the vapour pressure of the liquid at its operating temperature to avoid the problem of cavitation. Therefore, we find that the incorporation of a draft tube allows the turbine runner to be set above the tail race without any drop of available head by maintaining a vacuum pressure at the outlet of the runner.

Runner of the Francis Turbine

The shape of the blades of a Francis runner is complex. The exact shape depends on its specific speed. It is obvious from the equation of specific speed that higher specific speed means lower head. This requires that the runner should admit a comparatively large quantity of water for a given power output and at the same time the velocity of discharge at runner outlet should be small to avoid cavitation. In a purely radial flow runner, as developed by James B. Francis, the bulk flow is in the radial direction. To be more clear, the flow is tangential and radial at the inlet but is entirely radial with a negligible tangential component at the outlet. The flow, under the situation, has to make a 90° turn after passing through the rotor for its inlet to the draft tube. Since the flow area (area perpendicular to the radial direction) is small, there is a limit to the capacity of this type of runner in keeping a low exit velocity. This leads to the design of a mixed flow runner where water is turned from a radial to an axial direction in the rotor itself. At the outlet of this type of runner, the flow is mostly axial with negligible radial and tangential components. Because of a large discharge area (area perpendicular to the axial direction), this type of runner can pass a large amount of water with a low exit velocity from the runner. The blades for a reaction turbine are always so shaped that the tangential or whirling component of velocity at the outlet becomes zero ($V_{w2} = 0$). This is made to keep the kinetic energy at outlet a minimum.

Figure 4.1 shows the velocity triangles at inlet and outlet of a typical blade of a Francis turbine. Usually the flow velocity (velocity perpendicular to the tangential direction) remains constant throughout, i.e. $V_{f1} = V_{f2}$ and is equal to that at the inlet to the draft tube.

The Euler's equation for turbine [Eq.(1.2)] in this case reduces to

$$E/m = e = V_{w1} U_1 \quad (4.1)$$

where, e is the energy transfer to the rotor per unit mass of the fluid. From the inlet velocity triangle shown in Fig.4.1

$$V_{w1} = V_{f1} \cot \alpha_1 \quad (4.2a)$$

and
$$U_1 = V_{f1} (\cot \alpha_1 + \cot \beta_1) \quad (4.2b)$$

Substituting the values of V_{w1} and U_1 from Eqs. (4.2a) and (4.2b) respectively into Eq. (4.1), we have

$$e = V_{f1}^2 \cot \alpha_1 (\cot \alpha_1 + \cot \beta_1) \quad (4.3)$$

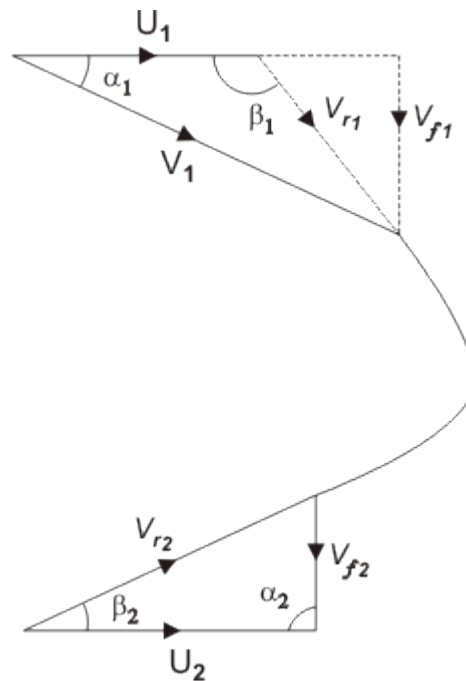

Figure Velocity triangle for a Francis runner

The loss of kinetic energy per unit mass becomes equal to $V_{f2}^2 / 2$. Therefore neglecting friction, the blade efficiency becomes

$$\begin{aligned} \eta_b &= \frac{e}{e + (V_{f2}^2 / 2)} \\ &= \frac{2V_{f1}^2 \cot \alpha_1 (\cot \alpha_1 + \cot \beta_1)}{V_{f2}^2 + 2V_{f1}^2 \cot \alpha_1 (\cot \alpha_1 + \cot \beta_1)} \end{aligned}$$

since $V_{f1} = V_{f2} \cdot \eta_b$ can be written as

$$\eta_b = 1 - \frac{1}{1 + 2 \cot \alpha_1 (\cot \alpha_1 + \cot \beta_1)}$$

The change in pressure energy of the fluid in the rotor can be found out by subtracting the change in its kinetic energy from the total energy released. Therefore, we can write for the degree of reaction,

$$R = \frac{e - \frac{1}{2}(V_1^2 - V_2^2)}{e} = 1 - \frac{\frac{1}{2}V_{f1}^2 \cot^2 \alpha_1}{e}$$

[since $V_1^2 - V_2^2 = V_1^2 - V_{f1}^2 = V_{f1}^2 \cot^2 \alpha_1$]

Using the expression of e from Eq. (4.3), we have

$$R = 1 - \frac{\cot \alpha_1}{2(\cot \alpha_1 + \cot \beta_1)} \quad (4.4)$$

The inlet blade angle β_1 of a Francis runner varies $45-120^\circ$ and the guide vane angle α_1 from $10-40^\circ$. The ratio of blade width to the diameter of runner B/D , at blade inlet, depends upon the required specific speed and varies from $1/20$ to $2/3$.

Expression for specific speed. The dimensional specific speed of a turbine, can be written as

$$N_{sT} = \frac{NP^{1/2}}{H^{5/4}}$$

Power generated P for a turbine can be expressed in terms of available head H and hydraulic efficiency η_h as

$$P = \rho Q g H \eta_h$$

Hence, it becomes

$$N_{sT} = N(\rho Q g \eta_h)^{1/2} H^{-3/4} \quad (4.5)$$

Again, $N = U_1 / \pi D_1$,

Substituting U_1 from Eq. (4.2b)

$$N = \frac{V_{f1} (\cot \alpha_1 + \cot \beta_1)}{\pi D_1} \quad (4.6)$$

Available head H equals the head delivered by the turbine plus the head lost at the exit. Thus,

$$gH = e + (V_{f2}^2 / 2)$$

since

$$V_{f1} = V_{f2}$$

$$gH = e + (V_{f1}^2 / 2)$$

with the help of Eq. (4.3), it becomes

$$gH = V_{f1}^2 \cot \alpha_1 (\cot \alpha_1 + \cot \beta_1) + \frac{V_{f1}^2}{2}$$

or,

$$H = \frac{V_{f1}^2}{2g} [1 + 2 \cot \alpha_1 (\cot \alpha_1 + \cot \beta_1)] \quad (4.7)$$

Substituting the values of H and N from Eqs (4.7) and (4.6) respectively into the expression N_{sT} given by Eq. (4.5), we get,

$$N_{sT} = 2^{3/4} g^{5/4} (\rho \eta_h Q)^{1/2} \frac{V_{f1}^{-1/2}}{\pi D_1} (\cot \alpha_1 + \cot \beta_1) [1 + 2 \cot \alpha_1 (\cot \alpha_1 + \cot \beta_1)]^{-3/4}$$

Flow velocity at inlet V_{f1} can be substituted from the equation of continuity as

$$V_{f1} = \frac{Q}{\pi D_1 B}$$

where B is the width of the runner at its inlet

Finally, the expression for N_{sT} becomes,

$$N_{sT} = 2^{3/4} g^{5/4} (\rho \eta_h)^{1/2} \left(\frac{B}{\pi D_1} \right)^{1/2} (\cot \alpha_1 + \cot \beta_1) [1 + 2 \cot \alpha_1 (\cot \alpha_1 + \cot \beta_1)]^{-3/4} \quad (4.8)$$

For a Francis turbine, the variations of geometrical parameters like $\alpha_1, \beta_1, B/D$ have been described earlier. These variations cover a range of specific speed between 50 and 400. Figure 4.2 shows an overview of a Francis Turbine. The figure is specifically shown in order to convey the size and relative dimensions of a typical Francis Turbine to the readers.

KAPLAN TURBINE

Higher specific speed corresponds to a lower head. This requires that the runner should admit a comparatively large quantity of water. For a runner of given diameter, the maximum flow rate is achieved when the flow is parallel to the axis. Such a machine is known as axial flow reaction turbine. An Australian engineer, Vikton Kaplan first designed such a machine. The machines in this family are called Kaplan Turbines.(Figure 5.1)



Figure A typical Kaplan Turbine

Development of Kaplan Runner from the Change in the Shape of Francis Runner with Specific Speed

Figure 5.2 shows in stages the change in the shape of a Francis runner with the variation of specific speed. The first three types [Fig. 5.2 (a), (b) and (c)] have, in order. The Francis runner (radial flow runner) at low, normal and high specific speeds. As the specific speed increases, discharge becomes more and more axial. The fourth type, as shown in Fig.5.2 (d), is a mixed flow runner (radial flow at inlet axial flow at outlet) and is known as Dubs runner which is mainly suited for high specific speeds. Figure 5.2(e) shows a propeller type runner with a less number of blades where the flow is entirely axial (both at inlet and outlet). This type of runner is the most suitable one for very high specific speeds and is known as Kaplan runner or axial flow runner.

From the inlet velocity triangle for each of the five runners, as shown in Figs (5.2a to 5.2e), it is found that an increase in specific speed (or a decreased in head) is accompanied by a reduction in inlet velocity V_1 . But the flow velocity V_{f1} at inlet increases allowing a large amount of fluid to enter the turbine. The most important point to be noted in this context is that the flow at inlet to all the runners, except the Kaplan one, is in radial and tangential directions. Therefore, the inlet velocity triangles of those turbines (Figure 5.2a to 5.2d) are shown in a plane containing the radial and tangential directions, and hence the flow velocity V_{f1} represents the radial component of velocity.

In case of a Kaplan runner, the flow at inlet is in axial and tangential directions. Therefore, the inlet velocity triangle in this case (Figure 30.2e) is shown in a plane containing the axial and tangential directions, and hence the flow velocity V_{f1} represents the axial component of velocity V_a . The tangential component of velocity is almost nil at outlet of all runners. Therefore, the outlet velocity triangle (Figure 5.2f) is identical in shape of all runners. However, the exit velocity V_2 is axial in Kaplan and Dubs runner, while it is the radial one in all other runners.

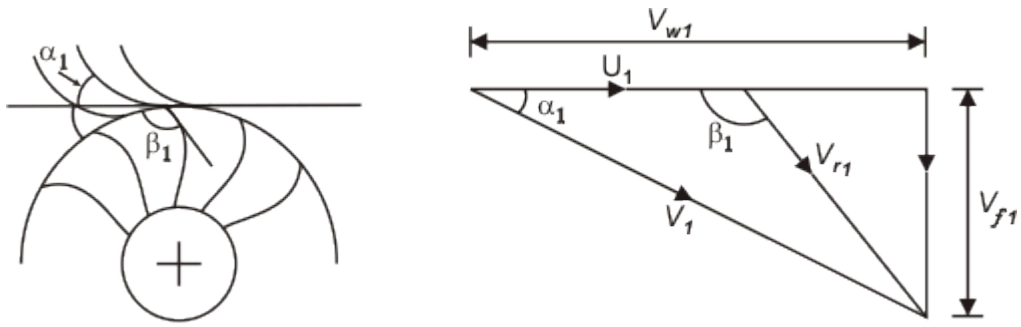

(a) Francis runner for low specific speeds

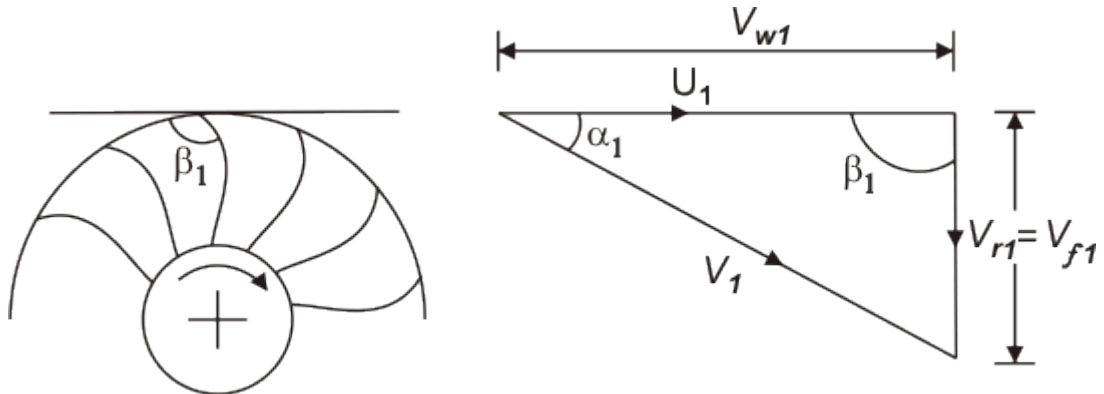

(b) Francis runner for normal specific speeds

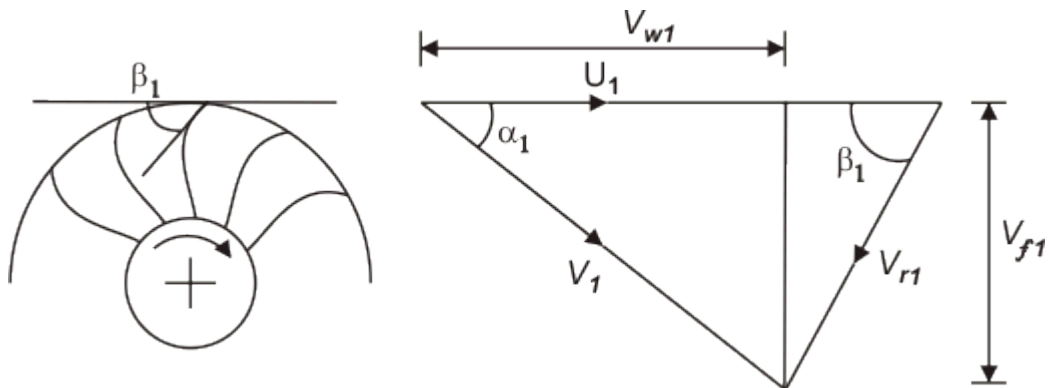

(c) Francis runner for high specific speeds

(d) Dubs runner

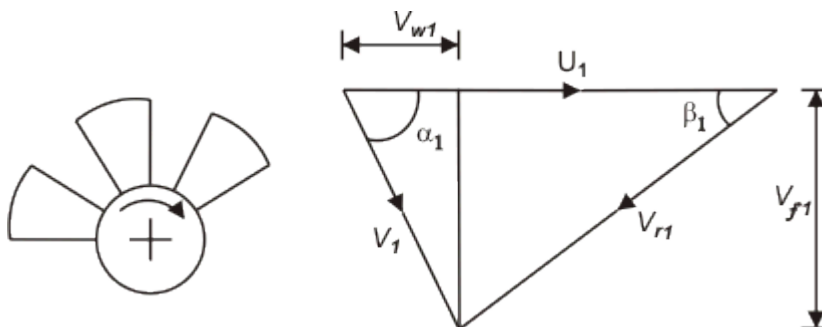

(e) Kalpan runner

(f) For allreaction
(Francis as well as
Kaplan) runners

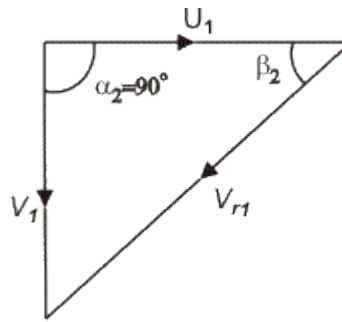

Outlet velocity triangle

Fig. 5.2 Evolution of Kaplan runner form Francis one

Figure 5.3 shows a schematic diagram of propeller or Kaplan turbine. The function of the guide vane is same as in case of Francis turbine. Between the guide vanes and the runner, the fluid in a propeller turbine turns through a right-angle into the axial direction and then passes through the runner. The runner usually has four or six blades and closely resembles a ship's propeller. Neglecting the frictional effects, the flow approaching the runner blades can be considered to be a free vortex with whirl velocity being inversely proportional to radius, while on the other hand, the blade velocity is directly proportional to the radius. To take care of this different relationship of the fluid velocity and the blade velocity with the changes in radius, the blades are twisted. The angle with axis is greater at the tip that at the root.

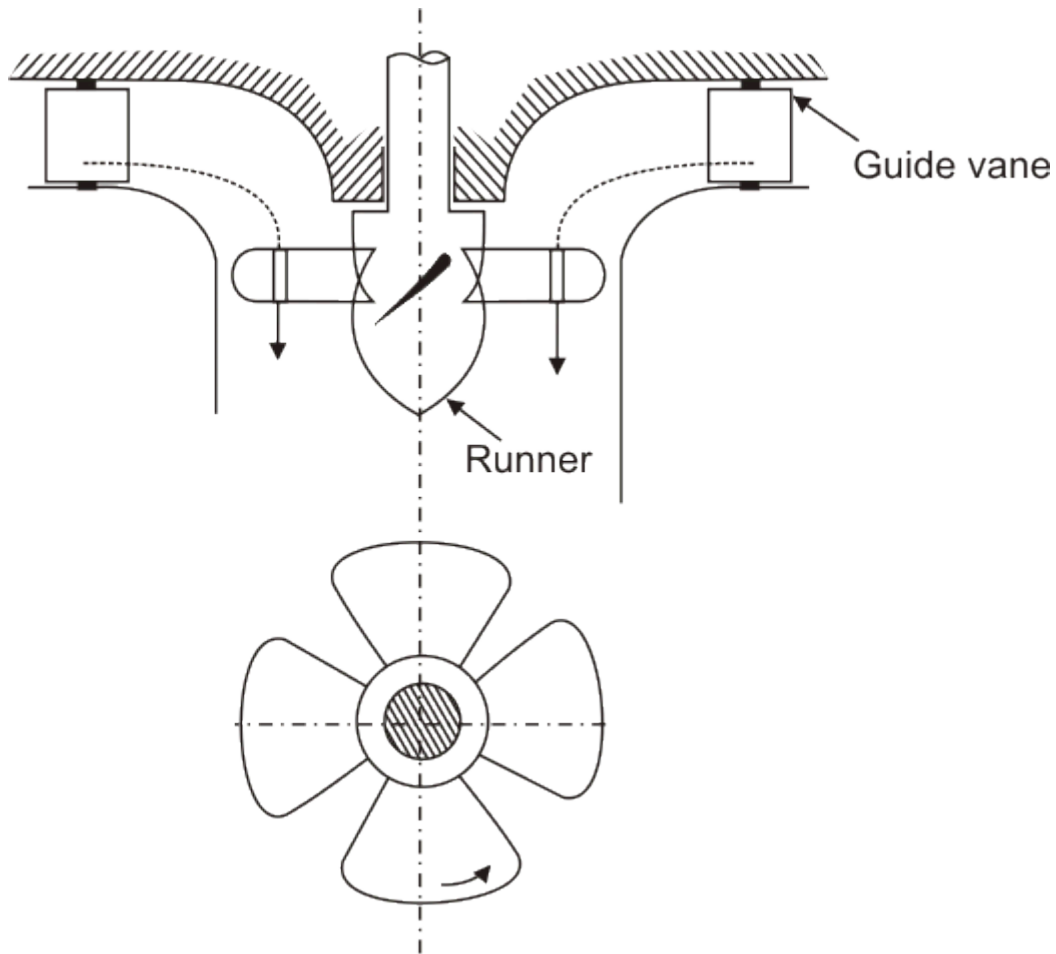

Fig. A propeller of Kaplan turbine

Different types of draft tubes incorporated in reaction turbines The draft tube is an integral part of a reaction turbine. Its principle has been explained earlier. The shape of draft tube plays an important role especially for high specific speed turbines, since the efficient recovery of kinetic energy at runner outlet depends mainly on it. Typical draft tubes, employed in practice, are discussed as follows.

Straight divergent tube [Fig. 5.4(a)] The shape of this tube is that of frustum of a cone. It is usually employed for low specific speed, vertical shaft Francis turbine. The cone angle is restricted to 8° to avoid the losses due to separation. The tube must discharge sufficiently low under tail water level. The maximum efficiency of this type of draft tube is 90%. This type of draft tube improves speed regulation of falling load.

Simple elbow type (Fig. 5.4b) The vertical length of the draft tube should be made small in order to keep down the cost of excavation, particularly in rock. The exit diameter of draft tube should be as large as possible to recover kinetic energy at runner's outlet. The cone angle of the tube is again fixed

from the consideration of losses due to flow separation. Therefore, the draft tube must be bent to keep its definite length. Simple elbow type draft tube will serve such a purpose. Its efficiency is, however, low (about 60%). This type of draft tube turns the water from the vertical to the horizontal direction with a minimum depth of excavation. Sometimes, the transition from a circular section in the vertical portion to a rectangular section in the horizontal part (Fig. 5.4c) is incorporated in the design to have a higher efficiency of the draft tube. The horizontal portion of the draft tube is generally inclined upwards to lead the water gradually to the level of the tail race and to prevent entry of air from the exit end.

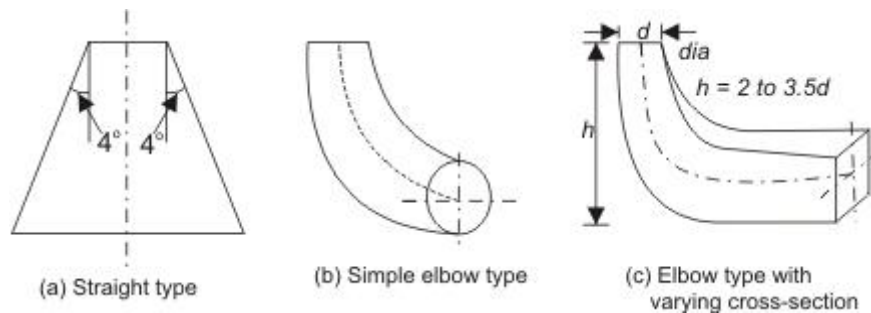

Figure Different types of draft tubes

Cavitation in reaction turbines

If the pressure of a liquid in course of its flow becomes equal to its vapour pressure at the existing temperature, then the liquid starts boiling and the pockets of vapour are formed which create vapour locks to the flow and the flow is stopped. The phenomenon is known as cavitation. To avoid cavitation, the minimum pressure in the passage of a liquid flow, should always be more than the vapour pressure of the liquid at the working temperature. In a reaction turbine, the point of minimum pressure is usually at the outlet end of the runner blades, i.e. at the inlet to the draft tube. For the flow between such a point and the final discharge into the tail race (where the pressure is atmospheric), the Bernoulli's equation can be written, in consideration of the velocity at the discharge from draft tube to be negligibly small, as

$$\frac{p_e}{\rho g} + \frac{V_e^2}{2g} + z = \frac{p_{atm}}{\rho g} + h_f \quad (6.1)$$

where, p_e and V_e represent the static pressure and velocity of the liquid at the outlet of the runner (or at the inlet to the draft tube). The larger the value

of V_e , the smaller is the value of p_e and the cavitation is more likely to occur. The term h_f in Eq. (6.1) represents the loss of head due to friction in the draft tube and z is the height of the turbine runner above the tail water surface. For cavitation not to occur $p_e > p_v$ where p_v is the vapour pressure of the liquid at the working temperature.

An important parameter in the context of cavitation is the available suction head (inclusive of both static and dynamic heads) at exit from the turbine and is usually referred to as the net positive suction head 'NPSH' which is defined as

$$NPSH = \frac{p_e}{\rho g} + \frac{V_e^2}{2g} - \frac{p_v}{\rho g} \quad (6.2)$$

with the help of Eq. (6.1) and in consideration of negligible frictional losses in the draft tube ($h_f = 0$), Eq. (6.2) can be written as

$$NPSH = \frac{p_{atm}}{\rho g} - \frac{p_v}{\rho g} - z \quad (6.3)$$

A useful design parameter σ known as Thoma's Cavitation Parameter (after the German Engineer Dietrich Thoma, who first introduced the concept) is defined as

$$\sigma = \frac{NPSH}{H} = \frac{(p_{atm} / \rho g) - (p_v / \rho g) - z}{H} \quad (6.4)$$

For a given machine, operating at its design condition, another useful parameter σ_c , known as critical cavitation parameter is defined as

$$\sigma_c = \frac{(p_{atm} / \rho g) - (p_e / \rho g) - z}{H} \quad (6.5)$$

Therefore, for cavitation not to occur $\sigma > \sigma_c$ (since, $p_e > p_v$).

If either z or H is increased, σ is reduced. To determine whether cavitation is likely to occur in a particular installation, the value σ of may be calculated. When the value of σ is greater than the value of σ_c for a particular design of turbine cavitation is not expected to occur.

In practice, the value of σ_c is used to determine the maximum elevation of the turbine above tail water surface for cavitation to be avoided. The parameter of increases with an increase in the specific speed of the turbine. Hence, turbines having higher specific speed must be installed closer to the tail water level.

Performance Characteristics of Reaction Turbine

It is not always possible in practice, although desirable, to run a machine at its maximum efficiency due to changes in operating parameters. Therefore, it becomes important to know the performance of the machine under conditions for which the efficiency is less than the maximum. It is more useful to plot the basic dimensionless performance parameters (Fig. 6.1) as derived earlier from the similarity principles of fluid machines. Thus one set of curves, as shown in Fig. 6.1, is applicable not just to the conditions of the test, but to any machine in the same homologous series under any altered conditions.

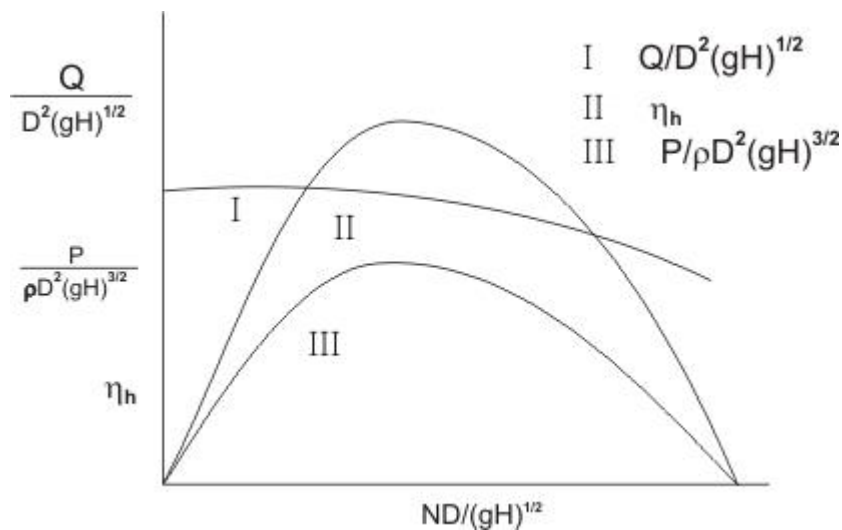

Figure performance characteristics of a reaction turbine (in dimensionless parameters)

Figure 6.2 is one of the typical plots where variation in efficiency of different reaction turbines with the rated power is shown.

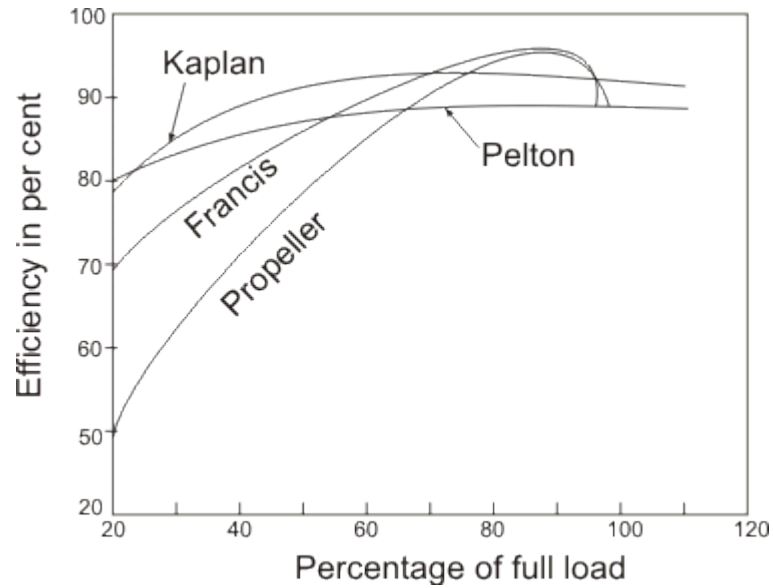

Figure Variation of efficiency with load

Comparison of Specific Speeds of Hydraulic Turbines

Specific speeds and their ranges of variation for different types of hydraulic turbines have already been discussed earlier. Figure 7.1 shows the variation of efficiencies with the dimensionless specific speed of different hydraulic turbines. The choice of a hydraulic turbine for a given purpose depends upon the matching of its specific speed corresponding to maximum efficiency with the required specific speed determined from the operating parameters, namely, N (rotational speed), p (power) and H (available head).

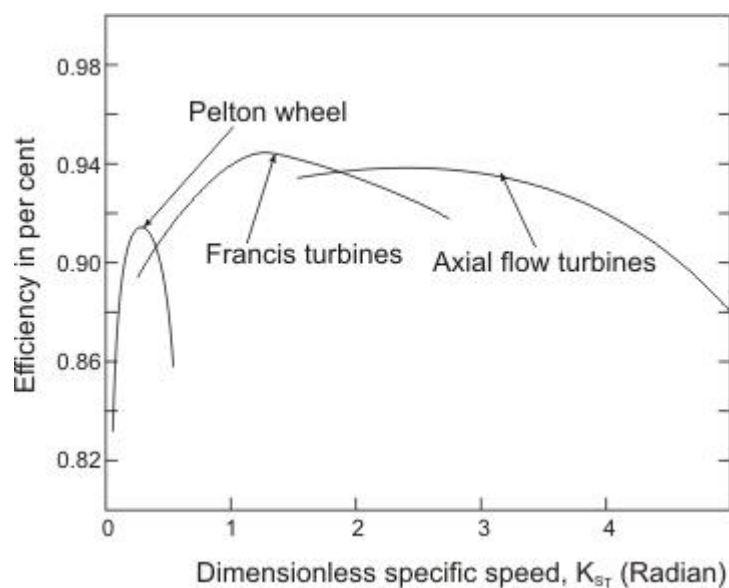

Figure Variation of efficiency with specific speed for hydraulic turbines

CHAPTER-5

Pumps

A pump is a device where mechanical energy is transferred from the rotor to the fluid by the principle of fluid motion through it. The energy of the fluid can be sensed from the pressure and velocity of the fluid at the delivery end of the pump. Therefore, it is essentially a turbine in reverse. Like turbines, pumps are classified according to the main direction of fluid path through them like (i) radial flow or centrifugal, (ii) axial flow and (iii) mixed flow types.

Centrifugal Pumps

The pumps employing centrifugal effects for increasing fluid pressure have been in use for more than a century. The centrifugal pump, by its principle, is converse of the Francis turbine. The flow is radially outward, and hence the fluid gains in centrifugal head while flowing through it. Because of certain inherent advantages, such as compactness, smooth and uniform flow, low initial cost and high efficiency even at low heads, centrifugal pumps are used in almost all pumping systems. However, before considering the operation of a pump in detail, a general pumping system is discussed as follows.

General Pumping System and the Net Head Developed by a Pump

The word pumping, referred to a hydraulic system commonly implies to convey liquid from a low to a high reservoir. Such a pumping system, in general, is shown in Fig. 33.1. At any point in the system, the elevation or potential head is measured from a fixed reference datum line. The total head at any point comprises pressure head, velocity head and elevation head. For the lower reservoir, the total head at the free surface is H_A and is equal to the elevation of the free surface above the datum line since the velocity and static pressure at A are zero. Similarly the total head at the free surface in the higher reservoir is $(H_A + H_S)$ and is equal to the elevation of the free surface of the reservoir above the reference datum.

The variation of total head as the liquid flows through the system is shown in Fig. 33.2. The liquid enters the intake pipe causing a head loss h_{in} for which the total energy line drops to point B corresponding to a location just after the entrance to intake pipe. The total head at B can be written as

$$H_B = H_A - h_m$$

As the fluid flows from the intake to the inlet flange of the pump at elevation z_1 the total head drops further to the point C (Figure 33.2) due to pipe friction and other losses equivalent to h_{f1} . The fluid then enters the pump and gains energy imparted by the moving rotor of the pump. This raises the total head of the fluid to a point D (Figure 33.2) at the pump outlet (Figure 33.1).

In course of flow from the pump outlet to the upper reservoir, friction and other losses account for a total head loss or h_{f2} down to a point E. At E an exit loss h_e occurs when the liquid enters the upper reservoir, bringing the total head at point F (Figure 33.2) to that at the free surface of the upper reservoir. If the total heads are measured at the inlet and outlet flanges respectively, as done in a standard pump test, then

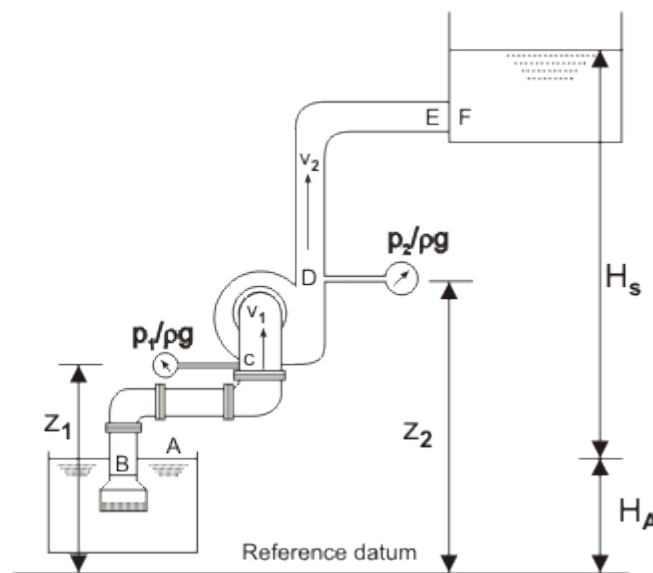

Figure A general pumping system

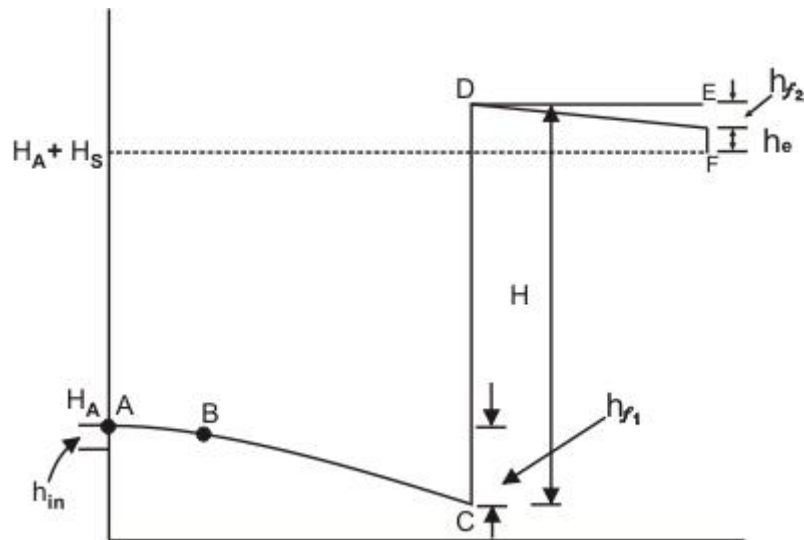

Figure Change of head in a pumping system

Total inlet head to the pump = $(p_1 + \rho g) + (V_1^2 / 2g) + z_1$

Total outlet head of the pump = $(p_2 + \rho g) + (V_2^2 / 2g) + z_2$

where V_1 and V_2 are the velocities in suction and delivery pipes respectively.

Therefore, the total head developed by the pump,

$$H = [(p_2 - p_1) / \rho g] + [(V_2^2 - V_1^2) / 2g] + [z_2 - z_1] \quad (33.1)$$

The head developed H is termed as *manometric head*. If the pipes connected to inlet and outlet of the pump are of same diameter, $V_2 = V_1$ and therefore the head developed or manometric head H is simply the gain in piezometric pressure head across the pump which could have been recorded by a manometer connected between the inlet and outlet flanges of the pump. In practice, $(z_2 - z_1)$ is so small in comparison to $(p_2 - p_1) / \rho g$ that it is ignored. It is therefore not surprising to find that the static pressure head across the pump is often used to describe the total head developed by the pump. The vertical distance between the two levels in the reservoirs H_s is known as static head or static lift. Relationship between H_s , the static head and H , the head developed can be found out by applying Bernoulli's equation between A and C and between D and F (Figure 33.1) as follows:

$$0 + 0 + H_A = \frac{p_1}{\rho g} + \frac{V_1^2}{2g} + z_1 + h_m + h_{f1} \quad (33.2)$$

Between D and F ,

$$\frac{p_2}{\rho g} + \frac{V_2^2}{2g} + z_2 = 0 + 0 + H_s + H_A + h_{f2} + h_e \quad (33.3)$$

substituting H_A from Eq. (33.2) into Eq. (33.3), and then with the help of Eq. (33.1),

we can write

$$\begin{aligned} H &= H_s + h_{im} + h_{f1} + h_{f2} + h_e \\ &= H_s + \sum \text{losses} \end{aligned} \quad (33.4)$$

Therefore, we have, the total head developed by the pump = static head + sum of all the losses.

The simplest form of a centrifugal pump is shown in Figure 33.3. It consists of three important parts: (i) the rotor, usually called as impeller, (ii) the volute casing and (iii) the diffuser ring. The impeller is a rotating solid disc with curved blades standing out vertically from the face of the disc. The impeller may be single sided (Figure 33.4a) or double sided (Figure 33.4b). A double sided impeller has a relatively small flow capacity.

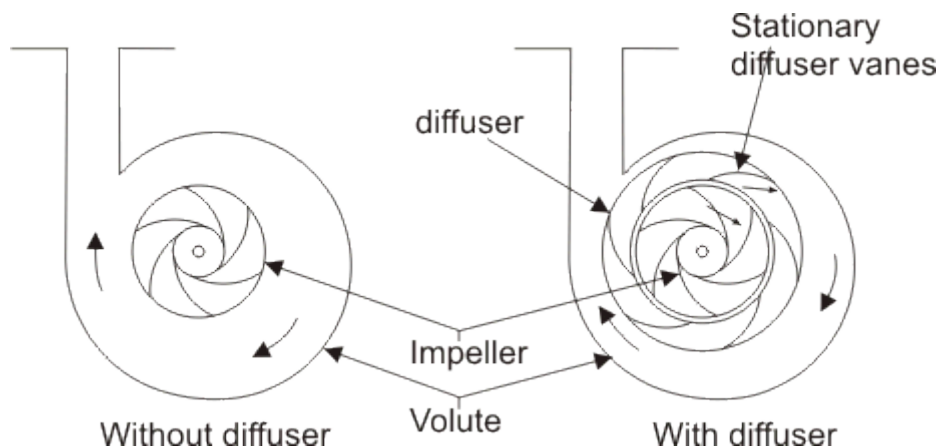

Figure A centrifugal pump

The tips of the blades are sometimes covered by another flat disc to give shrouded blades (Figure 33.4c), otherwise the blade tips are left open and the casing of the pump itself forms the solid outer wall of the blade passages. The advantage of the shrouded blade is that flow is prevented from leaking across the blade tips from one passage to another.

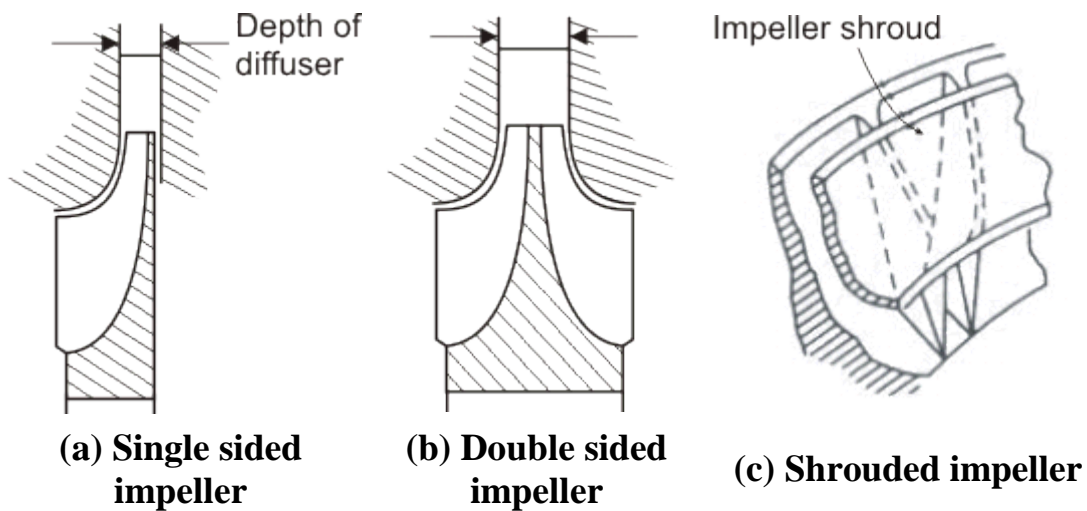

Figure Types of impellers in a centrifugal pump

As the impeller rotates, the fluid is drawn into the blade passage at the impeller eye, the centre of the impeller. The inlet pipe is axial and therefore fluid enters the impeller with very little whirl or tangential component of velocity and flows outwards in the direction of the blades. The fluid receives energy from the impeller while flowing through it and is discharged with increased pressure and velocity into the casing. To convert the kinetic energy of fluid at the impeller outlet gradually into pressure energy, diffuser blades mounted on a diffuser ring are used.

The stationary blade passages so formed have an increasing cross-sectional area which reduces the flow velocity and hence increases the static pressure of the fluid. Finally, the fluid moves from the diffuser blades into the volute casing which is a passage of gradually increasing cross-section and also serves to reduce the velocity of fluid and to convert some of the velocity head into static head. Sometimes pumps have only volute casing without any diffuser.

Figure 34.1 shows an impeller of a centrifugal pump with the velocity triangles drawn at inlet and outlet. The blades are curved between the inlet and outlet radius. A particle of fluid moves along the broken curve shown in Figure 34.1.

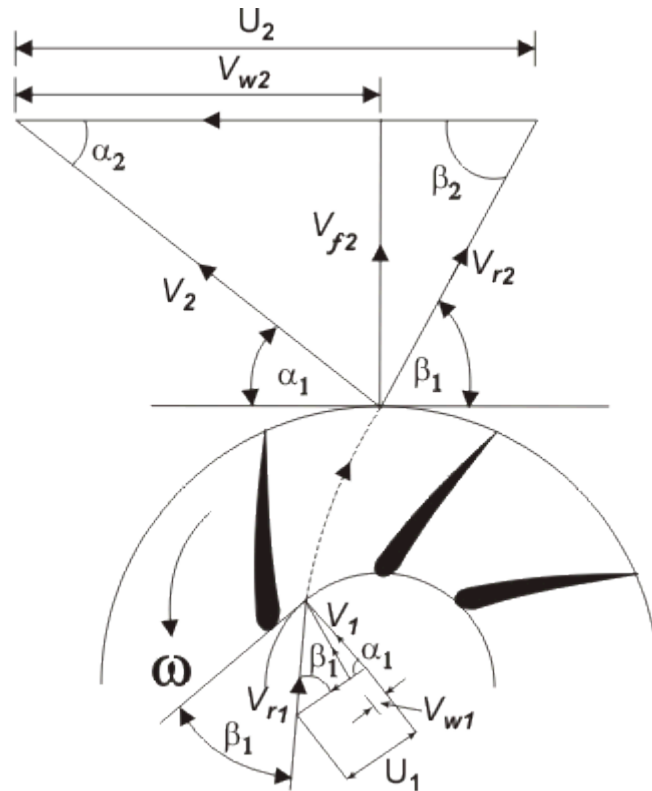

Figure Velocity triangles for centrifugal pump Impeller

Let α_1 be the angle made by the blade at inlet, with the tangent to the inlet radius, while β_2 is the blade angle with the tangent at outlet. V_1 and V_2 are the absolute velocities of fluid at inlet and outlet respectively, while V_{r1} and V_{r2} are the relative velocities (with respect to blade velocity) at inlet and outlet respectively. Therefore,

$$\begin{aligned} \text{Work done on the fluid per unit} \\ \text{weight} &= (V_{w2}U_2 - V_{w1}U_1) / g \end{aligned} \quad (34.1)$$

A centrifugal pump rarely has any sort of guide vanes at inlet. The fluid therefore approaches the impeller without appreciable whirl and so the inlet angle of the blades is designed to produce a right-angled velocity triangle at inlet (as shown in Fig. 34.1). At conditions other than those for which the impeller was designed, the direction of relative velocity V_r does not coincide with that of a blade. Consequently, the fluid changes direction abruptly on entering the impeller. In addition, the eddies give rise to some back flow into the inlet pipe, thus causing fluid to have some whirl before entering the impeller. However, considering the operation under design conditions, the inlet whirl velocity V_{w1} and accordingly the inlet angular momentum of the fluid

entering the impeller is set to zero. Therefore, Eq. (34.1) can be written as

$$\text{Work done on the fluid per unit weight} = V_{w2}U_2/g \quad (34.2)$$

We see from this equation that the work done is independent of the inlet radius. The difference in total head across the pump known as manometric head, is always less than the quantity $V_{w2}U_2/g$ because of the energy dissipated in eddies due to friction.

The ratio of manometric head H and the work head imparted by the rotor on the fluid $V_{w2}U_2/g$ (usually known as Euler head) is termed as manometric efficiency η_m . It represents the effectiveness of the pump in increasing the total energy of the fluid from the energy given to it by the impeller. Therefore, we can write

$$\eta_m = \frac{gH}{V_{w2}U_2} \quad (34.3)$$

The overall efficiency η_0 of a pump is defined as

$$\eta_0 = \frac{\rho Q g H}{P} \quad (34.4)$$

where, Q is the volume flow rate of the fluid through the pump, and P is the shaft power, i.e. the input power to the shaft. The energy required at the shaft exceeds $V_{w2}U_2/g$ because of friction in the bearings and other mechanical parts. Thus a mechanical efficiency is defined as

$$\eta_{\text{mech}} = \frac{\rho Q V_{w2} U_2}{P} \quad (34.5)$$

so that

$$\eta_0 = \eta_m \times \eta_{\text{mech}} \quad (34.6)$$

Slip Factor

Under certain circumstances, the angle at which the fluid leaves the impeller may not be the same as the actual blade angle. This is due to a phenomenon known as fluid slip, which finally results in a reduction in V_{w2} the tangential component of fluid velocity at impeller outlet. One possible explanation for slip is given as follows.

In course of flow through the impeller passage, there occurs a difference in pressure and velocity between the leading and trailing faces of the impeller blades. On the leading face of a blade there is relatively a high pressure and low velocity, while on the trailing face, the pressure is lower and hence the velocity is higher. This results in a circulation around the blade and a non-uniform velocity distribution at any radius. The mean direction of flow at outlet, under this situation, changes from the blade angle at outlet β_2 to a different angle β'_2 as shown in Figure 34.2. Therefore the tangential velocity component at outlet V_{w2} is reduced to V'_{w2} , as shown by the velocity triangles in Figure 34.2, and the difference ΔV_w is defined as the slip. The slip factor σ_s is defined as

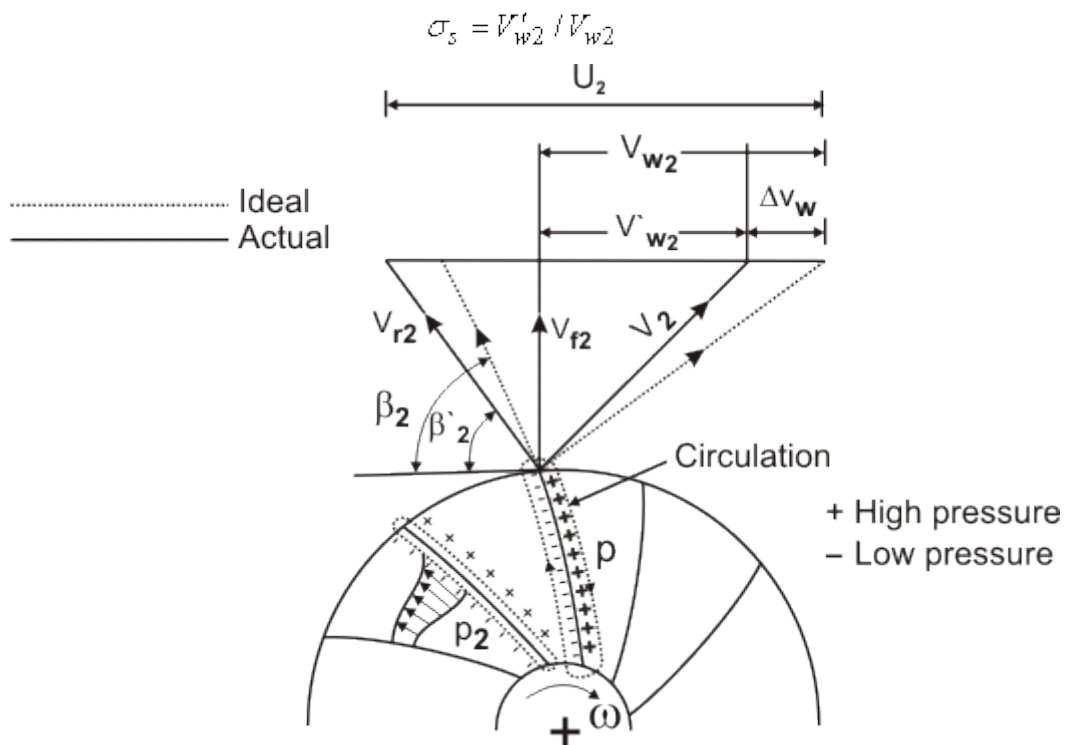

Figure Slip and velocity in the impeller blade passage of a centrifugal pump

With the application of slip factor σ_s , the work head imparted to the fluid (Euler head) becomes $\sigma_s V_{w2} U_2 / g$. The typical values of slip factor lie in the

region of 0.9.

Losses in a Centrifugal Pump

- Mechanical friction power loss due to friction between the fixed and rotating parts in the bearing and stuffing boxes.
- Disc friction power loss due to friction between the rotating faces of the impeller (or disc) and the liquid.
- Leakage and recirculation power loss. This is due to loss of liquid from the pump and recirculation of the liquid in the impeller. The pressure difference between impeller tip and eye can cause a recirculation of a small volume of liquid, thus reducing the flow rate at outlet of the impeller as shown in Fig. (34.3).

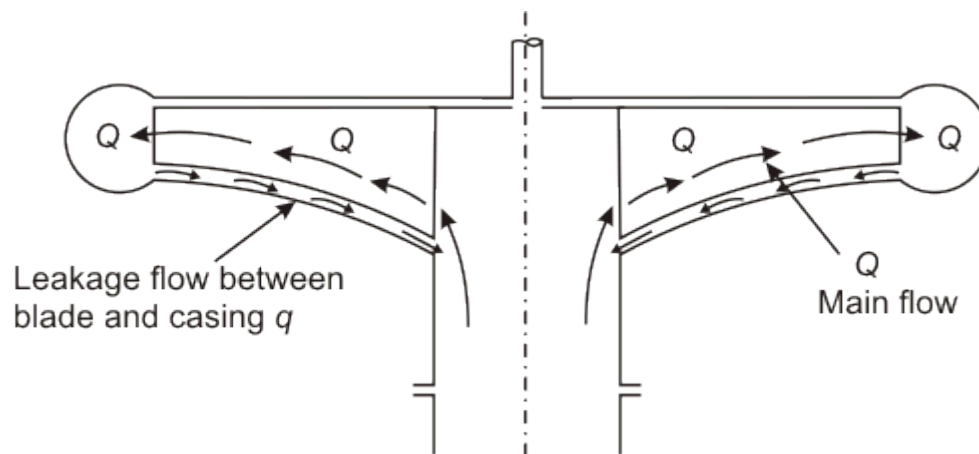

Figure Leakage and recirculation in a centrifugal pump

Characteristics of a Centrifugal Pump

With the assumption of no whirl component of velocity at entry to the impeller of a pump, the work done on the fluid per unit weight by the impeller is given by Equation (34.2). Considering the fluid to be frictionless, the head developed by the pump will be the same as can be considered as the theoretical head developed. Therefore we can write for theoretical head developed H_{theo} as

$$H_{\text{theo}} = \frac{V_{w2} U_2}{g} \quad (35.1)$$

From the outlet velocity triangle figure (34.1)

$$V_{w2} = U_2 - V_{f2} \cot \beta_2 = U_2 - (Q/A) \cot \beta_2 \quad (35.2)$$

where Q is rate of flow at impeller outlet and A is the flow area at the periphery of the impeller. The blade speed at outlet U_2 can be expressed in terms of rotational speed of the impeller N as

$$U_2 = \pi D N$$

Using this relation and the relation given by Eq. (35.2), the expression of theoretical head developed can be written from Eq. (35.1) as

$$\begin{aligned} H_{\text{theo}} &= \pi^2 D^2 N^2 - \left[\frac{\pi D N}{A} \cot \beta_2 \right] Q \\ &= K_1 - K_2 Q \end{aligned} \quad (35.3)$$

where, $K_1 = \pi^2 D^2 N^2$ and $K_2 = (\pi D N / A) \cot \beta_2$

For a given impeller running at a constant rotational speed, K_1 and K_2 are constants, and therefore head and discharge bears a linear relationship as shown by Eq. (35.3). This linear variation of H_{theo} with Q is plotted as curve I in Fig. 35.1.

If slip is taken into account, the theoretical head will be reduced to $\sigma_s V_{w2} U_2 / g$. Moreover the slip will increase with the increase in flow rate Q . The effect of slip in head-discharge relationship is shown by the curve II in Fig. 35.1. The loss due to slip can occur in both a real and an ideal fluid, but in a real fluid the shock losses at entry to the blades, and the friction losses in the flow passages

have to be considered. At the design point the shock losses are zero since the fluid moves tangentially onto the blade, but on either side of the design point the head loss due to shock increases according to the relation

$$h_{\text{shock}} = K_3(Q_f - Q)^2 \quad (35.4)$$

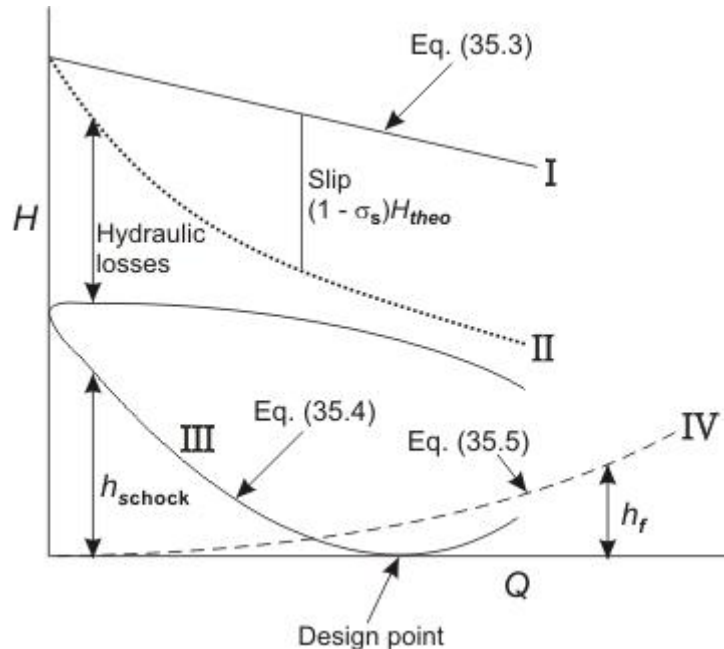

Figure Head-discharge characteristics of a centrifugal pump

where Q_f is the off design flow rate and K_3 is a constant. The losses due to friction can usually be expressed as

$$h_f = K_4 Q^2 \quad (35.5)$$

where, K_4 is a constant.

Equation (35.5) and (35.4) are also shown in Fig. 35.1 (curves III and IV) as the characteristics of losses in a centrifugal pump. By subtracting the sum of the losses from the head in consideration of the slip, at any flow rate (by subtracting the sum of ordinates of the curves III and IV from the ordinate of the curve II at all values of the abscissa), we get the curve V which represents the relationship of the actual head with the flow rate, and is known as head-discharge characteristic curve of the pump.

Effect of blade outlet angle

The head-discharge characteristic of a centrifugal pump depends (among other things) on the outlet angle of the impeller blades which in turn depends on blade settings. Three types of blade settings are possible (i) the forward facing for which the blade curvature is in the direction of rotation and, therefore, $\beta_2 > 90^\circ$ (Fig. 35.2a), (ii) radial, when $\beta_2 = 90^\circ$ (Fig. 35.2b), and (iii) backward facing for which the blade curvature is in a direction opposite to that of the impeller rotation and therefore, $\beta_2 < 90^\circ$ (Fig. 35.2c). The outlet velocity triangles for all the cases are also shown in Figs. 35.2a, 35.2b, 35.2c. From the geometry of any triangle, the relationship between V_w, U_2 and β_2 can be written as.

$$V_{w2} = U_2 - V_{r2} \cot \beta_2$$

which was expressed earlier by Eq. (35.2).

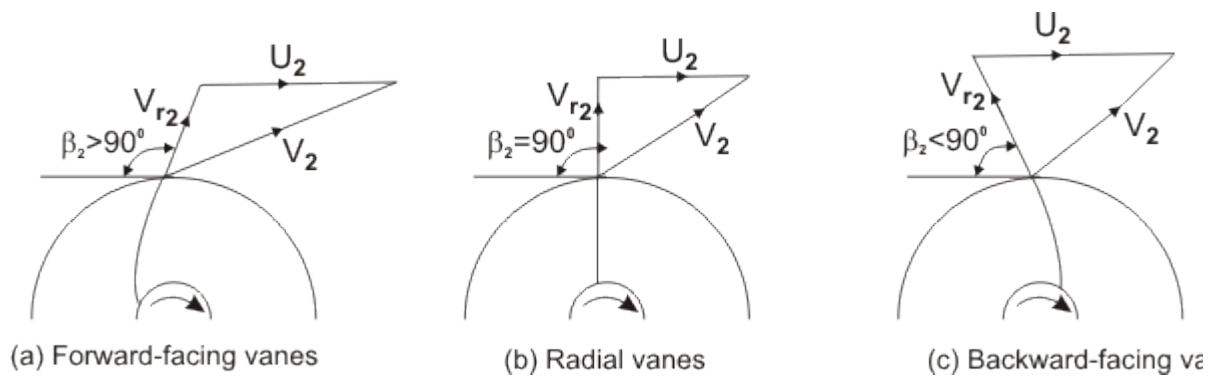

Figure Outlet velocity triangles for different blade settings in a centrifugal pump

In case of forward facing blade, $\beta_2 > 90^\circ$ and hence $\cot \beta_2$ is negative and therefore V_{w2} is more than U_2 . In case of radial blade, $\beta_2 = 90^\circ$ and $V_{w2} = U_2$. In case of backward facing blade, $\beta_2 < 90^\circ$ and $V_{w2} < U_2$. Therefore the sign of K_2 , the constant in the theoretical head-discharge relationship given by the Eq. (35.3), depends accordingly on the type of blade setting as follows:

For forward curved blades $K_2 < 0$

For radial blades $K_2 = 0$

For backward curved blades $K_2 > 0$

With the incorporation of above conditions, the relationship of head and discharge for three cases are shown in Figure 35.3. These curves ultimately

revert to their more recognized shapes as the actual head-discharge characteristics respectively after consideration of all the losses as explained earlier Figure 35.4.

For both radial and forward facing blades, the power is rising monotonically as the flow rate is increased. In the case of backward facing blades, the maximum efficiency occurs in the region of maximum power. If, for some reasons, Q increases beyond Q_D there occurs a decrease in power. Therefore the motor used to drive the pump at part load, but rated at the design point, may be safely used at the maximum power. This is known as self-limiting characteristic. In case of radial and forward-facing blades, if the pump motor is rated for maximum power, then it will be under utilized most of the time, resulting in an increased cost for the extra rating. Whereas, if a smaller motor is employed, rated at the design point, then if Q increases above Q_D the motor will be overloaded and may fail. It, therefore, becomes more difficult to decide on a choice of motor in these later cases (radial and forward-facing blades).

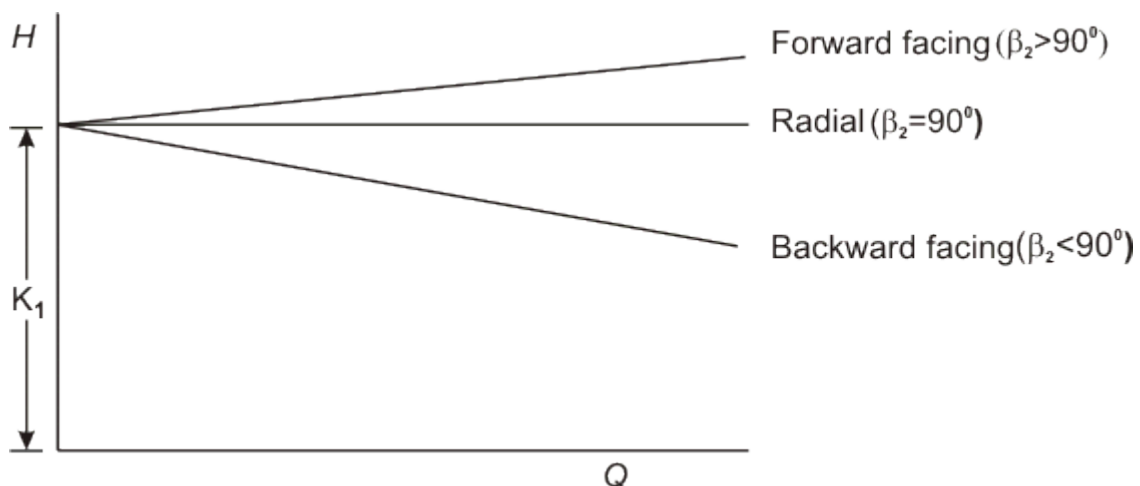

Figure Theoretical head-discharge characteristic curves of a centrifugal pump for different blade settings

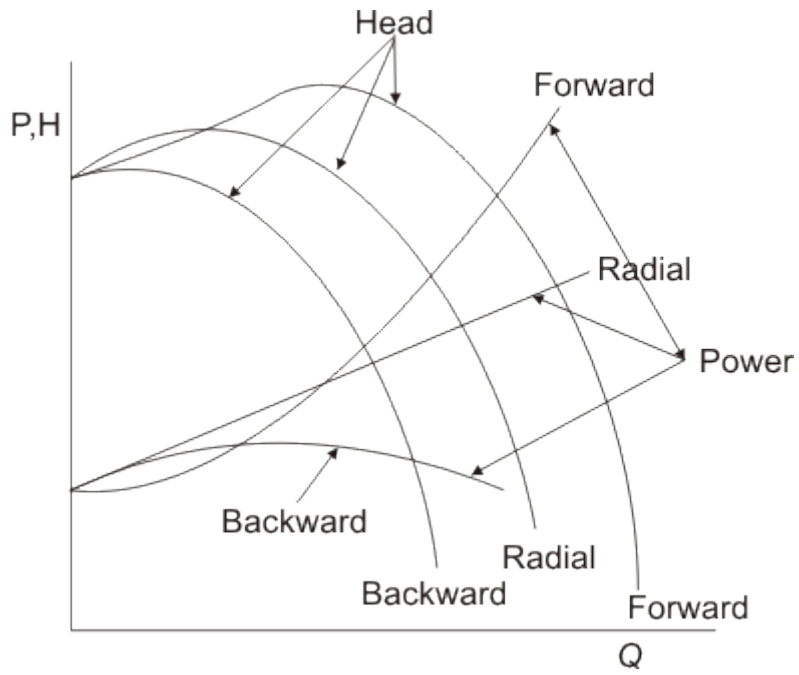

Figure Actual head-discharge and power-discharge characteristic curves of a centrifugal pump

Flow through Volute Chambers

Apart from frictional effects, no torque is applied to a fluid particle once it has left the impeller. The angular momentum of fluid is therefore constant if friction is neglected. Thus the fluid particles follow the path of a free vortex. In an ideal case, the radial velocity at the impeller outlet remains constant round the circumference. The combination of uniform radial velocity with the free vortex ($V_w \cdot r = \text{constant}$) gives a pattern of spiral streamlines which should be matched by the shape of the volute. This is the most important feature of the design of a pump. At maximum efficiency, about 10 percent of the head generated by the impeller is usually lost in the volute.

Vanned Diffuser

A vanned diffuser, as shown in Fig. 36.1, converts the outlet kinetic energy from impeller to pressure energy of the fluid in a shorter length and with a higher efficiency. This is very advantageous where the size of the pump is important. A ring of diffuser vanes surrounds the impeller at the outlet. The fluid leaving the impeller first flows through a vaneless space before entering the diffuser vanes. The divergence angle of the diffuser passage is of the order of $8-10^\circ$ which ensures no boundary layer separation. The optimum number of vanes are fixed by a compromise between the diffusion and the frictional loss. The greater the number of vanes, the better is the diffusion (rise in static pressure by the reduction in flow velocity) but greater is the frictional loss. The number of diffuser vanes should have no common factor with the number of impeller vanes to prevent resonant vibration.

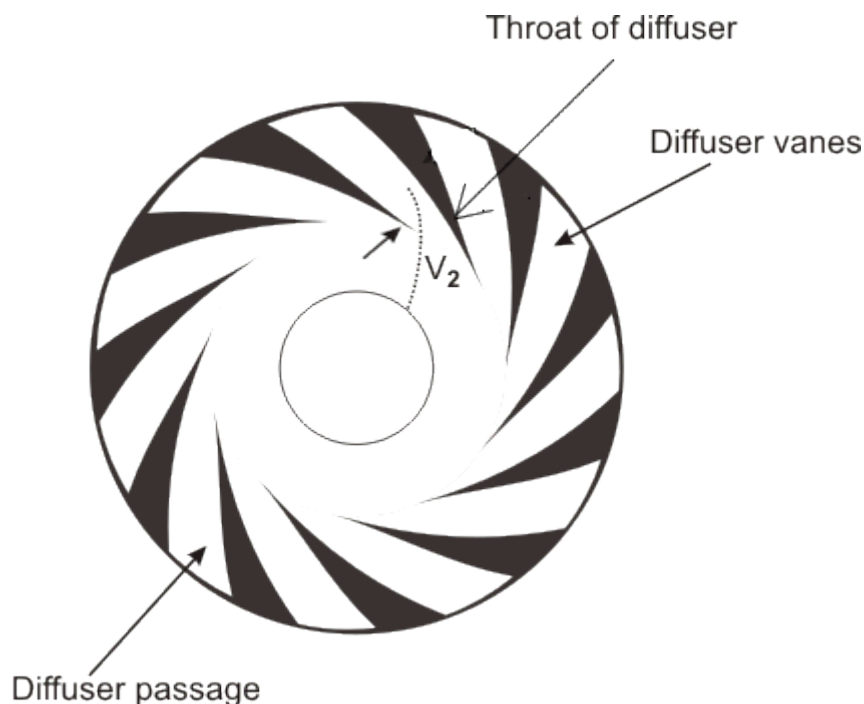

Figure A vanned diffuser of a centrifugal pump

Cavitation in centrifugal pumps

Cavitation is likely to occur at the inlet to the pump, since the pressure there is the minimum and is lower than the atmospheric pressure by an amount that equals the vertical height above which the pump is situated from the supply reservoir (known as sump) plus the velocity head and frictional losses in the suction pipe. Applying the Bernoulli's equation between the surface of the liquid in the sump and the entry to the impeller, we have

$$\frac{p_i}{\rho g} + \frac{V_i^2}{2g} + z = \frac{p_A}{\rho g} - h_f \quad (36.1)$$

where, p_i is the pressure at the impeller inlet and p_A is the pressure at the liquid surface in the sump which is usually the atmospheric pressure, ZI is the vertical height of the impeller inlet from the liquid surface in the sump, h_f is the loss of head in the suction pipe. Strainers and non-return valves are commonly fitted to intake pipes. The term h_f must therefore include the losses occurring past these devices, in addition to losses caused by pipe friction and by bends in the pipe.

In the similar way as described in case of a reaction turbine, the net positive suction head 'NPSH' in case of a pump is defined as the available suction head (inclusive of both static and dynamic heads) at pump inlet above the head corresponding to vapor pressure.

Therefore,

$$\text{NPSH} = \frac{p_i}{\rho g} + \frac{V_i^2}{2g} - \frac{p_v}{\rho g} \quad (36.2)$$

Again, with help of Eq. (36.1), we can write

$$\text{NPSH} = \frac{p_A}{\rho g} - \frac{p_v}{\rho g} - z - h_f$$

The Thomas cavitation parameter s and critical cavitation parameter σ_c are defined accordingly (as done in case of reaction turbine) as

$$\sigma = \frac{\text{NPSH}}{H} = \frac{(p_A / \rho g) - (p_v / \rho g) - z - h_f}{H} \quad (36.3)$$

$$\text{and } \sigma_c = \frac{(p_A / \rho g) - (p_i / \rho g) - z - h_f}{H} \quad (36.4)$$

We can say that for cavitation not to occur,

$$\sigma > \sigma_c \text{ (i.e. } p_i > p_v \text{)}$$

In order that s should be as large as possible, z must be as small as possible. In some installations, it may even be necessary to set the pump below the liquid level at the sump (i.e. with a negative value of z) to avoid cavitation.

Axial Flow or Propeller Pump

The axial flow or propeller pump is the converse of axial flow turbine and is very similar to it in appearance. The impeller consists of a central boss with a number of blades mounted on it. The impeller rotates within a cylindrical casing with fine clearance between the blade tips and the casing walls. Fluid particles, in course of their flow through the pump, do not change their radial locations. The inlet guide vanes are provided to properly direct the fluid to the rotor. The outlet guide vanes are provided to eliminate the whirling component of velocity at discharge. The usual number of impeller blades lies between 2 and 8, with a hub diameter to impeller diameter ratio of 0.3 to 0.6.

The Figure 37.1 shows an axial flow pump. The flow is the same at inlet and outlet. An axial flow pump develops low head but has high capacity. The maximum head for such a pump is of the order of 20m. The section through the blade at X-X (Figure 37.1) is shown with inlet and outlet velocity triangles in Figure 37.2.

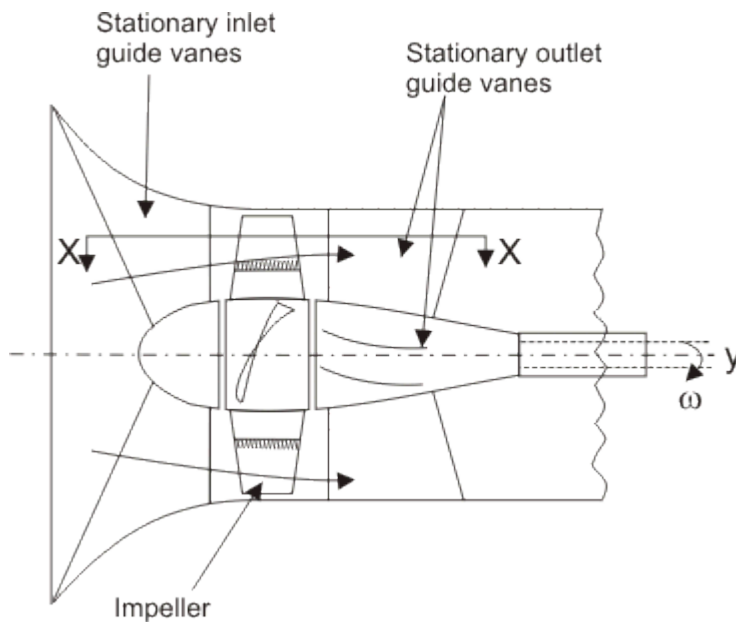

A propeller of an axial flow pump

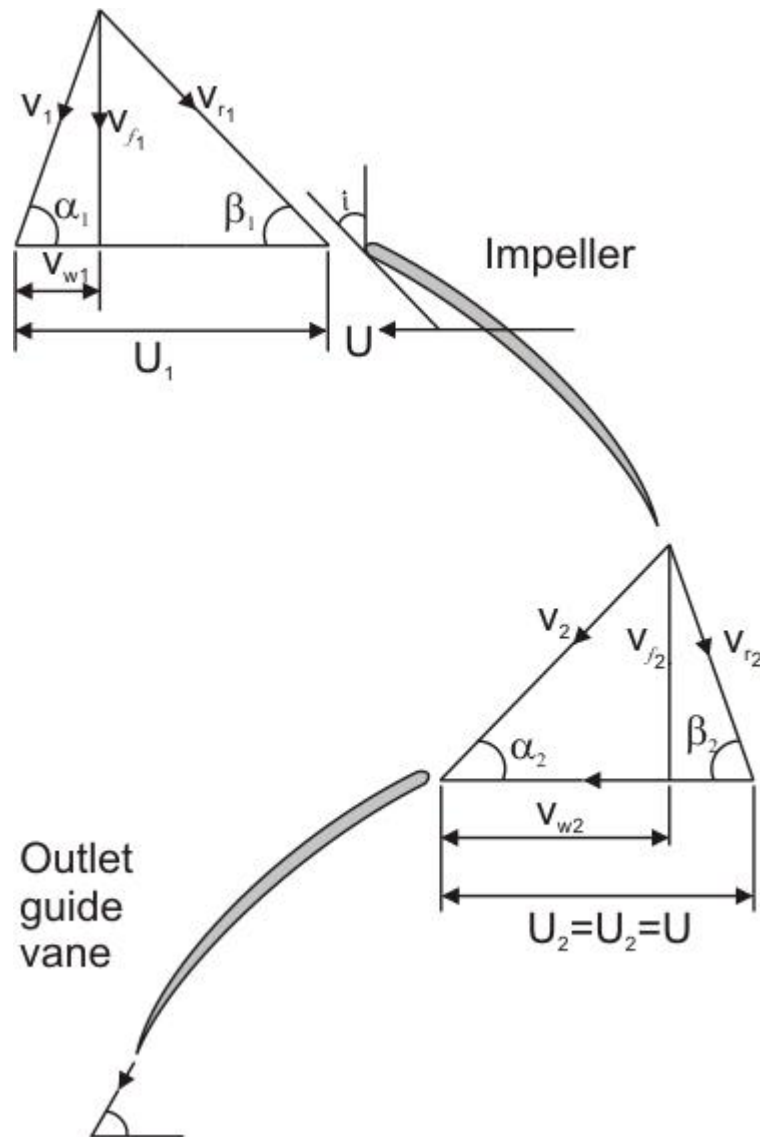

Figure Velocity triangles of an axial flow pump

Analysis

The blade has an aerofoil section. The fluid does not impinge tangentially to the blade at inlet, rather the blade is inclined at an angle of incidence (i) to the relative velocity at the inlet V_1 . If we consider the conditions at a mean radius r_m then

$$u_2 = u_1 = u = \omega r_m$$

where ω is the angular velocity of the impeller.

$$\text{Work done on the fluid per unit weight} = \frac{u(V_{w2} - V_{w1})}{g}$$

For maximum energy transfer , $V_{w1} = 0$, i.e $\alpha_1 = 90^\circ$.Again , from the outlet velocity triangle,

$$V_{w2} = u - V_{f2} \cot \beta_2$$

Assuming a constant flow from inlet to outlet

$$V_{f1} = V_{f2} = V_f$$

Then, we can write

Maximum energy transfer to the fluid per unit weight

$$= \frac{u(u - V_f \cot \beta_2)}{g} \quad (37.1)$$

For constant energy transfer over the entire span of the blade from hub to tip , the right hand side of Equation (37.1) has to be same for all values of r . It is obvious that u^2 increases with radius r , therefore an equal increase in $uV_f \cot \beta_2$ must take place, and since V_f is constant then $\cot \beta_2$ must increase. Therefore , the blade must be twisted as the radius changes.

Matching of Pump and System Characteristics

The design point of a hydraulic pump corresponds to a situation where the overall efficiency of operation is maximum. However the exact operating point of a pump, in practice, is determined from the matching of pump characteristic with the headloss-flow, characteristic of the external system (i.e. pipe network, valve and so on) to which the pump is connected.

Let us consider the pump and the piping system as shown in Fig. 15.18. Since the flow is highly turbulent, the losses in pipe system are proportional to the square of flow velocities and can, therefore, be expressed in terms of constant loss coefficients. Therefore, the losses in both the suction and delivery sides can be written as

$$h_1 = f_1 V_1^2 / 2gd_1 + K_1 V_1^2 / 2g \quad (37.2a)$$

$$h_2 = f_2 V_2^2 / 2gd_2 + K_2 V_2^2 / 2g \quad (37.2b)$$

where, h_1 is the loss of head in suction side and h_2 is the loss of head in

delivery side and f is the Darcy's friction factor, l_1, d_1 and l_2, d_2 are the lengths and diameters of the suction and delivery pipes respectively, while V_1 and V_2 are accordingly the average flow velocities. The first terms in Eqs. (37.1a) and (37.1b) represent the ordinary friction loss (loss due to friction between fluid and the pipe wall), while the second terms represent the sum of all the minor losses through the loss coefficients K_1 and K_2 which include losses due to valves and pipe bends, entry and exit losses, etc. Therefore the total head the pump has to develop in order to supply the fluid from the lower to upper reservoir is

$$H = H_s + h_1 + h_2 \quad (37.3)$$

Now flow rate through the system is proportional to flow velocity. Therefore resistance to flow in the form of losses is proportional to the square of the flow rate and is usually written as

$$h_1 + h_2 = \text{system resistance} = KQ^2 \quad (37.4)$$

where K is a constant which includes, the lengths and diameters of the pipes and the various loss coefficients. System resistance as expressed by Eq. (37.4), is a measure of the loss of head at any particular flow rate through the system. If any parameter in the system is changed, such as adjusting a valve opening, or inserting a new bend, etc., then K will change. Therefore, total head of Eq. (37.2) becomes,

$$H = H_s + KQ^2 \quad (37.5)$$

The head H can be considered as the total opposing head of the pumping system that must be overcome for the fluid to be pumped from the lower to the upper reservoir.

The Eq. (37.4) is the equation for system characteristic, and while plotted on H - Q plane (Figure 37.3), represents the system characteristic curve. The point of intersection between the system characteristic and the pump characteristic on H - Q plane is the operating point which may or may not lie at the design point that corresponds to maximum efficiency of the pump. The closeness of the operating and design points depends on how good an estimate of the expected system losses has been made. It should be noted that if there is no rise in static head of the liquid (for example pumping in a horizontal pipeline between two reservoirs at the same elevation), H_s is zero and the system curve passes through the origin.

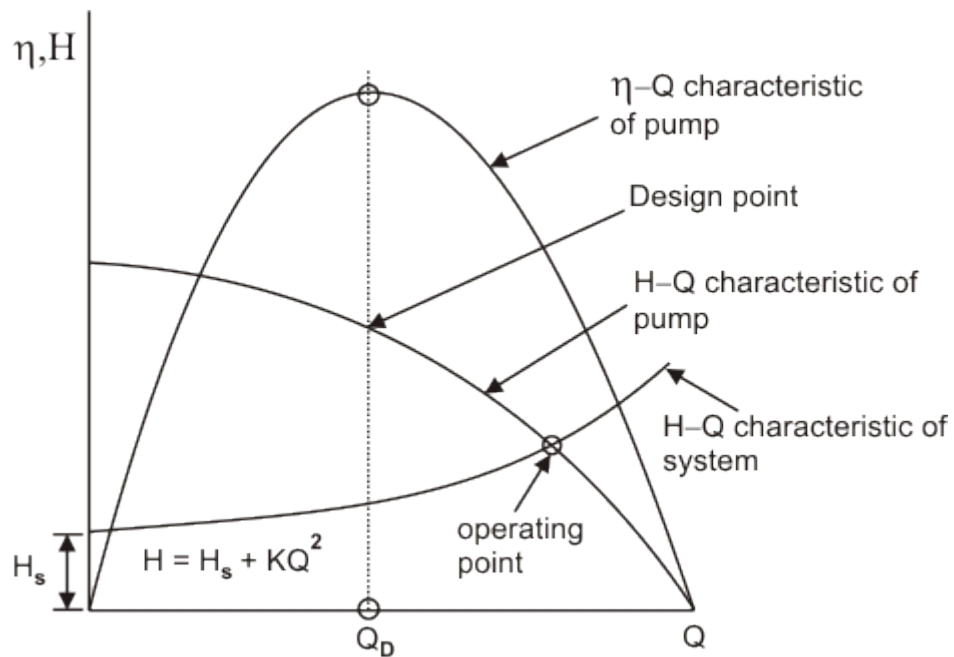

Figure H-Q Characteristics of pump and system

Effect of Speed Variation

Head-Discharge characteristic of a given pump is always referred to a constant speed. If such characteristic at one speed is known, it is possible to predict the characteristic at other speeds by using the principle of similarity. Let A, B, C be three points on the characteristic curve (Fig. 37.4) at speed N_1 .

For points A, B and C , the corresponding heads and flows at a new speed N_2 are found as follows:

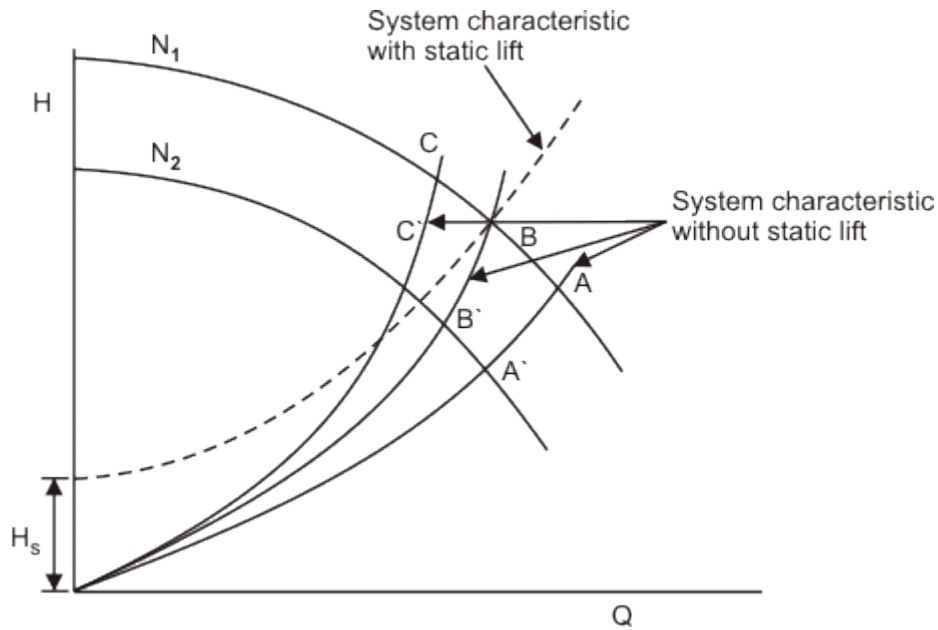

Figure Effect of speed variation on operating point of a centrifugal pump

From the equality of π_1 term [Eq. (3.1)] gives

$$Q_1 / N_1 = Q_2 / N_2 \quad (\text{since for a given pump } D \text{ is constant}) \quad (37.6)$$

and similarly, equality of π_2 term [Eq. (3.1)] gives

$$H_1 / N_1^2 = H_2 / N_2^2 \quad (37.7)$$

Applying Eqs. (37.6) and (37.7) to points A , B and C the corresponding points A' , B' and C' are found and then the characteristic curve can be drawn at the new speed N_2

Thus,

$$Q_2 = Q_1 N_2 / N_1 \quad \text{and} \quad H_2 = H_1 (N_2)^2 / (N_1)^2$$

which gives

$$\frac{H_2}{H_1} = \frac{Q_2^2}{Q_1^2}$$

or $H \propto Q^2 \quad (37.8)$

Equation (37.8) implies that all corresponding or similar points on Head-Discharge characteristic curves at different speeds lie on a parabola passing through the origin. If the static lift becomes zero, then the curve for system characteristic and the locus of similar operating points will be the same parabola passing through the origin. This means that, in case of zero static life, for an operating point at speed N_1 , it is only necessary to apply the similarity laws directly to find the corresponding operating point at the new speed since it will lie on the system curve itself (Figure 37.4).

Variation of Pump Diameter

A variation in pump diameter may also be examined through the similarity laws. For a constant speed,

$$\begin{aligned}
 & Q_1 / D_1^3 = Q_2 / D_2^3 \\
 \text{and} & \quad H_1 / D_1^2 = H_2 / D_2^2 \\
 \text{or,} & \quad H \propto Q^{2/3} \qquad \qquad \qquad (38.1)
 \end{aligned}$$

Pumps in Series and Parallel

When the head or flow rate of a single pump is not sufficient for a application, pumps are combined in series or in parallel to meet the desired requirements. Pumps are combined in series to obtain an increase in head or in parallel for an increase in flow rate. The combined pumps need not be of the same design. Figures 38.1 and 38.2 show the combined H - Q characteristic for the cases of identical pumps connected in series and parallel respectively. It is found that the operating point changes in both cases. Fig. 38.3 shows the combined characteristic of two different pumps connected in series and parallel.

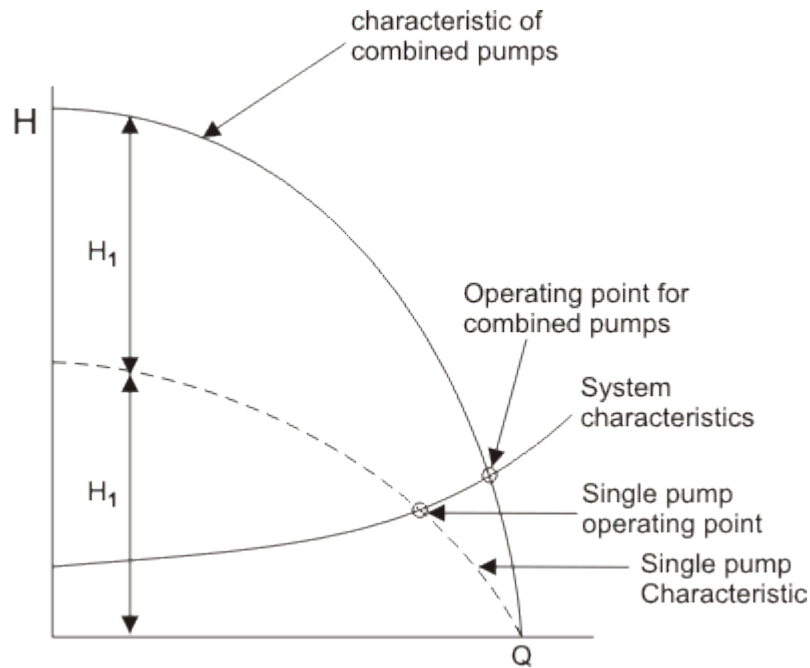

Figure Two similar pumps connected in series

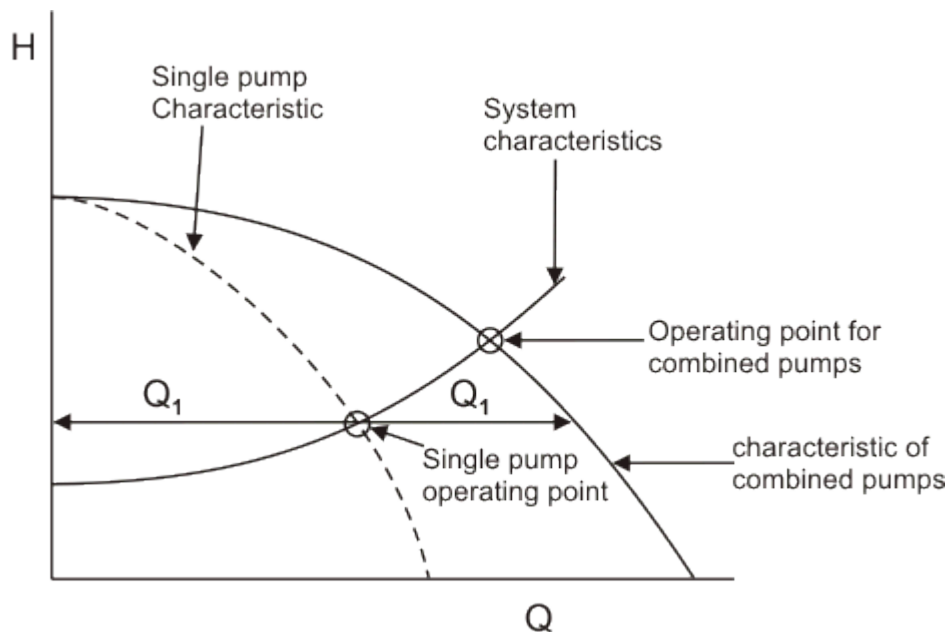

Figure Two similar pumps connected in parallel

Specific Speed of Centrifugal Pumps

The concept of specific speed for a pump is same as that for a turbine. However, the quantities of interest are N , H and Q rather than N , H and P like in case of a turbine.

For pump

$$N_{sp} = NQ^{1/2} / H^{3/4} \quad (38.2)$$

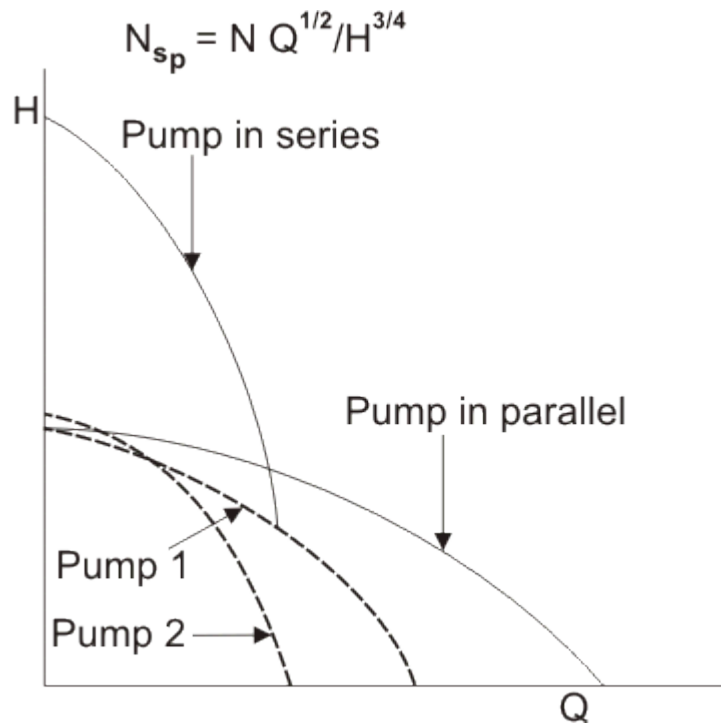

Figure Two different pumps connected in series and parallel

The effect of the shape of rotor on specific speed is also similar to that for turbines. That is, radial flow (centrifugal) impellers have the lower values of N_{sp} compared to those of axial-flow designs. The impeller, however, is not the entire pump and, in particular, the shape of volute may appreciably affect the specific speed. Nevertheless, in general, centrifugal pumps are best suited for providing high heads at moderate rates of flow as compared to axial flow pumps which are suitable for large rates of flow at low heads. Similar to turbines, the higher is the specific speed, the more compact is the machine for given requirements. For multistage pumps, the specific speed refers to a single stage.