

MARINE PRODUCTS

The Welding Handbook



UNITOR[®]

Maritime

Welding Handbook

Welding and
Related Processes
for Repair and Maintenance
Onboard

14th edition
2nd revision

Notice: All welding is carried out on the welder's own risk and account. Welding should be executed by a qualified and experienced welder and adequate safety measures should always be adhered to. The information and guidelines in this Welding Handbook are based on general information and knowledge at hand and are believed to be accurate and reliable, but the information and guidelines are not to be taken as a guarantee or warranty for a special purpose. The information and guidelines are provided to the welder solely for his own consideration, and Wilhelmsen Ships Service AS assumes no legal responsibility or liability for eventual damages and/or losses should the information and/or guidelines turn out to be incorrect or un-suitable. Wilhelmsen Ships Service AS is not liable for any loss or damages whatsoever and howsoever arising which is due to force majeure, other events beyond the reasonable control of Wilhelmsen Ships Service AS or events that could not reasonably be foreseen by Wilhelmsen Ships Service AS when this Welding Handbook was made. Wilhelmsen Ships Service AS is in no event liable for indirect, incidental or consequential damages or losses, including damages for loss of profits, resulting from lack of conformity, including but not limited to loss resulting from goods or software not working when connected to other goods/software or for any related cause thereto. Wilhelmsen Ships Service AS's liability shall in any event not exceed the total purchase price of the Wilhelmsen Ships Service AS goods used during the welding operations. These conditions are automatically accepted by anybody using the information and guidelines in this Welding Handbook.



INTRODUCTION

A ship at sea depends upon the knowledge, skills and self-reliance of the crew to carry out necessary maintenance and repair work. One of the important skills required is a good command of modern welding techniques.

The purpose of the Welding Handbook for maritime welders is to provide guidance in modern welding and related processes and to provide the welder with a source of practical information on the right solution to specific onboard welding problems.

Experience gained from user contact and welding training of crewmembers showed that documentation aimed specifically at on board welding solutions was needed. This led to the development of the first welding handbook for on-board repair and maintenance welding already the 1950es.

This edition of the UNITOR Welding Handbook builds upon all the earlier editions and on Wilhelmsen Ships Service's business activity.

Wilhelmsen Ships Service AS enjoys close co-operation with its customers and would like to thank the many who have taken the effort to contribute with examples of successful solutions to real life maintenance situations.

Unitor's business activity traces back to 1905 and the company NAG with Acetylene production as a basic activity. The first maritime deliveries from this period were supply of Acetylene as fuel gas for the guiding light beams from numerous lighthouses along the long and weather-beaten coast of Norway.

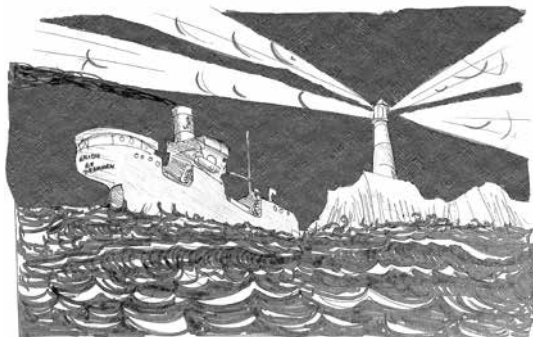

The focus changed towards gas and arc welding techniques when these were developed to useful production and repair methods through the 1930es.









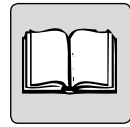















A main objective became to develop and maintain a range of welding equipment that is suitable for onboard welding, backed by a worldwide service network, training and documentation.

In 1943 the company name was changed to UNITOR. Mergers and increasing activity in the department for sales to ships led to the establishment of this department as a separate company; Unitor Ships Service AS in 1968.

In 2005 the company was bought by Wilh. Wilhelmsen ASA and the brand Unitor is now incorporated in Wilhelmsen Ships Service AS, a part of Wilhelmsen Maritime Services AS, a company in the Wilh. Wilhelmsen Group

UNITOR WELDING HANDBOOK



1 SAFETY IN WELDING			9	1.00
2 SOLUTIONS				
	2.01 Introduction & quick guides to processes		35	2.01
	2.02 Filler material consumption		47	2.02
	2.03 Metal identification		50	2.03
	2.04 Unalloyed / low alloyed steel		55	2.04
	2.05 Problem steels		62	2.05
	2.06 Stainless steels		65	2.06
	2.07 Cast iron		78	2.07
	2.08 Copper and copper alloys		104	2.08
	2.09 Aluminium		112	2.09
	2.10 Evaluation of welds		114	2.10
3 CONSUMABLES				
	3.01 Coated Electrodes		125	3.01
	3.02 TIG Welding Rods & Fluxes		197	3.02
	3.03 Wires for Wire Welding		217	3.03
	3.04 Gas Welding Rods & Fluxes		241	3.04
	3.05 Brazing Rods & Fluxes		249	3.05
	3.06 Cold Repair Compounds		275	3.06
4 ARC WELDING AND CUTTING PROCESS & EQUIPMENT				
	4.01 Electrode welding & gouging		331	4.01
	4.02 TIG Welding		381	4.02
	4.03 Wire Welding		403	4.03
	4.04 Plasma Cutting		441	4.04
5 GAS WELDING AND CUTTING PROCESS & EQUIPMENT				
	4.05 Current Distribution System		459	4.05
	5.01 AC/OX cutting, welding, brazing		465	5.01
	5.02 Gas Supplies and gas distribution system		517	5.02
6 MISCELLANEOUS INFORMATION			535	6.00



UNITOR WELDING HANDBOOK

1 SAFETY IN WELDING	9	2.06.02 Austenitic Stainless Steel	66
1.01 Introduction	10	2.06.03 Ferritic Stainless Steel	68
1.02 How to use the handbook	11	2.06.04 Martensitic Stainless Steel	69
1.03 Welding instructions and training	12	2.06.05 Duplex Stainless Steel	70
1.04 Personal protection	13	2.06.06 Clad Steel	71
1.04.01 Arc welding face shields	14	2.06.07 Stainless Steel corrosion types	72
1.04.02 Protective goggles	18	2.06.08 Storing and handling of Stainless Steel onboard	74
1.04.03 Welder's protective clothing ..	20	2.06.09 Grinding/cutting consumables for Stainless Steel	75
1.05 Work site protection	22	2.06.10 Unitor Safety Grinder	77
1.05.01 Welding curtain	22	2.07 Cast iron	78
1.05.02 Welding blanket	22	2.07.01 Introduction	78
1.05.03 Fire extinguisher	23	2.07.02 Grey cast iron	79
1.06 Welding fumes	24	2.07.03 White cast iron	80
1.06.01 Welding fumes	26	2.07.04 Malleable cast iron	80
1.06.02 Fume extraction	27	2.07.05 Ductile cast iron	81
1.07 Safety check list	30	2.07.06 High alloy cast iron	82
1.07.01 Equipment	30	2.07.07 Identification of cast iron	83
1.07.02 Work place	31	2.07.08 Preparation of the work piece	84
1.07.03 Hot work procedure	32	2.07.09 Arc welding of cast iron	87
1.07.04 Operator protection	32	2.07.10 Braze welding of cast iron	95
2 SOLUTIONS	35	2.07.11 Cold repair on cast iron	97
2.01 Introduction	36	2.08 Copper and copper alloys	104
2.01.01 Quick reference for cutting ...	37	2.08.01 Introduction	104
2.01.02 Quick reference for joining	38	2.08.02 Brass	104
2.01.03 Quick reference for rebuilding, hardfacing and coating	41	2.08.03 Aluminium brass (Yorcalbro) ..	105
2.01.04 Quick reference to cold repairs	43	2.08.04 Bronze	106
2.02 Filler material consumption	45	2.08.05 Nickel bronzes (Cunifer)	107
2.03 Metal identification	48	2.09 Aluminium	112
2.04 Unalloyed / low alloyed steel	53	2.10 Evaluation of welds	114
2.04.01 Introduction	53	2.10.01 Typical welding faults	114
2.04.02 Unalloyed steel	53	2.10.02 Inspection of welded joints ...	118
2.04.03 Low alloyed steel	53	2.10.03 Crack detection	123
2.04.04 Heat resistant steel	53	3 CONSUMABLES	125
2.04.05 Low temperature steel	54	3.01 Coated Electrodes	126
2.04.06 Weathering steel	54	3.01.01 Introduction	127
2.05 Problem steels	62	3.01.02 Types of electrodes	128
2.06 Stainless steels	65	3.01.03 Storing and re-drying	134
2.06.01 Introduction	65	3.01.04 Classification and approvals ..	140
		3.01.05 Welding positions	148

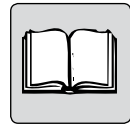

3.01.06 GPO-302 N General Purpose Electrode For Mild Steel	150	3.01.24 NICKEL-333 N Nickel Electrode for Cast Iron	184
3.01.07 GPR-300H High Recovery Electrode for Mild Steel	152	3.01.25 TINBRO-341 Electrode for Copper Alloys ...	186
3.01.08 SPECIAL-303 N Double Coated Electrode for Mild and Ship Quality Steel	154	3.01.26 ALBRONZE-344 Electrode for Copper Alloys ...	188
3.01.09 LH-314 N Low Hydrogen Electrode for Ship Quality Steel	156	3.01.27 ALUMIN-351 N Electrode for Aluminum	190
3.01.10 LHH-314 H High Recovery Low Hydrogen Electrode for Ship Quality Steel	158	3.01.28 CH-2-382 Electrode for Chamfering	192
3.01.11 LHV-316 N Vertical Down Welding Low Hydrogen Electrode for Ship Quality Steel	160	3.01.29 ACA-384 Electrode for Air Carbon Arc Gouging	194
3.01.12 LHT-318 N Electrode for High Temperature Steel	162	3.02 TIG welding rods and fluxes	197
3.01.13 LHL-319 N Electrode for Low Temperature Steel	164	3.02.01 Introduction	198
3.01.14 LHR-320 N Electrode for Weathering Steel	166	3.02.02 Classification	199
3.01.15 TENSILE-328 N Electrode for Difficult-to- Weld Steel	168	3.02.03 IMS-210	200
3.01.16 IMPACT-329 S Electrode for Heat Resistant Overlays	170	3.02.04 ICROMO-216	202
3.01.17 WEARMAX-327 Electrode for Joining & Wear Resistant Overlays	172	3.02.05 18/8 Mo-221	204
3.01.19 18/8-321 N Electrode for Stainless Steel ..	174	3.02.06 ALUMAG-235	206
3.01.20 23/14-322 N Electrode for Stainless Steel ..	176	3.02.07 IDUPLEX-222	208
3.01.21 DUPLEX-325 N Electrode for Duplex Steel	178	3.02.08 ICUNI-30-239	210
3.01.22 PICKLING GEL Pickling Gel for Stainless Steel	180	3.02.09 IALBRO	212
3.01.23 NIFE-334 N Nickel Iron Electrode for Cast Iron	182	3.02.10 I-FLUX-238 PF	214
		3.03 Wires for Wire Welding	217
		3.03.01 Introduction	218
		3.03.02 Classification	219
		3.03.03 Storage and handling for Flux Cored wires	221
		3.03.04 GPS-W-200	222
		3.03.05 MS-W-201 Selfshield	224
		3.03.06 Coreshield 8 Selfshield	226
		3.03.07 S 316 M-GF-221	228
		3.03.08 S 309 M-GF-222	230
		3.03.09 Icuni-W-239	232
		3.03.10 Ialbro-W-237	234
		3.03.11 Alumag-W-235	236
		3.03.12 Abratech-W-230	238
		3.04 Gas Welding Rods & Fluxes	241
		3.04.01 Introduction	242
		3.04.02 MS-200	244
		3.04.03 ALUMAG-235	246
		3.04.04 Aluflex-234 F	248



UNITOR WELDING HANDBOOK

3.05 Brazing Rods & Fluxes	249	4.01.05 UWI-150 TP	342
3.05.01 Introduction	250	4.01.06 UWI-230 TP AC/DC	345
3.05.02 Bronze-264	254	4.01.07 UWI-203 TP	348
3.05.03 FC-Bronze-261	256	4.01.08 UWI-320 TP	350
3.05.04 FC-Wearbro-262	258	4.01.09 UWI-500 TP	352
3.05.05 Cast Iron-237	260	4.01.10 Primary extension cables	359
3.05.06 AG-45-253	262	4.01.11 Secondary cables	360
3.05.07 AG-60-252	264	4.01.12 Electrode holders, cable connectors & return clamp assembly	362
3.05.08 Tin-241 AG	266	4.01.13 Accessories	370
3.05.09 Fluxes for Brazing	268	4.01.14 Welding techniques	371
3.05.10 Bronze Flux-261 PF	269	4.01.15 Edge preparation	373
3.05.11 Wearbro Flux-262 PF	270	4.01.16 Electrodes for electrode welding & gouging	374
3.05.12 AG-60/45 Flux-252 PF	271	4.01.17 Air Carbon arc gouging	377
3.05.13 Albro Flux-263 PF	272	4.02 TIG Welding	381
3.05.14 Cast Iron Flux-236 F	273	4.02.01 Introduction	382
3.06 Cold Repair Compounds	275	4.02.02 Basic principles	383
3.06.01 Introduction	276	4.02.03 Shielding gas	384
3.06.02 Typical application areas	276	4.02.04 Tungsten electrodes	386
3.06.03 How do Polymers work?	278	4.02.05 TIG torch	388
3.06.04 How to prepare the surface ...	279	4.02.06 Regulator & accessories	391
3.06.05 How to apply the product	280	4.02.07 Preparing the torch	393
3.06.06 Polymer Kit-A	282	4.02.08 Welding parameters	394
3.06.07 Product overview	284	4.02.09 Welding technique	395
3.06.08 Leak Stop - Pipe repair	286	4.02.10 Edge preparation	398
3.06.09 Metalgrade Ready-Stick	290	4.02.11 Rods and Flux for TIG welding	400
3.06.10 Metalgrade Express	294	4.03 Wire Welding	403
3.06.11 Metalgrade Rebuild	296	4.03.01 Introduction	404
3.06.12 Metalgrade Hi-Temp	302	4.03.02 Basic principles	405
3.06.13 Aquagrade Rebuild	306	4.03.03 Shielding gas	411
3.06.14 Ceramigrade Rebuild	310	4.03.04 Equipment	412
3.06.15 Ceramigrade Liner	314	4.03.05 UWW-161 TP	414
3.06.16 Ceramigrade Abrashield	318	4.03.06 UWF-102	420
3.06.17 Rubbergrade 6 Rebuild	322	4.03.07 Regulator & accessories	426
3.06.18 Rubbergrade 6 Remould	326	4.03.08 Application areas	428
4 ARC WELDING AND CUTTING PROCESS & EQUIPMENT	331	4.03.09 Preparation for welding	429
4.01 Electrode welding & gouging	333	4.03.10 Welding technique	431
4.01.01 Introduction	334	4.03.11 Edge preparation	434
4.01.02 Basic principles	337	4.03.12 Wires for wire welding	438
4.01.03 Power source characteristics	338	4.04 Plasma Cutting	441
4.01.04 Selecting power source	340	4.04.01 Introduction	443

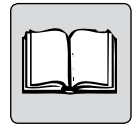

4.04.02 Basic principles	445	5.01.23 Consumables and parameters for gas welding	509
4.04.03 Plasma cutting equipment	446	5.01.24 Soldering and brazing techniques	510
4.04.04 UPC-310 TP	447	5.01.25 Edge preparation	512
4.04.05 UPC-1041	451	5.01.26 Consumables and parameters for brazing	514
4.04.06 Cutting technique	454		
4.04.07 Maintenance and trouble shooting	456		
4.05 Current Distribution System	459		
5 GAS WELDING AND CUTTING PROCESS & EQUIPMENT	463	5.02 Gas supplies and gas distribution system	517
5.01 Ac/Ox cutting, welding, brazing	465	5.02.01 Introduction	518
5.01.01 Introduction	466	5.02.02 Argon	519
5.01.02 The Combination Torch UCT-500	468	5.02.03 Argon-Carbon Dioxide mixture	520
5.01.03 UCT-500 Components and spares	470	5.02.04 Carbon-Dioxide	521
5.01.04 The Unitor Workshop Cabinet	472	5.02.05 Oxygen	522
5.01.05 Welding and grinding goggles	474	5.02.06 Acetylene	524
5.01.06 Accessories	475	5.02.07 Rules & Safety precautions for handling and use of Gas cylinders	528
5.01.07 Portable gas equipment	476	5.02.08 Gas Distribution System for Acetylene and Oxygen	530
5.01.08 Gas hoses	479		
5.01.09 Hose connectors	482	6 MISCELLANEOUS INFORMATION	535
5.01.10 Gas regulators for cylinders ...	485	5.04 International system of units	536
5.01.11 Flashback	487	5.05 The Greek Alphabet	537
5.01.12 Flashback arrestors	488	5.06 General conversion factors	538
5.01.13 The acetylene/oxygen flame ..	489	5.07 Roman numerals	539
5.01.14 Operating instructions for UCT-500 cutting torch	492	5.08 Metric and decimal equivalents of fractions of an inch	540
5.01.15 Cutting procedure	494	5.09 Wire cross section AWG/mm²	540
5.01.16 Common cutting faults	496	5.10 Common gauge series for sheet thickness and wire	541
5.01.17 Operating instructions for UCT-500 brazing, welding & heating torch	498	5.11 Physical properties of some elements	542
5.01.18 Maintenance of blowpipes	500	5.12 Hardness comparison table	543
5.01.19 Heating techniques	502	5.13 Corrosion of galvanic couples in sea water	544
5.01.20 Flame straightening techniques	503	5.14 Temperature scales	546
5.01.21 Welding techniques	505	5.15 Pressure variations related to temperature	547
5.01.22 Butt joints for gas welding of steel	508	5.16 Abbreviations and welding terminology.....	548



Introduction	10
How to use the handbook	11
Welding instructions and training	12
Personal protection	13
Work site protection	22
Welding fumes	24
Safety check list	30



SAFETY IN WELDING

1.00

Introduction

Welding and related thermal processes utilize compressed gas and/or electric current to provide a concentrated heat source which melts or burns away steel and other metals. Proper safety precautions are required to avoid accidents related to the gas and power supplies, to the sparks, heat, fumes, and visible and invisible rays from the heat source.

Authorities in most countries have laid down regulations and guidelines related to welding and other hot work processes, their application onboard ships, the equipment to be used and the protection of the operator.

These regulations must be available onboard, and be known and adhered to when hot work is to be done.

A welded component that fails may represent a safety hazard to crew, ship and cargo. Classification societies and other authorities have consequently issued regulations and welding procedures for a number of applications onboard. These should be known and followed wherever applicable, and welding should be

performed by qualified personnel under proper supervision.

In this chapter as well as in other parts of the handbook, you will find guidelines on safe handling of equipment, how to protect yourself, and safety precautions that should be observed when welding and related thermal processes are used on board a ship.

You will also find extensive information on how and where to use filler materials, and some guidelines as to identifying metals.

This handbook, however, cannot be considered to be a complete manual for each of these areas, dealing in detail with all the aspects of the various items.

Additional information

should be sought in other publications from Wilhelmsen Ships Service, from authorities and others and by attending training courses. Approved Unitor welding courses will deal in detail not only with the technique required for a successful weld, but also with the safety aspects around welding onboard.

SAFETY DEPENDS ON YOU

Do not install, operate or repair equipment for welding or related thermal processes unless you are thoroughly familiar with:

- The Instruction Manual for the equipment to be used.
- Rules and regulations relating to the handling and installation of the equipment.
- Rules and regulations relating to hot work onboard.
- Proper use of protective equipment and accessories related to the hot work, like fire extinguishers, fume extraction equipment, etc.
- Proper use of the filler material and fluxes for the job.



How to use the Handbook



Read this first

Familiarize yourself with the chapter you are now reading, and follow the advice given here whenever you weld. If you know little about welding and your objective is to become familiar with the welding processes on a self-study basis, start with the chapters at the back of the book and follow the processes from gas to flame, from primary power to arc and then through consumables to solutions. If, on the other hand, you have a basic understanding of welding, read the book from the beginning, starting with the chapter on solutions.



When facing a problem

Consult the solutions chapter. Here you will find quick guides to cutting, joining, rebuilding and coating, as well as information on how to identify metals, descriptions of the most common metals, and a number of examples on welding applications. You will also find tables for calculating filler material consumption.



Use the consumables correctly

When a solution is found you should check the specifics of the consumables you are going to use. The descriptions given in the chapter on consumables will not only give you technical information on the consumables, but also advise if special procedures should be followed for the particular product at hand.



The process

Before commencing work, take the time to check the details of the equipment and the technique you should use from the section on processes. You should also read through the special instruction manuals for the process and equipment you are going to use.



Power and gas supply



Safe operation and successful results depend on you being familiar with these chapters, and also the instruction manual on the specific power source you have onboard. Ensure that the gas supply is in proper order and correctly maintained, that the welding machine is suited for the process at hand, and that the cables are of correct size.



Cold repair components require no outside energy. The energy is built into the products and is released when the base and activator is mixed together. In order for the chemical reaction to take place, the temperature must be above +5°C.



The remaining questions

Reading through the handbook you will come across terminology and abbreviations you may not be familiar with. These are explained in an extensive "Abbreviations and welding terminology" section in the "Miscellaneous Information" chapter. In this chapter you will also find a number of useful tables and comparisons.



SAFETY IN WELDING

1.00

Welding instruction and training

As the world's leading welding supplier to the marine industry, Wilhelmsen Ships Service has designed and certified a number of well recognised welding academies around the world. These academies offer tailor made solutions for maintenance and repair welding onboard vessels.

It is crucial that pressurised gases and arc welding equipment are handled in a safe and secure way, and safety related issues are always a top priority for running the vessel. The consequences of not adhering to correct safety procedures can be both hazardous for the crew and damaging to the vessel. Therefore, health and safety issues are an essential and an important part of the welding training offered.

Welding and related processes are complex and require hands-on training, which teaches skills that are otherwise difficult to obtain. By attending approved training academies, the vessel's crew will be certified and trained to perform quality welding repairs onboard.

Working in the ship's operating environment, in awkward positions, and with the numerous kinds of metals onboard, can be very challenging. These are all elements the crew must take into consideration in order to work effectively. The Wilhelmsen Ships Service approved academies offer both practical and theoretical training as to how to select the correct welding methods and filler materials. These courses aim to help shipboard welders overcome the daily maintenance challenges onboard.

In order to meet world fleets logistical time challenges and requirements, we endeavour to offer flexible solutions, and can therefore arrange courses throughout the year. The pupils can be enrolled and trained at short notice, and courses may be tailor-made to fit the pupil's individual needs.

Over the years, thousands of seafarers have completed our courses, ensuring that high quality workmanship is carried out onboard the world's fleets.

The courses offer training in the following processes:

- Stick electrode welding
 - TIG (Tungsten Inert Gas) welding
 - MIG (Metal Inert Gas) welding
 - MAG (Metal Active Gas) welding
 - Plasma cutting
 - Gas welding, brazing, soldering and cutting
 - Cold repairs using cold repair components
- Materials:
- Steel
 - Stainless Steel
 - Copper and copper alloys
 - Cast iron
 - Cast steel
 - Aluminium

Throughout the years thousands of seafarers have completed our courses, ensuring that good quality workmanships is carried out onboard the world's fleet.

To sign up or to obtain more information please contact your local Wilhelmsen Ships service office or the below academies.



Unitor Welding Centre – Piraeus, Greece

Contact: wss.greece.cs@wilhelmsen.com
Phone: + 30 210 4239 100
Internet site: www.wilhelmsen.com/shipsservice

International Maritime Training Centre – Mumbai, India

Contact: imtc.mumbai@wilhelmsen.com
Phone: +91 22 2570 5570
Internet site: www.imtcmumbai.org

Norwegian Training Centre – Manila, the Philippines

Contact: training.manager@ntcm.com.ph
Phone: +632 8120 742
Internet site: www.ntcm.com.ph

Maritime Academy of Asia and the Pacific – Bataan, The Philippines

Contact: info@maap.edu.ph
Phone: + 632 7849100
Internet site: www.maap.edu.ph



Personal protection

Why do you need protective equipment?

Protection against electric shocks

Electric shocks can be the cause of two types of accidents:

- Direct accidents caused by the shock itself can be anything from minor burns to heart failure.
- Indirect accidents caused by falls from scaffolding and platforms.

Protection against burns

Burns may be caused by hot work pieces, sparks, molten metal, red-hot electrodes etc.

Protection against ultraviolet and infrared light

Many welders have experienced the discomfort of arc-eye or “sun-burnt” skin on unprotected parts of the body, usually due to insufficient or incorrect protective equipment.

Protection against chemicals

Most of the products in the Uitor Cold Repair Component range are to be considered harmless. Nevertheless we always recommend that one does the mixing and application in a ventilated area and always wear the gloves supplied with the set, when handling polymer products.

Protection against flying chips

When using a chipping hammer to remove slag from the weld, there is always a risk of flying chips which are a potential danger. The chips are sharp and can cause serious damage to the eyes.

General body protection

A welder at work is isolated from his surroundings. He must concentrate on the welding operation and cannot see what may be happening in the surrounding area. He must therefore always wear a safety helmet, safety shoes etc. which will offer him protection against accidents beyond his control.

A welder must always use complete personal protection equipment – but it is also important that he uses the correct type of equipment for the job. Wilhelmsen Ships Service, who supply a full range of welding equipment all over the world, can offer correct and complete protection equipment which will provide maximum safety for the welder in all situations.

Work site protection

In order to protect the surrounding area from sparks and spatter, ultra violet and infrared light, welding curtains and/or blankets should be used.



SAFETY IN WELDING

1.00

Arc welding face shields and glasses

A welder should bear in mind that proper protection is absolutely necessary to guard himself against the danger of electric shocks, burns, ultra-violet rays and bits of welding slag in the eye.

Unitor face shields for welding are made from a lightweight, robust plastic material which is unaffected by heat, cold or moisture, and both glasses and shields conform to relevant EN standards.



Fresh air kit for face shield

The AutoVision Plus Fresh Air Welding Shield

This Shield is the AutoVision Plus with respiratory unit. It gives the user clean, filtered air inside the helmet, and prevents inhalation of welding fumes. The airflow will keep the user fresh and let him concentrate on the work. The kit is CE approved and conforms to EN 12941:2009.

The fan battery recharges in 2-4 hours and will provide up to 220 liters of air per minute for at least 8 hours.



The AutoVision Welding face shield

The AutoVision Plus Welding face shield

The basis is a lightweight well designed shield which allows good air flow for the welder, and a head band that allows unique possibilities for adjustment:

- Distance to face
- Angle in relation to face
- Height on head
- Head diameter
- Stay-up friction

Replaceable inside and outside protective lenses, headband and sweatband for the headband is available as spares. The shield is equipped with a light powered quick automatic darkening glass that switches from low shade (4) to selected dark state within 0,4 milliseconds (0,0004 sec). The low shade state allows for good vision while chipping slag, grinding and repositioning for next arc striking. Dark mode is adjusted with a knob at the side of the shield, from shade 9 to 13 which is from the lowest TIG welding settings (5-10A) to extreme processes at + 400A arc current. Conforms to EN 175: 1997-08.

The Flip-Vision Welding face shield

The Flip-Vision face shield is fitted with a flip-up front frame. A clear safety glass is placed in the fixed frame under the flip-up frame protecting the eyes when chipping slag. The flip-up front frame is fitted with a filter shade glass with shade selected according to welding current used. The filter shade glass is protected

SAFETY IN WELDING



1.00

against spatter by a clear protection glass fitted in front of it. Shade 11 glass is supplied as standard with the shield. The glasses have dimension 60 x 110 mm.

Safety helmet with face shield

The Flip-Vision face shield is also available with safety helmet instead of headband.



The Flip-Vision Welding face shield

Face Shield with handle

The face shield with handle is also supplied with shade 11 dark glass and clear protection glass as standard. It is designed to also protect the hand holding it from radiation.



Face shield w/handle



Safety helmet w/face shield

The shields are CE approved and conforms to DIN/EN 175: 1997

Face shields

Description	Product no.
Autovision Plus, FreshAir Weldshield with respiratory unit	196 767000
AutoVision Plus, Welding Face Shield with Adjustable Shade 9 To 13	196 767001
FlipVision shield with flip-up frame, head band and shade 11 glass	196 709485
Safety helmet with face shield, flip-up front frame and shade 11 glass	196 619114
Face shield with handle and filter shade 11 glass	196 619098
Spares for AutoVision Plus	
Autovision Plus, Outside Cover Lens 10 pcs and 2 frames	196 766997
Autovision Plus, Headband complete with nuts and bolts	196 766998
Autovision Plus, FreshAir Headgear without hose and fan	196 766999
Autovision Plus, FreshAir Face seal with attachment screws	196 767002
Autovision Plus, FreshAir Filter	196 767003
Spares and accessories for Autovision (old model)	
Autovision Outside Cover Lens 10 pcs 112 X 93mm	196 709469
Autovision Inside Cover Lens 10 pcs 97 X 47mm	196 709477
Headband Complete For Autovision	196 709493
Sweat Band For Autovision	196 709501



SAFETY IN WELDING

1.00

Glasses for Arc Welding

The glasses have dimension 60 x 110 mm and are manufactured in accordance with DIN standard and are CE approved. When ordering face shields, filter shade glass of correct shade should be ordered in addition to the filter shade 11 glasses which is included.

The filter glasses are supplied in sets consisting of 5 safety glasses, 5 protection glasses and 5 filter shade glasses.

Items to be mounted into Unitor face shield in the following manner:

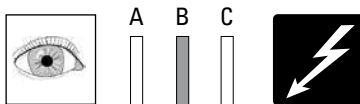

A. Safety glass (Polycarbonate)

The glass should be placed nearest to the eyes to protect against slag or other particles while chipping/grinding. When using a shield with a flip-up front frame, the safety glass shall be placed in the fixed frame.

B. Filter shade glass

Filters out harmful infra-red and ultra-violet rays from the welding arc, and reduces visible light to a level which is sufficient to see the welding process without straining the welder's eyes. Filter Shade Glass should be selected after consulting the welding process and amperage (see table). The glasses are marked Protane Shade SO 1 DIN 0196 CE

C. Protection glass

Is placed in front of the filter shade glass to protect against spatter. The protection glass should be replaced at regular intervals.

Guide to arc welding glasses

Amperage	Filter Shade	Quantity in Unit	Product number unit
< 20 A	8-9	5 sets	196-633230
20-40 A	9-10	5 sets	196-633248
40-80 A	10	5 sets	196-633255
80-175 A	11	5 sets	196-633263
175-300 A	12	5 sets	196-633271
300-500 A	13	5 sets	196-633289
Safety Glass		10 pcs	196-633222
Protection Glass		10 pcs	196-633214



SAFETY IN WELDING

1.00



Product	Pcs.	Product no.
Safety Spectacles – Clear	1	176-632943

Safety spectacles clear for eye protection

Comfortable protective spectacles with integrated side guards. The lens is made of scratch-resistant anti glare material. The temple arm length and angle is adjustable. For use during daily maintenance work in workshop and on site for protection against flying objects.

Comply to:
EN 166:2001



Product	Pcs.	Product no.
Safety Spectacles – Shade 5	1	176-632950

Safety spectacles Shade 5 for brazing and welding

Same modern lightweight design and features as the Clear version. Fitted with Shade 5 lens. For use when doing brazing and light duty gas welding and cutting work. Not for use when doing arc welding.

Comply to:
EN 166:2001



Product	Pcs.	Product no.
Welding/Grinding Goggles w/flip-up-frame	1	176-175273

Welding and grinding goggles

Lightweight goggles with soft and comfortable surfaces against the face. The ventilation slots are designed to prevent entry of sparks and spatter, at the same time ensuring sufficient air circulation to prevent dampness and fogging of the glasses.

The filter shade glass are mounted in a flip-up front frame. A protection glass must be placed in front of the filter shade glass in order to protect against spatter. One more protection glass must be placed in the fixed frame.

Comply to:
DIN EN 1598:2002-04

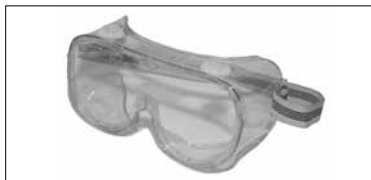

Product	Pcs.	Product no.
Safety grinding goggles non mist	1	176-653410

Safety grinding goggles

Half mask goggle of clear soft synthetic none-mist material. For grinding only.

Comply to:
EN 166:2001

SAFETY IN WELDING



1.00

Glasses for gas welding and cutting

The Unitor gas welding glasses have a diameter of 50 mm and fit the goggles. They are available in different grades of shade for various types of work. All glasses come in sets of 10 pcs.



Items to be mounted into Unitor face shield in the following manner:

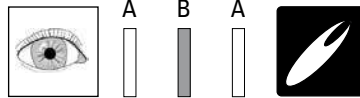

A. Protection glass

When using goggles with a flip-up front frame, the protection glass should be placed in the fixed frame.

B. Filter shade glass

In order to filter out the strong glare of the flame.

A. Protection glass

One protection glass must be placed in front of the filter shade glass in the flip-up front frame in order to protect against spatter. The protection glass should be replaced at regular intervals.

Guide to gas welding glasses

Application	Filter Shade Glass	Pcs/set	Product number
Silver Brazing	3	10	176-633305
Gas Welding & Cutting – General	5	10	176-633313
Gas Welding & Cutting – Thick material	6	10	176-633321
Protection Glass	7	10	176-633354
		10	176-633297





SAFETY IN WELDING

1.00



Welder's protective clothing

Made from specially treated leather, these protective clothes are heat and wear resistant. They provide protection during welding, especially when the welder has to work close to the workpiece or where movement is restricted. It is specially important that the welding jacket is worn when welding overhead, to protect the body and arms against falling sparks and slag.

In addition to protection against sparks and molten metal, the task of the protective leather clothing is also to protect against electric shock. When dry the leather acts as an electric insulator. Therefore always wear dry protective clothing when doing arc welding.

Protective clothing

Pos.	Product	Pcs/set	Product no.
A	Welders gloves for electric arc welding	6 pairs.	196-632786
B	TIG and gas welding gloves	6 pairs.	196-632794
	Working gloves	12 pairs	196-633057
C	Leather jacket, Large for welding	pcs	196-510438
C	Leather jacket, Extra large for welding	pcs	196-510446
D	Leather trousers with belt	pcs	196-633016
E	Arm protector	pair	196-184184
F	Leather apron	pcs	196-510420
G	Leather spats	pair	196-510453
	Heat resistant mitten	pcs	176-233148

SAFETY IN WELDING



1.00

Electric arc welding gloves

Gloves must always be worn when arc welding. Special welding gloves with long gauntlets are necessary. These must be of leather.

Long lined welding gloves are recommended for welding with coated electrodes.



TIG and Gas welding gloves

Thick welding gloves will hamper the control of the torch or rod. Special softskin gloves are available for this purpose. They will protect fully from sparks and the radiation from an arc, but will give less protection than the thicker welding gloves when touching hot metal.

Gloves for Arc and TIG welding
Comply to NEN-EN 12477 type A/B
Protection:

EN 388 3232

EN 407 332222.



Heat resistant mitten

This is a special mitten with a heat and fire resistant woven kevlar outer layer, and further insulation against heat in the inner layers. It is designed to make it possible to close an acetylene cylinder valve even if the escaping gas is on fire, and should always be kept by acetylene cylinders as a safety precaution. It is also suitable for handling hot work pieces.

Comply to:
EN 388:2003
EN 407:2004



Working gloves

This type of glove is not designed for hot work; just for handling of equipment and consumables.





SAFETY IN WELDING

1.00



Work site protection

Welding Curtain

The purpose of the Welding Curtain is to avoid other personnel being harmed by the welding work taking place. The curtain blocks out all hazardous ultraviolet and infrared light from the welding arc, but still enables one to see through the curtain. It is made of self-extinguishing material, but is not heat resistant to direct exposure to hot slag/iron spatter from the arc. Size: 2 m high and 1,3 m wide. The top of the curtain has 7 holes and the curtain comes complete with 7 heavy-duty hooks. With the hooks the curtain can be put in a frame, or hooked up on an existing pipe or wire. Maximum pipe diameter the hooks will fit on is 41 mm. In order for the curtain to be drawn freely the pipe should be less than 30 mm. It is possible to join two or more curtains together by the use of snap on buttons along the side. The curtain with hooks is supplied in a plastic bag. The curtains are in accordance with EN 1598: 2002-04.



Product	Pcs.	Product no.
Welding curtain w/ hooks, orange 1,4 x 2 m	1	196-633065

Welding spatter blanket

Non-asbestos woven glass fabric with a fire retardent weavelock, for protecting combustible materials and delicate machinery from spatter and spark during welding and cutting. Available in a roll 1m x 10m. Nom. Thickness 0,82mm. Max operating temperature 550 °C. The welding blanket is supplied in a carton box. Produced according to EN-ISO 25980: 2012



Product	Pcs.	Product no.
Welding spatter blanket	1	196-646067



Fire extinguisher

Always keep a fire extinguisher ready when welding outside workshop. The PP3P is a lightweight ABC dry powder fire extinguisher.

Technical Properties

This device was designed using highly reliable materials and the latest corrosion-resisting protection technologies. In order to be ideally suited to the requirements of the maritime environment.

It complies with European AENOR - EN 3 standard, and is of the highest performance in its category.



Weight: 4,7 kg.

Efficiency

Classes A, B or C

The multi-purpose nature of the ABC powder extinguisher ensures that it is effective against these three types of fire. For solid material fires (class A), it replaces the conventional water products, which are sometimes not recommended for use with electrical currents. For liquid, liquefiable solid and gas fires, it acts in the same conditions as the BC powder and is ideally suited for Industrial hazards.

Instructions for use



Temperature limits: -20 °C to +60 °C

Product	Pcs.	Product no.
PP3P	1	291-667394

Extinction Mechanism

The multi-purpose ABC powder acts:
 -on the flames, by negative catalysis,
 -on the embers, by cooling and forming a layer of heat insulating and fireproof "varnish", which coats the fire, preventing it from re-igniting.

When sprayed, the ABC powder forms an insulating screen, which protects the user from heat radiation.

Easy to use

Operation

Once the safety pin has been removed, the device is pressurised by

pressing on the striking handle. The flow rate is controlled by the tap on the final control valve. The fact that it is so simple to use means that risks of incorrect use are greatly reduced.



SAFETY IN WELDING

1.00

Welding fumes

Welding fumes, or smoke consists of a mixture of gases and dust particles. The composition of the fumes depends on:

1. The filler material and method of welding.
2. The base material.

Different welding methods and different metals, means that the fumes given off may contain numerous components which can be dangerous if inhaled. The best protection is the use of a smoke extraction unit. When correctly positioned, this unit will protect the welder against fume inhalation and also prevent the smoke spreading in the surrounding area and contaminating the area for others.

If it is not possible to use a smoke extraction unit, the welder can minimize the risk of fume inhalation by positioning himself so that the smoke rises some distance from his nose and mouth or by using a welding face shield with fresh air supply. For on board use a self contained unit with filter is a safe and flexible solution.

Electric arc welding with coated electrodes, may comprise several different components depending on the type of electrode. The composition of the smoke will therefore vary depending on the type of electrode. Electrodes are divided into smoke classes 1 to 7, which indicates the degree of smoke pollution. See the Coated Electrodes section on smoke classes.

Risks

The fumes given off when welding unalloyed or low-alloyed steel which has not been surface treated, are not considered to be particularly dangerous as long as inhalation of these

fumes is kept at a reasonable level. When the base metal has been surface-treated, the smoke may contain substances which could constitute a health risk.

Welding of galvanized materials or materials surface treated with substances containing zinc, gives off fumes which contain zinc oxide. Inhalation of these fumes can result in zinc poisoning with very unpleasant effects. It should be avoided by the use of a good extraction unit, or the use of a face shield with fresh air connection.

Cadmium plating is sometimes used instead of zinc plating. Welding or cutting cadmium-plated material can produce fumes which contain cadmium oxide. Lung damage can result from the inhalation of this substance.

When welding or cutting old steel plating, remember that the surface coating may contain lead or mercury. Fumes from these substances can result in serious health damage if inhaled.

When welding or cutting any type of material that has been plated or surface coated, precautions must be taken against dangerous fumes before welding commences.

Welding of stainless or acid-resistant steel produces smoke containing nickel and chrome. Copper alloys (tin bronze, leaded gun metal, leaded tin bronze and brass) contains items such as tin, zinc, lead, etc. Welding temperature tends to vaporise these items. Inhaling these substances can seriously affect the respiratory system.

When welding these types of steel or materials plated or coated with substances containing chrome, cadmium, nickel lead or mercury, it is essential



that a smoke extractor unit is used. If this is not possible, the welder must be equipped with, and must use a face shield with fresh air connection.

Welding, cutting and brazing with a gas torch can produce smoke which may contain several toxic substances. Of the gases given off, it is primarily the nitrous gases ($\text{NO}_2 + \text{NO}$) that are a health hazard. The amount of nitrous gases in the smoke depends on several conditions. The use of large size torches in confined spaces can quickly produce dangerous concentrations. No warning is given of the presence of these gases in the form of irritation of the mucous membrane in eyes, nose or throat. Proper ventilation must be arranged, and when working in confined spaces, the welder must not leave the torch alight when he is not actually using it.

Carbon monoxide may be given off due to incomplete combustion of the gases or if the material being welded or cut is plastic surfaced, varnished, painted or oily. High concentrations, which constitute a health risk, can be formed in confined spaces, tanks, pipes etc. Inhalation of large quantities of carbon monoxide can lead to suffocation.

This section points out some of the more usual risks connected with welding smoke. There are special books on the subject, and welding smoke is also undergoing continuous research. The result of this research work may bring new important factors to light and all those involved in welding should keep themselves informed of the development in this area, so precautions can be taken to protect against health risks which may, as yet, be unknown.

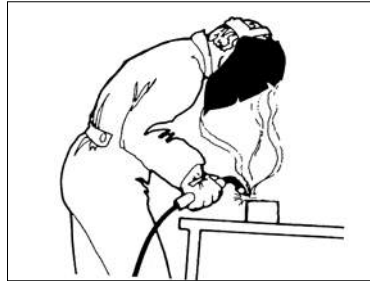

Avoid direct inhalation of welding fumes.



Use fume extraction.

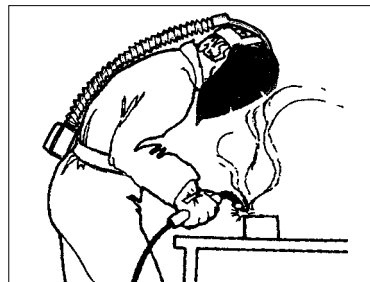

Use Fresh Air supply.



SAFETY IN WELDING

1.00

Welding fumes

All Unitor Electrodes are issued a fume Class number. These are the recommended precautions .

Fume Class 1: Ensure sufficient ventilation when welding in confined spaces. Other protective measures are normally not needed in larger well ventilated spaces.

Fume Class 2: Spot extraction is always recommended when welding in confined spaces. Larger spaces shall be well ventilated.

Fume Class 3: Spot extraction is recommended when welding indoors. Special protective measures are normally not needed outdoors if there is enough wind or draught to keep fumes and gases from the welders breathing zone.

Fume Class 4–7: Spot extraction shall be used when welding indoors. For outdoor welding see Fume Class 3.

The Recommendation states the connection between Fume Class and NHL* that is a theoretical value to describe the amount of fresh air needed to dilute the fumes to "safe" concentrations. It is important to understand that NHL* is a theoretical value and should not be used for calculating ventilation capacities:

Fresh air needed to dilute the fumes

Fume Class	NHL* (m ³ /h)
1	0 – <3000
2	3000 – < 7500
3	7500 – < 15000
4	15000 – < 35000
5	35000 – < 60000
6	60000 – < 100000
7	>100000

* NHL = Nominelt hygienisk luftbehov i m³/t
Nominal hygene air supply in m³/h



FumeClean 230 welding fume extractor

With this unit a welder is easily protected against inhaling welding fumes that might have harmful effects. It is compact and lightweight and can be used anywhere a welder can work.

Four-stage filtration system

When the welding fumes enter the unit they first pass a metal pre-separator, then the fumes flow through a aluminium pre-filter and into the main filter which has a total area of 12m². The large area of the main filter provides a long life and a constant high efficiency since filter cleaning does not have to take place very frequently.

The last stage is a High Efficiency Particle Arrestor HEPA 12 which guarantees a filtration efficiency of 99.9% under all circumstances.

Active carbon filter

If required an optional activated carbon filter can be placed on top of the main filter to remove smell. It is also possible to add hoses on the exhaust side to completely remove the filtered air from the area if required.

Two powerful motors

The two motors guarantee an adequate extraction capacity under all conditions. At low welding fume concentrations, the extraction capacity can be halved, in which situation both motors operate at half speed, thus providing a lower noise level and reduced maintenance.

Automatic start

When the welding cable is placed in a slit on top of the unit the automatic start/stop function can be used and the unit will automatically switch on when welding starts and off when welding stops.





SAFETY IN WELDING

1.00

Technical Data

Number of motors	2
Motor power consumption	2x1kW
Power supply 1phase	230V 50/60Hz
Noise level	70dB
High vacuum suction	22 000 Pa
Extraction volume speed setting 'low'	140 m ³ /h
Extraction volume speed setting 'high'	230m ³ /h
Filter surface main filter	12 m ²
Filter surface HEPA filter	0,4 m ²
Filter efficiency incl. HEPA filter	99,9%
Min. operating temperature	5°C
Max. operating temperature	40°C
Max. relative humidity	80 %
IP class	50
Net weight	16 kg

Dimensions

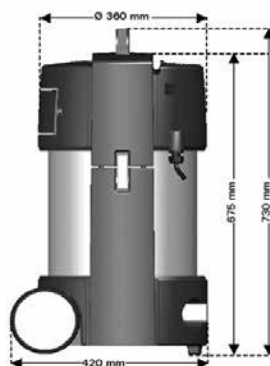

Ordering information

Description	Product no.
FumeClean 230 complete with 2,5 m hose and nozzle with magnet foot	196 735878

Optionals	
Bulkhead Bracket	196 740399
Hose Connection Outlet Side	196 740381
Active Carbon Filter	196 740431

Spare parts	
Disposable Cartridge Filter	196 740415
High Efficiency Particle Filter H12	196 740423
Funnel Nozzle With Magnetic Foot	196 740373
Extract/Exhaust Hose 2,5 M, Ø 45 mm	196 740449
Connection Piece For Two Hoses Ø 45 mm	196 740456
Carbon Brushes 2 Sets W. Seals 230V	196 740407





SAFETY IN WELDING

1.00

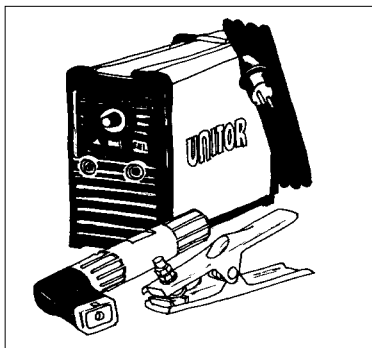

Keep your welding equipment well maintained.



Never use defective welding cables.

Safety check list for welding and related processes

Preparation for hot-work onboard should include, without being limited to the points below:

Equipment

- ✓ Check that the power source functions correctly, is correctly connected to mains, and that you are familiar with its operation.
- ✓ Ensure that gas cylinders are properly secured, in upright position, and fitted with correct and properly functioning regulators for the gas. Acetylene and oxygen regulators shall be fitted with flashback arrestors. Protect cylinders against heat and mechanical damage.
- ✓ The valve opening of the acetylene cylinder shall point away from other compressed gas cylinders, and a heat resistant mitten shall be available.
- ✓ Hoses shall be in good condition, without leaks or damage, and with correct colour coding for the gas. (Red for acetylene, blue for oxygen, black for shielding gases and filtered air). Use correct hose connectors and hose clamps. Pieces of pipe and twisted wire must never be used. Never use oil or grease in connection with welding gases and never use copper in connection with acetylene.
- ✓ Cables shall be of oil resistant type with undamaged insulation and properly mounted cable connectors. Use safety cable connectors where both halves are protected to prevent contact with deck when disconnected.



Keep cables and hoses clear of passage ways.

- ✓ Check that torches and electrode holders are in good working order.
- ✓ Check all gas connectors for leaks, including torch valves. Even Argon may be a safety risk if it replaces air in a confined area due to excessive leaks. Replace defective gaskets with original gaskets only.
- ✓ Keep hoses and cables clear of passage ways and protected from sparks, hot metal and mechanical damage e.g. in doorways, hatches, etc.
- ✓ Both welding and return clamp cables should be stretched to the work place, and the return clamp should be fastened with good electrical contact directly on the work piece.

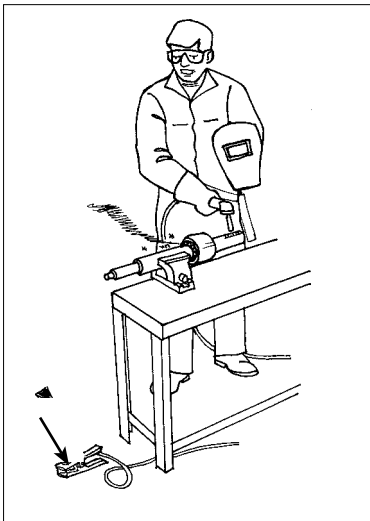

Return clamp must be fastened directly on the work piece.

Work place

Tidy up the work place and remove any flammable materials, liquids and gases from workplace and adjacent spaces including spaces above/below decks, behind bulkheads and inside pipes or containers. Cover any openings through which sparks may be led to other areas onboard which have not been prepared for hot work.

- ✓ Shield the work place to protect others from sparks and radiation from the arc, and post a warning sign that welding is in progress.
- ✓ Ensure that sufficient and correct fire fighting equipment is available at the workplace, and that personnel familiar with its use is present. Ensure that the work place is properly ventilated, if necessary with special fume extraction equipment. This is especially important when working on galvanized or coated surfaces which may produce harmful fumes when heated.



SAFETY IN WELDING

1.00

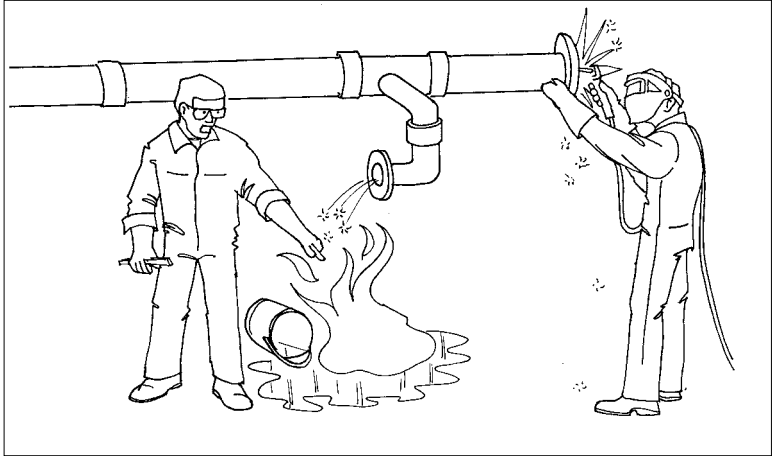

Cover openings! Sparks may travel far!

Hot work procedure

- ✓ Ensure that all relevant check lists, certificates and permits for hot work have been issued.
- ✓ If work is being done outside the ship's workshop, an assistant protected in the same manner as the welder should accompany him.
- ✓ If work has been done inside a confined space the assistant should be placed outside, within view of the welder and with possibility to cut off gas and power supply. (Gas quick couplings and an unlocked safety cable connector may act as emergency cut-offs).

Operator / assistant protection

- ✓ When working, wear safety shoes and a proper boiler suit with long sleeves. Do not wear clothes of highly combustible materials or wet clothes, and do not carry combustible material, e.g. matches, lighters, oily rags.
- ✓ Welding gloves should always be used, and when necessary also use additional leather clothing for protection against sparks, heat and electric shock.
- ✓ Use head and face protection (helmet, shield, goggles). Ensure that filter glasses are unbroken and have the correct shade.



Ensure proper ventilation.

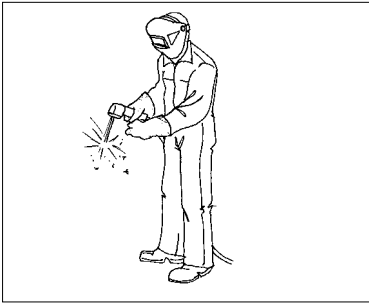

For light duty work (200 Amps or lower)

- Working overall w/long sleeves (flame retardant material). Preferably without too many pockets that easily catch sparks. For same reason avoid zips. Avoid synthetic materials, including nylon, rayon and polyester.
- Safety boots with steel toes.
- Face shield w/handle or face shield w/ head band
- Welders gloves



For work in vertical and overhead position

- Working overall
- Safety boots with steel toes.
- Face shield w/head band
- Welders gloves
- Arm protector
- Leather spats

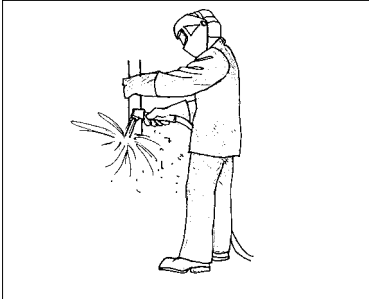

For heavy duty work (above 200 Amps)

- Working overall
- Safety boots with steel toes
- Face shield w/head band
- Welders gloves
- Leather jacket
- Leather trousers

- ✓ Where necessary use a fresh air unit or breathing apparatus to avoid inhaling fumes and dust from the welding process.
- ✓ Never use acetylene or oxygen to blow away dust from yourself or the workplace. Always keep dry and keep the workplace dry, especially when arc welding.

When work is paused or completed

- ✓ Always remove coated electrodes from the electrode holder and switch/close off gas and current at the source (welding machine, cylinder valve, gas outlet) also during short breaks for meals etc.
- ✓ Do not leave the workplace unattended. When hot work is completed the work place shall be inspected at regular interval to ensure that no risk of fire remains. Only when this has been assured should fire fighting equipment be returned to its normal storing place.

Available wall chart:

ID No. 811053 Wall Chart Safety Checklist.



ADDITIONAL WELDING LITERATURE AVAILABLE:

1.00



Cylinder safety
ID no 811034



Protect your gas cylinders and equipment
ID no 811032



Safety checklist for welding and related thermal processes
ID no 811053



The solutions guide
Unitor cold polymer repair
ID no 804004



Welding Consumables Selector
ID no 804006



The solutions guide
Unitor maintenance and repair welding
ID no 804005

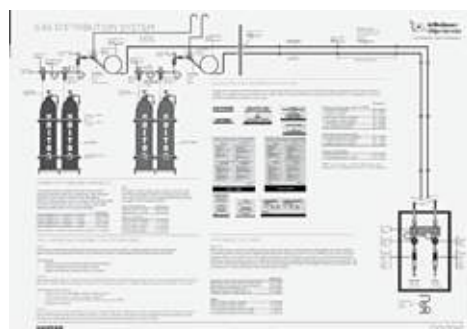

Gas distribution system
ID no 811036



Unitor Welding Handbook
ID no 805001

For latest product updates, approvals, user instructions and further technical details, please refer to our online product catalogue at <http://wssproducts.wilhelmsen.com>



Gas welding and cutting solution
ID no 811038

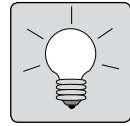

Introduction	36
• Quick reference for cutting	37
• Quick reference for joining	38
• Quick reference for rebuilding, hardfacing and coating	41
• Quick reference for cold repairs	43
Filler material consumption	45
Metal identification	48
Unalloyed/low alloyed steel	53
Problem steels	62
Stainless Steel	65
• Austenitic Stainless Steel	66
• Ferritic Stainless Steel	68
• Martensitic Stainless Steel	69
• Duplex Stainless Steel	70
• Clad Steel	71
• Stainless Steel corrosion types	72
• Storing and handling of Stainless Steel onboard	74
• Grinding/cutting consumables for Stainless Steel	75
Cast iron	78
Copper and copper alloys	104
• Aluminium brass (Yorc albro)	105
• Bronze	106
• Nickel bronzes (Cunifer)	107
Aluminium	112
Evaluation of weelds	114
• Typical welding faults	114
• Inspection of welded joints	118
• Crack detection	123

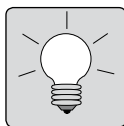

SOLUTIONS















2.01

Introduction

This chapter is intended to be a quick reference for finding alternative solutions to specific problems, indicating the process and filler material which should be used.



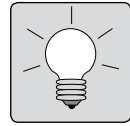

All solutions are linked to one of the symbols below which relates the solution to filler material type, process and gas/power supplies.

A successful solution is dependent not only on choosing the right filler material, but also on the electric power and gas supply of correct quality and sufficient quantity but also that the equipment used is the right one for the job. The overview on power/gas supply, equipment and processes show these relations.

SYMBOL	FILLER MATERIAL	PROCESS
		AC/OX Cutting
		AC/OX Heating
	Capillary Brazing Rods	AC/OX Brazing
	Braze Welding Rods	AC/OX Brazing
	Gas welding Rods	AC/OX Welding
	TIG Rods	Gas Tungsten Arc Welding
	Solid Wire	Gas Metal Arc Welding
	Flux Cored Wire	Flux Cored Arc Welding
	Coated Electrodes (Stick Electrodes)	Manual Metal Arc Welding
	Coated Gouging Electrodes	Manual Metal Arc Gouging
	Copper Coated Carbon Electrodes	Air Carbon Arc Gouging
		Plasma Cutting
	Cold Repair Compound	Cold Repairs
	Power Supplies	All arc processes
	Gas Supplies	All processes except coated electrodes and self-shielding flux cored wire.



Quick reference for cutting

PROCESS \ ALLOY	AC/OX 	MMA 	ACA 	Plasma 
Mild steel	A ₁	B	C	A ₂
Low alloy/ cast steels	A ₁	B	C	A ₂
High alloy/ stainless steels		B	C	A ₀
Cast iron		B	C	A ₀
Copper with alloys		B	C	A ₀
Aluminium with alloys		B	C	A ₀
Consumable parts	Cutting gouging nozzles. See AC/OX process.	CH-2 electrode	ACA electrode	Torch electrode and nozzle. See Plasma process.
		See coated electrodes and MMA processes.		

Comments

- A0: Best solution. Thickness limitation aprox. 30mm for portable equipment.
- A1: Best, most flexible solution, also for thicker materials, thickness limitation 100 mm or 500 mm with optional nozzles.
- A2: Good solution. Thickness limitation aprox. 30mm for portable equipment.
- B: Good solution for groove preparation, especially in cracks in combination with MMA welding.
- C: Best method for fast, efficient removal of old welds and weld residues, and also for large scale groove /crack preparation.

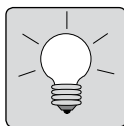

SOLUTIONS

Quick reference for joining

The table on the next pages will suggest some solutions for joining metals. Each possibility has its advantages and limitations, and further information will be found in this chapter under the metal in question, and under each of the filler materials.

You should also note that with the TIG (GTAW) arc or the gas flame it is fully possible to join metals without additional filler material when the material thickness is small and the joint is suited for it, e.g. welding

outside corners in sheet metal constructions.

How to use the table:

The metals are found both in the top horizontal row and in the left vertical column. The possibilities of joining one metal to another are found on the horizontal/vertical line connecting the metal through the diagram, as shown for stainless steel below. The corner box (box 7 in the example below) will always show the alternatives for joining the metal to itself.

METAL	Cunifer Nickel Alloys	Bronze	Yorcalbro	Brass	Copper	Cast Iron	Stainless Steels	"Problem" Steels	Unalloyed/Lowalloyed/Cast Steels
Unalloyed/Lowalloyed/Cast Steels	Icuni (W) Tinbro (E) *) **)	Ialbro (W) Icuni (W) Tinbro (E) Albronze (E) *) **)	Ialbro (W) Icuni (W) Tinbro (E) Albronze (E) *) **)	Ialbro (W) Icuni (W) Tinbro (E) Albronze (E) *) **)	Ialbro (W) Icuni (W) Tinbro (E) Albronze (E) *) **)	Nife (E) Nickel (E) Tinbro (E) Albronze (E) *) **)	23/14 (E) Tensile (E) Impact (E) *) **)	Tensile (E) Impact (E) *) **)	LH (E) LHV (E) LHT (E) LHL (E) *) **) ***)
"Problem" Steels	Icuni (W) Tinbro (E) *) **)	Ialbro (W) Icuni (W) Tinbro (E) Albronze (E) *) **)	Ialbro (W) Icuni (W) Tinbro (E) Albronze (E) *) **)	Ialbro (W) Icuni (W) Tinbro (E) Albronze (E) *) **)	Ialbro (W) Icuni (W) Tinbro (E) Albronze (E) *) **)	Tensile (E) Nickel (E) *) **)	Tensile (E) Impact (E) *) **)	Tensile (E) Impact (E) *) **)	
Stainless Steels	Icuni (W) Tinbro (E) 23/14 (E) *)	AG-60 AG-45	AG-60 AG-45	AG-60 AG-45	AG-60 AG-45	Tensile (E) 23/14 (E) 18/8 (E) *)	18/8Mo (W) 23/14 (E) 18/8 (E) Duplex (E) Iduplex (W) *)		
Cast Iron	Nickel (E) Tinbro (E) Albronze (E) *) **)	Tinbro (E) Albronze (E) *) **)	Tinbro (E) Albronze (E) *) **)	Tinbro (E) Albronze (E) *) **)	Tinbro (E) Albronze (E) *) **)	Nife (E) Nickel (E) Tinbro (E) Albronze (E) *) **) ***)			
Copper	Icuni (W) *)	Ialbro (W) Icuni (W) Tinbro (E) Albronze (E) *) **)	Ialbro (W) Icuni (W) Tinbro (E) Albronze (E) *) **)	Icuni (W) Tinbro (E) *) **)	Icuni (W) Tinbro (E) Albronze (E) *) **)				
Brass	Icuni (W) Tinbro (E) *)	Ialbro (W) Tinbro (W) Albronze (E) *) **)	Icuni (W) Tinbro (E) *) **)	Ialbro (W) Tinbro (E) Albronze (E) *) **)					
Yorcalbro	Icuni (W) Tinbro (E) *) **)	Ialbro (W) Icuni (W) Tinbro (E) Albronze (E) *) **)	Ialbro (W) *)						
Bronze	Icuni (W) Tinbro (E) *) **)	Ialbro (W) Tinbro (E) Albronze (E) *) **)							
Cunifer Nickel Alloys	Icuni (W) *)								

Example, joining stainless steel to:

- Cunifer/nickel alloys..... box 1
- Bronze: box 2
- Yorcalbro box 3
- Brass..... box 4
- Copper..... box 5
- Cast iron box 6
- Stainless steel..... box 7
- "Problem" steels..... box 8
- Low alloy steels..... box 9

Full scale table overleaf

SOLUTIONS

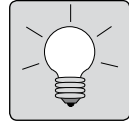

2.01

Quick reference for joining

METAL	Cu/nifer Nickel Alloys	Bronze	Yorcalbro	Brass	Copper	Cast Iron	Stainless Steels	"Problem" Steels	Unalloyed/ Low alloyed/ Cast Steels
Unalloyed/ Low alloyed/ Cast Steels	Icuni (W) Timbro (E) *) **) **)	Ialbro (W) Icuni (W) Timbro (E) Albranze (E) *) **) **)	Ialbro (W) Icuni (W) Timbro (E) Albranze (E) *) **) **)	Ialbro (W) Icuni (W) Timbro (E) Albranze (E) *) **) **)	Ialbro (W) Icuni (W) Timbro (E) *) **) **)	Nife (E) Nickel (E) Timbro (E) Albranze (E) *) **) **)	23/14 (E) Tensile (E) Impact (E) *) **) **)	Tensile (E) Impact (E) *) **) **)	LH (E) LHV (E) LHT (E) LHL (E) *) **) **) **)
"Problem" Steels	Icuni (W) Timbro (E) *) **) **)	Ialbro (W) Icuni (W) Timbro (E) Albranze (E) *) **) **)	Ialbro (W) Icuni (W) Timbro (E) Albranze (E) *) **) **)	Ialbro (W) Icuni (W) Timbro (E) Albranze (E) *) **) **)	Ialbro (W) Icuni (W) Timbro (E) *) **) **)	Tensile (E) Nickel (E) *) **) **)	Tensile (E) Impact (E) *) **) **)	Tensile (E) Impact (E) *) **) **)	Tensile (E) Impact (E) *) **) **)
Stainless Steels	Icuni (W) Timbro (E) 23/14 (E) *) **) **)	AG-60 AG-45	AG-60 AG-45	AG-60 AG-45	AG-60 AG-45	Tensile (E) 23/14 (E) 18/8 (E) *) **) **)	18/8Mo (W) 23/14 (E) 18/8 (E) Duplex (E) Duplex (W) *) **) **)	Tensile (E) Impact (E) *) **) **)	
Cast Iron	Nickel (E) Timbro (E) Albranze (E) *) **) **)	Timbro (E) Albranze (E) *) **) **)	Timbro (E) Albranze (E) *) **) **)	Timbro (E) Albranze (E) *) **) **)	Timbro (E) Albranze (E) *) **) **)	Nife (E) Nickel (E) Timbro (E) Albranze (E) *) **) **) **)			
Copper	Icuni (W) *) **) **)	Ialbro (W) Icuni (W) Timbro (E) Albranze (E) *) **) **)	Ialbro (W) Icuni (W) Timbro (E) Albranze (E) *) **) **)	Icuni (W) Timbro (E) *) **) **)	Icuni (W) Timbro (E) Albranze (E) *) **) **)				
Brass	Icuni (W) Timbro (E) *) **) **)	Ialbro (W) Timbro (W) Albranze (E) *) **) **)	Icuni (W) Timbro (E) *) **) **)	Ialbro (W) Timbro (E) Albranze (E) *) **) **)	Icuni (W) Timbro (E) Albranze (E) *) **) **)	E = Coated electrode W = Welding wire/rod			
Yorcalbro	Icuni (W) Timbro (E) *) **) **)	Ialbro (W) Icuni (W) Timbro (E) Albranze (E) *) **) **)	Ialbro (W) *) **) **)	Ialbro (W) Timbro (E) Albranze (E) *) **) **)	Icuni (W) Timbro (E) Albranze (E) *) **) **)				
Bronze	Icuni (W) Timbro (E) *) **) **)	Ialbro (W) Timbro (E) Albranze (E) *) **) **)							
Cu/nifer Nickel Alloys	Icuni (W) *) **) **)	Ialbro (W) Timbro (E) Albranze (E) *) **) **)							

*) Also capillary brazing with AG-60 and AG-45 (AG-60 only for Yorcalbro).
 **) Also brazing with FC-bronze (Bronze) or FC-Wearbro for surfacing.
 ***) For unalloyed steel IMS wire, and coated electrodes GPO, GPR, SPECIAL and GPR are additional alternatives.
 *****) Cast Iron components that may be heated evenly may be braze welded with cast iron 237.

Aluminium welding: Coated electrode: Alumin-351N
 Welding Wire: Alumag-W-235
 Rod: Alumag 235 (TiG / Gas welding)



WELDING HANDBOOK NOTES

2.01

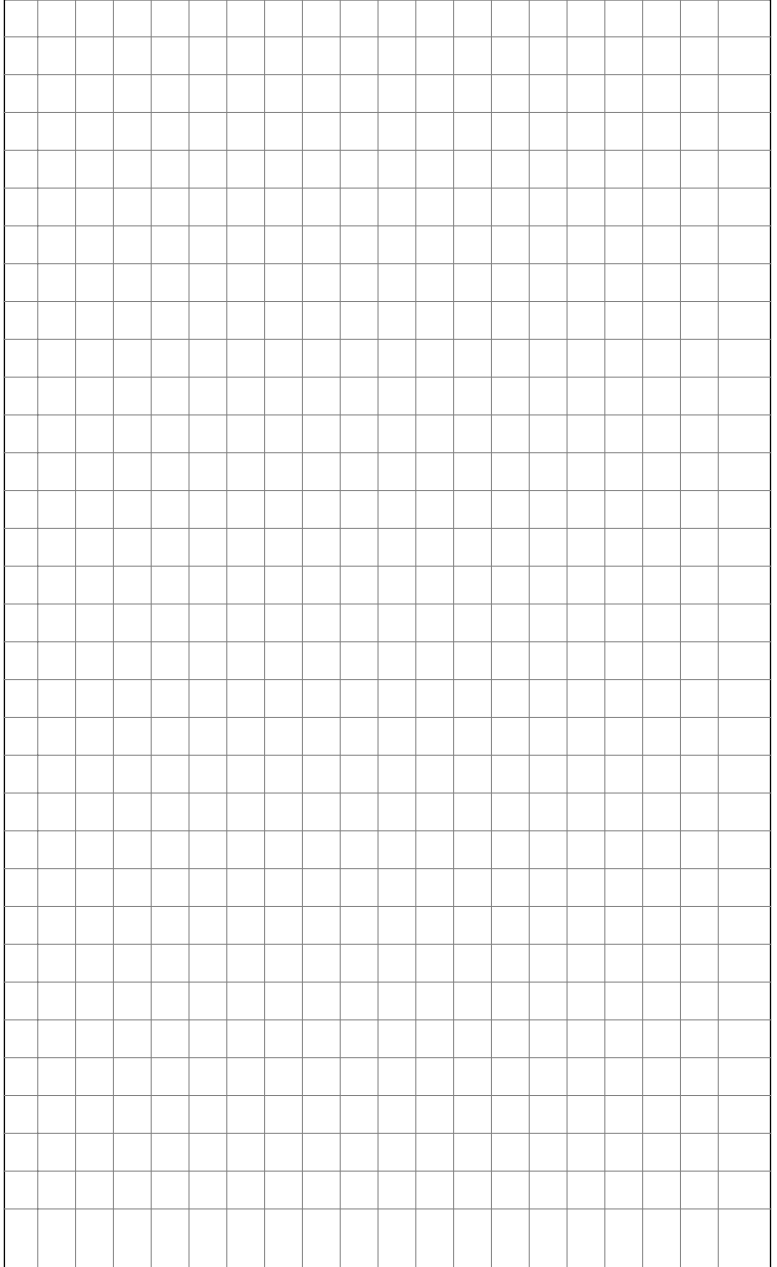

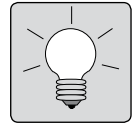

Quick reference for rebuilding, hardfacing and coating

The table shows all the possibilities within the Unitor range of filler materials for the applications listed. The various filler materials have

specific advantages or limitations, and further information will be found under each of the filler materials.

Examples of applications

Wearmax (E)
Tensile (E)

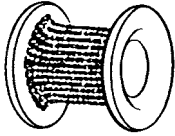

Chain, rope, wire drum

Wearmax (E)
Tensile (E)



Spot welds on ladder steps

Wearmax-327 (E)

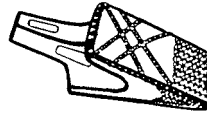

Cargo grab teeth

FC-Wearbro (B)

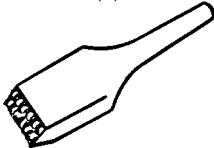

Spark proof overlay on tools

Tensile (E)
Impact (E)



Building up machine parts

Impact (E)

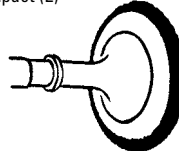

Rebuilding valve seats on exhaust valves

FC-Wearbro (B)

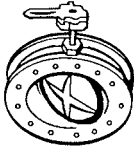

Rebuilding edges on butterfly valve

Tensile (E)
FC-Wearbro (B)

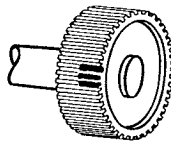

Rebuilding gear teeth

Impact (E)

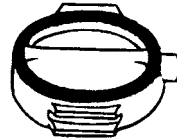

Rebuilding valve closing surfaces

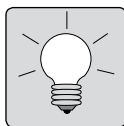

SOLUTIONS

Quick reference for rebuilding, hardfacing and coating

2.01

Property Base material	Rebuilding with approx. base material	Rebuilding with improved wear resistance properties	Rebuilding with improved corrosion resistance
Unalloyed/ low alloyed cast steels	IMS (W) LHT (E) LHR (E) LHL (E) GPR (E)	Wearmax (E) Impact (E) Tensile (E) FC-Wearbro (B)	Wearmax (E) Tensile (E) 23/14 (E) Duplex (E) FC-Wearbro (B)
"Problem" steels	Tensile (E)	Abratech-330 (E) Wearmax (E) Impact (E) FC-Wearbro (B)	Wearmax (E) Impact (E) FC-Wearbro (B)
Cast iron	Nife (E) Nickel (E) Cast iron (B)	Nife (E) Tinbro (E) FC-Wearbro (B)	Nickel (E) Albronze (E) FC-Wearbro (B)
Stainless steels	18/8 Mo (W) Duplex (E) 23/14 (E) 18/8 (E)	Tensile (E) Impact (E) Wearmax-327 (E)	W = Welding wire/rod E = Coated electrode B = Brazing alloy
Copper	Icuni (W) Tinbro (E) Albronze (E) FC-Wearbro (B)	Icuni (W) Tinbro (E) Albronze (E) FC-Wearbro (B)	
Brass	Ialbro (W) Tinbro (E) Albronze (E) FC-Wearbro (B)	Ialbro (W) Tinbro (E) Albronze (E) FC-Wearbro (B)	
Yorcalbro	Ialbro (W)	Icuni (W) FC-Wearbro (B)	
Bronze	Ialbro (W) Tinbro (E) Albronze (E) FC-Wearbro (B)	Ialbro (W) Tinbro (E) Albronze (E) FC-Wearbro (B)	
Cunifer	Icuni (W)	Nickel (E)	
Aluminium	Alumag (W) Alumin (E)		

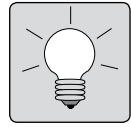

Quick reference for Cold repairs

When repairing a base material, always start with considering welding or brazing techniques. If one or more of the reasons below apply, consider using polymer.

1. Where there is a need for emergency repairs.

Cold repair compounds require no rigging-up time, and no need for energy in the form of oxygen / acetylene or electricity. The energy is built into the consumable (product) and is released when mixing base and activator. The curing time is down to a few minutes for several of the products.



2. Where hot work like welding is not permitted due to fire / explosion hazard.

Cold repair systems are cold-curing processes. There is no risk of heat ignition or sparks.



3. Where the base material is not weldable.

Certain casted metal alloys are not weldable due to their chemistry. Sometimes welding method /equipment / consumable or operator knowledge is not available. If the base material is so corroded that there is nothing to weld on, a new part can be “casted” with the repair compound.

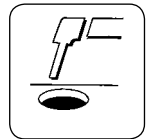

4. Where distortion of base material is unacceptable.

Welding causes expansion and contraction, leading up to distortion of the work piece.

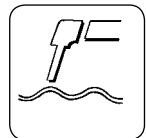

5. Where there is restricted space.

Polymer products can, if necessary, be injected through small diameter holes.

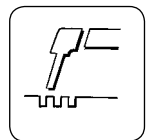

6. Where specific properties are required.

In many cases polymer compounds have better properties than weld overlays. Specifically, chemical resistance and wear resistant properties are improved. Large surfaces that are worn are also much faster overlaid with polymer compounds than with weld bead overlays.

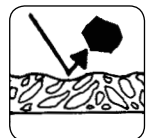

7. Where you need non-metal repairs.

Cold repair systems offer solutions for rubber gasket repairs or moulding, as well as solutions for repair or joining of plastics and composite materials.

For cold repairs products see, chapter 3 consumables.

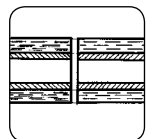

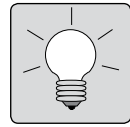

Filler material consumption

The tables give approximate weld deposit volume for various joint types. The steel weight of deposit per meter is also given.

- For steel welding wires and rods the deposit weight given equals the weight of filler material required.
- The approximate deposit weight in kg for aluminium is found by multiplying the deposit volume by 0.0027.
- The approximate deposit weight in kg of copper alloys is found by multiplying the deposit volume by 0.009.
- For coated electrodes the required number of electrodes (for steel) is found by dividing the deposit weight by the value “(number of electrodes per kg. weld metal)” found in the data table for each electrode in the filler material section.

Note that spatter, welding positions and work routines, e.g. throwing away long electrode stubbs, may influence on the total consumption.

Fillet Weld

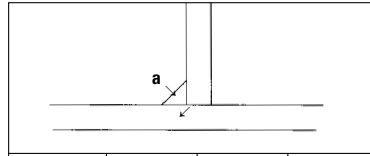

a measure	Section size	Deposit volume per m. V	Deposit weight per m. W
a	s		
mm	mm ²	cm ³ /m	kg/m
2	4	6	0.05
2.5	6.5	8.5	0.07
3	9	12.5	0.10
4	16	21	0.16
5	25	31.5	0.25
6	36	42	0.33
7	49	57	0.45
8	64	73.5	0.58
9	81	94	0.74
10	100	114	0.89
11	121	138	1.08
12	144	162	1.27
13	169	190	1.49
14	196	224	1.76
15	225	248	1.95

Outside Corner

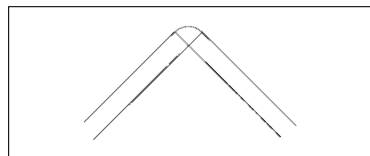
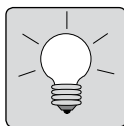

Plate thickness	Section size	Deposit volume per m. V	Deposit weight per m. W
t			
mm	mm ²	cm ³ /m	kg/m
2	2	3.5	0.03
3	4.5	7.5	0.06
4	8	10.5	0.08
5	12.5	16	0.13
6	18	22	0.17
7	24.5	31.5	0.25
8	32	40.5	0.32
9	40.5	51	0.40
10	50	64	0.50
12	72	93	0.73
15	113	141	1.11
18	162	204	1.60
20	200	252	1.98
22	242	204	2.39
25	323	405	3.18

Square Butt Joint

Plate thickness	Root opening	Deposit volume per m. V	Deposit weight per m. W
t	s		
mm	mm	cm ³ /m	kg/m
1	0	2	0.02
1.5	0.5	3	0.02
2	1	4	0.03
3	1.5	7	0.05
4	2	22	0.17
5	2.5	25	0.20
6	3	32	0.25
7	3	42	0.33



SOLUTIONS

2.02

Single V-joint

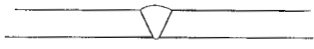

50° Flat

Plate thickness t	Root opening s	Deposit volume per m. V	Deposit weight per m. W
mm	mm	cm ³ /m	kg/m
4	1	11.5	0.09
5	1	16.5	0.13
6	1	23	0.17
7	1.5	33.5	0.26
8	1.5	42	0.31
9	1.5	51	0.38
10	2	66.5	0.49
11	2	78.5	0.56
12	2	91	0.65
14	2	120	0.86
15	2	135	0.97
16	2	151	1.04
18	2	189	1.33
20	2	227	1.63
25	2	341	2.46

Single V-joint



70° Vertical

Plate thickness t	Root opening s	Deposit volume per m. V	Deposit weight per m. W
mm	mm	cm ³ /m	kg/m
4	1	15	0.13
5	1	22.5	0.19
6	1	31	0.29
7	1.5	45	0.38
8	1.5	57	0.47
9	1.5	70	0.59
10	2	90	0.76
11	2	107	0.89
12	2	125	1.05
14	2	165	1.34
15	2	188	1.55
16	2	211	1.75
18	2	263	2.17
20	2	320	2.62
25	2	488	4.00

Single V-joint

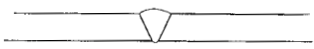

60° Flat

Plate thickness t	Root opening s	Deposit volume per m. V	Deposit weight per m. W
mm	mm	cm ³ /m	kg/m
4	1	13	0.10
5	1	20	0.15
6	1	27	0.20
7	1.5	39	0.30
8	1.5	49	0.37
9	1.5	61	0.44
10	2	78	0.57
11	2	92	0.66
12	2	107	0.77
14	2	141	1.02
15	2	160	1.15
16	2	180	1.23
18	2	223	1.60
20	2	271	1.94
25	2	411	2.94

Single V-joint



80° Vertical

Plate thickness t	Root opening s	Deposit volume per m. V	Deposit weight per m. W
mm	mm	cm ³ /m	kg/m
4	1	18	0.14
5	1	26	0.22
6	1	36	0.30
7	1.5	52	0.44
8	1.5	66	0.55
9	1.5	82	0.69
10	2	104	0.86
11	2	124	1.02
12	2	145	1.23
14	2	193	1.60
15	2	219	1.81
16	2	247	2.02
18	2	308	2.51
20	2	376	3.11
25	2	577	4.76

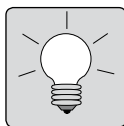

SOLUTIONS

Metal identification

2.03

Metal \ Test	Appearance of untreated metal surface	Appearance of surface after filling	Appearance of fracture surface and relative toughness	Comparative weight of metal	Other tests for identification, see following pages for description
Grey cast iron	Dark grey or rusty. Rough granular surface.	Light grey, rather smooth.	Dark grey, uneven granular surface. Rather brittle.	Heavy	Chiselling test.
White cast iron	As above	Normally too hard to file. Shiny white when polished.	Very finegrained, silvery crystalline surface. Very brittle.	Heavy	None
Unalloyed steel, wrought iron, low-alloy steel, carbon steel	Dark grey or rusty, can be smooth or rough, depending on field of application.	Shiny grey, very smooth surface. Some alloys are unfileable.	Medium-grey colour. Very tough to very brittle, depending on type.	Heavy	File test. Spark test. Magnet test. Chisel test
Stainless steel	Shiny silver-grey if polished. Matt grey if unpolished.	Shiny silver-grey. Smooth surface. Some are not fileable.	Fine-grained grey surface. From tough to brittle.	Heavy	Magnet test
Copper	Various grades of red-brown to green (verdigris).	Shiny coppered surface.	Not necessary	Heavy	None
Brass and bronze	Various grades of yellow-brown or green-brown.	From bronzered to Yellow, smooth surface.	Not necessary	Heavy	None
Aluminium and aluminium alloys	Very light grey	Very white and smooth surface.	Not necessary	Very light	Acid test
Lead and white metal	White to grey, smooth velvety surface.	White, very smooth shiny surface.	Not necessary	Very heavy	None

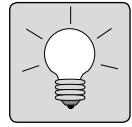





Filing test

Resistance to file	Type of steel	Brinell hardness
No resistance; the file bites into the metal.	Unalloyed and Low alloyed steel	100
Little resistance; the file bites into the metal, but the pressure has to be increased.	Medium-carbon steel	200
Medium resistance. The file does not bite into the metal and the pressure has to be increased.	High-alloy steel	300
High resistance. The metal can be filed, but with difficulty.	High-carbon steel	400
High resistance. The file leaves marks, but the metal is almost as hard as the file.	Tool steel	500

Spark test

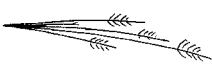
This test may be carried out in the ship's workshop and is very useful for identifying the type of steel and determining its approximate carbon content.

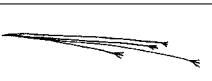
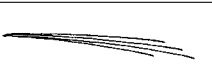
Hold a sample lightly against the grindstone and note the shape, colour and length of the sparks. Unalloyed and low alloyed steels are difficult to tell apart, but when tested together it is comparatively easy to see the difference.

Unalloyed steel		The sparks separate at the end into several small sparks (leaf shaped). Some sparks are short.
Manganese steel		The sparks split up, and end in stars.
High speed steel		Weak red sparks, with forked ends.
Stainless steel		Bright yellow sparks, with pointed ends.
Cast iron		Weak red sparks, ending in many pronged yellow stars.
Monel		Weak red sparks, quickly extinguished.

Chisel test

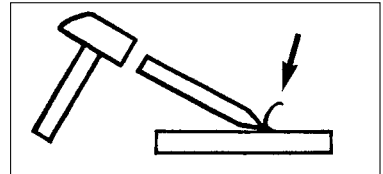

Unalloyed steel (Cast steel). Long (continuous) shavings are formed when chiselled.

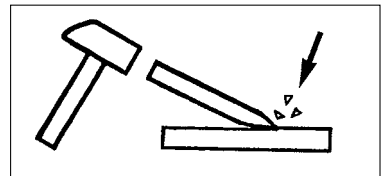

Cast iron. The metal does not give off shavings; material chiselled away is in the form of brittle fragments.

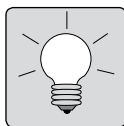

SOLUTIONS

2.03

Magnet test

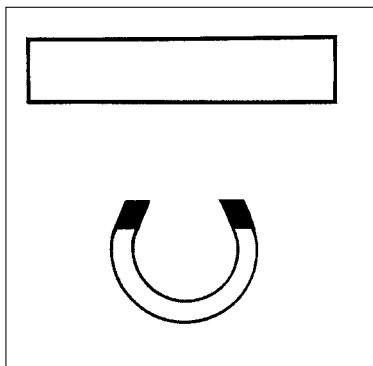

Non-magnetic

This indicates an Austenitic stainless steel.

Manganese steel, stainless steel:
good weldability, but remember: no pre-heating.

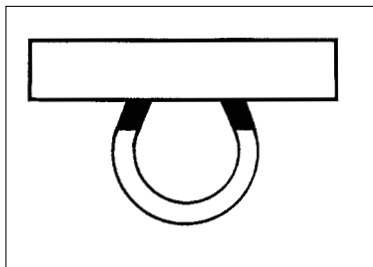

Magnetic

Indicates a Ferritic normal steel.
If stainless steel: poor weldability.

If unalloyed / low-alloyed steel:
good weldability.

Aluminium/magnesium test

1. Clean a small area of the metal.
2. Drip onto it one or two drops of 20% caustic soda (NaOH) solution.
3. Wait 5 minutes and wash with clean water.

Black: Al + Cu
Al + Ni
Al + Zn

Grey/brown: Al + Si (over 2%).

White: Pure aluminium.

Unchanged: Magnesium (Mg).

Flame test

Another simple test to find out whether the component is of aluminium, magnesium-alloyed aluminium or magnesium is as follows:

Place the component on a piece of paper and file some shavings onto the paper. Hold the paper over a flame and let the filings fall into the flame. If the filings glow the metal is aluminium. If some of the filings spark in the flame the aluminium is alloyed with magnesium (seawater resistant aluminium). If all the filings spark in the flame, the metal is magnesium and must not be welded.

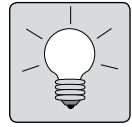

METAL IDENTIFICATION

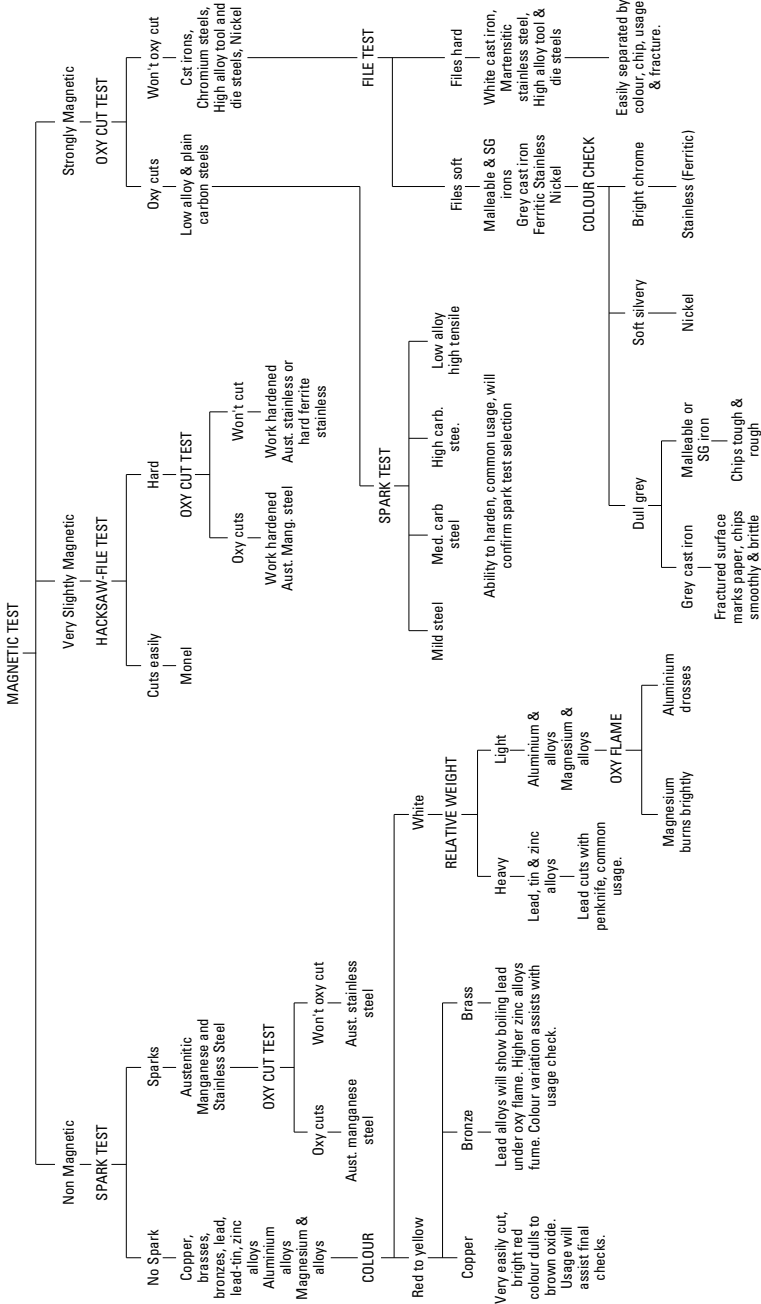

SOLUTIONS: Unalloyed/low alloyed steel

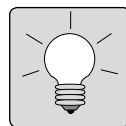

2.04

Introduction

Steel can be generally classified as an alloy of Ferrum (Fe), better known as iron, and carbon (C). Iron is the main component in most types of steel. Steel is classified in three grades:

- Unalloyed steel (containing up to 1% alloy elements). This type of steel is also termed mild steel, carbon steel and carbon manganese steel.
- Low alloy steel (containing 1–5% alloy elements).
- High alloy steel (containing more than 5% alloy elements).

Alloy elements are metals such as manganese (Mn), silicon (Si), chrome (Cr), nickel (Ni), molybdenum (Mo). Carbon is not an alloy element.

Unalloyed steel

Often referred to as carbon steel, mild steel or black steel. On board a ship, unalloyed steel will usually be found in the superstructure.

Angle iron, flat iron and rod iron are usually in unalloyed steel. A common composition of this type of steel is as follows (%):

Fe	C	Mn
Rest	0.18	0.60

Si	S	P
0.30	0.03	0.03

Use the following Unitor filler materials for welding unalloyed steel: GPO, GPR, LH, LHV, MS, IMS, SPECIAL

Low alloy steel

Low alloy steel includes construction steel, ship quality steel (sometimes referred to as high tensile steel), heat resistant steel, low temperature

steel, weather steel, and tool steel. On board a ship we find this type of steel in hullplates, frames, deck plates, deck beams and bulkheads. A common composition of this type of steel is (%):

C	Mn	Si
0.18	1.30	0.40

Al	P	S
0.057	0.02	0.03

Higher strength filler materials must be used for welding low alloy steel. Use: SPECIAL, LH, LHV, LHT, LHL, LHR, ICROMO, TENSILE, GPS.

If there is doubt as to whether steel to be welded is unalloyed or low alloy, higher strength filler materials should always be used. They should always be used for welding the following components (including components in unalloyed steel): –Lifting equipment subject to heavy loads. Lifting lugs and other parts subject to sudden loads.

- Parts which are subject to heavy vibration (pipes, engine mountings, etc.)
- Welding deck equipment in position (winches, cranes, etc.).
- Welding cast steel (important). To differentiate between cast steel and cast iron, see the section on identification of metals.

Heat resistant steel

Heat resistant steel is a low alloy steel, alloyed with a certain percentage of molybdenum (Mo) and sometimes also chromium (Cr). The addition of these alloying elements imparts heat resistant characteristics and the steel retains its strength at

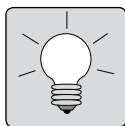

SOLUTIONS: Unalloyed/low alloyed steel

high temperatures. On board you will find this steel in boiler tubes, boiler plates and high pressure pipes.

A common composition is as follows (%):

Fe	C	Mn	Si
Main comp.	0.10	0.90	0.30

Mo	Cr	S	P
0.50	1.00	0.03	0.03

heat resistant filler materials in the Unitor range.

Low temperature steel

Low temperature steel containing nickel is today used more and more in processing equipment onboard ships carrying low temperature cargo. We also find this type of steel in Ice – class hull plates.

The LHL electrode are a low temperature electrode for use on this type of steel.

Weathering steel

Weathering steel can be exposed to the weather without being painted. Good corrosion resistance to seawater and flue gases. This type of steel contains Copper and Nickel. Use LHR electrode for welding.

For welding of heat resistant steel, filler material with heat resistant deposit only may be used. Selection of the correct electrode for the job will depend on the percentage of Mo and Cr in the alloy. LHT and ICROMO are

Standard construction steel

A.S.T.M. S.A.E. A.I.S.I.	EN	Werkstoff W.-Nr	DIN	BS 970	UNI	JIS
1018 1018 1018 1018 1045 1045 1045 1045 1140/1146 1140/1146 1215 1215 12L 14 12L 14 12L 14	C15D C18D C45 35S20 45S20 11SMn37 11SMnPb30 11SMnPb37	1.1141 1.0401 1.0453 1.0503 1.1191 1.1193 1.1194 1.0726 1.0727 1.0715 1.0736 1.0718 1.0737	CK15 C15 C16.8 C45 CK45 CF45 CQ45 35S20 45S20 9SMn28 9SMn36 9SMnPb28 9SMnPb36	040A15 080M15 080A15 EN3B 060A47 080A46 080M46 EN8D 212M40 En8M 230M07 En1A 230M07Leaded En1A Leaded	C15 C16 1C15 C45 1C45 C46 C43 CF9SMn28 CF9SMn36 CF9SMnPb28 CF9SMnPb36	S15 S15CK S15C S45C S48C SUM 25 SUM 22 SUM 22L SUM 23L SUM 24L
4130 4130 4130 4140/4142 4140/4142 4140/4142 4140/4142 4140/4142 4340 4340 8620 8620	42CrMo4 34CrNiMo6 20NiCrMo2-2	1.7218 1.7223 1.7225 1.7227 1.3563 1.6582 1.6562 1.6543 1.6523	25CrMo4 GS-25CrMo4 41CrMo4 42CrMo4 42CrMoS4 43CrMo4 34CrNiMo6 40 NiCrMo8 4 21NiCrMo22 21NiCrMo2	708A30 CDS 110 708M40 708A42 709M40 En 19 En 19C 817M40 En24 805A20 805M20	25CrMo4 (KB) 30CrMo4 30CrMo4 41CrMo4 38CrMo4 KB G40 CrMo4 42CrMo4 35NiCrMo6 KB 40NiCrMo7 KB 20NiCrMo2	SCM 420 SCM 430 SCCrM1 SCM 440 SCM 440H SNB 7 SCM 4M SCM 4 SNCM 447 SNB24-1-5 SNCM 220 (H)

SOLUTIONS: Unalloyed/low alloyed steel

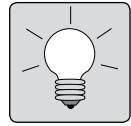

2.04

Corresponding steel classifications

Norske Veritas	Lloyds	Germanischer Lloyd	Bureau Veritas	American Bureau of Shipping	USSR Register	Nippon Kaigi Kyoka
A	A	A	A	A	A	A
B	B	B	B	B	B	B
D	D	D	D	SS	D	D
				CD/DS		
NV A27S						
NV D27S						
NV A32	AH 32	A 32	AH 32	AH 32	A 32	
NV D32	DH 32	D 32	DH 32	DH 32	D 32	
NV E32	EH 32	E 32	EH 32	EH 32	E 32	
	AH 34S					
	DH 34S					
	EH 34S					
NV A36	AH 35	A 36	AH 36	AH 36	A 36	
NV D36	DH 36	D 36	DH 36	DH 36	D 36	
NV E36	EH 36	E 36	EH 36	EH 36	E 36	
NV A40						
NV D40						
NV E40						
NV A420						
NV D420						
NV E420						

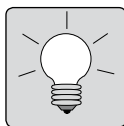









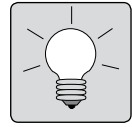

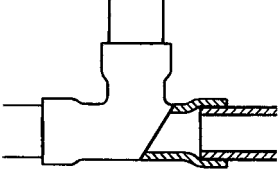

SOLUTIONS

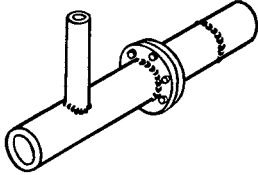
2.04

Mechanical properties typical values

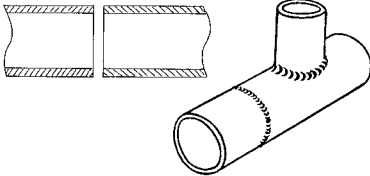
Grade	Yield stress $R_{p0.2}$ minimum (MPa)	Tensile strength R_m (MPa)	Elongation A_5 minimum (%)	Temperature (°C)	Impact energy L (J) $t \leq 50$ (mm)	ISO 630-80 4950/2/3 1981	EN EN 10025-93 EN 10113-93	ASTM	JIS
NV A	235	400 to 520	22	+20	—	Fe 360B Fe 360C Fe 360D	S235JRG2 S235J0 S235J2G3 S275NL/ML	A B D E	SM41B SM41B (SM41C) —
NV B									
NV D									
NV E									
NV A27S	265	400 to 530	22	0	27	Fe 430C Fe 430D	S275H0G3 S275N/M S275NL/ML	— — —	— — —
NV D27S									
NV E27S									
NV A32	315	440 to 570	22	0	31	— — —	— — —	AH32 DH32 EH32	SM50B (SM50C) —
NV D32									
NV E36									
NV A36	355	490 to 630	21	0	34	Fe 510C Fe 510D E355E	S355N/M S355N/M S355NL/ML	AH36 DH36 EH36	SM53B (SM50C) —
NV D36									
NV E36									
NV A40	390	510 to 660	20	0	39	E390CC E390DD E390E	S420N/M S420N/M S420NL/ML	AH40 DH40 EH40	(SM58) — —
NV D40									
NV E40									
NV A420	420	530 to 680	18	0	42	— — —	— — —	— — —	— — —
NV D420									
NV E420									

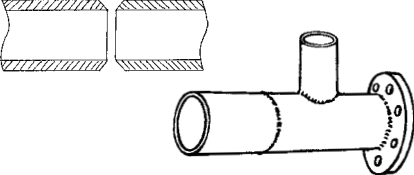

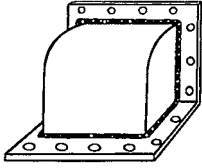

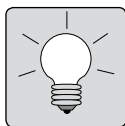







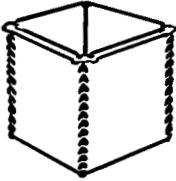



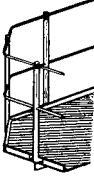

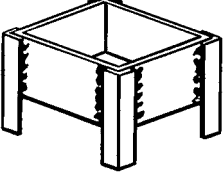

Description	Solution	Examples
Joining of smaller diameter steel pipes (diameter less than 30 mm) where a capillary joint may be used.	 AG-60-252  AG-45-253	
Small diameter steel pipes (diameter up to 160 mm) with a wall thickness of up to 3 mm forming an I-butt joint or T-joint (flange to pipe).	 MS-200  IMS-210	
Larger size steel pipes (over 160 mm) with a wall thickness more than 3 mm forming an I-butt joint, V-butt joint or a T-joint.	 GPO-302N  SPECIAL-303N  MS-200	
Joining galvanized steel pipes forming a V-butt joint, rounded edges on the joint.	 FC-BRONZE-261  BRONZE-264	
Thin plate galvanized steel constructions like air ducts and air channels.	 FC-BRONZE-261  BRONZE-264	

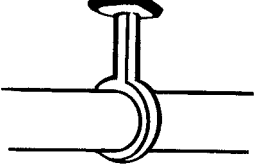

SOLUTIONS: Unalloyed/low alloyed steel



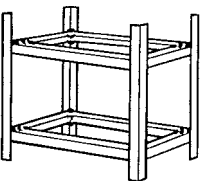



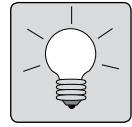





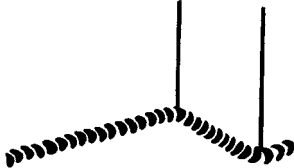



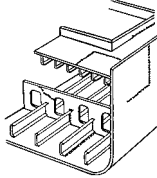

2.04

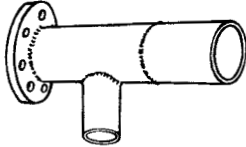
Description	Solution	Examples
Welding of thin sheet steel plate constructions as for example tanks and cover plates.	 GPO-302N/ SPECIAL-303N  MS-200  IMS-210	
General purpose repair welding of unalloyed steel parts.	 GPO-302N  SPECIAL-303N LH-314N  LHV-316N	
Fabrication of smaller steel parts like shelves, ladders and gangways in unalloyed steel.	 GPO-302N  SPECIAL-303N  LH-314N	
Welding of clamps and brackets, and tack welding constructions before full welding.	 GPO-302N  SPECIAL-303N  LH-314N	
Larger size fabrication and repair jobs like welding of unalloyed steel bulkheads and deck in all positions.	 GPO-302N  SPECIAL-303N  LH-314N	

SOLUTIONS: Unalloyed/low alloyed steel

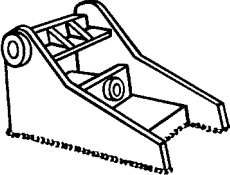



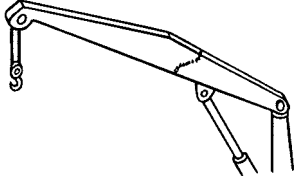

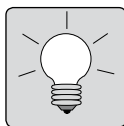





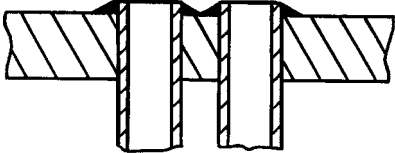

2.04

Description	Solution	Examples
<p>For a rapid and large size weld build up in the downhand position on unalloyed steel/low alloyed steel constructions.</p>	<p> GPR-300H</p> <p> LHH-314H</p>	
<p>Welding repairs of low alloyed ship-building steel used in the hull, beams, deck, bulkheads, stiffeners, tanks, holds, hatch covers, frames etc.</p>	<p> SPECIAL-303N</p> <p> LH-314N</p> <p> LHV-316N</p>	
<p>Steel that takes vibration, strain and sudden loads. Seawater, steam and cargo pipes made of low alloyed steel.</p>	<p> SPECIAL-303N</p> <p> LH-314N</p> <p> LHV-316N</p>	
<p>Deck and engine auxiliaries welded to deck or floor plates.</p>	<p> SPECIAL-303N</p> <p> LH-314N</p> <p> LHV-316N</p>	
<p>Welding on cranes and lifting equipment.</p>	<p> SPECIAL-303N</p> <p> LH-314N</p> <p> LHV-316N</p> <p> TENSILE-328N</p>	

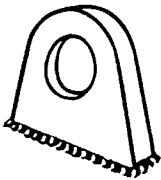

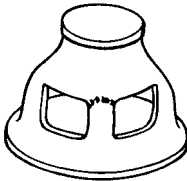
SOLUTIONS: Unalloyed/low alloyed steel

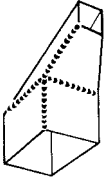
2.04

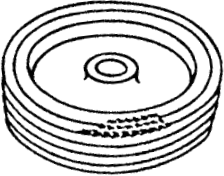
Description	Solution	Examples
Boiler plates and tubes of heat resistant chromium molybdenium alloyed steel.	 LHT-318N  ICROMO-216	
Welding subject to high loads (Lifting, lugs, etc.).	 SPECIAL-303N  LH-314N  LHV-316N  TENSILE-328N	
Cast steel repairs.	 LH-314N	
Weathering steel used for sea-water and flue gases.	 LHR-320N	
Low temperature applications. Ice-class hull plates.	 LHL-319N	

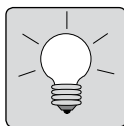

SOLUTIONS: Problem Steels

Problem Steels (difficult to weld steels)

Among the low alloy steels, there is also a large group of special steels with complicated chemical composition. These include spring steel, vanadium steel, high speed steel, tool steel, etc. All these steel types are difficult to weld. In many cases the steel has been hardened by annealing, and welding can destroy the hardening.

In principle, all these steels can be welded with matching ferritic consumables with the aid of preheating and postweld heat treatment to avoid hydrogen cracking in the heat affected zone (HAZ).

In the case of repair welding, it is, however, often not possible to preheat or to perform any postweld heat treatment.

So, in this case, welding with austenitic stainless or nickel-based consumables is considered to be one of the best methods. The risk of cracking is reduced by the higher solubility of hydrogen and the greater ductility of the weld metal.

There are so many types of low alloy steel on the market today that even specialists have difficulty in keeping track of the entire range. Numerous types of special alloys not classified under existing standards, are marketed by the steel works. Most types can be welded satisfactorily with Unitor Tensile having a tensile strength of 850 N/mm². This electrode may be used both for joining and for building-up work.

For cargo handling equipment and dredger applications the Unitor Wearmax-327 should also be considered.

The example on solutions for "problem" steel that are given here are all based on using the electrode:



Unitor Tensile-328N

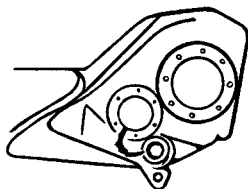

Cracks in bearing housings.

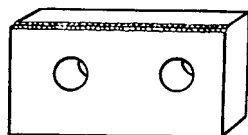

Machine parts, building up and restoring worn edges.

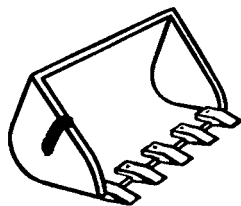

Grab shovels, cracks.

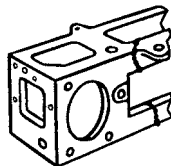

Joining machine parts in U.S. T1 steel, or heavily stressed machine parts. Including build-up work.

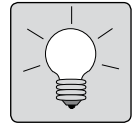

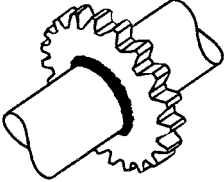
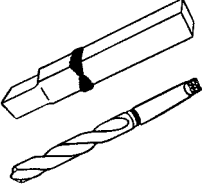
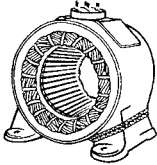
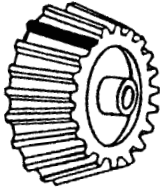
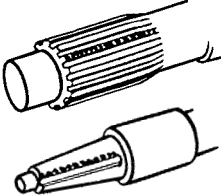
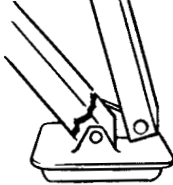
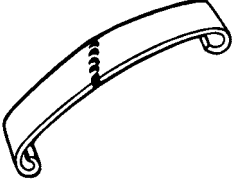
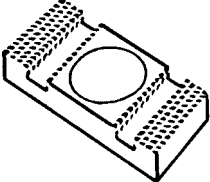
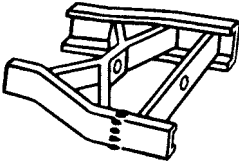
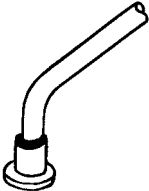
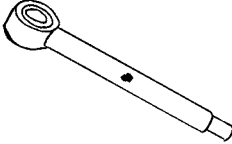
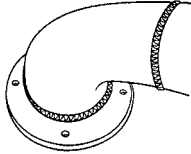
 <p><i>Welding pinion to shaft.</i></p>	 <p><i>Repair of tool steel and high speed steel.</i></p>	 <p><i>Steel that is difficult to weld, and steel subject to vibration and loads (engine foundations etc.).</i></p>
 <p><i>Rebuilding worn pinion teeth.</i></p>	 <p><i>Shafts, rebuilding damaged and keyways.</i></p>	 <p><i>Mechanical structures.</i></p>
 <p><i>Spring steel, joining.</i></p>	 <p><i>Sliding surfaces, repair and maintenance.</i></p>	 <p><i>Frame fractures.</i></p>
 <p><i>Cracks in fuel pipes.</i></p>	 <p><i>Pitting in hydraulic pistons. NB! Flame spraying with hard-alloy may also be a solution.</i></p>	 <p><i>Cast steel, cargo pipes, joining and repairing. NB! The electrode LH may also be used.</i></p>



WELDING HANDBOOK NOTES

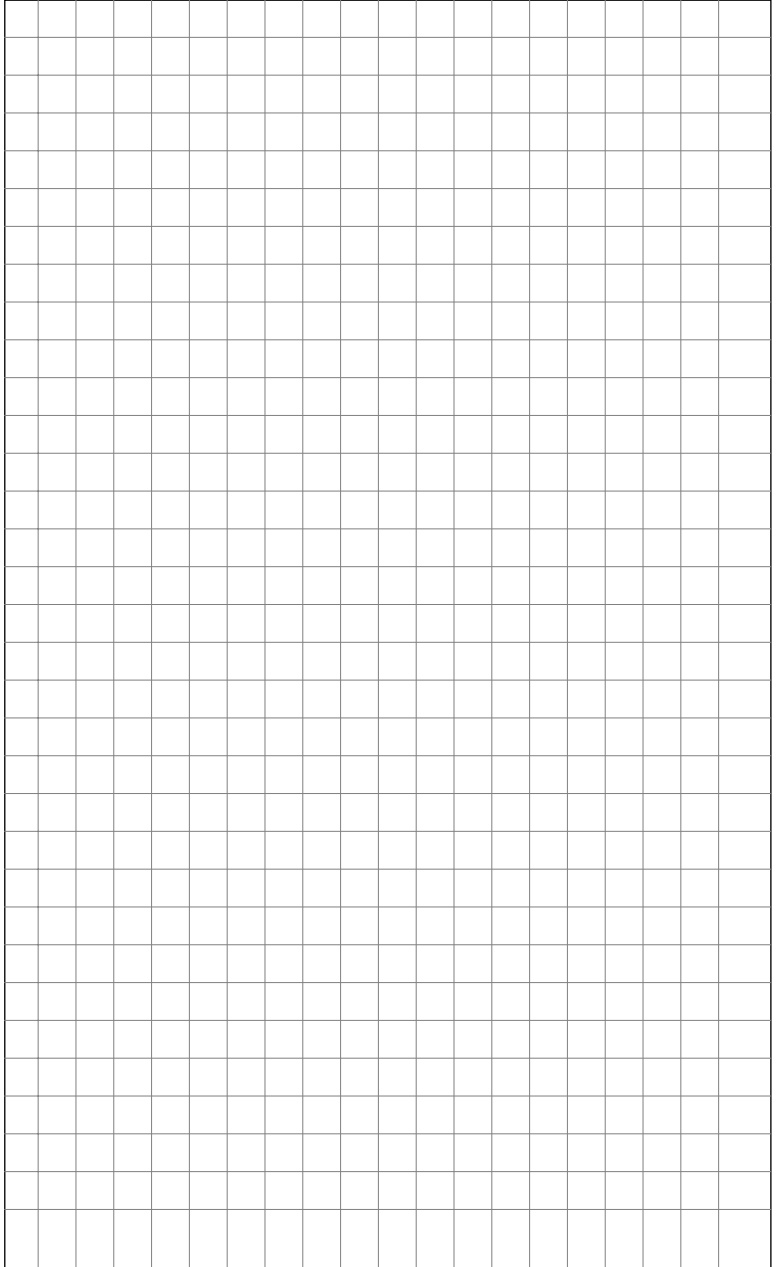

2.05

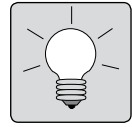

Introduction

Stainless steel belongs to the high alloy steel group.

Chromium (Cr) is the element that makes stainless steel stainless or corrosion resistant. The chromium combines with oxygen and creates an invisible though impregnable chromium oxide on the surface. It must contain at least 11,5% chromium, that is the content at which an effective layer is formed that seals the surface against any further atmospheric corrosion.

Many stainless alloys contain larger amounts of chromium for further improving corrosion resistance and to increase resistance to oxidation at high temperatures.

Nickel (Ni) in excess of about 6% increases corrosion resistance slightly and greatly improves mechanical properties. Small amounts of Molybdenum (Mo) increase resistance to pitting type corrosion and general resistance to certain corrosive media. Stainless steel alloy with molybdenum is therefore referred to as acid resistant. Molybdenum also improves high temperature strength.

Carbon increases strength, but in connection with stainless steel and in amounts above 0,04% it will cause chromium carbide formation (chrome carbide particles) between 430-870°C. The chrome carbide cannot combine with oxygen to create chrome oxide. This reduces the corrosion resistance in local areas leading to intergranular corrosion. The carbon content in stainless steel materials and consumables are therefore kept at a very low level.

By chemical composition or heat treatment, or a combination, the stainless steel receives one of the following micro structures when manufactured: Austenitic, Ferritic, Martensitic or Ferritic/Austenitic.

The American Iron and Steel Institute (AISI) established a numbering system to classify the stainless steel alloys. The AISI classifies stainless steel by their metallurgical structures. This system is useful because the structures (Austenitic, ferritic or martensitic) indicates the general range of mechanical and physical properties and weldability.

The following are some characteristic differences between stainless steel and normal steel:

1. Poorer heat conductivity (approx. 40% less).
2. Higher coefficient of expansion (approx. 40% higher).
3. Greater sensitivity to cold working.
4. Occurrence of structural changes following welding, (carbides – sigma phase – ferrite).
5. Sensitivity to certain corrosion phenomena, such as strong pitting, or crack formation along or through the crystals (stress corrosion).

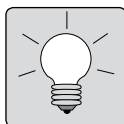

SOLUTIONS: Stainless Steel

Austenitic Stainless Steel

The highest tonnage of weldable stainless steel produced are of the austenitic grades. These are the chromium nickel steel of the AISI 200 and 300 series in which chromium usually exceeds 17% and nickel

with a few exceptions exceeds 7%. Austenitic grades are non-magnetic. Austenitic stainless steel has the highest corrosion resistance of all the stainless steel. Most materials for chemical carriers are selected from this group of materials, and AISI 316 L is the most commonly used.

2.06

AISI Type	Composition % *				May be welded with (E) Electrode (W) Wire Welding (T) Tig
	Carbon C	Chromium Cr	Nickel Ni	Other	
301	0,15	16,0 – 18,0	6,0 - 8,0	2,0 – 3,0 Si	18/8-321N (E)
302	0,15	17,0 – 19,0	8,0 – 10,0	–	
302 B	0,15	17,0 – 19,0	8,0 – 10,0	2,0 – 3,0 Si	
303	0,15	17,0 – 19,0	8,0 – 10,0	0,20 P 0,15 S (min) 0,60 Mo (opt)	S-316-M-GF-221 (W)
303 Se	0,15	17,0 – 19,0	8,0 – 10,0	0,20 P 0,06 S (min) 0,15 Se (min)	
304	0,08	18,0 – 20,0	8,0 - 12,0	–	18/8 Mo-221 (T)
304 L	0,03	18,0 – 20,0	8,0 – 12,0	–	
305	0,12	17,0 – 19,0	10,0 – 13,0	–	
308	0,08	19,0 – 21,0	10,0 – 12,0	–	
309	0,20	22,0 – 24,0	12,0 – 15,0	–	23/14-322N (E)
309 S	0,08	22,0 – 24,0	12,0 – 15,0	–	S-309-M-GF-222 (W)
310	0,25	24,0 – 26,0	19,0 – 22,0	1,5 Si	IMPACT-329S (E)
310 S	0,08	24,0 – 26,0	19,0 – 22,0	1,5 Si	
314	0,25	23,0 – 26,0	19,0 – 22,0	1,5 – 3,0 Si	
316	0,08	16,0 – 18,0	10 – 14,0	2,0 – 3,0 Mo	18/8-321N (E)
316 L	0,03	16,0 – 18,0	10 – 14,0	2,0 – 3,0 Mo	
316 N	0,08	16,0 – 18,0	10,0 – 14,0	1,0Si 2,0Mn 2,0-3,0Mo 0,10-0,16Ni	S-316-M-GF-221 (W)
					18/8 Mo-221 (T)
317	0,08	18,0 – 20,0	11,0 – 15,0	3,0 – 4,0 Mo	23/14-322N (E)
317 L	0,03	18,0 – 20,0	11,0 – 15,0	3,0 – 4,0 Mo	
321	0,08	17,0 – 19,0	9,0 – 12,0	Ti (5x%C min)	
329	0,10	25,0 – 30,0	3,0 – 6,0	1,0 – 2,0 Mo	
330	0,08	17,0 – 20,0	34,0 – 37,0	0,75-1,5 Si 0,04 P	
347	0,08	17,0 – 19,0	9,0 – 13,0	Cb + Ta (10x %C min)	
347 M	0,03	19,0	10,0	Cb 13 x Cmax 0,65	
348	0,08	17,0 – 19,0	9,0 – 13,0	Cb+Ta (10x%C min but 0,10 Ta max 0,20 Co)	

* Single values denote maximum percentage unless otherwise stated
Unless otherwise stated, other elements of all alloys listed include maximum contents of 2,0 % Mn, 1,0 % Si, 0,045 P and 0,03 % S. Balance Fe.

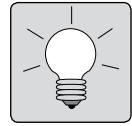

Austenitic stainless steel has the following characteristics:

- Non-magnetic.
- Cannot be hardened by heat treatment, but can be hardened by working.
- Can easily be welded
- Grade: 304 (most used), 310 (for high temperature), 316 (for better corrosion resistance), 317 (for best corrosion resistance).
- Unified Numbering system UNS: 30400, S 31000, S 31600, S 31700.

Some limitations:

Austenitic stainless steel has some limitations:

- The maximum temperature under oxidizing conditions is 925°C.
- They are suitable only for low concentrations of reducing acid.
- In crevices and shielded areas, there might not be enough oxygen to maintain the passive oxide film and crevice corrosion might occur (Duplex are available in these situations).
- Very high levels of halide ions, especially the chloride ion can also break down the passive surface film.

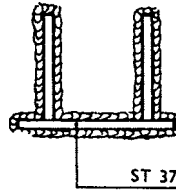

Avoid welding mild steel to stainless steel.

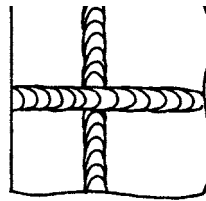

Crossed weld joints are undesirable. In general welds must not be located too close to one another.

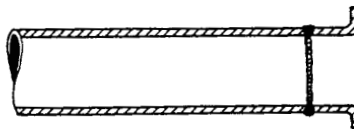

Flange ring made by hammering back the pipe end (mechanical working) must be avoided.

Flange ring welded on gives less stress set up in the material.

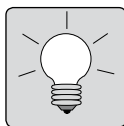



SOLUTIONS: Stainless Steel

Ferritic Stainless Steel

These are the grades AISI 400 series that contain from about 14 to 27% chromium and no nickel. They are non-hardening by heat treatment.

They are magnetic in all conditions. Principal applications are products requiring resistance to corrosion and scaling at elevated temperatures rather than high strength.

AISI Type	Composition % *				May be welded with: (E) Electrode (W) Wire Welding
	Carbon C	Chromium Cr	Manganese Ni	Other	
405 409 429	0.08 0.08 0.12	11.5 – 14.5 10.5 – 11.75 14.0 – 16.0	1.0 1.0 Max 1.0	0.1 – 0.3 Al 1.0 Si Max, Ti min. 6 x C, 0.045 S, 0.045 P 1.0 Si	 23/14-322N (E)
430 439 F 430Fse	0.12 0.12 0.12	14.0 – 18.0 14.0 – 18.0 14.0 – 18.0	1.0 1.25 1.25	– 0.060 P, 0.15 S (min), 0.60 Mo (opt) 0.60 P, 0.060 S, 0.15 Se (min)	
434 436 439	0.12 0.12 0.07	16.0 – 18.0 16.0 – 18.0 17.75 – 18.75	1.0 1.0 1.0	0.75 – 1.25 Mo, 1.0 Si 0.75 – 1.25 Mo, (Cb+Ta) Min 5 x % C, 1,0 Si 0,6 Si – 0,5 Ni, 0,15 Al, Ti 12 x C (1.0 max)	 S-309-M-GF-222 (W)
442 444 446	0.20 0.025 0.20	18.0 – 23.0 17.5 – 19.5 23.0 – 27.0	1.0 1.0 1.5	1,0 Ni, 1,75 – 2,5 Mo, 0,035 N max (Cb+Ta) min 0,2 + 4 (%C+%N) 0,25 N 0,75 Ni, 0,75 – 1,5 Mo 0,2 – 1,0 Ti	
26-1 29-4 29-4-2	0.06 0.01 0.01	25.0 – 27.00 28.0 – 30.0 28 – 30.0	0.75 0.3 0.3	0,04 Ni, 0,2 Cu 0,025, 0,75 Si 0,015 Ni, 3,5 – 4,2 Mo 0,15 Cu 0,02 Ni, 0,2 Si, 0,025 P, 0,02 S 2,0 – 2,5Ni, 3,5 – 4,2 Mo, 0,15 Cu 0,02Ni, 0,2 Si, 0,025P, 0,025 S	

* Single values denote maximum percentage unless otherwise noted. Unless otherwise noted, other elements of all alloys listed include maximum contents of 2.0 % Mn, 1.0 % Si, 0.045 % P and 0,030 % S. Balance is Fe

Ferritic stainless steel has the following characteristics:

- Magnetic.
- Cannot be hardened by heat treatment.
- Poor weldability.
- Grade: 409 (high temperature), 430 (most used).
- Unified numbering system UNS: S 40900, S 43000.

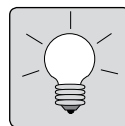

SOLUTIONS: Stainless Steel



Martensitic Stainless Steel

This steel, also in the AISI 400 series, is the iron chromium alloys capable of being heat treated to a wide range of hardness and strength levels. Chromium content is lower and carbon content higher than the ferritic group. These grades are magnetic

in all conditions. They are not as corrosion resistant as the austenitic and ferritic types. Martensitic grades are used to resist abrasion in stream and gas turbine components and for such applications as bearings, ball bearings, pump shafts etc.

AISI Type	Composition % *			May be welded with (E) Electrode (W) Wire Welding
	Carbon C	Chromium Cr	Other	
403	0,15	11,5 – 13,0	0.5 Si	 23/14-322N (E)
410	0,15	11,5 – 13,5	–	
414	0,15	11,5 – 13,5	1.25 – 2.5 Ni	
416	0,15	12,0 – 4,0	1.25 Mn, 0.15 S, (min.), 0.060 P, 0.60 Mo (opt)	 S-309-M-GF-222 (W)
416Se	0,15	12,0 – 14,0	1.25 Mn, 0.060P, 0.15 Se (min.)	
420	0,15 min.	12,0 – 14,0	–	
422	0,2 – 0,25	11,0 – 13,0	1.0 Mn, 0.5 – 10.0 Ni, 0.75 Si, 0.75 – 1.25 Mo, 0.75 – 1.25 W, 0.15 – 0.3 V, 0.025 P, 0.025 S	S-309-M-GF-222 (W)
431	0,20	15,0 – 17,0	1.25 – 2.5 Ni	
440A	0,60 – 0,75	16,0 – 18,0	0.75 Mo	Non-weldable
440B	0,75 – 0,95	16,0 – 18,0	0.75 Mo	
440C	0,95 – 1,20	16,0 – 18,0	0.75 Mo	

* Single values denote maximum percentage unless otherwise noted.

+ Unless otherwise noted, other elements of all alloys listed include maximum contents of 1.0 % Mn, 1.0% Si, 0.040% P, and 0.030% S. Balance is Fe.

Martensitic stainless steel, has the following characteristics:

- Magnetic.
- Can be hardened by heat treatment.
- Poor welding characteristics.
- Grade: 410 (most used), 440C (for very high hardness).
- Unified numbering system UNS: S 41000, S 42000, S 44004.

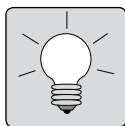

SOLUTIONS: Stainless Steel



Duplex Stainless Steel (Austenitic – Ferritic)

The duplex stainless steel consist of a microstructure of about 50% ferrite and 50% austenite. They were developed to provide a higher strength, corrosion resistant alternative to the 300 series austenitic stainless steel. Compositions are modified to favour the high ferrite levels by increasing the chromium to 22-26%, increasing molybdenum to 2-5%, decreasing the nickel to 4-8% and adding copper up to 2%.

These compositions provide excellent resistance to pitting, crevice

corrosion and stress corrosion cracking. Due to the high yield strength of duplex stainless steel the plate thickness can be reduced considerably in comparison to austenitic stainless steel. Weight savings can be up to 25%, however, the main reason for the increased use of duplex is that the resistance against pitting corrosion is superb compared to austenitic stainless steel. Duplex stainless steel is used for applications such as tanks, cargo loading pipes, heating coils, ladder material.

Duplex stainless steel has good weldability but great care must be taken to use the correct consumable and to follow the welding procedure.

Composition (%)											May be welded with
Manufacturer	Grade	Cr	Ni	Mo	N	Cu	Other	PREN	Product forms		
23% Cr Mo-free Duplex Stainless steel											 DUPLEX-325N Electrode  IDUPLEX-222 TIG-rod
Duplex stainless steel grades.											
Avesta	SAF 2304	23	4	–	0,1	–	–	25	all product forms plate, bars, forgings pipe		
Creusot Ind.	UR 35N	23	4	–	0,12	–	–	25			
Sandvik	SAF 2304	23	4	–	0,1	–	–	25			
22% Cr Duplex Stainless steel											
Avesta	2205	22	5,5	3	0,16	–	Mn 1.5	35	product forms depending on manufacturer		
Böhler	A 903										
Creusot Ind.	UR 45N	22	5,3	3	0,17	–	–				
Fabr. de Fer.	1,4462/PRE35										
Krupp	Falc 223										
Mannesmann	A F22(1,4462)	22	5,5	3	0,14	–	–	34/35			
Nippon Kokan	NK Cr22										
Sandvik	SAF 2205										
Sumitomo	SM 22Cr										
TEW	Remanit 4462										
Valourec	VS 22										

Duplex Stainless steel has the following characteristics:

- High resistance to stress corrosion cracking.
- Increased resistance to chloride ion attack.
- Very weldable.
- Have higher tensile and yield strength than austenitic or ferritic stainless steel.
- Grade: 2205.
- Unified numbering system UNS: S 31803.

SOLUTIONS: Stainless Steel

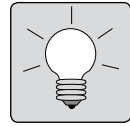

Clad steel

Clad steel is also referred to as compound steel or sandwich steel. Clad steel is composite materials, made by mill rolling or exploding a thin sheet of a metal that has desired properties over a base ("backing") plate of carbon or alloy steel. The cladding metal may be a stainless steel alloy, nickel or nickel alloy, or copper or copper alloy. The result is a composite with the strength of the backing steel and with corrosion resistance, abrasion resistance of the clad face.

1. For welding of the backing steel use: Basic coated Low Hydrogen electrodes LH-314N or SPECIAL-303N.
2. When the steel backing is one layer short of the stainless steel cladding, an over alloyed consumable like 23/14-322 N must be used.

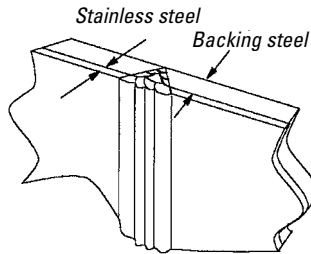



2.06

Alloy cladding

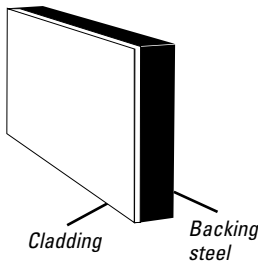
- Low carbon nickel
- Nickel
- Monel
- Inconel
- Cupro Nickel



Clad steel with a stainless cladding is found on board some chemical tankers. It is fully weldable if the proper procedure is followed.

Alloy Cladding (AISI)	Welding (E) Electrode (W) Wire Welding
405, 410, 430 304 304 L 347, 321 L 309 316 316 L 317	 23/14-322N (E)  S-309-M-GF-222 (W)

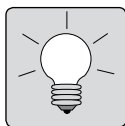

SOLUTIONS: Stainless Steel

Stainless steel corrosion types

A very thin layer of chromium oxide which is formed on the surface of the metal protects stainless steels against Corrosion. This passive layer can be damaged by mechanical or chemical action.

If the protecting layer is destroyed in an aggressive environment, the material will corrode.

Different types of corrosion can occur and the choice of stainless steel is based on the requirements from the actual environment.

General corrosion



This is a corrosion attack that proceeds at the same rate over the entire surface. It occurs almost exclusively in acidic or strongly alkaline solutions. The resistance against general corrosion is mainly improved by increasing the content of Cr and Mo in the steel.

Intergranular corrosion



A localized attack at and adjacent to the grain boundaries is called intergranular corrosion. Some stainless steels can be made sensitive to intergranular corrosion by elevated temperatures (500 °C-900 °C) at which carbide precipitation occurs at the grain boundaries resulting in

Cr depleted regions. These regions then have a decreased corrosion resistance.

The precipitation of chromium carbides can be prevented either by a low C content or by a stabilizing elements like Nb or Ti.

Pitting corrosion



This is a type of localized attack which is highly destructive, resulting in holes in the metal.

This kind of attack is most commonly found in stainless steel in chloride containing environments.

The resistance against pitting is improved with increased Cr and Mo contents. Also N has a favourable influence.

The Pitting Resistance Equivalent, PRE, is a way of describing the relative influence of the mentioned elements. One way of expressing PRE is:

$$PRE = \%Cr + 3.3 \times \%Mo + 16 \times \%N.$$

The maximum temperature at which a specimen in a special test solution shows no signs of pitting corrosion is called the Critical Pitting Temperature (CPT).

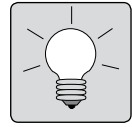

Crevice corrosion

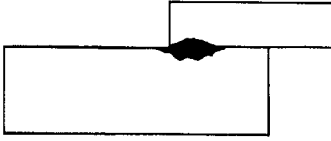

Crevice corrosion is a kind of corrosion which occurs in narrow crevices filled with a liquid and where the oxygen level is very low e.g. on gasket surfaces, lap joints and under bolt and rivet heads. A special form of crevice corrosion is called deposit corrosion. This is when the corrosion is found under non-metallic deposits or coatings on the metal surface.

Steels with good resistance to pitting corrosion have also good resistance to crevice corrosion.

solutions with temperatures below 60 °C.

The resistance of the austenitic stainless steels is improved by increased Ni content. The ferritic Cr steels totally without Ni are under normal conditions insensitive for SCC as well as steels which are ferritic-austenitic.

2.06

Stress corrosion cracking, SCC



Corrosion attacks on a metal subjected to a tensile stress and exposed to a corrosive environment are called stress corrosion cracking (SCC).

During stress corrosion cracking the metal or alloy can remain virtually unattacked on most of its surface, while fine cracks progress through it.

For austenitic stainless steels the risk for SCC is especially big in solutions containing chlorides or other halogens. The risk increases with increasing salt concentration, tensile stress and also increased temperature. SCC is seldom found in

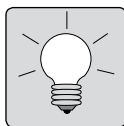

SOLUTIONS: Stainless Steel

Storing and handling of stainless steel onboard

- Stainless steel must be stored under deck and protected against moisture, dust, salt or iron particles that can trigger corrosion.
- Stainless steel should be kept separated from ordinary steel.
- Store in wood protected frames away from grit blasting and grinding.
- Pipe end should be covered (plugged) in order to prevent impurities from entering inside.
- Handling equipment, straps, hooks, forklift forks to be protected with wood, textiles or plastic in order to prevent direct contact with iron surfaces.
- Cover tank bottom so that equipment, tools, footwear do not get in direct contact with the stainless surface.
- Slag, electrode ends and coating to be removed after welding.
- Using ordinary unalloyed steel chipping hammers or wire brushes on stainless steel will deposit iron and iron oxides triggering rusting. Use only tools made out of stainless steel.



Stainless steel wire brush



Stainless steel martensitic chipping hammer

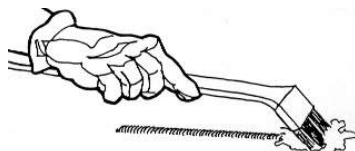

Special tools for welding of stainless steel

- Stainless steel wire brush. 2 rows. 6 pcs.
Product no: 196-632984
- Stainless steel chipping hammer made out of hardened Martensitic stainless steel.
Product no: 196-632992
- Pickling Gel to remove oxides and discoloration after welding. 2 litre.
Product no: 095-661778



Pickling gel for stainless steel

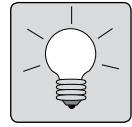

Grinding/cutting consumables for stainless steel

Generally:

When working on stainless steels, one should avoid polluting the steel surface with iron.

Iron on the the steel surface, will act as starting points for corrosion.

Stainless steels are normally softer than regular steels (Typical for AISI 304 & 316).

Working tools should be adapted to this (e.g. grinding consumables).

The corrosion resistance in stainless steels is created by oxide layers from one or several of the alloy components. (e.g. chrome)

This oxide layer can be drastically reduced around sharp edges, structural peaks etc.

To keep the stainless steel corrosion resistance at its best, the aim must be to keep a smooth/polished surface without structural peaks.

Avoid excessive heat to build up during grinding on steels. This may change the metal structure and

damage the properties of the steel. Flexible grinding tools enable better control of heat development (e.g. fibre discs / mop discs).

Never switch a grinding disc between stainless steels and normal steels! This will immediately pollute the stainless steel with iron.



Structural peaks acting as attack points for corrosion



Smooth surface. Provides better corrosion resistance

2.06



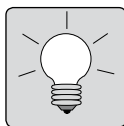

SOLUTIONS: Stainless Steel

INOX, disc with soft grit bonding for cutting and grinding on soft metals.

Contains no iron and the aluminium oxide grit used contains very small amounts of bonded iron.

Iron free (inox) grinding discs is to have less than 0.10 % content of iron, chlorine and sulphur compounds.



INOX depressed wheels SS

Grit: Aluminium oxide
 Grit size: #24
 Bonding: Resin, soft
 Applications: Grinding and cutting in stainless steels, aluminium, bronze and copper

2.06

Size	Cutting wheels Packs of 25 pcs	Grinding wheels Packs of 10 pcs
4" / 100mm	751008	750992
5" / 125mm	633595	633603
7" / 180mm	633611	633619
9" / 230mm	633627	633635

Mop discs

- Sanding paper flaps mounted on backing plate.
- The abrasive flaps contain alumina zirconia with resin bonding. Contains no iron.
- Very suitable for stainless steel grinding and polishing.
- Provides very smooth surfaces due to the flexibility of the disc.
- The fan pattern improves cooling during operation.

Mop discs for SS

Grit: Aluminium zirconia, iron free
 Bonding: Resin
 Applications: Grinding on almost any metal, incl. stainless steel, hardened and alloy steel, aluminium, wood, paint, plastics etc.

Size	Mop discs packs of 10 pcs	
Grit size:	#60	#80
4" / 100mm	633699	633707
5" / 125mm	633723	633731
7" / 180mm	633747	633755



Mop disc

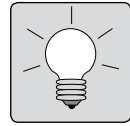

Unitor Safety Grinder

Safe Low Voltage Grinding machine utilizing the ships Welding Machine.

In conductive areas like in the metal hull of a ship or a drilling platform and in smaller area inside a metal tank, there is a high risk of electric shock, so low voltage hand tools should be used.

SafetyGrinder product no. 526015

- Supply cable 3m long and fork fitted with 2 pc DIX 25 male cable connectors. It will fit UWI-150TP and UWW-161TP.

Conversion cable product no. 526025

- Bigger size welding machines (UWI-203TP, UWI-230TP AC/DC, UWI-320TP and UWI-500TP) with DIX 70 connectors:
Make use of DIX 70 Male DIX 25 Female Conversion with 5m, 35mm² welding cable 2 pcs.



*Tool code: BA210D (42V)
Weight: 2.3 kg
Shaft for grinding disc Ø 100mm
Dead man switch
Side handle standard*

Mode setting on Unitor Welding machines to optimise the performance of the SafetyGrinder

UWI-150TP	TIG or TIG Puls Mode.
UWW-161TP	Electrode Mode.
UWI-230 TP AC/DC	Electrode, TIG DC and TIG ALU Mode.
UWI-230TP	TIG Mode.
UWI-320TP	Electrode and TIG Mode.
UWI-500TP	Electrode, Cel electrode, ACA and TIG mode.

NB. On older Unitor models or other brands you might experience speed variations (pulsing)

<i>Description</i>	<i>Unit</i>	<i>Product no.</i>
Grinding disc	10 pcs	633523
Cutting disc	25 pcs	633515
Mop disc	10 pcs	633699



Grinding disc



SOLUTIONS: Cast Iron

Introduction

To approach welding of cast iron, the special properties of this material must be understood, and the techniques for joining it together followed.

Welders who attempt to repair cast iron based upon their experience from welding steel, and on the assumption that "iron is iron" often end up with a poor result without understanding why.

Hence, cast iron repairs has been a feared operation to welders.

However, many grades of cast iron can indeed be welded successfully.

Cast iron is essentially an alloy of ferrum (iron), carbon and silicon. The carbon content ranges from 2.4% up to 4.5%, which means that it is present in excess of the amount that can be contained in solid solution. Although up to 6% of carbon can be dissolved in iron when molten, actually less than 1.75% can remain in solution when the metal solidifies. The excess carbon separates out during solidification and remains present and dispersed throughout the cast iron in the form of free carbon (graphite).

Two of the factors, which influence the amount of carbon, that separate out when the cast iron solidifies are the length of time it takes to solidify and the amount of silicon that is present. Silicon tends to drive out any carbon in solution as graphite if it is given enough time and temperature. Thus the percentage of free graphite is a function of the cooling rate.

This excess carbon is the reason for many of the desirable properties of cast iron, such as high fluidity, low

shrinkage, high damping capacity on vibrations and ready machinability.

But the carbon is also source of problems. Due to its high content the cast iron is brittle and has very little elongation when subjected to strain. Because of this it cracks easily when subjected to local heating and cooling, as is the case when welding. Thus the welding properties of cast iron differ from those of steel.

While steel melts at approximately 1450°C, the high carbon content of cast iron lowers the melting point to 1100–1300°C (depending on type), making it easier to melt and allowing it to run freely into a mold to assume the shape intended for the casting. On boars ships cast iron has found wide uses as for instant engine blocks, heads, liners, water jackets, transmissions, pump and valve housings, manifolds, pipe fittings, cargo lines, etc.

There are five common types of cast iron:

- Grey
- White
- Malleable
- Ductile
- High alloy

These different cast irons cannot be identified by chemical analysis alone. It is the form of the excess carbon that determines the kind of iron that the melt becomes. With regard to the fifth type, high alloy cast iron, this is obtained by adding quantities of alloying elements to gray, white or ductile irons. In the following we shall take a look at the characteristics of the various types.

SOLUTIONS: Cast Iron

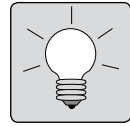

Grey cast iron

Grey cast iron is the least expensive and most commonly used of all cast metals. The raw materials – pig iron, cast iron scrap, steel scrap, limestone and coke – are all relatively inexpensive. We estimate that approximately 90% of all cast iron is in the form of gray iron.

When using casting molds of sand the molten metal gets a slow rate of cooling. This gives most of the carbon time to collect as graphite flakes between the iron crystal borders. In small or thin-walled parts the graphite is evenly dispersed throughout the material. In large-dimension castings the material near the surface will contain comparatively small graphite flakes, as this is the part of the casting, which will cool off first. In the middle the material will cool slower and contain fewer, but larger flakes. (illustration).

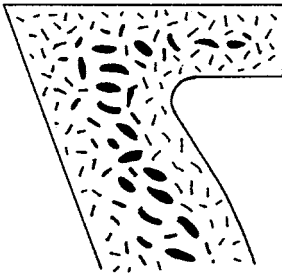

The presence of the graphite flakes promotes ready machinability, useful damping properties and resistance to wear. However, the flakes also serve as crack-indicators, and gray cast iron cannot be bent or forged to shape, neither in cold nor in red-hot condition.



Due to the presence of free graphite a fracture will have a gray appearance, which gives the alloy its name.

The wide range of strengths in gray irons, from 137 MPa to more than 390 MPa, plus manufacturing economy, explains the extensive use of these irons where high resistance to dynamic stress is not a governing factor.

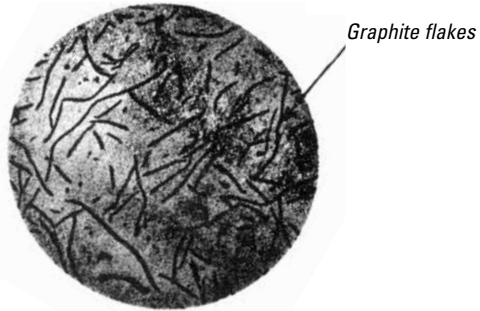

General analysis of gray cast iron:

Carbon	3,0–3,25%
Silicon	2,0–2,4%
Sulphur	0,2% maximum
Phosphorous	0,2% maximum
Manganese	0,6–0,7%
Ferrum	Rest.

Characteristics:

Soft.

Less brittle than white cast iron.

High machinability.

Good weldability (Unitor NICKEL-333N or NIFE-334N).



SOLUTIONS: Cast Iron

2.07

White cast iron

White cast iron has a similar chemistry to gray iron, but is different in that the carbon is present in the form of iron carbide (Fe_3C) instead of as free carbon (graphite). This is achieved by keeping the silicon content low and by rapid cooling, which does not permit the carbon to move to the crystal borders, but become trapped inside the crystals. This results in a martensitic structure, which is very brittle and hard. In a fracture the iron carbide will give the surface a silvery white appearance, hence the name white cast iron.

White cast irons are useful for wear resistant service but due to their crack sensitivity they are very difficult to weld and may be considered unweldable.

Characteristics:

Hard
Brittle
Abrasion-resistant
Non-weldable

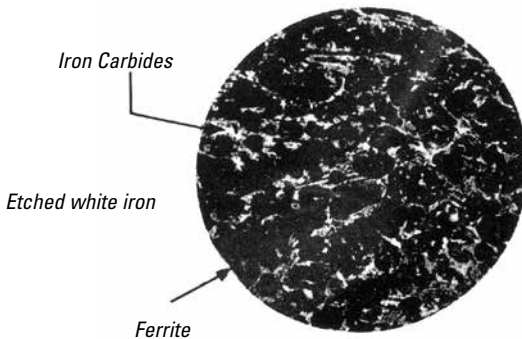

Malleable cast iron

Malleable cast iron starts life as an ordinary white cast iron, very hard and brittle. It is then annealed (heat treated) in a furnace at a temperature above $870^{\circ}C$, at which point the silicon can break down the iron carbides into iron and carbon. During a period from 1 to 6 days, the carbon actually moves through the solid iron to collect in little gobs or nodules of graphite. Iron with this microstructure is called malleable and its properties are opposite to those of white iron, from which it is derived. Instead of being hard and brittle, it is easily machinable, and is malleable. Due to the cost of manufacturing it, malleable cast iron is limited in application to relatively small parts. The strength of malleable cast iron varies from 340 MPa to 520 MPa.

Characteristics:

Will absorb mild to medium torsion forces.
Fair to good weldability.
When strength goes above 410 MPa welding becomes difficult.

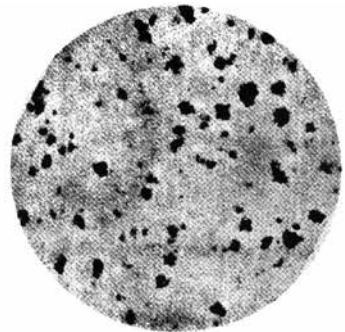

Malleable iron with temper carbon aggregates

SOLUTIONS: Cast Iron

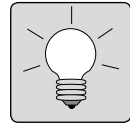

Ductile cast iron

Ductile cast iron (also known as nodular graphite iron, spheroidal graphite iron, and SG iron) bridges the gap between gray iron and steel.

It meets the demands for increased size of equipment, higher operating speeds and lower production costs by having high strength, toughness, and a resistance to shock loading.

By adding trace amounts of magnesium or cerium to the molten metal, the surface tension mechanism is altered and when the graphite precipitates it forms nodules or spheroids, instead of flakes as in gray iron, or compacted aggregates as in malleable iron.

This graphitic form dispersed thorough the casting contributes remarkable ductility to the casting, and creates strengths equaling many good grade steels, yet retains the advantages of superior castability and machinability. Ductile iron has mechanical properties approaching steel. It's tensile strength ranges from about 340 MPa to 1030 MPa as cast. It has yield strength from 275 MPa to 830 MPa with an elongation in 2 inches from 2% to 25%.

Ductile iron may be welded very satisfactorily with Unitor NIFE-334N

General analysis of nodular irons:

Carbon	3,2–4,1%
Silicon	1,8–2,8%
Manganese	Up to 0,8%
Phosphorous	0,1% max.
Sulphur	0,03% max.

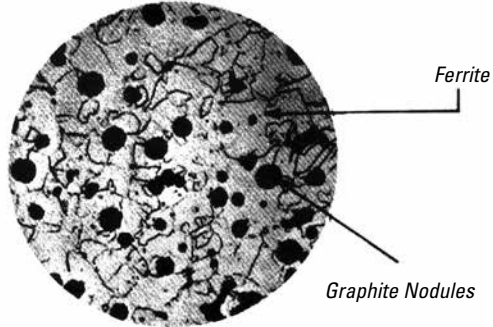

In addition magnesium not in excess of 0,08%, or cerium in quantity of a few thosandths of 1% is included.

2.07



SOLUTIONS: Cast Iron

2.07

High alloy cast irons

High alloy cast iron is a general classification that applies to gray iron, white irons, and ductile irons. They are considered high alloy when the alloy contents exceeds 3%.

The addition of alloys to that extent radically changes the microstructure and the properties of the castings to which they are added. The most common alloying elements are nickel, chromium and molybdenum. In general high alloy cast iron is weldable.

Meehanite

The name Meehanite refers to a group of cast ferrous materials manufactured under rigid metallurgical control so that their properties meet established engineering specifications. There are many types of Meehanite, ranging from soft types with exceptional machinability to stronger types whose strength properties approximate or exceed that of many cast steels.

Characteristics:

High density
Very high strength
Fair weldability

Ni-Resist irons

In this series of cast iron alloys the corrosion resistance of gray cast iron is enhanced by the addition of appreciable amounts of nickel, copper and silicon.

General analysis of Ni-Resist irons:

Carbon	1,8–2,6%
Silicon	5,0–6,0%
Manganese	0,4–1,0%
Nickel	13,0–32,0%
Chromium	1,8–5,5%
Copper	10,0% maximum
Molybdenum	1,0% maximum

Characteristics:

High resistance to corrosive acids and atmospheric corrosion.
Excellent weldability.
Strength 137 MPa - 313 Mpa

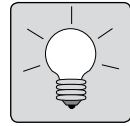

How to identify cast iron

Cast iron will, as the name implies, always be in the form of casting. Castings have one thing in common; they will have no welded joints, and most often they will have a visible casting line where the two halves of the mold they were cast in met.

One can easily identify a copper alloy or an aluminum alloy casting by their color. However, to distinguish between cast steel and cast iron by appearance alone is not easy. To help us establish which metal a casting is made from we have a couple of easy tests.

The perhaps simplest method to distinguish cast iron from cast steel is to use a hammer and chisel on a place of the casting where a little chiseling will do no harm. Cast steel when chiseled will form a continuous chip, while the cast iron forms no chip but comes away in small fragments:

A spark test will also give ready identification between the types of ferrous metals.

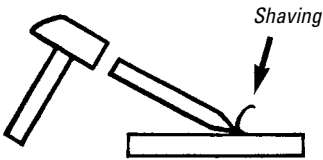

Unalloyed steel (Cast steel).

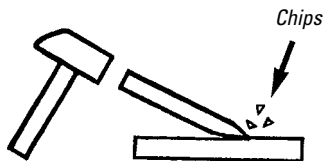

Cast iron.

Mild steel		
	The leaf is smaller and gives rise to a number of sparks. Some streaks are shorter.	
Cast iron		
	Faint red streaks terminating in complex bushy sparks yellow in colour.	
	GREY CAST IRON	MALLEABLE CAST IRON
Volume of Stream	Small	Moderate
Relative Length	0.6 m	0.75 m
Colour at Wheel	Red	Straw
Colour at end	Straw	Straw
Description of spark stream (compare with known samples).	Many small repeating sprigs.	Longer shaft than grey iron, small repeating sprigs.



SOLUTIONS: Cast Iron

Preparation of the work piece

First clean off all oil, grease, rust and paint from the surface, using a brush or by chemical means. Then remove casting skin to a width of 20 mm on both sides of the edges to be welded. A grinding machine may be used for this work. Remove imperfections in the weld area, such as blowholes, cracks, fatigue areas and porosities down to sound metal.

If the damage is in the form of a crack in the material, it may be difficult to determine where the crack actually

ends. The use of a crack detector set to find the complete extent of the crack is absolutely recommended (see "Inspection of welds").

When this has been established, drill a 3 mm hole at a distance of 3 mm in front of the crack. This will prevent the crack from opening further during the repair.

Cracks should be "V-ed" or "U-ed" out, using either a grinding machine or by gouging electrodes. Suitable groove profiles for various material thicknesses can be as follows:

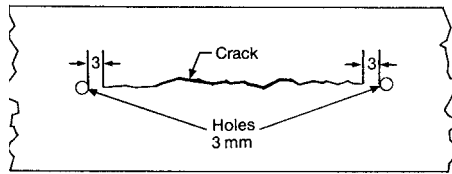

Preventing crack propagation

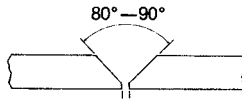

Material thickness up to 20 mm

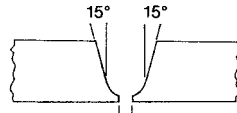

Material thickness 20-40 mm

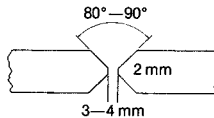

Material thickness above 40 mm

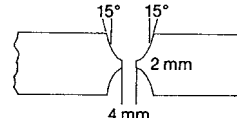

Alternative shape, thickness above 40 mm

Groove preparation by grinding

Grind a 90° V-groove as indicated in the sketches. If the part has broken into two or more pieces, the sides of the fracture should be ground to a 45° bevel.

Sharp corners and edges should be rounded off wherever possible, particularly on surfaces to be machined or filed later. This is necessary to prevent excessive melting of the base material in these

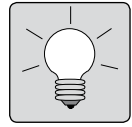

areas during the welding process. If edge rounding is omitted, hard spots will be evident in the weld deposit.

In preparing the casting by grinding, a certain amount of carbon (graphite) is removed from the metal and smeared over the surface to be welded by the grinding wheel. Before any welding can be done this carbon must be removed, as it will otherwise become part of the weld pool and combine with the iron to form a superhard zone of iron carbide in the weld.

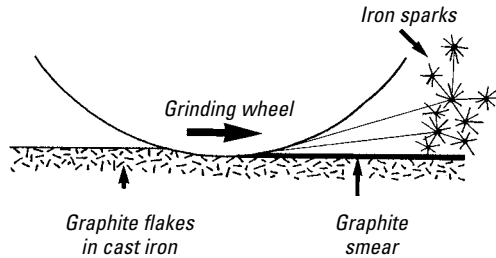

2.07

To avoid this, always remove a thin layer of the surface by a file after completing grinding. Use a steel brush to remove loose material.

Searing

The more carbon you can remove from the weld area, the less chance there will be for hard spots in the weld. To further remove excess carbon embedded in the surface the workpiece can be seared, using an oxy-acetylene torch with an oxidising (excess oxygen) flame.

Use a larger blowpipe and move the inner cone of the flame forward over both sides of the welding groove. You will know immediately when the free carbon is removed. As the carbon burns it looks like a bright red particle or "star". Use a wire brush over the surface from time to time.

Searing must not be confused with preheating, and is only intended to remove surface carbon. Take care not

Move torch rapidly along each side of the groove.

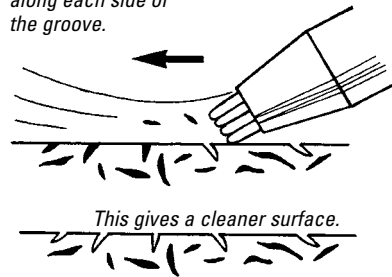

to put too much heat into the material when executing it.

Regardless of what we do to remove surface graphite, some graphite will nevertheless be melted up and become part of the weld. Unitor cast iron electrodes are so made that they can take up 1% graphite without causing the formation of iron carbide.

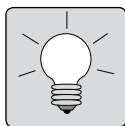

SOLUTIONS: Cast Iron

Groove preparation by electrode gouging

The most efficient method of removing unwanted metal and preparing surfaces for welding is to use gouging and chamfering electrode Unitor CH-2 382.

This method of groove preparation requires no other equipment than that used for ordinary arc welding and gives a very attractive U-shaped groove that is clean, bright and makes an ideal base for welding. In addition it gives the advantage that if the part to be welded is oil-impregnated (as a number of cast iron parts are bound to be), the heat generated by the process will cause the oil to evaporate from the graphite flakes in the welding zone.

Another advantage is using CH-2 382 to prepare the metal for welding is the small amount of heat imparted to the casting prior to welding. By removing the chill from the metal welding will be easier. The filler metal will have better flow characteristics and improved welds will be evident.

For correct application of gouging electrode CH-2 382, see the data sheet under "Technical Data for Consumables".

Repairs of areas requiring drilling and tapping

Before welding areas which will subsequently require drilling and tapping, it is essential that the following procedure be followed: Always remove enough metal initially so that, after filling, the final drilling and tapping can be performed entirely in the deposited weld metal without penetrating the base metal. The variance in density in the weld



A crack in cast iron. The carbon flakes in the metal are saturated with oil.



After gouging with Unitor CH-2 382. The oily deposits in the welding area have evaporated.

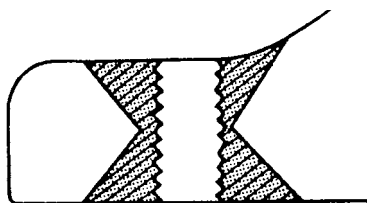

deposit and the base metal makes this necessary. Drill and tap breakage will result if this procedure is not adhered to. This method, of necessity, requires more preparation and welding, but increase in time and labor will be compensated for in tool savings.

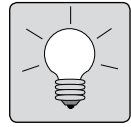

Arc welding of cast iron

Below is a short description of the cast iron electrodes Unitor NICKEL-333N and Unitor NIFE-334N to help you select the correct electrode for the work. Complete data on these electrodes are found in the section "Technical Data for Consumables". Remember that cold welding of cast iron can only be done by electric arc welding.

Unitor NICKEL-333N

For use on old, oil-impregnated cast iron and on thin material dimensions. Use this electrode to "butter" the sides of oily cast iron to seal the surface. Then finish the filling-up to join the parts together with Unitor NIFE-334N, which has greater tensile strength. Do not deposit more than maximum two layers for NICKEL-333N.

Unitor NIFE-334N

To be used on cast iron that takes strain, vibrations and sudden loads. Also to be used for joining cast iron to steel, copper alloys and stainless steel. NIFE-334N is used for multi-bead welding on heavy gauge material. It has greater tensile strength than NICKEL-333N.

Electrode binding test

Grind off a small area of the material close to the welding zone. Select a 3.2 mm electrode of NICKEL-333N and NIFE-334N, and deposit a 4-5 cm bead with each of them without weaving.

Use 100 Amps and the correct polarity. Use a hammer and chisel to remove the beads. The bead which exhibits the least porosity on the

contact surface indicates the most suitable electrode for the binding layer for this particular base metal. For information on porosity, it's causes and correction; see under heading "Poor Welds".

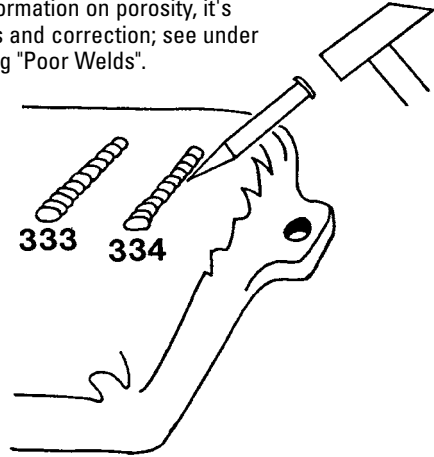

Hot welding

In hot arc welding the part must first be evenly heated to approximately 500°C. Especially if the casting to be welded has any appreciable material thickness it is important that the preheating proceeds slowly. Cast iron has a low coefficient of thermal conductivity, and demands care in preheating. Too quick heating can cause tension cracks. The temperature must be maintained throughout the welding operation.

As the means for preheating on board will normally be limited to the welding torch, it means that only smaller parts, and which can be dismantled and brought into the workshop can be hot welded on board.

When hot welding cast iron the temperature of the workpiece must be



SOLUTIONS: Cast Iron

monitored by means of temperature indicator crayons or by an electronic thermometer. It is important that the temperature does not exceed 600°C, as this may result in structural changes in the base material, which may drastically reduce its strength.

Opposed to cold welding, hot welding can proceed continuously. The finished welded part must then be allowed the slowest possible cooling down to room temperature. Burying the piece in kieselguhr, sand or cinders will help to give it a slow cooling rate. The reason why slow cooling is important is that if the rate of cooling is high, the carbon will have no time to segregate as graphite in the crystal border areas. We will instead have the carbon bound to the iron in the form of iron carbide. This structural state will be very similar to that of white cast iron; hard and brittle.

Smaller parts, free to expand, may be hot welded. NB: Allow to cool off slowly!

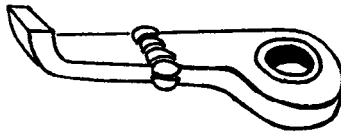

Cold welding

If the necessary equipment for preheating or for achieving the required slow cooling rate is not available, the alternative is "cold" arc welding. The method is so called because of the low heat input to the base material when correctly executed.

On board cold arc welding is by far the most commonly used method, and large cast iron parts, or parts which are difficult or time-consuming to dismantle should be cold welded.

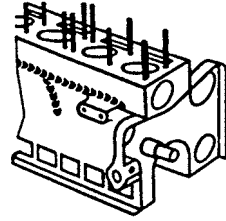

Large, complicated parts should be cold welded.

Amperage setting

When cold welding cast iron a low ampere setting should be used. Thereby deep fusion between the filler material and the base material is avoided. It should be remembered that deep fusion will dig up and bring into the weld pool more graphite than need be. This graphite will give rise to iron carbide, with resulting hard zones when the weld cools off. Deep fusion will also put lots of unwanted heat into the base material with increased risk of cracking.

In order to avoid digging into the base material, and to reduce the heat input, one can also point the electrode 10° in the direction of travel. This will cause the molten pool to blow forward and act as a cushion.

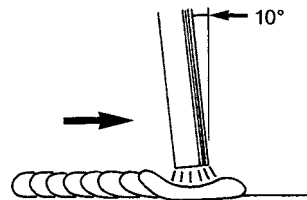

Do not overdo low amperage setting. The molten pool must be clear of slag, and easy to control. If the deposit has a high bead contour, the setting is too

SOLUTIONS: Cast Iron

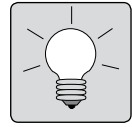

low. If there is excessive spatter and undercutting, the amperage is set too high.



Desired Bead Contour.

For Unitor NICKEL-333N and Unitor NIFE-334N amperages should be set approx. 10% lower than those used with conventional cast iron electrodes. Recommended amperages are as follows:

Unitor NICKEL-333N
- 2.5 mm 55-110 Amp.
- 3.2 mm 80-140 Amp.

Unitor NIFE-334N
- 3.2 mm 75-100 Amp.
- 4.0 mm 85-160 Amp.

The above settings are approximate. Setting will vary with the size of the job, type of machine, line load, etc. It is recommended practice to select a setting halfway between the figures and make a trial weld. NICKEL-333N has high ohmic resistance. If ampere setting is too high the electrode may become red hot.

In general, the welding current should be as low as possible, consistent with easy control, flat bead contour, and good wash at the edges of the deposit. The amperages listed are for flat or downhand welding positions. Reduce the amperage range by 5-10% for overhead welding, and about 5% for vertical welding.

To ensure good electric conductivity the return cable clamp should be

attached to the workpiece itself if possible.

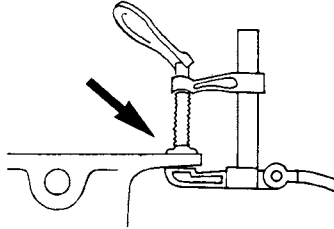

Choice of polarity

If the current source for the welding is a welding rectifier (DC-machine), the choice of correct polarity will influence very much on the result of the work. Some electrode manufacturers make cast iron electrodes that can only be used with negative polarity. Furthermore, some years ago the general low quality of cast iron electrodes made it necessary to use negative polarity to achieve binding between base material and weld deposit. However, the quality of Unitor cast iron electrode is very high, and the electrodes can be used with both polarities without difficulty. The operator must be aware of the effects of the different polarities, as the heat input and the melting of the base material varies considerably according to the polarity selected.

Straight polarity (Cathode)

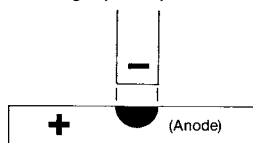

Reverse polarity (Anode)

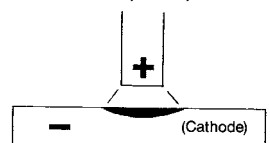

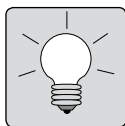

SOLUTIONS: Cast Iron

2.07

If the electrode is connected to the minus pole of the machine (straight polarity) we get high, concentrated heat input to the base material. This will cause excessive melting and digging into the material. In addition to contaminants such as phosphorous and sulphur, cast iron contains quantities of the gassed nitrogen, oxygen, carbon dioxide and carbon monoxide. Excessive melting will bring unwanted quantities of these impurities into the weld. The more impurities contained in the base material the lower the quality of the weld. The high heat input will also cause the formation of iron carbides, with hard zones in the weld and the heat affected area.

If we connect the electrode to the plus pole (reverse polarity) we get a wide, shallow weld zone with minimal amounts of graphite, phosphorous, sulphur and gasses. The low heat input will reduce the formation of iron carbides.

When welding with DC, reverse polarity to the electrode should be the first choice. However, in cases where the cast iron is heavily contaminated and has poor weldability, straight polarity may be tried in the first run in order to use the higher heat input and melting to achieve bonding between the base material and the weld deposit.

Length of arc

To reduce the voltage across the arc, and to help minimize heat input into the base material, the shortest practicable arc should be maintained. By experience it may be found that the first pass should in some cases be done with a somewhat longer arc than the following runs. This would be

in cases where the composition of the base material makes good bonding more difficult, and the first bead has to be "painted" on to it.

Correct size electrode

Always use the largest size diameter electrode that the groove can accept (but not at the expense of not getting down into the groove!). Using a large size diameter means that you reduce the heat input in relation to the amount of filler metal deposited. For instance a 4,0 mm electrode deposits four times as much weld metal at only two times as much amperage compared to a 2,5 mm electrode. However, if the first bead shows porosity, a small diameter electrode, low amperage setting and high welding speed should be used for this run to reduce heat input.

The welding

Remember that cast iron is very brittle, with only 1–2 % elongation. Should the shrink forces exceed the tensile strength of the cast iron it will crack. Hence, when welding it is crucial to the success of the operation that the heat input to the base material is kept at a minimum to avoid cracking.

The way to achieve this is to *avoid* putting down long, continuous beads (as when welding mild steel), and instead to weld short, straight stringer

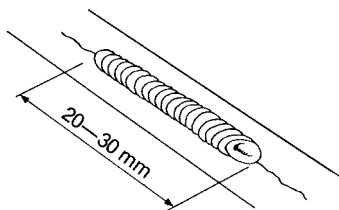

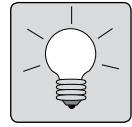

beads of maximum length 20–30 mm (1") at a time. Weaving should be avoided or kept to the minimum required to "wash out" the deposit and to catch the sides of the groves.

Do not weave in excess of one-half electrode diameter to each side of the direction of the weld. When each bead of 20–30 mm has been deposited, fill the crater and withdraw the electrode a little backward on the bead before breaking the arc.

While the bead is still hot, peen it with a round-nosed peen hammer. Since the casting is quite rigid, the filler metal must be ductile. Peening the bead immediately after depositing will stretch it to accommodate some dimensional change in the weld area, and will provide some stress relief.

Always peen from the crater back to the starting point. Use rapid moderate blows; just hard enough to leave a slight indent on the weld deposit is usually sufficient. Too heavy blows may cause cracks, while too light peening will have little or no effect in relieving stresses.

On thin dimensions the peening should not be vertical on the bead, as vibrations will reduce the effect:

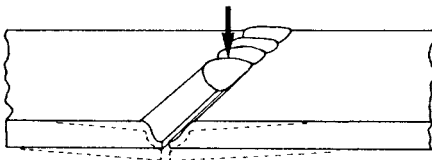

Wrong

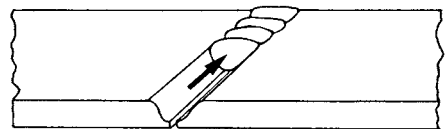

Correct

After the initial bead has been deposited and peened, the next bead should not be put down until the bare hand can be laid alongside the

first bead with comfort. If you burn yourself, it is too hot to go on with the welding. Take your time, do not spoil your work by trying to rush it.

$R = 3 \text{ mm}$



Rounded edge



Recommended shape of head.

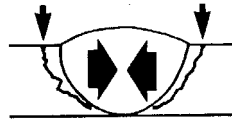

Weld contraction may cause cracks.

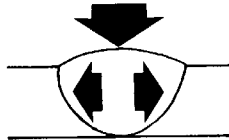

Peening offsets contraction forces.

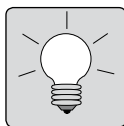

SOLUTIONS: Cast Iron

Sometimes more than one short run can be done at a time, but only when the length to be welded is considerable, and the beads can be

spaced well away from each other to prevent heat build-up. This technique is called skip-welding and speeds up the work considerably:

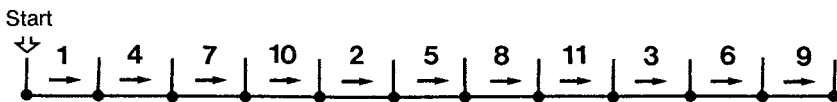

Repairing crack with free end

Start welding at tied end, then backstep towards free end.

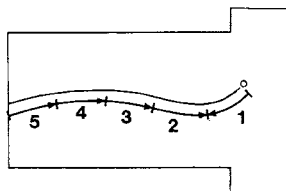

Repairing crack with tied ends

Put the two first beads (2 - 3 cm each) starting from the hole drilled at each end of the crack. Then weld alternatively from each end of the crack, using the backstep technique.

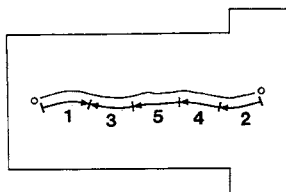

Repair of separated parts

Starting from one edge, use the backstep technique across the part to the opposite edge.

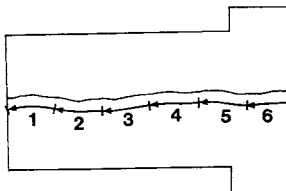

Parts subject to high stresses

To strengthen the transition zone transverse grooves may be cut in the sides of the welding groove, using chamfering electrode Unitor CH-2 382. First fill up these grooves with the electrode selected for the first layer, and then cover the entire surface of the groove with a deposit of the same electrode, without peening. Then proceed to fill up the groove. Remember the build-up should always be done with Unitor NIFE-334N



Cut transverse grooves in the sides. Fill them first, then cover the entire surface before proceeding to build up and join.

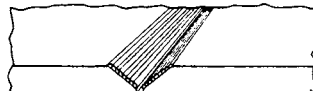

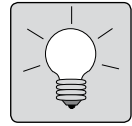

A way to reduce shrinkage stress

In order to reduce the shrinkage stresses, do not put down a complete root bead first, before proceeding to build up. "Stack" the beads stepwise as shown in the sketch, advancing each bead (starting always with the root bead) 2 - 3 cm forward at a time. Take care to keep the heat down (hand warm before proceeding each new bead!) and hammer each bead while still hot. A small pneumatic hammer is suitable for this kind of hammering.

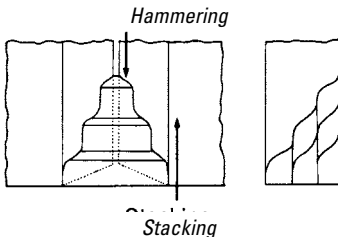

Steel insert technique

It is sometimes desirable to insert a steel patch in the centre section of a large housing or motor block. A gear may have shattered and pushed out an area in the housing. A frozen block may have suffered the same damage. Usually the pushed-out section has been broken in so many pieces that it is not practical to try to join the pieces. The least expensive method or repairs is to fit a steel patch into the hole. This is done as follows:

Remove all damage material on the casting. Avoid leaving sharp corners, round off wherever possible. Clean off dirt, paint, oil and grease from the area where the repairs is to take place. Use a Crack Detection kit to make sure there are no hidden

cracks. Grind the edges of the casting at an angel of 45° halfway down its wall thickness. Remember to file the ground area to remove surface graphite. Seal in the contaminants, using Unitor NICKEL-334N. Using a piece of cardboard cut a template to obtain the correct shape for the steel patch.

Select a piece of low carbon steel, one half the thickness of the casting's wall. Using the template as a guide cut the patch out of the piece of steel. It should fit the hole with a clearance of 2 - 3 mm. Grind the edge of the patch 45°. The patch should be "doomed" slightly by striking with a ball-peen hammer until a bulge is formed.

Place the patch in the hole and secure it in position but do not tackweld it. As this will prevent the patch from expanding to heat. Now weld the patch to the casting, using the backstep technique as indicated in the sketch. Be careful to let each bead of 2 - 3 cm cool off before proceeding with the next bead. Use Unitor NIFE-334N for the build-up.

Bevel edges to 45°.

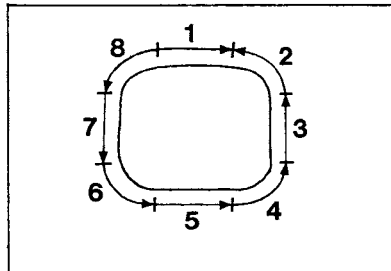
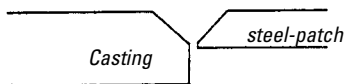

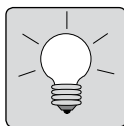

SOLUTIONS: Cast Iron

Build up of missing section

Occasionally, it will be necessary to rebuild parts where sections have been worn down or broken off. In explaining the salvage process a broken-off cog on a wheel is taken as an example.

Cut stress-relieving grooves in the area to be built up, using Unitor CH-2 382. If the area is large enough to accept more than one groove, there should be a minimum of 6 mm (1/4") between the grooves. Do not use a grinder for cutting stress relieving grooves. The grooves will not be geometrically correct for the dispersion of stresses from the casting surface.

Fill in the grooves. Then "paint" on weld metal by using a long arc and fast zigzag movements. Apply thin deposits (1,5 mm) to seal in all contaminants. Do not quench.

Built up section, use stringer beads.

When repairing defects in raised areas, such as bosses, which must be machined after welding, it is unwise merely to chip out the defects and fill the defective areas. It is better to prepare the area for repair by machining to a dept slightly below the desired final surface. Then build up the surface 2 mm (1/16") above the required dimension to allow for machining. All machining will then be done on the solid weld metal deposit, which is fully machinable.

Alternatively the parts may be rebuilt by braze welding, using Unitor Castiron 237 or Unitor FC-Wearbro 262.

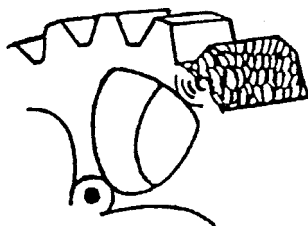
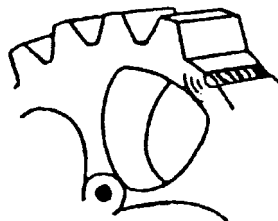
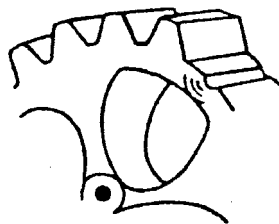

Filling holes that penetrate clear through the casting

Begin to weld at one side and run straight stringer beads side by side until the hole is closed. Weld from one side only. Do not alternate sides or weld around the edges. Such action will create stress cracks. Peen each weld pass lightly to reduce shrinkage stresses. Remove slag.

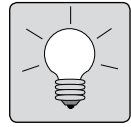

Braze welding of cast iron

General

The name braze welding comes from the relatively slow-flowing nature of the filler material, which gives the joining process much in common with ordinary gas welding.

A condition for using braze welding on cast iron is that it must be possible to preheat an area on each side of the weld zone to 400–600°C. In practice this limits braze welding to smaller parts and thinner dimensions. For larger components "cold" electric arc welding is recommended.

In braze welding the cast iron is not melted, and braze welding is thus a form of mechanical bonding, as opposed to gas welding, where the parent metal is melted and forms a chemical bonding with the filler metal.

The use of braze welding on cast iron has the decided advantages of low heat and ductility, both of which reduce and/or eliminate the two serious problems traditionally associated with welding cast iron.

These are:

- I. The tendency for high heat to form unwanted white cast iron, a form of martensitic cast iron that is very brittle and hard due to the presence of iron carbide. The low heat used in braze welding greatly reduces the possibility of this formation.
- II. The problem of contraction during cooling. These are avoided partly due to the lower heat required, and partly because the brazing filler alloy has a great capacity to yield and accommodate any cooling stresses. By braze welding cast iron is to a certain degree independent of the quality of the base material.

In braze welding the cast iron is heated to bonding temperature. This is the minimum temperature to which it must be heated to form a bond (surface alloy) between the filler metal and the cast iron. The phenomenon, which then occurs, is called "tinning" (also called "wetting out" or "bonding"). Actually, it refers to the almost microscopically thin layer in which the alloys of both the cast iron and the molten filler metal intermix.

While there is several processes for braze welding, the use of an oxy-acetylene torch to provide the necessary heat will be the method employed on board.

Preparation of the workpiece

Remove oil, paint and rust from the surface. Grind off casting skin to a width of 20 mm on each side of the edges to be welded. If the damage is in the form of a crack in the material, it is recommended to use the crack detector set to find the complete extent of the crack. Drill 3 mm holes at each end of the crack, at a distance of about 3 mm from the ends to prevent the crack from opening further during brazing.

Groove preparation

Prepare a 70°–90° groove. Remember that braze welding is a surface bonding, and that the larger the surface of a joint the better the bonding. If the part has been broken into two or more pieces, bevel each side of the fracture to 45°. Use a file to remove surface graphite from the groove, and round off edges and sharp corners.

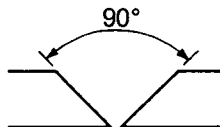

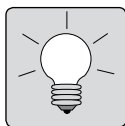

SOLUTIONS: Cast Iron

Searing

Even after filling there will still be graphite present in the surfaces to be joined. Graphite is a refractory material, which can inhibit "tinning". By playing the inner cone of an oxidising flame from the welding torch over the surfaces off the groove, most, if not all, of this graphite can be burnt away. This process, which is called "searing" should be practiced as a matter of course before attempting to braze weld cast iron.

Preheating

After the searing is completed, preheat the part(s) to 400–600 °C with a wide spread of heat to each side. Remember that cast iron is one of the more brittle and crack-sensitive base metals. Thus care should be exercised in the preheating to ensure that it is even and uniform.

Braze welding

When braze welding cast iron the flame should be adjusted to have a slight surplus of oxygen (oxidising flame).

Joining is done with the filler metal Unitor Castiron 237. This filler metal is extremely easy to work with, has high tensile strength and the structure and color of cast iron. Welded connections are compact and machinable. The filler also fuses to oil impregnated cast iron.

Typical uses are welding of cracked parts and building up worn surfaces such as gear and gear wheel teeth. Use Castiron 237 in combination with Castiron Flux 236F. Heat the end of the rod and dip it in the flux powder. The flux will stick to the rod

Heat the starting point to a dark red heat. Touch the rod to the surface and melt off a drop from the rod into the groove and spread it out by continually moving the torch, which should be held flat at an angle of about 15 - 30° to the workpiece, and approximately 1 cm above the groove. When the filler has flowed freely into the seam, melt off a new drop and repeat the procedure.

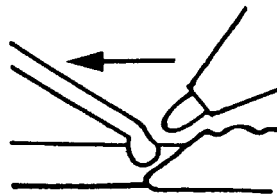

Braze leftward

When the brazing work is completed, the part should be allowed to cool slowly in kieselgur or dry sand. Surplus flux must be removed by hot water and brushing.

Alternatively, where a hardwearing surface is required, the joining can be done with the filler rod Unitor FC-Wearbro 262, applying the same technique as described for Castiron 237.

Unitor FC-Wearbro 262 has a low bonding temperature. However, the strength and machinability is lower than for Castiron 237.

Technical details on the rods are found in the section "Consumables".

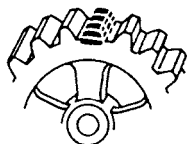

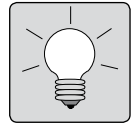

Cold repair of cast iron

General

Where there are limitations to hot work, cold repair materials are an alternative. Polymer materials are essentially epoxy or polyurethane products with additions of metal or ceramic filler. They are cold curing materials consisting of a base and activator that are mixed together. During solidification and curing it does not develop any heat. Polymer materials form a surface bonding and it is absolutely essential that the base materials surface be cleaned in order to give good addition.

Therefore:

- 1) Surfaces must be cleaned and ruffed up in order to give a good bonding.
- 2) Measure out base and activator according to instructions
- 3) Mix base and activator thoroughly together. Any unmixed material will not solidify.
- 4) At first only apply a small amount of product and make sure to press it hard into the prepared surface securing good bonding. Afterwards add more product and build up to required height. If needed, a reinforcement bandage can be added to the product in order to increase strength.

NB. In order for curing to take place the ambient temperature for polymers must at least be + 5°C. Polymer products are organic material that will start to carbonise at 150°C. This will make a natural limitation to polymer when it comes to high temperature application and in cases where there are specific demand for fire retardant properties. One must also check that the polymer product to be used is resistant to the cargo the part is handling.

Recommended products:

Metalgrade Express
Metalgrade Rebuild
Leak Stop Pipe repair I, II or III



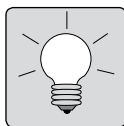

SOLUTIONS: Cast Iron

Repair case 1.

In some repair situations the cast iron is so corroded and oxidized that welding cannot be done. In this kind of situations cold repairs might be the solution.

Clean surface to remove grease and accumulated dirt. Remove as much of the loose metal and oxides as possible. Thoroughly abrade the edge and the surrounding surface of the hole.

If the hole is large, a metal mesh formed to the shape of the hole should be made. Measure up and mix a small quantity of Metalgrade Express and apply it along the edge of the hole. Remember to squeeze the product hard into the surface to secure good bonding. The first thin covering acts as a "wetting layer" to improve adhesion.

Place the pre cut mesh down in the hole so that it makes contact with the polymer along the edge. If needed secure it with additional polymer.

Allow drying for 6 minutes (at 20°C). With the mesh securely fastened measure up and mix a sufficient quantity of Metalgrade Rebuild. Apply the product on to the mesh spreading it out evenly. Apply the product to totally encapsulate the mesh and blend it in with the Metalgrade Express already on the cast-iron edge.

If the mesh size is too big, and the polymer falls trough, apply reinforcement bandage on the mesh to prevent it happening.

If necessary, support the mesh by placing steel wires across the hole. The wires can be fastened to the edge by a small tack weld or by drilling a hole with slightly bigger diameter.

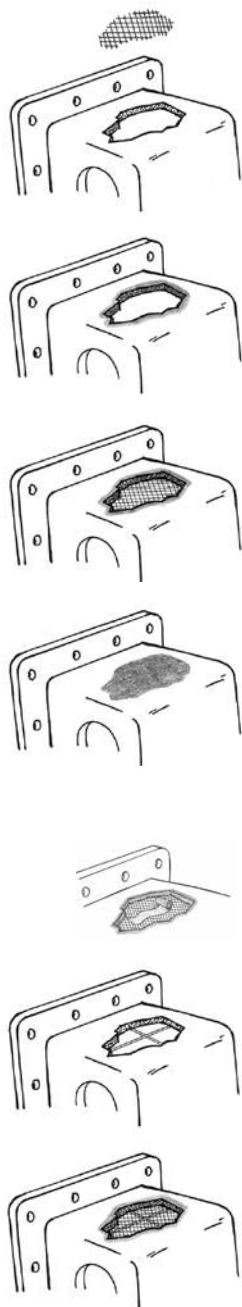

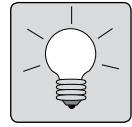

Repair case 2.

After welding has successfully been employed to weld a crack, it sometimes turns out that there is liquid penetrating through porosity in the weld or heat affected zone.

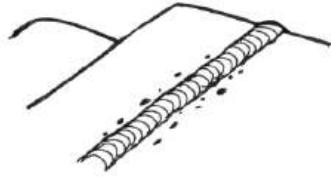

The porosity is often caused by residue oil in the cast iron structure. Instead of risking cracking by further welding, polymer can be used to seal the surface area. The surface must be thoroughly degreased and abraded.

In some cases grind or drill out the porosity to half its depth. Remember that grinding has a tendency to polish the surface and require abrading afterwards.

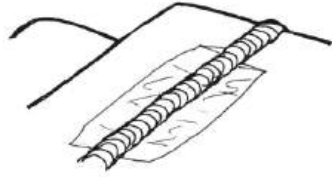

2.07

If you are repairing small areas, simply measure, mix and apply the Metalgrade Express. Use the Metalgrade Rebuild if larger areas are to be covered. It is very important to squeeze the product hard into the surface in order to secure good bonding and sealing.

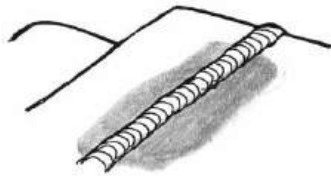

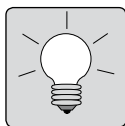

SOLUTIONS: Cast Iron

Repair case 3.

Another area of application where polymer can be useful is on pipes, conduit and ducting made of cast iron. Holes, cracks and splits in piping may be tackled from the outside of the pipe without complete disassembly of the system. Using polymer also avoids welding cast iron in position, something that can be difficult. Thoroughly degrease the area to be repaired. Remove all paint, rust and scale. Make sure the surface is abraded.

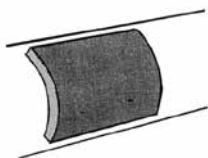

The repair may require the use of a metal backing plate to strengthen the repair. Select a piece of steel plate of equal thickness to the damaged pipe and shape it to the outside dimensions of the damaged area. The plate should extend 5 cm beyond each side of the damaged area.



Thoroughly abrade the inside and outside of the plate to achieve a coarse profile.

Measure up, mix and apply Metalgrade Rebuild or Express to the prepared pipe surface and to the



internal surface of the backing plate. Press the plate firmly over the area.

The plate should now be held in place until the product has set, this could be done using wire, plastic strapping or cable ties.



Once the patch has set the ties can be removed. Measure out, mix and apply more products over the patch to totally encapsulate it. If a high-pressure repair, the product must be applied to the patch and the complete circumference of the pipe.

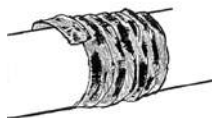
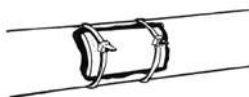

Wrap reinforcement tape around the pipe and patch totally encapsulating it. Make sure the product is impregnating the tape so that the final surface consists of product that can be smoothed out and blending in with the pipe surface.

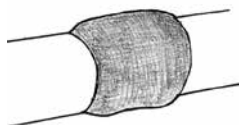

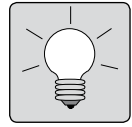

Repair case 4.



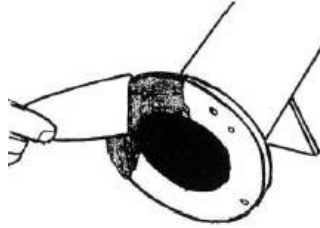

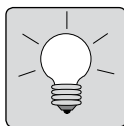



Polymer cold repair can also be used with good results on cast iron that requires large surface area repairs. Welding will in most cases crack the cast iron because of high heat input, while polymer being a cold curing process has none of these problems. Flange repairs are a typical application area and so are cast iron pump housings where cavitation wear gouges out the metal. When fluid flow environment is creating wear, the correct product to use is Ceramigrade Rebuild and/ or Liner (information on this products to be found in the Unitor Welding Handbook polymer chapter).

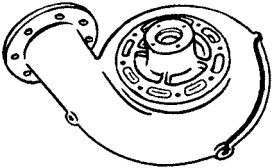

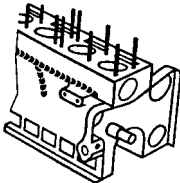

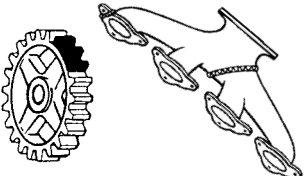
SOLUTIONS: Cast Iron

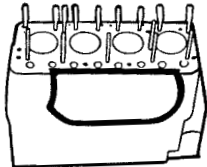
2.07

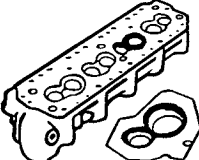
Description	Solution	Examples
Large cast iron components exposed to vibration, strain and sudden loads, and where several layers of weld metal may be needed, e.g. cargo pipes, valve bodies, machine bases, pump housings, pump impellers, flywheels.	 NIFE-334N	
Oil-impregnated cast iron, often found in motor blocks, gear boxes, cylinder heads, fuel pump cylinders, and frames in fuel oil purifiers.	 NICKEL-333N	
Smaller parts that can be preheated and allowed to cool slowly after welding, e.g. pump housings, levers, pillow blocks, exhaust manifolds, pulleys, and gear wheels with broken or worn teeth.	 CAST IRON-237  NIFE-334N	
Repair of holes in cast iron components by inserting a steel plate, welding cast iron to steel.	 NIFE-334N  NICKEL-333N	
Rebuilding cast iron, for example valve seats in cylinder heads, or exhaust valve housings.	 NIFE-334N  NICKEL-333N	

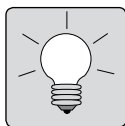

SOLUTIONS: Copper and Copper Alloys

Introduction

The most common type of copper is electrolytically refined and treated to obtain different qualities. Pure copper has limited use on board except as copper piping. Cast parts are usually in brass or bronze alloy.

Copper normally contains a small amount of oxygen. Oxygen combines with the copper forming copper oxide. The oxide is distributed in the metal in very small quantities and does not affect the mechanical characteristics of the metal. However, during welding

the oxide can cause porosity in the weld. Copper which is heated up to approx. 900°C will become brittle and weak as the copper oxide diffuses to the crystal boundaries where it collects and weakens the strength of the metal, in hot and cold condition. In this way, welding will weaken the metal in a joint. The best method of joining copper piping is therefore brazing with FC-BRONZE or with AG 45 or AG 60.

2.08

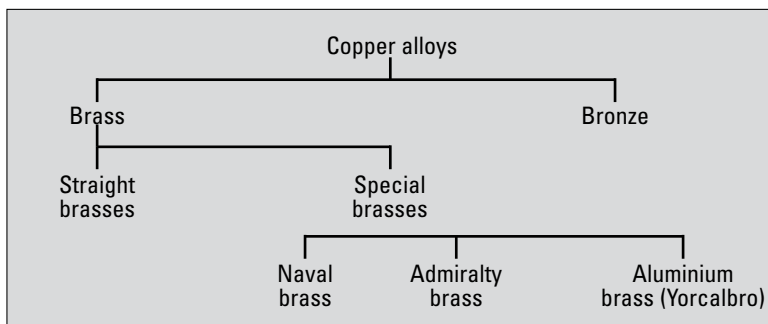

Brass

Brass is usually an alloy of copper and zinc, but other alloy elements may also be present. The zinc content in brass may vary from 5–50% in the different types.

The type of straight brasses used for mechanical purposes will usually contain between 63–75% copper, i.e.:

- Cu 70%, Zn 30% (70:30 brass)
- Cu 60%, Zn 40% (Muntz metal)

Brazing: AG 45 or AG 60 with
AG 60/45 FLUX

FC-BRONZE and
BRONZE FLUX

FC-WEARBRO and
WEARBRO FLUX

Different types of special brasses are also available:

e.g. Admiralty brass (Cu 70%, Zn 29%, Sn 1%) or Naval brass (Cu 58–64%, Sn 1%, Zn balance). Both these may be brazed the same way as straight brasses. Aluminium brass however should be treated in a special way.

SOLUTIONS: Copper and Copper Alloys

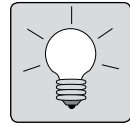

Aluminium brass (Yorcalbro)

Copper sea water piping on board ships has increasingly been replaced by Yorcalbro pipes. Yorcalbro (aluminium brass) is an alloy with the following chemical composition and mechanical specification:

Some years ago, numerous welding tests were carried out on Yorcalbro pipes using the TIG (GTAW) process. The results were very satisfactory. Both small and large size pipes were welded in these tests, and the conclusions were as follows:

Alloy:.....	Cu 76%, Al 2%, Zn 21,96%, As 0.04%
Tensile strength:.....	Hard (untreated) 580–700 N/mm ² Heat treated 360–470 N/mm ²
Annealed	310–370 N/mm ²
Hardness:	Hard (untreated) 165–194 HB Heat treated 83–111 HB Annealed 63–78 HB
Elongation:.....	Hard (untreated) 8–15% Heat treated 55–65% Annealed 65–75%
Specific weight:.....	8.34
Outside coefficient per °C:.....	000013.

2.08

The use of Yorcalbro piping allows a higher flow rate in the pipe than possible with copper piping. A flow rate up to 3.5m/s is permitted in Yorcalbro pipes compared to 1.52 m/s in copper pipes.

Aluminium brass pipes are more durable than copper pipes. Aluminium brass pipes have a widespread use in cooling water installations, sanitary installations, oil coolers, heat exchangers, heat coils etc.

In view of the widespread use of aluminium brass piping on ships, maintenance is inevitable. Common repairs include welding of leakages and replacement of pipe lengths subjected to corrosion. The most serious problems appear to arise in connection with the repair of leakages in large-dimension Yorcalbro pipes.

- Pipes with diameters less than 4" where the repair can take the form of an overlapped joint should be silver brazed using Unitor AG 60 and Unitor ALBRO flux.
- Pipes with diameters exceeding 4" should be TIG welded using Unitor IALBRO-237MF and the special flux, IFLUX-238PF.

Wire welding: IALBRO-W-237.

- Pipes should be unstressed before welding takes place, and cold bended piping should be annealed at 400–500°C for approximately 20–30 min. Finished welds, and an area covering approx. 15 cm to either side of the bead should be annealed. Annealing temperature 300–400°C for 30–40 min.

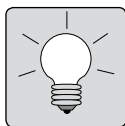

SOLUTIONS: Copper and Copper Alloys

Bronze

Bronze is principally an alloy of copper and tin, which may also contain small quantities of other alloys.

Phosphor bronze contains 0.05% to 0.1% phosphorus.

Lead bronze is used in bearings. Sn 10%, Pb 5–25%, remainder copper.
Gun metal, Cu 88%, Sn 10%, Zn 2%.

Welding: TINBRO-341

Brazing: AG 45, AG 60 and
AG 60/45 FLUX
FC-BRONZE and
BRONZE FLUX
FC-WEARBRO and
WEARBRO FLUX

contain up to 15% aluminium. Other alloy elements are Fe, Ni and Mn.

Nickel aluminium bronze contains Cu 79%, Al 9.5%, Ni 5%, Fe 4.2%, Mn 2.3%. This alloy shall not be preheated before welding.

Manganese aluminium bronze is used for ships' propellers and consists of Al 9–10%, Mn 11%, Fe 2–3%, Ni 1–2% and the remainder copper.

Welding: ALBRONZE-344

Brazing: AG 45, AG 60 and
AG 60/45 FLUX
FC-BRONZE and
BRONZE FLUX
FC-WEARBRO and
WEARBRO FLUX

2.08

Aluminium bronze (Cu + Al)

This type of bronze has good strength properties, may be machined, and is also suitable for casting. The main advantage of these bronzes is their excellent resistance to corrosion in seawater which makes them suitable for ships' propellers, etc. These alloys

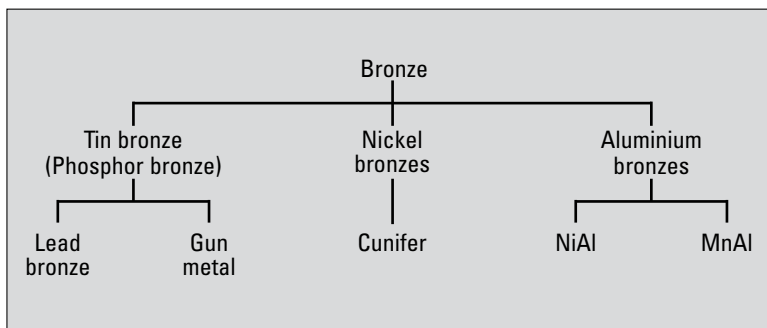

SOLUTIONS: Copper and Copper Alloys

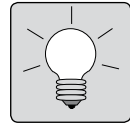

Nickel bronzes (Cunifer)

“Cunifer 10” (copper nickel) and “Cunifer 30” (cupro nickel) are supplementary alloys to Yorcalbro. These alloys are corrosion resistant – the higher the nickel content, the higher the resistance. Strength and hardness also increase in relation to nickel content.

port where the seawater is polluted by sulphides, the pipes may become coated with sulphide-containing sludge which can stimulate corrosion over a prolonged period even when the vessel moves to cleaner waters.

In such cases the use of “Cunifer 10” or “Cunifer 30” piping is recom-

	CUNIFER 10 (Copper nickel)	CUNIFER 30 (Cupro nickel)
(Alloy)	Ni 10%, Fe 2% Cu 87%, Mn 1%	Ni 30%, Fe 0.7% Cu 68.5%, Mn 0.8%
Tensile strength N/mm ² – Hard (untreated) – Heat treated – Annealed	530–580 390–500 310–390	630–700 360–400
Elongation % – Hard (untreated) – Heat treated – Annealed	10– 15 20– 35 40– 55	5– 10 40– 55
– Hardness HB – Hard (untreated) – Heat treated – Annealed	155–184 97–126 78– 97	165–204 87–107
Specific weight	8.9	8.9
– Outside coefficient per °CV	0.000016	0.000015

These alloys which have special properties and are widely used on vessels in river and canal traffic, on lakes, or on vessels which regularly call at ports where the water is heavily polluted or contains, sand or sludge. They have excellent resistance against wear by erosion, corrosion and abrasion.







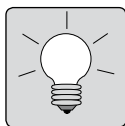

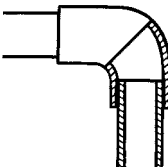

When it is envisaged that the piping in a cooling system will be exposed to sulphide polluted seawater, material with good resistance against water of this type should be chosen. Industrial discharge may contain sulphides, and even during a short stay in a

mended. The use of 70/30 piping was previously limited due to high cost. However, the recommendation for the use of these pipes over the entire dimension range is based on the fact that 70/30 pipes have a considerably higher resistance to pitting corrosion than 90/10 pipes. Thermal power plants all over the world use 70/30 pipes to handle polluted cooling water. The same recommendation applies to vessels which are regularly subjected to polluted water in cooling systems.

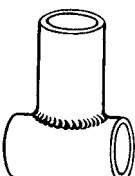

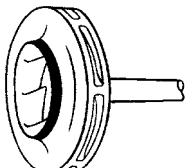





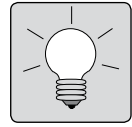

Brazing: AG60 and AG60/45 FLUX.
TIG welding: ICUNI 30-239.
Wire welding: ICUNI-W-239.

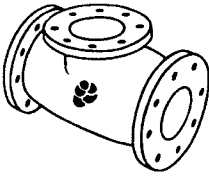

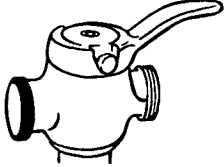
SOLUTIONS: Copper and Copper Alloys

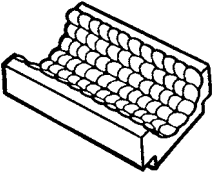

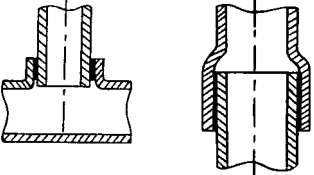

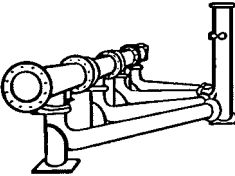

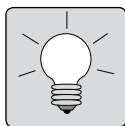



Description	Solution	Examples
Copper tubes and fittings of diameters up to 30 mm with capillary joint.	 AG-60-252  AG-45-253	
Copper pipe of more than 30 mm diameter where I-joint is used for butt welding or T-junction for branching.	 FC-BRONZE-261  BRONZE-264	
Bronze pump impeller, building up wear edges that have worn down.	 FC-WEARBRO-262  TINBRO-341	
Building up blade of pump impeller or walls in pump housing.	 TINBRO-341	
Repair of cracks in large pump housings, or rebuilding wear.	 TINBRO-341	

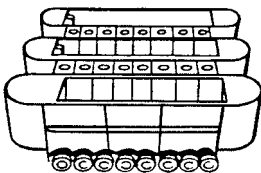

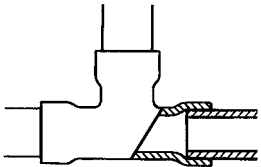
Description	Solution	Examples
Filling holes in small valve housings where wear or corrosion has caused damage.	 FC-BRONZE-261  BRONZE-264  TINBRO-341	
Building up worn threads or surfaces in valve and pump components.	 FC-BRONZE-261  BRONZE-264	
Rebuilding worn sliding surfaces on bronze bearings.	 FC-WEARBRO-262	
Yorcalbro-pipe diameter less than 100 mm, where a capillary joint can be made, for joining or for patching over pittings.	 AG-60-252	
Yolcalbro pipe diameter over 100 mm, for patching or for joining.	 IALBRO-237MF  IALBRO-W-237	

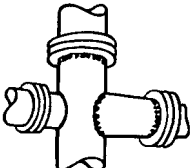

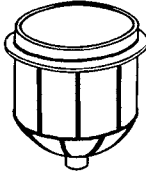
SOLUTIONS: Copper and Copper Alloys

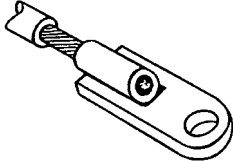
Description	Solution	Examples
Repair of large components in Yorcalbro, like heating coil boxes.	 IALBRO-237MF  IALBRO-W-237	
2.08 Joining Cunifer pipes with diameter under 100 mm, where capillary joint can be prepared.	 AG-60-252	
Cunifer pipes over 100 mm, for butt welding, for flanges and for T-junctions.	 ICUNI-30-239  ICUNI-W-239	
Large components in Cunifer, like heat exchangers.	 ICUNI-30-239  ICUNI-W-239	
Conductors and cables of copper.	 SOLDERING TIN-241 AG	

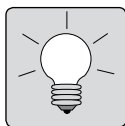

SOLUTIONS: Aluminium

Metals and welding solutions:

Aluminium

Pure aluminium (Al) is a soft, easily shaped metal with low strength. It is characterized by low weight, excellent corrosion resistance and good electrical conductivity.

The strength of aluminium can be considerably improved by the addition of small quantities of alloy elements. As an alloy, aluminium retains the same appearance as pure aluminium and approximately the same low weight, but strength can be compared to mild steel. Only a limited number of aluminium alloys are considered suitable for use on board ships.

AlMg 3 and AlMg 1 are seawater resistant aluminium alloys. When alloyed with copper and silicon, aluminium can be used for the manufacture of cast components (silumin).

When aluminium and its alloys come into contact with air, a refractory skin of oxide quickly forms on the surface. The melting point of aluminium oxide is over 2,000°C, considerably higher than that of aluminium, which melts at 660°C. Unless this layer of oxide is effectively removed during the welding operation, the difference in melting temperatures will make it difficult for the metal of the workpiece to bind with the filler.

Included oxides will also reduce the strength of the weld.

Thorough cleaning and the use of flux is therefore essential when gas welding aluminium.

Welding should be done immediately after cleaning, before a new oxide film has time to develop. Other characteristic properties of aluminium are a high coefficient of expansion, good electrical and heat conductivity, and the absence of colour change when heated to melting point.

Filler materials for Aluminium in the Unitor range are:









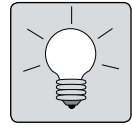

Coated electrode: ALUMIN-351N
Gas and TIG

welding rod: ALUMAG-235

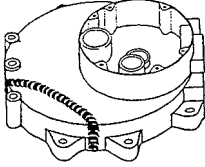
Wire welding: ALUMAG-W-235

For gas welding of aluminium it is required to use a flux that removes oxides. Use Unitor ALUFLUX-234F.

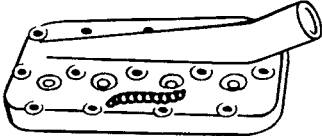

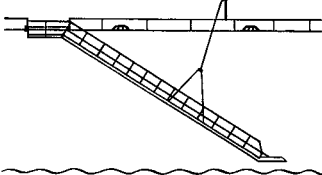
Description	Solution	Examples
Welding repairs of pure aluminium, seawater resistant aluminium and cast aluminium. Cover plates and smaller parts.	 ALUMAG-235 and ALUFLUX-234F  ALUMAG-235	
Cracks in larger parts.	 ALUMIN-351  ALUMAG-W-235	
Holes or fractures in smaller parts.	 ALUMAG-235 and ALUFLUX-234F  ALUMIN-351N  ALUMAG-235	
Plate and tube constructions in gang way.	 ALUMAG-W-235  ALUMAG-235	



SOLUTIONS: Evaluation of welds

Typical welding faults

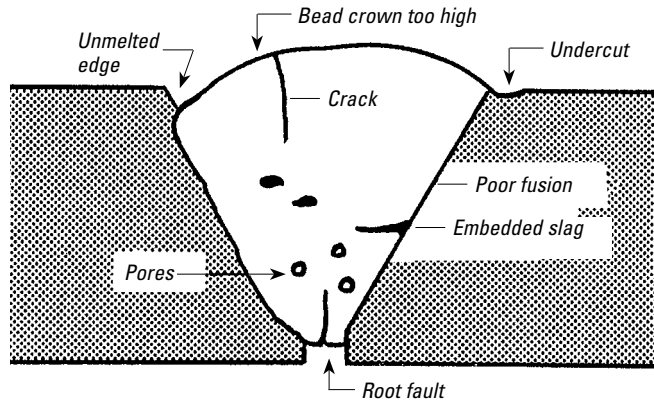

2.10

Root faults

When laying the first bead along the root in a butt joint, penetration at the root may be irregular or insufficient. When current is excessive, penetration will be too high.

Insufficient penetration may be due to the current setting being too low, or the rate of travel too high. The electrode may also be too large for the groove to be welded.

Fusion faults

If the current is too low or rate of travel too high, fusion faults may result, i.e. insufficient melting and fusion between the filler and the base metal.

Fusion faults may also occur if a small electrode is used on a large area of cold base material. A larger electrode diameter should be used, and the base material preheated.

Bead edge defects

Bead edge irregularities can occur if current output is too high. Bead edge faults may also occur at correct current output if the arc is too long or if electrode movement is incorrect. When welding upwards on a vertical plane and using a weaving movement, the electrode should be momentarily held still at each side of the bead to obtain good penetration and avoid edge defects. Edge faults and undercut may act as fracture indicators in the welded connection.

Pores

Pores in the weld may be due to moisture content in the electrode coating, especially when welding with basic electrodes. Pores in the weld may also arise if the base material to be welded is wet or damp. Other reasons can be because of too long an arc, allowing air into the weld zone. A porous weld will have reduced strength properties.

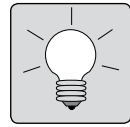

Heat cracks

Heat cracks may appear during or just after the cooling off period. There are two main causes:

Impurities in the base material which have a tendency to segregate and may form a layer in the middle of the weld. This layer prevents fusion of the crystals. Segregated substances are first and foremost carbon and sulphur. In cases where heat cracks are caused by these substances, switch to basic electrodes. If heat cracks appear when welding with basic electrodes, the material is not weldable.

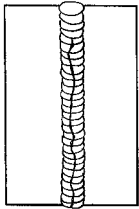

Tension across the weld can cause heat cracks even if the base material does not segregate in the weld. At a narrow, critical temperature range, just after coagulation of the bead, there is very little deformation property in a weld, and if shrinking in



Heat cracks

the metal is greater than the stretch in the weld, a heat crack will result. This type of crack can be avoided by clamping workpieces in special jigs which control shrinkage.

A heat crack will occur in the middle of the bead and will appear as a straight crack on the surface.

Shrinkage cracks

Shrinkage cracks occur when the deformation property (toughness) of the weld is less than the actual shrinkage movement. Shrinkage

cracks will usually appear across the weld direction and be caused by considerable lengthwise shrinkage. Basic electrodes are the best safeguard against shrinkage cracks.

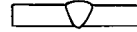
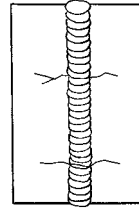

Shrinkage cracks

Hydrogen cracks (Cold cracks)

Weld metal cracks are caused by hydrogen and may occur in any type of steel which has been hardened or which may become hardened during the welding process. Steel with a high yield point will contain a certain amount of hardened structure, normally martensite. The higher the melting point, the higher is the risk of hydrogen cracks. The most

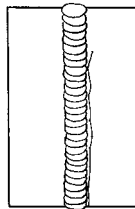

Hydrogen cracks
(cold cracks)

common reason for hydrogen cracks is that moist or damp electrodes is used during welding. The water in the coating will change into hydrogen in the arc and end up as hydrogen porosity dissolved in the weld metal and the heat affected zone (HAZ) immediately adjacent to the

molten zone. When combined with hard phases in the weld and sufficient stress it will form cracks.

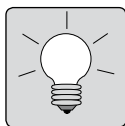

SOLUTIONS: Evaluation of welds

The cracks might occur long time after welding is completed and are therefor often referred to as cold cracks.

Other hydrogen sources are rust, oil, paint or condensation along the welding groove. Preheating the groove to say 50 °C will help considerably in reducing the amount of hydrogen.

Conclusion: Dry basic electrodes when there is risk of cold cracking.

Note the following:

Hard phases form when the weld is cooled rapidly from melting temperature to room rature. Alloying elements, mostly carbon, are forced to dissolve in the weld metal and make it brittle. The following formula describes this process in the case of standard carbon-manganese steel.

$$E_c = \%C + \frac{\%Mn}{6} + \frac{\%(Cr+Mo+V)}{5} + \frac{\%(Ni+Cu)}{15}$$

Steels with $E_c = 0.35$ and below are usually weldable without any problems at normal steel thickness. For the more highly alloyed steels and steels with thicker dimensions, an elevated working temperature is necessary in order to reduce the cooling rate.

The elevated temperature also allows the hydrogen to diffuse.

To determine elevated working temperatures, please consult BS 5135:1984 or SS 064025. If the E_c dimension of the plates and heat input are known, these standards will state whether heating is necessary and the level at which it should take place.

Tension cannot be avoided when welding, as steel expands when heated, although correct planning and heat treatment can reduce tension considerably.

Slag embedded in weld

Slag consists of non-metallic particles originating from the coating of the electrode. All slag must be properly removed after finishing each weld bead. Use a chipping hammer and wire brush for this purpose. Slag embedded in the weld will seriously affect the strength of the weld. Try to avoid burning cavities, as any slag deposited in such cavities will be difficult to remove.

When preparing the welding groove, make sure there is sufficient gap to provide good fusion and easy slag removal. Clean off mill scale and rust from the surfaces to be welded and make sure you choose the correct electrode for the welding position to be used.



SOLUTIONS: Evaluation of welds

Inspection of welded joints

Inspection indicates whether the prescribed standard of quality has been met. This function may be the responsibility of the superintendent or other representative of the ship owner:

Visual inspection from start to finish

Visual inspection is the best buy in Non Destructive Testing (NDT) but it must take place constantly, prior to, during and after welding. In a sense, everyone involved in the job, as well as the appointed inspector, participate in visual inspection. A conscientious worker does not knowingly pass on work in which he recognises discontinuities of his own making. Nevertheless, it is usually desirable that someone is assigned the responsibility for quality checking each operation. In addition to good eyesight and proper light, the tools for visual inspection are simple – a pocket rule, a weld-size gauge, a magnifying glass, and sometimes a straight edge and square for determining straightness, alignment, and perpendicularity.

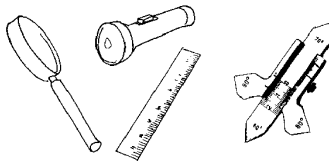

Inspector's tools: Magnifying glass, Torch, Ruler and Welders gauge

Prior to welding

Visual inspection should begin before the first arc is struck. The materials should be examined to see if they meet specifications for quality, type, size, cleanliness, and freedom from discontinuities. Foreign matter

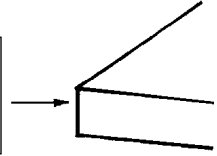

Check Material Certificate

– grease, paint, oil, oxide film, heavy scale – that should be detrimental to the weld shall be removed. The pieces to be joined should be checked for straightness, flatness, and dimensions. Warped, bent, improperly cut or damaged pieces should be ordered for repair or rejected. Alignment and fixtures should be scrutinised. Joint preparation should be checked. Often little more than a passing glance is required as a preliminary inspection, but, despite its almost casual nature, it can be a significant factor in weld quality. A good joint design will provide access for the welder, adequate root opening to permit full fused penetration and correct groove angle to minimise volume of weld metal. The joint preparation must be correct before welding is started, not only to meet the specifications, but also to give assurance of weld quality.

SOLUTIONS: Evaluation of welds

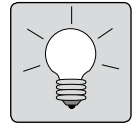

Remember:
50% of quality is edge preparation

Faults to look for:

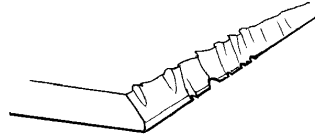

Improperly cut edges

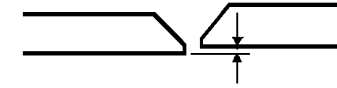

Disalignment

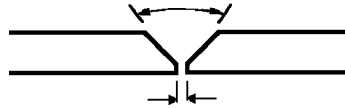

Groove angle and root opening

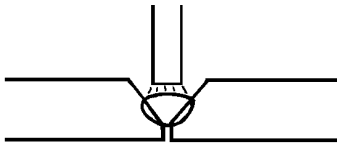

If the gap is too narrow, the weld will bridge the gap, leaving slag at the root.

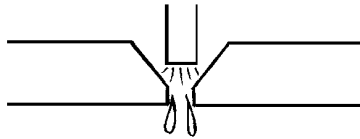

If the root opening is too wide, it will melt through

Inspection prior to welding also includes verification of correct process and procedures are to be employed – that the electrode type and size and the equipment settings for voltage and amperage are as specified – and that provisions are made for required preheat or post heat.

Each welding process has its advantages and limitations, and each introduces problems affecting joint preparation, welding procedures and operator training.

In most inspection situations the welding process is decided beforehand. So are the welding consumable (filler metals), but it is important that they have been stored properly in unopened containers unharmed by moisture.

To ensure uniform results the welders procedures must be spelled out in detail and followed rigorously during welding. Only qualified people must be assigned to the job.

Check at regular intervals that the consumables used match specification

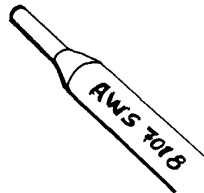



SOLUTIONS: Evaluation of welds

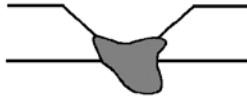

Excessive penetration

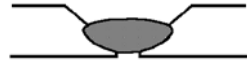

Lack of penetration

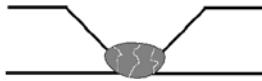

The root pass in multi pass grooves are especially susceptible to cracking



Groove welds are prone to undercut along the edges, increasing the risk of trapping slag when the next pass is made



Slag trapping may also be caused by a convex bead

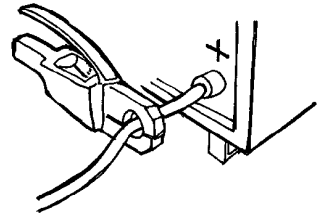

Check that welding parameters are according to procedure with regard to type of current, polarity, amperage, type of consumable etc.

2.10

During welding

Assuming the preliminary requirements are met, the productive inspection will take place while the weld is being done. Examination of a weld bead and the end crater may to a competent inspector reveal quality deficiencies such as cracks, inadequate penetration, and gas and slag inclusions.

On simple welds, inspection of a specimen at the beginning of the

operation and periodically as the work progresses may be adequate. When more than one layer of filler metal is deposited, however, it may be desirable to inspect each layer before the next.

The root pass in a multipass weld is the most critical one with regard to weld soundness.

Check that the welding parameters match the parameters laid down in the approved welding procedure.

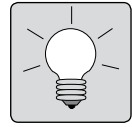

After welding

Visual inspection after welding has been completed is also useful in evaluating quality, even if ultrasonic, radiographic, or other methods are to be employed. As welding progresses, surface flaws such as cracks, porosity, and unfilled craters can be detected, leading to repairs or rejection of the work. There is no point in submitting an obvious bad weld to sophisticated inspection methods.

Dimensional variations from tolerances, warping, and faults in appearance are detected visually at this stage. The extent and continuity of the weld, its size, and the length of segments in intermittent welds can be readily measured or recorded.

Welds must be cleaned from slag to make inspection for surface flaws possible. A 10x magnifying glass is helpful in detecting fine cracks and other faults. Shot blasting should not be used prior to examination, since the peening action may seal fine cracks and make them invisible.

The objective of visual inspection at this stage is not only to detect non permissible faults, but also to give clues as to what may be wrong in the entire repair/fabrication process. If the inspector has a sound knowledge of welding, he can read much from what he sees. Thus, the presence of excessive porosity and slag inclusions may be an indication of insufficient current even if the dial readings on the machine tell otherwise. Subsequent tests will also give clues to faults in equipment or procedures, but the information acquired through visual examination allows corrections to be made before results from more sophisticated methods become available.

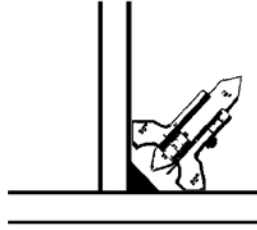

Underwelding is a violation of specification and can not be tolerated.

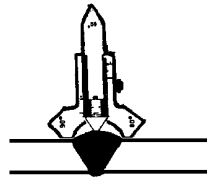

Overwelding is costly and serves no useful purpose. It only makes the construction stiffer and heavier.

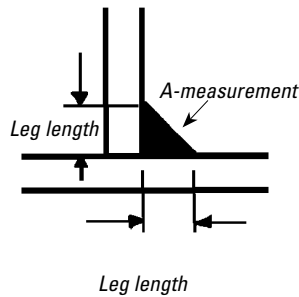

The designer has specified a weld size and this should be observed. For filled joints it is also important that the leg lengths are equal.



SOLUTIONS: Evaluation of welds

Summing up inspection of welded joints.

What to look for PRIOR TO WELDING:

- Type/state of base material
- Joint design
- Welding process
- Consumables
- Welding procedure
- Welder's qualifications

What to do DURING WELDING:

- Compare welding parameters with procedure
- Inspect each layer before the next

What to look for AFTER WELDING:

- The final weld result
- Size of weld (measuring)

Faults and causes:



Surface porosity

Excessive speed, rusty or dirty plates, wet electrodes or flux, insufficient flux/gas coverage.



Cold cracks (Hydrogen cracks)

Wet electrodes or flux. Insufficient preheating.

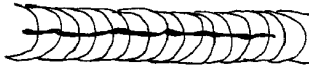

Hot cracks

Excessively high current. Insufficient preheat. High impurity level in base material



Slag inclusion

Faulty technique. Wrong electrode size or off-spec welding parameters.



Underfill

Too high welding speed

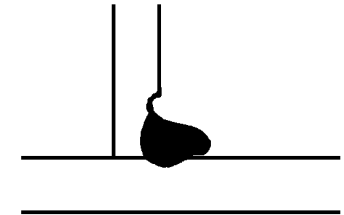

Undercut

High current, Insufficient electrode angle. Speed of travel too fast.

SOLUTIONS: Evaluation of welds

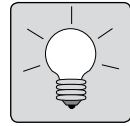

Crack Detection

By using dye penetrant we can detect surface cracks not readily visible to the eye. The dye penetrant kits consist of a cleaner to clean the surface for grease and oil, a dye penetrant that penetrates down in cracks and porosity, and a developer.

It is a low cost and easy to use, inspection method.

There are also other non-destructive methods. For detection of internal porosity, cracks and slag inclusions radiographic and ultrasonic methods must be used, but they require specialised personnel and equipment.

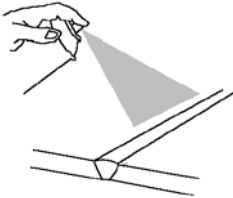

Step 1)
Remove surface rust, scale, paint by mechanical means, spray cleaner to degrease the inspection area. Leave to dry.

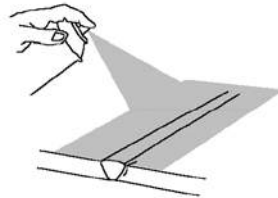

Step 2)
Spray penetrant over the area and allow to soak for about ten minutes.

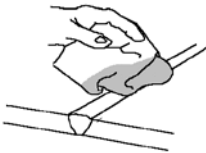

Step 3)
Remove all excess penetrant using a dry cloth and wipe dry.

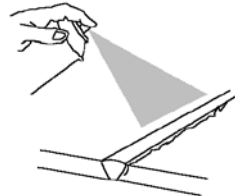

Step 4)
Spray developer evenly over the inspection area and wait a few minutes until the area dries white. Any surface defects will appear in red contrast.

2.10

Dye Penetrant Inspection product

Product description	Unit	Product no.
Magna Flux Crack detection kit*	Set	096-653535

* Kit comes in convenient Shoulder carry case and consist of: 3 pcs. Cleaner, 2 pcs. Penetrant, 3 pcs. Developer, 1 pcs. Cloth.

CONSUMABLES

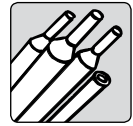

Coated Electrodes	126	
TIG Welding Rods & Fluxes	197	
Wires for Wire Welding	215	
Gas Welding Rods & Fluxes	239	
Brazing Rods & Fluxes	249	
Cold Repair Compounds	275	

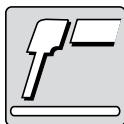

COATED ELECTRODES

Introduction	127
Types of electrodes	128
Storing and re-drying.....	134
Classification and approvals.....	140
Welding positions	149
GPO-302 N General Purpose Electrode For Mild Steel	150
GPR-300H High Recovery Electrode for Mild Steel	152
SPECIAL-303 N Double Coated Electrode for Mild and Ship Quality Steel	154
LH-314 N Low Hydrogen Electrode for Ship Quality Steel ..	156
LHH-314 H High Recovery Low Hydrogen Electrode for Ship Quality Steel	158
LHV-316 N Vertical Down Welding Low Hydrogen Electrode for Ship Quality Steel.....	160
LHT-318 N Electrode for High Temperature Steel	162
LHL-319 N Electrode for Low Temperature Steel.....	164
LHR-320 N Electrode for Weathering Steel	166
TENSILE-328 N Electrode for Difficult-to-Weld Steel.....	168
IMPACT-329 S Electrode for Heat Resistant Overlays	170
WEARMAX-327 Electrode for Joining & Wear Resistant Overlays	172
18/8-321 N Electrode for Stainless Steel	174
23/14-322 N Electrode for Stainless Steel	176
DUPLEX-325 N Electrode for Duplex Steel	178
PICKLING GEL Pickling Gel for Stainless Steel	180
NIFE-334 N Nickel Iron Electrode for Cast Iron	182
NICKEL-333 N Nickel Electrode for Cast Iron	184
TINBRO-341 Electrode for Copper Alloys	186
ALBRONZE-344 Electrode for Copper Alloys	188
ALUMIN-351 N Electrode for Aluminum.....	190
CH-2-382 Electrode for Chamfering	192
ACA-384 Electrode for Air Carbon Arc Gouging	194

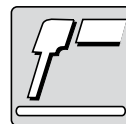

Introduction

The Unitor standard electrode range contains electrodes for:

- Mild and low alloy steels
- Cast steel
- Heat resistant steel
- Low temperature steel
- Weathering steel
- Stainless and acid-resistant steels
- Tool- and machine-part steels
- Cast iron
- Aluminium and aluminium alloys
- Copper and copper alloys
- Air-carbon-arc gouging
- Gouging with standard equipment

A Product Range Selected for Maritime Use

High quality coupled with versatility is a basic factor for the selection of arc welding electrodes in the Unitor standard range. It is composed to cover all normally occurring applications on board, yet to be as compact as possible. Each electrode therefore covers a wide range of applications. This reduces the number of electrode types needed on board.

With the Best Welding Properties

Special care has been taken to select electrodes with the best all-round welding properties. Easily welded electrodes are necessary to achieve good results without too stringent demands on the welder's skill.

Welding on board is often required in awkward positions. The Unitor standard range has been composed with this in mind, whenever possible the electrode's welding properties are equally good also in the vertical and over-head positions.

LMA Properties

All electrode coatings are hygroscopic (they absorb moisture from the atmosphere). When welding, the moisture turns into hydrogen in the arc that again ends up as hydrogen porosity in the weld deposit. Combined with other undesirable effects this can turn into hydrogen cracking also known as cold cracking in the weld. In order to extend the electrodes usable lifetime and safeguard against cold cracking, the Unitor electrodes for structural work have been given Low Moisture Absorption properties when manufactured. This greatly reduces the electrodes moisture absorption rate. Electrodes with LMA properties are marked "LMA electrodes".

Packed for Maritime Conditions

The electrode box is made of high density polyethylene making it the right place for storing and protecting electrodes from moisture pickup, contamination and physical damage.

The information label that is placed on the box gives all relevant information to how the electrodes are to be used. Label, cap and box are made out of the same recycled material and does not need to be separated when recycling.

All Unitor electrodes have an imprint with name, and if applicable, AWS number.





COATED ELECTRODES

Types of electrodes

What happens when the arc is struck?

The electrode is part of an electronic circuit.

To strike an arc the electrode must first touch the workpiece. This action causes a shortcircuit, and when the electrode is withdrawn slightly, the arc is formed.

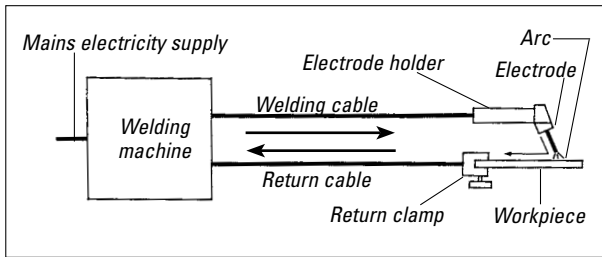

3.01

The arc will immediately melt some of the coating and core wire of the electrode tip, and the gas shield shown in the figure is formed. At the temperatures found in the arc (approx. 7000 °C) the gas will be ionized, providing good electrical conductivity in the arc.

The actual transfer of metal from the electrode to the workpiece is in the form of molten globules of different sizes depending on the type of electrode used. Some electrodes produce globules that are so large that they actually shortcircuit the arc for a moment.

In these cases it is of special importance that the welding power source has a fast dynamic response so that extreme currents and spatter are avoided.

High speed films have been taken of the process in the arc from a coated electrode. These films indicate that the globules actually explode. When a drop leaves the electrode, the extremely high temperature behind it causes an explosion-like expansion effect and the metal is drawn towards the molten pool. This so-called pinch force is stronger than the force of gravity, and overhead welding is thereby made possible.

As soon as the globule leaves the electrode, it is covered by slag material from the electrode coating. This drop is then carried through the arc to the molten pool. At this point the slag separates from the metal, floats up and forms a coating on top of the weld.

The core rod in the electrode melts faster than the coating, and the resulting crater in the end of the electrode aids directional stability of the weld.

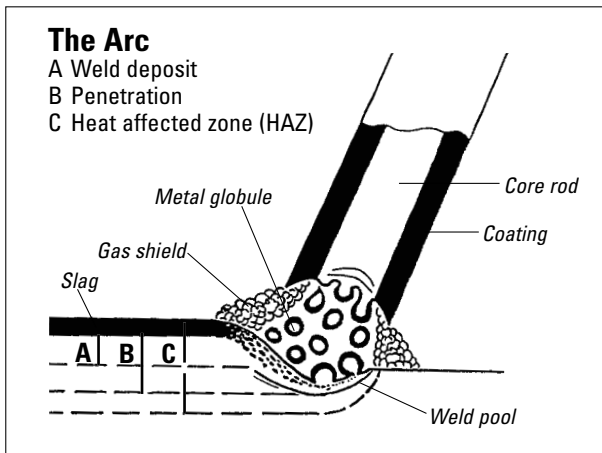

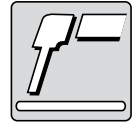

Types of electrodes

Electrodes for manual arc welding (sometimes referred to as stick welding) consist of a rod and a coating material. As a rule, the alloy in the rod will be similar to the material to be welded.

The rod forms part of the welding circuit, and when it is melted together with the coating material, it provides the filler which is necessary to obtain a welded joint.

The object of the electrode coating is to provide easy striking and a stable arc. The coating material also contains elements which affect the transport of metal across the arc and provide good mechanical and chemical properties to the alloy formed between the base material

and the rod core in the electrode. When molten, the coating also provides a gas shield around the molten pool, which acts as protection against the atmosphere during welding. The coating elements form a slag when cool which further protects the weld during the cooling down process. The coating may also contain substances (i.e. iron powder), which increase the metal depositing properties of the electrode during welding. Electrode size (2.5, 3.2, 4.0 mm etc.) indicates the diameter of the rod core.

Control of Recovery

By adding metal powder into the coating we can regulate the electrodes recovery (Deposition rate).

The coated electrode

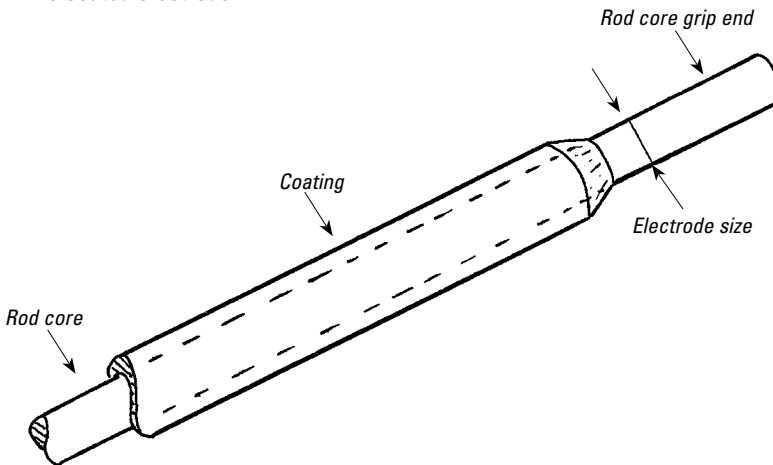



COATED ELECTRODES

Types of electrodes

The function of the core rod is to provide electricity to the arc and to melt and become weld deposit.

The coating consisting of metals, minerals and organic substances have several functions:

Ionisation

Air is a non conductor. By adding ionising elements that evaporates during welding we create a plasma cloud where the current can travel. For AC welding this function is essential in order to perform welding.



Alloying Elements

In the arc the temperature reaches 7000 °C. Many of the elements might evaporate and will have to be compensated for by putting alloying elements into the coating.

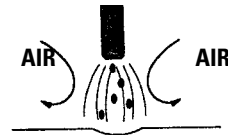

Crater Formation

Elements in coating that makes the melting boundary of the coating to be behind that of the core rod. The arc is in this way concentrated to one spot directly under the electrode tip.

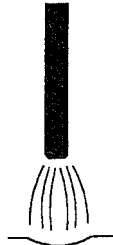

Gas Shield

The shielding ingredients in the coating is to provide a dense smoke shield preventing Oxygen and Nitrogen from reaching the pool / arc area

Slag Formation

Slag forming elements are part of the electrode coating and they are there in order to:

- 1) Protect crater and globules against oxygen during the droplet transfer,
- 2) Clean the weld pool by combining itself with impurities and bring them to the surface before solidification,
- 3) Give the weld a slow cooling rate,
- 4) Form the weld: Welding is a small scale casting operation and requires a mould. The slag is the mould.



Metal Transfer

The transfer of metal globules from the electrode tip to the molten pool is made possible by a combination of elements in the coating "exploding" the droplets over and the current that performs a "pinch" effect.



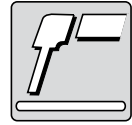

Types of electrodes

When selecting an electrode, the first rule is to select one which produces a weld metal quality equal to or better than that of the base material and, when necessary, is approved for the material in question. Welding position and type of joint are other factors, which influence the choice of electrode, as different electrodes have different properties in different welding positions and types of joint.

The most common types of electrodes are:

1. The Organic type (Cellulose)
2. The Rutile type
3. The Acid type
4. The Basic type (Low Hydrogen)

Organic electrodes contain large quantities of organic substances such as cellulose. The metal transfer is referred to as explosion arc and the electrodes are well suited for vertical down welding.

Rutile electrodes contain large quantities of the mineral rutile (up to 50 %) or components derived from Titanium Oxide. Rutile electrodes can also contain cellulose. The rutile type of electrode has especially good welding properties both with AC and DC. The organic-rutile electrode is usually the cold welding type, characterized by a spray arc globular transfer, which is an advantage when welding in different positions. This type of electrode is when alloyed well suited for re- and hard surfacing because of its shallow penetrations and high weld buildup. Big opening between plates can easily be bridged using this type of electrode. The rate of welding is not particularly high, but the deposit is of good quality and slag is easily removed.

Unalloyed rutile electrodes are not normally recommended for welding steel with nominal tensile strength exceeding 440 Mpa. The impact values are low because of oxygen level in the weld metal. Rutile electrodes are relatively insensitive to moisture.

Acid electrodes produce an Iron Oxide / Manganese Oxide / Silica type of slag, the metallurgical character which is an acid. The coating contains oxides of the low pH value hence the term acid.

Acid electrodes provide good fusion, a high rate of welding and are equally suitable for AC and DC. The arc is stable and slag is easily removable, even if it is the first bead in a V-groove weld.

Alloyed acid electrodes are suitable for welding steel with a nominal tensile strength of up to 440 Mpa.

Basic electrodes

Basic electrodes are often referred to as Low Hydrogen electrodes. After special heat treatment the coating has a very low hydrogen content, hence the name.

Basic electrodes with low moisture absorption (LMA) have a lower initial moisture content and the speed of remoisturing is much lower than of normal basic electrodes.

Unalloyed basic electrodes give moderate welding speed in the flat position but are faster than other types when welding vertically upwards. The reason for this is that basic electrodes can be deposited at a higher current in the vertical position than other types of electrode. In addition, the amount of weld metal deposited per electrode is greater than that of

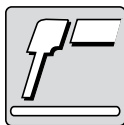

COATED ELECTRODES

other electrodes, which can be used in this position. This results in a smaller number of electrode changes. The normal result is therefore a higher fusion rate and higher arc-time factor when welding vertically upwards with basic electrodes compared with other types. The slag is normally not quite as easy to remove as the slag from acid or rutile electrodes, but, in spite of this, it can be classed as easily detachable. The slag from basic electrodes has a lower melting point than that from rutile or acid electrodes. The risk of slag inclusions during normal production welding is therefore unusually small when basic electrodes are used, even if the slag is not completely removed between beads during multi-run welding.

The weld metal from basic electrodes has a low hydrogen content and usually has good toughness even at low temperatures. Basic electrodes are less likely to produce either hot cracks or cold cracks compared with other types of electrode. The superiority of basic electrodes from this point of view appears when welding manganese-alloyed structural steels, pressure-vessel steels and ship's plate with a nominal tensile strength of 490-530 MPa. The higher the hardenability of the steel to be welded, the greater the necessity to use basic electrodes and the greater the need for low moisture content in the coating.

Double coated electrodes

These electrodes consist of a thin layer of rutile

coating extruded onto the core rod followed by a thicker basic layer. In this way the electrode gets the fine droplet transfer of rutile electrodes and the deposit strength of the basic electrode.

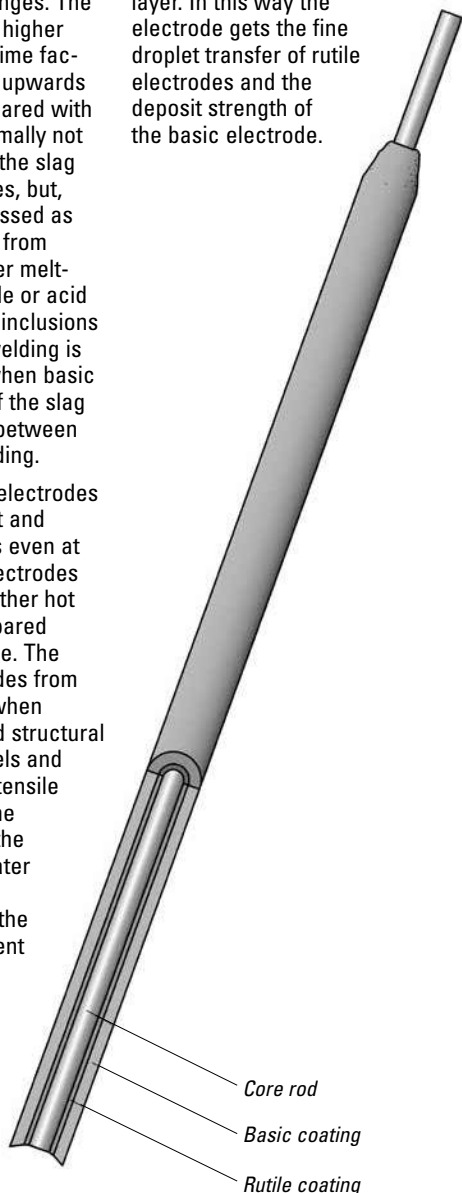

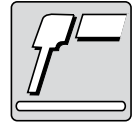

Unitor LMA electrodes

Electrodes with special coating properties.

LMA stands for Low Moisture Absorption, i.e. low moisture pick-up.

LMA gives you less problem with porosity.

An LMA- electrode is drier than ordinary electrodes from the very beginning. The pick-up of the surrounding air humidity during the day is very low. The electrode can be exposed longer and will still give you a porosity free weld metal.

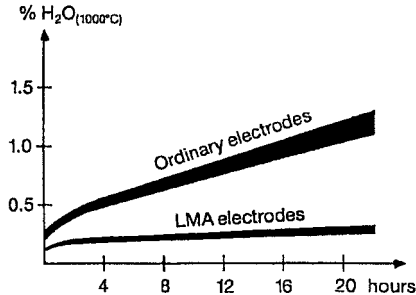

LMA will decrease the risk for HAZ cracking. (Cold cracks/Hydrogen cracks)

If you weld high tensile steels or very thick plates of medium strength, you will gain extra security with LMA electrodes. The risk for hydrogen cracking in the heat-affected zone will decrease.

All other properties are unchanged.

The LMA- coating does not affect other properties.

You will still get

- the same good weldability
- the same mechanical properties
- the same low fume formation
- the same price

Unitor LMA electrodes:

SPECIAL-303 N
LH-314 N
LHH-314 H
LHV-316 N
LHT-318 N
LHL-319 N
LHR-320 N
18/8-321 N
24/14-322 N
DUPLEX-325 N

Electrodes with LMA properties are marked

LMA
Electrode

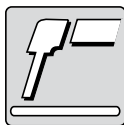

COATED ELECTRODES

Storing and re-drying

If properly stored, transported and used electrodes will form weld deposits with low hydrogen content. If not, hydrogen porosity can lead to hydrogen cracking (cold cracking) if the component welded is under strain, vibration or load.

General background

When welding carbon-manganese and low alloyed steels cold cracking (often referred to as hydrogen cracking) can occur. These cracks generally form in the coarse-grained, heat-affected zone (HAZ) of the base plate.

The most important factors which influence the risk of hydrogen cracking are:

- Chemical composition of the steel
- Cooling rate
- Hydrogen content of the weld metal

Hydrogen is always present in small quantities during welding and is a prerequisite for the occurrence of cold cracking.

The most common sources of hydrogen are:

- Moisture in the electrode coating
- Moisture in the air
- Condensation, rust, oil, paint or primer in the welding joint area.

By following the recommended storage, and procedures for handling and redrying, the moisture level in electrode coatings can be minimised, along with the associated risk of cold cracking.

Hydrogen levels are measured as ml H₂/100 g weld deposit and typical levels for different electrode coating types are as follows:

Rutile and Acid >15 ml/100 g
Basic < 10, < 5 and < 3 ml/100 g

Storage and handling

Welding consumables should be stored in their original packing. As a guideline we recommend the following temperatures in the storage room:

Temperatures °C	(°F)	Max. Relative humidity in %
5–15	(41–59)	60
15–25	(59–77)	50
Above 25	(77)	40

During the winter, it is possible to maintain low relative humidity by keeping the temperature in the store-room at least 10 °C (18 °F) above the outdoor temperature. During certain periods in the summer and in a tropical climate, sufficiently low relative humidity can be maintained by air de-humidification.

The purpose is to avoid hydrogen absorption to the extent possible.

Redrying

Rutile electrodes showing signs of damage by moisture can be redried at a temperature of 90–110 °C for 0.5–1 hour.

Basic electrodes are normally redried at a temperature of around 350 °C for 2 hours, to achieve a hydrogen level of 5–10 ml/100 g. (BS 5135, Scale C). Redrying should be restricted to a maximum of 3 cycles.

To achieve extreme low hydrogen levels, <4.0 ml/100 g, a redrying temperature of 42–400 °C is recommended for 1–2 hours. Redrying should be restricted to 1 cycle.

COATED ELECTRODES

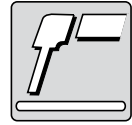

Re-dried basic electrodes can be stored in a heated cabinet at 80 °C without further moisture pick-up.

Stainless steel electrodes which have been stored outside of their electrode

box and have become damaged by moisture pick-up can be redried at a temperature of 300–350 °C for 1–2 hours. Redrying should be restricted to a maximum of 3 cycles.

Welding electrodes should be stored in their original package. Preferably in a de-humidified area or in a heating cabinet.

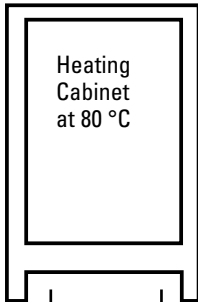

All basic electrodes and stainless steel electrodes should be re-dried before use. Always do when there is application requirements.

Rutile electrodes normally no need for re-drying.

Observe recommended re-drying temperatures and holding times for Unitor electrodes stated on box label

Unused electrodes should be re-dried before being returned to the heating cabinet.

Max exposure time for electrodes in the open is 8 hours.

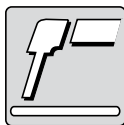

COATED ELECTRODES

Storing and re-drying

Minidryer-350

The Minidryer-350 is designed to restore moist electrodes, or to pre-dry electrodes before welding when this is required. The dryer may be used with electrodes of both 350 and 450 mm length. With the cover in an open position, the electrodes will protrude approximately 40 mm and are easily accessible.

The Minidryer-350 is equipped with 2 m primary cable and plug. It has a thermostat for continuous selection of the temperature from 100 to 350 °C (212 °F to 662 °F).

The dryer is very robust in design and are all-over insulated with 40 mm mineral wool. It can also stand permanently in a tilted position. When the dryer is in a tilted position, the cover cannot stand open, but always closes to prevent the intrusion of unwanted moist air. When the dryer is tilted, a rim around the opening prevents rainwater from entering.

Caution:

Use gloves when handling warm electrodes from inside the Minidryer-350. This product should be used for drying electrodes only.



The Minidryer-350

Ordering Information:

Minidryer-350.

Product number: 094-637827.

3.01

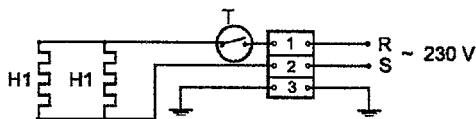

Type	Mains Voltage V	Heater Output W	Primary Current A	Operating Temperature °C	Width x Depth x Height		Electrode Capacity kg	Net Weight kg
					Inner Dimensions mm	Outer Dimensions mm		
Mini-dryer-350	230, 50/60 Hz	400	1.8	100 to 350	Ø100 x 460	170 x 170 x 570	8	7

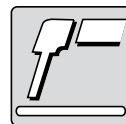

Re-drying of Electrodes

Customers are recommended to re-dry low hydrogen electrodes before use whenever there are application requirements relating to weld metal hydrogen content and / or radiographic soundness. This information is given on the box label for the individual electrodes. Failure to follow these recommendations may produce pores and weld failure.

Unitor Minidryer-350 (094-637827)

100–350 °C (212–662 °F) can be used for this purpose.

Recommended re-drying temperatures, holding time two hours, for Unitor electrodes:

GPO-302 N	Normally no need for re-drying
GPR-300 H	Normally no need for re-drying
SPECIAL- 303 N	300 °C (572 °F)
LH- 314 N	350 °C (662 °F)
LHH-314 H	350 °C (662 °F)
LHV-316 N	350°C (662 °F)
LHT-318 N	350 °C (662 °F)
LHL-319 N	350 °C (662 °F)
LHR-320 N	350 °C (662 °F)
TENSILE-328 N	250 °C (482 °F)
IMPACT-329 S	250 °C (482 °F) 1 hour
WEARMAX-327	250 °C (482 °F) 1 hour
18/8-321 N	350 °C (662 °F)
23/14-322 N	350 °C (662 °F)
DUPLEX-325 N	350 °C (662 °F)
NIFE-334 N	200 °C (392 °F)
NICKEL-333 N	200 °C (392 °F)
TINBRO-341	200 °C (392 °F) 1 hour
ALBRONZE-344	250 °C (482 °F) 1 hour
ALUMIN-351 N	80 °C (176 °F) 1 hour
CH-2-382	120°C (248 °F) 1 hour
ACA-384	180°C (356 °F) 10 hours*

Re-drying time is measured from the point at which the re-drying temperature has been reached. After re-drying, the electrodes can be returned to a heating cabinet and kept at a minimum temperature of 70 °C (158 °F).

Unitor Heating Cabinet-85 (094-637850)

85 °C (185 °F) can be used for this purpose.

Mild steel rutile and rutile / organic electrodes such as GPO-302 N normally need no re-drying

Re-drying covered electrodes more than three times is not recommended.

* The copper coating will oxidize during the process, but this will not influence the performance of the product.



COATED ELECTRODES

Storing and re-drying

The Heating Cabinet-85

This cabinet is specially designed as a ships' store for repair and maintenance electrodes.

A thermostat allows for stepless setting of the temperature from 30 °C up to 85 °C (86 °F up to 185 °F).

The cabinet contains five shelves and every shelf is removable. The shelves are slanted to prevent the content from sliding out when the door is opened in rough seas.

The active parts in this oven are enclosed in a unit located in the bottom of the oven. This unit can be easily removed as one unit.

The Heating Cabinet – 85 have 100 mm mineral wool in the bottom and 50 mm in the top and side walls.

It is delivered with 1,7 m cable and plug

Caution:

Use gloves when handling warm electrodes from inside the heating

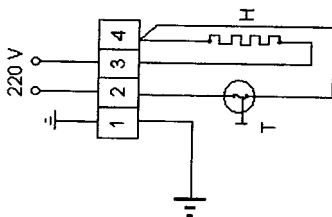

The Heating Cabinet -85

cabinet. No chemical products are to be used within the heating cabinet.

Ordering Information:

Heating Cabinet-85
Product number: 094-637850

Spare Parts:

Cassette complete
Product number 094-777853

Type	Mains Voltage V	Heater Output W	Primary Current A	Operating Temperature °C	Width x Depth x Height		Electrode Capacity kg	Net Weight kg
					Inner Dimensions mm	Outer Dimensions mm		
Heating Cabinet-85	230, 50/60 Hz	500	1,3	30-85	460 x 520 x 860	564 x 640 x 1095	350	70

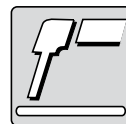

Storing and re-drying

Arc Welding Cabinet

A complete 'tool-box' for covered electrodes, including 27 packages of electrodes selected to cover all normal welding applications on mild steels, ship quality steel, stainless steels, 'problem steels', cast iron, copper alloys and aluminium.

- Compact design with easy access to contents, and separate room for the welding handbook.
- Sturdy, corrosion resistant construction from electrogalvanized steel plates, with final coating by powder spraying and baking, and with zinc/yellow-chromate passivated shelves for optimal corrosion and scratch resistance.



Arc Welding Cabinet

Product Description	Product no.
Electrode cabinet complete	094-670000
Electrode cabinet empty	094-669994

Dimensions:

600x600x300 mm
free distance above cabinet 310 mm.

Weight with electrodes

110,5 kg

Contents and Applications Areas

Instruction and information:
Unitor Welding Handbook:

Sheet metal and thin walled pipes:

SPECIAL-303 N 2,0 mm 1 package 1,7 kg

General mild steel repairs, all positions:

GPO-302 N 2,5 mm 1 package 5,2 kg
GPO-302 N 3,2 mm 2 packages 10,8 kg
GPO-302 N 4,0 mm 1 package 5,2 kg

General mild steel repairing, horizontal, high recovery:

GPR-300 H 4,0 mm 1 package 5,5 kg
GPR-300 H 5,0 mm 1 package 5,6 kg

Ship quality steel and cast steel:

SPECIAL-303 N 2,5 mm 1 package 4,1 kg
SPECIAL-303 N 3,2 mm 2 packages 8,2 kg
SPECIAL-303 N 4,0 mm 1 package 5,2 kg

Ship quality steel, horizontal, high recovery:

LHH-314 H 5,0 mm 1 package 5,5 kg

Ship quality steel, vertical down welding:

LHV-316 N 3,2 mm 1 package 4,8 kg

Heat resistant steel:

LHT-318 N 2,5 mm 1 package 1,7 kg
LHT-318 N 3,2 mm 1 package 1,7 kg

Low temperature steel:

LHL-319 N 3,2 mm 1 package 1,8 kg

Weathering resistant steel:

LHR-320 N 3,2 mm 1 package 1,8 kg

Stainless steel, stainless to mild steel, compound steel:

18/8-321 N 2,5 mm 1 package 1,7 kg
18/8-321 N 3,2 mm 1 package 1,7 kg
23/14-322 N 3,2 mm 1 package 2,0 kg

"Problem" steels:

TENSILE-328 N 2,5 mm 1 package 1,6 kg

Cast iron:

NICKEL-333 N 2,5 mm 1 package 2,0 kg
NICKEL-333 N 3,2 mm 1 package 2,2 kg

Aluminium:

ALUMIN-351 N 3,2 mm 1 package 1,1 kg

Bronze & brass:

ALBRONZE-344 3,2 mm 1 package 1,3 kg

Hardfacing:

WEARMAX-327 2,5 mm 1 package 1,6 kg

Cutting & gouging:

CH-2-382 3,2 mm 1 package 1,4 kg

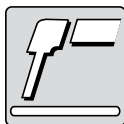

COATED ELECTRODES

Storing and re-drying

Arc Welding Cabinet Compact

A complete 'mini-store' for covered electrodes, including 9 packages of electrodes selected to cover normal welding applications on mild steels, ship quality steel, stainless steel, 'problem steels', cast iron, copper alloys and aluminium.

- Compact design with easy access to contents, and separate room for the welding handbook.
- Sturdy, corrosion resistant construction from electrogalvanized steel plates, with final coating by powder spraying and baking, and with zinc/yellow-chromate passivated shelves for optimal corrosion and scratch resistance.



3.01

Product Description	Product no.
Electrode cabinet Compact, complete	094-670001
Electrode cabinet Compact empty	094-669999

Width	350mm
Depth	165mm
Height open	685 mm
Height closed	550 mm
Weight empty	8 kg
Weight complete	33 kg

"Problem" steels:

TENSILE-328 N 2,5 mm 1 package 1,6 kg

Cast iron:

NICKEL-333 N 2,5 mm 1 package 2,0 kg
NIFE-334 N 3,2 mm 1 package 2,2 kg

Aluminium:

ALUMIN-351 N 3,2 mm 1 package 1,1 kg

Bronze & brass:

ALBRONZE-344 3,2 mm 1 package 1,3 kg

Contents and Applications Areas

Instruction and information:

Unitor Welding Handbook:

General mild steel repairs, all positions:

GPO-302 N 2,5 mm 1 package 5,2 kg
GPO-302 N 3,2 mm 1 packages 5,4 kg

Ship quality steel and cast steel:

LH-314N 2,5mm 1 package 4,0 kg

Stainless steel

18/8-321 N 2,5 mm 1 package 1,7 kg



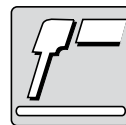

Classification and Approvals

The European Community for Standardization has developed a nomenclature in welding, Euronorm EN. This nomenclature replaces the current European standards like DIN, BS and NEN. Several new standards have come in force already and more

changes can be expected within the near future. In America one refers to AWS (American Welding Society) for classification of electrodes. Because of this we will mostly refer to EN and AWS in the Nomenclature for Welding Consumables.

EN 499	Covered electrodes for manual arc welding of non alloy and fine grain steel	DIN 1913 BS 639 NEN 2560 DIN 8529
EN 757	Covered electrodes for manual metal arc welding of high strength steel	DIN 8556 BS 2926 NEN 3581
EN 1600	Covered electrodes for manual metal arc welding of stainless and heat resisting steel	
EN 1599	Covered electrodes for manual metal arc welding of creep-resisting steel	DIN 8575 BS 2493 NEN 3580

Classification and Approvals

3.01

Product Name	CLASSIFICATIONS		APPROVALS				
	AWS	EN	DNV	GL	LR	BV	ABS
GPO-302 N	E 6013	E 38 0 RC 11	2	2	2		2
GPR-300 H	E 7024	E 42 0 RR 73	2	2Y	2Y	2Y	2
SPECIAL-303 N	E 7016	E 38 2B 32 H10	3YH10	3YH10	3YH15	3, 3YH10	3H10, 3Y
LH-314 N	E 7018	E 42 4 B 42 H5	3YH5	3YH5	3YH5	3, 3YH5	3YH5, 3Y
LHH-314 H	E 7028	E 42 4 B 73 H5	3YH5	3YH5	3YH5	3YH5	3YH5
LHV-316 N	E 8018-G	E 46 5 B 41 H5	3YH10	4YH10	4Y40H10	3YH10	3Y
LHT-318 N	E 8018-B2	E CrMo 1B 42 H5	- H10	-	-	1%Cr 0,5% Mo H5	SR
LHL-319 N	E 8018-C1	E 46 6 2Ni B 32 H5	5YH10	6Y46H5	5Y42H5	5Y40MH5	3Y400H5
LHR-320 N	E 8018-G	E 46 5 Z B 32	3YH10	3YH15	3YH15	3YH10	3YH5
18/8-321 N	E 316L-17	E 19 12 3 L R 1 2	316L	4571	316L	316L	E316L-17
23/14-322 N	E 309MoL-17	E 23 12 2 L R 3 2	309Mo	4459	SS/CMn	309Mo	SS/CMn
DUPLEX-325 N	E 2209-17	E 22 9 3 N L R 3 2	DUPLEX	4462	-	2209	DUPLEX
TENSILE-328 N	E 312-17	E 29 9R32					
IMPACT-329	-	-					
WEARMAX-327	E 307-26	-					
NIFE-334N	E Ni Fe-C1	-					
NICKEL-333N	E Ni-C1	-					
TINBRO-341	E Cu Sn C	-					
ALBRONZE-344	E Cu A1 A2	-					
ALUMIN-351 N	-	AL SI 12					

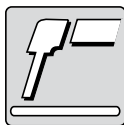

COATED ELECTRODES

Guide to Approvals

This page shows the grading which the electrode has under its relevant classification society approvals.

The full grading code consists of a digit and one or more letters. The digit indicates the tensile and notch toughness grade (see table). Letters indicate higher tensile steels.

Approvals may be carried out by the following classifications societies:

American Bureau of Shipping (ABS)
 Bureau Veritas (BV)
 Det Norske Veritas (DNV)
 Germanischer Lloyd (GL)
 Lloyds Register of Shipping (LR)

Lettering Code:

Y = approved for higher tensile steels.

H or H15 = hydrogen level in weld metal of <10 ml H₂/100g or <15 ml H₂/100g.

HH or H10 = hydrogen level in weld metal of <5 ml H₂/100g or <10 ml H₂/100g.

H5 = hydrogen level in weld metal of <5 ml H₂/100g.

Hydrogen diffusion equipment through vacuum extraction or carrier gas extraction is used to determine the level of hydrogen in weld deposit.

Grade	Tensile properties			Impact properties
	Yield strength MPa (min)	Tensile strength MPa	Elongation %	min. 47 J at °C
1	305	400-560	22	+20
2	305	400-560	22	+/-0
3	305	400-560	22	-20
2Y	375	460-660	22	+/-0
3Y	375	460-660	22	-20
4Y	375	460-660	22	-40
2Y40	400	510-690	22	+/-0
3Y40	400	510-690	22	-20
3Y42	420	520	20	-20
3Y46	460	550	19	-20
4Y40	400	510-690	22	-40
4Y42	420	520	20	-40
4Y46	460	550	19	-40
5Y40	400	510-690	22	-60
5Y42	420	520	20	-60
5Y46	460	550	19	-60

Note: ABS deviates slightly on yield and tensile strength limits for grades 2Y and 3Y and also on impact test values in all grades.

COATED ELECTRODES

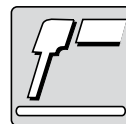

Guide to EN 499-1995

Symbol	Tensile strength MPa	Yield strength MPa	Elongation min. %
35	440-570	355	22
38	470-600	380	20
42	500-640	420	20
46	530-680	460	20
50	560-720	500	18

Symbol	Welding position
1	All positions.
2	All positions, except vertical down.
3	Flat butt weld, flat fillet weld, horizontal-vertical fillet weld.
4	Flat butt weld, flat fillet weld.
5	Vertical down and positions according to symbol 3.

Symbol	Metal recovery %	Type of current
1	<105	AC + DC
2	<105	DC
3	>105≤125	AC + DC
4	>105≤125	DC
5	>125≤160	AC + DC
6	>125≤160	DC
7	>160	AC + DC
8	>160	DC

E 46

Covered electrode for manual metal-arc welding.

Symbol	Impact energy Charpy-V Temp °C for 47J min.
Z	No requirements
A	+20
0	0
2	-20
3	-30
4	-40
5	-50
6	-60

6

2Ni

B

3

2

H5

Symbol	Coating type
A	Acid
B	Basic
C	Cellulosic
R	Rutile
RR	Rutile (thick coated)
RC	Rutile-Cellulosic
RA	Rutile-Acid
RB	Rutile-Basic

Symbol	Hydrogen ml/100 g deposited weld metal, max.
H5	5
H10	10
H15	15

Symbol	Chemical composition*		
	Mn	Mo	Ni
No symbol	2.0	—	—
Mo	1.4	0.3-0.6	—
MnMo	>1.4-2.0	0.3-0.6	—
1 Ni	1.4	—	0.6-1.2
2 Ni	1.4	—	1.8-2.6
3 Ni	1.4	—	>2.6-3.8
Mn 1 Ni	>1.4-2.0	—	0.6-1.2
1 NiMo	1.4	0.3-0.6	0.6-1.2
Z	Any other composition		

* If not specified Mo <0.2, Ni <0.3, Cr <0.2, V <0.05, Nb <0.05, Cu <0.3.
Single values shown in the table mean maximum values.

3.01



COATED ELECTRODES

Guide to EN 757-1997

Symbol	Yield strength min. MPa	Tensile strength MPa	Elongation min. %
55	550	610-780	18
62	620	690-890	18
69	690	760-960	17
79	790	880-1080	16
89	890	980-1180	15

Symbol	Welding positions
1	All positions
2	All positions, except vertical down
3	Flat butt weld, flat fillet weld, horizontal-vertical fillet weld.
4	Flat butt weld, flat fillet weld.
5	Vertical down and positions according to symbol 3.

Symbol	Metal recovery, %	Type of current
1	≤105	AC+DC
2	≤105	DC
3	>105 ≤ 125	AC+DC
4	>105 ≤ 125	DC
5	>125 ≤ 160	AC+DC
6	>125 ≤ 160	DC
7	>160	AC+DC
8	>160	DC

Indicates mechanical properties after stress relief treatment.

E 62

7

MnNi

B

3

4

H5

T

Covered electrode/
manual metal arc
welding.

Only basic electrode
covering.

Symbol	Hydrogen content, ml/100 g deposited weld metal, max
H5	5
H10	10

Symbol	Impact Energy Charpy-V Temp °C for 47J min.
Z	No requirements
A	+20
0	0
2	-20
3	-30
4	-40
5	-50
6	-60
7	-70
8	-80

Symbol	Chemical composition of all-weld metal, %*			
	Mn	Ni	Cr	Mo
Mn Mo	1.4-2.0	-	-	0.3-0.6
Mn 1Ni	1.4-2.0	0.6-1.2	-	-
1 Ni Mo	1.4	0.6-1.2	-	0.3-0.6
1.5 Ni Mo	1.4	1.2-1.8	-	0.3-0.6
2 Ni Mo	1.4	1.8-2.6	-	0.3-0.6
Mn 1 Ni Mo	1.4-2.0	0.6-1.2	-	0.3-0.6
Mn 2 Ni Cr Mo	1.4-2.0	1.8-2.6	-	0.3-0.6
Mn 2 Ni Mo	1.4-2.0	1.8-2.6	0.3-0.6	0.3-0.6
Mn 2 Ni Cr Mo	1.4-2.0	1.8-2.6	0.6-1.0	0.3-0.6
Z	Any other agreed composition			

* If not specified C 0.03-0.10, Ni<0.3, Cr<0.2, Mo<0.2, V<0.05, Nb<0.05, Cu<0.3, P<0.025, S<0.020.
Single values shown in the table are maximum values.

COATED ELECTRODES

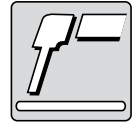

Guide to EN 1600-1977

Covered electrode/
manual metal arc
welding.

Type of electrode covering:
R= rutile covering
B= basic covering

Symbol	Metal recovery, %	Type of current
1	≤105	AC+DC
2	≤105	DC
3	>105 ≤ 125	AC+DC
4	>105 ≤ 125	DC
5	>125 ≤ 160	AC+DC
6	>125 ≤ 160	DC
7	>160	AC+DC
8	>160	DC

E

23

12

2L

R

3

2

Symbol	Welding positions
1	All positions
2	All positions, except vertical down
3	Flat butt weld, flat fillet weld, horizontal-vertical fillet weld.
4	Flat butt weld, flat fillet weld.
5	Vertical down and positions according to symbol 3.

Alloy Symbol	Chemical composition of all-weld metal, %*								
	C	Si	Mn	P	S	Cr	Ni	Mo	Other elements
Martensitic/ferritic									
13	0.12	1.0	1.5	0.030	0.025	11.0-14.0	-	-	-
13 4	0.06	1.0	1.5	0.030	0.025	11.0-14.5	3.0-5.0	0.4-1.0	-
17	0.12	1.0	1.5	0.030	0.025	16.0-18.0	-	-	-
Austenitic									
19 9	0.08	1.2	2.0	0.030	0.025	18.0-21.0	9.0-11.0	-	-
19 9L	0.04	1.2	2.0	0.030	0.025	18.0-21.0	9.0-11.0	-	-
19 9 Nb	0.08	1.2	2.0	0.030	0.025	18.0-21.0	9.0-11.0	-	Nb
19 12 2	0.08	1.2	2.0	0.030	0.025	17.0-20.0	10.0-13.0	2.0-3.0	-
19 12 3 L	0.04	1.2	2.0	0.030	0.025	17.0-20.0	10.0-13.0	2.5-3.0	-
19 12 3 Nb	0.08	1.2	2.0	0.030	0.025	17.0-20.0	10.0-13.0	2.5-3.0	Nb
19 13 4 N L	0.04	1.2	1.0-5.0	0.030	0.025	17.0-20.0	12.0-15.0	3.0-4.5	N 0.20
Austenitic-ferritic. High corrosion resistance									
22 9 3 N L	0.04	1.2	2.5	0.030	0.025	21.0-24.0	7.5-10.5	2.5-4.0	N 0.08-0.20
25 7 2 N L	0.04	1.2	2.0	0.035	0.025	24.0-28.0	6.0-8.0	1.0-3.0	N 0.20
25 9 3 Cu N L	0.04	1.2	2.5	0.030	0.025	24.0-27.0	7.5-10.5	2.5-4.0	N 0.10-0.25, Cu 1.5-3.5
25 9 4 N L	0.04	1.2	2.5	0.030	0.025	24.0-27.0	8.0-10.5	2.5-4.5	N 0.20-0.30, Cu 1.5, W 1.0
Fully austenitic. High corrosion resistance									
18 15 3 L	0.04	1.2	1.0-4.0	0.030	0.025	16.5-19.5	14.0-17.0	2.5-3.5	-
18 16 5 N L	0.04	1.2	1.0-4.0	0.035	0.025	17.0-20.0	15.5-19.0	3.0-5.0	N 0.20
20 25 5 Cu N L	0.04	1.2	1.0-4.0	0.030	0.025	19.0-22.0	24.0-27.0	4.0-7.0	Cu 1.0-2.0, N 0.25
20 16 3 Mn N L	0.04	1.2	5.0-8.0	0.035	0.025	18.0-21.0	15.0-18.0	2.5-3.5	N 0.20
25 22 2 N L	0.04	1.2	1.0-5.0	0.030	0.025	24.0-27.0	20.0-23.0	2.0-3.0	N 0.20
27 31 4 Cu L	0.04	1.2	2.5	0.030	0.025	26.0-29.0	30.0-33.0	3.0-4.5	Cu 0.6-1.5
Special types									
18 8 Mn	0.20	1.2	4.5-7.5	0.035	0.025	17.0-20.0	7.0-10.0	-	-
18 9 Mn Mo	0.04-0.14	1.2	3.0-5.0	0.035	0.025	18.0-21.5	9.0-11.0	0.5-1.5	-
20 10 3	0.10	1.2	2.5	0.030	0.025	18.0-21.0	9.0-12.0	1.5-3.5	-
23 12 L	0.04	1.2	2.5	0.030	0.025	22.0-25.0	11.0-14.0	-	-
23 12 Nb	0.10	1.2	2.5	0.030	0.025	22.0-25.0	11.0-14.0	-	Nb
23 12 2 L	0.04	1.2	2.5	0.030	0.025	22.0-25.0	11.0-14.0	2.0-3.0	-
29 9	0.15	1.2	2.5	0.035	0.025	27.0-31.0	8.0-12.0	-	-
Heat resisting types									
16 8 2	0.08	1.0	2.5	0.030	0.025	14.5-16.5	7.5-9.5	1.5-2.5	-
19 9 H	0.04-0.08	1.2	2.0	0.030	0.025	18.0-21.0	9.0-11.0	-	-
25 4	0.15	1.2	2.5	0.030	0.025	24.0-27.0	4.0-6.0	-	-
22 12	0.15	1.2	2.5	0.030	0.025	20.0-23.0	10.0-13.0	-	-
25 20	0.06-0.20	1.2	1.0-5.0	0.030	0.025	23.0-27.0	18.0-22.0	-	-
25 20 H	0.35-0.45	1.2	2.5	0.030	0.025	23.0-27.0	18.0-22.0	-	-
18 36	0.25	1.2	2.5	0.030	0.025	14.0-18.0	33.0-37.0	-	-

* Single values shown in the table are maximum values.

3.01



COATED ELECTRODES

Guide to AWS A5.1-1991

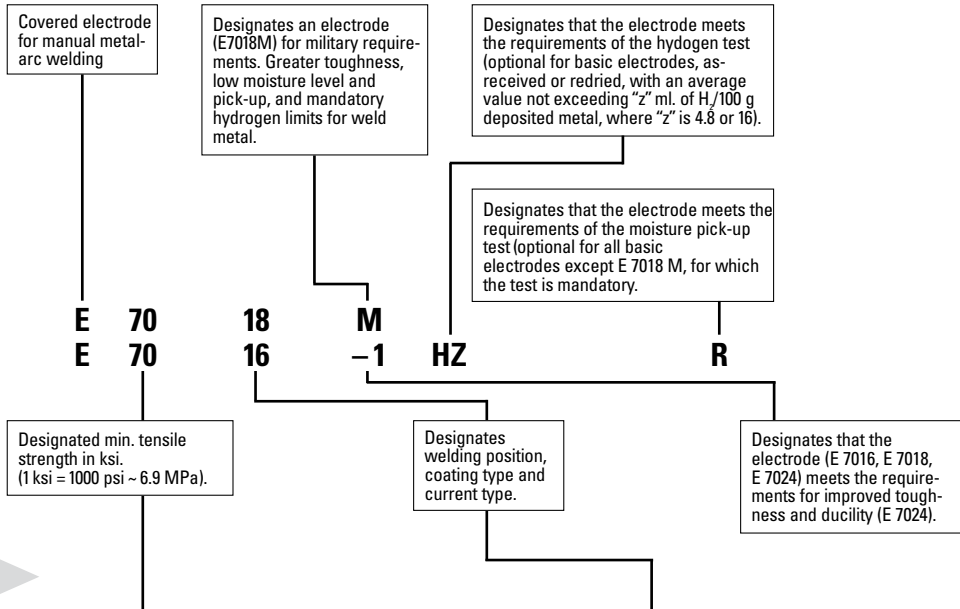

3.01

AWS Classification	Tensile Strength min.		Yield strength min.		Elongation min %	Impact Energy Charp-V J/°C	Welding Position	Type of coating	Type of Current	
	ksi	MPa	ksi	MPa					AC	DC
E 6010	60	414	48	331	22	27 / -29	10	Cellulosic	-	+ pol
E 6011	60	414	48	331	22	27 / -29	11	Cellulosic	x	+ pol
E 6012	60	414	48	331	17	Not spec.	12	Rutile	x	- pol
E 6013	60	414	48	331	17	Not spec.	13	Rutile	x	+ / - pol
E 6019	60	414	48	331	22	27 / -18	19	Rutile/Acid	x	+ / - pol
E 6020	60	414	48	331	22	Not spec.	20	Acid	x	c) + / - pol
E 6022	60	414	Not spec.	Not spec.	Not spec.	Not spec.	22	Acid	x	- pol
E 6027	60	414	48	331	22	27 / -29	27	Acid, high reco.	x	c) + / - pol
E 7014	70	482	58	399	17	Not spec.	14	Rutile, iron pow.	x	+ / - pol
E 7015	70	482	58	399	22	27 / -29	15	Basic	-	+ pol
E 7016	70	482	58	399	22	27 / -29	16	Basic	x	+ pol
E 7016-1	70	482	58	399	22	27 / -46	16	Basic	x	+ pol
E 7018	70	482	58	399	22	27 / -29	18	Basic, iron pow.	x	+ pol
E 7018-1	70	482	58	399	22	27 / -46	18	Basic, iron pow.	x	+ pol
E 7018M	a)	482	b)	b)	24	67 / -29	18	Basic, iron pow.	-	+ pol
E 7024	70	482	58	399	17	Not spec.	24	Rutile, high reco.	x	+ / - pol
E 7027	70	482	58	399	22	27 / -29	27	Acid, high reco.	x	c) + / - pol
E 7028	70	482	58	399	22	27 / -29	28	Basic, high reco.	x	+ pol
E 7048	70	482	58	399	22	27 / -29	48	Basic, iron pow.	x	+ pol

a) Nominal value 70 ksi (482 MPa).

b) Limits are 53-72 ksi (365-496 MPa). For \varnothing 2.4 mm the limit is max. 77 ksi (531 MPa).

c) H-V fillets: - pol.

In addition there are requirements on:

- Chemical composition of the weld metal
- Radiographic test.

Code	Welding position
1	All positions except vertical-down
2	Flat and H-V fillets.
4	All positions but in the vertical, V-down only.

COATED ELECTRODES



Guide to AWS A5.5-1996

Covered electrode for manual metal-arc welding

Designates welding position, coating type and current type.

E 80 18 C1

Designated min. tensile strength in ksi. (1 ksi = 1000 psi ~ 6.9 MPa).

AWS Classification	Welding Position	Type of coating	Type of current	
			AC	DC
E xx 10	1	Cellulosic	—	+ pol
E xx 11	1	Cellulosic	x	+ pol
E xx 12	1	Rutile	x	— pol
E xx 13	1	Rutile	x	+/- pol
E xx 15	1	Basic	—	+ pol
E xx 16	1	Basic	x	+ pol
E xx 18	1	Basic, iron powder	x	+ pol
E xx 20	2	Acid	x	c) +/- pol
E xx 27	2	Acid, high recovery	x	c) +/- pol

Designated chemical composition of weld metal.

AWS classification	Tensile strength min./MPa	Yield strength min./MPa
E 70 xx-x	480	390
E 80 xx-x	550	460
E 80 xx-C3	550	470-550
E 90 xx-x	620	530
E 90 xx-M	620	540-620
E 100 xx-x	690	600
E 100 xx-M	690	610-690
E 110 xx-x	760	670
E 110 xx-M	760	680-760
E 120 xx-x	830	740
E 120 xx-M	830	745-830
E 120 xx-M1	830	745-830

Code	Welding position
1	All positions except vertical-down
2	Flat and H-V fillets

3.01

AWS classification	Impact energy	
	min. J	°C
E 8018-NM	27	-40
E 8016-C3	27	-40
E 8018-C3	27	-40
E 8016-D3	27	-51
E 8018-D3	27	-51
E 9015-D1	27	-51
E 9018-D1	27	-51
E 10015-D2	27	-51
E 10016-D2	27	-51
E 10018-D2	27	-51
E 9018-M	27	-51
E 10018-M	27	-51
E 11018-M	27	-51
E 12018-M	27	-51
E 12018-M1	68	-18
E 7018-W	27	-18
E 8018-W	27	-18
E 8016-C1	27	-59
E 8018-C1	27	-59
E 7015-C1L	27	-73
E 7016-C1L	27	-73
E 7018-C1L	27	-73
E 8016-C2	27	-73
E 8018-C2	27	-73
E 7015-C2L	27	-101
E 7016-C2L	27	-101
E 7018-C2L	27	-101
All other	Not required	

Suffix	Alloying system	Nominal values Wt%
-A1	C/Mo	~0.1/0.5
-B1	Cr/Mo	~0.5/0.5
-B2	Cr/Mo	~1.3/0.5
-B2L*	Cr/Mo	~1.3/0.5
-B3	Cr/Mo	~2.3/1.0
-B3L*	Cr/Mo	~2.3/1.0
-B4L*	Cr/Mo	~2.0/0.5
-B5	Cr/Mo/V	~0.5/1.0/0.05
-C1	Ni	~2.5
-C1L*	Ni	~2.5
-C2	Ni	~3.5
-C2L*	Ni	~3.5
-C3	Ni/Cr/Mo/V	~1.0/0.1/0.3/0.05
-NM	Ni/Mo	~1.0/0.5
-D1	Mn/Mo	~1.5/0.3
-D2	Mn/Mo	~1.8/0.3
-D3	Mn/Mo	~1.5/0.5
-G/-M/-W	All other alloy steel electrodes	

* C max. 0.05%.

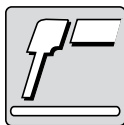

COATED ELECTRODES

Guide to AWS A5.4-1992

Covered electrode for manual metal-arc welding.

E 312 -17

Indicates compositional type.

Suffix	Coating type and usability characteristics
-15	For use with DC+ only. Usually basic coating. All positions.
-16	For use with DC+ and AC. Rutile coating. All positions.
-17	As for -16, but higher silica content in coating gives following: <ul style="list-style-type: none"> - More of a spray arc and finer rippled bead surface in H-V fillets. - Slower freezing slag permits improved handling with a drag technique. - Mitre to slight concave H-V fillets. - When making vertical-up fillets the slower freezing slag requires slight weave to produce flat profile.
-25	Same coating and types as for -15 but with a mild steel core wire. Flat and horizontal positions only.
-26	Same coating and type as for -16 but with a mild steel core wire. Flat and horizontal positions only.







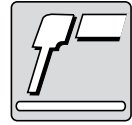

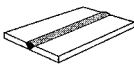
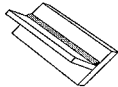
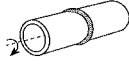
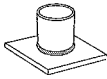

3.01

AWS classification	Chemical composition of undiluted weld metal										
	C	Cr	Ni	Mo	Nb + Ta	Mn	Si	P	S	N	Cu
E 209 -xx	0.06	20.5-24.0	9.5-12.0	1.5-3.0	-	4.0-7.0	0.90	0.04	0.03	0.10-0.30	0.75
E 219-xx	0.06	19.0-21.5	5.5-7.0	0.75	-	8.0-10.0	1.0	0.04	0.03	0.10-0.30	0.75
E 240-xx	0.06	17.0-19.0	4.0-6.0	0.75	-	10.5-13.5	1.0	0.04	0.03	0.10-0.30	0.75
E 307-xxx	0.04-0.14	18.0-21.5	9.0-10.7	0.5-1.5	-	3.30-4.75	0.90	0.04	0.03	-	0.75
E 308-xx	0.08	18.0-21.0	9.0-11.0	0.75	-	0.5-2.5	0.90	0.04	0.03	-	0.75
E 308 H-xx	0.04-0.08	18.0-21.0	9.0-11.0	0.75	-	0.5-2.5	0.90	0.04	0.03	-	0.75
E 308 L-xx	0.04	18.0-21.0	9.0-11.0	0.75	-	0.5-2.5	0.90	0.04	0.03	-	0.75
E 308 Mo-xx	0.08	18.0-21.0	9.0-12.0	2.0-3.0	-	0.5-2.5	0.90	0.04	0.03	-	0.75
E 308 MoL-xx	0.04	18.0-21.0	9.0-12.0	2.0-3.0	-	0.5-2.5	0.90	0.04	0.03	-	0.75
E 309-xx	0.15	22.0-25.0	12.0-14.0	0.75	-	0.5-2.5	0.90	0.04	0.03	-	0.75
E 309 L-xx	0.04	22.0-25.0	12.0-14.0	0.75	-	0.5-2.5	0.90	0.04	0.03	-	0.75
E 309 Cb-xx	0.12	22.0-25.0	12.0-14.0	0.75	0.70-1.00	0.5-2.5	0.90	0.04	0.03	-	0.75
E 309 Mo-xx	0.12	22.0-25.0	12.0-14.0	2.0-3.0	-	0.5-2.5	0.90	0.04	0.03	-	0.75
E 309 MoL-xx	0.04	22.0-25.0	12.0-14.0	2.0-3.0	-	0.5-2.5	0.90	0.04	0.03	-	0.75
E 310-xx	0.08-0.20	25.0-28.0	20.0-22.5	0.75	-	1.0-2.5	0.75	0.03	0.03	-	0.75
E 310 H-xx	0.35-0.45	25.0-28.0	20.0-22.5	0.75	-	1.0-2.5	0.75	0.03	0.03	-	0.75
E 310 Cb-xx	0.12	25.0-28.0	20.0-22.0	0.75	0.70-1.00	1.0-2.5	0.75	0.03	0.03	-	0.75
E 310 Mo-xx	0.12	25.0-28.0	20.0-22.0	2.0-3.0	-	1.0-2.5	0.75	0.03	0.03	-	0.75
E 312-xx	0.15	28.0-32.0	8.0-10.5	0.75	-	0.5-2.5	0.90	0.04	0.03	-	0.75
E 316-xx	0.08	17.0-20.0	11.0-14.0	2.0-3.0	-	0.5-2.5	0.90	0.04	0.03	-	0.75
E 316 H-xx	0.04-0.08	17.0-20.0	11.0-14.0	2.0-3.0	-	0.5-2.5	0.90	0.04	0.03	-	0.75
E 316 L-xx	0.04	17.0-20.0	11.0-14.0	2.0-3.0	-	0.5-2.5	0.90	0.04	0.03	-	0.75
E 317-xx	0.08	18.0-21.0	12.0-14.0	3.0-4.0	-	0.5-2.5	0.90	0.04	0.03	-	0.75
E 317 L-xx	0.04	18.0-21.0	12.0-14.0	3.0-4.0	-	0.5-2.5	0.90	0.04	0.03	-	0.75
E 318-xx	0.08	17.0-20.0	11.0-14.0	2.0-3.0	≥6xC≤1.0	0.5-2.5	0.90	0.04	0.03	-	0.75
E 320-xx	0.07	19.0-21.0	32.0-36.0	2.0-3.0	≥8xC≤1.0	0.5-2.5	0.60	0.04	0.03	-	3.0-4.0
E 320 LR-xx	0.03	19.0-21.0	32.0-36.0	2.0-3.0	≥8xC≤0.40	1.5-2.5	0.30	0.02	0.015	-	3.0-4.0
E 330-xx	0.18-0.25	14.0-17.0	33.0-37.0	0.75	-	1.0-2.5	0.90	0.04	0.03	-	0.75
E 330 H-xx	0.35-0.45	14.0-17.0	33.0-37.0	0.75	-	1.0-2.5	0.90	0.04	0.03	-	0.75
E 347-xx	0.08	18.0-21.0	9.0-11.0	0.75	≥8xC≤1.0	0.5-2.5	0.90	0.04	0.03	-	0.75
E 349-xx	0.13	18.0-21.0	8.0-10.0	0.35-0.65	0.75-1.20	0.5-2.5	0.90	0.04	0.03	-	0.75
E 383-xx	0.03	26.5-29.0	30.0-33.0	3.2-4.2	-	0.5-2.5	0.90	0.02	0.02	-	0.6-1.5
E 385-xx	0.03	19.5-21.5	24.0-26.0	4.2-5.2	-	1.0-2.5	0.75	0.03	0.02	-	1.2-2.0
E 410-xx	0.12	11.0-13.5	0.7	0.75	-	1.0	0.90	0.04	0.03	-	0.75
E 410 NiMo-xx	0.06	11.0-12.5	4.0-5.0	0.40-0.70	-	1.0	0.90	0.04	0.03	-	0.75
E 430-xx	0.10	15.0-18.0	0.6	0.75	-	1.0	0.90	0.04	0.03	-	0.75
E 502-xx	0.10	4.0-6.0	0.4	0.45-0.65	-	1.0	0.90	0.04	0.03	-	0.75
E 505-xx	0.10	8.0-10.5	0.4	0.85-1.20	-	1.0	0.90	0.04	0.03	-	0.75
E 630-xx	0.05	16.0-16.75	4.5-5.0	0.75	0.15-0.30	0.25-0.75	0.75	0.04	0.03	-	3.25-4.00
E 16-8-2-xx	0.10	14.5-16.5	7.5-9.5	1.0-2.0	-	0.5-2.5	0.60	0.03	0.03	-	0.75
E 7 Cr-xx	0.10	6.0-8.0	0.4	0.45-0.65	-	1.0	0.90	0.04	0.03	-	0.75
E 2209-xx	0.04	21.5-23.5	8.5-10.5	2.5-3.5	-	0.5-2.0	0.90	0.04	0.03	0.08-0.20	0.75
E 2553-xx	0.06	25.0-27.0	6.5-8.5	2.9-3.9	-	0.5-1.5	1.0	0.04	0.03	0.10-0.25	1.5-2.5

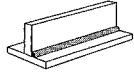
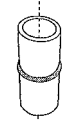
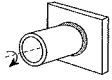
COATED ELECTRODES

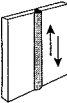
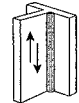
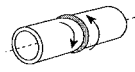
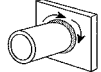

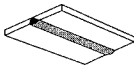
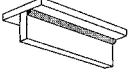
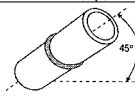
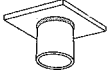
Welding positions

AWS according to ASME section IX EN according to ISO 6947, NEN-EN 287				Welding positions according to EN 26947	
					
AWS: 1G EN: PA	AWS: 1F EN: PA	AWS: 1G EN: PA	AWS: 2F EN: PB	PA	PB
					
AWS: 2G EN: PC	AWS: 2F EN: PB	AWS: 2G EN: PC	AWS: 2F EN: PB	PC	PB
					
AWS: 3G EN: PG (down) PF (up)	AWS: 3F EN: PG (down) PF (up)	AWS: 5G EN: PG (down) PF (up)	AWS: 5F EN: PG (down) PF (up)	PF	PG
					
AWS: 4G EN: PE	AWS: 4F EN: PD	AWS: 6G EN: H-L045	AWS: 4F EN: PD	PE	PD

3.01

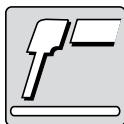

GPO-302 N

General Purpose Electrode for Mild Steel



Imprint
Unitor GPO-302 N/ 6013

Classifications

SFA/AWS A 5.1	EN-ISO 2560-A
E 6013	E 38 0 RC 11

Approvals

DNV	GL	LR	BV	ABS
2	2	2	2	2

Type of current



AC
DC+/-

Welding positions

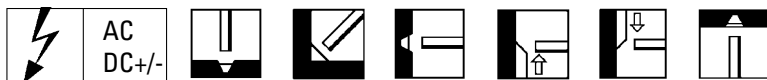

PA

PB

PC

PF

PG

PE, PD

Materials to be welded

General structural steel	DIN 17100 NF A35-501 BS 4360	S133, St37-2 to St44-3 A33, A34-2, E24-2 (-4), E28-2 (-3) E30-2 (-3) Gr. 40A-C, 43A-C Grade A, B, C, D
Ship plates	DIN 1681	GS38
Cast steel	DIN 17172	StE210.7, StE240.7, StE290.7, StE320.7, StE360.7
Pipe material	API 5 LX	X42, X46
Boiler & pressure vessel steel	DIN 1626-1630 DIN 17155 NF A 36-205 NF A36-207 BS 1501	St37.0/4, St44.0/4 H1, H11, 17Mn4 A37 (CP), A42 (CP), A48 (CP) A510AP, A530AP, A550AP 151/154/161-Gr. 360/400, 164-Gr.360
Elevated temperature steel	DIN 17175 DIN 17102 NF A36-203	St35.8, St45.8 StE255 to StE315 E275D
Fine grained steel		

All weld metal composition

C	Mn	Si
0.05 - 0.12	0.15 - 0.65	0.10 - 0.50

Typical mech. properties of weld metal

Tensile strength MPa	Yield strength MPa	Elongation %	Impact value ISO-V (J)
510	400	29	At 0°C = 70

Welding data

Diameter mm.	Current range, A	Arc time **/ electrode, sec.	Deposition rate** Kg/h	Electrodes per kg weld metal**	Fume class
2.5	60-100	50	0.8	86	1
3.2	80-150	57	1.3	53	2
4.0	100-200	65	1.6	39	2

* SDS available on request.

** 90% of max. amperage

Packaging data

Diameter mm.	Length mm.	Electrodes per box	Net weight, kg per box	Product No. per box	Boxes per carton
2.5	350	295	5.2	095-699165	3
3.2	350	190	5.4	095-699173	3
4.0	350	120	5.2	095-699181	3

Re-drying temperature: Normally no need.

GPO-302 N



Unitor GPO-302 N is a general purpose electrode with a medium thick organic rutile coating which produces a fast-freezing slag.

It is a versatile electrode for all mild steel constructions on board, except the higher grade steels that require basic coated electrodes (hull plates, beams, etc.)

GPO-302 N strikes and restrikes easily and is the electrode least affected by rust and paint residues on the work-piece.

The excellent restriking properties makes the electrode well suited for tack welding.

GPO-302 N may be used in all positions including vertical down, if necessary without changing the welding current setting.

This, and the electrode's ability to easily bridge large gaps makes it an excellent general purpose repair electrode on board.

Application areas range from tack welding of plate and tube constructions to complete welding jobs of medium strength.

With its good welding characteristics GPO-302 N 2,5 mm is, together with SPECIAL-303 N 2.0 mm, a good solution for thin sheetplate welding.

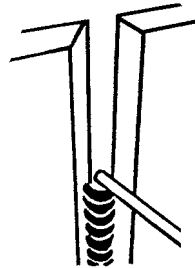

GPO-302 N bridges wide gap.

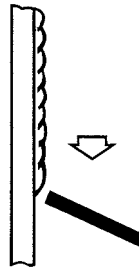

Suitable for welding in the vertical-down position.

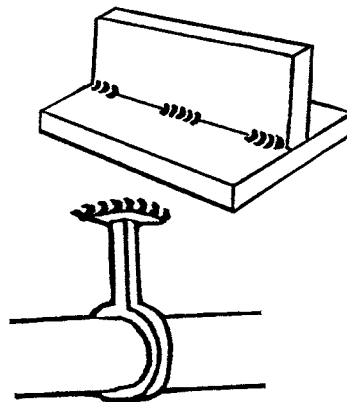

Suitable for tack welding and welding on clamp fitments.

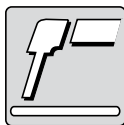

GPR-300 H

High Recovery Electrode for Mild Steel

Identification:

Imprint
Unitor GPR-300 H / 7024



Classifications

SFA/AWS A 5.1	EN-ISO 2560-A
E 7024	E 42 0 RR 73

Approvals

DNV	GL	LR	BV	ABS
2	2Y	2Y	2Y	2

Type of current



PA

PB

Welding positions

Materials to be welded

General structural steel	DIN 17100 NF A35-501 BS 4360	St33, St37-2 to St52-3 A33, A34-2, E24-2 (-4) to E36-2 (-4) Grade 43D, 50D Grade A, B, C, D, E, AH, DH, EH GS38, GS45, GS52 A1, A2, A3, AM1, AM2, AW1 StE210.7, StE240.7, StE290.7, StE320.7, StE360.7 X42, X46, X52, X60 St37.0/4, St44.0/4, ST52.0/4 H1, H11, 17Mn4, 19Mn5 A37 (CP, AP), A42 (CP, AP), A48 (CP, AP), A52 (CP, AP) A510 AP, A530 AP, A550 AP 151/154/161-Gr. 360/400/430, 164-Gr. 360/400 St.35.8, St.45.8 St.E255 to St.E420 E275 D, E344D, E390D, E430D, E455D
Ship plates	DIN 1681	
Cast steel	BS3100 DIN 17172	
Pipe material	API 5 L X DIN 1626-1630	
Boiler & pressure vessel steel	DIN 17155 NF A36-205 NF A36-207 BS 1501	
Elevated temperature steel	DIN 17175	
Fine grained steel	DIN 17102 NF A 36-203	

3.01

All weld metal composition

C	Mn	Si
max. 0.12	0.45 - 0.95	0.25 - 0.65

Typical mech. properties of weld metal

Tensile strength MPa	Yield strength MPa	Elongation %	Impact value ISO-V (J)	Recovery %
555	480	26	At -20°C = 50	180

Welding data

Diameter mm.	Current range, A	Arc time **/ electrode, sec.	Deposition rate** Kg/h	Electrodes per kg weld metal**	Fume class
3.2	130-170	69	2.5	21.0	2
4.0	180-230	69	3.8	13.5	2
5.0	250-340	68	5.8	9.1	3
6.0	300-430	72	7.5	6.6	4

* SDS available on request. ** 90% of max. amperage

Packaging data

Diameter mm.	Length mm.	Electrodes per box	Net weight, kg per box	Product No. per box	Boxes per carton
3.2	450	85	5.8	095-699231	3
4.0	450	51	5.5	095-699249	3
5.0	450	35	5.6	095-699256	3
6.0	450	23	5.3	095-699260	3

Re-drying temperature: Normally no need.

GPR-300 H



Unitor GPR-300 H is a high recovery electrode of rutile type for welding in the flat and horizontal-vertical position. It is specially suitable for horizontal-vertical and horizontal fillet welding.

GPR-300 H has a recovery value of approx. 180%, the coating containing approx. 60% iron powder.

During welding, the electrode should be pulled along the groove allowing the coating to be in contact with the base material. Preferably use DC-polarity.

The electrode can be used at a welding speed of up to 50 cm/min. when A-measurement (throath thickness) is 3.5 to 6 mm. When horizontal/vertical fillet welding on heavier material, a large electrode diameter e.g. 5 mm. in relation to A-measurement can be used.

The electrode is suitable for welding materials which have zinc and iron oxide rust protective primer coatings. However, observe all necessary safety precautions concerning the fumes from the primer. Consult the chapter on welding fumes.

GPR-300 H is a typical electrode where large sections of steel are to be replaced but it is also useful for general repair work. The high welding speed, good welding properties, and high deposition rate reduce the risk of heat deformation and stress.

Welding with this electrode ensures low spatter. The bead has a smooth surface and the slag is self-releasing.

This electrode is recommended for welding flanges to tubes in the horizontal position.

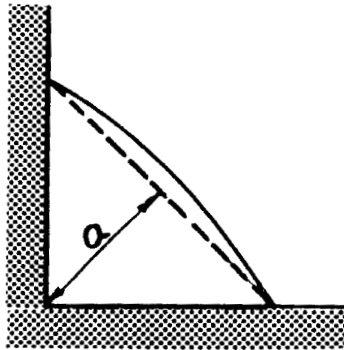
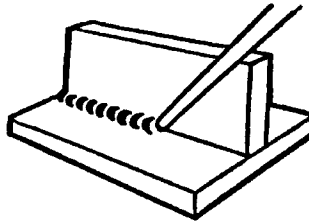

The A measurement should be 7/10 of material thickness.

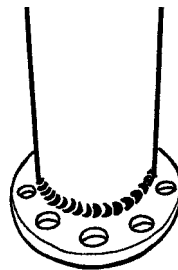



SPECIAL-303 N

Double Coated Electrode for Mild and Ship Quality Steel



Identification:

Imprint
Unitor SPECIAL-303 N / 7016

Classifications

SFA/AWS A 5.1	EN-ISO 2560-A
E 7016	E 38 2B 32 H10

Approvals

DNV	GL	LR	BV	ABS
3YH10	3YH10	3YH15	3, 3YH10	3H10, 3Y

Type of current



Welding positions

Materials to be welded

General structural steel	DIN 17100 NF A35-501 BS 4360	S133, St37-2 to St52-3 A33, A34-2, E24-2 (-4) to E36-2 (-4) Grade 43D, 50D Grade A, B, C, D, E, AH, DH, EH GS38, GS45, GS52
Ship plates	DIN 1681 BS3100	A1, A2, A3, AM1, AM2, AW1
Cast steel	DIN 17172 API 5 LX	StE210.7, StE240.7, StE290.7, StE320.7, StE360.7 X42, X46, X52, X60
Pipe material	DIN 1626-1630 DIN 17155	St37.0/4, St44.0/4, ST52.0/4 H1, H11, 17Mn4, 19Mn5
Boiler & pressure vessel steel	NF A36-205 NF A36-207 BS 1501	A37 (CP, AP), A42 (CP, AP), A48 (CP, AP), A52 (CP, AP) A510 AP, A530 AP, A550 AP 151/154/161-Gr. 360/400/430, 164-Gr. 360/400
Elevated temperature steel	DIN 17175 DIN 17102	St.35.8, St.45.8 St.E255 to St.E420
Fine grained steel	NF A 36-203	E275 D, E344D, E390D, E430D, E455D

All weld metal composition

C	Mn	Si
max. 0.10	0.70 - 1.20	0.30 - 0.70

Typical mech. properties of weld metal

Tensile strength MPa	Yield strength MPa	Elongation %	Impact value ISO-V (J)
530	420	28	At -20°C = 120

Welding data

Diameter mm.	Current range, A	Arc time **/ electrode, sec.	Deposition rate** Kg/h	Electrodes per kg weld metal**	Fume class
2.0	40-80	75	0.6	143	2
2.5	50-90	54	0.9	77	2
3.2	90-150	57	1.4	46	2
4.0	120-190	79	1.9	24	3

*SDS available on request. ** 90% of max. amperage

Packaging data

Diameter mm.	Length mm.	Electrodes per box	Net weight, kg per box	Product No. per box	Boxes per carton
2.0	350	115	1.7	095-699199	6
2.5	350	200	4.1	095-699207	3
3.2	350	120	4.1	095-699215	3
4.0	450	75	5.2	095-699223	3

Re-drying temperature: 300 °C (572 °F) for two hours.

SPECIAL-303 N

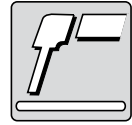

Unitor SPECIAL-303 N is a double coated basic electrode with special coating components combining the excellent running characteristics of a rutile electrode with the very good mechanical properties of a basic electrode.

Unitor SPECIAL-303 N welds on AC as on DC+ with minimal spatter level.

Very good positional welding properties, vertical welding should be conducted in the upward direction. Ideal electrode for high quality jobs performed by non-welders.

The 2 mm size is ideal for use on sheet metal plates and thin walled pipes.

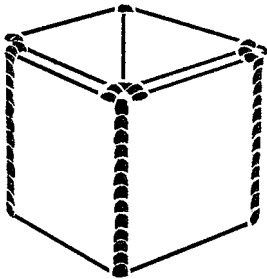
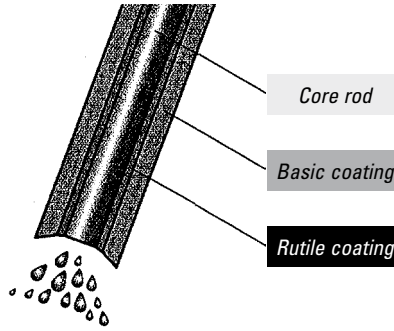

Sheet metal plates

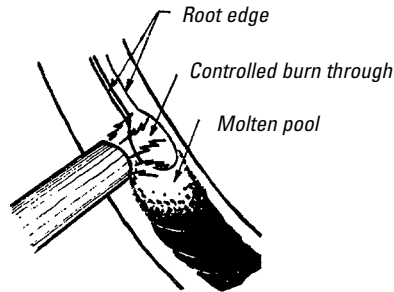

Roots runs on plate and pipes.

3.01

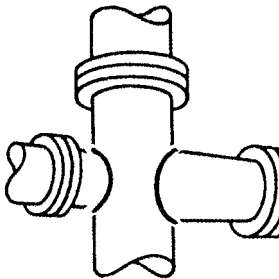

Excellent in difficult position welding

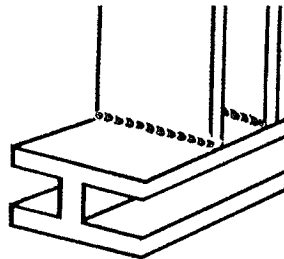

Welding mild and ship quality steel

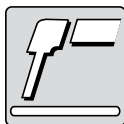

LH-314 N

Low Hydrogen Electrode for Ship Quality Steel

Identification:

Imprint
Unitor LH-314 N / 7018



Classifications

SFA/AWS A 5.1	EN-ISO 2560-A
E 7018	E 42 4 B 42 H5

Approvals

DNV/GL	LR	BV	ABS
3YH5	3YH5	3, 3YH5	3YH5, 3 Y

Type of current



DC+/-



PA



PB



PC



PF



PE, PD

Welding positions

Materials to be welded

General structural steel	DIN 17100 NF A35-501 BS 4360	St33, St37-2 to St52-3 A33, A34-2, E24-2 (-4) to E36-2 (-4) Grade 43D, 50D Grade A, B, C, D, E, AH, DH, EH GS38, GS45, GS52 A1, A2, A3, AM1, AM2, AW1 StE210.7, StE240.7, StE290.7, StE320.7, StE360.7 X42, X46, X52, X60 St37.0/4, St44.0/4, St52.0/4 H1, H11, 17Mn4, 19Mn5 A37 (CP, AP), A42 (CP, AP), A48 (CP, AP), A52 (CP, AP) A510 AP, A530 AP, A550 AP 151/154/161-Gr. 360/400/430, 164-Gr. 360/400 St.35.8, St.45.8 St.E255 to St.E420 E275 D, E344D, E390D, E430D, E455D
Ship plates	DIN 1681 BS3100	
Cast steel	DIN 17172	
Pipe material	API 5 LX DIN 1626-1630	
Boiler & pressure vessel steel	DIN 17155 NF A36-205 NF A36-207 BS 1501	
Elevated temperature steel	DIN 17175 DIN 17102	
Fine grained steel	NF A 36-203	

All weld metal composition

C	Mn	Si
0.02 - 0.10	0.75 - 1.25	0.30 - 0.70

Typical mech. properties of weld metal

Tensile strength MPa	Yield strength MPa	Elongation %	Impact value ISO-V (J)
540	445	29	At -20°C = 140 At -40°C = 70

Welding data

Diameter mm.	Current range, A	Arc time **/ electrode, sec.	Deposition rate** Kg/h	Electrodes per kg weld metal**	Fume class
2.5	75-105	58	1.0	62.5	2
3.2	95-155	80	1.5	31.3	3
4	125-210	85	2.1	20.5	3

* SDS available on request. ** 90% of max. amperage

Packaging data

Diameter mm.	Length mm.	Electrodes per box	Net weight, kg per box	Product No. per box	Boxes per carton
2.5	350	161	4.0	095-699264	3
3.2	450	95	5.0	095-699272	3
4	450	78	5.6	095-699280	3

Re-drying temperature: 350 °C (662 °F) for two hours.



Unitor LH-314 N is a heavily coated electrode of basic type for welding unalloyed, low alloyed and yield point controlled steel in all positions. Yield point controlled steel refers in this case to ships' steel normally used for deckplates, hull plates and frames. If you are uncertain as to whether the steel is unalloyed or low alloyed, you cannot go wrong when using a basic electrode. The electrode will operate with DC positive or negative polarity. Vertical welding should be carried out upwards. For vertical-down welding electrode LHV-316 N is recommended. All basic electrodes should be used with a short arc. LH-314 N has a recovery value of approx. 120%, the coating containing approx. 20% iron powder.



A short arc.

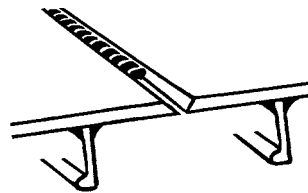

Joining deck and hull plates.

Hydrogen content is low, less than 5 ml/100g weldmetal, thus reducing the risk of cold cracks. Slag is easily removed. Basic electrodes produce a higher quality deposit than rutile and acid types. The electrode must be protected against humidity and welding with damp electrodes should not be attempted. See the section on after-drying of basic electrodes.

Unitor LH-314 N produces a weld of good mechanical properties and is therefore well suited for heavily loaded components such as lifting lugs, motor base plates and similar heavily stressed parts. Well suited for X-ray examination.



Lifting lugs.

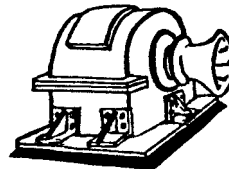

Motor base plates.

Unitor LH-314 N is commonly used for welding ordinary cast steel in high pressure valves and other machine parts. It should not be used for cast iron.

To determine whether you have cast iron or cast steel, use a hammer and chisel on the material and consult the chisel test under the section on metal identification.

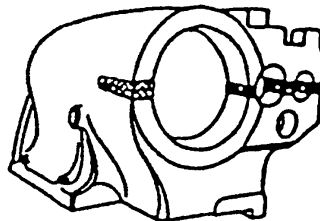

Welding cast steel.

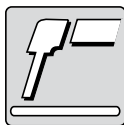

LHH-314 H

High Recovery Low Hydrogen Electrode for Ship Quality

Identification:

Imprint
Unitor LHH-314 H/ 7028



Classifications

SFA/AWS A 5.1	EN-ISO 2560-A
E 7028	E 42 4 B 73 H5

Approvals

DNV	GL	LR	BV	ABS
3YH5	3YH5	3YH5	3YH5	3YH5

Type of current

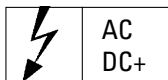

AC
DC+



PA



PB

Welding positions

Materials to be welded

General structural steel	DIN 17100 NF A35-501 BS 4360	St33, St37-2 to St52-3 A33, A34-2, E24-2 (-4) to E36-2 (-4) Grade 43D, 50D
Ship plates	DIN 1681	Grade A, B, C, D, E, AH, DH, EH
Cast steel	BS3100	GS38, GS45, GS52
Pipe material	DIN 17172 API 5 LX DIN 1626-1630	A1, A2, A3, AM1, AM2, AW1 StE210.7, StE240.7, StE290.7, StE320.7, StE360.7 X42, X46, X52, X60
Boiler & pressure vessel steel	DIN 17155 NF A36-205 NF A36-207 BS 1501	St37.0/4, St44.0/4, ST52.0/4 H1, H11, 17Mn4, 19Mn5 A37 (CP, AP), A42 (CP, AP), A48 (CP, AP), A52 (CP, AP) A510 AP, A530 AP, A550 AP
Elevated temperature steel	DIN 17175 DIN 17102	151/154/161-Gr. 360/400/430, 164-Gr. 360/400 St.35.8, St.45.8
Fine grained steel	DIN 17102 NF A 36-203	St.E255 to St.E420 E275 D, E344D, E390D, E430D, E455D

3.01

All weld metal composition

C	Mn	Si
0.07 - 0.10	0.85 - 1.25	0.25 - 0.65

Typical mech. properties of weld metal

Tensile strength MPa	Yield strength MPa	Elongation %	Impact value ISO-V (J)	Recovery %
540	430	26	At -20°C = 110 At -40 °C = 65	165

Welding data

Diameter mm.	Current range, A	Arc time **/ electrode, sec.	Deposition rate** Kg/h	Electrodes per kg weld metal**	Fume class
4.0	170-240	70	3.7	14.4	4
5.0	225-355	72	5.7	9.6	4

* SDS available on request. ** 90% of max. amperage

Packaging data

Diameter mm.	Length mm.	Electrodes per box	Net weight, kg per box	Product No. per box	Boxes per carton
4.0	450	54	5.5	095-699298	3
5.0	450	36	5.5	095-699306	3

Re-drying temperature: 350 °C (662 °F) for two hours.

LHH-314 H

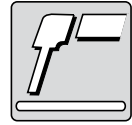

Unitor LHH-314 H is a high recovery electrode of zirconium-basic type for welding in the flat and horizontal-vertical position. It is specially suitable for horizontal-vertical and horizontal fillet welding.

LHH-314 H has a recovery value of approx. 165%, the coating containing approx. 65% iron powder.

During welding, the electrode should be pulled along the groove allowing the coating to be in contact with the base material.

The electrode can be used at a welding speed of up to 50 cm/min. when A-measurement (throath thickness) is 3.5 to 6 mm. When vertical fillet welding on heavier material, a large electrode diameter e.g. 5.0 mm. in relation to A-measurement can be used.

The electrode is suitable for welding materials which have zinc and iron oxide rust protective primer coatings. However, observe all necessary safety precautions concerning the fumes from the primer. Consult the chapter on welding fumes.

LHH-314 H is a typical electrode where large sections of steel are to be replaced but it is also useful for general repair work. The high welding speed, good welding properties, and high deposition rate reduce the risk of heat deformation and stress.

This electrode is recommended for welding flanges to tubes in the horizontal position.

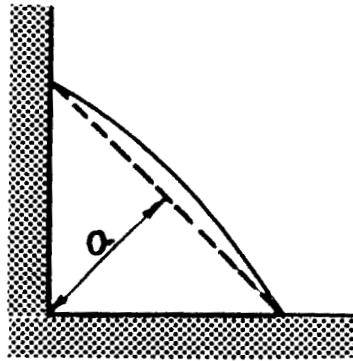
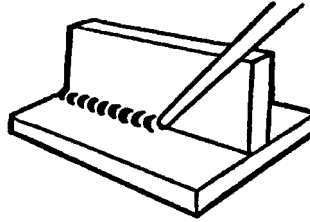

The A measurement should be 7/10 of material thickness.

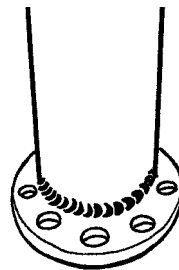

3.01

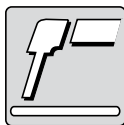

LHV-316 N

Vertical Down Welding Low Hydrogen Electrode for Ship Quality Steel



Imprint
Unitor LHV-316 N / 8018-G

Classifications

SFA/AWS A 5.5	EN-ISO 2560-A
E 8018-G	E 46 4 B 41 H5

Approvals

DNV	GL	LR	BV	ABS
3YH10	4YH10	4Y40H10	3YH10	3Y

Type of current



Welding positions

Materials to be welded

General structural steel	DIN 17100 NF A35-501 BS 4360	St33, St37-2 to St52-3 A33, A34-2, E24-2 (-4) to E36-2 (-4) Grade 43D, 50D Grade A, B, C, D, E, AH, DH, EH GS38, GS45, GS52 A1, A2, A3, AM1, AM2, AW1 StE210.7, StE240.7, StE290.7, StE320.7, StE360.7 X42, X46, X52, X60 St37.0/4, St44.0/4, ST52.0/4 H1, H11, 17Mn4, 19Mn5 A37 (CP, AP), A42 (CP, AP), A48 (CP, AP), A52 (CP, AP) A510 AP, A530 AP, A550 AP 151/154/161-Gr. 360/400/430, 164-Gr. 360/400 St.35.8, St.45.8 St.E255 to St.E420 E275 D, E355D, E390D, E430D, E455D
Ship plates	DIN 1681 BS3100	
Cast steel	DIN 17172 API 5 L X DIN 1626-1630	
Pipe material	DIN 17155 NF A36-205 NF A36-207 BS 1501	
Boiler & pressure vessel steel	DIN 17175 DIN 17102 NF A 36-203	
Elevated temperature steel		
Fine grained steel		

All weld metal composition

C	Mn	Si
0.06 - 0.09	1.00 - 1.40	0.3 - 0.7

Typical mech. properties of weld metal

Tensile strength MPa	Yield strength MPa	Elongation %	Impact value ISO-V (J)
570	470	27	At -20°C = 130 At -40°C = 100

Welding data

Diameter mm.	Current range, A	Arc time **/ electrode, sec.	Deposition rate** Kg/h	Electrodes per kg weld metal**	Fume class
3.2	110-150	53	1.6	43.7	2
4.0	180-220	50	2.8	27.0	2

* SDS available on request.

** 90% of max. amperage

Packaging data

Diameter mm.	Length mm.	Electrodes per box	Net weight, kg per box	Product No. per box	Boxes per carton
3.2	350	137	4.8	095-699314	3
4.0	350	99	5.0	095-699322	3

Re-drying temperature: 350 °C (662 °F) for two hours.

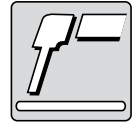

Unitor LHV-316 N is a heavily coated basic electrode for welding unalloyed, low alloy and some types of yield point controlled steel. It can be used in all positions. Its range of application covers hull plates, deckplates, and stressed or loaded parts such as frames, lifting lugs and electric motor baseplates.

LHV-316 N is specially developed for welding in the vertical-down position. When welding in this position the electrode should travel in a straight line and be kept in light contact with both sides of the groove. The electrode should be held at an angle of 40–85° to the direction of welding. The electrode can also be used for welding in the flat position and for overhead welding.

Unitor LHV-316 N produces a deposit with very good mechanical strength and high crack resistance. The slag from this electrode is very easily removed, even from narrow grooves.

LHV-316 N will weld any normal joint, e.g. V-grooves and fillets. It is often used for welding a root bead where LH-314 N is used for the subsequent build-up. This is an economical electrode, maximum welding current can be used also in vertical welding. This makes it possible to weld up to three times faster than normal.

There is little heat transfer to the base material when welding with LHV-316N and deformation and stress is therefore kept to a minimum.

The electrode must be protected against humidity and no attempt should be made to weld with damp electrodes. See the section on after-drying of basic electrodes.

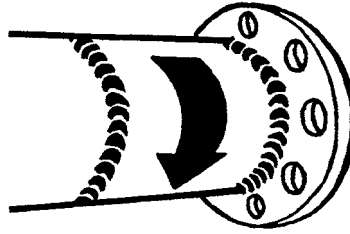

A short arc

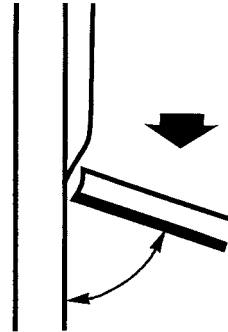

Joining deck and hull plates

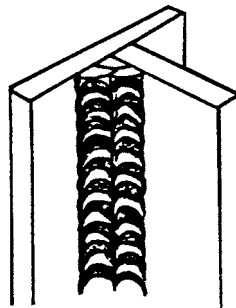

When a large weld cross-section is required, weld a bead on either side of the root bead as shown



LHT-318 N

Electrode for High Temperature Steel

Identification:

Imprint
Unitor LHT-318 N / 8018-B2



Classifications

SFA/AWS A 5.5	EN 1599
E 8018-B2	E CrMo 1B 42 H5

Approvals

DNV	GL	LR	BV	ABS
H 10	-	-	1% Cr 0,5% Mo, H5	SR

Type of current



Welding positions

Materials to be welded

Elevated temperature steel	DIN 17155 DIN 17200 NF A36-206	13CrMo44 25CrMo4 15CD2.05, 15C, D4.05
Case hardening steel	DIN 17210 NF A35-551	16MnCr5 18CD4, 16MnCr5, 20MnCr5
Q & T steel	NF A35-552	25CD4, 30CD4

Creep data:

Test temperature °C	400	450	500	550	600
Yield strength R _{0.2%} MPa	460	440	430	140	(80)
Creep strength R _{1/1000} MPa			300	110	(50)
Creep strength R _{1/10.000} MPa			350	80	(35)
Creep resistance R _{1/1.0%/10.000} MPa	250	170			

All weld metal composition

C	Mn	Si	P	S	Cr	Mo
0.05 - 0.10	0.30 - 0.80	0.20 - 0.50	max. 0.015	max. 0.020	1.25 - 1.45	0.50 - 0.65

Typical mech. properties * of weld metal

Tensile strength MPa	Yield strength MPa	Elongation %	Impact value ISO-V (J)
620	530	20	At -20°C = 38

* Stress relieved temp.: 700 °C, 1 hour

Welding data

Diameter mm.	Current range, A	Arc time **/ electrode, sec.	Deposition rate** Kg/h	Electrodes per kg weld metal**	Fume class
2.5	70-105	60	0.8	73	3
3.2	95-150	65	1.1	49	3

* SDS available on request.

** 90% of max. amperage

Packaging data

Diameter mm.	Length mm.	Electrodes per box	Net weight, kg per box	Product No. per box	Boxes per carton
2.5	350	75	1.7	095-699330	6
3.2	350	48	1.7	095-699348	6

Re-drying temperature: 350 °C (662 °F) for two hours.

LHT-318 N

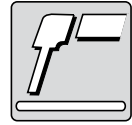

Unitor LHT-318 N is a heavily coated basic electrode for welding low alloy steel and cast steel with up to approx. 1% Chromium and 0.5% Molybdenum, used for working temperatures up to 550°C. Such type of steel is normally found in boilers, plates or pipes.

The basic coating is of extra moisture resistant type, but as for all basic electrodes, they should be protected against humidity. See section on afterdrying of basic electrodes.

For best results on Chromium alloyed materials thicker than 8–10 mm, pre-heating of the welding area to 200–250°C is recommended.

The electrodes may be used in all positions, with DC positive or negative polarity.

Vertical welding should be carried out upwards.

As for all basic electrodes the arc should be kept short.

For root pass in open joints DC negative polarity is preferable. For filling the joint use DC+ polarity.

Note that for root passes, TIG welding with Ichromo-216 may be an advantage.

V-groove with 60° angle is recommended for butt welding of ship plates up to 12 mm thickness. Root opening should be 1–2 mm, and nose thickness should be 0.5–1 mm.

In cases where stress relieving is demanded, the temperature should be between 620°C and 720°C. As a general rule the temperature should be maintained for 1 hour per inch plate thickness (30 minutes for 1/2" plate) to ensure full effect.



Electrode for heat resistant steels, e.g. boiler plate and boiler tubes

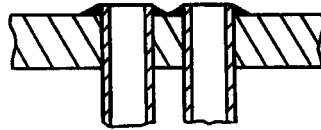

Boiler tubes welded to boiler tube plate

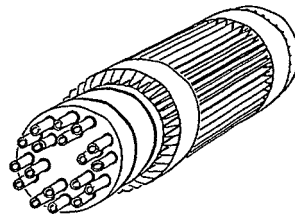

V-groove for plates up to 12 mm thickness:

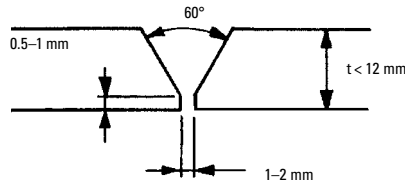

For $t > 12$ mm welding from both sides is recommended

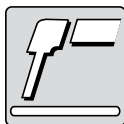

LHL-319 N

Electrode for Low Temperature Steel

Identification:

Imprint
Unitor LHL-319 N / 8018-C1



Classifications

SFA/AWS A 5.5	EN-ISO 2560-A
E 8018-C1	E 46 6 2 Ni B 32 H5

Approvals

DNV	GL	LR	BV	ABS
5YH10	6Y46H5	5Y42H5	5Y 40M H5	3Y400H5

Type of current



Welding positions

PA

PB

PC

PF

PE, PD

Materials to be welded

Pipe material
Boiler & pressure vessel steel (for low temp. applic.)

Fine grained steel

Low temperature steel

High strength steel

API 5 LX
NF A36-205
NF A36-207
BS 1501
DIN 17102
NF A36-203
DIN 17280
NF A36-208
NF A36-204

X52, X56, X60
A37FP, A42FP, A48FP, A52FP
A510FP, A530FP, A550FP
224-Gr. 490 to LT 60, 282
StE315 to StE460
E355D, E390D, E430D, E445D
11MnNi53, 13MnNi63, 14NiMn6, 10Ni14
1.5Ni 285/355 (15N6), 2.5Ni 285/355 (10N9)
E420T, E460T

Can also be used for welding CorTen steel and Mayari R steels.

3.01

All weld metal composition

C	Mn	Si	P	S	Ni
0.02 - 0.10	0.65 - 1.15	0.15 - 0.55	max. 0.020	max. 0.020	2.15 - 2.65

Typical mech. properties of weld metal

Tensile strength MPa	Yield strength MPa	Elongation %	Impact value ISO-V (J)
610	520	26	At -60°C = 105

Welding data

Diameter mm.	Current range, A	Arc time **/ electrode, sec.	Deposition rate** Kg/h	Electrodes per kg weld metal**	Fume class
2.5	70-110	55	0.9	70	2
3.2	105-150	63	1.4	42	3

* SDS available on request.

** 90% of max. amperage

Packaging data

Diameter mm.	Length mm.	Electrodes per box	Net weight, kg per box	Product No. per box	Boxes per carton
2.5	350	78	1.8	095-683631	6
3.2	350	48	1.8	095-683649	6

Re-drying temperature: 350 °C (662 °F) for two hours.

LHL-319 N

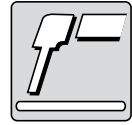

LHL-319 N is an all position basic electrode with 2.6% Nickel giving 115–120% recovery. The electrode is specially suited for low temperature applications. Low temperature steel containing Nickel is used more and more in processing equipment onboard ships carrying low temperature cargo. We also find this type of steel in Ice-Class hull plates.

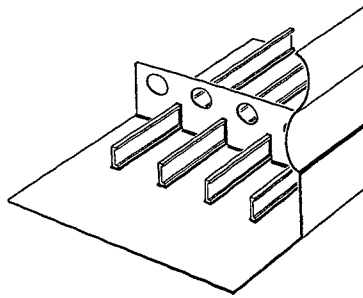

Excellent impact toughness at -60°C . Guide the electrode at a slight angle, with short arc. High notch values are obtained with max. weaving 2.5 times core wire diameter. High strength fine grained structural steel with thickness above 15 mm should be preheated to approx. 100°C (210°F). Interpass temperature max. 150°C (300°F). Store dry.

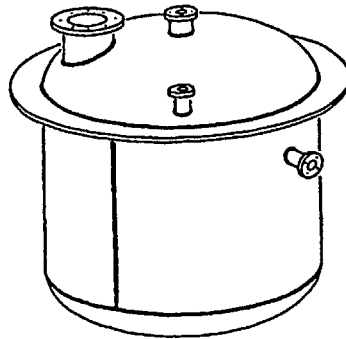

3.01

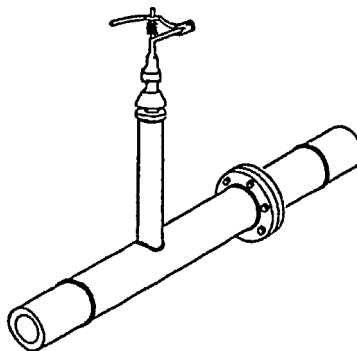

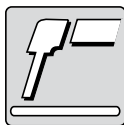

LHR-320 N



Electrode for Weathering Steel

Identification:

Imprint
Unitor LHR-320 N / 8018-G

Classifications

SFA/AWS A 5.5	EN-ISO 2560-A
E 8018-G	E 46 5 Z B 32

Approvals

DNV	GL	LR	BV	ABS
3YH10	3YH15	3YH15	3YH10	3YH5

Type of current



Welding positions



PA

PB

PC

PF

PE, PD

Materials to be welded

Pipe material
Boiler & pressure vessel steel (for low temp. applic.)

Fine grained steel

Low temperature steel

High strength steel

Weathering steel

API 5 LX
NF A36-205
NF A36-207
BS 1501
DIN 17102
NF A36-203
DIN 17280
NF A36-208
NF A36-204

Commercial names

X52, X56, X60
A37FP, A42FP, A48FP, A52FP
A510FP, A530FP, A550FP
224-Gr. 490 to LT 60, 282
StE315 to StE460
E355D, E390D, E430D, E445D
11MnNi53, 13MnNi63, 14NiMn6, 10Ni14
1.5Ni 285/355 (15N6), 2.5Ni 285/355 (10N9)
E420T, E460T

Patinax, Cor-ten A, Mayari R steels

3.01

All weld metal composition

C	Mn	Si	P, S	Ni	Cu
0.02 - 0.10	0.75 - 1.25	0.15 - 0.55	max. 0.020	0.50 - 0.90	0.30 - 0.50

Typical mech. properties of weld metal

Tensile strength MPa	Yield strength MPa	Elongation %	Impact value ISO-V (J)
590	500	27	At -20°C = 160 At -50°C = 70

Welding data

Diameter mm.	Current range, A	Arc time **/ electrode, sec.	Deposition rate** Kg/h	Electrodes per kg weld metal**	Fume class
2.5	80-115	59	0.9	66	2
3.2	100-150	70	1.3	40	2

* SDS available on request.

** 90% of max. amperage

Packaging data

Diameter mm.	Length mm.	Electrodes per box	Net weight, kg per box	Product No. per box	Boxes per carton
2.5	350	88	1.7	095-683656	6
3.2	350	48	1.8	095-699389	6

Re-drying temperature: 350 °C (662 °F) for two hours.

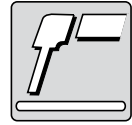

LHR-320 N is a NiCu-alloyed electrode, which deposits a weld metal with good corrosion resistance to sea-water and flue gases, for welding of weathering steel (Patinax steel, Cor-Ten A steel, Mayari R steel) and for ship hull construction steel.

The weld metal has excellent mechanical properties. It is particularly suitable for welding the shell plating of ice breakers and other ships, which work under conditions where the protective paint coating wears off.

Weathering steels are low-alloy steels that can be exposed to the weather without being painted. The steel protects itself by means of a dense oxide coating (patina) which forms naturally on the steel when it is exposed to the weather.

This tight oxide coating reduces continuing corrosion. The corrosion resistance of weathering steels is four to six times that of normal structural carbon steels, and two to three times that of many of the low-alloy structural steels.

The weathering steels are covered by the ASTM specification A242. These steels have a minimum yield strength of 350 Mpa (50,000 psi) with an ultimate tensile strength of 490 Mpa (70,000 psi).

To maintain the weather resistance characteristic of the steel, it is important to use an electrode with same chemical composition.

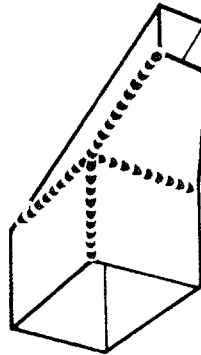
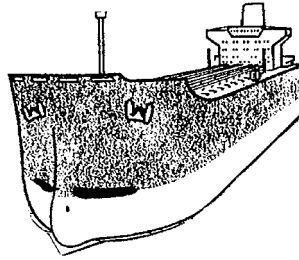

Flue gases corrosion

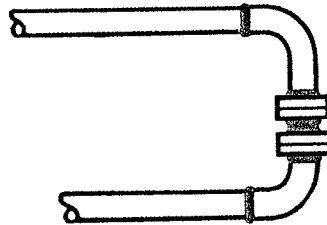

Sea water corrosion



TENSILE-328 N

Electrode for Difficult-to-Weld Steel



Identification:

Imprint
Unitor TENSILE-328 N / 312-17

Classifications

SFA/AWS A 5.4	EN-ISO 3581-A	EN 14 700
E 312-17	E 29 9 R 12	E Fe 11

Approvals

N.A.

Type of current



Welding positions

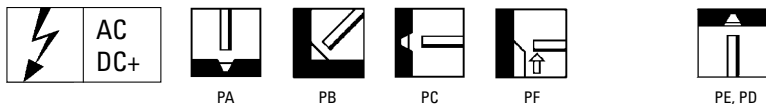

Materials to be welded

Various steel grades such as:

- Armour plate
- Hardenable steel including steels difficult to weld
- Non-magnetic austenitic manganese steel
- Work hardening austenitic manganese steel
- Dissimilar steel grades (CMn-steel to stainless steel)

3.01

All weld metal composition

C	Mn	Si	Cr	Ni
0.08 - 0.15	0.50 - 1.00	0.50 - 0.90	28.0 - 30.0	9.0 - 10.5

Typical mech. properties of weld metal

Tensile strength MPa	Yield strength MPa	Elongation %	Impact value ISO-V (J)
790	610	22	At +20°C = 30

Welding data

Diameter mm.	Current range, A	Arc time **/ electrode, sec.	Deposition rate** Kg/h	Electrodes per kg weld metal**	Fume class
2.5	50-85	48	0.9	78	6
3.2	80-125	65	1.3	42	7

* SDS available on request. ** 90% of max. amperage

Packaging data

Diameter mm.	Length mm.	Electrodes per box	Net weight, kg per box	Product No. per box	Boxes per carton
2.5	300	79	1.6	096-699470	6
3.2	350	50	2.0	096-699488	6

Re-drying temperature: 350 °C (662 °F) for two hours.

TENSILE-328 N

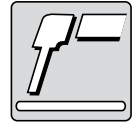

Unitor TENSILE-328 N is a rutile-acid high alloy electrode specially designed for use on steel types which are difficult to weld, e.g. spring steel, carbon steel, chrome-nickel, vanadium steel, highspeed steel, tool steel and manganese steel. These types of steel are commonly used in main engine rocker arms and push rods, pump shafts, gear wheels, etc.

This electrode can be used for joining as well as building up. It can also be used to form a primary buffer layer when building up a specially hard surface.

Before starting to weld, the welding area must be grinded and cleaned down to bare metal. Machined or threaded surfaces adjacent to the welding area must be protected from spatter and oxidation.

Power supply may be AC or DC positive polarity. Use a short arc and hold the electrode almost at right angles to the workpiece.

Preheating is not usually necessary. When welding machine parts it is advisable to keep heat transference as low as possible. This can be done by interrupting the welding operation to allow the workpiece to cool down before continuing.

Unitor TENSILE-328 N has excellent weldability and produces a deposit free from pores. The deposit may be filed, and may be polished to a high gloss finish. The slag is self-releasing.

Hardness as welded 200–300 HB, can workharden to approximately 450 HB.

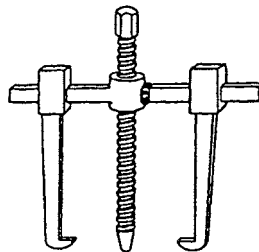
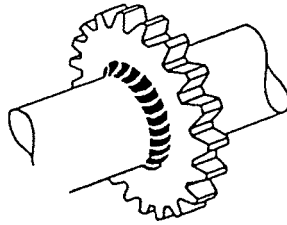
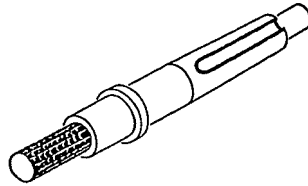
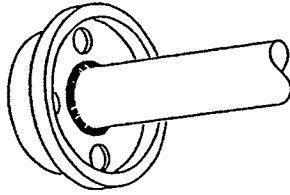

3.01



IMPACT-329 S

Electrode for Heat Resistant Overlays

Identification:

Imprint
Unitor IMPACT-329 S

Classifications

DIN 8555
E 20-UM-250-CRTZ



Approvals

N.A.

Type of current



Welding positions

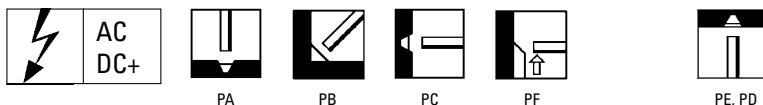

Materials to be welded

Main applications:

Rebuilding worn exhaust valves in combustion engines.

General applications: Wear resistant non-magnetic surface layers on most weldable steel surfaces, including cast steel, alloy steels and stainless steels, where following properties are required even at high working temperatures, up to 900°C:

- High "general" wear resistance
- High corrosion resistance
- High impact and pressure resistance
- High resistance against abrasion by metal to metal friction or cavitation

Application examples:

- Rocker arms
- Valve parts
- Pump parts
- Flapper gates
- Extrusion screws
- Stream through valves

All weld metal composition

Co	Cr	W	C	Ni	Fe	Mn	Si
Rest	20	15	0.1	10	2.0	1.0	0.8

Typical mech. properties of weld metal

Tensile strength MPa	Elongation %	Hardness as welded HB	Hardness after work hardening HB
850	25-30	250	440

Welding data

Diameter mm.	Current range, A	Arc time / electrode, sec.	Deposition rate Kg/h	Electrodes per kg weld metal	Fume class
3.2	70-120	66	1.36	40	7

* SDS available on request.

Packaging data

DDiameter mm.	Length mm.	Electrodes per box	Net weight, kg per box	Product No. per box	Boxes per carton
3.2	350	39	1.4	096-606460	6

Re-drying temperature: 250 °C (482 °F) for one hour.



1. Machine preparation

Align the spindle in a lathe and turn a suitably wide and deep groove in the hardened face to remove all stellite down to clean, pure base material

Make room for at least two layers of weld metal.

2. Weld preparation

Welding should as far as possible be carried out in the horizontal position. A suitable jig should be prepared, holding the spindle in a tilted position allowing it to be rotated.

Suggested jig for holding spindles.

3. Preheating

Preheat the valve head evenly to 50–200 °C and maintain during welding. Preheating temperature depending on type of alloy in valve.

4. Welding

Electrodes should be dried at 250 °C for 1 hour prior to use. The Unitor miniheater electrode quiver may be used for this. Keep the arc short and hold the electrode as near as possible to 90°C to the work piece.

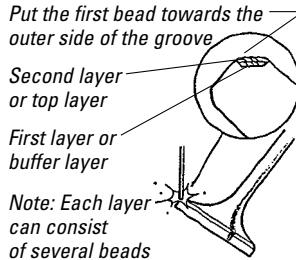

Welding with IMPACT-329 S does not require any other electrode. In order to minimise heat effects, the welding should be done in stages. Place the first bead towards the outer side of the groove, and do about one third of the circumference. Then start at the opposite side and do the second bead so it finishes where the first one started. Finally do the third, starting where the first one finished. For large diameter spindles the bead should be done in four parts.

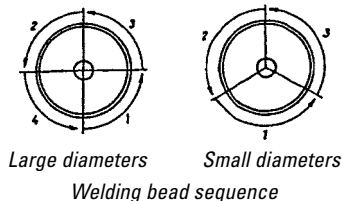

Grind the starting and stopping point of each bead. Also grind the bead itself to remove possible slag and spatter, in order to obtain a smooth transition between beads. Control the temperature adjacent to the welding zones and do not start the next bead until the base metal has regained the correct temperature.

5. Cooling

When the top layer is completed, the spindle should be immersed in insulating material or dry sand in order to ensure slow cooling.

6. Final machining

After cooling, machine to correct tolerances, use toolbit quality H1 or K10 with negative 4° cutting angle, low turning speed and fine feeding.

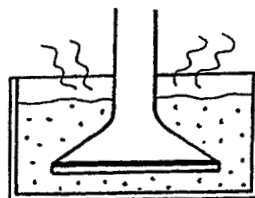

Ensure slow cooling.

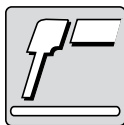

WEARMAX-327

Electrode for Joining & Wear Resistant Overlays

Identification:

Imprint
Unitor WEARMAX-327

Classifications

AWS A5.4
~ E 307-26



Approvals

N.A.

Type of current



Welding positions



PA



PB



PC



PF
(2.5mm only)



PE, PD

Materials to be welded

Repair of:

Worn winch wheels and anchor windlass wheels on anchoring systems. Cargo handling equipment and dredger equipment, T1-steel, N-A-Xtra steel, OXAR steel, Fine grain steel, Cr Mo steel, Manganese steel, Shear blades.

Trawler equipment subject to metal to earth wear and metal to metal wear. Suitable for both joining and making wear resistant overlays.

3.01

All weld metal composition

Fe	Cr	Ni	Mo	Mn	Si
Rest	16-20	7-10	1.3-2.3	5-7	1 (Max)

Typical mech. properties of weld metal

Tensile strength MPa	Yield strength MPa	Elongation %	Hardness as welded HB	Hardness after work hardening HB	Recovery %
650-700	480-530	30-40	190	415	150

Welding data

Diameter mm.	Current range, A	Arc time / electrode, sec.	Deposition rate Kg/h	Electrodes per kg weld metal	Fume class
2.5	75-140	80	0.9	48	6
3.2	90-170	103	1.2	31	6
4	120-240	105	1.8	21	7

* SDS available on request.

Packaging data

Diameter mm.	Length mm.	Electrodes per box	Net weight, kg per box	Product No. per box	Boxes per carton
2.5	350	49	1.6	095-606454	6
3.2	350	68	3.5	095-606455	3
4	350	42	3.4	095-606456	3

Re-drying temperature: 250 °C (482 °F) for one hour.

WEARMAX-327

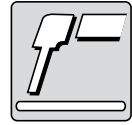

Unitor WEARMAX-327 is an electrode which produces a stainless deposit with excellent resistance against wear. The initial weld deposit is comparatively soft with high elongation. When subjected to grinding, machining or wear, the surface will harden to more than 400 HB providing a smooth hard and crack resistant layer with low coefficient of friction. This produces a surface, which despite being tough, does not cause wear on matching parts, like chain wires etc. The electrode is also designed to achieve high tensile strength and yield properties, making it an excellent electrode for joining dissimilar metals.

Areas of application:

Anchor winch wheels and guides, windlasses drums and rollers, cranes and track wheels, sprocket wheels.

Also used for joining Cr Mo steel, T1-steel, Manganese steel, N-A-Xtra steel, OXAR steel, HARDOX 400, fine grain steel and shear blades.

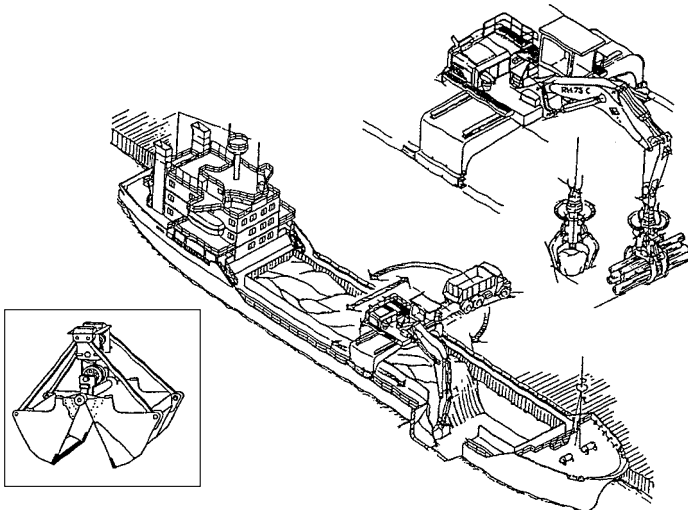
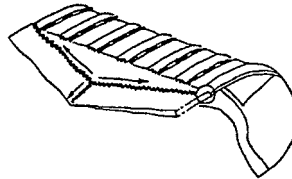
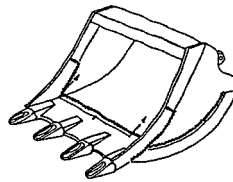
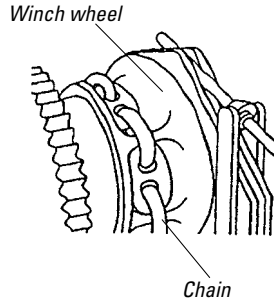

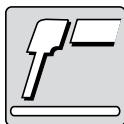

18/8-321 N

Electrode for Stainless Steel

Identification:

Imprint
Unitor 18/8-321 N / 316L-17



Classifications

SFA/AWS A5.4	EN-ISO 3581-A
E 316L-17	E 19 12 3 LR 12

Approvals

DNV	GL	LR	BV	ABS
316L	4571	316L	316L	E 316L 17

Type of current



Welding positions

Materials to be welded

Steel grades	BS 970 1554	DIN 17440/17445	W.Nr.	AFNOR NF A35-573/574/576/582	ASTM/ACI A240, A312, A351	SIS	UNS
Extra low carbon C<0.03%	316S11	X2CrNiMo17132	1.4404	Z2CND17.12	(TP) 316L CF-3M	2353	S31603 J92800
	316S13	X2CrNiMo18143 X2CrNiMoN17122 X2CrNiMoN17133	1.4435 1.4406 1.4429	Z2CND17.12 à l'N Z2CND17.13 à l'N	(TP) 316LN		S31653
Medium carbon C>0.03%	316S31	X5CrNiMo17122	1.4401	Z6CND17.11	316 (TP) 316	(2347)	S31600/ S30409 J92900
	316S33	X5CrNiMo17133	1.4436	Z6CND17.12		2343	
	316S33	G-X6CrNiMo1812	1.4437	Z6CND17.12	C (P) F-8M		
	316S33	G-X10CrNiMo189	1.4410				
Ti-Nb stabilized	316S33	G-X6CrNiMo1810	1.4408	Z6CND17.12	C (P) F-8M 316Ti	(2344)	J92900 S32100/ S31635
	320S31	G-X6CrNiMoTi17122	1.4571	Z6CNDT17.12			S34700/S34709 J92710
	347S31	X6CrNiNb1810	1.4550	Z6CNNb17.12	(TP) 347	2338	
	347S31	G-X5CrNiNb189	1.4552	Z6CNNb18.10	(TP) 347 CF-8C, CPF-8C	2338	

All weld metal composition

C	Mn	Si	Cr	Ni	Mo	FN
max. 0.030	0.5 - 1.2	max. 0.9	17.0 - 19.0	11.0 - 13.0	2.5 - 3.0	3-10

Typical mech. properties of weld metal

Tensile strength MPa	Yield strength MPa	Elongation %	Impact value ISO-V (J)
570	460	40	At +20°C = 60 At -20°C = 55

Welding data

Diameter mm.	Current range, A	Arc time **/ electrode, sec.	Deposition rate** Kg/h	Electrodes per kg weld metal**	Fume class
1.6	30-45	26	0.6	230	3
2.5	45-90	35	1.1	97	4
3.2	60-135	46	1.4	56	4

* SDS available on request. ** 90% of max. amperage

Packaging data

Diameter mm.	Length mm.	Electrodes per box	Net weight, kg per box	Product No. per box	Boxes per carton
1.6	300	213	1.7	095-699397	6
2.5	300	89	1.7	095-699405	6
3.2	350	54	1.7	095-699413	6

Re-drying temperature: 350 °C (662 °F) for two hours.

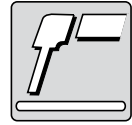

Unitor 18/8-321 N is a rutile basic type electrode for welding stainless and acid resistant steel containing 16–18% chromium, 10–14% nickel and 2–3% molybdenum.

It is suitable for all welding positions.

When welding tanks containing corrosive elements, it must be remembered that the final bead must be laid on the side exposed to corrosion, to prevent intercrystalline corrosion. The electrode will operate on AC or DC polarity. It is always preferable to use DC positive when welding stainless or acid-resistant steel.

Use a brush with stainless steel wire bristles when cleaning up the weld. If an ordinary wire brush is used, iron oxides will be deposited in scratches left by the brush, as this can lead to corrosion. The dark oxide deposit formed on either side of the bead should also be removed. Best result is obtained using Unitor Pickling Gel to remove discolouration and oxides after welding. For welding stainless/acid-resistant steel to low alloy steel, use Unitor electrode 23/14-322 N.

Welding:

1. Use a short arc. A long arc will increase arc tension, resulting in lower current output and poor fusion.
2. The electrode should be held almost at right angles to the work piece.
3. When terminating the weld, the electrode should be move in a circle over the molten pool and finally moved quickly backwards in the groove for a distance of approx. 10 mm. The formation of a pore containing high melt point slag in the middle of the crater is thereby avoided.

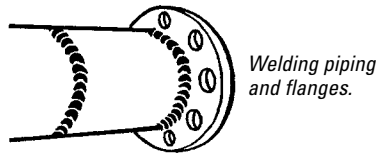
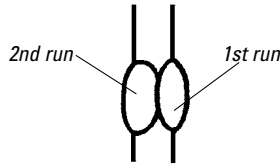

4. The electrode must be protected against humidity and welding with damp electrodes should not be attempted.

A stainless steel electrode should have the same alloy composition as the base material, but there are certain exceptions. An electrode of high alloy content may be used for welding material which has a slightly lower alloy content than the electrode.

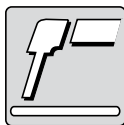

23/14-322 N

Electrode for Stainless Steel

Identification:

Imprint
Unitor 23/14-322 N / 309MoL-17



Classifications

SFA/AWS A5.4	EN-ISO 3581-A
E 309MoL-17	E 23 12 2 LR 32

Approvals

DNV	GL	LR	BV	ABS
309Mo	4459	SS/CMn	309Mo	SS/CMn

Type of current



Welding positions

PA

PB

PC

PF

PE, PD

Materials to be welded

Steel grades	BS 970	DIN 17440	W.Nr.	AFNOR	ASTM/ACI	SIS	UNS
First layer in CrNiMo-claddings	316S11	X2CrNiMo17132	1.4404	Z2CND17.12	(TP) 316L CF-3M	2353	S31603 J92800
	316S13	X2CrNiMo18143	1.4435	Z2CND17.12 à l'N	(TP) 316LN		S31653
		X2CrNiMoN17122	1.4406	Z2CND17.13 à l'N			
		X2CrNiMoN17133	1.4429	Z6CND17.12			
	316S31	X5CrNiMo17122	1.4401	Z6CND17.11	316 (TP) 316 (H)	(2347)	S31600/ S30409
	316S33	X5CrNiMo17133	1.4436	Z6CND17.12		2343	S31635/S32100
	320S31	X6CrNiMo17122	1.4571	Z6CNDT17.12	316Ti	(2344)	S31635
		X10CrNiMoTi1812	1.4573	Z6CNDT17.12	316Ti		S31640
		X6CrNiMoNb17122	1.4580	Z6CND17.12	C (P) F-8M		S31640
		X10CrNiMoNb1812	1.4583	Z6CNDNb17.13	316Cb		S31640

- Welding dissimilar metals: mild steel or low alloyed steel to stainless CrNiMo-steel up to max. thickness of 12 mm.
- Build up stainless overlays on mild or low alloyed steel.

All weld metal composition

C	Mn	Si	Cr	Ni	Mo	FN
max. 0.030	0.50 - 1.20	0.50 - 0.90	22.0 - 24.0	12.0 - 14.0	2.5 - 3.0	12-22

Typical mech. properties of weld metal

Tensile strength MPa	Yield strength MPa	Elongation %	Impact value ISO-V (J)
610	510	32	At +20°C = 50

Welding data

Diameter mm.	Current range, A	Arc time **/ electrode, sec.	Deposition rate** Kg/h	Electrodes per kg weld metal**	Fume class
2.5	50-90	36	1.2	81	4
3.2	90-120	53	1.7	43	5
4.0	85-180	56	2.5	28	6

* SDS available on request. ** 90% of max. amperage

Packaging data

Diameter mm.	Length mm.	Electrodes per box	Net weight, kg per box	Product No. per box	Boxes per carton
2.5	300	84	1.7	095-699421	6
3.2	350	50	2.0	095-699439	6
4.0	350	35	2.0	095-699447	6

Re-drying temperature: 350 °C (662 °F) for two hours.

23/14-322 N

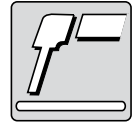

Unitor 23/14-322 N is a rutile-basic high alloyed electrode for welding stainless and acid-resistant steel.

It is specially designed for welding stainless compound steel, and as will be seen from the sketch, the unalloyed steel side is welded first using an unalloyed steel electrode, followed by 23/14-322 N on the stainless side.

A certain amount of mixing with the unalloyed steel is unavoidable and the electrode is therefore over-alloyed to ensure that the weld will remain stainless.

For this reason, 23/14-322 N can also be used for welding unalloyed steel to stainless steel. This combination should preferably be avoided, but providing an over-alloyed electrode is used the weld will remain stainless.

23/14-322 N provides a weld with good mechanical properties and high crack-resistance. It is suitable for all welding positions and can be used with AC or DC positive polarity.

The electrode may also be used for building up a stainless steel surface on ordinary steel.

The same rules as for 18/8-321 N apply with regard to cleaning up the weld.

Best result is obtained using Unitor Pickling Gel to remove discolouration and oxides after welding.

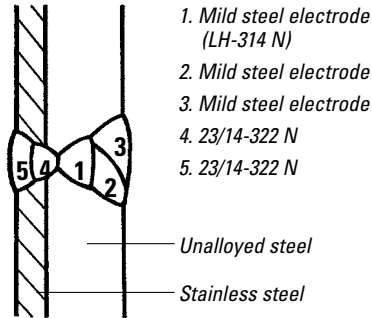

Procedure to be followed when welding compound steel.

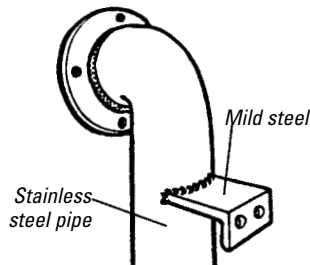

Welding mild steel to stainless steel.

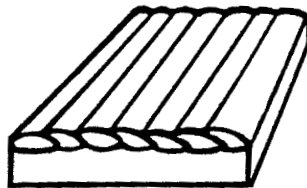



DUPLEX-325 N

Electrode for Duplex Steel

Identification:

Imprint
Unitor DUPLEX-325 N / 2209-17



Classifications

SFA/AWS A5.4	EN-ISO 3581-A
E 2209-17	E 22 9 3 N L R 32

Approvals

DNV	GL	LR	BV	ABS
DUPLEX	4462	-	2209	DUPLEX

Type of current



Welding positions

Materials to be welded

Duplex – stainless steel	EN 10088-11-2	X2CrNiMoN 22 53 X3CrNiMoN 27 52 X2CrNiN 23 4
	W. Nr.	1.4462 1.4417 1.4460 1.4362
	AFNOR	Z2 CN 22,5 á f'N
	ASTM/ACI	2205
	SIS	S 2377
	UNS	S 31803 S 31500 S 31200 S 32304

Can also be used for welding dissimilar materials: Unalloyed and low alloyed steels to Duplex stainless steel. Stainless steel to Duplex steels.

3.01

All weld metal composition

C	Mn	Si	Cr	Ni	Mo	FN
max. 0.030	0.50 - 1.20	0.50 - 0.90	21.5 - 23.0	8.5 - 10.5	2.7 - 3.3	25 - 40

Typical mech. properties of weld metal

Tensile strength MPa	Yield strength MPa	Elongation %	Impact value ISO-V (J)
820	660	25	At +20°C = 50

Welding data

Diameter mm.	Current range, A	Arc time **/ electrode, sec.	Deposition rate** Kg/h	Electrodes per kg weld metal**	Fume class
2.5	50-90	38	1.0	91	4
3.2	80-120	55	1.4	47	5

* SDS available on request.

** 90% of max. amperage

Packaging data

Diameter mm.	Length mm.	Electrodes per box	Net weight, kg per box	Product No. per box	Boxes per carton
2.5	300	91	1.7	095-699454	6
3.2	350	55	2.0	095-699462	6

Re-drying temperature: 350 °C (662 °F) for two hours.

DUPLEX-325 N



Unitor DUPLEX-325 N is a rutile basic type electrode for welding of Duplex stainless steel used in tanks, cargo loading pipes, heating coils and ladders.

Duplex stainless steel consists of two phases; austenite and ferrite, both about 50%. The combination of these two in one structure, results in a very high yield and tensile strength as well as an excellent protection against chloride-induced stress, corrosion and pitting.

DUPLEX-325 N can also be used for joining Duplex steel to mild steel, Duplex to stainless and stainless to mild steel.

It has high resistance to general corrosion and pitting corrosion. Applicable up to service temperatures of 250°C. Use a short arc. A long arc will increase arc tension, resulting in lower current output and poor fusion.

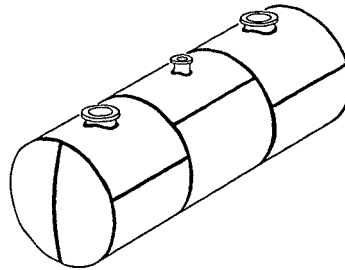
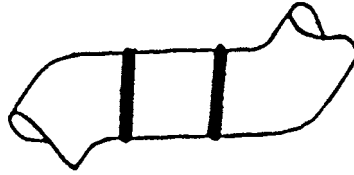

Best result is obtained using Unitor Pickling Gel to remove discolouration and oxides after welding.

3.01

Name	Material
1. Hull.	Mild steel.
2. Hull (Section weld).	Mild steel.
3. Stiffeners to hull.	Mild steel.
4. Stiffeners to bulkhead panel.	Mild to Duplex. Stainless steel.
5. Tanktop.	Duplex stainless steel.
6a. Bulkhead panel. (Section weld).	Duplex stainless steel.
b. Bulkhead to corrugated bulkhead panel.	Duplex stainless steel.
7. Bulkhead panel to tanktop + corrugated bulkhead panel to tanktop.	Duplex stainless steel.
8. Tanktop.	Duplex stainless to mild steel.

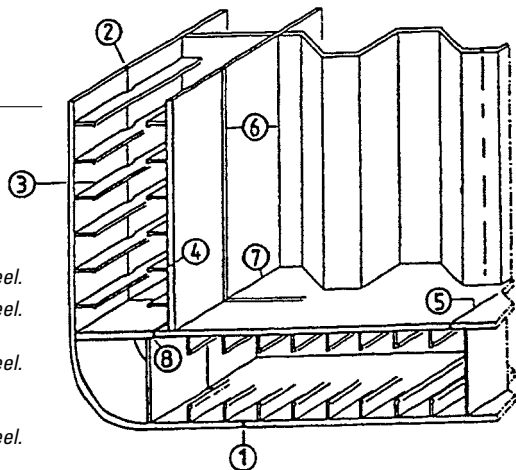

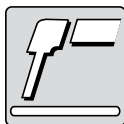

PICKLING GEL

Pickling Gel for Stainless Steel

Identification:

Packaging type	Product consistency and colour
White HD-polyethylene plastic container (approval according to UN- recommendation)	White gel

Classifications

ASTM A-380 A1	BS CP-312
---------------	-----------

Shelf life

13 months when stored in unopened original containers at 20°C.

Storage

Container should be stored indoors at 20°C. They should be kept in an upright position with the lids tightly closed. The storage area should be clearly defined and beyond the access of unauthorised persons. Pickling chemicals are sensitive to high temperatures.

Caution: Storage temperatures higher than 45°C must be avoided since they accelerate the ageing process and destroy the product. Pickling chemicals give best result when they are fresh.

Application data

Stir the gel to a smooth consistency. Spread a thick layer on to the work surface using the brush supplied. Allow the gel to remain for 50-90 minutes. Rinse off the remaining gel using fresh water. The waste water, after rinsing, contains acids and heavy metals, and must hence be treated according to local wastewater requirements before discharge. This can be done with neutralising agent or slaked lime. The waste water treatment should adjust the pH value of the clear water, pH 6,5-10, and precipitate heavy metals into a sludge which should be sent for waste disposal. Recommended temperature limits for application: 10°C - 40°C.

NB. Do not pickle in direct sunlight.

Chemical composition Vol. %

Hydrofluoric acid (HF)	Nitric Acid HNO ₃	Binder
0,5-5	8-20	Rest

pH: 0

Flamable: No

Do not contain chloride containing agents such as hydrochloric acid (HCL)

Packaging data

Container Content	Net Weight per container	Product No. per container	Containers per carton
2 litre	2,5 kg	095-661778	4 including 4 brushes

Protective clothing

Users should wear rubber boots, protective gloves, rubber apron and face visor.

SDS available on request.



PICKLING GEL

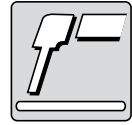

During welding of stainless steel the weld and the adjacent area to the weld will become exposed to the air at elevated temperature. The result will be oxidation ranging from light tinting to a blue and black scale. A corresponding chromium depletion in the metal below the oxide also occurs. If this is not removed, corrosion will be the result. Unitor Pickling Gel is used to remove this oxides and the underlying chromium depleted layer. It also removes surface micro slag particles and other contaminates which may cause local corrosion. Pickling restores completely the materials corrosion resistance.

Application

Pickling products are hazardous substances that must be handled with care. The pickling area should be ventilated. Users should wear protective gloves and face visor. Ref.: Safety Data Sheet.

1. Pretreat oxides; slag and weld defects mechanically, preferably when the welds are still warm and the weld oxides less hard.
2. Give the area to be pickled time to cool down to below 40°C after welding.
3. Organic contaminants such as grease, oil and paint have to be removed.
4. Stir the gel to a smooth consistency and spread a thick layer on to the work piece using the brush supplied.
5. The work piece should be cold when the gel is applied, although the air temperature must not be below + 5°C (41°F). Do not pickle in direct sunlight.
6. The gel should be allowed to remain for at least 50 minutes. For Mo-alloyed steels this time should be extended. If necessary the gel may be allowed to remain on the work piece over night as there is no risk for corrosion.
7. After appropriate time, rinse off the reminding gel using fresh water. If necessary brush the weld with a stainless steel wire brush.

8. Pickling residuals and rinse water should be neutralised to pH-7 i.e. with Neutralising Agent, and then rinsed with water. For the deposit of heavy metals, local water pollution control regulations should be consulted
9. The bottles must be stored in an upright position with the lid tightly closed. Storing temperature 20°C. Storage temperature higher than 45°C must be avoided since this accelerate the ageing process.

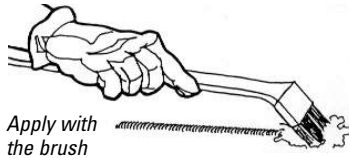
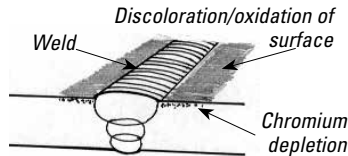

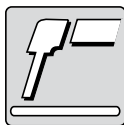

NIFE-334 N

Nickel Iron Electrode for Cast Iron



Imprint
Unitor NIFE-334 N / NiFe-C1

Classifications

SFA/AWS A5.15	EN-ISO 1071
E NiFe-CL-A	E NiFe-CL-A1

Approvals

N.A.

Type of current



Welding positions



PA

PB

PC

PF

PG

PE, PD

Materials to be welded

For welding and repair

DIN 1691

G G 10
G G 15
G G 20
G G 25
G G 30
G G 35

DIN 1692

GTS-35-10
GTS-45-06
GTS-55-4
GTW-35-04
GTW-40-05
GTW-45-07
GTW-S 38-12

DIN 1693

G GG-40
G GG-50
G GG-60

3.01

All weld metal composition

Ni	Fe	C
47.0 - 56.0	42.0 - 48.0	1.4 - 2.0

Typical mech. properties of weld metal

Tensile strength MPa	Yield strength MPa	Elongation %	Hardness HB
375	300	12	180

Welding data

Diameter mm.	Current range, A	Arc time **/ electrode, sec.	Deposition rate** Kg/h	Electrodes per kg weld metal**	Fume class
3.2	75-100	90	0.9	45	2
4.0	85-160	70	1.8	30	3

* SDS available on request.

** 90% of max. amperage

Packaging data

Diameter mm.	Length mm.	Electrodes per box	Net weight, kg per box	Product No. per box	Boxes per carton
3.2	350	68	2.2	096-699512	6
4.0	350	51	2.4	096-699520	6

Re-drying temperature: 200 °C (392 °F) for two hours.

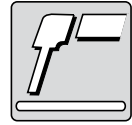

The Unitor NIFE-334 N electrode has been specially developed for cold welding of different types of cast iron especially nodular cast iron, malleable cast iron and grey cast iron.

The cold welding process is normally used on large, complicated cast iron parts where the use of heat would involve considerable risk of transverse fractures. In the cold welding process, the heat transfer to the base material is kept to a minimum by welding only very short beads (2–3 cm) at a time, the bead being peened and allowed to cool before welding the next bead. Smaller parts may be hot welded i.e. preheated to approx. 500°C and continuously welded. The weld metal is easily machineable.

Prepare the damage area in the following manner:

- Use crack detector to find the end of the crack fracture.
- Drill a hole at the end of the crack, using a 3 mm drill, to prevent further fracturing during welding.

The same welding procedure applies as for Nickel-333 N.

When welding oily cast iron, Unitor electrode CH-2-382 should be used to prepare the grooves. This is a special electrode for gouging without the use of oxygen. As well as forming a suitable welding groove, this process also burns out the oil contained in the carbon flakes, which are present in all types of cast iron. If the oil is not burnt off, it will have a tendency to surface during welding and form pores in the deposit.

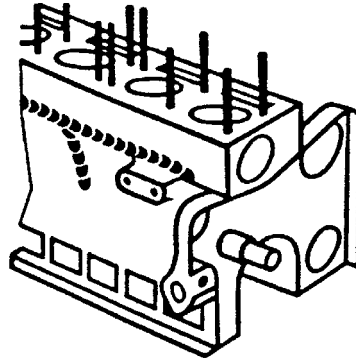

Large complicated parts should be cold welded.



*Smaller parts, free to expand, may be hot welded.
NB: Allow to cool off slowly.*



A crack in cast iron. The carbon flakes in the metal are saturated with oil.



After gouging with Unitor CH-2. The oily deposits in the welding area have evaporated.



NICKEL-333 N

Nickel Electrode for Cast Iron

Identification:

Imprint
Unitor NICKEL-333 N / Ni-C1



Classifications

SFA/AWS A5.15	EN-ISO 1071
E Ni-CL	E Ni-CL3

Approvals

N.A.

Type of current



Welding positions



PA

PB

PC

PF

PG

PE, PD

Materials to be welded

For welding and repair

DIN 1691

G G 10
G G 15
G G 20
G G 25
G G 30
G G 35

DIN 1692

GTS-35-10
GTS-45-06
GTS-55-4
GTW-35-04
GTW-40-05
GTW-45-07
GTW-S 38-12

DIN 1693

G GG-40
G GG-50
G GG-60

3.01

All weld metal composition

Ni	Fe	C
92.0 - 95.0	3.0 - 5.0	0.8 - 1.6

Typical mech. properties of weld metal

Tensile strength MPa	Yield strength MPa	Elongation %	Hardness HB
300	100	12	150

Welding data

Diameter mm.	Current range, A	Arc time **/ electrode, sec.	Deposition rate** Kg/h	Electrodes per kg weld metal**	Fume class
2.5	55-110	50	0.8	90	2
3.2	80-140	65	1.2	45	2

* SDS available on request.

** 90% of max. amperage

Packaging data

Diameter mm.	Length mm.	Electrodes per box	Net weight, kg per box	Product No. per box	Boxes per carton
2.5	300	121	2.0	096-699496	6
3.2	350	68	2.2	096-699504	6

Re-drying temperature: 80 °C (176 °F) for two hours.

NICKEL-333 N



Unitor NICKEL-333 N is a special electrode for cold welding of oily cast iron.

Prepare the damaged area in the following manner:

Use a crack detector to determine the actual length of the crack or fracture.

Drill a hole at the end of the crack, using a 3 mm drill, to prevent further fracturing during welding.

AC or DC negative or positive polarity may be used. Use a fairly short arc. Hold the electrode almost at a right angle to the work and weld in short beads of 2–3 cm at a time. When a bead is completed, it must be peened to counteract shrinkage. Start from the crater and work backwards to the starting point.

Allow the weld to cool before continuing. A general rule is that the welding area should be hand warm before welding the next bead of 2–3 cm (cold welding).

When repairing a crack which has not split the workpiece into two separate parts, always weld from the outer ends of the crack and inwards.

The thickness of the material is the deciding factor in choosing between NICKEL-333 N or NIFE-334 N. NICKEL-333 N is for use on thinner materials, or as a first bead on oily cast iron, to be followed by beads welded with NIFE-334 N. NIFE-334 N is used for multibead welding on heavy gauge materials.

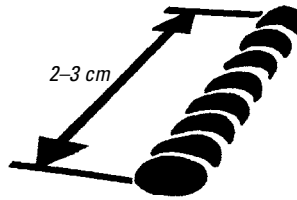

Weld in short beads.

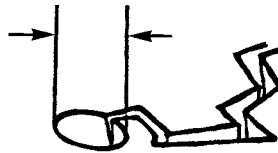

Drill a 3 mm hole at the end of the crack.

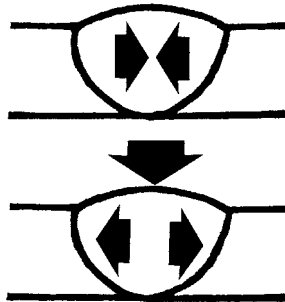

After welding, the bead's tendency to shrink can cause cracking. Peening the bead counteracts the shrinkage forces.

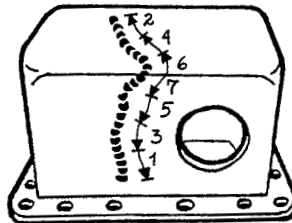

Start welding at the end of the crack and work inwards.



TINBRO-341

Electrode for Copper Alloys

Identification:

Imprint
Unitor TINBRO-341



Classifications

AWS A5.6	DIN 8555
~ E Cu SnC	E 30-UM-150-C

Approvals

N.A.

Type of current



Welding positions

PA

PB

PC

PF

PE, PD

Materials to be welded

Copper and copper alloys i.e.:

Brass
Bronze
Tin-Bronze
Leaded Gun-metal
Steel
Castiron
Seawater resistant deposit

3.01

All weld metal composition

Cu	Sn	Mn
Rest	7.5-9.5	1

Typical mech. properties of weld metal

Tensile strength MPa	Yield strength MPa	Elongation %	Hardness HB	Recovery %
350-400	220-260	15-25	100-150	103

Welding data

Diameter mm.	Current range, A	Arc time / electrode, sec.	Deposition rate Kg/h	Electrodes per kg weld metal	Fume class
3.2	70-90	63	1.33	43	6

* SDS available on request.

Packaging data

Diameter mm.	Length mm.	Electrodes per box	Net weight, kg per box	Product No. per box	Boxes per carton
3.2	350	42	1.4	096-606458	6

Re-drying temperature: 200 °C (392 °F) for one hour.

TINBRO-341



Unitor TINBRO-341 is a tin-bronze electrode for DC welding, positive polarity.

Areas of application include joining of brass and tin-bronze as well as joining these to steel and cast iron.

Clean the welding area thoroughly to remove any oily deposits, oxidation, etc. Machine or grind off fatigued material. When making joints, a 3 mm gap should be used. When material thickness is more than 4 mm, make an 80° welding groove with V or X profile.

It is recommended that larger copper alloy parts should be pre-heated to 300–500°C. This will facilitate welding, and welding current can be reduced.

Use a short arc and hold the electrode almost at right angles to the work. On parts requiring thin surfacing, weave the electrode from side to side, covering an area of up to three times the electrode diameter.

Parts not be overheated, or where minimum fusion with the base material is required, welding should be carried out at 80–110 Amps.

The electrodes must be stored in a dry place and must be handled carefully to avoid damage of the coating.

TINBRO-341 is not recommended for welding Yorcalbro (aluminium-brass) or Cunifer (copper-nickel, cupro-nickel). For welding these materials, the following processes should be used:

Yorcalbro

For dimensions up to approx. 4", braze with AG-60 and Albro Flux 263 PF. For larger dimensions, use TIG welding with Ialbro 237 MF.

Cunifer

Small parts should be brazed with AG-60 and AG-60/45 Flux-252 PF. Larger dimensions should be TIG welded with Icuni 30 329.

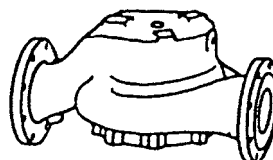
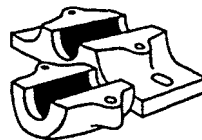
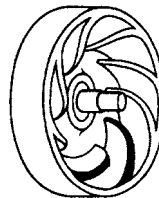
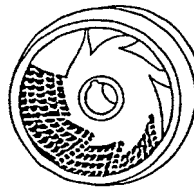
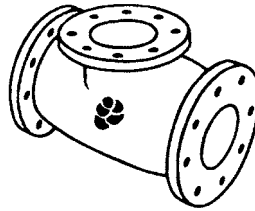

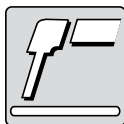

ALBRONZE-344

Electrode for Copper Alloys

Identification:

Imprint
Unitor ALBRONZE-344



Classifications

AWS A5.6	DIN 8555
~ E Cu Al A2	E 31-UM-150-C

Approvals

N.A.

Type of current



Welding positions



PA

PB

PC

PF

PE, PD

Materials to be welded

Copper and copper alloys i.e.:

Bronze
Aluminium bronze
Steel
Cast iron
Seawater resistant deposit

3.01

All weld metal composition

Cu	Al	Mn	Fe
Rest	7	1.2	2.8

Typical mech. properties of weld metal

Tensile strength MPa	Yield strength MPa	Elongation %	Hardness HB	Recovery %
550	350	10	140-170	103

Welding data

Diameter mm.	Current range, A	Arc time / electrode, sec.	Deposition rate Kg/h	Electrodes per kg weld metal	Fume class
3.2	80-160	81	0.92	48	6

* SDS available on request.

Packaging data

Diameter mm.	Length mm.	Electrodes per box	Net weight, kg per box	Product No. per box	Boxes per carton
3.2	350	46	1.3	096-606457	6

Re-drying temperature: 250 °C (482 °F) for one hour.

ALBRONZE-344

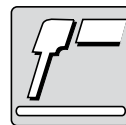

Unitor ALBRONZE-344 is a bronze electrode made specially for joining and cladding of bronze alloys as well as for joining these metals to steel and cast iron. It is also used for welding gliding surface overlays on steel.

The welded deposit has high strength properties and good resistance against cavitation wear and corrosion in seawater. The deposit has low coefficient of friction and excellent weldability.

Applications include ships' propellers, pumps, pump parts, bearing shells, condensers, valves and turbine blades.

Clean the welding area thoroughly and remove all oxidation. Machine or grind off fatigued metal. Make a suitable welding groove using a 60–90° angle. The groove can be formed by grinding.

Pre-heating is normally not required but it may be necessary to pre-heat large workpieces up to 150°C. The temperature must not exceed 200°C during welding. When surfacing steel parts, AC or DC positive polarity may be used. The pre-heating requirement will depend on the size and type of the base material.

Use a short arc. Hold the electrode almost at right angles to the workpiece and use a weaving movement. The length of each stroke should not exceed three times the electrode diameter. Remove the slag from the bead with chipping hammer and wire brush before starting on the next bead. Cast cupro-aluminium parts and similar materials must be annealed after welding by heating the welding area to 650°C. The workpiece must then be allowed to cool down slowly to below 500°C to ensure that the metal does not lose any of its properties.

Unitor ALBRONZE-344 is not recommended for welding Yorcalbro and Cunifer pipes.

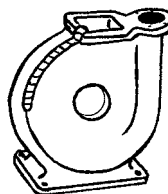
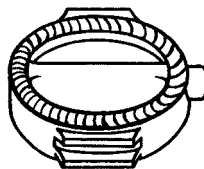
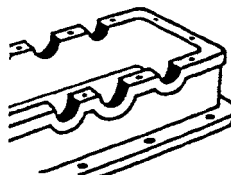
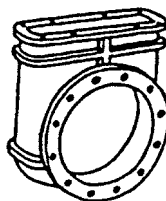
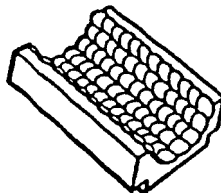

3.01

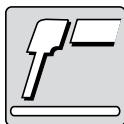

ALUMIN-351 N

Electrode for Aluminium

Identification:

Imprint
Unitor ALUMIN-351 N

Classifications

EN-ISO 18273
EL-AISi12



Approvals

N.A.

Type of current



Welding positions

PA

PB

PC

PF

Materials to be welded

For welding forged and cast aluminium alloy containing more than 7% Si as main alloying element.

G-Al Si 5 Mg (3.2341)
 G-Al Si 10 Mg (3.2381)
 G-Al Si 10 Mg (Cu) (3.2381)
 G-Al Si 12 (3.2581)
 G-Al Si 12 (Cu) (3.2583)
 G-Al Si 11
 G-Al Si 9 Mg
 G-Al Si 9 Cu 3
 G-Al Si 7 Mg
 G-Al Si 6 Cu 4

Also applicable as surfacing electrode.

3.01

All weld metal composition

Al	Si	Fe
86.0 - 89.0	11.0 - 13.5	max. 0.8

Typical mech. properties of weld metal

Tensile strength MPa	Yield strength MPa	Elongation %	Impact value ISO-V (J)
160		13	

Welding data

Diameter mm.	Current range, A	Arc time **/ electrode, sec.	Deposition rate** Kg/h	Electrodes per kg weld metal**	Fume class
3.2	70-120	32	0.7	164	3

* SDS available on request.

** 90% of max. amperage

Packaging data

Diameter mm.	Length mm.	Electrodes per box	Net weight, kg per box	Product No. per box	Boxes per carton
3.2	350	71	1.0	096-699538*	6

Re-drying temperature: 80 °C for 1 hour.

ALUMIN-351 N

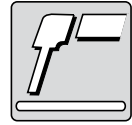

Unitor ALUMIN-351 N is used for joining and building up aluminium parts with a thickness of more than 2 mm sheets, sections, tubes, pistons, castings (covers), gangways, etc. When welding materials more than 3 mm thick, a 60° V-groove and an air gap of 1–3 mm should be used.

Grooves and the surrounding area must be thoroughly cleaned. Thin parts should be backed up before welding.

Use DC, positive polarity setting.

Large parts or castings should be pre-heated to approx. 300°C. Hold the electrode almost vertically the workpiece, the tip at a slight angle to the weld direction. It is preferable to weld in the flat position. Use as short arc as possible and weld rapidly. If welding is interrupted, remove the slag and overlap the end of the bead by about 1 cm when re-striking.

All slag must be cleaned off the finished weld with brush and water.

Aluminium electrodes absorb moisture very easily and must be stored in a dry, preferably moisture-controlled, place.

Aluminium or magnesium?

It may be difficult to determine whether a part is aluminium or magnesium. Magnesium parts must not be welded (magnesium bomb!). Use the following test to determine whether a part is aluminium or magnesium:

File a few shavings onto a small piece of paper. Hold the paper over a flame. If the filings spark or seem to explode in the flame, the material is magnesium. If there are only a few sparks here and there, and most of the filings just glow, the material is aluminium alloyed with magnesium, and may be welded.

NB. When welding with Aluminium electrodes: Arrange suitable ventilation or use Fresh Air kit mounted in face shield.

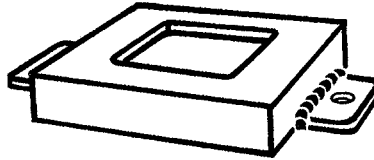

Cover plate ears welded back on

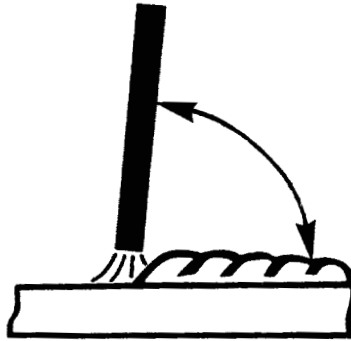

Hold the electrode almost at right angles to the workpiece, or at a slight angle to the weld direction

Note: Use the shortest possible arc.

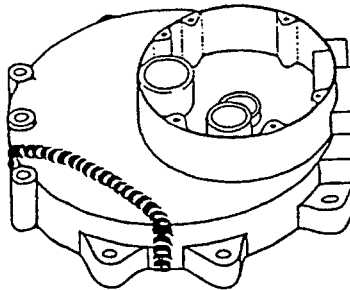

Joining a cast aluminium cover. Such parts should be pre-heated to approx. 300°C if possible



CH-2-382

Electrode for Chamfering

Identification:

Imprint
Unitor CH-2-382



Classifications N.A.

Approvals N.A.

Type of current



Welding positions



PA



PB



PC



PG



PE, PD

Materials to be chamfered

Steel/Cast steel
Stainless steel/Cast stainless steel
Cast iron
Copper/Copper alloys
Aluminium/Aluminium alloys

All weld metal composition N.A.

Typical mech. properties of weld metal N.A.

3.01

Welding data

Diameter mm.	Current range, A	Arc time / electrode, sec.	Deposition rate Kg/h	Electrodes per kg weld metal	Fume class
3.2	160–280	57	–	–	7

* SDS available on request.

Packaging data

Diameter mm.	Length mm.	Electrodes per box	Net weight, kg per box	Product No. per box	Boxes per carton
3.2	350	36	1.4	096-606459	6

Re-drying temperature: 120 °C (248 °F) for one hour.

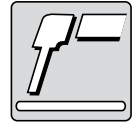

Gouging Technique

1. Hold the electrode vertically and press lightly against the workpiece. The arc will strike after a few seconds.
2. Hold the electrode at an angle of 15–20° to the workpiece.
3. Direction of travel.
4. **Warning!**
Do not cut down into the workpiece. Should this happen inadvertently, move the electrode back and lower to correct angle.
5. Work downwards when cutting into a vertical surface, otherwise as shown in figures 1–3.
6. If a deeper groove is required, proceed as in this sketch.

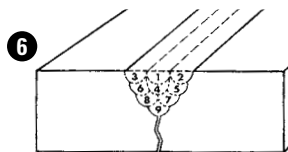
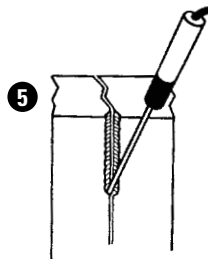
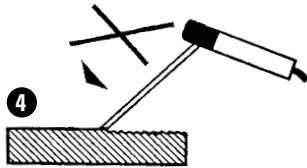
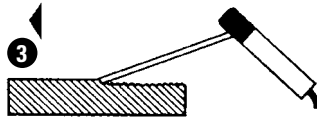
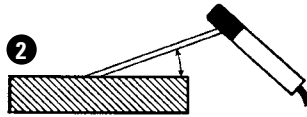
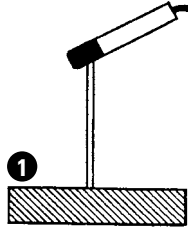



ACA-384

Electrode for Air Carbon Arc Gouging

Identification:

Copper coating over black carbon



Classifications N.A.

Approvals N.A.

Type of current



Welding positions

PA

PB

PC

PG

PE, PD

Materials to be gouged

Gouging and cutting of all electrically conductive materials. Can be used to groove, gouge, cut, bevel or pierce any material.

All weld metal composition N.A.

Metal removal capacity

Diameter mm.	Approx. kg/electrode
6.3	0.27
8.0	0.37
15 x 5	0.61

Welding data

Diameter mm.	Current range, Amps.	Air pressure (bar) (Consumption 400–900 l/min)	Fume class
6.3	200–350	At electrode holder 6–9 (80 psi)	7
8.0	200–450	At electrode holder 6–9 (80 psi)	7
15 x 5	400–600	At electrode holder 6–9 (80 psi)	7

* SDS available on request.

Packaging data

Diameter mm.	Length mm.	Electrodes per box	Net weight, kg per box	Product No. per box	Boxes per carton
6.3	305	50	0.8	096-758474	5
8.0	305	50	1.3	096-758466	5
15 x 5	305	50	2.1	096-758458	5

Re-drying temperature: 180 °C (356 °F) for 10 hours.

Note: The copper coating will oxidize during the process, but this will not influence the performance of the product.



Unitor ACA-384 is a DC electrode for gouging by the air-arc method. In this process, the arc is used to melt the metal, and the molten metal is then blown away by a jet of compressed air. This method has several advantages – it can be used for cutting stainless steel and other materials which are difficult to cut with an oxy-acetylene torch. Most of those who have had some welding or cutting experience should be able to master the gouging technique by practising 2 or 3 times a day for about a week.

A typical application of the air-arc method is the removal of sections which have been welded to the deck for securing deck cargo (flushing). Hold the electrode holder so that the electrode slopes back from the direction of travel. The air blast is directed along the rear of the electrode towards the arc. The depth and contour of the groove is controlled by the electrode angle and speed of travel. It is possible to cut grooves with a depth of up to 25 mm. A combination of wide electrode angle and slow speed of travel will produce a narrow, deep groove. The width of the groove will usually be about 3 mm wider than the electrode diameter. An electrode angle of approx. 35° will provide a normal groove depth and highest speed of travel. An electrode angle of 45–70° is used to obtain the deepest groove. Adjust the speed of travel to obtain an even, hissing sound and clean, smooth groove surface. The amount of metal which can be removed increases with increasing current. However, every electrode has an ideal current level which is slightly below its maximum. If the ideal level is exceeded, the welder will notice a considerable increase in electrode consumption.

When air-arc gouging with 8 mm electrodes and using 100 m cable, the cable size should be minimum 95 mm².

WARNING!

Wet or damp air-carbon-arc electrodes will give off splinters and are dangerous in use. Damp electrodes must be dried out in a drying oven at 180 °C (356 °F) for 10 hours before use. The fumes from air-carbon-arc electrodes are dangerous and must not be inhaled. Arrange for suitable ventilation or use an air mask. Use approved ear protectors when working with air-arc electrodes and protect your body and head against molten metal spray.

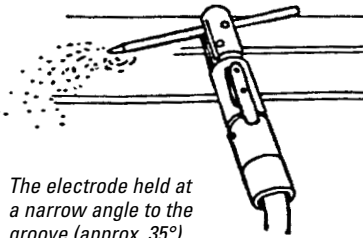

The electrode held at a narrow angle to the groove (approx. 35°)

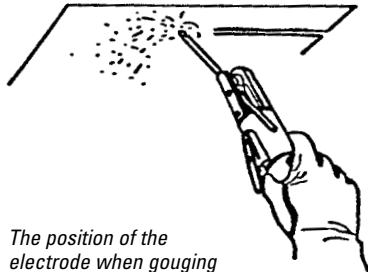

The position of the electrode when gouging in the overhead position

TIG WELDING RODS AND FLUXES



Introduction	198
Classification	199
IMS-210	200
ICROMO-216	202
18/8 Mo-221	204
IDUPLEX-222	206
ALUMAG-235	208
ICUNI-30-239	210
IALBRO-237 MF	212
I-FLUX-238 PF	214



TIG WELDING RODS AND FLUXES

Introduction

In Tungsten Inert Gas welding (TIG), an arc is struck between a Tungsten electrode and the workpiece. An inert gas flow (Argon) protects the electrode and pool from the surrounding air. The electrodes do not melt. The filler metal is inserted into the molten pool in the form of a separate rod. The process has a similar welding technique as gas welding but use electricity as energy source.

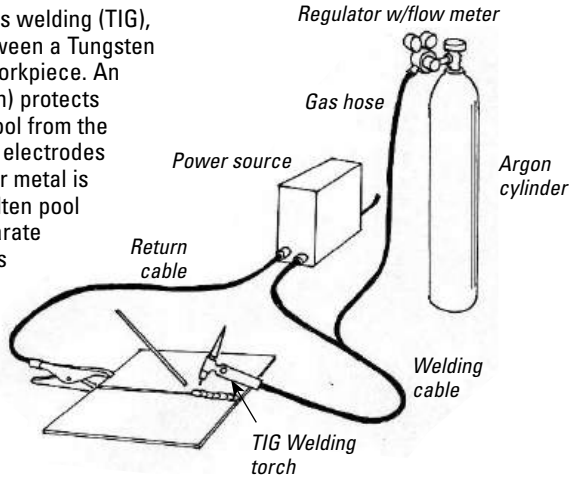

Rods for TIG welding

Unitor rods for TIG Welding are supplied in sealed plastic containers. All rods are supplied in 500 mm lengths for convenient use. The label on each container fully identifies the contents, and also gives rod data and basic information on application areas and use.

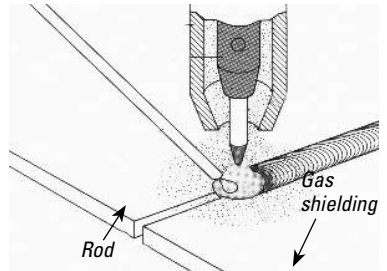

3.02

Work piece





Classification

Guide to AWS A5.28-1979

AWS Classifications	Mechanical properties of weld metal				
	Tensile strength min. MPa	Yield strength min. MPa (0.2% proof)	Elongation min. %	Impact Energy Charpy-V J/°C	Condition
ER 80 S-B2	550	470	19	Not required	*1)
ER 80 S-B2L	550	470	19	Not required	*1)
ER 90 S-B3	620	540	17	Not required	*2)
ER 90 S-B3L	620	540	17	Not required	*2)
ER 80 S-Ni1	550	470	24	27/-46	As-welded
ER 80 S-Ni2	550	470	24	27/-62	*1)
ER 80 S-Ni3	550	470	24	27/-73	*1)
ER 80 S-D2	550	470	17	27/-29	As-welded
ER 100 S-1	690	610-700	16	68/-51	As-welded
ER 100 S-2	690	610-700	16	68/-51	As-welded
ER 110 S-1	760	660-740	15	68/-51	As-welded
ER 120 S-1	830	730-840	14	68/-51	As-welded
ER XX S-G	Not required	Not required	Not required	Not required	As-welded

*1) PWHT 620 +/-15°C Heat in furnace to given temperature, hold for 1 hour, cool in furnace to 316°C and then in still air.

*2) PWHT 690 +/-15°C Heat in furnace to given temperature, hold for 1 hour, cool in furnace to 316°C and then in still air.

Suffix	Alloying system	Nominal value, wt%
-B2	Cr/ Mo	~1.3/ 0.5
-B2L*	Cr/ Mo	~1.3/ 0.5
-B3	Cr/ Mo	~2.5/ 1.1
-B3L*	Cr/ Mo	~2.5/ 1.1
-Ni1	Ni	~1.0
-Ni2	Ni	~2.4
-Ni3	Ni	~3.4
-D2	Mn/ Mo	~1.8/ 0.5

* C max. 0.05%



IMS 210

Description:

TIG welding rod for welding of unalloyed and low alloy creep resistant 0.5% Mo steels and fine grained steels suitable for working temperatures from -45°C up to 550°C . Also recommended for welding of high tensile steels.



Identification:

Copper coated. Imprint 1.5424 / WMoSi

Classification

AWS A5.28	EN 12070	DIN 8575	Werkstoff No.
ER 80 SG	W MoSi	SG Mo	1.5424

Type of current



Welding positions

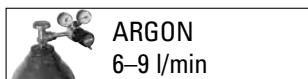

Flux

No flux required.

Materials to be welded

Boiler & pressure vessel steel	DIN 17155 NF A36-205 NF A36-206 BS 1501-261 DIN 17175	17Mn4, 19Mn5, 15Mo3 A42 (CP, AP, FP), A48 (CP, AP, FP), A52 (CP, AP) 15D3, 18MD4.05 0.5% Mo-types, plate, casting and forgings 15Mo3, 15Mo5 St45.8, 15Mo3
Elevated temperature steel Pipe material for elevated temperatures	DIN 17102	StE285 to StE400
Fine grained steel	NF A36-203	E275D, E355D, E390D, E430D

Chemical composition as welded (W%)

C	Mn	Si	Mo	Fe
0.1	1	0.6	0.5	Rest

Mechanical properties as welded

Tensile strength MPa	Yield strength MPa	Elongation %	Impact value ISO-V (J)
≥ 570	≥ 480	≥ 23	At $+20^{\circ}\text{C}$ = ≥ 180 At -45°C = ≥ 47

Packaging data

Diameter mm.	Length mm.	Rods per package	Net weight per package kg	Product No. per package
2.0	500	150	1.5	097-604850



Unitor IMS-210 is a copper coated TIG welding rod for welding of unalloyed and low alloyed creep-resistant Molybdenum (up to 0.5%) steel and fine grained steel suitable for working temperatures from -45°C up to 550°C . It is also recommended for welding of high tensile steel.

In general, TIG welding of steel is suitable for thin sheets and pipes of small diameters where the wall thickness of pipes does not exceed 6 mm.

IMS-210 can also be used to advantage when making root runs on large thicknesses where the subsequent filler and capping runs are done by arc welding with coated electrodes.

Thoroughly clean the welding area before commencing welding.

Gas welding rods for mild steel welding (including MS-200) have a low silicon content. TIG welding rods on the other hand, have a high silicon content to keep the molten pool fluid. A TIG welding rod used for Gas welding will become too fluid and give a porous weld

It is therefore important not to use gas welding rods for TIG and vice versa.

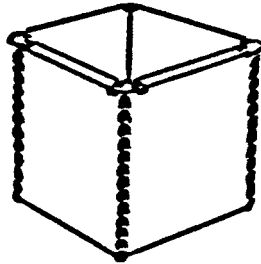

3.02

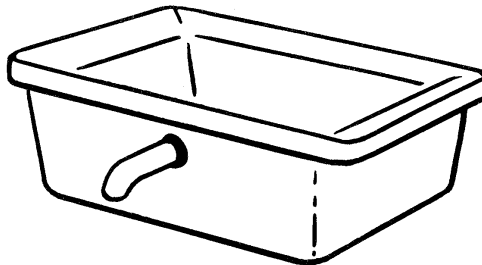



ICROMO 216

Description:

TIG welding rod for welding of low alloy creep and hydrogen resistant Cr-Mo steels. Suitable for working temperatures up to 550°C. Also recommended for welding of high tensile steels.



Identification:

Copper coated.

Classification

AWS SFA 5.28	EN 12070	BS 2901	DIN 8575	Werkstoff No.
ER 80 SG *	WCr Mo1 Si	A 32	SG Cr Mo 1	1.7339

* Nearest ER 80-B2

Type of current



Welding positions

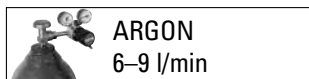

Flux

No flux required.

Materials to be welded

Elevated temperature steel

DIN 17155 13CrMo4 4
DIN 17200 25CrMo4
NF A36-206 15CD 2.05
15CD 4.05

Case hardening steel

DIN 17210 16MnCr5
NF A35-551 18CD4, 16MC5, 20MC5

Quenched & Tempered steel

NF A35-552 25CD4, 30CD4

Chemical composition as welded (W%)

C	Si	Mn	Cr	Mo	Fe
0.1	0.6	1	1.2	0.5	Rest

Mechanical properties as welded

Temperature	Tensile strength MPa	Yield strength MPa	Elongation %	Impact value ISO-V(J)
AW	≥560	≥460	≥22	+20°C ≥100
SR 680/2h	>520	>440	≥22	+20°C ≥130

Packaging data

Diameter mm.	Length mm.	Rods per package	Net weight per package kg	Product No. per package
2.5	500	56	1	097-305532

ICROMO 216



Unitor ICROMO-216 is a Chrome-Molybdenum alloyed rod for TIG welding of heat resistant steel, like boiler tubes. It is suitable for working temperatures up to 550°C. On heavy wall thicknesses it can be used for making the root run while filler and capping runs can be done by arc welding with coated electrodes.

Direct current is used, negative to electrode, with pointed wolfram electrode.

The workpiece is welded with the Leftward welding technique.

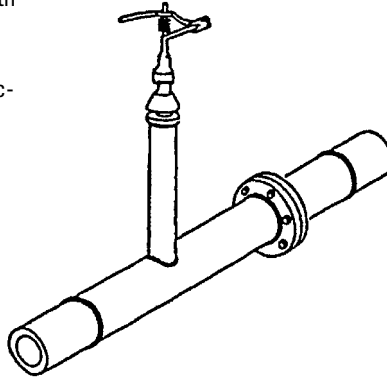

3.02

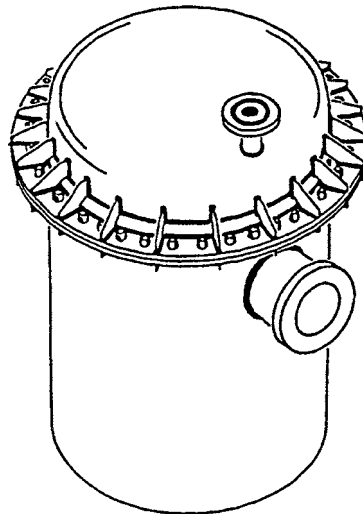



18/8 Mo 221

Description:

TIG welding rod with extra low carbon for welding stainless CrNiMo-steels.



Identification:

Stainless surface appearance. Imprint: ER 316LSi / RW 1.4430

Classification

AWS A5.9	EN 12072	DIN 8556	Werkstoff No.
ER 316 LSi	W 19 12 3 LSi	Mo 1912	1.4430

Type of current

Welding positions

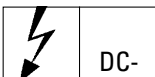

Flux

No flux required.

Materials to be welded

Steel grades	BS 970	DIN 17440/1744.5	W.Nr.	AFNOR NF A35-	ASTM/ACI	SIS	UNS
	1554			573/574/576/582	A240/A312/A351		
Ext. low carb. C<0.03%	316S11	X2CrNiMo 17 13 2	1.4404	Z2CND 17.12	CF-3M (TP) 316L CF-3M	2353	J92800 S31603 J92800
	316S13	X2CrNiMo 18 14 3 X2CrNiMoN 17 2 2	1.4435 1.4406	Z2CND 17.12a1'N	(TP) 316LN		S31653
Med carbon C>0.03%	316S31	X2CrNiMoN 17 12 2	1.4401	Z6CND 17.11	316 (TP) 316	(2347)	S31600/
	316S33	X5CrNiMo17 13 3	1.4436	Z6CND 17.12		2343	S30409
	316S33	G-X6CrNiMo 18 12	1.4437	Z6CND 17.12	C(P)F-8M		J92900
Ti,Nb- stabilized	316S33	G-X10CrNiMo18 9	1.4410				
	316S33	G-X6CrNiMo 18 10	1.4408	Z6CND 17.12	C(P)F-8M		J92900
	320S31	X6CrNiMoTi 17 12 2	1.4571	Z6CNDT 17.12	316Ti	(2344)	S32100/S31635
	347S31	X6CrNiNb 18 10	1.4450	Z6CNNb17.12	(T) 347	2338	34700/S34709

Chemical composition as welded (W%)

C	Mn	Si	Cr	Ni	Mo	Fe
<0.02	1.7	0.8	18.8	12.5	2.8	Rest

Mechanical properties as welded

Tensile strength MPa	Yield strength MPa	Elongation %	Impact value ISO-V(J)
≥550	≥320	≥35	At + 20°C = ≥80 At -120°C = ≥35

Packaging data

Diameter mm.	Length mm.	Rods per package	Net weight per package kg	Product No. per package
2.0	500	42	0.5	097-602979



Unitor 18/8 Mo 221 is a rod for welding stainless and acid resistant steel. Application areas are similar to those for the coated electrode 18/8 321 N, but with the advantages TIG can offer. When welding thin sheets and pipes (less than 2 mm) it is always an advantage to use TIG. This filler rod may also be used as a root bead when welding thicker sheets with prepared V-grooves. The groove can subsequently be filled, using coated electrodes. Burn-through is difficult to avoid when using coated electrodes on thin sheets.

As 18/8 Mo may be used on both stainless and acid resistant sheet and pipes, it is a very useful filler rod on board chemical tankers.

For TIG welding DC negative polarity welding current is used, combined with a pointed tungsten electrode alloyed with rare earth metals. The Leftward welding technique is used.

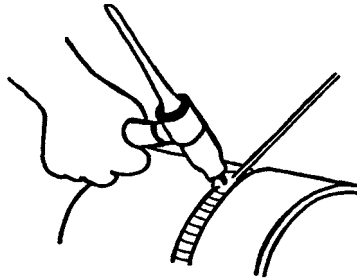
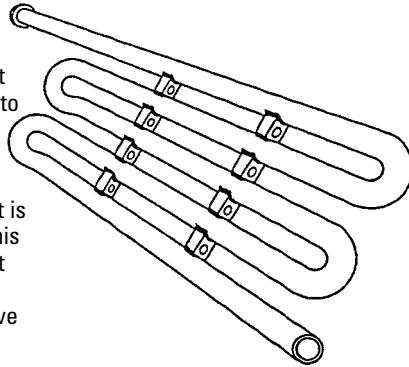

TIG welding thin sheets and pipes...

Note: The hot surface of the back of the weld will be attacked by air unless it is shielded. In piping this can be done by introducing argon gas and blocking the pipe ends. When welding sheets, a suitable grooved back-up sheet underneath the weld will prevent oxidation.

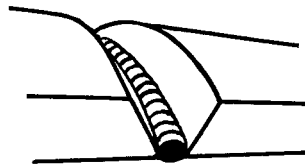

... or used as root bead in V-grooves.

Remember there is considerably more shrinkage in stainless steel than in mild steel and the tacks should therefore be placed as closely as possible.

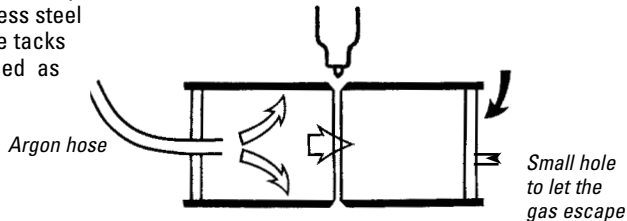

Argon backing gas used to prevent oxidation inside pipes.



IDUPLEX-222

TIG welding rod for welding of Duplex stainless steel



Identification:

Stainless surface appearance. Imprint: RW 2293 NL/ ER 2209.

Classification

AWS A5.9	EN 12072	DIN 8556	Werkstoff No.
ER 2209	W 22 9 3 L	SG X2CrNiMo N 2293	1.4462

Type of current



Welding positions



Flux No flux required.

Materials to be welded

EN 10088

Duplex stainless steel
X2 CrNiMoN 22-5-3
X3 CrNiMoN 27-5-2
X2 CrNiN 23-4

W. No.

1.4462
1.4417
1.4460
1.4362

Dissimilar joints as welding unalloyed and low-alloyed steel to duplex stainless steel. Welding 316 LN stainless steel to duplex stainless steel

3.02

Chemical composition as welded (W%)

C	Mn	Si	Cr	Ni	Mo	N	Fe
0,025	1,6	0,5	23,0	9,0	3,0	0,14	Rest

Mechanical properties as welded

Tensile strength MPa	Yield strength MPa	Elongation %	Impact value ISO-V (J)
> 680	>480	>22	At +20°C=>50

Packaging data

Diameter mm.	Length mm.	Rods per package	Net weight per package kg	Product No. per package
2,0	500	42	0,5	097-725309

IDUPLEX-222



Unitor Iduplex-222 is a TIG rod for welding duplex stainless steel grades like WNr.1.4462, UNS 31803. The deposit offers elevated mechanical strength and toughness resistance to stress corrosion cracking. Application areas are similar to those for coated electrode Duplex-325 N, but with the advantages TIG can offer. When welding thin sheets and pipes (less than 2 mm) it is always an advantage to use TIG. This filler rod may also be used as a root bead when welding thicker sheets with prepared U or V-grooves. The groove can subsequently be filled, using coated electrodes. Burn-through is difficult to avoid when using coated electrodes on thin sheets. The rod can also be used for welding duplex to mild steel and duplex to stainless steel (AISI 304, AISI 316 LN). For TIG welding connect the torch to DC negative polarity. A pointed Tungsten electrode alloyed with lanthanum (Gold colour code) must be used. Shielding gas must be Argon. Interpass temperature should not exceed 250°C during welding. After welding, remove discoloration by using Unitor Pickling Paste.

Note: The back of the weld will oxidize (oxygen will attack the hot surface) unless it is shielded. In piping this can be done by blocking the pipe ends and introducing Argon gas.

Remember there is considerably more shrinkage in duplex stainless steel than in mild steel and the tacks should therefore be placed as closely as possible

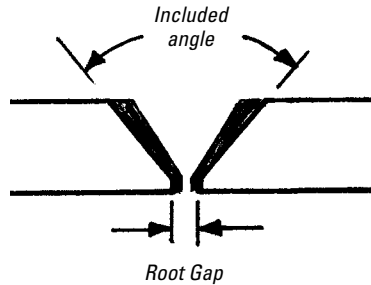

When welding V and U butt welds the included angle and root gap is slightly bigger than for AISI 316 stainless steel.

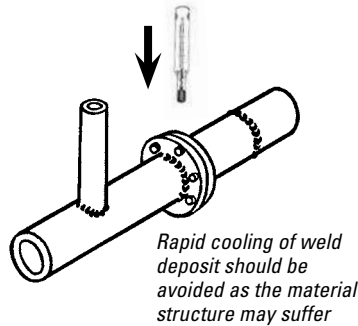

3.02



Remember to only use stainless steel wire brushes and chipping hammers when working with stainless steel



ALUMAG 235



Description

Gas and TIG welding rod for wrought and cast aluminium alloys containing up to 5% Mg. Generally it can be used for all cast alloys containing magnesium as the main alloying element.

Identification

Imprint 5356 ALMG 5

Classification

AWS A5.10	DIN 1732	Werkstoff No.
ER 5356	WSG-Al Mg5	3.3556

Type of current



Flux No flux required.

Materials to be welded

Aluminium wrought alloys:

DIN 1725/Part 1: AlMg5, AlMg4.5, AlMg3, AlMg2Mn0.8, AlMg2.7Mn, AlMg4Mn

Aluminium cast alloys:

DIN 1725/Part 2: G-AlMg3, G-AlMg3Si, G-AlMg3(Cu), G-AlMg5, G-AlMg5Si, G-AlMg9 (generally all cast alloys containing magnesium as main alloying element).

3.02

Chemical composition as welded (W%)

Mn	Ti	Mg	Cr	Al
0.4	<0.15	5.0	≤0.15	Rest

Mechanical properties as welded

Tensile strength MPa	Yield strength MPa	Elongation %	Melting range °C
≥240	≥110	≥17	562-633

Packaging data

Diameter mm.	Length mm.	Rods per package	Net weight per package kg	Product No. per package
3	500	47	0.5	092-514265

ALUMAG 235



Unitor ALUMAG 235 is used for welding pure aluminium, seawater-resistant aluminum and cast aluminium.

Clean the joints and adjacent surfaces thoroughly. Use a stainless steel brush, not an ordinary steel brush which will rub iron oxides into the aluminum and contaminate the weld pool. Cast aluminum should be pre-heated to approximately 300°C. Make sure that pre heated cast components are well supported, so that they do not sag when the temperature rises. Cast alloys that have been pre-heated must be allowed to cool slowly after being welded.

TIG (GTAW) welding

For TIG welding of aluminium it is necessary to use an alternating current (AC) power source. AC is required to break the oxide layer on the aluminium surface.

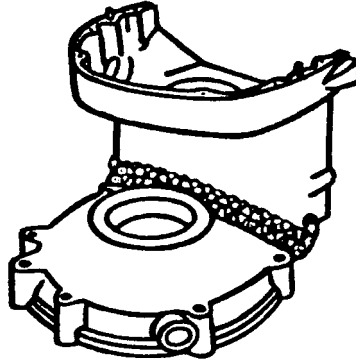

Repair of aluminium cover plate.



ICUNI 30 239

Description:

TIG welding rod for welding of copper-nickel alloys (cunifer, cupronickel pipes) containing up to 31% Ni.



Identification:

Copper-nickel colour surface appearance.

Classification

AWS A5.7	BS 2901	DIN 1733	Werkstoff No.
ER Cu Ni	C 18	WSG-Cu Ni 30 Fe	2.0837

Type of current



Welding positions



Flux

No flux required.

Materials to be welded

Copper-nickel wrought alloys

Grade Cu Ni 20 Fe (DIN 17664)
 Grade Cu Ni 30 Mn 1 Fe (DIN 17664)
 Grade Cu Ni 30 Fe 2 Mn 2 (DIN 17664)
 Werkstoff No. 2.0872
 Werkstoff No. 2.0875
 Werkstoff No. 2.0883

Copper-nickel cast alloys

Grade G-Cu Ni 10
 Grade G-Cu Ni 30
 Werkstoff No. 2.0815
 Werkstoff No. 2.0835

3.02

Chemical composition as welded (W%)

Ni	Mn	Fe	Ti	Cu
31.0	1.0	0.5	0.4	Rest

Mechanical properties as welded

Tensile strength MPa	Yield strength MPa	Elongation %	Hardness HB
≥420	≥200	≥30	±115

Packaging data

Diameter mm.	Length mm.	Rods per package	Net weight per package kg	Product No. per package
2.5	500	92	2.0	097-335547



Unitor ICUNI 30 329 is a TIG welding rod for welding of copper nickel alloys, like, for example, Cunifer pipes.

For TIG welding DC negative polarity is used in combination with a thorium alloyed electrode. No flux is used in this process. Pure argon must be used as shielding gas.

Thoroughly clean the welding and adjacent area with a stainless steel brush or emery paper before commencing welding. If practically possible use backing gas inside pipe to further improve the result.

Typical applications are welding flanges on pipes, pipe joints, patching leaking pipes, etc. Joint surfaces and adjacent areas must be thoroughly cleaned with a stainless steel brush or emery paper before welding begins. If practically possible, use backing gas.

Small diameter Cunifer pipes can be joined by means of overlap joints (capillary action) using Unitor AG-60 silver brazing rod combined with AG-60/45 Flux 252 PF. Larger pipe diameters are usually TIG welded with Unitor ICUNI 30.

Whenever possible, welding should take place in the workshop so that, as far as possible, beads can be laid in the horizontal position.

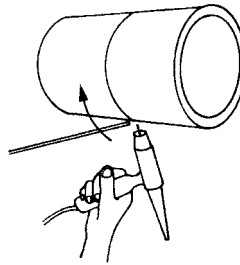
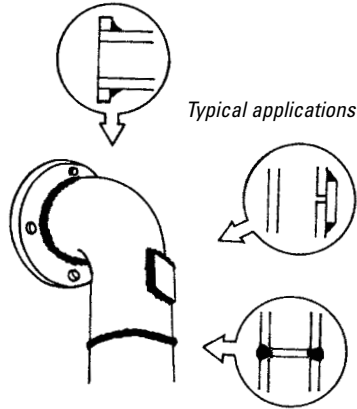

*Permanently installed pipe.
Horizontal axis.*

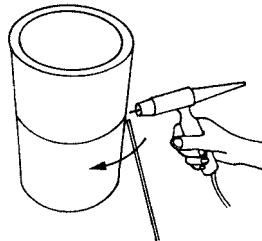

*Permanently installed pipe.
Vertical axis.*



IALBRO 237 MF

Description:

Flux-coated TIG welding rod for welding of aluminium-brass pipes also known as Yorcalbro pipes.



Identification:

Gray flux.

Classification

AWS A5.7	DIN 1733
ER Cu A1-A2	SG-CuAl8Ni2

Type of current



Welding positions



Flux I-FLUX 238 PF, 250 gram container, order No. 097-603092.

Materials to be welded

Wrought copper aluminium alloys:

- Grade Cu AL 5A (DIN 17665)
- Grade Cu AL 8 (DIN 17665)
- Werkstoff No. 2.0918
- Werkstoff No. 2.0920

Cast copper aluminium alloys:

- Grade G-Cu AL 8 Mn (DIN 1714)
- Werkstoff No. 2.0962

Trade name types:

- Yorcalbro (Cu 76%, Al 2%, Zn21, 96%, As 0.04%)

3.02

Chemical composition as welded (W%)

AL	Mn	Ni	Cu
8.5	1.0	0.5	Rest

Mechanical properties as welded

Tensile strength MPa	Yield strength MPa	Elongation %	Hardness HB
500-600	250-300	25	115

Packaging data

Diameter mm.	Length mm.	Rods per package	Net weight per package kg	Product No. per package
2.4	500	65	1.2	097-778992

IALBRO 237 MF



Unitor IALBRO 237 MF is a flux-coated filler rod for TIG welding of aluminum-brass pipes also known as Yorcalbro pipe. This alloy is widely used in sea-water resistant piping. In TIG welding of joints it is strongly recommended that I-Flux 238 PF is applied to both sides of the joint and on the inside. This improves welding penetration considerably. Flux deposits must be washed off with water.

Yorcalbro pipes with diameter less than 4" can be joined by means of overlap joint (capillary action) and silver brazed using Unitor AG-60 combined with Albro Flux 263 PF. Larger pipes should be TIG welded using Unitor IALBRO 237 MF.

Welding procedure:

- Piping must be unstressed before welding.
- Cold bent piping should be annealed at 400–500°C for approx. 20–30 min.
- As a general rule, pipes with a thickness up to and including 1.5 mm may be butt welded with a 1.5 mm aperture, no V-groove being necessary. For thicknesses exceeding 1.5mm, a 70° V-groove with 1.5 mm root gap is recommended.
- Thoroughly clean the welding area with a steel brush or emery paper.
- Strike the arc on a separate piece of metal placed close to the weld zone.
- Weld in long continuous beads as quickly as possible. When the arc is extinguished the groove must be cleaned before the bead is continued.
- Base material temperature during welding should never exceed 150°C

- Completed welds, as well as the area covering approx. 15 cm on either side of the bead should be annealed. Annealing temperature 300–400°C for 30–40 min.
- Use a contact thermometer when annealing Yorcalbro pipes.

Whenever possible, welding should take place in the workshop, in the horizontal position.

In cases where this is not possible, position welding may be used with Leftward welding technique.



Also use I-flux 238 PF inside pipe joints

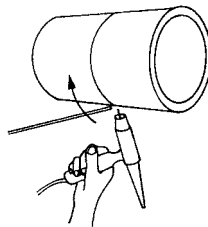
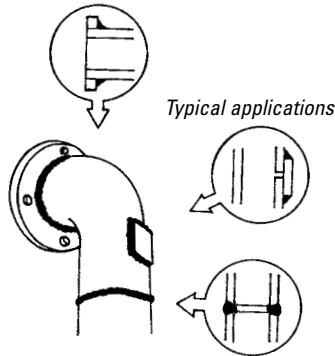

Permanently installed pipe. Horizontal axis.

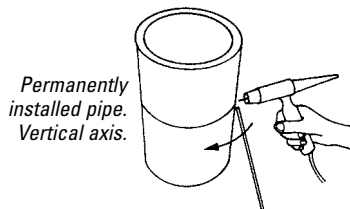



I-FLUX 238PF

Description:

Flux for TIG welding rod IALBRO-237 MF for use on Yorkalbro.

Identification:

White/Grey flux in paste form inside container.

Application Apply with brush. Use as additional flux on both sides of the joint, especially on the inside of pipes. Working area should be adequately ventilated.

The flux is corrosive. Remove with brush and hot water after brazing.

HARMFUL	R22	Harmful if swallowed
	R36/37/38	Irritating to eyes, respiratory system and skin
	R48/20/22	Harmful: danger of serious damage to health by prolonged exposure through inhalation and if swallowed
	R52/53	Harmful to aquatic organisms, may cause long-term adverse effects in the aquatic environment
	S2	Keep out of the reach of children
	S22	Do not breathe dust
	S26	In case of contact with eyes, rinse immediately with plenty of water and seek medical advice
	S36/39	Wear suitable protective clothing and eye/face protection
S46	If swallowed, seek medical advice immediately and show this container or label	
S56	Dispose of this material and its container to hazardous or special waste collection point	

3.02

Packaging data

Gross weight in grams	Product No.
250	097-603092

*SDS available on request.



WIRES FOR WIRE WELDING

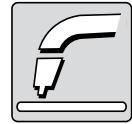

Introduction	216
Classification	217
Storage and handling for Flux Cored wires	219
GPS-W-200	220
MS-W-201	222
Coreshield 8	224
S 316 M-GF-221	226
S 309 M-GF-222	228
Icuni-W-239	230
Ialbro-W-237	232
Alumag-W-235	234
Abratech-W-230	236



WIRES FOR WIRE WELDING

Introduction

In Wire welding an arc is struck between a continuously fed wire and the workpiece. An inert gas, active gas or a mixture of the two protects the pool from the surrounding air. The wire used can be solid or flux cored. In some cases the flux cored wire is self shielded and does not require any additional shielding gas.

Wires for wire welding (GMAW and FCAW): Description

Unitor standard range of welding wires for Gas Metal Arc Welding (GMAW) and Flux Cored Arc Welding (FCAW) is supplied on 200mm Diameter spools, 51 mm width, shaft Diameter 50 mm. The spools are packed in individually sealed plastic bags and cardboard cartons and labelled with information fully identifying the wire with technical data and classifications. The labels also provide basic information on use.

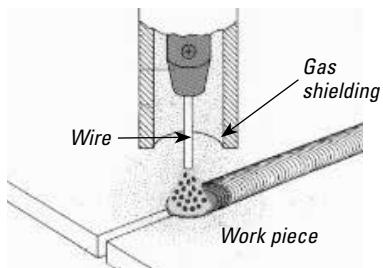
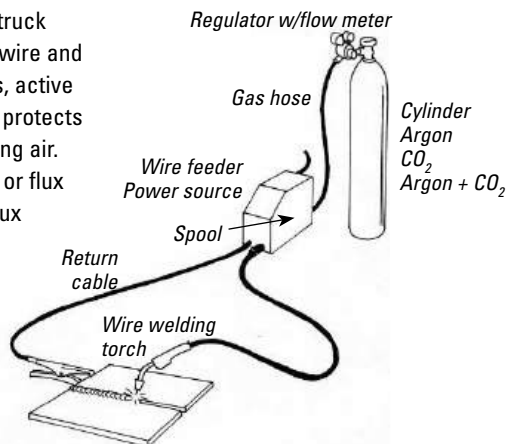

WIRES FOR WIRE WELDING

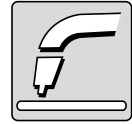

Classification Guide to AWS A5.18-1993

AWS Classifications	Chemical composition of wire or rod					
	C	Mn	Si	P	S	Cu
ER 70 S-2	<0.07	0.90-1.40	0.40-0.70	<0.025	<0.035	<0.50
ER 70 S-3	0.06-0.15	0.90-1.40	0.45-0.70	<0.025	<0.035	<0.50
ER 70 S-4	0.07-0.15	1.00-1.50	0.65-0.85	<0.025	<0.035	<0.50
ER 70 S-5	0.07-0.19	0.90-1.40	0.30-0.60	<0.025	<0.035	<0.50
ER 70 S-6	0.07-0.15	1.40-1.85	0.80-1.15	<0.025	<0.035	<0.50
ER 70 S-7	0.07-0.15	1.50-2.00	0.50-0.80	<0.025	<0.035	<0.50
ER 70 S-G	-	-	-	<0.025	<0.035	<0.50

AWS Classifications	Mechanical properties of weld metal				
	Tensile strength min. MPa	Yield strength min. MPa (0.2% proof)	Elongation min. %	Impact Energy Charpy-V J/°C	Shielding gas
ER 70 S-2	500	420	22	27/-29	CO ₂ or Ar/CO ₂
ER 70 S-3	500	420	22	27/-18	CO ₂ or Ar/CO ₂
ER 70 S-4	500	420	22	Not required	CO ₂ or Ar/CO ₂
ER 70 S-5	500	420	22	Not required	CO ₂ or Ar/CO ₂
ER 70 S-6	500	420	22	27/-29	CO ₂ or Ar/CO ₂
ER 70 S-7	500	420	22	27/-29	CO ₂ or Ar/CO ₂
ER 70 S-G	500	420	22	Not required	CO ₂ or Ar/CO ₂

3.03



WIRES FOR WIRE WELDING

Classification Guide to AWS A5.20-1995

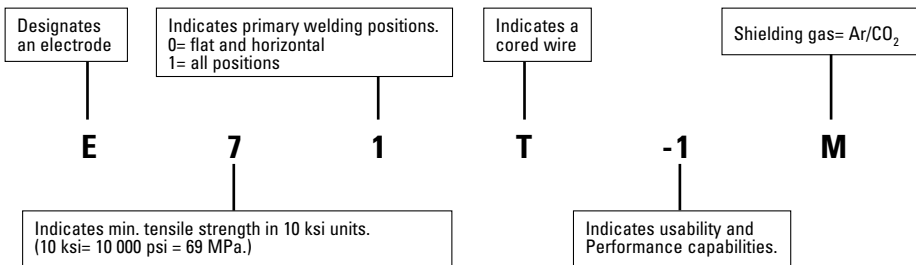

AWS Classifications	Tensile strength MPa	Yield strength min. MPa	Elongation min. %	Impact Energy Charpy-V J/PC
E 6xT-1	428	345	22	27/-18
E 6xT-4	428	345	22	No requirements
E 6xT-5	428	345	22	27/-29
E 6xT-6	428	345	22	27/-29
E 6xT-7	428	345	22	No requirements
E 6xT-8	428	345	22	27-29
E 6xT-11	428	345	22	No requirements
E 6xT-G	428	345	22	No requirements
E 6xT-GS	No requirements	No requirements	No requirements	No requirements
E 7xT-1	497	414	22	27/-18
E 7xT-2	497	No requirements	No requirements	No requirements
E 7xT-3	497	No requirements	No requirements	No requirements
E 7xT-4	497	414	22	No requirements
E 7xT-5	497	414	22	27/-29
E 7xT-6	497	414	22	27/-29
E 7xT-7	497	414	22	No requirements
E 7xT-8	497	414	22	27/-29
E 7xT-10	497	No requirements	No requirements	No requirements
E 7xT-11	497	414	22	No requirements
E 7xT-G	497	414	22	No requirements
E 7xT-GS	497	No requirements	No requirements	No requirements

Suffix	Shielding gas	Multiple-pass	Single-pass	Flux type	Current type
-1	x	x	x	Rutile	DC+pol
-2	x		x	Rutile	DC+pol
-3			x	Rutile	DC+pol
-4		x	x	Basic-Rutile	DC+pol
-5	x	x	x	Basic	DC+/-pol
-6		x	x	Rutile	DC+pol
-7		x	x	Basic-Rutile	DC-pol
-8		x	x	Basic-Rutile	DC-pol
-10			x	Rutile	DC-pol
-11		x	x	Rutile	DC-pol
-G	x	x		-	-
-GS	x		x	-	-

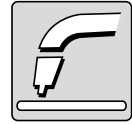

Storage and handling recommendation for Flux-cored Wires used in Gas-shielded Flux-cored Arc Welding and Self Shielded Flux-cored Arc Welding

Scope

Tubular cored wires on coil or spool for Flux-cored Arc Welding and Self-shielded Flux-cored Arc Welding. Applicable for all types: Packaged in plastic bag and outer carton.

Storage

Tubular cored wire, even when packed in the original undamaged cartons, requires controlled storing conditions to prevent excessive moisture contamination. Recommended storing conditions include:

- temperature 15–25 °C, relative humidity max. 60%.
- temperature 25–35 °C, relative humidity max. 40%.

Cored wire, properly stored to prevent moisture contamination, can be stored for up to three years.

Handling

Self shield range, unbaked version: Coils and spool taken out of protective packaging may be exposed to normal on-board workshop conditions for maximum 2 weeks.

Gas shield range

Coils taken out of protective packaging may be exposed to normal on-board workshop conditions for maximum of 48 hours.

In all cases the products shall be protected against contamination of moisture, dirt and dust. During work stops exceeding more than 8 hours, the wire coils shall be stored under the conditions mentioned above in a plastic bag.

Only products on steel coil can be stored in a holding oven at 40–100 °C for a maximum of 30 days.

Deteriorated products

Cored wire products that are rusty, have suffered from serious water- or moisture contamination, or have been exposed to atmospheric moisture contamination over long periods of time cannot be restored to their original condition and shall be discarded.

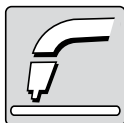

GPS W 200



Description:

Solid wire for GMA welding of structural steels.

Wire identification:

Solid copper coated steel wire on a spool.

Classification

AWS A 5.18	EN 440	DIN 8559	Werkstoff No.
ER 70 S-6	G422CG3Si1	SG 2	1.5125

Type of current



DC+



PA



PB



PC



PF



PG



PE, PD

Welding positions

Shielding gas



ARGON +20% CO₂ or
pure CO₂
10–15 l/min.

Materials to be welded

General structural steel	DIN 17100 NF A35-501 BS 4360	St33, St37-2 to St52-3 A33, A43-2, E24-2 (-4 to E36 -2 (-4) 50D, 43D
Ship plates	DIN 17172	Grade A, B, C, D, E, AH, DH, EH
Pipe material	API 5 LX DIN 1626-1630	StE210.7, StE240.7, StE290.7, StE320.7, StE360.7 X42, X46, X52, X60
Boiler & pressure vessel steel	DIN 17155 NF A 36-205 BS 3059	St37.0/4, St44.0/4, St52.0/4 H1, H11, 17Mn4, 19Mn5
Elevated temperature steel	NF A36-207 DIN 17175	A37 (CP, AP), A42 (CP, AP), A48 (CP, AP), A52 (CP, AP) Part 1 HPS 33
Fine grained steel	NF A36-207 DIN 17102 NF A36-203	A510AP, A530AP, A550AP St35.8, St45.8 StE255 to StE420 E275D, E355D, E390D, E430D, E445D

Chemical composition as welded (W%)

3.03

C	Mn	Si	S	P	Fe
0.08	1.4	0.85	≤0.03	≤0.025	Rest

Mechanical properties as welded

Tensile strength MPa	Yield strength MPa	Elongation %	Impact value ISO-V (J)
≥510	≥430	≥22	At +20°C = >120 At -20°C = ≥70

Welding data

Wire speed	Volt	Stick out	Deposition rate kg/h	Kg wire/kg weldmetal	Fume class* SS-062802
7.5 m/min	22 V	10–20 mm	0.67–2.68	1.05	1

Packaging data

Diameter mm	Spool size mm	Net weight per spool kg	Product No. per spool
0.8	200 x 55	5	090-590117

GPS W 200

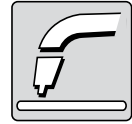

GPS-W-200 is a copper coated welding wire for welding of unalloyed and low alloyed structural steel. It can be used for welding sheets in thin as well as larger thicknesses. Stable arc and little spatter.

Clean all rust, scale and old paint from the area.

Use 80/20% Ar/CO₂ or pure CO₂ shielding gas.

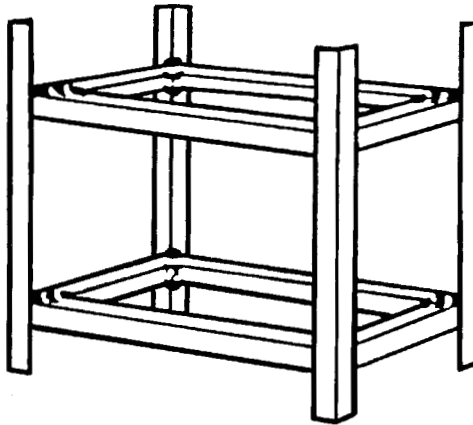
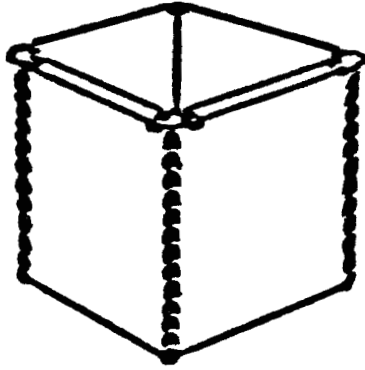

3.03

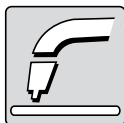

MS-W-201 SELFSHIELD

Description:

General Purpose Self-Shielded Electrode wire for the welding of mild steel and ships steel. All position welding, including vertical down.



Wire identification:

Tubular Flux Cored Wire on a spool.

Classification

AWS A 5.20	EN
E 71 T-GS	—

Type of current



Welding positions

Shielding gas

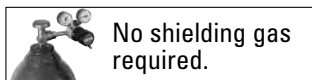

Materials to be welded

General structural steel

DIN 17100
NF A35-501
BS 4360

St33, St37-2 to St44-3
A33, A34-2, E24-2 (-4), E28-2 (-3) E30-2 (-3)
Gr. 40A-C, 43A-C
Grade A, B, C, D

Ship plates
Cast steel
Pipe material

DIN 1681
DIN 17172
API 5 LX
DIN 1626-1630

GS38
StE210.7, StE240.7, StE290.7, StE320.7, StE360.7
X42, X46
St37.0/4, St44.0/4

Chemical composition as welded (W%)

3.03

C	Mn	Si	P	S	Al	Fe
0.23	0.7	0.4	0.007	0.01	2	Rest

Mechanical properties as welded

Tensile strength MPa
615

Welding data

Wire speed	Volt	Stick out	Deposition rate kg/h	Kg wire/kg weldmetal	Fume class* SS-062802
12 m/min.	20 V	9,5 mm	0.4-0.7	1.3	7

Packaging data

Diameter mm	Spool size mm	Net weight per spool kg	Product No. per spool
0.8	200 x 55	4.5	090-160100

MS-W-201 SELFSHIELD

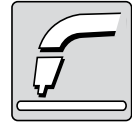

Unitor MS-W-201 Selfshield is a self-shielded electrode wire designed for the welding of mild steel where superior weld metal mechanical properties are required.

It has all-position welding capabilities, including the 3G vertical up and vertical down positions.

Unitor MS-W-201 Selfshield has good arc action and low spatter for excellent operator appeal. Slag removal is very good with minimal slag sticking.

It will make root beads in groove welds without backing bars.

Typical applications

General plate welding, including hull plate and stiffener welding on ships.

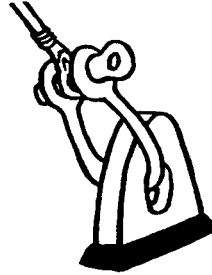

Lifting lugs

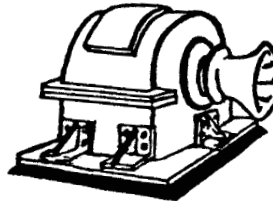

Motor base plates

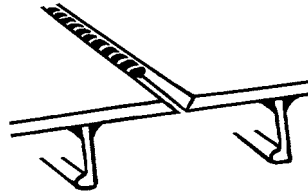

Joining deck and hull plates

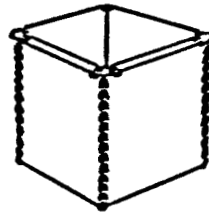

Mild steel welding in thin sheet metal



CORESHIELD 8 SELFSHIELD

Description:

General Purpose Self-Shielded Electrode wire for the welding of mild steel and ships steel.



Wire identification:

Tubular Flux Cored Wire on a coil.

Classification

AWS A5.20	EN ISO	BS 7084	NFA 81-350
E 71 T-8	T42 2Y N2	T 532 NWH	T SS 51.2.2. BH

Approvals

DNV / GL	LR	BV	ABS
III YMS (H10)	3S 3YS (H10)	SA 3 YM(HH)	3SA 3YSA (H10)

Type of current

Welding positions



DC-

PA

PB

PC

PF

PE, PD

Shielding gas



No shielding gas required.

Materials to be welded

General structural steel	DIN 17100 NF A35-501 BS 4360	St33, St37-2 to St52-3 A33, A43-2, E24-2 (-4) to E36-2 (-4) Grade 43D, 50D
Ship plates	DIN 1681	Grade A, B, C, D, E, AH, DH, EH
Cast steel	BS100	GS38, GS45, GS52
Pipe material	DIN 17172 API 5 LX DIN 1628-1630	A1, A2, A3, AM1, AM2, AW1 StE210.7, StE240.7, StE290.7, StE320.7, StE360.7 X42, X46, X52, X60
Boiler & pressure vessel steel	NF A 36-205 NF A36-207 BS 1501	St37.0/4, St44.0/4, St52.0/4 H1, H11, 17Mn4, 19Mn5
Elevated temperature steel	DIN 17175	A37 (CP, AP), A42 (CP, AP), A48 (CP, AP), A52 (CP, AP)
Fine grained steel	DIN 17102	A510AP, A530AP, A550AP
Low temperature steel	NF A36-203 SEV 680-70	151/154/161/164-Gr. 360 to 223/224/225-Gr. 490 St35.8, St45.8 StE255 to StE420 E275D, E355D, E390D, E430D, E445D TTSt35, TTSt41, TTSt45

Chemical composition as welded (W%)

C	Mn	Si	Cr	Ni	Cu	Mo	Al
0.18	0.55	0.14	0.1	0.25	0.1	0.03	0.75

Mechanical properties as welded

Tensile strength MPa	Yield strength MPa	Elongation %	Impact value ISO-V (J)
490-600	400	22	At -40°C = 43

Welding data

Wire speed	Volt	Stick out	Deposition rate kg/h	Kg wire/kg weldmetal	Fume class* SS-062802
3.8-7.6 m/min.	18-24 V	15 mm	1.9-3.7	1.33	7

Packaging data

Diameter mm	Spool size mm	Net weight per spool kg	Product No. per spool
1.6	300 x 55	11.3	094 - 750187

CORESHIELD 8 SELFSHIELD

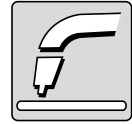

Unitor Coreshield 8 is designed for the Self Shielded Wire welding of 5 mm and thicker steel. It has excellent low temperature impact toughness.

Recommended for single and multi-pass welds. Ideal for fillet welding. Deposit rate up to 3 kg/h, out of position. Size diam. 1.6 mm is recommended for welds where it is necessary to produce wider passes (weave technique) and for welding plate with contaminations such as oil, rust, paint or primer.

Coreshield 8 generates a fast freezing slag which supports high deposit rates. This feature results in fast joint speeds for economical welding in the flat position. The superior arc action and handling of Coreshield 8 make it a high operation appeal electrode.

The Coreshield 8 also has excellent slag removal. On many applications the slag is self peeling.

Typical applications:

General plate welding, including hull plate and stiffener welding on ships, rebuilding pitting corrosion in cargo and ballast tanks.

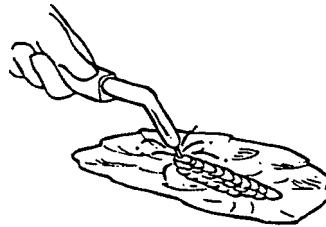
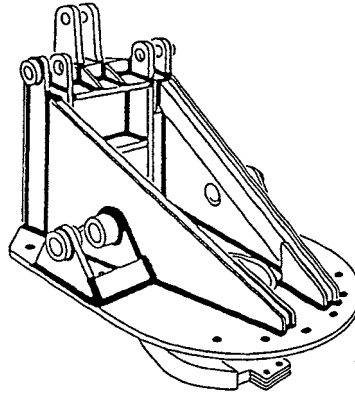
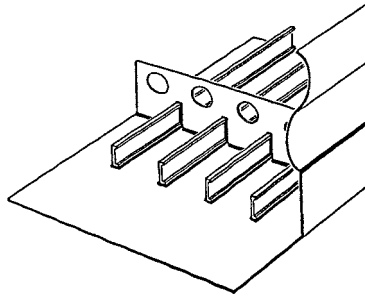



S 316 M-GF 221



Description:

Flux cored wire for welding of stainless steel: 19% Cr/12% Ni/3% Mo types.

Wire identification:

Tubular stainless steel wire on a spool.

Classification

AWS A522	EN 12073	Werkstoff No.
E 316 LT 1-4/-1	T 19123 LPM (C) 1	1.4430

Type of current



DC+



PA



PB



PC



PF



PG

Welding positions

Shielding gas



ARGON +20% CO₂
22-25 l/min.

Materials to be welded

Steel grades	BS 970	DIN 17440/1745	W.Nr.	AFNOR NF A35-	ASTM/ACI	SIS	UNS
Ext. low carb. C<0.03%	1554						
	316S11	X2CrNiMo 17 13 2	1.4404	573/574/576/582 Z2CND 17.12	A240, A312, A351 (TP) 316L CF-3M	2353	S31603 J92800
	316S13	X2CrNiMo 18 14 3 X2CrNiMoN 17 12 2 X2CrNiMoN 17 13 3	1.4435 1.4406 1.4429	Z2CND 17.12 á 1'N Z2CND 17.13 á 1'N	(TP) 316LN		S31653
Med. carbon C>0.03%	316S31	X5CrNiMo 17 12 2	1.4401	Z6CND 17.11	316 (TP) 316	(2347)	S31600/
	316S33	X5CrNiMo17 13 3	1.4436	Z6CND 17.12		2343	S30409
	316S33	G-X6CrNiMo 18 12	1.4437	Z6CND 17.12	C(P)F-8M		J92900
Ti-Nb stabilized	316S33	G-X10CrNiMo18 9	1.4410				
	316S33	G-X6CrNiMo 18 10	1.4408	Z6CND 17.12	C(P)F-8M		J92900
	320S31	X6CrNiMoTi 17 12 2	1.4571	Z6CNDT 17.12	316Ti	(2344)	S32100/S31635
	347S31	X6CrNiNb 18 10	1.4450	Z6CNNb17.12	(TP) 347	2338	34700/S34709

3.03

Chemical composition as welded (W%)

C	Si	Mn	Cr	Ni	Mo	Fe
≤0.03	0.6	1.5	19.0	12.0	2.8	Rest

Mechanical properties as welded

Tensile strength MPa	Yield strength MPa	Elongation %	Impact value ISO-V (J)
≥510	≥350	≥30	At +20°C = ≥47 -120°C = ≥32

Welding data

Wire speed	Volt	Stick out	Deposition rate kg/h	Kg wire/kg weldmetal	Fume class* SS-062802
11 m/min	22 V	15-25 mm	1.2-3.2	1.10	7

Packaging data

Diameter mm	Coil size mm	Net weight per spool kg	Product No. per spool
0.9	200 x 55	2.5	090-597518

S 316 M-GF 221



Unitor S 316 M-GF is a rutile flux cored wire designed for welding 19% Cr, 12% Ni, 3% Mo types of stainless steel. It is also suitable for related stabilised steel grades if service temperature is below 400 °C. The wire operates with a very stable, spatter free arc producing a bright, smooth weld bead surface.

The slag is self-releasing.

As shielding gas use 80% Ar 20% CO₂

When welding very thin sheet and pipes (less than 2 mm), TIG welding should be considered.

If there is an overlap joint (capillary joint) silver brazing should also be considered.

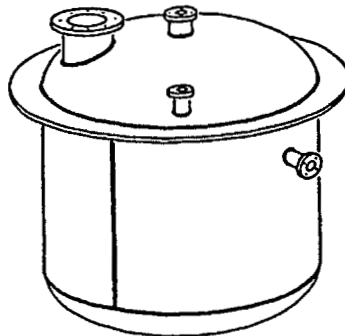

3.03

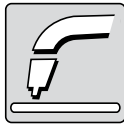

S 309 M-GF 222



Description:

Flux cored wire for welding of stainless steel and welding mild steel to stainless steel. Also welding of clad steel.

Wire identification:

Tubular stainless steel wire on a spool.

Classification

AWS A5.22	EN ISO 1763-A	EN ISO 1763-B
E 309 No T0-4 (1)	T 23 12 2 L P M (C) 1	TS 309LMo – FBO

Type of current



DC+



PA



PB



PC



PF



PG

Welding positions

Shielding gas



ARGON +20% CO₂
22–25 l/min.

Materials to be welded

Steel grades	BS 970	DIN 17440	W.Nr.	AFNOR	ASTM/ACI	SIS	UNS
First layer in CrNiMo-claddings	316S11	X2CrNiMo 17 13 2	1.4404	Z2CND 17.12	(TP) 316L CF-3M	2353	S31603 J92800
	316S13	X2CrNiMo 18 14 3	1.4435	Z2CND 17.12 á 1'N	(TP) 316LN		S31653
		X2CrNiMoN 17 12 2	1.4406	Z2CND 17.13 á 1'N			
		X2CrNiMoN 17 13 3	1.4429	Z2CND 17.13 á 1'N			
	316S31	X5CrNiMo 17 12 2	1.4401	Z6CND 17.11	316 (TP) 316 (H)	(2347)	S31600/
	316S33	X5CrNiMo 17 13 3	1.4436	Z6CND 17.12		2343	S30409
	320S31	G-X6CrNiMoTi 17 12 2	1.4571	Z6CNDT 17.12	316Ti	(2344)	S31635/
		X10CrNiMoTi18 12	1.4573	Z6CNDT 17.12	316Ti		S31635
		X6CrNiMoNb 17 12 2	1.4580	Z6CNDNb 17.13	316Cb		S31640
		X10CrNiMoNb 18 12	1.4583	Z6CNDNb 17.13	316Cb		S31640

- Welding dissimilar metals: mild steel or low alloyed steel to stainless CrNiMo-steel up to max. thickness of 12 mm.
- Build up stainless overlays on mild or low alloyed steel.

3.03

Chemical composition as welded (W%)

C	Mn	Si	Cr	Ni	Mo	Fe
≤0.03	1.4	0.6	23	12.5	2.7	Rest

Mechanical properties as welded

Tensile strength MPa	Yield strength MPa	Elongation %	Impact value ISO-V (J)
≥550	≥450	≥25	At +20°C = >47 -60°C = ≥32

Welding data

Wire speed	Volt	Stick out	Deposition rate kg/h	Kg wire/kg weldmetal	Fume class* SS-062802
13 m/min	24 V	15–25 mm	1.2–3.2	1.10	7

Packaging data

Diameter mm	Spool size mm	Net weight per spool kg	Product No. per spool
0.9	200 x 55	5	090-309000

S 309 M-GF 222

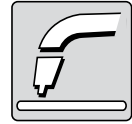

Unitor S 309 M-GF is a rutile flux cored wire designed for welding of clad steel (compound steel), stainless steel, mild steel and corrosion resistant overlays on mild steel.

It can also be used for welding of stainless steel with chemical composition of up to 23% Cr, 13% Ni, and 2.3% Mo.

No granulation of crystals up to 350 °C, no oxidation below 800 °C working temperature.

Use 80%/20% Ar/CO₂ preferably as shielding gas.

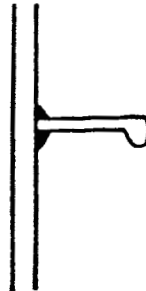
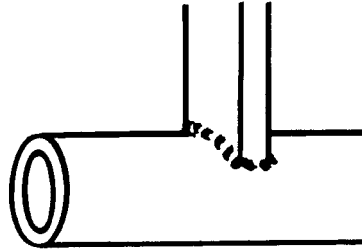

Mild steel stiffener to stainless steel

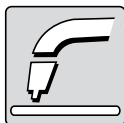

ICUNI W 239



Description:

Solid wire for GMA welding of copper-nickel alloys containing 10–30% Ni.

Wire identification:

Solid copper-nickel wire on a spool.

Classification

AWS A5.7	DIN 1733	Werkstoff No.
ER Cu Ni	SG-Cu Ni 30Fe	2,0837

Type of current

Welding positions



DC+



PA



PB



PC



PF



PE, PD

Shielding gas



ARGON
15–20 l/min.

Materials to be welded

Copper-nickel wrought alloys	DIN 17664	W.No.	UNS
CuNi10Fe1Mn		2.0872	C 70600
CuNi20Fe		2.0878	
CuNi30Mn1Fe 2.0882		2.0882	C 71500
CuNi30FeMn2		2.0883	C 71600
Copper-nickel cast alloys	DIN 17658	W.No.	
G-CuNi 10		2.0815	
G-CuNi 30		2.0835	

3.03

Chemical composition as welded (W%)

Mn	Ni	Fe	Ti	Cu
0.80	30	0.6	<0.5	Rest

Mechanical properties as welded

Tensile strength MPa	Yield strength MPa	Elongation %	Hardness HB
≥360	>200	≥30	120

Welding data

Wire speed	Volt	Stick out	Deposition rate kg/h	Kg wire/kg weldmetal	Fume class* SS-062802
7.5 m/min	22 V	8–10 mm	1.2–2.80	1.05	1

Packaging data

Diameter mm	Spool size mm	Net weight per spool kg	Product No. per spool
0.8	200 x 55	5	090-592015

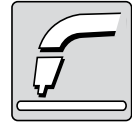

Unitor ICUNI-W is a wire for welding copper-nickel alloys (cunifer) in wrought or cast form, containing up to 30% Nickel, and for joining these to steel, stainless steel, cast iron, bronze or brass. It may also be used to provide corrosion resistant overlays on cast iron and mild steel. Use pure Argon as shielding gas.

Thoroughly clean the welding and adjacent area with a stainless steel brush or emery paper before commencing welding. If practically possible, use backing gas inside pipe to further improve the result.

Cunifer pipes with a small diameter and thin walls should be welded using TIG welding.

If there is an overlap joint (capillary joint) silver brazing should be considered.

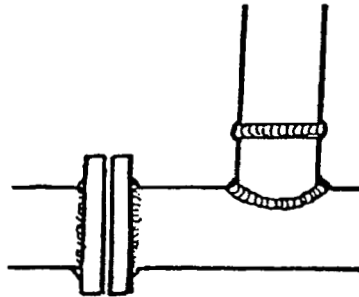
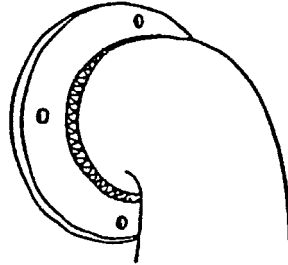



IALBRO W 237

Description:

Solid wire for GMA welding of copper-aluminium alloys e.g. Yorcalbro.
High resistance to corrosion and wear.



Wire identification:

Solid copper-aluminium wire on a spool.

Classification

AWS A5.7	DIN 1733	Werkstoff No.
ER Cu Al-1	MSG-Cu Al 8	2.0921

Type of current

Welding positions



PA

PB

PC

PF

PE, PD

Shielding gas



Materials to be welded

Copper-nickel wrought alloys	DIN 17665	W.No.
	CuAl5As CuAl8	2.0918 2.0920
Copper-aluminium cast alloys	DIN 1714	W.No.
	G-CuAl8Mn	2.0962

Trade name types:

– Yorcalbro (Cu 76%, Al 12%, Zn 21.96%, As 0.04%)

3.03

Chemical composition as welded (W%)

Mn	Al	Cu
≤1.0	8	Rest

Mechanical properties as welded

Tensile strength MPa	Yield strength MPa	Elongation %	Hardness HB	Melting range °C
≥430	≥180	≥40	± 120	1030–1040

Welding data

Wire speed	Volt	Stick out	Deposition rate kg/h	Kg wire/kg weldmetal	Fume class* SS-062802
7.5 m/min	22 V	8–10 mm	1.43–2.63	1.05	1

Packaging data

Diameter mm	Spool size mm	Net weight per spool kg	Product No. per spool
0.8	200 x 55	5	090-777972

IALBRO W 237

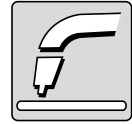

Unitor IALBRO-W is suited for welding most bronze/brass alloys, including aluminum bronzes like Yorcalbro, in wrought as well as cast forms. It is also suited for rebuilding or joining materials to steel or cast iron, and for wear or corrosion resistant overlays on steel and cast iron. Use pure Argon as shielding gas.

Thoroughly clean the welding area with a stainless steel brush or emery paper before commencing welding.

Yorcalbro pipes with a small diameter and thin walls should be welded using TIG welding. If there is an overlap joint (capillary joint) silver brazing should be considered.

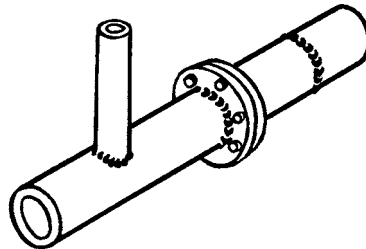
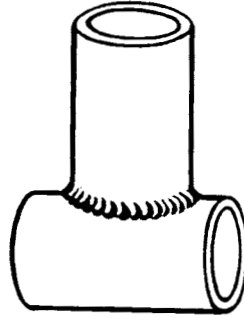



ALUMAG W 235

**Description:**

Solid wire for GMA welding of aluminium alloys with maximum 5% Mg.

Wire identification:

Solid aluminium wire on a spool.

Classification

AWS A5.10	DIN 1732	Werkstoff Nr.
ER 5356	MSG-ALMg5	3.3556

Type of current**Welding positions**

PA

PB

PC

PF

Shielding gas**Materials to be welded**Aluminium wrought alloys:

DIN 1725/Part 1: AIMg5, AIMg4.5, AIMg3
AIMg2Mn0.8, AIMg2.7Mn, AIMg4Mn

Aluminium cast alloys:

DIN 1725/Part 2: G-AIMg3, G-AIMg3Si, G-AIMg3 8 (Cu)
G-AIMg5, G-AIMg5Si
(generally all cast alloys containing magnesium as main alloying element)

Chemical composition as welded (W%)

3.03

Mn	Ti	Mg	Cr	Al
0.4	<0.15	5.0	≤0.15	Rest

Mechanical properties as welded

Tensile strength MPa	Yield strength MPa	Elongation %
≥240	≥110	≥17

Welding data

Wire speed	Volt	Stick out	Deposition rate kg/h	Kg wire/kg weldmetal	Fume class* SS-062802
12 m/min	23 V	8-10 mm	0.69-1.57	1.05	1

Packaging data

Diameter mm	Spool size mm	Net weight per spool kg	Product No. per spool
1	200 x 55	2	090-590083

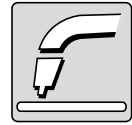

Unitor Alumag-W is a magnesium alloyed wire for welding all common wrought and cast aluminium alloys, e.g. AlMg, AlMgMn, AlMgSi and AlMg(Cu) alloys. It is specially suited for welds which must be resistant to seawater and high tension, and also where high ductility is required. Use pure Argon as shielding gas.

As the aluminium wire is quite soft, torch cables of more than 3 m length should be avoided. Longer cables may cause uneven or interrupted wire feed.

Clean the joints and adjacent surfaces thoroughly. Use a stainless steel brush, not an ordinary steel brush which will rub iron oxides into the aluminium and contaminate the weld pool. Cast aluminium should be pre-heated to approximately 300 °C before welding is commenced. Make sure that cast components that have to be pre-heated are well supported, so that they do not sag when temperature rises. Cast alloys that have been pre-heated must be allowed to cool slowly after being welded.

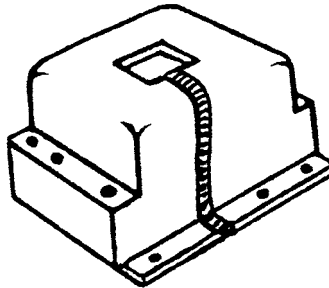
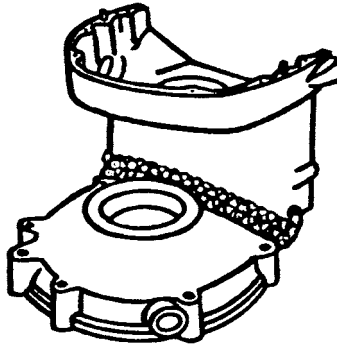

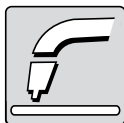

ABRATECH-W-230

Description:

Self-Shielded Flux Cored Wire for Hard Surfacing

Wire identification:

Tubular Flux Cored Wire on spool

Classifications

DIN 8555

MF 10-60

Type of current**Welding positions**

PA

PB

PC

Shielding gas

No shielding gas
required

**Materials
to be welded**

Hard surfacing of:

Low/medium carbon steels,
Austenitic manganese steel with 12- 14 % Mn

**Chemical
composition
as welded (W %)**

C	Mn	Si	Cr	B
4,5	0,5	1	26	0,4

**Mechanical
properties as
welded**

Hardness
HRC

60

Welding data

Wire speed	Volt	Stick out	Deposition rate kg/h	Kg wire/kg weldmetal	Fume class* SS-062802
8.5 m/min	32 V	10 mm	5.7	6.3	7

Packaging data

Diameter mm	Spool size mm	Net weight per spool kg	Product No. per spool
1,6	300 X 100	15	090-230230

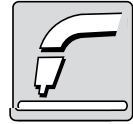

General information

Unitor Abratech-W-230 is a hard surfacing self shielded flux cored wire with excellent resistance to abrasive wear under moderate impact and pressure. The wire deposit chromium carbides in an austenitic matrix.

Edge preparation: Left over of previous welds should be removed using gouging electrode CH-2-382.

Pre-heating: Depends on steels carbon equivalent (Ce) and the shape and size of part to be welded. We recommend as follows:

Ce <0,2	No need for pre-heating
Ce 0,2-0,4	Pre-heat to 100 - 200°C
Ce 0,4-0,8	Pre-heat to 200 - 300°C

Austenitic Manganese steel must not be pre-heated. The interpass temperature of the object not to exceed 250°C

Connect the torch to + polarity. There is no need for shielding gas because the wire is a self shielded flux cored wire producing its own gas protection. Weld using a small weaving motion from side to side. The required hardness is obtained in one layer. There is no slag to be removed after welding.

The deposit will crack because of its hardness at regular intervals without this cracks progressing into the base material

Areas of application:

Protection of surfaces subject to extreme wear and abrasion caused by solids or slurry. Specifically meant for dredgers and cement carriers facing heavy abrasion combined with medium and light impact.

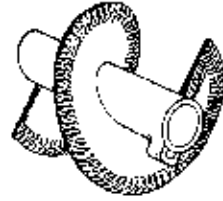

Feeder screws

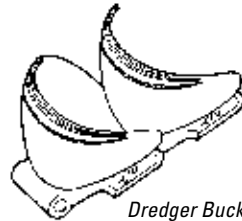

Dredger Buckets

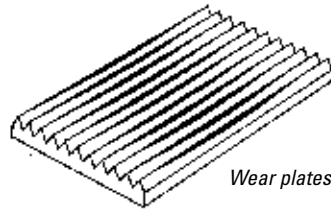

Wear plates

GAS WELDING RODS AND FLUXES



Introduction	242
MS-200	244
Alumag-235	246
Aluflux-234 F.....	248



GAS WELDING RODS AND FLUXES

Introduction

Gas welding utilizes the high flame temperature in the oxy-acetylene flame (3100 °C) to melt the base material.

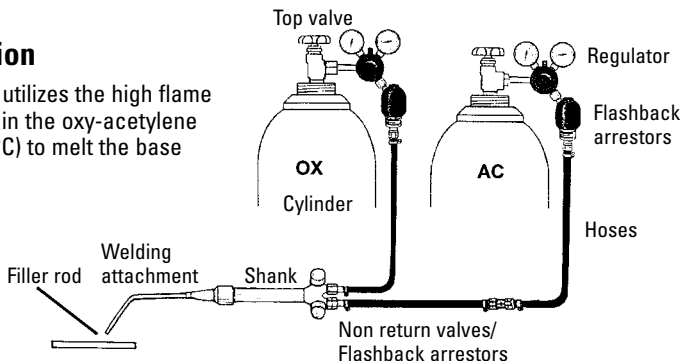

A consumable in the form of a filler rod is added to the pool. The weld is an alloy consisting of the parent material and the filler rod.

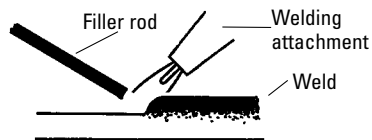

We distinguish between two different welding techniques: Leftward welding and Rightward welding.

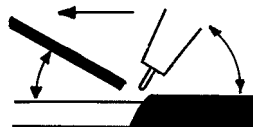

Leftward welding.

For material thickness up to 3.2 mm (1/8 in) use Leftward welding.

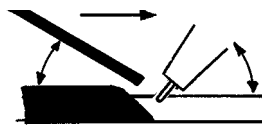

Rightward welding.

For material thickness above 3.2 mm (1/8 in) use Rightward welding.

Rods for gas welding

Unitor rods for Gas welding are supplied in sealed plastic containers. All rods are supplied in 500 mm length for convenient use. The label on each container fully identifies the contents, and also gives rod data and basic information on application areas and use.



GAS WELDING RODS AND FLUXES



The neutral flame

Two distinct zones may be seen in the neutral flame. The inner cone of the flame has a bright blue light and extends only a short distance from the tip. Around this inner cone is the flame envelope which is darker and less intensely blue. This flame is neutral, and is used for heating, cutting and for most steel welding work.

The carburizing flame

The carburizing flame has excess of acetylene, and is recognised by a secondary flame zone between the inner cone and the flame envelope. This zone is less bright and more white in colour than the inner cone, but is considerably brighter than the flame envelope.

When igniting an Ac/Ox torch one normally opens fully for Acetylene and only slightly for Oxygen, obtaining a strongly carburizing flame. By adding Oxygen (and if necessary reducing the Acetylene flow) the secondary zone will be reduced, and a neutral flame is obtained just as the secondary zone disappears.

Reducing the Oxygen flow slightly again will give a carburizing flame with a small secondary flame zone, approximately twice as long as the inner cone. This soft flame (also called a reducing flame) is used for welding of aluminum and aluminum alloys, and for soft soldering.

The oxidising flame

By increasing the Oxygen flow slightly beyond the point where the secondary zone disappears one will obtain an oxidising flame (with excess oxygen). The flame will be shorter and sharper than the neutral flame, with a shorter, more pointed inner cone. This flame is slightly hotter than the neutral flame, and is used for welding cast iron, brass, bronze and zinc alloys, and for brazing.

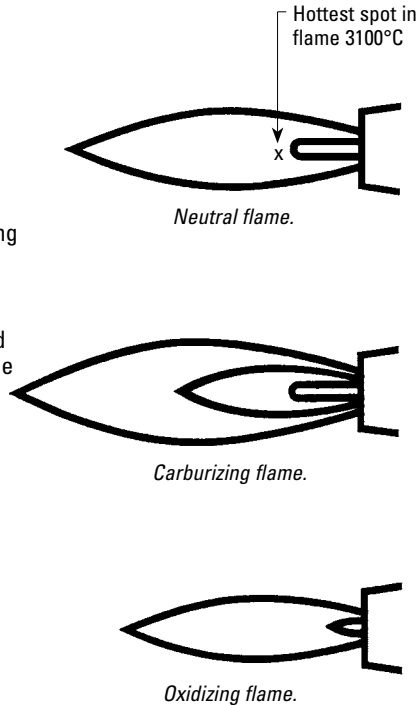



MS 200

Description

Gas welding rod for welding of unalloyed and low alloyed structural steel with a carbon content of less than 0.2%.



Identification

Copper coated steel rod.

Classification

AWS / A 5.2	EN 12536	BS 1453	DIN 8554
R 60	OII	A 2	61121

Flame setting



Flux No flux required.

Materials to be welded

R St 37.2, U St 37.2, St 37.3
St 44.2, St 44.3
St 37.0, U St 37.0, St 44.0
P235GH-P265 GH, HI, HII

Chemical composition as welded (W%)

C	Si	Mn	S	P	Fe
0.1	0.15	1.0	≤0.030	≤0.030	Rest

Mechanical properties as welded

Tensile strength MPa	Yield strength MPa	Elongation %	Impact value ISO-V (J)
≥390-440	≥300	20	+20°C = ≥50

Packaging data

Diameter mm.	Length mm.	Rods per package	Net weight per package kg	Product No. per package
2.0	500	280	3.5	092-539551
3.0	500	125	3.5	092-539569



Unitor MS 200 is a Gas welding rod for welding of unalloyed and low alloyed structural steel. It can be used for welding thin as well as heavier sheets.

Select the diameter of the wire according to the thickness of the workpiece. Clean all rust, scale and old paint from the area.

In general, gas welding of unalloyed steel is suitable for thin sheets and pipes of small diameters, where the wall thickness does not exceed 6 mm.

For larger dimensions it may be advantageous to use electric arc welding with coated electrodes.

The MS rod is specially suited for gas welding, having a viscosity that makes in-position gas welding easy. Select the blowpipe according to the thickness of the workpiece. The flame should be neutral. Workpieces less than 4 mm thick should be welded with the Leftward technique, thicker workpieces should be welded Rightwards. Do not overheat the workpiece. Maximum temperature of the workpiece should be 350°C.

Gas welding rods including our MS 200 for mild steel have a low silicium contents in order to perform satisfactorily when gas welded. TIG welding rods have a high silicium content making the molten pool fluid. It is therefore important that Gas welding rods are not used for TIG welding and vice versa.

For TIG welding use IMS-210.

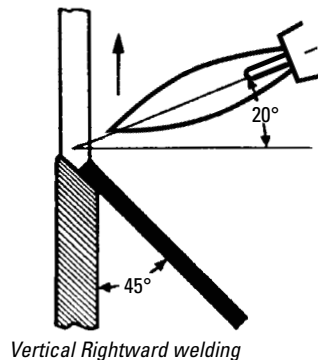
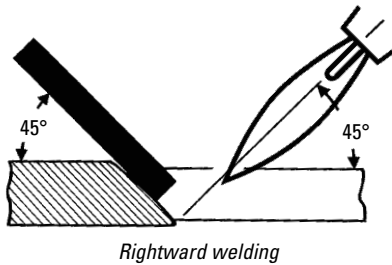
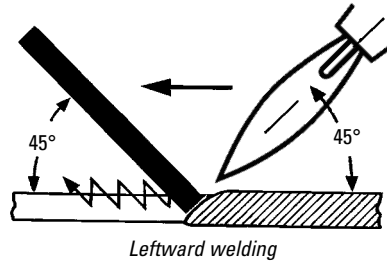



ALUMAG 235



Description

Gas and TIG welding rod for wrought and cast aluminium alloys containing up to 5% Mg. Generally it can be used for all cast alloys containing magnesium as the main alloying element.

Identification

Imprint 5356 ALMG 5

Classification

AWS A5.10	DIN 1732	Werkstoff No.
ER 5356	WSG-AI Mg5	3.3556

Flame setting



Flux Aluflux 234 F, 250 gram container. Order no. 092-603043.

Materials to be welded

Aluminium wrought alloys:

DIN 1725/Part 1: AlMg5, AlMg4.5, AlMg3,
AlMg2Mn0.8, AlMg2.7Mn, AlMg4Mn

Aluminium cast alloys:

DIN 1725/Part 2: G-AlMg3, G-AlMg3Si, G-AlMg3(Cu)
G-AlMg5, G-AlMg5Si, G-AlMg9
(generally all cast alloys containing magnesium as main alloying element).

Chemical composition as welded (W%)

3.04

Mn	Ti	Mg	Cr	Al
0.4	<0.15	5.0	≤0.15	Rest

Mechanical properties as welded

Tensile strength MPa	Yield strength MPa	Elongation %	Melting range °C
≥240	≥110	≥17	562-633

Packaging data

Diameter mm.	Length mm.	Rods per package	Net weight per package kg	Product No. per package
3	500	47	0.5	092-514265

Alumag-235 may be used for TIG-welding using AC welding machine.
Shielding gas: Argon, 6-9 l/min.

ALUMAG 235



Unitor ALUMAG 235 is used for welding pure aluminium, seawater-resistant aluminum and cast aluminium.

Clean the joints and adjacent surfaces thoroughly. Use a stainless steel brush, not an ordinary steel brush which will rub iron oxides into the aluminum and contaminate the weld pool. Cast aluminum should be pre-heated to approximately 300°C. Make sure that pre heated cast components are well supported, so that they do not sag when the temperature rises. Cast alloys that have been pre-heated must be allowed to cool slowly after being welded.

Gas welding

In gas welding a flame with a slight excess of acetylene is used, together with ALUFLUX 234 F, a flux which reduces oxides and counteracts oxidation in the welding zone. This flux which is in powder form can be mixed with clean water into a paste that is painted onto the welding area and the welding rod. If the work pieces are thick, it is also recommended to use flux at the back of the joint. The flux is highly corrosive on aluminum and should be removed immediately after welding, by scrubbing with hot water.

TIG (GTAW) welding

For TIG welding of aluminium it is necessary to use a special alternating current (AC) power source. AC is required to break the oxide layer on the aluminium surface.

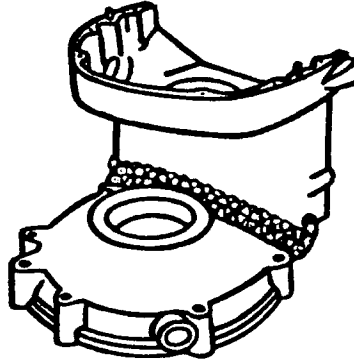

Repair of aluminium cover plate.



*Carburising flame.
Slight surplus of acetylene.*



Remember that fluxes can be contaminated. Therefore, always replace the lid after use.

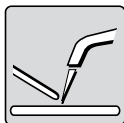

ALUFLUX 234 F

Description

Flux for gas welding rod Alumag-235 on aluminium.

Identification

White flux in powder form inside container.

Application Mix to a paste with distilled water and apply with brush on rod and joint edges. The flux is corrosive. Remove with brush and hot water after brazing.

HARMFUL	R22	Harmful if swallowed
	R48/20/22	Harmful : danger of serious damage to health by prolonged exposure through inhalation and if swallowed
	R52/53	Harmful to aquatic organisms, may cause long-term adverse effects in the aquatic environment
	S9	Keep container in a well-ventilated place
	S13	Keep away from food, drink and animal feedingstuffs
	S22	Do not breathe dust
	S29	Do not empty into drains
S60	This material and its container must be disposed of as hazardous waste	

Packaging data

Gross weight in grams	Product No.
250	092-603043

* SDS available on request.

3.04



BRAZING RODS AND FLUXES



Introduction	250
Bronze-264	254
FC-Bronze-261	256
FC-Wearbro-262	258
Cast Iron 237	260
AG-45-253	262
AG-60-252	264
Tin-241 AG	266
Fluxes for Brazing	268
Bronze Flux-261 PF	269
Wearbro Flux-262 PF	270
AG-60/45 Flux-252 PF	271
Albro Flux-263 PF	272
Cast Iron Flux 236 F	273



BRAZING RODS AND FLUXES

Introduction

When brazing, the parent metal is heated to bonding temperature. This is the minimum temperature to which the parent metal must be heated to form an alloy of the filler metal and the parent material.

When adding the brazing rod *and flux* we obtain a surface alloying.

Brazing is a mechanical bonding.

Welding is a chemical bonding which involves structural changes in the base material.

Each brazing alloy has its own bonding temperature which is independent of the parent material.

Because brazing is a surface alloy the surface must be cleaned.

In most cases an oxide-film covers the surface of the parent metal and the rod before and during brazing.

This film acts as isolation that prevents bonding.

The function of the flux is to dissolve oxides, detach them from the parent metal and the rod, and keep them in suspension.

The composition of the flux must be matched to type of brazing rod.

The flux should liquify approx. 100°C before bonding temperature.

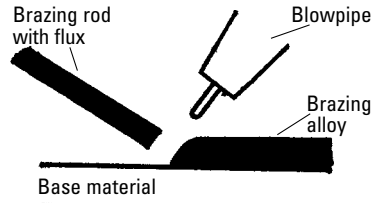

When brazing, the parent material is not melted, but brought to the bonding temperature.



A clean surface with sufficient flux allows the brazing alloy to flow out and bind to the surface

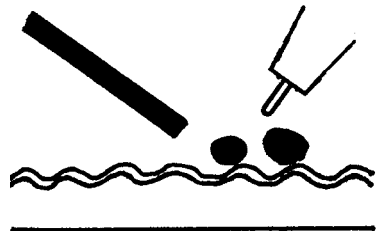

Without the flux to suspend water vapour, grease and oxides, a film will prevent the brazing alloy from bonding

BRAZING RODS AND FLUXES

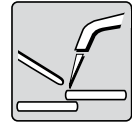

If the bonding temperature is below 400°C the method is termed Soldering. If the bonding temperature is above 400°C the method is called Brazing. Brazing can further be divided into Capillary brazing/Silver brazing and Braze welding.

In Capillary Brazing the alloys are thin flowing in consistency (Silver brazing) and they are ideal for use in capillary joints.

In Braze welding the alloys are mostly thick floating in consistency and the joint preparation like in welding.

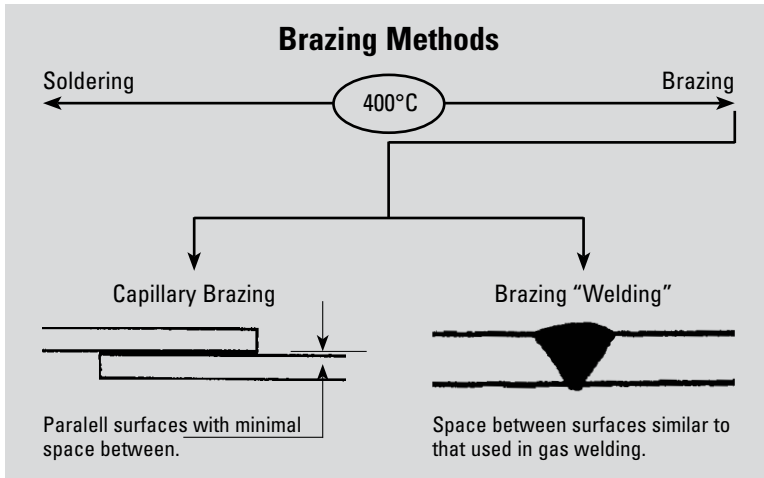

3.05

Typical Capillary/Silver brazing joints. Note that they all utilise capillary action.

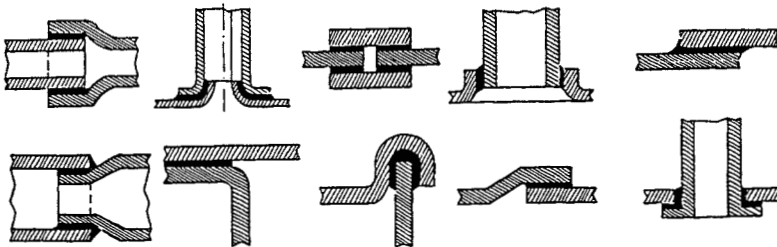



BRAZING RODS AND FLUXES

Unitor soldering and brazing alloys have been selected with versatility and ease of use in mind. In the industry there is a wide range of brazing alloys available for special applications, but a number of these are developed for special applications, and may be dangerous if used incorrectly. Many brazing alloys contain Cadmium or Phosphorous. These elements offer certain advantages with regard to price, because the silver content can be reduced without reduction of the capillary effect. Both elements, however, are dangerous or prohibited in applications frequently needed on board. Phosphorous is prohibited (by Norwegian regulations) on brass pipes and red bronze. Cadmium is extremely poisonous and must not be used on any piping or equipment carrying drinking water or food.

Unitor brazing alloys are all Cadmium free, and only the cast-iron brazing rod contains phosphorous. Unitor brazing rods may therefore safely be used as true general purpose filler material onboard. Each alloy has been selected to cover a wide range of applications. This reduces the number of alloys needed to be kept in stock

and gives the operator an easier choice.

Where practical flux-coated rods have been selected to ensure the best soldering/brazing properties. In addition a range of fluxes is supplied. They are designed specially for use with the Unitor alloys, either as addition to the flux coating on the rod, or with the un-fluxed rods.

The soldering tin contains flux in ducts inside the solder. Apart from the soldering tin, which is supplied on a spool, all alloys are supplied in 500 mm lengths, which is a suitable length if unnecessary bending of the rod shall be avoided. Even though special care has been taken to ensure flexibility in the coating, excessive bending should be avoided to ensure that the coating remains undamaged. It is good economy to braze the remaining part of a rod to the next instead of discarding the stump

Both rods and fluxes are supplied in sealed plastic containers for protection against humidity. The label on each container fully identifies the contents, and also gives basic information on application areas.





BRONZE 264

Description

An easy-flowing, universal brazing bronze (brass) rod for the brazing of steel, cast iron, copper and copper alloys, nickel and nickel alloys. It gives a very smooth and attractive surface. The addition of Si, Mn and Sn guarantees a strong and high-quality deposit.



Identification

Bare bronze coloured rod.

Classification

AWS A5.8	EN 1044	BS 1453/1845	DIN 8513	Werkstoff. No.
RB CuZn A	CU 304	C2/CZ 6AC	L-Cu Zn 39 Sn	2.0531

Type of joint

Classification

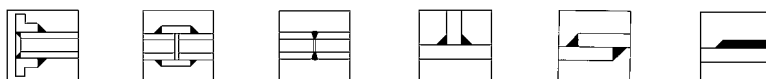

Flame setting



Flame setting

Working temperature °C	Melting range °C
900	870-900

Flux

Bronze flux-261 PF (250 g container) product no. 093-603076.

Chemical composition approx. (%)

Cu	Mn	Si	Sn	Al	Ni	Zn
60	0.6	0.4	0.35	≤0.005	≤0.01	Rest

Mechanical properties

Tensile strength MPa	Yield strength MPa	Elongation %	Hardness HB	Melting range °C
≥490	—	≥35	100	870-900

Packaging data

Diameter mm.	Length mm.	Quantity per package	Net weight per package kg	Product No. per package
3	500	54	1.7	093-174326
5	500	36	3	093-514240

BRONZE 264

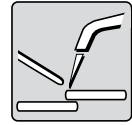

Unitor Bronze 264 is used to braze welding steel, cast iron, malleable cast iron, copper and brass with high copper content (red bronze) and also for welding brass and bronze. Use silver solder AG 60-252 for Yorcalbro and Cunifer.

Cast iron joint surfaces must be clean and bright (i.e. cleaned off with grinder). Graphite should be removed with a sharp tool or by means of chemicals. Clean off burr, round off sharp edges.

The use of bronze rod for joint brazing has become widespread as brazing is easier than ordinary welding and requires less heat. Brazing provides a tough, strong joint.

Bronze brazing requires thorough cleaning of the joint surfaces, good mating of the parts and correct working temperature.

Choice of welding neck will depend on the thickness and size of the workpiece. Do not use too large a welding neck, or you may overheat the joint. The flame should be adjusted with a slight excess of oxygen (oxidising).

Apply Unitor Bronze Flux 261 PF paste to the rod and joint edges. Check the temperature by melting off a drop from the rod on the joint surface and move the torch in a circle around the drop until it melts and flows outwards. Repeat this process to form a continuous bead. Braze with Leftward technique.

Flux is corrosive, so any surplus after brazing should be cleaned off with hot water.

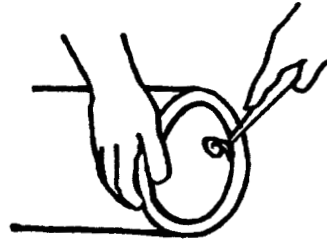
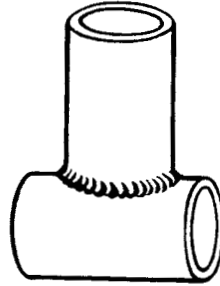

Remove inside burr.

Bronze Flux 261 PF.

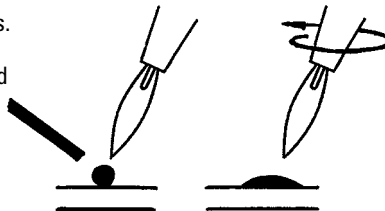

Melt of a drop.

Move the torch in a circle until the drop melts and flows outwards.



FC BRONZE 261

Description

A flux-coated brazing rod for joining and surfacing copper, brass, bronze, aluminium bronze, cast iron and steel. May be used for brazing galvanized steel without destroying the galvanized surface.



Identification

Flux coated rod. Yellow flux.

Classification

NF A 81-362	ISO 3677
59 C 1	B Cu 59 ZnAgSi 870-890

Type of joint

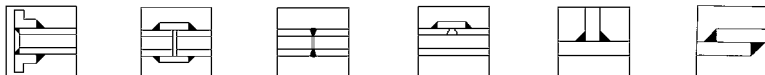

Flame setting



Working range

Working temperature °C	Solidus-Liquidus °C
890	870-890

Flux Bronze flux-261 PF (250 g container) product no. 093-603076.

Chemical composition approx. (%)

Cu	Mn	Sn	Ag	Zn
60	0.3	0.1	1	Rest

3.05

Mechanical properties

Tensile strength MPa	Elongation %	Hardness HB
450-550	30	125

Packaging data

Diameter mm.	Length mm.	Quantity per package	Net weight per package kg	Product No. per package
2	500	69	1	093-233551
3	500	32	1	093-233569

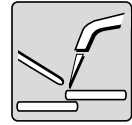

Description and uses

Unitor FC-Bronze 261 is a flux-coated special brazing bronze with a low melting point for joining and surfacing copper, brass, bronze, aluminium-bronze, cast iron, steel and galvanized steel.

Brass may be brazed without melting the base metal, due to the low melting point of the filler.

Galvanized piping can be brazed without destroying the galvanized surface to any significant degree.

FC-Bronze 261 is not recommended for use on Yorcalbro and Cunifer pipes, use silver solder AG-60 252 instead.

Workpieces up to 5 mm thick may be brazed without grooving. Round off the edges and clean thoroughly. Paint Unitor Bronze flux 261 PF on the joint surfaces.

For brazing brass and galvanized steel, use an oxidising flame (with surplus of oxygen), otherwise a neutral flame.

Bulky, solid parts must be thoroughly pre-heated with a good spread. Heat the starting point to dark red glow. Place the filler rod in the groove and melt off a drop. Lift away the rod and spread out the filler before applying the rod again.

Unitor FC-Bronze 261 is specially suitable for position welding. Hold the torch at an angle of 35–40°C and the flame tip about 10 mm from the metal. Braze with Leftward technique. Wash off surplus flux with water after brazing.

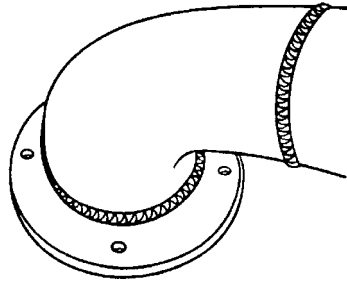

A typical application.

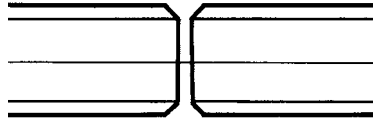

Joint preparation for brazing galvanized pipes.

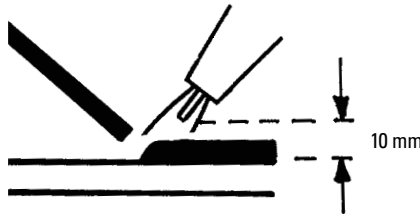

Leftward brazing.



FC WEARBRO 262

Description

A flux-coated wear-resistant bronze rod used for applying a hard-wearing surface to bronze, brass, copper, steel, cast iron and malleable cast iron. Also used for braze welding cast iron.



Identification

Flux coated rod. Blue flux.

Classification

ISO 3677

B-Cu 48ZnNi Si 890-920

Type of joint



Flame setting

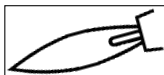

Neutral or slight oxygen surplus.

Working range

Working temperature °C	Solidus-Liquidus °C
910	890-920

Flux Wearbro flux-262 PF (250 g container) product no. 093-603068.

Chemical composition approx. (%)

Cu	Ni	Zn
49	10	Rest

3.05

Mechanical properties

Tensile strength MPa	Elongation %	Hardness HB
400-600	15-20	175

Packaging data

Diameter mm.	Length mm.	Quantity per package	Net weight per package kg	Product No. per package
3	500	33	1	093-233577
5	500	13	1.1	093-233585

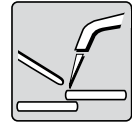

Description and uses

Unitor FC-Wearbro 262 is a flux-coated wear-resistant bronze for surfacing bronze, brass, copper, steel, cast iron and malleable iron. The metal is tough, wear-resistant, non-porous and easily machineable. It has a low coefficient of friction and is seawater resistant.

Unitor FC-Wearbro 262 is specially suitable for building up damaged machine parts which have been subjected to impact, wear or bending strain, e.g. gear wheels, cams of all types, valve seats, bearing surfaces and shaft journals. Due to its low bonding temperature, high strength and toughness, it is also suitable for braze welding cast iron.

The surface must be cleaned down to bare metal and rough edges rounded off. Apply Wearbro Flux 262 PF to the area to be surfaced. In the case of cast iron, the surfaces must be filed down with a coarse file to remove surface graphite.

Adjust the flame with a slight surplus of oxygen (oxidising) and heat the area where work is to commence to a dark red heat. Apply the end of the rod to the surface and melt off a drop. Spread the filler out with the flame before melting off the next drop, then continue the process. Braze with Leftward technique. Avoid overheating. Powder residue must be removed after brazing. The finished surface is easily machined.

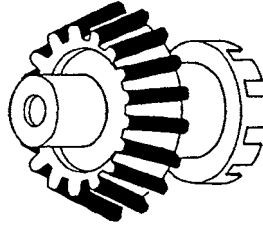

Building up worn teeth on a gear wheel.

Building up worn shaft journals.

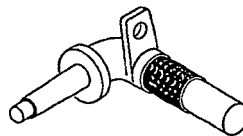
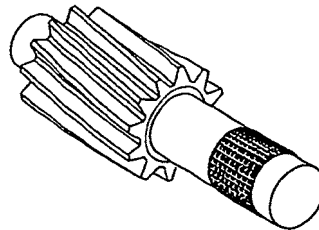
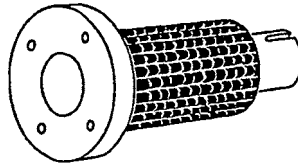



CAST IRON 237

Description

Rod for joining and surfacing cast iron and gas welding cast iron to steel. Oil impregnated cast iron may also be gas welded with Cast Iron 237.



Identification

Metal rod.

Classification DIN 8573: Grd Fe CL-1. AWS / ASME / SFA 5.15: R – C1.

Type of joint

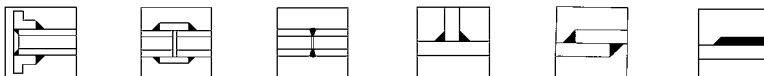

Flame setting



Working range

Working temperature °C	Solidus-Liquidus °C
1170	1150–1190

Flux Cast Iron Flux 236F (250g container) product no 764487.

Chemical composition approx. (%)

C	Si	Mn	P	Fe
3.3	3.0	0.5	0.6	Rest

Mechanical properties

Tensile strength MPa	Hardness HB
254–294	200

Packaging data

Diameter mm.	Length mm.	Quantity per package	Net weight per package kg	Product No. per package
5	500	15	1.1	093-764485

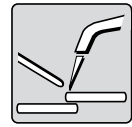

Description and uses

Unitor Cast iron is a filler metal for welding cast iron, malleable iron and cast iron/steel joints.

The filler metal is extremely easy to work with, has high tensile strength and the structure and colour of cast iron. Welded connections are compact and machinable. The filler also fuses to oil contaminated cast iron. Typical uses are welding of cracked parts and building up worn surfaces such as gears and sprockets. The choice of method – gas welding or arc welding – for repairs to cast iron depends on the size, shape and thickness of the workpiece.

As a general rule, gas welding is used for small machine parts and arc welding (cold welding) on larger, more complicated parts.

Adjust the flame to give a slight surplus of oxygen (oxidising). The area to be brazed must be properly cleaned and any casting skin removed. Round off any sharp edges or corners. Cracks must be surface ground or prepared with a 90° V-groove along the crack. It is usual to drill a hole at the end of the crack. Preheat the parts with a good spread of heat on either side, to 400–600°C. Heat the end of the rod and dip it in the flux powder. The flux will stick to the hot rod. Heat the starting point to a dark red heat. Melt off a drop from the flux-coated rod into the groove and spread out by continually moving the torch, which should be kept at an angle of 15–30° to the workpiece. When the filler has flowed freely into the seam, melt off a new globule and repeat the procedure. Stir the weld pool with the filler rod. Weld with Leftward technique.

After gas welding, allow the part to cool slowly in diatomite or dry sand. Surplus flux must be removed.

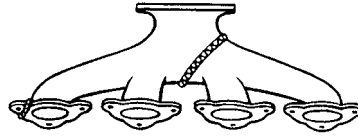

Brazing a cast iron manifold

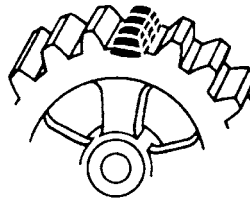

Building up worn parts such as gear wheels

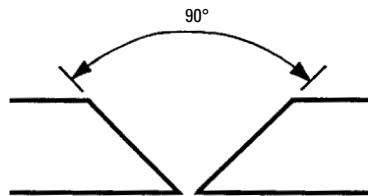

Preparation of joint

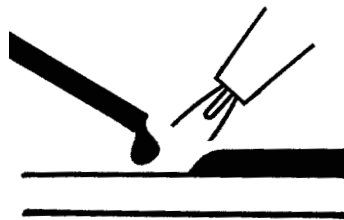

Gas weld Leftward. Note that the weld pool must not be stirred with the filler rod



AG 45 253

Description

Bare cadmium free silver rod for joining of all types of steel, stainless steel, copper, copper alloys, nickel and nickel alloys, cast iron and hard metals. This brazing rod gives a very good joint and can be used for brazing nipples, sleeves and unions to copper pipes.



Identification

Bare silver coloured rod.

Classification

ISO 3677	DIN 8513
B AG 44 CuZn 675-735	L-AG 44

Type of joint

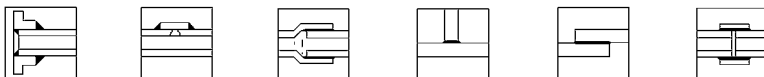

Flame setting



Working range

Working temperature °C	Solidus-Liquidus °C
730	680-740

Flux AG-60/45 Flux 252 PF (250 g container) product no. 093-778461.

Chemical composition approx. (%)

Cu	Ag	Zn
30	44	Rest

Mechanical properties

Tensile strength MPa	Elongation %	Hardness HB
400-480	20	130

Packaging data

Diameter mm.	Length mm.	Quantity per package	Net weight per package kg	Product No. per package
2.0	500	28	0.4	093-519744

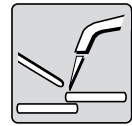

Description and uses

Unitor AG-45 is a very fluid silver brazing alloy with high capillary action, for joining all types of steel, stainless steel, copper alloys, nickel alloys, cast steel, malleable iron, SG iron and hard metal.

The alloy is cadmium-free and may therefore be used for brazing equipment carrying drinking water or food. AG-45 utilises capillary action and good mating of joint faces is essential to obtain the required.

Maximum capillary gap is 0.1 mm.

When silver brazing brass fittings to copper pipe, the filler metal must have 45% silver content in order to obtain a proper joint.

AG-45 is Phosphorous free. (Norwegian regulations prohibit the use of filler metal with phosphorous content for brazing brass pipes or red bronze (sleeve bends)).

The joint faces must be cleaned properly. Apply flux AG-60/45 Flux-252 PF, which is in paste form, to the filler rod and the surfaces. It is essential to coat the surfaces with paste in order to «moisten» the metal and ensure correct capillary action. Use a neutral flame. The area to be brazed should be heated evenly to 600–650°C, and the flame must be kept in continuous motion until the flux has melted. Too much heat may give unsatisfactory results. Melt off and spread a drop of the rod while moving the flame continuously. Flux residue after brazing must be removed with hot water and a steel wire brush.

For brazing of salt water-resistant Yorcalbro and Cunifer pipes, Unitor AG 60 252 is recommended.

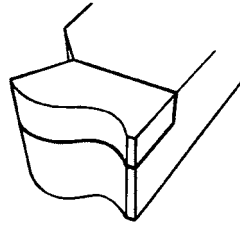

Hard metal bit, silver brazed to a lathe tool

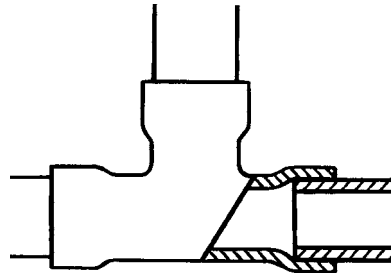
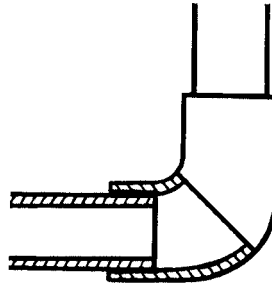

Brazing brass bends to copper pipes. Maximum capillary gap between joint surfaces 0.1 mm. Coat joint surfaces with flux



AG 60 252

Description

A flux coated cadmium free, seawater resistant, high strength silver rod for joining all types of steel, stainless steel, copper, copper alloys, nickel, nickel alloys, cast iron, Yorcibro pipes (aluminium-brass), unifer pipes type 90/10 and 70/30.



Identification

Flux coated rod. Pink flux.

Classification

ISO 3677	DIN 8513
B AG 55 ZnCuSn 620-660	L-AG 55 Sn

Type of joint

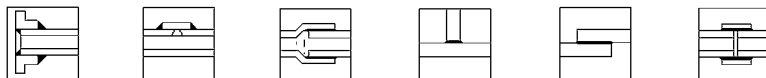

Flame setting

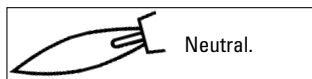

Working range

Working temperature °C	Solidus-Liquidus °C
650	630-660

Flux

AG-60/45 Flux 252 PF (250 g container) product no. 093-778461.

On Yorc Albro:

ALBRO FLUX 263 PF (250 g container) product no. 093-604371.

3.05

Chemical composition approx. (%)

Cu	Ag	Sn	Zn
21	55	2.5	Rest

Mechanical properties

Tensile strength MPa	Elongation %	Hardness HB
430	25	130

Packaging data

Diameter mm.	Length mm.	Quantity per package	Net weight per package kg	Product No. per package
2.0	500	24	0.5	093-233601

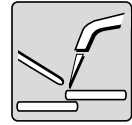

Description and uses

Unitor AG-60 is an easy flowing flux-coated brazing alloy containing approx. 55% silver. It is specially suitable for joints requiring high corrosion resistance and strength.

For capillary brazing of saltwater pipes, a filler containing at least 50% silver is required for providing the joint with the same degree of corrosion resistance as the metal in the pipe.

AG-60 is Cadmium-free and may therefore be used for brazing workpieces which will be in contact with foodstuff, drinking water, etc.

AG-60 is a capillary filler. In order to obtain a good capillary joint, proper mating of the joint surfaces is essential. Ideally, the capillary gap between joint surfaces should not exceed 0.1mm.

In addition to the flux coating on the rod, the joint surfaces must also be coated with flux, e.g. when brazing pipe nipples, unions, patching pipes, etc.

On aluminum bronze and Yorcalbro, use ALBRO Flux 263 PF. On other metals use AG-60/45 Flux-252 PF.

Brazing a patch on a pitted pipe.

Cut out the patch and make sure it mates well with the pipe surface. Clean the contact surfaces thoroughly, preferably with emery paper. Clean off any burrs. The patch should not be larger than necessary, otherwise it may be difficult to obtain sufficient heat beneath the patch.

The larger the patch, the more heat must be applied to the outside of it in order to build up the correct brazing temperature at the centre of the patch. This can result in overheating

of the pipe. Large patches should be TIG welded.

Coat the joint surfaces with flux. Use a neutral or reducing flame, with slight surplus of acetylene. Preheat thoroughly with a good spread. The correct temperature is reached when the flux melts. Melt off a drop of AG-60 and spread evenly with the flame. Flux residue should be cleaned off with hot water and a steel wire brush.

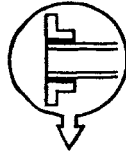

Typical uses and types of joint on Yorcalbro and Cunifer pipes

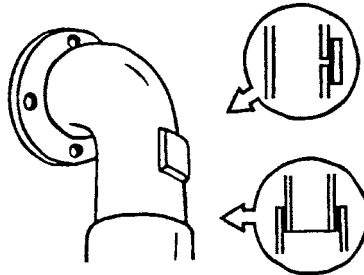

*Use additional flux AG-60/45 Flux 252 PF
For Yorcalbro use Albro flux 263 PF*



TIN 241 AG

Description

Flux cored lead free silver alloyed soft solder wire on spool for tinning and joining of electric conductors, electrical connections, electrical instruments, radios, batteries, refrigeration plants, etc.



Identification

Flux cored tin wire on spool.

Classification

DIN EN 61190

Sn96 Ag04 Cu0,7

Type of joint

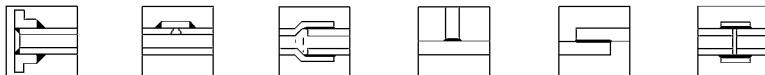

Flame setting

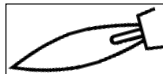

Preferably use soldering iron. If welding torch: Soft reducing flame.

Working range

Working temperature °C	Melting range °C
230	217

Flux

Additional flux not necessary.

Chemical composition approx. (%)

Sn	Ag	Cu
95.5	3.8	0.7

Mechanical properties

Tensile strength MPa
90 (Ms 58)

Packaging data

Diameter mm.	Length mm.	Quantity per package	Net weight per package kg	Product No. per package
1.5	–	–	0.5	093-777973

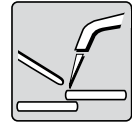

Description and uses

Unitor SOLDERING TIN 241 AG is a soft soldering wire on a spool, the wire has ducts filled with high quality flux. The use of flux-filled ducts ensures that the flux melts before the solder. It is not normally necessary to apply any additional flux except in the case of materials having an oxide surface coating of high melting point (use liquid flux or hydrochloric acid).

The surfaces must be clean and free from oily deposits, oxides, etc. Heat may be applied with a welding torch or a soldering iron. A soldering iron is recommended, but if a welding torch is used, adjust to a reducing flame and avoid direct contact between flame and solder. Apply the heat indirectly so that it travels through the metal to the soldering point.

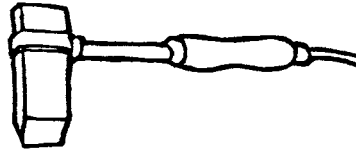

A soldering iron is preferred.

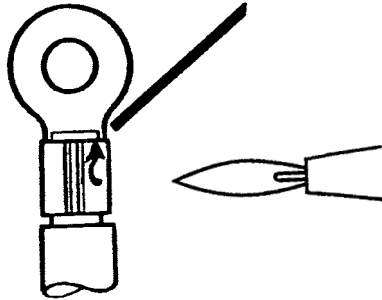

Heat indirectly when using a welding torch.



BRAZING RODS AND FLUXES

Fluxes for Brazing

A flux must possess the following properties:

- It must dissolve oxides
- It must prevent the formation of new oxide skin
- It must reduce the surface tension of the filler metal
- It must act as a heat indicator
- It must remain active for a time at melting temperature, without burning.

Unitor fluxes are normally in paste form, but may also be supplied as powders. Flux powder may be mixed with distilled water or methylated spirits if a paste is required. Always replace the cap on the flux tin after use to prevent drying out and contamination.

When handling flux, avoid direct contact with the skin, especially if you have scratches or open cuts. Always wash your hands afterwards. Good ventilation is necessary wherever welding or brazing takes place.

The different types of fluxes are formulated to melt at a temperature just below the bonding temperature of the filler metal. In this way the flux medium acts as a temperature indicator and shows when the correct bonding temperature has been reached.

Surplus flux remaining on the workpiece after brazing should be removed by rinsing in clean water and brushing.

Fluxes for welding are dealt with in the chapter on welding rods.



BRONZE FLUX 261 PF

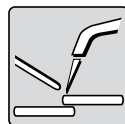

Description

Flux for brazing rod Bronze-264 and FC-Bronze-261.

Identification

Yellow flux in paste form inside container.

Application

Apply with brush.

With Bronze-264: On rod and joint edges.

With FC Bronze-261: As additional flux on joint edges. The flux is corrosive.

Remove with brush and hot water after brazing.

Toxicity	R60	May impair fertility
Harmful	R61	May cause harm to the unborn child
	S53	Avoid exposure - obtain special instructions before use
	S1/2	Keep locked up and out of the reach of children
	S29/56	Do not empty into drains, dispose of this material and its container at hazardous or special waste collection point
	S45	In case of accident or if you feel unwell, seek medical advice immediately (show the label where possible)

Packaging data

Gross weight in grams	Product No.
250	093-603076



3.05



WEARBRO FLUX 262 PF

Description

Flux for brazing rod FC-Wearbro 262.

Identification

Blue flux in paste form inside container.

Application

Apply with brush.
Use as additional flux for surface that are to be overlaid.
The flux is corrosive.
Remove with brush and hot water after brazing.

Toxicity

R60 May impair fertility

Harmful

R61 May cause harm to the unborn child

S53 Avoid exposure - obtain special instructions before use

S1/2 Keep locked up and out of the reach of children

S29/56 Do not empty into drains, dispose of this material and its container at hazardous or special waste collection point

S45 In case of accident or if you feel unwell, seek medical advice immediately (show the label where possible)

Packaging data

Gross weight in grams	Product No.
250	093-603068

3.05



AG 60/45 FLUX 252 PF

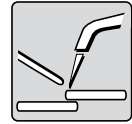

Description

Flux for silver brazing rods AG-60-252 and AG-45-253.

Identification

Pink flux in paste form inside container.

Application

Apply with brush.

With AG 45-253: On rod and joint edges.

With AG60-252: As additional flux for joint edges.

Flux is corrosive. Remove with brush and hot water after brazing.

Toxicity

- R60 May impair fertility
R61 May cause harm to the unborn child
R25 Also toxic if swallowed
R34 Causes burns
S1/2 Keep locked up and out of the reach of children
S26 In case of contact with eyes, rinse immediately with plenty of water and seek medical advice
S36/37/39 Wear suitable protective clothing, gloves and eye/face protection
S45 In case of accident or if you feel unwell, seek medical advice immediately (show the label where possible)
S56 Dispose of this material and its container to hazardous or special waste collection point

Packaging data

Gross weight in grams	Product No.
250	093-778461





ALBRO FLUX 263 PF

Description

Flux for silver brazing rod AG-60-252 on Yorcalbro.

Identification

White flux in paste form inside container.

Application Apply with brush as additional flux for joint edges.
Flux is corrosive. Remove with brush and hot water after brazing.

Contents Potassium bifluoride, zinc chloride, other components and water.

Toxicity

HARMFUL, DANGEROUS TO ENVIRONMENT

R36/37/38 Irritating to eyes, respiratory system and skin

R48/20/22 Harmful: danger of serious damage to health by prolonged exposure through inhalation and if swallowed

R51/53 Toxic to aquatic organisms, may cause long-term adverse effects in the aquatic environment

S2 Keep out of the reach of children

S23 Do not breathe vapour

S26 In case of contact with eyes, rinse immediately with plenty of water and seek medical advice

S29/56 Do not empty into drains, dispose of this material and its container at hazardous or special waste collection point

S36 Wear suitable protective clothing

S46 If swallowed, seek medical advice immediately and show this container or label

Packaging data

Gross weight in grams	Product No.
250	093-604371

3.05



CAST IRON FLUX 236 F

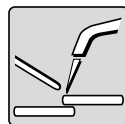

Description

Flux for Castiron-237.

Identification

Flux in powder form inside container.

Application Heat the end of the rod and dip it in the flux powder. The flux will stick to the hot rod.

Toxicity	R60	May impair fertility
	R61	May cause harm to the unborn child
	R25	Toxic if swallowed
	R34	Causes burns
	S1/2	Keep locked up and out of the reach of children
	§36/37/39	Wear suitable protective clothing, gloves and eye/face protection
	S45	In case of accident or if you feel unwell, seek medical advice immediately, (show the label where possible)
S56	Dispose of this material and its container at hazardous or special waste collection point	

Packaging data

Gross weight in grams	Product No.
250	092-764487



3.05

COLD REPAIR COMPOUNDS



Introduction	276
Typical application areas	276
How do Cold Repairs work?	278
How to prepare the surface	279
How to apply the product	280
Cold Repair Kit-A.	282
Product overview	284
Leak Stop – Pipe repair	286
Metalgrade Ready-Stick	290
Metalgrade Express	294
Metalgrade Rebuild	298
Metalgrade Hi-Temp.	302
Aquagrade Rebuild.	306
Ceramigrade Rebuild	310
Ceramigrade Liner	314
Ceramigrade Abrashield	318
Rubbergrade 6 Rebuild	322
Rubbergrade 6 Remould	326



COLD REPAIR COMPOUNDS

Introduction

Unitor Metalgrade and Ceramigrade products are a range of cold curing metal repair and rebuilding materials based on the latest polymer resin technology which is the result of many years of development.

Unitor Rubbergrade products are cold-vulcanising elastomeric repair materials for use on rubber as well as metal components.

The products are compatible with all ferrous and non-ferrous metals as well as most plastics, and have in many cases proved themselves as permanent repairs. They have

excellent chemical resistance and are suitable for permanent immersion in many environments including seawater, hydrocarbons, oils and a very wide range of chemical solutions.

The basic range of products is selected in order to provide a versatile program for on-board applications. The application areas complement and extend the various welding and related thermal processes already in use, providing an even more complete repair system than previously.

Typical application areas:

Where there is a need for emergency repairs.

Cold repair compounds require no rigging-up time, and no need for energy in the form of oxygen / acetylene or electricity. The energy is built into the consumable (product) and is released when mixing the base and activator. The curing time is down to a few minutes for several of the products.

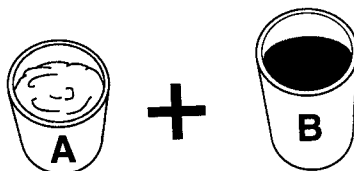

Activator + base

Where hot work like welding is not permitted due to fire / explosion hazard.

Cold repair systems are cold-curing processes. There is no risk of heat ignition or sparks.



Where the base material is not weldable.

Certain casted metal alloys are not weldable due to their chemistry. Sometimes welding method / equipment / consumable or operator

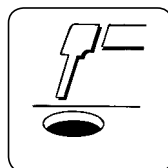

COLD REPAIR COMPOUNDS



knowledge is not available. If the base material is so corroded that there is nothing to weld on, a new part can be “casted” with the repair compound.

Where distortion of base material is unacceptable.

Welding causes expansion and contraction; resulting in distortion of the work piece.

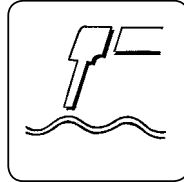

Where there is restricted space.

Polymer products can, if necessary, be injected through small diameter holes.

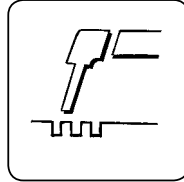

Where specific properties are required.

In many cases polymer compounds have better properties than weld overlays. Specifically, chemical resistance and wear resistant properties are improved. Large surfaces that are worn are also much faster overlaid with polymer compounds than with weld bead overlays.

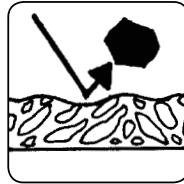

Where you need non-metal repairs.

Cold repair systems offer solutions for rubber gasket repairs or moulding, as well as solutions for repair or joining of plastics and composite materials.

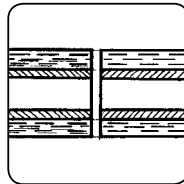



COLD REPAIR COMPOUNDS

How do Cold Repairs work?

Cold repair compounds are basically chemical reactions between resin (Base) and hardener (Activator) producing an extensive interlocking polymer network.

The adhesion to the base material (substrate) is partly mechanical (approx. 75%) and partly chemical hydrogen bonding (approx. 25%). It is a cold curing repair method that needs no specialised application equipment or outside energy.

Since it is mostly a mechanical bonding, it does not influence the base material by diluting it. The type of base material is thus of no concern.

All these repair materials are essentially polymers, i.e. extremely long, chain-like molecules resulting from the chemical reaction between a large number of much smaller molecules.

Provided that these small molecules contain at least two reactive "groups" of "sites" per molecule, the chemical reaction can proceed in a progressive, chain building fashion to yield long molecules made up for regular, repeating units.

In the uncombined state, the reactive components are generally liquids on account of their relatively small size or low "molecular weight". As the chemical reaction or "cure" progresses, the size of the polymer chain increases until ultimately the material becomes a solid.

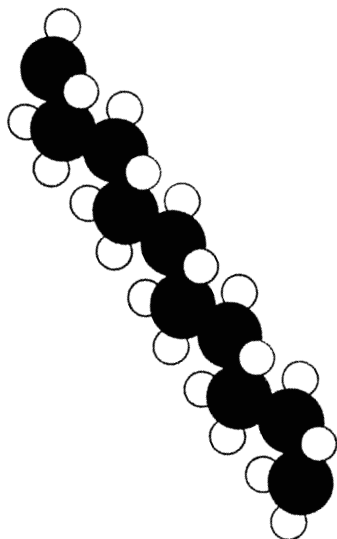
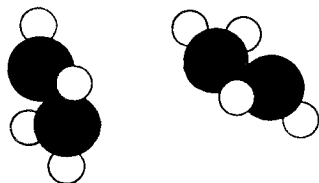
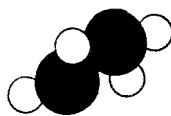

COLD REPAIR COMPOUNDS



How to prepare the surface

Heavy contamination due to oil or grease must be removed using a cleaner. Remove all loose rust and surface coatings.

Roughen surface with a coarse file, rasp, abrasive paper or saw blade. Create if possible a cross scoring pattern. A die grinder, needle scaler or angle grinder may also be used. If grinding, make sure the surface is roughened, not polished. Carry out a final degreasing with a cleaner before applying product. Rubber surfaces must be roughened using the special abrading tool.

CRITICAL applications (eg. pump repairs) should be abrasive blasted to a minimum standard SA 2 1/2. Profile 75-125 microns. The blasting medium should be angular grit. Parts which have been salt or chemically impregnated should be heated to 80°C by hot air overnight to sweat out the contamination. Remove contamination using a cleaner then re-blast the surface. Parts which should not adhere to the products must be coated with a release agent.

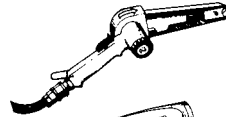
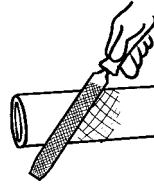

Abrading tool for rubber.



Use release agent on the threads of a bolt.

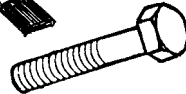

Roughening increases the surface area and gives a better "key".



Most castings have an open structure that contaminants can penetrate into.

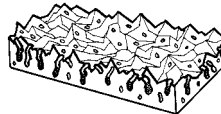



COLD REPAIR COMPOUNDS

How to apply the product

Application should be carried out as soon as possible after surface preparation is completed, otherwise oxidation can take place. Do not apply product when relative humidity exceeds 85% nor when surface is less than 3 °C above the dew point.

NB: The work site temperature must be above 5°C (40°F) in order for the polymer chemical reaction to take place.

Always measure out Base/Activator quantities accurately in line with the instructions on the data sheet. If a critical application, use mixing ratio by weight. Mix Base and Activator until streak free. Paste materials should be mixed on a clean flat surface. Spreading the mixed product out thinly on a board will assist in dissipating the heat and slow down the curing reaction. This will also remove any entrapped air present in the mix. Fluid grade materials can be mixed together in the base container.

When applying the product on the surface to be repaired, do not heap the product on. This will lead to bad bonding and entrapment of impurities.

A good bonding is secured by pressing a thin layer of product onto the surface, working it down in cracks and openings, squeezing out any impurities like oil and water.

After securing the surface, add more product, building up to the required height. In order to add further strength to the repair, add the Reinforcement Bandage. Wrap the bandage to required thickness and cover it with product.

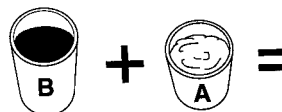

Incomplete

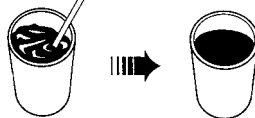

Do not heap the product when mixing



Spread out evenly

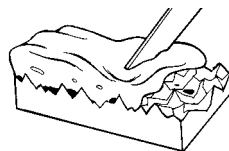

Do not heap product when applying

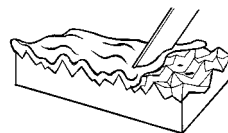

Press on a thin layer



POLYMER COLD REPAIR KIT-A

Unitor Cold Repair System for High Performance Repairs

Cold repair System KIT-A

Total weight of kit 12,5 kg

Product no.
106-659300

The Unitor Cold Repair system covers emergency repairs as well as permanent repairs on pipes, all types of mechanical equipment and machine components onboard, including non-weldable materials.

Unitor Metalgrade, Aquagrade and Ceramigrade products are a range of cold-curing metal repair and rebuilding materials based on the latest polymer resin technology which is the result of many years of development.

Unitor Rubbergrade products are cold-vulcanising elastomeric repair materials for use on rubber as well as metal components.

The products are compatible with all ferrous and non-ferrous metals as well as most plastics, and have proved themselves as permanent repairs. They have excellent chemical resistance and are suitable for permanent immersion in many environments including sea water, hydrocarbons, oils and a very wide range of chemical solutions.

The basic range of products is selected in order to provide a versatile program for onboard applications. The application areas complement and extend the various welding and related thermal processes already in use, providing an even more complete repair system than previously available.



The complete basic package

is available in a handy kit. Each product has its specified place in the kit, and the individual products may be refilled as needed.

The kits consists of:

- 1 set Leak-Stop II
- 1 set Metalgrade Ready-stick
- 1 set Metalgrade Express
- 1 set Metalgrade Rebuild
- 1 set Metalgrade Hi-Temp
- 1 set Aquagrade Rebuild
- 1 set Ceramigrade Rebuild
- 1 set Ceramigrade Liner
- 1 set Rubbergrade 6 Rebuild
- 1 set Rubbergrade 6 Remould



PRODUCT OVERVIEW

Repair Set

Each set comes complete with all necessary application equipment technical data sheets and Health & Safety Data sheets.



Name	Description	Set weight kg	Product no.
Leak Stop Pipe repair Sets	A special bandage impregnated with a resin system which is activated by immersion in water. Ideal for repairs to leaking pipes, simply immerse in water then wrap around the leak. The Metalgrade Ready Stick be used to plug the actual hole before putting on the tape.		
Leak Stop I Set	For pipes $\varnothing < 1"$ (25 mm) 1 tape 2' x 4' (50 mm x 1200 mm)	0,16 kg	100-630384
Leak Stop II Set	For pipes $\varnothing 1-2"$ (25 mm - 50 mm) 1 tape 2' x 12' (50 mm x 3600 mm)	0,23 kg	100-606006
Leak Stop III Set	For pipes $\varnothing > 2"$ (50 mm) 1 tape 4' x 12' (100 mm x 3600 mm)	0,33 kg	100-630392
Metalgrade Ready Stick Set	Base and activator in two separate sticks. Cut off the needed length and knead the two parts together till streak free. Use for sealing of leaks in pipes, tanks, ducts etc. Can be used together with Leak Stop to plug the hole before wrapping the tape. <i>Set of 3 pairs of sticks giving: 0,72 kg Repair Compound</i>	0,86 kg	101-659227
Metalgrade Express Set	A two component extremely fast cold-curing metal repair compound supplied in Base and Activator containers. Used wherever there is an emergency and urgent need to get equipment back into action. <i>Base & Activator giving: 0,25 l Rapid Repair Compound.</i>	0,58 kg	101-659235
Metalgrade Rebuild Set	A two component normal cold-curing engineering repair compound. A good machineable product with high mechanical properties and good heat resistance. <i>Base & Activator giving: 0,50 l Engineering Repair Compound.</i>	1,10 kg	101-659243
Metalgrade Hi Temp Set	A ceramic and stainless-filled one part water based paste. It is temperature resistant up to 1093 °C (2000 °F). It is used to seal joints, defects, cracks and voids in cast iron, steel and stainless steel <i>Tin giving: 0,13 l Repair Compound.</i>	0,42 kg	101-663427
Aquagrade Rebuild Set	A two component engineering repair compound. The product can be mixed applied and will cure under water. Preferably mix above water. <i>Base & Activator giving: 0,5 l Engineering Repair Compound.</i>	0,95 kg	104-659250

PRODUCT OVERVIEW



Name	Description	Set weight kg	Product no.
Ceramigrade Rebuild Set	A two component ceramic cold-curing compound with excellent resistance to cavitation and erosion found in fluid flow environments. Used for rebuilding heavy wear on pumps, impellers, valves etc. <i>Base & Activator giving: 0,5 l Engineering Repair Compound.</i>	1,00kg	102-659268
Ceramigrade Liner Set	A two component ceramic cold curing fluid that is used as a liner in order to prevent cavitation and erosion found in fluid flow environments. <i>Base & Activator giving: 0,5 l Engineering Repair Fluid.</i>	0,92 kg	102-659276
Ceramigrade Abrashield Set	A two component ceramic cold curing compound with excellent resistance against heavy abrasion. Specifically ment for Dredgers and Cement carriers.	5,4 kg	102-725291
Rubbergrade 6 Rebuild Set	A two component cold-curing vulcanising repair compound. Provides a strong long term repair on rubber items or on metallic surfaces. For repairs of hoses, gaskets, electric cables etc. <i>Set of 3 x 0,143 l Engineering Repair Compound</i>	0,59 kg	103-659284
Rubbergrade 6 Remould Set	A two component cold-curing vulcanising repair fluid that can be moulded or painted on to rubber or metallic surfaces. <i>Set 3 x 0,143 l Engineering Repair Fluid.</i>	0,59 kg	103-659292

3.06



LEAK STOP



Product specification sheet – Leak Stop

Product Description

Product name/ Product No./Kit weight	Kit consists of:	Application
Leak Stop I 100-630384 / 158 g.e	1 pc. 2"x4' (50 mm x 1,2 m) black repair tape in a pouch	For use on pipe diameter 0–1" (0 mm–25 mm)
Leak Stop II 100-606006 / 232 g.e	1 pc. 2"x12' (50 mm x 3,6 m) black repair tape in a pouch	For use on pipe diameter 1"–2" (25 mm–50 mm)
Leak Stop III 100-630392 / 325 g.e	1 pc. 4"x12' (100 mm x 3,6 m) black repair tape in a pouch	For use on pipe diameter 2"–4" (50 mm–100 mm)

With all kits comes 1 x pair of Gloves, 1 pc. Working data sheet, 1 pc. Safety Data Sheet

Identification

Grey knitted fibreglass tape

Application data

Mixing ratio	Pot life (mins) (working life)
Ready for use as supplied only requires wetting with water before use	2–3 minutes

Recommended Temperature Limits For Application 5 °C to 30 °C/40 °F–100 °F

Curing time

Curing times in minutes at ambient temperature	20 °C (68 °F)
Initial setting	5
Full mechanical strength	30

Technical data

18 Gauge knitted fibreglass

Values are determined after 48 hours at 20 °C (68 °F)

3.06

Phys / Mec properties

Bond Strength	ASTM D2095-72	16 kg/cm ²	230 psi
Tensile Strength	ASTM D638-111	275 kg/cm ²	3920 psi
Flexural Strength	ASTM D790-1-B	159 kg/cm ²	2260 psi
Hardness (Shore D)	ASTM D2240	82 type (d)	

Service temperatures

Dry heat	Minimum temp.
+ 260 °C/500 °F	- 29 °C/- 20 °F

Chemical resistance

Suitable for permanent immersion at 20 °C (68 °F) in a limited range of chemicals.

Health and Safety

As long as good practise is observed Leak Stop can be safely used. Wearing of rubber gloves is advisable during use. Prior to using this product please consult the Safety Data Sheet provided with each packaged product.



Instructions for use

Before proceeding, please read the following information application carefully to ensure that proper procedures are fully understood.

Leak Stop Repair Tape is a specially treated and knitted fibreglass impregnated with a polyurethane resin which is activated by immersion in water. Areas of application: Repairs to leaking pipes.

1. Surface preparation

Remove all pressure from the pipe, including gravity fed drip. For active leaks when pressure cannot be removed: Holes should be stopped using a pipe repair clamp. Remove oil, grease, loose rust scale, sealant tape and paint from repair area. Rough score a four inch (10 cm) path 360° around the pipe centring leak site.

Leak Stop works best on a rough surface. If the pipe surface is pitted by rust, remove the loose scale. If the surface is smooth, as with copper or stainless, you must roughen the area with a coarse file, rasp or saw blade. For plastic pipe, the external mould release must be removed.

Abrade surfaces with a coarse grit sandpaper. A saw blade must also be used to create a cross hatch pattern. This is particularly useful on polypropylene and PVDF piping.

2. Mixing

During mixing and application gloves should be worn at all times to protect the hands.

Open pouch at the notch, remove **Leak Stop Repair Tape**, submerge the roll in water and squeeze two or three times, for about five seconds.

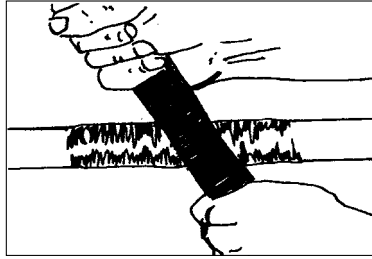

Rough score surface



Water activate Leak Stop

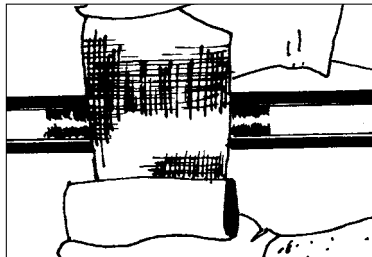

Position over leak site

NOTE: Water activates the resins, so apply entire roll as any amount remaining cannot be saved. **WORKING TIME** is three to five minutes. So **BE PREPARED TO WORK SWIFTLY.**



LEAK STOP

3. Application

Remove roll from water and wrap quickly and tightly as follows: Centre tape over leak site, wrap from bottom of roll, pulling firmly throughout application. After 5–7 plies, you will observe resin foam coming through the tape which is desirable and aided by pulling tightly. Continue until entire roll is applied, building to a minimum thickness of 1/2 inch (12 mm) and use a second roll if necessary.

Firmly press and smooth end of roll into wrap in the direction of application. Wet gloves in water, smooth and firmly press the wet resin back into the wrap.

KEEP HANDS MOVING QUICKLY AND WET GLOVES FREQUENTLY TO AVOID STICKING.

Continue rapid hand movement pressing and polishing resin in motions around and parallel to the pipe. Continue process until resins are no longer tacky.

The repair should now have a smooth hard surface and an enamel-like appearance with no fibreglass substance showing through the resins.

NOTE: If thicker application is needed spend a little less time finishing the first roll and immediately begin the application of the next. Finish the final roll as if a single roll application.

4. Cleaning

After application dispose of gloves.

5. Health and safety

As long as normal good practices are observed **Leak Stop** can be safely used.

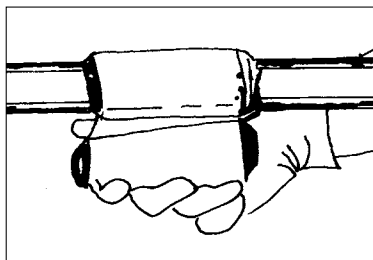

Wrap while pulling firmly

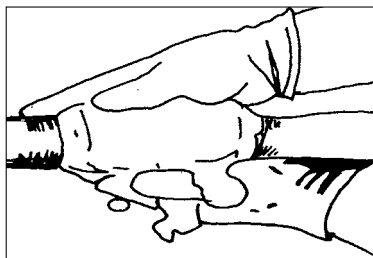

Wet gloves, smooth out

A fully detailed **Material Safety Data Sheet** is included with the set.

The information provided in this instruction for use sheet is intended as a general guide only. Users should determine the suitability of the product for their own particular purposes by their own tests.

LEAK STOP



The Leak Stop products are available in three sizes.
The product is recommended for pressures up to 400 psi (28 bar).

Leak Stop I 100-630384 1 pc. 2' x 4' (50 mm x 1,2 m) black repair tape in a pouch.
For use on pipe diameter 0–1" (0–25 mm).
If used outside this diameter area:

Nominal Pipe Size	Number of Leak Stop I rolls		
	50 psi/3,5 bar	150 psi/10,5 bar	400 psi/28 bar
1/2" (13 mm)	1	1	1
3/4" (19 mm)	1	1	1
1" (25 mm)	1	1	2
1 1/4" (21 mm)	1	2	3
1 1/2" (38 mm)	2	2	3

Leak Stop II 100-606006 1 pc. 2' x 12' (50 mm x 3,6 m) black repair tape in a pouch.
For use on pipe diameter 1"–2" (25–50 mm).

Leak Stop III 100-630392 1 pc. 4" x 12' (100 mm x 3,6 m) black repair tape in a pouch.
For use on pipe diameter 2"–4" (50–100 mm).
If used outside this diameter area:

Nominal Pipe Size	Number of Leak Stop I rolls		
	50 psi/3,5 bar	150 psi/10,5 bar	400 psi/28 bar
1" (25 mm)	1	1	1
1 1/2" (38 mm)	1	1	1
2" (50 mm)	1	1	1
2 1/2" (63 mm)	1	1	2*
3" (75 mm)	1	2*	2*
3 1/2" (88 mm)	1	2*	2*
4" (10 mm)	1	2*	2*
5" (125 mm)	2*	2*	3*
6" (150 mm)	2*	2*	4*
8" (200 mm)	2*	3*	5*
10" (250 mm)	3*	4*	6*
12" (300 mm)	4*	5*	8*
14" (350 mm)	4*	6*	8*
16" (400 mm)	5*	7*	9*
18" (450 mm)	5*	8*	9*

* Leak Stop III should be used in multiple roll applications



METALGRADE READY-STICK



Product specification sheet – Metalgrade Ready-Stick

Product Description

PRODUCT NAME	PRODUCT NO	KIT CONSISTS OF
Metalgrade Ready-Stick Engineering Repair Compound Supplied complete with all necessary equipment all in one carton box set	Product No 101-659227 Metalgrade Ready-Stick 0,75 Kg Engineering Repair Compound Gross Weight: 0,86 kg	3 x 120 g Putty Base 3 x 120 g Putty Activator 1 Pair of Gloves 1 Spatula 1 Technical Data Sheet

Identification

Activator Component				Base Component			
Appearance		Colour		Appearance		Colour	
Putty		Beige / Brown		Putty		Black	

Application Data

Mixing Ratio Volume		Mixing Ratio Weight		Pot Life (mins) (Working Life)							
Activator	Base	Activator	Base	5 °C	10 °C	15 °C	20 °C	25 °C	30 °C	35 °C	40 °C
1	1	1	1	30	25	20	15	15	12	10	5

Recommended Temperature Limits For Application: 5 °C TO 40 °C

Curing Time

Curing Times in minutes at ambient temperature	5 °C	10 °C	15 °C	20 °C	25 °C	30 °C	35 °C	40 °C
Initial Setting / Light Loading	80	60	45	35	30	28	26	20
Machining	180	120	90	70	60	60	55	45
Full Mechanical Strength	8 days	7 days	6 days	4 days	3 days	2 days	2 days	1 day
Full Chemical Resistance	9 days	8 days	7 days	5 days	5 days	4 days	4 days	3 days

Technical Data

Density g/cm ³			Volume Solids	Volume Capacity	Slump Resistance
Activator	Base	Mixed	%	cc/1000gm	15 mm thickness
1,95	1,96	1,96	100	500	Excellent

Phys/Mec Properties

Compressive Strength	ASTM D412	70 MPa	10200 psi
Tensile Shear Adhesion	ASTM D412	8 MPa	1200 psi
Abrasion Resistance	ASTM D4060	-	
Corrosion Resistance	ASTM B117	> 5000 hours	
Hardness (Shore D)	ASTM D2246	80	
Impact Resistance	ASTM D256	> 5 kJ/m ²	

Values are determined after 48 hours at 20 °C

Service Temperatures

Dry heat	Wet heat	Minimum temp
+ 90 °C / 195 °F	+ 80 °C / 176 °F	- 20 °C / - 4 °F

Chemical resistance

Suitable for permanent immersion at 20 °C (68 °F) in a limited range of chemicals. For a more detailed description refer to the Chemical Resistance Chart.

Manufactured under a quality program certified to ISO 9002

Health and Safety

As long as good practise is observed MetalGrade Ready-Stick can be safely used. Wearing of rubber gloves is advisable during use. Prior to using this product please consult the Safety Data Sheet provided with each packaged product.



Instructions for use

Before proceeding, please read the following information application carefully to ensure that proper procedures are fully understood.

MetalGrade Ready-Stick is a two component, solvent free, fast curing, synthetic metal repair compound. Areas of application Sealing of leaks in pipes, tanks, radiators, ducts etc.

1. Surface preparation

Heavy contamination due to oil or grease must be removed using a Cleaner. Where possible, abrasive blasting is the preferred surface preparation, especially in fluid flow repairs.

A) Remove all contamination (oil, grease and dirt) with a cleaner.

B) Remove all loose rust and surface coatings.

C) Roughen the surface, preferably with abrasive blasting. Alternatively a die grinder, needle scalar or angle grinder may be used. If grinding make sure the surface is roughened, not polished. Where grinding or needle gunning is used, the surface should be cross scored to improve adhesion.

D) To ensure that all contamination is removed carry out a final degreasing with a cleaner. Cloths should be frequently changed to avoid spreading contamination. On deeply pitted surfaces of porous castings, the cleaner should be worked into the surface by brush and washed off using excess cleaner.

E) Parts (for example, threads or bearing surfaces) which must remain in position during application but which should not adhere to **MetalGrade Ready-Stick** must be coated with a release agent.

2. Mixing

Only sufficient product which can be applied within the usable life should be mixed. This should be broken off or cut from both sticks in the ratio of 1 : 1. Cut off equal size pieces from both the Base and Activator sticks.

Mix Base and Activator in the ratio of 1 : 1. Re-close the plastic wrapper sleeve immediately after use. The two components should then be thoroughly mixed by hand kneading until completely streak free and in a uniform black colour.

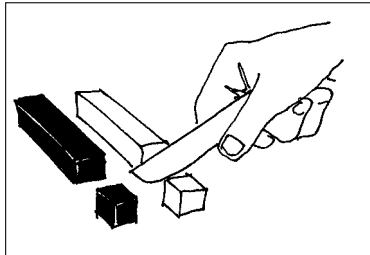

Cut off equal length of Base & Activator sticks

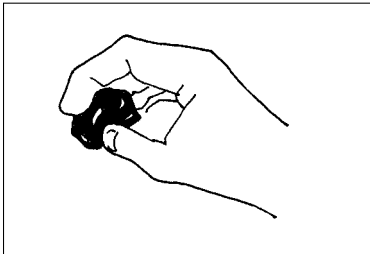

Thoroughly mix by hand kneading until streak free



METALGRADE READY-STICK

3. Application

Prepared Surfaces should be dry. The mixed material should be pressed firmly onto the prepared area, working the material into any cracks or surface defects.

When **MetalGrade Ready-Stick** is used to repair leaking pipes, the **flow** through the pipe should be discontinued until the repair is made and the **MetalGrade Ready-Stick** is set. Any leaking fluid must be wiped from the prepared surface before undertaking the repair.

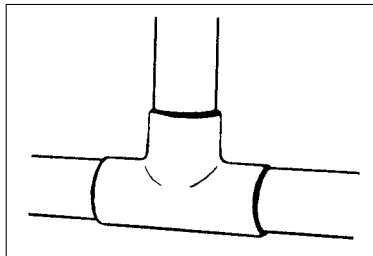

Pipe Joints

4. Machining

Once the **MetalGrade Ready-Stick** has cured for the minimum time indicated in the Curing Properties Section of the product specification sheet, sanding, grinding and machining etc. can be carried out using standard engineering practices.

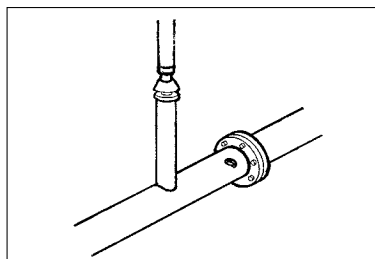

Hole in small diameter pipe

5. Cleaning

All equipment should be cleaned **IMMEDIATELY** after each use with a cleaner. Failure to follow this procedure will result in application equipment becoming unusable.

6. Health and safety

As long as normal good practices are observed MetalGrade Ready-Stick can be safely used. A fully detailed Material Safety Data Sheet is included with the set. The information provided in this Instruction for use sheet is intended as a general guide only. Users should determine the suitability of the product for their own particular purposes by their own tests.

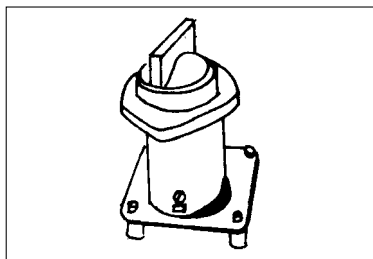

Valve taps



METALGRADE EXPRESS



Product specification sheet – Metalgrade Express

Product Description

PRODUCT NAME	PRODUCT NO	KIT CONSISTS OF
Metalgrade Express Engineering Repair Compound	Product No 101-659235 Metalgrade Express 0,25 ltr Engineering Compound Gross Weight: 0,86 kg	435 g Base + Activator 1 Mixing Container 1 Pair of Gloves 1 Spatula 1 Applicator 1 Roll reinforcement bandage 1 Technical Data Sheet
Supplied complete with all necessary equipment all in one		

Identification

Activator Component				Base Component			
Appearance		Colour		Appearance		Colour	
Paste		Beige		Paste		Metallic Grey	

Application Data

Mixing Ratio Volume		Mixing Ratio Weight		Pot Life (mins) (Working Life)							
Activator	Base	Activator	Base	5 °C	10 °C	15 °C	20 °C	25 °C	30 °C	35 °C	40 °C
1	1	0,9	1	8	5	4	3 1/2	3	2	1,5	1

Recommended Temperature Limits For Application: 5 °C TO 40 °C

Curing Time

Curing Times in minutes at ambient temperature	5 °C	10 °C	15 °C	20 °C	25 °C	30 °C	35 °C	40 °C
Initial Setting / Light Loading	9	8	7	6	5	3	2	2
Machining	90	45	35	25	20	15	15	10
Full Mechanical Strength	300	150	120	90	80	70	60	40
Full Chemical Resistance	7 days	5 days	4 days	3 days	2 days	2 days	1 day	1 day

Technical Data

Density g/cm ³			Volume Solids	Volume Capacity	Slump Resistance
Activator	Base	Mixed	%	cc/1000gm	15 mm thickness
1,6	1,8	1,7	100	585	Excellent

Phys/Mec Properties

Compressive Strength	ASTM D695	47 MPa	7000 psi
Tensile Shear Adhesion	ASTM D1002	18,5 MPa	2700 psi
Flexural Strength	ASTM D790	48 MPa	6600 psi
Corrosion Resistance	ASTM B117	5000 hours	
Hardness (Shore D)	ASTM D2246	78	
Hardness (Rockwell R)	ASTM D785	100	
Dielectric Strength	ASTM D149	30 volts/mil	
Surface Resistivity	ASTM D257	1 x 10 ⁹ Ohm/cm	

Values are determined after 48 hours at 20 °C

Service Temperatures

Dry heat	Wet heat	Minimum temp
+ 80 °C / 176 °F	+ 70 °C / 158 °F	- 20 °C / - 4 °F

Chemical resistance

Suitable for permanent immersion at 20 °C (68 °F) in a limited range of chemicals. For a more detailed description refer to the Chemical Resistance Chart.

Manufactured under a quality program certified to ISO 9002

Health and Safety

As long as good practice is observed MetalGrade Express can be safely used. Wearing of rubber gloves is advisable during use. Prior to using this product please consult the Safety Data Sheet provided with each packaged product.



Instructions for use

Before proceeding, please read the following information application carefully to ensure that proper procedures are fully understood.

MetalGrade Express is a two component, solvent free, fast curing, synthetic metal repair compound. Areas of application Sealing of leaks in pipes, tanks, radiators, ducts etc.

1. Surface preparation

Heavy contamination due to oil or grease must be removed using a cleaner. Where possible, abrasive blasting is the preferred surface preparation, especially in fluid flow repairs.

A) Remove all contamination (oil, grease and dirt) with a cleaner.

B) Remove all loose rust and surface coatings.

C) Roughen the surface, preferably with abrasive blasting. Alternatively a die grinder, needle scalar or angle grinder may be used. If grinding make sure the surface is roughened, not polished. Where grinding or needle gunning is used, the surface should be cross scored to improve adhesion.

D) To ensure that all contamination is removed carry out a final degreasing with a cleaner. Cloths should be frequently changed to avoid spreading contamination. On deeply pitted surfaces of porous castings, a cleaner should be worked into the surface by brush and washed off using excess cleaner.

E) Parts (for example, threads or bearing surfaces) which must remain in position during application but which should not adhere to **MetalGrade Express** must be coated with a release agent.

2. Mixing

Only sufficient product which can be applied within the usable life should be mixed.

Mix Base and Activator from the respective jars onto a clean mixing surface in the ratio indicated. Lids should be replaced immediately after use. The two components should then be thoroughly mixed until completely streak free, using the spatula provided.

3. Application

Prepared Surfaces should be **dry**. Using the Spatula provided the mixed material should be pressed firmly

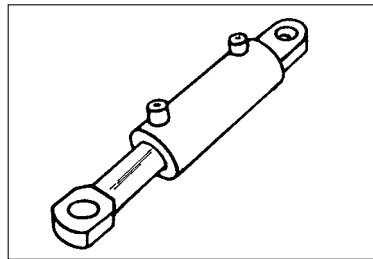

Scored hydraulic or pneumatic rams

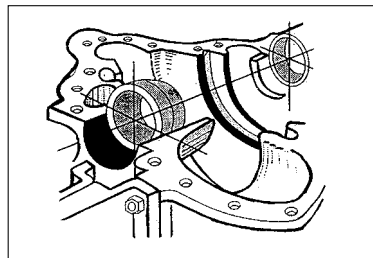

Worn bearing housing



METALGRADE EXPRESS

onto the prepared area, working the material into any cracks and surface defect.

If Reinforcement Bandage is used to strengthen the repair, the bandage should be impregnated with **MetalGrade Express**, or the bandage should be laid over the surface of the **MetalGrade Express** and pressed into the surface. Additional **MetalGrade Express** should then be applied over the surface.

Once the **MetalGrade Express** has reached initial set the material can be separated from surfaces treated with release agent.

When **MetalGrade Express** is being used to repair leaking pipes, the **flow** through the pipe should be discontinued until the repair is made and the **MetalGrade Express** is set. Any leaking fluid must be wiped from the prepared surface before undertaking the repair.

4. Machining

Once the **MetalGrade Express** has cured for the minimum time indicated in the Curing Properties Section of the product specification sheet, sanding, grinding and machining etc. can be carried out using standard engineering practices.

5. Cleaning

All equipment should be cleaned **IMMEDIATELY** after each use with a Cleaner. Failure to follow this procedure will result in application equipment becoming unusable.

6. Health and safety

As long as normal good practices are observed **MetalGrade Express** can be safely used. A fully detailed Material Safety Data Sheet is included with the set. The information provided in this Instruction for use sheet is intended as a general guide only. Users should determine the suitability of the product for their own particular purposes by their own tests.

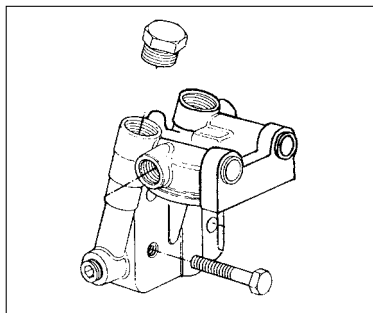

Repairing stripped threads

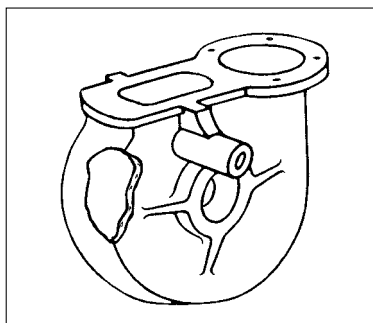

Small pump housing repair



METALGRADE REBUILD



Product specification sheet – Metalgrade Rebuild

Product Description

PRODUCT NAME	PRODUCT NO	KIT CONSISTS OF
Metalgrade Rebuild Engineering Repair Compound Supplied complete with all necessary equipment all in one	Product No 101-659243 Metalgrade Rebuild 0,5 ltr Engineering Repair Compound Gross Weight: 1,08 kg	933 g Base + Activator 1 Mixing Container 1 Pair of Gloves 1 Spatula 1 Applicator 1 Roll reinforcement bandage 1 Technical Data Sheet

Identification

Activator Component				Base Component			
Appearance		Colour		Appearance		Colour	
Paste		Beige		Paste		Metallic Grey	

Application Data

Mixing Ratio Volume		Mixing Ratio Weight		Pot Life (mins) (Working Life)							
Activator	Base	Activator	Base	5 °C	10 °C	15 °C	20 °C	25 °C	30 °C	35 °C	40 °C
1	2	1	2,5	20	18	15	13	12	10	9	6

Recommended Temperature Limits For Application: 5 °C TO 40 °C

Curing Time

Curing Times in minutes at ambient temperature	5 °C	10 °C	15 °C	20 °C	25 °C	30 °C	35 °C	40 °C
Initial Setting / Light Loading	50	45	40	35	30	25	20	15
Machining	100	70	60	55	50	45	35	25
Full Mechanical Strength	8 days	6 days	5 days	4 days	3 days	3 days	48h	24h
Full Chemical Resistance	14 days	10 days	9 days	7 days	5 days	4 days	3 days	2 days

Technical Data

Density g/cm ³			Volume Solids	Volume Capacity	Slump Resistance
Activator	Base	Mixed	%	cc/1000gm	15 mm thickness
1,7	1,9	1,85	100	540	Excellent

Phys/Mec Properties

Compressive Strength	ASTM D695	55 MPa	8000 psi
Tensile Shear Adhesion	ASTM D1002	19 MPa	2800 psi
Flexural Strength	ASTM D790	38 MPa	5600 psi
Corrosion Resistance	ASTM B117	5000 hours	
Hardness (Shore D)	ASTM D2246	80	
Hardness (Rockwell R)	ASTM D785	100	
Nuclear Decontamination	BS 4247 Part 1	Excellent	

Values are determined after 48 hours at 20 °C

Service Temperatures

Dry heat	Wet heat	Minimum temp
+ 90 °C / 195 °F	+ 80 °C / 176 °F	- 20 °C / - 4 °F

Chemical resistance

Suitable for permanent immersion at 20 °C (68 °F) in a limited range of chemicals. For a more detailed description refer to the Chemical Resistance Chart.

Manufactured under a quality program certified to ISO 9002

Health and Safety

As long as good practice is observed MetalGrade Rebuild can be safely used. Wearing of rubber gloves is advisable during use. Prior to using this product please consult the Safety Data Sheet provided with each packaged product.



Instructions for use

Before proceeding, please read the following information application carefully to ensure that proper procedures are fully understood.

MetalGrade Rebuild is a dual component, solvent free, synthetic metal repair compound. Areas of application : Worn or damaged shafts, oversized bearing housing, cracked casings, distorted flange faces, cracked engine blocks, sloppy keyways, scored hydraulic rams etc.

1. Surface preparation

Heavy contamination due to oil or grease must be removed using a cleaner. Where possible, abrasive blasting is the preferred surface preparation, especially in fluid flow repairs.

A) Remove all contamination (oil, grease and dirt) with a cleaner.

B) Remove all loose rust and surface coatings.

C) Roughen the surface, preferably with abrasive blasting. Alternatively a die grinder, needle scalar or angle grinder may be used. If grinding make sure the surface is roughened, not polished. Where grinding or needle gunning is used, the surface should be cross scored to improve adhesion.

D) To ensure that all contamination is removed carry out a final degreasing with a cleaner. Cloths should be frequently changed to avoid spreading contamination. On deeply pitted surfaces of porous castings, a cleaner should be worked into the surface by brush and washed off using excess cleaner.

E) Parts (for example, threads or bearing surfaces) which must remain in position during application

but which should not adhere to **MetalGrade Rebuild** must be coated with a release agent.

2. Mixing

Mix Base and Activator from the respective jars into the mixing container provided in the ratio indicated. Lids should be replaced immediately after use. The two components should then be thoroughly mixed until completely streak free, using the spatula provided.

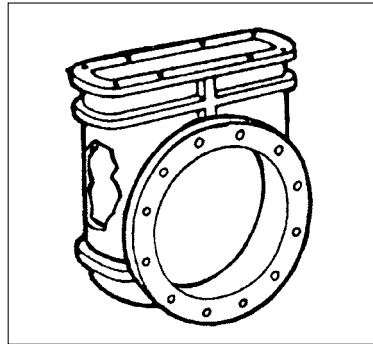

Hole in metal casing

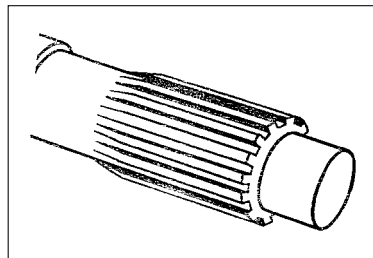

Worn spline



METALGRADE REBUILD

3. Application

Prepared surfaces should be dry. Using the Spatula provided, the mixed material should be pressed firmly onto the prepared area, working the material into any cracks and surface defect.

If Reinforcement Bandage is used to strengthen the repair, the bandage should be impregnated with **MetalGrade Rebuild**, or the bandage should be laid over the surface of the **MetalGrade Rebuild** and pressed into the surface. Additional **MetalGrade Rebuild** should then be applied over the surface.

Once the **MetalGrade Rebuild** has reached initial set the material can be separated from surfaces treated with release agent.

When **MetalGrade Rebuild** is being used to repair leaking pipes, the **flow** through the pipe should be discontinued until the repair is made and the **MetalGrade Rebuild** is set. Any leaking fluid must be wiped from the prepared surface before undertaking the repair.

4. Machining

Once the **MetalGrade Rebuild** has cured for the minimum time indicated in the Curing Properties Section of the product specification sheet, sanding, grinding and machining etc. can be carried out using standard engineering practices.

5. Cleaning

All equipment should be cleaned **IMMEDIATELY** after each use with a cleaner. Failure to follow this

procedure will result in application equipment becoming unusable.

6. Health and safety

As long as normal good practices are observed **MetalGrade Rebuild** can be safely used. A fully detailed Material Safety Data Sheet is included with the set. The information provided in this Instruction for use sheet is intended as a general guide only. Users should determined the suitability of the product for their own particular purposes by their own tests.

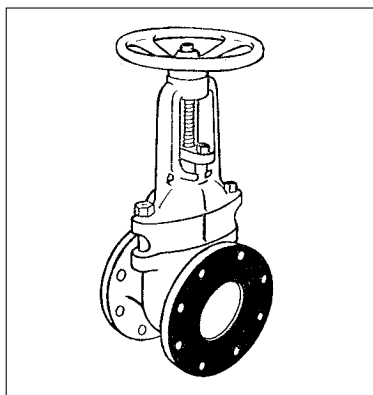

Flange rebuilt

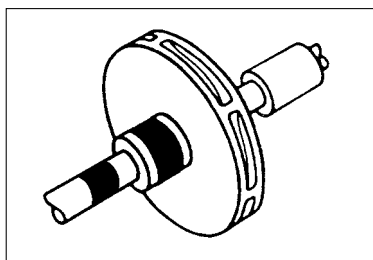

Worn impeller shaft



METALGRADE HI-TEMP



Product specification sheet – Hi-Temp

Product Description

PRODUCT NAME	PRODUCT NO	KIT CONSISTS OF	APPLICATION
Metal Grade HI-TEMP	Product No 101-663427 0,13 l repair compound. Kit weight 420 g.e	Tin with repair compound, 5 pair of gloves, one working data sheet	For use on high temperature applications

With all kits comes 5 x pair of Gloves, 1 pc. Working data sheet, 1 pc. Safety Data Sheet

Identification

Tin with metallic grey paste

Application data

Mixing ratio	Pot life (mins) (working life)
Ready for use as supplied only stir	15*

* Paste will begin to dry and "skin" immediately when the tin is opened, although sub-surface phase will not dry fully for 16–24 hours

Best applied when the ambient temperature is: 7 °C to 35 °C/45 °F–95 °F

Curing time

Option 1)
Air dry for 16–24 hours then gradually raise temperature to operating conditions. Water blisters may appear if transition through 100 °C (210 °F) is too rapid.
Option 2)
Air dry for 5–7 hours then cure at 100 °C (210 °F) for 2–4 hours prior to operation.

Technical data

Specific Gravity 1,56 g/cm³

Phys / Mec properties

Coefficient of thermal expansion	ASTM E-831-93, °C ⁻¹	8x10 ⁻⁶	
Shear Strength ASTM D 1002	6 hours at room temp.	0,6 MPa	90 psi
	24 hours at room temp.	1,9 MPa	280 psi
	6 hours at room temp. + 1 hour at 200 °C / 400 °F	2,7 MPa	390 psi
	24 hours at room temp. +		

Service temperatures

Temp. Continuously	Temp. Intermittently	Minimum Temp.
+ 538 °C/1000 °F	+ 1093 °C/2000 °F	- 40 °C/- 40 °F

Chemical resistance

This product is resistant to a wide range of acids, bases and solvents. However, immersion service is not recommended due to it's slightly porous structure.

Health and Safety

As long as good practice is observed MetalGrade Hi-Temp can be safely used. Wearing of rubber gloves is advisable during use. Prior to using this product please consult the Safety Data Sheet provided with each packaged product.



Instructions for use

Before proceeding, please read the following information application carefully to ensure that proper procedures are fully understood.

Metal Grade **Hi-Temp** repair compound is a ceramic and stainless-filled one-part water based paste. It is formulated using the most advanced inorganic resin technology and is temperature resistant up to 1093 °C (2000 °F). **Hi-Temp** is used to seal joints, defects, cracks and voids in cast iron, steel and stainless steel. NB. **Hi-Temp** should not be used on aluminium or aluminium alloys.

1. Surface preparation

Heavy contamination due to oil or grease should be removed using a cleaner. Abrasive blasting is the preferred surface preparation.

A) Remove all contamination (oil, grease and dirt) with a cleaner.

B) Remove all loose rust and surface coatings.

C) Roughen the surface, preferably with abrasive blasting. Alternatively, a die grinder, needle scalar or angle grinder may be used. If grinding, make sure the surface is roughened, not polished. Where grinding or needle gunning is used, the surface should be cross-scored to improve adhesion.

D) To ensure that all contamination is removed, carry out a final degreasing with a cleaner. Cloths should be frequently changed to avoid spreading of contamination. On deeply pitted surfaces of porous castings, the cleaner should be worked into the surface with a brush and washed off using excess cleaner. If embedded oils are present in porous castings, they should be burned out at high temperature.

E) Parts (for example, threads or bearing surfaces) which must remain in position during application but which should not adhere to **Hi-Temp** must be coated with a release agent.

2. Mixing

Hi-Temp is a ready to use, single part paste. Prior to applying the product, make sure content is mixed thoroughly by stirring. Use a small spatula and apply required amount of product onto a clean working surface.

3. Application

Prepared surfaces should be dry. Use a spatula or putty knife and press the material into any cracks and surface defects. **Hi-Temp** can be used for applications up to 9 mm (3/8") thick. Let the product air dry for five to seven hours at room temperature.

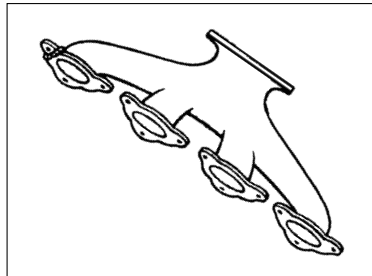

Repairs pin holes, cracks and warped surfaces on high temperature, low pressure systems including incinerators, manifolds, stacks, heat exchangers and turbines.



METALGRADE HI-TEMP

When used on heavy sections and where build-up will exceed 9 mm (3/8") use the following technique:

Fill section up to 9 mm (3/8") in one step. Let the product fully cure (16–24 hours) before adding another 9 mm (3/8") in a second step. Let the product cure again. Continue this procedure until the groove is filled. The reason for 9 mm (3/8") maximum thickness per layer for the **Hi-Temp** product is that it is a single component system in an aqueous solution. The water must have the possibility to dry out. The water in sections above 9 mm (3/8") would not dry out, and upon exposure to high temperatures would effervesce and bubble. It is also recommended that the paste be heat cured at 90 °C (200 °F) between applications.

For repairing holes, repairs should be made using a metal screen. First apply **Hi-Temp**, then form and place the screen inside the hole and then apply second coating of **Hi-Temp** to cover the screen.

4. Machining

When the material is fully cured for a minimum of 24 hours at 20 °C (68 °F), sanding, grinding and machining etc. can be carried out using standard engineering practices. **Hi-Temp** exhibit high thermal conductivity as well as excellent resistance to abrasives, fuels, oils and solvents.

5. Cleaning

In uncured state **Hi-Temp** is cleaned up with soap and water.

First step

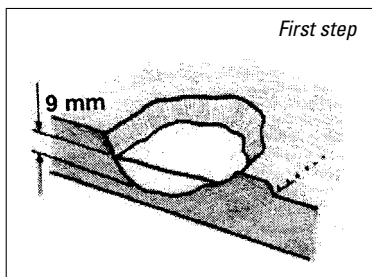

Work procedure for heavy build up

Second step

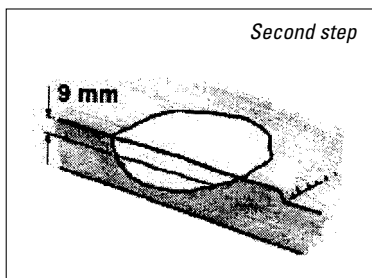

Cure for 16–24 hours before applying second layer

6. Health and safety

Hi-Temp can be safely used as long as normal good practices are observed.

A fully detailed Material Safety Data Sheet is included with the kit. The information provided in this Instructions for Use sheet is intended as a general guide only. Users should determine the suitability of the product for their own particular purposes by their own tests.



AQUAGRADE REBUILD



Product specification sheet – Aquagrade Rebuild

Product Description

PRODUCT NAME	PRODUCT NO	KIT CONSISTS OF
Aquagrade Rebuild Engineering Repair Compound Supplied complete with all necessary equipment all in one	Product No 104-659250 Aquagrade Rebuild 0,5 ltr Engineering Repair Compound Gross Weight: 0,95 kg	805 g Base + Activator 1 Mixing Container 1 Pair of Gloves 1 Spatula 1 Applicator 1 Technical Data Sheet

Identification

Activator Component		Base Component	
Appearance	Colour	Appearance	Colour
Paste	Beige	Paste	White

Application Data

Mixing Ratio Volume		Mixing Ratio Weight		Pot Life (mins) (Working Life)							
Activator	Base	Activator	Base	5 °C	10 °C	15 °C	20 °C	25 °C	30 °C	35 °C	40 °C
1	1	1	1	45	40	35	25	25	20	20	15

Recommended Temperature Limits For Application: 5 °C TO 40 °C

Curing Time

Curing Times in minutes at ambient temperature	5 °C	10 °C	15 °C	20 °C	25 °C	30 °C	35 °C	40 °C
Initial Setting / Light Loading	360	240	120	80	90	80	70	60
Machining	480	360	300	240	180	180	150	120
Full Mechanical Strength	14 days	10 days	8 days	7 days	7 days	7 days	6 days	5 days
Full Chemical Resistance	16 days	12 days	10 days	8 days	8 days	7 days	7 days	6 days

Technical Data

Density g/cm ³			Volume Solids	Volume Capacity	Slump Resistance
Activator	Base	Mixed	%	cc/1000gm	15 mm thickness
1,55	1,7	1,6	100	625	Good

Phys/Mec Properties

Compressive Strength	ASTM D412	34 MPa	5100 psi
Tensile Shear Adhesion	ASTM D412	18 MPa	2600 psi
Abrasion Resistance	ASTM D4060	-	
Corrosion Resistance	ASTM B117	> 5000 hours	
Hardness (Shore D)	ASTM D2246	85	
Impact Resistance	ASTM D256	4 kJ/m ²	

Values are determined after 48 hours at 20 °C

Service Temperatures

Dry heat	Wet heat	Minimum temp
+ 80 °C / 176 °F	+ 70 °C / 158 °F	- 20 °C / - 4 °F

Chemical resistance

Suitable for permanent immersion at 20 °C (68 °F) in a limited range of chemicals. For a more detailed description refer to the Chemical Resistance Chart.

Manufactured under a quality program certified to ISO 9002

Health and Safety

As long as good practice is observed AquaGrade Rebuild can be safely used. Wearing of rubber gloves is advisable during use. Prior to using this product please consult the Safety Data Sheet provided with each packaged product.



Instructions for use

Before proceeding, please read the following information application carefully to ensure that proper procedures are fully understood.

AquaGrade Rebuild is a two component, solvent free, **wet surface** and **underwater repair** compound. Areas of application : bonding, fastening and filling in underwater applications e.g pipes, pumps, valves, tanks etc.

AquaGrade Rebuild is designed to be mixed, applied and set on wet surfaces or underwater in both fresh and salt water.

1. Surface preparation

Heavy contamination due to oil or grease must be removed using a cleaner. Where possible, abrasive blasting is the preferred surface preparation, especially in fluid flow repairs.

A) Remove all contamination (oil, grease and dirt) with a cleaner.

B) Remove all loose rust and surface coatings.

C) Roughen the surface, preferably with abrasive blasting to SA2.

Alternatively a die grinder, needle scaler or angle grinder may be used. If grinding make sure the surface is roughened, not polished. Where grinding or needle gunning is used, the surface should be cross scored to improve adhesion.

2. Mixing

Transfer the contents of Base and Activator containers from the respective jars into the mixing container provided. Mix in the ratio

indicated. Lids should be replaced immediately after use. The two components should be thoroughly mixed until completely streak free and a uniform colour is achieved, using the spatula provided.

3. Application

Using the spatula provided the mixed material should be spread evenly onto the prepared area, working the material into any cracks and surface

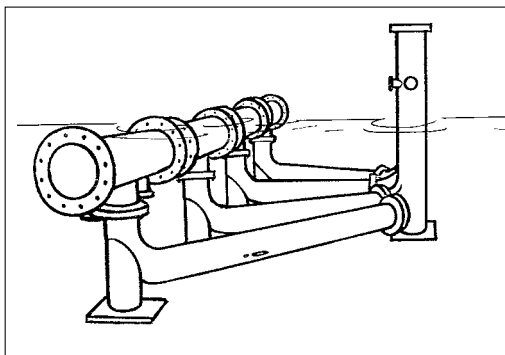

Leaking pipes underwater

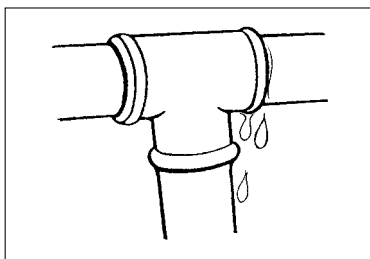

Pipes leaking water



AQUAGRADE REBUILD

defect. Apply on wet surfaces or underwater in the same manner as above water.

4. Machining

Once the **AquaGrade Rebuild** has cured for the minimum time indicated in the Curing Properties Section of the product specification sheet, sanding and grinding can be carried out using standard engineering practices.

5. Cleaning

All equipment should be cleaned **IMMEDIATELY** after each use with a cleaner. Failure to follow this procedure will result in application equipment becoming unusable.

6. Health and safety

As long as normal good practices are observed **AquaGrade Rebuild** can be safely used. A fully detailed Material Safety Data Sheet is included with the set. The information provided in this Instruction sheet is intended as a general guide only. Users should determine the suitability of the product for their own particular purposes by their own tests.

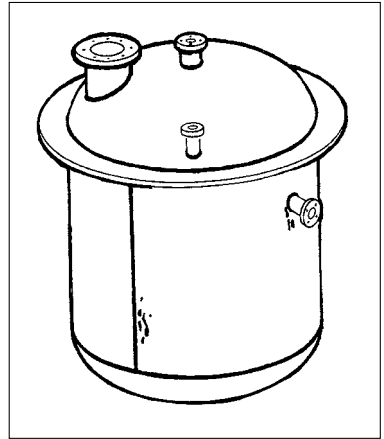

Leaking tanks



CERAMIGRADE REBUILD



Product specification sheet – CeramiGrade Rebuild

Product Description

PRODUCT NAME	PRODUCT NO	KIT CONSISTS OF
CeramiGrade Rebuild Engineering Repair Compound	Product No 102-659268 CeramiGrade Rebuild 0,5 ltr Engineering Repair Compound Gross Weight: 1,04 kg	895 g Base + Activator 1 Mixing Container 1 Pair of Gloves 1 Plastic Spatula 1 Plastic Applicator 1 Technical Data Sheet
Supplied complete with all necessary equipment all in one		

Identification

Activator Component				Base Component			
Appearance		Colour		Appearance		Colour	
Paste		Off White		Paste		Light Blue	

Application Data

Mixing Ratio Volume		Mixing Ratio Weight		Pot Life (mins) (Working Life)							
Activator	Base	Activator	Base	5 °C	10 °C	15 °C	20 °C	25 °C	30 °C	35 °C	40 °C
1	2,5	1	2,5	18	15	12	10	10	8	6	5

Recommended Temperature Limits For Application: 5 °C TO 40 °C

Curing Time

Curing Times in minutes at ambient temperature	5 °C	10 °C	15 °C	20 °C	25 °C	30 °C	35 °C	40 °C
Initial Setting / Light Loading	90	80	60	40	30	20	15	10
Machining	240	180	120	90	90	60	60	50
Full Mechanical Strength	7 days	6 days	6 days	5 days	5 days	3 days	2 days	2 days
Full Chemical Resistance	8 days	7 days	7 days	6 days	5 days	4 days	4 days	3 days

Technical Data

Density g/cm ³			Volume Solids	Volume Capacity	Slump Resistance
Activator	Base	Mixed	%	cc/1000gm	10 mm thickness
1,8	1,8	1,8	100	555	Good

Phys/Mec Properties

Compressive Strength	ASTM D412	84 MPa	12400 psi
Tensile Shear Adhesion	ASTM D412	24 MPa	3500 psi
Abrasion Resistance	ASTM D4060	0,08 cc / 100 cycles	
Corrosion Resistance	ASTM B117	> 5000 hours	
Hardness (Shore D)	ASTM D2246	80	
Impact Resistance	ASTM D256	3 kJ/m ²	

Values are determined after 48 hours at 20 °C

Service Temperatures

Dry heat	Wet heat	Minimum temp
+ 80 °C / 176 °F	+ 70 °C / 158 °F	- 20 °C / - 4 °F

Chemical resistance

Suitable for permanent immersion at 20 °C (68 °F) in a limited range of chemicals. For a more detailed description refer to the Chemical Resistance Chart.

Manufactured under a quality program certified to ISO 9002

Health and Safety

As long as good practice is observed CeramiGrade Rebuild can be safely used. Wearing of rubber gloves is advisable during use. Prior to using this product please consult the Safety Data Sheet provided with each packaged product.



Instructions for use

Before proceeding, please read the following information application carefully to ensure that proper procedures are fully understood.

CeramiGrade Rebuild is a two component, solvent free, fast curing, synthetic repair compound. Areas of application: Re-building pumps, impellers, propellers, turbine blades, valves etc.

1. Surface preparation

Heavy contamination due to oil or grease must be removed using a cleaner. Where possible, abrasive blasting is the preferred surface preparation, especially in fluid flow repairs.

If Reinforcement Bandage is used to strengthen the repair, the bandage should be impregnated with **CeramiGrade Rebuild**, or the bandage should be laid over the surface of the **CeramiGrade Rebuild** and pressed into the surface. Additional **CeramiGrade Rebuild** should then be applied over the surface.

A) Remove all contamination (oil, grease and dirt) with a cleaner.

B) Remove all loose rust and surface coatings.

C) Roughen the surface, preferably with abrasive blasting to SA2. Alternatively a die grinder, needle scaler or angle grinder may be used. If grinding make sure the surface is roughened, not polished. Where grinding or needle gunning is used, the surface should be cross scored to improve adhesion.

D) Equipment which has been salt-impregnated should be heated to sweat out the salt contamination, then the surface re-blasted. Repeat this

process until all salt contamination is eliminated.

E) To ensure that all contamination is removed carry out a final degreasing with a cleaner. Cloths should be frequently changed to avoid spreading contamination. On deeply pitted surfaces of porous castings, a cleaner should be worked into the surface by brush and washed off using excess cleaner.

F) Parts (for example, threads or bearing surfaces) which must remain in position during application but which should not adhere to **CeramiGrade Rebuild** must be coated with a release agent.

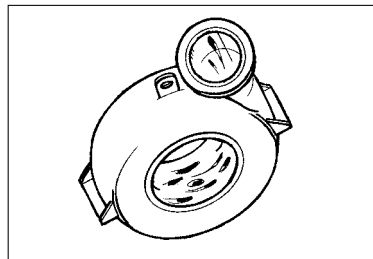

Cavitation in housing

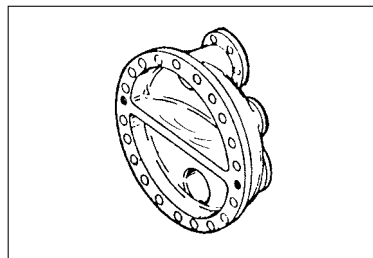

Rebuilding end covers



CERAMIGRADE REBUILD

2. Mixing

Transfer the contents of Base and Activator containers from the respective jars into the mixing container provided. Mix in the ratio indicated. Lids should be replaced immediately after use. The two components should be thoroughly mixed until completely streak free and a uniform colour is achieved, using the spatula provided.

3. Application

Prepared Surfaces should be dry. Using the spatula provided the mixed material should be spread evenly onto the prepared area, working the material into any cracks and surface defect. Once the **CeramiGrade Rebuild** has reached initial set the material can be separated from surfaces treated with release agent.

When **CeramiGrade Rebuild** is being used to repair leaking pipes, the **flow** through the pipe should be discontinued until the repair is made and the **CeramiGrade Rebuild** is set. Any leaking fluid must be wiped from the prepared surface before undertaking the repair. When a second coat is required, this should be done as soon as the first coat has set. (within 4 hours)

4. Machining

Once the **CeramiGrade Rebuild** has cured for the minimum time indicated in the Curing Properties Section of the product specification sheet, sanding, grinding and machining etc. can be carried out using standard engineering practices.

5. Cleaning

All equipment should be cleaned **IMMEDIATELY** after each use with a cleaner. Failure to follow this procedure will result in application equipment becoming unusable.

6. Health and safety

As long as normal good practices are observed **CeramiGrade Rebuild** can be safely used. A fully detailed Material Safety Data Sheet is included with the set. The information provided in this Instruction sheet is intended as a general guide only. Users should determine the suitability of the product for their own particular purposes by their own tests.

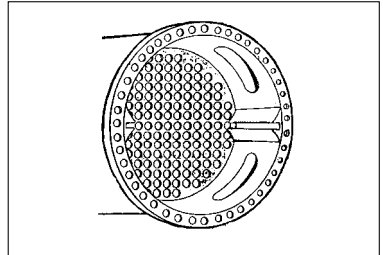

Corroded tube plates

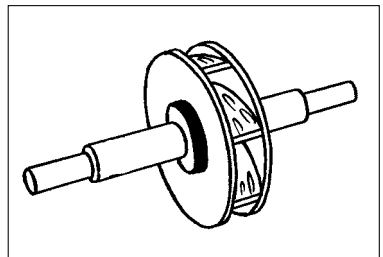

Eroded impellers



CERAMIGRADE LINER



Product specification sheet – Ceramigrade Liner

Product Description

PRODUCT NAME	PRODUCT NO	KIT CONSISTS OF
Ceramigrade Liner Engineering Repair Fluid	Product No 102-659276 Ceramigrade Liner 0,5 ltr Engineering Repair Compound Gross Weight: 0,92 kg	775 g Base + Activator 1 Mixing Container 1 Pair of Gloves 1 Plastic Spatula 1 Technical Data Sheet 2 Safety Data Sheets
Supplied complete with all necessary equipment all in one		

Identification

Activator Component		Base Component	
Appearance	Colour	Appearance	Colour
Liquid	Clear/Amber	Liquid	Blue

Application Data

Mixing Ratio Volume		Mixing Ratio Weight		Pot Life (mins) (Working Life)							
Activator	Base	Activator	Base	5 °C	10 °C	15 °C	20 °C	25 °C	30 °C	35 °C	40 °C
1	4	1	5	45	35	30	25	20	15	13	10

Recommended Temperature Limits For Application: 5 °C TO 40 °C

Curing Time

Curing Times in minutes at ambient temperature	5 °C	10 °C	15 °C	20 °C	25 °C	30 °C	35 °C	40 °C
Initial Setting / Light Loading	300	240	210	180	180	150	130	120
Machining	360	300	270	240	240	210	190	180
Full Mechanical Strength	10 days	9 days	8 days	7 days	7 days	5 days	3 days	2 days
Full Mechanical Resistance	20 days	15 days	15 days	14 days	14 days	10 days	7 days	3 days

Technical Data

Density g/cm ³			Volume Solids	Volume Capacity	Slump Resistance
Activator	Base	Mixed	%	cc/1000gm	2 mm thickness
1,0	1,67	1,55	100	645	n/a

Phys/Mec Properties

Compressive Strength	ASTM D412	70 MPa	10200 psi
Tensile Shear Adhesion	ASTM D412	16 MPa	2300 psi
Abrasion Resistance	ASTM D4060	0,09 cc / 100 cycles	
Corrosion Resistance	ASTM B117	5000 hours	
Hardness (Shore D)	ASTM D2246	80	
Impact Resistance	ASTM D256	5 kJ/m ²	

Values are determined after 48 hours at 20 °C

Service Temperatures

Dry heat	Wet heat	Minimum temp
+ 70 °C / 158 °F	+ 60 °C / 140 °F	- 20 °C / - 4 °F

Chemical resistance

Suitable for permanent immersion at 20 °C (68 °F) in a limited range of chemicals. For a more detailed description refer to the Chemical Resistance Chart.

Manufactured under a quality program certified to ISO 9002

Health and Safety

As long as good practice is observed CeramiGrade Liner can be safely used. Wearing of rubber gloves is advisable during use. Prior to using this product please consult the Safety Data Sheet provided with each packaged product.

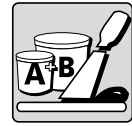

Instructions for use

Before proceeding, please read the following information application carefully to ensure that proper procedures are fully understood.

CeramiGrade Liner is a two component, solvent free, fast curing, synthetic repair fluid. Areas of application : Re-building pumps, impellers, propellers, turbine blades, valves etc.

1. Surface preparation

Heavy contamination due to oil or grease must be removed using a cleaner. Where possible, abrasive blasting is the preferred surface preparation, especially in fluid flow repairs.

A) Remove all contamination (oil, grease and dirt) with a Cleaner.

B) Remove all loose rust and surface coatings.

C) Roughen the surface, preferably with abrasive blasting to SA2. Alternatively a die grinder, needle scaler or angle grinder may be used. If grinding make sure the surface is roughened, not polished. Where grinding or needle gunning is used, the surface should be cross scored to improve adhesion.

D) Equipment which has been salt-impregnated should be heated to sweat out the salt contamination, then the surface re-blasted. Repeat this process until all salt contamination is eliminated.

E) To ensure that all contamination is removed carry out a final degreasing with a cleaner. Cloths should be frequently changed to avoid spreading contamination. On deeply pitted surfaces of porous castings, a cleaner should be worked into the

surface by brush and washed off using excess cleaner.

F) Parts (for example, threads or bearing surfaces) which must remain in position during application but which should not adhere to **CeramiGrade Liner** must be coated with a release agent.

2. Mixing

Transfer the contents of Base and Activator containers from the respective jars into the mixing

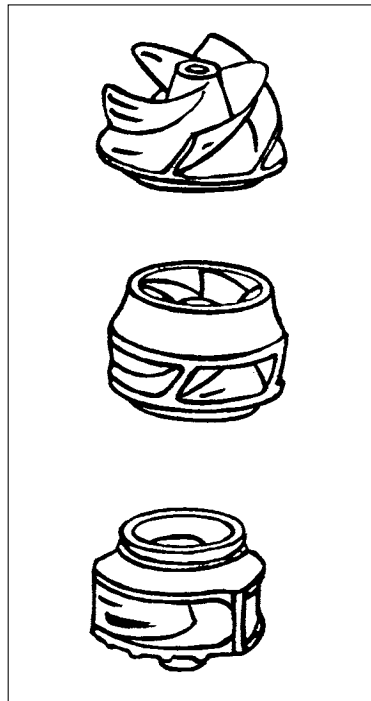

Impeller resurfacing



CERAMIGRADE LINER

container provided. Mix in the ratio indicated. Lids should be replaced immediately after use. The two components should be thoroughly mixed until completely streak free and a uniform colour is achieved, using the spatula provided. The mixture is initially fluid, but becomes thicker as it sets.

3. Application

Prepared Surfaces should be dry. Using the brush provided the mixed material should be painted evenly onto the prepared area, working the material into any cracks and surface defect. Once the **CeramiGrade Liner** has reached initial set the material can be separated from surfaces treated with release agent.

When **CeramiGrade Liner** is used to repair leaking pipes, the **flow** through the pipe should be discontinued until the repair is made and the **CeramiGrade Liner** is set. Any leaking fluid must be wiped from the prepared surface before undertaking the repair. When a second coat is required, this should be done as soon as the first coat has set (within 4 hours).

4. Machining

Once the **CeramiGrade Liner** has cured for the minimum time indicated in the Curing Properties Section of the product specification sheet, sanding, grinding and machining etc. can be carried out using standard engineering practices.

5. Cleaning

All equipment should be cleaned **IMMEDIATELY** after each use with a cleaner. Failure to follow this

procedure will result in application equipment becoming unusable.

6. Health and safety

As long as normal good practices are observed **CeramiGrade Liner** can be safely used. A fully detailed Material Safety Data Sheet is included with the set. The information provided in this Instruction sheet is intended as a general guide only. Users should determine the suitability of the product for their own particular purposes by their own tests.

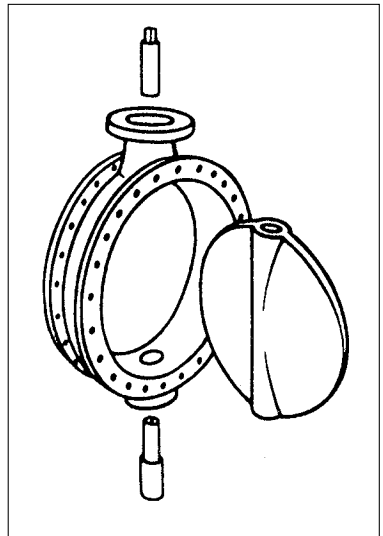

General wear on butterfly valve surface



CERAMIGRADE ABRASHIELD



Product specification sheet – Ceramigrade Abrashield

Product Description

PRODUCT NAME	PRODUCT NO	KIT CONSISTS OF
Ceramigrade Abrashield Engineering Repair Compound	Product No 102-725291 Ceramigrade Abrashield 5,4 kg Engineering Repair Compound Gross Weight: 5,84 kg	5400 g Base + Activator (3600 g Base in a 2 liter tin) (1800 g Activator in a 1 liter tin) 1 Spatula 1 Applicator 1 Technical Data Sheet
Supplied complete with all necessary equipment all in one		

Identification

Activator Component				Base Component			
Appearance		Colour		Appearance		Colour	
Paste		Red		Paste		White	

Application Data

Mixing Ratio Volume		Mixing Ratio Weight		Pot Life (mins) (Working Life)									
Activator	Base	Activator	Base	5 °C	10 °C	15 °C	20 °C	25 °C	30 °C	35 °C	40 °C		
38	100	33	100	50	45	35	25	15	11	8	5		

Recommended Temperature Limits For Application: 5 °C to 40 °C

Curing Time

Curing Times in minutes at ambient temperature	5 °C	10 °C	15 °C	20 °C	25 °C	30 °C	35 °C	40 °C
Initial Setting / Light Loading	120	100	60	40	30	25	20	10
Machining	380	350	320	300	240	220	200	180
Full Mechanical Strength	72 hours							
Full Chemical Resistance	7 days							

Technical Data

Density g/cm ³			Volume Solids %		Volume Capacity	Slump Resistance
Activator	Base	Mixed	Activator	Base	cc/1000gm	10 mm thickness
1,86	1,91	1,9	30	31,5	526	Good

Phys/Mec Properties

Compressive Strength	DIN 53454	80–85 MPa	00000 psi
Tensile Shear Adhesion	DIN 53455	> 20 MPa	0000 psi
Abrasion Resistance	SABS 1449–1996	90–95 mm ³	
Corrosion Resistance	ASTM B117	> 5000 hours	
Hardness (Shore D)	DIN 53505	78–81	
Impact Resistance	DIN 53453	2,5 kJ/m ²	
Flexural Strength	DIN 53452	70–75 MPa	
Lap Shear Strength	ISO 4587	5,5 MPa	

Values are determined after 48 hours at 20 °C

Service Temperatures

Dry heat	Wet heat	Minimum temp
+ 85–90 °C / 000 °F	+ 80–85 °C / 000 °F	- 20 °C / - 4 °F

Below - 20 °C impact resistance will be considerably reduced. The product will become brittle.

Chemical resistance

Excellent against water, oil, grease, detergents, diluted acids and alkaline. Resistant to solvents, aliphatic alcohols and aromatics. Against esters, ketones and chlorinated hydrocarbons, tests are recommended.

Manufactured under a quality program certified to ISO 9002

Health and Safety

As long as good practice is observed Ceramigrade Abrashield can be safely used. Wearing of rubber gloves is advisable during use. Prior to using this product please consult the Safety Data Sheet provided with each packaged product.



Instructions for use

Before proceeding, please read the following information application carefully to ensure that proper procedures are fully understood.

Ceramigrade Abrashield is a two component, solvent free, fast curing, synthetic repair compound. It consists of large ceramic particles in an epoxy matrix. Areas of application: Protection of surfaces subject to extreme wear and abrasion caused by solids or slurry. Specifically meant for Dredgers and Cement carriers facing heavy abrasion combined with medium and light impact.

1. Surface preparation

- A) Heavy contamination due to oil or grease must be removed using a cleaner. Where possible, abrasive blasting is the preferred surface preparation.
- B) Remove all loose rust and surface coatings
- C) Roughen the surface preferably with abrasive blasting to SA2. Alternatively a die grinder, needle scaler or angle grinder may be used. If grinding make sure the surface is roughened, not polished. Where grinding or needle gunning is used, the surface should be cross-scored to improve adhesion.
- D) Surfaces subject to abrasive wear is often gouged out and highly polished and must be cross-scored to secure bonding.
- E) Where deep abrasive wear and/or a high build up is required, bonding can be secured and improved by welding small angle irons to the surface to be coated. "Anchoring" the product in this way will give a better key.

2. Mixing

Transfer the content of Base and Activator containers from the respective jars onto a clean mixing plate. Mix in the ratio indicated. Preferably the mixing ratio should be by weight. Lids should be replaced immediately after use. The two components should be thoroughly mixed until completely streak free and a uniform colour is achieved, using the spatula provided.

3. Application

Prepared surfaces should be dry. Using the spatula provided the mixed material should be spread evenly onto the prepared area, working the material into groves and surface defects. First pressing and squeezing a thin layer of product hard onto the surface secure a good bonding. Afterwards add more product, building up to the required height. Guide to coverage rate: 1,8 Kg per 1m² on 1 mm thick application.

4. Machining

Once the Ceramigrade Abrashield has cured for the minimum time indicated in the Curing Properties Section of the product specification sheet, sanding, grinding and machining etc. can be carried out using standard engineering practices.

5. Cleaning

All equipment should be cleaned IMMEDIATELY after each use with a cleaner. Failure to follow this



CERAMIGRADE ABRASHIELD

procedure will result in application equipment becoming unusable.

6. Health and safety

As long as normal good practices are observed Ceramigrade Abrashield can be safely used. A fully detailed

Material Safety Data Sheet is included with the set. The information provided in this Instruction sheet is intended as a general guide only. Users should determine the suitability of the product for their own particular purposes by their own tests.

Wear plates and conveyer line pan



Bearing plates for clinker chutes

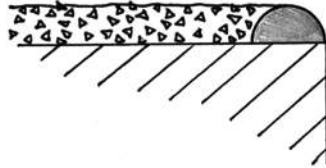
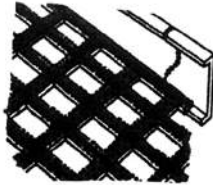

Grading and vibrating screens. Edges are welded with Abratech-330. Large surfaces filled in with Ceramigrade Abrashield

3.06



Improve addition by "Anchoring" the product by welding small angle irons to the surface to be coated.



Ceramigrade Abrashield can also be used in combination with the hard surfacing electrode Abratech-330 to fill in between runs. The welding runs give the polymer side support and stability.



RUBBERGRADE 6 REBUILD



Product specification sheet – Rubbergrade 6 Rebuild

Product Description

PRODUCT NAME	PRODUCT NO	KIT CONSISTS OF
Rubbergrade 6 Rebuild Engineering Repair Compound	Product No 103-659284 Rubbergrade 6 Rebuild 0,43 ltr Engineering Repair Compound Gross Weight: 590 g	3 x 150 g packs Base + Activator 1 Spatula 1 Applicator 1 Pair of gloves 1 Technical Data Sheet 2 Safety Data Sheets
Supplied complete with all necessary equipment all in one		

Identification

Activator Component				Base Component			
Appearance		Colour		Appearance		Colour	
Liquid		Brown		Paste		Black	

Application Data

Mixing Ratio Volume		Mixing Ratio Weight		Pot Life (mins) (Working Life)							
Activator	Base	Activator	Base	5 °C	10 °C	15 °C	20 °C	25 °C	30 °C	35 °C	40 °C
-	-	-	-	15	10	10	8	8	7	6	5

Recommended Temperature Limits For Application: 5 °C TO 40 °C

Curing Time

Curing Times in minutes at ambient temperature	5 °C	10 °C	15 °C	20 °C	25 °C	30 °C	35 °C	40 °C
Initial Setting / Light Loading	60	50	35	25	25	20	15	15
Machining	480	240	180	180	150	150	150	120
Full Mechanical Strength	14 days	10 days	8 days	7 days	7 days	7 days	6 days	5 days
Full Chemical Resistance	18 days	15 days	14 days	12 days	12 days	8 days	7 days	7 days

Technical Data

Density g/cm ³			Volume Solids	Volume Capacity	Slump Resistance
Activator	Base	Mixed	%	cc/1000gm	12 1/2 mm thickness
1,2	0,98	1,04	100	962	Excellent

Phys/Mec Properties

Tensile Strength	ASTM D412	4 MPa	600 psi
Tear Strength	ASTM D624	4,5 MPa	650 psi
Elongation	ASTM D790	260 %	
Hardness (Shore A)	ASTM D2240	65	
Dielectric Strength	ASTM D149	-	
Surface Resistivity	ASTM D257	-	
Volume Resistivity	ASTM D257	-	

Values are determined after 48 hours at 20 °C

Service Temperatures

Dry heat	Wet heat	Minimum temp
+ 80 °C / 176 °F	+ 70 °C / 158 °F	- 20 °C / - 4 °F

Chemical resistance

Suitable for permanent immersion at 20 °C (68 °F) in a limited range of chemicals. For a more detailed description refer to the Chemical Resistance Chart.

Manufactured under a quality program certified to ISO 9002

Health and Safety

As long as good practice is observed Rubbergrade 6 Rebuild can be safely used. Wearing of rubber gloves is advisable during use. Prior to using this product please consult the Safety Data Sheet provided with each packaged product.

RUBBERGRADE 6 REBUILD



Instructions for use

Before proceeding, please read the following information application carefully to ensure that proper procedures are fully understood.

RubberGrade 6 Rebuild is a two component, solvent free, synthetic rubber repair compound. Areas of application: hoses, gaskets, rubber rollers, ducting, impellers, valves etc.

1. Surface preparation

Heavy contamination due to oil or grease must be removed using a cleaner. Any areas of frayed or fragmented rubber should be cut away to provide a sound repair area.

Rubber surfaces are best roughened using a stiff-bristled or stiff-wire brush. All surfaces **MUST** be **dry**.

Edges of repair areas should be rebuilt. All loose dust particles must be removed and the surface wiped with a cleaner.

On certain repairs such as gaskets and castings where one surface is not required to bond to RubberGrade 6 Rebuild, these surfaces should be treated with a release agent.

2. Mixing

Remove the twin pack from the aluminium outer foil by cutting along the lines indicated. Take care not to puncture the pack. Remove the divider strip (black rubber) and take off the plastic divider clip. The contents are now ready to be mixed.

Mix the two components by kneading and squashing them together for 4 -5 minutes. The pack will warm up as it is being mixed.

Ensure there is no unmixed material caught in the corners of the pack. If there is, ease them out of the corners using the white plastic clip.

Cut any corner and squeeze out the RubberGrade 6 Rebuild onto the repair surface/s.

3. Application

Using the spatula provided the mixed material should be spread evenly onto the prepared area, working the material into any cracks and surface

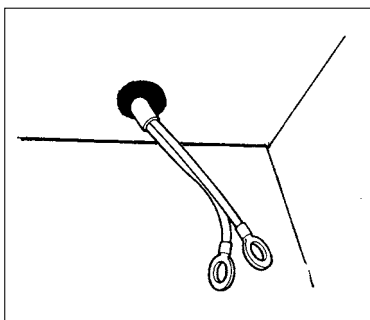

Electrical insulation repairs

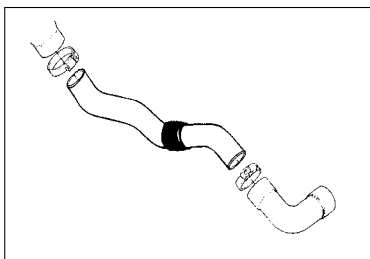

Hose repairs



RUBBERGRADE 6 REBUILD

defects. Take care not to trap air bubbles in deep cavities.

4. Machining

Once the **RubberGrade 6 Rebuild** has cured for the minimum time indicated in the Curing Properties Section of the product specification sheet, sanding and grinding can be carried out using standard engineering practices.

5. Cleaning

All equipment should be cleaned **IMMEDIATELY** after each use with a cleaner. Failure to follow this procedure will result in application equipment becoming unusable.

6. Health and safety

As long as normal good practices are observed **RubberGrade 6 Rebuild** can be safely used. A fully detailed Material Safety Data Sheet is included with the set. The information provided in this Instruction sheet is intended as a general guide only. Users should determine the suitability of the product for their own particular purposes by their own tests.

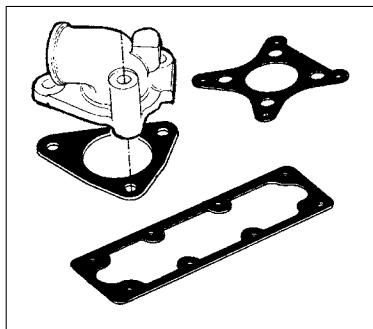

Gaskets and seals repairs

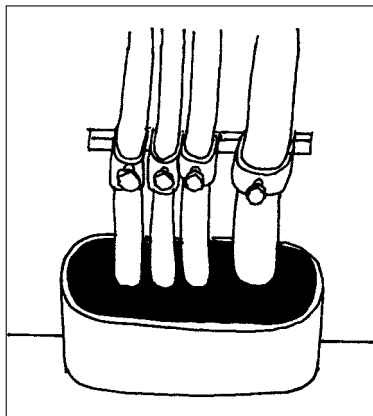

Electrical insulation repairs



RUBBERGRADE 6 REMOULD



Product specification sheet – Rubbergrade 6 Remould

PRODUCT NAME	PRODUCT NO	KIT CONSISTS OF
Product Description Rubbergrade 6 Remould Engineering Repair Fluid Supplied complete with all necessary equipment all in one	Product No 103-659292 Rubbergrade 6 Remould 0,43 ltr Engineering Repair Compound Gross Weight: 590 g	3 x 150 g packs Base + Activator 1 Spatula 1 Applicator 1 Pair of gloves 1 Technical Data Sheet 2 Safety Data Sheets

Identification

Activator Component				Base Component			
Appearance		Colour		Appearance		Colour	
Liquid		Brown		Liquid		Black	

Application Data

Mixing Ratio Volume		Mixing Ratio Weight		Pot Life (mins) (Working Life)							
Activator	Base	Activator	Base	5 °C	10 °C	15 °C	20 °C	25 °C	30 °C	35 °C	40 °C
-	-	-	-	15	10	10	8	8	7	6	5

Recommended Temperature Limits For Application: 5 °C TO 40 °C

Curing Time

Curing Times in minutes at ambient temperature	5 °C	10 °C	15 °C	20 °C	25 °C	30 °C	35 °C	40 °C
Initial Setting / Light Loading	60	50	35	25	25	20	15	15
Machining	480	240	180	180	150	150	150	120
Full Mechanical Strength	14 days	10 days	8 days	7 days	7 days	7 days	6 days	5 days
Full Chemical Resistance	18 days	15 days	14 days	12 days	12 days	8 days	7 days	7 days

Technical Data

Density g/cm ³			Volume Solids	Volume Capacity	Slump Resistance
Activator	Base	Mixed	%	cc/1000gm	12 1/2 mm thickness
1,2	0,98	1,04	100	962	-

Phys/Mec Properties

Tensile Strength	ASTM D412	7 MPa	1015 psi
Tear Strength	ASTM D624	4,5 MPa	650 psi
Elongation	ASTM D790	250 %	
Hardness (Shore A)	ASTM D2240	65	
Dielectric Strength	ASTM D149	-	
Surface Resistivity	ASTM D257	-	
Volume Resistivity	ASTM D257	-	

Values are determined after 48 hours at 20 °C

Service Temperatures

Dry heat	Wet heat	Minimum temp
+ 80 °C / 176 °F	+ 70 °C / 158 °F	- 20 °C / - 4 °F

Chemical resistance

Suitable for permanent immersion at 20 °C (68 °F) in a limited range of chemicals. For a more detailed description refer to the Chemical Resistance Chart.

Manufactured under a quality program certified to ISO 9002

Health and Safety

As long as good practice is observed Rubbergrade 6 Remould can be safely used. Wearing of rubber gloves is advisable during use. Prior to using this product please consult the Safety Data Sheet provided with each packaged product.

RUBBERGRADE 6 REMOULD



Instructions for use

Before proceeding, please read the following information application carefully to ensure that proper procedures are fully understood.

RubberGrade 6 ReMould is a two component, solvent free, synthetic rubber repair compound. Areas of application : hoses, gaskets, rubber rollers, ducting, impellers, valves etc.

Ensure there is no unmixed material caught in the corners of the pack. If there is, ease them out of the corners using the white plastic clip.

Cut any corner and pour out the **RubberGrade 6 ReMould** onto the repair surface/s.

1. Surface preparation

Heavy contamination due to oil or grease must be removed using a cleaner. Any areas of frayed or fragmented rubber should be cut away to provide a sound repair area.

Rubber surfaces are best roughened using a stiff-bristled or stiff-wire brush. All surfaces **MUST** be **dry**.

Edges of repair areas should be rebuilt. All loose dust particles must be removed and the surface wiped with a cleaner.

On certain repairs such as gaskets and castings where one surface is not required to bond to **RubberGrade 6 ReMould**, these surfaces should be treated with release agent.

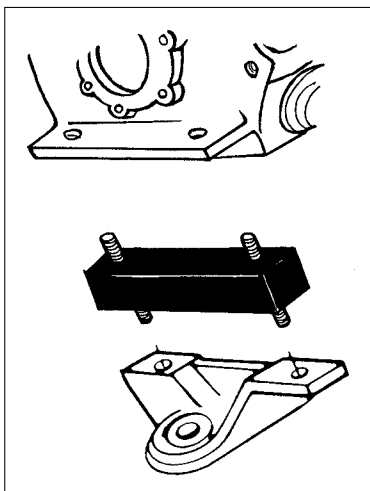

Castings of shock absorbers

2. Mixing

Remove the twin pack from the aluminium outer foil by cutting along the lines indicated. Take care not to puncture the pack. Remove the divider strip (black rubber) and take off the plastic divider clip. The contents are now ready to be mixed.

Mix the two components by kneading and squashing them together for 4 -5 minutes. The pack will warm up as it is being mixed.

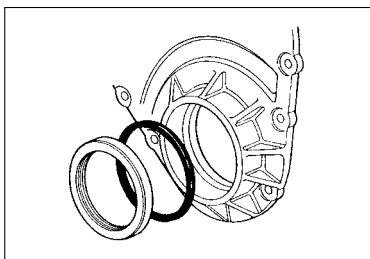

Making a new O-ring



RUBBERGRADE 6 REMOULD

3. Application

Using the spatula provided the mixed material should be spread evenly over the prepared area, working the material into any cracks and surface defects. Take care not to trap air bubbles in deep cavities.

4. Machining

Once the **RubberGrade 6 ReMould** has cured for the minimum time indicated in the Curing Properties Section of the product specification sheet, sanding and grinding can be carried out using standard engineering practices.

5. Cleaning

All equipment should be cleaned **IMMEDIATELY** after each use with a cleaner. Failure to follow this procedure will result in application equipment becoming unusable.

6. Health and safety

As long as normal good practices are observed **RubberGrade 6 ReMould** can be safely used. A fully detailed Material Safety Data Sheet is included with the set. The information provided in this Instruction sheet is intended as a general guide only. Users should determine the suitability of the product for their own particular purposes by their own tests.

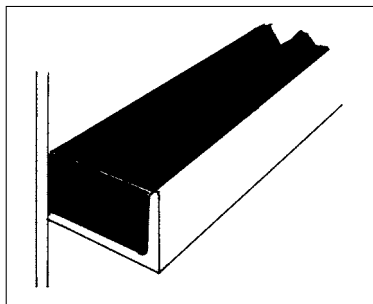

Hatch cover seals

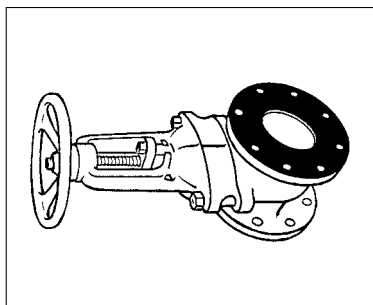

Flanges and mating repairs

ARC PROCESSES & EQUIPMENT



Electric Welding Equipment	333	
Electrode welding & gouging	333	
TIG welding	381	
Wire welding	403	
Plasma cutting & gouging	441	
Current distribution system	459	

ELECTRODE WELDING AND GOUGING



Introduction	334
Basic principles	337
Power source characteristics	338
Selecting power source	340
UWI-150 TP	342
UWI-230 TP AC/DC	345
UWI-203 TP	348
UWR-320 TP	350
UWI-500 TP	352
Primary extension cables	359
Secondary cables	360
Electrode holders, cable connectors & return clamp assembly	362
Accessories	370
Welding techniques	371
Edge preparation	373
Electrodes for electrode welding & gouging	374
Air Carbon arc gouging	377

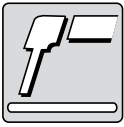

ELECTRODE WELDING AND GOUGING

Introduction

The principle of Manual Metal Arc Welding (MMAW) commonly called “stick electrode” welding is, as for all arc welding processes, based on the electric circuit. The electric arc formed between electrode and workpiece has two objectives, to melt the edges of the joint forming a melt pool on the workpiece, and to melt the tip of the coated electrode. The electrode is consumed and acts as a filler material mixing with the melted base material to fill up the joint.

Initially manual metal arc welding was done with bare metal electrodes without any coating, a process that was first introduced in 1888 in Russia.

The first coated electrode was patented by the Swedish engineer Oskar Kjellsberg in 1905, but it took some years of refining coatings and testing the reliability of welded joints before the process was accepted in the fabrication of steel constructions. In 1938, however, the world’s first wholly welded oceangoing ship was launched in Malmø, thereby introducing MMA welding as a production process for the maritime market.

The popularity of the Manual Metal Arc Welding process is to a large degree based on its versatility in addition to its modest requirements for equipment. Even quite unsophisticated welding machines like a step-down transformer may be used as power supply, at least for the less demanding electrodes, and the only welding equipment required in addition to the power supply is a suitable electrode holder.

By selecting the correct electrode, most metallic material may be arc welded in any position and in any thickness down to approximately 2 mm.

Different electrode holders are required depending on the type of welding work. In this chapter the following will be described:

- Normal welding/gouging with coated electrodes
- Air-Carbon-Arc gouging with copper coated carbon electrodes

Each of these areas require their special electrode holder.

4.01

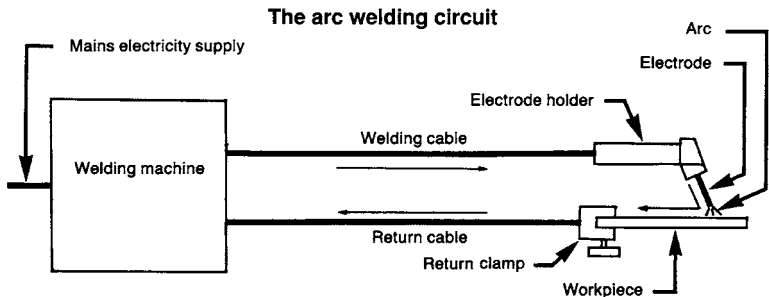

Arc processes require a complete electric circuit. Always remember proper connection of the return clamp.

ELECTRODE WELDING AND GOUGING

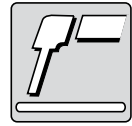

To establish an arc for welding and cutting, an electric circuit is required, consisting of the power source, welding cable, electrode holder or torch depending on the process, electrode, arc, workpiece, return clamp and return cable. The welding current flows through the entire system and back to the power source. Note that the workpiece must be a part of the electric circuit in all arc welding processes. Properly connected return cable is therefore always required to ensure good welding conditions and avoid accidents by unintended welding arcs being established e.g. at a poor return cable connection.

The arc, being the heat source for the welding or cutting process, will have a temperature between approximately 6000°C in the arc from a coated electrode and up to 28000°C (8 times the surface temperature of the sun) in the plasma arc used for cutting.

Practical setup

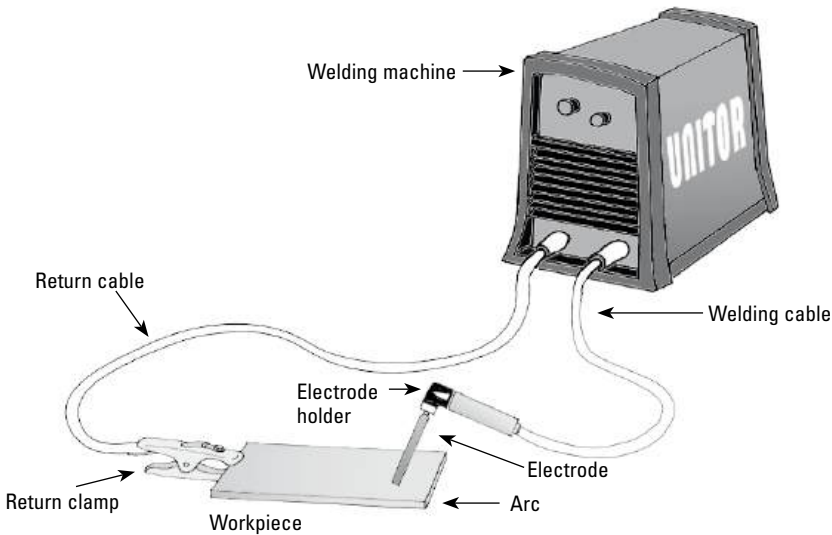

4.01

Welding current

The arc properties are dependent on the current supplied to it. Basically there are two different types of electric current; alternating current (AC) and direct current (DC). DC is a stream of negatively charged electrons flowing through the cable, moving from the negative pole (-) to the positive pole (+). AC is achieved when the power supply switches positive and negative polarity at a frequency which normally is 50 or 60 times per second (50 or 60 Hz). The electrons will then no longer flow in a steady stream but flow back and forth in the cable, and 100 or 120 times a second the current will actually be zero, as shown in the diagram.

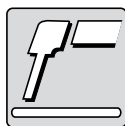

ELECTRODE WELDING AND GOUGING

AC as welding current

Mains power will normally be AC, and the simplest form of welding power sources are transformers that reduce the mains voltage and provide means for adjusting the amperage (welding current), still delivering AC to the welding arc. As the AC actually is zero each time it changes direction only electrodes specially developed for AC will be usable with welding transformers.

The pulsating effect of AC has proven to be especially dangerous to an operator in case of electric shock. Where burns are the main danger from an electric shock from DC, the AC pulses may in addition cause cramps and heart failure as the pulses affect the nervous system. Authorities in several countries have therefore issued special regulations and demands for open circuit voltage reducing equipment for welding power sources with AC output.

The only welding application that requires AC as welding current is TIG welding of aluminium, as the back and forth flowing electrons serve the purpose of tearing up the unmelting oxide layer that forms on top of an aluminium melt pool. However, in onboard repair and maintenance welding the Wire Welding Process Gas Metal Arc Welding (GMAW) process is an alternative for aluminium welding which offers several advantages, and is done with DC.

DC as welding current

DC is by far the best suited and most commonly used current for welding processes. It is normally obtained through a welding power source

(inverter or rectifier) that rectifies the AC from the mains supply to a DC of correct amperage and voltage for welding. To avoid the dangers the current pulses represent in cases of electric shock, several countries have issued regulations on how smooth the DC current shall be in order to be accepted as DC without requirements for open circuit voltage reducing devices. These requirements should be observed when installing welding equipment on board.

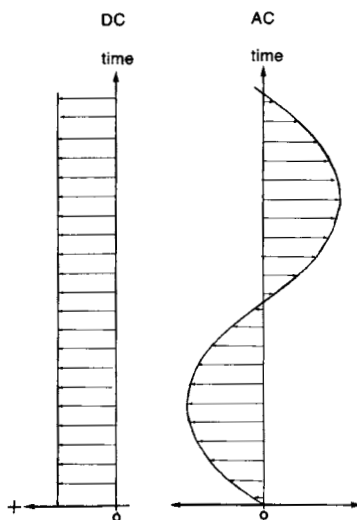

DC current, constant towards the positive (+) pole.

AC current cycling from one direction through zero to the opposite direction, 50 or 60 complete cycles per second.

ELECTRODE WELDING AND GOUGING



Basic principles

There are three different types of current used for Welding: DC-, DC+ and AC.

Transformer power sources produce alternating current (AC). This type of current changes direction 50 or 60 times per second (50-60 Hz). There are restrictions on alternating current used on board ships because this type of current goes deep into the body and can harm vital organs if the body becomes part of the electric circuit. Rectifier and inverters produce direct current (DC) which is regarded as a safe type of current to use on board. This type of current runs in one direction (from - to +) so we can manipulate by connecting the electrode to either - or + polarity. If we want deep penetration we can connect the electrode to - polarity and thereby bombard the base material with electrons that make 70% of the heat accumulating in the base material. Connecting the electrode to + polarity gives the opposite reaction with a high burn-off rate on the electrode, high weld build up and shallow penetration. Most root runs are done with DC- polarity to get the necessary penetration, while filler passes and capping runs are done with DC+ polarity.

The principal task of all power sources is to take alternating current from the mains and bring the high voltage down to a suitable working voltage. Rectifiers and inverters also convert the AC current into DC current.

Manual Metal Arc welding

Transformers: Alternating Current
Inverters & Rectifiers: Direct Current
+ or -

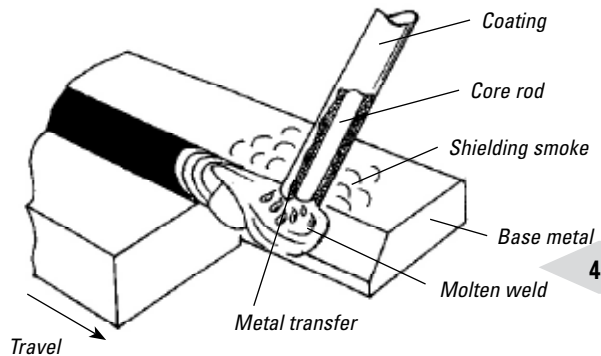
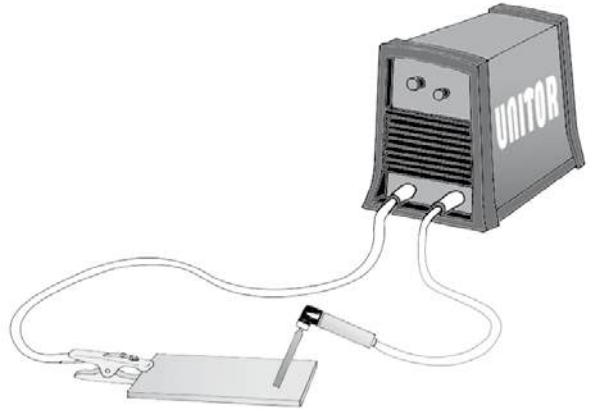

4.01

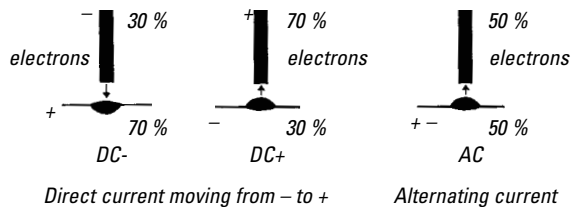

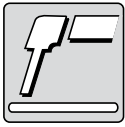

ELECTRODE WELDING AND GOUGING

Power source characteristics

A welding power source shall not only supply current of a set amperage and voltage, it shall also automatically adjust these values as conditions in the welding arc changes. A quick response to changes in the arc characterizes a well designed welding power source and is a prerequisite for good welding properties.

When welding with electrodes with large droplet transfer, small short circuits will constantly occur in the arc. As the short circuit starts, a current peak will occur before the machine adjusts to the short circuit condition. When the short circuit is broken a voltage peak will occur. Excessive height or duration of these peaks will give an unstable arc and spatter from the weld pool, and may increase the possibility of welding faults.

These dynamic properties of the welding power source are expressed in the dynamic characteristic of the machine.

The relation between amperage and voltage supplied from a welding power source is called the static characteristic of the machine. The two basic types of static characteristics are constant current (CC) and constant voltage (CV).

Constant current characteristic (CC)

Machines with constant current characteristic are designed to keep the welding current approximately constant, with variations within a narrow range when the arc length, and thereby the arc voltage, increases or decreases. The optimal current variation range is different for different processes.

For TIG welding a steep characteristic

with very little current variation is best. For Air Carbon Arc gouging a flatter characteristic, with more current variation and high short circuit current, is preferred. Welding with coated electrodes needs characteristics between these two.

Some welding power sources will have adjustable characteristics to enable the welder to choose exactly the characteristic suited for the job at hand, as shown in the figure below.

Constant voltage characteristic (CV)

This characteristic is used only for the Wire Welding process when a wire feeder with constant feed speed is used.

The power source will attempt to keep a constant arc voltage by increasing / decreasing the amperage as the arc length shortens / increases, and the characteristic curve will therefore be practically flat.

This characteristic is required for gas metal arc welding in the short arc range, and will also offer advantages in the spray arc range.

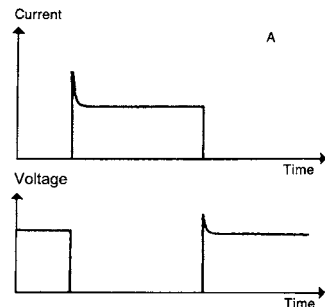

Dynamic characteristics of a short circuit

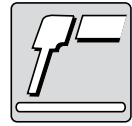

Constant Current characteristic (ACA)

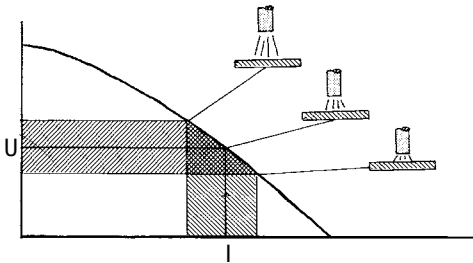

A flatter constant current characteristic is optimal for Manual Metal Arc Welding (stick), providing a higher current (within limits) when the arc length shortens.

$$U = 20 + 0,04 * I$$

(IEC 974)

Constant Voltage characteristic (CV)

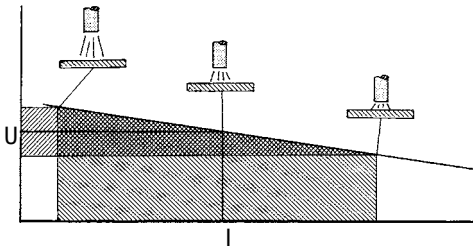

For Wire Welding the ideal characteristic is constant voltage. It will reduce the current if arc gets too long, thereby reducing the melt-off and allowing the welding wire to be fed closer to the melt pool again. If the arc gets too short the current will increase, the melt-off will increase, and normal arc length will automatically be established again.

$$U = 14 + 0,05 * I$$

(IEC 974)

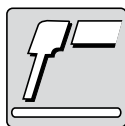

ELECTRODE WELDING AND GOUGING

Selecting power source

The four most important considerations when choosing a welding machine for use on board are:

1. Construction and operation must meet all requirements with regard to operator safety, including special requirements to current type (AC/DC) and open circuit voltage that exists for welding machines used on board.
2. Machines must be suitable for the special environment on board a ship and must be able to handle the special and varying voltages provided by the vessels' power supply.
3. As welding is only one of many skills which must be mastered by a ship's mechanic, operation should be simple and should provide ease of welding so that continual practice should not be necessary to achieve good results.
4. A welding machine must be able to supply sufficient power, and be able to handle all the necessary welding jobs that are needed on board.

By choosing a welding inverter (DC arc welding) from the Uinitor range, the first three points on our check list will normally be fulfilled, and the remaining question is the size and capacity of the machine. The choice will depend on how well prepared you wish to be to cope with unexpected repair on board, the efficiency and quality required in general repair work and also the welding processes to be handled by the power source.



UWI-150 TP



UWI-230 TP AC/DC



UWI-203 TP



UWI-320 TP



UWI-500 TP

ELECTRODE WELDING AND GOUGING

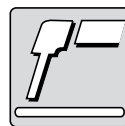

Selection guide, power sources:

Unitor welding machine range →	UWI 150TP	UWI 203TP	UWR 320TP	UWI 500TP	UWW 161TP	UWI-230 TP AC/DC
Light welding repairs and tack welding with coated Electrodes, max. 3.25 mm	x	x	x	x	x	x
Repair welding, pipe welding and light plating work Using coated electrodes, max 4.0 mm		x	x	x		x
All types of repair welding, including comprehensive Plating work using all dimensions of coated electrodes			x	x		
Preparing grooves with gouging electrodes		x	x	x		x
Air-Carbon-Arc gouging, cutting, hole piercing, weld-removal or surface "flushing" of steel plates				x		
TIG welding, all types of work including large dimensioned pipes		x	x	x		x
TIG welding, lighter work with 1.6 – 2.4 mm Tungsten electrodes	x	x	x	x	x	x
Wire welding.				x	x	
Weight kg.	4,4	12,2	18	47	12,6	19,5
Parallell connection.			x	x		x

Properties:

Choice of welding characteristic to suit all types of work (Electrode, TIG, Wire welding)	x*	x*	x*	x	x	x
Stepless full-range welding current adjustment during welding	x	x	x	x	x	x
Remote control of welding current by cable during welding	x		x	x		x
Possible to parallel connect two machines				x		x

4.01

Connection to mains:

1 phase 230 Volt 50/60 Hz	x				x	x
3 phase 380-440 Volt 50/60 Hz		x	x	x		

*) Not wire welding.

For information on the capacity of the individual models when welding with long welding cables, consult the section dealing with welding cables.

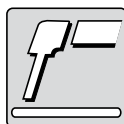

ELECTRODE WELDING AND GOUGING

UWI-150 TP Stick / TIG Dual Process Welding Inverter

Compact and only 4,4kg weight for ease of use onboard, the UWI-150 TP offers excellent performance-to-weight ratio with full capacity for welding all normal coated electrodes up to 3,2mm, including Aluminum electrodes.

Lift-Arc TIG start provides contamination free deposit. Amperage remote control on torch ensures full control during welding and downslope when finishing.

Easy to use TIG pulse option provides excellent sheet metal welding properties which cannot be obtained with standard TIG characteristic.

Plugs in anywhere, 1phase 230V and only 16A slow fuses.



- Line Voltage compensation keeps output of the power source constant regardless of fluctuation in input power of +/- 10%
- Automatic hot start provides easy arc start and prevents sticking.
- Thermal overload protection with indicator lights helps prevent machine damage if the duty cycle is exceeded or airflow is blocked.
- TP function (Total Protection) prevents damage to the machine if primary supply voltage is too high.
- Safe in use. VRD function reduces touchable open circuit voltage to only 9V when the welding arc is broken. Full arc striking voltage is re-established immediately when the electrode touches the work-piece.
- Casing of high-grade aluminium and panels of high grade industrial plastic reduces weight and risk of corrosion.
- Delivered complete in carrying case with electrode holder and return clamp

Technical Data

Description	Unit	Property
Welding current range MMA	A	5-150
Welding current range TIG	A	5-150
Max touchable OCV voltage	V	9
Duty cycle at max current	%	30
Maximum input power	kVA	6,2
Power factor		0,72
Main phases	phase	1
Power supply voltage	V	230
Power supply cycles	Hz	50/60
Recommended fuses (Slow)	A	16
Certifying authority/institution		S, CE
IP protection		23 S
Weight	kg	4,4
Length	mm	310
Width	mm	120
Height	mm	215

ELECTRODE WELDING AND GOUGING

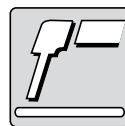

Ordering Information:

The order numbers include:

- UWI-150 TP welding machine
- 1 pc carrying strap
- 3m primary cable, mounted on the welding machine with Schuko plug 3 x 2,5 mm²
- 3m welding cable with dix 25 quick connector and electrode holder
- 3m return cable with dix 25 quick connector and return clamp
- All delivered in a strong protective suitcase
- Instruction manual

<i>Description</i>	<i>Unit</i>	<i>Product no.</i>
UWI-150 TP with basic accessories	pcs	191-150150

UWI-150 TP

Application set-up for Stick Electrode welding

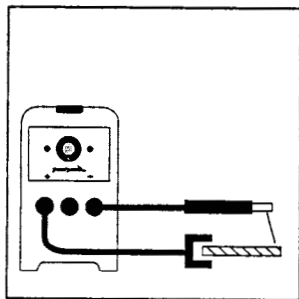

UWI-150 TP as a manual electrode welding unit

3m Welding cable with quick connectors and electrode holder

and

3m return cable with quick connector and return clamp are included

Optional Equipment

<i>Description</i>	<i>Unit</i>	<i>Product no.</i>
Face shield with handle and filter shade 11 glass		196 619098
Flip-Vision shield with flip-up frame, head band and filter shade 11 glass		196 709485
Filter glass set shade 9 for up to 40 A,	5 set	196 633248
Filter glass set shade 10 for up to 80 A,	5 set	196 633255
Filter glass set shade 11 for up to 175 A,	5 set	196 633263
Long lined welding gloves,	6 pairs	196 632786
Wire brush, steel, 2 rows,	6 pcs	196 632976
Wire brush, stainless steel, 2 rows,	6 pcs	196 632984
Chipping hammer steel,	2 pcs	196 633008
Chipping hammer stainless steel		196 632992
Welding gauge type J		196 516161

Miscellaneous:

Spare part kit* for UWI-150 TP **191-150161**

* Spare part kit includes power board, necessary additional components and complete instructions for replacement.

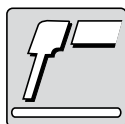

ELECTRODE WELDING AND GOUGING

Application set-up for TIG welding

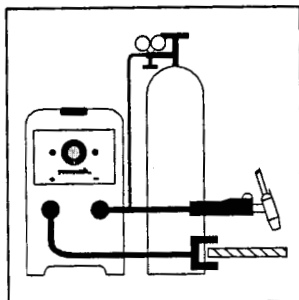

TIG welding Accessories for UWI-150 TP

<i>Description</i>	<i>Units</i>	<i>Product no.</i>
Specially thin and soft TIG gloves, TIG-torch T-150 with gas valve and DIX 25 for UWI-150	6 pairs	197 632794
Accessories kit for TIG-torch		197 150000
Remote control		197 607810
Argon regulator with flow adjustment 0-32 l/min		191 150151
Manometer gauge guard		197 510010
Flowcontrol meter for use at torch nozzle		197 619379
Flowcontrol needle valve for gas flow adjustment		197 597328
		197 597310

Argon for TIG shielding is available in 10 l cylinders (E-10)
and 50 l cylinders (E-50)

ELECTRODE WELDING AND GOUGING

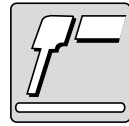

UWI-230 TP AC/DC Stick / TIG Dual Process Welding Inverter

- Small lightweight portable Welding machine for Electrode and TIG welding fast and easy access to all locations onboard
- Connects to 1 phase 230V 50/60Hz readily available power point onboard to supply this type of current
- Total Protection (TP) function that protects the machine toward voltage surges protects the machine towards damage and keep it working
- Voltage Reduction Device (VRD) keep Open Circuit Voltage at 9V protects the welder against electric shock
- Deliver Direct Current 180 Ampere for Electrode Stick Welding and 220 Ampere TIG welding makes it possible to weld 4mm electrodes and heavy thick material TIG welding jobs
- Modifies Direct Current into Square Wave Current makes it easy to TIG weld aluminum without the use of alternating current
- Turbo booster increasing heat input when welding aluminum dramatically increase welding speed and ability to weld thick material
- Lift Arc TIG start. No use of High Frequency disturbing radio communication onboard
- Remote control making it possible to adjust current during welding
- Built according to rules and regulations avoid accidents and legal implications
- Part of Unitor range fits all Unitor range transport trolley's and skid options
- Casing of high grade aluminum and industrial plastic to eliminate corrosion damage also contributes to low-weight which together with compact outer dimensions provides good portability.
- Wind tunnel design for the internal cooling air flow protects electrical components and PC boards from dirt, dust, debris, greatly improving reliability.
- Thermal overload protection with indicator lights helps prevent machine damage if the duty cycle is exceeded or airflow is blocked.
- Total Protection function with indicator light prevents machine damage if the primary power supply exceeds 275V.
- Supplied with instruction manual, primary cable, carrying strap, electrode holder and return clamp.



Technical Data

Description	Unit	Property
Welding current range, TIG	A	5-220
Welding current range, MMA	A	10-180
Open circuit voltage, max	V	10
Duty cycle at max. current	%	35
Maximum input power	KVA	6,2
Power factor		0.97
Mains phases		1
Mains phase, frequency		50/60 Hz
Mains voltage	V	230
Recommended fuses (slow)	A	16@
Protection class		IP 23S
Approval marks		CE
Height	mm	325
Length	mm	460
Width	mm	230
Weight	kg	19.4



4.01



Open circuit voltage below 67V provides conformance with the British DOT:
CODE OF SAFE WORKING PRACTICE FOR MERCHANT SEAMEN

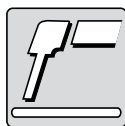

ELECTRODE WELDING AND GOUGING

Ordering Information:

The order numbers include:

- UWI-230 TP AC/DC welding machine
- 1 pce carrying strap
- 3,5 m primary cable, mounted on the welding machine 3x2 ,5 mm²
- Instruction manual

Description	Unit	Product no.
UWI-230 TP AC/DC	pcs	191-230231

UWI-230 TP AC/DC

Application set-up for Stick Electrode welding

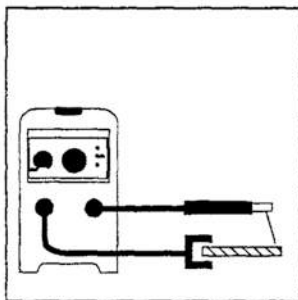

Description	Unit	Product no.
Basic accessories kit for UWI-230 TP AC/DC Consisting of: Return clamp assembly. 400 A Dix 70, 3 m cable 50 mm	set pcs	191-670406 195-594317
Electrode holder assembly. 400 A Dix70, 3 m cable 50 mm	pcs	196-594325
Remote amp. control 8 m	pcs	191-670414
Welding gloves	par	
Face shield with flip-up front frame, head band and filter shade 11 glass.	pcs	196-709485
Chipping hammer steel.	pcs	
Wire brush steel, two rows.	pcs	
Unitor Welding Handbook.	pcs	ID no. 811002
Miscellaneous:		
Skid Trolley for protection	pcs	191-764550
Spare part kit* for UWI-230 TP AC/DC	pcs	191-230233

* Spare part kit includes power board, necessary additional components and complete instructions for replacement.

Application set-up for TIG welding

4.01

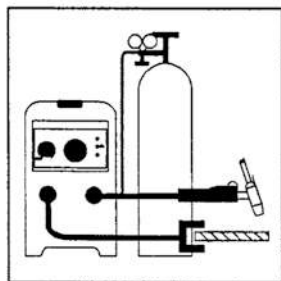

Description	Unit	Product no.
Specially thin and soft TIG gloves,	6 pairs	197 632794
TIG-torch T- 200 with gas valve and Dlx 70 connector		197 200000
Accessories kit for TIG-torch		197 607810
Argon regulator with flow adjustment 0-3 l/min		197 510010
Flowcontrol meter for use at torch nozzle		197 597328
Flowcontrol needle valve for gas flow adjustment		197 597310
Trolley for machine and E10/M10 shielding gas cylinders		196 778149

E10/M10 shielding gas cylinders

Argon for TIG shielding is available in 10 l cylinders (E-10) and 50 l cylinders (E-50)

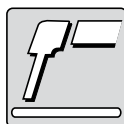

ELECTRODE WELDING AND GOUGING

UWI-203 TP Stick / TIG Dual Process Welding Inverter

- Connects to any primary voltage between 380 and 440V without need for any action from the operator.
- Line Voltage compensation keeps output of the power source constant regardless of fluctuation in input power from 10% below lowest to above highest rated input voltage.
- Safe in use. Open Circuit Voltage below the 70V limit set by the Code of Safe Working Practices for Merchant Seamen.
- Automatic Hot Start for stick arc starts makes arc striking easy and prevents electrode sticking.
- Adjustable Arc Force for stick electrode welding allows the arc characteristics to be -changed for specific applications and electrodes:

Low Arc Force setting for smooth running electrodes like LH and SPECIAL.

Increased setting provides optimal characteristics for stiffer, more penetrating electrodes like E6010 types, chamfering electrodes like CH2 and electrodes for ACA gouging.

- Lift-Start in TIG mode provides easy and soft TIG arc starting.
- Step-less adjustment of welding current through whole current range: 5 –200A.
- Casing of high grade aluminium and industrial plastic to eliminate corrosion damage also contributes to low-weight which together with compact outer dimensions provides good portability.
- Wind tunnel design for the internal cooling air flow protects electrical components and PC boards from dirt, dust, debris, greatly improving reliability.
- Thermal overload protection with indicator lights helps prevent machine damage if the duty cycle is exceeded or airflow is blocked.
- Total Protection (TP) function close the machine down in case one phase in the power supply falls out.
- Supplied with instruction manual, primary cable, carrying strap, electrode holder and return clamp



Technical Data

Description

Description	Unit	Property
Welding current range, DC	A	5-200
Open circuit voltage from serial no 129431	V	13
Duty cycle at max. current	%	40
Maximum input power	kVA	6,7
Power factor		0,95
Mains phases		3
Mains phase, frequency		50/60 Hz
Mains voltage	V	380-440
Recommended fuses (slow)	A	10
Protection class		IP 23S
Approval marks		CE
Height	mm	325
Length	mm	460
Width	mm	230
Weight	kg	12,2



Open circuit voltage below 70V provides conformance with the British DOT: CODE OF SAFE WORKING PRACTICE FOR MERCHANT SEAMEN

Ordering Information:

The order numbers include:

- UWI-203 welding machine
- 1 pce carrying strap
- 3,5 m primary cable, mounted on the welding machine 4 x 1,5 mm²
- 3 m welding cable with quick connector and electrode holder
- 3 m return cable with quick connector and return clamp
- Instruction manual

Description	Product no.
UWI-203 TP with basic accessories	191-203203

ELECTRODE WELDING AND GOUGING

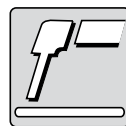

UWI-203 TP

Application set-up for Stick Electrode welding

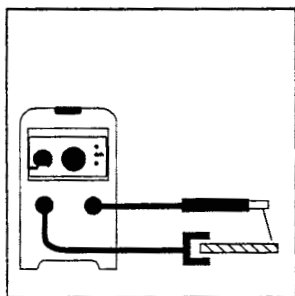

UWI-203 TP as a manual electrode welding unit
3m Welding cable with quick connectors and electrode holder and 3m return cable with quick connector and return clamp are included with the UWI-203 TP.

Optional Equipment UWI-203 TP

Description	Unit	Product no.
Face shield with handle and filter shade 11 glass		196 619098
Flip-Vision shield with flip-up frame, head band and filter shade 11 glass		196 709485
Filter glass set shade 9 for up to 40 A,	5 set	196 633248
Filter glass set shade 10 for up to 80 A,	5 set	196 633255
Filter glass set shade 11 for up to 175 A,	5 set	196 633263
Long lined welding gloves,	6 pairs	196 632786
Wire brush, steel, 2 rows,	6 pcs	196 632976
Wire brush, stainless steel, 2 rows,	6 pcs	196 632984
Chipping hammer steel,	2 pcs	196 633008
Chipping hammer stainless steel		196 632992
Welding gauge type J		196 516161



Miscellaneous:

Skid Trolley for protection		191 764550
Spare part kit* for UWI-203 TP		191-203205

Application set-up for TIG welding

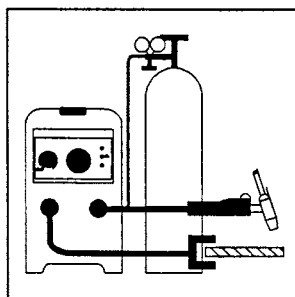

TIG welding Accessories for UWI-203 TP

Description	Units	Product no.
Specially thin and soft TIG gloves,	6 pairs	197 632794
TIG-torch T-200 with gas valve and DIX 70 connector		197 200000
Accessories kit for TIG-torch		197 607810
Argon regulator with flow adjustment 0-32 l/min		197 510010
Flowcontrol meter for use at torch nozzle		197 597328
Flowcontrol needle valve for gas flow adjustment		197 597310
Trolley for machine and E10/M10 shielding gas cylinders		196 778149

Argon for TIG shielding is available in 10 l cylinders (E-10) and 50 l cylinders (E-50)

* Spare part kit includes power board, necessary additional components and complete instructions for replacement.

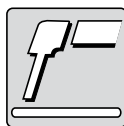

ELECTRODE WELDING AND GOUGING

UWI-320 TP Stick / TIG Dual Process Welding Inverter



- Connects to any primary voltage between 380 and 440V without need for any action from the operator.
- Line Voltage compensation keeps output of the power source constant regardless of fluctuation in input power from 10% below lowest to above highest rated input voltage.
- Safe in use. Open Circuit Voltage only 8V, well below the 70V limit set by the Code of Safe Working Practices for Merchant Seamen.
- Automatic Hot Start for stick arc starts makes arc striking easy and prevents electrode sticking.
- Adjustable Arc Force for stick electrode welding allows the arc characteristics to be -changed for specific applications and electrodes: Low Arc Force setting for smooth running electrodes like LH and SPECIAL. Increased setting provides optimal characteristics for stiffer, more penetrating electrodes like E6010 types, chamfering electrodes like CH2 and electrodes for ACA gouging.
- Lift-Start in TIG mode provides easy and soft TIG arc starting.
- Step-less adjustment of welding current through whole current range: 5 –320A.
- Casing of high grade aluminium and industrial plastic to eliminate corrosion damage also contributes to low-weight which together with compact outer dimensions provides good portability.
- Wind tunnel design for the internal cooling air flow protects electrical components and PC boards from dirt, dust, debris, greatly improving reliability.
- Thermal overload protection with indicator lights helps prevent machine damage if the duty cycle is exceeded or airflow is blocked.
- Total Protection (TP) function close the machine down in case one phase in the power supply falls out.
- Supplied with instruction manual, primary cable, carrying strap, electrode holder and return clamp.

Technical Data

Description	Unit	Property
Welding current range, DC	A	5-320
Open circuit voltage, max	V	9
Duty cycle at max. current	%	30
Maximum input power	kVA	14,9
Power factor		0,77
Mains phases		3
Mains phase, frequency		50/60 Hz
Mains voltage	V	380-440
Recommended fuses (slow)	A	10
Protection class		IP 23S
Approval marks		CE
Height	mm	325
Length	mm	460
Width	mm	230
Weight	kg	18



Open circuit voltage below 70V provides conformance with the British DOT: CODE OF SAFE WORKING PRACTICE FOR MERCHANT SEAMEN.

Ordering Information:

The order numbers include:
 UWI-320 TP welding machine
 1 pce carrying strap
 3,5 m primary cable, mounted on the welding machine 4 x 2,5 mm²
 Instruction manual.

Description	Unit	Product no.
UWI-320 TP	pcs	191-320320

ELECTRODE WELDING AND GOUGING

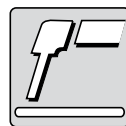

UWI-320 TP

Application set-up for Stick Electrode welding

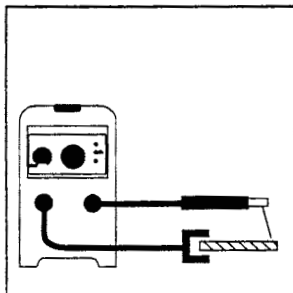

Basic accessories kit for UWI-320 TP

<i>Description</i>	<i>Unit</i>	<i>Product no.</i>
Basic accessories kit for UWI-320 TP	set	191-670406
Consisting of:		
Return clamp assembly. 400 A Dix 70, 3 m cable 50 mm ²	pcs	195-594317
Electrode holder assembly. 400 A Dix 70, 3 m cable 50 mm ²	pcs	196-594325
Remote amp. control 8 m	pcs	191-670414
Welding gloves	par	
Face shield with flip-up front frame, head band and filter shade 11 glass	pcs	196-709485
Chipping hammer steel	pcs	
Wire brush steel, two rows	pcs	
Unitor Welding Handbook	pcs	ID no. 811002
Miscellaneous:		
Skid Trolley for protection	pcs	191-764550
Spare part kit* for UWI-320 TP	pcs	191-320323

Application set-up for TIG welding

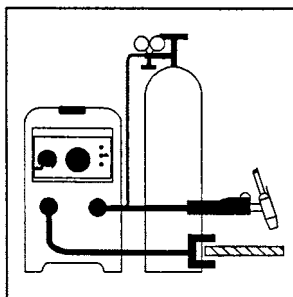

TIG welding Accessories for UWI-320 TP

<i>Description</i>	<i>Units</i>	<i>Product no.</i>
Specially thin and soft TIG gloves,	6 pairs	197 632794
TIG-torch T-200 with gas valve and DIX 70 connector		197 200000
Accessories kit for TIG-torch		197 607810
Argon regulator with flow adjustment 0-32 l/min		197 510010
Flowcontrol meter for use at torch nozzle		197 597328
Flowcontrol needle valve for gas flow adjustment		197 597310
Trolley for machine and E10/M10 shielding gas cylinders		196 778149

Argon for TIG shielding is available in 10 l cylinders (E-10) and 50 l cylinders (E-50)

* Spare part kit includes power board, necessary additional components and complete instructions for replacement.

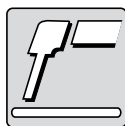

ELECTRODE WELDING AND GOUGING

UWI-500 TP Multi process welding inverter

- The UWI-500 TP is designed for welding with all types and sizes of welding wires, coated electrodes, carbon electrodes and TIG rods, with current range: 5 – 500A.
- Automatic adjustment to any primary voltage between 380 and 440V.
- Line Voltage compensation keeps output of the power source constant regardless of fluctuation in input power from 10% below lowest to above highest rated input voltage.
- Total Protection function with indicator light prevents machine damage if one phase in the primary power supply falls out or if over-voltage is supplied to the machine.
- Thermal overload protection with indicator lights helps prevent machine damage if the duty cycle is exceeded or airflow is blocked.
- Safe in use. The Voltage Reduction Device function reduces touchable open circuit voltage to only 9V, providing optimal safety for the operator.
- The remote amperage control can be used for all processes, and also for two machines in parallel for up to 1000 Amp. for Air Carbon Arc gouging.
- Separate characteristics are available for welding with standard electrodes, for cellulosic electrodes, for TIG, for Air Carbon Arc gouging and for Wire welding with or without shielding gas. This ensures optimal properties for all processes
- Adjustable Hot Start for MMA welding provides optimal arc striking for all electrode types and prevents electrode sticking.
- Adjustable Arc Force for MMA welding allows the arc characteristics to be changed for specific applications and electrodes.
- 2-step TIG-torch control with Lift-Arc provides an easy and soft TIG arc start, and remote control from 5 amp to maximum ensures total arc control both during welding and for the down-slope finish of the weld.



Technical Data

Description	Unit	Property
Welding current range, DC	A	5-500
Open circuit voltage, max	V	9
Duty cycle at max. current	%	50
Maximum input power	kVA	26,5
Power factor		0,85
Mains phases		3
Mains phase, frequency		50/60 Hz
Mains voltage	V	380-440
Recommended fuses (slow)	A	32
Protection class		IP 23S
Approval marks		CE
Height	mm	510
Length	mm	670
Width	mm	290
Weight	kg	47

Open circuit voltage below 70V provides conformance with the British DOT: CODE OF SAFE WORKING PRACTICE FOR MERCHANT SEAMEN

Ordering Information:

The order numbers include:
UWI-500 TP
5 m primary cable 4 x 6 mm².
Instruction manual.

Description	Unit	Product no.
UWI-500 TP	pcs	191-500500

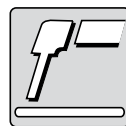

UWI-500 TP Application set-up for Stick Electrode welding



UWI-500 TP as a manual stick electrode welding unit with a remote control unit and welding cables.

Stick Electrode accessories

<i>Description</i>	<i>Unit</i>	<i>Product no.</i>
Basic accessories kit for UWI-500 TP	set	191-670406
Consisting of:		
Return clamp assembly, 400 A Dix 70, 3 m cable 50 mm ²	pcs	195-594317
Electrode holder assembly, 400 A Dix 70, 3 m cable 50 mm ²	pcs	196-594325
Remote amp. control 8 m	pcs	191-670414
Welding gloves	par	
Face shield with flip-up front frame, head band and filter shade 11 glass	pcs	196-709485
Chipping hammer steel	pcs	
Wire brush steel, two rows	pcs	
Unitor Welding Handbook	pcs	
Miscellaneous		
Remote control cable extension, 25 m		191-670422
Undercarrige for UWI-500 TP	pcs	196-500103
Spare part kit* for UWI-500 TP	pcs	191-500505

* Spare part kit includes power board, necessary additional components and complete instructions for replacement.

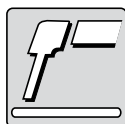

ELECTRODE WELDING AND GOUGING

UWI-500 TP

Application set-up for TIG welding



UWI-500 TP as TIG welding unit with a remote control unit, TIG torch set and return cable.

TIG welding accessories (Based on having Stick electrode accessories)

Description	Unit	Product no.
TIG torch T-200 complete with DIX 70	pcs	197-200000
Remote amp. control 8 m must be used for TIG welding	pcs	191-670414
Accessories kit for TIG torch	pcs	197-607810
Argon / CO ₂ regulator with flow adjustment 0-32 l/min.	pcs	197-510010
Flow control meter for use on torch nozzle	pcs	197-597328
Flow control needle valve for gas flow adjustment	pcs	197-597310
Gas hose 1/4" black for shielding gases, mtr.	mtr	176-576157
Hose joint for 1/4" hose, pcs.	pcs	176-175596
Clip 8-14 mm for hose, 10 pcs.	pck	401-729442
Specially thin and soft TIG gloves,	6 pairs	197-632794
Trolley for one 40-50l gas cylinder	pcs	176-778147

Argon for TIG shielding gas is available in 10 l cylinders (E-10) and 50 l cylinders (E-50).

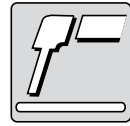

UWI-500 TP

Application set-up for Wire welding



UWI-500 TP with UWF-102 wire feeder, wire welding torch and return cable.

Wire welding accessories (Based on having Stick electrode accessories)

<i>Description</i>	<i>Unit</i>	<i>Product no.</i>
Wire feeder UWF-102 ex. Torch	pcs	193-500102
Wire torch T-400MP w/3 m cable for gas shielded wire welding	pcs	193-607451
Wire torch T-350 w/3 m cable for gasless wire welding	pcs	193-607451
Argon/CO ₂ regulator w / flow adjustment 0-32 l/min.	pcs	197-510010
CO ₂ regulator with flow adjustment	pcs	197-510012
Flow control meter for use on torch nozzle	pcs	197-597328
Flow control needle valve for gas flow adjustment	pcs	197-597310
Gas hose 1/4" black for shielding gases	mtr	176-576157
Hose joint for 1/4" hose	pcs	176-175596
Clip 8-14 mm for hose, 10 pcs	pck	401-729442
Specially thin and soft gloves	6 pairs	197-632794
Trolley for one 40-50l gas cylinder	pcs	197-778147

Argon or Argon CO₂ for Wire Welding shielding gas available in 10 l cylinders (E-10/M-10) and 50 l cylinders (E-50/M-50)

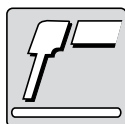

ELECTRODE WELDING AND GOUGING

Application set-up for Air Carbon Arc Gouging or Stick Electrode welding using 2 x UWI-320 TP or 2 x UWI-500 TP in parallel Electrode/return clamp assembly

2 x UWI-320 TP, max output 640 Amps.

2 x UWI-500 TP, max output 1000 Amps.

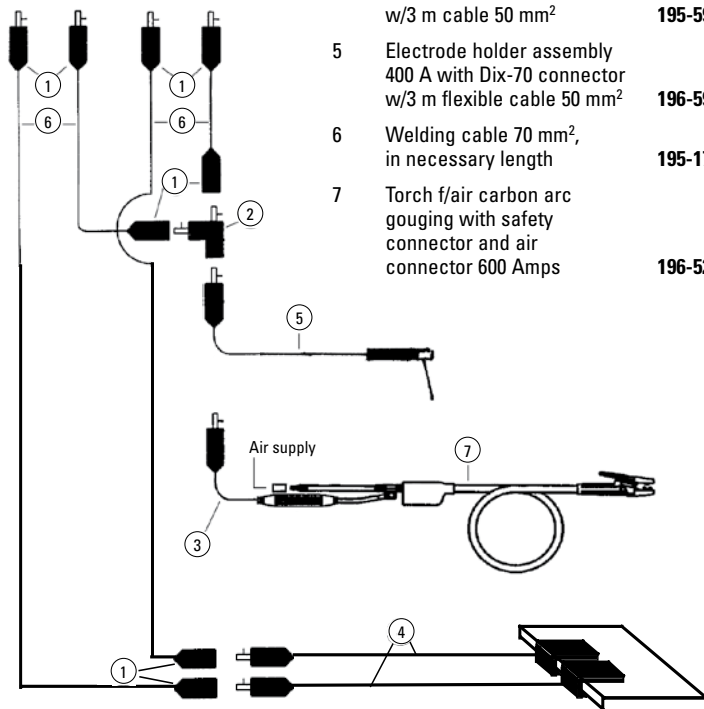

Pos.	Description	Product no.	Unit
1	Cable connector Dix-70 male/female complete	195-632894	pcs
2	Triple connection Dix-70 male/male/female, 2 pcs	195-632901	pcs
3	Conversion assembly safety Dix-70 male, 2 pcs	195-634121	pcs
4	Return clamp assembly 400 A with Dix-70 connector w/3 m cable 50 mm ²	195-594317	pcs
5	Electrode holder assembly 400 A with Dix-70 connector w/3 m flexible cable 50 mm ²	196-594325	pcs
6	Welding cable 70 mm ² , in necessary length	195-175851	m
7	Torch f/air carbon arc gouging with safety connector and air connector 600 Amps	196-528703	pcs

4.01



Remote control assembly

Important:

If parallel connection of two 320 TP or two UWI-500 TP machines, both machines must be switched on. If only one machine is switched on the current in the parallel cable may damage the other machine.

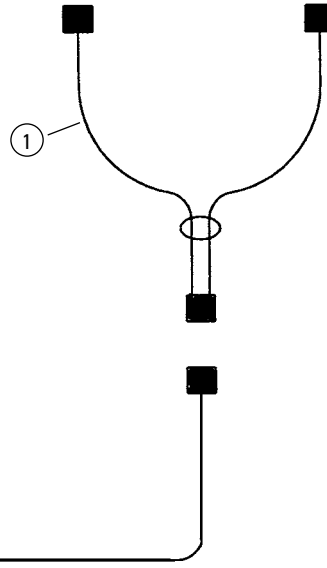

<i>Pos.</i>	<i>Description</i>	<i>Product no.</i>
1	Remote control parallel connection cable	191-676973
2	Remote amp. control 8 m	191-670414

NB In this location the remote control extension cables can be mounted

Remote control cable extension 25 m Product No. **191-670422**

Length depends on distance from welding machine to work site and desired work radius. The extension cable can be connected into longer lengths if necessary.

ELECTRODE WELDING AND GOUGING

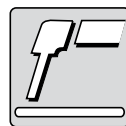

Primary extension cables

The Unitor power sources are delivered with a 2 or 3 meter primary cable. If a longer primary cable is needed this is our recommendation for length and dimension. Note that dimensioning of the cable does not only depend on cable length but also the voltage on the mains.



Size	Product no. per m.
3 x 2,5 mm ² + G	195-526335
3 x 4,0 mm ² + G	195-526343
3 x 10 mm ² + G	195-526350

UWI-150 TP, UWW-161 TP, UWI-230 TP AC/DC

Conductor size	230 V	380 V	440 V
2.5 mm ²	≤ 45 m	–	–
4.0 mm ²	≤ 60 m	–	–



2+G

UWI-203 TP

Conductor size	230 V	380 V	440 V
1.5 mm ²	–	≤ 30 m	≤ 200 m
2.5 mm ²	–	≤ 50 m	≤ 300 m
4.0 mm ²	–	≤ 80 m	≤ 500 m



3+G

UWI-320 TP

Conductor size	230 V	380 V	440 V
2.5 mm ²	≤ 60 m	≤ 150 m	≤ 200 m
4.0 mm ²	≤ 100 m	≤ 250 m	≤ 350 m



3+G

4.01

UWI-500 TP

Conductor size	230 V	380 V	440 V
4.0 mm ²	–	≤ 50 m	≤ 50 m
6.0 mm ²	–	≤ 100 m	≤ 100 m
10.0 mm ²	–	≤ 150 m	≤ 150 m



3+G



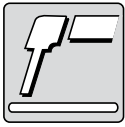

ELECTRODE WELDING AND GOUGING

Secondary cables (welding and return cables)

The cross-section dimension of a welding cable must be compatible with both the welding current which will be used and the total length of welding and return cable which will be used in the welding circuit.

The first requirement is the maximum load the cable can carry without overheating. The following maximum load ratings apply to neoprene insulated welding cable at 25°C ambient temperature.

Cable Cross-Section	Maximum welding current at varying duty cycles			Weight kg per m.
	100%	60%	30%	
35 mm ²	225A	290A	410A	0,42
50 mm ²	285A	365A	520A	0,56
70 mm ²	335A	460A	650A	0,78
95 mm ²	430A	560A	790A	1,03

As guideline, it should be noted that normal hand welding using coated stick electrodes and TIG welding is carried out at a duty cycle (effective welding time) of 30-40%, while wire welding and air carbon arc gouging may have a duty cycle of up to 60%.

The maximum current values are based on the capacity of the cables alone. However, the voltage drop in the cables will often be the decisive factor when choosing the right cable size. The theoretical voltage drop in 100 meters copper cable of four different cross sections is shown for increasing currents in the following diagram:

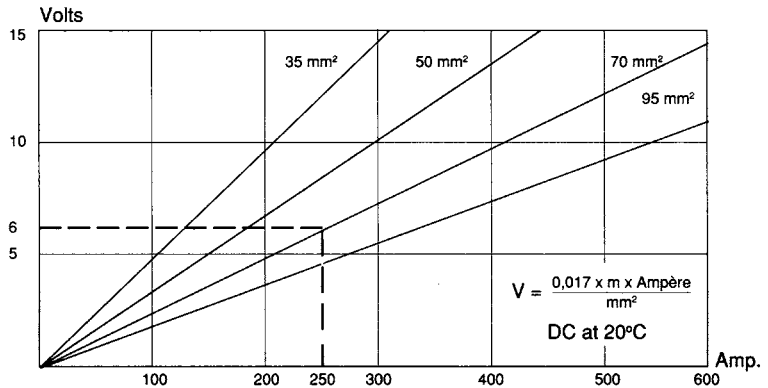

ELECTRODE WELDING AND GOUGING

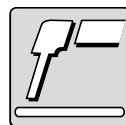

It will be seen that the voltage drop in 100 meters 70 mm² cable is 6 V at 250 A DC. When using longer lengths of cable, the voltage drop will increase proportionately, i.e. on a 200 meter length of 70 mm² cable, the voltage drop will be 12 V at the same amperage. It should be noted that for AC current, the voltage drop can be more than double the value for DC current due to inductive resistance, especially when the welding cables lie across a steel deck. When the voltage drop is excessive, welding characteristics suffer accordingly. How large a voltage drop that can be tolerated will depend on the type of welding machine and type of electrode.

The following table shows the theoretical cable lengths relevant to

the different cable cross-sections and the different types of welding machines based on the following calculation:

Maximum allowed voltage drop for a welding machine is:

- the maximum output voltage at the corresponding current.
- minus the conventional load voltage (IEC 60974-1).

The maximum length of welding cable (total length from return cable and electrode holder cable) for this voltage drop is calculated as followed:

Length \approx voltage drop/current · conductivity of copper (58) · cable cross section.

Current	Cable cross-Section	Welding machine type			
		UWI-500 TP	UWI-320 TP	UWI-203 TP	UWI-150
150 A	35 mm ²	460 m	298 m	176 m	64 m
	50 mm ²	657 m	425 m	251 m	91 m
	70 mm ²	920 m	595 m	352 m	128 m
200 A	50 mm ²	391 m	255 m	97 m	
	70 mm ²	548 m	357 m	136 m	
	95 mm ²	740 m			
300 A	50 mm ²	174 m	77 m		
	70 mm ²	243 m	108 m		
	95 mm ²	330 m			
400 A	70 mm ²	x)			
	95 mm ²	x)			

x) Bring machine to work site and use short electrode/ground cables only

Note:

By connecting two cables in parallel, the voltage drop can be halved and the distance from machine to welding area thereby doubled.

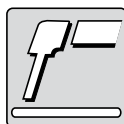

ELECTRODE WELDING AND GOUGING

Unitor Welding Cable

Welding cables used on board, on deck or in an engine room, are exposed to both rough weather, oil and mechanical wear. The welding cable supplied by Unitor has wear, flame and oil-resistant insulation on a polychloroprene rubber basis. It is recognized by its marking at regular intervals with the text "Unitor oil resistant welding cable", size of cable, and the standard for welding cable H01N2-D.

H01N2-D means that the cable is produced to an international harmonized standard.

The conductor is built up from 0.2 mm diameter tinned copper strands to ensure flexibility.

The cable is available in cross section areas 35 mm², 50 mm² and 70 mm², and may be supplied in standard lengths of 10 m, 20 m or 50 m, fitted with Unitor Safety cable connectors.

It may also be ordered in other lengths, without connectors mounted.

Cable drum

The cable drum with crank and floor stand is used for storage of up to 100 m cable. The crank may be disengaged to avoid accidents when unwinding cable.

Note that welding cables should always be stretched out when used, and excessive lengths should not be used. A coiled up cable, whether on a drum or in a coil on deck will act as an electromagnet when welding current is flowing. This will cause increased resistance in the welding circuit which may have negative influence on the welding result. The electromagnetic field created may also influence vulnerable equipment in the vicinity of the coil.

Cable size comparison

AWG	mm ²	AWG	mm ²
3	26.7	2/0	67.4
2	33.6	3/0	85.0
1	42.4	4/0	107.2
1/0	53.5		



4.01

Ordering information

Cross-section area	Product no.					
	Max Amp at 60 % D/C	Weight kg/m	Pr. meter	10m incl. connectors	20 m incl. connectors	50 m incl. connectors
35 mm ²	290	0,42	195-175836	195-175794	195-175786	195-175778
50	365	0,56	195-175844	195-175828	195-175810	195-175802
70	460	0,78	195-175851		195-320010	195-183665
95	560	1,03	195-655266			
Cable drum for up to 100 m cable, order no.						195-175729

ELECTRODE WELDING AND GOUGING

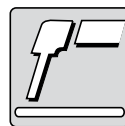

Electrode holders, Cable connectors and return clamp assemblies

Cable connectors and return clamps are important – but often neglected – parts of the welding current circuit. The voltage drop in a poor or a wrongly positioned return clamp can be considerable, equal to many meters of additional cable, and the welding arc will suffer accordingly (see section on voltage drop in welding cable).

The Electrode holders

Unitor's fully insulated electrode holders are of the lever screw type and feature an especially robust and safe clamping arrangement for the electrodes. The holders are of strong and simple construction. There are three types of electrode holder available, the 200A, 400A and 600 A.

The return connection

The return connector must be sufficiently dimensioned to provide good contact for the welding current load to be used. The positioning of the return clamp determines how large a part of the vessel or of the work piece is to be utilized as part of the welding current circuit. The return clamp should always be placed as close as possible to the welding area, or on the work piece itself if this is not an integral part of the hull. The thickness of material between welding point and return clamp must be sufficient to carry the current load that is to be used. Think carefully before fixing the return clamp so that sensitive machine

parts such as ball bearings etc. are not used as a bridge for welding current.

The Cable connectors

Cable connectors must be insulated in such a way that the danger of handling or short-circuiting through the deck is reduced to a minimum. This applies both to connected and unconnected parts. There should be no possibility of short-circuiting in connected plugs and sockets attached to cables, even if they should come into occasional contact with salt water. There must be good contact and little resistance at the contact areas and at the welding cable connections to the connectors. Unitor Safety cable connectors meet these requirements, more than 1400 mm² contact area ensuring good contact between plug and socket, and when carefully assembled, the connectors are as good as watertight against spray and when decks are sporadically washed. The connectors may be used on cable dimensions from 35 mm² up to 95 mm² and are designed to accept up to 750 A welding current.

Dix quick-action connectors are used for front panel connections on the welding machines. These provide easy polarity changes, but are not fully insulated and are therefore not recommended as cable connectors for cable extensions along open deck. Adapters for connection to Unitor Safety connectors are available.

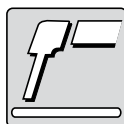

ELECTRODE WELDING AND GOUGING

Electrode holder assemblies

Electrode holder assembly
200 A with Dix 25 connector
w/3 m cable 25 mm²

Product no. **196-627877**

For use on UWI-150 and
UWW 161 TP



Electrode holder assembly
200 A with Dix 70 connector

w/3 m cable 35 mm²

Product no. **196-627885**

For use on UWI-200, -201, -202,
-203 TP



Electrode holder assembly
400 A with Dix 70 connector
w/3 m cable 50 mm²

Product no. **196-594325**

For use on UWR-303, UWI-320 TP and
UWI-500 TP



Electrode holder assembly
400 A with Safety connector
w/3 m Super flexible cable 50 mm²

Product no. **196-522680**

All electrode holder assemblies
are produced in accordance with
Standard 2006/95/EEG concerning
low voltage, and conform to CEI/IEC
60974-7: 2005-07





Return Clamp Assemblies

Return clamp assembly
200 A with Dix 25 connector
w/3 m cable 25 mm²

Product no. **195-633164**

For use on UWI-150 and UWW-161 TP



Return clamp assembly
200 A with Dix 70 connector
w/3 m cable 35 mm²

Product no. **195-633172**

For use on UWI-200, -201, -202, -203
TP



Return clamp assembly
400 A with Dix 70 connector
w/3 m cable 50 mm²

Product no. **195-594317**

For use on UWR-303, UWI-320 TP and
UWI-500 TP



Return clamp assembly
400 A with Safety connector
w/3 m cable 50 mm²

Product no. **195-633180**

For use with extension cables where
Safety connectors are used



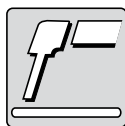

ELECTRODE WELDING AND GOUGING

Electrode holders

Electrode holder Twisty 200 Amps.
For electrode dia. 1.6–3.2 mm.

Product no. **196-552497**



Electrode holder Twisty 400 Amps.
For electrode dia. 1.6–5.0 mm

Product no. **196-513051**



Electrode holder 600 Amps.
For electrode dia. 1.6–8.0 mm.

Product no. **196-511006**



Electrode holders are produced in accordance with Standard 2006/95/EEG concerning low voltage, and conform to EN 60974-11

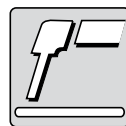

Return clamps

Return clamp 400 Amps.
Jaw opening 70 mm.

Product no. **195-653899**

Return clamp 800 Amps.
Jaw opening 60 mm.

Product no. **195-175745**



Return clamp 400 A. Grind off rust and paint before connecting return clamp in order to ensure optimal contact with the workpiece



Place return clamp in direct contact with work piece. Use of the ships hull as return conductor is against regulations. Make sure to grind the connection surface free from paint and rust before connecting the return clamp.

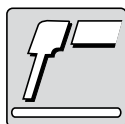

ELECTRODE WELDING AND GOUGING

Cable Connectors

Cable connector Dix 25 male/female
complete
230 A / 60 % Duty Cycle.
Cable size 10–25 mm²

Product no. **195-632885**



Cable connector Dix 70 male/female
complete
460 A / 60 % Duty Cycle.
Cable size 35–70 mm²

Product no. **195-632893**



Cable connector Dix 120 male/female
complete
650 A / 60 % Duty Cycle.
Cable size 90–120 mm²

Product no. **195-736744**



Cable connector Safety male/female
complete
460 A / 60 % Duty Cycle.
Cable size 35–70 mm²

Product no. **195-513044**



ELECTRODE WELDING AND GOUGING

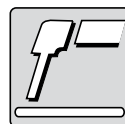

Conversion assembly
Safety Dix 70 male, 2 pcs
70 mm² cable 0,3 m long.

Product no. **195-634121**



Triple connection Dix 70 male/male/female, 2 pcs.

Product no. **195-632901**

For parallel connecting 2xUWI-400 welding machines.
For stick welding or air carbon arc gouging



Adapter plug Dix 70/25, female70 – male 25, 2 pcs.

Product no. **195-633073**



This is how the Adapter Plug works:

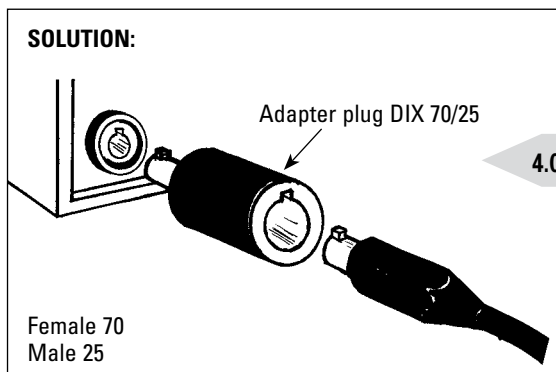
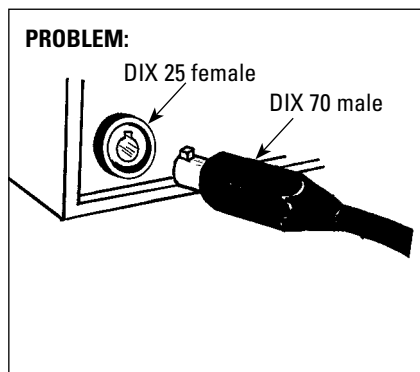

4.01

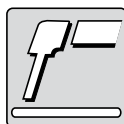

ELECTRODE WELDING AND GOUGING

Accessories

Chipping hammer

The chipping hammer is used for the removal of slag after arc welding. The hammer is of robust construction and well balanced.

Available in mild steel and stainless steel.



Wire brush

A wire brush is used for cleaning the welding surfaces, removal of slag, rust etc. The brush is available with steel or stainless steel bristles.

When working on stainless steel, a brush with stainless steel bristles and a chipping hammer made of stainless steel must always be used.



Welding gauge

Correct groove preparation and sufficient weld deposit is required for a successful welded joint. The welding gauge type "J" provides the possibility to measure 60°, 70°, 80° and 90° groove angles, for measuring throat thickness (a-measure) up to 20 mm and reinforcement up to 10 mm.



4.01

<i>Description:</i>	<i>Unit</i>	<i>Product no.</i>
Wire brush, steel, 2 rows,	6 pcs	196-632976
Wire brush, stainless steel, 2 rows,	6 pcs	196-632984
Chipping hammer, steel,	2 pcs	196-633008
Chipping hammer, stainless steel,	pcs	196-632992
Welding gauge type J,	pcs	196-516161

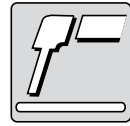

Welding Techniques

Having examined the necessary equipment and studied the safety precautions which must be carefully followed, we shall now look at the actual welding operation.

In order to obtain a good weld we must ensure that the following points are correct:

- The current
- The length of the arc
- The angle of the electrode
- Electrode travel

Current

Current output is the most important factor in arc welding, and this is where most mistakes are made. It is a good rule to use slightly more current than required rather than risk using too little. If the current output is insufficient, fusing with the base material will be unsatisfactory. Slag may become embedded in the weld, and other faults are likely to occur. When current, electrode travel and angle are correct, the molten pool of the weld will proceed smoothly and slag will form behind the pool. Approximate current values are given in the descriptions of the different types of electrodes, and are also shown on the electrode package labels.

Welding surface appearance at different current values:



Current value too low, uneven surface.

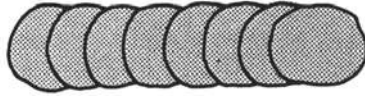

Surface welded at correct current value. Current output too high, even, but coarsely



beaded surface.

Settings

The table gives the ampere limits for the most important electrode diameters, as well as rules of thumb for calculating them. The values given are only valid for unalloyed and low-alloy electrodes and for the stated electrode lengths. For root-welding, vertical-up and overhead welding the welder should use the lower limit. For fillet-welding in horizontal and flat positions and also for vertical-down welding, the amperage is set near to the upper limit.

Diameter	2.0	2.5	3.25	4.0	5.0	6.0
Length	250/300	350	350/450	350/450	450	450
Amperage	40-80	50-100	90-150	120-200	180-270	220-360

Length of arc

When arc welding with electrodes, it is important that the arc be kept as short as possible in order to avoid the formation of pores and to prevent slag becoming embedded in the weld. A short arc prevents the formation of molten slag ahead of the molten pool. This is of particular importance when welding with basic electrodes. The guiding rule is that the arc gap should be equal to the diameter of the wire core of the electrode.



ELECTRODE WELDING AND GOUGING

Electrode angle

The electrode must be held at the correct angle during the welding operation. The illustration shows the angles to be used when welding in the horizontal welding position.

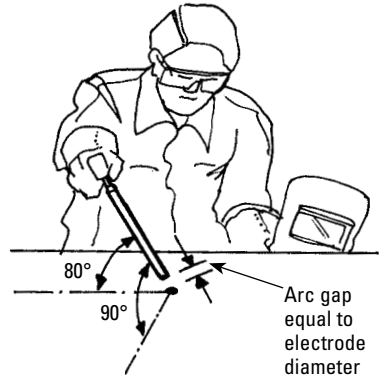

Electrode travel

Move the electrode at an even rate of travel in the welding direction, with or without weaving. Correct rate of travel is important to achieve a good weld. The illustration shows the faults that can occur if the electrode is moved too quickly or too slowly in a fillet weld.

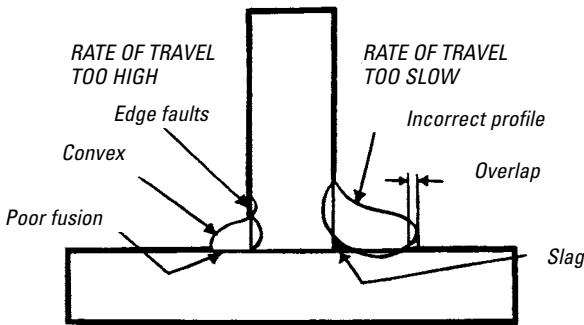

When building up a flat surface, the electrode should be held at an angle of 60° and weaved gently from side to side as the weld advances so that the height of the deposited filler is about 1/3 of the width of each bead. When starting the next parallel buildup run, the tip of the electrode should overlap the previous bead by about 1/3 of the bead width. In this way an even surface can be built up without high spots or craters.

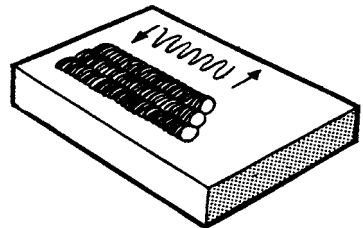

Correct



Incorrect



Edge preparation

T = 1 - 5 mm
Open I-groove

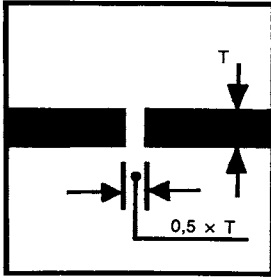

T = 5 - 24 mm
V-groove with root

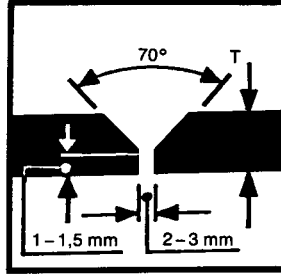

T = 4 - 25 mm
V-groove in horizontal-vertical position

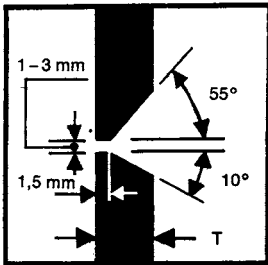

T = 12 - 30 mm
X-groove

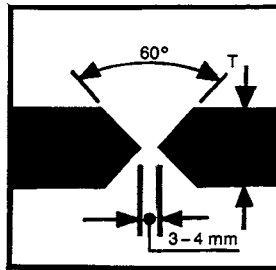

T = Up to 15 mm

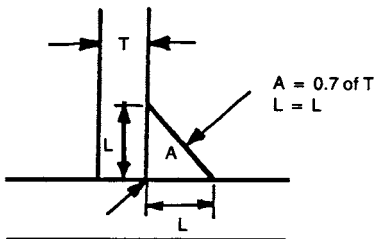

T = More than 15 mm

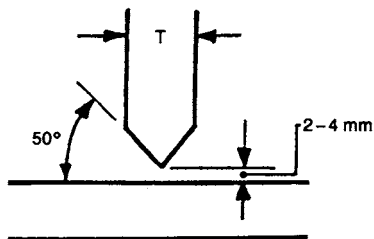

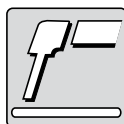

ELECTRODE WELDING AND GOUGING

The complete Unitor range of maintenance electrodes for shipboard use

Product name	Diameter	Product no.	Application onboard
GPO-302 N	2,5 3,2 4,0	095-699165 095-699173 095-699181	Unalloyed steel. General applications. Easy to weld, all positions including vertical down.
GPR-300 H	3,2 4,0 5,0 6,0	095-699231 095-699249 095-699256 095-699260	Unalloyed steel. Large welds in flat position.
SPECIAL-303 N	2,0 2,5 3,2 4,0	095-699199 095-699207 095-699215 095-699223	Unalloyed & Low alloyed steel. Thin plate material. General applications. Double coated electrode, easy to weld.
LH-314 N	2,5 3,2 4,0	095-699264 095-699272 095-699280	Unalloyed & Low alloyed steel. General applications.
LHH-314 H	4,0 5,0	095-699298 095-699306	Unalloyed & Low alloyed steel. Large welds in flat position.
LHV-316 N	3,2 4,0	095-699314 095-699322	Unalloyed & Low alloyed steel. Specially suitable for vertical down welding.
LHT-318 N	2,5 3,2	095-699330 095-699348	High temp. steel. Boiler plates and pipes up to 550 dgr.C. Up to 1% Cr, 0,5% Mo.
LHL-319 N	2,5 3,2	095-683631 095-683649	Low temp. steel. Ice Class hull plates. Up to 2,7% Ni.
LHR-320 N	2,5 3,2	095-683656 095-699389	Weather resistant steel. Corrosion resistant to sea-water and flue gases.
18/8-321 N	1,6 2,5 3,2	095-699397 095-699405 095-699413	Stainless steel. AISI 304/316 L. Tanks, piping, pumps and valves.
23/14-322 N	2,5 3,2 4,0	095-699421 095-699439 095-699447	Stainless steel. AISI 309. Joining stainless to steel. Compound steel. Stainless steel overlays.

ELECTRODE WELDING AND GOUGING

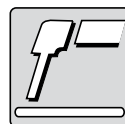

Product name	Diameter	Product no.	Application onboard
DUPLEX -325 N	2,5 3,2	095-699454 095-699462	Duplex steel. Joining of duplex to stainless and steel.
TENSILE-328 N	2,5 3,2	096-699470 096-699488	Difficult to weld steel. Spring steel, vanadium steel, tool steel, high carbon steel.
NIFE-334 N	3,2 4,0	096-699512 096-699520	Cast iron. High strength. Many layers. Joining cast iron to steel.
NICKEL-333 N	2,5 3,2	096-699496 096-699504	Oily cast iron. Tolerant to high carbon content.
TINBRO-341	3,2	096-606458	Copper alloys bronze and brass. Joining copper alloys to steel.
ALBRONZE-344	3,2	096-606457	Bronze and brass. Joining copper alloys to steel.
ALUMIN-351 N	3,2	096-699538	Aluminium rolled, drawn and castings.
WEARMAX -327	2,5 3,2 4,0	095-606454 095-606455 095-606456	Hard surfacing. Wear resistant overlays. Winchwheel pockets, cable drums.
IMPACT-329 S	3,2	096-606460	Hard surfacing. High temp.wear resistant overlays. Exhaust valves.
CH-2-382	3,2	096-606459	Chamfering/Gauging using standard equipment.
ACA-384	6,3 8,0 15x5	096-758474 096-758466 096-758458	Chamfering/Gauging. Air carbon arc gouging. Gouging and weld removal using compressed air.

Tech sheets for all products under section Consumables.



Air-Carbon-Arc Gouging

The air-carbon-arc process utilizes the arc effect to melt the metal, which is subsequently blown away by a jet of compressed air. The method is therefore also useful for cutting stainless steel and other materials, which are difficult to cut by the oxy-acetylene method. The air carbon arc process leaves a clean surface, free from slag, and further surface preparation is usually not necessary.

General uses include:

- Forming welding grooves.
- Cutting and perforating.
- Removal of defective welds.
- Removing defects on cast iron and removing excess metal.
- Removing welding beads and burrs from plating.

The equipment consists of a welding power source suitable for air carbon arc gouging, a special electrode holder with air ducts, copper coated carbon

graphite electrodes, a compressed air source (5-7 bar), cable and air hose.

The power source

In the Unitor range, model UWI-500 TP is a suitable power source for air-arc cutting having the special characteristic required for this process.

Two welding machines may also be connected together in parallel by connecting the negative terminal from both machines to ground at the worksite. The cables from the positive terminals are then lead to the worksite and connected at the electrode holder. For smaller jobs using small size carbon electrodes, model UWR-320 TP may be used as power source.

It is also possible to connect together 2 x UWI-320 TP and get 640 Amp for bigger size carbon electrodes.

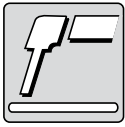

ELECTRODE WELDING AND GOUGING

The electrode holder

A special jaw-type electrode holder is used for air carbon arc gouging. The jaws are fitted with nozzles, which direct jets of compressed air parallel with the electrode to the molten pool. The holder is also equipped with a cut-off valve for compressed air. Compressed air supply 400–900 l/min at a pressure of approx. 5–7 bar. The holder will accept round and flat electrodes. It is supplied complete with integrated compressed air hose/welding cable, cable connectors and a quick connector 30UPH for compressed air.

General rules for air-carbon-arc gouging

- Check that all screw connections are properly tightened to minimize any loss of effect.
- Clean the electrode jaws occasionally with a steel brush to ensure good contact. Blow out the air line before connecting to the holder to remove any condensation.
- Set the air pressure at 5 to 7 bar.
- Check connections for correct polarity.
- Fit the electrode in the holder so that it protrudes approx. 150 mm from the holder.
- When the electrode is moved from right to left, the air outlets in the electrode jaws must be positioned on the right side of the electrode so that the main stream of the compressed air jet is lead beneath the electrode.

- Check the current and remember that the high arc voltage will usually require a higher than usual setting on the amperage scale. If amperage is too low, gouging will be unsatisfactory.
- Check that the air supply is switched on and the air-valve on the holder is in the open position before striking the arc.
- Keep the arc short, but avoid touching the workpiece with the electrode once gouging has commenced.
- When gouging in the overhead position, make sure that molten metal does not fall directly on to the electrode holder.
- When the equipment is in regular use, dismantle and clean the valve at least once a month and make sure that the air passage is not obstructed. Lubricate the O-rings with special valve grease.



Electrode holder for air carbon arc gouging

ELECTRODE WELDING AND GOUGING

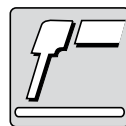

Torch for Air Carbon Arc Gouging with safety cable connector and air connector

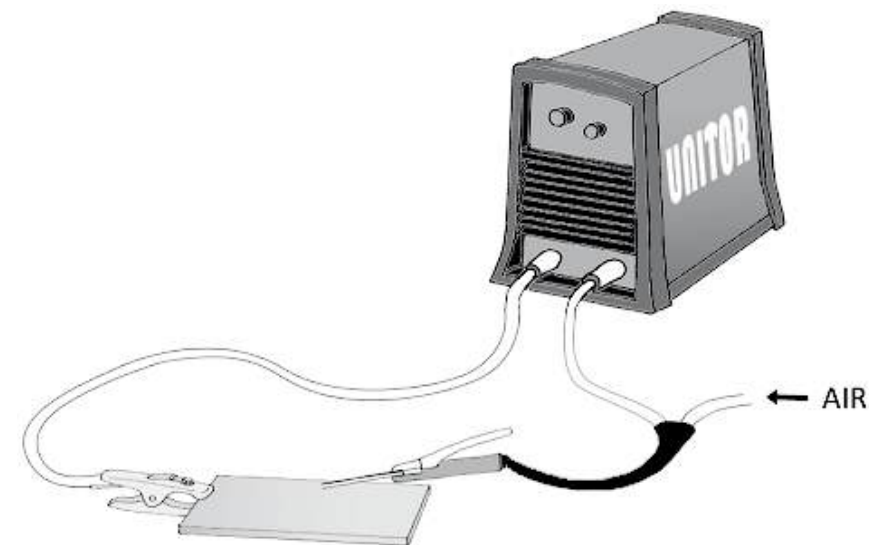

Air hose
Length: 30 cm
Dia: 3/8"
Connector : 30UPH

Monocable with swivel connection. Length 2,5 m.

Gouging torch

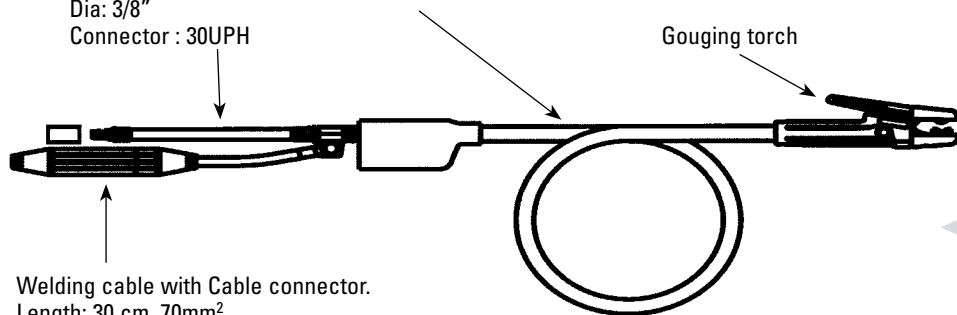

Welding cable with Cable connector.
Length: 30 cm. 70mm²

4.01

Product no	Description	Max. Electrode size
196 528703	Torch for Air Carbon Arc Gouging 600A with safety cable connector and air connector	10 mm
196 740969	Torch for Air Carbon Arc Gouging 1600A with DIX-120 cable connector and air connector	19 mm
195 634121	Conversion assembly Safety Dix-70 male, 2 pcs	

TIG WELDING



Introduction	382
Basic principles	383
Shielding gas	384
Tungsten electrodes	386
TIG torch	388
Regulator & accessories	391
Preparing the torch	393
Welding parameters	394
Welding techniques	395
Edge preparation	398
Rods and Flux for TIG welding	400



TIG WELDING

Introduction

The TIG welding process is in many cases the only practical solution to several necessary repair jobs on board. The most frequently used applications are welding of aluminium-brass (Yorcalbro), Cunifer, and stainless, heat resistant or acid resistant steels, but the process may be used with good results on all weldable materials. Among the unique advantages of using the argon gas protected TIG arc as heat source for welding are:

- An easy-to-learn method which may be used in all positions.
- A stable, intense and well directed heat supply which ensures deep penetration and small heat affected zones.
- Clean, smooth welds of high quality, with little need for finishing (no slag).

The TIG Equipment

Unitor TIG equipment is easy and uncomplicated to use. It may be used with UWI-inverters with lift-start. Apart from the welding machine, a complete TIG-equipment consists of a supply of argon gas with flow-meter, TIG torch and an accessories kit.



UWI-161 TP with trolley and a 10l Argon cylinder is an excellent mobile solution for TIG welding needs on board. It will in addition do stick electrode welding of up to 3,2mm electrodes and wire welding with or without shielding gas and up to 1mm wire.



Basic principle

Onboard applications normally require welding current up to max 150 ampere direct current (DC).

The Unitor Welding Rectifiers and inverters are well suited for TIG welding. Remote control for welding current should be used, as it is a definite advantage to adjust current during welding.

Tungsten Inert Gas (TIG) welding (also called Gas Tungsten Arc Welding GTAW) is a process that is primarily used for high quality metals such as stainless steel, Cunifer and York Albro. It is also used on thin walled plates and pipes up to 3 mm.

Heat is produced by an electric arc that is struck between a Tungsten electrode and the work piece. The electrode tip is grinded to a point to constrict the arc to a single spot on the metal surface. The arc and the electrode are shielded by an inert gas (usually Argon) that also surrounds the weld pool and prevents oxidation.

A welding rod is added to the pool to produce a weld build-up. The welding rod is normally made of a metal similar to the metal being welded. The Tungsten electrode will not melt despite very high temperatures, but it will be gradually be consumed during ignition and to some extent during actual work. This is referred to as the burn-off rate. In time, it will be necessary to regrind the electrode to a point.

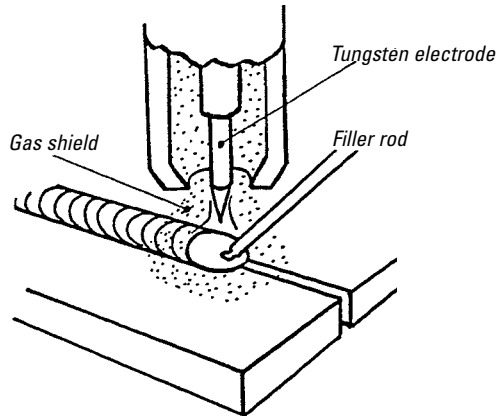

The TIG welding, basic principle.

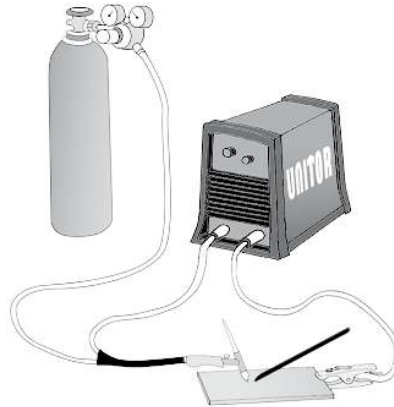

All Unitor welding machines are supplied with characteristics especially suited for TIG.

Equipment set-up:

- Gas cylinder with supply to torch.
- Torch connected to negative polarity of DC power source.
- Return clamp and return cable from workpiece to positive polarity



TIG WELDING

Shielding gas

Shielding gas is necessary for the TIG process. The gas which must be chemically inactive (inert), has several functions in the TIG process:

- To provide the atmosphere needed for ionization, ensuring a stable arc and suitable heat transfer.
- To protect the hot tungsten electrode against the oxidizing effect of the air.
- To protect the molten pool against contamination and oxidation from the air.
- To protect the hot end of the filler metal rod from oxidation.
- To protect melt pool and electrode during cooling after the arc is broken.

Argon has proven to be the most suitable gas for this purpose. It is a colourless and odourless inert gas, heavier than air, non-toxic and non-flammable. It is obtained from air which contains approximately 1% argon.

For the TIG process, a purity of 99,95% is commonly used.

It is necessary to adjust the gas flow and a regulator with flow-meter is therefore needed.

Onboard a ship it is necessary to have a flow-meter that functions correctly also when positioned out of vertical.

The Unitor R510 gas flow regulator for argon is specially designed for this purpose and has a capacity of 0–32 l/min. Note that when welding stainless steel it may also be necessary to use backing gas to protect the backside of the weld from the oxidizing effect of the air.



R510 regulator with flow meter in order to adjust gas flow in l/min.



Argon is supplied in 10 or 50 litres 200 bar gas cylinders.

A separate gas supply (cylinder, regulator and hoses) should be used for this purpose.

TIG WELDING



Shielding gas

ARGON Ar

Argon is a colourless, odourless gas, slightly heavier than air. It is non-toxic and non-combustible. Argon is an inert gas used as a shielding gas for TIG and MIG welding, primarily to protect the molten pool against contaminants in the atmosphere.

For use on:

Steel
Stainless steel
Aluminium
Yorcalbro
Cunifer

Cylinder data

<i>Cylinder type:</i>	<i>E-10</i>	<i>E-50</i>
Product No:	715-905565	715-905174
Application	Welding	Welding
Colour	Grey	Grey
Water capacity l	10	50
Gas capacity kg	3.6	18
Gas capacity nM ³	2.2	11
Filling pressure bar	200	200
Empty weight kg appr.	18	81
Gross weight kg appr.	22	99
Overall length mm appr.	1000	1690
Outside diameter mm	140	230
Valve outlet connection	W24,32mm x1/14"	W24,32mm x1/14"
Valve type	Forged brass with bursting disc, inlet filter and positive pressure cartridge	
1 nM ³ = 1.637 kg.	1 bar = 14.5 psi	1kg = 2.2 lbs
1kg =0.611 nM ³	1 M ³ =35.3ft ³	
Ar 4,5 (99, 995)		



TIG WELDING

Tungsten electrodes

Thoriated TIG welding electrodes with 2 % thorium oxide (colour code red) are currently the most widely used electrodes worldwide. Thorium is however a radioactive element and as such represents a potential danger to health and environment. Thorium is a so-called "a-emitter," but when enclosed in a tungsten matrix, the "a" radiation emitted externally is negligible. The danger to the welder arises when thorium oxide gets into the respiratory canals.

This problem can occur during welding (vapours) as well as when grinding the electrode tip (grinding dust). In the near future, more stringent legal regulations regarding production, use and disposal of thoriated electrodes are expected. It is expected that TIG-welding electrodes containing thorium will disappear from the market in the foreseeable future, especially as an environmentally friendly and technically better solution is already available.

Unitor tungsten electrodes is alloyed with Lanthanum (colour code gold) and is sold in sturdy boxes of 10 pcs.

The new electrodes offer:

- Environmentally friendly-no radioactive constituents
- Can be transported, stored and disposed of without legal restrictions
- Suitable for welding all materials
- Better ignition performance than thorium alloyed type electrodes
- Low burn off rate, longer service life

Standardised in national and international norms (ISO 6848, EN 26848, AWS A5.12, JIS Z3233)



4.02

<i>Description</i>	<i>Unit</i>	<i>Product no.</i>
Tungsten electrodes 1.6 mm.	10 pcs	197-674710
Tungsten electrodes 2.4 mm.	10 pcs	197-674736



Overview of Tungsten electrodes

CODE	OXIDE ADDITIVES Wt. %	COLOUR CODE	REMARKS
WL10 WL15 WL20	0.90-1.20 La ₂ O ₃ 1.5 La ₂ O ₃ 1.80-2.20 La ₂ O ₃	Black Gold Blue	Lanthanum AC and DC
WC20	1.80-2.20 CeO ₂	Grey	Cerium DC low current
WP		Green	Pure Tungsten AC only
WZ8	0.70-0.90 ZrO ₂	White	Zirconium AC only
WT10 WT20 WT30 WT40	0.90-1.20 ThO ₂ 1.80-2.20 ThO ₂ 2.80-3.20 ThO ₂ 3.80-4.20 ThO ₂	Yellow Red Purple Orange	Thorium DC only
WS	Rare earths	Turquoise	AC and DC low current

Correct Grinding of Tungsten electrodes for DC welding

For DC TIG welding use pointed tip. For AC TIG welding use rounded tip.

The angle of grinding depends on the welding current. If the electrode has too long a point compared to the welding current, the point will melt and contaminate the weld with tungsten deposit. Too short a point, give an unstable arc and insufficient heat concentration.

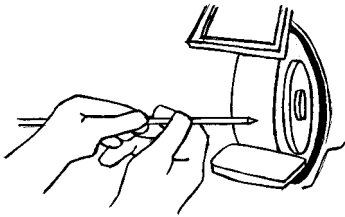

Grinding must be done length wise, straight towards the point. Wrong grinding will result in an unstable arc and that bits of tungsten will brake off and fall into the weld deposit during welding.



Wrong grinding

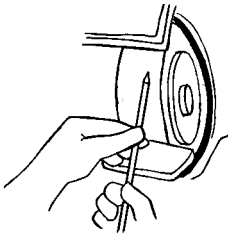

Correct grinding

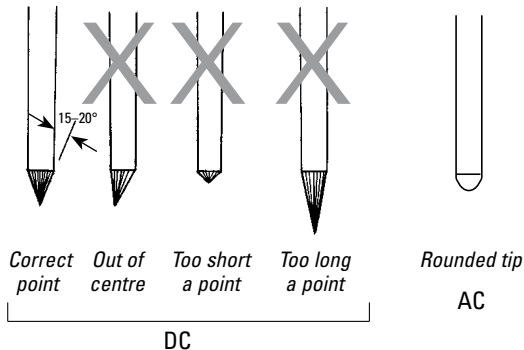



TIG WELDING

TIG TORCH

General description

The Unitor TIG torches are lightweight torches well adapted to general applications onboard. To ensure full electrical insulation, the head of the torch is produced with a resilient, high-temperature non-conductive silicone coating.

The replaceable heat-shield (3) in front of the torch head is made from teflon and has the combined function of forming a gas tight seal for the alumina nozzle (6) and of deflecting heat from the torch head.

The torches are rated at 150A and 200A at 60% duty cycle. Cable and gas hose are protected by a heat and spatter resistant sheeting to ensure long working life. The handle ensures a secure grip and reduces heat transfer to the welder's hand. A screw type gas valve opens fully at only 3/4 turn, switches the gas on and off.

Being gas cooled, the torches have low weight and are easy to operate for repair and maintenance work in all positions. Used with the short back cap (1), the total length of the head, including nozzle, is less than 10 cm, ensuring accessibility in narrow spaces.

The torches are supplied with 4 m cable/hose package. Separate welding cable and gas hose (8) ensure that extensions may be easily connected. The gas connection fits directly onto the Unitor argon regulator or to the standard right hand threaded screw couplings for gas hoses. As standard, Unitor is supplying nozzles of aluminium oxide (AL2O3), recognizable by the pink colour. These nozzles will stand for higher temperatures than the ordinary

ceramic cups, which are recognized by a light brown color. Note that TIG gas nozzles are brittle and may break if dropped or treated carelessly.

A remote amperage control can be fixed on the TIG torch by velcro straps in order to adjust amperage during welding.



Accessories

The torches are supplied complete for use, but the accessories kit is recommended as it contains necessary spares.

NB:

TIG welding of aluminium use electrode with rounded tip.

Use Alumina nozzle no 8. This will give better gas shielding.



Parts list and order numbers

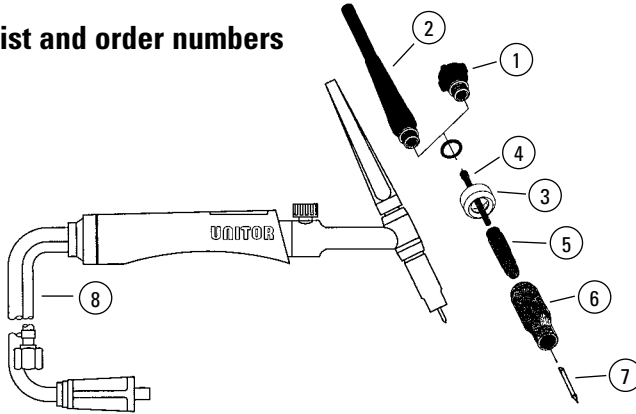

Pos. no.	Product no	Unit	Description
–	197-150000	pcs	TIG-torch T-150 complete with DIX 25 incl. electrode and nozzle, for UWI-150 TP.
–	197-160010	pcs	TIG-torch T-161 with 4 m cable, euro-connector and torch mounted trigger for UWW-161 TP
–	197-200000	pcs	TIG-torch T-200 complete with DIX 70, incl. electrode and nozzle, for UWI-200, -201, -202, -203 TP, -320 TP, -400 and 500 TP
–	197-607810	pcs	Accessories kit for Unitor TIG-torches, including short back cap. spare heatshield, collets, collet bodies, nozzles and electrodes.

Spares

1	197-551192	pcs	Short back-cap
2	197-551200	pcs	Long back-cap
3	197-551143	pcs	Heat shield
4	197-551168	pcs	Collet 1.6mm
4	197-551150	pcs	Collet 2.4mm
5	197-551184	pcs	Collet body 1.6 mm
5	197-551176	pcs	Collet body 2.4 mm
6	197-551135	pcs	Alumina nozzle 6
6	197-551127	pcs	Alumina nozzle 7
6	197-778924	pcs	Alumina nozzle 8
7	197-674710	pck	Tungsten electrode (10 pcs) 1.6 mm alloyed for AC/DC TIG welding
7	197-674736	pck	Tungsten electrode (10 pcs) 2.4 mm alloyed for AC/DC TIG welding

Accessories kit consists of:

Short back cap	1 pcs
Heat-shield	1 pcs
Collet 1.6mm	3 pcs
Collet 2.4mm	3 pcs
Collet body 1.6 mm	1 pcs
Collet body 2.4mm	1 pcs
Alumina nozzle 6	2 pcs
Alumina nozzle 7	2 pcs
Tungsten electrodes 1.6 mm alloyed for AC/DC TIG welding	3 pcs
Tungsten electrodes 2.4 mm alloyed for AC/DC TIG welding	3 pcs



Accessories kit for TIG-torches.



TIG WELDING

Remote control set-up

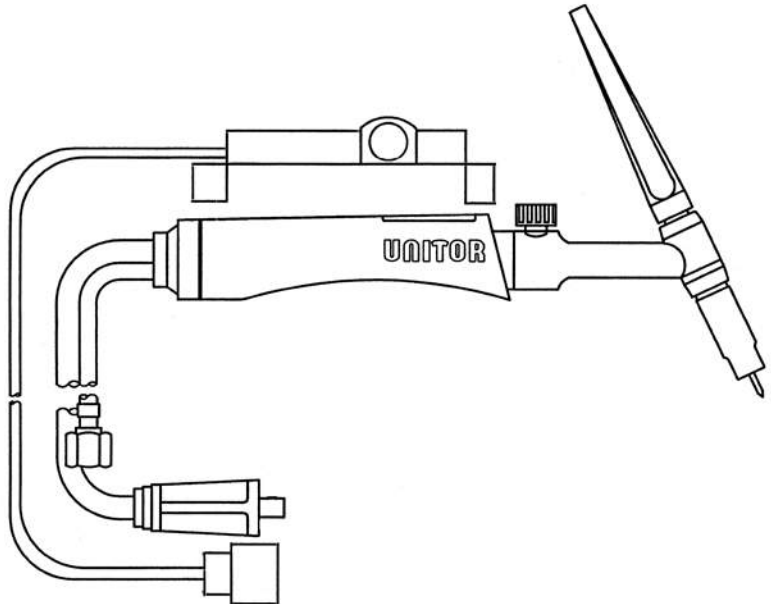

UWI-320 TP, UWI-500 TP and UWI-230 TP AC/DC

TIG torch T-200 complete with DIX 70	197-200000
Remot amp control 8 m	191-670414
Temote amp control cable extension 25 m	191-670422

UWI-150 TP

TIG torch T-150 complete with DIX 25	197-150000
Remote amp control 3 m	191-150151

The remote controls may also be used for stick electrode welding.



Regulator & Accessories

The R510 regulator with flow meter supply a steady stream of shielding gas to the torch. The flow rate in l/min is adjusted on the regulator.

Actual gas flow at the TIG or wire torch may deviate from what is set on the gas outlet station or on the cylinder regulator, especially if long gas hoses are used. The Flowcontrol meter measures actual flow at the torch nozzle and is a useful tool for the operator. Combined with the Flowcontrol needle valve used at the gas inlet of the machine or the wire feeder full flow adjustment is available at the work place regardless of distance to the gas cylinder/gas outlet.



Also recommended are soft-skin TIG welding gloves. They give good protection of the hands while they ensure easy control of the torch and eventual welding rod. In addition standard protective equipment for arc welding should be used.

<i>Product description</i>	<i>Unit</i>	<i>Product no</i>
Argon regulator with flow adjustment 0-32 l/min	pcs	197-510010
Gas hose 1/4" black, for shielding gases	mtr	176-576157
Hose joint for 1/4" hose, 3/8" RH threads	pcs	176-175596
Clip 8-14 mm for hose, 10 pcs	pck	401-729442
Quick coupling Argon, regulator to 6,3mm hose	pcs	197-320202
Quick coupling Argon, hose to hose, 6,3mm	pcs	197-320201
Spare parts for regulator:		
Flow meter gauge for Argon 0-32 L/min	pcs	171-550210
Contents gauge for regulator	pcs	171-550178
Flowcontrol meter for use at torch nozzle	pcs	197-597328
Flowcontrol needle valve for use with machine/	pcs	197-597310
TIG Gloves for TIG and Gas welding	6 pairs	197-632795



TIG WELDING

TIG Equipment & Accessories for Unitor Welding Machine Range

Welding Machine	TIG Torch Pr. Pcs.	Remote Control Pr. Pcs.	Acces. KIT Pr. Pcs.	Ar. Regl. Pr. Pcs.	Gas hose Pr. m	Hose Joint Pr. Pcs.	Hose Clip, pck of 10	TIG gloves 6 pairs	Flow contr. needle valve pcs. Pr. Pcs.	Flow contr. meter at Nozzle pcs. Pr. Pcs.
UWI-150 TP	197-150000	191-719575	197-607810	197-510010	176-576157	176-175596	401-729442	196-632794	197-597310	197-597328
UWWW-161 TP	197-160010	N.A.								
UWI-203 TP	197-200000	N.A.								
UWI-230 TP AC/DC	197-200000	197-670414								
UWI-320 TP	197-200000	197-670414								
UWI-500 TP	197-200000	191-670414								



Preparing the torch

Always disconnect the torch from the power supply before changing nozzles or adjusting the electrode. This is easily done, by disconnecting the Dix Connector at the end of the torch cable.

Ensure that correct and unharmed nozzle, heat shield, collet body, collet and electrode are used.

If the welding current is to be 100A or lower, the small nozzle 6 (ø 9mm) should be used, together with the 1.6 mm (1/16") electrode, collet and collet body.

For welding above 100A it is recommended to use the large nozzle 7 (ø 11mm) and 2,4 mm (3/32") electrode, collet and collet body.

Check if the work at hand makes it necessary to use the short back cap.

Ensure that collet body, nozzle, and back cap are properly tightened, and that the electrode is properly pointed. The electrode shall protrude 3-6mm outside the gas nozzle.

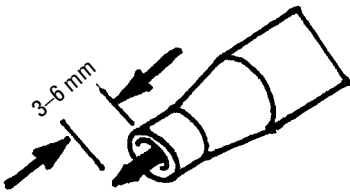

Check electrode protrusion

Connection to Gas Supply

Connect the gas hose to the argon regulator, and make sure all connections are properly tightened.

Open gas cylinder valve fully, open torch valve 3/4 turn and adjust the regulator to a flow of 9-10 l/mm.

Let the gas flow a few minutes so that the whole gas system is thoroughly purged, with inert gas. This will prevent contamination of the welds. Then set correct flow for the job at hand and close the torch valve. For flow setting see table on welding parameters.

If additional gas supply for backing gas is needed, this should be taken from a separate gas supply. By taking backing gas from the same regulator that supplies the torch, it will be impossible to adjust to correct gas flow for the torch.

Connection to Welding Machine

Two-thirds of the total heat developed in the TIG arc is developed on the positive side of the arc, which is bombarded by the electron flow. The TIG torch must therefore always be connected to the negative pole of the welding machine (straight polarity). If connected wrong, the tungsten electrode tip will melt, and the nozzle and torch head may be damaged.

The return clamp should preferably be fastened directly to the work piece, and the return cable shall be connected to the welding rectifier's plus pole.

If available, connect the remote control to the welding machine and have the current regulator available at the work site. For current setting see table on welding parameters.



TIG WELDING

Welding Parameters

It is necessary to decide approximate range of welding current needed for the job at hand to select correct electrode, nozzle and gas flow setting.

The material thicknesses given in the table below for the different current ranges are indicative. Actual current needed to form a proper molten pool will also partly depend on the size of the workpiece, the type of joint, and the amount of preheating used.

Material thickness Steels and Stainless steels	<1.5mm	1.5 - 2.5mm	2.5 - 4mm	>4mm
Material thickness Copper alloys	<1.0mm	1.0-1.5mm	1.5-2.5mm	>2.5mm
Welding current, DC, electrode-	20-70A	50-120A	100-180A	150-250A
Gas flow, pure argon	6 l/min	7 l/min	8 l/min	9 l/min
Electrode point angle	35°	45°	60°	60°
Collet size, diameter of electrode	1.6mm-1/16"	1.6mm-1/16"	2.4mm-3/32"	2.4mm-3/32"
Collet body, size diameter of opening	1.6mm-1/16"	1.6mm-1/16"	2.4mm-3/32"	2.4mm-3/32"
Nozzle number and diameter of opening	no.6 (9mm)	no.6 (9mm)	no.7 (11mm)	no.7 (11mm)
Tungsten electrode size	1.6mm-1/16"	1.6mm-1/16"	2.4mm-3/32"	2.4mm-3/32"



Welding Techniques

Before welding starts, check that the torch is connected to the negative (-) polarity of a DC constant current power source, and that sufficient gas is available from the gas supply. Open the argon cylinder valve and the torch valve. If necessary, purge the gas system before setting correct gas flow on the regulator.

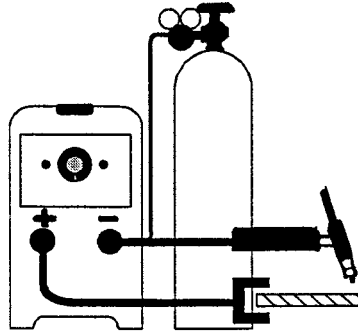

Striking the Arc

Check that the electrode is properly pointed and protrudes 3-6mm from the nozzle. Do not touch the electrode unless the DIX connector is disconnected. If current remote control is available, adjust to low or minimum current.

Ensure that the gas valve is fully open, (3/4 turn from closed). Place the gas nozzle in a tilted angle on the ignition location so that there is a gap of 2-3 mm between the tungsten electrode tip and the workpiece. Gradually tilt up the welding torch until the tungsten electrode tip touches the workpiece. This will trigger the lift arc function. Raise the torch and lift it into the normal position- the arc ignites and increase in intensity to the set amperage.

Note: To be absolutely certain that contamination is avoided the arc may be started on a copper plate placed on the workpiece, and then moved to the beginning of the bead.

Adjust welding current to correct setting and hold the arc steady until a molten pool is formed.

Connect the equipment and purge the gas system. Check electrode and electrode stick-out.

The lift arc function

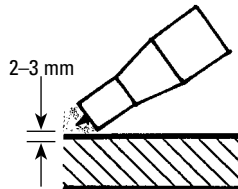

Place nozzle on location.

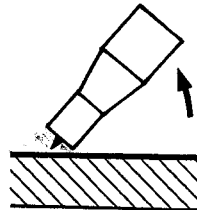

Gradually tilt up.

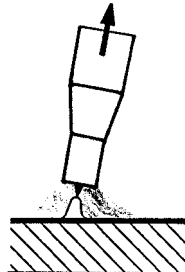

Raise the torch



TIG WELDING

Welding

TIG welding can be carried out in all welding positions and the procedure is largely similar to the gas welding forehand welding technique. Vertical welding is normally done upwards.

Keep an arc length of approximately 3–6mm. Note that a longer arc will increase the heat input and a shorter arc will reduce it, contrary to what happens in gas welding. If welding current remote control is used, the heat input may be adjusted through the whole process by adjusting the current. Hold the torch at an angle of approximately 75° to the workpiece. The arc may be used just to melt the edges of the joint together, or additional filler material may be used.

Use of Filler Material

Introduce the rod to the molten pool, but in such a way that it does not touch the electrode or enter the arc between electrode tip and workpiece. Filler material may be added continuously or in a slightly dipping motion. The hot end of the rod shall be kept close to the melt pool and protected by the argon gas to avoid oxidation, which will contaminate the weld. Hold the rod at an angle of approximately 30° to the workpiece.

Finishing the Bead

Remove the welding rod from the pool. Adjust welding current to minimum and rapidly lift the torch so the arc is broken. Lower the torch again to approximately 5mm distance from electrode tip to bead, and keep it in place for 15 to 20 seconds with the gas flowing to protect the molten pool and the electrode during the cooling-off period.

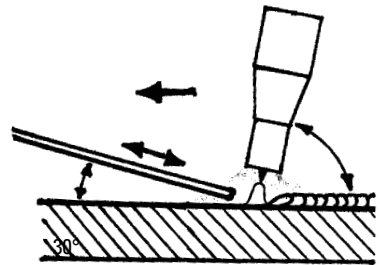

Welding with the forehand technique.

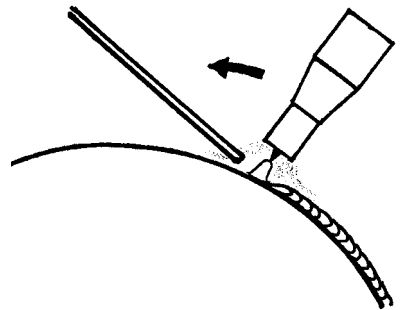

Vertical welding upwards with the forehand technique.

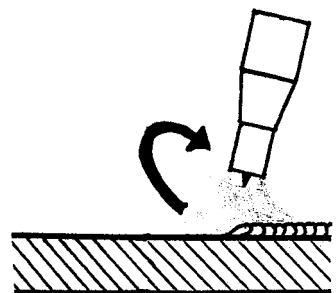

Finishing the bead.

TIG WELDING



Contaminated Tungsten Electrode

The tungsten electrode may be contaminated through contact with the molten pool or the filler metal rod.

It will also be contaminated (by oxidation) if the shielding gas supply is not opened before the arc is struck, or if the gas is shut off before the electrode has cooled down to below red glowing temperature.

If there is little contamination the electrode may be cleaned by striking an arc against a copper plate and letting it burn for a few seconds. Remember gas supply.

If the electrode is heavily contaminated the welding current supply must be disconnected, the electrode removed and the contaminated part broken off. The electrode must be reground to the correct point and replaced in the torch.

Contaminated Weld Pool

This can be caused by insufficient or excessive supply of argon to the torch, by polluted argon, by insufficient cleaning of the weld area or of the filler rod, or by the electrode being polluted.

Check the following:

- That the gas hose has been properly purged.
- That the gas flow has been correctly set.
- That the electrode is held at the correct angle.
- That the gas nozzle is not defective or polluted.
- That the correct size gas nozzle is being used.
- That welding groove and filler rod are clean.

- That air does not enter into the gas hose.
- That wind or draft does not blow away the shielding gas.
- That the argon supply is not contaminated (try changing to fresh cylinder).

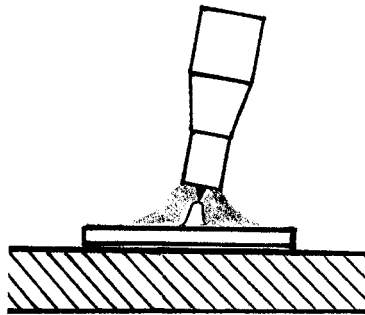

Clean the electrode by striking an arc against a copper plate.

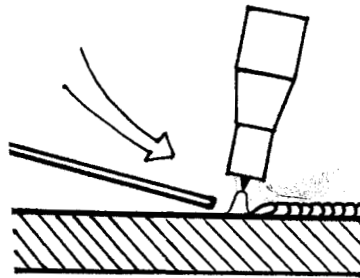

Strong draft may blow away the argon shield, resulting in contaminated weld deposit.



TIG WELDING

Edge preparation

Stainless steel

Material thickness mm	Type of joint	Welding current A			Tungsten electrode mm \varnothing
		Horizontal	Vertical	Overhead	
1		25–60	23–55	22–54	1.6
		60	55	54	1.6
		40	37	36	1.6
		55	51	50	1.6
2		80–110	75–100	70–100	1.6
		110	100	100	1.6
		80	75	70	1.6
		105	98	95	2.4
3		120–200	110–185	110–180	2.4
		130	120	115	2.4
		110	100	100	1.6
		125	115	110	2.4
4		120–200	110–185	110–180	2.4
		185	170	165	2.4
		180	165	160	2.4



Edge preparation

Copper alloys (Cunifer, Yorcalbro)

Material thickness mm	Type of joint	Welding current, Horizontal	Tungsten electrode mm \varnothing
1		90–100	1.6
		100–115	1.6
		100–115	1.6
2		115–130	1.6
3		170–200	2.4
		190–220	2.4
		190–220	2.4

NB: When welding Stainless steel and Cunifer, backing gas must be used inside piping.

In order to avoid surface oxidation, pipes of stainless steel must be purged with inert gas sufficiently to remove all oxygen inside the pipe in the weld area. The usual way to achieve this is to seal off a small length of the pipe on each side of the weld groove. This restricted volume is then purged with a suitable inert gas, sufficiently to remove all oxygen.

The ideal concentration of oxygen is below 25 ppm, as this is insufficient to oxidize stainless steel.

Backing gas tool for larger pipe dia.

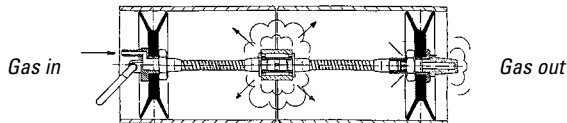

Backing gas tool for small dia. pipe

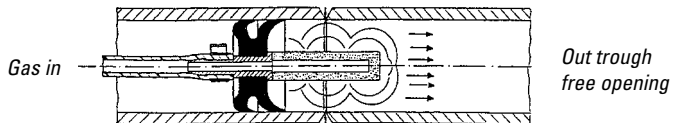

The most common gas to use is Argon or Formier gas (90% N² and 10% H²)



TIG WELDING

Rods and Flux for TIG welding

Welding rods

<i>Product</i>	<i>Product no.</i>	<i>Description</i>
IMS-210 2.0 mm	097-604850	Unitor IMS is a welding rod for unalloyed and low alloyed steels. Rods with diameter 2.0mm are most used for TIG welding.
ICROMO-216 2.5 mm	097-305532	Icromo is a chromium-molybdenum alloyed welding rod for heat resistant steels types 10 Cr Mo-910 and 13 Mo-44 found in boiler tubes and other heat resistant components. Tensile strength 560 Mpa.
18/8 Mo-221 2.0 mm	097-602979	18/8 Mo is a wire for welding stainless and acid resistant steel. The silisium content of the wire ensures smooth transfer and good profile of the bead. Application areas are similar to the coated electrode 18/8-321 N in 1.7 mm, but with the advantages TIG can offer. When welding very thin sheets and pipes (less than 2mm) it is always an advantage to use the TIG process. This is also an advantage for the root bead when welding thicker sheets with prepared V-grooves.
IDUPLEX-222 2.0 mm	097-725309	Iduplex-222 is at TIG rod for welding Duplex stainless steel, Duplex to Mild steel and Duplex to Stainless steel. The deposit offers elevated mechanical strength and toughness resistance to stress corrosion cracking. It is an advantage to use TIG welding in thin sheets and pipe walls. Can also be used for welding the root run in thick wall piping where the rest of the groove is filled up using the duplex electrode Duplex-325 N.
ALUMAG-235 3,0 mm	092-514265	A welding rod for Gas and TIG welding of wrought and cast aluminum alloys containing up to 5 % Mg.
ICUNI-30-239 2.5 mm	097-335547	A welding rod for TIG welding of copper nickel alloys, for example Cunifer pipes. No flux is used in this process. Typical applications are welding flanges on pipes, pipe joints, patching leaking pipes etc. Joint surfaces and adjacent areas must be thoroughly cleaned before welding. Small diameter Cunifer pipes can be joined by means of overlap joints (capillary action) using AG-60 silver solder combined with AG-60 Flux.
IALBRO-237 MF 2.4 mm	097-519736	IALBRO is a flux-coated filler rod for TIG welding of aluminium-brass pipes (Yorcalbro). This type of alloy is widely used in seawater resistant piping. In TIG welding of joints it is strongly recommended that I-Flux 238 be applied to both sides of the joint on the inside. Yorcalbro pipes with a diameter less than 4" which can be joined by means of an overlap joint (capillary action) may be silver brazed using AG-60 combined with Albro Flux.
IFLUX-238 PF	097-603092	Unitor flux is supplied in paste form for use with the TIG rod Ialbro-237 MF for welding of Yorcalbro. The flux is complementary to the flux found in the serrations of the Ialbro TIG rod. While the flux on the rod is sufficient for the actual welding zone, it is strongly recommended to use additional IFLUX on both sides of the joint, especially on the inside of e.g. pipes. This will improve bonding and penetration. Flux residues must be washed off with water after welding. IFLUX is supplied in 250 gram tins.

Tech sheets for all above products under section Consumables.

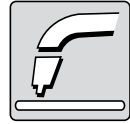

Introduction	404
Basic principles	405
Shielding gas	411
Equipment	412
UWW-161 TP	414
UWF-102	420
Regulator & accessories	426
Application areas	428
Preparation for welding	429
Welding technique	431
Edge preparation	434
Wires for wire welding	438



WIRE WELDING

Introduction

In Wire Welding a wire from a reel is fed through a welding torch passing a contact tip supplying the welding current. The wire melts and is transferred to the pool through the arc that is shielded by a gas. The shielding gas is necessary to prevent oxygen from the air oxidising the pool.

The gas has the same function as the coating on an electrode producing a smoke shield.

The advantages of wire welding are:

- Increased deposition rate (Weight of weld deposited per hour).
- Increased operating factor (The time that the welder actually is welding).

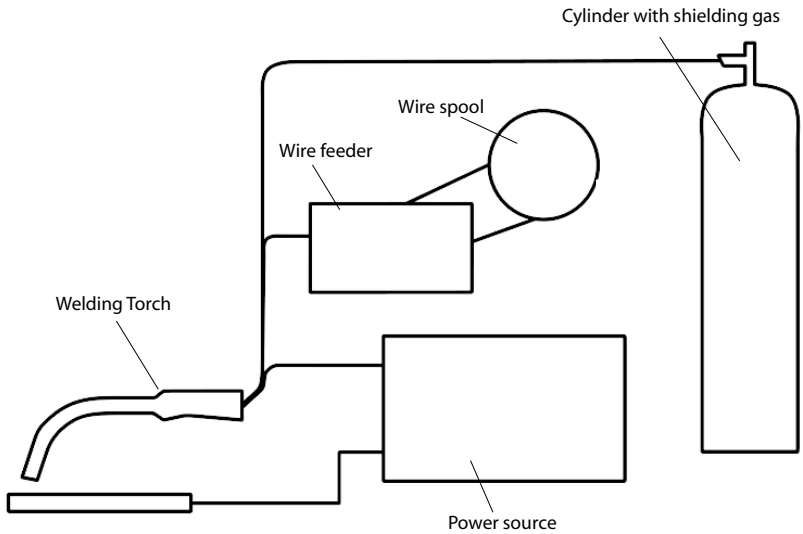

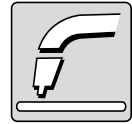

Basic principle

The process can roughly be divided into two distinctive methods depending on the wire being fed.

GMAW – Gas metal arc welding and
FCAW – Flux cored arc welding.

GMAW – Gas metal arc welding

uses a solid wire. Depending on shielding gas the process can further be divided into:

MIG welding (Metal Inert Gas)
and MAG welding (Metal Active Gas).

In MAG welding we use a reactive gas like Carbon Dioxide (CO_2) to shield the pool. Carbon Dioxide is suitable for arc shielding when welding low carbon and low-alloy steel.

In MIG welding we use inert gases like Argon. Pure inert gas shielding is essential for welding alloys of aluminium, magnesium, copper, titanium, stainless steel, nickel alloys and highly alloyed steel.

Gas mixtures of inert gases and reactive gases (Argon + CO_2) are regarded as MIG welding.

Metal transfer with the GMAW process is by one of two methods:

Spray Arc or Short Circuiting Arc

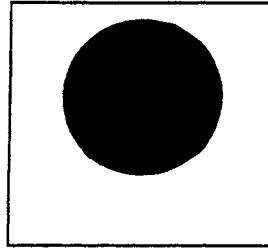

Solid wire

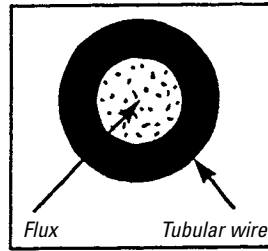

Flux tubular wire.

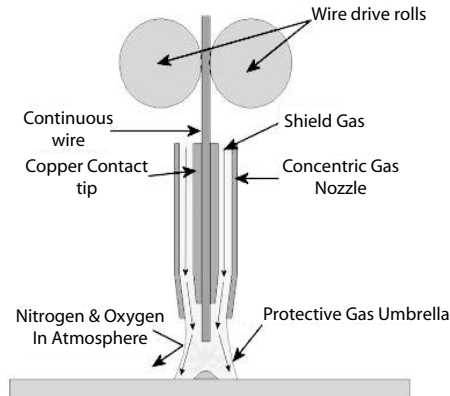



WIRE WELDING

Spray-Arc

The spray-Arc is recognized by a relatively intense arc between the welding wire and the work piece. The metal transfer is in the form of a continuous spray of molten metal droplets from the wire tip through the arc to the surface of the melted pool. The arc is almost spatter free and provides deep penetration in the base material. The deposit rate is high, and this arc type is recommended for material thickness above 3 mm.

To obtain a spray-arc it is necessary to have welding current above a certain minimum value, the transition current. This current level depends on the shielding gas, (consisting of minimum 80% Argon or Helium), the alloy and the size of the welding wire. As a guideline a 0.8 mm solid steel wire will provide a spray arc if the welding current is above approximately 150 Ampere. At currents below this level the steady spray will consist of gradually larger droplets until a spray no longer can be maintained, and the short-arc is established.

Short Arc

is also called short circuit transfer. No metal is transferred through the arc with this technique, but is instead

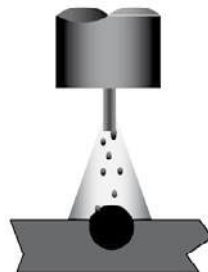

Spray-arc welding

transferred through rapid short circuits between wire and work piece. The wire touches the work piece and the welding current increases immediately, melting of a drop of filler material. As this drop is melted off the arc is re-established, heating wire tip and base material until the wire feed speed again pushes the wire into contact with the work piece.

This sequence repeats itself continuously approximately 100 times per second, providing a concentrated arc with low heat input to the work piece and rapidly solidifying deposit.

The short-arc method is therefore excellently suited for sheet metal welding, and also for bridging large gaps in poorly aligned joints. The rapidly solidifying deposit also makes short-arc welding easy in any welding position.

4.03

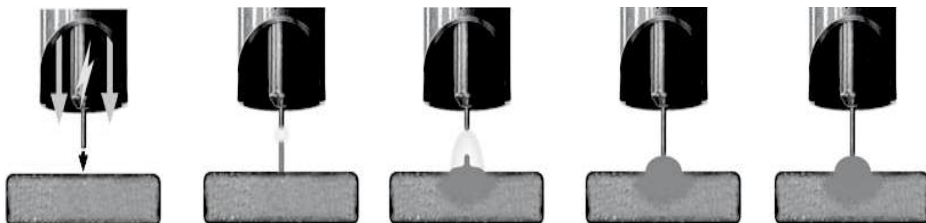

Short circuiting (short arc welding)

WIRE WELDING

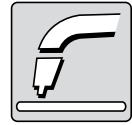

Flux Cored Arc Welding (FCAW) Self-Shielded.

In flux cored arc welding the heat is obtained from an arc between a continuous flux cored wire and the work. The flux provides gas shielding for the arc and a slag covering of the weld deposit.

The self-shielded flux-cored arc welding process is a development from the shielded metal arc welding. The versatility and maneuverability of stick electrodes in manual welding stimulated efforts to mechanize the process allowing a continuous wire electrode to be used. A continuous electrode would eliminate the welding time lost in changing electrodes and would eliminate the material lost in electrode stubs. The main problem with a continuous coated electrode is to find suitable

means of making electrical contact with the core wire and coiling it without cracking the brittle coating. The need for a continuous arc welding electrode led to the development of the self shielding flux cored wire where the material needed for shielding is contained inside the core of a hollow wire.

The "inside-out" construction of the flux cored wire solved both problems. Continuous electrical contact can be made with the wires at any distance from the arc and they can be coiled and packaged on any of the standard spools used for filler wire. The outcome of these efforts was the development of the semiautomatic and full-automatic processes for welding with continuous flux-cored tubular "wires". Such wires contain in their cores the ingredients for fluxing and deoxidizing molten metal and

The arc:

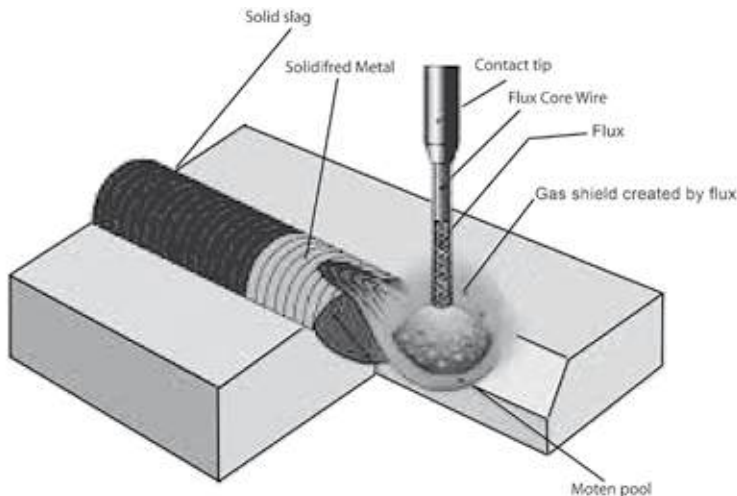



WIRE WELDING

for generating shielding gases and vapors and slag coverings.

In essence, semiautomatic welding with flux-cored wires is equivalent to manual shielded metal-arc welding with an electrode several feet long instead of one of a few inches. By the press of the trigger completing the welding circuit, the operator activates the mechanism that feeds the wire to the arc. He uses a welding gun instead of an electrode holder, but it is correspondingly light in weight and easy to maneuver. The only difference being the weld metal of the electrode surrounding the shielding and fluxing chemicals, rather than being surrounded by them.

In the flux-core arc welding process, partial shielding is provided by vaporization of ingredients of the flux, which form a protective gas covering of the weld pool. When molten weld metal is transferred across the arc, it may not be completely covered by molten flux since the metal surrounds the flux, as both are heated. This means that some oxidation and nitrogen pickup may occur before the metal enters the weld pool. However, as opposed to the gas-shielded flux cored process, the self-shielded

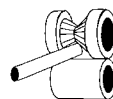
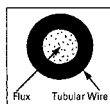

Knurled wire feeder rolls to be used

flux-cored process does not depend on gas shielding, it can operate satisfactorily outdoors where strong air currents are encountered.

The self-shielded flux cored process is characterized by long wire extension beyond the contact tip (stickout). Extensions from 6 mm to 30 mm are used depending upon the application.

Welding equipment for Gas Metal Arc Welding (GMAW) can in most cases also be used for Self Shielded Flux Cored Arc Welding with small modifications (wire feeder rolls should be knurled, insulation nozzle instead of gas nozzle etc.). Also note that self-shielded flux cored arc welding takes place with welding torch connected to minus (-) polarity.

Wires for self-shielded flux cored arc welding are available in standard sizes from 1 mm to 4 mm in mild steel and in some low alloy steel.

WIRE WELDING

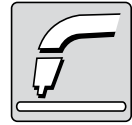

Flux Cored Arc Welding (FCAW) Gasshielded.

The gas-shielded flux-cored process may be looked upon as a hybrid between self-shielded flux-cored arc welding and gas metal-arc welding. Tubular electrode wire is used as in the self-shielded process, but the ingredients in its core are for fluxing, deoxidizing, scavenging, and sometimes alloying additions, rather than for the generation of protective vapours. In this respect, the process has similarities to the self-shielded flux-cored wire process, and the tubular wires are classified by the AWS along with wires used in the self-shielded process. On the other hand, the process is similar to gas metal-arc welding in as much as a gas is separately applied to act as an arc shield.

The guns and welding heads for semiautomatic and full-automatic welding with the gas-shielded processes are out of necessity more complex than those used in self-shielded flux-cored welding. Space

passages must be included for the flow of gases. If the gun is water-cooled, additional space is required. The wire feeder and power source is similar to the equipment used with the self-shielded flux-cored wire process, and gas metal arc welding with only small modifications (wire feed rolls should be knurled). Note that the welding gun should be connected to the positive terminal (+).

Although CO_2 is generally used as the shielding gas, mixtures of 20% CO_2 -80% Argon and 95% Argon - 5% Oxygen, may also be used.

The gas-shielded flux-cored process is used for welding mild steel, low-alloy steels and stainless steel. It gives high deposition rates, high deposition efficiencies, and high operating factors. Radiographic quality welds are easily produced, and the weld metal with mild and low-alloy steels has good ductility and toughness. The process is adaptable to a wide variety of joints and gives the capability for all-position welding.

The arc:

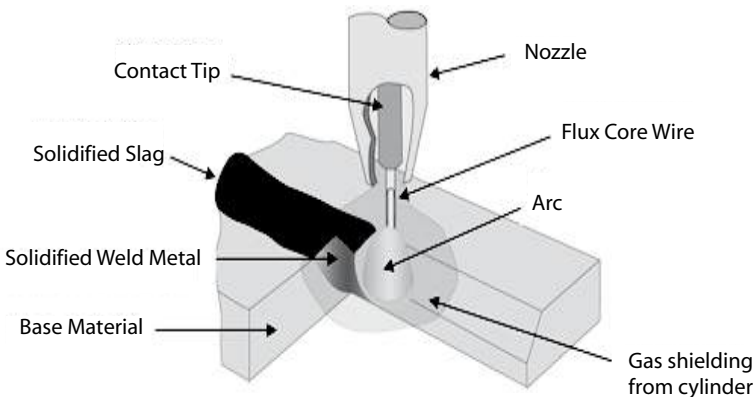



WIRE WELDING

Maintaining the arc.

The basic principle of all arc welding is that an electric arc melts the surface of the work piece (joint), and whatever filler material introduced into the melt pool. In processes where the arc is established between a filler material which is continuously fed into the arc, and the work piece, the arc length and thereby the arc voltage must be kept at a constant value to obtain a uniform weld. This can be obtained in two ways:

1. By adjusting the filler material feed speed to exactly the same speed as it melts.
2. By adjusting the amperage to exactly the value needed to melt the quantity of filler material. When welding with coated electrodes (SMAW) the welder's task is to feed the electrode according to alternative 1, while the power source provides constant current.

In GMAW welding both parameters are guided by the equipment, thereby demanding less from the welder's skill but more from the equipment.

Constant current power source

If a traditional power source with constant current characteristic is

used, it will supply relatively constant current regardless of arc length. Alternative 2 above is therefore not applicable. A wire feeder, which automatically adjusts the filler material feed speed (alternative 1 above) is therefore required.

The combination of such a wire feeder and a constant current power source is a fully acceptable solution when welding in the spray-arc area, and especially when flux cored wires are used. It is not, however, possible to use such a combination if welding in the short-arc area is required, as the mechanical adjustment of feed speed will be too slow to maintain a proper short-arc.

Constant voltage power source.

To maintain a proper short-arc requires the combination of a constant voltage power source and a constant speed wire feeder. The constant voltage characteristic of the power source will automatically maintain the arc length by adjusting the amperage according to need, once the arc voltage and thereby the arc length has been selected. The constant voltage characteristic is also suitable for spray-arc welding, but cannot be used for any other arc welding processes.

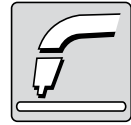

Shielding gas

ARGON Ar

Argon is a colourless, odourless gas, slightly heavier than air. It is non-toxic and non-combustible. Argon is an inert gas used as a shielding gas for TIG and MIG welding, primarily to protect the molten pool against contaminants in the atmosphere.

For use on:

Aluminium
Yorcalbro
Cunifer

Cylinder data

<i>Cylinder type:</i>	<i>E-10</i>	<i>E-50</i>
Product No:	715-905565	715-905174
Application	Welding	Welding
Colour	Grey	Grey
Water capacity l	10	50
Gas capacity kg	3.6	18
Gas capacity nM ³	2.2	11
Filling pressure bar	200	200
Empty weight kg appr.	18	81
Gross weight kg appr.	22	99
Overall length mm appr.	1000	1690
Outside diameter mm	140	230
Valve outlet connection	W24,32mm x1/14"	W24,32mm x1/14"
Valve type	Forged brass with bursting disc, inlet filter and positive pressure cartridge	
1 nM ³ = 1.637 kg. 1kg =0.611 nM ³	1 bar = 14.5 psi 1 M ³ =35.3ft ³	1kg = 2.2 lbs

ARGON - CO₂ MIXTURES

Argon - CO₂ mixtures are used as shielding gas in MIG/ MAG welding processes. The 80 % Argon and 20 % CO₂ mixture is suitable for welding all un- and low alloyed carbon steels and stainless steels. The mixture gives a very stable molten pool together with optimum energy-transmission. Each cylinder is labelled with the correct contents identification label.

For use on:

Stainless steel
Steel

Cylinder data

<i>Cylinder type:</i>	<i>M-10</i>	<i>M-50</i>
Product No:	715-905573	715-905581
Application	Welding	Welding
Colour	Grey/Yellow	Grey/Yellow
Water capacity l	10	50
Gas capacity kg	3.4	17.1
Gas capacity nM ³	2.2	10.9
Filling pressure bar	200	200
Empty weight kg appr.	18	81
Gross weight kg appr.	21	98
Overall length mm appr.	1000	1690
Outside diameter mm	140	230
Valve outlet connection	W24,32mm x1/14"	W24,32mm x1/14"
Valve type	Forged brass with bursting disc, gas mix tube and positive pressure Cartridge.	
1 nM ³ = 1.571 kg. 1kg =0.598 nM ³	1 bar = 14.5 psi 1 M ³ =35.3ft ³	1kg = 2.2 lbs



WIRE WELDING

Equipment

The basic elements in a complete equipment package for the Wire Welding process are:

1. Power source with amperage or voltage control.
2. Welding current switch (contactor).
3. Power supply to wire feeder and gas valve.
4. Gas cylinder
5. Gas regulator with flow adjustment.
6. Gas valve (solenoid).
7. Wire spool.
8. Wire feed motor with drive rolls.
9. Wire feed control.
10. Torch cable package containing welding current cable, gas hose, control circuit cables and wire feed tube (liner).
11. Torch with contact tip for supplying current to the nozzle, and control switch.

In a welding sequence these elements function as follows when the welder points the torch towards the starting point of the weld and pushes the torch control switch:

- Gas valve opens to supply gas.
- Contactor closes to supply welding current from the power source to the torch contact tip and wire.
- Wire feed motor starts, feeding wire through the torch.
- The arc starts as the wire touches the workpiece, and welding proceeds.

When welding is to be stopped the welder releases the torch control switch and the following sequence of events take place:

- Wire feed motor stops.
- After a brief moment the contactor opens, preventing further current supply, and the arc is extinguished.

- The gas valve closes, preventing further gas supply.

The sequence of events and the time delay between them is essential for a successful termination of the weld, first to avoid that the wire sticks in the weld deposit, secondly to ensure gas shield of deposit and wire tip until sufficient cooling has been obtained.

Depending on the area of use the elements of the Wire Welding equipment are arranged in different ways, more or less suited to onboard use.

Most commonly used are constant voltage power sources where all elements 1-9 are assembled in one unit, often even with the gas cylinder mounted on the assembly. As the practical length of the torch cable package with wire feed liner is limited to 3-4 m (especially when welding aluminium) these units are limited to applications close to the machine.

Another system is built around very small wire spools, incorporating elements 7-11 in the torch, and the other elements either in a control box or in the power source. This is a flexible system regarding distance from the power source, but limits the selection of wires to mainly aluminium alloys, due to the small wire spools.

Wire feeder principle

The most flexible system is to include elements 2 - 9 except gas cylinder regulator in a compact portable wire feeder unit, which has the ability to utilize power sources with constant voltage characteristic. Unitor Wire Feeder is based on this principle and requires only welding current as power supply.

WIRE WELDING

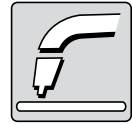

With a capacity of 500A at 100% duty cycle and selection possibility (DC+ or-to wire) this system covers the complete range of continuous wire welding applications for onboard repair and maintenance, including short-arc welding if constant voltage power is available.

UWW-161 TP wire welder principle

Short-arc welding does not normally require amperages above 100-150A, which is obtainable in portable units.

The Unitor Wire Welder UWW-161 TP includes polarity selection possibility. The unit is therefore also able to use self-shielding flux cored wires, and covers all thin plate and light construction welding applications.

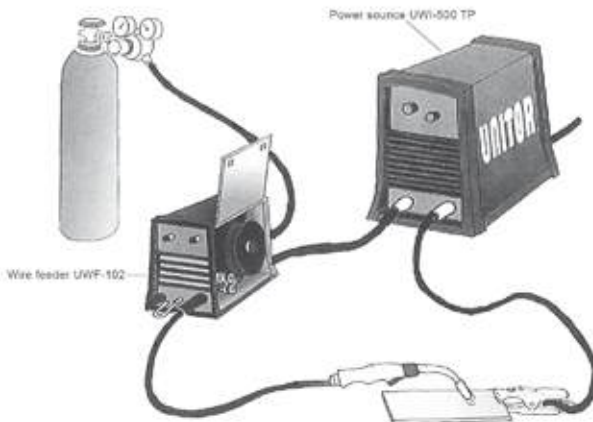

Separate wire feeder principle, supply current from DC-power source.



Wire feeder intergrated together with powe source.



WIRE WELDING

Unitor Wire Welder UWW-161 TP

Multi Process Welding Inverter for Stick, TIG and wire welding



- Fully portable, only 12kg net weight. 1 phase 230V 16A for use anywhere on board.
- Safe in use. Voltage reduction function reduces touchable Open Circuit Voltage to 10V.
- Individual, step-less adjustment of both wire speed and welding voltage through whole adjustment range provide optimal settings for any wire
- Select between softer or crisper arc on the front panel to optimize the wire welding arc.
- 2-step or 4-step trigger function for wire welding operator comfort
- 2-step TIG-torch control with Lift-arc start and adjustable gas post-flow.
- Polarity selection allows for wire welding with all wires including self-shielding wires without shielding gas.
- Automatic hot start and arc force control provides easy start and a stable arc in MMA modus
- Protection against both overload and high input voltage, with indicator light on the front panel, prevent machine damage from wrong primary voltage and overheating.
- CE-marked. Conforms with IEC/EN 60974-1, 5 and 10.

Technical Data

Primary voltage	1 phase 230V 50-60Hz
Recommended fuse size	16A slow fuses
Duty cycle	35 % (at max amperage)
Maximum input power	5,4 kVA
Power factor	0,79
Maximum touchable open circuit voltage	10V
Voltage adjustment range for wire welding	10-26V
Wire speed adjustment range for wire welding	2-13m/min
Welding current range for MMA (Stick) electrode welding	5-140A
Postflow gas adjustment range	0-3sec
Length x Width x Height	460x230x325mm
Weight (ex. Accessories)	12,2kg



230

325



460

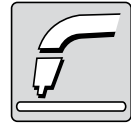

Ordering Information

UWW-161 TP is supplied with:

- 2.5 m primary cable with Schuko plug, fitted on the welding machine 3 x 2,5 mm²
- Gas hose socket with nut and hose clamp for connection to gas inlet
- Wire welding torch with 3 m cable and connector complete for 0.8 mm wire
- Electrode holder for MMA (stick) electrode welding with 3 m cable and Dix 25 connector
- 3 m return cable with Dix 25 connector and return clamp
- Adjustable carrying strap
- Instruction manual



Unitor Wire Welder UWW-161 TP,
Skid Trolley for protection,
Trolley for machine, accessories and 1-2 10l shielding gas cylinders,
Spare part kit* for UWW-161 TP

193 161161
191 764550
196 778149
191-150161

* Spare part kit includes power board, necessary additional components and complete instructions for replacement.

Application set-up for Stick Electrode welding

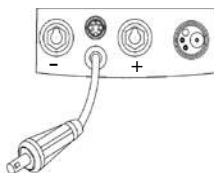
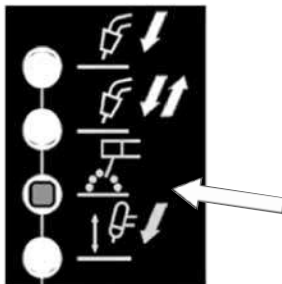

Select MMA (stick) welding:

In this mode a constant current characteristic for MMA welding is set and the terminals are live (10V).

An automatic hot-start enables easy arc start. And an automatic arc-force maintains a smooth and stable arc by momentarily increasing the current if bigger droplets in the arc tends to produce short circuits.

An automatic anti-stick function will cut the power if the electrode should get stuck in the melt-pool so that it can be removed without damage.

Select polarity

Disconnect the TIG/MIG polarity selection cable from the +/- cable connection sockets.

Connect the electrode holder to the correct polarity for the electrode to be used.

Connect the return cable to the other socket.

Connect the return clamp directly to the work piece.



WIRE WELDING

Application set-up for TIG (Tungsten Inert Gas) welding

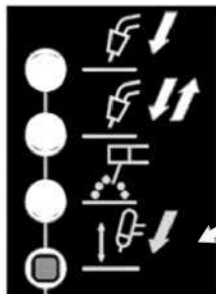

Select TIG welding

In this mode a constant current characteristic for TIG welding is set

Select polarity

Connect the TIG/MIG voltage selection cable to the negative (-) cable connection socket and the electrode holder to the Euro-contact.

Connect the return cable to the + socket and return clamp directly to the work piece

Connect gas

Set amperage

TIG welding

Touch the electrode to the work piece and press the torch button. Shielding gas and very small "signal" current will start flowing.

Lift the torch slowly, the signal current will initialize an arc and an up-slope function that increases the current to set value.

Release the button (step 2) in order to start the slope-down function that gradually reduces the welding current to zero.

The supply of gas will continue for the selected post-gas time.

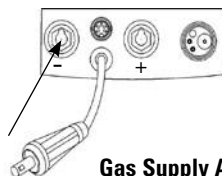

Gas Supply Accessories

Gas regulator with flow adjustment 0-32 l/min, for Argon and Argon/CO2

Flow control meter for use at torch nozzle

Flow control needle valve for gas flow adjustment at the gas inlet to the machine

Gas hose 1/4" black, for shielding gas

Hose clamps, one ear for 1/4" hose, non-protruding stainless, bag of 10 pcs

Pliers for ear clamps

Argon 10 litres

Argon CO2 mix

Product numbers

197 619247

197 597328

197 597310

176 576157

401 729442

401 768507

715 905565

715 905573

TIG Accessories

TIG-Torch T-161 with 4 m cable, euro-connector and torch-mounted trigger

TIG accessories kit

The kit contains:

- short back cap
- spare heat-shield
- 6 collets
- 2 collet bodies
- 4 nozzles
- 3 electrodes 1.6mm
- 3 electrodes 1.6mm

Product numbers

197 160010

197 607810



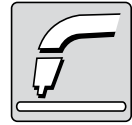

Application set-up for Wire (MIG/MAG) welding

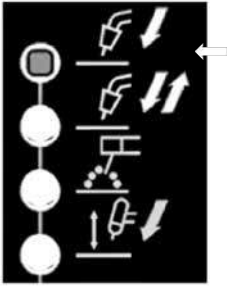

Select Wire welding:

In this mode a constant voltage characteristic for wire welding is set.

Select polarity

Connect the TIG/MIG voltage selection cable to the correct polarity for the selected wire, check information on the label.

Select Wire speed and Voltage

Wire speed is set with the m/min knob on the front panel.

Welding current is set with the VA knob on the front panel, white scale.

2 step wire welding (upper mode)

Bring the torch close to the work-piece. Press (step 1) and hold the torch button. The wire advances until it contacts with the work-piece and the arc is lit.

Release the button (step 2) to stop welding. The gas flow continues for the selected post-gas time.

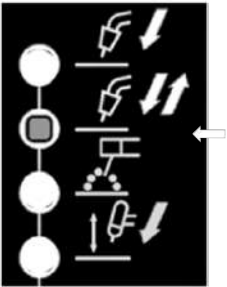

4 step wire welding (second mode)

Bring the torch close to the work-piece. Press (step 1) and release (step 2) the torch button. The wire advances until it contacts with the work-piece and the arc is lit.

Press (step 3) and release (step 4) the button to stop welding. The gas flow continues for the selected post-gas time.

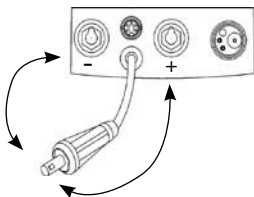
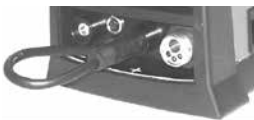



WIRE WELDING

Drive rolls

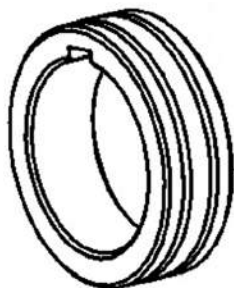

The drive rolls in the wire feed system must be selected according to wire size and type, see table.

Each drive roll has two grooves in different sizes.

UWW-161 is delivered with the V-groove 160003.



Smooth
V-groove



Knurled
V-groove



Smooth
V-groove

Wire Loading

Release the spring loaded pressure arm (1) and swing the roll arm (2) up from the wire feed drive roll (3).

Ensure that the groove size in the feeding position on the drive roll matches the wire type and size.

Place the wire spool in place on the wire spool spindle (4). Make sure that the stud (5) engages in the corresponding hole in the wire spool.

Check the Friction Brake Adjustment, a bolt inside the spindle (6).

When properly adjusted, the brake should provide only enough drag to prevent overrun of the spool and excess slack in the wire. Too much drag may result in wire feeding problems.

Replace the cap (7).

Carefully detach the end of the wire from the spool, cut the bent portion of wire off and straighten the first 10cm.

Thread the wire through the ingoing guide tube (8), over the drive roll (3), and into the outgoing guide tube.

Close the idle roll arm (2) and latch the spring loaded pressure arm (1) in place.

The roll pressure on the wire is adjusted with the screw on the pressure arm nut above the spring. It should be sufficient to ensure smooth feeding of the wire.

Rotate the spool counterclockwise if required to take up extra slack in the wire.

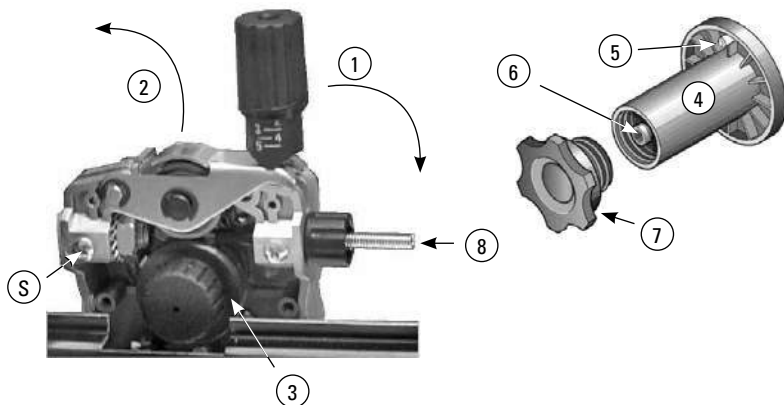

WIRE WELDING

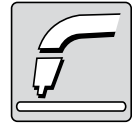

WIRE TORCH:

MIG/MAG Torch M-161 with 3 m cable and euro connector

Product no. 161163

Drive roll / Liner / Contact tip combinations

Product number	Product description	Wire size mm	Application area					
			Cored wire steel	Solid wire steel	Cored wire stainless	Solid wire stainless	Solid wire non-iron	Aluminium wire
WIRE FEED DRIVE ROLLS								
160003	Drive Roll V-groove	0.6–0.8	0	X	0	X	X	0
160004	Drive roll U-groove	0.8–1.0	–	–	–	–	–	X
160005	Drive roll V-groove knurled	1.0–1.2	X	0	X	0	–	–
OUTGOING WIRE GUIDE TUBE								
161164	Outgoing wire guide tube	Max. 2	X	X	X	X	X	X
WIRE FED LINERS								
590075	Non iron liner *	0.6–1.2	X	X	X	X	X	X
613756	Steel liner **	0.6–1.2	X	X	–	–	–	–
CONTACT TIPS								
711986	10 tips 0.6 mm	0.6	X	X	X	X	X	**
711994	10 tips 0.8 mm	0.8	X	X	X	X	X	**
712000	10 tips 1.0 mm	0.9–1.0	X	X	X	X	X	**
712018	10 tips 1.0–1.2 mm	1.2	X	X	X	X	X	X
GAS NOZZLES								
160001	GAS NOZZLE	0.6–1.2	All wires requiring gas shielding					

X = Well suited

0 = May be used, but not the best solution

– = Not recommended, do not use

* = Non iron liner can be used for all welding wires, but wears down quicker than steel liners

** = Steel liner is a more wear resistant alternative for black steel welding but should be avoided for stainless and non iron wires to avoid contamination of the weld

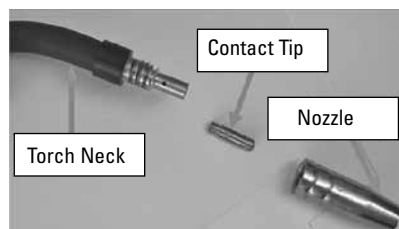



WIRE WELDING

Unitor Wire Feeder UWF-102

A wire feeder specially developed for the multi-process welding power source UMI-500 TP.

By connecting UWF-102 to UWI-500 TP it is, in addition to wire welding, also possible to do stick electrode welding and Air Carbon Arc gouging from the wire feeder without reconnecting back to UWI-500 TP.

For wire range 0,6 to 2 mm. Adjustable wire spool friction brake and roll pressure setting for the feed system provides smooth feeding of both self shielded smooth wires, gas shielded flux cored wires, and gas shielded solid wires. Standard spools with 300 mm diameter are fitted vertically inside the wire feeder, fully protected. Cable/hose



extensions may be used between power source and wire feeder.

Included with wire feeder is 4 m connection cables to welding machine and a drive roll kit for 0.8–1.0 mm solid wire.

Technical Data

Type of input Power	48 Volt AC Single Phase 1.5 Amperes 50/60 HZ
Welding Power Source Type	Constant Voltage CV/DC
Wire Feed Speed Range	1.5–18 m/min
Wire Diameter Range	0.6 to 2 mm
Welding Circuit Rating	400 amperes 100% Duty Cycle
IP Rating	23
Overall Dimensions	
Height	440 mm
Length	690 mm
With	385 mm
Weight	17.4 kg

UWF-102 Wire Feeder for UWI-500 TP with 4 m connection cables and hose, torches not included, order number **191-500102**.

WIRE WELDING

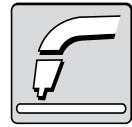

Connecting UWF-102 to UWI-500 TP and shielding gas

The wire feeder is delivered with the required hoses and cables for connection to shielding gas and UWI-500 TP

4m hose for shielding gas is connected here:
The other end has nut with 3/8" RH threads for connection to a shielding gas regulator on a gas cylinder.

4m remote control cable for connection to the back side of UWI-500 TP is connected here:

The 4m connection cable for welding current is connected here:

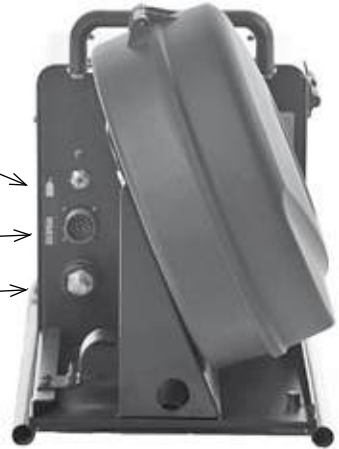

NOTE:

Correct polarity for the welding process must be selected when connecting the welding cables to correct polarity for welding and return at the power source.

If cable extensions are used the return cable should also be extended to the work place for polarity selection there.

The welding cable should always be connected to the + or - terminals on front panel of UWI-500 TP to ensure that correct polarity for the wire is used.

Positive + polarity is normally used for gas-shielded wires.

Negative - polarity is normally used for self-shielded wires.



The 4m control cable from UWF-102 is connected at the back of the UWI-500 TP here:



WIRE WELDING

Drive rolls

V-groove:

The groove walls are smooth and these drive rolls are used for all solid wires except aluminium.



U-groove:

These drive rolls prevent deformation and are specially designed for Aluminium which is soft and will be deformed when sufficient pressure for steady feeding is applied with a V-groove drive roll. This may result in poor welding results.

Knurled V-groove:

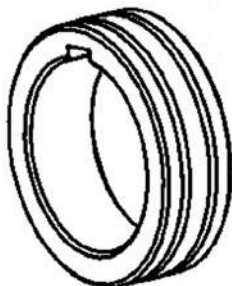
These drive rolls are specially developed for flux-cored wires and provide excellent grip on the hard surface of these wires without requiring a pressure that will deform these tubular wires.



V-groove		Knurled groove		U-groove	
					
Size	Order no	Size	Order no	Size	Order no
0.8–1.0 mm	778192	0.8–1.0 mm	778195	0.8–1.0 mm	778197
1.2–1.6 mm	778194	1.2–1.6 mm	778196	1.2–1.6 mm	778198

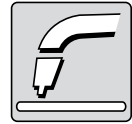

Accessories for Unitor Wire Feeder UWF-102

Torches with tools

Torch for gas shielded wire welding	191 607451
Torch for gasless wire welding	191 750179
Multi purpose pliers for wire welding	192 591990
Anti spatter spray for use at torch nozzle	191 597328

Shielding gasses

Argon regulator with flow adjustment	197 510010
Gauge guard for regulator	171 619379
Needle valve for flow control at the torch	197 597310
Flow control meter for use at the torch nozzle when using the needle valve	197 597328
Argon E-10 10l 200 bar filling	715 905565
Argon E-50 50l 200 bar filling	715 905174
Argon-CO2 80/20 M-10 10l 200 bar filling	715 905573
Argon-CO2 80/20 M-50l 200 bar filling	715 905581
Trolley for one 50-50l gas cylinder	176 778147

Cable and gas hose extensions

Control cable 25 m	191 500104
Welding cable 50mm 2 per m	195 175844
Welding cable 70mm 2 per m	195 175851
Welding cable 95mm 2 per m	195 655266
Cable connector, male/female	195 632893
Gas hose black 1/4" per m	176 576157
Hose clips one ear, bag of 10	401 729442
Hose joint 1/4" RH, screw type	176 175596
Pincher tool for ear clamps	401 768507





WIRE WELDING

T-350 torch for gasless welding with self-shielded wire, complete with 1.6mm contact tip and 1.4–1.6mm steel liner. Order number 193-750179



The torch has a bent swan-neck to ensure optimal feed stability and electrical contact to the wire.

With no shielding gas for cooling the heat radiation from the arc an melt pool is intense, and the torch has a heat shield to ensure protection of the operator's hand.

Pos.	Order number	Unit	Product description.
1	n.a.	n.a.	End of swan neck on torch
2	193-594614	pcs	Torch liner, Steel for 0.6–1.0 mm wire (blue) 3.0 m long
2	193-607457	pcs	Torch liner, Steel for 1.0–1.4 mm wire (red) 3.0 m long
2	193-777846	pcs	Torch liner, Steel for 1.4–1.6 mm wire (yellow) 3.0 m long
3	193-750185	pcs	Tip adaptor for torch
4	193-750181	set	Contact tips 1.0 mm 10 pcs
4	193-750182	set	Contact tips 1.6 mm 10 pcs
5	193-750184	pcs	Ceramic nozzle for torch

WIRE WELDING

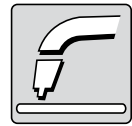

T-400 torch for gas shielded wire welding, complete with contact tip 1.0–1.2 mm and Teflon liner. Order number 193-607451

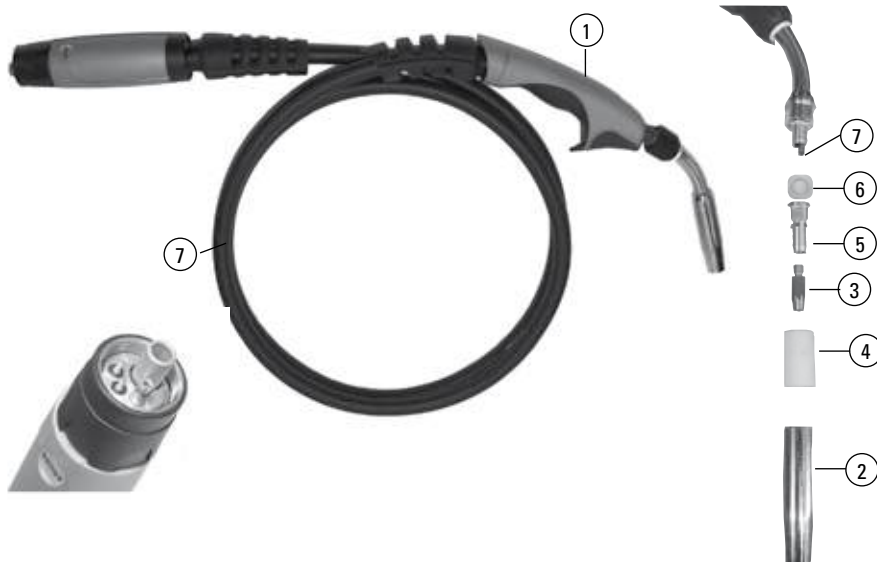

Torch T-400 MP

The torch has adjustable neck and is delivered complete with tools for neck adjustment and contact tip change. It is delivered with 3 m cable, complete with liner and contact tips for 0.8–1.2 mm wire. The teflon liner allows for all wire types including aluminium.

Pos.	Order number	Unit	Product description.
1	193-607451	pcs	Wire torch T-400 complete
2	193-551192	pcs	Gas nozzle for torch
3	193-594622	set	Contact tips 0.6_0.8 mm 10 pcs
3	193-594630	set	Contact tips 1.0–1.2 mm 10 pcs
3	193-607455	set	Contact tips 1.2–1.4 mm 10 pcs
3	193-607456	set	Contact tips 1.6–2.0 mm 10 pcs
4	193-613766	set	Nozzle insulator 5 pcs
5	193-613763	set	Gas diffuser 5 pcs
6	193-613764	set	Neck insulation 5 pcs
7	193-594606	pcs	Torch liner, Teflon for 0.6–1.2 mm wire 4.5 m long
7	193-594614	pcs	Torch liner, Steel for 0.6–1.0 mm wire (blue) 3.0 m long
7	193-607457	pcs	Torch liner, Steel for 1.0–1.4 mm wire (red) 3.0 m long
7	193-777846	pcs	Torch liner, Steel for 1.4–1.6 mm wire (yellow) 3.0 m long



WIRE WELDING

Regulator & Accessories

The R 300 + regulator with flow meter supply a steady stream of shielding gas to the torch. The flow rate in l/min is adjusted on the regulator.

Actual gas flow at the TIG or wire torch may deviate from what is set on the gas outlet station or on the cylinder regulator, especially if long gas hoses are used. The Flowcontrol meter measures actual flow at the torch nozzle and is a useful tool for the operator. Combined with the Flowcontrol needle valve used at the gas inlet of the machine or the wire feeder full flow adjustment is available at the work place regardless of distance to the gas cylinder/gas outlet.

Also recommended are soft-skin TIG welding gloves. They give good protection of the hands while they ensure easy control of the torch and eventual welding rod. In addition standard protective equipment for arc welding should be used.



<i>Product description</i>	<i>Unit</i>	<i>Product no</i>
Argon regulator with flow adjustment 0-32 l/min	pcs	197-510010
CO ₂ regulator with flow adjustment	pcs	197-510012
Gas hose 1/4" black, for shielding gases	mtr	176-576157
Hose joint for 1/4" hose, 3/8" RH threads	pcs	176-175596
Clip 8-14 mm for hose, 10 pcs	pck	401-729442
Quick coupling Argon, regulator to 6,3mm hose	pcs	197-320202
Quick coupling Argon, hose to hose, 6,3mm	pcs	197-320201
Spare parts for regulator:		
Flow meter gauge for Argon 0-32 L/min	pcs	171-550210
Contents gauge for regulator	pcs	171-550178
Flowcontrol meter for use at torch nozzle	pcs	197-597328
Flowcontrol needle valve	pcs	197-597310
TIG Gloves for TIG and Gas welding	6 pairs	197-632795

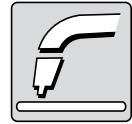

Accessories

The multipurpose pliers provides means for spatter removal from the nozzle inside, tip and outside. It has jaws for contact tip and nozzle removal and installation, and for cutting and pulling wire.

The Anti spatter spray prevents the spatter from the welding arc from sticking to the metal surface being welded. By spraying on a thin layer on each side of where the welding is to take place, a barrier is formed preventing the molten globules from burning on to the surface. The spatter can easily be wiped off with a brush after welding. Time consuming chipping and grinding is prevented. The spray is packed in an outer carton containing 6 X 400 ml canisters.



<i>Product description</i>	<i>Unit</i>	<i>Product no.</i>
Multipurpose pliers for torch	pcs	193-591990
Anti Spatter Spray, 6 pcs of 400 ml in a box	set	193-633149





WIRE WELDING

Application areas

GMAW and FCAW processes cover a wide range of applications known from MMAW (coated electrodes) and partly also the TIG process. Among the most distinct advantages of the processes are:

- Welding technique is easy to learn.
- High quality welds.
- High deposition rate.
- No slag, or for FCAW very little slag.
- Unique advantages for sheet metal and aluminium welding.

The last may be the most important advantage for repair and maintenance applications, as especially aluminium welding with gas or coated electrode is difficult and requires considerable experience and skill from the welder. The only other alternative, TIG, need special equipment and is only usable on materials of limited thickness.

Disadvantages of the process have been among others heavy equipment and the need for using several different premixed shielding gases for different metals and alloys. These are to a large degree being eliminated by design of equipment as described under the UWW-161 TP and UWF-102 principle, and by carefully selecting wires with or without flux core according to application area.

Non-ferrous metals

Aluminium and copper alloys are excellently weldable both in spray- and short-arc mode using argon as shielding gas, and solid wire filler material of Alumag, Icuni and Ialbro type. Overlap between short- and spray-arc mode will normally be in the material thickness range 3–6 mm, even though thicker materials may be welded with UWF-102 and short arc. Welding is easily done in all positions.

Unalloyed/low alloyed and stainless steels

Numerous gas mixtures based on Argon, Oxygen, Carbon Dioxide, Helium, Hydrogen, and even traces of other gases, have been introduced to the market for ferrous materials, all claiming their superiority for certain alloy types, welding positions, arc types etc. In onboard repair and maintenance a stock of several gas mixtures will be expensive and highly impractical, and with proper selection of filler material, not necessary.

Based on one shielding gas, a mixture of 75-80% Argon and 20-25% Carbon Dioxide, the following applications are covered:

- MS type solid wire, short-arc, all positions, all steels weldable with GPO/GPR/SPECIAL /LH/LHV electrodes.
- 18/8 type flux cored wire, all positions all stainless steels weldable with 18/8 electrodes or 18/8 Mo rods.
- 23/14 type flux cored wire, all positions all stainless steels weldable with 23/14 electrodes.

Flux cored wires with self-shielding properties requiring no shielding gas at all are being developed to cover an expanding range of applications, and will further add to the usefulness of the GMAW/FCAW processes in onboard repair and maintenance.

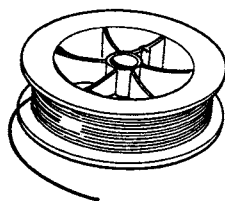

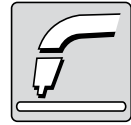

Preparation for Welding

As for other arc welding processes the GMAW and FCAW processes require that the welder and welder's assistant use correct protective equipment and face shields with correct shade filter glass. The guidelines given in the chapter on safety should always be followed.

Preparing the equipment

Before welding starts make sure that correct shielding gas in sufficient quantity is available, if shielding gas is to be used. Check that the equipment is set for correct polarity according to the wire, normally positive pole (+) to torch if solid wires are used, and negative pole (-) to torch for some flux cored wires.

Ensure that the return clamp is properly fastened to the workpiece, with good electrical contact. Poor return connection will influence on the equipment's ability to provide the correct arc.

Mounting the wire spool

- Check, and if necessary clean the wire feed rolls and the wire liner in the torch cable. Ensure that the rolls and liner are of correct size and quality for the wire to be used. Teflon liners are often an advantage for aluminium and stainless steel wires.
- Check that the torch contact tip and nozzle are free from spatter, and that the contact tip is of correct size for the wire to be used. Worn contact tips or liners should be replaced. When aluminium wire is used the contact tip should have a slightly larger inner diameter than with other alloys, to allow for the heat expansion in aluminium.

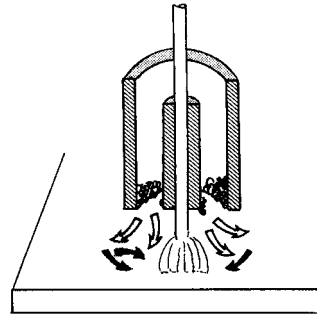

Spatter must be removed to avoid disturbance in shielding gas flow.

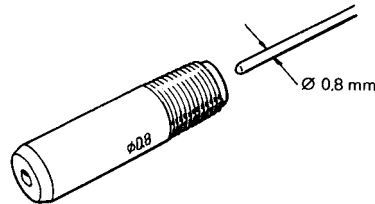

Use correct size contact tip.

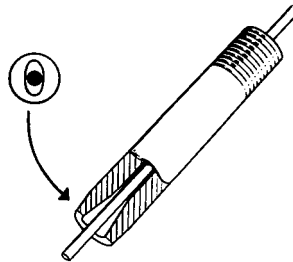

A worn contact tip will give insufficient electrical contact.



WIRE WELDING

- Insert the wire spool in the wire feeder and straighten approximately 10-15cm of the wire end. To avoid damaging the liner or getting the wire stuck when feeding it through the liner, it may be an advantage to round off the wire end with a file. Then insert the wire in the torch cable liner, fasten the feeder rolls and feed the wire through until it protrudes from the torch.

Checking the wire feed function

- Check and if necessary adjust the wire spool resistance. Even at the highest wire feed speed the spool shall stop immediately when the torch micro-switch is released, without uncoiling excessive wire between spool and feed rolls.
- The feed roll pressure should be adjusted to a pressure where they slide on the wire if the wire is stopped at the torch. This is checked by stopping the wire at the torch nozzle while keeping the feed button depressed. Do not touch the wire when testing this unless the equipment has a cold feed switch. The roll pressure may be tested by cutting the wire level with the torch nozzle and using an electrically insulating material to hold the wire back.
- To provide best conditions for arc start the wire should be cut off at a sharp angle 10-15 mm away from the nozzle tip before welding starts. The sharp point will provide a better starting point for the arc than a flat wire tip surface, especially for larger wire diameters.

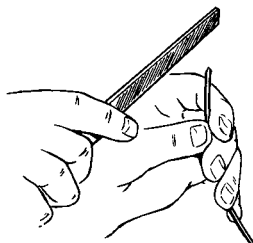

Round off wire tip before inserting wire in liner.

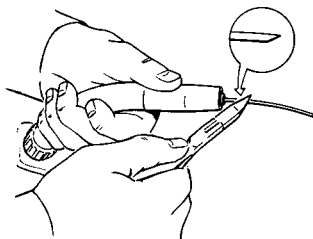

A sharply pointed wire will improve arc start.

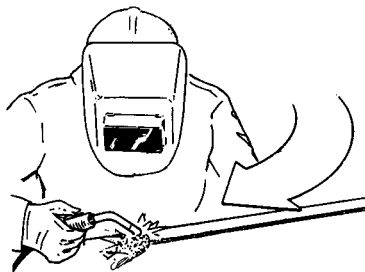

Strong draft may disturb the gas shield.

Shielding the workplace

Strong draft may disturb the shielding gas flow and cause welding faults. When necessary, the weld bead should therefore be shielded. Welding fume extractors must be positioned with care to ensure they do not affect the shielding gas.

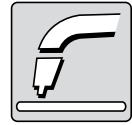

Welding technique

Set the correct parameters given for the base material, wire and shielding gas that are to be used. These parameters include:

- (1) Gas flow rate.
- (2) Wire feed speed.
- (3) Amperage or voltage setting.

When setting the gas flow rate, allow the gas to flow for a while to ensure that the gas supply system is fully purged. If in doubt of the actual wire feed speed at a certain setting on the machine, this may be checked by pressing the torch micro-switch and initiate wire feed for exactly 6 seconds. Measure the wire length that has been fed, multiply by 10 and you will have feed rate per minute.

When doing this remember to keep the wire away from contact with deck or workpiece. While feeding in this way the wire will be electrically live and an arc will occur if contact is made.

While welding the welder controls five variables; wire stickout (4), travel speed and direction (5), torch angles (6) and weaving (7).

Wire stickout

The stick-out is the distance from the end of the contact tip to the baseplate, including the arc length. This distance decides how long the current carrying part of the welding wire is to be. The electric resistance and voltage drop in the wire increases with increasing stickout. This voltage drop is part of what the equipment measures as arc voltage, and the welding current will decrease with increasing stickout and vice versa.

Too long stickout may result in too

cold arc and insufficient gas shield and must be avoided.

Too short stickout may overheat the contact tip and will also allow more spatter to reach the nozzle. This may again cause turbulence in the gas flow, and insufficient shielding. When Flux Cored Arc Welding Self Shielded is to be used, a too short a stick out will give porosity.

Within limits, and depending on the characteristic of the power source, the welder may use the stick out to adjust the welding parameters while welding. Increasing stick out will:

- decrease penetration.
- increase deposition rate.
- increase bead size.
- decrease bead width.

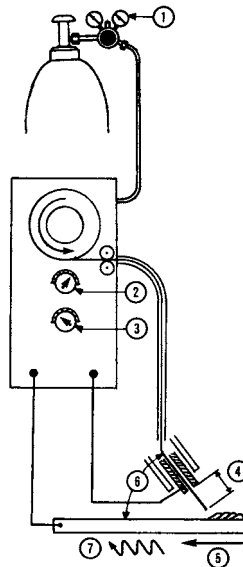



WIRE WELDING

Travel speed and direction

The speed with which the torch is passed along the bead will influence on bead size and width, and will also decide the heat input per distance to the base material. Welding may be done with the forehand (push) or backhand (pull) technique, depending on welding position and alloy. Generally the difference with the two methods are as follows:

Backhand technique:
When Flux Cored Arc Welding Self Shielded wire are used.

Forehand technique:
When "Gas Metal Arc Welding" and "Flux Cored Arc Welding Gas Shielded" wires are used.

To avoid oxides in the deposit the forehand technique is always used for all welding of aluminium and aluminium alloys.

For steel and stainless steels both techniques are used, often with preference for forehand welding with solid wire and backhand for flux-cored wire.

Torch angles

Torch angles may be defined as longitudinal angle - the angle between torch and workpiece along the weld, and transverse angle - the angle between torch and workpiece sideways from the weld.

The longitudinal angle will affect the penetration and bead form. Too small angle should be avoided as the shielding gas flow may drag air in between torch and workpiece, contaminating the weld.

For horizontal welding an angle between 70°-80° is frequently used.

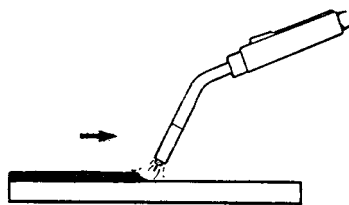

Backhand technique

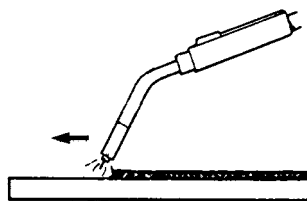

Forehand technique

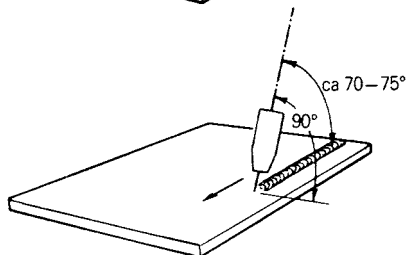
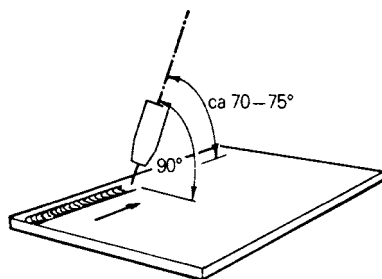

Torch angles

WIRE WELDING

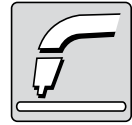

Transverse angle will normally be 90° on a flat workpiece, and 45° for fillet welds. When multiple passes are used, the transverse angle is increased or decreased to place the deposit correctly in the joint.

Weaving

To obtain a wider deposit than obtainable with a straight welding pattern, the torch may be moved along the groove in a side to side movement (weaving). When this technique is used the side to side movement must be stopped shortly at each side to ensure sufficient deposit at the sides of the weld. Weaving in a continuous movement may easily result in insufficient deposit and undercut, which will weaken the joint considerably.

Arc starting and stopping

When starting the arc on a cold workpiece, penetration may be insufficient to provide sufficient binding for a short moment before the weld pool is properly established. To avoid a weakness in the joint the arc may either be started on a plate attached to the workpiece at the beginning of the joint, or the welder may increase the heat input. This may be done by starting the arc approximately 2-3 cm after the beginning of the joint, moving the arc quickly back to the actual starting point and continue welding over the slightly preheated area. Reduced electrode stickout for the first 1-2 cm will further improve heat input.

When finishing the weld the heat input should be reduced to reduce

penetration depth and weld pool size. This may be done by increasing travel speed and/or stickout the last 3-5 cm of the weld, and releasing the torch switch immediately when the stop point is reached. Keep the torch in position over the weld until gas flow stops, in order to protect the deposit until the metal has solidified.

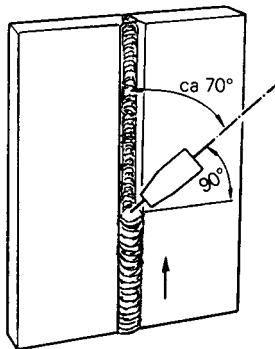
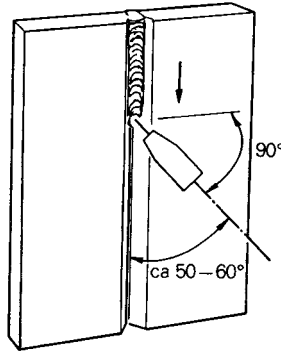

Torch angles in vertical welding, backhand technique



WIRE WELDING

Edge preparation

Steel, Position welding, 80% Ar, 20% CO₂ Shielding gas

Material thickness mm	Type of joint	Welding position	Gas consumption l/min.	Wire diameter mm	Welding parameters			Number of layers
					Amp	Volt	Wire speed cm/min	
0.9		Horizontal & Vertical down.	6-10	0,8	55	16	290	1
1.2					65	17	340	1
1.6					80	17	420	1
1.6					85	17-18	440	1
2.0					95	18	500	1
2.0					105	18	550	1

Steel, Position welding, 80% Ar, 20% Co₂ Shielding gas

Material thickness mm	Type of joint	Joint opening mm	Welding position	Gas consumption l/min.	Wire diameter mm	Welding parameters			Number of layers
						Amp	Volt	Wire speed cm/min	
2		1	H & VD	10-12	0.8	95	19	430	1
3		1-2	H & VD	10-12	0.8	110	19,5	510	1
3			H & VD	10-12	0.8	125	22	480	1
4			H & VD	10-12	0.8	130	22	500	1
4		2	H & VD	10-12	0.8	120	20	460	2
6		1.5	VD	12-15	0.8	120	20	460	2
			H	12-15	1.2	150	21	330	2
6		1	H	15-20	1.2	330	32	1100	1
10		1	VU	15-20	1.2	145	21	320	3
10			VU	15-20	1.2	150	21	330	1
			H	15-20	1.2	300	30	900	1

H: Horizontal, VD: Vertical down, VU: Vertical up

WIRE WELDING

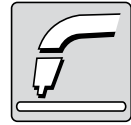

Edge preparation

Stainless steel, Position welding, 80% Ar, 20% CO₂ Shielding gas

Material thickness mm	Type of joint	Gas consumption l/min.	Wire diameter mm	Welding parameters			Welding speed cm/min	Number of layers
				Amp	Volt	wire speed cm/min.		
1.6		8-12	0,9	85	15	460	45	1
1.6				85	15	460	50	1
2				90	15	480	35	1
2				90	15	480	30	1
2.4				105	17	580	38	1
3.2				125	17	720	40	1

Stainless steel, Horizontal welding, 80% Ar, 20% CO₂ Shielding gas

Material thickness mm	Type of joint	Gas consumption l/min.	Wire diameter mm	Welding parameters		Number of layers
				Amp	wire speed cm/min.	
3 (1/8")		18	1.6	200-250	280-380	1
6.5 (1/4")		18	1.6	250-300	380-490	2
9.5 (3/8")		20	1.6	275-325	460-570	2
12.7 (1/2")		20	2.4	300-350	190-215	3-4
19 (3/4")		20	2.4	350-375	215-235	5-6
25.4 (1")		20	2.4	350-375	215-235	7-8



WIRE WELDING

Edge preparation

Aluminium, Horizontal welding, Argon Shielding gas

Material thickness mm	Type of joint	Gas consumption l/min.	Wire diameter mm	Welding parameters			Welding speed cm/min
				Amp	Volt	Wire speed cm/min	
1		15	1.0	40	15	600	50
1.3		10	1.0	50	15	700	38
1.6		10	1.0	60	15	810	38
2.4		10	1.0	90	15	1050	38

Aluminium, Horizontal welding, Argon Shielding gas

Material thickness mm	Type of joint	Backing plate	Gas consumption l/min.	Wire diameter mm	Welding parameters		Welding speed cm/min	Number of layers
					Amp	Volt		
6.5 (1/4")		With	18	1.2	180	24	38	1
6.5 (1/4")		With	20	1.2	250	26	40	1
6.5 (1/4")		With out	18	1.2	220	24	60	2
9.5 (3/8")		With	20	1.6	280	27	60	2
9.5 (3/8")		With out	20	1.6	260	26	45	2
9.5 (3/8")		With out	25	1.6	270	26	55	2
12.7 (1/2")		With	25	1.6	310	27	45	2
12.7 (1/2")		With out	25	1.6	300	27	45	3

WIRE WELDING

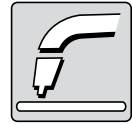

Edge preparation

Aluminium, Position welding, Argon Shielding gas

Material thickness mm	Type of joint *	Welding position	Gas consumption l/min.	Wire diameter mm	Welding parameters		Welding speed cm/min	Number of layers
					Amp	Volt		
6.5 (1/4")		V	20	1.2 or 1.6	180	23	50	2
6.5 (1/4")		OH	20	1.2 or 1.6	200	23-24	55	2
9.5 (3/8")		V	20	1.2 or 1.6	210	23	45	3
9.5 (3/8")		OH	23	1.6	220	23-24	50	3
12.7 (1/2")		V	23	1.6	215	22-23	30	3
12.7 (1/2")		OH	25	1.6	225	23-24	40	4
19 (3/4")		V	25	1.6	225	23-24	25	4
19 (3/4")		OH	25	1.6	240	24	35	6

V: Vertical, OH: Over head

*4 mm (1/16")

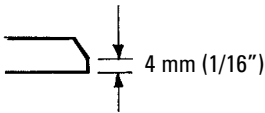

Copper alloys, Horizontal, Argon Shielding gas

Material thickness mm	Type of joint	Gas consumption l/min.	Wire diameter mm	Welding parameters		
				Amp	Volt	Wire speed cm/min
3 (1/8")		15-20	1.6	310	27	500
6.5 (1/4")		15-20	2.4	460	26	345
9.5 (3/8")		15-20	2.4	500	27	380
12.7 (1/2")		15-20	2.4	540	27	420

NB: When welding Cunifer backing gas must be used



WIRE WELDING

Wires for Wire Welding

Unitor Wire	Size mm	Order no.	Shielding gas	Current type	Wire speed	Voltage
GPS-W-200	0.8	090-590117	Ar/CO ₂	DC+	7.5	22
MS-W-201	1.0	090-160100	None	DC-	12	20
Coeshield 8	1.6	090-750187	None	DC-	7	23
S 316 M-GF-221	0.9	090-597518	Ar/CO ₂	DC+	11	22
S 309 M-GF-222	0.9	090-309000	Ar/CO ₂	DC+	13	24
Ialbro-W-237	0.8	090-777972	Ar	DC+	7.5	22
Icuni-W-239	0.8	090-592015	Ar	DC+	7.5	22
Alumag-W-235	1.0	090-590083	Ar	DC+	12	23
Abratech-W-230	1.6	090-230230	None	DC+	8	30

Note: Approx. values only

Final adjustment to be set by welder depending on welding position and wall thickness | plate thickness of base material Argon, Argon/CO₂ Mix: 20 l/mm.

Tech sheets for all above products under section Consumables.

PLASMA CUTTING AND GOUGING

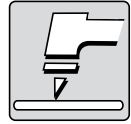

Introduction	443
Basic principles	445
Plasma cutting equipment.....	446
UPC-310 TP	447
UPC-1041	451
Cutting technique	454
Maintenance and trouble shooting.....	456

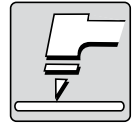

Introduction

In flame cutting, the cutting torch with its high flame temperature of 3100 °C (5612°F) is used to heat the steel to its kindling temperature (ignition temperature) and then by introducing a stream of pure oxygen, to create a rapid oxidation of the steel (the steel

catches fire and burns to become a slag). The stream of oxygen, at high pressure, also assists in removing the material from the cut. Steel melts at 1535°C (2795°F) but can be ignited at 884°C (1623°F). This process is referred to as a chemical process

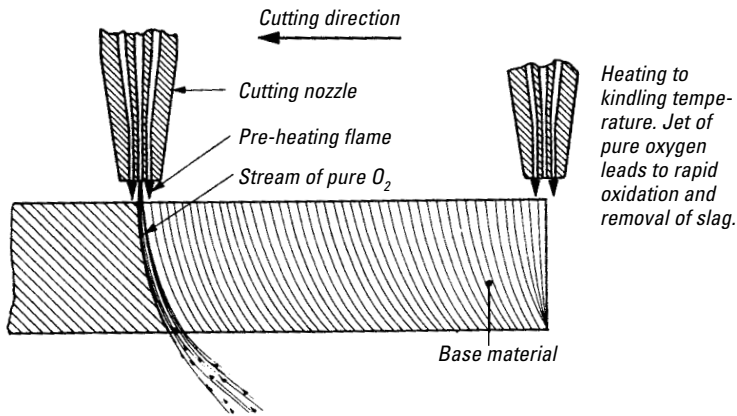

So why cannot aluminum, copper, stainless steel and those other metals be cut by this process?

In order for a metal to be flame cut the following conditions must apply:

- 1) The melting point of the metal must be above kindling point (ignition point).
- 2) The oxides (rust) of the metal should melt at a lower temperature than the metal itself.
- 3) The heat produced by the combustion of the metal with oxygen must be sufficient to maintain the flame cutting operation.
- 4) The thermal conductivity must be low enough so that the material can be brought to its kindling temperature.

- 5) The oxides formed in cutting should be fluid when molten so as not to interrupt the cutting operation. Some metals have refractory oxides (sluggish heavy kind of oxides with high melting point).

Iron and low carbon steels fit all the above requirements and are readily flame cut.

Cast iron is not readily flame cut because the kindling temperature is above the melting point. It melts before it can be ignited. It also has a refractory silicate oxide, which produces a slag coating.

Aluminum and its alloys are not possible to flame cut because its oxides have a higher melting point than the metal itself. Pure aluminum melts at 658°C (1216°F) but the aluminum oxides melts at 1926°C (3500°F)

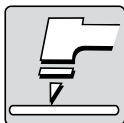

PLASMA CUTTING AND GOUGING

Non-ferrous metals such as aluminum and copper also have refractory oxides coverings, which prohibit normal flame cutting. In addition they also have high thermal conductivity.

Stainless steel cannot be flame cut with standard flame cutting equipment and technique because of the refractory chromium oxide formed on the surface.

So how can we overcome these nature's physical laws for a process to work on a given metal? Simply by changing process from chemical (Flame cutting) to an electric (Plasma cutting).

In Plasma cutting only one condition must apply in order to perform cutting:

- 1) The metal must be electrically conductive.

What is Plasma?

One common description of plasma is that it is the fourth state of matter. We normally think of the three states

of matter as solid, liquid, and gas. For most commonly known element, water these three states are ice, water and steam. The significant difference between these states relate to the energy level. If we add energy in the form of heat to ice, the ice melts and the result is water, a liquid. If we add more energy to water, it vaporizes to the gas we normally call steam. By adding even more energy to the steam the gas become ionized. This ionization process causes the gas to become electrically conductive. This electrically conductive ionized gas is called plasma.

(At a temperature of between 2000°C (3600°F) and 10000°C (18000°F) a process of ionization and dissociation of the gas molecules take place. The molecules are split in molecular and atomic ions and free electrons. When this happens, the gas, which has now become plasma, is electrically conductive because free electrons are available to carry current).

The process utilizes the electrically

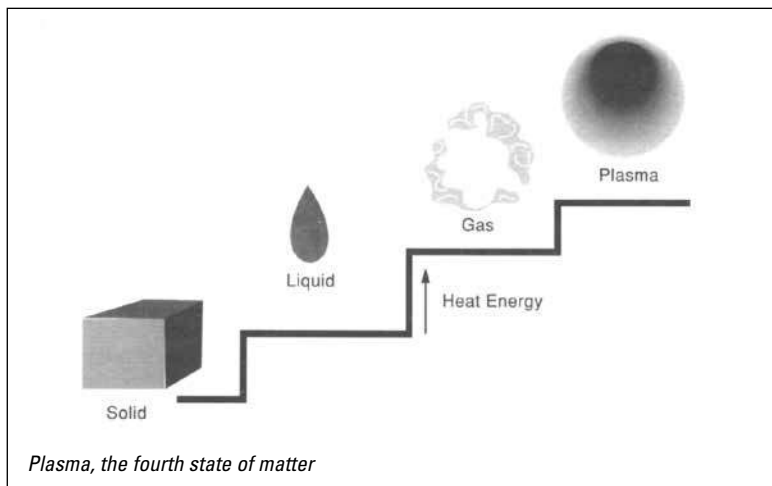

PLASMA CUTTING AND GOUGING

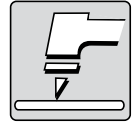

Basic principles

Conductive gas to transfer energy from an electrical power source through a plasma-cutting torch to the material being cut.

Inside the plasma torch the arc is struck between the cathode (electrode - polarity) and an anode (tip + polarity) As compressed air is introduced in the arc, plasma is produced and forced out through the tip with high kinetic velocity, forming what is referred to as the pilot arc. Upon impact with the positive pole of the work piece the arc is transferred from electrode / tip to electrode work piece following the plasma gas. Due to the design of the torch tip this arc and the high velocity of flow of free

electrons and ionized particles called the plasma jet is constricted to a very small cross section with high-energy concentration. In the impact zone the high inherent energy of the jet, consisting of heat, ionization energy and dissociation energy is released, creating temperatures up to 28000°C (50000°F). The high velocity air plasma jet will efficiently melt and blow away practically any electrically conductive material, and provide a narrow smooth cut.

The basic plasma cutting equipment consists of a constant current DC power supply, an arc starting circuit (High frequency or air type) and a torch.

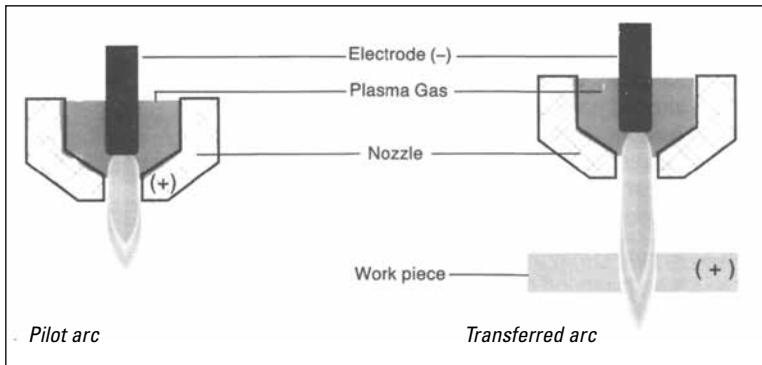



PLASMA CUTTING AND GOUGING

Plasma cutting equipment

The output current (Amperage) of the power supply determines the speed and cut thickness capacity of the system. Most of these hand held systems are rated at under 100 Amps, for cutting materials under 16 mm (5/8") thick. The main function of the power supply is to provide the correct energy to maintain the plasma arc after ionization.

The arc starting circuit uses compressed air to force back the electrode from the tip, creating an electric arc. This in turn, positively charges the air stream, creating a plasma arc. This method is referred to as "blowback" technology. The Unitor UPC-1041 uses NO HIGH FREQUENCY to initiate the plasma arc. This is of great importance for shipboard use.

The torch serves as the holder for the consumable tip and electrode, and provides cooling to these parts. The tip and electrode constrict and maintain the plasma jet.

The process generally uses a single gas (usually air or nitrogen) Air is the most widely used plasma gas, due to the fact that compressed air is readily available at most location and that it is cheap compared to single gases. Consumable parts life is acceptable (usually between 100 to 200 starts). The consumable part life depends largely on air quality that must be oil and water free.

UPC-1041

Primary side input:
Compressed air 6–7 bar
440 V 3-phase min. 20A
slow fuse

UPC-1041

Power source output:
Max. current 100 A
Working pressure:
5.0 bar



UPC-310 TP

Primary side input:
Compressed air 4–79 bar
230/110 V 1-phase min. 16/32A
slow fuse



UPC-310 TP

Power source output:
Max. current 30 A
Working pressure:
3.5 bar

PLASMA CUTTING AND GOUGING

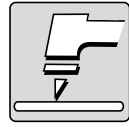

UNITOR UPC-310 TP Plasma Cutter

UPC-310 TP is a lightweight single-phase 110-230V high capacity air plasma cutter. Air is utilized both for plasma gas and for cooling the torch.

The plasma process is highly efficient for precision cutting of most electrically conductive materials, and the process is especially suitable for copper alloys, aluminium and stainless steel, which cannot be cut with Acetylene/Oxygen cutting process.

The UPC-310 TP uses a NO HIGH FREQUENCY blowback ignition system. This is of great importance for shipboard use. (Do not interfere with radio communication and other electronically controlled equipment.)

Cutting capacity is up to 10mm steel and typical cutting speed is 500mm/min on 6mm steel.

The output is steplessly adjustable for precision cutting at lower speeds.

Compact and Portable, the unit is built on the inverter principle which in addition to excellent cutting properties provides low weight and compact dimensions. The plasma cutter may easily be passed through manholes and brought to any workplace on board.

To protect the operator a micro switch in the torch will cut the current to the torch if the nozzle is loosened. The unit will also shut down if the air supply is insufficient or if the duty cycle is exceeded causing the unit to heat up. Power will automatically be restored when the unit has cooled. The air regulator includes both filter and water separator to protect the torch. Automatic air post flow provides rapid cooling of the torch after cutting.

The UPC-310 TP is equipped with Total Protection (TP), which means that the power supply is monitored and if the voltage should drop below or exceed the tolerance for the unit it will shut down to protect the unit.

The unit is also equipped with Flexible Voltage (FV), which means that the machine can be connected to both 230 and 110V without any internal rewiring. * For 110V, higher fuse size is required.



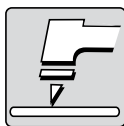

PLASMA CUTTING AND GOUGING

The unit consists of power source, 4 m PTA 25-torch, power cable with Euro connector, Return cable, Instruction manual and Starter Kit

included Starter kit consists of 2 pieces of electrodes, 2 nozzles and 1 distance cutting guide in a plastic package.

The unit consists of power source, 4 m PTA 25-torch, power cable with Euro connector, Return cable, Instruction manual and Starter Kit included Starter kit consists of 2 pieces of electrodes, 2 nozzles and 1 distance cutting guide in a plastic package.



UNITOR UPC-310 TP Plasma Cutter Technical Data:

<i>Description</i>	<i>Unit</i>	<i>Value</i>
Output data		
Current adjustment range	A	5-30A
Maximum current	A	30
Duty cycle at rated current	%	35 (230V supply) 25 (110V supply)
Apparent power:	kVA	2,85
Open circuit voltage:	V	424
Cooling:	F	F
Temperature class:	°C	F (155)*
Input data		
Supply voltage	V	230 (110)
Frequency	Hz	50-60
Phases		1
Fuses min. slow blow	A	16 (32)
Air/Nitrogen supply		
Supply pressure range to machine	bar	4-9
Setting on machine at free flow	bar	3.5
Air consumption	L/min	115
	m³/h	6.9
Miscellaneous		
Protection class	IP	23S
Approval marks	CE	
RoHS declaration		Yes*
Non asbestos declaration		Yes
Weight	kg	9.5
Weight with torch	kg	11
Width	mm	190
Height	mm	320
Length	mm	440

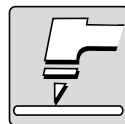

Torch consumables and spares

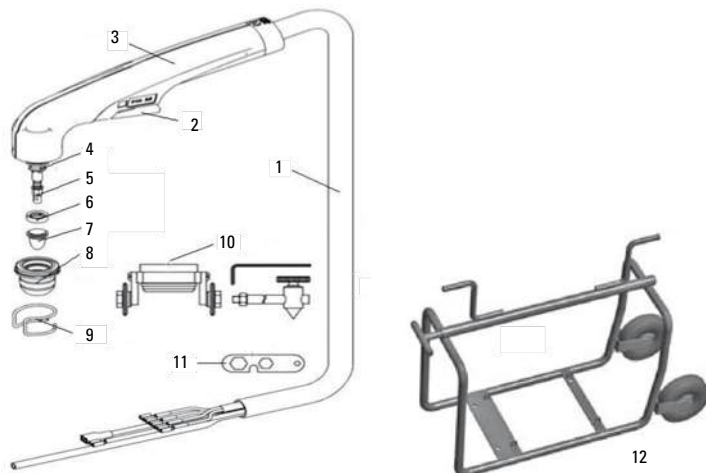

Pos. no.	Description	Product no.
–	UPC-310 TP Plasma cutter with 4m. PTA 25	192-310310
–	Torch PTA 25 4m.	192-310328
1.	Hose assembly PTA 25 4m.	On request
2.	Trigger button PTA 25	On request
3.	Handle PTA 25	On request
4.	Torch body PTA 25	On request
5.	Electrode PTA 25	10pcs 192-310312
6.	Swirl ring PTA 25	2pcs 192-310316
7.	Nozzle 0.8 PTA 25	10pcs 192-310314
8.	Protective cup PTA	25 2pcs 192-310318
9.	Distance cutting guide	5pcs 192-310320
10.	Circle cutting guide	192-310326
11.	Tool PTA 25	192-310322
12.	Skid trolley for protection	191-764550
–	Consumable kit with plastic box.	192-310324
	3pcs of Electrode	
	3pcs of Nozzle	
	1pc of Swirl ring	
	1 pc of Distance cutting guide	
	1pc of Protective cup	
	1pc of Tool	

PLASMA CUTTING AND GOUGING

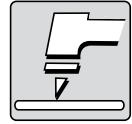

UPC-1041 Plasma Cutter

UPC-1041 is a high capacity air plasma cutter. Air is utilised both for plasma gas and for cooling the torch.

The plasma process is highly efficient for precision cutting and gouging of most electrically conductive materials, and the process is especially suitable for copper alloys, aluminium and stainless steel, which cannot be cut with the Acetylene/Oxygen cutting process.

The UPC-1041 uses NO HIGH FREQUENCY to ignite the plasma arc. This is of great importance for shipboard use. (Do not interfere with radio communication and other electronically controlled equipment.)

Cutting capacity is up to 40 mm steel, and typical cutting speed is 500 mm/min on 12 mm steel plate.

The output is steplessly adjustable for precision cutting at slower speeds. A special nozzle for gouging is available.

Compact and Portable, the unit is built on the inverter principle which in addition to excellent cutting properties provides low weight and compact dimensions. The plasma cutter may easily be passed through manholes and brought to any workplace on board.

To protect the operator a micro switch built into the torch will cut the current to the torch if the nozzle is loosened. The unit will also automatically shut down if the air supply is insufficient, or if the duty cycle is exceeded, causing the unit to heat up. Power will automatically be restored when the air supply is corrected or the unit has cooled. The air regulator includes both filter and water separator to protect the torch, and automatic air post flow provides rapid cooling of the nozzle after cutting.



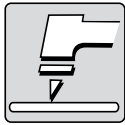

PLASMA CUTTING AND GOUGING



195



575

410

Unitor Plasma Cutter UPC-1041 Technical Data

<i>Description</i>	<i>Unit</i>	<i>Value</i>
Output data		
Current adjustment range	A	20-100
Maximum current	A	100
Duty cycle at max. current	%	35
Input data		
Supply voltage	V	440
Frequency	Hz	50-60
Phases		3
Fuses, min. slow blow	A	20
Air / Nitrogen supply		
Supply pressure range to machine	bar	6-7
Setting on machine at free flow	bar	5,0
Air consumption	L/min	190
	m ³ /h	11,4
Micellaneous		
Protection class	IP	23
Approval marks		CE
Weight	kg	15
Width	mm	195
Height	mm	410
Length	mm	575

UPC-1041 is supplied complete with

- Torch, complete with 6 m cable and connector
- Insulated return clamp with cable
- Built-in air regulator with filter and water separator
- Accessories kit

<i>Description</i>	<i>Unit</i>	<i>Product no.</i>
UPC-1041 plasma cutter complete with basic accessories & torch	pcs	192-404100

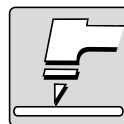

Torch consumables and spares

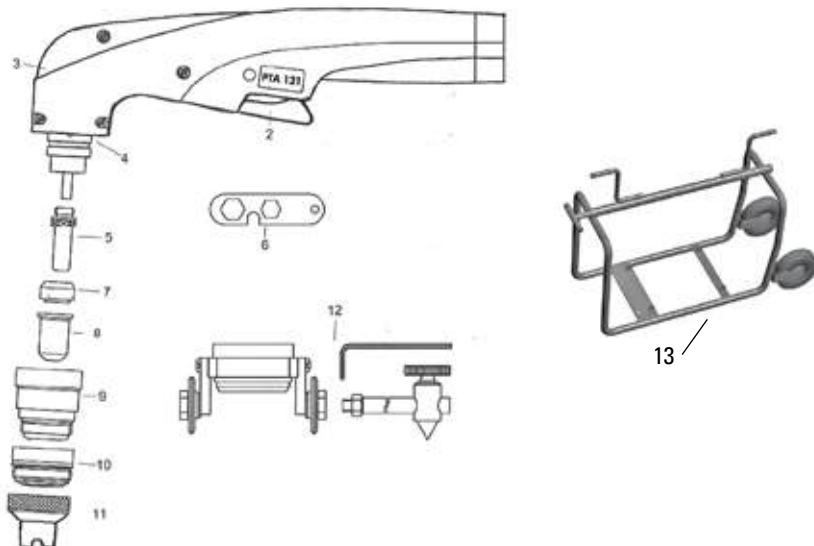

<i>Pos.no</i>	<i>Description</i>	<i>Product no.</i>
–	UPC-1041 Plasma cutter complete with 6m cable	192-404100
–	Torch PTA 121 with 6 m cable and drag shield for UPC-1041 (optional)	192-404114
–	Torch PTA 121 with 15 m cable and drag shield for UPC-1041 (optional)	192-404115
	Hose assembly for PTA 121 torch 6 m, excl. torch head and handle	On request
	Hose assembly for PTA 121 torch 6 m, excl. torch head and handle	On request
2	Trigger button for UPC-1041 w. PTA 121	On request
3	Handle for UPC-1041 w. PTA 121	On request
4	Torch head fir UPC-1041 w. PTA 121	On request
5	Electrode for UPC-1041 w. PTA 121 5 pcs	192-404005
6	Tool for electrode change	–
7	Swirl ring for UPC-1041 w. PTA 121 2 pcs	192-404006
8	Nozzle 1.0 mm 20–40 Amps for UPC-1041 w. PTA 121 5 pcs	192-404007
8	Nozzle 1.25 mm 50–100 Amps for UPC-1041 w. PTA 121 5 pcs	192-404008
8	Nozzle gouging 2.5 mm for UPC-1041 w. PTA 121 5 pcs	192-404009
9	Shield cup for UPC-1041 w. PTA 121 2 pcs	192-404010
10	Spatter shield for UPC-1041 w. PTA 121 2 pcs	192-404111
11	Drag shield for UPC-1041 w. PTA 121 2 pcs	192-404112
–	Consumables kit complete (included with machine) The kit includes: 3 electrodes (pos 5), 1 tool for electrodes (pos 5), 3 nozzles 1.2 (pos 8), 1 spatter shield (pos 11), 1 drag shield (pos 12), 1 gauging nozzle 2.5 (pos 9)	192-404013
12	Wheeled cutting guide with circle cutting attachment (optional accessory)	192-404016
13	Skid Trolley for protection	191-764550

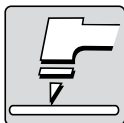

PLASMA CUTTING AND GOUGING

Cutting technique

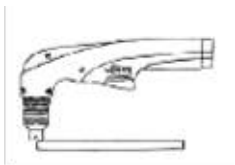

Place the torch in position for cutting or gouging. For most cutting operations the contact cutting shield should be used. It is placed directly on the work piece at the edge where cutting should start.

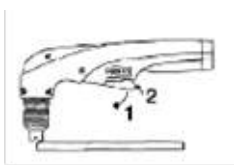

Lift the trigger protection and press the trigger-switch on the torch handle.

Air will flow for one second before the pilot arc strikes.

The pilot arc will burn for about 3 seconds.

If contact with the work piece is not obtained within this time, the pilot arc goes out.

Reposition the torch to ensure that the pilot arc will reach the work-piece and make a new try.

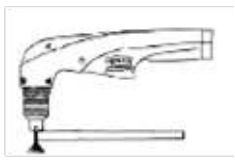

When the cutting arc is established, pull the torch slowly across the surface that is to be cut. At correct speed the sparks goes straight through the metal with only a slight bending towards the beginning of the cut.

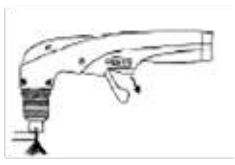

Pause briefly at the end of cut before releasing the trigger.



The plasma arc goes out immediately. Air will continue to flow for about 30 seconds. When removing the finger from the trigger, the trigger protection will close over the button.

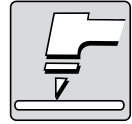

For piercing holes

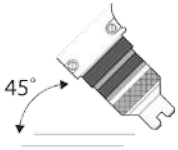

Rest the contact drag shield on the work piece at 45° angle.

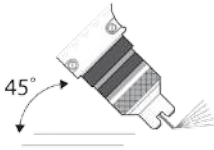

Press the trigger-switch on the torch handle. Air will flow for one second before the pilot arc strikes.

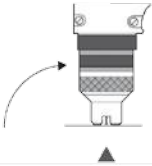

After cutting arc starts, slowly and in one smooth movement, straighten torch back up until 90° angle to plate.

Start moving torch across plate when observing that the arc penetrates.

Circle cutting guide

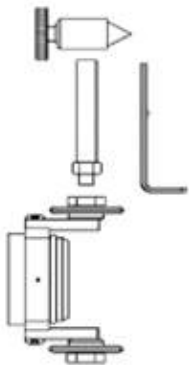

The wheeled wagon in the circle cutting set should be used when cutting on uneven surfaces where it is difficult to use the drag shield.

1. Pull off the drag shield.
2. Insert the torch to a position where the distance from nozzle tip to work piece is 3–4mm.
3. Tighten the allen screw on the inner ring.
4. Tighten the allen screw on the outer ring with the wheels axis at 90° to the torch handle.

For cutting circles the allen screw in point 4 must be loosened to allow the torch to rotate in the wagon. The circle cutting bar is screwed into the wheel centre, and the centre tap is fastened at the correct radius.

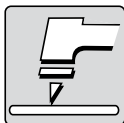

PLASMA CUTTING AND GOUGING

Maintenance and trouble shooting

Disconnect power before maintenance

- Check torch
- Check tip
- Check electrode
- Check drag shield

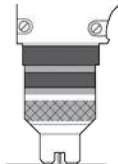

DAILY

Inspect and, if necessary, change the torch consumable parts.

Note:

Electrode and nozzle must be changed at regular intervals, as a general guideline after 2 hours continues use, or after 200 starts.

Always replace the electrode if the center has a pit more than 2 mm (1/16" deep). Replace the nozzle if the opening is deformed or clearly oversized.

Failure to replace worn nozzle or electrode in time will dramatically reduce the cutting capacity and eventually ruin the torch.

Inspect and, if necessary, empty the moisture trap on the filter regulator on the rear side of the machine. The trap is emptied by pressing the bottom sealing while compressed air is connected. If cleaning the trap is necessary, completely unscrew the glass cup after disconnecting compressed air.

Carefully inspect the hose assembly and torch body with regard to any leak or damage.

Never use a damaged torch.

EVERY THREE TO SIX MONTHS

Disconnect the machine from compressed air and electricity.

Remove the cover.

Clean the machine with dry, clean and oil free compressed air. Inspect cable connections and gas system.

In especially dirty environments this procedure should be carried out more often.

Check gas/Air Pressure

UPC-1041 require 6–7 bar supply pressure

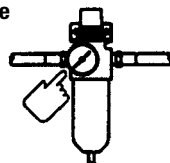

Air Supply Precaution

Air supply precaution: Use only oil-free dry compressed air. Normally the control air on board will have the best quality.

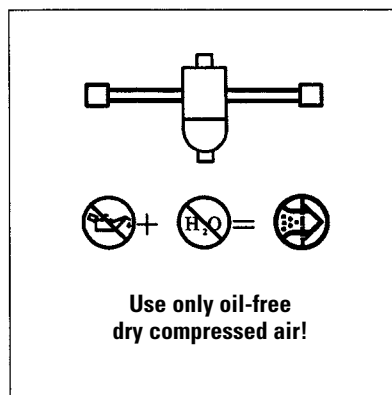

PLASMA CUTTING AND GOUGING

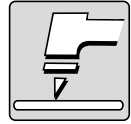

In order to ensure oil and water free air for plasma cutting, Unitor recommend the following set up:

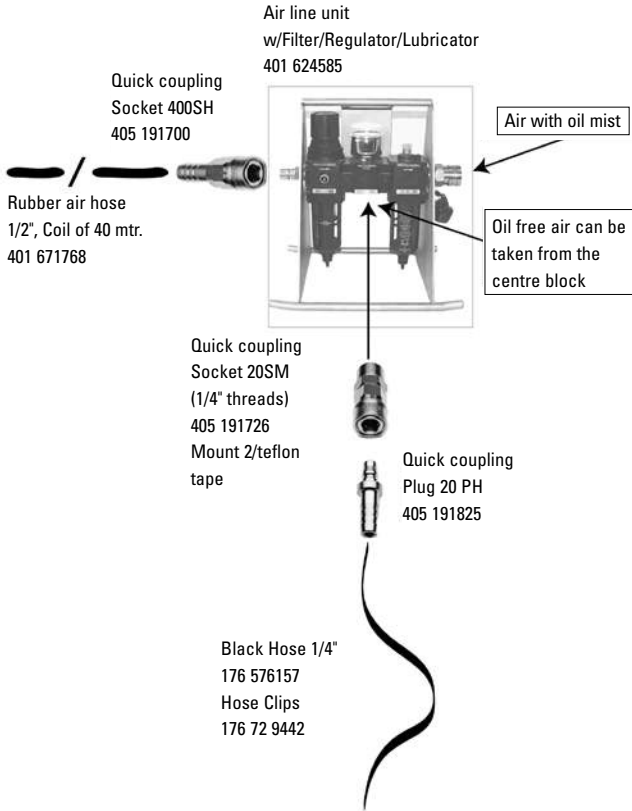

CURRENT DISTRIBUTION SYSTEM

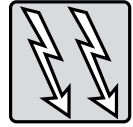

Arc Welding Current Distribution System 460

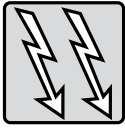

CURRENT DISTRIBUTION SYSTEM

Arc Welding Current Distribution System

Unitor welding current distribution system may be tailor made to suit the specific needs of ship or offshore installations. The basic rule in this system is that the main welding power source(s) are located permanently in the workshop. The welding machine will be connected to the inlet station in the distribution system by flying leads, when welding outside the workshop. Permanently installed welding and remote control cables lead to the welding outlets, which are mounted on strategic places for immediate use by the welders on board, providing the following advantages:

- Accidental falling/tripping due to loose cables along decks, in ladders etc. are avoided.
- Accidental short circuiting somewhere along the often excessive lengths of live welding cables lying about is prevented.
- The need for replacement of damaged lengths of welding cable is eliminated.
- Manhandling of long welding cables, often more time consuming and strenuous than the actual welding job, is avoided.
- Fire and gas proof doors can be kept shut.
- Outlets in possible gas danger areas may be disconnected when not in use.
- Permanently installed and correctly dimensioned cables ensure more efficient use of power from welding machine.
- Correct welding parameters are easily obtainable as all the remote control possibilities of the welding machine is available at the outlet.

The inlet/outlets are made in stainless steel quality. The hinged door is closed with a key. The remote control

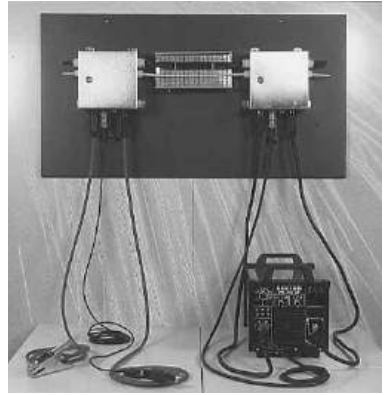

socket is a 10 pole amphenol type, female for both inlet and outlet stations. The socket is equipped with a screw cover. The remote control connection is done with a special connection cable and/or adaptor, see ordering information. A red diode 130 V AC is placed between the welding terminals to warn when outlet is live. The housing is mounted to the bulkhead by use of brackets that are included with the inlets / outlets.

Installation, with size and positions of cable glands will vary for different installations, therefore glands are not included, and holes for cable glands have not been drilled / locked out in the housing. This must be done by the installer. Connection of welding cables in the inlet/outlet is done with cable shoes. Cable size must be chosen according to welding machine. There is a 10 position connection rail for connection of remote control cable. Minimum 1,0 mm² cable for remote control is recommended.

The system comes in two sizes, for 400A and 800A. The 400A boxes uses standard Dix 70 contacts for welding

CURRENT DISTRIBUTION SYSTEM

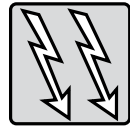

current, male on inlet station and female on the outlet, and standard Dix 70 cable connectors are used for connection.

The 800A boxes uses special heavy duty Dix 120 contacts for welding current, male on inlet station and female on the outlet. For these contacts the special Dix 120 cable connectors must be used. These connectors allows for up to 120mm2 welding cable.



Welding current inlet



Welding current outlet

Description	Unit	Product no.
Inlet station Stainless steel 400 A 240x240x150 mm with Dix 70 male	Pcs.	195-624320
Outlet station stainless steel 400 A 240x240x150 mm with Dix 70 female	Pcs.	195-624338
Inlet station Stainless steel 800 A 300x300x200 mm with Dix 120 male	Pcs.	195-736728
Outlet station stainless steel 800 A 300x300x200 mm with Dix 120 female	Pcs.	195-736736
Remote control connection cable for UWI-320/400/500/UWR-852	Pcs.	195-608760
Remote control connection cable for UWR-303	Pcs.	195-603993
Remote control adapter for UWI-320/400/500/UWR-852	Pcs.	195-604157
Remote control adapter for UWR-303	Pcs.	195-604306
Cable connector Dix 70 male/female	Pcs.	195-632893
Cable connector Dix 120 male/female	Pcs.	195-736744

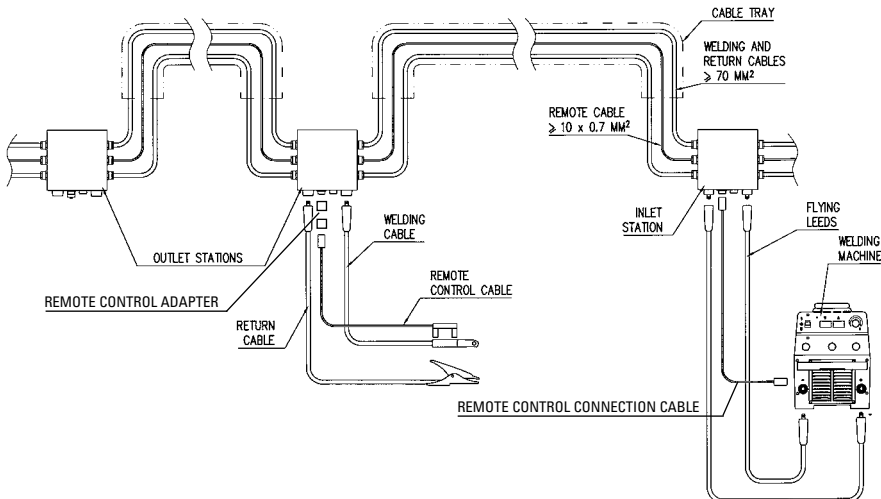

PROCESS & EQUIPMENT



Gas Welding Equipment	463
Ac/Ox cutting, welding, brazing.....	465
Gas supplies and gas distribution system.....	517





Introduction	466
The Combination Torch UCT-500	468
UCT-500 Components and spares	470
The Unitor Workshop Cabinet	472
Welding and grinding goggles	474
Accessories	475
Portable gas equipment.	476
Gas hoses.	479
Hose connectors.	482
Gas regulators for cylinders	485
Flashback	487
Flashback arrestors	488
The acetylene/oxygen flame.	489
Operating instructions for UCT-500 cutting torch	492
Cutting procedure.	494
Common cutting faults.	496
Operating instructions for UCT-500 brazing, welding & heating torch	498
Maintenance of blowpipes	500
Heating techniques	502
Flame straightening techniques.	503
Welding techniques	505
Butt joints for gas welding of steel	508
Consumables and parameters for gas welding	509
Soldering and brazing techniques.	510
Edge preparation	512
Consumables and parameters for brazing	514



AC/OX CUTTING/WELDING/BRAZING

Introduction

The Acetylene/Oxygen flame is an efficient heat source which has been used for welding and related thermal processes since the early 1900's. Acetylene is the fuel gas burning with the highest temperature, maximum approximately 3160 °C when mixed with oxygen (ratio 1 part acetylene to 1.5 parts oxygen).

Even the neutral flame used for welding (mix ratio 1:1.1) has a

temperature of 3100 °C, compared to e.g. propane 2800 °C.

This temperature difference, which in itself is not impressive, is one reason for the high efficiency of the acetylene flame. At temperatures around 3000 °C a relatively high degree of dissociation of hydrogen molecules takes place in the flame core. The molecules are split in free atoms, thereby storing energy. This stored energy is transferred through the flame and released immediately when the free atoms hit the workpiece and recombine to molecules. The total energy release from the acetylene/oxygen flame is therefore comparable to the energy from a theoretical flame with temperature 4500 °C.

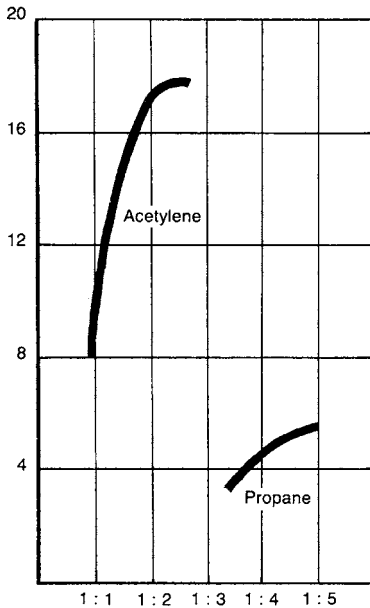

The energy (kJ/cm²·S) from the core flame of acetylene compared to propane at various mixing rates with oxygen.



Hydrogen molecules dissociate on the surface of the core flame and recombine on the surface of the workpiece.

AC/OX CUTTING/WELDING/BRAZING

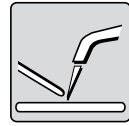

Another advantage of the acetylene/oxygen flame is the high combustion velocity of the mixture. This ensures a concentrated flame which quickly heats up a limited spot to high temperature. The concentrated heat reduces total heat input in a workpiece, and thereby the possibility for heat distortion.

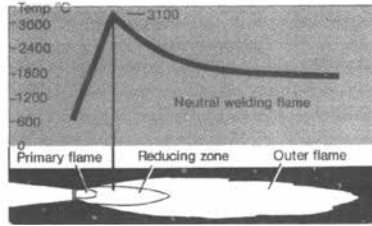

Temperature variation through a neutral acetylene/oxygen flame.

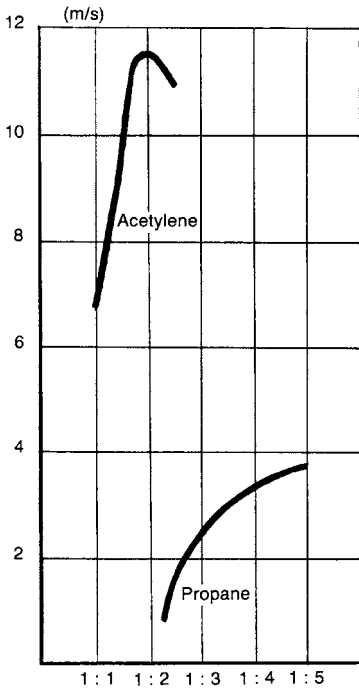

Combustion velocity of acetylene compared to propane.

Main application areas for the acetylene/oxygen flame in onboard repair and maintenance are cutting, brazing and heating. It is also used for sheet metal welding and welding of small diameter pipes.

In the following the equipment and techniques used for these applications will be described.

Safety:

Acetylene specific gravity is 0,9 so it is lighter than air.

Propane specific gravity is 1,5 so it is heavier than air.

This is an important safety factor to consider when working onboard a ship.



AC/OX CUTTING/WELDING/BRAZING

The Combination Torch UCT-500

The Union Combination Torch UCT-500 covers all normally occurring, heating, brazing, welding and cutting applications for which the acetylene/oxygen flame may be used on board. The torch is simple to use, light in weight compared to capacity, well balanced and easy to handle. It is a high-pressure torch of the equalized pressure type. One of the advantages of a high-pressure torch is an especially stable flame and high resistance to persistent flashback.

The connection between torch handle and heating/welding/cutting attachments is based on O-ring seals which ensures a gas-tight connection even if the connection nut should loosen. Attachments are easily changed without the use of tools, and may be turned in any desired angle to the handle/gas valves.

The gas valves are symmetrically placed at the back of the handle and suit both left- and right-handed persons.

Acetylene and Oxygen inlets are fitted with non-return valves as standard. The non-return valve is a spring-loaded valve which permits the gas to pass in one direction only; towards the blowpipe. It is fitted to the blowpipe handle to prevent any return flow which could allow gases to mix in the hoses, with the danger of hose explosions. Non-return valves, however, do not replace flashback arrestors in the gas supply system.

UCT-500 Master kit in heavy duty PVC case

The UCT-500 Master kit has been assembled to cover all ordinary welding, brazing and cutting work that may occur on board.

It includes a range of seven welding attachments, covering most brazing/welding applications. The larger attachments also function as monoflame heating attachments.

Cutting nozzles covering cutting of steel up to 100 mm are included, also a roller guide for cutting edges from 90° to 45° angle of plate surface.

The circular motion bar with centering pivot allows for cutting circular holes up to 960 mm diameter.

In addition to spanner, cleaning needles and a spare parts kit with all the most commonly needed spares, the UCT-500 case contains an instruction book giving complete information on the use and maintenance of the equipment.

UCT-500 compact kit in heavy duty PVC case

The compact kit contains the UCT-500 shank, the three most commonly used welding attachments (80 ltr, 230 ltr and 650 ltr) and the cutting attachment with nozzles for cutting up to 25 mm steel. Cleaning needles, spanner and full instructions for use and maintenance are also included.

Conform to: EN /ISO 5172



UCT-500 Master kit in heavy duty PVC case,
Product number: **170-500000**



UCT-500 Compact kit in heavy duty PVC case,
Product number: **170-500001**



AC/OX CUTTING/WELDING/BRAZING

UCT-500 components and spares

UCT-500 Master kit in heavy duty PVC case, containing complete instructions and one each of all items marked 1) below.

UCT-500 Compact kit in PVC case containing complete instructions and one each of all items marked 2) below.

Shank

	Product No.
1)2) Shank complete w/ sockets and non-return valves	170-174656

Welding attachments

Size*	Material thickness mm	Product No.
1) 0-A 40	<0,5	170-174565
1)2) 0-A 80	0,5-1,0	170-174573
1)2) 0-A 230	2-3	170-174581
1) 0-A 400	3-5	170-174599
1)2) 0-A 650	5-7	170-174607
1) 0-A 1000	7-10	170-174615
1) 0-A 1250	9-14	170-174623



Flexible welding attachment

The attachment can be bent to any desired shape.

Size*	Material thickness mm	Product No.
0-A160	1-2	170-183780



Singleflame heating attachments

Size*	Product No.
0-A 5000	170-183756



Multiflame heating attachments

Size*	Product No.
0-A5000	170-603399



* The size indicates consumption of oxygen in nl/ h. Acetylene consumption is approx. 10% lower. Material thickness refers to mild steel.

AC/OX CUTTING/WELDING/BRAZING



Cutting attachments

	Product no.:
1) 2) Cutting attachments 75° Head Angle	170-174664
1) 2) Cutting attachments 90° Head Angle	170-234807
1) 2) Cutting attachments 0° Head Angle	170-234815



Cutting nozzles- general use

	Nozzle type	Material thickness mm	Gas consumption		Product no.
			OX nl/h	Ac nl/h	
1) 2)	302 No. 2	3-10	1300	460	170-174698
1) 2)	302 No. 3	10-25	2150	520	170-174706
1)	302 No. 4	25-50	5650	690	170-174714
1)	302 No. 5	50-100	7800	810	170-174722



Cutting nozzles for difficult access, 165 mm length

Nozzle length mm	Material thickness mm	Gas consumption		Product no.
		OX nl/h	Ac nl/h	
140	40-75	7000	800	170-183855



Gouging nozzle with stellite tip

Furrow dimensions		Gas consumption		Product no.
Width mm	Depth mm	OX nl/h	Ac nl/h	
8-11	6-11	11500	1750	170-174730

Cutting guides

	Product no.
1) Roller guide 0°-45° nozzle angle	170-174672
1) Circular motion bar complete, 84-960 mm holde diam. for use with roller guide	170-174680



Tools

	Product no.
1) 2) Spanner for UCT-500	170-174649
1) 2) Cleaning needles for UCT-500 nozzles	176-175356

Spares for UCT-500

	Product no.
Socket/ Non-return valve for shank AC, 6 mm	170-597336
Socket/ Non-return valve for shank OX, 6 mm	170-597344
1) 2) Socket/ Non-return valve for shank AC, 9 mm	170-651265
1) 2) Socket/ Non-return valve for shank OX, 9 mm	170-651257
Flashback arrestor set FR-20AC+OX, for UCT-500 shank*	170-619270
Lubricant for O-rings	170-234997
1) SPARE PART KIT COMPLETE	170-500100
Containing 1 of each item below:	
Oxygen valve assembly (blue)	170-174789
Acetylene valve assembly (red)	170-613762
O-ring set for welding/cutting attachments	170-535005
Coupling nut welding/cutting attachments	170-174771
Coupling screw for cutting nozzles	170-174813
Clamp sleeve for roller guide	n.a
Sleeve for circular motion in roller guide	n.a



* Comply to EN 730-1



AC/OX CUTTING/WELDING/BRAZING

The Unitor workshop cabinet for Gas Cutting, Welding, Heating and Brazing.

	Product no.
Gas welding cabinet complete	094 589861
Gas welding cabinet empty	094 589846

A complete workshop for all the gas welding, brazing and cutting operations normally occurring onboard.

- New compact design with improved access to contents, and ample room for additional spares and accessories.
- Sturdy, corrosion resistant construction from electro-galvanized steel plates, with final coating by powder spraying and baking.
- Shelves are zinc/ yellow-chromate passivated for optimal corrosion and scratch resistance, with hardplast protection surface for nozzles and blowpipes.
- The door construction provides a stable work surface for torch assembly when open, and allows for mounting the cabinet in corners or narrow openings.

Contents:

Torch components:

UCT-500 shank with non-return valves, hose sockets and hose clamps.

Welding attachments: 40, 80, 230, 400, 650, 1000 and 1250 nl/h. Cutting attachments 900 with spare nozzle screw and nozzles for 3–10 mm, 10–25 mm, 25–50 mm and 50–100 mm steel thickness.

Roller guide for 0°-45° cutting angles, with spare clamp sleeve and circular motion bar compl. w. centre and sleeve for 84-960 mm Diameters.



*Dimensions: 600 x 600 x 300mm
Free distance above cabinet 310 mm.
Weight complete 56 kg.*

Torch maintenance equipment

Spanner 15-, 17-, 18-, 19-, 23-and 24 mm for UCT-500. Cleaning needle set for UCT-500 welding attachments cutting nozzles.

Spare valve and complete O-ring set for UCT-500. Spare coupling nut for welding attachments.

Welder's accessories:

Gas goggles with lift front.
Softskin welding gloves for gas and TIG welding.
Gas ignitor Triplex.
Double row steel wire brush.

AC/OX CUTTING/WELDING/BRAZING



Silver brazing:

AG-60 2.0mm 0.5 kg.

AG-45 2.0mm 0.4 kg.

One box each AG-60/45 flux for general use and Albroflux for use with AG-60 on Yorcalbro.

Bronze brazing:

FC Bronze 2.0mm 1.0 kg. 3.0mm 1.0 kg.

Bronze 3.0mm 1.7 kg.

FC-Wearbro 3.0mm 1.0 kg. 5.0mm 1.0 kg.

One box each of Bronzeflux and Wearbroflux.

Cast iron joining and rebuilding:

Cast Iron, rod for braze welding 5mm 1,1kg.

One box of Cast Iron flux.

Aluminium joining:

Alumag 3.0 mm 0.5 kg and one box Aluflux.

Tin soldering:

Tin-241 AG soft solder on spool. 1.6 mm/0.5 kg.

Mild steel/heat resistant steels:

MS 2.0 mm 3.5 kg, MS 3.0 mm 3.5 kg and Icromo 2.5 mm 2kg.

Instructions and information:

UNITOR Welding handbook, UCT-500 instruction manual.



AC/OX CUTTING/WELDING/BRAZING

Welding and Grinding Goggles

Lightweight goggles with soft and comfortable surfaces against the face. The ventilation slots are designed to prevent entry of sparks and spatter, at the same time ensuring sufficient air circulation to prevent dampness and fogging of the glasses.

The filter shade glass are mounted in a flip-up front frame. A protection glass must be placed in front of the filter shade glass in order to protect against spatter. One more protection glass must be placed in the fixed frame.



	Product no.
Welding and grinding goggles w/flip-up front frame	176-175273
Comply to:	DIN EN 1598:2002-04



Glasses for Gas Welding and Cutting

The Unitor gas welding glasses have a diameter of 50mm and fit the goggles. They are available in different grades of shade for various types of work. All glasses comes in sets of 10 pcs.

Filter Shade Glass

Application	Filter Shade	Pcs/set	Product no.
Silver brazing	4	10	176-633305
General gas welding and cutting	5	10	176-633313
	6	10	176-633321
Gas welding and cutting thick material	7	10	176-633354
Protection glass		10	176-633297

Safety Spectacles

Safety spectacles clear	pcs	176-632943
Safety spectacles shade 5	pcs	176-632950
Safety grinding goggles non mist	pcs	176-653410

Safety spectacles and grinding goggles comply to:
EN 166:2001



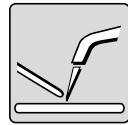

Accessories

Heat Resistant Mitten

Special mitten with woven kevlar outer layer and ample insulation against heat in the inner layers. It should always be kept by acetylene cylinders and outlets to make it possible to close the valve in case of fire. Also suitable for handling hot workpieces. May be used on either right or left hand.

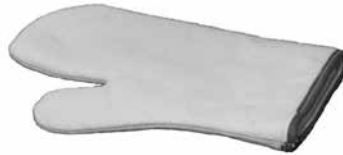

	Product no.
--	-------------

Heat resistant mitten	176-233148
-----------------------	-------------------

Comply to:

EN 388:2003

EN 407:2004

Gas Welding Gloves

Special soft-skin gloves which protect without hindering feeling or move ability for handling torch valves or rod while welding. Used for Gas and TIG welding.



	Product no.
--	-------------

Gas welding gloves 6 pairs/pack	176-632794
---------------------------------	-------------------

Comply to:

NEN-EN 12477 type A/B

Protection:

EN 388 3232

EN 407 332222

Triplex Gas Igniter

Easy to use, with large sparks. Three flints mounted on head.



	Product no.
--	-------------

Triplex gas ignitor 2 pcs/pack	176-633198
--------------------------------	-------------------

Spare flint set 10 pcs/pack	176-633206
-----------------------------	-------------------



Miscellaneous

Welders chalk is used to mark out positions when gas and plasma cutting on metals. The chalk is flat and can easily be kept in pockets and tool boxes.

Temperature sticks are a wax that melts at a preset temperature. Simply select a stick with the desired temperature and make a

mark on the surface to be heated. When the stick mark goes from solid to liquid the temperature have been reached

	Product no.
--	-------------

Welders chalk, flat	196-632968
---------------------	-------------------

5x13x127 144 pcs/pack	
-----------------------	--

Galvanizing spray	196-633156
-------------------	-------------------



AC/OX CUTTING/WELDING/BRAZING

Portable Gas Equipment

On board large ships, or where mobility is necessary for other reasons, the gas cabinet and gas supply from the gas central can be supplemented by mobile welding and cutting equipment.

Mobile equipment considerably simplifies repair- and maintenance jobs by allowing cylinders and welding equipment to be brought to the worksite as a unit. The necessary equipment required for a complete mobile workshop is built up from Unitor standard gas accessories, one of the two UCT-500 kits available, and a suitable transport device for cylinders.

Standard Accessories Kit for Acetylene and Oxygen Cylinders

The Unitor range offers a complete accessories kit comprising all necessary equipment for use with Acetylene and Oxygen cylinders.

The kit includes:

- Acetylene and Oxygen cylinder regulators.
- Flashback arrestors.
- 10 m twin hose 1/4" with clips.
- Gas ignitor
- Welding goggles.
- Gas welding gloves.



- Heat resistant mitten.
- Unitor Welding handbook.

	Product no.
Gas accessories kit	176-526509

Portable Welding Table

This sturdy work table is made of steel and fully galvanized for corrosion protection. It includes a holding clamp for small workpieces. To ensure a stable work surface all four legs are adjustable in length. The legs have pointed ends to ensure high friction and a good hull contact when used for arc welding.

The table is excellent for use as a welding table in workshops on board, and in cases when it is needed outside the workshop it is easily transported as the legs may be detached and fastened under the table surface.

Dims. (WxDxH)	600 x 400 x 630mm
Dims.folded	600 x 400 x 80mm
Weight	14 kg

	Product no.
Welding table	176-176024

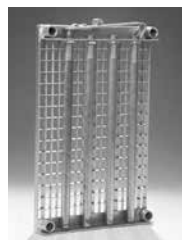



Gas Welding Transportable Equipment

A-40/0-40 Cylinder Trolleys

Trolley for Two 40 L or 50 L Cylinders for Mobile Gas Welding.

This trolley is specially designed for on board use. The sturdy but lightweight construction of steel pipes is fully galvanized for corrosion protection. The trolley takes both 40 L and 50 L size cylinders, which are firmly secured in the trolley by means of two clamps with wing screws. As the weight of two full gas cylinders is approximately 150 kilos, the trolley has been fitted with extra large rubber wheels for easy mobility. For transport by crane the trolley is fitted with a lifting bow. As safety in transportation and lifting of gas cylinders is a paramount demand, the trolleys are tested and certified according to the International Labour Office for the test and examination of lifting gear used in the loading and unloading of ships. The trolleys are test loaded to 400 kg, and certified for Safe Working Load (S.W.L.) 200 kg.

Being intended to function as a complete mobile gas welding workshop, the trolley is fitted with a large, lockable accessories box. This box is dimensioned to take the complete UCT-500 welding and cutting set in steel case, plus a standard accessories kit for gas welding.

Weight of the trolley itself is 28 kg. For a complete mobile gas welding workshop the following items should be ordered (in addition to gas cylinders and consumables):



Description	Product no.
Trolley for A-40/0-40 cylinders	176-778145
Standard gas welding accessories	176-526509
UCT-500 Master kit in PVC case	170-500000

For One Cylinder

Unitor has also developed a trolley for transport of a single 40 l or 50 l cylinder.

The cylinder is firmly locked in place on the trolley, which is also certified for lifting by crane.

For full information on trolley, see under "Gas distribution".

Test load:	200 kg
Safe working load:	10 kg

Description	Product no.
Trolley for one cylinder	176-778147





AC/OX CUTTING/WELDING/BRAZING

Gas Welding Transportable Equipment

A-5/0-5 Cylinder - Trolley and Back-Frame

The Unitor A-5/0-5 trolley is the basis for a small but efficient portable welding and cutting workshop. It is specially designed by Unitor for on board use, and has a low center of gravity which will keep it standing upright even at 30° out of vertical with all equipment mounted.

The strong lightweight steel construction is hot zinc coated for high corrosion resistance. It is fitted with solid rubber wheels for easy transport. Handles at top and bottom ensure easy carrying and lifting. Two double brackets for Unitor rod containers give the possibility to include a selection of four different rod types when transporting.

The UCT-500 compact kit may be placed in a holder on top of the trolley and the accessories box at the back will take all other necessary equipment for work.

A double bracket with wing nut ensures safe and vibration-free fastening of 5 litre Acetylene and Oxygen cylinders.

For a complete, portable welding workshop the following items should be ordered (in addition to 5 litre gas cylinders and the consumables required):

Description	Product no.
Unitor A-5/0-5 trolley	176-778143
Standard gas welding accessories	176-526509
UCT-500 compact kit in PVC case	170-500001

Also available for transport of 5 litre cylinders are the back-frame and the portable rack.

Description	Product no.
Portable Cutting Set	393-184408
Back-frame for 5 litre cylinders	176-176040
Portable rack for 5 litre cylinders	176-176032

The trolley is tested and certified according to the international labour office for testing and examination of lifting gear used in loading and unloading of ships.

Test load: 100 kg
Safe working load: 50 kg



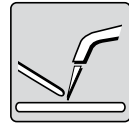

Gas Hoses

UNITOR's hoses for Acetylene and Oxygen are specially made for use with welding and cutting equipment. The hoses comply with the International norm ISO 3821 specifications for welding hose:

Requirements:

Maximum working pressure	20 bar
Test pressure	40 bar
Minimum bursting pressure	60 bar

Oxygen hoses are colour-coded blue. Acetylene hoses are colour-coded red. Unitor's product range comprises the following hose dimensions:

NB: Gas hoses are measured on their internal diameter.

Description	Product no.
Twin gas hoses, 6mm (1/4") blue/red AC + OX/m	176-526434
Twin gas hoses, 9,0 mm (3/8") blue/red AC + OX/m	176-624312
Gas hose, red 6,3 mm (1/4") Acetylene/m	176-175554
Gas hose, blue 6,3 mm (1/4") Oxygen/m	176-175562
Gas hose, red 9,0 mm (3/8") Acetylene/m	176-175539
Gas hose, blue 9,0 mm (3/8") Oxygen/m	176-175547
Gas hose, black 6,3 mm (1/4") Argon/m	176-576157

6 mm (1/4"), hose is adequate for the gas consumption for all blowpipes and cutting nozzles in the welding and cutting set UCT-500.

Normal hose lengths are 5 or 10 meters. If long hoses or equipment requiring greater gas flows than 8.000 nl/h (normal liters per hour) are used, 9 mm (3/8") hoses are recommended. For medium and large gas consumption the supply pressure must be increased when longer hoses and/or smaller hose diameters are used.

Do not use gas hoses for other purposes, e.g. for compressed air or propane, and do not use air hoses

for welding gases. Blow new hoses clean internally before connecting to blowpipes. Nitrogen or another inert gas should be preferred to blow through Acetylene and Oxygen hoses. Never use compressed air, which may contain oil.

Keep hoses away from strong heat and extreme cold, oil and grease, chemicals, and from slag and sparks from electric welding, gas welding or Oxygen cutting. Avoid undue stretching and kinking of hoses. Hanging hoses must be supported at suitable intervals.

When gas hoses are not in use they must be coiled and hung up so as to avoid, as far as possible, the entry of damp or dirt.

Faulty hoses

Inspect hoses at regular intervals. Hoses of doubtful quality or condition should be scrapped.

Do not use hoses that have been damaged by flashback or hose fires. Check that the rubber is supple and without cracks (do this by bending the hose).

Check the hoses for leakage by dipping them in water while they are under normal pressure. Hoses must never be repaired by patching. Repair a leak immediately by cutting off the damaged part.

The drum for gas hoses takes up to approximately 100 m. of twin hose and is fitted with brackets for bulkhead mounting.

Description	Product no.
Drum for gas hose	195-175729





AC/OX CUTTING/WELDING/BRAZING

Self-retracting Hose Reel for Acetylene and Oxygen

For safety, tidiness and reduced wear and tear

The handling of hoses cluttering the workshop floor is awkward and a waste of time. Self-Retracting hose reels let you pull out the required length of hose and store the rest out of harms way. This saves time, makes the job easier and contributes to increased efficiency.

A workshop floor free from hoses reduces tripping accidents, improves access for carts and trolleys and allows for easier cleaning.

The Unitor Self-Retaining hose reel are of robust construction, it is easy to installed, and have a well proven design that vouches for safe and maintenance free usage.

Single-layer retraction of the hose.

Open design for safety and easy service.

All steel construction.

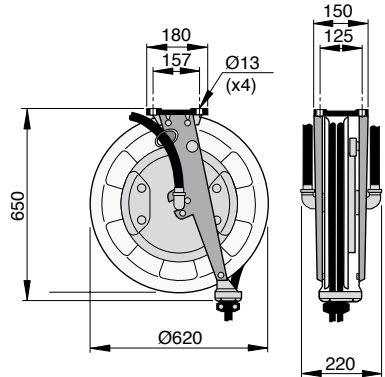

Technical data

Medium	Max working pressure Mpa (psi)	Hose dimensions		Net weight Including hose Kg	Product no.
		Hose size mm	Length m		
Oxygen/ Acetylene	2.0 (290)	2X6,3	20	30	176-725260



AC/OX CUTTING/WELDING/BRAZING

Hose connectors

Hose connectors have loose hose nipples for 9 mm (3/8") and 6 mm (1/4") welding hose. The connecting nuts on the Oxygen couplings are right-hand threaded. The Acetylene couplings are left-hand threaded and the connecting nut has an indentation in the corners of the hexagon for easy identification. This is international practice, and gives the operator extra protection by reducing the possibility of interchanging hoses.

Hose connectors are used where long lengths of hose are needed. Screw the couplings together into a gastight joint (check with soapy water). It is not necessary to use force. Gentle tightening spares the sealing surfaces and should give a perfectly gastight connection.

Always use the correct hose couplings to connect the welding

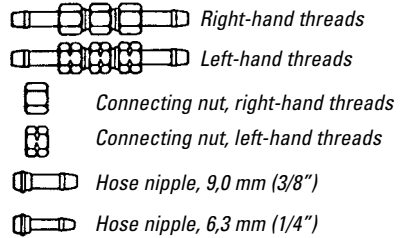

hoses – never use metal tubing.

There are also snap-couplings for quick connection of hoses and regulators, or outlet stations, or to join lengths of hose. Such snap-couplings must be specially made for use with Oxygen and Acetylene, and so designed that the interchange of Acetylene and Oxygen hose is impossible.

Ear clamps offer a better and safer solution compared to screw type mounting hoses. In some countries the use of screw type (worm type/jubilee clips) is not allowed. Ear clamps are than the alternative product.

Screw-couplings for Gas Hoses

The screw-couplings are supplied in sets. Each set consists of two hose sockets with nuts for connection to gas regulator and torch. Included is also a connection stub for using the set as a hose joint. Nuts and connection stub for Acetylene are lefthand threaded and marked with a groove.

Material is high-grade brass.

Description	Product no.
Hose joint for 6,3 mm (1/4") Acetylene hose	176-175588
Hose joint for 6,3 mm (1/4") Oxygen hose	176-175596
Hose joint for 9,0 mm (3/8") Acetylene hose	176-175604
Hose joint for 9,0 mm (3/8") Oxygen hose	176-175612
Ear clamp for 6,3 mm (1/4") hose, set of 20 pcs	401-768416
Ear clamp for 9 mm (3/8") hose, set of 20 pcs	401-768432
Pincher tool for ear clamps	401-768507
Hose clamp for 1/4" hose, set of 10 pcs	401-729442
Hose clamp for 3/8" hose, set of 10 pcs	401-729443

Use good hose clips, not metal wire, to fix hose to nipples.



Twist-Lock Quick Couplings for Oxygen, Acetylene and Shielding gases

- No uncontrolled escape of gas when disconnected. This is prevented by automatic cut off valve in the female part.
- Gases cannot be mixed, the probes for Oxygen, Acetylene and Shielding gas are different and not interchangeable.
- All brass design, and female parts are colour coded RED for Acetylene, BLUE for Oxygen and BLACK for Shielding gas.
- Kink free hoses; the male plug and the female socket will swivel relative to each other if the hose is twisted.
- Quick and flexible extensions of hoses without tools make it easy to use short extensions, excessive hose lengths are avoided and risk of damage to the hose reduced.
- The unique twist-lock function prevents accidental opening of the connector when the hose is pulled over edges or other obstacles.



Conform to: ISO 7289, EN 561*

* Special brand deviation from EN 561, 6.1 on socket/plug geometries.

TWIST-LOCK safety function:

Twist sleeve this way to lock male and female part together

Twist sleeve this way to open the lock

The sleeve may now be pulled back to remove / insert the probe

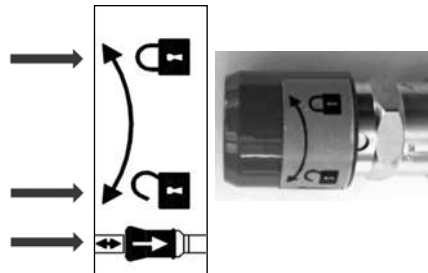



AC/OX CUTTING/WELDING/BRAZING

Twist-Lock Quick Couplings for Oxygen, Acetylene and Shielding gases



Hose size	Gas	Colour marking	Letter marking	Nut marking	Threads	Application	Part Number
1/4" 6.3mm ID	Ac	Red	A	Groove	G3/8"LH	Regulator to Hose	176 320206
					n.a.	Hose to Hose	176 320205
	Ox	Blue	O	Plain	G3/8"RH	Regulator to Hose	176 320204
					n.a.	Hose to Hose	176 320203
	Shielding	Black	N	Plain	G3/8"RH	Regulator To Hose	197 320202
					n.a.	Hose to Hose	197 320201
3/8" 9.0mm ID	Ac	Red	A	Groove	G3/8"LH	Regulator to Hose	176 320208
					n.a.	Hose to Hose	176 320207
	Ox	Blue	O	Plain	G3/8"RH	Regulator to Hose	176 320210
					n.a.	Hose To Hose	176 320209

Lubricants for gas fittings

IMPORTANT:

Oil, grease or other organic lubricants must NEVER be used for the lubrication of fittings that come into contact with oxygen. Explosion hazard!

If needed, use only special lubricants for use in pure Oxygen.

If these lubricants thicken after long storage they must be thinned only with the thinners specified on the label. Never use White Spirit, oil or the like to thin lubricating paste.

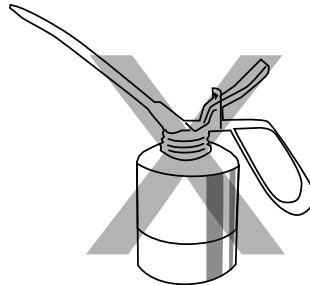



Gas Regulators for Cylinders

The purpose of a pressure regulator is to reduce gas pressure, e.g. the pressure in a gas cylinder, to a suitable working pressure and to keep this as constant as possible.

Unitor gas regulators are designed for reliability and safety of use, and for sufficient capacity for all normally occurring purposes, providing a constant flow of gas.

The large adjustment knobs are colour coded red for Acetylene, blue for Oxygen and black for Argon, for easy identification of gas type.

All regulators are delivered with spare washers, hose connection for 6 mm (1/4") and 9 mm (3/8") gas hoses and full instructions for use.

The connection to cylinder valves fit standard Unitor gas cylinder valves. A sturdy one-piece manometer guard is available, and fits all the regulators. All the cylinder regulators have safety valves that protect the gas hoses from excessive pressure.

Conform to: EN/ISO 2503

As a general rule: Regulators should be replaced with 5 years intervals.



Cylinder Regulator for	Acetylene	Oxygen	Argon/CO ₂ w/flow meter
Max. inlet pressure bar	15	200	200
Outlet pressure bar	0-2,5	0-16	0-35l/min.
Safety valve opens at bar	3-4	12-14	6,0-7,8
Max. capacity m ³ /h	5	40	2
Max. capacity l/h	5000	40 000	2000
Cylinder connection	3/4" BSP	W21.8x1/14"	24.32x 1/14"
Colour coding	Red	Blue	Black
Product number, regulator R-510	171-510001	171-510000	197-510010
Gauge guard for cylinder regulators	171-619379		
Spare contents gauge w. gasket	171-550186	171-550178	171-550178
Spare working gauge w. gasket	171-550202	171-550194	171-550210
Cylinder connection washer (10pcs)	171-550152	171-550160	171-550160



AC/OX CUTTING/WELDING/BRAZING

Connection

1. Never use a regulator for gases or pressures for which it was not designed. Before connecting up, make sure that the outlet union on the cylinder valve and the connector of the regulator fit each other. Never force a connection that does not fit.
2. Before connecting the regulator to the gas cylinder, blow the cylinder valve clean by opening it for a moment. Do not stand in front of the outlet or hold your hand in front of it whilst blowing it clean. Valves of cylinders containing flammable gases must never be blown clean if there is any risk of ignition of the gas.
3. Check the inlet union gasket and replace it if it is damaged. Make sure to use original gaskets and not home made ones, which may be a source of danger.
4. Screw the regulator to the cylinder valve. Use a thick spanner to avoid damaging the connection nut.
5. Between an Acetylene or Oxygen regulator and the hoses in use a flashback arrestor should always be installed.

NOTE:

Regulators and other equipment for Oxygen must never be lubricated with ordinary oil or grease, as this brings the risk of explosion. Use only the lubricants prescribed by the manufacturer. If a pressure gauge does not register zero when the pressure is released, or it has other defects, it must be replaced.

Check all connections for leakage by covering with soapy water or the like. As a rule, such leaks can be stopped by carefully tightening the screwed connection at the point in question. If not, the seal or the complete part must be replaced.

Apart from replacing damaged or faulty gauges, repairs should never be attempted on gas regulators. Faulty, old or corroded regulators should be replaced. Internal seals and membranes will deteriorate with time, and as a rule gas regulators should be replaced with maximum 5 years intervals. This also applies to flashback arrestors.

Operation

1. Make sure that the regulator is closed by turning the regulating screw so far out that it runs freely on its threads.
2. Open the cylinder valve slowly until the contents pressure gauge shows the cylinder pressure (the working pressure gauge should not move). Then open the cylinder valve fully.
3. Set the desired working pressure by turning the regulating screw inwards until the correct working pressure can be read on the working pressure gauge. For correct pressure see the operating instructions for the torch you are using.
4. During interruptions, or when finishing work, close the cylinder valve. Relieve the pressures on the regulator until both gauges show zero.
5. Shut the regulator by turning the regulating screw outwards until it runs freely on its threads.



Flashback

Flashback is a phenomenon that may occur when, for some reason or other, the speed of combustion at one or more places in the flame hole becomes greater than the speed of gas flow, allowing the flame to burn back into the blowpipe. The degree of safety against flashback in a blowpipe depends on its design.

Various types of flashback:

- 1) A Backfire implies that the flame burns back into the torch with a sharp bang. Either the flame is extinguished, or it is reignited at the nozzle opening. A backfire is fairly harmless in itself, but it can be a sign of some fault in the equipment or gas supply.
- 2) In a Sustained Backfire the flame bums back into the torch with continued burning in the mixer, often at the mixing point itself. A sustained backfire is characterised by an initial bang (backfire) followed by a whistling or screeching sound from the continued combustion. If the sustained backfire is not quickly interrupted, melting will occur in the torch, and escaping combustion products can cause injuries.

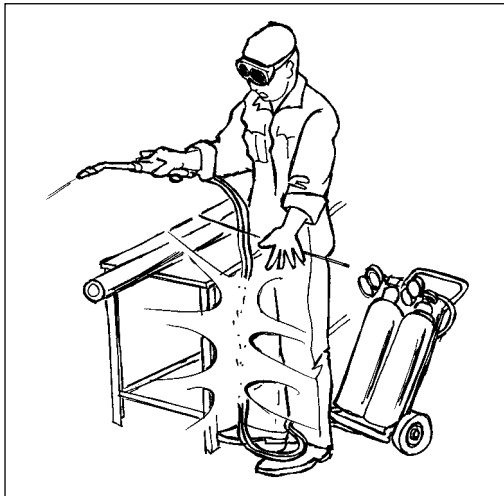

Flashback can result in the hose exploding, and/or catching fire. In extreme cases, the regulator may catch fire.

3) Flashback implies that the flame burns back through the torch and into the gas supply system, i.e. the hoses and in the worst cases even the regulators. If a flashback reaches an Acetylene cylinder, which lacks the necessary safety equipment a serious accident can occur. Flashback is mostly caused by reverse flow, e.g. flow of oxygen into the Acetylene hose, so that an explosive mixture is present in the hose. This mixture can then be ignited by a backfire, which occurs when the torch is lit. The hose will then explode.

Handling of blowpipes in the event of flashback:

In the event of sustained backfire the oxygen valve of the blowpipe must be shut first, then the Acetylene valve. Shut them as quickly as possible.

Sustained backfire is the result of incorrect handling and/or poor maintenance of the blow pipe. Before re-lighting after a sustained backfire the blowpipe must be cooled. Under no circumstances should welding or cutting be continued before both the equipment and the handling routines have been checked thoroughly.

A full flashback occurs only from very faulty handling, bad maintenance of the blowpipe or by wrongly set working pressure.

A backfire (popping) can easily occur if the flamehole is dirty or damaged

– see separate chapter on maintenance of blowpipes.

To protect against a full flashback and the dangers this entails, the welding equipment should be fitted with flashback arrestors and non-return valves.



AC/OX CUTTING/WELDING/BRAZING

Flashback Arrestors

Flashback Arrestors Type W-66S and S-55

Maritime authorities, such as the Norwegian Maritime Directorate, require the installation of flashback arrestors for acetylene and oxygen, as incorrect maintenance or use of gas welding equipment may cause flashbacks of various types. Normally these will stop in a well designed torch, and are only noticed as a popping sound in the torch. However, faulty handling, maintenance or gas pressure setting may lead to a penetrating flashback. This means that the gas flame passes back through the hose(s). In some cases it may also pass the regulator and ultimately reach the cylinder. The flashback arrestors supplied by Unitor are designed for use both with gas cylinders and gas outlet stations and incorporate several safety functions:

- Non-return valve preventing reverse flow of gases, thereby preventing a gas mixture from reaching pipelines or cylinders.
- Flame filter to quench the flame front of a flashback or a burnback.
- Temperature activated cut-off to prevent further gas supply in case of fire (activated if the temperature rises to approx. 100°C).
- Pressure activated cut-off to prevent further gas supply after a flashback (activated by the pressure shock in front of the flashback).
- Pressure relief valve to vent off excessive pressure in case of flashback or wrongly set working pressure (on W-66S only).

- Indicator lever showing that the pressure activated cut-off has been activated. The lever is also used for resetting the flashback arrestor. (W-66 only)
- Indicator ring showing that the pressure activated cut-off has been activated. The ring is also used for resetting the flashback arrestor (S55 only)

As a general rule: Flashback arrestors should be replaced with 5 years intervals.

Conform to: EN 730/ISO 5175
BAM Certification No: ZBF/009/12

Full instructions for use are supplied with the units.

Description	Capacity (m ³ /hour)	Capacity (l/hour)	At inlet pressure (bar)	Product no.
W-66S f/Acetylene	19	19 000	1,5	171 183970
W-66S f/Oxygen	110	110 000	10	171 302976
S55 f/Acetylene	8,5	8 500	1,5	171 708537
S55 f/Oxygen	50	50 000	10	171 708545



Type W-66S



Type S55



The Acetylene/Oxygen Flame

A correct Acetylene/Oxygen flame from a cutting nozzle or blowpipe is dependent on correct gas pressure being supplied to the torch. Inaccurate regulators or long gas hoses may result in pressure deviations that gives wrong pressure to the torch. In such cases the actual pressure at the torch connection should be checked. Too low gas pressures may give a gas flow which is slower than the flame velocity of the gas mixture. This can cause the flame to burn backwards into the nozzle opening and accelerate through the gas channels, resulting in flashback.

Too high gas pressures may cause the flame to leave the nozzle tip, starting at the distance from the tip where the gas flow has slowed down to match the flame velocity.

If the gas pressure is too high it may be difficult or impossible to ignite a flame.

The correct Acetylene/Oxygen flame shall be a quiet stable flame, burning close to the nozzle tip, but well away from the point where flashbacks may occur.

NOTE!

The Acetylene/Oxygen flame uses the oxygen supplied from the nozzle for the primary reaction taking place in the inner cone.

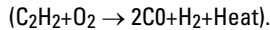

In the flame envelope a secondary reaction takes place.

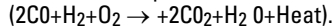

This reaction needs as much Oxygen as the primary reaction, but the required Oxygen is taken from the surrounding air. Therefore always ensure proper ventilation when working with the Acetylene/Oxygen flame.

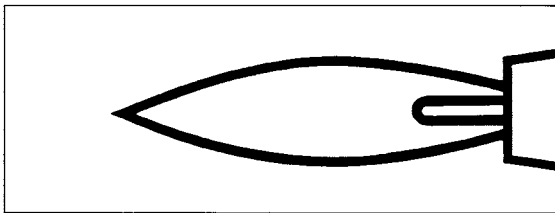

The neutral flame

Two distinct zones may be seen in the neutral flame. The inner cone of the flame has a bright blue light and extends only a short distance from the tip. Around this inner cone is the flame envelope which is darker and less intensely blue. This flame is metallurgically neutral, and is used for heating, cutting and for most steel welding work.



AC/OX CUTTING/WELDING/BRAZING

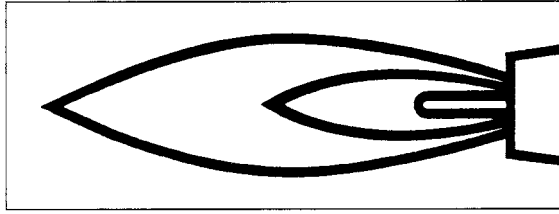

The carburizing flame

The carburizing flame has an excess of Acetylene, and is recognized by a secondary flame zone between the inner cone and the flame envelope. This zone is less bright and more white in colour than the inner cone, but is considerably brighter than the flame envelope.

When igniting an Ac/Ox torch one normally opens fully for Acetylene and only slightly for Oxygen, obtaining a strongly carburizing flame. By adding Oxygen (and if necessary

reducing the Acetylene flow) the secondary zone will be reduced, and a neutral flame is obtained just as the secondary zone disappears.

Reducing the Oxygen flow slightly again will give a carburizing flame with a small secondary flame zone, approximately twice as long as the inner cone. This soft flame (also called a reducing flame) is used for welding of Aluminium and Aluminium alloys, and for soft soldering.

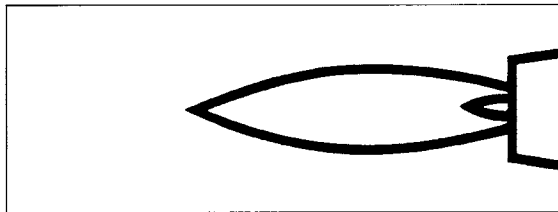

The oxidizing flame

By increasing the Oxygen flow slightly beyond the point where the secondary zone disappears one will obtain an oxidizing flame (with excess Oxygen). The flame will be shorter and sharper than the

neutral flame, with a shorter, more pointed inner cone. This flame is slightly hotter than the neutral flame, and is used for welding cast iron, brass, bronze and zinc alloys, and for brazing.



AC/OX CUTTING/WELDING/BRAZING

Operating instructions for Cutting Torch

- a. All valves are shut at the commencement of work: Cylinder valves (1 and 2) are shut, the regulator adjusting screws (3 and 4) are screwed so far out that they run freely on their threads, and all torch valves (5, 6, 7 and 8) are closed.
- b. Select the cutting nozzle (9) to suit the type and thickness of the workpiece. The required nozzle and working pressure for mild steel when using 6 mm (1/4") hoses 10 m long are given in the cutting table. Other materials and hoses may require other nozzles and working pressures than those given in the table.
- c. Slowly open the cylinder valves for Oxygen (1) and Acetylene (2).
- d. Fully open the torch Oxygen needle valve (5) and the valve for preheating Oxygen (7). Then press the cutting Oxygen valve lever (8), and adjust the working pressure by means of the Oxygen regulator adjusting screw (3).
- e. Release the cutting Oxygen valve lever (8) and shut the valve for preheating Oxygen (7).
- f. Fully open the torch Acetylene needle valve (6), and adjust the working pressure by means of the Acetylene regulator setting screw (4).
- g. Slightly open the preheating Oxygen valve (7) to provide a little extra Oxygen to prevent troublesome sooting when the torch is lit.
- h. Light the torch and adjust to neutral flame, using the valve for preheating Oxygen (7).
- i. Press down the cutting Oxygen lever (8) and readjust to normal flame by means of the valve for preheating Oxygen (7). The torch is now ready for cutting. NB. When cutting, the torch Oxygen needle valve must be kept fully open.
- j. In the event of sustained backfire, which is recognized by a whistling or hissing sound, first close the valve for preheating Oxygen (7) as quickly as possible, releasing the cutting Oxygen valve lever (8) at the same time. Then shut the torch Acetylene needle valve (6).
- k. The torch is normally extinguished by first closing the torch Acetylene needle valve (6) and then the valve for preheating Oxygen (7). Finally, relieve the pressure in the hoses and close all valves.

Important

1. After finishing work, release the pressure in the hoses by closing the cylinder valves (1 and 2) and empty one hose at a time, keeping the torch needle valve for the other gas shut. Finally, make sure that all torch valves are shut, and unscrew the regulator adjusting screws (3 and 4) so far that they run freely on their threads.
2. Check the sealing rings at regular intervals for damage, deformation or wear. Replace them if they are defective. To facilitate changes of torch or cutter tips, the sealing rings and sealing surfaces in the torch connection head should be lightly smeared with a special lubricant.

Oil or grease must **never** be used.

AC/OX CUTTING/WELDING/BRAZING

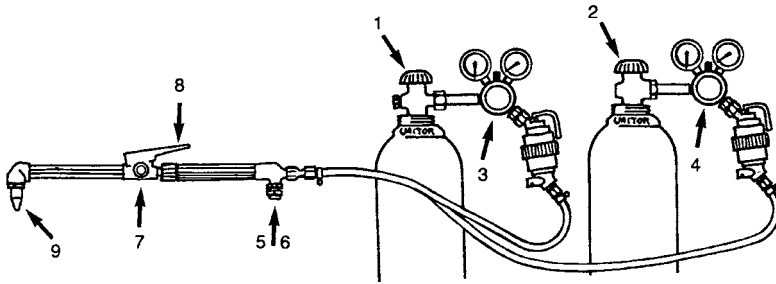
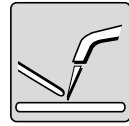

Cutting table – UCT-500

Material thickness, mm	3-10	10-25	25-50	50-100
Distance to core tip	2	3	5	5
Acetylene pressure bar	0.2	0.2	0.2	0.3-0.8
Oxygen pressure bar	1.0-2.5	1.5-4.0	1.5-4.0	3.0-6.0
Product No.	170-174698	170-174706	170-174714	170-174722
Cutting nozzle, type no.	A 311-2	A 311-3	A 311-4	A 311-5
Gas consumption l/h Ox	1600	3600	6800	7800-14100
Gas consumption l/h Ac	300	400	500	700
Cutting speed mm/min	950-430	580-350	500-300	380-180

Table for groove-cutter (Unitor Product No. 174730)

Dimensions of groove in mm		Working pressure		Gas consumption ltr./hr.	
Width	Depth	Oxygen	Acetylene	Oxygen	Acetylene
8-11	6-11	5.7	0.5	11500	1750



AC/OX CUTTING/WELDING/BRAZING

Cutting Procedure

Oxygen cutting is a process in which mild steel burns (oxidizes) in oxygen. It is not a melting process. The work-piece is heated up to approximately 900 °C, – after which oxygen is applied, which burns (cuts) mild steel.

When cutting, it is important to move the cutting torch nozzle evenly. This is most easily done, by starting the cut as far away from you as practicable. Then bring the cutting torch towards you.

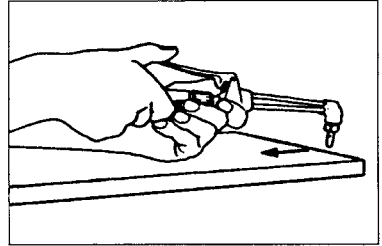

Starting the cut from an edge

1. Direct the preheating flame against the starting point at the edge of the plate. Keep the flame cores 2–3 mm above the steel plate and preheat until the steel is brightly red hot.
2. Move the torch tip slightly off the edge of the plate to ensure that the cutting Oxygen jet passes the edge of the plate.

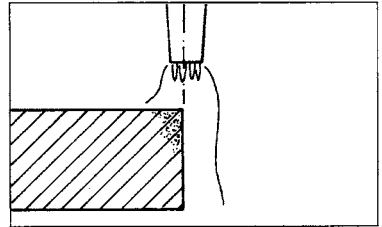

Open slowly but fully for the cutting Oxygen by depressing the cutting Oxygen lever. Keep the nozzle at the distance from the plate indicated in the cutting table (2–5 mm) and move the nozzle onto the plate.

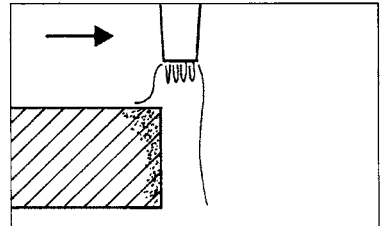

3. Guide the torch steadily along the line to be cut. Use a cutting speed within the limits given in the cutting table and ensure that the slag blows through completely resulting in a steady stream of sparks downwards from the bottom of the cut.

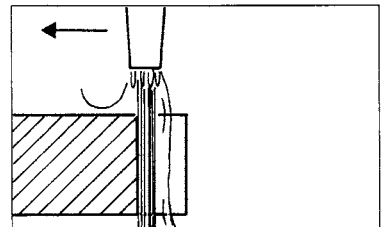

Methods for improving cuts

A piece of angle iron can be clamped to the plate being cut. The angle iron can be used to guide the torch for both square and bevel cuts.

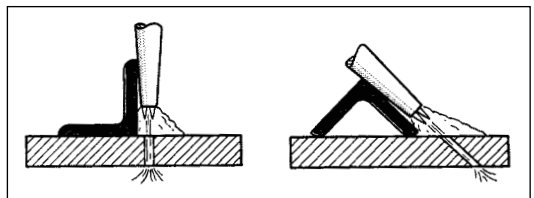



Starting a cut by piercing

1. Direct the preheating flame against the starting point. Keep the flame cores 4 - 5 mm above the steel plate and preheat until the steel is red to white hot.
2. Lift the nozzle to approximately 12–20 mm above the surface. Open slowly for the cutting oxygen. Make sure that spatter of molten metal does not reach the nozzle tip, if necessary by inclining the torch slightly so that the sparks fly sideways.
3. With the cutting oxygen lever fully depressed lower the nozzle as the cutting jet pierces the plate. Keep the nozzle at correct distance from the plate (see cutting table) and proceed in the direction to be cut.

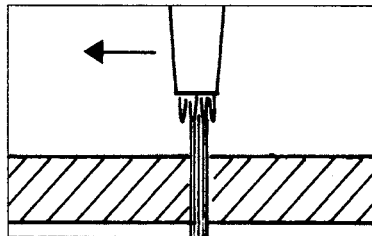
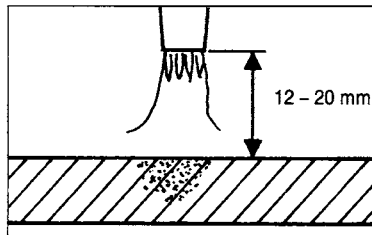
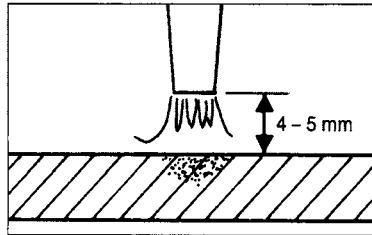

Cutting guide

In order to ensure smooth cutting in steel plate the guide for UCT-500 should be used. In this guide the torch may be used in any angle between 90° and 45° to the surface. By using the sleeve for free movement of the nozzle in the guide and attaching the circular motion bar with center tip complete circles with radius 42 to 480 mm may be cut.

Guide for UCT-500 cutting torch



Circular motion bar



AC/OX CUTTING/WELDING/BRAZING

Common cutting faults

A. A correct cut shall give square corners and a smooth cut surface without pronounced cut gouges.



B. Too low cutting speed or too low cutting oxygen pressure will give a rounded top edge and uneven surface with gouges in the lower part of the cut.



C. Too high cutting speed will give an uneven top edge, pronounced drag lines in the surface and a rounded lower edge.

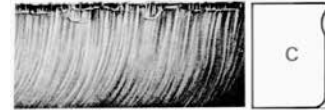

D. Too long distance between nozzle and plate will give a melted and rounded top edge and cutback in upper part of the surface. Lower part will be smooth and bottom edge sharp.



E. Too short distance between nozzle and plate will give melted, rounded top edge, surface and the bottom edge will be acceptable, or in some cases with pronounced drag lines.

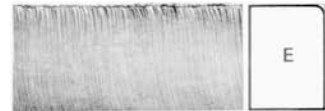

F. Too high oxygen cutting pressure or contaminated cutting oxygen hole in the nozzle will give slightly rounded upper edge and pronounced cutback in upper part of the surface.

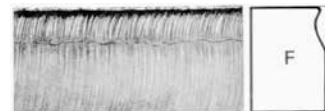

G. Too strong preheating flame will give a melted and rounded upper edge and pronounced cutback down through the surface, contaminated with slag and melted steel.





AC/OX CUTTING/WELDING/BRAZING

Operating Instructions For UCT-500 Brazing, Welding and Heating Torch

- a. All valves are shut at the commencement of work: Cylinder valves (1 and 2) are shut, the regulator adjusting screws (3 and 4) are screwed so far out that they run freely on their threads and both torch needle valves (5 and 6) are closed.
- b. Select your blowpipe (10) to suit the type and thickness of workpiece. The required blowpipe and working pressure for mild steel when using 6 mm (1/4") hoses 10 m in length are given in the welding table. The working pressures relate to medium-strength flame.
- c. Slowly open the cylinder valves for Oxygen (1) and Acetylene (2).
- d. Fully open the torch Oxygen needle valve (5) and adjust the working pressure by means of the Oxygen regulator adjusting screw (3).
- e. Shut the torch Oxygen valve (5).
- f. Fully open the torch Acetylene needle valve (6), and adjust the working pressure by means of the Acetylene regulator adjusting screw (4).
- g. Slightly open the torch Oxygen needle valve (5) to provide a little extra Oxygen to prevent troublesome sooting when the torch lightening lit.
- h. Hold the torch so that the nozzle points away from flammable objects. Light the torch, and adjust to desired flame characteristic by means of the torch Oxygen needle valve (5). The torch is now ready for use.
- i. In the event of sustained backfire, which is recognized by a whistling or hissing sound, first close the torch Oxygen needle valve (5) as quickly as possible, then the Acetylene needle valve (6).
- j. The torch is normally extinguished by first closing the torch Acetylene needle valve (6) and then the torch Oxygen needle valve (5). Finally, relieve the pressure in the hoses and close all valves.

Important

1. After finishing work, release the pressure in the hoses by closing the cylinder valves (1 and 2) and empty one hose at a time, keeping the torch needle valve for the other gas shut. Finally, make sure that all torch valves are shut, and unscrew the regulator adjusting screws (3 and 4) so far that they run freely on their threads.
2. Check the sealing rings at regular intervals for damage, deformation or wear. Replace them if they are defective. To facilitate changes of torch or cutter tips, the sealing rings and sealing surfaces in the torch connection head should be lightly smeared with a special lubricant.

Oil or grease must **never** be used.

AC/OX CUTTING/WELDING/BRAZING

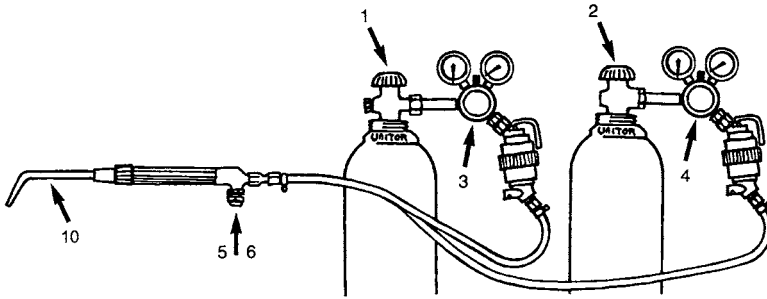
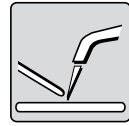

Select the correct blowpipe to suit the thickness and size of material to be welded. Adjust the working pressure for one gas at a time. To adjust the

working pressure, open the torch needle valve so that the gas can flow freely during adjustment.

Table for welding, brazing, heating

Working pressure and gas consumption for Unitor UCT-500								
Material thickness, mm	<0.5	0.5 1	2 3	3 5	5 7	Major welding and brazing jobs (heating torch)		
Product No.	174565	174573	174581	174599	174607	174615	174623	174631
Size of welding attachment	40	80	230	400	650	1000	1250	1800
Acetylene pressure bar	0.3	0.3	0.3	0.3	0.3	0.3	0.3	0.3
Oxygen pressure bar	0.3	0.3	0.3	0.3	0.3	0.3	0.3	0.3
Gas consumption Ox	40	80	230	400	650	1000	1250	1800
litre per hour Ac	39	73	209	364	591	909	1136	1636



AC/OX CUTTING/WELDING/BRAZING

Maintenance of Blowpipes

Clean the flame and cutting oxygen holes with Unitor cleaning drills. These should run freely in the holes. Do not twist them, just stick them straight in and pull them out.

Never use steel wire, reamers or spiral drills for cleaning. These can ruin the smooth surfaces of the hole.

It is very important that the small holes in the sealing end of the cutting nozzles should not be enlarged in any way.

Torches and cutting nozzles may be carefully cleaned externally by means of a soft brass brush. Do not use a steel brush.

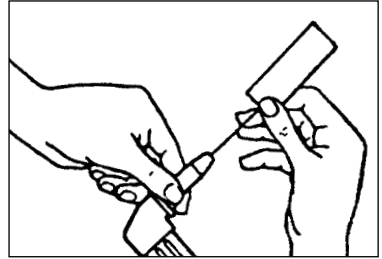

Grinding blowpipes and cutting nozzles

If the end of a welding or cutting nozzle has been damaged, it can be repaired, by grinding the surface against fine emery paper placed on a flat surface. The correct flame and an even flow of cutting oxygen can be obtained only by keeping the edges of the holes sharp and at right angles to the axis of the passages. A nozzle hole with an uneven edge or widened orifice will also increase the risk of backfire.

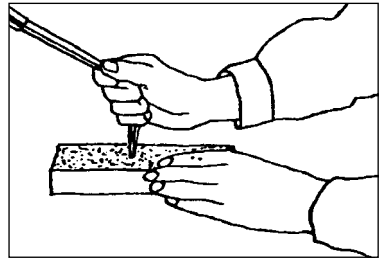

Grinding down the nozzle end of a blowpipe

Welding blowpipes are so made that the length of the nozzle holes can be shortened by grinding off up to 3 times the hole diameter without the flame becoming smaller than that of a new burner. Thus a cylindrical part will always be left having a length at least equal to the diameter of the hole. It ought not to be shorter than this, to avoid backfire (popping). On cutting nozzles up to approximately 4mm of material may be removed.



AC/OX CUTTING/WELDING/BRAZING

Heating Techniques

The Acetylene/Oxygen flame is frequently used for heating workpieces onboard, whether it is for preheating/postheating in combination with welding processes or for heating steel for bending or forming. A normal welding flame or a normal flame from special multiflame heating attachments may be used. No special techniques are required except the need to be careful not to overheat and weaken parts. There is, however, one area of heating that needs special know-how, the straightening of steel constructions.

The steadily growing use of welding calls for an economical method of dealing with the deformations, which often arise in welded steel constructions.

Beside purely mechanical methods, straightening is largely performed with a welding flame. This is a convenient method, normally demanding no other equipment than ordinary gas welding equipment. However, you need a good knowledge of how the work reacts to heating and cooling, and how the shrinkage forces should be exploited in straightening.

In flame straightening, the temperature should not exceed 550–600 °C. The work should be allowed to cool slowly, especially in the case of high tensile steel.

Also, heat should not be applied to a spot that has been heated previously, as this can cause deterioration.

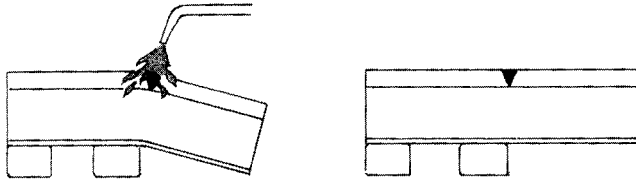

When heat is applied as shown in the sketch, the heated part has a tendency to expand. As longitudinal expansion is prevented by the surrounding cold metal, a convexity is created in the heated part.

On cooling, the heated metal contracts, with the result that the end of the section moves upwards.

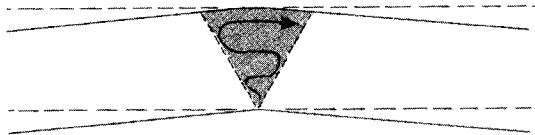

Section bars are normally straightened with the help of heating wedges, as shown above. On the next page we will give some guidelines on how to apply these heating wedges.



Flame straightening techniques

Angle bars, straightening in flange direction

Only heat the horizontal flange and start at the arrow head 1.

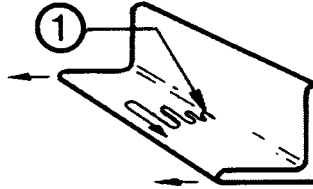

Angle bars, straightening in web direction

Heat both flanges, first no. 1 starting at the arrow head, and then no. 2.

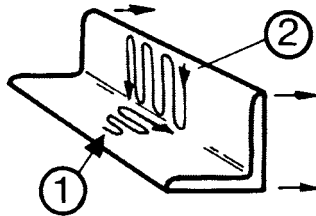

T-bars, straightening in flange direction.

Only heat the horizontal flange and start at arrow head 1.

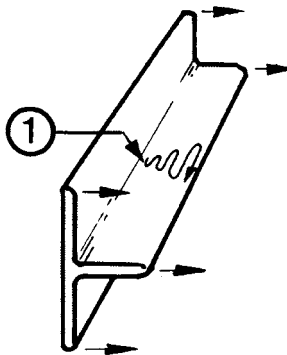



AC/OX CUTTING/WELDING/BRAZING

T-bars, straightening in web direction

Heat both flanges, first no. 1 starting at the arrow head, and then no. 2.

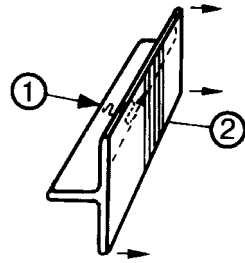

T-bars, straightening the web sideways

Heat both flanges, first no.1 starting at the arrow head, and then no. 2.

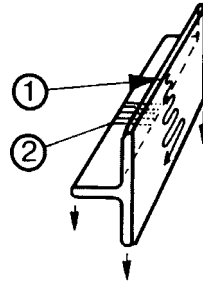

U-girders, straightening in flanges direction

Heat both flanges at the same time, starting from the arrow heads 1.

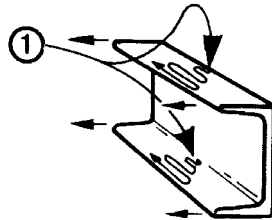

U-girders, straightening the web sideways

First heat the web no. 1, starting at the arrow head, and then flange no. 2.

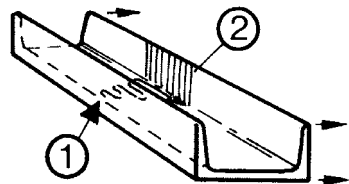



Welding Techniques

After lighting the torch, adjust the flame until it has the characteristics required for the operation to be undertaken.

A normal flame is used for welding all types of steel, and copper.

A flame with a slight surplus of Acetylene is used for welding Aluminium.

A flame with an excess of Oxygen is used for welding cast iron, brass, bronze and zinc alloys, and for brazing.

It is important to adjust welding flame correctly for the material to be welded. Flame types are given under the descriptions of the various filler materials.

In gas welding, the joined edges of the workpiece melt and fuse, with or without filler material.

Welding can be either leftward or rightward technique. The direction of weld is selected according to the thickness of the material. Rightward welding requires more expertise, and welders with limited experience are therefore recommended to use leftward welding, which is the simpler method. In either case, make sure that the weld penetrates completely and evenly on the reverse side of the material with no imperfections.

NB. Correct alignment of the workpieces is essential to a good joint.



Leftward welding



Rightward welding



AC/OX CUTTING/WELDING/BRAZING

Leftward welding

When the filler rod is held in front of the torch in the welding direction, this is called leftward welding. The welding flame points away from the finished weld. Leftward welding is used for sheet thicknesses up to 3–4 mm and for thinwalled pipes. When welding cast iron and non-ferrous metals, such as aluminium and brass, always weld leftward. Brazing should also be performed using this technique.

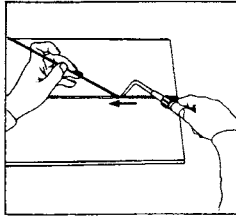

Vertical leftward welding

Sheet steel up to 2.5 mm thick can be welded by vertical leftward welding.

Weld in the same manner as for horizontal welding.

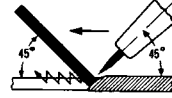
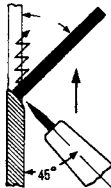

Horizontal leftward welding

Adjust the equipment for the correct flame. Move the torch with a slight rotational movement to melt both edges of the workpiece. Do not hold the torch too far away from the workpiece. (The core of the flame should be 2–3 mm from the workpiece). When the material begins to melt, feed the filler rod into the weld pool with small movements, and welding is in process. Make sure to find the right speed. The metal on each side of the seam must melt before the filler rod is fed into the weld pool.

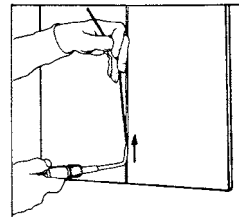

Vertical leftward welding, filler rod angles:

Material thickness 1.0–1.5 mm 30°

Material thickness 1.5–3.0 mm 30°–60°



Rightward welding

In rightward welding, the filler rod follows the torch in the direction of the weld. Rightward welding is recommended for the joining of sheet metal and plate of more than 3–4 mm in thickness and for pipe welding. With rightward welding, the risk of tensions in the workpiece is less than in the case of leftward welding.

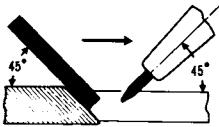

Rightward welding

Rightward welding is used for material thicknesses from 4 mm and up. The filler rod follows the torch in the welding direction.

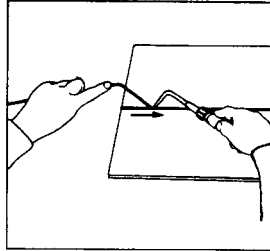

Horizontal rightward welding

Start on the left-hand side of the workpiece and weld from left to right. Move the torch in the direction of weld and feed the filler rod with small rotating movements. The blowpipe must not be moved sideways. It is easier to handle the rod if it is bent as shown in the drawing. See also horizontal leftward welding.

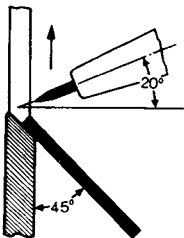

Vertical rightward welding

This is used for material thicknesses from 4 mm and up.

Vertical rightward welding and rightward overhead welding.

The principle is the same as for horizontal rightward welding.



AC/OX CUTTING/WELDING/BRAZING

Butt Joints for Gas Welding of Steel

(T = thickness of workpiece)

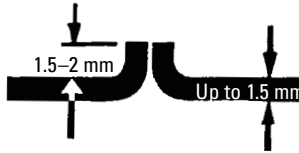

Flange butt joint

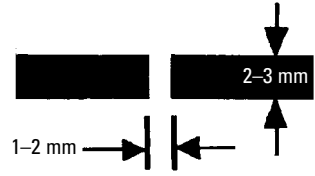

Open square butt joint

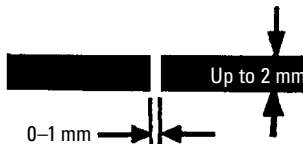

Close square butt joint

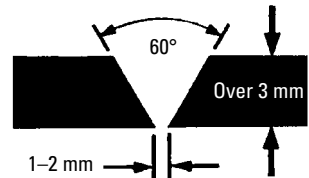

Single V-butt joint w/feather edge



Consumables and parameters for Gas Welding

MS-200

Description

Gas welding rod for welding of unalloyed structural steel with a carbon content of less than 0.2 %.

Packaging data:

Diameter Mm	Length mm	Rods per package	Net weight per package kg	Product no. per package
2.0	500	280	3.5	092-539551
3.0	500	125	3.5	092-539569

Flux: No flux required



ALUMAG-235

Description

Gas welding rod for wrought and cast aluminium alloys containing up to 5 % Mg. Generally it can be used for all cast alloys containing magnesium as the main alloying element.

Packaging data:

Diameter Mm	Length mm	Rods per package	Net weight per package kg	Product no. per package
3	500	47	0.5	092-514265

Flux: Aluflux 234 F, 250 gram container.

Product no. **092-603043**

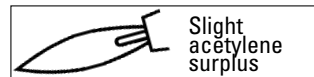

Detailed information on these consumables to be found under the section Consumables.



AC/OX CUTTING/WELDING/BRAZING

Soldering and Brazing Techniques

Soldering and brazing are thermal fusion processes for joining metals. The processes are related to welding, but whereas both filler material and workpiece surfaces are melted in welding, only the filler material is melted in soldering and brazing processes.

The filler material will always have a lower melting temperature than the material to be joined.

When heated, it will reach melting temperature range, liquefy and with the help of the flux spread out and bind to the surfaces of the workpieces. This bond is a result of the filler material's ability to "wet" the workpiece. In this process there is a very faint alloying zone between the melted filler material and the base material. When the filler solidifies it will stick firmly to the base material.

Fluxes

In brazing and soldering processes it is most often required to use a flux suited for the filler material and base material. Fluxes serve three basic functions that are required to obtain a successful result.

1. Flux eliminates the oxide layer on the surface of the base material during the heating process, and protects against further oxidation.
2. The flux is adapted to the filler material in such a way that it melts slightly before correct working temperature is reached, thereby indicating when filler material should be applied.
3. When the filler material is applied the flux reduces the surface tension

of the liquified alloy so that it can spread uniformly, ensuring good wetting of the base material.

The dissolving ability of the fluxes is limited and they cannot be heated for any period of time. The soldering/brazing time should, therefore not exceed 3 - 5 minutes. Overheating may also destroy the properties of the flux.

Surplus flux remaining on the workpiece after brazing should be removed by rinsing in clean water and brushing.

Keep in mind that most fluxes have a toxic content. This applies not only to Unitor's fluxes, but to all types. Make sure that there is proper ventilation whenever you braze or solder and avoid contact with eyes, mucous membranes, skin and open wounds.

Advantages of brazing and soldering

1. A quick and cheap method of joining materials which does not involve expensive equipment.
2. Most metals and combinations of metals can be joined by brazing and soldering.
3. If the correct filler metal and flux is chosen, brazing produces a bond of high tensile strength with good corrosion resistance.
4. Due to the relatively low temperatures applied, there is little deformation and change of structure in the workpiece.



A good brazed or soldered joint depends on:

1. Correct mating of the surfaces to be joined. Whether the joint is to be made by capillary brazing, soldering or braze welding depends on the type of joint and strength required.
2. It is essential that the surfaces to be joined are clean. Keep in mind that brazing and soldering are surface bonds.
3. Correct preheating. The workpiece must be preheated to a temperature equal to the melting point of the filler metal.
4. Correct flux, and no overheating.



*Reducing flame.
Slight surplus of Acetylene.*

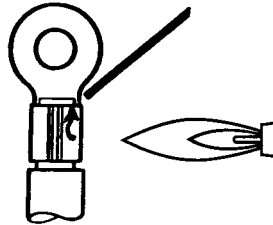

Heat indirectly when using a welding torch for soldering.

Soft soldering

The principal difference between soldering and brazing is the working temperature of the filler material used. In soldering the working temperature of the filler alloy is always below 400 °C. The filler alloy is normally based on tin (Sn).

Soft soldering is commonly used in electrical connections, and in joints where a leak-tight connection is required.

Compared with brazing soldering gives a weaker joint. The solders alloyed with silver will normally have the best mechanical strength.

AC/OX soldering is done with a soft, slightly carburizing (reducing) flame. The parts must be heated evenly so that the entire soldering area reaches soldering temperature at the same time. Be careful not to overheat. This may destroy the bonding properties of the solder.

Brazing

The term brazing is used when the melting point of the filler material is above 400 °C and below the melting point of the material in the workpiece. With correct joint preparation and brazing technique it is possible to obtain joints with high mechanical strength, and tensile strength of up to 490 Mpa is fully possible with a high quality general purpose brazing alloy like e.g. AG-60. The general term brazing covers two different application methods; capillary brazing and what is often called braze welding.



AC/OX CUTTING/WELDING/BRAZING

Edge preparation

Capillary brazing

Capillary brazing requires a filler material, which melts to a thin flowing liquid with excellent wetting properties, and a joint with parallel surfaces. The opening between the surfaces should preferably be 0,05 - 0,1 mm to obtain sufficient strength and capillary effect. This effect is based on the surface tension of the liquid filler metal, which will pull the filler in between the surfaces.

Where possible the surfaces should overlap 3–5 times the wall thickness of the thinner part.

Heating should be done with a neutral or slightly reducing flame, which will give assistance to the flux in removing oxides from the surface. Heat the entire area of the joint uniformly. Starting with the thicker part to ensure that both surfaces reach correct temperature quickly and simultaneously, within max. 2-3 minutes to avoid damaging the flux. Do not heat directly on the filler material. When the joint has reached correct temperature the end of the brazing rod should be touched to the joint, and the heat from the workpiece will melt off filler material.

Allow sufficient time for the capillary action to take full effect. With proper joints this will happen very quickly.

Keep the workpiece in position until it has cooled off and the filler has solidified. The workpiece can then be released, and if the material allows, cooled off in water.

Flux residues should be removed to avoid corrosion.

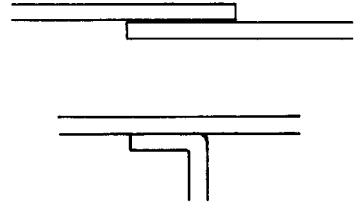

Joint types

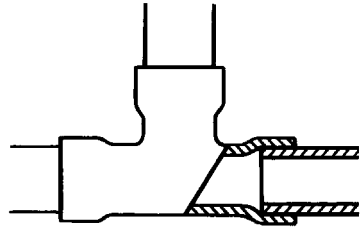

*Maximum capillary gap between joint
Surface 0.1 mm.
Coat joint surface with flux*

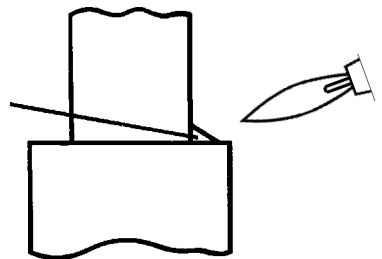

Heat evenly



Edge preparation

Braze welding

Contrary to the term braze welding is not a welding process, as the base material is not melted. The brazing technique is, however, similar to gas welding with the leftward method, and the joint types will be similar to gas welding except that the joint edges must be rounded off.

Braze welding may be used to join a wide range of metals, and is also used for rebuilding wear surfaces. As with capillary brazing the surfaces must be cleaned and correct flux should be applied where required.

The joint should be preheated sufficiently before filler material is applied and melted off with the flame. When the applied drop of filler flows outwards, wetting the workpiece surface correct temperature has been reached, and brazing may proceed using the forehand technique described under gas welding.

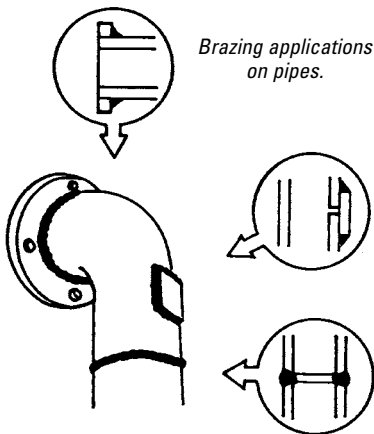
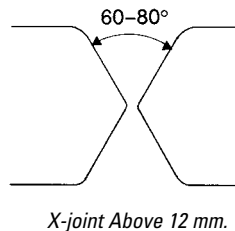
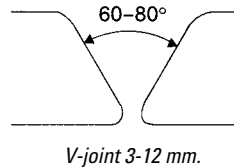
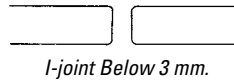
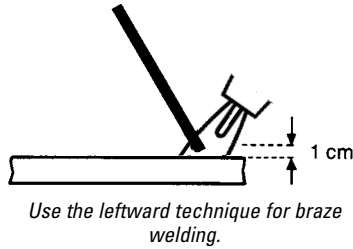



AC/OX CUTTING/WELDING/BRAZING

Consumables and parameters for Brazing

TIN 241 AG

Description:

Flux cored soft solder wire on spool for tinning and joining of electric conductors, electrical connections, electrical instruments, radios, batteries, refrigeration plants, etc.

Packaging data

Diameter mm	Length mm	Quantity per package	Net weight per package kg	Product no per package
1.5	-	-	0.5	093-777973

AG-45-253

Description:

Bare cadmium free silver rod for joining of all types of steel, stainless steel, copper, copper alloys, nickel and nickel alloys, cast iron and hard match. This brazing rod gives a very good joint and can be used for brazing nipples, sleeves and unions to copper pipes.

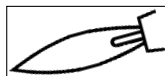

Preferably use soldering iron. If welding torch: Soft reducing flame.

Packaging data

Diameter mm	Length mm	Quantity per package	Net weight per package kg	Product no per package
2.0	500	28	0.4	093-519744

Flux AG-60/45 Flux 252 PF (250g container) product no. **093-778461**

AG-60-252

Description:

A flux coated cadmium free, seawater resistant, high strength silver rod for joining all types of steel, stainless steel, copper, copper alloys, nickel, nickel alloys, cast iron, Yorcalbro pipes (aluminiumbrass), cunifer pipes type 90/10 and 70/30.

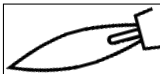

Neutral.

Packaging data

Diameter mm	Length mm	Quantity per package	Net weight per package kg	Product no per package
2.0	500	24	0.5	093-233601

Flux AG-60/45 Flux 252 PF (250g container)

Product no. **093-778461**

On Yorcalbro:

ALBRO FLUX 263 PF (250 g container)

Product no. **093-604371**

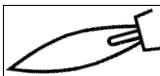

Neutral.

Detailed information on these consumables can be found under the section Consumables.



Consumables and parameters for Brazing

BRONZE-264

Description

An easy-flowing, universal brazing bronze (brass) rod for the brazing of steel, cast iron, copper and copper alloys, nickel and nickel alloys. It gives a very smooth and attractive surface. The addition of Si, Mn and Sn guarantees a strong and high-quality deposit.

Packaging data:

Diameter Mm	Length mm	Rods per package	Net weight per package kg	Product no. per package
3	500	54	1.7	093-174326
5	500	36	3	093-514240

Flux: Bronze flux-261 PF (250 g container) product no. **093-603076**.



FC-BRONZE-261

Description

A flux-coated brazing rod for joining and surfacing copper, brass, bronze, aluminium bronze, cast iron and steel. May be used for brazing galvanized steel without destroying the galvanized surface.

Packaging data:

Diameter Mm	Length mm	Rods per package	Net weight per package kg	Product no. per package
2	500	69	1	093-233551
3	500	32	1	093-233569

Flux: Bronze flux-261 PF (250 g container) product no. **093-603076**.

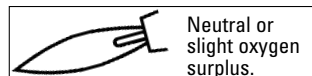

Detailed information on these consumables can be found under the section Consumables.



AC/OX CUTTING/WELDING/BRAZING

FC-WEARBRO-262

Description

A flux-coated wear-resistant bronze rod used for applying a hard-wearing surface to bronze, brass, copper, steel, cast iron and malleable cast iron. Also used for braze welding cast iron.

Packaging data

Diameter Mm	Length mm	Rods per package	Net weight per package kg	Product no. per package
3	500	33	1	093-233577
5	500	13	1.1	093-233585

Flux: Wearbroflux 262 PF (250g container) product no. **603068**

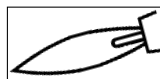

Neutral or
slight oxygen
surplus.

CAST IRON-237

Description

Gas welding rod for joining and surfacing cast iron and brazing cast iron to steel. Oil impregnated cast iron may also be brazed with FC-Castiron 268.

Packaging data

Diameter Mm	Length mm	Rods per package	Net weight per package kg	Product no. per package
4	500	12	0.7	096-682310

Flux: Cast Iron Flux 236F (250g container) product no **764487**

Detailed information on these consumables can be found under the section Consumables.

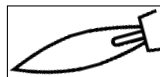

Slight oxygen
surplus.

GAS SUPPLIES AND GAS DISTRIBUTION SYSTEM



Introduction	518
Argon.	519
Argon-Carbon Dioxide mixture.	520
Carbon Dioxide	521
Oxygen	522
Acetylene.	524
Rules & Safety precautions for handling and use of Gas cylinders	528
Gas Distribution System for Acetylene and Oxygen	530

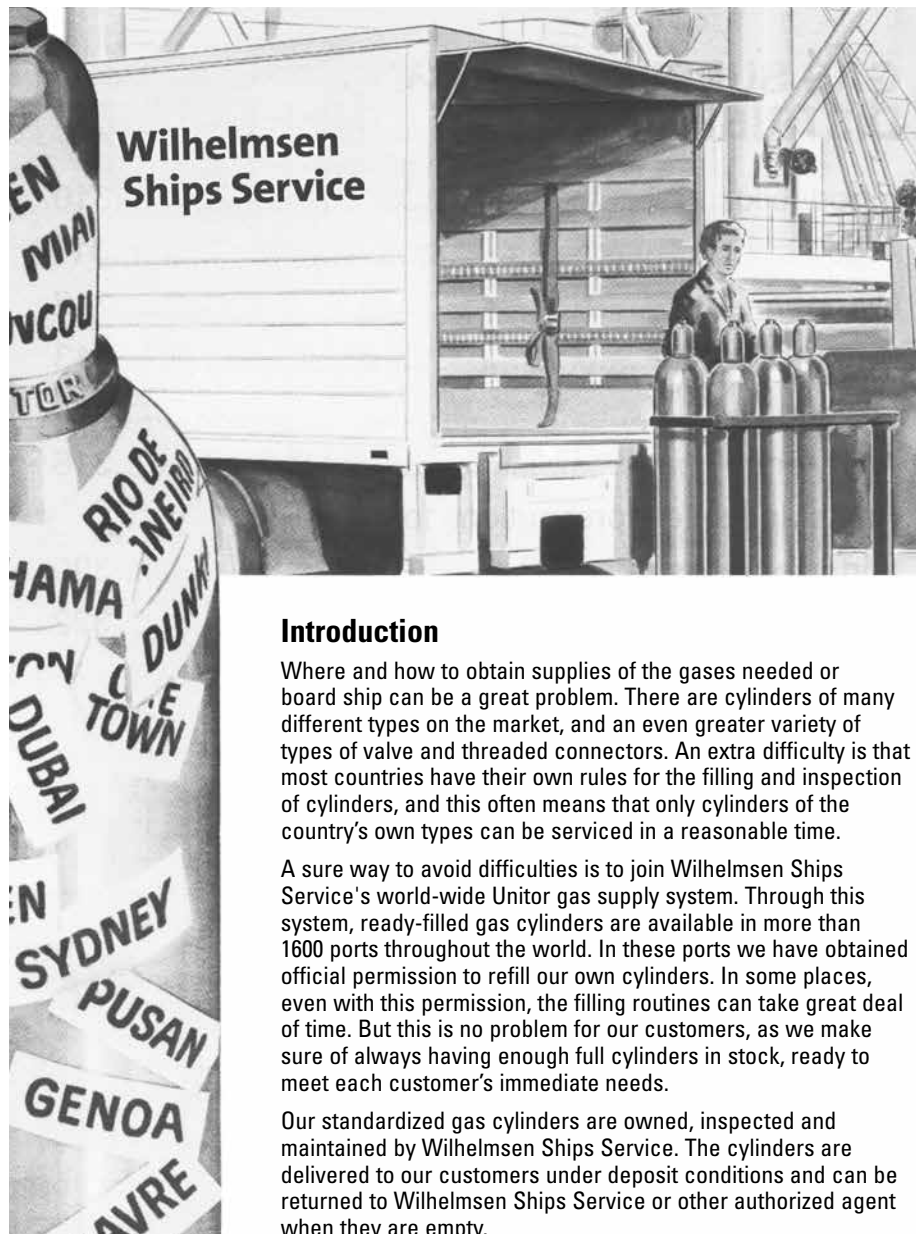

Introduction

Where and how to obtain supplies of the gases needed or board ship can be a great problem. There are cylinders of many different types on the market, and an even greater variety of types of valve and threaded connectors. An extra difficulty is that most countries have their own rules for the filling and inspection of cylinders, and this often means that only cylinders of the country's own types can be serviced in a reasonable time.

A sure way to avoid difficulties is to join Wilhelmsen Ships Service's world-wide Unitor gas supply system. Through this system, ready-filled gas cylinders are available in more than 1600 ports throughout the world. In these ports we have obtained official permission to refill our own cylinders. In some places, even with this permission, the filling routines can take great deal of time. But this is no problem for our customers, as we make sure of always having enough full cylinders in stock, ready to meet each customer's immediate needs.

Our standardized gas cylinders are owned, inspected and maintained by Wilhelmsen Ships Service. The cylinders are delivered to our customers under deposit conditions and can be returned to Wilhelmsen Ships Service or other authorized agent when they are empty.

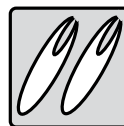

ARGON

Product name Argon	Formula Ar	Hazard class Nonflammable gas
Appearance and colour Colourless, odourless		IMDG code 2.2
Specific gravity (Air=1) 1.38 (heavier than air)		Substance Identification UN-1006

Cylinder characteristics

Colour code: Body – Grey

Cylinder Size	Outlet Connection	Nominal Contents (cu. Metres) (See note 1.)	Filled Pressure (bar) at 15°C (max)	Nominal Wt. Of Gas (kg) (See note 1.)	Approx. Dimensions (mm) (See note 2.)	Approx. Cylinder Wt. (kg) (See note 3.)
E-10	W24.32mm x 1/14"	2.2	200	3.6	140 x 1000	18
E-50	W24.32mm x 1/14"	11	200	18	230 x 1690	81

Note:

1. Actual contents and weight of gas in individual cylinders will vary about the nominal contents and weight of gas indicated.
2. The length includes an allowance of 70mm for a top outlet valve.
3. The approximate cylinder weight includes cylinder, valve and neck-ring. The approximate weight of a full cylinder is obtained by adding the nominal weight of contained gas to this figure. Greater weights may be found among cylinders manufactured to older standards.

ARGON

Argon is a colourless, odourless gas, slightly heavier than air. It is non-toxic and non-combustible. Together with Helium, Neon, Krypton, Xenon and Radon, it constitutes a special group of gases known as the "rare", "inert" or "noble" gases. The terms inert and noble mean that the gases have an extremely weak tendency to react with other compounds or elements. Argon forms no known chemical compounds.

Argon is present in the atmosphere at a concentration of 0.934% at sea level. Air is the only known source for the production of pure argon.

Argon is non-toxic, but it is included among the simple asphyxiant gases. Argon is used as a protective shielding gas in TIG and MIG welding. In this process argon serves as an inert covering round the point of the electrode/ wire and the molten pool in order to protect the welding zone from the harmful effect of the air.

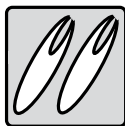

GAS SUPPLIES AND GAS DISTRIBUTION SYSTEM

ARGON- CARBON DIOXIDE MIXTURE

Product name Unimix	Formula Ar - CO ₂ (80%/20%)	Hazard class Nonflammable gas
Appearance and colour Colourless, odourless gas		IMDG code 2.2
Specific gravity (Air=1) 1.40 (heavier than air)		Substance Identification UN-1956

Cylinder characteristics

Colour code: Body – Grey/Yellow

Cylinder Size	Outlet Connection	Nominal Contents (cu. Metres) (See note 1.)	Filled Pressure (bar) at 15°C (max)	Nominal Wt. Of Gas (kg) (See note 1.)	Approx. Dimensions (mm) (See note 2.)	Approx. Cylinder Wt. (kg) (See note 3.)
M-10	W24.32mm x 1/14"	2.2	200	3.4	140 x 1000	18
M-50	W24.32mm x 1/14"	10.9	200	17.1	230 x 1690	81

Note:

1. Actual contents and weight of gas in individual cylinders will vary about the nominal contents and weight of gas indicated.
2. The length includes an allowance of 70mm for a top outlet valve.
3. The approximate cylinder weight includes cylinder, valve and neck-ring. The approximate weight of a full cylinder is obtained by adding the nominal weight of contained gas to this figure. Greater weights may be found among cylinders manufactured to older standards.

ARGON-CARBON DIOXIDE MIXTURES

ARGON-CARBON DIOXIDE MIXTURE (UNIMIX) is a mixture of 80% argon and 20% Carbon Dioxide, which is used as a shielding gas in the MIG/MAG welding process. The mixture is suitable for welding all un- and low alloyed carbon steels. The mixture gives a very stable molten pool together with optimum energy-transmission.

The mixture is relative inert in its chemical properties and is non toxic.

Because the gas mixture is heavier than air, it will collect in confined and low areas. The result will be that the Oxygen level is reduced which can be a potential hazard. More on the effect of exposure to Oxygen deficient atmospheres can found on the next pages describing Oxygen. In general it can be said that when working with compressed gases, you should work in a well ventilated area.



CARBON DIOXIDE

Product name Carbon dioxide	Formula CO ₂	Hazard class Nonflammable gas
Appearance and colour Colourless, odourless		IMDG code 2.2
Specific gravity (Air=1) 1.53 (heavier than air)		Substance Identification UN-1013

Cylinder characteristics

Colour code: Body – Grey

Cylinder Size	Outlet Connection	Nominal Contents (cu. Metres)	Nominal Wt. Of Gas (kg) (See note 1.)	Approx. Dimensions (mm) (See note 2.)	Approx. Cylinder Wt. (kg) (See note 3.)
C-9	CgA320	4.95	9	203 x 560	19
C-27	CgA320	14.85	27	230 x 1210	55

Note:

1. Actual contents and weight of gas in individual cylinders will vary about the nominal contents and weight of gas indicated.
2. The length includes an allowance of 70mm for a top outlet valve.
3. The approximate cylinder weight includes cylinder and valve.
The approximate weight of a full cylinder is obtained by adding the nominal weight of contained gas to this figure.

CARBON DIOXIDE

Carbon dioxide is a colourless, odourless gas, slightly heavier than air. It is non-toxic and non-combustible.

It is considered an inert gas. The terms inert mean that the gases have an extremely weak tendency to react with other compounds or elements.

Carbon dioxide is present in the atmosphere at a concentration of 0.04% at sea level. It is produced by burning fossil fuels or chemical reactions.

Carbon dioxide is non-toxic at low concentration but it is included among the simple asphyxiate gases. Concentrations above 5% are considered as dead threatening.

Carbon dioxide is used as a protective shielding gas in MAG welding. In this process carbon dioxide serves as an active gas covering round the point of the electrode/ wire and the molten pool in order to protect the welding zone from the harmful effect of the air.

It is additionally greatly used in the food and beverage industry either as a protective gas to conserve food products or carbonation of soft drinks and beers. A new application is water treatment to balance the acidity of potable water.



AC/OX CUTTING/WELDING/BRAZING

OXYGEN

Product name Oxygen	Formula O ₂	Hazard class Nonflammable gas
Appearance and colour Colourless, odourless, tasteless gas		IMDG code 2.2 + 5.1
Specific gravity (Air=1) 1.11 (Slightly heavier than air)		Substance Identification UN-1072

Cylinder characteristics

Colour code: Body – Blue

Cylinder Size	Outlet Connection	Nominal Contents (cu. Metres) (See note 1.)	Filled Pressure (bar) at 15°C (max)	Nominal Wt. Of Gas (kg) (See note 1.)	Approx. Dimensions (mm) (See note 2.)	Approx. Cylinder Wt. (kg) (See note 3.)
0-5	W21.80mm x 1/14"	1	200	1.3	140 x 620	12
0-40	W21.80mm x 1/14"	6.4	150	7.8	230 x 1360	52

Note:

1. Actual contents and weight of gas in individual cylinders will vary about the nominal contents and weight of gas indicated.
2. The length includes an allowance of 70mm for a top outlet valve.
3. The approximate cylinder weight includes cylinder, valve and neck-ring. The approximate weight of a full cylinder is obtained by adding the nominal weight of contained gas to this figure. Greater weights may be found among cylinders manufactured to older standards.

OXYGEN

Oxygen (O₂) is a colourless, odourless gas, slightly heavier than air. Oxygen normally amounts to 21% by volume of the earth's atmosphere at sea level. Oxygen is produced industrially by rectification (distillation) of liquid air, from which the Oxygen boils off at minus 183 °C, and can thus be separated from the other air gases, for compression in steel cylinders.

Oxygen itself will not burn, but the gas sustains combustion in the normal sense of the word. In pure oxygen combustion proceeds much more rapidly than in air, and the higher the pressure, the more violent the combustion. Even materials that are normally not combustible, or are difficult to ignite, can catch fire spontaneously or be set alight in pure Oxygen. We make use of this phenomenon for the Oxygen-cutting of steel.

Oxygen can lead to the explosive ignition of ordinary oil, grease or other organic substances. For this reason a welder must never wear working clothes or use equipment that is contaminated with oil or grease. Be particularly careful to prevent equipment or fittings for Oxygen to come in contact with oil or grease. Only special lubricants may be used for Oxygen equipment.

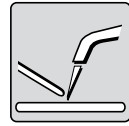

Rules relating to Oxygen

- Oxygen that leaks out into the air increases the danger of combustible materials igniting, i.e. body hair, clothes etc. catching fire. This can occur even with a small increase in the Oxygen content of the air, and can cause serious burns and other injuries.
- Never use Oxygen instead of air to start a diesel engine. Never use Oxygen to blow dust from working clothes. If clothing has been accidentally exposed to an increase in Oxygen content it may take a long time to get rid of the excess Oxygen, often several hours.
- Never use Oxygen to freshen the air

when you are working in a confined space.

- Fittings for Oxygen must be kept free of dust and metal particles because of the danger of spontaneous combustion.

Oxygen-deficient atmospheres

The normal Oxygen content of air is approximately 21%. Depletion of Oxygen content in air, either by combustion or displacement with inert gas, is a potential hazard to personnel. A general indication of what can potentially occur relative to the percentage of Oxygen available is given in the table below.

Oxygen Content (% by Volume)	Effects and Symptoms (At Atmospheric Pressure)
15-19%	Decreased ability to work strenuously. May impair coordination and may induce early symptoms in persons with coronary, pulmonary, or circulatory problems.
12-14%	Respiration increases in exertion, pulse up, impaired coordination, perception, and judgment.
10-12%	Respiration further increases in rate and depth, poor judgment, lips blue.
8-10%	Mental failure, fainting, unconsciousness, ashen face, blueness of lips, nausea, and vomiting.
6-8%	8 minutes; 100% fatal, 6 minutes; 50% fatal, 4-5 minutes; recovery with treatment.
4-6%	Coma in 40 seconds, convulsions, respiration ceases, death.

Note: Exposure to atmospheres containing 12% or less Oxygen will bring about unconsciousness without warning and so quickly that the individual cannot help or protect himself.

An asphyxia victim should be taken into the open air quickly and given Oxygen or artificial respiration. Medical attention should be obtained immediately. Inhalation of an Oxygen-rich atmosphere also requires medical attention.



GAS SUPPLIES AND GAS DISTRIBUTION SYSTEM

ACETYLENE

Product name Acetylene	Formula C ₂ H ₂	Hazard class Flammable gas
Appearance and odour Pure acetylene is a colourless gas with an ethereal odour Commercial (carbide)acetylene has a distinctive garlic-like odour		IMDG code 2.1
Specific gravity (Air=1) 0.906 (Lighter than air)		Substance Identification UN-1001
FLammable limits % by volume LEL 2.2 UEL 80-85		Extinguishing media CO ₂ . Dry chemical

Unusual fire and explosion hazard

Gaseous Acetylene is spontaneously combustible in air at pressure above 2,0 BAR. It requires a very low ignition energy so that fires which have been extinguished without stopping the flow of gas can easily reignite with possible explosive force. Acetylene has a density very similar to that of air so when leaking it does not readily dissipate.

Pure Acetylene can ignite by decomposition above 2.0 BAR, therefore, the UEL is 100% if the ignition source is of sufficient intensity.

Cylinder characteristics

Acetylene (Dissolved in a solvent supported in a porous medium) Colour: Maroon.

Cylinder Size	Outlet Connection	Nominal Contents (cu. Metres) (See note 1.)	Nominal Wt. Of Gas (kg) (See note 1.)	Approx. Dimensions (mm) (See note 2.)	Approx. Cylinder Wt. (kg) (See note 3.)
A-5	G 3/4" BSP	0.7	0.8	140 x 620	14
A-40	G 3/4" BSP	5.6	6.2	230 x 1360	67

Note:

1. Actual contents and weight of gas in individual cylinders will vary about the nominal contents and weight of gas indicated.
2. The length includes an allowance of 70mm for a top outlet valve.
3. The approximate cylinder weight includes cylinder, valve and neck-ring. The approximate weight of a full cylinder is obtained by adding the nominal weight of contained gas to this figure. Greater weights may be found among cylinders manufactured to older standards.



ACETYLENE

Acetylene is a colourless, flammable, and in the pure state odourless gas. It can be manufactured by reacting Calcium Carbide with water in Acetylene generators. Ordinary commercial grades of Acetylene contain traces of impurities such as Phosphine, Arsine, Hydrogen Sulfide and Ammonia, and have a garlic-like odour. The gas is slightly lighter than air.

Acetylene alone burns in air with a very hot, bright and sooty flame. Mixed with air or Oxygen in the right proportion, Acetylene gives a concentrated, sootfree flame. When mixed with Oxygen the combustion is more intense than in air, and because of the Acetylene's high carbon content (92.3% by weight) its maximum flame temperature is about 3100°C. Because of its high temperature, thermal value and speed of combustion (11.6 m/s), this is the most suitable gas flame both for welding and for cutting.

Explosion and decomposition hazards

Acetylene, is a highly flammable and explosive gas, and a mixture of Acetylene and air or Oxygen is explosive within wide limits. The explosive limits in air range from 2% to 82%, while if mixed with Oxygen the explosive range is from 2.5% to 93%. For this reason care must be taken to prevent an unnecessary or uncontrolled escape of Acetylene, and good ventilation must be assured in places where Acetylene is stored or used.

Should escaping Acetylene from an open top valve or from the regulator, catch fire, put out the flame by closing the top valve. For this eventuality a fire-resistant mitten should always be

kept handy. Should the flame make closing of the top valve difficult or impossible, it must first be put out by a Carbon Dioxide (CO₂) or dry powder extinguisher.

Another property, which should be known and understood by personnel engaged in transporting or using Acetylene is that the gas can decompose into its constituents, Carbon and Hydrogen, if it is exposed to temperatures above 350°C (662°F) or if gaseous Acetylene at a pressure of more than 2 bar (200 kPa; 29 psig) is subjected to shock during storage or transportation. Decomposition proceeds rapidly and liberates a great deal of energy. Because of this property, Acetylene cannot be stored under pressure in the same way, for example, that Oxygen is stored.

To avoid the decomposition characteristics of compressed, gaseous Acetylene the cylinders for storing the gas are filled with a porous mass, having minute cellular spaces. This eliminates the risk that any pocket of appreciable size remains, in which Acetylene in gaseous form may collect. The porous mass is saturated with Acetone, in which the Acetylene actually dissolves. The combination of these features - porous mass and solvent allows the Acetylene to be contained in cylinders at moderate pressure with greatly reduced danger of explosive decomposition occurring during normal handling and use.

However, there still exists the chance that decomposition may be started by careless handling of the cylinder, such as hitting or dropping it, heating it, or by using incomplete or badly maintained welding equipment, thereby permitting a complete flash-



GAS SUPPLIES AND GAS DISTRIBUTION SYSTEM

back of the welding flame into the cylinder. The signs of decomposition are:

- The temperature of the cylinder shell rises, starting at the area within which the decomposition commenced.
- The cylinder pressure increases (only evident when the cylinder is in use and a regulator with gauges is fitted on the top valve).
- If, after a complete flash-back, the gas released from the top valve contains soot, and has an unusual smell.

On suspicion that decomposition may have started in the cylinder, shut the top valve immediately, and remove regulator or other fittings attached to it. The cylinder must be checked for increase in temperature by repeatedly feeling the cylinder shell all over by hand.

If temperature of the shell rises, but has not exceeded hand-heat (about 50°C) the cylinder must be taken to the railing immediately and thrown over board. The cylinder must be cooled by copious amounts of water while it is being moved. If the ship is in port, hang the cylinder by a rope into the sea and call the fire brigade.

It is possible to stop a decomposition by keeping the top valve closed and cooling the cylinder with large quantities of cold water, but if this is to succeed it must be commenced at the latest five minutes after the decomposition has started, and must continue until the cylinder remains cold. However, out of consideration for the crew and the ship, do not try to save the cylinder but throw it over board as quickly as possible.

If decomposition has reached a point where the cylinder can no

longer be touched by the bare hand (more than about 50 °C), the danger of an explosion is imminent and the cylinder must not be moved. Start cooling the cylinder immediately with large amounts of cold water from a protected position. All personnel not taking part in this operation must be evacuated from the area. When the cylinder has been cooled until the water no longer steams from the shell, it can be moved to the railing and thrown over board. Remember that cooling must be continued without interruption throughout the removal operation.

WARNING: The top valve of a cylinder containing decomposing Acetylene must be kept shut at all times!

Fatal mistakes have been made in cases of this kind; even experienced welders have opened the cylinder valve fully, in the mistaken belief that this would release the pressure in the cylinder. In fact, the opposite happens. The Acetylene that evaporates out of the Acetone passes the decomposition zone on its way to the top valve, decomposition becomes explosive and the pressure in the cylinder increases much faster than it can be released, with the result that the cylinder may explode within seconds.

Inhalation hazards

Acetylene is a non-toxic but mildly anesthetic gas. Formerly pure Acetylene was combined with Oxygen and used as an anesthetic in hospitals. There is a risk of asphyxia when the Acetylene level in respiratory air reduces the Oxygen content to three-fourths or less of



normal concentration. Hence it is important that Acetylene is handled only in well ventilated areas.

Important safety reminders

Under certain conditions Acetylene forms readily explosive compounds with copper, silver and mercury. For this reason contact between Acetylene and these metals, their salts, compounds and high-concentration alloys must be avoided. It is generally accepted that brass containing less than 65% copper in the alloys, and certain nickel alloys, are suitable for use in Acetylene service under normal conditions. Never use makeshift hose connectors made out of pieces of copper pipe - use a proper hose connector.

Acetylene cylinders must be stored and used in an upright position. If the cylinders are used when lying on their sides or sloping, some of the Acetone will run out and into the reduction valve and hose.

Drawing gas from Acetylene cylinders

The Acetylene cylinders are filled with a porous mass, which is saturated with Acetone. An Acetylene cylinder with a volume of 40 litres normally contains 16 litres of Acetone. The Acetylene gas dissolves in (is absorbed by) the Acetone. At a

pressure of 15 bar and a temperature of 15°C the cylinder will contain 6.000 n/l of dissolved Acetylene. To fill the cylinder with this quantity of Acetylene normally takes 8 hours.

When you open the top valve to use the Acetylene, the pressure in the cylinder falls and the gas is released from the Acetone. If this process proceeds too quickly, ((boiling)) occurs in the cylinder, rather similar to the effect of opening a bottle of sodawater, and some of the Acetone will emerge with the gas. This is harmful both to the cylinder and to the weld. Admittedly, Acetone burns, but with very different characteristics from Acetylene. The rule is therefore that the cylinder should not be emptied more rapidly than by about one-eighth of the contents per hour. This corresponds to about 750 n/l per hour. However, for a short while (maximum 30 minutes) extraction from a full cylinder at about 15°C may be increased to about 2.500 n/l per hour. After that, the cylinder must be set aside for a period of rest.

If gas consumption is greater than a single Acetylene cylinder can deliver, a sufficiently dimensioned gas central installation is normally used. The following gives the extraction rates for various combinations of interconnected A-40 Acetylene cylinders:

Acetylene Cylinders A-40	Maximum extraction, nl/hr	
	Continuous	Intermittent*
1	700	2500
2	1400	5000
3	2100	7500
4	2800	10000
5	3500	12500

*Full cylinders at approx. 15 °C.



GAS SUPPLIES AND GAS DISTRIBUTION SYSTEM

Rules and safety precautions for handling and use of Gas Cylinders

- Always make sure that the cylinder cap that protects the top valve is in place and screwed down before moving the cylinder. Cylinders, when not in active use, should have the cylinder cap in place and properly secured to prevent them from falling.
- Never use slings, chains or magnets to lift gas cylinders. Use racks, baskets or cylinder trolleys specially designed for hoisting gas cylinders, and equipped with proper lifting lugs.
- Cargo nets are not recommended for lifting gas cylinders. If a cargo net has to be used, it must be covered internally with a good tarpaulin to prevent the cylinders from sliding out through the mesh.
- If a crane or winch is used to lift gas cylinders, and the crane driver is not in a position from which he can see the entire hoisting operation, a signalman must be stationed where he can see both the load and the crane driver.
- Gas cylinders must never be hoisted or dragged by the cylinder cap or top valve.
- Do not subject the cylinders to unnecessary impacts or jolts during transport. Do not allow the cylinders to fall, or knock against one another.
- During transport, gas cylinders must always be handled as if they were full. Never be indifferent or careless because they are “empties”. Mistakes can be made, and full cylinders may be mixed with empty ones. Therefore, during transport treat all cylinders as if they were full.

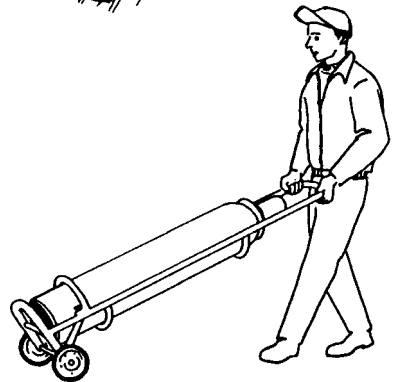
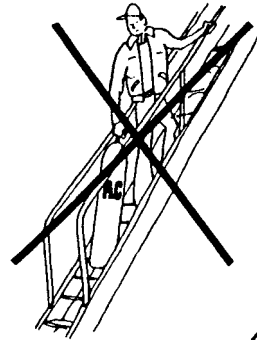
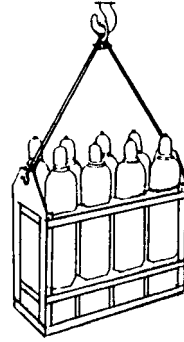



– If the cylinder valve cannot be opened by hand alone, put the cylinder aside and inform the supplier. Never use wrenches or other tools to open cylinder valves. On valves intended for valve keys, use only valve keys supplied by or approved by the gas manufacturer. Valves with hand-wheels must be operated by hand only, without tools. Never hammer the hand-wheel in order to get the valve open or shut.

– It is important to make sure that the cylinder valve outlet union and the connector of the equipment to be used are a proper fit. Never force a connection that does not fit. Make sure that seals are in good condition and of the correct type.

– Use only regulators, flashback arrestors, hoses, etc., designed for use with the gas in question.

Improvising or substituting equipment can lead to serious accidents.

– Never use gas cylinders as rollers or props for other cargo, or for any purpose whatever other than to contain a specific gas.

– Take care to avoid using or storing gas cylinders in places where they could become part of an electrical circuit. Never touch a cylinder with a live electrode.

– Check for gas leaks using soapy water.

– Never use an open flame!

– Never use flames to raise the pressure of a cylinder. Cylinders should not be subjected to temperatures above 45°C

– As far as possible, avoid exposure of gas cylinders to moisture or salt water. Never expose cylinders to corrosive chemicals or gases.

– The information that is cast or stamped on the cylinders must not be altered or removed.

– Never try to repair or alter any feature of a gas cylinder or valve.

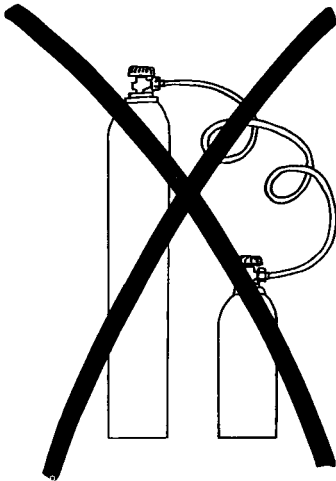

WARNING

It is extremely dangerous, and therefore forbidden, to attempt to transfer oxygen or acetylene from one cylinder to another on one's own.

Filling of gas cylinders shall be carried out only by qualified personnel at the filling factories.

Failure to observe this rule has unfortunately led to the loss of several lives.



GAS SUPPLIES AND GAS DISTRIBUTION SYSTEM

Gas Distribution System for acetylene and oxygen

Unitor's gas distribution system for the storage and distribution of Acetylene and Oxygen was introduced in order to increase safety on board ship. The system was developed in close collaboration with the Norwegian maritime authorities, and is now included in the rules and regulations that apply to the handling and use of welding gases on board Norwegian ships. The authorities of several other countries have shown interest in the system, and have introduced it for use on board the ships of their own nations. The installation of Unitor's central system on board ship reduces the risk of accidents to a far greater extent than before, because the gas cylinders remain stored in the cylinder store with the welding gases being fed to the point of use through permanently installed pipelines and fittings.

Naturally, this does not entirely eliminate the need to take cylinders out of the store from time to time in order to carry out certain welding or

cutting operations in various parts of the ship, but the practice of keeping gas cylinders in the engine room and transporting them from place to place, with the risk this entailed, has now practically ceased. Instead, one or two outlets for welding gases are provided in the workshop and engine room. The location of the cylinder central with direct access to the open deck (as provided in the Regulations) makes it easy to get rid of the cylinders in the event of an outbreak of fire, and everybody on board knows exactly where the cylinders are located.

Efficiency and economy are improved by the fact that a sufficient supply of gas is assured, even for jobs needing large amounts of gas, e.g. for heating purposes. Acetylene can be drawn from two or more cylinders at the same time, which means less gas used per unit of time per cylinder, thus ensuring more efficient emptying of the cylinders.

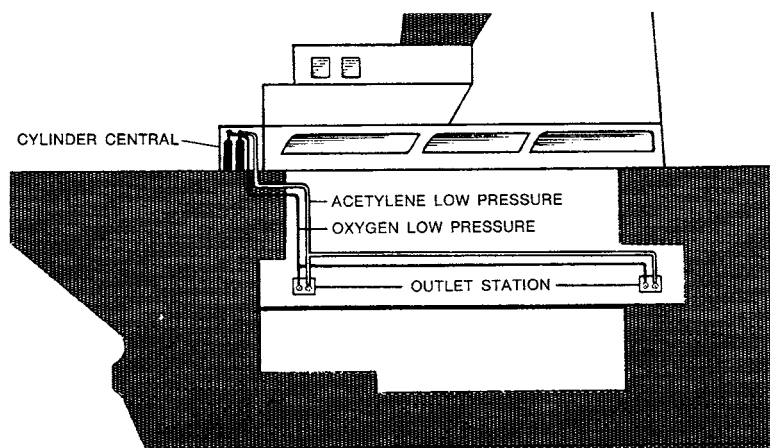



Extracts from regulations relating to central system

A central system for Acetylene and Oxygen consists of a cylinder store with fittings, piping systems and one or more outlet stations. The various components of the central system are subject to rules laid down by the Norwegian Maritime Directorate or similar organisations, and fittings are required to be of approved types. We quote from the Regulations:

- The gas cylinder store shall be a separate room on or above the upper continuous deck. The room shall have bulkheads, deck and deckhead of steel and have a gastight separation from adjacent rooms.
- On drilling platforms and special purpose ships the gas cylinder store may be located on an open deck.
- The gas cylinder store shall be insulated, ventilated and so arranged that the temperature does not normally exceed 40°C.
- The ventilation system shall not be connected to any other ventilation system on board.
- The room shall not be used for any other purpose than the storage of gas cylinders.
- Electrical installations in a gas cylinder system shall be of explosion-proof types.
- Acetylene and Oxygen cylinders shall not be kept in the engine room.
- Pipes (on the low-pressure side) shall be seamless, of material ST35 or equivalent, and of wall thickness not less than 2.0 mm. On drilling platforms and special-purpose ships the wall thickness of pipelines on open deck shall be not less than 2.5 mm.

- Pipelines shall be laid with the fewest possible joints. Joints shall be made by butt welds, of good workmanship.
- Connections such as unions, sleeves, flanges etc. are not accepted as alternatives to welding.
- Normally, only two outlet stations are allowed for each pipe system from the cylinder store or cabinet. On drilling platforms and special-purpose ships a greater number of outlet stations may be permitted. Approval of the number of outlet stations must be obtained in each individual case.
- When the central plant is not in use the gas cylinder valves and other valves shall be shut.

The above points are only extracts from some of the rules relating to central plants in ships. The complete rules are to be found in “Regulations relating to welding equipment etc. for the welding gases Acetylene and Oxygen on board ships, mobile drilling platforms and special-purpose vessels in offshore operations”, issued by the Norwegian Maritime Directorate. A copy of these Regulations can be obtained from Unitor.

Approval and certification of central plants

Before a central plant is allowed to be brought into use it must be inspected, degreased, blown through and pressure-tested in compliance with the rules of the Norwegian Maritime Directorate or similar organisations. When the plant is found to be in order an installation certificate is issued, valid for 5 years.

The original of the installation certificate is to be posted in the



GAS SUPPLIES AND GAS DISTRIBUTION SYSTEM

central gas storage. If any important component of the system is damaged, changed or replaced, the system shall be inspected again and a new installation certificate issued.

The layout of the central system

The layout of the central system and various components are shown in the drawing on the next page. The central store where the cylinders are kept must be situated on or above the upper continuous deck, and it must have access to the open deck. The door to the central store must be marked with a notice warning of gas under pressure.

Fastening arrangements (1) for the number of Acetylene and Oxygen cylinders to be kept on board are to be welded to the bulkhead. The design of the fastening clamps makes it very easy to release the cylinders in case of a fire. From the cylinders the gas is carried through high-pressure hoses (2) to T-valves (3).

The connection nuts for the high-pressure hoses are right-hand threaded for Oxygen and left-hand threaded for Acetylene, to eliminate the possibility of the hoses being wrongly connected. Non-return valves are fitted to prevent gas from flowing back through the T-valve to the gas cylinders.

By using several T-valves connected by expansion pipes (4) it is possible to connect in series any desired number of cylinders. The last T-valve in the series is closed with a blind plug and connecting nut (5). From the T-valves the gas is led to a shut-off valve (6) where the central regulator R520(7) is located. The regulator has an adjusting

screw with a locknut for pressure regulation. When the correct pressure has been set on the regulator (8 bar for oxygen and 0.8 bar for acetylene), the setting is locked by tightening the locknut. This makes it unnecessary to reset the pressures every time the plant is used, the gas flow being controlled simply by opening and closing the shut-off valve (6).

The desired working pressure is set by means of a regulating valve at the outlet station, as required for the individual welding and cuffing operations. The safety valve of the central regulator (8) must be connected to a pipe to carry any escaping gas out to the open deck. The end of this pipe must be located not less than 3 metres above deck, and the outlet must be marked with a regulation sign as follows: "Gas danger. Fire, open lights and smoking prohibited."

From the low-pressure side of the regulator the gas is fed through a low-pressure steel expansion pipe (9) and connected to the permanent piping system. The pipelines are colour-coded. Blue pipes are for Oxygen and red for Acetylene.

Where a pipe passes through bulkheads or decks it must be led through bushings (10), and the pipes are to be fastened to bulkheads with pipe clamps (11) at intervals of about 2.5 metres. The outlet stations are to be installed at suitable locations which are well ventilated and where the outlet station is protected from mechanical damage. The standard cabinet (12) which is delivered with the outlet station is a steel plate design for mechanical protection indoors.

GAS SUPPLIES AND GAS DISTRIBUTION SYSTEM



Outlet stations on open decks must always be enclosed in protective cabinets. A special corrosion free glass fibre cabinet is available for this purpose. Each outlet station is fitted with shut-off valves (13) which should be closed during short interruptions in work.

Also fitted at the outlet station are regulators to set the desired working pressure (14) and flashback arrestors (15) for Acetylene and Oxygen.

NOTE: There is a filter in the threaded inlet union for the shut-off valve of the gas pipeline, to prevent particles passing into the outlet fittings. In time this filter can become clogged; it should be unscrewed for inspection from time to time.

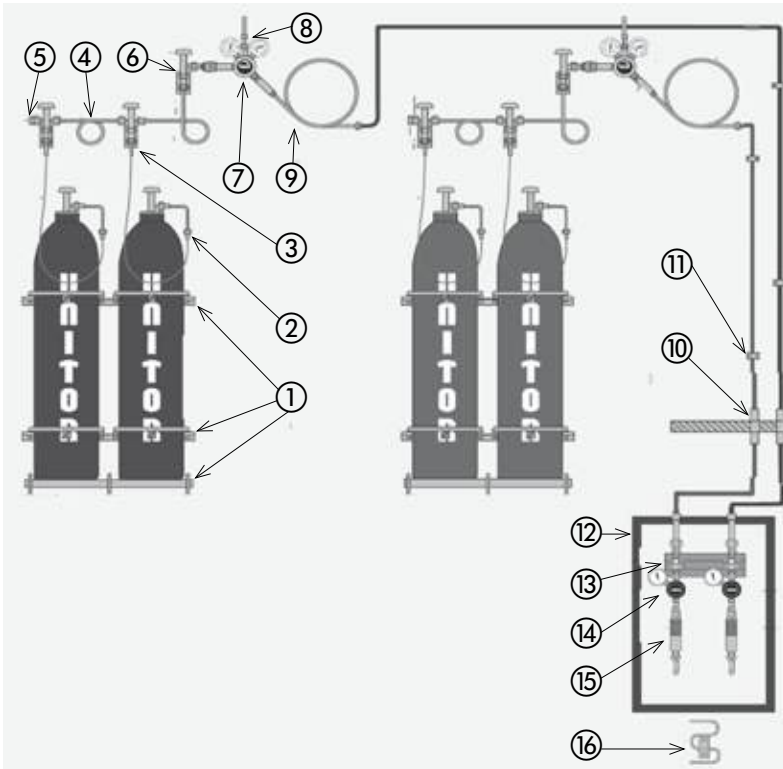



GAS SUPPLIES AND GAS DISTRIBUTION SYSTEM

Pos. No	Prod. no	Description
1	176297	Rack for 2 cylinders.
1	320358	Rack for 1 cylinder.
1	176313	Clamp assembly.
2	305292	High pressure hose Ox 1 mtr.
2	520403	High pressure hose Ac 1 mtr.
3	303198	T-valve N2/Ox W/non.
3	520379	T-valve AC W/non return.
3	511089	Non return valve Ox.
3	520387	Non return valve Ac.
4	302505	High Pressure connector Ox.
4	517086	High Pressure connector Ac.
5	302547	Blind plug.
5	302539	Conection nut Ox 1/4 in.
5	51708	Connection nut Ac 1/4 in.
6	302992	Closing valve Ox W bracket.
6	520395	Closing valve Ac.
7	510020	Regulator 520 Ac pressure 0–2.5 bar.
7	510021	Regulator 520 Ox pressure 0–16 bar.
7	585372	Flashback arrestor Ac 85–10.
7	682427	Flashback arrestor Ox 85–10.
9	621565	High Pressure connector AC.
9	621573	High Pressure connector OX.
10	624684	Bushing for steel pipes.
11	320226	Clamp No. 20 F/steel pipe.
12	550335	Cabinet F/outlet station, steel.
12	536805	Cabinet F/outlet station, glass fibre.
13	550319	Twin valve unit F/outlet.
14	510030	Regulator 530 Ac pressure 0–2.5 bar.
14	510031	Regulator 530 Ox pressure 0–16 bar.
15	708537	Flasback arrestor S55 Ac.
15	708545	Flashback arrestor S55 Ox.
16	235010	Stretch relief bracket.

Signs for entrance doors

526533	«Acetylene» (100x500)
526541	«Oxygen» (100x500)
183202	«Gas under pressure» (250x450)
526566	«Gas danger» small (150x300)
516625	«Gas danger» large (300x600)
526558	«No admittance» (200x500)

Instructions signs for gas central

176404	«Acetylene instruction» (350x300)
176412	«Oxygen instruction» (350x300)
183236	«Piperline pressure» (190x145)

Signs for outlet station

183244	«Close valves (90x75)
511253	«Working pressures» (70x200)

NOTE: The «Gas danger» small sign shall be placed at the outlet point of the ventilation pipes from the central regulators.

(Size in mm HxW)

MISCELLANEOUS INFORMATION

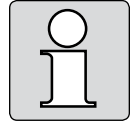

International system of units	536
The Greek Alphabet	537
General conversion factors	538
Roman numerals	539
Metric and decimal equivalents of fractions of an inch	540
Wire cross section AWG/mm ²	540
Common gauge series for sheet thickness and wire	541
Physical properties of some elements	542
Hardness comparison table	543
Corrosion of galvanic couples in sea water	544
Temperature scales	546
Pressure variations related to temperature	547
Abbreviations and welding terminology	548



MISCELLANEOUS INFORMATION

International System of Units (SI)

The International System of Units (SI for short) is built upon seven base units and two supplementary units. Derived units are related to base and supplementary units by formulas in the right hand column. Symbols for units with specific names are given in parentheses.

Quantity	Unit	Formula
Base Units		
Length	metre (m)	
mass	kilogram (kg)	
time	second (s)	
electric current	ampere (A)	
thermodynamic temperature	kelvin (K)	
amount of substance	mole (mol)	
luminous intensity	candela (cd)	
Supplementary Units		
plane angle	radian (rad)	
solid angle	steradian (sr)	
Derived Units		
acceleration	metre per second squared	m/s^2
activity (of a radioactive source)	disintegration per second	(disintegration)/s
angular acceleration	radian per second squared	rad/s^2
angular velocity	radian per second	rad/s
area	square metre	m^2
density	kilogram per cubic metre	kg/m^3
electric capacitance	farad (F)	$A \cdot s/V$
electric conductance	stemens (S)	A/V
electric field strength	volt per metre	V/m
electric inductance	henry (H)	$V \cdot s/A$
electric potential difference	volt (V)	W/A
electric resistance	ohm (Ω)	V/A
electromotive force	volt (V)	W/A
energy	joule (J)	$N \cdot m$
entropy	joule per Kelvin	J/K
force	newton (N)	$kg \cdot m/s^2$
frequency	hertz (Hz)	(cycle)/s
illuminance	lux (lx)	lm/m^2
luminance	candela per square metre	cd/m^2
luminous flux	lumen (lm)	$cd \cdot sr$
magnetic field strength	ampere per metre	A/m
magnetic flux	weber (Wb)	$V \cdot s$
magnetic flux density	tesla (T)	Wb/m^2
magnetomotive force	ampere (A)	-
power	watt (W)	J/s
pressure	pascal (Pa)	N/m^2
quantity of electricity	coulomb (C)	$A \cdot s$
quantity of heat	joule (J)	$N \cdot m$

MISCELLANEOUS INFORMATION



Quantity	Unit	Formula
radiant intensity	watt per steradian	W/sr
specific heat	joule per kilogram-kelvin	J/kg•K
stress	pascal (Pa)	N/m ²
thermal conductivity	watt per metre-kelvin	W/m•K
velocity	metre per second	m/s
viscosity, dynamic	pascal-second	Pa•s
viscosity, kinematic	square metre per second	m ² /s
voltage	volt (V)	W/A
volume	cubic metre	m ³
wavenumber	reciprocal metre	(wave)/m
work	joule (J)	N•m

Multiplication Factors	Prefix	SI Symbol
1 000 000 000 000 = 10 ¹²	tera	T
1 000 000 000 = 10 ⁹	giga	G
1 000 000 = 10 ⁶	mega	M
1 000 = 10 ³	kilo	k
100 = 10 ²	hecto*	h
10 = 10 ¹	deka*	da
0,1 = 10 ⁻¹	deci*	d
0,01 = 10 ⁻²	centi*	c
0,001 = 10 ⁻³	milli	m
0,000 001 = 10 ⁻⁶	micro	μ
0,000 000 001 = 10 ⁻⁹	nano	n
0,000 000 000 001 = 10 ⁻¹²	pico	p
0,000 000 000 000 001 = 10 ⁻¹⁵	femto	f
0,000 000 000 000 000 001 = 10 ⁻¹⁸	atto	a

* To be avoided where possible.

THE PHONETIC ALPHABET

A	B	C	D	E	F	G	H	I
Alpha	Bravo	Charlie	Delta	Echo	Foxtrot	Golf	Hotel	India
J	K	L	M	N	O	P	Q	R
Juliet	Kilo	Lima	Mike	November	Oscar	Papa	Quebec	Romeo
S	T	U	V	W	X	Y	Z	
Sierra	Tango	Uniform	Victor	Whiskey	X-ray	Yankee	Zulu	

THE GREEK ALPHABET

Aα	Bβ	Γγ	Δδ	Eε	Zζ	Hη	Θθ
Alpha	Beta	Gamma	Delta	Epsilon	Zeta	Eta	Theta
Iι	Kκ	Λλ	Mμ	Nν	Ξξ	Oο	Ππ
Jota	Kappa	Lambda	My	Ny	Xi	Omikron	Pi
Pρ	Σσ	Ττ	Υυ	Φφ	Χχ	Ψψ	Ωω
Rho	Sigma	Tau	Ypsilon	Phi	Chi	Psi	Omega



MISCELLANEOUS INFORMATION

General conversion factors

Unit	Conversion to	Multiply by	Reciprocal
Linear Measure			
mil (0,001 inch)	millimetre	0,0254	39,37
inch	millimetre	25,4	0,03937
foot	metre	0,3048	3,281
yard	metre	0,9144	1,0936
mile	kilometre	1,6093	0,6214
nautical mile	kilometre	1,8532	0,5396
Square Measure			
square inch	square millimeter	645,2	0,00155
square inch	square centimeter	6,452	0,155
square foot	square metre	0,0929	10,764
square yard	square metre	0,8361	1,196
acre	square metre	4047,	0,0002471
acre	square foot	43560,	0,00002296
square mile	acre	640,	0,001562
square mile	square kilometer	2,590	0,3863
Volume			
cubic inch	cubic centimeter	16,387	0,06102
cubic foot	cubic metre	0,02832	35,31
cubic foot	gallon (U.S.)	7,48	0,1337
cubic foot	litre	28,32	0,03531
cubic yard	cubic metre	0,7646	1,3079
ounce (U.S., liq.)	cubic centimeter	29,57	0,03382
quart (U.S., liq.)	litre	0,9464	1,0566
gallon (U.S.)	gallon (Imperial)	0,8327	1,2009
gallon (U.S.)	litre	3,785	0,2642
barrel (U.S.Petroleum)	gallon (U.S.)	42,	0,0238
barrel (U.S.Petroleum)	litre	158,98	0,00629
Mass			
grain	milligram	64,8	0,01 543
ounce (oz)	gram	28,35	0,03527
pound (lbs)	kilogram	0,4536	2,205
short ton	metric ton	0,9072	1,1023
long ton	metric ton	1,0161	0,9842
Pressure or Stress			
pound force per inch ² (psi)	pascal	6895,	0,0001450
kip per inch ² (ksi)	megapascal	6,895	0,145
pound force per inch ² (psi)	bar	0,06895	14,50
kip per inch ²	kilogram per millimetre ²	0,7031	1,4223
atmosphere	mm Hg	760,	0,001316
atmosphere	pound force per inch ²	14,696	0,06805

MISCELLANEOUS INFORMATION



Unit	Conversion to	Multiply by	Reciprocal
Pressure or Stress (Cont.)			
atmosphere	bar	1,013	0,9872
atmosphere	megapascal	0,1013	9,872
torr (mm Hg)	pascal	133,32	0,007501
inch of water	pascal	248,8	0,004019
foot of water	pound force per inch ²	0,4335	2,307
dyne per centimetre ²	pascal	0,1000	10,00
Work, Heat and Energy			
British thermal unit (Btu)	joule	1055,	0,0009479
foot pound-force	joule	1,356	0, 7375
calorie	joule	4,187	0,2389
Btu	foot pound-force	778,	0,001285
kilocalorie	Btu	3,968	0,252
Btu	kilogram metre	107,56	0,009297
Btu per hour	watt	0,2929	3,414
watthour	joule	3600,	0,0002778
horse power	kilowatt	0,7457	1,341
Miscellaneous			
pound per gallon (U.S.)	gram per litre	119,8	0,00835
pound mole (gas)	cubic foot (STP)	359,	0,00279
gram mole (gas)	litre (STP)	22,4	0,0446
board foot	cubic metre	0,00236	423,7
milliampere per foot ²	milliampere per metre ²	10,76	0,0929
gallons (U.S.) per minute	metre ³ per day	5,451	0,1835
pound-force	newton	4,448	0,2248
kilopond (Kp)	newton (N)	9,81	0,102

Roman Numerals

Basic numerals:	I	V	X	L	C	D	M
	1	5	10	50	100	500	1000

Combination rules:

- A smaller numeral in front of a larger is subtracted from the larger
- A smaller numeral after a larger is added to the larger
- Equal numerals after each other are added together
- II and III are never placed in front of a larger numeral, e.g. 7 is always VII, never IIIX

Examples:

1961	=	1000	+	900	+	60	+	1	
				-100+1000		50+10			
		M		CM		LX		I	= MCMLXI
1838	=	1000	+	800	+	30	+	8	
				500+100+100+100		10+10+10		5+1+1+1	
		M		DCCC		XXX		VIII	= MDCCCXXXVIII

A horizontal line above a numeral multiplies this numeral with 1000. A horizontal line above together with a vertical line on each side of the numeral multiplies the numeral with 100.000.

$\overline{\text{XII}}$ = 12 000 $[\text{XII}]$ = 1200 000



MISCELLANEOUS INFORMATION

Metric and Decimal Equivalents of Fractions of an Inch

Inches		mm	inches		mm
1/64	0.015	0.3968	33/64	0.516	13.0966
1/32	0.031	0.7937	17/32	0.531	13.4934
3/64	0.047	1.1906	35/64	0.547	13.8903
1/16	0.063	1.5876	9/16	0.563	14.2872
5/64	0.078	1.9843	37/64	0.578	14.6841
3/32	0.094	2.3812	19/32	0.594	15.0809
7/64	0.109	2.7780	39/64	0.609	15.4778
1/8	0.125	3.1749	5/8	0.625	15.8747
9/64	0.141	3.5718	41/64	0.641	16.2715
5/32	0.156	3.9686	21/32	0.656	16.6684
11/64	0.172	4.3655	43/64	0.672	17.0653
3/16	0.188	4.7624	11/16	0.688	17.4621
13/64	0.203	5.1592	45/64	0.703	17.8590
7/32	0.219	5.5561	23/32	0.719	18.2559
15/64	0.234	5.9530	47/64	0.734	18.6527
1/4	0.250	6.3498	3/4	0.750	19.0496
17/64	0.266	6.7467	49/64	0.766	19.4465
9/32	0.281	7.1436	25/32	0.781	19.8433
19/64	0.297	7.5404	51/64	0.797	20.2402
5/16	0.313	7.9373	13/16	0.813	20.6371
21/64	0.328	8.3342	53/64	0.828	21.0339
11/32	0.344	8.7310	27/32	0.844	21.4308
13/64	0.359	9.1279	55/64	0.859	21.8277
3/8	0.375	9.5248	7/8	0.875	22.2245
25/64	0.391	9.9216	57/64	0.891	22.6214
13/32	0.406	10.3185	29/32	0.906	23.0183
27/64	0.422	10.7154	59/64	0.922	23.4151
7/16	0.438	11.1122	15/16	0.938	23.8120
29/64	0.453	11.5091	61/64	0.953	24.2089
15/32	0.469	11.9060	31/32	0.969	24.6057
31/64	0.484	12.3029	63/64	0.984	25.0026
1/2	0.500	12.6997	1/1	1.000	25.3995

Wire cross sections

AWG	mm ²
20	0,519
18	0,823
16	1,31
14	2,08
12	3,31

AWG	mm ²
10	5,26
8	8,367
6	13,30
4	21,15
2	33,62

AWG	mm ²
1	42,41
1/0	53,49
2/0	67,43
3/0	85,01
4/0	107,2

MISCELLANEOUS INFORMATION

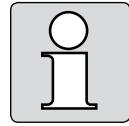

Common Gauge series used for Sheet thickness and Wire

Name	Abbreviation	Name	Abbreviation
American Wire Gauge	AWG	Standard Wire Gauge (British)	SWG
Birmingham Wire Gauge	BWG	Manufacturer's Standard (U.S.)	MSG
Brown and Sharp (identical to AWG)	B&S	U.S. Standard Plate	USC
Galvanized Iron	GSG	Zinc (American Zinc Gauge)	AZG

Thickness in mm

Gauge No.	Al(U.S.)	Galv. Iron GSG	Al(U.K.) SWG	Stainless Steel			Zinc AZG
	Copper Brass B&S AWG			Steel MSG	Sheet USG	Strip BWG	
7/0			12,7				
6/0			11,8				
5/0			11,0				
4/0			10,2				
3/0			9,4				
2/0			8,8				
1/0			8,2				
1	7,34		7,62		7,14		
2	6,55		7,01		6,75		
3	5,82		6,40	6,07	6,35		0,15
4	5,18		5,89	5,69	5,95		0,20
5	4,62		5,38	5,31	5,56		0,25
6	4,11		4,88	4,93	5,16		0,30
7	3,66		4,47	4,55	4,76	4,57	0,36
8	3,25	4,27	4,06	4,17	4,37	4,19	0,41
9	2,90	3,89	3,66	3,78	3,97	3,76	0,46
10	2,59	3,50	3,25	3,40	3,57	3,40	0,51
11	2,31	3,18	2,95	3,05	3,18	3,05	0,61
12	2,06	2,79	2,64	2,67	2,78	2,77	0,71
13	1,83	2,41	2,34	2,29	2,38	2,41	0,81
14	1,63	2,03	2,03	1,90	1,98	2,11	0,91
15	1,45	1,80	1,83	1,70	1,79	1,83	1,02
16	1,30	1,63	1,63	1,52	1,59	1,65	1,14
17	1,14	1,47	1,42	1,37	1,42	1,47	1,27
18	1,02	1,32	1,22	1,22	1,27	1,24	1,40
19	0,91	1,17	1,02	1,07	1,11	1,07	1,52
20	0,81	1,02	0,91	0,91	0,95	0,89	1,78
21	0,71	0,94	0,81	0,84	0,87	0,81	2,03
22	0,64	0,86	0,71	0,76	0,79	0,71	2,29
23	0,58	0,79	0,61	0,69	0,71	0,64	2,54
24	0,51	0,71	0,56	0,61	0,64	0,56	3,18
25	0,46	0,64	0,51	0,53	0,56	0,51	6,35



MISCELLANEOUS INFORMATION

Physical properties of some elements

	Symbol	Density g/cm ³ 20°C	Melting Point °C		Symbol	Density g/cm ³ 20°C	Melting Point °C
Aluminum	Al	2,70	660	Manganese	Mn	7,2	1260
Antimony	Sb	6,68	630	Mercury	Hg	13,55	-38,9
Argon	A	1,784*	-189,2	Molybdenum	Mo	10,2	2620
Arsenic	As	5,73	814	Nickel	Ni	8,90	1455
Barium	Ba	3,5	725	Niobium	Nb	8,55	2500
Beryllium	Be	1,85	1280	Nitrogen	N	1,25*	-209,9
Bismuth	Bi	9,80	271	Oxygen	O	1,429*	-218,4
Boron	B	2,3	2300	Phosphorus	P	1,82	44,1
Bromine	Br	3,12	-7,2	Platinum	Pt	21,37	1773
Cadmium	Cd	8,65	321	Potassium	K	0,87	62,3
Calcium	Ca	1,55	842	Rhodium	Rh	12,5	1966
Carbon	C	2,25	3550	Selenium	Se	4,8	220
Chlorine	Cl	1,56**	-103	Silicon	Si	2,42	1420
Chromium	Cr	7,2	1890	Silver	Ag	10,50	960,5
Colbalt	Co	8,9	1495	Sodium	Na	0,97	97,5
Copper	Cu	8,92	1083	Sulphur	S	2,07	119
Fluorine	F	1,69*	-223	Tantalum	Ta	16,6	2996
Gold	Au	19,32	1063	Tin	Sn	7,31	231,9
Hafnium	Hf		3300	Titanium	Ti	4,5	1800
Helium	He	0,177*	-272,2	Tungsten	W	19,3	3370
Hydrogen	H	0,090*	-259,2				
Iodine	I	4,93	113,5	Vanadium	V	5,96	1710
Iron	Fe	7,87	1535	Zinc	Zn	7,14	419,5
Lead	Pb	11,35	327,4	Zirconium	Zr	6,4	1857
Lithium	Li	0,53	186				
Magnesium	Mg	1,74	651				

* kg/Nm³

** Liquid, at boiling point -37°C



Hardness comparison table

Brinell HB	Vickers HV (>5 kpl)	Rockwell (*HRB) HRC	Tensile strength N/mm ²
80	80	36,4*	275
85	85	42,2*	295
90	90	47,4*	315
95	95	52,0*	325
100	100	56,4*	345
105	105	60,0*	365
110	110	63,4*	380
115	115	66,4*	390
120	120	69,4*	410
125	125	72,0*	420
130	130	74,4*	440
135	135	76,4*	460
140	140	78,4*	470
145	145	80,4*	490
150	150	82,2*	500
155	155	83,8*	520
160	160	85,4*	540
165	165	86,8*	550
170	170	88,2*	570
175	175	89,6*	590
180	180	90,8*	610
185	185	91,8*	620
190	190	93,0*	640
195	195	94,0*	660
200	200	95,0*	670
205	205	95,8*	685
210	210	96,6*	715
215	215	97,6*	705
220	220	98,2*	735
225	225	99,0*	755
230	230	19,2	765
235	235	20,2	785
240	240	21,2	805
245	245	22,1	825
250	250	23,0	835
255	255	23,8	855
260	260	24,6	875
265	265	25,4	885
270	270	26,2	900
275	275	26,9	920
280	280	27,6	940
285	285	28,3	950
290	290	29,0	970
295	295	29,6	990

Brinell HB	Vickers HV (>5 kpl)	Rockwell HRC	Tensile strength N/mm ²
300	300	30,3	1010
310	310	31,5	1040
320	320	32,7	1070
330	330	33,8	1100
340	340	34,9	1140
350	350	36,0	1170
359	360	37,0	1205
368	370	38,0	1235
376	380	38,9	1265
385	390	39,8	1295
392	400	40,2	1325
400	410	41,5	1355
408	420	42,4	1385
415	430	43,2	1400
423	440	44,0	1430
430	450	44,8	1460
436	460	45,5	1490
443	470	46,3	1520
451	480	47,0	1540
459	490	47,7	1570
467	500	48,3	1600
481	520	49,6	1660
495	540	50,9	1765
508	560	52,1	1825
521	580	53,3	1715
535	600	54,4	1875
548	620	55,4	1930
561	640	56,4	1980
574	660	57,4	2030
588	680	58,4	2080
602	700	59,3	2130
615	720	60,2	2170
627	740	61,1	2215
639	760	61,9	2255
650	780	62,7	
661	800	63,5	
672	820	64,3	
682	840	65,0	
692	860	65,7	
701	880	66,3	
711	900	66,9	
	920	67,5	
	940	68,0	



MISCELLANEOUS INFORMATION

Corrosion of Galvanic couples in Sea water at 4–27 °c

- No marking** Unfavorable – Normal Deterioration of either material may be increased moderately or severely.
- X** Uncertain – Direction and/or magnitude of effect on normal behavior may vary, depending on circumstances.
- 0** Compatible – Deterioration of either material is normally within tolerable limits.
- S** – Exposed area of the metal under consideration is small compared with the area of the metal with which it is coupled.
- E** – Exposed area of the metal under consideration is approximately equal to that of the metal with which it is coupled.
- L** – Exposed area of the metal under consideration is large compared with that of the metal with which it is coupled.

Note: These numbers correspond with the numbers and alloy designations listed in the left column.

METAL CONSIDERED ↓	COUPLED WITH →	1	2	3	4	5	6	7	8	9	10	11	12	13	14	15	16	17	
1 Zinc	S	Shaded																	
	E	Shaded																	
	L	0	0	0	0	0	0												
2 Aluminum Alloys	S	0	Shaded																
	E	X	Shaded																
	L		X	X	X	X										X	X	X	
3 Mild Steel, Wrought Iron	S	0	X	Shaded															
	E	0	X	Shaded		0	X												
	L				0	0	0	0	0	0	0	0	0	0	0	0	0	0	0
4 Cast Iron, Flake or Ductile	S	0	X	0	Shaded		X												
	E			0	Shaded		X	X											
	L							0	X	X	X	X	X	X	X	X	X	0	0
5 Low Alloy High Strength Steel	S	0	X	0		Shaded													
	E			X	X	Shaded		X											
	L				X	Shaded		0	0	0	0	0	0	0	0	0	0	0	0
6 Austenitic Cast Irons, Types 1 & 2	S	0	X	0	0	0	Shaded												
	E				X	X	Shaded											X	
	L						Shaded		0	0	0	0	0	0	0	0	0	0	0

MISCELLANEOUS INFORMATION

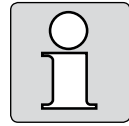

METAL CONSIDERED ↓	COUPLED WITH →	1	2	3	4	5	6	7	8	9	10	11	12	13	14	15	16	17		
7 Naval Br (CA464), Yel.Br. (CA268), AlBr (CA687), Red Br (CA230, Adm'ty Br(CA443), Mn Bronze	S			O	X	O	O													
	E								X	X	X	X	X	X				X	X	
	L								X	X	X	X	X	X	X			X	O	
8 Copper (CA102, 110), Si Bronze (CA655)	S			O	X	O	O	X												
	E							X		X	X	X	X	X				X	X	
	L								X	X	X	X	X	X	X				O	
9 Tin Bronze (G&M)	S			O	X	O	O	X	X										X	X
	E							X	X			O	X	X	X	X		X	O	
	L											X	O	O	X	X		X	O	
10 90/10 Copper-Nickel (CA706)	S			O	X	O	O	X	X	X				X						
	E							X	X	O			O	O	X	X		X	X	
	L								X				O	O	O			O	O	
11 70/30 Copper-Nickel (CA715)	S			O	X	O	O	X	X	O				O	X					
	E							X	X	X	O			O	X	X		X	O	
	L								X					O	O	O		O	O	
12 Nickel-Aluminium-Bronze	S			O	X	O	O	X	X	O	O				X					
	E							X	X	X	O	O			X	X		X	X	
	L								X	X	O				O	O		O	O	
13 Nickel	S			O	X	O	O	X	X	X	O	O	O							
	E							X	X	X	X	X	X			X		X	X	
	L								X	X	X					X		O	O	
14 Silver	S			O	X	O	O	X	X	X	O	O	O	X					X	X
	E								X	X	X	X	X					X	X	
	L																	X	X	
15 Stainless Steel, 18 Cr, 8 Ni (AISI Types 302, 304, 321, 347)	S		X	O	X	O	O													
	E						X													
	L																			
16 Stainless Steel, 18 Cr, 12 Ni-Mo (AISI Types 316, 317)	S		X	O	O	O	O	X		X	O	O	O	O	X				X	
	E						O	X	X	X	X	X	X	X	X				X	
	L								X						X				X	
17 Titanium, Nickel alloys C, C-276, 625	S		X	O	O	O	O	O	O	O	O	O	O	O	X				X	
	E			X	X	X	O	X	X	O	X	O	X	X	X				X	
	L								X						X				X	



MISCELLANEOUS INFORMATION

Temperature Scales

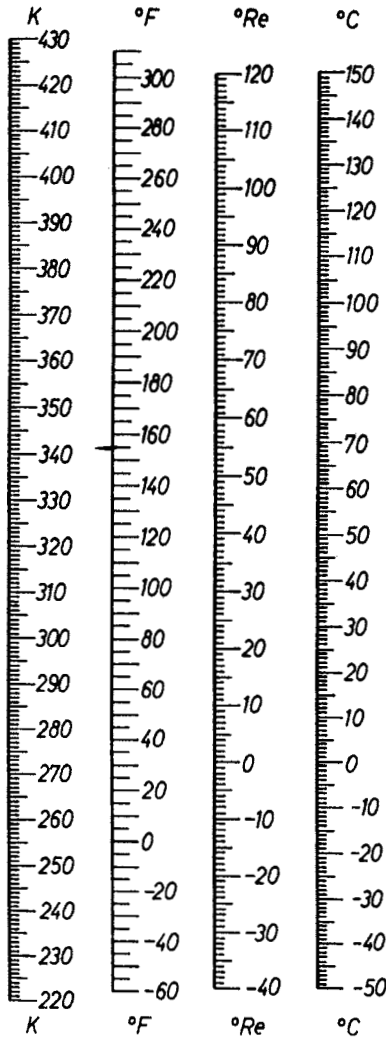

t (°C) = temperature, degrees Celsius

T (K) = temperature, degrees Kelvin

t_{re} (°Re) = temperature, degrees Réaumur

t_f (F°) = temperature, degrees Fahrenheit

0 °C = $273,15$ K = 0 °Re
= 32 °F = $491,67$ °R

100 °C = $373,15$ K = 80 °Re
= 212 °F = $671,67$ °R

t = $5/9 (t_f - 32)$

t = $5/4 t_{re}$

t = $T - 273,15$

t = $5/9 T_R - 273,15$

t_f = $9/5 t + 32$

t_f = $T_R - 459,67$

t_f = $9/4 (t_{re} + 32)$

T = $t + 273,15$

T = $5/9 t_f + 255,37$

T = $5/9 T_R$

T_R = $t_f + 459,67$

T_R = $9/5 t + 491,67$

T_R = $9/5 T$

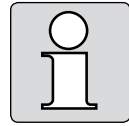

Pressure variations related to Temperature

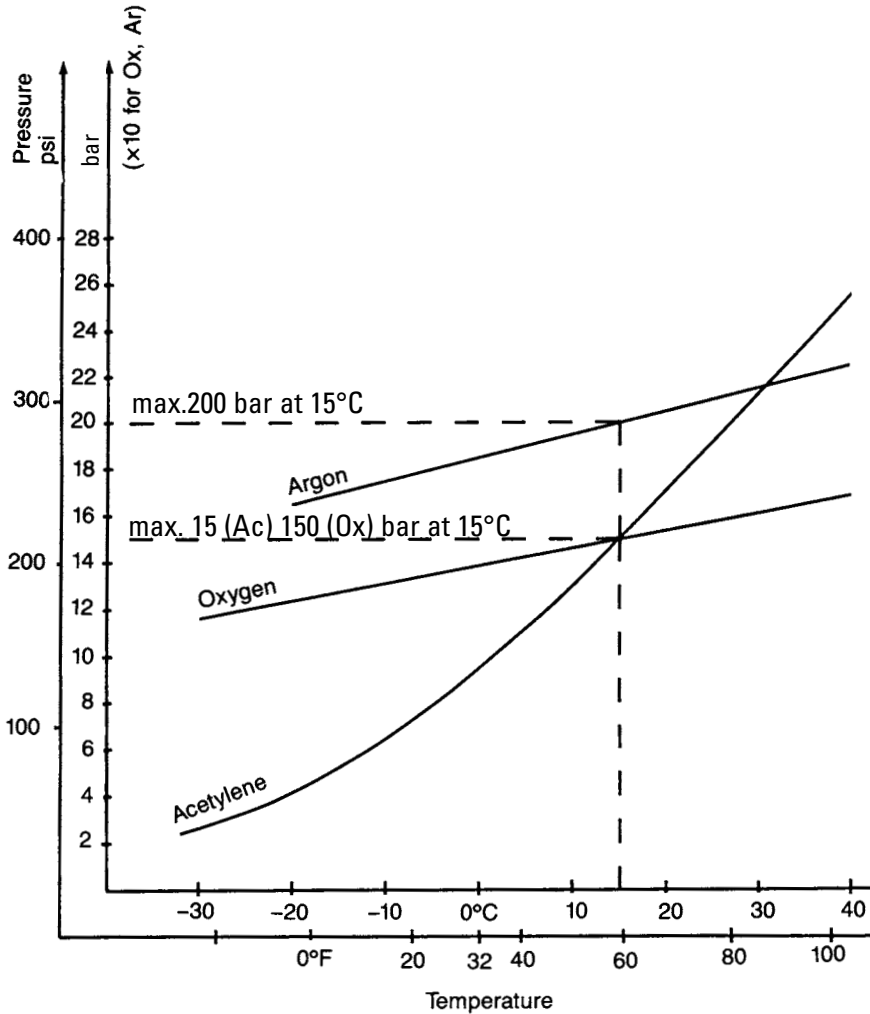

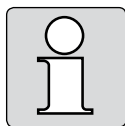

MISCELLANEOUS INFORMATION

Abbreviations and Welding Terminology

ABS	Abbreviation for American Bureau of Shipping (classification institute).
ACETONE	Colourless, volatile, water-soluble, flammable liquid.
ACETYLENE	Colourless gas with high carbon content, lighter than air, C_2H_2 .
AC	Alternating current
AIR CARBON ARC GOUGING	Removal of material from electrically conductive metals by means of an electric arc between carbon electrode and workpiece combined with an air pressure jet adjacent to the electrode.
AISI	Abbreviation for American Iron and Steel Institute.
ALLOYED STEEL	Steel which, in addition to carbon, contains certain alloy elements to provide special characteristics.
ALUMINIUM BRONZE	Aluminium alloys with high copper content. See section on Metals and Alloys.
«A»-MEASUREMENT	Measurement denoting depth of fillet welds.
AMMETER	Instrument for measuring electrical current measured in amperes.
AMPERAGE	Strength of an electrical current measured in amperes.
ANNEAL	Removal of internal stresses in metal by heating and slow cooling.
ANSI	Abbreviation for American National Standard Institute.
ARC BLOW	Deflection of intended arc pattern by magnetic fields.
ARGON	Inert gas – used as shielding gas in wire welding and TIG welding.
ASM	Abbreviation for American Society for Metals.
ASME	Abbreviation for American Society of Mechanical Engineering. Issues regulations relating to planning and construction of welded installations.
ASPHYXIATION	Loss of consciousness due to lack of oxygen.
ASTM	Abbreviation for American Society for Testing and Materials.
AUSTENITE	Nonmagnetic stainless steel that cannot be hardened by heat treatment. This type of steel is characterized by its unique grain structure. Contains at least 11 % chromium with varying amounts of nickel.

MISCELLANEOUS INFORMATION

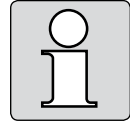

AWS	Abbreviation for American Welding Society.
BACKUP BAR	Tool or fixture attached to the root of weld joint. Tool may or may not control the shape of the penetrating metal.
BACKUP GAS	Shielding gas which protects the root of the weld from the atmosphere.
BASE MATERIAL	The material in components to be joined by welding. The composition and dimension of the base materials are the deciding factors for the welding process and filler material to be used.
BASIC COATING	Electrode coating consisting of calcite, fluorspar, ferromanganese and ferrosilicium.
BERYLLIUM	Hard, light metallic element used in copper for better fatigue endurance.
BEVEL	Angular type of edge preparation.
BOILER STEEL	Better known as heat resistant construction steel. Weldable and corrosion resistant steel with satisfactory resistance under high thermic conditions, approx. 500–700°C. This type of steel may be unalloyed, low alloyed or stainless.
BORE	Inside diameter of hole, tube or hollow object.
BRAZING	The method where surface bonding between the base material and filler metal is achieved.
BRIGHT METAL	Material preparation where the surface has been ground or machined to a bright surface to remove scale or oxides.
BRINELL HARDNESS	Abbreviated HB, denoting load in kp from a hard steel ball divided by the spherical area of indentation in mm ² . Expressed in kp mm ² .
BS	Abbreviation for British Standard.
BURNTHROUGH	Weld which has melted through, resulting in a hole and excessive penetration.
BV	Abbreviation for Bureau Veritas (French classification institute).
CADMIUM	White ductile metallic element used for plating material to prevent corrosion.
CAPILLARY BRAZING	Method of brazing using the capillary forces to draw the filler metal into narrow gaps. Max. gap for capillary brazing is 0.1 mm.

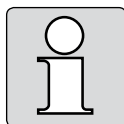

MISCELLANEOUS INFORMATION

CARBIDES	Compound of carbon with one or more metal elements.
CAST IRON ELECTRODES	Welding electrode specially suitable for welding and repair of cast iron. The electrode has a core of nickel or nickel alloy and a slag forming and arc stabilizing coating.
CE	Equipment with CE-markings fulfils the the basic requirements of the Low Voltage and Electromagnetic Compatibility Guideline.
CLADDING	Layer of material applied to a surface for the purpose of improved corrosion resistance.
COLD LAPS	Area of weld that has not fused with the base metal.
CONCAVE WELD CROWN	Weld crown that is curved inward.
CONSTRUCTION STEEL	General expression denoting weldable steel in strength classification 37–60 kp/mm ² .
CONTAMINATION	Indicates a dirty part, impure shielding gas or impure filler metal.
CONTOUR	Shape of the weld bead or pass.
CONVEX WELD CROWN	Weld crown that is curved outward.
COPPER	Metal element with melting point at 1083 °C. Cu.
CORROSION	Eating away of material by a corrosive medium.
CRATER	Depression at the end of a weld that has insufficient cross section.
CRATER CRACKS	Cracking that occurs in the crater.
CSA	Equipment with CSA-Test mark fulfils the requirements made in the relevant standards for Canada and the USA.
CUNIFER	Alloy of copper and nickel. Seawater resistant. See section on Metals and Alloys.
DC	Direct current.
DEEP WELDING ELECTRODES	Electrodes with acid or rutile organic coatings which increase the arc effect and generation of heat in the melting-in process.
DEMURRAGE	Monetary charge applied to the user of gas cylinders beyond agreed rental period.
DEOXIDIZED FILLER MATERIALS	Filler materials which contains deoxidizers such as aluminium, zirconium and titanium for welding steels.

MISCELLANEOUS INFORMATION

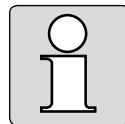

DESTRUCTIVE TESTING	DT – series of tests by destruction to determine the quality of a weld.
DEWARS	Specially constructed tank similar to a vacuum bottle for the storage of liquified gases.
DIN	Abbreviating for Deutsche Institut für Normung.
DIRECT CURRENT	Flow of current (electrons) in only one direction, either to the workpiece or to the electrode.
DIRECT CURRENT ELECTRODE NEGATIVE (DCEN)	Direct current flowing from electrode to the work.
DIRECT CURRENT ELECTRODE POSITIVE (DCEP)	Direct current from work to the electrode.
DIRECT CURRENT REVERSE POLARITY (DCRP)	See Direct Current Electrode Positive.
DIRECT CURRENT STRAIGHT POLARITY (DCRP)	See Direct Current Electrode Negative.
DNV	Abbreviation for Det Norske Veritas (Norwegian classification institute).
DUCTILITY	Property of material causing it to deform permanently, or to exhibit plasticity without breaking while under tension.
DUTY CYCLE	Arc/time factor – the relationship between the time the arc is in operation and the total working time measured over a period of 10 minutes. Expressed in % of the time the welding machine can work at a certain amperage in this period. I.e. a 30% intermittence the arc can be in operation 3 min. of the period. During the remaining time the machine will be at rest while electrodes are changed, slag removed etc.
ELECTRIC STEEL	Steel produced in an electro-furnace.
ELONGATION	Permanent elastic extension which metal undergoes during tensile testing. Amount of extension is usually indicated by percentages of original gauge length. Measurements is usually based on 5 x D or 10 x D, where «D» is the diameter of the test rod.
EN	The European Community for standardization has developed a nomenclature in welding, Euronorm E.N.

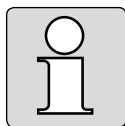

MISCELLANEOUS INFORMATION

FCAW	Flux Cored Arc Welding
FERROUS METALS	Group of metals containing substantial amounts of iron.
FERRUM	Latin name for chemically pure iron (Fe).
FILLET WELD	Weld of approximately triangular cross section joining two surfaces approximately at right angles and a lap joint, «T» joint or corner joint.
FILLET WELD LEG	Leg length of largest isosceles right triangle which can be inscribed within fillet weld cross section.
FLOW METER	Mechanical device used for measuring shielding gas rate of flow. Usually measurements are liter per. min. – «l/min.» or in cubic feet per hour – «CFH».
FLUX	Material in the form of powder or paste, used in gas welding and brazing to prevent or facilitate removal of oxide and other contaminating substances from the surface of the base material. Fluxes may be corrosive.
GAS SHIELDED ARC WELDING	Welding processes where the arc and molten pool are surrounded by a protective – shielding – gas. The gas may be of inert type or Carbon Dioxide or a mixture of these gases together with Hydrogen or Oxygen.
GMAW	Gas Metal Arc Welding.
GRAPHITE	Carbon flakes in cast iron. (Not chemically fused with the iron).
GREY CAST IRON	Cast iron in which most of the carbon is in the form of graphite flakes.
GROOVE ANGLE	The angle of a V-groove expressed in degrees. Normal groove angle for electric arc welding is 50–60°, depending on welding position and metal thickness.
GTAW	Gas Tungsten Arc Welding. The shielding gas will here always be of INERT type. Same welding method as TIG welding.
HARD BRAZING	A common name of brazing methods where capillary forces are used. See Capillary brazing.
HARD SURFACING	Hard material applied to surface of softer material for protection from abrasion and wear.
HIGH ALLOY STEEL	Steel containing more than 5% of one or more alloy elements.
IMPACT RESISTANCE	The energy, expressed in kp.m or Joule, absorbed by a test rod of predetermined shape at a certain temperature.

MISCELLANEOUS INFORMATION

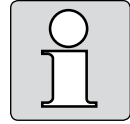

INERT GAS	Gas that does not normally combine chemically with the base metal or filler material. Also referred to as nobel gas.
INTERMITTANCE	See duty cycle.
INTERPASS TEMPERATURE	In multiple pass weld, minimum and maximum temperature specified for the deposited metal before next weld pass is started.
INVERTER	Welding power source where the normal frequency is set to a very high value thereby reducing the need for a heavy iron core in order to reduce the voltage.
ISO	Abbreviation for International Standardization Organisation.
KILLED STEEL	Steel which contains fairly large quantities of ferrosilicium or aluminium. This type of steel is suitable for welded connections.
LOW ALLOY STEEL	Steel containing 1–5% alloy elements.
LR	Lloyds Register of Shipping (British classification institute).
MAGNETIC ARC BLOW	See Arc Blow.
MAG-WELDING	Metal Active Gas-welding. (see also GMAW).
MANGANESE	An important alloy in steel, melting point 1245 °C. Chemical symbol Mn.
MARTENSITE	Structure obtained when steel is heated and cooled to achieve its maximum hardness.
MIG-WELDING	Metal Inert Gas-welding. See also Gas Shielded Arc Welding and GMAW.
MILD STEEL	Unalloyed steel, maximum carbon content 0.25%.
MPa	Mega Pascal
NDT-TESTS	Abbreviation for Non-Destructive Testing, i.e. testing and investigation materials or components without destroying these. Involves use of radiography, supersonic testing, magnetic powder, penetrating fluids etc.
NON-RETURN VALVE	An appliance fitted on the outlet of the regulator of a gas cylinder which prevent any flame from a backfire in the welding torch from returning to the gas cylinder.

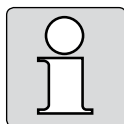

MISCELLANEOUS INFORMATION

NS	Abbreviation for the Norwegian Standards Association.
NSFI	Abbreviation for the Norwegian Research Institute for Ships.
OUT-OF POSITION WELDING	Welding that is performed in a non-standard way such as vertical or overhead.
OXIDE FILM	Film formed on base material as a result of exposure to oxidizing agents, atmosphere, chemicals or heat.
OXYGEN	Colourless gas without odour or taste. Chemical symbol O ₂ . Oxygen is not flammable itself, but feeds flames and is used together with Acetylene for welding and cutting.
ORGANIC ELECTRODES	Electrodes having consumable organic components in the coating i.e. cellulose. Small slag deposits.
POLARITY	Direction of current. Current moving from the electrode to the workpiece is DCEN or DCSP. Current flow from the workpiece to the electrode is DCEP or DCRP.
POLYMER	Chemical reaction between resin (Base) and a hardener (Activator) producing an extensive interlocking polymer network.
POROSITY	Pores within a weld caused by gas entrapment during solidification of weld metal.
POSTHEAT	Heat which is applied at the end of the weld cycle to slow down cooling rate to prevent cracking and to relieve stress.
PPM-VALUE	Parts per million.
PRIMARY CABLE	The cable which carries current from the mains supply to the primary side of a welding machine.
PROPANE	Colourless, flammable gas, heavier than air, chemical formula C ₃ H ₈
RECTIFIER	A welding power-source which gives DC welding current. Part of a power-source which converts AC to DC.
REGULATOR	An appliance for the reduction of gas pressure from a gas cylinder to a suitable pressure for welding or cutting. Equipped with pressure gauges indicating cylinder pressure and working pressure.
REMOTE CONTROL	Control of welding current from the welding area. Adjustment is by means of additional cable or through the welding cable.

MISCELLANEOUS INFORMATION

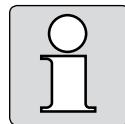

ROOT PASS	The first welding pass in a groove.
RUTILE ELECTRODES	Coated electrodes containing ilmenite, TiO_2 , in the coating.
SECONDARY CABLE	The cable which carries current from the secondary side of a welding machine to the workpiece and electrode holder.
S	Power source for use in spaces with increased electrical danger (e.g. boilers) must be identified by the «S» (for «Safety») mark.
SPATTER	Small pieces of metal which have been ejected from molten pool and attached to base material outside the weld.
SPOT WELD	Controlled weld cycle to procedure sheet metal weld with specific characteristics. Belongs to the group «Resistance Welding».
STAINLESS STEEL	Common term for two main groups: chrome alloy (ferritic) and chrome-nickel alloy (austenitic) steel. Austenitic steel is non-magnetic.
STRINGER BEAD	Weld bead made without oscillation, side-to-side motion.
SURFACING	Applying material to the surface of another material for protection from chemicals, heat, wear, rust etc.
TACK WELD	Weld made to hold parts of weldment in alignment until final weld is made.
TENSILE STRENGTH	Indicates the breaking strength of a material, expressed in N/mm^2 .
TENSILE TEST	A destructive test where a weld is pulled apart. This test determines how much tension a weld can withstand before the weld gives.
THERMIC SPRAYING	A method of building up a workpiece by spraying on finely powdered metal alloys. Can also be used for spraying zinc and plastic powders for surface protection.
TIG WELDING	Tungsten inert gas welding.
THERMOCROME CRAYONS	Temperature indicating crayons. Used to control temperature levels.
TUNGSTEN ELECTRODE	An electrode of pure tungsten or tungsten alloyed with rare earths, lanthanum, cerium, thorium or zirconium. High melting point – 3410 °C. Used for TIG welding. Tungsten is also known as Wolfram.



MISCELLANEOUS INFORMATION

UNALLOYED STEEL	Steel containing up to 1 % alloy elements.
WASH BEAD	Weld beads made with an oscillation – side-to-side technique to widen the weld bead.
WELDING DIRECTION	An expression used in welding and brazing indicating the direction of the welding process in relation to the welder.
WELDING TRANSFORMER	Welding power-source giving AC welding current.
WHISKERS	Pieces of weld wire which have penetrated through the weld joint and melted. The wire extends beyond the penetration on the root side of the weld.
WIG	Wolfram Inert Gas. Same welding method as TIG welding.
WROUGHT MATERIAL	Material made by processes other than casting.
YIELD POINT	The stress level at which a steel material starts to become plastic and shows signs of cross-contraction and permanent deformity. Expressed in N/mm ² .
YORCALBRO	Seawater resistant alloy of aluminium and brass.

