

Geometrical Optics

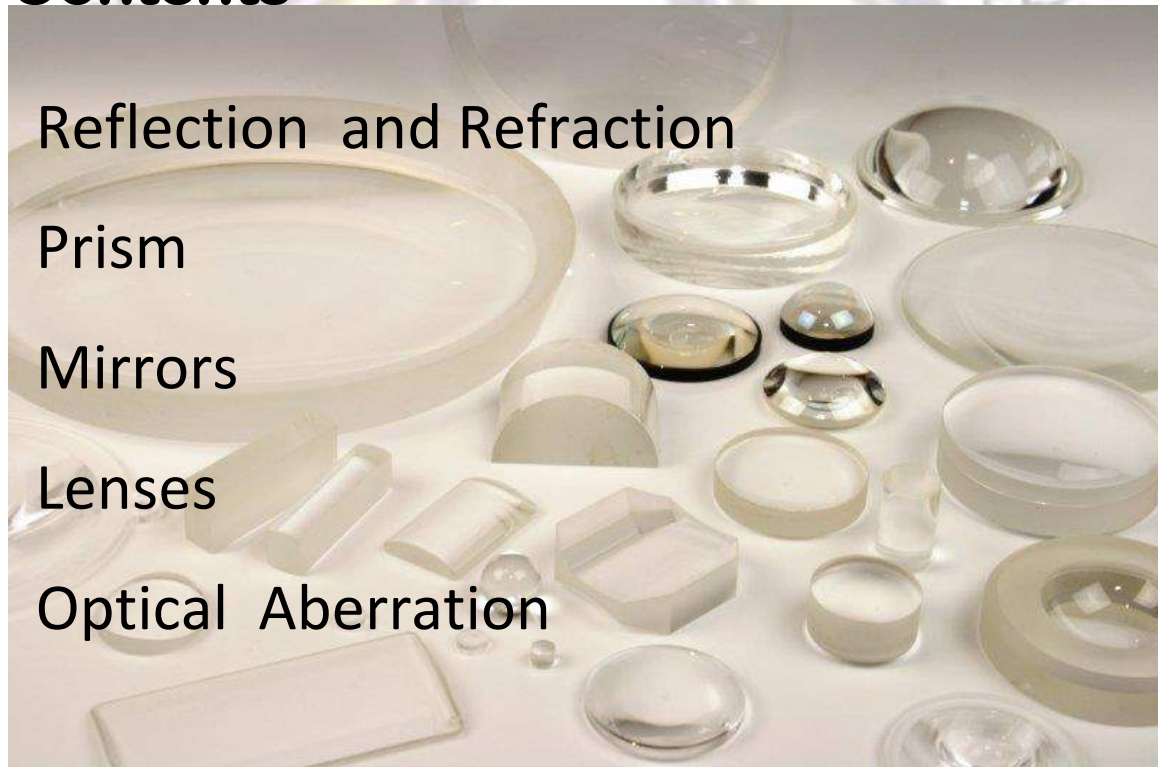

First Year

Contents



Reflection and Refraction

Prism

Mirrors

Lenses

Optical Aberration

Dr. Suha Mousa Alawsi

Course Title: Geometrical Optics

Optics is the cornerstone of photonics systems and applications. In this module, you will learn about one of the two main divisions of basic optics—*geometrical (ray) optics*. In the module to follow, you will learn about the other—*physical (wave) optics*. *Geometrical optics* will help you understand the basics of light reflection and refraction and the use of simple optical elements such as mirrors, prisms, lenses, and fibers. *Physical optics* will help you understand the phenomena of light wave interference, diffraction, and polarization; the use of thin film coatings on mirrors to enhance or suppress reflection; and the operation of such devices as gratings and quarter-wave plates.



CHAPTER ONE

REFLECTION AND REFRACTION

THE LAWS OF REFLECTION AND REFRACTION

We begin our study of *basic geometrical optics* by examining how light reflects and refracts at smooth, plane interfaces. Figure 1-1a shows ordinary reflection of light at a plane surface, and Figure 1-1b shows refraction of light at two successive plane surfaces. In each instance, light is pictured simply in terms of straight lines, which we refer to as *light rays*.

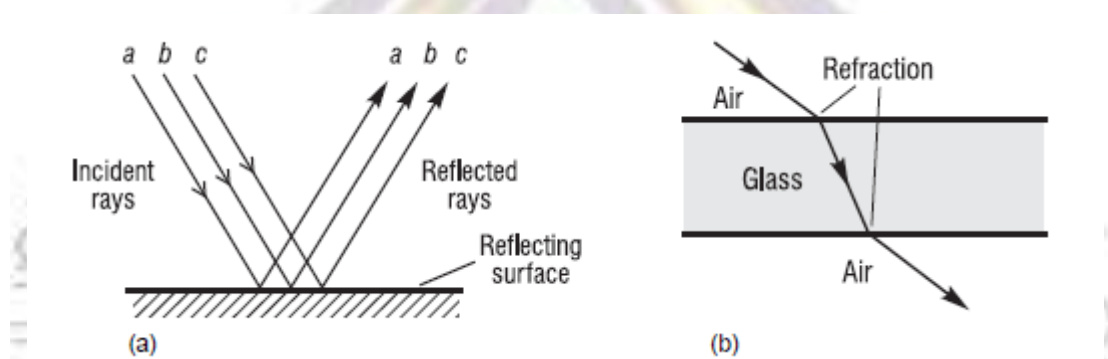

Figure 1-1 Light rays undergoing reflection and refraction at plane surfaces

After a study of how light reflects and refracts at plane surfaces, we extend our analysis to smooth, curved surfaces, thereby setting the stage for light interaction with mirrors and lenses the basic elements in many optical systems

Reflection of light from optical surfaces When light is incident on an *interface* between two transparent optical media—such as between air

and glass or between water and glass—four things can happen to the incident light.

- It can be partly or totally reflected at the interface.
- It can be scattered in random directions at the interface.
- It can be partly transmitted via refraction at the interface and enter the second medium.
- It can be partly absorbed in either medium.

In our introductory study of geometrical optics we shall consider only smooth surfaces that give rise to *specular* (regular, geometric) reflections (Figure 1-4a) and ignore ragged, uneven surfaces that give rise to *diffuse* (irregular) reflections (Figure 1-4b).

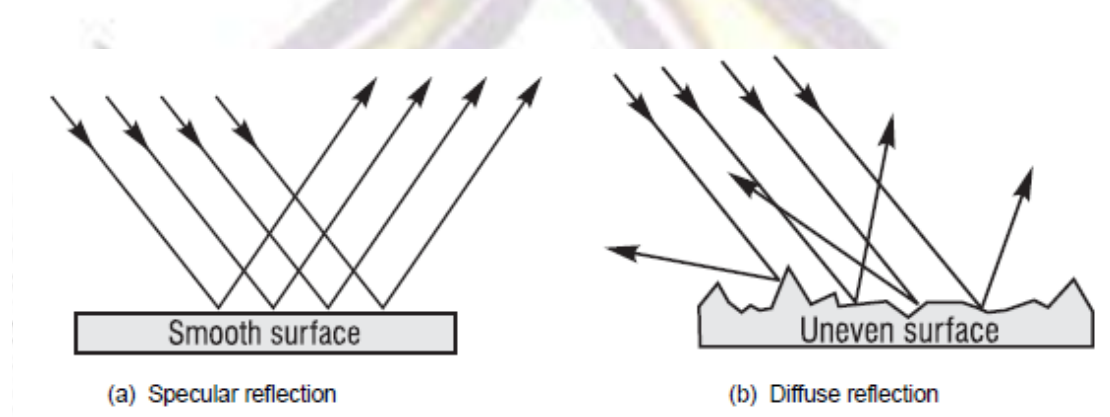

Figure 1-4 *Specular and diffuse reflection*

In addition, we shall ignore absorption of light energy along the path of travel, even though absorption is an important consideration when percentage of light transmitted from source to receiver is a factor of concern in optical systems.

The law of reflection: plane surface. When light reflects from a plane surface as shown in Figure 3-5, the angle that the reflected ray makes with the *normal* (line perpendicular to the surface) at the point of incidence *is always equal to* the angle the incident ray makes with the

same normal. Note carefully that the incident ray, reflected ray, and normal always lie in the *same* plane.

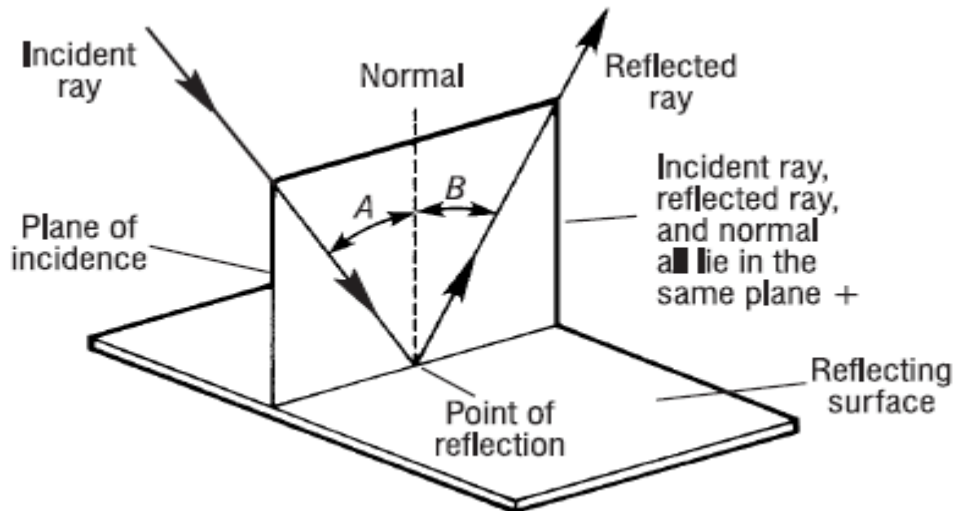

Figure -5 Law of reflection: Angle B equals angle A .

The geometry of Figure 1-5 reminds us that reflection of light rays from a plane, smooth surface is like the geometry of pool shots “banked” along the wall of a billiard table. With the *law of reflection* in mind, we can see that, for the specular reflection shown earlier in Figure 1-4a, each of the incident, parallel rays reflects off the surface at the same angle, thereby remaining parallel in reflection as a group. In Figure 1-4b, where the surface is made up of many *small*, randomly oriented plane surfaces, each ray reflects in a direction different from its neighbor, even though each ray does obey the *law of reflection* at its own small surface segment.

Reflection from a curved surface. With spherical mirrors, reflection of light occurs at a curved surface. The *law of reflection* holds, since at each point on the curved surface one can draw a *surface tangent* and erect a *normal* to a point P on the surface where the light is incident, as shown in Figure 1-6. One then applies the *law of reflection* at point P just as was illustrated in Figure 1-5, with the incident and reflected rays making the

same angles (A and B) with the normal to the surface at P . Note that successive surface tangents along the curved surface in Figure 1-6 are *ordered* (not random) sections of “plane mirrors” and serve—when smoothly connected—as a spherical surface mirror, capable of forming distinct images.

Since point P can be moved anywhere along the curved surface and a normal drawn there, we can always find the direction of the reflected ray by applying the *law of reflection*. We shall apply this technique when studying the way mirrors reflect light from the image.

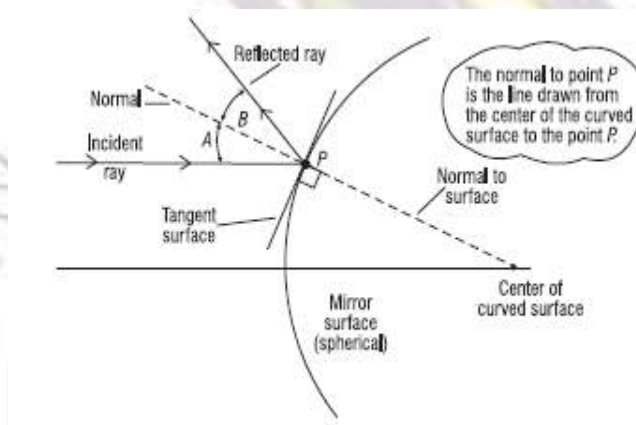

Figure 1-6 Reflection at a curved surface: Angle B equals angle A

Index of refraction. The two transparent optical media that form an interface are distinguished from one another by a constant called the *index of refraction*, generally labeled with the symbol n . The index of refraction for any transparent optical medium is defined as the ratio of the speed of light in a vacuum to the speed of light in the medium, as given in Equation 1-1

$$n = \frac{c}{v}$$

where c = speed of light in free space (vacuum)

v = speed of light in the medium

n = index of refraction of the medium

The index of refraction for free space is exactly *one*. For air and most gases it is very nearly one, so in most calculations it is taken to be 1.0. For other materials it has values greater than one. Table 1-1 lists indexes of refraction for common materials.

Table 1-1 Indexes of Refraction for Various Materials at 589 nm

Substance	n	Substance	n
Air	1.0003	Glass (flint)	1.66
Benzene	1.50	Glycerin	1.47
Carbon Disulfide	1.63	Polystyrene	1.49
Corn Syrup	2.21	Quartz (fused)	1.46
Diamond	2.42	Sodium Chloride	1.54
Ethyl Alcohol	1.36	Water	1.33
Gallium Arsenide (semiconductor)	3.40	Ice	1.31
Glass (crown)	1.52	Germanium	4.1
Zircon	1.92	Silicon	3.5

The greater the index of refraction of a medium, the lower the speed of light in that medium and the more light is bent in going from air into the medium. Figure 1-7 shows two general cases, one for light passing from a medium of lower index to higher index, the other from higher index to lower index. Note that in the first case (lower-to-higher) the light ray is *bent toward the normal*. In the second case (higher-to-lower) the light ray is *bent away from the normal*. It is helpful to memorize these effects since they often help one trace light through optical media in a generally correct manner.

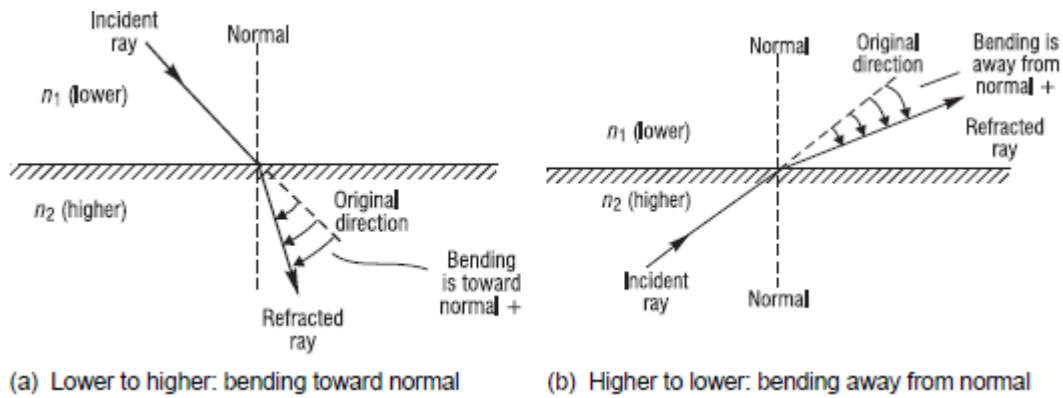

Figure 1-7 Refraction at an interface between media of refractive indexes n_1 and n_2

Snell's law. Snell's law of refraction relates the sines of the angles of incidence and refraction at an interface between two optical media to the indexes of refraction of the two media. The law is named after a Dutch astronomer, Willebrord Snell, who formulated the law in the 17th century. Snell's law enables us to calculate the direction of the refracted ray if we know the refractive indexes of the two media and the direction of the incident ray. The mathematical expression of Snell's law and an accompanying drawing are given in Figure 1-8.

Snell's Law	
$\frac{\sin i}{\sin r} = \frac{n_r}{n_i}, \text{ where}$	
i is the angle of incidence	
r is the angle of refraction	
n_i is the index in the incident medium	
n_r is the index in the refracting medium	

Figure 1-8 Snell's law: formula and geometry

Note carefully that both the angle of incidence (i) and refraction (r) are measured with respect to the surface normal. Note also that the incident ray, normal, and refracted ray all lie in the same geometrical plane. In practice Snell's law is often written simply as equation 1-2

$$n_i \sin i = n_r \sin r$$

Now let's look at an example that make use of *Snell's law*.

Example 1

In a handheld optical instrument used under water, light is incident from water onto the plane surface of flint glass at an angle of incidence of 45° .

- What is the angle of reflection of light off the flint glass?
- Does the refracted ray bend toward or away from the normal?
- What is the angle of refraction in the flint glass?

Solution:

(a) From the *law of reflection*, the reflected light must head off at an angle of 45° with the normal. (Note: The angle of reflection is **not** dependent on the refractive indexes of the two media.)

(b) From Table 1-1, the index of refraction is 1.33 for water and 1.63 for flint glass. Thus, light is moving from a lower to a higher index of refraction and will bend **toward** the normal.

We know then that the angle of refraction r should be less than 45° .

(c) From *Snell's law*, Equation 3-2, we have:

$$n_i \sin i = n_r \sin r$$

where $n_i = 1.33$, $i = 45^\circ$, and $n_r = 1.63$

$$\text{Thus, } \sin r = \frac{1.33 \sin 45^\circ}{1.63} = \frac{(1.33)(0.707)}{1.63} = 0.577$$

$$\text{So } r = \sin^{-1}(0.577) = 35.2^\circ$$

The angle of refraction is about 35° , clearly less than 45° , just as was predicted in part (b).

Note: The function \sin^{-1} is of course the *arcsin*. We will use the \sin^{-1} notation since that is what is found on scientific calculators.

Critical angle and total internal reflection. When light travels from a medium of higher index to one of lower index, we encounter some interesting results. Refer to Figure 1-9 where we see four rays of light originating from point O in the higher-index medium, each incident on the interface at a different angle of incidence. Ray 1 is incident on the interface at 90° (normal incidence) so there is no bending.

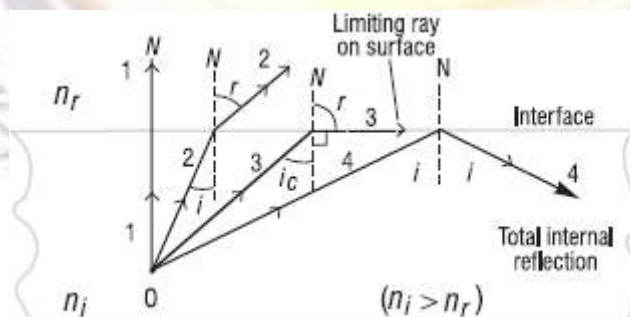

Figure 1-9 Critical angle and total internal reflection

The light in this direction simply speeds up in the second medium (why?) but continues along the same direction. Ray 2 is incident at angle i and refracts (bends away from the normal) at angle r . Ray 3 is incident at the *critical angle* i_c , large enough to cause the refracted ray bending away from the normal (N) to bend by 90° , thereby traveling along the interface between the two media. (This ray is trapped in the interface.) Ray 4 is incident on the interface at an angle *greater than* the critical angle, and is *totally reflected* into the same medium from which it came. Ray 4 obeys the *law of reflection* so that its angle of reflection is exactly equal to its angle of incidence. We exploit the phenomenon of total internal reflection when designing light propagation in fibers by trapping the light in the fiber through successive internal reflections along the fiber. We do this also when designing “retroreflecting” prisms. Compared with ordinary reflection from mirrors, the sharpness and brightness of totally internally reflected light beams is enhanced considerably.

The calculation of the critical angle of incidence for any two optical media—whenever light is incident from the medium of higher index—is accomplished with *Snell’s law*. Referring to Ray 3 in Figure 3-10 and using Snell’s law in Equation 3-2 appropriately, we have

$$n_i \sin i_c = n_r \sin 90^\circ$$

here n_i is the index for the incident medium, i_c is the critical angle of incidence, n_r is the index for the medium of lower index, and $r = 90^\circ$ is the angle of refraction at the critical angle. Then, since $\sin 90^\circ = 1$, we obtain for the critical angle, equation 1-3

$$i_c = \sin^{-1} \left(\frac{n_r}{n_i} \right)$$

Let's use this result and Snell's law to determine the entrance cone for light rays incident on the face of a clad fiber if the light is to be trapped by total internal reflection at the core-cladding interface in the fiber.

Example 2

A step-index fiber 0.0025 inch in diameter has a core index of 1.53 and a cladding index of 1.39. See drawing. Such clad fibers are used frequently in applications involving communication, sensing, and imaging.

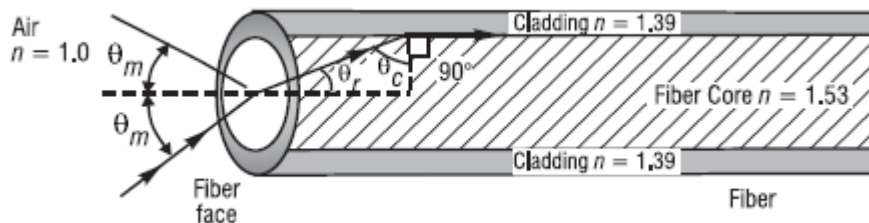

What is the maximum acceptance angle θ_m for a cone of light rays incident on the fiber face such that the refracted ray in the core of the fiber is incident on the cladding at the critical angle?

Solution: First find the critical angle θ_c in the core, at the core-cladding interface. Then, from geometry, identify θ_r and use Snell's law to find θ_m .

(1) From Equation 1-3, at the core-cladding interface

$$\theta_c = \sin^{-1} \left(\frac{1.39}{1.53} \right) = 65.3^\circ$$

(2) From right-triangle geometry, $\theta_r = 90 - 65.3 = 24.7^\circ$

(3) From Snell's law, at the fiber face,

$$n_{air} \sin \theta_m = n_{core} \sin \theta_r$$

and $\sin \theta_m = \left(\frac{n_{core}}{n_{air}} \right) \sin \theta_r = \left(\frac{1.53}{1.00} \right) \sin (24.7^\circ)$

from which $\sin \theta_m = 0.639$

and $\theta_m = \sin^{-1} 0.639 = 39.7^\circ$

Thus, the maximum acceptance angle is 39.7° and the acceptance cone is twice that, or $2 \theta_m = 79.4^\circ$. The acceptance cone indicates that any light ray incident on the fiber face within the acceptance angle will undergo total internal reflection at the core-cladding face and remain trapped in the fiber.

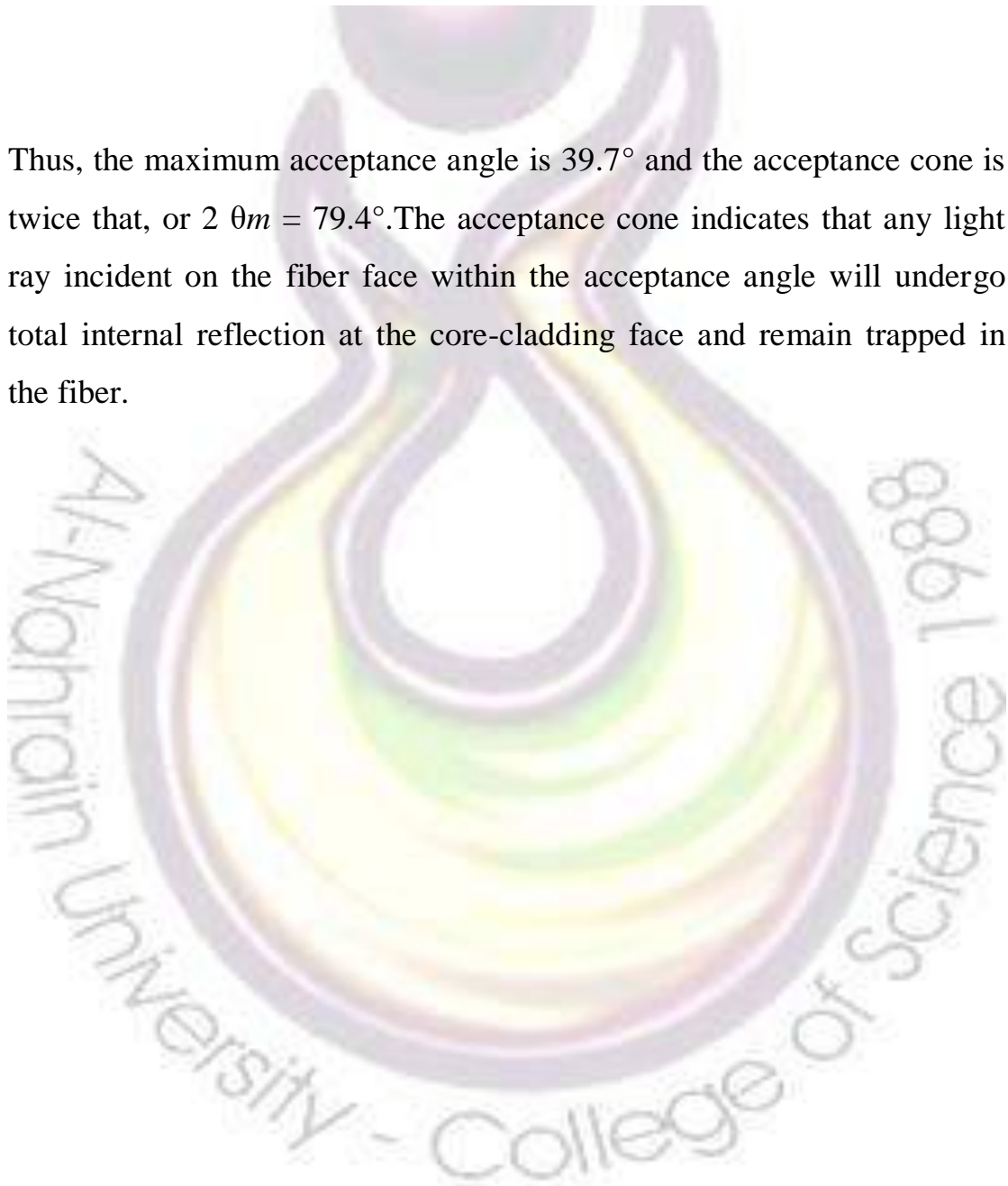

CHAPTER TWO

PRISM

Refraction in prisms

Glass prisms are often used to bend light in a given direction as well as to bend it back again (retroreflection). The process of refraction in prisms is understood easily with the use of light rays and Snell's law. Look at Figure 1-10a. When a light ray enters a prism at one face and exits at another, the exiting ray is *deviated* from its original direction. The prism shown is isosceles in cross section with *apex angle* $A = 30^\circ$ and refractive index $n = 1.50$. The incident angle θ and the *angle of deviation* δ are shown on the diagram.

Figure 1-10b shows how the angle of deviation δ changes as the angle θ of the incident ray changes. The specific curve shown is for the prism described in Figure 3-11a. Note that δ goes through a minimum value, about 23° for this specific prism. Each prism material has its own unique *minimum angle of deviation*.

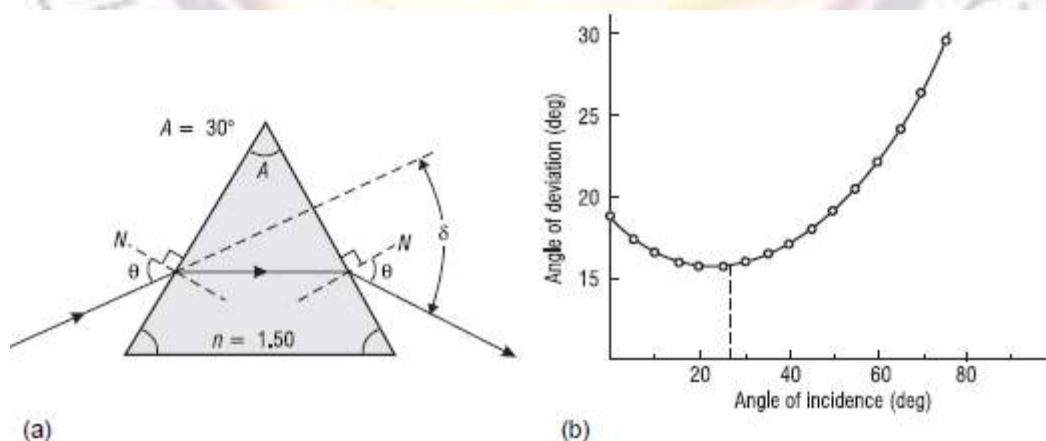

Figure 1-10 Refraction of light through a prism

Minimum angle of deviation. It turns out that we can determine the refractive index of a transparent material by shaping it in the form of an isosceles prism and then measuring its *minimum* angle of deviation. With reference to Figure 1-10a, the relationship between the refractive index n , the prism apex angle A , and the minimum angle of deviation δ_m is given by equation 1-4

$$n = \frac{\sin\left(\frac{A + \delta_m}{2}\right)}{\sin\frac{A}{2}}$$

where both A and δ_m are measured in degrees.

The derivation of Equation 1-4 is straightforward, but a bit tedious. Details of the derivation making use of Snell's law and geometric relations between angles at each refracting surface can be found in most standard texts on geometrical optics. (See suggested references at the end of the module.) Let's show how one can use Equation 3-4 in Example 4 to determine the index of refraction of an unknown glass shaped in the form of a prism

Example 3

A glass of unknown index of refraction is shaped in the form of an isosceles prism with an apex angle of 25° . In the laboratory, with the help of a laser beam and a prism table, the *minimum* angle of deviation for this prism is measured carefully to be 15.8° . What is the refractive index of this glass material?

Solution: Given that $\delta m = 15.8^\circ$ and $A = 25^\circ$, we use Equation 3-4 to calculate the refractive index.

$$n = \frac{\sin\left(\frac{A + \delta_m}{2}\right)}{\sin\left(\frac{A}{2}\right)} = \frac{\sin\left(\frac{25^\circ + 15.8^\circ}{2}\right)}{\sin\left(\frac{25^\circ}{2}\right)} = \frac{\sin(20.4^\circ)}{\sin(12.5^\circ)} = \frac{0.3486}{0.2164}$$

$$n = 1.61$$

Dispersion of light.

Table 1-1 lists indexes of refraction for various substances independent of the wavelength of the light. In fact, the refractive index is slightly wavelength dependent. For example, the index of refraction for flint glass is about 1% higher for blue light than for red light. The variation of refractive index n with wavelength λ is called *dispersion*. Figure 1-11a shows a normal dispersion curve of $n\lambda$ versus λ for different types of optical glass. Figure 1-11b shows the separation of the individual colors in white light—400 nm to 700 nm after passing through a prism. Note that $n\lambda$ decreases from short to long wavelengths, thus causing the red light to be less deviated than the blue light as it passes through a prism. This type of dispersion that accounts for the colors seen in a rainbow, the “prism” there being the individual raindrops.

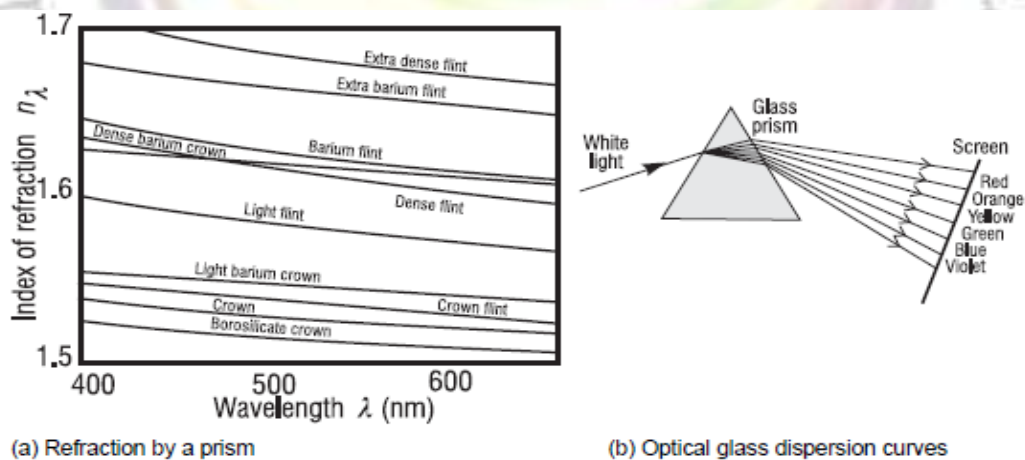

Figure 1-11 Typical dispersion curves and separation of white light after refraction by a prism

CHAPTER THREE

MIRRORS

IMAGE FORMATION WITH MIRRORS

Mirrors, of course, are everywhere—in homes, auto headlamps, astronomical telescopes, and laser cavities, and many other places. Plane and spherical mirrors are used to form three dimensional images of three-dimensional objects. If the size, orientation, and location of an object relative to a mirror are known, the *law of reflection* and ray tracing can be used to locate the image graphically. Appropriate mathematical formulas can also be used to calculate the locations and sizes of the images formed by mirrors. In this section we shall use both graphical ray tracing and formulas.

plane mirrors

Images with mirrors are formed when many nonparallel rays from a given point on a source are reflected from the mirror surface, converge, and form a corresponding image point. When this happens, point by point for an extended object, an image of the object, point by point, is formed. Image formation in a plane mirror is illustrated in several sketches shown in Figure 2-1

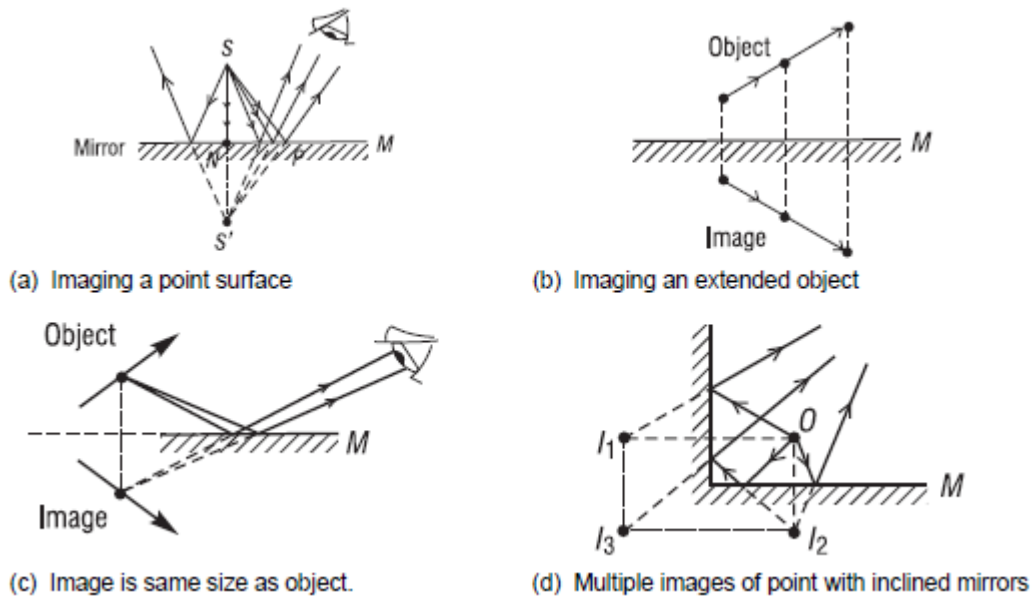

Figure 2-1 Image formation in a plane mirror

In Figure 2-1a, point object S sends nonparallel rays toward a plane mirror, which reflects them as shown. The *law of reflection* ensures that pairs of triangles like SNP and $S'NP$ are equal, so that all reflected rays appear to originate at the *image point* S' , which lies along the normal line SN , and at such depth that the *image distance* $S'N$ equals the *object distance* SN .

The eye sees a point image at S' in exactly the same way it would see a real point object placed there. Since the actual rays do not exist below the mirror surface, the image is said to be a *virtual image*. The image S' cannot be projected on a screen as in the case of a *real image*. An extended object, such as the arrow in Figure 3-14b, is imaged point by point by a plane mirror surface in similar fashion. Each object point has its image point along its normal to the mirror surface and *as far below the reflecting surface as the object point lies above the surface*. Note that image position does not depend on the position of the eye.

The construction in Figure 2-1b also makes clear that the image size is identical to the object size, giving a *magnification* of unity. In addition, the transverse orientations of object and image are the same. A right-handed object, however, appears left-handed in its image. In Figure 2-1c, where the mirror does not lie directly below the object, the mirror plane may be extended to determine the position of the image as seen by an eye positioned to receive reflected rays originating at the object. Figure 2-1d illustrates multiple images of a point object O formed by two perpendicular mirrors. Each image, I_1 and I_2 , results from a single reflection in one of the two mirrors, but a third image I_3 is also present, formed by sequential reflections from both mirrors.

spherical mirrors

The *law of reflection* can be used to determine the direction along which any ray incident on a spherical mirror surface will be reflected. Using the *law of reflection*, we can trace rays from any point on an object to the mirror, and from there on to the corresponding image point. This is the method of *graphical ray tracing*.

Graphical ray-trace method. To employ the method of ray tracing, we agree on the following:

- Light will be incident on a mirror surface *initially* from the left.
- The axis of symmetry normal to the mirror surface is its *optical axis*.
- The point where the optical axis meets the mirror surface is the *vertex*.

To locate an image we use two points common to each mirror surface, the *center of curvature* C and the *focal point* F . They are shown in Figure 2-2, with the mirror vertex V , for both a *concave* and a *convex* spherical mirror.

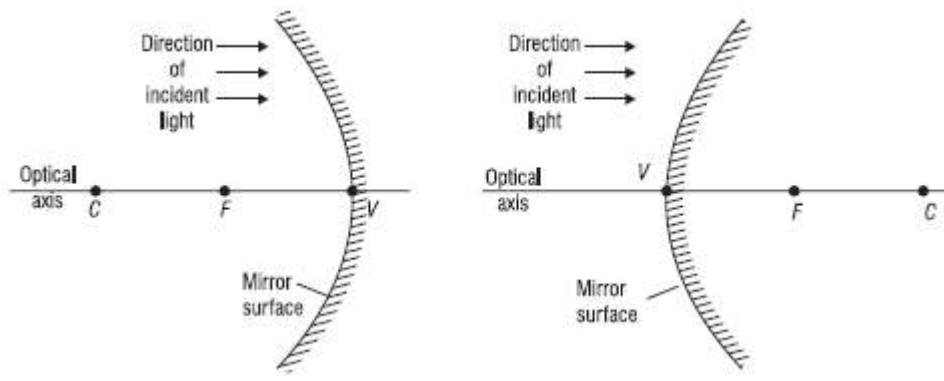

(a) Concave mirror surface

(b) Convex mirror surface

Figure 2-2 Defining points for concave and convex mirrors

The edges of *concave* mirrors always bend toward the oncoming light. Such mirrors have their center of curvature C and focal point F located to the *left* of the vertex as seen in Figure 2-2a. The edges of *convex* mirrors always bend away from the oncoming light, and their center of curvature C and focal point F are located to the *right* of the vertex. See Figure 2-2b. The important connection between parallel rays and the focal points for mirror surfaces is shown in Figure 2-3 a, b. Parallel rays are light rays coming from a very distant source (such as the sun) or from a collimated laser beam. The *law of reflection*, applied at each point on the mirror surface where a ray is incident, requires that the ray be reflected so as to pass through a focal point F in front of the mirror (Figure 2-3a) or be reflected to appear to come from a focal point F behind the mirror (Figure 2-3b). Notice that a line drawn from the center of curvature C to any point on the mirror is a *normal* line and thus bisects the angle between the incident and reflected rays. As long as the transverse dimension of the mirror is not too large, simple geometry

shows that the point F , for either mirror, is located at the midpoint between C and V , so that the distance FV is one-half the radius of curvature CV . The distance FV is called the *focal length* and is commonly labeled as f .

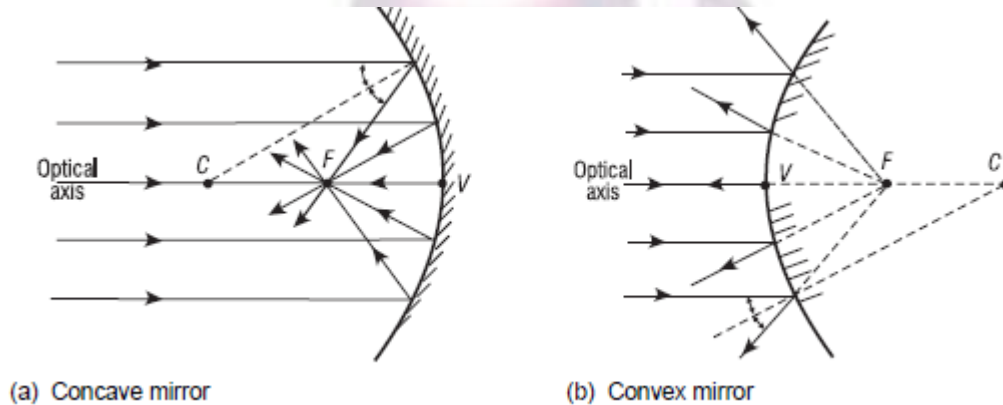

Figure 2-3 *Parallel rays and focal points*

Derivation of the mirror formula. The drawing we need to carry out the derivation is shown in Figure 2-4. The important quantities are the object distance p , the image distance q , and the radius of curvature r . Both p and q are measured relative to the mirror vertex, as shown, and the sign on r will indicate whether the mirror is concave or convex. All other quantities in Figure 2-4 are used in the derivation but will not show up in the final “mirror formula”

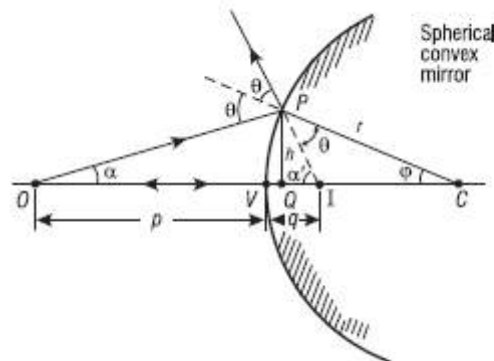

Figure 2-4 *Basic drawing for deriving the mirror formula*

The mirror shown in Figure 2-4 is convex with center of curvature C on the right. Two rays of light originating at object point O are drawn, one normal to the convex surface at its vertex V and the other an arbitrary ray incident at P . The first ray reflects back along itself; the second reflects at P as if incident on a plane tangent at P , according to the *law of reflection*. Relative to each other, the two reflected rays diverge as they leave the mirror. The intersection of the two rays (extended backward) determines the image point I corresponding to object point O . The image is virtual and located behind the mirror surface. Object and image distances measured from the vertex V are shown as p and q , respectively. A perpendicular of height h is drawn from P to the axis at Q . We seek a relationship between p and q that depends on only the radius of curvature r of the mirror. As we shall see, such a relation is possible only to a first-order approximation of the sines and cosines of angles such as α and ϕ made by the object and image rays at various points on the spherical surface. This means that, in place of expansions of $\sin \phi$ and $\cos \phi$ in series as shown here,

$$\sin \phi = \phi - \frac{\phi^3}{3!} + \frac{\phi^5}{5!} - \dots$$

$$\cos \phi = 1 - \frac{\phi^2}{2!} + \frac{\phi^4}{4!} - \dots$$

we consider the first terms only and write

$$\sin \phi \cong \phi \text{ and } \cos \phi \cong 1, \text{ so that } \tan \phi = \sin \phi / \cos \phi \cong \phi$$

These relations are accurate to 1% or less if the angle ϕ is 10° or smaller. This approximation leads to *first-order (or Gaussian) optics*, after Karl Friedrich Gauss, who in 1841 developed the foundations of this subject.

Returning now to the problem at hand—that of relating p , q , and r notice that two angular relationships may be obtained from Figure 2-4, because the exterior angle of a triangle equals the sum of its interior angles. Thus,

$$\theta = \alpha + \phi \text{ in } \triangle OPC \text{ and } 2\theta = \alpha + \alpha' \text{ in } \triangle OPI$$

which combine to give

$$\alpha - \alpha' = 2\phi$$

Using the small-angle approximation, the angles α , α' , and ϕ above can be replaced by their tangents, yielding

$$\frac{h}{p} - \frac{h}{q} = -2 \frac{h}{r}$$

Note that we have neglected the axial distance VQ , small when ϕ is small. Cancellation of h produces the desired relationship, equation (2-1)

$$\frac{1}{p} - \frac{1}{q} = -\frac{2}{r}$$

If the spherical surface is chosen to be concave instead, the center of curvature will be to the left. For certain positions of the object point O , it is then possible to find a real image point, also to the left of the mirror. In these cases, the resulting geometric relationship analogous to Equation (2-1) consists of the same terms, but with different algebraic signs, depending on the *sign convention* employed. We can choose a sign convention that leads to a single equation, the *mirror equation*, valid for both types of mirrors. It is Equation (2-2)

$$\boxed{\frac{1}{p} + \frac{1}{q} = -\frac{2}{r}}$$

Sign convention.

The sign convention to be used in conjunction with Equation 3-6 and Figure 2-4 is as follows.

- Object and image distances p and q are both *positive* when located to the *left* of the vertex and both *negative* when located to the *right*.
- The radius of curvature r is *positive* when the center of curvature C is to the *left* of the vertex (concave mirror surface) and *negative* when C is to the *right* (convex mirror surface).
- Vertical dimensions are positive above the optical axis and negative below.

In the application of these rules, light is assumed to be directed initially, as we mentioned earlier, from left to right. According to this sign convention, *positive* object and image distances correspond to *real* objects and images, and *negative* object and image distances correspond to *virtual* objects and images. *Virtual objects* occur only with a sequence of two or more reflecting or refracting elements.

Magnification of a mirror image. Figure 2-5 shows a drawing from which the *magnification*—ratio of image height h_i to object height h_o —can be determined. Since angles θ_i , θ_r , and α are equal, it follows that triangles VOP and VIP' are similar. Thus, the sides of the two triangles are proportional and one can write

$$\frac{h_i}{h_o} = \frac{q}{p}$$

This gives at once the magnification m to be

$$m \equiv \frac{h_i}{h_o} = \frac{q}{p}$$

When the *sign convention* is taken into account, one has, for the *general case*, a single equation, Equation 2-3, valid for both convex and concave mirrors.

$$m = -\frac{q}{p}$$

If, after calculation, the value of m is positive, the image is erect. If the value is negative, the image is inverted.

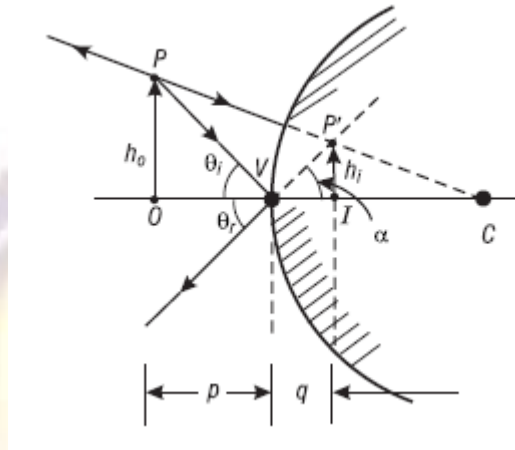
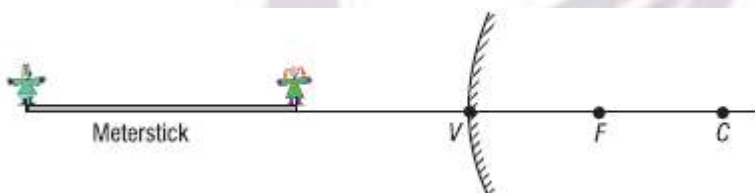

Figure 2-5 Construction for derivation of mirror magnification formula

Example 1

A meter stick lies along the optical axis of a convex mirror of focal length 40 cm, with its near end 60 cm from the mirror surface. Five-centimeter toy figures stand erect on both the near and far ends of the meter stick. (a) How long is the virtual image of the meter stick? (b) How tall are the toy figures in the image, and are they erect or inverted?



Solution: Use the mirror equation

$$\frac{1}{p} + \frac{1}{q} = -\frac{2}{r}$$

twice, once for the near end and once for the far end of the meterstick.

Use the magnification equation m for each figure

$$m = -\frac{q}{p}$$

(a) Near end: Sign convention gives $p = +60$ cm, $r = 2f = -(2 \times 40) = -80$ cm

$$\therefore \frac{1}{60} + \frac{1}{q_n} = -\frac{2}{80}, \text{ so } q_n = -24 \text{ cm}$$

Negative sign indicates image is *virtual*, 24 cm to the right of V .

Far end: $p = +160$ cm, $r = -80$ cm

$$\frac{1}{160} + \frac{1}{q_f} = -\frac{1}{40}, \text{ so } q_f = -32 \text{ cm}$$

Far-end image is *virtual*, 32 cm to the right of V .

\therefore Meterstick image is $32 \text{ cm} - 24 \text{ cm} = 8 \text{ cm}$ long.

(b) Near-end toy figure:

$$m_n = \frac{-q}{p} = \frac{-(-24)}{60} = +0.4 \text{ (Image is erect since } m \text{ is positive.)}$$

The toy figure is $5 \text{ cm} \times 0.4 = 2 \text{ cm}$ tall, at near end of the meterstick image.

Far-end toy figure:

$$m_f = \frac{-q}{p} = \frac{-(-32)}{160} = +0.2 \text{ (Image is erect since } m \text{ is positive.)}$$

The toy figure is $5 \text{ cm} \times 0.2 = 1 \text{ cm}$ tall, at far end of the meterstick image.



CHAPTER FOUR

LENSES

IMAGE FORMATION WITH LENSES

Lenses are at the heart of many optical devices, not the least of which are cameras, microscopes, binoculars, and telescopes. Just as the *law of reflection* determines the imaging properties of mirrors, so *Snell's law of refraction* determines the imaging properties of lenses. Lenses are essentially light-controlling elements, used primarily for image formation with visible light, but also for ultraviolet and infrared light. In this section we shall look first at the types and properties of lenses, then use graphical ray-tracing techniques to locate images, and finally use mathematical formulas to locate the size, orientation, and position of images in simple lens systems.

A. Function of a lens

A lens is made up of a transparent refracting medium, generally of some type of glass, with spherically shaped surfaces on the front and back. A ray incident on the lens refracts at the front surface (according to Snell's law) propagates through the lens, and refracts again at the rear surface. Figure 3-1 shows a rather thick lens refracting rays from an object OP to form an image $O'P'$. The ray-tracing techniques and lens formulas we shall use here are based again on *Gaussian optics*, just as they were for mirrors.

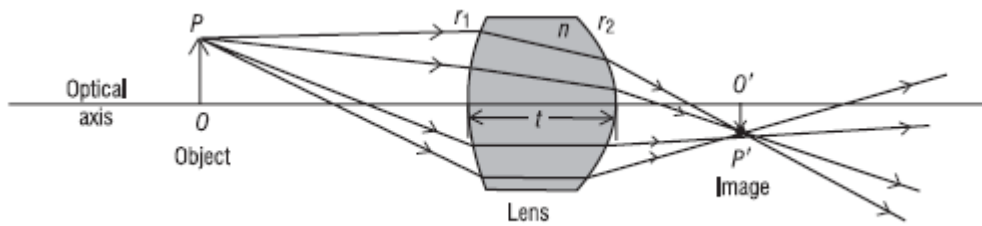

Figure 3-1 Refraction of light rays by a lens

As we have seen, *Gaussian optics*—sometimes called *paraxial optics*—arises from the basic approximations $\sin \phi \cong \phi$, $\tan \phi \cong \phi$, and $\cos \phi \cong 1$. These approximations greatly simplify ray tracing and lens formulas, but they do restrict the angles the light rays make with the optical axis to rather small values of 20° or less.

B. Types of lenses

If the axial thickness of a lens is small compared with the radii of curvature of its surfaces, it can be treated as a *thin* lens. Ray-tracing techniques and lens formulas are relatively simple for thin lenses. If the thickness of a lens is not negligible compared with the radii of curvature of its faces, it must be treated as a *thick* lens. Ray-tracing techniques and lens-imaging formulas are more complicated for thick lenses, where computer programs are often developed to trace the rays through the lenses or make surface-by-surface calculations. In this basic introduction of geometrical optics, we shall deal with only thin lenses.

1. Converging and diverging thin lenses.

In Figure 3-2, we show the shapes of several common “thin” lenses. Even though a “thickness” is shown, the use of thin lenses assumes

that the rays simply refract at the front and rear faces without a translation through the lens medium. The first three lenses are *thicker in the middle than at the edges* and are described as *converging* or *positive* lenses. They are converging because they cause parallel rays passing through them to bend toward one another. Such lenses give rise to positive focal lengths. The last three lenses *thinner in the middle than at the edges* and are described as *diverging* or *negative* lenses. In contrast with converging lenses, they cause parallel rays passing through them to spread as they leave the lens. These lenses give rise to negative focal lengths. In Figure 3-2, names associated with the different shapes are noted.

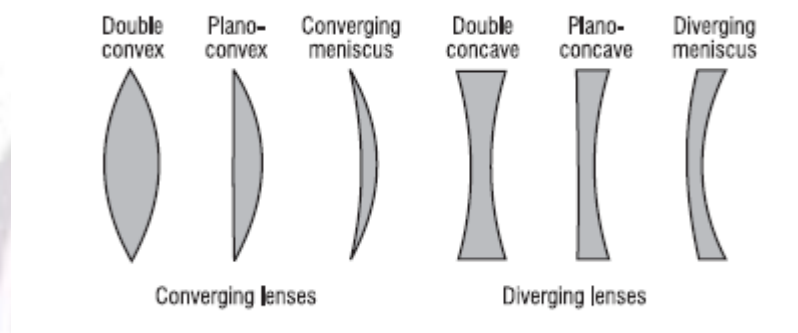

Figure 3-2 Shapes of common thin lenses

2- Focal points of thin lenses.

Just as for mirrors, the *focal points* of lenses are defined in terms of their effect on parallel light rays and plane wave fronts. Figure 3-22 shows parallel light rays and their associated plane wave fronts incident on a *positive* lens (Figure 3-3a) and a *negative* lens (Figure 3-3b). For the positive lens, refraction of the light brings it to focal point F (real image) to the right of the lens. For the negative lens, refraction of the light causes it to diverge as if it is coming from focal point F (virtual image) located

to the left of the lens. Note how the plane wave fronts are changed to converging spherical wave fronts by the positive lens and to diverging spherical wave fronts by the negative lens. This occurs because light travels more slowly in the lens medium than in the surrounding air, so the thicker parts of the lens retard the light more than do the thinner parts.

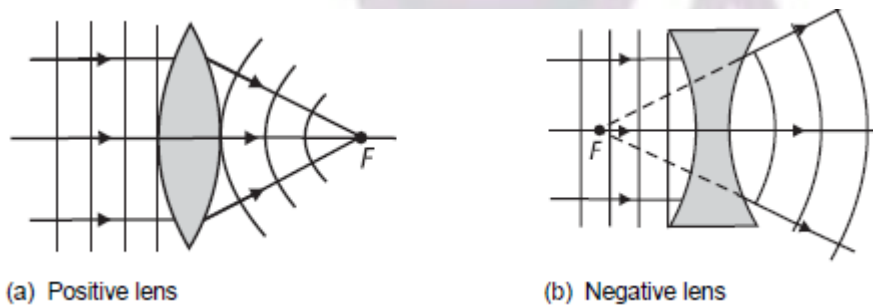

Figure 3-3 Focal points for positive and negative lenses

Recall that, for mirrors, there is but a *single* focal point for each mirror surface since light remains always on the same side of the mirror. For thin lenses, there are *two* focal points, symmetrically located on each side of the lens, since light can approach from either side of the lens. The sketches in Figure 3-4 indicate the role that the two focal points play, for positive lenses (Figure 3-4a) and negative lenses (Figure 3-4b). Study these figures carefully.

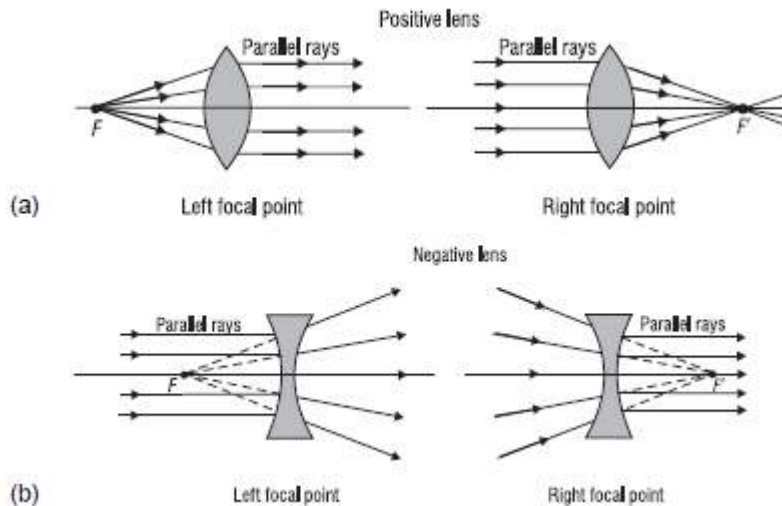

Figure 3-4 Relationship of light rays to right and left focal points in thin lenses

3- f -number and numerical aperture of a lens.

The size of a lens determines its light gathering power and, consequently, the brightness of the image it forms. Two commonly used indicators of this special characteristic of a lens are called the f -number and the numerical aperture. The f -number, also referred to as the *relative aperture* and the f /stop, is defined simply as the ratio of the focal length f of the lens, to its diameter D , as given in Equation 3-1.

$$f\text{-number} = f/D$$

In addition, the numerical aperture is closely related to the acceptance angle discussed. Since the rays entering the fiber face are in air, the numerical aperture $N.A.$ is equal simply to equation 3-2

$$N.A. = \sin \alpha.$$

It is shown in most basic books on optics (see references listed at end of this module) that image brightness is dependent on values of the f -number

or numerical aperture, in accordance with the following proportionalities:
equation 3-3

$$\text{image brightness} \propto 1/(f\text{-number})^2$$

$$\text{image brightness} \propto (N.A.)^2$$

In summary, one can *increase* the light-gathering power of a lens and the brightness of the image formed by a lens by *decreasing* the f -number of the lens (increasing lens diameter) or by *increasing* the numerical aperture of the lens (increasing the refraction index and thus making possible a larger acceptance angle).

C. Image location by ray tracing

To locate the image of an object formed by a thin lens, we make use of three key points for the lens and associate each of them with a defining ray. The three points are the left focal point F , the right focal point F' , and the lens vertex (center) V . In Figure 3-5 the three rays are shown locating an image point P' corresponding to a given object point P , for both a positive and a negative lens. The object is labeled OP and the corresponding image IP' . The defining rays are labeled to show clearly their connection to the points F , F' , and V . In practice, of course, only two of the three rays are needed to locate the desired image point. Note also that the location of image point P' is generally sufficient to sketch in the rest of the image IP' , to correspond with the given object OP .

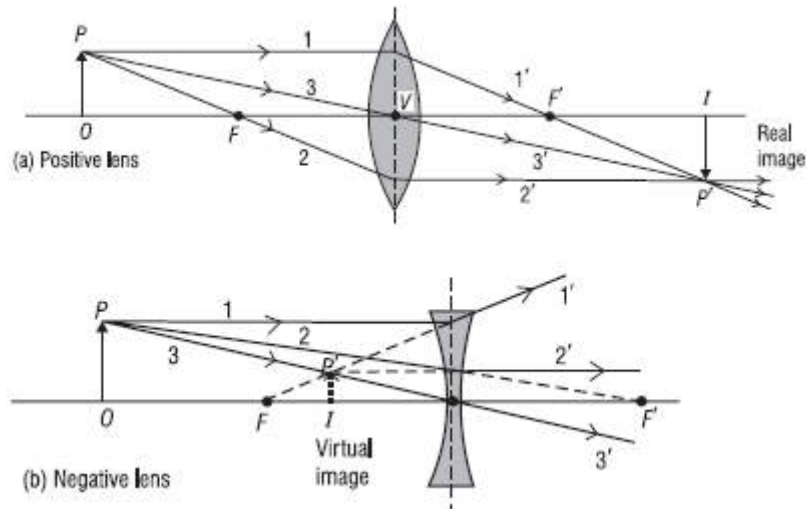

Figure 3-5 Ray diagrams for image formation by positive and negative lenses

The behavior of rays 1 and 2—connected with the left and right focal points for both the positive and negative lenses—should be apparent from another look at Figure 3-3. The behavior of ray 3—going straight through the lens at its center V —is a consequence of assuming that the lens has zero thickness. Note, in fact, that, for both Figures 3-3 and 3-5, all the bending is assumed to take place at the dashed vertical line that splits the drawn lenses in half. Also, it should be clear in Figure 3-5 that the positive lens forms a real image while the negative lens forms a virtual image.

D. Lens formulas for thin lenses

As with mirrors, convenient formulas can be used to locate the image mathematically. The derivation of such formulas—as was carried out for spherical mirrors in the previous section can be found in most texts on geometrical optics. The derivation essentially traces an arbitrary ray *geometrically* and *mathematically* from an object point through the two surfaces of a thin lens to the corresponding image point. *Snell's law* is applied for the ray at each spherical refracting surface. The details of the

derivation involve the geometry of triangles and the approximations mentioned earlier— $\sin \phi \cong \phi$, $\tan \phi \cong \phi$, and $\cos \phi \cong 1$ —to simplify the final results. Figure 3-6 shows the essential elements that show up in the final equations, relating object distance p to image distance q , for a lens of focal length f with radii of curvature r_1 and r_2 and refractive index n_g . For generality, the lens is shown situated in an arbitrary medium of refractive index n . If the medium is air, then, of course, $n = 1$.

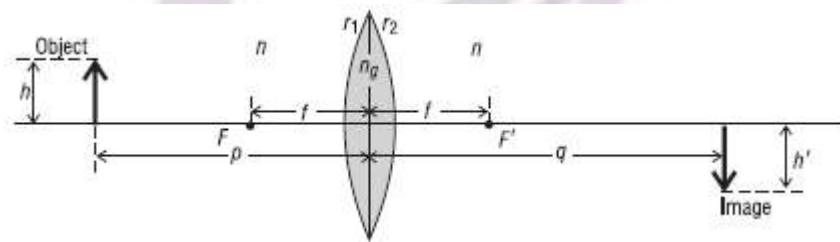

Figure 3-6 Defining quantities for image formation with a thin lens

1. Equations for thin lens calculations. The *thin lens equation* is given by Equation 3-4.

$$\boxed{\frac{1}{p} + \frac{1}{q} = \frac{1}{f}}$$

where p is the object distance (from object to lens vertex V)

q is the image distance (from image to lens vertex V)

and f is the focal length (from either focal point F or F' to the lens vertex V). For a lens of refractive index n_g situated in a medium of refractive index n , the relationship between the parameters n , n_g , r_1 , r_2 and the focal length f is given by the *lensmaker's equation* in Equation 3-5.

$$\boxed{\frac{1}{f} = \left(\frac{n_g - n}{n} \right) \left(\frac{1}{r_1} - \frac{1}{r_2} \right)}$$

where n is the index of refraction of the surrounding medium

n_g is the index of refraction of the lens materials

r_1 is the radius of curvature of the front face of the lens

r_2 is the radius of curvature of the rear face of the lens

The magnification m produced by a thin lens is given in Equation 3-6

$$m = \frac{h_i}{h_o} = -\frac{q}{p}$$

where m is the magnification (ratio of image size to object size)

h_i is the transverse size of the image

h_o is the transverse size of the object

p and q are object and image distance respectively

2-Sign convention for thin lens formulas.

Just as for mirrors, we must agree on a sign convention to be used in the application of Equations 3-4, 3-5, and 3-6. It is:

- Light travels initially from left to right toward the lens.
- Object distance p is *positive* for *real* objects located to the *left* of the lens and *negative* for *virtual* objects located to the *right* of the lens.
- Image distance q is *positive* for *real* images formed to the *right* of the lens and *negative* for *virtual* images formed to the *left* of the lens.
- The focal length f is *positive* for a *converging* lens, *negative* for a *diverging* lens.
- The radius of curvature r is *positive* for a *convex* surface, *negative* for a *concave* surface.

- Transverse distances (h_o and h_i) are *positive above* the optical axis, *negative below*.

Now let's apply Equations 3-4, 3-5, and 3-6 in several examples, where the use of the sign convention is illustrated and where the size, orientation, and location of a final image are determined.

Example 1

A double-convex thin lens such as that shown in Figure 3-21 can be used as a simple “magnifier.” It has a front surface with a radius of curvature of 20 cm and a rear surface with a radius of curvature of 15 cm. The lens material has a refractive index of 1.52. Answer the following questions to learn more about this simple magnifying lens.

- What is its focal length in air?
- What is its focal length in water ($n = 1.33$)?
- Does it matter which lens face is turned toward the light?
- How far would you hold an index card from this lens to form a sharp image of the sun on the card?

Solution:

(a) Use the lensmaker's equation. With the sign convention given, we have $n_g = 1.52$, $n =$

1.00, $r_1 = +20$ cm, and $r_2 = -15$ cm. Then

$$\frac{1}{f} = \left(\frac{n_g - n}{n} \right) \left(\frac{1}{r_1} - \frac{1}{r_2} \right) = \left(\frac{1.52 - 1}{1} \right) \left(\frac{1}{20} - \frac{1}{-15} \right) = 0.0607$$

So $f = +16.5$ cm (a converging lens, so the sign is positive, as it should be)

$$\text{(b)} \quad \frac{1}{f} = \left(\frac{1.52 - 1.33}{1.33} \right) \left(\frac{1}{20} - \frac{1}{-15} \right) = 0.0167$$

$f = 60$ cm (converging but less so than in air)

(c) No, the magnifying lens behaves the same, having the same focal length, no matter which surface faces the light. You can prove this by reversing the lens and repeating the calculation with Equation 3-5. Results are the same. But **note carefully**, reversing a *thick* lens changes its effect on the light passing through it. The two orientations are *not* equivalent.

(d) Since the sun is very far away, its light is collimated (parallel rays) as it strikes the lens and will come to a focus at the lens focal point. Thus, one should hold the lens about 16.5 cm from the index card to form a sharp image on the card.

Example 2

A two-lens system is made up of a converging lens followed by a diverging lens, each of focal length 15 cm. The system is used to form an image of a short nail, 1.5 cm high, standing erect, 25 cm from the first lens. The two lenses are separated by a distance of 60 cm. See accompanying diagram. Locate the final image, determine its size, and state whether it is real or virtual, erect or inverted.

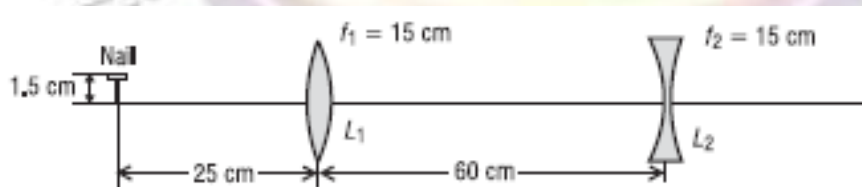

Solution: We apply the thin lens equations to each lens in turn, making use of the correct sign convention at each step.

$$\text{Lens } L_1: \frac{1}{p_1} + \frac{1}{q_1} = \frac{1}{f_1} \quad \text{or} \quad \frac{1}{25} + \frac{1}{q_1} = \frac{1}{15} \quad (f_1 \text{ is } + \text{ since lens } L_1 \text{ is converging.})$$

$q_1 = +37.5 \text{ cm}$ (Since the sign is positive, the image is real and located 37.5 cm to the right of lens L_1 .)

$$\text{Lens } L_2: \frac{1}{p_2} + \frac{1}{q_2} = \frac{1}{f_2} \quad \text{where } p_2 = (60 - 37.5) = 22.5 \text{ cm}$$

Since the first image, a distance q_1 from L_1 , serves as the object for the lens L_2 , this object is to the left of lens L_2 , and thus its distance p_2 is positive. The focal length for L_2 is negative since it is a diverging lens. So, the thin lens equation becomes

$$\frac{1}{22.5} + \frac{1}{q_2} = \frac{1}{-15}, \quad \text{giving } q_2 = -9 \text{ cm}$$

Since q_2 is negative, it locates a *virtual* image, 9 cm to the left of lens L_2 . The overall magnification for the two-lens system is given by the combined magnification of the lenses. Then

$$m_{\text{sys}} = m_1 \times m_2 = \left(-\frac{q_1}{p_1} \right) \left(-\frac{q_2}{p_2} \right) = \left(-\frac{37.5}{25} \right) \left(-\frac{-9}{22.5} \right) = -0.6$$

Thus, the final image is inverted (since overall magnification is negative) and is of final size

$$(0.6 \times 1.5 \text{ cm}) = 0.9 \text{ cm.}$$

Exercises and Problems

1. Use the *law of reflection* to determine the (a) minimum height and (b) position for a plane mirror that just allows a 5'6" woman standing on the floor in front of the mirror to see both her head and feet in the mirror. See sketch.

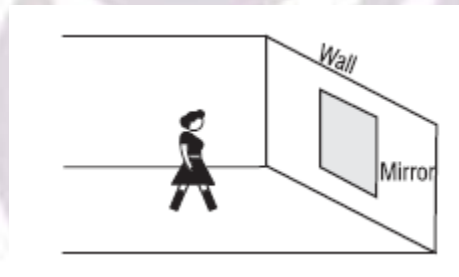

2. White light contains all wavelengths from deep blue at 400 nm to deep red at 700nm. A narrow beam of collimated white light is sent through a prism of apex angle 20° as shown. The prism is made of light flint glass whose refractive index at 400 nm is 1.60 and at 700 nm is 1.565. What is the angular spread between the red and blue light at the minimum angle of deviation for each?

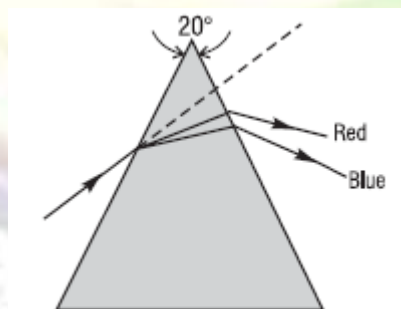

3. A ray of sodium light at 589 nm is incident on a rectangular slab of crown glass at an angle of 45° with the normal. (a) At what angle to the normal does this ray exit the slab? (b) What is the direction of the exiting

ray relative to the entering ray? (c) Sketch an accurate trace of the ray through the slab.

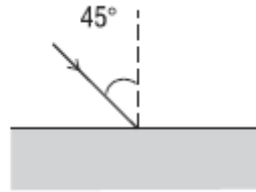

4. An object 3 cm high is placed 20 cm to the left of (a) a convex and (b) a concave spherical mirror, each of focal length 10 cm. Determine the position and nature of the image for each mirror.

5. Make a ray-trace diagram—on an 8½" × 11" sheet of white paper—that locates the image of a 2-cm object placed 10 cm in front of a concave spherical mirror of curvature 6 cm. Make your drawing *to scale*. Where is the image located and what are its orientation and its size? Repeat this for a convex spherical mirror of the same curvature.

6. A fish in a lake looks up at the surface of the water. At what distance d along the surface, measured from the normal, is a water-skimming insect safe from the roving eye of the fish?

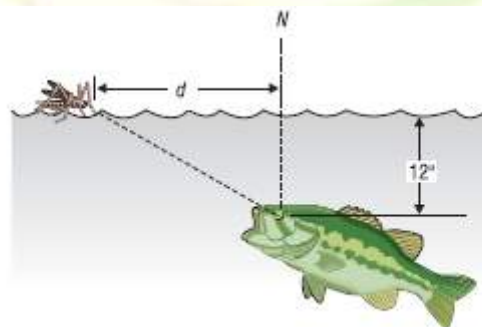

7. What is the light cone acceptance angle for an optical fiber of diameter 100 μ , located in air, having a plastic core of index 1.49 and a plastic cladding of index 1.39? Make a sketch of the fiber, showing a limiting

ray along the surface of the acceptance cone entering the fiber and refracting appropriately.

8. A laser beam is incident on the end face of a cylindrical rod of material as shown in the sketch. The refractive index of the rod is 1.49. How many internal reflections does the laser beam experience before it exits the rod?

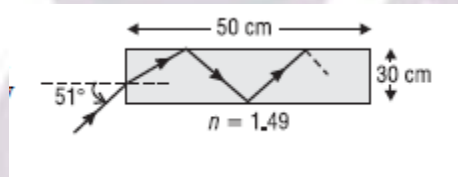

9. A thin, double-convex lens has a refractive index of 1.50. The radius of curvature of the front surface is 15 cm and that of the rear surface is 10 cm. See sketch. (a) How far from the lens would an image of the sun be formed? (b) How far from the lens would an image of a toy figure 24 cm from the lens be formed? (c) How do the answers to (a) and (b) change if you flip the lens over?

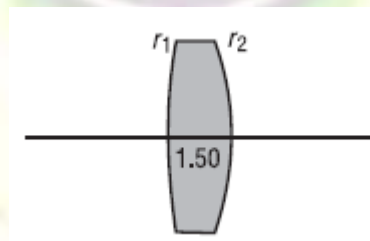

10. The object shown in the accompanying sketch is midway between the lens and the mirror. The radius of curvature of the mirror is 20 cm. The concave lens has a focal length of 16.7 cm. (a) Where is the light that travels first to the mirror and then to the lens finally imaged? (b) Where is the light finally imaged that travels first to the lens? (Note: Be especially careful of applying the sign convention!)

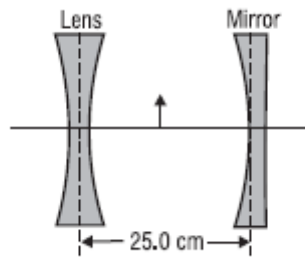

11. A ray of light makes an angle of incidence of 45° at the center of one face of a transparent cube of refractive index 1.414. Trace the ray through the cube, providing backup calculations to support your answer.

12. Two positive thin lenses, each of focal length $f = 3$ cm, are separated by a distance of 12 cm. An object 2 cm high is located 6 cm to the left of the first lens. See sketch. On an $8\frac{1}{2}'' \times 11''$ sheet of paper, make a drawing of the two-lens system, *to scale*.

(a) Use ray-tracing techniques to locate the final image and describe its size and nature.

(b) Use the thin-lens equation to locate the position and size of the final image. How well do your results for (a) and (b) agree?

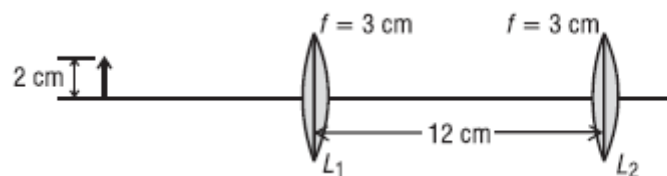

CHAPTER Five

Optical Aberration

An **optical aberration** is a departure of the performance of an optical system from the predictions of paraxial optics.^[1] In an imaging system, it occurs when light from one point of an object does not converge into (or does not diverge from) a single point after transmission through the system. Aberrations occur because the simple paraxial theory is not a completely accurate model of the effect of an optical system on light (due to the wave nature of light), rather than due to flaws in the optical elements.

Aberration leads to blurring of the image produced by an image-forming optical system. Makers of optical instruments need to correct optical systems to compensate for aberration.

1-Monochromatic aberration

The elementary theory of optical systems leads to the theorem: Rays of light proceeding from any *object point* unite in an *image point*; and therefore an *object space* is reproduced in an *image space*. The introduction of simple auxiliary terms, due to C. F. Gauss (*Dioptrische Untersuchungen*, Göttingen, 1841), named the focal lengths and focal planes, permits the determination of the image of any object for any system (see lens). The Gaussian theory, however, is only true so long as the angles made by all rays with the optical axis (the symmetrical axis of the system) are infinitely small, i.e. with infinitesimal objects, images and

lenses; in practice these conditions may not be realized, and the images projected by uncorrected systems are, in general, ill-defined and often completely blurred, if the aperture or field of view exceeds certain limits.

The investigations of James Clerk Maxwell (*Phil. Mag.*, 1856; *Quart. Journ. Math.*, 1858) and Ernst Abbe^[3] showed that the properties of these reproductions, i.e. the relative position and magnitude of the images, are not special properties of optical systems, but necessary consequences of the supposition (in Abbe) of the reproduction of all points of a space in image points (Maxwell assumes a less general hypothesis), and are independent of the manner in which the reproduction is effected. These authors proved, however, that no optical system can justify these suppositions, since they are contradictory to the fundamental laws of reflection and refraction. Consequently, the Gaussian theory only supplies a convenient method of approximating to reality; and no constructor would attempt to realize this unattainable ideal. At present, all that can be attempted is to reproduce a single plane in another plane; but even this has not been altogether satisfactorily accomplished: aberrations always occur, and it is improbable that these will ever be entirely corrected.

Ta-Spherical aberration is an optical effect observed in an optical device (lens, mirror, etc.) that occurs due to the increased refraction of light rays when they strike a lens or a reflection of light rays when they strike a mirror near its edge, in comparison with those that strike nearer the centre. It signifies a deviation of the device from the norm, i.e., it results in an imperfection of the produced image.

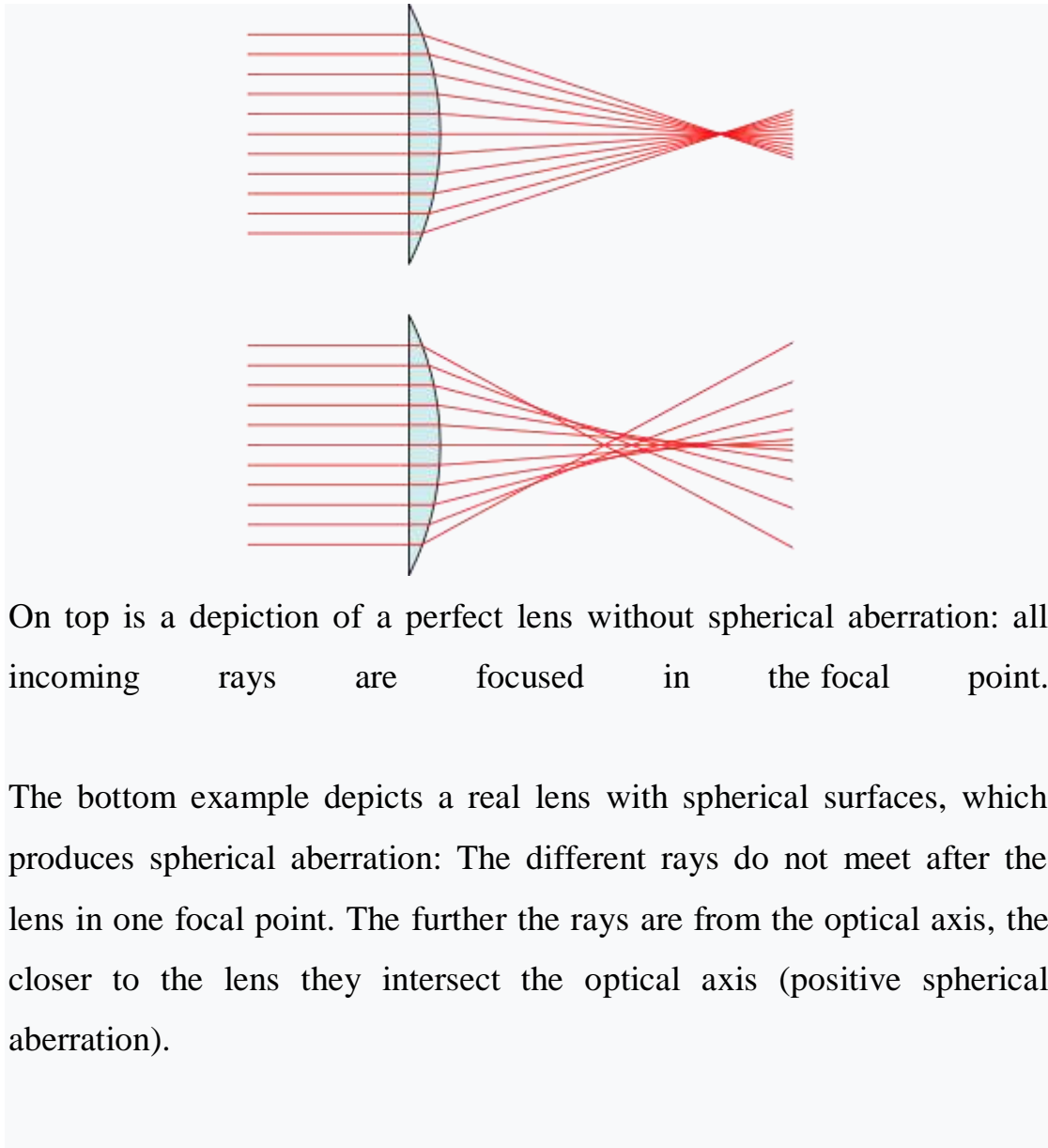

On top is a depiction of a perfect lens without spherical aberration: all incoming rays are focused in the focal point.

The bottom example depicts a real lens with spherical surfaces, which produces spherical aberration: The different rays do not meet after the lens in one focal point. The further the rays are from the optical axis, the closer to the lens they intersect the optical axis (positive spherical aberration).

A spherical lens has an aplanatic point (i.e., no spherical aberration) only at a radius that equals the radius of the sphere divided by the index of refraction of the lens material. A typical value of refractive index for crown glass is 1.5 (see list), which indicates that only about 43% of the area (67% of diameter) of a spherical lens is useful. It is often considered to be an imperfection of telescopes and other instruments which makes their focusing less than ideal due to the spherical shape of lenses and mirrors. This is an important effect, because spherical shapes are much easier to produce than aspherical ones. In many cases, it is cheaper to use

multiple spherical elements to compensate for spherical aberration than it is to use a single spherical lens.

"Positive" spherical aberration means peripheral rays are bent too much. "Negative" spherical aberration means peripheral rays are not bent enough.

The effect is proportional to the fourth power of the diameter and inversely proportional to the third power of the focal length, so it is much more pronounced at short focal ratios, i.e., "fast" lenses.

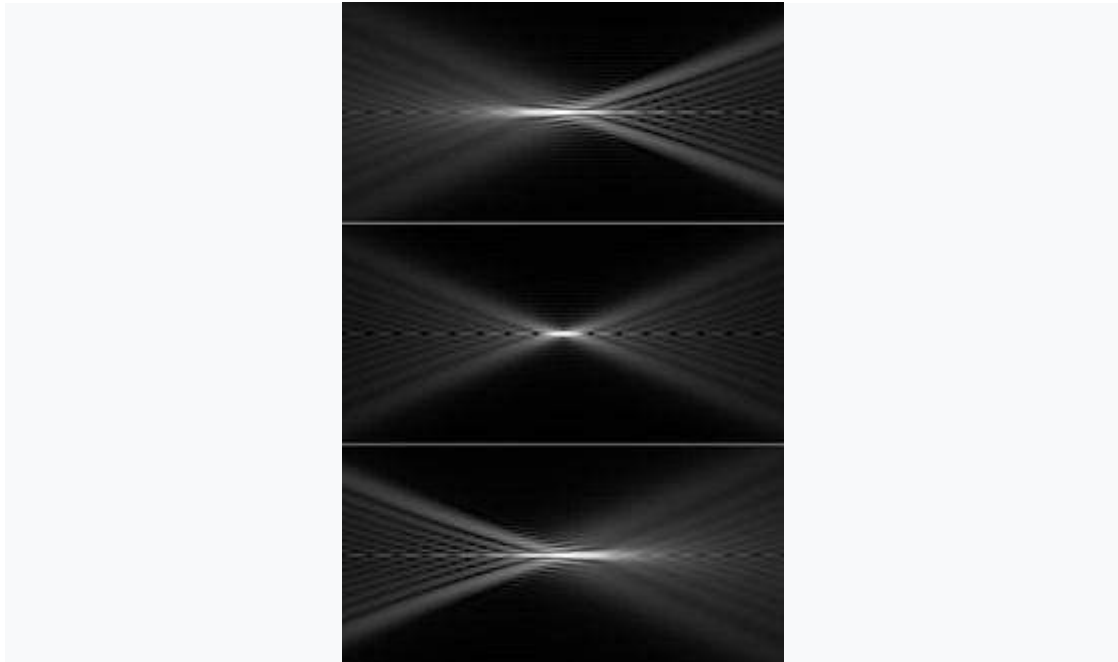

Longitudinal sections through a focused beam with negative (top row), zero (middle row), and positive spherical aberration (bottom row). The lens is to the left.

In lens systems, the effect can be minimized using special combinations of convex and concave lenses, as well as using aspheric lenses or aplanatic lenses.

For simple designs one can sometimes calculate parameters that minimize spherical aberration. For example, in a design consisting of a single lens with spherical surfaces and a given object distance o , image distance i , and refractive index n , one can minimize spherical aberration by adjusting the radii of curvature and of the front and back surfaces of the lens such that

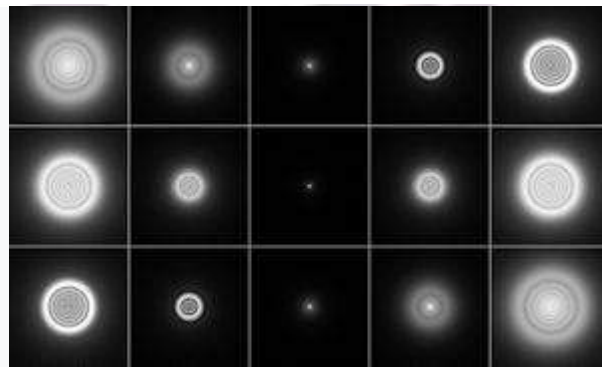

A point source as imaged by a system with negative (top row), zero (middle row), and positive spherical aberration (bottom row). The middle column shows the focused image, columns to the left shows defocusing toward the inside, and columns to the right show defocusing toward the outside.

For small telescopes using spherical mirrors with focal ratios shorter than $f/10$, light from a distant point source (such as a star) is not all focused at the same point. Particularly, light striking the inner part of the mirror focuses farther from the mirror than light striking the outer part. As a result the image cannot be focused as sharply as if the aberration were not present. Because of spherical aberration, telescopes shorter than $f/10$ are usually made with non-spherical mirrors or with correcting lenses.

Astigmatism is one where rays that propagate in two perpendicular planes have different foci. If an optical system with astigmatism is used to form an image of a cross, the vertical and horizontal lines will be in sharp focus at two different distances. The term comes from the Greek α - (*a*-) meaning "without" and $\sigma\tau\acute{\iota}\gamma\mu\alpha$ (*stigma*), "a mark, spot, puncture"

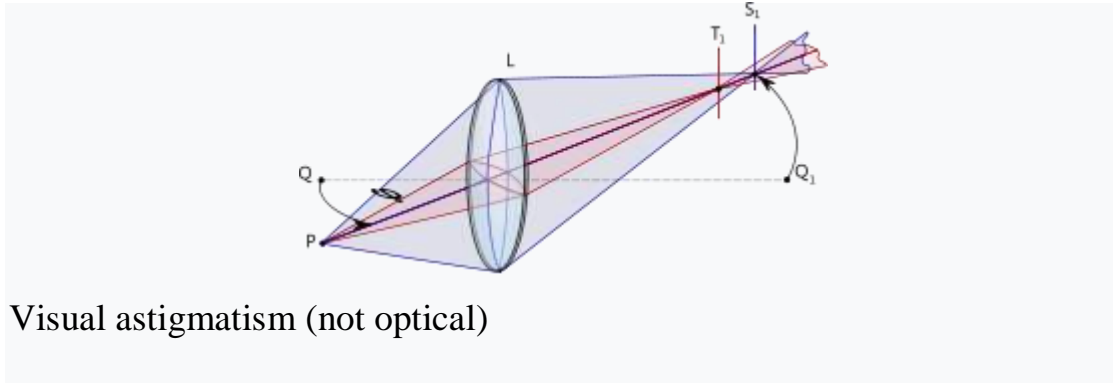

Visual astigmatism (not optical)

There are two distinct forms of astigmatism. The first is a third-order aberration, which occurs for objects (or parts of objects) away from the optical axis. This form of aberration occurs even when the optical system is perfectly symmetrical. This is often referred to as a "monochromatic aberration", because it occurs even for light of a single wavelength. This terminology may be misleading, however, as the *amount* of aberration can vary strongly with wavelength in an optical system.

The second form of astigmatism occurs when the optical system is not symmetric about the optical axis. This may be by design (as in the case of a cylindrical lens), or due to manufacturing error in the surfaces of the components or misalignment of the components. In this case, astigmatism is observed even for rays from on-axis object points. This form of astigmatism is extremely important in vision science and eye care, since the human eye often exhibits this aberration due to imperfections in the shape of the cornea or the lens.

c-Coma, or comatic aberration: in an optical system refers to aberration inherent to certain optical designs or due to imperfection in the lens or other components that results in off-axis point sources such as stars appearing distorted, appearing to have a tail (coma) like a comet. Specifically, coma is defined as a variation in magnification over the entrance pupil. In refractive or diffractive optical systems, especially those imaging a wide spectral range, coma can be a function of wavelength, in which case it is a form of chromatic aberration.

Coma is an inherent property of telescopes using parabolic mirrors. Unlike a spherical mirror, a bundle of parallel rays parallel to the optical axis will be perfectly focused to a point (the mirror is free of spherical aberration), no matter where they strike the mirror. However, this is only true if the rays are parallel to the axis of the parabola. When the incoming rays strike the mirror at an angle, individual rays are not reflected to the same point. When looking at a point that is not perfectly aligned with the optical axis, some of the incoming light from that point will strike the mirror at an angle. This results in an image that is not in the center of the field looking wedge-shaped. The further off-axis (or the greater the angle subtended by the point with the optical axis), the worse this effect is. This causes stars to appear to have a cometary coma, hence the name.[1]

Schemes to reduce spherical aberration without introducing coma include Schmidt, Maksutov, ACF and Ritchey-Chrétien optical systems. Correction lenses, "coma correctors" for Newtonian reflectors have been designed which reduce coma in telescopes below $f/6$. These work by means of a dual lens system of a plano-convex and a plano-concave lens fitted into an eyepiece adaptor which superficially resembles a Barlow lens. [1][2]

Coma of a single lens or a system of lenses can be minimized (and in some cases eliminated) by choosing the curvature of the lens surfaces to match the application. Lenses in which both spherical aberration and coma are minimized at a single wavelength are called *bestform* or *aplanatic* lenses.

Vertical coma is the most common higher-order aberration in the eyes of patients with keratoconus.^[3] Coma is also a common temporary symptom of corneal injuries or abrasions, in which case the visual defect gradually resolves as the cornea heals.

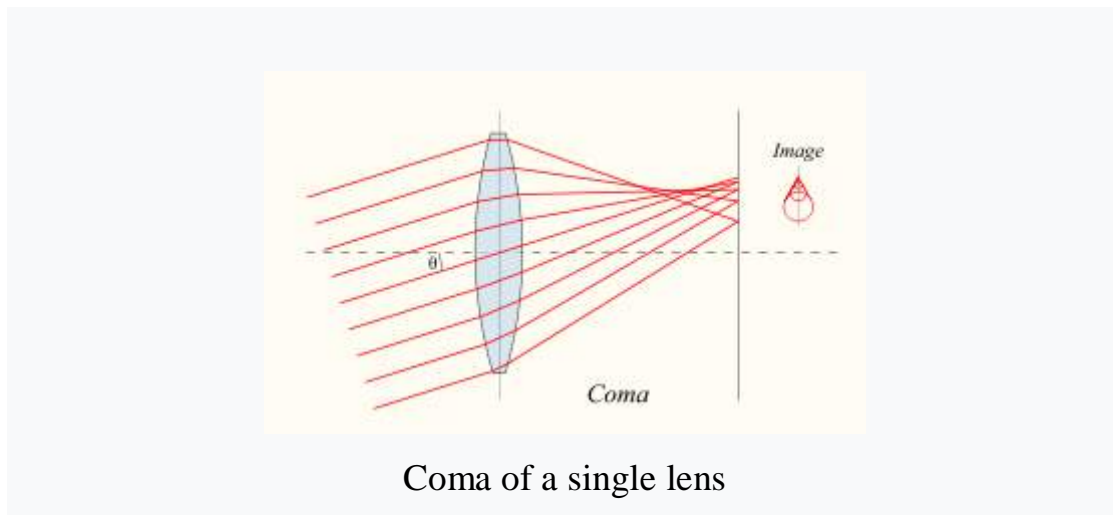

d-Distortion is a deviation from rectilinear projection, a projection in which straight lines in a scene remain straight in an image. It is a form of optical aberration.

Although distortion can be irregular or follow many patterns, the most commonly encountered distortions are radially symmetric, or approximately so, arising from the symmetry of a photographic lens. These *radial distortions* can usually be classified as either *barrel* distortions or *pincushion* distortions. See van Walree.^[1]

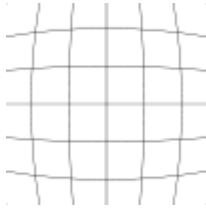

Barrel

In barrel distortion, image magnification decreases with distance from the optical axis. The apparent effect is that of an image which has been mapped around a sphere (or barrel). Fisheye lenses, which take hemispherical views, utilize this type of distortion as a way to map an infinitely wide object plane into a finite image area. In a zoom lens barrel distortion appears in the middle of the lens's focal length range and is worst at the wide-angle end of the range.^[2]

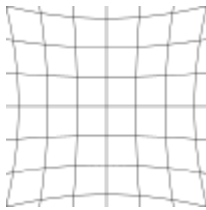

Pincushion

In pincushion distortion, image magnification increases with the distance from the [optical axis](#). The visible effect is that lines that do not go through the centre of the image are bowed inwards, towards the centre of the image, like a [pincushion](#).

Mustache

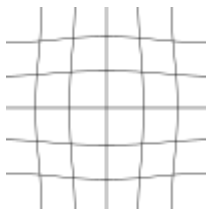

A mixture of both types, sometimes referred to as *mustache distortion* (*moustache distortion*) or *complex distortion*, is less common but not rare. It starts out as barrel distortion close to the image center and gradually turns into pincushion distortion towards the image periphery, making horizontal lines in the top half of the frame look like a [handlebar mustache](#)

e-Petzval field curvature, named for Joseph Petzval,^[1] describes the optical aberration in which a flat object normal to the optical axis (or a non-flat object past the hyperfocal distance) cannot be brought properly into focus on a flat image plane. Consider an "ideal" single-element lens system for which all planar wave fronts are focused to a point at distance f from the lens. Placing this lens the distance f from a flat image sensor, image points near the optical axis will be in perfect focus, but rays off axis will come into focus before the image sensor, dropping off by the cosine of the angle they make with the optical axis. This is less of a problem when the imaging surface is spherical, as in the human eye.

Most current photographic lenses are designed to minimize field curvature, and so effectively have a focal length that increases with ray angle. The Petzval lens is one design which has significant amount of field curvature, images taken with the lens are very sharp in the centre, but at greater angles the image is out of focus. Film cameras, may be able to bend their image planes to compensate, particularly when the lens is fixed and known. This also includes plate film, which could still be bent slightly. Digital sensors are difficult to bend, although experimental products have been produced.^[2] By 2016 the only consumer cameras featuring curved sensors were "selfie" Sony Cybershot KW-1 and KW-11. Large mosaics of sensors (necessary anyway due to limited chip sizes) can be shaped to simulate a bend over larger scales.^[citation needed]

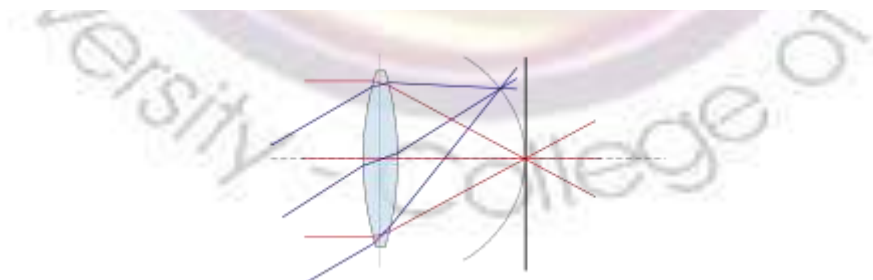

2- Chromatic Aberration

There are two types of chromatic aberration: *axial (longitudinal)*, and *transverse (lateral)*. Axial aberration occurs when different wavelengths of light are focused at different distances from the lens, i.e., different points on the optical *axis* (*focus shift*). Transverse aberration occurs when different wavelengths are focused at different positions in the focal plane (because the magnification and/or distortion of the lens also varies with wavelength; indicated in graphs as (change in) *focus length*). The acronym LCA is used, but ambiguous, and may refer to either longitudinal or lateral CA; for clarity, this article uses "axial" (shift in the direction of the optical axis) and "transverse" (shift perpendicular to the optical axis, in the plane of the sensor or film).^[2]

These two types have different characteristics, and may occur together. Axial CA occurs throughout the image and is specified by optical engineers, optometrists, and vision scientists in the unit of focus known widely as diopters,^[4] and is reduced by stopping down. (This increases depth of field, so though the different wavelengths focus at different distances, they are still in acceptable focus.) Transverse CA does not occur in the center, and increases towards the edge, but is not affected by stopping down.

In digital sensors, axial CA results in the red and blue planes being defocused (assuming that the green plane is in focus), which is relatively difficult to remedy in post-processing, while transverse CA results in the red, green, and blue planes being at different magnifications (magnification changing along radii, as in geometric distortion), and can be corrected by radially scaling the planes appropriately so they line up.

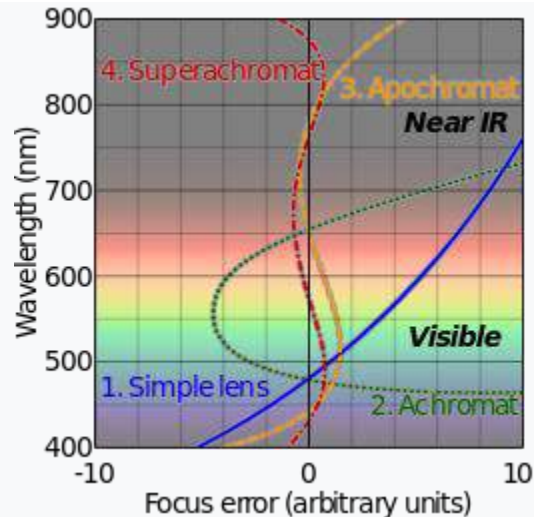

Chromatic correction of visible and near infrared wavelengths. Horizontal axis shows degree of aberration, 0 is no aberration. Lenses: 1: simple, 2: achromatic doublet, 3: apochromatic and 4: superachromat.

In the earliest uses of lenses, chromatic aberration was reduced by increasing the focal length of the lens where possible. For example, this could result in extremely long telescopes such as the very long aerial telescopes of the 17th century. Isaac Newton's theories about white light being composed of a spectrum of colors led him to the conclusion that uneven refraction of light caused chromatic aberration (leading him to build the first reflecting telescope, his Newtonian telescope, in 1668^[5]).

There exists a point called the *circle of least confusion*, where chromatic aberration can be minimized.^[6] It can be further minimized by using an achromatic lens or *achromat*, in which materials with differing dispersion are assembled together to form a compound lens. The most common type is an achromatic doublet, with elements made of crown and flint glass. This reduces the amount of chromatic aberration over a certain range of wavelengths, though it does not produce perfect correction. By combining more than two lenses of different composition, the degree of correction can be further increased, as seen in

an apochromatic lens or *apochromat*. Note that "achromat" and "apochromat" refer to the *type* of correction (2 or 3 wavelengths correctly focused), not the *degree* (how defocused the other wavelengths are), and an achromat made with sufficiently low dispersion glass can yield significantly better correction than an achromat made with more conventional glass. Similarly, the benefit of apochromats is not simply that they focus 3 wavelengths sharply, but that their error on other wavelength is also quite small.^[7]

Many types of glass have been developed to reduce chromatic aberration. These are low dispersion glass, most notably, glasses containing fluoride. These hybridized glasses have a very low level of optical dispersion; only two compiled lenses made of these substances can yield a high level of correction.^[8]

The use of achromats was an important step in the development of the optical microscope and in telescopes.

An alternative to achromatic doublets is the use of diffractive optical elements. Diffractive optical elements are able to generate arbitrary complex wave fronts from a sample of optical material which is essentially flat.^[9] Diffractive optical elements have negative dispersion characteristics, complementary to the positive Abbe numbers of optical glasses and plastics. Specifically, in the visible part of the spectrum diffractives have a negative Abbe number of -3.5 . Diffractive optical elements can be fabricated using diamond turning techniques.^[10]

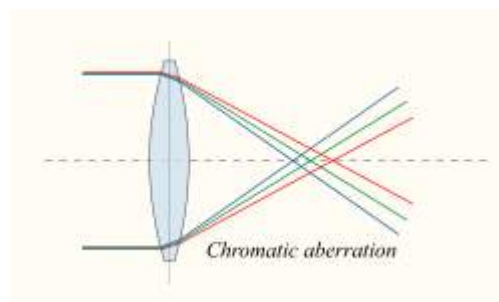

Chromatic aberration of a single lens causes different wavelengths of light to have differing focal lengths

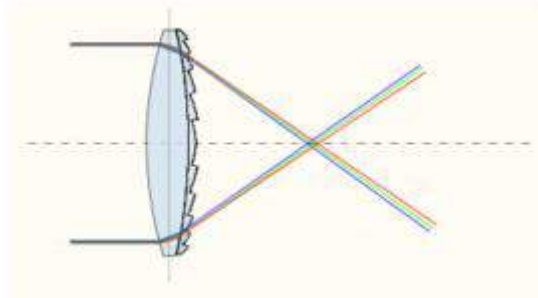

Diffractive optical element with complementary dispersion properties to that of glass can be used to correct for color aberration

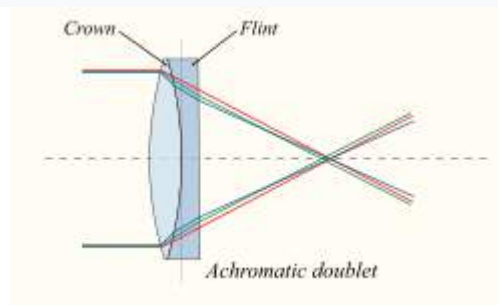

For an achromatic doublet, visible wavelengths have approximately the same focal length

