



ALUMINUM
EXTRUDERS
COUNCIL

Aluminum Extruders Council

1000 N Rand Rd, Suite 214

Wauconda, IL 60084

Tel: 1-847-526-2010

Email: mail@aec.org

Web: www.aec.org

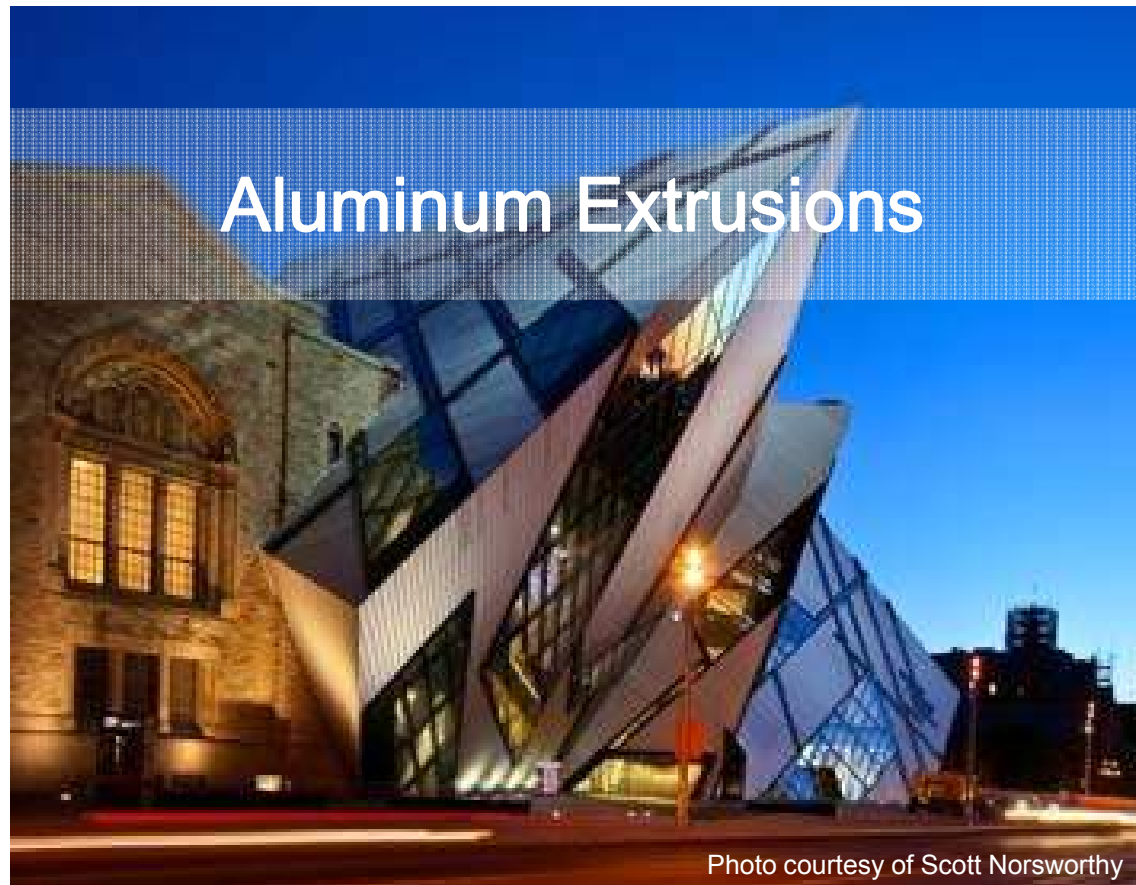

©2012, 2013 Aluminum Extruders Council. The material contained in this course was researched, assembled, and produced by Aluminum Extruders Council and remains its property. "LEED" and related logo is a trademark owned by the U.S. Green Building Council and is used by permission. Questions or concerns about the content of this course should be directed to the program instructor.

Aluminum Extrusions

Presented By: Aluminum Extruders Council
1000 N Rand Rd, Suite 214
Wauconda, IL 60084

Description: Provides an overview of the characteristics, technical information, and benefits of aluminum extrusions used as a building material, with a focus on whole building design, sustainability and application possibilities.

Purpose and Learning Objectives

Purpose: Provides an overview of the characteristics, technical information, and benefits of aluminum extrusions used as a building material, with a focus on whole building design, sustainability and application possibilities.

Learning Objectives:

At the end of this program, participants will be able to:

- provide technical information as to the benefits of aluminum extrusions used as building material in terms of strength and durability
- outline the sustainable characteristics of extruded aluminum building products
- present solutions on how to address some of today's building design challenges in light of the increasing demand for green buildings
- showcase various building and construction applications and innovations using aluminum extrusions, and
- relate the holistic applications of extruded aluminum products to the “whole building design” concept.

A Few Facts About Aluminum

Lightweight

Aluminum is lightweight (low density)—about $\frac{1}{3}$ of copper or steel—yet is one of the strongest construction materials available.

Aluminum's high strength-to-weight ratio means that less of a building's structure is spent supporting its own weight.

Aluminum offers undiminished structural integrity over a long service life.

Buildings in seismic zones benefit even more from reduced weight, since seismic forces are proportional to the structure's weight.

A Few Facts About Aluminum

Structural Strength

Aluminum's structural strength and stability is consistently strong, even under extreme conditions and temperature changes, in terms of elastic modulus/stiffness. Where plastics may become brittle at low temperatures, aluminum actually becomes even stronger at extremely cold temperatures, which is why NASA chooses it for many aerospace applications.

Aluminum:

- is 34 times stronger than vinyl
- is 43 times stronger than wood, and
- when appropriately alloyed and treated, can be stronger than some steels, with ultimate tensile strengths as high as 80,000 psi to 90,000 psi or more.

A Few Facts About Aluminum

Tensile Strength

Aluminum's tensile strength and structural stability and rigidity mean that extruded aluminum building components are more resistant to deformation caused by climate changes and building movement over time. Aluminum's unique enduring properties guarantee long-term performance with minimal maintenance.

Structural integrity is judged based upon the ability of a material to withstand loads—i.e., its strength.

Tensile strength determines maximum load a material can carry under tension (when stretched).

Structural stiffness and strength combine with light weight and ease of fabrication to form the ideal building material.

A Few Facts About Aluminum

Modulus of Elasticity (E-value)

In terms of E-value, the modulus of elasticity, aluminum has greater resistance to deformation than either wood or vinyl.

By using extruded aluminum for window frames and curtain walls, manufacturers can design slimmer, more elegant framing without sacrificing strength and rigidity. Slimmer frames mean larger glass areas and more natural daylighting.

The modulus of elasticity (E-value) indicates rigidity (stiffness) or resistance to bending.

Aluminum is 72 times more rigid than wood, and 23.2 times more rigid than vinyl (PVC).

A Few Facts About Aluminum

Resists the Ravages of Time and Temperature

Aluminum resists the forces of time. It's impervious to humidity, temperature and warping, or becoming brittle; that translates to longer service life. Because aluminum doesn't absorb moisture, it won't swell, shrink, split, crack, rot, or rust.

In terms of appearance, aluminum's corrosion resistance means that a building's façade will retain the finishes and visual appeal envisioned by the designer through decades of wear.

Aluminum retains its physical properties over time.

Extruded aluminum building components resist deformation caused by climate changes and building movement, and aluminum extrusions retain their basic structure, strength, stability, and durability.

Aluminum Comes in Various Alloys and Tempers

Aluminum alloy designations begin with 1xxx series alloys. In the 2xxx series, aluminum is alloyed with copper. The 3xxx series alloys aluminum with manganese. 1xxx and 3xxx alloys are non-heat-treatable. They develop their strength characteristics from cold work after extruding, section shape permitting. The 4xxx series alloys are not widely used due to their low level of extrudability.

1xxx Series: 99%+ Aluminum	2xxx Series: Al + Copper	3xxx Series: Al + Manganese	4xxx Series: Al + Silicon
<ul style="list-style-type: none">• High corrosion resistance• Excellent finish surface• Easily joined by all methods• Lower strength• Excellent workability/poor machinability• High electrical and thermal conductivity• Applications: heat exchangers, pipe and tubing for carrying chemicals, foodstuffs and refrigerants	<ul style="list-style-type: none">• High strength• Relatively low corrosion resistance• Excellent machinability• Heat-treatable• Applications: hydraulic components, forging stocks	<ul style="list-style-type: none">• Low to medium strength• Good corrosion resistance• Good workability and thermal stability• Applications: condensers	<ul style="list-style-type: none">• Not widely used in extrusions

Aluminum Comes in Various Alloys and Tempers

The 5xxx series alloys aluminum with magnesium and is also non-heat-treatable. The 6xxx alloys combine aluminum with magnesium and silicon. The 2xxx, 6xxx, and 7xxx series alloys, which are the highest strength aluminum alloys, attain their maximum strength through controlled heat treatment in the extrusion press, and sometimes in a separate furnace. Properties and characteristics of aluminum extrusions, such as density, conductivity, corrosion resistance, finish, mechanical properties, and thermal expansion are modified, depending on the alloying element.

5xxx Series: <i>Al + Magnesium</i>	6xxx Series: <i>Al + Magnesium & Silicon</i>	7xxx Series: <i>Al + Zinc, Magnesium, Copper</i>
<ul style="list-style-type: none">• Low to moderate strength• Excellent marine corrosion resistance• Very good weldability• Applications: marine	<ul style="list-style-type: none">• Most popular extrusion alloy• Good finish surface and strength• Good extrudability• Good corrosion resistance• Good machinability and weldability• Good formability and heat-treatable• Applications: windows, doors, curtain walls, storefronts, sign panels, light fixtures, van bodies, boat masts, scaffolds, cranes, truck trailers, railroad components, substations, towers and general structures	<ul style="list-style-type: none">• High strength and toughness• Heat-treatable and good machinability• Applications: automotive, bumpers, head-rest bars, bumper back-up bars

Aluminum Tempers

Temper designation refers to aluminum alloys being classified as heat-treatable or non-heat-treatable, depending on the method used to attain their maximum strength. Non-heat-treatable alloys in the 1xxx, 3xxx, and 5xxx series develop strength characteristics through cold work after extruding, if the section shape permits.

Basic Temper Designations			Typical Extrusion Tempers
F	As Extruded	No special control over thermal conditions or strain hardening; no mechanical property limits	
O	Annealed	Thermally treated (fully annealed) to obtain the lowest strength temper	<ul style="list-style-type: none"> • O = Fully annealed
H	Strain-hardened	Cold working used to increase strength and hardness	<ul style="list-style-type: none"> • H112 = Strain-hardened; used for non-heat-treatable alloys
T	Thermally Treated	Thermally treated to produce stable tempers other than F/O/H	<ul style="list-style-type: none"> • T1 = Press-quenched and naturally aged • T4 = Solution heat-treated and naturally aged • T5 = Press-quenched and artificially aged • T6 = Solution heat-treated and artificially aged

Aluminum Is Sustainable

Aluminum is a non-combustible and natural material:

- It is the third most abundant element in the earth's crust next to oxygen and silicon, and the most abundant metal in nature.
- Aluminum is environmentally friendly and non-toxic, including at high temperatures.

Global Bauxite Mining Site Rehabilitation, km²

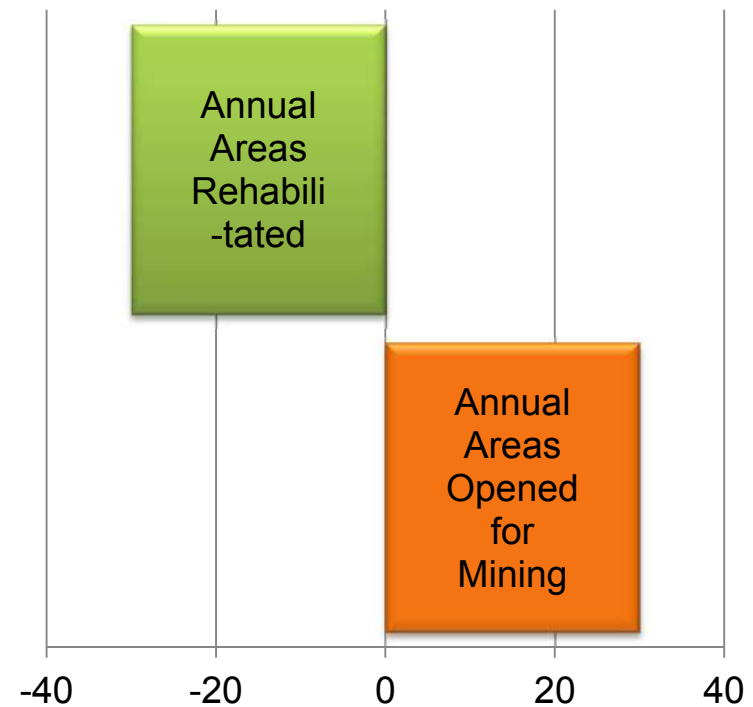

Aluminum Is Sustainable

Aluminum is recyclable:

- It is 100% recyclable with high scrap value.
- Aluminum can be repeatedly recycled, retaining the same material physical properties.
- 73% of all the aluminum ever produced is still in use today.

Recycled aluminum retains value:

- At the end of its life, aluminum is 100% reusable.
- In a 2004 study, the Delft University of Technology found that “95% of the aluminum used in building and construction is recycled at the structure’s end-of-life.”
- During deconstruction, aluminum is extracted for scrap value and reduces environmental impact by not being deposited in landfills.



Aluminum Is Sustainable

Primary Energy Demand for Aluminum Production

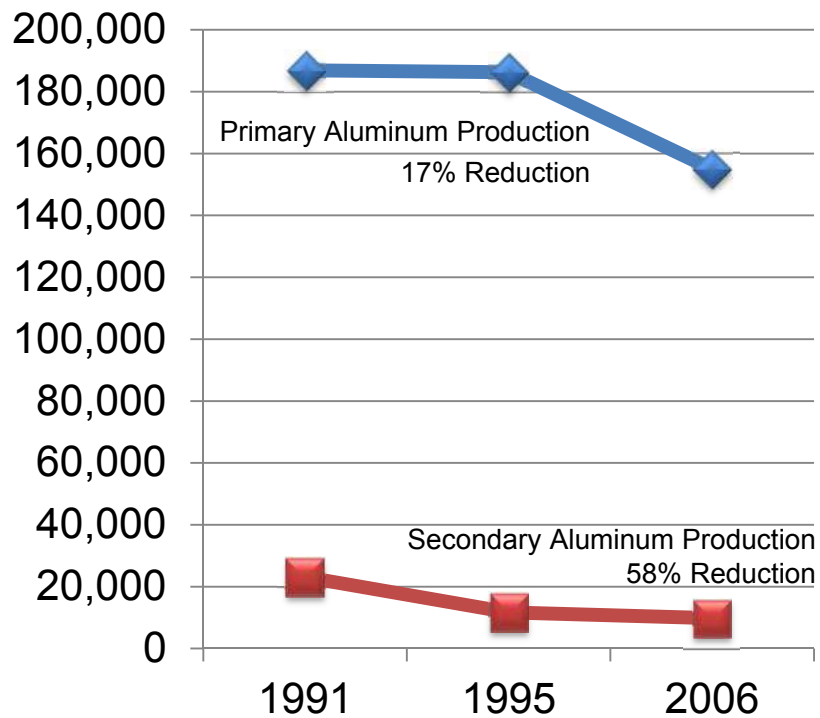

Greenhouse Gas Emissions Caused by Aluminum Production

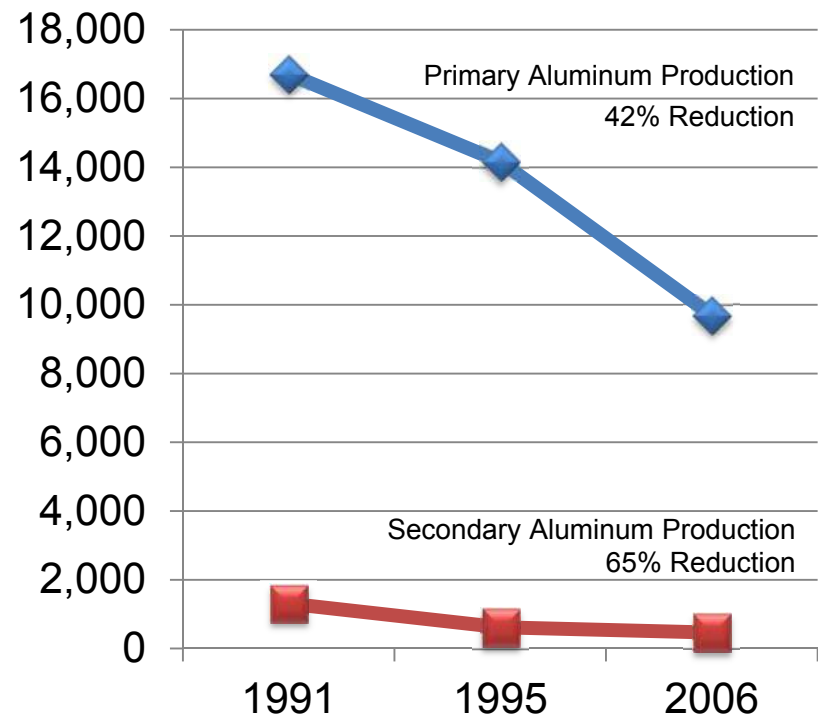

Recycling saves 95% of energy and GHG emissions compared to primary production.

Aluminum Is Sustainable

Benefits of Aluminum Recycling

Annually:

- About 70 million barrels of crude oil equivalent of energy is saved—enough oil to feed U.S. consumption for three days, or nearly one day of the world's oil supply.
- Approximately 2.4 million square meters of land is saved.
- More than 45 million tons of fresh and sea water use is avoided—enough water to provide for the needs of New York City's eight million people for ten days.
- Approximately 7.5 million tons of solid waste is avoided.
- About 27 million tons of CO₂ equivalent of greenhouse gas emissions is avoided—equivalent to eliminating five large (1,000 MW) coal-fired power plants.

Total Life Cycle Impact: Recycling Is Key

What Is an Aluminum Extrusion?

The extrusion process involves taking an aluminum alloy billet and forming it into an extruded shape by forcing it through a die that is designed in whatever configuration is required for a particular building component. Complex and customized shapes are often ordered, as well as a wide range of standard shapes and sizes.



Formability: Limitless Design Options

Aluminum extrusions are a truly versatile building material, especially when used on commercial fenestration and building products.

Aluminum is ductile and easily formable, and can be extruded into a vast array of shapes, including complex, multi-void hollows, and customized designs. Extrusions provide for the placement of metal precisely where it's needed. Tight tolerances, even on thin-walled extrusions, can be consistently maintained.

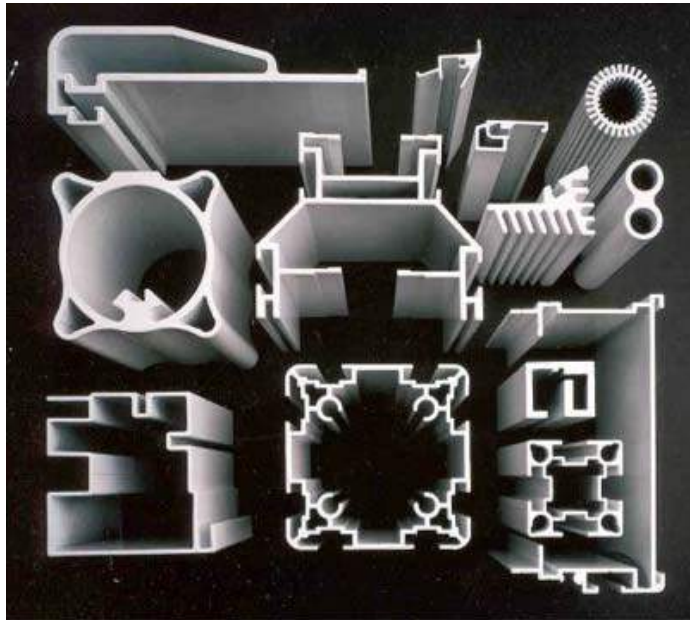

Extrusions enable sophisticated design features to be easily incorporated as integral building components.

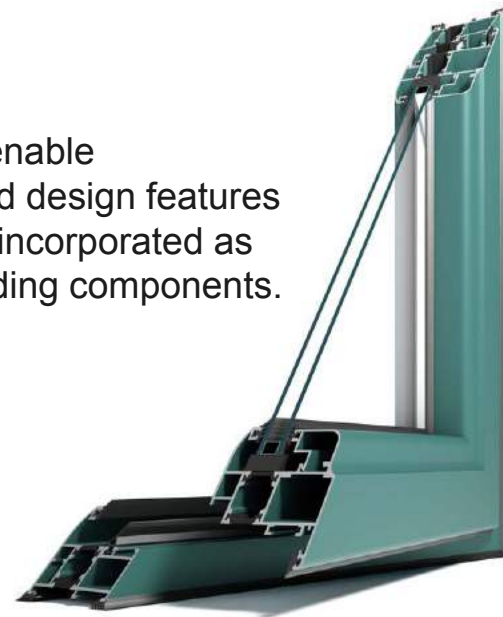

Wide Selection of Finishing Options

For many applications, aluminum needs no protective coating because it is adequately protected by the thin, transparent oxide which covers its surface on exposure to air.

Aluminum extrusions are particularly receptive to high-performance architectural coatings, helping to ensure maintenance-free performance and longer service life.

Where additional protection or decorative finishes are desired, aluminum accepts a range of finishing options. Finishing methods include anodizing, painting and powder coating, allowing a customized look and limitless color choices. Technological advances make these finishes extremely durable and environmentally friendly. Pre-treated aluminum provides the ideal material on which to deposit a coating or finish. Aluminum manufacturers have developed coatings using pigments and binders which are inherently lightfast to achieve the longest possible coating life under various environmental conditions.



Finishing: Anodizing

Anodizing is an electrolytic process that forms a durable, porous oxide film on the surface of aluminum, adding to the protection provided by its natural oxide layer.

- **Durability:** Anodic coating is part of the base metal and will not chip or peel.
- **Environmental:** Anodizing emits no VOCs, and no heavy metals are used in the process.
- **Recyclability:** Anodized aluminum is easily recycled without any extra steps.
- **Color Availability:** Two-step electrolytic color is available in bronze and black. More colors are available in dyed finishes.
- **Color Stability:** Two-step electrolytic color will not fade over time in UV light.
- **Maintenance:** Anodized finishes are easily maintained.
- **Specification:** AAMA 611 - Class I 0.7 mils coating, Class II 0.4 mils coating.



Finishing: Paint and Lacquers

Aluminum readily accepts paints and lacquers. Paints and lacquers may be applied to aluminum by any of these popular methods: electrostatic spraying, electrodeposition, powder coating, dip coating, flow coating.

- Provides corrosion resistance
- Consistent color from lot to lot
- Color availability: some paints easily mixable in small batches
- Can sometimes cover minor metal defects
- PVDF is chemically inert and can outlast other finishes in corrosive environments
- Used in a broad range of applications: architectural and consumer products, industrial equipment, automotive applications
- Specifications: AAMA 2603 (Acrylic and most high-solid polyester resins), AAMA 2604 (50% PVDF-based resins), AAMA 2605 (70% PVDF-based resins)



Municipal Parking Garage
Naples, FL.

Finishing: Paint and Lacquers

Summary AAMA Liquid Paint Specifications for Extrusion

SPECIFICATIONS:	AAMA 2603*	AAMA 2604*	AAMA 2605*
	Voluntary Specification, Performance Requirements and Test Procedures for Pigmented Organic Coatings on Aluminum Extrusions and Panels	Voluntary Specification, Performance Requirements and Test Procedures for High Performance Organic Coatings on Aluminum Extrusions and Panels	Voluntary Specification, Performance Requirements and Test Procedures for Superior Performing Organic Coatings on Aluminum Extrusions and Panels
Suggested Uses	Residential, All Interior Applications	Commercial/Industrial, High-end Residential, High Traffic areas	High performance, Architectural and Monumental Applications
South Florida Exposure	1 Year	5 Years	10 Years
Color Retention	1 Year - Fade	5 yrs. - Fade = 5 Delta E	10 yrs. - Fade = 5 Delta E
Chalk Resistance	1 Year - Chalk	5 yrs. - Chalk = 8	10 yrs. - Chalk = 8 (colors) 10 yrs. - Chalk = 6 (whites)
Gloss Retention	No Specification	5 yrs. - 30% Retention	10 yrs. - 50% Retention
Erosion Resistance	No Specification	5 yrs. - 10% Loss	10 yrs. - 10% Loss
Dry Film Thickness	0.80 mils minimum	1.20 mils minimum	1.20 mils minimum (2-coats)
Pretreatment System	Chrome or Chrome Free	Chrome or Chrome Free	Chrome = 40mg/sq. ft.
Accelerated Testing			
Salt Spray	1,500 Hours	3,000 Hours	4,000 Hours
Humidity	1,500 Hours	3,000 Hours	4,000 Hours
Color Uniformity	Final Color Approval should be made with applicator prepared production lines samples	Final Color Approval should be made with applicator prepared production lines samples	Final Color Approval should be made with applicator prepared production lines samples

*Contact AAMA for latest revisions/changes to AAMA Specifications – www.aamanet.org

Finishing: Mechanical Finishes

Aluminum can be given many different types of surface texture, from rough or patterned to mirror-shiny, by a variety of mechanical methods including:

- grinding
- perforating
- embossing
- brushing or polishing
- satin finishing
- barrel tumbling
- barrel burnishing
- sandblasting, shot blasting, and/or
- glass bead blasting.



These methods may be applied as: a final surface finish; to improve surface quality; or, as preparation for a variety of final cosmetic finishes. They can often enhance the finish when done in conjunction with anodizing and are an ideal way to “hide” surface imperfections.

Ease of Fabrication

Easy to fabricate:

- Often, designing with aluminum extrusions can eliminate many fabrication and assembly steps.
- Aluminum extrusions can be made with almost any cross-sectional shape. Parts can be easily cut, machined, finished, fabricated, and assembled.

Joinable by various methods:

- Aluminum extrusions can be joined to other aluminum products or to different materials by all major methods, including welding, soldering, brazing, bolts, rivets, clips, adhesives, clinching, and slide-on, snap-together or interlocking joints.

Suitable for easy-assembly designs:

- Aluminum extrusions can be designed for easy assembly with other parts including mating surfaces or shapes that match up for easy joining.

By using aluminum extrusion's ability to easily and cost effectively produce complex, integral profiles, designers can often accomplish tremendous part-count reductions!



Courtesy of
Alexandria Extrusion

Extrusion Tooling and Lead-Time Economics

Aluminum extrusion offers advantages over other processes in both the cost and the lead-time of tooling design and manufacture. Aluminum extrusion dies often cost from \$500 to \$5000 depending on the size and whether the shape is a solid or hollow profile. Comparable injection molding dies, die castings or roll forming can cost \$25,000 or more.

The initial costs and lead-times of aluminum extrusion dies and supporting tools are usually a good deal lower than the tooling required for other processes (often a few weeks versus 12–20 weeks for comparable processes).

Process	Typical Tooling Cost (\$)
Aluminum Extrusions	\$500 to \$5,000
Vinyl Extrusion	\$1,500 and up
Injection Molding	\$25,000 and up
Die Castings	\$25,000 and up
Roll Forming	\$30,000 and up
Stampings	\$5,000 and up

Application Examples Using Aluminum Extrusions

Here are some of the innovative applications for aluminum extrusions in commercial buildings:

- Windows and doors (including hurricane- and blast-resistant)
- Skylights/rotundas
- Curtain walls
- Sun shades and louvers
- Photovoltaic panel framing
- Reflective solar roof panel framing
- Atriums and enclosures
- Sun rooms
- Observatories
- Walkways, entryways and gateways
- Panel systems
- Store fronts
- Elevator cab framing
- Bridge decks
- Steeples
- Gates and archways
- Canopies
- Space frame systems
- Garages and parking covers
- Geodesic domes and structures
- Rain screens and water collection systems
- Supports for aluminum composite panel systems
- Housing for interior lighting grids
- Demountable interior walls and light-deflecting shelves
- And more...

The versatility of the extrusion process applied to aluminum continues to stir the imagination of designers and architects everywhere.

Application: Commercial Windows and Doors

Aluminum extrusions were used for the windows of Northwestern University's Chicago campus in the Ward Building. Aluminum windows and doors provide energy efficiency, structural integrity, superior resistance to air and water infiltration, aesthetics, as well as long-term durability.



Northwestern University, Ward Building, Chicago, IL
© The Apple Group Architectural Photography

Application: Curtain Walls and Storefronts

There are numerous reasons why aluminum extrusions are the framing material of choice for curtain walls and storefronts.

- Strength-to-weight ratio
- Glazing and wind load capability
- Minimal expansion and contraction coefficients
- Ability to seal to the building structure
- Maximal indoor daylighting
- Design flexibility
- Maintenance
- Ease of fabrication and assembly
- Aesthetics
- Finishing options
- Thermal capabilities



W-Austin Hotel and Residences, Austin, TX
© Wes Thompson Photography

Photo courtesy of Kawneer/Traco

Application: Skylights and Sun Rooms

Aluminum extrusions are also commonly used for skylight applications and are especially well-suited for sunrooms and atriums such as these areas in a banquet hall.



Photo courtesy of *Light Metal Age* magazine



Photo courtesy of Four Seasons Solar Products LLC

Application: Photovoltaic Panels

Aluminum extrusions provide the framing hardware system for today's photovoltaic panels for commercial construction.

Here, thin-layer PV is applied on glass, and polycrystalline silicon wafers are laminated between two glass panes within an extruded aluminum framework. The photovoltaic solar cells convert light into electrical energy that operates a building, or is fed into a supply network.



Application: Ceiling Panels

There are plenty of ways extrusions are used in a building's interior. Here, the extruded aluminum framing grid has a pendant-mounted up-lighting system. The lobby's marble-clad elevator core houses high-capacity elevator cabs framed entirely with aluminum extrusions.



Photos courtesy of James Steinkamp Photography. Used with permission of Goettsch Partners, Inc.

Application: Almost endless....

Aluminum extrusions are used throughout the world for exquisite architectural designs. Aluminum extrusion building components are also used in many types of arches, entryways, and gateways, such as this Florida SunPass gantry which uses round, tubular extrusions. Aluminum extrusions are continuously being used in various construction applications.



Photo courtesy of *Light Metal Age* magazine



Courtesy of CST Covers

Today's Challenges for Commercial Buildings

This section of the course will focus on some of today's architectural and design challenges involving overall commercial building performance.

- Reducing energy and resource consumption
- Energy codes becoming more stringent
- Increasing demand for sustainable buildings
- New Green Building codes being introduced
- LEED® being specified
- Impact resistance being mandated
- Increased security (i.e. bullet-resistant glass, high-security entrances, etc.)

Challenge: Reducing Energy and Resource Consumption

- Buildings use 39% of ALL U.S. energy consumed.
- 72% of all electricity and 54% of all natural gas in the U.S. is consumed in buildings. (U.S. Department of Energy - <http://energy.gov/>)
- Buildings use 40% of world's raw materials—3 billion tons per year. (Worldwatch Institute - <http://www.worldwatch.org/>)
- 170 million tons of U.S. building-related construction and demolition debris is generated every year. (U.S. Environmental Protection Agency - <http://www.epa.gov/>)

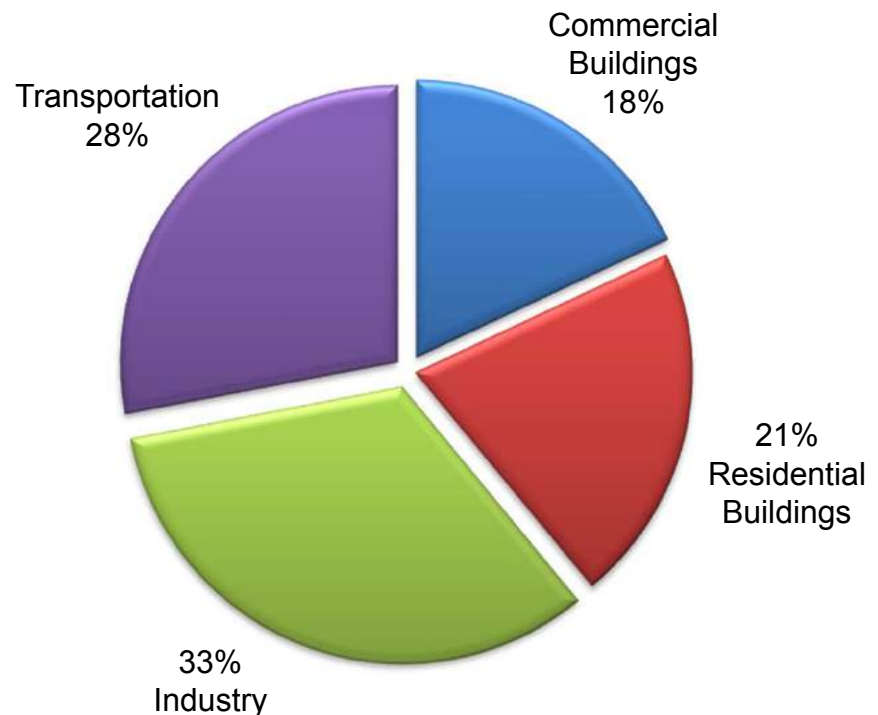

Green design and building technologies lower construction costs and reduce operating expenses. Buildings are draining our nation's total energy, much more so than the transportation industry.

Challenge: Energy Codes Becoming More Stringent

Energy codes are all around us. Each state, county, or city has building codes that also include requirements for building energy efficiency. This includes requirements for the thermal performance of windows, doors, and skylights, based upon location or climate zone.

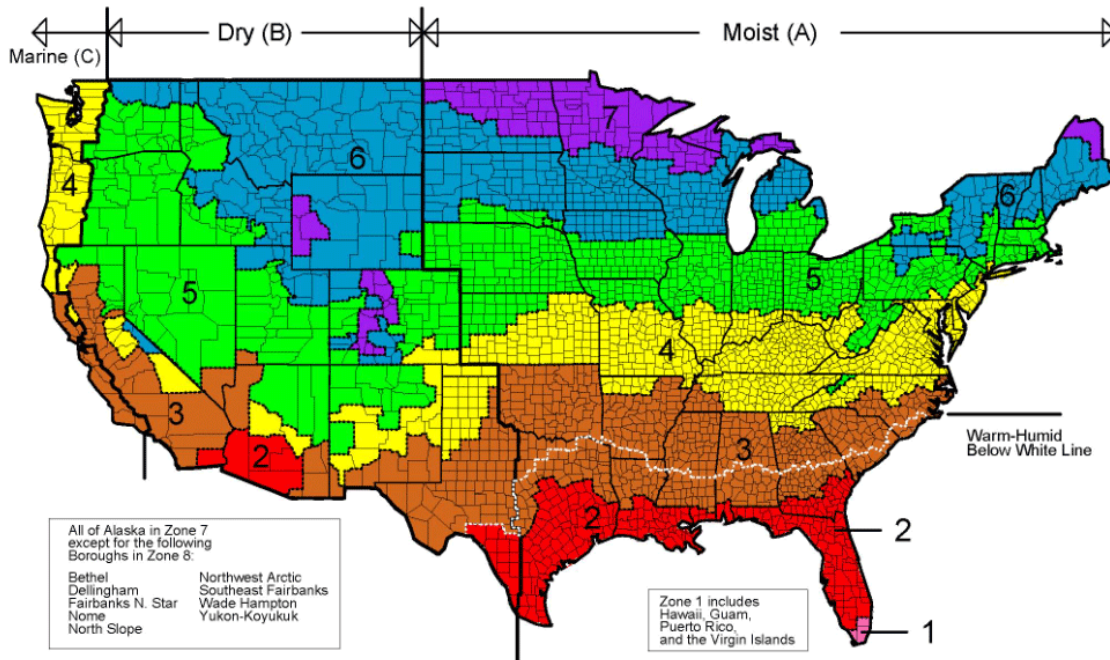

Climate zones used by the *International Energy Conservation Code* and *ASHRAE 90.1*.

Challenge: Increasing Demand for Sustainable Buildings

The demand for commercial green buildings is increasing globally, with a focus on:

- curbing greenhouse gas emissions
- increasing overall energy efficiency
- reducing heating and cooling costs, and
- integrating high-demand design elements:
 - structural, mechanical, botanic, air quality, lighting, plumbing, and water use.

Increasing demand for green buildings is reflected in end-use shipments of extruded aluminum products. According to AEC and the Aluminum Association, 1.3 billion pounds of aluminum rod, bar, pipe, tube, and extruded profiles were used in 2007 in building and construction, primarily in windows, doors, and curtain walls. Commercial structures that use aluminum extrusions emit less carbon dioxide and reduce energy costs through increased heating and cooling efficiency. Automatically controlled indoor lighting and improved natural daylighting also cut energy costs, and provide economic benefits from increased worker health and productivity due to the improved indoor environment.

Challenge: New Green Building Codes Being Introduced

Recently, new green building codes have been developed, including the 2012 International Green Construction Code and ASHRAE 189.1. These incorporate even higher levels of energy efficiency, but also bring in concepts like requirements for sustainable materials.

Again, aluminum framed products meet the thermal performance requirements in every location, with increased use of thermal barriers, low-e glass, and triple glazing. Also, exterior shading including aluminum sunshades is *required* in certain buildings. Finally, there is an increasing demand for building materials to be sustainable, recyclable, and supported by environmental impact studies such as life cycle analysis.

Challenge: Leadership in Energy and Environmental Design (LEED®)

An ever-increasing number of construction projects, whether new or retrofitting construction, are specifying the projects to meet LEED certification. LEED-certified projects are becoming more and more a requirement rather than an option.

A few facts about LEED:

- According to the U.S. Green Building Council (USGBC), as of November 2012, there were 15,000 LEED-certified commercial buildings in the U.S.¹
- LEED-certified annual construction value is expected to exceed \$1 billion by 2013.²

Conclusion: The demand for LEED® construction projects continues to grow.



¹Source: U.S. Green Building Council website. <http://www.usgbc.org/>. Accessed May 2013.

²Source: USGBC. "Green Jobs Study." USGBC. <http://www.usgbc.org/ShowFile.aspx?DocumentID=6435>. Accessed May 2012.

Challenge: Impact Resistance Is Being Mandated

Many states mandate the use of impact-resistant products in wind-borne debris regions. As represented in yellow, this area stretches from Texas, around the Gulf Coast, up the entire Eastern Seaboard and the Hawaiian Islands.

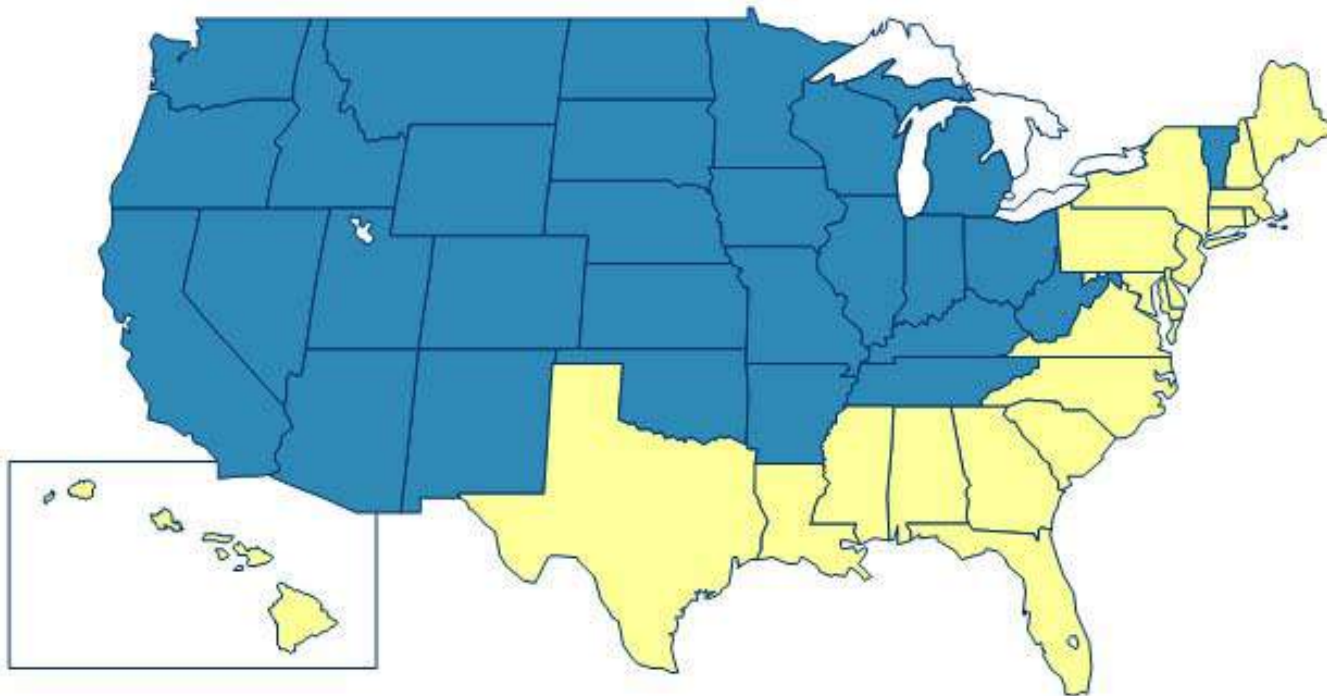

States in yellow = impact-resistant products mandated

Reducing Building's Energy and Resource Consumption

According to the Department of Energy's 2010 Buildings Energy Data Book, windows are responsible for 1.88 Quadrillion BTUs (Quads) of energy for heating and 3.86 Quads of energy for cooling commercial buildings.³

Aluminum windows, through the use of thermal barriers and low-e glazing, meet and exceed all of ASHRAE 90.1-2013 and 2012 IECC vertical fenestration U-factor insulation requirements for commercial buildings in every U.S. climate zone.

³Source: CSBR, Windows and Daylighting Group. "Performance: Energy & Cost." *Windows for High-Performance Commercial Buildings*
<http://www.commercialwindows.org/energy.php>. Accessed May 2012.

What Does a Thermal Barrier System Do?

Thermally separating extruded aluminum windows greatly improves thermal efficiency in the sash and frame, and vastly reduces thermal conductivity to energy-efficient levels. Thermally separating extruded aluminum windows allows aluminum's many key properties to be utilized.

When thermal barrier materials, such as polyurethane and glass fiber reinforced polyamide, are used in conjunction with extruded aluminum framing, the resulting thermal efficiency in a window's sash and frame are greatly improved. Manufacturers have been able to reduce thermal conductivity to a fraction of the original value. Aluminum fabricators, using thermal separators as barriers, have overcome thermal conductivity issues in order to utilize the sustainable attributes of aluminum, and create highly thermally efficient window frames.

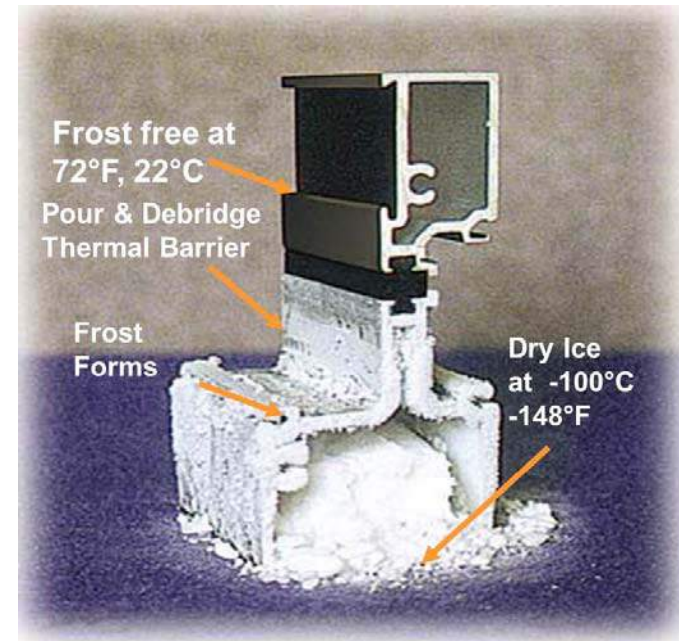

A thermal barrier is a material of low thermal conductivity inserted between members of high conductivity in order to reduce the heat transfer. The thermal barrier material conductivity shall not be more than $0.52 \text{ W/m}^{\circ}\text{k}$ ($3.6 \text{ Btu}^{\circ}\text{in/hr}^{\circ}\text{ft}^2^{\circ}\text{F}$). - NFRC 100

What Does a Thermal Barrier System Do?

The thermal barrier makes an extruded aluminum window, skylight, or door highly energy efficient, reducing heating and cooling costs substantially.

Thermal barrier material must not only be strong and resist deterioration over time, but it must also insulate. The material acts as a barrier to heat flow from a warm interior to a cold exterior in winter, and blocks heat entering a building in summer.

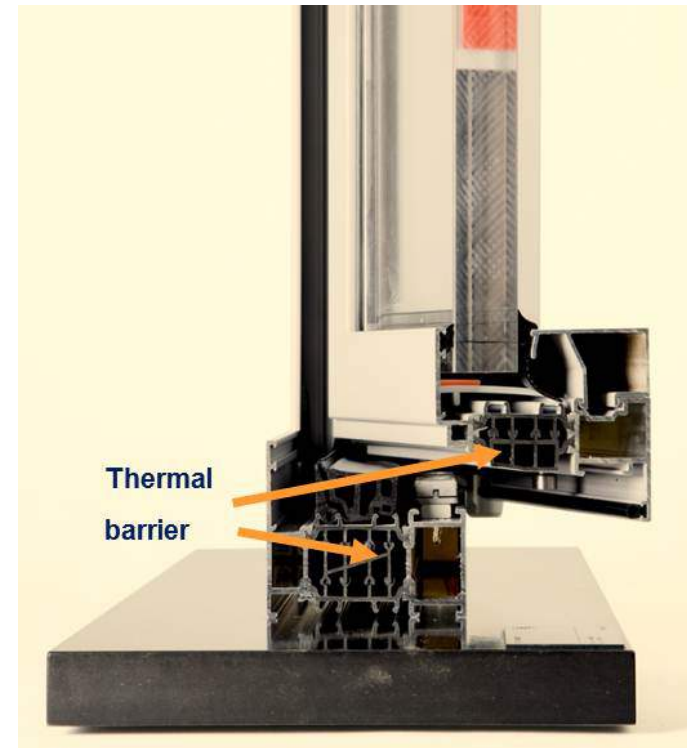

Thermal Barrier Categories

The NFRC breaks down the thermal barrier description into two of the most widely used thermal barrier product categories.

- **Thermally Improved Member**

- Enhances efficiency due to design or thermal materials used
- May not offer the highest efficiency available
- System members with a $>1.6\text{mm}$ (0.062 in.) separation provided by a material where the conductivity is $<0.5\text{ W/m}\cdot\text{K}$ ($<3.6\text{ Btu}\cdot\text{in}/\text{hr}\cdot\text{ft}^2\cdot\text{F}$), or open air space between the interior and exterior surfaces
- Such systems include members with exposed interior or exterior trim attached with clips and all skip debridged systems
- NFRC 100

- **Thermally Broken Member**

- Products used to gain further energy efficiency
- System members with a $>5.3\text{mm}$ (0.210 in.) separation provided by a low-conductance material where the conductivity is $<0.5\text{ W/m}\cdot\text{K}$ ($<3.6\text{ Btu}\cdot\text{in}/\text{hr}\cdot\text{ft}^2\cdot\text{F}$), or open air space between the interior and exterior surfaces.
- Such systems include pour and debridged urethane systems, crimped-in-place polyamide systems and pressure-glazed systems with intermittent fasteners
- NFRC 100

Thermal Performance

Poured and Debridged Thermal Barrier

High-performance polymer (polyurethane) is poured into a specially designed cavity formed by a thin metal bridge temporarily connecting the interior and exterior sections of the frame. Once the material has cured, the metal bridge is removed (debridged) to form the thermal barrier.

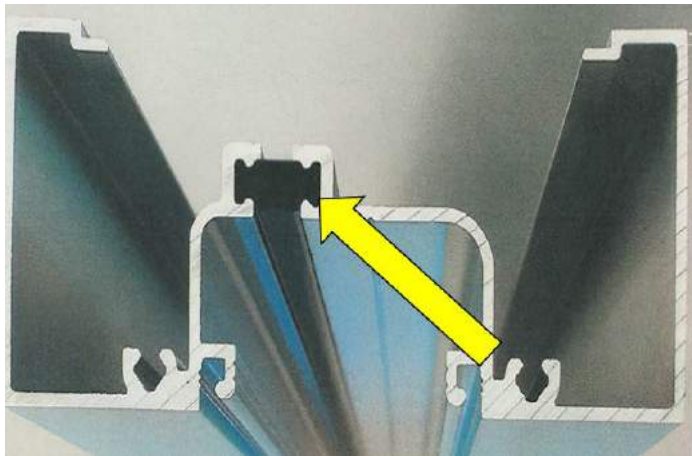

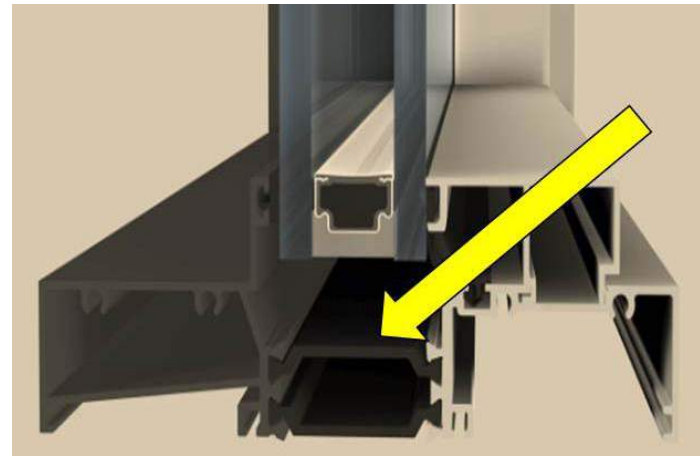

Polyamide Strip Thermal Barrier

Reinforced polyamide profiles (nylon-based polymer reinforced with glass fibers) mechanically join separately extruded interior and exterior aluminum profiles.

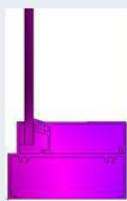
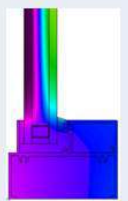
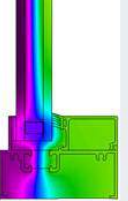
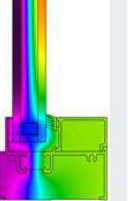
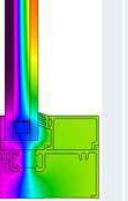
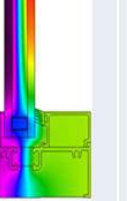
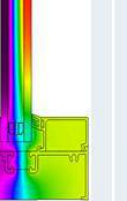
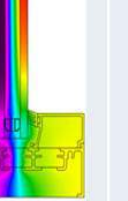

Thermal Performance

Fenestration systems manufacturers have responded to energy savings requirements with continuous innovation, before it was popular. This timeline demonstrates that aluminum products have led in energy savings, improving product efficiency nearly three-fold.

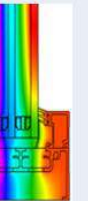
Fenestration Innovation Timeline										
	1950	1960	1970	1980	1990	2000	2005	2010	2011	2012
										
	Single Glazed	IG Unit	Thermal barrier	Low-E Hard Coat	Low-E Soft Coat	+ Argon filled IG	+ Spacer Warm-edge	+ Dual Cavity	+ Low-E Surface #4	+ Triple Glazing foam in frame
U-factor	1.00	0.66	0.50	0.44	0.41	0.39	0.37	0.32	0.28	0.16
CR*	16	28	52	54	55	56	61	65	62	71
U-cog (Btu/h ft ² F)	1.03	0.49	0.49	0.36	0.29	0.24	0.24	0.24	0.19	0.11
Thermal graphics created with THERM 5 and Windows 5 * NFRC 500 Condensation Resistance © AZON USA INC 2012										

Thermal Performance

This cross-section shows a typical aluminum framed window. Key thermal improvements give this window a U-factor of .41. In this example, the thermal barrier alone represents nearly half of the U-factor improvement. In the second image, adding argon or a similar gas between the insulated glass unit's panels allows extruded aluminum fenestration products to meet and exceed an overall U-factor of .38, making a highly efficient thermal barrier system. Nearly 50% of U-factor improvement comes from the thermal barrier.

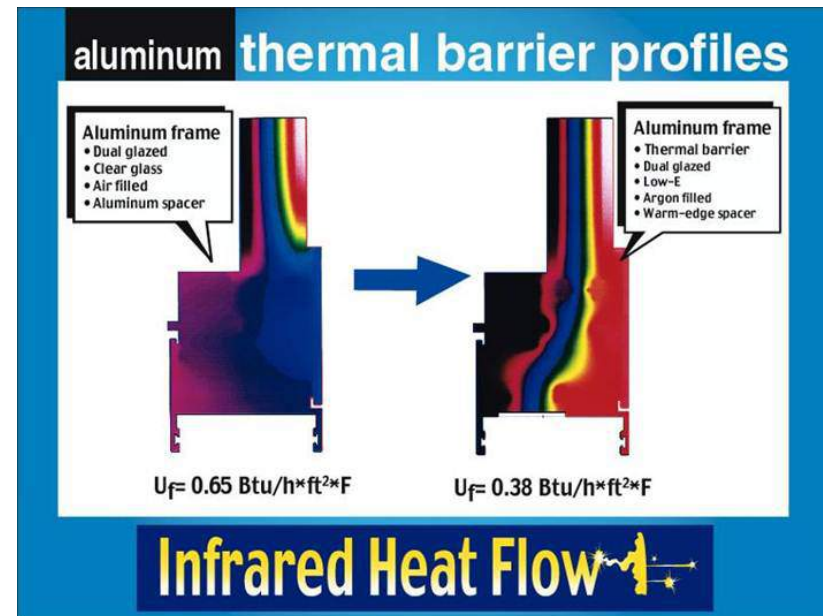
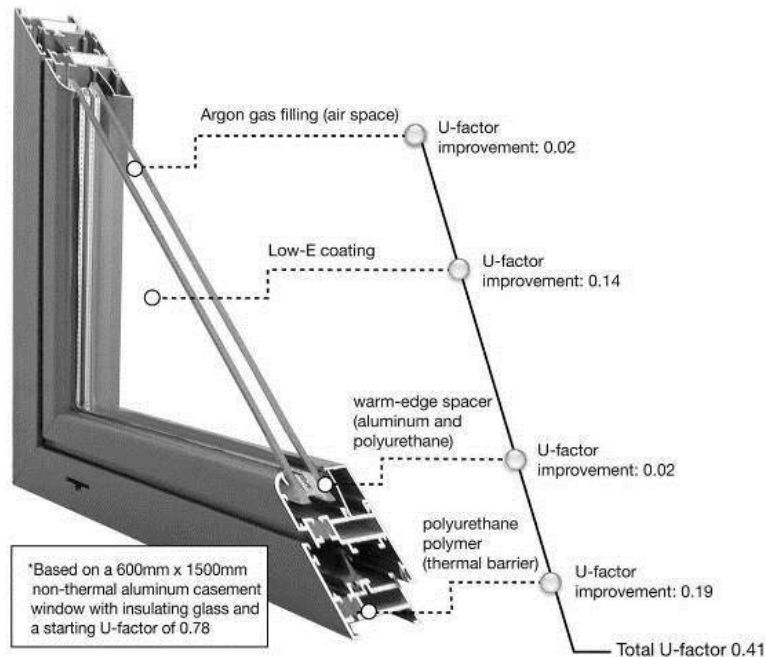

Reduced Energy Usage and Cost

In this “real world” example, the Empire State Building’s six-thousand-plus windows were retrofitted with extruded aluminum window framing with thermal barriers. Thermal conductivity is minimized by thermally separating both window sash and main frame, using an outer extruded frame, a central insulating core material, and an inner extruded frame. The structural core acts as a barrier to heat flow in winter from the warm interior to the cold exterior, and vice versa in summer.



For the Empire State Building, a computer program calculated the savings in heating and cooling costs with the system versus the non-thermal barrier windows. There are 102 stories with 6,400 windows.

Original steel windows, single glaze	\$1,000,000/year
New, TR-9000 windows with thermal barrier	\$222,230/year
ENERGY SAVINGS	\$777,770/year
Lifespan (30 years)	\$23,000,000

Thermal Conductivity

Today, extruded aluminum fenestration products are typically manufactured with an installed thermal barrier to effectively insulate and moderate interior temperatures. And with the use of warm edge glass spacers, these fenestration products provide exceptional condensation resistance. The thermal barrier prevents the inside and outside aluminum from touching by placing the insulator between them so that heat and cold do not transfer, keeping the unit rigid, stable, and operating smoothly with low maintenance.

Conduction, the mechanism by which a solid transmits heat, causes heat loss through sealed insulating glass units, and is the primary cause of heat loss through window sashes and frames. The insulating value of sealed insulating glass units can be improved by increasing the number of glass panes and air spaces, or by filling the units with gas. Sealed glazing units with 1/2-inch air spaces between panes provide optimal thermal performance.

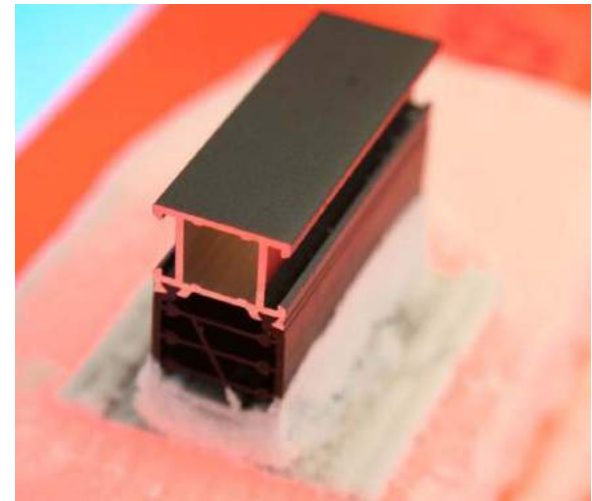

Case Study

Thermally broken aluminum windows were a smart choice for replacement windows in this renovated building on the University of Notre Dame campus in South Bend, Indiana.



Photos courtesy of Oldcastle BuildingEnvelope™

Increasing Demand for Sustainable Buildings

After only a few years, the energy consumed by a building during its functional life exceeds the energy required for its construction. ***Higher initial investment in façades reduces long-term operating costs, especially when coupling thermally-insulated windows with photovoltaic panels.***

One of the most cutting-edge applications for extruded aluminum today is photovoltaic panels. Based on U.S. Department of Energy models, high-tech photovoltaic panels have the potential to reduce the cost of producing a building's electricity from 20 cents per kilowatt hour, down to 5 cents per kilowatt hour.



Photos courtesy of Schüco International KG

Photovoltaic Applications

Aluminum extrusions are also commonly used on photovoltaic applications. State-of-the-art integrated photovoltaic systems will make solar power affordable, and aluminum extruders are working to ensure that the housing framework for these systems can be easily integrated into a variety of façade elements. Aluminum-glass-photovoltaic façades are playing an increasingly key role in reducing energy consumption and increasing occupant comfort.

- Ventilated façade
- Ventilated/non-ventilated façade
- Non-ventilated façade
- Skylight construction
- Canopy
- Solar shading
- Balcony
- Conservatory



Ventilated façade



Solar shade

Photovoltaic Technology and Aluminum Extrusions

Photovoltaic modules, and their extruded aluminum framing, are customized to architectural requirements for shape, color and optical structures. Because these modules are integrated into the building, they perform the function of infill units throughout the building envelope.

This ultra-thin rolled sheet of photovoltaic technology incorporates a polycrystalline thin film layer applied to a powder-coated extruded aluminum blade.



Photo courtesy of Schüco International KG

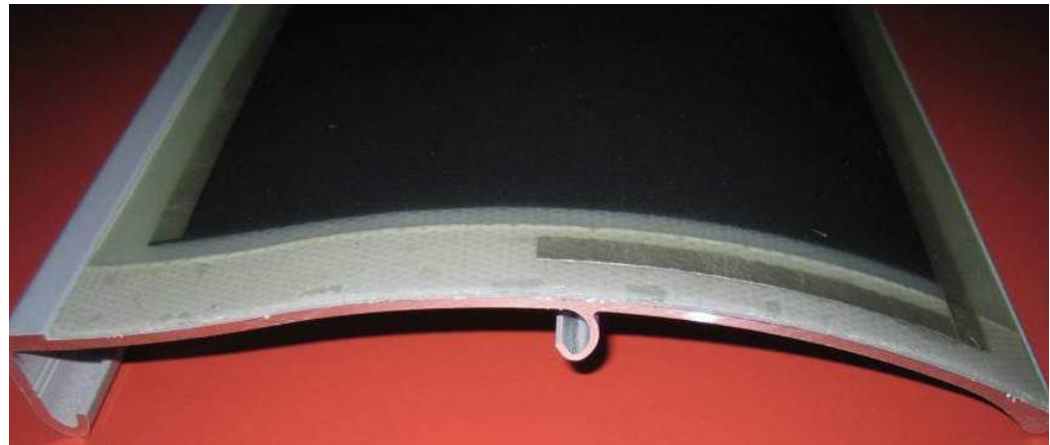

Photo courtesy of Hydro Building Systems GmbH and Ascent Solar Technologies, Inc.

Photovoltaic Technology and Aluminum Extrusions

Photovoltaic elements are integrated and positioned into a building façade so that the sun influences the form and orientation of the building. To prevent overheating on a hot summer day, the façade does not allow solar rays to penetrate to the building's interior, yet the interior receives as much natural daylighting as possible.



Photo courtesy of Hydro Building Systems GmbH

Photovoltaic Technology and Aluminum Extrusions

This close-up of the Linz building's louvers shows the façade must respond actively and flexibly to changing requirements throughout the day, and from season to season, mediating between indoor and outdoor climates. Photovoltaic electricity-generating cells are fixed onto the louver blades, framed and mounted with aluminum extrusions. The sun tracking system is powered by a Girasol thermohydraulic sun tracking device, without expensive or complex electro-mechanical control systems.



Photo courtesy of Colt International Licensing, Ltd.

Photovoltaic Technology and Aluminum Extrusions

Here, multi-functional photovoltaic modules become insert units in this skylight construction, framed in extruded aluminum. The versatility of extruded shapes and configurations allows a wide range of designs. The semi-transparent units protect against sun, heat, and glare and target natural light. Large surface areas with optimal tilt angles maximize solar energy use.

Building-integrated photovoltaic insulating glass modules framed in extruded aluminum



Photos courtesy of Schüco International KG

Photovoltaic Technology, Net Zero and Aluminum Extrusions

The advent of integrated photovoltaic systems has spurred a new era of “solar” architecture, and is facilitating the drive for “net zero” structures, which have the promise of generating as much or more energy than they consume.

- DOE has set a goal that 100% of new commercial buildings will be “net zero” by 2025
- Net zero typically requires use of the building façade for energy generation, as few buildings have sufficient roof space for the needed volume of PV panels
- Façade applications typically generate 70-75% of the energy/sq. ft. as do rooftops

Façade elements can include PV infill panels, glazed units with integral PV strips, PV-faced louvers and sun-shades (which can be angled to generate power equivalent to rooftop panels).



Office Park Vienna International Airport – Wien
This office park at the Vienna International Airport maximizes daylighting with strategically placed photovoltaic panels through the façade.

Photo courtesy of Hydro Building Systems GmbH

Photovoltaics, Net Zero and Aluminum Extrusions

Aluminum extrusions are the structural framework in which this revolution is taking place in commercial construction. In addition to aesthetic appeal, the extruded aluminum façade protects against cold, heat, rain, and noise, and facilitates a “plug and play” addition of photovoltaics:

- Preserving thermal, water and air performance
- Providing for stress relief bushings
- Protecting wiring
- Employing typical installation teams
 - Glass & Glazing Subcontractor
 - Electrical Subcontractor

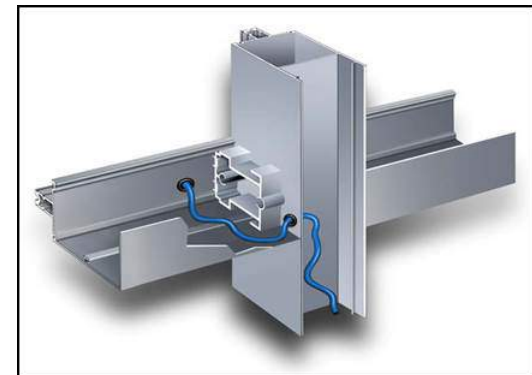
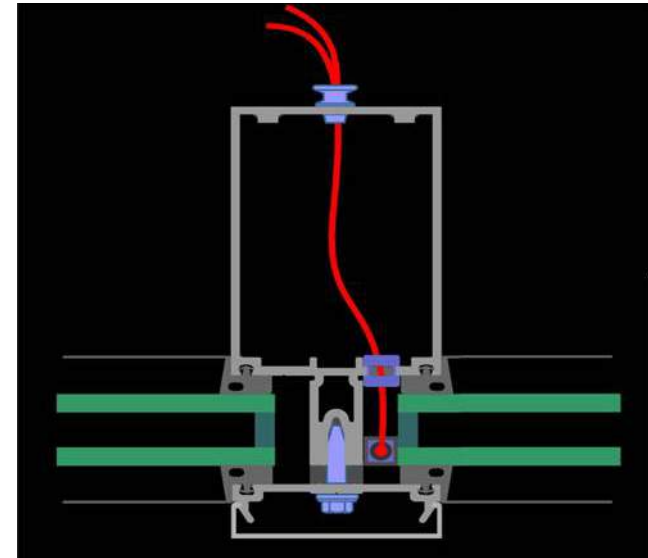

Photos courtesy of Consulting Collaborative

LEED

Aluminum extrusions contribute to LEED points:

Energy & Atmosphere

- EA1: Optimize Energy Efficiency (1-19 points)
 - Increased performance
 - Thermal barrier aluminum frames, sunshades, light shelves, skylights
- EA2: On-Site Renewable Energy (1-7 points)
 - Aluminum framing for rooftop solar panels, PV integrated into windows, overhangs
 - Being expanded in next version to start in 2014



Photos courtesy of Schüco
International KG

Aluminum and LEED

There are also numerous credits related to the use of sustainable materials. Aluminum's ability to be infinitely recycled while maintaining its properties means it can contribute a number of LEED points in these categories:

Materials & Resources

- MR2.1 and 2.2: Construction Waste Management (1-2 points)
 - Aluminum recycling
- MR4.1 and 4.2: Recycled Content (1-2 points)
 - Recycled content in aluminum extrusions
- MR5.1 and 5.2: Regional Materials (1-2 points)
 - Recycled content recovered, reprocessed near project

Aluminum and LEED

As a sustainable material, aluminum can also qualify for credits for conducting a life cycle analysis or using Cradle to Cradle Certified^{CM} products (which also looks at full life cycle analysis). There is also a credit for reducing or avoiding materials that can be sources of “persistent bioaccumulative toxic” chemicals or PBTs, such as PVC. Aluminum window frames with thermal breaks are specifically listed as a strategy for meeting this credit.

Innovation in Design

- ID1: 1 point for using Cradle to Cradle Certified^{CM} materials

Pilot Credits

- Pilot Credit 1: 1 point for conducting a life cycle analysis (LCA)
- Pilot Credit 2: 1 point for reducing halogenated organic compounds (e.g., PVC)
 - Aluminum frames with thermal breaks specifically listed as an allowed material

Aluminum and LEED

Indoor Environmental Quality

- EQ2, EQ6.2: Ventilation and Thermal Comfort (1-2 points)
 - Control increased use of operable windows
- EQ8.1 and 8.2: Daylight and Views (1-2 points)
 - Increased use of windows, skylights, atriums, light shelves



Aluminum and LEED v4

Proposed MR changes for LEEDv4 being balloted in June 2013

The Materials & Resources category focuses on holistic decision making through life cycle thinking. The proposed revisions include credits to “encourage the use of products and materials for which life-cycle information is available and that have environmentally, economically, and socially preferable life-cycle impacts.”

- Building Life-Cycle Impact Reduction (up to 5 points)
- Building Product Disclosure and Optimization - Environmental Product Declarations (up to 2 points)
- Building Product Disclosure and Optimization - Sourcing of Raw Materials (up to 2 points)
- Building Product Disclosure and Optimization - Material Ingredients (up to 2 points)

The Life Cycle of Aluminum

According to FLSmidth, the world has produced about 800 million tons of aluminum since the modern aluminum industry began in 1886, and about 73% is still in use today. Aluminum's ability to be recycled repeatedly with no loss in quality is central to its claim as a sustainable material. For aluminum, there is no "end-of-life"; it can be reused again and again by future generations. The visual below explains the life cycle of aluminum.

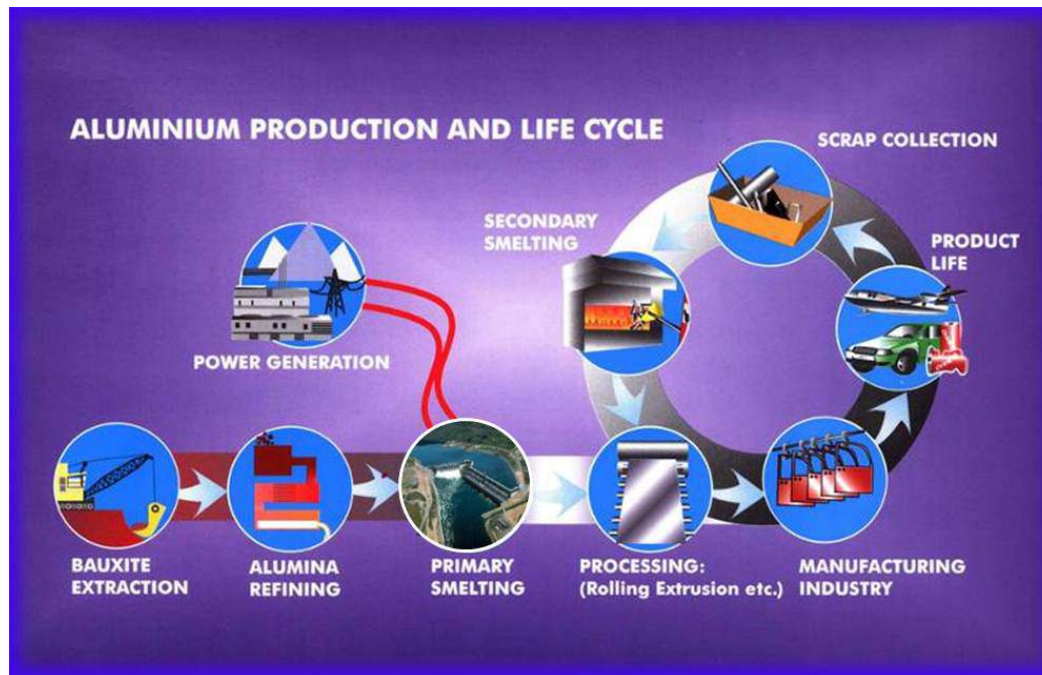

- 73% of all aluminum produced since 1886 is still in use today.
- Recycled aluminum uses only 5% of the energy, and generates 5% of the emissions, associated with the production of aluminum from virgin ore.
- Recycling makes aluminum last forever.

The Living Building Challenge

Google Materials Red List

In 2011, Google reported opening office spaces at a rate of 40,000 square feet per week.

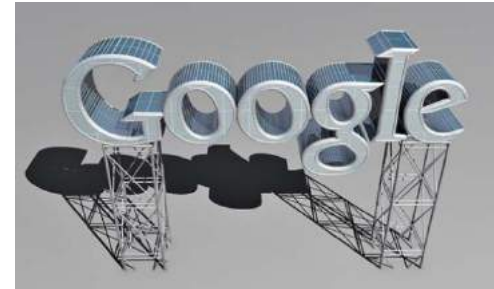

Based on the Cascadia Region Green Building Council's "The Living Building Challenge," Google sanctioned the "red list" of materials used in construction that include components made from materials and chemicals such as:

- Asbestos
- Cadmium
- Chlorinated Polyethylene
- Chlorosulfonated Polyethylene
- Chlorofluorocarbons (CFCs)
- Chloroprene (Neoprene)
- Formaldehyde
- Halogenated Flame Retardants
- Hydrochlorofluorocarbons (HCFCs)
- Lead
- Mercury
- Petrochemical Fertilizers and Pesticides
- Phthalates
- Polyvinyl Chloride (PVC)
- Wood treatments containing creosote, arsenic, or pentachlorophenol

Note: Aluminum and aluminum extrusions are not listed as "red" materials.

Aluminum and LEED

Perkins + Will's 1315 Peachtree office building renovation in Atlanta, Georgia demonstrates how aluminum extrusions are instrumental in achieving a high-performance building that meets ambitious sustainability goals using key extruded aluminum components such as: exterior curtain wall, horizontal and raked shading airfoils, caps for glass terrace rail, and interior demountable wall structures, bench seating systems, and light fixture housings, as part of a whole building approach that has achieved a LEED Platinum rating for Perkins + Will.



Impact Resistance

A great deal of thought and care goes into storefront, curtain wall and window design that can withstand the wrath of mother nature. Unfortunately, many commercial building owners and homeowners have learned this lesson the hard way by weathering some of nature's worst storms over the last few years. The slightly higher initial price of impact-resistant products can help save thousands of dollars in repair following brutal hurricane winds and the associated debris.

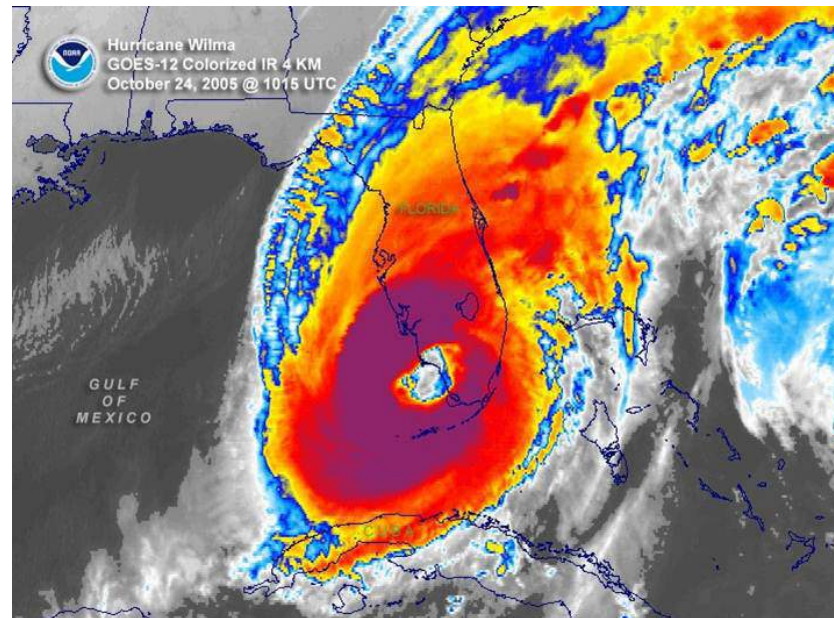

Hurricane Wilma – October 24, 2005

Photo courtesy of YKK AP

Hurricane Impact Resistance

While maintaining required structural integrity, light weight, and low cost, aluminum sets itself apart from all other materials. Extruded aluminum thermally broken window framing is rated for high-missile impact and hurricane zone requirement areas, such as Dade County, Florida.



The Impact Test

The High Velocity Hurricane Zone section of the Florida Building Code requires that every exterior opening—residential or commercial—be provided with protection against wind-borne debris caused by hurricanes. Such protection could either be shutters or impact-resistant products.

There are two types of impact-resistant products: large missile-resistant and small missile-resistant.

A. Large missile-resistant test

A product exposed to various impacts with a piece of lumber weighing approximately 9 pounds, measuring 2" x 4" x 9' in size, traveling at a speed of 50 feet per second (34 mph). Then the product is subjected to hurricane loading of 9,000 wind cycles, positive and negative.

B. Small missile-resistant test

A product that has been exposed to various impacts with 10 ball bearings traveling at a speed of 80 feet per second (50 mph). The product is then subjected to wind loads for 9,000 cycles. If the doors and windows are more than 30 feet from the ground, then they must be either large or small missile-compliant.

Security: Blast Resistance

Aluminum extrusions are commonly used in the design of impact- and blast-resistant windows and doors. The strength of aluminum framing members makes this material a viable choice for impact-resistant products.

Aluminum is an effective material for blast hazard mitigation due to its high yield strength, which has been tested to 40,000 psi without steel reinforcement.⁴ Blast loads require fenestration material to bend but not break to absorb energy, which is easily accomplished with aluminum extrusions. It also meets testing standards and protocols.

Aluminum fenestration products that have been successfully tested for blast hazard mitigation include: curtain walls, store front entrances and framing, and windows in a variety of types and configurations.

⁴Source: CSBR, Windows and Daylighting Group. "Performance: Energy & Cost." *Windows for High-Performance Commercial Buildings*. <http://www.commercialwindows.org/energy.php>. Accessed May 2012.



Photo courtesy of Schüco International KG

Buildings Using Extruded Aluminum

Here is a sampling of the types of commercial buildings that use aluminum extrusions:

- Office complexes
- Colleges and universities
- Libraries
- Hospitals
- Stores/malls
- Airports
- Sports stadiums
- Schools
- Restaurants
- Hotels and resorts
- Convention centers
- Government and public buildings
- Mass transit hubs



Hurst Conference Center, Hurst, TX
© Wes Thompson Photography
Photos courtesy of Kawneer / Traco

Notable Buildings Using Aluminum Extrusions

The 111 S. Wacker building in Chicago was the first high-rise in the nation to be awarded Gold LEED Certification by the U.S. Green Building Council.

The building incorporates aluminum extrusions into every aspect of its design, including the curvilinear design of its lobby. According to the building's architect, Steve Nilles of Goettsch Partners in Chicago, "Aluminum is extremely lightweight in relation to its strength, allowing us to do more with less material. It is aesthetically flexible and inherently recyclable, concepts that tie directly into sustainable design initiatives."



Photo courtesy of James Steinkamp Photography. Used with permission of Goettsch Partners, Inc.

Notable Buildings Using Aluminum Extrusions

The UBS Tower high-rise on Wacker Drive in Downtown Chicago features extruded aluminum curtain wall sections, including on the tower's uppermost floors, where the sections must withstand lateral buckling forces and high winds. The UBS Tower not only delivers energy efficiency, but adds streetscape beauty to Wacker Drive.



Photos courtesy of Hedrich Blessing. Used with permission of Goettsch Partners, Inc.

Notable Buildings Using Aluminum Extrusions

The United Airlines Terminal at Chicago's O'Hare International Airport, designed by architect Helmut Jahn, won the R.S. Reynolds Memorial Award for distinguished architecture using aluminum. The design was achieved using a variety of aluminum extrusions, tubing, sandwich panels and skylights.

Cincinnati State University in Ohio also used extruded aluminum window framing extensively throughout its campus. Such energy-efficient windows are often retrofitted into older buildings, as well as being custom-designed for new construction.

Top photo courtesy of the Aluminum Extruders Council
Bottom photo courtesy WALTEK & Company, Ltd., and Akzo Nobel



Notable Buildings Using Aluminum Extrusions

The 12-story South Tower of the Children's Hospital of Philadelphia in Pennsylvania uses curved, painted silver expanses of custom-extruded aluminum curtain wall during Phase One of their \$650-million dollar expansion. It connects to the existing hospital via a new atrium, which has been re-clad with aluminum extrusions.

This custom-designed extruded aluminum entryway overhang provides shelter and distinctive design, while maximizing natural daylighting on the southeast-oriented entrance of the Fidelity Corporate Office Park in Lake Zurich, Illinois.



Top photo courtesy of Children's Hospital of Philadelphia
Bottom photo courtesy of CST Covers

Notable Buildings Using Aluminum Extrusions

The Lynx Central Station in Orlando, Florida uses a universal extruded aluminum space frame system, allowing a geometric free-form style and a structural footprint that are limited only by the designer's imagination. The lightweight aluminum extruded space frame has a concealed fastening system, tapered end connectors, round members, and solid aluminum hubs. The extrusion system is inherently strong with smooth, clean lines, and is ideal for large-span applications.



Photos courtesy of CST Covers

Notable Buildings Using Aluminum Extrusions

This parking canopy enclosure at the Milwaukee Children's Hospital uses I-beam and custom extrusions. The curvilinear extrusions combine with the extruded I-beams and integrated lighting for a lightweight design that withstands the temperature and weather extremes of Wisconsin.

The Halsell Conservatory in San Antonio, Texas uses round and rectangular extrusions, allowing natural daylight in to create an interior environment ideal for nurturing the conservatory's plant life.



Photos courtesy of CST Covers

Notable Buildings Using Aluminum Extrusions

This dome spans the Hunan Provincial Government Offices and Exhibition Center in Changsha, Hunan, China, using pre-fabricated I-beam extrusions. Its high strength is derived from a proprietary connection design forming geometric patterns using high-strength aluminum alloys. Many shapes are possible with versatile extrusion configurations, including oval, circular, and ellipsoid.



Photo courtesy of
CST Covers

Notable Buildings Using Aluminum Extrusions

The Texas Star glass in this cupola skylight at the Gaylord Texan Resort and Convention Center in Grapevine, Texas is framed in extruded aluminum, and uses 206 tons of glass covering over 90,000 square feet on the main skylight. Nearly 208,000 pounds of aluminum extrusions were used in the skylights, curtain wall, and entrances.

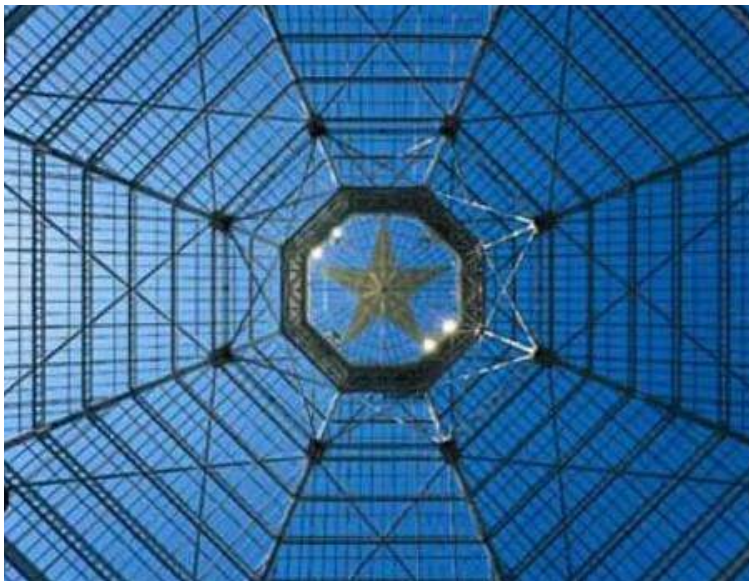

Photos courtesy of Oldcastle BuildingEnvelope™

Notable Buildings Using Aluminum Extrusions



Photo courtesy of CST Covers, © Photo by Greg Hursley

The vast complex of extruded aluminum and glass at the Halsell Conservatory becomes an exciting visual forum for blending form and function. Working with architects, extruded space frames may be designed, engineered, fabricated, and installed—from start to finish.



Photo courtesy of TRACO

The original windows in the Empire State Building had deteriorated and were losing energy from air leakage. The renovated historic structure boasts 6,400 new extruded aluminum window frames, which were custom matched with the original windows' red color and finish.

Notable Buildings Using Aluminum Extrusions

The Molecular Foundry at the Lawrence Berkeley National Laboratory conducts nanotechnology research for the Department of Energy. Its construction site, on a narrow, steep slope in an earthquake-prone zone was a joint pilot project of the DOE and the U.S. EPA for design and construction of a sustainable lab facility. Construction of the six-story foundry utilized aluminum and energy-efficient glass, and required cutting 70 feet into the hillside. Recycled aluminum panels cover the entire exterior, earning LEED points. Twelve-foot aluminum-encased trusses help support the cantilevered portion of the building. The lab expects to consume 30% less energy than the tough California standards currently require.



Photo courtesy of Lawrence Berkeley National Laboratory

Notable Buildings Using Aluminum Extrusions

The Michael Lee-Chin Crystal building, an addition to the Royal Ontario Museum, opened in Toronto, Canada in 2007. The addition was created by Studio Daniel Libeskind. Over 18 miles of aluminum extrusions (90,000 square feet) were used in the structure, which contains one vertical wall and no right angles. The building's exterior is 75% aluminum and 25% glass. The extruded brushed silver aluminum cladding is the outermost of three layers, and the extrusions are positioned with gaps in between to channel water and snow runoff away from the patrons below.



Photo courtesy of Scott Norsworthy

Notable Buildings Using Aluminum Extrusions

This is the Biodesign Institute on the Arizona State University campus. The extruded aluminum interior louvers, seen on the left-hand side of the building facing east, are computer-controlled to track the sun to minimize heat gain from the abundance of glass and skylights. The louvers become a major green design feature of the building's 15-foot-high curtain wall windows.



Photo courtesy of Arizona State University

Notable Buildings Using Aluminum Extrusions

The Aluminium Centrum building in the Netherlands is an 11,000-square-foot building that sits on 368 hollowed-out aluminum pillars. These pillars support the building with lightweight strength while housing all of the electrical and phone cables, and hydraulic systems. Energy performance is exceeded by 50%, according to Netherlands standards, with the help of high-efficiency heat pumps and heat exchangers, and double-glazed windows. The building, which uses 100 metric tons of aluminum extrusions, won a prestigious international architecture prize.



Photo courtesy of
Aluminium Centrum

Notable Buildings Using Aluminum Extrusions

Here, aluminum extrusions formed the framing for the expansive storefront and curtain wall systems of Churchill Downs' renovated entryway and clubhouse complex. Curtain wall and window finishes and details were carefully matched to the original style of the famous "Twin Spires" area, which is in the National Registry of Historic Places. The 3,000-pound prefab skylight is the centerpiece of the new rotunda at Churchill Downs in Louisville, Kentucky. The skylight's custom-fabricated extruded aluminum framework is strong enough to support 1,500 pounds of downward force from which this new glass horse sculpture is suspended on a cable system.



Photos
courtesy of
Churchill
Downs

Notable Buildings Using Aluminum Extrusions

About 700,000 pounds of aluminum extrusions frame the glass curtain walls of the new Dallas Cowboys football stadium in Arlington, Texas. This one-billion-dollar stadium opened in 2009, seats 80,000 fans, and features a quarter-mile-long retractable roof.

Oldcastle BuildingEnvelope™ supplied the custom-engineered curtain walls and retractable glass end zone doors, which are all framed in extruded aluminum. Custom extrusion and finishing helped meet the stringent requirements for the complex assemblies. The stadium's 86-foot-high walls contain 5,070 glass panels. The end zone doors, at 120 feet high x 180 feet long, are the world's largest movable glass walls. They like to do everything bigger in Texas!

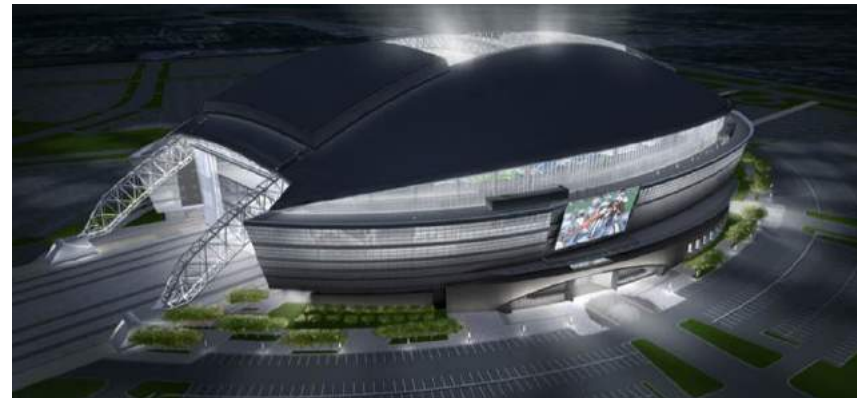

© Photo courtesy of the Dallas Cowboys, Arlington, Texas and Oldcastle BuildingEnvelope™, Santa Monica, California



Notable Buildings Using Aluminum Extrusions

The renovation of the Statue of Liberty involved replacing the 25 windows of Lady Liberty's crown with bronze-colored extruded aluminum windows of varying size, angle, and curvature. Individual aluminum templates were constructed and custom-engineered. Each window was hand carried to the top of the statue for installation. Even the scaffolding used to renovate the statue was all extruded aluminum.



Photo courtesy
of TRACO



Photo courtesy
of the Aluminum
Extruders
Council

Whole Building Design

The Energy Policy Act of 2005 defines high-performance buildings as: “buildings that integrate and optimize all major high-performance building attributes, including energy efficiency, durability, life-cycle performance, and occupant productivity.”⁵

To support this Act, the Energy Independence and Security Act (EISA) of 2007 established an aggressive plan for achieving energy independence in our nation’s building stock by the year 2030. The Act requires that federal buildings (new and renovations) achieve fossil fuel-generated energy consumption reductions on the order of 55% in the year 2010 to 100% in 2030. The Act also requires that sustainable design principles be applied to siting, design, and construction. The Act defines high-performance buildings as the integration and optimization on a life cycle basis of all major high-performance attributes, including energy conservation, environment, safety, security, durability, accessibility, cost-benefit, productivity, sustainability, functionality, and operational considerations. These issues are the basis for the concept of whole building design.

⁵Source: Prowler, Don, FAIA. “The Role of Buildings and the Case for Whole Building Design.” *Whole Building Design Guide*. http://www.wbdg.org/wbdg_approach.php. Accessed May 2012.

Whole Building Design

The concept of whole design combines the synergies from an integrated design approach and an integrated team process to work together throughout the project, to evaluate the design cost, quality-of-life, future flexibility, efficiency, overall environmental impact, productivity, and how the occupants will be enlivened. All the integrated components work together to provide the benefits of reduced energy consumption, cost savings, improved indoor environment for occupants, and a sustainable high-quality building envelope that performs for decades.

The knowledge pool of all the stakeholders is being drawn all across the life cycle of the project, from defining the need for a building, through planning, design, construction, building occupancy, and operations.

Whole Building Design

Modern energy-efficient buildings are designed in the following order:

- Mass and orientation
- Optimizing the building envelope
- Building's systems and infrastructure

Whole building design allows design flexibility; for example, thermally broken aluminum window frames may be used in combination with increased insulation, HVAC efficiency, ambient lighting, high-tech glazing, ventilation and shading devices, providing many more options in designing energy efficiency into the overall building envelope. Architects, designers and building engineers are now striking a new balance between performance and aesthetics.

Whole Building Design: The Benefits of Daylighting

According to the July 2002 study entitled “A Literature Review of the Effects of Natural Light on Building Occupants” by L. Edwards and P. Torcellini, daylight provides a better lighting environment than cool white or energy-efficient fluorescent electrical light sources. The study indicates that occupants in daylight and full-spectrum office buildings reported an increase in general well-being. Specific benefits in these types of office environments include better health, reduced absenteeism, increased productivity, financial savings, and preference of workers. They state to, “First, optimize daylighting through orientation and greater window-to-wall ratios. Second, use systems such as shading systems and automated control units to manage the light intensity.”⁶

Benefits to the office worker are so great that many countries in Europe require that workers be within 27 feet of a window. Today, the technology for both aluminum frames and glass insulation is evolving to meet the new performance requirements of glazing systems in all climates, allowing buildings to be designed with greater window-to-wall ratios for more daylighting.

⁶Source: Edwards, L. and P. Torcellini. “A Literature Review of the Effects of Natural Light on Building Occupants.” *NREL*. <http://www.nrel.gov/docs/fy02osti/30769.pdf>. Accessed May, 2012.

Source: Prowler, Don, FAIA. “The Role of Buildings and the Case for Whole Building Design.” *Whole Building Design Guide*. http://www.wbdg.org/wbdg_approach.php. Accessed May 2012.

Whole Building Design

Features of the Linz Office Building in Austria:

- A sun tracking aluminum extruded shadovoltaic louver system generates more than 40% of the building's electricity requirements.
- The curvature facing southeast results in a good relationship between the façade area and usable internal area.
- The aluminum extruded louver system acts autonomously to the sun's position and optimizes energy production through photovoltaic cells.
- Daylight entry is carefully controlled, reducing glare. On the right, advanced, high-efficiency photovoltaic systems, and extruded aluminum metal shading combine sustainable design and innovative technology for an environmentally responsible façade.

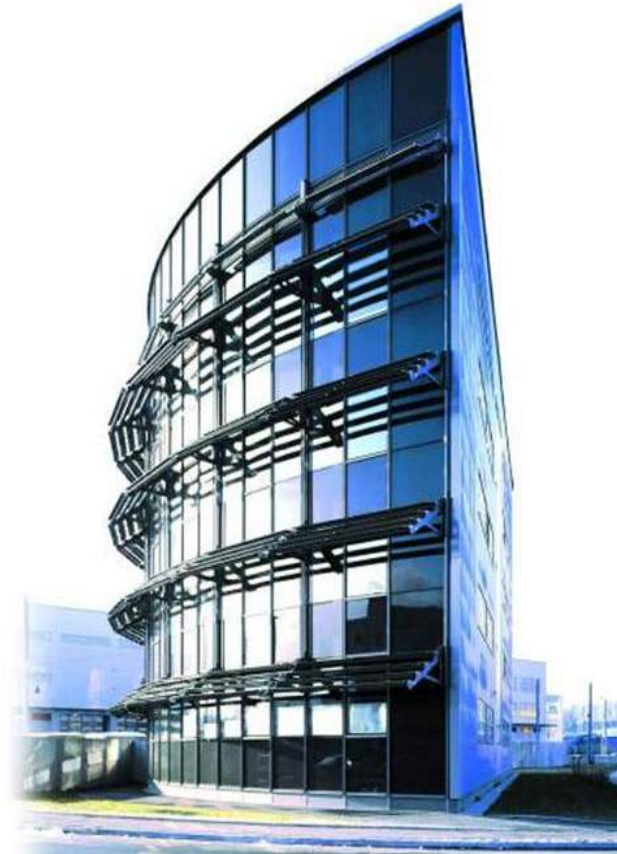

Linz Office Building, Austria
Photo courtesy of Colt International
Licensing, Ltd.

Whole Building Design

Integrated photovoltaic technology creates a multi-functional building envelope that both saves and generates energy, and is a viable alternative to conventional façades and skylights.

Unique design possibilities unfold when combining photovoltaic technology with the complex shapes and curves that are possible with extruded aluminum.



Photo courtesy of Schüco International KG

Endless Design Possibilities



Photo courtesy of Schüco International KG

Because the PV panels are framed in aluminum extrusions, their configurations can be customized to work with uniquely-shaped architectural features.



Photo courtesy of Hydro Building Systems GmbH

Installation of rigidly-mounted or guided photovoltaic systems in roofs, façades, and sunshades meets both sustainable technology and aesthetic requirements.

Summary

The use of aluminum extrusions in the wide range of product applications as covered throughout this course provides the most benefits to the holistic approach of the “whole building design” concept:

- Performance
- Durability
- Flexibility
- Sustainability
- Aesthetics

What other materials provide all these advantages?

Conclusion



©2012, 2013 Aluminum Extruders Council. The material contained in this course was researched, assembled, and produced by Aluminum Extruders Council and remains its property. "LEED" and related logo is a trademark owned by the U.S. Green Building Council and is used by permission. Questions or concerns about the content of this course should be directed to the program instructor.