

TIG welding – Method and Application

TIG welding

Definition

The designation TIG comes from USA and is an abbreviation of Tungsten Inert Gas.

Tungsten - also called wolfram - is a metal with a fusion point of more than 3300°C, which means more than double the fusion point of the metals which are usually welded.

Inert Gas is the same thing as inactive gas, which means a type of gas that will not combine with other elements.

In Germany this method is called WIG welding, the W meaning wolfram.

TIG welding is the international standardised designation for this welding method.

According to DS/EN 24063 this welding process has number 141.

The Principle of TIG Welding

TIG welding is an electric arc welding process in which the fusion energy is produced by an electric arc burning between the workpiece and the tungsten electrode.

During the welding process the electrode, the arc and the weld pool are protected against the damaging effects of the atmospheric air by an inert shielding gas.

By means of a gas nozzle the shielding gas is led to the welding zone where it replaces the atmospheric air.

TIG welding differs from the other arc welding processes by the fact that the electrode is not consumed like the electrodes in other processes such as MIG/MAG and MMA.

If it is necessary to use filler material, it is added either manually or automatically as a bare wire.

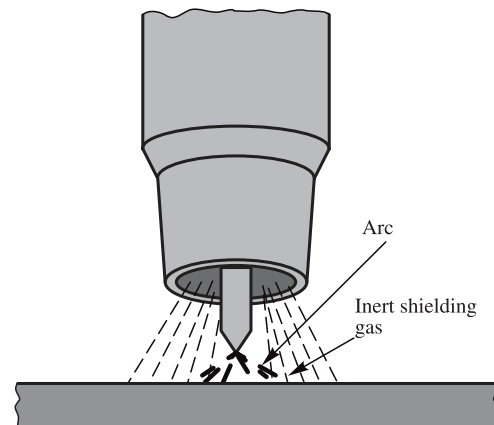

TIG welding Principle

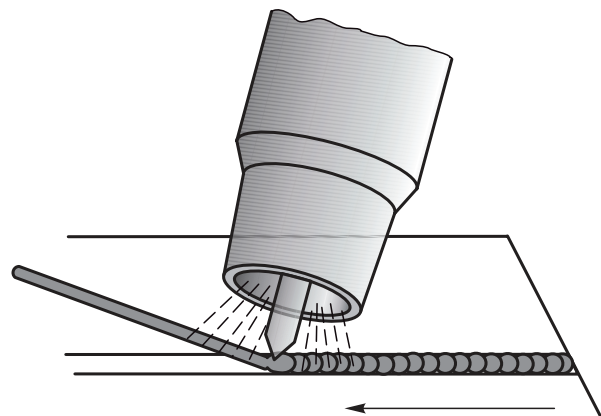

Feeding of filler material

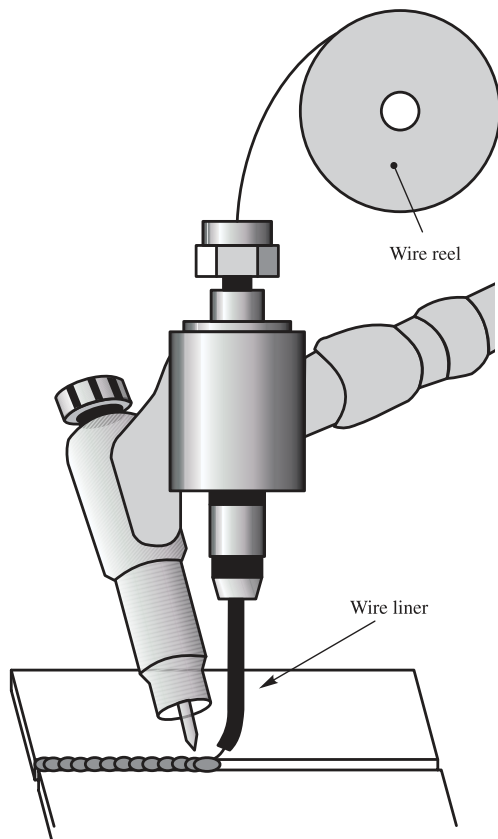
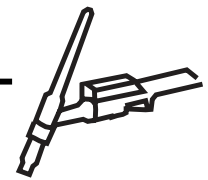

Automatic feeding of filler material

The TIG Arc

As mentioned before the fusion energy in TIG welding is produced in the arc burning between the tungsten electrode and the workpiece.

The wire feeding can be done manually or mechanically.

In DC TIG welding the tungsten electrode is usually connected to negative polarity and the workpiece to positive polarity.

According to the theory of electrons the negatively charged electrons and positively charged ions will migrate when the arc is ignited.

The electrons will migrate from the negative pole to the positive pole while the ions will travel in the opposite direction.

In the arc there will therefore be a collision between the electron and the ions and this collision produces heat energy.

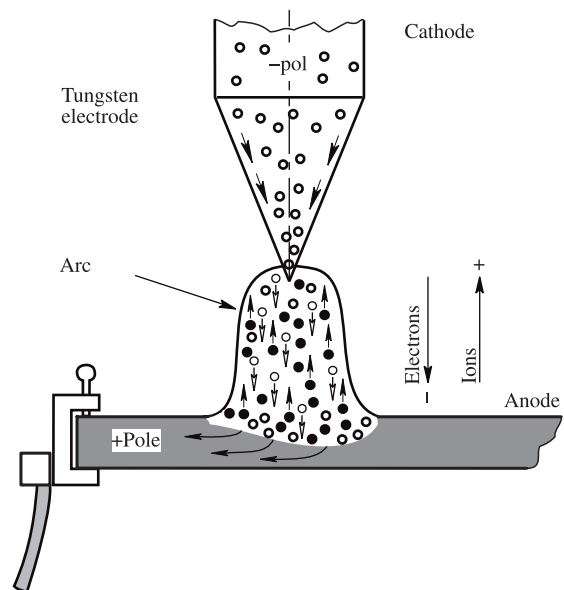

Migration of electrons and ions in TIG welding

The flow of electrons from the point of the electrode takes place at a very high speed and when it hits the workpiece a substantial amount of heat energy is produced.

When the flow of ions hits the point of the electrode there is not produced a similar amount of heat energy.

The total produced heat energy is distributed by approx. 30% to the point of the electrode that is connected to the negative pole and approx. 70% to the workpiece connected to the positive pole.

Alternating Current

Alternating current is characterised by the fact that the voltage changes polarity a certain number of times, usually 100 times per second.

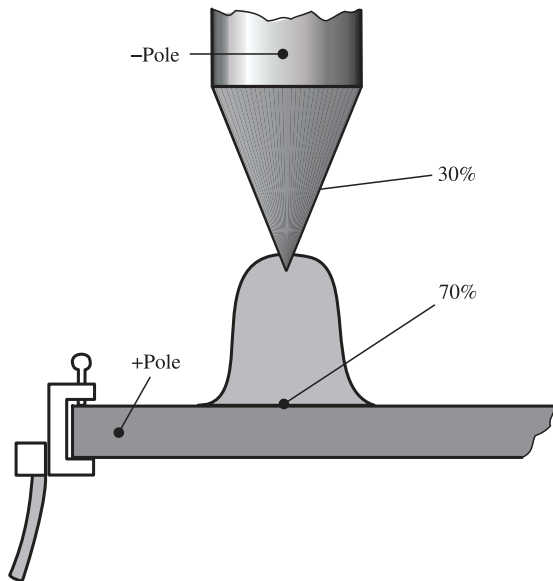
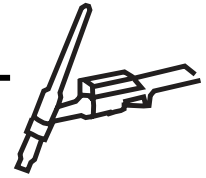

Heat distribution at TIG welding

The electrode has positive polarity in a semi-period and in the same semi-period the workpiece is negative.

In the next semi-period the polarity is reversed, which means that the heat energy distributes with 50% on the electrode and 50% on the workpiece.

Application

Advantages

The TIG welding process has a very large area of application due to its many advantages, e.g.:

- It provides a concentrated heating of the workpiece.
- It provides an effective protection of the weld pool by an inert shielding gas.
- It can be independent of filler material.
- The filler materials do not need to be finely prepared if only the alloying is all right.
- There is no need for after treatment of the weld as no slag or spatter are produced.
- Places of difficult access can be welded.

Areas of application

TIG welding is often used for jobs that demand high quality welding such as for instance:

- The offshore industry
- Combined heat and power plants
- The petrochemical industry
- The food industry
- The chemical industry
- The nuclear industry

Materials for TIG welding

The most important area of application is:

- Welding of thin materials in stainless steels
- Aluminium
- Nickel
- Nickel alloys

The increasing demands to the weld quality has made TIG welding very popular for welding of smaller tube dimensions as well as root runs in both non-alloyed and alloyed materials in heavier plates.

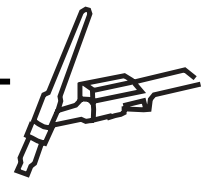

The below table shows which materials can be TIG welded and the recommended types of current and polarity.

Material	Type of current	Electrode polarity
Unalloyed steels	=	-
Low-alloyed steels	=	-
Chromium/nickel steels	=	-
Chromium steels	=	-
Copper alloys	=	-
Nickel alloys	=	-
Titanium	=	-
Lead	=	-
Aluminium alloys	~	
Magnesium alloys	~	

Legend: = DC, ~ AC, - negative, + positive

Direct current with negative polarity on the electrode is used for TIG welding of most materials.

Welding aluminium and magnesium is usually not possible with direct current. The reason for this is that a strong layer of oxide, which is difficult to break through due to its high fusion point, covers these materials.

Therefore aluminium, magnesium and their alloys are usually welded with alternating current which is capable of breaking the oxide layer.

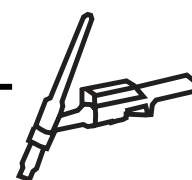

TIG Welding Equipment

Configuration

In order to handle the TIG welding process and make it work to its full capability you need equipment consisting of different parts with their own separate function.

- The TIG welding equipment chiefly consists of:
- A TIG torch that is the tool the welder uses to control the arc.
 - A power source which is capable of providing the necessary welding current.
 - A TIG unit with incorporated control systems that make it possible to adjust the welding current, arc initiation etc.
 - A shielding gas cylinder with pressure reducing valve and flowmeter.

- 1 Cable for welding current
- 2 Cable for welding current
- 3 Control cable for TIG unit
- 4 Shielding gas
- 5 Cable for welding cable for TIG torch
- 6 Control cable for TIG torch
- 7 Welding cable with +polarity

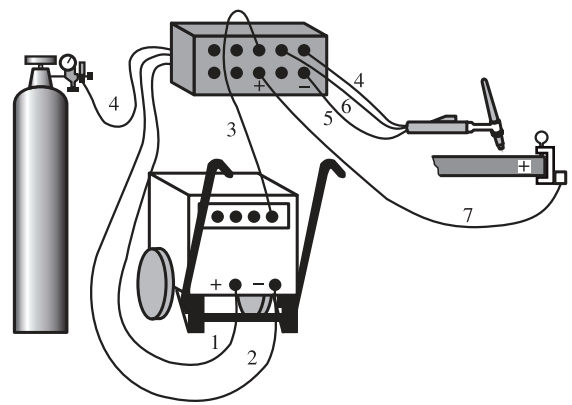

Example for configuration of welding equipment

Many TIG welding machines are constructed in such a way that the power source and the TIG unit are one unit.

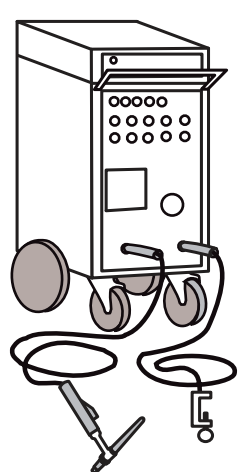

Power source and TIG unit in one unit

TIG Torch

The main purpose of the TIG torch is to carry the welding current and shielding gas to the weld.

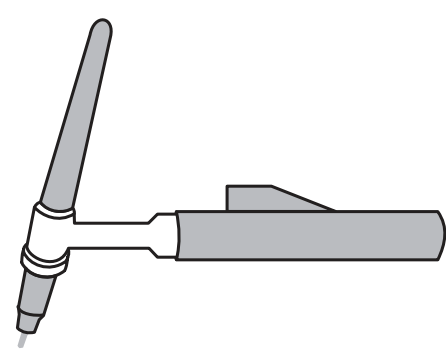

TIG Torch

The TIG torch is constructed on the basis of the welding handle and a torch head that is coated with an electrically insulated material.

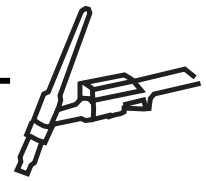

The torch handle is usually fitted with a switch to turn the welding current and the shielding gas on and off.

1. Torch head
2. Handle
3. Control switch
4. Electrode cap
5. Sealing ring
6. Electrode collet
7. Heat shield
8. Collet body
9. Gas nozzle

The electrode collet is split in order it can compress to fit tight around the electrode when the electrode cap is tightened.

In order to avoid a too heavy current load on the electrode the torch is constructed in a way that the current transfer to the electrode takes place very close to the electrode point.

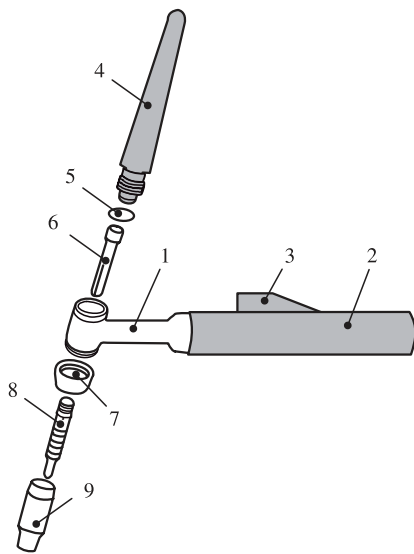

Drawing of TIG welding torch

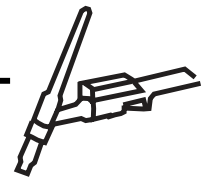

The long torch cap, shown on the drawing, can be exchanged by a shorter version in order for the torch to be used at restricted areas.

However, the cap is usually so long that it can cover an electrode of normal length.

TIG torches are available in many different sizes and designs according to the maximum required current loads and the circumstances under which the torch is to be used.

The size of the torch will also depend on its cooling capacity during welding.

Cooling of the TIG Torch

Some torches are constructed in such a way that it is the flowing shielding gas that cools the torch. However, the torch also gives off heat to the surrounding air.

Other torches are constructed with cooling tubes. Water-cooled torches are mainly used for welding with larger current intensities and AC-welding.

Usually a water-cooled TIG torch is smaller than an air-cooled torch designed to the same maximum current intensities.

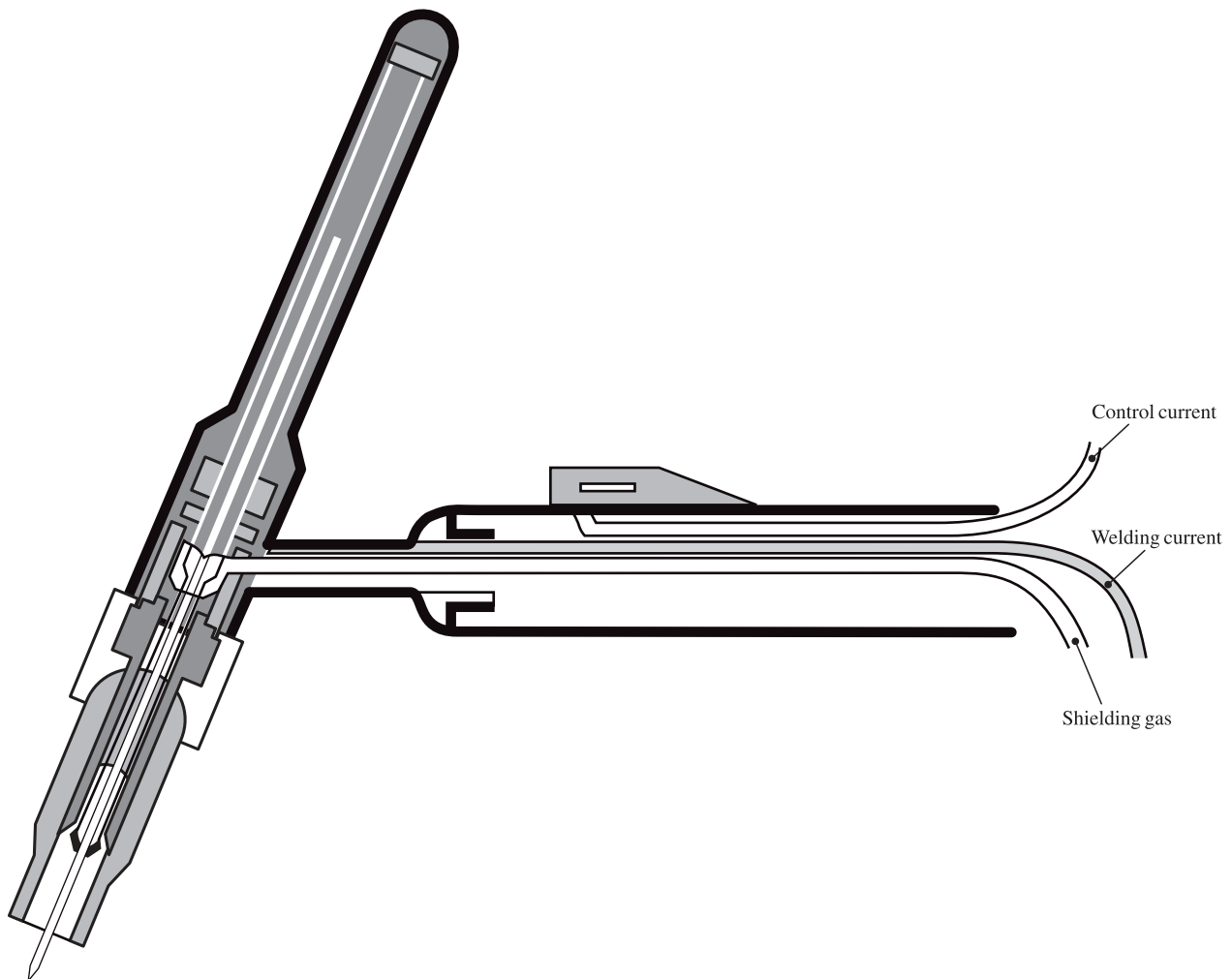

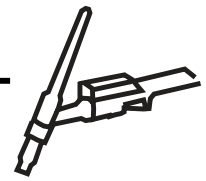

Some of the new TIG torches also have a trigger on the torch handle for control of the welding current during welding.

The Gas Nozzle

The function of the gas nozzle is to lead the shielding gas down around the welding zone and thereby replace the atmospheric air.

The gas nozzle is screwed onto the TIG torch so it can be exchanged if required. It is usually made of a ceramic material able to stand the massive heat.

The size of the gas nozzle is often indicated by a number that refers to the interior diameter of the orifice in 1/16".

Example

A gas nozzle no. 4 has an interior diameter of 4/16" corresponding to 6.4 mm.

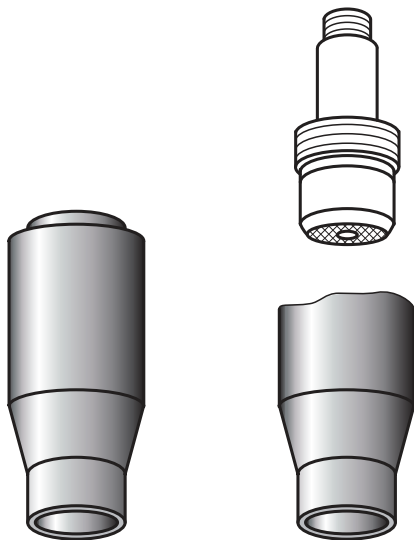

Common gas nozzle and gas nozzle with gas lens

Gas Lens

Another type of gas nozzle is the gas lens which is constructed in a way that the shielding gas passes through a wire grid in order to make the flow of gas more stable at a longer distance.

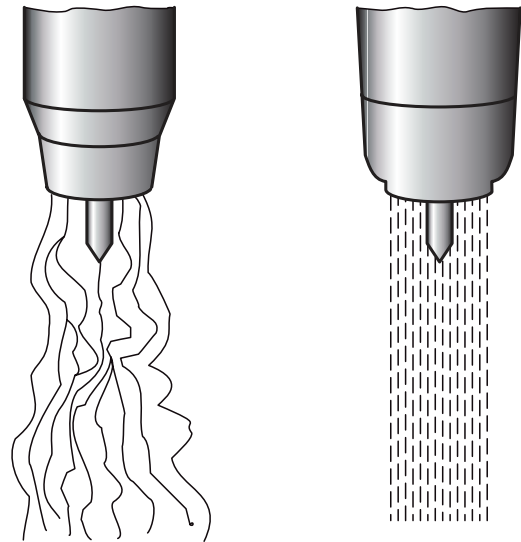

Flow of shielding gas

The advantage of the long gas flow is the fact that the electrode can have a longer stick-out thus allowing the welder to have a better view of the weld pool. By means of a gas diffuser it is also possible to reduce the consumption of shielding gas.

The Power Source

The power sources for TIG welding generally have an open circuit voltage of about 70 to 80 V.

For welding with direct current a power source is used that rectify the alternating current of the mains supply of 400 V to the suitable output for the TIG process and at the same time changes the current intensity to the level set by the welder on the welding machine.

Modern welding machines are capable of welding of welding either in a DC mode or some units provide both AC and DC modes.

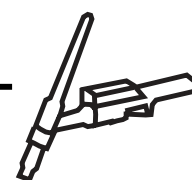

TIG Boxes

The control system of the TIG equipment can be either very simple or very advanced with many different functions.

In its most simple version only the welding current is controlled and the shielding gas is turned on/off by a small valve on the TIG torch.

The more advanced TIG boxes are capable of controlling the shielding gas so it is lead to the welding place before the arc is ignited, and delaying the interruption of the shielding gas after the welding current is cut off.

This means that the tungsten electrode and the weld pool are also protected from the atmospheric air during the cooling period.

Furthermore, the TIG box usually has an ignition facility in order to avoid having to scratch the electrode against the workpiece and thus damaging the electrode point.

This ignition facility can be a high frequency unit (HF) which increases the frequency to 2 to 4 million periods per second and the voltage to several thousand volts.

The high frequency and the voltage make it possible to produce a spark between the electrode point and the surface of the workpiece that transfers the arc.

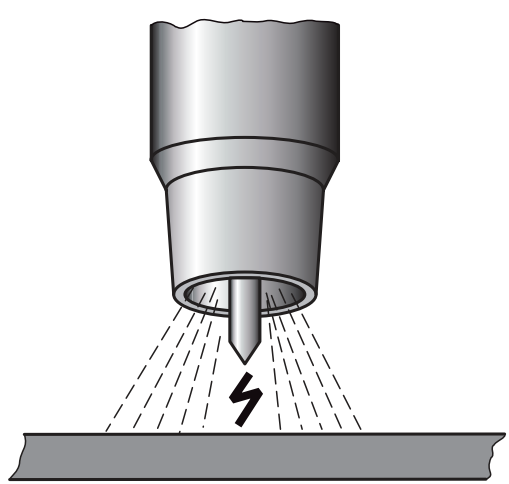

High frequency ignition

Another type of control of the ignition can be an incorporated unit which is capable of limiting the short-circuit current at the moment of ignition, so that when welding starts the point of the tungsten electrode can be placed directly on the workpiece without sticking. The control then increases the welding current intensity when the electrode is lifted from the workpiece thus igniting the arc.

This kind of control has several names as for instance LIFTARC or LIFTIG.

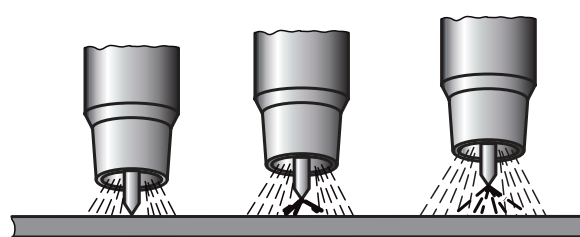

Ignition with the LIFT method.

Other possibilities for control of the ignition are:

- Slope control that makes it possible to pre-program the increase of the welding current when welding starts and the decrease of the welding current when welding stops. Slope control is especially important at the end of welding to help eliminate porosity and shrink holes.



Slope facility

Current pulsation means that two welding current levels are pre-programmed. These are pulse current and base current.

The base current is only large enough to maintain the arc.

The fusion of the base material then takes place when the pulse current is present and the weld pool cools when the base current is present but the arc is maintained.

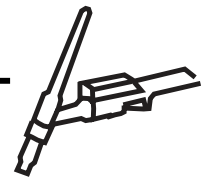

The pulse and base current periods are also controllable.

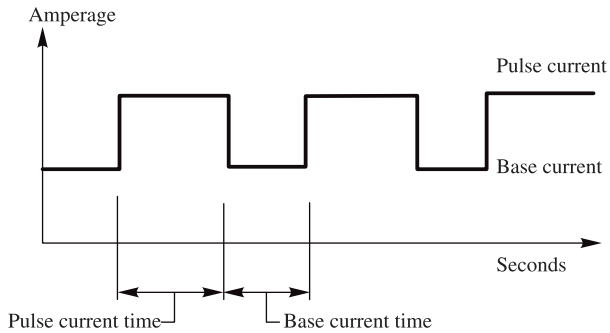

When welding is done with pulsing welding mode the weld is in principle a row of spot welds overlapping to a larger or smaller extent depending on the welding speed.



Example of a weld with pulsing arc

Many double-current machines are equipped with a control function which makes it possible to modify the curve of the alternating current in order to make more square, and also modify the balance between the positive and the negative semi-periods.

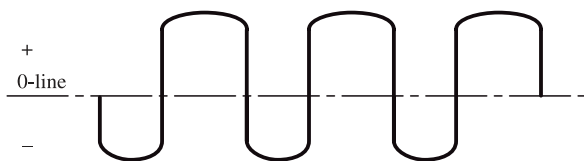

Example of a modified AC curve

These control possibilities are very advantageous when TIG welding aluminium, magnesium and their alloys.

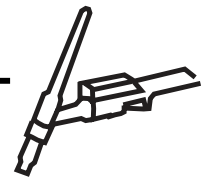

TIG Welding – Grinding of Tungsten Electrodes

Electrodes for TIG Welding

For TIG welding the applied electrode is mainly made of tungsten.

Pure tungsten is a very heat resistance material with a fusion point of approximately 3,380°C.

By alloying tungsten with a few per cent of a metal oxide the conductivity of the electrode can be increased which has the advantage that it can thereby resist a higher current load.

The alloyed tungsten electrodes therefore have a longer lifetime and better ignition properties than electrodes of pure tungsten.

The most frequently used metal oxides used for alloying of tungsten are:

- Thorium oxide ThO₂
- Zirconium oxide ZrO₂
- Lanthanum oxide LaO₂
- Cerium oxide CeO₂

Colour Indications on Tungsten Electrodes

As the pure tungsten electrodes and the different alloyed ones look the same, it is impossible to tell the difference between them. Therefore a standard colour indication on the electrodes has been agreed.

The electrodes are marked with a particular colour on the last 10 mm.

The most commonly used types of tungsten electrodes are:

- Pure tungsten is marked with green colour. This electrode is especially used for AC welding in aluminium and aluminium alloys.
- Tungsten with 2% thorium is marked with red colour. This electrode is mostly used for welding of non-alloyed and low-alloyed steels as well as stainless steels.
- Tungsten with 1% lanthanum is marked with black colour. This electrode is equally suited for welding of all TIG weldable metals.

Electrode Dimensions

Tungsten electrodes are available in different diameters from 0.5 to 8 mm.

The most frequently used dimensions for TIG welding electrodes are 1.6 - 2.4 - 3.2 and 4 mm.

The diameter of the electrode is chosen on basis of the current intensity, which type of electrode that is preferred and whether it is alternating or direct current.

Grinding Angle

An important condition for obtaining a good result of TIG welding is that the point of the tungsten electrode must be ground correctly.

When welding is done with direct current and negative polarity, the electrode point should be conical in order to obtain a concentrated arc that will provide a narrow and deep penetration profile.

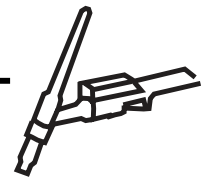

The following thumb rule indicates the relation between the diameter of the tungsten electrode and the length of its ground point.

A small pointed angle gives a narrow weld pool and the larger the pointed angle the wider the weld pool.

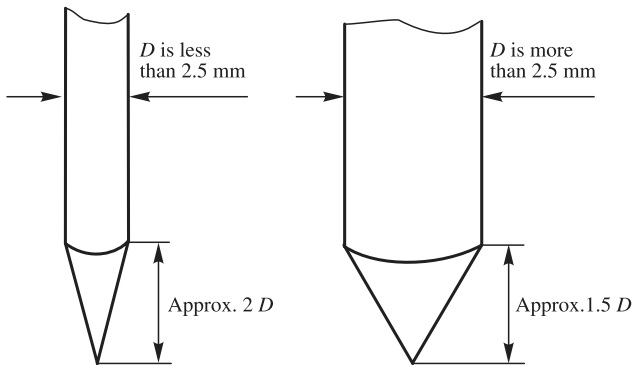

Example of grinding of tungsten electrodes for DC welding

The pointed angle also has an influence of the penetration depth of the weld.

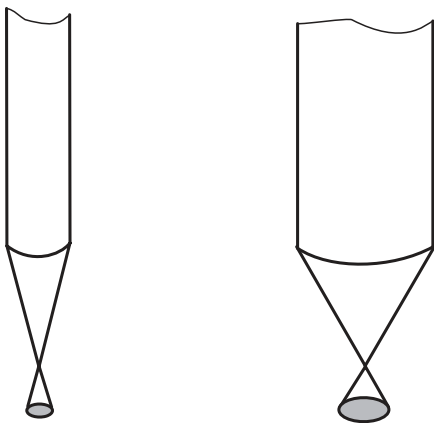

Connection between the pointed angle and the weld pool

Blunting the electrode point to make a flat area with a diameter of about 0.5 mm can increase the lifetime of the tungsten electrode.

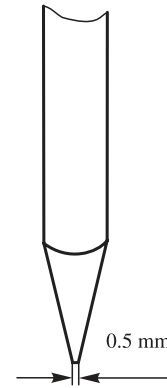

Flat electrode point

For AC TIG welding the tungsten electrode is rounded as during the welding process it is so heavily loaded that it is melted into a half globular form.



Tungsten electrode for AC welding

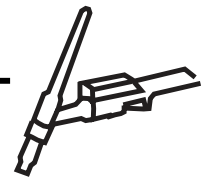

Grinding of the Tungsten Electrode

When grinding the electrode its point must point in the direction of the rotation of the grinding disc so the grinding traces will lie lengthways the electrode.

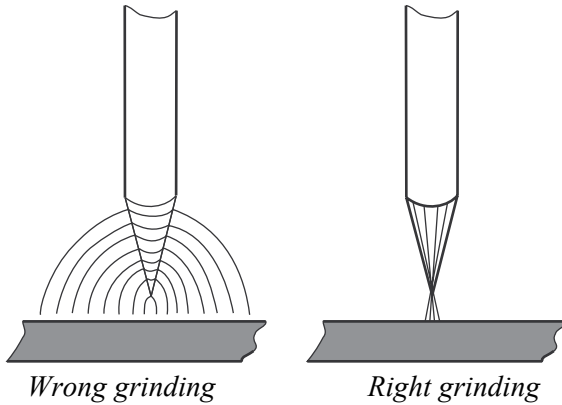

In order to obtain an extra fine grinding of the electrodes, the use of a grinding machine especially for the grinding of electrodes can be advantageous.

Such machines have a rotating diamond coated disc which makes very fine grinding traces. Usually these machines are equipped with a device for fixation of the electrodes with an adjustable grinding angle adding to a uniform grinding.



Tungsten grinding machine

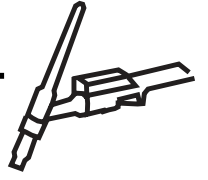

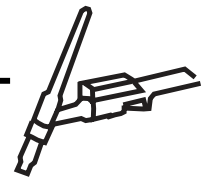

TIG Welding - Shielding Gas

Gases

The shielding gas has several functions. One of them is to replace the atmospheric air so it will not combine with the weld pool and the incandescent tungsten electrode.

Furthermore, the shielding gas also plays an important role in connection with the transfer of current and heat in the arc.

For TIG welding two of the inert gases used are argon (Ar) and helium (He) of which argon is the more frequently used.

The two inactive shielding gases can be mixed with each other or each of them mixed with a type of gas which has a reducing effect.

To say that a gas is reducing means that it can combine with oxygen.

In connection with TIG welding the two reducing gases, hydrogen (H₂) and nitrogen (N₂) are used.

The shielding gas can be chosen on the basis of the material to be welded.

	Non-alloyed and low-alloyed steels	Stainless steels	Nickel-alloyed	Copper-alloyed	Aluminium-alloyed
Ar	x	x	x	x	x
Ar/H₂		x	x		
Ar/He			x	x	x
He				x	x

The choice of the correct shielding gas.

For protection of the backside of the weld it can be advantageous to use a mixture of the reducing gases, N₂/H₂, the so-called backing gas.

The shielding gases are supplied in cylinders of steel painted in standardised colours in order to make them easily recognisable. For this purpose the colour of the actual cylinder and the colour of its shoulder area is used.

	Colour of the cylinder	Colour of the shoulder
Ar	Turquoise	Turquoise
Ar/H₂	Turquoise	Red
Ar/He	Turquoise	Brown
He	Brown	Brown
N₂/H₂	Light grey	Red

Colour indications on shielding gas cylinders

Pressure Reducing Valve and Flowmeter

The pressure in the steel cylinders is between 200 and 300 bar. In order to use the shielding gas the high pressure must be reduced to a suitable working pressure.

A pressure-reducing valve is used to reduce the pressure. The pressure-reducing valve is usually fitted with a gauge where the actual cylinder pressure can be read.

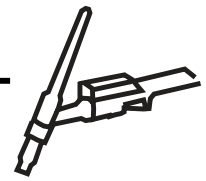

In order adjust the required gasflow for the TIG welding the drawing below shows a pressure-reducing valve with incorporated flowmeter.

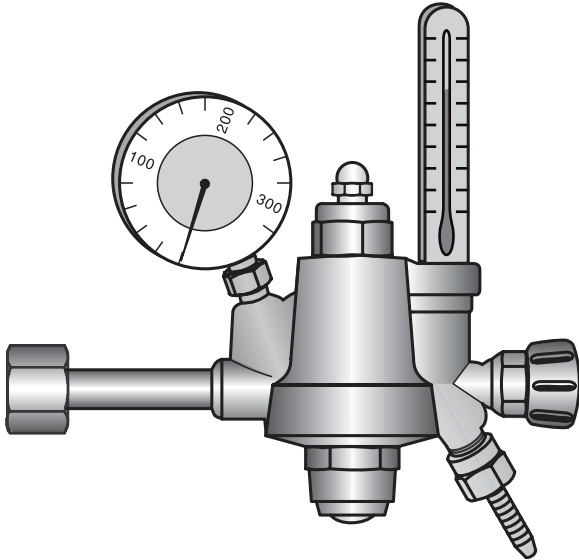

Pressure reducing valve with flowmeter

In the flowmeter there is a small ball which is elevated by the flowing gas thus making it possible to read the gas flow in litres per minute.

Please note that the measuring meter of the flowmeter must be placed vertically and that the flowmeter is designed for the used type of shielding gas or else there is a risk for error readings.

Not all pressure-reducing valves are equipped with a flowmeter. Some types have a working gauge with a litre scale, or use a separate flowmeter.

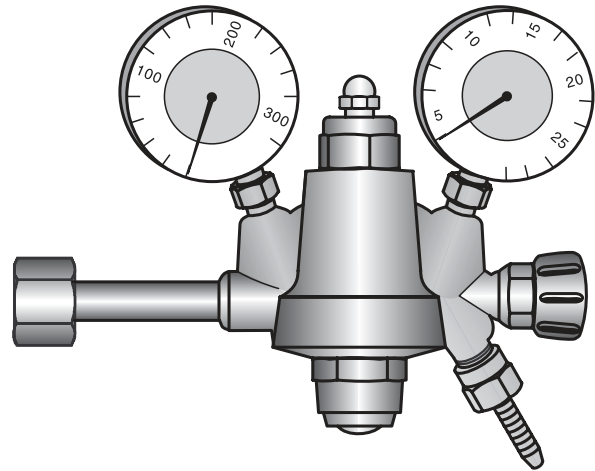

Pressure reducing valve with working manometer with a litre scale

A flowmeter, which measures directly on the gas nozzle, can be used to control that the requested amount of shielding gas exists at the opening of the gas nozzle.

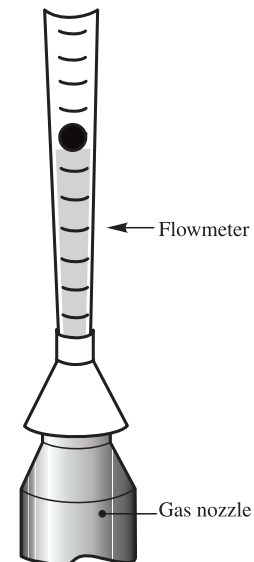

Direct measurement on the gas nozzle

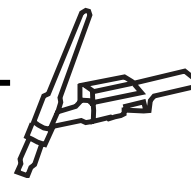

The amount of shielding gas depends on the interior diameter of the gas nozzle.

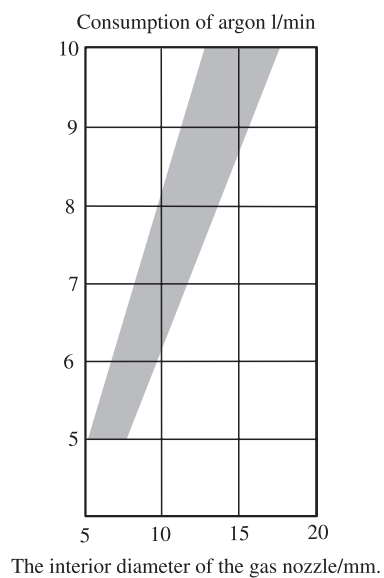

Indicated values for the amount of shielding gas.

A too large amount of gas increases the outflow speed in the gas nozzle. This may cause air to be whirled into the shielding gas due to the injector effect.

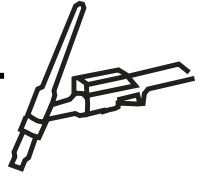

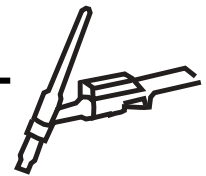

TIG Welding - Personal Safety

Heat and Welding Light

The light emitted from the arc is very damaging to the eyes and may cause “arc eyes” which feels like having sand in the eyes. The heat emission may cause cataracts, which is a destruction of the eyeball. The light from the arc is very damaging to the skin and may cause the same symptoms as a serious sun burn on the uncovered skin.

Protection against Light and Heat

Welding Helmet

The welding shield protects the face and the eyes from heat and light and is available as a hand shield or welding helmet. The shields are fitted with dark, graded filter lens that reduces the light and protects the eyes from the arc radiation. In front of the dark filter is a clear cover protecting the dark one.

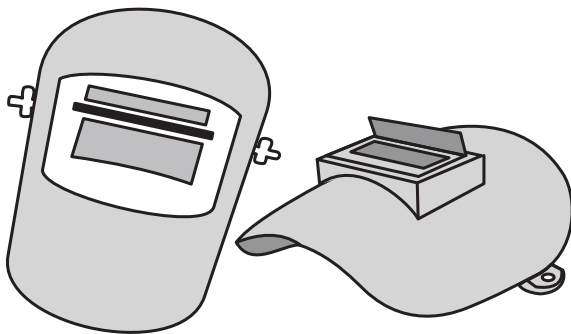

Types of Shielding Filters

The types of the shielding filters have been standardised by the British or European standards but are usually supplied according to German standard (DIN), Deutsche Industrie Norm. The type of the filter should be chosen according to the strength of the arc, the light in the room and the welder’s eyes. The area surrounding the welding area must also be a suitable shade so that the light emitted from the arc does not disturb the welder, but not so dark that it makes it difficult to see the surroundings of the weld zone when the arc is established.

For arc welding the following density of welding filters are recommended. These recommendations are meant as guidelines. New examination methods have established those welding filters with a density of > DIN 5 provides protection of the eye.

Less than 100 A	DIN 7-9
100 to 300 A	DIN 10-11
More than 300 A	DIN 12-14

Shielding of the Working Place

By shielding off his working place the welder can protect other persons in the room from the welding light. Even at a distance of 10 metres the arc may cause “arc eyes”, if you look directly into it.

Working Clothes

Working clothes protect the skin against the light and heat radiation.



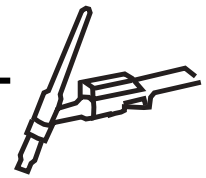

Working Gloves

The working gloves protect the hands and wrists against heat and light. The gloves are usually made of leather and the top should be at least 120 mm long. The gloves should be kept dry due to the electrical safety (electrical leak resistance is greatest at dry gloves).

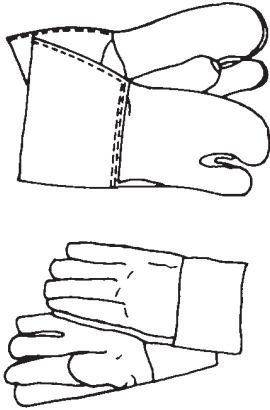

Arc Eyes

Effect

Flashes from the arc and reflections from shiny objects can cause “arc eyes”. The cornea dries up and may burst. Arc eyes feel very uncomfortable, like having sand in the eyes. Normally arc eyes do not cause lasting damage, but repetitive exposure to welding light may cause a reduction of the vision power.

Treatment

Cold packs offers palliation and certain ointments will provide a local anaesthetic. If the pain persists you should see a doctor who can prescribe an eye lotion that palliates the pain. When using such ointment or lotion will anaesthetise the eye so that grinding dust may enter the eye without being noticed.

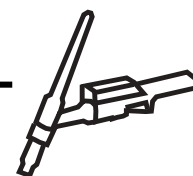

Pressure Gas Cylinders

Appellation	Chemical designation	Areas of application	Colour of bottle		Connecting thread
			Cylindrical part	Shoulder part	
Acetylene (gas)	C ₂ H ₂	Welding, cutting and the like	Reddish brown		RG inside right
Argon	Ar	Shielding gas welding of all metals	Light grey		24, 32 WG outside right 14 thread/inch
Hydrogen	H ₂	Reduction- and shielding gas for chemical- and metal-working industry. Generator cooling. Plasma welding and -cutting	Light grey		21, 8 WG outside left 14 thread/inch
Air	–	Compressed air Inhalation	Black	White Black	RG inside right
Nitrogen	N ₂	Gaseous: Shielding gas for metal-working industry, chemical industry, food industry and electro industry. Liquid: Cooling and freezing	Green	Black	24, 32 WG outside right 14 thread/inch
Oxygen Technical	O ₂	Gas welding Flame cutting	Light blue	White	21, 8 WG outside right 14 thread/inch
Oxygen, Technical	O ₂	Welding, cutting and the like	Light blue	White	21, 8 WG outside right 14 thread/inch

Cylinders under pressure must be secured against overturning, rolling, falling and heat (sun exposure and heat from boiler systems). They must be easily accessible and easy to remove in case of fire. At entrances where pressure cylinders are kept there must be a sign shown indicating hazards.

Transport of cylinders

Cylinder should be handled in a safe and proper manner using the appropriate trolleys etc.



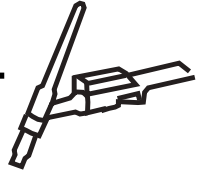

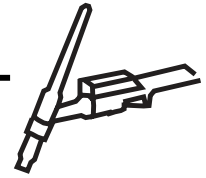

Electric Safety in TIG Welding

Electric current and risks

Electricity is a good servant, but a hard master. The electrical danger of electric arc welding is usually quite small if the necessary safety regulations are observed.

Open Circuit Voltage

Welding equipment must observe the allowed present open circuit voltages as indicated in the current electrical regulations.

Equipment for manual or semiautomatic operation:

- Alternating current - 80 V (effective value)
- Direct current ripple voltage > 10% 80 V (effective value)
- Direct current ripple voltage < 10% 100 V (mean value)
- Transportable equipment for private use - 70 V (effective value)

Mains Voltage Supply

230 or 400 V is highly dangerous, but normally it is unlikely to get into contact with the main voltage supply.

Defective Insulation

Defective insulation of the main supply may cause leaks and dangerous contacts.

Earth Protection

All machines should be earthed especially older machines which may not be double insulated.

Maintenance of the Welding Equipment

The operator should carry out daily housekeeping checks on the welding equipment to pick up normal wear and tear. Equipment should also be maintained on a regular basis to ensure that it is safe to use and kept in peak operating condition.

Electrical Safety in TIG Welding

Power Source

Power sources with both direct and alternating current are often used for TIG welding. The open circuit voltage of these power sources is often within the same range as that of equipment used for ordinary arc welding with coated electrodes.

The welding machine is often equipped with a high frequency facility for ignition of the arc.

If the machine is not equipped with a high frequency facility it can be used according to the same regulations as equipment for ordinary arc welding with coated electrodes. If however, the equipment is fitted with a high frequency facility the electric hazards are increased and it should therefore only be operating in a dry environment.

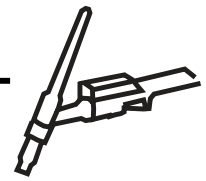

Primary Connection

Mains Connection

Fitting of the mains connection on machines such as welding machines must only be done by a competent person.

Two errors often occur when mounting welding machines:

- Incorrect connection of the cables
- Missing or incorrectly fitted cable gland.

An incorrect connection can occur when e.g. a three-pole cable is connected to the three clamps of the welding machine. A phase and an earth connection could be mistaken, so that the machine casing could be alive, and it would then be highly dangerous to touch the machine.

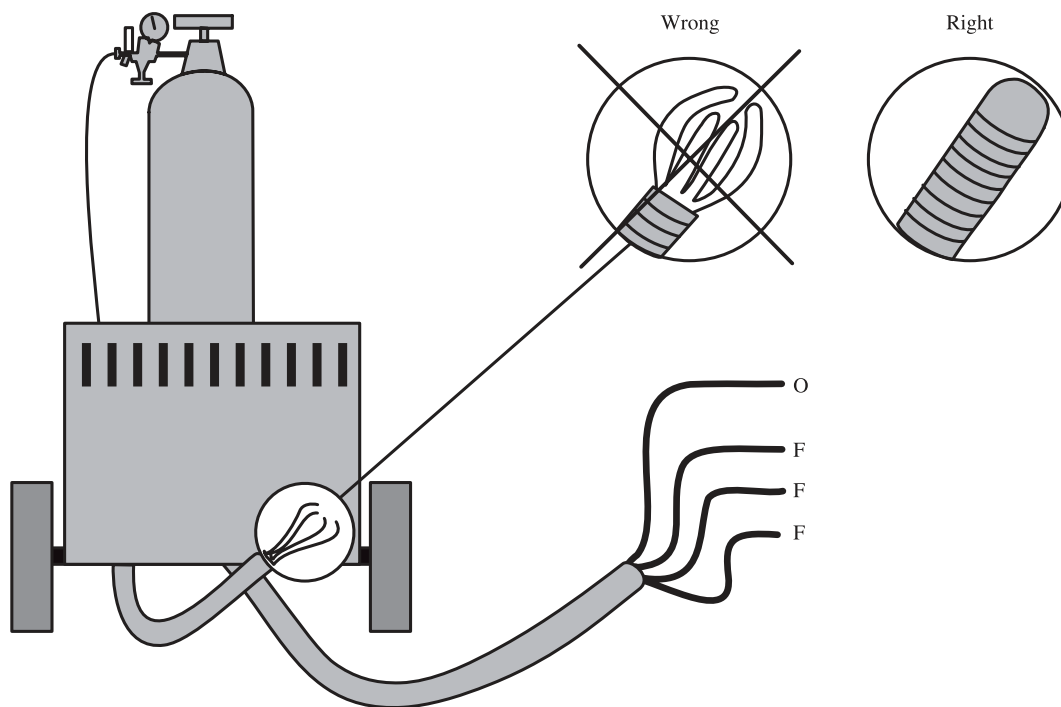

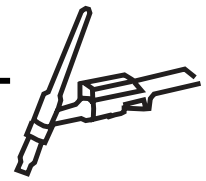

Secondary Connection

Cables and Connections

All cables and connections must be insulated. This means that all connections should be made with insulating straight-through joints and not like it is often seen, with metal cable rings tightened together with a bolt screw.

If the insulation of the cable is ruined, the cable must be discarded or the insulation repaired. In electric arc welding it is important that the cable cross-section is sufficiently large throughout the entire circuit.

Too thin cables with torn cores or poor switches may cause both an unstable welding current and unintentional heating which may have disastrous consequences.

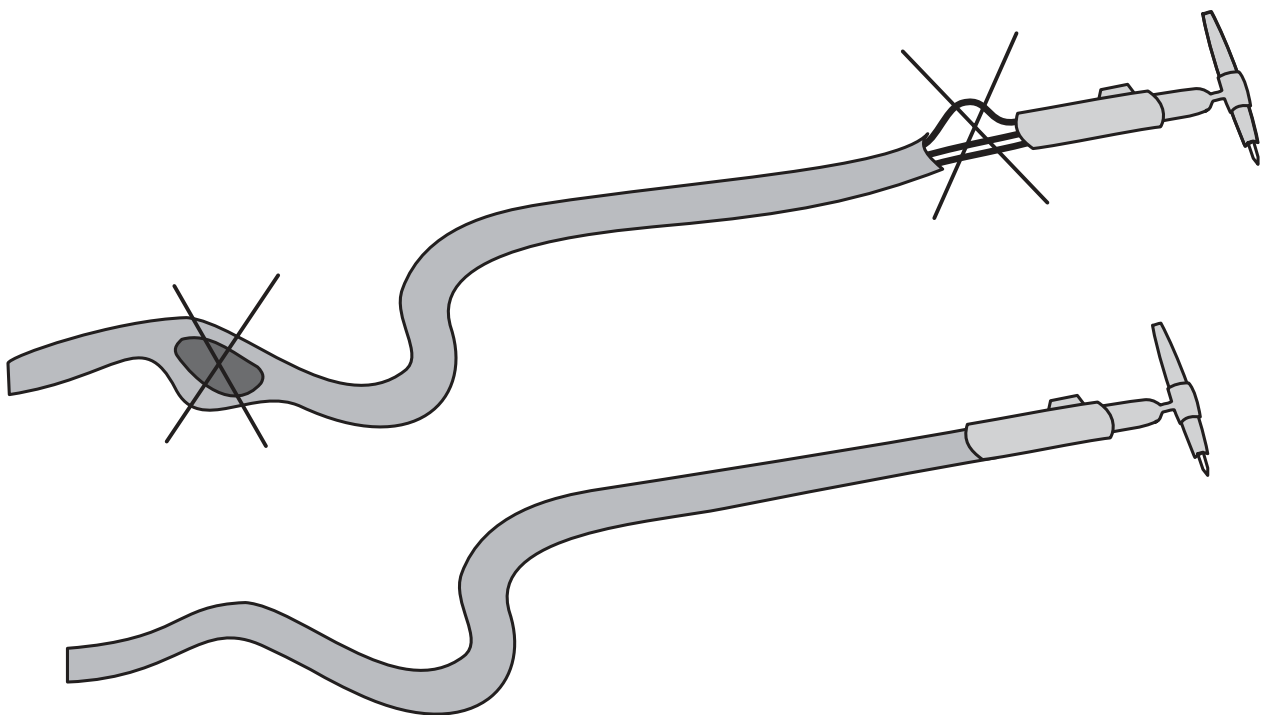

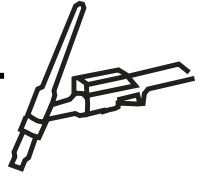

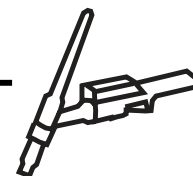

TIG Welding - Fumes Production

General Information of Welding Fumes and TIG Welding

At a first glance there are no fumes production or very little fumes to be seen when TIG welding. But that should not lead us to think that TIG welding does not produce any unhealthy substances.

Different factors influence on the concentration of unhealthy substances in the inhaled air, e.g. the current intensity, the steel quality (unalloyed, low-alloyed and high-alloyed steels) and the cleaning of the materials of for instance cutting lubricants and anti-corrosives.

Welding Fumes and Gases

Nitrous Gases

When welding with shielding gas smaller concentrations of nitrous gases are produced. The gases are produced because of the strong generation of heat, which is a result of the chemical reaction between nitrogen and oxygen.

Nitrous gases is a common name for a group of elements which are also called nitric oxides of which there are several different ones.

Only two of these have a fixed TLV (Threshold Limit Value). The TLV of nitrogen oxide (NO) is 25 PPM. The TLV of nitrogen dioxide (NO₂) is 3 PPM.

If nitrogen oxide and ozone is mixed (as it is the case when TIG welding) they produce nitrogen pentoxide which is more toxic than the other nitrous gases.

Nitrous gases only feel faintly irritating and it is therefore harder to discover in due time. When exposed to concentrations more than the TLV this substance may cause instant and highly dangerous damages to the lungs, e.g. pulmonary oedema and the pulmonary disease emphysema.

Ozone

Ozone is produced when the oxygen of the air is exposed to ultraviolet radiation, as is the case with TIG welding. There are only a few different wavelength ranges within the UV-radiation that can produce ozone. The most efficient part of the wavelengths between 130 and 175 nm will be completely absorbed in the closest air layer immediately outside the shielding gas, and large amounts of ozone is produced. This is happening because of the high absorption in the oxygen. In the shielding gas there is no absorption and therefore no production of ozone. The TLV of ozone is 1.0 PPM.

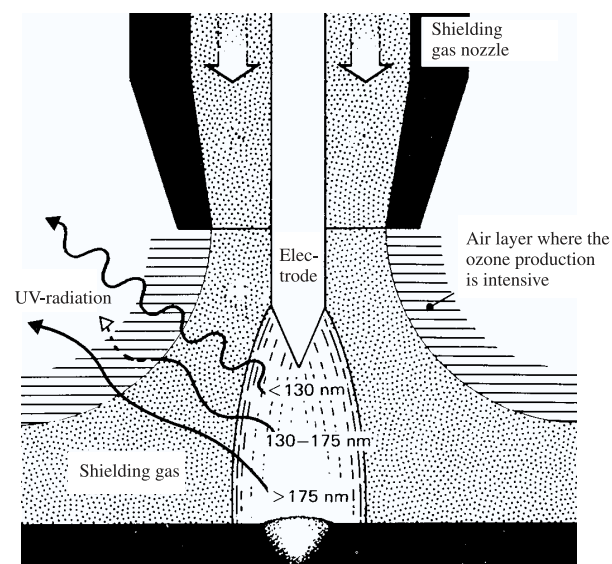

Opposite the nitrous gases, ozone can be detected by its very characteristic smell. Even in low concentrations ozone feels strongly irritating on the eyes and respiratory passages. It may cause headaches and fatigue and after a longer period of exposure the pulmonary function will be reduced.

Iron Oxide

Iron is the most important element in steel. The heating of iron produces fumes with a content of iron oxide. Inhalation of large amounts of iron oxide may cause reduced pulmonary function.

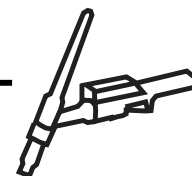

Manganese

Manganese is set free by welding in steels with manganese e.g. non-alloyed and low-alloyed steels. Manganese influences on the brain causing symptoms such as headaches, weakness, loss of appetite and sleeping problems.

Manganese is harmful to the respiratory passages and increases the risk of pneumonia. High concentrations may cause metallic fumes fever.

Chromium

Chromium is set free during welding in low- and high-alloyed steels. A distinction is drawn between chromium 3 and chromium 6:

The threshold limit value of chromium 3 is 0.5 mg/m³.

The threshold limit value of chromium 6 is 0.02 mg/m³.

Both chromium 3 and chromium 6 may cause allergy e.g. as a rash in the face when welding in stainless steels. Chromium 6 causes serious irritations to the respiratory passages and may cause sores in the oral cavity, nasal cavity and throat. There is also a risk of chronic bronchitis. Chromium 6 is also suspected to be carcinogenic.

Nickel

Nickel is set free during welding in low- and high-alloyed steels.

The threshold limit value of nickel is 1 mg/m³ (difficulty soluble combinations). The threshold value of nickel is 0.1 mg/m³ (soluble combinations).

Nickel is a highly allergy-causing agent that also causes rashes and asthma-like diseases. Nickel is also suspected to be carcinogenic.

Hygienic Limit Values

Threshold Limit Values (TLV)

The Danish National Labour Inspection has set up threshold limit values of the highest permissible concentrations of harmful elements in the inhaled air in order to protect the welders among others. The TLV indicates the highest permissible mean value of harmful elements in the inhaled air during one day. The concentration is either

indicated in PPM (parts per million) cm³/m³ or in mg/m³.

The TLVs are based on the present knowledge of the influences of the elements. If new knowledge makes it appropriate, the present TLVs will be revised. TLVs are not to be considered strict limits between harmful and not harmful concentrations, as such limits do not exist. It should not be considered adequate to merely reducing the air pollution to the level of the TLVs.

Even though a concentration of a particular air pollution corresponding to the TLV of the element in question will normally be harmful to the health, it should nevertheless always be a goal to keep the concentrations of the air pollution as far below the TLVs as possible.

Exceeding the Threshold Limit Values

In general the TLVs indicate the highest permissible mean concentrations of an 8-hour working day. This means that brief exceeding of the TLVs is permitted if the concentrations are otherwise so far below the TLV that the time-weighted mean value lies below the TLV. However, gratuitous high, brief exceeding of the TLVs is not permitted even though the mean value of a whole day's work is kept below the limit.

How long time and how large exceeding that is permitted must be considered in each case and should be evaluated by the Danish National Labour Inspection.

The below table shows the exceeding which can be tolerated in periods up to 15 minutes under the precondition that the weighed mean value does not exceed the TLV. The below figures are meant as a thumb rule only.

	Permitted exceeding
GV < 1	3 X GV
1 < GV < 10	2 X GV
10 < GV < 100	1.5 X GV
100 < GV < 1.000	1.25 X GV

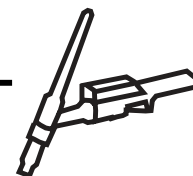

When calculating the allowed exceeding according to the below table, the unit PPM is used for gases, and vapours and the unit mg/m³ for particles (dust, fumes and mists).

A substance of TLV = 1 PPM is therefore allowed a maximum of $1 \times 3 = 3$ PPM for a period of 15 minutes. A substance of TLV = 10 PPM is allowed a maximum of $10 \times 2 = 20$ PPM. And finally a substance of TLV = 50 PPM is allowed a maximum of $50 \times 1.5 = 75$ PPM. The allowed number of exceeding the TLV per day is determined by the fact that the time-weighted mean value must be less than the TLV.

Threshold Limit Value	PPM	mg/m ³
Iron oxide	-	3.5
Chrome 3	-	0.5
Chrome 6	-	0.02
Manganese	-	1.0
Nickel, difficult decomposable combinations	-	1.0
Nickel combinations, decomposable	-	0.1
Nitrogen oxide	25.0	30.0
Nitrogen dioxide	3.0	5.6
Ozon	0.1	0.2

Table of TLVs

How to Prevent Air Pollution

Process Ventilation

Process ventilation is one the most important technical means of reducing the pollution of the air in the workshop. However, it is not the meaning that in every connection ventilation should be regarded the ultimate means for improvement of the working environment. It may be that in spite of a thoroughly considered and well done ventilation system it is not possible to solve the present environmental problem. Therefore it is important to evaluate all the different possibilities for preventing the production and spreading of unhealthy air pollution before you start on the technical ventilation examinations.

Ventilation can be divided into two main groups:

- Comfort ventilation
- Process ventilation

Process ventilation aims at creating a safe and healthy environment while the purpose of comfort ventilation is to increase the well-being in order to obtain the best possible conditions of a good working environment. As previously mentioned it is process ventilation that should make certain that undesirable influences in the form of air pollution are prevented.

Process ventilation can be divided into three gross groups:

- Local exhaust ventilation of the welding place
- Local exhaust ventilation of the welding cabin
- General ventilation system

In order to remove the welding fumes as effectively as possible it is necessary to use all three types of ventilation.

Welding is not to take place unless adequate measures have been taken against the air pollution that is a result of welding.

Where it is practically possible, the unhealthy air pollution must be removed before it reaches the inhalation range of the welder and lead immediately into free air.

If at indoor jobs it is not possible to remove the fumes immediately at the place of production, mechanical ventilation of the room must be established so that the content of polluting substances in the inhaled air does not exceed the hygienic limit value of the mixture.

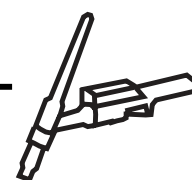

Local Exhaust Ventilation of the Welding Place

Local exhaust ventilation of the welding place is a type of ventilation that removes the pollution from its place of production. This type of exhaust ventilation offers valuable advantages, because it significantly reduces the requirements to the general ventilation system and it also normally offers an improved environment in comparison with a general ventilation system without further exhaust systems.

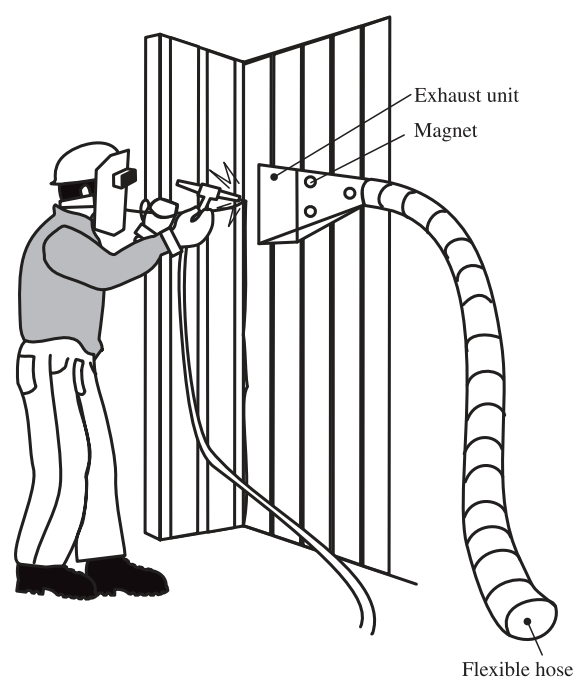
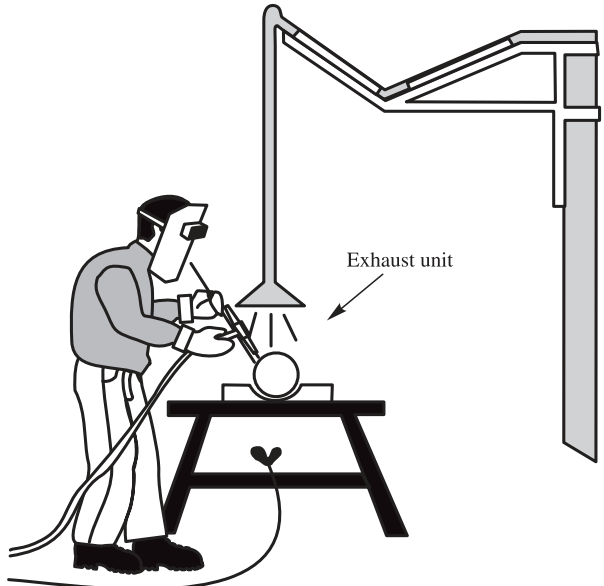

A common demand for all suitable local exhaust units is that they are efficient, easy to operate, produces little noise and do not disturb the working process. If these demands are not met, the exhaust unit will not be used and the investment will be wasted.

The actual exhaust unit are available in many different designs e.g. a swivel arm or flexible hoses which at all times can be adapted to the welding or cutting job in question.

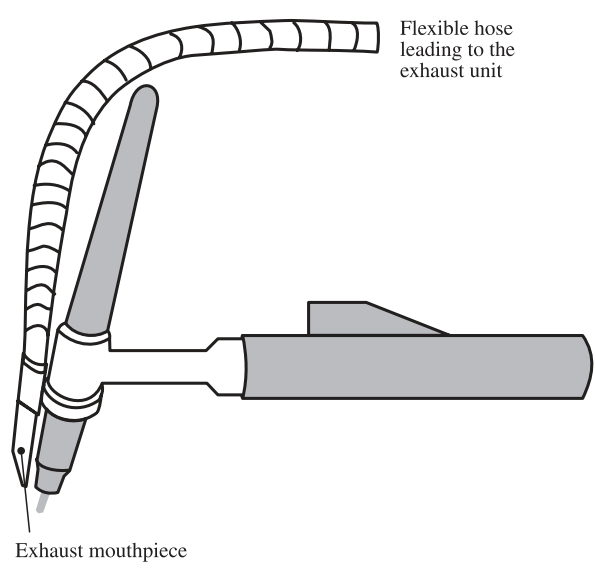

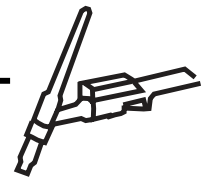

Local exhaust ventilation of the welding cabin

In addition to the ventilation described above, local exhaust ventilation systems are also used at stationary welding cabins. This type of exhaust ventilation ventilates the individual welding area without directly removing the fumes from the welding place. It can be a welding table with an exhaust unit in the tabletop that is often made with a grid or with exhaust in the back or top plates.

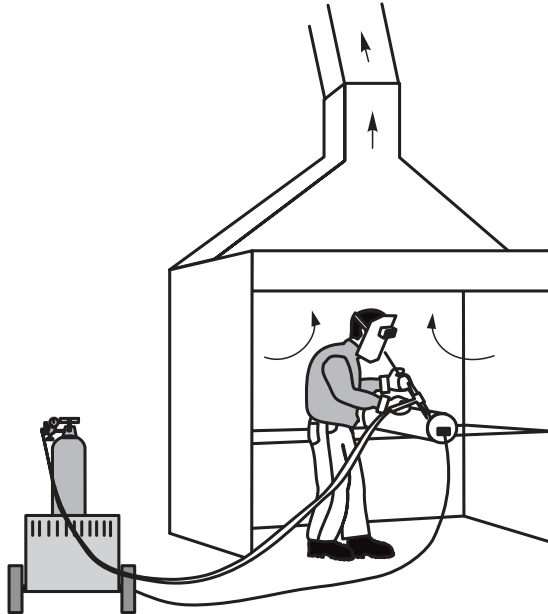

General ventilation

General ventilation systems are designed to ensure a satisfactory working environment in the room.

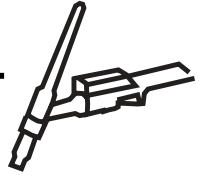

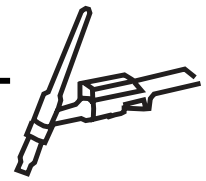

TIG Welding - Filler Materials - Welding Techniques

Filler Materials

During welding the torch are guided forward at a lateral perpendicular angle of 80 to 90o in the welding direction.

The filler wire are fed in step with the progressing welding in an angle of about 10 to 20o to the base material.

The welding method is much like that of MIG/MAG welding, leftward welding with small dipping movements.

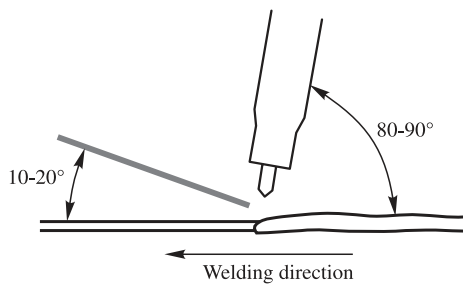

During welding it is important that the filler wire is kept strictly within the gas flow from the gas nozzle.

This will prevent the melting and still hot wire from oxidising in connection with the atmospheric air.

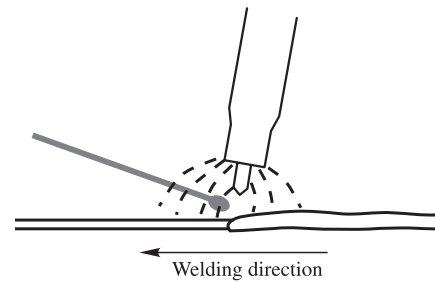

Every form of oxidation and pollution of the filler wire will cause a contamination of the weld pool.

It is therefore very important that the welder only uses clean filler materials that are not dirty, greasy or moist.

Mostly grease and dirt will come from using dirty gloves. It is therefore a good idea to clean the filler wire with for instance acetone immediately before the welding starts.

Grease and moisture both on the filler wire and on the base material may cause serious welding errors such as porosities, hydrogen cracks, etc.

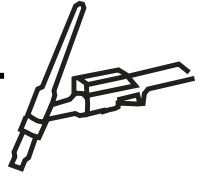

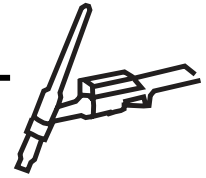

Types of Errors in TIG Welding of Butt Welds

Introduction

The technological development means that increasingly heavier demands are made on the steel materials and therefore new materials of improved tensile strength are being developed continuously.

The use of these new materials make it possible to reduce the dimensions of the materials so that when previously you had to use 8 mm plates you now only use 6 mm plates to obtain the same strength.

When making a butt weld if the material dimension is reduced the area of the welding is also reduced.

The development causes an increasing demand to the quality of the individual weld and of the welded construction in general.

The increasing demands of welding means that TIG welding is in use more frequently.

The quality demands will in the first place be made on the engineers, the welding technicians and the welder.

The engineer is responsible for the design of the construction.

The welding technicians are responsible for choosing the correct welding method, elaboration of the welding procedure specification and the internal control.

The welder carries out the actual welding job and he is therefore responsible for the quality of the welds.

Even though all parties involved are very careful with their jobs, welding errors will occur.

Therefore the welder is not necessarily to blame for the errors, but it is a fact that errors do occur in this process.

The following sections will deal with the errors on which the welder has influence when TIG welding butt welds.

Designations and Definitions of Welding Errors DS/ISO 6520

DS/ISO 6520 is a present Danish and international standard indicating designations and definitions of errors that occur in welding.

The standard lists all types of errors including those that cannot be controlled visually.

The types of errors are divided into the following six main groups:

- Cracks
- Porosities
- Inclusions
- Lack of fusion and lack of penetration
- Imperfect shape
- Various errors that do not belong to any of the above groups

The standard indicates the different types of errors in columns with explanations and illustrations.

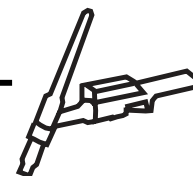

Fejltype nummer	IIW-radiografisk reference	Fejlens benævnelse Dansk Engelsk Fransk	Forklaring Engelsk	Forklaring Dansk	Illustration
1	2	3	4	5	6
100	E	Revner Cracks Fissures	A discontinuity produced by a local rupture which may arise from the effect of cooling or stresses	Diskontinuiteter i form af et lokalt brud, der kan være forårsaget af hurtig afkøling eller af spændinger	
1001		Mikrorevne Microfissure (microcrack) Microfissure	When a crack has microscopic dimensions it is known as a microfissure or microcrack	Når en revne er af mikroskopiske dimensioner, betegnes den som mikrorevne	
101 1011 1012 1013 1014	Ea	Langsgående revne Longitudinal crack Fissure longitudinale	A crack substantially parallel to the axis of the weld. It may be situated: - in the weld metal, - at the weld junction, - in the heat-affected zone, - in the parent metal.	Revne, der væsentligst forløber parallelt med svejse sømmens længdeakse. Langsgående revner kan findes i: - svejsemetallet - bindingszonen - den varmepåvirkede zone - grundmaterialet	

- Column 1 Indicates every type of error by a number.
- Column 2 Indicates a group of letters that refers to the radiographic evaluation IIW (International Institute of Welding).
- Column 3 Indicates the designation of the error in Danish, English and French. The German designation is in appendix B.
- Column 4 Indicates the explanation in English.
- Column 5 Indicates the explanation in Danish.
- Column 6 An illustration of the error when further explanation is necessary.

DS/ISO 6520 does not provide any requirements for the size of the errors and is therefore not suited for an evaluation of the weld.

The visual evaluation with indication of the marking is made according to DS/R 325.

The marking of the radiographic evaluation can be given on the basis of the IIW's radiographic evaluation table.

Welding Errors

Cracks

Cracks in connection with TIG welding are rarely seen, but may occur both as vertical or horizontal cracks.

The cracks can occur in the weld metal, the heat-affected zone or in the parent metal.

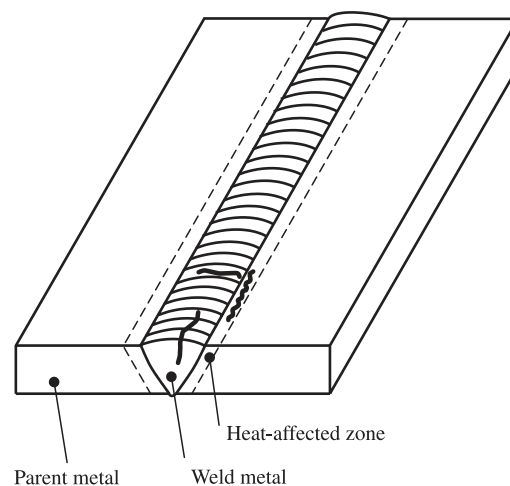

Error type no. 100

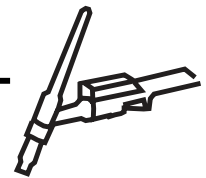

The most frequent type of cracks in TIG welding are cracks in the ending crater, the so-called crater cracks.

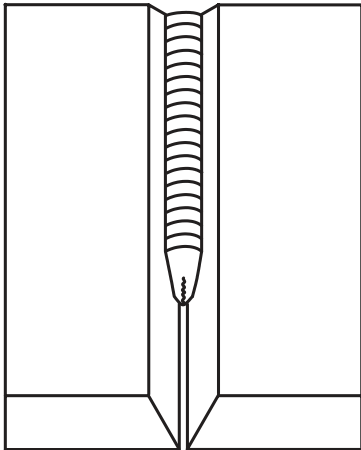

Error type no. 104

The reason for the formation of cracks can be:

- Wrong or no use of the slope-down facility
- Too small or too few stitches
- Wrong welding order
- Too rapid cooling of the weld zone
- Wrong or no pre-heating and post heating treatment

Cavities

According to DS/ISO 6520 cavities are defined as cavities in the weld due to entrapped gases.

Cavities are often found in TIG welds due to the many possibilities for this error to occur.

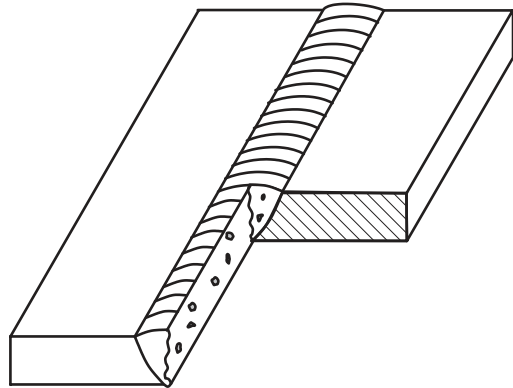

Error type no. 200

The reason for the formation of porosities can be:

- Lacking or impure shielding gas
- Inadequate cleaning of the groove edges and filler material
- Incorrect adjustment of the flow of shielding gas
- Wrong inclination of the torch
- Wrong size of gas nozzle
- Too quickly an interruption of the shielding gas by the end of a weld
- Draught caused by a wrongly placed exhaust unit
- Leaking hose connections
- Inadequate airing of the TIG torch before welding

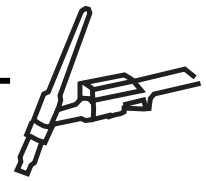

Shrinkage Cavity

A shrinkage cavity is a cavity that occurs by the end of a weld.

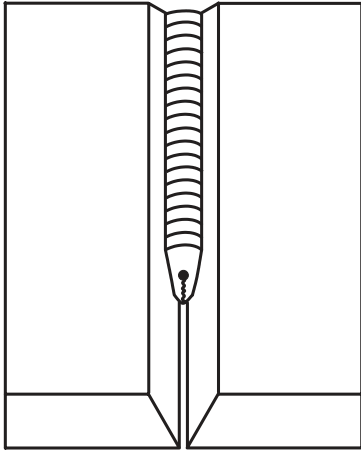

Error type no. 202

This error occurs when the weld metal solidifies too quickly.

It can be avoided by a gradually slope down of the welding current which makes the weld metal solidify less quickly.

Metallic Inclusion

Inclusions of tungsten are a particular problem for TIG welding.

An inclusion of tungsten in the weld may cause the formation of cracks as tungsten has another expansion coefficient than steel.

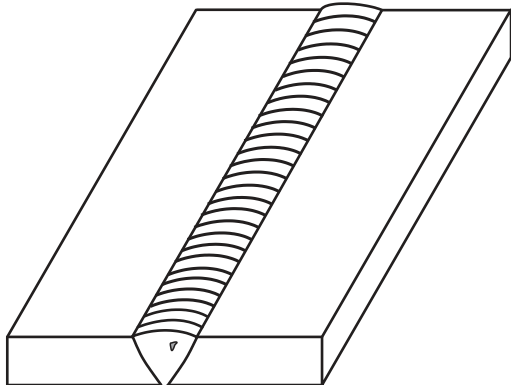

Error type no. 304

The reasons for these inclusions of tungsten can be:

- The point of the tungsten electrode has touched the weld pool or the groove edges.
- The point of the electrode has a wrong sharpening angle.
- The type and dimension of the electrode are incorrect.
- Too long stick-out.

Lack of Fusion and Penetration

Lack of fusion and penetration is an error which occurs when the fusion between the weld metal and the parent metal or between the welding passes are inadequate.

Lack of fusion may also occur in the bottom run. The error is not very frequent in TIG welding due to the large penetration ability of this method.

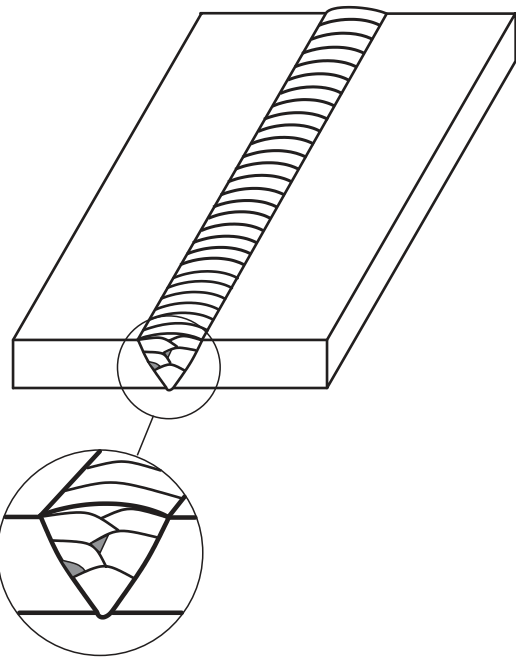

Error type no. 400

Lacks of fusion and penetration may be caused by:

- Too small current intensity
- Wrong inclination angle of the TIG torch
- Too much feeding of filler wire
- Too large dimension of filler wire

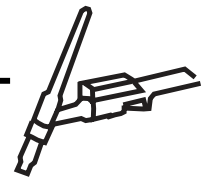

Lack of fusion at the root of the weld

This error occurs when the penetration of the root run is incomplete. The error is not very common in TIG welding due to the large penetration ability of this method.

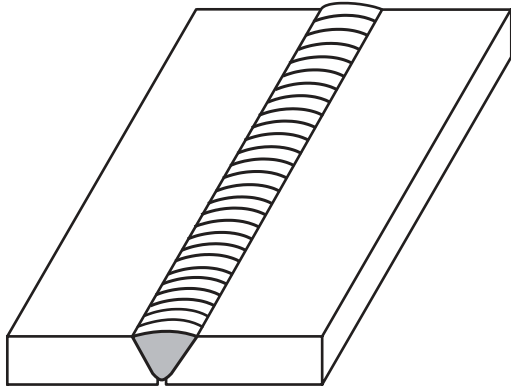

Error type no. 402

Lack of fusion at the root of the weld can be caused by:

- Wrong adaptation of the weld preparation.
- Too large “root nose” (insufficient blunting of the bottom of the V-prep by grinding)
- Too small welding current intensity
- Wrong inclination angle of the TIG torch
- Too large wire dimensions

Undercut

An undercut usually appears in the zone between the weld metal and the parent metal and can occur both on the front and the backside.

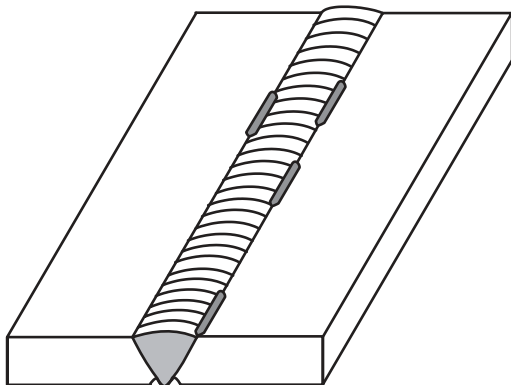

Error type no. 501

Undercuts can be caused by:

- Too high welding current intensity
- Too long arc
- Wrong inclination angle of the TIG torch
- Lack of filler wire
- Feeding of filler wire at the wrong place

Excess of Weld Material

The excess of weld material will cause a weakness of the welded construction similar to the effects of undercut.

Furthermore, there is used an excessive amount of filler wire which means unnecessary welding costs.

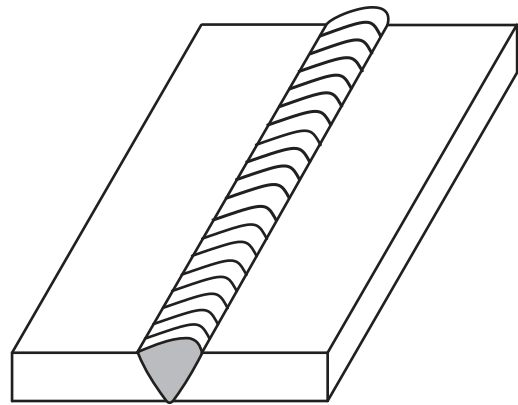

Error type no. 502

Excess of weld material is mostly due to an excessive feeding of filler wire.

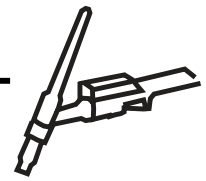

Excessive Penetration

Excessive penetration is an error which occurs when the weld metal protrudes through the root of a weld made from one side where it weakens the strength of the weld where the weld metal and the parent metal meet.

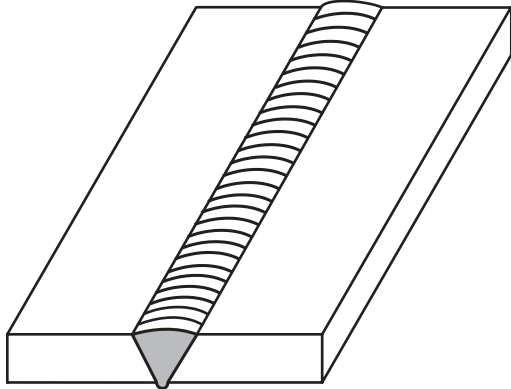

Error type no. 504

Excessive root penetration can be caused by:

- Too high welding current
- Too large “root nose” (insufficient blunting of the bottom of the V-prep by grinding)
- Wrong feeding of filler wire
- Too hot welding of middle and closing runs

Incompletely Filled Preparation

Incomplete filling of the preparation is a channel in the weld metal due to insufficient deposition of weld metal.

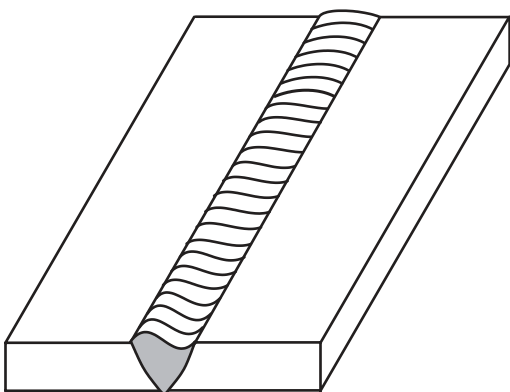

Error type no. 511

Incompletely filled weld preparation can be caused by:

- Insufficient feeding of filler wire
- Wrong feeding of filler wire
- Too hot welding

Root Concavity

A shallow groove due to shrinkage of a butt weld at the root when the weld metal solidifies.

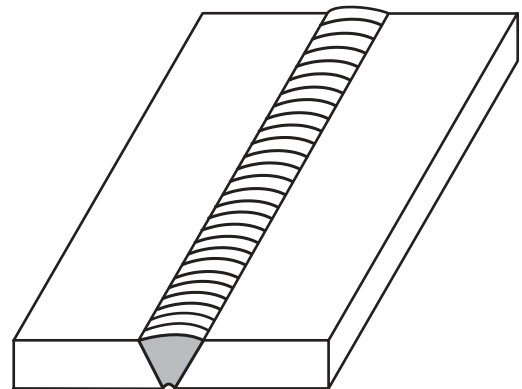

Error type no. 515

Root concavities can be caused by:

- Insufficient feeding of filler wire
- Excessive heating when welding middle and closing runs

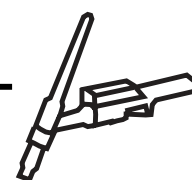

Metallurgy - Stainless Steels

Generally

Stainless steels include all the types of steel which are made corrosion-resistant by alloying the steel with different alloying elements.

However, corrosion-resistant steels can “corrode” under the influence of different substances.

The term “stainless steel” may therefore seem a misnomer, which is why the term “stainless steel” will be used as the term for the whole group of steels in which chromium is alloyed for its corrosion-resistant properties.

In the following section the chemical names of a number of alloying elements are used. Below is a list of their chemical designation and names:

Cr	Chromium
C	Carbon
Ti	Titanium
Nb	Niobium
N	Nitrogen
Mo	Molybdenum
Ta	Tantalum

Types of Stainless Steels

Stainless steels are alloys of iron, chromium, nickel, manganese, molybdenum, titanium, niobium, carbon and others just to mention the most important ones.

Stainless steels can be divided into three main groups and in addition a smaller group as shown in the below table.

The division is based on the crystal structure.

As you can see there are in principle two groups:

- Chromium-alloyed types
- Chromium-nickel-alloyed types

Of the chromium-nickel-alloyed types the martensitic ones are hardenable due to the relatively high carbon content. The other types cannot be hardened by heat-treatment.

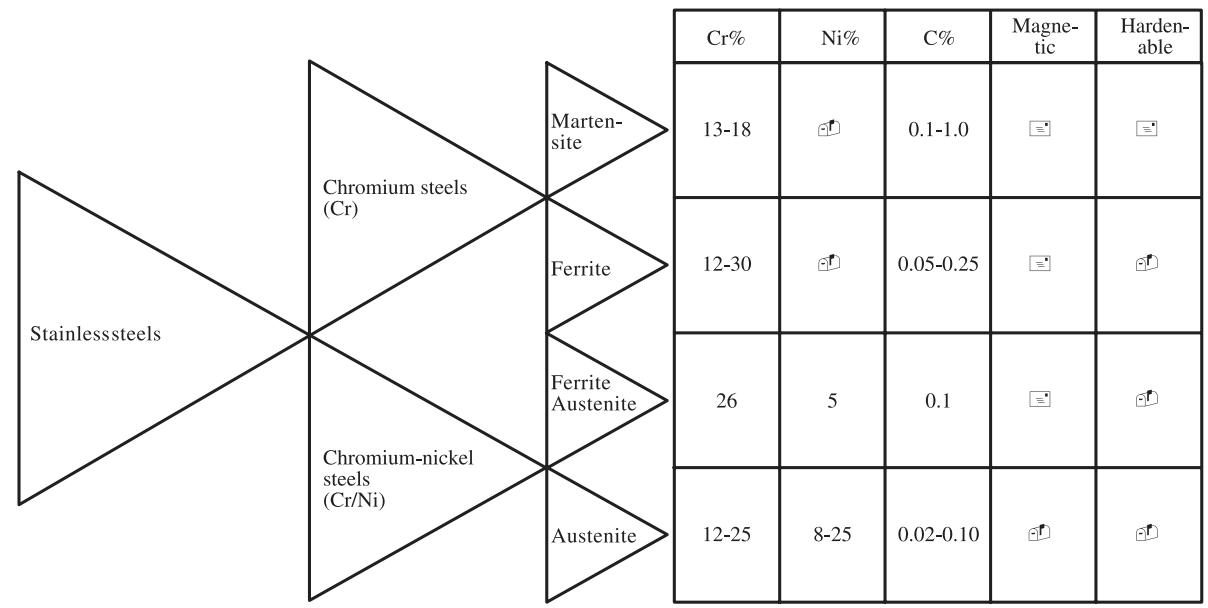

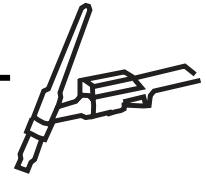

Chromium-alloyed Steels

Martensitic Stainless Steels

This group of steels has a carbon content from 0.1 to 1.0%. The Cr content varies from 13 to 18%.

These steels are maraging and air-hardenable. This means that the steels cannot be welded without pre-heating and the following tempering. These steels therefore belong to the machine steels.

These steels are spheroidizable and in that condition workable by cutting. They obtain a considerable strength in heat-treated condition and also an improved corrosion-resistance.

These steels are used for machine parts that are exposed to corrosion, e.g.:

- Valve shafts
- Pump shafts
- Knives, etc.

Machine steels are steel types that are used for machine components such as:

- Axles
- Gear wheels
- Valves, etc.

Normally the requirement for the weldability of these steels is not very great as they are often joined together in other ways.

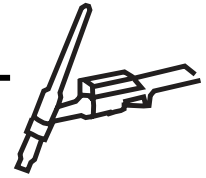

Spheroidizing (softening)

Steels with a large content of cementite or alloyed steels with a large content of carbide are only difficultly weldable by cold deformation and cutting which is caused by the great hardness and plate-shaped formations of the carbides. When forging or welding, during which the steel is heated to more than A3-Acm temperature, this structure is changed into a structure with plate-shaped perlite and grain boundary carbides which cannot be cut by cutting tools without great wear on the tools.

The steel is spheroidized at a temperature below the A1 temperature. The spheroidization means that the carbide plates transform into ball-like formations.

Usually, this heat-treatment is carried out at the steel mill.

When machining the spheroidized material the hard balls are pressed into the softer ferrite base material.

The hardness has decreased and the ductility has increased.

Ferritic Cr-alloyed stainless steels

These steels are ferritic at all temperatures if the percentage of C and the percentage of Cr are balanced to each other. The content of Cr may vary from 12 to 30%.

If the percentage of Cr is 27% a content of C until 0.25% is allowed. If the content of Cr is 13% the C percentage must not exceed 0.05%, see the drawing on the next page.

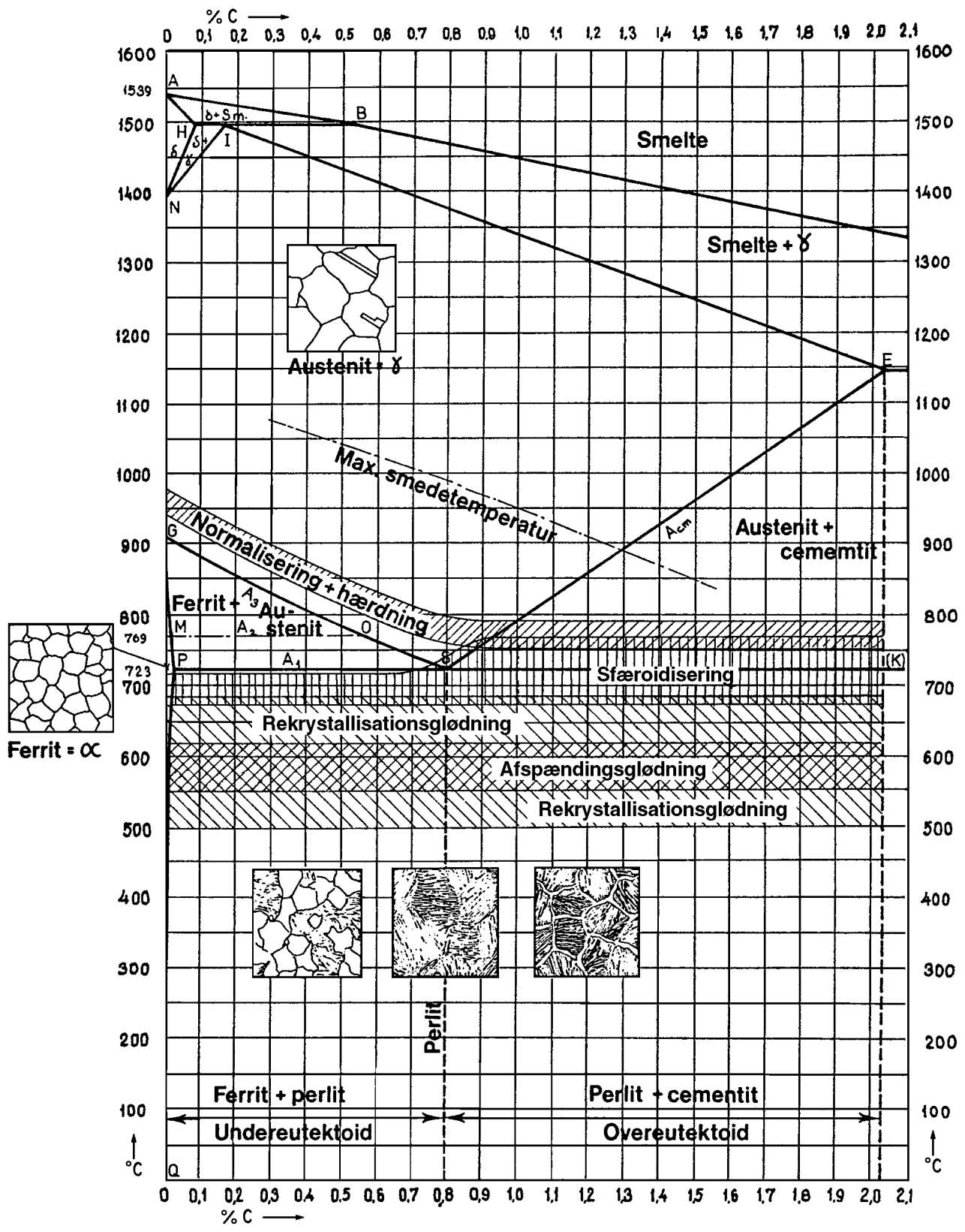
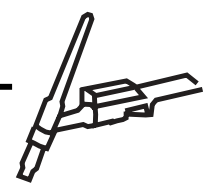

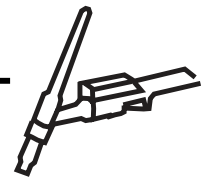

The ferritic steels are harder to weld than the austenitic steels as there is a risk of cracks in the heat-affected zone (HAZ) due to the grain formation.

The formation of coarse grains cannot be prevented by heat-treatment because the steel is also ferritic at high temperatures.

Small amounts of vanadium (V) and molybdenum (Mo) can counteract the formation of coarse grains.

These steels cannot be martensitically hardened, but increase their strength by cold-deformation.

The steels are suitable for deformation shaping and are used for home appliances among other things.

Intergranular corrosion may appear in these steels as a consequence of chromium-carbide precipitation.

The precipitation of carbide will happen at a temperature of 900 to 1000°C.

The error cannot be rectified by means of a heat-treatment of these steels because a solution heat-treatment will cause a great growth of grains, and in spite of a quick chilling new carbide precipitation will take place due to the fine conditions for diffusion in the cubic centered space lattice.

If the heat-treatment takes place at 700 to 800°C there will, however, be a balancing of the concentration of the remaining amount of chromium in the crystals.

Stabilising the steels with Ti and Nb can reduce the inclination of the ferritic steels to intergranular corrosion.

Another way to avoid intergranular corrosion is to use ELI-steel which is steels with a very low content of carbon 0.003% (C) and nitrogen (N), but the content of chromium then has to be very high as both C and N have an austenitic effect, see the Schaeffler diagram.

A long time heating from 550 to 800°C of ferritic chromium steels of more than 20% Cr will cause

brittleness due to the formation of the so-called sigma-phase.

In this phase the material is brittle why its ductility is significantly reduced while the tensile strength is increased. The phase is resolvable by heating to more than 800°C after which a quick chilling will prevent this phase from reappearing.

Chromium-Nickel Alloyed Stainless Steels

Ferrite-austenitic Stainless Steels

These steels are alloyed with 18 to 26% chromium, 5 to 6% nickel and 0.03 to 0.15% carbon. The steels are more easily weldable than the purely ferritic ones and their corrosion resistance is more or less like that of the 18/8 steel.

These steels have a significantly better impact strength than the ferritic steels, but they can be cold brittle. In some types there can be a formation of martensite during welding.

Due to the fine casting properties of these steels, they are often used for stainless foundry goods such as valves and similar products.

Austenitic Stainless Steels

One of the first produced stainless steel had the following analysis:

C	0.12%
Cr	18%
Ni	8%

This steel was called an 18/8 steel and it is from this type that later on there has been developed a number of other types of stainless steels.

By adding up to 5% Mo together with a larger content of nickel an improvement of the corrosion-resistant properties was achieved.

This steel is monophasic steel, which means that it is austenitic at all temperatures except that delta-ferrite can form in certain steels at high temperatures.

The percentage of carbon must be low in the austenitic steels as chromium is a very strong producer of carbide, and as chromium-carbide formation is an undesirable element in most stainless steels.

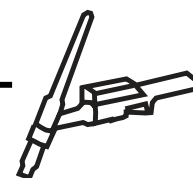

It is very difficult and expensive to diminish the content of carbon to such low a level and therefore the steel is often alloyed with Ti and Nb which are strong generators of carbide, in order to avoid the formation of chromium carbides. stålet med Ti og Nb, som er stærke karbiddannere, så dannelsen af kromkarbider undgås.

The austenitic steel can be divided into four groups according to the alloying composition particularly with regard to the percentage of carbon:

- Steels with a content of approx. 0.10% of carbon
- Steels with a content of approx. 0.06% of carbon
- ELC steels with an extra low percentage of carbon, approx. 0.03%
- Stabilising steel alloyed with Ti or Ni, carbon content is approx. 0.06%

Carbon will combine with titanium or niobium and thus prevent the generation of chromium-carbide.

Alloying of Mo will improve the corrosion-resistant properties against chlorides and diluted acids.

In order to preserve the austenitic structure the content of Ni must be increased when the content of Mo is increased.

Analysis - weight %

Cr	Ni	Mo	Cu
18	8		
18	10	1,5	
18	12	2,7	
18	14	3,4	
20	25	4,5	1,5

Examples of content of Cr-Ni-Mo in austenitic steels

The Weldability of Austenitic Steels

Austenitic steels are easily weldable without generating martensite in the heat-affected zone (HAZ).

However, it has to be taken into consideration that austenitic steels have a low thermal conductivity, approx. 40% lower than that of ordinary steel.

The thermal expansion coefficient is approx. 50% larger than that of ordinary steel.

These conditions mean a larger tendency to tensions and distortions. If the percentage of carbon is sufficiently high there can be a precipitation of chromium carbides in the HAZ, where the temperature rises to the range of 450 to 800oC.

The precipitation mainly takes place in the grain boundaries of the austenite and it means that areas of gamma crystals near to the chromium carbides become “de-chromed” and thereby loose their corrosion resistance (See the section: Types of Corrosion).

The content of carbon should be sufficiently large to generate the chromium carbides. This is the case in the before-mentioned groups 1 and 2, and therefore these types of steels must undergo a heat-treatment after the welding process in order to place the chromium content in the austenite grains again.

This heat-treatment can be carried out at a temperature of 1,000 to 1,100oC at which the chromium carbides dissolves, and the chromium content is evenly re-distributed in the gamma crystals.

The chilling to below 400oC should take place very quickly to avoid the reformation of carbides. Even at such high heat-treatment temperature the austenitic steel is not very inclined to grow grains.

When working with construction so large that such heat-treatment is not possible, it is necessary to choose a ELC steel group 3 which has a very low content of carbon and therefore does not generate carbides.

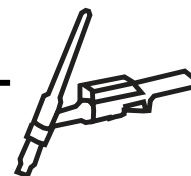

The Weldability of Stabilised Steel

The stabilised steels (group 4 acc. to page 45) can also be welded without heat-treatment afterwards.

The steel can be alloyed with Ti, Ni, Cr or Ta which has a greater affinity to carbon than chromium. These elements consume the carbon and make the generation of chromium carbide impossible.

Due to the difficulties of the above-mentioned heat-treatment, weldable stainless steels which do not require heat-treatment after welding (group 4 steels with a carbon content less than 0.1%).

These steels are also suitable for applications at higher temperatures.

When alloying with stabilisers such as Ta, Ti or Nb, stable carbides are generated preventing the generation of the undesirable chromium carbides.

The amount of stabilisers depends on the C-content.

The Ti-content should be 10 times the C-content, and the Ta-content, which normally replaces a part of the Nb-content, should be 20 times the amount of C.

Ti is not used in the filler material as it easily oxidises and generates TiO. The filler material is normally stabilised with Nb.

Ti holds important economic advantages, but is none the less regarded less active than Nb. Ti has the disadvantage that it is difficult to obtain a completely smooth surface by polishing.

The normal manufacturing of plates and profiles causes the carbon to link as titanium carbide, so that the steels are usually resistant against intergranular corrosion.

The stabilised steels are advantageous to constructions under high pressure and high temperatures as their creep strength and tensile strength at high temperatures are better than those of non-stabilised steels. They are also more stable to intergranular corrosion at temperatures above 400°C.

When stabilised steels are annealed for several hours and slowly cooled they will not generate chromium carbides.

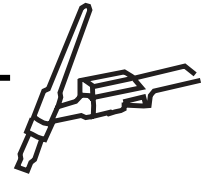

Handling of Stainless Materials

Corrosion Resistance

The corrosion resistance is due to the formation of a thin layer of metallic oxide on the surface and is conditional on the preservation of this layer. In this way the corrosion resistance will be integrated into the material together with the other material properties, and therefore the corrosion resistance also depends on how the materials are treated.

The optimum corrosion resistance of stainless materials is achieved when the surface is metallically clean, which means that it is free from tarnish, scales and similar polluting elements.

After-treatment of stainless materials is very costly why it is important to protect the material and handle it with great care as scratches and marks significantly increases the costs of the after-treatment.

In order to protect stainless materials in the best way, the first thing to do when a new job is started should be to paste a piece of paper or plastic foil onto the workpiece.

Furthermore, stainless materials should be kept separated from other steel materials. Steel shelves can be clad with wood or plastic in order to avoid direct contact between the stainless materials and the steel.

Tools used for treatment of stainless steel should be polished and clean, e.g.:

- Anvils
- Straightening plates
- Straightedges
- Hammers

It should also be avoided to work on both stainless steel and ordinary steels at the same time or in the same area in order to prevent a pollution of the stainless material by steel particles or dust from the ordinary steel.

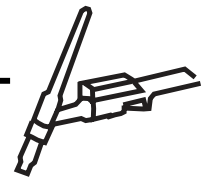

Cleaning

Even the smallest impurities cause the formation of porosities.

Stainless steel is sensitive to undercuts especially if it is exposed to a dynamic load. It is therefore extremely important when welding stainless steel that all welding surfaces are completely clean. All dirt and dust must be removed and if there is rolling lubricant or grease left on the material, it should be removed by a solvent. Grease becomes liquid under the influence of the welding heat and has a tendency to creep towards the welding groove. It is therefore important to degrease a rather large area on both sides of the welding zone.

Also the welding equipment such as cables, welding helmet, gloves, torch, rectifier, etc. should be clean in order not to contaminate the welding zone during welding.

With large plate construction the welder has to walk on the plates and also draw his welding cables on the plates. Therefore it is important to keep the floor clean, so that the welder will not import the dirt from the floor onto the plates.

A painted floor is easier to keep clean than a rough floor.

Before welding begins the welding zone and the over and underside of the workpiece should be brushed with a stainless steel wire brush. This is done in order to remove the oxide layer, which always exists on the surface of the material.

When TIG welding it is important to take care that the filler material is clean before welding is started. If necessary the filler material should be cleaned by a cloth with solvent, polished by steel wool, or dipped into caustic soda and rinsed in water. The filler material must be completely dry before welding starts.

Welding Table and Fixtures

In order to avoid deformations and to ensure that the finished product has the correct shape after being welded, it is important to clamp the individual parts to the welding table and maybe tack weld them.

For serial productions you often use clamping tools with easily adjustable clamps. The advantages of using fixtures cannot be emphasised enough.

First and foremost the welds will have a better quality and the welding costs reduced. Especially in serial production it pays to invest both money and thoughts on the fixtures. Furthermore, fixtures ensure a uniform product when producing several pieces of the same product.

The additional cooling effect provided by the fixtures will often be an advantage when welding stainless steels.

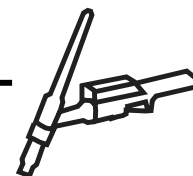

The Influence of the Alloying Elements

Introduction

Stainless steel achieves its properties by the alloying of different elements to the steel.

Most alloys contain 70 to 75% or more iron why the metallurgic properties of the iron must be very important.

Alloying Element	%	Influence
Chromium	13-25-30	Makes the steel corrosion resistant. At least 13% Cr.
Nickel	0-25	Provides higher ductility and heat-resistance to the steel.
Carbon	0.02-1	Undesirable for welding.
Molybdenum	1-4.5	Provides acid-resistance.
Titanium	0.5	Stabiliser. Improves welding properties.
Niobium	0.5	Stabiliser. Reduces durability.
Ferrit	The remaining percentage	Base material to which the elements are alloyed.

Table of important alloying elements and their influence

Chromium (Cr)

Cr increases the tensile strength by some 80 N/mm² per percentage of chromium. Due to its inclination to generate carbides, Cr increases the hardness. Steels with more 12% Cr are corrosion resistant to water and certain acids. Cr increases the heat-resistance in particular together with Ni.

When oxidised Cr forms a tight oxide layer that is relatively corrosion resistant and may cause the steels to become ferritic at all temperatures.

Nickel (Ni)

Ni is both ductile and strong, but as it is rather expensive it is only used to a limited degree. Ni increases the tensile strength by some 40 N/mm² per percentage. Ni reduces the critical cooling speed. When alloyed by more than 25% of Ni, austenitic steels that are non-magnetic and corrosion resistant are produced.

If the steel is also alloyed with Cr the desired austenitic state is obtained with a content of 8% Ni and 18% Cr (18/8 chromium-nickel steel).

Molybdenum (Mo)

Mo increases the strength, ductility and heat-resistant properties of the steel. Mo is strongly carbide generating and is used in high-speed steels (HS steels) and heat-treatment steels as it increases the tempering resistance.

Mo in stainless steels provides an increased corrosion resistance against:

- Sulphuric acid
- Phosphoric acid
- Formic acid
- Various hot organic acids

Mo also protects against pitting corrosion in particular for chlorous solutions.

Pitting is further described in the section "Types of Corrosion".

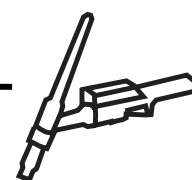

Titanium (Ti)

The advantages of using pure Ti lies in its fine corrosion resistance which is more or less the same as that of stainless steel, and the good strength in relation to its weight.

However, these fine properties disappear at high temperatures, at which Ti reacts strongly and generates chemical combinations with all gases except the inert gases. For instance, will Ti “burn” in pure nitrogen at 800oC to titanium nitride under fierce heat-generation.

Ti is much used as an efficient deoxydation and denitrating agent for instance in certain stainless steels with which it mainly combines carbon to titanium carbide, but also combines with the harmful nitrogen to titanium nitride.

Niobium (Nb)

Nb is a strong carbide generator, and in austenitic Chromium-nickel steels it prevents undesirable precipitation of carbide of other elements.

Chromium-nickel Alloys

In the two-phase system iron-chromium the gamma area is ligated, and from approx. 12.5% of chromium there will be only ferrite from the fusion temperature to room temperature (cubical space-centred grid structure).

When the content of nickel is increased the gamma area in to two-phase system iron-nickel is extended. From a given nickel content the structure will become purely austenitic (cubically surface centred).

The elements that will be used for alloying stainless steels in order to achieve certain specific properties can be divided into two main groups:

- Ferrite generating elements - Cr, Si, Al, Mo, Nb, Ti, W and V
- Austenite generating elements - Ni, Mn, C, Co and N

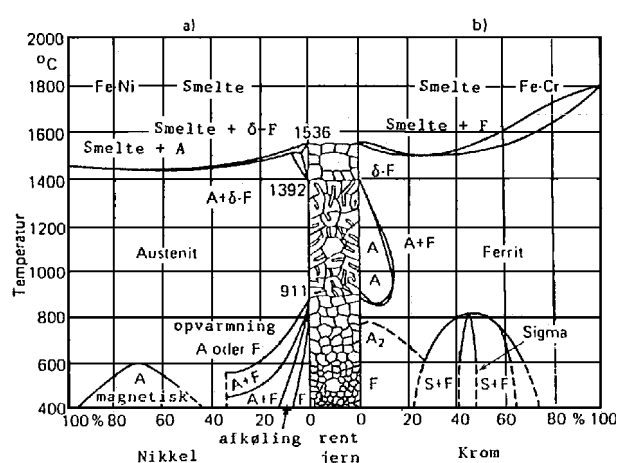

Two-phase system, iron-nickel, iron-chromium

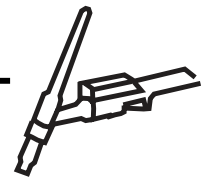

Stainless Steel - Welding - Heat-Affected Zone

Generally

The tempering which is a consequence of the welding process or other heat-treatment of stainless steel, is a damage of the passive material surface that significantly reduces the corrosion resistance. This tempering is made of very chromium-rich high-temperature oxides that form a very brittle and leaking layer. The underlying material will thus be very poor in chromium and the corrosion resistance will be reduced.

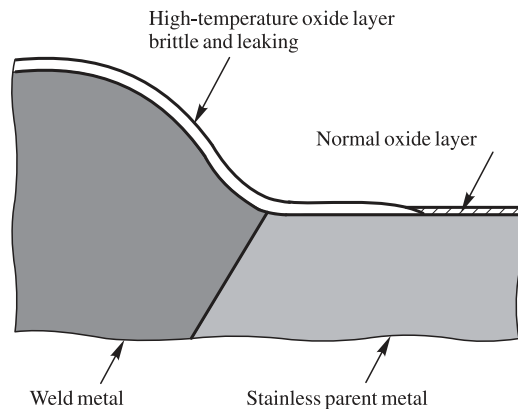

Rustfast materiale med kromoxidhinde

The chromium-oxides must be removed or measures should be taken to prevent their formation. When welding with shielding gas the oxide formation can be significantly reduced by means of a gas diffuser or shoe that follows immediately after the torch. The diffuser/shoe will protect the heated weld seam at the same time as the flowing argon or nitrogen mixture cools the weld seam. It goes without saying that the back of the weld is shielded.

It is mainly argon that is used as shielding gas with manual TIG welding. The gas is connected to the TIG torch and will protect the tungsten electrode and flow over the weld pool shielding it from the oxygen in the air.

Argon, sometimes mixed with a small percentage of hydrogen, is often used to protect the back of the weld. A protection with former gas is cheaper and in many cases a better choice. In order to avoid the harmful tempering of the steel it is necessary to maintain the flow of gas until the temperature is lower than 200°C.

Suitable back gas tools can contribute to a reduced consumption of gas and an improved gas quality.

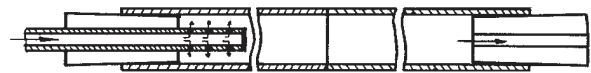

Flow of shielding gas in a piece of pipe

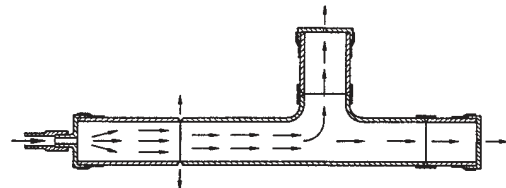

Flow of shielding gas in a pipe section

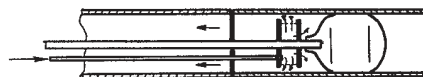

Blockade and supply of shielding gas

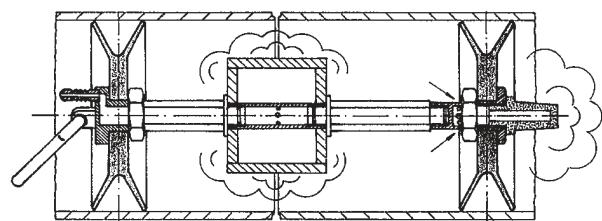

Construction of the back gas tool

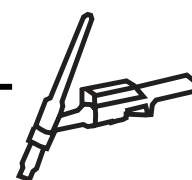

Guidelines for Welding of Stainless Steels

As there do not at present exist any normative guidelines for welding of stainless materials, the following points may serve as indicative guidelines:

Welding Quality

- The welding quality must meet the standard demands to e.g. complete penetration.
- The welding must be performed with skill and with an even and consistent weld seam.
- The transition area between the weld and the parent metal should be even and the surface should be smooth.
- The weld must appear without visible welding errors and discoloration due to a lack of shielding gas.

Precautions

- The filler material should be chosen so that metallurgic and corrosion-connected complications are avoided.
- The welding method and the welding equipment must be suitable, so that the welding zone will be homogenous and free of heat cracks and welding errors.
- The back of the weld should be protected with a suitable back gas or a suitable backing material, unless the undercut is ground off.

Cleaning

- The surface must be metallically clean and free of discoloration, welding and grinding spatter and glue residue.
- Marks caused by handling or treatment by e.g. the bending press, and contamination from e.g. copper backing or clamps must be removed.
- A suitable cleaning or passivating agent should clean the entire workpiece including the undercut.

The Heat-Affected Zone (HAZ)

The HAZ areas around the weld seam that do not melt are exposed to a fierce heating and this causes the micro-structure of the steel to change. The extent of these changes depends on the composition of the material and the speed by which the HAZ is heated. The cooling speed is also important and it depends on the thickness of the material, the dimensions of the workpiece, the heat input produced by the welding process and the cooling method.

1	Weld metal
2	Incomplete
3	Overheated
4	Normalised
5	Incomplete transformation
6	Parent material

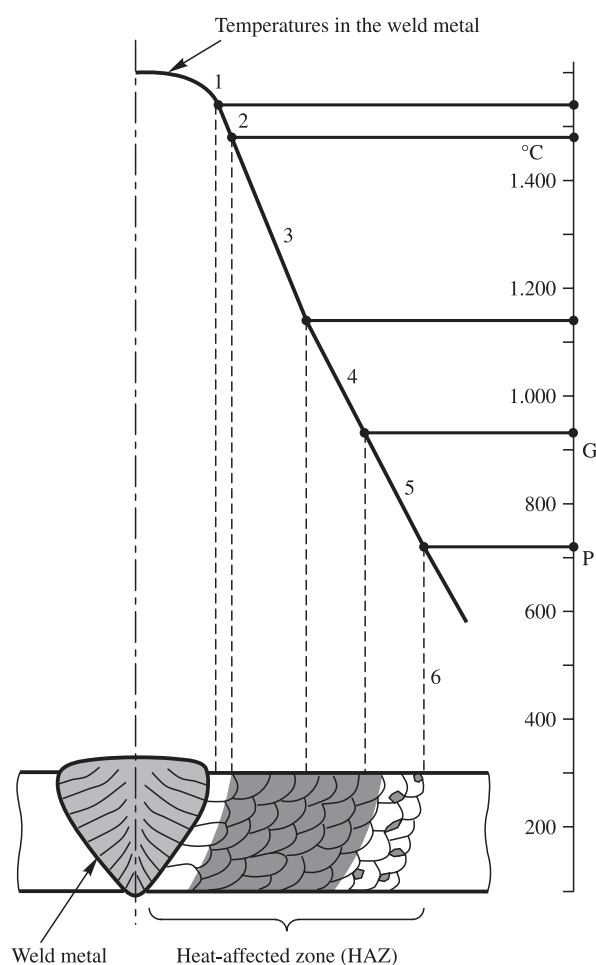

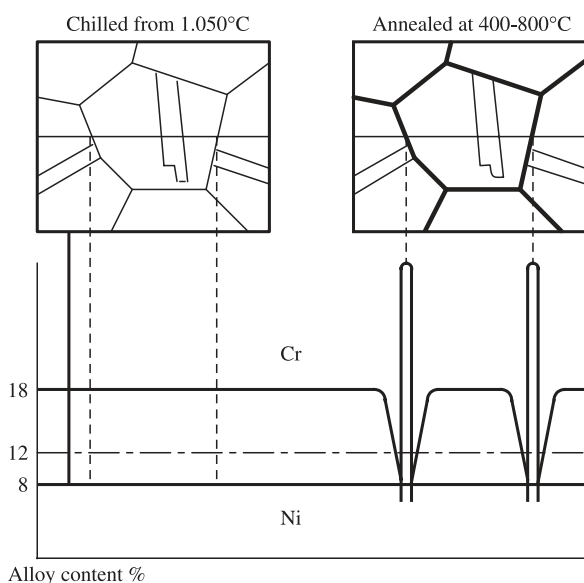
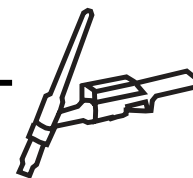

A reduction of chromium due to carbide generation in the grain boundaries in austenitic Cr/Ni steel (table)

Welding of Martensitic Stainless Steels

Of the stainless steels the martensitic steels are the lowest alloyed steels. Typical analysis is indicated in the table on page 54, which is primarily based on Swedish steel qualities. As this survey is not complete it is important to read the information from the steel manufacturers and other steel norms.

The martensitic stainless steels are generally less suitable for welding. When cooled from a temperature at more than 800°C it hardens by aircooling. The same conditions for cooling count for the HAZ of welding, and thus martensite is generated. The accompanying volume changes result in very strong strain. In combination with the thermal strain this means that cracks easily appear in the martensitic areas. The higher the content of carbon is the more important is this problem. Welding in steels with a carbon content of more than 0.10 to 0.15% should be avoided.

Furthermore, the austenite transformation will not be complete when the carbon content is higher, and slow transformation residual austenite may appear.

A preheating temperature at minimum 200°C is used for welding. It primarily serves to reduce the

thermal strain. If an improvement of the ductility and a reduction of the hardness after welding are desirable, the steel must undergo heat-treatment.

Welding of Ferritic Stainless Steels

The ferritic steels do not harden when welded and they are therefore easier to weld. The heating to degrees of 900 to 1000°C, which will take place in the HAZs during welding, will result in a brittleness of these zones due to the grain formation.

This grain formation may be accompanied by brittle precipitations in the grain boundaries, which in some cases may cause intergranular corrosion.

The above risk can be eliminated by heat-treatment, and at the same time the brittleness will disappear that comes from the precipitations of grain boundaries. The brittleness that alone comes from the grain formation cannot be eliminated by heat-treatment. Cold working followed by a heat-treatment, a method that is hardly applicable in practice, can only eliminate it.

Welding of Ferrite-austenitic Stainless Steels

These types of steel are more suitable for welding than the two above-mentioned. The inclination to precipitation's and grain formation in the HAZs does exist, but is less significant cf. the ferritic steels.

Welding of Austenitic Stainless Steels

This type of steel does not cause any welding problems, if the ordinary procedures are observed and the welder is adequately skilled.

As the steel is austenitic in the whole temperature range and does not harden during cooling, a cooling after welding will reduce the formation of grain boundary carbides, intergranular corrosion, as can be seen from the illustration (ma104-02).



	Retningsanalyse %										Standards							Værdi stål. Værdi Værdi
	C	Cr	Ni	Mo	Øvrige	SIS stål	BS En	Werkstoffnr.	AISI	Uddeholir NU Stainle	Avesta	Bofors	Fagersta	Nyby	Sandviken	STORA	Wikmans Hyttan	
Martensitisk stål hærbare ved varmebehandling	0,10	13,2	-	-	-	2302	410S21	1.4006	410	1	393 M	-	R 110	1410	(2C27)	502	WH 601	1301
	≤0,08	13,2	-	-	-	2301	403S17	1.4000	410S	1M	393 M	-	R 100	1C27	(545)	502	WH 601	1301
	0,22	13,2	0,5	-	-	2303	(420S37)	1.4021	420	31	739	2 R 47	R 700	4C27	511	WH 605	-	
	0,13	13,2	-	-	S	2380	416S21	(1.4005)	416	41	-	-	-	-	(516)	511	(WH 618)	1302
	0,10	13,2	-	1,0	-	-	-	(1.4119)	-	51	393 S	-	R 140	1410 Mo	-	(509)	WH 626	1301/Mo
	0,20	16,9	1,6	-	-	2321	(431S29)	1.4057	(431)	22	-	RE 39	R 220	4N2C 34	525	WH 607	-	
	0,32	13,6	-	-	-	2304	420S45	1.4028	420	6	-	2 R 77	R 710	6C27	512	(WH 614)	-	
	0,35	13,6	-	1,0	-	-	-	-	716	7	-	(2 RO 189)	R 740	7C27 Mo 2	(517)	WH 617	-	
	0,95	13,5	-	-	-	-	-	-	AEB	-	-	-	R 770	18C29	-	-	-	
	0,13	5,3	-	0,6	-	-	-	1.4362	501	UDDCO 5	-	-	-	HT 3	-	-	-	
0,09	9,0	-	1,0	-	2203	-	-	UDDCO 9	-	-	-	-	HT 9	-	-	-	-	
0,19	11,7	0,6	1,0	W:0,3 V:0,3	-	-	1.4395	-	UDDCO 12	-	-	-	0908 Mo	-	-	-	-	
Ferritisk stål ikke hærbare	≤0,06	13,2	-	-	-	-	405S17	1.4002	405	21	-	-	-	1408	-	545	-	-
	0,08	17,1	-	-	-	2320	405S15	1.4016	430	2	249 MV	R 200	-	1708	2C34	522	WH 620	-
	0,13	17,0	-	0,3	S	2383	-	1.4104	(430F)	72	-	-	-	2C34A	527	WH 623	-	
	≤0,08	17,5	-	1,7	-	2325	(432S19)	(1.4113)	(434)	82	-	2 RL 3	-	1708 Mo	(1C345)	523	-	-
	0,20	25,2	-	-	-	2322	-	(1.4772)	446	5	831	S 1 R	-	2520	4C54	532	WH 627	-
	0,10	18,0	8,5	-	-	2331	302S25	1.4300	302	3	832	R 29	R 300	12-12 EL	12R10, 12R11	555	WH 662	-
	0,07	18,0	8,5	-	-	(2332)	(302S25)	(1.4301)	(304)	3M	832M, MP	RIM 29	R 320	18-8	-	554	WH 642	18/8
	≤0,05	18,0	9,0	-	-	2333	304S15	1.4301	304	3MM	832 MV	RIM 291	R 350	18-8 L	-	553	WH 639	-
	≤0,03	18,0	10,0	-	N	2371	-	1.4311	-	3LN	832 MVFN	RIM 290	R 367	18-8 EL	5R10	582	-	-
	0,03	18,0	10,0	-	-	2352	304S12	(1.4306)	304L	3L	832 MVR	RIM 290	R 360	18-8 ULN	3R19	552	WH 637	-
0,09	17,6	10,5	-	-	3055S19	-	-	305	703	832 EMV	RIM 290	R 310	18-8 UL	3R12	-	-	-	
≤0,06	12,4	12,4	-	-	-	-	1.4307	-	33MM	832 P	-	R 590	12-12 EL	-	559	WH 653	-	
0,09	17,0	7,5	-	-	-	301S21	1.4310	301	673	-	-	-	-	-	-	-	-	
0,08	17,6	9,5	0,5	S	2346	303S21	1.4305	303	43	832 C	RLH 2	R 380	18-8 A	10RA 50	556	WH 641	-	
≤0,06	18,0	10,0	-	-	2337	321S12	1.4541	321	53	832 MVT	RIM 294	R 359	18-8 LT	8R30	558	WH 643	18/11	
≤0,08	18,0	10,0	-	Ti	2337	321S12	1.4541	312	753	832 MVT	RIM 294	R 350	18-8 LT	8R30	558	WH 643	-	
≤0,06	18,0	10,0	-	Nb	2338	347S17	1.4550	347	63	832 MVN	RIM 295	R 353	18-8 LNb	8R90	558 Nb	WH 640	-	
0,06	17,5	9,5	1,6	-	2340	-	(1.4420)	-	4	832 S	R 400	R 400	18-8 LMo	10R 52	563	WH 648	-	
≤0,05	17,5	10,5	1,6	-	-	315S16	(1.4420)	-	4MM	832 SV	R 400	R 450	18-8 EMO	6R 55	562	WH 646	-	
≤0,05	17,2	11,5	2,3	-	2347	316S16	1.4401	316	14	832 SF	(RIM 1215)	R 420	18-10 EMO	(6R 66)	562 N	-	-	
≤0,03	17,2	11,5	2,3	-	2348	(316S12)	1.4404	316L	14L	832 SFR	(RIM 1215)	R 420	18-10 UMO	-	-	-	-	
≤0,06	17,0	12,0	2,3	Ti	2350	(320S17)	1.4571	316Ti	54	832 SFT	RIM 213	(R 429)	18-10 LMoT	(8R70)	563 N	-	-	
≤0,05	17,5	12,0	2,8	-	2343	316S16	1.4436	316	24	832 SK	RIM 215	R 440	18-12 EMO	5R 60	564	WH 650	18/10/2,5	
≤0,03	17,5	13,0	2,8	-	2353	316S12	1.4435	316L	24L	832 SKR	RIM 217	R 460	18-12 UMO	3R 60	561	WH 656	-	
≤0,03	17,5	13,0	2,8	N	2375	-	1.4429	-	24LN	832 SKRN	RIM 217	R 460	18-12 UMoN	3R 69	586	-	-	
≤0,06	17,5	13,0	2,8	Ti	-	320S17	-	1.4573	524	832 SKRN	(RIM 213)	R 449	18-12 LMoT	(8R70)	568	WH 649	-	
≤0,06	17,5	13,0	2,8	Nb	(2367)	(317S12)	1.4438	(318)	624	832 SKNb	(RIM 213)	R 449	18-12 LMoNb	8R 80	-	WH 651	18/15/4,5	
≤0,03	17,5	13,5	3,4	-	-	-	1.4583	(317L)	734L	832 SKNb	-	-	18-14 UMO	3R 64	-	-	-	
≤0,05	17,4	13,9	4,3	-	-	-	1.4449	-	34	832 SNR	-	-	18-14 UMO	3R 64	-	-	-	
≤0,03	17,4	14,5	4,3	-	-	-	(1.4449)	-	34L	832 SL	-	-	18-15 EMO	3R 65	-	-	-	
≤0,06	18,0	18,0	2,2	Cu, Nb	-	-	(1.4505)	-	64	832 SLR	-	-	18-15 UMO	3R 65	-	-	-	
≤0,07	18,5	20,5	-	-	-	310S24	1.4845	(311)	15	254	-	-	18-20 LMoCuNb	-	-	-	-	
≤0,07	23,5	21,5	-	-	2361	310S24	1.4845	310S	25	254 EM	-	-	20-20	7RE 10	576	WH 657	25/23	
0,14	23,0	13,0	-	-	309S24	309S24	(1.4828)	(309)	55	252 M	-	-	25-21 L	-	-	WH 660	-	
≤0,02	20,0	25,0	4,5	Cu, Nb	-	-	1.4311	-	904L 32N	-	254 SSKX	-	23-14 L	2R 65	-	-	-	
Ferrit- austenitisk stål ikke hærbare	0,08	25,0	5,3	1,5	-	2324	-	1.4460	(329)	44	453 S	R 640	27-5 LMo	10RE 21	566	WH 634	2601/5 Mo	
	0,10	25,5	4,8	-	-	-	-	1.4820	(327)	45	453 E	-	27-4 L	10RE 20	-	WH 632	2601/5	
	≤0,03	18,5	4,7	2,7	Si	-	-	-	-	-	-	-	-	3RE 60	-	-	-	

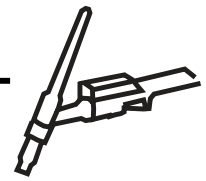

TIG Welding in Stainless Steel

TIG welding is an economically advantageous to welding of thinner stainless steels. It makes clean, smooth welds without porosities and craters possible even without welding from the backside.

Welding is done in DC with negative polarity on the electrode. The electrode is made of tungsten that does not melt. A shielding gas, usually argon, shields the arc, the electrode and the weld pool. The welding torch is cooled either by the surrounding air alone or by a water flow inside the torch. The water and the shielding gas must be kept separated in order to avoid porosities.

There are many types of tungsten electrodes available. Normally you use a tungsten electrode alloyed with thorium as it is less inclined to cause inclusions of tungsten in the weld metal. It is also easier to ignite and offers clean welds. The electrode is ground to a point in order to facilitate the ignition. If it is polluted with weld metal or oxides, it will melt more readily, the welding will be inferior and tungsten will be transferred to the weld pool. This issue is further described in the section "TIG Welding - Tungsten Electrodes".

The most common impurity in the shielding gas is moisture. The dew point should be below -50°C . This is usually observed at the manufacturer, but if the cylinders are returned with open valves, the manufacturer's care is of little use. Furthermore, all hose connections and similar things must be tight and dry. The workpiece should be dry and clean. Finally, the weld and the electrode must be shielded by argon until they have cooled to below 200°C .

By use of HF-ignition a contamination of the weld pool as the arc is ignited without touching the weld pool. Starting points, end craters and undercuts appear as errors. By equipping the welding machine with a foot switch it is possible to control the current during welding, which means that, the undercuts and end craters can be avoided, and the penetration in the beginning of the weld can be increased. The end crater can be avoided by a gradual reduction of the current. When the current is reduced gradually the weld pool will become smaller and thus the deep crater,

which is also called the crater porosity and often ends in a crack, is avoided. The ignition of the arc is further described in the section "TIG Welding - Ignition of the Arc".

TIG welding is mostly used for thin materials. If the weld requires more than three passes, viz. from 6 mm, MMA welding with a coated electrode or MIG welding can be used for filling.

Weld zone and Filler Material

If it is necessary to make an even weld back without the possibility of welding after, e.g. pipe welding, a careful preparation of the weld zone is very important and the back of the weld should be protected against oxidisation. The weld prep gap should be uniform, but with a foot control a skilled welder will be able to compensate for small variations.

The protection of the back of the weld can be done with argon (Ar) or helium (He). However, it is cheaper to use a nitrogen-hydrogen mixture (N) (H) that also provides a back of weld without porosities and oxides. The absorption of nitrogen, even in the root pass, is so small that it lies within the diffusion of the analysis values.

A filler wire is used for filling the weld zone. The weld prep gap is usually a bit smaller than the wire diameter.

Welding can be done without filler material. Then the butt edges must be placed up against each other. In square butts filler material can be left out, as the sinking of the surface is limited. In V preps only the bottom run can fuse together. To fill the V prep you have to use filler material.

However, in full austenitic base material there is an increased risk of cracks as it is not possible to reduce the ferrite content by 5 to 10%. In general the filler material should be chosen in co-operation with the supplier of materials.

Another version of TIG welding is welding with a pulsing arc, which means that the welding current comes in pulses. The peak current pulse makes a penetration of the weld seam, after which the current falls to a lower value and the weld pool almost solidifies. Then another peak current pulse follows.

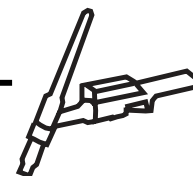

The weld takes the form of an overlapping row of spot welds. The weld pool is only molten for such a short time that it cannot spread into the weld zone. Pulsed TIG welding can be used for automatic welding in all positions without adjusting the current. Pulsed TIG welding is further described in the section “TIG Welding with Pulsing Arc”.

In all welding processes it is important to have an efficient shielding against the atmospheric air. If this shielding is not adequate, important alloying elements may burn off causing an inferior weld metal. Elements that give off carbon must not exist in the weld material or the shielding gas as they can increase the content of carbon in the weld metal. Moisture should be avoided as it causes porosities.

When preparing the weld it is important that grease, discoloration's, dirt and other contamination's are removed as they may cause a carburization of the weld metal.

Sigma-Phase

The sigma-phase is a hard, brittle and non-magnetic combination precipitated under longtime annealing at 600 to 900oC of chromium and chromium-nickel steels with a high content of chromium. It consists of about 52% Cr and 48% Fe but may also contain other elements. The combination is generated at about 800oC at the quickest. At lower temperatures the precipitation speed is usually so low that there is no risk of a sigma-phase.

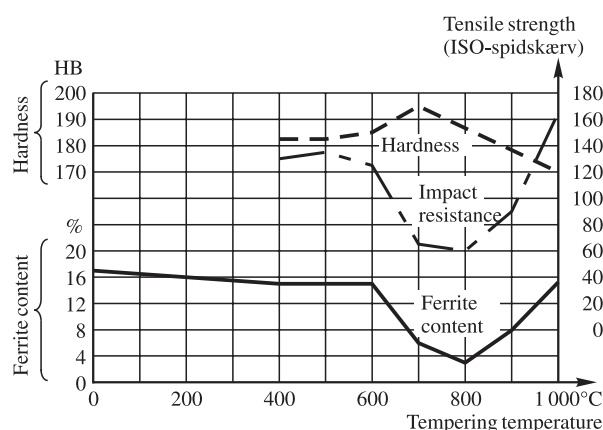

The sigma-phase is normally generated by delta-ferrite completely or partly transformed to sigma-phase and austenite.

Weld metal with a high content of deltaferrite is therefore more sensitive than weld metal with a low content of deltaferrite.

When welding ferritic chromium steels and austenitic chromium-nickel steels with a ferrite content the ductility in the HAZ can be reduced by the welding heat because the sigma-phase is made of ferrite.

Therefore it is important to avoid strain-free annealing at temperatures from 600 to 900oC. It may happen that sigma-phase is made directly from austenite, but it demands a long time of annealing, e.g. in 25% Cr/20% Ni steel.

Weld metals with a higher content of Mo or Nb is very inclined to generate sigma-phase. When the molybdenum content is more than 3% precipitation of sigma-phase has been known to happen immediately after welding multiple-passes. Nb further increased this tendency.

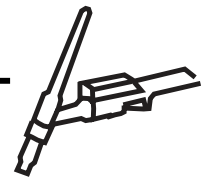

The above illustration shows the influence of the sigma-phase. The original ferrite content of approx. 16%, which is mostly desired to improve the ductility, is reduced to approx. 4% by annealing at 800oC. The impact resistance falls and the hardness increases.

Annealing at 950 to 1050oC can dissolve the sigma-phase, and hardness and impact resistance returns to normal. For workpieces that work at high operation temperatures there is no need to fear the sigma-phase, as the impact resistance at temperatures above 300 to 400oC is sufficiently high, especially if the ferrite content is below 7 to 8%.

Influence on the Corrosion Properties by Welding
Welding can reduce the corrosion properties of stainless steel. It may reduce the durability of the workpiece to such a degree that it becomes useless.

It is therefore important that when elaborating the welding procedures and methods these conditions are taken into consideration.

For stainless steels it is the surface that determines the corrosion resistance. Especially the surface around the welds must be clean, smooth and metallurgically shining, which means free of exterior elements, slag, scales, tempering discoloration and oxides.

These latter dissolve easily in an aggressive agent and form metallic salts which will cause serious corrosion to most steels.

It is therefore recommendable to give the welds an after-treatment for instance with pickle together with a mechanical surface treatment.

The recommendations of the steel manufacturers should be observed in every respect.

When selecting a suitable stainless material and its suitability to be a part of the present product, the procedure of selection should begin with finding the cheapest material that meets the mechanical requirements, and in which standard components it is supplied.

The corrosion resistance of the material in the relevant environment should be evaluated. For

this purpose the suppliers of steels have information available.

If this information is not adequate, it is necessary to find additional information in literature or to carry out a number of tests to provide proofs of the suitability of the selected material.

