











PRACTICAL KARATE, AGAIN

By Josep Claramonte

Yuzenkai China Branch Chief



## Index

Preface

Intro

Chapter 1: Just some exploration	page 14
Chapter 2: Do it with style	page 28
Chapter 3: The paradigm	page 34
Chapter 4: Close contacts	page 43
Chapter 5: Getting physical	page 50
Chapter 6: The weapons you carry	page 99
Chapter 7: Of vital importance	page 153
Chapter 8: May the Force be with you	page 177
Chapter 9: On the dance floor	page 186
Chapter 10: Throw one to me	page 219
Chapter 11: Riding the iron horse	page 226



## Preface

This text is not meant as a ground breaking Karate discovery. It is not meant as a showing off of my Karate skills and knowledge. It is not even a training manual, as I do not know if it would be too advanced for beginners or too basic for experts.

I was asked to write a little article for my next promotion so I started this little project, where I wanted to explain one side of my Karate experience. This soon came out of control and expanded and grew in some different directions, so I had to rethink the project as a whole and give it a purpose. All the information in this book has now one and only one purpose: self-defense. If it helps even just one person when he or she is attacked then my job has been useful.

The result is a snapshot of my Karate journey. A collection of information and practices that I find valuable at this moment, at this time. I tried (maybe I have not succeeded) to create a coherent body of knowledge that has a meaning by itself, each part supporting the others and giving a complete message that is more meaningful than its parts alone.

I did not create any martial knowledge by myself. I just stored what I could from the countless training sessions that I endured along the 30 years that I

have been in this martial journey. This knowledge came from some great instructors and greater training partners.

Just to name a few, Tomás Pastor Sensei (Yosheikan Judo and Aikido), Celedonio García Sensei (Celvic Dojo, Shotokan), Kazunori Omoto Shihan (Kancho of Yuzenkai, Goju Ryu), Kanazawa Nobuaki, Murakami, Tanaka, Suzuki and Ichihara Senseis (SKIF Hombu), Hokama Sensei (Okinawa Goju Ryu), Huang Wei Dong Sensei (Kyokushinkai), Huanghai Shihan (Master of all the Arts), Kirita and Karasira Senseis (Shenyang JKA) and countless others that have shared their time and effort with me.

There are many faces of Martial Arts practice, many theories, many concepts and many techniques. I will not explore the whole, but some parts that (to me) make sense together. We could also talk about energy redirection, breathing, concentration and awareness but I chose a selection of what I am working on right now. If I had written this paper in a different time the point of view could have been different, or maybe an extension volume will come in the future where I will address some different ideas.

Thank you to Maciej Karasiński for posing for the photos in Chapter 6.

Thank you to Chen Sheng Sensei, for the dojo and for posing for the photos in Chapters 9, 10 and 11. Find him in Shanghai Karate Box 110-B, Gate 2, N° 989 Tianshan Road, Changning District.

Please, feel free to drop me an email after reading. Your opinion is much appreciated: [josep\\_cla@hotmail.com](mailto:josep_cla@hotmail.com)





## Intro

Karate is the (un?)armed method of self-defense that bloomed in the Ryukyu Kingdom a few centuries ago. As it seems, the Okinawan islands served as meeting point for different cultures, each of them having their own martial ways.

It was the work of pioneers like Funakoshi, Miyagi, Mabuni, Motobu and others what started the popularization of Karate worldwide, something unthinkable for them at that time.

Some say that the rawness and effectivity of Karate was *lost in translation*. I say lack of understanding (coupled with WWII) undermined the way Karate was taught, practiced and applied outside of Okinawa.

Knowledge is still available to be taken, learnt and used as means of self-preservation.

Some say that the pursue of "Do" instead of "Jutsu" made Karate impractical. I say the "Do" aspects are truly beneficial to any karateka, but to be true to the ancient Karate pioneers we must pursue the "Jutsu" (physical methods of surviving a fight) side of Karate with all our means.

And, like it or not, that means adapting Karate to our times. The Karate we will leave to the next generation must be one that preserves all the knowledge, all the kata, all the training methods, all its history. But we must make sure

that we contribute to the evolution, development and growth of Karate by making sure that we understand how to use Karate principles in our modern times.



## Chapter 1: Just some exploration

Last year I travelled again to Japan. I met great people, I trained hard and learnt some awesome Karate. The most awesome of it was the use of vital points as part of kata bunkai.





Yes, we all know some spots of the human body that can produce a great deal of pain when struck/touched. But that was different: I could see a new way of using those weak spots of the human body in a way that fits the kata movements and applications. Under Omoto Kancho's guidance I could learn a new way of applying Karate to self-defense. I had learnt some of these with my Sensei (Celedonio García) in Spain some years ago but I was not ready yet to understand.

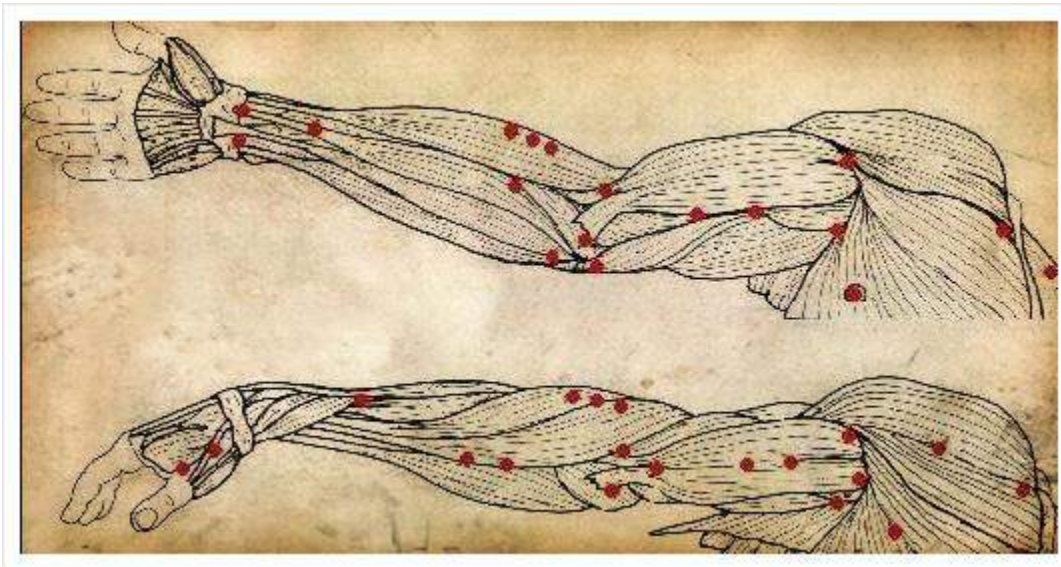

In the same trip I was lucky enough to visit Okinawa for the first time. There, all this knowledge was ratified and further trained.

It was December. Nice autumn weather in Japan, 25° tropical weather in Okinawa, -30° in the cold Northern China.

So I came back to China, where I live, teach and train. I came back excited about what I had learnt, excited about the endless possibilities open in front of me, excited to show everyone the wonders of my new abilities.

To my dismay, nobody cared...

Well, just a few. The rest discarded it as being "awesome, but not Karate". Funny how people with short experience know more than Japanese and Okinawan masters about Karate.

For the few that cared, we had to do our training out in the park, as many other times. So, there we went, with our winter coats, long scarfs, skiing gloves, snow boots, thick trousers and big enthusiasms.



-Let me find this place in your arm... no I can't find it with gloves... but without gloves I can't feel my fingers... but even if I could, I can't feel your arm under 6 layers of clothing... and if I try to use the vital points in your feet, well, if we both use boots then it's not possible... and if I try to attack your neck, my gloves don't allow for enough precision... Ok, let me twist your arm... but you can escape easily using your coat... then your neck, but it's not easy to secure a grip if you use a scarf... what if I punch you?... you are wearing too much clothing to feel my knuckles in your vital point...



How could all that amazing Karate that I learnt and combined with my previous knowledge be so useless? How came that the more I know Karate the more worthless to defend myself is? Why can't I use all this new skill to protect me? Are those who say that Karate is only kicking and punching correct?

Or is it that maybe the highest Karate levels are only meant to be used in the safety of a well-polished wooden floored dojo against your well-mannered and better dressed fellow karateka? If so, what good Karate is for?

Some historical perspective first:

Karate was developed (invented, evolved, combined, used) in the tropical island of Okinawa. Tropical means that the weather is warm and wet the whole year.

This means that the clothing can not be too thick. This means that anatomical structures are readily available for manipulation.

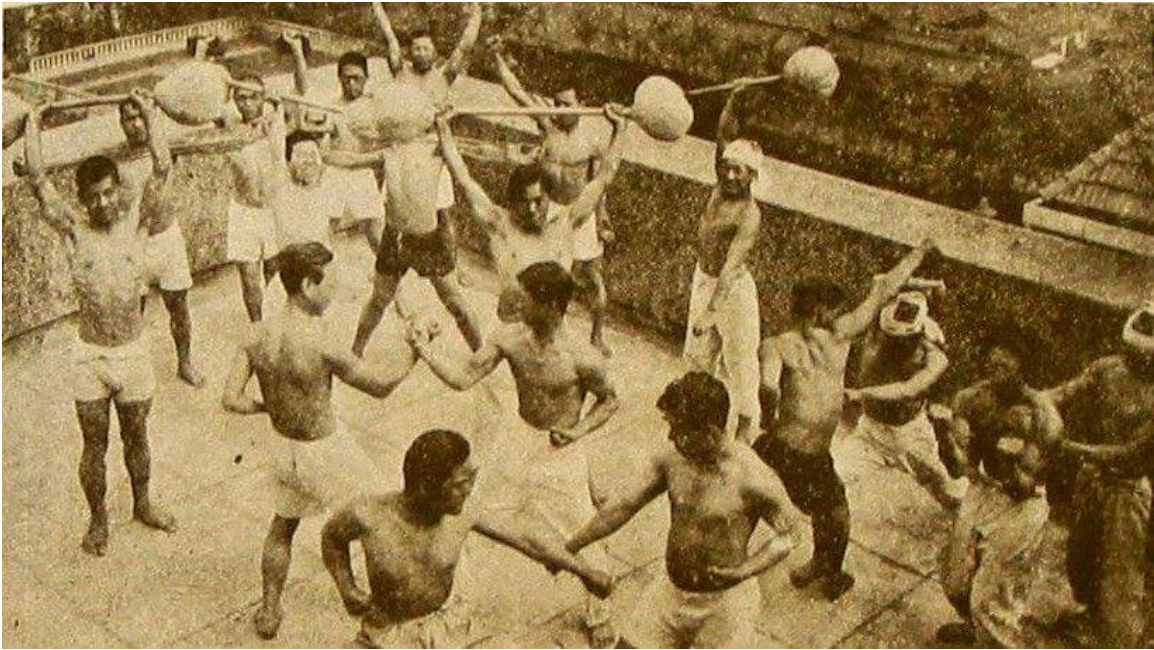

As you can see in the picture above, the temperature is so warm that outdoors training in underwear was the norm.

Is the conclusion that we must refrain from learning advanced Karate because we can not use it other than in the beach, the sauna, the baths or even Okinawa itself?

No.



My conclusion is that, in order to be able to use Karate as a plausible mean of self-defense, we must learn how to use it in our current circumstances. Adapting the art will make it meaningful for us, and at the same time we will help it evolve, so we can pass it to the future generations.

So, how to do it?

Using the vital points example, I can assure the reader that a well-placed elbow to the side of the head is still a formidable weapon, regardless of clothes. The tip of the elbow is a pointy weapon that can produce great damage to other people. The head is a vulnerable target so any powerful hit will lead to pain and shock. The point under the nose can also be struck with the elbow, the knee and the forehead. The groin is still ready for taking a knee. The knees can be damaged with kicks. The (inner and outer) thighs will also take a knee nicely. The eyes can be attacked using the fingers, gloved or not. A scarf can not protect the nose and mouth well enough...

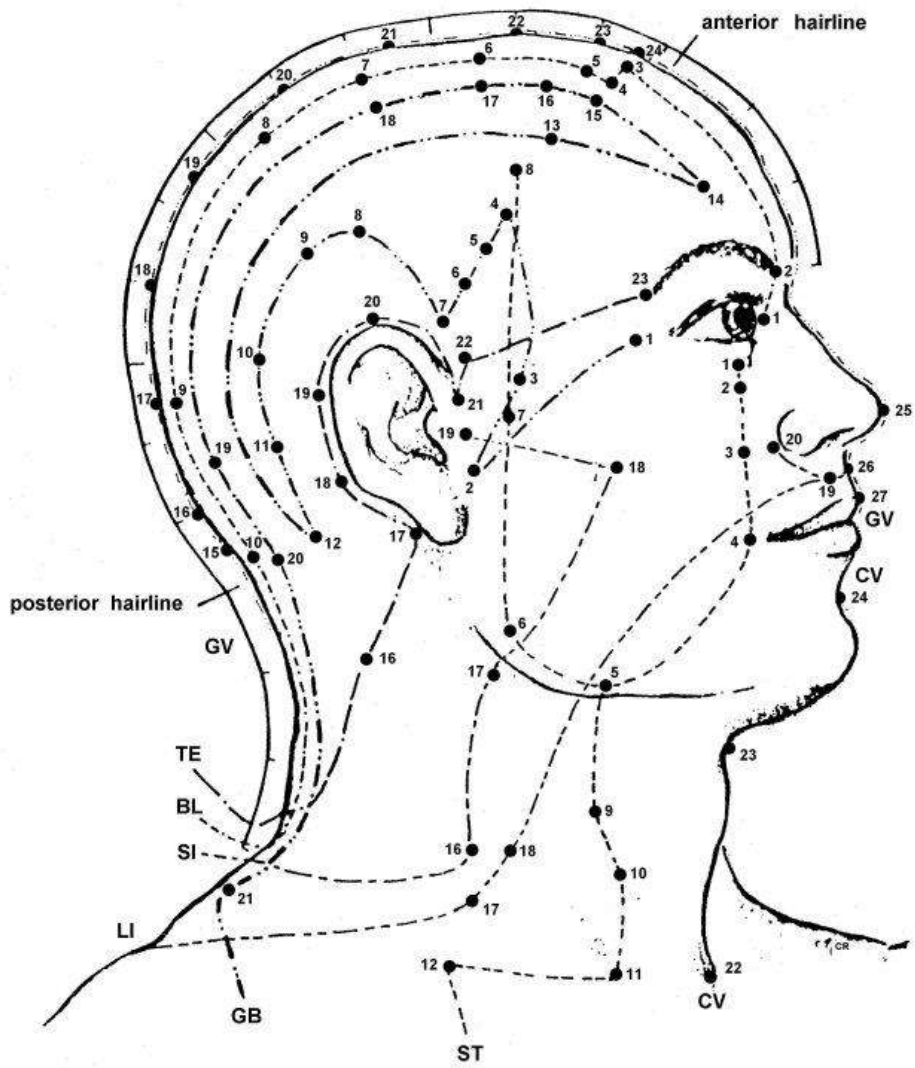

As you can see, all the previous paragraph is full of ideas with a common principle: using gross motor skills to already weak and vulnerable areas. This is not only convenient when fighting wearing winter clothes, but also in summer, as fine motor skills can get very difficult to perform under stressful circumstances.

Another idea is hitting hard, so even if you miss the point the attack still have chances of bringing a successful result to you.

Karate should be studied as a whole: punches, kicks, joint locks, throws, vital points, weapons, chokes, ground work... From all the available techniques it is important to know which ones can work under what conditions. Not all techniques are good all the time, not all techniques are useless all the time. Good timing, brought by continuous training, and good decisions are what will help you defend yourself in the chaotic events of a fight.

Another amazing Karate particularity that I learnt was that Okinawan Karate (in all its versions) uses kicking and punching in a very different way Japanese Karate do.

I mean no disrespect for any Karate style, as I have been a long time student of Japanese styles of Karate myself, that I still keep in high regard. But it is true that Japanese Karate (in general) has specialized in the delivery of impact techniques. Punches and kicks can be really useful as self-defense techniques, and the specialization on those means that Japanese Karate can kick and punch with great power, speed and precision.

On the other hand, in my Goju Ryu experience, kicks and punches are just one component of the technical vocabulary, important, but not the most important, and are used generally as finishing techniques.

Yes, a Goju Ryu karateka can punch his (or her) way out of a fight, as well as any Shotokan karateka can choke an attacker, and a Kyokushin karateka could apply an elbow lock to subdue an attacker. But I have observed that the different styles have different tendencies towards how to address a fight.

Probably all work just fine, under the perfect conditions. Perfect conditions in an assault at night?

We all (from any branch of Karate) can evaluate the techniques at our hand (and feet) and see the way other styles use them. Learning strategies and usages from other people will help us to build a wider array of scenarios where our Karate is probable to work. This will mean incorporating new points of view and discarding those that don't work. What can work in the dojo might not work in the snow, with plenty of thick and restrictive clothes.

How many techniques do you know?

Which ones can you use in a snowy forest? Which ones while at the beach? Which ones in an elevator? What about a supermarket? What if you have your family with you? What would you need to do against two attackers? What about three?



How good are your techniques while on your knees?

After a strong foundation on the basics, a beginner karateka must try to learn as much as he/she can from his Sensei. But the Sensei can only point the way. It IS the student responsibility to think by him/herself about all the learnt in the dojo. The same as a University Professor can only provide you with a lecture, you must do your homework and study, think and research yourself about the contents of the lesson if you want to be a good student.

Talking about dojos... how many karateka train on perfectly flat wooden floors?  
How many on foam mats?

I would say that most do.

What are the odds of being on a not even floor if attacked? It may rain, be windy, dusty, dirty, be on a slope, on the stairs, the countryside, the forest, the desert, a warehouse, a workshop, a parking lot, a crowded place...

Yes, I said I train in the park quite often. Not by choice but because my dojo space availability is reduced, but I train in the park and I find that my stances can not be perfect, that it is full of rocks, full of people, full of dogs, full of trees, full of bugs that disturb my training. As much as I do not like it is a wonderful training environment to get used to kick with shoes on a slippery ground. When we do kumite we use very few rules, allowing throws and ground



work. That is painful and unpleasant, so we use our skills the best we can to avoid being thrown.



It provides a real life environment for fighting training. This is invaluable.

On top of that, training using shoes and everyday clothing makes the training closer to what is a normal life situation, when it is more probable to be assaulted.

Jeans will not allow high kicks, shoes will not allow the foot to bend in your trained position, jackets will make you slow and stiff, a tie will be a rope around your neck. Clothes can be grabbed and pulled, making escape more difficult. Stances will not be possible in uneven ground.

If we find ourselves in the middle of an unprovoked fight then we need to use our Karate at its best. Consider the surrounds, the ground, the clothes you wear, the clothes the others wear. Consider where to strike and where to protect yourself. Consider how many foes there are. Consider if you need to protect someone.

No, you can not make such considerations while in the middle of a battle for your life. You must do them before. You must do them while on training, while walking, while shopping, while travelling... Mind training is as much important as physical trainings. To be ready, your mind must be ready. Imagine how it will be, imagine your mistakes, imagine your success.



## Chapter 2: Do it with style

What is my Karate style? I guess one needs to know if he/she can feel identified the contents of this work. If my methods and theories are aligned with those of his/her Dojo. Fair enough.

What is my Karate style? That is a fair question with a complicated answer.

My first Art was Judo, which I started to learn when I was six years old. Even though I never stopped training I did it in a discontinuous manner, never caring too much about it. I never thought it could be used in a fight, until recently.

After that I joined a Shotokan Karate class, not by choice (I wanted to learn Kick boxing) but because it was the only kicking-and-punching option available at that time, until I broadened my martial circle of friends and became involved in full contact styles.

Many years and a few dans later I was forced to move my residence to China, having Kyokushin as my only choice for the first years after I landed. After that I met many people involved in a variety of arts who were gracious enough as to invite me to train with them. I could do Boxing, Sanda, Muay Thai, Kendo, Kalaripayatu, Kobudo, Shotokan, Judo, Brazilian Jujitsu (gi and no gi), MMA, Taekwondo (WTF and ITF), Aikido, Shorin Ryu and Wing Chun.

In the meantime I joined Goju Ryu International Karate Kobudo Yuzenkai too, where I got introduced to its practices.

So, what is my style? All. And none.

Let me explain: after all of my training sessions with so many different martial artists and fighters of different schools and traditions I see no styles. I do not see rigid divisions between what a group does and another groups does not do. I now can not force myself to accept that there are techniques that are not allowed to me just because they are not part of the curriculum of a particular school. I do not even see divisions between different Martial Arts!

If you read the works of the Karate pioneers they all share a common interest to improve by sharing what they know with others. There were no styles in Okinawa a century ago. Why should we have them now? Most of the revered Masters of old had instructors from the Naha and the Shuri lines. Funakoshi, Mabuni and Oyama Senseis, just to name the ones with the most following these days.

Of course, we should keep the traditions alive and pay homage to the Masters who handed down Martial Arts to us. But following a tradition does not mean that you must abandon critical thinking and that you can not learn a technique that is not in the syllabus. MMA fighters got it right very quickly. One must be able to use a variety of techniques in any range and situation, standing or laying.

I am not the first one and will not be the last to feel a natural continuation from kicking to punching to elbow to grappling to take down and to ground fighting. I can not say where Shotokan ends and Kyokushin starts, where Judo takes over or what Art my punch came from.

If I punch before performing an elbow lock, I am doing Karate or Aikido?

Of course the answer is both, and none.

I do not want to upset anyone saying that styles are unimportant or that I am above all the styles I have mentioned (or above any). Beginners must strictly adhere to the syllabus and teachings of the instructor, but cross-training and "seeing what others are doing" are highly recommended by the autor.

I am lucky to have learnt a great variety of kata from different styles and, even if I can not remember all the kata I have practiced in my life, I can choose the kata that feel better for my practice. I am lucky that I can practice standing and ground fighting with my friends. I am busy because I have many techniques to work on, striking and grappling, empty handed and with weapons. It makes me feel good that I can practice with anyone in the planet at any time in whatever style that person can do, but at the same time it makes me feel sad that there are so many aspects of the Martial Arts that I will never be able to practice with enough depth.

The whole book must be read with a no-style-mind, an open mind who can see the goal (self-defense) and who does not care about labels and limits.

Let me quote some Martial Arts experts:

"If we examine, analyze and breakdown the essence of Shorin-ryu and Shorei-ryu we can see that the strikes, kicks, techniques, the application of strength

and pliability, etc., are the same. Even if some differences can be seen, such as differences in speed in advanced forms, this is simply a natural extension of karate training. It is normal in karate to have different notions of the use of speed, strength and pliability when training. Therefore the idea of different styles is fundamentally wrong. We can only conclude then, that Shorin-ryu and Shorei-ryu are both one and the same.

Regardless of the method, almost all empty hand techniques fall within the range of goho (剛法 - hard method) and juho (柔法 - pliable method). Boxing is the hard method of karate, while Judo is the pliable method of karate. People think that karate is simply a hard method but people simply do not know what karate is. Karate as a martial art includes both methods of go and ju. Pliability (ju) can be found in the hard method (go) and hardness (go) can be found in the pliable method (ju)." Toyama Kanken Sensei.

"Atemi accounts for 99% of Aikido" and "In a real battle, atemi is seventy percent, technique is thirty percent", as by Morihiro Saito and Gōzō Shioda Senseis.

"In karate, hitting, thrusting, and kicking are not the only methods, throwing techniques and pressure against joints are included ... all these techniques should be studied referring to basic kata", as said by Funakoshi Sensei.

"Atemi-waza (striking techniques) are the most serious attack techniques and essential for victory in combat. They consist of strikes, kicks, hits and attacks

using the fist, foot, elbow, kneecap, side of the palm, shoulder, or head, to attack the opponent's vital points until he is beaten." Kyuzo Mifune Sensei.

So, if Karate is a grappling method of throws and locks, Judo uses the head, knees and elbows and Aikido is mainly a striking Art, I can not see the reason why the top dogs in modern Martial Arts are insisting in keeping the Arts self-limited.

The huge success of MMA tournaments has shown that for a Martial Art to be effective it must cover all the fighting possibilities: all possible attacks and being attacked by all possible means. More and more artists are starting to realize the uselessness of limiting themselves to a unique method (striking or grappling).

After WWII the dojos in Japan (most of them, at least) became specialized in just one kind of technique, while before that all the Arts gathered all the knowledge that they could. Specialization means you will become really good in a very narrow field, and that made the Arts grow, but in isolation.

I believe it is time to go back to the roots.

Let us train in a constructive and useful way.





### Chapter 3: The paradigm

I will start to explain the paradigm. A paradigm is all the assumptions that act as the foundations of the theory. That means that you need a frame in where to put your ideas to work. As my interest in Martial Arts is to defend myself and others from harm I will need to address what are the dangers of a confrontation and how to avoid them.

I will run away from complicated techniques of dubious usefulness, I will not go into deep explanations, I will not embellish the techniques and I will not assume the reader is a martial artist of incredible prowess. I will keep it simple because simplicity can save your life.

My paradigm has three central points:

- 1) If attacked, the most probable attack will be an attempt to hit your face. The face is a vulnerable place with plenty of weak spots to harm. If surprised, you will be lucky to avoid the first attack. That first attack, if lands, will determine the outcome of the fight, live or death, therefore it is of vital importance to avoid being hit. Other body parts are also vulnerable and care should also be taken to not allow your enemy to hit you at all.
- 2) If hit, you can not give up, turn around and pretend that that was it. After being hit once, more will probably come, so you must try your best to keep up and defend yourself. Getting used to be hit hard is one thing that you must accomplish in the Dojo. Pain must be your well known

companion, not something to fear during training. Of course, the body and limbs are better suited for conditioning but we see boxers and MMA fighters being hit repeatedly on their faces and show no sign of disappointment. If hit on the body, other than getting used to be hit, you must have cultivated a strong body through vigorous exercising that can cope with some punishment.

- 3) If you are attacked, hurt or not, your survival depends on your ability to stop the attacker of attacking you again. If words do not work, you may be forced to use violence to stop violence.

Disclaimer: I am not advocating violence. Violence is a serious thing: it can cost lives. Please, follow the laws of your country regarding the use of "appropriate force". Above all, use common sense and mercy, and do not hurt anyone more than needed to stop him/her from hurting you. Some of the techniques shown in this book are potentially fatal and I hope no one will have the need to put them into practice. Self-defense is not winning a fight: it is to do not have a fight in the first place. Awareness of your surroundings is key to stay safe.

After saying this, if you find yourself in a fight, you must stop the fight. And I mean that if violence is required to make sure you are safe then you must attack in a vicious and overwhelming fashion. If you react to a slap with a slap, that will do nothing to stop the fight. Your response must be one that leaves no other option to your enemy than to stop fighting. You must give no chance to the attacker of attacking you again. And you must not stop fighting until

the fight has ended. When your enemy is no longer a threat then you can (and must) stop hitting, twisting or choking, but not before.

You can and must use any technique or object at your disposal to save your life. It must not be fair: you have been attacked. It must not be knightly: you have been attacked. It must not be manly: you have been attacked. You can punch, kick, bite, gouge, rip, pinch, pull, twist and use whatever action to increase the odds of surviving. That also means using weapons.

I will not talk about Kobudo in this book, but the training with weapons will give you an edge that could be decisive. If you are used to train with weapons (sai, tonfa, bo, sansetsu kon, sword, naginata, nunchaku, bow, knife, short stick...) then you can transfer those same skills to any other object that you may encounter (broomstick, bottle, umbrella, backpack, belt, shoe, fork, spoon, rock, scissors, cue...).

And also important: if you are used to be attacked in the Dojo by armed partners then your chances of reacting correctly against an attacker waving an object will be increased.

Of course, if faced with a knife or a gun one must try to remove him/herself from the situation as quickly as possible, even complying with hateful demands, as trying to disarm an experienced knife fighter or a thug with a gun may cost you your life.

And you need to learn to hit REAL hard.

I want to introduce some Japanese Budo concepts that will give us more options and more considerations:

-*Go no sen*: block and counter

-*Sen no sen*: simultaneous block and counter

-*Sen sen no sen*: preemptive striking

Please, understand that I am not Japanese so my understanding of these may be too simplistic or completely wrong, but nevertheless I will treat them as theoretical background for my explanations.

In *Go no sen* we can say that the situation has escalated to physical violence. You have been physically attacked. You may have been hit or you may have eluded the hit, but because you have been already attacked (and still alive) you must take considerations about how to end the fight to preserve your safety.

In the most basic example, you have blocked a punch to your face and then you decide to punch back. Sounds like the perfect application of Funakoshi Sensei's 空手に先手無し (*Karate ni sente nashi*), there is no first attack in Karate: the enemy attacks you and you react to it.





*Sen no sen* in the other hand implies a higher Martial Arts level, meaning that you can avoid and attack and at the same time hit your attacker. This simultaneity will be safer for you because after one punch your foe will be able to throw another punch, so if you can hurt him during his attack then he will not attack you again.

As an example, your enemy tries to hit your face, you duck the punch while punching him in the gut. It still respects Funakoshi Sensei's maxim in the sense that you react to an attack, instead of initiating it.

In the highest level of Budo we find *Sen sen no sen*, called (maybe wrongly) preemptive striking. Here, you hit your enemy before he even tries to hit you and thus you became the attacker.

Why should you do this?

Well, things are never black or white, but you can sense that danger is coming. Shouting, waving of hands, threatening (to yourself or to family members), invasion of personal space, holding of improvised weapons, aggressive behavior and such will give you clues of an incoming attack.

In this case the situation is that you feel threatened, you fear for your personal safety and for your life so you decide that the best course of action is to end the fight before it starts.

Actually the fight started when you were threatened, when you were pushed, when someone got hold of you. It may be reasonable, in some instances, to be the first one to use violence as to increase the odds of surviving. If you do this, your action must be full of commitment and void of regrets and second thoughts because if you half-heartedly hit someone who is already angry and showing violent behavior you will only make things worse, increasing his anger and making sure he will go to finish you with no regrets.

Not only you were the one to start the fight but you will be the one hurt.

So, what would Funakoshi Sensei say about hitting first? He actually said that you must do it if necessary.



I like to interpret his precept as "you must not start fights and look for trouble". This makes more sense and is understandable in a more general sense. I think everybody in the world will agree that going out to pick up fights is not a reasonable way of conducting oneself. We all karateka hope to be ready if trouble finds us but we also hope that we never need to check the extent of our abilities.

Please, refer to the laws in your country regarding when preemptive striking is legal or not. Do not do it lightly. Most confrontations do not get violent, even if people are shouting. Do not punch everyone who shouts at you because maybe you made a mistake and made someone angry (driving anyone?). In this case, apologize and try to deescalate. Most of the time fights will not happen, even between angry individuals. People need to exteriorize their feelings, some people more than others. Please differentiate between people complaining at your actions and people threatening your life.



## Chapter 4: Close contacts



I am convinced that one of the ways of making our training useful is by including full contact fighting in the training, and including all ranges and techniques: standing, long range, close quarters, ground work...

What are the benefits of training kumite with full contact? What is the difference between full contact and no contact?

When training kumite in WKF version the rules forbid the contenders with hitting each other with full power. It is not allowed to use the full force of your karate techniques into the other person.

One may think that in order to keep karateka healthy and free of injuries this method is the best one. Well, these rules do not avoid injuries, however they avoid several benefits of the karate practice:

- Experimenting the full power of your techniques
- Knowing if your techniques are really good and powerful enough
- Confronting yourself against someone who can hurt you
- Making your body able to resist hard hits
- Get you used to a stress situation

Let's revise one by one:

If your tsuki and geri are always used trying to not touch your opponent, they will likely not touch your enemy if a fight starts in the street. This will be a great danger for you.

And if you manage to land the tsuki your hand is not used to such impact. The anatomy of the human body in movement is extremely different to that of a sand bag, the pads and the makiwara. These tools are useful and have their

benefits when used correctly but their uses and intentions are different. Only hitting a human body you will get used to it without danger for yourself.

Yes, everybody can hit the sand bag really hard. Everybody can make the makiwara shake. Everyone can hurt a friend with a full power punch. But... will that be enough to end a fight? Will you be able to hit a vulnerable spot? Will you land your technique where you want to? Will you hit with the part of your hand you expect to? Will you knock out someone bigger than you with a chudan tsuki?

Knowing what works is extremely important because will allow you to focus on the techniques that are more effective and to not waste your energy and precious time in useless movements.

If your opponent can not hurt you because the rules do not allow him to do so, why should you defend yourself?

One can argue that WKF fighters defend from each other with foot work, blocks and anticipation. That is true, but usually your opponent is focused in scoring points without being touched. In a real fight your enemy might be drunk or on drugs or angry and not fully aware of his acts, so he may act unreasonably, attacking without control.

Experience under this circumstance is extremely useful.

And, by the way, one can train foot work, distance, aiming, stamina and many other things while combating with contact.



If you get hit repeatedly on the Dojo by your mates your body will grow accustomed to the blows. After some time you will be strong enough to do not really care about one hit more or less. On top of that you can add exercises where you and your partner hit each other in turns to the chest, abs, legs, shoulders and face with increasingly amounts of power realizing with time that being hit is not so terrible.

In doing this one must be careful to do not use excessive force to the most vulnerable parts of the partner's anatomy. Common sense must be observed and communication between partners must be fluid.

This last one is my favorite:

The previous ones are obviously benefits, but can be argued by budoka of different traditions. You may not be fully convinced, and it is legit to have doubts. But having a kumite with real fire against someone stronger than you puts you in a really uncomfortable situation.

Being hit from all angles, feeling unable to defend, having to fight with pain, exhausted, scared... This is a gift for our training. If full contact kumite is conducted regularly one can get used to the stress situation of being in a (almost) real battle. This will allow oneself to get ready to think, to decide what the best thing to do (punch, kick, move, push...) is and, definitively, will help you to REACT when attacked.

If you are unable to react under stress all your training will be useless. You will be defenseless. You will be dead.

Full contact kumite is not easy or pleasant, not even when you "win" the fight. But it is the closest thing to a fight so getting used to it can help you save your live.

Talking about kumite, one can find many uses for it. One of those is training for fighting more than one attacker at the same time. Let us say that you are attacked by two thugs on your way home. The way of coping two people at the same time is to not face them at the same time: you need to use the space

available so as to keep one of them between the other and you, making a line of three instead of a triangle. This way, you will only face one at a time.

You can also practice the skill of protecting a weaker person, like a child. In this case you should do the opposite thing, that is keeping the child away from the attacker, positioning yourself between attacker and victim.

These two skills can be trained in the Dojo while multiple variations of these will enhance your real world self-defense capabilities.





## Chapter 5: Getting physical

As important as technical training is physical training. And by physical I mean body (muscles, tendons, bones) training (as my Kyokushin friends happily made very obvious to me the day I joined the Dojo).

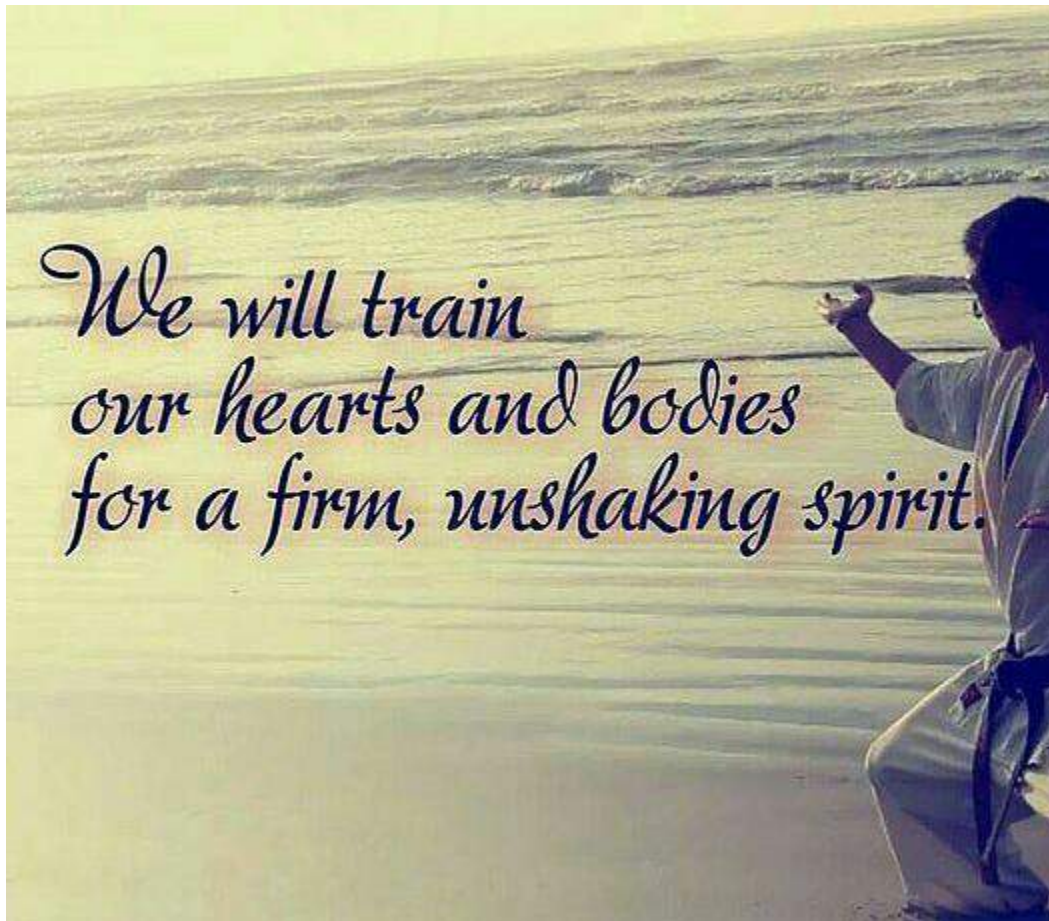

Any training, even of the lowest intensity, would be better than no training at all. At the same time, optimal training is not so difficult to obtain. It is important that we evaluate our Karate training and assess our body weakness and strengths to configure the most adequate training program to suit our needs, goals and special circumstances.

One thing that needs to be addressed is the use of weights. Weights have been used through the ages in order to develop bigger and stronger muscles. The use of stones, logs and other home-made implements has been the norm in the past, until the modern day gyms appeared. I also use some *devices* to help with my training at home, but are far from optimal.

We karateka must consider ourselves lucky as a complete system of body conditioning was developed by the Okinawan pioneers, and passed down to us virtually unadulterated.

# 補助運動

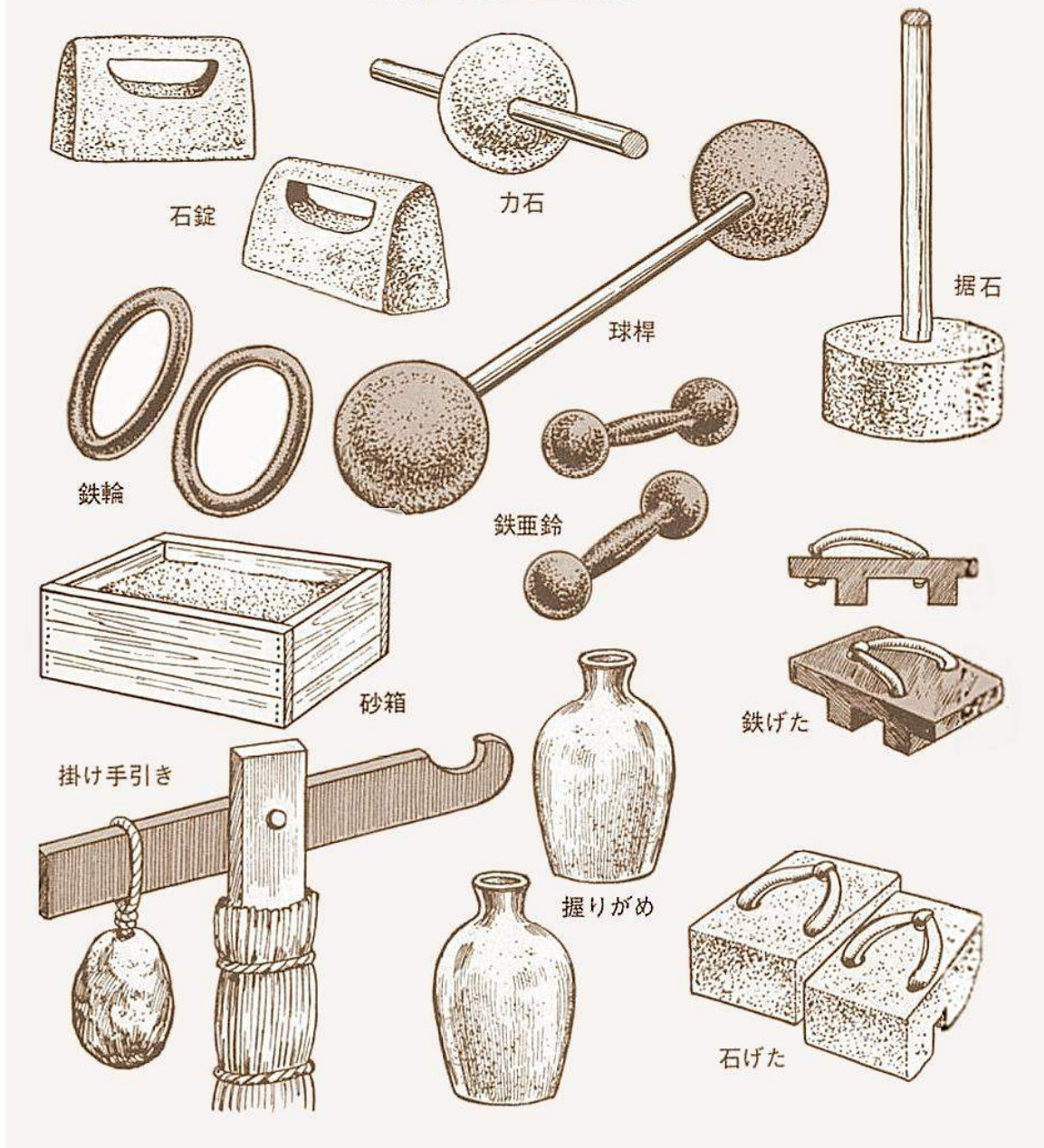

Yes, these are the traditional Okinawan Karate body training tools. And as I see the benefit of using all of them I also see the benefit of substituting

(improving) the training by using modern training science and knowledge to get the most of our training efforts.

Please, refer to a professional about the correct and safe way of doing the exercises and lifting weights.

Please, forgive the use of sports clothes instead of wearing a gi in the following pictures. These are the clothes I wear when I am at the MMA gym that I visit regularly to test my Karate and my Judo against professional MMA fighters to ensure they are up ready to face modern dangers and situations and to make sure they stay relevant in this modern-day fighting systems evolution.

Ishi sashi:



Traditionally a carved stone with a handle, it is used to develop arm, shoulder and leg strength. It can be used in a variety of ways to train the muscles and joints from different angles.





The modern evolution is the kettle bell. Born in the Russian army out of outdated cannon balls, when the need for standard projectiles arose. The old balls were added a handle and used for weight training.

The benefit of using kettle bells in the gym is that there are probably a large selection of them with the weight impressed on the side, allowing you to know exactly how much work are you doing, how much are improving and helping you to set milestones.



## The Swing:



Swinging the kettlebell will work on shoulders, abs and core muscles. With the added squat you will also work on the legs.

Strict form is a must to avoid injuries. Also, consider your physical strength before choosing the weight: too heavy and the exercise can be dangerous.

Press:

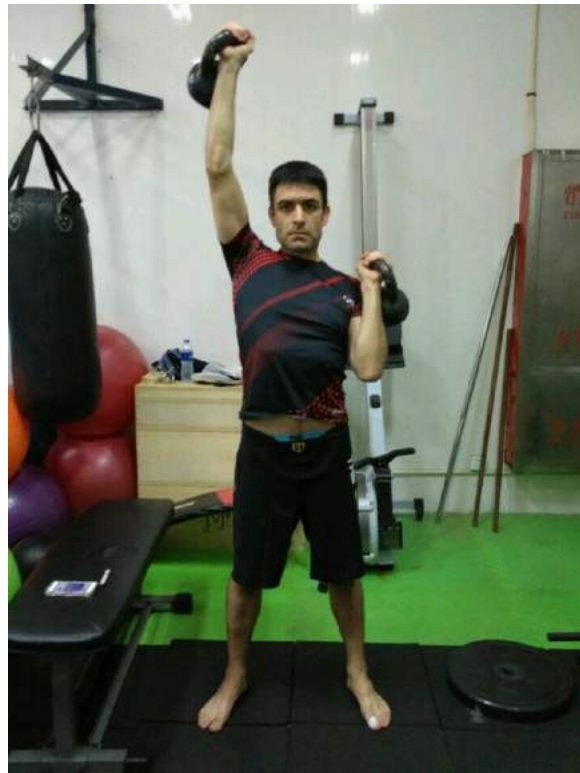

One handed or two hands presses will develop shoulder power, and balance and core muscles at the same time.

Doing this in an explosive way will make your punches faster and stronger too.

The two handed version develops muscles on the shoulders and back of the arm, used while punching.

Sitting version will focus more on the deltoids muscles and can help you lift more weight, but the standing version will recruit more muscular groups and give a more whole body training.

## Deadlift:



The Deadlift will work on lower back and core muscles, also increasing your grip power.

Russian twist:





The weighted twist is a terrific exercise for the whole body but specifically for the abdominals and core. Highly recommended to make the abs thicker and burning some fat.

Lunge press:



Compound free weight exercises work better than isolation exercises for our purposes (increasing our physical strength to improve our Karate and avoid injuries). The Lunge Press works legs and shoulders as main targets but it is a whole body exercise using many muscular groups.

Kettlebell row:



The Row is a great exercise to develop the upper back muscles, important for pulling actions in Karate.

Biceps and lower back also get exercised.

Curls:



Curling is the best method for making your biceps and forearms stronger.



## Shoulder lifts:

Front and side lifts will improve the power of your shoulders and some of the other small muscles that act as stabilizers.

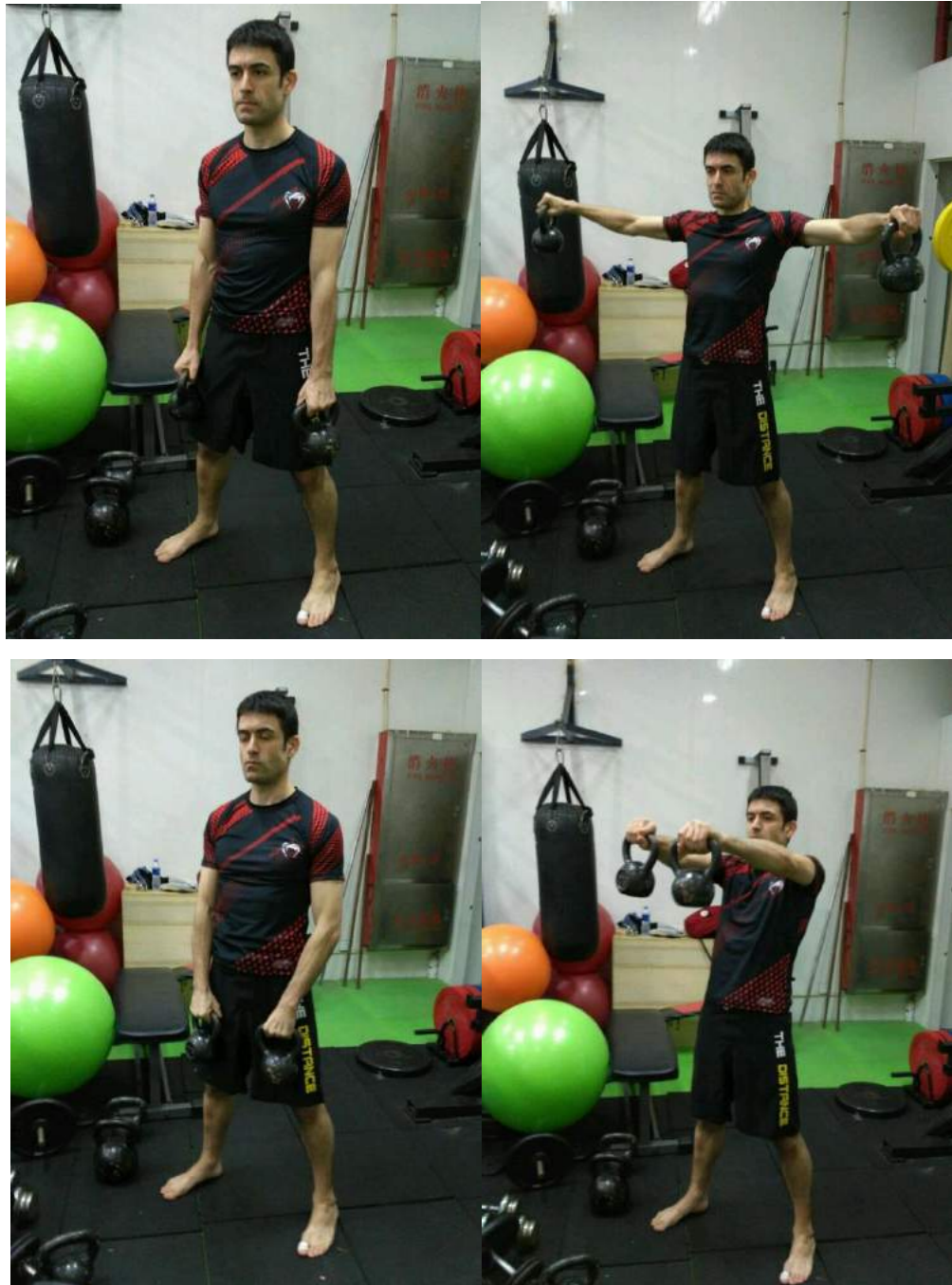



(Please, forgive this poor tentative of being funny)

Makiwara:



The makiwara has helped countless karateka worldwide to develop massive punching power, and as such we must be grateful to the man who invented it in the first time. As an added benefit, punching a wooden post will make your hands and wrists stronger and better suited to heavy impacts.

The drawback is that the human body is not like a piece of wood. It has soft spots with bones inside, making the point of impact less that homogeneous.

As good as the makiwara is, it has added benefits if you can combine the practice between makiwara and sand bag.





The surface of the bag is not as hard as a makiwara. Instead, the punches will penetrate the surface. This means your fingers will twist in unexpected ways, making the punches painful in different places of your hand. The makiwara can be hit with the knuckles of the first two fingers with perfect consistency, but a swinging heavy sand bag reacts more like a human body (except the bones) making the training a bit more lively and real.

As an addition to these, foam pads can be used too. They will allow the work of combinations of punches and kicks in rapid succession while forcing you to use the correct punching technique.

Of course, gloves can be used. But we karateka train to be ready to defend our lives in a confrontation so it is better to train our hands without gloves, as we will not have gloves if attacked outside the Dojo.

Let us see some techniques performed on the bag:



















A Thai wall makiwara also offers a nice variation:

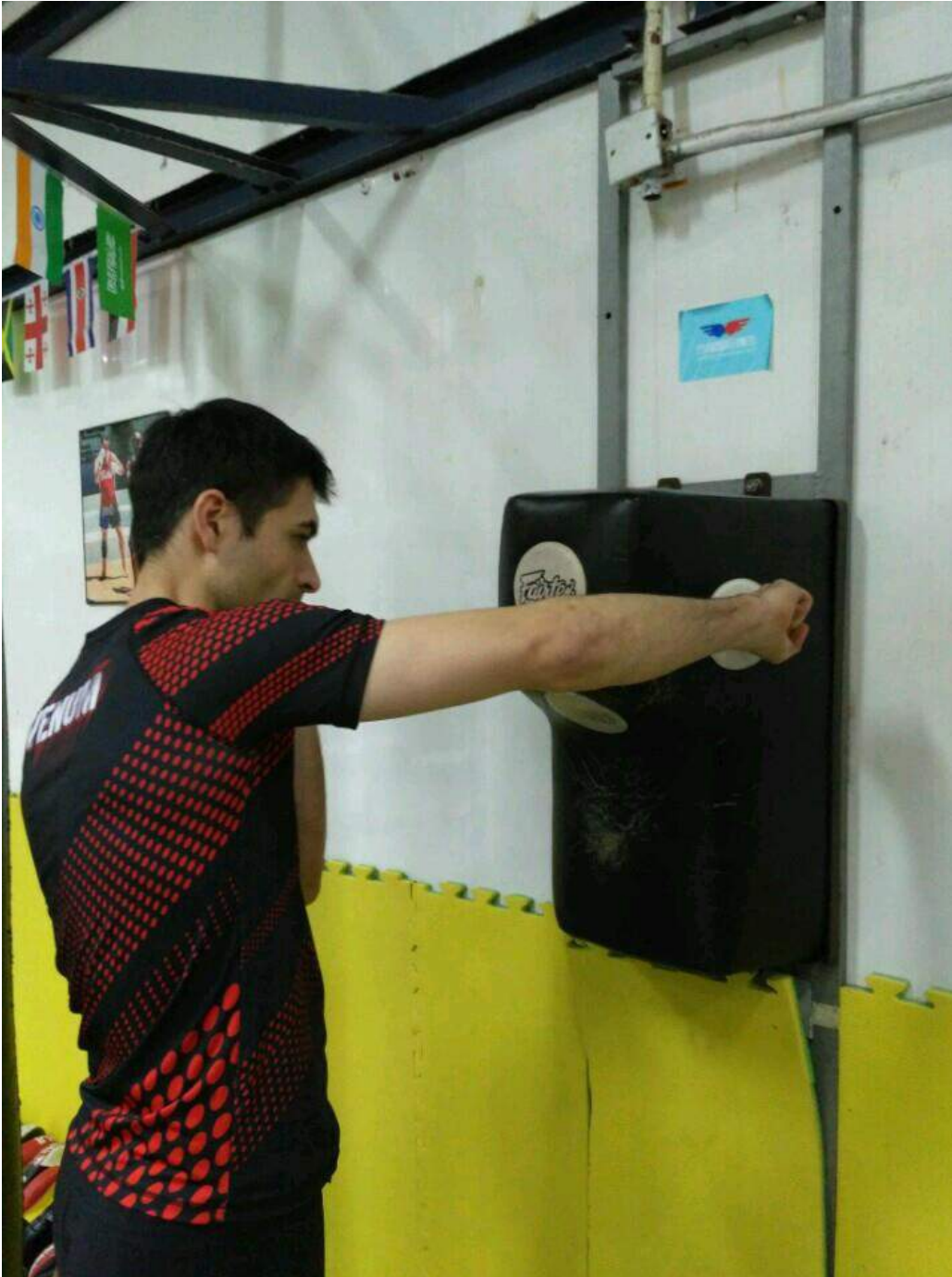









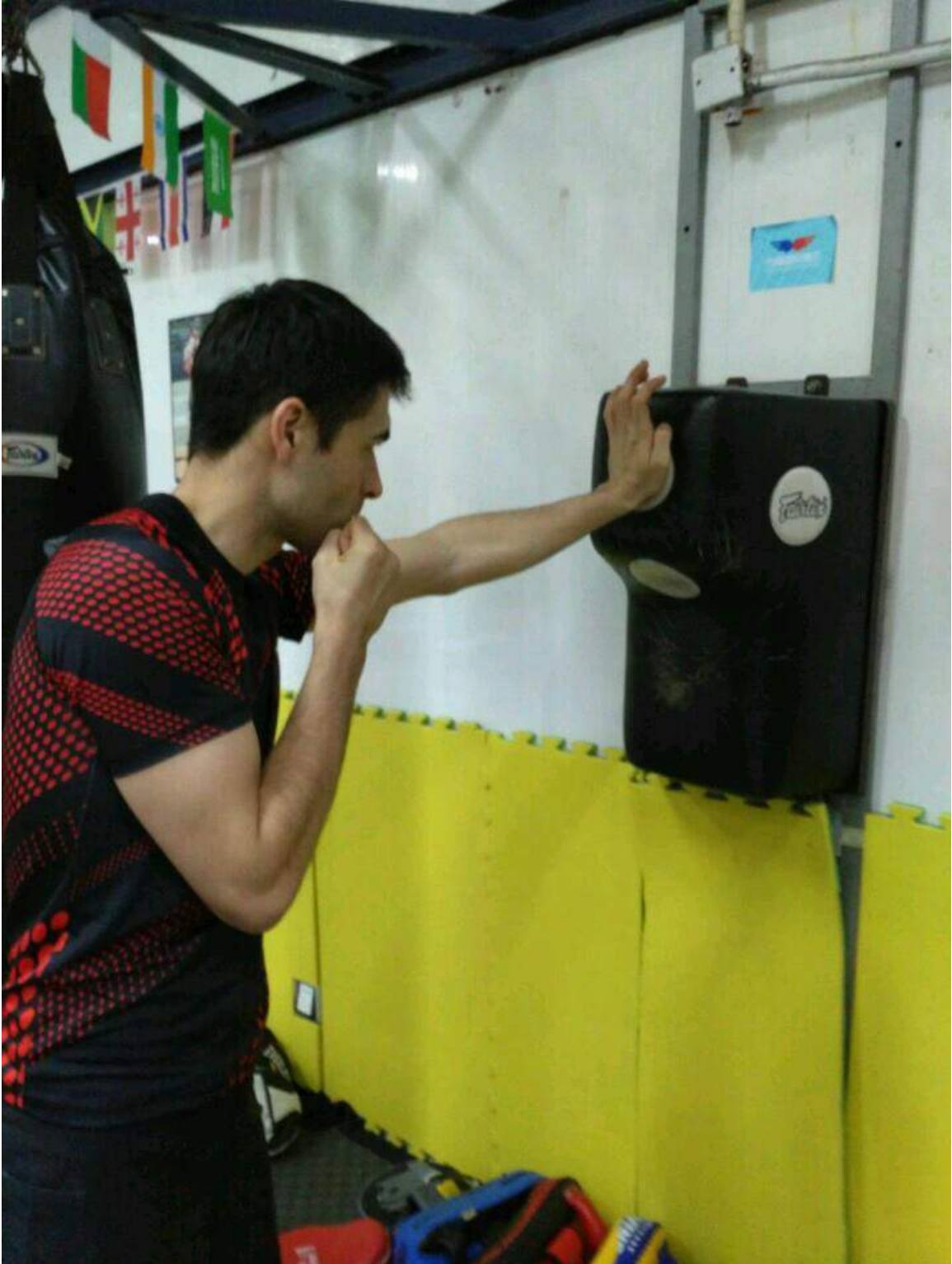

And for those feeling adventurous:

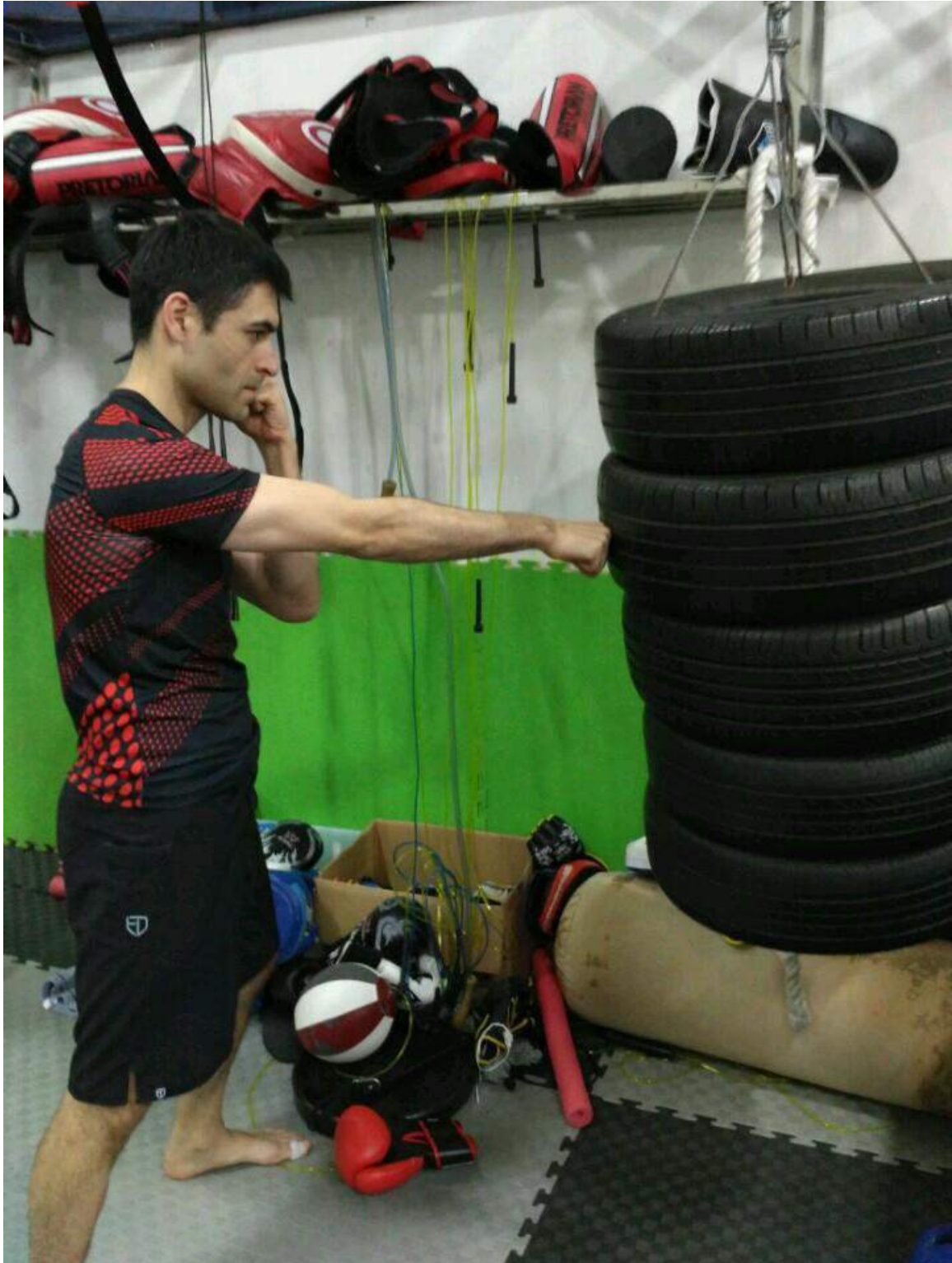



Tetsu geta:



The iron shoes, as my Sensei called them, are used to help develop the muscles in the legs, making stances and kicks stronger. However, the lifting of weights strapped to the feet can develop lower back pain conditions, and aggravate existing ones. Also, caution must be used for speed kicking will damage the knee joint quite fast.

Weight machines are a great way of working on those leg muscles. Presses, curls and extensions are among the preferred exercises for the lower body. They allow practitioners to choose the weight and keep them aware of the improvements too.

As a gym favorite to train the legs we find the squat:



Squatting (without weights) is a good way of training the leg muscles, but adding weights will make the legs get stronger. Caution must be had and perfect technique to protect the knees and the lower back.

Isometric exercises (using our own body as a weight) are an easy and fun way to train our bodies. The amount of exercises and variations that one can do is really vast, and no equipment is needed, meaning that you can exercise anywhere anytime.

Push-ups are the most extended method of working your chest in an isometric way. They can be done in different ways changing the distance between the hands, the angle of the body, the speed, the repetitions, the height...

They also work the triceps and the deltoids muscles. They are a great exercise for the core too, as you need to keep the body straight.



Using some implements to change the angle or the difficulty of the push up will provide a more varied workout to your chest muscles and improve the exercise efficiency.

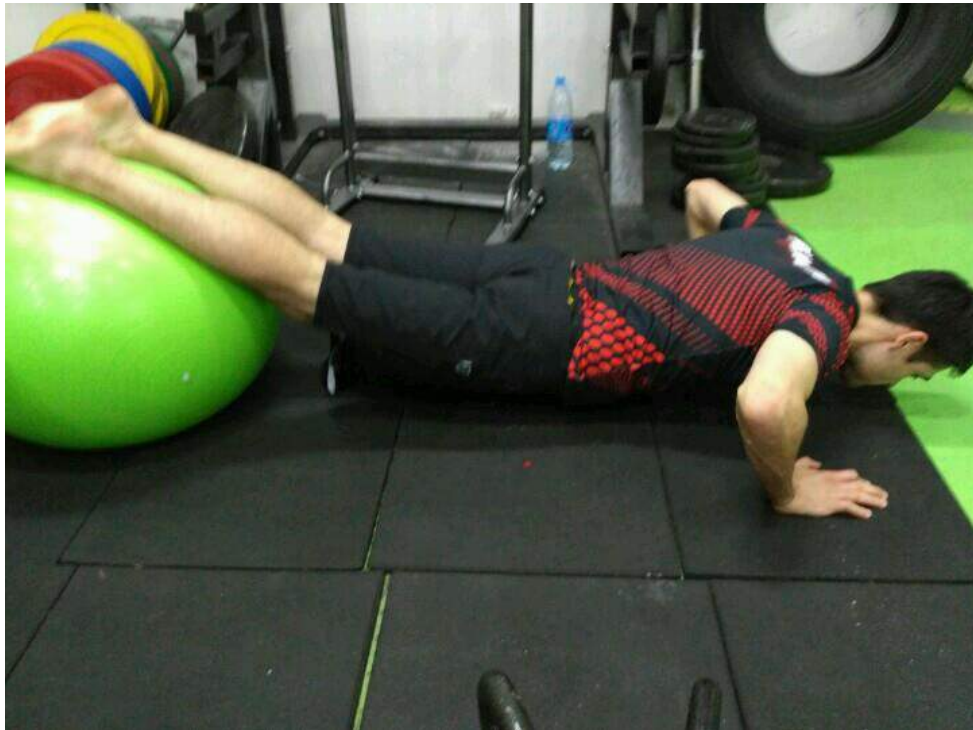



In the other hand, the best exercise to develop a strong chest is the bench press.



With or without the help of a partner pushing a free weight up requires tremendous strength. The continued training can work wonders on the pectoral flesh. It also works on the stabilizer muscles on the shoulders, abs and core. Good workout for the triceps as another benefit.

Flat bench press as your main chest exercise is what all fitness trainers recommend, regardless of your training goals. It can be combined with angled press, downward press and with crosses. As a side note, I always warm up with push-ups and try to do a final push-ups series after the bench training for added punishment.

The core muscles are the most important for a karateka, as they support your whole body and connect the lower with the upper body. Special attention must be paid to them.

One of the most popular exercises for the abdominal muscles are the crunches.



Bending your body forward can work the abdominal wall in its whole, giving also some training to the intercostals, to the thighs and to the diaphragm. This is a good exercise (despite some saying it is bad for your neck) but can be improved by the use of weights and variations.

A medicinal ball, a weight disc, a bottle of water can add resistance leading to greater improvements. Doing it at an angle will also make it more difficult, and twisting the body right and left alternatively will work more muscles.







As for isometric exercises, there is one that is Karate specific. This is Sanchin kata, where total muscle tension must be made during the whole performance of the kata.



Even if some people say that Sanchin contributes to hypertension and other health problems, this has not been proved and thousands of karateka worldwide benefit from its continual practice.

An exercise that has the same benefits and structure than Sanchin is the plank.



The plank is a whole body training tool. Working on the core muscles, the balance and the shoulders the benefits for any person doing physical exercise are quickly patent. A good thing of the plank is that it can be a challenging game, timing how long can you hold it. A body, mind and spirit training that can be done before or after any other workout.

Pull ups:

Placing special attention on your lats and your biceps, pulling oneself up is a hard and wonderful exercise:



And if you are not already using a battle rope, I can speak firsthand about its benefits:

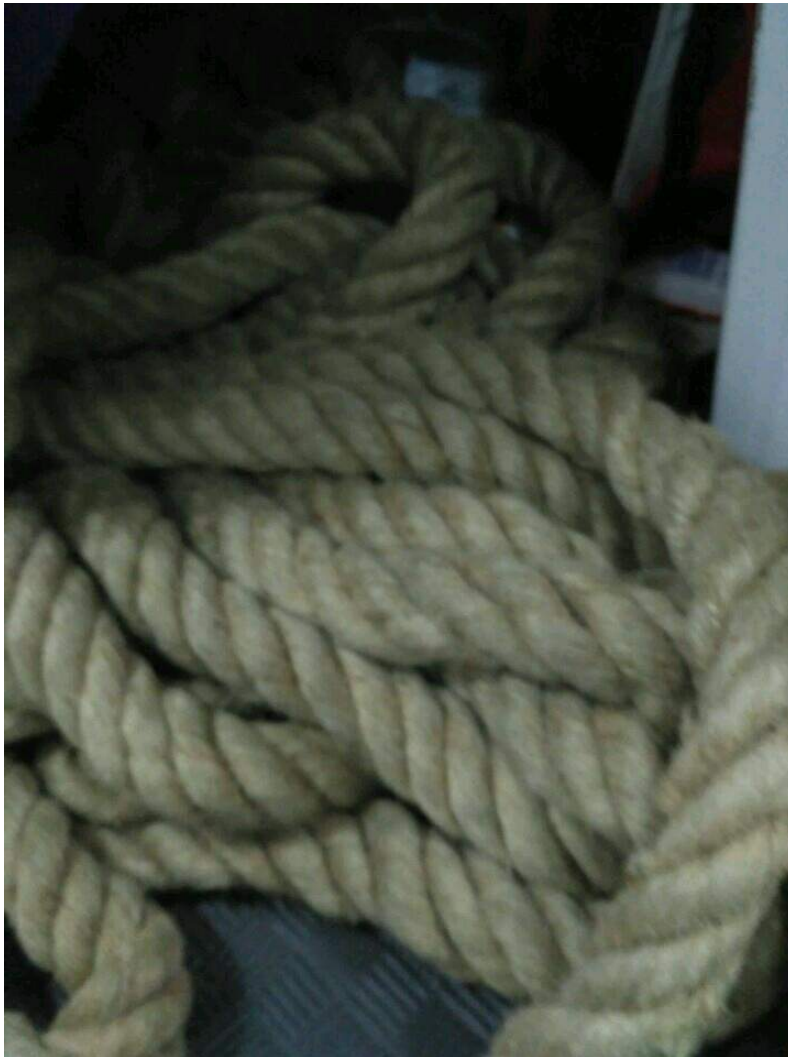

How to use it?

Experiment and you will discover.



As an extra, another exercise that will work your whole body, specially the abs and the core, the headstand:









Some say the use of weights and physical training will make you slower. Nothing further from the truth. The sports science has demonstrated the benefits of weights training at many levels: fat burn, strength, speed, recovery, injury prevention..

Yes, the hugest of the bodybuilders may not be fast, but being fast is not a consideration for them. They just need to be big; there is no time for speed or flexibility training. We, karateka, also need to adapt our training to our goals, and our goals should be to be better at Karate as a whole.

As another benefit, being stronger will help you make your Karate techniques stronger. Even Itosu Sensei himself said that a strong body is fundamental for a good karateka.



## Chapter 6: The weapons you carry

So now you have been training for some few years and have learnt different ways of hitting people. You have your punches, your kicks and some other weird hand positions that appear on kata. Let's examine some of the possibilities your body has to offer when talking about hitting people and where is a good (safe?) place to use every weapon.

I will show and explain ways of hitting people effectively while at the same time you keep your hands and feet unbroken. I had to learn this the hard way, so please refer to the explanations, use common sense and ask your instructor.

The rule of thumb when using body parts to hit someone else's body parts is this: use a hard weapon against a soft target, and use a soft weapon against a hard target.

Please, excuse the quality of the pictures. Also, some of the hand formations are not right. I will try to address the details under each picture.

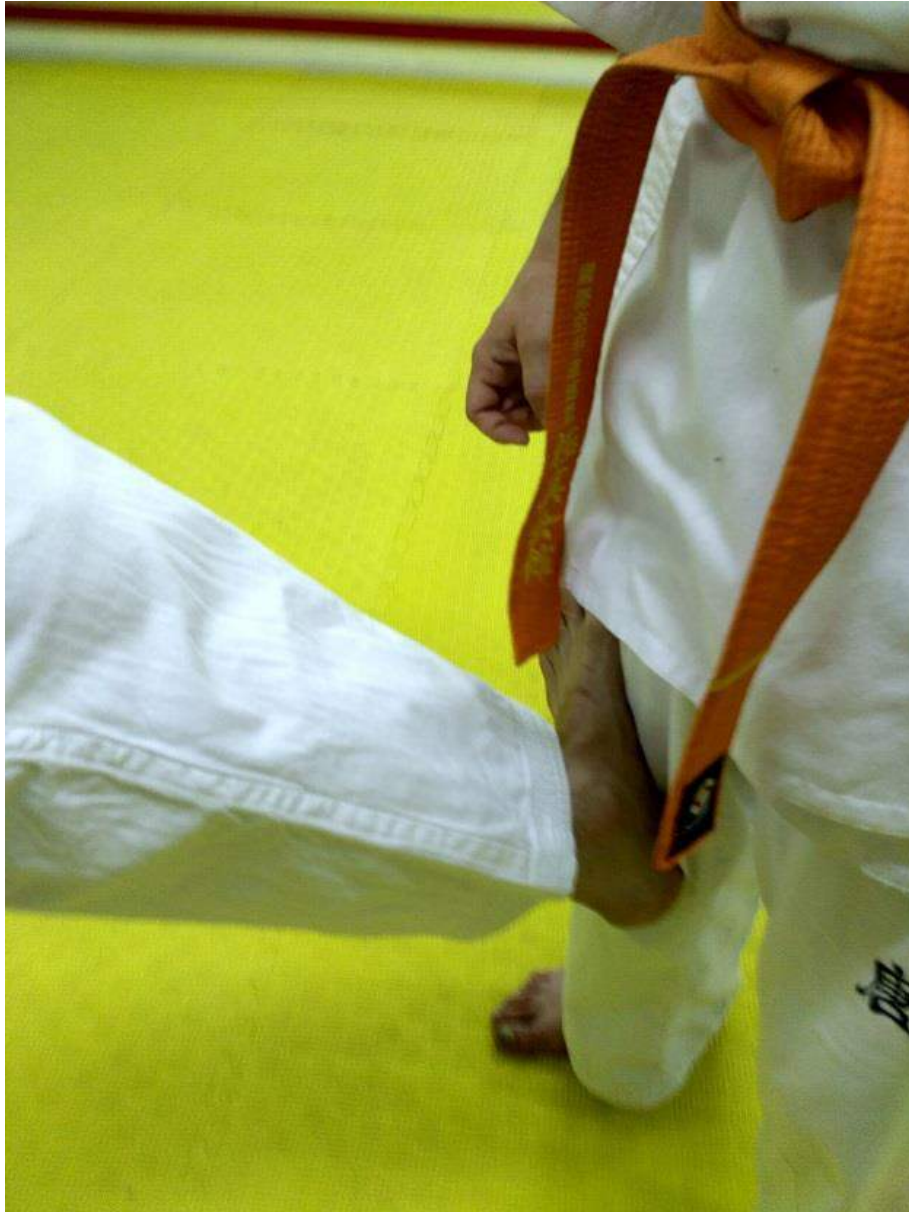

Sokutei, sole of the foot, is a weapons I find most useful when you need to have a big contact with the enemy's body, like attacking the knee (from the front, side or behind). Also, it is a safe way to kick someone, as the sole is not likely to be damaged from an impact.

It can be used to attach the face and the body too.

We can use this technique in Bassai Dai kata, in the first kiai.

The sole of the foot is a good weapon that does not require great aiming or precision but because of that can not provide a concentrated striking area, reducing its effectiveness.

In the other hand (or in the other foot) if used against the face can result in a crushed nose, that is a remarkable outcome.





Haisoku, instep, is mostly used in mawashi geri. After having been kicked on the head many times with this technique I must conclude that is not very effective, but for people of limited flexibility (as myself) haisoku is the only way to roundhouse someone in the head.

The feeling is more like a slap than a real hit. It can be used as a distraction to set up a more decisive technique.

It can, obviously, be used as kin(teki) geri, making it really useful.

During kumite is very easy to damage your own foot kicking this way: elbows, knees and other bones use to get in the way of your kick causing damage to the fragile bones that support the toes. A good mawashi geri to the ribcage is going to really hurt your opponent but if he/she is a trained fighter he/she will keep his/her elbows tucked in protecting the ribs, causing pain and maybe injury to your foot.



A safer and more destructing way to hit with a mawashi geri is to use the shin bone as the contact point. It is harder than the top of your foot, is a thicker bone and is sharper, meaning that any hit will feel like hit with an iron bar.

The small bones of the feet (and the hands) are easy to break. In the other hand, the shin is more resistant. It can break, but it is more unlikely.



Kakato, heel, is an effective way of kicking someone, high or low. When contact is made with the vital point at the top of the skull a knock out is produced, even with small power.

For people of lower flexibility I must recommend using it to attack the face, causing great damage to eyes, nose and mouth. It can be used from top to bottom, in a spinning kick such as ushiro mawashi geri or also with the non-sport version of the ura mawashi geri.

I have used kakato to kick the outer part of the thigh during kumite. It is an effective technique sure to surprise many opponents.

Kakato is also my chosen way of impacting my yoko geri kekomi, as the heel is harder and safer than the side of the foot. I use kakato in mae geri too, as I tend to damage my toes quite frequently.

Now I must say that the correct way of delivering a technique must be learnt. Kakato is not the standard way of using mae geri. In my case, it is a matter of adaptation of the technique to my own personal circumstances. This is not to be made lightly, or used as an excuse for poor technique, but as you grow older the injuries take longer to heal and a choice must be made: I adapt my Karate to my limitations or I keep injuring myself.

Please, learn the correct technique from your instructor and in case of doubt, ask him/her.



Koshi, ball of the foot, is the preferred way of doing mae geri. It is assured to cause a great amount of pain and injury. As Shirai Sensei once told me "mae geri: with this *weapon*, it is finished".

Koshi can be used to kick on the tummy, the chest, the throat, the face, the knee... It can withstand full power contact to hard surfaces, but as the human body is not homogeneous the foot can be "sucked in" the body, making the toes bend backwards too much, causing an injury. To prevent this it is important to



use correct technique that straightens the foot and bends the toes backwards as much as possible before the impact.



Yes, it can also be used in mawashi geri, making the kick very difficult but also highly effective if it impacts at the intended location.

I find this way of kicking more dangerous for your own foot too. If one wants to use it a lot of practice must be done before it can be used safely in kumite. Hitting pads and sand bags will help to develop correct koshi mawashi geri.



Sokuto, side of the foot, is the sportified way of doing yoko geri.

It will not end a fight if you hit your enemy in the chest or the tummy. You will hurt your foot if it impact in the chin. It is not strong enough to break a knee (or even the ribs).

But it will work great on the throat. The space between collar bones and chin is too narrow for a foot, but a bent foot can fit in. This is how I use this way

of kicking (although not much, as requires tremendous amounts of precision and timing).

It can be used from behind, making your foe bend the knee forward.

If you happen to grab an enemy's hand you can use it to attack the vital point in the armpit (although I would recommend use kakato instead, because if you miss the point, you can still break some ribs in the process, as I sadly did once to my training mate...).

My photo looks more as a sole than as an edge, meaning that there is no much difference on execution of the techniques, but of focus and aiming.



Tsumasaki, tip of the toes, is the supposedly way of kicking in Okinawa.

My photo shows an attack to the groin, which is a suitable target (specially if wearing shoes, as we normally do). There is also an attack to the hip socket in Saifa.

I have seen old Okinawans break heavy boards with their toes and I must say that, impressive as it is, it takes a long time to condition them to that degree, so this is not to be done carelessly.

If done with shoes, then most of the body parts are valid targets: neck, groin, ribs, tummy...



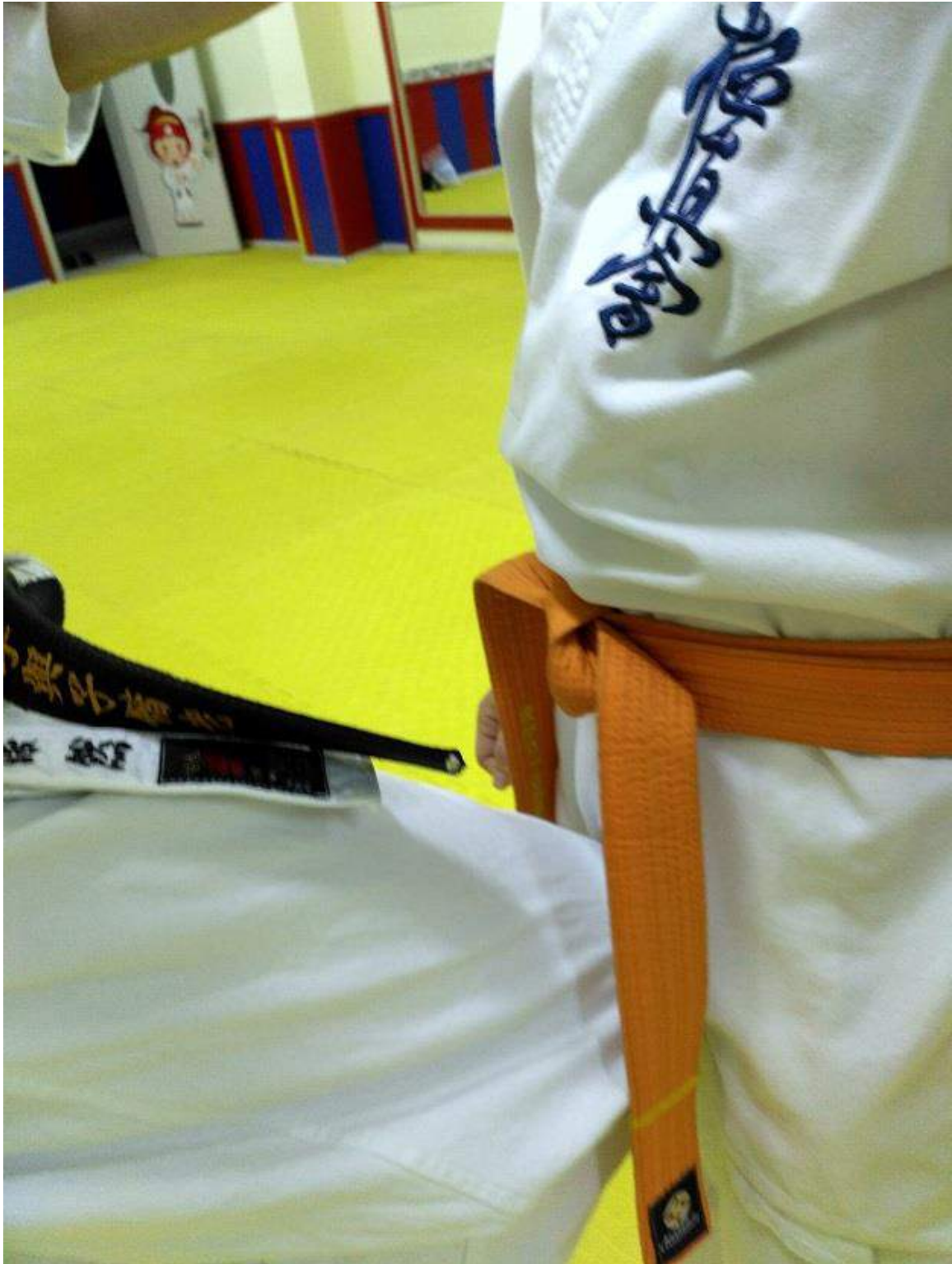

Hiza geri, knee kick.

Illustrated as a nasty attack to the groin (where it is really effective, causing paralyzing pain, nausea and medical complications, it takes some time for the full effect to be felt).

Good for attacking the face (as in Pinan/Heian Yondan), the ribs, the side of the thigh or the gut (may need a jump if your attacker is taller than you).

I just found in the news this morning that a MMA fighter got his forehead fractured as a result of a flying knee kick during a bout, so be careful with it.

The knee can also be used to support a fallen enemy while you perform a choke, as a point of impact if you throw your enemy over it and also as a pivotal point for an elbow lock.

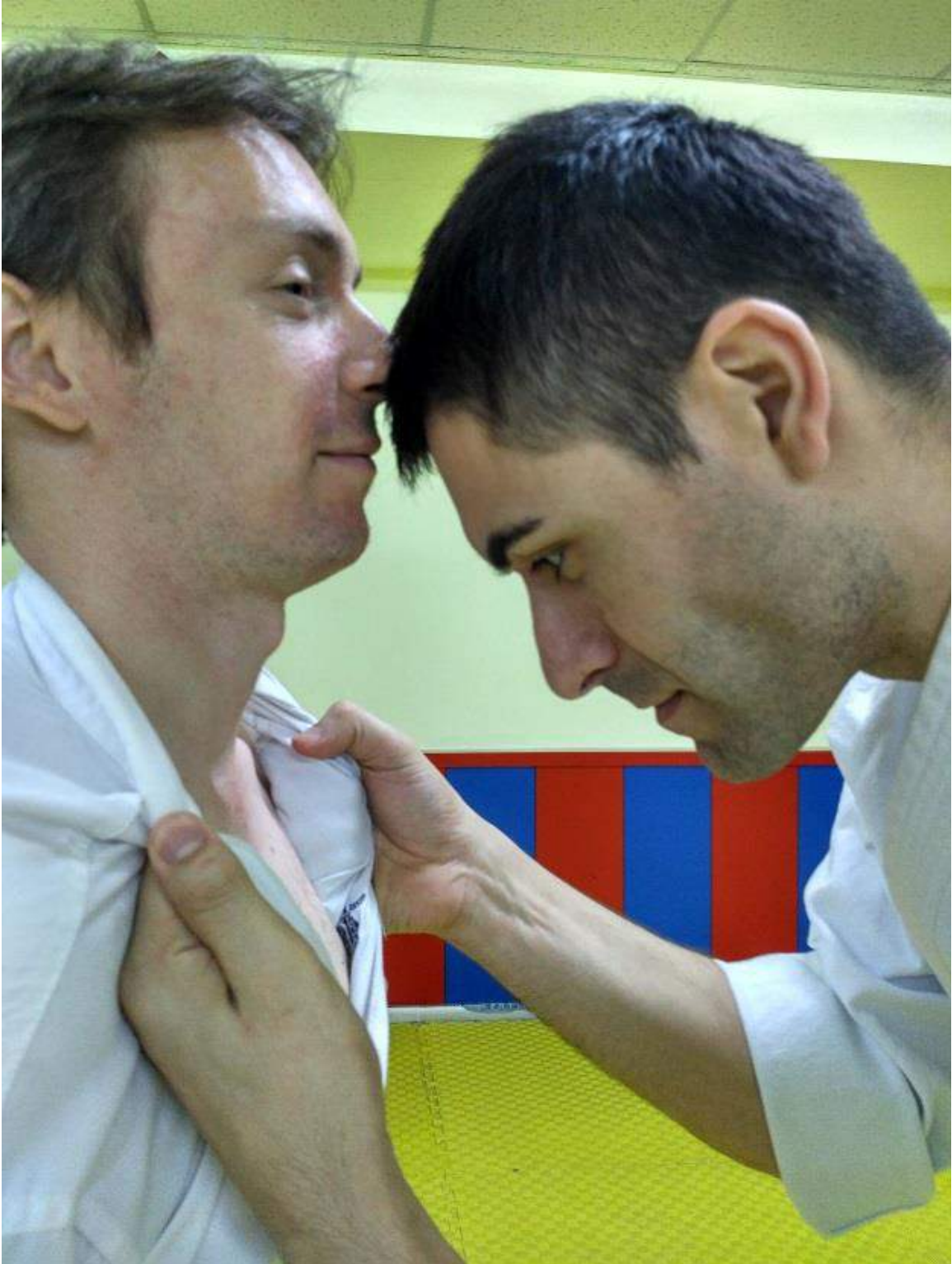

Atama, head.

Dangerous weapons if used wrong.

The rule of thumb is (for your own safety) hit with a part of your head higher than your eyebrows to a part of your enemy's head that is lower than his eyebrows.

Example: use your forehead to smash his nose.

The effect can be augmented with a grab (as in the picture) also known as "the Glasgow kiss".

A hit with the head can be defended by lowering your chin (so keeping your eyebrows lower than your attacker's), by placing your elbow in front of your face and (as you probably have seen in boxing or MMA fights) keeping your head in contact with the other person's head so there is no room for movement.



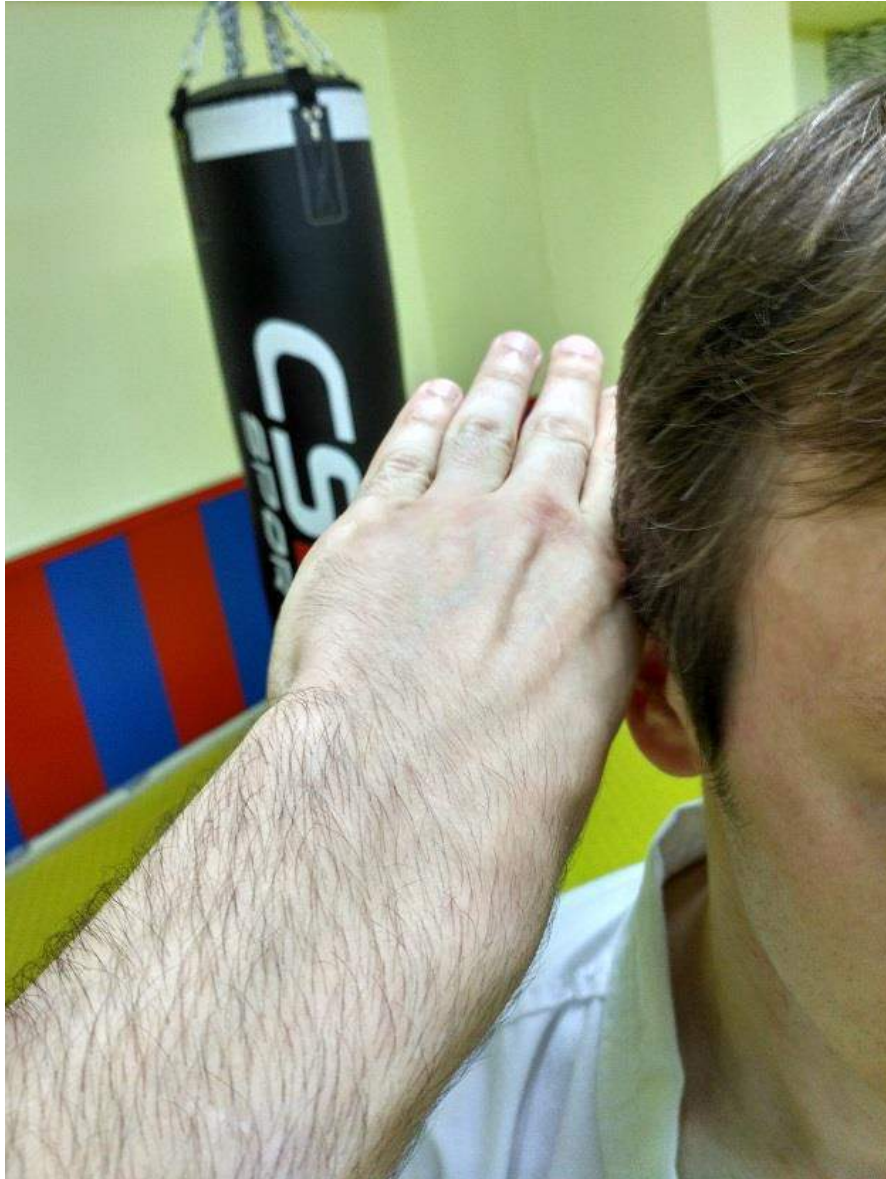

Haito, ridge hand, must hide the thumb behind the other fingers to protect it.



Suitable as an attack to the temple (it can cause unconsciousness, or even death) it also must be hardened before it can be used safely, meaning that hitting the makiwara with haito is not out of the question.

I have seen it used (successfully) in old JKA kumite tournaments as a way of getting a quick knock out.

I use it extensively during kumite, attacking the shoulders (there are some soft spots there, and most people will not condition their shoulders) and causing pain, confusion and paralysis to my training partners.

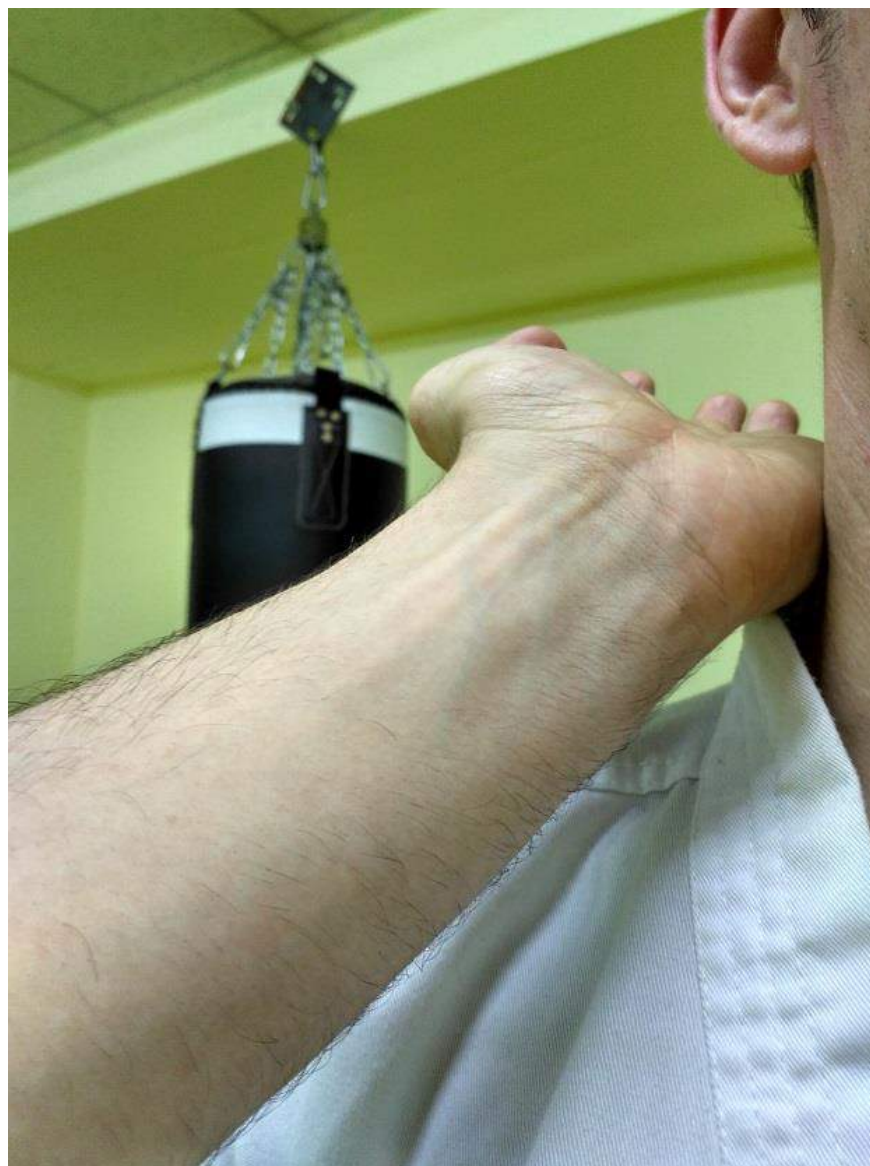

Shuto, knife hand, is one of Karate favorites, but nobody seems to use it as a fighting technique.

Used extensively in kata from most of the styles and surprisingly absent in Goju Ryu. I believe that you can hit with shuto to most body parts but to use it defensively you must get rid of the "correct" technique itself. I will explain: when using shuto uke bunkai the *other* hand is the one actually blocking,

meaning that the shuto hand will be controlling the enemy's arm after the block. I firmly believe that shuto uke of Shuri-te is mawashi uke of Naha-te.

When using shuto uchi to hit of course the neck (from all sides), the ribs (from the side), the face (from the side), the back and the spine (from behind), the temple (from the side) and the arms (from the side).

I need to include the position where you are when hitting because if you square off with your opponent it will be difficult to use a shuto uchi that works and that is fast enough to be faster than the other guy's punch to your face. It is a slow technique because you need a big arm movement to produce enough power to defeat a threat, but it can be used if you slide past his/her defenses and position yourself in his/her blind spot. From there, you can hit at will (and then you must consider that shuto may not be the best option), specially to the neck. Example of this in Heian Shodan-Nidan, Kanku Dai and many other kata.



Seiken, fist.

Not much to say about it. The most used attack in mankind history.

Anyway, make sure you use the two first knuckles to deliver the power, as I broke my hand once by using the last knuckle and hitting a Russian hip.

Great against faces, chests, tummies, shoulders, backs, groins and most body parts. Make sure you condition it enough on makiwara or sand bag, as it can also break if you hit a hard body part (hips, skull...).

It can be used as a straight punch, a walking punch, a lunge punch, a round punch, an uppercut... Best used in rapid succession to overwhelm your enemy.





Nukite, spear hand.

It first appears in Heian kata, making beginners and inexperienced instructor believe that it is an attack to the chest. Well, try it.

Probably useful if used by the same Okinawan who can break thick boards with his toes and fingers, but not by most of us mortals. So, why did they include this useless technique in so many kata?

I personally use it as an attack to the neck, specifically to the vital points in the side to the neck. Sometimes to the hole behind the collar bones. The amount of pain is simply too huge to hit back. My Sensei liked to use it to the throat.

It probably works at its best when attacking the eyes, but we must be careful during training not to hurt our partners and friends.



Ippon nukite, one finger strike.

Make sure to keep the index finger close to the rest of the fingers, not like in this picture.

This is specifically designed to attack the eyes, so not much to say.



It can be modified as nippon nukite (two fingers) for added support (and safety) to your index, or to attack both eyes at the same time. This requires really good timing and aiming and the probability of missing the eyes is big, so you better condition your fingers to withstand a hard hit. Finger pushups work wonders, as a bucket full of sand (or gravel, or beans). Using the gripping jars will also help.









Ippon ken, one point punch.

Showed here in two versions, Shotokan and Goju Ryu.

The thumb supports the bent index finger to deliver the strike. Used mainly to attack vital points in chest, ribs, arms or head it has the advantage of concentrating all the power on a small surface, making the punch feel like a needle penetrating your body (a thick needle).

I would recommend using it as a finishing blow, but not in a dojo kumite, for the index finger can break (and so does the thumb).



Nakadaka ippon ken, middle finger one point punch.

Just another variation, favored by my Sensei.

Please, note the knuckle of the index finger not bent enough, causing the middle finger to be in an awkward position. This is due to an injury I sustained during training in my index finger first joint. Try to keep your fingers as tucked away as possible.



Empi, elbow.

A very good weapon for close quarters combat. It can strike from the side, from up, from down and also to the front. Surely to cause a big deal of pain and some injuries.

The face must be the primary target in self-defense, or the temple if possible. Body, shoulders, arms and many other places can be distressed by the use of the elbow.

As I show in the picture, the tip of the elbow is the point of impact, concentrating the power in a single spot. Do not make the mistake of using part of the forearm to deliver the strike, as the effectiveness will be reduced.

Used in conjunction with the knees Muai Thai style will make your close combat striking a thing to be feared. Of course, striking can be used as a set up for a lock or a throw (or after a lock or a throw, depending on your preference).





Kumade, bear's paw.

Consider it a soft weapon that can cause a bloody mess in any face. Not really good for attacking the body.

Remember to bend the fingers enough, to protect them.





Hiraken, fore knuckle fist.

No, not for the body. Good for the eyes but better as a substitute for nukite if fighting a bigger person or someone with heavy clothes. The fingers can get bent and break but with hiraken they are somewhat better protected.

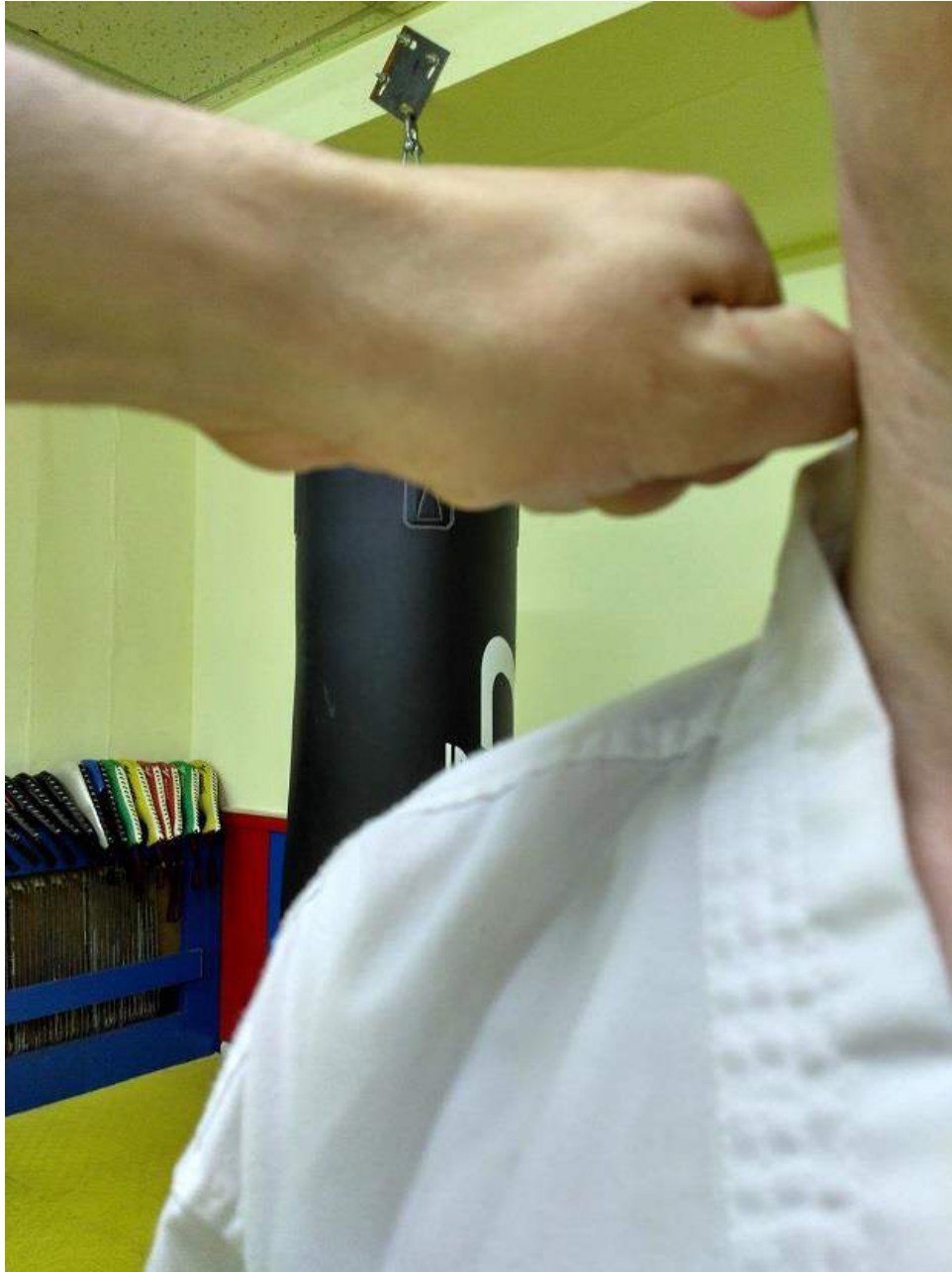

Boshi ken, thumb fist.

Ideal for attacking the side of the neck (better if both sides at a time) it requires really low skills to make it work. Make sure to find the vital points to get the desired results. Not a finishing technique but a painful one. You will need to keep fighting, so maybe good as a way of releasing yourself from a bear hug or a lock, or if the fight has come to the ground it can be used as a disengaging trick to regain your feet quickly.

It can be also used in other vital points (like the ribs or armpits) for the same results.

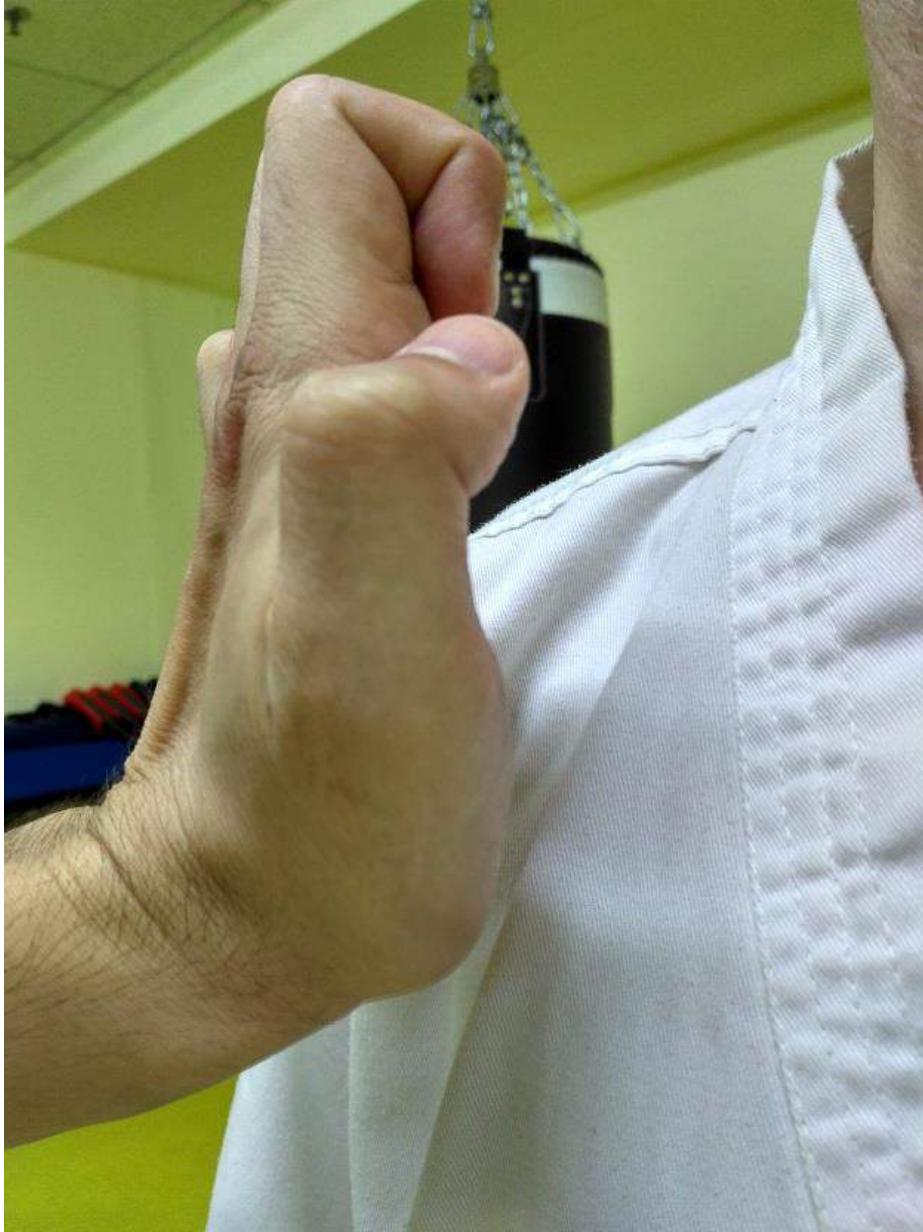

Teisho, palm heel.

The difference with kumade is that in teisho you strike with the heel, not with the whole palm. It help to concentrate the damage in one point.

Used in Jion kata, I find it useful as a body attack when you are sideways to your opponent, but my favorite application is as a substitute of seiken to the

face. To use seiken to the face your hand must have the right orientation and shape to hurt without being hurt. Using teisho you can be less careful about hand shape and just hit with full power. Teisho is not likely to be damaged when hitting hard (maybe just some pain, but no real injury).





Uraken, back of the fist.

Showed in the picture as a body attack, it may work better when attacking the temple (if used sideways) or the face (if used from top to bottom).

You should hit with the two first knuckles, as in seiken, to hurt and not get hurt. If you hit with the back of your hand to a hard surface (as the chin) the small bones that hold your hand together will break.

There are two ways (that I know) of using it: one is keeping the wrist straight and the other is keeping the wrist relaxed and mobile.

If you keep it straight the energy transfer should be higher and your wrist should be safer. Also, this adds some tension to your arm giving some protection to your elbow and shoulder too.

If you leave it relaxed then the fist will have a whip-like effect, making it faster at the end. More speed equals more power, and also bigger chance of getting injured.

I practice both ways and I am sure of paying attention to which one I use. You can also try both and decide which one works better for you, but follow your Sensei instructions.

I use it during kumite, specially sideways, to attack the head or, mainly, the shoulders.



Tetsui, hammer fist.

A very safe technique, as it is unlike to break any bone doing it.

Tetsui can be an attack to the body or the face, mainly. Not likely to damage shoulders or legs.



Haishu, back of the hand.

Featured as the first technique in Tekki kata, I believe it is meant as a slap in the face used as a distraction to buy some time to use another technique.

In Shorin Ryu versions on Naihanchi the technique is substituted for a haito to the neck, making it a finisher from the spot.

Pictured in a really useless way, hitting the chest, it will work as a deterrent against weaker people (children and small adults) where the use of full force will not be adequate to the situation.





Seiryuto, ox jaw hand.

I just discovered it while surfing the net, so I do not have much experience with it, but I will comment on the anatomy of it.

It looks like the impact is made with the pyramidal bone, a small bone in the edge of the palm opposite to the thumb with the shape (roughly) of a pyramid. This bone is an evolutionary remora and it is disappearing from humans,



although still a big percentage of us have it. If you have it you can feel it move, as it is not acting as part of any joint.

It is so small that is almost impossible to break it. Probably a good attack to the temple, or a good substitution for shuto uchi if you need some more hardness.



Kakuto, bent wrist.

Please note that my finger tips are all together in the picture: this is wrong. They must be tense and separated a little bit. This will make the striking surface stronger.

Great weapon to attack the temple, the face (Chinese style) and the chin (specially if you are being hold and can not make sure where your technique will land).

It can be dangerous for yourself if you do not bend the wrist enough, because you will impact with the thin bones in your hand, hurting them.

We have this technique at the end of Suparinpei kata.



Washide, eagle hand.

Keep your fingertips together to attack the eyes or under the chin. Probably not many other uses, but it appears twice in Gojushiho Dai kata, so I will keep researching washide.

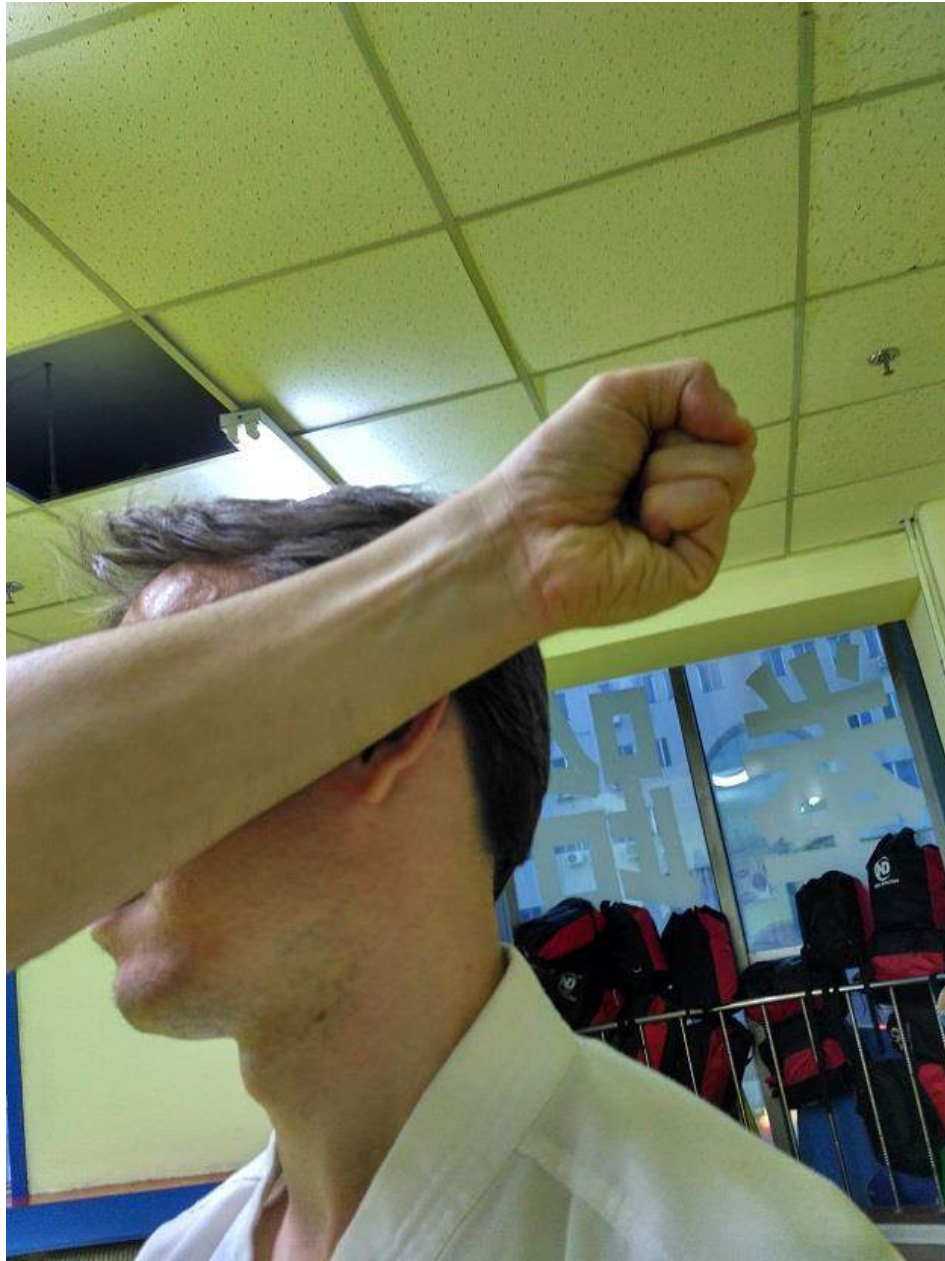

Haiwan, top of the arm.



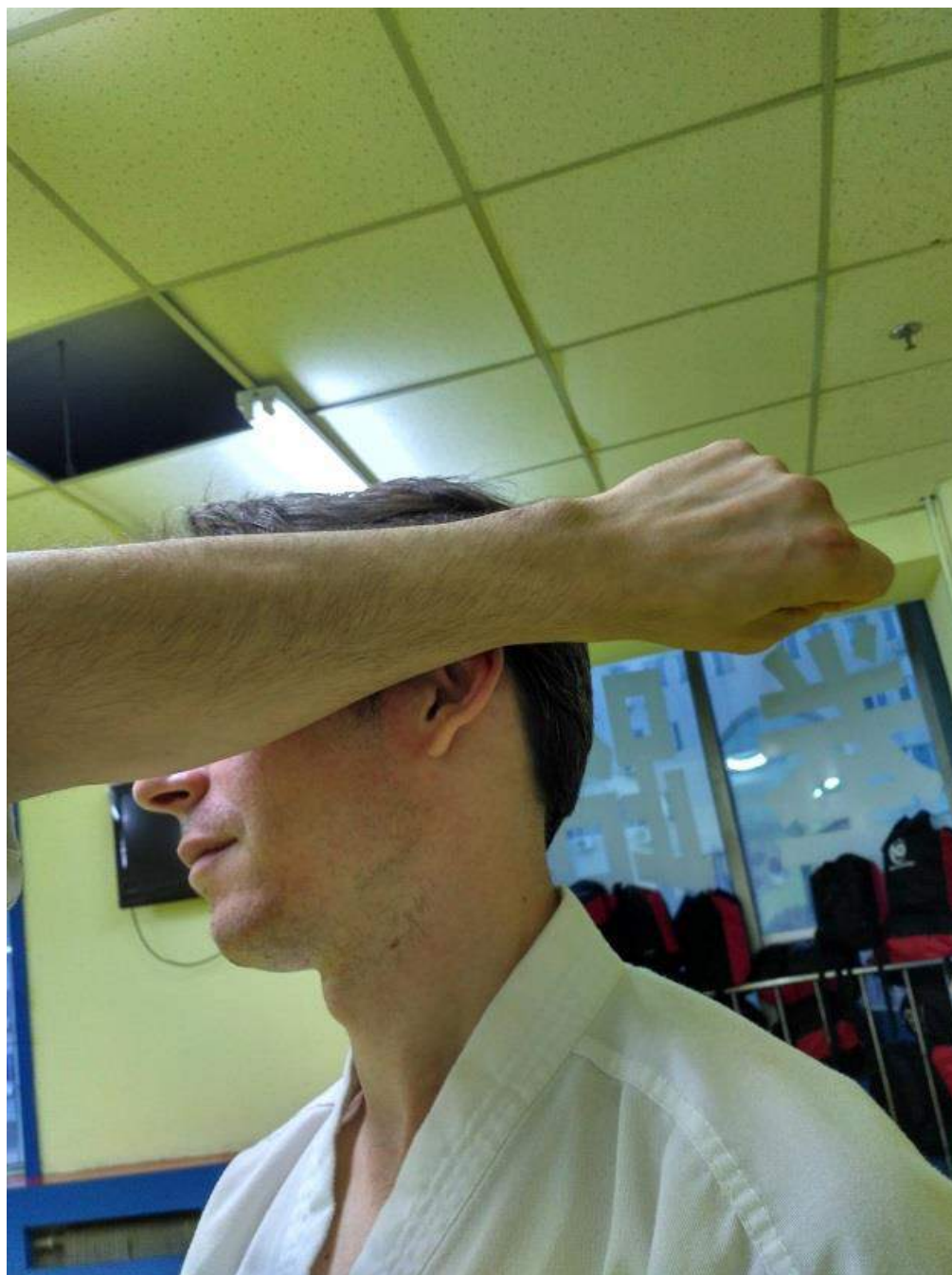

Shuwan, bottom of the arm.

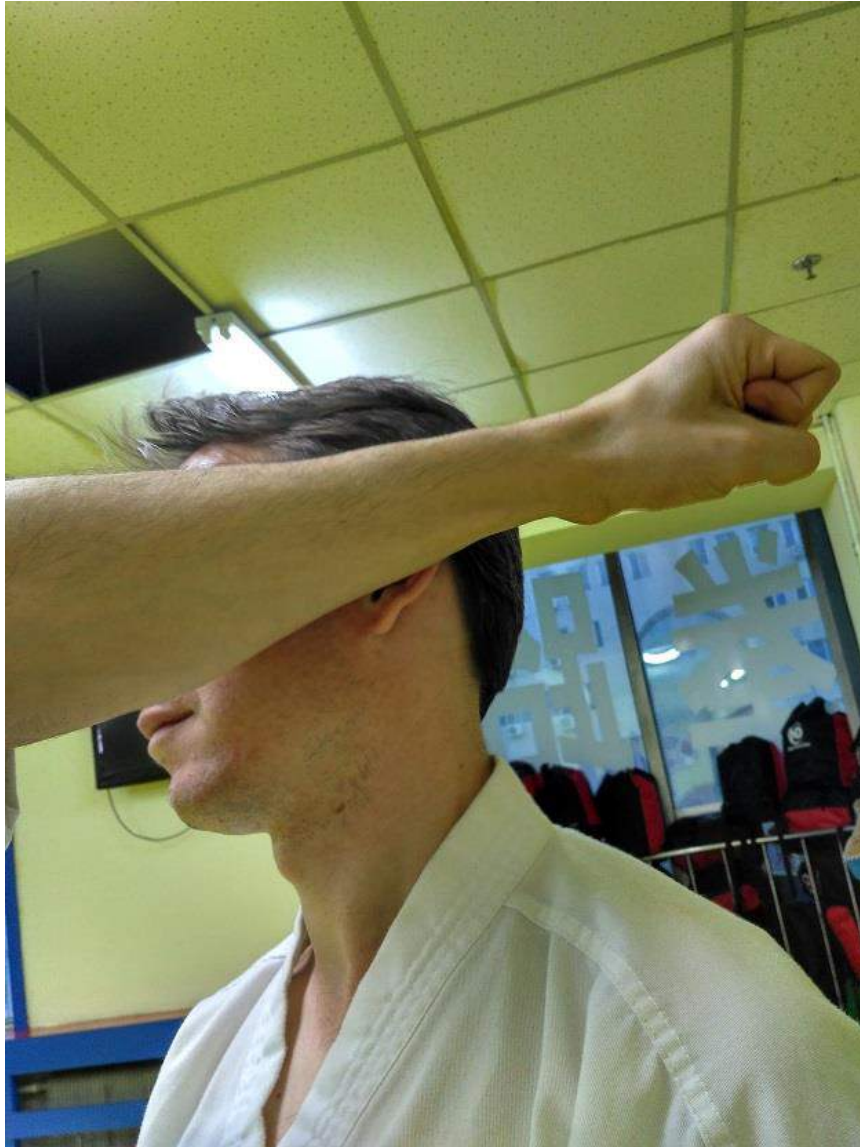

Gaiwan, outer arm.





Naiwan, inner arm.

These four pictures show the four surfaces of the forearm that can be used to block, deflect and attack.

I would recommend that you harden them to increase the functionality of your arm.

Used in soto uke, uchi uke, age uke, gedan barai and many other defensive techniques, I would only use the forearm as an offensive technique if I am too close to use my hands and too far to use my elbows, making the window of usage very narrow.

Also, as the ulna and radius are long bones and not too thick they can break on impact if the power is hard enough and they hit a heavy surface, as a head.





## Chapter 7: Of vital importance

Let us have a closer look to vital points.

As stated before, attacking vital points will cause pain and compliance, but are not easy to use. If trained properly their manipulation can make your strikes more powerful, release you from a grab or hug and increase the likeliness of success in a joint lock.

They can be protected by something as simple as normal clothing, they are difficult to spot on a moving person and the adrenaline rush that you will feel during a fight will make your fine motor skills disappear making the task at hand even more complicated. These reasons also support my idea that the training sessions must be full contact in order to get used to use your techniques under unfavorable conditions.

But, what are vital points? Under this esoteric name are what also can be called pressure points. They are not magical places where you can kill your enemies with your fingertips but anatomical structures that can be rubbed, touched, hit or manipulated to cause pain. As karateka we can use them to increase the effects of our blows, to enhance techniques or to subdue without hurting.

The vital points are points of the body where nerves cross, where they are closer to the skin, points where blood vessel surface, weak parts of tendons...

They are not insubstantial points but real parts of the body that hurt more when attacked. We all know some of those weak spots but we are going now to check them on a Chinese acupuncture map. Acupuncture points are not the same as the vital points that we are studying. Acupuncture theory is based on meridians (qi vessels that run through the body), theory that I am not familiar with, but most vital points are located in acupuncture points. We will use the following charts as starting points. The reader can use them to check his/her own body and see the effects: self-discovery will lead to better remembering.

According to acupuncture theory, any manipulation of the points in the charts will produce positive benefits, so do not fear a potential health problem by just checking if it hurts or not.

If it hurts, it can be used in actual combat.

You will find a little information in the subsequent pages about how to induce pain and the body weapon that I find more suitable to do the job. But if you happen to have an object in your hand it can also be used to attack the points: a key, a ball pen, a spoon, a stick... or even a pressure-point-fighting designed weapon, like the kubotan.

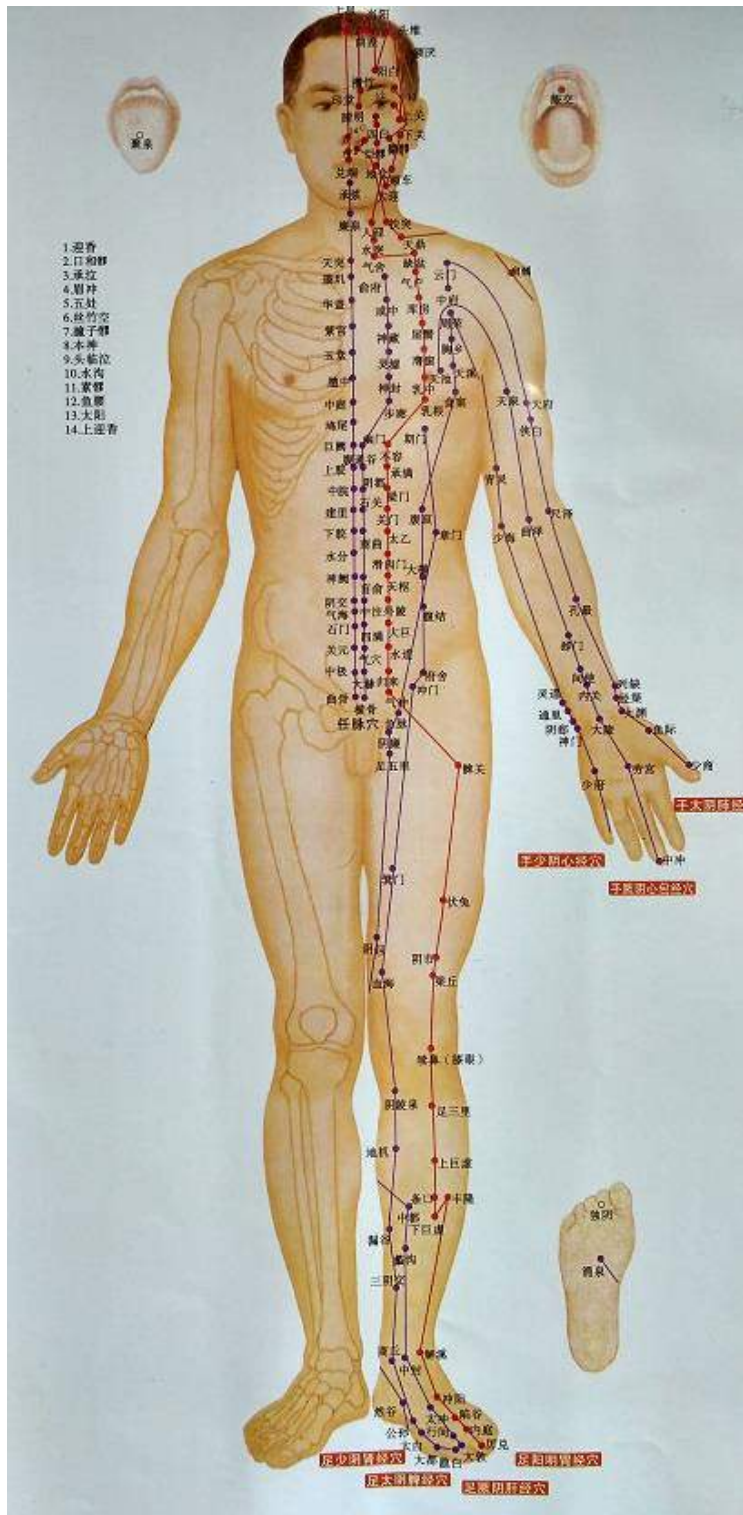

In this whole body map you can see the center line that runs from the head to the groin. Attacking the center line will always produce a good effect. The points in the sternum can be attacked by seiken, the points in the face by any body weapon.

The ones in the chest (not the center line ones) are located in the pectoral muscle, one of the biggest and strongest, so a punch there may cause pain but not enough to end a fight. Better attacked by knuckles during close fighting, as on the ground.

The point in the center of the arm, over the elbow, will be really painful when inserting the thumb there.

The points of the leg can be attacked using the heel. Even if your kick misses the point it will be a useful technique.

The one at the top of the head will cause a knock out if kakato geri is used.

The points of the foot can be attacked with a stomp if you are grabbed from behind, and also using your toe to step on them.

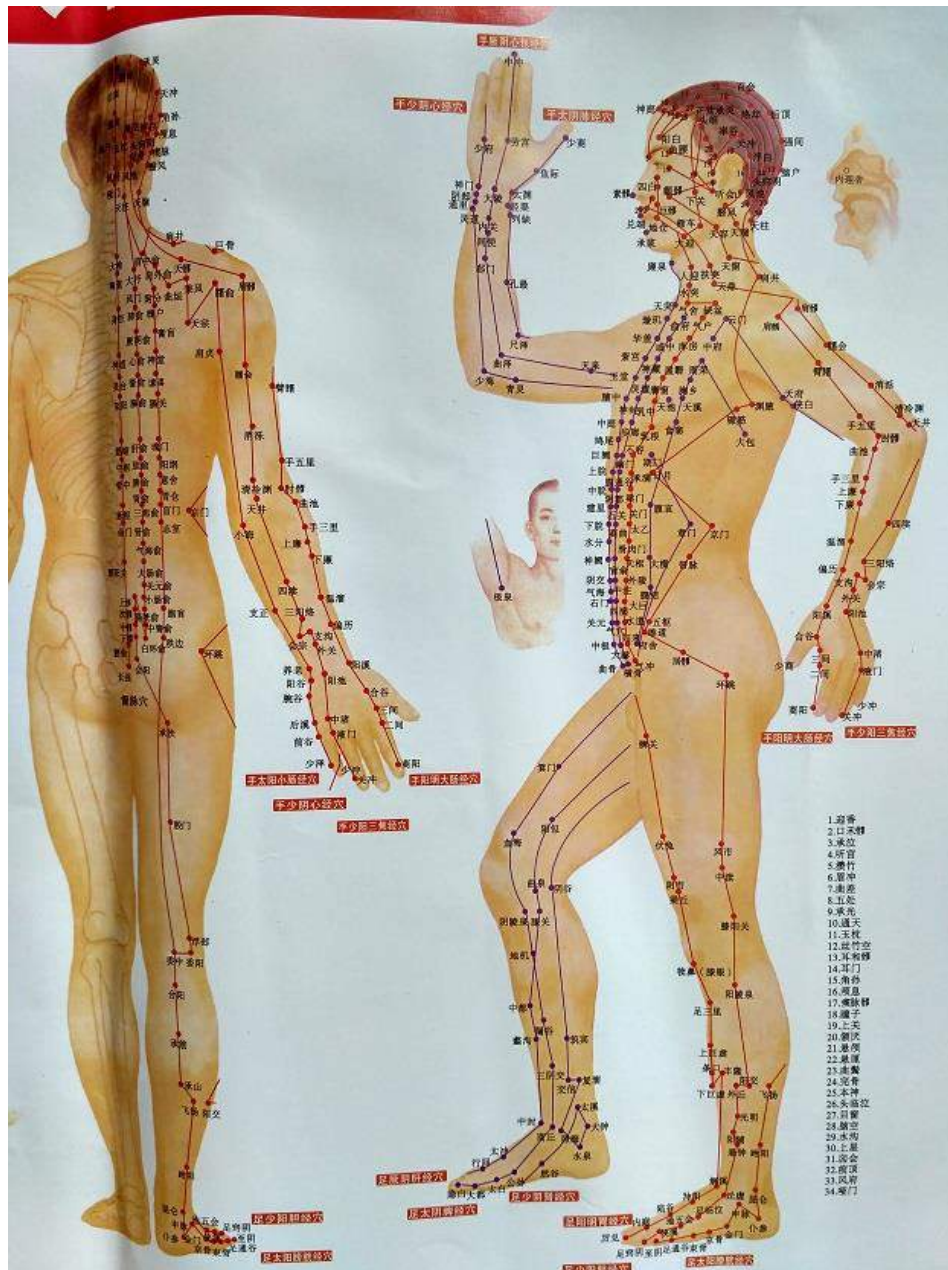

In this side view we can see a small detail of the armpit. The tumb can be used there, for it is difficult to access with a punch. A yoko geri kekomi using kakato can be used too.



The shoulder can be punched with mawashi tsuki causing the arm to stop responding.

The points in the ribs under the armpit can be punched for a knock out or pressed with the thumbs for a shocking reaction.

You can notice that there is no mention of the weak spot in the middle of the thigh. But we can use it still. A good mawashi geri with the shin bone will work wonders. The knee is also a good option.

I don not recommend to attack the point at the hip insertion from the side, as it is a really hard place and it will be more painful for yourself, and also a waste of time.

All the points of the head can be used with a punch or other hand techniques, such as shuto or haito.

Regarding the back chart, the center line of the back runs over the spine, so any hard blow there will cause regrettable effects, so the highest care must be had.

The point in the middle of the calf is a ground fighting favorite.

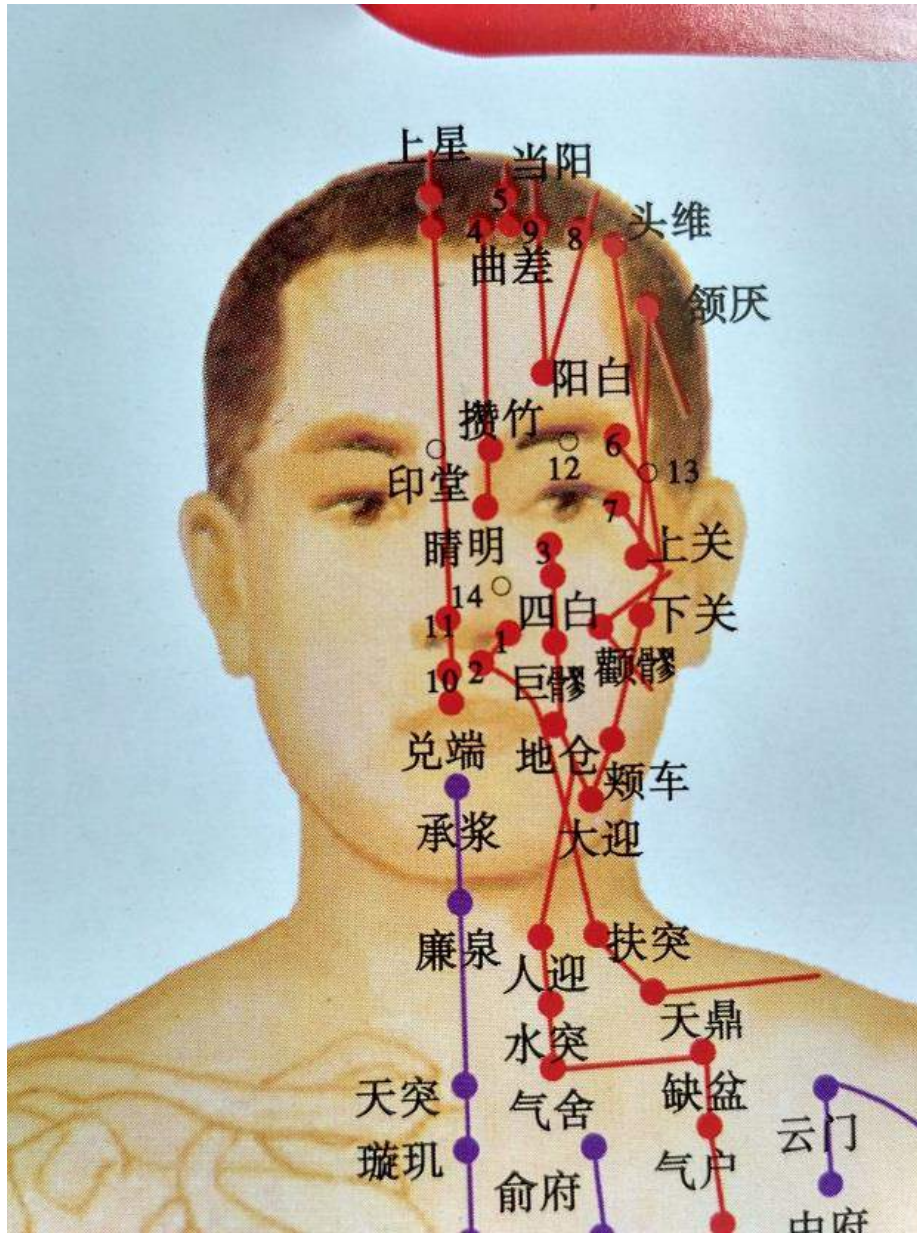

Let's have a closer look at the face chart.

The nose can be attached with seiken, or simply by using pressure with teisho. You can use the other hand in the back of the head to have augmented pressure, and this will give you the choice of where you want your foe's head to be.

The points along the jaw will produce unconsciousness if hit hard. It is what we see in boxing or MMA when a seemingly soft punch ends with one of the combatants on the floor.

Using the points of the neck and collarbones with nukite (all fingers or only one) to produce excruciating pain.



The points of the neck can be manipulated with the knuckle of the thumb, the fingertips or any point object, such as a call pen or a key.

The temple can be punched with devastating effects.



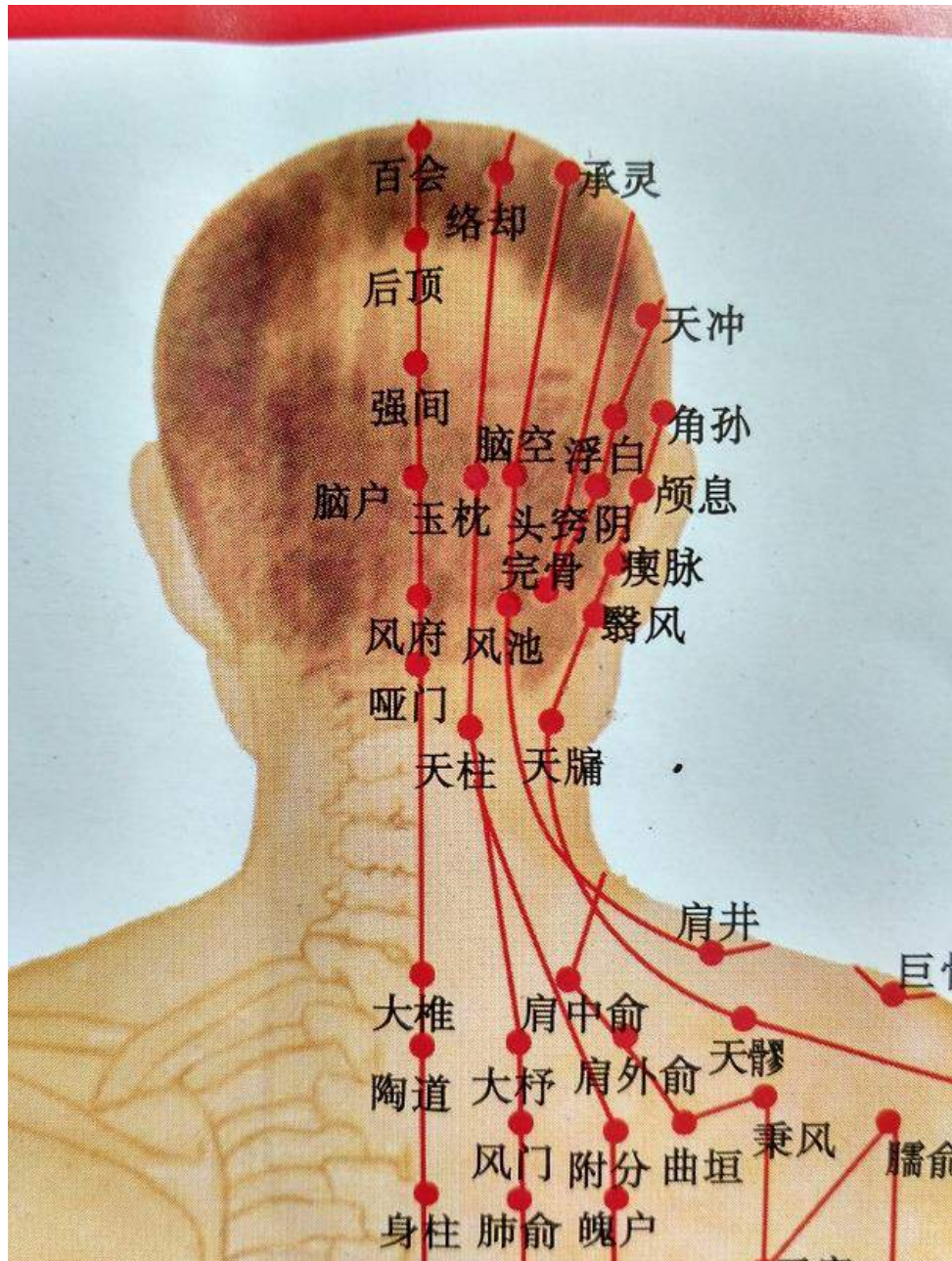

These back of the head points are not really suitable for manipulation.



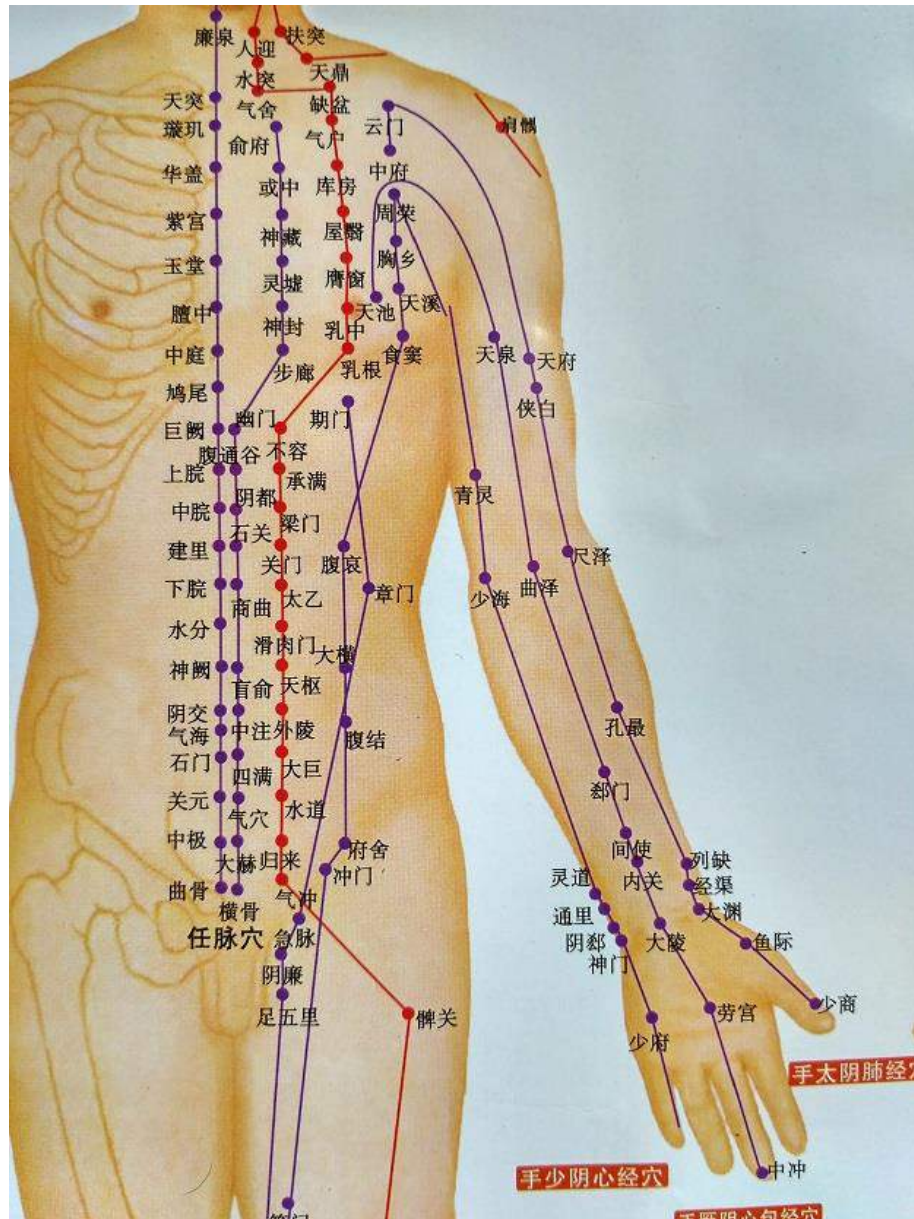

A closer look at the arm and hands reveals some places where grabbing can help to set up a joint lock. It also shows where to attack if you are being grabbed.

I want to pay special consideration to the wrist points (both sides). If you use soto uke or uchi uke to block a punch you will find that sometimes the block

causes a big pain in your arm. If you are the one who punches you can also feel it. They can be hardened to reduce these effects, but you can use them when you block to cause some pain to your adversary.

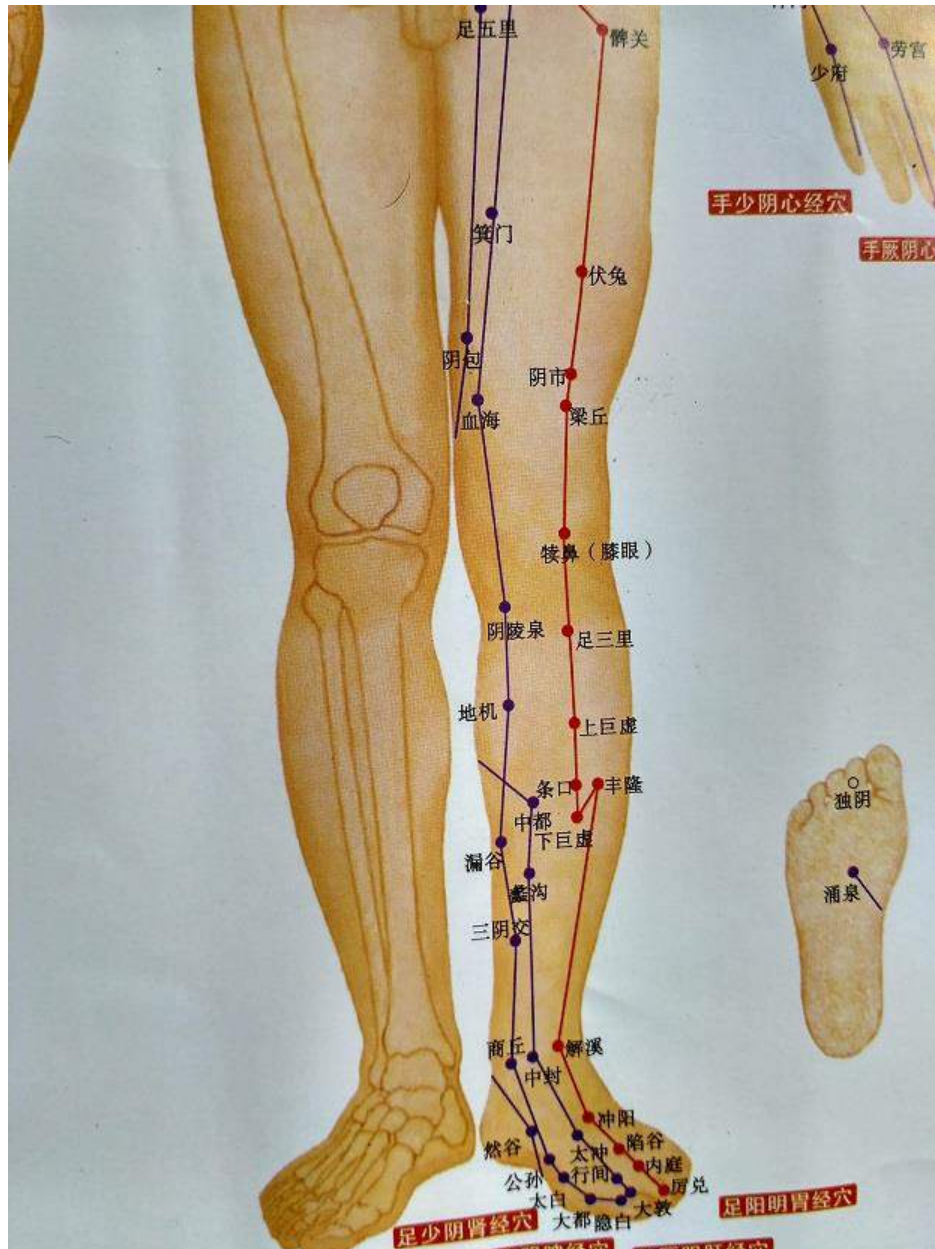



This close up of the leg shows a very interesting point, about five centimetres over the ankle, in the inside of the shin bone. If pressed with the knuckle 45° downwards it can take down a man as big as a bull. Easy as that. It can be also stepped on, Naihanchi style.

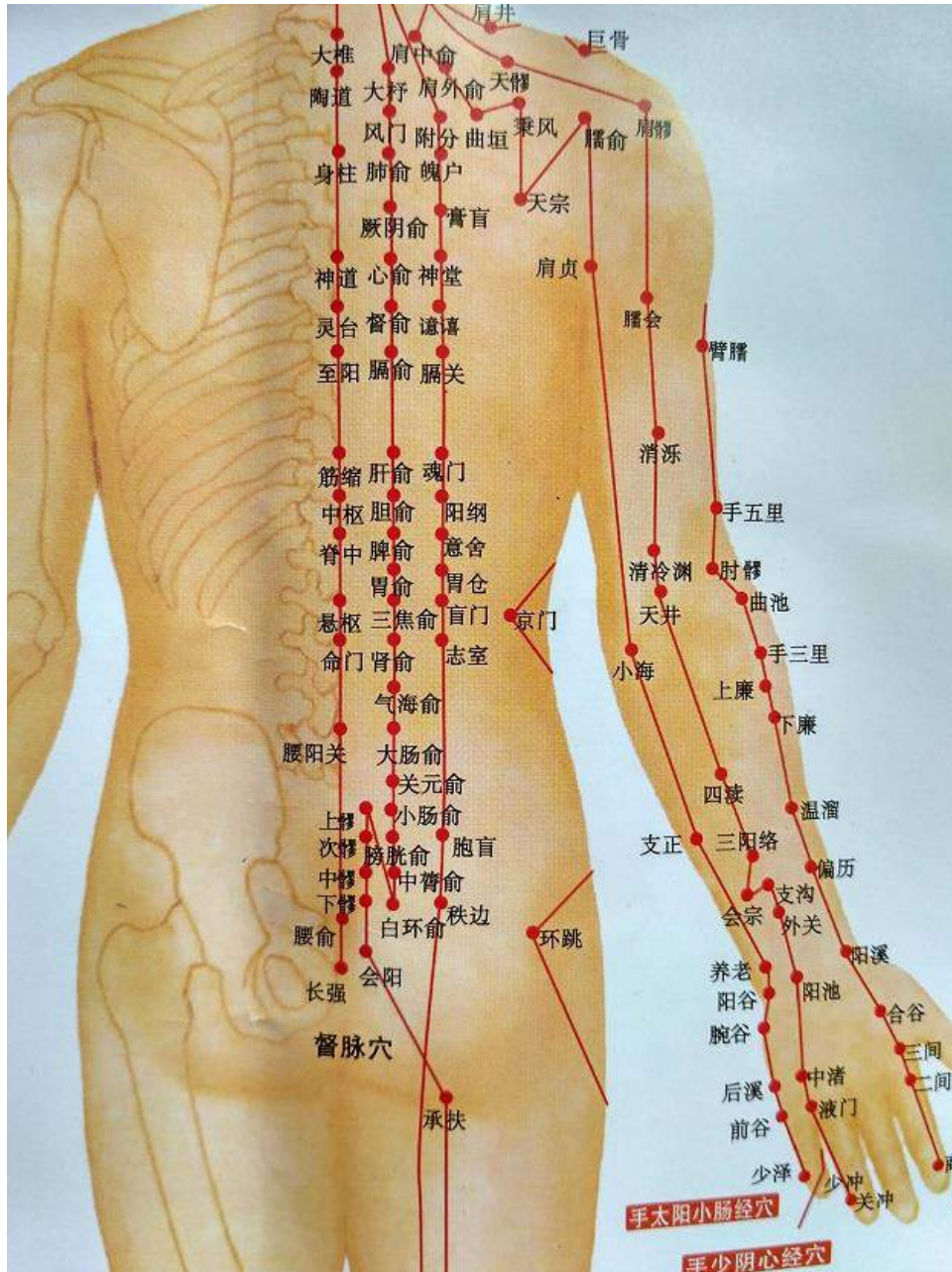

The point over the elbow (not the tip of the elbow, but the one just over it) is where you must apply pressure if you want your elbow lock to succeed. Miss it and it will not work. It can be pressed with any part of the hand, or any other body part: knee, armpit, shin, elbow...

The point just between the pinky and the ring finger can be attacked with your finger nails, as I painfully learnt in Okinawa.

The back of the forearm kind of mirrors the front side, and can the fingers can be used to cause pain, but a big force must be applied to make it useful.

A good technique if you are being hugged is to rake your knuckles along the back of the grabbers hand. There are plenty of places to cause pain, specially along the line between ring and pinky fingers.

Not marked on these chart but the the anus is a place that can cause a great deal of pain and discomfort. Not exactly elegant, but useful.

You can see the coxis end that can be broken with a kick with really serious results.

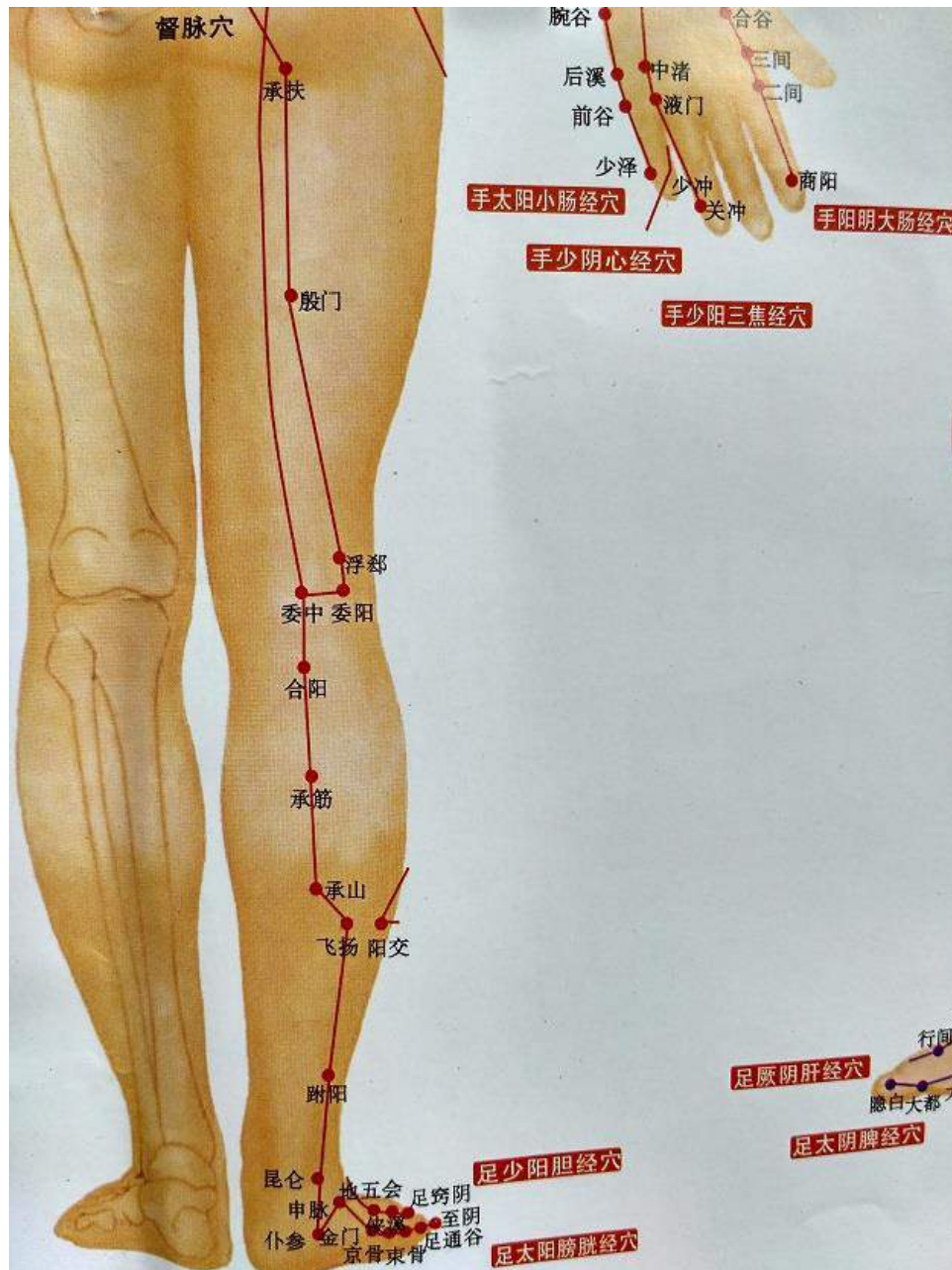

A closer look to the back of the leg and edge of the foot. The edge of the foot may be easier to reach than the back of the leg, so you can experiment with it.



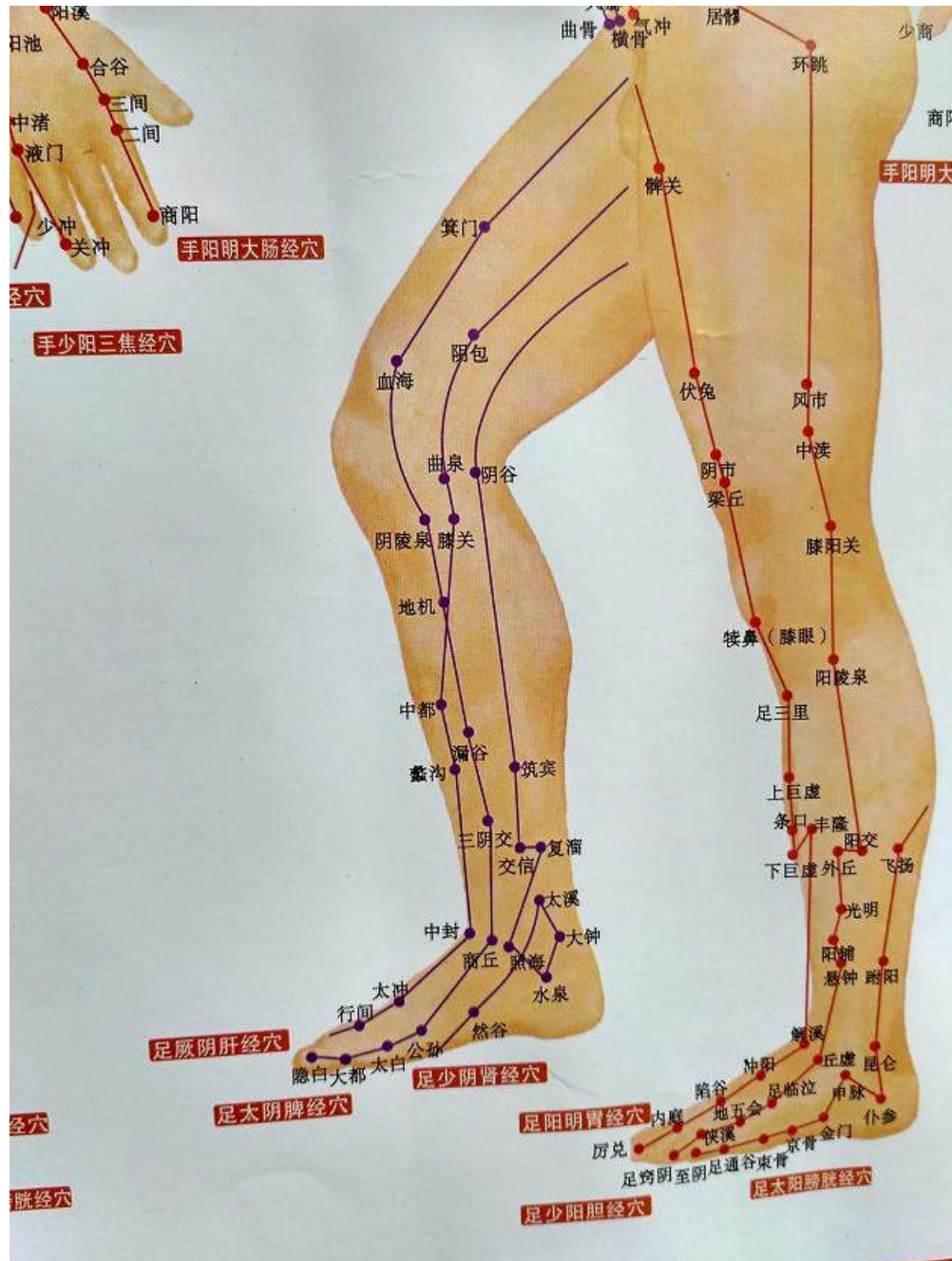

Some knee points where you can kick to produce a break or a throw.

After knowing several of these points one must try to use them while training to achieve results related to self protection. As an example:

- have a partner hug you and try to escape pressing on the ribs, nose or neck points

- experiment with an elbow lock using and missing the vital point to see if results change

- lay down under a partner pinning you and get rid of him attacking the nipples, the ribs or the back of the hand

- get mentally used (also mentally used) to kicking the groin of your partner (with protection or without much power)

- grab and twist the ears to achieve a head twist

- the anus is a painful place that can be attacked with the thumb in close quarters situations and will cause a shock

- not a vital point per se but twisting (or breaking) a finger will render a hand useless for fighting

- placing the thumbs over the eyes, using the palm to secure the grip on the face, is a favourite Okinawan kumite technique

These special places of the human body can also be used to achieve health benefits. I am no expert on these matters so I will just make a shallow introduction.

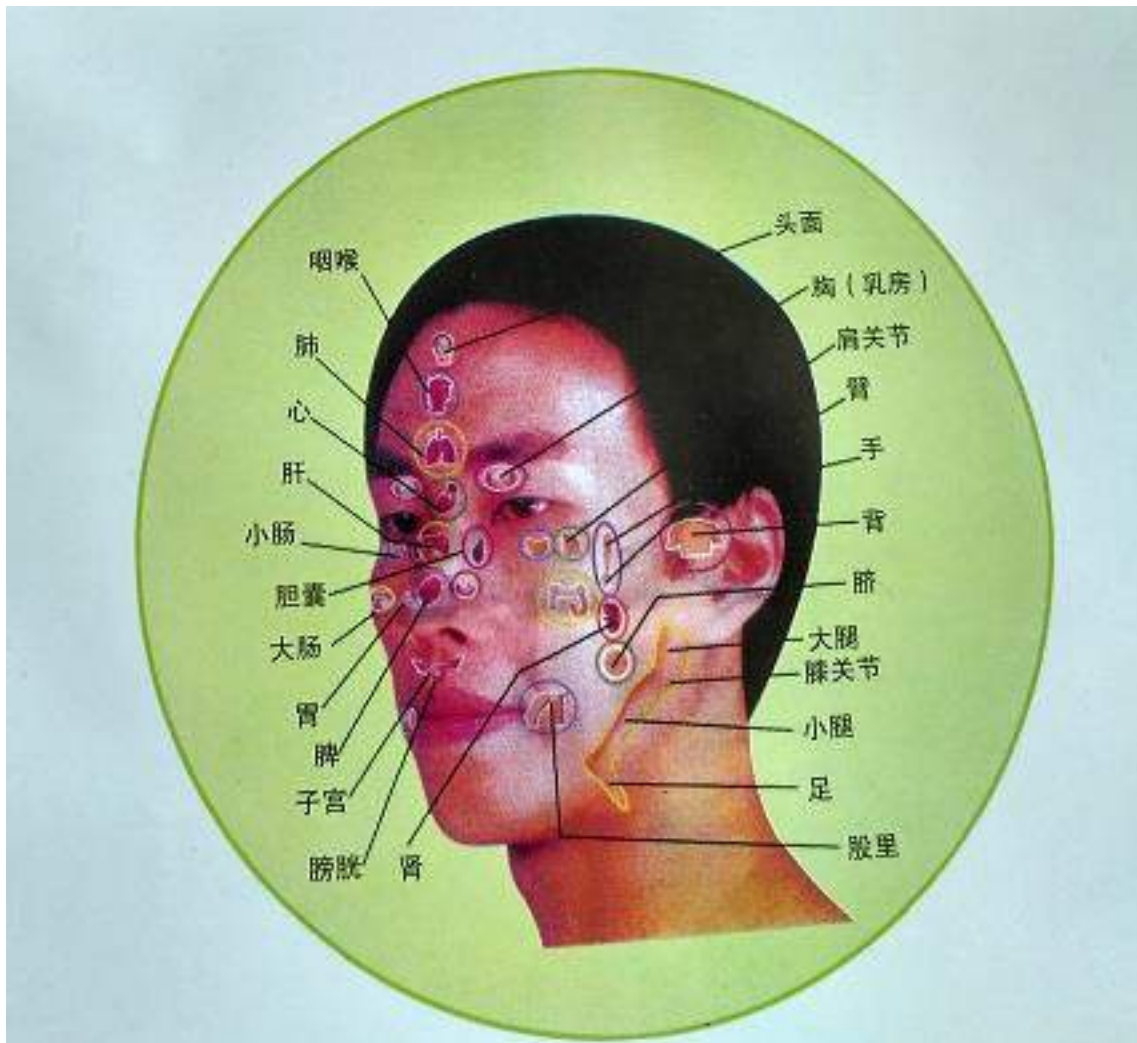

This picture shows how different points of the face are (supposedly) connected to the organs and other body parts. This is based in ancient Chinese medicine

theories, with which I am not familiar, but I included it because the readers may be interested in this extra information. Sadly, I can not translate the writing, but there are illustrations to help you understand.



The hands also reflect body parts. Massaging the points in them can lead to improved health in your organs. All points should produce a little bit of pain when manipulated.



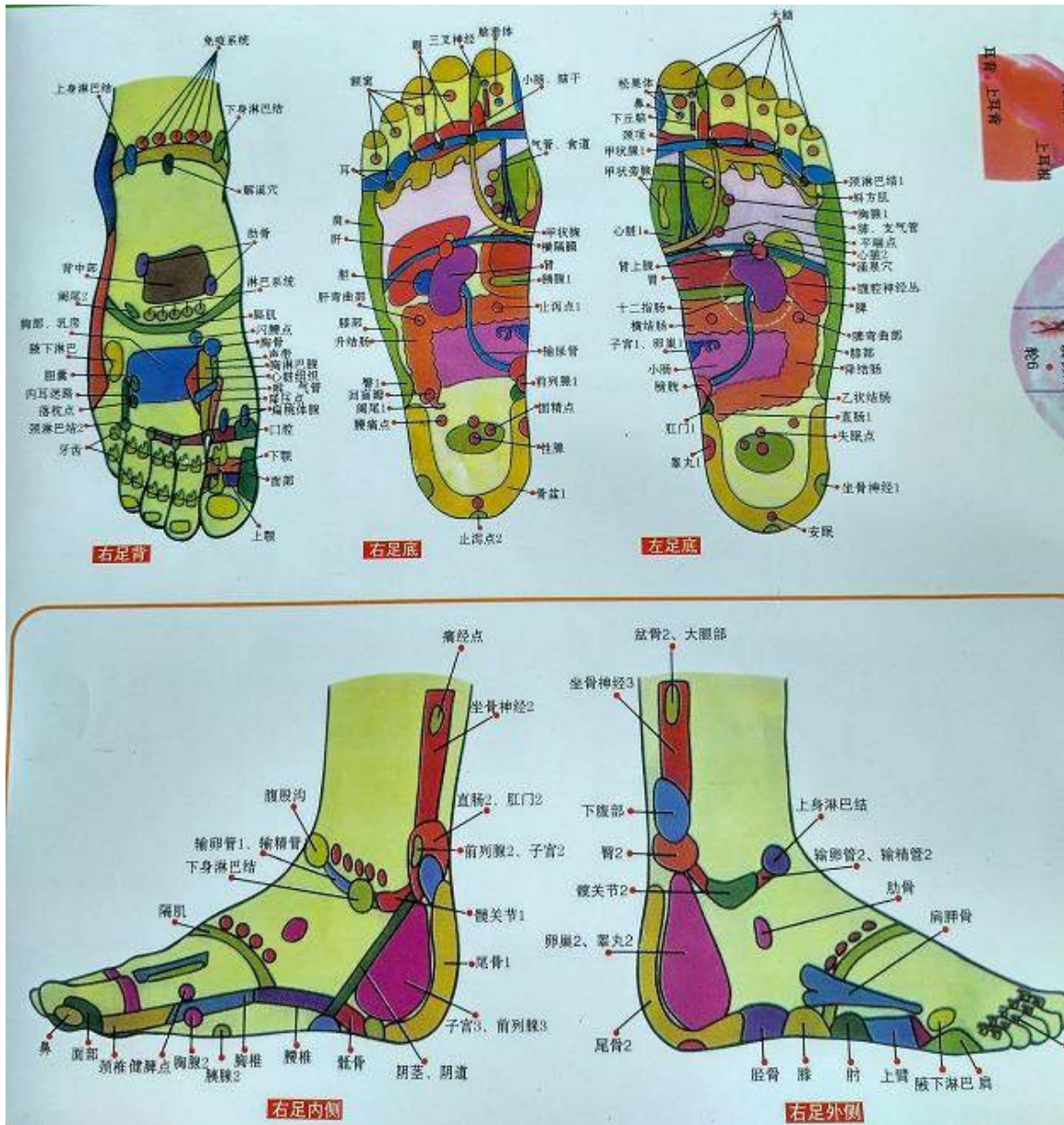

The feet seem to have those organ connections too, so the sole can be massaged to access to health benefits.



So, what can you do if your enemy has knowledge of these vital points? Should you lose all hope?

Actually, you can resist a vital point manipulation. There are several components to it, but the fundamental one is that you can train yourself to endure the pain. Easy as that. You can locate a point in your arm and rub it with your knuckles and cause pain to yourself. You will get used to it. I remember in my old Dojo we had competitions to find out who could endure it for longer time.

One of the effects of training this is that you will learn to recognize the feeling of it, so you will not be caught by surprise. You will know the reason of the pain so you can just discard the discomfort and focus on the task: defending your physical integrity.

A thing I do when I get a massage is asking the masseur to do it strong. That way I get used to hard manipulation of pressure points and also helps me to locate new painful spots.

Before you try it, your eyes will not get used to it, so do NOT try.

As a side note, you can notice that most of the martial arts books assume that the attacker will be a male because, as a matter of fact, males are more prone to fighting. One must assume that when attacked one will face a bigger and stronger enemy so determination and technique must go together in order to save yourself.

But the thing is that you can also be attacked by a woman that is bigger and stronger than you. In this case, all the information in this book still applies but we can add another painful part of the feminine anatomy that can also be used to protect ourselves. The breasts are a very sensitive part of the female bodies and any punch, push, pinch or twist will most surely help you break a hold and buy you some time to escape.

I have never read this advice in a book, and I know it can be controversial, but I feel it can be useful to someone in a moment of danger so I decided to include it.

As a conclusion, I will add the vital points used in Judo atemi waza (yes, Judo has atemi waza):

1. TENTO (heavenly knock out). Position: The middle of the crown of the head. Blow: Downward with the fist.
2. UTO (the sun and the moon). Position: The roots of the eyebrows. Blow: With the fist or knee.
3. JINCHU (center of man). Position: The base of the nose. Blow: With the fist, side of hand or knee.
4. GWANTO (the head of rock). Position: The point of the chin. Blow: Upward or downward with the fist, knee or foot.
5. KASUMI (mist). Position: Temple of the head. Blow: With the fist or side of the hand.

6. SUIGETSU (watery moon). Position: Solar plexus. Blow: With the fist, elbow, knee or foot.
7. DENKO (lightning). Position: Right floating ribs. Blow: With the fist, knee or foot.
8. TSUKIKAGE (shadow of moon). Position: Left floating ribs. Blow: With the fist, knee or foot.
9. MYOJO (bright star). Position: About 1-1/2 inches below the navel. Blow: With the fist, elbow, knee or foot.
10. TSURIGANE. Position: Between the legs. Blow: With the knee, foot or fist.



## Chapter 8: May the Force be with you

Let me talk now about power. About raw power. About how to produce enough power in your techniques to really overcome a much bigger or stronger opponent.

To simplify, I will focus only on front hand punches, oi tsuki (jabs), but the principles behind this chapter can be adapted to blocks, kicks and other kind of techniques as well. I will also forget to mention about the relationship between mass, weight, acceleration and speed, as I feel it would complicate the writing (and the reading, specially) too much.

There are always two components in a powerful punch: power generation and power transmission.

Ever thought of the two as different entities?

I have met countless martial artists in my life who were good at only one of them, producing substandard results in their techniques, even if they were strong people.

Please, excuse my (lack of) artistic skills that I will use to illustrate my ideas. I hope they, at least, serve the illustration purpose I intended.



First, power generation.

The important idea about generating power for your punches is that they must travel as fast as possible from their current location (hopefully near your chin) to their intended destination (your enemy's face).

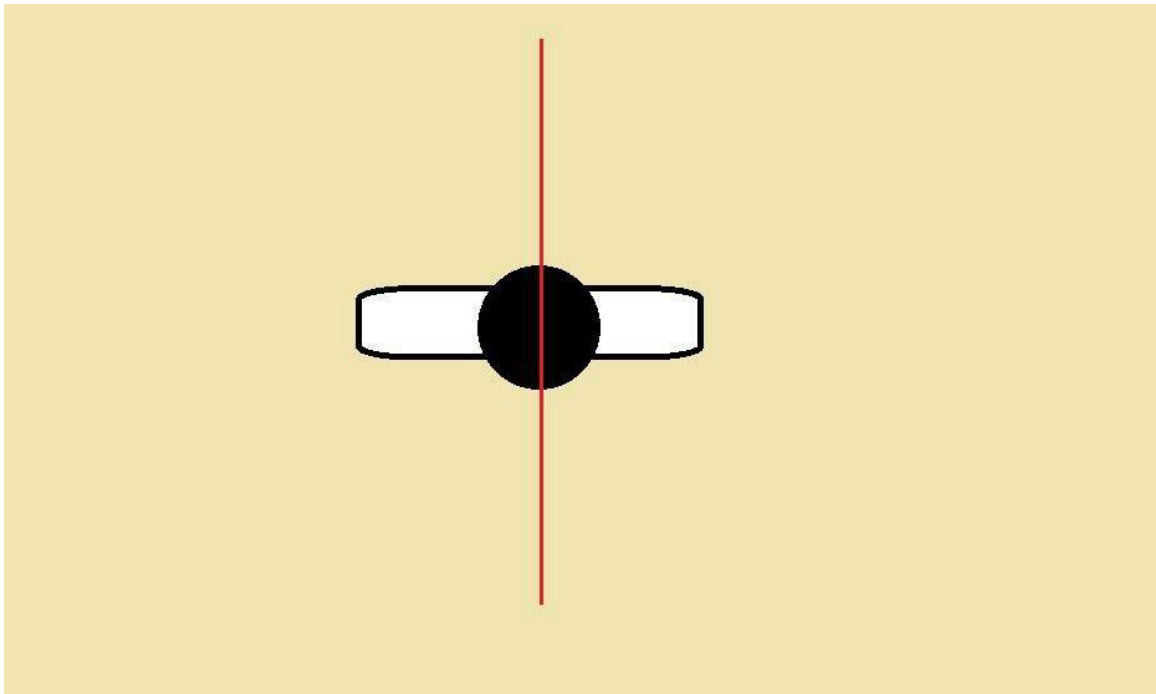

Here we see a fellow karateka form above, facing North. For simplification purposes we will assume his shoulders and hips are on the same line.

His center line is pictured in red.

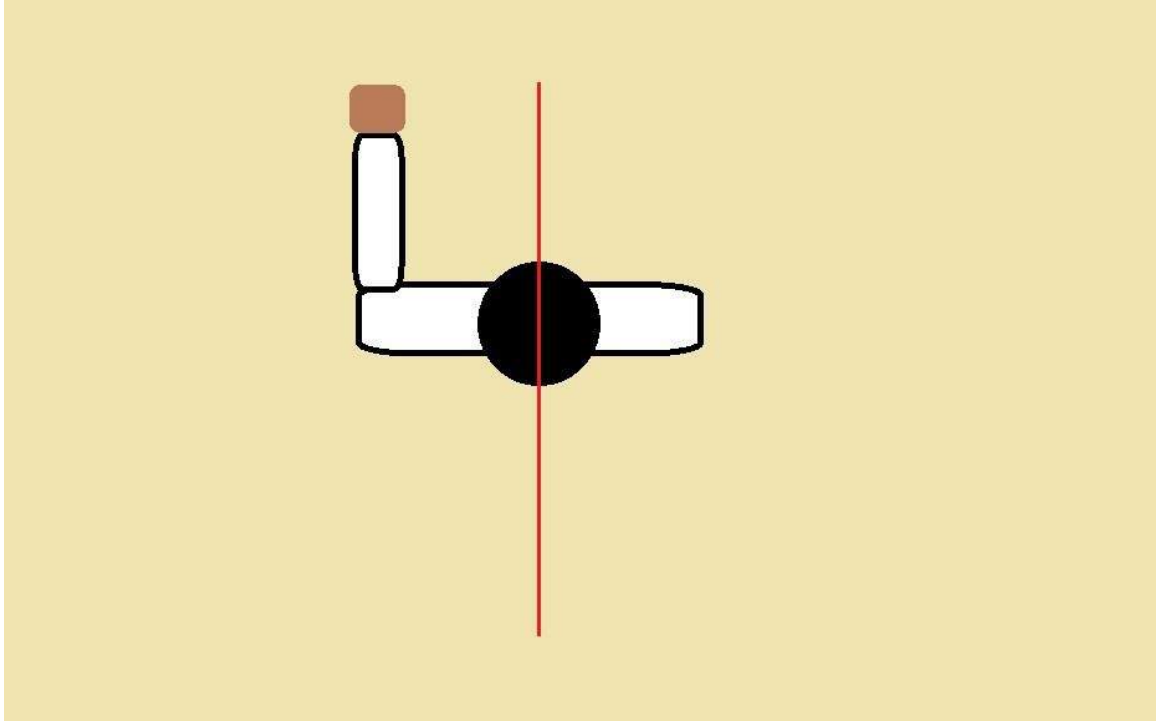

As we know, just moving your hand forward will not be strong enough, so we need to add our hips (whole body, actually) movement behind it.

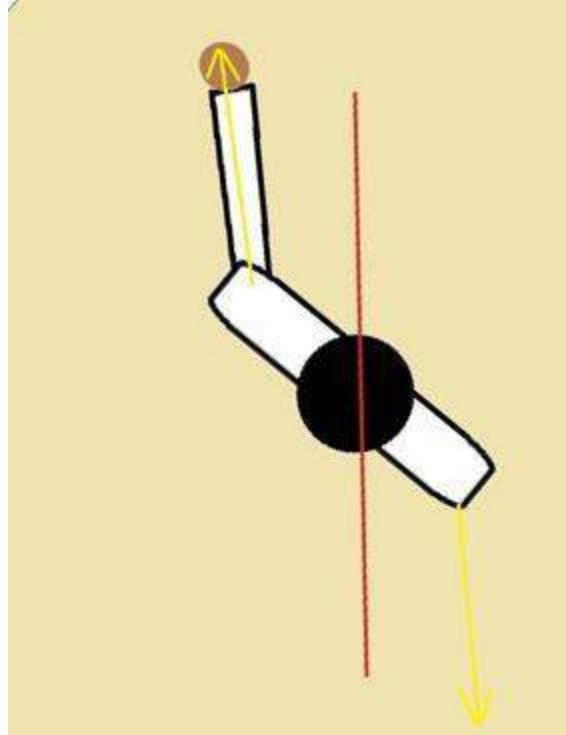

Twisting of the hips and moving the shoulder forward is one movement that us karateka are familiar with.

The problem with this is that many people twist their hips around their center lines. This causes the force to be produced forward, yes, but we are also losing some body weight that we could be adding behind the fist. Here, pictured in yellow are the body weight movements that go forward and backward.

So, what can we do?

The ideal movement is to twist your body using the opposite hip as the center of rotation:

The right axis of rotation is pictured as a blue line.

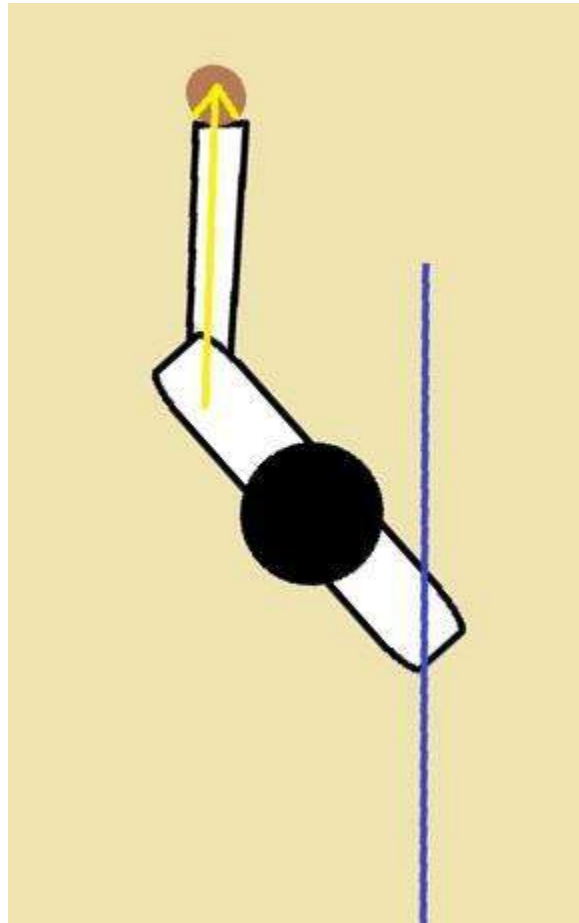

Here we see how all the forces travel in the same direction, making the punch stronger.

In the same fashion, for a reverse punch (gyaku tsuki, cross) we need to use the opposite hip as the center of our circle.

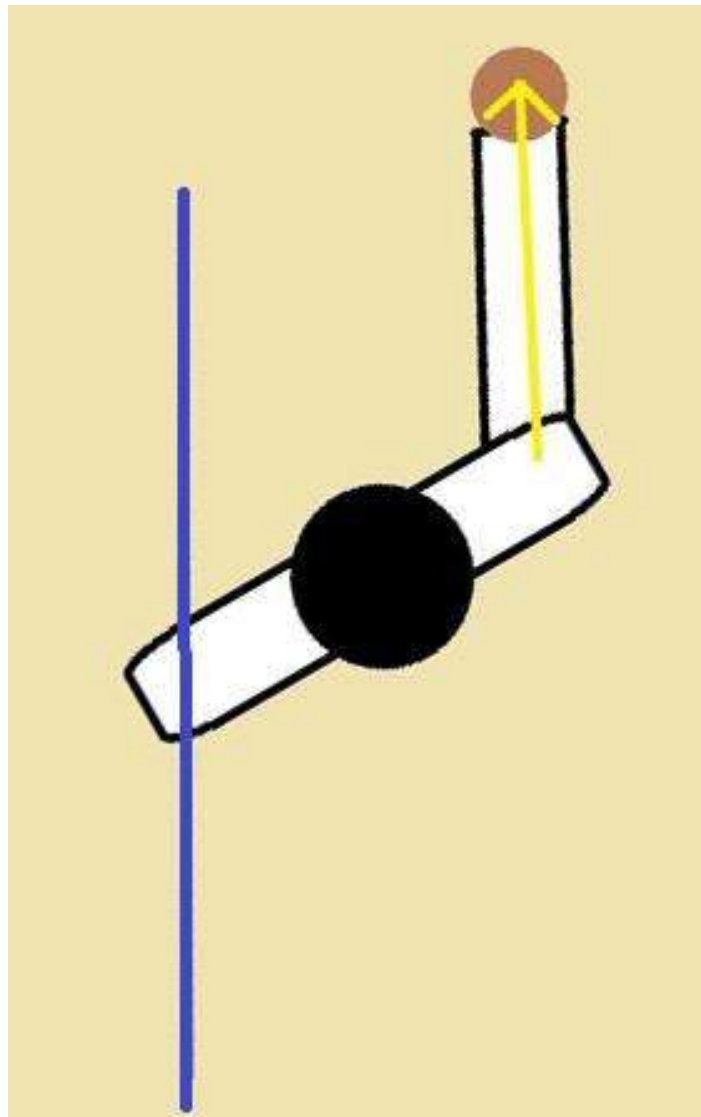

See how all the body moves behind the fist?



This is the way to make more weight travel behind your fist without the need to make the arm bigger (which you can also do).

I do not want to confuse the reader into thinking that this is the only way: moving towards the enemy, raising and lowering your body, pushing the ground forward with your feet and some others are all valid ways of increasing your punching (or kicking, or blocking) power, but I wanted to focus on the horizontal level because it is there where I use to see more mistakes being made.

So, how can we transmit all this newfound power into the enemy's body?

First, we need to aim into a point that is behind the surface of his skin. We need to aim for somewhere inside his body (some suggest his spine) so our power can travel inside him and produce the effect we want.

Second, our full body must be hard enough to not leave any energy scape. In the same manner that all striking weapons are made of stiff materials (wood, metal, PVC...) our body needs to be hard a rock when we hit. Loose muscles are great for the most part of our lives, except when we make contact with a foe. *Kime*, we call it in Karate: a split second contraction of all our muscles, tendons and joints in order to deliver our power without letting it be lost.

This is the reason we *kiai!* Shouting and yelling when we practice techniques is no (only) to scare the enemys: the abdominal contraction that you achieve

while yelling will make your core muscles, your abs, your legs and your arms all contract at the same time, producing this amazing hard-as-a-rock body that can hit really hard.

Practicing Sanchin will help with this matter too.

Also, contracting the whole body while striking will have a protective effect if you are countered at the same time.



## Chapter 9: On the dance floor

To be a master of ground work one must study an Art focused on making you superior to the other guy, focused on achieving a better position where you can pin or subdue him/her, focused on victory by way of attacking the blood/air flow to the brain and by way of joint dislocation.

Judo is a more complete Art, but shares its time between throwing and ground work. Brazilian Jujitsu is a more specific Art focused almost exclusively on ground fighting, so the reader (if interested) must try and decide what works best for his/her purposes.

Having the skills to dominate another human being if you find yourself in the unlucky position of fighting on the ground will prove worth the effort to acquire them.

But spending time on the floor may be fatal when you are attacked by more than one person (you will never know before it is too late) so your goal must be to regain your feet as soon as possible. If it is not possible then you must finish the fight before being free to stand up again.

Of course, some of the techniques on the ground are useful while standing as well.

And, please, do not forget that you can also strike your enemy while one or both of you are on the ground.



Being under an enemy does not mean you can not strike him.





Using the elbow in close quarters can be easier than using the fists.



If you can bring your knee to his head you may gain an advantage.



Try to strike in vulnerable points, such as the nose, the temple, the groin...



Try to practice all the kicks you know, but while you are under another person.





When someone is on top of you is a perfect moment to use the vital points to cause pain and disruption. This can break a grip and buy you some time.





This point is vulnerable to manipulate. When hit hard can shut down a person.



Use any technique that feels natural and has big chances of working.



Grab the ear to gain head control. Doing this you can easily reverse the position and end up on top.



Hair pulling is also possible.





It is always a good idea to practice some arm bars and submissions because, even if they are not the most practical solution to being attacked, sometimes the fight can put you in the position of pulling one.





The triangle, as shown in *Gankaku kata*, is an easy and powerful technique.



The top position has always the advantage, so you must try to get it. If you can sit on top of his torso then you can have punching advantage.



Gravity is your friend and can help you to add power to your elbows.

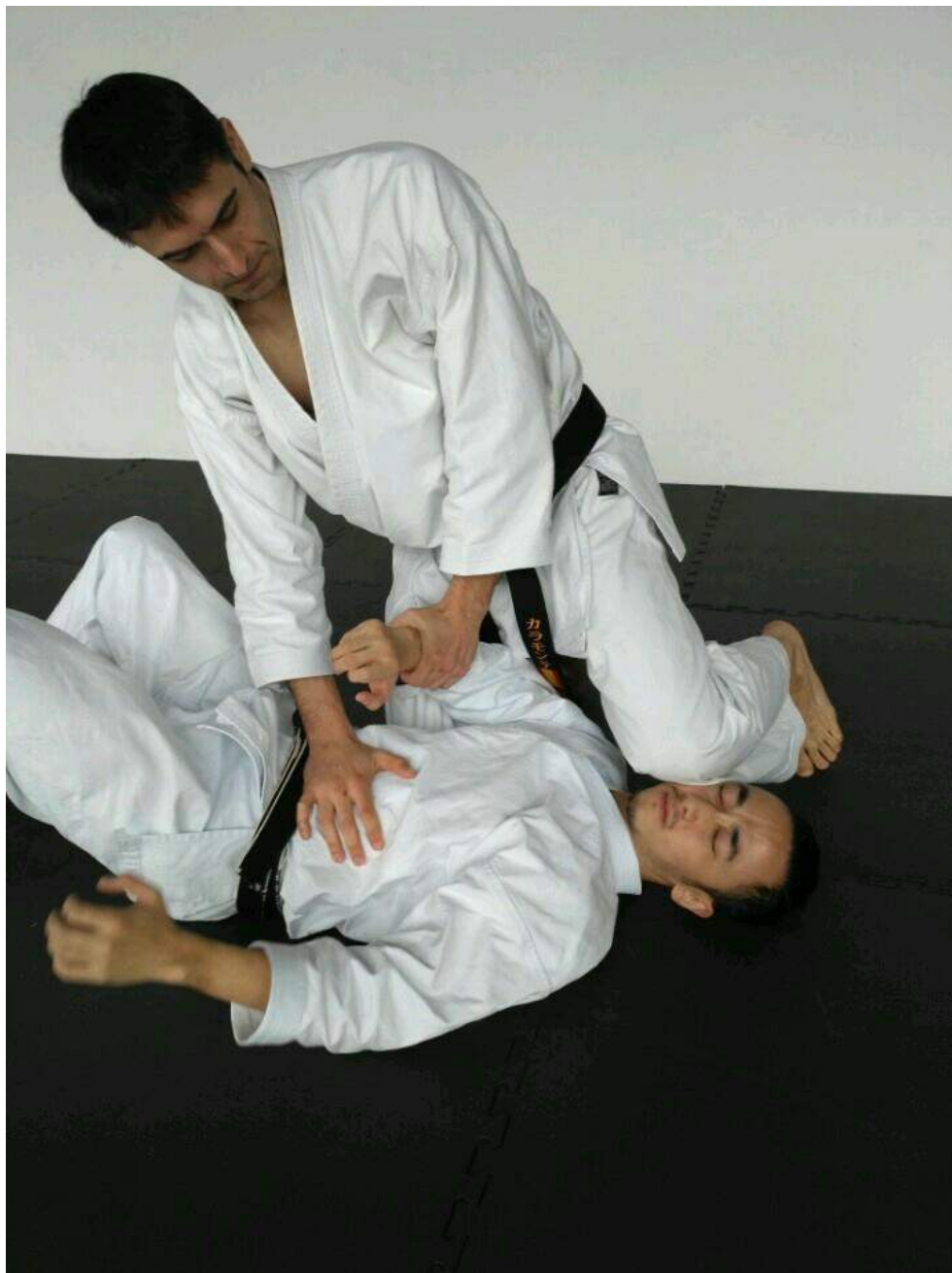

You can use the knee to hit, but also to control the head and keep the enemy on the darkness.



Knees can also be used to attack the ribs, causing fractures, or to help control the body of the foe under you.



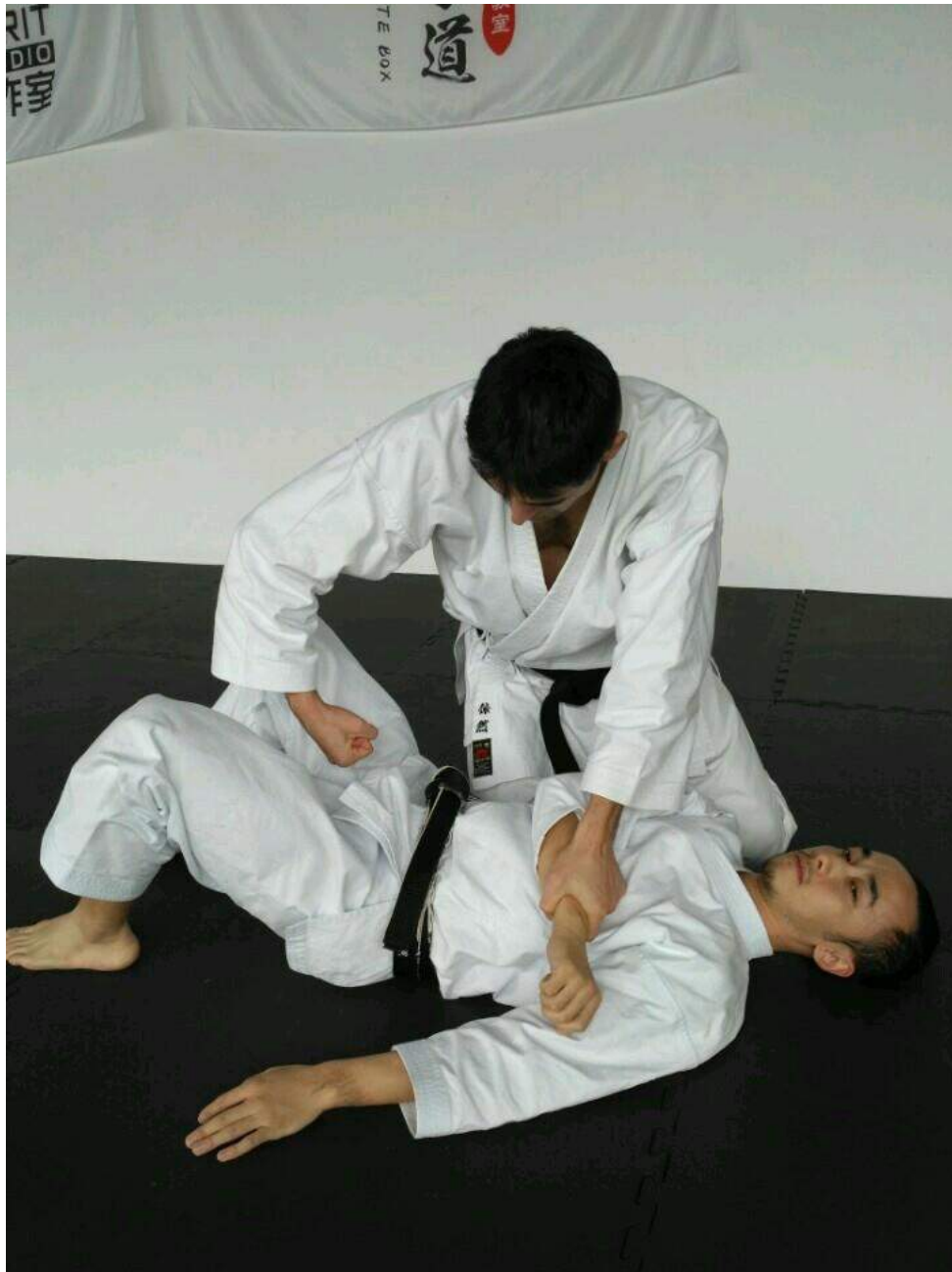

Not very elegant, but very effective.



Even better!



Head-butts are a tokui waza of many Valetudo fighters.

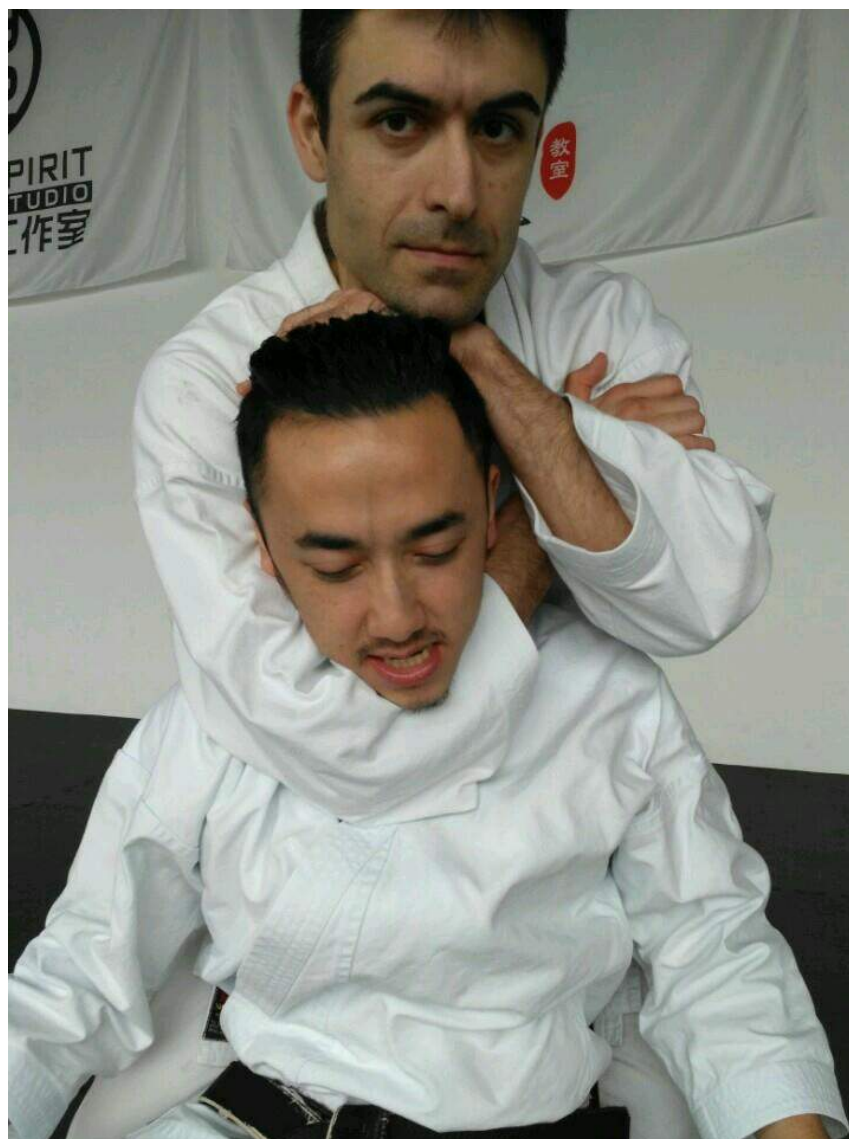

A good choke. Sometimes striking may not be the best option, so if you are in a position to apply it, it works well if hands placement and pressure are right.

Use your arm to block the blood or the air and use the other arm to add pressure.

Of course, you need to be behind your enemy to make it happen.





Hooking your knees and raising your hips will take it to another level.





Alternative hand positioning.

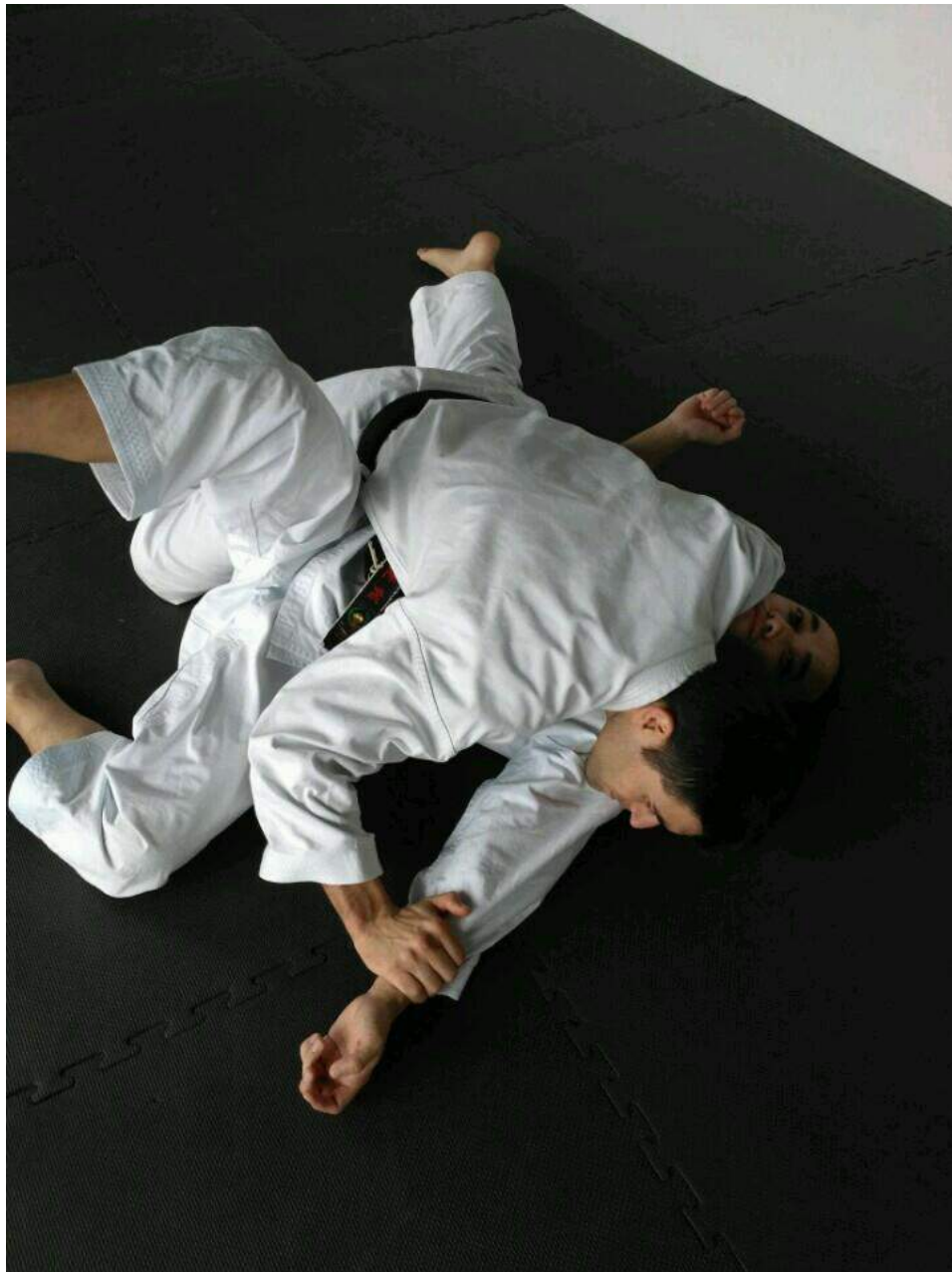

Using your body weight to block the movements of your attacker can help you gain control and avoid danger temporarily. Try to control arms and legs to avoid being hit. At the same time, keep your heads together so to not be susceptible to a head-butt.



Double lapel choke. Only works if the other guy has suitable clothes.  
Remember to put your hands as deep as possible into the collar.

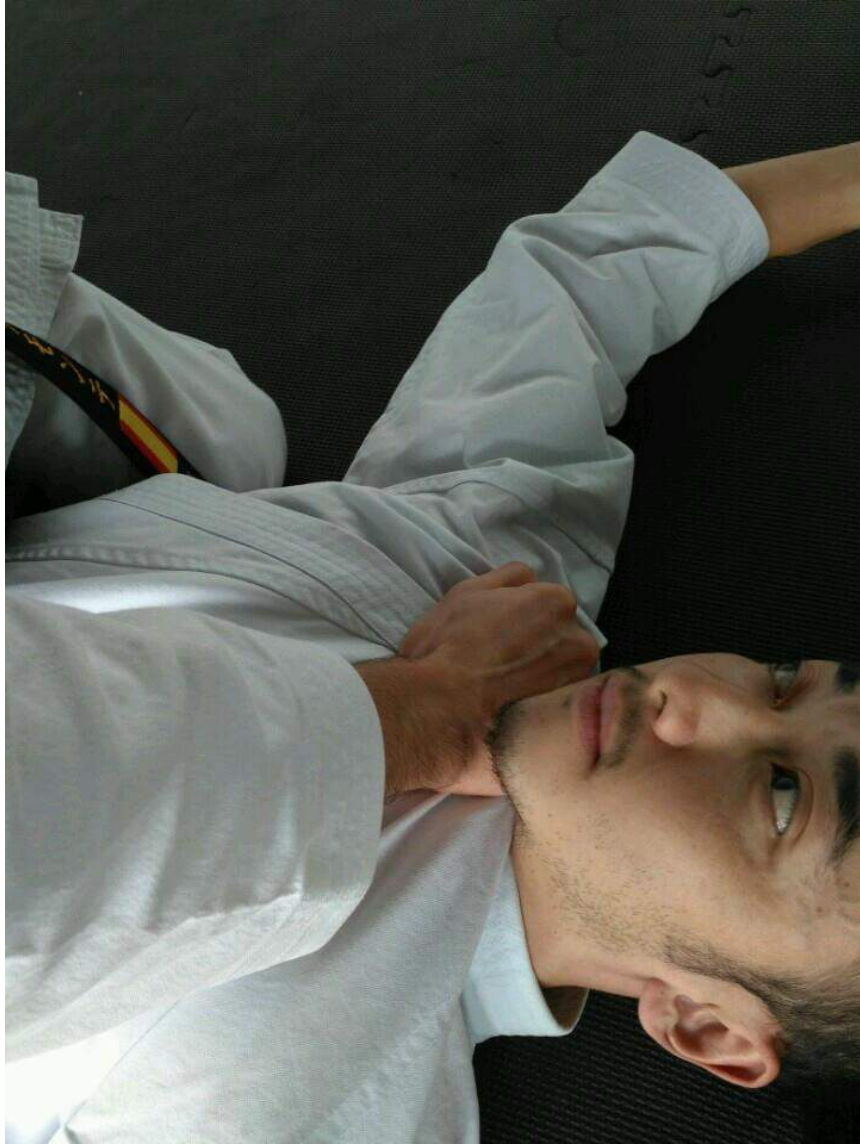

Single lapel choke. Put your body weight behind your hand.





Use nukite to blind your attacker.



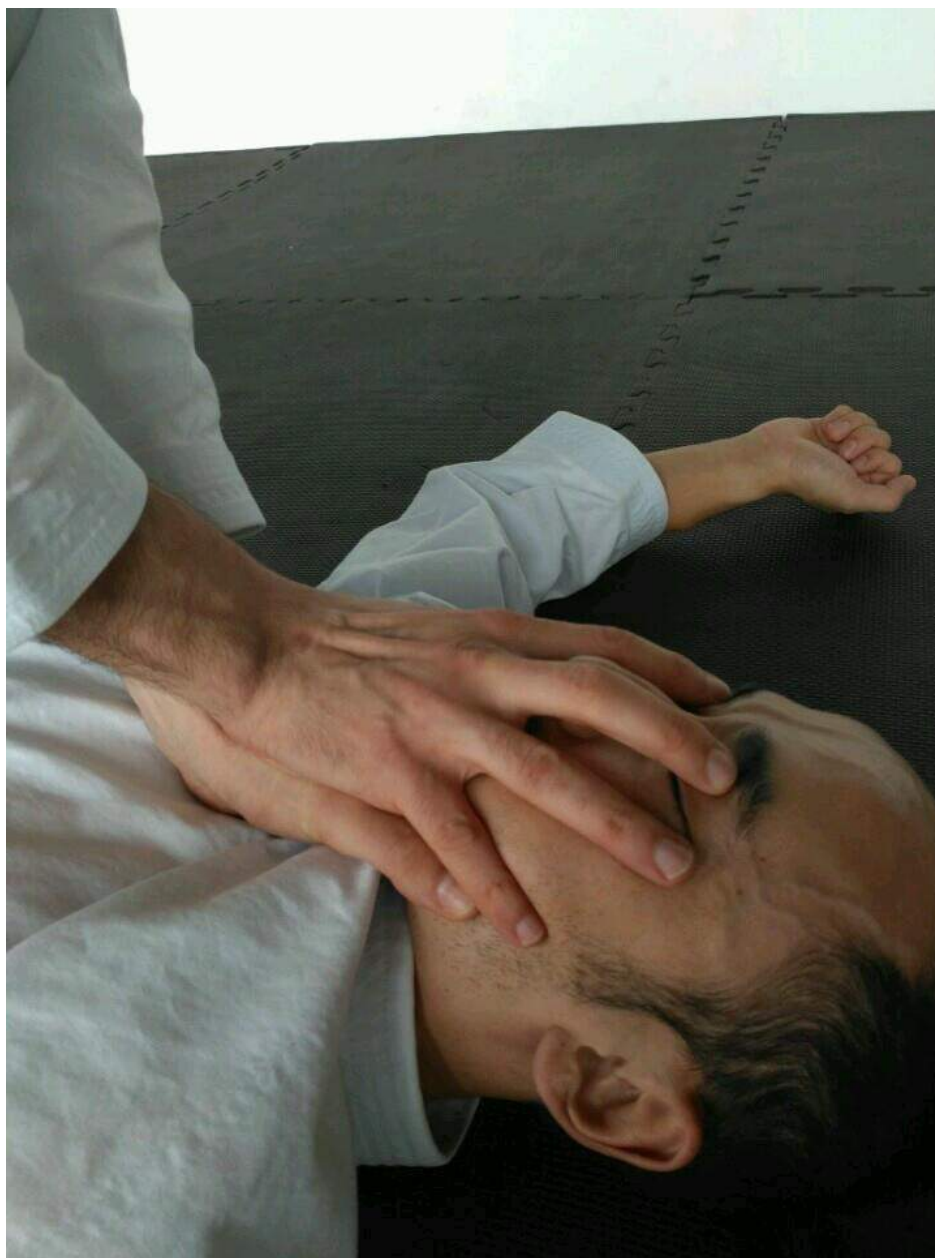

Using this way you can place your palm on his face before finding the eyes.  
Works without the need of seeing his eyes.

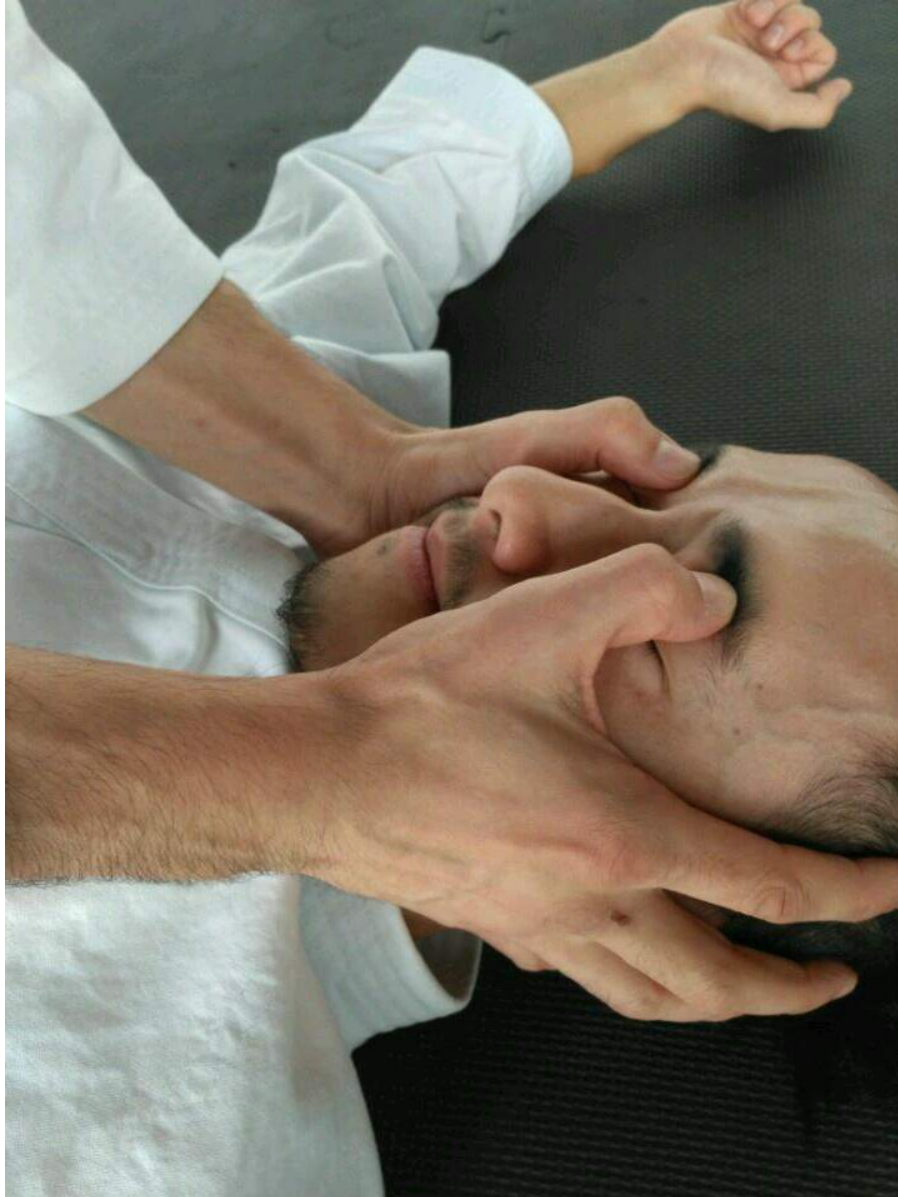

Another variation.



Vital point attack intended to cause pain and discourage more attacks.



Punch to the temple when on top. Very dangerous, should be used only in extreme danger situations.





Fish hooks straight from Hangetsu kata.





## Chapter 10: Throw one to me

I am going now to introduce some basic throwing theory. One may argue that throws are Judo's technique. It is true that Judo has a focus on tossing people around but as I said before some basic knowledge about how to throw someone may be good to have.

I will not introduce all of Kodokan syllabus but just a couple ideas that can be easily learnt and applied. For most of the throws a previous imbalance on the attacker must have been achieved but for most of what I will proceed to show that it can be done without being a Judo expert. Of course, the more you practice the better you will become.

Other reason to include throws in this book is because the kata are full of throws. If throws were so important to the creators of kata then we need to consider that they play a capital role in protecting our body integrity. Look for them in spins, turns, changes of direction and when you have a kosa dachi.

Another practical reason to learn throws is that if you practice them in free kumite or randori then you will get used to being attacked by throws and, eventually, you will discover ways to defend from them.



Using pulling and pulling your enemy will react with (most surely) an opposite direction resistance force.

It is at the moment when he swifts weight from one foot to the other that you sweep that foot.



Please, note that in this picture my foot is way over the ankle. This is to show a variation. If you sweep the ankle/foot you have a de ashi barai, but if you place your foot on the knee then you achieve hiza guruma.

Please experiment with pushing and pulling and different foot placements to see what combination works better for you.

This throw has the benefit that you are holding your enemy in front of you, securing his arms and having him in your line of sight.

Another thing that you can do is to work on your body movement and try to place yourself behind the enemy line of balance. If you can do this and you have your enemy unbalanced then you can sweep the leg from behind and do o soto gari.





The third category of throws I want to introduce involves turning around and showing your back to the enemy, so utmost caution must be used if you are to try it in a real fight. Practice uchikomi and your form will get better with time. Many variations exist, such as uchi mata, harai goshi, ippon seoi nage, morote nage... But all use the same principles: unbalance the enemy, place your hip lower than his and lift him over/around your shoulder/hips.



And do not forget the wonderful suki nage of Funakoshi Sensei himself. One of his infamous "Nine throws of Shotokan", even if forgotten by most of his followers.





## Chapter 11: Riding the iron horse

I am going to try to put some of the information together in this chapter that is comprised mainly by a Tekki/Naihanchi Shodan performance and bunkai.

I will show different ways of performing the kata as different instructors have shown me different ways of doing it, and how those reflect different possible applications to the movements.

This may make sense by itself but I want to link it to the previous chapters of vital points and the different body parts that can be used as weapons. This is how all the book will come together to an end.

My paradigm of kata is that, for the most part, it helps you to cope with the third point of the fight: stopping the fight. For that, multiple kata have multitude of answers about how to make someone unable to hit you again. I will interpret kata under this light while trying to introduce some fighting concepts that I find useful and that can be found hidden in kata too.

Of course, some sections of kata also deal with blocks and ways of avoiding being hit, and sometimes in a *sen no sen* fashion, but we are going to explore kata not exclusively but mainly under the former perspective.

One thing I would like you to consider is the opening of the kata (not only this one). Some kata have a particular hand formation to start it with. Some say it is a salutation or that even some religious meaning is implied. I say that you must consider that the fight has been started before you do the first

technique of the kata, meaning that the "salutation" is indeed a technique in itself.

But, why did I chose this kata? Not the most beautiful or showy, that is for sure (I have never seen it in a tournament) but it was a favorite in old Okinawa. Motobu and Funakoshi were some of the Masters that wrote about its importance. Even if they were not in the best terms they agreed on this. Ohtsuka and Oyama Senseis were also adepts to its practice. Even Miyagi Sensei said it is one of the three most important kata in Karate (along with Sanchin and Tensho).

In my case, it was the kata I performed for my Shodan grading. It felt great that day! It gives me great pleasure to perform it and most of its techniques have easy translation as live-protection maneuvers.

And I also feel that it is an under-understood kata, even if it has much to offer in the ways of self-defense.

Will I show the true bunkai of this kata?

Most probably not.

Let me explain. No one of us where there when the kata was created, no one than the creator (and perhaps his direct students) know the original way of performing a kata and the original intended applications.

This can be a controversial idea and I am ready to recognize that I can be wrong and that some lineages can have preserved the original ideas of some



kata. But for the most part I see kata that just look similar between styles, with many interesting points being different and open to different interpretations. Change and evolution are human phenomenon and I will not believe that I am the inheritor of an unbroken line of transmission of knowledge from the creator of the kata to me. Since I have seen my instructors to perform kata different than their instructors and I have seen the pictures and footage of the modern styles founders performing kata way different to them I must conclude that the kata change over time, sometimes by choice and sometimes by mistake.

If kata change, then we can not know how the original one looked like and most likely we can not know what the original applications were.

But actually, I do not think it is important to freak out about who is doing the original unchanged kata. Call me pragmatist if you like, but I feel that, since I practice Karate as self-defense, having useful ways of protecting yourself is more important (for me) than finding out what the original ones are. For this reason, I research my kata hoping to find physical movements that I can (could) use if find myself in the middle of a fight. And, (un)fortunately, I have found out that my training has been useful up to this moment.

Do not get me wrong, please.

I do not mean that everyone else is wrong on their kata practice. On the contrary, I can not be sure that my practice is true to the original, so I rather make sure that I am true to the creator's goal: self-defense.

Having access to old style kata that have been handed down through venerable Masters who have worked hard to preserve what their Masters taught them is an invaluable treasure. One must cherish such an opportunity to learn and also try to preserve and transmit what one has learnt.

Even if you have a relatively young instructor you must adhere to his way of practicing for that will make you progress in your chosen art. I am not advocating changing the kata or making out new ideas just because one is too lazy to learn from his instructor.

What I will show here is my personal interpretation of the kata. Techniques that worked for me.

What is the meaning of "work"?

I mean that I can use the technique to prevent a person from trying to hit me again.

A good punch in the face will make most of people losing the will to fight. A broken elbow joint will render that arm unable to pose a threat. A choke that causes unconsciousness will end the fight for sure.

When one is attacked facing a potential fatal situation will probably feel an adrenaline rush, making fine motor skills disappear, causing tunnel vision, anxiety and other disturbing effects. At the same time, your threshold of pain will raise, helping you to fight and scape.

For this reason I will show techniques that, when learnt and practiced, can be (have been) used even beginners and weak people alike. No complications, just

well proven simple techniques. When I show these to people with no Martial Arts experience they always get hooked and enroll in my class.

I did not invent any of the techniques. I just put my knowledge and experience to the service of the kata. It could be interpreted in a variety of other ways, but I choose to "read" it under my personal pragmatic interpretation, as I fear will never will have access to an uncontended original explanation.

The way I "read" kata can be exported to any kata. I do not claim to know bunkai of any movement in any kata in any style, but for the most of it, I can see the stance (weight distribution, direction of the attack/defense), the embusen (where are you going/coming from), the angles (respect to the attacker), turns (can be used as throws, or can be hidden in kosa dachis), the "groups" of techniques (that can be used in sequence), if a lock or a hit is implied (punches/kicks vs slow flowing motions) and so on.

I also assume that there are "hidden" techniques in kata. By hidden I mean implied. We are people trained to react and dominate in a fight, aren't we? We should know that even if the kata says "throw" we should know that we can punch the face before and after the throw to increase the likeliness of success. Before to disrupt the balance and after to finish him/her. Strike to disrupt, disrupt to strike.

One must be fast to apply a fight stopping technique with full commitment as your attacker may have friends nearby, so engaging in a "duel" will not help you a bit. One can be attacked from behind, surrounded, ambushed and so on (criminals have no honor) so one must be aware of the danger at all times and

finish the fight in a split second in order to be able to respond to a second or third threat.

#### Performance:

I am not World Champion and my technique is not flawless, but the intention of this book is not to teach how to perform the kata. I am aware that the pictures are less than perfect and contain some mistakes and weird poses. Please, excuse this imperfections and refer to any video or book of this kata performed by a experienced karateka what an aim to show the perfect form.

I want to show an integration of Tekki Shodan of Shotokan and Naihanchi of Shorin Ryu. I do not intend to create something new but I feel like the variations between these two styles open up the kata for more varied applications.

Please, excuse the weird location of the belt and the gi sometimes. The pictures are not professional and were taken in a hurry and could not bother the dojo owner again.



Yoi.





Rei.





Bring the hands in front of you making a big circle from in/down to out/up and in/down again.



Make sure your left hand is on top of your right hand when they come together.



Initial position of the kata.





Drop your weight and walk to the right, sideways, crossing the feet, not moving the hands.



Shotokan: bring up your knee to the front while keeping the hips at the same level.

Shorin Ryu: just finish the step. No knee lift.



Right hand under left hand. Both hands open, ready to strike (or to grab).



Haito uchi to the right side. Left hand in hikite.

I have seen this variation in some Shorin Ryu styles. Kyokushin substitutes this technique with a mawashi shuto uchi.





Using the back of the hand seems more common among Shotokan practitioners.





Even if it is not in the kata, a tetsui seems like a plausible alternative (mainly if we interpret this motion as a strike).



Left elbow hitting the right palm. Twist the hips but do not lean forward.



Shotokan: bring your two fists to the chamber position by the hips with a violent motion.

Shorin Ryu: do it slowly.



Gedan barai to the left, hikite to the right.





Hook "punch" to the left with the right hand. Keep the kiba dachi.





Step to the left keeping the hands in the same position.



Bring the knee up if you do Shotokan while you keep your hook in place.



Shorin Ryu: finish the step.



Shotokan: move the hand into a uchi uke with a strong arm motion at the time of the landing.



Simultaneous high block to the left and punch to the front with the right hand.





Shotokan: right hand comes into the hook again while the left goes forward as an ura tsuki. Elbow resting on the back of the hand.

Shorin Ryu: first put the hands in position, then throw them forward and strike like this.

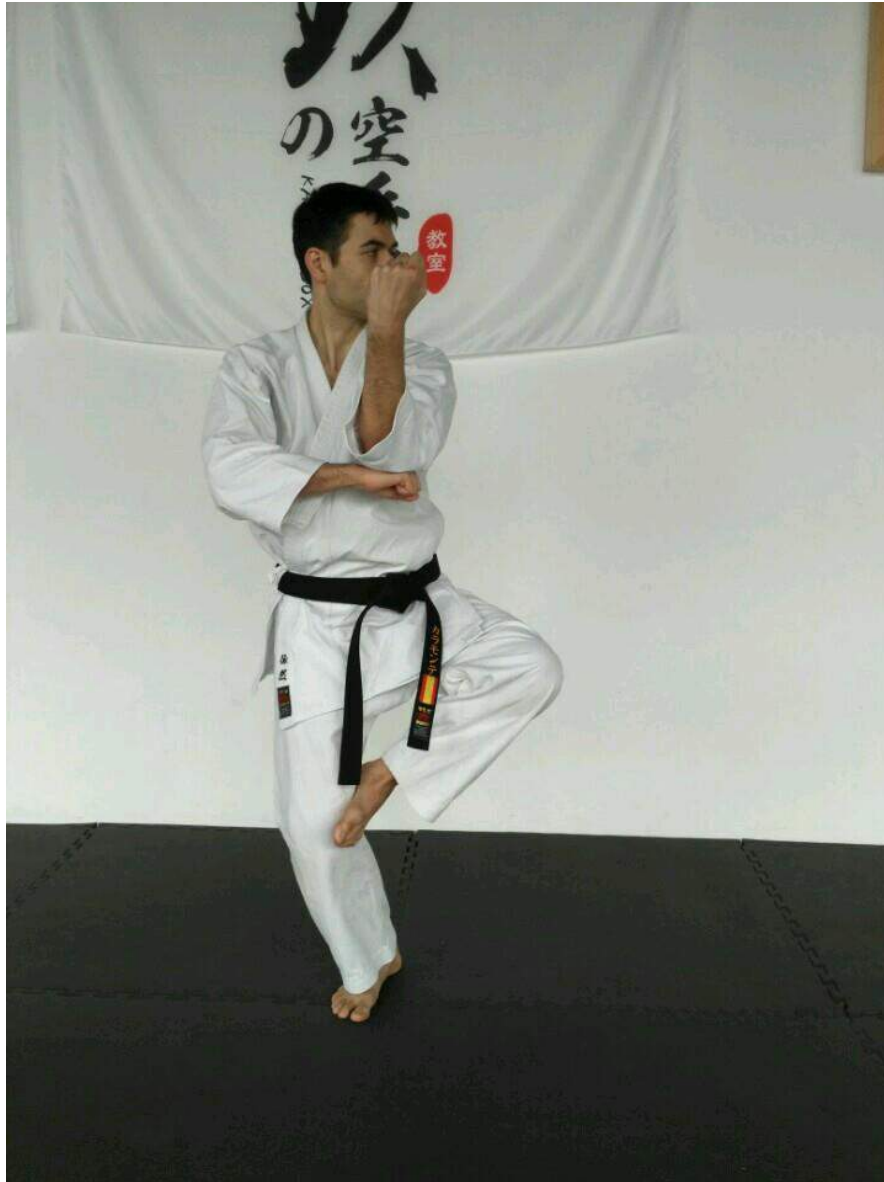

Nami gaeshi. Lift the left knee storing power for the next motion.



Block to the outside without changing the hand formation.



Lift the other knee.



Twist your hips for an inside block. Hands do not move yet.





Bring the hands to the hips again.



Get ready for the kiai.



Throw both fists and kiai.



Repeat to the other side in a symmetric manner.



















































Bring your hands together again.



Raise.



Ready to bow.



Rei.





Bunkai:

I hope all the readers are aware of the *Kaisai no genri* rules for studying kata. I will not presume to use (or even understand the true meaning) them in a proper way, but I think it is interesting to write them here, just as a reference:

The rule set is broken down in to three basic rules and nine advanced rules (copy and paste from Wikipedia, as written down by Toguchi Seikichi:

*Shuyo san gensoko* - Three basic rules

1. Don't be deceived by the shape (embusen) of the kata.

The kata embusen is designed to allow the kata to be performed within a small space. The shape of the embusen has no bearing on the meaning of the techniques in the kata.

2. Techniques executed while advancing are offensive. Those executed while retreating are defensive.

3. There is only one opponent and he is in front of you.

Turning to face a new direction while performing the kata does not mean you are turning to face a new opponent.

*Hosoku joko* - Advanced rules

1. Every movement in kata is significant and is to be used in application.

There are no "salutation", religious or empty movements in kata. All movements in the kata have meaning.

2. A closed pulling hand returning to chamber usually has some part of the opponent in it.

When pulling a hand to the chamber position, particularly if it is closed, it should be considered to have some part of the opponent in its grip. e.g. an arm, wrist or even head.

3. Utilize the shortest distance to your opponent.

The kata will typically attack the opponent with the closest part of your body.

4. If you control an opponent's head you control the opponent.

Kata techniques often target Kyusho (vital or weak points of the body), many of the most important of these are in the head. e.g. eyes or throat.

5. There are no blocks.

Uke are not blocks, they are "defenses", however in kata they may not even represent defenses, but simply be the movements of the limbs required to execute a more complex technique like a throw.

6. Angles in kata are very important.

The angle to which you turn represents the angle which you must take relative to the opponent for the technique to work.

It does not represent turning to face a new opponent.

7. Touching your own body in kata indicates that you are touching part of your opponent.

In the absence of a partner to practice with, where the kata touches your own body, you would be touching or holding part of the opponent's body.

8. Don't attack hard parts of your opponent with hard parts of your body.

The kata typically strikes hard parts of the opponent with soft parts of your body and soft parts with hard parts of your body.

9. There are no pauses in the application.

The rhythm of the performance of kata has no bearing on the performance of the techniques extracted from it.



For the opening of the kata we will start with a double lapel grip by our opponent.

From here we are open to being head-butted, kneed, pushed and pulled.

If it was a single lapel grip then we would be also open to punches (with added hikite).





The enemy pulls us in, so we bring our hands out and up in a big circle around his arms.



Like this.



We force his wrists down with power.

If the opponent is strong and resisting then we can attack the vital point in the forearm, near the wrists, for added pain and compliance.

The kata has us to practice a low kidadachi/shikodachi for the most part, so a drop in weight would help us to produce more power to break the grip. The opening of the kata is still in a natural stance, so I chose to show the technique here without the body drop.



Here the enemy grabs our neck with two hands, pushing us down. If you control the head you control where the body goes.





We do the exact same motion we did before. We need to take into consideration difference in heights and distances.





We can also attack the vital points in the forearm that are close to the elbow, for better pain delivery.



Finish the circular motion pushing your hands (and his) down and out.



Now the enemy has some wrestling experience so he gets ready for a double leg takedown.



He shoots in for the takedown.

The picture is in motion, not a static one, so the timing and the body placement may not be correct. Anyway, we are trying to show the defending technique now, not the attack.





And we do the same circular motion, this time pushing his head down.





We sprawl moving our feet back and use the ground to smash his head. Now we have control over his head, and we can apply a choke, we can strike him or we can just control him.





Now the attacker has seized both our wrists.



The same motion can be used to break the grip. Make the big circle (Aikido like) and control the movement of his arms.





Break the grip by attacking the weak part of the closed hand: the opening of the thumb.





The initial position of the kata has us to place our hands together pointing down.

This could signify an attack to the vital point in the pubis. A dangerous attack for your fingers if you do it wrong, but it can be an option to be explored.



Now the fight has started and we square out to exchange blows.



But before that happens I use the blind spot under his right hand to grab his wrist.



Then I use my right hand to do a finger lock.





Applying the pressure forward and down, in a circular manner I can take the enemy to the ground, or break his fingers.

It can only be applied if the enemy has his hand open. If he already closed his fists then we should look for another technique.





Now he grabs our collars again.



So I use the hand position of the opening of the kata to propel myself forward with my head pointing to his face.



Now we have clinched, but my hands have been placed behind his neck. I control his head and bring it down to be smashed with mine.



We have a clinch where we both have secured grips so we can not punch each other.





Pushing and pulling the enemy I make him loose balance.





It is at this point where I use the first step in the kata to sweep the foot.



Depending on the opportunities opened during his imbalance I may sweep differently.



Alternatively, I can attack the vital point in the ankle with my heel.

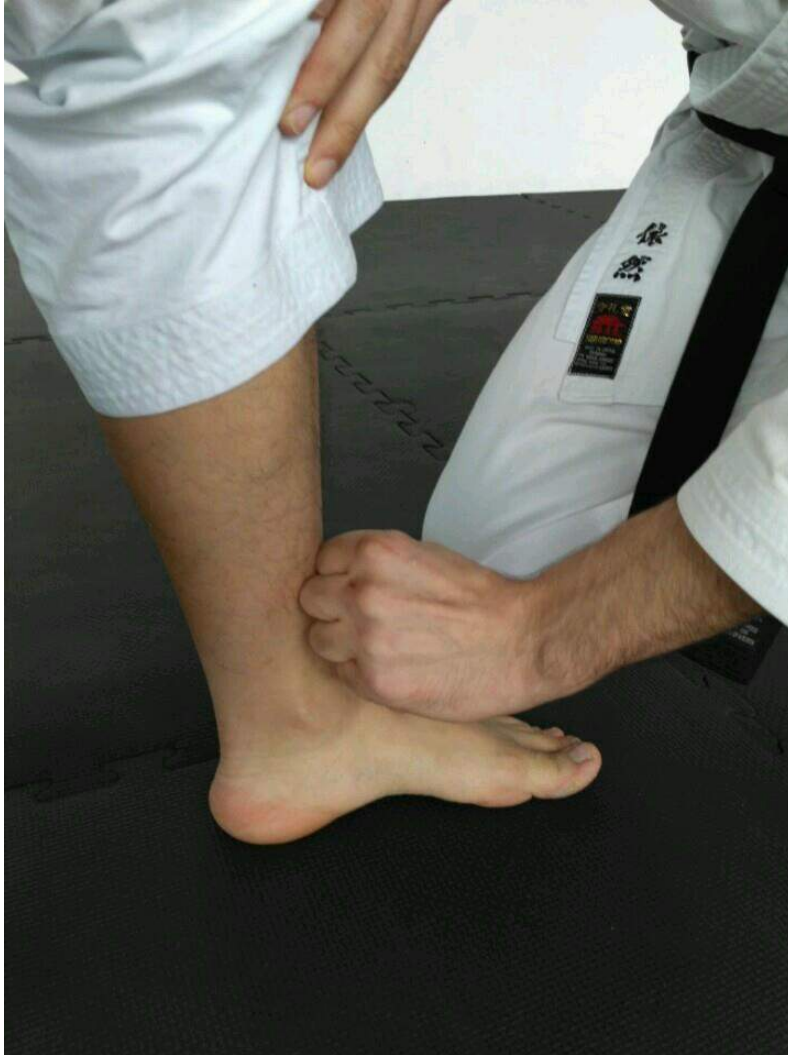

Here is that point.

If struck, it hurts.

If pressed, it hurts.

If pressed more, it is what I call "one finger take down".



Just apply pressure and your enemy will fall.

Of course, we will not seek to use this technique as shown now in a self-defense situation because dropping to attack the ankle would be suicidal, but if we are down, we can use it.





The step in the kata resembles kosadachi, so I am going to use it as a spin.

While I place my feet between his I am going to grab my enemy from his clothes (alternatively, with over or under hooks).



I need to drop my center of gravity lower than his and keep our bodies together.

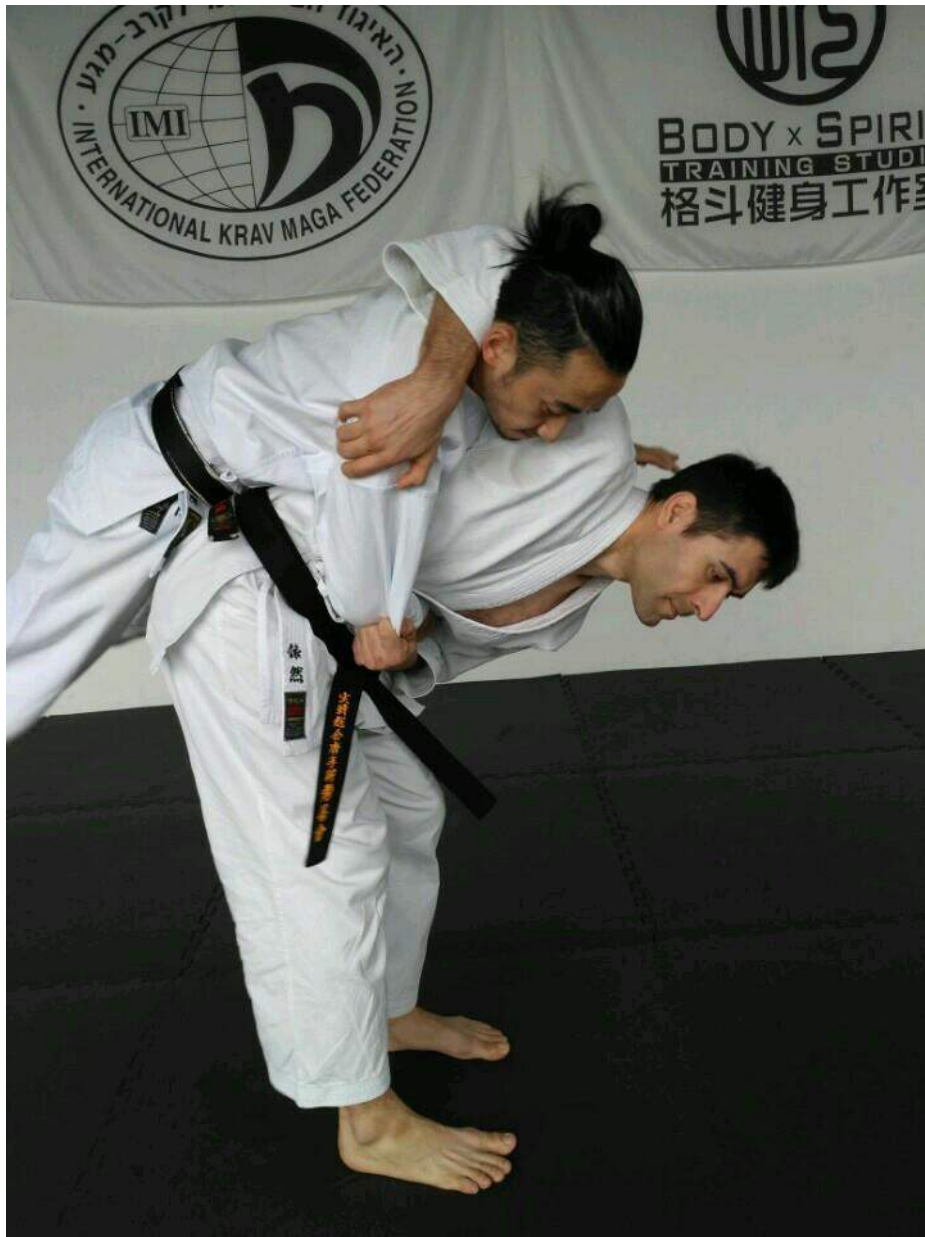

Then extend your legs and pull him up in a twisting motion.



Spin him around your hips.





And drop him with as much force as you can.

Keeping the grips for a follow up on the ground is optional. If the enemy is finished, then you should leave. If not, you can transition into a choke or hit him till he is done.





If the jaw is open to attack then it can be a good place to land a blow.



Haito to the temple, as in the kata.



Although the neck is also a valuable place.



Back of the hand, or even back of the fist, to the face can disrupt an attack.





And here is the full sequence of him trying to punch, you deflecting the punch and then striking him.





Different hand formations can be used for striking.



Overextending his attacking arm and then applying pressure on his elbow with our body will get us a nice elbow lock, while at the same time we mess with his neck.

Just a little push with our knee and we can have "folding screen" take down.



The elbow lock can also be achieved with this alternative hand placement. Just make sure his arm is twisted enough by your hikite.



Your extended hand can grab his hair (like in Saifa).





And then you move on for a nice empi to the face.





Grab his head in two places: up and down, left and right or front and back.



Twist his head in a downward spiral. First (according to my grip on the pictures) bring the chin up and the hair down.



Keep twisting and bring him down and to the side.

Please, exert extreme caution with your training partners as this technique can be fatal.



Step back to add more twisting and more power to your motion.





Drop him and get ready to punch.



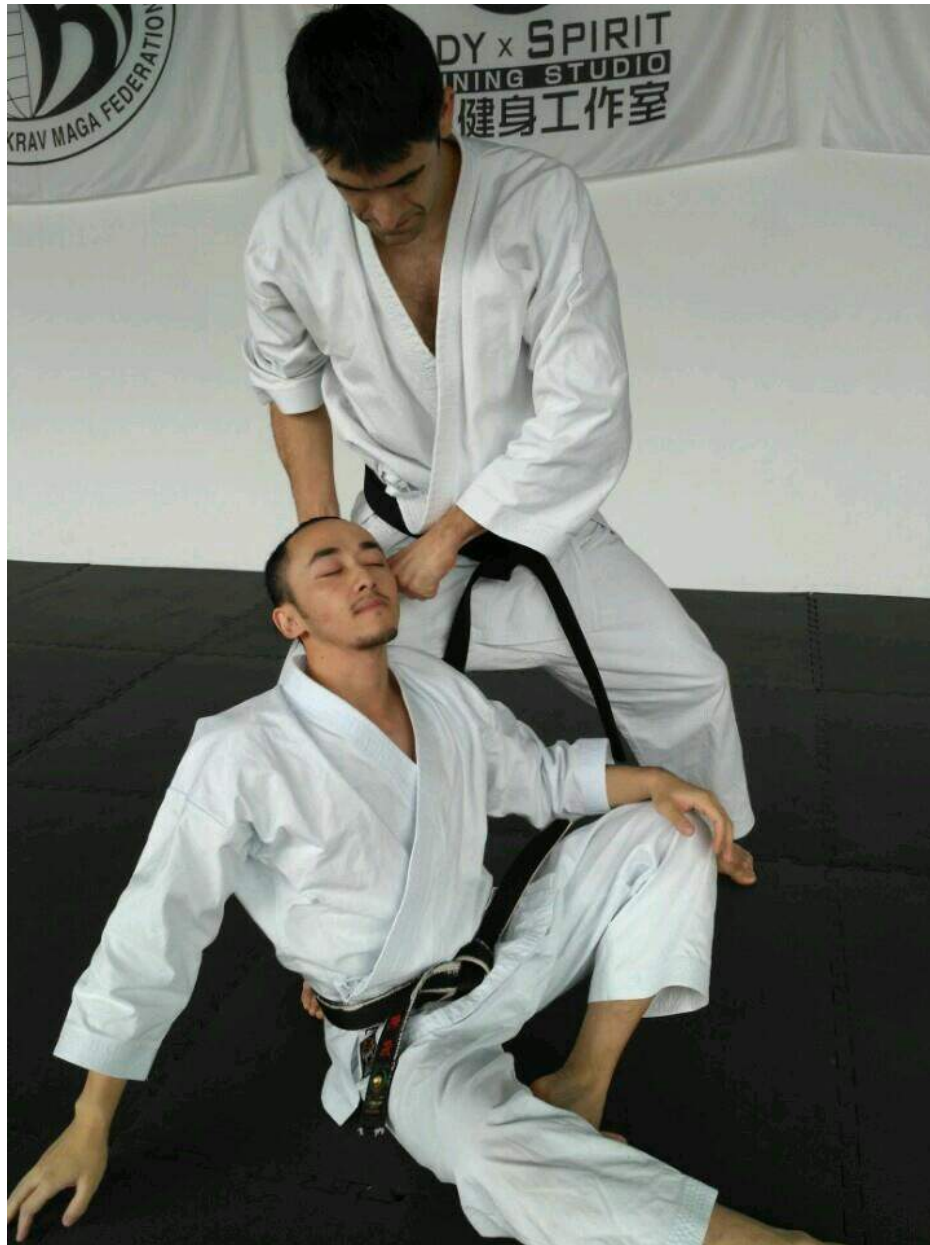

Try to land your attack in a vital point: temple, jaw...



Let me explain how to twist the neck to have complete head control.

Please, excuse the pictures. I am grabbing an imaginary head unimaginable large.



You need to understand that in order to make this motion impossible to resist you need to apply forces in some different direction at the same time and change the directions of these forces while not stopping.

It is difficult to explain with words but easy with a head in my hands.

You need to twist, spin and rotate up, down, right, left, forward and backward in a descending spiral motion all at the same time.





Move your body on your vertical axis while manipulating the enemy's head and add another layer of twist.





Continue applying the rotation and twist while the center of the (imaginary) head describes and arch in the air.



And finally bend your knees to complete the neck breaking technique.

It will be impossible for anyone to resist so many different forces in so many different directions in such a short time lapse.

This motion is also present in *Gojusiho Sho* and *Seipai*.



The gedan barai, as stated by Funakoshi Sensei, can be used as an elbow lock.



But I also like the shoulder lock very much, so here it is.

Do not forget to drop your weight for maximum punishment.



From there, not so difficult to produce a tetsui to the face.





Let's explore the kage tsuki now.

Yes, we can use it a punch to the face of a downed opponent, and also as a rib punch while standing. But, can we use it for anything else?

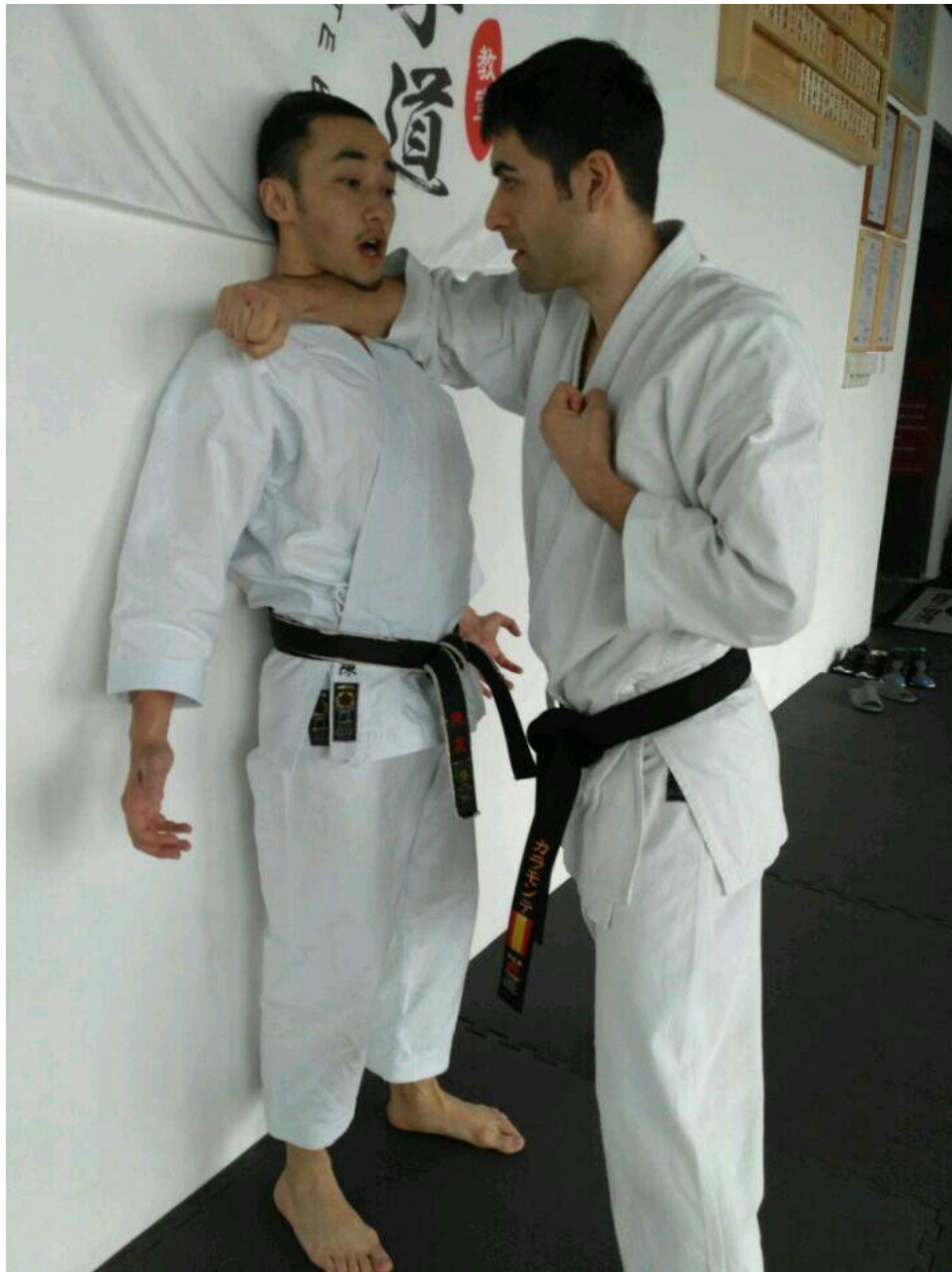

I am going to use the *shape* of the punch to show some useful ways of defending yourself.

First, if you can push your enemy to the wall then you can use your forearm to press on his neck and have some control over him.



And from here you can punch him.



If my back is against the wall then I use it to stop the enemy from coming closer.





If on the ground, I use it to stay on top and, hopefully, choke him.





And I can use the hook under his neck, to help me control his movements.



Same shape that can be used as a rear choke.



If we have the enemy in our guard we can use the hook to bring him closer for better control.





Or place it on his neck to keep him away.



Same ideas, but standing.





Add the body weight drop and break his posture.



The same shape can be used to grab around the waist.



And proceed with a throw.



In this new situation we have been grabbed by the wrist.





We do this twisting motion and we reverse the situation.





Or continue moving the arm to break the grip.



Let me show a variation.



Use your other hand to control his wrist (how many times did I say "control"?  
Yes, if you are in control of the fight, then good for you).



Attack the vital point of the wrist, as also shown in Tekki/Naihanchi Sandan and Bassai Dai.





Once more.





Use some tai sabaki to produce more power.



Break his posture, lock the elbow, deliver pain.



And control him on the floor.



The enemy is focused on not letting me go.





But I move my arms at the same time so I can strike the face to get my other arm free.





If it is a same side wrist grab...



Maybe you can not break the grip, but you can bring his arm up behind your head as a set up for another follow up.



This is not an elbow lock: this is an elbow break.

Pulling the arm overextending it and hitting with your own elbow in the weak spot behind his elbow can lead to severe injury.



Use the motions of the kata to bring the head down and chamber your finishing blow.





Attack the vital point of the top of the head, that can lead to knock out.





If you are too close for that, then you can hit the neck, collarbone, spine or any other surface available.



Use the element of surprise to make this variation work. Open him and...



Move in with your elbow for a raising hit.



I will now show a knife defense, but it is really advisable for the reader to run away from knives if possible. If not possible, then we better be ready.





Attacker comes forward with a thrust to our belly.





We (hopefully) intercept it and change its direction (there is a variation of this technique in Wankan kata).



We move the knife away from our body and strike with all our might to cause a concussion and end the fight.

Ideally, the block and the strike should be done at the same time.



The enemy now knows a little boxing and squares off to surprise us with a sucker punch.



Even if he jabbed before, his power punch is a haymaker (jodan mawashi tsuki) aimed at our temple trying to do the most possible damage.





We use the same side arm to block.

This is a very interesting technique for Kyokushin karateka, as many training partners will attack your shoulders during kumite.

It can also be an interpretation of jodan age uke.





And punch him on the face.

This sequence resembles the opening in Heian/Pinan Nidan (called Pinan Shodan in Shorin Ryu).

I also believe it is implied in Seipai kata, even if not shown to the fully extend.



Some name gaeshi applications now.

The enemy tries a foot sweep on us while we are in a clinch.



And we just move our foot out of the way.



We can use the same motion to attack vital point in the ankle.





If a bit higher then we can strike the groin.





There are several targets in this area: the thigh, the knee...



Striking the outer thigh, a nice technique for kumite.



We can also step on the knee to cause a sprain, or even a break.

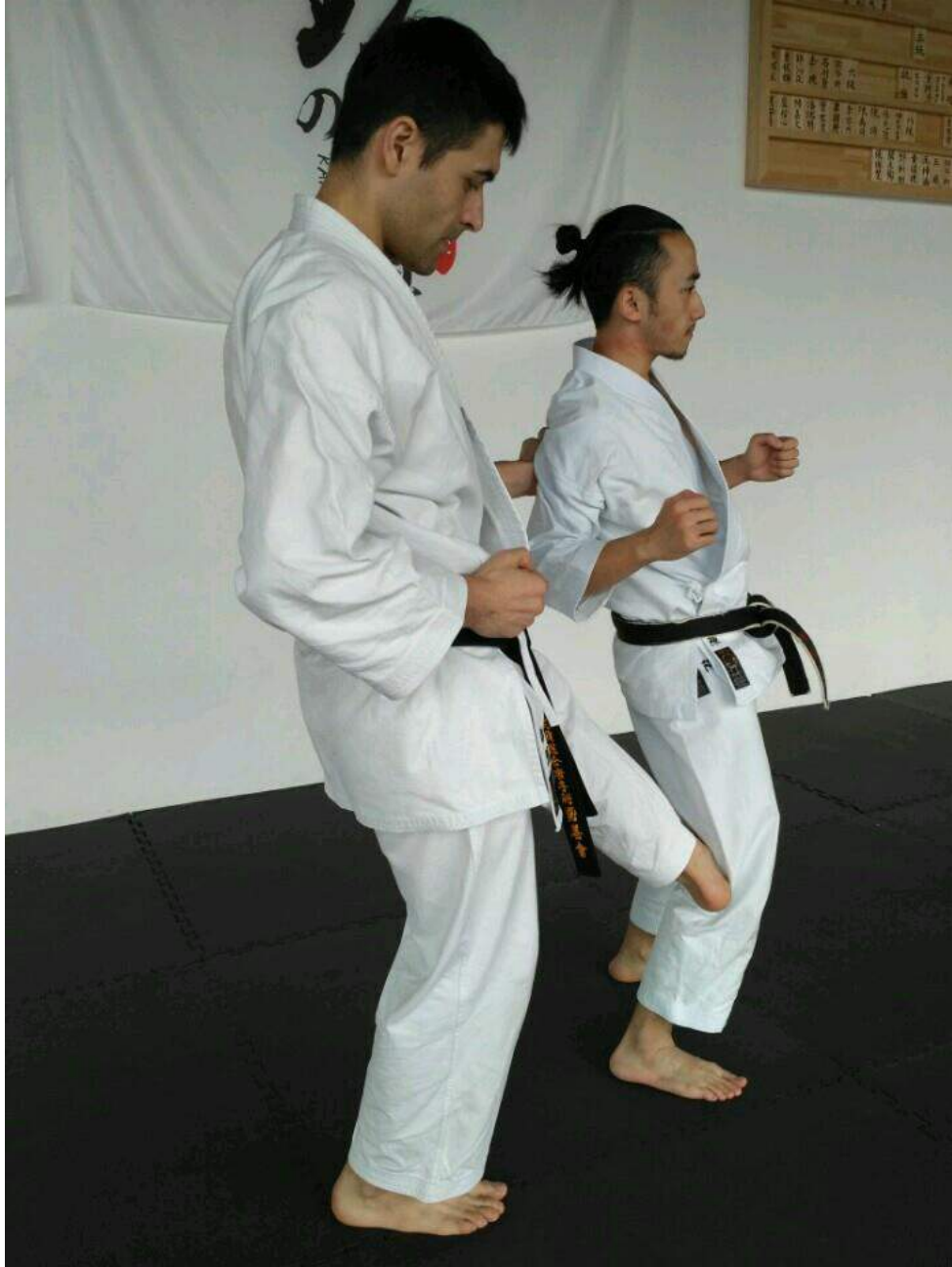

If we step on the back of the knee then we can take the enemy down quite easily.





If we exaggerate the motion we can place our foot behind enemy's foot.





What opens up possibilities for a throw.



Like o soto gari.



Nami gaeshi motion can be used to step on the face of a downed attacker (fumikomi).



We can also use it another throw, hiza guruma.





From another angle.





Now I use pressure with my forearm to disrupt his balance and focus.



And use the opportunity to deliver close quarters tetsuis to the head.



Attacking the temple, in addition to the neck and face.



Striking is possible from inside to outside or from outside to inside.

Hammer fist can be used, and the knuckles too.





Another use of name gaeshi, striking the legs during the clinch at the same time that we deliver hits to the head.





If we are being hugged and we manage to get our arm between the attacker and us then we can use it to open a space and separation.

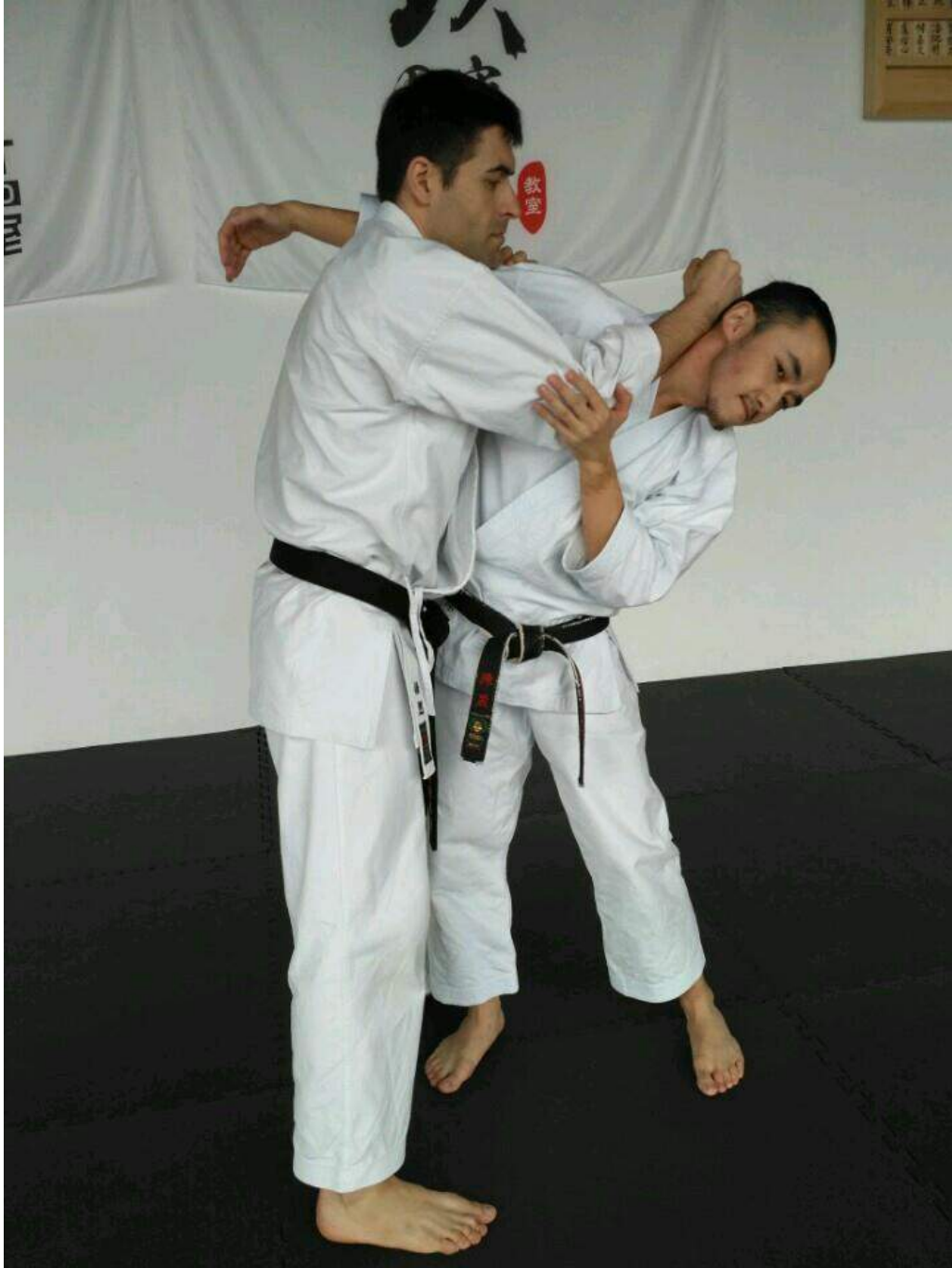

Then, hitting becomes easier.



If we get a grip on the head (hair, ears, beard...) or clothes then using our legs to strike is also possible.



We can use this pose of two hands together as a way of striking with one hand while we keep the other one close to our face for protection and ready to strike again.





We repeat the circular motion again, grabbing the head.





This time is not a control, but a neck-break. My attacker's friends are close and I need to finish him quickly to have a chance to scape.



Twist the neck and bring the head down violently.



Release and run for cover.



We grab the punching hand and pull it in with violent hikite to augment the power of our own punch.

Also found in Jion kata.





If our punch misses, then we can hit with the elbow or forearm on the throat.





We can alternatively use folding screen to drop the enemy.



Push the neck and the knee to complete the take down.



Continue rotating the bodies.



And drop him on a hard surface.





Bring your arm under his elbow to find another way to his head, as found in Seienchin kata too.





Grab the back of his head.



And bring him to your fist.



Or bring his eyes to your fingertips.



You can also attack the vital points of the neck if you just need compliance and not injury.









This book is copyrighted ©. All rights reserved.

Copying, printing and sharing of this work, as whole or as parts, for any monetary reason is strictly forbidden.

Sharing for educational and training purposes is encouraged.

Please, do not print it if you do not need to. If you do so, please use recycled paper.

First part written in Shenyang, China (沈阳, 中国), second part written in Shanghai, China (上海, 中国) during 2016.

Josep Claramonte // カラモンテ 優塞

