

General Physics I:

Classical Mechanics

David G. Simpson

Dept. of Natural Sciences, Prince George's Community College, Largo, Maryland

Larry L. Simpson

Union Carbide Corporation (ret.), South Charleston, West Virginia

Fall 2020

Last updated: October 8, 2020

Contents

	Acknowledgments	11
1	What is Physics?	12
2	Units	14
	2.1 Systems of Units	14
	2.2 SI Units	15
	2.3 CGS Systems of Units	19
	2.4 British Engineering Units	19
	2.5 Units as an Error-Checking Technique	19
	2.6 Unit Conversions	20
	2.7 Currency Units	22
	2.8 Odds and Ends	22
3	Problem-Solving Strategies	24
4	Density	26
	4.1 Specific Gravity	27
	4.2 Density Trivia	27
5	Kinematics in One Dimension	29
	5.1 Position	29
	5.2 Velocity	29
	5.3 Acceleration	30
	5.4 Higher Derivatives	31
	5.5 Dot Notation	31
	5.6 Inverse Relations	31
	5.7 Constant Acceleration	32
	5.8 Summary	34
	5.9 Geometric Interpretations	35
6	Vectors	37
	6.1 Introduction	37
	6.2 Vector Arithmetic: Graphical Methods	38
	6.3 Vector Arithmetic: Algebraic Methods	38
	6.4 The Zero Vector	43
	6.5 Derivatives	43

6.6	Integrals	44
6.7	Other Vector Operations	44
7	The Dot Product	45
7.1	Definition	45
7.2	Component Form	45
7.3	Properties	46
7.4	Matrix Formulation	48
8	Kinematics in Two or Three Dimensions	49
8.1	Position	49
8.2	Velocity	49
8.3	Acceleration	49
8.4	Inverse Relations.	50
8.5	Constant Acceleration	50
8.6	Vertical vs. Horizontal Motion.	51
8.7	Summary	52
9	Projectile Motion	54
9.1	Range	55
9.2	Maximum Altitude.	56
9.3	Shape of the Projectile Path	57
9.4	Hitting a Target on the Ground.	57
9.5	Hitting a Target on a Hill.	59
9.6	Exploding Projectiles	60
9.7	Other Considerations	60
9.8	The Monkey and the Hunter Problem	60
9.9	Summary	62
10	Newton's Method	63
10.1	Introduction	63
10.2	The Method	63
10.3	Example: Square Roots	63
10.4	Projectile Problem	65
11	Mass	66
12	Force	67
12.1	The Four Forces of Nature	67
12.2	Hooke's Law.	68
12.3	Weight.	68
12.4	Normal Force	68
12.5	Tension	69
13	Newton's Laws of Motion	70
13.1	First Law of Motion	70
13.2	Second Law of Motion.	70
13.3	Third Law of Motion	72

14	The Inclined Plane	73
15	Atwood's Machine	75
16	Statics	79
16.1	Mass Suspended by Two Ropes	79
16.2	The Elevator	82
16.3	The Catenary	82
17	Friction	84
17.1	Introduction	84
17.2	Static Friction	84
17.3	Kinetic Friction	85
17.4	Rolling Friction	85
17.5	The Coefficient of Friction.	85
18	Blocks and Pulleys	87
18.1	Horizontal Block and Vertical Block.	87
18.2	Inclined Block and Vertical Block	88
19	Resistive Forces in Fluids	91
19.1	Introduction	91
19.2	Model I: $F_R \propto v$	91
19.3	Model II: $F_R \propto v^2$	93
20	Circular Motion	96
20.1	Introduction	96
20.2	Centripetal Force	97
20.3	Centrifugal Force	98
20.4	Relations between Circular and Linear Motion.	99
20.5	Examples	99
21	Work	100
21.1	Introduction	100
21.2	Case I: Constant $\mathbf{F} \parallel \mathbf{r}$	100
21.3	Case II: Constant $\mathbf{F} \nparallel \mathbf{r}$	101
21.4	Case III: Variable $\mathbf{F} \parallel \mathbf{r}$	101
21.5	Case IV (General Case): Variable $\mathbf{F} \nparallel \mathbf{r}$	102
21.6	Summary	102
22	Simple Machines	103
22.1	Inclined Plane	104
22.2	Wheel and Axle	104
22.3	Pulley	105
22.4	Lever	106
22.5	Wedge	108
22.6	Screw	108
22.7	Gears	108

23	Energy	110
23.1	Introduction	110
23.2	Kinetic Energy	110
23.3	Potential Energy	111
23.4	Other Forms of Energy.	114
23.5	Conservation of Energy	114
23.6	The Work-Energy Theorem	115
23.7	The Virial Theorem	115
24	Conservative Forces	117
25	Power	118
25.1	Energy Conversion of a Falling Body	119
25.2	Rate of Change of Power	120
25.3	Vector Equation	120
26	Linear Momentum	121
26.1	Introduction	121
26.2	Conservation of Momentum	121
26.3	Newton's Second Law of Motion	121
27	Impulse	123
28	Collisions	125
28.1	Introduction	125
28.2	The Coefficient of Restitution	125
28.3	Perfectly Inelastic Collisions.	126
28.4	Perfectly Elastic Collisions	126
28.5	Newton's Cradle	128
28.6	Inelastic Collisions.	129
28.7	Collisions in Two Dimensions	129
29	The Ballistic Pendulum	131
30	Rockets	133
30.1	Introduction	133
30.2	The Rocket Equation.	133
30.3	Mass Fraction	134
30.4	Staging	135
31	Center of Mass	136
31.1	Introduction	136
31.2	Discrete Masses	136
31.3	Continuous Bodies.	137
32	The Cross Product	140
32.1	Definition	140
32.2	Component Form	141
32.3	Properties	141

32.4	Matrix Formulation	143
32.5	Inverse	143
33	Rotational Motion	145
33.1	Introduction	145
33.2	Translational vs. Rotational Motion	145
33.3	Example Problems	147
34	Moment of Inertia	149
34.1	Introduction	149
34.2	Radius of Gyration.	153
34.3	Parallel Axis Theorem	154
34.4	Plane Figure Theorem	155
34.5	Routh's Rule.	155
34.6	Lees' Rule	156
35	Torque	157
35.1	Introduction	157
35.2	Rotational Version of Hooke's Law	158
35.3	Couples	158
36	Measuring the Moment of Inertia	159
36.1	Torque Method.	159
36.2	Pendulum Method	160
37	Newton's Laws of Motion: Rotational Versions	162
37.1	First Law of Rotational Motion	162
37.2	Second Law of Rotational Motion	162
37.3	Third Law of Rotational Motion	163
38	The Pendulum	164
38.1	Introduction	164
38.2	The Simple Plane Pendulum	164
38.3	The Spherical Pendulum.	165
38.4	The Conical Pendulum.	165
38.5	The Torsional Pendulum.	167
38.6	The Physical Pendulum	167
38.7	Other Pendulums	169
39	Simple Harmonic Motion	170
39.1	Energy	172
39.2	Frequency and Period	174
39.3	The Vertical Spring	174
39.4	Frequency and Period	174
39.5	Mass on a Spring	175
39.6	More on the Spring Constant.	175
40	Rocking Bodies	178
40.1	The Half-Cylinder	178

41	Rolling Bodies	181
41.1	Introduction	181
41.2	Velocity	181
41.3	Acceleration	182
41.4	Kinetic Energy	183
41.5	The Wheel	184
41.6	Ball Rolling in a Bowl	185
42	Galileo's Law	187
42.1	Introduction	187
42.2	Modern Treatment	187
43	The Coriolis Force	189
43.1	Introduction	189
43.2	Examples	190
44	Angular Momentum	191
44.1	Introduction	191
44.2	Conservation of Angular Momentum	191
45	Conservation Laws	193
46	The Gyroscope	194
46.1	Introduction	194
46.2	Precession	194
46.3	Nutation	195
47	Elasticity	196
47.1	Introduction	196
47.2	Longitudinal (Normal) Stress	196
47.3	Transverse (Shear) Stress—Translational	197
47.4	Transverse (Shear) Stress—Torsional	198
47.5	Volume Stress	198
47.6	Elastic Limit	199
47.7	Summary	199
48	Fluid Statics	200
48.1	Introduction	200
48.2	Archimedes' Principle	200
48.3	Floating Bodies	200
48.4	Pressure	201
48.5	Change in Fluid Pressure with Depth	202
48.6	Pascal's Law	203
49	Fluid Dynamics	204
49.1	The Continuity Equation	205
49.2	Bernoulli's Equation	205
49.3	Torricelli's Theorem	206
49.4	The Siphon	208

49.5	Viscosity	209
49.6	The Reynolds Number	211
49.7	Stokes's Law	211
49.8	Fluid Flow through a Pipe	212
49.9	Gases	212
49.10	Superfluids.	214
50	Hydraulics and Pneumatics	217
50.1	Hydraulics: The Hydraulic Press.	217
50.2	Pneumatics	219
51	Gravity	220
51.1	Newton's Law of Gravity	220
51.2	Gravitational Potential	220
51.3	The Cavendish Experiment	221
51.4	Helmert's Equation	221
51.5	Earth Density Model.	222
51.6	Escape Velocity	224
51.7	Gauss's Formulation	224
51.8	General Relativity	228
51.9	Black Holes	229
52	Earth Rotation	230
52.1	Introduction	230
52.2	Precession	230
52.3	Nutation	230
52.4	Polar Motion.	232
52.5	Rotation Rate	232
53	Geodesy	234
53.1	Introduction	234
53.2	Radius of the Earth	235
53.3	The Cosine Formula	235
53.4	Vincenty's Formulæ: Introduction	236
53.5	Vincenty's Formulæ: Direct Problem	236
53.6	Vincenty's Formulæ: Inverse Problem	238
54	Celestial Mechanics	241
54.1	Introduction	241
54.2	Kepler's Laws	241
54.3	Time	242
54.4	Orbit Reference Frames	242
54.5	Orbital Elements.	243
54.6	Right Ascension and Declination	244
54.7	Computing a Position	245
54.8	The Inverse Problem.	246
54.9	Corrections to the Two-Body Calculation	246
54.10	Bound and Unbound Orbits	247
54.11	The <i>Vis Viva</i> Equation	247

54.12	Bertrand's Theorem	248
54.13	Differential Equation for an Orbit	248
54.14	Lagrange Points	249
54.15	The Rings of Saturn	250
54.16	Hyperbolic Orbits	252
54.17	Parabolic Orbits	253
55	Astrodynamics	254
55.1	Circular Orbits	254
55.2	Geosynchronous Orbits	256
55.3	Elliptical Orbits	257
55.4	The Hohmann Transfer	260
55.5	Gravity Assist Maneuvers	261
55.6	The International Cometary Explorer	263
56	Partial Derivatives	265
56.1	First Partial Derivatives	265
56.2	Higher-Order Partial Derivatives	266
57	Lagrangian Mechanics	267
57.1	Examples	268
58	Hamiltonian Mechanics	270
58.1	Examples	270
59	Special Relativity	273
59.1	Introduction	273
59.2	Postulates	273
59.3	Time Dilation	273
59.4	Length Contraction	274
59.5	An Example	274
59.6	Momentum	274
59.7	Addition of Velocities	275
59.8	Energy	275
60	Quantum Mechanics	277
60.1	Introduction	277
60.2	Review of Newtonian Mechanics	277
60.3	Quantum Mechanics	277
60.4	Example: Simple Harmonic Oscillator	279
60.5	The Heisenberg Uncertainty Principle	280
61	The Standard Model	281
61.1	Matter	281
61.2	Antimatter	282
61.3	Forces	282
61.4	The Higgs Boson	283
	Further Reading	284

	Appendices	287
A	Greek Alphabet	289
B	Trigonometry	290
C	Hyperbolic Trigonometry	296
D	Useful Series	298
E	Table of Derivatives	299
F	Table of Integrals	301
G	Mathematical Subtleties	303
H	SI Units	305
I	Gaussian Units	308
J	British Engineering Units	310
K	Units of Physical Quantities	312
L	Physical Constants	315
M	Astronomical Data	316
N	Unit Conversion Tables	317
O	Angular Measure	321
P	Vector Arithmetic	323
Q	Matrix Properties	326
R	Newton's Laws of Motion (Original)	328
S	The Simple Plane Pendulum: Exact Solution	329
T	Motion of a Falling Body	334
U	Table of Viscosities	336
V	Calculator Programs	338
W	Round-Number Handbook of Physics	339
X	Short Glossary of Particle Physics	341

Y	Fundamental Physical Constants — Extensive Listing	342
Z	Periodic Table of the Elements	349
	References	349
	Index	353

Acknowledgments

The author (DGS) wishes to express his deepest thanks to his father, L.L. Simpson, for valuable comments and contributions to material throughout the text, especially in the areas of resistive forces in fluids, fluid dynamics, geodesy.

Chapter 1

What is Physics?

Physics is the most fundamental of the sciences. Its goal is to learn how the Universe works at the most fundamental level—and to discover the basic laws by which it operates. *Theoretical physics* concentrates on developing the theory and mathematics of these laws, while *applied physics* focuses attention on the application of the principles of physics to practical problems. *Experimental physics* lies at the intersection of physics and engineering; experimental physicists have the theoretical knowledge of theoretical physicists, and they know how to build and work with scientific equipment.

Physics is divided into a number of sub-fields, and physicists are trained to have some expertise in all of them. This variety is what makes physics one of the most interesting of the sciences—and it makes people with physics training very versatile in their ability to do work in many different technical fields.

The major fields of physics are:

- *Classical mechanics* is the study the motion of bodies according to Newton's laws of motion, and is the subject of this course.
- *Electricity and magnetism* are two closely related phenomena that are together considered a single field of physics.
- *Quantum mechanics* describes the peculiar motion of very small bodies (atomic sizes and smaller).
- *Optics* is the study of light.
- *Acoustics* is the study of sound.
- *Thermodynamics* and *statistical mechanics* are closely related fields that study the nature of heat.
- *Solid-state physics* is the study of solids—most often crystalline metals.
- *Plasma physics* is the study of plasmas (ionized gases).
- *Atomic, nuclear, and particle physics* study of the atom, the atomic nucleus, and the particles that make up the atom.
- *Relativity* includes Albert Einstein's theories of special and general relativity. *Special relativity* describes the motion of bodies moving at very high speeds (near the speed of light), while *general relativity* is Einstein's theory of gravity.

The fields of *cross-disciplinary physics* combine physics with other sciences. These include *astrophysics* (physics of astronomy), *geophysics* (physics of geology), *biophysics* (physics of biology), *chemical physics* (physics of chemistry), and *mathematical physics* (mathematical theories related to physics).

Besides acquiring a knowledge of physics for its own sake, the study of physics will give you a broad technical background and set of problem-solving skills that you can apply to wide variety of other fields. Some students of physics go on to study more advanced physics, while others find ways to apply their knowledge of physics to such diverse subjects as mathematics, engineering, biology, medicine, and finance.

Another benefit of learning physics is that, unlike courses in technology, everything you learn in this course will never be obsolete. Although theories at the cutting edge of physics research may change, the basic physics you'll learn in these courses will not. You will be able to use what you learn in this course throughout your life.

Deductive Logic

Solving physics problems makes extensive use of *deductive logic*. One begins with a set of known facts (given in the problem) and a set of relevant equations and definitions (which you select, based on the problem). Using logic and mathematics, you then deduce the conclusion (the solution to the problem).

As a simple example, suppose you are given that a body travels 700 meters in 10 seconds, and are asked to find its average speed. You must search your knowledge of physics to decide what additional facts are needed to solve this problem. In this case, you decide to use the definition of "average speed": the total distance divided by the total time. Putting the given information together with this definition, you find the solution to be 700 meters divided by 10 seconds, or 70 meter per second.

If you enjoy solving logic problems, cryptograms, and similar puzzles, then you'll enjoy solving physics problems. Solving physics problems is the primary skill you'll be developing in this course. Professional physicists solve similar types of problems — often more complex problems. They also do experiments to try to deduce the correct laws of Nature. In this course we'll present some of the laws of Nature that have been deduced so far, along with some of the important results and consequences of those laws.

Chapter 2

Units

The phenomena of Nature have been found to obey certain physical laws; one of the primary goals of physics research is to discover those laws. It has been known for several centuries that the laws of physics are appropriately expressed in the language of *mathematics*, so physics and mathematics have enjoyed a close connection for quite a long time.

In order to connect the physical world to the mathematical world, we need to make *measurements* of the real world. In making a measurement, we compare a physical quantity with some agreed-upon standard, and determine how many such standard units are present. For example, we have a precise definition of a unit of length called a *mile*, and have determined that there are about 92,000,000 such miles between the Earth and the Sun.

It is important that we have very precise definitions of physical units — not only for scientific use, but also for trade and commerce. In practice, we define a few *base units*, and derive other units from combinations of those base units. For example, if we define units for length and time, then we can define a unit for speed as the length divided by time (e.g. miles/hour).

How many base units do we need to define? There is no magic number; in fact it is possible to define a system of units using only *one* base unit (and this is in fact done for so-called *natural units*). For most systems of units, it is convenient to define base units for length, mass, and time; a base electrical unit may also be defined, along with a few lesser-used base units.

2.1 Systems of Units

Several different systems of units are in common use. For everyday civil use, most of the world uses *metric* units. The United Kingdom uses both metric units and an *imperial* system. Here in the United States, *U.S. customary units* are most common for everyday use.¹

There are actually several “metric” systems in use. They can be broadly grouped into two categories: those that use the meter, kilogram, and second as base units (MKS systems), and those that use the centimeter, gram, and second as base units (CGS systems). There is only one MKS system, called *SI units*. We will mostly use SI units in this course, but we will use other systems from time to time so that you get some experience with using them.

¹In the mid-1970s the U.S. government attempted to switch the United States to the metric system, but the idea was abandoned after strong public opposition. One remnant from that era is the two-liter bottle of soda pop.

2.2 SI Units

SI units (which stands for *Système International d'unités*) are based on the *meter* as the base unit of length, the *kilogram* as the base unit of mass, and the *second* as the base unit of time. SI units also define four other base units (the *ampere*, *kelvin*, *candela*, and *mole*, to be described later). Any physical quantity that can be measured can be expressed in terms of these seven base units or some combination of them. SI units are summarized in Appendix H.

SI units were originally based mostly on the properties of the Earth and of water. Under the *original* definitions:

- The *meter* was defined to be one ten-millionth the distance from the equator to the North Pole, along a line of longitude passing through Paris.
- The *kilogram* was defined as the mass of 0.001 m^3 of water.
- The *second* was defined as $1/86,400$ the length of a day (one rotation of the Earth).
- The definition of the *ampere* is related to electrical properties, ultimately relating to the meter, kilogram, and second.
- The *kelvin* was defined in terms of the thermodynamic properties of water, as well as absolute zero.
- The *candela* was defined by the luminous properties of molten tungsten and the behavior of the human eye.
- The *mole* was defined by the density of the carbon-12 nucleus.

Many of these original definitions have been replaced over time with more precise definitions, as the need for increased precision has arisen. Most recently, on May 20, 2019, there was a major re-definition of SI units, in which the definitions of the kilogram, ampere, kelvin, and mole were all changed. SI units now really have only one unit that is determined experimentally: the unit of time, which is the *second*. The other base units are now defined by defining exact, unchanging values for several of the physical constants.

Length (Meter)

The SI base unit of length, the *meter* (m), has been re-defined more times than any other unit, due to the need for increasing accuracy. Originally (1793) the meter was defined to be $1/10,000,000$ the distance from the North Pole to the equator, along a line going through Paris.² Then, in 1889, the meter was re-defined to be the distance between two lines engraved on a prototype meter bar kept in Paris. Then in 1960 it was re-defined again: the meter was defined as the distance of 1,650,763.73 wavelengths of the orange-red emission line in the krypton-86 atomic spectrum. Still more stringent accuracy requirements led to the the current definition of the meter, which was implemented in 1983: the meter is now defined to be the distance light in vacuum travels in $1/299,792,458$ second. Because of this definition, the speed of light is now *exactly* 299,792,458 m/s.

U.S. Customary units are legally defined in terms of metric equivalents. For length, the *foot* (ft) is defined to be exactly 0.3048 meter.

²If you remember this original definition, then you can remember the circumference of the Earth: about 40,000,000 meters.

Mass (Kilogram)

Originally the *kilogram* (kg) was defined to be the mass of 1 liter (0.001 m^3) of water. The need for more accuracy required the kilogram to be re-defined to be the mass of a standard mass called the *International Prototype Kilogram* which is kept in a vault at the Bureau International des Poids et Mesures (BIPM) in Paris. Each country was given its own copy of the IPK to use as its own national standard.

In 2019, the kilogram was re-defined (somewhat indirectly) by defining *Planck's constant* (used in quantum mechanics) to be *exactly* equal to $h = 6.62607015 \times 10^{-34} \text{ kg m}^2 \text{ s}^{-1}$. Since the meter and second are given precise experimental definitions, fixing the value of h has the effect of defining the value for the kilogram.

Another common metric (but non-SI) unit of mass is the *metric ton*, which is 1000 kg (a little over 1 short ton).

In U.S. customary units, the *pound-mass* (lbm) is defined to be exactly 0.45359237 kg.

Mass vs. Weight

Mass is not the same thing as *weight*, so it's important not to confuse the two. The *mass* of a body is a measure of the total amount of matter it contains; the *weight* of a body is the gravitational force on it due to the Earth's gravity. At the surface of the Earth, mass m and weight W are proportional to each other:

$$W = mg, \tag{2.1}$$

where g is the acceleration due to the Earth's gravity, equal to 9.80 m/s^2 . Remember: mass is mass, and is measured in kilograms; weight is a force, and is measured in force units of *newtons*.

Time (Second)

Originally the base SI unit of time, the *second* (s), was defined to be $1/60$ of $1/60$ of $1/24$ of the length of a day, so that 60 seconds = 1 minute, 60 minutes = 1 hour, and 24 hours = 1 day. High-precision time measurements have shown that the Earth's rotation rate has short-term irregularities, along with a long-term slowing due to tidal forces. So for a more accurate definition, in 1967 the second was re-defined to be based on a definition using atomic clocks. The second is now defined to be the time required for 9,192,631,770 oscillations of a certain type of radiation emitted from a cesium-133 atom.

Although officially the symbol for the second is "s", you will also often see people use "sec" to avoid confusing lowercase "s" with the number "5".

The Ampere, Kelvin, and Candela

For this course, most quantities will be defined entirely in terms of meters, kilograms, and seconds. There are four other SI base units, though: the *ampere* (A) (the base unit of electric current); the *kelvin* (K) (the base unit of temperature); the *candela* (cd) (the base unit of luminous intensity, or light brightness); and the *mole* (mol) (the base unit of amount of substance). With the 2019 re-definition of SI units, the *ampere* is now defined by fixing the value of the elementary charge to *exactly* $e = 1.602176634 \times 10^{-19} \text{ A s}$. The *kelvin* is now defined by fixing the value of *Boltzmann's constant* to *exactly* $k_B = 1.380649 \times 10^{-23} \text{ J/K}$. The *candela* is a unit that measures the brightness of light, and has a somewhat complex definition that includes a model of the response of the human eye to light of different wavelengths.

Amount of Substance (Mole)

Since we may have a use for the mole in this course, let's look at its definition in detail. The simplest way to think of it is as the name for a number. Just as "thousand" means 1,000, "million" means 1,000,000, and "bil-

lion” means 1,000,000,000, in the same way “mole” refers to the number³ 602,214,076,000,000,000,000, or $6.02214076 \times 10^{23}$. You could have a mole of grains of sand or a mole of Volkswagens, but most often the mole is used to count atoms or molecules. There is a reason this number is particularly useful: since each nucleon (proton and neutron) in an atomic nucleus has an average mass of $1.66053906660 \times 10^{-24}$ grams (called an *atomic mass unit*, or amu), then there are $1/(1.66053906660 \times 10^{-24})$, or $6.02214076 \times 10^{23}$ nucleons per gram. In other words, one mole of nucleons has a mass of 1 gram. Therefore, if A is the atomic weight of an atom, then A moles of nucleons has a mass of A grams. But A moles of nucleons is the same as 1 mole of atoms, so *one mole of atoms has a mass (in grams) equal to the atomic weight*. In other words,

$$\text{moles of atoms} = \frac{\text{grams}}{\text{atomic weight}} \quad (2.2)$$

Similarly, when counting molecules,

$$\text{moles of molecules} = \frac{\text{grams}}{\text{molecular weight}} \quad (2.3)$$

In short, the mole is useful when you need to convert between the mass of a material and the number of atoms or molecules it contains.

It’s important to be clear about what exactly you’re counting (atoms or molecules) when using moles. It doesn’t really make sense to talk about “a mole of oxygen”, any more than it would be to talk about “100 of oxygen”. It’s either a “mole of oxygen atoms” or a “mole of oxygen molecules”.⁴

For convenience, sometimes the word *entity* is used to mean “atom or molecule.” Then the formula for determining the number of moles from the mass becomes

$$\text{moles of entities} = \frac{\text{grams}}{\text{entity weight}} \quad (2.4)$$

where *entity weight* means either atomic weight or molecular weight, depending on whether it’s atoms or molecules that are being discussed.

Note that although the base SI unit of mass is the *kilogram*, the mole is defined by having the number of *grams* equal to the entity weight. Other kinds of “moles” have been defined, such as the *pound-mole*, *ounce-mole*, and *kilogram-mole*, in which the indicated unit of mass is numerically equal to the entity weight. For example, 1 kilogram-mole of carbon-12 atoms is 12 kilograms of carbon-12, and contains $6.02214076 \times 10^{26}$ carbon atoms. The SI mole is the same things as a gram-mole.

With the 2019 SI units re-definition, the mole is defined by setting Avogadro’s constant equal to *exactly* $N_A = 6.02214076 \times 10^{23} \text{ mol}^{-1}$.

Interesting fact: it’s estimated that there is roughly one mole of stars in the observable Universe.

SI Derived Units

In addition to the seven base units (m, kg, s, A, K, cd, mol), there are a number of so-called *SI derived units* with special names. We’ll introduce these as needed, but a summary of all of them is shown in Appendix H (Table H-2). These are just combinations of base units that occur often enough that it’s convenient to give them special names.

Plane Angle (Radian)

One derived SI unit that we will encounter frequently is the SI unit of plane angle. Plane angles are commonly measured in one of two units: *degrees* or *radians*.⁵ You’re probably familiar with degrees already: one full

³Six hundred two sextillion, two hundred fourteen quintillion, seventy-six quadrillion.

⁴Sometimes chemists will refer to a “mole of oxygen” when it’s understood whether the oxygen in question is in the atomic (O) or molecular (O₂) state.

⁵A third unit implemented in many calculators is the *grad*: a right angle is 100 grads and a full circle is 400 grads. You may encounter grads in some older literature, such as Laplace’s *Mécanique Céleste*. Almost nobody uses grads today, though.

circle is 360° , a semicircle is 180° , and a right angle is 90° .

The SI unit of plane angle is the *radian*, which is defined to be that plane angle whose arc length is equal to its radius. This means that a full circle is 2π radians, a semicircle is π radians, and a right angle is $\pi/2$ radians. To convert between degrees and radians, then, we have:

$$\text{degrees} = \text{radians} \times \frac{180}{\pi} \quad (2.5)$$

and

$$\text{radians} = \text{degrees} \times \frac{\pi}{180} \quad (2.6)$$

The easy way to remember these formulæ is to think in terms of units: 180 has units of degrees and π has units of radians, so in the first equation units of radians cancel on the right-hand side to leave degrees, and in the second equation units of degrees cancel on the right-hand side to leave radians.

Occasionally you will see a formula that involves a “bare” angle that is not the argument of a trigonometric function like the sine, cosine, or tangent. In such cases it is understood that the angle must be *in radians*. For example, the radius of a circle r , angle θ , and arc length s are related by

$$s = r\theta, \quad (2.7)$$

where it is understood that θ is in radians.

See Appendix O for a further discussion of plane and solid angles.

SI Prefixes

It's often convenient to define both large and small units that measure the same thing. For example, in English units, it's convenient to measure small lengths in inches and large lengths in miles.

In SI units, larger and smaller units are defined in a systematic way by the use of *prefixes* to the SI base or derived units. For example, the base SI unit of length is the meter (m), but small lengths may also be measured in centimeters (cm, 0.01 m), and large lengths may be measured in kilometers (km, 1000 m). Table H-3 in Appendix H shows all the SI prefixes and the powers of 10 they represent. You should *memorize* the powers of 10 for all the SI prefixes in this table.

To use the SI prefixes, simply add the prefix to the front of the name of the SI base or derived unit. The symbol for the prefixed unit is the symbol for the prefix written in front of the symbol for the unit. For example, kilometer (km) = 10^3 meter, microsecond (μs) = 10^{-6} s. But put the prefix on the *gram* (g), *not* the kilogram: for example, 1 microgram (μg) = 10^{-6} g. For historical reasons, the kilogram is the only SI base or derived unit with a prefix.⁶

The 2019 Re-definition of SI Units

On May 20, 2019, a major re-definition of SI units went into effect. With this re-definition, experimental definitions of several of the SI units have been replaced by *defining* the values of several fundamental physical constants, so that these values become fixed and unchanging, no matter how many future experiments are performed. The defined constants are shown in Table 2-1.

⁶Originally, the metric standard of mass was a unit called the *grave* (*GRAH-veh*), equal to 1000 grams. When the metric system was first established by Louis XVI following the French Revolution, the name *grave* was considered politically incorrect, since it resembled the German word *Graf*, or “Count” — a title of nobility, at a time when titles of nobility were shunned. The *grave* was retained as the unit of mass, but under the more acceptable name *kilogram*. The gram itself was too small to be practical as a mass standard.

Table 2-1. New SI base quantities, defining constants, and definitions.

Base quantity	Defining constant	Definition	Defines SI unit
Frequency	$\Delta\nu(^{133}\text{Cs})_{\text{hfs}}$	The unperturbed ground-state hyperfine splitting frequency of the cesium-133 atom is exactly 9,192,631,770 Hz.	s
Velocity	c	The speed of light in vacuum c is exactly 299,792,458 m/s.	m
Action	h	The Planck constant h is exactly $6.62607015 \times 10^{-34}$ J s.	kg
Electric charge	e	The elementary charge e is exactly $1.602176634 \times 10^{-19}$ C.	A
Heat capacity	k_B	The Boltzmann constant k_B is exactly 1.380649×10^{-23} J/K.	K
Amount of substance	N_A	The Avogadro constant N_A is exactly $6.02214076 \times 10^{23}$ mol ⁻¹ .	mol
Luminous intensity	K_{cd}	The luminous efficacy K_{cd} of monochromatic radiation of frequency 540×10^{12} Hz is exactly 683 lm/W.	cd

2.3 CGS Systems of Units

In some fields of physics (e.g. solid-state physics, plasma physics, and astrophysics), it has been customary to use CGS units rather than SI units, so you may encounter them occasionally. There are several different CGS systems in use: *electrostatic*, *electromagnetic*, *Gaussian*, and *Heaviside-Lorentz* units. These systems differ in how they define their electric and magnetic units. Unlike SI units, none of these CGS systems defines a base electrical unit, so electric and magnetic units are all derived units. The most common of these CGS systems is Gaussian units, which are summarized in Appendix I.

SI prefixes are used with CGS units in the same way they're used with SI units.

2.4 British Engineering Units

Another system of units that is common in some fields of engineering is *British engineering units*. In this system, the base unit of length is the foot (ft), and the base unit of time is the second (s). The base unit of force is called the *pound-force* (lbf), and mass is measured units of *slugs*, where 1 slug has a weight of 32.17404855 lbf.

A related unit of mass (not part of the British engineering system) is called the pound-mass (lbm). At the surface of the Earth, a mass of 1 lbm has a weight of 1 lbf, so sometimes the two are loosely used interchangeably and called the *pound* (lb), as we do every day when we speak of weights in pounds.

SI prefixes are not used in the British engineering system.

2.5 Units as an Error-Checking Technique

Checking units can be used as an important error-checking technique called *dimensional analysis*. If you derive an equation and find that the units don't work out properly, then you can be certain you made a mistake somewhere. If the units are correct, it doesn't necessarily mean your derivation is correct (since you could be off by a factor of 2, for example), but it does give you some confidence that you at least haven't made a units error. So checking units doesn't tell you for certain whether or not you've made a mistake, but it does help.

Here are some basic principles to keep in mind when working with units:

1. Units on both sides of an equation must match.
2. When adding or subtracting two quantities, they must have the same units.
3. Quantities that appear in exponents must be dimensionless.
4. The argument for functions like sin, cos, tan, \sin^{-1} , \cos^{-1} , \tan^{-1} , log, and exp must be dimensionless.

5. When checking units, radians and steradians can be considered dimensionless.
6. When checking complicated units, it may be useful to break down all derived units into base units (e.g. replace newtons with kg m s^{-2}).

Sometimes it's not clear whether or not the units match on both sides of the equation, for example when both sides involve derived SI units. In that case, it may be useful to break all the derived units down in terms of base SI units (m, kg, s, A, K, mol, cd). Table H-2 in Appendix H shows each of the derived SI units broken down in terms of base SI units.

2.6 Unit Conversions

It is very common to have to work with quantities that are given in units other than the units you'd like to work with. Converting from one set of units to another involves a straightforward, virtually foolproof technique that's very simple to double-check. We'll illustrate the method here with some examples.

Appendix N gives a number of important conversion factors. More conversion factors are available from sources such as the *CRC Handbook of Chemistry and Physics*.

1. Write down the unit conversion factor as a ratio, and fill in the units in the numerator and denominator so that the units cancel out as needed.
2. Now fill in the numbers so that the numerator and denominator contain the same length, time, etc. (This is because you want each factor to be a multiplication by 1, so that you don't change the quantity—only its units.)

Simple Conversions

A simple unit conversion involves only one conversion factor. The method for doing the conversion is best illustrated with an example.

Example. Convert 7 feet to inches.

Solution. First write down the unit conversion factor as a ratio, filling in the units as needed:

$$(7 \text{ ft}) \times \frac{\text{in}}{\text{ft}} \quad (2.8)$$

Notice that the units of feet cancel out, leaving units of inches. The next step is to fill in numbers so that the same length is in the numerator and denominator:

$$(7 \text{ ft}) \times \frac{12 \text{ in}}{1 \text{ ft}} \quad (2.9)$$

Now do the arithmetic:

$$(7 \text{ ft}) \times \frac{12 \text{ in}}{1 \text{ ft}} = 84 \text{ inches.} \quad (2.10)$$

More Complex Conversions

More complex conversions may involve more than one conversion factor. You'll need to think about what conversion factors you know, then put together a chain of them to get to the units you want.

Example. Convert 60 miles per hour to feet per second.

Solution. First, write down a chain of conversion factor ratios, filling in units so that they cancel out correctly:

$$60 \frac{\text{mile}}{\text{hr}} \times \frac{\text{ft}}{\text{mile}} \times \frac{\text{hr}}{\text{sec}} \quad (2.11)$$

Units cancel out to leave ft/sec. Now fill in the numbers, putting the same length in the numerator and denominator in the first factor, and the same time in the numerator and denominator in the second factor:

$$60 \frac{\text{mile}}{\text{hr}} \times \frac{5280 \text{ ft}}{1 \text{ mile}} \times \frac{1 \text{ hr}}{3600 \text{ sec}} \quad (2.12)$$

Finally, do the arithmetic:

$$60 \frac{\text{mile}}{\text{hr}} \times \frac{5280 \text{ ft}}{1 \text{ mile}} \times \frac{1 \text{ hr}}{3600 \text{ sec}} = 88 \frac{\text{ft}}{\text{sec}} \quad (2.13)$$

Example. Convert 250,000 furlongs per fortnight to meters per second.

Solution. We don't know how to convert furlongs per fortnight directly to meters per second, so we'll have to come up with a chain of conversion factors to do the conversion. We *do* know how to convert: furlongs to miles, miles to kilometers, kilometers to meters, fortnights to weeks, weeks to days, days to hours, hours to minutes, and minutes to seconds. So we start by writing conversion factor ratios, putting units where they need to be so that the result will have the desired target units (m/s):

$$250,000 \frac{\text{furlong}}{\text{fortnight}} \times \frac{\text{mile}}{\text{furlong}} \times \frac{\text{km}}{\text{mile}} \times \frac{\text{m}}{\text{km}} \times \frac{\text{fortnight}}{\text{week}} \times \frac{\text{week}}{\text{day}} \times \frac{\text{day}}{\text{hr}} \times \frac{\text{hr}}{\text{min}} \times \frac{\text{min}}{\text{sec}}$$

If you check the units here, you'll see that almost everything cancels out; the only units left are m/s, which is what we want to convert to. Now fill in the numbers: we want to put either the same length or the same time in both the numerator and denominator:

$$\begin{aligned} 250,000 \frac{\text{furlong}}{\text{fortnight}} &\times \frac{1 \text{ mile}}{8 \text{ furlongs}} \times \frac{1.609344 \text{ km}}{1 \text{ mile}} \times \frac{1000 \text{ m}}{1 \text{ km}} \times \frac{1 \text{ fortnight}}{2 \text{ weeks}} \times \frac{1 \text{ week}}{7 \text{ days}} \times \frac{1 \text{ day}}{24 \text{ hr}} \times \frac{1 \text{ hr}}{60 \text{ min}} \times \frac{1 \text{ min}}{60 \text{ sec}} \\ &= 41.58 \text{ m/s} \end{aligned}$$

Conversions Involving Powers

Occasionally we need to do something like convert an area or volume when we know only the length conversion factor.

Example. Convert 2000 cubic feet to gallons.

Solution. Let's think about what conversion factors we know. We know the conversion factor between gallons and cubic inches. We don't know the conversion factor between cubic feet and cubic inches, but we can convert between feet and inches. The conversion factors will look like this:

$$2000 \text{ ft}^3 \times \left(\frac{\text{in}}{\text{ft}} \right)^3 \times \frac{\text{gal}}{\text{in}^3} \quad (2.14)$$

With these units, the whole expression reduces to units of gallons. Now fill in the same length in the numerator and denominator of the first factor, and the same volume in the numerator and denominator of the second factor:

$$2000 \text{ ft}^3 \times \left(\frac{12 \text{ in}}{1 \text{ ft}} \right)^3 \times \frac{1 \text{ gal}}{231 \text{ in}^3} \quad (2.15)$$

Now do the arithmetic:

$$2000 \text{ ft}^3 \times \left(\frac{12 \text{ in}}{1 \text{ ft}} \right)^3 \times \frac{1 \text{ gal}}{231 \text{ in}^3} = 14,961 \text{ gallons} \quad (2.16)$$

2.7 Currency Units

Money has units that can be treated like any other units, using the same techniques we've just seen. Two things are unique about units of currency:

- Each country has its own currency units. Examples are United States dollars (\$), British pounds sterling (£), European euros (€), and Japanese yen (¥).
- The conversion factors from one country's currency to another's is a function of time, and even varies minute to minute during the day. These conversion factors are called *exchange rates*, and may be found, for example, on the Internet at

<http://www.xe.com/currencyconverter/>

Example. You're shopping in Reykjavík, Iceland, and see an Icelandic wool scarf you'd like to buy. The price tag says 6990 kr. What is the price in U.S. dollars?

Solution. The unit of currency in Iceland is the Icelandic króna (kr). Looking up the exchange rate on the Internet, you find it is currently \$1 = 119.050 kr. Then

$$6990 \text{ kr.} \times \frac{\$1.00}{119.050 \text{ kr.}} = \$58.71 \quad (2.17)$$

2.8 Odds and Ends

We'll end this chapter with a few miscellaneous notes about SI units:

- In a few special cases, we customarily drop the ending vowel of a prefix when combining with a unit that begins with a vowel: it's *megohm* (not "megaohm"); *kilohm* (not "kiloohm"); and *hectare* (not "hectoare"). In all other cases, keep both vowels (e.g. *microohm*, *kiloare*, etc.). There's no particular reason for this—it's just customary.
- In pharmacology (on bottles of vitamins or prescription medicine, for example), it is usual to indicate micrograms with "mcg" rather than " μg ". While this is technically incorrect, it is done to avoid misreading the units. Using "mc" for "micro" is not done outside pharmacology, and you should not use it in physics. Always use μ for "micro".
- Sometimes in electronics work the SI prefix symbol may be used in place of the decimal point. For example, 24.9 M Ω may be written "24M9". This saves space on electronic diagrams and when printing values on electronic components, and also avoids problems with the decimal point being nearly invisible when the print is tiny. This is unofficial use, and is only encountered in electronics.
- One sometimes encounters older metric units of length called the *micron* (μ , now properly called the *micrometer*, 10^{-6} meter) and the *millimicron* ($\text{m}\mu$, now properly called the *nanometer*, 10^{-9} meter). The micron and millimicron are now obsolete.
- At one time there was a metric prefix *myria-* (my) that meant 10^4 . This prefix is obsolete and is no longer used.

- In computer work, the SI prefixes are often used with units of bytes, but may refer to powers of 2 that are near the SI values. For example, the term “1 kB” may mean 1000 bytes, or it may mean $2^{10} = 1024$ bytes. Similarly, a 100 GB hard drive may have a capacity of 100,000,000,000 bytes, or it may mean $100 \times 2^{30} = 107,374,182,400$ bytes. To help resolve these ambiguities, a set of *binary prefixes* has been introduced (Table H-4 of Appendix H). These prefixes have not yet entirely caught on in the computing industry, though.

Chapter 3

Problem-Solving Strategies

Much of this course will focus on developing your ability to solve physics problems. If you enjoy solving puzzles, you'll find solving physics problems is similar in many ways. Here we'll look at a few general tips on how to approach solving problems.

- At the beginning of a problem stated in SI units, immediately convert the units of all the quantities you're given to base SI units. In other words, convert all lengths to meters, all masses to kilograms, all times to seconds, etc.: all quantities should be in un-prefixed SI units, except for masses in kilograms. When you do this, you're guaranteed that the final result will also be in base SI units, and this will minimize your problems with units. As you gain more experience in problem solving, you'll sometimes see shortcuts that let you get around this suggestion, but for now converting all units to base SI units is the safest approach.
- Similarly, if the problem is stated in CGS units immediately convert all given quantities to base CGS units (lengths in centimeters, masses in grams, and times in seconds). If the problem is stated in British engineering units, immediately convert all given quantities to base units (lengths in feet, masses in slugs, and times in seconds).
- Look at the information you're given, and what you're being asked to find. Then think about what equations you know that might let you get from what you're given to what you're trying to find.
- Be sure you understand under what conditions each equation is valid. For example, we'll shortly see a set of equations that are derived by assuming constant acceleration. It would be inappropriate to use those equations for a mass on a spring, since the acceleration of a mass under a spring force is *not* constant. For each equation you're using, you should be clear what each variable represents, and under what conditions the equation is valid.
- As a general rule, it's best to derive an algebraic expression for the solution to a problem first, then substitute numbers to compute a numerical answer as the very last step. This approach has a number of advantages: it allows you to check units in your algebraic expression, helps minimize roundoff error, and allows you to easily repeat the calculation for different numbers if needed.
- If you've derived an algebraic equation, *check the units* of your answer. Make sure your equation has the correct units, and doesn't do something like add quantities with different units.
- If you've derived an algebraic equation, you can check that it has the proper behavior for extreme values of the variables. For example, does the answer make sense if time $t \rightarrow \infty$? If the equation contains an angle, does it reduce to a sensible answer when the angle is 0° or 90° ?

- Check your answer for reasonableness—don't just write down whatever your calculator says. For example, suppose you're computing the speed of a pendulum bob in the laboratory, and find the answer is 14,000 miles per hour. That doesn't seem reasonable, so you should go back and check your work.
- You can avoid rounding errors by carrying as many significant digits as possible throughout your calculations; don't round off until you get to the final result.
- Write down a reasonable number of significant digits in the final answer—don't write down all the digits in your calculator's display. Nor should you round too much and use too few significant digits. There are rules for determining the correct number of significant digits, but for most problems in this course, 3 or 4 significant digits will be about right.
- Don't forget to put the correct units on the final answer! You will have points deducted for forgetting to do this.
- The best way to get good at problem solving (and to prepare for exams for this course) is *practice*—practice working as many problems as you have time for. Working physics problems is a skill much like learning to play a sport or musical instrument. You can't learn by watching someone else do it—you can only learn it by doing it yourself.

Chapter 4

Density

As an example of a quantity involving mixed units, consider the important quantity called *density*. Density is defined to be mass per unit volume:

$$\rho = \frac{M}{V} \quad (4.1)$$

Here ρ is the density of a body, M is its mass, and V is its volume. The SI units of density are kg/m^3 ; mass has SI units of kg , and volume has SI units of m^3 .

Density is a measure of how heavy something is for a fixed volume. For example, lead has a high density; styrofoam has a low density.

It is common to find densities of materials listed in handbooks in units of g/cm^3 . Since the density of water is 1 g/cm^3 , this makes it easy to compare a material's density with water. But in doing calculations involving density, you'll need to use SI units, kg/m^3 . A useful conversion factor to remember to convert between these units is the density of water: it's $1 \text{ g/cm}^3 = 1000 \text{ kg/m}^3$.

Occasionally we'll run into other definitions of density. For two-dimensional bodies, for example, we define an *area density* σ (mass per unit area) by $\sigma = M/A$. For one-dimensional bodies, we define a *linear density* λ (mass per unit length) by $\lambda = M/L$. And sometimes we may need to define something like a *charge density* (electric charge per unit volume) or a *number density* (number of particles per unit volume). Unless otherwise indicated, though, the word "density" usually refers to *mass* density.

Often the density of a material is a useful clue to determining its composition. For example, suppose you're handed a gold-colored brick. Is the brick solid gold, or is it just a block of lead covered with gold paint? Of course, you could just scratch the brick to see if the gold is just painted on, but suppose you don't want to damage the brick? One test you might do is determine the brick's density. First, determine the volume of the block (either by measuring the brick or by immersing it in a calibrated beaker of water). Then place the brick on a scale to find its mass. Now divide the mass by the volume to find the density, and compare with the densities of gold (19.3 g/cm^3) and lead (11.3 g/cm^3).¹

Densities of some common materials are shown in Table 4-1.

¹It happens that tungsten also has a density of 19.3 g/cm^3 , so the density test alone would not be sufficient to distinguish a solid gold brick from a gold-painted tungsten brick. In that case, some other test would be required, such as measuring the brick's hardness or electrical resistivity.

Table 4-1. Densities of some materials.

Material	Density (g/cm ³)
Air (STP)	0.001275
Ice	0.9169
Water	1.000
Aluminum	2.6989
Iron	7.874
Silver	10.50
Lead	11.35
Mercury	13.55
Gold	19.3
Osmium	22.59

4.1 Specific Gravity

A concept closely related to density is *specific gravity*, which is defined to be the ratio of the density of a substance to the density of water. Since the density of water is 1.00 g/cm³, the specific gravity is numerically equal to the density in units of g/cm³. Note, though, that specific gravity is dimensionless (i.e. has no units). For example, the density of gold is 19.3 g/cm³, and so its specific gravity is 19.3 (with no units).

4.2 Density Trivia

- Anything with a density less than 1 g/cm³ will float on water; anything with a greater density will sink.
- Most substances are more dense in the solid state than they are in the liquid state, so that as they freeze, the frozen parts sink. An important exception is water, which has its maximum density at 4 °C in the liquid state. Frozen water (ice) is less dense than liquid water, so the frozen parts float. This has been important for life on Earth: aquatic life is able to survive freezing temperatures because ice floats to the top of bodies of water, forming a layer of ice that insulates the water below. If ice were more dense than water, lakes and rivers would freeze solid and destroy most aquatic life.
- The chemical element with the *lowest* density is hydrogen, with a density of 0.0899 g/cm³ at standard temperature and pressure. But excluding gases, the lightest element is lithium, with a density of 0.534 g/cm³. Lithium and potassium are the only two solid elements light enough to float on water (although they will also chemically react with water).
- The chemical element with the *highest* density is osmium. There has been some debate over the years about whether osmium or iridium is the densest element, and the densities of the two are very close. But calculations show that for a perfect crystalline sample of each element, the density of osmium is 22.59 g/cm³, while that of iridium is 22.56 g/cm³, making osmium the winner by a small margin.² Either element is twice as dense as lead.
- Among the planets, Earth has the largest average density (5.515 g/cm³). The least dense planet is Saturn, with a density of 0.687 g/cm³. Saturn is the only planet in the Solar System that would float on water (given a large enough ocean).

²Arblaster, J. W. "Densities of osmium and iridium: recalculations based upon a review of the latest crystallographic data". *Platinum Metals Review*, **33**, 1, 14–16 (1989).

- Why was the International Prototype Kilogram made of a 90/10 platinum-iridium alloy? Platinum was chosen because of its high density. Making the standard kilogram from a high-density material minimizes its size, which minimizes the surface area that is subject to contamination, and also minimizes the buoyant force of the surrounding air. Osmium and iridium are denser but much more difficult to machine; platinum is dense, yet fairly easy to work with. The addition of 10% iridium hardens the platinum somewhat to minimize wear (which would alter the mass).
- The lightest solids around are called *aerogels*. These are artificial materials that are essentially *very* light solid silica foams, and have the appearance of “solid smoke”. They are excellent thermal insulators, and have been used by NASA to capture small dust particles from a comet (because they can gradually decelerate the particles with minimal damage). Aerogels have been made with densities as low as 0.001 g/cm^3 . If held up in the air and released, such an aerogel will remain almost stationary in the air, falling very slowly to the earth.
- Except for a black hole (which has, in a sense, infinite density), the densest object in Nature is a *neutron star*. Normally a star is in a state of equilibrium, with outward radiation pressure balancing the inward gravitational pressure. But when the star runs out of fuel, the outward radiation pressure is gone, and the star collapses under its own gravity. If the star is large enough, gravity can be strong enough to push the electrons of the atoms into the nucleus, forming a “neutron star”, which is essentially a giant ball of neutrons. A typical neutron star has a density of $\sim 10^{14} \text{ g/cm}^3$. To get an idea of how dense this is:
 - One pound of neutron star material would be about the size of a speck of dust.
 - A bit of neutron star material the size of a grain of sand would weigh as much as *two* fully fueled Saturn V Moon rockets.
 - 1/4 teaspoon of neutron star material would weigh as much as the borough of Manhattan.
 - 1 teaspoon of neutron star material would weigh as much as 5000 *Gerald R. Ford*-class aircraft carriers.
 - 1 cup of neutron star material would weigh as much as Mt. Everest.
 - A cube of neutron star material occupying 1/2 the college campus would weigh more than the entire Earth.

Chapter 5

Kinematics in One Dimension

Kinematics is the study of motion, without regard to the forces responsible for the motion. In kinematics, we describe the motion of an object by analyzing its position, velocity and acceleration.

Dynamics is the study of motion which includes kinematics along with the forces present that influence the motion. With dynamics, we introduce the ideas of *force* and *mass*. A special case of dynamics is called *statics*, and is the study of those problems in which the forces balance and there is no motion in the system.

We'll begin our study of kinematics in one dimension; the generalization to two or three dimensions is fairly straightforward. Studies of dynamics and statics will come later.

5.1 Position

Let's consider the motion of a *particle*—that is, a point mass. In one dimension, a particle is constrained to move back and forth along the x axis. At any given time t , we can specify the *position* of the particle by giving its x coordinate. Giving the x coordinate for all times t provides all the information we need for a complete description of the motion.

We are free to define the coordinate system however we want; the coordinate system is a mathematical construction that we define for our own convenience, and it won't affect the physics. For one-dimensional motion, we align the x axis with the direction of the motion, and we are free to choose the origin at any place that's convenient. Also, we will generally be free to choose the zero time $t = 0$ to be whenever is convenient.

Related to position is the concept of *displacement*. If a particle is at position x_1 at some time t_1 , then at position x_2 at some later time t_2 , then the particle has undergone a displacement

$$\Delta x = x_2 - x_1. \tag{5.1}$$

Note that the displacement depends only on the beginning and ending positions of the particle, not on what happens in between. For example, if the particle starts out at position $x_1 = 3$ m, then moves to 50 m, then back to $x_2 = 3$ m again, the displacement $\Delta x = 0$. The displacement is *not* the same as the total distance traveled—it is the *net* distance traveled.

5.2 Velocity

The *velocity* of a particle is a measure of how much distance it covers in a given time.¹ SI units of velocity are meters per second (m/s, or m s^{-1}). There are two ways we can talk about velocity: the *average* velocity over some finite time interval Δt , or the *instantaneous* velocity at an instant in time t .

¹The magnitude (absolute value) of velocity is called *speed*.

Average Velocity

Suppose a particle is at position x_1 at time t_1 , and it's at position x_2 at time t_2 . Then over the time interval $\Delta t = t_2 - t_1$, the particle undergoes a displacement $\Delta x = x_2 - x_1$. The *average velocity* v_{ave} of the particle over time interval Δt is defined to be

$$v_{\text{ave}} = \frac{\Delta x}{\Delta t} = \frac{x_2 - x_1}{t_2 - t_1}. \quad (5.2)$$

Example. If a particle travels 400 meters in 5 seconds, then its average velocity is $v_{\text{ave}} = \Delta x / \Delta t = (400 \text{ m}) / (5 \text{ s}) = 80 \text{ m/s}$. Remember that $\Delta x = 400 \text{ m}$ means that the particle's position at the end of the time interval is 400 meters beyond its position at the start of the interval. It might have traveled millions of meters in between, but we don't care about that: all that matters is the starting position and ending position.

Instantaneous Velocity

Suppose we want to know the *instantaneous velocity* at a single instant in time t , rather than an average over a time interval Δt . The calculus gives us a method to do that: we just use Eq. (5.2) to find the average velocity over a time interval Δt , then make the time interval arbitrarily small. Mathematically, this is just the derivative:

$$v = \lim_{\Delta t \rightarrow 0} \frac{\Delta x}{\Delta t} = \frac{dx}{dt}. \quad (5.3)$$

Example. Suppose we have a formula for the position x of a particle at any time t —for example, $x(t) = 5t^2 + 7 \text{ m}$. Then we can get a formula for the velocity v at any time t by taking the derivative: $v(t) = dx/dt = 10t \text{ m/s}$.

5.3 Acceleration

In a similar way, we can take the derivative velocity with respect to time to get *acceleration*, which is the *second* derivative of x with respect to t :

$$a = \frac{dv}{dt} = \frac{d^2x}{dt^2} \quad (5.4)$$

SI units of acceleration are meters per second squared (m/s^2).

Example. In the previous example, we found a formula for the velocity of a particle as $v(t) = 10t$. The acceleration of the particle in this example is $a(t) = 10 \text{ m/s}^2$, a constant.

As we'll see later when we discuss gravity, all objects at the surface of the Earth will accelerate downward with the same acceleration, 9.80 m/s^2 . This important constant is called the *acceleration due to gravity*, and is given the symbol g :

$$g = 9.80 \text{ m/s}^2 \quad (= 32 \text{ ft/s}^2). \quad (5.5)$$

This value is an average for the Earth; for a more exact value of g , you can use Helmert's equation (Section 51.4).

The acceleration due to gravity gives rise to a common (non-SI) unit of acceleration, also called the g :

$$1 \text{ g} = 9.80665 \text{ m/s}^2. \quad (5.6)$$

This number is a standardized conventional value that has been adopted by international agreement.

5.4 Higher Derivatives

Occasionally one may have a use for higher derivatives of position with respect to time. The time derivative of acceleration is called *jerk*, and the time derivative of jerk is called *jounce*. One published paper² whimsically named the fourth, fifth, and sixth derivatives of x “snap”, “crackle”, and “pop” after the cartoon characters on boxes of Rice Krispies® breakfast cereal.

We will seldom, if ever, have need of these higher-order derivatives of x for this course, but for reference, they are summarized in Table 5-1.

Table 5-1. Time derivatives of position.

Derivative	Symbol	Name
0	x	position
1	dx/dt	velocity
2	d^2x/dt^2	acceleration
3	d^3x/dt^3	jerk
4	d^4x/dt^4	jounce, snap
5	d^5x/dt^5	crackle
6	d^6x/dt^6	pop

5.5 Dot Notation

Derivatives of quantities with respect to time are so common in mechanics that physicists often use a special shorthand notation for them. The derivative with respect to time is indicated with a *dot* over the quantity; a second derivative is indicated with two dots, etc. You can think of this as similar to the “prime” notation for derivatives encountered in calculus, except that the “dot” over a variable always indicates a derivative with respect to *time*. This dot notation is especially common in more advanced mechanics courses.

For example, velocity and acceleration in one dimension may be written in dot notation as follows:

$$\dot{x} = dx/dt \quad (\text{velocity}) \quad (5.7)$$

$$\ddot{x} = d^2x/dt^2 \quad (\text{acceleration}) \quad (5.8)$$

This dot notation for derivatives (\dot{x} , \ddot{x} , etc.) is due to Sir Isaac Newton. The notation dx/dt , d^2x/dt^2 , etc. was originated by the German mathematician Gottfried Leibniz, who is believed to have been an independent co-discoverer of the calculus, along with Newton. The “prime notation” sometimes used ($x'(t)$, $x''(t)$, etc.) is due to Italian mathematician Joseph-Louis Lagrange.

5.6 Inverse Relations

Given the definition of (instantaneous) velocity

$$v = \frac{dx}{dt}, \quad (5.9)$$

²Visser, Matt. Jerk, Snap, and the Cosmological Equation of State. *Classical and Quantum Gravity*, **21** (11): 2603-2616.

we can invert this by multiplying both sides by dt and integrating to get an expression for $x(t)$: it is the integral of velocity v with respect to time t :

$$x(t) = \int v(t) dt. \quad (5.10)$$

Similarly, we can invert the definition of acceleration

$$a = \frac{dv}{dt} \quad (5.11)$$

to get

$$v(t) = \int a(t) dt. \quad (5.12)$$

5.7 Constant Acceleration

The definitions of velocity and acceleration we've seen so far ($v = dx/dt$, $a = dv/dt$) are *always* true. But now let's look at an important special case: *constant acceleration*. First, assume that the acceleration a is a constant. Then by Eq. (5.12),

$$v(t) = \int a dt \quad (5.13)$$

$$= a \int dt \quad (5.14)$$

$$= at + C, \quad (5.15)$$

where C is a constant. The assumption of constant acceleration comes in Eq. (5.14), where we use that assumption to bring a outside the integral.

What is the physical significance of the integration constant C ? Let's look at what Eq. (5.15) gives us when $t = 0$:

$$v(0) = a \cdot 0 + C = C. \quad (5.16)$$

So C is just the velocity of the particle at time $t = 0$ (the *initial velocity*), which we'll write³ as $v(0) = v_0$. Then Eq. (5.15) is written

$$\boxed{v(t) = at + v_0.} \quad (5.17)$$

Now let's substitute Eq. (5.17) for $v(t)$ into Eq. (5.10) to get an expression for $x(t)$ for constant acceleration:

$$x(t) = \int (at + v_0) dt \quad (5.18)$$

$$= \int at dt + \int v_0 dt \quad (5.19)$$

$$= a \int t dt + v_0 \int dt \quad (5.20)$$

$$= \frac{1}{2}at^2 + v_0t + C'. \quad (5.21)$$

³The quantity v_0 is customarily pronounced "v-nought", *nought* being an old-fashioned term for *zero*. Similarly, x_0 is pronounced "x-nought".

What is the physical significance of the integration constant C' ? We do the same trick we did before, and look at what happens when $t = 0$:

$$x(0) = \frac{1}{2}a \cdot 0^2 + v_0 \cdot 0 + C' = C'. \quad (5.22)$$

So C' is the position of the particle at time $t = 0$ (the *initial position*), which we'll write as $x(0) = x_0$. Then Eq. (5.21) becomes

$$\boxed{x(t) = \frac{1}{2}at^2 + v_0t + x_0.} \quad (5.23)$$

Example. Suppose you're standing on a bridge, and want to know how high you are above the river below. You can do this by dropping a rock from the bridge and counting how many seconds it takes to hit the river.

We begin solving this problem by defining a coordinate system with $+x$ pointing downward, and the origin at the bridge. This is an arbitrary choice; we could just as easily define the x axis pointing up instead of down, and in either case we could put the origin at the bridge or at the river (or anywhere else, for that matter), and you'll get the same answer at the end. But putting the origin at the bridge simplifies the equations somewhat, and pointing the $+x$ axis downward makes the acceleration and velocity positive. The coordinate system is an artificial mathematical construction that we introduce into the problem; the choice of origin and direction will not affect the physics or the final answer, so we're free to choose whatever is convenient.

The acceleration is constant in this case (and equal to the acceleration due to gravity), so we can use the constant-acceleration expression for x , Eq. (5.23). Since the acceleration is always downward and we've defined $+x$ downward, we have $a = +g$. We'll define time $t = 0$ as the instant the rock is released; then $v_0 = 0$ since the rock is released from rest, and $x_0 = 0$ because we defined the origin to be at the point of release. Then Eq. (5.23) becomes

$$x = \frac{1}{2}gt^2. \quad (5.24)$$

Let's say it takes 4 seconds for the rock to hit the water. Then the height of the bridge above the river is $x = gt^2/2 = (9.80 \text{ m/s}^2)(4 \text{ s})^2/2 = 78.4 \text{ m}$.

Sometimes we'll find a problem involving position and velocity, but not time. For such problems with constant acceleration, it is useful to have an expression for velocity v in terms of position x , i.e. $v(x)$. We begin by solving Eq. (5.17) for time t :

$$t = \frac{v - v_0}{a}. \quad (5.25)$$

Now substitute this expression for t into Eq. (5.23):

$$x = \frac{1}{2}a \left(\frac{v - v_0}{a} \right)^2 + v_0 \left(\frac{v - v_0}{a} \right) + x_0. \quad (5.26)$$

We've eliminated time t ; now we just need to solve this for v :

$$x = \frac{1}{2} \frac{(v - v_0)^2}{a} + \frac{vv_0 - v_0^2}{a} + x_0 \quad (5.27)$$

$$2ax = (v^2 - 2vv_0 + v_0^2) + 2(vv_0 - v_0^2) + 2ax_0 \quad (5.28)$$

$$2a(x - x_0) = v^2 - 2vv_0 + v_0^2 + 2vv_0 - 2v_0^2 \quad (5.29)$$

$$2a(x - x_0) = v^2 - v_0^2 \quad (5.30)$$

and so

$$\boxed{v^2 = v_0^2 + 2a(x - x_0)} \quad (5.31)$$

This says that under constant acceleration, if the particle has velocity v_0 at position x_0 , then it will have velocity v at position x .

Example—impact velocity. Suppose we drop a rock from a bridge that we know to be $h = 125$ m above water. What is the impact velocity of the rock, i.e. the velocity of the rock just before it hits the water?

Notice that there is no time involved in this problem: only a distance and a velocity. This suggests using Eq. (5.31) to find the impact velocity. As in the previous example, we begin by defining a coordinate system, and we'll use the same system as before: with the origin at the bridge, and $+x$ pointing downward. Then $x_0 = 0$ (because of where we defined the origin), $v_0 = 0$ (because the rock is released from rest), and $a = +g$ (because we defined $+x$ as downward). Then Eq. (5.31) becomes

$$v^2 = 2gh \quad (5.32)$$

Solving for v gives the velocity at position $x = h$ (at the water). We'll use only the *positive* square root of this equation, which gives the magnitude of the velocity, i.e. the speed:

$$v = \sqrt{2gh} \quad (5.33)$$

$$= \sqrt{2(9.8 \text{ m/s}^2)(125 \text{ m})} \quad (5.34)$$

$$= 49.5 \text{ m/s} \quad (5.35)$$

Just to show that the definition of coordinate system doesn't affect the final answer, let's re-work the problem using a coordinate system that has the origin *at the water* instead of at the bridge, and let's construct the x axis so that $+x$ points *upward*. In this case the rock will have velocity $v_0 = 0$ at position $x_0 = h$, $a = -g$ (because the x axis now points upward), and we wish to find the velocity v at $x = 0$. Then Eq. (5.31) becomes

$$v^2 = 2(-g)(0 - h) \quad (5.36)$$

$$v = \sqrt{2gh}, \quad (5.37)$$

where we have again used only the positive square root, and we get the same result as before—the result is independent of how we define the coordinate system.

5.8 Summary

Let's summarize the results so far:

Always True

These equations are definitions, and are always true:

$$v = \frac{dx}{dt} \quad \Rightarrow \quad x(t) = \int v(t) dt \quad (5.38)$$

$$a = \frac{dv}{dt} = \frac{d^2x}{dt^2} \quad \Rightarrow \quad v(t) = \int a(t) dt \quad (5.39)$$

Constant Acceleration

These equations are valid *only for constant acceleration* a :

$$x(t) = \frac{1}{2}at^2 + v_0t + x_0 \quad (5.40)$$

$$v(t) = at + v_0 \quad (5.41)$$

$$v^2 = v_0^2 + 2a(x - x_0) \quad (5.42)$$

5.9 Geometric Interpretations

Recall these ideas from your study of the calculus:

- The derivative of a function $f(t)$ with respect to t at any time t is the *slope* of the tangent to the curve at t .
- The integral of a function $f(t)$ with respect to t is the *area* under the curve (with negative f counting as negative area).

Now if you're given a *formula* for $x(t)$, you can use $v = dx/dt$ to find a formula for the velocity v . But suppose that instead of a formula, you're given a data table or plot of x vs. t .⁴ Then you can find the velocity at any time by finding the slope of the curve at that point—which is geometrically the same thing as finding the derivative.

Similarly, if you're given a formula for $v(t)$, you can use $x = \int v dt$ to find a formula for the position x . Suppose, though, that instead of a formula, you have a data table or plot of v vs. t . Then you can find the net distance traveled between times t_1 and t_2 by finding the area under the v vs. t curve between times t_1 and t_2 .

For example, consider the motion of a particle that moves in one dimension according to $x(t) = 5t^2 + 3t + 7$ (where x is in meters and t is in seconds), as illustrated in Figure 5.1. The position x at any time t is shown by the parabolic curve in Figure 5.1(a); you can read off the position of the particle at any time just by looking at the graph. The *slope* of the graph at any time gives the velocity at that time. For example, at $t = 30$ sec, we can draw a straight line tangent to the curve, as shown in Fig. 5.1(a); measuring the slope of that line (as the “rise” divided by the “run”), we find $v(30 \text{ sec}) = 33 \text{ m/s}$.

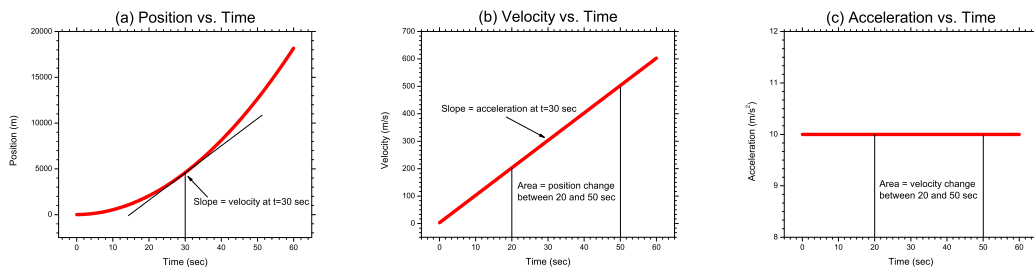

Figure 5.1: Plots of position, velocity, and acceleration vs. time for a particle moving according to $x(t) = 5t^2 + 3t + 7 \text{ m}$. From the calculus, we find (b) $v(t) = dx/dt = 10t + 3 \text{ m/s}$, and (c) $a(t) = dv/dt = 10 \text{ m/s}^2$. The same results are found geometrically, as described in the text.

⁴The word *versus* (*vs.*) has a specific meaning in plots: it's always the ordinate vs. the abscissa (e.g. y vs. x).

Figure 5.1(b) shows velocity vs. time for the same particle. In this case, you can read off the velocity v at any time t by inspection of the plot. The slope of the plot at any time t gives the *acceleration* at that time. In this case, the plot of v vs. t is a straight line with constant slope, so the acceleration is the same at all times: $a = 10 \text{ m/s}^2$. The *area* under the curve gives the change in position between two times. For example, again in Fig. 5.1(b), the area under the v vs. t curve from $t = 20$ sec to $t = 50$ sec (the area of a trapezoid in this case) gives the change in position during that time interval: 10,590 m.

Figure 5.1(c) shows acceleration vs. time for the same particle. As before, you can read off the acceleration a at any time t by inspection of the plot. In this case, the acceleration is a constant 10 m/s^2 for all times. The slope of the plot at any time t gives the *jerk* at that time. In this case, since the line is horizontal with zero slope, the jerk is zero at all times. The area under the curve in Fig. 5.1(c) gives the change in velocity between two times. For example, the area under the curve between $t = 20$ sec and $t = 50$ sec gives the velocity change during that interval, 300 m/s. This may be confirmed in Fig. 5.1(b): the velocity changes from 203 m/s at $t = 20$ sec to 503 m/s at $t = 50$ sec.

Chapter 6

Vectors

We will next want to extend our knowledge of kinematics from one dimension to two and three dimensions. However, the equations will be expressed in the mathematical language of *vectors*, so we'll need to examine the mathematics of vectors first.

6.1 Introduction

Some quantities we measure in physics have only a *magnitude*; such quantities are called *scalars*. Examples of scalars are mass and temperature. Other quantities have both a magnitude and a *direction*; such quantities are called *vectors*. Examples of vectors are velocity, acceleration, and electric field.

You can represent a vector graphically by drawing an *arrow*. The direction of the arrow indicates the direction of the vector, while the length of the arrow represents the magnitude of the vector on some chosen scale. By convention, we write vector names in boldface type in typeset text (e.g. \mathbf{A}); when writing vectors by hand, it is customary to draw a small arrow over the name (e.g. \vec{A}).

Besides drawing a vector in the plane of the page, occasionally you may want to draw a vector diagram in which you want to indicate a vector pointing directly into or out of the page. You can do this using these symbols:

Symbol	Meaning
\longrightarrow	Vector <i>in plane of page</i>
\otimes	Vector <i>into page</i>
\odot	Vector <i>out of page</i>

The symbol \otimes is supposed to look like the tail feathers of an arrow flying away from you, while the symbol \odot is supposed to resemble the head of an arrow flying directly toward you. Of course, if you use these two symbols, you can only indicate the *direction* of the vector, not its magnitude—but this is often all that's needed.

It is possible to do arithmetic on vectors: for example, you can add or subtract two vectors, or multiply a vector by a scalar. These operations may be done either graphically or algebraically. Both methods will be described here.

6.2 Vector Arithmetic: Graphical Methods

Vector arithmetic can be done graphically, by drawing the vectors as arrows on graph paper, and measuring the results with a ruler and protractor. The advantage of the graphical methods are that they give a good intuitive picture of what's going on to help you visualize what you're trying to do. The disadvantages are that the graphical methods can be time-consuming, and not very accurate.

In practice, the graphical methods are usually used to make a quick sketch, to help organize and clarify your thinking, so you can be clear that you're doing things correctly. The algebraic methods are then used for the actual calculations.

When drawing vectors, you are free to move the vector around the page however you want, as long as you don't change the direction or magnitude.

Addition

We'll begin with addition. There are two methods available to add two vectors together: the first is called the *parallelogram method*. In this method, you draw the two vectors to be added with their tail end points at the same point. This figure forms half a parallelogram; draw two additional lines to complete the parallelogram. Now draw a vector from the tail endpoint across the diagonal of the parallelogram. This diagonal vector is the sum of the two original vectors (Fig. 6.1(a)).

The second graphical method of vector addition is called the *triangle method*. In this method, you first draw one vector, then draw the second so that its tail is at the head of the first vector. To find the sum of the two vectors, draw a vector from the tail of the first vector to the head of the second (Fig. 6.1(b)).

The triangle method can be extended to add any number of vectors together. Just draw the vectors one by one, with the tail of each vector at the head of the previous one. The sum of all the vectors is then found by drawing a vector from the tail of the first vector in the chain to the head of the last one (Fig. 6.1(c)). This is called the *polygon method*.

Subtraction

To subtract two vectors graphically, draw the two vectors so that their tail endpoints are at the same point. To draw the difference vector, draw a vector from the head of the subtrahend vector to the head of the minuend vector (Fig. 6.1(d)).

Scalar Multiplication

Multiplying a vector by a scalar will change the length of the vector. Multiplying by a scalar greater than 1 (in absolute value) will lengthen the vector; multiplying by a scalar less than 1 in absolute value will shrink the vector. If the scalar is positive, the product vector will have the same direction as the original; if the scalar is negative, the product vector will be opposite the direction of the original (Fig. 6.1(e)).

6.3 Vector Arithmetic: Algebraic Methods

Although the graphical methods just described give a good intuitive picture of the mathematical operations, they can be a bit tedious to draw. A much more convenient and accurate alternative is the set of *algebraic* methods, which involve working with numbers instead of graphs. Before we can do that, though, we need to find a way to quantify a vector—to change it from a graph of an arrow to a set of numbers we can work with.

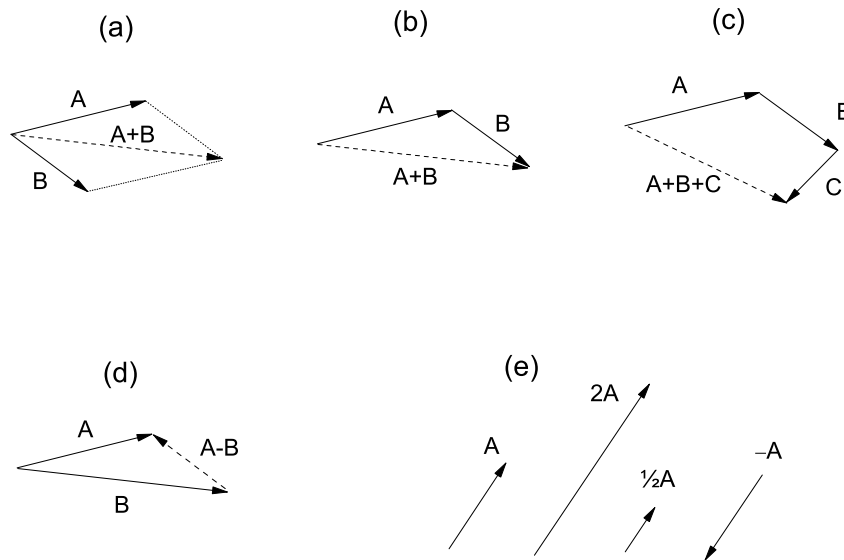

Figure 6.1: Graphical methods for vector arithmetic. (a) Addition of vectors \mathbf{A} and \mathbf{B} using the parallelogram method. (b) Addition of the same vectors \mathbf{A} and \mathbf{B} using the triangle method. (c) Addition of vectors \mathbf{A} , \mathbf{B} , and \mathbf{C} using a generalization of the triangle method called the *polygon method*. The sum vector points from the tail of the first vector to the head of the last. (d) Vector subtraction: $\mathbf{A} - \mathbf{B}$ points from the head of \mathbf{B} to the head of \mathbf{A} . (e) Multiplication of a vector \mathbf{A} by various scalars. Multiplying by a scalar greater than 1 makes the vector longer; multiplying by a scalar less than 1 makes it shorter. The resulting vector will be in the same direction as \mathbf{A} unless the scalar is negative, in which case the result will point opposite the direction of \mathbf{A} .

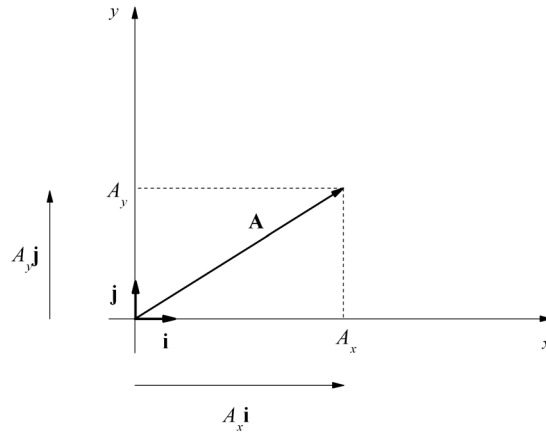

Figure 6.2: Cartesian components of a vector.

Rectangular Form

One idea would be to keep track of the coordinates of the head and tail of the vector. But remember that we are free to move a vector around wherever we want, as long as the direction and magnitude remain unchanged. So let's choose to always put the tail of the vector at the origin—that way, we only have to keep track of the head of the vector, and we cut our work in half. A vector can then be completely specified by just giving the coordinates of its head.

There's a little bit of a different way of writing this, though. We begin by defining two *unit vectors* (vectors with magnitude 1): \mathbf{i} is a unit vector in the x direction, and \mathbf{j} is a unit vector in the y direction. (In three dimensions, we add a third unit vector \mathbf{k} in the z direction.)

Referring to Fig. 6.2, let A_x be the projection of vector \mathbf{A} onto the x -axis, and let A_y be its projection onto the y -axis. Then, recalling the rules for the multiplication of a vector by a scalar, $A_x\mathbf{i}$ is a vector pointing in the x -direction, and whose length is equal to the projection A_x . Similarly, $A_y\mathbf{j}$ is a vector pointing in the y -direction, and whose length is equal to the projection A_y . Then by the parallelogram rule for adding two vectors, vector \mathbf{A} is the sum of vectors $A_x\mathbf{i}$ and $A_y\mathbf{j}$ (Fig. 6.2). This means we can write a vector \mathbf{A} as

$$\mathbf{A} = A_x\mathbf{i} + A_y\mathbf{j}, \quad (6.1)$$

or, if we're working in three dimensions,

$$\mathbf{A} = A_x\mathbf{i} + A_y\mathbf{j} + A_z\mathbf{k}. \quad (6.2)$$

Eq. (6.1) or (6.2) is called the *rectangular* or *cartesian*¹ form of vector \mathbf{A} .

¹The name *cartesian* is from *Cartesius*, the Latin form of the name of the French mathematician René Descartes, the founder of analytic geometry.

Magnitude

The *magnitude* of a vector is a measure of its total “length.” It is indicated with absolute value signs around the vector ($|\mathbf{A}|$ in type, or $|\vec{A}|$ in handwriting), or more simply by just writing the name of the vector in regular type (A ; no boldface or arrow). In terms of rectangular components, the magnitude of a vector is simply given by the Pythagorean theorem:

$$|\mathbf{A}| = A = \sqrt{A_x^2 + A_y^2 + A_z^2}. \quad (6.3)$$

Example. The magnitude of vector $\mathbf{A} = 2\mathbf{i} + 5\mathbf{j}$ is

$$|\mathbf{A}| = A = \sqrt{2^2 + 5^2} = \sqrt{29} = \boxed{5.3852}$$

Polar Form

Instead of giving the x and y coordinates of the head of the vector, an alternative form is to give the magnitude and direction of the vector. This is called the *polar* form of a vector, and is indicated by the notation

$$\mathbf{A} = A\angle\theta, \quad (6.4)$$

where A is the magnitude of the vector, and θ is the direction, measured counterclockwise from the $+x$ axis.

By convention, in polar form, we always take the magnitude of a vector as positive. If the magnitude comes out negative (as the result of a calculation, for example), then we can make it positive by changing its sign and adding 180° to the direction.

Converting between the rectangular and polar forms of a vector is fairly straightforward. To convert from polar to rectangular form, we use the definitions of the sine and cosine to get $\sin \theta = \text{opp/hyp} = A_y/A$, and $\cos \theta = \text{adj/hyp} = A_x/A$. Therefore to convert from polar to rectangular form, we use

$$A_x = A \cos \theta \quad (6.5)$$

$$A_y = A \sin \theta \quad (6.6)$$

To go the other way (rectangular to polar form), we just invert these equations to solve for A and θ . To solve for A , take the sum of the squares of both equations and add; to solve for θ , divide the A_y equation by the A_x equation. The results are

$$A = \sqrt{A_x^2 + A_y^2} \quad (6.7)$$

$$\tan \theta = \frac{A_y}{A_x} \quad (6.8)$$

To find θ , you must take the arctangent of the right-hand side of Eq. (6.8). But be careful: to get the angle in the correct quadrant, you first compute the right-hand side of Eq. (6.8), then use the arctangent (TAN^{-1}) function on your calculator. If $A_x > 0$, then the calculator shows θ . But if $A_x < 0$, you must remember to add 180° (π rad) to the calculator's answer to get θ in the correct quadrant.

It is also possible to write three-dimensional vectors in polar form, but this requires a magnitude and *two* angles. We won't have any need to write three-dimensional vectors in polar form for this course.

Example: Polar to rectangular. Convert the vector $\mathbf{A} = 7\angle 40^\circ$ from polar form to rectangular form:

$$A_x = A \cos \theta = 7 \cos 40^\circ = 5.3623 \quad (6.9)$$

$$A_y = A \sin \theta = 7 \sin 40^\circ = 4.4995 \quad (6.10)$$

so the rectangular form is $\mathbf{A} = 5.3623 \mathbf{i} + 4.4995 \mathbf{j}$

Example: Rectangular to polar. Convert the vector $\mathbf{B} = -4 \mathbf{i} + 8 \mathbf{j}$ from rectangular form to polar form:

$$|\mathbf{B}| = \sqrt{B_x^2 + B_y^2} = \sqrt{(-4)^2 + 8^2} = \sqrt{16 + 64} = \sqrt{80} = 8.9443 \quad (6.11)$$

$$\tan \theta = \frac{B_y}{B_x} = \frac{8}{-4} = -2 \quad \Rightarrow \quad \theta = 116.565^\circ \quad (6.12)$$

so the polar form is $8.9443\angle 116.565^\circ$.

Notice that to find θ , we take the inverse tangent of -2 and the calculator returns -63.435° . But because the denominator (-4) is *negative*, we add 180° to the calculator's answer: $-63.435^\circ + 180^\circ = 116.565^\circ$. If the denominator had been *positive*, we would *not* have added this 180° . For example, the rectangular vector $\mathbf{C} = 4 \mathbf{i} - 8 \mathbf{j}$ would be $8.9443\angle -63.435^\circ$ in polar form.

Vector Equality

In order for two vectors to be *equal*, they must have the same magnitude and point in the same direction. This means that each of their components must be equal. For example, if $\mathbf{A} = \mathbf{B}$, then all of the following must be true:

$$A_x = B_x \quad (6.13)$$

$$A_y = B_y \quad (6.14)$$

$$A_z = B_z \quad (6.15)$$

Addition

Now we're ready to describe the algebraic method for the addition of two vectors. First, both vectors *must be in rectangular (cartesian) form*—you *cannot* add vectors in polar form. If you're given two vector in polar form and must add them, you must first convert them to rectangular form using Eq. (6.5-6.6).

Once the vectors are in rectangular form, you simply add the two vectors component by component: the x -component of the sum is the sum of the x components, etc.:

$$\begin{array}{rcl} \mathbf{A} & = & A_x \mathbf{i} + A_y \mathbf{j} + A_z \mathbf{k} \\ + \mathbf{B} & = & B_x \mathbf{i} + B_y \mathbf{j} + B_z \mathbf{k} \\ \hline \mathbf{A} + \mathbf{B} & = & (A_x + B_x) \mathbf{i} + (A_y + B_y) \mathbf{j} + (A_z + B_z) \mathbf{k} \end{array}$$

Subtraction

Just as with addition, vectors must be in rectangular (cartesian) form before they can be subtracted. Vector subtraction is similar to vector addition: you simply subtract the two vectors component by component:

$$\begin{array}{rcl} \mathbf{A} & = & A_x \mathbf{i} + A_y \mathbf{j} + A_z \mathbf{k} \\ - \mathbf{B} & = & B_x \mathbf{i} + B_y \mathbf{j} + B_z \mathbf{k} \\ \hline \mathbf{A} - \mathbf{B} & = & (A_x - B_x) \mathbf{i} + (A_y - B_y) \mathbf{j} + (A_z - B_z) \mathbf{k} \end{array}$$

Scalar Multiplication

Multiplication of a vector by a scalar may be done in either rectangular or polar form. In rectangular form, you multiply each component of the vector by the scalar. For example, given the vector \mathbf{A} and scalar c :

$$c\mathbf{A} = c(A_x\mathbf{i} + A_y\mathbf{j} + A_z\mathbf{k}) \quad (6.16)$$

$$= cA_x\mathbf{i} + cA_y\mathbf{j} + cA_z\mathbf{k} \quad (6.17)$$

It's even simpler in polar form: if the vector $\mathbf{A} = A\angle\theta$, then

$$c\mathbf{A} = (cA)\angle\theta. \quad (6.18)$$

It's conventional to keep the vector magnitude positive, so if $cA < 0$, you should change the sign of the magnitude cA , then add 180° (π radians) to the angle θ .

Example: Addition. Add the vectors $\mathbf{A} = 6\mathbf{i} - 9\mathbf{j}$ and $\mathbf{B} = 2\mathbf{i} + 12\mathbf{j}$:

$$\begin{array}{r} \mathbf{A} = 6\mathbf{i} - 9\mathbf{j} \\ + \mathbf{B} = 2\mathbf{i} + 12\mathbf{j} \\ \hline \mathbf{A} + \mathbf{B} = 8\mathbf{i} + 3\mathbf{j} \end{array}$$

Example: Subtraction. Subtract the vectors $\mathbf{A} = 6\mathbf{i} - 9\mathbf{j}$ and $\mathbf{B} = 2\mathbf{i} + 12\mathbf{j}$:

$$\begin{array}{r} \mathbf{A} = 6\mathbf{i} - 9\mathbf{j} \\ - \mathbf{B} = 2\mathbf{i} + 12\mathbf{j} \\ \hline \mathbf{A} - \mathbf{B} = 4\mathbf{i} - 21\mathbf{j} \end{array}$$

Example: Scalar multiplication. Multiply the vector $\mathbf{A} = 6\mathbf{i} - 9\mathbf{j}$ by 5:

$$5 \times (6\mathbf{i} - 9\mathbf{j}) = 30\mathbf{i} - 45\mathbf{j}$$

6.4 The Zero Vector

The *zero vector* is the vector $\mathbf{0} = 0\mathbf{i} + 0\mathbf{j} + 0\mathbf{k}$. It has zero magnitude, and its direction is undefined. The zero vector is *not* the same thing as the scalar 0: $\mathbf{0} \neq 0$. One is a vector, and the other is a scalar.

6.5 Derivatives

You can take the derivative of a vector component-by-component. For example, if a vector $\mathbf{A}(t)$ is a function of time t , then $\mathbf{A}(t) = A_x(t)\mathbf{i} + A_y(t)\mathbf{j} + A_z(t)\mathbf{k}$, and

$$\frac{d\mathbf{A}(t)}{dt} = \frac{dA_x(t)}{dt}\mathbf{i} + \frac{dA_y(t)}{dt}\mathbf{j} + \frac{dA_z(t)}{dt}\mathbf{k}. \quad (6.19)$$

It's possible to take other kinds of derivatives of vectors, known as the *divergence* ($\nabla \cdot$) and *curl* ($\nabla \times$). You'll learn about these in a course on vector calculus.

6.6 Integrals

Integrating a vector is similarly done term-by-term. If a vector $\mathbf{A}(t)$ is a function of time t , then $\mathbf{A}(t) = A_x(t)\mathbf{i} + A_y(t)\mathbf{j} + A_z(t)\mathbf{k}$, and

$$\int \mathbf{A}(t) dt = \int A_x(t) dt \mathbf{i} + \int A_y(t) dt \mathbf{j} + \int A_z(t) dt \mathbf{k}. \quad (6.20)$$

6.7 Other Vector Operations

Other mathematical operations with vectors are possible. For example, is it possible to *add* a vector and a scalar together? The answer is: sort of. You get something similar to a *quaternion*, which is a hypercomplex number of the form $a + bi + cj + dk$ (where $i^2 = j^2 = k^2 = -1$). Quaternions are sometimes used in aeronautical and astronautical engineering to describe the rotation of one coordinate system with respect to another.

What about multiplying a vector by another vector? Yes, this is possible. In fact, there are *three* different kinds of multiplication that can be used to multiply two vectors together, as described in the next chapter.

How about division—can you divide by a vector? No; division by a vector is not defined. A vector may be a dividend, but not a divisor. But you can divide a vector by a *scalar* by simply multiplying by the reciprocal of the scalar:

$$\frac{\mathbf{A}}{c} = \frac{1}{c}(A_x\mathbf{i} + A_y\mathbf{j} + A_z\mathbf{k}) \quad (6.21)$$

$$= \frac{A_x}{c}\mathbf{i} + \frac{A_y}{c}\mathbf{j} + \frac{A_z}{c}\mathbf{k}. \quad (6.22)$$

Chapter 7

The Dot Product

7.1 Definition

In the arithmetic you're accustomed to (involving scalars), there is only one type of multiplication defined—for example, $2 \times 3 = 6$. But with vectors, there are *three* different kinds of multiplication:

- The *dot product* $\mathbf{A} \cdot \mathbf{B}$, in which you multiply two vectors together and get a *scalar* result.
- The *cross product* $\mathbf{A} \times \mathbf{B}$, in which you multiply two vectors together and get another *vector* as the result.
- The *direct product* $\mathbf{A}\mathbf{B}$, in which you multiply two vectors together and get a *tensor* result.

In this chapter we'll look at the dot product, which is sometimes called the *scalar product*.

The *dot product* of two vectors \mathbf{A} and \mathbf{B} (written $\mathbf{A} \cdot \mathbf{B}$, and pronounced “ \mathbf{A} dot \mathbf{B} ”) is defined to be the product of their magnitudes, times the cosine of the angle between them:

$$\boxed{\mathbf{A} \cdot \mathbf{B} = AB \cos \theta.} \tag{7.1}$$

Why do we define it this way? It turns out that this combination occurs frequently in physics; the dot product is related to the *projection* of one vector onto the other.

7.2 Component Form

Suppose we have two vectors in rectangular form. What is the dot product of the two in terms of their components? To answer this, we begin with the definition of the dot product, Eq. (7.1):

$$\mathbf{A} \cdot \mathbf{B} = AB \cos(\beta - \alpha), \tag{7.2}$$

where α is the angle vector \mathbf{A} makes with respect to the x axis, and β is the angle vector \mathbf{B} makes with respect to the x axis, so that $\beta - \alpha$ is the angle between the two vectors (Fig. 7.1). We now use a trigonometric identity to expand the argument of the cosine:

$$\mathbf{A} \cdot \mathbf{B} = AB(\cos \beta \cos \alpha + \sin \beta \sin \alpha) \tag{7.3}$$

Now making use of the relations $\cos \theta = \text{adj}/\text{hyp}$ and $\sin \theta = \text{opp}/\text{hyp}$, we have

$$\cos \alpha = \frac{A_x}{A}; \quad \cos \beta = \frac{B_x}{B}; \quad \sin \alpha = \frac{A_y}{A}; \quad \sin \beta = \frac{B_y}{B} \tag{7.4}$$

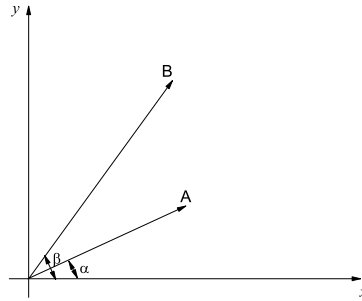

Figure 7.1: The two vectors \mathbf{A} and \mathbf{B} are to be multiplied using the dot product to get $\mathbf{A} \cdot \mathbf{B}$.

Making these substitutions into Eq. 7.3, we have

$$\mathbf{A} \cdot \mathbf{B} = AB \left(\frac{B_x}{B} \frac{A_x}{A} + \frac{B_y}{B} \frac{A_y}{A} \right) \quad (7.5)$$

$$= A_x B_x + A_y B_y \quad (7.6)$$

This result can be generalized from two to three dimensions to get

$$\boxed{\mathbf{A} \cdot \mathbf{B} = A_x B_x + A_y B_y + A_z B_z} \quad (7.7)$$

Example. Suppose vectors $\mathbf{A} = 3\mathbf{i} + 4\mathbf{j} - 2\mathbf{k}$ and $\mathbf{B} = \mathbf{i} - 5\mathbf{j} + 2\mathbf{k}$. Then the dot product of the two vectors is

$$\mathbf{A} \cdot \mathbf{B} = (3)(1) + (4)(-5) + (-2)(2) = \boxed{-21}$$

Notice that the final result is a *scalar*, not a vector.

7.3 Properties

Commutativity

Let's look at a few properties of the dot product. First of all, the dot product is *commutative*:

$$\mathbf{A} \cdot \mathbf{B} = \mathbf{B} \cdot \mathbf{A} \quad (7.8)$$

The proof of this property should be obvious from Eqs. (7.1) and (7.7). This isn't a trivial property; in fact, the other two types of vector multiplication are *non-commutative*.

Projections

The dot product is defined as it is because it gives the projection of one vector onto the direction of another. For example, dotting a vector \mathbf{A} with any of the cartesian unit vectors gives the projection of \mathbf{A} in that direction:

$$\mathbf{A} \cdot \mathbf{i} = A_x \quad (7.9)$$

$$\mathbf{A} \cdot \mathbf{j} = A_y \quad (7.10)$$

$$\mathbf{A} \cdot \mathbf{k} = A_z \quad (7.11)$$

In general, the projection of vector \mathbf{A} in the direction of unit vector $\hat{\mathbf{u}}$ is $\mathbf{A} \cdot \hat{\mathbf{u}}$.

Magnitude

From Eq. (7.7), it follows that $\mathbf{A} \cdot \mathbf{A} = A_x^2 + A_y^2 + A_z^2 = A^2$; so the magnitude of a vector \mathbf{A} is given in terms of the dot product by

$$A^2 = \mathbf{A} \cdot \mathbf{A} \quad (7.12)$$

$$A = \sqrt{\mathbf{A} \cdot \mathbf{A}} \quad (7.13)$$

Angle between Two Vectors

The dot product is also useful for computing the separation angle between two vectors. From Eq. (7.1),

$$\cos \theta = \frac{\mathbf{A} \cdot \mathbf{B}}{AB} \quad (7.14)$$

Example. We wish to find the angle between the two vectors $\mathbf{A} = 3\mathbf{i} + 4\mathbf{j} - 2\mathbf{k}$ and $\mathbf{B} = \mathbf{i} - 5\mathbf{j} + 2\mathbf{k}$. We first find the dot product of the two vectors:

$$\mathbf{A} \cdot \mathbf{B} = (3)(1) + (4)(-5) + (-2)(2) = -21$$

The magnitudes of the two vectors are

$$A = \sqrt{3^2 + 4^2 + (-2)^2} = \sqrt{29}$$

$$B = \sqrt{1^2 + (-5)^2 + 2^2} = \sqrt{30}$$

Therefore

$$\cos \theta = \frac{-21}{\sqrt{29}\sqrt{30}} = -0.711967$$

and so the angle between \mathbf{A} and \mathbf{B} is

$$\theta = \boxed{135.40^\circ}$$

You do not need to worry about getting the angle θ in the correct quadrant, because θ will necessarily always be between 0° and 180° , and the inverse cosine function will always return its result in this range.

Orthogonality

Another useful property of the dot product is: if two vectors are orthogonal, then their dot product is zero. For example, for the cartesian unit vectors:

$$\mathbf{i} \cdot \mathbf{j} = \mathbf{j} \cdot \mathbf{k} = \mathbf{i} \cdot \mathbf{k} = 0. \quad (7.15)$$

The converse is also true: if the dot product is zero, then the two vectors are orthogonal.

The cartesian unit vectors \mathbf{i} , \mathbf{j} , and \mathbf{k} are *orthonormal*, so that

$$\mathbf{i} \cdot \mathbf{i} = \mathbf{j} \cdot \mathbf{j} = \mathbf{k} \cdot \mathbf{k} = 1. \quad (7.16)$$

Derivative

The derivative of the dot product is similar to the familiar product rule for scalars:

$$\frac{d(\mathbf{A} \cdot \mathbf{B})}{dt} = \mathbf{A} \cdot \frac{d\mathbf{B}}{dt} + \frac{d\mathbf{A}}{dt} \cdot \mathbf{B}. \quad (7.17)$$

7.4 Matrix Formulation

The dot product can also be written in matrix form. To begin, let's represent vectors as *column vectors*—that is, 3×1 matrices. We'll define the vectors \mathbf{A} and \mathbf{B} as the column vectors

$$\mathbf{A} = \begin{pmatrix} A_x \\ A_y \\ A_z \end{pmatrix}; \quad \mathbf{B} = \begin{pmatrix} B_x \\ B_y \\ B_z \end{pmatrix} \quad (7.18)$$

The dot product can then be written

$$\mathbf{A} \cdot \mathbf{B} = \mathbf{A}^T \mathbf{B} = \begin{pmatrix} A_x & A_y & A_z \end{pmatrix} \begin{pmatrix} B_x \\ B_y \\ B_z \end{pmatrix} = (A_x B_x + A_y B_y + A_z B_z). \quad (7.19)$$

This is the product of a 1×3 row array with a 3×1 column array, which gives a 1×1 result (i.e. a scalar).

Chapter 8

Kinematics in Two or Three Dimensions

Armed with a knowledge of vector algebra, we are now in a position to examine kinematics in two and three dimensions. The approach will be very similar to kinematics in one dimension, except that we replace the position x , velocity v , and acceleration a with their vector counterparts: the position vector \mathbf{r} , velocity vector \mathbf{v} , and acceleration vector \mathbf{a} .

8.1 Position

Let's begin with the position vector. First define a two-dimensional coordinate system (or a three-dimensional system for a three-dimensional problem), placing the origin and axis directions in any way that's convenient. Then the *position vector* \mathbf{r} of a particle is a vector pointing from the origin to the particle.

8.2 Velocity

We define the velocity vector \mathbf{v} in a way that's analogous to the definition of the scalar velocity, using the vector version of the definition of a derivative:

$$\mathbf{v} = \lim_{\Delta t \rightarrow 0} \frac{\Delta \mathbf{r}}{\Delta t} = \frac{d\mathbf{r}}{dt}, \quad (8.1)$$

where $\Delta \mathbf{r} = \mathbf{r}_2 - \mathbf{r}_1$ is the difference in the position vectors \mathbf{r}_1 and \mathbf{r}_2 at two closely spaced times t_1 and t_2 , respectively.

8.3 Acceleration

Similarly, the acceleration vector \mathbf{a} is defined as

$$\mathbf{a} = \lim_{\Delta t \rightarrow 0} \frac{\Delta \mathbf{v}}{\Delta t} = \frac{d\mathbf{v}}{dt} = \frac{d^2\mathbf{r}}{dt^2}, \quad (8.2)$$

where $\Delta \mathbf{v} = \mathbf{v}_2 - \mathbf{v}_1$ is the difference in the velocity vectors \mathbf{v}_1 and \mathbf{v}_2 at two closely spaced times t_1 and t_2 , respectively.

8.4 Inverse Relations

Equations (8.1) and (8.2) may be inverted, as was done in one dimension:

$$\mathbf{r}(t) = \int \mathbf{v}(t) dt \quad (8.3)$$

$$\mathbf{v}(t) = \int \mathbf{a}(t) dt \quad (8.4)$$

8.5 Constant Acceleration

As was done in one-dimensional kinematics, we may derive a set of equations for the motion of a particle under a constant acceleration. In two or three dimensions, though, it's a constant acceleration *vector* \mathbf{a} . If the acceleration vector \mathbf{a} is constant, we can bring it outside the integral sign of Eq. (8.4) just as we do with constant scalars. We get

$$\mathbf{v}(t) = \int \mathbf{a} dt = \mathbf{a} \int dt \quad (8.5)$$

or

$$\mathbf{v}(t) = \mathbf{a}t + \mathbf{C} \quad (8.6)$$

where \mathbf{C} is the constant of integration. By setting $t = 0$, we can see that physically, just as in one-dimensional kinematics, $\mathbf{C} = \mathbf{v}_0 = \mathbf{v}(0)$ represents the velocity vector at time $t = 0$, so

$$\boxed{\mathbf{v}(t) = \mathbf{a}t + \mathbf{v}_0.} \quad (8.7)$$

Substituting this result into Eq. (8.3), we have

$$\mathbf{r}(t) = \int (\mathbf{a}t + \mathbf{v}_0) dt \quad (8.8)$$

$$= \int \mathbf{a}t dt + \int \mathbf{v}_0 dt \quad (8.9)$$

$$= \mathbf{a} \int t dt + \mathbf{v}_0 \int dt \quad (8.10)$$

or

$$\boxed{\mathbf{r}(t) = \frac{1}{2}\mathbf{a}t^2 + \mathbf{v}_0t + \mathbf{r}_0,} \quad (8.11)$$

where $\mathbf{r}_0 = \mathbf{r}(0)$ is the position vector at time $t = 0$.

The remaining constant-acceleration formula is a formula for $\mathbf{v}(\mathbf{r})$, in which we eliminate time t to get an expression for velocity in terms of position. We did this in one dimension by solving the equation for $v(t)$ for t , then substituting into the equation for $x(t)$ and solving for v . Unfortunately, that technique won't work with vectors, because it would require dividing by a vector, which is not defined. Instead, being guided by the knowledge that the vector formula must reduce to the known scalar formula when the vectors are one-dimensional, we proceed as follows. Start with Eq. (8.11) for $\mathbf{r}(t)$ for constant acceleration:

$$\mathbf{r}(t) = \frac{1}{2}\mathbf{a}t^2 + \mathbf{v}_0t + \mathbf{r}_0 \quad (8.12)$$

$$\mathbf{r} - \mathbf{r}_0 = \frac{1}{2}\mathbf{a}t^2 + \mathbf{v}_0t \quad (8.13)$$

Now take the dot product of both sides with the acceleration \mathbf{a} :

$$\mathbf{a} \cdot (\mathbf{r} - \mathbf{r}_0) = \mathbf{a} \cdot \left(\frac{1}{2}\mathbf{a}t^2 + \mathbf{v}_0t\right) \quad (8.14)$$

$$= \frac{1}{2}a^2t^2 + \mathbf{a} \cdot \mathbf{v}_0t, \quad (8.15)$$

and multiply both sides by 2:

$$2\mathbf{a} \cdot (\mathbf{r} - \mathbf{r}_0) = a^2t^2 + 2\mathbf{a} \cdot \mathbf{v}_0t. \quad (8.16)$$

The left-hand side looks similar to the second term on the right-hand side of the one-dimensional Eq. (5.31), but we still need to eliminate t on the right-hand side. To do that, let's start by working on the first term on the right-hand side of Eq. (8.16). Starting with Eq. (8.7), we have

$$\mathbf{v}(t) = \mathbf{a}t + \mathbf{v}_0 \quad (8.17)$$

$$\mathbf{v} - \mathbf{v}_0 = \mathbf{a}t \quad (8.18)$$

Now take the dot product of the left-hand side of Eq. (8.18) with itself, and dot the right-hand side with itself:

$$(\mathbf{v} - \mathbf{v}_0) \cdot (\mathbf{v} - \mathbf{v}_0) = (\mathbf{a}t) \cdot (\mathbf{a}t) \quad (8.19)$$

$$v^2 - 2\mathbf{v} \cdot \mathbf{v}_0 + v_0^2 = a^2t^2. \quad (8.20)$$

Next, let's work on the second term on the right-hand side of Eq. (8.16). To do this, let's take the dot product of both sides of Eq. (8.18) with \mathbf{v}_0 :

$$\mathbf{v}_0 \cdot (\mathbf{v} - \mathbf{v}_0) = \mathbf{v}_0 \cdot \mathbf{a}t \quad (8.21)$$

$$2\mathbf{v} \cdot \mathbf{v}_0 - 2v_0^2 = 2\mathbf{a} \cdot \mathbf{v}_0t \quad (8.22)$$

Now we have all the pieces we need to eliminate t . In Eq. (8.16), we use Eq. (8.20) to replace a^2t^2 , and we use Eq. (8.22) to replace $2\mathbf{a} \cdot \mathbf{v}_0t$:

$$2\mathbf{a} \cdot (\mathbf{r} - \mathbf{r}_0) = (v^2 - 2\mathbf{v} \cdot \mathbf{v}_0 + v_0^2) + (2\mathbf{v} \cdot \mathbf{v}_0 - 2v_0^2) \quad (8.23)$$

$$= v^2 - v_0^2, \quad (8.24)$$

or

$$\boxed{v^2 = v_0^2 + 2\mathbf{a} \cdot (\mathbf{r} - \mathbf{r}_0)} \quad (8.25)$$

8.6 Vertical vs. Horizontal Motion

Consider the experiment shown in Figure 8.1: two balls are initially at the same height above the floor; both are released at the same time, but one is allowed to fall vertically, while the other is given an initial velocity v_0 in the horizontal direction. Which ball hits the floor first?

You might be inclined to think that the ball that falls vertically would hit the floor first, because it doesn't have as far to go. But the correct answer is that *both balls land at the same time*. The reason is that the horizontal and vertical components of the motion are independent—the horizontal motion of the second ball has no effect on its vertical motion. Let's set up a coordinate whose origin is at the release point, with $+x$ to the right and $+y$ upward. Then for the first ball (the one falling vertically), we have $\mathbf{a} = -g\mathbf{j}$, $\mathbf{v}_0 = \mathbf{0}$, and $\mathbf{r}_0 = \mathbf{0}$; therefore

$$\mathbf{r}(t) = \frac{1}{2}\mathbf{a}t^2 + \mathbf{v}_0t + \mathbf{r}_0 \quad (8.26)$$

$$= -\frac{1}{2}gt^2\mathbf{j} \quad (8.27)$$

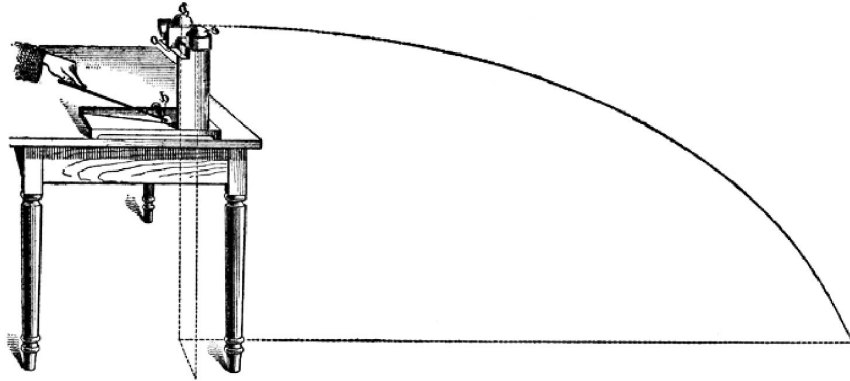

Figure 8.1: Vertical vs. horizontal motion. If two objects are released simultaneously (one falling vertically and one given an initial horizontal velocity), then they both land on the floor at the same time. (Ref. [9])

or

$$x(t) = 0 \quad (8.28)$$

$$y(t) = -\frac{1}{2}gt^2. \quad (8.29)$$

For the second ball (the one given an initial horizontal velocity v_0), we have $\mathbf{a} = -g\mathbf{j}$, $\mathbf{v}_0 = v_0\mathbf{i}$, and $\mathbf{r}_0 = \mathbf{0}$; therefore

$$\mathbf{r}(t) = \frac{1}{2}\mathbf{a}t^2 + \mathbf{v}_0t + \mathbf{r}_0 \quad (8.30)$$

$$= v_0t\mathbf{i} - \frac{1}{2}gt^2\mathbf{j} \quad (8.31)$$

or

$$x(t) = v_0t \quad (8.32)$$

$$y(t) = -\frac{1}{2}gt^2. \quad (8.33)$$

So both balls have the same vertical (y) component of motion. Both balls fall together vertically, but the second ball has a uniform horizontal motion superimposed on its vertical motion; the combination of horizontal and vertical motions gives the second ball a parabolic path, as we'll see in Chapter 9.

8.7 Summary

Let's summarize the results so far for two- and three-dimensional kinematics:

Always True

These equations are definitions, and are always true:

$$\mathbf{v} = \frac{d\mathbf{r}}{dt} \quad \Rightarrow \quad \mathbf{r}(t) = \int \mathbf{v}(t) dt \quad (8.34)$$

$$\mathbf{a} = \frac{d\mathbf{v}}{dt} = \frac{d^2\mathbf{r}}{dt^2} \quad \Rightarrow \quad \mathbf{v}(t) = \int \mathbf{a}(t) dt \quad (8.35)$$

Constant Acceleration

These equations are valid *only for constant acceleration a*:

$$\mathbf{r}(t) = \frac{1}{2}\mathbf{a}t^2 + \mathbf{v}_0t + \mathbf{r}_0 \quad (8.36)$$

$$\mathbf{v}(t) = \mathbf{a}t + \mathbf{v}_0 \quad (8.37)$$

$$v^2 = v_0^2 + 2\mathbf{a} \cdot (\mathbf{r} - \mathbf{r}_0) \quad (8.38)$$

Chapter 9

Projectile Motion

An important example of two-dimensional motion under constant acceleration is the motion of a projectile (e.g. a cannonball fired from a cannon) at the surface of the Earth (Fig. 9.1). The acceleration in this case is the acceleration due to gravity, so the constant-acceleration equations apply. The position vector as a function of time is given by Eq. (8.11):

$$\mathbf{r}(t) = \frac{1}{2}\mathbf{a}t^2 + \mathbf{v}_0t + \mathbf{r}_0, \quad (9.1)$$

where \mathbf{v}_0 is the initial velocity of the cannonball, called the *muzzle velocity*. Let's take time $t = 0$ to be the instant the cannonball leaves the cannon. Then if we choose the origin to be at the cannon (Fig. 9.1), then $\mathbf{r}_0 = \mathbf{0}$. The acceleration in this case is in the $-y$ direction, so $\mathbf{a} = -g\mathbf{j}$, and Eq. (9.1) becomes

$$\mathbf{r}(t) = -\frac{1}{2}gt^2\mathbf{j} + \mathbf{v}_0t, \quad (9.2)$$

where the initial velocity $\mathbf{v}_0 = v_{x0}\mathbf{i} + v_{y0}\mathbf{j}$. This vector equation actually represents two scalar equations: one for $x(t)$ and one for $y(t)$:

$$x(t) = v_{x0}t \quad (9.3)$$

$$y(t) = -\frac{1}{2}gt^2 + v_{y0}t \quad (9.4)$$

Typically in real life you will not know the cartesian components of the velocity vector (v_{x0} and v_{y0}); instead you are more likely to know the magnitude of the muzzle velocity v_0 and the launch angle θ . Converting the muzzle velocity vector from rectangular to polar form,

$$v_{0x} = v_0 \cos \theta \quad (9.5)$$

$$v_{0y} = v_0 \sin \theta \quad (9.6)$$

Equations (9.3) and (9.4) then become

$$x(t) = (v_0 \cos \theta)t \quad (9.7)$$

$$y(t) = -\frac{1}{2}gt^2 + (v_0 \sin \theta)t \quad (9.8)$$

These equations give the x and y coordinates of the projectile at any time t .

Now let's consider a few questions we can ask about the motion of a projectile.

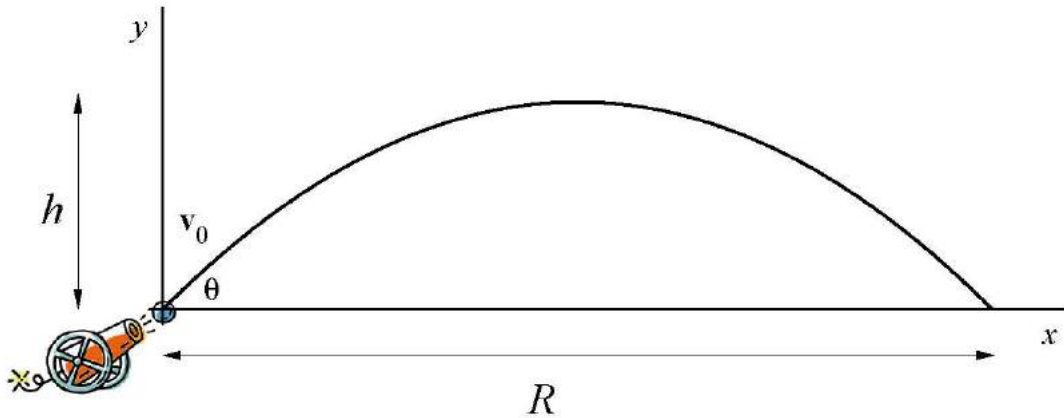

Figure 9.1: Parabolic path of a projectile launched with muzzle velocity v_0 at angle θ . Here the x axis is along the ground, R is the range, and h is the maximum altitude.

9.1 Range

The first question we'll look at is: how far will the projectile go? This is called the *range*, and is shown as R in Fig. 9.1. How do we find this? We need to look at what conditions are unique to the problem we're trying to solve; in this case, what's unique about the range R is that it's the x coordinate of the projectile when $y = 0$. So let's set $y = 0$ in Eq. (9.8) and see what happens:

$$0 = -\frac{1}{2}gt^2 + (v_0 \sin \theta)t \quad (9.9)$$

What we're after is the value of x when $y = 0$, so let's try solving this for time t , then plugging that into Eq. (9.7). Solving Eq. (9.9) for t by factoring out a t , we have¹

$$0 = [-\frac{1}{2}gt + v_0 \sin \theta] t. \quad (9.10)$$

This means that for $y = 0$, either $t = 0$ (which it is at launch), or else $-\frac{1}{2}gt + v_0 \sin \theta = 0$. The second case is the one we're interested in:

$$0 = -\frac{1}{2}gt + v_0 \sin \theta \quad (9.11)$$

or

$$\boxed{t = \frac{2}{g}v_0 \sin \theta.} \quad (9.12)$$

This is the total time the projectile is in the air, and is called the *time in flight* (t_f). Substituting this time into Eq. (9.7) gives the range:

$$R = x(t_f) = (v_0 \cos \theta) \left(\frac{2}{g}v_0 \sin \theta \right). \quad (9.13)$$

¹Note that we cannot divide Eq. (9.9) by the variable t without losing roots. The proper procedure is to factor out a factor of t , then use the fact that if the product of two factors is zero, then one or both factors must be zero. It is OK to divide through by a nonzero *constant*, though.

Using the identity $\sin 2\theta \equiv 2 \sin \theta \cos \theta$, this becomes

$$\boxed{R = \frac{v_0^2}{g} \sin 2\theta.} \quad (9.14)$$

A related question is: at what launch angle θ do you get the *maximum* range for a fixed muzzle velocity v_0 ? Examining Eq. (9.14), the largest value the sine can have is 1, so

$$\sin 2\theta = 1 \quad (9.15)$$

$$2\theta = 90^\circ \quad (9.16)$$

$$\theta = 45^\circ \quad (9.17)$$

So a projectile will go the farthest if launched at an angle of 45° from the horizontal. Another way to arrive at the same result is to use the first derivative test: Eq. (9.14) gives $R(\theta)$, so to find the value of θ that gives the maximum range R , we set $dR/d\theta = 0$:

$$\frac{dR}{d\theta} = \frac{d}{d\theta} \left(\frac{v_0^2}{g} \sin 2\theta \right) = 0, \quad (9.18)$$

or, using the chain rule,

$$\frac{2v_0^2}{g} \cos 2\theta = 0 \quad (9.19)$$

$$\cos 2\theta = 0 \quad (9.20)$$

Now $\cos 2\theta = 0$ implies $2\theta = 90^\circ$ or $2\theta = 270^\circ$, and therefore $\theta = 45^\circ$ or $\theta = 135^\circ$. We discard the solution $\theta = 135^\circ$ on physical grounds: it corresponds to pointing the cannon *backwards* at 45° from the horizontal, which is a solution we're not interested in.

9.2 Maximum Altitude

Let's look at another question: what is the maximum altitude reached by the projectile? Let's think about what is unique about the point where the projectile is at its maximum altitude: the y component of the velocity is momentarily zero at that point. Eq. (8.7) gives the velocity vector of the projectile at any time t :

$$\mathbf{v}(t) = \mathbf{a}t + \mathbf{v}_0 \quad (9.21)$$

$$= -gt\mathbf{j} + \mathbf{v}_0, \quad (9.22)$$

which is equivalent to the two scalar equations

$$v_x(t) = v_{x0} = v_0 \cos \theta \quad (9.23)$$

$$v_y(t) = -gt + v_{y0} = -gt + v_0 \sin \theta \quad (9.24)$$

To find the maximum altitude, we want to set $v_y = 0$:

$$0 = -gt + v_0 \sin \theta. \quad (9.25)$$

Solving for time t ,

$$t = \frac{v_0}{g} \sin \theta. \quad (9.26)$$

This is the amount of time it takes the projectile to reach the point where $v_y = 0$, which is the point of maximum altitude. Note that this is half of the time in flight (Eq. (9.12)), so the projectile reaches its maximum height half-way through its flight. (You could also arrive at this same result by using Eq. (9.8) for $y(t)$, then setting $dy/dt = 0$ by the first derivative test.)

Plugging this time into Eq. (9.8) gives the maximum altitude h :

$$h = y\left(\frac{t_f}{2}\right) = -\frac{1}{2}g\left(\frac{v_0}{g}\sin\theta\right)^2 + (v_0\sin\theta)\left(\frac{v_0}{g}\sin\theta\right) \quad (9.27)$$

$$= -\frac{1}{2}\frac{v_0^2\sin^2\theta}{g} + \frac{v_0^2\sin^2\theta}{g} \quad (9.28)$$

so the maximum altitude is

$$\boxed{h = \frac{v_0^2\sin^2\theta}{2g}} \quad (9.29)$$

9.3 Shape of the Projectile Path

What is the shape of the projectile's path in Fig. 9.1? To find out, we can solve Eq. (9.7) for the time t and plug the resulting expression into Eq. (9.8) to eliminate t and get an equation for $y(x)$. First solve Eq. (9.7) for t :

$$t = \frac{x}{v_0\cos\theta}. \quad (9.30)$$

Now substitute this into Eq. (9.8):

$$y = -\frac{1}{2}g\left(\frac{x}{v_0\cos\theta}\right)^2 + (v_0\sin\theta)\left(\frac{x}{v_0\cos\theta}\right) \quad (9.31)$$

or

$$\boxed{y(x) = \left(-\frac{g}{2v_0^2\cos^2\theta}\right)x^2 + (\tan\theta)x.} \quad (9.32)$$

This is the equation of a *parabola* passing through the origin, so the projectile follows a parabolic path.

Actually, this is just an approximation, assuming the acceleration due to gravity is a constant downward in the $-y$ direction. A more careful calculation would have to allow for the curvature of the Earth, which would show the actual path is that of a highly eccentric *ellipse*. But over relatively short distances where the curvature of the Earth is not important, the elliptical path can be approximated as a parabola.

9.4 Hitting a Target on the Ground

Now let's look at the problem of using a projectile to hit a target on the ground at range R . We could do this by fixing the muzzle velocity and varying the launch angle, or by fixing the launch angle and varying the muzzle velocity, or by varying both.

Fixed Launch Angle

The less common situation is to fix the launch angle θ and allow the muzzle velocity v_0 to vary. Beginning with Eq. (9.14),

$$R = \frac{v_0^2}{g} \sin 2\theta, \quad (9.33)$$

we solve for muzzle velocity:

$$v_0 = \sqrt{\frac{gR}{\sin 2\theta}}. \quad (9.34)$$

There will always be a solution to this equation unless $\theta \geq 90^\circ$, which corresponds to pointing the cannon backwards. In this case v_0 will be imaginary, and there is no muzzle velocity that will allow the projectile to reach the target.

Example. Suppose we have a cannon fixed at an angle of 25° and wish to hit a target at a distance of $R = 250$ m. What muzzle velocity v_0 is required?

Solution. By Eq. (9.34),

$$v_0 = \sqrt{\frac{gR}{\sin 2\theta}} = 56.55 \text{ m/s}. \quad (9.35)$$

Fixed Muzzle Velocity

The more common situation is trying to hit a target when the muzzle velocity is fixed and the launch angle is allowed to vary. In this case we solve Eq. (9.14) for θ :

$$\theta = \frac{1}{2} \sin^{-1} \left(\frac{gR}{v_0^2} \right). \quad (9.36)$$

Example. Suppose the muzzle velocity is $v_0 = 40$ m/s and the target is at a distance of $R = 75$ m. What launch angle is needed to hit the target?

Solution. The launch angle is given by

$$\theta = \frac{1}{2} \sin^{-1} \left(\frac{gR}{v_0^2} \right) = 13.67^\circ \text{ and } 76.33^\circ. \quad (9.37)$$

Recall that the arcsine of a number returns two angles in the range $[0, 2\pi)$, so there will generally be two solutions to Eq. (9.36). In this example, the “calculator” solution is 13.67° , and other solution is 76.33° . In general, there will be *two* complementary launch angles that will both hit the target.

Example. As a second example, suppose the muzzle velocity is $v_0 = 40$ m/s and the target is at a distance of $R = 200$ m. What launch angle is needed to hit the target?

Solution. The launch angle is given by

$$\theta = \frac{1}{2} \sin^{-1} \left(\frac{gR}{v_0^2} \right) = \frac{1}{2} \sin^{-1} 1.225 = ??? \quad (9.38)$$

The arcsine of a number greater than 1 is not defined², so θ cannot be found in this case. Physically, this means that the target is out of range at this muzzle velocity. For a muzzle velocity of 40 m/s, the maximum range is for $\theta = 45^\circ$, which by Eq. (9.14) is 163 m — so 200 m is out of range.

9.5 Hitting a Target on a Hill

In the previous section, we looked at how to aim a projectile so that it hits a target *on the ground*. Now let's look at a more general case: suppose the target is not necessarily on the ground, but on a hill, so that it's located at coordinates (x_t, y_t) . How do we aim the projectile to hit the target in this case?

Fixed Launch Angle

Let's first look at the case where the launch angle is fixed and we can vary the muzzle velocity. We require that the projectile's parabolic path pass through both the origin and the target's position (x_t, y_t) , so let's begin by substituting the point (x_t, y_t) into Eq. (9.32):

$$y_t = \left(-\frac{g}{2v_0^2 \cos^2 \theta} \right) x_t^2 + (\tan \theta) x_t. \quad (9.39)$$

We just need to solve this for the muzzle velocity v_0 :

$$(\tan \theta) x_t - y_t = \left(\frac{g}{2v_0^2 \cos^2 \theta} \right) x_t^2 \quad (9.40)$$

$$\tan \theta - \frac{y_t}{x_t} = \frac{g x_t}{2v_0^2 \cos^2 \theta} \quad (9.41)$$

$$v_0^2 = \frac{g x_t}{2 \left(\tan \theta - \frac{y_t}{x_t} \right) \cos^2 \theta} \quad (9.42)$$

or

$$v_0 = \sqrt{\frac{g x_t}{2 \left(\tan \theta - \frac{y_t}{x_t} \right) \cos^2 \theta}}. \quad (9.43)$$

Note that y_t/x_t is tangent of the angle that the *target* makes with the horizontal, as seen from the origin; we'll call this angle θ_t . Then Eq. (9.43) becomes

$$v_0 = \sqrt{\frac{g x_t}{2 (\tan \theta - \tan \theta_t) \cos^2 \theta}}. \quad (9.44)$$

If we aim *directly* at the target, then $\theta = \theta_t$, the denominator becomes zero, and we get $v_0 = \infty$: this says that the muzzle velocity would have to be infinite to get it to follow a straight-line path directly to the target.

Fixed Muzzle Velocity

Now let's look at the more common problem, where the muzzle velocity fixed and we're allowed to vary the launch angle. As before, we substitute the point x_t, y_t into Eq. (9.32):

$$y_t = \left(-\frac{g}{2v_0^2 \cos^2 \theta} \right) x_t^2 + (\tan \theta) x_t. \quad (9.45)$$

²Actually, it's *complex*; in this case, $\sin^{-1} 1.225 = 90^\circ - 37.75^\circ i$.

Now we solve this for the launch angle θ . Multiplying both sides by $2 \cos^2 \theta$,

$$2y_t \cos^2 \theta = \left(-\frac{g}{v_0^2}\right)x_t^2 + (2 \sin \theta \cos \theta)x_t \quad (9.46)$$

Now using the identity $\sin 2\theta \equiv 2 \sin \theta \cos \theta$,

$$\boxed{x_t \sin 2\theta - 2y_t \cos^2 \theta = \frac{gx_t^2}{v_0^2}} \quad (9.47)$$

It turns out that this is about the best we can do—we just can't solve this equation for θ in closed form. To find θ , we must resort to a numerical method such as Newton's method, as described in the following chapter.

9.6 Exploding Projectiles

If a projectile explodes in mid-air, the force from the explosion will cause the various fragments of the original body to follow new trajectories—each of which will be a segment of a new parabola. However, *the center of mass of the fragments will continue along the original parabolic trajectory*. (The center of mass is discussed in Chapter 31.)

9.7 Other Considerations

In our study of projectile motion, we have made a number of approximations:

1. We have assumed the acceleration due to gravity is a constant, so we've ignored the curvature of the Earth. If a projectile travels a long distances, then it would be important to take this into account, and treat the motion as an ellipse.
2. We have assumed the projectile is in a vacuum—we did not account for air resistance. The results we've derived will be *approximately* correct, but to get answers that match reality more closely we would need to allow for the effects of air resistance (Chapter 19).
3. We have not allowed for the effects of *wind*. If a wind is blowing, it will alter the course of the projectile.
4. If the projectile travels a long distance, then we would need to allow for the rotation of the Earth by accounting for the *Coriolis force* (Chapter 43).

9.8 The Monkey and the Hunter Problem

A famous problem involving projectile motion is the “monkey and hunter problem” (Fig. 9.2). A hunter spots a monkey hanging from a tree branch, aims his rifle directly at the monkey, and fires. The monkey, hearing the shot, lets go of the branch at the same instant the hunter fires the rifle, hoping to escape by falling to the ground. Will the monkey escape? The unexpected answer is “no”: the bullet will *always* hit the monkey anyway, regardless of the angle of the rifle, the speed of the bullet, or the distance to the monkey, as long as the monkey is in range.

To show that this is so, let's first define a coordinate system. Let the origin be at the end of the rifle, with the x axis pointing horizontally to the right, and y pointing vertically upward. Let D be the horizontal distance of the monkey from the origin, and H be the initial height of the monkey (Fig. 9.2).

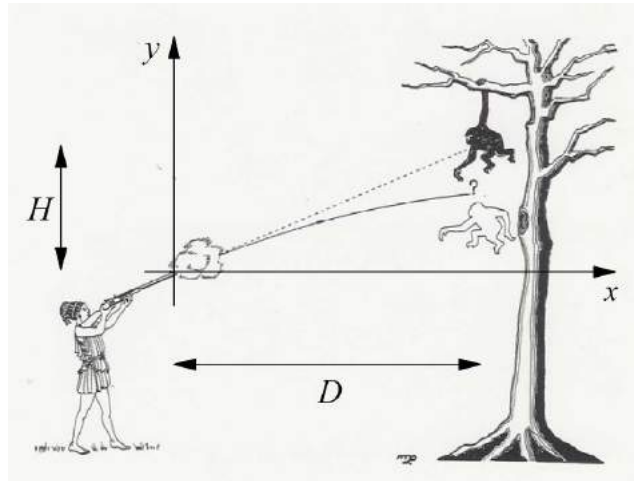

Figure 9.2: The “monkey and hunter” problem. (Credit: The English School, Fahaheel, Kuwait.)

Now we’ll show that at $x = D$, the monkey and the bullet will both be at the same height y . Let the muzzle velocity of the rifle be v_0 , and let the angle of fire of the rifle from the horizontal be θ . Let’s begin by finding the time t needed for the bullet to travel the horizontal distance D from the rifle. Since the horizontal component of the velocity is a constant $v_0 \cos \theta$ (Eq. 9.7), the x coordinate of the bullet at time t is

$$x_b(t) = (v_0 \cos \theta)t. \quad (9.48)$$

Setting $x_b(t) = D$ and solving for the time t , we find (calling this time t_f)

$$t_f = \frac{D}{v_0 \cos \theta}. \quad (9.49)$$

Next, let’s find the y coordinate of the *bullet* at this time t_f . By Eq. (9.8)

$$y_b(t) = -\frac{1}{2}gt^2 + (v_0 \sin \theta)t. \quad (9.50)$$

Substituting $t = t_f = D/(v_0 \cos \theta)$, we have

$$y_b = -\frac{1}{2}g \left(\frac{D}{v_0 \cos \theta} \right)^2 + (v_0 \sin \theta) \left(\frac{D}{v_0 \cos \theta} \right) \quad (9.51)$$

$$= -\frac{gD^2}{2v_0^2 \cos^2 \theta} + D \tan \theta. \quad (9.52)$$

But from trigonometry, $\tan \theta = H/D$; making this substitution in the second term on the right, we have

$$y_b = H - \frac{gD^2}{2v_0^2 \cos^2 \theta} \quad (\text{bullet}). \quad (9.53)$$

Finally, let’s find the y coordinate of the *monkey* at time t_f . The monkey falls in one dimension; its y coordinate at time t is (using Eq. (5.23) with y instead of x , and with $a = -g$, $v_0 = 0$ and $y_0 = H$):

$$y_m(t) = H - \frac{1}{2}gt^2. \quad (9.54)$$

Now substituting $t = t_f = D/(v_0 \cos \theta)$,

$$y_m = H - \frac{g}{2} \left(\frac{D}{v_0 \cos \theta} \right)^2 \quad (9.55)$$

$$y_m = H - \frac{gD^2}{2v_0^2 \cos^2 \theta} \quad (\text{monkey}). \quad (9.56)$$

Comparing Eqs. (9.53) and (9.56), you can see that the monkey and bullet will have the same y coordinate when $x = D$, so the monkey will always get hit, regardless of the values of D , H , v_0 , or θ . *Q.E.D.*³

Essentially what's happening here is that the monkey and bullet are both accelerated by the same amount, $g = 9.8 \text{ m/s}^2$, so for a given amount of time, the monkey will fall the same distance as the bullet falls from the straight-line path it would take if there were no gravity. Therefore, the bullet always hits the monkey.

9.9 Summary

This following table summarizes the formulæ for a projectile initially at the origin, fired with initial velocity v_0 at an angle θ from the horizontal.

Table 9-1. Summary of formulæ for projectile motion.

Quantity	Formula
$x(t)$	$x = (v_0 \cos \theta)t$
$y(t)$	$y = -\frac{1}{2}gt^2 + (v_0 \sin \theta)t$
$y(x)$	$y(x) = \left(-\frac{g}{2v_0^2 \cos^2 \theta} \right) x^2 + (\tan \theta)x$
Time in flight	$t_f = \frac{2}{g}v_0 \sin \theta$
Range at angle θ	$R = \frac{v_0^2}{g} \sin 2\theta$
Max. range (at $\theta = 45^\circ$)	$R_{\max} = \frac{v_0^2}{g}$
Angle needed to hit target at range R for fixed v_0	$\theta = \frac{1}{2} \sin^{-1} \left(\frac{gR}{v_0^2} \right)$
Speed needed to hit target at range R for fixed θ	$v_0 = \sqrt{\frac{gR}{\sin 2\theta}}$
Max. altitude	$h = \frac{v_0^2 \sin^2 \theta}{2g}$
Speed needed to hit target at (x_t, y_t) for fixed θ	$v_0 = \sqrt{\frac{gx_t}{2(\tan \theta - \frac{y_t}{x_t}) \cos^2 \theta}}$
Angle needed to hit target at (x_t, y_t) for fixed v_0	$x_t \sin 2\theta - 2y_t \cos^2 \theta = \frac{gx_t^2}{v_0^2}$

Note that this last expression must be solved iteratively for θ .

³*Q.E.D.* is an abbreviation for the Latin phrase *quod erat demonstrandum*, meaning "which was to be demonstrated."

Chapter 10

Newton's Method

10.1 Introduction

As we have seen in the study of projectile motion, some problems in physics result in equations that cannot be solved in closed form, but must be solved numerically. The study of the methods of solving such problems is the field of *numerical analysis*, and is a course in itself. Here we look at one very simple method for numerically finding the roots of equations, called *Newton's method*.

10.2 The Method

Newton's method is a numerical method for finding the root(s) x of the equation

$$f(x) = 0. \tag{10.1}$$

The method requires that you first make an initial estimate x_0 of the root. From that initial estimate, you calculate a better estimate using the formula

$$x_{n+1} = x_n - \frac{f(x_n)}{f'(x_n)} \tag{10.2}$$

Applying this formula (with $n = 0$) to the initial estimate x_0 gives a better estimate x_1 . This better estimate x_1 is then run through the formula again ($n = 1$) to get an even better estimate x_2 , etc. The process may be repeated indefinitely to yield a solution to whatever accuracy is desired.

If the equation $f(x) = 0$ has more than one root, then the method will generally find the one closest to the initial estimate. Choosing different initial estimates closer to the other roots will find those other roots.

If there is no root (for example, $f(x) = x^2 + 1 = 0$), the method will tend to “blow up”: instead of converging to a solution, you may just get bigger and bigger numbers, or you may get a series of different numbers that show no sign of converging to a single value.

10.3 Example: Square Roots

When the first electronic calculators became available in the mid-1970s, many of them were simple “four-function” calculators that could only add, subtract, multiply, and divide. The author's father, L.L. Simpson (Ref. [11]), showed him how he could calculate square roots on one of these calculators using Newton's method, as described here.

To calculate the square root of a number k , we wish to find the number x in the equation

$$x = \sqrt{k}. \quad (10.3)$$

Squaring both sides then subtracting k from both sides, we get a function of the form of Eq. (10.1):

$$f(x) = x^2 - k = 0. \quad (10.4)$$

The values of x that satisfy this equation are the desired square roots of k . Newton's method for finding square roots is then Eq. (10.2) with this $f(x)$ (and with $f'(x) = 2x$):

$$x_{n+1} = x_n - \frac{x_n^2 - k}{2x_n}. \quad (10.5)$$

For example, to calculate $\sqrt{5}$, set $k = 5$. Make an initial estimate of the answer—say $x_0 = 2$. Then we calculate several iterations of Newton's method (Eq. 10.5) to get better and better estimates of $\sqrt{5}$:

$$x_0 = 2 \quad (10.6)$$

$$x_1 = x_0 - \frac{x_0^2 - 5}{2x_0} = 2 - \frac{2^2 - 5}{2 \times 2} = 2.2500 \quad (10.7)$$

$$x_2 = x_1 - \frac{x_1^2 - 5}{2x_1} = 2.2500 - \frac{2.2500^2 - 5}{2 \times 2.2500} = 2.2361 \quad (10.8)$$

$$x_3 = x_2 - \frac{x_2^2 - 5}{2x_2} = 2.2361 - \frac{2.2361^2 - 5}{2 \times 2.2361} = 2.2361 \quad (10.9)$$

After just a few iterations, the solution has converged to four decimal places: we have $\sqrt{5} = 2.2361$.

There are actually two square roots of 5. To find the other solution, we choose a different initial estimate—one that is closer to the other root. If we take the initial estimate $x_0 = -2$, we get

$$x_0 = -2 \quad (10.10)$$

$$x_1 = x_0 - \frac{x_0^2 - 5}{2x_0} = -2 - \frac{(-2)^2 - 5}{2 \times (-2)} = -2.2500 \quad (10.11)$$

$$x_2 = x_1 - \frac{x_1^2 - 5}{2x_1} = -2.2500 - \frac{(-2.2500)^2 - 5}{2 \times (-2.2500)} = -2.2361 \quad (10.12)$$

$$x_3 = x_2 - \frac{x_2^2 - 5}{2x_2} = -2.2361 - \frac{(-2.2361)^2 - 5}{2 \times (-2.2361)} = -2.2361 \quad (10.13)$$

So to four decimals, the other square root of 5 is -2.2361 .

L.L. Simpson notes that Eq. (10.5) for computing square roots was typically used in the equivalent form

$$x_{n+1} = \frac{1}{2} \left(x_n + \frac{k}{x_n} \right), \quad (10.14)$$

so that you repeatedly find the average of x_n and k/x_n . For the above example of finding $\sqrt{5}$, this gives:

Initial est.	=	2
1st iter.: Average of 2 and 5/2	=	2.25
2nd iter.: Average of 2.25 and 5/2.25	=	2.2361
3rd iter.: Average of 2.2361 and 5/2.2361	=	2.2361 (converged)

10.4 Projectile Problem

Recall the problem from Section 9.5 of directing a projectile to hit a target on a hill at position (x_t, y_t) , when the muzzle velocity is fixed and we're allowed to vary the angle. We found that in order to hit the target, the launch angle θ is the solution to Eq. (9.47),

$$x_t \sin 2\theta - 2y_t \cos^2 \theta = \frac{gx_t^2}{v_0^2}, \quad (10.15)$$

which cannot be solved in closed form and must be solved numerically. To solve this for θ using Newton's method, we must first put it in the form $f(\theta) = 0$:

$$f(\theta) = x_t \sin 2\theta - 2y_t \cos^2 \theta - \frac{gx_t^2}{v_0^2} = 0 \quad (10.16)$$

Newton's method also requires the derivative of f :

$$f'(\theta) = 2x_t \cos 2\theta + 4y_t \cos \theta \sin \theta \quad (10.17)$$

$$= 2x_t \cos 2\theta + 2y_t \sin 2\theta \quad (10.18)$$

Using these expressions for $f(\theta)$ and $f'(\theta)$ in Newton's method (Eq. (10.2)), we find an iterative expression that lets us solve numerically for the launch angle θ :

$$\theta_{n+1} = \theta_n - \frac{x_t \sin 2\theta_n - 2y_t \cos^2 \theta_n - gx_t^2/v_0^2}{2x_t \cos 2\theta_n + 2y_t \sin 2\theta_n}. \quad (10.19)$$

Here the target coordinates (x_t, y_t) are known, as are the muzzle velocity v_0 and acceleration due to gravity g , so the only variable on the right-hand side is θ_n . To use this expression, we begin with an initial guess for the launch angle, θ_0 (in *radians*). Then plug this θ_0 into the right-hand side, which returns θ_1 ; for the next iteration, plug this θ_1 into the right-hand side, which returns θ_2 , etc. After a few iterations, you should get approximately the same angle over and over again on successive iterations. If the target is out of range, the method will "blow up" and not converge, typically by returning larger and larger values of θ_n for each iteration.

For this type of iterative calculation, it is handy to program the iteration formula into a programmable calculator, or write a computer program.

Chapter 11

Mass

Mass is a measure of the amount of matter in a body. As discussed earlier, it is measured in units of *kilograms* (kg) in SI units. In CGS units, mass is measured in grams (g), and in British engineering units, mass is measured in *slugs*.

Technically, there are two kinds of mass: *inertial mass* and *gravitational mass*. Inertial mass is a measure of a body's resistance to being accelerated: you have to push harder on a high-mass body than on a low-mass body to get it to accelerate by a given amount. As we'll see shortly, inertial mass m_i is given by Newton's second law of motion:

$$m_i = \frac{F}{a}, \quad (11.1)$$

where F is the force on a body, and a is the resulting acceleration.

Gravitational mass is a measure of how strong a gravitational field a body produces. For example, if two identical bodies each have a gravitational mass m_g and are separated by a distance r , then the gravitational force between them is given by Newton's law of gravity: $F = Gm_g^2/r^2$. The gravitational mass is then

$$m_g = r \sqrt{\frac{F}{G}}. \quad (11.2)$$

Experiments have shown that, to the highest accuracy that we can measure, inertial and gravitational mass are the same:

$$m_i = m_g. \quad (11.3)$$

Because of this, we normally don't bother to distinguish between the two, and just refer to the "mass" m .

We really don't understand why inertial and gravitational mass are the same; it just turns out that way experimentally. This equivalence between inertial and gravitational mass, called the *equivalence principle*, was established in a famous experiment that was conducted around 1900 by the Hungarian physicist Loránd Eötvös (*UT-vush*). In the Eötvös experiment, two unequal masses were connected by a rod; the rod was then connected at its balance point by a vertical wire to the ceiling, forming a torsional pendulum. The instrument was set up in such a way that if the gravitational and inertial masses were different, it would set the rod rotating in a horizontal plane, but no such rotation was observed. Today the validity of the equivalence principle has been demonstrated to high accuracy.

Chapter 12

Force

Intuitively, a *force* is a push or a pull. In SI units, force is measured in units of *newtons* (N), named for the English physicist Sir Isaac Newton. In terms of base units,

$$1 \text{ N} = 1 \frac{\text{kg m}}{\text{s}^2}. \quad (12.1)$$

In CGS units, force is measured in *dynes* (dyn):

$$1 \text{ dyne} = 1 \frac{\text{g cm}}{\text{s}^2}. \quad (12.2)$$

In the British engineering system, force is measured in *pounds* (lb). This is sometimes called *pounds-force* (lbf) when it's important to clearly distinguish it from pounds-mass (lbm).

$$1 \text{ lbf} = 1 \frac{\text{slug ft}}{\text{s}^2}. \quad (12.3)$$

12.1 The Four Forces of Nature

There are four fundamental forces in Nature:

- *Gravitational force.* The gravitational force is a force between any two bodies due to their mass. The gravitational force is the force responsible for keeping you attached to the floor at this moment: the Earth's mass is pulling you down toward its center, and your mass is attracting the Earth upward toward you. Without the gravitational force, you would be floating freely around the room.

The gravitational force is always attractive, and it is the weakest of the four forces. Gravity is described in more detail in Chapter 51.

- *Electromagnetic force.* The electromagnetic force is responsible for the attraction and repulsion of electric charges, and is also responsible for the magnetic force.

Most forces you encounter in everyday life (besides gravity) are electromagnetic in nature. When you push on something with your hand, for example, you are not really in direct contact with it: the outermost electrons of the atoms at the surface of the object are being electrically repelled by the outermost electrons in the atoms at the surface of your hand. Similarly, when you're standing on the floor, you're actually hovering a small distance above the floor: the outermost electrons at the bottom of your shoes are electrically repelling the outermost electrons at the top of the floor.

The classical theory of the electromagnetic force is given by *Maxwell's equations*, which you'll study in General Physics II. The most modern and comprehensive theory of the electromagnetic force is the theory of *quantum electrodynamics*, which you can learn about in a graduate course in physics.

- *Strong nuclear force.* The strong nuclear force is the force that holds together protons and neutrons in the atomic nucleus, and overpowers the electromagnetic mutual repulsion of the nuclear protons. It is also responsible for *nuclear fusion*, which is the process that causes the Sun to shine and is also present in the detonation of a hydrogen bomb.
- *Weak nuclear force.* The weak nuclear force is responsible for a process called β decay, in which a neutron in the atomic nucleus decays into a proton and an electron, and the electron escapes from the atom.

Every force we encounter in Nature is ultimately due to one of these four forces.

12.2 Hooke's Law

If a mass is attached to a spring and the spring is extended or compressed, then the spring will exert a force on the mass that's proportional to the distance that the mass is moved from its "natural" position (the *equilibrium position*). This fact was discovered by English physicist Robert Hooke, and is known as *Hooke's law*. It is expressed mathematically as

$$F = -kx, \quad (12.4)$$

where F is the force, x is the distance the mass is moved away from the spring's equilibrium position. The constant k is called the *spring constant*, and is a measure of the stiffness of the spring. The spring constant has units of N/m.

Hooke's law is an example of an *empirical law*: it's something that has been found, by experiment, to be at least approximately true over some range of physical conditions. In the case of a spring, Hooke's law applies over a range of positions x , but it breaks down if you compress the spring to the point that the turns of the spring are touching, or if the spring is extended beyond its elastic limit.

Hooke's law may be used to describe not only forces due to springs, but can also describe the reaction of elastic materials. It can also be used to *approximately* describe many other forces over a small range of displacements x .

12.3 Weight

Another important force was mentioned earlier in Chapter 2: *weight* is the force on an object due to the Earth's gravity. If the object is near the surface of the Earth, then its weight W is given by

$$W = mg, \quad (12.5)$$

where m is the mass and $g = 9.80 \text{ m/s}^2$ is the acceleration due to gravity.

12.4 Normal Force

If an object is resting on a table, then there are two forces acting on it: a gravitational force (its weight) acting downward toward the center of the Earth, and an upward force of equal magnitude acting upward, due to the mutual electromagnetic repulsion between the outermost electrons in the object and the outermost electrons

in the table. This latter force is called the *normal force*. For an object sitting on a horizontal surface, the normal force is given by $n = mg$ so that it exactly balances the weight. This isn't always the formula for the normal force, though. For example, if an object is sitting on a surface that's inclined by an angle θ to the horizontal, then the normal force will be $n = mg \cos \theta$, and will exactly balance the component of the weight normal to the surface, which is $W_{\perp} = mg \cos \theta$.

12.5 Tension

If a force is applied to both ends of a rope or wire in opposite directions (so as to stretch the rope or wire), then we say it is under *tension*. Tension, like other forces, is measured in newtons, and is equal to the force applied at either end.

Chapter 13

Newton's Laws of Motion

Classical mechanics (sometimes called *Newtonian mechanics*) is based on three laws of motion described by physicist Sir Isaac Newton (1643-1727, Figure ??) in his monumental work *Philosophiæ Naturalis Principia Mathematica* (“Mathematical Principles of Natural Philosophy”) in 1687.

Newton's three laws of motion are, in modern language and notation:¹

1. *Law of Inertia.* A body at rest will remain at rest, and a body moving with constant velocity will continue moving with that velocity, unless acted upon by some outside force.
2. $F = ma$: If a force F is applied to a body of mass m , it will accelerate with acceleration $a = F/m$.
3. Forces always come in pairs that act in opposite directions. If body 1 acts on body 2 with a force F , then body 2 will act back on body 1 with force F (equal in magnitude and opposite in direction).

13.1 First Law of Motion

Newton's first law states that bodies have a property called *inertia*, which means that once given a velocity, they will travel at that same velocity forever, unless acted upon by some outside force. Nobody knows why this is; it's just the way the Universe works.

In retrospect, this was a brilliant deduction by Newton. In real life, if you push an object across the floor, it will slide for a while, then come to a stop. This behavior caused Aristotle to believe a moving body was filled with some sort of substance that was “used up” as the body moved. But in spite of observations like this, Newton was able to deduce that this slowing of an object is due to an external force (friction), and that if it weren't for friction, the body would travel at the same velocity forever.

Today we have a little easier time of it than Newton did—we can imagine the behavior of bodies in space, where frictional forces are negligible.

13.2 Second Law of Motion

Newton's second law of motion states that the net force F on a body is proportional to its resulting acceleration a :

$$F = ma. \tag{13.1}$$

¹Appendix R gives Newton's laws of motion in their original form.



Figure 13.1: Sir Isaac Newton.

When a force F is applied to a body, it will accelerate with acceleration $a = F/m$ —the larger the mass, the smaller the acceleration.

If the force F is a function of position, and using acceleration $a = d^2x/dt^2$, this becomes a differential equation

$$F(x) = m \frac{d^2x}{dt^2}. \quad (13.2)$$

Solving this differential equation for $x(t)$ gives a complete description of the motion.

As we'll see later when we discuss momentum, the most general form of Newton's second law is *not* $F = ma$, but $F = dp/dt$, where p is momentum. This reduces to $F = ma$ when mass is constant.

In Newton's second law as given in Eq. (37.1) is only its simple scalar form, and suitable for one-dimensional problems. More generally, both force and acceleration are *vectors*, so that Newton's second law takes the form

$$\mathbf{F} = m\mathbf{a} \quad (13.3)$$

Here \mathbf{F} is the *net* force on the body — that is, the vector sum of all the individual forces acting on it. We might write this more explicitly as

$$\sum_i \mathbf{F}_i = m\mathbf{a} \quad (13.4)$$

In other words, the vector sum of all the forces acting on a body equals its mass times the resulting acceleration. This vector formula is really a shorthand for writing *three* scalar formulas. Taking the x , y , and z components of both sides of Eq. (13.4), we get

$$x : \quad \sum_i F_{xi} = ma_x \quad (13.5)$$

$$y : \quad \sum_i F_{yi} = ma_y \quad (13.6)$$

$$z : \quad \sum_i F_{zi} = ma_z \quad (13.7)$$

(Of course, we omit the z equation when working in only two dimensions.) We'll see some examples of the use of these equations shortly.

13.3 Third Law of Motion

Newton's third law of motion states that forces always come in pairs that act in opposite directions. For example, the Earth exerts a gravitational force on the Moon, and the Moon in turn exerts a gravitational force back on the Earth.

As a more complicated example, consider the forces present when you are standing on the floor:

1. There is a downward gravitational force acting on you due to your mass and the Earth's mass (your weight).
2. There is an upward gravitational force acting on the Earth due to your mass and the Earth's mass.
3. There is an upward normal force acting on you due to the floor.
4. There is a downward force acting on the floor due to you.

Items 1 and 2 are action-reaction pairs, as are items 3 and 4. Two of these forces are acting on you: your weight downward, and the normal force upward. These two forces must be equal, because you're not accelerating, and therefore the net force on you is zero.

Chapter 14

The Inclined Plane

An *inclined plane* (Fig. 14.1) is one of the classical *simple machines*.¹ Let's consider the motion of a block sliding down a frictionless inclined plane.

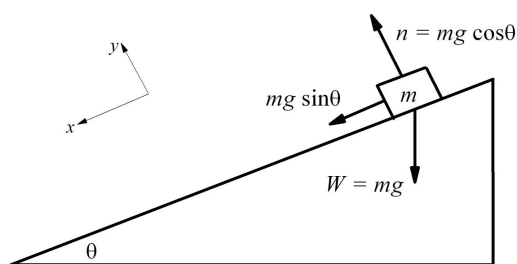

Figure 14.1: An object sliding on an inclined plane.

First, let's define a coordinate system: let's take the origin at the block's initial position, $+x$ pointing down the plane (in the direction of motion), and $+y$ pointing upward perpendicular to the plane. Let's apply Newton's second law to the x and y directions:

$$x : \sum F_x = mg \sin \theta = ma \quad (14.1)$$

$$y : \sum F_y = n - mg \cos \theta = 0 \quad (14.2)$$

In Eq. (14.1), the sum of the forces in the x direction is $mg \sin \theta$; solving this equation gives the acceleration of a block down an incline:

$$\boxed{a = g \sin \theta.} \quad (14.3)$$

In Eq. (14.2), the forces in the y direction are n (in the $+y$ direction) and the y component of the weight ($mg \cos \theta$) in the $-y$ direction. Solving this equation gives the magnitude of the normal force: $n = mg \cos \theta$.

From this example, we can see the general procedure for solving problems like this:

1. Define a coordinate system. You're free to define the direction and origin however you wish, so choose something convenient that will make the equations simple.

¹The others are the lever, the wheel and axle, the pulley, the wedge, and the screw. See Chapter 22.

2. Identify all the forces acting on the body. You may wish to draw a free-body diagram if it helps you to identify the forces.
3. Find the projection of each force onto the coordinate axes you defined.
4. Apply Newton's second law ($\sum_i F_i = ma$) in both the x and y directions.
5. Solve the equations to find whatever you're asked to find.

Chapter 15

Atwood's Machine

Atwood's machine is a device invented in 1784 by the English physicist Rev. George Atwood. (See Fig. 15.1 at right.) The purpose of the device is to permit an accurate measurement the acceleration due to gravity g . In the 18th century, without accurate timepieces or photogate timers, this was a difficult measurement to make with good accuracy. Atwood's machine has the effect of essentially scaling g to a smaller value, so the masses accelerate more slowly and allow g to be determined more easily.

Let's see how the machine works. There are two identical masses (labeled A and B in the figure) connected by a light string that is strung over a pulley. Since the masses are identical, they will not move, regardless of whether one is higher than the other. The tall (8 ft) vertical pole has a distance scale marked off in inches. To use the machine, we move mass A to the top of the scale, and place a small U-shaped bar on top of the mass. (The bar is labeled M in the figure, but is shown somewhat enlarged; the actual bar would be just a little longer than the diameter of the ring.) Now mass A will begin accelerating downward until it reaches ring R . The mass will then pass through ring R , but the ring will lift the bar off the mass, so that the bar is left behind, sitting on the ring—in effect, the ring “locks in” the final post-acceleration velocity. After A passes through the ring, the masses on both ends of the string will be the same, so the acceleration will be zero and mass A will continue moving with a constant velocity until it lands on stage S . Both ring R and stage S are movable, and can be moved up and down the scale as needed.

To use the machine, we move mass A to the top of the scale, and place a small U-shaped bar on top of the mass. (The bar is labeled M in the figure, but is shown somewhat enlarged; the actual bar would be just a little longer than the diameter of the ring.) Now mass A will begin accelerating downward until it reaches ring R . The mass will then pass through ring R , but the ring will lift the bar off the mass, so that the bar is left behind, sitting on the ring—in effect, the ring “locks in” the final post-acceleration velocity. After A passes through the ring, the masses on both ends of the string will be the same, so the acceleration will be zero and mass A will continue moving with a constant velocity until it lands on stage S . Both ring R and stage S are movable, and can be moved up and down the scale as needed.

To collect data, we use a pendulum as a timing device. Move ring R up and down until it takes one

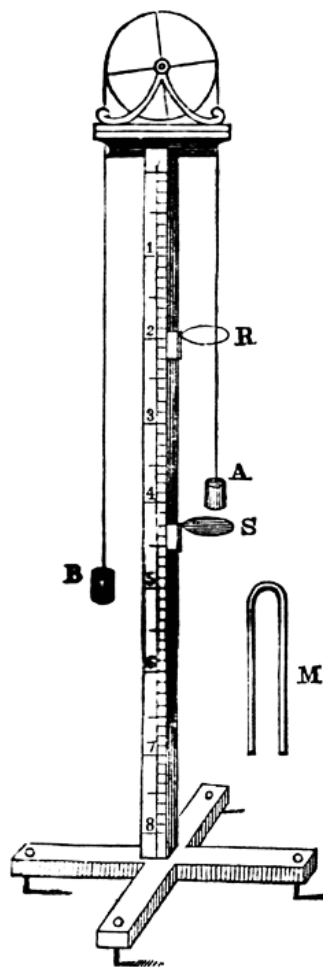

Figure 15.1: Atwood's machine (Ref. [3]).

second for mass A (with bar M on it) to fall from the beginning of the scale to the ring. Then move stage S up and down until it takes one second for mass A (now missing bar M) to move from ring R to the stage S . The distance between the ring and the stage (divided by one second) gives the speed of mass A after it has accelerated for one second. Now repeat the experiment for the case where mass A takes two seconds to fall from the top of the scale to ring R , then again for three and four seconds; in each case move stage S so it is one second's falling time below the ring. In each case, the distance between the ring and the stage gives the velocity v of mass A after A has accelerated by the given number of seconds. Now since the acceleration is constant,

$$v = at + v_0 \quad (15.1)$$

and $v_0 = 0$, so the acceleration is $a = v/t$; for each experiment, we can then determine the acceleration a . In theory, a should be the same for each experiment, so we just take the average of the results.

Now that we've determined the acceleration of the masses a , how do we determine the actual acceleration due to gravity g ? To begin the analysis, let's first define some coordinate systems. For mass A , let $+x$ be downward, and for mass B , let $+x$ be upward; that way, as mass A is accelerating downward and B is accelerating upward, both will be accelerating in the $+x$ direction; obviously both masses must have the same acceleration a . Let the masses of A and B each be m , let the mass of the bar be m_{bar} , and let the tension in the string be T , which is the same throughout the length of the string. Now let's apply Newton's second law to both masses:

$$A : \sum F_x = (m + m_{\text{bar}})g - T = (m + m_{\text{bar}})a \quad (15.2)$$

$$B : \sum F_x = -mg + T = ma \quad (15.3)$$

Adding these two equations together, we get

$$m_{\text{bar}}g = (2m + m_{\text{bar}})a \quad (15.4)$$

and so the acceleration due to gravity g is determined from

$$g = \frac{2m + m_{\text{bar}}}{m_{\text{bar}}} a, \quad (15.5)$$

where the acceleration a is determined as described earlier.

Conversely, if you already know g and wish to predict the acceleration of the masses in the machine,

$$a = \frac{m_{\text{bar}}}{2m + m_{\text{bar}}} g. \quad (15.6)$$

More generally, if we refer to the two masses by their total mass and call them $m_A = m + m_{\text{bar}}$ and $m_B = m$, then the two masses accelerate with acceleration

$$a = \frac{m_A - m_B}{m_A + m_B} g. \quad (15.7)$$

The above equations may also be solved for the string tension T :

$$T = 2m \left(\frac{m + m_{\text{bar}}}{2m + m_{\text{bar}}} \right) g = \frac{2m_A m_B}{m_A + m_B} g \quad (15.8)$$

Complete Solution

Just for fun, let's work out the complete general solution for the Atwood's machine shown in Fig. 15.1. Suppose the mass with the bar is released from near the top of the scale at time $t = 0$ and position x_0 on the scale; that the ring at position x_r lifts the bar off of the mass at time t_r ; and that the mass hits the stage at position x_s at time t_s . What is the acceleration due to gravity g in terms of x_0 , t_r , x_r , t_s , and x_s ?

Let's begin with the motion between the release at time $t = 0$ and reaching the ring at time $t = t_r$. The mass is accelerating with constant acceleration a , so from the equations of one-dimensional kinematics (Eq. (5.23)), we have at $t = t_r$

$$x_r = \frac{1}{2}at_r^2 + v_0t_r + x_0, \quad (15.9)$$

where $v_0 = 0$ since the mass is released from rest. Assuming the scale increases going *downward*, the acceleration will be positive and given by Eq. (15.6); we then have

$$x_r = \frac{1}{2} \left(\frac{m_{\text{bar}}}{2m + m_{\text{bar}}} g \right) t_r^2 + x_0. \quad (15.10)$$

If we knew the time t_r at which the mass reaches the ring, then we would be finished, just by solving Eq. (15.10) for g —there would be no need for the stage later on. So apparently the time t_r was not measured directly in practice. Let's continue the analysis, incorporating information about the motion of the mass between the ring and the stage.

After the ring lifts the bar off of the mass, the mass will be moving at a constant velocity v_r given by

$$v_r = at_r + v_0 \quad (15.11)$$

$$= \left(\frac{m_{\text{bar}}}{2m + m_{\text{bar}}} g \right) t_r. \quad (15.12)$$

Solving for t_r ,

$$t_r = \left(\frac{2m + m_{\text{bar}}}{m_{\text{bar}}g} \right) v_r. \quad (15.13)$$

Substituting this for t_r into Eq. (15.10), we have

$$x_r = \frac{1}{2} \left(\frac{m_{\text{bar}}g}{2m + m_{\text{bar}}} \right) \left(\frac{2m + m_{\text{bar}}}{m_{\text{bar}}g} \right)^2 v_r^2 + x_0 \quad (15.14)$$

$$= \frac{1}{2} \left(\frac{2m + m_{\text{bar}}}{m_{\text{bar}}g} \right) v_r^2 + x_0 \quad (15.15)$$

We don't know the velocity v_r , so we'll need to eliminate it. At velocity v_r , the mass will move from the ring at $x = x_r$ to the stage at $x = x_s$ in time

$$\Delta t = \frac{x_s - x_r}{v_r}, \quad (15.16)$$

where $\Delta t \equiv t_s - t_r$. Solving for v_r ,

$$v_r = \frac{x_s - x_r}{\Delta t}. \quad (15.17)$$

Using this expression to substitute for v_r in Eq. (15.15), we have

$$x_r = \frac{1}{2} \left(\frac{2m + m_{\text{bar}}}{m_{\text{bar}}g} \right) \left(\frac{x_s - x_r}{\Delta t} \right)^2 + x_0. \quad (15.18)$$

Solving for g ,

$$2(x_r - x_0) = \left(\frac{2m + m_{\text{bar}}}{m_{\text{bar}}g} \right) \left(\frac{x_s - x_r}{\Delta t} \right)^2 \quad (15.19)$$

$$2(x_r - x_0) \left(\frac{\Delta t}{x_s - x_r} \right)^2 = \frac{2m + m_{\text{bar}}}{m_{\text{bar}}g} \quad (15.20)$$

or

$$g = \left[\frac{2m + m_{\text{bar}}}{2m_{\text{bar}}(x_r - x_0)} \right] \left(\frac{x_s - x_r}{\Delta t} \right)^2. \quad (15.21)$$

Simplifying somewhat, we have

$$g = \left[\frac{(m/m_{\text{bar}}) + \frac{1}{2}}{x_r - x_0} \right] \left(\frac{x_s - x_r}{\Delta t} \right)^2. \quad (15.22)$$

Apparently in operating Atwood's machine, one needed to measure the masses (m and m_{bar}), the positions of the ring and stage (x_r and x_s), and the amount of time Δt it takes the mass to move from the ring to the stage. Then the acceleration due to gravity g would be given by Eq. (15.22).

Chapter 16

Statics

Statics is the branch of mechanics that deals with systems in equilibrium, where bodies are all stationary. In this case the forces all balance, and the *net* force on each body is zero.

16.1 Mass Suspended by Two Ropes

As a typical example of a problem in statics, consider the situation shown in Fig. 16.1(a). A block of mass m is suspended by a wire, and the upper end of the wire is attached to two more ropes or wires that connect to the ceiling. Each of the three ropes is under tension; the tensions are labeled T_1 , T_2 , and T_3 .

To begin the analysis of this situation, it is often helpful to draw a *free-body diagram* for each body in the problem. A free-body diagram shows all the forces acting on the body, and helps clarify your thinking when doing the analysis. For this problem, there are two bodies present: the block and the knot. Fig. 16.1(b) is a free-body diagram for the block, and Fig. 16.1(c) is a free-body diagram for the knot.

Now let's begin the analysis; our goal will be to determine the three tensions T_1 , T_2 , and T_3 , given the mass m and two angles θ_1 and θ_2 . First, let's look at the free-body diagram for the block (Fig. 16.1(b)). For the block, the tension and weight vectors are given by

$$\mathbf{T}_3 = T_3 \mathbf{j} \quad (16.1)$$

$$\mathbf{W} = -mg \mathbf{j} \quad (16.2)$$

(Note the x and y directions indicated in Fig. 16.1(a).) Now let's apply Newton's second law in both the x and y directions, noting that $F = ma = 0$ in this case:

$$x : \quad \sum F_x = ma_x \quad \Rightarrow \quad 0 = 0 \quad (16.3)$$

$$y : \quad \sum F_y = ma_y \quad \Rightarrow \quad T_3 - mg = 0 \quad (16.4)$$

Both right-hand sides are zero because the acceleration of the block is zero. The x equation (Eq. 16.3) yields a tautology $0 = 0$, which gives us no information. The y equation (Eq. 16.4) tells us $T_3 = mg$, so we've just found tension T_3 .

We can find the other two tensions (T_1 and T_2) by analyzing the other body: the knot (Fig. 16.1(c)). For the knot, the three tension vectors are given by

$$\mathbf{T}_1 = -T_1 \cos \theta_1 \mathbf{i} + T_1 \sin \theta_1 \mathbf{j} \quad (16.5)$$

$$\mathbf{T}_2 = T_2 \cos \theta_2 \mathbf{i} + T_2 \sin \theta_2 \mathbf{j} \quad (16.6)$$

$$\mathbf{T}_3 = -T_3 \mathbf{j} \quad (16.7)$$

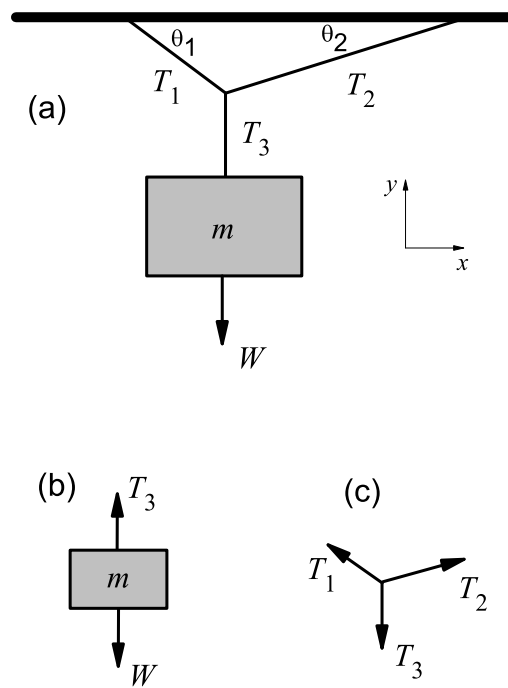

Figure 16.1: A block suspended from the ceiling by ropes. (a) Diagram of the situation. The block of mass m is suspended by a rope; the upper end of the rope is attached to two other ropes that are attached to the ceiling. (b) Free-body diagram for the block. (c) Free-body diagram for the knot.

Now let's apply Newton's second law ($F = ma = 0$) individually to the x and y components:

$$x : \sum F_x = ma_x \quad \Rightarrow \quad -T_1 \cos \theta_1 + T_2 \cos \theta_2 = 0 \quad (16.8)$$

$$y : \sum F_y = ma_y \quad \Rightarrow \quad T_1 \sin \theta_1 + T_2 \sin \theta_2 - T_3 = 0 \quad (16.9)$$

Again both right-hand sides are zero because the knot is not accelerating. Since T_3 is already known, this gives two simultaneous equations in the two unknown tensions T_1 and T_2 . One method for solving this system of equations is to write the equations in matrix form:

$$\begin{pmatrix} -\cos \theta_1 & \cos \theta_2 \\ \sin \theta_1 & \sin \theta_2 \end{pmatrix} \begin{pmatrix} T_1 \\ T_2 \end{pmatrix} = \begin{pmatrix} 0 \\ T_3 \end{pmatrix}. \quad (16.10)$$

Now multiplying both sides on the left by the inverse of the 2×2 matrix, we have

$$\begin{pmatrix} T_1 \\ T_2 \end{pmatrix} = \begin{pmatrix} -\cos \theta_1 & \cos \theta_2 \\ \sin \theta_1 & \sin \theta_2 \end{pmatrix}^{-1} \begin{pmatrix} 0 \\ T_3 \end{pmatrix}. \quad (16.11)$$

Since the tension T_3 and the angles θ_1 and θ_2 are all known, this gives the two unknown tensions T_1 and T_2 .

We can further simplify this by computing the matrix inverse explicitly. The determinant of the 2×2 matrix is (Appendix Q)

$$\det \begin{pmatrix} -\cos \theta_1 & \cos \theta_2 \\ \sin \theta_1 & \sin \theta_2 \end{pmatrix} = -\cos \theta_1 \sin \theta_2 - \sin \theta_1 \cos \theta_2 \quad (16.12)$$

$$= -\sin(\theta_1 + \theta_2), \quad (16.13)$$

and the matrix of cofactors is

$$\text{cof} \begin{pmatrix} -\cos \theta_1 & \cos \theta_2 \\ \sin \theta_1 & \sin \theta_2 \end{pmatrix} = \begin{pmatrix} \sin \theta_2 & -\sin \theta_1 \\ -\cos \theta_2 & -\cos \theta_1 \end{pmatrix}. \quad (16.14)$$

Hence the matrix inverse, which is the transposed matrix of cofactors divided by the determinant, is

$$\begin{pmatrix} -\cos \theta_1 & \cos \theta_2 \\ \sin \theta_1 & \sin \theta_2 \end{pmatrix}^{-1} = -\frac{1}{\sin(\theta_1 + \theta_2)} \begin{pmatrix} \sin \theta_2 & -\cos \theta_2 \\ -\sin \theta_1 & -\cos \theta_1 \end{pmatrix} \quad (16.15)$$

$$= \frac{1}{\sin(\theta_1 + \theta_2)} \begin{pmatrix} -\sin \theta_2 & \cos \theta_2 \\ \sin \theta_1 & \cos \theta_1 \end{pmatrix}. \quad (16.16)$$

The tensions T_1 and T_2 are therefore

$$\begin{pmatrix} T_1 \\ T_2 \end{pmatrix} = \frac{1}{\sin(\theta_1 + \theta_2)} \begin{pmatrix} -\sin \theta_2 & \cos \theta_2 \\ \sin \theta_1 & \cos \theta_1 \end{pmatrix} \begin{pmatrix} 0 \\ T_3 \end{pmatrix} \quad (16.17)$$

$$= \frac{T_3}{\sin(\theta_1 + \theta_2)} \begin{pmatrix} \cos \theta_2 \\ \cos \theta_1 \end{pmatrix}. \quad (16.18)$$

Recall that we've already found $T_3 = mg$; then the final results are

$$T_1 = \frac{mg \cos \theta_2}{\sin(\theta_1 + \theta_2)}, \quad (16.19)$$

$$T_2 = \frac{mg \cos \theta_1}{\sin(\theta_1 + \theta_2)}, \quad (16.20)$$

$$T_3 = mg. \quad (16.21)$$

16.2 The Elevator

An *elevator* is a large box (called a *car*) that is used to lift and lower passengers or cargo, typically operated by a pulley arrangement.

Suppose an elevator contains a passenger of mass m , standing on a scale. The scale will then measure the *total* force on the passenger. If the elevator is stationary, the scale measures the passenger's weight, mg . If the elevator is moving up or down with a constant velocity, then the scale *still* measures only the passenger's weight, mg . But if the elevator is accelerating *upward* with acceleration a , then the passenger will feel heavier; the elevator's upward acceleration will be added to the acceleration due to gravity, and the scale will read $m(g + a)$. If the elevator is accelerating *downward* with acceleration a , then the passenger will feel lighter; the elevator's downward acceleration will be subtracted from the acceleration due to gravity, and the scale will read $m(g - a)$. If the cable holding the elevator breaks, the elevator will fall downward with an acceleration $a = g$, and the scale will read zero; in other words, there will be no force on the passenger, who will begin floating inside the elevator car, similar to the way astronauts float inside a spacecraft.¹

Suppose you fall asleep, and wake up in a closed, windowless elevator car in which you have your normal weight. How do you know whether you're sitting stationary on the surface of the Earth, or if you're in space, being accelerated by rockets at 9.8 m/s^2 ? A remarkable consequence of Einstein's General Theory of Relativity (Section 51.8) is: you can't tell. There is no experiment you can do that would enable you to distinguish gravity from an acceleration of the elevator car. Gravity and acceleration are equivalent. This result has been proposed as a means for providing artificial gravity to astronauts during a long space voyage: the spacecraft can accelerate at 9.8 m/s^2 to provide artificial gravity for the astronauts up to the half-way point of their trip; then the ship can rotate 180° and de-accelerate at 9.8 m/s^2 for the last half of the trip.

16.3 The Catenary

Consider a chain elevated above ground, attached only at its two ends, both ends at the same height, and hanging under its own weight. The chain will sag, forming a hyperbolic cosine curve called a *catenary*. With a coordinate system defined as shown in Figure 16.2, the equation of the catenary is found to be

$$y = a \cosh\left(\frac{x}{a}\right) - a \quad (16.22)$$

where $a = H/w$, H is the horizontal tension in the chain at the pole (in newtons), and w is the linear weight density of the chain (in newtons per meter).

The arc length s of the catenary from $x = 0$ to x is given by

$$s(x) = a \sinh\left(\frac{x}{a}\right) \quad (16.23)$$

so that if the poles are separated by a distance d , the total arc length s_t is

$$s_t = 2a \sinh\left(\frac{d}{2a}\right) \quad (16.24)$$

Note that if the horizontal tension H is very large (the chain is pulled very taut), then $a = H/w$ is very large, $d/2a$ is very small, and so $\sinh(d/2a) \approx d/2a$, so that $s_t \approx d$, as expected.

¹In real life, elevators are built with several levels of safety devices to prevent this kind of free fall. If the power goes out, the brakes automatically engage, since the power holds the brakes open. If the car goes too far inside the shaft, another independent set of brakes engages. Also, there is a large spring at the bottom of the shaft to catch the passengers just in case everything else fails.

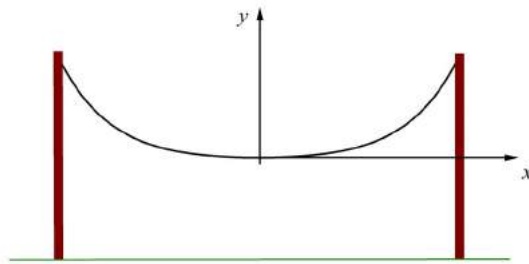

Figure 16.2: A chain hanging under its own weight, forming a catenary curve.

Chapter 17

Friction

17.1 Introduction

Friction is a resistive force between two solid bodies in contact that inhibits the motion of the objects. We're all familiar with friction in everyday life: if you try to slide an object across the floor, it does not continue in a straight line at constant speed, as might be expected from Newton's first law of motion. Instead, the object's speed decreases until it comes to a stop. The reason is given by Newton's first law: there must be an external force present—the frictional force.

Friction is caused by the interaction of the surfaces of two objects rubbing against each other. For example, as an object is sliding across the floor, the top layer of atoms in the floor are constantly making and breaking chemical bonds with the bottom layer of atoms in the object. This interaction of the atomic layers causes the object's kinetic energy to be converted to heat bit by bit, so both the object and the floor become hotter as the object slows down. (We'll learn about kinetic energy in Chapter 23.)

Here are a few facts about friction:

- Friction is a force that always acts *opposite* the direction of motion of the object.
- Experimentally, we find that the frictional force f is proportional to the normal force n : $f = \mu n$, where μ is called the *coefficient of friction*.
- Traditionally physicists describe *three* types of frictional force: *static friction*, *kinetic friction*, and *rolling friction*. Static friction is at work when the object is stationary; kinetic friction is at work when the object is in motion; and rolling friction applies to rolling bodies. But under carefully controlled conditions, experiments show that the two tend to become indistinguishable.
- No one has yet been able to derive the relation $f = \mu n$ from first principles. It's an example of an *empirical law*: something that has been found to be at least approximately true under many conditions.

17.2 Static Friction

You know from everyday experience that if an object is sitting on the floor and you give it a very light push, it will not move. That's because a frictional force is at work: you have to give the object some minimum force in order to get it to move at all. This is the *static* frictional force. It is found experimentally to be proportional to the normal force:

$$\boxed{f_s \leq \mu_s n,} \tag{17.1}$$

where f_s is the static frictional force, n is the normal force, and μ_s is the *coefficient of static friction*.

Notice the “less than or equal to” sign in Eq. (17.1). The static frictional force f_s is equal in magnitude to the applied force, whatever the applied force may be—up until the point just before the object starts moving. The equality sign holds when the object is just on the verge of moving. Once it begins to move, the *kinetic* frictional force is in play.

It is notoriously difficult to reliably reproduce measurements of the coefficient of static friction, which suggests that it is due to nicks or bumps or other imperfections in the surfaces, or to bits of dust or other gunk that hinder the initial movement of the object.

17.3 Kinetic Friction

Once you push on an object enough to get it moving, there is a *kinetic* frictional force that will tend to slow it down unless you keep pushing on it. If you apply just enough force to keep it moving at a constant velocity, then the force you’re applying will be exactly equal to the the *kinetic* frictional force, which, like the static frictional force, is found to be proportional to the normal force:

$$f_k = \mu_k n. \quad (17.2)$$

Here f_k is the static frictional force, n is the normal force, and μ_k is the *coefficient of kinetic friction*. The direction of the force of kinetic friction is always opposite the direction in which the body is moving.

If you push an object with a force less than f_k , it will not move, and will be held in place by the static frictional force f_s . If you push it with a force greater than f_k , it will accelerate with an acceleration $a = (F_{\text{app}} - f_k)/m$, where F_{app} is the applied force.

17.4 Rolling Friction

A different kind of frictional force applies to rolling bodies like wheels. If a wheel rolls along the ground without slipping, there is a rolling frictional force at the point of contact between the wheel and the ground, due to the forming of chemical bonds between the wheel and the ground at that point, and the breaking of those bonds as the wheel moves along to the next point. This is not kinetic friction, because the wheel is not sliding across the ground — each point of the wheel is just momentarily in contact with the ground. The rolling frictional force is found to be, like the other two frictional forces, proportional to the normal force:

$$f_r = \mu_r n. \quad (17.3)$$

Here f_r is the rolling frictional force, n is the normal force, and μ_r is the *coefficient of rolling friction*. The direction of the rolling frictional force is always opposite the direction of motion of the axis of the wheel. For example, if the wheel is rolling to the right, then the rolling frictional force points to the left.

17.5 The Coefficient of Friction

Some physics textbooks and handbooks include tables of coefficients of friction (μ_s and μ_k) for rubber on wood, metal on metal, etc. These tables are all false, and should be ignored. The coefficient of friction depends on a number of factors, including the smoothness of the surfaces and complex surface chemistry (including contaminants from the air sticking on the surfaces), and cannot be simply looked up in a table.

So how *do* we determine the coefficient of friction? One simple method is to place an object of mass m on an inclined plane (Fig. 17.1). Now tilt the plane up to higher and higher angles, gradually increasing

θ until just before the object starts to move; let's call this angle θ_s . Now let's apply Newton's second law ($F = ma = 0$ since the acceleration is zero) to the x and y components of the motion:

$$x : \sum F_x = ma_x \quad \Rightarrow \quad mg \sin \theta_s - f_s = 0 \quad (17.4)$$

$$y : \sum F_y = ma_y \quad \Rightarrow \quad n - mg \cos \theta_s = 0 \quad (17.5)$$

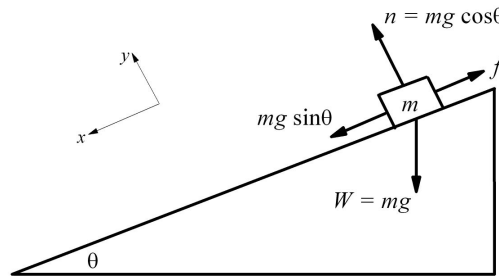

Figure 17.1: An object sliding on an inclined plane, with friction included.

The x equation (Eq. 17.4) tells us the magnitude of the maximum static frictional force:

$$f_s = \mu_s n = mg \sin \theta_s. \quad (17.6)$$

The y equation (Eq. 17.5) tells us the magnitude of the normal force:

$$n = mg \cos \theta_s \quad (17.7)$$

Now using Eq. (17.7) to substitute for the normal force n in Eq. (17.6), we have

$$f_s = \mu_s (mg \cos \theta_s) = mg \sin \theta_s. \quad (17.8)$$

To solve for μ_s , we divide through by $mg \cos \theta_s$:

$$\boxed{\mu_s = \tan \theta_s.} \quad (17.9)$$

So the coefficient of static friction between the object and the inclined plane is just the tangent of angle θ_s .

Now increase the incline angle θ a little more as you give the mass m little taps to get it going. At some angle θ_k , the object will keep moving, at a constant velocity. (Tipping the incline up farther will cause the object to accelerate; you want the angle at which the object moves down the incline at constant velocity, without accelerating.) Once again in this case the acceleration of the object is zero, and the analysis follows just as with the static case. The coefficient of kinetic friction is then

$$\boxed{\mu_k = \tan \theta_k.} \quad (17.10)$$

So the coefficient of kinetic friction between the object and the inclined plane is just the tangent of angle θ_k .

As a general rule, the coefficient of static friction is greater than the coefficient of kinetic friction; in other words, it generally takes a larger force (acting against friction) to *get* an object moving than to *keep* it moving:

$$\mu_s > \mu_k \quad (\text{generally}). \quad (17.11)$$

But as mentioned earlier, under carefully controlled conditions, one finds the relationship tends toward $\mu_s = \mu_k$, so the two frictional forces tend to become indistinguishable.

The coefficient of rolling friction is typically much less than the coefficient of kinetic friction:

$$\mu_r \ll \mu_k \quad (\text{generally}). \quad (17.12)$$

Chapter 18

Blocks and Pulleys

In this chapter, we will examine the dynamics of two blocks connected with a string, where the blocks lie on smooth (frictionless) surfaces, rough surfaces, or are hanging vertically.

18.1 Horizontal Block and Vertical Block

Consider the following problem: a block of mass m_1 is on a frictionless horizontal surface, and connected by a string, through a pulley, to a mass m_2 hanging vertically (Figure 18.1). (We assume the string is unbreakable, unstretchable, and of negligible mass.) What is the acceleration of the system?

First, we recognize that the block m_1 will accelerate to the right, and block m_2 downward, with the *same* acceleration a , since the two blocks are tied together. Next, consider the forces on block m_1 : it has a weight m_1g , and is acted upon by a normal force, also of magnitude m_1g , so that the net force in the vertical direction is zero. This is as expected, since the block is not accelerating in the vertical direction. In the horizontal direction, the only force acting on m_1 is the string tension T . Thus for m_1 , Newton's second law gives, in the horizontal direction,

$$\Sigma_i F_i = m_1 a \quad \Rightarrow \quad T = m_1 a \quad (18.1)$$

There are no horizontal forces acting on mass m_2 , but there are *two* vertical forces: the upward tension T (equal to the tension acting on m_1) and the downward weight force mg . Then Newton's second law for m_2 ,

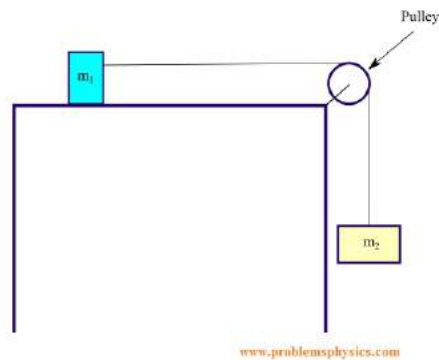

Figure 18.1: Horizontal and vertical pulley connected by a string.

in the vertical (downward) direction, is

$$\Sigma_i F_i = m_2 a \quad \Rightarrow \quad m_2 g - T = m_2 a \quad (18.2)$$

This gives us two simultaneous equations in the two unknowns a and T . Adding the two equations will eliminate the tension T ; we can then solve for the acceleration a to find

$$\boxed{a = \frac{m_2}{m_1 + m_2} g} \quad (18.3)$$

And then by Eq. (18.1), the tension in the string is

$$\boxed{T = \frac{m_1 m_2}{m_1 + m_2} g} \quad (18.4)$$

Now let's consider the same problem, but this time we'll include friction acting on the horizontal block. In this case, Newton's second law for m_1 (Eq. (18.1)) will include a frictional force $f = \mu n = \mu m_1 g$ (where μ is the coefficient of (kinetic) friction) acting to the left, and becomes

$$\Sigma_i F_i = m_1 a \quad \Rightarrow \quad T - \mu m_1 g = m_1 a \quad (18.5)$$

Newton's second law applied to mass m_2 is the same as before:

$$\Sigma_i F_i = m_2 a \quad \Rightarrow \quad m_2 g - T = m_2 a \quad (18.6)$$

Adding these two equations to eliminate the tension T , we find the acceleration a to be

$$\boxed{a = \frac{m_2 - \mu m_1}{m_1 + m_2} g} \quad (18.7)$$

and the tension to be (using Eq. (18.5)),

$$\boxed{T = \frac{(1 + \mu)m_1 m_2}{m_1 + m_2} g} \quad (18.8)$$

Notice that these last two equations reduce to their frictionless counterparts when $\mu = 0$.

18.2 Inclined Block and Vertical Block

Now let's generalize the previous problem by placing block m_1 on an upward inclined plane that makes an angle θ to the horizontal (Figure 18.2). We'll begin with the case where the inclined plane is frictionless. The forces on mass m_1 are the upward tension T as before, *plus* a downward acceleration $m_1 g \sin \theta$ down the inclined plane.

Taking upslope as positive and downslope as negative, Newton's second law for m_1 is then

$$\Sigma_i F_i = m_1 a \quad \Rightarrow \quad T - m_1 g \sin \theta = m_1 a \quad (18.9)$$

Newton's second law for m_2 , in the vertical (downward) direction, is the same as before:

$$\Sigma_i F_i = m_2 a \quad \Rightarrow \quad m_2 g - T = m_2 a \quad (18.10)$$

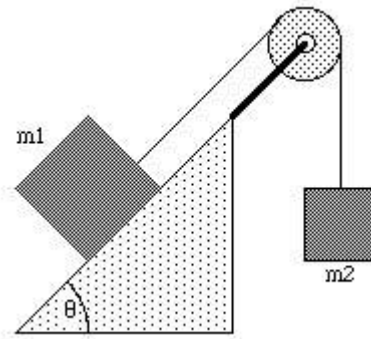

Figure 18.2: Inclined block and vertical block.

As before, we add these two equations to eliminate the tension T and solve for the acceleration a . We find

$$a = \frac{m_2 - m_1 \sin \theta}{m_1 + m_2} g \quad (18.11)$$

and then solving for the tension T , we find

$$T = \frac{m_1 m_2 (1 + \sin \theta)}{m_1 + m_2} g \quad (18.12)$$

Notice that these equations reduce to the equations for m_1 on a horizontal surface (Section 18.1) when we set $\theta = 0$, as expected.

Note particularly how we chose the signs in this problem. When the system is released, the vertical block will fall downward; we'll choose to call this the *positive* ($+a$) direction. Since this will result in the block on the plane accelerating *upslope*, this means we must choose upslope to be the positive direction to keep the signs consistent.

Now let's generalize this even further by adding friction to the inclined plane. In this case, mass m_1 will experience an upslope force equal to the tension T and a downslope force $m_1 g \sin \theta$. In addition, there will be a frictional force $f = \mu n = \mu m_1 g \cos \theta$ acting opposite the direction of motion (downslope). Thus

$$\Sigma_i F_i = m_1 a \quad \Rightarrow \quad T - m_1 g \sin \theta - \mu m_1 g \cos \theta = m_1 a \quad (18.13)$$

Newton's second law for m_2 , in the vertical (downward) direction, is the same as before:

$$\Sigma_i F_i = m_2 a \quad \Rightarrow \quad m_2 g - T = m_2 a \quad (18.14)$$

As before, we add these two equations to eliminate the tension T and solve for the acceleration a :

$$a = \frac{m_2 - m_1 (\mu \cos \theta + \sin \theta)}{m_1 + m_2} g \quad (18.15)$$

and we find the tension to be

$$T = \frac{m_1 m_2 (1 + \mu \cos \theta + \sin \theta)}{m_1 + m_2} g \quad (18.16)$$

The last two equations are generalizations of all the previous problems. Setting $\theta = 0$ recovers the equations for m_1 on a horizontal surface, and setting $\mu = 0$ recovers the frictionless formulas. Furthermore, setting $\mu = 0$ and $\theta = 90^\circ$ produces the equations for the acceleration and tension for the Atwood's machine discussed in Chapter 15.

Chapter 19

Resistive Forces in Fluids

19.1 Introduction

In the last chapter we examined the frictional force between solid bodies in direct contact. Another type of resistive force applies to objects moving through a fluid¹ such as air. In such a situation, the resistive force F_R is generally found to be proportional to some power of the velocity v of the body:

$$F_R \propto v^n. \quad (19.1)$$

We'll examine two common models of this resistive force: one where $n = 1$, and another where $n = 2$. Examples with $n = 1$ include flow through fine fibrous mats such as furnace filters, and the movement of fog, mist, and dust particles through the atmosphere. Examples with $n = 2$ include most falling objects, parachute flight, and aerodynamic drag on automobiles.

19.2 Model I: $F_R \propto v$

In this first model, we model the resistive force F_R through a fluid as being proportional to the first power of the velocity v :

$$F_R = -bv, \quad (19.2)$$

where b is the constant of proportionality; the minus sign shows that the resistive force is always *opposite* the direction of motion.

Under this model, the net downward force on the falling body is $mg + F_R = mg - bv$. Then by Newton's second law,

$$F = ma \quad (19.3)$$

$$mg - bv = m \frac{dv}{dt}. \quad (19.4)$$

Dividing through by m , we have

$$\frac{dv}{dt} + \frac{b}{m}v = g. \quad (19.5)$$

¹A *fluid* is a substance that flows (a gas or a liquid).

This is a first-order differential equation, which you will learn to solve for $v(t)$ in a course on differential equations. But briefly, for a differential equation of the form

$$\frac{dy}{dt} + p(t)y = q(t), \quad (19.6)$$

the solution $y(t)$ is found to be (Ref. [2])

$$y(t) = \frac{1}{\mu(t)} \left[\int \mu(t) q(t) dt + C \right], \quad (19.7)$$

where C is a constant that depends on the initial conditions, and $\mu(t)$ is an *integrating factor*, given by

$$\mu(t) = \exp \left[\int p(t) dt \right]. \quad (19.8)$$

Since this is a first-order differential equation, there will be one arbitrary constant of integration, and it is the constant C in Eq. (19.7).

Comparing Eq. (19.5) with Eq. (19.6), we have

$$y(t) = v(t), \quad (19.9)$$

$$p(t) = b/m, \quad (19.10)$$

$$q(t) = g. \quad (19.11)$$

Then the integrating factor $\mu(t)$ is, from Eq. (19.8),

$$\mu(t) = \exp \left[\int p(t) dt \right] \quad (19.12)$$

$$= \exp \left[\int \frac{b}{m} dt \right] \quad (19.13)$$

$$= Ae^{bt/m}, \quad (19.14)$$

where A is a constant of integration. The solution to Eq. (19.5) is then given by Eq. (19.7):

$$v = \frac{e^{-bt/m}}{A} \left[\int Ae^{bt/m} g dt + C \right] \quad (19.15)$$

$$= e^{-bt/m} \left[\frac{mg}{b} e^{bt/m} + C' \right] \quad (19.16)$$

$$= \frac{mg}{b} + C' e^{-bt/m}. \quad (19.17)$$

To find the constant C' , we use the initial condition: if we release the body at time zero, then $v = 0$ when $t = 0$; Eq. (19.17) then becomes at $t = 0$

$$0 = \frac{mg}{b} + C' \quad (19.18)$$

and so

$$C' = -\frac{mg}{b}. \quad (19.19)$$

Therefore, from Eq. (19.17), the solution is

$$v = \frac{mg}{b} - \frac{mg}{b} e^{-bt/m}, \quad (19.20)$$

or

$$v = \frac{mg}{b} \left(1 - e^{-bt/m}\right). \quad (19.21)$$

This is the solution we're after: it gives the falling object's velocity v at any time t , assuming that it's dropped from rest at time $t = 0$.

Now let's examine what happens to the solution (Eq. 19.21) as $t \rightarrow \infty$. In this case, the exponential term approaches zero, and the falling object's velocity approaches the limiting value

$$v_{\infty} = \frac{mg}{b}. \quad (19.22)$$

This is called the *terminal velocity*, and is a general feature of bodies falling through resistive fluids: at some point the resistive force balances the downward gravitational force, and the body stops accelerating and moves at a constant velocity.² Sky divers experience this phenomenon: some time after jumping out of an airplane, a sky diver will reach a terminal velocity of roughly 100 miles per hour, and will not change speed further until the parachute is deployed.

19.3 Model II: $F_R \propto v^2$

Now let's consider a different model of resistive force in a fluid, in which the resistive force is proportional to the *square* of the velocity:

$$F_R \propto v^2. \quad (19.23)$$

This model is appropriate for most situations when Model I is not used. We find experimentally that the resistive force in this case is proportional to the area A normal to the flow direction, and to the density ρ of the fluid. We write Eq. (19.23) as

$$F_R = \frac{1}{2} C_D \rho A v^2, \quad (19.24)$$

where C_D is called the *drag coefficient*, and the factor of $1/2$ is conventional. The drag coefficient C_D depends on things like the shape of the falling body, its smoothness, and how turbulent the flow of fluid around the body is.

Proceeding as with Model I, we have, starting with Newton's second law,

$$F = ma \quad (19.25)$$

$$mg - \frac{1}{2} C_D \rho A v^2 = m \frac{dv}{dt}. \quad (19.26)$$

This is a nonlinear differential equation that is much more difficult to solve than the one we had for Model I (Eq. 19.5). Instead of trying to solve for $v(t)$, we'll simply note that we can find the terminal velocity v_{∞} by setting the acceleration $dv/dt = 0$ in Eq. (19.26). This immediately gives

$$v_{\infty} = \sqrt{\frac{2mg}{C_D \rho A}}. \quad (19.27)$$

So Model II of the resistive force, like Model I, exhibits a terminal velocity: as time $t \rightarrow \infty$, the velocity of the falling body will approach a constant, v_{∞} .

Example. With what speed do raindrops hit the Earth?

Solution. Assume the following rough estimates:

²A simpler way to arrive at Eq. 19.22 is to simply set the acceleration $dv/dt = 0$ in Eq. (19.5), which immediately gives $v_{\infty} = mg/b$.

- Cloud base height: $h = 1000$ m
- Air density: $\rho_{\text{air}} = 1.29$ kg/m³
- Raindrop (spherical) diameter: $d = 2$ mm
- Raindrop (water) density: $\rho_w = 1.00 \times 10^3$ kg/m³
- Raindrop coefficient of friction: $C_D = 0.5$

First, let's try a naïve approach, and neglect air resistance. As seen in Chapter 5, the velocity v of a raindrop falling under gravity through a height h is given by

$$v = \sqrt{2gh} \quad (19.28)$$

$$= \sqrt{2(9.8 \text{ m/s}^2)(1000 \text{ m})} \quad (19.29)$$

$$= 140 \text{ m/s} \quad (19.30)$$

$$= 313 \text{ mph} \quad (19.31)$$

Clearly raindrops are not hitting the Earth with a speed of 313 mph, or they would be lethal. The problem here is that it is very important to consider air resistance, or you will not get even close to the correct answer.

A more accurate analysis would be to allow for air resistance by computing the terminal velocity. After falling 1000 meters, a raindrop will have more than enough time to reach the terminal velocity, so the impact velocity will equal the terminal velocity, given by Eq. (19.27). We're given g , C_D , and ρ ; the cross-sectional $A = \pi d^2/4$; and the raindrop mass $m = \rho_w V = \rho_w (\pi d^3/6)$. Then by Eq. (19.27), the impact velocity will be

$$v_\infty = \sqrt{\frac{2mg}{C_D \rho A}} \quad (19.32)$$

$$= \sqrt{\frac{2(\rho_w \pi d^3/6)g}{C_D \pi \rho d^2/4}} \quad (19.33)$$

$$= \sqrt{\frac{4\rho_w dg}{3C_D \rho}} \quad (19.34)$$

$$= \sqrt{\frac{4(1000 \text{ kg/m}^3)(2 \times 10^{-3} \text{ m})(9.8 \text{ m/s}^2)}{3(0.5)(1.29 \text{ kg/m}^3)}} \quad (19.35)$$

$$= 6.37 \text{ m/s} \quad (19.36)$$

$$= 14.2 \text{ mph} \quad (19.37)$$

Whether or not it's important to consider air resistance in a particular problem is a matter of judgment and experience. With practice you develop an intuition about when it's likely to be important to include these kinds of effects.

Example. Consider the following problem due to L.L. Simpson (Ref. [11]): if it is considered safe for an adult to jump off of a three-foot high ladder without injury, what is the maximum design load for a conical parachute that is 30 feet in diameter and has a drag coefficient of 1.5? The design air density is 0.08 lb/ft³.

Solution. First, let's convert everything to SI units:

- Height: 3 ft = 0.9144 m.
- Parachute diameter: 30 ft = 9.144 m.
- Air density: 0.08 lb/ft³ = 1.281477 kg/m³.

Here's the general approach to the solution: from the first part of the problem, we can calculate the impact velocity of an adult jumping from a three-foot ladder. That impact velocity is considered safe, so we'll use that as the terminal velocity (using Eq. (19.27), since Model II is applicable for parachutes). We then solve for the weight mg , which is the required maximum weight that can be attached to the parachute and still have it reach a safe terminal velocity.

Let's begin. The impact velocity is given by Eq. (5.33),

$$v = \sqrt{2gh} \quad (19.38)$$

$$= \sqrt{2(9.8 \text{ m/s}^2)(0.9144 \text{ m})} \quad (19.39)$$

$$= 4.23347 \text{ m/s.} \quad (19.40)$$

We'll set the parachute terminal velocity v_∞ equal to this impact velocity. Now solve Eq. (19.27) for the weight mg :

$$mg = \frac{1}{2}C_D\rho Av_\infty^2. \quad (19.41)$$

Next replace the parachute area A with $\pi d^2/4$, where d is the parachute diameter:

$$mg = \frac{1}{8}\pi C_D\rho d^2v_\infty^2, \quad (19.42)$$

and substitute the numbers we're given:

$$mg = \frac{1}{8}\pi(1.5)(1.281447 \text{ kg/m}^3)(9.144 \text{ m})^2(4.23347 \text{ m/s})^2 \quad (19.43)$$

$$= 1131.1670 \text{ N} \quad (19.44)$$

$$= 254 \text{ lbf,} \quad (19.45)$$

where in the final step we've converted back to British engineering units; the maximum design load is a weight of 254 lbf.

Chapter 20

Circular Motion

20.1 Introduction

As we've already seen, the acceleration vector \mathbf{a} is defined by Eq. (8.2):

$$\mathbf{a} = \frac{d\mathbf{v}}{dt}. \tag{20.1}$$

This says that acceleration is the time rate of change of the velocity. We typically think of an acceleration as being a change in the *magnitude* of the velocity, but it can also be a change in the *direction* of the velocity. For example, if a particle is moving in a circle at constant speed, it is still accelerating: the velocity vector, while not changing its magnitude, *is* changing its direction with time.

So if we have a particle moving in a circle of radius r with a constant speed v , then it's accelerating; what are the magnitude and direction of the acceleration vector? The situation is shown in Fig. 20.1.

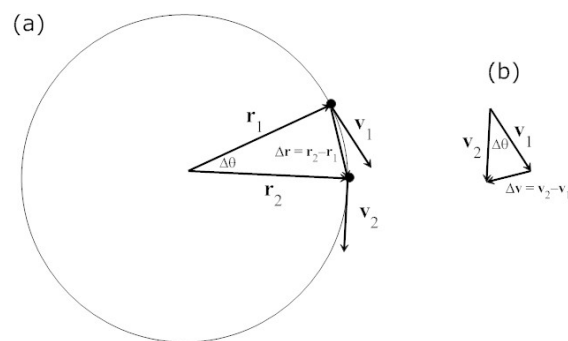

Figure 20.1: (a) A body moving in a circular path of radius r with constant speed v . At time t_1 , the body is at position \mathbf{r}_1 and has velocity \mathbf{v}_1 ; at a slightly later time t_2 , it is at position \mathbf{r}_2 and has velocity \mathbf{v}_2 . (b) The difference in velocity vectors $\mathbf{v}_2 - \mathbf{v}_1$ is the direction of the acceleration vector.

Note that since the path is circular, the triangle in Fig. 20.1(a) is an isosceles triangle with apex angle $\Delta\theta$. Since the speed v is constant, the triangle in Fig. 20.1(b) is also isosceles, and also has apex angle $\Delta\theta$. Since the two isosceles triangles have the same vertex angle, it follows from geometry that the two triangles are similar. Therefore

$$\frac{|\Delta\mathbf{v}|}{v} = \frac{|\Delta\mathbf{r}|}{r}. \quad (20.2)$$

Multiplying both sides by $v/\Delta t$,

$$\frac{|\Delta\mathbf{v}|}{\Delta t} = \frac{v}{r} \frac{|\Delta\mathbf{r}|}{\Delta t}. \quad (20.3)$$

Taking the limit as $\Delta t \rightarrow 0$,

$$\lim_{\Delta t \rightarrow 0} \frac{|\Delta\mathbf{v}|}{\Delta t} = \frac{v}{r} \lim_{\Delta t \rightarrow 0} \frac{|\Delta\mathbf{r}|}{\Delta t}, \quad (20.4)$$

or

$$\frac{dv}{dt} = \frac{v}{r} \frac{dr}{dt}. \quad (20.5)$$

The left-hand side dv/dt is just the acceleration a_c ; the second factor on the right-hand side dr/dt is the velocity v . Therefore this equation becomes

$$\boxed{a_c = \frac{v^2}{r}}. \quad (20.6)$$

We've now found the magnitude of the acceleration of a particle moving in a circle: it's the square of its speed divided by the radius of the circle. This acceleration is called the *centripetal acceleration*.

The direction of the centripetal acceleration vector can be seen by examining Fig. 20.1(b): by inspection, you can see that the acceleration vector \mathbf{a} points *inward*, toward the center of the circle.¹

In summary, if a particle is moving in a circular path of radius r with constant speed v , its acceleration is:

- in magnitude: $a_c = v^2/r$;
- in direction: *inward*, toward the center of the circle.

20.2 Centripetal Force

By Newton's first law of motion, a body in motion will tend to continue that motion in a straight line, unless acted upon by some outside force. Therefore, if a body is moving in a circle, there must be some force present that is *causing* it to move in a circle. Whatever force is responsible for making the body move in a circle we identify as the *centripetal force*. The magnitude of the centripetal force is equal to the mass of the body times the centripetal acceleration v^2/r :

$$F_c = \frac{mv^2}{r}. \quad (20.7)$$

For example, for a satellite orbiting the Earth, the centripetal force is the gravitational force. If you tie a small weight to the end of a string and swing it over your head in a circle, then the centripetal force is the tension in the string.

¹Since $\mathbf{a} = \Delta\mathbf{v}/\Delta t$ points in the same direction as $\Delta\mathbf{v}$.

Typically the way we approach problems involving uniform circular motion is to write down an expression for the centripetal force, and set it equal to mv^2/r .

Example. The International Space Station orbits the Earth at an altitude of about 350 km. How fast is it moving?

Solution. We'll write down an expression for the gravitational force and set it equal to mv^2/r . The radius of the Earth is 6378.140 km; if you add that to the altitude of the Space Station above the Earth's surface, you find the radius of its orbit $r = 6378.140 \text{ km} + 350 \text{ km} = 6728.140 \text{ km} = 6728140 \text{ m}$. The centripetal force in this case is the gravitational force, which (as will be seen later) is given by $F = GM_{\oplus}m/r^2$, where M_{\oplus} is the mass of the Earth, m is the mass of the space station, r is the radius of the orbit, and G is the universal gravitational constant. Setting this expression for the gravitational force equal to the centripetal force mv^2/r , we have

$$G \frac{M_{\oplus}m}{r^2} = \frac{mv^2}{r}. \quad (20.8)$$

Multiplying both sides by r/m ,

$$v^2 = G \frac{M_{\oplus}}{r}, \quad (20.9)$$

and so

$$v = \sqrt{\frac{GM_{\oplus}}{r}}. \quad (20.10)$$

Using the orbital radius $r = 6728140 \text{ m}$ and $GM_{\oplus} = 3.986005 \times 10^{14} \text{ m}^3 \text{ s}^{-2}$, we have the velocity of the Space Station as

$$v = \sqrt{\frac{GM_{\oplus}}{r}} \quad (20.11)$$

$$= \sqrt{\frac{3.986005 \times 10^{14} \text{ m}^3 \text{ s}^{-2}}{6728140 \text{ m}}} \quad (20.12)$$

$$= 7697 \text{ m/s} \quad (20.13)$$

$$= 17,200 \text{ mph} \quad (20.14)$$

A note about Eq. 20.12: the product GM_{\oplus} is known to higher accuracy than either G or M_{\oplus} individually; therefore we use the product here. See Appendix L for a listing of common physical constants.

20.3 Centrifugal Force

Sometimes it is helpful to think of uniform circular motion in terms of a fictitious *centrifugal force*. We've all experienced this: when you're in an automobile making a tight turn at high speed, you feel what appears to be a "force" pushing you outward, away from the center of the circle. This is called *fictitious force* because there really is no force pushing you outward; instead, you're trying to continue moving in a straight line while the car is turning underneath you. The "centrifugal force" is really just inertia: it is an artifact of making an observation in the rotating reference frame of the car, rather than in an "inertial" (non-accelerating) frame.

The centrifugal force, like the centripetal force, has a magnitude of mv^2/r .

20.4 Relations between Circular and Linear Motion

It's a simple matter to derive some very useful relations between circular and linear motion. We begin with the relation between arc length s and angle θ (in radians) for a circle of radius r :

$$s = r\theta. \quad (20.15)$$

Taking the derivative with respect to time of both sides gives a relation between linear velocity $v = ds/dt$ and angular velocity $\omega = d\theta/dt$:

$$\boxed{v = r\omega.} \quad (20.16)$$

20.5 Examples

Example—motion in a horizontal circle.

Suppose you spin a mass m in a horizontal circle of radius r over your head; then the centripetal force (the tension in the string) is mv^2/r , where v is the speed of the mass.

Assume there is no gravity present; then what happens if the string suddenly breaks? Then the mass will immediately move in a straight line tangent to the circle.

Example—motion in a vertical circle.

If you spin a bucket of water in a circle in a vertical plane (Fig. 20.2), then (if you're spinning it fast enough) the centrifugal force (i.e. inertia) will keep the water in the bucket. How fast must you spin the bucket?

At top of the swing (when the string is vertical and the bucket is upside-down), the outward centrifugal force mv^2/r must be greater than or equal to the weight of the water mg ; so the minimum speed v of the bucket is given by

$$\frac{mv^2}{r} = mg \quad (20.17)$$

or

$$v = \sqrt{gr} \quad (20.18)$$

The time T required for the bucket to make one complete circle (called the *period* of the motion) is then

$$T = \frac{2\pi r}{v} = \frac{2\pi r}{\sqrt{gr}}, \quad (20.19)$$

or

$$T = 2\pi \sqrt{\frac{r}{g}} \quad (20.20)$$

For example, if the bucket is swung in a circle of radius 0.8 meters, this formula gives a period of 1.80 seconds; in other words, if you swing the bucket in a vertical circle at a constant speed so that it completes each circle in not more than 1.80 seconds, the water will stay in the bucket, even at the top of the swing.



Figure 20.2: A bucket of water being spun in a vertical circle. Inertia (sometimes thought of as a fictitious “centrifugal force”) keeps the water in the bucket, even when upside-down. (Ref. [18]).

Chapter 21

Work

21.1 Introduction

If a force is applied to an object over some distance, the force is said to have done *work* on the object. The work done is equal to the product of the force and the distance through which the force acts.

Work is measured in SI units in *joules* (J), named for the English physicist James Joule:

$$1 \text{ J} = 1 \text{ N m} = 1 \frac{\text{kg m}^2}{\text{s}^2}. \quad (21.1)$$

In CGS units, work is measured in *ergs*:

$$1 \text{ erg} = 1 \text{ dyne cm} = 1 \frac{\text{g cm}^2}{\text{s}^2}. \quad (21.2)$$

The British engineering system does not have any special name for work; it is simply measured in *foot-pounds* (ft-lbf).

Although work is always the product of force and distance, there are simpler expressions if the force is constant or in the direction of motion. We'll look at these special cases before examining the general case.

21.2 Case I: Constant $\mathbf{F} \parallel \mathbf{r}$

Suppose that the applied force is constant and parallel to the direction of motion. Then the work W done by the force F acting through a distance x is simply

$$W = Fx. \quad (21.3)$$

Example. Suppose you have a box sitting on the floor. You apply a force of 50 N to the box over a distance of 4 meters, causing it to accelerate. Then the amount of work done by you on the box is $W = (50 \text{ N})(4 \text{ m}) = 200 \text{ J}$.

Example. Suppose a mass m is sitting on the floor; you pick it up and lift it a height h . Then you have done work $W = mgh$ on the mass against gravity. Another way to think of this is to say the gravitational force has done work $-mgh$ on the mass against you. If you now lower the mass down to the ground, you're doing *negative* work $-mgh$ on the mass against gravity, and gravity is doing work $+mgh$ on the mass against

you. It's important to keep the signs straight when computing work: be sure you're clear about what force is doing the work.

Note that the physics sense of "work" is a bit different from the everyday sense. If you're standing with a 100-lb mass in your arms, your muscles are exerting quite a bit of effort to hold up the heavy mass. But in the physics sense of the word, you're doing *zero* work against gravity. Only if you *lift* the mass are you doing work.

21.3 Case II: Constant $\mathbf{F} \nparallel \mathbf{r}$

Now let's look at a more general case. Suppose the applied force \mathbf{F} is still constant, but not necessarily in the direction of motion. Then the work W done by the force is equal to the *component* of \mathbf{F} that's in the direction of motion times the distance over which the force is applied. We can write this using the dot product:

$$W = \mathbf{F} \cdot \mathbf{r}, \quad (21.4)$$

where \mathbf{r} is a vector in the direction of motion, whose magnitude is equal to the distance over which the force is applied.

Example. Suppose a constant force \mathbf{F} of magnitude $F = 60$ N acting 30° from the horizontal is applied to a box sitting on the floor for a horizontal distance of 12 m. Then the work done by the force is $W = \mathbf{F} \cdot \mathbf{r} = Fr \cos \theta = (60 \text{ N})(12 \text{ m})(\cos 30^\circ) = 623.5 \text{ J}$.

21.4 Case III: Variable $\mathbf{F} \parallel \mathbf{r}$

Now let's take another case: suppose the force F is in the direction of motion, but suppose F is not constant, but is a function of position x . Now take the straight-line path over which object moves and divide it into many infinitesimal segments, each of length dx . Then over distance dx , the force F can be considered constant, and the work dW done over distance dx is $F(x)dx$. To get the total work done by the force F , we sum up all these contributions $F dx$ by doing an integral:

$$W = \int F(x) dx. \quad (21.5)$$

Example. For a mass on a spring, the work done by the spring force is given by Hooke's law: $F(x) = -kx$, where k is the spring constant. Then the work done *by* the spring is

$$W = \int F(x) dx \quad (21.6)$$

$$= \int (-k)x dx \quad (21.7)$$

$$= -k \int x dx \quad (21.8)$$

$$= -\frac{1}{2}kx^2. \quad (21.9)$$

In extending the spring a distance x from equilibrium, a work $-kx^2/2$ is done *by* the spring; work $+kx^2/2$ is done *by* you, *against* the spring.

21.5 Case IV (General Case): Variable $\mathbf{F} \nparallel \mathbf{r}$

In the most general case, an object moves through some arbitrary path in space, and the force \mathbf{F} is variable, which we'll write as $\mathbf{F}(\mathbf{r})$. Then we'll divide the path into infinitesimal segments $d\mathbf{r}$, and the force along $d\mathbf{r}$ can be considered constant over that short distance. The work done by the force along $d\mathbf{r}$ is $dW = \mathbf{F}(\mathbf{r}) \cdot d\mathbf{r}$. Then the *total* work done by the force is computed with an integral:

$$W = \int \mathbf{F}(\mathbf{r}) \cdot d\mathbf{r}. \quad (21.10)$$

This means that you imagine dividing the entire path into infinitesimal segments $d\mathbf{r}$; at each segment, you compute the force $\mathbf{F}(\mathbf{r})$ at that segment, and take the dot product $\mathbf{F}(\mathbf{r}) \cdot d\mathbf{r}$. You then add together all those dot products with an integral to get the total work done by the force.

This general expression for work reduces to the other formulæ under the special conditions mentioned earlier. For example, if \mathbf{F} acts in the direction of motion, then $\mathbf{F}(\mathbf{r}) \cdot d\mathbf{r} = F(x) dx$, and we get Eq. (21.5). If the force \mathbf{F} in Eq. (21.10) is constant, then \mathbf{F} can be taken outside the integral, and we recover Eq. (21.4). And if \mathbf{F} and \mathbf{r} are parallel, then Eq. (21.4) reduces to Eq. (21.3).

21.6 Summary

The following table shows all four work formulæ, and the conditions under which they may be used.

Table 21-1. Formulæ for computing work.

Formula	$\mathbf{F} \parallel \mathbf{r}$?	Constant \mathbf{F} ?
$W = Fx$	✓	✓
$W = \mathbf{F} \cdot \mathbf{r}$		✓
$W = \int F dx$	✓	
$W = \int \mathbf{F} \cdot d\mathbf{r}$		

Chapter 22

Simple Machines

A given amount of work may often be accomplished with less effort by employing some sort of machine. Classical physics has, since the Renaissance, recognized six basic *simple machines*. All other machines in use today may be considered as combinations of two or more of these simple machines. The simple machines are:

1. inclined plane
2. wheel and axle
3. pulley
4. lever
5. wedge
6. screw

Each of these simple machines allows work to be performed with less effort, by trading off effort (applied force) for distance. Recall that work is the product of force and distance: $W = Fx$, so that the same amount of work W may be accomplished by applying a smaller force F over a greater distance x . This is what simple machines do.

We define the *mechanical advantage* of a simple machine to be the ratio of the *resistance* (resistive force) F_R to the *effort* (effort force) F_E :

$$M.A. = \frac{F_R}{F_E} \quad (22.1)$$

For example, the resistive force F_R may be the weight of a body, and the effort force F_E may be the force required to lift it. Suppose, for example, that we have a body of mass m , and we wish to lift it onto the top of a table. In this case, the resistive force is the weight of the body, mg ; the force required to lift it directly onto the table is equal to also its weight mg , so the mechanical advantage for lifting the body directly (with no machine) is $M.A. = mg/mg = 1$. If one uses a simple machine such as an inclined plane or pulley, the same body may be lifted with less force, and therefore a mechanical advantage greater than 1. In the sections below, we'll see how to compute the mechanical advantage for each of the simple machines.

We may also define the *efficiency* of a simple machine to be the ratio of the output work W_o to the input work W_i . Since work is force times distance,

$$\eta = \frac{W_o}{W_i} = \frac{F_R x_R}{F_E x_E} \quad (22.2)$$

where $W_o = F_R x_R$ is the output work—the resistive force times the distance over which the resistive force moves, and $W_i = F_E x_E$ is the input work—the input effort force times the distance over which the effort force is applied. In the absence of friction, the efficiency of a simple machine will be 1, or 100%, and the input and output work are equal. If friction is present, then a larger input effort force F_E will be required to overcome friction, and the efficiency will be less than 1.

22.1 Inclined Plane

An *inclined plane* (previously encountered in Chapter 14) is a flat surface tilted at some angle θ from the horizontal. For example, if you're ever rented a moving van, the van will have an inclined plane (a "ramp") at the back of the truck. Instead of lifting heavy items directly into the back of the truck, one may push or roll them up the ramp. This requires less force (effort), at the expense of having to move it farther. (Figure 22.1)

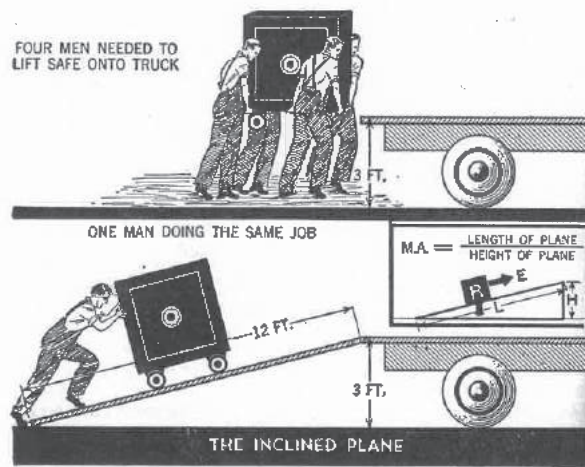

Figure 22.1: The inclined plane. In this example, $L = 12$ ft, $H = 3$ ft, so the mechanical advantage is $M.A. = L/H = 4$. Rolling the safe up the incline requires only $1/4$ the force of lifting it directly. (Ref. [17])

In the case of an inclined plane whose inclined length is L and whose high end is at height H , the mechanical advantage is found from $W_i = W_o$, or

$$F_E L = F_R H \quad (22.3)$$

so the mechanical advantage $M.A. = F_R/F_E$ is

$$\boxed{M.A. = \frac{L}{H} = \csc \theta} \quad (22.4)$$

Note that as $\theta \rightarrow 90^\circ$, the inclined plane approaches a vertical ramp, and the mechanical advantage approaches 1, as expected. The mechanical advantage of the inclined plane may be made arbitrarily large by increasing the length L of the plane.

22.2 Wheel and Axle

A *wheel and axle* consists of a large wheel rigidly attached to a smaller axle. The resistive force is attached to the axle, and the applied effort force is attached to the larger wheel. Then the distance traveled by the

resistive force is $2\pi r_a$, where r_a is the axle radius. The distance through which the effort force is applied is $2\pi r_w$, where r_w is the wheel radius. (Figure 22.2.)

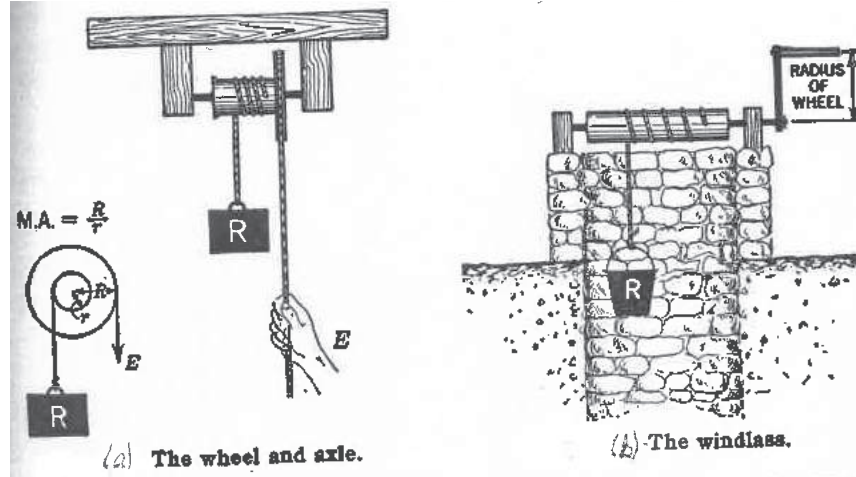

Figure 22.2: (a) The wheel and axle. (b) The windlass, another type of wheel and axle. Here R is the resistance (resistive force) and E is the effort (effort force). (Ref. [17])

The input and output work are

$$W_i = F_E 2\pi r_w \quad (22.5)$$

$$W_o = F_R 2\pi r_a \quad (22.6)$$

In the absence of friction, $W_i = W_o$, so

$$F_E 2\pi r_w = F_R 2\pi r_a \quad (22.7)$$

The mechanical advantage is then

$$M.A. = \frac{F_R}{F_E} = \frac{2\pi r_w}{2\pi r_a} \quad (22.8)$$

or

$$\boxed{M.A. = \frac{r_w}{r_a}} \quad (22.9)$$

22.3 Pulley

A *pulley* is a grooved wheel mounted in a frame. Pulleys may be connected to other pulleys to form compound pulley systems that have a large mechanical advantage. One may use such pulley arrangements to allow just one or two men to lift a large, heavy object such as a piano or safe. (Figure 22.3)

The mechanical advantage of a set of pulleys is equal to the number of strands N_R holding up the resistive force:

$$M.A. = N_R \quad (22.10)$$

Therefore one can gain a larger mechanical advantage (and thus lift a heavier weight) by using more pulleys.

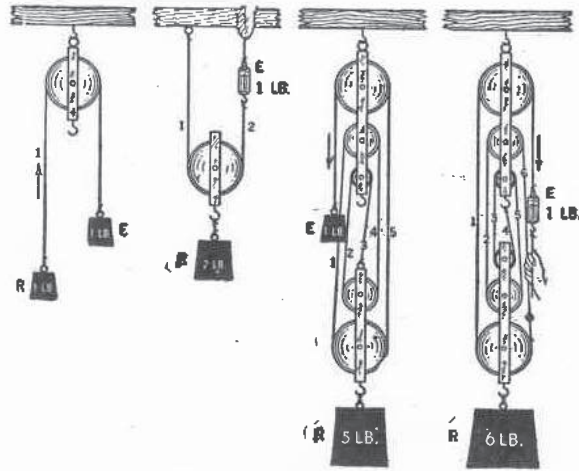

Figure 22.3: Systems of pulleys. These systems have a mechanical advantage of (left to right): 1, 2, 5, and 6, so that each example requires only 1 lb of effort to lift 1, 2, 5, and 6 pounds, respectively. Note that the leftmost arrangement only changes the direction of the applied effort force, by allowing us to pull downward to lift the weight upward; it does not provide any mechanical advantage. (Ref. [17])

22.4 Lever

δωσ μοι πα στω και ταν γαν κινωσω. (*Give me a place to stand, and I shall move the Earth.*)
—Archimedes

In this famous quote, Archimedes is referring to the *lever*. A lever is a rigid bar free to turn around a pivot point called the *fulcrum*. Levers may be divided into three classes, according to the relative position of the effort, resistance, and fulcrum (Figure 22.4):

- *First class* — the fulcrum is between the resistance and the effort.
- *Second class* — the resistance is between the fulcrum and the effort.
- *Third class* — the effort is between the fulcrum and the resistance.

The mechanical advantage of the lever may be found simply. The distance from the effort to the fulcrum is called the *effort arm* (r_E); the distance from the fulcrum to the resistance is called the *resistance arm* (r_R). Then in the absence of friction, the input work equals the output work:

$$W_i = W_o \quad (22.11)$$

or

$$F_E r_E = F_R r_R \quad (22.12)$$

Thus the mechanical advantage is then F_R/F_E , or the effort arm divided by the resistance arm:

$$\boxed{M.A. = \frac{r_E}{r_R}} \quad (22.13)$$

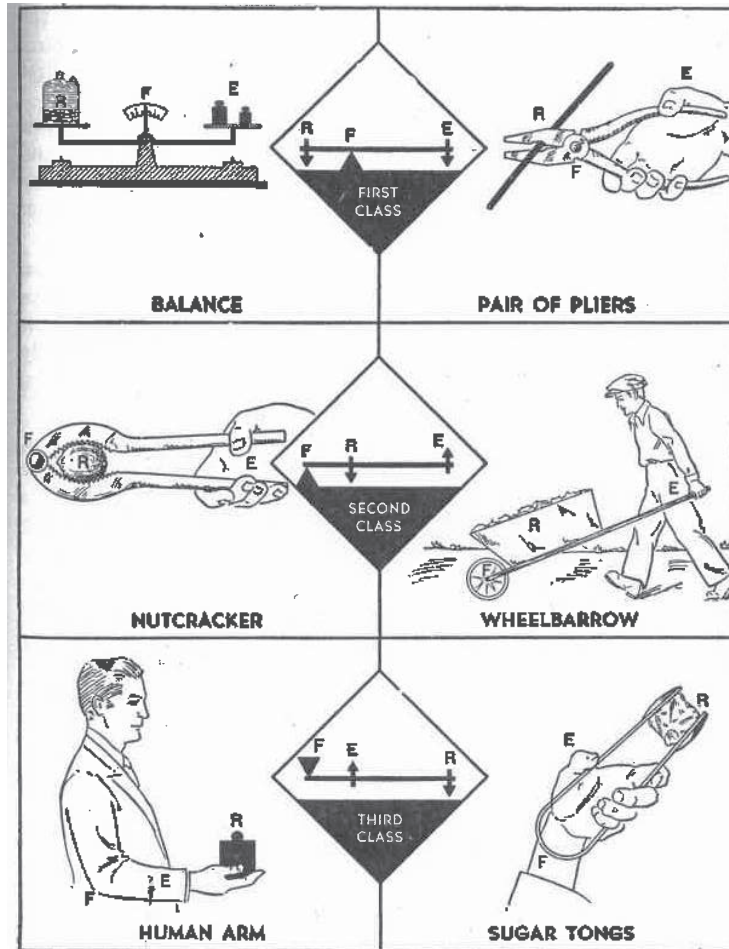

Figure 22.4: The three classes of levers. (Ref. [17])

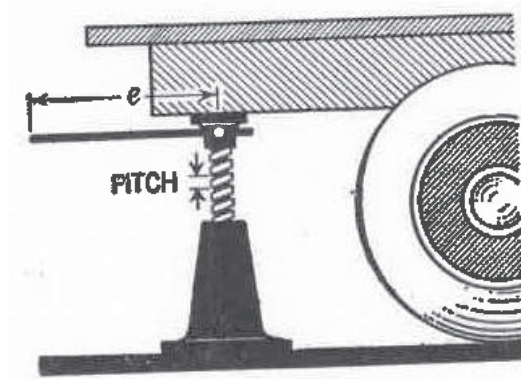

Figure 22.5: A jackscrew, here used to lift the back of a truck. (Ref. [17])

22.5 Wedge

The *wedge* is a movable inclined plane, used to split a body. Examples are axes, chisels, knives, nails, and pins. Because friction plays a large role in the operation of the wedge, it is difficult to determine its mechanical advantage.

22.6 Screw

The screw is essentially an inclined plane wound around cylinder. A common example is a *jackscrew* (Figure 22.5). Let ℓ be the length of the arm, and let p be the *pitch* of the screw (the distance between successive threads). Then one complete turn of the arm will move the end of the arm a distance $2\pi\ell$, and this will result in the load being moved a distance p .

Since the input work is equal to the output work,

$$W_i = W_o \quad (22.14)$$

or

$$F_E(2\pi\ell) = F_R p \quad (22.15)$$

The mechanical advantage of the jackscrew is then F_R/F_E , or

$$\boxed{M.A. = \frac{2\pi\ell}{p}} \quad (22.16)$$

22.7 Gears

Some writers list the *gear* as a seventh simple machine, but it isn't. There are only six simple machines. The gear is a compound machine: a combination of the wheel and axle and the pulley.

A system of two connected gears can provide a mechanical advantage, in a rotational sense. The rotational work done by a rotating disk like a gear is¹ $W = \tau\theta$, where τ is the torque applied to the gear, and θ is the angle through which the gear is turned. Since the input work is equal to the output work,

$$W_i = W_o \quad (22.17)$$

¹Rotational motion is described later in these notes.

or

$$\tau_E \theta_E = \tau_R \theta_R \quad (22.18)$$

The mechanical advantage of the two gears is then τ_R/τ_E , or

$$M.A. = \frac{\theta_E}{\theta_R} = \frac{\omega_E}{\omega_R} = \frac{r_R}{r_E} = \frac{N_R}{N_E} \quad (22.19)$$

Here one of the two gears (E) is the “input” (effort) gear, and the other gear (R) is the “output” (resistance) gear. Therefore the mechanical advantage is the ratio of the input angle rotated (θ_E) to the output angle rotated (θ_R). It is also equal to the ratio of the angular speeds of the input to output gears; to the ratio of the output to input gear radii (r_R/r_E); and to the ratio of the number of teeth in the output gear to the number of teeth in the input gear (N_R/N_E).

The mechanical advantage is also known as the *gear ratio*.

If the input gear is smaller than the output gear ($r_E < r_R$), then several turns of the input gear are needed for each turn of the output gear. The mechanical advantage (gear ratio) is greater than 1, and less input torque is required to do the same work.

If the input gear is larger than the output gear ($r_E > r_R$), then one turn of the input gear will produce several turns of the output gear. The mechanical advantage (gear ratio) is less than 1, and more input torque is required to do the same work; this can be used to turn the output gear at high speed while turning the input gear at low speed.

An example of the use of gears is in the bicycle. The input gear (the *chainring*) is attached to the pedals, and the output gear (the *cog*) to the rear wheel. In addition, most bicycles provide several gears on both the chainring and the cog, and the rider is able to select a different gear for each. For a bicycle, the gear ratio is usually less than 1, so that each turn of the pedals will result in more than one turn of the rear wheel. A larger gear ratio (a small front chainring gear used with a large rear cog gear) provides a larger mechanical advantage, and is used for pedaling up hills with less effort. A smaller gear ratio (a large front chainring gear used with a small rear cog gear) provides a smaller mechanical advantage, and is used for pedaling at high speed on level ground or downhill.

Chapter 23

Energy

23.1 Introduction

Energy is one of the most important concepts in all of physics, although it's a bit difficult to define exactly.

Units for energy are the same as the units of work: *joules* in SI units, *ergs* in CGS units, and *foot-pounds* in British engineering units.

Another common (non-SI) unit of energy is the *electron volt* (eV). This is a small unit of energy, commonly used in atomic, nuclear, particle, and plasma physics. It is defined as the amount of energy gained by accelerating an electric charge equal to the electron charge through an electric potential difference of 1 volt, and has a value of $1 \text{ eV} = 1.602176634 \times 10^{-19} \text{ J}$.

23.2 Kinetic Energy

Kinetic energy is the energy a body has as a consequence of it being in motion. If a body is at rest, it has zero kinetic energy; if it is in motion, it has more kinetic energy the faster it's going.

Kinetic energy is defined to be *the amount of work required to accelerate a body of mass m from rest to velocity v* . We can compute an explicit formula for it as follows: by definition, the kinetic energy K is, by Eq. (21.5),

$$K = W = \int F dx. \quad (23.1)$$

Applying Newton's second law $F = ma$,

$$K = \int ma dx \quad (23.2)$$

$$= \int m \frac{dv}{dt} dx. \quad (23.3)$$

Now applying the chain rule,

$$K = \int m \frac{dv}{dx} \frac{dx}{dt} dx \quad (23.4)$$

Cancelling dx in denominator with the final dx ,

$$K = \int_0^v m \frac{dx}{dt} dv. \quad (23.5)$$

Now dx/dt is just the velocity v , so

$$K = \int_0^v mv \, dv \quad (23.6)$$

$$= m \int_0^v v \, dv \quad (23.7)$$

or

$$\boxed{K = \frac{1}{2}mv^2.} \quad (23.8)$$

Sometimes it's useful to write this in vector form:

$$\boxed{K = \frac{1}{2}m\mathbf{v} \cdot \mathbf{v}.} \quad (23.9)$$

23.3 Potential Energy

Potential energy is *stored energy*; energy is stored in the system in some fashion. Once the potential energy is released, it can do work.

Since potential energy U is the ability to do work, it can be expressed as

$$U = -W = - \int F(x) \, dx, \quad (23.10)$$

where W is the work done by the force. Unlike the kinetic energy K , for which there is a single formula (Eq. 23.8), potential energy has many formulæ, depending on what force is present.

Gravity

For example, suppose the force is gravity between two point masses, for which the force given by $F = -Gm_1m_2/r^2$. Then the potential energy is

$$U(r) = - \int F(r) \, dr \quad (23.11)$$

$$= -\frac{Gm_1m_2}{r} + C. \quad (23.12)$$

We now have a formula for the potential energy for the gravitational force—but what do we do with the integration constant C ? It turns out that C is completely arbitrary; you can set it to any convenient value. Values of potential energy actually have no physical meaning; it is only *differences* in potential energy that are physically meaningful, and for differences in potential energy, the integration constants C cancel out. This is an important feature of potential energy that you should keep in mind.

By convention, one generally chooses the integration constant for gravity so that $U = 0$ when $r = \infty$, and by inspection of Eq. (23.12) this implies that we choose $C = 0$. So for gravity we find the potential energy function $U(r)$ to be

$$\boxed{U(r) = -\frac{Gm_1m_2}{r} \quad (\text{gravity}).} \quad (23.13)$$

Note that the gravitational potential energy is always negative; as the masses become increasingly separated, the potential energy increases, becoming less and less negative, finally reaching zero when the masses are infinitely far apart.

Eq. (23.12) may be used to find an expression for the gravitational potential energy of a mass m due to the Earth, which has mass M_{\oplus} and radius R_{\oplus} :

$$U(r) = -\frac{GM_{\oplus}m}{r} + C. \quad (23.14)$$

Here one may choose $U = 0$ at $r = \infty$ (for which $C = 0$), or one may choose $U = 0$ at the surface of the Earth ($r = R_{\oplus}$). The choice is arbitrary, and just depends on what is most convenient for the problem at hand. In the second case ($U = 0$ at $r = R_{\oplus}$), we can find C by noting that

$$U(R_{\oplus}) = -\frac{GM_{\oplus}m}{R_{\oplus}} + C = 0, \quad (23.15)$$

so

$$C = \frac{GM_{\oplus}m}{R_{\oplus}} \quad (23.16)$$

Thus

$$U(r) = GM_{\oplus}m \left(\frac{1}{R_{\oplus}} - \frac{1}{r} \right), \quad (23.17)$$

or in terms of the altitude $h = r - R_{\oplus}$,

$$\boxed{U(h) = GM_{\oplus}m \left(\frac{1}{R_{\oplus}} - \frac{1}{h + R_{\oplus}} \right)} \quad (\text{gravity, Earth}). \quad (23.18)$$

An important special case of this is when a body of mass m is a *short* altitude h above the surface of the Earth. In this case, Eq. (23.18) may be reduced to a much simpler form. First, expand $1/(h + R_{\oplus})$ into a binomial series:

$$\frac{1}{h + R_{\oplus}} = \frac{1}{R_{\oplus}} - \frac{h}{R_{\oplus}^2} + \frac{h^2}{R_{\oplus}^3} - \frac{h^3}{R_{\oplus}^4} + \dots \quad (23.19)$$

Now substitute this result into Eq. (23.18):

$$U(h) = GM_{\oplus}m \left[\frac{1}{R_{\oplus}} - \left(\frac{1}{R_{\oplus}} - \frac{h}{R_{\oplus}^2} + \frac{h^2}{R_{\oplus}^3} - \frac{h^3}{R_{\oplus}^4} + \dots \right) \right] \quad (23.20)$$

$$= GM_{\oplus}m \left(\frac{h}{R_{\oplus}^2} - \frac{h^2}{R_{\oplus}^3} + \frac{h^3}{R_{\oplus}^4} - \dots \right) \quad (23.21)$$

If $h \ll R_{\oplus}$, we can neglect all but the first term in the series in parentheses; we then have

$$U(h) \approx GM_{\oplus}m \left(\frac{h}{R_{\oplus}^2} \right) \quad (23.22)$$

$$= \frac{GM_{\oplus}}{R_{\oplus}^2} mh \quad (23.23)$$

Or, since $GM_{\oplus}/R_{\oplus}^2 = g$,

$$\boxed{U(h) = mgh} \quad (\text{gravity, near Earth surface}). \quad (23.24)$$

In this case, h is the height above any convenient surface. Choose what height you want to use for the $U = 0$ level at the beginning of a problem, then stay with that choice throughout the solution to the problem. A typical choice for many problems is to choose $U = 0$ at the floor, ground, or a tabletop, so that h is the height above that surface. But remember: the choice of where you choose $U = 0$ is arbitrary, so you can use any choice that is convenient.

Electric Potential Energy

As a third example, consider the electrostatic force between two point charges, which is similar in form to the gravitational force between point masses. The electrostatic force is given by *Coulomb's law*,

$$F = \frac{1}{4\pi\epsilon_0} \frac{q_1q_2}{r^2}, \quad (23.25)$$

where q_1 and q_2 are the two charges in coulombs, r is their separation, and ϵ_0 is the permittivity of free space. Proceeding as we did with gravity, we find

$$U(r) = \frac{q_1q_2}{4\pi\epsilon_0 r} \quad (\text{electric force}), \quad (23.26)$$

where again we choose, by convention, to have $U = 0$ at $r = \infty$. In this case $U(r)$ will be negative if the charges are attracted, and positive if they are repelled.

Elastic Potential Energy

As a fourth example, consider the elastic force on a mass attached to a spring. In this case, the force is given by Hooke's law, $F = -kx$. The potential energy function is

$$U(r) = -\int (-kx) dx \quad (23.27)$$

$$= \frac{1}{2}kx^2 + C. \quad (23.28)$$

Conventionally we choose $C = 0$, so that

$$U(r) = \frac{1}{2}kx^2 \quad (\text{spring, Hooke's law}). \quad (23.29)$$

Summary

In summary:

- There are many different formulæ for potential energy, depending on what force is present. A few such formulæ are shown in Table 23-1.
- You can always add an arbitrary constant to the potential energy; it is only *differences* in potential energy that are physically meaningful.

Table 23-1. A few formulæ for potential energy.

Force	Formula
Gravity	$U = -\frac{Gm_1m_2}{r}$
Gravity (near Earth surface)	$U = mgh$
Electric	$U = \frac{q_1q_2}{4\pi\epsilon_0 r}$
Elastic (spring)	$U = \frac{1}{2}kx^2$

23.4 Other Forms of Energy

The sum of the kinetic and potential energies is called the *mechanical energy*:

$$\text{M.E.} = K + U. \quad (23.30)$$

Energy can occur in a number of other forms besides kinetic and potential. For example:

- *Thermal energy* is the energy of heat.
- *Acoustic energy* is the energy of sound.
- *Electromagnetic energy* is radiant light energy.
- *Mass energy*. Einstein showed that mass itself can be converted directly into energy, the clearest illustration being the mutual annihilation of matter and antimatter. If a mass m is converted entirely into energy, the amount of energy produced is given by Einstein's famous equation,

$$E_0 = mc^2, \quad (23.31)$$

where E_0 is the mass energy and c is the speed of light in vacuum.

Energy can be converted from one form to another. For example, if you hold an object a height h above the floor, its energy is all potential. When you release it, its energy is converted little by little from potential to kinetic as it falls. By the time the object is about to hit the ground, all of its potential energy has been converted to kinetic energy. After it hits the ground, all of that kinetic energy has been converted to thermal energy (causing both the floor and the object to get hotter) and acoustic energy (you can hear the sound of the object hitting the floor).

23.5 Conservation of Energy

One of the most important laws in physics is called the *law of conservation of energy*. It states that, if you add up all the energy in a system in all its forms (giving the *total energy* E), that total energy will not change with time. Energy may be converted from one *form* to another, but the total energy will remain constant as long as the system is closed (i.e. no energy enters or leaves the system).

The conservation of energy is not only an important physical principle, but it can also be used as a shortcut in solving certain problems.

Example. A body of mass m is dropped from a height h . What is its impact velocity (i.e. its velocity just before hitting the floor)?

Solution. There are a number of ways of approaching this problem. We could, for example, use Eq. (5.23) for $x(t)$ to solve for the time t it takes the body to fall, then substitute into Eq. (5.17) to find the impact velocity. Alternatively, we could use Eq. (5.31) to find the impact velocity directly.

A third approach is to use the conservation of energy. When the body is a height h above the floor, its potential energy is $U_i = mgh$, and, since it's at rest, its kinetic energy is $K_i = 0$; its total energy is therefore $E_i = U_i + K_i = mgh$. Just before it hits the ground, all of that potential energy has been converted to kinetic energy; its potential energy is now $U_f = 0$, its kinetic energy is $K_f = mv^2/2$, and its total energy is therefore $E_f = U_f + K_f = mv^2/2$. Since *total energy* E is conserved, we must have

$$E_i = E_f \quad (23.32)$$

$$mgh = \frac{1}{2}mv^2 \quad (23.33)$$

or, solving for v ,

$$v = \sqrt{2gh}. \quad (23.34)$$

23.6 The Work-Energy Theorem

Not only can energy be converted from one form to another, but it can also be converted into work, and *vice versa*. If a force is applied to a moving body over some distance, then work is done on the body, causing a change in its kinetic energy. The change in kinetic energy of the body is equal to the amount of work done. This result is called the *work-energy theorem*:

$$\boxed{W = \Delta K.} \quad (23.35)$$

Example. Suppose a body of mass 1000 kg is moving at a speed of 50 m/s; then its kinetic energy is $K = mv^2/2 = 1,250,000$ J. If we now do a work of 200,000 J on the body in the direction of motion, then by the work-energy theorem its kinetic energy will increase to 1,450,000 J. Its final velocity will then be $v = \sqrt{2K/m} = 53.85$ m/s.

23.7 The Virial Theorem

The *virial theorem* relates the time-average kinetic energy of a system to the time-average potential energy. In the common situation that the force is proportional to some power of the distance,

$$F \propto r^n, \quad (23.36)$$

then the virial theorem states that the time-average kinetic energy $\langle K \rangle$ is related to the time-average potential energy $\langle U \rangle$ by

$$\boxed{\langle K \rangle = \frac{n+1}{2} \langle U \rangle.} \quad (23.37)$$

Since the total energy $E = \langle K \rangle + \langle U \rangle$, we can use the virial theorem (Eq. 23.37) to derive a useful expression for the total energy in terms of the time-average energies:

$$\boxed{E = \frac{n+3}{n+1} \langle K \rangle = \frac{n+3}{2} \langle U \rangle.} \quad (23.38)$$

Example. For the spring (Hooke's law) force $F = -kx$, we have $n = 1$. So by the virial theorem (Eq. 23.37),

$$\langle K \rangle = \langle U \rangle. \quad (23.39)$$

It turns out in this case that $\langle K \rangle = \langle U \rangle = kA^2/4$, where A is the amplitude of the motion. By Eq. (23.38),

$$E = 2\langle K \rangle = 2\langle U \rangle = \frac{1}{2}kA^2. \quad (23.40)$$

Example. For the gravitational force given by Newton's law of gravity ($F = -Gm_1m_2/r^2$), and so $n = -2$. Then by the virial theorem,

$$\langle K \rangle = -\frac{1}{2}\langle U \rangle. \quad (23.41)$$

In this case, $\langle K \rangle = Gm_1m_2/(2r)$. By Eq. (23.38),

$$E = -\langle K \rangle = \frac{1}{2}\langle U \rangle = -\frac{Gm_1m_2}{2r}. \quad (23.42)$$

This second example has some interesting consequences. Suppose we have a body orbiting the earth with orbital radius r . Its velocity is then given by Eq. (20.10):

$$v = \sqrt{\frac{GM_{\oplus}}{r}}, \quad (23.43)$$

where G is the gravitational constant and M_{\oplus} is the mass of the Earth. Now suppose we increase r , putting the body into a higher orbit. What happens to the energy? Since the potential energy is $U = -GM_{\oplus}m/r$, boosting the body to a higher orbit *increases* its potential energy. By Eq. (23.43), its velocity will *decrease*, thereby decreasing its kinetic energy. What happens to the total energy? By the virial theorem, the second example shows that the increase in potential energy is *twice* the decrease in potential energy, so overall, the total energy is increased for higher orbits.

Now suppose you're in a spacecraft, trying to dock with the International Space Station, which is in orbit ahead of you (looking in the direction of motion), at the same orbital radius. To reach the Space Station, you must do something counterintuitive: fire your spacecraft jets *toward* the station, so that there's a force pushing you *away* from the Station. This will slow the spacecraft down, decreasing its total energy, thereby dropping it into a lower orbit, where its velocity will increase—causing the spacecraft to move toward the Space Station.

Chapter 24

Conservative Forces

A *conservative force* is one which has the following properties:

- The work done by the force is independent of path.
- The work done by the force over a closed path is zero:

$$\oint \mathbf{F} \cdot d\mathbf{r} = 0. \quad (24.1)$$

- The force can be written as the derivative of a potential energy function U :

$$F = -\frac{dU}{dx}. \quad (24.2)$$

These three properties are all equivalent statements of the same thing. Examples of conservative forces are gravity and the electrostatic force.

Some forces, such as friction, are *not* conservative. Such forces have no corresponding potential energy function. For the frictional force, for example, the work done *does* depend on the path taken by the body, and the frictional force has no potential energy function.

Chapter 25

Power

Simply put, *power* is the rate of change of energy (or work) with time:

$$\mathcal{P} = \frac{dE}{dt}. \quad (25.1)$$

In SI units, power is measured in units of *watts* (W), named for the Scottish engineer James Watt:

$$1 \text{ W} = 1 \frac{\text{J}}{\text{s}} = 1 \frac{\text{kg m}^2}{\text{s}^3}. \quad (25.2)$$

In CGS units, power is measured in units of *statwatts*:

$$1 \text{ statwatt} = 1 \frac{\text{erg}}{\text{s}} = 1 \frac{\text{g cm}^2}{\text{s}^3}. \quad (25.3)$$

The British engineering unit of power has no special name; it is simply a foot-pound per second (ft-lbf/sec).

Another common unit that is *not* part of the British engineering system is the *horsepower* (hp): 1 hp = 550 ft-lbf/sec, or about 745.7 watts. The power produced by an automobile engine is traditionally measured in horsepower. A few examples:

- Lawn mower: 5 hp
- Smart car: 90 hp
- Typical modern automobile engine: about 200 hp
- 1967 Pontiac GTO “muscle car”: 360 hp
- Semi truck (tractor): 500 hp
- Modern farm tractor: 500 hp
- Formula One engine used in a modern Indianapolis 500 race car: 700 hp or more
- “Monster truck” (as seen at county fairs): 1500 hp

25.1 Energy Conversion of a Falling Body

As an example, let's look at a body of mass m (near the surface of the Earth) released from height h and falling under the influence of gravity. As the body falls, we've noted that the initial potential energy is gradually converted to kinetic energy, until at impact, when the energy is all kinetic. At what rate are these energies changing with time? (These rates of change will be powers, in watts.)

Let's start with the kinetic energy: the time rate of change of kinetic energy is

$$\frac{dK}{dt} = \frac{d}{dt} \left(\frac{1}{2}mv^2 \right) \quad (25.4)$$

$$= mv \frac{dv}{dt}. \quad (25.5)$$

But $dv/dt = a = g$, the acceleration due to gravity; hence

$$\frac{dK}{dt} = mgv. \quad (25.6)$$

Since the gravitational force $F = mg$, this gives a general expression for power:

$$\boxed{\mathcal{P} = Fv.} \quad (25.7)$$

Now what is the time rate of change of potential energy?

$$\frac{dU}{dt} = -\frac{d}{dt}(mgy) \quad (25.8)$$

$$= -mg \frac{dy}{dt}. \quad (25.9)$$

But dy/dt is the velocity v , so we get

$$\frac{dU}{dt} = -mgv. \quad (25.10)$$

So as the body falls, its kinetic energy K increases at the rate $dK/dt = mgv$, while the potential energy U decreases at the rate $dU/dt = -mgv$. Therefore the total energy $E = K + U$ remains constant, which is consistent with the conservation of energy.

Since v increases as the body falls, the rate of change of the kinetic and potential energies increases as the body falls. At any height y , the potential energy is $U = mgy$. Since the total energy is $E = mgh$, the kinetic energy at height y must be $K = E - U = mg(h - y)$. Therefore the velocity v at height y is given by

$$K = \frac{1}{2}mv^2 = mg(h - y) \quad (25.11)$$

$$v = \sqrt{2g(h - y)}. \quad (25.12)$$

So the time rates of change of the energies as a function of y is

$$\frac{dK}{dt} = \frac{dU}{dt} = Fv \quad (25.13)$$

$$= mg \sqrt{2g(h - y)} \quad (25.14)$$

$$= m \sqrt{2g^3(h - y)}. \quad (25.15)$$

Right after the body is released, $dK/dt = -dU/dt = 0$; after the body falls through a height h , the rates of change have increased to $dK/dt = -dU/dt = m\sqrt{2g^3h}$.

25.2 Rate of Change of Power

As seen in the previous section, the powers (rates of change of kinetic and potential energy) of falling bodies change with time. But if the force is constant, then the rates of change of these powers (rate of change of rate of change of energy) is constant. Let's see why this is so: since the power \mathcal{P} is given by

$$\mathcal{P} = Fv, \quad (25.16)$$

the time rate of change of power is, if the force F is constant,

$$\frac{d\mathcal{P}}{dt} = F \frac{dv}{dt} = Fa. \quad (25.17)$$

By Newton's second law, $F = ma$, so this gives

$$\frac{d\mathcal{P}}{dt} = ma^2 \quad (\text{constant } a). \quad (25.18)$$

For the example of a body of mass m released from height h , this gives

$$\frac{d\mathcal{P}}{dt} = mg^2. \quad (25.19)$$

25.3 Vector Equation

Eq. (25.7) is valid in one dimension; we can develop an analogous equation in two or three dimensions by noting that the kinetic energy $K = mv^2/2 = m\mathbf{v} \cdot \mathbf{v}/2$:

$$\mathcal{P} = \frac{dK}{dt} \quad (25.20)$$

$$= \frac{d}{dt} \left(\frac{1}{2} m \mathbf{v} \cdot \mathbf{v} \right). \quad (25.21)$$

Now using Eq. (7.17), we get

$$\mathcal{P} = m\mathbf{v} \cdot \frac{d\mathbf{v}}{dt}, \quad (25.22)$$

and so, since $\mathbf{F} = m d\mathbf{v}/dt$,

$$\boxed{\mathcal{P} = \mathbf{F} \cdot \mathbf{v}.} \quad (25.23)$$

Chapter 26

Linear Momentum

26.1 Introduction

The *linear momentum* (or simply *momentum*) p of a body of mass m is defined as

$$p = mv, \tag{26.1}$$

where v is its velocity. More generally, momentum is a vector, defined by

$$\boxed{\mathbf{p} = m\mathbf{v}.} \tag{26.2}$$

Curiously, there is no named SI unit for measuring momentum. Momentum in SI units is measured in units of kg m/s.

26.2 Conservation of Momentum

Momentum, like energy, is a *conserved* quantity: in a closed system (in which no momentum enters or leaves the system), the total momentum is constant. Unlike energy, though, momentum is a conserved *vector* quantity. This means that the following are all conserved:

- The vector momentum, \mathbf{p} ;
- The magnitude of the momentum, p ; and
- Each component of the momentum, p_x , p_y , and p_z .

In a closed system, momentum may be transferred from one body to another, but the *total* momentum—the sum of the momenta of all bodies in the system—will remain constant. Detailed examples of momentum conservation will be given in Chapter 28.

26.3 Newton's Second Law of Motion

As shown in Appendix R, Newton's second law of motion, as he originally presented it, is (in modern notation),

$$\boxed{F = \frac{dp}{dt}.} \tag{26.3}$$

Using the definition of momentum (Eq. 26.1), we get

$$F = \frac{dp}{dt} = \frac{d(mv)}{dt} \quad (26.4)$$

$$= m \frac{dv}{dt} + v \frac{dm}{dt}. \quad (26.5)$$

If the mass m is *constant*, then $dm/dt = 0$, and this reduces to

$$F = \frac{dp}{dt} = m \frac{dv}{dt} = ma. \quad (26.6)$$

So the formulation of Newton's second law $F = ma$ is a special case, that applies when the mass is constant. The more general formulation is $F = dp/dt$.

Chapter 27

Impulse

When two bodies move toward each other until they come into direct contact, the event is called a *collision*. The time during which the two bodies are in direct contact with one another¹ is actually quite short, and during that short time the force between the bodies is very large (Fig. 27.1). We can characterize such a collision by the *impulse* I , which is defined as the area under the force vs. time curve:

$$I = \int F(t) dt. \quad (27.1)$$

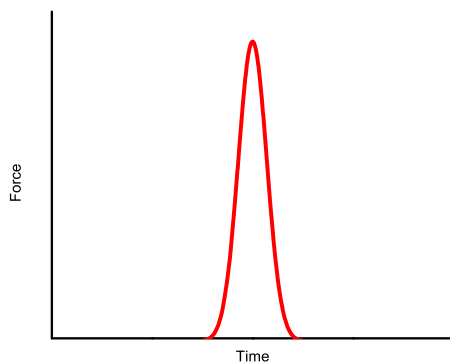

Figure 27.1: Force between two colliding bodies vs. time. There is a large force between the bodies, but it lasts only for a short time. The area under the curve is the impulse I .

¹Two colliding bodies normally never come into *direct* contact with each other; rather the outermost electrons in their outermost atomic layers repel each other under the electrostatic force.

The SI units of impulse are newton-seconds (N s).

The impulse is closely related to the average force between the bodies during the collision. Recall from the calculus that the average of a function $f(x)$ over the interval $x = a$ to $x = b$ is

$$\overline{f(x)} = \frac{1}{b-a} \int_a^b f(x) dx. \quad (27.2)$$

Therefore the average of a force $F(t)$ over the time interval $t = t_1$ to $t = t_2$ is given by

$$F_{\text{ave}} = \frac{1}{t_2 - t_1} \int_{t_1}^{t_2} F(t) dt. \quad (27.3)$$

The integral is just the impulse I . Writing $\Delta t = t_2 - t_1$, we then have the average force F_{ave} as

$$\boxed{F_{\text{ave}} = \frac{I}{\Delta t}.} \quad (27.4)$$

There is a close relationship between impulse and momentum. Recall by Newton's second law (Eq. 26.3) that $F = dp/dt$; substituting this into Eq. (27.1) gives

$$I = \int F dt = \int \frac{dp}{dt} dt = \int dp = \Delta p, \quad (27.5)$$

and so the impulse is just the change in momentum of the body during the collision:

$$\boxed{I = \Delta p.} \quad (27.6)$$

For many collision problems, the large force at work during the collision is so much larger than other forces present (friction, etc.) that the other forces can be neglected. Also, the duration Δt of the collision is so short that the motion of the bodies during the collision can be neglected; in other words, we can consider the collision to be essentially instantaneous. These assumptions together are referred to as the *impulse approximation*.

Example: golf ball. Suppose you hit a golf ball with a driver, giving it an initial velocity of 134 miles per hour. The club is in contact with the ball for 0.5 ms. What is the average force of the club on the ball?

Solution. From the change in the ball's momentum we can find the impulse, and from the impulse we can find the average force. The ball is initially at rest, so its initial momentum is zero. After being hit by the driver, the ball has a velocity of 134 miles per hour = 59.9 m/s. The mass of a golf ball is 45.0 g, so its final momentum is (59.9 m/s)(0.045 kg) = 2.6955 kg m/s. Therefore the impulse for the collision is

$$I = \Delta p = p_f - p_i = 2.6955 \text{ kg m/s} - 0 \quad (27.7)$$

$$= 2.6955 \text{ kg m/s}. \quad (27.8)$$

Then by Eq. (27.4), the average force during the collision is

$$F_{\text{ave}} = \frac{I}{\Delta t} \quad (27.9)$$

$$= \frac{2.6955 \text{ kg m/s}}{0.5 \times 10^{-3} \text{ s}} \quad (27.10)$$

$$= 5391 \text{ N} \quad (27.11)$$

$$= 1212 \text{ lbf}. \quad (27.12)$$

Chapter 28

Collisions

28.1 Introduction

As mentioned earlier, a *collision* is an event in which two bodies briefly come into direct contact with each other. During the collision, it's possible that some of the initial kinetic energy of the bodies may be converted into heat and sound energy, and energy that does work in deforming the colliding bodies. Based on the extent to which this happens, we classify collisions into three categories:

- A *perfectly elastic collision* is one in which *none* of the initial kinetic energy is converted into heat or deformation.
- A *perfectly inelastic collision* is one in which *all* of the initial kinetic energy is converted into heat and deformation.
- Most collisions lie between these two extremes, and *some* of the initial kinetic energy is converted into heat. Such collisions are called *inelastic*.

Each of these cases is treated differently mathematically, as we'll see shortly.

28.2 The Coefficient of Restitution

We can compute a dimensionless number called the *coefficient of restitution* that measures how elastic a collision is. The coefficient of restitution ϵ is defined as

$$\epsilon = \frac{p_f}{p_i}, \quad (28.1)$$

where p_f is the final momentum of the body, and p_i is its initial momentum. For a perfectly elastic collision, $\epsilon = 1$; for a perfectly inelastic collision, $\epsilon = 0$; and for an inelastic collision, ϵ is some number between 0 and 1, being closer to 1 the more elastic it is.

An easy way to measure the coefficient of restitution is to drop a body on a flat surface. The height to which the body rebounds will determine the coefficient of restitution. Suppose the body is initially dropped from a height h_i , and rebounds to a height h_f . By conservation of energy, the kinetic energy of the body just before it hits the floor is $mv_i^2/2 = mgh_i$, so its velocity is $v_i = \sqrt{2gh_i}$. Similarly, just after the collision the velocity is $v_f = \sqrt{2gh_f}$. Therefore the coefficient of restitution ϵ is

$$\epsilon = \frac{p_f}{p_i} = \frac{mv_f}{mv_i} = \frac{v_f}{v_i} = \frac{\sqrt{2gh_f}}{\sqrt{2gh_i}}, \quad (28.2)$$

or

$$\epsilon = \sqrt{\frac{h_f}{h_i}}. \quad (28.3)$$

The coefficient of restitution is just the square root of the ratio of the rebound height to the initial height.¹

Now let's first look at a mathematical analysis of collisions in one dimension, where the analysis is simpler. At the end of the chapter we'll examine collisions in two dimensions.

28.3 Perfectly Inelastic Collisions

The easiest type of one-dimensional collision to analyze is a perfectly inelastic collision. In this type of collision, *all* of the initial kinetic energy is converted into heat and into work that deforms the bodies. After the collision, the two bodies stick together, forming a single combined mass equal to the sum of the original masses. Momentum is conserved, but *not* kinetic energy.

To analyze this situation, consider two bodies moving along the x axis: one of mass m_1 moving with initial velocity v_{1i} , and one of mass m_2 moving with initial velocity v_{2i} . After the collision, the two bodies stick together, forming a single body of mass $m_1 + m_2$ moving with velocity v . The question is: given the masses m_1 and m_2 and initial velocities v_{1i} and v_{2i} , what is the final velocity v of the combined mass?

To answer this question, we make use of the principle of conservation of momentum. Before the collision, the initial momentum p_i of the system is the sum of the momenta of all the bodies in the system:

$$p_i = m_1 v_{1i} + m_2 v_{2i}. \quad (28.4)$$

After the collision, the total energy of the system is

$$p_f = (m_1 + m_2)v. \quad (28.5)$$

Since momentum is conserved, the initial and final momenta must be the same: $p_i = p_f$, so

$$m_1 v_{1i} + m_2 v_{2i} = (m_1 + m_2)v. \quad (28.6)$$

The final velocity v is then

$$v = \frac{m_1 v_{1i} + m_2 v_{2i}}{m_1 + m_2}. \quad (28.7)$$

28.4 Perfectly Elastic Collisions

A slightly more difficult situation to analyze is the perfectly elastic collision. In this type of collision, *none* of the kinetic energy is lost, and so kinetic energy is conserved.²

Let's begin the analysis of a perfectly elastic collision in one dimension. We begin with two masses m_1 and m_2 with initial velocities v_{1i} and v_{2i} , respectively. After the collision, the two masses have velocities v_{1f} and v_{2f} . The typical problem is: given the masses and initial velocities, what are the final velocities?

¹The 1961 Disney movie *The Absent-Minded Professor* is about a college professor who invents a material called *flubber*, whose coefficient of restitution is greater than 1, so that it bounces higher and higher with each bounce. Among other uses, it is attached to the bottoms of the shoes of the college basketball team, giving the players a significant advantage.

²Note that in general, *total* energy is conserved, but kinetic energy is not. Kinetic energy is only conserved in perfectly elastic collisions.

We know the total momentum of the system is conserved, so the sum of the momenta before the collision equals the sum of the momenta after the collision:

$$p_i = p_f \quad (28.8)$$

$$m_1 v_{1i} + m_2 v_{2i} = m_1 v_{1f} + m_2 v_{2f}. \quad (28.9)$$

But because the collision is *perfectly elastic*, we know that the kinetic energy is also conserved. This gives us a second equation:

$$K_i = K_f \quad (28.10)$$

$$\frac{1}{2}m_1 v_{1i}^2 + \frac{1}{2}m_2 v_{2i}^2 = \frac{1}{2}m_1 v_{1f}^2 + \frac{1}{2}m_2 v_{2f}^2 \quad (28.11)$$

$$m_1 v_{1i}^2 + m_2 v_{2i}^2 = m_1 v_{1f}^2 + m_2 v_{2f}^2 \quad (28.12)$$

Equations (28.9) and (28.12) give two simultaneous equations in the two unknown final velocities v_{1f} and v_{2f} :

$$m_1 v_{1i} + m_2 v_{2i} = m_1 v_{1f} + m_2 v_{2f} \quad (28.13)$$

$$m_1 v_{1i}^2 + m_2 v_{2i}^2 = m_1 v_{1f}^2 + m_2 v_{2f}^2 \quad (28.14)$$

To solve these equations simultaneously, let's rearrange to put the m_1 terms on the left and the m_2 terms on the right:

$$m_1(v_{1i} - v_{1f}) = m_2(v_{2f} - v_{2i}) \quad (28.15)$$

$$m_1(v_{1i}^2 - v_{1f}^2) = m_2(v_{2f}^2 - v_{2i}^2) \quad (28.16)$$

Expanding the difference of squares in Eq. (28.16), we have

$$m_1(v_{1i} - v_{1f}) = m_2(v_{2f} - v_{2i}) \quad (28.17)$$

$$m_1(v_{1i} + v_{1f})(v_{1i} - v_{1f}) = m_2(v_{2f} + v_{2i})(v_{2f} - v_{2i}) \quad (28.18)$$

Now divide Eq. (28.18) by Eq. (28.17) to get

$$v_{1i} + v_{1f} = v_{2i} + v_{2f}. \quad (28.19)$$

To solve for the final velocities v_{1f} and v_{2f} , we write Eqs. (28.13) and (28.19) in matrix form:

$$\begin{pmatrix} m_1 & m_2 \\ 1 & -1 \end{pmatrix} \begin{pmatrix} v_{1f} \\ v_{2f} \end{pmatrix} = \begin{pmatrix} m_1 v_{1i} + m_2 v_{2i} \\ -v_{1i} + v_{2i} \end{pmatrix} \quad (28.20)$$

and solve for the final velocities:

$$\begin{pmatrix} v_{1f} \\ v_{2f} \end{pmatrix} = \begin{pmatrix} m_1 & m_2 \\ 1 & -1 \end{pmatrix}^{-1} \begin{pmatrix} m_1 v_{1i} + m_2 v_{2i} \\ -v_{1i} + v_{2i} \end{pmatrix} \quad (28.21)$$

Let's now expand the matrix inverse as the transposed matrix of cofactors divided by the determinant (Appendix Q):

$$\begin{pmatrix} v_{1f} \\ v_{2f} \end{pmatrix} = \frac{1}{m_1 + m_2} \begin{pmatrix} 1 & m_2 \\ 1 & -m_1 \end{pmatrix} \begin{pmatrix} m_1 v_{1i} + m_2 v_{2i} \\ -v_{1i} + v_{2i} \end{pmatrix} \quad (28.22)$$

$$= \frac{1}{m_1 + m_2} \begin{pmatrix} m_1 v_{1i} + m_2 v_{2i} - m_2 v_{1i} + m_2 v_{2i} \\ m_1 v_{1i} + m_2 v_{2i} + m_1 v_{1i} - m_1 v_{2i} \end{pmatrix} \quad (28.23)$$

$$= \frac{1}{m_1 + m_2} \begin{pmatrix} (m_1 - m_2)v_{1i} + 2m_2 v_{2i} \\ 2m_1 v_{1i} + (m_2 - m_1)v_{2i} \end{pmatrix} \quad (28.24)$$

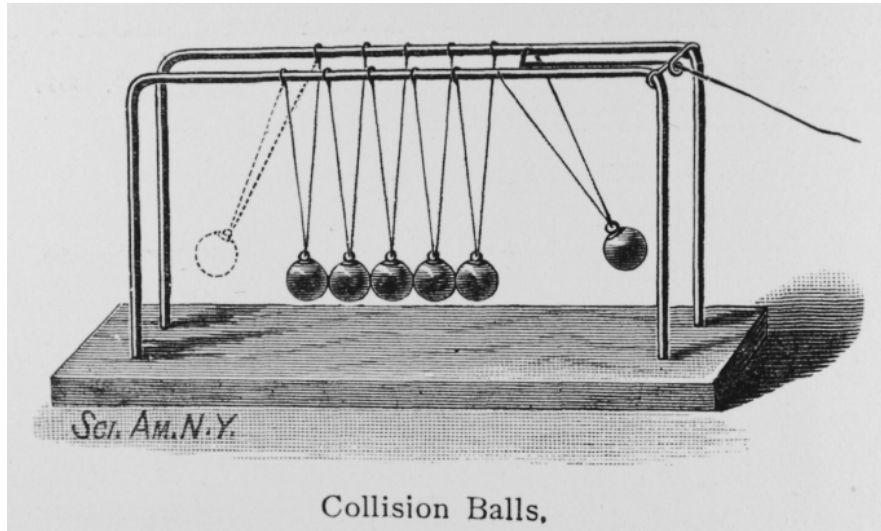

Figure 28.1: Newton's cradle. (Credit: *Scientific American*.)

Thus

$$v_{1f} = \left(\frac{m_1 - m_2}{m_1 + m_2} \right) v_{1i} + \left(\frac{2m_2}{m_1 + m_2} \right) v_{2i} \quad (28.25)$$

$$v_{2f} = \left(\frac{2m_1}{m_1 + m_2} \right) v_{1i} + \left(\frac{m_2 - m_1}{m_1 + m_2} \right) v_{2i} \quad (28.26)$$

Eqs. (28.25) and (28.26) are the general solution for finding the final velocities in a one-dimensional perfectly elastic collision.

28.5 Newton's Cradle

Newton's cradle is a device consisting of several identical suspended steel balls hanging in a row such that adjacent balls are touching (Fig. 28.1). If you pull one ball away from the end and release it, it will collide with the row of other balls, and one ball at the opposite end of the row will fly upward to almost the same height from which the original ball was released.

It is easy to see that momentum is conserved during the collision: assuming each ball has mass m , the first ball hits the rest of the balls with speed v , and so it has momentum $p = mv$. The ball flying off of the other end after the collision will have initial speed v , so it also has momentum $p = mv$. So just before the collision of the first ball, the system has momentum $p = mv$, and has this same momentum $p = mv$ after the collision.

But momentum could also be conserved if the device sent up *two* balls after the collision, each with speed $v/2$. Before the collision, the momentum of the system (due to the motion of the first ball) is $p = mv$; after the collision, the momentum of the system in this case would be $p = m(v/2) + m(v/2) = mv$, and momentum is still conserved. So if momentum is conserved in either case, how does the device “know” to send up one ball, rather than two, after the collision?

The answer is that the collision between the steel balls is close to being perfectly elastic, and so *kinetic energy* is also conserved (not just momentum). The initial kinetic energy of the system just before the collision is equal to the kinetic energy of the first ball: $K = mv^2/2$. If *one* ball goes up after the collision, then the

kinetic energy after the collision is also $K = mv^2/2$, and kinetic energy is conserved, as required for an elastic collision. But if *two* balls go up (each with speed $v/2$ to conserve momentum), then the kinetic energy just after the collision is $K = m(v/2)^2/2 + m(v/2)^2/2 = mv^2/4$, and kinetic energy would not be conserved. Therefore if one ball is raised initially (as shown in the figure), then only one ball will fly off of the other end after the collision.

28.6 Inelastic Collisions

Now let's consider a one-dimensional *inelastic* collision of two bodies—one for which the coefficient of restitution is some number between 0 and 1. Then the conservation of momentum applies (Eq. 28.9), so that the sum of the momenta before the collision equals the sum of the momenta after the collision:

$$m_1 v_{1i} + m_2 v_{2i} = m_1 v_{1f} + m_2 v_{2f}. \quad (28.27)$$

This is one equation, but assuming that we know the masses and initial velocities, there are two unknowns: the final velocities v_{1f} and v_{2f} . In order to solve simultaneous equations, there must be as many equations as unknowns, so we're one equation short. So this problem cannot be solved unless we're given some more information, such as one of the final velocities or the coefficient of restitution.

28.7 Collisions in Two Dimensions

Now consider a collision in *two dimensions* between two masses m_1 and m_2 (Fig. 28.2). Without loss of generality, we can work in a coordinate system that is at rest with respect to mass m_2 , and in which mass m_1 is moving in the $+x$ direction, as shown in the figure. Then before the collision, mass m_1 is moving with velocity $\mathbf{v}_{1i} = v_{1i}\mathbf{i}$. After the collision, mass m_1 moves with velocity $\mathbf{v}_{1f} = (v_{1f} \cos \theta_1)\mathbf{i} - (v_{1f} \sin \theta_1)\mathbf{j}$; mass m_2 moves with velocity $\mathbf{v}_{2f} = (v_{2f} \cos \theta_2)\mathbf{i} + (v_{2f} \sin \theta_2)\mathbf{j}$.

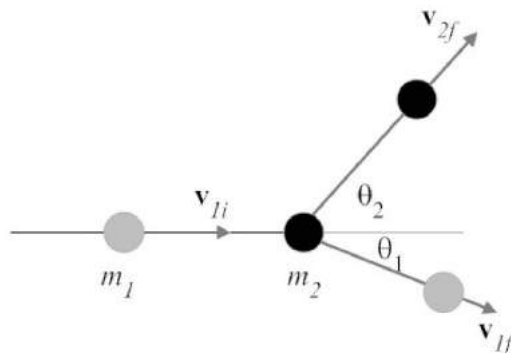

Figure 28.2: A collision in two dimensions.

By conservation of momentum, we know that *both* the x and y components of the total system momentum are independently conserved. This gives two equations: in the x direction,

$$p_{ix} = p_{fx} \quad (28.28)$$

$$m_1 v_{1i} = m_1 v_{1f} \cos \theta_1 + m_2 v_{2f} \cos \theta_2, \quad (28.29)$$

and in the y direction,

$$p_{iy} = p_{fy} \quad (28.30)$$

$$0 = -m_1 v_{1f} \sin \theta_1 + m_2 v_{2f} \sin \theta_2. \quad (28.31)$$

So Eqs. (28.29) and (28.31) give us two equations—but in this case there are *four* unknowns (v_{1f} , v_{2f} , θ_1 , and θ_2). To determine the four unknowns, we need as many equations as we have unknowns, so we're two equations short and we need to provide some more information. For example, if we assume that the collision is perfectly elastic, then we can add another equation, since kinetic energy will be conserved in this case:

$$K_i = K_f \quad (28.32)$$

$$\frac{1}{2} m_1 v_{1i}^2 = \frac{1}{2} m_1 v_{1f}^2 + \frac{1}{2} m_2 v_{2f}^2. \quad (28.33)$$

Now we have *three* equations (Eqs. 28.29, 28.31, and 28.33), but we still have four unknowns—we still need more information to find the final velocities. To solve the problem, we could be given one of the four unknowns, for example. But the piece of information that's really missing here is the *impact parameter* of the collision, which is the perpendicular distance between the center of mass m_2 and the line along the the initial velocity vector \mathbf{v}_{1i} . If the impact parameter is zero, then mass m_1 hits mass m_2 head-on. If the impact parameter is equal to the sum of the radii of m_1 and m_2 , then the two masses will barely touch in a glancing blow. Knowing the impact parameter is necessary for finding the angles θ_1 and θ_2 .

Collisions in two dimensions are more general than you might think: under a central-force law, motion will be in a plane, so the particles will move in two dimensions. Analyzing two-dimensional collisions of this type is common in particle physics. There the particles typically do not actually touch, but are repelled or attracted by the electrostatic force. The same laws apply in particle physics as what we've described here.

Chapter 29

The Ballistic Pendulum

How fast does a bullet travel when it leaves the barrel of a rifle? To measure the speed of a bullet, you might imagine an elaborate setup with high-precision timing and stop-action photography, but there's a much simpler method using the *ballistic pendulum* (Fig. 29.1).

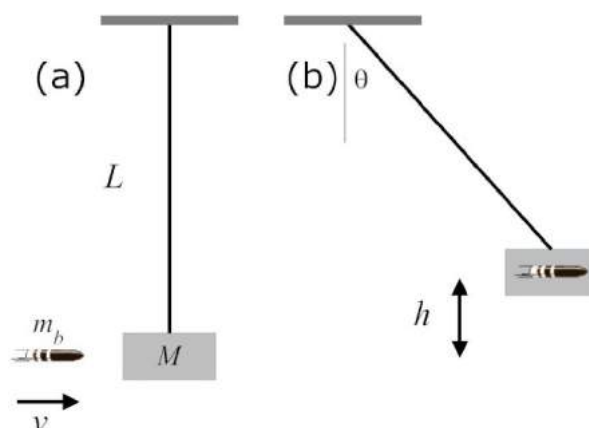

Figure 29.1: The ballistic pendulum. (a) Just before the collision, the pendulum is vertical and at rest; the bullet is moving at speed v . (b) After the collision, the bullet has embedded itself into the block. The final position of the pendulum is at an angle θ from the vertical; the block has moved a vertical height h .

The bullet is fired into a wooden block that forms the bob of a pendulum, as shown. The bullet becomes embedded in the block, and the bullet-block combination swings up and is held in its final position with a ratcheting mechanism. The initial speed of the bullet v can then be determined from the angle θ .

Let's determine the relationship between the bullet's initial speed v and the angle θ . First, the bullet embeds itself into the wooden block; this is a perfectly inelastic collision so the speed v_0 of the block-bullet combination just after the bullet hits the block is given by Eq. (28.7):

$$v_0 = \frac{m_b v + M(0)}{M + m_b} = \frac{m_b v}{M + m_b}. \quad (29.1)$$

This relation comes from the conservation of momentum.¹ As the pendulum is hanging vertically, its energy

¹We cannot use the conservation of energy at this point, because some of the bullet's initial kinetic energy is converted into heat. Using conservation of energy would require knowing things like the increase in the temperature of the block, which we don't know.

is all kinetic; the pendulum will begin swinging upward, gradually converting its kinetic energy into potential energy until it reaches its maximum height at angle θ , where it is held in place. The block's initial kinetic energy is

$$K_0 = \frac{1}{2}(M + m_b)v_0^2 \quad (29.2)$$

$$= \frac{1}{2}(M + m_b) \left(\frac{m_b v}{M + m_b} \right)^2 \quad (29.3)$$

$$= \frac{m_b^2 v^2}{2(M + m_b)} \quad (29.4)$$

All of this kinetic energy goes into raising the block-bullet combination by a height h , so by conservation of energy,

$$K_0 = U \quad (29.5)$$

$$\frac{m_b^2 v^2}{2(M + m_b)} = (M + m_b)gh \quad (29.6)$$

Solving for the bullet speed v , we find

$$v = \frac{M + m_b}{m_b} \sqrt{2gh}. \quad (29.7)$$

Now from geometry, the height h is given in terms of the pendulum length L and the angle θ by

$$h = L - L \cos \theta = L(1 - \cos \theta). \quad (29.8)$$

Substituting this into Eq. (29), we have the initial speed v of the bullet:

$$\boxed{v = \left(\frac{M}{m_b} + 1 \right) \sqrt{2gL(1 - \cos \theta)}}. \quad (29.9)$$

Chapter 30

Rockets

30.1 Introduction

A *rocket* is a vehicle that propels itself through space by ejecting a propellant gas at high speed in a direction opposite the desired direction of motion. The German V-2 rocket was an early example, as were the United States rockets such as Juno, Redstone, Agena, and Saturn. The largest and most powerful rocket ever built is the United States Saturn V Moon rocket, which took the Apollo astronauts to the Moon in the 1960s and 1970s.

In order to place a spacecraft into low-Earth orbit, a rocket must accelerate its payload from rest to a speed of about 17,000 miles per hour. In order to reach this speed, most of the rocket's mass must be fuel. The amount of fuel required for a given mass of payload is governed by the *rocket equation*, which will be derived here.

Some critics of early space exploration claimed that rockets would not be able to travel in space because “they would have nothing to push against.” As we'll see here, such arguments are silly—one needs only to make use of the conservation of momentum to show that rockets can work in space.

30.2 The Rocket Equation

Let's now derive the rocket equation. Given a rocket of mass m , we will wish to find an equation that tells us how much fuel (propellant) is required to change the rocket's speed by an amount Δv . The complication here is that the rocket loses mass as it expels propellant, so we need to allow for that.

Suppose that at an initial time $t = 0$, a rocket has velocity v and total mass m , including propellant mass. The total momentum of the rocket and propellant at time $t = 0$ is therefore mv .

Now let's look at the situation an instant later, at time $t = dt$. Let dm be the (negative) change in mass of the rocket due to the expulsion of propellant, and let dv be the corresponding (positive) change in the velocity of the rocket. Then at time $t = dt$, a mass of propellant $-dm$ is expelled at velocity $v - v_p$. (The rocket is moving at velocity v with respect to the Earth, the propellant is moving at speed $-v_p$ relative to the rocket, and so the velocity of the propellant relative to the Earth is $v - v_p$.) This expulsion of propellant will cause the rocket to then have mass $m + dm$ and velocity $v + dv$. The total momentum of the system at $t = dt$ is then the sum of the rocket and propellant momenta, $(m + dm)(v + dv) + (v - v_p)(-dm)$. By conservation

of momentum, the momentum of the system at time $t = 0$ must equal the momentum at time $t = dt$:

$$mv = (m + dm)(v + dv) + (v - v_p)(-dm) \quad (30.1)$$

$$= mv + v dm + m dv + dm dv - v dm + v_p dm \quad (30.2)$$

$$(30.3)$$

Now the two mv terms cancel, the two $v dm$ terms cancel, and the term $dm dv$ is a second-order differential, which can also be cancelled. We're then left with

$$0 = m dv + v_p dm \quad (30.4)$$

$$m dv = -v_p dm \quad (30.5)$$

$$dv = -v_p \frac{dm}{m} \quad (30.6)$$

Now let the rocket burn all its propellant. The rocket's velocity will change by a total amount Δv and its mass will change from m to its empty mass m_e . Integrating Eq. (30.6) over the entire propellant burn, we find

$$\int_v^{v+\Delta v} dv = -v_p \int_m^{m_e} \frac{dm}{m} \quad (30.7)$$

Or, evaluating the integrals,

$$\Delta v = -v_p \ln \frac{m_e}{m} \quad (30.8)$$

or

$$\boxed{\Delta v = v_p \ln \frac{m}{m_e}} \quad (30.9)$$

Eq. (30.9) is called the *rocket equation*. It relates the fueled and empty masses of the rocket and the velocity of the propellant to the total change in velocity of the rocket.

30.3 Mass Fraction

The fraction of the total initial mass m that is propellant is

$$\frac{\text{propellant mass}}{\text{total initial mass}} = \frac{m - m_e}{m} = 1 - \frac{m_e}{m}. \quad (30.10)$$

Solving Eq. (30.8) for this fraction, we find

$$1 - \frac{m_e}{m} = 1 - e^{-\Delta v/v_p} \quad (30.11)$$

Eq. (30.11) tells what fraction of the rocket's total mass must be fuel in order to achieve a desired change in rocket velocity Δv .

Example

Let's take as an example the launch of a rocket from the Earth's surface to low-Earth orbit. In this case, the rocket's velocity will need to change by an amount $\Delta v = 17,000$ mph, or about 7600 m/s. Let's say we have a rocket that can expel propellant with a speed $v_p = 4000$ m/s. Then by Eq. (30.11),

$$1 - \frac{m_e}{m} = 1 - e^{-\Delta v/v_p} = 0.85, \quad (30.12)$$

so 85% of the rocket's initial mass must be propellant.

30.4 Staging

In practice, it is found that it can be more efficient to launch rockets in *stages*, where part of the rocket structure drops away when it is no longer needed, thus decreasing the amount of mass that needs to be placed in orbit. For example, the Saturn V rocket had three stages. The large lower first stage contained a large fuel tank and large engines. When all the fuel contained in that stage had been spent, the entire first stage separated and dropped away, and a smaller second stage was ignited. When all the second-stage fuel was spent, it too separated and dropped away, and the third stage engine ignited, which placed the spacecraft into Earth orbit. This staged approach requires much less fuel than launching the entire Saturn V rocket into orbit.

Chapter 31

Center of Mass

31.1 Introduction

The *center of mass* of a body or collection of bodies is the mean position of the mass. Usually the center of mass is the same as the *center of gravity*, which is the balance point of a body. For example, imagine supporting a rod or sheet of material at the point where it is perfectly balanced; this will be the body's center of mass.

The center of mass may be defined for a collection of discrete masses, or for a continuous body; it may also be defined in one, two, or three dimensions.

31.2 Discrete Masses

For a collection of discrete point masses in one dimension, the center of mass x_{cm} is defined to be

$$x_{\text{cm}} = \frac{\sum_i m_i x_i}{\sum_i m_i}, \quad (31.1)$$

where the summations are over all of the point masses. This is just the weighted average of the positions of the masses, where the “weights” are the masses. Note that the denominator is the total mass of all the point masses.

Example. Suppose there is a mass of 3 kg at $x = 1$ m, a mass of 2 kg at the origin, and a mass of 4 kg at $x = 2$ m. Where is the center of mass?

Solution. Let's put the data in a table:

i	m_i (kg)	x_i (m)
1	3.0	1.0
2	2.0	0.0
3	4.0	2.0

Then by Eq. (31.1),

$$x_{\text{cm}} = \frac{(3 \text{ kg})(1 \text{ m}) + (2 \text{ kg})(0 \text{ m}) + (4 \text{ kg})(2 \text{ m})}{3 \text{ kg} + 2 \text{ kg} + 4 \text{ kg}} \quad (31.2)$$

$$= 1.222 \text{ m}. \quad (31.3)$$

In two or three dimensions, the x , y , and z coordinates of the center of mass are calculated independently:

$$x_{\text{cm}} = \frac{\sum_i m_i x_i}{\sum_i m_i} \quad (31.4)$$

$$y_{\text{cm}} = \frac{\sum_i m_i y_i}{\sum_i m_i} \quad (31.5)$$

$$z_{\text{cm}} = \frac{\sum_i m_i z_i}{\sum_i m_i}. \quad (31.6)$$

Example. In two dimensions: suppose there is a mass of 3 kg at $(x, y) = (1, 3)$ m, a mass of 2 kg at the origin, and a mass of 4 kg at $(x, y) = (5, -1)$ m. Where is the center of mass?

Solution. Let's put the data in a table:

i	m_i (kg)	x_i (m)	y_i (m)
1	3.0	1.0	3.0
2	2.0	0.0	0.0
3	4.0	5.0	-1.0

Then by Eqs. (31.4) and (31.5),

$$x_{\text{cm}} = \frac{(3 \text{ kg})(1 \text{ m}) + (2 \text{ kg})(0 \text{ m}) + (4 \text{ kg})(5 \text{ m})}{3 \text{ kg} + 2 \text{ kg} + 4 \text{ kg}} \quad (31.7)$$

$$= 2.556 \text{ m}. \quad (31.8)$$

and

$$y_{\text{cm}} = \frac{(3 \text{ kg})(3 \text{ m}) + (2 \text{ kg})(0 \text{ m}) + (4 \text{ kg})(-1 \text{ m})}{3 \text{ kg} + 2 \text{ kg} + 4 \text{ kg}} \quad (31.9)$$

$$= 0.556 \text{ m}. \quad (31.10)$$

The center of mass is at $(x_{\text{cm}}, y_{\text{cm}}) = (2.556, 0.556)$ m.

31.3 Continuous Bodies

To find the center of mass of a *continuous* body, just imagine dividing the body up into little infinitesimal pieces, each of which has mass dm ; then treat each of these infinitesimal masses as a point mass, and add together the products of dm and its position using an integral. In one dimension:

$$x_{\text{cm}} = \frac{\int x \, dm}{\int dm}, \quad (31.11)$$

where the integrals are taken over the entire length of the body. But there's a problem here. How are we going to integrate x with respect to m ? We need to write both the integrand and the variable of integration with respect to the same variable. If we have a rod in one dimension, for example, then we would want to integrate over the entire length of the rod, so it's natural to want the variable of integration to be x . Somehow, then, we need to change the variable of integration from m to x .

We do this through the *density*. In the case of a one-dimensional problem, we'll use the *linear mass density* (mass per unit length) λ :

$$\lambda = \frac{dm}{dx}, \quad (31.12)$$

where λ has units of kg/m. In general, the density λ can be variable across the body, so it will be a function of x , so we can write it as $\lambda(x)$. In terms of x , we can therefore write the mass dm as

$$dm = \lambda(x) dx. \quad (31.13)$$

Making this substitution into Eq. (31.11), we have the one-dimensional formula

$$x_{\text{cm}} = \frac{\int x \lambda(x) dx}{\int \lambda(x) dx}. \quad (31.14)$$

The denominator $\int \lambda(x) dx$ is the total mass of the body M .

Example. Suppose we have a rod of length 5 m, whose density is given by $\lambda(x) = 2x + 3$ kg/m, where x is in meters from the left end of the rod. Where is the center of mass of the rod?

Solution. Let's first solve the more general problem: where is the center of mass of a rod of length L , when the density is given by $\lambda(x) = ax + b$. The center of mass is given by Eq. (31.25):

$$x_{\text{cm}} = \frac{\int_0^L x \lambda(x) dx}{\int_0^L \lambda(x) dx} \quad (31.15)$$

$$= \frac{\int_0^L x (ax + b) dx}{\int_0^L (ax + b) dx} \quad (31.16)$$

$$= \frac{\int_0^L (ax^2 + bx) dx}{\int_0^L (ax + b) dx} \quad (31.17)$$

$$= \frac{(\frac{1}{3}ax^3 + \frac{1}{2}bx^2)|_0^L}{(\frac{1}{2}ax^2 + bx)|_0^L} \quad (31.18)$$

$$= \frac{\frac{1}{3}aL^3 + \frac{1}{2}bL^2}{\frac{1}{2}aL^2 + bL} \quad (31.19)$$

$$= \frac{2aL^3 + 3bL^2}{3aL^2 + 6bL} \quad (31.20)$$

Now substitute $a = 2$ kg/m², $b = 3$ kg/m, and $L = 5$ m, and we get

$$x_{\text{cm}} = \frac{2(2 \text{ kg/m}^2)(5 \text{ m})^3 + 3(3 \text{ kg/m})(5 \text{ m})^2}{3(2 \text{ kg/m}^2)(5 \text{ m})^2 + 6(3 \text{ kg/m})(5 \text{ m})} \quad (31.21)$$

$$= \frac{725 \text{ kg m}}{240 \text{ kg}} \quad (31.22)$$

$$= 3.021 \text{ m}. \quad (31.23)$$

(The denominator is the total mass, $M = 240$ kg.)

We can take a similar approach with a two-dimensional continuous object. The position vector \mathbf{r}_{cm} of the center of mass in two dimensions is

$$\mathbf{r}_{\text{cm}} = \frac{\int \mathbf{r} \sigma(\mathbf{r}) dA}{\int \sigma(\mathbf{r}) dA} \quad (31.24)$$

$$= \frac{\iint \mathbf{r} \sigma(\mathbf{r}) dx dy}{\iint \sigma(\mathbf{r}) dx dy} \quad (31.25)$$

where $\sigma(\mathbf{r})$ is the *area mass density* of the body (mass per unit area), in units of kg/m^2 . Here we imagine dividing the body up into infinitesimal squares of area $dA = dx dy$, and treat each square as a point mass. The integrals in Eq. (31.25) are called *double integrals*, which you will learn more about when you study the calculus of several variables in a calculus course. Briefly, though, a double integral is interpreted as

$$\iint f(x, y) dx dy = \int \left[\int f(x, y) dx \right] dy \quad (31.26)$$

To evaluate this, you first evaluate the integral inside the square brackets, treating x as the variable of integration and treating y as a constant. You then use the result as the integrand of the outer integral, this time treating y as the variable of integration.

Similarly, in three dimensions, the position vector \mathbf{r}_{cm} of the center of mass is

$$\mathbf{r}_{\text{cm}} = \frac{\int \mathbf{r} \rho(\mathbf{r}) dV}{\int \rho(\mathbf{r}) dV} \quad (31.27)$$

$$= \frac{\iiint \mathbf{r} \rho(\mathbf{r}) dx dy dz}{\iiint \rho(\mathbf{r}) dx dy dz} \quad (31.28)$$

where $\rho(\mathbf{r})$ is the familiar *volume mass density* of the body (mass per unit volume), in units of kg/m^3 . In this case we imagine dividing the body into infinitesimal cubes of volume $dV = dx dy dz$, and treat each cube as a point mass. The integrals in Eq. (31.28) are called a *triple integrals*. Such an integral is interpreted as

$$\iiint f(x, y, z) dx dy dz = \int \left\{ \int \left[\int f(x, y, z) dx \right] dy \right\} dz \quad (31.29)$$

Here you evaluate the innermost integral (in square brackets) first, treating x as the variable of integration, treating y and z as constants. You then use this result as the integrand for the next integral (curly braces), treating y as the variable of integration, with z constant. Finally, you use *that* result as the integrand for the outermost integral, treating z as the variable of integration.

Chapter 32

The Cross Product

Many of the equations involving rotational motion of bodies involve the vector cross product, so before proceeding further, let's examine the *cross product* of two vectors in some detail.

You'll recall from Chapter 7 that there are several different ways of multiplying one vector by another vector. There we examined one such type of multiplication, the *dot product*. Before we study rotational motion, we'll need to learn about another type of vector multiplication, the *cross product*. In the cross product, one multiplies a vector by another vector, and gets *another vector* back as the result (unlike the dot product, which returns a scalar result).

Unlike the other two kinds of vector multiplication, the cross product is only defined for *three-dimensional* vectors.¹

32.1 Definition

The cross product (sometimes called the *vector product*) is indicated with a cross sign ($\mathbf{A} \times \mathbf{B}$) and is pronounced “ \mathbf{A} cross \mathbf{B} .” When you take the cross product of two vectors, you get back another vector, whose magnitude is

$$|\mathbf{A} \times \mathbf{B}| = AB \sin \theta, \quad (32.1)$$

where θ is the angle separating vectors \mathbf{A} and \mathbf{B} .²

The *direction* of the vector $\mathbf{A} \times \mathbf{B}$ is perpendicular to the plane of vectors \mathbf{A} and \mathbf{B} . But there are *two* possible choices for direction of a vector perpendicular to a plane; which one do we choose? By convention, we choose the one given by a *right-hand rule*: if you curl the fingers of your right hand from vector \mathbf{A} toward vector \mathbf{B} , then the thumb of your right hand points in the direction of $\mathbf{A} \times \mathbf{B}$ (Fig. 32.1).

Since $\mathbf{A} \times \mathbf{B}$ is perpendicular to the plane formed by vectors \mathbf{A} and \mathbf{B} , it is also perpendicular to both *vectors* \mathbf{A} and \mathbf{B} :

$$(\mathbf{A} \times \mathbf{B}) \perp \mathbf{A} \quad (32.2)$$

$$(\mathbf{A} \times \mathbf{B}) \perp \mathbf{B} \quad (32.3)$$

¹It is also possible to define a vector cross product in *seven* dimensions. A meaningful vector cross product can only be defined in three or seven dimensions.

²An old physics joke: What do you get when you cross an elephant with a banana? *Ans.* “Elephant banana sine θ .”

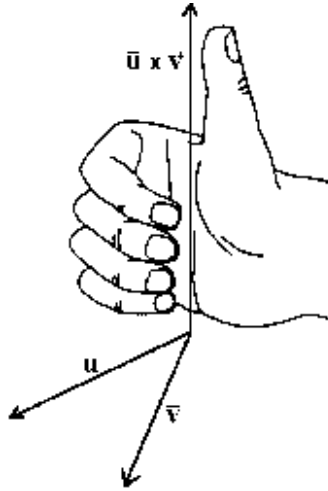

Figure 32.1: The vector cross product $\mathbf{A} \times \mathbf{B}$ is perpendicular to the plane of \mathbf{A} and \mathbf{B} , and in the right-hand sense. (Credit: “Connected Curriculum Project”, Duke University.)

32.2 Component Form

A convenient mnemonic for finding the rectangular components of the cross product is through a matrix determinant:

$$\mathbf{A} \times \mathbf{B} = \begin{vmatrix} \mathbf{i} & \mathbf{j} & \mathbf{k} \\ A_x & A_y & A_z \\ B_x & B_y & B_z \end{vmatrix} \quad (32.4)$$

$$= (A_y B_z - A_z B_y)\mathbf{i} - (A_x B_z - A_z B_x)\mathbf{j} + (A_x B_y - A_y B_x)\mathbf{k}. \quad (32.5)$$

For example, if $\mathbf{A} = 3\mathbf{i} + 5\mathbf{j} + 2\mathbf{k}$ and $\mathbf{B} = 2\mathbf{i} - \mathbf{j} + 4\mathbf{k}$, then $\mathbf{A} \times \mathbf{B} = (20 - (-2))\mathbf{i} - (12 - 4)\mathbf{j} + (-3 - 10)\mathbf{k} = 22\mathbf{i} - 8\mathbf{j} - 13\mathbf{k}$.

32.3 Properties

Anti-Commutativity

The cross product is *anti-commutative*:

$$\mathbf{A} \times \mathbf{B} = -\mathbf{B} \times \mathbf{A}, \quad (32.6)$$

as should be clear by applying the right-hand rule.

Orthogonality

If two vectors are parallel or anti-parallel, their cross product will be zero. For example, for the cartesian unit vectors,

$$\mathbf{i} \times \mathbf{i} = \mathbf{j} \times \mathbf{j} = \mathbf{k} \times \mathbf{k} = \mathbf{0}. \quad (32.7)$$

Notice that the result is the zero *vector*, encountered earlier in Chapter 6: a vector whose components are all zero. The zero vector has magnitude zero, and no defined direction.

Also, the products of any two different cartesian unit vectors permute cyclically:

$$\mathbf{i} \times \mathbf{j} = \mathbf{k}; \quad \mathbf{j} \times \mathbf{i} = -\mathbf{k} \quad (32.8)$$

$$\mathbf{j} \times \mathbf{k} = \mathbf{i}; \quad \mathbf{k} \times \mathbf{j} = -\mathbf{i} \quad (32.9)$$

$$\mathbf{k} \times \mathbf{i} = \mathbf{j}; \quad \mathbf{i} \times \mathbf{k} = -\mathbf{j} \quad (32.10)$$

Derivative

The derivative of the cross product is similar to the familiar product rule for scalars:

$$\frac{d(\mathbf{A} \times \mathbf{B})}{dt} = \mathbf{A} \times \frac{d\mathbf{B}}{dt} + \frac{d\mathbf{A}}{dt} \times \mathbf{B}. \quad (32.11)$$

Note, though, that since the cross product is not commutative, you must keep the order of multiplications as they're shown here.

The Triple Vector Product

Unlike normal scalar multiplication, the cross product is *non-associative*: $\mathbf{A} \times (\mathbf{B} \times \mathbf{C}) \neq (\mathbf{A} \times \mathbf{B}) \times \mathbf{C}$. The cross products of three vectors may be expanded like so:

$$\mathbf{A} \times (\mathbf{B} \times \mathbf{C}) = \mathbf{B}(\mathbf{A} \cdot \mathbf{C}) - \mathbf{C}(\mathbf{A} \cdot \mathbf{B}) \quad (32.12)$$

$$(\mathbf{A} \times \mathbf{B}) \times \mathbf{C} = \mathbf{B}(\mathbf{A} \cdot \mathbf{C}) - \mathbf{A}(\mathbf{B} \cdot \mathbf{C}) \quad (32.13)$$

Eq. (32.12) is sometimes remembered as the “back cab” rule (from the letters “BAC CAB” on the right-hand side), but this requires remembering where the parentheses are on the left-hand side. A better way to remember *both* products in Eqs. (32.12) and (32.13) is: “The middle vector times the dot product of the two on the ends, minus the dot product of the two vectors straddling the parenthesis times the remaining one.”

Products of Two Cross Products

The dot product of two cross products can be expanded as

$$(\mathbf{A} \times \mathbf{B}) \cdot (\mathbf{C} \times \mathbf{D}) = (\mathbf{A} \cdot \mathbf{C})(\mathbf{B} \cdot \mathbf{D}) - (\mathbf{A} \cdot \mathbf{D})(\mathbf{B} \cdot \mathbf{C}), \quad (32.14)$$

while the cross product of two cross products can be expanded as

$$(\mathbf{A} \times \mathbf{B}) \times (\mathbf{C} \times \mathbf{D}) = (\mathbf{A} \times \mathbf{B} \cdot \mathbf{D})\mathbf{C} - (\mathbf{A} \times \mathbf{B} \cdot \mathbf{C})\mathbf{D}. \quad (32.15)$$

The Triple Scalar Product

An interesting vector product is the so-called *triple scalar product*, $\mathbf{A} \cdot \mathbf{B} \times \mathbf{C}$, involving one dot product and one scalar product. No parentheses are needed here: the cross product must be done before the dot product. (Attempting to do the dot product first results in the cross product of a scalar with a vector, which is not defined.) The result is a scalar.

The triple scalar product has a number of interesting properties:

- The dot and cross operators can be exchanged without changing the result: $\mathbf{A} \cdot \mathbf{B} \times \mathbf{C} = \mathbf{A} \times \mathbf{B} \cdot \mathbf{C}$. (Because of this property, the triple scalar product is sometimes written simply as $[\mathbf{A}, \mathbf{B}, \mathbf{C}]$.)
- Vectors \mathbf{A} , \mathbf{B} , and \mathbf{C} can be permuted cyclically without changing the result: $\mathbf{A} \cdot \mathbf{B} \times \mathbf{C} = \mathbf{B} \cdot \mathbf{C} \times \mathbf{A} = \mathbf{C} \cdot \mathbf{A} \times \mathbf{B}$.

- The absolute value of the triple scalar product is equal to the volume of the parallelepiped whose edges are formed by the vectors **A**, **B**, and **C**.
- In terms of cartesian components, the triple scalar product can be written as a determinant:

$$\mathbf{A} \cdot \mathbf{B} \times \mathbf{C} = \begin{vmatrix} A_x & A_y & A_z \\ B_x & B_y & B_z \\ C_x & C_y & C_z \end{vmatrix} \quad (32.16)$$

$$= A_x B_y C_z - A_x B_z C_y - A_y B_x C_z + A_y B_z C_x + A_z B_x C_y - A_z B_y C_x \quad (32.17)$$

32.4 Matrix Formulation

Another way to represent the components of the cross product is to write the components of vector **A** into an antisymmetric 3×3 matrix, then multiply that matrix by the column vector **B**:

$$\mathbf{A} \times \mathbf{B} = \begin{pmatrix} 0 & -A_z & A_y \\ A_z & 0 & -A_x \\ -A_y & A_x & 0 \end{pmatrix} \begin{pmatrix} B_x \\ B_y \\ B_z \end{pmatrix} \quad (32.18)$$

$$= \begin{pmatrix} A_y B_z - A_z B_y \\ A_z B_x - A_x B_z \\ A_x B_y - A_y B_x \end{pmatrix}. \quad (32.19)$$

32.5 Inverse

Suppose we have vectors **A**, **B**, and **C** such that $\mathbf{A} \times \mathbf{B} = \mathbf{C}$. If vectors **B** and **C** are known, can we solve for vector **A**?

There is no such thing as a “cross division” operation, so we can’t do anything similar to $A = C/B$. In fact, there is *no* unique solution for vector **A**. There are an infinite number of vectors that can be crossed with **B** to yield vector **C**; the smaller the angle between **A** and **B**, the larger the magnitude **A** must have to yield a given vector **C**.

To solve $\mathbf{A} \times \mathbf{B} = \mathbf{C}$ for vector **A**, we will need to know vectors **B** and **C**, along with one other piece of information, such as the magnitude of vector **A** or the angle θ between **A** and **B**. Suppose the magnitude A of vector **A** is known; then since $|\mathbf{A} \times \mathbf{B}| = AB \sin \theta = C$, we have

$$\sin \theta = \frac{C}{AB}. \quad (32.20)$$

On the other hand, if θ is known, then

$$A = \frac{C}{B \sin \theta}. \quad (32.21)$$

In either case, we now know both the magnitude A and the angle θ . Then since $\mathbf{A} \cdot \mathbf{B} = AB \cos \theta$, we can now find the dot product $\mathbf{A} \cdot \mathbf{B}$. Now let’s take

$$\mathbf{A} \times \mathbf{B} = \mathbf{C}. \quad (32.22)$$

Crossing both sides on the right with vector **B**, we get

$$(\mathbf{A} \times \mathbf{B}) \times \mathbf{B} = \mathbf{C} \times \mathbf{B}. \quad (32.23)$$

The left-hand side is a vector triple product; applying Eq. (32.13), we get

$$\mathbf{B}(\mathbf{A} \cdot \mathbf{B}) - B^2 \mathbf{A} = \mathbf{C} \times \mathbf{B}. \quad (32.24)$$

Solving for vector \mathbf{A} , we find

$$\mathbf{A} = \frac{1}{B^2} [(\mathbf{B} \times \mathbf{C}) + (\mathbf{A} \cdot \mathbf{B}) \mathbf{B}] \quad (32.25)$$

So if either A or θ is known, then we can find $\mathbf{A} \cdot \mathbf{B} = AB \cos \theta$; knowing this and \mathbf{B} and \mathbf{C} , Eq. (32.25) lets us solve for vector \mathbf{A} (provided $\mathbf{B}, \mathbf{C} \neq \mathbf{0}$).

Chapter 33

Rotational Motion

33.1 Introduction

We can describe the *rotation* of a solid body about an axis in a manner similar to the way we describe linear motion.

First, instead of the giving position of the body along an axis, we specify its rotation angle θ relative to an agreed-upon zero rotation angle. Then we define an *angular velocity* ω in a way similar to the definition of linear velocity:

$$\omega = \frac{d\theta}{dt}. \quad (33.1)$$

We also define an *angular acceleration* α that's analogous to linear acceleration:

$$\alpha = \frac{d\omega}{dt} = \frac{d^2\theta}{dt^2}. \quad (33.2)$$

33.2 Translational vs. Rotational Motion

There are some important relations between translational and rotational motion. Recall the relation between an angle θ (in radians) and arc length s :

$$\boxed{s = r\theta}, \quad (33.3)$$

where r is the radius of rotation. Taking derivatives of both sides with respect to time and using $ds/dt = v$, $d\theta/dt = \omega$, and r is constant, we get a relation between linear and angular velocities:

$$\boxed{v = r\omega}, \quad (33.4)$$

since the radius of rotation r is constant. Taking derivatives with respect to time again, we get a relation between the linear and angular accelerations:

$$\boxed{a = r\alpha}. \quad (33.5)$$

Many of the formulæ involving rotational motion are similar to the formulæ we saw in translational motion, and we can use the same methods for working with them. Each of the quantities we encountered in translational motion has a rotational counterpart, as shown in Table 33-1. (Time t is the same in both translational and rotational motion.)

Table 33-1. Translational and rotational quantities. This table shows several quantities related to translational motion, along with their counterparts in rotational motion and how the two are related.

Translational Motion		Rotational Motion		Relationship
Name	Symbol	Name	Symbol	
Position	x	Angle	θ	$\theta = s/r$
Velocity	v	Angular velocity	ω	$\omega = v_t/r$
Acceleration	a	Angular acceleration	α	$\alpha = a_t/r$
Mass	m	Moment of inertia	I	$I = \int r^2 dm$
Force	F	Torque	τ	$\boldsymbol{\tau} = \mathbf{r} \times \mathbf{F}$
Momentum	p	Angular momentum	L	$\mathbf{L} = \mathbf{r} \times \mathbf{p}$

(In the first three lines, s is arc length, and v_t and a_t are the tangential components of the velocity and acceleration, respectively.)

Many of the translational formulæ we've encountered so far have a similar formula in rotational motion. We can generally find these rotational formulæ by replacing the translational variables with the corresponding rotational variables from Table 33-1. Examples of such formulæ are shown in Table 33-2.

Table 33-2. Translational and rotational formulæ. This table shows a number of formulæ from translational mechanics, along with their rotational counterparts.

Description	Translational Motion	Rotational Motion
Velocity	$v = dx/dt$	$\omega = d\theta/dt$
Acceleration	$a = dv/dt$	$\alpha = d\omega/dt$
Constant acceleration	$x = \frac{1}{2}at^2 + v_0t + x_0$	$\theta = \frac{1}{2}\alpha t^2 + \omega_0t + \theta_0$
” ”	$v = at + v_0$	$\omega = \alpha t + \omega_0$
” ”	$v^2 = v_0^2 + 2a(x - x_0)$	$\omega^2 = \omega_0^2 + 2\alpha(\theta - \theta_0)$
Newton's 2nd law (const. mass)	$F = ma$	$\tau = I\alpha$
Newton's 2nd law (general)	$F = dp/dt$	$\tau = dL/dt$
Momentum	$p = mv$	$L = I\omega$
Work	$W = Fx$	$W = \tau\theta$
Kinetic energy	$K = \frac{1}{2}mv^2$	$K = \frac{1}{2}I\omega^2$
” ”	$K = p^2/2m$	$K = L^2/2I$
Hooke's Law	$F = -kx$	$\tau = -\kappa\theta$
Potential energy (spring)	$U_s = \frac{1}{2}kx^2$	$U_s = \frac{1}{2}\kappa\theta^2$
Power	$P = Fv$	$P = \tau\omega$

33.3 Example Problems

Translational Problem

Consider the following translational problem: a body of mass $m = 3.0$ kg is initially at rest; then a force of $F = 5.0$ N is applied to it for time $t = 7.0$ seconds. What is the final velocity v of the body?

Solution. Given the force, we can find the acceleration; knowing the acceleration and time, we can find the velocity. The applicable equations are

$$F = ma \quad (33.6)$$

$$v = at + v_0. \quad (33.7)$$

Solving Eq. (33.6) for a and substituting into Eq. (33.7), we have

$$v = \left(\frac{F}{m}\right)t + v_0. \quad (33.8)$$

Substituting the given values of F , m , and t , and using $v_0 = 0$, we have

$$v = \left(\frac{5.0 \text{ N}}{3.0 \text{ kg}}\right)(7.0 \text{ s}), \quad (33.9)$$

or

$$\boxed{v = 11.67 \text{ m/s}} \quad (33.10)$$

Rotational Problem

Now consider the following similar rotational problem, which can be solved using the same method: a body of moment of inertia $I = 3.0 \text{ kg m}^2$ is initially at rest (not rotating); then a torque of $\tau = 5.0 \text{ N m}$ is applied to it for time $t = 7.0$ seconds. What is the final angular velocity ω of the body?

Solution. Given the torque, we can find the angular acceleration; knowing the angular acceleration and time, we can find the angular velocity. The applicable equations are analogous to those used for the translational problem:

$$\tau = I\alpha \quad (33.11)$$

$$\omega = \alpha t + \omega_0. \quad (33.12)$$

Solving Eq. (33.11) for α and substituting into Eq. (33.12), we have

$$\omega = \left(\frac{\tau}{I}\right) t + \omega_0. \quad (33.13)$$

Substituting the given values of τ , I , and t , and using $\omega_0 = 0$, we have

$$\omega = \left(\frac{5.0 \text{ N m}}{3.0 \text{ kg m}^2}\right) (7.0 \text{ s}), \quad (33.14)$$

or

$$\boxed{\omega = 11.67 \text{ rad/s}} \quad (33.15)$$

Chapter 34

Moment of Inertia

34.1 Introduction

The *moment of inertia* is the rotational counterpart of mass. It takes into account not only the total mass of the body, but also how far the mass is distributed from the axis of rotation: a body will have a higher moment of inertia if it has a higher mass, or if more of the mass is distributed farther from the rotation axis. Two bodies can have the same mass, but different moments of inertia, if their mass is distributed through the bodies differently.

To introduce the concept of moment of inertia, let's first look at a point mass m moving in a circle of radius r (Fig. 34.1). The moment of inertia of the point mass is defined to be the mass times the square of its rotation radius:

$$I = mr^2. \tag{34.1}$$

In SI units, moment of inertia has units of kg m^2 .

Knowing the definition of the moment of inertia of a single point mass, we may make use of the calculus to find the moment of inertia of *any* extended body. Imagine that we have some solid body that is rotating about some axis. Now imagine dividing the body into many infinitesimal cubes of mass dm , and treat each of these cubes as a point mass. If r is the perpendicular distance of dm from the rotation axis, then the moment of inertia of the body is found by adding up all the contributions $r^2 dm$ over the entire body by means of an integral:

$$I = \int r^2 dm. \tag{34.2}$$

Note that, unlike with mass, it makes no sense to refer simply to the moment of inertia of a body—you must also specify the *axis* about which the body is rotated.

Example. As a simple example, let's find the moment of inertia of a uniform rod of length L and mass M when rotated about its center of mass (Fig. 34.2). To set up the problem, we'll define an x axis running along the axis of the rod, and define the origin at the center of mass, as shown in the figure.

Now imagine dividing the rod into many infinitesimal segments of length dx . Each of these segments then has mass λdx , where λ is the density of the rod. Therefore, the moment of inertia of the rod is given by

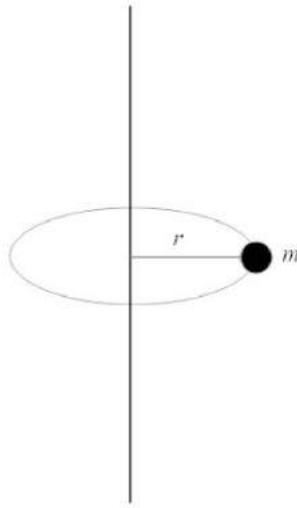

Figure 34.1: The moment of inertia of a point mass m moving in a circle of radius r is $I = mr^2$.

Eq. (34.2). Since the distance r of dm from the rotation axis is $r = |x|$, we have

$$I = \int r^2 dm \quad (34.3)$$

$$= \int_{-L/2}^{L/2} x^2 \lambda dx \quad (34.4)$$

$$= \frac{\lambda}{3} x^3 \Big|_{-L/2}^{L/2} \quad (34.5)$$

$$= \frac{\lambda}{3} \left(\frac{L^3}{8} + \frac{L^3}{8} \right) \quad (34.6)$$

$$= \frac{1}{12} \lambda L^3. \quad (34.7)$$

Since the rod is uniform, its density is a constant $\lambda = M/L$; hence

$$I = \frac{1}{12} \frac{M}{L} L^3 \quad (34.8)$$

So the moment of an inertia of a uniform rod of length L and mass M when rotated about an axis perpendicular rod and passing through the center is

$$\boxed{I = \frac{1}{12} ML^2.} \quad (34.9)$$

Example. Let's repeat the previous example, but find the moment of inertia of the rod of length L and mass M when rotated *about one end*. We move origin of the coordinate system to the left end; in this case

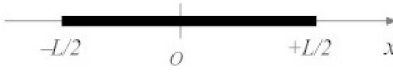
Figure 34.2: Coordinate system for a rod of length L .

$r = x$, we integrate from 0 to L , and we have

$$I = \int r^2 dm \quad (34.10)$$

$$= \int_0^L x^2 \lambda dx \quad (34.11)$$

$$= \frac{\lambda}{3} x^3 \Big|_0^L \quad (34.12)$$

$$= \frac{\lambda}{3} (L^3 - 0) \quad (34.13)$$

$$= \frac{1}{3} \lambda L^3. \quad (34.14)$$

Since the rod is uniform, its density is a constant $\lambda = M/L$; hence

$$I = \frac{1}{3} \frac{M}{L} L^3 \quad (34.15)$$

So the moment of inertia of a uniform rod of length L and mass M when rotated about an axis perpendicular rod and passing through one end is

$$\boxed{I = \frac{1}{3} ML^2.} \quad (34.16)$$

Example. As a third example, let's find the moment of inertia of a uniform thin hoop of mass M and radius R , when rotated about an axis passing through the center of the hoop and perpendicular to the plane of the hoop. We imagine dividing the hoop into many infinitesimal segments of length ds . If the (constant) linear mass density of the hoop is λ , then the mass of each such segment is $dm = \lambda ds$. But the arc length $ds = R d\theta$, so the mass of each segment becomes $dm = \lambda R d\theta$. Since the distance of each segment from the rotation axis $r=R$, the moment of inertia I is then

$$I = \int r^2 dm \quad (34.17)$$

$$= \int_0^{2\pi} R^2 \lambda R d\theta \quad (34.18)$$

$$= \lambda R^3 \int_0^{2\pi} d\theta \quad (34.19)$$

$$= 2\pi \lambda R^3. \quad (34.20)$$

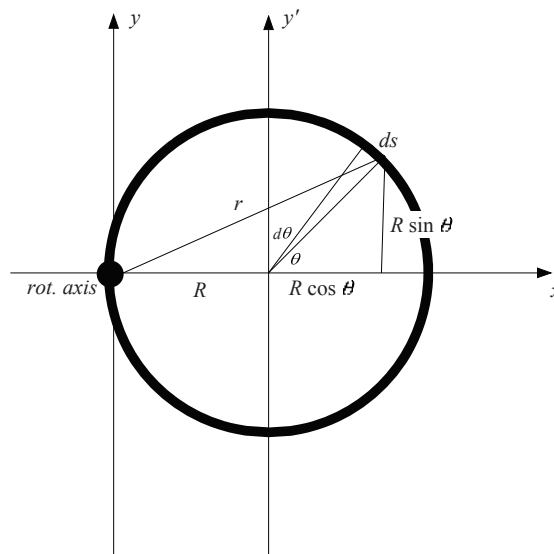

Figure 34.3: Calculation of the moment of inertia of a hoop when rotated about an axis passing through the hoop.

The linear mass density of the hoop λ is the total mass M divided by the total length $2\pi R$, so

$$I = 2\pi \left(\frac{M}{2\pi R} \right) R^3. \quad (34.21)$$

so the moment of inertia of the hoop is

$$\boxed{I = MR^2}. \quad (34.22)$$

Example. As a fourth example, consider the same uniform thin hoop of mass M and radius R from the previous example — but this time, let's rotate it about an axis passing through the *rim* of the hoop, and perpendicular to the plane of the hoop (Figure 34.3). Then the moment of inertia is calculated as

$$I = \int r^2 dm \quad (34.23)$$

$$= \int_0^{2\pi} r^2 \lambda R d\theta \quad (34.24)$$

as before. But this time, the distance from the infinitesimal piece of hoop at angle θ to the rotation axis is not R , but some more complicated function of θ . We'll need to derive a formula $r(\theta)$ for the distance to the rotation axis.

Looking at Figure 34.3, this distance must be (from the Pythagorean theorem)

$$r^2 = (R + R \cos \theta)^2 + (R \sin \theta)^2 \quad (34.25)$$

$$= R^2[(1 + \cos \theta)^2 + \sin^2 \theta] \quad (34.26)$$

$$= R^2(1 + 2 \cos \theta + \cos^2 \theta + \sin^2 \theta) \quad (34.27)$$

$$= R^2(2 + 2 \cos \theta) \quad (34.28)$$

$$= 2R^2(1 + \cos \theta) \quad (34.29)$$

This is the desired function $r(\theta)$ for the distance to the rotation axis. Putting this expression into the integral for the moment of inertia I , we have

$$I = \int_0^{2\pi} [2R^2(1 + \cos \theta)] \lambda R d\theta \quad (34.30)$$

$$= 2\lambda R^3 \int_0^{2\pi} (1 + \cos \theta) d\theta \quad (34.31)$$

$$= 2\lambda R^3 \left(\int_0^{2\pi} d\theta + \int_0^{2\pi} \cos \theta d\theta \right) \quad (34.32)$$

$$= 2\lambda R^3 \left(2\pi + \sin \theta \Big|_0^{2\pi} \right) \quad (34.33)$$

$$= 2\lambda R^3(2\pi) \quad (34.34)$$

$$= 4\pi \lambda R^3 \quad (34.35)$$

Since the hoop is uniform, its density is the total mass divided by the total length: $\lambda = M/(2\pi R)$. The moment of inertia is then

$$I = 4\pi \left(\frac{M}{2\pi R} \right) R^3 \quad (34.36)$$

$$= \boxed{2MR^2} \quad (34.37)$$

In this same way, we can work out the moments of inertia of a number of common geometries. The results of such calculations are shown in Figure 34.4.

34.2 Radius of Gyration

A quantity closely related to the moment of inertia is the *radius of gyration* k . Whatever the shape of a body, if all its mass were to be located at the radius gyration k , then the moment of inertia would be unchanged. The radius of gyration is given by

$$k = \sqrt{\frac{I}{m}} \quad (34.38)$$

where I is the moment of inertia and m is the mass of the body. As with moment of inertia, the radius of gyration depends upon the axis about which the body is rotated.

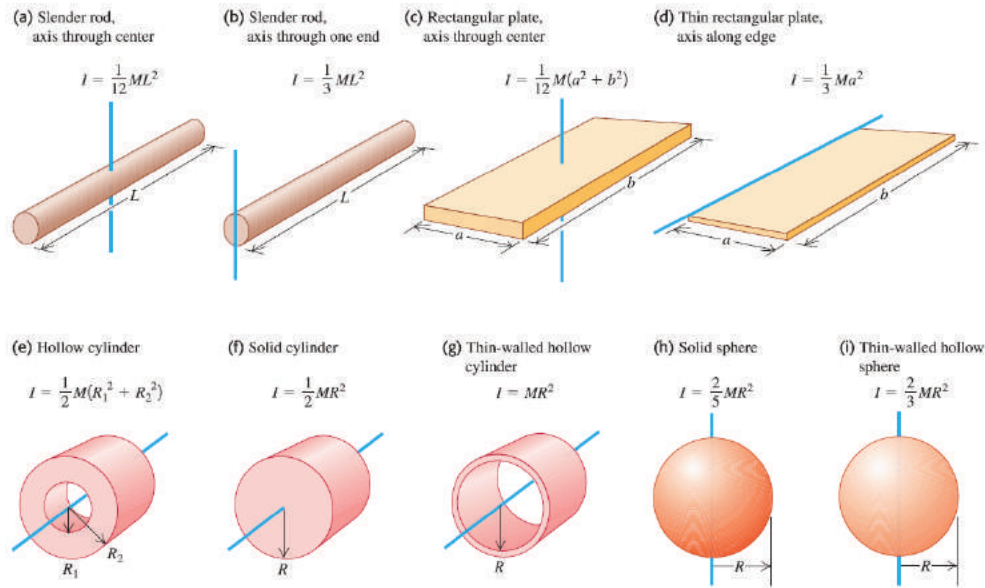

Figure 34.4: Table of moments of inertia of uniform bodies. (Credit: University of Pennsylvania.)

34.3 Parallel Axis Theorem

There are some theorems that allow us to extend Table 34-1 to other rotation axes. The most important of these is called the *parallel axis theorem* (sometimes called *Steiner's theorem*). It relates the moment of inertia I_{cm} about an axis A passing through the center of mass to the moment of inertia I about another axis parallel to A . If the two rotation axes are separated by a distance h , then

$$I = I_{\text{cm}} + Mh^2. \quad (34.39)$$

Example. Consider the fourth example in the previous section, where a hoop was rotated about an axis going through the rim of the hoop. The same result may be found much more simply using the parallel axis theorem. From Figure 34.4, the moment of inertia of the hoop when rotated about its center is $I_{\text{cm}} = MR^2$. The distance h from the center to the rim is R . Therefore, by the parallel axis theorem,

$$I = MR^2 + MR^2 = 2MR^2, \quad (34.40)$$

in agreement with the previous result.

Example. Using the parallel axis theorem, find the moment of inertia of a rod of mass M and length L about an axis perpendicular to the rod and passing through one end.

Solution. From Table 34-1, the moment of inertia about an axis perpendicular to the rod and passing through the center of mass is $I_{\text{cm}} = \frac{1}{12}ML^2$. The distance between an axis passing through the center of

mass and an axis passing through one end is $h = L/2$. Therefore, by the parallel axis theorem, we have

$$I = I_{\text{cm}} + Mh^2 \quad (34.41)$$

$$= \frac{1}{12}ML^2 + M\left(\frac{L}{2}\right)^2 \quad (34.42)$$

$$= \left(\frac{1}{12} + \frac{1}{4}\right)ML^2 \quad (34.43)$$

$$= \frac{1}{3}ML^2, \quad (34.44)$$

in agreement with the result in Table 34-1.

34.4 Plane Figure Theorem

Another, lesser known, theorem involving moments of inertia is the *plane figure theorem*, and relates to the moment of inertia of a two-dimensional (plane) figure. The theorem states that given the moments of inertia I_x and I_y of the figure about two perpendicular axes in the plane of the figure, the moment of inertia I_z about an axis perpendicular to the first two is given by

$$I_z = I_x + I_y. \quad (34.45)$$

Example. What is the moment of inertia of a uniform disk of mass M and radius R when rotated about an axis passing through the center of the disk and lying in the plane of the disk?

Solution. Define a coordinate system such that the x axis lies along the rotation axis, and the z axis is perpendicular to the disk and passing through the center of the disk. Then by symmetry, the desired moment of inertia $I = I_x = I_y$. Furthermore, we know from Table 34.4 that $I_z = \frac{1}{2}MR^2$. Therefore, by the plane figure theorem,

$$I_z = I_x + I_y. \quad (34.46)$$

which becomes

$$\frac{1}{2}MR^2 = I + I \quad (34.47)$$

so

$$I = \frac{1}{4}MR^2 \quad (34.48)$$

34.5 Routh's Rule

Routh's rule is a mnemonic formula for finding the moment of inertia of a symmetrical solid. The rule works for a circular or elliptical cylinder rotated about the cylinder axis, or for a circular or elliptical disk about any of the axes of symmetry.

Routh's rule states that the moment of inertia I of a body of mass M about an axis is given by

$$I = M \left(\frac{\text{sum of squares of the perpendicular semi-axes}}{3, 4, \text{ or } 5} \right), \quad (34.49)$$

where the denominator is 3 for a rectangular body, 4 for an elliptical body, or 5 for an ellipsoidal body.

Example

For example, consider the moment of inertia of a circular disk of radius R rotated about an axis perpendicular to the plane of the disk and passing through its center. Then the numerator in Eq. (34.49) is $R^2 + R^2 = 2R^2$, while the denominator is 4 (a circle is a special case of ellipse), so $I = M(2R^2/4) = (1/2)MR^2$.

Example

As a second example, we find the moment of inertia of a solid sphere rotated about an axis passing through its center. Then the numerator of Eq. (34.49) is $R^2 + R^2$, while the denominator is 5 (a sphere is a special case of ellipsoid); hence $I = (2/5)MR^2$.

34.6 Lees' Rule

Lees' rule, like Routh's rule, is a formula for computing the moment of inertia of a symmetrical solid. It is really a kind of mnemonic device for helping to recall several moment of inertia formulae.

Lees' rule states that the moment of inertia I of a body of mass M about an axis is given by

$$I = M \left(\frac{a^2}{3+n} + \frac{b^2}{3+n'} \right), \quad (34.50)$$

where a and b are the lengths of the semi-axes perpendicular to the rotation axis, and n and n' are the "numbers of principal curvature" that terminate semi-axes a and b , respectively ($n, n' = 0$ for a flat surface, 1 for a cylindrical surface, or 2 for a spherical surface).

Example

For example, suppose we want the moment of inertia of a rectangular plate of dimensions $\ell \times w$, about an axis through the center of the plate and perpendicular to the plane of the plate. Then $a = \ell/2$, $b = w/2$, and $n = n' = 0$ because the surfaces are flat. Then Lees' rule gives

$$I = M \left(\frac{\ell^2/4}{3} + \frac{w^2/4}{3} \right) = \frac{1}{12}M(\ell^2 + w^2). \quad (34.51)$$

Example

As another example, consider the moment of inertia of a solid cylinder of radius R rotated about its axis. In this case $a = b = R$, and $n = n' = 1$. Lees' rule in this case gives

$$I = M \left(\frac{R^2}{4} + \frac{R^2}{4} \right) = \frac{1}{2}MR^2. \quad (34.52)$$

Example

As a third example, consider the moment of inertia of a solid cylinder of radius R and length ℓ rotated about an axis perpendicular to the cylinder axis, and passing through the center of the cylinder. In this case, $a = R$, $b = \ell/2$, $n = 1$, and $n' = 0$. Then Lees' rule gives

$$I = M \left(\frac{R^2}{4} + \frac{\ell^2/4}{3} \right) = M \left(\frac{R^2}{4} + \frac{\ell^2}{12} \right) \quad (34.53)$$

Chapter 35

Torque

35.1 Introduction

Torque is the rotational counterpart of force. Suppose a body rotates about an axis and a force F is applied some distance r from the axis (Fig. 35.1). The distance from the rotation axis to the point at which the force is applied is called the *moment arm*. If the force is applied perpendicular to the moment arm (Fig. 35.1(a)), then torque τ is defined as

$$\tau = Fr. \quad (35.1)$$

Torque in SI units is measured in units of newton-meters (N m); in CGS units it is measured in dyne-centimeters (dyn cm); and in British engineering units, it is measured in foot-pounds (ft lbf).

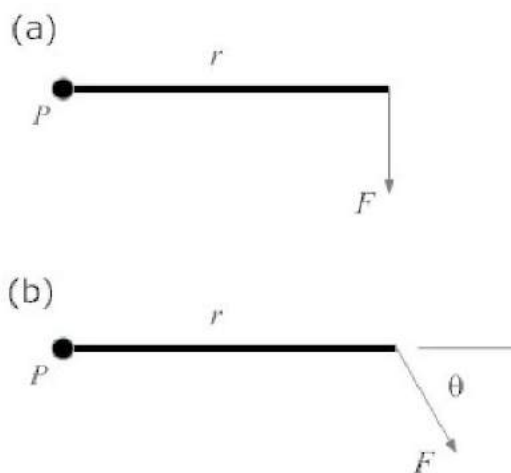

Figure 35.1: Torque on a rod that pivots about point P . (a) Force F applied normal to the rod; (b) force F applied obliquely.

More generally, suppose the force is applied at some angle θ to the moment arm (Fig. 35.1(b)). Then only the *component* of the force F perpendicular to the moment arm contributes to the torque:

$$\tau = Fr \sin \theta. \quad (35.2)$$

Torque is actually a *vector* quantity. Its magnitude is as described above; its direction is perpendicular to the plane containing the force and the moment arm. Let \mathbf{r} be a vector pointing from the rotation axis to the point at which the force is applied. Then the torque vector $\boldsymbol{\tau}$ is defined as

$$\boldsymbol{\tau} = \mathbf{r} \times \mathbf{F}. \quad (35.3)$$

The direction of $\boldsymbol{\tau}$ is given by a right-hand rule: if you curl the fingers of your right hand from \mathbf{r} into \mathbf{F} , then the thumb of your right hand points in the direction of $\boldsymbol{\tau}$.

35.2 Rotational Version of Hooke's Law

There is a rotational counterpart of Hooke's law:

$$\tau = -\kappa\theta, \quad (35.4)$$

where κ is the spring constant, in units of N m rad^{-1} . This version of Hooke's law applies to something like a torsional pendulum, in which a mass suspended by a wire is allowed to twist back and forth.

35.3 Couples

A *couple* is two forces, equal in magnitude and opposite in direction, but which are separated by some distance (Figure 35.2). Since the two forces are equal and opposite, a couple results in zero net force on the body. However, it does result in a *torque* on the body. If the forces act along lines separated by a distance l , then the torque τ acting on the body due to the couple is given by

$$\tau = Fl \quad (35.5)$$

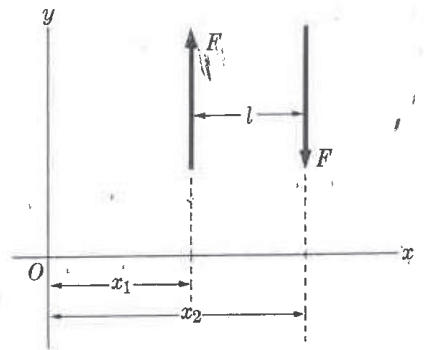

Figure 35.2: A couple. The torque here is $Fx_2 - Fx_1 = F(x_2 - x_1) = Fl$.

Chapter 36

Measuring the Moment of Inertia

Measuring the mass of a body is easy: place the body on a scale or beam balance, and read the mass directly. Measuring the moment of inertia of a body is not quite as easy; here we describe two methods that could be used to measure a body's moment of inertia.

36.1 Torque Method

The first method involves building a device specifically for the purpose (Figure 36.1).

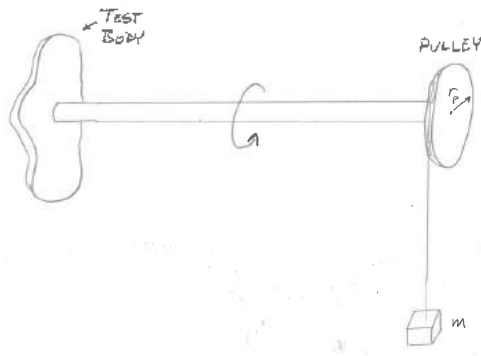

Figure 36.1: A simple device for measuring the moment of inertia.

A rotating rod has a pulley at one end and the body to be measured attached to the other end. A string with a weight of mass m at one end is wrapped around the pulley, so that the falling weight will unwrap the string. If the pulley has radius r_p , then the falling weight will apply a force mg to the pulley, which will result in a torque mgr_p on the pulley. This torque is then applied to the pulley, to the rod, and to the test body at the other end of the rod. The rotation angle of the pulley at any time t is thus given by

$$\theta = \frac{1}{2}\alpha t^2 = \frac{1}{2}\frac{\tau}{I}t^2 \quad (36.1)$$

where α is the angular acceleration, which, by the rotational version of Newton's second law, is equal to τ/I , where $\tau = mgr_p$ is the torque and I is the total moment of inertia, including the pulley, the test body, and

the rod. Let's write this total moment of inertia as

$$I = I_p + I_r + I_b \quad (36.2)$$

where I_p is the moment of inertia of the pulley, I_r is the moment of inertia of the rod, and I_b is the moment of inertia of the test body, which is what we're trying to measure. The rotation angle θ is given by $\theta = 2\pi N$, where N is the number of revolutions of the pulley. But N is also equal to the total length L of the string divided by the circumference of the pulley: $N = L/(2\pi r_p)$. Thus

$$\theta = 2\pi \frac{L}{2\pi r_p} = \frac{L}{r_p} \quad (36.3)$$

Combining all these results, Eq. (36.1) becomes

$$\frac{L}{r_p} = \frac{1}{2} \frac{m g r_p}{I_p + I_r + I_b} t^2 \quad (36.4)$$

Solving for the moment of inertia of the body,

$$I_b = \frac{m g r_p^2 t^2}{2L} - I_p - I_r \quad (36.5)$$

The pulley and rod are both disks, so their respective moments of inertia are $I_p = \frac{1}{2} m_p r_p^2$ and $I_r = \frac{1}{2} m_r r_r^2$, where m_p and r_p are the mass and radius of the pulley, and m_r and r_r the mass and radius of the rod. Equation (36.6) then becomes

$$I_b = \frac{r_p^2}{2} \left(\frac{m g t^2}{L} - m_p \right) - \frac{1}{2} m_r r_r^2 \quad (36.6)$$

To use the machine, we attach the test body to the end of the rod opposite the weight, wrap the string around the pulley, release the weight, and measure how much time t it takes the string to completely unwind. The moment of inertia of the test body is then given by Eq. (36.6). The weight m can be adjusted so that the unwinding time t is long enough to be measured easily (say, several seconds).

36.2 Pendulum Method

A second method for measuring a body's moment of inertia has been described by Rhett Allain of Southeastern Louisiana University.¹ The idea of this method is to attach the body to be measured to a long string, forming a physical pendulum. One measures the period T of the pendulum at a variety of different lengths L . Now recall that the period T of a physical pendulum is given by

$$T = 2\pi \sqrt{\frac{I}{m g L}} \quad (36.7)$$

Solving for the moment of inertia, we get

$$I = \frac{T^2 m g L}{4\pi^2} \quad (36.8)$$

¹<https://www.wired.com/2017/05/physics-of-a-fidget-spinner/>

By the parallel-axis theorem,

$$I = I + mL^2 \quad (36.9)$$

Combining these equations, we get

$$\frac{T^2mgL}{4\pi^2} = I + mL^2 \quad (36.10)$$

If we plot the left-hand side vs. L^2 , we will get a straight line of slope m and ordinate intercept equal to the moment of inertia I .

In summary, the steps for measuring the moment of inertia are:

1. Attach the test object to the end of a string, forming a physical pendulum.
2. Measure the period T of the pendulum at various lengths L .
3. Perform a linear regression analysis on the data (treating L^2 as the independent variable, and $T^2mgL/4\pi^2$ as the dependent variable).
4. The ordinate intercept is then the desired moment of inertia.

Chapter 37

Newton's Laws of Motion: Rotational Versions

Newton's three laws of motion have rotational counterparts. The rotational version of Newton's laws of motion are:

1. *Law of Rotational Inertia.* A body at rest (non-rotating) will remain at rest, and a body rotating with constant angular velocity will continue rotating with that same angular velocity, unless acted upon by some outside torque.
2. $\tau = I\alpha$: If a torque τ is applied to a body of moment of inertia I , it will accelerate with angular acceleration $\alpha = \tau/I$.
3. Torques always come in pairs that act in opposite directions. If body 1 acts on body 2 with a torque τ , then body 2 will act back on body 1 with torque τ (equal in magnitude and opposite in direction).

37.1 First Law of Rotational Motion

The rotational form of Newton's first law states that bodies have a property called *rotational inertia*, which means that once given an initial angular velocity, they will continue spinning with that same angular velocity forever, unless acted upon by some outside torque. Nobody knows why this is; just like with linear inertia, it's just the way the Universe works.

37.2 Second Law of Rotational Motion

The rotational form of Newton's second law of motion states that the torque τ on a body is proportional to its resulting angular acceleration α :

$$\tau = I\alpha. \tag{37.1}$$

When a torque τ is applied to a body, its spinning will accelerate with angular acceleration $\alpha = \tau/I$ —the larger the moment of inertia, the smaller the angular acceleration.

If the torque τ is a function of angle, and using acceleration $\alpha = d^2\theta/dt^2$, this becomes a differential equation

$$\tau(\theta) = I \frac{d^2\theta}{dt^2}. \tag{37.2}$$

Solving this differential equation for $\theta(t)$ gives a complete description of the rotational motion.

The most general form of Newton's second law is *not* $\tau = I\alpha$, but $\tau = dL/dt$, where L is the angular momentum. This reduces to $\tau = I\alpha$ when the moment of inertia is constant.

The rotational form of Newton's second law may also be expressed in vector form:

$$\boldsymbol{\tau} = I\boldsymbol{\alpha}, \quad (37.3)$$

where $\boldsymbol{\alpha}$ is the angular acceleration *vector*, which lies along the axis of rotation. Most generally, the moment of inertia I is a *tensor*, i.e. a 3×3 matrix, so that $\boldsymbol{\tau}$ and $\boldsymbol{\alpha}$ do not necessarily lie in the same direction.

37.3 Third Law of Rotational Motion

The rotational form of Newton's third law of motion states that torques always come in pairs that act in opposite directions. For example, imagine an astronaut floating in space next to a space capsule. He has a wrench in his hand, and wishes to tighten a bolt on the spacecraft. But if he uses the wrench to turn the bolt clockwise, the bolt will, in turn, apply a torque back on him, and the astronaut will rotate himself counterclockwise. To avoid this, the astronaut can anchor his feet to the space capsule. The same thing will still happen, but this time the astronaut *and* the capsule will rotate counterclockwise. Since the capsule's moment of inertia is so large, the angular acceleration of the capsule $\alpha = \tau/I$ will be very small.

The rotational form of Newton's third law may be used to advantage in controlling spacecraft attitude (orientation). Spacecraft contain a set of spinning wheels called *reaction wheels*. By applying a torque to one of these wheels, the spacecraft can be rotated in the opposite direction.

Chapter 38

The Pendulum

38.1 Introduction

A *pendulum* is a body that is supported from a pivot point and allowed to swing back and forth under the influence of gravity. Among their other uses, pendulums were an essential component of clocks for centuries.

38.2 The Simple Plane Pendulum

A *simple plane pendulum* is a pendulum that consists of a point mass m at the end of a string of length L of negligible mass (Fig. 38.1). The pendulum is displaced from vertical by an angle θ_0 and released; after that, it swings back and forth under the influence of gravity. The pendulum is constrained to swing back and forth in a plane.

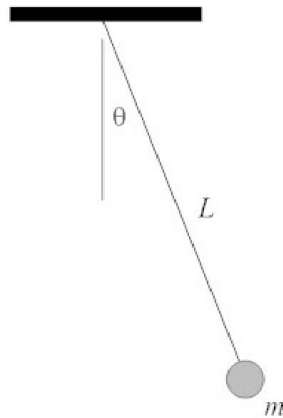

Figure 38.1: A simple plane pendulum.

When the pendulum makes an angle θ from the vertical, the torque acting to move it back toward vertical

is $-mgL \sin \theta$. Then by the rotational version of Newton's second law of motion,

$$\tau = I\alpha \quad (38.1)$$

$$-mgL \sin \theta = mL^2 \frac{d^2\theta}{dt^2} \quad (38.2)$$

$$\frac{d^2\theta}{dt^2} = -\frac{g}{L} \sin \theta \quad (38.3)$$

This is a second-order differential equation that is fairly difficult to solve; the solution is shown in Appendix S. If we constrain the pendulum to *small* angles θ , then we can make the approximation

$$\sin \theta \approx \theta \quad (\theta \text{ in radians}). \quad (38.4)$$

Under this approximation, Eq. (38.3) becomes

$$\frac{d^2\theta}{dt^2} = -\frac{g}{L}\theta. \quad (38.5)$$

This is a second-order differential equation that's fairly easy to solve; you'll learn how to solve differential equations like this in a course on differential equations. The solution turns out to be

$$\theta(t) = \theta_0 \cos(\omega t + \delta), \quad (38.6)$$

where θ_0 is the (angular) *amplitude* of the motion (in radians), $\omega = \sqrt{g/L}$ is the angular frequency of the motion (rad/s), and δ is an arbitrary integration constant (seconds). The solution can be verified by direct substitution into Eq. (38.5).

The period T of the motion (the time required for one complete back-and-forth cycle) is given by

$$T = \frac{2\pi}{\omega}, \quad (38.7)$$

or

$$\boxed{T = 2\pi \sqrt{\frac{L}{g}}}. \quad (38.8)$$

Remember that this is an approximation, and is valid only for small θ . The period of motion for a large period is given by an infinite series, and is shown in Appendix S.

38.3 The Spherical Pendulum

A *spherical pendulum* is similar to a simple plane pendulum, except that the pendulum is not constrained to move in a plane; the mass m is free to move in two dimensions along the surface of a sphere. Figure 38.2 shows a photograph of the movement of a spherical pendulum.

38.4 The Conical Pendulum

A *conical pendulum* is also similar to a simple plane pendulum, except that the pendulum is constrained to move along the surface of a cone, so that the mass m moves in a horizontal circle of radius r , maintaining a constant angle θ from the vertical.

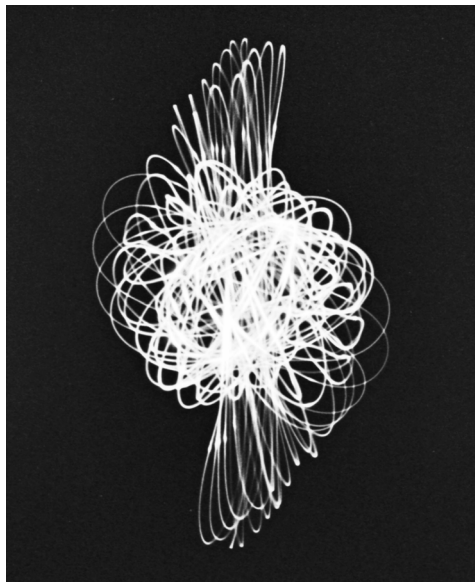

Figure 38.2: Trace of the motion of a spherical pendulum, made by the author. A flashlight lens was covered with a piece of cardboard in which a small hole was punched. The flashlight was then suspended by a string from the ceiling (lens downward) to create a pendulum. The room was then darkened, the flashlight turned on, and the flashlight pendulum allowed to swing back and forth for several minutes above a camera which was on the floor pointing up toward the ceiling. The camera shutter was kept open, allowing this time-exposure image to be made on the film. (*Image Copyright © 2011 D.G. Simpson.*)

For a conical pendulum, we might ask: what speed v must the pendulum bob have in order to maintain an angle θ from the vertical? To solve this problem, let the pendulum have length L , and let the bob have mass m . A general approach to solving problems involving circular motion like this is to identify the force responsible for keeping the mass moving in a circle, then set that equal to the centripetal force mv^2/r . In this case, the force keeping the mass moving in a circle is the horizontal component of the tension T , which is $T \sin \theta$. Setting that equal to the centripetal force, we have

$$T \sin \theta = \frac{mv^2}{r}. \quad (38.9)$$

The vertical component of the tension is

$$T \cos \theta = mg \quad (38.10)$$

Dividing Eq. (38.9) by Eq. (38.10),

$$\tan \theta = \frac{v^2}{gr} \quad (38.11)$$

From geometry, the radius r of the circle is $L \sin \theta$. Making this substitution, we have

$$\tan \theta = \frac{v^2}{gL \sin \theta}. \quad (38.12)$$

Solving for the speed v , we finally get

$$v = \sqrt{Lg \sin \theta \tan \theta}. \quad (38.13)$$

38.5 The Torsional Pendulum

A *torsional pendulum* (Fig. 38.3) consists of a mass m attached to the end of a vertical wire. The body is then rotated slightly and released; the body then twists back and forth under the force of the twisting wire. As described earlier, the motion is governed by the rotational version of Hooke's law, $\tau = -\kappa\theta$.

38.6 The Physical Pendulum

A *physical pendulum* consists of an extended body that allowed to swing back and forth around some pivot point. If the pivot point is at the center of mass, the body will not swing, so the pivot point should be displaced from the center of mass. As an example, you can form a physical pendulum by suspending a meter stick from one end and allowing to swing back and forth.

In a physical pendulum of mass M , there is a force Mg acting on the center of mass. Suppose the body is suspended from a point that is a distance h

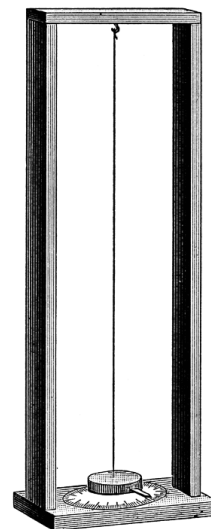

Figure 38.3: A torsional pendulum. (Ref. [1])

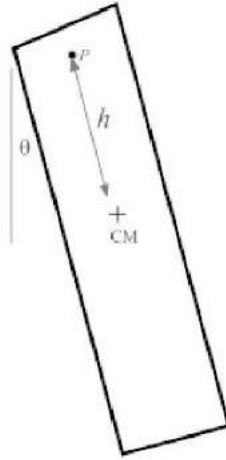

Figure 38.4: A physical pendulum. The object has mass M and is suspended from point P ; h is the distance between P and the center of mass.

from the center of mass (Fig. 38.4). Then there is a weight force Mg acting on the center of mass of the body, which creates a torque $-Mgh \sin \theta$ about the pivot point. Then by the rotational version of Newton's second law,

$$\tau = I\alpha \quad (38.14)$$

$$-Mgh \sin \theta = I \frac{d^2\theta}{dt^2}, \quad (38.15)$$

where I is the moment of inertia of the body when rotated about its pivot point. As with the simple plane pendulum, this is a second-order differential equation that is difficult to solve. But if we constrain the oscillations to small amplitudes, we can make the approximation $\sin \theta \approx \theta$ as before, and the equation becomes

$$\frac{d^2\theta}{dt^2} = -\frac{Mgh}{I}\theta. \quad (38.16)$$

We can solve this second-order differential equation as before, and get

$$\theta(t) = \theta_0 \cos(\omega t + \delta), \quad (38.17)$$

where θ_0 is the (angular) amplitude of the motion (in radians), $\omega = \sqrt{Mgh/I}$ is the angular frequency of the motion (rad/s), and δ is an arbitrary integration constant (seconds). The solution can be verified by direct substitution into Eq. (38.16).

The period T of the motion (the time required for one complete back-and-forth cycle) is given by

$$T = \frac{2\pi}{\omega}, \quad (38.18)$$

or

$$T = 2\pi \sqrt{\frac{I}{Mgh}}. \quad (38.19)$$

38.7 Other Pendulums

- *Double pendulum.* A *double pendulum* is formed by attaching one pendulum to the bob of another, so that the two pendulums are attached vertically and both bobs are free to move. The motion of a double pendulum is a classic exercise in Lagrangian mechanics, to be described later.
- *Ballistic pendulum.* A *ballistic pendulum* is a type of pendulum used to measure the speed of high-speed objects like bullets. The ballistic pendulum is described in Chapter 29.
- *Foucault pendulum.* A *Foucault pendulum* is a type of simple plane pendulum that is used to demonstrate the rotation of the Earth. As the pendulum swings back and forth in a plane, the Earth rotates underneath the pendulum, causing its trace along the ground to drift with time.

Chapter 39

Simple Harmonic Motion

The small-angle approximation of the simple plane pendulum is an example of what is called *simple harmonic motion*. Simple harmonic motion is the motion that a particle exhibits when under the influence of a force of the form given by *Hooke's law* (named for the 17th century English scientist Robert Hooke):

$$F = -kx. \quad (39.1)$$

A force of this form describes, for example, the force on a mass attached to a spring with spring constant k , where k is a measure of the stiffness of the spring. In this case F is the force exerted by the spring, and x is the distance of the mass from its *equilibrium position*—that is, the “resting” position at which the mass can be left where it will not oscillate.

Substituting Hooke's law as the force in Newton's second law $F = ma$ (and recalling the acceleration $a = d^2x/dt^2$) gives the equation

$$-kx = m \frac{d^2x}{dt^2}. \quad (39.2)$$

This is a second-order linear differential equation with constant coefficients, and can be solved for $x(t)$ using standard methods from the theory of differential equations. We won't go into the theory of differential equations here, but just present the result. The solution is

$$x(t) = A \cos(\omega t + \delta). \quad (39.3)$$

Here ω is called the *angular frequency* of the motion, and measures how fast the particle oscillates back and forth. The constant A is called the *amplitude* of the motion, and is the maximum distance the particle travels from its equilibrium position, $x = 0$. The constant δ called the *phase constant*, and determines where in its cycle the particle is at time $t = 0$. A plot of $x(t)$ is shown in Fig. 39.1.

Since the sine and cosine function differ only by a phase shift ($\sin \theta \equiv \cos(\theta - \pi/2)$), we could replace the cosine function in Eq. (39.3) with a sine by simply adding an extra $\pi/2$ to the phase constant δ . So either the sine or the cosine can be used equally well to describe simple harmonic motion; here we will choose to use the cosine function.

The calculus may also be used to find the velocity of the particle at any time t ; the result is

$$v(t) = -A\omega \sin(\omega t + \delta). \quad (39.4)$$

so that the maximum speed of the simple harmonic oscillator is

$$|v_{\max}| = A\omega \quad (39.5)$$

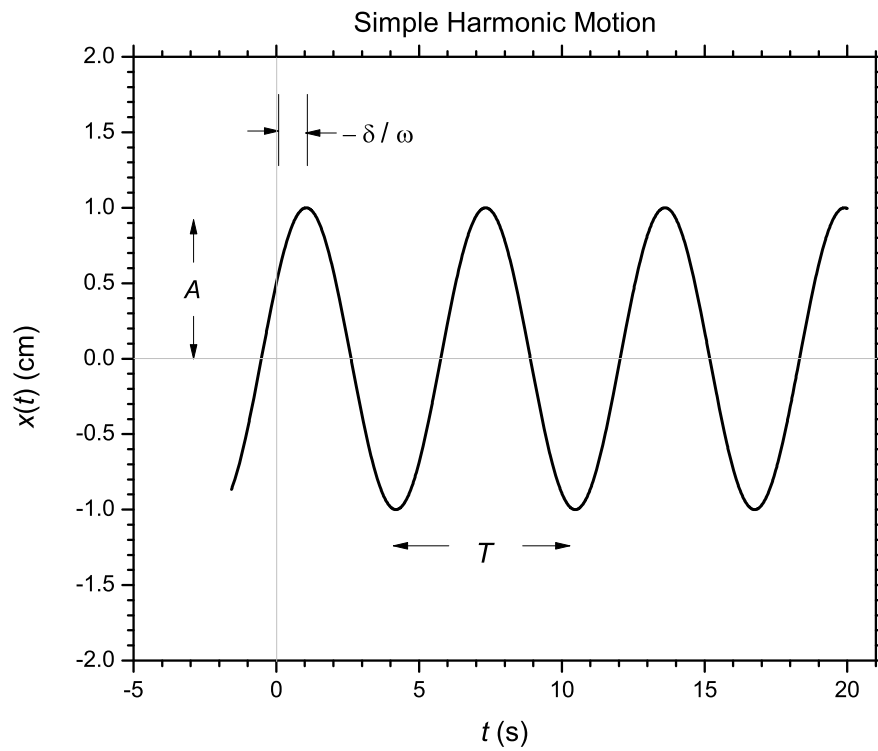

Figure 39.1: Simple harmonic motion. Shown are the amplitude A , period T , and phase constant δ . The horizontal line $x(t) = 0$ is the equilibrium position.

Further, it can be shown that the acceleration at any time t is

$$a(t) = -A\omega^2 \cos(\omega t + \delta) \quad (39.6)$$

$$= -\omega^2 x(t). \quad (39.7)$$

Multiplying Eq. (39.7) by the particle mass m , we find

$$ma(t) = F(t) = -m\omega^2 x(t). \quad (39.8)$$

Comparing this with Eq. (39.1) we see that

$$k = m\omega^2, \quad (39.9)$$

or

$$\omega = \sqrt{\frac{k}{m}}. \quad (39.10)$$

In Eq. (39.3), the amplitude A depends on how far the particle was displaced from equilibrium before being released; the phase constant δ just depends on when we choose time $t = 0$; but the angular frequency ω depends on the physical parameters of the system: the stiffness of the spring k and the mass of the particle m .

39.1 Energy

The kinetic energy K of a particle of mass m moving with speed v is defined to be the work required to accelerate the particle from rest to speed v ; this is found to be

$$K = \frac{1}{2}mv^2. \quad (39.11)$$

From Hooke's law, the potential energy U of a simple harmonic oscillator particle at position x can be shown to be

$$U = \frac{1}{2}kx^2. \quad (39.12)$$

The *total* mechanical energy $E = K + U$ of a simple harmonic oscillator can be found by observing that when $x = \pm A$, we have $v = 0$, and therefore the kinetic energy $K = 0$ and the total energy is all potential. Since the potential energy at $x = \pm A$ is $U = kA^2/2$ (by Eq. (39.12)), the total energy must be

$$E = \frac{1}{2}kA^2. \quad (39.13)$$

Since total energy is conserved, the energy E is constant and does not change throughout the motion, although the kinetic energy K and potential energy U do change.

In a simple harmonic oscillator, the energy sloshes back and forth between kinetic and potential energy, as shown in Fig. 39.2. At the endpoints of its motion ($x = \pm A$), the oscillator is momentarily at rest, and the energy is entirely potential; when passing through the equilibrium position ($x = 0$), the energy is entirely kinetic. In between, kinetic energy is being converted to potential energy or vice versa.

We can find the velocity v of a simple harmonic oscillator as a function of position x (rather than time t) by writing an expression for the conservation of energy:

$$E = K + U \quad (39.14)$$

$$\frac{1}{2}kA^2 = \frac{1}{2}mv^2 + \frac{1}{2}kx^2 \quad (39.15)$$

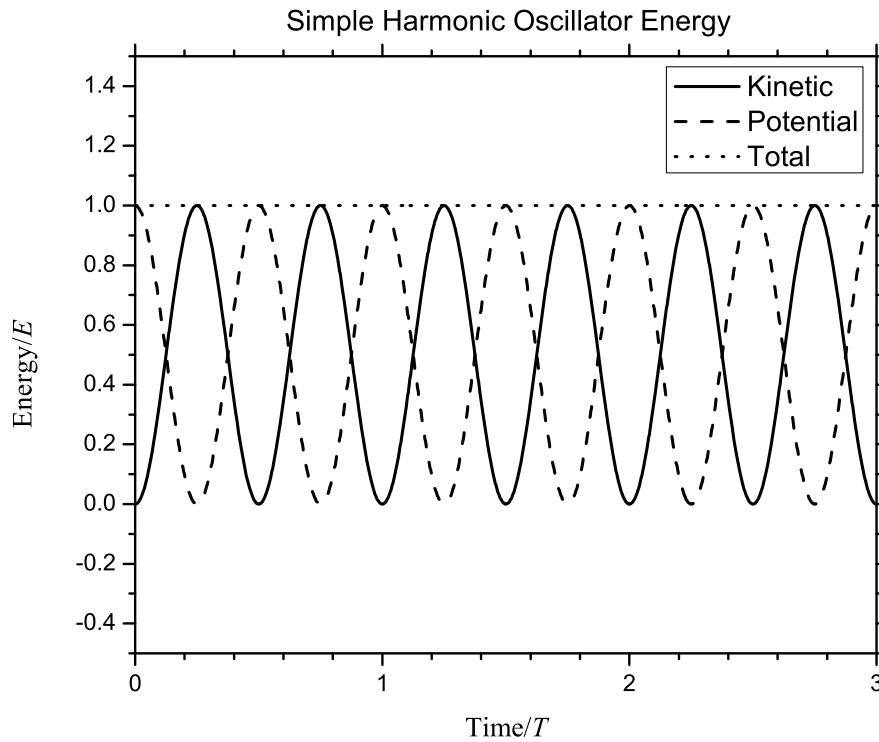

Figure 39.2: Kinetic, potential, and total energy of the simple harmonic oscillator as a function of time. The oscillator continuously converts potential energy to kinetic energy and back again, but the total energy E remains constant.

Solving for v , we find

$$v(x) = \pm A \sqrt{\frac{k}{m}} \sqrt{1 - \frac{x^2}{A^2}}. \quad (39.16)$$

This can be simplified somewhat by using Eq. (39.10) to give

$$v(x) = \pm A\omega \sqrt{1 - \frac{x^2}{A^2}}, \quad (39.17)$$

where $A\omega$ is, by inspection of Eq. (39.4), the maximum speed of the oscillator (the speed it has while passing through the equilibrium position).

39.2 Frequency and Period

The angular frequency ω described earlier is a measure of how fast the oscillator oscillates; specifically, it measures how many radians of its motion the oscillator moves through each second, where one complete cycle of motion is 2π radians. A related quantity is the *frequency* f , which describes how many complete cycles of motion the oscillator moves through per second. The two frequencies are related by

$$\omega = 2\pi f. \quad (39.18)$$

You can think of ω and f as really being the same thing, but measured in different units. The angular frequency ω is measured in units of radians per second (rad/s); the frequency f is measured in units of hertz (Hz), where $1 \text{ Hz} = 1/\text{sec}$.

The reciprocal of the frequency is the *period* T , and is the time required to complete one cycle of the motion:

$$T = \frac{1}{f} = \frac{2\pi}{\omega}. \quad (39.19)$$

The period is measured in units of seconds. As shown in the plot of $x(t)$ (Fig. 39.1), the period T is the time between peaks in the motion.

39.3 The Vertical Spring

If a horizontal mass on a spring is turned to a vertical position, then the spring is stretched by an amount $x_0 = mg/k$, giving it a new equilibrium position. For the vertical spring, the potential energy is still given by $U = \frac{1}{2}kx^2$, but x in this case refers to the distance from the *original* (horizontal) equilibrium position.

39.4 Frequency and Period

The angular frequency ω described earlier is a measure of how fast the oscillator oscillates; specifically, it measures how many radians of its motion the oscillator moves through each second, where one complete cycle of motion is 2π radians. A related quantity is the *frequency* f , which describes how many complete cycles of motion the oscillator moves through per second. The two frequencies are related by

$$\omega = 2\pi f. \quad (39.20)$$

You can think of ω and f as really being the same thing, but measured in different units. The angular frequency ω is measured in units of radians per second (rad/s); the frequency f is measured in units of hertz (Hz), where $1 \text{ Hz} = 1/\text{sec}$.

The reciprocal of the frequency is the *period* T , and is the time required to complete one cycle of the motion:

$$T = \frac{1}{f} = \frac{2\pi}{\omega}. \quad (39.21)$$

The period is measured in units of seconds. As shown in the plot of $x(t)$ (Fig. 39.1), the period T is the time between peaks in the motion.

39.5 Mass on a Spring

The discussion so far has applied to simple harmonic motion in general; there are many specific examples of physical systems that act as simple harmonic oscillators. The most commonly cited example is a mass m on a spring with spring constant k . The spring constant k is a measure of how stiff the spring is, and is measured in units of newtons per meter (N/m). Specifically, k describes how much force the spring exerts per unit distance it is extended or compressed.

A mass on a spring oscillates with angular frequency

$$\omega = \sqrt{\frac{k}{m}}, \quad (39.22)$$

and therefore has period $T = 2\pi/\omega$, or

$$T = 2\pi \sqrt{\frac{m}{k}}. \quad (39.23)$$

It really doesn't matter whether a mass on a spring moves horizontally on a frictionless surface, or bobs up and down vertically. The motion is the same—the only difference is that if you take a horizontal spring and hang it vertically, the equilibrium position will change because of gravity. The period and frequency of motion will be the same.

The importance of the spring example is not that there are government laboratories filled with researchers studying springs; rather the spring example serves as an important model and approximation for other problems. Often even a complicated force can be *approximated* as a linear force (Eq. (39.1)) over some limited range. In this case one may approximately model the force as a spring force with an “effective spring constant” k , and allow at least an approximate answer to what might otherwise be a difficult problem.

There are several other examples of systems that form simple harmonic oscillators: the torsional pendulum, the simple plane pendulum, a ball rolling back and forth inside a bowl, etc.

39.6 More on the Spring Constant

It is often not appreciated that the spring constant k depends not only on the *rigidity* of the spring, but also on the diameter of the spring and the total number of turns of wire in the spring. Consider a vertical spring with spring constant k , and a mass m hanging on one end. Assume the system is in its equilibrium position, and in this position it has length L_0 and consists of N turns of wire. Now if you apply an additional downward force F to the mass, the string will stretch by an additional amount x given by Hooke's law: $x = F/k$. This stretching will manifest itself as an additional spacing of x/N between adjacent turns of the spring. It is this additional spacing per turn that is the true measure of the inherent “stiffness” of the spring.

Now suppose this spring is cut in half and put in its equilibrium position. Its new length will be $L_0/2$, and will consist of $N/2$ turns of wire. When the same additional force F is applied to the mass m , the additional spacing between adjacent turns of the spring will be the same as before, x/N , because the spring still has

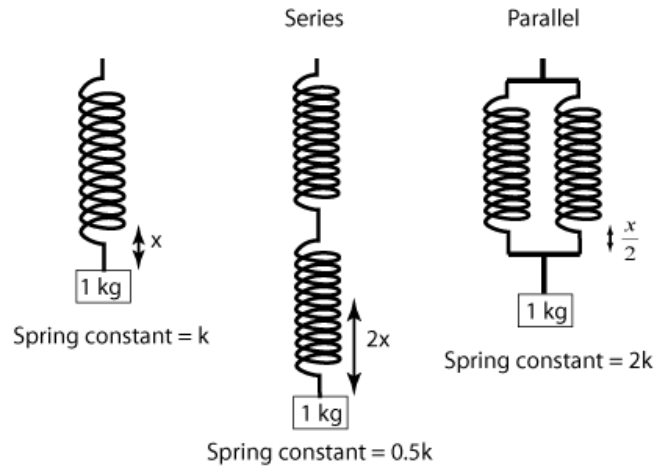

Figure 39.3: Springs in series and parallel (Credit: <http://spmphysics.onlinetuition.com.my>).

the same stiffness. Since the number of turns is now $N/2$, this means that the additional total stretching of the spring is $x/2$, so it will stretch by only half as much as before. By Hooke's law, the spring constant is now $k' = F/(x/2) = 2F/x = 2k$, so the spring constant is now twice what it was before. In other words, *cutting the spring in half will double the spring constant*. Likewise, doubling the length (number of turns) of the spring will halve its spring constant.

Another way to think of this is to consider two springs connected in series or in parallel (Fig. 39.3). If several springs are connected end-to-end (i.e. *in series*), then the equivalent spring constant k_s of the system will be given by

$$\frac{1}{k_s} = \sum_i \frac{1}{k_i} \quad (39.24)$$

$$= \frac{1}{k_1} + \frac{1}{k_2} + \frac{1}{k_3} + \dots \quad (39.25)$$

If the springs are connected *in parallel*, then the equivalent spring constant k_p of the system will be

$$k_p = \sum_i k_i \quad (39.26)$$

$$= k_1 + k_2 + k_3 + \dots \quad (39.27)$$

For example, if two identical springs, each of spring constant k , are connected in series, then the combination will have an equivalent spring constant of $k/2$. If the two identical springs were instead connected in parallel, then the combination would have an equivalent spring constant of $2k$, as shown in Figure (39.3).

Now imagine you have a long spring of spring constant k . You can imagine it as being two identical springs connected in series, each having spring constant $2k$, so that the combination has a total equivalent spring constant of $[(1/2k) + (1/2k)]^{-1} = k$. If the long spring is cut in half, then you are left with only one of those smaller springs of spring constant $2k$, so again we reach the conclusion that cutting the spring in half will double the spring constant.

It's possible to calculate the spring constant from the geometry of the spring. The formula is ¹

$$k = \frac{Gd^4}{8ND^3} \quad (39.28)$$

where d is the wire diameter, N is the number of active turns in the spring, D is the coil diameter (measured from the *center* of the wire), and G is called the *modulus of rigidity* of the spring material; G is given by

$$G = \frac{Y}{2(1 + \nu)} \quad (39.29)$$

where Y is the *Young's modulus* of the material (a measure of how much it stretches when pulled or compressed), and ν is the material's *Poisson ratio* (a measure of how much it squeezes sideways when compressed). These are properties that are characteristic of the material, and can be looked up in a handbook of material properties. Values for a few materials are shown in the table below.

Table 39-1. Young's Moduli and Poisson Ratios.

Material	Young's Modulus Y (N/m ²)	Poisson Ratio ν
Aluminum	69×10^9	0.334
Bronze	100×10^9	0.34
Copper	117×10^9	0.355
Lead	14×10^9	0.431
Magnesium	45×10^9	0.35
Stainless steel	180×10^9	0.305
Titanium	110×10^9	0.32
Wrought iron	200×10^9	0.278

Notice from Eq. (39.28) that if the spring is cut in half, N will be half its original value, and so the spring constant k will be doubled, in agreement with what we've found earlier.

Example. Suppose we make a spring of 1 mm diameter copper wire, the diameter of the spring is 1 cm, and there are 50 turns of wire in the spring. What is the spring constant?

Solution. From the above table, for copper, $Y = 117 \times 10^9$ N/m² and $\nu = 0.355$. From Eq. (39.29), we have

$$G = \frac{Y}{2(1 + \nu)} = \frac{117 \times 10^9 \text{ N/m}^2}{2(1 + 0.355)} = 43.2 \times 10^9 \text{ N/m}^2$$

And the spring constant is found from Eq. (39.28)

$$k = \frac{Gd^4}{8ND^3} = \frac{(43.2 \times 10^9 \text{ N/m}^2)(10^{-3} \text{ m})^4}{8(50)(10^{-2} \text{ m})^3} = 108 \text{ N/m}$$

¹See e.g. http://www.engineersedge.com/spring_comp_calc_k.htm

Chapter 40

Rocking Bodies

Another example of simple harmonic motion is that of a *rocking body* — a body that, as it rotates, will experience a torque that tends to return it to an equilibrium position. A rocking chair is a common example.

40.1 The Half-Cylinder

To analyze rocking motion, let's consider a fairly simple body: a uniform right circular cylinder of radius r that has been cut in half by a plane passing through the axis of the cylinder to form a half-cylinder, whose cross-section is a semicircle (Figure 40.1), and which is resting on a flat table. Let m be the mass of the half-cylinder.

It can be shown using the multivariate calculus that the distance p between the axis S and the center of mass T is

$$p = \frac{4r}{3\pi} \quad (40.1)$$

We will need to find the moment of inertia I_H of the half-cylinder when rotated about an axis that lies along the line of contact between the half-cylinder and the table. We'll find this by first finding the moment of inertia I_T about an axis parallel to the half-cylinder axis and passing through the center of mass T ; from that, we can then use the parallel axis theorem to find I_H . We'll find I_T by first finding I_S , the moment of inertia when rotated about the cylinder axis. In summary, we'll find I_S , then I_T , then I_H .

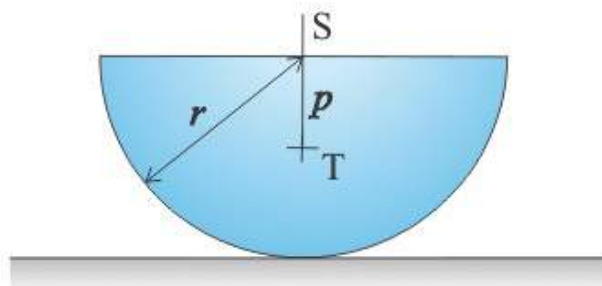

<http://physicstasks.eu/>

Figure 40.1: Rocking half-cylinder. The center of mass is at point T .

To find I_S , note that if we take two half-cylinders and place their flat ends together, we will have a full cylinder of mass $2m$ and moment of inertia equal to the sum of the moments of inertia of the two half-cylinders, $I_S + I_S$. The moment of inertia of a solid cylinder when rotated about its axis is $1/2$ its mass times the square of its radius, so this full cylinder would have moment of inertia

$$I_S + I_S = \frac{1}{2}(2m)r^2 \quad (40.2)$$

so

$$I_S = \frac{1}{2}mr^2 \quad (40.3)$$

For the half-cylinder, the moments of inertia I_S and I_T are related by the parallel-axis theorem,

$$I_S = I_T + mp^2 \quad (40.4)$$

and the moments of inertia I_T and I_H are related by (again using the parallel-axis theorem),

$$I_H = I_T + m(r - p)^2 \quad (40.5)$$

and so

$$I_H = (I_S - mp^2) + m(r - p)^2 \quad (40.6)$$

$$= \left(\frac{1}{2}mr^2 - mp^2\right) + m(r - p)^2 \quad (40.7)$$

$$= \frac{1}{2}mr^2 - mp^2 + mr^2 - 2mrp + mp^2 \quad (40.8)$$

$$= \frac{3}{2}mr^2 - 2mrp \quad (40.9)$$

$$= \frac{3}{2}mr^2 - 2mr \left(\frac{4r}{3\pi}\right) \quad (40.10)$$

or

$$I_H = mr^2 \left(\frac{3}{2} - \frac{8}{3\pi}\right) \quad (40.11)$$

Now we'll find the period of oscillation using conservation of energy. Let's rock the cylinder by some small angle α_0 (Figure 40.2). In this position, the cylinder is momentarily at rest, so it has zero kinetic energy. It *does* have a potential energy, though, equal to mgh , where h is the height of the center of mass above its height when in equilibrium. (Here we choose zero potential energy to be when the cylinder is in its equilibrium position.)

From the figure and using geometry, we see that

$$h = p - p \cos \alpha_0 = p(1 - \cos \alpha_0) \quad (40.12)$$

and so the potential energy is

$$mgh = mg(p - p \cos \alpha_0) = mgp(1 - \cos \alpha_0) \quad (40.13)$$

Now, starting from angle α_0 , we release the half-cylinder. When the half-cylinder reaches its equilibrium position, its potential energy is zero, but it has kinetic energy $\frac{1}{2}I_H\omega_m^2$, where $\omega_m = \alpha_0\omega$ is the angular velocity at the equilibrium point (cf. Eq. (39.5)). By conservation of energy, the total energy at angle α_0 must equal the total energy at the equilibrium position:

$$0 + mgp(1 - \cos \alpha_0) = \frac{1}{2}I_H\omega_m^2 + 0 \quad (40.14)$$

$$= \frac{1}{2}I_H(\omega\alpha_0)^2 + 0 \quad (40.15)$$

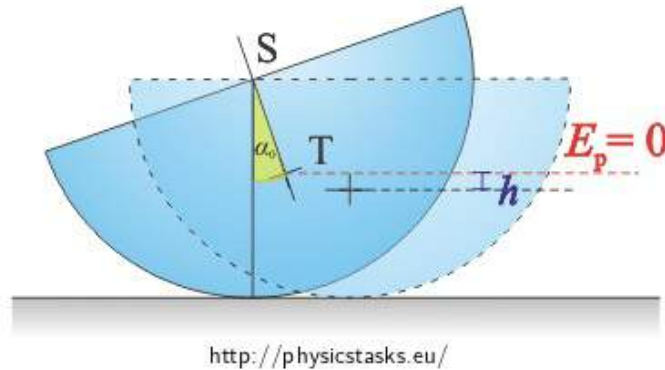
Figure 40.2: Rocking cylinder rocked by angle α_0 .

We now use the small-angle approximation

$$\cos \alpha_0 \approx 1 - \frac{\alpha_0^2}{2} \quad \Rightarrow \quad 1 - \cos \alpha_0 \approx \frac{\alpha_0^2}{2} \quad (40.16)$$

we get (approximately)

$$m g p \left(\frac{\alpha_0^2}{2} \right) = \frac{1}{2} I_H \omega^2 \alpha_0^2 \quad (40.17)$$

Solving for the angular frequency ω , we find

$$\omega = \sqrt{\frac{m g p \alpha_0^2}{I_H \alpha_0^2}} = \sqrt{\frac{m g \left(\frac{4r}{3\pi} \right)}{m r^2 \left(\frac{3}{2} - \frac{8}{3\pi} \right)}} \quad (40.18)$$

We now do some simplifying:

$$\omega = \sqrt{\frac{g \left(\frac{4r}{3\pi} \right)}{r^2 \left(\frac{9\pi - 16}{6\pi} \right)}} \quad (40.19)$$

$$= \sqrt{\frac{g(4r)(6\pi)}{3\pi r^2 (9\pi - 16)}} \quad (40.20)$$

$$= \sqrt{\frac{8g}{r(9\pi - 16)}} \quad (40.21)$$

and so the period of oscillation $T = 2\pi/\omega$ is

$$\boxed{T = 2\pi \sqrt{\frac{r(9\pi - 16)}{8g}}} \quad (40.22)$$

Notice that $T \propto \sqrt{r}$, so the larger the radius, the longer the period of oscillation. Notice also that the period is independent of the mass m , so that all half-cylinders of the same radius will rock with the same period.

Chapter 41

Rolling Bodies

41.1 Introduction

The motion of a body like a sphere or a cylinder *rolling* (without slipping) down an inclined plane introduces a complication into the motion: the body as a whole moves down the incline, while at the same time the body rotates about its axis. The net movement of the body is a combination of both motions: a *translational* movement of the whole body down the incline, together with a *rotational* motion about its axis. We'll examine here the velocity, acceleration, and kinetic energy of a round body rolling down an incline.

41.2 Velocity

Let's imagine the following scenario: suppose we have an inclined plane, inclined at an angle θ to the horizontal. Now place a round body of mass M and radius R at a height h above the base of the incline. If we release the body from rest, what will be its speed v at the bottom of the incline?

Let's look at the problem from a point of view of energy. At any given instant, the rolling body will be pivoting about the point of contact with the incline (we'll call this point P). Its total kinetic energy is therefore the rotational kinetic energy

$$K = \frac{1}{2}I_P\omega^2, \quad (41.1)$$

where I_P is the moment of inertia about P and ω is the rotational angular velocity of the body. Now by the parallel axis theorem, we know

$$I_P = I_{\text{cm}} + MR^2, \quad (41.2)$$

where I_{cm} is the moment of inertia of the body about its center of mass. Substituting into Eq. (41.1), we get

$$K = \frac{1}{2}(I_{\text{cm}} + MR^2)\omega^2 \quad (41.3)$$

$$= \frac{1}{2}I_{\text{cm}}\omega^2 + \frac{1}{2}MR^2\omega^2. \quad (41.4)$$

Now using $v = R\omega$ in the second term on the right, we have

$$K = \frac{1}{2}I_{\text{cm}}\omega^2 + \frac{1}{2}Mv^2. \quad (41.5)$$

This says that the total kinetic energy of the body is the sum of the rotational kinetic energy (the first term on the right) and the translational kinetic energy (the second term on the right).

Now let's use the conservation of energy to solve for the speed v at the bottom of the incline. At the top of the incline, the body is at rest, and its energy is all potential and equal to Mgh . At the bottom of the incline, the energy is all kinetic, and is given by Eq. (41.5). Then by conservation of energy,

$$Mgh = \frac{1}{2}I_{\text{cm}}\omega^2 + \frac{1}{2}Mv^2. \quad (41.6)$$

Substituting $\omega = v/R$ into the first term on the left,

$$Mgh = \frac{1}{2}I_{\text{cm}}\left(\frac{v}{R}\right)^2 + \frac{1}{2}Mv^2. \quad (41.7)$$

Now out factor $v^2/2$ on the right-hand side to get

$$Mgh = \left(I_{\text{cm}}\frac{1}{R^2} + M\right)\frac{v^2}{2}. \quad (41.8)$$

Now dividing through by M ,

$$gh = \left(\frac{I_{\text{cm}}}{MR^2} + 1\right)\frac{v^2}{2}. \quad (41.9)$$

The dimensionless combination $I_{\text{cm}}/(MR^2)$ occurs often enough that it's convenient to introduce the abbreviation

$$\beta \equiv \frac{I_{\text{cm}}}{MR^2}. \quad (41.10)$$

(Values of β for several common geometries are shown in Table 41-1.) With this definition, Eq. (41.9) becomes

$$gh = (\beta + 1)\frac{v^2}{2}. \quad (41.11)$$

Solving for v , we finally have the speed at the bottom of the incline given by

$$v = \sqrt{\frac{2gh}{\beta + 1}} \quad (41.12)$$

41.3 Acceleration

Now let's find the (translational) acceleration of the body down the incline. If the distance down the incline is x , then the velocity v at the bottom of the incline is related to x by

$$v^2 = 2ax \quad (41.13)$$

By geometry, $\sin \theta = h/x$, and so $x = h/\sin \theta$; using this to substitute for x , we have

$$v^2 = 2a\frac{h}{\sin \theta}, \quad (41.14)$$

or, solving for the acceleration a ,

$$a = \frac{v^2 \sin \theta}{2h}. \quad (41.15)$$

Now let's use Eq. (41.12) to substitute for v ; the result is an expression for the acceleration of a body rolling down an incline,

$$a = \frac{g \sin \theta}{\beta + 1} \quad (41.16)$$

Table 41-1 shows values of β and a for several common geometries.

Equation (41.16) has some interesting consequences. For example, if you start a solid sphere and a cylindrical shell at the top of an incline and release them at the same time, which one will reach the bottom first? From Table 41-1, you can see that the solid sphere will win: its acceleration $(5/7)g \sin \theta$ is greater than the cylindrical shell's acceleration of $(1/2)g \sin \theta$. What's surprising about this is that *all* solid spheres will beat *all* cylindrical shells, *regardless of mass or radius*. In general, the object with the *smaller* β will win such a race, since that will give the smallest denominator in Eq. (41.16) and therefore the larger acceleration.

41.4 Kinetic Energy

As a body rolls down an incline, its potential energy is converted partly into translational kinetic energy, and partly into rotational kinetic energy. How much goes into translational kinetic energy, and how much into rotational form?

First, let's compute the *translational* kinetic energy, $K_t = Mv^2/2$. Using Eq. (41.12) to substitute for v gives

$$K_t = \frac{1}{2} M v^2 = \frac{1}{2} M \left(\frac{2gh}{\beta + 1} \right), \quad (41.17)$$

or

$$K_t = \frac{Mgh}{\beta + 1} \quad (41.18)$$

Now let's find the *rotational* kinetic energy, $K_r = I_{\text{cm}}\omega^2/2$. Using $\omega = v/R$,

$$K_r = \frac{1}{2} I_{\text{cm}} \left(\frac{v}{R} \right)^2. \quad (41.19)$$

Again using Eq. (41.12) to substitute for v ,

$$K_r = \frac{1}{2} \frac{I_{\text{cm}}}{R^2} \frac{2gh}{\beta + 1}. \quad (41.20)$$

Multiplying the numerator and denominator by M ,

$$K_r = \frac{I_{\text{cm}}}{MR^2} \frac{Mgh}{\beta + 1}. \quad (41.21)$$

The first factor on the right is just β , so we finally have for the rotational kinetic energy

$$K_r = Mgh \left(\frac{\beta}{\beta + 1} \right) = \beta K_t \quad (41.22)$$

Knowing that the total kinetic energy is $K = Mgh$, we can now use Eqs. (41.18) and (41.22) to find the ratio of the translational kinetic energy to the total kinetic energy:

$$\frac{K_t}{K} = \frac{1}{\beta + 1}. \quad (41.23)$$

Similarly, the ratio of the rotational to total kinetic energy is given by

$$\frac{K_r}{K} = \frac{\beta}{\beta + 1}. \quad (41.24)$$

Values of these ratios for common body geometries are shown in Table 41-1. It is interesting to note that substituting $\beta = 0$ into the formulæ we've derived here recovers the formulæ for an object *sliding* down an incline without rolling, as shown in the last line of the table.

Table 41-1. Accelerations and energy ratios for rolling bodies.

Body	β	a	K_t/K	K_r/K
Cylindrical shell	1	$(1/2) g \sin \theta$	1/2	1/2
Solid cylinder	1/2	$(2/3) g \sin \theta$	2/3	1/3
Spherical shell	2/3	$(3/5) g \sin \theta$	3/5	2/5
Solid sphere	2/5	$(5/7) g \sin \theta$	5/7	2/7
Sliding object	0	$g \sin \theta$	1	0

41.5 The Wheel

Imagine a wheel of radius r rolling along the ground without slipping. When the wheel makes one complete revolution, the axis will have been directly above each point on the circumference of the wheel exactly once. Therefore the axis of the wheel has traveled a horizontal distance equal to the circumference of the wheel, or $2\pi r$. In other words, each revolution of the wheel causes the axis (or any vehicle attached to the wheel) to move a distance of $2\pi r$.

As a consequence of this observation, we can relate the angular velocity ω of the wheel to the linear velocity v of the axis. Let's say that it takes a time Δt for the wheel to rotate once on its axis. Then the linear velocity of the outer edge of the wheel is $2\pi r/\Delta t$. During that same time, the axis of the wheel has traveled the same distance $2\pi r$, and so the linear velocity of the axis is also $2\pi r/\Delta t$. Both the velocity of the axis and the linear velocity of the outside edge of the wheel are equal to $v = r\omega$. In other words: *The linear velocity of the axis with respect to the ground is equal to the linear velocity of the outer edge of the wheel with respect to the axis.*

Example. A bicycle with wheels of radius 34 cm is traveling with a speed of 7 m/s. What is the angular velocity of the wheels?

Solution. From the above discussion, the velocity of the bicycle v is equal to the linear velocity of the outer edge of the wheels, $r\omega$. Therefore $v = r\omega$, so $\omega = v/r = (7 \text{ m/s})/(0.34 \text{ m}) = 20.6 \text{ rad/s}$.

41.6 Ball Rolling in a Bowl

Suppose a ball of mass m and radius r is allowed to roll (without slipping) back and forth inside a hemispherical bowl of radius R . Does this constitute simple harmonic motion? And if so, what is the period of the motion?

To begin, let θ be the angle the ball makes with the vertical, so that $\theta = 0$ when the ball is at the bottom of the bowl. Also let ω be the rotational angular velocity of the ball about its center of mass, $\Omega = d\theta/dt$ be the angular velocity of the ball's motion within the bowl, and $v = (R - r)\Omega$ the translational speed of the ball. It turns out that we can find the equation of motion by computing the time derivative of the total mechanical energy of the ball. The ball's total mechanical energy is the sum of three components: its translational kinetic energy, its rotational kinetic energy, and its gravitational potential energy.

The translational kinetic energy of the ball is

$$K_t = \frac{1}{2}mv^2 \quad (41.25)$$

$$= \frac{1}{2}m(R - r)^2\Omega^2 \quad (41.26)$$

The rotational kinetic energy of the ball about its axis is

$$K_r = \frac{1}{2}I\omega^2 \quad (41.27)$$

where I is the moment of inertia of the ball about its center of mass. If we take zero potential energy to be the point where the ball is at the bottom of the bowl, then the potential energy of the ball is

$$U = mg(R - r)(1 - \cos \theta). \quad (41.28)$$

Therefore the total mechanical energy of the ball is

$$E = K_t + K_r + U \quad (41.29)$$

$$= \frac{1}{2}m(R - r)^2\Omega^2 + \frac{1}{2}I\omega^2 + mg(R - r)(1 - \cos \theta) \quad (41.30)$$

We'll want to get all terms of this equation in terms of θ ; to do this, we'll need to write ω in terms of Ω . Since the ball rolls without slipping, we know $v = r\omega$, and so

$$v = r\omega = (R - r)\Omega \quad (41.31)$$

$$\omega = \left(\frac{R - r}{r}\right)\Omega. \quad (41.32)$$

Substituting this into Eq. (41.29), we have

$$E = \frac{1}{2}m(R - r)^2\Omega^2 + \frac{1}{2}I\left(\frac{R - r}{r}\right)^2\Omega^2 + mg(R - r)(1 - \cos \theta). \quad (41.33)$$

Writing the moment of inertia as $I = \beta m r^2$, the total energy may be written

$$E = \frac{1}{2}m(R-r)^2\Omega^2 + \frac{1}{2}\beta m r^2 \left(\frac{R-r}{r}\right)^2 \Omega^2 + mg(R-r)(1 - \cos \theta) \quad (41.34)$$

$$= \frac{1}{2}m(R-r)^2\Omega^2 + \frac{1}{2}\beta m(R-r)^2\Omega^2 + mg(R-r)(1 - \cos \theta) \quad (41.35)$$

$$= \frac{1}{2}m(R-r)^2\Omega^2(\beta + 1) + mg(R-r)(1 - \cos \theta) \quad (41.36)$$

$$= \frac{1}{2}m(R-r)^2 \left(\frac{d\theta}{dt}\right)^2 (\beta + 1) + mg(R-r)(1 - \cos \theta) \quad (41.37)$$

$$(41.38)$$

where in the last step we substituted the definition $\Omega = d\theta/dt$. We can find the equation of motion by taking the time derivative dE/dt , which must be zero, since E must be constant:

$$\frac{dE}{dt} = m(R-r)^2 \left(\frac{d\theta}{dt}\right) \left(\frac{d^2\theta}{dt^2}\right) (\beta + 1) + mg(R-r) \sin \theta \left(\frac{d\theta}{dt}\right) = 0 \quad (41.39)$$

And so, cancelling a common $d\theta/dt$ on both sides, we get

$$m(R-r)^2 \left(\frac{d^2\theta}{dt^2}\right) (\beta + 1) = -mg(R-r) \sin \theta. \quad (41.40)$$

Cancelling a common $m(R-r)$ on both sides,

$$(R-r) \left(\frac{d^2\theta}{dt^2}\right) (\beta + 1) = -g \sin \theta \quad (41.41)$$

Now solving for $d^2\theta/dt^2$, we get the equation of motion:

$$\frac{d^2\theta}{dt^2} = -\frac{g}{(\beta + 1)(R-r)} \sin \theta. \quad (41.42)$$

This is the same as Eq. (38.3) for a simple plane pendulum, with effective length

$$L_{\text{eff}} = (\beta + 1)(R-r). \quad (41.43)$$

The ball rolling in the hemispherical bowl is, like the simple plane pendulum, not *exactly* a simple harmonic oscillator; but it is *approximately* a simple harmonic oscillator for small oscillations.

For small oscillations, the period of oscillation T is given by Eq. (38.8), with L replaced by L_{eff} in Eq. (41.43):

$$T = 2\pi \sqrt{\frac{(\beta + 1)(R-r)}{g}}. \quad (41.44)$$

For example, if the ball is a uniform solid sphere, then $\beta = 2/5$, and so $\beta + 1 = 7/5$ and we have

$$T = 2\pi \sqrt{\frac{7(R-r)}{5g}}. \quad (41.45)$$

A ball rolling in a hemispherical bowl will have a period greater than that of a simple plane pendulum of the same length, by a factor of $\sqrt{\beta + 1} = \sqrt{7/5} \approx 1.1832$.

Chapter 42

Galileo's Law

42.1 Introduction

Galileo Galilei (1564–1642) was an Italian physicist to did some of the early work in classical mechanics. One of his major contributions was in the area of falling bodies. Galileo recognized that bodies falling due to the Earth's gravity will fall with a constant acceleration, and that he could study that acceleration by, in effect, slowing it down through the use of an inclined plane.

Galileo constructed an inclined plane tilted at a slight angle (4°), with a groove in the center. He then rolled a solid brass ball in the groove down incline and studied how the ball moved as a function of time. He could do this by placing small bumps in the groove in which the ball rolled; whenever the ball hit a bump, it made a noise. By studying the timing of the noises and comparing that to the distance between the bumps, he could make some quantitative studies of the ball accelerating down the incline.

Unfortunately, Galileo did not have access to accurate timepieces—using his own pulse was about the best method available. If he made the bumps equally spaced apart along the incline, he could tell that the noises of the ball hitting the bumps got closer together as the ball rolled down the incline, but had no way to measure the times accurately.

Then Galileo hit upon an idea: instead of spacing the bumps equally far apart, he would adjust their spacing until he could hear that the *time* between the ball hitting the bumps was the same. As a skilled player of the Renaissance lute, Galileo had a well-developed sense of musical rhythm, and was able to judge fairly accurately when the *click-click-click-click* of the ball rolling down the incline and hitting the bumps on the incline were separated by equal time intervals. Once he was satisfied that the sounds of the balls hittings the bumps were all equally separated in time, he could accurately measure the distances between the bumps.

He discovered that the distance from the top of the incline to the second bump was 4 times the distance to the first bump; the distance to the third bump was 9 times the distance to the first bump; the distance to the fourth bump was 16 times the distance to the first bump, and so on. This allowed him to deduce what is now called *Galileo's law*: the total distance x covered in time t is proportional to the square of the time:

$$\boxed{x \propto t^2} \tag{42.1}$$

42.2 Modern Treatment

Developments in the theory of classical mechanics since Galileo's time allow us to investigate his experiment in more detail. For one thing, we now know that the proportionality constant in Eq. (42.1) is $a/2$, where a is

the acceleration of the ball down the incline; Galileo's law then becomes

$$x = \frac{1}{2} at^2. \quad (42.2)$$

Furthermore, we now know that the acceleration a of a solid ball rolling down an inclined plane is given by

$$a = \frac{g \sin \theta}{1 + \frac{I_{\text{cm}}}{MR^2}} = \frac{g \sin \theta}{1 + \beta}, \quad (42.3)$$

where g is the acceleration due to gravity (9.8 m/s^2), θ is the inclination of the inclined plane, I_{cm} is the moment of inertia of the ball about its center of mass, M is the mass of the ball, R is the radius of the ball, and $\beta \equiv I_{\text{cm}}/(MR^2)$. For a solid spherical ball, we know

$$I_{\text{cm}} = \frac{2}{5} MR^2, \quad (42.4)$$

so $\beta \equiv I_{\text{cm}}/(MR^2) = 2/5$; the acceleration of a solid ball down an inclined plane is therefore

$$a = \frac{5}{7} g \sin \theta. \quad (42.5)$$

Galileo's law for a solid ball rolling down an incline then becomes

$$x = \frac{1}{2} at^2 \quad (42.6)$$

$$= \frac{1}{2} \left(\frac{5}{7} g \sin \theta \right) t^2 \quad (42.7)$$

$$= \frac{5}{14} (g \sin \theta) t^2. \quad (42.8)$$

Using $g = 9.8 \text{ m/s}^2$ and $\theta = 4^\circ$ for Galileo's incline, we get

$$x = 0.244 t^2, \quad (42.9)$$

where x is in meters and t is in seconds.

Chapter 43

The Coriolis Force

43.1 Introduction

Imagine you're on a rotating merry-go-round, and you throw a ball to another person who's on the opposite side of the merry-go-round. If you aim directly at the other person, you'll miss them—the ball will travel in a straight line relative to the ground, but the merry-go-round will have rotated during the time the ball is in the air. Relative to the merry-go-round, the ball will appear to move along a curved path. You can attribute this curvature to a “fictitious force” called the *Coriolis force*. The Coriolis force is not a real force—it's just an artifact of viewing the ball's motion in a rotating reference frame. The ball really moves in a straight line relative to the ground.

So in the rotating reference frame of the merry-go-round, you'll see the ball move in a curved path, which can't happen unless there is a “force” present. We can compute the magnitude of this Coriolis force by considering the following situation. Suppose you're at the center of the merry-go-round, and throw a ball outward with velocity v while the merry-go-round is rotating with an angular velocity Ω . After a time t , the ball will have moved a radial distance $r = vt$. At time t , a point on the merry-go-round a distance r from the center will have moved through an arc length

$$s = r\theta \tag{43.1}$$

$$= r(\Omega t) \tag{43.2}$$

$$= (vt)\Omega t \tag{43.3}$$

$$= \Omega vt^2. \tag{43.4}$$

But under a constant acceleration a_c , we know

$$s = \frac{1}{2}a_c t^2. \tag{43.5}$$

Comparing Eq. (43.4) with Eq. (43.5), we deduce that the Coriolis acceleration a_c is given by

$$a_c = 2\Omega v. \tag{43.6}$$

More generally, in terms of vectors, the Coriolis acceleration vector \mathbf{a}_c is given by

$$\boxed{\mathbf{a}_c = -2(\boldsymbol{\Omega} \times \mathbf{v})} \tag{43.7}$$

From Newton's second law, the corresponding Coriolis force \mathbf{F}_c on a body of mass m is then

$$\boxed{\mathbf{F}_c = -2m(\boldsymbol{\Omega} \times \mathbf{v})} \tag{43.8}$$

43.2 Examples

Golf

For example, suppose we're on the surface of the Earth, in the northern hemisphere, and hit a golf ball due south with velocity v . Since the Earth rotates to the east, the Earth's angular velocity vector Ω is along the Earth's axis, northward out of the north pole. Then by Eq. (43.8), there will be a *westward* Coriolis force acting on the golf ball, equal in magnitude to

$$F_c = 2m\Omega v \sin \varphi, \quad (43.9)$$

where φ is the latitude and m is the mass of the golf ball. This will cause the ball to slice the right. The effect is very slight, though. For example, given the rotation rate of the Earth $\Omega = 7.2921 \times 10^{-5}$ rad/s, the mass of the golf ball $m = 45$ g, a typical ball speed $v = 50$ m/s, and a latitude of $\varphi = 39^\circ$, the Coriolis force only amounts to $F_c = 206.5 \mu\text{N}$, or about 0.05% of the weight of the golf ball.

The Coriolis force is zero at the equator, and greater at higher latitudes. In the southern hemisphere, the Coriolis force will cause a slight hook of the ball to the left, rather than the slice it will experience in the northern hemisphere.

Weather

By Eq. (43.8), we can see that in the northern hemisphere, air currents moving northward are deflected to the east; eastward currents are deflected to the south; southward currents are deflected to the west; and westward currents are deflected to the north. If a low-pressure area forms in the atmosphere, then the pressure gradients will cause the air currents to flow toward the center of the area; but because of the Coriolis deflections, the result will be that the air currents will flow counter-clockwise, creating an air pattern called a *cyclone* around the low-pressure area. Similarly, in the southern hemisphere, cyclones will be air currents rotating clockwise.

Hurricanes, tornados, water spouts, and whirlpools all rotate counterclockwise in the northern hemisphere due to the Coriolis force (and clockwise in the southern hemisphere).

Chapter 44

Angular Momentum

44.1 Introduction

The rotational counterpart of momentum is called *angular momentum*. Just as linear momentum is defined as the product of mass and velocity ($p = mv$), angular momentum L is defined as the product of moment of inertia and angular velocity:

$$L = I\omega. \quad (44.1)$$

More generally, angular momentum, like linear momentum is a vector quantity:

$$\boxed{\mathbf{L} = I\boldsymbol{\omega}.} \quad (44.2)$$

SI units for angular momentum are $\text{kg m}^2 \text{s}^{-1}$, or N m s .

Angular momentum \mathbf{L} is related to linear momentum \mathbf{p} according to

$$\boxed{\mathbf{L} = \mathbf{r} \times \mathbf{p}.} \quad (44.3)$$

If you recall, Newton's second law of motion states that $F = dp/dt$, where F is force and p is momentum; in the special case where mass is constant, this reduces to $F = ma$, where a is the acceleration. There are analogous formulae in rotational motion, which can be derived by taking the time derivative of Eq. (44.3):

$$\frac{d\mathbf{L}}{dt} = \mathbf{r} \times \frac{d\mathbf{p}}{dt}. \quad (44.4)$$

The right-hand side is the torque; the result is the rotational form of Newton's second law:

$$\boxed{\boldsymbol{\tau} = \frac{d\mathbf{L}}{dt},} \quad (44.5)$$

where $\boldsymbol{\tau}$ is torque and \mathbf{L} is angular momentum. In the case where the moment of inertia is constant, this reduces to $\boldsymbol{\tau} = I\boldsymbol{\alpha}$, where $\boldsymbol{\alpha}$ is the angular acceleration.

44.2 Conservation of Angular Momentum

Angular momentum, like linear momentum, is a *conserved* vector quantity: in a closed system (in which no angular momentum enters or leaves the system), the total angular momentum is constant. Since angular momentum is a vector, this means that the following are all conserved:

- The vector angular momentum, \mathbf{L} ;
- The magnitude of the angular momentum, L ; and
- Each component of the angular momentum, L_x , L_y , and L_z .

In a closed system, angular momentum may be transferred from one body to another, but the *total* angular momentum—the sum of the angular momenta of all bodies in the system—will remain constant.

As a common example, conservation of angular momentum is illustrated by the spinning of a figure skater. As she's doing a spin, a figure skater will rotate about a vertical axis. As she brings her arms in closer to her body, the figure skater decreases her moment of inertia. By Eq. (44.3), if the moment of inertia I decreases, then the angular velocity ω must increase in order to keep the angular momentum L constant.

Chapter 45

Conservation Laws

There are four conserved quantities in classical physics:

- Energy
- Linear momentum
- Angular momentum
- Electric charge

Two of these (energy and electric charge) are scalar quantities; the other two (linear momentum and angular momentum) are vector quantities.

We've seen the first three of these quantities in this course. You'll meet the fourth — conservation of electric charge — in General Physics II.

In addition to these four, there are a few more esoteric conservation laws related to particle physics; but these conservation laws are beyond the scope of this course.

Chapter 46

The Gyroscope

46.1 Introduction

A *gyroscope* (from the Greek $\gammaυροσ$, “a ring,” and $σκοπεω$, “see”) is a wheel attached to an axle; the wheel and axle are spun to rotate at an angular velocity ω , so that the gyroscope has an angular momentum $L = I\omega$, where the moment of inertia $I \approx MR^2$. The gyroscope has various uses as a children’s toy (where it is similar to a top), as an apparatus for demonstrating principles of physics, or as an instrument for navigation. The Hubble Space Telescope, for example, has six gyroscopes on board that are used to help determine the *attitude* of the spacecraft (its orientation in space).

46.2 Precession

The gyroscope can be used to illustrate some properties of rotating bodies. For example, suppose the axis of the gyroscope is held vertical, and the axle is supported from the bottom end only. If the gyroscope is not spinning, then the instrument is unstable: the slightest movement from a perfectly balanced vertical position will cause it to topple over. But suppose we set the gyroscope spinning first, then set it down so the axle is vertical and supported from the bottom end. The instrument will still tend to topple over, but in doing so it will pivot about the bottom end of the axle, creating a torque about that point. The spinning gyroscope already has an angular momentum \mathbf{L} ; the torque $\boldsymbol{\tau} = d\mathbf{L}/dt$ due to gyroscope wanting to tip over causes the instrument’s angular momentum to change with time, causing it to move in a circle.

For example, suppose the gyroscope is vertical and spinning counterclockwise as seen from above. Then by the right-hand rule, its angular momentum vector \mathbf{L} points upward. If you’re watching the gyroscope from the side and it begins to topple over to the right, then there is a torque vector $\boldsymbol{\tau}$ pointing away from you. Since $\boldsymbol{\tau} = d\mathbf{L}/dt$, this means the torque and the change in angular momentum will be in the same direction, so the gyroscope will start to rotate away from you. Essentially the falling over of the gyroscope is turned sideways, causing the gyroscope to describe a circular motion called *precession*.

The angular velocity vector $\boldsymbol{\omega}_P$ of this precession is found to satisfy

$$\boldsymbol{\tau} = \boldsymbol{\omega}_P \times \mathbf{L}. \quad (46.1)$$

Solving for the magnitude of the angular velocity of the precession ω_P , we find

$$\omega_P = \frac{MgD}{L \sin \theta}, \quad (46.2)$$

where M is the mass of the gyroscope wheel, D is the distance between the bottom end of the axle and the

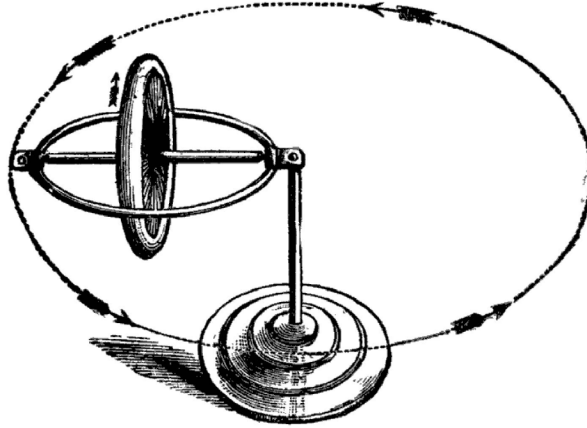

Figure 46.1: Motion of a gyroscope. By the right-hand rule, the angular momentum of the wheel is to the left. The torque vector due to the gyroscope tipping over is horizontal, toward the observer. This torque vector “pushes” the angular momentum vector around counterclockwise, as shown; the resulting motion is called *precession*. (From Ref. [13])

wheel, L is the angular momentum of the gyroscope about its axis, and θ is the angle of the gyroscope axis from the vertical.

46.3 Nutation

As the gyroscope tips over, this “tipping over” motion is turned sideways, resulting in the precession just described. But in general, the tip of the gyroscope axis will tend to “overshoot” the nominal plane of precession, causing the gyroscope to momentarily dip below this plane before moving back upwards. The resulting motion, called *nutation*, is a kind of “nodding” of the axis up and down, superimposed on the precessional motion. The actual motion of the gyroscope axis will be a *cycloid* superimposed on the circular precessional circle.

Chapter 47

Elasticity

47.1 Introduction

We have generally been treating solid bodies as if they are infinitely rigid, and do not deform when forces are applied to them, and this is often not a bad approximation. But in the real world, solid bodies *do* deform somewhat, and we sometimes need to allow for these deformation effects. *Elasticity* refers to the ability of a material to be deformed somewhat, then return to its original state. Broadly speaking, we apply a *stress* (deforming force) to a body, which produces a *strain* (deformation). The body responds following a law similar to Hooke's law:

$$\sigma = E\varepsilon, \tag{47.1}$$

where σ is the stress, ε is the strain, and E is the *elastic modulus*, which takes the place of the spring constant in Hooke's law.

In Eq. (47.1), the stress σ and elastic modulus E both have units of N/m^2 ; the strain ε is dimensionless.

There are different types of stress, depending on the method by which the body is deformed. The three main categories are (1) *longitudinal* (or *normal*) stress, (2) *transverse* (or *shear*) stress, and (3) *volume* stress. In all cases, the stress σ is defined as the force F applied to the body, divided by the area A over which the force acts:

$$\sigma = \frac{F}{A}. \tag{47.2}$$

There are three types of elastic moduli, depending on the stress involved: the *Young's modulus*, *shear modulus*, and *bulk modulus*. These moduli are described below.

47.2 Longitudinal (Normal) Stress

In *longitudinal* (or *normal*) stress, the applied force is *normal* (perpendicular) to the surface.

Imagine a metal rod, for example: pulling on both ends of the rod (so as to stretch it to a longer length) is called *tensile stress*. If instead we *push* the ends of the rod together (so as to compress the rod to a shorter length), it is called *compressional stress*. In either case, the area A in Eq. (47.2) is the cross-sectional area of the rod; the longitudinal stress is then the force applied to either end of the rod divided by the rod's cross-sectional area.

Strain

When applying a longitudinal stress to the rod, it changes from its original length L_0 to a new deformed length L . Then the longitudinal strain ε is defined by

$$\varepsilon = \frac{\Delta L}{L_0}, \quad (47.3)$$

where $\Delta L = L - L_0$ is the change in the length of the rod from its original length, and will be positive for tensile stress and negative for compressional stress.

Young's Modulus

In the case of a longitudinal stress, the appropriate elastic modulus is the *Young's modulus* Y :

$$Y = \frac{F_n L_0}{A \Delta L}. \quad (47.4)$$

Here F_n is the force applied normal to the area A , L_0 is the original (unstressed) length of the rod, L is the stressed length of the rod, and $\Delta L = L - L_0$.

47.3 Transverse (Shear) Stress—Translational

In *transverse* (or *shear*) stress, the applied force is *parallel* to the surface. There are two types of transverse stress: *translational* and *torsional*. In this section we'll examine translational transverse stress.

As an example of translational transverse stress, imagine placing your physics textbook face-up on a table. Now put your hand on the front cover and push the cover to the right, so that the front cover moves to the right but the rear cover remains stationary on the table (by friction). Now if you look at the bottom end of the book, it will look like a parallelogram. In this case, the stress is given by Eq. (47.2), where the force F is the component of the force parallel to the surface (front cover of the book), and A is the area of the surface (the area of the book cover).

Strain

For translational transverse stress, the strain is the angle ϕ (in radians) by which the body is deformed (Fig. 47.1). For small deformations, we can write $\phi \approx \tan \phi = d/l$, and so the strain

$$\phi \approx d/l. \quad (47.5)$$

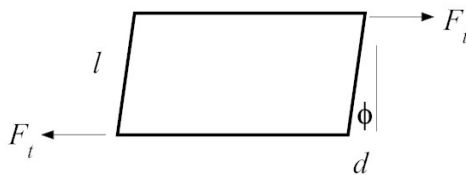

Figure 47.1: Transverse shear stress.

Shear Modulus

In the case of translational transverse stress, the appropriate elastic modulus is the *shear modulus* S . Since the elastic modulus is the ratio of the stress to the strain, we have

$$S = \frac{F_t/A}{d/l}, \quad (47.6)$$

where F_t is the component of the applied force parallel to the area A , d is the displacement of the body, and l is its thickness (Fig. 47.1).

47.4 Transverse (Shear) Stress—Torsional

The other type of transverse stress is *torsional stress*. This is the type of stress produced, for example, by applying a torque to a bolt with a wrench.

Strain

For torsional transverse stress, imagine we have a right circular cylinder of length ℓ , fastened in place at one end, and with a torque τ applied to the other end. Then the strain is the arc length s through which the cylinder is twisted, divided by the length of the cylinder: $\varepsilon = s/\ell$. If the cylinder is twisted through an angle θ , then this becomes

$$\varepsilon = r\theta/\ell. \quad (47.7)$$

Shear Modulus

In the case of the torsional transverse stress on a cylinder of length ℓ and radius r twisted through an angle θ by a torque τ , it can be shown that the shear modulus is

$$S = \frac{2\tau\ell}{\pi r^4\theta}. \quad (47.8)$$

47.5 Volume Stress

The other types of stress described so far (longitudinal and transverse) deform a solid body, but do not change its volume. A third type of stress, the *volume stress* (or *hydrostatic pressure*), involves a change in volume. It typically occurs with the compression or expansion of a gas.

For a gas, the volume stress is just the gas pressure P . Pressure in SI units is measured in Pascals (Pa), named for the French mathematician and physicist Blaise Pascal. One pascal is equal to 1 N/m^2 .

Strain

For volume stress, the strain is the fractional change in volume:

$$\varepsilon = -\Delta V/V_0, \quad (47.9)$$

where $\Delta V = V - V_0$ is the change in volume, V_0 is the original (unstressed) volume and V is the stressed volume. If the gas is compressed, then ΔV is negative and the strain ε is positive; if the gas expands, then ΔV is positive and the strain ε is negative.

Bulk Modulus

In the case of volume stress, the appropriate elastic modulus is the *bulk modulus* B . Since the elastic modulus is the ratio of the stress to the strain, we have

$$B = -\frac{P}{\Delta V/V_0}. \quad (47.10)$$

47.6 Elastic Limit

Rigid bodies can only be deformed by a certain amount before the deformation becomes permanent. The maximum stress that can be applied to a material before it becomes permanently deformed is called the *elastic limit*. If a stress less than the elastic limit is applied, then the body will resume its original shape once the stress is removed.

A related quantity is the *tensile strength*, which is the maximum stress a sample can endure before fracturing.

47.7 Summary

The types of stress are:

- Longitudinal (normal)
 - Tensile
 - Compressional
- Transverse (shear)
 - Translational
 - Torsional
- Volume

The following table summarizes the formulæ involved in elasticity.

Table 47-1. Summary of elasticity equations.

Type of Stress	Stress	Strain ϵ	Elastic modulus E
Longitudinal (tensile or compressional)	F_n/A	$\Delta L/L_0$	$Y = F_n L_0/(A\Delta L)$
Transverse (translational)	F_t/A	$\phi \approx d/l$	$S = (F_t/A)/(d/l)$
Transverse (torsional)	F_t/A	$r\theta/\ell$	$S = 2\tau\ell/(\pi r^4\theta)$
Volume	P	$-\Delta V/V_0$	$B = -P/(\Delta V/V_0)$

Chapter 48

Fluid Statics

48.1 Introduction

A *fluid* is any substance that flows. Although it is usually a liquid or a gas, a granular solid or powder can behave as a fluid in certain processes such as *fluidization*. The study of fluids and fluid flow is its own branch of mechanics, and an active area of research. In this chapter and the next, we'll present a broad overview of the basics of fluid statics (stationary fluids) and fluid dynamics (fluids in motion).

48.2 Archimedes' Principle

One of the simplest principles of fluid statics is *Archimedes' principle*, which states that if a body is wholly or partially submerged in a fluid, then it is buoyed upward by a buoyant force B equal to the weight of the displaced fluid:

$$\boxed{B = W}, \quad (48.1)$$

where B is the buoyant force, and $W = \rho g V$ is the weight of the displaced fluid: ρ is the density of fluid displaced, V is the volume of fluid displaced, and g is the acceleration due to gravity.

Suppose we have a body of volume V and density ρ_b completely submerged in a fluid of density ρ_f . What will happen? There will be two forces acting on the body: the weight of the body, acting downward¹ ($W = -\rho_b V g$), and the buoyant force, acting upward ($B = \rho_f V g$). The net force is then $F = B + W = (\rho_f - \rho_b) V g$. This implies that:

- If $\rho_b = \rho_f$ (the body is the same density as the fluid), then there is no net force on the body.
- If $\rho_b < \rho_f$ (the body is less dense than the fluid), then $F > 0$ and there is a net upward force on the body: the body will float up toward the surface.
- If $\rho_b > \rho_f$ (the body is denser than the fluid), then $F < 0$ and there is a net downward force on the body: the body will sink.

48.3 Floating Bodies

If a solid body is placed in a fluid, it will float if its density is less than the fluid density. Suppose we have a body of mass m_b and volume V_b floating in a liquid of density ρ_0 . Then part of the body will be submerged,

¹We take positive to be upward, and negative downward.

and part will be above the surface of the liquid. How much of the body will be submerged?

To answer this, let V_s be the submerged volume of the body. Then if the body is in equilibrium, the weight of the body $m_b g$ (acting downward) must equal the upward buoyant force. But by Archimedes' principle, the buoyant force is equal to the weight of the displaced liquid. Now the mass of the displaced liquid is the displaced volume V_s times the density of the liquid, ρ_0 , and so the weight of displaced fluid is $V_s \rho_0 g$. Then since the weight of the body equals the upward buoyant force, we have

$$m_b g = V_s \rho_0 g \quad (48.2)$$

$$m_b = V_s \rho_0 \quad (48.3)$$

To write this another way, note that the mean density of the body is $\rho_b = m_b / V_b$. Using this to substitute for m_b in the above equation, we get

$$V_b \rho_b = V_s \rho_0 \quad (48.4)$$

and so

$$\boxed{\frac{V_s}{V_b} = \frac{\rho_b}{\rho_0}} \quad (48.5)$$

In other words, the fraction of the body's volume that is submerged is equal to the mean density of the body divided by the density of the liquid. The less dense the body, the higher it will "ride" in the liquid; the denser the body, the lower it will be submerged.

Example. We use the phrase "the tip of the iceberg" to indicate a small part of something much larger. The phrase has its origin in observation that an iceberg floating in water has only a small part of its volume visible above the water surface. In a real iceberg, how much of the iceberg is above water, and how much is below water?

Solution. First, note that the iceberg itself is made of fresh water, and is typically floating in sea water. The density of ice is about $\rho_b = 0.9169 \text{ g/cm}^3$, and the density of sea water is about 1.025 g/cm^3 . Therefore the fraction of the iceberg that is submerged is $\rho_b / \rho_0 = 0.9169 / 1.025 = 0.895$. So an iceberg has about 90% of its volume submerged below water, and about only about 10% above water.

48.4 Pressure

Pressure P is defined to be force divided by the area over which that force is applied:

$$P = \frac{F}{A}. \quad (48.6)$$

For a fluid, imagine placing a small area A inside the fluid. Then the pressure at the location of A is the force due to the fluid on one side of A on the fluid on the other side of A , divided by the area A .

Pressure in SI units is measured in Pascals (Pa), named for the French mathematician and physicist Blaise Pascal. One pascal is equal to 1 N/m^2 . Other common units are:

- *atmospheres* ($1 \text{ atm} = 101,325 \text{ Pa}$)
- *torr* ($1 \text{ torr} = 1 \text{ mmHg} = 133.3223684210526315789 \text{ Pa}$)
- *bar* ($1 \text{ bar} = 100,000 \text{ Pa}$; $1 \text{ millibar} = 100 \text{ Pa}$)
- *pounds per square inch* (*psi*) ($1 \text{ psi} = 6894.757293168361336723 \text{ Pa}$)

- *inches of mercury* (1 inHg = 3386.388157894736842105 Pa)
- *dynes per square centimeter* (dyne/cm²) (1 dyne/cm² = 0.1 Pa)

The pressure P is sometimes called the *absolute pressure*; this is to distinguish it from the *gauge pressure* P_g , which is the difference between absolute pressure and atmospheric pressure P_a : $P_g = P - P_a$.

48.5 Change in Fluid Pressure with Depth

The pressure in a fluid in a gravitational field increases in the downward direction. A common example is the pressure of the Earth's atmosphere: atmospheric pressure is highest at the surface of the Earth, and decreases as you go up in altitude. Above a certain altitude (about 8000 feet above sea level), passengers in aircraft and mountain climbers need extra oxygen to be able to breathe properly. Another common example is well known to divers: water pressure increases with depth.

We can compute the change in pressure with depth using Archimedes' principle. Suppose we have a fluid like water, and we want to find how the pressure P increases with depth h from the surface. Imagine a slab of fluid (inside the bulk fluid) of area A and thickness Δh . We'll call the pressure on the top surface P_1 , and the pressure on the bottom surface P_2 . The net buoyant force on the slab of fluid will be $(P_2 - P_1)A = \Delta PA$. But by Archimedes' principle,

$$\Delta PA = \rho g A \Delta h, \quad (48.7)$$

and so

$$\frac{\Delta P}{\Delta h} = \rho g. \quad (48.8)$$

Taking the limit as $\Delta h \rightarrow 0$, we have

$$\boxed{\frac{dP}{dh} = \rho g.} \quad (48.9)$$

Constant Density

Let's consider a special case where the density ρ is constant (as with water, for example). From Eq. (48.9), we have

$$dP = \rho g dh. \quad (48.10)$$

Integrating both sides gives

$$\boxed{P = P_0 + \rho gh,} \quad (48.11)$$

where P_0 is the pressure at depth $h = 0$.

Variable Density

Now consider another special case, where the density ρ is *not* constant. For a gas like the Earth's atmosphere, we typically have the density proportional to the pressure, so let's let the density $\rho = KP$, where K is a constant with units of $s^2 m^{-2}$. Also, for the atmosphere, it will be convenient to use the upward-pointing altitude $y = -h$ rather than the downward-pointing depth. Eq. (48.9) then becomes

$$\frac{dP}{dy} = -KPg. \quad (48.12)$$

Now re-write this as

$$\frac{dP}{P} = -Kgy \quad (48.13)$$

and integrate both sides; the result is

$$\ln P = -Kgy + C, \quad (48.14)$$

where C is a constant. Taking e to the power of both sides, we get

$$P = e^C e^{-Kgy} \quad (48.15)$$

If $y = 0$, then this reduces to $P = e^C$, so e^C is the pressure at $y = 0$, which we'll write as P_0 . Then the pressure P at altitude y is

$$P = P_0 e^{-Kgy}. \quad (48.16)$$

The quantity $H = 1/(Kg)$ has units of length, and is called the *scale height*. When the altitude y is equal to the scale height H , the pressure will be $1/e \approx 0.368$ of its value at $y = 0$. For the the lowest layer of the Earth's atmosphere (called the *troposphere*), the scale height is about 8 km.

In terms of the scale height H , Eq. (48.16) may be written

$$\boxed{P = P_0 e^{-y/H}}. \quad (48.17)$$

Equation (48.17) assumes an isothermal (constant temperature) atmosphere. In reality, temperature decreases with increasing height at the rate of $0.0065 \text{ }^\circ\text{C/m}$ in the troposphere. This fact can be used with Eq. (48.9) to show that

$$P = P_0 \left(1 - \frac{y}{\mathcal{H}}\right)^n, \quad (48.18)$$

where for the Earth's troposphere $\mathcal{H} = 44,329 \text{ m}$ and $n = 5.255876$. This expression for pressure vs. altitude is part of a numerical model of the atmospheric pressure, density, and temperature of the Earth's atmosphere called the *U.S. Standard Atmosphere* (Ref. [15]).

48.6 Pascal's Law

Another important principle in fluid statics is *Pascal's law*. It states that when a pressure change is applied to a fluid (as with a piston, for example), the pressure change is transmitted undiminished throughout the fluid and to the walls of the container. In other words, there's nothing special happening in the direction of movement of the piston; the pressure change will be "felt" equally throughout the fluid.

Chapter 49

Fluid Dynamics

Fluid dynamics, also termed *fluid mechanics*, is a very important and broad study of fluids in motion, impacting most engineering disciplines, weather and climate modeling, city and home water distribution systems, etc. Here we will focus on internal flows in piping, tubing, hoses, and fittings transporting a single gas or liquid phase, thereby excluding multi-phase flows such as gas-liquid, gas-solid, and liquid-solid mixtures. Also outside the scope of this material is high-speed gas flow (sonic and supersonic), hydraulic hammer (liquids), and open channel flow (culverts).

Fluid dynamics is a complex subject; in fact it's probably the most complex of the physical sciences. Even fairly simple physical systems can have very complicated solutions, and some subjects, such as fluid turbulence, are a long way from being well understood. The study of fluid flow is of great importance in fields like chemical engineering and meteorology.

The flow of fluids can be characterized by a number of properties:

- *Steadiness*. Fluid flow may be steady (*laminar*) or full of irregular eddies (*turbulent*).
- *Compressibility*. Fluids generally change density with changing pressure; such fluids are called *compressible*. A fluid that does not change density with changing pressure is called *incompressible*; this is sometimes used as an approximation for real fluids.
- *Viscosity*. Real fluids exhibit a kind of internal friction called *viscosity* that measures how “thick” the liquid is. Honey and molasses, for example, are fluids with a high viscosity, while water and gasoline have relatively low viscosity. Viscosity is discussed in detail in section 49.5.
- *Rotation*. A fluid is *rotational* if it exhibits angular momentum about some point (so that a small paddle inserted at that point would begin to rotate). A fluid with no such points is called *irrotational*.

In many cases the fluid can be treated as though it had no viscosity, resulting in frictionless flow. Such a fluid is called an *ideal fluid*. The flow of an ideal fluid can be incompressible or compressible; it is neither laminar nor turbulent.

Flow in piping may be laminar, transitional, or turbulent. Laminar flow is characterized by a parabolic velocity profile having a centerline velocity equal to two times the average (Figure 49.1). Flow is very orderly and there is no radial or tangential movement. Behavior is predictable with little uncertainty as long as the fluid viscosity is *Newtonian*: i.e., constant, and independent of shear rate. Most low-viscosity fluids, such as air, water, alcohol, and gasoline are Newtonian. Laminar flow is usually associated with low velocities, small equipment and/or viscous liquids.

Unlike laminar flow, turbulent flow is chaotic, and the technology relies on empirical correlations to predict physical behavior. Wall friction produces eddies, some as large as the pipe, which produce smaller eddies that ultimately dissipate as heat. British physicist Lewis Fry Richardson said it best:

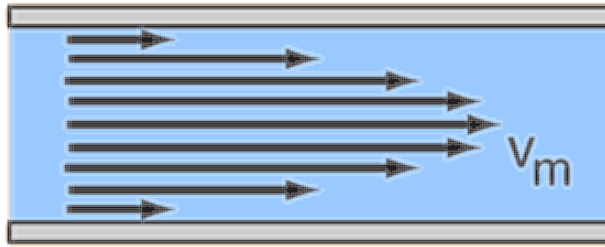

Figure 49.1: Laminar fluid flow through a pipe. The maximum flow velocity v_m is at the centerline and is equal to twice the average flow velocity. (Figure from Georgia State University, <http://hyperphysics.phy-astr.gsu.edu/hbase/pfric2.html>)

*Large whirls have little whirls
That feed on their velocity;
And little whirls have lesser whirls,
And so on to viscosity.*

Also unlike laminar flow, turbulent flow depends on the surface roughness of the containing pipe.

It is also possible to have *transitional flow* which switches between laminar and turbulent flow in an irregular manner.

49.1 The Continuity Equation

Consider a fluid flowing with velocity v_1 through a pipe of cross-sectional area A_1 . Then in a time Δt , a volume $v_1 \Delta t A_1$ of fluid passes a fixed point on that pipe. Now suppose the pipe flares to a larger or smaller pipe of area A_2 . If the fluid is incompressible, then the same volume must pass a fixed point in the new pipe in time Δt . Therefore the fluid velocity in the new pipe must change to a new velocity v_2 that satisfies $v_1 \Delta t A_1 = v_2 \Delta t A_2$, or $v_1 A_1 = v_2 A_2$. This implies that for incompressible fluid flow, the *flow rate* Av must be constant:

$$\boxed{Av = \text{constant.}} \quad (49.1)$$

The flow rate Av has units of volume per unit time (m^3/s). This relation is called the *continuity equation*.

You may be familiar with this idea in playing with a garden hose with the nozzle removed. Water flows out of the hose relatively slowly; but if you place your thumb over the opening to block most of the flow, then water squirts out of the small remaining opening at high velocity.

49.2 Bernoulli's Equation

Bernoulli's equation was developed by 18th-century Swiss physicist Daniel Bernoulli. Given fluid flow in a pipe that varies in elevation, the equation relates the velocity, pressure, and elevation as the fluid flows through the pipe. It states

$$\boxed{\frac{P}{\rho g} + \frac{v^2}{2g} + y = \text{constant,}} \quad (49.2)$$

where P is the pressure, v is the fluid velocity, y is elevation, ρ is the fluid density, and g is the acceleration due to gravity. Each term in Bernoulli's equation has units of length and is called a *head*: the $P/(\rho g)$ term is called the *pressure head*, the $v^2/(2g)$ term is called the *velocity head*, and the y term is called the *elevation head*.

Example. Suppose we have a vertical pipe containing a stationary incompressible fluid of density ρ . How does the pressure P vary with depth h ?

Solution. Let the pressure at depth $h = 0$ be P_0 . Since the fluid is stationary, the fluid velocity v is zero everywhere. Then Bernoulli's equation becomes (with $y = -h$)

$$\frac{P_0}{\rho g} + \frac{0}{2g} + 0 = \frac{P}{\rho g} + \frac{0}{2g} - h \quad (49.3)$$

$$\frac{P_0}{\rho g} = \frac{P}{\rho g} - h \quad (49.4)$$

$$P_0 = P - \rho gh \quad (49.5)$$

$$P = P_0 + \rho gh, \quad (49.6)$$

in agreement with Eq. (48.11).

49.3 Torricelli's Theorem

As another example of Bernoulli's equation, consider a cylinder filled with liquid, and with a hole in the side of the cylinder through which the liquid can leak out (Fig. 49.2). With what velocity does the liquid flow out of the hole?

We can analyze this using Bernoulli's equation. At the top surface of the liquid in the cylinder (which we'll call elevation y_1), the pressure will be atmospheric pressure P_0 . The liquid level drops here as water flows out of the cylinder, but at a very slow rate, so we'll take the velocity of the liquid here to be approximately zero.

At the hole in the side of the cylinder (where we'll call the elevation y_2), the pressure will also be atmospheric pressure P_0 , since the hole is exposed to the atmosphere here also. If the liquid is incompressible with density ρ , then by Bernoulli's equation,

$$\frac{P_0}{\rho g} + \frac{0}{2g} + y_1 = \frac{P_0}{\rho g} + \frac{v^2}{2g} + y_2 \quad (49.7)$$

$$y_1 = \frac{v^2}{2g} + y_2 \quad (49.8)$$

$$y_1 - y_2 = \frac{v^2}{2g}. \quad (49.9)$$

Calling the difference in elevations $h \equiv y_1 - y_2$, we get

$$\boxed{v = \sqrt{2gh}}. \quad (49.10)$$

This result, called *Torricelli's theorem* after 17th century Italian physicist Evangelista Torricelli, gives the fluid velocity when the difference between the fluid level in the cylinder and the position in the hole is h . The formula may look familiar: it's the same as the formula for the impact velocity of a point mass dropped from a height h .

In Fig. 49.2, the water leaving the cylinder follows a parabolic path, just as a projectile would. Using the constant-acceleration formulæ, we find that if the hole is a height H above the platform, then the amount

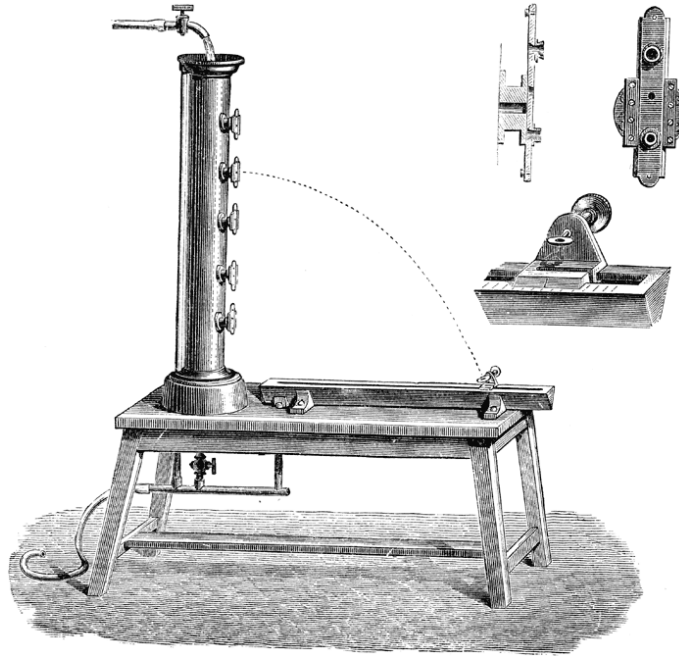

Figure 49.2: Apparatus for demonstrating Torricelli's theorem. (Ref. [14])

of time required for a parcel of water to fall to the platform will be $t = \sqrt{2H/g}$. Therefore the horizontal distance the water travels will be $x = v\sqrt{2H/g}$. Substituting the horizontal velocity v given by Eq. (49.10), we have the horizontal distance x traveled by the water stream as

$$x = 2\sqrt{Hh}, \quad (49.11)$$

where again H is the height of the hole above the platform, and h is the height of the liquid surface in the cylinder above the hole.

If the cylinder in Fig. (49.2) is filled all the way to the top and all five holes in the cylinder are opened, which stream will travel farthest horizontally? To answer this, let's number the top hole 1, the bottom hole 5, and let's choose a coordinate system with $+y$ pointing upward and the origin at the platform. If the distance between the holes is a , then the liquid in the cylinder is at $y = 6a$, and so $h = 6a - H$; then by Eq. (49.11),

- Hole 1: $H = 5a$, $h = a$, so $x = 2a\sqrt{5}$.
- Hole 2: $H = 4a$, $h = 2a$, so $x = 2a\sqrt{8}$.
- Hole 3: $H = 3a$, $h = 3a$, so $x = 2a\sqrt{9}$.
- Hole 4: $H = 2a$, $h = 4a$, so $x = 2a\sqrt{8}$.
- Hole 5: $H = a$, $h = 5a$, so $x = 2a\sqrt{5}$.

The water from the *center* hole (number 3) will travel farthest, a horizontal distance $x = 6a$.

Another way to think about this result is that hole 1 is high above the platform, but the water velocity is low, so it doesn't travel very far horizontally. The water velocity is highest at hole 5, but the hole is so close to the platform that it also doesn't travel far. Hole 3 is a compromise between height and fluid velocity that gives the maximum horizontal distance.

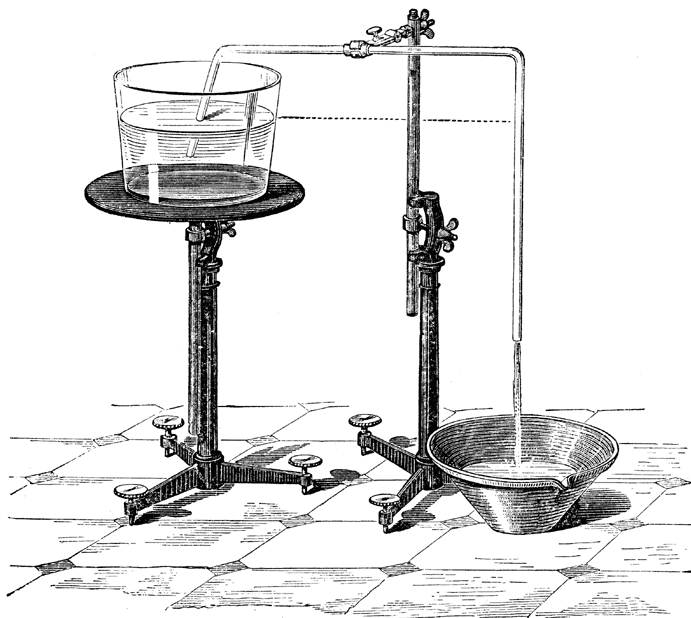

Figure 49.3: A siphon. (From Ref. [14])

49.4 The Siphon

A *siphon* (or *syphon*, from the Greek $\sigma\iota\varphi\omega\nu$) is a tube that transfers liquid from a reservoir at higher elevation to a reservoir at lower elevation, without the need for a pump—even though the liquid must travel uphill for part of the journey (Fig. 49.3).

It is a common misconception that a siphon works by atmospheric pressure pushing the water through the siphon, but this is not correct; siphons have been known to work even in vacuum. It's actually gravity that allows the siphon to work: water in the downward part of the siphon (the *downleg*) “pulls” the water in the rest of the tube along as it falls under gravity.

Siphons must be started or “primed” by filling the siphon tube with liquid before the siphon works. If the liquid to be moved is clean water, for example, one may sometimes start a siphon by mouth, creating a suction on one end as one would use a drinking straw. Once the tube is filled, you insert one end into the source reservoir, lower the other end into the target reservoir, and the siphon will begin to operate. But you would *not* want to start a siphon this way with a toxic liquid such as gasoline. (Service stations post a notice near the gasoline pumps, warning “do not siphon by mouth”.)

We can analyze the flow of liquid through a siphon using Bernoulli's equation, Eq. (49.2). Let's let atmospheric pressure be P_0 and the velocity of liquid through the siphon be v . We'll define a coordinate system with the $+y$ axis pointing upward, and with the origin at the surface of the liquid in the higher (“source”) reservoir, so all elevations will be measured with respect to this level. As seen in Fig. 49.3, the upper end of the siphon tube is immersed in the liquid; let's say it's at a depth d below the surface of the liquid, so it is at elevation $y = -d$. Let's call the height of the upper horizontal tube above the upper reservoir liquid level h , so it is at elevation $y = h$; and let's call the distance between the upper liquid level and the lower end of the downleg L , so $y = -L$ there. Then applying Bernoulli's equation to various points along

the siphon,

$$\frac{P_1}{\rho g} + \frac{v^2}{2g} - d = k \quad \text{Upper end of siphon (entrance)} \quad (49.12)$$

$$\frac{P_0}{\rho g} + \frac{0}{2g} + 0 = k \quad \text{Surface of upper reservoir} \quad (49.13)$$

$$\frac{P_2}{\rho g} + \frac{v^2}{2g} + h = k \quad \text{Top (horizontal) portion of siphon} \quad (49.14)$$

$$\frac{P_0}{\rho g} + \frac{v^2}{2g} - L = k \quad \text{Lower end of downleg (exit)} \quad (49.15)$$

Notice that the constant k on the right-hand side is the same for all equations, since the equations all apply to the same siphon. We've used the atmospheric pressure P_0 in Eqs. (49.13) and (49.15), because the surface of the upper reservoir and the exit point are both open to the atmosphere. Note also that the velocity of liquid at the surface of the upper reservoir has been set to zero; this is not strictly true because the liquid level in the upper reservoir is dropping, but the speed with which it drops is very slow compared to the siphon velocity v , so we'll set the liquid level velocity to zero as an approximation. Pressure P_1 is the liquid pressure at the siphon entrance, and P_2 is the pressure in the upper (horizontal) part of the siphon.

Let's try to find the velocity v of liquid through the siphon. Combining Eqs. (49.13) and (49.15),

$$\frac{P_0}{\rho g} + \frac{0}{2g} + 0 = \frac{P_0}{\rho g} + \frac{v^2}{2g} - L \quad (49.16)$$

$$0 = \frac{v^2}{2g} - L \quad (49.17)$$

or

$$\boxed{v = \sqrt{2gL}} \quad (49.18)$$

So the velocity v of liquid through the siphon depends only on the distance L between the upper reservoir liquid level and the exit end of the siphon.¹

Siphons are more complex than this brief analysis would indicate. Pressures in the tubing above the upper reservoir will be less than atmospheric pressure. As the water rises, gases will be liberated, and with large values of h , the volumetric gas rate will lower the effective density of the water, thereby increasing the maximum siphon height. When the pressure is near the vapor pressure of water,² the water will boil and can greatly reduce the effective water density. Under some circumstances, this water vapor can collapse violently in the downleg, causing severe vibration.

There doesn't seem to be a limit to the siphon height h , but 40 ft (12 m) or more are possible. There is no limit to the length of the downleg L ; values as high as 200 ft (61 m) have been tested.

49.5 Viscosity

Real fluids (especially liquids) exhibit a kind of internal friction called *viscosity*. Fluids that flow easily (like water and gasoline) have a fairly low viscosity; liquids like molasses that are "thick" and flow with difficulty have a high viscosity.

¹It's actually a little more complicated than this, because of inlet losses and pipe friction. When considering just the inlet losses, the liquid velocity is limited to $v_{\max} = \sqrt{gL}$.

²The vapor pressure of water depends on temperature; at 20 °C it is 2339 Pa.

There are two different types of viscosity defined. The more common is *dynamic viscosity*; the other is *kinematic viscosity*. Both are described below.

Dynamic Viscosity

Recall from the study of elasticity (Chapter 47) that when a body is placed under transverse (shear) stress $\sigma = F_t/A$, the resulting strain ε is the tangential displacement x divided by the transverse distance l :

$$\sigma = E\varepsilon \quad (49.19)$$

$$\frac{F_t}{A} = S \frac{x}{l}, \quad (49.20)$$

where S is the shear modulus. Fluid flow undergoes a similar kind of shear stress; however, with fluids, we find that the stress is not proportional to the strain, but to the *rate of change* of strain:

$$\frac{F_t}{A} = \mu \frac{d}{dt} \frac{x}{l} = \mu \frac{v}{l}, \quad (49.21)$$

where v is the fluid velocity. The proportionality constant μ , which takes the place of the shear modulus, is the *dynamic viscosity*. The SI units of dynamic viscosity are pascal-seconds (Pa s). Other common units are the *poise* (1 P = 0.1 Pa s) and the *centipoise* (1 cP = 0.001 Pa s).

Viscosity, especially liquid viscosity, is temperature dependent. You've probably noticed this from everyday experience: refrigerated maple syrup is fairly thick (high viscosity), but if you warm it on the stove it becomes much thinner (low viscosity).

The following table shows dynamic viscosities of some common liquids at room temperature. A more extensive table is given in Appendix U.

Table 49-1. Viscosities of common liquids (room temperature).

Liquid	Dynamic viscosity μ	
	(Pa s)	(cP)
gasoline	5×10^{-4}	0.5
water	8.9×10^{-4}	0.89
mercury	0.0016	1.6
olive oil	0.09	90
ketchup	1.3	1300
honey	5	5000
molasses	7	7000
peanut butter	250	250,000

Kinematic Viscosity

In addition to the dynamic viscosity μ , one sometimes encounters a *kinematic viscosity* ν . The kinematic viscosity is defined as the dynamic viscosity divided by the density:

$$\nu = \frac{\mu}{\rho}. \quad (49.22)$$

SI units for kinematic viscosity are m^2/s . Other common units are *stokes* (1 St = $10^{-4} \text{ m}^2/\text{s}$) and *centistokes* (1 cSt = $10^{-6} \text{ m}^2/\text{s}$).

49.6 The Reynolds Number

Experiments have shown that there is a combination of four factors that determines whether flow of a viscous fluid through a pipe is laminar or turbulent. These four factors can be combined into a single dimensionless number called the *Reynolds number* Re , whose value gives an indication of whether flow will be laminar or turbulent:

$$\boxed{Re = \frac{\rho v D}{\mu}} \quad (49.23)$$

Here ρ is the fluid density, v is the average velocity, D is the diameter of the pipe, and μ is the dynamic viscosity. Experience shows that, as a general rule of thumb:

- $Re < 2000$: laminar flow
- $2000 < Re < 3000$: transition region
- $Re > 3000$: turbulent flow

In the transition region (Re between 2000 and 3000), the fluid is unstable and may change back and forth between laminar and turbulent flow.

49.7 Stokes's Law

Stokes's law gives the resistive force on a sphere moving through a viscous fluid. It was developed by the 19th century English physicist and mathematician George Stokes. Stokes's law states that the resistive force on the sphere is given by

$$\boxed{F_R = 6\pi\mu r v} \quad (49.24)$$

where F_R is the resistive force on the sphere, r is its radius, μ is the dynamic viscosity of the fluid, and v is the relative velocity between the fluid and the sphere. This is generally valid for low Reynolds numbers ($Re < 1$).

Notice that the Stokes's law force is of the form of a Model I resistive force described in Chapter 19 ($F_R \propto v$), with the resistance coefficient $b = 6\pi\mu r$. By Eq. (19.22) the terminal velocity for Model I is $v_\infty = mg/b$; so for a sphere moving through a viscous fluid, we have by Stokes's law

$$v_\infty = \frac{mg}{6\pi\mu r} \quad (49.25)$$

Example. What is the terminal velocity of a steel ball of diameter 1 cm falling through a jar of honey?

Solution. Taking the density of steel as $\rho = 7.86 \text{ g/cm}^3$, we find the mass of the steel ball as

$$m = \rho V = \rho \left(\frac{4}{3}\pi r^3\right) = 4.115 \text{ g} = 4.115 \times 10^{-3} \text{ kg} \quad (49.26)$$

From Table 49-1, the dynamic viscosity μ of honey is 5 Pa s; the terminal velocity is then given by Eq. (49.25):

$$v_\infty = \frac{mg}{6\pi\mu r} \quad (49.27)$$

$$= \frac{(4.115 \times 10^{-3} \text{ kg})(9.80 \text{ m/s}^2)}{6\pi(5 \text{ Pa s})(0.5 \times 10^{-2} \text{ m})} \quad (49.28)$$

$$= 8.56 \text{ cm/s} \quad (49.29)$$

49.8 Fluid Flow through a Pipe

If a viscous fluid is flowing through a pipe, then there is an additional term called the *friction head* introduced into Bernoulli's equation:

$$\frac{P}{\rho g} + f \frac{L}{D} \frac{v^2}{2g} + \frac{v^2}{2g} + y = \text{constant}, \quad (49.30)$$

where the second term on the left is the friction head; f is a dimensionless constant called the *friction factor*,³ L is the pipe length, D is the pipe diameter, and v is the *average* fluid velocity (the fluid will flow faster at the center of the pipe than near the edges).

For laminar flow, the friction factor f is given simply by

$$f = \frac{64}{\text{Re}} \quad (\text{laminar flow}), \quad (49.31)$$

where Re is the Reynolds number. For a nonviscous fluid, the viscosity $\mu = 0$, the Reynolds number $\text{Re} = \infty$, and so $f = 0$, so that Eq. (49.30) reduces to the previous form of Bernoulli's equation, Eq. (49.2).

For turbulent flow, the analysis to find the friction factor is more complicated and depends on the Reynolds number and the ratio of the pipe surface roughness to pipe diameter. There is a general formula due to S.W. Churchill that gives the friction factor f for *all* values of Reynolds numbers and all types of flow (laminar, transitional, and turbulent) through both rough and smooth pipes. Churchill's equation (as modified by L.L. Simpson to produce accurate results for turbulent flow) is

$$f = \left| \left(\frac{64}{\text{Re}} \right)^{12} + \left\{ \left[2 \log_{10} \left(\frac{\varepsilon}{3.7D} - \frac{5.02}{\text{Re}} \log_{10} \left(\frac{\varepsilon}{3.7D} + \left(\frac{7}{\text{Re}} \right)^{0.9} \right) \right) \right]^{16} + \left(\frac{13269}{\text{Re}} \right)^{16} \right\}^{-3/2} \right|^{1/12} \quad (49.32)$$

where ε is the pipe roughness and D is the pipe diameter. The friction factor vs. Reynolds number is shown in Figure 49.4.

49.9 Gases

The study of the physics of gases can be fairly involved, and is usually studied as part of *thermodynamics*, or the study of heat. In this section, we'll cover a few basic properties of gases.

A *gas* is a state of matter in which the atoms or molecules making up the gas are not attached to one another, so that they are free to move about independently. The air we breath is an example of a gas; it consists primarily of 78% nitrogen molecules (N_2) and 21% oxygen molecules (O_2); the remainder is argon and a few other gases.

Studies of gases in the 18th and 19th centuries revealed a few basic properties of a gas of volume V and

³Sometimes f is called the *Moody friction factor*, *Weisbach friction factor*, or *Darcy friction factor*. One sometimes also encounters the *Fanning friction factor* equal to $f/4$, and the *Stanton friction factor* equal to $f/8$. The Moody friction factor used here is the most common.

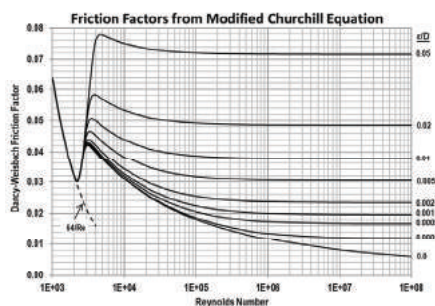

Figure 49.4: Friction factor as a function of Reynolds number, for both laminar and turbulent flow. (Ref. [11])

(absolute) temperature⁴ T , under a pressure P :

$$P \propto \frac{1}{V} \quad (\text{Boyle's law}) \quad (49.33)$$

$$P \propto T \quad (\text{Amonton's law}) \quad (49.34)$$

$$V \propto T \quad (\text{Charles's law}) \quad (49.35)$$

where in each case, the unnamed variable (T , V , and P , respectively) is assumed to be held constant. These three equations can be combined into one, called the *ideal gas law* that relates the pressure P , volume V , and temperature T of an ideal gas:

$$PV = nRT \quad (49.36)$$

Here n is the number of moles of gas atoms or molecules present, and R is a constant called the (molar) gas constant; it is equal to *exactly*

$$R = 8.31446261815324 \text{ J mol}^{-1} \text{ K}^{-1} \quad (49.37)$$

The ideal gas law is sometimes expressed in the equivalent form

$$PV = Nk_B T \quad (49.38)$$

where N is the total number of atoms or molecules of gas present, and k_B is *Boltzmann's constant*; it is equal to *exactly*

$$k_B = 1.380649 \times 10^{-23} \text{ J/K} \quad (49.39)$$

⁴Temperature must be in kelvins (K) for SI or CGS units, or in degrees Rankine ($^{\circ}\text{R}$) in English units. Fahrenheit ($^{\circ}\text{F}$) and Celsius ($^{\circ}\text{C}$) are not absolute temperature scales, and may not be used here.

The ideal gas law is an *equation of state* for the gas; it assumes the gas is “ideal” — that is, the atoms making up the gas are of negligible size, and that the atoms do not interact with each other chemically (only through collisions). Other equations of state may be used, such as the *van der Waals equation of state*, that takes into account the finite size of the atoms or molecules making up the gas, and the intermolecular forces between nearby molecules:

$$\left[P + a \left(\frac{n}{V} \right)^2 \right] \left(\frac{V}{n} - b \right) = RT \quad (49.40)$$

If the coefficients a and b describing these effects are known, then the van der Waals equation may be a more realistic equation of state than the ideal gas law.

49.10 Superfluids

When liquid helium-4 (${}^4\text{He}$) is cooled below a critical temperature of 2.17 K (called the *lambda point*), a sudden phase transition occurs, and the helium becomes an exotic fluid called *helium II*.⁵ Helium II is the best-known example of a *superfluid*—a fluid with odd properties that are governed by the laws of quantum mechanics.

As helium I is cooled toward the lambda point, it boils violently; but when the lambda point is reached, the boiling suddenly stops. This is due to a sudden increase in the thermal conductivity of the liquid when it transitions to the superfluid state. The thermal conductivity of superfluid helium II is more than a million times greater than that of liquid helium I, and helium II is a better conductor of heat than any metal.

Superfluid helium II is perhaps best known for its unusual viscosity. One method for measuring the viscosity of a liquid is to allow it to flow through a thin tube or channel called a *capillary*: the more viscous the liquid, the larger the diameter of the capillary needed to permit the liquid to flow. Helium II can flow through capillaries much less than $1 \mu\text{m}$ in diameter, and in such experiments behaves as though it has *zero* viscosity. This ability of helium II to flow through very tiny capillaries is called *superflow*.

Another method for measuring viscosity is to rotate a small cylinder inside the liquid; viscosity will cause the liquid to be dragged along with the cylinder, and a small rotatable paddle placed near the axis of the rotating cylinder will show whether the rotating cylinder is causing the liquid to rotate. In such experiments, helium II *does* exhibit some viscosity. No ordinary liquid exhibits this sort of dual behavior with respect to viscosity.

A common model to explain this odd behavior is called the *two-fluid model*. In this model, liquid helium II is thought of as consisting of two interpenetrating components: a *normal* (viscous) component, and a *superfluid* (nonviscous) component. In the capillary experiment, only the superfluid component flows through the tiny capillaries, but in the rotating-cylinder experiment, the normal component is dragged along with the cylinder, causing circulation in the liquid.

Another unusual phenomenon observed in helium II is called the *fountain effect* (Fig. 49.5). A tube with a porous plug in the bottom is placed inside a bath of helium II. A superflow of helium is observed to flow through the tiny ($\ll 1 \mu\text{m}$) capillaries *toward* the heater; upon being heated, the superfluid component is converted to a normal component, and the fluid is unable to flow back out through the fine capillaries in the plug. Pressure builds in the tube until the helium squirts out of the capillary in the top of the tube, creating a “helium fountain”. Since the second law of thermodynamics states that heat cannot flow from lower to higher temperatures, this implies that the superfluid component carries no heat: any heat in the helium II must be in the normal component.

Yet another interesting property of helium II is the formation of a very thin film called a *Rollin film* when the liquid is placed in a container. The Rollin film will creep up the sides of the container, and if the container is open, it will creep back down the outside, so that the helium II will spontaneously creep out of the container

⁵Above 2.17 K, liquid helium is a (mostly) ordinary liquid called *helium I*.

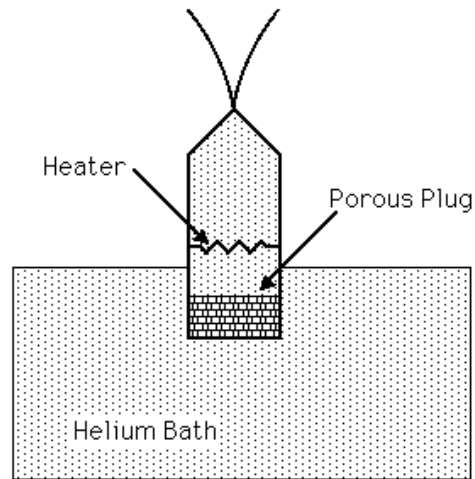

Figure 49.5: The fountain effect in superfluid liquid helium II. (Credit: NASA.)

(Fig. 49.6). The Rollin film is much less than $1 \mu\text{m}$ in thickness; its creeping speed is slow just below the lambda point, but may reach a speed as high as 35 cm/s at lower temperatures.

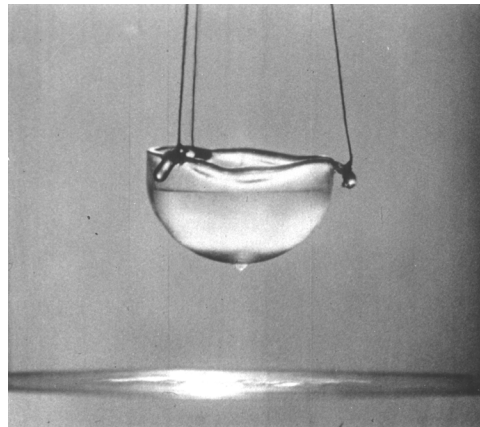

Figure 49.6: A Rollin film of superfluid helium II. The film creeps up the sides of the container and back down the outside, collecting in small drops at the bottom. (Credit: *Liquid Helium II: The Superfluid*, University of Michigan.)

Finally, helium II exhibits an unusual way of conducting heat. Normally, substances conduct heat through diffusion, where the rate of heat flow is proportional to the temperature difference; but in superfluid helium II, heat is conducted by *waves*. This phenomenon is called *second sound*, and no other substance exhibits this behavior. The speed of second sound is small just below the lambda point; at a lower temperature of 1.6 K, it is about 20 m/s.

It should be kept in mind that the two-fluid model of helium II discussed here is simply a *model*—a convenient way of thinking about the behavior of the liquid. Superfluid helium II is a quantum liquid, and a complete description of its behavior requires the application of quantum mechanics.

Chapter 50

Hydraulics and Pneumatics

Fluids can be used to practical advantage for constructing certain machines. The practical application of liquid mechanics is called *hydraulics*.

50.1 Hydraulics: The Hydraulic Press

The properties of liquids may be exploited to make it possible to lift large, heavy objects using a machine called a *hydraulic press* (Fig. 50.1). Referring to the figure, we know by Pascal's law that pressure P_1 must be equal to pressure P_2 :

$$P_1 = P_2. \quad (50.1)$$

Therefore

$$\frac{F_1}{A_1} = \frac{F_2}{A_2}, \quad (50.2)$$

where A_1 and A_2 are the cross-sectional areas of the pistons on the left and right. Solving for F_1 , we find

$$\boxed{F_1 = F_2 \frac{A_1}{A_2}}. \quad (50.3)$$

Since $A_2 > A_1$, the force F_1 is multiplied by the factor A_2/A_1 . One may place a heavy object like an automobile on the right, and lift it by applying a relatively small force on the left. The price for gaining this multiplication of force is that the piston on the left must be moved through a greater distance than the object on the right will be raised. To find the distance d_1 through which the piston on the left must be moved in order to lift the object on the right a distance d_2 , we note that the liquid is essentially incompressible; therefore the volume change on the left must equal the volume change on the right:

$$A_1 d_1 = A_2 d_2. \quad (50.4)$$

Therefore the distance d_1 is

$$d_1 = d_2 \frac{A_2}{A_1}. \quad (50.5)$$

We can find d_1 in terms of the ratio of forces using Eq. (50.3) to substitute for A_2/A_1 ; we get

$$d_1 = d_2 \frac{F_2}{F_1}. \quad (50.6)$$

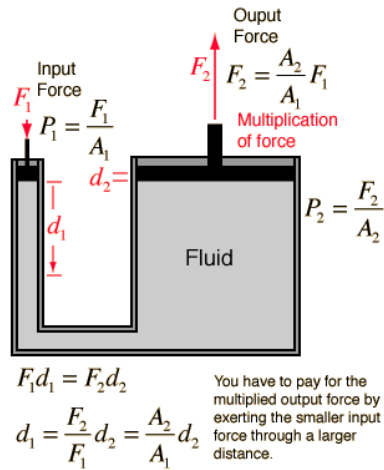

Figure 50.1: The hydraulic press. (Credit: HyperPhysics project, Georgia State University, Ref. [7]).

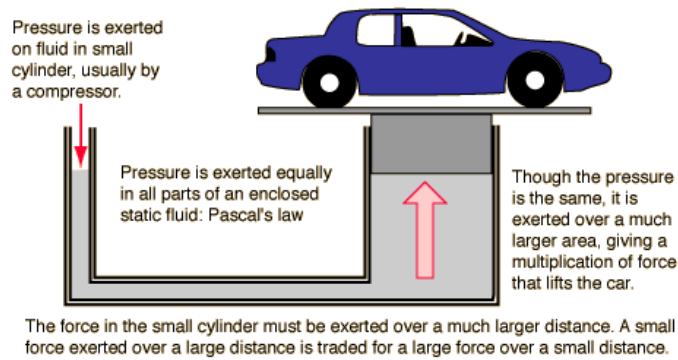

Figure 50.2: An automobile on a hydraulic press. (Credit: HyperPhysics project, Georgia State University, Ref. [7]).

Example. Suppose the piston on the left has a diameter of 10 cm, and the piston on the right has a diameter of 1 m. What force must be applied on the left to lift a 1000-kg automobile on the right? (See Fig. 50.2.)

Solution. The automobile has a weight $F_2 = mg = (1000 \text{ kg})(9.8 \text{ m/s}^2) = 9.8 \times 10^3 \text{ N}$. The area $A_1 = \pi r^2/4 = (\pi/4)(0.1 \text{ m})^2 = (\pi/4) \times 10^{-2} \text{ m}^2$. The area $A_2 = \pi r^2/4 = (\pi/4)(1 \text{ m})^2 = \pi/4 \text{ m}^2$. The force F_1 is then

$$F_1 = F_2 \frac{A_1}{A_2} \quad (50.7)$$

$$= (9.8 \times 10^3 \text{ N}) \frac{\pi/4 \times 10^{-2} \text{ m}^2}{\pi/4 \text{ m}^2} \quad (50.8)$$

$$= 98 \text{ N}. \quad (50.9)$$

In this case, the piston on the left must be pushed in 1 m to lift the car by 1 cm.

50.2 Pneumatics

The science of the mechanical properties of air (or other elastic fluids) is called *pneumatics* (after the Greek word $\piνευμα$, meaning *breath* or *air*). It is a counterpart of hydraulics, but using air instead of water as the working fluid. The primary difference between the two fluids is that air is fairly compressible, while water is largely incompressible.

Chapter 51

Gravity

51.1 Newton's Law of Gravity

The English physicist Sir Isaac Newton developed his theory of the gravitational force in his famous work *Philosophiæ Naturalis Principia Mathematica*. In modern language and notation, it states that the force F between two point masses m_1 and m_2 separated by a distance r is given by

$$F = -G \frac{m_1 m_2}{r^2}, \quad (51.1)$$

where G is the universal gravitational constant, $6.67430 \times 10^{-11} \text{ m}^3 \text{ kg}^{-1} \text{ s}^{-2}$. Here we take the usual convention in one dimension, where a negative force is attractive, and a positive force is repulsive. Since mass is always positive, the gravitational force is always attractive.

In vector form, Newton's law of gravity becomes

$$\mathbf{F}_{12} = G \frac{m_1 m_2}{r^2} \hat{\mathbf{r}}_{12}, \quad (51.2)$$

where \mathbf{F}_{12} is the force on mass 1 due to mass 2, and $\hat{\mathbf{r}}_{12}$ is a unit vector pointing from mass 1 to mass 2.

From Newton's law of gravity, we can deduce the acceleration due to gravity at the Earth's surface. The gravitational force between the Earth of mass M_\oplus and an object on the surface of mass m is (in magnitude)

$$F = G \frac{M_\oplus m}{R_\oplus^2}, \quad (51.3)$$

where R_\oplus is the radius of the Earth. By Newton's second law, the gravitational force on m at the Earth's surface is $F = ma = mg$, so $g = F/m$, and we have

$$g = \frac{GM_\oplus}{R_\oplus^2} = 9.8 \text{ m/s}^2. \quad (51.4)$$

51.2 Gravitational Potential

Sometimes it is useful to define a *gravitational potential*, which is a property of space, rather than a property of the bodies present the way force and potential energy are. To find the gravitational potential, suppose we have a mass m creating a gravitational field in space. We put a small "test mass" m_0 in space near mass

m , determine the gravitational potential energy on the test mass due to m 's mass, and divide the resulting potential energy by m_0 . The result is the gravitational potential \mathcal{G} . For a point mass m ,

$$\mathcal{G} = -\frac{Gm}{r}. \quad (51.5)$$

51.3 The Cavendish Experiment

Determining the universal gravitational constant G is a fairly difficult problem because of the weakness of the gravitational force. The problem was solved in a famous experiment by the English physicist Henry Cavendish. In his experiment, Cavendish attached two heavy masses to the ends of a rod; the rod was then suspended at its balance point from a vertical wire that was attached to the ceiling, forming a torsional pendulum. Two very large stationary masses were then placed next to the two suspended masses, so that each mass on the rod was adjacent to one of the large stationary masses. The gravitational attractive force between the masses caused the rod to rotate slightly. From knowing the masses, their separation, the torsional ‘‘Hooke’s law’’ constant κ , and the angle of rotation, Cavendish was able to determine the value of G .

51.4 Helmholtz’s Equation

The acceleration due to gravity g is

$$g = G \frac{M_{\oplus}}{R_{\oplus}^2} = 9.8 \text{ m/s}^2, \quad (51.6)$$

to two significant digits, where M_{\oplus} is the Earth’s mass and R_{\oplus} is its radius. But what if we want to use a more exact value for g ?

You might be tempted to use a value found in some reference books: $g = 9.80665 \text{ m/s}^2$, but that would actually be wrong. This value is just a standard value used for the definitions of some units (for example, in the conversion between pounds-force and newtons). You should never use this value in a physics formula that contains g as the acceleration due to gravity—it’s only used when doing certain unit conversions.

The acceleration due to gravity g at the surface of the Earth varies over the surface of the Earth for a number of reasons:

1. As you get closer to the equator, the Earth’s rotation rate gets larger, resulting in a greater centrifugal force that counteracts gravity. This has the effect of reducing g closer to the equator.
2. Also, the Earth has an equatorial bulge due to its rotation, so that you’re farther from the center of the Earth near the equator. This also has the effect of reducing g closer to the equator.
3. There is also an elevation effect: the higher you are in elevation, the smaller g is.

These effects can be approximately accounted for using an equation called *Helmholtz’s equation*. According to Helmholtz’s equation, the acceleration due to gravity is given by

$$g = 9.80616 - 0.025928 \cos 2\phi + (6.9 \times 10^{-5}) \cos^2 2\phi - (3.086 \times 10^{-6})H \text{ m/s}^2, \quad (51.7)$$

where ϕ is the latitude and H is the elevation (in meters) above sea level. For example, for Largo, Maryland, the latitude ϕ is $38^{\circ}8'98''$ and the elevation H is about 174 feet (53.0 meters). Substituting these values into Helmholtz’s equation, we find g at Largo is about 9.80052 m/s^2 . In other cities around the world, the value ranges from 9.779 m/s^2 (Mexico City) to 9.819 m/s^2 (Helsinki). For most problems we just use an average value of 9.8 m/s^2 . (You should *never* round this to 10 m/s^2 unless you’re doing a very rough order-of-magnitude estimation.)

51.5 Earth Density Model

Suppose we have a uniform, spherical body (such as a planet) of radius R and mass M . What is the acceleration g due to gravity as a function of r for r both inside and outside the body ($0 \leq r < \infty$)?

First, consider the case where we're *inside* the body ($r \leq R$). In this case, the acceleration due to gravity at r is $g(r) = Gm/r^2$, where m is the total mass inside a sphere of radius r :

$$m = \frac{4}{3}\pi r^3 \rho \quad (51.8)$$

where the (uniform) density $\rho = M/(\frac{4}{3}\pi R^3)$. Thus

$$g(r) = \frac{GM}{R^3} r \quad (0 \leq r < R) \quad (51.9)$$

so inside the body, $g \propto r$.

Second, consider the case where we're *outside* the body ($r > R$). In this case, the total mass inside a sphere of radius r is M , and so

$$g(r) = \frac{GM}{r^2} \quad (r \geq R) \quad (51.10)$$

so that outside the body, $g \propto 1/r^2$. The maximum value of g is at the surface, $g = GM/R^2$ at $r = R$ (Figure 51.1).

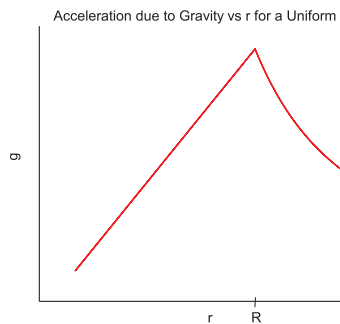

Figure 51.1: Acceleration due to gravity for a uniform sphere.

However, planetary bodies are generally not uniform. For example, the Earth has a higher density closer to its core, and its density decreases closer to the surface. One density model of the Earth given by Dziewonski and Anderson¹ is shown in Figure 51.2. We can use this density model to compute a more realistic model of $g(r)$ inside the Earth:

$$g(r) = \int_0^r \frac{G\rho(r)}{r^2} dV = \int_0^r \frac{G\rho(r)}{r^2} (4\pi r^2) dr = 4\pi G \int_0^r \rho(r) dr \quad (51.11)$$

The result is plotted in Figure 51.3. We see that in a more realistic model of the Earth's interior, the maximum value of the acceleration to to gravity g occurs just outside the outer core, where $g = 10.7 \text{ m/s}^2$.

¹Dziewonski, A.M., and Anderson, D.L., Preliminary Earth reference model. *Physics of the Earth and Planetary Interiors*, **25** (1981) 297–356.

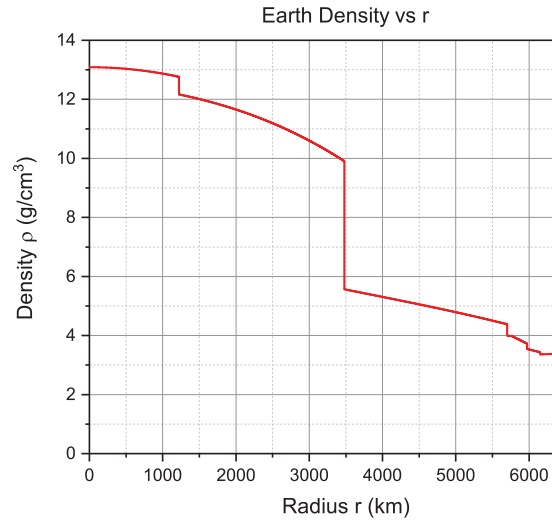

Figure 51.2: Earth density model (Dziewonski and Anderson, 1981.)

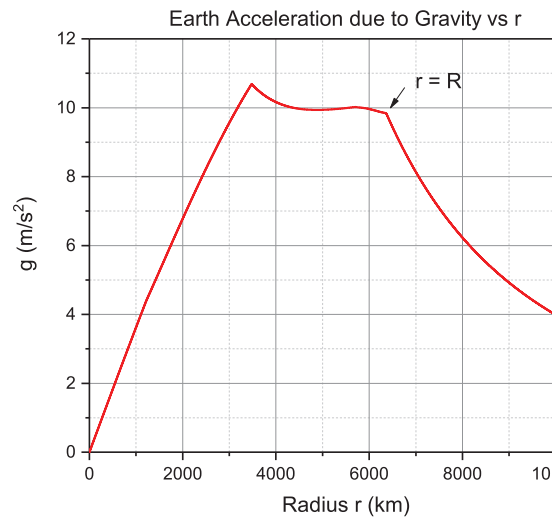

Figure 51.3: Modeled acceleration due to gravity for Earth.

51.6 Escape Velocity

The *escape velocity* is the initial velocity a particle must have to escape the gravity of its parent body. Typically it refers to the initial velocity a particle must have at the surface of a planet in order to leave the planet forever, and never be pulled back by the planet's gravity. If a particle leaves the surface of a planet with an initial velocity equal to the escape velocity, then the body will move more and more slowly as the particle moves farther from the planet, finally reaching a velocity of zero at $r = \infty$. (We assume only the particle and the planet are present, and ignore all other bodies.)

To compute the escape velocity, consider running the problem with time running backwards: the body starts at $r = \infty$ with zero velocity and falls *toward* the planet. The impact velocity from infinity will be the same as the escape velocity. Now at $r = \infty$, the potential energy $U = -GM_p m/r = 0$, where M_p is the mass of the planet and m is the mass of the particle. Since the particle is at rest at $r = \infty$, the kinetic energy there is also zero, so the total mechanical energy $K + U = 0$. Now let the particle begin falling from $r = \infty$ under the influence of the planet's gravity, until it impacts the planet at $r = R_p$, where R_p is the radius of the planet. At the point of impact the potential energy is $U = -GM_p m/R_p$, and its kinetic energy will be $K = mv_e^2/2$, where v_e is the impact (escape) velocity. By the law of conservation of energy, the total mechanical energy at $r = \infty$ must be the same as it is at $r = R_p$:

$$K + U = \frac{1}{2}mv_e^2 - \frac{GM_p m}{R_p} = 0. \quad (51.12)$$

Solving for the escape velocity v_e , we find

$$v_e = \sqrt{\frac{2GM_p}{R_p}}. \quad (51.13)$$

For the Earth, for example, we have (from Appendix L) $GM_p = 3.986005 \times 10^{14} \text{ m}^3 \text{ s}^{-2}$ and $R_p = 6378.140 \times 10^3 \text{ m}$; substituting these values into Eq. 51.13, we find the escape velocity for Earth is $v_e = 11.2 \text{ km/s}$. In other words, if you were to fire a projectile from the surface of the Earth with an initial velocity of 11.2 km/s, it would be able to escape the Earth's gravity, going more and more slowly the higher it goes, finally coming to rest at $r = \infty$.

51.7 Gauss's Formulation

It is possible to re-cast Newton's law of gravity into a different mathematical form using a mathematical theorem known as *Gauss's law*. This is *not* a separate theory of gravity—it is still Newton's law, but in different mathematical clothing. This form of Newton's law of gravity lets us easily solve some problems that would be fairly difficult using Newton's original formulation.

An alternative formulation of Newtonian gravity is Gauss's law for gravity. It states that the acceleration g due to gravity of a mass m (not necessarily a point mass) is given by

$$\oint_S \mathbf{g} \cdot \hat{\mathbf{n}} \, dA = -4\pi Gm \quad (51.14)$$

This equation requires a bit of explanation. The circled integral sign indicates an area integral evaluated over a *closed* surface S . A closed surface may be a sphere, cube, cylinder, or some irregular shape—any closed surface that has a well-defined “inside” and “outside.” The integral is an area integral: we imagine that the surface S is divided into many infinitesimal squares, each of which has area dA . Performing the integral means summing up the integrand times dA over the entire closed surface S .

The vector \mathbf{g} is the acceleration due to gravity, as a *vector*. The vector always points *toward* the mass.

The vector $\hat{\mathbf{n}}$ is a *unit vector*, perpendicular (“normal”) to the surface S , and pointing *outward* from S .

On the right-hand side of Equation (51.14), we find familiar constants (π and G), along with mass m . Here m is the total mass *inside* surface S . It doesn't matter what shape the mass m is, or how it is distributed; m is just the total mass inside surface S .

So Gauss's law for gravity says this: we're given some mass m , which may be of some arbitrary shape. Now imagine constructing an *imaginary* surface S around mass m (a sphere, or any other closed shape). Divide surface S into many infinitesimally small squares, each of which has area dA . At each square, draw a unit normal vector $\hat{\mathbf{n}}$ that is perpendicular to the surface at that square's location, and which is pointing outward from S . Let \mathbf{g} be the acceleration due to gravity at that square. If we take the dot product of \mathbf{g} and $\hat{\mathbf{n}}$ at that square, multiply by the area of the square dA , then sum up all of those products for all the squares making up surface S , then the result will be $-4\pi G$ times the total mass enclosed by S .

This law applies in general, but in practice it is most useful for finding the acceleration to to gravity g due to a highly symmetrical mass distribution (a point, sphere, line, cylinder, or plane of mass). In these cases, the integral is particularly easy to evaluate, and we can easily solve for g in just a few steps.

Point Mass

For example, let's use Gauss's law to find the acceleration g due to the gravity of a *point* mass m . Since $F = Gmm'/r^2$ and $F = m'g$, the result should be

$$g = \frac{Gm}{r^2}. \quad (51.15)$$

We begin with a point mass m sitting in space. We now need to construct an imaginary closed surface S surrounding m . While in theory any surface would do, we should pick a surface that will make the integral easy to evaluate. Such a surface should have these properties:

1. The gravitational acceleration g should be either perpendicular or parallel to S everywhere.
2. The gravitational acceleration g should have the same value everywhere on S . (Or it may be zero on some parts of S .)
3. The surface S should pass through the point at which you wish to calculate the acceleration due to gravity.

If we can find a surface S that has these properties, the integral will be very simple to evaluate. For the point mass, we will choose S to be a *sphere* of radius r centered on mass m . Since we know \mathbf{g} points radially inward toward mass m , it is clear that \mathbf{g} will be perpendicular to S everywhere. Also, by symmetry, it is not hard to see that g will have the same value everywhere on S .

Having chosen a surface S , let us now apply Gauss's law for gravity. The law states that

$$\oint_S \mathbf{g} \cdot \hat{\mathbf{n}} \, dA = -4\pi Gm. \quad (51.16)$$

Now everywhere on the sphere S , $\mathbf{g} \cdot \hat{\mathbf{n}} = -g$ (since \mathbf{g} and $\hat{\mathbf{n}}$ are anti-parallel— \mathbf{g} points inward, and $\hat{\mathbf{n}}$ points outward). Since $-g$ is a constant, Eq. (51.16) becomes

$$-g \oint_S dA = -4\pi Gm. \quad (51.17)$$

Now the integral is very simple: it is just dA integrated over the surface of a sphere, so it's just the area of a sphere:

$$\oint_S dA = 4\pi r^2. \quad (51.18)$$

Equation (51.17) is then just

$$-g(4\pi r^2) = -4\pi Gm, \quad (51.19)$$

or (cancelling -4π on both sides)

$$\boxed{g = \frac{Gm}{r^2}} \quad (51.20)$$

in agreement with Eq. (51.15) from Newton's law.

Line of Mass

The Gaussian formulation allows you to easily calculate the gravitational field due to a few other shapes. For example, suppose you have an infinitely long *line* of mass, having linear mass density λ (kilograms per meter), and you wish to calculate the acceleration g due to the gravity of the line mass at a perpendicular distance r of the mass. The appropriate imaginary "Gaussian surface" S in this case is a cylinder of length L and radius r , whose axis lies along the line mass. In this case, everywhere along the curved surface of cylinder S , the gravitational acceleration \mathbf{g} (pointing radially inward) is anti-parallel to the outward normal unit vector $\hat{\mathbf{n}}$. Everywhere along the flat ends of the cylinder S , the gravitational acceleration \mathbf{g} is *perpendicular* to the outward normal vector $\hat{\mathbf{n}}$, so that on the ends, $\mathbf{g} \cdot \hat{\mathbf{n}} = 0$, and the ends contribute nothing to the integral. We therefore need only consider the curved surface of cylinder S .

Now apply Gauss's law:

$$\oint_S \mathbf{g} \cdot \hat{\mathbf{n}} \, dA = -4\pi Gm. \quad (51.21)$$

Since \mathbf{g} is anti-parallel to $\hat{\mathbf{n}}$ along the curved surface of cylinder S , we have $\mathbf{g} \cdot \hat{\mathbf{n}} = -g$ there. Bringing this constant outside the integral, we get

$$-g \oint_S dA = -4\pi Gm. \quad (51.22)$$

The integral is just the area of a cylinder:

$$\oint_S dA = 2\pi rL, \quad (51.23)$$

so Eq. (51.22) becomes

$$-g(2\pi rL) = -4\pi Gm. \quad (51.24)$$

Now m is the total mass enclosed by surface S . This is a segment of length L and density λ , so it has mass λL . This gives

$$-g(2\pi rL) = -4\pi G(\lambda L). \quad (51.25)$$

Cancelling $-2\pi L$ on both sides gives

$$\boxed{g = \frac{2G\lambda}{r}} \quad (51.26)$$

Plane of Mass

In addition to spherical and cylindrical symmetry, this technique may also be applied to plane symmetry. Imagine that you have an infinite *plane* of mass, having area mass density σ (kilograms per square meter), and you wish to calculate the acceleration g due to the gravity of the plane at a perpendicular distance r from the plane. The approach is similar to the previous cases: draw an imaginary closed “Gaussian surface,” write down Gauss’s law for gravity, evaluate the integral, and solve for the acceleration g .

In this case, the appropriate Gaussian surface S is a “pillbox” shape—a short cylinder whose flat faces (of area A) are parallel to the plane of mass. In this case, everywhere along the curved surface of S , the gravitational acceleration \mathbf{g} is *perpendicular* to the outward normal unit vector $\hat{\mathbf{n}}$, so the curved sides of S contribute nothing to the integral. Only the flat ends of the pillbox-shaped surface S contribute to the integral. On each end, \mathbf{g} is anti-parallel to $\hat{\mathbf{n}}$, so $\mathbf{g} \cdot \hat{\mathbf{n}} = -g$ on the ends.

Now apply Gauss’s law to this situation:

$$\oint_S \mathbf{g} \cdot \hat{\mathbf{n}} \, dA = -4\pi Gm. \quad (51.27)$$

Here the integral needs only to be evaluated over the two flat ends of S . Since $\mathbf{g} \cdot \hat{\mathbf{n}} = -g$, we can bring $-g$ outside the integral to get

$$-g \oint_S dA = -4\pi Gm. \quad (51.28)$$

The integral in this case is just the area of the two ends of the cylinder, $2A$ (one circle of area A from each end). This gives

$$-g(2A) = -4\pi Gm. \quad (51.29)$$

Now let’s look at the right-hand side of this equation. The mass m is the total amount of mass enclosed by surface S . Surface S is sort of a “cookie cutter” that punches a circle of area A out of the plane. The mass enclosed by S is a circle of area A and density σ , so it has mass σA . Then Eq. (51.29) becomes

$$-g(2A) = -4\pi G(\sigma A) \quad (51.30)$$

Cancelling $-2A$ on both sides, we get

$$\boxed{g = 2\pi G\sigma} \quad (51.31)$$

Note that this is a constant: the acceleration due to gravity of an infinite plane of mass is independent of the distance from the plane!

In his science fiction novel *2010: Odyssey Two*, author Arthur C. Clarke describes a large rectangular slab that has been build by an alien race and placed in orbit around Jupiter. Astronauts are able to calculate the mass of the slab by placing a small spacecraft near the center of the large face and timing it to see how long it takes to fall to the surface of the slab. By approximating the slab as an infinite plane, they use Eq. (51.31) to find the acceleration; from that and the falling time, they can calculate the mass. (Actually, Dr. Clarke got the wrong answer in the book. You may want to find the book and see if you can calculate the correct answer.)

Gauss’s Law for Electrostatics

You will find the techniques described here will appear again in your study of electricity and magnetism. Classical electricity and magnetism is described by four equations called *Maxwell’s equations*; one of these is *Gauss’s law*, and describes the electric field \mathbf{E} produced by an electric charge q :

$$\boxed{\oint_S \mathbf{E} \cdot \hat{\mathbf{n}} \, dA = \frac{q}{\epsilon_0}} \quad (51.32)$$

This equation is of the same form as Gauss's law for gravity, so everything discussed previously for gravity also applies here. Although this equation is true in general, it has a good practical use for easily calculating the electric field E due to a point, sphere, line, cylinder, or plane of electric charge. To do this, you do just as we did with the gravity examples: draw an imaginary Gaussian surface around the charge q , write down Gauss's Law, evaluate the integral, and solve for the electric field E . Here q is the total electric charge enclosed by S . The electric field \mathbf{E} points away from positive electric charge, and toward negative charge. The constant ϵ_0 is called the *permittivity of free space*, and has a value of $8.854187817 \times 10^{-12}$ F/m.

You'll find more details about Maxwell's equations in General Physics II.

51.8 General Relativity

Our best theory of gravity to date is Albert Einstein's *general theory of relativity*. A full description of general relativity is beyond the scope of this course, as it makes use of advanced mathematical ideas such as differential geometry. But briefly, the idea is that mass causes space and time to become distorted, and it is this distortion that is the nature of the gravitational force.

The central equation governing general relativity is called the *Einstein field equation*:

$$\boxed{R_{\mu\nu} - \frac{1}{2}Rg_{\mu\nu} = \frac{8\pi G}{c^4}T_{\mu\nu}} \quad (51.33)$$

The indices μ and ν range from 0 to 3, and stand for the coordinates t , x , y , and z , so that each side of the equation is a 4×4 matrix. Broadly speaking, the left-hand side of this equation represents the curvature of space time, and the right-hand side represents the distribution of mass. Here:

- $R_{\mu\nu}$ is the *Ricci curvature tensor*, and describes the curvature of space-time.
- R is the *scalar curvature*, and is an overall average curvature of space-time.
- $g_{\mu\nu}$ is the *metric tensor*, and defines the "distance" between neighboring points in space-time.
- $T_{\mu\nu}$ is the *stress-energy tensor*, and measures the mass density of matter.
- G is the gravitational constant, and c is the speed of light in vacuum.

In the special case where the gravitational field is weak, it can be shown that Einstein's field equation reduces to Gauss's law for gravity (Eq. 51.14), i.e. Newtonian gravity.

A few consequences of general relativity are:

- Time moves more slowly in a strong gravitational field than in a weak field. For example, clocks run more slowly at sea level than at the top of a mountain.
- Light can be bent by gravity. This was an important early test of general relativity: the amount of light bending predicted by general relativity was confirmed by measuring the positions of stars near the Sun during a solar eclipse in 1919. This effect has been observed recently by the Hubble Space Telescope in the form of *gravitational lensing*: the gravity of a relatively nearby galaxy will bend the light from more distant objects, producing multiple images of the distant object.
- Gravitational redshift: light emitted by a massive object will tend to be redder than it would be if the gravity were not present.
- Orbit precession: the orbits of planets "precess" due to gravitational effects, causing the perihelion position to slowly move around the Sun. The amount of this precession predicted by general relativity is slightly different than what would be predicted by Newtonian gravity. The effect is very slight, and most noticeable in the orbit of Mercury.

51.9 Black Holes

A star like our Sun exists in a state of equilibrium: its own gravity tries to pull the Sun's mass inward toward the center, but the outward radiation force due to nuclear fusion (which burns hydrogen fuel to create helium, causing the Sun to shine) is pushing outward. The inward and outward forces are in balance, and the Sun assumes the shape of a sphere of its current size.

Eventually (about 5 billion years from now), the Sun will run out of hydrogen fuel to burn, and the Sun will begin to collapse. The collapse will cause the Sun's material to heat again; the Sun will then enter a phase where it becomes a *red giant* star and burns helium as fuel to create carbon and other heavy elements. Once the helium fuel is used up, what's left behind will be a dense stellar core called a *white dwarf* star. Eventually, over 10 billion years or so, a white dwarf star will cool into a *black dwarf* star.² A similar fate awaits any star with a mass less than about 4 to 8 solar masses.

For a bigger star (4–8 up to about 10–15 solar masses), the star's gravity is strong enough to actually collapse the atoms in what would have been a white dwarf at the end of the star's life. The electrons are pushed into the atomic nuclei, forming essentially a giant ball of neutrons called a *neutron star*. As described in Chapter 4, neutron star material is *extremely* dense.

Stars with an initial mass of greater than about 10–15 solar masses face an even more exotic destiny. The gravitational force will be so strong that even the neutrons are collapsed. Once the star runs out of fuel, the entire star collapses into a mathematical point called a *singularity*: it is essentially a hole punched in space itself. Surrounding the black hole is a spherical region of space called the *event horizon*, where the force of gravity is so strong that not even light can escape. Any matter—even light—that crosses inside the event horizon can never escape from the black hole's gravity, and effectively becomes cut off from the rest of our Universe. The radius of the event horizon (called the *Schwarzschild radius*) is found by setting the escape velocity (Eq. 51.13) to the speed of light c , which gives

$$R = \frac{2GM}{c^2}. \quad (51.34)$$

The existence of black holes is predicted by general relativity, and their reality has been confirmed to the satisfaction of most astronomers. A well-known example is called *Cygnus X-1*, an X-ray source in the constellation Cygnus.

In addition to the stellar-mass black holes described here, astronomers have recently discovered that most, if not all, galaxies contain a *supermassive black hole* at their center, with a mass on the order of millions or billions of solar masses. Our own Milky Way galaxy has such a supermassive black hole at its center called *Sagittarius A**, with a mass of 4 million solar masses.

We don't know what goes on inside a black hole's event horizon. Some astrophysicists believe a *wormhole* may be formed—essentially a tunnel leading to a distant part of our Universe, or even to another Universe. Black hole research is still in its infancy, and is at the frontier of astrophysics research.

²No black dwarf stars have yet been detected.

Chapter 52

Earth Rotation

52.1 Introduction

You already know that the Earth rotates on its axis once every 24 hours. But if you look at the rotational motion in detail, you find that it's more complicated than that. Slight redistributions in the Earth's mass cause changes in the moment of inertia, which are reflected in slight changes in the rotation rate. These mass redistributions may be seasonal, or unpredictable one-time events like mass shifts due to earthquakes or tsunamis. Even the construction of a dam can cause tiny, measurable changes in the Earth's rotation rate. And besides these short-term events, there is a long-term slowing of the Earth's rotation due to tidal friction, so that days are becoming gradually slower over the long term.

In addition, the direction of the Earth's axis itself is moving around in a complicated way; the resulting motions of the axis, called *precession* and *nutation*, will be described here.

52.2 Precession

The Earth's rotation axis is currently oriented so that the north axis points near the direction of the star Polaris (α Ursæ Minoris, sometimes called the "North Star"). The north axis has not *always* pointed toward Polaris, though; the Earth's rotation axis actually moves in a big circle (of radius 23.5°) with a period of about 26,000 years; this motion is called *precession*. The precession is caused by the gravitational pull by the Moon and Sun on the Earth's equatorial bulge.

Because of precession, the "North star" is different stars at different times. While it is now Polaris, in ancient times (c. 3000 B.C.) the "North star" was the star Thuban (α Draconis). In the distant future, the north rotation axis will be near other stars: it will be near Deneb (α Cygni) in A.D. 10,000, and near the very bright star Vega (α Lyræ) in A.D. 14,000. Figure 52.1 shows a star chart with the direction of the Earth's north pole over time.

52.3 Nutation

Superimposed on the long-term (26,000-year) precession of the Earth's axis is a more complicated, shorter-term motion called the *nutation*. It is a complex motion composed of the superposition of several different harmonic motions, the largest of which has a period of about 18.6 years. It is generally perpendicular to the precessional direction, so that it is a kind of "nodding" up and down of the Earth's axis (see Figure 52.2).

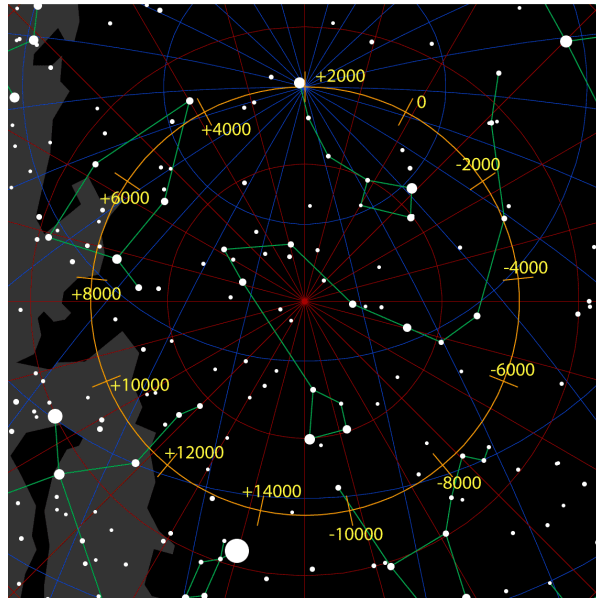

Figure 52.1: Star chart showing the direction of the Earth's north pole for different years. The movement is due to precession of the Earth's axis, and has a period of about 26,000 years. (Credit: *Tau'olunga, Wikipedia.*)

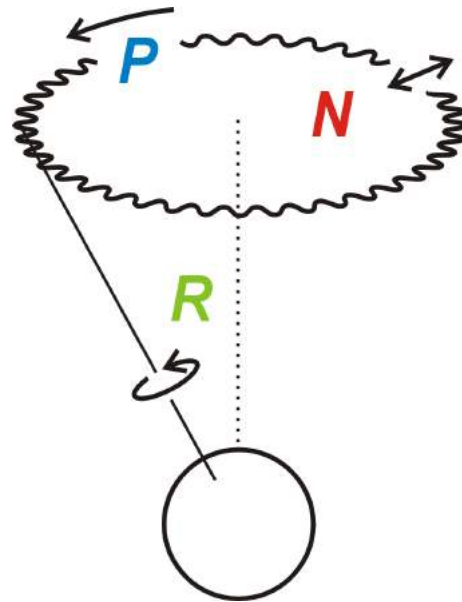

Figure 52.2: Precession (P) and nutation (N) of the Earth's rotation axis R . The nutation is a small "nodding" motion superimposed on the larger precessional motion. This figure shows the general shape of the nutation, with a period of about 18.6 years; the actual motion, when seen in detail, is more complex. (Credit: ©GNU-FDL, Wikimedia Commons.)

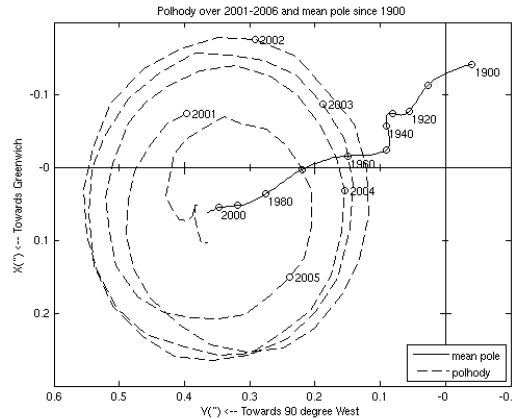

Figure 52.3: Polar motion. The dashed line shows the polar motion for the period 2001–2006. The solid line shows the drift in the mean pole position over the period 1900–2006. The axes are in units of seconds of arc subtended from the center of the Earth (0.1 arcsec = 3 meters). (Credit: *International Earth Rotation Service*.)

52.4 Polar Motion

In addition to a change in the direction of the Earth’s rotation axis described so far, there is also a small movement of the location of the intersection of the rotation axis with the Earth’s surface; this movement is called *polar motion*. It consists of three major components:

- An annual oscillation with a period of 365 days, due to small changes in the gravitational attraction of the Sun caused by the eccentricity of the Earth’s orbit.
- An oscillation with a period of 435 days, called the *Chandler wobble*. This is attributed to factors such as ocean floor pressure variation and wind.
- Superimposed on these two oscillations is a long-term drift, so that the north pole moves in the general direction of 80° west longitude.

The two oscillations “beat” together, so that the pole moves in a circle that expands and contracts in diameter with a frequency equal to the beat frequency (the difference in frequencies of the two motions); therefore the *period* of the change in diameter is

$$\left(\frac{1}{365 \text{ d}} - \frac{1}{435 \text{ d}} \right)^{-1} = 6 \text{ years.} \quad (52.1)$$

The rate of long-term drift is irregular, but over the last 100 years has averaged about 12 cm per year.

52.5 Rotation Rate

As mentioned earlier, shifts in the distribution of the Earth’s mass due to earthquakes, tsunamis, or even dams cause small changes in the Earth’s moment of inertia, that are reflected in tiny changes in the Earth’s rotation rate. There are also seasonal variations: ice melts in one hemisphere or the other depending on the season, which also causes small changes in the mass distribution.

Superimposed on the smaller effects is a long-term slowing of the Earth's rotation due to tidal drag. As the Moon pulls on the Earth's oceans, there is a friction force created that tends to slow the Earth's rotation over long time scales. From the beginning of the Paleozoic era (about 542 million years ago) to the present, the length of the day (LOD) has been found to be [4, 5, 16]

$$\text{LOD} = 24.00 - 4.98\tau, \quad (52.2)$$

where LOD is the length of the day in hours, and τ is the time in billions of years ago (Ga). (Prior to the beginning of the Paleozoic era, the slowing of the Earth's rotation was thought to have been at a slower rate than this 4.98 hr/Gyr rate.) Using this formula, the day length at the beginning of the Age of Dinosaurs (the Mesozoic era, about 250 million years ago) was only about 22 hours 45 minutes, or an hour and 15 minutes shorter than it is today.

This slowing of the Earth's rotation continues today, and is the source of some difficulty in timekeeping. We keep time by very precise atomic clocks, but at the same time we would like to keep our clocks in synchronization with the Earth's rotation. In fact, for historical reasons, the SI second as defined by atomic clocks corresponds to the length of the day as it was around 1820. Since the Earth's rotation has slowed since then, it means atomic clocks are running fast compared to the Earth rotation. To accommodate this, we from time to time insert *leap seconds* into our civil time scale (called Coordinated Universal Time, or UTC). A leap second inserts an extra second at the end of a day (generally a June 30 or December 31), so that clocks just before midnight read: 23:59:58, 23:59:59, 23:59:60, 00:00:00. This has the effect of setting the clock back one second to keep it in synchronization with the Earth's rotation.

The Earth's moment of inertia is roughly constant, so as the Earth's rate of rotation ω decreases, its angular momentum $L = I\omega$ must also decrease. But angular momentum is conserved; where does the angular momentum go? It turns out that it is transferred to the Moon, in the form of increased *orbital* angular momentum. As the Earth's rotation slows, the Moon recedes away from the Earth to conserve angular momentum. This lunar recession has been confirmed using Earth-based lasers and retroreflectors left on the lunar surface by the *Apollo* astronauts: the Moon is currently receding from the Earth at a rate of about 4 cm per year. This recession should continue until the Earth becomes tidally locked to the Moon the same way the Moon is now tidally locked to the Earth: not only will the Moon always present the same face to the Earth, but the Earth will always present the same face to the Moon. At that point, the Moon will appear stationary in the sky, and from some parts of the Earth will never be visible.

However, it's not likely that this tidal locking of the Earth to the Moon will ever happen. Calculations show that it would not occur for another 50 billion years¹; in about 5 billion years the Sun will reach its red giant stage, and may expand enough to consume both the Earth and the Moon.

¹For comparison, the current age of the Universe is 13.7 billion years.

Chapter 53

Geodesy

53.1 Introduction

Geodesy is the study of the measurement of the Earth, its precise shape, and the details of its gravitational field. With precise determinations of latitude and longitude around the globe, geodesists provide a means to tie together results of local land surveys into a consistent, coherent, global system.

Although the Earth is often considered to be a sphere, it is much closer to being an oblate spheroid, bulging slightly at the equator due rotation over time. The equatorial and polar radii, set by the WGS 84 standard¹, are $a = 6378.1370$ km and $b = 6356.7523142$ km, respectively. The polar radius b is calculated from the equatorial radius a and a flattening parameter.² These two radii approximate the Earth's size at sea level. From them we can calculate the constants given in Table 53-1.

Table 53-1. WGS 84 Derived Constants.

Surface area of oblate spheroid	$5.10065622 \times 10^8 \text{ km}^2$
Volume of oblate spheroid	$3.44795987 \times 10^{11} \text{ km}^3$
Mean radius of semi-axes	6371.00877 km
Radius of sphere of equal area	6371.00718 km
Radius of sphere of equal volume	6371.00079 km
Equatorial circumference	40075.0167 km
Polar circumference	40007.8629 km

This oblate spheroid is part of the satellite-based Global Positioning System (GPS) and serves as the reference for coordinate calculations. GPS can also be used to estimate elevation; however the accuracy is reduced, in large part because sea level is not the shape of an oblate spheroid, but varies with the gravity, which in turn varies with latitude and local terrain and ground composition. Sea level is modeled as an irregularly shaped surface known as the *geoid*. Its local value is referenced to the spheroid.

The Earth's volume exceeds that of the oblate spheroid due to the land volume above sea level, which is estimated to be $3.755 \times 10^7 \text{ km}^3$, based on the global mean elevation of 231.3 meters.

Note that one fourth of the polar circumference is less the 2 km more than the pole-to-equator dimension used to define the original meter. A large part of this discrepancy is due to a calculation error made during

¹1984 World Geodetic System.

²The flattening factor $f = (a - b)/a = 1/298.257223563$. so $b = a(1 - f)$.

the survey that was made in the late 18th century to determine the distance from the equator to the North Pole for the purpose of defining the meter. The resulting error led to our current meter being about 0.2 mm shorter than intended.³

In this chapter, we'll examine some formulæ used in geodesy to find the distance between two points on the globe. The so-called *cosine formula* is a fairly simple method for determining distance along the Earth's surface, under the assumption that the Earth is a perfect sphere. More precise results may be obtained by using *Vincenty's formulæ*, which model the Earth as an ellipsoid. Vincenty's formulæ are much more complicated, but they have two advantages over the cosine formula: they give more accurate results, and they also give the *direction* between the two points.

53.2 Radius of the Earth

There is a useful formula that gives the radius of the Earth R at any latitude ϕ :

$$R(\phi) = \sqrt{\frac{(a^2 \cos \phi)^2 + (b^2 \sin \phi)^2}{(a \cos \phi)^2 + (b \sin \phi)^2}} \quad (53.1)$$

where, as before, the equatorial radius $a = 6378.1370$ km, and the polar radius $b = a(1-f) = 6356.7523142$ km (WGS 84).

53.3 The Cosine Formula

The *cosine formula* from spherical trigonometry gives the angular separation between two points on the surface of a sphere, where the apex of the angle is at the center of the sphere. If the two points have latitudes ϕ_1 and ϕ_2 and longitudes L_1 and L_2 , then the cosine formula gives the angular separation of the two points θ :

$$\cos \theta = \sin \phi_1 \sin \phi_2 + \cos \phi_1 \cos \phi_2 \cos(L_1 - L_2) \quad (53.2)$$

This formula may be used to compute, for example, the angular separation between two stars in the sky, where $\phi = \delta$ and $L = \alpha$ are the celestial counterparts of latitude and longitude, called *declination* and *right ascension*, respectively (see Chapter 54). To find the distance s between two points on the Earth's surface, convert θ to radians and use $s = R_{\oplus} \theta$, where $R_{\oplus} = 6371.0$ km is the average radius of the Earth.

If the angular separation θ between the two points is small, better accuracy may be obtained by using the *haversine* function, $\text{hav}(x)$. The haversine is defined by

$$\text{hav } \theta \equiv \sin^2 \left(\frac{\theta}{2} \right), \quad (53.3)$$

and so the inverse haversine function is given by

$$\text{hav}^{-1} y \equiv 2 \sin^{-1} \sqrt{y}. \quad (53.4)$$

Using the haversine function, the cosine formula can be replaced by

$$\text{hav } \theta = \text{hav}(\phi_1 - \phi_2) + \cos \phi_1 \cos \phi_2 \text{hav}(L_1 - L_2). \quad (53.5)$$

³The story of this survey is described in the book *The Measure of All Things* by Ken Alder.

53.4 Vincenty's Formulae: Introduction

Vincenty's formulae were developed by the Polish American geodesist Thaddeus Vincenty in the mid-1970s. Like the cosine and haversine formulae, they are used to calculate the distance between two points on the Earth's surface. Unlike those formulae, though, Vincenty's formulae model the Earth's surface as an ellipsoid, and they also provide the *direction* between the two points.

There are two sets of Vincenty's formulae:

- One set solves the *direct problem*: given one point on the Earth's surface (latitude and longitude), a direction, and a distance, these equations find the latitude and longitude of the ending point.
- The other set solves the *inverse problem*: given *two* points on the Earth's surface (latitudes and longitudes), these equations find the distance between the two points, as well as the direction from one point to the other.

53.5 Vincenty's Formulae: Direct Problem

In the direct problem, we're given the latitude ϕ_1 (north positive) and longitude L_1 (east positive) of one point on the Earth's surface; a distance s ; and a direction α_1 (measured clockwise from north). The goal of the direct problem is to find the latitude ϕ_2 and longitude L_2 of the point you would reach by starting at (ϕ_1, L_1) and traveling a distance s in the direction α_1 .

We're also given the following constants that define the size and shape of the Earth ellipsoid:⁴

- Earth ellipsoid semi-major axis (i.e. equatorial radius): $a = 6378137.0$ meters.
- Earth flattening factor $f = 1/298.257223563$. This is defined as the difference between semi-major and semi-minor axes, divided by the semi-major axis: $f = (a - b)/a$.

We begin by finding the semi-minor axis b of the Earth's ellipsoid:

$$b = (1 - f)a. \quad (53.6)$$

Then calculate the following, step by step, working with all angles in *radians*:

$$\tan U_1 = (1 - f) \tan \phi_1 \quad (53.7)$$

$$U_1 = \tan^{-1}(\tan U_1) \quad (53.8)$$

$$\sigma_1 = \arctan\left(\frac{\tan U_1}{\cos \alpha_1}\right) \quad (53.9)$$

$$\sin \alpha = \cos U_1 \sin \alpha_1 \quad (53.10)$$

$$\cos^2 \alpha = (1 - \sin \alpha)(1 + \sin \alpha) \quad (53.11)$$

$$u^2 = (\cos^2 \alpha) \left(\frac{a^2 - b^2}{b^2} \right) \quad (53.12)$$

⁴These are the values used for the WGS-84 ellipsoid, used by GPS receivers.

$$A = 1 + \frac{u^2}{16384} \{4096 + u^2 [-768 + u^2(320 - 175u^2)]\} \quad (53.13)$$

$$B = \frac{u^2}{1024} \{256 + u^2 [-128 + u^2(74 - 47u^2)]\} \quad (53.14)$$

Then, using an initial value $\sigma = s/bA$, iterate Eqs. (53.15) through (53.17) until there is no significant change in σ :

$$2\sigma_m = 2\sigma_1 + \sigma \quad (53.15)$$

$$\Delta\sigma = B \sin \sigma \left\{ \cos(2\sigma_m) + \frac{1}{4} B [\cos \sigma (-1 + 2 \cos^2(2\sigma_m))] - \frac{1}{6} B \cos(2\sigma_m) (-3 + 4 \sin^2 \sigma) (-3 + 4 \cos^2(2\sigma_m)) \right\} \quad (53.16)$$

$$\sigma = \frac{s}{bA} + \Delta\sigma \quad (53.17)$$

Once σ is obtained to sufficient accuracy, calculate:

$$\phi_2 = \arctan \left(\frac{\sin U_1 \cos \sigma + \cos U_1 \sin \sigma \cos \alpha_1}{(1-f)\sqrt{\sin^2 \alpha + (\sin U_1 \sin \sigma - \cos U_1 \cos \sigma \cos \alpha_1)^2}} \right) \quad (53.18)$$

$$\lambda = \arctan \left(\frac{\sin \sigma \sin \alpha_1}{\cos U_1 \cos \sigma - \sin U_1 \sin \sigma \cos \alpha_1} \right) \quad (53.19)$$

$$C = \frac{f}{16} \cos^2 \alpha [4 + f(4 - 3 \cos^2 \alpha)] \quad (53.20)$$

$$L = \lambda - (1 - C)f \sin \alpha \{ \sigma + C \sin \sigma [\cos(2\sigma_m) + C \cos \sigma (-1 + 2 \cos^2(2\sigma_m))] \} \quad (53.21)$$

$$L_2 = L_1 + L \quad (53.22)$$

$$\alpha_2 = \arctan \left(\frac{\sin \alpha}{-\sin U_1 \sin \sigma + \cos U_1 \cos \sigma \cos \alpha_1} \right) \quad (53.23)$$

Then (ϕ_2, L_2) are the latitude and longitude of the ending point (in radians).

Example. If you travel exactly 1000 miles northwest of the sounding rocket in Chesapeake Hall at Prince George's Community College ($38^\circ 53' 17.62''$ N, $76^\circ 49' 23.40''$ W), where do you end up? (Give the answer as latitude, longitude, and describe the location.)

Solution. The coordinates of Chesapeake Hall are: $\phi_1 = +38.888228^\circ$, $L_1 = -76.823167^\circ$. The given distance is 1000 miles = 1609.344 km, and the given azimuth $\alpha_1 = 315^\circ$. Employing Vincenty's formulæ (direct method), we find:

$$\begin{aligned} b &= 6356752.3 \text{ meters} \\ U_1 &= 38.794230^\circ \\ \sigma_1 &= 48.663693^\circ \\ \cos^2 \alpha &= 0.696266995365 \\ u^2 &= 0.0046924891470 \\ A &= 1.0011720921377 \\ B &= 0.0011703772996 \\ \sigma &= 14.482402^\circ \\ \phi_2 &= 48.206878^\circ \\ \lambda &= -15.357896^\circ \\ C &= 5.84547783404 \times 10^{-4} \\ L &= -15.331156^\circ \\ L_2 &= -92.154324^\circ \end{aligned}$$

Hence the ending point is at latitude $48^\circ 12' 24.76''$ N, longitude $92^\circ 09' 15.56''$ W. This is in northern Minnesota (St. Louis county), within Superior National Forest, just a few miles south of the Canadian border.

53.6 Vincenty's Formulæ: Inverse Problem

In the inverse problem, we're given two points on the Earth's surface (ϕ_1, L_1) and (ϕ_2, L_2) and want to calculate the distance s between them, as well as the direction from one to the other. We'll use the constants defining the Earth's ellipsoid as before:

- Earth ellipsoid semi-major axis (i.e. equatorial radius): $a = 6378137.0$ meters.
- Earth flattening factor $f = 1/298.257223563$. This is defined as the difference between semi-major and semi-minor axes, divided by the semi-major axis: $f = (a - b)/a$.

In performing the following calculations, work with all angles in *radians*. We begin by calculating

$$U_1 = \tan^{-1}[(1 - f) \tan \phi_1] \quad (53.24)$$

$$U_2 = \tan^{-1}[(1 - f) \tan \phi_2] \quad (53.25)$$

$$L = L_2 - L_1 \quad (53.26)$$

$$b = (1 - f) a \quad (53.27)$$

Now set an initial value $\lambda = L$. Then iterate on Eqs. (53.28) through (53.35) until λ converges:

$$\sin \sigma = \sqrt{(\cos U_2 \sin \lambda)^2 + (\cos U_1 \sin U_2 - \sin U_1 \cos U_2 \cos \lambda)^2} \quad (53.28)$$

$$\cos \sigma = \sin U_1 \sin U_2 + \cos U_1 \cos U_2 \cos \lambda \quad (53.29)$$

$$\sigma = \arctan \frac{\sin \sigma}{\cos \sigma} \quad (53.30)$$

$$\sin \alpha = \frac{\cos U_1 \cos U_2 \sin \lambda}{\sin \sigma} \quad (53.31)$$

$$\cos^2 \alpha = 1 - \sin^2 \alpha \quad (53.32)$$

$$\cos(2\sigma_m) = \cos \sigma - \frac{2 \sin U_1 \sin U_2}{\cos^2 \alpha} \quad (53.33)$$

$$C = \frac{f}{16} \cos^2 \alpha [4 + f(4 - 3 \cos^2 \alpha)] \quad (53.34)$$

$$\lambda = L + (1 - C)f \sin \alpha \{ \sigma + C \sin \sigma [\cos(2\sigma_m) + C \cos \sigma (-1 + 2 \cos^2(2\sigma_m))] \} \quad (53.35)$$

When λ has converged to the desired degree of accuracy, continue calculating:

$$u^2 = (\cos^2 \alpha) \left(\frac{a^2 - b^2}{b^2} \right) \quad (53.36)$$

$$A = 1 + \frac{u^2}{16384} \{ 4096 + u^2 [-768 + u^2(320 - 175u^2)] \} \quad (53.37)$$

$$B = \frac{u^2}{1024} \{ 256 + u^2 [-128 + u^2(74 - 47u^2)] \} \quad (53.38)$$

$$\Delta \sigma = B \sin \sigma \left\{ \cos(2\sigma_m) + \frac{1}{4} B [\cos \sigma (-1 + 2 \cos^2(2\sigma_m))] - \frac{1}{6} B \cos(2\sigma_m) (-3 + 4 \sin^2 \sigma) (-3 + 4 \cos^2(2\sigma_m)) \right\} \quad (53.39)$$

$$s = bA(\sigma - \Delta \sigma) \quad (53.40)$$

$$\alpha_1 = \arctan \left(\frac{\cos U_2 \sin \lambda}{\cos U_1 \sin U_2 - \sin U_1 \cos U_2 \cos \lambda} \right) \quad (53.41)$$

$$\alpha_2 = \arctan \left(\frac{\cos U_1 \sin \lambda}{-\sin U_1 \cos U_2 + \cos U_1 \sin U_2 \cos \lambda} \right) \quad (53.42)$$

Then s is the distance between the two points.

Example. Find the distance between the sounding rocket in Chesapeake Hall at Prince George's Community College ($38^\circ 53' 16.87''$ N, $76^\circ 49' 23.14''$ W) and the top (apex) of the Great Pyramid of Giza in Egypt ($29^\circ 58' 45.03''$ N, $31^\circ 08' 03.69''$ E).

Solution. The given parameters are the coordinates $\phi_1 = 38.888019^\circ$, $L_1 = -76.823094^\circ$, $\phi_2 = 29.979175^\circ$, $L_2 = +31.134358^\circ$. Employing Vincenty's formulæ (inverse method), we find:

$$U_1 = 38.794230^\circ$$

$$U_2 = 29.895958^\circ$$

$$L = 339.15856744^\circ$$

$$b = 6356752.3 \text{ meters}$$

$$\lambda = 108.139490^\circ$$

$$u^2 = 0.00393162979$$

$$A = 1.00098218405082$$

$$B = 9.809796134747123 \times 10^{-4}$$

$$\Delta\sigma = 0.054160886^\circ$$

$$s = 9351378.858 \text{ meters}$$

$$\alpha_1 = 55.910048^\circ$$

$$\alpha_2 = 131.801775^\circ$$

So the distance $s = 9351.378858$ km (5280 miles, 3576 feet, 10 inches), in the direction 55.910048° (10.91° south of northeast).

Chapter 54

Celestial Mechanics

54.1 Introduction

The area of classical mechanics that deals with the orbits of astronomical bodies around each other under the influence of gravity is called *celestial mechanics*. Celestial mechanics is a vast (and very interesting) field; here we'll get just a taste for how to do some basic calculations, where we examine a simple orbit of one body around another — the so-called “two-body problem”.

54.2 Kepler's Laws

Kepler's laws of planetary motion were derived by the German astronomer Johannes Kepler in the early 17th century, based on astronomical observations made by the Danish astronomer Tycho Brahe. They describe some of the basic motion of planets orbit the Sun (although they apply more generally to any two-body orbit problem).

Kepler's First Law

Each of the planets orbits the Sun in an elliptical orbit, with the Sun at one of the foci of the ellipse.

Before Kepler's time, it was assumed that the planets moved around the Sun in circles (or circles orbiting on circles), but the predictions failed to satisfactorily match observations. Kepler was the first to recognize that the planets did not move in circles, but in *ellipses*.

One can derive the equation of the orbital ellipse in plane polar coordinates, in the plane of the orbit. The result is

$$r = \frac{a(1 - e^2)}{1 + e \cos(\theta - \omega)}. \quad (54.1)$$

Here (r, θ) are the plane polar coordinates of the planet, a is the semi-major axis of the orbit, e is the eccentricity of the orbit, and ω is the argument of perihelion.

Kepler's Second Law

A line drawn from the Sun to a planet sweeps out equal areas in equal times.

The essence of this law is that planets move more slowly when they're farther from the Sun, and speed up as they get closer to the Sun. A comet in a highly elliptical orbit will spend most of its time far from the Sun, moving very slowly; as it gets close to the Sun, it will speed up, quickly whip around the Sun, and then move away again.

Quantitatively, the area per unit time swept out by a line joining the Sun to a planet is given by

$$\frac{dA}{dt} = \frac{1}{2} \sqrt{GMa(1 - e^2)}, \quad (54.2)$$

where A is the area, G is the universal gravitational constant, and M is the mass of the Sun. Since everything on the right-hand side of this equation is a constant, it follows that dA/dt is constant.

Kepler's Third Law

The square of the period of the orbit is proportional to the cube of the semi-major axis.

This law relates the period of a planet's orbit (i.e. the time required to complete one orbit) to its distance from the Sun. Mathematically, this law is expressed as

$$P^2 \propto a^3, \quad (54.3)$$

where P is the period of the orbit. The proportionality constant turns out to be $4\pi^2/GM$, so Kepler's third law becomes

$$P^2 = \frac{4\pi^2}{GM} a^3. \quad (54.4)$$

54.3 Time

The way we measure time for civil use (years, months, days, weeks, etc.) is not particularly convenient for astronomical calculations. A more convenient way to measure time is with the *Julian day*. The Julian Day is simply a count of the total number of days that have elapsed since *noon* on Monday, January 1, 4713 B.C. (by the old Julian calendar). (Notice that the Julian Day begins at noon, not at midnight as on our civil calendar.) As an example, December 1, 2010 (midnight, beginning of December 1) is Julian Day 2455531.5.

The calendar date may be converted to and from the Julian Day using some fairly simple, well-known algorithms (see e.g. Meeus, 1991), or by the use of pre-computed tables.

The Julian day makes it very easy to find the number of days between two dates: just convert both dates to their corresponding Julian day, and subtract. This is how computer programs like spreadsheets deal with dates: they store dates internally as Julian Days, and use standard algorithms to convert to and from the calendar date that is displayed on the screen.

54.4 Orbit Reference Frames

In order to describe the orientation of an orbit in space, we need to have a reference frame with respect to which the orbit will be described. Such a reference system is defined by a reference *plane*, and a reference *direction* that lies in that plane. The two common choices are the *equatorial* and *ecliptic* reference frames.

In the *equatorial* reference frame, the reference plane is the plane of the Earth's equator, and the reference direction is the direction of the *vernal equinox*. The vernal equinox is the direction from the Earth to the Sun on the first day of spring (around March 21). This equatorial frame is commonly used for bodies orbiting the Earth, such as artificial satellites.

In the *ecliptic* reference frame, the reference plane is the plane of the *ecliptic* (i.e. the plane of the Earth's orbit around the Sun), and the reference direction is again in the direction of the vernal equinox. The ecliptic frame is used for most astronomical bodies: planets, comets, etc.

The plane of the equator and the plane of the ecliptic intersect along a line, and the direction of the vernal equinox lies along that line of intersection. The two planes are separated by a dihedral angle of about 23.5° (the tilt angle of the Earth's axis); this angle is called the *obliquity of the ecliptic* (ϵ).

54.5 Orbital Elements

Now suppose that we want to describe the orbit of one body around another: for example, the Moon around the Earth, or the planet Saturn around the Sun. We first choose an appropriate reference frame, and then we need to describe the orbit. The orbit is specified using a set of seven numbers called the *orbital elements* of the orbit, which are described here.

Figure 54.1 shows a typical orbit and reference frame. In this figure, the xy -plane is the reference frame (either the equator or the ecliptic), and the x direction is the reference direction (the vernal equinox). The orbit plane intersects the reference plane along a line called the *line of nodes*. The point where the orbiting body moves from below the reference plane to above the reference plane is called the *ascending node*, and is marked N in Fig. 1. The opposite point on the line of nodes, where the body moves from above the reference plane to below is called the *descending node*.

The point of closest approach of the orbiting body to the center body is called the *pericenter*, and the point of farthest approach is called the *apocenter*. In the case where the body is orbiting the Earth, these are called the *perigee* and *apogee* (respectively); when the body is orbiting the Sun, these points are called the *perihelion* and *aphelion* (respectively). The line connecting the pericenter to the apocenter is called the *line of apsides*.

Now to the orbital elements. First, we need to specify the *size* of the orbit. Bodies in closed orbits always orbit in *ellipses*, where the body being orbited is at one of the two foci of the ellipse. The size of the orbit is specified by giving the *semi-major axis* a of the ellipse.

Second, we need to specify the *shape* of the orbit. We do this by specifying the *eccentricity* e of the ellipse. The eccentricity is a number between 0 and 1, and is measure of how elongated the ellipse is: $e = 0$ for a circle, and values of e close to 1 are long, cigar-shaped ellipses. The eccentricity e is related to the semi-major axis a and semi-minor axis b of the ellipse by

$$e = \frac{\sqrt{a^2 - b^2}}{a}. \quad (54.5)$$

Next, we need to specify the *orientation* of the orbit in space. This requires three angles: (1) the *inclination* i of the orbit with respect to the reference plane; (2) the *longitude of the ascending node* Ω , which is the angle between the vernal equinox and the ascending node, measured in the reference plane; and (3) the *argument of pericenter* ω , which is the angle between the ascending node and the orbit pericenter, measured in the plane of the orbit. These three angles are illustrated in Fig. 54.1.

Now we've completely specified the orbit itself, but we need one more bit of information: *where* the body is in this orbit. This requires two numbers: an angle, and a time at which the body is at that angle. The angle is called the *mean anomaly at epoch* M_0 , and gives the angle from the pericenter to the body (measured in the plane of the orbit) at a specified *epoch time* T_0 .

The seven orbital elements are summarized in the table below, and illustrated in Figure 54.1.

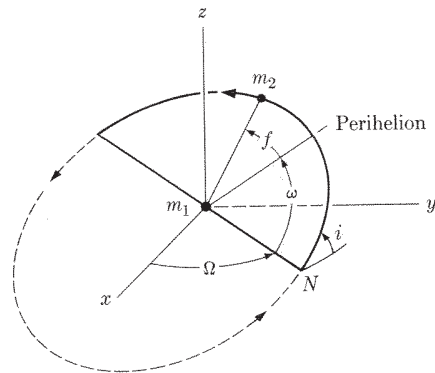

Figure 54.1: Orbital elements for a body of mass m_2 orbiting a body of mass m_1 . The xy -plane is the reference plane, and x is the direction of the vernal equinox. Shown are the orbital elements i , Ω , and ω , along with the true anomaly f . Point N is the ascending node of the orbit. (From McCuskey, 1963 [12].)

Table 54-1. Orbital elements.

Element	Symbol
Semi-major axis	a
Eccentricity	e
Inclination	i
Longitude of ascending node	Ω
Argument of pericenter	ω
Mean anomaly at epoch	M_0
Epoch time	T_0

54.6 Right Ascension and Declination

The goal of the orbit calculation is to find the position of a body in the sky, given its orbital elements. The final result, the position in the sky, will be given in a coordinate system that is analogous to the longitude-latitude system used to locate places on the surface of the Earth. Imagine rotating the Earth on its axis until the prime meridian (0° longitude) intersects the direction of the vernal equinox. Then projecting the lines of geographic longitude into the sky gives lines of *right ascension* for astronomical objects. Similarly, projecting the lines of geographic latitude into the sky give lines of *declination*.

Here's another way to think of this: imagine the Earth is a hollow glass sphere, with longitude and latitude lines drawn on it. Rotate the Earth on its axis until the prime meridian intersects the direction of the vernal equinox, and hold the Earth still at that position. Now if you are at the center of the Earth and look out toward the sky, the lines drawn on the glass will be lines of right ascension and declination.

Right ascension ranges from 0° to 360° , and declination ranges from -90° to $+90^\circ$ (where $+$ is north). Often right ascension is given in units of *hours*, rather than degrees ($1 \text{ hour} = 15^\circ$). Under this convention, right ascension ranges from 0h to 24h.

54.7 Computing a Position

Now let's put all this together and see how you go about computing the position of a body in an elliptical orbit — let's say a planet orbiting the Sun — at a time t , given its orbital elements. We begin by computing the *mean daily motion* n of the body, which is how many revolutions it makes in its orbit per day. This is found from Kepler's third law:

$$n = \frac{86400}{2\pi} \sqrt{\frac{GM_{\odot}}{a^3}}, \quad (54.6)$$

where G is the universal gravitational constant, M_{\odot} is the mass of the central body, and a is the semi-major axis of the orbit. The factor $86400/2\pi$ in front converts to units of rev/day.

Next we find the *mean anomaly* M at time t :

$$M = M_0 + 2\pi n(t - T_0) \quad (54.7)$$

Essentially what we're doing here is assuming the orbit is a perfect circle; knowing the mean anomaly M_0 at the epoch time T_0 , this equation finds the mean anomaly M at some other time t . Here both M and M_0 are in units of radians, t and T_0 are Julian days, and n is in units of rev/day.

Of course, the real orbit is generally an ellipse, not a circle, so the next step is to adjust the mean anomaly M to correct it for the eccentricity of the orbit. The result is called the *eccentric anomaly* E . We find the eccentric anomaly by solving the following equation, called *Kepler's equation*, for E :

$$M = E - e \sin E \quad (54.8)$$

(Here M and E are both in radians.) Kepler's equation cannot be solved for E in closed form, so we need to make use of some iterative method such as Newton's method to solve for E .

Having found E , the next step is to correct the orbit for the fact that the body is at one of the foci of the ellipse, not at the center of the ellipse. This correction gives what's called the *true anomaly* f (again in radians):

$$\tan\left(\frac{f}{2}\right) = \sqrt{\frac{1+e}{1-e}} \tan\left(\frac{E}{2}\right) \quad (54.9)$$

The true anomaly f is the true polar coordinate of the body, measured from the pericenter to the body, in the plane of the orbit.

Next we find radial distance r of the orbiting body from the central body:

$$r = a(1 - e \cos E) \quad (54.10)$$

The quantities r and f are the plane polar coordinates of the orbiting body, with the central body at the origin. The remainder of the calculations are essentially a set of coordinate transformations to find the right ascension and declination of the body.

We begin these coordinate transformations by finding the *argument of latitude* u (radians):

$$u = \omega + f \quad (54.11)$$

Next, we find the heliocentric cartesian ecliptic coordinates (x, y, z) of the orbiting body:

$$x = r(\cos u \cos \Omega - \sin u \sin \Omega \cos i) \quad (54.12)$$

$$y = r(\cos u \sin \Omega + \sin u \cos \Omega \cos i) \quad (54.13)$$

$$z = r \sin u \sin i \quad (54.14)$$

For the orbit of a planet around the Sun, these are the cartesian coordinates of the body in a coordinate system centered at the Sun.

We don't want to know where the body will appear in the sky as seen from the Sun, though—we want to know where it will be in the sky as seen from the Earth. So next we move the origin of this coordinate system from the Sun to the Earth, giving the geocentric cartesian ecliptic coordinates (x_e, y_e, z_e) of the body:

$$x_e = x + x_{\odot} \quad (54.15)$$

$$y_e = y + y_{\odot} \quad (54.16)$$

$$z_e = z + z_{\odot} \quad (54.17)$$

where $(x_{\odot}, y_{\odot}, z_{\odot})$ are the geocentric cartesian coordinates of the Sun at time t .

Now we convert from cartesian to spherical coordinates. Assuming the reference plane is the ecliptic, this gives the geocentric *ecliptic longitude* λ and *ecliptic latitude* β :

$$\tan \lambda = \frac{y_e}{x_e} \quad (54.18)$$

$$\sin \beta = \frac{z_e}{\sqrt{x_e^2 + y_e^2 + z_e^2}} \quad (54.19)$$

Finally, we convert these ecliptic coordinates to right ascension α and declination δ :

$$\tan \alpha = \frac{\sin \lambda \cos \varepsilon - \tan \beta \sin \varepsilon}{\cos \lambda} \quad (54.20)$$

$$\sin \delta = \sin \beta \cos \varepsilon + \cos \beta \sin \varepsilon \sin \lambda, \quad (54.21)$$

where ε is the obliquity of the ecliptic (about 23.5°).

Eqs. (54.20) and (54.21) are the solution to the problem: we could find a star atlas (which has lines of right ascension and declination marked on it), locate the planet, and find where in the sky the planet can be seen.

54.8 The Inverse Problem

The problem we just solved is: given the orbital elements of the planet, we found its position in the sky at any given time. But how did we get the orbital elements in the first place? This has to do with the inverse of the problem just solved: given the position of the planet in the sky, what are the orbital elements?

It turns out that we require *three* separate observations of the body at three different times. Knowing the right ascension α and declination δ of the body at three different times, one can derive the orbital elements. Details are given in Chapter 4 of the reference by McCuskey [12].

54.9 Corrections to the Two-Body Calculation

We've described here the basics of a two-body orbit calculation, but there are a number of corrections that would need to be made to make a more accurate calculation; for example:

- The reference frames are actually not fixed, but move in time because of motions of the Earth. A more careful calculation would take these effects (precession and nutation of the Earth) into account.
- The orbital elements change with time — notably the longitude of the ascending node Ω and the argument of pericenter ω .

- Other bodies are always present – not just the planet and the Sun. More complex calculations take the effect of other bodies into account.
- Parallax corrections: the position of the body in the sky varies slightly depending on the position of the observer on the surface of the Earth.
- Atmospheric refraction can cause small changes in the apparent position of the body in the sky.

54.10 Bound and Unbound Orbits

The planetary orbits we've considered so far are *elliptical* orbits: the planets (according to Kepler's first law) move in ellipses, with the Sun at one focus. Similarly, satellites of the planets move in ellipses around the parent body. In general, the motion of a body under the inverse-square gravitational force is a *conic section*, i.e. a circle, ellipse, parabola, or hyperbola. Circular and elliptical orbits are *bound* orbits: if only two bodies are present, then the orbit retraces itself indefinitely. Parabolic and hyperbolic orbits are *unbound*: the body will orbit its parent body once, then move off toward infinity, leaving the vicinity of the parent body forever.

- A *circular* orbit is a special case of an elliptical orbit, for which the eccentricity $e = 0$.
- An *elliptical* orbit is one in which the body orbits its parent body, with the parent at one of the foci of the ellipse. Elliptical orbits have eccentricity $0 < e < 1$.
- A *parabolic* orbit is barely unbound, and lies at the boundary between a highly eccentric elliptical orbit and a hyperbolic orbit. Parabolic orbits have eccentricity $e = 1$.
- A *hyperbolic* orbit is unbound, and has eccentricity $e > 1$. In a hyperbolic orbit, the body orbits its parent *once* along one of the branches of the hyperbola, with the parent body at the focus of that branch of the hyperbola.

One could argue that in the real world there are no truly circular or parabolic orbits, since the eccentricity e will never be *exactly* 0 or 1. But some orbits have their eccentricities close enough to 0 or 1 for them to at least be *approximated* as circular or parabolic.

While the planets all orbit the Sun in elliptical orbits, *comets* may orbit the Sun in any kind of orbit. Some comets like Halley's comet are in highly eccentric elliptical orbits that return to the Sun at regular intervals. Other comets are in unbound orbits, and visit the Sun only once; they have sufficient energy to leave the solar system forever along hyperbolic orbits.

54.11 The Vis Viva Equation

When an object of small mass m orbits a body of much larger mass M , we can use conservation of energy considerations to find the smaller body's velocity v at radial distance r . We have for the small body m :

$$K = \frac{1}{2}mv^2 \quad (\text{kinetic energy}) \quad (54.22)$$

$$U = -\frac{GMm}{r} \quad (\text{potential energy}) \quad (54.23)$$

$$E = -\frac{GMm}{2a} \quad (\text{total energy}) \quad (54.24)$$

where the quantity a is the radius for a circular orbit, the semi-major axis for an elliptical orbit, the negative of the semi-major axis for a hyperbolic orbit, or infinity for a parabolic orbit.

By conservation of energy,

$$E = K + U \quad (54.25)$$

$$-\frac{GMm}{2a} = \frac{1}{2}mv^2 - \frac{GMm}{r}. \quad (54.26)$$

Solving for the orbit speed v , we find

$$v = \sqrt{GM \left(\frac{2}{r} - \frac{1}{a} \right)}. \quad (54.27)$$

This result is known as the *vis viva equation* (Latin for “live force”).

54.12 Bertrand's Theorem

There is a theorem in classical mechanics called *Bertrand's theorem*, which proves that there are only two types of force law that can possibly lead to *closed* orbits (orbits for which the particle eventually retraces its own footsteps):

1. An inverse-square law force $F \propto 1/r^2$ (e.g. gravity or electrostatics); and
2. A Hooke's law force $F \propto r$ (e.g. a spring).

For a proof of Bertrand's theorem, see Appendix A of Ref. [8].

54.13 Differential Equation for an Orbit

It can be shown (Ref. [8]) that a central force $F(r)$ satisfies the differential equation

$$F \left(\frac{1}{u} \right) = -\frac{l^2 u^2}{m} \left(\frac{d^2 u}{d\theta^2} + u \right), \quad (54.28)$$

where the equation is in polar coordinates, l is the angular momentum of the orbit, m is the mass, and $u \equiv 1/r$. This equation has an interesting application: given the orbit function in polar coordinates $r(\theta)$, you can solve for the force law $F(r)$ that gives that orbit. In theory, you could, for example, use Eq. (54.28) to find what force law would be necessary to produce a square orbit.

Example. As a simple example, suppose we observe a mass m in circular orbit of radius R around a parent mass M , so that the orbit equation is $r(\theta) = R$ (a constant), and so $u = 1/R$. If the force present is gravity, then the orbital angular momentum of m will be $l = m\sqrt{GMR}$. Eq. (54.28) then gives

$$F = -\frac{l^2 u^2}{m} \left(\frac{d^2 u}{d\theta^2} + u \right) \quad (54.29)$$

$$= -\frac{m^2 GMR}{mR^2} \left(\frac{1}{R} \right) \quad (54.30)$$

$$= -\frac{GMm}{R^2}, \quad (54.31)$$

and we recover Newton's law of gravity. This is *not* by any means a derivation of Newton's law of gravity—in order to get the result in this example, we had to assume Newton's law of gravity to get the expression for

angular momentum l . This example is really just an illustration of how you can derive the force law if you're given the orbit and its angular momentum.

Example. Suppose a particle orbits in a circle that passes through the center of force. Show that the force law must be an inverse-fifth law force ($F \propto 1/r^5$).

Solution. The polar equation of a circle passing through the origin is $r = 2a \cos \theta$, where a is the radius of the circle. From Eq. (54.28), we can find the force law. Since $r = 2a \cos \theta$, we have

$$u = \frac{1}{r} = \frac{1}{2a \cos \theta}. \quad (54.32)$$

We'll need the second derivative of u with respect to θ :

$$\frac{du}{d\theta} = \frac{\sin \theta}{2a \cos^2 \theta} \quad (54.33)$$

$$\frac{d^2u}{d\theta^2} = \frac{2a \cos^3 \theta + 4a \cos \theta \sin^2 \theta}{4a^2 \cos^4 \theta} \quad (54.34)$$

$$= \frac{2a \cos^3 \theta + 4a \cos \theta (1 - \cos^2 \theta)}{4a^2 \cos^4 \theta} \quad (54.35)$$

$$= \frac{2a \cos^3 \theta + 4a \cos \theta - 4a \cos^3 \theta}{4a^2 \cos^4 \theta} \quad (54.36)$$

$$= \frac{1}{2a \cos \theta} + \frac{1}{a \cos^3 \theta} - \frac{2}{2a \cos \theta} \quad (54.37)$$

$$= \frac{1}{a \cos^3 \theta} - \frac{1}{2a \cos \theta} \quad (54.38)$$

$$= \frac{8a^2}{8a^3 \cos^3 \theta} - \frac{1}{2a \cos \theta} \quad (54.39)$$

$$= 8a^2 u^3 - u \quad (54.40)$$

Using this result, Eq. (54.28) becomes

$$F = -\frac{l^2 u^2}{m} \left(\frac{d^2 u}{d\theta^2} + u \right) \quad (54.41)$$

$$= -\frac{l^2 u^2}{m} (8a^2 u^3 - u + u) \quad (54.42)$$

$$= -\frac{8a^2 l^2}{m} u^5 \quad (54.43)$$

$$= -\frac{8a^2 l^2}{m} \frac{1}{r^5}. \quad \text{Q.E.D.} \quad (54.44)$$

54.14 Lagrange Points

In any two-body system (the Sun-Earth system, for example), there are five points called *Lagrange points* (or *libration points*) where the net force on a body at that point would be zero. For example, the Sun-Earth Lagrange points are (see Figure 54.2):

1. The L_1 point is between the Sun and the Earth.
2. The L_2 point is on the Sun-Earth line, but farther from the Sun than the Earth.
3. The L_3 point is also on the Sun-Earth line, but on the other side of the Sun.
4. The L_4 point forms an equilateral triangle with the Sun and Earth, and leads the Earth.
5. The L_5 point, like L_4 , forms an equilateral triangle with the Sun and Earth, but trails the Earth.

There is a similar set of five Lagrange points for the Earth-Moon system: the Earth-Moon L_1 point is between the Earth and Moon, etc. One distinguishes between these two sets by referring to them as the “Sun-Earth Lagrange points” and the “Earth-Moon Lagrange points.”

The Lagrange points L_1 , L_2 , and L_3 are unstable: a body placed at any of those points would experience zero net force, but if it were moved slightly away from the Lagrange point it would continue to move farther away. Lagrange points L_4 and L_5 are both stable: if a body placed at either of these points were moved slightly away from the Lagrange point, the forces present would tend to push it back toward the Lagrange point.

Although Lagrange points L_1 , L_2 , and L_3 are unstable, spacecraft are often placed at these (Sun-Earth) positions in so-called *halo orbits*, where the various forces present cause them to move in closed “orbits” around the Lagrange point.

A number of asteroids called *Trojan asteroids* have accumulated at the Sun-Jupiter L_4 and L_5 Lagrange points.¹ One asteroid (called 2010 TK7) has recently been discovered at the Sun-Earth L_4 point.

54.15 The Rings of Saturn

If you look at the planet Saturn through a telescope (Fig. 54.3), you’ll see it surrounded by a prominent set of rings. Although the rings look solid, they are actually composed of a vast number of chunks of ice or ice-covered rock, ranging in size from small grains to chunks the size of buildings. It was shown by the Scottish physicist James Clerk Maxwell (following Laplace) that Saturn’s rings cannot be solid. For one thing, if the rings *were* solid, Maxwell showed that their orbit would be unstable and they would eventually crash onto Saturn’s surface.

For another thing, tidal forces would tear the rings apart. According to the *vis viva* equation (Eq. 54.27), for a circular orbit, the velocity v of a body in orbit decreases with increasing distance from the planet by $v \propto r^{-1/2}$. But if the rings were solid, they would rotate as a solid body, obeying $v = r\omega$, so $v \propto r$ — the velocity would *increase* with increasing distance. The orbital velocity can’t both increase and decrease with distance, so the result would be a large stress on the rings that would tear them apart.

In general, it has been shown that *no* body that is held together by gravity can avoid being torn apart if it orbits a planet with an orbital radius inside the so-called *Roche limit*, which is given by

$$r = 2.44R_p \sqrt[3]{\frac{\rho_p}{\rho_b}}, \quad (54.45)$$

where R_p is the radius of the planet, ρ_p is its density, and ρ_b is the density of the orbiting body.

The rings of Saturn are also extremely thin—maybe only 100 yards or so thick. Why are Saturn’s rings so thin? It has to do with the ring particles colliding with each other. Ring particles that are high above or below the rings are in a highly inclined orbit, and have more energy than ring particles that are closer to the ring plane. When those particles collide with other particles, some of their energy is lost, so causing them to move to lower-energy orbits closer to the ring plane. Over time, the ring particles (especially the larger ones)

¹By convention, the Trojan asteroids near the L_4 point are given names of characters from the Greek side of the Trojan War chronicled in Greek mythology; the Trojan asteroids near the L_5 point are given names from the Trojan side of the war.

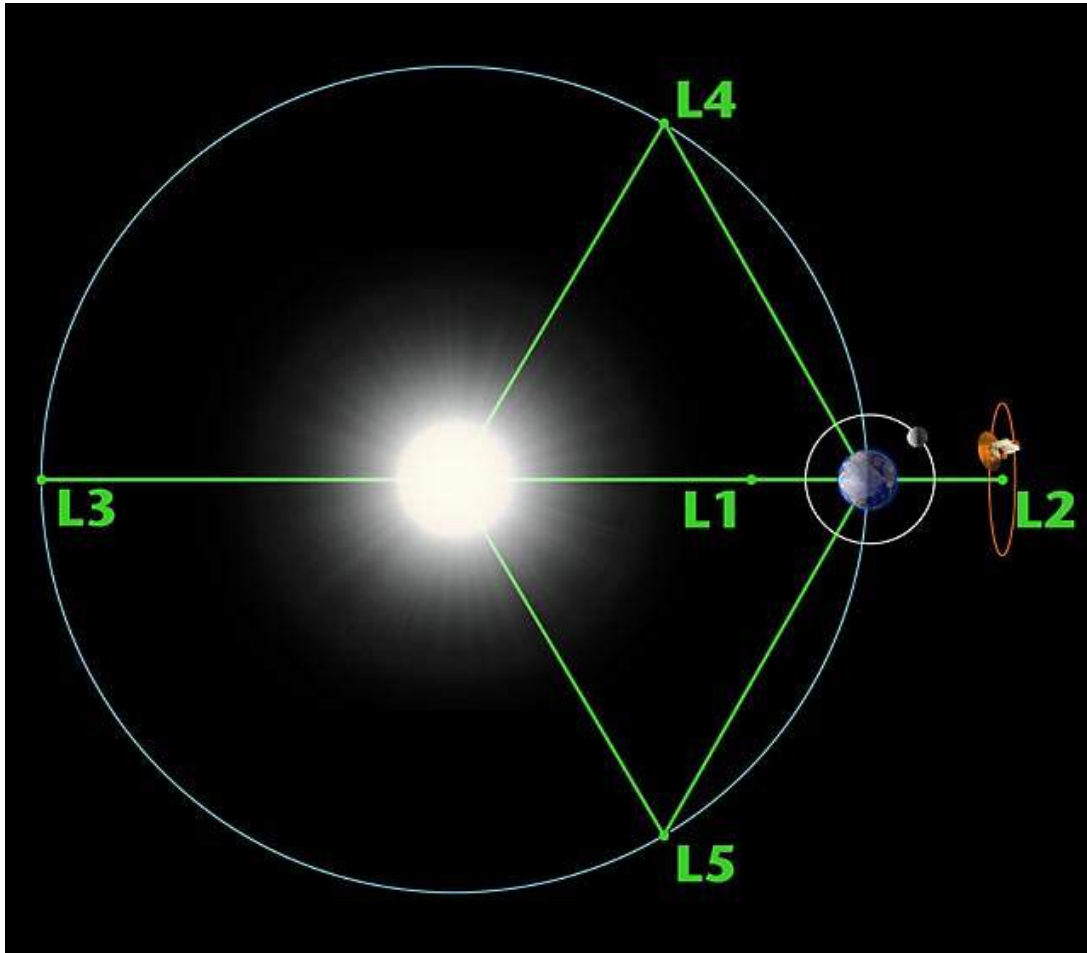

Figure 54.2: The Sun-Earth Lagrange points. The Wilkinson Microwave Anisotropy Probe (WMAP) spacecraft is shown orbiting the L_2 Lagrange point in a halo orbit. (Credit: NASA.)

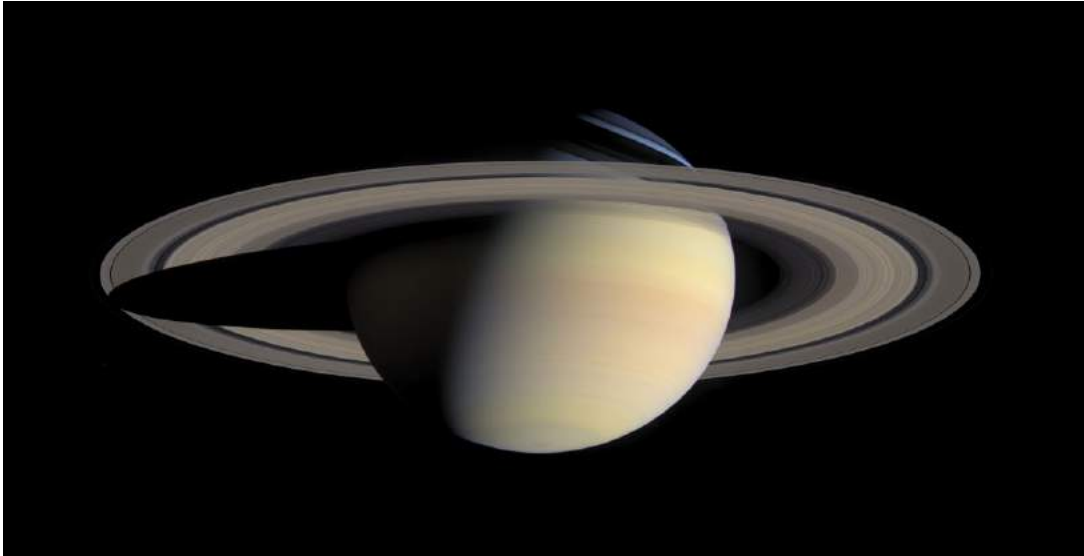

Figure 54.3: Saturn and its rings, as seen by the Cassini spacecraft. (Credit: NASA.)

tend to flatten themselves into a thin plane, as we see today. This is the general picture, but the details are still being worked out.

54.16 Hyperbolic Orbits

Suppose we wish to calculate the position of a body that is in a *hyperbolic* orbit ($e > 1$), as is the case with some comets in orbit around the Sun. The procedure is the same as outlined in Section 54.7, except for Equations (54.8) through (54.10).

For hyperbolic orbits, in place of Kepler's equation (Eq. (54.8)), we use the *hyperbolic Kepler's equation*:

$$M = e \sinh F - F, \quad (54.46)$$

where M is the mean anomaly (in radians), and F is a variable that takes the place of the eccentric anomaly. As with the elliptical Kepler's equation, the hyperbolic version cannot be solved for F in closed form; instead we must rely on some numerical method like Newton's method to solve for F . Once we have found F , we solve for the true anomaly f using this replacement for Eq. (54.9):

$$\tan\left(\frac{f}{2}\right) = \sqrt{\frac{e+1}{e-1}} \tanh\left(\frac{F}{2}\right). \quad (54.47)$$

Finally, the radial distance from the Sun to the body is found by this replacement for Eq. (54.10):

$$r = a(e \cosh F - 1), \quad (54.48)$$

where for a hyperbola a is the distance from the center of the hyperbola to either vertex. The rest of position calculation is the same as described in Section 54.7 for elliptical orbits.

54.17 Parabolic Orbits

Suppose we wish to calculate the position of a body that is in a *parabolic* or near-parabolic orbit ($e \approx 1$), as is the case with some comets in orbit around the Sun. The procedure is the same as outlined in Section 54.7, except for Equations (54.6) through (54.10).

For parabolic orbits, in place of the semi-major axis of the ellipse a , we use the *perihelion distance* q , and in place of the epoch time we use the *time of perihelion passage* T_p . Then the true anomaly f at time t is given by *Barker's equation*,

$$\tan\left(\frac{f}{2}\right) + \frac{1}{3}\tan^3\left(\frac{f}{2}\right) = \sqrt{\frac{GM}{2q^3}}(t - T_p). \quad (54.49)$$

In the case of a body orbiting the Sun, GM is the gravitational constant of the Sun, equal to $1.32712440041 \times 10^{20} \text{ m}^3 \text{ s}^{-2}$. It is possible to solve Barker's equation (54.49) for the true anomaly f directly (see e.g. McCuskey [12]) in just a few steps. Let K be the right-hand side of Eq. (54.49):

$$K \equiv \sqrt{\frac{GM}{2q^3}}(t - T_p). \quad (54.50)$$

Then the true anomaly f is found through a series of steps:

$$\cot s = \frac{3}{2}|K| = \frac{3\sqrt{GM}}{(2q)^{3/2}}|t - T_p| \quad (54.51)$$

$$\cot\left(\frac{s}{2}\right) = \sqrt{1 + \cot^2 s} + \cot s \quad (54.52)$$

$$\cot w = \sqrt[3]{\cot\left(\frac{s}{2}\right)} \quad (54.53)$$

$$\cot 2w = \frac{\cot^2 w - 1}{2 \cot w} \quad (54.54)$$

$$\tan\left(\frac{f}{2}\right) = (2 \cot 2w) \times \text{sgn}(t - T_0) \quad (54.55)$$

Here $\text{sgn}(x)$ is the *signum function*, and is defined as

$$\text{sgn}(x) = \begin{cases} -1 & (x < 0) \\ 0 & (x = 0) \\ +1 & (x > 0) \end{cases} \quad (54.56)$$

Once the true anomaly f has been found, the radial distance from the Sun to the body is found by this replacement for Eq. (54.10):

$$r = q \sec^2\left(\frac{f}{2}\right). \quad (54.57)$$

The rest of position calculation is the same as described in Section 54.7 for elliptical orbits.

Chapter 55

Astrodynamics

Astrodynamics is a field closely related to celestial mechanics, except that it deals only with man-made orbits of spacecraft, rather than the orbits of natural astronomical objects. Astrodynamists design spacecraft orbits to optimize time or energy, and to also fall within the constraints of the mission. For example, during the *Apollo* missions to the Moon in the 1960s and 1970s, the spacecraft orbits were designed to land at low-latitude locations on the Moon's surface, with the constraint that the landing location had to be on the near side of the Moon, while the day side is in daylight.

55.1 Circular Orbits

As a simple example, suppose we wish to place a spacecraft of mass m into a circular orbit around the Earth. If the orbit radius is r , then the potential energy U of the spacecraft (with $U = 0$ at $r = \infty$) is

$$U_c = -G \frac{M_{\oplus} m}{r}, \quad (55.1)$$

where G is Newton's gravitational constant and M_{\oplus} is the mass of the Earth. The kinetic energy of the spacecraft is

$$K_c = \frac{1}{2} m v^2. \quad (55.2)$$

Here the orbit velocity v at orbital radius r is found by setting the centripetal force $m v^2 / r$ equal to the gravitational force $G M_{\oplus} m / r^2$:

$$\frac{m v^2}{r} = \frac{G M_{\oplus} m}{r^2} \quad (55.3)$$

so, solving for v ,

$$v_c = \sqrt{\frac{G M_{\oplus}}{r}}. \quad (55.4)$$

Substituting this result into Eq. (55.2), we have an expression for the kinetic energy K in terms of the orbit radius r :

$$K = G \frac{M_{\oplus} m}{2r} \quad (55.5)$$

From Eqs. (55.1) and (55.5), we find the total orbit energy E is

$$E_c = U_c + K_c = -G \frac{M_{\oplus} m}{2r}. \quad (55.6)$$

This is an important result, since total energy is conserved. Another important result is the angular momentum of the spacecraft, since that's also conserved. The angular momentum of the spacecraft in a circular orbit is $L = mvr$; using Eq. (55.4), we have

$$L = m \sqrt{GM_{\oplus} r}. \quad (55.7)$$

Launch Velocity

Suppose we wish to launch a spacecraft from the surface of the Earth into a circular orbit of radius r , using only a single blast of the engines on the ground and coasting the rest of the way. The initial velocity with which the spacecraft is launched is called the *launch velocity*, and can be found using the conservation of energy:

$$E = U + K \quad (55.8)$$

$$= -G \frac{M_{\oplus} m}{r} + \frac{1}{2} m v^2 \quad (55.9)$$

and so solving for v gives the launch velocity v_L :

$$v_L = \sqrt{2 \left(\frac{E}{m} + G \frac{M_{\oplus}}{r} \right)} \quad (55.10)$$

In real life, however, there are a number of complications that require an analysis more complex than this:

- Spacecraft are not launched with a single initial blast and allowed to coast. Instead, the engines are continuously burned over some extended period.
- The mass of the spacecraft decreases during launch, as fuel is burned, so that the rocket equation must be employed. (See Chapter 30.)
- Most spacecraft are *staged* in some way (as described in Chapter 30), which also causes the spacecraft mass to decrease with time during launch.
- The drag due to the Earth's atmosphere must be accounted for, which we have not done here.

There's another issue here. The above analysis assumes the spacecraft is launched from a non-rotating Earth. In real life, we launch from a *rotating* Earth, which we can use to our advantage. Since the Earth is rotating, we can use its rotational velocity to contribute to the needed launch velocity, as long as the spacecraft is launched to the east so that it orbits the Earth in the same sense as the Earth's rotation. The linear velocity of the Earth due to its rotation is $R_{\oplus} \omega$, where R_{\oplus} is the radius of the Earth (about 6378 km) and ω is the angular velocity of the Earth:

$$\omega = \frac{1 \text{ rev}}{24 \text{ hr}} = \frac{2\pi \text{ rad}}{86400 \text{ sec}} = 7.2722 \times 10^{-5} \text{ rad/s}. \quad (55.11)$$

At latitude ϕ , the linear velocity of the Earth is

$$v = R_{\oplus} \omega \cos \phi. \quad (55.12)$$

The closer the launch site is to the equator ($\phi = 0$), the larger v is, and the more we can take advantage of the Earth's rotation in helping to achieve the desired launch velocity. This is why the Kennedy Space Center is located in Florida: it's in the southern United States, about as close to the equator as we can get within the United States.¹ The latitude of the Kennedy Space Center is $\phi = 28.5^\circ$, which gives $v = 408$ km/s that we get "for free" from the Earth toward the launch velocity.

To take maximum advantage of the Earth's rotation, a spacecraft would be launched due east from the Kennedy Space Center. Once the spacecraft is in orbit, it cannot just orbit the Earth at the latitude of the launch site; the laws of physics require the plane of the orbit to pass through the center of the Earth. The result is a circular orbit, inclined with respect to the equator by an angle equal to the latitude of the launch site (28.5° for a launch from Kennedy). Many launches from the Kennedy space center are therefore circular (or near-circular) orbits with an inclination of 28.5° with respect to the equator.

55.2 Geosynchronous Orbits

Consider the motion of an artificial satellite in a circular orbit of radius r around the Earth. In order to be orbiting at radius r , it will have orbital speed v given by setting the centripetal force equal to the gravitational force:

$$\frac{mv^2}{r} = \frac{GM_{\oplus}m}{r^2}, \quad (55.13)$$

where G is Newton's gravitational constant and M_{\oplus} is the mass of the Earth. Solving for the orbital velocity v ,

$$v = \sqrt{\frac{GM_{\oplus}}{r}}. \quad (55.14)$$

Notice the one-to-one correspondence between r and v : for each orbital radius r there is a specific orbital velocity v for any object in that orbit.

The period T is the time required to complete one orbit, and is equal to the length of one orbit $2\pi r$ divided by the orbit velocity v :

$$T = \frac{2\pi r}{v}. \quad (55.15)$$

Using Eq. (55.14) to substitute for v , we find the period of an orbit at radius r to be

$$T = \frac{2\pi r}{v} \quad (55.16)$$

$$= 2\pi r \sqrt{\frac{r}{GM_{\oplus}}} \quad (55.17)$$

$$= 2\pi \sqrt{\frac{r^3}{GM_{\oplus}}} \quad (55.18)$$

This shows that at any given orbital radius r , there is a specific orbital period for a body in a circular orbit of that radius.

Now suppose an artificial satellite is orbiting directly above the Earth's equator, and in the same sense as the Earth's rotation (counterclockwise as seen from above the north pole). If the period T is 24 hours,

¹Also, by using the east coast of Florida and launching to the east, we launch out over the Atlantic Ocean instead of over populated areas. This is another important factor that makes the east coast of Florida a desirable launch site.

the satellite will stay directly above the same point on the equator as it orbits the Earth, and will appear to “hover” above the Earth. Such an orbit is called a *geosynchronous orbit*.

The radius of a geosynchronous orbit can be found by solving Eq. (55.18) for r :

$$\frac{T^2}{4\pi^2} = \frac{r^3}{GM_{\oplus}}, \quad (55.19)$$

or

$$r = \sqrt[3]{\frac{GM_{\oplus}T^2}{4\pi^2}}. \quad (55.20)$$

Now setting $T = 24$ hours $= 86400$ sec and $GM_{\oplus} = 3.986005 \times 10^{14} \text{ m}^3 \text{ s}^{-2}$, we find the radius of a geosynchronous orbit to be

$$r = 42,241 \text{ km} = 6.62R_{\oplus}, \quad (55.21)$$

where $R_{\oplus} = 6378.140$ km is the equatorial radius of the Earth. The altitude of a geosynchronous orbit is

$$r - R_{\oplus} = 35,863 \text{ km} = 22,284 \text{ miles}. \quad (55.22)$$

(This number is the origin of the address of the former COMSAT Laboratories: 22300 Comsat Drive, Clarksburg, Maryland.)

Geosynchronous orbits are often used for communications satellites and satellite television. Since the satellites appear to hover over the equator, the satellite antenna dish need only be pointed at the satellite once; the satellite will not move appreciably from the point of view of the observer. Three geosynchronous satellites placed over the equator 120° in longitude apart are sufficient to cover the whole Earth (except for regions near the poles).

Some people have proposed the construction of *space elevators* to move people and cargo into space. A strong light cable would connect a geosynchronous satellite to the surface of the Earth, and elevator cars would move up and down the cable. The technology necessary to construct a space elevator is still some distance in the future, though.

55.3 Elliptical Orbits

Several of the results we found earlier for a circular orbit can be generalized for an elliptical orbit. Suppose an elliptical orbit has semi-major axis a and eccentricity e . The semi-minor axis $b = a\sqrt{1 - e^2}$, and the distance from the center of the ellipse to either of the two foci is $c = ae = \sqrt{a^2 - b^2}$. Then the distance from the center of the Earth (located at one focus) to the perigee point is

$$r_p = a - c = a(1 - e), \quad (55.23)$$

and the distance from the center of the Earth to the apogee point is

$$r_a = a + c = a(1 + e). \quad (55.24)$$

A little algebra gives an expression for the semi-major axis a in terms of the perigee and apogee distances:

$$a = \frac{r_p + r_a}{2}, \quad (55.25)$$

and similarly we can get an expression for the eccentricity e :

$$e = \frac{r_a - r_p}{r_a + r_p}. \quad (55.26)$$

Energy

The total orbit energy E of a spacecraft in an elliptical orbit turns out to be

$$\boxed{E = -G \frac{M_{\oplus} m}{2a}} \quad (55.27)$$

The potential and kinetic energies vary with r around the orbit. The potential energy at r is given by Eq. (55.1). The orbit velocity at r is found from the *vis viva* equation, Eq. (54.27),

$$v = \sqrt{GM_{\oplus} \left(\frac{2}{r} - \frac{1}{a} \right)} \quad (54.27)$$

from which we find the kinetic energy at r to be

$$K = GM_{\oplus} m \left(\frac{1}{r} - \frac{1}{2a} \right) \quad (55.28)$$

At perigee, $r = r_p = a(1 - e)$, and so

$$v_p = \sqrt{\frac{GM_{\oplus}}{a} \frac{1+e}{1-e}} \quad (55.29)$$

$$K_p = \frac{GM_{\oplus} m}{2a} \frac{1+e}{1-e} \quad (55.30)$$

At apogee, $r = r_a = a(1 + e)$, and so

$$v_a = \sqrt{\frac{GM_{\oplus}}{a} \frac{1-e}{1+e}} \quad (55.31)$$

$$K_a = \frac{GM_{\oplus} m}{2a} \frac{1-e}{1+e} \quad (55.32)$$

Angular Momentum

The angular momentum also varies with r , and is given by

$$L = mrv \cos \phi. \quad (55.33)$$

Here ϕ is called the *elevation angle*, and is the angle between the tangent to the ellipse at the spacecraft and the spacecraft velocity vector.

At either perigee or apogee, $\phi = 0$, so $L = mrv$. At perigee, $r_p = a(1 - e)$, and so the angular momentum is

$$L_p = mv_p a(1 - e). \quad (55.34)$$

At apogee, $r_a = a(1 + e)$, and so

$$L_a = mv_a a(1 + e). \quad (55.35)$$

Since angular momentum is conserved, then $L_p = L_a$; if the orbit parameters a and e are known and the velocity at either the apogee or perigee point is known, then the velocity at the other point is known:

$$L_p = L_a \quad (55.36)$$

$$mv_p a(1 - e) = mv_a a(1 + e) \quad (55.37)$$

$$v_p(1 - e) = v_a(1 + e) \quad (55.38)$$

Thus the perigee velocity v_p is related to the apogee velocity v_a through

$$\frac{v_p}{v_a} = \frac{1+e}{1-e}. \quad (55.39)$$

In terms of the apogee and perigee distances r_a and r_p ,

$$\frac{v_p}{v_a} = \frac{r_a}{r_p}. \quad (55.40)$$

Example. Suppose a spacecraft is in an Earth-orbiting elliptical orbit with a semi-major axis $a = 8000$ km and eccentricity $e = 0.1500$. What are its velocities at perigee and apogee?

Solution. From Eq. (55.29), the perigee velocity is

$$v_p = \sqrt{\frac{GM_\oplus}{a} \frac{1+e}{1-e}} \quad (55.41)$$

$$= \sqrt{\frac{3.986005 \times 10^{14} \text{ m}^3 \text{ s}^{-2}}{8000 \times 10^3 \text{ m}} \frac{1+0.1500}{1-0.1500}} \quad (55.42)$$

$$= \underline{8210 \text{ km/s.}} \quad (55.43)$$

The apogee velocity can be found using Eq. (55.39):

$$v_a = v_p \frac{1-e}{1+e} = 8210 \text{ km/s} \frac{1-0.1500}{1+0.1500} = \underline{6069 \text{ km/s.}} \quad (55.44)$$

Circularizing an Orbit

An elliptical orbit may be *circularized* by changing the spacecraft velocity appropriately. One can change the spacecraft velocity at perigee to create a circular orbit whose radius is equal to the perigee distance, or one can change the spacecraft velocity at apogee to create a circular orbit whose radius is equal to the apogee distance. To calculate the change in spacecraft velocity (called the *Delta v*, or Δv), one uses the principle of conservation of energy.

Suppose a spacecraft is in an elliptical orbit with semi-major axis a and eccentricity e , and we wish to circularize it at *perigee*. The spacecraft velocity at perigee is given by Eq. (55.29), and the circular velocity at $r = r_p$ is given by Eq. (55.4). The required change in spacecraft velocity at perigee is their difference. Using these equations along with Eq. (55.23) gives, after a little algebra,

$$\Delta v = v_c - v_p = \sqrt{\frac{GM_\oplus}{a(1-e)}} (1 - \sqrt{1+e}). \quad (55.45)$$

Similarly, if we wanted to circularize the orbit at *apogee*, the required change in spacecraft velocity at apogee is found by finding the difference of Eqs. (55.4) and (55.31); using these equations along with Eq. (55.24), we get

$$\Delta v = v_c - v_a = \sqrt{\frac{GM_\oplus}{a(1+e)}} (1 - \sqrt{1-e}). \quad (55.46)$$

If the spacecraft velocity vector is perpendicular to the radius vector \mathbf{r} at some instant in time, then the magnitude of the velocity determines what kind of orbit the spacecraft is in:

- If $v = v_c$ (Eq. (55.4)), then the spacecraft is in a circular orbit.
- If $v > v_c$, then the spacecraft is at perigee in an elliptical orbit.
- If $v < v_c$, then the spacecraft is at apogee in an elliptical orbit.

Example. Suppose we have an Earth-orbiting spacecraft in an elliptical orbit, with perigee distance 8000 km and apogee distance 12000 km. We wish to circularize the orbit at apogee to create a circular orbit with radius 12000 km. From Eqs. (55.23) and (55.24), we have

$$a = \frac{r_p + r_a}{2} = \frac{8000 \text{ km} + 12000 \text{ km}}{2} = 10000 \text{ km.} \quad (55.47)$$

The eccentricity is

$$e = \frac{r_a - r_p}{r_a + r_p} = 0.200 \quad (55.48)$$

Circularizing the elliptical orbit to the apogee distance will require a single engine burn at the apogee point that results in a change in spacecraft velocity given by Eq. (55.46):

$$\Delta v = \sqrt{\frac{GM_\oplus}{a(1+e)}} (1 - \sqrt{1-e}) \quad (55.49)$$

$$= \sqrt{\frac{3.986005 \times 10^{14} \text{ m}^3 \text{ s}^{-2}}{(10000 \times 10^3 \text{ m})(1 + 0.200)}} (1 - \sqrt{1 - 0.200}) \quad (55.50)$$

$$= \underline{608 \text{ m/s}} \quad (55.51)$$

55.4 The Hohmann Transfer

On occasion we need to re-shape an orbit. One common situation is that we need to move a spacecraft from a circular orbit to another circular orbit with a different radius. How do we do this?

It can be shown that the most efficient method for performing such a maneuver is to connect the two orbits with an ellipse that is tangent to one circular orbit at its perigee point, and tangent to the other circular orbit at its apogee point (Fig. 55.1). One changes the spacecraft velocity twice, using two engine burns: one burn on the initial circular orbit to create an elliptical transfer orbit, and a second burn at apogee or perigee to circularize the orbit. This type of two-burn maneuver is called a *Hohmann transfer*.

One can use a Hohmann transfer to move a spacecraft from a low-altitude circular orbit to a higher-altitude circular orbit by increasing the speed with the first burn to create an elliptical orbit with the desired apogee, then circularizing the orbit with the second burn. The Δv for the first burn will be given by the negative of Eq. (55.45), and the Δv for the second burn will be given by Eq. (55.46). (Both Δv burns will be positive, since both will be adding energy to the orbit.)

To move a spacecraft from high-altitude orbit down to a low-altitude circular orbit, one decreases the speed with the first burn to create an elliptical orbit with the desired perigee, then circularizes the orbit with the second burn. The Δv for the first burn will be given by Eq. (55.46), and the Δv for the second burn will be given by the negative of Eq. (55.45). (Both Δv burns will be negative, since both will be subtracting energy from the orbit.)

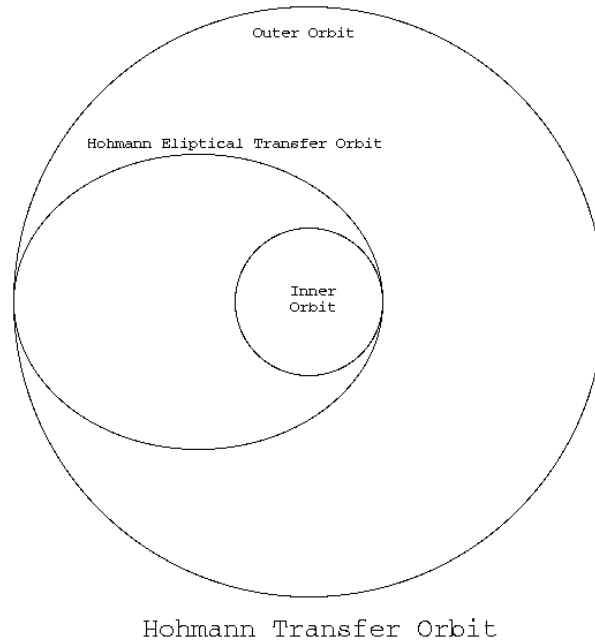

Figure 55.1: A Hohmann transfer orbit.

55.5 Gravity Assist Maneuvers

To send a spacecraft to another planet, one may often get a “free” boost in velocity by flying by another planet along the way, thus shortening the trip. These free velocity increases are called *gravity assist maneuvers*.

To see how this works, consider Fig. 55.2, which shows a spacecraft flying past the planet Jupiter, where Jupiter is assumed to be *stationary* in space. The spacecraft speeds up as it heads toward Jupiter, then slows down again as it moves away from Jupiter. The net result is that the spacecraft leave the encounter having its velocity vector change *direction*, but without any change in magnitude.

Now consider the same situation, but with Jupiter *moving* in its orbit around the Sun (Fig. 55.3). In the figure, the spacecraft is flying “behind” Jupiter (i.e. so that at the point where the spacecraft passes Jupiter’s orbit, Jupiter is moving *away* from the spacecraft). The velocity of Jupiter in its orbit around the Sun (or a significant portion of it) is added to velocity vector of the spacecraft, as shown in the two vector diagrams. As you can see from the vector diagrams, the velocity vector increases in magnitude after the Jupiter flyby, so that the spacecraft has gained speed.

How is this possible? The spacecraft has gained energy, but energy is conserved; where did the extra energy come from? The answer is: Jupiter. When the spacecraft flies behind Jupiter, it tugs on Jupiter a bit, due to the gravitational attraction between Jupiter and the spacecraft. This causes Jupiter to slow down a tiny bit, thereby losing orbital energy, so it moves in toward the Sun a tiny bit. Of course, Jupiter is so massive that this movement toward the Sun is immeasurably tiny, but the effect on the spacecraft is significant.

This gravity assist maneuver is often used to send spacecraft to the outer Solar System; it allows the spacecraft to reach their destinations sooner, and does not require extra fuel to gain the extra speed. In fact, it is often advantageous to send a spacecraft first to the *inner* Solar System to take advantage of gravitational flybys before sending it to the planets. For example, when the *Cassini* spacecraft was sent to orbit Saturn, it was first sent to Venus for two gravity assists from that planet; it then flew past Earth and Jupiter for two additional gravity assists before arriving at Saturn.

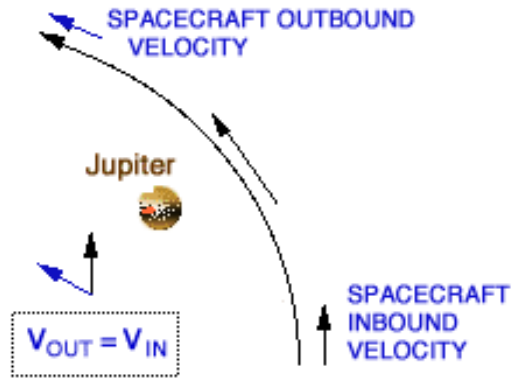

Figure 55.2: Spacecraft flying past a *stationary* Jupiter. *Credit: NASA Jet Propulsion Laboratory.*

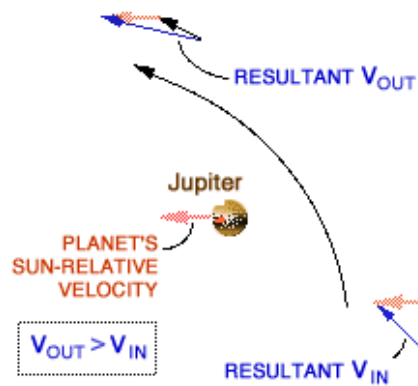

Figure 55.3: Spacecraft flying past a *moving* Jupiter; Jupiter is moving to the left in its orbit around the Sun. In this case, the spacecraft is passing “behind” Jupiter, and gains speed during the encounter. *Credit: NASA Jet Propulsion Laboratory.*

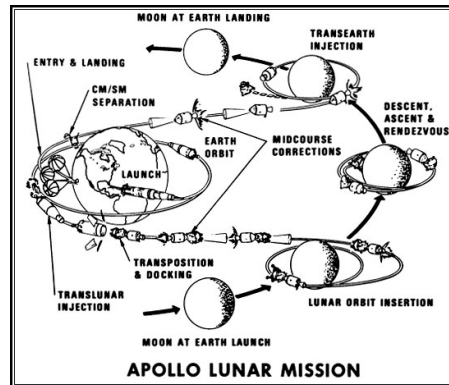

Figure 55.4: Orbits of *Apollo* spacecraft 8 and 10–17. The spacecraft enters lunar orbit *in front* of the Moon, to help slow its velocity. (Credit: NASA.)

Similarly, *Voyager 2* made gravity-assist flybys of Jupiter, Saturn, and Uranus, and it made studies of each of those planets as it flew past them. After its encounter with Uranus, *Voyager 2* flew past Neptune and made observations there; however, it flew over Neptune's north pole, so it did not gain extra speed from the Neptune encounter. The spacecraft has now reached the outer boundary of the Solar System and is entering interstellar space. In about 40,000 years, *Voyager 2* will pass 1.7 light-years from the star Ross 248 and in about 296,000 years, it will pass 4.3 light-years from Sirius, the brightest star in the sky. Both *Voyager 2* and its sister spacecraft *Voyager 1* will travel through the Milky Way galaxy indefinitely.

Contrariwise, if the spacecraft were to fly *in front* of Jupiter (so that Jupiter is moving *toward* it when it crosses Jupiter's orbit), then the spacecraft would *lose* speed. This was used to advantage during the *Apollo* missions to the Moon, when this type of gravity assist maneuver with the Moon was used to reduce the amount of fuel needed to place the spacecraft into lunar orbit (Fig. 55.4).

55.6 The International Cometary Explorer

Figure 55.5 shows a very complex example of an orbit design, in which the ISEE-3 (International Sun-Earth Explorer 3) spacecraft was re-named ICE (International Cometary Explorer) and sent to intercept two comets.

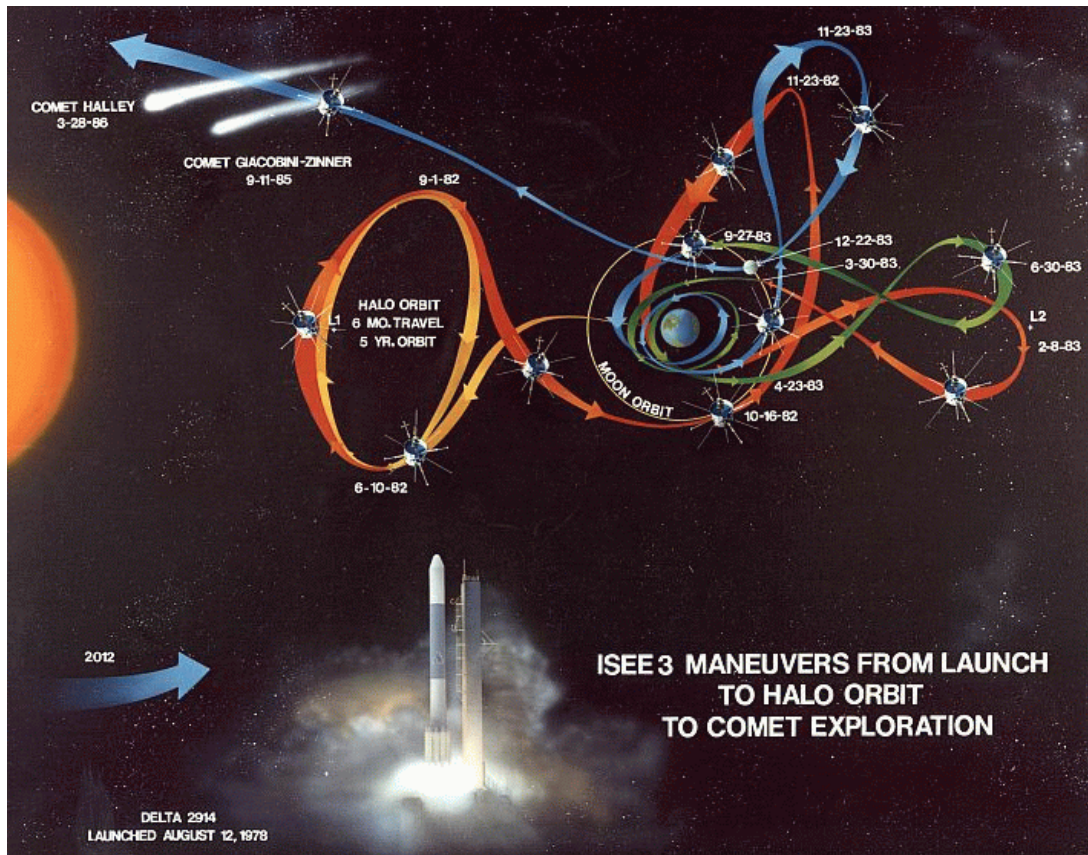

Figure 55.5: In 1982, the International Sun/Earth Explorer 3 (ISEE-3) spacecraft was re-purposed to become the International Cometary Explorer (ICE), so that it could explore comets Giacobini-Zinner and Halley. ISEE-3 orbited the L_1 Sun-Earth Lagrange point. Getting the spacecraft to intercept the two comets involved one of the most complex trajectories ever designed (shown here). (Credit: NASA.)

Chapter 56

Partial Derivatives

Before introducing the advanced Lagrangian and Hamiltonian formulations of classical mechanics, we'll need a some additional mathematical background, since the equations of these formulations are expressed in the language of partial differential equations. We will leave the methods for solving such equations to a more advanced course, but we can still write down the equations and explore some of their consequences. First, in order to understand these equations, we'll first need to understand the concept of *partial derivatives*.

56.1 First Partial Derivatives

You've already learned in a calculus course how to take the derivative of a function of one variable. For example, if

$$f(x) = 3x^2 + 7x^5 \quad (56.1)$$

then

$$\frac{df}{dx} = 6x + 35x^4. \quad (56.2)$$

But what if f is a function of more than one variable? For example, if

$$f(x, y) = 5x^3y^5 + 4y^2 - 7xy^6 \quad (56.3)$$

then how do we take the derivative of f ? In this case, there are *two* possible first derivatives: one with respect to x , and one with respect to y . These are called *partial derivatives*, and are indicated using the “backward-6” symbol ∂ in place of the symbol d used for ordinary derivatives.

To compute a partial derivative with respect to x , you simply treat all variables except x as constants. Similarly, for the partial derivative with respect to y , you treat all variables except y as constants. For example, if $g(x, y) = 3x^4y^7$, then the partial derivative of g with respect to x is $\partial g/\partial x = 12x^3y^7$, since both 3 and y^7 are considered constants with respect to x .

As another example, the partial derivatives of Eq. (56.3) are

$$\frac{\partial f}{\partial x} = 15x^2y^5 - 7y^6 \quad (56.4)$$

$$\frac{\partial f}{\partial y} = 25x^3y^4 + 8y - 42xy^5 \quad (56.5)$$

Notice that in Eq. (56.4), the derivative of the term $4y^2$ with respect to x is 0, since $4y^2$ is treated as a constant.

56.2 Higher-Order Partial Derivatives

It is similarly possible to take higher-order partial derivatives. For a function of two variables $f(x, y)$, there are *three* possible second derivatives:

$$\frac{\partial^2 f}{\partial x^2} = \frac{\partial}{\partial x} \left(\frac{\partial f}{\partial x} \right); \quad \frac{\partial^2 f}{\partial x \partial y} = \frac{\partial}{\partial x} \left(\frac{\partial f}{\partial y} \right); \quad \text{and} \quad \frac{\partial^2 f}{\partial y^2} = \frac{\partial}{\partial y} \left(\frac{\partial f}{\partial y} \right). \quad (56.6)$$

In the second case, the order of differentiation doesn't matter: $\partial^2 f / (\partial x \partial y) \equiv \partial^2 f / (\partial y \partial x)$. This property is known as *Clairaut's theorem*.

For example, suppose $f(x, y)$ is as given by Eq. (56.3). Then the second partial derivatives of f are found by taking partial derivatives of Eqs. (56.4) and (56.5):

$$\frac{\partial^2 f}{\partial x^2} = 30xy^5 \quad (56.7)$$

$$\frac{\partial^2 f}{\partial x \partial y} = 75x^2y^4 - 42y^5 \quad (56.8)$$

$$\frac{\partial^2 f}{\partial y^2} = 100x^3y^3 + 8 - 210xy^4 \quad (56.9)$$

Chapter 57

Lagrangian Mechanics

In this course we have been studying classical mechanics as formulated by Sir Isaac Newton; this is called *Newtonian mechanics*. Newtonian mechanics is mathematically fairly straightforward, and can be applied to a wide variety of problems. Newton's formulation of mechanics is not unique, however; other formulations are possible. Here we will look at two common alternative formulations of classical mechanics: *Lagrangian mechanics* and *Hamiltonian mechanics*. Lagrangian mechanics will be discussed in this chapter; Hamiltonian mechanics will be covered in Chapter 58.

It is important to understand that all of these formulations of mechanics are equivalent. In principle, any of them could be used to solve any problem in classical mechanics. The reason they're important is that in some problems one of the alternative formulations of mechanics may lead to equations that are much easier to solve than the equations that arise from Newtonian mechanics. Unlike Newtonian mechanics, neither Lagrangian nor Hamiltonian mechanics requires the concept of force; instead, these systems are expressed in terms of energy. Although we will be looking at the equations of mechanics in one dimension, all these formulations of mechanics may be generalized to two or three dimensions.

The first alternative to Newtonian mechanics we will look at is *Lagrangian mechanics*. Using Lagrangian mechanics instead of Newtonian mechanics is sometimes advantageous in certain problems, where the equations of Newtonian mechanics would be quite difficult to solve.

In Lagrangian mechanics, we begin by defining a quantity called the *Lagrangian* (L), which is defined as the difference between the kinetic energy K and the potential energy U :

$$L \equiv K - U \tag{57.1}$$

Since the kinetic energy is a function of velocity v and potential energy will typically be a function of position x , the Lagrangian will (in one dimension) be a function of both x and v : $L(x, v)$.

The motion of a particle is then found by solving *Lagrange's equation*; in one dimension it is

$$\boxed{\frac{d}{dt} \left(\frac{\partial L}{\partial v} \right) - \frac{\partial L}{\partial x} = 0} \tag{57.2}$$

57.1 Examples

Example: Simple Harmonic Oscillator

As an example of the use of Lagrange's equation, consider a one-dimensional simple harmonic oscillator. We wish to find the position x of the oscillator at any time t .

We begin by writing the usual expression for the kinetic energy K :

$$K = \frac{1}{2}mv^2 \quad (57.3)$$

The potential energy U of a simple harmonic oscillator is given by

$$U = \frac{1}{2}kx^2 \quad (57.4)$$

The Lagrangian in this case is then

$$L(x, v) = K - U \quad (57.5)$$

$$= \frac{1}{2}mv^2 - \frac{1}{2}kx^2 \quad (57.6)$$

Lagrange's equation in one dimension is

$$\frac{d}{dt} \left(\frac{\partial L}{\partial v} \right) - \frac{\partial L}{\partial x} = 0 \quad (57.7)$$

Substituting for L from Eq. (57.6), we find

$$\frac{d}{dt} \left[\frac{\partial}{\partial v} \left(\frac{1}{2}mv^2 - \frac{1}{2}kx^2 \right) \right] - \frac{\partial}{\partial x} \left(\frac{1}{2}mv^2 - \frac{1}{2}kx^2 \right) = 0 \quad (57.8)$$

Evaluating the partial derivatives, we get

$$\frac{d}{dt} (mv) + kx = 0 \quad (57.9)$$

or, since $v = dx/dt$,

$$m \frac{d^2x}{dt^2} + kx = 0, \quad (57.10)$$

which is a second-order ordinary differential equation that one can solve for $x(t)$. Note that the first term on the left is $ma = F$, so this equation is equivalent to $F = -kx$ (Hooke's Law). The solution to the differential equation (57.10) turns out to be

$$x(t) = A \cos(\omega t + \delta), \quad (57.11)$$

where A is the *amplitude* of the motion, $\omega = \sqrt{k/m}$ is the angular frequency of the oscillator, and δ is a phase constant that depends on where the oscillator is at $t = 0$.

Example: Plane Pendulum

Part of the power of the Lagrangian formulation of mechanics is that one may define any coordinates that are convenient for solving the problem; those coordinates and their corresponding velocities are then used in place of x and v in Lagrange's equation.

For example, consider a simple plane pendulum of length ℓ with a bob of mass m , where the pendulum makes an angle θ with the vertical. The goal is to find the angle θ at any time t . In this case we replace x with the angle θ , and we replace v with the pendulum's angular velocity ω . The kinetic energy K of the pendulum is the rotational kinetic energy

$$K = \frac{1}{2}I\omega^2 = \frac{1}{2}m\ell^2\omega^2, \quad (57.12)$$

where I is the moment of inertia of the pendulum, $I = m\ell^2$. The potential energy of the pendulum is the gravitational potential energy

$$U = mg\ell(1 - \cos \theta) \quad (57.13)$$

The Lagrangian in this case is then

$$L(\theta, \omega) = K - U \quad (57.14)$$

$$= \frac{1}{2}m\ell^2\omega^2 - mg\ell(1 - \cos \theta) \quad (57.15)$$

Lagrange's equation becomes

$$\frac{d}{dt} \left(\frac{\partial L}{\partial \omega} \right) - \frac{\partial L}{\partial \theta} = 0 \quad (57.16)$$

Substituting for L ,

$$\frac{d}{dt} \left\{ \frac{\partial}{\partial \omega} \left[\frac{1}{2}m\ell^2\omega^2 - mg\ell(1 - \cos \theta) \right] \right\} - \frac{\partial}{\partial \theta} \left[\frac{1}{2}m\ell^2\omega^2 - mg\ell(1 - \cos \theta) \right] = 0 \quad (57.17)$$

Computing the partial derivatives, we find

$$\frac{d}{dt} (m\ell^2\omega) + mg\ell \sin \theta = 0. \quad (57.18)$$

Since $\omega = d\theta/dt$, this gives

$$m\ell^2 \frac{d^2\theta}{dt^2} + mg\ell \sin \theta = 0, \quad (57.19)$$

which is a second-order ordinary differential equation that one may solve for the motion $\theta(t)$. The first term on the left-hand side is the torque τ on the pendulum, so this equation is equivalent to $\tau = -mg\ell \sin \theta$.

The solution to the differential equation (57.19) is quite complicated, but we can simplify it if the pendulum only makes *small* oscillations. In that case, we can approximate $\sin \theta \approx \theta$, and the differential equation (57.19) becomes a simple harmonic oscillator equation with solution

$$\theta(t) \approx \theta_0 \cos(\omega t + \delta), \quad (57.20)$$

where θ_0 is the (angular) amplitude of the pendulum, $\omega = \sqrt{g/\ell}$ is the angular frequency, and δ is a phase constant that depends on where the pendulum is at $t = 0$.

Chapter 58

Hamiltonian Mechanics

Besides Lagrangian mechanics, another alternative formulation of Newtonian mechanics we will look at is *Hamiltonian mechanics*. In this system, in place of the Lagrangian we define a quantity called the *Hamiltonian*, to which Hamilton's equations of motion are applied. While Lagrange's equation describes the motion of a particle as a single second-order differential equation, Hamilton's equations describe the motion as a coupled system of two first-order differential equations.

One of the advantages of Hamiltonian mechanics is that it is similar in form to *quantum mechanics*, the theory that describes the motion of particles at very tiny (subatomic) distance scales. An understanding of Hamiltonian mechanics provides a good introduction to the mathematics of quantum mechanics.

The *Hamiltonian* H is defined to be the *sum* of the kinetic and potential energies:

$$H \equiv K + U \tag{58.1}$$

Here the Hamiltonian should be expressed as a function of position x and momentum p (rather than x and v , as in the Lagrangian), so that $H = H(x, p)$. This means that the kinetic energy should be written as $K = p^2/2m$, rather than $K = mv^2/2$.

Hamilton's equations in one dimension have the elegant nearly-symmetrical form

$\frac{dx}{dt} = \frac{\partial H}{\partial p} \tag{58.2}$
$\frac{dp}{dt} = -\frac{\partial H}{\partial x} \tag{58.3}$

58.1 Examples

Example: Simple Harmonic Oscillator

As an example, we may again solve the simple harmonic oscillator problem, this time using Hamiltonian mechanics. We first write down the kinetic energy K , expressed in terms of momentum p :

$$K = \frac{p^2}{2m} \tag{58.4}$$

As before, the potential energy of a simple harmonic oscillator is

$$U = \frac{1}{2}kx^2 \tag{58.5}$$

The Hamiltonian in this case is then

$$H(x, p) = K + U \quad (58.6)$$

$$= \frac{p^2}{2m} + \frac{1}{2}kx^2 \quad (58.7)$$

Substituting this expression for H into the first of Hamilton's equations, we find

$$\frac{dx}{dt} = \frac{\partial H}{\partial p} \quad (58.8)$$

$$= \frac{\partial}{\partial p} \left(\frac{p^2}{2m} + \frac{1}{2}kx^2 \right) \quad (58.9)$$

$$= \frac{p}{m} \quad (58.10)$$

Substituting for H into the second of Hamilton's equations, we get

$$\frac{dp}{dt} = -\frac{\partial H}{\partial x} \quad (58.11)$$

$$= -\frac{\partial}{\partial x} \left(\frac{p^2}{2m} + \frac{1}{2}kx^2 \right) \quad (58.12)$$

$$= -kx \quad (58.13)$$

Equations (58.8) and (58.11) are two coupled first-order ordinary differential equations, which may be solved simultaneously to find $x(t)$ and $p(t)$. Note that for this example, Eq. (58.8) is equivalent to $p = mv$, and Eq. (58.11) is just Hooke's Law, $F = -kx$.

Example: Plane Pendulum

As with Lagrangian mechanics, more general coordinates (and their corresponding momenta) may be used in place of x and p . For example, in finding the motion of the simple plane pendulum, we may replace the position x with angle θ from the vertical, and the linear momentum p with the angular momentum \mathcal{L} .

To solve the plane pendulum problem using Hamiltonian mechanics, we first write down the kinetic energy K , expressed in terms of angular momentum \mathcal{L} :

$$K = \frac{\mathcal{L}^2}{2I} = \frac{\mathcal{L}^2}{2m\ell^2}, \quad (58.14)$$

where $I = m\ell^2$ is the moment of inertia of the pendulum. As before, the gravitational potential energy of a plane pendulum is

$$U = mg\ell(1 - \cos \theta). \quad (58.15)$$

The Hamiltonian in this case is then

$$H(\theta, \mathcal{L}) = K + U \quad (58.16)$$

$$= \frac{\mathcal{L}^2}{2m\ell^2} + mg\ell(1 - \cos \theta) \quad (58.17)$$

Substituting this expression for H into the first of Hamilton's equations, we find

$$\frac{d\theta}{dt} = \frac{\partial H}{\partial \mathcal{L}} \quad (58.18)$$

$$= \frac{\partial}{\partial \mathcal{L}} \left[\frac{\mathcal{L}^2}{2m\ell^2} + mg\ell(1 - \cos \theta) \right] \quad (58.19)$$

$$= \frac{\mathcal{L}}{m\ell^2} \quad (58.20)$$

Substituting for H into the second of Hamilton's equations, we get

$$\frac{d\mathcal{L}}{dt} = -\frac{\partial H}{\partial \theta} \quad (58.21)$$

$$= -\frac{\partial}{\partial \theta} \left[\frac{\mathcal{L}^2}{2m\ell^2} + mg\ell(1 - \cos \theta) \right] \quad (58.22)$$

$$= -mg\ell \sin \theta \quad (58.23)$$

Equations (58.18) and (58.21) are two coupled first-order ordinary differential equations, which may be solved simultaneously to find $\theta(t)$ and $\mathcal{L}(t)$. Note that for this example, Eq. (58.18) is equivalent to $\mathcal{L} = I\omega$, and Eq. (58.21) is the torque $\tau = -mg\ell \sin \theta$.

Chapter 59

Special Relativity

59.1 Introduction

The classical mechanics described by Sir Isaac Newton begins to break down at very high velocities, i.e. at velocities near the speed of light $c = 299,792.458$ km/s. For bodies moving at a significant fraction of the speed of light, Newton's mechanics needs to be modified. The necessary modifications were developed by physicist Albert Einstein in the early 20th century, in a theory now called the *special theory of relativity*.

59.2 Postulates

Einstein discovered that the necessary modifications to Newtonian mechanics could be derived by assuming two postulates:

1. Absolute uniform motion cannot be detected.
2. The speed of light is independent of the motion of the source.

The first postulate says that all motion is relative—that there is no reference frame that all observers can agree to be absolutely at rest. The second postulate says that light does not obey the usual laws of velocity addition. For example, if someone is moving toward you at 99% of the speed of light and turns on a flashlight in your direction, you will measure the light's speed to be the same as if that person were at rest.

Although these postulates seem quite reasonable, they lead to some surprising consequences. Let's examine a few of those consequences.

59.3 Time Dilation

It turns out that one consequence of Einstein's postulates is that time runs more slowly for someone moving relative to you; this effect is called *time dilation*. If someone is moving at speed v relative to you, then their clocks will run slower than yours. If a clock measures a time interval Δt_0 when it's at rest, then when it's moving at a speed v relative to you, you will measure that time interval to be longer by a factor γ :

$$\Delta t = \gamma \Delta t_0, \tag{59.1}$$

where Δt is the time interval measured by the moving clock, Δt_0 is the time interval measured on the clock when it's at rest, and γ is an abbreviation for the factor

$$\gamma \equiv \frac{1}{\sqrt{1 - v^2/c^2}}. \tag{59.2}$$

(Note that $\gamma \geq 1$.) The time interval Δt_0 , measured when you're at rest with respect to the clock, is called the *proper time*.

This effect means that time travel is possible—at least time travel into the future. One simply builds a spacecraft and travels close to the speed of light, then turns around and returns to Earth. (It is not clear whether time travel into the past is possible, but it might be possible under Einstein's *general* theory of relativity.)

59.4 Length Contraction

Another consequence of the postulates is that a moving body will appear to be shortened in the direction of motion; this effect is called *length contraction*. The length of a moving body will appear to be shortened by this same factor of γ :

$$L = \frac{L_0}{\gamma} \quad (59.3)$$

Here L_0 is the length of the body when it is at rest, and is called the *proper length*. Since $\gamma \geq 1$, the moving body will be shorter when it is moving.

59.5 An Example

As an example, let's imagine that a spacecraft is launched at high speed relative to the nearest star, Alpha Centauri (which is about 4 light-years away). The ship travels at 80% of the speed of light during the trip. From Earth, we see that the whole trip takes 5 years. We also see the astronaut's clocks running more slowly than ours by a factor of $\gamma = 2.78$, so that when the astronauts arrive, they are only 1.8 years older.

What do the astronauts see from their point of view on the spacecraft? Their clocks run at what seems a normal rate for them, but they see that the *distance* to Alpha Centauri has been length-contracted by a factor of $\gamma = 2.78$. They're traveling at a speed of $0.80c$, but they only have to travel a distance of $(4 \text{ light-years})/\gamma = 1.44 \text{ light-years}$. When they arrive at Alpha Centauri, they're older by $(1.44 \text{ light-years})/0.80c = 1.8 \text{ years}$.

In summary, observers on Earth see the astronaut's clocks moving more slowly, but the astronauts have to travel the full 4 light-years. The astronauts see their clocks moving at normal speed, but the distance they have to travel is shorter. All observers agree that the astronauts are only 1.8 years older when they arrive.

59.6 Momentum

In Newton's classical mechanics, momentum is $\mathbf{p} = m\mathbf{v}$. Under special relativity, this is modified to be

$$\mathbf{p} = \gamma m\mathbf{v}. \quad (59.4)$$

Relativistically, it is this definition of momentum that is conserved. Newton's second law in the form $\mathbf{F} = m\mathbf{a}$ is no longer valid under special relativity, but Newton's original form $\mathbf{F} = d\mathbf{p}/dt$ is still valid, using this definition of momentum \mathbf{p} .

Notice that as $v \rightarrow c$, we have $\gamma \rightarrow \infty$ (by Eq. (59.2)), and so momentum $p \rightarrow \infty$. As a body goes faster, its momentum increases in such a way that it becomes increasingly difficult to make it go even faster. This means that it is not possible for a body to move faster than the speed of light in vacuum, c .

59.7 Addition of Velocities

Let's suppose that we have two bodies moving in one dimension. The first is moving at speed u , and the second is moving at speed v . What is the speed of the second relative to the first? In other words, what will you measure as the speed of the second body if you're sitting on the first body?

In classical Newtonian mechanics, the speed w of the second body relative to the first is simply

$$w = v - u. \quad (59.5)$$

For example, if the first body is moving to the right with speed $u = 10$ m/s, and the second body is moving toward it to the left with speed $v = -20$ m/s, then an observer on the first body will see the second body moving toward it with a speed of $w = 30$ m/s.

In the special theory of relativity, this seemingly self-evident equation for adding velocities must be modified as follows:

$$w = \frac{v - u}{1 - uv/c^2}. \quad (59.6)$$

This reduces to Eq. (59.5) unless the speeds involved are near the speed of light. For the above example, where $u = 10$ m/s and $v = -20$ m/s, Eq. (59.6) gives $w = 29.9999999999993324$ m/s, rather than $w = 30$ m/s given by Eq. (59.5). As you can see, for many applications, the difference between the classical formula (Eq. (59.5)) and the exact relativistic formula (Eq. (59.6)) is not enough to justify the extra complexity of using the relativistic formula.

But for speeds near the speed of light, using the relativistic formula is important. For example, if $u = 0.99c$ and $v = -0.99c$, then the classical formula of Eq. (59.5) would give $w = 1.98c > c$, in violation of special relativity; but using the exact expression in Eq. (59.6) gives the correct answer, $w = 0.9999494975c$.

Eq. (59.6) makes it impossible for the relative speeds to be greater than the speed of light c . In the extreme case $u = c$ and $v = -c$, Eq. (59.6) gives $w = c$, in agreement with the Einstein's second postulate.

59.8 Energy

Rest Energy

Einstein showed that mass is a form of energy, as shown by his most famous equation,

$$E_0 = mc^2. \quad (59.7)$$

E_0 is called the *rest energy* of the particle of mass m . The clearest illustration of this formula is the mutual annihilation of matter and *antimatter* (a kind of mirror-image of ordinary matter). When a particle of matter collides with a particle of antimatter, the mass of the two particles is converted completely to energy, the amount of energy liberated being given by Eq. (59.7).

As examples, the rest energy of the electron is 511 keV, and the rest energy of the proton is 938 MeV. (1 eV is one *electron volt*, and is equal to $1.602176634 \times 10^{-19}$ J.)

Kinetic Energy

In classical Newtonian mechanics, the kinetic energy is given by $K = mv^2/2$. The relativistic version of this equation is

$$K = (\gamma - 1)mc^2. \quad (59.8)$$

It is not obvious that this reduces to the classical expression until we expand γ into a Taylor series:

$$\gamma = \left(1 - \frac{v^2}{c^2}\right)^{-1/2} = 1 + \frac{1}{2} \frac{v^2}{c^2} + \frac{3}{8} \frac{v^4}{c^4} + \frac{5}{16} \frac{v^6}{c^6} + \frac{35}{128} \frac{v^8}{c^8} + \frac{63}{256} \frac{v^{10}}{c^{10}} + \frac{231}{1024} \frac{v^{12}}{c^{12}} + \dots \quad (59.9)$$

Substituting this series expansion for γ into Eq. (59.8), we get

$$K = \frac{1}{2}mv^2 + \frac{3}{8}m\frac{v^4}{c^2} + \frac{5}{16}m\frac{v^6}{c^4} + \frac{35}{128}m\frac{v^8}{c^6} + \frac{63}{256}m\frac{v^{10}}{c^8} + \frac{231}{1024}m\frac{v^{12}}{c^{10}} + \dots \quad (59.10)$$

Unless the speed v is near the speed of light c , all but the first term on the right will be very small and can be neglected, leaving the classical equation.

Total Energy

If the only forms of energy present are the rest energy E_0 and the kinetic energy K , then the total energy E will be the sum of these:

$$E = E_0 + K = \gamma mc^2. \quad (59.11)$$

It is often useful to know the total energy of a particle in terms of its momentum p rather than its velocity v . It can be shown that the total energy is given in terms of momentum by

$$E^2 = (pc)^2 + (mc^2)^2. \quad (59.12)$$

In the case where the total energy is much larger than the rest energy ($E \gg E_0$), we may neglect the second term on the right, and use

$$E \approx pc. \quad (59.13)$$

Chapter 60

Quantum Mechanics

60.1 Introduction

In this course we have been studying mechanics as formulated by Sir Isaac Newton; this is called *classical mechanics*. Although classical mechanics can be applied to a wide range of situations, it was discovered at the beginning of the 20th century that it cannot be applied to very small distance scales—say on the order of the size of an atom or smaller. For these small distance scales, classical mechanics no longer works, and a completely different system of mechanics is needed, called *quantum mechanics*. Here we will present a brief overview of quantum mechanics, so that you can get a sense for what it is all about. For simplicity, we will be working in one dimension, although the equations can be generalized for three dimensions.

60.2 Review of Newtonian Mechanics

We begin by reviewing Newtonian classical mechanics in one dimension. In this formulation, we begin by writing Newton's second law, which gives the force F required to give an acceleration a to a mass m :

$$F = ma. \tag{60.1}$$

Generally the force is a function of x . Since the acceleration $a = d^2x/dt^2$, Eq. (60.1) may be written

$$F(x) = m \frac{d^2x}{dt^2}. \tag{60.2}$$

This is a second-order ordinary differential equation, which we solve for $x(t)$ to find the position x at any time t . Solving a problem in Newtonian mechanics then consists of these steps:

1. Write down Newton's second law (Eq. 60.2);
2. Substitute for $F(x)$ the specific force present in the problem;
3. Solve the resulting differential equation for $x(t)$.

60.3 Quantum Mechanics

The quantum world at very small distance scales (atomic sizes and smaller) is very alien and strange, and completely beyond our everyday experience. Here are a few of the key concepts in quantum mechanics:

1. In quantum mechanics, it generally makes no sense to talk about the the exact position x of a particle at a time t . Instead, a particle is thought of as being in many different places at the same time. Only when we go *measure* the position of the particle does it appear at a precise location. When we're not measuring its position, it is, in a sense, in many places at once.
2. The concept of the position x of a particle is replaced by the concept of a *wave function* $\psi(x, t)$. The physical interpretation of the wave function is that its square, $|\psi(x, t)|^2$, gives the *probability* that when we measure the particle's position at time t , it will appear at position x . This idea of probability is a central concept of quantum mechanics: when we go to measure the position of a particle, it is fundamentally impossible to predict where it will appear, no matter how much information we have. It is only possible to predict the probability that it will be found at a given location.
3. This idea of a wave function is closely connected the the idea of *wave-particle duality*: matter fundamentally behaves like both a wave and a particle at the same time. For example, both photons (particles of light) and electrons show both particle-like behavior and wave-like behavior.
4. It is fundamentally impossible to know both a particle's exact position and its velocity at the same time. (This is in contrast to Newtonian mechanics, where a particle's position and velocity can both be measured to arbitrary accuracy.) This idea is called the *Heisenberg uncertainty principle*, and is described in more detail below.
5. In bound systems, we generally find that a particle cannot have just *any* value of energy. Instead, we find that the particle can have only certain *discrete* values of energy; we thus say that the energy is *quantized*. The particle cannot have an energy that lies in between the allowed discrete values. We also often find that quantities like position and angular momentum are also quantized. For example, an electron in orbit around an atom has its orbital position quantized: it can only be at certain allowed positions with respect to the nucleus, and other positions are now allowed.

You may wonder: how can it be that a particle is in many places at once, or that the place where it appears is completely unpredictable, or that it is in an unknown state unless we're measuring it, or that it can be both a particle and a wave at the same time? The truth is that *nobody* really understands how it can be this way—it just *is*. We can write down the equations to describe it, and predict the outcomes of experiments to high accuracy, but nobody has a good intuitive picture of how things can possibly be this way. Nature is far stranger than we can imagine.

Now for a mathematical description of quantum mechanics. Recall how we work with Newtonian mechanics: we write down Newton's second law, substitute a specific force for $F(x)$, and solve the resulting differential equation for $x(t)$. Quantum mechanics does not use the concept of a force; rather, everything is formulated in terms of energy. In place of Newton's second law, we use the *time-dependent Schrödinger equation*, which is a partial differential equation:

$$\boxed{-\frac{\hbar^2}{2m} \frac{\partial^2 \psi}{\partial x^2} + U(x)\psi(x, t) = i\hbar \frac{\partial \psi}{\partial t}} \quad (60.3)$$

where m is the mass of the particle, $U(x)$ is the potential energy function, and $\psi(x, t)$ is the wave function we wish to solve for. The constant \hbar (pronounced "h-bar") is an abbreviation for Planck's constant h divided by 2π , and has the value $\hbar \equiv h/2\pi = 1.054571726 \times 10^{-34}$ J s. Notice the presence of the factor $i = \sqrt{-1}$ on the right-hand side: in general, quantum mechanical wave functions are *complex*, but the physically meaningful quantity is the *square* of the wave function, which is real.

Solving a problem in quantum mechanics consists of the following steps (analogous to the steps described earlier for Newtonian mechanics):

1. Write down the Schrödinger equation (Eq. 60.3);

2. Substitute for $U(x)$ the specific potential energy present in the problem;
3. Solve the resulting differential equation for $\psi(x, t)$.

It turns out that it is possible to separate the solution $\psi(x, y)$ into the product of two parts: a part that depends only on x and a part that depends only on t . The solution is $\psi(x, t) = \varphi(x)e^{-iEt/\hbar}$, where $\varphi(x)$ is the solution to the *time-independent Schrödinger equation*:

$$\boxed{-\frac{\hbar^2}{2m} \frac{d^2\varphi}{dx^2} + U(x)\varphi(x) = E\varphi(x)} \quad (60.4)$$

and where E is the total energy of the particle. So to solve the *time-dependent* Schrödinger equation for $\psi(x, t)$, we first solve the *time-independent* Schrödinger equation for $\varphi(x)$, then multiply that solution by $e^{-iEt/\hbar}$.

60.4 Example: Simple Harmonic Oscillator

As an example of the use of the Schrödinger equation, consider a one-dimensional simple harmonic oscillator. We wish to find the wave function $\psi(x, t)$ of the oscillator at any position x and time t .

The potential energy U of a simple harmonic oscillator is given by

$$U(x) = \frac{1}{2}kx^2, \quad (60.5)$$

where k is the spring constant. With this potential energy function, the time-independent Schrödinger equation (Eq. 60.4) becomes

$$-\frac{\hbar^2}{2m} \frac{d^2\varphi}{dx^2} + \frac{1}{2}kx^2\varphi(x) = E\varphi(x) \quad (60.6)$$

This is a second-order differential equation whose solution can be worked out using the theory of differential equations. The solution turns out to be

$$\varphi_n(x) = \sqrt{\frac{\alpha}{\sqrt{\pi}2^n n!}} H_n(\alpha x) e^{-\frac{1}{2}\alpha^2 x^2} \quad (n = 0, 1, 2, 3, \dots) \quad (60.7)$$

Here α is defined by $\alpha^4 \equiv mk/\hbar^2$ and the H_n are special functions called *Hermite polynomials*, the first few of which are shown in Table 60-1. Notice that the solution is *quantized*: only certain discrete solutions are allowed, which we find by substituting the integers 0, 1, 2, 3, ... for n .

The solutions to the time-dependent Schrödinger equation are then found by multiplying Eq. (60.7) by $e^{-iEt/\hbar}$:

$$\psi_n(x, t) = \sqrt{\frac{\alpha}{\sqrt{\pi}2^n n!}} H_n(\alpha x) e^{-\frac{1}{2}\alpha^2 x^2} e^{-iE_n t/\hbar} \quad (n = 0, 1, 2, 3, \dots) \quad (60.8)$$

The physical significance of the wave function is that its square, $|\psi|^2 = \psi^* \psi$, gives the probability of finding the particle at position x .¹ Squaring Eq. (60.8), we find this probability function for the harmonic oscillator is

$$|\psi_n(x)|^2 = \frac{\alpha}{\sqrt{\pi}2^n n!} [H_n(\alpha x)]^2 e^{-\alpha^2 x^2} \quad (n = 0, 1, 2, 3, \dots) \quad (60.9)$$

It turns out that the energy, like the wave function, is also quantized; the allowed values of E are

$$E_n = (n + \frac{1}{2})\hbar\omega \quad (n = 0, 1, 2, 3, \dots) \quad (60.10)$$

where $\omega = \sqrt{k/m}$ is the angular frequency of a classical simple harmonic oscillator. This is in contrast to the *classical* harmonic oscillator, which can have *any* value of energy, $E = kA^2/2$.

¹Technically, it's the probability of finding the particle between positions x and $x + dx$.

Table 60-1. Hermite polynomials.

$H_0(x) = 1$
$H_1(x) = 2x$
$H_2(x) = 4x^2 - 2$
$H_3(x) = 8x^3 - 12x$
$H_4(x) = 16x^4 - 48x^2 + 12$
$H_5(x) = 32x^5 - 160x^3 + 120x$
$H_6(x) = 64x^6 - 480x^4 + 720x^2 - 120$

Notice that the quantum simple harmonic oscillator has a minimum energy, called the *zero-point energy*, when $n = 0$: $E_0 = \hbar\omega/2$. The classical harmonic oscillator can have zero energy, but the not quantum harmonic oscillator—in quantum mechanics, there is always a minimum non-zero energy that the particle must have. The same is true of the atom: an electron can be in the lowest-energy K shell of the atom, but cannot have any lower energy. This is fortunate: if the electron energy were not quantized, it would have no minimum energy, and could spiral all the way in to the nucleus. Quantization of energy is what keeps the atom from collapsing.

60.5 The Heisenberg Uncertainty Principle

The *Heisenberg uncertainty principle* states that it is fundamentally impossible to simultaneously measure, to arbitrary accuracy, certain pairs of variables. No matter how good the experiment, the fundamental randomness of Nature restricts the accuracy to which it is possible to make these measurements.

The Heisenberg uncertainty principle can be stated mathematically by the following relations:

$$\Delta x \Delta p \geq \hbar/2 \quad (60.11)$$

$$\Delta \phi \Delta L \geq \hbar/2 \quad (60.12)$$

$$\Delta E \Delta t \geq \hbar/2 \quad (60.13)$$

Eq. (60.11) states that we cannot simultaneously measure the position x of a particle and its momentum p to arbitrary accuracy; the product of the uncertainties cannot be less than $\hbar/2$. The more accurately you measure the position, the less accurately you know the momentum. Similarly, Eq. (60.12) states that you cannot simultaneously measure a particle's angular position ϕ and its angular momentum L to arbitrary accuracy. Eq. (60.13) relates the uncertainty in measuring a particle's energy E and the uncertainty in time t required to make that measurement.

Notice that each of these Heisenberg relations involves the product of the uncertainties in a *conserved* quantity and its so-called *conjugate variable*.

Chapter 61

The Standard Model

The *Standard Model* of particle physics is our current best theory of how the Universe is put together at its most fundamental level. It describes the fundamental nature of both matter and forces. This is still very much at the frontier of physics research, so it's not clear how much of our understanding of this is correct.

61.1 Matter

All of (ordinary) matter is found to be made of two types of particles: *quarks* and *leptons*. There are six types of quarks (called *up*, *down*, *charmed*, *strange*, *top*, and *bottom*) and six types of leptons (the *electron*, *muon*, *tau lepton*, and their associated *neutrinos*.) (Table 61-1.)

Table 61-1. The basic particles of matter.

Quarks	Leptons
Up (u)	Electron (e^-)
Down (d)	Electron neutrino (ν_e^0)
Charmed (c)	Muon (μ^-)
Strange (s)	Muon neutrino (ν_μ^0)
Top (t)	Tau lepton (τ^-)
Bottom (b)	Tau neutrino (ν_τ^0)

Quarks are never observed in isolation: they occur only as a system of three quarks (called a *baryon*), or as a quark-antiquark pair (called a *meson*). (An antiquark is a form of *antimatter*, described below.) Examples of baryons are the *proton* (which consists of two “up” quarks and one “down” quark) and the *neutron* (which consists of two “down” quarks and one “up” quark). Baryons and mesons together are collectively known as *hadrons*, so a hadron refers to a collection of bound quarks.

Quarks are held together in hadrons by a very strong force that becomes stronger the farther apart the quarks are separated. This is why they are not observed in isolation.

Leptons consist of the electron, the muon (which acts like a heavy electron), and the tau lepton (which acts like a very heavy electron). Each of these particles has a charge of $-e$. In reactions in which these particles are produced, there is generally also a neutrino particle. Neutrinos are very light particles with almost no mass, and for the most part they pass right through ordinary matter; in fact, there are billions of them passing through your body right now. Only very rarely do they interact with ordinary matter, but occasionally they do. Physicists have built neutrino “telescopes” to detect them; these telescopes consist of underground pools

filled with cleaning fluid surrounded by light detectors. In the rare event that a neutrino interacts with ordinary matter, it emits a brief flash of light which is detected and recorded.

Both quarks and leptons are, as far as we can observe, point masses. None of them has any internal structure that we're currently aware of.

61.2 Antimatter

Each quark and lepton has a corresponding mirror-image particle that has the same mass but opposite charge; such particles are called *antimatter*. The antimatter counterpart of the electron is called the *positron* (e^+); for other particles, you just add the prefix *anti-* (e.g. *anti-proton*, *anti-neutron*, etc.)

Whenever a particle of ordinary matter comes in contact with its antimatter counterpart, the two particles are destroyed and converted to energy in the form of gamma rays. The amount of energy created is given by Einstein's famous formula, $E_0 = mc^2$, where m is the sum of the particle masses and c is the speed of light in vacuum.

61.3 Forces

We know of four fundamental forces in Nature: the *gravitational force*, the *electromagnetic force*, and two *nuclear forces* (Table 61-2.) We're all familiar with the gravitational force (which is keeping you attached to the ground as you read this). Most of the other forces you encounter in everyday life are electromagnetic in nature. The strong nuclear force is responsible for holding atomic nuclei together against the mutual electrostatic repulsion of protons, and is also responsible for nuclear fusion reactions that occur in the Sun and in hydrogen bombs. The weak nuclear force is responsible for a process called β decay, in which a neutron in an atomic nucleus decays into a proton, electron, and anti-neutrino, and the electron escapes from the atom in the process.

Table 61-2. The four forces.

Force	Vector boson
Gravitational	Graviton (?)
Electromagnetic	Photon
Strong nuclear	Gluon
Weak nuclear	W, Z

According to the Standard Model, each of these forces is mediated by a particle called a *vector boson*. In effect, each force is thought to be caused by the exchange of these particles.¹

The electromagnetic and weak nuclear forces have been (somewhat) unified into a combined "electroweak theory", although this theory is not entirely complete. Many physicists believe that the electromagnetic, strong nuclear, and weak nuclear forces can be shown to be different aspects of a single underlying force, and thus all covered by a single "Grand Unified Theory". No Grand Unified Theory has yet been discovered.

Our best theory of gravity to date is Einstein's General Theory of Relativity, and has so far been shown to be consistent with experimental results. However, general relativity says that the gravitational force is due to the curvature of space-time; this is at odds with the Standard Model view, which is that gravity is caused by the exchange of particles called *gravitons*. No experiment has yet detected the existence of gravitons, and it's uncertain whether or not general relativity is the correct final theory of gravity.

¹The gravitational force is not considered to be part of the Standard Model.

Some physicists believe that it may be possible to show that *all four* forces (including gravity) are aspects of a single underlying force, and covered by a theory called the “Theory of Everything”. Such a theory (which is essentially a grand unified theory plus gravity) has not yet been found, nor is it known whether such a theory even exists. Some theories such as *string theory* have been proposed, but are far from being experimentally verified. These are issues to be worked out by future generations of physicists.

61.4 The Higgs Boson

A key piece of the Standard Model is *Higgs field*, which is responsible for giving particles their mass. The Higgs field fill all of space, even in places where there would otherwise be a vacuum. The degree to which a particle interacts with the Higgs field determines its mass: particles interacting weakly with the Higgs field are light, while those that interact strongly with the Higgs field are heavy. Particles that don't interact with the Higgs field at all, like the photon, are massless.

The Standard Model predicts that fields that fill all space should be associated with a particle — for example, as we've seen each of the four fundamental forces is associated with a vector boson particle.² The particle associated with the Higgs field is the *Higgs boson*. The Higgs boson was detected experimentally at the CERN particle physics accelerator³ in 2015, thus confirming the existence of the Higgs field and giving increased confidence in the Standard Model.⁴

²Except, perhaps, for gravity.

³CERN stands for Conseil Européen pour la Recherche Nucléaire, and is a facility located on the border between France and Switzerland.

⁴See http://www.nobelprize.org/nobel_prizes/physics/laureates/2013/popular-physicsprize2013.pdf

Further Reading

General

- *Classical Mechanics* (2nd ed.) by Herbert Goldstein (Addison-Wesley, Reading, Mass., 1980). The standard graduate-level text on classical mechanics.
- *The Feynman Lectures on Physics* (Definitive Edition; 3 vol.) by Richard P. Feynman, Robert B. Leighton, and Matthew Sands (Addison-Wesley, Reading, Mass., 2006). This classic work is well known to all students of physics. These lectures were presented by Nobel laureate Richard Feynman to his physics class at the California Institute of Technology in the 1960s, and are considered a masterpiece of physics exposition by one of its greatest teachers. (The audio for these lectures is also available on CD, in 20 volumes.)
- *Thinking Physics* (3rd ed.) by Lewis Carroll Epstein (Insight Press, San Francisco, 2009). A very nice collection of thought-provoking physics puzzles.

Numerical Analysis (Chapter 10)

- *Numerical Recipes* by Press, Teukolsky, Vetterling, and Flannery (Cambridge, 1987). Numerical analysis is a whole subject in itself, and quite a number of books have been written about it. This book is a good starting point. It includes not only computer codes for various methods, but also a good discussion of the motivation behind the methods.

Friction (Chapter 17)

- “Friction at the Atomic Scale” by Jacqueline Krim, *Scientific American*, October 1996, pp. 74–80.
- An excellent discussion of friction is available in Volume 1, Chapter 12, Section 12-2 of *The Feynman Lectures on Physics* (Definitive Edition) by Richard P. Feynman, Robert B. Leighton, and Matthew Sands (Addison-Wesley, Reading, Mass., 2006).
- A review article in the journal *Reviews of Modern Physics* examines friction in detail, at an advanced level. See Andrea Vanossi *et al.*, Colloquium: Modeling friction: From nanoscale to mesoscale. *Rev. Mod. Phys.*, **85**, 529–552 (April–June 2013).

Energy (Chapter 23)

- *Energy, the Subtle Concept* by Jennifer Coopersmith (Oxford, 2010). An extended discussion of the concept of energy, with a number of biographical anecdotes and minimal mathematics.

Pendulums (Chapter 38)

- *The Pendulum: A Case Study in Physics* by G.L. Baker and J.A. Blackburn (Oxford, 2005). An entire book about pendulums, at roughly the level of this course.

The Gyroscope (Chapter 46)

- Volume 1, Chapter 20, Section 20-3 of *The Feynman Lectures on Physics* (Definitive Edition) by Richard P. Feynman, Robert B. Leighton, and Matthew Sands (Addison-Wesley, Reading, Mass., 2006).

Superfluids (Chapter 48 and 49)

- *Liquid Helium II, the Superfluid* (film), Alfred Leitner films, Michigan State University, 1963. (Available on YouTube.)

Gravity and General Relativity (Chapter 51)

- *Black Holes and Time Warps: Einstein's Outrageous Legacy* by Kip Thorne (Norton, 1995). A very readable introduction to black holes, for the general reader.
- *It Must Be Beautiful: Great Equations of Modern Science* by Graham Farmelo (ed.) (Granta Books, New York, 2002). The chapter "The Rediscovery of Gravity" by Roger Penrose gives a brief overview of general relativity at about the level of this course.
- *A First Course in General Relativity* (2nd ed.) by Bernard Schutz (Cambridge, 2009). This is an excellent first text on general relativity.
- *Gravitation* by Misner, Thorne, and Wheeler (Freeman, 1973). This huge tome (over 1200 pages) is the granddaddy of all general relativity texts. It's excellent, and well known to all students of general relativity. This is probably the text you would use in a graduate school course.

Earth Rotation (Chapter 52)

- *The Earth's Variable Rotation* by Kurt Lambeck (Cambridge, 1980). An extended discussion of irregularities in the Earth's rotation, at a graduate-school level.

Geodesy (Chapter 53)

- *The Measure of All Things: The Seven-Year Odyssey and Hidden Error That Transformed the World* by Ken Alder (Free Press, 2003).

Celestial Mechanics (Chapter 54)

- *Introduction to Celestial Mechanics* by S.W. McCuskey (Addison-Wesley, Reading, Mass., 1963). A brief, excellent introduction to celestial mechanics.

- *Astronomical Algorithms* by Jean Meeus (Willmann-Bell, Richmond, 1991). Another excellent book, with 58 chapters of material covering how to do practical calculations of all sorts related to celestial mechanics.
- *The Astronomical Almanac* (U.S. Government Printing Office). This is published in a new edition each year, and is full of data related to celestial mechanics.
- *Explanatory Supplement to the Astronomical Almanac* by P.K. Seidelmann (ed.) (University Science Books, 1992). A gold mine of information related to celestial mechanics and the calculation of ephemerides. A very well-known and respected work, and very interesting to read.

Astrodynamics (Chapter 55)

- *Fundamentals of Astrodynamics* by Roger R. Bate, Donald D. Mueller, and Jerry E. White (Dover, Mineola, N.Y., 1971). A good introductory text on astrodynamics at about the level of this course.
- *An Introduction to the Mathematics and Methods of Astrodynamics* (revised ed.) by Richard H. Battin (AIAA, Reston, Va., 1999). An advanced text on astrodynamics, with emphasis on mathematical methods.
- *Fundamentals of Astrodynamics and Applications* (4th ed.) by David A. Vallado (Microcosm Press, 2013). One of the standard references on astrodynamics. An advanced text.

Special Relativity (Chapter 59)

- *Spacetime Physics* (2nd ed.) by E.F. Taylor and J.A. Wheeler (Freeman, 1992). An excellent introductory treatment of special relativity, at about the level of this course. The authors are very well known and highly respected in the field of relativity. The last chapter is a brief overview of general relativity.

Quantum Mechanics (Chapter 60)

There doesn't seem to be any one standard quantum mechanics text, but the ones listed below are some popular choices for undergraduate and graduate school courses in quantum mechanics.

- *Quantum Mechanics* (3rd ed.) by Leonard I. Schiff (McGraw-Hill, New York, 1968).
- *Quantum Mechanics* (2 vol.) by Cohen-Tannoudji, Diu, and Laloe (Wiley, New York, 1977).
- *Principles of Quantum Mechanics* (2nd ed.) by R. Shankar (Springer, New York, 1994).

Just for Fun

- *Physics of the Impossible* by Michio Kaku (Doubleday, 2008). A noted physicist discusses the possibility of time travel, force fields, invisibility cloaks, transporters, etc.
- *The Disappearing Spoon* by Sam Kean (Little, Brown & Co., 2010). A very entertaining collection of stories surrounding the periodic table of the elements.

- *Mr. Tompkins in Paperback* by George Gamow (Cambridge, 1993). A famous Russian physicist wrote these stories of a world in which the speed of light is just 30 mph so relativistic effects are visible, and more stories of a world where Planck's constant is so large that quantum effects are visible. An updated version has also been written, *The New World of Mr. Tompkins* (Cambridge, 2001).
- *Dragon's Egg* by Robert L. Forward (Del Rey, 2000). Physicist Robert Forward wrote this novel about humans who discover a civilization of creatures living on the surface of a neutron star.

Appendices

Appendix A

Greek Alphabet

Table A-1. The Greek alphabet.

Letter	Name
A α	Alpha
B β	Beta
Γ γ	Gamma
Δ δ	Delta
E ϵ	Epsilon
Z ζ	Zeta
H η	Eta
Θ θ	Theta
I ι	Iota
K κ	Kappa
Λ λ	Lambda
M μ	Mu
N ν	Nu
Ξ ξ	Xi
O \omicron	Omicron
Π π	Pi
P ρ	Rho
Σ σ	Sigma
T τ	Tau
Υ υ	Upsilon
Φ ϕ	Phi
X χ	Chi
Ψ ψ	Psi
Ω ω	Omega

(Alternate forms: $\delta = \beta$, $\epsilon = \varepsilon$, $\vartheta = \theta$, $\kappa = \kappa$, $\varpi = \pi$, $\varrho = \rho$, $\varsigma = \sigma$, $\phi = \varphi$.)

Appendix B

Trigonometry

Basic Formulæ

$$\sin^2 \theta + \cos^2 \theta \equiv 1$$

$$\sec^2 \theta \equiv 1 + \tan^2 \theta$$

$$\csc^2 \theta \equiv 1 + \cot^2 \theta$$

Angle Addition Formulæ

$$\sin(\alpha \pm \beta) \equiv \sin \alpha \cos \beta \pm \cos \alpha \sin \beta$$

$$\cos(\alpha \pm \beta) \equiv \cos \alpha \cos \beta \mp \sin \alpha \sin \beta$$

$$\tan(\alpha \pm \beta) \equiv \frac{\tan \alpha \pm \tan \beta}{1 \mp \tan \alpha \tan \beta}$$

Double-Angle Formulæ

$$\sin 2\theta \equiv 2 \sin \theta \cos \theta \equiv \frac{2 \tan \theta}{1 + \tan^2 \theta}$$

$$\cos 2\theta \equiv \cos^2 \theta - \sin^2 \theta \equiv 1 - 2 \sin^2 \theta \equiv 2 \cos^2 \theta - 1 \equiv \frac{1 - \tan^2 \theta}{1 + \tan^2 \theta}$$

$$\tan 2\theta \equiv \frac{2 \tan \theta}{1 - \tan^2 \theta}$$

Triple-Angle Formulæ

$$\sin 3\theta \equiv 3 \sin \theta - 4 \sin^3 \theta$$

$$\cos 3\theta \equiv 4 \cos^3 \theta - 3 \cos \theta$$

$$\tan 3\theta \equiv \frac{3 \tan \theta - \tan^3 \theta}{1 - 3 \tan^2 \theta}$$

$$\cot 3\theta \equiv \frac{\cot^3 \theta - 3 \cot \theta}{3 \cot^2 \theta - 1}$$

Quadruple-Angle Formulæ

$$\sin 4\theta \equiv 4 \cos^3 \theta \sin \theta - 4 \cos \theta \sin^3 \theta$$

$$\cos 4\theta \equiv \cos^4 \theta - 6 \cos^2 \theta \sin^2 \theta + \sin^4 \theta$$

$$\tan 4\theta \equiv \frac{4 \tan \theta - 4 \tan^3 \theta}{1 - 6 \tan^2 \theta + \tan^4 \theta}$$

$$\cot 4\theta \equiv \frac{\cot^4 \theta - 6 \cot^2 \theta + 1}{4 \cot^3 \theta - 4 \cot \theta}$$

Half-Angle Formulæ

$$\sin \frac{\theta}{2} \equiv \pm \sqrt{\frac{1 - \cos \theta}{2}}$$

$$\cos \frac{\theta}{2} \equiv \pm \sqrt{\frac{1 + \cos \theta}{2}}$$

$$\tan \frac{\theta}{2} \equiv \frac{\sin \theta}{1 + \cos \theta} \equiv \frac{1 - \cos \theta}{\sin \theta}$$

Products of Sines and Cosines

$$\sin \alpha \cos \beta \equiv \frac{1}{2} [\sin(\alpha + \beta) + \sin(\alpha - \beta)]$$

$$\cos \alpha \sin \beta \equiv \frac{1}{2} [\sin(\alpha + \beta) - \sin(\alpha - \beta)]$$

$$\cos \alpha \cos \beta \equiv \frac{1}{2} [\cos(\alpha + \beta) + \cos(\alpha - \beta)]$$

$$\sin \alpha \sin \beta \equiv -\frac{1}{2} [\cos(\alpha + \beta) - \cos(\alpha - \beta)]$$

Sums and Differences of Sines and Cosines

$$\sin \alpha + \sin \beta \equiv 2 \sin \frac{\alpha + \beta}{2} \cos \frac{\alpha - \beta}{2}$$

$$\sin \alpha - \sin \beta \equiv 2 \cos \frac{\alpha + \beta}{2} \sin \frac{\alpha - \beta}{2}$$

$$\cos \alpha + \cos \beta \equiv 2 \cos \frac{\alpha + \beta}{2} \cos \frac{\alpha - \beta}{2}$$

$$\cos \alpha - \cos \beta \equiv -2 \sin \frac{\alpha + \beta}{2} \sin \frac{\alpha - \beta}{2}$$

Power Reduction Formulæ

$$\sin^2 \theta \equiv \frac{1}{2} (1 - \cos 2\theta)$$

$$\cos^2 \theta \equiv \frac{1}{2} (1 + \cos 2\theta)$$

$$\tan^2 \theta \equiv \frac{1 - \cos 2\theta}{1 + \cos 2\theta}$$

Other Formulæ

$$\tan \theta \equiv \cot \theta - 2 \cot 2\theta$$

Trig Cheat Sheet

Definition of the Trig Functions

Right triangle definition

For this definition we assume that

$$0 < \theta < \frac{\pi}{2} \text{ or } 0^\circ < \theta < 90^\circ.$$

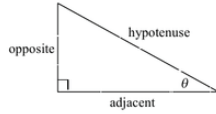

$$\begin{aligned} \sin \theta &= \frac{\text{opposite}}{\text{hypotenuse}} & \csc \theta &= \frac{\text{hypotenuse}}{\text{opposite}} \\ \cos \theta &= \frac{\text{adjacent}}{\text{hypotenuse}} & \sec \theta &= \frac{\text{hypotenuse}}{\text{adjacent}} \\ \tan \theta &= \frac{\text{opposite}}{\text{adjacent}} & \cot \theta &= \frac{\text{adjacent}}{\text{opposite}} \end{aligned}$$

Unit circle definition

For this definition θ is any angle.

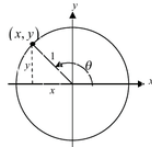

$$\begin{aligned} \sin \theta &= \frac{y}{1} = y & \csc \theta &= \frac{1}{y} \\ \cos \theta &= \frac{x}{1} = x & \sec \theta &= \frac{1}{x} \\ \tan \theta &= \frac{y}{x} & \cot \theta &= \frac{x}{y} \end{aligned}$$

Facts and Properties

Domain

The domain is all the values of θ that can be plugged into the function.

$\sin \theta$, θ can be any angle

$\cos \theta$, θ can be any angle

$$\tan \theta, \theta \neq \left(n + \frac{1}{2}\right)\pi, n = 0, \pm 1, \pm 2, \dots$$

$$\csc \theta, \theta \neq n\pi, n = 0, \pm 1, \pm 2, \dots$$

$$\sec \theta, \theta \neq \left(n + \frac{1}{2}\right)\pi, n = 0, \pm 1, \pm 2, \dots$$

$$\cot \theta, \theta \neq n\pi, n = 0, \pm 1, \pm 2, \dots$$

Range

The range is all possible values to get out of the function.

$$-1 \leq \sin \theta \leq 1 \quad \csc \theta \geq 1 \text{ and } \csc \theta \leq -1$$

$$-1 \leq \cos \theta \leq 1 \quad \sec \theta \geq 1 \text{ and } \sec \theta \leq -1$$

$$-\infty < \tan \theta < \infty \quad -\infty < \cot \theta < \infty$$

Period

The period of a function is the number, T , such that $f(\theta + T) = f(\theta)$. So, if ω is a fixed number and θ is any angle we have the following periods.

$$\sin(\omega\theta) \rightarrow T = \frac{2\pi}{\omega}$$

$$\cos(\omega\theta) \rightarrow T = \frac{2\pi}{\omega}$$

$$\tan(\omega\theta) \rightarrow T = \frac{\pi}{\omega}$$

$$\csc(\omega\theta) \rightarrow T = \frac{2\pi}{\omega}$$

$$\sec(\omega\theta) \rightarrow T = \frac{2\pi}{\omega}$$

$$\cot(\omega\theta) \rightarrow T = \frac{\pi}{\omega}$$

Formulas and Identities

Tangent and Cotangent Identities

$$\tan \theta = \frac{\sin \theta}{\cos \theta} \quad \cot \theta = \frac{\cos \theta}{\sin \theta}$$

Reciprocal Identities

$$\csc \theta = \frac{1}{\sin \theta} \quad \sin \theta = \frac{1}{\csc \theta}$$

$$\sec \theta = \frac{1}{\cos \theta} \quad \cos \theta = \frac{1}{\sec \theta}$$

$$\cot \theta = \frac{1}{\tan \theta} \quad \tan \theta = \frac{1}{\cot \theta}$$

Pythagorean Identities

$$\sin^2 \theta + \cos^2 \theta = 1$$

$$\tan^2 \theta + 1 = \sec^2 \theta$$

$$1 + \cot^2 \theta = \csc^2 \theta$$

Even/Odd Formulas

$$\sin(-\theta) = -\sin \theta \quad \csc(-\theta) = -\csc \theta$$

$$\cos(-\theta) = \cos \theta \quad \sec(-\theta) = \sec \theta$$

$$\tan(-\theta) = -\tan \theta \quad \cot(-\theta) = -\cot \theta$$

Periodic Formulas

If n is an integer,

$$\sin(\theta + 2\pi n) = \sin \theta \quad \csc(\theta + 2\pi n) = \csc \theta$$

$$\cos(\theta + 2\pi n) = \cos \theta \quad \sec(\theta + 2\pi n) = \sec \theta$$

$$\tan(\theta + \pi n) = \tan \theta \quad \cot(\theta + \pi n) = \cot \theta$$

Double Angle Formulas

$$\sin(2\theta) = 2\sin \theta \cos \theta$$

$$\cos(2\theta) = \cos^2 \theta - \sin^2 \theta$$

$$= 2\cos^2 \theta - 1$$

$$= 1 - 2\sin^2 \theta$$

$$\tan(2\theta) = \frac{2 \tan \theta}{1 - \tan^2 \theta}$$

Degrees to Radians Formulas

If x is an angle in degrees and t is an angle in radians then

$$\frac{\pi}{180} = \frac{t}{x} \Rightarrow t = \frac{\pi x}{180} \quad \text{and} \quad x = \frac{180t}{\pi}$$

Half Angle Formulas

$$\sin^2 \theta = \frac{1}{2}(1 - \cos(2\theta))$$

$$\cos^2 \theta = \frac{1}{2}(1 + \cos(2\theta))$$

$$\tan^2 \theta = \frac{1 - \cos(2\theta)}{1 + \cos(2\theta)}$$

Sum and Difference Formulas

$$\sin(\alpha \pm \beta) = \sin \alpha \cos \beta \pm \cos \alpha \sin \beta$$

$$\cos(\alpha \pm \beta) = \cos \alpha \cos \beta \mp \sin \alpha \sin \beta$$

$$\tan(\alpha \pm \beta) = \frac{\tan \alpha \pm \tan \beta}{1 \mp \tan \alpha \tan \beta}$$

Product to Sum Formulas

$$\sin \alpha \sin \beta = \frac{1}{2}[\cos(\alpha - \beta) - \cos(\alpha + \beta)]$$

$$\cos \alpha \cos \beta = \frac{1}{2}[\cos(\alpha - \beta) + \cos(\alpha + \beta)]$$

$$\sin \alpha \cos \beta = \frac{1}{2}[\sin(\alpha + \beta) + \sin(\alpha - \beta)]$$

$$\cos \alpha \sin \beta = \frac{1}{2}[\sin(\alpha + \beta) - \sin(\alpha - \beta)]$$

Sum to Product Formulas

$$\sin \alpha + \sin \beta = 2 \sin\left(\frac{\alpha + \beta}{2}\right) \cos\left(\frac{\alpha - \beta}{2}\right)$$

$$\sin \alpha - \sin \beta = 2 \cos\left(\frac{\alpha + \beta}{2}\right) \sin\left(\frac{\alpha - \beta}{2}\right)$$

$$\cos \alpha + \cos \beta = 2 \cos\left(\frac{\alpha + \beta}{2}\right) \cos\left(\frac{\alpha - \beta}{2}\right)$$

$$\cos \alpha - \cos \beta = -2 \sin\left(\frac{\alpha + \beta}{2}\right) \sin\left(\frac{\alpha - \beta}{2}\right)$$

Cofunction Formulas

$$\sin\left(\frac{\pi}{2} - \theta\right) = \cos \theta \quad \cos\left(\frac{\pi}{2} - \theta\right) = \sin \theta$$

$$\csc\left(\frac{\pi}{2} - \theta\right) = \sec \theta \quad \sec\left(\frac{\pi}{2} - \theta\right) = \csc \theta$$

$$\tan\left(\frac{\pi}{2} - \theta\right) = \cot \theta \quad \cot\left(\frac{\pi}{2} - \theta\right) = \tan \theta$$

Credit: trigidentities.net, ©2005 Paul Dawkins.

Exact values of trigonometric functions at 3° intervals. (Ref. [6])

θ	$\sin \theta$	$\cos \theta$	$\tan \theta$
$0^\circ = 0\pi$	0	1	0
$3^\circ = \frac{\pi}{60}$	$\frac{1}{16} [(\sqrt{6} + \sqrt{2})(\sqrt{5} - 1) - 2(\sqrt{3} - 1)\sqrt{5 + \sqrt{5}}]$	$\frac{1}{16} [2(\sqrt{3} + 1)\sqrt{5 + \sqrt{5}} + (\sqrt{6} - \sqrt{2})(\sqrt{5} - 1)]$	$\frac{1}{4} (\sqrt{5} - \sqrt{3})(\sqrt{3} - 1)(\sqrt{10 + 2\sqrt{5}} - \sqrt{5} - 1)$
$6^\circ = \frac{\pi}{30}$	$\frac{1}{8} (\sqrt{30 - 6\sqrt{5}} - \sqrt{5} - 1)$	$\frac{1}{8} (\sqrt{15} + \sqrt{3} + \sqrt{10 - 2\sqrt{5}})$	$\frac{1}{2} (\sqrt{10 - 2\sqrt{5}} - \sqrt{15} + \sqrt{3})$
$9^\circ = \frac{\pi}{20}$	$\frac{1}{8} (\sqrt{10} + \sqrt{2} - 2\sqrt{5 - \sqrt{5}})$	$\frac{1}{8} (\sqrt{10} + \sqrt{2} + 2\sqrt{5 - \sqrt{5}})$	$\sqrt{5} + 1 - \sqrt{5 + 2\sqrt{5}}$
$12^\circ = \frac{\pi}{15}$	$\frac{1}{8} (\sqrt{10 + 2\sqrt{5}} - \sqrt{15} + \sqrt{3})$	$\frac{1}{8} (\sqrt{30 + 6\sqrt{5}} + \sqrt{5} - 1)$	$\frac{1}{2} (3\sqrt{3} - \sqrt{15} - \sqrt{50 - 22\sqrt{5}})$
$15^\circ = \frac{\pi}{12}$	$\frac{1}{4} (\sqrt{6} - \sqrt{2})$	$\frac{1}{4} (\sqrt{6} + \sqrt{2})$	$2 - \sqrt{3}$
$18^\circ = \frac{\pi}{10}$	$\frac{1}{4} (\sqrt{5} - 1)$	$\frac{1}{4} \sqrt{10 + 2\sqrt{5}}$	$\frac{1}{5} \sqrt{25 - 10\sqrt{5}}$
$21^\circ = \frac{7\pi}{60}$	$\frac{1}{16} [2(\sqrt{3} + 1)\sqrt{5 - \sqrt{5}} - (\sqrt{6} - \sqrt{2})(\sqrt{5} + 1)]$	$\frac{1}{16} [(\sqrt{6} + \sqrt{2})(\sqrt{5} + 1) + 2(\sqrt{3} - 1)\sqrt{5 - \sqrt{5}}]$	$\frac{1}{4} (\sqrt{5} - \sqrt{3})(\sqrt{3} + 1)(\sqrt{10 - 2\sqrt{5}} - \sqrt{5} + 1)$
$24^\circ = \frac{2\pi}{15}$	$\frac{1}{8} (\sqrt{15} + \sqrt{3} - \sqrt{10 - 2\sqrt{5}})$	$\frac{1}{8} (\sqrt{30 - 6\sqrt{5}} + \sqrt{5} + 1)$	$\frac{1}{2} (\sqrt{50 + 22\sqrt{5}} - 3\sqrt{3} - \sqrt{15})$
$27^\circ = \frac{3\pi}{20}$	$\frac{1}{8} (2\sqrt{5} + \sqrt{5} - \sqrt{10} + \sqrt{2})$	$\frac{1}{8} (2\sqrt{5} + \sqrt{5} + \sqrt{10} - \sqrt{2})$	$\sqrt{5} - 1 - \sqrt{5 - 2\sqrt{5}}$
$30^\circ = \frac{\pi}{6}$	$\frac{1}{2}$	$\frac{1}{2} \sqrt{3}$	$\frac{1}{3} \sqrt{3}$
$33^\circ = \frac{11\pi}{60}$	$\frac{1}{16} [(\sqrt{6} + \sqrt{2})(\sqrt{5} - 1) + 2(\sqrt{3} - 1)\sqrt{5 + \sqrt{5}}]$	$\frac{1}{16} [2(\sqrt{3} + 1)\sqrt{5 + \sqrt{5}} - (\sqrt{6} - \sqrt{2})(\sqrt{5} - 1)]$	$\frac{1}{4} (\sqrt{5} - \sqrt{3})(\sqrt{3} - 1)(\sqrt{10 + 2\sqrt{5}} + \sqrt{5} + 1)$
$36^\circ = \frac{\pi}{5}$	$\frac{1}{4} \sqrt{10 - 2\sqrt{5}}$	$\frac{1}{4} (\sqrt{5} + 1)$	$\sqrt{5} - 2\sqrt{5}$
$39^\circ = \frac{13\pi}{60}$	$\frac{1}{16} [(\sqrt{6} + \sqrt{2})(\sqrt{5} + 1) - 2(\sqrt{3} - 1)\sqrt{5 - \sqrt{5}}]$	$\frac{1}{16} [2(\sqrt{3} + 1)\sqrt{5 - \sqrt{5}} + (\sqrt{6} - \sqrt{2})(\sqrt{5} + 1)]$	$\frac{1}{4} (\sqrt{5} + \sqrt{3})(\sqrt{3} - 1)(\sqrt{10 - 2\sqrt{5}} - \sqrt{5} + 1)$
$42^\circ = \frac{7\pi}{30}$	$\frac{1}{8} (\sqrt{30} + 6\sqrt{5} - \sqrt{5} + 1)$	$\frac{1}{8} (\sqrt{10 + 2\sqrt{5}} + \sqrt{15} - \sqrt{3})$	$\frac{1}{2} (\sqrt{15} + \sqrt{3} - \sqrt{10 + 2\sqrt{5}})$
$45^\circ = \frac{\pi}{4}$	$\frac{1}{2} \sqrt{2}$	$\frac{1}{2} \sqrt{2}$	1
$48^\circ = \frac{4\pi}{15}$	$\frac{1}{8} (\sqrt{10 + 2\sqrt{5}} + \sqrt{15} - \sqrt{3})$	$\frac{1}{8} (\sqrt{30 + 6\sqrt{5}} - \sqrt{5} + 1)$	$\frac{1}{2} (3\sqrt{3} - \sqrt{15} + \sqrt{50 - 22\sqrt{5}})$
$51^\circ = \frac{17\pi}{60}$	$\frac{1}{16} [2(\sqrt{3} + 1)\sqrt{5 - \sqrt{5}} + (\sqrt{6} - \sqrt{2})(\sqrt{5} + 1)]$	$\frac{1}{16} [(\sqrt{6} + \sqrt{2})(\sqrt{5} + 1) - 2(\sqrt{3} - 1)\sqrt{5 - \sqrt{5}}]$	$\frac{1}{4} (\sqrt{5} - \sqrt{3})(\sqrt{3} + 1)(\sqrt{10 - 2\sqrt{5}} + \sqrt{5} - 1)$
$54^\circ = \frac{3\pi}{10}$	$\frac{1}{4} (\sqrt{5} + 1)$	$\frac{1}{4} \sqrt{10 - 2\sqrt{5}}$	$\frac{1}{5} \sqrt{25 + 10\sqrt{5}}$
$57^\circ = \frac{19\pi}{60}$	$\frac{1}{16} [2(\sqrt{3} + 1)\sqrt{5 + \sqrt{5}} - (\sqrt{6} - \sqrt{2})(\sqrt{5} - 1)]$	$\frac{1}{16} [(\sqrt{6} + \sqrt{2})(\sqrt{5} - 1) + 2(\sqrt{3} - 1)\sqrt{5 + \sqrt{5}}]$	$\frac{1}{4} (\sqrt{5} + \sqrt{3})(\sqrt{3} + 1)(\sqrt{10 + 2\sqrt{5}} - \sqrt{5} - 1)$
$60^\circ = \frac{\pi}{3}$	$\frac{1}{2} \sqrt{3}$	$\frac{1}{2}$	$\sqrt{3}$
$63^\circ = \frac{7\pi}{20}$	$\frac{1}{8} (2\sqrt{5} + \sqrt{5} + \sqrt{10} - \sqrt{2})$	$\frac{1}{8} (2\sqrt{5} + \sqrt{5} - \sqrt{10} + \sqrt{2})$	$\sqrt{5} - 1 + \sqrt{5 - 2\sqrt{5}}$
$66^\circ = \frac{11\pi}{30}$	$\frac{1}{8} (\sqrt{30 - 6\sqrt{5}} + \sqrt{5} + 1)$	$\frac{1}{8} (\sqrt{15} + \sqrt{3} - \sqrt{10 - 2\sqrt{5}})$	$\frac{1}{2} (\sqrt{10 - 2\sqrt{5}} + \sqrt{15} - \sqrt{3})$
$69^\circ = \frac{23\pi}{60}$	$\frac{1}{16} [(\sqrt{6} + \sqrt{2})(\sqrt{5} + 1) + 2(\sqrt{3} - 1)\sqrt{5 - \sqrt{5}}]$	$\frac{1}{16} [2(\sqrt{3} + 1)\sqrt{5 - \sqrt{5}} - (\sqrt{6} - \sqrt{2})(\sqrt{5} + 1)]$	$\frac{1}{4} (\sqrt{5} + \sqrt{3})(\sqrt{3} - 1)(\sqrt{10 - 2\sqrt{5}} + \sqrt{5} - 1)$
$72^\circ = \frac{2\pi}{5}$	$\frac{1}{4} \sqrt{10 + 2\sqrt{5}}$	$\frac{1}{4} (\sqrt{5} - 1)$	$\sqrt{5} + 2\sqrt{5}$
$75^\circ = \frac{5\pi}{12}$	$\frac{1}{4} (\sqrt{6} + \sqrt{2})$	$\frac{1}{4} (\sqrt{6} - \sqrt{2})$	$2 + \sqrt{3}$
$78^\circ = \frac{13\pi}{30}$	$\frac{1}{8} (\sqrt{30 + 6\sqrt{5}} + \sqrt{5} - 1)$	$\frac{1}{8} (\sqrt{10 + 2\sqrt{5}} - \sqrt{15} + \sqrt{3})$	$\frac{1}{2} (\sqrt{15} + \sqrt{3} + \sqrt{10 + 2\sqrt{5}})$
$81^\circ = \frac{19\pi}{60}$	$\frac{1}{8} (\sqrt{10} + \sqrt{2} + 2\sqrt{5 - \sqrt{5}})$	$\frac{1}{8} (\sqrt{10} + \sqrt{2} - 2\sqrt{5 - \sqrt{5}})$	$\sqrt{5} + 1 + \sqrt{5 + 2\sqrt{5}}$
$84^\circ = \frac{7\pi}{15}$	$\frac{1}{8} (\sqrt{15} + \sqrt{3} + \sqrt{10 - 2\sqrt{5}})$	$\frac{1}{8} (\sqrt{30 - 6\sqrt{5}} - \sqrt{5} - 1)$	$\frac{1}{2} (\sqrt{50 + 22\sqrt{5}} + 3\sqrt{3} + \sqrt{15})$
$87^\circ = \frac{29\pi}{60}$	$\frac{1}{16} [2(\sqrt{3} + 1)\sqrt{5 + \sqrt{5}} + (\sqrt{6} - \sqrt{2})(\sqrt{5} - 1)]$	$\frac{1}{16} [(\sqrt{6} + \sqrt{2})(\sqrt{5} - 1) - 2(\sqrt{3} - 1)\sqrt{5 + \sqrt{5}}]$	$\frac{1}{4} (\sqrt{5} + \sqrt{3})(\sqrt{3} + 1)(\sqrt{10 + 2\sqrt{5}} + \sqrt{5} + 1)$
$90^\circ = \frac{\pi}{2}$	1	0	∞

θ	$\sec \theta$	$\csc \theta$	$\cot \theta$
$0^\circ = 0\pi$	1	∞	∞
$3^\circ = \frac{\pi}{60}$	$\frac{1}{2}(\sqrt{10}-\sqrt{6})(\sqrt{5+2\sqrt{3}-2+\sqrt{3}})$	$\frac{1}{2}(\sqrt{10}+\sqrt{6})(2+\sqrt{3}+\sqrt{5+2\sqrt{3}})$	$\frac{1}{4}(\sqrt{5}+\sqrt{3})(\sqrt{3}+1)(\sqrt{10+2\sqrt{3}}+\sqrt{5}+1)$
$6^\circ = \frac{\pi}{30}$	$\sqrt{3}-\sqrt{5-2\sqrt{3}}$	$\sqrt{15+6\sqrt{3}}+\sqrt{3}+2$	$\frac{1}{2}(\sqrt{50+22\sqrt{3}}+3\sqrt{3}+\sqrt{15})$
$9^\circ = \frac{\pi}{20}$	$\frac{1}{2}(3\sqrt{2}+\sqrt{10}-2\sqrt{5+\sqrt{3}})$	$\frac{1}{2}(3\sqrt{2}+\sqrt{10}+2\sqrt{5}+\sqrt{3})$	$\sqrt{3}+1+\sqrt{5+2\sqrt{3}}$
$12^\circ = \frac{\pi}{15}$	$\sqrt{15-6\sqrt{3}}-\sqrt{3}+2$	$\sqrt{5+2\sqrt{3}}+\sqrt{3}$	$\frac{1}{2}(\sqrt{15}+\sqrt{3}+\sqrt{10+2\sqrt{3}})$
$15^\circ = \frac{\pi}{12}$	$\sqrt{6}-\sqrt{2}$	$\sqrt{6}+\sqrt{2}$	$2+\sqrt{3}$
$18^\circ = \frac{\pi}{10}$	$\frac{1}{2}\sqrt{50-10\sqrt{5}}$	$\sqrt{5}+1$	$\sqrt{5+2\sqrt{3}}$
$21^\circ = \frac{7\pi}{60}$	$\frac{1}{2}(\sqrt{10}-\sqrt{6})(2+\sqrt{3}-\sqrt{5-2\sqrt{3}})$	$\frac{1}{2}(\sqrt{10}+\sqrt{6})(\sqrt{5-2\sqrt{3}}+2-\sqrt{3})$	$\frac{1}{4}(\sqrt{5}+\sqrt{3})(\sqrt{3}-1)(\sqrt{10-2\sqrt{3}}+\sqrt{5}-1)$
$24^\circ = \frac{2\pi}{15}$	$\sqrt{15+6\sqrt{3}}-\sqrt{3}-2$	$\sqrt{3}+\sqrt{5-2\sqrt{3}}$	$\frac{1}{2}(\sqrt{10-2\sqrt{3}}+\sqrt{15}-\sqrt{3})$
$27^\circ = \frac{3\pi}{20}$	$\frac{1}{2}(2\sqrt{5}-\sqrt{3}-3\sqrt{2}+\sqrt{10})$	$\frac{1}{2}(2\sqrt{5}-\sqrt{3}+3\sqrt{2}-\sqrt{10})$	$\sqrt{3}-1+\sqrt{5-2\sqrt{3}}$
$30^\circ = \frac{\pi}{6}$	$\frac{2}{3}\sqrt{3}$	2	$\sqrt{3}$
$33^\circ = \frac{11\pi}{60}$	$\frac{1}{2}(\sqrt{10}-\sqrt{6})(\sqrt{5+2\sqrt{3}}+2-\sqrt{3})$	$\frac{1}{2}(\sqrt{10}+\sqrt{6})(2+\sqrt{3}-\sqrt{5+2\sqrt{3}})$	$\frac{1}{4}(\sqrt{5}+\sqrt{3})(\sqrt{3}+1)(\sqrt{10+2\sqrt{3}}-\sqrt{3}-1)$
$36^\circ = \frac{\pi}{5}$	$\sqrt{5}-1$	$\frac{1}{2}\sqrt{50+10\sqrt{5}}$	$\frac{1}{2}\sqrt{25+10\sqrt{5}}$
$39^\circ = \frac{13\pi}{60}$	$\frac{1}{2}(\sqrt{10}+\sqrt{6})(\sqrt{5-2\sqrt{3}}-2+\sqrt{3})$	$\frac{1}{2}(\sqrt{10}-\sqrt{6})(2+\sqrt{3}+\sqrt{5-2\sqrt{3}})$	$\frac{1}{4}(\sqrt{5}-\sqrt{3})(\sqrt{3}+1)(\sqrt{10-2\sqrt{3}}+\sqrt{5}-1)$
$42^\circ = \frac{7\pi}{30}$	$\sqrt{5+2\sqrt{3}}-\sqrt{3}$	$\sqrt{15-6\sqrt{3}}+\sqrt{3}-2$	$\frac{1}{2}(3\sqrt{3}-\sqrt{15}+\sqrt{50-22\sqrt{3}})$
$45^\circ = \frac{\pi}{4}$	$\sqrt{2}$	$\sqrt{2}$	1
$48^\circ = \frac{4\pi}{15}$	$\sqrt{15-6\sqrt{3}}+\sqrt{3}-2$	$\sqrt{5+2\sqrt{3}}-\sqrt{3}$	$\frac{1}{2}(\sqrt{15}+\sqrt{3}-\sqrt{10+2\sqrt{3}})$
$51^\circ = \frac{17\pi}{60}$	$\frac{1}{2}(\sqrt{10}-\sqrt{6})(2+\sqrt{3}+\sqrt{5-2\sqrt{3}})$	$\frac{1}{2}(\sqrt{10}+\sqrt{6})(\sqrt{5-2\sqrt{3}}-2+\sqrt{3})$	$\frac{1}{4}(\sqrt{5}+\sqrt{3})(\sqrt{3}-1)(\sqrt{10-2\sqrt{3}}-\sqrt{5}+1)$
$54^\circ = \frac{3\pi}{10}$	$\frac{1}{2}\sqrt{50+10\sqrt{5}}$	$\sqrt{5}-1$	$\sqrt{5-2\sqrt{3}}$
$57^\circ = \frac{19\pi}{60}$	$\frac{1}{2}(\sqrt{10}+\sqrt{6})(2+\sqrt{3}-\sqrt{5+2\sqrt{3}})$	$\frac{1}{2}(\sqrt{10}-\sqrt{6})(\sqrt{5+2\sqrt{3}}+2-\sqrt{3})$	$\frac{1}{4}(\sqrt{5}-\sqrt{3})(\sqrt{3}-1)(\sqrt{10+2\sqrt{3}}+\sqrt{5}+1)$
$60^\circ = \frac{\pi}{3}$	2	$\frac{2}{3}\sqrt{3}$	$\frac{1}{3}\sqrt{3}$
$63^\circ = \frac{7\pi}{20}$	$\frac{1}{2}(2\sqrt{5}-\sqrt{3}+3\sqrt{2}-\sqrt{10})$	$\frac{1}{2}(2\sqrt{5}-\sqrt{3}-3\sqrt{2}+\sqrt{10})$	$\sqrt{3}-1-\sqrt{5-2\sqrt{3}}$
$66^\circ = \frac{11\pi}{30}$	$\sqrt{3}+\sqrt{5-2\sqrt{3}}$	$\sqrt{15+6\sqrt{3}}-\sqrt{3}-2$	$\frac{1}{2}(\sqrt{50+22\sqrt{3}}-3\sqrt{3}-\sqrt{15})$
$69^\circ = \frac{23\pi}{60}$	$\frac{1}{2}(\sqrt{10}+\sqrt{6})(\sqrt{5-2\sqrt{3}}+2-\sqrt{3})$	$\frac{1}{2}(\sqrt{10}-\sqrt{6})(2+\sqrt{3}-\sqrt{5-2\sqrt{3}})$	$\frac{1}{4}(\sqrt{5}-\sqrt{3})(\sqrt{3}+1)(\sqrt{10-2\sqrt{3}}-\sqrt{5}+1)$
$72^\circ = \frac{2\pi}{5}$	$\sqrt{5}+1$	$\frac{1}{2}\sqrt{50-10\sqrt{5}}$	$\frac{1}{2}\sqrt{25-10\sqrt{5}}$
$75^\circ = \frac{5\pi}{12}$	$\sqrt{6}+\sqrt{2}$	$\sqrt{6}-\sqrt{2}$	$2-\sqrt{3}$
$78^\circ = \frac{13\pi}{30}$	$\sqrt{5+2\sqrt{3}}+\sqrt{3}$	$\sqrt{15-6\sqrt{3}}-\sqrt{3}+2$	$\frac{1}{2}(3\sqrt{3}-\sqrt{15}-\sqrt{50-22\sqrt{3}})$
$81^\circ = \frac{19\pi}{60}$	$\frac{1}{2}(3\sqrt{2}+\sqrt{10}+2\sqrt{5}+\sqrt{3})$	$\frac{1}{2}(3\sqrt{2}+\sqrt{10}-2\sqrt{5}+\sqrt{3})$	$\sqrt{3}+1-\sqrt{5+2\sqrt{3}}$
$84^\circ = \frac{7\pi}{15}$	$\sqrt{15+6\sqrt{3}}+\sqrt{3}+2$	$\sqrt{3}-\sqrt{5-2\sqrt{3}}$	$\frac{1}{2}(\sqrt{10-2\sqrt{3}}-\sqrt{15}+\sqrt{3})$
$87^\circ = \frac{29\pi}{60}$	$\frac{1}{2}(\sqrt{10}+\sqrt{6})(2+\sqrt{3}+\sqrt{5+2\sqrt{3}})$	$\frac{1}{2}(\sqrt{10}-\sqrt{6})(\sqrt{5+2\sqrt{3}}-2+\sqrt{3})$	$\frac{1}{4}(\sqrt{5}-\sqrt{3})(\sqrt{3}-1)(\sqrt{10+2\sqrt{3}}-\sqrt{3}-1)$
$90^\circ = \frac{\pi}{2}$	∞	1	0

Appendix C

Hyperbolic Trigonometry

Basic Formulæ

$$\cosh^2 x - \sinh^2 x \equiv 1$$

$$\operatorname{sech}^2 x \equiv 1 - \tanh^2 x$$

$$\operatorname{csch}^2 x \equiv \operatorname{coth}^2 x - 1$$

Angle Addition Formulæ

$$\sinh(x \pm y) \equiv \sinh x \cosh y \pm \cosh x \sinh y$$

$$\cosh(x \pm y) \equiv \cosh x \cosh y \pm \sinh x \sinh y$$

$$\tanh(x \pm y) \equiv \frac{\tanh x \pm \tanh y}{1 \pm \tanh x \tanh y}$$

Double-Angle Formulæ

$$\sinh 2x \equiv 2 \sinh x \cosh x$$

$$\cosh 2x \equiv \cosh^2 x + \sinh^2 x$$

$$\tanh 2x \equiv \frac{2 \tanh x}{1 + \tanh^2 x}$$

Half-Angle Formulæ

$$\sinh \frac{x}{2} \equiv \pm \sqrt{\frac{\cosh x - 1}{2}}$$

$$\cosh \frac{x}{2} \equiv \sqrt{\frac{\cosh x + 1}{2}}$$

$$\tanh \frac{x}{2} \equiv \frac{\sinh x}{\cosh x + 1} \equiv \frac{\cosh x - 1}{\sinh x}$$

Products of Hyperbolic Sines and Cosines

$$\sinh x \cosh y \equiv \frac{1}{2} [\sinh(x + y) + \sinh(x - y)]$$

$$\cosh x \sinh y \equiv \frac{1}{2} [\sinh(x + y) - \sinh(x - y)]$$

$$\cosh x \cosh y \equiv \frac{1}{2} [\cosh(x + y) + \cosh(x - y)]$$

$$\sinh x \sinh y \equiv \frac{1}{2} [\cosh(x + y) - \cosh(x - y)]$$

Power Reduction Formulæ

$$\sinh^2 x \equiv \frac{1}{2} (\cosh 2x - 1)$$

$$\cosh^2 x \equiv \frac{1}{2} (\cosh 2x + 1)$$

Relations to Plane Trigonometric Functions

$$\sinh x \equiv -i \sin(ix)$$

$$\cosh x \equiv \cos(ix)$$

$$\tanh x \equiv -i \tan(ix)$$

Appendix D

Useful Series

The first four series are valid if $|x| < 1$; the fifth is valid for $x^2 < a^2$; and the last three are valid for all real x .

$$(1+x)^{1/2} = 1 + \frac{1}{2}x - \frac{1}{8}x^2 + \frac{1}{16}x^3 - \frac{5}{128}x^4 + \frac{7}{256}x^5 - \frac{21}{1024}x^6 + \frac{33}{2048}x^7 - \frac{429}{32768}x^8 + \dots \quad (\text{D.1})$$

$$(1-x)^{1/2} = 1 - \frac{1}{2}x - \frac{1}{8}x^2 - \frac{1}{16}x^3 - \frac{5}{128}x^4 - \frac{7}{256}x^5 - \frac{21}{1024}x^6 - \frac{33}{2048}x^7 - \frac{429}{32768}x^8 - \dots \quad (\text{D.2})$$

$$(1+x)^{-1/2} = 1 - \frac{1}{2}x + \frac{3}{8}x^2 - \frac{5}{16}x^3 + \frac{35}{128}x^4 - \frac{63}{256}x^5 + \frac{231}{1024}x^6 - \frac{429}{2048}x^7 + \frac{6435}{32768}x^8 - \dots \quad (\text{D.3})$$

$$(1-x)^{-1/2} = 1 + \frac{1}{2}x + \frac{3}{8}x^2 + \frac{5}{16}x^3 + \frac{35}{128}x^4 + \frac{63}{256}x^5 + \frac{231}{1024}x^6 + \frac{429}{2048}x^7 + \frac{6435}{32768}x^8 + \dots \quad (\text{D.4})$$

$$\frac{1}{a+x} = \frac{1}{a} - \frac{x}{a^2} + \frac{x^2}{a^3} - \frac{x^3}{a^4} + \frac{x^4}{a^5} - \frac{x^5}{a^6} + \dots \quad (\text{D.5})$$

$$e^x = 1 + x + \frac{x^2}{2} + \frac{x^3}{6} + \frac{x^4}{24} + \frac{x^5}{120} + \frac{x^6}{720} + \frac{x^7}{5040} + \frac{x^8}{40320} + \frac{x^9}{362880} + \dots \quad (\text{D.6})$$

$$\sin x = x - \frac{x^3}{6} + \frac{x^5}{120} - \frac{x^7}{5040} + \frac{x^9}{362880} - \frac{x^{11}}{39916800} + \frac{x^{13}}{6227020800} - \dots \quad (\text{D.7})$$

$$\cos x = 1 - \frac{x^2}{2} + \frac{x^4}{24} - \frac{x^6}{720} + \frac{x^8}{40320} - \frac{x^{10}}{3628800} + \frac{x^{12}}{479001600} - \dots \quad (\text{D.8})$$

Appendix E

Table of Derivatives

$$\frac{d}{dx} a = 0 \tag{E.1}$$

$$\frac{d}{dx} x = 1 \tag{E.2}$$

$$\frac{d}{dx} x^n = nx^{n-1} \tag{E.3}$$

$$\frac{d}{dx} \sqrt{x} = \frac{1}{2\sqrt{x}} \tag{E.4}$$

$$\frac{d}{dx} \sin x = \cos x \tag{E.5}$$

$$\frac{d}{dx} \cos x = -\sin x \tag{E.6}$$

$$\frac{d}{dx} \tan x = \sec^2 x \tag{E.7}$$

$$\frac{d}{dx} \sec x = \tan x \sec x \tag{E.8}$$

$$\frac{d}{dx} \csc x = -\cot x \csc x \tag{E.9}$$

$$\frac{d}{dx} \cot x = -\csc^2 x \tag{E.10}$$

$$\tag{E.11}$$

$$\frac{d}{dx} e^x = e^x \quad (\text{E.12})$$

$$\frac{d}{dx} \ln x = \frac{1}{x} \quad (\text{E.13})$$

$$\frac{d}{dx} a^x = a^x \ln a \quad (\text{E.14})$$

$$\frac{d}{dx} \log_a x = \frac{1}{x \ln a} \quad (\text{E.15})$$

$$\frac{d}{dx} \sin^{-1} x = \frac{1}{\sqrt{1-x^2}} \quad (\text{E.16})$$

$$\frac{d}{dx} \cos^{-1} x = \frac{-1}{\sqrt{1-x^2}} \quad (\text{E.17})$$

$$\frac{d}{dx} \tan^{-1} x = \frac{1}{1+x^2} \quad (\text{E.18})$$

$$\frac{d}{dx} \sec^{-1} x = \frac{1}{|x|\sqrt{x^2-1}} \quad (\text{E.19})$$

$$\frac{d}{dx} \csc^{-1} x = \frac{-1}{|x|\sqrt{x^2-1}} \quad (\text{E.20})$$

$$\frac{d}{dx} \cot^{-1} x = \frac{-1}{1+x^2} \quad (\text{E.21})$$

$$\frac{d}{dx} \sinh x = \cosh x \quad (\text{E.22})$$

$$\frac{d}{dx} \cosh x = \sinh x \quad (\text{E.23})$$

$$\frac{d}{dx} \tanh x = \text{sech}^2 x \quad (\text{E.24})$$

Appendix F

Table of Integrals

In the following table, an arbitrary constant C should be added to each result.

$$\int dx = x \tag{F.1}$$

$$\int a dx = ax \tag{F.2}$$

$$\int x^n dx = \frac{x^{n+1}}{n+1} \quad (n \neq -1) \tag{F.3}$$

$$\int \sqrt{x} dx = \frac{2}{3} \sqrt{x^3} \tag{F.4}$$

$$\int \frac{1}{x} dx = \ln|x| \tag{F.5}$$

$$\int \sin x dx = -\cos x \tag{F.6}$$

$$\int \cos x dx = \sin x \tag{F.7}$$

$$\int \tan x dx = \ln|\sec x| \tag{F.8}$$

$$\tag{F.9}$$

$$\int \sec x \, dx = \ln |\sec x + \tan x| \quad (\text{F.10})$$

$$\int \csc x \, dx = \ln |\csc x - \cot x| \quad (\text{F.11})$$

$$\int \cot x \, dx = \ln |\sin x| \quad (\text{F.12})$$

$$\int e^x \, dx = e^x \quad (\text{F.13})$$

$$\int \ln x \, dx = x \ln x - x \quad (\text{F.14})$$

$$\int a^x \, dx = \frac{a^x}{\ln a} \quad (\text{F.15})$$

$$\int \log_a x \, dx = \frac{x \ln x - x}{\ln a} \quad (\text{F.16})$$

$$\int \sinh x \, dx = \cosh x \quad (\text{F.17})$$

$$\int \cosh x \, dx = \sinh x \quad (\text{F.18})$$

$$\int \tanh x \, dx = \ln \cosh x \quad (\text{F.19})$$

Appendix G

Mathematical Subtleties

- When taking the square root of both sides of an equation, a \pm sign must always be introduced. For example:

$$x^2 = a \quad \Rightarrow \quad x = \pm\sqrt{a}$$

Both roots may be valid, or, depending on the problem, it may be that one root or the other may be rejected on mathematical or physical grounds.

- Dividing an equation through by a variable may result in losing roots. For example, suppose we have

$$x^2 - ax = 0$$

Dividing through by the variable x will result in one solution, $x = a$; the solution $x = 0$ has been lost. Instead of dividing through by the variable x , the proper procedure is to *factor out* an x :

$$x(x - a) = 0$$

Since the product on the left-hand side is zero, it follows that either $x = 0$ or $x - a = 0$, and we retain both roots.

- The relation

$$\sqrt{x}\sqrt{y} = \sqrt{xy} \tag{G.1}$$

is valid only for $x, y \geq 0$.

- Some mathematical conventions:

- ★ 1 is *not* considered a prime number.
- ★ $0! = 1$
- ★ $0^0 = 1$
- ★ Towers of exponents are evaluated from the top down: $a^{b^c} = a^{(b^c)}$

- When taking an inverse trigonometric function, there will in general be *two* correct values; your calculator will give only one value, the *principal value* (P.V.). The other value is found using the table below.

Function	P.V.	Other value
arcsin	θ	$\pi - \theta$
arccos	θ	$-\theta$
arctan	θ	$\pi + \theta$
arcsec	θ	$-\theta$
arccsc	θ	$\pi - \theta$
arccot	θ	$\pi + \theta$

For $\arctan(y/x)$, add π to the calculator's principal value answer if $x < 0$.

Appendix H

SI Units

Table H-1. SI base units.

Name	Symbol	Quantity
meter	m	length
kilogram	kg	mass
second	s	time
ampere	A	electric current
kelvin	K	temperature
mole	mol	amount of substance
candela	cd	luminous intensity

Table H-2. Derived SI units.

Name	Symbol	Definition	Base Units	Quantity
radian	rad	m / m	—	plane angle
steradian	sr	m ² / m ²	—	solid angle
newton	N	kg m s ⁻²	kg m s ⁻²	force
joule	J	N m	kg m ² s ⁻²	energy
watt	W	J / s	kg m ² s ⁻³	power
pascal	Pa	N / m ²	kg m ⁻¹ s ⁻²	pressure
hertz	Hz	s ⁻¹	s ⁻¹	frequency
coulomb	C	A s	A s	electric charge
volt	V	J / C	kg m ² A ⁻¹ s ⁻³	electric potential
ohm	Ω	V / A	kg m ² A ⁻² s ⁻³	electrical resistance
siemens	S	A / V	kg ⁻¹ m ⁻² A ² s ³	electrical conductance
farad	F	C / V	kg ⁻¹ m ⁻² A ² s ⁴	capacitance
weber	Wb	V s	kg m ² A ⁻¹ s ⁻²	magnetic flux
tesla	T	Wb / m ²	kg A ⁻¹ s ⁻²	magnetic induction
henry	H	Wb / A	kg m ² A ⁻² s ⁻²	induction
lumen	lm	cd sr	cd sr	luminous flux
lux	lx	lm / m ²	cd sr m ⁻²	illuminance
becquerel	Bq	s ⁻¹	s ⁻¹	radioactivity
gray	Gy	J / kg	m ² s ⁻²	absorbed dose
sievert	Sv	J / kg	m ² s ⁻²	dose equivalent
katal	kat	mol / s	mol s ⁻¹	catalytic activity

Table H-3. SI prefixes.

Prefix	Symbol	Definition	English
yotta-	Y	10^{24}	septillion
zetta-	Z	10^{21}	sextillion
exa-	E	10^{18}	quintillion
peta-	P	10^{15}	quadrillion
tera-	T	10^{12}	trillion
giga-	G	10^9	billion
mega-	M	10^6	million
kilo-	k	10^3	thousand
hecto-	h	10^2	hundred
deka-	da	10^1	ten
deci-	d	10^{-1}	tenth
centi-	c	10^{-2}	hundredth
milli-	m	10^{-3}	thousandth
micro-	μ	10^{-6}	millionth
nano-	n	10^{-9}	billionth
pico-	p	10^{-12}	trillionth
femto-	f	10^{-15}	quadrillionth
atto-	a	10^{-18}	quintillionth
zepto-	z	10^{-21}	sextillionth
yocto-	y	10^{-24}	septillionth

Table H-4. Prefixes for *computer use only*.

Prefix	Symbol	Definition
yobi-	Yi	$2^{80} = 1,208,925,819,614,629,174,706,176$
zebi-	Zi	$2^{70} = 1,180,591,620,717,411,303,424$
exbi-	Ei	$2^{60} = 1,152,921,504,606,846,976$
pebi-	Pi	$2^{50} = 1,125,899,906,842,624$
tebi-	Ti	$2^{40} = 1,099,511,627,776$
gibi-	Gi	$2^{30} = 1,073,741,824$
mebi-	Mi	$2^{20} = 1,048,576$
kibi-	Ki	$2^{10} = 1,024$

Appendix I

Gaussian Units

Table I-1. Gaussian base units.

Name	Symbol	Quantity
centimeter	cm	length
gram	g	mass
second	s	time
kelvin	K	temperature
mole	mol	amount of substance
candela	cd	luminous intensity

Table I-2. Derived Gaussian units.

Name	Symbol	Definition	Base Units	Quantity
radian	rad	m / m	—	plane angle
steradian	sr	m ² / m ²	—	solid angle
dyne	dyn	g cm s ⁻²	g cm s ⁻²	force
erg	erg	dyn cm	g cm ² s ⁻²	energy
statwatt	statW	erg / s	g cm ² s ⁻³	power
barye	ba	dyn / cm ²	g cm ⁻¹ s ⁻²	pressure
galileo	Gal	cm / s ²	cm s ⁻²	acceleration
poise	P	g / (cm s)	g cm ⁻¹ s ⁻¹	dynamic viscosity
stokes	St	cm ² / s	cm ² s ⁻¹	kinematic viscosity
hertz	Hz	s ⁻¹	s ⁻¹	frequency
statcoulomb	statC		g ^{1/2} cm ^{3/2} s ⁻¹	electric charge
franklin	Fr	statC	g ^{1/2} cm ^{3/2} s ⁻¹	electric charge
statampere	statA	statC / s	g ^{1/2} cm ^{3/2} s ⁻²	electric current
statvolt	statV	erg / statC	g ^{1/2} cm ^{1/2} s ⁻¹	electric potential
statohm	statΩ	statV / statA	s cm ⁻¹	electrical resistance
statfarad	statF	statC / statV	cm	capacitance
maxwell	Mx	statV cm	g ^{1/2} cm ^{3/2} s ⁻¹	magnetic flux
gauss	G	Mx / cm ²	g ^{1/2} cm ^{-1/2} s ⁻¹	magnetic induction
oersted	Oe	statA s / cm ²	g ^{1/2} cm ^{-1/2} s ⁻¹	magnetic intensity
gilbert	Gb	statA	g ^{1/2} cm ^{3/2} s ⁻²	magnetomotive force
unit pole	pole	dyn / Oe	g ^{1/2} cm ^{3/2} s ⁻¹	magnetic pole strength
stathenry	statH	erg / statA ²	s ² cm ⁻¹	induction
lumen	lm	cd sr	cd sr	luminous flux
phot	ph	lm / cm ²	cd sr cm ⁻²	illuminance
stilb	sb	cd / cm ²	cd cm ⁻²	luminance
lambert	Lb	1/π cd / cm ²	cd cm ⁻²	luminance
kayser	K	1 / cm	cm ⁻¹	wave number
becquerel	Bq	s ⁻¹	s ⁻¹	radioactivity
katal	kat	mol / s	mol s ⁻¹	catalytic activity

Appendix J

British Engineering Units

Table J-1. British Engineering base units.

Name	Symbol	Quantity
foot	ft	length
slug	slug	mass
second	s	time
degree Rankine	°R	temperature
pound-mole	lb-mol	amount of substance
candle	candle	luminous intensity

Table J-2. Derived British Engineering units.

Name	Symbol	Definition	Base Units	Quantity
radian	rad	ft / ft	—	plane angle
steradian	sr	ft ² / ft ²	—	solid angle
pound-force	lbf	slug ft s ⁻²	slug ft s ⁻²	force
hertz	Hz	s ⁻¹	s ⁻¹	frequency
becquerel	Bq	s ⁻¹	s ⁻¹	radioactivity

Appendix K

Units of Physical Quantities

Table K-1. Units of physical quantities.

Quantity	SI Units	Gaussian Units
Absorbed dose	Gy	erg g ⁻¹
Acceleration	m s ⁻²	cm s ⁻²
Amount of substance	mol	mol
Angle (plane)	rad	rad
Angle (solid)	sr	sr
Angular acceleration	rad s ⁻²	rad s ⁻²
Angular momentum	N m s	dyn cm s
Angular velocity	rad s ⁻¹	rad s ⁻¹
Area	m ²	cm ²
Bulk modulus	Pa	ba
Catalytic activity	kat	kat
Coercivity	A m ⁻¹	Oe
Crackle	m s ⁻⁵	cm s ⁻⁵
Density	kg m ⁻³	g cm ⁻³
Distance	m	cm
Dose equivalent	Sv	erg g ⁻¹
Elastic modulus	N m ⁻²	dyn cm ⁻²
Electric capacitance	F	statF
Electric charge	C	statC
Electric conductance	S	statΩ ⁻¹
Electric conductivity	S m ⁻¹	statΩ ⁻¹ cm ⁻¹
Electric current	A	statA
Electric dipole moment	C m	statC cm
Electric displacement (<i>D</i>)	C m ⁻²	statC cm ⁻²

Table K-1 (cont'd). Units of physical quantities.

Quantity	SI Units	Gaussian Units
Electric elastance	F^{-1}	stat F^{-1}
Electric field (E)	$V m^{-1}$	stat $V cm^{-1}$
Electric flux	$V m$	stat $V cm$
Electric permittivity	$F m^{-1}$	—
Electric polarization (P)	$C m^{-2}$	stat $C cm^{-2}$
Electric potential	V	stat V
Electric resistance	Ω	stat Ω
Electric resistivity	Ωm	stat Ωcm
Energy	J	erg
Enthalpy	J	erg
Entropy	$J K^{-1}$	erg K^{-1}
Force	N	dyn
Frequency	Hz	Hz
Heat	J	erg
Heat capacity	$J K^{-1}$	erg K^{-1}
Illuminance	lx	ph
Impulse	$N s$	dyn s
Inductance	H	stat H
Jerk	$m s^{-3}$	$cm s^{-3}$
Jounce	$m s^{-4}$	$cm s^{-4}$
Latent heat	$J kg^{-1}$	erg g^{-1}
Length	m	cm
Luminance	$cd m^{-2}$	sb
Luminous flux	lm	lm
Luminous intensity	cd	cd
Magnetic flux	Wb	Mx
Magnetic induction (B)	T	G
Magnetic intensity (H)	$A m^{-1}$	Oe
Magnetic dipole moment (B convention)	$A m^2$	pole cm
Magnetic dipole moment (H convention)	$Wb m$	pole cm
Magnetic permeability	$H m^{-1}$	—
Magnetic permeance	H	s
Magnetic pole strength (B convention)	$A m$	unit pole
Magnetic pole strength (H convention)	Wb	unit pole
Magnetic potential (scalar)	A	$Oe cm$
Magnetic potential (vector)	$T m$	$G cm$
Magnetic reluctance	H^{-1}	s^{-1}

Table K-1 (cont'd). Units of physical quantities.

Quantity	SI Units	Gaussian Units
Magnetization (M)	$A\ m^{-1}$	$Mx\ cm^{-2}$
Magnetomotive force	A	Gb
Mass	kg	g
Memristance	Ω	stat Ω
Molality	$mol\ kg^{-1}$	$mol\ g^{-1}$
Molarity	$mol\ m^{-3}$	$mol\ cm^{-3}$
Moment of inertia	$kg\ m^2$	$g\ cm^2$
Momentum	$N\ s$	$dyn\ s$
Pop	$m\ s^{-6}$	$cm\ s^{-6}$
Power	W	statW
Pressure	Pa	ba
Radioactivity	Bq	Bq
Remanence	T	G
Retentivity	T	G
Shear modulus	$N\ m^{-2}$	$dyn\ cm^{-2}$
Snap	$m\ s^{-4}$	$cm\ s^{-4}$
Specific heat	$J\ K^{-1}\ kg^{-1}$	$erg\ K^{-1}\ g^{-1}$
Strain	—	—
Stress	$N\ m^{-2}$	$dyn\ cm^{-2}$
Temperature	K	K
Tension	N	dyn
Time	s	s
Torque	$N\ m$	$dyn\ cm$
Velocity	$m\ s^{-1}$	$cm\ s^{-1}$
Viscosity (dynamic)	$Pa\ s$	P
Viscosity (kinematic)	$m^2\ s^{-1}$	St
Volume	m^3	cm^3
Wave number	m^{-1}	kayser
Weight	N	dyn
Work	J	erg
Young's modulus	$N\ m^{-2}$	$dyn\ cm^{-2}$

Appendix L

Physical Constants

Table L-1. Fundamental physical constants (CODATA 2018).

Description	Symbol	Value
Speed of light (vacuum)	c	2.99792458×10^8 m/s
Gravitational constant	G	6.67430×10^{-11} m ³ kg ⁻¹ s ⁻²
Elementary charge	e	$1.602176634 \times 10^{-19}$ C
Permittivity of free space	ϵ_0	$8.8541878128 \times 10^{-12}$ F/m
Permeability of free space	μ_0	1.2566370621210^{-6} N/A ²
Coulomb constant ($1/(4\pi\epsilon_0)$)	k_c	8.9875517923×10^9 m/F
Electron mass	m_e	$9.1093837015 \times 10^{-31}$ kg
Proton mass	m_p	$1.67262192369 \times 10^{-27}$ kg
Neutron mass	m_n	$1.67492749804 \times 10^{-27}$ kg
Atomic mass unit (amu)	u	$1.66053906660 \times 10^{-27}$ kg
Planck constant	h	$6.62607015 \times 10^{-34}$ J s
Planck constant $\div 2\pi$	\hbar	$1.0545718176461564 \times 10^{-34}$ J s
Boltzmann constant	k_B	1.380649×10^{-23} J/K
Avogadro constant	N_A	$6.02214076 \times 10^{23}$ mol ⁻¹

Table L-2. Other physical constants.

Description	Symbol	Value
Acceleration due to gravity at Earth surface	g	9.80 m/s ²
Radius of the Earth (eq.)	R_\oplus	6378.140 km
Mass of the Earth	M_\oplus	5.97320×10^{24} kg
Earth gravity constant	GM_\oplus	3.986005×10^{14} m ³ s ⁻²
Speed of sound in air (20°C)	v_{snd}	343 m/s
Density of air (sea level)	ρ_{air}	1.29 kg/m ³
Density of water	ρ_w	1 g/cm ³ = 1000 kg/m ³
Index of refraction of water	n_w	1.33
Resistivity of copper (20°C)	ρ_{Cu}	1.68×10^{-8} Ω m

Appendix M

Astronomical Data

Table M-1. Astronomical constants.

Description	Symbol	Value
Astronomical unit	AU	$1.49597870 \times 10^{11}$ m
Obliquity of ecliptic (J2000)	ε	23°4392911
Solar mass	M_{\odot}	1.9891×10^{30} kg
Solar radius	R_{\odot}	696,000 km
Earth grav. const.	GM_{\oplus}	$3.986004415 \times 10^{14}$ m ³ s ⁻²
Sun grav. const.	GM_{\odot}	$1.32712440041 \times 10^{20}$ m ³ s ⁻²

Table M-2. Planetary Data.

Planet	Mass (Yg)	Eq. radius (km)	Orbit semi-major axis (Gm)
Mercury	330.2	2439.7	57.91
Venus	4868.5	6051.8	108.21
Earth	5973.6	6378.1	149.60
Mars	641.85	3396.2	227.92
Jupiter	1,898,600	71,492	778.57
Saturn	568,460	60,268	1433.53
Uranus	86,832	25,559	2872.46
Neptune	102,430	24,764	4495.06
Pluto	12.5	1195	5906.38

Appendix N

Unit Conversion Tables

Time

1 day = 24 hours = 1440 minutes = 86400 seconds

1 hour = 60 minutes = 3600 seconds

1 year = 31 557 600 seconds $\approx \pi \times 10^7$ seconds

Length

1 mile = 8 furlongs = 80 chains = 320 rods = 1760 yards = 5280 feet = 1.609344 km

1 yard = 3 feet = 36 inches = 0.9144 meter

1 foot = 12 inches = 0.3048 meter

1 inch = 2.54 cm

1 nautical mile = 1852 meters = 1.15077944802354 miles

1 fathom = 6 feet

1 parsec = 3.26156376188 light-years = 206264.806245 AU = $3.08567756703 \times 10^{16}$ meters

1 ångström = 0.1 nm = 10^5 fermi = 10^{-10} meter

Mass

1 kilogram = 2.20462262184878 lb

1 pound = 16 oz = 0.45359237 kg

1 slug = 32.1740485564304 lb = 14.5939029372064 kg

1 short ton = 2000 lb

1 long ton = 2240 lb

1 metric ton = 1000 kg

Velocity

15 mph = 22 fps

1 mph = 0.44704 m/s

1 knot = 1.15077944802354 mph = 0.5144444444444444 m/s

Area

$$1 \text{ acre} = 43560 \text{ ft}^2 = 4840 \text{ yd}^2 = 4046.8564224 \text{ m}^2$$

$$1 \text{ mile}^2 = 640 \text{ acres} = 2.589988110336 \text{ km}^2$$

$$1 \text{ are} = 100 \text{ m}^2$$

$$1 \text{ hectare} = 10^4 \text{ m}^2 = 2.47105381467165 \text{ acres}$$

Volume

$$1 \text{ liter} = 1 \text{ dm}^3 = 10^{-3} \text{ m}^3 \approx 1 \text{ quart}$$

$$1 \text{ m}^3 = 1000 \text{ liters}$$

$$1 \text{ cm}^3 = 1 \text{ mL}$$

$$1 \text{ ft}^3 = 1728 \text{ in}^3 = 7.48051948051948 \text{ gal} = 28.316846592 \text{ liters}$$

$$1 \text{ gallon} = 231 \text{ in}^3 = 4 \text{ quarts} = 8 \text{ pints} = 16 \text{ cups} = 3.785411784 \text{ liters}$$

$$1 \text{ cup} = 8 \text{ floz} = 16 \text{ tablespoons} = 48 \text{ teaspoons}$$

$$1 \text{ tablespoon} = 3 \text{ teaspoons} = 4 \text{ fluidrams}$$

$$1 \text{ dry gallon} = 268.8025 \text{ in}^3 = 4.40488377086 \text{ liters}$$

$$1 \text{ imperial gallon} = 4.54609 \text{ liters}$$

$$1 \text{ bushel} = 4 \text{ pecks} = 8 \text{ dry gallons}$$

Density

$$1 \text{ g/cm}^3 = 1000 \text{ kg/m}^3 = 8.34540445201933 \text{ lb/gal} = 1.043175556502416 \text{ lb/pint}$$

Force

$$1 \text{ lbf} = 4.44822161526050 \text{ newtons} = 32.1740485564304 \text{ poundals}$$

$$1 \text{ newton} = 10^5 \text{ dynes}$$

Energy

$$1 \text{ calorie} = 4.1868 \text{ joules}$$

$$1 \text{ BTU} = 1055.05585262 \text{ joules}$$

$$1 \text{ ft-lb} = 1.35581794833140 \text{ joules}$$

$$1 \text{ kW-hr} = 3.6 \text{ MJ}$$

$$1 \text{ eV} = 1.602176634 \times 10^{-19} \text{ joules}$$

$$1 \text{ joule} = 10^7 \text{ ergs}$$

Power

$$1 \text{ horsepower} = 745.69987158227022 \text{ watts}$$

$$1 \text{ statwatt} = 1 \text{ abwatt} = 1 \text{ erg/s} = 10^{-7} \text{ watt}$$

Angle

$$\text{rad} = \text{deg} \times \frac{\pi}{180} \quad \text{deg} = \text{rad} \times \frac{180}{\pi}$$

$$1 \text{ deg} = 60 \text{ arcmin} = 3600 \text{ arcsec}$$

Temperature

$$^{\circ}\text{C} = (^{\circ}\text{F} - 32) \times \frac{5}{9} \quad ^{\circ}\text{F} = (^{\circ}\text{C} \times \frac{9}{5}) + 32$$

$$\text{K} = ^{\circ}\text{C} + 273.15$$

$$^{\circ}\text{R} = ^{\circ}\text{F} + 459.67$$

Pressure

$$\begin{aligned} 1 \text{ atm} &= 101325 \text{ Pa} = 1.01325 \text{ bar} = 1013.25 \text{ millibar} = 760 \text{ torr} \\ &= 760 \text{ mmHg} = 29.9212598425197 \text{ inHg} = 14.6959487755134 \text{ psi} \\ &= 2116.21662367394 \text{ lb/ft}^2 = 1.05810831183697 \text{ ton/ft}^2 \\ &= 1013250 \text{ dyne/cm}^2 = 1013250 \text{ barye} \end{aligned}$$

Electromagnetism

$$1 \text{ statcoulomb} = 3.335640951981520 \times 10^{-10} \text{ coulomb}$$

$$1 \text{ abcoulomb} = 10 \text{ coulombs}$$

$$1 \text{ statvolt} = 299.792458 \text{ volts}$$

$$1 \text{ abvolt} = 10^{-8} \text{ volt}$$

$$1 \text{ maxwell} = 10^{-8} \text{ weber}$$

$$1 \text{ gauss} = 10^{-4} \text{ tesla}$$

$$1 \text{ oersted} = 250/\pi (= 79.5774715459477) \text{ A/m}$$

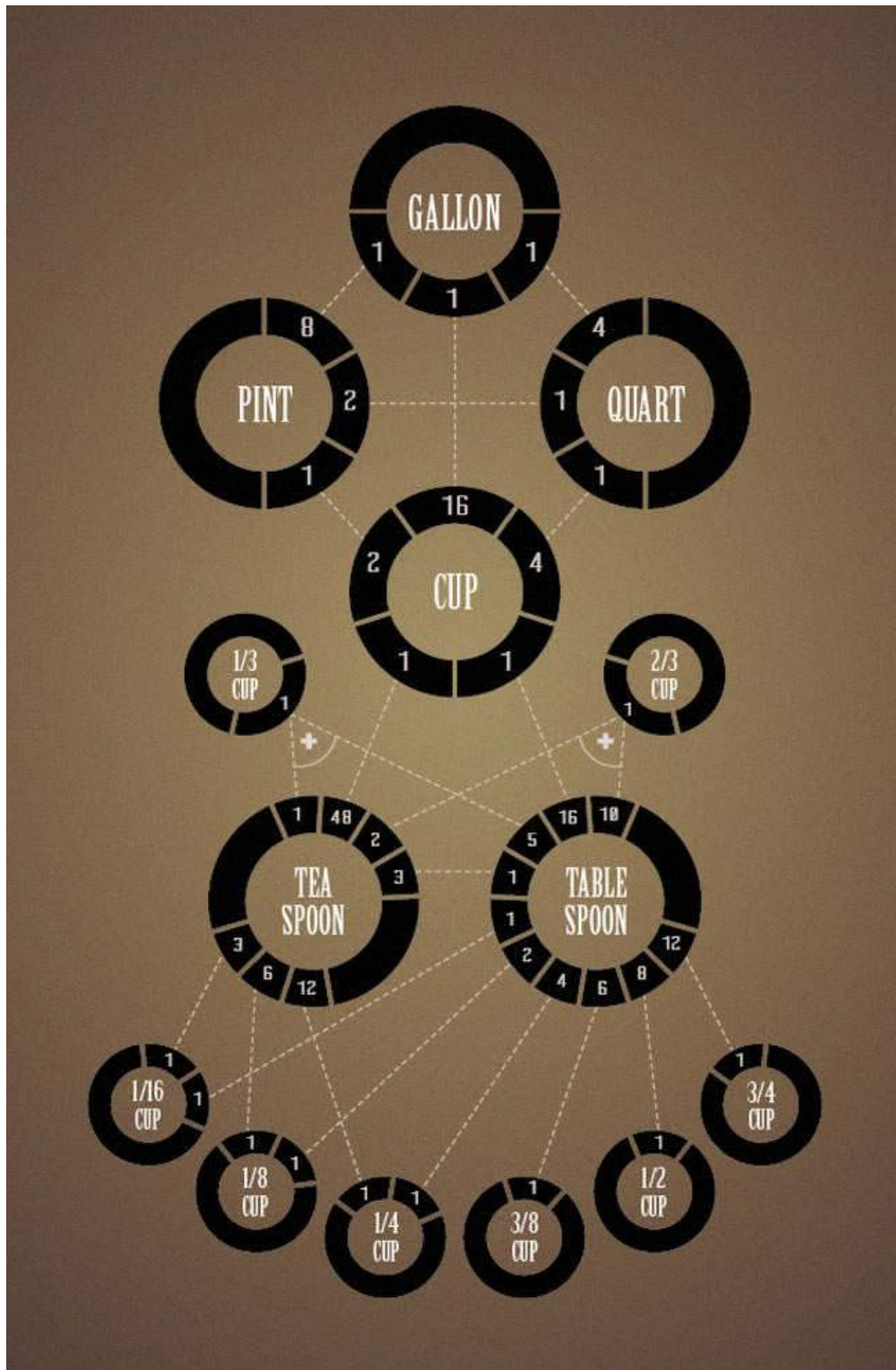

Figure N.1: Conversion chart for kitchen measurements. (Credit: S.B. Lattin Design.)

Appendix O

Angular Measure

Plane Angle

The most common unit of measure for plane angle is the *degree* ($^{\circ}$), which is $1/360$ of a full circle. Therefore a circle is 360° , a semicircle is 180° , and a right angle is 90° .

A similar unit (seldom used nowadays) is a sort of “metric” angle called the *grad*, defined so that a right angle is 100 grads, and so a full circle is 400 grads.

The SI unit of plane angle is the *radian* (rad), which is defined to be the angle that subtends an arc length equal to the radius of the circle. By this definition, a full circle subtends an angle equal to the arc length of a full circle ($2\pi r$) divided by its radius r — and so a full circle is 2π radians.

Since a hemisphere is 180° or π radians, the conversion factors are:

$$\text{rad} = \frac{\pi}{180} \times \text{deg} \tag{O.1}$$

$$\text{deg} = \frac{180}{\pi} \times \text{rad} \tag{O.2}$$

Subunits of the Degree

For small angles, a degree may be subdivided into 60 *minutes* ($'$), and a minute into 60 *seconds* ($''$). Thus a minute is $1/60$ degree, and a second is $1/3600$ degree.¹ Angles smaller than 1 second are sometimes expressed as *milli-arcseconds* ($1/1000$ arcsecond).²

Solid Angle

A *solid angle* is the three-dimensional version of a plane angle, and is subtended by the vertex of a cone. The SI unit of solid angle is the *steradian* (sr), which is defined to be the solid angle that subtends an area equal to the square of the radius of a circle. By this definition, a full sphere subtends an area equal to the area of a sphere ($4\pi r^2$) divided by the square of its radius (r^2) — so a full sphere is 4π steradians, and a hemisphere is 2π steradians.

¹Sometimes these units are called the *minute of arc* or *arcminute*, and the *second of arc* or *arcsecond* to distinguish them from the units of time that have the same name.

²In an old system (Ref. [10]), the second was further subdivided into 60 *thirds* ($'''$), the third into 60 *fourths* ($''''$), etc. Under this system, 1 milli-arcsecond is 3.6 fourths of arc. This system is no longer used, though; today the second of arc is simply subdivided into decimals (e.g. $32.86473''$).

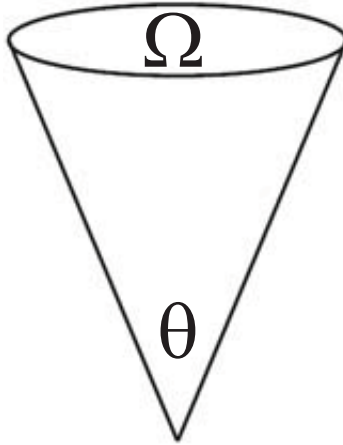

Figure O.1: Relation between plane angle θ and solid angle Ω for a right circular cone.

There is a simple relation between plane angle and solid angle for a right circular cone. If the vertex of the cone subtends an angle θ (the *aperture angle* of the cone), then the corresponding solid angle Ω is (Fig. O.1)

$$\Omega = 2\pi \left(1 - \cos \frac{\theta}{2}\right). \quad (\text{O.3})$$

Another unit of solid angle is the *square degree* (deg^2):

$$\text{sq. deg.} = \text{sr} \times \left(\frac{180}{\pi}\right)^2. \quad (\text{O.4})$$

In these units, a hemisphere is $20,626.48 \text{ deg}^2$, and a complete sphere is $41,252.96 \text{ deg}^2$.

Appendix P

Vector Arithmetic

A vector \mathbf{A} may be written in cartesian (rectangular) form as

$$\mathbf{A} = A_x\mathbf{i} + A_y\mathbf{j} + A_z\mathbf{k}, \quad (\text{P.1})$$

where \mathbf{i} is a *unit vector* (a vector of magnitude 1) in the x direction, \mathbf{j} is a unit vector in the y direction, and \mathbf{k} is a unit vector in the z direction. A_x , A_y , and A_z are called the x , y , and z *components* (respectively) of vector \mathbf{A} , and are the projections of the vector onto those axes.

The *magnitude* (“length”) of vector \mathbf{A} is

$$|\mathbf{A}| = A = \sqrt{A_x^2 + A_y^2 + A_z^2}. \quad (\text{P.2})$$

For example, if $\mathbf{A} = 3\mathbf{i} + 5\mathbf{j} + 2\mathbf{k}$, then $|\mathbf{A}| = A = \sqrt{3^2 + 5^2 + 2^2} = \sqrt{38}$.

In two dimensions, a vector has no \mathbf{k} component: $\mathbf{A} = A_x\mathbf{i} + A_y\mathbf{j}$.

Addition and Subtraction

To add two vectors, you add their components. Writing a second vector as $\mathbf{B} = B_x\mathbf{i} + B_y\mathbf{j} + B_z\mathbf{k}$, we have

$$\mathbf{A} + \mathbf{B} = (A_x + B_x)\mathbf{i} + (A_y + B_y)\mathbf{j} + (A_z + B_z)\mathbf{k}. \quad (\text{P.3})$$

For example, if $\mathbf{A} = 3\mathbf{i} + 5\mathbf{j} + 2\mathbf{k}$ and $\mathbf{B} = 2\mathbf{i} - \mathbf{j} + 4\mathbf{k}$, then $\mathbf{A} + \mathbf{B} = 5\mathbf{i} + 4\mathbf{j} + 6\mathbf{k}$.

Subtraction of vectors is defined similarly:

$$\mathbf{A} - \mathbf{B} = (A_x - B_x)\mathbf{i} + (A_y - B_y)\mathbf{j} + (A_z - B_z)\mathbf{k}. \quad (\text{P.4})$$

For example, if $\mathbf{A} = 3\mathbf{i} + 5\mathbf{j} + 2\mathbf{k}$ and $\mathbf{B} = 2\mathbf{i} - \mathbf{j} + 4\mathbf{k}$, then $\mathbf{A} - \mathbf{B} = \mathbf{i} + 6\mathbf{j} - 2\mathbf{k}$.

Scalar Multiplication

To multiply a vector by a scalar, just multiply each component by the scalar. Thus if c is a scalar, then

$$c\mathbf{A} = cA_x\mathbf{i} + cA_y\mathbf{j} + cA_z\mathbf{k}. \quad (\text{P.5})$$

For example, if $\mathbf{A} = 3\mathbf{i} + 5\mathbf{j} + 2\mathbf{k}$, then $7\mathbf{A} = 21\mathbf{i} + 35\mathbf{j} + 14\mathbf{k}$.

Dot Product

It is possible to multiply a vector by another vector, but there is more than one kind of multiplication between vectors. One type of vector multiplication is called the *dot product*, in which a vector is multiplied by another vector to give a *scalar* result. The dot product (written with a dot operator, as in $\mathbf{A} \cdot \mathbf{B}$) is

$$\mathbf{A} \cdot \mathbf{B} = AB \cos \theta = A_x B_x + A_y B_y + A_z B_z, \quad (\text{P.6})$$

where θ is the angle between vectors \mathbf{A} and \mathbf{B} . For example, if $\mathbf{A} = 3\mathbf{i} + 5\mathbf{j} + 2\mathbf{k}$ and $\mathbf{B} = 2\mathbf{i} - \mathbf{j} + 4\mathbf{k}$, then $\mathbf{A} \cdot \mathbf{B} = 6 - 5 + 8 = 9$.

The dot product can be used to find the angle between two vectors. To do this, we solve Eq. (P.6) for θ and find $\cos \theta = \mathbf{A} \cdot \mathbf{B} / (AB)$. Applying this to the previous example, we get $A = \sqrt{38}$ and $B = \sqrt{21}$, so $\cos \theta = 9 / (\sqrt{38}\sqrt{21})$, and thus $\theta = 71.4^\circ$.

An immediate consequence of Eq. (P.6) is that two vectors are perpendicular if and only if their dot product is zero.

Cross Product

Another kind of multiplication between vectors, called the *cross product*, involves multiplying one vector by another and giving another *vector* as a result. The cross product is written with a cross operator, as in $\mathbf{A} \times \mathbf{B}$. It is defined by

$$\mathbf{A} \times \mathbf{B} = (AB \sin \theta) \mathbf{u} \quad (\text{P.7})$$

$$= \begin{vmatrix} \mathbf{i} & \mathbf{j} & \mathbf{k} \\ A_x & A_y & A_z \\ B_x & B_y & B_z \end{vmatrix} \quad (\text{P.8})$$

$$= (A_y B_z - A_z B_y) \mathbf{i} - (A_x B_z - A_z B_x) \mathbf{j} + (A_x B_y - A_y B_x) \mathbf{k}, \quad (\text{P.9})$$

where again θ is the angle between the vectors, and \mathbf{u} is a unit vector pointing in a direction perpendicular to the plane containing \mathbf{A} and \mathbf{B} , in a right-hand sense: if you curl the fingers of your right hand from \mathbf{A} into \mathbf{B} , then the thumb of your right hand points in the direction of $\mathbf{A} \times \mathbf{B}$ (Fig. P.1). As an example, if $\mathbf{A} = 3\mathbf{i} + 5\mathbf{j} + 2\mathbf{k}$ and $\mathbf{B} = 2\mathbf{i} - \mathbf{j} + 4\mathbf{k}$, then $\mathbf{A} \times \mathbf{B} = (20 - (-2))\mathbf{i} - (12 - 4)\mathbf{j} + (-3 - 10)\mathbf{k} = 22\mathbf{i} - 8\mathbf{j} - 13\mathbf{k}$.

Rectangular and Polar Forms

A two-dimensional vector may be written in either *rectangular form* $\mathbf{A} = A_x \mathbf{i} + A_y \mathbf{j}$ described earlier, or in *polar form* $\mathbf{A} = A \angle \theta$, where A is the vector magnitude, and θ is the direction measured counterclockwise from the $+x$ axis. To convert from polar form to rectangular form, one finds

$$A_x = A \cos \theta \quad (\text{P.10})$$

$$A_y = A \sin \theta \quad (\text{P.11})$$

Inverting these equations gives the expressions for converting from rectangular form to polar form:

$$A = \sqrt{A_x^2 + A_y^2} \quad (\text{P.12})$$

$$\tan \theta = \frac{A_y}{A_x} \quad (\text{P.13})$$

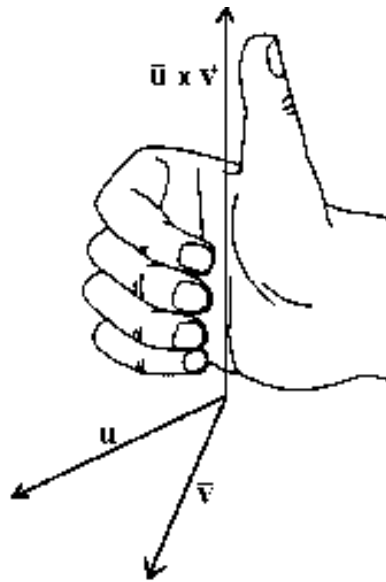

Figure P.1: The vector cross product $\mathbf{A} \times \mathbf{B}$ is perpendicular to the plane of \mathbf{A} and \mathbf{B} , and in the right-hand sense. (Credit: "Connected Curriculum Project", Duke University.)

Appendix Q

Matrix Properties

This appendix presents a brief summary of the properties of 2×2 and 3×3 matrices.

2×2 Matrices

Determinant

The determinant of a 2×2 matrix is given by the well-known formula:

$$\det \begin{pmatrix} a & b \\ c & d \end{pmatrix} = ad - bc. \quad (\text{Q.1})$$

Matrix of Cofactors

The matrix of cofactors is the matrix of signed minors; for a 2×2 matrix, this is

$$\text{cof} \begin{pmatrix} a & b \\ c & d \end{pmatrix} = \begin{pmatrix} d & -b \\ -c & a \end{pmatrix} \quad (\text{Q.2})$$

Inverse

Finally, the inverse of a matrix is the transpose of the matrix of cofactors divided by the determinant. For a 2×2 matrix,

$$\begin{pmatrix} a & b \\ c & d \end{pmatrix}^{-1} = \frac{1}{ad - bc} \begin{pmatrix} d & -b \\ -c & a \end{pmatrix} \quad (\text{Q.3})$$

3×3 Matrices

Determinant

The determinant of a 3×3 matrix is given by:

$$\det \begin{pmatrix} a & b & c \\ d & e & f \\ g & h & i \end{pmatrix} = a(ei - fh) - b(di - fg) + c(dh - eg). \quad (\text{Q.4})$$

Matrix of Cofactors

The matrix of cofactors is the matrix of signed minors; for a 3×3 matrix, this is

$$\text{cof} \begin{pmatrix} a & b & c \\ d & e & f \\ g & h & i \end{pmatrix} = \begin{pmatrix} ei - fh & fg - di & dh - eg \\ ch - bi & ai - cg & bg - ah \\ bf - ce & cd - af & ae - bd \end{pmatrix} \quad (\text{Q.5})$$

Inverse

Finally, the inverse of a matrix is the transpose of the matrix of cofactors divided by the determinant. For a 3×3 matrix,

$$\begin{pmatrix} a & b & c \\ d & e & f \\ g & h & i \end{pmatrix}^{-1} = \frac{1}{a(ei - fh) - b(di - fg) + c(dh - eg)} \begin{pmatrix} ei - fh & ch - bi & bf - ce \\ fg - di & ai - cg & cd - af \\ dh - eg & bg - ah & ae - bd \end{pmatrix} \quad (\text{Q.6})$$

Appendix R

Newton's Laws of Motion (Original)

Newton's laws of motion appear at the beginning of Book I of *Philosophiæ Naturalis Principia Mathematica*:

Axiomata, sive Leges Motus¹

- I. Corpus omne perseverare in statis suo quiescendi vel movendi uniformiter in directum, nisi quatenus a viribus impressis cogitur statum illum mutare.
- II. Mutationem motus proportionalem esse vi motrici impressæ, & fieri secundum lineam rectam qua vis illa imprimitur.
- III. Actioni contrariam semper & æqualem esse reactionem: sive corporum duorum actiones in se mutuo semper esse æquales & in partes contrarias dirigi.

In modern language,

- *Vis* means *force*.
- *Actio* (action) and *reactio* (reaction) also refer to force.
- *Motus* (motion) is equivalent to what we now call *momentum*.

¹Axioms, or Laws of Motion

- I. Every body preserves in its state of being at rest or of moving uniformly straight forward, except in so far as it is compelled to change its state by forces impressed.
- II. A change in motion is proportional to the motive force impressed and takes place along the straight line in which that force is impressed.
- III. To any action there is always an opposite and equal reaction; in other words, the actions of two bodies upon each other are always equal and always opposite in direction.

Appendix S

The Simple Plane Pendulum: Exact Solution

The solution to the simple plane pendulum problem described in Chapter 38 is only approximate; here we will examine the *exact* solution, which is surprisingly complicated. We will begin by deriving the differential equation of the motion, then find expressions for the angle θ from the vertical and the period T at any time t . We won't go through the derivations here—we'll just look at the results. Here we'll assume the amplitude of the motion $\theta_0 < \pi$, so that the pendulum does *not* spin in complete circles around the pivot, but simply oscillates back and forth.

The mathematics involved in the exact solution to the pendulum problem is somewhat advanced, but is included here so that you can see that even a very simple physical system can lead to some complicated mathematics.

Equation of Motion

To derive the differential equation of motion for the pendulum, we begin with Newton's second law in rotational form:

$$\tau = I\alpha = I \frac{d^2\theta}{dt^2}, \quad (\text{S.1})$$

where τ is the torque, I is the moment of inertia, α is the angular acceleration, and θ is the angle from the vertical. In the case of the pendulum, the torque is given by

$$\tau = -mgL \sin \theta, \quad (\text{S.2})$$

and the moment of inertia is

$$I = mL^2. \quad (\text{S.3})$$

Substituting these expressions for τ and I into Eq. (S.1), we get the second-order differential equation

$$-mgL \sin \theta = mL^2 \frac{d^2\theta}{dt^2}, \quad (\text{S.4})$$

which simplifies to give the differential equation of motion,

$$\frac{d^2\theta}{dt^2} = -\frac{g}{L} \sin \theta. \quad (\text{S.5})$$

Solution, $\theta(t)$

If the amplitude θ_0 is small, we can approximate $\sin \theta \approx \theta$, and find the position $\theta(t)$ at any time t is given by Eq. (38.6) in Chapter 38. But when the amplitude is not necessarily small, the angle θ from the vertical at any time t is found (by solving Eq. (S.5)) to be a more complicated function:

$$\theta(t) = 2 \sin^{-1} \left\{ k \operatorname{sn} \left[\sqrt{\frac{g}{L}} (t - t_0); k \right] \right\}, \quad (\text{S.6})$$

where $\operatorname{sn}(x; k)$ is a *Jacobian elliptic function* with modulus $k = \sin(\theta_0/2)$. The time t_0 is a time at which the pendulum is vertical ($\theta = 0$) and moving in the $+\theta$ direction.

The Jacobian elliptic function is one of a number of so-called “special functions” that often appear in mathematical physics. In this case, the function $\operatorname{sn}(x; k)$ is defined as a kind of inverse of an integral. Given the function

$$u(y; k) = \int_0^y \frac{dt}{\sqrt{(1-t^2)(1-k^2t^2)}}, \quad (\text{S.7})$$

the Jacobian elliptic function is defined as:

$$\operatorname{sn}(u; k) = y. \quad (\text{S.8})$$

Values of $\operatorname{sn}(x; k)$ may be found in tables of functions or computed by specialized mathematical software libraries.

Period

As found in Chapter 38, the approximate period of a pendulum for small amplitudes is given by

$$T_0 = 2\pi \sqrt{\frac{L}{g}}. \quad (\text{S.9})$$

This equation is really only an *approximate* expression for the period of a simple plane pendulum; the smaller the amplitude of the motion, the better the approximation. An *exact* expression for the period is given by

$$T = 4 \sqrt{\frac{L}{g}} \int_0^1 \frac{dt}{\sqrt{(1-t^2)(1-k^2t^2)}}, \quad (\text{S.10})$$

which is a type of integral known as a *complete elliptic integral of the first kind*.

The integral in Eq. (S.10) cannot be evaluated in closed form, but it *can* be expanded into an infinite series. The result is

$$T = 2\pi \sqrt{\frac{L}{g}} \left\{ 1 + \sum_{n=1}^{\infty} \left[\frac{(2n-1)!!}{(2n)!!} \right]^2 \sin^{2n} \left(\frac{\theta_0}{2} \right) \right\} \quad (\text{S.11})$$

$$= 2\pi \sqrt{\frac{L}{g}} \left\{ 1 + \sum_{n=1}^{\infty} \left[\frac{(2n)!}{2^{2n}(n!)^2} \right]^2 \sin^{2n} \left(\frac{\theta_0}{2} \right) \right\}. \quad (\text{S.12})$$

We can explicitly write out the first few terms of this series; the result is

$$T = 2\pi \sqrt{\frac{L}{g}} \left[1 + \frac{1}{4} \sin^2 \left(\frac{\theta_0}{2} \right) + \frac{9}{64} \sin^4 \left(\frac{\theta_0}{2} \right) + \frac{25}{256} \sin^6 \left(\frac{\theta_0}{2} \right) + \frac{1225}{16384} \sin^8 \left(\frac{\theta_0}{2} \right) + \frac{3969}{65536} \sin^{10} \left(\frac{\theta_0}{2} \right) + \frac{53361}{1048576} \sin^{12} \left(\frac{\theta_0}{2} \right) + \frac{184041}{4194304} \sin^{14} \left(\frac{\theta_0}{2} \right) + \frac{41409225}{1073741824} \sin^{16} \left(\frac{\theta_0}{2} \right) + \frac{147744025}{4294967296} \sin^{18} \left(\frac{\theta_0}{2} \right) + \frac{2133423721}{68719476736} \sin^{20} \left(\frac{\theta_0}{2} \right) + \dots \right]. \quad (\text{S.13})$$

If we wish, we can write out a series expansion for the period in another form—one which does not involve the sine function, but only involves powers of the amplitude θ_0 . To do this, we expand $\sin(\theta_0/2)$ into a Taylor series:

$$\sin \frac{\theta_0}{2} = \sum_{n=1}^{\infty} \frac{(-1)^{n+1} \theta_0^{2n-1}}{2^{2n-1} (2n-1)!} \quad (\text{S.14})$$

$$= \frac{\theta_0}{2} - \frac{\theta_0^3}{48} + \frac{\theta_0^5}{3840} - \frac{\theta_0^7}{645120} + \frac{\theta_0^9}{185794560} - \frac{\theta_0^{11}}{81749606400} + \dots \quad (\text{S.15})$$

Now substitute this series into the series of Eq. (S.11) and collect terms. The result is

$$T = 2\pi \sqrt{\frac{L}{g}} \left(1 + \frac{1}{16} \theta_0^2 + \frac{11}{3072} \theta_0^4 + \frac{173}{737280} \theta_0^6 + \frac{22931}{1321205760} \theta_0^8 + \frac{1319183}{951268147200} \theta_0^{10} + \frac{233526463}{2009078326886400} \theta_0^{12} + \frac{2673857519}{265928913086054400} \theta_0^{14} + \frac{39959591850371}{44931349155019751424000} \theta_0^{16} + \frac{8797116290975003}{109991942731488351485952000} \theta_0^{18} + \frac{4872532317019728133}{668751011807449177034588160000} \theta_0^{20} + \dots \right). \quad (\text{S.16})$$

An entirely different formula for the exact period of a simple plane pendulum has appeared in a recent paper (Adlaj, 2012). According to Adlaj, the exact period of a pendulum may be calculated more efficiently using the *arithmetic-geometric mean*, by means of the formula

$$T = 2\pi \sqrt{\frac{L}{g}} \times \frac{1}{\text{agm}(1, \cos(\theta_0/2))} \quad (\text{S.17})$$

where $\text{agm}(x, y)$ denotes the arithmetic-geometric mean of x and y , which is found by computing the arithmetic and geometric means of x and y , then the arithmetic and geometric mean of those two means, then iterating this process over and over again until the two means converge:

$$a_{n+1} = \frac{a_n + g_n}{2} \quad (\text{S.18})$$

$$g_{n+1} = \sqrt{a_n g_n} \quad (\text{S.19})$$

Here a_n denotes an arithmetic mean, and g_n a geometric mean.

Shown in Fig. S.1 is a plot of the ratio of the pendulum's true period T to its small-angle period T_0 ($T/(2\pi\sqrt{L/g})$) vs. amplitude θ_0 for values of the amplitude between 0 and 180°, using Eq. (S.17). As you can see, the ratio is 1 for small amplitudes (as expected), and increasingly deviates from 1 for large amplitudes. The true period will always be longer than the small-angle period T_0 .

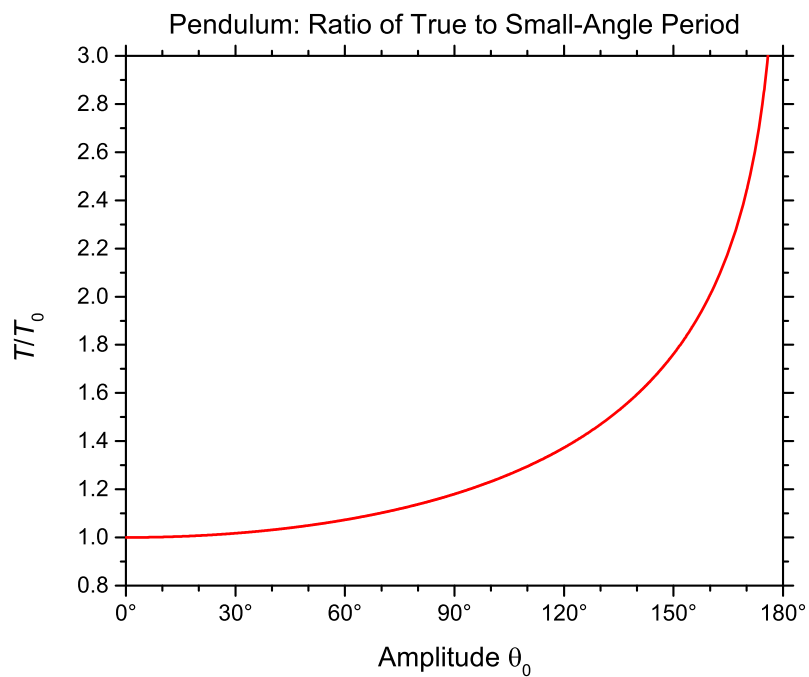

Figure S.1: Ratio of a pendulum's true period T to its small-angle period $T_0 = 2\pi\sqrt{L/g}$, as a function of amplitude θ_0 . For small amplitudes, this ratio is near 1; for larger amplitudes, the true period is longer than predicted by the small-angle approximation.

References

1. L.P. Fulcher and B.F. Davis, "Theoretical and experimental study of the motion of the simple pendulum", *Am. J. Phys.*, **44**, 51 (1976).
2. R.A. Nelson and M.G. Olsson, "The pendulum—Rich physics from a simple system", *Am. J. Phys.*, **54**, 112 (1986).
3. E.T. Whittaker, *A Treatise on the Analytical Dynamics of Particles and Rigid Bodies* (Cambridge, New York, 1937), 4th ed., p. 73.
4. G.L. Baker and J.A. Blackburn, *The Pendulum: A Case Study in Physics* (Oxford, New York, 2005).
5. S. Adlaj, An Eloquent Formula for the Perimeter of an Ellipse. *Notices Amer. Math. Soc.*, **59**, 8, 1094 (September 2012).

Appendix T

Motion of a Falling Body

Given a body of mass m released from rest at time $t = 0$ from a height h above the floor, we find the following results about the motion. Here the y axis points upward and has its origin at the floor, and so the acceleration due to gravity is $-g$.

- Position y at time t :

$$y(t) = h - \frac{1}{2}gt^2 \quad (\text{T.1})$$

- Velocity v :

$$v(t) = -gt \quad (\text{T.2})$$

$$v(y) = -\sqrt{2g(h - y)} \quad (\text{T.3})$$

- Fall time t_f :

$$t_f = \sqrt{\frac{2h}{g}} \quad (\text{T.4})$$

- Impact velocity v_f :

$$v_f = -\sqrt{2gh} \quad (\text{T.5})$$

- Total energy E :

$$E = mgh \quad (\text{T.6})$$

- Kinetic energy K :

$$K(t) = \frac{1}{2}mg^2t^2 \quad (\text{T.7})$$

$$K(y) = mg(h - y) \quad (\text{T.8})$$

- Potential energy U :

$$U(t) = mgh - \frac{1}{2}mg^2t^2 \quad (\text{T.9})$$

$$U(y) = mgy \quad (\text{T.10})$$

- Time derivatives of kinetic energy:

$$\frac{dK}{dt} = -mgv = mg^2t = mg\sqrt{2g(h-y)} \quad (\text{T.11})$$

$$\frac{d^2K}{dt^2} = mg^2 \quad (\text{T.12})$$

- Time derivatives of potential energy:

$$\frac{dU}{dt} = mgv = -mg^2t = -mg\sqrt{2g(h-y)} \quad (\text{T.13})$$

$$\frac{d^2U}{dt^2} = -mg^2 \quad (\text{T.14})$$

- Time averages:

$$\langle v \rangle = -\frac{1}{2}\sqrt{2gh} \quad (\text{T.15})$$

$$\langle K \rangle = \frac{1}{3}mgh \quad (\text{T.16})$$

$$\langle U \rangle = \frac{2}{3}mgh \quad (\text{T.17})$$

- Virial theorem ($n = 0$):

$$\langle K \rangle = \frac{1}{2}\langle U \rangle \quad (\text{T.18})$$

Appendix U

Table of Viscosities

The following table of viscosities is from the G.E. Alves and E.W. Brugmann, "Estimate Viscosities by Comparison with Known Materials," *Chemical Engineering*, **68**, 19, 182 (September 18, 1961).

VISCOSITY SPECTRUM

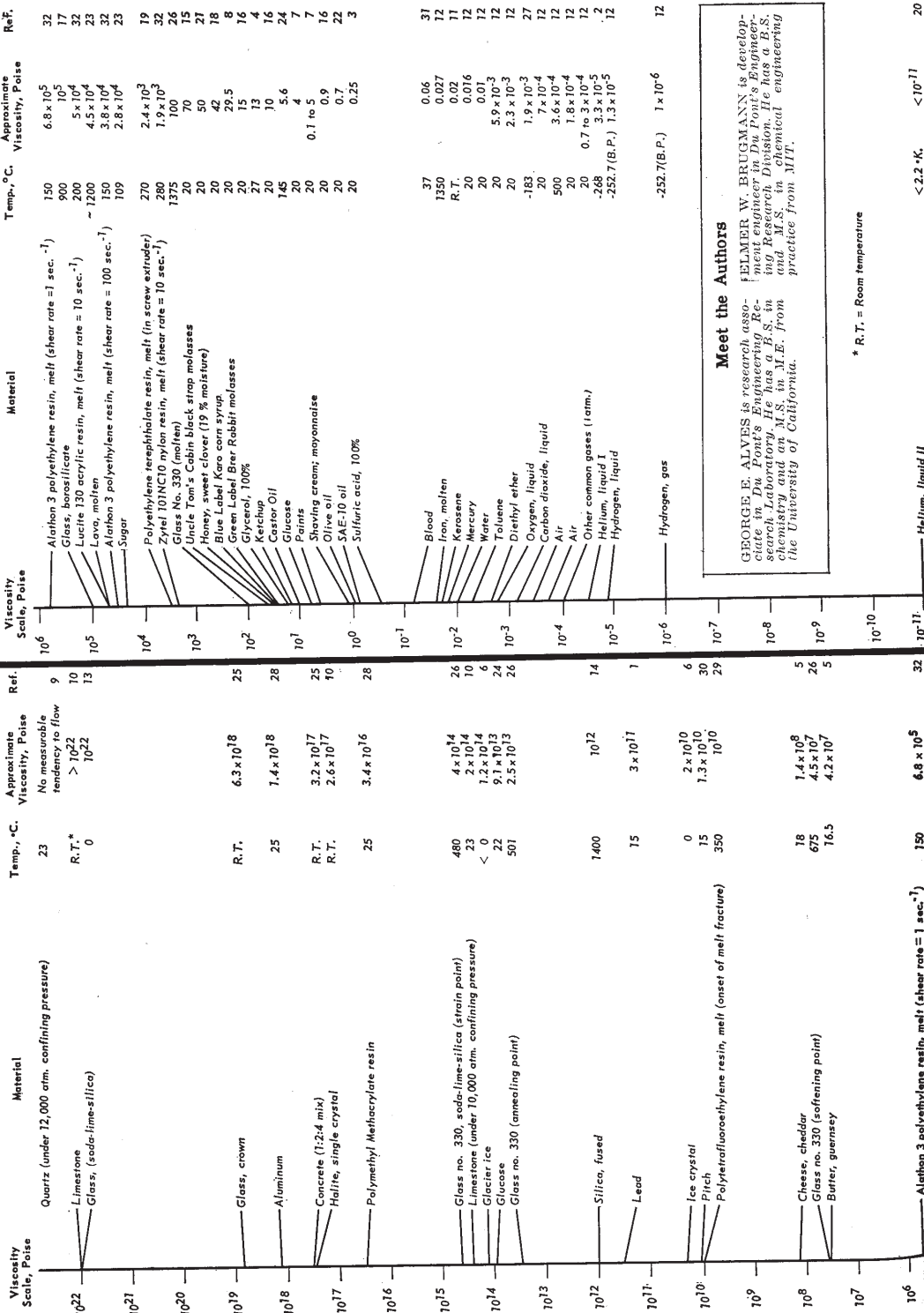

Meet the Authors
 GEORGE E. ALVES is research associate in Du Pont's Engineering Research Laboratory. He has a B.S. in chemistry and an M.S. in M.E. from the University of California.
 FELMER W. BRUGMANN is development engineer in Du Pont's Engineering Research Division. He has a B.S. and M.S. in chemical engineering practice from MIT.

* R. T. = Room temperature

Appendix V

Calculator Programs

On the class Web site you will find several physics-related programs for a variety of electronic calculator models. The programs are available at:

<http://www.pgccphy.net/1030/software.html>

Contents

1. **Projectile Problem**
2. **Kepler's Equation**
3. **Hyperbolic Kepler's Equation**
4. **Barker's Equation**
5. **Reduction of an Angle**
6. **Helmert's Equation**
7. **Pendulum Period**
8. **1D Perfectly Elastic Collisions**

Appendix W

Round-Number Handbook of Physics

The one-page *Round Number Handbook of Physics* on the following page is by Edward M. Purcell of Harvard University, and appeared in the January 1983 issue of the *American Journal of Physics*. It is intended as a brief reference for doing quick “back of the envelope”, order-of-magnitude calculations.

ROUND-NUMBER HANDBOOK OF PHYSICS

CONSTANTS

$$\begin{aligned}
 c &= 3 \times 10^{10} \text{ cm s}^{-1} \\
 \hbar &= 10^{-27} \text{ erg s} \\
 N_0 &= 6 \times 10^{23} \text{ mole}^{-1} \\
 n_0 &= 3 \times 10^{19} \text{ cm}^{-3} \\
 g &= 10^3 \text{ cm s}^{-2} \\
 e &= 4.8 \times 10^{-10} \text{ esu} \\
 &= 1.6 \times 10^{-19} \text{ C} \\
 k &= 1.4 \times 10^{-16} \text{ erg deg}^{-1} \\
 \alpha &= e^2/\hbar c = 1/137 \\
 (\mu_0/\epsilon_0)^{1/2} &= 377 \Omega \\
 G &= 7 \times 10^{-8} \text{ g cm}^{-4} \text{ s}^{-2} \\
 \mu_0 &= 4\pi \times 10^{-7} \text{ N A}^{-2} \\
 \epsilon_0 &= 8.8 \times 10^{-12} \text{ N}^{-1} \text{ A}^2 \text{ m}^{-2} \text{ s}^2 \\
 R &= 2 \text{ cal/mole deg}
 \end{aligned}$$

CONVERSIONS

$$\begin{aligned}
 1 \text{ cal} &= 4 \text{ J} = 4 \times 10^7 \text{ erg} \\
 1 \text{ N} &= 10^5 \text{ dyn} \\
 680 \text{ lumens} &= 1 \text{ W} (5550 \text{ \AA}) \\
 1 \text{ ft} &= 30 \text{ cm} \\
 1 \text{ lb} &= 4.4 \text{ N} \\
 1 \text{ ci} &= 4 \times 10^{10} \text{ disint/s} \\
 1 \text{ eV} &= 1.6 \times 10^{-12} \text{ erg} \\
 1 \Omega^{-1} &= 9 \times 10^{11} \text{ cm/s} \\
 \text{pc(eV)} &= 300 \text{ Br(G cm)}
 \end{aligned}$$

MASSES

$$\begin{aligned}
 m_e &= 10^{-27} \text{ g} \\
 m_{\text{pion}} &= 270m_e \\
 m_{\text{kaon}} &= 1000m_e \\
 m_{\text{nucleon}} &= 2000m_e \\
 m_e c^2 &= 0.5 \text{ MeV} \\
 m_{\text{muon}} &= 200m_e
 \end{aligned}$$

USEFUL NUMBERS

$$\begin{aligned}
 \text{classical electron radius} &= r_0 = e^2/m_e c^2 = 3 \times 10^{-13} \text{ cm} \\
 \text{Bohr radius} &= a_0 = \hbar^2/m_e e^2 = 5 \times 10^{-9} \text{ cm} \\
 \text{Rydberg wavelength} &= \lambda_R = \hbar^3 c/m_e e^4 = 7 \times 10^{-7} \text{ cm} \\
 \text{Compton wavelength} &= \lambda_c = \hbar/m_e c = 4 \times 10^{-11} \text{ cm} \\
 \text{Bohr magneton} &= e\hbar/2mc = 10^{-20} \text{ erg/G} \\
 \text{Stefan-Boltzman const} &= 6 \times 10^{-12} \text{ W/deg}^4 \text{ cm}^2 \\
 \text{Min. ionization loss} &= 2 \text{ MeV/g cm}^2 \\
 kT_{\text{room}} &= 0.025 \text{ eV} \\
 R_{\text{nuclear}} &= A^{1/3} \times 10^{-13} \text{ cm} \\
 e^2/a_0 &= 26 \text{ eV}
 \end{aligned}$$

$$h\nu(\text{visible}) = 2 \text{ eV}$$

$$\text{Band gaps: Si} = 1.1 \text{ eV; Ge} = 0.7 \text{ eV}$$

$$\text{Spin precession: } e: 3 \text{ MHz/G; } p: 4 \text{ kHz/G}$$

MATERIALS

$$\begin{aligned}
 \text{Resistivities in } \Omega \text{ cm: Cu: } &2 \times 10^{-6} \text{ (room temp.)} \\
 \text{H}_2\text{O(pure): } &2 \times 10^7; \text{ seawater: } 25 \Omega \text{ cm} \\
 \text{Specific heat (solid or liquid)} &= 0.5 \text{ cal/cm}^3 \text{ deg} \\
 \text{Linear expansion (solid or liquid)} &= 2 \times 10^{-5}/\text{deg} \\
 \text{Heat conduction (insulator)} &= 10^{-2} \text{ cal/s cm deg} \\
 \text{(metal)} &= 1.0(\rho_{\text{Cu}}/\rho_{\text{metal}}) \text{ cal/s cm deg} \\
 \text{Heat of combustion (food or fuel)} &= 10^4 \text{ cal/g} \\
 \text{Heat of vaporization} &= 10^4 \text{ cal/mole} \\
 \text{Elastic moduli (solids)} &= 10^{11}\text{--}10^{12} \text{ dyn/cm}^2 \\
 \text{Tensile strength (solids)} &= 10^8\text{--}10^{10} \text{ dyn/cm}^2 \\
 \text{Surface tension: H}_2\text{O} &= 50 \text{ dyn/cm} \\
 \text{Diffusion: H}_2\text{O } &10^{-5}, \text{ air: } 0.2 \text{ cm}^2/\text{s} \\
 \text{Viscosity: H}_2\text{O } &10^{-2}, \text{ air: } 2 \times 10^{-4} \text{ dyn s/cm}^2
 \end{aligned}$$

ASTRONOMICAL

$$\begin{aligned}
 1 \text{ pc} &= 3 \times 10^{18} \text{ cm} \\
 1 \text{ mag} &= -4 \text{ dB} \\
 m_{\text{abs}} &= m \text{ at } 10 \text{ pc} \\
 m_{\text{abs}}(\text{sun}) &= +5 \\
 B_{\text{Earth}}(\text{pole}) &= 0.5 \text{ G} \\
 M_{\text{Earth}} &= 6 \times 10^{27} \text{ g} \\
 R_{\text{Earth}} &= 6 \times 10^8 \text{ cm} \\
 M_{\odot} &= 2 \times 10^{33} \text{ g} \\
 R_{\odot} &= 8 \times 10^{10} \text{ cm} \\
 L_{\odot} &= 2 \times 10^{33} \text{ erg/s} = 1 \text{ kW/m}^2 \text{ at Earth} \\
 r_{\text{moon}} &= 4 \times 10^{10} \text{ cm} \\
 r_{\text{sun}} &= 1 \text{ AU} = 1.5 \times 10^{13} \text{ cm} \\
 M_{\text{Galaxy}} &= 2 \times 10^{44} \text{ g} \\
 \text{Distance to center of galaxy} &= 3 \times 10^{22} \text{ cm} \\
 \text{Distance between galaxies} &= 10^{25} \text{ cm} \\
 \text{Energy density: starlight} &= 10^{-12} \text{ erg/cm}^3 \\
 \text{Primary cosmic rays: } &1/\text{cm}^2 \text{ s} \\
 R_{\text{Universe}} &= 3000 \text{ Mpc}
 \end{aligned}$$

ATMOSPHERE (STP)

$$\begin{aligned}
 P_{\text{atm}} &= 10^6 \text{ dyn/cm}^2 = 15 \text{ psi} \\
 V_{\text{sound}} &= V_{\text{molec}} = 4 \times 10^4 \text{ cm/s} \\
 \text{Radiation length} &= 36 \text{ g/cm}^2 \\
 \text{Density} &= 10^{-3} \text{ g/cm}^3 \\
 \text{Mean free path} &= 7 \times 10^{-6} \text{ cm} \\
 \text{Scale height} &= 8 \text{ km}
 \end{aligned}$$

Appendix X

Short Glossary of Particle Physics

baryon, a particle made up of three quarks.

boson, any particle that has integer spin.

electron, a lepton of negative charge, found to surround the atomic nucleus in atoms of ordinary matter.

fermion, any particle that has half-integer spin.

hadron, any particle that “feels” the strong nuclear force.

Higgs boson, the particle associated with the Higgs field, that gives mass to other particles.

lepton, one of six light fundamental particles: e^- , ν_e^0 , μ^- , ν_μ^0 , τ^- , ν_τ^0 .

meson, a particle consisting of a quark-antiquark pair.

neutron, an uncharged baryon, found in the nucleus of atoms of ordinary matter.

proton, a baryon of positive charge, found in the nucleus of atoms of ordinary matter.

quark, one of six heavy fundamental particles: u , d , c , s , t , b .

vector boson, a particle responsible for mediating a force.

Appendix Y

Fundamental Physical Constants — Extensive Listing

The following tables, published by the National Institutes of Science and Technology (NIST), give the current best estimates of a large number of fundamental physical constants. These values were determined by the Committee on Data for Science and Technology (CODATA) for 2018, and are a best fit of the constants to the latest experimental results. These values include the 2019 re-definition of SI units.

(Source: <https://physics.nist.gov/cuu/Constants/index.html>)

Fundamental Physical Constants — Extensive Listing

Quantity	Symbol	Value	Unit	Relative std. uncert. u_r
UNIVERSAL				
speed of light in vacuum	c	299 792 458	m s^{-1}	exact
vacuum magnetic permeability $4\pi\alpha\hbar/e^2c$ $\mu_0/(4\pi \times 10^{-7})$	μ_0	$1.256\,637\,062\,12(19) \times 10^{-6}$ $1.000\,000\,000\,55(15)$	N A^{-2} N A^{-2}	1.5×10^{-10} 1.5×10^{-10}
vacuum electric permittivity $1/\mu_0c^2$	ϵ_0	$8.854\,187\,8128(13) \times 10^{-12}$	F m^{-1}	1.5×10^{-10}
characteristic impedance of vacuum μ_0c	Z_0	$376.730\,313\,668(57)$	Ω	1.5×10^{-10}
Newtonian constant of gravitation	G	$6.674\,30(15) \times 10^{-11}$	$\text{m}^3 \text{kg}^{-1} \text{s}^{-2}$	2.2×10^{-5}
Planck constant*	\hbar	$6.708\,83(15) \times 10^{-39}$ $6.626\,070\,15 \times 10^{-34}$ $4.135\,667\,696 \dots \times 10^{-15}$	$(\text{GeV}/c^2)^{-2}$ J Hz^{-1} eV Hz^{-1}	2.2×10^{-5} exact exact
	\hbar	$1.054\,571\,817 \dots \times 10^{-34}$ $6.582\,119\,569 \dots \times 10^{-16}$	J s eV s	exact exact
	$\hbar c$	$197.326\,980\,4 \dots$	MeV fm	exact
Planck mass $(\hbar c/G)^{1/2}$	m_{P}	$2.176\,434(24) \times 10^{-8}$	kg	1.1×10^{-5}
energy equivalent	$m_{\text{P}}c^2$	$1.220\,890(14) \times 10^{19}$	GeV	1.1×10^{-5}
Planck temperature $(\hbar c^5/G)^{1/2}/k$	T_{P}	$1.416\,784(16) \times 10^{32}$	K	1.1×10^{-5}
Planck length $\hbar/m_{\text{P}}c = (\hbar G/c^3)^{1/2}$	l_{P}	$1.616\,255(18) \times 10^{-35}$	m	1.1×10^{-5}
Planck time $l_{\text{P}}/c = (\hbar G/c^5)^{1/2}$	t_{P}	$5.391\,247(60) \times 10^{-44}$	s	1.1×10^{-5}
ELECTROMAGNETIC				
elementary charge	e	$1.602\,176\,634 \times 10^{-19}$	C	exact
	e/\hbar	$1.519\,267\,447 \dots \times 10^{15}$	A J^{-1}	exact
magnetic flux quantum $2\pi\hbar/(2e)$	Φ_0	$2.067\,833\,848 \dots \times 10^{-15}$	Wb	exact
conductance quantum $2e^2/2\pi\hbar$	G_0	$7.748\,091\,729 \dots \times 10^{-5}$	S	exact
inverse of conductance quantum	G_0^{-1}	$12\,906.403\,72 \dots$	Ω	exact
Josephson constant $2e/h$	K_{J}	$483\,597.848\,4 \dots \times 10^9$	Hz V^{-1}	exact
von Klitzing constant $\mu_0c/2\alpha = 2\pi\hbar/e^2$	R_{K}	$25\,812.807\,45 \dots$	Ω	exact
Bohr magneton $e\hbar/2m_e$	μ_{B}	$9.274\,010\,0783(28) \times 10^{-24}$ $5.788\,381\,8060(17) \times 10^{-5}$	J T^{-1} eV T^{-1}	3.0×10^{-10} 3.0×10^{-10}
	μ_{B}/h	$1.399\,624\,493\,61(42) \times 10^{10}$	Hz T^{-1}	3.0×10^{-10}
	μ_{B}/hc	$46.686\,447\,783(14)$	$[\text{m}^{-1} \text{T}^{-1}]^\dagger$	3.0×10^{-10}
	μ_{B}/k	$0.671\,713\,815\,63(20)$	K T^{-1}	3.0×10^{-10}
nuclear magneton $e\hbar/2m_{\text{p}}$	μ_{N}	$5.050\,783\,7461(15) \times 10^{-27}$ $3.152\,451\,258\,44(96) \times 10^{-8}$	J T^{-1} eV T^{-1}	3.1×10^{-10} 3.1×10^{-10}
	μ_{N}/h	$7.622\,593\,2291(23)$	MHz T^{-1}	3.1×10^{-10}
	μ_{N}/hc	$2.542\,623\,413\,53(78) \times 10^{-2}$	$[\text{m}^{-1} \text{T}^{-1}]^\dagger$	3.1×10^{-10}
	μ_{N}/k	$3.658\,267\,7756(11) \times 10^{-4}$	K T^{-1}	3.1×10^{-10}
ATOMIC AND NUCLEAR				
General				
fine-structure constant $e^2/4\pi\epsilon_0\hbar c$	α	$7.297\,352\,5693(11) \times 10^{-3}$		1.5×10^{-10}
inverse fine-structure constant	α^{-1}	$137.035\,999\,084(21)$		1.5×10^{-10}
Rydberg frequency $\alpha^2m_e c^2/2\hbar = E_{\text{h}}/2\hbar$	cR_∞	$3.289\,841\,960\,2508(64) \times 10^{15}$	Hz	1.9×10^{-12}
energy equivalent	hcR_∞	$2.179\,872\,361\,1035(42) \times 10^{-18}$ $13.605\,693\,122\,994(26)$	J eV	1.9×10^{-12} 1.9×10^{-12}
Rydberg constant	R_∞	$10\,973\,731.568\,160(21)$	$[\text{m}^{-1}]^\dagger$	1.9×10^{-12}
Bohr radius $\hbar/\alpha m_e c = 4\pi\epsilon_0\hbar^2/m_e e^2$	a_0	$5.291\,772\,109\,03(80) \times 10^{-11}$	m	1.5×10^{-10}
Hartree energy $\alpha^2m_e c^2 = e^2/4\pi\epsilon_0 a_0 = 2hcR_\infty$	E_{h}	$4.359\,744\,722\,2071(85) \times 10^{-18}$ $27.211\,386\,245\,988(53)$	J eV	1.9×10^{-12} 1.9×10^{-12}
quantum of circulation	$\pi\hbar/m_e$	$3.636\,947\,5516(11) \times 10^{-4}$	$\text{m}^2 \text{s}^{-1}$	3.0×10^{-10}

Fundamental Physical Constants — Extensive Listing

Quantity	Symbol	Value	Unit	Relative std. uncert. u_r
	$2\pi\hbar/m_e$	$7.273\,895\,1032(22) \times 10^{-4}$	$\text{m}^2 \text{s}^{-1}$	3.0×10^{-10}
	Electroweak			
Fermi coupling constant [‡]	$G_F/(\hbar c)^3$	$1.166\,3787(6) \times 10^{-5}$	GeV^{-2}	5.1×10^{-7}
weak mixing angle [§] θ_W (on-shell scheme) $\sin^2 \theta_W = s_W^2 \equiv 1 - (m_W/m_Z)^2$	$\sin^2 \theta_W$	0.222 90(30)		1.3×10^{-3}
	Electron, e^-			
electron mass	m_e	$9.109\,383\,7015(28) \times 10^{-31}$	kg	3.0×10^{-10}
		$5.485\,799\,090\,65(16) \times 10^{-4}$	u	2.9×10^{-11}
energy equivalent	$m_e c^2$	$8.187\,105\,7769(25) \times 10^{-14}$	J	3.0×10^{-10}
		0.510 998 950 00(15)	MeV	3.0×10^{-10}
electron-muon mass ratio	m_e/m_μ	$4.836\,331\,69(11) \times 10^{-3}$		2.2×10^{-8}
electron-tau mass ratio	m_e/m_τ	$2.875\,85(19) \times 10^{-4}$		6.8×10^{-5}
electron-proton mass ratio	m_e/m_p	$5.446\,170\,214\,87(33) \times 10^{-4}$		6.0×10^{-11}
electron-neutron mass ratio	m_e/m_n	$5.438\,673\,4424(26) \times 10^{-4}$		4.8×10^{-10}
electron-deuteron mass ratio	m_e/m_d	$2.724\,437\,107\,462(96) \times 10^{-4}$		3.5×10^{-11}
electron-triton mass ratio	m_e/m_t	$1.819\,200\,062\,251(90) \times 10^{-4}$		5.0×10^{-11}
electron-helion mass ratio	m_e/m_h	$1.819\,543\,074\,573(79) \times 10^{-4}$		4.3×10^{-11}
electron to alpha particle mass ratio	m_e/m_α	$1.370\,933\,554\,787(45) \times 10^{-4}$		3.3×10^{-11}
electron charge to mass quotient	$-e/m_e$	$-1.758\,820\,010\,76(53) \times 10^{11}$	C kg^{-1}	3.0×10^{-10}
electron molar mass $N_A m_e$	$M(e), M_e$	$5.485\,799\,0888(17) \times 10^{-7}$	kg mol^{-1}	3.0×10^{-10}
reduced Compton wavelength $\hbar/m_e c = \alpha a_0$	λ_C	$3.861\,592\,6796(12) \times 10^{-13}$	m	3.0×10^{-10}
Compton wavelength	λ_C	$2.426\,310\,238\,67(73) \times 10^{-12}$	[m] [†]	3.0×10^{-10}
classical electron radius $\alpha^2 a_0$	r_e	$2.817\,940\,3262(13) \times 10^{-15}$	m	4.5×10^{-10}
Thomson cross section $(8\pi/3)r_e^2$	σ_e	$6.652\,458\,7321(60) \times 10^{-29}$	m^2	9.1×10^{-10}
electron magnetic moment	μ_e	$-9.284\,764\,7043(28) \times 10^{-24}$	J T^{-1}	3.0×10^{-10}
to Bohr magneton ratio	μ_e/μ_B	$-1.001\,159\,652\,181\,28(18)$		1.7×10^{-13}
to nuclear magneton ratio	μ_e/μ_N	$-1838.281\,971\,88(11)$		6.0×10^{-11}
electron magnetic moment anomaly $ \mu_e /\mu_B - 1$	a_e	$1.159\,652\,181\,28(18) \times 10^{-3}$		1.5×10^{-10}
electron g -factor $-2(1 + a_e)$	g_e	$-2.002\,319\,304\,362\,56(35)$		1.7×10^{-13}
electron-muon magnetic moment ratio	μ_e/μ_μ	206.766 9883(46)		2.2×10^{-8}
electron-proton magnetic moment ratio	μ_e/μ_p	$-658.210\,687\,89(20)$		3.0×10^{-10}
electron to shielded proton magnetic moment ratio (H ₂ O, sphere, 25 °C)	μ_e/μ'_p	$-658.227\,5971(72)$		1.1×10^{-8}
electron-neutron magnetic moment ratio	μ_e/μ_n	960.920 50(23)		2.4×10^{-7}
electron-deuteron magnetic moment ratio	μ_e/μ_d	$-2143.923\,4915(56)$		2.6×10^{-9}
electron to shielded helion magnetic moment ratio (gas, sphere, 25 °C)	μ_e/μ'_h	864.058 257(10)		1.2×10^{-8}
electron gyromagnetic ratio $2 \mu_e /\hbar$	γ_e	$1.760\,859\,630\,23(53) \times 10^{11}$	$\text{s}^{-1} \text{T}^{-1}$	3.0×10^{-10}
		28 024.951 4242(85)	MHz T ⁻¹	3.0×10^{-10}
	Muon, μ^-			
muon mass	m_μ	$1.883\,531\,627(42) \times 10^{-28}$	kg	2.2×10^{-8}
		0.113 428 9259(25)	u	2.2×10^{-8}
energy equivalent	$m_\mu c^2$	$1.692\,833\,804(38) \times 10^{-11}$	J	2.2×10^{-8}
		105.658 3755(23)	MeV	2.2×10^{-8}
muon-electron mass ratio	m_μ/m_e	206.768 2830(46)		2.2×10^{-8}
muon-tau mass ratio	m_μ/m_τ	$5.946\,35(40) \times 10^{-2}$		6.8×10^{-5}
muon-proton mass ratio	m_μ/m_p	0.112 609 5264(25)		2.2×10^{-8}

Fundamental Physical Constants — Extensive Listing

Quantity	Symbol	Value	Unit	Relative std. uncert. u_r
muon-neutron mass ratio	m_μ/m_n	0.112 454 5170(25)		2.2×10^{-8}
muon molar mass $N_A m_\mu$	$M(\mu), M_\mu$	$1.134\,289\,259(25) \times 10^{-4}$	kg mol ⁻¹	2.2×10^{-8}
reduced muon Compton wavelength $\hbar/m_\mu c$	$\lambda_{C,\mu}$	$1.867\,594\,306(42) \times 10^{-15}$	m	2.2×10^{-8}
muon Compton wavelength	$\lambda_{C,\mu}$	$1.173\,444\,110(26) \times 10^{-14}$	[m] [†]	2.2×10^{-8}
muon magnetic moment	μ_μ	$-4.490\,448\,30(10) \times 10^{-26}$	J T ⁻¹	2.2×10^{-8}
to Bohr magneton ratio	μ_μ/μ_B	$-4.841\,970\,47(11) \times 10^{-3}$		2.2×10^{-8}
to nuclear magneton ratio	μ_μ/μ_N	$-8.890\,597\,03(20)$		2.2×10^{-8}
muon magnetic moment anomaly				
$ \mu_\mu /(e\hbar/2m_\mu) - 1$	a_μ	$1.165\,920\,89(63) \times 10^{-3}$		5.4×10^{-7}
muon g -factor $-2(1 + a_\mu)$	g_μ	$-2.002\,331\,8418(13)$		6.3×10^{-10}
muon-proton magnetic moment ratio	μ_μ/μ_p	$-3.183\,345\,142(71)$		2.2×10^{-8}
	Tau, τ^-			
tau mass [¶]	m_τ	$3.167\,54(21) \times 10^{-27}$	kg	6.8×10^{-5}
		$1.907\,54(13)$	u	6.8×10^{-5}
energy equivalent	$m_\tau c^2$	$2.846\,84(19) \times 10^{-10}$	J	6.8×10^{-5}
		$1776.86(12)$	MeV	6.8×10^{-5}
tau-electron mass ratio	m_τ/m_e	$3477.23(23)$		6.8×10^{-5}
tau-muon mass ratio	m_τ/m_μ	$16.8170(11)$		6.8×10^{-5}
tau-proton mass ratio	m_τ/m_p	$1.893\,76(13)$		6.8×10^{-5}
tau-neutron mass ratio	m_τ/m_n	$1.891\,15(13)$		6.8×10^{-5}
tau molar mass $N_A m_\tau$	$M(\tau), M_\tau$	$1.907\,54(13) \times 10^{-3}$	kg mol ⁻¹	6.8×10^{-5}
reduced tau Compton wavelength $\hbar/m_\tau c$	$\lambda_{C,\tau}$	$1.110\,538(75) \times 10^{-16}$	m	6.8×10^{-5}
tau Compton wavelength	$\lambda_{C,\tau}$	$6.977\,71(47) \times 10^{-16}$	[m] [†]	6.8×10^{-5}
	Proton, p			
proton mass	m_p	$1.672\,621\,923\,69(51) \times 10^{-27}$	kg	3.1×10^{-10}
		$1.007\,276\,466\,621(53)$	u	5.3×10^{-11}
energy equivalent	$m_p c^2$	$1.503\,277\,615\,98(46) \times 10^{-10}$	J	3.1×10^{-10}
		$938.272\,088\,16(29)$	MeV	3.1×10^{-10}
proton-electron mass ratio	m_p/m_e	$1836.152\,673\,43(11)$		6.0×10^{-11}
proton-muon mass ratio	m_p/m_μ	$8.880\,243\,37(20)$		2.2×10^{-8}
proton-tau mass ratio	m_p/m_τ	$0.528\,051(36)$		6.8×10^{-5}
proton-neutron mass ratio	m_p/m_n	$0.998\,623\,478\,12(49)$		4.9×10^{-10}
proton charge to mass quotient	e/m_p	$9.578\,833\,1560(29) \times 10^7$	C kg ⁻¹	3.1×10^{-10}
proton molar mass $N_A m_p$	$M(p), M_p$	$1.007\,276\,466\,27(31) \times 10^{-3}$	kg mol ⁻¹	3.1×10^{-10}
reduced proton Compton wavelength $\hbar/m_p c$	$\lambda_{C,p}$	$2.103\,089\,103\,36(64) \times 10^{-16}$	m	3.1×10^{-10}
proton Compton wavelength	$\lambda_{C,p}$	$1.321\,409\,855\,39(40) \times 10^{-15}$	[m] [†]	3.1×10^{-10}
proton rms charge radius	r_p	$8.414(19) \times 10^{-16}$	m	2.2×10^{-3}
proton magnetic moment	μ_p	$1.410\,606\,797\,36(60) \times 10^{-26}$	J T ⁻¹	4.2×10^{-10}
to Bohr magneton ratio	μ_p/μ_B	$1.521\,032\,202\,30(46) \times 10^{-3}$		3.0×10^{-10}
to nuclear magneton ratio	μ_p/μ_N	$2.792\,847\,344\,63(82)$		2.9×10^{-10}
proton g -factor $2\mu_p/\mu_N$	g_p	$5.585\,694\,6893(16)$		2.9×10^{-10}
proton-neutron magnetic moment ratio	μ_p/μ_n	$-1.459\,898\,05(34)$		2.4×10^{-7}
shielded proton magnetic moment (H ₂ O, sphere, 25 °C)	μ'_p	$1.410\,570\,560(15) \times 10^{-26}$	J T ⁻¹	1.1×10^{-8}
to Bohr magneton ratio	μ'_p/μ_B	$1.520\,993\,128(17) \times 10^{-3}$		1.1×10^{-8}
to nuclear magneton ratio	μ'_p/μ_N	$2.792\,775\,599(30)$		1.1×10^{-8}
proton magnetic shielding correction $1 - \mu'_p/\mu_p$ (H ₂ O, sphere, 25 °C)	σ'_p	$2.5689(11) \times 10^{-5}$		4.2×10^{-4}

Fundamental Physical Constants — Extensive Listing

Quantity	Symbol	Value	Unit	Relative std. uncert. u_r
proton gyromagnetic ratio $2\mu_p/\hbar$	γ_p	$2.675\,221\,8744(11) \times 10^8$ $42.577\,478\,518(18)$	$s^{-1} T^{-1}$ MHz T ⁻¹	4.2×10^{-10} 4.2×10^{-10}
shielded proton gyromagnetic ratio $2\mu'_p/\hbar$ (H ₂ O, sphere, 25 °C)	γ'_p	$2.675\,153\,151(29) \times 10^8$ $42.576\,384\,74(46)$	$s^{-1} T^{-1}$ MHz T ⁻¹	1.1×10^{-8} 1.1×10^{-8}
Neutron, n				
neutron mass	m_n	$1.674\,927\,498\,04(95) \times 10^{-27}$ $1.008\,664\,915\,95(49)$	kg u	5.7×10^{-10} 4.8×10^{-10}
energy equivalent	$m_n c^2$	$1.505\,349\,762\,87(86) \times 10^{-10}$ $939.565\,420\,52(54)$	J MeV	5.7×10^{-10} 5.7×10^{-10}
neutron-electron mass ratio	m_n/m_e	$1838.683\,661\,73(89)$		4.8×10^{-10}
neutron-muon mass ratio	m_n/m_μ	$8.892\,484\,06(20)$		2.2×10^{-8}
neutron-tau mass ratio	m_n/m_τ	$0.528\,779(36)$		6.8×10^{-5}
neutron-proton mass ratio	m_n/m_p	$1.001\,378\,419\,31(49)$		4.9×10^{-10}
neutron-proton mass difference	$m_n - m_p$	$2.305\,574\,35(82) \times 10^{-30}$ $1.388\,449\,33(49) \times 10^{-3}$	kg u	3.5×10^{-7} 3.5×10^{-7}
energy equivalent	$(m_n - m_p)c^2$	$2.072\,146\,89(74) \times 10^{-13}$ $1.293\,332\,36(46)$	J MeV	3.5×10^{-7} 3.5×10^{-7}
neutron molar mass $N_A m_n$	$M(n), M_n$	$1.008\,664\,915\,60(57) \times 10^{-3}$	kg mol ⁻¹	5.7×10^{-10}
reduced neutron Compton wavelength $\hbar/m_n c$	$\lambda_{C,n}$	$2.100\,194\,1552(12) \times 10^{-16}$	m	5.7×10^{-10}
neutron Compton wavelength	$\lambda_{C,n}$	$1.319\,590\,905\,81(75) \times 10^{-15}$	[m] [†]	5.7×10^{-10}
neutron magnetic moment	μ_n	$-9.662\,3651(23) \times 10^{-27}$	J T ⁻¹	2.4×10^{-7}
to Bohr magneton ratio	μ_n/μ_B	$-1.041\,875\,63(25) \times 10^{-3}$		2.4×10^{-7}
to nuclear magneton ratio	μ_n/μ_N	$-1.913\,042\,73(45)$		2.4×10^{-7}
neutron g -factor $2\mu_n/\mu_N$	g_n	$-3.826\,085\,45(90)$		2.4×10^{-7}
neutron-electron magnetic moment ratio	μ_n/μ_e	$1.040\,668\,82(25) \times 10^{-3}$		2.4×10^{-7}
neutron-proton magnetic moment ratio	μ_n/μ_p	$-0.684\,979\,34(16)$		2.4×10^{-7}
neutron to shielded proton magnetic moment ratio (H ₂ O, sphere, 25 °C)	μ_n/μ'_p	$-0.684\,996\,94(16)$		2.4×10^{-7}
neutron gyromagnetic ratio $2 \mu_n /\hbar$	γ_n	$1.832\,471\,71(43) \times 10^8$ $29.164\,6931(69)$	$s^{-1} T^{-1}$ MHz T ⁻¹	2.4×10^{-7} 2.4×10^{-7}
Deuteron, d				
deuteron mass	m_d	$3.343\,583\,7724(10) \times 10^{-27}$ $2.013\,553\,212\,745(40)$	kg u	3.0×10^{-10} 2.0×10^{-11}
energy equivalent	$m_d c^2$	$3.005\,063\,231\,02(91) \times 10^{-10}$ $1875.612\,942\,57(57)$	J MeV	3.0×10^{-10} 3.0×10^{-10}
deuteron-electron mass ratio	m_d/m_e	$3670.482\,967\,88(13)$		3.5×10^{-11}
deuteron-proton mass ratio	m_d/m_p	$1.999\,007\,501\,39(11)$		5.6×10^{-11}
deuteron molar mass $N_A m_d$	$M(d), M_d$	$2.013\,553\,212\,05(61) \times 10^{-3}$	kg mol ⁻¹	3.0×10^{-10}
deuteron rms charge radius	r_d	$2.127\,99(74) \times 10^{-15}$	m	3.5×10^{-4}
deuteron magnetic moment	μ_d	$4.330\,735\,094(11) \times 10^{-27}$	J T ⁻¹	2.6×10^{-9}
to Bohr magneton ratio	μ_d/μ_B	$4.669\,754\,570(12) \times 10^{-4}$		2.6×10^{-9}
to nuclear magneton ratio	μ_d/μ_N	$0.857\,438\,2338(22)$		2.6×10^{-9}
deuteron g -factor μ_d/μ_N	g_d	$0.857\,438\,2338(22)$		2.6×10^{-9}
deuteron-electron magnetic moment ratio	μ_d/μ_e	$-4.664\,345\,551(12) \times 10^{-4}$		2.6×10^{-9}
deuteron-proton magnetic moment ratio	μ_d/μ_p	$0.307\,012\,209\,39(79)$		2.6×10^{-9}
deuteron-neutron magnetic moment ratio	μ_d/μ_n	$-0.448\,206\,53(11)$		2.4×10^{-7}

Fundamental Physical Constants — Extensive Listing

Quantity	Symbol	Value	Unit	Relative std. uncert. u_r
Triton, t				
triton mass	m_t	$5.007\,356\,7446(15) \times 10^{-27}$	kg	3.0×10^{-10}
		$3.015\,500\,716\,21(12)$	u	4.0×10^{-11}
energy equivalent	$m_t c^2$	$4.500\,387\,8060(14) \times 10^{-10}$	J	3.0×10^{-10}
		$2808.921\,132\,98(85)$	MeV	3.0×10^{-10}
triton-electron mass ratio	m_t/m_e	$5496.921\,535\,73(27)$		5.0×10^{-11}
triton-proton mass ratio	m_t/m_p	$2.993\,717\,034\,14(15)$		5.0×10^{-11}
triton molar mass $N_A m_t$	$M(t), M_t$	$3.015\,500\,715\,17(92) \times 10^{-3}$	kg mol ⁻¹	3.0×10^{-10}
triton magnetic moment	μ_t	$1.504\,609\,5202(30) \times 10^{-26}$	J T ⁻¹	2.0×10^{-9}
to Bohr magneton ratio	μ_t/μ_B	$1.622\,393\,6651(32) \times 10^{-3}$		2.0×10^{-9}
to nuclear magneton ratio	μ_t/μ_N	$2.978\,962\,4656(59)$		2.0×10^{-9}
triton g -factor $2\mu_t/\mu_N$	g_t	$5.957\,924\,931(12)$		2.0×10^{-9}
Helion, h				
helion mass	m_h	$5.006\,412\,7796(15) \times 10^{-27}$	kg	3.0×10^{-10}
		$3.014\,932\,247\,175(97)$	u	3.2×10^{-11}
energy equivalent	$m_h c^2$	$4.499\,539\,4125(14) \times 10^{-10}$	J	3.0×10^{-10}
		$2808.391\,607\,43(85)$	MeV	3.0×10^{-10}
helion-electron mass ratio	m_h/m_e	$5495.885\,280\,07(24)$		4.3×10^{-11}
helion-proton mass ratio	m_h/m_p	$2.993\,152\,671\,67(13)$		4.4×10^{-11}
helion molar mass $N_A m_h$	$M(h), M_h$	$3.014\,932\,246\,13(91) \times 10^{-3}$	kg mol ⁻¹	3.0×10^{-10}
helion magnetic moment	μ_h	$-1.074\,617\,532(13) \times 10^{-26}$	J T ⁻¹	1.2×10^{-8}
to Bohr magneton ratio	μ_h/μ_B	$-1.158\,740\,958(14) \times 10^{-3}$		1.2×10^{-8}
to nuclear magneton ratio	μ_h/μ_N	$-2.127\,625\,307(25)$		1.2×10^{-8}
helion g -factor $2\mu_h/\mu_N$	g_h	$-4.255\,250\,615(50)$		1.2×10^{-8}
shielded helion magnetic moment (gas, sphere, 25 °C)	μ'_h	$-1.074\,553\,090(13) \times 10^{-26}$	J T ⁻¹	1.2×10^{-8}
to Bohr magneton ratio	μ'_h/μ_B	$-1.158\,671\,471(14) \times 10^{-3}$		1.2×10^{-8}
to nuclear magneton ratio	μ'_h/μ_N	$-2.127\,497\,719(25)$		1.2×10^{-8}
shielded helion to proton magnetic moment ratio (gas, sphere, 25 °C)	μ'_h/μ_p	$-0.761\,766\,5618(89)$		1.2×10^{-8}
shielded helion to shielded proton magnetic moment ratio (gas/H ₂ O, spheres, 25 °C)	μ'_h/μ'_p	$-0.761\,786\,1313(33)$		4.3×10^{-9}
shielded helion gyromagnetic ratio $2 \mu'_h /\hbar$ (gas, sphere, 25 °C)	γ'_h	$2.037\,894\,569(24) \times 10^8$	s ⁻¹ T ⁻¹	1.2×10^{-8}
		$32.434\,099\,42(38)$	MHz T ⁻¹	1.2×10^{-8}
Alpha particle, α				
alpha particle mass	m_α	$6.644\,657\,3357(20) \times 10^{-27}$	kg	3.0×10^{-10}
		$4.001\,506\,179\,127(63)$	u	1.6×10^{-11}
energy equivalent	$m_\alpha c^2$	$5.971\,920\,1914(18) \times 10^{-10}$	J	3.0×10^{-10}
		$3727.379\,4066(11)$	MeV	3.0×10^{-10}
alpha particle to electron mass ratio	m_α/m_e	$7294.299\,541\,42(24)$		3.3×10^{-11}
alpha particle to proton mass ratio	m_α/m_p	$3.972\,599\,690\,09(22)$		5.5×10^{-11}
alpha particle molar mass $N_A m_\alpha$	$M(\alpha), M_\alpha$	$4.001\,506\,1777(12) \times 10^{-3}$	kg mol ⁻¹	3.0×10^{-10}
PHYSICOCHEMICAL				
Avogadro constant	N_A	$6.022\,140\,76 \times 10^{23}$	mol ⁻¹	exact
Boltzmann constant	k	$1.380\,649 \times 10^{-23}$	J K ⁻¹	exact
		$8.617\,333\,262 \dots \times 10^{-5}$	eV K ⁻¹	exact
	k/h	$2.083\,661\,912 \dots \times 10^{10}$	Hz K ⁻¹	exact

Fundamental Physical Constants — Extensive Listing

Quantity	Symbol	Value	Unit	Relative std. uncert. u_r	
		hc/k	$69.503\,480\,04\dots$	$[\text{m}^{-1}\text{K}^{-1}]^\dagger$	exact
atomic mass constant					
$m_u = \frac{1}{12}m(^{12}\text{C}) = 2hcR_\infty/\alpha^2c^2A_r(\text{e})$	m_u	$1.660\,539\,066\,60(50) \times 10^{-27}$	kg		3.0×10^{-10}
energy equivalent	$m_u c^2$	$1.492\,418\,085\,60(45) \times 10^{-10}$	J		3.0×10^{-10}
		931.494 102 42(28)	MeV		3.0×10^{-10}
molar mass constant	M_u	$0.999\,999\,999\,65(30) \times 10^{-3}$	kg mol ⁻¹		3.0×10^{-10}
molar mass of carbon-12 $A_r(^{12}\text{C})M_u$	$M(^{12}\text{C})$	$11.999\,999\,9958(36) \times 10^{-3}$	kg mol ⁻¹		3.0×10^{-10}
molar Planck constant	$N_A h$	$3.990\,312\,712\dots \times 10^{-10}$	J Hz ⁻¹ mol ⁻¹		exact
molar gas constant $N_A k$	R	8.314 462 618 ...	J mol ⁻¹ K ⁻¹		exact
Faraday constant $N_A e$	F	96 485.332 12 ...	C mol ⁻¹		exact
standard-state pressure		100 000	Pa		exact
standard atmosphere		101 325	Pa		exact
molar volume of ideal gas RT/p					
$T = 273.15\text{ K}, p = 100\text{ kPa}$	V_m	$22.710\,954\,64\dots \times 10^{-3}$	m ³ mol ⁻¹		exact
or standard-state pressure					
Loschmidt constant N_A/V_m	n_0	$2.651\,645\,804\dots \times 10^{25}$	m ⁻³		exact
molar volume of ideal gas RT/p					
$T = 273.15\text{ K}, p = 101.325\text{ kPa}$	V_m	$22.413\,969\,54\dots \times 10^{-3}$	m ³ mol ⁻¹		exact
or standard atmosphere					
Loschmidt constant N_A/V_m	n_0	$2.686\,780\,111\dots \times 10^{25}$	m ⁻³		exact
Sackur-Tetrode (absolute entropy) constant ^{**}					
$\frac{5}{2} + \ln[(m_u k T_1 / 2\pi\hbar^2)^{3/2} k T_1 / p_0]$					
$T_1 = 1\text{ K}, p_0 = 100\text{ kPa}$	S_0/R	$-1.151\,707\,537\,06(45)$			3.9×10^{-10}
or standard-state pressure					
$T_1 = 1\text{ K}, p_0 = 101.325\text{ kPa}$		$-1.164\,870\,523\,58(45)$			3.9×10^{-10}
or standard atmosphere					
Stefan-Boltzmann constant					
$(\pi^2/60)k^4/\hbar^3c^2$	σ	$5.670\,374\,419\dots \times 10^{-8}$	W m ⁻² K ⁻⁴		exact
first radiation constant for spectral radiance $2hc^2\text{ sr}^{-1}$	c_{1L}	$1.191\,042\,972\dots \times 10^{-16}$	[W m ² sr ⁻¹] ^{††}		exact
first radiation constant $2\pi hc^2 = \pi\text{ sr } c_{1L}$	c_1	$3.741\,771\,852\dots \times 10^{-16}$	[W m ²] ^{††}		exact
second radiation constant hc/k	c_2	$1.438\,776\,877\dots \times 10^{-2}$	[m K] [†]		exact
Wien displacement law constants					
$b = \lambda_{\text{max}} T = c_2/4.965\,114\,231\dots$	b	$2.897\,771\,955\dots \times 10^{-3}$	[m K] [†]		exact
$b' = \nu_{\text{max}}/T = 2.821\,439\,372\dots c/c_2$	b'	$5.878\,925\,757\dots \times 10^{10}$	Hz K ⁻¹		exact

* The energy of a photon with frequency ν expressed in unit Hz is $E = h\nu$ in J. Unitary time evolution of the state of this photon is given by $\exp(-iEt/\hbar)|\varphi\rangle$, where $|\varphi\rangle$ is the photon state at time $t = 0$ and time is expressed in unit s. The ratio Et/\hbar is a phase.

† The full description of m⁻¹ is cycles or periods per meter and that of m is meter per cycle (m/cycle). The scientific community is aware of the implied use of these units. It traces back to the conventions for phase and angle and the use of unit Hz versus cycles/s. No solution has been agreed upon.

‡ Value recommended by the Particle Data Group (Tanabashi, *et al.*, 2018).

§ Based on the ratio of the masses of the W and Z bosons m_W/m_Z recommended by the Particle Data Group (Tanabashi, *et al.*, 2018). The value for $\sin^2\theta_W$ they recommend, which is based on a variant of the modified minimal subtraction ($\overline{\text{MS}}$) scheme, is $\sin^2\hat{\theta}_W(M_Z) = 0.231\,22(4)$.

¶ This and other constants involving m_r are based on $m_r c^2$ in MeV recommended by the Particle Data Group (Tanabashi, *et al.*, 2018).

|| The relative atomic mass $A_r(X)$ of particle X with mass $m(X)$ is defined by $A_r(X) = m(X)/m_u$, where $m_u = m(^{12}\text{C})/12 = 1\text{ u}$ is the atomic mass constant and u is the unified atomic mass unit. Moreover, the mass of particle X is $m(X) = A_r(X)\text{ u}$ and the molar mass of X is $M(X) = A_r(X)M_u$, where $M_u = N_A\text{ u}$ is the molar mass constant and N_A is the Avogadro constant.

** The entropy of an ideal monoatomic gas of relative atomic mass A_r is given by $S = S_0 + \frac{3}{2}R \ln A_r - R \ln(p/p_0) + \frac{5}{2}R \ln(T/K)$.

†† The full description of m² is m⁻² × (m/cycle)⁴. See also footnote for m⁻¹.

Appendix Z

Periodic Table of the Elements

References

- [1] Elroy M. Avery, *School Physics* (Sheldon and Co., New York, 1895).
- [2] William E. Boyce and Richard C. DiPrima, *Elementary Differential Equations and Boundary Value Problems* (3rd ed.) (Wylie, New York, 1977).
- [3] J.L. Comstock, M.D., *A System of Natural Philosophy: In Which Are Explained the Principles of Mechanics, Hydrostatics, Hydraulics, Pneumatics, Acoustics, Optics, Astronomy, Electricity, Magnetism, Steam-Engine, Electro-Magnetism, Electrotpe, Photography, and Daguerreotype; to Which Are Added Questions for the Examination of Pupils Designed for the Use of Schools and Academies* (Farmer, Brace, & Co., New York, 1857).
- [4] Denis, C., Schreider, A.A., Varga, P., Z' avoti, J.: 2002, *J. Geodyn.*, **34**, 667 (2002).
- [5] "Length of the day and evolution of the Earths core in the geological past", Denis, C., Rybicki, K.R., Schreider, Tomecka-Suchoń, S., and Varga, P., *Astron. Nachr.*, **AN 332**, No. 1, 24–35 (2011).
- [6] E. Gelin, *Éléments de Trigonométrie plane et sphérique à l'usage des élèves des Cours professionnels des candidats aux Écoles spéciales des Universités et à l'École militaire de Bruxelles* (1888).
- [7] Georgia State University HyperPhysics project, <http://hyperphysics.phy-astr.gsu.edu/hbase/hframe.html>.
- [8] H. Goldstein, *Classical Mechanics* (2nd ed.) (Addison-Wesley, Reading Mass., 1980).
- [9] V. I. Hallock, *I.C.S. Reference Library* (International Textbook Company, Scranton Penn., 1905) 7:11.
- [10] John Leslie, *The Philosophy of Arithmetic; Exhibiting a Progressive View of the Theory and Practice of Calculation, with Tables for the Multiplication of Numbers as Far as One Thousand*. Abernethy & Walker, Edinburgh, 1820.
- [11] L.L. Simpson, private communication.
- [12] S.W. McCuskey, *Introduction to Celestial Mechanics* (Addison-Wesley, Reading, Mass., 1963).
- [13] Charles Morris, *Winston's Cumulative Loose-Leaf Encyclopedia Volume V* (Philadelphia: The John C. Winston Company, 1918.)
- [14] A. Privat-Deschanel, *Elementary Treatise on Natural Philosophy* (D. Appleton and Co., New York, 1884).
- [15] *U.S. Standard Atmosphere, 1976*. NOAA/NASA/USAF (U.S. Government Printing Office, Stock No. 003-017-00323-0, 1976.)
- [16] Varga, P., Denis, C., and Varga, T., *J. Geodyn.*, **25**, 61 (1998).

[17] Taffel, Alexander, *Visualized Physics*, Oxford Book Co., New York, 1955.

[18] D.A. Wells, *The Science of Common Things; A Familiar Explanation of the First Principles of Physical Science* (1857).

Index

- Acceleration, 30
 - constant, 32
- Acoustics, 12
- Aerogel, 28
- Amonton's law, 213
- Ampere, 16
- Amplitude, 165, 168, 170
- Angular acceleration, 145
- Angular frequency, 170
- Angular momentum, 191
- Angular velocity, 99, 145
- Antimatter, 114, 282
- Aphelion, 243
- Apocenter, 243
- Apogee, 243
- Apsides, line of, 243
- Archimedes, 106
 - principle of, 200
- Argument of latitude, 245
- Argument of pericenter, 243
- Arithmetic-geometric mean, 331
- Ascending node, 243
 - longitude of, 243
- Asteroid 2010 TK7, 250
- Astro dynamics, 254
- Astronomical unit, 316
- Astrophysics, 12
- Atmosphere, 201
- Atomic mass unit (amu), 17
- Atomic physics, 12
- Atwood's machine, 75

- "Back cab" rule, 142
- Ballistic pendulum, 131
- Bar, 201
- Barker's equation, 253
- Baryon, 281
- Base units, 14
- Beat frequency, 232
- Bernoulli's equation, 205
- Bertrand's theorem, 248

- Beta decay, 68, 282
- Binary prefixes, 23
- Biophysics, 12
- Black dwarf, 229
- Black hole, 229
 - supermassive, 229
- Boltzmann's constant, 213
- Boyle's law, 213
- Bulk modulus, 196, 199

- Candela, 16
- Capillary, 214
- Catenary, 82
- Cavendish experiment, 221
- Center of mass, 60, 136
- Centrifugal force, 98
- Centripetal
 - acceleration, 97
 - force, 97
- Chainring, 109
- Chandler wobble, 232
- Charles's law, 213
- Chemical physics, 12
- Churchill equation, 212
- Clairaut's theorem, 266
- Classical mechanics, 12
- Cog, 109
- Collision, 123, 125
 - elastic, 125
 - inelastic, 125, 126
- Comet, 247
- Compressible fluid, 204
- COMSAT, 257
- Conservative force, 117
- Continuity equation, 205
- Coordinated Universal Time, 233
- Coriolis force, 60, 189
- Cosine formula, 235
- Coulomb's law, 113
- Couple, 158
- Crackle, 31

- Cross product, 45, 140, 324
 inverse, 143
- Cross-disciplinary physics, 12
- Curl, 43
- Currency exchange rates, 22
- Cycloid, 195
- Cyclone, 190
- Cygnus X-1, 229
- Darcy friction factor, 212
- Declination, 235, 244, 246
- Degree, 17, 321
 square, 322
- Delta v , 259
- Deneb, 230
- Density, 26, 138
- Descending node, 243
- Dimensional analysis, 19
- Direct product, 45
- Displacement, 29
- Divergence, 43
- Dot product, 45, 324
- Double integral, 139
- Downleg, 208
- Drag coefficient, 93
- Dynamics, 29
- Dyne, 67
- Earth, 316
 radius of, 235
- Eccentric anomaly, 245
- Eccentricity, 243
- Ecliptic, 243
 obliquity of, 243, 246
- Ecliptic latitude, 246
- Ecliptic longitude, 246
- Efficiency
 simple machine, 103
- Effort, 103
- Einstein field equation, 228
- Elastic limit, 199
- Elastic modulus, 196
- Elasticity, 196
- Electricity and magnetism, 12
- Electromagnetic force, 67
- Electromagnetic force, 282
- Electromagnetic units, 19
- Electron volt, 110
- Electrostatic units, 19
- Electroweak theory, 282
- Elevation angle, 258
- Elevator, 82
- Empirical law, 68, 84
- Energy, 110, 275
 conservation of, 114
 kinetic, 84, 110, 275
 mechanical, 114
 potential, 111
 table, 113
 total, 114
- Entity, 17
 weight, 17
- Eötvös experiment, 66
- Epoch time, 243
- Equation of state, 214
- Equator, 242
- Equilibrium, 68
- Equilibrium position, 170
- Equivalence principle, 66
- Erg, 100, 110
- Escape velocity, 224
- Event horizon, 229
- Fanning friction factor, 212
- Fictitious force, 98
- Flattening factor, Earth, 236, 238
- Floating bodies, 200
- Flow rate, 205
- Flubber, 126
- Fluid, 91, 200
 compressible, 204
 dynamics, 204
 ideal, 204
 incompressible, 204
 irrotational, 204
 mechanics, 204
 Newtonian, 204
 rotational, 204
 statics, 200
- Fluidization, 200
- Foot, 15
- Force, 67
 conservative, 117
- Fountain effect, 214
- Fourth (of arc), 321
- Free-body diagram, 79
- Frequency, 174
- Friction, 84
 coefficient of, 84, 85
 kinetic, 85

- rolling, 85
- static, 84
- Friction factor, 212
- Fulcrum, 106
- g (acceleration unit), 30
- Galilei, Galileo, 187
- Galileo's law, 187
- Gas constant, 213
- Gases, 212
- Gauss's law, 224, 227
 - electrostatics, 227
 - gravity, 224
- Gaussian units, 19
- Gear, 108
- Gear ratio, 109
- General relativity, 82, 228
- Geodesy, 234
- Geoid, 234
- Geophysics, 12
- Geosynchronous orbit, 257
- Global Positioning System, 234
- Grad, 17, 321
- Grand Unified Theory, 282
- Grave (*f.n.*), 18
- Gravitation, 67
- Gravitational force, 282
- Gravitational lensing, 228
- Gravitational potential, 220
- Graviton, 282
- Gravity
 - acceleration, 30
- Gravity assist maneuvers, 261
- Gyration, radius of, 153
- Gyroscope, 194
- Hadron, 281
- Halley's comet, 247
- Halo orbit, 250
- Hamiltonian, 270
- Hamiltonian mechanics, 270
- Haversine, 235
- Head, 206, 212
- Heaviside-Lorentz units, 19
- Heisenberg uncertainty principle, 278, 280
- Helium II, 214
- Helmert's equation, 221
- Hermite polynomials, 279, 280
- Higgs
 - boson, 283
 - field, 283
- Hohmann transfer, 260
- Hooke's law, 68, 113, 158, 167, 170, 196, 248
- Horsepower, 118
- Hubble Space Telescope, 194, 228
- Hydraulic press, 217
- Hydraulics, 217
- Hydrostatic pressure, 198
- Hyperbolic functions, 296
- Ideal fluid, 204
- Ideal gas law, 213
- Impact parameter, 130
- Impact velocity, 34
- Imperial units, 14
- Impulse, 123
 - approximation, 124
- Inclined plane, 73, 104
- Incompressible fluid, 204
- Inertia, 70
 - law of, 70, 162
 - rotational, 162
- Inertial reference frame, 98
- International Prototype Kilogram (IPK), 16, 28
- Iridium, 27
- Irrotational fluid, 204
- Jackscrew, 108
- Jacobi elliptic function, 330
- Jerk, 31
- Joule, 100, 110
- Joule, James, 100
- Jounce, 31
- Julian day, 242
- Jupiter, 316
- Kelvin, 16
- Kepler's equation, 245
 - hyperbolic, 252
- Kepler's laws, 241
 - first, 241, 247
 - second, 241
 - third, 242
- Kinematics, 29
- Kinetic energy, see Energy, kinetic
- Lagrange points, 249
- Lagrangian, 267
- Lagrangian mechanics, 267
- Lambda point, 214

- Laminar flow, 204, 211
 Leap second, 233
 Lees' rule, 156
 Length contraction, 274
 Lepton, 281
 Lever, 106
 Libration points, 249
 Lithium, 27
 Logic, deductive, 13
 Longitude of ascending node, 243

 Mars, 316
 Mass, 66
 gravitational, 66
 inertial, 66
 Mathematical physics, 12
 Maxwell's equations, 68, 227
 Mean anomaly, 243, 245
 Mean daily motion, 245
 Mechanical energy, see Energy, mechanical
 Mercury, 316
 Meson, 281
 Mesozoic era, 233
 Meter, 15
 Metric tensor, 228
 Metric ton, 16
 Metric units, 14
 Micron, 22
 Modulus of rigidity, 177
 Molar gas constant, 213
 Mole, 16
 Moment arm, 157
 Moment of inertia, 149
 measurement of, 159
 Momentum, 121, 274
 angular, 191
 Monkey and hunter problem, 60
 Moody friction factor, 212
 Muzzle velocity, 54

 Natural units, 14
 Neptune, 316
 Neutron, 281
 Neutron star, 229
 Newton, 16, 67
 Newton's cradle, 128
 Newton's law of gravity, 66, 220
 Gauss's formulation, 224
 Newton's laws of motion, 12, 70, 162
 first, 70
 original, 328
 rotational, 162
 second, 66, 70, 121, 122, 147, 162, 191
 third, 70, 72, 163
 Newton's method, 63
 Newton, Sir Isaac, 67
 Newtonian fluid, 204
 Normal force, 69
 North star, 230
 Nought, 32
 Nuclear fusion, 68
 Nuclear physics, 12
 Nutation, 195, 230

 Obliquity of the ecliptic, 243, 246, 316
 Optics, 12
 Orbit
 bound, 247
 closed, 248
 differential equation of, 248
 unbound, 247
 Orbital elements, 243
 Osmium, 27

 Paleozoic era, 233
 Parallel
 springs, 176
 Parallel axis theorem, 154
 Parallelogram method, 38
 Partial derivative, 265
 Particle, 29
 Particle physics, 12
 Pascal, 198, 201
 Pascal's law, 203
 Pendulum, 164
 ballistic, 131, 169
 conical, 165
 double, 169
 Foucault, 169
 nonlinear, 329
 physical, 167
 simple plane, 164, 329
 spherical, 165
 torsional, 167
 Pericenter, 243
 argument of, 243
 Perigee, 243
 Perihelion, 243
 Period, 99, 174, 175, 256
 Permittivity of free space, 228

- Phase constant, 170
 Physics, 12
 Pitch, 108
 Planck's constant, 278
 Plane figure theorem, 155
 Plasma physics, 12
 Pluto, 316
 Pneumatics, 219
 Poise, 210
 Poisson ratio, 177
 Polar motion, 232
 Polaris, 230
 Polygon method, 38
 Pop, 31
 Position, 29
 initial, 33
 vector, 49
 Potassium, 27
 Potential energy, see Energy, potential
 Pound, 19
 force, 19
 mass, 16, 19
 Power, 118
 Precession, 194, 195, 230
 Pressure, 198, 201
 absolute, 202
 gauge, 202
 hydrostatic, 198
 Projectile, 54
 exploding, 60
 summary of formulæ, 62
 Proton, 281
 Psi (lb/in^2), 201
 Pulley, 105
 Pythagorean theorem, 41, 153

Q.E.D. (f.n.), 62
 Quantum electrodynamics, 68
 Quantum mechanics, 12, 214, 216, 277
 Quark, 281
 Quaternion, 44

 Radian, 17, 321
 Radius of gyration, 153
 Range, 55
 Red giant, 229, 233
 Relativity, 12
 general, 12, 82, 228, 274
 special, 12, 273
 Resistance, 103

 Restitution, coefficient of, 125
 Reynolds number, 211
 Ricci curvature tensor, 228
 Rice Krispies, 31
 Right ascension, 235, 244, 246
 Right-hand rule, 140, 158, 324
 Roche limit, 250
 Rocket, 133
 Rocket equation, 133, 134
 Rocking bodies, 178
 Rocking cylinder, 178
 Rollin film, 214
 Rolling bodies, 181
 Rotation, 145
 Rotational fluid, 204
 Rotational motion, 145
 Routh's rule, 155

 Sagittarius A*, 229
 Saturn, 27, 250, 316
 Saturn V (rocket), 133, 135
 Scalar, 37
 Scalar curvature, 228
 Scalar product, 45
 Scale height, 203
 Schrödinger equation
 time independent, 279
 time-dependent, 278
 Schwarzschild radius, 229
 Screw, 108
 Second (of time), 16
 Second sound, 216
 Semi-major axis, 243
 Series
 springs, 176
 Shear modulus, 196, 198
 SI units, 15
 Signum function, 253
 Simple harmonic motion, 170
 kinetic energy, 172
 potential energy, 172
 total energy, 172
 Simple harmonic oscillator, 268, 270, 279
 Simple machines, 73, 103
 Singularity, 229
 Siphon, 208
 Slug, 19
 Snap, 31
 Solid angle, 321
 Solid-state physics, 12

- Space elevator, 257
Specific gravity, 27
Speed, 29
Spring
 vertical, 174
Spring constant, 68, 170, 175
Staging, 135, 255
Standard Atmosphere, 203
Standard Model, 281
Stanton friction factor, 212
Statics, 29, 79
Statistical mechanics, 12
Statwatt, 118
Steiner's theorem, 154
Steradian, 321
Stokes, 210
Stokes's law, 211
Strain, 196–198
Stress, 196
 compressional, 196
 longitudinal, 196
 normal, 196
 shear, 196, 197
 tensile, 196
 torsional, 197, 198
 translational, 197
 transverse, 196, 197
 volume, 196, 198
Stress-energy tensor, 228
String theory, 283
Strong nuclear force, 68, 282
Superflow, 214
Superfluid, 214
Syphon, see Siphon
- Tensile strength, 199
Tension, 69
Tensor, 163
Terminal velocity, 93
Thermodynamics, 12, 212
Third (of arc), 321
Thuban, 230
Time dilation, 273
Time in flight, 55
Torque, 157
Torr, 201
Torricelli's theorem, 206
Transitional flow, 205
Triangle method, 38
Triple integral, 139
Triple scalar product, 142
Triple vector product, 142
Trojan asteroids, 250
Troposphere, 203
True anomaly, 245
Turbulent flow, 204, 211
Two-fluid model, 214
- U.S. Standard Atmosphere, 203
Unit vector, 40, 323
Uranus, 316
UTC, 233
- Van der Waals equation, 214
Vector, 37, 323
 magnitude, 41
 polar form, 324
 rectangular form, 324
 zero, 43, 141
Vector boson, 282
Vector product, 140
Vega, 230
Velocity, 29
 average, 30
 impact, 34
 initial, 32
 instantaneous, 30
Venus, 316
Vernal equinox, 242
Versus (vs.) (*f.n.*), 35
Vincenty's formulæ
 direct problem, 236
 inverse problem, 238
Virial theorem, 115, 335
Vis viva equation, 248
Viscosity, 204, 209, 336
 dynamic, 210
 kinematic, 210
- W boson, 282
Watt, 118
Watt, James, 118
Wave function, 278
Wave-particle duality, 278
Weak nuclear force, 68, 282
Wedge, 108
Weight, 16, 68
Weisbach friction factor, 212
Wheel, 184
Wheel and axle, 104

White dwarf, 229

Work, 100

Work-energy theorem, 115

World Geodetic System (WGS), 234

Wormhole, 229

Young's modulus, 177, 196, 197

Z boson, 282

Zero vector, 43, 141

Zero-point energy, 280