

CLOSET DRESSER SECTION

BUILD TIME = 1 DAY | EST. COST TO BUILD = \$250 | SKILL LEVEL = INTERMEDIATE / ADVANCED

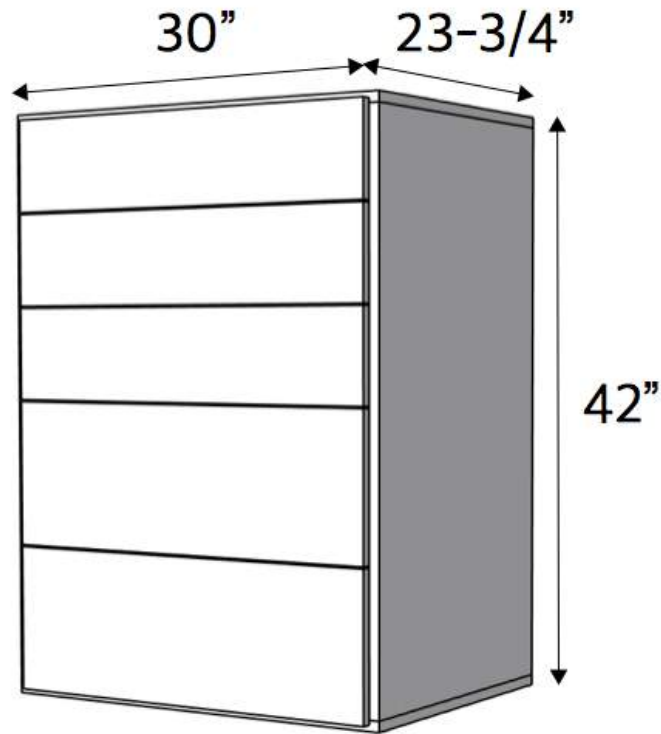

REQUIRED TOOLS

- Drill / Driver
- Circular Saw &/or Table Saw
- Speed Square
- Brad Nailer (Optional)
 - To hold box in place during assembly
- Tape Measure
- Pencil
- Safety Glasses
- Hearing Protection

MATERIALS

- 3/4" x 2' x 4' MDF or Plywood
 - For Drawer Fronts
- 3/4" x 4' x 8' MDF or Plywood
 - For Box and Drawer Fronts
- Qty 2 - 3/4" x 4' x 8' Plywood
 - For Drawer Boxes
- Qty 5 - Drawer Slides
- 1-1/2" Trim Screws
- 3" Wood Screws
- 1-1/2" Brad Nails (optional)
- Wood Glue
- Wood Filler

CUT LIST

3/4" x 2' x 4' MDF or Plywood

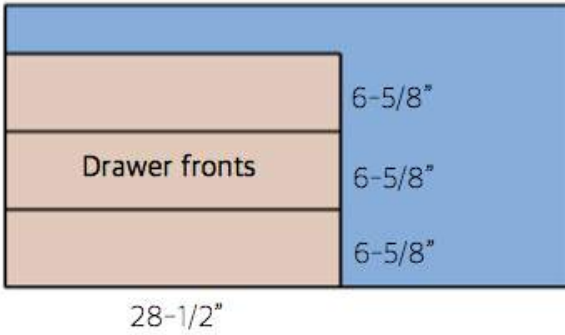

3/4" x 4' x 8' MDF or Plywood

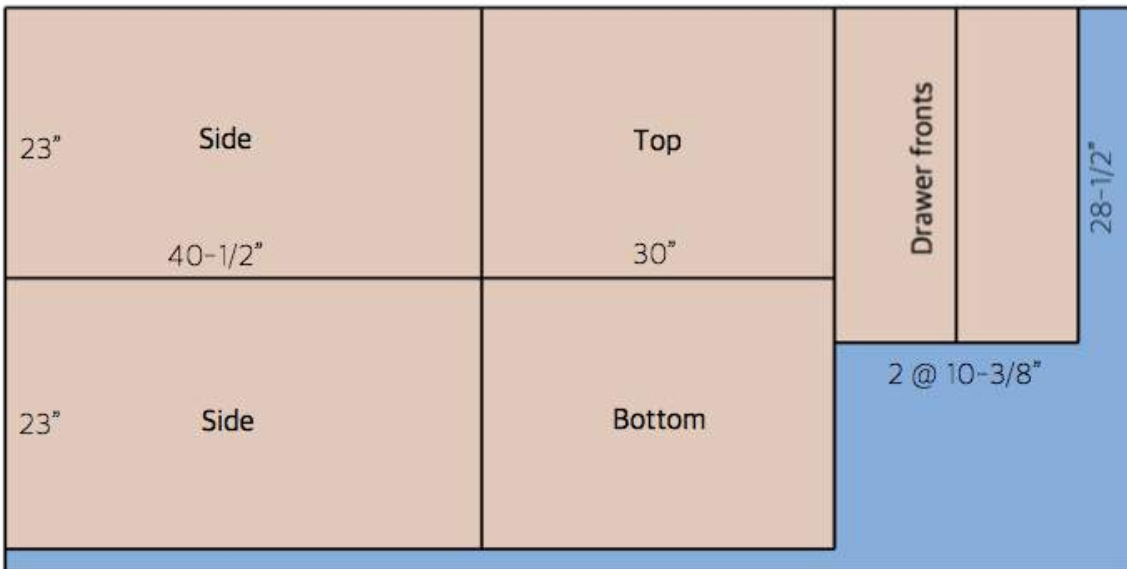

Note: Width of drawer fronts may change depending on final opening and overall installation/appearance.



3/4" x 4' x 8' Plywood (Qty 2)

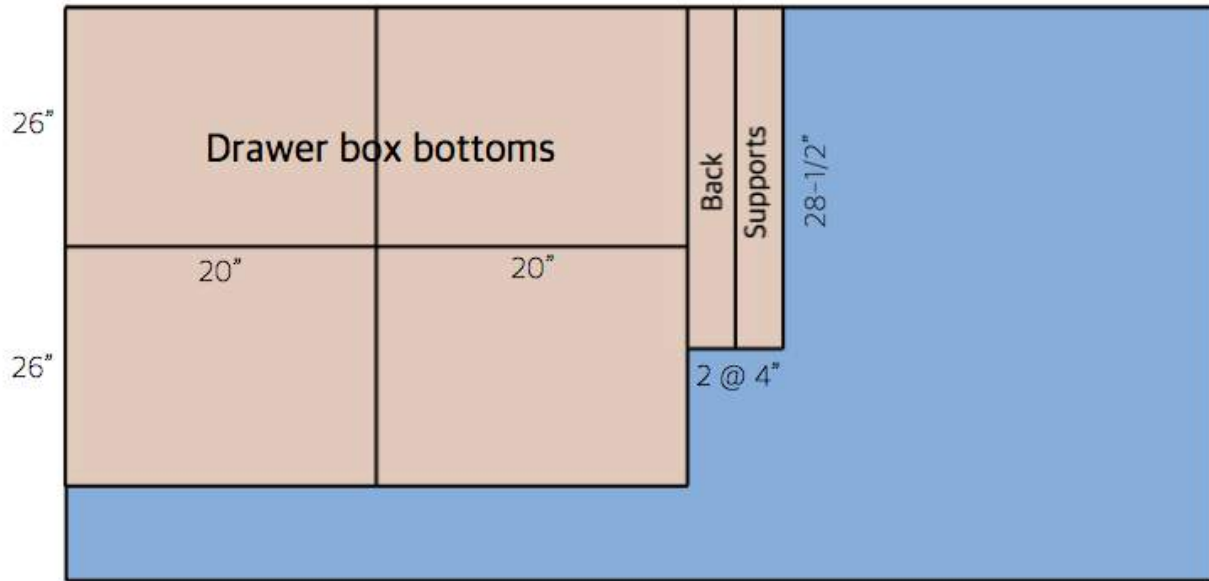
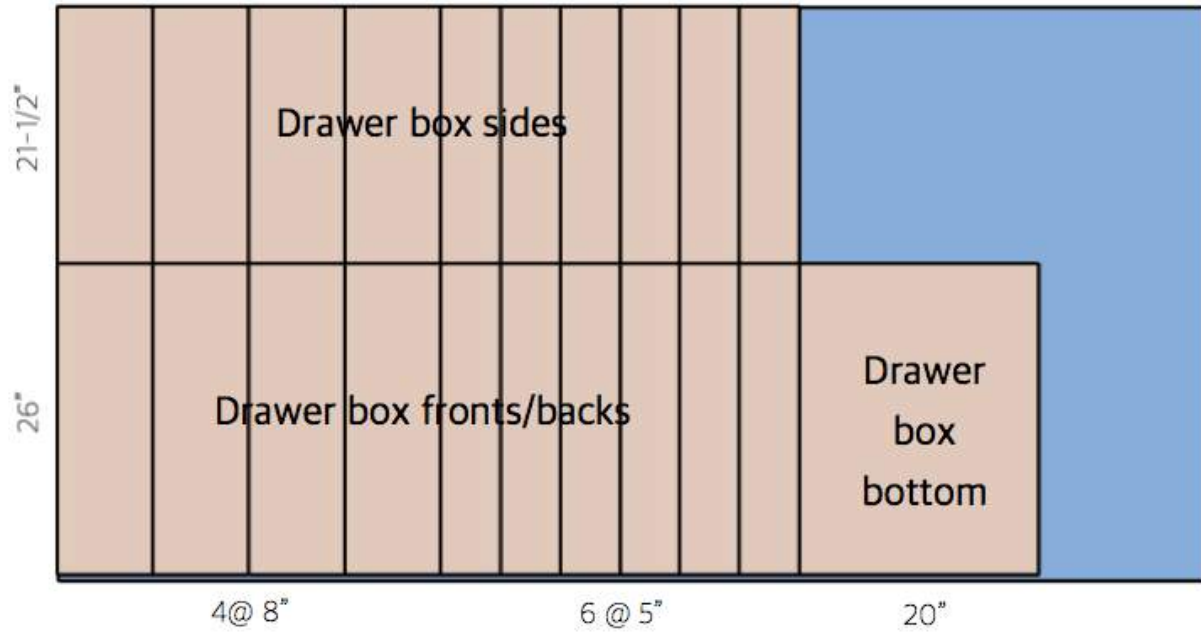

Note: Width of drawer fronts, backs and bottoms may change depending on final opening and overall installation/appearance.

Step 1: Assemble Box

Pre-drill and assemble using 1-1/2" trim screws. (Not all shown)

Then, locate the wall studs using a stud finder. Using a level, make sure the front and sides of the unit are plumb and secure the unit to the wall studs using at least 3" wood screws.

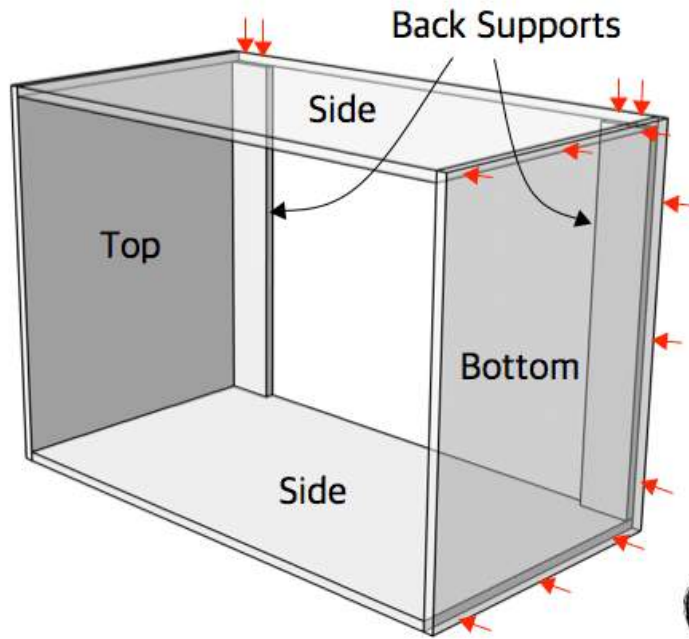

Step 2: Drawer Boxes

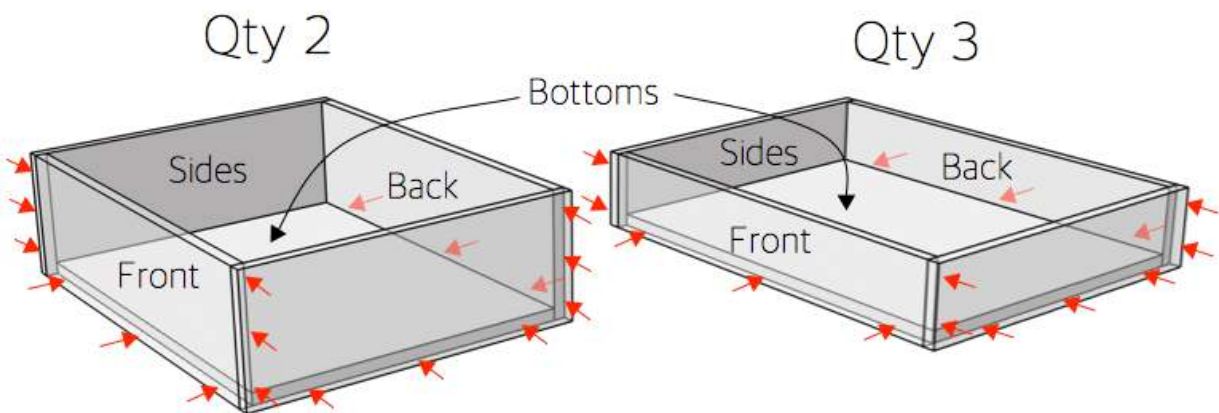

Assemble drawer boxes with wood glue and 1-1/2" staples or 18g brad nails



Step 3: Install Drawers

Install drawers at heights shown using drawer slides and included hardware.

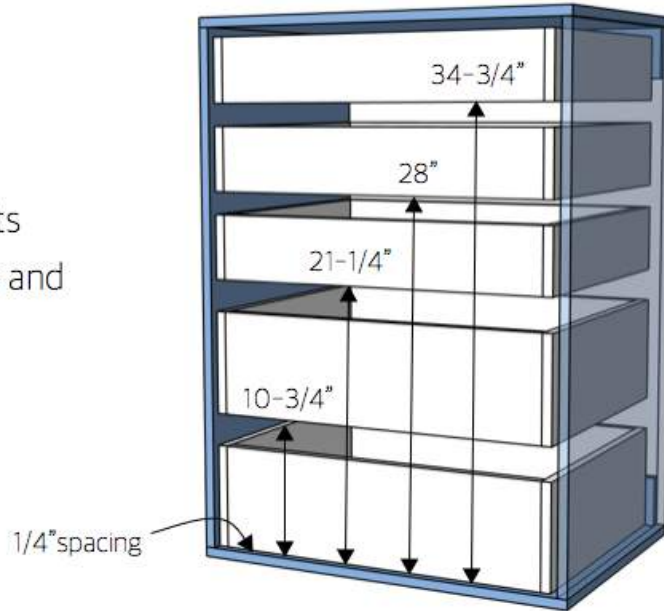

Step 4: Install Drawer Fronts

Locate bottom most drawer front and space the remaining drawer fronts 1/8" apart. Temporarily install with hot glue or double faced tape. Install drawer fronts with 1-1/4" wood screws from within the drawers.

