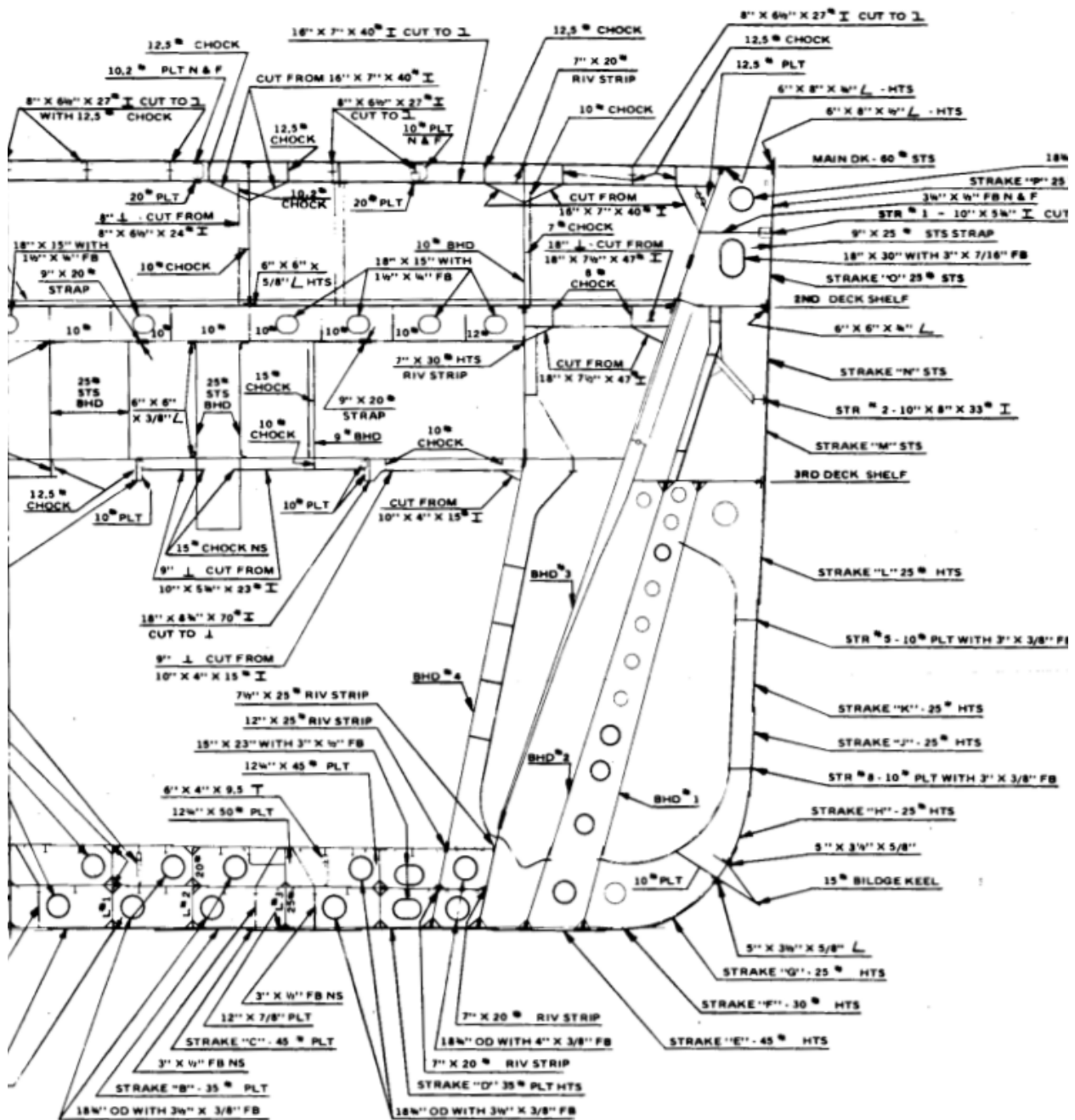


# EN400

## Principles of Ship Performance

### Course Notes



*Iowa - Class Midships Section*  
**Version: Summer 2020**

# Table of Contents

## I. Introduction

Course Policy  
Equations and Conversion Factors  
Symbols and Abbreviations

## II. Course Notes

Chapter 1: Engineering Fundamentals  
Chapter 2: Hull Form and Geometry  
Chapter 3: Hydrostatics  
Chapter 4: Stability  
Chapter 5: Properties of Naval Materials  
Chapter 6: Ship Structure  
Chapter 7: Resistance and Powering of Ships  
Chapter 8: Seakeeping  
Chapter 9: Ship Maneuverability  
Chapter 10: Submarines and Submersibles

## III. Appendices

Appendix A: Table of Fresh and Salt Water Density  
Appendix B: Table of Fresh and Salt Water Kinematic Viscosity  
Appendix C: Properties of Common Geometric Shapes

## IV. Ship Data Section (Curves of Form and Cross Curves of Intact Stability)

FFG 7 Class	CVN 65 Class
DDG 51 Class (Flt II/IIA)	AOE 6 Class
LCS 1 Class	USNA Yard Patrol (New)
27-B-1 Hydro Lab Model	

## V. Laboratory Handouts

Lab 1: Numerical Integration  
Lab 2: Archimedes and Center of Flotation  
Lab 3: Inclining Experiment  
Lab 4: Righting Arm – Vertical & Transverse Shifts in Center of Gravity  
Lab 5: Free Surface Effect and Damage Stability  
Lab 6: Materials and Material Testing  
Lab 7: Hull Resistance and Effective Horsepower  
Lab 8: Propeller Demonstration  
Lab 9: Seakeeping

# Course Wide Policies

---

---

## Introduction

The world is becoming increasingly technologically advanced. The modern individual must rely on a technical foundation to positively contribute to teams and problem solving. A Naval Officer benefits from a solid foundation in engineering principles, whether their duties are to make policy decisions, command skilled enlisted personnel, maintain and operate state-of-the-art equipment or partner with civilian technicians and engineers.

USNA recognizes this fact and consequently maintains a requirement for students majoring in the Division of Mathematics and Science, Division of Humanities and Social Sciences and General Engineering to complete certain engineering courses. Principles of Ship Performance (EN400) is just such a course. Affectionately known as ‘Boats,’ the course is relevant to all future Naval and Marine Corp Officers, regardless of designator. Even if your future career path takes you into the skies or the mud, you will interface with things that float. You have entered a seafaring service.

---

---

## The Course

EN400 develops a general technical foundation and applies these principles specifically to how ships function. EN400 also approaches material to balance the training needs of a future ship operator with the required level of mathematics and science understanding suitable for a Bachelor of Science degree.

Students are introduced to a number of different engineering practices including mathematical approximation, graphical interpolation and engineering modeling. These practices may appear difficult to comprehend at first. Remember, they are being taught for a relevant purpose.

Course material is organized into chapters which can largely be viewed as ‘stand alone,’ however the information and techniques used in early chapters will be called upon again. The first chapter delivers a basic level of engineering knowledge that students should be familiar with before the course begins. Students are advised to read Chapter 1 before the first day of class, as instructors only provide a brief overview of its contents. If there are areas of Chapter 1 requiring further assistance, raise concerns early and seek extra instruction. The understanding of this pre-requisite information is vital for the Naval Engineering that follows.

---

---

## **Laboratories**

EN400 consists of 9 laboratory experiments ranging from computer labs to model boat towing in the hydrodynamics laboratory (hydro lab). They are a vital element in understanding the course material, totaling 40% of the time available per week. The theory and techniques first presented in the classroom will come to life in the lab periods. Many labs have pre-lab sections to bridge this gap between reading, lecture, and experimentation. The theory and techniques to be employed in the lab are explained, and ensuring completion of the pre-lab before any lab leads to a smooth experiment and more enjoyable experience.

---

---

## **Instructor Policy**

Your section instructor will provide their own teaching, examination, and grading policy during one of your first classes. Indeed, the everyday classroom environment is their responsibility. In general, the course provides one homework and one lab per chapter. Quizzes may be administered periodically between each of the major exam periods. These are not merely an assessment tool for the instructor, but also a means by which students can assess their own progress in the subject, before an exam. Failure to submit work on time will hurt your grade directly, and will also remove this valuable self-assessment tool.

---

---

## **Conclusion**

The facilities in Rickover Hall are some of the best available anywhere in the world, and instructors and laboratory staff will add a great deal of technical and fleet experience to the course material. Make the most of your time remaining before commissioning. Come prepared to lessons and laboratories. You will only get out of this course the effort you put into it.

EN400 Course Coordinator

## EN400 EQUATIONS AND CONVERSIONS

The following equations and conversions will be given as part of quizzes and exams:

Properties of water at 59°F:	$\rho_{FW} = 1.94 \frac{lb \cdot s^2}{ft^4}$	$\rho g_{FW} = 62.4 \frac{lb}{ft^3}$	$\nu_{FW} = 1.226 \times 10^{-5} \frac{ft^2}{s}$
	$\rho_{SW} = 1.99 \frac{lb \cdot s^2}{ft^4}$	$\rho g_{SW} = 64.0 \frac{lb}{ft^3}$	$\nu_{SW} = 1.2791 \times 10^{-5} \frac{ft^2}{s}$
Miscellaneous Conversions:	$1 LT = 2240 lb$	$g = 32.17 \frac{ft}{s^2}$	
	$1 ft^3 = 7.4805 gal$	$1 kt = 1.688 \frac{ft}{s}$	

$$A_{WP} = 2 \int_0^L y(x) dx \quad A_{SECT} = 2 \int_0^T y(z) dz \quad \nabla_S = \int_0^L A_{SECT}(x) dx = \int_0^T A_{WP}(z) dz$$

$$LCF = \frac{2 \int_0^L x \cdot y(x) dx}{A_{WP}} \quad LCB = \frac{\int_0^L x \cdot A_{SECT}(x) dx}{\nabla_S} \quad KB = \frac{\int_0^T z \cdot A_{WP}(z) dz}{\nabla_S}$$

Simpson's 1<sup>st</sup> Method:  $\int y(x) dx \approx \frac{Sta. Spacing}{3} (1 \cdot y_0 + 4 \cdot y_1 + 2 \cdot y_2 + 4 \cdot y_3 + 2 \cdot y_4 + \dots + 2 \cdot y_{n-2} + 4 \cdot y_{n-1} + 1 \cdot y_n)$   
( $n$  must be even)

$$Sta. Spacing = \frac{L_{PP}}{\#Sta. - 1} \quad F_B = \Delta = \rho g \nabla_S \quad TPI = \frac{A_{WP}}{420 ft^2} \frac{LT}{in} \quad \delta T_{PS} = \frac{w}{TPI} \quad \delta T_{Trim} = \frac{w \cdot l}{MT1''}$$

$$P_{hyd} = \rho g z \quad Trim = |T_{aft} - T_{fwd}| \quad T_{mean} = \frac{T_{fwd} + T_{aft}}{2} \quad \delta T_{fwd/aft} = \frac{\delta T_{Trim} \cdot d_{fwd/aft}}{L_{PP}}$$

$$\overline{KM}_T = \overline{KB} + \overline{BM}_T = \overline{KG} + \overline{GM}_T \quad \tan(\phi) = \frac{TCG}{\overline{GM}_T} \quad wt = \Delta \cdot \overline{GM}_T \cdot \tan(\phi)$$

$$\overline{KG}_{new} = \frac{\overline{KG}_{old} \cdot \Delta_{old} + \sum \pm w_i \cdot \overline{Kg}_i}{\Delta_{old} + \sum \pm w_i} \quad TCG_{new} = \frac{TCG_{old} \cdot \Delta_{old} + \sum \pm w_i \cdot \pm tcg_i}{\Delta_{old} + \sum \pm w_i}$$

$$T_{final, fwd/aft} = T_{initial, fwd/aft} \pm \delta T_{PS} \pm \delta T_{fwd/aft} \quad FSC = \frac{\rho_t \cdot i_t}{\rho_S \cdot \nabla_S} \quad i_t = \frac{l \cdot b^3}{12} \text{ (for rectangular shapes)}$$

$$\overline{GZ}_{final} = \overline{GZ}_{cc} - \overline{KG} \sin(\phi) - TCG \cos(\phi) - FSC \sin(\phi) = \overline{GZ}_{initial} - \delta \overline{KG} \sin(\phi) - \delta TCG \cos(\phi) - \delta FSC \sin(\phi)$$

$$\overline{M}_{eff} = \overline{GM}_T - FSC \quad RM = \overline{GZ} \cdot \Delta$$

$$e = L_f - L_0 \quad \varepsilon = \frac{L_f - L_0}{L_0} \quad \sigma_{bending} = \frac{M \cdot y}{I} \quad \sigma = \frac{F}{A} \quad E = \frac{\sigma}{\varepsilon}$$

$$\lambda = \frac{L_S}{L_M} \quad \lambda^2 = \frac{S_S}{S_M} \quad \lambda^3 = \frac{\nabla_S}{\nabla_M} \quad \frac{V_M}{\sqrt{L_M}} = \frac{V_S}{\sqrt{L_S}} \quad \text{Speed to Length Ratio} = \frac{V_S \text{ (in kts)}}{\sqrt{L_S}}$$

$$V_{hull} \text{ (in kts)} = 1.34 \sqrt{L_S} \text{ (in ft)} \quad C_T = \frac{R_T}{\frac{1}{2} \rho_S \cdot V^2} \quad \eta_P = PC = \frac{EHP}{SHP} \quad EHP = \frac{R_T \cdot V_S}{550 \frac{ft \cdot lb}{HP \cdot sec}}$$

$$\mathcal{R}_n = \frac{L_{PP} \cdot V}{\nu} \quad F_n = \frac{V}{\sqrt{L_{PP} \cdot g}} \quad \eta_I = \frac{2}{1 + \sqrt{1 + C_t}} \quad C_t = \frac{T}{\frac{1}{2} \rho A_0 V_A^2}$$

$$L_w = \frac{2\pi V^2}{g} \quad \omega = \frac{2\pi}{T} = \sqrt{\frac{k}{m}} \quad \omega_e = \omega_w - \frac{\omega_w^2 V_S \cos(\mu)}{g} \quad \tan(\theta) = \frac{wl}{\Delta \overline{BG}}$$

## SYMBOLS AND ABBREVIATIONS

Below is a list of symbols and abbreviations used in the course. Do not attempt to memorize them now! Their meaning and uses will develop as the course progresses.

DWL	Design water line
FP or F <sub>P</sub>	Forward perpendicular
⊙	Midships
AP or A <sub>P</sub>	Aft perpendicular
LBP or L <sub>PP</sub>	Length between perpendiculars, ft
LOA	Overall length, ft
K	Keel
D	Depth, ft
T	Draft, ft
T <sub>fwd</sub>	Draft at FP, ft
T <sub>aft</sub>	Draft at AP, ft
T <sub>m</sub>	Mean Draft, ft
Trim	Trim, ft
δ <sub>Trim</sub>	Change in Trim
B	Beam, ft
℄	Centerline
℔	Baseline
WL	Waterline
A <sub>WP</sub> or WPA	Waterplane area, ft <sup>2</sup>
A <sub>SECT</sub>	Sectional Area, ft <sup>2</sup>
∇	Submerged volume, ft <sup>3</sup>
Δ <sub>S</sub>	Displacement, LT ( <i>weight of the ship</i> )
w	weight of an object, LT (+ if weight added, - if weight removed)

### Distance/Position Conventions:

(+ to starboard, - to port) or (+ fwd of midships, - aft of midships) or (+ aft of FP)

G	Center of Gravity of ship
g	Center of Gravity of an object
KG or K <sub>g</sub>	Distance from keel to the center of gravity, ft
(or VCG, v <sub>cg</sub> )	Vertical Center of Gravity, ft
TCG or T <sub>cg</sub>	Transverse Center of Gravity, ft ( <i>Distance from ℄ to G</i> )
LCG or l <sub>cg</sub>	Longitudinal Center of Gravity, ft ( <i>Distance from FP or ⊙ to G</i> )
F	Center of Floatation
LCF	Longitudinal Center of Floatation, ft
TCF	Transverse Center of Floatation, ft
VCF	Vertical Center of Floatation, ft ( <i>always on the waterline</i> )
B	Center of Buoyancy
LCB	Longitudinal Center of Buoyancy, ft
TCB	Transverse Center of Buoyancy, ft
KB or VCB	Distance from keel to the Center of Buoyancy, ft
	Vertical Center of Buoyancy, ft

$M_T$	Transverse Metacenter
$M_L$	Longitudinal Metacenter
TPI	Tons per inch or Immersion, LT/in
MT1"	Moment to trim one inch, ft-LT/in
$KM_L$	Distance from keel to longitudinal metacenter, ft
$KM_T$	Distance from keel to transverse metacenter, ft
$GM_T$	Transverse Metacentric Height, ft ( <i>Distance from <math>M_T</math> to <math>G</math></i> ) (+ $M$ is above $G$ , - $M$ is below $G$ )
$BM_T$	Transverse Metacentric Radius, ft
$\phi$	Angle of heel or list, degrees
$\theta$	Angle of trim, degrees
P	Pressure, psi
$\rho$	Density, lb-s <sup>2</sup> /ft <sup>4</sup>
g	Acceleration due to gravity
$F_B$	Buoyant Force, LT
$d_{fwd}$	Distance from FP to F, ft
$d_{aft}$	Distance from AP to F, ft
$\delta T_{PS}$	Change in draft due to parallel sinkage, ft
$\delta T_{fwd}$	Change in draft forward, ft
$\delta T_{aft}$	Change in draft aft, ft
RM	Righting moment, LT-ft
GZ	Righting arm, ft
FSC	Free surface correction, ft
$I_T$	Transverse second moment of area, ft <sup>4</sup>
$I_L$	Longitudinal second moment of area, ft <sup>4</sup>
$GM_{eff}$	Effective Metacentric Height, ft,
$\sigma$	Stress, psi (+ <i>Tensile</i> , - <i>Compressive</i> ; or <i>Bending</i> )
$\sigma_y$	Yield strength, psi
$\sigma_{UTS}$	Ultimate Tensile Strength, psi
$\epsilon$	Strain, in/in
E	Young's Modulus or Modulus of Elasticity, psi
$L_f$	Final Length, in or ft
$L_0$	Initial Length, in or ft
M	Moment, ft-lb or ft-LT
y	Distance from the Neutral Axis, in or ft
e	Elongation, in
NDT	Non-Destructive Test
VT	Visual testing
PT	Dye penetrant testing

MT	Magnetic particle testing
RT	Radiographic testing
UT	Ultrasonic testing
BHP	Brake Horsepower, HP
SHP	Shaft Horsepower, HP
DHP	Delivered Horsepower, HP
THP	Thrust Horsepower, HP
EHP	Effective Horsepower, HP
$\eta_H$	Hull Efficiency
$\eta_P$ or PC	Propulsive Efficiency or Propulsive Coefficient
$R_T$	Total Hull Resistance, lb
$V_S$	Ship Speed, ft/s or kts (knots)
S	Wetted surface area of the submerged hull, ft <sup>2</sup>
$C_T$	Coefficient of Total Hull Resistance
$C_V$	Coefficient of Viscous Resistance
$C_F$	Coefficient of Skin Friction
$C_W$	Coefficient of Wave Making Resistance
$C_A$	Correlation Allowance
$R_n$	Reynolds Number
$F_n$	Froude Number
$\nu$	Kinematic Viscosity, ft <sup>2</sup> /s
K	Form Factor
$\lambda$	Scale Factor
$V_A$	Speed of Advance, ft/s
$V_W$	Speed of the Wake, ft/s
$\eta_{\text{propeller}}$	Propeller Efficiency
$A_0$	Blade Area, ft <sup>2</sup>
$C_t$	Coefficient of Thrust Loading
$\omega$	Frequency, rad/s
$\omega_n$	Natural frequency, rad/s
$\omega_w$	Wave frequency, rad/s
$\omega_e$	Encounter frequency, rad/s
$\mu$	Ship's heading relative to the direction of seas, ° relative
$\omega_{\text{heave}}$	Natural Heave frequency, rad/s
$\omega_{\text{roll}}$	Natural Roll frequency, rad/s
$\omega_{\text{pitch}}$	Natural Pitch frequency, rad/s
$T_{\text{roll}}$	Period of Roll, s
k	Spring Constant, lb/in
m	Mass, kg or slug
$\overline{BG}$	Submerged Metacentric Height, ft



# **Course Notes**

# **COURSE OBJECTIVES**

## **CHAPTER 1**

### **1. ENGINEERING FUNDAMENTALS**

1. Be familiar with engineering graphing, drawing, and sketching techniques
2. Explain what dependent and independent variables are, notation used, and how relationships are developed between them
3. Be familiar with the unit systems used in engineering, specifically for this course
4. Understand unit analysis and be able to use units effectively in calculations and in checking your final answer for correctness
5. Use exact numbers and significant figures correctly in calculations
6. Conduct linear interpolation on data tables and graphs
7. Obtain a working knowledge of scalars, vectors, and the symbols used in representing them, as related to this course
8. Obtain a working knowledge of forces, moments, and couples
9. Obtain a working knowledge of and be able to solve basic problems related to the concept of static equilibrium
10. Understand the difference between a distributed force and a resultant force
11. Calculate the geometric centroid of an object
12. Calculate the first moment of area of a region about an axis
13. Calculate second moment of area of a region about an axis, including application of the parallel axis theorem
14. Name and describe the six degrees of freedom of a floating ship, and know which directions on a ship are associated with the X, Y, and Z axes.
15. Know and discuss the following terms as they relate to naval engineering: longitudinal direction, transverse direction, athwartships, midships, amidships, draft, mean draft, displacement, resultant weight, buoyant force, centerline, baseline, and keel.
16. Be familiar with the concepts involved in Bernoulli's Theorem

## 1.1 Graphing, Drawing, and Sketching

Graphing, sketching, and drawing; are they different? Bananas, oranges, and coconuts are all edible fruits, yet they all have a sharp contrast in taste and texture. On the contrary, they all must be peeled to be eaten. Clearly, there are similarities and differences in bananas, oranges, and coconuts, just as there are in graphing, sketching, and drawing.

The common thread in graphing, drawing, and sketching is that they are all forms of visual communication. Each says something important about the relationship of two or more parameters. Engineering is all about communicating ideas to others, and these are three principle methods by which ideas are communicated. A graph, drawing, or sketch must effectively communicate information to a different party unrelated to the work. See Table 1.1 for a summary of similarities and differences in these three visual communication methods.

	<b>Graph</b>	<b>Drawing</b>	<b>Sketch</b>
Similarities:	<ul style="list-style-type: none"> <li>• Form of visual communication</li> <li>• Effectively communicate information to a party unrelated to the work</li> <li>• Says something about the relationship between two parameters</li> </ul>		
Differences:	<ul style="list-style-type: none"> <li>• Relationship between variables or data</li> <li>• Exact coordinates, axes and scales</li> <li>• Title, legend, and units</li> </ul>	<ul style="list-style-type: none"> <li>• Relationship between objects</li> <li>• Exact shape</li> <li>• To scale</li> </ul>	<ul style="list-style-type: none"> <li>• Quick “free-hand” picture of drawing or graph</li> <li>• General relationship between (not exact)</li> <li>• Some labels</li> </ul>

**Table 1.1** Comparison between Graph, Sketch and Drawing

**1.1.1** Graphs are used to represent the relationships between variables, such as data taken during an experiment. Graphs are also used to represent analytical functions like  $y = mx + b$ . Graphs require that you use exact coordinates and visually represent relationships between variables in perfect proportions on the paper. A proper graph can be time consuming and require skill to prepare. Computers and spreadsheet programs can be used as tools in effectively preparing a graph.

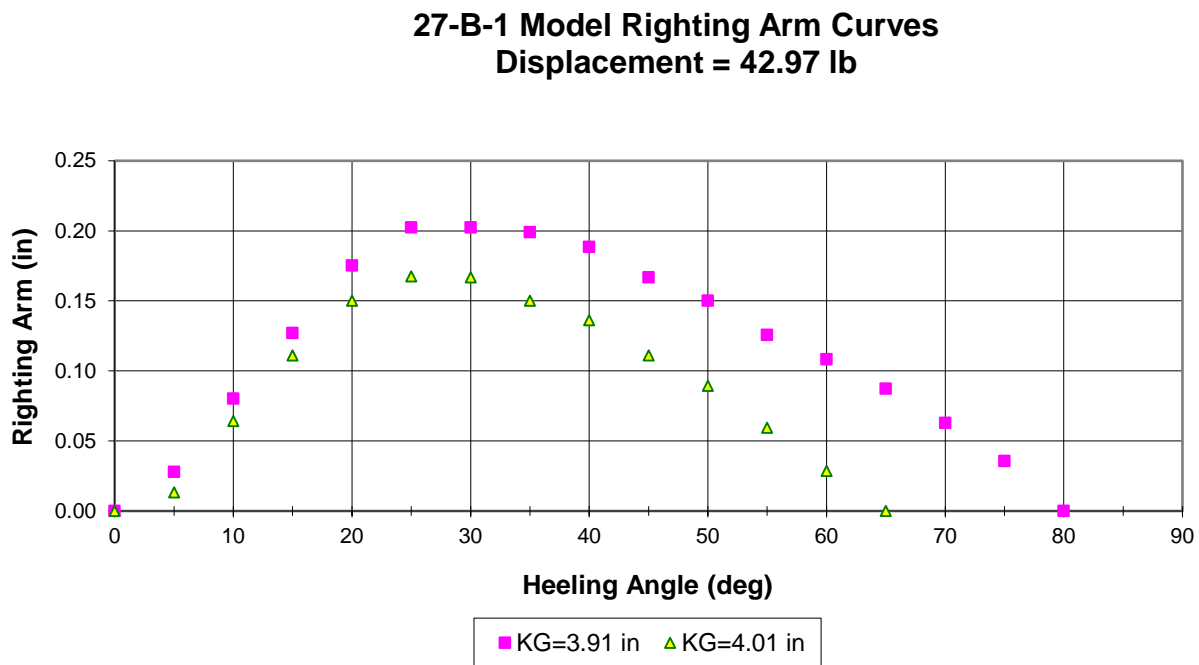
Graphs are to be done on graph paper (or with a computer) that has major and minor axes in both the vertical and horizontal directions. Major axes are to be subdivided such that they are easy to read and construct. Axis subdivisions should be consistent with the line spacing on the graph paper. Axis subdivisions that require a lot of interpolation and guessing when obtaining data are to be avoided.

Graphs must have a title that describes what is being plotted, and each axis must have a title that thoroughly describes the variable being plotted. Additionally, each axis title must include the symbol for the variable being plotted, and appropriate units for that variable.

When more than one set of data is being plotted, you must clearly identify each set of data. This is best accomplished using a legend, or by individually labeling each curve.

Graphs usually reveal a relationship that may not have been readily apparent. For instance, a graph may show a linear relationship between two variables, or it may show that one variable varies exponentially with respect to the other variable. This relationship may not be apparent when just looking at a list of numbers.

Figure 1.1 is an example of a properly prepared graph. Note that data points only have been plotted. The creator of a plot may choose to fair a curve through the data.



**Figure 1.1** Graph example

**1.1.2** Drawings are prepared to scale and used to show the exact shape of an object or the relationship between objects. For example, ship’s drawings are used by builders to place a pump within a space or to route pipes through compartments. Drawings are also used to define the shape of a ship’s hull.

**1.1.3** Sketches, on the other hand, are quick and easy pictures of drawings or graphs. The idea behind a sketch is not to show an exact, scale relationship, but to show general relationships between variables or objects. The idea is not to plot out exact points on graph paper but to quickly label each axis and show the general shape of the curve by “free-handing” it.

## 1.2 Dependent and Independent Variables and Their Relationships

In general, the horizontal axis of a graph is referred to as the *x-axis*, and the vertical axis is the *y-axis*. Conventionally, the *x-axis* is used for the independent variable and the *y-axis* is the dependent variable. The dependent variable's value will *depend* on the value of the independent variable. An example of an independent variable is time. Time marches on quite independently of other physical properties. So, if we were to plot how an object's velocity varies with time, time would be the independent variable, and velocity would be the dependent variable. There can be, and often is, more than one independent variable in a mathematical relationship.

The concept of a dependent and independent variable is fundamental and extremely important. The relationship of the dependent variable to the independent variable is what is sought in science and engineering. Sometimes you will see the following notation in math and science that lets you know what properties (variables) that another variable depends on, or is a function of.

$$\text{Parameter Name} = f(\text{independent variable \#1, independent variable \#2, etc})$$

“Parameter name” is any dependent variable being studied. For example, you will learn that the power required to propel a ship through the water is a function of several variables, including the ship's speed, hull form, and water density. This relationship would be written as:

$$\text{Resistance} = f(\text{velocity, hull form, water density, etc})$$

There are several ways to develop the relationship between the dependent and independent variable(s). One is by doing an experiment and collecting raw data. The data is plotted as discrete points on some independent axis. Figure 1.1 shows how the righting arm of a model used in lab varies with the angle at which it is heeled. Note that data points have been plotted as individual points. Once plotted, a curve is *faired* through the data. Never just connect the points like a “connect the dots” picture in a children's game book. Nature just doesn't behave this way. Fairing or interpolating a curve through experimental data is an art that requires skill and practice. Computers with the appropriate software (curve fitting program) can make the task of fairing a curve relatively simple, producing an empirical equation for the faired curve through regression analysis.

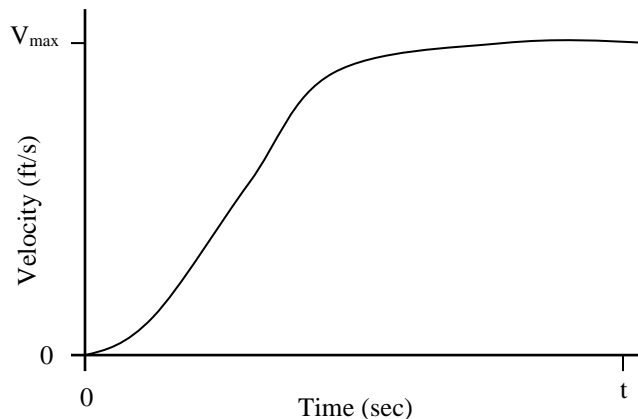
Besides an empirical curve fitting experimental data to arrive at a relationship, a scientist or engineer may go about finding a relationship based on physical laws, theoretical principles, or postulates. For example, if theory states that a ship's resistance will increase exponentially with speed, the engineer will look for data and a relationship between variables that supports the theory.

### 1.3 The Region Under a Curve and the Slope of a Curve

As discussed previously, the shape of a curve on a graph reveals information about the relationship between the independent and dependent variables. Additionally, more information can be obtained by understanding what the region under the curve and the slope of the plot is telling you.

The region between a curve and one axis is referred to as the area under the curve. The term “area” can be misleading because this “area” can physically represent any quantity or none at all. Don’t be confused or misled into thinking that the area under the curve always represents area in square feet. Instead, it may represent a behavior or relationship.

In calculus, you integrated many functions as part of the course work. In reality, integration is the task of calculating the area under a curve. Engineers often integrate experimental data to see if a new relationship between the data can be found. Many times this involves checking the units of the area under the curve and seeing if these units have any physical meaning. To find the units of the area under the curve, multiply the units of the variable on the x-axis by the units of the variable on the y-axis. If the area under the curve has any meaning, you will often discover it in this manner. For example, Figure 1.2 shows how the velocity of a ship increases over time.



**Figure 1.2** Ship’s speed as a function of time

To find the area under the curve from a time of zero seconds until time  $t$ , integrate the function as shown below:

$$A = \int_0^t V(t) dt$$

To see if the area under the curve has physical meaning, multiply the units of the x-axis by the units of the y-axis. In this case the x-axis has units of seconds and the y-axis has units of feet per second. Multiplying these together yields units of feet. Therefore, the area under the curve represents a distance; the distance the ship travels in  $t$  seconds.

The slope of a curve is the change in the dependent variable over some change in the independent variable. Many times the slope is referred to as the “rise over run.” In calculus, the slope of a function is referred to as the derivative of the function. Just as the area under a curve may have physical meaning, the slope of a curve may also have physical meaning.

The slope of a curve at any point is called the instantaneous slope, since it is the value of the slope at a single instance on the curve. Strict mathematicians may only use the term “instantaneous” when the independent variable is time, as in the slope at a particular instant in time. However, engineers often interpret the slope in more broad terms. To determine if the slope of a curve has physical meaning, divide the units of the y-axis by the units of the x-axis (the rise over the run). For example, look once again at Figure 1.2. The slope of the curve is written in calculus form as:

$$\text{slope} = \frac{dV}{dt}, \text{ the change in velocity with respect to time}$$

To analyze the units of the slope, divide the units of velocity (feet per second) by the units of time (seconds). This yields units of feet per second squared, the units of acceleration. Thus, the slope of the curve in Figure 1.2 has meaning: the acceleration of the ship at any point in time.

## 1.4 Unit Systems

There are three commonly used unit systems in engineering, each preferred by different disciplines in science by convention. For example, the unit system of science is the metric system, known as the International System of Units (SI) from the French name, Le Système International d'Units. The SI system is used worldwide in science, engineering, and commerce. Another common system of units is the English “pound force – pound mass” system. This system is commonly used in the fields of thermodynamics and heat transfer. The third unit system is the system we will use for this course: the British gravitational system. The British gravitational system is also known as the “pound – slug” system. The “pound – slug” system of units is used by naval architects and structural engineers. It is also the system of units that we tend to use in our daily lives, whether we realize it or not.

	<b>Force</b>	<b>Mass</b>	<b>Length</b>	<b>Time</b>
<b>S.I.</b>	newton ( <i>derived</i> )	kilogram	meter	second
<b>British G.S.</b>	pound	slug ( <i>derived</i> )	foot	second

**Table 1.2** Systems of Units Comparison

The SI system and the British “pound – slug” systems of units have their roots in Newton’s second law of motion: force is equal to the time rate of change of momentum. Newton’s second law defines a direct relationship between the four basic physical quantities of mechanics: force, mass, length, and time. The relationship between force and mass is written mathematically as:

$$\vec{F} = m\vec{a}$$

where “ $F$ ” denotes force, “ $m$ ” denotes mass, and “ $a$ ” denotes acceleration,

As per Table 1.2, the basic units of the SI system are mass, length, and time, and force has units derived from the basic units. One Newton is defined to be the force required to accelerate a mass of one kilogram at a rate of one meter per second squared ( $1 \text{ m/s}^2$ ). Mathematically, this can be written as:

$$F = (1 \text{ kg}) \times (1 \text{ m/s}^2)$$

$$F = 1 \text{ kg}\cdot\text{m/s}^2 = 1 \text{ Newton}$$

The basic units of the British gravitational (pound –slug) system are force (lb), length (ft), and time (s). In this system, units of mass are derived from the base units. The derived unit of mass is called the *slug*. One slug is defined as the mass that will be accelerated at a rate of one foot per second squared ( $\text{ft/s}^2$ ) by one pound of force (lb). Therefore:

$$F = ma$$

$$1 \text{ lb} = (\text{mass}) \times (1 \text{ ft/s}^2)$$



$$\text{or, } \quad \text{mass} = \frac{1\text{lb}}{1\frac{\text{ft}}{\text{s}^2}} = 1\frac{\text{lb} \cdot \text{s}^2}{\text{ft}} = 1\text{slug}$$

To find the weight of an object using the “pound-slug” system, one would use Equation 1.1, substituting the magnitude of the acceleration of gravity as the acceleration term. In the “pound-slug” system, the acceleration of gravity ( $g$ ) is equal to  $32.17 \text{ ft/s}^2$ .

**Example 1.1** An object has a mass of 1 slug. Calculate its corresponding weight.

$$\text{Weight} = (\text{mass}) \times (\text{acceleration})$$

$$\text{Weight} = (1 \text{ slug}) \times (32.17 \text{ ft/s}^2) = (1 \text{ lb} \cdot \text{s}^2/\text{ft}) \times (32.17 \text{ ft/s}^2)$$

$$\text{Weight} = 32.17 \text{ lb}$$

Table 1.3 is a listing of some of the common physical properties used in this course and their corresponding units in the British gravitational system.

Property	Length	Time	Force	Mass	Density	Pressure
Units	foot (ft)	seconds (s)	pounds (lb) or long ton (LT)	slug or lb-s <sup>2</sup> /ft	slug/ft <sup>3</sup> or lb-s <sup>2</sup> /ft <sup>4</sup>	lb/in <sup>2</sup>

**Table 1.3** Common physical properties and their corresponding units.

### 1.4.1 Unit Analysis

Unit analysis is a useful tool to help you solve a problem. Unit analysis is nothing more than ensuring that the units that correspond to numeric values in an equation produce units that correspond to the property you are solving for. For example, if a problem calls for you to find the weight of an object, you should know that you want your final result to be in pounds or long tons.

The best method for conducting unit analysis is to use the “ruled lines” method. Using this method divides numeric values for variables and their units into an organized equation that is easy to follow.

**Example 1.2** A ship floating in salt water has a displaced volume of  $4,000 \text{ ft}^3$ . Calculate the ship’s weight in long tons.

As you will find out in the next chapter, a ship’s weight is equal to the weight of the volume of water displaced by the ship (Archimedes Principle). This is written mathematically as:

$Displacement = (water\ density) \times (acceleration\ of\ gravity) \times (volume)$

or,  $\Delta = \rho g \nabla$

$$\rho = 1.99\text{ lb}\cdot\text{s}^2/\text{ft}^4$$

$$g = 32.17\text{ ft/s}^2$$

$$1\text{ LT} = 2240\text{ lb}$$

$\nabla = \text{object's submerged volume, ft}^3$

$$\Delta = \left[ \frac{1.99\text{ lb}\cdot\text{s}^2}{\text{ft}^4} \right] \times \left[ \frac{32.17\text{ ft}}{\text{s}^2} \right] \times \left[ \frac{4,000\text{ ft}^3}{1} \right] \times \left[ \frac{\text{LT}}{2240\text{ lb}} \right]$$

$$\Delta = 114.32\text{ LT}$$

Step 1, write the equation in symbolic form.

Step 2, rewrite the equation in order with numeric values for each variable, including appropriate units.

Step 3, cancel units that are the same in the numerators and denominators until the desired units are obtained.

Notice how neat and organized this approach makes the calculation. This makes it very easy for a reviewer or grader to understand and verify the work. Please do all calculations for this course in this manner. It is a wonderful engineering practice that effectively communicates with others. You will have plenty of opportunity throughout your career to communicate ideas, and this method is highly desirable when presenting calculations to higher authority.

Lastly, check your final answer for reasonability in magnitude and for proper units. You should have a “ball park” idea on the magnitude of the final answer. If you get a seemingly outrageous result, state that “this result is unreasonable” on the paper. Part of engineering is being able to recognize when a result doesn’t make sense. For instance, if you are trying to calculate the final draft of a YP after placing a pallet of sodas on the main deck, and you end up with a final draft of 35 feet (a YP’s normal draft is approximately 6 feet), you should recognize that the result of 35 feet makes no physical sense (the YP would have sunk). Also, watch the units in the final answer. For example, if you are calculating a volume (cubic feet) but unit analysis shows pounds, you should recognize that you’ve made a mistake. When grading homework and exams, units are a dead giveaway when it comes to finding mistakes in your calculations. A quick verification of units can save you many points on an exam. Analogy: if you are trying to find corruption in business, follow the money. If you are trying to find errors in engineering, follow the units.

## 1.5 Rules for Significant Figures

In this course you will perform calculations involving values obtained from a variety of sources, including graphs, tables, and laboratory data. The accuracy of these numbers gives rise to the subject of significant figures and how to use them. Numbers that are obtained from measurements contain a fixed number of reliable digits called significant figures. The number “13.56” has four significant figures.

There are two types of numbers used in engineering calculations. The first type of number is called an *exact number*. An exact number is one that comes from a direct count of objects, or that results from definitions. For example, if you were to count 5 oranges, there would be exactly 5 oranges. By definition, there are 2,240 pounds per long ton. Exact numbers are considered to possess an infinite number of significant figures.

The second type of numbers used in engineering calculations is a *measurement*. The number of significant figures used in measurements depends on the precision or accuracy of the measuring device. A micrometer capable of measuring an object to the fourth decimal place is much more accurate than a ruler marked off in 1/8 inch increments. The more precise the measuring device, the more significant figures you can use when reporting your results.

When combining several different measurements, the results must be combined through arithmetic calculations to arrive at some desired final answer. To have an idea of how reliable the calculated answer is we need to have a way of being sure the answer reflects the precision of the original measurements. Here are a few simple rules to follow:

For addition and subtraction of measurement values, the answer should have the same number of decimal places as the quantity having the least number of decimal places. For example, the answer in the following expression has only one decimal place because “125.2” is the number with the least number of decimal places and it only contains one.

$$3.247 + 41.36 + 125.2 = 169.8$$

Many people prefer to add the original numbers and then round the answer. If we enter the original numbers in the calculator, we obtain the sum “169.807”. Rounding to the nearest tenth (one decimal place) again gives the answer “169.8”

For multiplication and division, the number of significant figures in the answer should not be greater than the number of significant figures in the least precise factor. For example, the answer in the following expression has only two significant figures because the least precise factor “0.64” contains only two.

$$\frac{3.14 \times 2.751}{0.64} = 13.$$

When using exact numbers in calculations, we can forget about them as far as significant figures are concerned. When you have mixed numbers from measurements with exact numbers

(common in labs) you can determine the number of significant figures in the answer the usual way, but take into account only those numbers that arise from measurements.

For convenience in this course, you can assume all numbers are exact unless otherwise told. Give a reasonable number of decimal places in your answer (two or three are usually sufficient) and use some common sense. For example, if someone asked how much you weigh you wouldn't say 175.2398573 pounds. As a general rule give at least two numbers after the decimal or as many as it takes to show the work is accurate.

Some comments on computational accuracy: your calculator is a tool, enabling you to be much more accurate in calculating numbers. Use your tools wisely. When confronted with the task of multiplying a whole number by a fraction such as  $2/3$ , many students will write out and input a value of "0.66" into their calculator instead of " $2/3$ ". There is a huge difference in these two values. The factor " $2/3$ " is much more accurate than "0.66" and will yield a more accurate result. The same thing applies with the value of "pi". Let the calculator carry "pi" out to however many decimal places it wants rather than use the grade school value of "3.14." Do not round intermediate calculation steps. Keep sufficiently long numbers (or let the calculator carry the full answer forward), and then round the final answer to the appropriate significant figures.

## 1.6 Linear Interpolation

Engineers are often faced with having to interpolate values out of a table. For example, you may need the density of fresh water at a temperature of 62.3°F in order to solve a problem, however, tabulated data gives you densities at 62°F and 63°F. Finding the density of water at 62.3°F requires interpolation. The most common assumption in interpolation is that parameters vary in linear fashion between the listed parameters. This means that you can approximate the curve between values in the table with a straight line and easily determine the desired value.

**Example 1.3** Given the following values of the density of fresh water, find its density at a temperature of 62.7°F.

Temperature (°F)	Density (lb-s <sup>2</sup> /ft <sup>4</sup> )
61	1.9381
62	1.9379
63	1.9377

Solve for the density at 62.7°F as follows:

$$\frac{62.7^{\circ}F - 62^{\circ}F}{63^{\circ}F - 62^{\circ}F} = \frac{\rho_{62.7^{\circ}F} - \rho_{62^{\circ}F}}{\rho_{63^{\circ}F} - \rho_{62^{\circ}F}}$$

The algebraic solution for density at 62.7°F yields:

$$\rho_{62.7^{\circ}F} = \rho_{62^{\circ}F} + \left( \frac{62.7^{\circ}F - 62^{\circ}F}{63^{\circ}F - 62^{\circ}F} \right) (\rho_{63^{\circ}F} - \rho_{62^{\circ}F})$$

Doing the numerical substitution and solving,

$$\rho_{62.7^{\circ}F} = 1.9379 \frac{lb-s^2}{ft^4} + \left( \frac{62.7 - 62}{63 - 62} \right) \left( 1.9377 \frac{lb-s^2}{ft^4} - 1.9379 \frac{lb-s^2}{ft^4} \right)$$

$$\rho_{62.7^{\circ}F} = 1.93776 \frac{lb-s^2}{ft^4}$$

When interpolating, always check your result and make sure it is between the other values in the table.

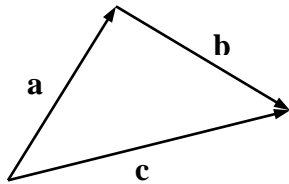
## 1.7 A Physics Review

The science of physics is the foundation of engineering. Therefore, we will undertake a short review of some concepts of physics prior to commencing our study of naval engineering. This review of physics will touch on the basics of scalars, vectors, moments, and couples. In addition, we will also take a look at the basics of statics.

### 1.7.1 Scalars and Vectors

A scalar is a quantity that only has magnitude. Mass, speed, work, and energy are examples of scalar quantities. A vector, on the other hand, is expressed in terms of both a magnitude and direction. Common vector quantities include velocity, acceleration, and force. Engineers denote vectors by placing a small arrow over the vector quantity. For example, a force vector would be written as  $\vec{F}$ . One other method to denote a vector, especially in textbooks, is to show a vector quantity in boldface type, such as  $\mathbf{F}$ .

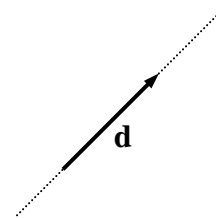
As mentioned above, a vector quantity has both a magnitude and direction, and they obey the parallelogram law of vector addition. Figure 1.3 shows the how vectors  $\mathbf{a}$ ,  $\mathbf{b}$ , and  $\mathbf{c}$  are related.



**Figure 1.3** Vector addition

$$\mathbf{a} + \mathbf{b} = \mathbf{c}$$

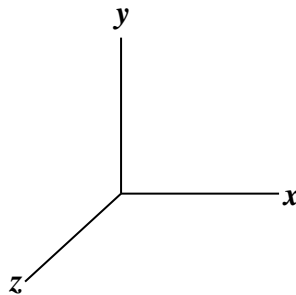
$$\mathbf{c} - \mathbf{a} = \mathbf{b}$$



**Figure 1.4** Vector line of action

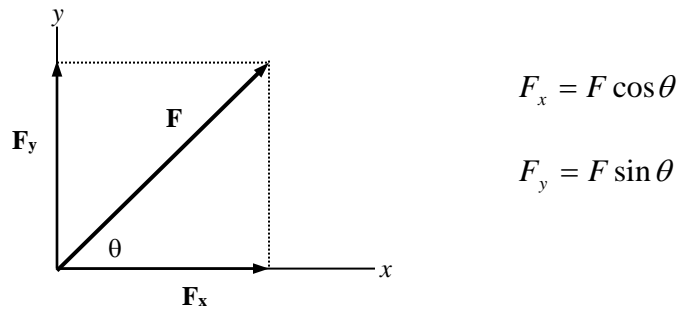
The line of action of a vector is an imaginary line running coincident with the vector extending to infinity in both directions along the line, as shown by vector  $\mathbf{d}$  in Figure 1.4.

Many times it is useful to resolve vectors into components in each principle direction. In the rectangular coordinate system, the principle directions are the  $x$ ,  $y$ , and  $z$  directions, as per Figure 1.5.



**Figure 1.5** Rectangular coordinate system

Consider the vector,  $\mathbf{F}$ , in the  $x$ - $y$  plane as shown in Figure 1.6.  $\mathbf{F}$  can be resolved into components in both the  $x$  and  $y$  direction,  $\mathbf{F}_x$  and  $\mathbf{F}_y$ . The scalar magnitudes of  $\mathbf{F}_x$  and  $\mathbf{F}_y$  can be found using the relationships shown in Figure 1.6.



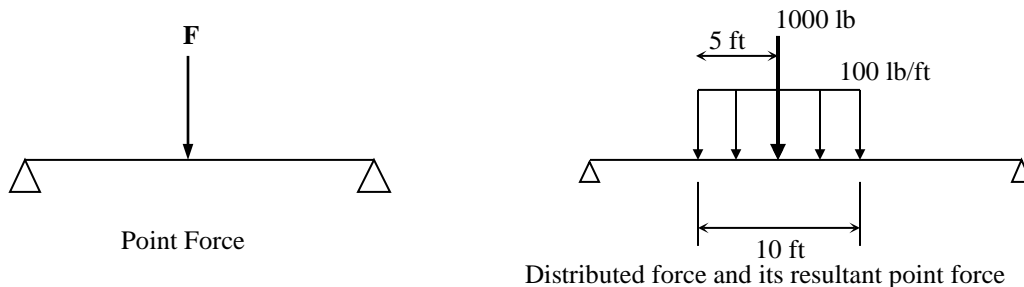
**Figure 1.6** Resolution of a vector into its components

In engineering diagrams, vectors are shown as arrows. The length of the arrow, from tail to head should represent the magnitude of the vector (the larger the magnitude, the longer the vector), and the arrow's direction represents the direction in which the vector acts. The exact placement of the vector is important in engineering. Either the head or tail of a vector may be placed at its point of application.

### 1.7.2 Forces

In this course we will use two types of forces: a point force and a distributed force. A point force is a force that has a single point of application. An example of a point force would be a person standing in the middle of a bridge; the weight of the person is considered to act at a single point on the bridge. A distributed force is a force that acts over a distance or an area. An example of a distributed force would be a pile of gravel that is dumped onto the bridge. Figure 1.7 shows the difference between a point force and a distributed force. A force causes an object to accelerate in the direction of the force's line of action. This motion is also called translation.

A distributed force can be resolved into a single, point force acting at the centroid of the distributed force. Figure 1.7 shows a distributed force of 100 lb/ft acting over a distance of 10 ft. The resultant, point force would be found by multiplying the magnitude of the distributed force by the distance over which it acts, in this case yielding a resultant point force of 1000 lb. This point force then acts at the centroid of the distributed force.



**Figure 1.7** Point forces and distributed forces

### 1.7.2.1 Force versus Weight

One vector force that acts on every object is the weight of that object. When an object is near the earth's surface it will experience a gravitational force due to the acceleration of gravity acting on the object's mass, known as weight. When you know the mass and acceleration of an object, you can use Newton's second law to calculate the force exerted on the object. A vector representing an object's weight **always** acts towards the center of the earth, and is drawn vertically with the vector's head pointing down. The weight of an object is represented with units of pounds, or for most of this course, units of long tons (LT). The weight (or displacement) of a ship is always given in long tons (1 LT = 2240 lb), and is represented by the Greek letter delta,  $\Delta_S$ .

### 1.7.3 Moments Created by Forces

A moment is created by the action of a force applied at some distance from a reference point, such that the line of action of the force does not pass through the reference point. Whereas a force causes translation of an object, application of a moment creates the tendency for an object to rotate. Additionally, the force creating the moment can also cause translation of the object.

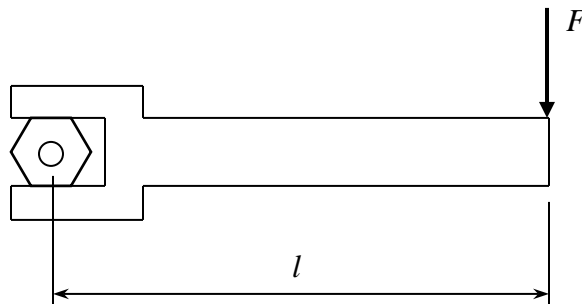
A common example of an applied moment is when you tighten a nut with a wrench. A force is applied to the end of the wrench opposite the nut, causing the wrench handle to move and the nut to rotate. The force acting on the wrench handle creates a moment about the nut.

The magnitude of a moment is the product of the magnitude of the force applied and the distance between a reference point and the force vector. Moments have units of force multiplied by distance: foot-pounds (ft-lb) or foot-long tons (ft-LT). Mathematically, the magnitude of a moment is written as:

$$\text{Moment} = \text{Force} \times \text{Distance}$$

$$M = F \times d$$

Figure 1.8 shows a wrench turning a nut. The wrench handle has length  $l$ , with a force of magnitude  $F$  acting at the end of the wrench. Force  $F$  creates a moment about the nut, causing the nut to rotate. The magnitude of the moment about the nut is  $F \times l$ . Note that the magnitude of the moment will increase if either the force is increased, or the length of the wrench handle is increased.

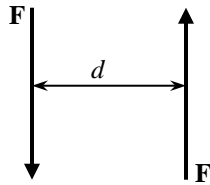


**Figure 1.8** Example of a moment applied with a wrench



### 1.7.4 Couples

A couple is a special type of moment that causes pure rotation without translation. A couple is formed by a pair of forces, equal in magnitude, acting parallel to each other but in opposite directions, separated by some distance. Figure 1.9 shows two forces creating a couple.



**Figure 1.9** Two forces creating a couple

The magnitude of a couple is calculated by multiplying the magnitude of **one** force by the distance separating the two forces. In Figure 1.9, the magnitude of the couple would be:

$$\text{Couple} = \text{Force} \times \text{distance}$$

$$C = F \times d$$

Just as moments have units of foot-pounds, couples also have units of foot-pounds.

### 1.7.5 Static Equilibrium

When one or more forces is acting on an object, the sum of forces in the  $x$ ,  $y$ , and  $z$  directions will ultimately tell you if the object will translate or rotate. If the sum of forces and/or moments does not equal zero, the object will translate or rotate. If the sum of all forces equals zero, and the sum of all moments equals zero, the object will neither translate nor rotate, a condition referred to as “static equilibrium”. The two necessary and sufficient conditions for static equilibrium are:

1. The sum (resultant) of all forces acting on a body is equal to zero.
2. The sum (resultant) of all moments acting on a body is equal to zero.

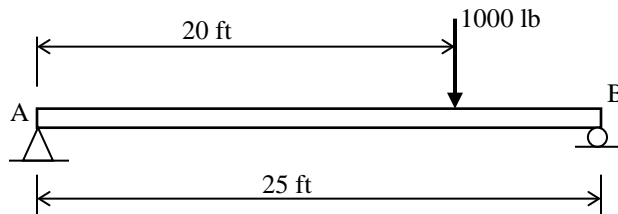
Mathematically, this is written as:

$$\sum \vec{F} = 0 \qquad \sum \vec{M} = 0$$

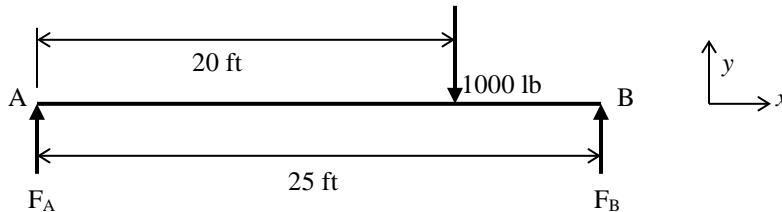
The analysis of an object in static equilibrium is also known as the study of “statics”. The analysis of ships in static equilibrium is the study of hydrostatics. This course will use the principle of static equilibrium to explain the effects of list and trim on a ship, as well as describing the behavior of materials under different loading conditions.

The principles of static equilibrium are very useful when solving for unknown forces acting on a body, as demonstrated in the following example problem.

**Example 1.4** A beam 25 ft in length is supported at both ends as shown below. One end of the beam is pinned (fixed) in place, and rollers support the other end. A force of 1000 lb is applied 20 ft from end “A”. Calculate the vertical reaction forces exerted on the beam by the supports.



Re-drawing the beam with reaction forces at points “A” and “B”, gives the following *free body diagram*.



To solve for the reaction forces,  $F_A$  and  $F_B$ , we will use the principles of static equilibrium. Summing forces in the vertical (y) direction and setting the sum equal to zero yields:

$$\begin{aligned} \sum F_y &= 0 \\ F_A + F_B - 1000lb &= 0 \end{aligned} \quad \text{equation (1)}$$

Summing moments about point “A” and setting the sum equal to zero yields:

$$\begin{aligned} \sum M_A &= 0 \\ (1000\text{ lb})(20\text{ ft}) - (F_B)(25\text{ ft}) &= 0 \end{aligned}$$

Solving for the reaction force,  $F_B$  yields:

$$F_B = \frac{(1000\text{ lb})(20\text{ ft})}{25\text{ ft}} = 800\text{ lb} \quad \text{the reaction force at “B” equals } 800\text{ lb}$$

Substituting  $F_B$  into equation (1) and solving for  $F_A$  yields:

$$\begin{aligned} F_A &= 1000\text{ lb} - F_B = 1000\text{ lb} - 800\text{ lb} \\ F_A &= 200\text{ lb} \quad \text{the reaction force at “A” equals } 200\text{ lb} \end{aligned}$$

Reviewing the methodology for problem solving:

1. Write down a problem statement.
2. Draw a diagram that shows the relationship between all variables.
3. Write general equations (no numbers at this point) that govern the problem.
4. Algebraically solve the equations for the desired final value.
5. Make numerical substitutions and solve your final answer.

Finally, look at your answer(s) and determine if it makes sense. If your answer doesn't make physical sense, you've probably made a mistake somewhere.

### 1.7.6 Pressure and Hydrostatic Pressure

On the most fundamental level, pressure is the effect of molecules colliding. All fluids (liquids and gases), have molecules moving about each other in a random chaotic manner. These molecules will collide and change direction exerting an impulse. The sum of all the impulses produces a distributed force over an area which we call pressure. Pressure has units of pounds per square inch (psi).

Fluid dynamics uses three kinds of pressure: static, dynamic, and total pressure. The pressure described in the first paragraph is static pressure. Dynamic pressure is the pressure measured in the face of a moving fluid. Total pressure is the sum of static and dynamic pressure. If a fluid is assumed to be at rest, dynamic pressure is equal to zero. The pressures we will be using in this course will be based on fluids being at rest.

Consider a small object sitting in water at some depth,  $z$ . If the object and water are at rest (velocity equals zero), then the sum of all forces acting on the object is zero, and the dynamic pressure acting on the object is zero. The pressure that the water exerts on the object is static pressure only; in the analysis of fluids, this static pressure is referred to as "hydrostatic pressure." Hydrostatic pressure is made up by distributed forces that act normal to the surface of the object in the water. These forces are referred to as "hydrostatic forces". The hydrostatic forces can be resolved into horizontal and vertical components. Since the object is in static equilibrium, the horizontal components of hydrostatic force must sum to zero and cancel each other out. For the object to remain at rest, the vertical component of hydrostatic force must equal the weight of the column of water directly above the object. The weight of the column of water is determined using the equation:

$$\text{Weight} = (\text{density}) \times (\text{gravity}) \times (\text{volume of water})$$

$$W = \rho g V = \rho g A z$$

where:  $\rho$  = water density (lb-s<sup>2</sup>/ft<sup>4</sup>)

$g$  = acceleration of gravity (ft/s<sup>2</sup>)

$A$  = projected area of the object (ft<sup>2</sup>)

$z$  = depth of the object below the water's surface (ft)

Therefore, the hydrostatic force acting on an object at depth,  $z$  creates the following pressure:

$$F_{hyd} = \rho g A z = (\rho g z) * A = P_{hyd} \times Area \quad \rightarrow \quad P_{hyd} = \rho g z$$

This equation can be used to find the hydrostatic pressure acting on any object at any depth. Note that hydrostatic pressure varies linearly with the depth of the object.

### 1.7.7 Mathematical Moments

In science and math, the following integrals appear in the mathematical descriptions of physical processes:

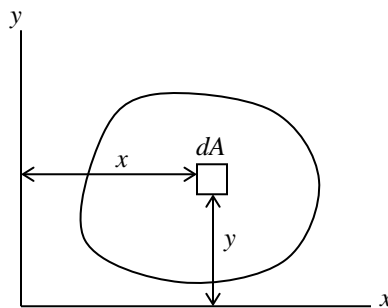
$$\int s dm \qquad \int s^2 dm$$

Where “ $s$ ” typically represents a distance and “ $dm$ ” is any differential property “ $m$ ”. Because these integrals are familiar across many disciplines of science and engineering, they are given special names, specifically the first moment and second moment. The order of the moment is the same as the exponent of the distance variable “ $s$ ”. Common properties of “ $m$ ”, as used in naval engineering are length, area, volume, mass, and force (weight).

Some common mathematical moments used in this course, along with their physical meanings and uses, are given below.

#### First Moment of Area

Consider the region shown in Figure 1.10. The region has a total area, “ $A$ ” and is divided into differential areas “ $dA$ ”. The moment of each  $dA$  about an axis is the distance of each  $dA$  from the axis multiplied by the area  $dA$ . The total first moment of area about an axis can be found by summing all the individual moments of area through the integral process.



**Figure 1.10** Diagram used for moment of area calculations

The first moment of area about the x-axis is found using the following equation:

$$M_x = \int y dA$$

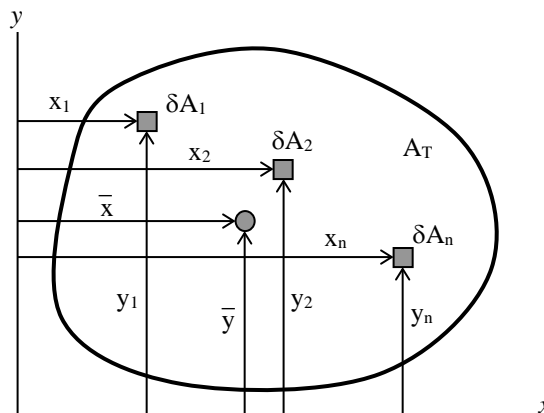
The first moment of area about the y-axis is found using:

$$M_y = \int x dA$$

Note that the first moment of area will have units of distance cubed (i.e. ft<sup>3</sup>). The first moment of area will be used in the calculation of the region's centroid.

### Geometric Centroids

The centroid of an object is its geometric center. We will use this in future chapters to calculate the center of gravity, center of buoyancy and center of flotation. To calculate the centroid of an area, consider the region shown in Figure 1.11. The region has total area ( $A_T$ ), and is subdivided into small areas of equal size,  $\delta A_n$ , located a distance  $x_n$  from the y-axis and  $y_n$  from the x-axis. The centroid of the region as measured from the y-axis is denoted " $\bar{x}$ ", and as measured from the x-axis is denoted " $\bar{y}$ ".



**Figure 1.11** Diagram for the calculation of a geometric centroid

The centroid of an object can be thought of as the average distance that all  $\delta A$ 's are from each axis. This is determined by calculating the first moment of area of each  $\delta A$ , summing each individual first moment, and then dividing by the total area of region  $A$ . Mathematically, the centroid of the region from each axis is written as:

$$\bar{y} = \frac{y_1 \delta A_1 + y_2 \delta A_2 + \dots + y_n \delta A_n}{\delta A_1 + \delta A_2 + \dots + \delta A_n} = \frac{\sum_{i=1}^n y_i \delta A_i}{\sum_{i=1}^n \delta A_i} = \frac{\sum_{i=1}^n y_i \delta A_i}{A_T}$$

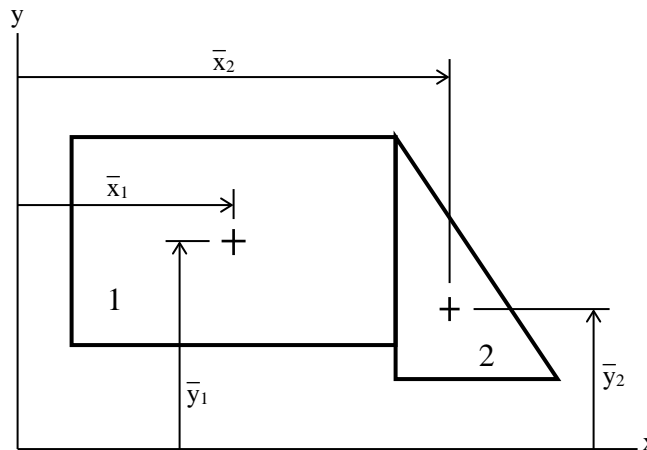
$$\bar{x} = \frac{x_1 \delta A_1 + x_2 \delta A_2 + \dots + x_n \delta A_n}{\delta A_1 + \delta A_2 + \dots + \delta A_n} = \frac{\sum_{i=1}^n x_i \delta A_i}{\sum_{i=1}^n \delta A_i} = \frac{\sum_{i=1}^n x_i \delta A_i}{A_T}$$

where  $y_i$  = vertical distance of each  $\delta A$  from the x-axis (ft)  
 $x_i$  = horizontal distance of each  $\delta A$  from the y-axis (ft)  
 $A_T$  = total area of the region (ft<sup>2</sup>)

The previous relationships can also be written as calculus equations. As each element  $\delta A$  becomes small enough, it becomes a differential area,  $dA$ , and the distance of each element from its axis becomes  $x$  or  $y$  instead of  $x_i$  and  $y_i$ . The equation for the centroid can then be written as:

$$\bar{y} = \frac{\int y dA}{\int dA} = \frac{\int y dA}{A_T} \quad \text{and} \quad \bar{x} = \frac{\int x dA}{\int dA} = \frac{\int x dA}{A_T}$$

Many times in engineering, we are confronted with calculating the centroid of regular geometric shapes. Calculation of the centroid of a regular geometric shape can best be illustrated using the shape consisting of a rectangle and right triangle as shown below in Figure 1.12.



**Figure 1.12** Diagram for calculating the centroid of a regular geometric shape

The region in Figure 1.12 is divided into two known geometric areas, rectangle 1 and right triangle 2. The centroid of the total region is found as shown below:

$$\bar{x} = \frac{\bar{x}_1 A_1 + \bar{x}_2 A_2}{A_1 + A_2} \quad \text{and,} \quad \bar{y} = \frac{\bar{y}_1 A_1 + \bar{y}_2 A_2}{A_1 + A_2}$$

where:  $\bar{x}_1$  and  $\bar{x}_2$  are the x distances to the centroid of areas 1 and 2 respectively  
 $A_1$  and  $A_2$  are the areas of 1 and 2 respectively

This procedure can be used to find the centroid of any regular geometric shape by using the following equations:

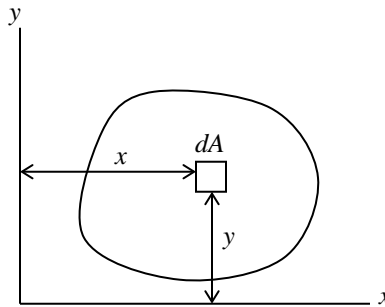
$$\bar{x} = \frac{\sum_{i=1}^n \bar{x}_i A_i}{\sum_{i=1}^n A_i} \quad \text{and} \quad \bar{y} = \frac{\sum_{i=1}^n \bar{y}_i A_i}{\sum_{i=1}^n A_i}$$

Although any axis system may be used, the same axis system must be used to measure the distance to every differential element or known geometric area. The solution will then provide a distance from that chosen reference axis system. A table can make solving this type of problem easier. When solving Figure 1.12, the columns of a table may be Area of each shape, x-distance of each shape, y-distance of each shape, x·Area and y·Area for each shape. Adding the columns provides values for the sum of x·Area, sum of y·Area, and the sum of Areas, which are divided to solve for the centroids,  $\bar{x}$  and  $\bar{y}$ .

### Second Moment of Area

The second moment of area ( $I$ ) is a quantity that is commonly used in naval architecture and structural engineering. The second moment of area is used in calculations of stiffness of structures and can also represent to external forces acting on a ship's hull. The larger the value of the second moment of area, the less likely an object is to deform. The second moment of area is calculated using the following equation:

$$I = \int s^2 dA \quad \text{where } s \text{ represents a distance from an axis, } dA \text{ represents a differential area, and } I \text{ denotes the second moment of area}$$



**Figure 1.13** Diagram for the determination of the second moment of area

Using Figure 1.13, the second moment of area of the region about the x-axis can be found using the following equation:

$$I_x = \int y^2 dA$$

Likewise, the second moment of area of the region about the y-axis can be found using:

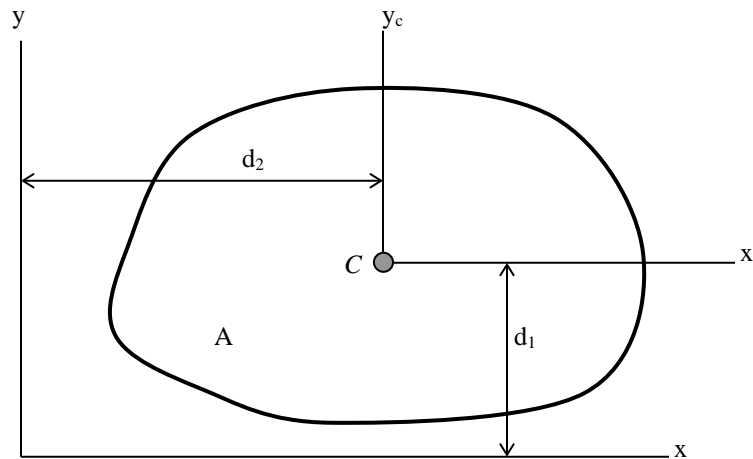
$$I_y = \int x^2 dA$$

Note that the second moment of area will have units of length to the fourth power (in<sup>4</sup> or ft<sup>4</sup>).

Engineering calculations commonly require the second moment of area to be calculated about an object's centroidal axes. To make life easier for engineers, many texts and reference manuals provide equations for the second moment of area of many shapes about their centroidal axes. Appendix C contains equations for the second moment of area and other properties of some common geometric shapes.

### Parallel Axis Theorem

Many times there exists a requirement that the second moment of area of an object be calculated about an axis that does not pass through the object's centroid. This calculation is easily accomplished using the parallel axis theorem. The parallel axis theorem can best be illustrated using Figure 1.14. The region shown has area  $A$ , and has its centroid located at point "C" with axes  $x_c$  and  $y_c$  passing through the centroid of the region, and parallel to the  $x$  and  $y$  axes respectively. The centroid of the region is located a distance  $d_1$  from the  $x$ -axis, and distance  $d_2$  from the  $y$ -axis.



**Figure 1.14** Diagram for calculating the second moment of area

The second moment of area of the region is calculated using the following equations. The derivation of these equations is not presented here, but can be found in any statics or strength of materials text.



Second moment of area about the x-axis:

$$I_x = I_{xc} + Ad_1^2$$

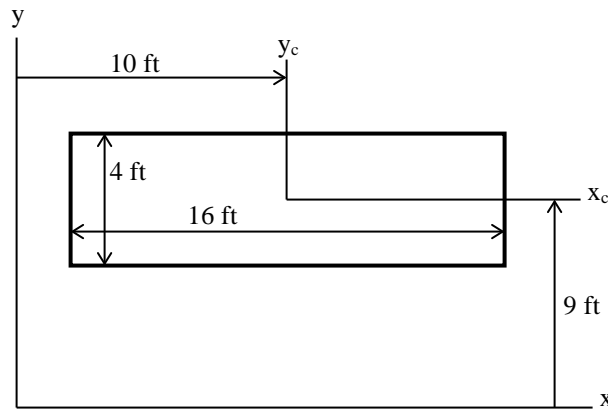
where:  $I_x =$  second moment of area about the x-axis,  $\text{ft}^4$   
 $I_{xc} =$  second moment of area about the x-axis passing through the centroid of the region,  $\text{ft}^4$   
 $A =$  area of the region,  $\text{ft}^2$   
 $d_1 =$  distance of the region's centroidal x-axis from the x-axis, ft

Similarly, the second moment of area of the region about the y-axis can be found using:

$$I_y = I_{yc} + Ad_2^2$$

What follows is an example for calculating the second moment of area of an object using the parallel axis theorem.

**Example 1.5** Calculate the second moment of area of the rectangle about the x-axis.



**Figure 1.15** Illustrating the parallel axis theorem

The second moment of area of the rectangle about the x-axis is found using the parallel axis theorem:

$$I_x = I_{xc} + Ad_1^2$$

where:  $I_{xc} =$  second moment of area of the rectangle about its centroidal axis,  $\text{ft}^4$   
 $A =$  area of the rectangle,  $\text{ft}^2$   
 $d_1 =$  distance of the x-axis from the rectangle's centroidal axis parallel to the x-axis, ft

$$A = (16 \text{ ft})(4 \text{ ft}) = 64 \text{ ft}^2$$

From Appendix I, the second moment of area of a rectangle about axis  $x_c$  is:

$$I_{x_c} = \frac{bh^3}{12} = \frac{(16\text{ ft})(4\text{ ft})^3}{12} = 85.33\text{ ft}^4$$

Now apply the parallel axis theorem to find the second moment of area of the rectangle about the x-axis:

$$I_x = (85.33\text{ ft}^4) + (64\text{ ft}^2)(9\text{ ft})^2 = 5269.33\text{ ft}^4$$

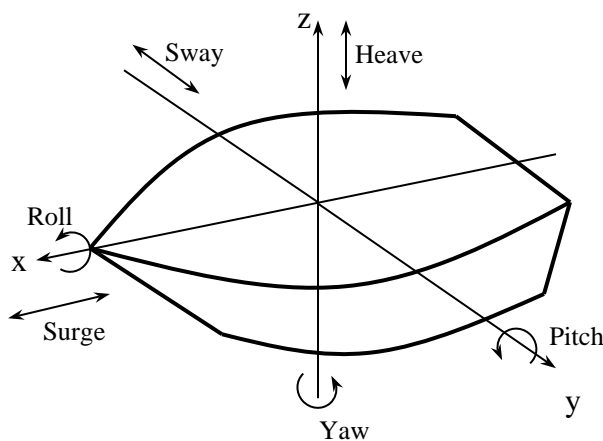
## 1.8 Definition of a Ship's Axes and Degrees of Freedom

A ship floating freely in water is subject to six degrees of freedom (exactly the same as an airplane flying in the sky): three translational and three rotational. Figure 1.16 shows the 6 degrees of freedom of a ship. All directions are measured from an imaginary point in the bottom center of the ship: located on the centerline (port/stbd), on the keel baseline (up/down), and amidships (fore/aft). Sometimes, for ease of computation, the longitudinal origin may be placed at the bow or stern.

In naval architecture, the longitudinal axis of a ship (meaning from bow to stern or stern to bow) is always defined as the  $x$ -axis. Motion in the longitudinal direction is referred to as *surge*. The  $x$ -axis of a ship is usually defined as the ship's centerline with its origin at amidships and the keel. Therefore, positive longitudinal measurements are forward of amidships and negative longitudinal measurements are aft of amidships. Rotation in motion about the  $x$ -axis is referred to as *roll*. There are also two static conditions of rotation about the  $x$ -axis, meaning the ship is rotated in that direction and remains non-moving at that location. These are *list* and *heel*. List is a condition produced by a weight shift on the ship. Heel is a condition produced by an external force such as the wind.

A ship's  $y$ -axis is used for measurements in the transverse or athwartships (port and starboard) direction. The  $y$ -axis has its origin at the keel and on the centerline. Naval architecture convention states that the positive  $y$ -direction is starboard of the centerline and that negative measurements are port of centerline. Translational motion in the  $y$ -direction is referred to as *sway*, and rotational motion about the  $y$ -axis is *pitch*. The static condition of rotation about the  $y$ -axis is referred to as *trim*. Similar to list, trim is a condition produced by a weight shift on the ship.

Vertical measurements in a ship are referenced to the keel. Therefore a ship's vertical or  $z$ -axis has its origin at the keel and centerline. For most ships, the keel is also the *baseline* for vertical measurements. Translational motion in the  $z$ -direction is referred to as *heave*, and rotational motion about the  $z$ -axis is *yaw*.



**Figure 1.16** A ship's axes and degrees of freedom

## 1.9 Bernoulli's Equation

External fluid flow is the situation that occurs when water flows around a ship's rudder, submarine planes, hydrofoils, or the hull of any vessel moving through the water. The study and analysis of fluid flow is a complex subject, and a subject that will challenge researchers for many years to come. However, as students of naval engineering, you should have some basic knowledge of external fluid flow.

Consider a fluid flowing at some velocity,  $V$ . Now, think of a line of fluid molecules that are moving in a direction tangent to the fluid's velocity. This line of movement is referred to as a streamline. One method of flow analysis is to consider the fluid to be made up of many streamlines, each layered on top of the other. We will be looking at a group of fluid molecules traveling along one streamline. To further our analysis of the fluid, the fluid flow is assumed to be incompressible, meaning that its density is not changing anywhere along the flow, and that there is no contraction or dilation of the fluid molecules. If the water molecules are not rotating, the flow is called irrotational and the fluid is said to have a vorticity of zero. If there are no shearing stresses between layers of the flow, the fluid is said to be inviscid. Finally, if we assume that a fluid's properties at one point on the streamline do not change with time (although the fluid's properties can change from location to location along the streamline), the fluid flow is said to be steady. In this course, our analysis will assume steady incompressible inviscid flow.

For steady incompressible inviscid flow, the sum of the flow work plus the kinetic energy plus the potential energy is constant along a streamline. This is Bernoulli's Equation and it can be applied to two different points along a streamline to yield the following equation:

$$\frac{p_1}{\rho} + \frac{V_1^2}{2} + gz_1 = \frac{p_2}{\rho} + \frac{V_2^2}{2} + gz_2 = \text{constant}$$

where:

$p$	=	hydrostatic pressure at any point on the streamline, psi
$V$	=	the speed of the fluid at any point on the streamline, ft/s
$g$	=	acceleration of gravity, ft/s <sup>2</sup>
$z$	=	height of the streamline above some reference datum, ft
$\rho$	=	fluid density, slug/ft <sup>3</sup> or lb·s <sup>2</sup> /ft <sup>4</sup>

The " $p/\rho$ " term in the equation is the flow work at any point on the streamline. The " $V^2/2$ " term is the fluid's kinetic energy at any point on the streamline. The " $gz$ " term is the fluid's potential energy at any point on the streamline.

Using Bernoulli's equation, we can explain why lift and thrust are generated by flow over hydrofoils, rudders, submarine planes, and propeller blades. We can also describe the pressure distribution of fluid flowing around a ship's hull.

## PROBLEMS - CHAPTER 1

1.
  - a. Sketch the velocity of a Yard Patrol Craft (YP) moving from zero ft/s to its top speed of 20 ft/s. Time to reach maximum speed is 26 seconds. Use velocity as the dependant variable and time as the independent variable.
  - b. Give the calculus equation that represents the area under the sketched curve between zero and 10 seconds. What does this area physically represent?
  - c. How would you calculate the acceleration of the YP at  $t = 5$  seconds?
  
2. What does the area under a plot of “ship’s sectional area” versus “longitudinal distance” physically represent? State the units of each axis and the area under the curve.
  
3. Which system of units is used in Naval Engineering I (EN400)? State the units in this system for the following parameters:
 

Force	Mass	Volume	Time	Density
Moment	Couple	Pressure	Second moment of area.	
  
4. A ship’s weight (displacement) varies with its draft as shown in the table below.

Draft (ft)	Weight (LT)
0	0
2	520
4	1050
6	1480
8	2000
10	2420
12	3000

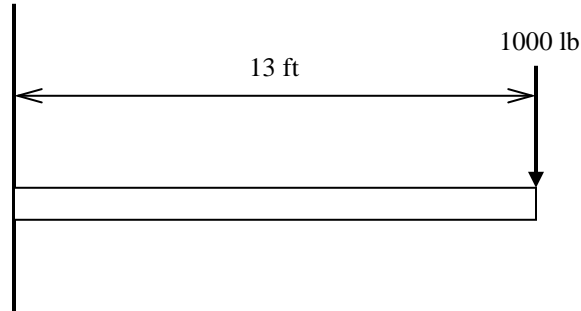
- a. Plot the ship’s weight as a function of draft.
- b. Fit a linear curve to the data and calculate the slope.
- c. What does the slope physically represent?
- d. What is the ship’s weight at a draft of 9.3 ft?

5. The deflection of a spring varies with the force applied to the spring as shown in the following experimental data:

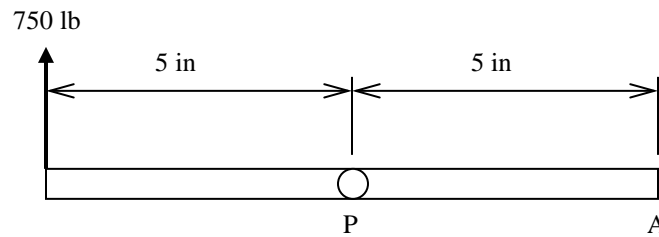
Force (lb)	Deflection (inches)
0	0
1	0.08
2	0.17
3	0.20
4	0.27
5	0.34
6	0.43
7	0.50

- a. Plot the spring's deflection as a function of force and determine the slope of the resulting curve.
- b. What physical property does the slope of the data represent?
- c. From your plotted data, determine how much the spring will deflect if a force of 4.6 pounds is applied.
- d. Write an equation representing the curve you fit to the data
6. An oiler transfers 100,000 gallons of F-76 fuel to the tanks of a frigate. The density of the fuel is  $1.616 \text{ lb-s}^2/\text{ft}^4$ .
- a. The weight of a volume of fluid can be found by the equation  $W = \rho gV$ , where  $g$  represents the acceleration of gravity and  $V$  represents the volume. Calculate how many long tons of fuel were transferred from the oiler to the frigate.
- b. If the oiler's draft changes 1 inch for every 136 LT added or removed, how many feet will the oiler's draft change after transferring the fuel?
- c. If the frigate's draft changes 1 inch for every 33 LT added or removed, how many inches will the frigate's draft change after receiving the fuel?
7. A force of 250 lb is acting at an angle of 30 degrees to the x-axis. Determine the x and y components of the 250 lb force.
8. What are the necessary and sufficient conditions for static equilibrium?

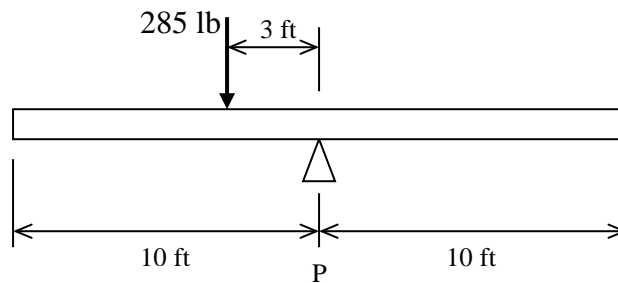
9. A 1000 lb weight is placed on a beam cantilevered from a wall as shown below. What is the magnitude of the moment that the weight exerts at the wall?



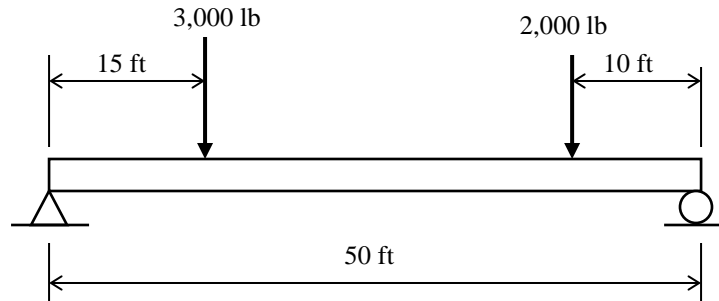
10. A force of 750 lb is applied to the linkage arm as shown below. The arm pivots about point "P".
- A second force is to be applied at point "A". What is necessary magnitude and direction of this force such that a couple is created about "P"?
  - What is the magnitude of the resulting couple about "P"?



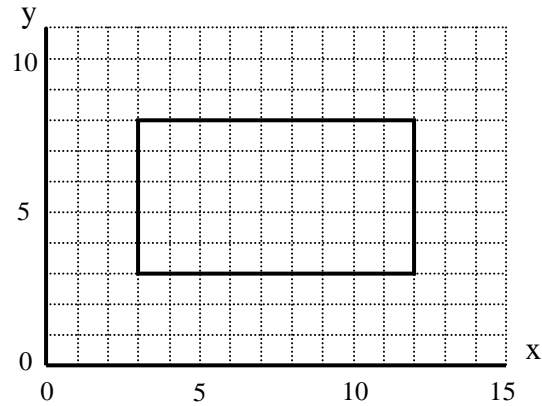
11. A 285 lb football player is sitting on a see-saw as shown below. Where must a 95 lb gymnast sit in order to balance the see-saw? What is the force at point "P"?



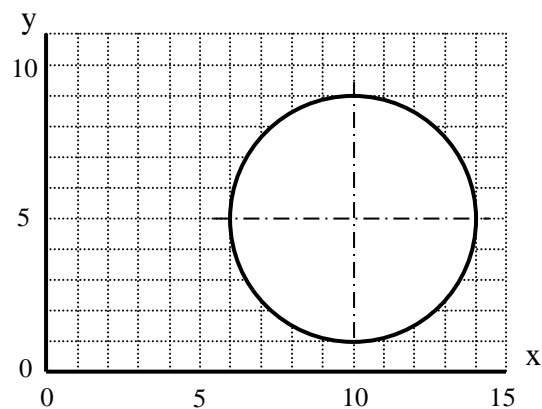
12. A simply supported beam 50 feet in length is loaded as shown below. Calculate the vertical reaction forces at each end of the beam.



13. Determine the first moment of area of the shape below about both the  $x$  and  $y$  axes.

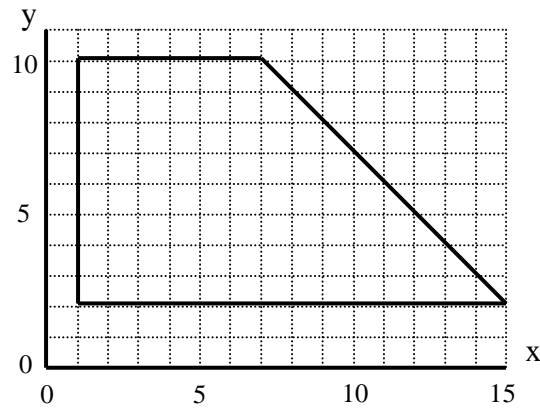


14. Determine the first moment of area of the shape below about both the  $x$  and  $y$  axes.

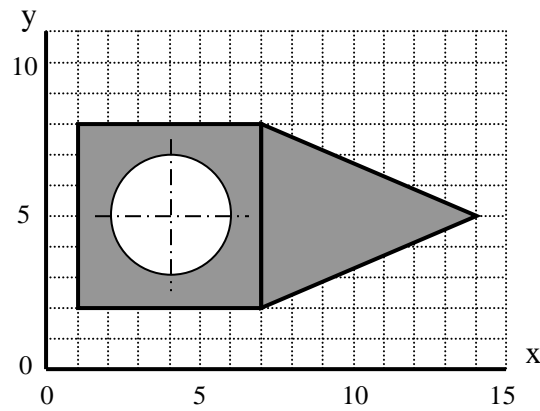




15. Determine the centroid of the shape below about both the x and y axes.

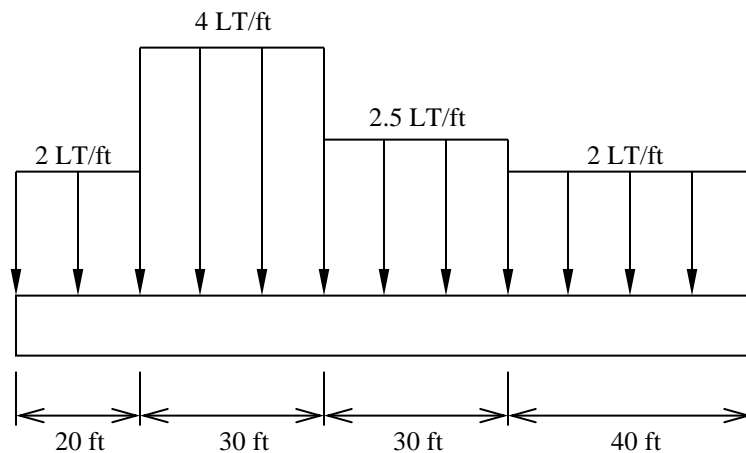


16. Determine the centroid of the shaded area about the x and y axes.

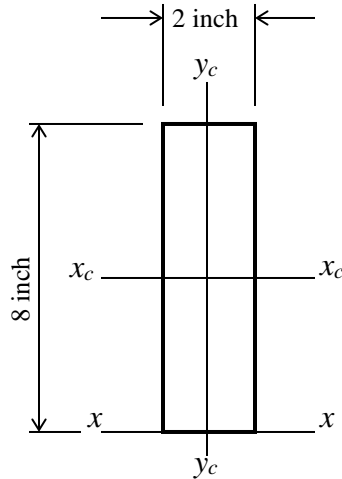


17. The following diagram represents the distributed weight of a small ship.

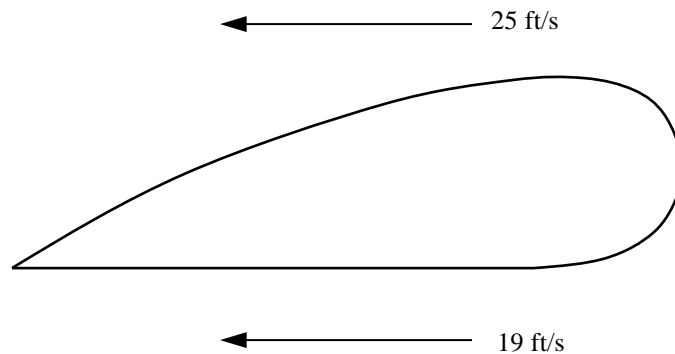
- What is the difference between a distributed force and a resultant force?
- Calculate the resultant weight of the ship. The concept of weighted averages may be useful.
- At what point on the ship would the resultant weight be applied?



18. Calculate the second moment of area of the below object about the following axes:
- Axis  $x_c-x_c$  (centroidal axis in the  $x$ -direction)
  - Axis  $y_c-y_c$  (centroidal axis in the  $y$ -direction)
  - Axis  $x-x$  (use of the parallel axis theorem is necessary)



19. Sketch a diagram showing the six degrees of freedom of a floating ship. Name each one on your diagram using the correct Naval Engineering terminology
20. Describe the difference between a ship's list, heel, and roll.
21. The diagram below shows the flow velocities past a submerged hydrofoil connected to an advanced marine vehicle. Use Bernoulli's Theorem to explain the forces being experienced by the hydrofoil.



# COURSE OBJECTIVES

## CHAPTER 2

### 2. HULL FORM AND GEOMETRY

1. Be familiar with ship classifications
2. Explain the difference between aerostatic, hydrostatic, and hydrodynamic support
3. Be familiar with the following types of marine vehicles: displacement ships, catamarans, planing vessels, hydrofoil, hovercraft, SWATH, and submarines
4. Learn Archimedes' Principle in qualitative and mathematical form
5. Calculate problems using Archimedes' Principle
6. Read, interpret, and relate the Body Plan, Half-Breadth Plan, and Sheer Plan and identify the lines for each plan
7. Relate the information in a ship's lines plan to a Table of Offsets
8. Be familiar with the following hull form terminology:
  - a. After Perpendicular (AP), Forward Perpendiculars (FP), and midships,  $\overline{\overline{\quad}}$
  - b. Length Between Perpendiculars ( $L_{PP}$  or LBP) and Length Overall (LOA)
  - c. Keel (K), Depth (D), Draft (T), Mean Draft ( $T_m$ ), Freeboard and Beam (B)
  - d. Flare, Tumble home and Camber
  - e. Centerline, Baseline and Offset
9. Define and compare the relationship between "centroid" and "center of mass"
10. State the significance and physical location of the center of buoyancy (B) and center of flotation (F); locate these points using LCB, VCB, TCB, TCF, and LCF
11. Use Simpson's 1<sup>st</sup> Rule to calculate the following (given a Table of Offsets):
  - a. Waterplane Area ( $A_{wp}$  or WPA)
  - b. Sectional Area ( $A_{sect}$ )
  - c. Submerged Volume ( $\nabla_s$ )
  - d. Longitudinal Center of Flotation (LCF)
12. Read and use a ship's Curves of Form to find hydrostatic properties and be knowledgeable about each of the properties on the Curves of Form
13. Calculate trim given  $T_{aft}$  and  $T_{fwd}$  and understand its physical meaning

## 2.1 Introduction to Ships and Naval Engineering

Ships are the single most expensive product a nation produces for defense, commerce, research, or nearly any other function. If we are to use such expensive instruments wisely, we must understand how and why they operate the way they do.

Ships employ almost every type of engineering system imaginable. Structural networks hold the ship together and protect its contents and crew. Machinery propels the ship and provides for all of the needs of the ship's inhabitants. Every need of every member of the crew must be provided for: cooking, eating, trash disposal, sleeping, and bathing. The study of ships is a study of structural and systems engineering.

There are many types of ships from which to choose, and each type has advantages and disadvantages. Factors which may influence the ship designer's decisions or the customer's choices include: cost, size, speed, seakeeping, radar signature, draft, maneuverability, stability, operational requirement (mission) and any number of special capabilities. The designer must weigh all of these factors, and others, when trying to meet the customer's specifications. Most ships sacrifice some characteristics, like low cost, for other factors, like speed. Building a ship is like building a car – a bus won't be as efficient as a Prius just as you wouldn't haul trash in a Camaro. Similarly, you wouldn't haul commercial goods in a DDG, and you wouldn't pay good money to take a cruise on a barge.

The study of naval engineering is the merging of the art and craft of ship building with the principles of physics and engineering sciences to meet the requirements of a naval vessel. It encompasses research, development, design, construction, operation, maintenance, and logistical support of naval vessels. This introductory course in naval engineering is meant to give each student an appreciation in each of the more common areas of study. It is meant as a survey course that will give some good practical knowledge to every officer assigned to naval service on land, sea or in the air.



Shipbuilding and design is a practice that dates back to the first caveman who dug a hole in a log to make a canoe. The birth of “modern” shipbuilding, that is the merging of art and science, is attributed to Sir Anthony Deane, a shipwright who penned his treatise, *Doctrine of Naval Architecture* in 1670.

## 2.2 Categorizing Ships

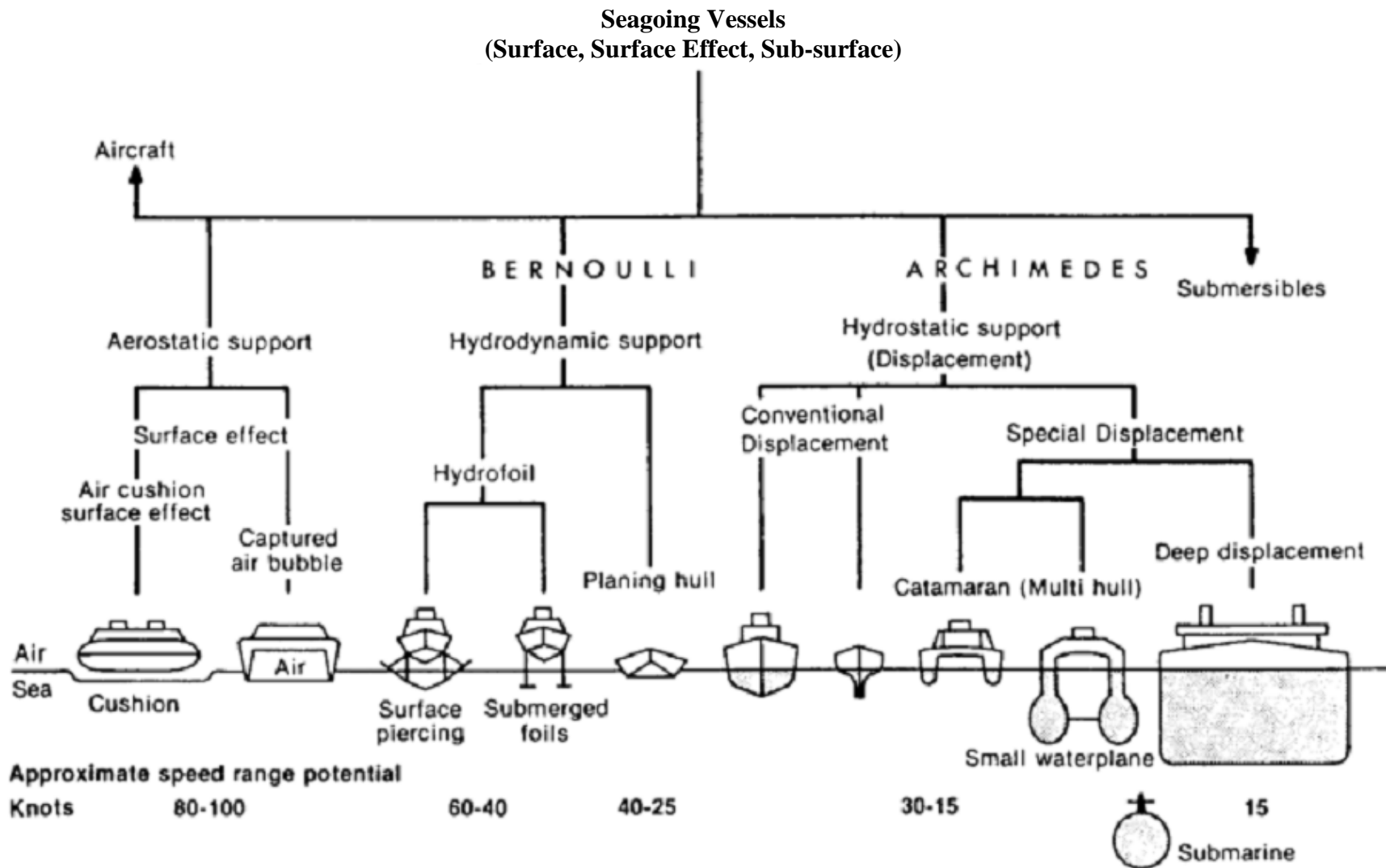
The term “ship” can be used to represent a wide range of vessels operating on, above or below the surface of the water. To help organize this study, ships are often categorized into groups based on either usage, means of support while in operation, or both.

A list of classification by usage might include the following.

- **Merchant Ships:** These ships are intended to earn a profit in the distribution of goods. A cash flow analysis is done of income versus costs in the calculation of a rate of return on the investment. Engineering economy studies must include receipts earned, acquisition costs, operating and maintenance costs, and any salvage value remaining when the ship is sold in a time value of money study.
- **Naval and Coast Guard Vessels:** Classified as combatants or auxiliaries. These ships tend to be extremely expensive because their missions require many performance capabilities such as speed, endurance, weapons payload, ability to operate and survive in hostile environments and reliability under combat conditions.
- **Recreational and Pleasure Ships:** Personal pleasure craft and cruise liners are a specialized class of ships that are run to earn a profit by providing recreation services to the general public. Comfort and safety are of utmost importance.
- **Utility Tugs:** Designed for long operation and easy maintenance with a no frills approach.
- **Research and Environmental Ships:** Highly specialized equipment must be kept and often deployed into and out of the water.
- **Ferries:** People and vehicles must load and unload with efficiency and safety in accordance with a strict time schedule in all weather conditions.

Ships can also be classified by the means of physical support while in operation. Three broad classifications that are frequently used by naval architects are shown in Figure 2.1, reproduced from “Introduction to Naval Architecture” by Gillmer and Johnson.

- **Aerostatic Support**
- **Hydrodynamic Support**
- **Hydrostatic Support**



**Figure 2.1** Categories of Seagoing Vessels According to Mode of Support

## **2.2.1 Aerostatic Support**

Aerostatic support is achieved when the vessel rides on a cushion of air generated by lift fans. These vessels tend to be lighter weight and higher speed vessels. The two basic types of vessels supported aerostatically are air cushion vehicle (ACV) and surface effect ships (SES).

### **2.2.1.1 Air Cushion Vehicles (ACVs)**

Air Cushion Vehicles (ACVs) or hovercraft continuously force air under the vessel allowing some of the air to escape around the perimeter as new air is forced downwards. They are usually propelled forward by airplane propeller type devices above the surface of the water with rudders behind the air flow to control the vessel. The Navy utilizes some hovercraft as LCACs (Landing Craft Air Cushion vehicles) because of this ability. Their use has opened over 75% of the world's coastline to amphibious assault compared with 5% with conventional landing craft.

Pro: Amphibious operations on sea *and* land; fast (over the horizon insertion)

Con: Very expensive for their payload capacity; low directional stability with air rudders; loud; require good seas; low survivability; and poor fuel efficiency

### **2.2.1.2 Surface Effect Ship (SES)**

The Surface Effect Ship (SES) or Captured Air Bubble (CAB) craft, is similar to the ACV due to its use of a cushion of air to lift the vessel. However, the SES has rigid side walls that extend into the water, providing directional stability and hydrostatic or hydrodynamic lift. They are usually propelled by water jets or super-cavitating propellers.

There were two SESs operated by the USN from about 1972-1975. They were the SES-100 A and B models (displacement 100 LT) capable of traveling at speeds of over 80 knots. The SES-100 was meant as an experimental platform carrying only 6 to 7 people. More recently, SES-200 (displacement 200 LT) was retired from the Naval Air Station at Patuxent River. Several European Navies operate SESs as fast patrol boats, designed to operate in coastal waters.

Pro: Less air lift requirement, more directionally stable, and more payload (compared to ACV)

Con: Not amphibious; expensive for their payload capacity

## **2.2.2 Hydrodynamic Support**

Hydro is the prefix for water and dynamic indicates movement. The two basic types of vessels supported hydrodynamically are planing vessels and hydrofoils.

### **2.2.2.1 Planing Vessels**

Planing vessels use the hydrodynamic pressures developed on the hull at high speeds to support the ship. They ride comfortably in smooth water, but when moving through waves, planing vessels ride very roughly, heavily stressing both the vessel structure and passengers. This was

particularly true of older types which used relatively flat bottom hulls. Modifications to the basic hull form, such as deep V-shaped sections, have helped to alleviate this problem somewhat.

These factors above serve to limit the size of planing vessels. However, these ships are used in a variety of roles such as pleasure boats, patrol boats, missile boats, and racing boats. At slow speeds the planing craft acts like a displacement ship and is supported hydrostatically. The Navy's Special Operations Force typically invests in planing vessels to support rapid insertion/recovery of Navy SEALs to/from targets ashore.

Pro: Fast 50+ kt; comfortable ride in smooth seas

Con: Large engines for size; slam into waves in moderate/high seas; limited capacity

### **2.2.2.2 Hydrofoils**

Hydrofoil craft are supported by underwater foils, similar to the wings of an aircraft. At high speeds these underwater surfaces develop lift and raise the hull out of the water. Bernoulli's Principle is often used to explain how a wing develops lift. Compared to planing boats, hydrofoils experience much lower vertical accelerations in moderate sea states making them more comfortable to ride. The hydrofoil can become uncomfortable or even dangerous in heavy sea states due to the foils breaking clear of the water and the hull impacting the waves. If the seaway becomes too rough the dynamic support is not used, and the ship becomes a displacement vessel.

The need for the hydrofoils to produce enough upward force to lift the ship out of the water places practical constraints on the vessel's size. Therefore, the potential crew and cargo carrying capacity of these boats is limited. Hydrofoils are also very expensive for their size in comparison to conventional displacement vessels.

The U.S. Navy formerly used hydrofoils from 1977 – 1993 as fast attack patrol craft and to carry anti-ship missiles (*Pegasus Class*), but does not use them anymore due to their high acquisition and maintenance costs. The Navy has re-tested newer models, to include the VT Halper Marine Mk Mod 2 High Speed Assault Craft, which is not yet in service.

Pro: Fast 40-60 kt; smoother ride in moderate seas (compared to planing)

Con: Expensive for their size; dangerous in heavy seas; limited capacity; unpredictable seakeeping behavior; complex construction and maintenance.

### **2.2.3 Hydrostatic Support**

Hydrostatically supported vessels are by far the most common type of waterborne craft and the predominant vessel support for the US Navy, USCG, USMC, and MSC. They describe any vessel that is supported by "Archimedes' Principle."

#### **Word definition of Archimedes Principle**



*“An object partially or fully submerged in a fluid will experience a resultant vertical force equal in magnitude to the weight of the volume of fluid displaced by the object.”*

This force is often referred to as the “buoyant force” or the “force of buoyancy.” Archimedes Principle can be written in mathematical format as follows.

$$F_B = \rho g \nabla$$

Where:  $F_B$  is the magnitude of the resultant buoyant force (**lb**)  
 $\rho$  is the density of the fluid (**lb-s<sup>2</sup>/ft<sup>4</sup>**)  
 $g$  is the acceleration due to gravity (**32.17 ft/s<sup>2</sup>**)  
 $\nabla$  is the volume of fluid displaced by the object in (**ft<sup>3</sup>**)

**Example 2.1** Calculate the buoyant force being experienced by a small boat with a submerged volume of 20 ft<sup>3</sup> when floating in seawater. ( $\rho_{\text{salt}} = 1.99 \text{ lb-s}^2/\text{ft}^4$ ).

$$F_B = \rho g \nabla = 1.99 \text{ lb sec}^2 / \text{ft}^4 \cdot 32.17 \text{ ft} / \text{sec}^2 \cdot 20 \text{ ft}^3$$

$$F_B = 1,280 \text{ lb}$$

**Example 2.2** What is the submerged volume of a ship experiencing a buoyant force of 4000 LT floating in fresh water? ( $\rho_{\text{fresh}} = 1.94 \text{ lb-s}^2/\text{ft}^4$ , 1 LT = 2240 lb)

$$F_B = \rho g \nabla$$

$$\nabla = \frac{F_B}{\rho g} = \frac{4000 \text{ LT} \cdot 2240 \text{ lb} / \text{LT}}{1.94 \text{ lb sec}^2 / \text{ft}^4 \cdot 32.17 \text{ ft} / \text{sec}^2}$$

$$\nabla = 143,570 \text{ ft}^3$$

### 2.2.3.1 Displacement Ships

Hydrostatically supported ships are referred to as “displacement ships”, since they float by displacing their own weight in water, according to Archimedes Principle. These are the oldest form of ships coming in all sizes and being used for such varied purposes as hauling cargo, bulk oil carrying, launching and recovering aircraft, transporting people, fishing, and war fighting.

Displacement hulls have the advantage of being a very old and common type of ship. Therefore, many aspects of their performance and cost have been well studied. In comparison to other types of vessels the cost of displacement ships is fairly low with respect to the amount of payload they can carry.

Pro: Vast experience in design and operation; lower cost; high payload; reliable/predictable behavior

Con: Limited speed; some difficulty seakeeping in waves (compared to SWATH)

### 2.2.3.2 SWATH

A special displacement ship is the Small Waterplane Area Twin Hull (SWATH). Most of the underwater volume in the SWATH ship is concentrated well below the water's surface as shown in Figure 2.1. This gives them very good seakeeping characteristics. They also have a large open deck and are therefore useful in a variety of applications requiring stable platforms and a large expanse of deck space. SWATH vessels are currently utilized as cruise ships, ferries, research vessels, and towed array platforms. These vessels present the designer with structural problems differing from other ships, particularly with respect to transverse bending moments. The USNS Impeccable is the Navy's SWATH surveillance ship. Similar in behavior (but not technically a SWATH ship) is the trimaran LCS-2 *Independence* class ship.

Pro: Excellent seakeeping in waves; large deck for operations

Con: Deep draft; higher cost; structural loading

### 2.2.3.3 Submarines

Submarines are hydrostatically supported, but above 3 to 5 knots, depth control can be achieved hydrodynamically due to the lift created by the submarines planes and the body of the hull.

Submarines have typically been used as weapons of war, but lately have also seen some non-military application. Some submarines are being designed for the purpose of viewing underwater life and reefs, for example. Unmanned submersibles have been used for scientific purposes, such as finding the *Titanic*, as well as a wide variety of oceanographic research.

Pro: Stealth; unique mission capabilities

Con: High cost; requires meticulous attention to structural integrity

There are many differences between the engineering problems faced by the surface ship designer and those faced by the submarine designer. Many of these differences will be covered in the last chapter of this course.

## 2.3 The Traditional Way to Represent the Hull Form

A ship's hull is a very complicated 3D shape. With few exceptions, an equation cannot be written that fully describes the shape of a ship. Therefore, engineers have placed great emphasis on the graphical description of hull forms. Until very recently, most of this work was done by hand. Today high-speed digital computers assist the engineer with the drawings, but they are not substitutes for imagination and sound judgment.

Traditionally, the ship's hull form is represented graphically by a lines drawing. The lines drawings consist of the intersection of the hull with a series of planes. The planes are equally spaced in each of the three dimensions. Planes in one dimension will be perpendicular to planes in the other two dimensions. We say that the sets of planes are mutually perpendicular or orthogonal planes.

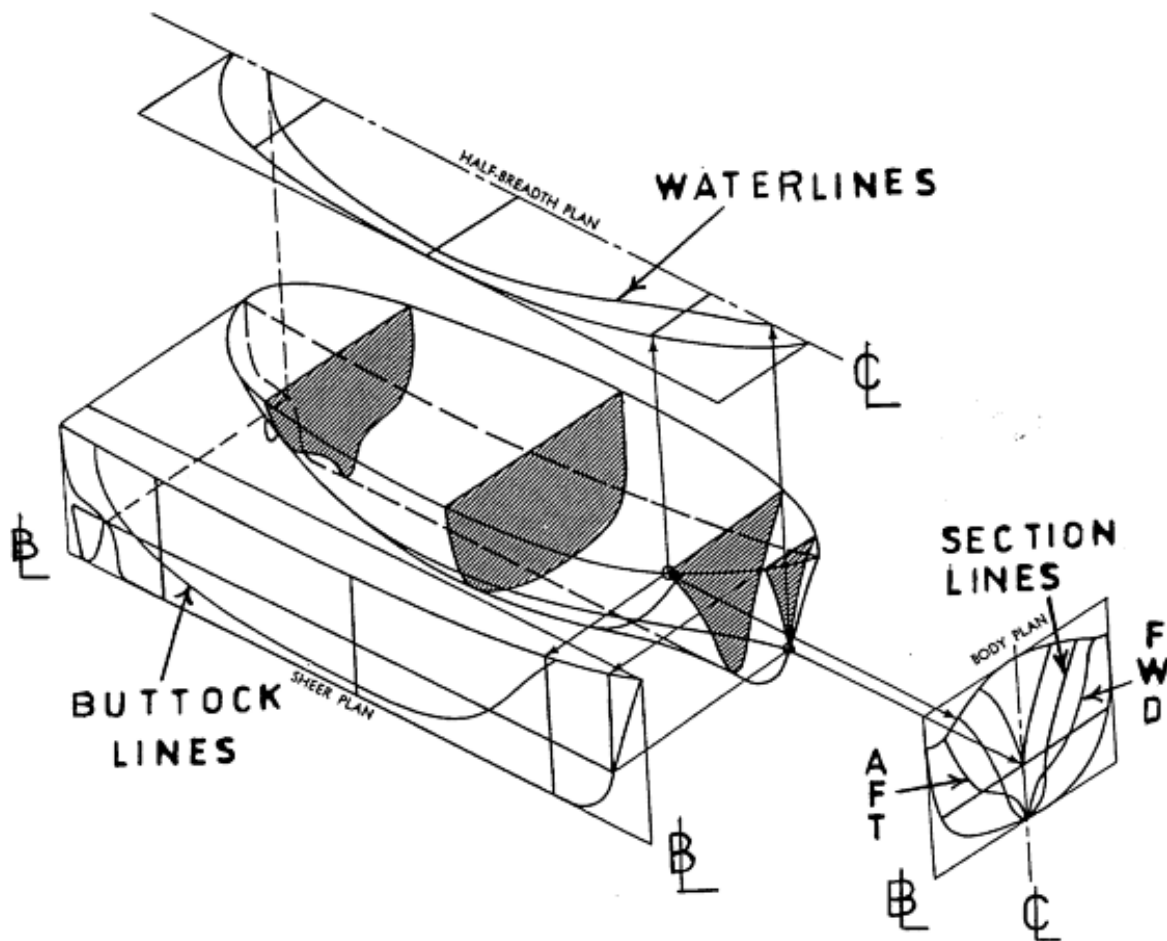
The points of intersection of these planes with the hull results in a series of lines that are projected onto a single plane located on the front, top, or side of the ship. This results in three separate projections, or views, called the Body Plan, the Half-Breadth Plan, and the Sheer plan, respectively. Figure 2.2 displays the creation of these views.



Representing a 3D shape with three orthogonal plane views is a common practice in all aspects of engineering. The engineer must be able to communicate an idea graphically so that it can be fabricated by a machinist or technician. In engineering terms, this type of mechanical drawing is referred to as an “orthographic plate” because it contains three orthogonal graphic pictures of the object. Orthographic projections are used in all engineering fields.

To visualize how a “lines drawing” works, place the ship in an imaginary rectangular box whose sides just touch the keel and sides of the ship. A viewed from the front, slice the box like a loaf of bread, and then trace each slice onto the front imaginary wall. Repeat slicing and tracing from the bottom and side, as the basis for three orthogonal projection screens. The lines to be projected result from the intersection of the hull with planes that are parallel to each of the three orthogonal planes mentioned. Refer to Figure 2.2.

To draw a ship's hull, first a convenient axis and reference system must be understood. Using the three conventional plans, each plan will show a grid and curves. A grid on one plan may represent a curve on another plan for the same hull, and vice versa. Measurements to port or starboard are measured from a centerline (C) out to a buttock line. To measure the vertical location, distance from a baseline (B) at the ship's keel is determined. Each vertical spacing above this baseline is called a waterline (WL). To measure longitudinal distance, a forward perpendicular (FP), aft perpendicular (AP), and midships (M) are convenient reference planes. Stations or section lines are measured aft of the FP. These reference planes will be explained further and used in developing the three orthogonal lines plans



**Figure 2.2** The Projection of Lines onto Three Orthogonal Planes

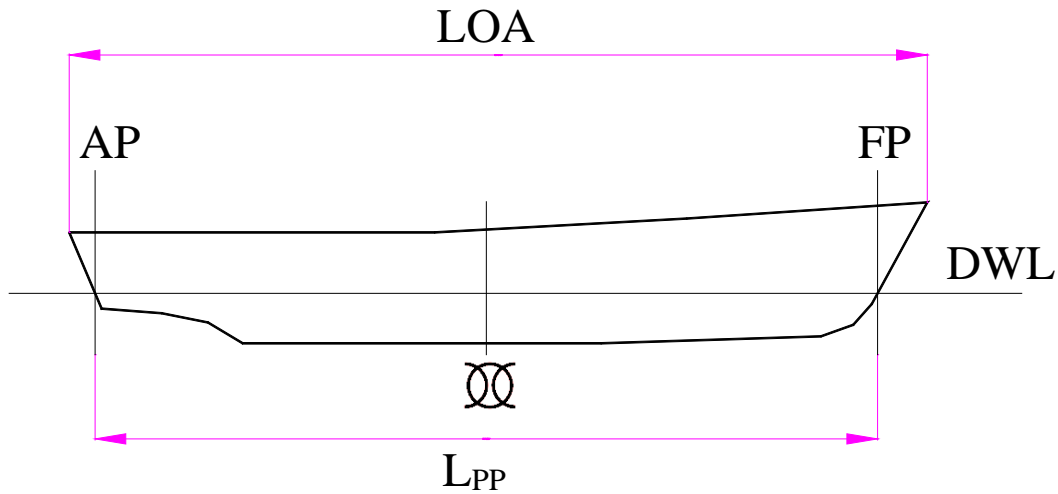
Planes parallel to the front and back of the imaginary box are called stations. A ship is typically divided into 11, 21, 31, or 41 evenly spaced stations, with larger ships having more stations. An odd number of stations results in an even number of equal blocks between the stations.

The first forward station at the bow is usually labeled station number zero. This forward station is called the forward perpendicular (FP). By definition, the FP is located at a longitudinal position as to intersect the stem of the ship at the DWL.

The after-most station is called the after perpendicular (AP). By definition the AP is located at a longitudinal position as to intersect the stern at the DWL for ships with a transom stern or alternatively through the rudder stock of the vessel.

The station midway between the perpendiculars is called the midships station, usually represented by the  $\overline{00}$  symbol. The length between perpendiculars has the symbol "L<sub>PP</sub>." Engineers typically use the L<sub>PP</sub> for calculations. There is also an overall ship length "LOA" that

might be a more useful number to use if you were docking the ship. Figure 2.3 displays these hull form characteristics.



**Figure 2.3** Hull Form Nomenclature

### 2.3.1 The Sheer Plan

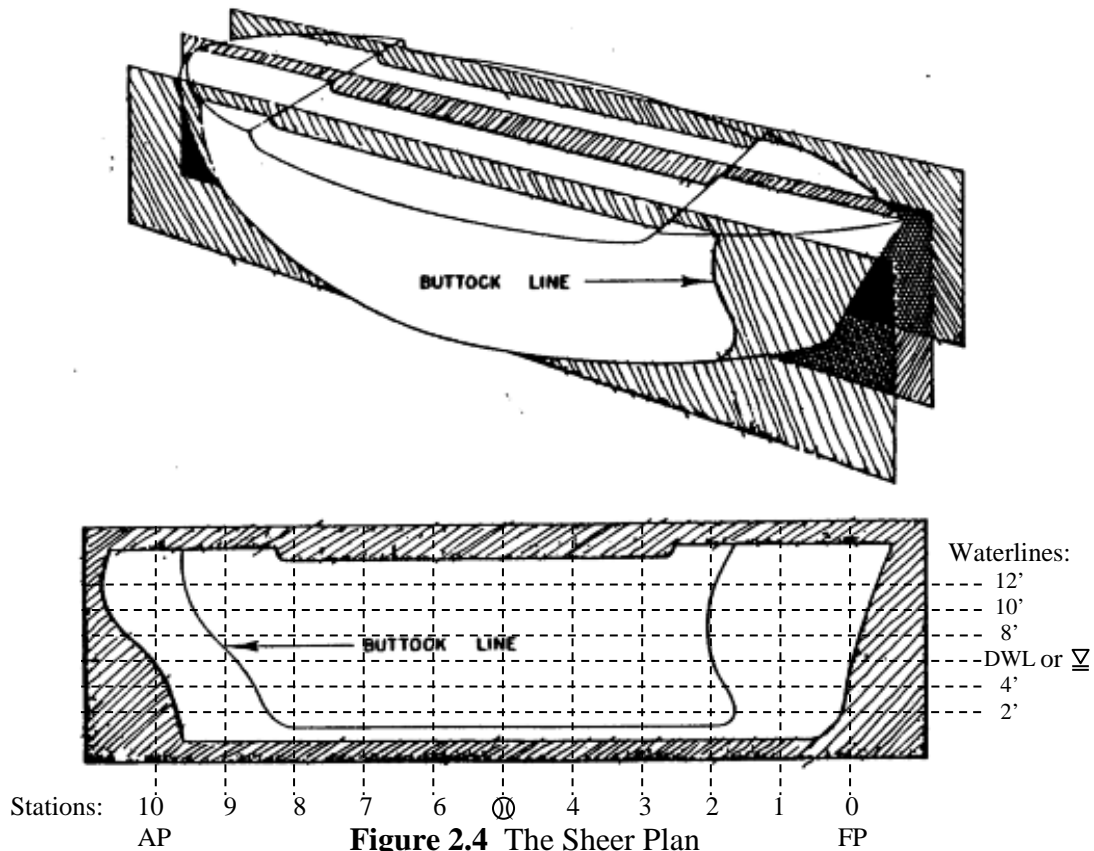
Grid lines: Waterlines and Station lines

Curves: Buttock lines (measured port/stbd from centerline)

A plane that runs from bow to stern directly through the center of the ship and parallel to the sides of the imaginary box is called the centerline plane. A series of planes parallel to one side of the centerline plane are imagined at regular intervals from the centerline. Each plane will intersect the ship's hull and form a curved line at the points of intersection. These lines are called "buttock" or "butt lines" and are all projected onto a single plane called the "Sheer Plan". Figure 2.4 shows the creation of this plan.

Each buttock line shows the true shape of the hull from the side view for some distance from the centerline of the ship. This allows them to serve as a pattern for the construction of the ship's longitudinal framing.

ⓘ The centerline plane shows a special butt line called the "profile" of the ship.



**Figure 2.4** The Sheer Plan



The sheer plan gets its name from the idea of a sheer line on a ship. The sheer line on a ship is the upward longitudinal curve of a ship's deck or bulwarks. It is the sheer line of the vessel which gives it a pleasing aesthetic quality.

Note: Naval Architects typically draw the sheer plan FWD to AFT from Right to Left for standard convention ("Bow Left"). In later chapters, we will draw the sheer plan from FWD to AFT from the origin on a cartesian coordinate system to facilitate the application of calculus for finding hull properties. When so displayed, the hull appears as "Bow Right."

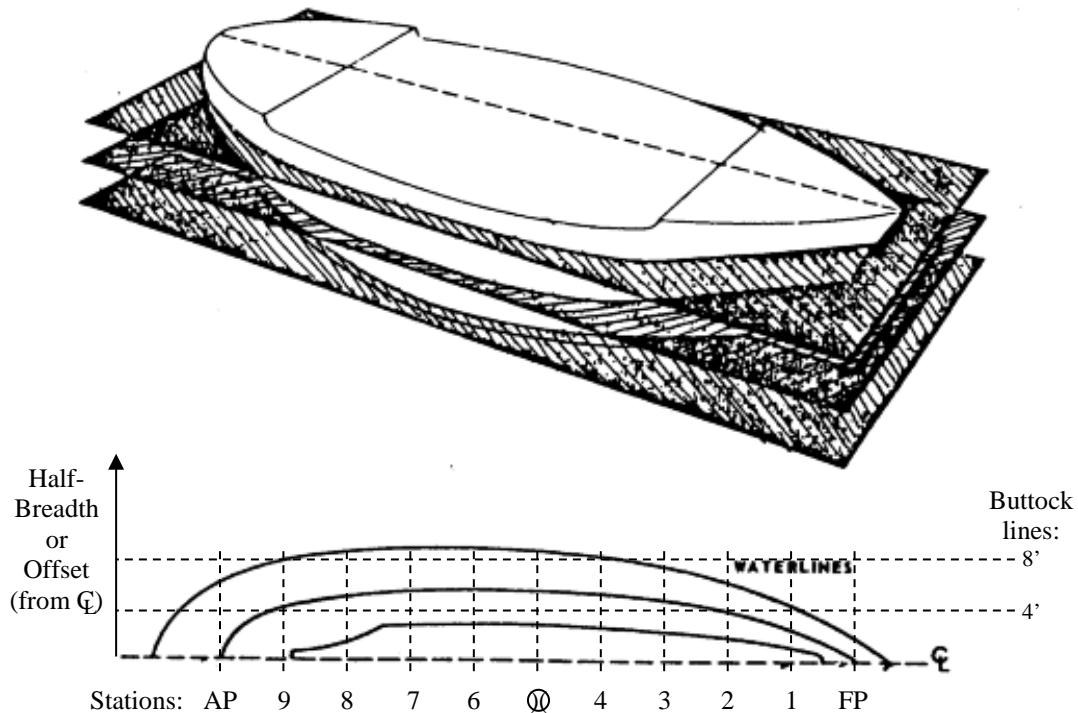
### 2.3.2 The Half-Breadth Plan

Grid lines: Buttock lines and Station lines

Curves: Waterlines (measured vertically up from baseline)

The bottom of the "box" is a reference plane called the base plane (think of this plan as a "bird's eye view"). The base plane is usually level with the keel. A series of planes parallel and above the base plane are imagined at regular intervals, usually at every foot. Each plane will intersect the ship's hull and form a curved line at the points of intersection. These lines are called "waterlines" and are all projected onto a single plane called the "Half Breadth Plan." Figure 2.5 shows the creation of this plan.

Each waterline shows the true shape of the hull from the top view for some elevation above the base plane (or keel) which allows this line to serve as a pattern for the construction of the ship's framing. For simplicity, and because hulls are symmetrical, only half of the waterplane is shown for the half-breadth plan.



**Figure 2.5** The Half-Breadth Plan

- ⓘ The waterlines referred to here are not necessarily where the ship actually floats. These waterlines are the intersection of the ship's hull with some imaginary plane above the base plane. There will be one plane above the base plane that coincides with the normal draft of the ship; this waterline is called the "Design Water Line." The design water line is often represented on drawings as DWL or  $\nabla$ .
- ⓘ Since ships are symmetric about their centerline they only need be drawn for the starboard or port side, thus the name of "Half Breadth Plan." Naval Architects typically draw the port side by standard convention.

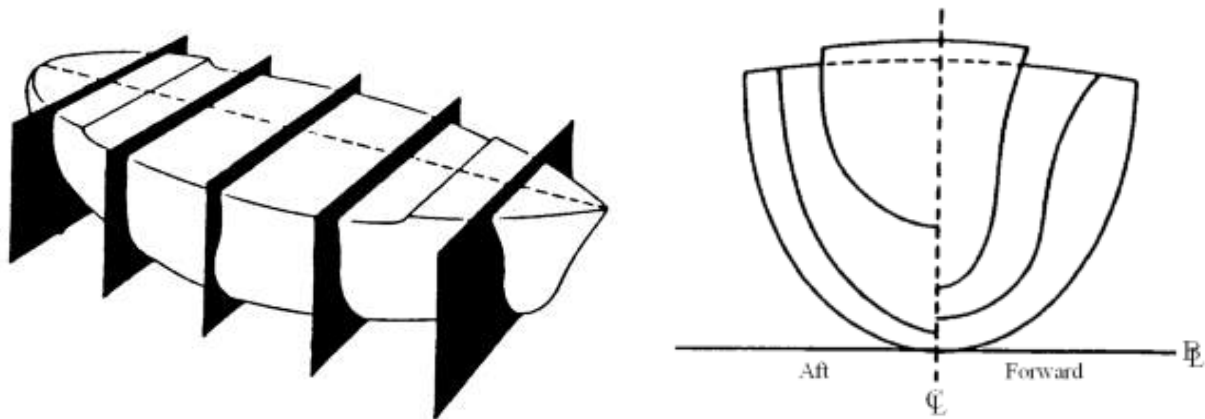
### 2.3.3 The Body Plan

Grid lines: Waterlines and Buttock lines  
 Curves: Stations or section lines (measured aft of FP)

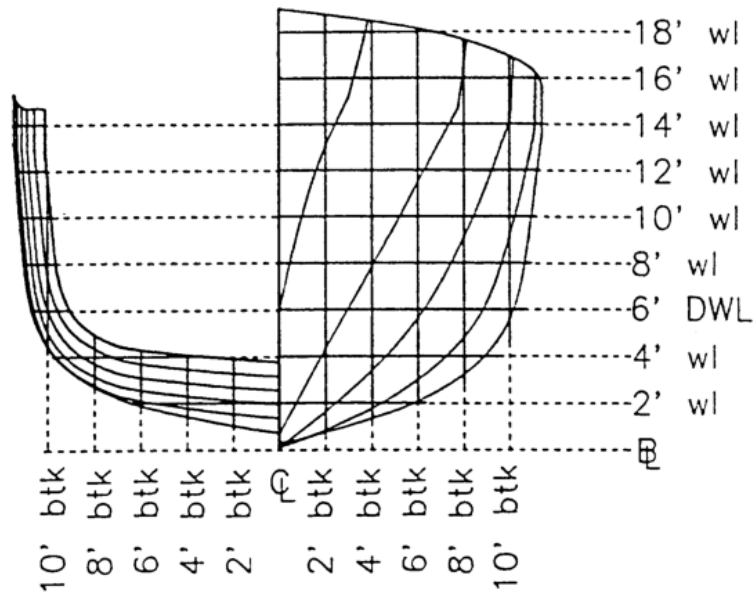
Each station plane will intersect the ship's hull and form a curved line at the points of intersection. These lines are called "sectional lines" or "stations" and are all projected onto a single plane called the "Body Plan." Refer to Figures 2.6 and 2.7.

The body plan takes advantage of the ship's symmetry. Like the half-breadth plan, only half of each section is drawn because the other half is identical. By convention, the sections forward of amidships are drawn on the right side, and the sections aft of amidships are drawn on the left side. The amidships section is generally shown on both sides of the body plan. The vertical line in the center separating the left and right half of the ship is called the centerline (C).

Each sectional line shows the true shape of the hull from the front view for some longitudinal position on the ship which allows this line to serve as a pattern for the construction of the ship's transverse framing.

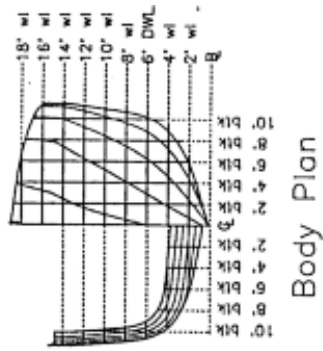


**Figure 2.6** The Body Plan

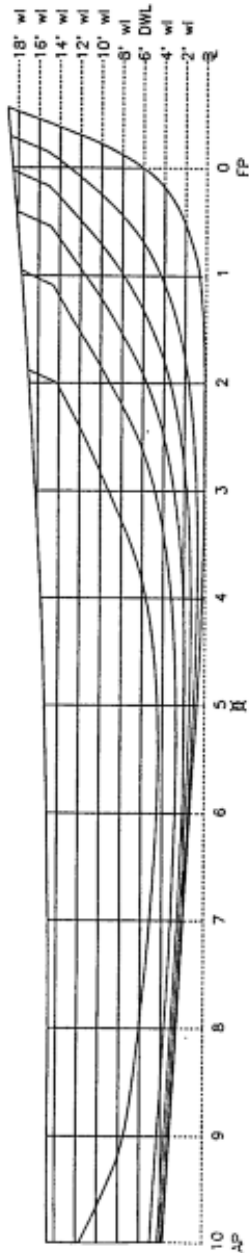


**Figure 2.7a** Modified USNA Yard Patrol Craft Body Plan





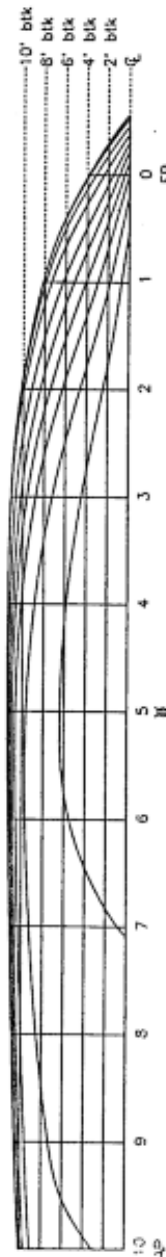
Body Plan



Sheer Plan

Principal Dimensions	
LOA	107' 4"
LPP	101' 8"
Beam Max	22' 9"
Station Spacing	10' 2"
Draft	6' 0"

USNA Yard Patrol Craft  
Modified Lines Plan  
Scale 1/10  
Copyright © 1988 USNA



Half Breadth Plan

Figure 2.7b Modified Lines Plan of the USNA Yard Patrol Craft

## 2.4 Table of Offsets

To calculate geometric characteristics of the hull using numerical techniques, the information on the lines drawing is converted to a numerical representation in a table called the table of offsets.

The Table of Offsets lists the distance in the y-direction from the center plane to the outline of the hull at each station and waterline. This distance is called the “offset” or “half-breadth distance.” Figure 2.8 shows how these measurements are organized by row and column to form a table of offsets.

There is enough information in the Table of Offsets to produce all three plans of the lines plan. Additionally, a table of offsets may be used to calculate geometric properties of the hull, such as sectional area, waterplane area, submerged volume and the longitudinal center of flotation. Figure 2.9 is the table of offsets for the Naval Academy’s Yard Patrol Craft.

Of the two tables, Half-Breadths from the Centerline is the more useful as will be explained when numerical calculations are performed in the next section.

<b>HB from CL</b>	X-direction (stations aft of forward perpendicular)
Z-direction (waterlines vertically up from baseline)	Y-direction (half-breadth or buttock line port/stbd from centerline)
<b>Heights above BL</b>	X-direction (stations aft of forward perpendicular)
Y-direction (buttock line port/stbd from CL)	Z-direction (waterlines vertically up from baseline)

**Figure 2.8** Organization of the Table of Offsets

## USNA YARD PATROL CRAFT - TABLE OF OFFSETS

### Half-breadths from Centerline (ft)

Stations	0	1	2	3	4	5	6	7	8	9	10
Top of Bulwark	3.85	8.14	10.19	11.15	11.40	11.40	11.26	11.07	10.84	10.53	10.09
18' Waterline	3.72	-	-	-	-	-	-	-	-	-	-
16' Waterline	3.20	7.92	10.13	11.15	-	-	-	-	-	-	-
14' Waterline	2.41	7.36	9.93	11.10	11.39	11.40	11.26	11.07	10.84	10.53	10.09
12' Waterline	1.58	6.26	9.20	10.70	11.19	11.32	11.21	11.02	10.76	10.45	10.02
10' Waterline	0.97	5.19	8.39	10.21	10.93	11.17	11.05	10.84	10.59	10.27	9.84
8' Waterline	0.46	4.07	7.43	9.63	10.64	10.98	10.87	10.66	10.41	10.07	9.65
6' Waterline	0.00	2.94	6.25	8.81	10.15	10.65	10.56	10.32	9.97	9.56	9.04
4' Waterline	-	1.80	4.60	7.23	8.88	9.65	9.67	9.25	8.50	7.27	3.08
2' Waterline	-	0.72	2.44	4.44	5.85	6.39	5.46	0.80	-	-	-

### Heights Above Baseline (ft)

Stations	0	1	2	3	4	5	6	7	8	9	10
Top of Bulwark	18.50	17.62	16.85	16.19	15.65	15.24	14.97	14.79	14.71	14.71	14.70
10' Buttock	-	-	14.20	9.24	5.63	4.48	4.49	5.11	6.08	7.52	11.75
8' Buttock	-	16.59	9.14	4.82	3.24	2.71	2.77	3.16	3.71	4.36	4.97
6' Buttock	-	11.51	5.65	3.00	2.07	1.88	2.10	2.55	3.10	3.69	4.30
4' Buttock	-	7.87	3.40	1.76	1.32	1.41	1.78	2.30	2.86	3.45	4.08
2' Buttock	13.09	4.36	1.63	0.82	0.73	1.02	1.53	2.10	2.68	3.27	3.91
Keel	6.00	0.66	0.10	0.09	0.28	0.71	1.34	1.95	2.54	3.14	3.76

**Figure 2.9** Table of Offsets for YP Hull

## 2.5 Hull Form Characteristics

The hull form characteristics applicable to the sheer view of a ship can be seen in Figure 2.3. However, there are a number of others which are relevant to a view of the ship from the bow or stern.

As mentioned previously, the keel is at the bottom of the ship. The bottoms of most ships are not flat. Distances above the keel are usually measured from a constant reference plane, the baseplane. The keel is denoted by "K" on diagrams with the distance above the keel being synonymous with the distance above the baseline.

### 2.5.1 Depth (D), Draft (T) and Beam (B).

The depth of the hull is the distance from the keel to the deck. Sometimes the deck is cambered, or curved, so the depth may also be defined as the distance from the keel to the deck at the intersection of deck and side or the "deck at edge." The symbol used for depth is "D." The depth of the hull is significant when studying the stress distribution throughout the hull structure.

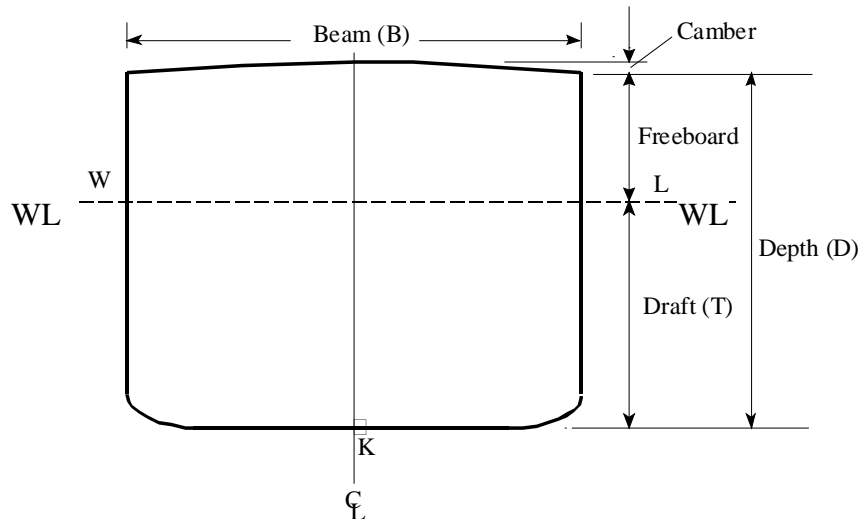
The draft (T) of the ship is the distance from the keel to the surface of the water (the waterline). The mean draft ( $T_m$ ) is the average of the bow and stern drafts at the perpendiculars. The mean draft is typically the draft at amidships.

$$T_{mean} = \frac{T_{fwd} + T_{aft}}{2}$$

Freeboard is the difference between "D" and "T".

The beam (B) is the transverse distance across each section (or the width of each section). Typically when referring to the beam of a ship, the maximum beam at the DWL is implied.

Figure 2.10 shows the dimensions of these terms on a typical midship section of a ship.



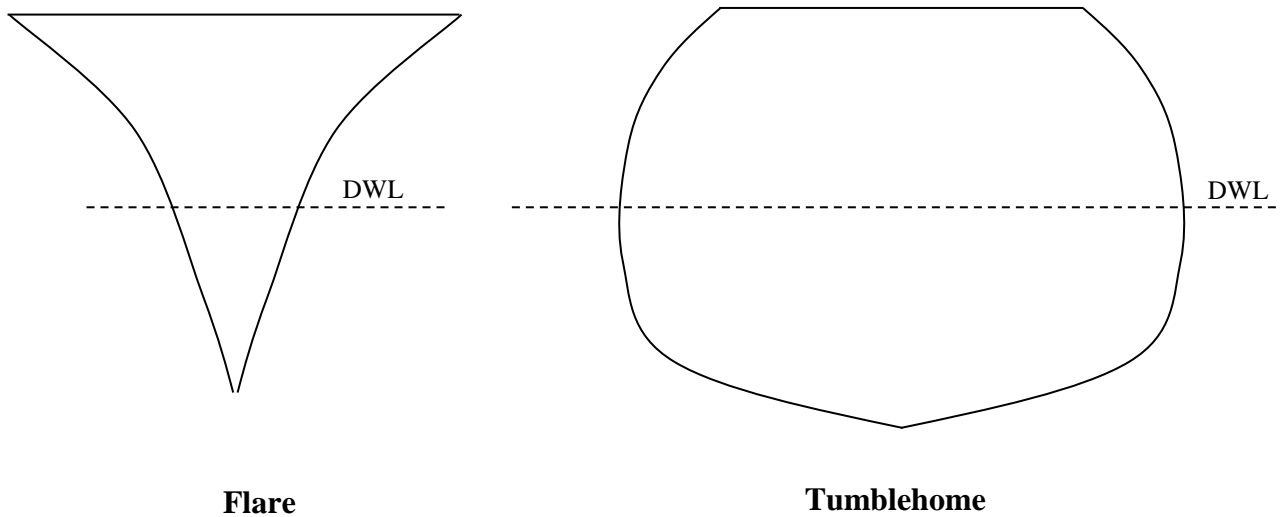
**Figure 2.10** Hull Form Characteristics

### 2.5.2 Flare and Tumblehome

The forward sections of most ships have a bow characteristic called flare. On a flared bow, the half-breadths increase as distance above the keel increases. Flare improves a ship's wave piercing performance, resistance to roll, and increases the available deck space.

Tumblehome is the opposite of flare and the beam at the deck is smaller than the beam at the waterline. This is typically an unstable design for a ship, particularly when turning at high speeds. While it is uncommon on modern surface ships, DDG-1000 has significant tumblehome for the purpose of reducing the Radar Cross Section (RCS). sailing yachts and submarines also have tumblehome.

Figure 2.11 shows flare and tumblehome.



**Figure 2.11** Ships with Flare and Tumblehome

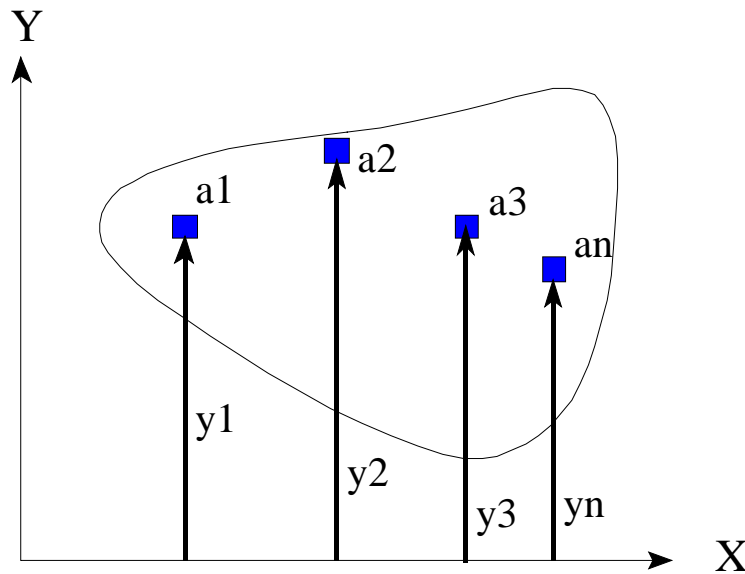
## 2.6 Centroids

A centroid is defined as the geometric center of a body.

The center of mass is often called the center of gravity and is defined as the location where all the body's mass or weight can be considered located if it were to be represented as a point mass. In a perfect world, an object could be set and balanced on a pin located at the center of mass.

If the object has uniform density (i.e. homogenous), then the centroid will be coincident with the body's center of mass. Likewise, if an object is symmetrical about an axis, the centroid and center of mass are on that axis. For example, the transverse location of the centroid and center of mass of a ship are often on the centerline. Conceptually, and in their application to ships, there is a big difference between a centroid and a center of mass.

Both centroids and centers of mass can be found by doing weighted averages as discussed in chapter one. For example, Figure 2.12 is a two dimensional uniform body with an irregular shape. The "Y" location of the centroid of this shape can be found by breaking the area up into little pieces and finding the average "Y" distance to all the area. This can be repeated for the "X" location of the centroid. This will result in the coordinates of the centroid of the area shown with respect to the arbitrary coordinate axis system chosen.



**Figure 2.12** Showing the Calculation of a Centroid of an Irregular Plane Area

The following steps show mathematically how to do the weighted average.

1. “Weight” each differential area element by its distance from some reference (i.e.,  $y_1a_1, y_2a_2, \dots, y_na_n$ ). In Figure 2.11, the reference is the x-axis.
2. Sum the products of area and distance to calculate the first moment of area about the reference:

$$\sum_{i=0}^n y_i a_i = \sum (y_1 a_1 + y_2 a_2 + y_3 a_3 + \dots + y_n a_n)$$

3. Divide the first moment of area by the total area of the object to get the position of the centroid with respect to the original reference. Note the ratio of the small piece of area over the total area is the weighting factor as discussed in chapter one. This represents a weighted average based on an area weighting.

$$\bar{y} = \frac{\sum_{i=0}^n y_i a_i}{A_T} = \sum_{i=0}^n y_i \left( \frac{a_i}{A_T} \right)$$

where:  $y$  is the vertical location of the centroid from the x-axis (ft)  
 $A_T$  is the total area of the shape (ft<sup>2</sup>)  
 $y_i$  is the distance to element “i” (ft)  
 $a_i$  is the area of element “i” (ft<sup>2</sup>)

❗ If we were to use masses instead of areas then the center of mass would be found.

Consider why the coordinates found for the centroid would be the same as those found for the center of mass if the body is uniform. If the body is made of different materials and densities, consider why centroid and center of mass may be different.

Several ships U.S. warships were built with different materials for the hull and superstructure. FFG-7 and CG-47 used aluminum in the superstructure as opposed to steel (like the rest of the hull) because aluminum has higher strength-to-weight performance (due to its low density), and thus reduced weight and lowered the center of gravity, improving cost and seakeeping performance. This later proved to be detrimental due to corrosion and cracking in the superstructure, and the Navy ultimately returned to predominately steel superstructures in warship design. The LCS-2 *Independence* Class is a notable exception.

## **2.7 Two Very Important Centroids - The Center of Flotation and The Center of Buoyancy.**

The concept of a centroid is important in naval engineering because it defines the location of two extremely useful points in the analysis of the static stability of a ship: the center of flotation and the center of buoyancy.

### **2.7.1 Center of Flotation (F)**

The centroid of the operating waterplane is the point about which the ship will list and trim. This point is called the center of flotation (F) and it acts as a fulcrum or pivot point for a floating ship.

The distance of the center of flotation from the centerline of the ship is called the “transverse center of flotation” (TCF). When the ship is upright, the center of flotation is located on the centerline so that the  $TCF = 0$  feet.

The distance of the center of flotation from amidships (or the forward or after perpendicular) is called the “longitudinal center of flotation” (LCF). LCF is referenced from midships or from one of the perpendiculars. If the reference is amidships, one must also indicate if the distance is forward or aft of midships. By convention, a negative sign is used to indicate distances aft of midships.

The center of flotation is always located at the centroid of the current waterplane, meaning its vertical location is always on the plane of the water. When the ship lists to port or starboard, trims down by the bow or stern, or changes draft, the shape of the waterplane will change, thus the location of the centroid will move, leading to a change in the location of the center of flotation.

### **2.7.2 Center of Buoyancy (B)**

The centroid of the underwater volume of the ship is the location where the resultant buoyant force acts. This point is called the center of buoyancy (B) and is extremely important in static stability calculations.

The distance of the center of buoyancy from the centerline of the ship is called the “transverse center of buoyancy” (TCB). When the ship is upright the center of buoyancy is located on the centerline so that the  $TCB = 0$  feet.

The vertical location of the center of buoyancy from the keel (or baseplane) is written as “VCB” or as “KB” with a line over the letters “KB” indicating it is a line segment from point “K” to point “B.”

The distance of the center of buoyancy from amidships (or the forward or after perpendicular) is called the “longitudinal center of buoyancy” (LCB). Similar to LCF, LCB is referenced from



FP, AP, or  $\bar{x}$ . If referenced from amidships, the distance forward or aft of  $\bar{x}$  must be annotated (+ FWD, - AFT).

The center of buoyancy is always located at the centroid of the submerged volume of the ship. When the ship lists to port or starboard, or trims down by the bow or stern, or changes draft, the shape of the submerged volume will change, thus the location of the centroid will move and alter the center of buoyancy. As opposed to center of flotation, the center of buoyancy is always located below the plane of the water.

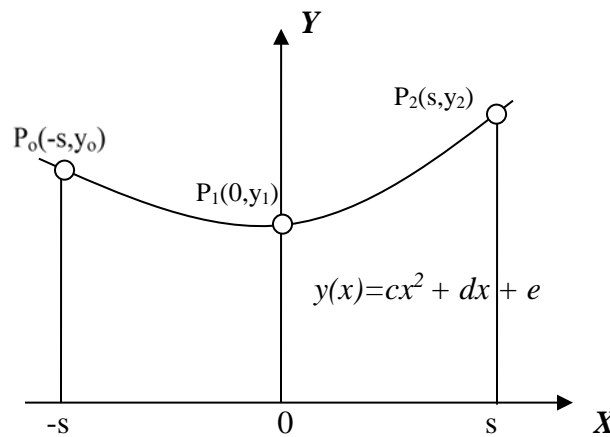
## 2.8 Fundamental Geometric Calculations

As previously stated, the shape of a ship's hull cannot usually be described by mathematical equations. In order to calculate fundamental geometric properties of the hull, naval architects use numerical methods. The trapezoidal rule and Simpson's 1<sup>st</sup> Rule are two methods of numerical integration frequently used. In this course Simpson's 1<sup>st</sup> Rule will be the numerical integration technique used to calculate geometric properties because of its greater accuracy when using a small number of points.

### 2.8.1 Simpson's 1<sup>st</sup> Rule Theory

Simpson's 1<sup>st</sup> Rule is used to integrate a curve with an odd number of ordinates evenly spaced along the abscissa as in Figure 2.13.

Simpson's Rule assumes that the points are connected three at a time by an unknown second order polynomial.



**Figure 2.13** Curve with evenly spaced, odd number of ordinates

The area under the curve over the range of  $x$  from  $-s$  to  $s$  is given by:

$$Area = \int (cx^2 + dx + e)dx = \frac{s}{3}(2cs^2 + 6e)$$

The coordinates of the points on the curve,  $P_0$ ,  $P_1$ , and  $P_2$ , are solutions to the second order polynomial that describes the curve between the points:

$$@ x = -s \quad y_0 = cs^2 - ds + e$$

$$@ x = 0 \quad y_1 = e$$

$$@ x = +s \quad y_2 = cs^2 + ds + e$$

and therefore the following is true:

$$y_0 + 4y_1 + y_2 = 2cs^2 + 6e$$

$$Area = \frac{s}{3}(y_0 + 4y_1 + y_2)$$

If the curve extends over more than three ordinates, then the integration scheme may be extended. For example: to calculate the area under a curve over five evenly spaced points,  $x = x_0$  to  $x = x_4$ , do multiple calculations of area three points at a time

$$\begin{array}{r}
 \phantom{Area} + \phantom{=} \phantom{(1/3)(s)(y_0)} + \phantom{=} \phantom{4y_1} + \phantom{=} \phantom{y_2} \\
 \phantom{Area} + \phantom{=} \phantom{(1/3)(s)(y_0)} + \phantom{=} \phantom{4y_1} + \phantom{=} \phantom{y_2} + \phantom{=} \phantom{4y_3} + \phantom{=} \phantom{y_4} \\
 \hline
 Area = (1/3)(s)(y_0 + 4y_1 + 2y_2 + 4y_3 + y_4)
 \end{array}$$

for  $x = x_0$  to  $x = x_4$ .

This integration technique may be used for any odd number of equally spaced data points

$$\int y(x)dx = \frac{s}{3}[(1)y(x_0) + (4)y(x_1) + (2)y(x_2) + (4)y(x_3) + \dots + (2)y(x_{n-2}) + (4)y(x_{n-1}) + (1)y(x_n)]$$

### 2.8.2 Application of Simpson's 1<sup>st</sup> Rule

To apply Simpson's 1<sup>st</sup> rule to any integral:

- replace the integral by 1/3
- change the differential to the equi-distant spacing (dx to an "s" in this case)
- multiply by any constants, and
- multiply by the Simpson's sum

The Simpson's sum is the sum of the products of the multipliers (1,4,2,4...2,4,1) times their respective variables magnitudes. The multipliers will always start with a "one" for the first term, a "four" for the second term, and continue to repeat the sequence "two" and "four" for the remaining terms, however always ending with a "four" and a "one" for the last two terms. In order to establish this pattern an odd number of terms are required with the smallest number of terms being 3. Note that  $x_0$  through  $x_4$  is five data points, an odd number.

To exercise Simpson's 1<sup>st</sup> Rule, attempt calculating the area of common shapes, such as a square, triangle, and semi-circle. Then increase the number of ordinates and try again. What effect does increasing the number of ordinates have upon your answer?

**Student Exercise** Use Simpson's 1<sup>st</sup> Rule to calculate the area of the following common shapes of known dimensions: square, triangle, semi-circle

- a. What shape gives the most accurate area?
- b. What effect does increasing the number of ordinates have on accuracy?

## 2.9 Numerical Calculations Using Simpson's 1<sup>st</sup> Rule.

Please always follow these steps when doing these calculations. This is not an option! The example problems that follow have been done this way.

1. Start with a picture of what you are about to integrate
2. Show the differential element you are using
3. Properly label your axis and drawing
4. Write out the generalized calculus equation written in the same symbols you used to label your picture
5. Write out Simpson's equation in generalized form
6. Substitute each number into the generalized Simpson's equation
7. Calculate a final answer



The final numerical answer is the least important part of this process. The idea is not to speed through these calculations to get a final answer but to show each step to display understanding of the equations and application.

Figure 2.14 shows the relationship of Chapter 2 material that builds to solving the four Simpsons Rule calculations required in this course.

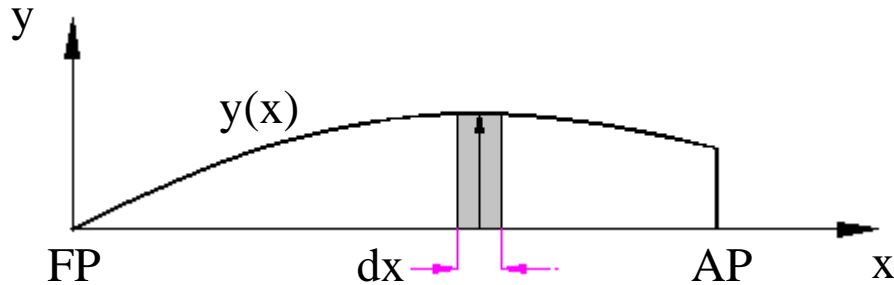
**Column on Table of Offsets to plot on section →**  
**Body Plan →**  
**Sectional Area (by Simpsons), for each station →**  
**Submerged Volume (by Simpsons)**

**Row on Table of Offsets to plot one waterline →**  
**Half-Breadth Plan →**  
**Waterplane Area (by Simpsons) →**  
**Longitudinal Center of Flotation (by Simpsons)**

**Figure 2.14** Relationships of material in Chapter Two

### 2.9.1 Waterplane Area

A waterplane is described numerically by half-breadths at each station. Begin by drawing a picture of a typical operating waterplane area with the proper “X-Y” axis. Draw a typical differential unit on this diagram and label the base and height of this rectangle.



Then and only then, write out the calculus equation by summing up all the differential pieces. Multiply by “2”, as your distances are only half breadths.

$$A_{WP} = 2 \int_{Area} dA = 2 \int_0^{L_{pp}} y(x) dx$$

- where:
- $A_{wp}$  is the waterplane area (ft<sup>2</sup>)
  - $dA$  is the differential area of one element (ft<sup>2</sup>)
  - $y(x)$  is the “y” offset or half-breadth at each value of “x” (ft)
  - $dx$  is the differential width of one element (ft)

Write out the Generalized Simpson’s Equation based on your calculus equation.

$$A_{WP} = 2 \frac{1}{3} \Delta x [(1)(y_0) + (4)(y_1) + (2)(y_2) + \dots]$$

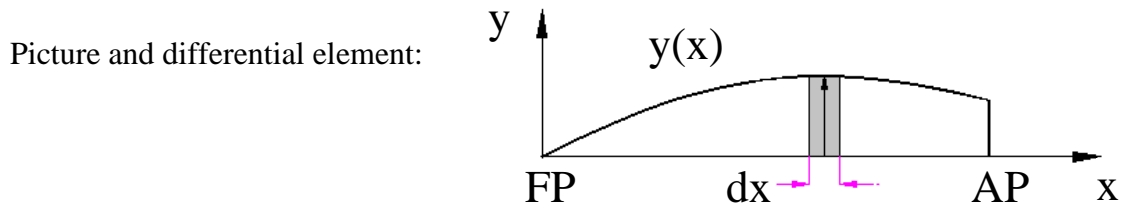
Notice the “dx” becomes “Δx” and equals the distance between stations. In a real problem the next step would be to substitute each number into the generalized equation and calculate a final answer.

**Example 2.3** The offsets for the 16-ft waterline of a particular ship with five stations are given below. The length between perpendiculars is 326.4 feet. Compute the waterplane area for the sixteen foot waterline.

16-foot Waterplane

Station	0	1	2	3	4
Half-breadth	0.39 ft	12.92 ft	20.97 ft	21.71 ft	12.58 ft

Solution:



Calculus equation:

$$A_{WP} = 2 \int_{Area} dA = 2 \int_0^{L_{pp}} y(x) dx$$

Simpson's Equation:

$$A_{WP} = 2 \frac{1}{3} \Delta x [(1)(y_0) + (4)(y_1) + (2)(y_2) + \dots]$$

Station spacing calculation:

$$\Delta x = \frac{L_{pp}}{n-1} = \frac{326.4 ft}{4} = 81.6 ft$$

where n = the number of stations.

Substitution of numbers and numerical answer:

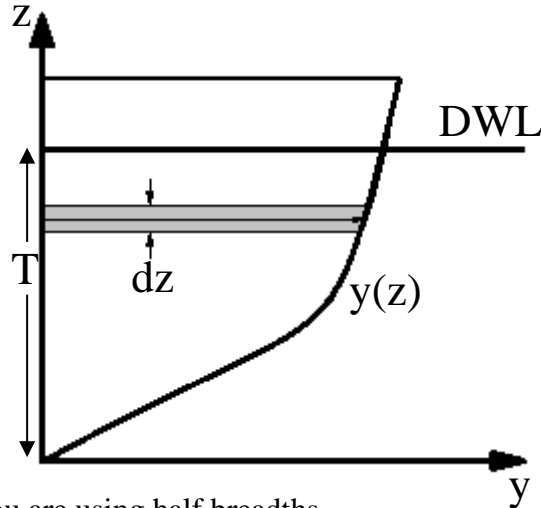
$$A_{wp} = (2/3)(81.6 ft)[0.39 + 4(12.92) + 2(20.97) + 4(21.71) + 12.58] ft = 10,523 ft^2$$

The area calculated is more accurate when the distance between stations (or equi-distant interval) decreases. A ship's length is typically divided into 11, 21, 31, or 41 stations yielding 10, 20, 30, and 40 equi-distant intervals, respectively.

### 2.9.2 Sectional Area

A sectional area is described numerically by half-breadths at each elevation or waterline above the baseline. There is a different sectional area at each station. Begin by drawing a picture of a typical sectional area at a station with the proper “Y-Z” axis. Draw a typical differential unit on this diagram and label the base and height of this rectangle.

Then and only then, write out the calculus equation by summing up all the differential pieces.



The “2” is required since you are using half breadths.

$$A_{sect} = 2 \int_{Area} dA = 2 \int_0^T y(z) dz$$

- Where:
- $A_{sect}$  is the sectional area up to some chosen waterline (ft<sup>2</sup>)
  - $dA$  is the differential area of one element (ft<sup>2</sup>)
  - $y(z)$  is the “y” offset or half-breadth at each value of “z” (ft)
  - $dz$  is the differential width of one element (ft)

Write out the Generalized Simpson’s Equation based on your calculus equation.

$$A_{sect} = 2 \frac{1}{3} \Delta z [(1)(y_0) + (4)(y_1) + (2)(y_2) + \dots]$$

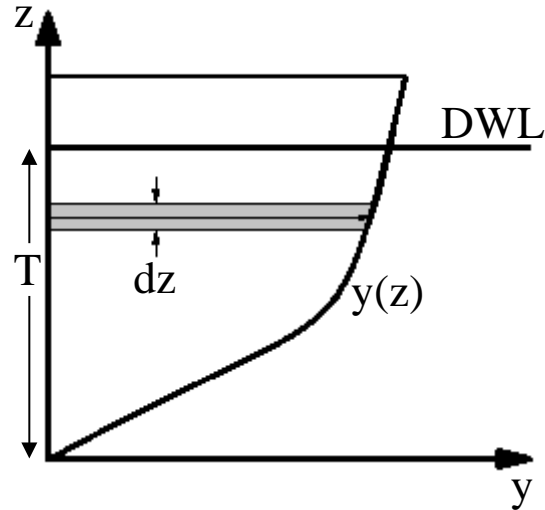
Notice the “dz” becomes a “Δz” and equals the distance between waterlines. In a real problem the next step would be to substitute each number into the generalized equation and calculate a final answer.

**Example 2.4** The offsets for station 5 of a particular ship are given below. Compute the sectional area for station 5 up to the 16 foot waterline.

Station 5					
Waterline	0 ft	4 ft	8 ft	12 ft	16 ft
Half-breadth	0.58 ft	14.48 ft	19.91 ft	21.88 ft	22.59 ft

Solution:

Picture and differential element:



Calculus equation:

$$A_{\text{sect}} = 2 \int_{\text{Area}} dA = 2 \int_0^T y(z) dz$$

Simpson's Equation:

$$A_{\text{sect}} = 2 \frac{1}{3} \Delta z [(1)(y_0) + (4)(y_1) + (2)(y_2) + \dots]$$

Substitution of numbers and numerical answer:

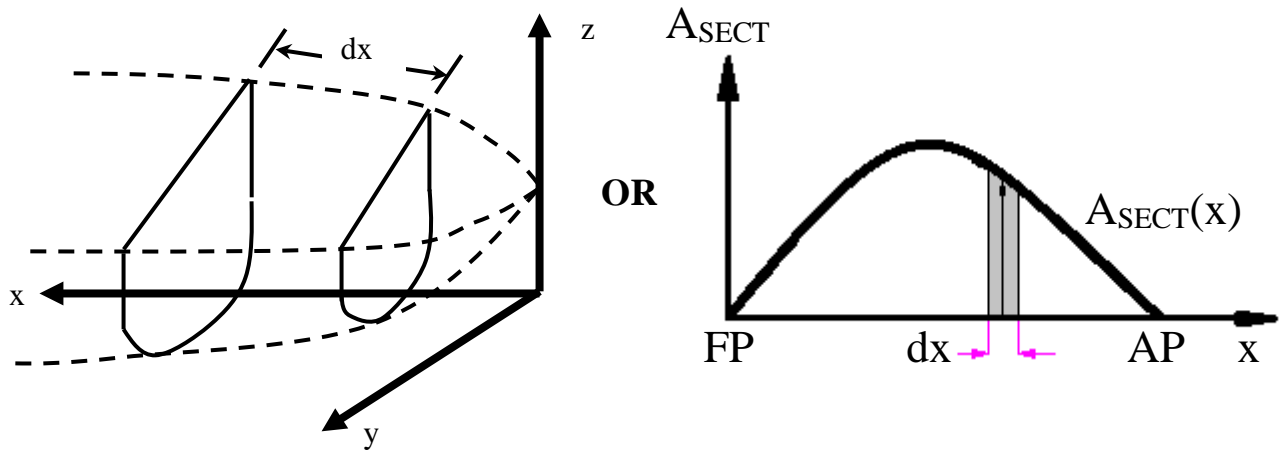
$$A_{\text{sect}} = (2/3)(4 \text{ ft})[0.58 + 4(14.48) + 2(19.91) + 4(21.88) + 22.59] \text{ ft}$$

$$A_{\text{sect}} = 556 \text{ ft}^2$$



### 2.9.3 Submerged Volume: Longitudinal Integration

The submerged volume can be calculated by integration of the sectional areas over the length of the ship. Begin by drawing a picture. The picture is harder to draw since it is a three dimensional shape. It is rather hard to show the differential volume but it is the product of the sectional area with the differential thickness “dx.” Alternatively, you could sketch the sectional area curve.



Then and only then, write out the calculus equation by summing up all the differential pieces. Notice “2” is NOT required since you are using full areas already.

$$V_{submerged} = \nabla_S = \int_{Volume} dV = \int_0^{L_{pp}} A_{sect}(x) dx$$

where:

- $\nabla_S$  is the submerged volume (ft<sup>3</sup>)
- $dV$  is the differential volume of one element (ft<sup>3</sup>)
- $A_{sect}(x)$  is the value of the sectional area at each value of “x” (ft<sup>2</sup>)
- $dx$  is the differential width of one element (ft)

Write out the Generalized Simpson’s Equation based on your calculus equation.

$$\nabla_S = \frac{1}{3} \Delta x [(1)(A_0) + (4)(A_1) + (2)(A_2) + \dots]$$

Notice the “dx” becomes a “Δx” and equals the distance between stations. In a real problem the next step would be to substitute each number into the generalized equation and calculate a final answer.

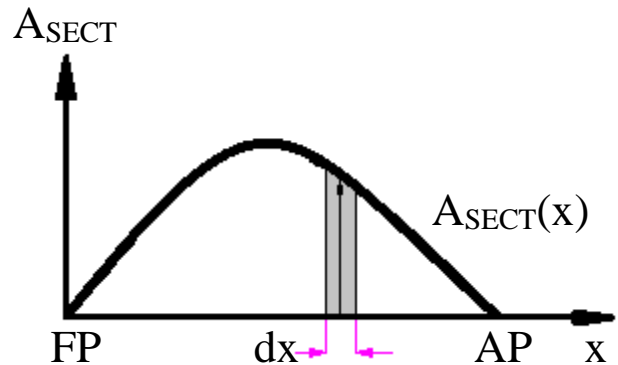
**Example 2.5** The full sectional areas for a particular ship are given below. Compute the submerged volume at the 16 foot waterline. The length between perpendiculars is 140 feet.

Sectional Areas up to 16 ft Waterline

Station	0	1	2	3	4
Sectional Area (ft <sup>2</sup> )	12.6	242.7	332.0	280.5	92.0

Solution:

Picture and differential element:



Calculus equation:

$$V_{submerged} = \nabla_S = \int_{Volume} dV = \int_0^{L_{pp}} A_{sect}(x) dx$$

Simpson's Equation:

$$\nabla_S = \frac{1}{3} \Delta x [(1)(A_0) + (4)(A_1) + (2)(A_2) + \dots]$$

Station spacing calculation:

$$\Delta x = \frac{L_{pp}}{n-1} = \frac{140 \text{ ft}}{4} = 35 \text{ ft}$$

Substitution of numbers and numerical answer:

$$\nabla_S = (1/3)(35 \text{ ft})[12.6 + 4(242.7) + 2(332.0) + 4(280.5) + 92] \text{ ft}^2 = 33,383 \text{ ft}^3$$

## 2.9.4 Longitudinal Center of Flotation (LCF)

The centroid of the current waterplane area is the center of flotation (F). Recall, this is the point about which the ship lists and trims.

The Longitudinal Center of Flotation (LCF) is the distance from a longitudinal reference point to the center of flotation. Usually the reference is the forward perpendicular or midships. When the reference is the forward perpendicular, all distances to the center of flotation are positive. When the reference is midships, distances aft of midships are assigned as negative and distances forward of midships are assigned as positive, by convention.

Ⓢ Many students mix up the point (F) with the distance to the point (LCF).

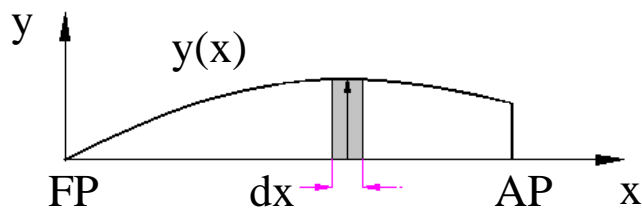
One of the easiest ways to construct the calculus equation for the calculation of the LCF is to use the idea of weighted averages. The LCF is nothing more than the average “x” distance to all the waterplane area. Recall the following statements from chapter 1.

To find the weighted average of any variable “X,” take the variable you are averaging and multiply it by the weighting factor for that value of “X.” Do this for all values and then sum up. In calculus, this translates to the following.

$$\begin{aligned} \text{The average of variable "X"} &= \int_{\text{all } X} (\text{a value of } X)(\text{it's weighting factor}) \\ &\cong \sum_{\text{all } X} (\text{a value of } X)(\text{it's weighting factor}) \\ &\cong \sum (\text{a value of } X) \left( \frac{\text{a small piece}}{\text{the total}} \right) \end{aligned}$$

Applying this idea to the calculation of LCF, the variable being averaged is the “x” distance and the weighting factor is a ratio of areas. The small piece of area is the differential waterplane area and the denominator is the total waterplane area. You may have to do a separate calculation to find the total waterplane area as shown in Section 2.9.1.

First, draw a picture of a typical waterplane area with the proper “X-Y” axis. Draw a typical differential unit of area on this diagram and label the base and height of this rectangle.



Write out the weighted average equation as discussed above. The “2” is required since you’re using half breadths, and you want to find the area for a full breadth, thus doubling the area of the half breadth.

Write out the Generalized Simpson's Equation based on your calculus equation.

Notice the "dx" becomes "Δx" and equals the distance between stations. "x<sub>0</sub>" is the distance from the reference point to station 0. "x<sub>1</sub>" is the distance from the reference point to station 1, and so on. The reference plane is either the FP or midships. Recall, when using midships as a reference you must be sure to include a negative sign for distances aft of midships.

In a real problem the next step would be to substitute each number into the generalized equation and calculate a final answer.

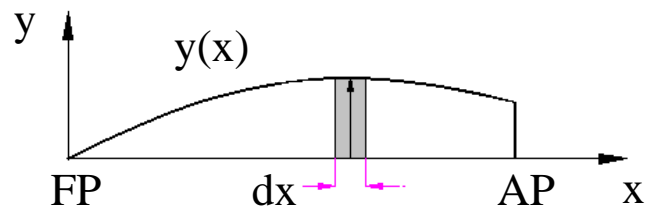
ⓘ Sometimes students feel more comfortable making tables to do these calculations. It helps to organize your work and makes it easy to program in a spreadsheet. The following example shows how such a table might be constructed and used as an aid in the calculation of LCF.

**Example 2.6** The offsets for the 16-ft waterline of a particular ship with five stations are given below. The length between perpendiculars is 326.4 feet. The waterplane area for the 16 foot waterline is 10,523 square feet. Compute the LCF for the sixteen foot waterline.

Station	0	1	2	3	4
Half-breadth	0.39 ft	12.92 ft	20.97 ft	21.71 ft	12.58 ft

Solution:

Picture and differential element:



Calculus equation:

$$LCF = \int_{Area} x \frac{dA}{A_{WP}} = 2 \int_0^{L_{pp}} x \frac{y(x) dx}{A_{WP}}$$

$$LCF = \frac{2}{A_{WP}} \int_0^{L_{pp}} x \cdot y(x) dx$$

Simpson's Equation:

$$LCF = \frac{2}{A_{WP}} \frac{1}{3} \Delta x [(1)(x_0)(y_0) + (4)(x_1)(y_1) + (2)(x_2)(y_2) + (4)(x_3)(y_3) + (1)(x_4)(y_4)]$$

Station spacing calculation:

$$\Delta x = \frac{L_{pp}}{n-1} = \frac{326.4 \text{ ft}}{4} = 81.6 \text{ ft}$$

Substitution of numbers with the aid of a table and numerical answer:

16-foot Waterplane

Station	Half-Breadth y(x) (ft)	Distance from FP x (ft)	Moment x*y(x) (ft <sup>2</sup> )	Simpson Multiplier	Product of Multiplier and Moment (ft <sup>2</sup> )
0	0.39	81.6(0) = 0	0	1	0
1	12.92	81.6(1) = 81.6	1054.3	4	4217.2
2	20.97	81.6(2) = 163.2	3422.3	2	6844.6
3	21.71	81.6(3) = 244.8	5314.6	4	21258.4
4	12.58	81.6(4) = 326.4	4106.1	1	4106.1
Sum =					36,426

$$LCF = \frac{2}{10,523 \text{ ft}^2} \frac{1}{3} 81.6 \text{ ft} [36,426.3 \text{ ft}^2]$$

$$LCF = 188.3 \text{ ft aft of the forward perpendicular}$$

ⓘ LCF is commonly expressed as a distance from amidships. In this case...

$$LCF = L_{pp} / 2 - 188.3 \text{ ft}$$

$$LCF = (326.4 \text{ ft}) / 2 - 188.3 \text{ ft} = -25.1 \text{ ft}$$

The minus indicates aft of amidships. Negative values should be explained in your answer.

$$LCF = 25.1 \text{ ft aft of midships}$$

### 2.9.5 Centroid: Vertical Center of Buoyancy (KB or VCB)

(OPTIONAL)

The center of buoyancy (B) is the centroid of the ship's underwater volume. The vertical location of the center of buoyancy above the keel is expressed as KB, and is found by dividing the first moment of the underwater volume about the keel by the total underwater volume.

$$KB = \frac{\int z A_{WP}(z) dz}{\nabla}$$

where:  $z$  is the height of the waterplane above the keel (ft)  
 $A_{WP}(z)$  is the waterplane area at each waterline (ft<sup>2</sup>)  
 $dz$  is the interval between waterlines (ft)  
 $\nabla$  is the underwater hull volume (ft<sup>3</sup>)

Numerically, the products  $z A_{WP}(z)$  will be integrated using Simpson's 1<sup>st</sup> Rule. The following example illustrates this calculation. The submerged volume used was calculated in section 2.9.3.

Draft, $z$ (ft)	$A_{WP}(z)$ (ft <sup>2</sup> )	$z A_{WP}(z)$ (ft <sup>3</sup> )
0	415.3	0
4	1423	5692
8	2310	18,480
12	2877	34,524
16	2988	47,808

$$\int z A_{WP}(z) dz = (1/3)(4 \text{ ft})[0 + 4(5692) + 2(18,480) + 4(34,524) + 47,808] \text{ft}^3$$

$$= 327,510 \text{ ft}^4$$

$$KB = \frac{\int z A_{WP}(z) dz}{\nabla} = \frac{327,510 \text{ ft}^4}{33,383 \text{ ft}^3}$$

$$= 9.81 \text{ ft}$$

### 2.9.6 Centroid: Longitudinal Center of Buoyancy (LCB)

(OPTIONAL)

The longitudinal location of the center of buoyancy with respect to a longitudinal reference plane is expressed as LCB, and is found by dividing the first moment of the underwater volume about the forward perpendicular by the total underwater volume.

$$LCB = \frac{\int x A_{Sect}(x) dx}{\nabla}$$

where:  $x$  is the distance of the station aft of the forward perpendicular (ft)  
 $A_s(x)$  is the sectional area at each station (ft<sup>2</sup>)  
 $dx$  is the interval between each station (ft)  
 $\nabla$  is the underwater volume (ft<sup>3</sup>)

The products  $x A_s(x)$  will be integrated numerically using Simpson's 1<sup>st</sup> Rule. Underwater volume corresponds to the draft of interest and has been calculated previously in section 2.9.3.

Station Spacing = 35 ft

Station	$A_s$ (ft <sup>2</sup> )	$x$ (ft)	$x A_s$ (ft <sup>3</sup> )
0	12.6	0	0
1	242.7	35	8494.5
2	332.0	70	23240
3	280.5	105	29452.5
4	92.0	140	12880

$$\begin{aligned} 1^{\text{st}} \text{ Moment of Volume} &= (1/3)(35 \text{ ft})[0 + 4(8494.5) + 2(23240) + 4(29452.5) + (12880)]\text{ft}^3 \\ &= 2,463,400 \text{ ft}^4 \end{aligned}$$

$$LCB = \frac{\int x A_{Sect}(x) dx}{\nabla} = 2,463,400 \text{ ft}^4 / 33,383 \text{ ft}^3 = 73.8 \text{ ft aft of FP}$$

In this example  $L_{PP}$  is 140 feet; therefore, LCB is 3.8 feet aft of amidships. Many ships will have LCB's and LCF's aft of amidships because bows are typically narrow in order to minimize resistance.

### 2.9.7 Transverse Second Moment of Area of a Waterplane

(OPTIONAL)

The transverse second moment of area of a waterplane about the centerline ( $I_T$ ) is useful when determining whether a ship will remain upright or list to one side, and in estimating the vertical position of the transverse metacenter above the keel.

The approach taken is to divide the waterplane (actually half of the waterplane) into small rectangles. The height of a rectangle is the half-breadth  $y(x)$ , and the width is the station spacing,  $dx$ . The second moment of area of each rectangle is summed resulting in the second moment of area of the entire waterplane.

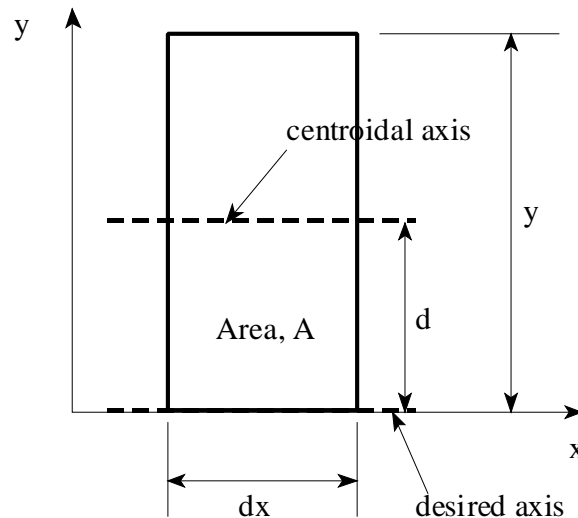
The second moment of area of a rectangle is found from the integral  $\int y^2 dA$  in general. The second moment of area of a rectangle about its own centroid is  $(1/12)y^3 dx$ . To perform the summation desired, the second moment of area of all the rectangles must be referenced to the same axis. The Parallel Axis Theorem is used to calculate the second moment of area of a shape about an axis parallel to its centroidal axis. Mathematically, the theorem states the following:

$$I_d = I_c + Ad^2$$

where:  $I_d$  is the second moment of area of the shape about an axis (the desired axis) other than the centroidal axis ( $\text{ft}^4$ )  
 $I_c$  is the second moment of area of the shape about the centroidal axis ( $\text{ft}^4$ )  
 $A$  is the area of the shape ( $\text{ft}^2$ )  
 $d$  is the distance between the centroidal axis and the desired axis (ft)

Figure 2.14 provides an example of these quantities.

ⓘ Notice that the second moment of area of a shape is always least about the centroidal axis.



**Figure 2.14** Diagram for the parallel axis theorem



Applying the Parallel Axis Theorem to the rectangle under consideration gives the following:

$$I_{\text{CENTERLINE}} = (1/12)y^3 dx + (y dx)(y/2)^2 = (1/3)y^3 dx.$$

This makes the integral for the transverse second moment of area of the entire waterplane:

$$I_T = 2 \int \frac{y^3}{3} dx = \frac{2}{3} \int y^3 dx$$

To evaluate this integral numerically, the cube of each half-breadth will be integrated, and the result will be multiplied by (2/3).

Station	Half-Breadth (ft)	(Half-Breadth) <sup>3</sup> (ft <sup>3</sup> )
0	0.39	0.0593
1	12.92	2156.7
2	20.97	9221.4
3	21.71	10,232
4	12.58	1990.9

$$I_T = (2/3) [ (1/3)(81.6 \text{ ft}) \{0.0593 + 4(2156.7) + 2(9221.4) + 4(10,232) + 1990.9\} ] \text{ft}^3$$

$$I_T = 1,269,126 \text{ ft}^4$$

### 2.9.8 Longitudinal Second Moment of Area of a Waterplane

(OPTIONAL)

The longitudinal second moment of area of the waterplane about the LCF is used when solving trim problems. The calculation weighs each piece of area,  $y dx$ , by the square of its distance from a reference, in this case amidships. Integrating the products  $x^2 y dx$  adds up the second moments of area of all the differential pieces giving the second moment of area of the entire shape about amidships.

The required integral is  $I_L = \int x^2 y dx$ . In order to apply Simpson's 1<sup>st</sup> Rule, the quantity  $x^2 y$  must be determined for each station. Simpson's algorithm and station spacing take care of the  $\int$  and the  $dx$  parts of the equation.

16-foot Waterplane (Station Spacing = 81.6 ft)

Station	Half Breadth, y (ft)	Distance from midships, x (ft) (- Aft)	$x^2 y$ (ft <sup>3</sup> )
0	0.39	163.2	10,387
1	12.92	81.6	86,029
2	20.97	0	0
3	21.71	-81.6	144,557
4	12.58	-163.2	335,059

$$I_L (\text{midships}) = \int x^2 y dx$$

$$I_L (\text{midships}) = (2)(1/3)(81.6 \text{ ft})[10,387 + 4(86,029) + 2(0) + 4(144,557) + 335,059] \text{ft}^3$$

$$I_L (\text{midships}) = 68,967,776 \text{ ft}^4$$

What is really desired is the second moment of area about the LCF, so the Parallel Axis Theorem must be used.

$$I_L (\text{about LCF}) = I_L (\text{about } \bar{x}) - A_{wp} \cdot d^2$$

The term  $A_{wp} \cdot d^2$  is subtracted because the LCF is the centroid of the waterplane.  $A_{wp}$  is the area of the waterplane of interest, previously calculated. The distance between the two axes is  $d$ , or the distance from amidships to the LCF, also calculated previously.

So substituting the previous values

$$I_L (\text{LCF}) = I_L (\text{amidships}) - A_{wp} d^2$$

$$I_L (\text{LCF}) = 68,967,776 \text{ ft}^4 - (10,523 \text{ ft}^2)(23.0 \text{ ft})^2$$

$$I_L (\text{LCF}) = 63,401,109 \text{ ft}^4$$

This completes the numerical integrations necessary for determining all of the quantities graphed on the curves of form. Some additional knowledge is given in the next chapter concerning the specific uses of these quantities.

## 2.10 Curves of Form

All the geometric properties of a ship as a function of mean draft have been computed and put into a single graph, called the “curves of form.” Each ship has unique curves of form. There are also tables with the same information which are called the tabular curves of form.

It is difficult to fit all the different properties on a single sheet because they vary so greatly in magnitude. To fit all the curves on a single sheet of paper one of two things must be done.

- One: Provide a series of different scales on the “x” axis so that each property has its own “x” axis scale.
- Two: Plot each characteristic against a common scale on the “x” axis and use a scaling factor to bring the curves numerically closer.

Using the second method requires you to read a value off the common scale and then multiply that value by the curves scale factor to obtain the real value. Each scale factor also has units associated with it. Don’t forget to do this extra step!

Curves of form for common navy ships are provided in the back of this text under the “Ship’s Data” section. For convenience, the curves of form for the Naval Academy’s Yard Patrol Craft has been provided (Figure 2.15) as well as in the “Ship’s Data” section.

The curves of form assume that the ship is floating on an even keel (i.e. zero list and zero trim). If the ship has a list or trim then the ship’s mean draft should be use when entering the curves of form.

Keep in mind that all properties on the “curves of form” are functions of mean draft and geometry. When weight is added, removed, or shifted, the operating waterplane and submerged volume change form, and thus all the geometric properties also change.



In typical calculations only small draft changes occur so that the properties in the curves of form also only undergo small changes. This means for most problems it doesn’t matter if you look up the properties at the initial mean draft, final mean draft, or average mean draft. Numerically they all will be very close and shouldn’t affect your final answer. If the draft changes by an amount that causes large changes in the properties, then an average draft of the initial and final drafts should be used.

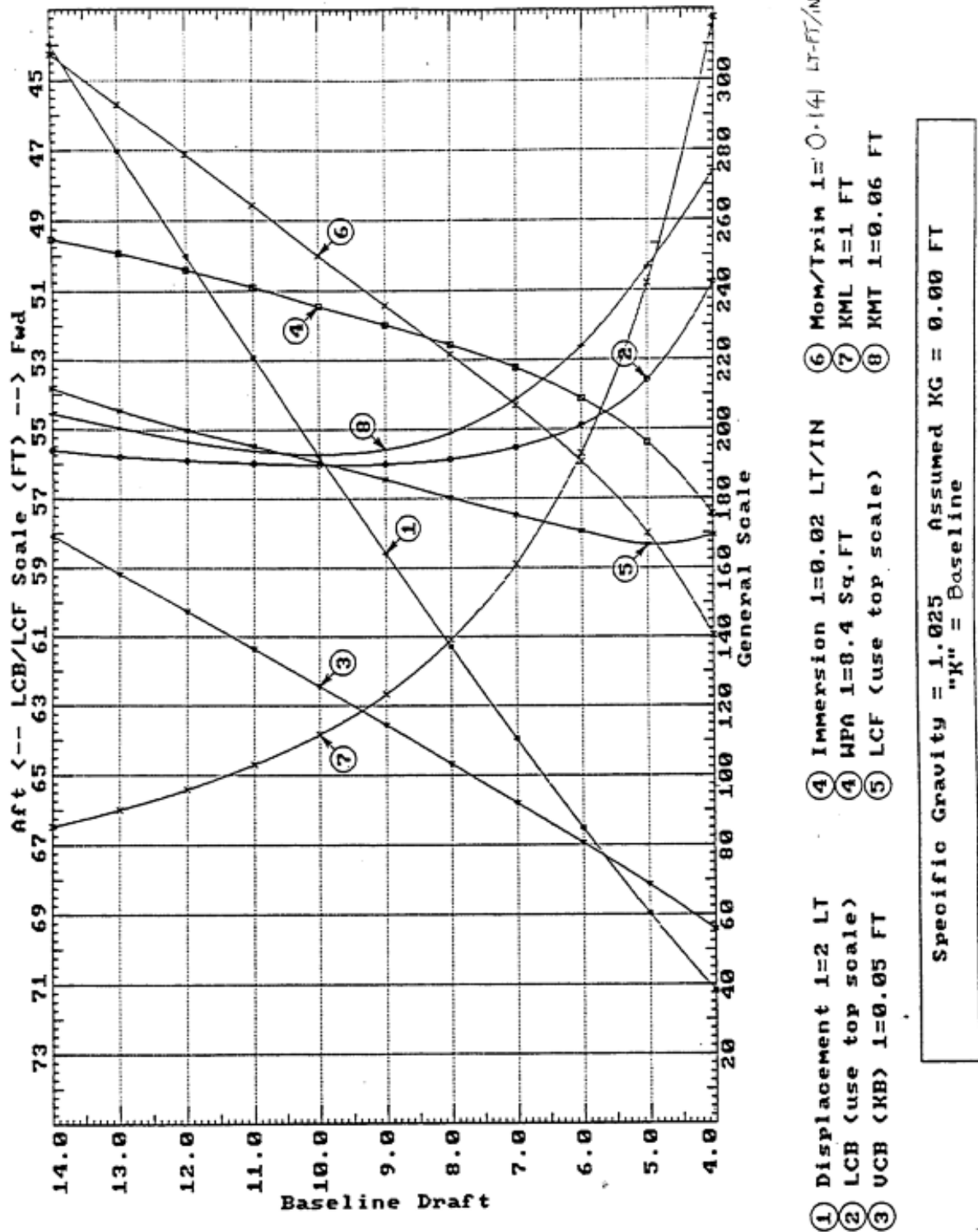


Figure 2.15 USNA Yard Patrol Craft Curves of Form

The following is a list of each characteristic found on the “curves of form” with a brief explanation of its meaning.

### **2.10.1 Displacement ( $\Delta$ )**

Displacement is the weight of the water displaced by the ship for a given draft, assuming the ship is in salt water with a density of  $1.99 \text{ lb s}^2 / \text{ft}^4$ . For a freely floating ship in salt water this is numerically equal to the weight of the ship. The typical unit on displacement for Naval Ships is the long ton. One long ton (LT) equals 2240 lb.

⚠ Other disciplines of science also use the word ton as follows. A long ton (LT) is the same as the ton, equal to 2240 lb. A short ton (ST) is equal to 2000 lb . A metric ton (Tonne) is equal to 1000 kg. In this course “ton” will always mean 2240 lb.

### **2.10.2 LCB**

LCB stands for the longitudinal center of buoyancy, which is the distance in feet from the longitudinal reference position to the center of buoyancy. The reference position could be the FP or midships. If it is midships, remember that distances aft of midships are negative.

### **2.10.3 VCB**

VCB stands for the vertical center of buoyancy, which is the distance in feet from the baseplane to the center of buoyancy. Sometimes this distance is labeled KB with a bar over the letters.

### **2.10.4 Immersion or TPI**

TPI stands for tons per inch immersion, or sometimes just called immersion. TPI is defined as the tons required to obtain one inch of parallel sinkage in salt water. Parallel sinkage is when the ship changes it's forward and after drafts by the same amount so that no change in trim occurs.

To obtain just parallel sinkage, the weight added would need to be “effectively” added to the center of flotation because the center of flotation is the pivot point of the ship while it is floating. The units of TPI are long tons per inch. If an equivalent weight is removed than you lose one inch of parallel sinkage. TPI is used in chapter 3 for trim problems.

⚠ An approximate formula for TPI based on the area of the waterplane can be derived as follows:

$$TPI = \frac{\text{Weight required for one inch}}{1 \text{ inch}}$$

$$TPI = \frac{(\text{Volume required for one inch})\rho_{\text{salt } g}}{1 \text{ inch}}$$

$$TPI = \frac{A_{WP}(\text{ft}^2)(1 \text{ inch})(64 \text{ lb/ft}^3)}{1 \text{ inch}} \frac{1 \text{ ft}}{12 \text{ inch}} \frac{1 \text{ LT}}{2240 \text{ lb}}$$

$$TPI = \frac{A_{WP}(\text{ft}^2)}{420} \left( \frac{\text{LT}}{\text{inch}} \right)$$

Note 1: Archimedes equation has been used to convert weight to the product of volume, density, and the magnitude of the acceleration of gravity.

Note 2: TPI is defined for a ship in salt water at 59 °F, which allows the use of 1.99 lb s<sup>2</sup> / ft<sup>4</sup> for the density.

Note 3: The solution assumes the waterplane area doesn't change much in one inch, so the volume required for one inch of submergence can be approximated by the product of the waterplane area and 1 inch of thickness. This is the same as assuming the volume is a right prism with the waterplane as the cross section and a height of one inch.

To calculate the change in draft due to parallel sinkage the following equation is used:

$$\delta T_{PS} = \frac{w}{TPI}$$

where: $\delta T_{PS}$	change in draft due to parallel sinkage (in)
$w$	amount of weight added or removed from the ship (LT)
$TPI$	from curves of form (LT/in)

### 2.10.5 WPA or AWP

WPA or A<sub>wp</sub> stands for the waterplane area. The units of WPA are ft<sup>2</sup>. This is the same waterplane area that was calculated with Simpson's rule in Section 2.9.1.

### 2.10.6 LCF

LCF is the longitudinal center of flotation, which is the distance in feet from the longitudinal reference to the center of flotation. The reference position could be the FP or midships. If it is midships, remember that distances aft of midships are negative. You were shown how to calculate the LCF using a table of offsets and Simpson's rule in Section 2.9.4 .

### 2.10.7 Moment/ Trim 1" or MT1"

This stands for the moment to change trim one inch. The units are LT times ft per inch. The ship will rotate about the center of flotation when a moment is applied to it. The moment can be produced by adding, removing, or shifting a weight some distance from the center of flotation. There are an infinite number of possible combinations of weights and distances to achieve a given moment. This concept is used when doing changes in trim problems in chapter 3.



Trim is defined as the draft aft minus the draft forward.

By convention, when a ship is down by the bow it is assigned a negative trim.

To compute the change in trim due to a weight shift or addition, the following equation is used:

$$\delta Trim = \frac{wl}{MT1''}$$

where:

$\delta Trim$  total change in trim (in)

$w$  amount of weight added, removed, or shifted (LT)

$l$  distance the weight was moved; or if weight was added or removed, the distance of the weight from F (ft)

MT1'' Moment to Change Trim 1 inch (from curves of form) (LT·ft/in)

Most points in Naval Architecture are 3-Dimensional, except for the metacenter. The metacenter is represented by two, 2-D points, one represented longitudinally ( $KM_L$ ) and one transversely ( $KM_T$ ).


### 2.10.8 $KM_L$

$KM_L$  stands for the distance in feet from the keel to the longitudinal metacenter. For now, just assume the metacenter is a convenient reference point vertically above the keel of the ship for naval architecture calculations. This distance is on the order of one hundred to one thousand feet, whereas the distance from the keel to the transverse metacenter is only on the order of ten to thirty feet.

### 2.10.9 $KM_T$

$KM_T$  stands for the distance in feet from the keel to the transverse metacenter. Typically, naval architects do not bother putting the subscript "T" for any property in the transverse direction because it is assumed that when no subscript is present the transverse direction is implied. Naval architects primarily focus on ship behaviour in the transverse direction because it is the least stable and most responsive (i.e. our ships are slender!).



 You have done the calculations for at least two of the properties listed in the curves of form. This should have given you an appreciation for how the curves of form are constructed. Given more time and a little more instruction you could use a table of offsets and numerical integration to obtain the rest of the properties. Be grateful that all these calculations have been done already, so that all you have to do is look up these values.

Be sure that, given a ship's curves of form and a mean draft, you can find any of the properties listed above. You will need this skill to obtain the values for calculations that will follow in subsequent chapters.

## PROBLEMS - CHAPTER 2

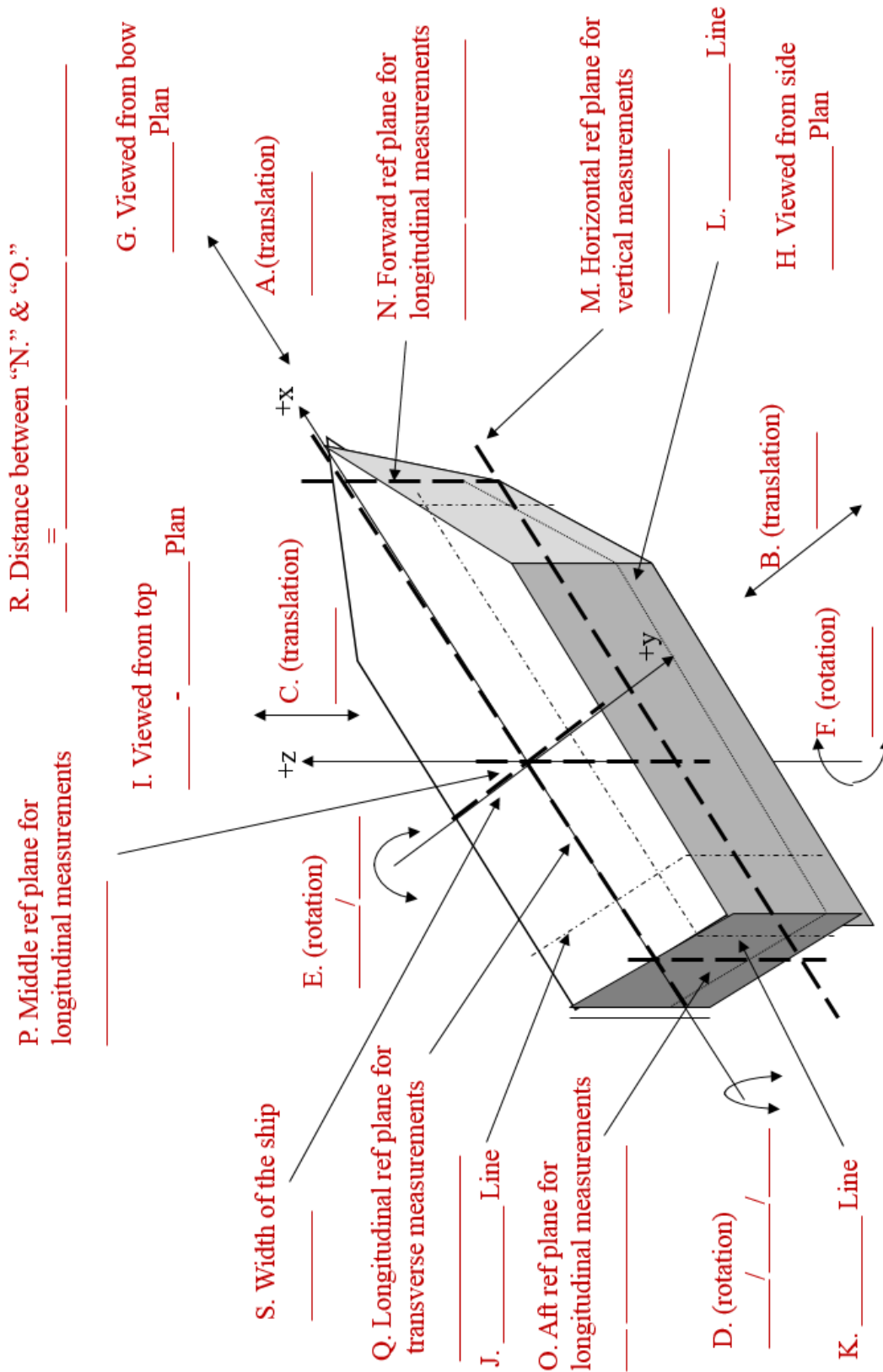
### Section 2.2 Ship Categories

1. A small boat weighing 40 LT has a submerged volume of 875 ft<sup>3</sup> when traveling at 20 knots in seawater. ( $\rho = 1.99 \text{ lb-s}^2/\text{ft}^4$  ; 1 LT = 2240 lb)
  - a. Calculate the magnitude of the hydrostatic support being experienced by boat.
  - b. What other type of support is the boat experiencing?
  - c. Calculate the magnitude of this other type of support.
  - d. What will happen to the submerged volume of the boat if it slows to 5 knots? Explain your answer.
2. How are Hovercraft and Surface Effect Ships supported when moving across water. Briefly describe the advantages and disadvantages of each.
3.
  - a. What does the acronym SWATH stand for?
  - b. What kind of support does the SWATH have while in operation?
  - c. What are the advantages associated with a SWATH design?

### Sections 2.3-2.5 Ship Plans

4. Sketch a profile of a ship and show the following:
  - a. Forward Perpendicular
  - b. After Perpendicular
  - c. Sections, assuming the ship has stations numbered 0 through 10.
  - d. Length Between Perpendiculars
  - e. Length Overall
  - f. Design Waterline
  - g. Amidships
5. Sketch a section of a ship and show the following:
  - a. Keel
  - b. Depth
  - c. Draft
  - d. Beam
  - e. Freeboard

6. Fill in the blank for the following terms



7. For this question, use a full sheet of graph paper for each drawing. Choose a scale that gives the best representation of the ship's lines. Use the FFG-7 Table of Offsets given on the following page for your drawings.
- For stations 0-10 draw a Body Plan for the ship up to the main deck. Omit stations 2.5 and 7.5.
  - Draw a half-breadth plan showing the 4 ft, 12 ft, 24 ft waterlines, and the deck edge.
  - Draw the sheer profile of the ship.

### **Section 2.7 Center of Flotation & Center of Buoyancy**

8. A box-shaped barge has the following dimensions: Length = 100 feet, Beam = 40 feet, Depth = 25 feet. The barge is floating at a draft of 10 feet.
- Draw a waterplane, profile, and end view of the barge. On each view indicate the following: centerline, waterline, midships, center of buoyancy (B), and center of flotation (F).
  - On your drawing show the following distances: KB, LCF referenced from the forward perpendicular, and LCB referenced from amidships.
  - Based on the given dimensions of the barge, determine the following dimensions:
    - KB
    - LCF referenced to amidships
    - LCB referenced to the forward perpendicular
    - Height of F above the keel

## FFG-7 TABLE of OFFSETS

Half-breadths given in feet from centerline

Lpp = 408 ft

DWL = 16 ft

### Station Numbers

Waterline (ft) above baseline	<b>-0.5</b>	<b>0 (FP)</b>	<b>0.5</b>	<b>1</b>	<b>2</b>	<b>2.5</b>	<b>3</b>	<b>4</b>	<b>5</b>	<b>6</b>	<b>7</b>	<b>7.5</b>	<b>8</b>	<b>9</b>	<b>10 (AP)</b>	Waterplane Area (ft <sup>2</sup> )
<b>24</b>	0.0	2.08	6.16	9.93	16.08	18.43	20.23	22.38	23.19	23.33	22.93	22.57	22.01	19.87	16.06	15513.2
<b>16 (DWL)</b>		0.33	3.68	6.93	12.93	15.52	17.75	21.00	22.61	22.74	21.74	20.82	19.59	16.72	12.46	13826.0
<b>12</b>				5.78	11.60	14.07	16.31	19.92	21.89	21.79	20.24	19.07	17.54	13.16		12273.2
<b>8</b>				4.82	10.18	12.39	14.43	18.02	19.93	19.21	16.24	14.1	11.12			9213.7
<b>4</b>				3.62	7.63	9.24	10.77	13.36	14.48	12.86	8.71					5930.1
<b>0 (Keel)</b>				0.68	0.68	0.68	0.68	0.68	0.68	0.68						314.4

Sectional Area to DWL (ft <sup>2</sup> )		0.88				357.9			556.3			334.1			33.22
---	--	------	--	--	--	-------	--	--	-------	--	--	-------	--	--	-------

Half-Breadth at Deck Edge (ft)	0.00	9.66		16.0	20.91		22.74	23.29	23.51	23.5	23.4		23.1	21.2	17.5
--------------------------------------	------	------	--	------	-------	--	-------	-------	-------	------	------	--	------	------	------

Height of Deck above Baseline (ft)	41.0	39.58	38.18	36.77	34.59	33.61	32.62	31.3	30.25	29.41	29.07	29.15	29.23	29.88	30.84
--	------	-------	-------	-------	-------	-------	-------	------	-------	-------	-------	-------	-------	-------	-------

Height of Keel above Baseline (ft)	41.0	14.35	1.0	0.0	0.0	0.0	0.0	0.0	0.0	0.0	0.93	2.85	4.77	9.29	13.62
--	------	-------	-----	-----	-----	-----	-----	-----	-----	-----	------	------	------	------	-------

## Section 2.8 Simpson's Rule

For each Simpson's Rule problem, show **all** solution steps in your work (i.e. diagram, differential element and its dimensions, labels, general calculus equation, general Simpson equation, numeric substitution, and final answer)

9. Using Simpson's Rule calculate the areas of the following objects:
  - a. Right triangle with base length of "a" and a height of length "b".
  - b. Semi-circle of radius "r".
  - c. Equilateral triangle with each side having length "a".

## Section 2.9 Waterplane Area

10. The FFG-7 table of offsets gives waterplane areas calculated using all stations. Using data for stations 0, 2.5, 5, 7.5, and 10, calculate the waterplane area at the DWL and compare your result with the given waterplane area.
11. Using the FFG-7 table of offsets, calculate the sectional area of station 3 up to the DWL.
12. Using the FFG-7 table of offsets, calculate the area of station 6 up to the 24 foot waterline.
13. Using the sectional areas for stations 0, 2.5, 5, 7.5, and 10 calculate the following:
  - a. Submerged volume of the FFG-7 up to the design waterline.
  - b. Displacement in salt water.
  - c. Displacement in fresh water.
14. Using the FFG-7 table of offsets, and stations 0, 2.5, 5, 7.5, and 10, calculate the location of the longitudinal center of flotation (LCF) of the DWL referenced to amidships.

## Section 2.10 Curves of Form

15. The Curves of Form for a ship are a graphical representation of its hydrostatic properties. When computing a ship's hydrostatic properties and creating the Curves of Form, what 2 assumptions are made?
16. An FFG-7 is floating on an even keel at a draft of 14 feet. Using its Curves of Form, find the following parameters:
  - a. Displacement (D)
  - b. Longitudinal center of flotation (LCF)
  - c. Vertical center of buoyancy (KB)
  - d. Tons per inch immersion (TPI)
  - e. Moment to trim 1 inch (MT1")
  - f. Submerged volume
17. An FFG-7 is floating with a forward draft of 14.9 feet and an aft draft of 15.5 feet. Determine the following:
  - a. Displacement (D)
  - b. Longitudinal center of flotation (LCF)
  - c. Moment to trim 1 inch (MT1")
18. The FFG in problem 15 changes its draft from 14 feet to 15.5 feet. What is the new value of TPI? Why does this value of TPI change?
19. A DDG-51 is floating on an even keel at a draft of 21.5 feet. A piece of machinery weighing 150 LT is added to the ship.
  - a. At which position on the ship must the weight be added so that trim does not change?
  - b. What is the change in ship's draft, in feet, due to the weight addition?
  - c. Compute the final draft after the weight addition.
20. A DDG-51 is floating on an even keel at a draft of 21.5 feet. A piece of machinery weighing 50 LT is moved from the center of flotation to a point 150 feet forward of F. What is the change in ship's trim due to this weight shift.

# COURSE OBJECTIVES

## CHAPTER 3

### 3. HYDROSTATICS

1. Explain a distributed force and a resultant force and relate them to a submerged ship's hull.
2. Calculate the absolute pressure below the surface of the water.
3. Apply Archimedes' Principle to a ship.
4. Know the necessary and sufficient conditions for static equilibrium and apply these conditions to various situations in Naval Engineering.
5. Draw a picture of a ship's section at midships that has been inclined due to a transverse weight shift. Show all the relevant forces acting on this section and properly label the diagram.
6. Calculate a ship's vertical center of gravity from an Inclining Experiment. State the purpose and explain the process of an inclining experiment, including the derivation of relevant equations, figures, and diagrams. Complete calculations associated with an inclining experiment.
7. Due to the addition, removal or shift of weight on a ship:
  - a. Qualitatively describe the direction of shift in a ship's center of gravity
  - b. Calculate a ship's vertical center of gravity
  - c. Calculate a ship's transverse center of gravity
  - d. Calculate the angle of list (less than  $10^\circ$ )
  - e. Calculate forward and aft drafts, including showing geometric relationships in the problems
8. Define trim.
9. Define, understand, and use Metacentric Height and Metacentric Radius.
10. Understand the dangers and basic procedures followed in drydocking.



## 3.1 Archimedes' Principle Revisited and Static Equilibrium

Most people find it truly amazing that steel ships weighing hundreds of thousands of tons can float in water. We know that they float because we have seen it with our own eyes, but what we have seen somehow seems contrary to other everyday experiences. Take a steel bar, throw it into the water and it will sink immediately. Why will a pound or so of metal sink, whereas several tons of the same metal will float?

From your study of Chapter 2 you realize that each object in the water is buoyed up with a force equal to the weight of the water displaced by the object. To get an object to float, the object must be able to displace a volume of water equal in weight to the weight of the object itself. With this knowledge you can build a concrete canoe!

At this point, you know the name of the Greek mathematician who discovered this principle of flotation – Archimedes'.

ⓘ Be sure that you can verbally and mathematically define Archimedes' Principle.

Let us combine the concepts of Archimedes' Principle with static equilibrium as applied to a free-floating ship in calm water.

### 3.1.1 Forces Acting on a Floating Body

The forces of concern on a freely floating ship are the distributed gravitational forces and the distributed buoyant forces. The forces are said to be distributed because they act over the entire ship. Some engineering analysis requires the use of the distributed force system to do the modeling (this will be used in Chapter 6). Other analysis allows the engineer to replace the distributed force system with an equivalent single resultant vector. The resultant vector is the sum of the distributed force system and is considered to act at such a location as to create the same effect on the body as the distributed system.

ⓘ In this chapter all distributed forces are replaced with resultant vectors to do the hydrostatic analysis.

#### 3.1.1.1 Force due to Gravity

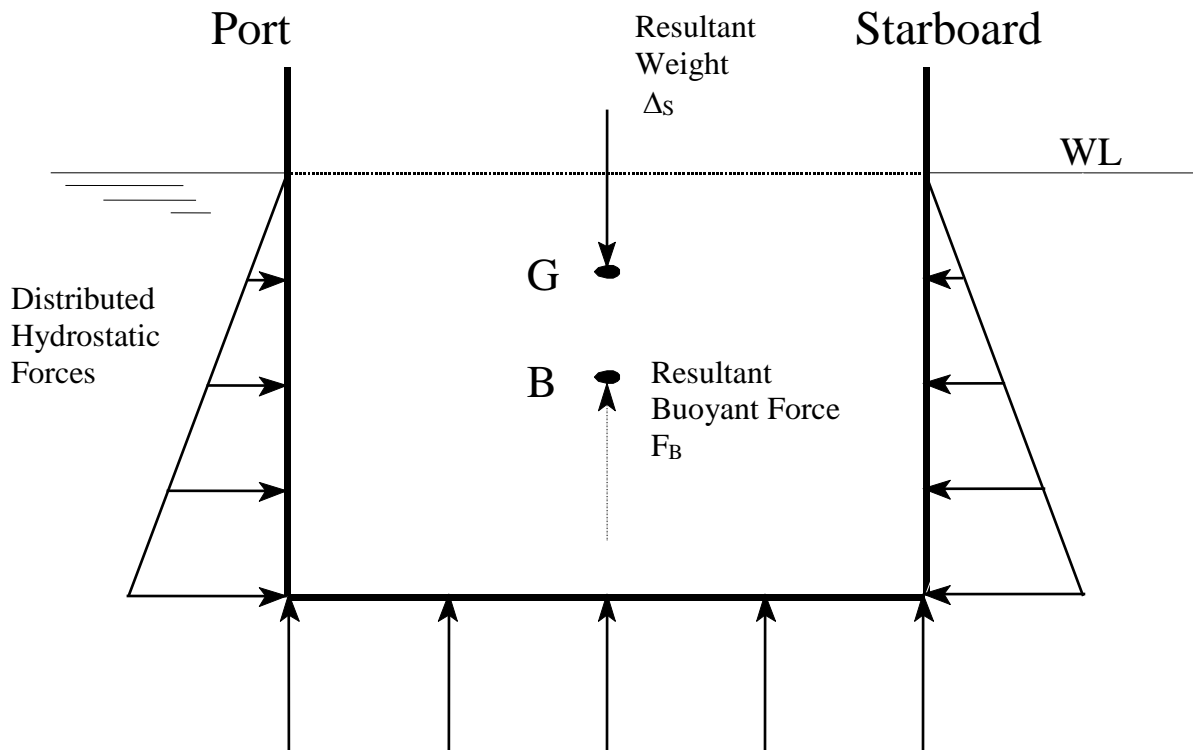
The force of gravity acts on each little part of the ship. Instead of dealing with millions of weights acting at millions of places throughout a ship, we resolve all of these weights into one resultant force, called the resultant weight or displacement ( $\Delta_S$ ) of the ship. This gravitational force, or resultant weight, is resolved to act at the center of gravity (G), which is simply the weighted average location of all of the weights that make up a ship. See Figure 3.1.

### 3.1.1.2 Force due to Buoyancy

The second system of distributed forces on a freely floating ship comes from the pressure exerted on the submerged part of the hull by the water. These hydrostatic forces act perpendicular to the surface of the hull and can be resolved into horizontal and vertical components with respect to the surface of the water.

The sum of the horizontal hydrostatic forces will be zero. This should make sense to you. If the horizontal forces didn't balance it would imply that a ship would move through the water all by itself without power or external forces. This kind of spontaneous movement does not occur.

The sum of the vertical hydrostatic forces is not zero. The net vertical force is called the resultant buoyant force ( $F_B$ ). This force, like weight, is resolved to act at a unique point. The buoyant force acts at the center of buoyancy (B), which is the geometric centroid of the underwater volume. See Figure 3.1.



**Figure 3.1** Ship at Static Equilibrium Showing Resultant Weight and Distributed & Resultant Buoyant Forces.

#### Notes on Figure 3.1:

- The distributed forces shown on the outside of the hull are being replaced by the resultant buoyant force. Normally you would not show both because it is redundant.

- The absolute pressure at depth “z” below the water surface is due to the atmospheric pressure plus the pressure from the column of water above the point of interest. This is shown in Equation 3-3.

$$P_{absolute} = P_{atm} + \rho g z \frac{1 ft^2}{144 in^2}$$

where:	$P_{absolute}$	absolute pressure at depth “z” (psi)
	$P_{atm}$	atmospheric pressure at the surface of the water (psi)
	$\rho$	density of the water (lb·s <sup>2</sup> /ft <sup>4</sup> )
	$g$	magnitude of the acceleration of gravity (32.17 ft/s <sup>2</sup> )
	$\rho g z$	gage pressure (psi)

- The resultant weight and the resultant buoyant force always act perpendicular to the surface of the water. Resultant buoyant force acts upward while the resultant weight force acts downward.
- The vector arrows representing the resultant weight and resultant buoyant force must have their heads (or tails) attached to the center of gravity and center of buoyancy, be equal in length, and be labeled with symbols.
- We always use a capital “G” for the ship’s center of gravity and a lower case “g” for the center of gravity of some object or fluid on the ship. You must use this convention in your diagrams.
- The magnitude of the resultant weight is the displacement ( $\Delta_s$ ). The resultant weight is a vector and the displacement is a scalar. Both have units of LT.
- The center of buoyancy is at the centroid of the submerged volume of the hull.

### 3.1.2 Static Equilibrium

Static Equilibrium is defined as a condition where:

*“.....the sum of the forces and the sum of the moments on a body are zero so that the body has no tendency to translate or rotate.”*

Each of the conditions is met in Figure 3.1. Let us explore each of them in the following paragraphs.

#### 3.1.2.1 Forces

In general, there are two ways to mathematically state that the sum of the forces is zero. The following expression shows the vector equation stating this.

$$\sum \vec{F} = 0$$

This vector expression may be broken into an equivalent set of scalar equations:

$$\sum F_x = 0 \quad \sum F_y = 0 \quad \sum F_z = 0$$

In Figure 3.1 there are only two vertical forces shown. Immediately we can see that these forces must be equal and opposite or else the ship would sink or fly! We can prove this formally by applying condition of static equilibrium of forces to the vector diagram shown in Figure 3.1.

$$\sum F_x = 0 \quad \sum F_y = 0 \quad \sum F_z = 0 = F_B - \Delta_s$$

$$F_B = \Delta_s$$

where:  $\sum F_z$  is the sum of the forces in the vertical direction with positive “z” as the up direction

$F_B$  is the magnitude of the resultant buoyant force (lb)

$\Delta_s$  is the magnitude of the resultant weight of the ship, called the displacement (lb)

**Example 3.1** Calculate the submerged volume of a DDG51 floating at a draft of 21.0 ft and level trim in sea water. ( $\rho = 1.99 \text{ lb-s}^2/\text{ft}^4$ ) ( $g = 32.17 \text{ ft/s}^2$ ) (1LT = 2240 lb).

*From DDG51 curves of form.*

$$\begin{aligned} & @ 21 \text{ ft draft} - \text{curve } 1 = 144 \\ \Rightarrow \quad \Delta_s & = 144 \times 60 \text{ LT} \\ \Delta_s & = 8640 \text{ LT} \end{aligned}$$

*From Principle of Static Equilibrium*

$$\begin{aligned} F_B & = \Delta_s \\ \Rightarrow F_B & = 8640 \text{ LT} \end{aligned}$$

*From Archimedes' Principle*

$$F_B = \rho g \nabla$$

$$\nabla = \frac{F_B}{\rho g}$$

$$\nabla = \frac{8640 \text{ LT} * 2240 \text{ lb/LT}}{1.99 \text{ lb} \frac{\text{s}^2}{\text{ft}^4} * 32.17 \frac{\text{ft}}{\text{s}^2}}$$

$$\nabla = 302,300 \text{ ft}^3$$

### 3.1.2.2 Moments

Equilibrium of forces alone would not guarantee static equilibrium. The sum of the moments must also be zero! For the forces shown in Figure 3.1, the sum of moments about any arbitrary reference point would be zero. This is because the two resultant vertical forces shown have equal magnitudes, opposite direction, and lines of action that are coincident.

The following expression shows how to mathematically state the sum of the moments is zero about any reference point “p”. Notice it is a vector equation. The direction of the vector is normal to the plane containing the lever arm and the force.

$$\sum \vec{M}_p = 0$$



The concept of a moment was discussed in Chapter 1 Section 1.9.4. Please go back and re-read that section if you are not comfortable with the concept of a moment.

### 3.1.3 Summary

In summary, Figure 3.1 shows a ship in static equilibrium because the two necessary and sufficient conditions for static equilibrium have been met; the vector sum of the forces are zero and the vector sum of the moments are zero. This means that the ship will have no tendency to move either in translation or rotation. It will just sit in the same position until something changes with the ship or an outside force acts on it. Further, it means that Archimedes’ Principle can be used to find the displacement of a freely floating ship since it is equal to the magnitude of the buoyant force.

**Student Exercise:** Draw the same ship in static equilibrium assuming that a large weight has been shifted from port to starboard so that the center of gravity of the ship has moved off the centerline. Label this figure “Figure 3.2” and add a caption to describe what you are trying to show.

### 3.2 New States of Static Equilibrium Due to Weight Additions, Weight Removals and Weight Shifts on a Floating Ship

Section 3.1 applies static equilibrium to a freely floating ship. Now we want to be able to determine the new static equilibrium condition after changing the weight distribution on a ship.

An altered weight distribution will cause the Center of Gravity (G) to move. To fully identify the location of G before and after its movement, we must be able to reference it in 3D space in the three Cartesian directions. As with the other centroids, the location of G is referenced vertically from the keel (KG) or the Vertical Center of Gravity (VCG), transversely from the centerline with the Transverse Center of Gravity (TCG) and longitudinally from either of the perpendiculars or midships with the Longitudinal Center of Gravity (LCG). Recall that the correct sign convention is negative to port of the centerline and aft of midships.

The weight distribution on a ship can change whenever...

- A weight is shifted in any one of three separate directions
- A weight is added or removed from anywhere on a ship
- By some combination of the above.

At first, determining the effect of any of these changes upon the location of G may seem overwhelming. However, it is manageable if we break it down into a study of three separate directions and then further break it down into addition, removal, and shift of weight in each of these directions. This process will be stepped through over the following pages.

Think of how practical this study of hydrostatics could be. On a ship the distribution of weight is constantly changing, and it would be desirable to know the final static equilibrium position of your ship after these changes. If these final conditions are undesirable the captain can take actions to avoid or minimize the effects.

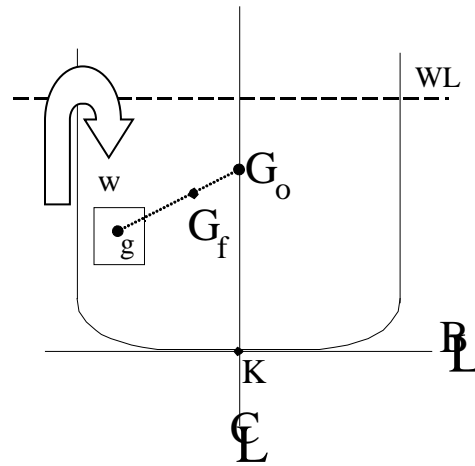
**Student Exercise:** With the help of your instructor make a list of ways weight is distributed differently over time from planned and unplanned evolutions:

### 3.2.1 Qualitative Analysis of Weight Additions, Removals and Shifts

Adding, removing, or shifting weight on a ship changes the location of  $G$  on a ship. A qualitative understanding of what is occurring can help in as a check upon the quantitative work that follows.

#### 3.2.1.1 Weight Addition

A ship's center of gravity moves towards the location of added weight. Consequently, the Center of Gravity of the ship ( $G$ ) will move in a straight line from its current position toward the center of gravity of the weight ( $g$ ) being added. An example of this is shown in Figure 3.3.

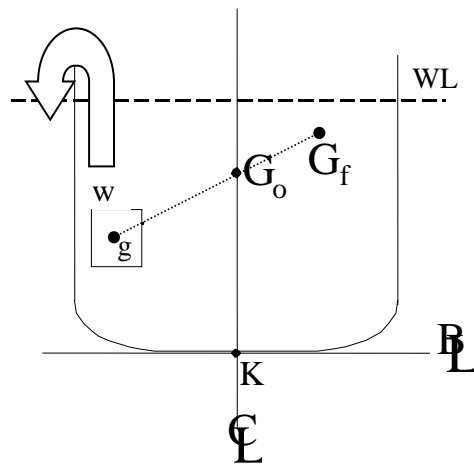


F  
F

**Figure 3.3** Ship center of gravity ( $G$ ) moves towards the location of added weight ( $g$ )

#### 3.2.1.2 Weight Removal

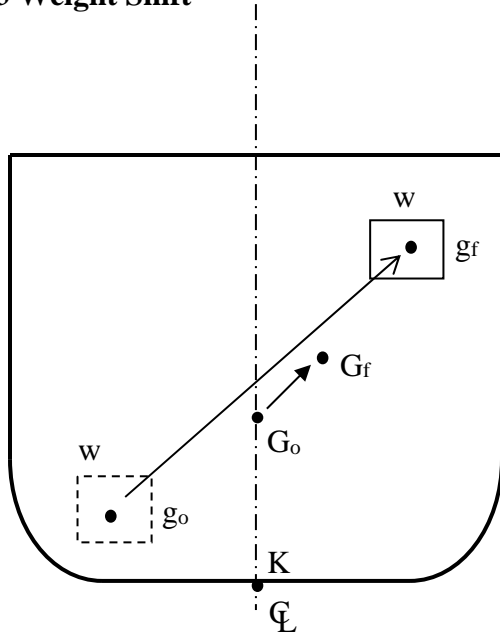
A ship's center of gravity moves away from the location of removed weight. Consequently, the Center of Gravity of the ship ( $G$ ) will move in a straight line from its current position away from the center of gravity of the weight ( $g$ ) being removed. See Figure 3.4.



F

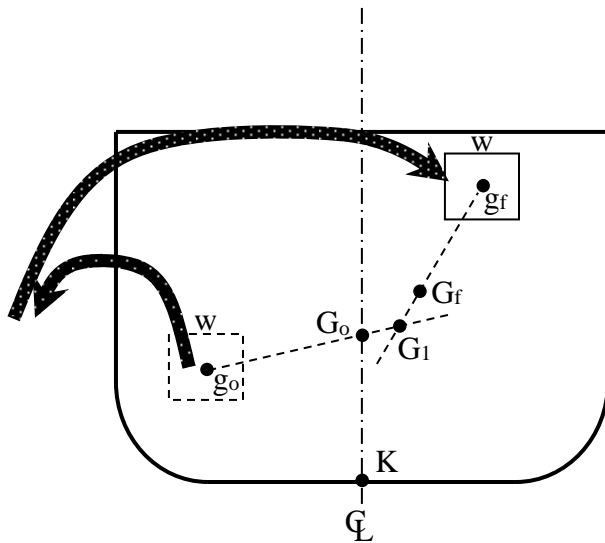
**Figure 3.4** The Effect of a weight Removal Upon the Center of Gravity of a Ship.

### 3.2.1.3 Weight Shift



A ship's center of gravity **moves parallel** to a shift in weight onboard. Ship's  $G$  will not move as far as the weight being shifted ( $g$ ) because the weight is only a small fraction of the total weight of the ship. An example of this is shown in Figure 3.5.

**Figure 3.5** The Effects of a Weight Shift on the Center of Gravity of a Ship



A weight shift can be modelled as the removal of a weight from its previous position and the addition of a weight to its new position. Figure 3.6 demonstrates this principle using the rules governing weight additions and removals discussed previously.

**Figure 3.6** A Weight Shift Being Modeled as a Weight Removal Followed By a Weight Addition



### 3.2.2 Quantitative Changes in the Ship's Center of Gravity Due to Vertical Weight Additions, Removals, or Shifts

The same equation may be used to separately measure changes in the ship's center of gravity in the vertical and transverse directions. Both of these directions are calculated separately and then combined for a final location.

The same equation may be used for weight addition, removal, and shifts. Positive weight is weight added and negative weight is weight removed. Weight shifts are modelled as being removed from the previous location and added to the new location.

#### 3.2.2.1 Weighted Average Technique

The  $\overline{KG}_{new}$  of the ship can be calculated by doing a weighted average of the distances from the keel to ship's  $G_{old}$  and object's  $g$  with a weighting factor based on a weight ratio.

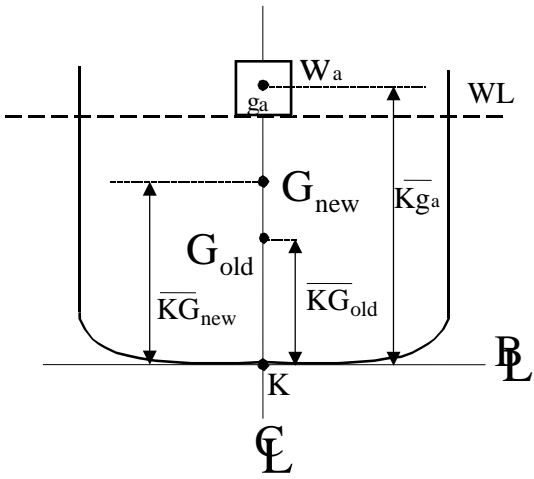
$$\overline{KG}_{new} \cdot \Delta_{s_{new}} = \overline{KG}_{old} \Delta_{s_{old}} + \sum_{i=1}^N (\pm w_i) (\overline{Kg}_i)$$

where: $\overline{KG}_{new}$	is the final vertical position of the center of gravity of the ship as referenced from the keel (ft)
$\overline{KG}_{old}$	is the initial vertical position of the center of gravity of the ship as referenced from the keel (ft)
$\Delta_{s_{new}}$	is the final displacement of the ship (LT) ( $= \Delta_{s_{old}} + \Sigma \pm w_i$ )
$\Delta_{s_{old}}$	is the initial displacement of the ship (LT)
$\overline{Kg}_i$	is the vertical position of the center of gravity of the weight being added/removed/shifted as referenced from the keel (ft)
$w_i$	is the object's weight (+ added/- removed) (LT)

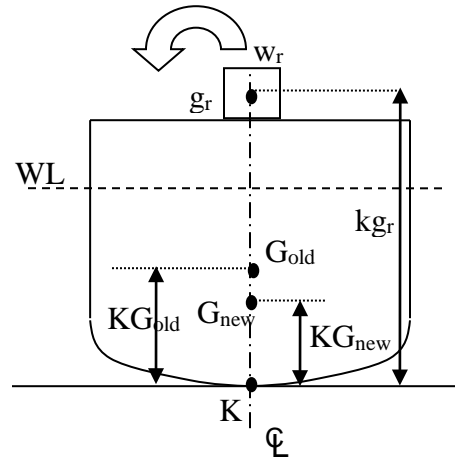
ⓘ To shift weight, first remove it from its old position and then add it to its new position. Since the weight removed and added are the same, ship displacement is unchanged.

ⓘ If several separate weights are added, removed, or shifted, one equation may be used. Repeat the  $(Kg \cdot w)$  term for each weight change

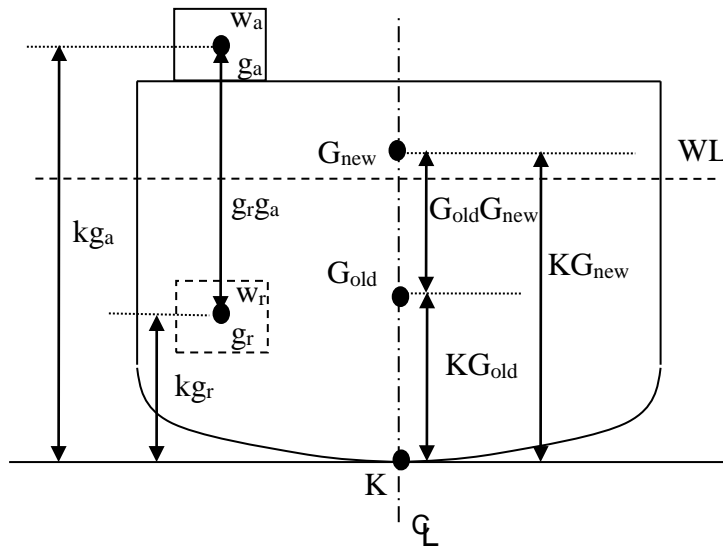
For a visual depiction of these changes to center of gravity, see Figures 3.7, 3.8, and 3.9.



**Figure 3.7** Vertical Weight Addition



**Figure 3.8** Vertical Weight Removal



**Figure 3.9** Vertical Weight Shift

After you calculate a new center of gravity, qualitatively check your answer. For example:

Suppose your old KG is 18 feet and a fuel tank Kg is 14 feet. After “steaming” for some time, the fuel tank is half empty. Suppose you calculate a final KG of 15 feet. Immediately you should know you made a mistake because removing weight below the existing center of gravity of the ship should cause the center of gravity of the ship to rise. Your answer should have been something greater than 18 feet!

You can also check the magnitude of the change. Suppose you calculated a new KG of the ship to be 100 feet. This change is much too large to be reasonable.

The moral of this story is *always check* your final answer. This implies you have a qualitative understanding of the physical processes involved in the calculation of the number! In exam, test and quizzes, you will be graded more when you show a qualitative understanding than simply submitting an answer which is obviously incorrect.

**Example 3.2** An FFG-7 class frigate has an initial displacement of 4092 LT and an initial vertical location of the center of gravity of the ship of 18.9 feet above the keel. If 200 LT are added 10 feet above the keel, and 75 LT are removed 20 feet above the keel, what is the new vertical location of the center of gravity of the ship?

Solution:

$$\overline{KG}_{new} = \frac{\overline{KG}_{old} \Delta_{s\ old} - \overline{Kg}_r w_r + \overline{Kg}_a w_a}{\Delta_{s\ old} - w_r + w_a}$$

$$\overline{KG}_{new} = \frac{(18.9\ ft)(4092\ LT) - (20\ ft)(75\ LT) + (10\ ft)(200\ LT)}{4092\ LT - 75\ LT + 200\ LT}$$

$$\overline{KG}_{new} = \frac{77839\ ft - LT}{4217\ LT} = 18.5\ ft$$

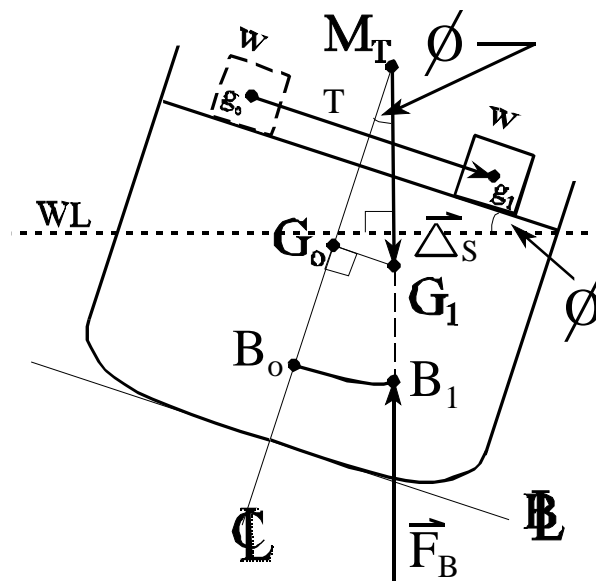
**Remember:** Always check your final answer for reasonability and consistency of units.

- Final KG should be a smaller number since both the addition and removal lower the center of gravity of the ship. Adding 200 LT below the initial center of gravity of the ship causes the center of gravity of the ship to move lower (towards weight added). Removing 75 LT above the initial center of gravity of the ship should cause the center of gravity of the ship to move lower (away from weight removed).
- The direction and magnitude of the change are both reasonable.
- The units of the final answer are consistent with the parameter being found.

### 3.2.3 Quantitative Changes in the Ship's Center of Gravity Due to Transverse Weight Additions, Removals, or Shifts

Recall the transverse direction is the “side to side” direction (or the port to starboard direction). The centerline of the ship separates the port from the starboard. Recall that distances to the port are defined to be negative, and distances to the starboard are positive. In general, we use the symbol “y” as the general variable to represent a transverse distance from the centerline of the ship. Other names you might hear in referencing this direction are “half breadth” and “athwartships.”

Qualitatively, we know that should a weight be added or removed off center (not on the centerline) or a weight is shifted transversely across the ship, the ship will assume some angle of inclination. This angle is called an “angle of list”. List is the condition where the ship is in static equilibrium and down by the port or starboard side. In other words, the ship is not level in the water from side to side. The list angle is created because the weight change has resulted in the Center of Gravity (G) of the ship to move from the centerline. There are no external forces acting on the ship to keep it down by the port or starboard. The angle is maintained because the resultant weight and buoyant force are vertically aligned as shown in Figure 3.2 and Figure 3.10.



**Figure 3.10** The Locations of G and B for a Listing Ship

The off center G causes a moment to be created within the ship that causes it to rotate. As the ship rotates, the underwater volume changes shape which causes the Center of Buoyancy (B) of the ship to move. At small angles of list, B moves in an arc, centered at the transverse metacenter (M). It continues to move until the shape of the underwater volume causes B to move directly vertically underneath G, causing the ship to be back in static equilibrium.

⚠ The concept of the metacenter and B movement will be discussed in greater detail later in this chapter.

### 3.2.3.1 Measurement in the Transverse Direction

The amount of list is usually measured in degrees of incline from the level condition. When the ship lists to port the angles are assigned negative values and when the ship lists to starboard the angles are assigned positive values. In general, we use the symbol  $\phi$  (phi) as the general variable to represent an angle of inclination to the port or starboard side.

The center of gravity (G) is referenced in the transverse direction from the centerline of the ship. The distance from the centerline of the ship to the center of gravity of the ship is called the transverse center of gravity (TCG) and is measured in units of feet.

### 3.2.3.2 Weighted Average Technique

The final TCG after a transverse weight change can be quantitatively determined by using a weighted average equation or by equating moments about the centerline before and after the change in a similar manner shown for vertical changes of weight. The equation takes on the same form as previously discussed with two differences.

- The first difference is that the KG terms have been replaced with TCG since we are working in the transverse direction.
- The second difference is that distances to port must have a negative sign. In the vertical case all distances were positive since the reference point was the keel. In the transverse case the reference point is the centerline so that the TCG can be either negative or positive.
- Typically, your  $TCG_0$  is 0 ft at problem start (if the ship starts at even keel, even list, even trim), but this is not always the case.

The generalized equation for changes in the transverse center of gravity due to shifts, additions, and removals is:

$$TCG_{new} * \Delta_{s new} = \pm TCG_{old} \Delta_{s old} + \sum_{i=1}^N (\pm w_i) (tcg_i)$$

where: $TCG_{new}$	is the new transverse position of the center of gravity <u>of the ship</u> as reference from the centerline (ft)
$TCG_{old}$	is the old transverse position of the center of gravity <u>of the ship</u> as reference from the centerline (ft)
$\Delta_{s new}$	is the new displacement of the ship (LT) ( $= \Delta_{s old} + \Sigma \pm w_i$ )
$\Delta_{s old}$	is the old displacement of the ship (LT)
$tcg_i$	is the transverse position of the center of gravity <u>of the weight being added or removed</u> as referenced from the centerline (ft)
$w_i$	is the object's weight (+ added/- removed) (LT)



This equation works the same as the vertical shift equation (KG), except distance are measured from the centerline with **negative to port and positive to starboard.**

**Example 3.3** An FFG 7 ship has a displacement of 4092 LT, and an initial transverse center of gravity 2 feet starboard of the centerline. A 75 LT weight is moved from a position 10 feet port of the centerline to a position 20 feet port of centerline and a 50 LT weight is added 15 feet port of the centerline. What is the final location of the ship's transverse center of gravity?

Solution:

$$TCG_{new} = TCG_{old} \frac{\Delta_{s\ old}}{\Delta_{s\ new}} - Tcg_{75\ ton\ r} \frac{w_{75\ ton}}{\Delta_{s\ new}} + Tcg_{75\ ton\ a} \frac{w_{75\ ton}}{\Delta_{s\ new}} + Tcg_{50\ ton} \frac{w_{50\ ton}}{\Delta_{s\ new}}$$

$$TCG_{new} = \frac{TCG_{old} \Delta_{s\ old} - Tcg_{75\ ton\ r} w_{75\ ton} + Tcg_{75\ ton\ a} w_{75\ ton} + Tcg_{50\ ton} w_{50\ ton}}{\Delta_{s\ new}}$$

$$TCG_{new} = \frac{TCG_{old} \Delta_{s\ old} + w_{75\ ton} (Tcg_{75\ ton\ a} - Tcg_{75\ ton\ r}) + Tcg_{50\ ton} w_{50\ ton}}{\Delta_{s\ old} - w_{75\ ton} + w_{75\ ton} + w_{50\ ton}}$$

$$TCG_{new} = \frac{+2\ ft\ 4092\ LT + 75\ LT(-20\ ft - -10\ ft) + -15\ ft\ 50\ LT}{4092\ LT - 75\ LT + 75\ LT + 50\ LT}$$

$$TCG_{new} = \frac{+2\ ft\ 4092\ LT + 75\ LT(-20\ ft + 10\ ft) + -15\ ft\ 50\ LT}{4092\ LT + 50\ LT}$$

$$TCG_{new} = \frac{8184\ LT - ft - 750\ LT - ft - 750\ LT - ft}{4142\ LT}$$

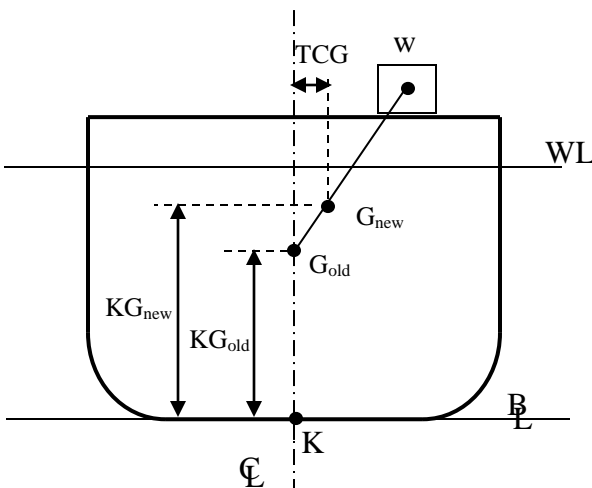
$$TCG_{new} = \frac{6684\ LT - ft}{4142\ LT} = 1.61\ ft\ to\ starboard\ of\ centerline$$

### 3.2.4 Combining Vertical and Transverse Weight Shifts

Rare does a weight change occur on board a ship that results in only a vertical movement of  $G$  or only a transverse movement of  $G$ . Usually, a weight change will result in both. Figure 3.11 shows an example with a weight addition.

Qualitatively, we know that  $G$  will move directly towards the location of the added weight. In this example, it results in an increase in  $KG$  and a  $TCG$  starboard of the centerline. Theoretically, it should be possible to calculate the new location of  $G$  in one step. However, significant simplification is achieved by breaking the problem down into the vertical and transverse directions.

The steps for carrying out an analysis of this situation would be:



- Qualitatively determine the approximate location of  $G_{new}$ .
- Perform a vertical analysis to calculate  $KG_{new}$
- Perform a transverse analysis to calculate  $TCG_{new}$
- Check your vertical and transverse answers with your qualitative work.

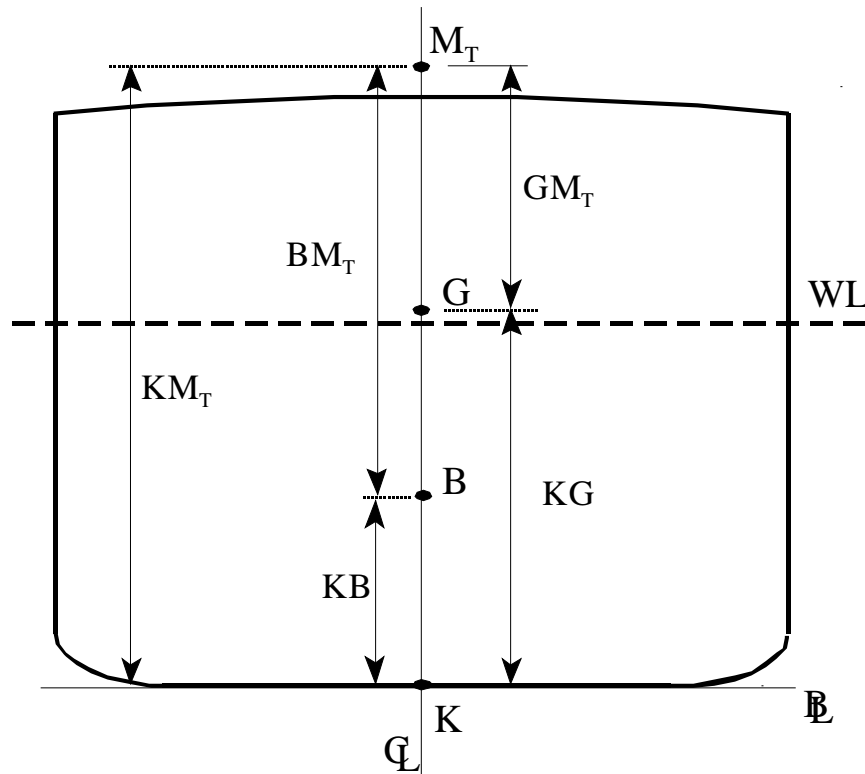
**Figure 3.11** Combining Vertical and Transverse Weight Changes

Using this type of method, you should be assured of success in weight shift, addition and removal problems. We will now move on and examine the listing ship created by an “off center”  $G$  in more detail. However, before we can do this, we must understand the meaning of the metacenter.

### 3.3 Transverse Metacentric Radius and the Transverse Metacentric Height

Figure 3.12 shows a typical sectional view of a ship's hull when the ship is floating level in the water with no list or trim. The important points for hydrostatic calculations are the keel (K), the center of buoyancy (B), the center of gravity (G), and the transverse metacenter ( $M_T$ ).

#### 3.3.1 The Metacenter



**Figure 3.12** Important Locations and Line Segments used in Hydrostatic Calculations

The metacenter was briefly introduced in Section 2.10. It was stated there that the metacenter is a convenient reference point for hydrostatic calculations at small angles. Recall, there is one metacenter associated with rotating the ship in the transverse direction ( $M_T$ ) and another one when rotating the ship in the longitudinal direction ( $M_L$ ). It was pointed out that the transverse metacenter is on the order of 10 to 30 feet above the keel whereas the longitudinal metacenter is on the order of 100 to 1000 feet above the keel.

The metacenter is a stationary point for small angles of inclination. We define “small” to be less than 10 degrees. This is the reason the metacenter and the geometry derived here is only applicable to small angles of inclination. Beyond  $\sim 10$  degrees the location of the metacenter moves off the centerline in a curved arc.



### 3.3.1.1 Metacentric Radius

To locate the metacenter for small angles requires the construction of two lines. The intersection of these lines defines the location of the transverse metacenter. The first line is the line of action of the buoyant force when the ship is upright with no list. The second line is the line of action of the buoyant force when the ship is inclined a small amount.

When a ship is inclined at small angles (<10 degrees), the center of buoyancy (B) moves in an arc. The center of this arc is the transverse metacenter ( $M_T$ ). Picture in your mind a piece of string attached to the metacenter at the top and to the center of buoyancy at the other end. This is why the distance from the metacenter (M) to the center of buoyancy (B) is called the transverse metacentric radius ( $BM_T$ ). The metacentric radius is a line segment measured in feet and it is a commonly used parameter in naval architecture calculations.

### 3.3.1.2 Metacentric Height

Another important line segment used in naval architecture calculations is the distance from the center of gravity (G) to the transverse metacenter ( $M_T$ ). This line segment is called the transverse metacentric height ( $GM_T$ ). As we shall see in the next chapter, the magnitude and sign of the metacentric height will reveal how strongly the ship will want to remain upright at small angles. The importance of this parameter will be made clear in the next chapter.

## 3.3.2 Calculations

Very often in the calculations you will be doing you will need the distance between two of the points shown on Figure 3.12. It is often the case that you know some of the distances but not others. To find any other distance you need, simply draw a quick sketch of Figure 3.12 and use your sketch to see the relationships between what you know and don't know.

For example, to find  $KG$  you could subtract  $KM - GM_T$ .  $KG$  is the line segment that gives the vertical distance to the center of gravity from the keel. The line segment  $KM_T$  is the "transverse metacentric height above the keel". You may recall that it can be found on the curves of form if you know the mean draft of the ship. We will see later in this chapter that the  $GM$  of a ship can be experimentally measured by doing an inclining experiment.

### 3.3.2.1 Advanced Calculations

(OPTIONAL)

To obtain the values of KM in the curves of form, KB is added to BM. Recall that KB can be calculated by numerical integration of the table of offsets as was shown in Section 2.9.5. BM is related to the second moment of area of the waterplane and can be calculated by the following equation.

$$\overline{BM}_T = \frac{2 \int y^2 y dx}{3 \nabla_s} = \frac{2 \int y^3 dx}{3 \nabla_s} = \frac{I_T}{\nabla_s}$$

(the derivation of this equation is beyond the scope of this introductory course)

where:  $y$  is the half breadth distance (ft)  
 $y dx$  is the area of the differential element on the operating waterplane (ft<sup>2</sup>)  
 $\nabla_s$  is the submerged volume of the ship's hull (ft<sup>3</sup>)  
 $I_T$  is the second moment of the operating waterplane area in the transverse direction with respect to the x-axis (ft<sup>4</sup>)



Physically the second moment of area in this case is a measure of the rotational resistance. The second moment of area is a “strong” function of the width of the ship since it is proportional to the half-breadth cubed. In general, this tells us that a wider ship will be harder to roll.

## 3.4 Calculating (small) Angles of List Due to Transverse Shift of Weight

For small angles of list ( $<10$  degrees) we can easily relate the transverse shift in the center of gravity of the ship to the angle of inclination. The theory and derivation developed here are necessary components of the inclining experiment discussed in the next section.

### 3.4.1 Theory

As discussed previously, when the center of gravity of the ship shifts away from the centerline there is an instantaneous misalignment of the resultant weight of the ship with the resultant buoyant force. This causes a moment, rotating the ship to the side the shift occurred to. As the ship inclines the submerged volume changes form, resulting in a new location of the centroid of the underwater volume formed by the hull. The ship will continue to rotate until the centroid shifts far enough to once again be in vertical alignment with the line of action of the resultant weight of the ship.

To keep the following derivation simple we will assume that we always start with a ship that has no initial list so that the initial transverse center of gravity is zero feet. In other words, the initial center of gravity will lie on the centerline of the ship. We will label this point “ $G_0$ .” The final transverse center of gravity will be the distance from the centerline to a point we will label “ $G_t$ .”

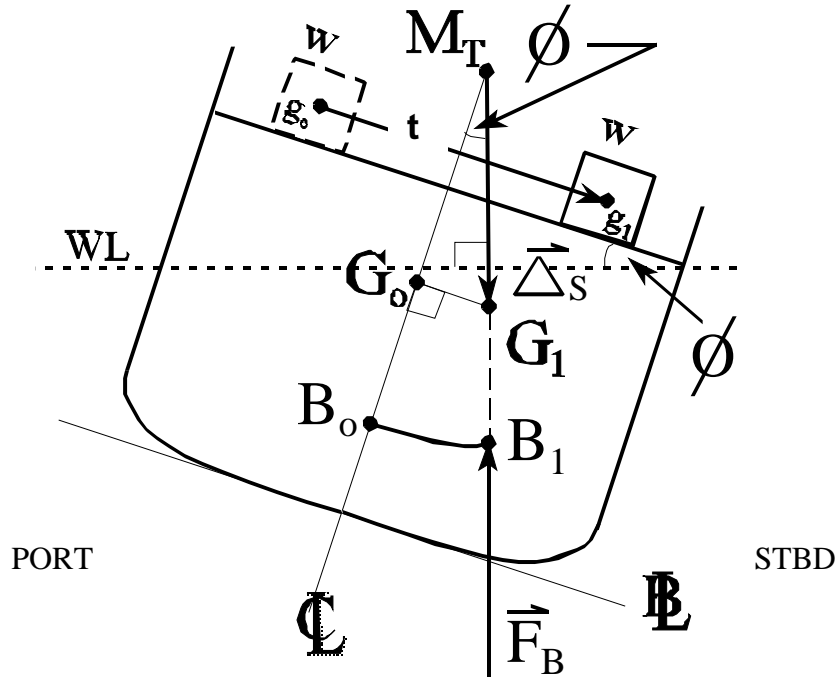
### 3.4.2 Diagram

The first thing we must do is to draw a typical cross section of a ship’s hull inclined as a result of a transverse weight shift in the center of gravity. Figure 3.13 shows the inclined hull with the location of all the key points for our derivation. Additionally, the resultant weight of the ship, the resultant buoyant force, and the waterline are also shown.

You must be able to understand this diagram and be able to draw it without the use of your notes. If you understand the concepts it will be very easy to do so.



Do not attempt to blindly memorize the diagrams in this text. They must be constructed using the fundamental concepts in a logical progression of thought. Further, you should practice drawing each figure because it takes a little artistic skill to do them correctly.



**Figure 3.13** Inclined ship to the starboard side due to a shift in the center of gravity

You should notice the following key items on your diagram when you draw it. Very often these are the items that students get wrong on exams.

- By convention, the right side of the paper is starboard. Rotate the ship, which also rotates the baseline and centerline with the ship.
- Waterline remains horizontal (parallel to top of paper). Resultants of force of buoyancy (up) and force of gravity (Displacement), (down), remain vertical (perpendicular to waterline). In static equilibrium, these two forces are co-linear, located with their heads at their respective points B and G.
- The shift in the center of gravity of the ship is perpendicular to the centerline because the weight shift was perpendicular to the centerline. If your diagram doesn't look like it is then put a small square indicating perpendicularity to your instructor.
- All items should be labeled with the proper symbols including:
  - the waterline (WL), centerline ( $C_L$ ), and keel (K) or Baseline (BL), PORT, STBD
  - the ship's initial center of gravity ( $G_0$ ), and initial center of buoyancy (often but not always on the centerline)
  - the resultant weight of the ship ( $\Delta S$ ) at the ship's final center of gravity ( $G_1$ ), and the resultant buoyant force ( $F_B$ ) at the final center of buoyancy (B)
  - the transverse metacenter ( $M_T$ ), and angle of inclination ( $\phi$ )

### 3.4.3 Relationship

Once you have sketched Figure 3.13 the derivation of the relationship between the “shift in the center of gravity of the ship” and the “angle of inclination” is evident. Notice the right triangle formed by the points ( $M_T G_0 G_1$ ). The line segment  $G_0 G_1$  (of length  $\delta TCG$ ) opposite from the angle of inclination. The metacentric height ( $G_0 M_T$ ) is adjacent to the angle of inclination. The opposite side over the adjacent side of a right triangle defines the tangent of the angle. Solving for ( $G_0 G_1$ ) yields:

$$\tan \phi = \frac{opp}{adj} = \frac{\overline{G_0 G_1}}{\overline{G_0 M_T}}$$

$$\overline{G_0 G_1} = \overline{G_0 M_T} \tan \phi$$

Since  $G_0$  is on the centerline, distance  $G_0 G_1$  is the same as  $TCG_{new}$ . And  $g_0 g_1$  is the same as  $tcg$ , which will be simplified to just distance ‘t’. Substitution of the above expression into the equation for a single transverse weight shift (from Section 3.2.3.2) yields:

$$TCG_{new} \cdot \Delta_{s\ new} = \pm TCG_{old} \Delta_{s\ old} + \sum_{i=1}^N (\pm w_i) (tcg_i)$$

$$\overline{G_0 G_1} \cdot \Delta_s = (0\ ft \cdot \Delta_s) + w \overline{g_0 g_1}$$

$$\overline{G_0 G_1} = \frac{w \overline{g_0 g_1}}{\Delta_s}$$

Setting the two derived  $G_0 G_1$  equations equal to each other yields:

$$\overline{G_0 M_T} \tan \phi = \frac{w t}{\Delta_s}$$

where: “t” is the transverse distance the weight is shifted ( $g_0 g_1$ ) (ft)

This is the relationship we sought. It relates the transverse shift in the center of gravity of a ship to the angle of inclination for angles less than 10 degrees. This is the basic relationship used in the inclining experiment in the very next section.

### 3.5 The Inclining Experiment

**The goal of the Inclining Experiment is to use small angle hydrostatics to compute the vertical center of gravity of a ship** as referenced from the keel (KG). The basic process of an inclining experiment is straight-forward.

1. A known weight ( $w_i$ ) is moved a known transverse distance ( $t_i$ ). This transverse weight shift causes a transverse shift in the center of gravity of the ship, which in turn causes the ship to list to the side of the weight shift.
2. The amount of weight used ( $w_i$ ), the distance it is shifted ( $t_i$ ), and the resulting angle of list ( $\phi_i$ ) are measured and recorded. The process is repeated moving different weights different distances, port and starboard, causing port and starboard angles of list. This yields sets of ( $w_i, t_i, \tan\phi_i$ ) data where the subscript “ i ” is just a counting variable.
3. The data from several weight shifts is plotted and the slope is used to reduce error from just one data point. Slope of the curve allows solving  $GM_T$ .
4. With  $KM_T$  from Curves of Form, one may solve  $KG_{incl}$  for the experimentally inclined ship. With a simple weight removal calculation, one may solve the  $KG_{light}$  for the ship without experimental gear onboard.

Before this process can begin, the ship has to be prepared for the experiment. The experiment is conducted alongside, in calm water with the ship free to list. It is usually performed with the ship in its light-ship condition. The light-ship displacement ( $\Delta_{light}$ ) is defined by Gilmer and Johnson as:

*“the weight of the ship complete in every respect, including hull, machinery, outfit, equipment, water in the boilers at steaming level, and liquids in machinery and piping, but with all tanks and bunkers empty and no crew, passengers, cargo, stores, or ammunition on board.”*

*Introduction to Naval Architecture, p131.*

It is necessary to determine the displacement of the light-ship ( $\Delta_{light}$ ). This is achieved by observing the fwd and aft draft marks and consulting the ship’s curves of form. In this step it is also important to find the density of the water the ship is floating in so that a correction can be made to the displacement read from the curves of form for the true water density.

Once the ship has been prepared, the inclining weights and apparatus are brought on board. Typically, the inclining weights are approximately 2% of the displacement of the light-ship ( $\Delta_{light}$ ). With the inclining weights and apparatus on board, the ship is said to be in an inclined condition. All quantities are then given the inclined suffix. For example  $\Delta_{incl}$ ,  $KG_{incl}$ .

With the inclining weights and equipment on board, the experiment can then proceed as described above. This often requires a great deal of co-ordination and the use of riggers etc. For larger ships, it is common to use a crane to move the inclining weights from and to different transverse locations. 2% of the displacement of a ship is a considerable weight to move.

### 3.5.1 Finding $G_0M_T$ inclined

The equation to find list angle from a single transverse weight shift is expressed in terms of the metacentric height ( $G_0M_T$ ) as:

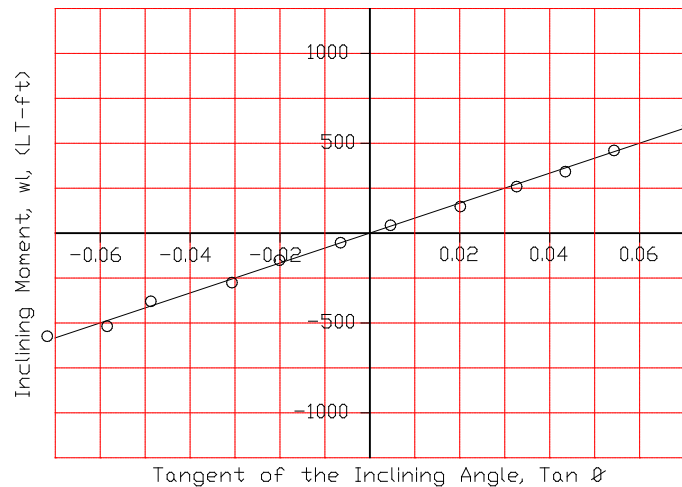
$$\overline{G_0M_{T\text{incl}}} = \frac{w_i t_i}{\tan \phi_i} \frac{1}{\Delta_{S\text{incl}}}$$

Any one set of ( $w_i$ ,  $t_i$ ,  $\phi_i$ ) could be used in this equation to find a value for the inclined transverse metacentric height. Each set should yield the same value of metacentric height for small angles. However, there are experimental errors and deviations from the ideal that will yield a slightly different value for each set of ( $w_i$ ,  $t_i$ ,  $\phi_i$ ) used.

To achieve an average value for the transverse metacentric height ( $G_0M_T$ ) the slope from a graph of “tangent of the inclining angle” ( $\tan \phi_i$ ) versus the “inclining moment” ( $w_i t_i$ ) is calculated. See Figure 3.14. The first group of parameters in the equation above is the slope of this graph. By dividing the slope by the displacement of the ship, the average value of  $G_0M_T$  is obtained as shown below:

$$\overline{G_0M_T} = \frac{w_i t_i}{\tan \phi_i} \frac{1}{\Delta_{S\text{incl}}}$$

$$\text{Average } \overline{G_0M_T} = \frac{(\text{slope of the "tan } \phi_i \text{ vs } w_i t_i \text{ " curve)}}{\Delta_{S\text{incl}}}$$



**Figure 3.14** A Typical Plot of Data from an Inclining Experiment

The slope is calculated by picking any two points on the line of best fit and doing a change in “y” over a change in “x” calculation. Be sure to pick points on the line of best fit! A common student mistake is to use the original data points to calculate the slope. It is possible that none of these

data points will be on the line you have drawn, the line represents the average of the data! An advantage of analyzing the data in this manner is that one stray data point can be “thrown out” or “ignored” as a bad point.

$$\text{slope of a line} = \frac{\text{Rise}}{\text{Run}} = \frac{dy}{dx} \equiv \frac{\delta y}{\delta x} = \frac{(y_2 - y_1)}{(x_2 - x_1)}$$



There is also a mathematical technique to do the linear regression called “least squares”. The mathematical technique is less subjective since no matter who does the calculation it will yield the same results. The linear regression by the least squares method can be easily done with a spreadsheet program on a computer. The computer will give the entire equation of the straight line to many decimal places. This technique minimizes the sum of the “squares of the error” between each data point and the line, thus the name least squares method.

Obtaining the average value of the transverse metacentric height ( $G_0M_T$ ) is not the objective of the inclining experiment. Keep in mind the objective is to find the vertical location of the center of gravity of the ship without inclining gear aboard ( $KG_{light}$ ). Two more steps are required once the average value of  $G_0M_T$  is obtained.

### 3.5.2 Finding $KG_{incl}$ and Correcting this for the Removal of Inclining Apparatus

The first step is find the vertical location of the center of gravity of the ship with the inclining gear on board by subtracting the average metacentric height from the value of  $KM_T$ . The value of  $KM_T$  is found on the curves of form as a function of mean draft.

$$\overline{KG}_{incl} = \overline{KM}_T - \overline{G_0M}_T$$

The second step is to calculate the vertical location of the center of gravity of the ship without the inclining weights aboard ( $KG_{light}$ ). This is accomplished by doing a weight removal calculation as explained earlier in Chapter 3.

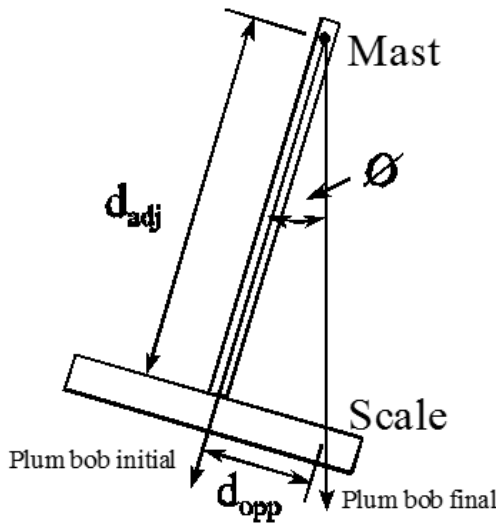
$$\overline{KG}_{light} = \frac{\overline{KG}_{incl} \Delta_{incl} - \sum \overline{Kg}_{incl\ weights} \cdot w_{incl\ weights}}{\Delta_{light}}$$

$$\overline{KG}_{light} = \frac{\overline{KG}_{incl} \Delta_{incl} - \sum \overline{Kg}_{incl\ weights} \cdot w_{incl\ weights}}{\Delta_{inclined} - \sum w_{incl\ weights}}$$



### 3.5.3 Inclining Experiment Practicalities

The inclining experiment is easily performed on a ship and it is likely that you will see it carried out or be a part of the evolution sometime in your career.



The tangent of the inclining angle for each placement can be measured by attaching a “plum bob” on a long wire suspended from a tall mast. The plum bob will always hang vertically downward and perpendicular to the waterplane. This plum bob can be used to measure the number of inches of deflection the bob makes when the ship is inclined from the level position. Figure 3.15 shows the right triangle formed by the mast, wire and horizontal scale. The tangent of the inclining angle can be calculated from this right triangle by dividing the deflection distance by the length of the wire as shown below:

**Figure 3.15** Measurement of  $\tan \phi$  during an inclining experiment

$$\tan \phi_i = \frac{\text{opposite side of right triangle}}{\text{adjacent side of right triangle}} = \frac{d_{opp}}{d_{adj}}$$

These are the more common problems in doing an inclining experiment:

- Keeping track of all the weights onboard before and during the evolution.
- The presence of liquids in less than full tanks creates errors in the measurements. The shift in the fluid in a less than full tank creates a virtual rise in the center of gravity of the tank. This is called the “free surface effect” and it will be discussed in Chapter 4.
- The test must be done in calm conditions (test performed pierside typically).
- Potentially dangerous in that adding weights high on a ship reduces stability and/ or the deck may not be able to support the inclining weights. Additionally, moving large weights creates a safety concern to personnel involved. (These concerns are evaluated before the procedure ever takes place.)

**Example 3.4** A ship undergoes an inclining experiment resulting in a graph of “the tangent of the list angle” versus “the inclining moment” (similar to Figure 3.14) with a slope of 28591 ft-LT. The displacement is 7986 LT and  $KM = 22.47$  ft. What is the  $\overline{KG}$  of the ship without the inclining gear aboard if the center of mass of the inclining gear is 30 feet above the keel with a weight of 50 LT?

Solution:

*Finding  $\overline{GM}_{inclined}$*

$$\overline{GM}_{inclined} = \frac{\text{slope of "tan } \phi \text{ vs wt" curve}}{\Delta_{inclined}}$$

$$\overline{GM}_{inclined} = \frac{28591 \text{ LT-ft}}{7986 \text{ LT}}$$

$$\overline{GM}_{inclined} = 3.58 \text{ ft}$$

*Finding  $\overline{KG}_{inclined}$*

$$\overline{KG}_{inclined} = \overline{KM}_{inclined} - \overline{GM}_{inclined}$$

$$\overline{KG}_{inclined} = 22.47 \text{ ft} - 3.58 \text{ ft} = 18.89 \text{ ft}$$

*Finding  $\overline{KG}_{light}$*

$$\overline{KG}_{light} = \overline{KG}_{inclined} \Delta_{inclined} - \overline{Kg}_{inclining \text{ weight}} \cdot w_{inclining \text{ weight}}$$

$$\overline{KG}_{light} = \frac{18.89 \text{ ft} \cdot 7986 \text{ LT} - 30 \text{ ft} \cdot 50 \text{ LT}}{7986 \text{ LT} - 50 \text{ LT}}$$

$$\overline{KG}_{light} = \frac{150856 \text{ LT-ft} - 1500 \text{ LT-ft}}{7936 \text{ LT}} = 18.82 \text{ ft}$$

### 3.6 Longitudinal Changes in the Ship's Center of Gravity Due to Weight Shifts, Weight Additions, and Weight Removals

So far we have calculated vertical and transverse weight shifts, weight additions, and weight removals. In this section we will look at longitudinal weight shifts, weight additions, and weight removals. Longitudinal problems are done in a different manner because we are usually not concerned with the final position of G, but the new trim condition of the ship.

The consequence of longitudinal shifts, additions, and removals of weight is that the ship undergoes a change in the forward and after drafts. When the forward and after drafts have different magnitudes the ship is said to have trim. Recall from Chapter 2, that trim is defined by the difference between the forward and after drafts. Also recall, that T is the symbol for draft.

$$\text{Trim} = T_{\text{aft}} - T_{\text{fwd}}$$

If a ship is "trimmed by the bow," then the forward draft is bigger than the after draft. In other words, the bow sits deeper in the water than the stern. A ship "trimmed by the stern" has an after draft bigger than the forward draft. Recall that the ship rotates about the center of flotation (F) which is the centroid of the waterplane area. (It does not rotate about midships!) When the centroid of the waterplane area is aft of midships the forward draft will change by a larger amount than the after draft. This is usually the case since a typical ship is wider aft of midships than forward of midships.

The curves of form assume the ship is level with no trim, but they may be used for a ship in a trimmed condition, so long as the trim is not too large. If the ship is trimmed, the entering argument to the curves of form is the mean draft:

$$T_{\text{mean}} = \frac{T_{\text{fwd}} + T_{\text{aft}}}{2}$$

The goal of a longitudinal problem is to determine the final drafts forward and aft given the initial drafts and a description of the weight shifts, weight additions, and weight removals that occurred.

It is helpful in the modeling process to physically visualize the weight shift occurring. Picture a large wooden crate on the weather deck of a ship that is being pushed more forward or more aft. Try to predict if the ship will go down by the bow or go down by the stern from your mental picture.

- Notice it doesn't matter what position the crate starts from on the ship only that it moves forward or aft.
- Remember to visualize the weight shift. Pushing a weight forward makes the bow go down and the forward draft increase. Pushing a weight aft makes the stern go down and the after draft increase. Use this knowledge to determine when to add to or subtract from a draft. Additionally, test your final answer for reasonability and consistency. If you add weight forward, the bow's draft is likely to increase, and so on.

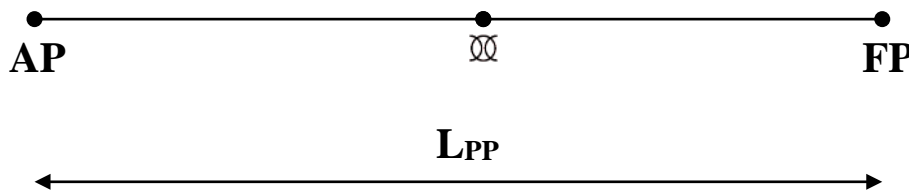
### 3.6.1 Trim Diagram

To quantify the changes in the forward and after drafts from a weight change requires an engineering analysis of the process. The analysis starts by developing a picture that shows all the geometric relationships that exist. This picture is developed logically in a step wise procedure.

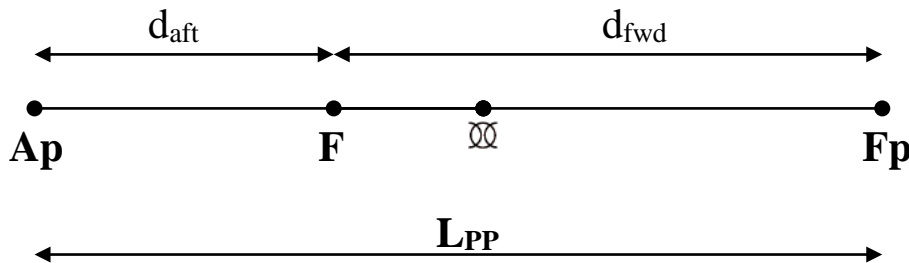
1. Draw a single horizontal line that represents the waterplane of the ship from the sheer plan view. The length of the line represents the length of the ship.



2. Decide which end is the bow and which is the stern, label them. Show the midpoint of the line and label it as midships.

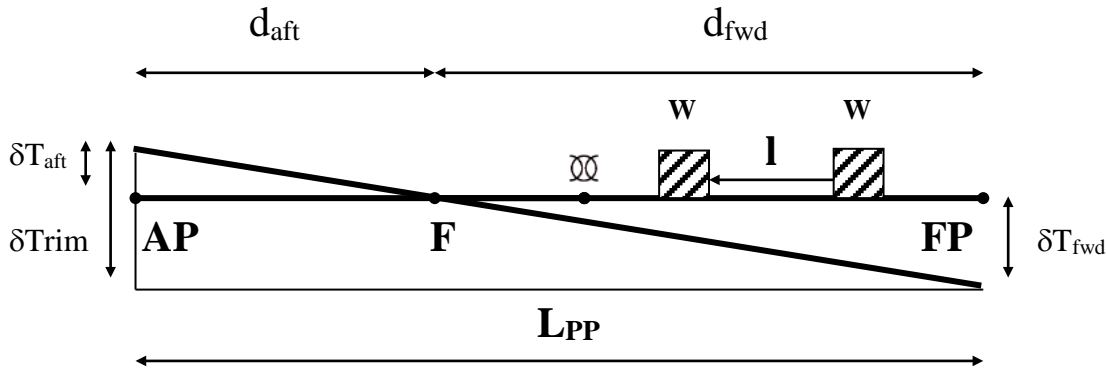


3. Show the center of flotation (F) and label it. Normally assume it is located aft of midships. Dimension and label the distances from the AP to the center of flotation ( $d_{aft}$ ) and the FP to the center of flotation ( $d_{fwd}$ ).



4. Show the weight change that is occurring and the new waterplane that would exist after the weight change. To draw this correctly simply rotate your paper in a clockwise or counter clockwise direction and draw a horizontal line through the center of flotation. By rotating your paper you have the advantage of simulating the bow or the stern going down and the water surface remaining level with the bottom of your desk.

In this example we will consider a weight shifted more aft.



5. Put your paper level again. Any distance above the first waterline is positive and any distance below is negative. According to this convention the after draft increased by a positive number which is consistent with what actually happens when weight is shifted more aft. Draw vertical lines from the ends of the first waterline to the second waterline forming two similar triangles. Label those vertical distances with “ $\delta T_{aft}$ ” and “ $\delta T_{fwd}$ .”
6. Form the third similar triangle by drawing a third waterline parallel to the first and starting with the upper or lower most draft. The vertical leg of this third largest triangle should be labeled “ $\delta Trim$ ” since the change in trim is equal to the change in draft aft minus the change in draft forward (See note 3 below). Label the angle of trim with the symbol “ $\theta$ .” Avoid using “ $\phi$ ” since that is used to express angles of rotation in the transverse direction.

**Each time a change in trim problem is performed, this diagram must be completed in full.** All the expressions that follow can only be written if you have a diagram.

Note 1: Notice what happens to the change in trim when the ship goes down by the stern. The change in draft aft is positive and the change in draft forward is negative. You’re subtracting a positive number minus a negative number to get a larger positive number. This is consistent with the idea that trim down by the stern is positive by convention.

Note 2: It is really not necessary to follow all the sign conventions in a formal sense if you use your diagram and a little common sense. The procedure has been written very formally here to show you that the sign conventions and definitions are consistent throughout.

Note 3: The following is the derivation of the “ $\delta trim$ ” equation. Recall a change in a property is always the final value of the property minus the initial value of the property. You can always find a change in any parameter using this definition.

### 3.6.2 Trim Calculation

The starting equation to calculate the final draft forward or aft is based on an accounting concept. To find the final balance in a bank account you need to start with the initial balance, add the receipts and subtract the debits. Similarity, the final draft forward (or aft) is equal to the initial draft forward (or aft) minus any decreases in the draft forward (or aft), plus any increases in the draft forward (or aft).

$$T_{fwd\ new} = T_{fwd\ old} \pm \delta T_{fwd\ due\ to\ trimming\ moment} \pm \delta T_{fwd\ due\ to\ parallel\ rise\ or\ sinkage}$$

$$T_{aft\ new} = T_{aft\ old} \pm \delta T_{aft\ due\ to\ trimming\ moment} \pm \delta T_{aft\ due\ to\ parallel\ rise\ or\ sinkage}$$

We have discussed one way for the drafts to change, by a shift in a weight which creates a moment about the center of flotation ( $\delta T_{fwd\ due\ to\ wl}$  or  $\delta T_{aft\ due\ to\ wl}$ ). There are other ways to change the drafts forward or aft, specifically by adding and/or removing weight. First, we will go over a single weight shift and then discuss adding and/or removing weight.

To decide if the change in draft forward should be added or subtracted refer to your trim diagram and common sense. For example shifting weight forward increases the forward draft so the change in draft forward should be added making the final draft larger than the initial. Let's call this first equation the "accounting equation." It is shown by the preceding equations for the final forward draft and the final after draft.

- The first term these equations are the initial drafts. These are typically given as an initial condition of the problem. Most of your problems start even keel (zero list, zero trim) and  $T_{mean} = T_{fwd} = T_{aft}$ . This is not *always* the case.
- The second term in these equations must be calculated by using the similar triangles shown by the diagram previously developed.
- The third term in these equations will be found by dividing the weight added or removed by the TPI.
- By looking at the trim diagram we can develop the following equation from the similar triangles.

$$\frac{\delta T_{aft\ due\ to\ wl}}{d_{aft}} = \frac{\delta T_{fwd\ due\ to\ wl}}{d_{fwd}} = \frac{\delta Trim}{L_{PP}}$$

The magnitudes of the distances shown above are evident in the trim diagram. If we can find the magnitude of the "δtrim" parameter, we can solve for both the change in draft aft and forward due to the trimming moment, "wl".

The change in trim is found by dividing the moment creating the change in trim ( $wl$ ) by a parameter called  $MT1''$ . The  $MT1''$  has unit of LT-ft per inch and is on the curves of form as a function of mean draft.

$$\delta Trim = \frac{w l}{MT1''}$$

Where:  $w$  = weight added/removed or shifted to produce the trim moment (LT)  
 $MT1''$  = moment to change trim 1'' (LT·ft/in)  
 $l$  = for a weight shift, the total longitudinal distance that weight “w” is shifted (ft)

-or-

for a weight addition/removal, the distance the weight lies from F (F acts as the fulcrum for the trim problem) (ft)

At this point you are ready to do any weight shift problem by drawing your picture and solving for the unknowns. Note for a weight shift problem the last term in “accounting” trim equations is zero.

Weight additions or removals are modeled as a two step process.

- For a weight addition, step one is to assume the weight is added at the center of flotation. Step two is to assume the weight is moved from the center of flotation to the resting position of the weight.
- For a weight removal, step one is to assume the weight is shifted from its resting position to the center of flotation. Step two is to assume the weight is removed from the center of flotation.



Weight additions require you to do all the work that you would do for a weight shift problem and to do one additional calculation. The additional calculation is to find the *change in draft aft or forward due to adding or removing weight at the center of flotation*. Since the center of flotation is at the pivot point of a floating ship, adding or removing weight at this location only causes the ship to sink or rise in a “parallel” fashion. In other words, there will be no change in trim, the after and forward drafts will change by the same amount. The resulting waterline, after the addition or removal of weight from the center of flotation, is parallel to the original waterline. This occurrence is called “parallel change” or in the case of weight addition “parallel sinkage.”

- The change in draft aft or forward due to adding or removing weight at the center of flotation ( $\delta T_{PS}$ ) can be found as shown below and it is the last term in “accounting” trim equation.

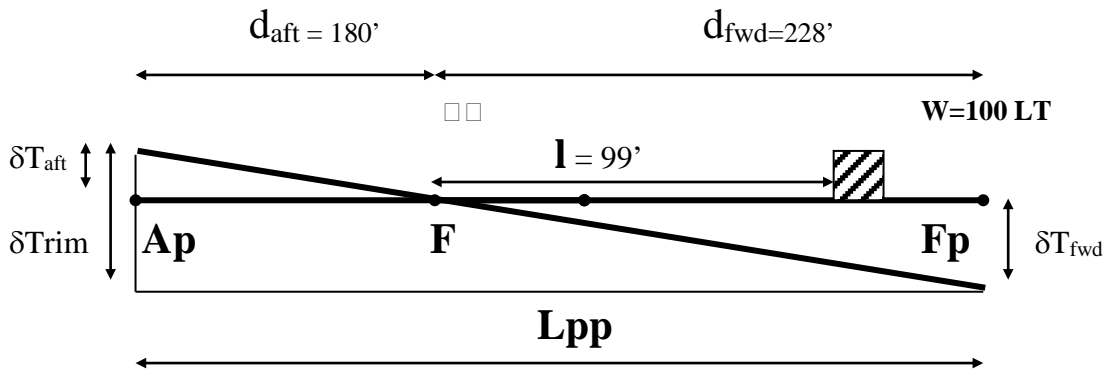
$$\delta T_{PS} = \frac{w}{TPI}$$

Where:  $\delta T_{PS}$  is the change in draft due to parallel sinkage, adding or removing weight (in)  
 $w$  is the amount of weight added or removed at the center of flotation (LT)  
 $TPI$  is the tons per inch immersion conversion factor (LT/in)



**Exercise 3.5:** An FFG7 is originally at a draft of 16.25 ft in level trim. 100 LT are removed from a location 75 ft forward of amidships. What are the final forward and after drafts? An FFG7 is 408 ft long and has the following characteristics:

T (ft)	$\Delta$ (LT)	TPI (LT/in)	MT1" (ft-LT/in)	LCF (ft) aft amidships
16.00	3992	33.0	793.4	24.03
16.25	4092	33.2	800.7	24.09



$$\delta T_{PS} = \frac{w}{TPI} = \frac{100 \text{ LT}}{33.2 \text{ LT/in}}$$

$$\delta T_{PS} = 3.01 \text{ in} = 0.25 \text{ ft}$$

$$\delta Trim = \frac{wl}{MT1''} = \frac{100 \text{ LT} \cdot 99 \text{ ft}}{800 \text{ LT-ft/in}}$$

$$\delta Trim = 12.38 \text{ in} = 1.03 \text{ ft}$$

$$\frac{\delta trim}{Lpp} = \frac{\delta T_{aft}}{d_{aft}} = \frac{\delta T_{fwd}}{d_{fwd}} \Rightarrow \delta T_{aft} = \delta Trim \frac{d_{aft}}{Lpp} = 1.03 \text{ ft} \frac{180 \text{ ft}}{408 \text{ ft}} = 0.45 \text{ ft}$$

$$\delta T_{fwd} = \delta Trim \frac{d_{fwd}}{Lpp} = 1.03 \text{ ft} \frac{228 \text{ ft}}{408 \text{ ft}} = 0.58 \text{ ft}$$

$$T_{aft \text{ new}} = T_{aft \text{ old}} - \delta T_{PS} + \delta T_{aft} = 16.25 \text{ ft} - 0.25 \text{ ft} + 0.45 \text{ ft} = 16.45 \text{ ft}$$

$$T_{fwd \text{ new}} = T_{fwd \text{ old}} - \delta T_{PS} - \delta T_{fwd} = 16.25 \text{ ft} - 0.25 \text{ ft} - 0.58 \text{ ft} = 15.42 \text{ ft}$$

### 3.7 Correction to Displacement for Trim

(Optional)

The curves of form are calculated assuming a ship with zero trim. So long as the trim is not significant, most of the quantities found will be sufficiently accurate.

Since the entering argument for the curves of form is mean draft, it will be useful to see what the effect of trim is on the displacement gained from the curves of form. The LCF is normally aft of amidships. If the ship trims by the stern, then the mean draft will be less than if the ship were in level trim. Therefore, you will enter the curves at a smaller draft and read a displacement smaller than the actual displacement.

$$\delta\Delta = \Delta_{T_{mean}} + (\delta\Delta_{1ft})(Trim)$$

The correction to displacement for trim is made in the following manner:

- where:  $\delta\Delta$  is the correction to displacement  
 $\Delta_{T_{mean}}$  is the displacement read from the curves of form at the mean draft  
 $\delta\Delta_{1ft}$  is the correction to displacement for a 1 ft trim read at  $T_{mean}$  on the curves of form  
 $Trim$  is the difference between the fore and aft drafts.

**Example 3.5** DDG51 has a mean draft of 20.75 ft and is trimming 1.5 ft by the stern. What is the displacement?

Draft (T)	Displacement $\Delta$	Corr. to Disp. for 1 ft Trim
20.75 ft	8443 LT	31.1 LT/ft

Solution:

$$\delta\Delta = (31.1 \text{ LT/ft})(1.5 \text{ ft}) = 46.7 \text{ LT}$$

$$\Delta = 8443 \text{ LT} + 46.7 \text{ LT} = 8490 \text{ LT}$$

### 3.8 Drydocking

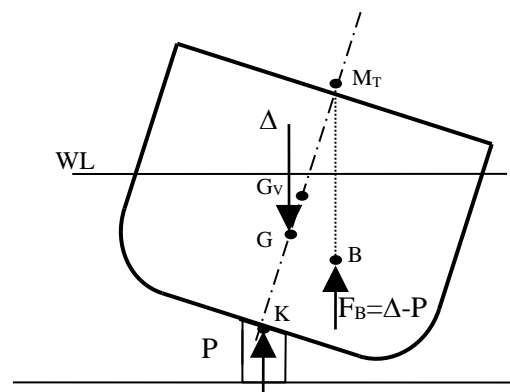
Due to the nature and complexity of repair and maintenance that must be performed on the underwater hull, openings, and sea-connected systems of ships, it is often necessary to perform this work in a drydock. The object of drydocking is to properly support the ship while it is out of the water. There are three distinct phases to drydocking: preparation, docking, and undocking. An error during any phase may lead to catastrophe: ship tilting, hull structural damage, damage to appendages, and possibly, personnel injury.

- Preparation is critical to the success of all phases. The Dockmaster and Docking Officer must carefully evaluate the type of ship to be docked and where to place the supports on the ship. This task is accomplished by evaluating the ship's lines plans, structural drawings, and all of the underwater appendages on the ship. A Predocking Conference is held between the drydock and the ship to discuss plans, responsibilities, and procedures.
- Docking is a slow, closely orchestrated evolution. Once the dock is flooded above the blocks and the Docking Officer is ready, the ship is carefully pushed and/or pulled into the dock by tugs, workboats and dockside lines. Once the ship is in the correct position over the blocks (this is often verified by divers) pumping of the drydock can commence. Landing the ship on the blocks is a critical step in this evolution and as such, it is carefully approached. As the ship lands (usually stern first), part of the ship is supported by the blocks (P) and part of the ship is supported by the buoyant force. This causes a virtual rise in the center of gravity and a decreased metacentric height.

$$\overline{G_v M_T} = \overline{K M_T} - \frac{\overline{K G} \cdot \Delta}{\Delta - P}$$

Where:

- $\overline{G_v M_T}$  = virtual metacentric height of ship at current waterline (ft)
- P = upward force exerted by the keel blocks (LT)
- $\overline{K M_T}$  = distance from keel to meta-center at the current waterline (ft)
- KG = distance from keel to center of gravity (ft)
- $\Delta$  = displacement of waterborne ship at current waterline (LT)



**Figure 3.16** Stability in Drydock

If a list develops as the ship lands and continues to increase, pumping operations are stopped until the cause is found and corrected. There is a possibility during landing that the ship may develop a negative metacentric height and capsize (this will be explained more in Chapter 4). If all goes well, the ship lands on the blocks and work can start.

- Undocking can be just as precarious as the docking phase if not done carefully. Additionally, the hull and its openings must be tested for watertight integrity before the ship is floated and leaves the dock. Undocking follows the same basic procedure as docking, but in reverse.

## PROBLEMS - CHAPTER 3

### Section 3.1 Archimedes' Principle and Static Equilibrium

1. State the necessary conditions for static equilibrium and show with a diagram how they apply to a free floating ship
2. Calculate the gage pressure and absolute pressure 20 feet below the surface for both salt water and fresh water. Assume that the atmospheric pressure is at 14.7 psi.
3. Calculate the resultant hydrostatic force being experienced by a box shaped barge 100 ft long 20 ft wide floating at a draft of 6 ft in salt water. How does this compare with the buoyant force ( $F_B$ ).
4. At a draft of 23.5 feet, the underwater volume of a ship is 350,000 ft<sup>3</sup>. The ship is floating in salt water. What is its displacement in LT?
5. The displacement of a CG47 class cruiser is 9846 LT.
  - a. What is the underwater volume of the ship if it is floating in 59°F salt water?.
  - b. What is the underwater volume if the ship is floating in fresh water at the same temperature?
  - c. Explain the difference, if any, in terms of Archimedes Principle and static equilibrium.
6. A Marine landing craft can be approximated by a box-shaped, rectangular barge with the following dimensions: Length = 120 feet, Beam = 25 feet, and Depth = 7.5 feet. When empty the barge has a draft of 2.5 feet. You are the Combat Cargo Officer on an amphibious ship responsible for the safe loading of landing craft.
  - a. The landing craft has a maximum safe draft of 5.25 feet. How many tons of cargo can be loaded without exceeding this draft?
  - b. An amphibious operation requires that the landing craft must cross a shoal that is 150 yards from the beach. At high tide the charted depth at the shoal is 4.5 feet. How many tons of cargo can be loaded on the barge so that it will safely arrive at the beach and not run aground?
  - c. The landing craft is loaded to a draft of 5 feet in salt water, and is going to a pier located in a fresh water river. At low tide the depth of water pierside is 5.5 feet. Will the boat ground itself at low tide? Why or why not?

### Section 3.2 Vertical and Transverse Shifts in the Center of Gravity

7. *USS CURTS* (FFG-38) is floating on an even keel at a draft of 15.5 feet, with  $KG = 19$  feet on the centerline.  $Lpp = 408$  feet. When refueling the ship takes on 186 LT (60000 gallons) of F-76 to a tank located on the centerline, 7 feet above the keel. Find the new vertical center of gravity after receiving fuel.
8. *USS SUPPLY* (AOE-6) is underway in the North Atlantic preparing to UNREP ammunition and stores to the Battle Group. The ship is currently at a draft of 38 feet, and the center of gravity is located 33 feet above the keel on the centerline.  $Lpp = 734$  feet. In preparation for the UNREP, 1000 LT of ammunition, fresh, and frozen stores are moved from a location 15 feet above the keel to the main deck, which is located 25 feet above the waterline. Determine the vertical location of the ship's center of gravity after moving stores up on deck.
9. *USS FREEDOM* (LCS-1) enters a shipyard for an overhaul. As it entered the shipyard, the ship's displacement was 2860 LT with  $KG = 19.7$  ft, on the centerline. During overhaul the following work was performed.

Removed Items		
Item	Weight	Kg
ASW Fire Control Package	15.0 LT	25.0 ft
Portable Towed Array	6.0 LT	15.0 ft
Enigne Upgrades	3.0 LT	8.0 ft

Added Items		
Item	Weight	Kg
VBSS Tactical Control Package	20.0 LT	34.0 ft
Two 50-cal Small Arms Stations	8.0 LT	45.0 ft
Antenna Upgrades	5.0 LT	64.0 ft

- a. Determine the ship's displacement and  $KG$  after the overhaul.
  - b. Determine the ship's draft before and after overhaul
10. *USS THACH* (FFG-43) departs Singapore for a seven day transit to Yokosuka, Japan. The ship got underway at a draft of 16.3 feet, with the center of gravity on the centerline, 18.7 feet above the keel.  $Lpp = 408$  feet. *THACH* departed port with 605 LT (195000 gallons) of fuel. During the transit the ship burned 65% of its fuel. The fuel came from tanks located on the centerline, 5 feet above the keel. Determine the vertical location of the ship's center of gravity upon its arrival in Yokosuka.
  11. *USS THOMAS S GATES* (CG-51) has a displacement of 9600 LT, and  $KG = 23.19$  ft. The TCG is on the centerline. 5 LT of water are shifted from a location 5 ft above the keel and 22 ft starboard of centerline to a location 5 ft above the keel and 10 ft port of centerline.
    - a. What is the final  $KG$ ?
    - b. What is the final TCG?

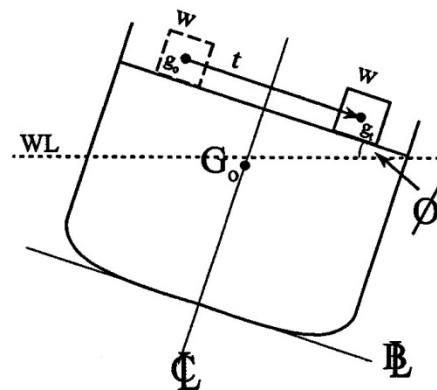
12. *USS FREEDOM* (LCS-1) is floating upright with a displacement of 3100 LT and  $KG = 18.0$  ft. 25 LT of equipment are added to the ship at an average location 30 ft above the keel and 8 ft starboard of the ship's centerline.
- What is the new  $KG$ ?
  - What is the new  $TCG$ ?
  - This new location of  $G$  is unsatisfactory. At what transverse and vertical location would you add 20 LT of lead ballast to return to the ship's original  $KG$  and  $TCG$ ?
13. *USS RUSSELL* (DDG-59) is floating on an even keel at a draft of 20.5 feet. The center of gravity is located on the centerline, 21.3 feet above the keel.  $L_{pp} = 465$  ft. 150 LT of machinery is removed from a location 10 feet above the keel, 17 feet to port of centerline.
- Determine  $KG$  after the machinery is removed.
  - Determine the ship's new  $TCG$  after removing the machinery.
  - Draw a diagram showing the ship in static equilibrium after the machinery has been removed.

### Section 3.3 The Metacenter

14. Define in terms of  $K$ ,  $B$ , and  $G$  and show on a diagram:
- Transverse Metacentric Height ( $GM_T$ )
  - Transverse Metacentric Radius ( $BM_T$ )
15. Using the curves of form for the FFG7, determine its Transverse and Longitudinal Metacentric Heights ( $GM_T$  &  $GM_L$ ) when it is floating at level trim with a mean draft ( $T_M$ ) of 12.4 ft with  $KG = 19$  ft. Why is  $GM_L$  much larger than  $GM_T$ ?

### Section 3.4 Angle of List

16. A small weight is shifted from port to starboard as shown on the figure. Redraw the figure showing the final positions of the center of gravity ( $G$ ), center of buoyancy ( $B$ ), the resultant weight of the ship ( $\Delta_S$ ), the resultant buoyant force ( $F_B$ ), the keel ( $K$ ), the transverse metacenter ( $M_T$ ). Be neat, clearly label, and use a straight edge where possible. Assume the angle of list is small.



17. *USS SIMPSON* (FFG-56) is underway on an even keel at a draft of 16 feet.  $L_{pp} = 408$  ft.  $KG = 20.2$  ft on the centerline. After 4 hours of steaming the ship has burned 10000 gallons (31 LT) of fuel from a service tank located 11 ft port of the centerline, 13 ft above the keel.
- Calculated the new  $KG$  and  $TCG$ .
  - Calculate the ship's angle of list,
  - To refill the service tank, 10000 gallons (31 LT) of fuel are pumped from a storage tank located 5 ft starboard of the centerline, 9 ft above the keel to the port service tank. Determine the ship's metacentric height and angle of list after transferring fuel.
18. *USS NIMITZ* (CVN-68) is underway on an even keel at a draft of 38 feet. The ship's center of gravity is located 36 ft above the keel on the centerline.  $L_{pp} = 1040$  ft. In preparation for flight operations, V4 Division transfers 500000 gallons of JP-5 ( $\rho_{fuel} = 1.616 \text{ lb s}^2/\text{ft}^4$ ) from tanks located 20 ft above the keel, 49 ft starboard of the centerline to tanks located 20 ft above the keel, 45 ft port of the centerline.
- Calculate the ship's angle of list after the fuel transfer.
  - In order to safely move aircraft, the ship cannot have a list greater than 1 degree. In order to return the ship to an even keel, how many tons of salt water ballast must the DCA add to tanks located 65 ft starboard of the centerline?

### Section 3.5 Inclining Experiments

19. a. Given the diagram in question 16 with a small weight shift from port to starboard, derive an expression for the metacentric height ( $GM_T$ ) in terms of the tangent of the list angle ( $\tan \phi$ ), the displacement of the ship ( $\Delta_S$ ), and the moment produced from the weight shift ( $w$ ). The starting line of your derivation should be...

$$TCG_f = \frac{TCG_o \Delta_o - tcg_o w + tcg_f w}{\Delta_f}$$

(Note: A derivation is a series of steps that someone should be able to follow logically to the conclusion. Show this derivation in detail.)

- What is the goal of doing an inclining experiment?
- Show and explain how the equation derived in part "a" is used to obtain the stated goal of the inclining experiment in part "b".
- Where does the value  $KM$  come from and what are the units?
- What is  $KM$  a function of?

20. The following data was taken on an inclining experiment:

Ship: LCS-1

Level trim, draft = 14 ft in the light ship condition

Inclining gear weighs 28 LT and is loaded 43 ft from the keel on the centerline

<u>Inclining moment</u>	<u>List Angle</u>
880 ft-LT (stbd)	2.3 deg stbd
528 ft-LT (stbd)	1.2 deg stbd
0	0.2 deg port
528 ft-LT (port)	1.5 deg port
880 ft-LT (port)	2.3 deg port

Determine the location of the ship's vertical center of gravity in the light ship condition.

### Section 3.6 Longitudinal Trim Problems

21. A ship has a forward draft of 20 feet and an after draft of 21.6 feet. What is the trim, both magnitude and direction? What is the mean draft?
22. *USS OLIVER HAZARD PERRY* (FFG-7) is preparing to enter drydock for overhaul. The ship is currently at a draft of 14 ft.  $KG = 21.5$  ft on the centerline.  $L_{pp} = 408$  ft. To enter drydock the ship must be trimmed 9 inches by the stern.
- To maintain the ship's stability, the mean draft cannot change. What must be done to achieve the desired trim condition?
  - To achieve the desired amount of trim, it is decided to transfer fresh water ballast from a tank located 106 ft forward of amidships to a tank located 75 ft aft of amidships. How many LT of water must be transferred?
23. *USS ARLEIGH BURKE* (DDG-51) is originally in level trim at a draft of 21.00 ft. 180 LT of equipment are moved from a position 90 feet aft of amidships to a position 100 feet fwd of amidships.  $KG$  is 23.82 feet, and the length is 466 feet. Draw a diagram showing the weight shift, longitudinal center of flotation, and the initial and final waterlines to find:
- Final forward and after drafts
  - Final mean draft



24. *USS FREEDOM* (LCS-1) is floating at a draft of 13.5 feet with zero trim. Ship length is 324 feet. 500 LT are added at a location 122 feet aft of amidships. Draw a diagram showing the location of the weight added, the parallel sinkage, the final longitudinal center of flotation and the initial and final waterlines to find:
- Final forward and after drafts
  - Final mean draft
25. CVN-68 is underway on an even keel at a draft of 38 ft.  $L_{pp} = 1,040$  ft and  $KG = 36$  ft. In preparation for flight operations, the following aircraft are moved forward a distance of 800 ft: 2 F-14 (69,000 lb each), 3 F-18 (48,000 lb each), and 1 E-2 (50,000 lb). Construct an appropriate trim diagram and determine the following:
- Final drafts at the forward and aft perpendiculars.
  - The Air Boss desires that the ship return to an even keel. To achieve this, the DCA must transfer salt water between two ballast tanks located 650 ft apart. How many LT of ballast must be transferred to return the ship to an even keel?
26. An FFG-7 class ship is sitting on an even keel at a draft of 15.5 ft.  $L_{pp} = 408$  ft, and the ship's center of gravity is 19.5 ft above the keel. 63 LT are removed from a location 24 feet aft of amidships. Construct a trim diagram and determine the ship's final draft at the forward and aft perpendiculars.
27. An LCS-1 class ship is pierside with a forward draft of 14.0 ft and an aft draft of 15.0 ft.  $L_{pp} = 324$  ft. 70 LT of equipment is added 132 ft forward of amidships. Using an appropriate diagram, determine the ship's final drafts at the FP and AP.
28. A DDG-51 class ship is floating on an even keel at a draft of 21 ft.  $L_{pp} = 465$  ft. During a yard period, 230 LT is removed from a location 57 ft forward of amidships, 5 ft above the keel, and 5 ft port of centerline.
- How has the weight removal affected  $KG$ ,  $TCG$ , and  $LCG$ ?
  - Construct a trim diagram and determine the ship's final draft at FP and AP.
29. *USS RANIER* (AOE-7) is underway on an even keel at a draft of 38 ft.  $KG = 33$  ft on the centerline.  $L_{pp} = 734$  ft. During a day of UNREP, 750000 gallons of F-76 and JP-5 are transferred from tanks located on the centerline, 19 ft above the keel, and 225 ft aft of amidships to ships of an ARG. ( $\rho_{fuel} = 1.616$  lb  $s^2/ft^4$ )
- How many tons of fuel was transferred to the ARG?
  - What is the new  $KG$  of the ship after UNREP?
  - Using an appropriate diagram determine the ship's forward, aft, and mean drafts following the UNREP.

# COURSE OBJECTIVES

## CHAPTER 4

### 4. STABILITY

1. Explain the concepts of righting arm and righting moment and show these concepts on a sectional vector diagram of the ship's hull that is being heeled over by an external couple.
2. Calculate the righting moment of a ship given the magnitude of the righting arm.
3. Read, interpret, and sketch a Curve of Intact Statical Stability (or Righting Arm Curve) and draw the sectional vector diagram of forces that corresponds to any point along the curve.
4. Discuss what tenderness and stiffness mean with respect to naval engineering.
5. Evaluate the stability of a ship in terms of:
  - a. Range of Stability
  - b. Dynamic Stability
  - c. Maximum Righting Arm
  - d. Maximum Righting Moment
  - e. Angle at which Maximum Righting Moment Occurs
6. Create a Curve of Intact Statical Stability for a ship at a given displacement and assumed vertical center of gravity, using the Cross Curves of Stability.
7. Correct a GZ curve for a shift of the ship's vertical center of gravity and interpret the curve. Draw the appropriate sectional vector diagram and use this diagram to show the derivation of the sine correction.
8. Correct a GZ curve for a shift of the ship's transverse center of gravity and interpret the curve. Draw the appropriate sectional vector diagram and use this diagram to show the derivation of the cosine correction.
9. Determine the initial slope of the GZ curve using Metacentric Height.
10. Analyze and discuss damage to ships, including:
  - a. Use added weight method to calculate ship trim, angle of list and draft
  - b. Qualitatively discuss lost buoyancy method
  - c. Navy Damage Stability Criteria for ships

11. Analyze and discuss free surface effects, including:
  - a. Consequences of free surface on overall ship stability
  - b. Ways to limit the effects of free surface
  - c. Calculate the effective metacentric height
  - d. The meaning of a negative metacentric height and show this condition on a sectional vector diagram of the ship's hull.
  - e. Correct the GZ curve

## 4.1 Introduction

In the last chapter we studied hydrostatics of a displacement ship. In that chapter there were only two internally produced forces and no external forces were considered. The resultant buoyant force and the resultant weight of the ship were in vertical alignment so that no moments were produced. The criteria for static equilibrium were met so that the displacement ship would forever sit motionless until external forces acted on the ship or a weight change occurred.

In this chapter we are concerned with the ability of the ship to remain upright when external forces are trying to roll it over. We are mostly concerned with the transverse movement or heeling because it is nearly impossible to tip a ship end to end (longitudinally). Here the resultant weight of the ship is very often not in vertical alignment with the resultant buoyant force so that internal moments are produced.

- First, we will study the general principle of a righting moment for a ship. We will see how the magnitude of the righting moment is a function of the heeling angle.
- Second, we will show how the righting moment is affected by changes in the vertical and transverse location of the center of gravity of the ship.
- Third, we will discuss how stability is affected by hull damage and learn ways to model a damaged ship.
- Fourth, we will study the effects of free surface (fluids in less than full tanks or compartments) on the righting moment.
- Finally, we will show the effects of a negative metacentric height on the stability of ship.

## **4.2 The Internal Righting Moment Produced by a Heeling Ship**

Understanding overall stability comes down to understanding how the relative positions of the resultant weight of the ship and the resultant buoyant force change when a ship is heeled over by an external moment or couple.

### **4.2.1 The External Couple**

The external couple can be caused by the action of wind pushing on one side of the ship, trying to translate the ship in that direction, and the water pushing back on the hull in the opposite direction. The resultant forces from these two distributed forces would be acting parallel to the water's surface. The resultant wind force would be above the water and the resultant water force would be below the water. Thus the two resultant forces would not be aligned. They would form an external couple or moment causing the ship to rotate. A good analogy can be made by picturing a steering wheel -- the wind is pushing at the top of the steering wheel and the water is pushing in the opposite direction at the bottom. The steering wheel will rotate when acted upon by these unbalanced forces. Refer to Figure 4.1.

### **4.2.2 The Internal Couple**

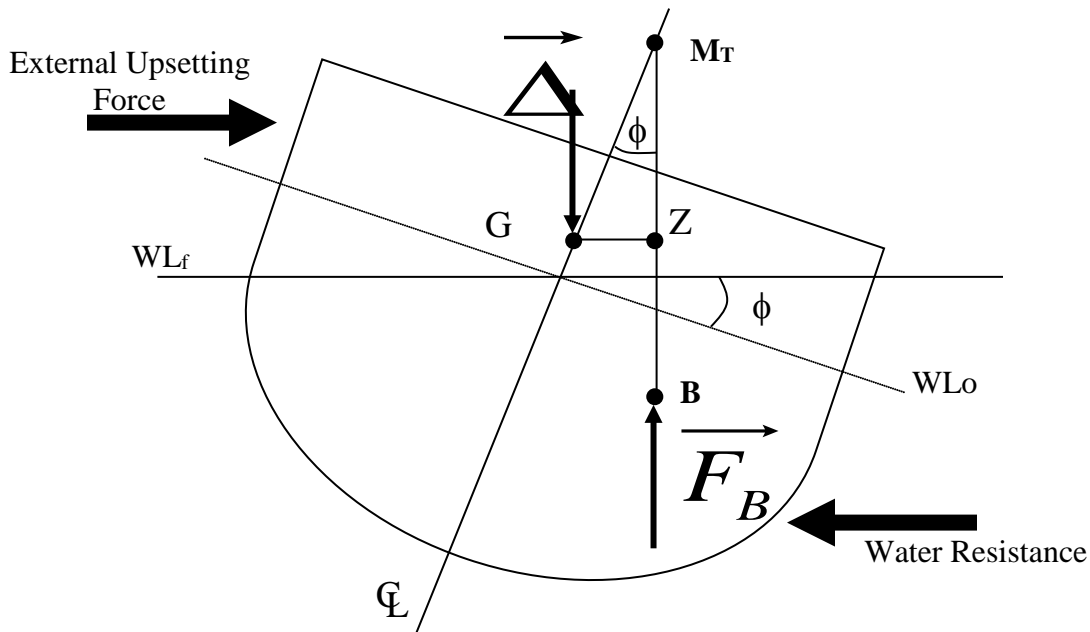
A ship will also tend to rotate when acted upon by wind and water. However, as the ship heels over due to an external moment it also develops an internal moment. The internal moment acts in response to the external moment and in the opposite rotational direction. If the internal and external moments balance the ship will stay heeled at that angle of inclination, otherwise it will keep heeling until the ship capsizes.

To understand how the ship develops an internal moment, consider how the relative positions of the resultant weight of the ship and the resultant buoyant force change as the ship is heeled over.

The resultant weight of the ship acts vertically downward at the center of gravity. Only changes in the distribution of weight affect the location of the center of gravity. If no weight changes occur then no shifts in the center of gravity will occur.

The resultant buoyant force acts vertically upward at the center of buoyancy. The center of buoyancy is located at the centroid of the underwater volume of the ship. When the ship is heeled over by an external moment the underwater shape changes and thus the centroid moves. Where the center of buoyancy moves with respect to the center of gravity defines the stability characteristics of the ship as the ship is heeled over.

Figure 4.1 shows the sectional view of a ship that is being heeled over due to an external moment. It shows the relative positions of the center of gravity and center of buoyancy for a ship that has been designed properly. Notice the perpendicular distance between the lines of action of the resultant weight and resultant buoyant force. This distance is the "righting arm" (GZ).



**Figure 4.1** Heeled Ship due to an External Moment

ⓘ You should be able to draw Figure 4.1 without the use of your notes.

To find the internal righting moment multiply the righting arm by the magnitude of the resultant weight of the ship (or the magnitude of the resultant buoyant force since the magnitude of these forces are equal). The equation below shows this relationship.

$$RM = \overline{GZ} \Delta = \overline{GZ} F_B$$

where: RM is the internal righting moment of the ship (LT-ft)  
 $\Delta_S$  is the displacement of the ship (LT)  
 $F_B$  is the magnitude of the resultant buoyant force (LT)  
 GZ is the righting arm (ft) which is the perpendicular distance between the line of action of the resultant buoyant force and the resultant weight of the ship. This distance is a function of the heeling angle.

### 4.3 The Curve of Intact Statical Stability

Figure 4.1 is only a snapshot of the total stability picture. We are really interested in how Figure 4.1 changes as the ship is heeled over from zero degrees to large enough angles of heel to make the ship capsize. To help us conceptualize this process, a graph of heeling angle (degrees) versus righting arm (GZ) is constructed. This graph is called the “curve of intact statical stability” or the “Righting Arm Curve”.

The curve of intact statical stability assumes the ship is being heeled over quasi-statically in calm water. Quasi-static means that the external moment heeling the ship over is doing so in infinitely small steps so that equilibrium is always present. Of course this is impossible, but it is an acceptable idealization in the modeling of ship stability. Be sure to realize that the predictions made by the curve of intact statical stability can not be directly applied to a rolling ship in a dynamic seaway. The dynamics of such a system, including the application of additional external forces and the presence of rotational momentum, are not considered in the intact statical stability curve. However, the intact statical stability curve is useful for comparative purposes. The stability characteristics of different hull shapes can be compared as well as differences in operating conditions for the same hull type.

Figure 4.2 shows a typical intact statical stability curve. When the ship is in equilibrium with no outside forces acting on it, the resultant weight of the ship will be vertically aligned with the resultant buoyant force. As an external moment heels the ship to port or starboard, the resultant weight and the resultant buoyant force will become out of vertical alignment creating the righting arm. The righting arm will obtain a maximum value and then decrease until the resultant weight of the ship and the resultant buoyant force are again in vertical alignment. Heeling any further will cause the ship to capsize. See Figure 4.3.



You should be able to draw Figure 4.2 without the use of your notes and to draw the sectional vector diagram of forces (as shown by Figure 4.3) that corresponds to any point along the curve on Figure 4.2.

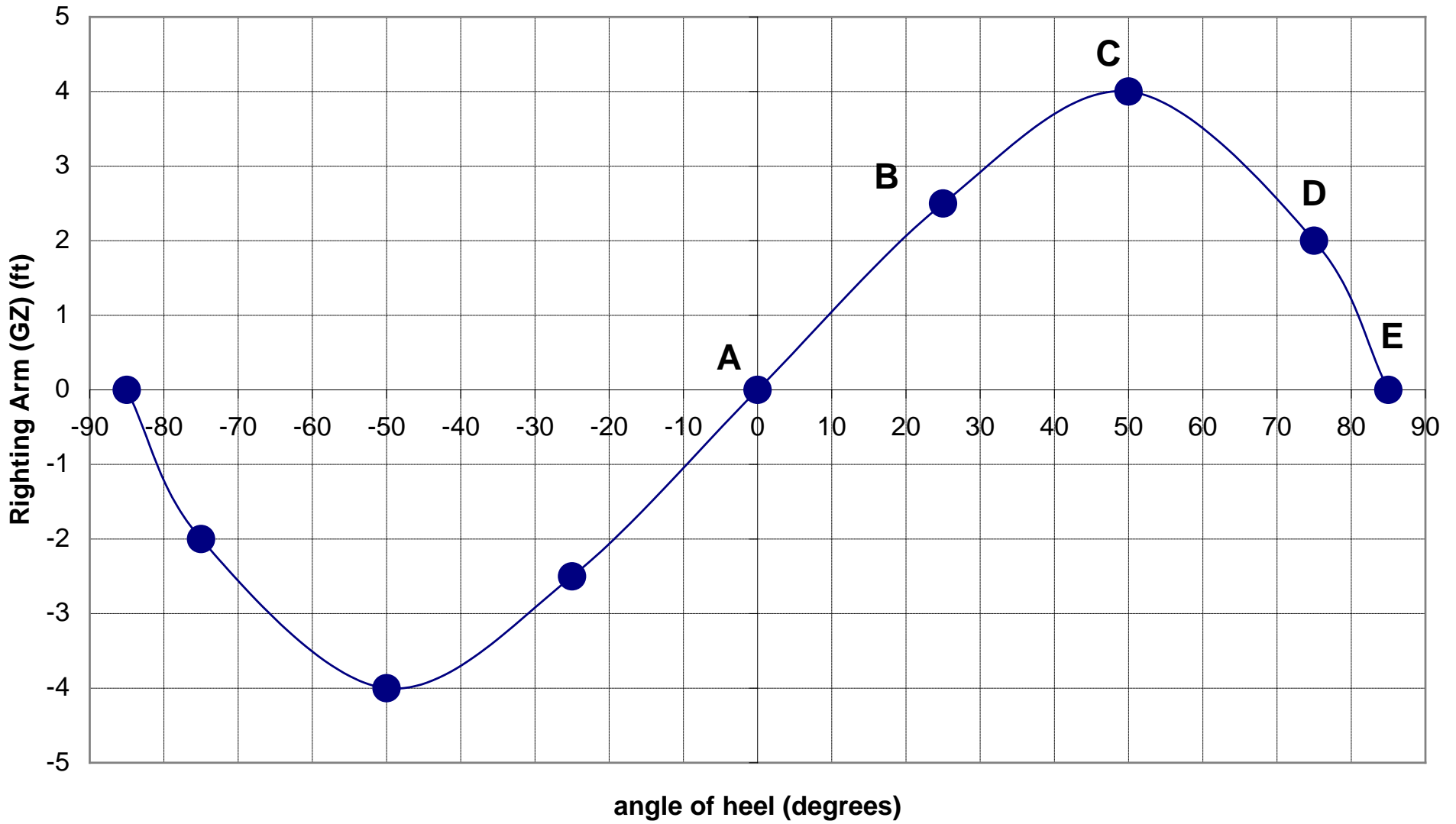
Typically only the starboard side of the intact statical stability curve is shown. The entire curve is shown in Figure 4.2 to give the entire picture of the statical stability curve. Notice how the port side is drawn in quadrant 3 since angles to port are assigned a negative and righting arms to port are assigned a negative. This is only a convention used to distinguish between port and starboard heeling.

Each intact statical stability curve is for a given displacement and given vertical center of gravity. The process of obtaining the actual intact statical stability curve is done by reading values off the “cross curves of stability” for a given displacement of the ship, and then making a sine correction to account for the proper vertical location of the center of gravity of the operating ship. You will learn about the sine correction later in this chapter.

# Curve of Intact Statical Stability General Shape

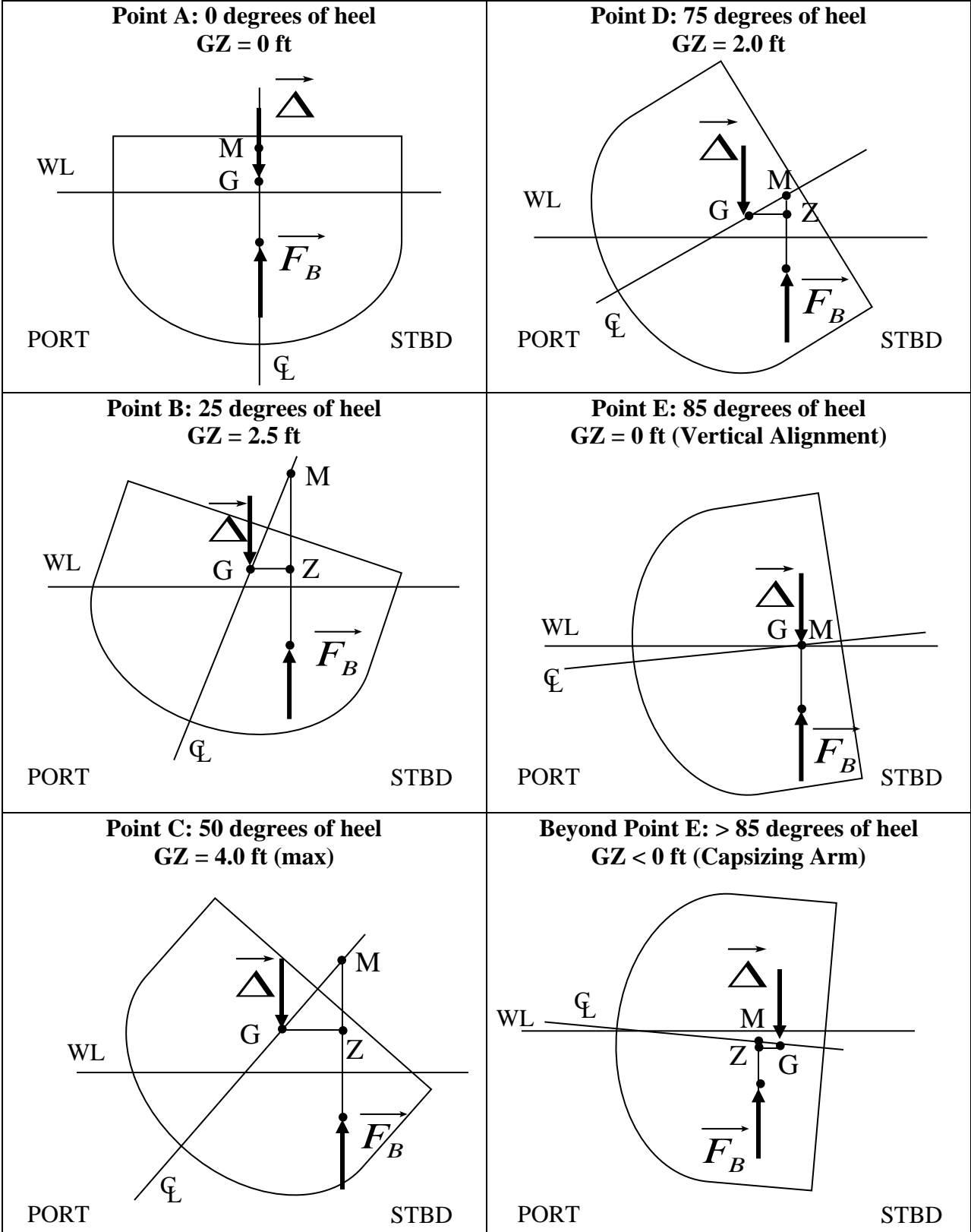
**PORT HEELS**

**STBD HEELS**



**Figure 4.2** Curve of Intact Statical Stability





**Figure 4.3** Vector Drawings Associated with Figure 4.2

### 4.3.1 Cross Curves of Stability

The cross curves of stability are a series of curves on a single set of axes. The X-axis is the displacement of the ship in LT. The Y-axis is the righting arm of the ship in feet. Each curve is for one angle of heel. Typically angles of heel are taken each 5 or 10 degrees. Figure 4.4 is a set of cross curves for the FFG-7. There are cross curves for some of the more common ships used in the Navy in the ship data section.

The entire series of curves assumes an arbitrary location for the vertical center of gravity of the ship. Sometimes the assumed location of the center of gravity is at the keel. This may seem strange to you at first but it makes sense when you consider the following. The actual location of the center of gravity of the ship will always be above the keel. This means that the sine correction can always be subtracted from the value read off the cross curves. Otherwise, the sine correction would sometimes be subtracted and sometimes be added. The actual location of the assumed value of the center of gravity of the ship will always be marked on the cross curves.

The cross curves are made by a series of integrations based on hull geometry. You had a hint of this in Chapter 2. It is beyond the scope of this course to explain in detail how the cross curves are derived from the basic geometry of the hull.

In summary, the intact static stability curve, for a single displacement, comes from reading values off the cross curves of stability and using a sine correction for the actual location of the vertical center of gravity.



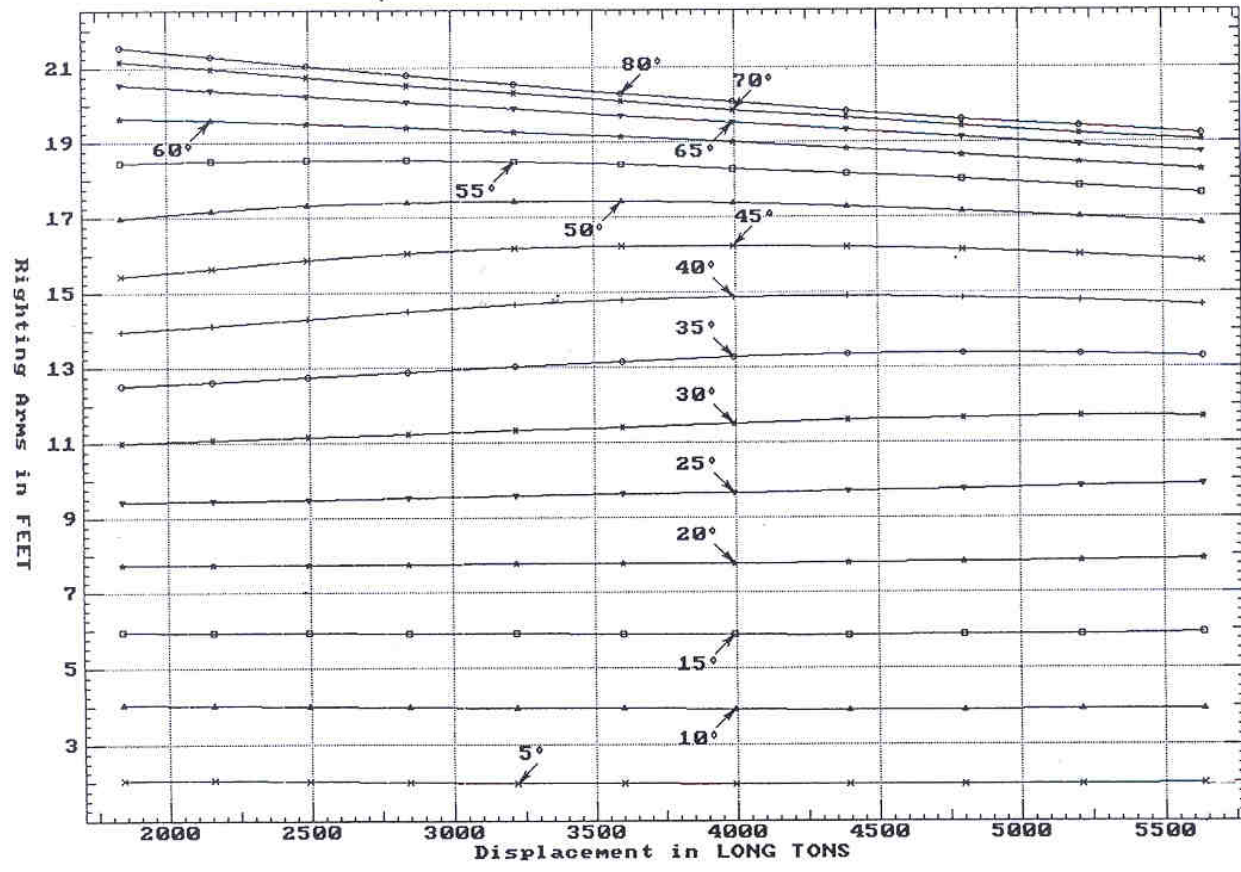
Be able to sketch a set of cross curves with fictitious numbers without the use of your notes.

**Student Exercise:** On a separate piece of paper draw an intact static stability curve for a FFG-7 displacing 4000 LT. Assume the FFG-7 has a  $KG=0$  so that a sine correction is unnecessary.

This is unrealistic, but for now you are learning how to read values off the cross curves to construct the intact static stability curve. Later in this chapter you will learn how to do the sine correction to account for the actual location of the vertical center of gravity of the ship.

Insert this page in your notes.

CROSS CURVES OF STABILITY - Stbd Heel  
at LEVEL TRIM (initial)

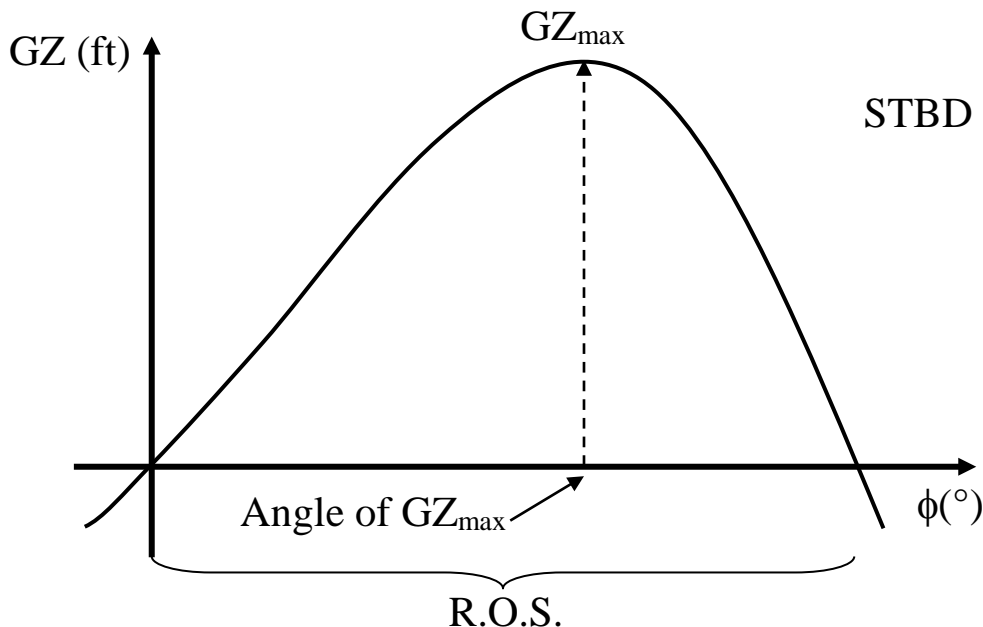


Specific Gravity = 1.025    Assumed KG = 0.00 FT  
"K" = Base Plane

**Figure 4.4** Cross Curves of Stability for FFG-7

#### 4.4 Obtainable Stability Characteristics from the Curve of Intact Statical Stability

Several overall stability characteristics can be obtained from the curve of intact statical stability. A simplified GZ curve diagram is shown below in Figure 4.5:



**Figure 4.5** The Simplified Intact Statical Stability Curve depicting select stability characteristics

##### 4.4.1 Range of Stability (R.O.S.)

This is the range of angles for which there exists a righting moment. The range starts at the angle corresponding to the ship's equilibrium position with no external moments applied to it and goes to the angle at which the ship will capsize. For a ship with no initial angle of list the starting angle would be zero degrees. If the ship has a permanent angle of list, then the range is given from that angle of list to the capsizing angle of the heeled side.

*In Figure 4.2 the Range of Stability is*      *0 - 85 degrees for stbd heels*  
    *0 - 85 degrees for port heels*

The greater the range of stability, the less likely the ship will capsize. If the ship is heeled to any angle in the range of stability, the ship will exhibit an internal righting moment that will right the ship if the external moment ceases.

##### 4.4.2 Maximum Righting Arm (GZ<sub>max</sub>)

This is the largest internal moment arm created by the vertical mis-alignment of the buoyant force and the resultant weight vectors. It is simply measured as the peak of the curve of intact statical stability.

*In Figure 4.2 the Maximum Righting Arm is 4.1 ft*

#### **4.4.3 Maximum Righting Moment**

This is the largest static moment the ship can produce. It is simply calculated from the product of the ship's displacement ( $\Delta_s$ ) by the maximum righting arm ( $GZ_{max}$ ). The units are LT-ft.

The larger the value of the maximum righting moment the less likely the ship will capsize. The maximum righting moment can't be shown directly on the curve of intact statical stability. Only the maximum righting arm can be shown. However, there is only a scaling difference between the righting arm and righting moment.

#### **4.4.4 Angle of $GZ_{max}$**

This is the angle of heel at which the maximum righting moment occurs. Beyond this angle the righting moment decreases to zero.

*In Figure 4.2 the Angle of  $GZ_{max}$  is 50 degrees*

It is desirable to have this angle occur at large degrees of heel so that a rolling ship will experience a righting moment that increases in magnitude over a greater range of heeling angles.

#### **4.4.5 Dynamic Stability**

This is the work done by quasi statically (very slowly) rolling the ship through its range of stability to the capsizing angle. Mathematically, this work is,

$$\Delta_s \int GZ d\phi$$

This is the product of the ship's displacement with the area under the curve of intact statical stability. The units are LT-ft. The dynamic stability can't be shown directly on the curve of intact statical stability but the area under the curve can be shown.



The work represented by dynamical stability is not necessary representative of the work required to capsize a ship in a real seaway. This is because the statical stability curve does not account for rotational momentum, or additional forces that may be present on a real ship in a seaway. It is useful for a comparative basis with other ships or ships of the same type under different operating conditions.

#### **4.4.6 A Measure of the Tenderness or Stiffness**

The initial slope of the intact statical stability curve indicates the rate at which a righting arm is developed as the ship is heeled over.

If the initial slope is large, the righting arm develops rapidly as the ship is heeled over and the ship is said to be “stiff.” A stiff ship will have a short period of roll and react very strongly to external heeling moments. The ship will try to upright itself very quickly and forcefully. If the ship is too stiff, violent accelerations can damage ship structures and be harmful to personnel.

If the initial slope is small, the righting arm develops slowly as the ship is heeled over and the ship is said to be “tender”. A tender ship will have a long period of roll and react sluggishly to external heeling moments. Too tender of a ship can compromise stability and leave too little margin for capsizing.

## 4.5 The Effects of a Vertical Shift in the Center of Gravity of the Ship on the Righting Arm ( GZ ): Sine Correction

We have already seen that the Curve of Intact Statical Stability can be created from the Cross Curves of Stability. However, the Cross Curves assume a value for KG (regularly KG = 0 ft). To obtain the true Righting Arm Curve, the values from the cross curves must be corrected for the true vertical location of G. This is achieved using the sine correction.

There are 2 instances when the sine correction is necessary.

- Correcting the Curve of Intact Statical Stability for the true vertical location of G.
- Correcting the Curve of Intact Statical Stability for changes in KG.

The theory behind the sine correction can be seen by an analysis of Figure 4.5. It is obvious from the Figure that a rise in KG decreases the righting arm. If  $G_v$  is the final vertical location of the center of gravity, and  $G_0$  is its initial location, then the value of  $G_v Z_v$  at each angle of heel may be found using the following relationship:

$$G_v Z_v = G_0 Z_0 - G_0 G_v \sin \phi$$

where:  $G_v Z_v$  is the righting arm created by the final center of gravity (ft).  
 $G_0 Z_0$  is the righting arm created by the initial center of gravity (ft).  
 $G_0 G_v$  is the vertical distance between  $G_0$  and  $G_v$  (ft).  
 $G_0 G_v \sin \phi$  is the sine correction term (ft).

This equation should be evident from Figure 4.5 by examining the right angled triangle  $G_0 P G_v$  and by observing that the distance  $G_v Z_v$  is the same as the distance  $P Z_0$ .

$$G_v Z_v = P Z_0 = G_0 Z_0 - G_0 P \text{ and } G_0 P = G_0 G_v \sin \phi$$

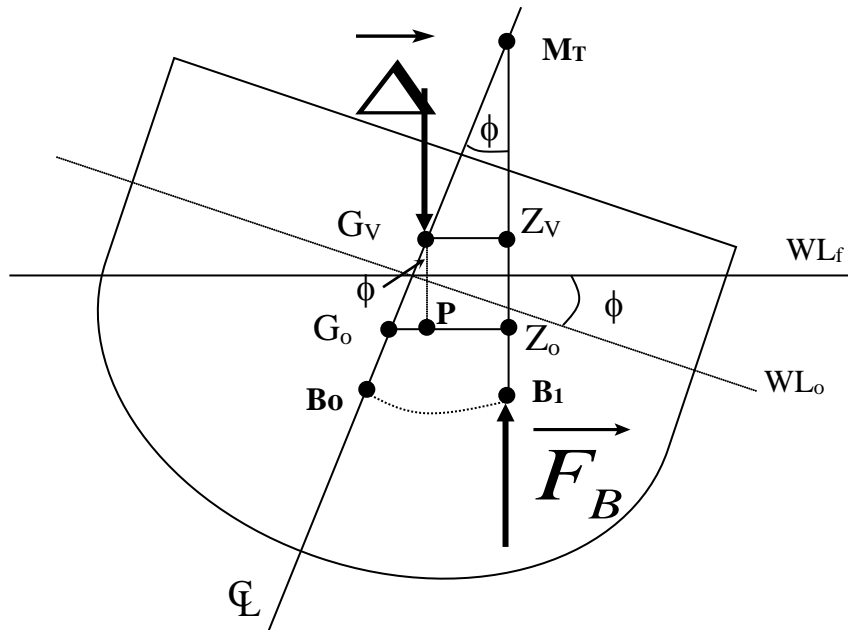
$$\Rightarrow G_v Z_v = G_0 Z_0 - G_0 G_v \sin \phi$$

or:

$$\overline{GZ}_{final} = \overline{GZ}_{initial} - \delta \overline{KG} \sin \phi$$

ⓘ Students must be able to draw Figure 4.5 and be able to derive the sine correction from this Figure.

A similar analysis to Figure 4.6 should reveal that the sine correction term must be added if KG is reduced.



**Figure 4.6** The Sine Correction Derivation

In this Figure, the following segments are defined:

$WL_0$  is the original waterline

$WL_f$  is the new waterline

$G_0Z_0$  is the righting arm prior to a shift in the center of gravity

$G_VZ_V$  is the righting arm after a shift in the center of gravity

$B_1$  is the center of buoyancy after the ship lists

$B_0$  is the center of buoyancy before the ship lists



**Example 4.1** Draw the intact statical stability curve for the DDG51 assuming a displacement of 8600 LT and a vertical center of gravity of 23.84 ft above the keel. Graph both  $G_0Z_0$  and  $G_vZ_v$  values as a function of heeling angle on the intact statical stability curve. The cross curves for the DDG51 are located in the ship data section.

Solution: The general form of the sine correction at each angle is

$$G_vZ_v = G_0Z_0 - 23.84 \sin \phi.$$

For instance, at 20 degrees:

$$G_vZ_v = 10.10 - 23.84 \sin (20) = 1.95 \text{ ft.}$$

However, it is often more convenient to use a table.

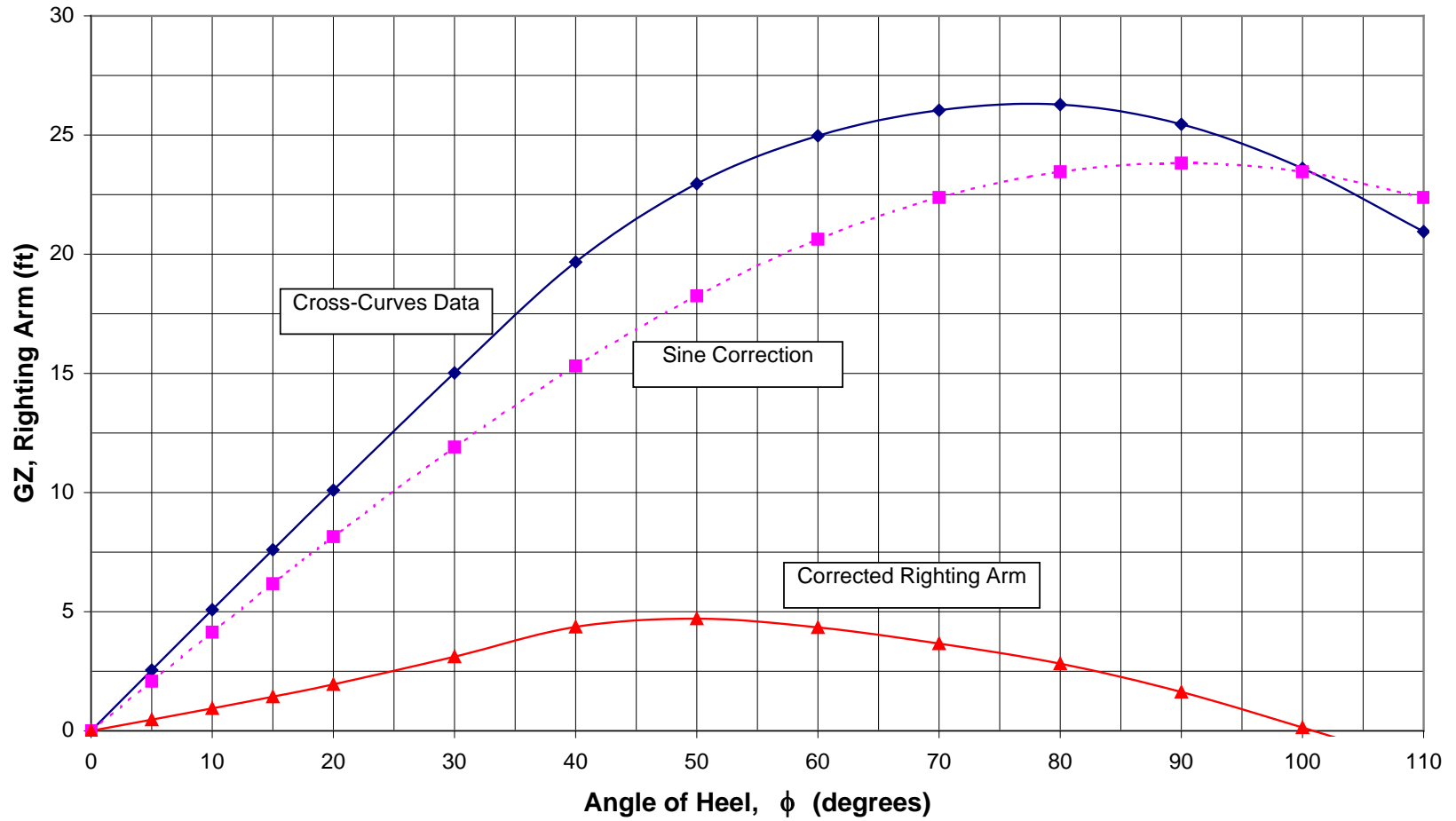
Angle of Heel, $\phi$ (degrees)	0	5	10	15	20	30	40
Righting Arm from Cross Curves, $G_0Z_0$ (ft)	0	2.55	5.08	7.60	10.10	15.02	19.67
Sine Correction Term (ft)	0	2.08	4.14	6.17	8.15	11.91	15.31
Corrected Righting Arm, $G_vZ_v$ (ft)	0	0.47	0.94	1.43	1.95	3.11	4.36

Angle of Heel, $\phi$ (degrees)	50	60	70	80	90	100	110
Righting Arm from Cross Curves, $G_0Z_0$ (ft)	22.96	24.97	26.04	26.28	25.45	23.60 (given)	20.95 (given)
Sine Correction Term (ft)	18.25	20.63	22.38	23.46	23.82	23.46	22.38
Corrected Righting Arm, $G_vZ_v$ (ft)	4.71	4.34	3.66	2.82	1.63	0.14	-1.43

When plotted, these new  $G_vZ_v$  values will give a Curve of Intact Statical Stability for DDG51 which is correct for a displacement of 8600 LT and  $KG = 23.84$  ft. If displacement changes, then new  $G_0Z_0$  values must be obtained from the Cross Curves and corrected for  $KG$ . If  $KG$  changes, then a sine correction can be made between 23.84 ft and the new value of  $KG$ .

# Example 4.1 - Statical Stability Curve

DDG-51 @ 8600 LT, KG = 23.84 ft.



## 4.6 The Effects of a Transverse Shift in the Center of Gravity of the Ship on the Righting Arm ( GZ ): Cosine Correction

The stability analysis so far has considered the center of gravity on the centerline, or TCG = 0 ft. We saw in Chapter 3 that the center of gravity may be moved off the centerline by weight additions, removals, or shifts such as cargo loading, ordinance firing, and movement of personnel. When this occurs, there is an effect upon the stability of the ship.

The effect upon stability of a transverse shift in G can be calculated using the cosine correction.

There are 2 instances when the cosine correction is necessary.

- Correcting the Curve of Intact Statical Stability for the true transverse location of G.
- Correcting the Curve of Intact Statical Stability for changes in TCG.

An analysis of Figure 4.7 showing a shift in the transverse location of G from the centerline enables the cosine correction to be quantified. The new righting arm may be computed at each angle using the following equation.

$$G_t Z_t = G_v Z_v - G_v G_t \cos \phi$$

*or*

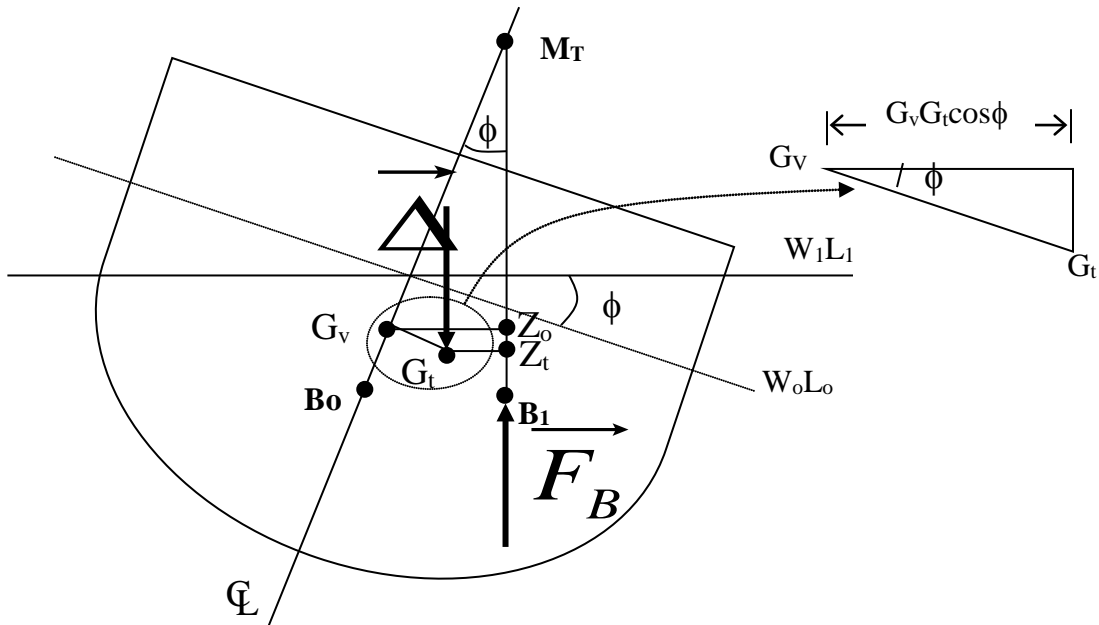
$$\overline{GZ}_{final} = \overline{GZ}_{initial} - \delta TCG \cos \phi$$

where: $G_t Z_t$	is the corrected righting arm (ft)
$G_v Z_v$	is the uncorrected righting arm (ft)
$G_v G_t$	is the transverse distance from the centerline to the center of gravity (ft)
$G_v G_t \cos \phi$	is the cosine correction term (ft)

This equation should be evident from Figure 4.7 by examining the enlarged right angled triangle at the top of the Figure.



Students must be able to draw Figure 4.7 and be able to derive the cosine correction from this Figure.



**Figure 4.7** The Cosine Correction Derivation



The new righting arm ( $G_t Z_t$ ) created due to the shift in the transverse center of gravity is smaller than the righting arm created if the transverse center of gravity had not been moved ( $G_0 Z_0$ ).

*However*, if heeling to port was considered the righting arm would increase. A similar diagram to Figure 4.7 can show that for the opposite side to the weight shift, the cosine correction is added to give the corrected righting arm.

**Example 4.2** For a DDG51 with a displacement of 8600 LT, a vertical location of the center of gravity of 23.84 ft from the keel, and a transverse location of the center of gravity of 0.4 feet to the starboard of centerline, graph the intact statical stability curve.

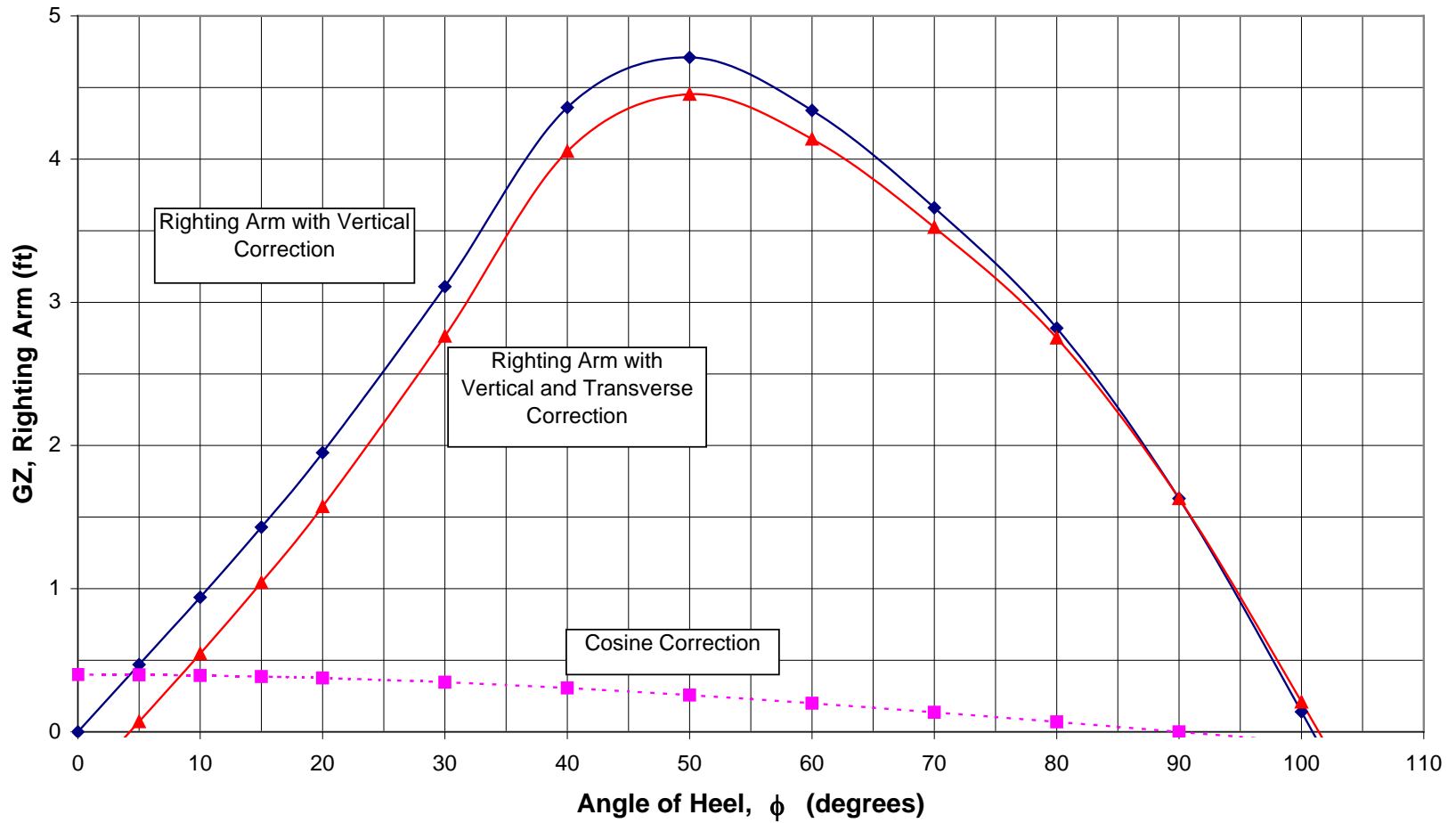
Solution: (First four rows are from Example 4.1)

Angle of Heel, $\phi$ (degrees)	0	5	10	15	20	30	40
Righting Arm from Cross Curves, $G_0Z_0$ (ft)	0	2.55	5.08	7.60	10.10	15.02	19.67
Sine Correction, (ft)	0	2.08	4.14	6.17	8.15	11.91	15.31
Vertically Corrected Righting Arm, $G_vZ_v$ (ft)	0	0.47	0.94	1.43	1.95	3.11	4.36
<b>Cosine Correction, (ft)</b>	<b>0.40</b>	<b>0.40</b>	<b>0.39</b>	<b>0.39</b>	<b>0.38</b>	<b>0.35</b>	<b>0.31</b>
<b>Transversely Corrected Righting Arm, <math>G_tZ_t</math> (ft)</b>	<b>-0.40</b>	<b>0.07</b>	<b>0.55</b>	<b>1.04</b>	<b>1.57</b>	<b>2.76</b>	<b>4.05</b>

Angle of Heel, $\phi$ (degrees)	50	60	70	80	90	100	110
Righting Arm from Cross Curves, $G_0Z_0$ (ft)	22.96	24.97	26.04	26.28	25.45	23.60	20.95
Sine Correction, (ft)	18.25	20.63	22.38	23.46	23.82	23.46	22.38
Vertically Corrected Righting Arm, $G_vZ_v$ (ft)	4.71	4.34	3.66	2.82	1.63	0.14	-1.43
<b>Cosine Correction, (ft)</b>	<b>0.26</b>	<b>0.20</b>	<b>0.14</b>	<b>0.07</b>	<b>0</b>	<b>-0.07</b>	<b>-0.14</b>
<b>Transversely Corrected Righting Arm, <math>G_tZ_t</math> (ft)</b>	<b>4.45</b>	<b>4.14</b>	<b>3.52</b>	<b>2.75</b>	<b>1.63</b>	<b>0.21</b>	<b>-1.29</b>

## Example 4.2 - Statical Stability Curve

DDG-51 @ 8600 LT, KG = 23.84 ft., TCG = 0.4 ft.



The following should be considered, regarding transverse weight shifts:

- As in the case of a vertical increase in the center of gravity, a horizontal shift away from centerline results in worsened stability characteristics on the side to which G moves. This should be evident from the example.
- A horizontal shift results in improved stability characteristics on the side opposite to which G moves. This can explain the need to lean out when attempting to prevent a small sailing craft from capsizing.
- Capsizing. It is interesting to note that, according to the curves calculated, the ship will capsize at a greater angle with G off of the centerline. In reality, the ship will capsize before the angle at which  $GZ = 0$  ft in any case. These curves do not account for the fact that at extreme angles non-watertight parts of the hull and superstructure will be immersed (in particular the gas turbine exhaust stacks), allowing water to enter the ship resulting in a capsize 10 - 20 degrees earlier than predicted by these curves. Also, at extreme angles equipment is likely to move within the ship, further decreasing stability.

**Student Exercise:** Figure 4.8 is a statical stability curve for the DDG-51 with a 0.4 ft starboard shift in the center of gravity with a displacement of 8600 LT and a KG of 23.84 ft. Fill in Figure 4.8 on the following page with the sectional diagrams for each of the points indicated on Figure 4.7. In your diagrams include G, B,  $\Delta_S$ ,  $F_B$ , etc.

(This is similar to Figure 4.2, but this time there is a transverse shift in the center of gravity.)

# Curve of Intact Statical Stability

DDG-51 @ 8600 LT, KG = 23.84 ft., TCG = 0.4 ft.

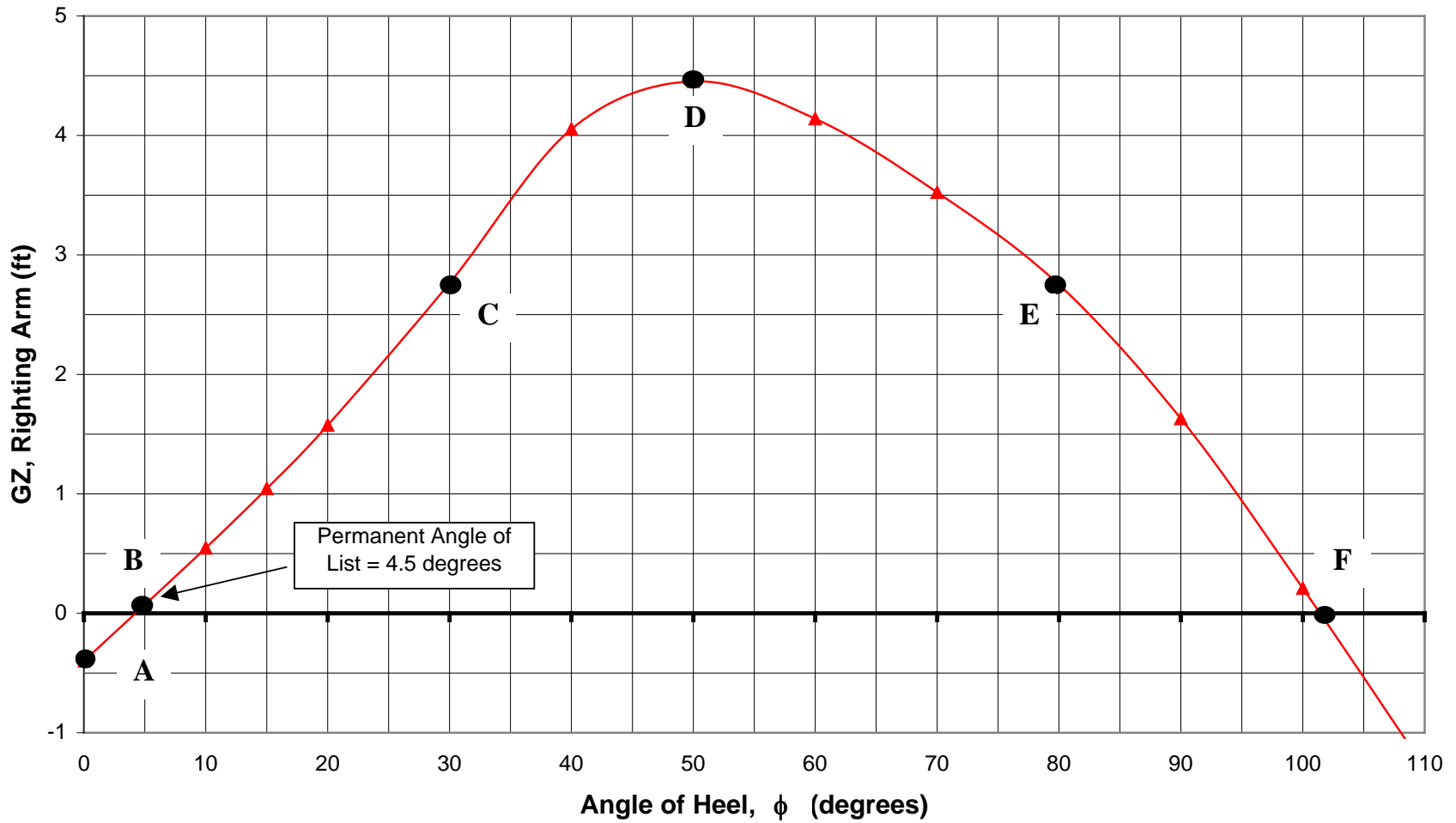


Figure 4.8 Curve of Intact Statical Stability for Student Exercise



<b>Point A</b> - 0 degrees of heel	<b>Point B</b> - 4.5 degrees of heel
<b>Point C</b> - 30 degrees of heel	<b>Point D</b> - 50 degrees of heel
<b>Point E</b> - 80 degrees of heel	<b>Point F</b> - 102 degrees of heel

**Figure 4.9** Vector Diagrams Associated with Figure 4.7

## **4.7 Damage Stability**

Naval ships are intended to go in harms way. When the shooting starts the object is to do harm to others, but sometimes damage to your ship is unavoidable. If the watertight portion of the hull is breached and water pours into the ship, the draft will increase, the trim will change, a permanent angle of list will result, and stability will be affected. In extreme circumstances the ship could be lost.

This section discusses the fundamental behavior of a damaged ship and introduces two techniques that allow its analysis.

- The Lost Buoyancy Method.
- The Added Weight Method.

The lost buoyancy method will be discussed only briefly. However, the added weight method will be covered in a little more depth. You will be required to perform simplified damaged ship calculations using the added weight method.

US Navy Damage Stability standards will also be covered so that you will have some idea how your ship will respond, and how much it is designed to take.

### **4.7.1 Lost Buoyancy Method**

One method to examine the behavior of a damaged ship is by the lost buoyancy method. In the lost buoyancy method we analyze changes in buoyancy rather than the center of gravity or displacement. Simply stated, the center of gravity remains the same (the ship weight, metal etc is constant) and any changes due to damage effect the distribution of the buoyancy volume. The total buoyant volume must remain constant since the weight of the ship is not changing. The draft will increase and the ship will list and trim until the lost buoyant volume is regained.

The lost buoyancy method allows a damaged ship to be modeled mathematically so that the final drafts, list, and trim can be determined from assessed damage. The engineer can analyze every conceivable damage scenario and produce a damage stability handbook that may be used by the crew in the event of flooding. Using the lost buoyancy method allows “a prior” knowledge of the resulting stability condition of the ship so that appropriate procedures can be written and followed in the event of a breach in the ship’s hull.

### **4.7.2 The Added Weight Method**

Another method of examining the damaged ship is with the “Added Weight” method. As the name suggests, in this technique, the ship is assumed undamaged, but part of it is filled with the water the ship is floating in. This is equivalent to a weight addition and can be modeled using the techniques for shifts in the center of gravity of the ship (G) covered in Chapter 3.

Provided the volume of the damaged compartment, its average location from the centerline, Keel & midships and the water density is known, the shift in G can be predicted along with the consequences of this shift upon the draft, trim and list of the ship.

#### 4.7.2.1 Permeability

An added complication to the analysis of a damaged ship is the space available in a damaged compartment for the water to fill.

When a compartment is flooded, it is rare for the total volume of this compartment to be completely filled with water. This is because the compartment will already contain certain equipment or stores depending upon its use. The ratio of the volume that can be occupied by water to the total gross volume is called the “permeability”.

$$\text{Permeability} = \frac{\text{volume available for flooding}}{\text{total gross volume}} = \mu$$

For calculating the affected volume,

$$V_{\text{actual}} = V_{\text{total}} \cdot (\mu)(\% \text{ Flooded})$$

The table below from “Basic Ship Theory - 4th Edition” by Rawson & Tupper lists some typical ship compartment permeabilities.

Space	Permeability (%)
Watertight Compartment (Warship)	97
Watertight Compartment (Merchant Ship)	95
Accommodation Spaces	95
Machinery Compartments	85
Dry Cargo Spaces	70
Bunkers, Stores or Cargo Holds	60

We should now be in a position to perform simple added weight damage calculations.

**Example 4.3** An FFG-7 displacing 3992 LT and of length 408 ft has KG = 18.5 ft, TCG = 0 ft. It is floating in sea-water at level trim with a draft of 16.0 ft. At this draft, TPI = 33.0 LT/in, MT1" = 793.4 LT-ft/in and LCF = 24.03 ft aft of midships.

A collision causes the complete flooding of the auxiliary machinery space. This space has a volume of 6400 ft<sup>3</sup>, permeability of 85% and a centroid on the centerline, 6.6 ft above the keel and 30ft fwd of midships.

Calculate:

- a. The KG in the damaged condition.

- b. TCG in the damaged condition.  
 c. The  $T_{fwd}$  in the damaged condition.

Solution:

a.  $Volume\ available\ for\ flooding = permeability \times volume = 0.85 \times 6400\ ft^3 = 5400\ ft^3$

$Weight\ of\ water\ in\ compartment = \rho g (flooded\ volume)$

$$= 1.99 \frac{lb-s^2}{ft^4} \cdot 32.17 \frac{ft}{s^2} \cdot 5400\ ft^3 \cdot \frac{1\ LT}{2240\ lb} = 155\ LT$$

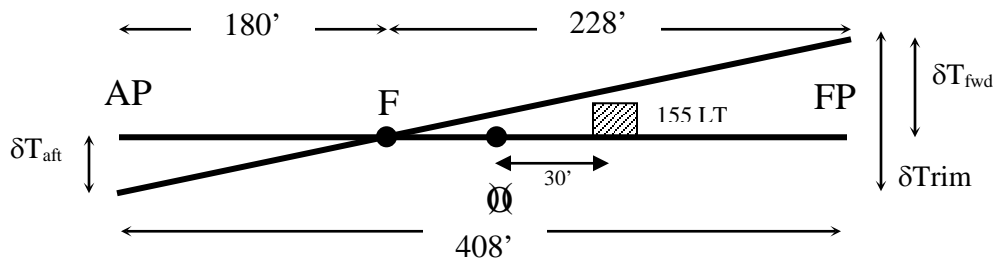
$$KG_{damaged} = \frac{KG_{old} \Delta_{old} + w_{flooding} kg}{\Delta_{damaged}}$$

$$KG_{damaged} = \frac{3992\ LT \cdot 18.5\ ft + 155\ LT \cdot 6.6\ ft}{3992 + 155\ LT}$$

$$KG_{damaged} = 18.06\ ft$$

b.  $TCG_{damaged} = TCG_{old} = 0\ ft$  (Damaged compartment centroid is on centerline)

c.



$$\delta T_{trim} = \frac{wl}{MTI''} = \frac{155\ LT \cdot (24 + 30)\ ft}{793.4\ ft\ LT / in} \cdot \frac{1\ ft}{12\ in} = 0.88\ ft$$

$$\delta T_{ps} = \frac{w}{TPI} = \frac{155\ LT}{33.0\ LT / in} \cdot \frac{1\ ft}{12\ in} = 0.39\ ft$$

From the trim diagram

$$\frac{\delta T_{fwd}}{d_{fwd}} = \frac{\delta T_{trim}}{L_{pp}}$$

$$\delta T_{fwd} = d_{fwd} \frac{\delta T_{trim}}{L_{pp}} = 228\ ft \frac{0.88\ ft}{408\ ft} = 0.49\ ft$$

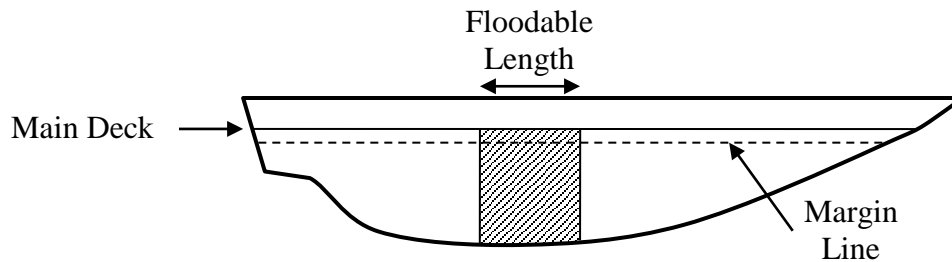
So:

$$T_{fwd\ damaged} = T_{fwd,old} + \delta T_{ps} + \delta T_{fwd}$$

$$T_{fwd\ damaged} = 16.0\ ft + 0.39\ ft + 0.49\ ft$$

$$T_{fwd\ damaged} = 16.88\ ft$$

### 4.7.3 US Navy Damage Stability Design Criteria



**Figure 4.10** Illustration of Damage Stability Terms

**Margin Line** The margin line is a line defining the highest permissible location on the side of the vessel of any damaged waterplane in the final condition of sinkage, trim and heel. It is in no case permitted to be less than 3 inches (0.075 m) below the top of the bulkhead deck at the side. (PNA pp178)

**List** The heel caused by damage shall not exceed 20 degrees. This angle is too great for continuous operation of equipment. Naval machinery is designed to operate indefinitely at a permanent list of 15 degrees, although most equipment will probably remain functional up to about 25 degrees for at least a few hours. Personnel can continue damage control efforts effectively at a permanent list of 20 degrees. At a permanent list of 20 degrees, the ship will possess adequate stability against wind and waves to be towed at the very least.

#### ***Floodable Length***

1. Ships less than 100 ft long are required to withstand flooding in one compartment.
2. Ships 100 - 300 ft long are required to withstand flooding in any two adjacent compartments.
3. Warships, troop transports and hospital ships over 300 ft long are required to withstand a hull opening of 15 % of the length between perpendiculars.
4. Any other ship over 300 ft long are required to withstand a hull opening of 12.5% of the length between perpendiculars.

### 4.7.4 Foundering and Plunging

A damaged ship could be lost in one of several ways.

- If the ship is left with inadequate maximum righting moment or dynamical stability, it could simply be overwhelmed by the seaway and the weather.

- If the angle of list or trim is too great, placing non-watertight parts of the ship underwater, then additional flooding will occur. In this case the ship could lose transverse stability, roll over and capsize.
- Longitudinal stability could also be lost in a similar manner causing the ship to plunge (go down bow or stern first). One of the most notable examples of plunging is the *Titanic*.
- A ship may be lost even if stability is not compromised. It may simply sink. This is called *foundering*.



The preceding discussion concerned ships which were in a static condition, meaning that the damage had occurred and the ship was in equilibrium. From the time damage occurs until equilibrium is reached the ship is in a very vulnerable state. The water rushing into the ship and the sudden changes in effective volume cause a number of dynamic effects in the face of reduced stability.

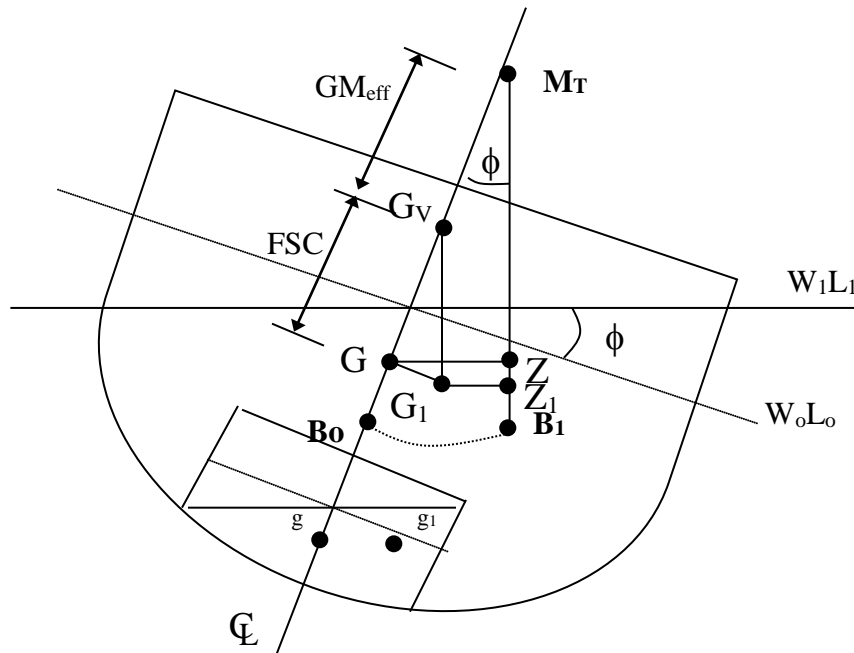
In some cases it is useful to flood a tank on the side of the ship opposite the damage in order to reduce the angle of list and lower KG. This is called *counter flooding*. However, counter flooding can be very dangerous.

Counter flooding results in an increase in displacement, causing ship's draft to increase. The increase in draft results in a loss of freeboard and a reduction in the angle of heel at which the deck edge will go underwater. The increase in displacement may also make the ship deeper than its limiting draft, which may cause further stability and structural problems. Additionally, if counter flooding is not done correctly, the possibility exists of adding an additional free surface to the ship, a very serious stability problem.

## 4.8 Free Surface Correction at Small Angles of Heel

A free surface is fluid that is allowed to move freely, such as water in a partially filled tank. As the ship lists, the fluid in the tank moves. The fluid movement acts like a weight shift, causing the center of gravity of the fluid to move which causes the ship's center of gravity to shift in both the vertical and horizontal directions. The effect of the vertical shift is negligible at small angles ( $\phi < 5^\circ$  to  $7^\circ$ ) and is discounted, but the horizontal (transverse) shift of the center of gravity causes a decrease in the righting arm (GZ).

It is shown graphically in Figure 4.11 that a vertical rise in the center of gravity also causes a shortened righting arm. The distance the center of gravity would have to rise to cause a reduction in the righting arm equivalent to that caused by the actual transverse shift is called the *Free Surface Correction* (FSC). The position of this new center of gravity is called the "virtual" center of gravity ( $G_v$ ). The distance from the virtual center of gravity to the metacenter is called the *Effective Metacentric Height* ( $GM_{eff}$ ).



Note:  $\phi < 5 - 7$  degrees (list angle in drawing is exaggerated to show geometry)

**Figure 4.11** The Free Surface Correction

### 4.8.1 Static Effects

The static effects of free surface are adverse resulting in a virtual rise in the center of gravity, a smaller range of stability, a smaller maximum righting arm, a small angle at which the maximum righting arm occurs, and an exaggerated list and trim if the ship is listing or trimming.

### 4.8.2 Dynamic Effects

It should be noted that the preceding analysis is referring to only the static effects of free surface. Free surfaces also produce dynamic effects of the water rushing back and forth. This is also detrimental but is not described by the free surface correction. ***It is a common misconception to mix the dynamic effects of free surface with the static analysis and the FSC.***

To understand the dynamic effects fill a Tupperware plastic container half full of water, close it with a lid, and put it in the palm of your hand. Move the container so that it lists and trims. Notice how the geometry affects the magnitude of the roll and momentum of the fluid mass when the container is rolled in a listing condition versus a trimming condition. Another example of the dynamic effect is a fire engine carrying water down the road. If baffles are not put in the tank the truck will literally jump from side to side because of the water moving back and forth. Baffles are a good way to minimize the dynamic effects of free surface.

### 4.8.3 Calculating the FSC and $GM_{eff}$

The free surface correction (FSC) created by a tank within a ship is given by the following equation:

$$FSC = \frac{\rho_t i_t}{\rho_s \nabla_s}$$

where:  $\rho_t$  is the density of the fluid in the tank (lb-s<sup>2</sup>/ft<sup>4</sup>)  
 $\rho_s$  is the density of the water the ship is floating (lb-s<sup>2</sup>/ft<sup>4</sup>)  
 $\nabla_s$  is the underwater volume of the ship (ft<sup>3</sup>)  
 $i_t$  is the transverse second moment of area of the tank's free surface area (ft<sup>4</sup>)

The formula for  $i_t$  is given on the next page.

Note: “Tank” is used synonymously with “compartment” or “space” when discussing/calculating FSC for damage stability.

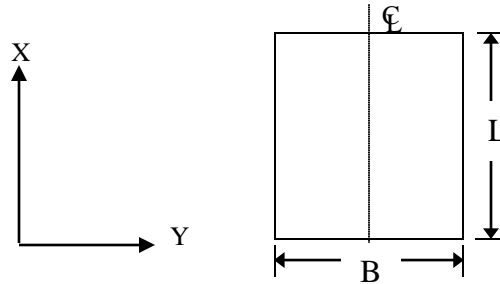


### 4.8.3.1 The Second Moment of Area ( $i_t$ )

The formula for the second moment of area of a rectangle is given by the following equation. The distances refer to Figure 4.12.

$$i_t = \frac{(\text{length})(\text{width})^3}{12}$$

$$i_t = \frac{l \cdot b^3}{12}$$



**Figure 4.12** Tank Geometry for FSC

The free surface correction is applied to the original metacentric height to find the effective metacentric height:

$$\overline{GM}_{eff} = \overline{GM} - FSC = \overline{KM} - \overline{KG} - FSC$$

### 4.8.4 Minimizing the Effects of Free Surface

- **Compartmentalization:** A quick observation of the equation for  $i_t$  and FSC above should reveal that splitting a tank transversely with dividers running longitudinally will reduce the distance B and consequently have a major effect upon the magnitude of the FSC.
- **Pocketing:** Tanks should be kept at least 90% full so that pocketing occurs. Pocketing is when the liquid hits the top of the tank thus reducing the free surface effects. Pocketing therefore is a desirable physical event.
- **Compensated Fuel Oil Tanks:** Some ships use a water compensated fuel oil system to minimize the free surface effect (a small FSC remains due to the density difference between oil and seawater). This system replaces used fuel with salt water so no free surface occurs. The salt water is immiscible with the oil so no mixing occurs. Typically at least two tanks are used so that the boundary between salt water and the oil always stays one tank away from the engine. The intermediate tank is often referred to as a *clean fuel oil tank*. These types of tanks are used on CG-47, DDG-51, and nuclear submarines (shielding).
- **Empty Tanks:** Obviously, the FSC is reduced completely if the tanks are empty!



Flooding aboard a ship can create compartments with free surface. This can affect the stability of the ship. Flooding can be caused by fire fighting as well as breaches in the hull. Putting fires out by a fire hose can add weight high in the ship and create free surface. Both of these will cause a rise in the center of gravity, smaller righting arms and less overall stability.

**Example 4.4** An FFG-7 class ship displacing 4092 LT has  $KG=18.9$  ft and  $KM=22.49$  ft. There is a tank filled with fuel oil with a density of  $1.5924 \text{ lb-s}^2/\text{ft}^4$  creating a free surface 30 ft wide and 60 ft long. The ship is floating in salt water with a density of  $1.9905 \text{ lb-s}^2/\text{ft}^4$ . What is the effective metacentric height?

Solution:

$$\Delta_s = \rho g \nabla_s$$

$$\nabla_s = \frac{\Delta_s}{\rho g} = \frac{4092 \text{ LT} \cdot 2240 \text{ lb} / \text{LT}}{1.9905 \text{ lb-s}^2 / \text{ft}^4 \cdot 32.17 \text{ ft} / \text{s}^2} = 143,143 \text{ ft}^3$$

$$i_t = \frac{l \cdot b^3}{12} = \frac{60 \text{ ft} \cdot (30 \text{ ft})^3}{12} = 135,000 \text{ ft}^4$$

$$FSC = \frac{\rho_t i_t}{\rho_s \nabla_s}$$

$$FSC = \frac{1.5924 \text{ lb-s}^2 / \text{ft}^4 \cdot 135,000 \text{ ft}^4}{1.9905 \text{ lb-s}^2 / \text{ft}^4 \cdot 143,143 \text{ ft}^3} = 0.75 \text{ ft}$$

$$\overline{GM}_{eff} = \overline{KM} - \overline{KG} - \overline{FSC}$$

$$\overline{GM}_{eff} = 22.49 \text{ ft} - 18.9 \text{ ft} - 0.75 \text{ ft}$$

$$\overline{GM}_{eff} = 2.84 \text{ ft}$$

#### 4.8.5 Effect of a Free Surface on GZ and Angle of List

As discussed earlier in this section, and shown in Figure 4.9, a free surface causes a reduction in the ship's righting arm, range of stability, and dynamic stability. With a free surface, the ship now behaves as if the center of gravity were located at the virtual center of gravity. To calculate the effective righting arm of a ship with a free surface, the original righting arm must be corrected for the virtual rise in G caused by the free surface. Fortunately, you already have the tool with which to make this correction: the sine correction. Using Figure 4.9 as a guide, the effective righting arm of a ship may be given as:

$$\overline{G_1 Z_1} = \overline{GZ} - \overline{GG_v} \sin \phi \quad \text{or} \quad \overline{G_1 Z_1} = \overline{GZ} - \overline{FSC} \sin \phi$$

The worst case for a free surface is when the ship's transverse center of gravity is located off of the centerline. Section 4.6 demonstrated that a transverse shift in G resulted in a reduction in the

righting arm and overall stability. A free surface coupled with G being off the centerline is an especially bad case. Not only has the overall stability been reduced by the transverse location of G, but the effective rise in G due to the free surface further reduces righting arms, range of stability, and dynamic stability. To correct the righting arm curve for a free surface and a transverse change in G, one must first correct  $GZ$  for the virtual rise in G caused by the free surface using the sine correction, then correct  $GZ$  for the transverse location of G using the cosine correction. This correction is given by the following equation:

$$\overline{G_1Z_1} = \overline{GZ} - FSC \sin \phi - TCG \cos \phi$$

A free surface will also exaggerate a list angle. Recall from Chapter 3 that the angle of list for a transverse change in the center of gravity can be found by:

$$\phi = \tan^{-1} \left( \frac{TCG}{GM_T} \right)$$

When a free surface is present, the angle of list is now found using:

$$\phi = \tan^{-1} \left( \frac{TCG}{GM_{eff}} \right)$$

**Example 4.5** The FFG-7 in Example 4.4 has a righting arm of 1.33 feet at a heeling angle of  $20^\circ$  and  $KG = 18.9$  ft. What is the effective righting arm of the ship with the free surface present?

From Example 4.4:  $KM = 22.49$  ft,  $GM_{eff} = 2.84$  ft,  $FSC = 0.75$  ft

Solution:

$$\begin{aligned} \overline{GZ}_{eff} &= \overline{GZ} - FSC \sin \phi \\ \overline{GZ}_{eff} &= 1.33 \text{ ft} - (0.75 \text{ ft})(\sin 20) \\ \overline{GZ}_{eff} &= 1.07 \text{ ft} \end{aligned}$$

If the ship's transverse center of gravity is located 0.5 ft starboard of the centerline, calculate the ship's righting arm and angle of list.

$$\begin{aligned} \overline{GZ}_{eff} &= \overline{GZ} - FSC \sin \phi - TCG \cos \phi \\ \overline{GZ}_{eff} &= 1.33 \text{ ft} - (0.75 \text{ ft})(\sin 20) - (0.5 \text{ ft})(\cos 20) \\ \overline{GZ}_{eff} &= 0.60 \text{ ft} \end{aligned}$$

Notice the effect of the transverse location of G on the ship's righting arm!

$$\phi = \tan^{-1} \left( \frac{TCG}{GM_{eff}} \right)$$

$$\phi = \tan^{-1} \left( \frac{0.5 \text{ ft}}{2.84 \text{ ft}} \right)$$

$$\phi = 9.98^\circ$$

#### 4.8.6 – Damage Control and its Effect on Stability and Buoyancy

Naval and commercial ships are designed to resist varying degrees of accidental and battle damage. Design features to mitigate or prevent damage include structural strength members (Chapter 6), watertight compartments, and the stability and buoyancy criteria discussed in this chapter. Maintaining these features at their optimum capabilities requires a constant state of vigilance which you will be partly responsible for whether you are the Damage Control Assistant (DCA) in charge of most of the maintenance on these systems and training the crew or an embarked Marine ensuring that the watertight door you just passed through is shut and dogged.



Conventional wisdom says that 90 percent of the damage control needed to save the ship takes place before the ship is damaged (training, drills, inspection, and maintenance) and only 10 percent can be accomplished after the damage has occurred.

However, once damage has occurred the damage control efforts on the ship are a vitally important all-hands evolution which may often mean the difference between losing or saving the ship:

##### USS Cole (DDG-67), Gulf of Aden, Yemen, 2000

*USS Cole* suffered a large hole in its side while refueling in the harbor as a result of a terrorist attack. The explosion ripped through one of the ship's engine rooms and resulted in massive amounts of flooding, a severe list, and loss of electrical power (i.e. no electric bilge pumps). Three days of valiant damage control efforts by the crew kept the ship afloat in the harbor. Damage control methods ranged from judicious use of *counter-flooding* to "bucket-brigades" bailing water out of flooded spaces.

##### RMS Titanic, 1912

The "practically unsinkable" ship had a two/three compartment standard with many watertight compartments to minimize the effects of flooding but rapid crack propagation in the brittle hull plating led to *progressive flooding* in six adjacent watertight compartments. This flooding alone would eventually sink the ship; however, experts estimate that the ship could have stayed on the surface several hours longer than it did had the crew plugged the cracks in the hull which were only several inches wide with mattresses or some other material. These vital hours could have been long enough to allow the deployment of lifeboats in an orderly fashion and for help to arrive.

SS Normandie, 1942

This ship caught fire in New York City harbor while being converted from a luxury passenger liner to a troop transport to support the war effort. The resulting firefighting efforts from off-hull led to massive weight additions high on the upper decks and large free-surfaces inside the ship. After the fire was extinguished, the ship capsized in calm water pier side as a result of the negative stability introduced by the free-surface and vertical weight shift. This would have been avoided had the ship been *de-watered* following the fire.

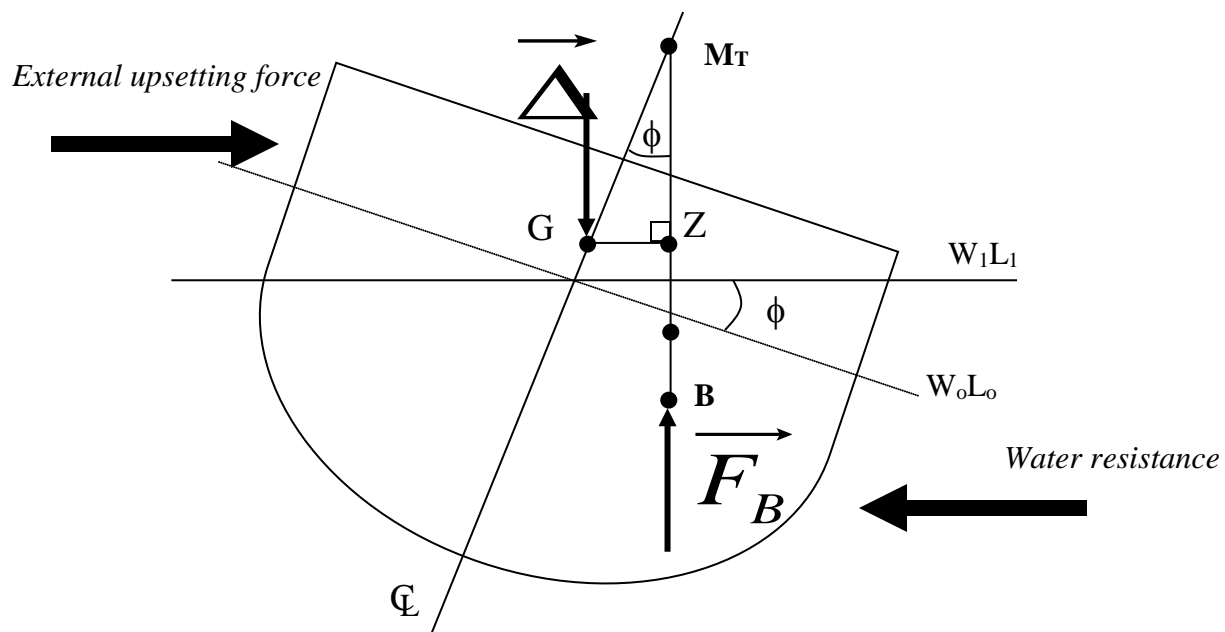
## 4.9 Metacentric Height and the Curve of Intact Statical Stability

So far in this chapter we have considered the overall stability of a ship through all angles by creating and analyzing the curve of intact statical stability. However, in chapter 3 we often used the quantity called the metacentric height (GM), the distance from the center of gravity (G) to the metacenter (M). We also stated that the metacentric height was a measure of a ship's initial stability, its ability to remain upright at small angles. Clearly, there must be some link between GM and the curve of intact statical stability.

⚠ Recall, that when G is below M, the metacentric height is considered to be positive and when G is above M it is considered to be negative.

### 4.9.1 The Link Between GM and the Righting Arm Curve

The link can be determined from an analysis of Figure 4.13 showing a ship heeling at small angles.



**Figure 4.13** A Ship Heeling at Small Angles

At small angles, the right angled triangle (G, Z, M) reveals the following equation for the righting arm.

$$\overline{GZ} = \overline{GM} \sin \phi$$

In the limit as  $\phi$  approaches 0 radians, where the metacenter is defined, the expression may be simplified to  $GZ = GM \phi$  if the angle is given in radians. This is because

$$\sin \phi = \phi \quad (\text{in radians})$$

Using this, at small angles the equation above becomes:

$$\overline{GZ} = \overline{GM} \phi$$

$$\overline{GM} = \frac{\overline{GZ}}{\phi}$$

The smallest angle that can be achieved is zero radians = zero degrees. Consequently, the magnitude of GM is equal to the magnitude of the initial slope of the Curve of Intact Statical Stability.

Hence the link between GM and the righting arm curve has been established. We will now examine three different ship conditions.

- A ship with positive GM
- A ship with zero GM
- A ship with negative GM



To find the magnitude of the initial slope on the curve of intact statical stability construct two lines and use the intersection of those two lines to determine the magnitude off the “y-axis”. The first line is a line tangent to the slope at zero degrees of heel. The statical stability curve must run through zero for this technique to work. If it doesn’t go through zero you can draw a parallel line to the tangent line to the slope that does go through zero and proceed with the rest of the steps. The second line is a vertical line at one radian or 57.3 degrees. Where these two lines cross, read over horizontally to the “y-axis” the value of the righting arm. This will be the magnitude of GM.

#### 4.9.2 A Positive Metacentric Height (GM)

This is the ship condition that all the stability examples have been worked with so far. The center of gravity is below the metacenter so that as soon as the ship heels, a righting arm will begin to develop.

Figure 4.14 shows the configuration of the centroids for a ship with positive GM and a typical curve of intact statical stability created by this configuration. The ship has one position where it is static equilibrium which is at zero degrees of heel (provided TCG = 0 ft).

The stability condition is analogous to a marble rolling in a dish. A displacement of the marble to the left or right will result in the marble rolling back to its central stable position. It is in a state of positive stability.

#### 4.9.2.1 Tenderness, Stiffness and the Magnitude of GM

Figure 4.14 also shows the way the magnitude of GM affects the shape of the righting arm curve.

- Large positive GM creates a curve with a steep slope passing through zero degrees of heel. This creates a “stiff” ship, a ship that develops a large righting arm very quickly - the ship is very stable.
- Small positive GM creates a curve with a shallow slope passing through zero degrees of heel. This creates a “tender” ship that develops a righting arm very slowly - the ship is not very stable.

The subject of stiffness versus tenderness will be covered in greater detail when the seakeeping properties of a ship are discussed in chapter 8.

#### 4.9.3 Zero Metacentric Height (GM)

A ship with zero metacentric height is a very rare ship condition. It is where the center of gravity (G) coincides with the ship metacenter (M), there is zero distance between the two points.

Figure 4.14 shows this configuration. It is clear that at small angles of heel, the lines of action of the weight of the ship and the buoyant force remain in vertical alignment. Consequently there is no internal couple created to return the ship to zero degrees of heel. So if the external upsetting force is removed, the ship will remain at this angle!

This condition can be represented by the righting arm curve at Figure 4.12. At small angles of heel to port and starboard, there is zero righting arm developed. The shape of this curve also reaffirms the initial slope being equivalent to the magnitude of GM.

$$\overline{GM} = 0 \Rightarrow \text{Initial slope} = 0 \Rightarrow \overline{GZ}(\phi) \text{ is a horizontal line}$$

Consequently, there is a range of angles of heel where the ship is in static equilibrium.

The condition is analogous to a marble rolling on a flat surface. A displacement of the marble to the left or right will cause the marble to remain in this new position. It is in a state of neutral stability.



Once the ship heels beyond small angles of heel, the movement of M causes a misalignment between the buoyant force and the weight of the ship and a righting arm is developed. However, the curve is very tender.

#### **4.9.4 A Negative Metacentric Height (GM)**

A ship with a negative metacentric height has its center of gravity (G) above its metacenter (M). This condition can be created whenever weight shifts, removal or additions significantly elevate G.

Figure 4.12 shows the ship in this condition. As soon as the ship moves beyond zero degrees of heel, the misalignment of the buoyant force and ship's weight vectors tend to help the external upsetting force and continue to roll the ship. The ship is initially unstable.

The righting arm curve for the ship in this condition is also shown at Figure 4.12. Notice that the slope of the curve is negative at zero degrees of heel, supporting the negative value of GM. This condition is analogous to a marble rolling on an upturned bowl. A displacement of the marble to the left or right will cause the marble to continue to roll away from its initial position. It is in a state of negative stability.

##### **4.9.4.1 Lolling**

At larger angles of heel, the movement of M causes a righting arm to develop that opposes the roll motion. The curve of intact statical stability in Figure 4.12 supports this. This creates 2 angles of heel where the ship is in static equilibrium, one on the port side and one to starboard. When moving in this condition the ship will oscillate between these 2 conditions creating a very unfavorable motion for those on board. This is called Lolling. The 2 angles of heel at which the ship naturally sits are both called the "angle of loll".

Lolling is an unacceptable situation at sea. Often commercial tankers that are empty can have their center of gravity sufficiently elevated to have a negative metacentric height so that lolling occurs. To stop the lolling, the ship can take on ballast low to lower the center of gravity of the ship to obtain a righting moment at small angles.

Navy ships are designed so that lolling should not occur. If it does, it is telling you that something is wrong operationally and the cause should be determined. If a ship with a negative metacentric height is not lolling it will at least have an initial list.

Metacentric Height (GM)	Section Cut Vector Diagram	Curve of Intact Statical Stability GZ (ft) vs. $\phi$ (deg)	Marble Analogy
Positive		<p>Slope = GM (+)</p>	
Neutral		<p>Slope = GM = 0</p>	
Negative		<p>Slope = GM (-)</p>	

Figure 4.14 Positive, Neutral, and Negative Metacentric Height

#### 4.9.5 Summary

It is critically important to remember that overall ship stability can never be assessed by the sign and magnitude of the metacentric height (GM) alone. The overall measures of statical stability were discussed in Section 4.4. They were:

- Range of stability
- Dynamic stability
- Maximum righting arm
- Maximum righting moment
- The Angle at which the maximum righting moment occurs.

It is incorrect to use GM as the sole yardstick for ship stability. Metacentric Height only indicates whether or not the ship will remain upright over small angles of heel. Additional indicators of ship stability include KG, and draft with respect to limiting draft.

To ensure adequate stability for a ship under all loading conditions every ship has limits on the maximum KG, minimum GM, maximum draft (displacement), and a minimum range of stability. The location of G and ship's displacement with respect to limiting draft can place a ship into one of four distinct stability categories. These categories will determine, for each ship, the amount of weight that can be added or removed from the ship, and the location at which the weight addition or removal may occur.

- Status 1* - The ship has adequate weight and stability margins and a weight change at any height is generally acceptable.
- Status 2* - The ship is close to limiting draft and stability (KG) limits. Any weight increase or rise in G is unacceptable.
- Status 3* - The ship is very close to its stability limit but has adequate weight margin. If a weight change is above the allowable KG value and would cause a rise in G, the addition of solid ballast (lead or concrete) low in the ship may be used to compensate for the weight addition high in the ship.
- Status 4* - An adequate stability margin exists, but the ship is departing port very close to its limiting draft. This condition generally applies to tankers and amphibious landing craft.

## PROBLEMS - CHAPTER 4

### Section 4.2 The Righting Arm

1. Briefly describe why a ship displaying positive stability will return to a condition of static equilibrium after being subjected to an external upsetting moment. Use a diagram in your explanation.
2. A ship has a submerged volume of  $112,000\text{ft}^3$  and a righting arm of 2ft when heeling to 15 degrees. Calculate its righting moment when heeling at this angle.
3. Sketch a diagram showing a positively stable ship heeling to port.

### Section 4.3 The Curve of Intact Statical Stability

4. a. Use the following data to plot the Curve of Intact Statical Stability of a ship for starboard heels only. The data is taken from a ship displacing 3600 LT with a KG of 18.0 ft. Remember to title your plot and label the axis correctly.

Angle of Heel, $\phi$ (degrees)	0	20	40	60	80	100
Righting Arm, GZ (ft)	0.0	1.2	2.8	4.1	2.7	0.0

- b. Use your plot to sketch a diagram of the ship heeling to 30 degrees to starboard. Calculate the righting moment being developed at this angle.
  - c. By observation of your sketch, what would happen to the magnitude of the righting moment calculated in (b), if the center of gravity was raised so that KG increased to 18.5 ft.
5. Using the Cross Curves provided for the FFG7 in the notes, graph the Curve of Intact Statical Stability for FFG7 at a displacement of 3500 LT with  $KG = 0$  ft.

## Section 4.4 Overall Stability Characteristics

6. a. Plot a curve of intact statical stability for starboard heels only for a ship with the following overall stability characteristics.

Overall Stability Characteristic	Value
Range of Stability	0 - 90 degrees
Maximum Righting Arm	3.8 ft
Angle of Maximum Righting Arm	50 degrees
Righting Arm at 30 degrees of heel	2 ft

- b. On your plot in part (a) sketch the curve of intact statical stability for a ship with a stiffer righting arm. Which ship is more stable?
- c. How would you calculate the dynamic stability from your plot in part (a)?

## Section 4.5 Sine Correction

7. A DDG-51 has a displacement of 8,350 LT and  $KG = 21.5$  ft. In this condition it develops a righting arm of 2.1 ft when heeling to 20 degrees.
- a. Use a suitable diagram to derive an equation for the magnitude of the new righting arm if the center of gravity shifted so that  $KG$  increased.
- b. Use the equation you derived and the data above to calculate the magnitude of the new righting arm at 20 degrees of heel if the  $KG$  of the DDG-51 increased to 22.6 ft.
8. Using the Cross Curves provided for the FFG7 in the notes, correct the Curve of Intact Statical Stability for FFG7 at a displacement of 4000 LT for its true  $KG = 19$  ft. Plot its curve of intact statical stability.
- a. What is the Maximum Righting Moment?
- b. What is the Range of Stability?
- c. What is the Angle of  $GZ_{max}$ ?
- d. What happens to the ship if a moment greater than the Maximum Righting Moment is applied?
- e. What happens if the ship rolls to an angle greater than the range of stability?

9. A ship has a displacement of 6250 LT and  $KG = 17.6$  ft. In this condition the ship develops a righting arm of 5.5 ft when heeling to 30 degrees.
- Draw a diagram showing the effect that lowering the center of gravity has on the righting arm. Include on your diagram the old and new locations of G, old and new locations of the center of buoyancy, the metacenter, angle of heel, initial and final righting arms, and displacement and buoyant force vectors.
  - A weight shift causes the ship's center of gravity to be lowered by 1.5 ft. Calculate the ship's righting arm at a heeling angle of  $30^\circ$  after the weight shift.
10. *USS SUPPLY* (AOE-6) is preparing to UNREP its Battle Group. Prior to UNREP the ship was steaming on an even keel at a draft of 38.5 ft. The center of gravity was located 37 ft above the keel.  $L_{pp} = 717$  ft.

When UNREP is complete, AOE-6 has discharged 10000 LT (3.2 million gallons) of F-76 and JP-5 to the Battle Group. The fuel is assumed to have had a center of gravity on the centerline, 25 ft above the keel of AOE-6.

Using the curves of form and cross curves of stability, determine the following:

- Displacement and draft of *SUPPLY* after UNREP.
- Ship's KG and TCG following UNREP
- Compute and plot the righting arm curves for the initial and final conditions of the ship. Do this for starboard heeling angles only. Note: use of a spreadsheet program is encouraged.
- From your results in part (c), complete the following table and comment on the UNREP's effect on stability.

Parameter	Before UNREP	After UNREP
Displacement, $\Delta$ (LT)		
Center of Gravity, KG (ft)		
Maximum Righting Arm, $GZ_{max}$ (ft)		
Angle of $GZ_{max}$ (degrees)		
Range of Stability (degrees)		

## Section 4.6 The Cosine Correction

11. A ship has a displacement of 7250 LT and  $KG = 23.5$  ft on the centerline. At this condition the ship has the following stability characteristics:
- |                       |   |
|-----------------------|---|
| Range of stability:   | $0^\circ - 85^\circ$                    |
| Maximum righting arm: | 5.2 ft at a heeling angle of $50^\circ$ |
- a. What happens to the ship's stability characteristics if the center of gravity is raised?
- b. What happens to the ship's stability characteristics if the center of gravity is lowered?
- c. What happens to the ship's stability characteristics if there is a change in the transverse location of G with no vertical change in G?
12. A DDG-51 has a displacement of 8,350 LT,  $KG = 21.5$  ft and  $TCG = 0$  ft. In this condition it develops a righting arm of 2.1 ft when heeling to 20 degrees.
- a. Use a suitable diagram to derive an equation for the magnitude of the new righting arm if the center of gravity shifted transversely.
- b. Use the equation you derived and the data above to calculate the magnitude of the new righting arm at 20 degrees of heel to starboard if the center of gravity shifts transversely to starboard by 0.5 ft.
13. An LCS1 has a displacement of 3000 LT and  $KG = 14.0$  ft. Use Cross Curves of Stability found in the Ship's Data section.
- a. Plot the Curve of Intact Statical Stability for starboard heels for the ship at  $TCG = 0$  ft. On the same axes, plot a second curve for the LCS1 in the same condition but with  $TCG = 1$  ft.
- b. Compare the two curves. In which condition is the ship more stable?
- c. What is the permanent angle of list when  $TCG = 1.0$  ft?

14. An FFG-7 class ship is underway at a displacement of 3990 LT.  $KM = 22.8$  ft,  $KG = 19.3$  ft,  $L_{pp} = 408$  ft. 9000 gallons (28 LT) of F-76 are transferred from a storage tank located on the centerline, 6 ft above the keel, to a service tank located 6 ft above the keel and 15 ft to port of centerline.
- Determine the ship's TCG after transferring fuel.
  - What is the ship's list angle after the fuel transfer?
  - Draw a diagram of the ship heeling to port. Show the initial and final locations of G and B ( $G_0, G_f, B_0, B_f$ ), initial and final righting arms ( $G_0Z_0, G_fZ_f$ ), metacenter (M), heeling angle ( $\phi$ ), and displacement and buoyant force vectors.
  - Using the cross curve for the FFG-7, calculate and plot for both port and starboard heeling angles, the ship's GZ curve before and after transferring fuel. Use of a spreadsheet program for the computations and plotting is encouraged.

### Section 4.7 Damage Stability

15. A compartment has a volume of  $600 \text{ ft}^3$  and permeability of 90%. How many LT of fresh water would it hold if it were completely full. ( $\rho_{\text{fresh}} = 1.94 \text{ lb-s}^2/\text{ft}^4$ ,  $1 \text{ LT} = 2240 \text{ lb}$ ).
16. The compartment described in Q15 has a centroid 12 ft port of the centerline and 6 ft above the keel and makes up part of a 6000LT ship with  $KG = 22$  ft and  $TCG = 0$  ft. Calculate the damaged KG and TCG if the compartment is flooded by 80 % of its volume with fresh water. ( $\rho_{\text{fresh}} = 1.94 \text{ lb-s}^2/\text{ft}^4$ ,  $1 \text{ LT} = 2240 \text{ lb}$ ).
17. The compartment described in Q15 and 16 has a centroid that vertically aligned with the location of the ship's center of floatation. Calculate the change in trim created by the damage.



18. *USS ROSS (DDG-71)* is underway in the North Atlantic during the winter season. The ship encounters a severe storm which covers the weather decks, superstructure, and masts with a layer of ice 1.5 inch thick. Prior to the storm the ship was on an even keel at a draft of 20.5 ft,  $KG = 21.3$  ft.  $L_{pp} = 465$  ft.

The ice has the following characteristics:

$\rho_{ice} = 56 \text{ lb/ft}^3$	$kg = 68 \text{ ft}$
Area ice covers = $71250 \text{ ft}^2$	$tcg = 0 \text{ ft}$
Ice thickness = 1.5 inches	$l_{cg} = 75 \text{ ft fwd of amidships}$

Using the curves of form and cross curves of stability, determine the following:

- Weight of ice on the ship.
- Ship's  $KG$  after the storm
- Ship's forward, aft, and mean drafts after the storm.
- Metacentric height before and after the storm.
- Calculate and plot the ship's righting arm curve (for starboard heeling angles only) before and after the storm. Use of a computer is encouraged.
- Discuss the effects of ice accumulation of the ship's overall stability. Include in your discussion the effects of ice on ship's trim, metacentric height, range of stability, maximum righting arm, dynamic stability, and stiffness or tenderness.

19. *USS CURTS (FFG-38)* is in port Subic Bay when a nearby volcano erupts, covering the ship in wet, volcanic ash. Prior to the eruption the ship was at a draft of 16 ft, center of gravity located on the centerline, 19.5 ft above the keel.  $L_{pp} = 408$  ft.

The wet ash has a weight density of  $125 \text{ lb/ft}^3$  and covers a deck area of  $15260 \text{ ft}^2$  to a uniform depth of 6 inches. The ash is assumed to have its center of gravity located 37 ft above the keel, 1.5 ft starboard of the centerline, and 24 ft aft of amidships.

Using the curves of form and cross curves of stability, determine the following:

- a. Weight of volcanic ash on the ship.
  - b. Location of G after the eruption.
  - c. Ship's draft after the eruption.
  - d. Angle of list.
  - e. Metacentric height before and after the eruption.
  - f. Calculate and plot the ship's GZ curve, for starboard heeling angles only, before and after the eruption. Use of a computer is encouraged.
20. *USS NIMITZ (CVN-68)* is underway in the North Atlantic during the winter season. A severe storm covers the flight deck to a uniform depth of 3 ft with a mixture of snow and ice. The flight deck has an area of  $196,000 \text{ ft}^2$ , and the flight deck is located 82 ft above the keel. Prior to the storm the ship was on an even keel at a draft of 37 ft,  $KG = 37.5$  ft,  $L_{pp} = 1040$  ft.

The snow and ice have a combined weight density of  $33 \text{ lb/ft}^3$  and has its center of gravity located on the ship's centerline at amidships.

Using the curves of form and cross curves of stability determine the following:

- a. Weight of snow and ice on the flight deck.
- b. Location of G following the storm.
- c. Ship's forward and aft drafts after the ice accumulation.
- d. Calculate and plot the ship's righting arm curve (starboard heeling angles only) before and after the storm.
- e. How has the accumulation of snow and ice affected the ship's stability? Discuss your answer in terms of metacentric height, maximum righting arm, range of stability, dynamic stability, etc.

21. A LCS1 class ship suffers a major flood in the forward portion of the ship resulting in the total flooding of  $7800 \text{ ft}^3$  (i.e no free surface). The flood's center of gravity is located 142 ft forward of amidships, 8 ft above the keel, and 1 ft starboard of centerline. Prior to the flood, the ship was on an even keel at a draft of 14 ft,  $KG = 12 \text{ ft}$ .  $L_{pp} = 324 \text{ ft}$ .

Using the curves of form and cross curves of stability determine the following:

- a. Weight of flooding water.
  - b. Ship's  $KG$  and  $TCG$  of the ship after flooding has occurred.
  - c. Angle at which the ship is listing.
  - d. Ship's forward, aft, and mean drafts after the flood occurs.
  - e. Compute and plot the ship's righting arm curve before and after the flood. Use of a computer is encouraged.
  - f. What affect does the flooding have on the ship's stability and seaworthiness?
22. In the lost buoyancy method, which of the following change after damage?
- a. Displacement.
  - b.  $KG$
  - c.  $LCB$
  - d.  $KB$

### Section 4.8 Free Surface Correction

23. How does the free surface of fluid in a rectangular tank effect the overall stability of a ship? Draw a diagram to show what effectively happens and what really happens to the center of gravity and the Metacentric Height. Be sure to show the Free Surface Correction.
24. Describe 2 ways that the Free Surface Effect can be reduced.
25. An FFG-7 class ship displacing 4000 LT has  $KG = 18.5 \text{ ft}$  and  $KM = 22.5 \text{ ft}$ . There is a tank filled with fuel oil with a density of  $1.600 \text{ lb-s}^2/\text{ft}^4$  creating a free surface 32 ft wide and 50 ft long. The ship is floating in salt water with a density of  $1.9905 \text{ lb-s}^2/\text{ft}^4$ . What is the effective metacentric height?

26. A ship has a displacement of 12,200 LT,  $KG = 22.6$  ft on the centerline. At this displacement the ship has  $KM_T = 37$  ft. The ship has a free surface in a fuel tank ( $\rho_{fuel} = 1.616$  lb s<sup>2</sup>/ft<sup>4</sup>). The tank is 35 ft long, 40 ft wide, and 15 ft deep.
- Calculate the effective metacentric height if the center of the fuel tank is located on the centerline, 15 ft above the keel.
  - Calculate the ship's effective metacentric height if the center of the fuel tank is located 15 ft above the keel and 10 ft starboard of the centerline.
27. An FFG-7 class ship is on an even keel at a draft of 16.2 ft,  $KG = 19.1$  ft,  $L_{pp} = 408$  ft. The ship suffers a major fire in CIC. While extinguishing the fire, the fire party fills CIC 50% full with saltwater. CIC has the following characteristics:
- |                     |                                    |
|---------------------|------------------------------------|
| length = 45 ft      | kg = 46 ft                         |
| width = 35 ft       | tcg = 4 ft starboard of centerline |
| height = 10 ft      | lcg = 47 ft forward of amidships   |
| permeability = 90 % |                                    |

Using the cross curves of stability and curves of form, determine the following:

- Weight of firefighting water in CIC.
- Location of the ship's center of gravity following the fire.
- Ship's forward, aft, and mean drafts after the fire.
- Calculate the ship's effective metacentric height after the fire.
- Using the effective location of the vertical center of gravity, determine the ship's angle of list following the fire.
- Calculate and plot the ship's righting arm curve, for port and starboard heeling angles, before and after the fire. When computing the GZ curve after the fire, use the effective location of the center of gravity. Use of a computer is encouraged.
- The DCA realizes the ship's stability is threatened and proposes to counter-flood on the port side by filling a ballast tank 75% full with salt water. The ballast tank is located 7.5 ft above the keel, 12 ft port of centerline, and 98 ft aft of amidships. The tank is 20 ft long, 20 ft wide, and 15 ft high. Is the DCA's proposal a valid proposal? Discuss why or why not.

## Section 4.9 Metacentric Height

28. A large oil tanker is preparing to transit from CONUS to the Persian Gulf to load crude oil. The ship is currently empty, and is floating on an even keel at a draft of 16 ft. At this condition the ship's center of gravity is located 33 ft above the keel. The ship is 850 ft long, a beam of 120 ft, and when fully loaded has a draft of 70 ft. At a draft of 16 ft the ship has the following hydrostatic parameters:

$$\begin{array}{ll} \Delta = 38,500 \text{ LT} & \text{MT1}'' = 3872 \text{ LT ft/in} \\ \text{KB} = 8.5 \text{ ft} & \text{TPI} = 206.4 \text{ LT/in} \\ \text{KM}_T = 40 \text{ ft} & \text{LCF} = 10 \text{ ft aft of amidships} \end{array}$$

To improve the ship's stability and lower the center of gravity, the Cargo Officer recommends filling the smallest cargo tank 50% full with salt water ballast. The cargo tank has the following characteristics:

$$\begin{array}{ll} \text{length} = 100 \text{ ft} & \text{l}_{cg} \text{ at LCF} \\ \text{width} = 120 \text{ ft} & \text{tcg on the centerline} \\ \text{height} = 60 \text{ ft} & \text{kg of ballast} = 15 \text{ ft} \\ \text{permeability} = 99 \% & \end{array}$$

- a. Determine the weight of water to be taken on as ballast.
  - b. Determine the ship's center of gravity in the ballasted condition.
  - c. Assuming that the ship is wall-sided, and that TPI and MT1'' do not change, determine the mean draft of the ship in the ballasted condition.
  - d. Determine the ship's effective metacentric height after taking on ballast. At a draft of 20 ft,  $\text{KM} = 42 \text{ ft}$ .
  - e. What effect does the free surface have on the ship's stability? Is the Cargo Officer's recommendation a good recommendation? Explain your answer in terms of metacentric height, dynamic stability, and range of stability. Use a sketch of the GZ curve before and after ballasting to help explain your answer.
  - f. What could be done to achieve the Cargo Officer's goal of improving stability over that of the empty condition?
29. Define tenderness and stiffness as used in Naval Architecture. How does Metacentric Height relate to tenderness, stiffness and initial stability.
30. Define lolling. Draw the curve of intact statical stability for a lolling ship and a stiff ship on the same graph and compare their initial stability characteristics.
31. Draw a diagram of a ship heeling to starboard by external forces with a negative GM.

32. Describe why a tanker unloading at pier can begin to loll.
33. A Navy LCU can be modeled as a rectangular, box-shaped barge. The barge has the following dimensions and hydrostatic parameters:

Length = 135 ft	<u>Draft (ft)</u>	<u>KM (ft)</u>	<u>TPI (LT/in)</u>
Beam = 35 ft	4	27.5	11.25
Depth = 7 ft	5	22.9	11.25
Deck located 7 ft above keel	6	20.0	11.25
gunwales extend 4 ft above the deck			

When empty the barge floats at a draft of 4 ft,  $KG = 1.9$  ft. The barge is then loaded to maximum capacity with 3 M-60 tanks. Each tank weighs 60 LT and has a center of gravity 4 ft above the ground (i.e., 4 feet above the deck).

- Determine the draft and displacement of the barge after loading the tanks.
- What is the barge's center of gravity after loading vehicles?
- What is the metacentric height of the barge before and after the vehicle on load? How is the barge's stability affected when loaded to maximum capacity?
- In a heavy monsoon rainstorm the barge accumulates 2 inches of freshwater on deck. Calculate the weight of water added to the barge and the barge's new  $KG$ .
- The rainwater creates a free surface on deck. Calculate the barge's effective metacentric height following the storm.
- On the same axes, sketch a righting arm curve for the barge in the following conditions: unloaded, fully loaded, free surface on deck.
- What can be done to eliminate the possibility of a free surface?

# **COURSE OBJECTIVES**

## **CHAPTER 5**

### **5. PROPERTIES OF NAVAL MATERIALS**

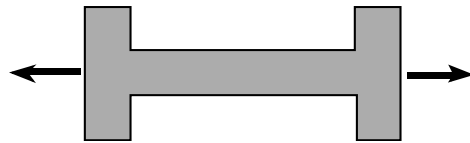
1. Define a normal load, shear load, and torsional load on a material.
2. Define tension and compression.
3. Understand the concepts of stress and strain.
4. Calculate stress and strain.
5. Interpret a Stress-Strain Diagram including the following characteristics:
  - a. Slope and Elastic Modulus
  - b. Elastic Region
  - c. Yield Strength
  - d. Plastic Region
  - e. Strain Hardening
  - f. Tensile Strength
6. Be familiar with the following material characteristics:
  - a. Ductility
  - b. Brittleness
  - c. Toughness
  - d. Transition Temperature
  - e. Endurance Limit
7. Be familiar with the following methods of non-destructive testing:
  - a. Visual Test
  - b. Dye Penetrant Test
  - c. Magnetic Particle Test
  - d. Ultrasonic Test
  - e. Radiographic Test
  - f. Eddy Current Test
  - g. Hydrostatic Test

## 5.1 Classifying Loads on Materials

### 5.1.1 Normal Loads

One type of load which can be placed on a material is a *Normal Load*. Under a normal load, the material supporting the load is perpendicular to the load, as in Figures 5.1 and 5.2.

Normal loads may be either tensile or compressive. When a material is in tension, it is as if the ends are being pulled apart to make the material longer. Pulling on a rope places the rope in tension. Compression is the opposite of tension. When a material is in compression, it is as if the ends are being pushed in, making the material smaller. Pressing down on a book lying on a table places the book in compression.



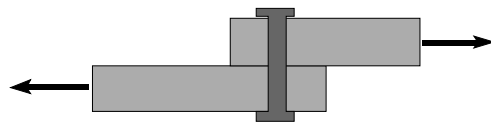
**Figure 5.1** Normal Tension



**Figure 5.2** Normal Compression

### 5.1.2 Shear Loads

A second type of loading is called shear. When a material experiences shear, the material supporting the load is parallel to the load. Pulling apart two plates connected by a bolt, as in Figure 5.3, places the bolt in shear.

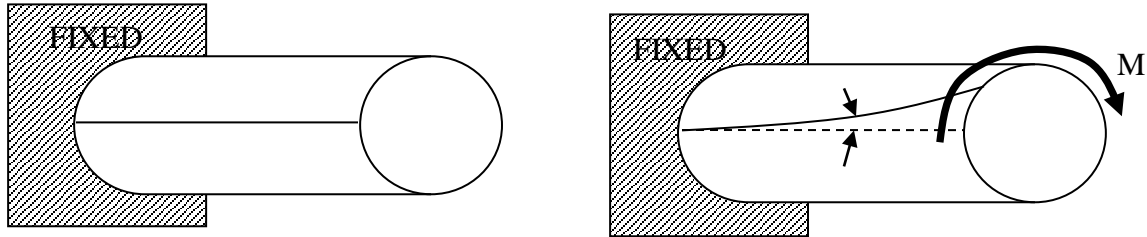


**Figure 5.3** Shear



### 5.1.3 Torsion Loads

Another common type of loading is due to torsion. A component, such as a shaft, will “twist” or angularly distort due to an applied moment ( $M$ ) or torque. This type of loading is seen on helicopter rotor shafts and ship propulsion shafting and may result in large amounts of angular deflection. Figure 5.4 illustrates torsional loading on a shaft.



**Figure 5.4** Torsion on a circular shaft



Angular deflection of a shaft is a function of geometry (length and diameter), material type, and the amount of moment applied. Longer, thinner, and more ductile shafts will distort the most.

### 5.1.4 Thermal Loads

When a material is heated it tends to expand and conversely, when it is cooled it contracts. If the material is constrained from expanding or contracting in any direction, then the material will experience a normal load in the plane(s) that it is constrained. This is a special type of normal load that depends on the heat transfer characteristics of the material.

## 5.2 Stress and Strain

### 5.2.1 Stress

Very thick lines or wire ropes are used to moor an aircraft carrier to a pier. The forces on these mooring lines are tremendous. Obviously, thin steel piano wires cannot be used for this purpose because they would break under the load. The mooring lines and the piano wire may both be made of the same material, but because one will support the load and the other will not, the need to compare the magnitude of the load to the amount of material supporting the load is illustrated.

The concept of stress performs that comparison. Stress ( $\sigma$ ) is the quotient of load ( $F$ ) and area ( $A$ ) as shown in Equation 5-1. The units of stress are normally pounds per square inch (psi).

$$\sigma = \frac{F}{A}$$

where:  $\sigma$  is the stress (psi)  
 $F$  is the force that is loading the object (lb)  
 $A$  is the cross sectional area of the object ( $\text{in}^2$ )

**Example 5.1** A particular mooring line with a diameter of 1.00 inch is under a load of 25,000 lbs. Find the normal stress in the mooring line.

Solution:

$$\text{Cross Sectional Area (A)} = \pi r^2 = \pi \left(\frac{1 \text{ in}}{2}\right)^2 = 0.785 \text{ in}^2$$

$$\text{Normal Stress } (\sigma) = \frac{F}{A} = \frac{25,000 \text{ lb}}{0.785 \text{ in}^2} = 31,800 \text{ psi}$$

### 5.2.2 Strain

If the original and final length of the cable were measured, one would find that the cable is longer under the 25,000 pound load than when it was unloaded. A steel cable originally 75 feet long would be almost an inch longer under the 25,000 pound load. One inch is then the elongation ( $e$ ) of the cable. Elongation is defined as the difference between loaded and unloaded length as shown in Equation 5-2.

$$e = L - L_o$$

where:  $e$  is the elongation (ft)  
 $L$  is the loaded length of the cable (ft)  
 $L_o$  is the unloaded (original) length of the cable (ft)

The elongation also depends upon original length. For instance, if the original cable length were only  $\frac{1}{2}(75 \text{ ft}) = 32.5 \text{ ft}$ , then the measured elongation would be only 0.5 inch. If the cable length was instead twice 75 feet, or 150 feet, then the elongation would be 2 inches. A way of comparing elongation and length would seem useful.

Strain is the concept used to compare the elongation of a material to its original, undeformed length. Strain ( $\epsilon$ ) is the quotient of elongation ( $e$ ) and original length ( $L_0$ ) as shown in Equation 5-3. Strain has no units but is often given the units of in/in or ft/ft.

$$\epsilon = \frac{e}{L_0}$$

where:  $\epsilon$  is the strain in the cable (ft/ft)  
 $e$  is the elongation (ft)  
 $L_0$  is the unloaded (original) length of the cable (ft)

**Example 5.2** Find the strain in a 75 foot cable experiencing an elongation of one inch.

Solution:

$$\text{Strain}(\epsilon) = \frac{e(\text{ft})}{L_0(\text{ft})} = \frac{1 \text{ in } (1\text{ft}/12\text{in})}{75 \text{ ft}} = 1.11 \times 10^{-3} \text{ ft} / \text{ft}$$

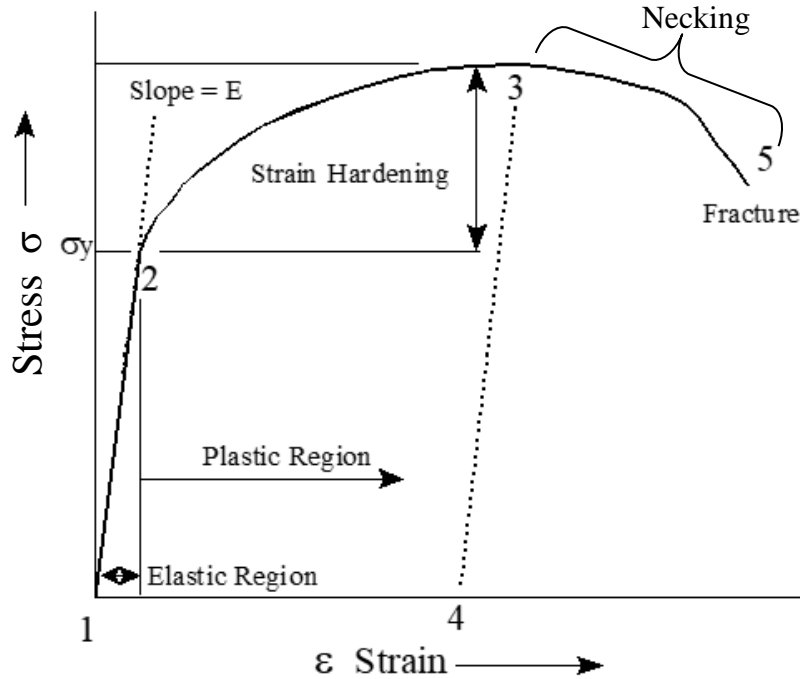


One can easily substitute the elongations and original lengths from above and see that the numerical value of strain remains the same regardless of the original length of the cable.

Also, note that a conversion from inches to feet is necessary.

### 5.3 Stress-Strain Diagrams and Material Behavior

Stress and strain are calculated from easily measurable quantities (normal load, diameter, elongation, original length) and can be plotted against one another as in Figure 5.5. Such Stress-Strain diagrams are used to study the behavior of a material from the point it is loaded until it breaks. Each material produces a different stress-strain diagram.



**Figure 5.5** Stress/Strain Diagram

Point 1 on the diagram represents the original undeformed, unloaded condition of the material. As the material is loaded, both stress and strain increase, and the plot proceeds from Point 1 to Point 2. If the material is unloaded before Point 2 is reached, then the plot would proceed back to Point 1.

If the material is unloaded anywhere between Points 1 and 2, then it will return to its original shape, like a rubber band. This type of behavior is termed *Elastic* and the region between Points 1 and 2 is the *Elastic Region*.

The Stress-Strain curve also appears linear between Points 1 and 2. In this region stress and strain are proportional. The constant of proportionality is called the *Elastic Modulus* or *Young's Modulus* ( $E$ ). The relationship between stress and strain in this region is given by Equation 5-4.

$$E = \frac{\sigma}{\epsilon} \quad \text{or} \quad \sigma = E\epsilon$$

where:

- $\sigma$  is the stress (psi)
- $E$  is the Elastic Modulus (psi)
- $\epsilon$  is the strain (in/in)



The Elastic Modulus is also the slope of the curve in this region, solved by taking the slope between data points (0,0) and  $(\sigma_y, \epsilon_y)$ .

Point 2 is called the *Yield Strength* ( $\sigma_y$ ). If it is passed, the material will no longer return to its original length. It will have some permanent deformation. This area beyond Point 2 is the *Plastic Region*. Consider, for example, what happens if we continue along the curve from Point 2 to Point 3, the stress required to continue deformation increases with increasing strain. If the material is unloaded the curve will proceed from Point 3 to Point 4. The slope (Elastic Modulus) will be the same as the slope between Points 1 and 2. The difference between Points 1 and 4 represents the permanent strain of the material. Once in the plastic region, the material remains in the plastic region until failure.

If the material is loaded again, the curve will proceed from Point 4 to Point 3 with the same Elastic Modulus (slope). The Elastic Modulus will be unchanged, but the Yield Strength will be increased. Permanently straining the material in order to increase the Yield Strength is called *Strain Hardening*.

If the material is strained beyond Point 3, stress decreases as non-uniform deformation and necking occur. The sample will eventually reach Point 5 at which it fractures.

The largest value of stress on the diagram is called the *Tensile Strength (TS)* or *Ultimate Tensile Strength (UTS)*. This is the most stress the material can support without breaking.

**Example 5.3** A tensile test specimen having a diameter of 0.505 in and a gauge length of 2.000 in was tested to fracture-load and deformation data obtained during the test were as follows:

Load (lb)	Change in length (inch)
0	0.0000
2,200	0.0008
4,300	0.0016
6,400	0.0024
8,200	0.0032
8,600	0.0040
8,800	0.0048
9,200	0.0064
9,500	0.0080
9,600	0.0096
10,600	0.0200
11,800	0.0400

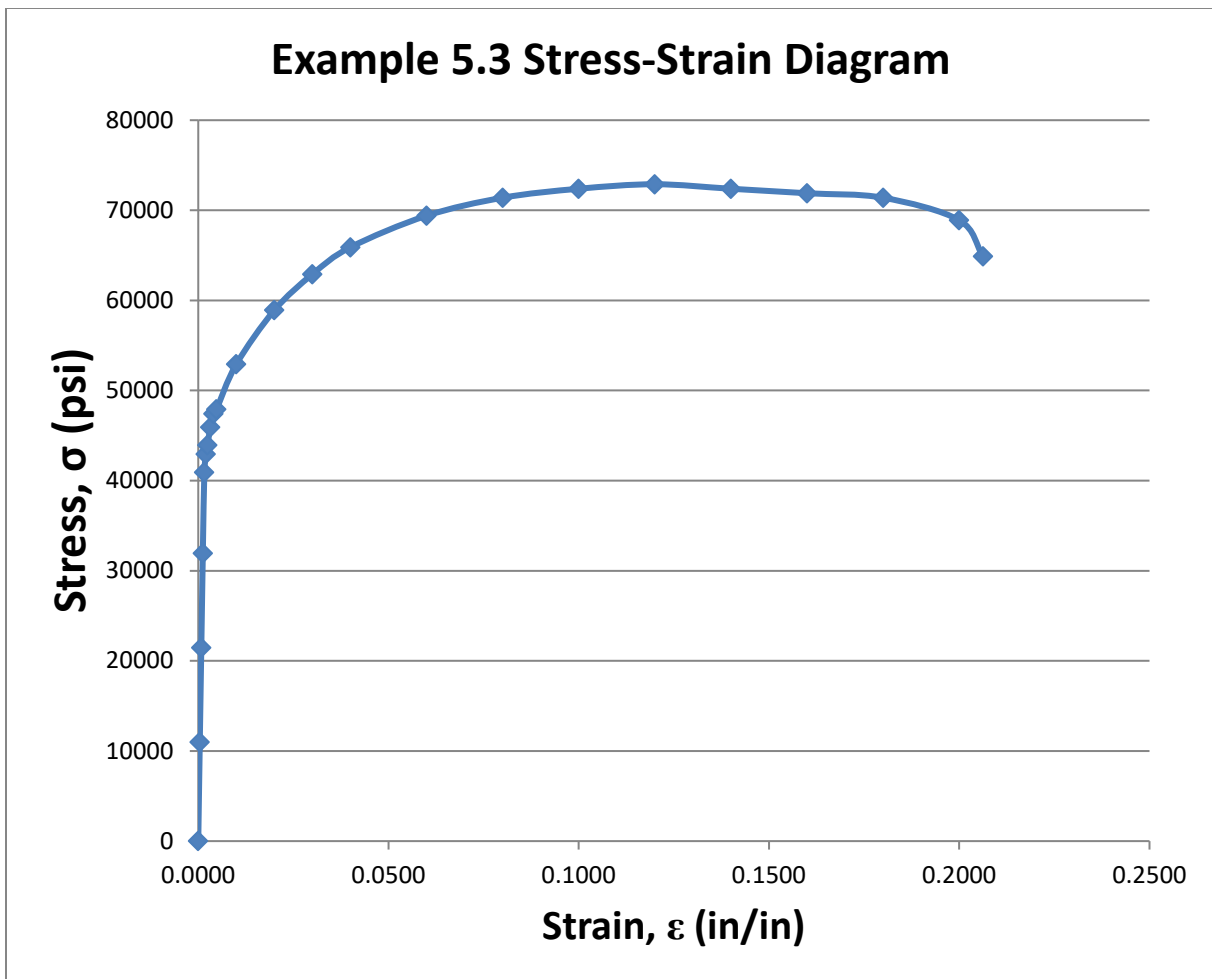
Load (lb)	Change in length (inch)
12,600	0.0600
13,200	0.0800
13,900	0.1200
14,300	0.1600
14,500	0.2000
14,600	0.2400
14,500	0.2800
14,400	0.3200
14,300	0.3600
13,800	0.4000
13,000	0.4125 (Fracture)

- Make a table of stress and strain and plot the stress-strain diagram.
- Determine the modulus of elasticity
- Determine the ultimate strength
- Determine the yield strength
- Determine the fracture stress
- Determine the true fracture stress if the final diameter of the specimen at the location of the fracture was 0.425 inch.

Solution:

- a. Make a table of stress and strain and plot the stress-strain diagram.

(1)	(2)	(3)	(4)
Load P (lb)	Stress $\sigma = P/A$ (psi) (2) = (1) / 0.2003 in <sup>2</sup>	Elongation e (in)	Strain $\epsilon = e/L_0$ (in/in) (4) = (3) / 2 in
0	0	0.0	0.0
2200	10984	0.0008	0.0004
4300	21468	0.0016	0.0008
6400	31952	0.0024	0.0012
8200	40939	0.0032	0.0016
8600	42936	0.0040	0.0020
8800	43934	0.0048	0.0024
9200	45931	0.0064	0.0032
9500	47429	0.0080	0.0040
9600	47928	0.0096	0.0048
10600	52921	0.0200	0.0100
11800	58912	0.0400	0.0200
12600	62906	0.0600	0.0300
13200	65901	0.0800	0.0400
13900	69396	0.1200	0.0600
14300	71393	0.1600	0.0800
14500	72391	0.2000	0.1000
14600	72891	0.2400	0.1200
14500	72391	0.2800	0.1400
14400	71892	0.3200	0.1600
14300	71393	0.3600	0.1800
13800	68897	0.4000	0.2000
13000	64903	0.4125 (Fract)	0.2063



- b. Determine the modulus of elasticity (See plot)

$$E = \frac{32,000 \text{ psi}}{0.0012 \text{ in/in}} = 26.7 \times 10^6 \text{ psi}$$

- c. Determine the ultimate tensile strength (See plot)

$$UTS = \frac{14,600 \text{ lb}}{0.2003 \text{ in}^2} = 72,890 \text{ psi}$$



- d. Determine the yield strength (See plot)

$$\sigma_Y = 32,000 \text{ psi}$$

- e. Determine the fracture stress (See plot)

$$\sigma_F = \frac{13,000 \text{ lb}}{0.2003 \text{ in}^2} = 64,903 \text{ psi}$$

- f. Determine the true fracture stress if the final diameter of the specimen at the location of the fracture was 0.425 inch.

$$\text{Cross Sectional Area at Fracture } (A_F) = \pi r_F^2 = \pi \left( \frac{0.425 \text{ in}}{2} \right)^2 = 0.142 \text{ in}^2$$

$$\sigma_{\text{true-F}} = \frac{13,000 \text{ lb}}{0.142 \text{ in}^2} = 91,638 \text{ psi}$$


## 5.4 Material Properties

There are five material properties that do a good job at describing the characteristics of a material. They are strength, hardness, brittleness, toughness, and ductility. Most terms are used to describe materials comparatively to one another, and help to determine the type of material desired for a specific application.

### 5.4.1 Strength

*Strength* is a measure of the material's ability to resist deformation and to maintain its shape. Strength can be quantified in terms of yield stress or ultimate tensile strength. Both yield stress and ultimate tensile strength can be determined from tensile test data by plotting a stress strain curve.

High carbon steels and metal alloys exhibit higher strength characteristics than pure metals. Ceramics also exhibit high strength characteristics.

 High strength steels used in submarine construction, designated HY-80 and HY-100 have yield stresses of 80,000 psi and 100,000 psi respectively!

### 5.4.2 Hardness

*Hardness* is a measure of the material's ability to resist indentation, abrasion and wear. Hardness is quantified by arbitrary hardness scales such as the Rockwell hardness scale or the Brinell hardness scale. These measurements are obtained by a special apparatus that uses an indenter that is loaded with standard weights. The indenter can have various shapes such as a pyramid or a sphere and is pressed into the specimen. Either the depth of penetration or the diameter of the indentation made is measured to quantify material hardness.

Hardness and strength correlate well because both properties are related to inter-molecular bonding.

### 5.4.3 Ductility

*Ductility* is a measure of the material's ability to deform before failure. Ductility can be quantified by reading the value of strain at the fracture point on the stress strain curve or by doing a percent reduction in area calculation.

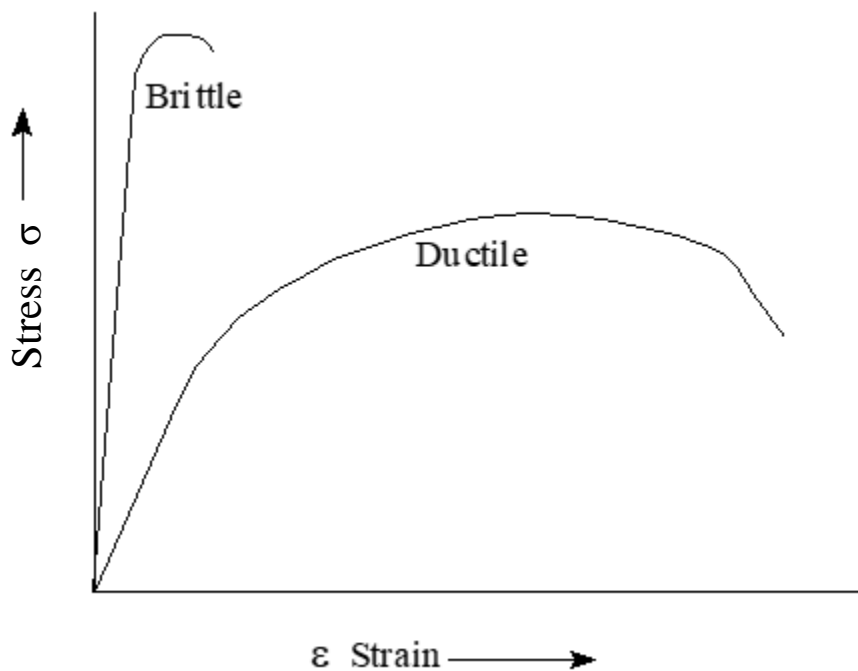
Low carbon steels, pure aluminum, copper, and brass are examples of ductile materials.

### 5.4.3 Brittleness

*Brittleness* is a measure of a material's inability to deform before failure. Brittleness is the opposite of ductility. Brittleness is not quantified since it is the inability to deform. However, ductility is quantified as discussed above.

Examples of brittle materials include glass, cast iron, high carbon steels, and many ceramic materials.

Figure 5.6 shows the difference between ductile and brittle behavior on a stress-strain diagram.



**Figure 5.6** Ductile and Brittle Behavior

### 5.4.5 Toughness

*Toughness* is a measure of a materials ability to absorb energy. There are two measures of toughness.

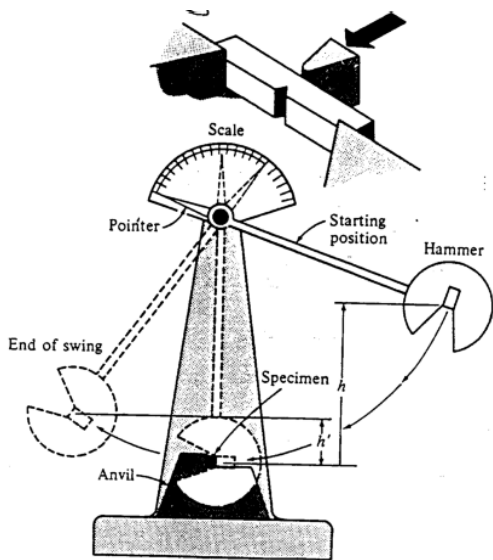
**5.4.5.1 Material Toughness** can be measured by calculating the area under the stress strain curve from a tensile test. The units on this measure of toughness are  $\text{in}\cdot\text{lb}/\text{in}^3$ . These are units of energy per volume. *Material Toughness* equates to a slow absorption of energy by the material.

**5.4.5.2 Impact Toughness** is measured by doing a Charpy V-notch Test. For this test, a specimen of material is broken by a pendulum as shown in Figure 5.7.

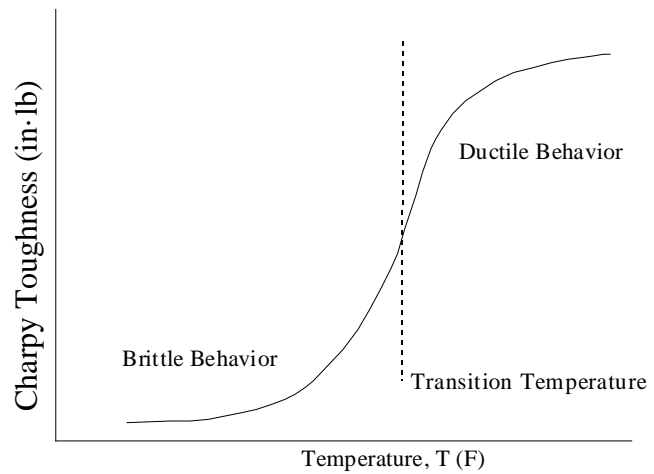
Knowing the initial and final height of the pendulum allows the engineer to calculate the initial and final potential energy of the pendulum. The difference in potential energy is the energy it takes to break the material or its *impact toughness*. *Impact toughness* is a measure of a rapid absorption of energy by the material.

The Charpy test for a single material is done with many different specimens where each specimen is held at a different temperature. The purpose of the Charpy test is to evaluate the

impact toughness of a specimen as a function of temperature. Figure 5.8 shows a typical Charpy plot for a body centered cubic metal.



**Figure 5.7** Charpy v-notch Impact Test



**Figure 5.8** Temperature and Impact Toughness

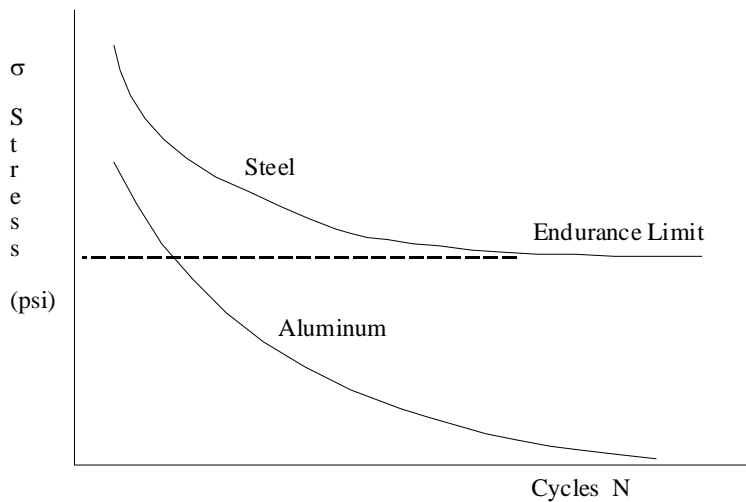
At low temperatures, where the material is brittle and not strong, little energy is required to fracture the material. At high temperatures, where the material is more ductile and stronger, greater energy is required to fracture the material. The *Transition Temperature* is the boundary between brittle and ductile behavior. The transition temperature is an extremely important parameter in the selection of construction materials.

⚠ Impact toughness can also be adversely affected by other factors such as external pressure, corrosion and radiation. It is important to take these factors into account for applications such as deep diving submersibles and reactor plant design.

### 5.4.7 Fatigue

Another important material property is its ability to withstand fatigue. *Fatigue* is the repeated application of stress typically produced by an oscillating load or vibration. Fatigue characteristics of a material can be found by repeatedly subjecting the material to a known level of stress. By changing the stress level and counting the repetitions of stress application until failure, a plot similar to Figure 5.9 can be created.

Figure 5.9 shows a plot of stress against number of cycles required to cause failure. It is clear that provided stresses remain below a certain threshold called the *endurance limit*, fatigue failure will not occur. The endurance limit of a material is a very important quantity when designing mechanical systems. It will be below the yield stress. As long as the level of stress in a material is kept below the endurance limit, fatigue failure will not occur.



**Figure 5.9** Material Fatigue Characteristics  
*(Note: Aluminum has no endurance limit)*

⚠ Fatigue is the enemy of the pilot and the mechanics that care for his/her plane. Plane fuselages, wings, tails, and engines are constantly inspected to ensure that small cracks are found and fixed before they become big and lead to disaster.

#### 5.4.8 Factors Effecting Material Properties

All of the material characteristics discussed so far are affected by temperature to varying degrees. In short, increasing temperature increases ductility which makes a material less brittle.

Material properties and performance are affected by a great many factors in addition to temperature. Alloying elements, heat treatments (annealing, tempering, quenching, etc), and manufacturing methods (cold rolling, hot rolling, forging, etc) also effect material properties, particularly yield strength, ultimate strength, and ductility.

##### 5.4.8.1 Alloying

Alloying is the addition of elements to the base metal for the purpose of changing the material characteristics. Alloyed metals are generally more expensive than mild carbon steel or pure aluminum but their use is often necessary in order to achieve the desired strength, hardness, ductility, fatigue, and corrosion resistance properties in an engineering structure.

The principal alloying elements used in steels are: carbon (increases strength), chromium (increases hardness, strength, and corrosion resistance), nickel (increases toughness, hardness, and corrosion resistance), manganese (reduces brittleness), molybdenum (increases high-temperature strength and hardness), and tungsten (increases hardness). Stainless steels, for example, may contain up to 26% chromium to achieve superior corrosion resistance. Alloying, however, is a series of trade-offs and finding the “optimum” material is difficult. For example, increasing the strength of steel by adding carbon comes at the price of increased brittleness, lower toughness, and more difficult welding techniques.

The major alloying elements used with aluminum are: copper, manganese, silicon, magnesium, and zinc. Most of these alloying elements are used to improve the hardness, ductility, and strength of aluminum – aluminum, by its nature, is more corrosion resistant and alloys such as “stainless aluminum” are never seen.

#### **5.4.8.2 Thermal Treatment of Metals**

*Annealing* is used to relieve the internal stresses, change the internal grain size, and improve manufacturability of steel. In the annealing process, the steel is heated to slightly higher than its upper critical temperature (~723-910°C) and allowed to slowly cool in a furnace (1 to 30 hours). This process ultimately improves the hardness, strength, and ductility characteristics of the steel. Steel used in ship hulls is partially annealed.

*Hardening* consists of heating the steel to 100°F higher than its upper critical temperature, allowing the metal to change granularly, and then rapidly *quenching* the steel in water, oil, or brine. This process makes the steel harder. Horseshoes, armor plate, and chain mail are often quenched. Quenching too rapidly leads to thermal cracking.

*Tempering*, like annealing, is also used to relieve internal stresses, change the internal grain size, and improve manufacturability of steel. In the tempering process, the steel is heated to below its critical temperature and allowed to slowly cool. This process is often used after hardening to make the steel softer and tougher. Steak knives and razor blades are tempered. High quality swords are often quenched and tempered.

*Hot-working* is the process of mechanical forming the steel at temperatures above its critical temperature. Plastic strain develops as a result of the mechanical working. Annealing occurs due to the temperature which relieves some of the internal strain. As a result, the material remains ductile. One type of hot-working is forging, which gives the highest strength steel components. You may be familiar with this type of hot-working if you have ever watched a blacksmith work.

*Cold-working* a steel results in plastic deformations developing in the metal due to mechanical forming or working process being conducted at a temperature below the steel’s upper critical temperature. This process does not allow internal stresses to relieve and results in a stronger, harder, and more brittle material. If done too much, the material will become too brittle to be useful.

*Precipitation Hardening* is the most common heat treatment for aluminum. It consists of a series of controlled tempering and quenching, followed by a single rapid quenching and often ending with a process called *aging*, which is simply holding the material for a period of time at a set temperature.

#### **5.4.8.3 Corrosion**

Corrosion is defined as the deterioration or destruction of a material resulting from a chemical attack by its environment. Corrosion is the enemy to all marine structures and it is important to understand why it occurs and how to prevent it. This short discussion will not attempt to delve

into the many mechanisms, causes, and factors affecting corrosion; rather, we will discuss how to prevent or at least, slow the effects of corrosion on your ship, tank, or aircraft.

Corrosion control can be accomplished by many means: design, coatings, and cathodic protection systems.

- **Design:** Design methods to control corrosion include limiting excessive stresses (stress corrosion), avoiding dissimilar metal contact (galvanic corrosion), avoiding crevices or low flow areas (crevice corrosion), and excluding air whenever possible. Good design also entails selecting the best material for a given application. The ocean environment is extremely deleterious to mild steel, yet these steels are often used in many marine structures due to their relatively low cost and high strength. After a careful economic analysis, the service life of most ships is determined by the effects of corrosion on the hull structure and the fatigue life on these thinner, degraded components. The service life may be extended by good design and effective use of other corrosion control methods explained below.
- **Coating:** Coatings range from simple paint to ceramic or glass enamels. These coatings separate the material from the corrosive marine environment. On a weight and cost basis, use of coatings is the most effective protection against corrosion. Navy ships make effective and frequent use of this method as you probably learned on your summer cruises! If done improperly, painting can become tiresome rework. A ship with a lot of paint can gain several LT's in displacement over its service life.
- **Cathodic Protection:** Cathodic protection is accomplished by impressing an electrical current on a material to slow or stop the chemical process of corrosion. Another method of cathodic protection protects the structural material by providing another dissimilar sacrificial material to preferentially corrode (often referred to as "sacrificial anodes" or "zincs"). Sacrificial anodes and cathodic protection are used in areas where it is not practical to constantly paint and re-paint components, such as heat exchangers, ballast tanks, bilges, and components fully submerged below the waterline such as the shaft and screw.

## 5.5 Non-Destructive Testing

Nondestructive testing (NDT) methods are inspections for material defects. In the Navy, they are often performed to insure quality control in acquisition and after installation. The governing documents are MIL-STD-271 F and NAVSEA 8000 and 9000 series manuals. Non-destructive testing methods may be grouped into two categories, external and internal inspection techniques. Additionally, we will cover two more methods, specifically hydrostatic and weight tests.

### 5.5.1 External (Surface) Inspection Techniques

The three most commonly used external (surface) inspection techniques currently in use are the Visual Test, Dye Penetrant Test, and Magnetic Particle Test.

- **Visual Testing (VT)** should be done during all phases of maintenance. It can usually be performed quickly and easily and at virtually no cost. Sometimes photographs are made as a permanent record. Visual inspections only allow the inspector to examine the surface of a material.

⚠ You will perform VT countless times through your Navy or Marine career. Whether it is your pre-flight checks as an aviator or inspecting your Marines' rifles, you will be doing a VT, (a form of NDT).

- **Dye Penetrant Testing (PT)** uses dyes in order to make surface flaws visible to the naked eye. It can be used as a field inspection for glass, metal, castings, forgings, and welds. The technique is simple and inexpensive and is shown schematically at Figure 5.10. Only surface defects may be detected, and great care must be taken to ensure cleanliness.

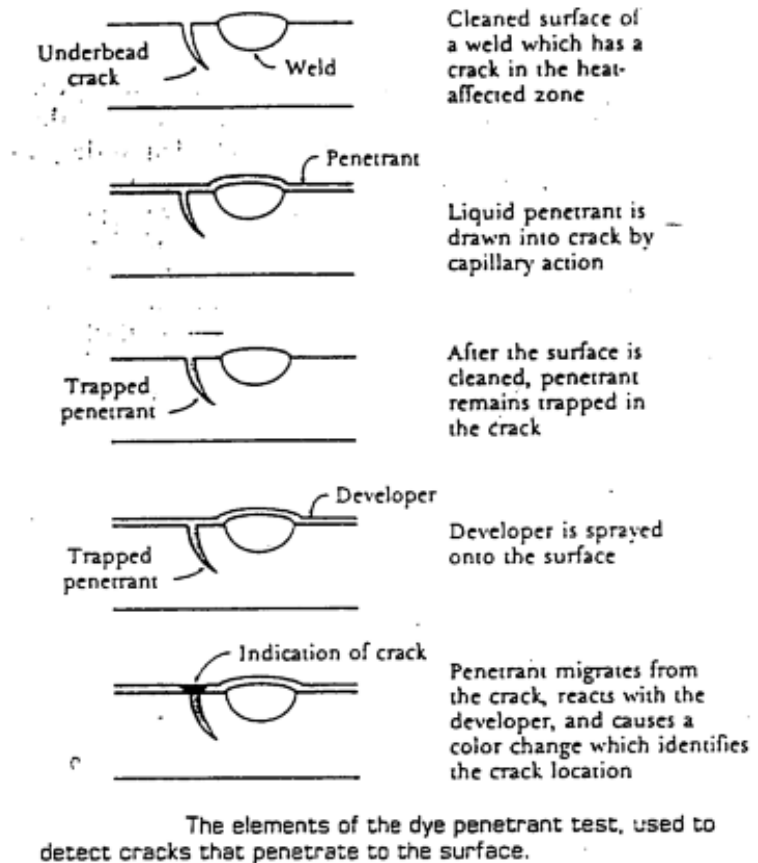
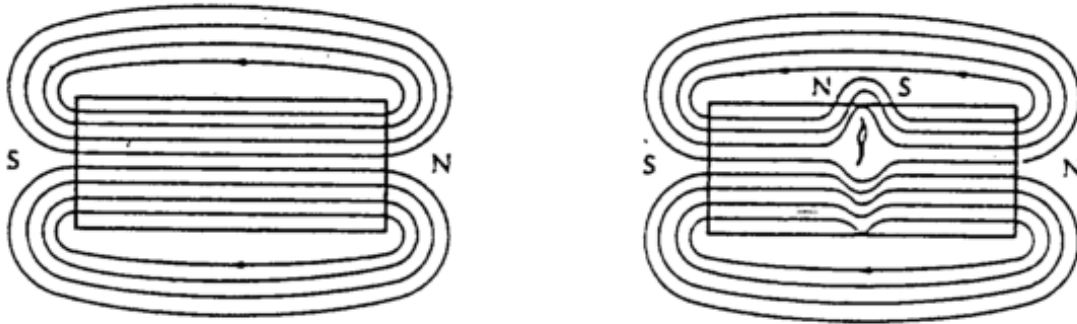


Figure 5.10 Dye Penetrant Testing



- **Magnetic Particle Testing (MT)** is only used on ferromagnetic materials. This method involves covering the test area with iron filings and using magnetic fields to align the filings with defects. Figure 5.11 shows the deformation of a magnetic field by the presence of a defect. Magnetic particle tests may detect surface and shallow subsurface flaws, and weld defects. It is simple and inexpensive to perform, however a power source is required to apply the magnetic field.



A flaw in a ferromagnetic material causes a disruption of the normal lines of magnetic flux. If the flaw is at or near the surface, lines of flux leak from the surface. Magnetic particles are attracted to the flux leakage and indicate the location of the flaw.

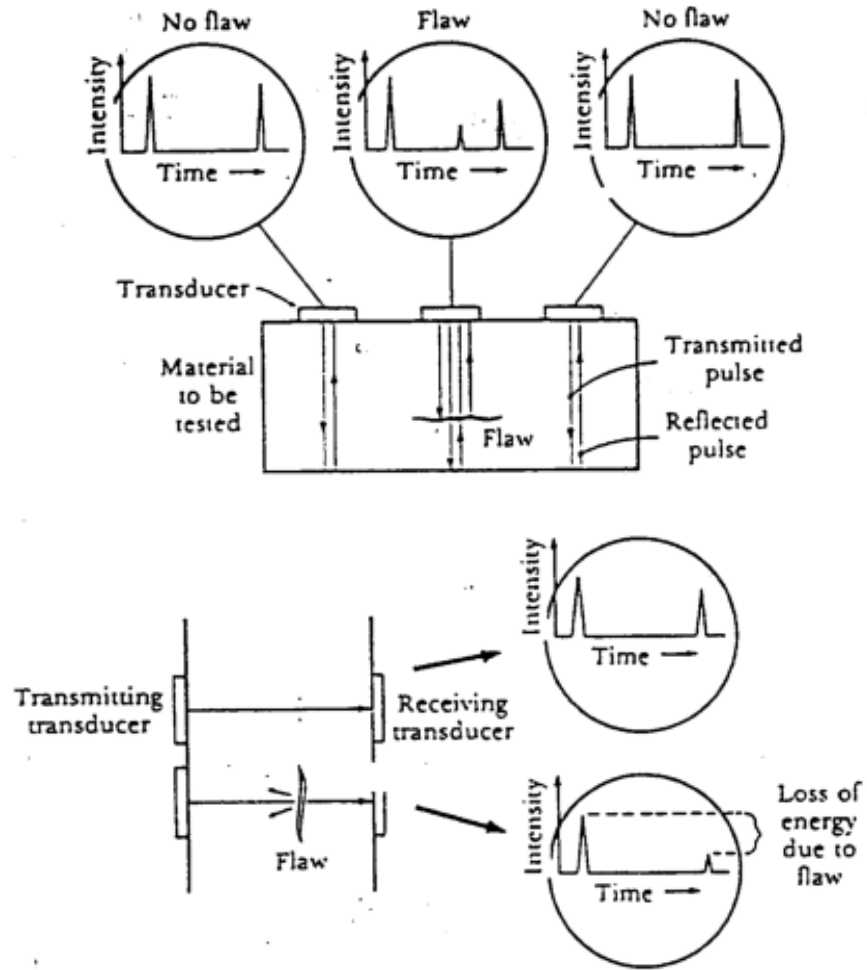
**Figure 5.11** Magnetic Particle Testing

### 5.5.2 Internal (Sub-surface) Inspection Techniques

The three most common internal (subsurface) techniques are the Ultrasonic Testing, Radiographic Testing, and Eddy Current Testing.

- **Radiographic Testing (RT)** is accomplished by exposing photographic film to gamma or x-ray sources. This type of testing detects a wide variety of internal flaws of thin or thick sections and provides a permanent record. These methods of testing require trained technicians and present radiation hazards during testing.

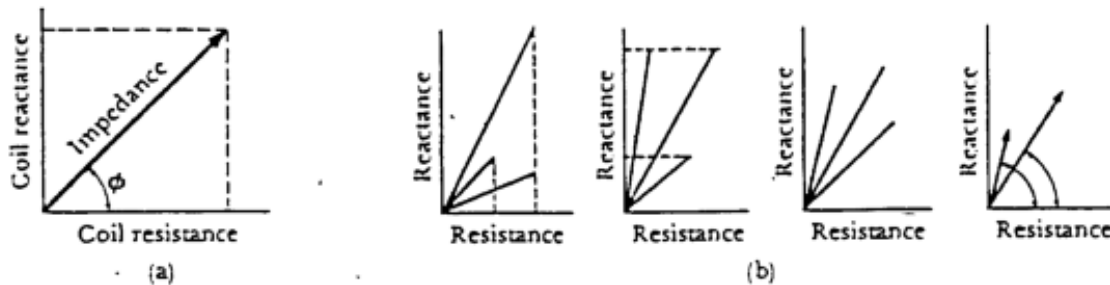
- Ultrasonic Testing (UT)** utilizes a transducer to send sound waves through a material. It may be used on all metals and nonmetallic materials. UT is an excellent technique for detecting deep flaws in tubing, rods, brazed and adhesive-jointed joints. The equipment is portable, sensitive and accurate. Interpretation of the results requires a trained technician. Figure 5.12 shows two ultrasonic transducer configurations.



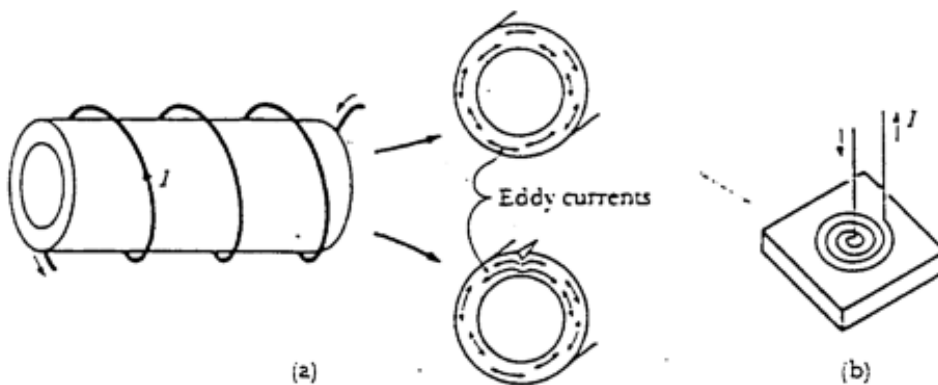
The through-transmission ultrasonic test. The presence of a discontinuity reflects a portion of the transmitted beam, thus reducing the intensity of the pulse at the receiving transducer.

**Figure 5.12** Ultrasonic Testing

- **Eddy Current Testing** involves the creation of a magnetic field in a specimen and reading field variations on an oscilloscope. It is used for the measurement of wall thicknesses and the detection of longitudinal seams and cracks in tubing. Test results may be affected by a wide variety of external factors. This method can only be used on very conductive materials, and is only good for a limited penetration depth. Once very common, it is being replaced by the increasing usage of ultrasonic testing. Figure 5.13 demonstrates.



The impedance is important in the eddy current test. (a) The impedance is defined both by its magnitude and its direction,  $\phi$ . (b) We must measure two components to define the impedance; it is possible that the impedance may be different even though the resistance, reactance, magnitude, or angle are identical.



(a) The through-coil method and (b) the probe method for eddy current inspection.

**Figure 5.13** Eddy Current Testing

Two additional types of NDT common to the U.S. Navy are the hydrostatic and weight tests, used frequently in almost every form of mechanical equipment certification.

- Another type of test that you are likely to encounter is the **Hydrostatic Test**. In this test, a section of a system is isolated and pressurized by a pump to (or more commonly above) system operating pressure, as required by test specifications. Following a specified waiting period at pressure, the system is then inspected for leaks at joints, pipe welds, valve bonnets, etc. Sometimes, the ability of a valve to hold pressure is tested (seat tightness) and the pressure drop over time is noted. A hydrostatic test is a simple test *to verify system integrity*. It is typically performed following any maintenance or replacement which could impact that system's integrity.
- An equivalent type of test for gear used to lift large loads or weapons is the **Weight or Pull Test**. In this test, the gear or fixture is loaded to the same (or typically greater) weight than it is expected to endure in operation for a specified duration. Following release of the load, the equipment is inspected using NDT techniques (commonly VT and/or PT) for evidence of damage or permanent deformation. This test is repeated at specified periodicities or whenever maintenance or damage occurs which could impact the weight handling capacity of the gear. As an officer, you might need to verify that the weight handling gear your men are using has been tested within the required periodicities and is being used within the specified capacities for their and your own safety.

### 5.5.3 Non-Destructive Techniques Summary

TEST	MEASURES	USED FOR	ADVANTAGES	LIMITATIONS
Visual Test (VT)	<ol style="list-style-type: none"> <li>1. Finish</li> <li>2. Surface Defects</li> </ol>	ALL	<ol style="list-style-type: none"> <li>1. Cheap</li> <li>2. Easy, no Equipment Required</li> </ol>	<ol style="list-style-type: none"> <li>1. Only for surface defects</li> <li>2. No quantitative result.</li> </ol>
ROCKWELL HARDNESS	<ol style="list-style-type: none"> <li>1. Hardness (Strength)</li> </ol>	<ol style="list-style-type: none"> <li>1. Testing the strength of metals</li> </ol>	<ol style="list-style-type: none"> <li>1. Non-destructive</li> </ol>	<ol style="list-style-type: none"> <li>1. Not exact value of Strength</li> </ol>
RADIOGRAPHIC (RT)	<ol style="list-style-type: none"> <li>1. Internal Defects</li> <li>2. Density Variations</li> </ol>	<ol style="list-style-type: none"> <li>1. Welds</li> <li>2. Forgings</li> <li>3. Castings</li> </ol>	<ol style="list-style-type: none"> <li>1. Gives Permanent record.</li> <li>2. Great Penetration</li> <li>3. Good on most geometries</li> <li>4. Portable</li> <li>5. Sensitive to density variations</li> </ol>	<ol style="list-style-type: none"> <li>1. Costly</li> <li>2. Radiation Hazard</li> <li>3. Need highly skilled operators</li> </ol>
DYE PENETRANT (DT)	<ol style="list-style-type: none"> <li>1. Surface Defects</li> <li>2. Porosities open to the surface</li> </ol>	<ol style="list-style-type: none"> <li>1. Welds</li> <li>2. Forgings</li> <li>3. Castings</li> </ol>	<ol style="list-style-type: none"> <li>1. Low COST</li> <li>2. Portable</li> <li>3. Easily interpreted</li> </ol>	<ol style="list-style-type: none"> <li>1. Surface defects only</li> <li>2. Must clean surface before and after test</li> </ol>
MAGNETIC PARTICLE (MT)	<ol style="list-style-type: none"> <li>1. Surface, shallow subsurface flaws</li> <li>2. Cracks and Porosities</li> </ol>	<ol style="list-style-type: none"> <li>1. Ferrous Materials</li> <li>2. Forgings and Castings</li> </ol>	<ol style="list-style-type: none"> <li>1. Can locate very tight cracks which might not see with Dye</li> <li>2. Low Cost</li> <li>3. Fairly portable</li> <li>4. Subsurface capability</li> </ol>	<ol style="list-style-type: none"> <li>1. Alignment of magnetic field is critical</li> <li>2. Must demagnetize after the test</li> <li>3. Must clean magnetic dust after test</li> <li>4. Surface coating masks results.</li> </ol>
EDDY CURRENT	<ol style="list-style-type: none"> <li>1. Surface and shallow Subsurface defects</li> <li>2. Alloy content</li> </ol>	<ol style="list-style-type: none"> <li>1. Tubes</li> <li>2. Wires</li> <li>3. Ball Bearings</li> </ol>	<ol style="list-style-type: none"> <li>1. High Speed</li> <li>2. Automated</li> <li>3. Gives Permanent Record</li> </ol>	<ol style="list-style-type: none"> <li>1. Need a Conductive material</li> <li>2. Requires reference standard</li> <li>3. Shallow defects only</li> <li>4. Standard Geometry only</li> </ol>
ULTRASONIC (UT)	<ol style="list-style-type: none"> <li>1. Internal Defects</li> <li>2. Material Thickness</li> <li>3. Delaminations in Composites</li> <li>4. Young's Modulus</li> </ol>	<ol style="list-style-type: none"> <li>1. Welds/Brazed Joints</li> <li>2. Wrought Metals</li> <li>3. Hull Thickness</li> <li>4. In-Service Parts</li> </ol>	<ol style="list-style-type: none"> <li>1. Most sensitive to Cracks</li> <li>2. Results known Immediately</li> <li>3. Permanent record</li> <li>4. Portable</li> <li>5. High Penetration</li> </ol>	<ol style="list-style-type: none"> <li>1. Only on limited Geometries</li> <li>2. Need Trained Operators</li> </ol>

## 5.6 Other Engineering Materials

In your Navy career you will undoubtedly work with equipment that is not made of steel, aluminum or even metal. These other materials may be used for varying reasons: strength, weight, cost, corrosion resistance, manufacturability, etc. Below you will find a short description of some other common engineering materials: glass reinforced plastic (GRP), fiber reinforced plastic (FRP), ceramics, and concrete.

*Glass Reinforced Plastic (GRP)* – Also known as fiberglass, glass reinforced plastic is made by using glass fibers to reinforce plastic matrices (such as polyester or epoxy) in order to form structural composite and molding materials. GRP materials have high strength to weight ratios, good resistance to heat, cold, moisture and corrosion, are easy to fabricate and are relatively inexpensive. GRP materials are used in applications all around you: boats, cars, insulation, etc. The largest one-piece GRP component made is the sonar-dome of a *Trident* submarine.

*Fiber Reinforced Plastic (FRP)* – Carbon or aramid polymer fibers are used to reinforce plastic matrices to form structural composite and molding materials. FRP materials have high strength to weight ratios and large moduli of elasticity (E). These properties make FRP very attractive in aerospace, marine, and some automotive applications. Kevlar is an example of an aramid FRP made by DuPont. High-end FRP products include the *JSF* Wings, spars, ship propeller shafts, and golf clubs. FRP materials are generally more expensive than GRP.

*Ceramics* – Ceramic materials are typically hard and brittle with low toughness and ductility. Ceramics have high melting temperatures and are stable in many adverse environments. Engineering ceramics typically consist of compounds such as aluminum oxide, silicon carbide, and silicon nitride. These hard, heat resistant materials lend themselves well to applications such as engine design (e.g., gas turbine components) and circuit boards. The “skin” of the Space Shuttle is comprised of ceramic tiles.

*Concrete* – Concrete is the most common engineering material used in structural construction due to its low cost, durability, and ease of fabrication. Its disadvantages include low tensile strength and low ductility. Concrete is comprised of coarse material (aggregate) embedded in cement paste (binder).



At this point, you should be able to prove that it is possible to build a barge (that will float) entirely out of concrete ( $\rho_{\text{concrete}}=150 \text{ lb/ft}^3$ ).

## PROBLEMS - CHAPTER 5

### Section 5.2 Stress & Strain

1.
  - a. What two things does stress compare? Write the equation for stress using the quantities compared.
  - b. A 2 in diameter circular steel cable is being used to lift a hydrofoil out of the water. The vessel has a weight of 200LT, calculate the stress in the cable.
2.
  - a. What two things does strain compare? Write the equation for strain using the quantities compared.
  - b. A 30 ft long cable is strained to 0.01 in/in when lifting a load. Calculate its elongation.
3. Give two examples of normal and shear loads.

### Section 5.3 Stress/Strain Diagrams

4. Sketch a stress-strain diagram and show the following:
  - a. Elastic Region
  - b. Yield Strength
  - c. Plastic Region
  - d. Strain Hardening
5. Describe with the aid of your sketch in Question 4 how the elastic modulus of a material can be calculated from a stress strain diagram.
6. A 60 ft long, 1 in diameter circular steel cable is being stressed to 30,000 psi. The material has a  $\sigma_Y$  of 43,000 psi,  $\sigma_{UTS}$  of 72,000 psi and  $E = 29 \times 10^6$  psi.
  - a. Calculate the magnitude of the force causing the stress.
  - b. Is the cable operating in the plastic or elastic region? Explain your answer.
  - c. Calculate the strain in the cable.
  - d. Calculate the length of the cable while it is being subjected to this stress.

7. Tensile testing was performed on three different materials. Each test sample had a diameter of 0.5 inches and a gage length of 2.25 inches. Test data is recorded in the following table.

Test Data	Material #1	Material #2	Material #3
Load at yield point (lb)	5,880	7,840	7,840
Elongation at yield (inch)	0.0038	0.0034	0.01
Maximum load (lb)	8,036	11,760	8,836
Elongation at maximum load (inch)	0.005	0.25	0.20
Load at fracture (lb)	7,900	9,200	8,100
Elongation at fracture (in)	0.0055	0.50	0.35

- a. Using the test data, calculate each material's yield strength, ultimate tensile strength, and elastic modulus.
  - b. On the same set of axes, plot stress-strain diagrams for each material.
8. What is Plastic Deformation?

### Section 5.4 Material Properties

9. On the same set of axes, draw the stress-strain diagrams for a ductile material and a brittle material. Indicate how toughness could be measured from the diagrams.
10. Using the tensile test data in Question 7, which material is the most ductile, most brittle, strongest, and toughest.
11. Sketch a typical Charpy V-Notch toughness curve showing the following Transition Temperature, Brittle Region and the Ductile Region. How does the toughness measured from this test compare with that described in Question 9.
12. State the effect of lowering temperature on the properties of ductility and toughness. Draw a stress-strain diagram and Charpy diagram to show the effects you described.
13. What material property is sacrificed by strain hardening a material? What is gained? Use a diagram to illustrate your explanation.
14. What is fatigue of a material? What is the Endurance Limit of a material? Name one material which has an Endurance Limit and one which does not.



15. Why would it be to the advantage of an engineer to design something using a brittle material. Give a military example of the use of a brittle material.
16. Cast iron (and most cast materials in general) is an inherently brittle material, yet it is commonly used for engine blocks. What advantage is there to using such a brittle material for an application involving high temperatures?
17. A CH-53E helicopter is rated to lift a 25,000 lb suspended load. A steel wire rope pendant is used to lift the load. Wire rope has the following properties:  $E = 14 \times 10^6$  psi,  $\sigma_Y = 100,000$  psi. To ensure that the pendant does not break, it is desired that the pendant be able to carry twice its rated load. Calculate the minimum diameter rope required for the lifting pendant.
18. A crane rigged with 1 inch diameter wire rope ( $E = 12 \times 10^6$  psi,  $\sigma_Y = 93,000$  psi) is to lift a 20,000 lb bridge section into place.
  - a. Calculate the stress present in the cable.
  - b. Prior to lifting the bridge section, the cable was 150 ft long. How many inches will the cable stretch when lifting the 20,000 lb load?
  - c. What is the maximum load the cable can carry without causing permanent deformation?
  - d. What is the minimum diameter of cable that can be used without causing permanent deformation of the cable?
  - e. It is desired that the crane lift a load weighing 50,000 lb. What can be done to enable the crane to perform the lift?
19. As a Marine 2LT, you have been tasked to build a support for a 500 gallon fuel tank at a forward refueling point ( $\rho_{\text{fuel}} = 1.616 \text{ lb-s}^2/\text{ft}^4$ ). When empty, the tank weighs 200 lbs. To enable proper fueling of vehicles, the bottom of the tank must be 7 ft above the ground, and must be supported by 4 legs. Calculate the minimum cross-sectional area of each leg if the legs are made out of:
  - a. Mild (1018) steel:  $E = 30 \times 10^6$  psi,  $\sigma_Y = 29,000$  psi
  - b. Aluminum alloy:  $E = 10.4 \times 10^6$  psi,  $\sigma_Y = 40,000$  psi
  - c. HY-80 steel:  $E = 30 \times 10^6$  psi,  $\sigma_Y = 80,000$  psi

20. A long wire,  $\frac{1}{2}$  inch in diameter is hanging vertically in air under its own weight. What is the greatest possible length the wire may have without yielding if the wire is made of:
- Steel, having a yield stress of 40,000 psi and a weight density of 490 lb/ft<sup>3</sup>.
  - Aluminum, having a yield stress of 20,000 psi and density of 170 lb/ft<sup>3</sup>.
  - Copper, with a yield stress of 48,000 psi and density of 556 lb/ft<sup>3</sup>.

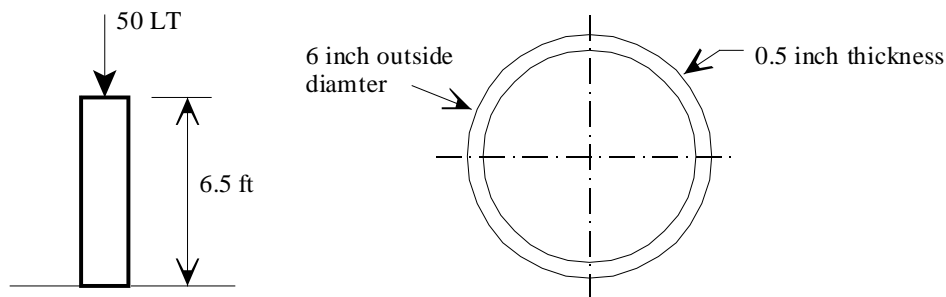
21. A ship's berthing compartment is flooded 60% full with sea water. The compartment has the following dimensions:

Length = 50 ft  
 Width = 40 ft  
 Height = 12 ft  
 Permeability = 90%

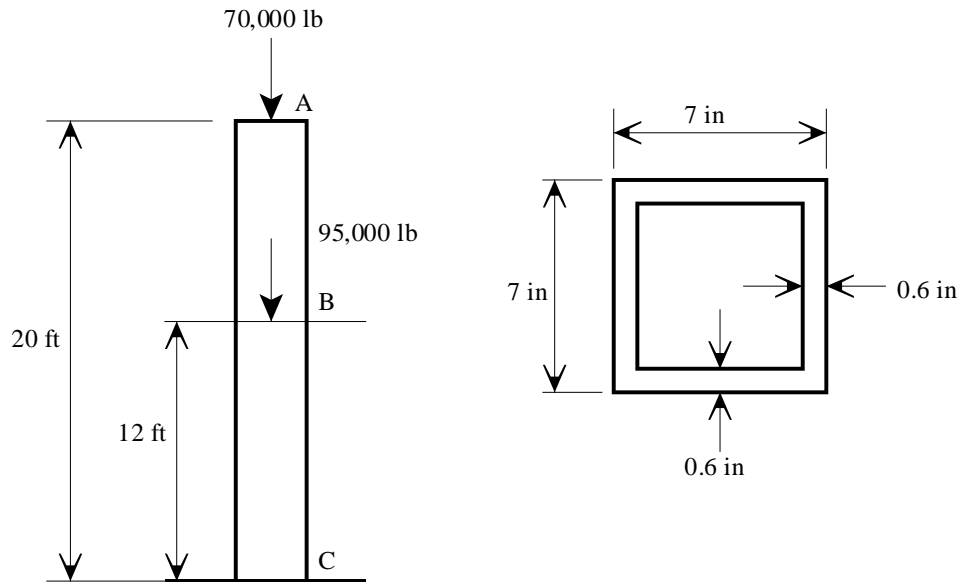
The compartment's deck is in danger of collapsing. To prevent collapse, you must shore the deck. The only shoring material available is wood ( $E = 1.6 \times 10^6$  psi,  $\sigma_Y = 4,000$  psi).

- Calculate the total cross section area of shoring required to support the deck (neglect punch-through).
  - If the only shoring available is 4x4 lumber, how many 4x4's will be required to support the deck?
22. A circular pipe stanchion has an outside diameter of 6 inches and a wall thickness of  $\frac{1}{2}$  inch. When supporting a 50 LT load, the stanchion is 6.5 feet high. The stanchion is made of aluminum alloy with the following properties:  $E = 10.4 \times 10^6$  psi,  $\sigma_Y = 30,000$  psi.

- Calculate the stress in the stanchion. Is this stress tensile or compressive?
- Calculate the length of the stanchion prior to applying the 50 LT load.
- Calculate the maximum weight the stanchion can support without yielding.

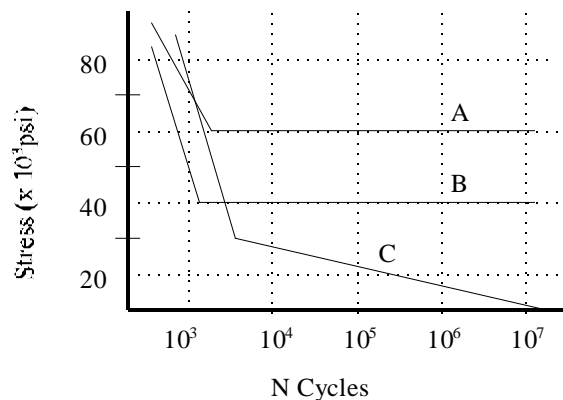


23. A steel column is being used to support a two story building as shown below. The column stands 20 ft high and has a cross-section as shown. The roof load at Point A is 70,000 lb and the weight of the first floor is 95,000 lb and acts at Point B.



- Neglecting the weight of the column, calculate the stress present at the base of the column (Point C).
- Neglecting the weight of the column, calculate the stress in the column at Point B.
- If the column weighs 53 lb/ft, what is the stress at Point C?

Shown below is a fatigue diagram for three different materials. Use this figure for problems 24-27.



24. What is the endurance limit for each material shown in the fatigue diagram?
25. It is desired that the crankshaft for an engine should have an indefinite life. Which material would you choose to use? Why?
26. Material "B" has been selected for an application requiring an indefinite life. What is the minimum cross-section area required to meet that particular design requirement?
27. Material "C" has been chosen to be used in an aircraft wing. The predicted level of stress in the wing is 20,000 psi.
  - a. How many cycles can the wing withstand before failure?
  - b. This particular aircraft is designed to have a maximum flight time of 3 hours and research shows that the wing will flex 100 times per flight. How many flight hours will the wing last?
  - c. Why would material "C" be selected for use in an aviation application?

### **Section 5.5 Non-Destructive Testing**

28. Which NDT's are surface inspections, and which are subsurface inspections?
29. Which NDT inspection can only be used on ferro-magnetic materials?
30. Condenser tubes are made of copper and are very difficult to inspect. They must be tested for wall thickness periodically to ensure they will not fail. Which two NDT methods are appropriate for determining tube wall thickness?
31. Which NDT inspection should be done throughout all maintenance procedures?
32. Which NDT inspection involves ionizing radiation? During the conduct of this procedure, you will be required to take numerous precautions including the establishment of boundaries, and possibly the removal of personnel from adjacent spaces.
33. What is a Hydrostatic Test and when is it used?

34. You are assigned to a salvage ship recovering an F-18 located in 160 ft of water. The ship's salvage crane is rigged with 2 inch diameter wire rope ( $E = 15 \times 10^6$  psi,  $\sigma_Y = 80,000$  psi). Prior to crashing, the aircraft had a known weight of 73,000 lb.
- The tech manual you are using for the salvage operation states that a submerged F-18 has a lifting weight of 70,000 lb. Why is the lifting weight less than the known weight?
  - Calculate the stress in the wire rope during the submerged porting of the salvage operation.
  - How many inches will a 130 ft length of rope stretch with the aircraft attached?
  - Once the aircraft clears the water, the crane must support the entire 73,000 lbs of aircraft weight. What is the stress in the cable after the aircraft clears the water?
  - What is the minimum diameter of rope that can be used to lift the aircraft?
  - What NDT should be performed prior to any lifting operation?
  - As the diameter of wire rope increases, the stress in the rope will decrease. What are some disadvantages of using larger diameter rope?

The salvage ship has the following dimensions and hydrostatic parameters:

$L_{pp} = 240$ ft	$TPI = 21.3$ LT/in	$LCF = 13$ ft aft of amidships
$B = 51$ ft	$MT1'' = 470$ LT-ft/in	$LCB = 6$ ft aft of amidships
$T = 13$ ft	$KM_T = 19.2$ ft	$D = 40$ ft
$\Delta = 3150$ LT	$KM_L = 456$ ft	
$KG = 12.5$ ft on centerline	$KB = 7.6$ ft	

- The crane is located 13 ft aft of amidships. How much does the ship's draft change when lifting the aircraft?
- Suspended weights are assumed to act at the head of the crane's boom. Assuming the base of the crane is located on the ship's centerline and that the boom is 50 ft in length and makes an angle of  $50^\circ$  with the deck, what is the vertical and transverse location of the ship's center of gravity while lifting the aircraft? The bottom of the crane is located 40 feet above the keel.
- At what angle is the ship listing?
- While lifting the aircraft, is the ship more stable, or less stable? Why?

# COURSE OBJECTIVES

## CHAPTER 6

### 6. SHIP STRUCTURES

1. Qualitatively describe:
  - a. How shear stress is created in a ship structure
  - b. The effect of shear stress on a ship structure
  - c. why longitudinal bending is created in a ship structure
  - d. the effect of longitudinal bending moments on a ship structure
  - e. Hull-superstructure interaction, including use of expansion joints
2. Define hogging and sagging.
3. Identify waves which can increase hogging and sagging.
4. Define the neutral axis of a structural cross section and know its significance to bending stress.
5. Use the elastic flexure formula to describe the distribution of bending stress in a section.
6. Be qualitatively familiar with hull-superstructure interaction, including the use of expansion joints.
7. Identify the following structural components:
  - a. Keel
  - b. Plating
  - c. Frame
  - d. Floor
  - e. Longitudinal
  - f. Stringers
  - g. Deck Beams
  - h. Deck Girders
8. Be familiar with the basic purposes, advantages and disadvantages of transverse and longitudinal framing elements.
9. Describe what constitutes a double bottom.
10. Be qualitatively familiar with the following modes of structural failure:
  - a. Tensile/Compressive Yield
  - b. Buckling
  - c. Fatigue
  - d. Brittle Fracture

## 6.1 Unique Aspects of Ship Structures

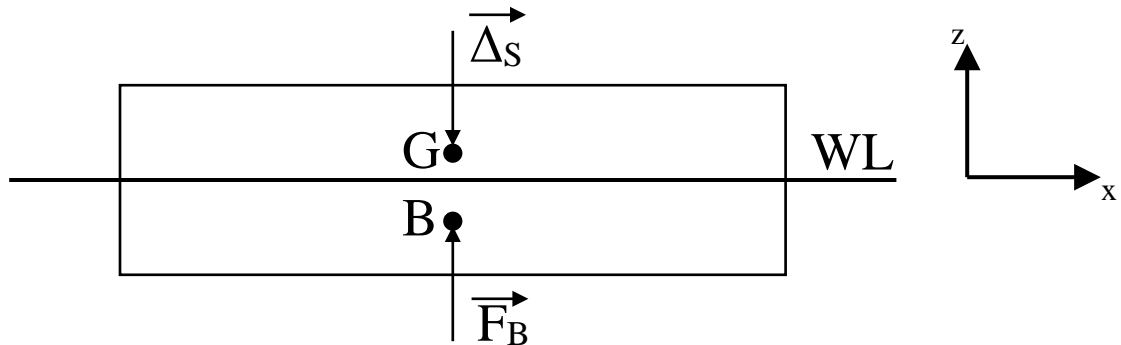
Ship structures are unique in many ways:

- Ships can be gargantuan in their proportions. A *Nimitz* class aircraft carrier displaces about 97,000 LT, and is roughly 1115 ft by 252 ft.
- The loads these structures are subjected to are dynamic and random. Loads may range from small equipment vibrations to extreme wave impacts on the hull. Cargo weight and distribution also play a significant role in the structural requirements and response of a ship.
- The outer skin and supporting structure are multi-purpose. They not only keep the water out, but also subdivide the interior, act as a cargo carriage, and enhance safety.
- Unlike a building, a ship structure is a complicated three-dimensional shape subjected to a variety of directional loads that are cyclic in nature. The shape is determined more by resistance, powering, and internal arrangement considerations than by the desire to optimize the structure's shape for load carrying capability.
- Furthermore, ship structures are designed in the face of uncertainty in both demand and capability. The environment in which the ship will operate and the actual operational profile the ship will follow are usually unknown when the ship is designed and built. The precise material properties over time, the quality of workmanship during construction and maintenance, the shortcomings of analytical models, and the random nature of some failure modes (fatigue, corrosion) present the designer additional dilemmas.
- Naval ships operate in a combat environment. They must be able to resist underwater explosions, gunfire, blasts and projectiles. The shock produced by a ship's own weapons (16 inch guns, rockets) and nuclear air blast loading must factor into the design as well.
- In the face of all these requirements, considerations and uncertainties, a ship structure must also be lightweight, not take up space needed for other things, and cost as little as possible.

## 6.2 Ship Structural Loads

### 6.2.1 Distributed Forces

So far in this course we have considered the 2 principle forces associated with weight and buoyancy of a ship to be the resultant forces of Displacement ( $\Delta_S$ ) and the Buoyant Force ( $F_B$ ). These forces pass through the 2 centroids of the center of gravity (G) and center of buoyancy (B) respectively. Provided  $\Delta_S$  and  $F_B$  are equal in magnitude and the centroids G and B are vertically in line, the vessel is said to be in a state of static equilibrium. Figure 6.1 shows this situation.

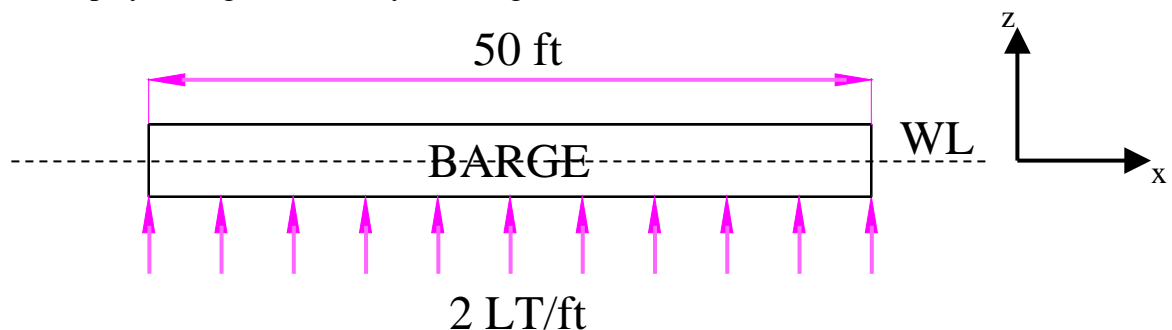


**Figure 6.1** Floating Body in Static Equilibrium

In fact, this representation is a convenient approximation to the true situation on a ship.  $\Delta_S$  and  $F_B$  are the resultant forces associated with 2 distributed forces along the length of a ship.

#### 6.2.1.1 Distributed Buoyancy

In structural analysis, it is convenient to consider the buoyant force ( $F_B$ ) as a distributed force. This is often displayed diagrammatically as in Figure 6.2.



**Figure 6.2** Box Shaped Barge with Distributed Force

Figure 6.2 represents a uniformly distributed buoyant force. This type of distribution is very rare and would be associated with a box-shaped barge floating at level trim.

ⓘ Despite its rarity, this simple distribution pattern will be used in this course to represent the distributed buoyant force.

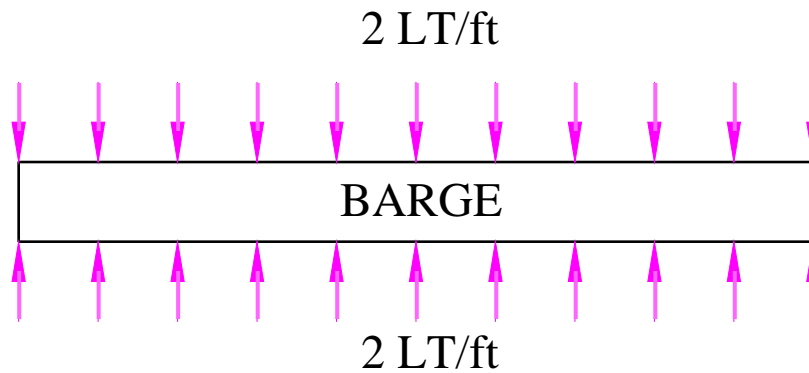


It is a fairly straightforward calculation to determine the overall buoyant force represented at Figure 6.2. The figure shows a force of 2 LT/ft over a 50 ft long barge. Hence:

$$F_B = 2 \frac{LT}{ft} * 50ft = 100 LT$$

### 6.2.1.2 Distributed Weight

In a similar manner to the buoyant force, the weight of a vessel is more accurately represented as a distributed force along its length. For example, the box shaped barge described at Figure 6.2 could also have a uniformly distributed weight down its length. It is evident that to place the barge in static equilibrium, the magnitude of this force would have to match the magnitude of the distributed buoyant force. Figure 6.3 displays this situation.

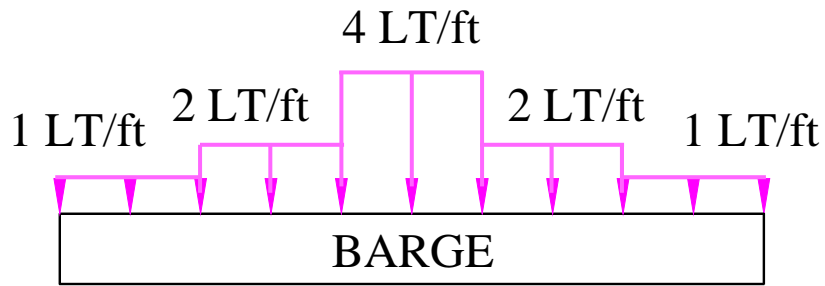


**Figure 6.3** Box Shaped Barge with Distributed Buoyant Force and Displacement

Calculations similar to that for the buoyant force can be performed to reveal the magnitude of the resultant displacement ( $\Delta_s$ )

$$\Delta_s = 2 \frac{LT}{ft} * 50 ft = 100 LT$$

In practice, the weight of a vessel is not typically uniformly distributed. Elements of a ship such as engines, cargo and superstructure often provide an uneven distribution of weight along a vessels length. For example, the box shaped barge carrying cargo in its center holds could have a distribution as described at Figure 6.4.



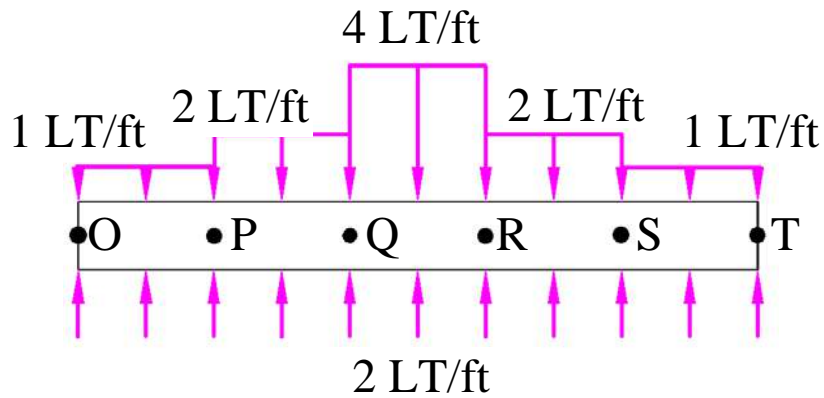
**Figure 6.4** Realistic Weight/Displacement Distribution

As before, the resultant displacement ( $\Delta_S$ ) can be calculated.

$$\Delta_S = \left[ \frac{1}{5} * \frac{1 \text{ LT}}{\text{ft}} + \frac{1}{5} * \frac{2 \text{ LT}}{\text{ft}} + \frac{1}{5} * \frac{4 \text{ LT}}{\text{ft}} + \frac{1}{5} * \frac{2 \text{ LT}}{\text{ft}} + \frac{1}{5} * \frac{1 \text{ LT}}{\text{ft}} \right] * 50 \text{ ft}$$

$$\Delta_S = 100 \text{ LT}$$

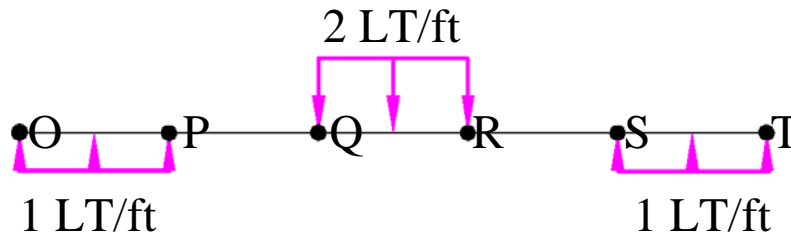
To achieve static equilibrium, the magnitude of the buoyant force  $F_B$  would have to equal this displacement. Consequently, the overall distributions of both displacement and buoyancy for the box shaped barge would be as depicted in Figure 6.5.



**Figure 6.5** Overall Buoyancy and Displacement Distributions

## 6.2.2 Shear Stress

An analysis of the distributed forces on the box shaped barge at Figure 6.5 soon reveals the presence of significant shear stress at points P, Q, R, and S. This is easily acquired by summing the forces vertically at each point down the vessel to produce the overall force distribution as described at Figure 6.6. This is often referred to as the load diagram.



**Figure 6.6** The Load Diagram

Figure 6.6 clearly represents the shear planes being generated within the hull of the barge at these points.

### 6.2.2.1 Reducing Shear Stress

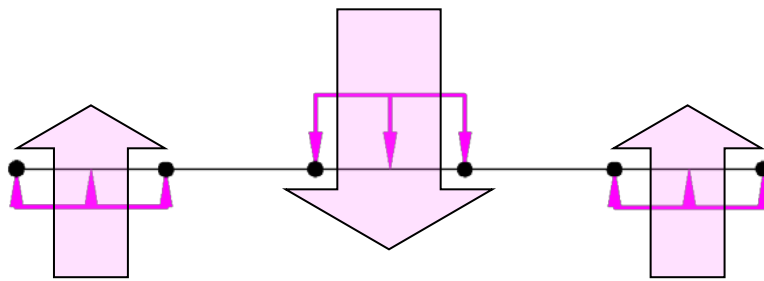
The effects of shear stress described above could be minimized in two ways.

- The shape of the underwater hull of the barge could be altered so that its buoyancy distribution matched that of the weight distribution. There are 2 problems with this:
  - a. The step like shape would be very inefficient with regard to the resistance or drag force associated with the hull.
  - b. For a vessel such as the barge, the weight distribution will change every time a loading or unloading operation is performed.
- The hull's strength could be concentrated in areas known to be subjected to large shear forces.

This last method is obviously more feasible. An analysis as described above can easily identify areas of a ship where shear forces will be generated. Using higher strength materials or increasing the cross sectional area of the ship structure at these points will reduce the possibility of the structure failing due to shear.

## 6.2.3 Longitudinal Bending Stress

A further analysis of the load diagram at Figure 6.6 quickly reveals the presence of a bending moment being applied to the vessel. Figure 6.7 repeats the load diagram and shows this bending effect.



**Figure 6.7** Load Diagram Showing Longitudinal Bending

The greater concentration of buoyancy at the bow and stern, and the concentration of weight at the center has an overall effect attempting to bend the barge in the middle. The magnitude of the bending moment could be found by integrating the shear force over the length of the ship.

### 6.2.3.1 Sagging

The force distribution at Figure 6.7 is making the barge appear to “sag” in the middle, consequently this bending condition is referred to as “sagging.” This condition is analogous to resting a ruler between two surfaces and pressing down on its middle.

The “sagging” longitudinal bending condition is creating significant stresses in the structure termed bending stresses. The bending direction is stretching the lower portion of the structure, hence tensile stresses are being created in the keel region. Conversely, the weather deck is being placed in compression because the bending direction is trying to shorten this part of the structure.

### 6.2.3.2 Hogging

A reversal of the overall weight distribution at Figure 6.7 would result in the opposite bending condition being created. This is called “hogging.” In this condition the overall weight is greatest near the bow and stern, with buoyancy being larger near midships. This has the effect of bending the structure in the other direction, placing the keel in compression and the deck in tension.

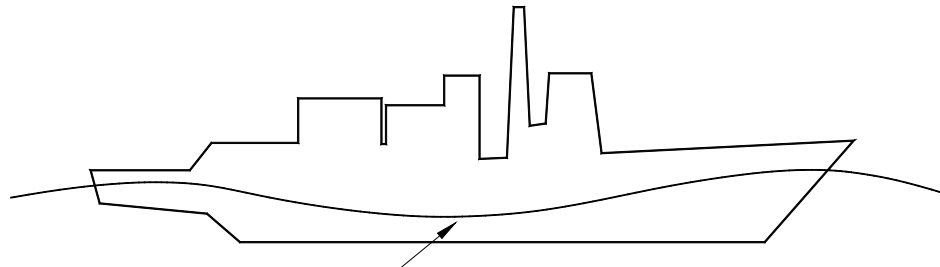


You may wish to use the analogy of carrying a pig over your shoulder to remember the term “hogging.”

### 6.2.3.3 Wave Effects

In addition to the still water effects described so far, the presence of waves can further increase the magnitude of bending stresses being created in a ship structure.

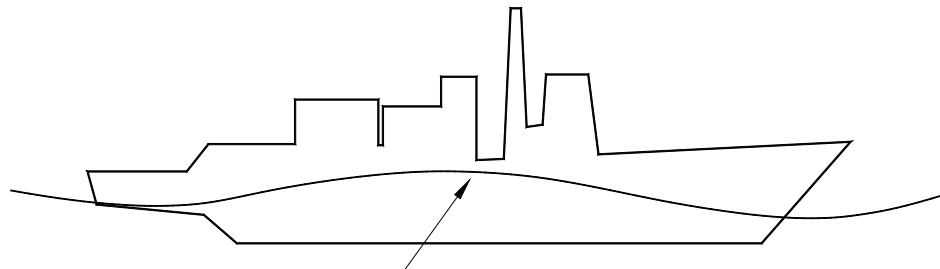
For example, if a ship is subjected to the wave shown at Figure 6.8 with crest at the bow and stern, the buoyant force will be concentrated more at the ends than in the middle, because less of the middle of the ship is underwater. The net effect is that the middle gets less support, the ends get more support, and the ship wants to sag in the middle, hence sagging.



Wave Trough at Midships

**Figure 6.8** Sagging in Waves

Conversely, if the wave crest is amidships, then a hogging condition will result. More of the underwater volume is concentrated amidships, increasing the upward forces there while the ends of the ship receive less support. Pushing up more in the middle can give the ship a negative curvature as shown at Figure 6.9.



Wave Peak at Midships

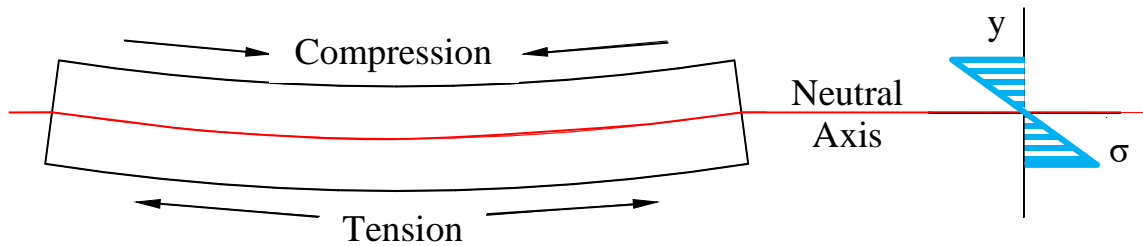
**Figure 6.9** Hogging in Waves

The worst case bending moments occur when the length of the ship is nearly equal to the length of the waves.

#### **6.2.3.4 Quantifying Bending Stress**

During the structural analysis of a ship it is important that the magnitudes of any bending stresses being created by sagging and hogging conditions can be quantified. In this analysis it is convenient to model the ship structure as a box shaped beam, all calculations can then be performed using simple beam theory.

Figure 6.10 shows the arrangement used to describe the sagging condition. As discussed previously, sagging creates a compression in the deck and tension in the keel.



**Figure 6.10** Variation in Bending Stress Across a Sagging Beam

Obviously, there must be a transition between tension and compression in a section, this is called the neutral axis. The position of the neutral axis is easily found as it is also the geometric centroid of the cross section.

With the neutral axis found, the actual bending stresses being experienced by the ship structure are easily quantified by using the elastic flexure formula.

$$\text{Bending Stress } (\sigma) = \frac{M \cdot y}{I}$$

where  $M$  = the bending moment in LT-ft. This can be found from an analysis of the overall load diagram such as that at Figure 6.6.

$I$  = the second moment of area of the cross section of the structure in  $\text{ft}^4$ . This is measured from the dimensions of the ship structure.

$y$  = the vertical distance from the neutral axis.

Figure 6.10 shows the variation in bending stress being created in the section of a ship at different distances from the neutral axis. Notice it is a linear relationship. By convention, compressive stress is negative and tensile stress is positive.

The bending stress is zero at the neutral axis where  $y = 0$  ft.

The bending stress is maximum at the deck and keel where  $y$  is at its largest.

**Student Exercise** In the space below, redraw Figure 6.10 to show a ship structure in a hogging condition. Beside your drawing, sketch how the bending stress alters from the keel to the deck.

### 6.2.3.5 Reducing the Effects of Bending Stress

Clearly, bending stress is a major cause of concern in establishing a safe ship structure. Unfortunately, because the ship is designed to go to sea where it will experience wave action, there is no method of removing the presence of bending moments. However, an analysis as described above can allow the areas of the ship that will experience the greatest bending stresses to be determined.

Typically, bending moments are largest at the midship area of a ship. Also, because of the elastic flexure formula, it is clear that the keel and deck will experience the greatest magnitude of bending stress. Consequently, it is important that these areas have sufficient strength to combat these stresses. Higher strength steels are common in these regions, and the cross sectional area of longitudinal structural elements increases the as you move further from the neutral axis.

### 6.2.3.6 Hull - Superstructure Interaction

Due to its distance from the neutral axis, bending stresses in the superstructures of ships can be very large. Unfortunately, it is often undesirable to use high strength materials or structural elements with large cross sections in the superstructure due to the problems this could create with stability. Consequently, other methods of reducing stress must be found.

One solution is the use of expansion joints. The primary reason for using expansion joints involves the shear between the deck and the superstructure. If a ship is hogging, then the deck is under tension. The deck also makes the bottom of the superstructure curve by pulling it outward, or placing it in tension. This outward pull, or shear load, between the superstructure and the hull is aggravated by the sharp corners where the hull and superstructure connect. As a result, ships like those having *Ticonderoga* (CG 47) class hulls experience concentrated cracking in these areas. This is also a potential problem for the *Arleigh Burke* (DDG 51) class destroyers and YP-703.

Another solution is to break the superstructure up into short sections. However, this is often unsatisfactory in terms of space efficiency and ship habitability.

⚠ *USS Princeton* (CG 59) struck a mine during Desert Storm. As a result of the explosion and the large stresses placed on the hull, 10% of the superstructure separated from the main deck.

### 6.2.3.7 Actual Ship Bending Analysis

(OPTIONAL)

Ships are designed to withstand stresses caused by being balanced on a wave of a particular length and height. In so-called standard strength calculations, the length of the wave is assumed to be equal to the length of the ship and the height is assumed to be  $L/20$  ft. Such standard calculations are performed assuming static conditions. The resulting stresses can therefore only be used as a basis of comparison between ships of similar types engaged in similar mission under similar conditions.

The resulting stresses in the ship are based on the maximum longitudinal bending moment derived from the graphical integration of the load curve. This load curve is obtained by plotting the algebraic difference between the weight and buoyancy at successive points along the length of the ship similar to that of Figure 6.6. However, instead of using a uniformly distributed buoyant force, the true buoyant force distribution is determined by an analysis of the change in submerged sectional area down the length of the ship.

#### **6.2.4 Hydrostatic Loads**

Another major source of loading on a ship is that associated with hydrostatic pressure. This force can be considerable, especially in submarines and submersibles, and is constantly attempting to crush the sides of a ship.

Calculation of the load associated with hydrostatic pressure is fairly straightforward as the pressure at any depth is given by the following:

$$P = P_{atm} + \rho gh$$

#### **6.2.5 Torsional Loads**

Torsional loads are often insignificant, but they can have an effect on ships with large openings in their weatherdeck. This is often desirable on merchant ships such as container vessels where large deck openings make for efficient space utilization and faster loading/unloading times.

#### **6.2.6 Weapon Loads**

For military ships, another major load can be created by the impact of explosions both in the air, underwater and directly against a ship structure. Ships must be designed and manufactured with sufficient strength to resist these forces.

To assess ship survivability after a weapon impact, military ships will often go through a series of Shock Trials during their Sea Trials. For example, a whole series of Shock Trials at increasing levels of intensity were performed on a DDG 53 to assess current design practices and ship building methods.



### 6.2.7 Hull Deflection

You may have noted that up to this point no mention has been made about what type of material is used in the hull construction. Recall from section 6.2.3.4 that bending stress is solely a function of the applied moment and hull geometry. This is not to say that the choice of material is not important. In fact, the material characteristics, most notably, the Elastic Modulus (E) has a large impact on *how much* the hull bends under an applied moment. Under the same loading (i.e., bending moment) a more ductile material, such as aluminum will bend more than something less ductile, like steel. Again, the amount of deflection also depends upon the geometry of the hull.

$$\text{total hull deflection} \propto \frac{ML^2}{EI}$$

where:

- M = the maximum bending moment in LT-ft.
- I = the second moment of area of the cross section of the structure in ft<sup>4</sup>.
- E = the Elastic Modulus in LT/ft<sup>2</sup>
- L = the length of ship in ft

## 6.3 Ship Structure

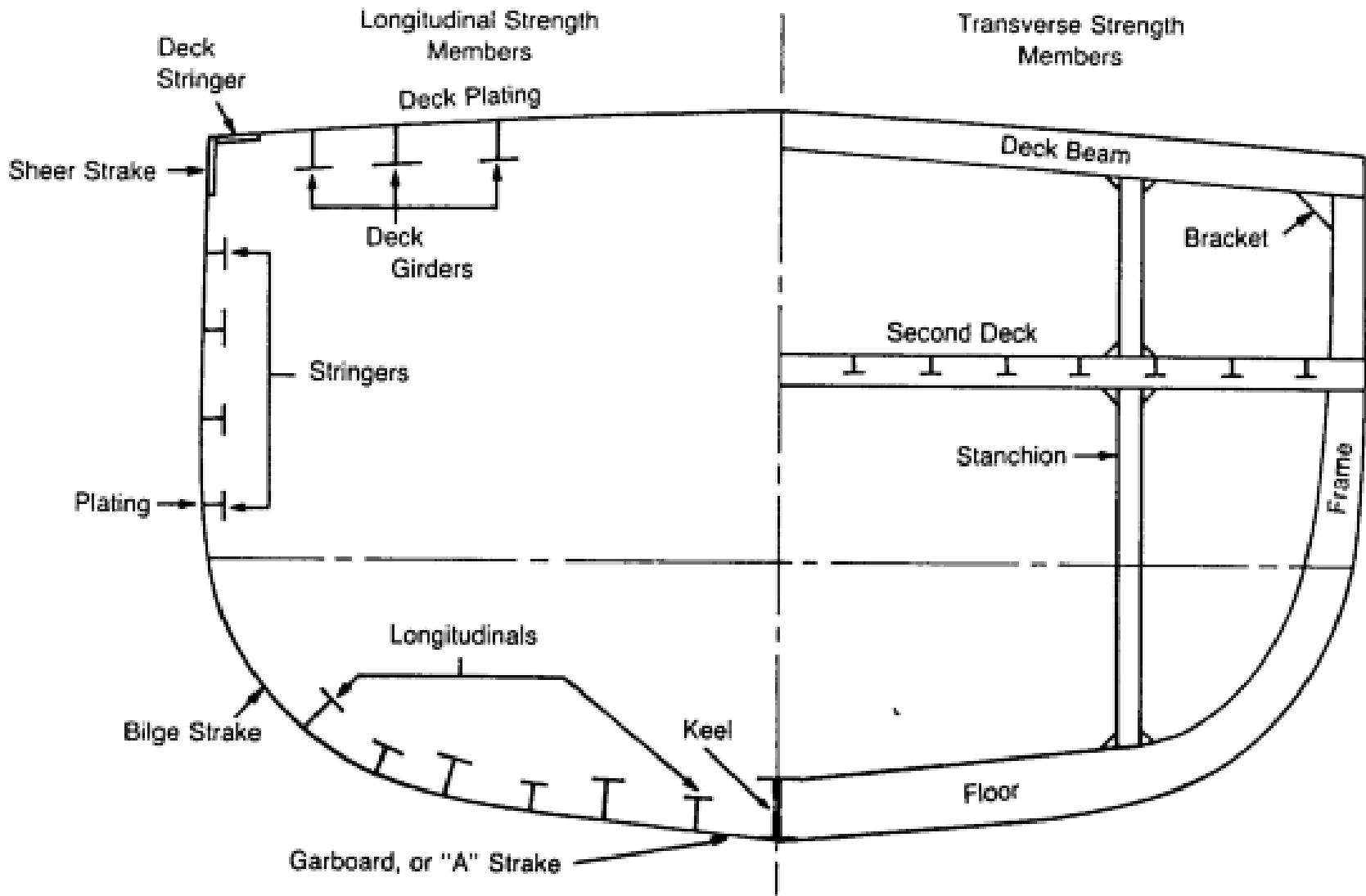
A ship structure usually consists of a network of plates and supporting structure.

The supporting structure consists of large members running both longitudinally and transversely and is often known as the frame. The ship plating is attached to the frame.

### 6.3.1 Structural Components

Figure 6.11 repeated from “Introduction to Naval Architecture” by Gilmer and Johnson shows the structural components listed below.

<b><i>Keel</i></b>	A large center plane girder running longitudinally along the bottom of the ship, usually the strongest structure due to its size. Commonly referred to as the ship’s backbone.
<b><i>Plating</i></b>	Thin pieces closing in the top, bottom, and sides of the structure. Plating makes a significant contribution to longitudinal hull strength, and resists the hydrostatic pressure load.
<b><i>Frame</i></b>	A transverse member running continuously from the keel to the deck. Resists transverse loads (i.e. - waves hitting the side of the ship and hydrostatic pressure). Commonly referred to as ribs.
<b><i>Floor</i></b>	Deep frames running from the keel to the turn of the bilge. Frames may be attached to floors - the frame would be that part above the turn of the bilge. Note: in the Navy, we do not refer to floors as we do everywhere else! What you walk on is the deck, not the floor!
<b><i>Longitudinal</i></b>	Girders which run parallel to the keel along the bottom of the ship. Longitudinals intersect floors at right angles, and provide longitudinal strength along the bottom of the hull.
<b><i>Stringers</i></b>	Girders running along the sides of the ship against plating. Typically smaller than longitudinals, they also provide longitudinal strength.
<b><i>Deck Beams</i></b>	Transverse members of the deck frame.
<b><i>Deck Girders</i></b>	Longitudinal members of the deck frame.



**Figure 6.11** Typical Transverse and Longitudinal Strength Members

### 6.3.2 Framing Systems

The number and size of the different framing elements used in the construction of a ship's frame is dependent upon a number of different factors. Clearly, it would be possible to make a ship very strong simply by adding more and more framing elements and increasing the thickness of its plating. However, this would make the ship increasingly inefficient in terms of space utilization and eventually cause it to sink when its displacement exceeded its possible buoyant force!

There has to be a compromise between the requirements of strength and the conflicting but equally important requirements of buoyancy, space utilization and cost. This compromise is to use an appropriate framing system to combat the types of load a particular ship is likely to encounter.

#### 6.3.2.1 Longitudinal Strength Members

The longitudinal elements such as the keel, longitudinals, stringers and deck girders described in 6.3.1 have a primary role in combating the longitudinal bending stress created by the ship sagging and hogging. These conditions are maximized when the ship's length is equal to the wave length of a wave. A typical wave length associated with an ocean wave is about 300 ft; consequently, ships of this length and greater are likely to experience considerable longitudinal bending. Shorter ships experience much lower levels of bending because they tend to "terrain follow" a wave like a roller coaster.

Consequently, ships that are longer than about 300 ft tend to have a greater number of longitudinal elements to their structures than transverse elements. This is taken to extremes in very long ships where their structure is almost totally based upon longitudinal elements. A ship framed in this manner is said to be *longitudinally framed*.

#### 6.3.2.2 Transverse Strength Members

The transverse elements such as frames and hull plating have a primary role to combat the hydrostatic load. For ships shorter than 300 ft and those designed to operate at large depths, this is the primary load of concern. Hence short ships and submarines have structures consisting of many frames and fairly thick plating. A ship structured in this manner is said to be *transversely framed*.

#### 6.3.2.3 Combination Framing System

Modern Naval vessels typically use a *Combination Framing System* which combines the other two methods. A typical combination framing network might consist of longitudinals and stringers with shallow web frames. Every third or fourth frame would be a deep web frame. The purpose of such a system is to optimize the structural arrangement for the expected loading, while minimizing weight and cost.

### **6.3.3 Double Bottoms**

Double bottoms are just that, two watertight bottoms with a void space in between. They are strong and can withstand the upward pressure of the sea in addition to the bending stresses. Double bottoms provide a space for storing fuel oil, fresh water (not potable), and salt water ballast. The structure can withstand considerable bottom damage caused by grounding or underwater blasts without flooding the ship provided the inner bottom remains intact. Also, a double bottom provides a smooth inner bottom. This makes it easier to arrange cargo and equipment while providing better accessibility for cleaning.

### **6.3.4 Watertight Bulkheads**

The structural element that has not been mentioned so far is the watertight bulkhead. These are large bulkheads that split the hull of a ship into separate sections. In addition to their stiffening of the overall ship structure, they have a primary role in reducing the effects of damage on a ship.

Ships are designed so that they can withstand specified levels of damage before water creeps onto the weather deck. The rules for the damage stability of USN ships were covered in chapter 4. The careful positioning of these watertight bulkheads allows the ship to fulfill these rules and withstand certain damage conditions.

To enable watertight bulkheads to fulfill their role and withstand the pressures associated with flooded compartments, they are stiffened by steel members in the vertical and horizontal directions.

## 6.4 Modes of Structural Failure

In structural analysis, the word "failure" must be carefully defined. Sometimes it means total collapse, other times it means that a certain stress level is exceeded although only slight permanent damage occurs. A structure can be designed to withstand great punishment with virtually no damage, but cost and weight usually makes such a design unfeasible. The four basic modes of failure that we will consider are:

- Tensile or compressive yield
- Buckling/Instability
- Fatigue
- Brittle Fracture

### 6.4.1 Tensile or Compressive Yield

*“Slow plastic deformation of a structural component due to an applied stress greater than yield stress.”*

The failure criteria for many structures is that the yield stress shall not be exceeded, and that there shall be no permanent deformation resulting from a load. To ensure this does not occur, a factor of safety is applied during the design of a ship's structure so that the largest expected stress is only 1/2 or 1/3 of the yield strength. Because most Naval ships spend almost all of their service lives sagging, placing the bottom structure in tension, this is typically a criteria placed on bottom structure.

### 6.4.2 Buckling

*“An unstable condition caused by the compression of long slender columns resulting in substantial dimensional changes and a sudden loss of stiffness.”*

The compressive load at which a structure will buckle is called its buckling or bifurcation load. There are numerous equations available to calculate this value and by using factors of safety similar to those mentioned in 6.4.1, it should be possible to design structures that will not buckle. Unfortunately, many of the compressive loads delivered to a ships structure are very difficult to estimate. In particular, impact loads created by rough seas cause problems.

Buckling is influenced by the geometry of the component, the type of material used in the component, how the component is loaded, and how the component is being held in place with respect to the loading (called its end or boundary conditions). To illustrate, get a plastic ruler and stand it up on a table lengthwise. Push down on the ruler lengthwise and note how much compressive force it takes for the ruler to buckle. Now, do it again, but while you are pushing down on the ruler also push in on the flat side of the ruler. You should have seen that it took much less force to cause the ruler to buckle. Try it again it with someone rigidly holding the end of the ruler on the desk and see how that effects the buckling load. Also, try using a wooden or metal ruler. In all cases, you should have noted that the ruler remained in its elastic region (except for maybe the wood!) and returned to its original shape when it was unloaded.

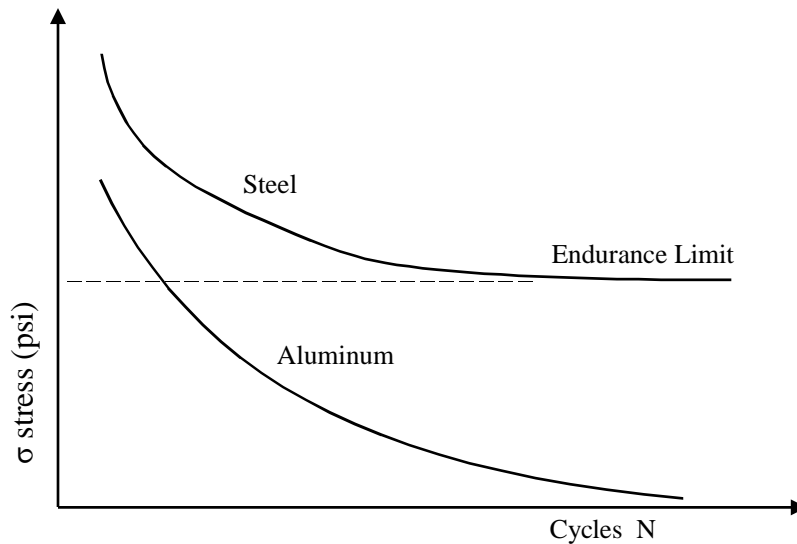
Buckling is likely to occur on cross-stiffened deck panels on a ship due to large compressive stresses from longitudinal bending. Some *Ticonderoga* class cruisers have had problems with deck buckling.

### 6.4.3 Fatigue Failure

*“The failure of a material from repeated applications of stress, such as from vibration.”*

You will recall from chapter 5 that fatigue failure can occur even though the Yield Strength of the material is never exceeded. Figure 6.12 shows a plot of stress vs number of cycles required to cause failure. As the applied stress becomes lower, the number of cycles required increases until the curve flattens out. This flat region implies that applied stresses below a certain level will not cause failure at any number of cycles.

The *Endurance Limit* is the stress below which the material will not fail from fatigue. Steel exhibits the fatigue characteristics described. Aluminum, on the other hand, does not have an endurance limit. Aluminum structures, like the superstructures in some ships, must be designed to withstand a reasonable number of cycles over the expected life of the ship.



**Figure 6.12** Fatigue Characteristics

Fatigue failure in a real structure is greatly affected by such things as material composition (impurities, carbon content, internal defects), surface finish (smooth surfaces), environment (salt water is worse than air, moist air is worse than dry air), geometry (sharp corners and discontinuities promote crack propagation through stress concentration), and workmanship. All these will create stress concentrations. A stress concentration anywhere in a ship's structure that

causes a localized stress to exceed the materials endurance limit will eventually cause a fatigue failure to occur.

The most common consequence of fatigue in ships is the development and propagation of cracks. If such cracks are not repaired, they can result in catastrophic failure.

#### 6.4.4 Brittle Fracture

*“the sudden catastrophic failure of a structure with little or no plastic deformation”*

As with Fatigue, the concepts of brittleness and toughness were also discussed in Chapter 5. The brittle fracture failure mode involves the rapid propagation of a small crack, often deep below the surface, into a large crack ultimately leading to fracture. The cracks are usually a consequence of fatigue. The risk of brittle fracture occurring depends on the material, temperature, geometry, and rate of loading.

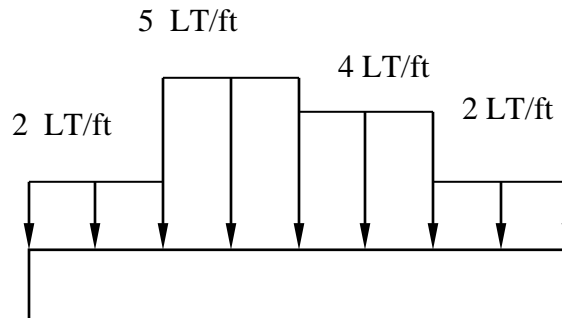
- **Material** A material with low toughness is susceptible to brittle fracture. Low carbon steels are less brittle than high carbon steels. During the construction of the *Seawolf* hull, some welds were permitted to cool too rapidly, pinning carbon atoms in the wrong place within the metal's atomic structure. The resulting defects made the welds too brittle, and the work had to be scrapped and started over from the beginning. Poor welding practices were also the cause of the brittle fractures experienced by liberty ships during the early part of WWII.
- **Temperature** A material operating below its transition temperature is much more susceptible to brittle fracture because the toughness is very low. In 1954 the British ship *World Concord* brittle fractured and split up in the cold Irish Sea. Another interesting case occurred in Boston in 1919 when a 2,300,000 gallon molasses container brittle fractured, drowning 12 people and several horses.
- **Geometry** Cracks having sharp edges are worse than those which are rounded. A smaller crack is better than a big one. Even the orientation of the crack with respect to the loading is a factor. One of the quick methods of stopping the propagation of a crack is to “drill it out,” thereby reducing its edge sharpness and ability to propagate (grow).
- **Rate of Loading** Impact loads are more likely to cause brittle fracture than loads applied gradually and smoothly.



## PROBLEMS - CHAPTER 6

### Section 6.2 Ship Structural Loads

1. An 80 ft rectangular, box-shaped barge is experiencing a uniformly distributed buoyant force of 4 LT/ft.
  - a. Calculate the resultant buoyant force.
  - b. At what point is the resultant buoyant force acting? Where is this point relative to the forward perpendicular?
  - c. Assuming the barge is in static equilibrium, what is its displacement?
  
2. A loaded box-shaped barge has the following weight distribution. The barge is 120 ft in length.

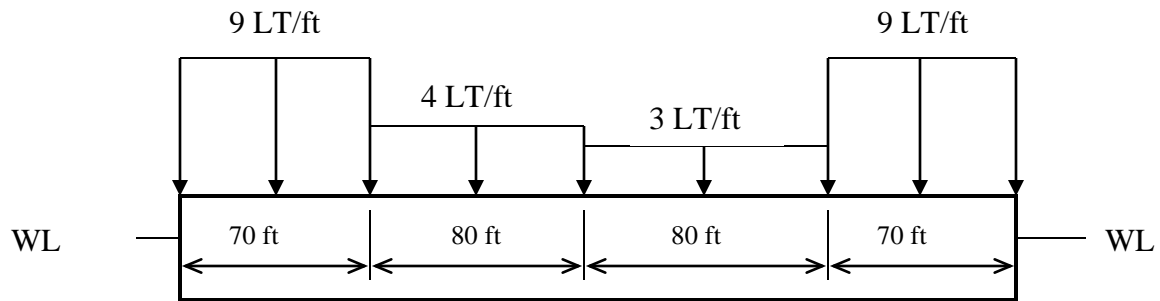


- a. Calculate the barge's displacement.
- b. Redraw the barge with the uniformly distributed buoyant force that would be required to place the barge in static equilibrium.
- c. Why can the buoyant force be considered to be uniformly distributed?
- d. Use your answer in part (b) to draw the barge's load diagram.
- e. At what locations will the barge experience significant shear stress?
- f. What longitudinal bending condition will the barge experience in still water?

3. A rectangular, box-shaped barge has the following dimensions:

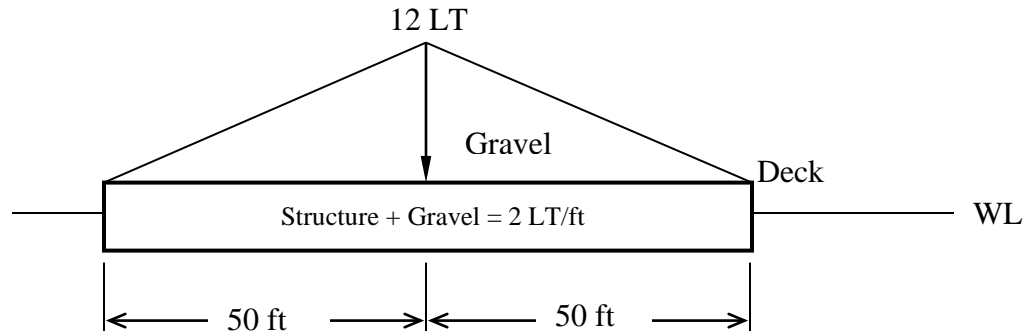
Length = 300 ft  
 Beam = 50 ft  
 Draft when empty = 5 ft

The empty barge is then loaded with containers. The containers are loaded as shown below.



- a. Calculate the barge's displacement when empty.
  - b. Assuming the barge's structure is a homogeneous, calculate the distributed weight of the empty barge.
  - c. Calculate the barge's displacement when loaded.
  - d. Calculate the uniformly distributed buoyant force acting on the barge when the barge is loaded.
  - e. Based on your results from parts (b) and (d), draw the barge's load diagram.
  - f. In calm water, what longitudinal bending condition will the barge experience?
  - g. At what points will the barge experience significant shear stress?
4. On a profile sketch of a ship, show a wave that results in sagging and the areas of the ship that are in tension and compression.
  5. On a profile sketch of a ship, show a wave that results in hogging and the areas of the ship that are in tension and compression.
  6. Box-shaped barges have a uniformly distributed buoyant force. Explain why destroyers (and most other hull forms) do not have a uniformly distributed buoyant force. What problem does this non-uniform distribution of buoyant force pose to the designer?

7. A 100 ft long box-shaped barge is loaded with gravel as shown below. The interior of the barge is uniformly loaded up to the deck. The combined weight of the barge's internal load and structure is 2 LT/ft. Once the level of the deck is reached, the load varies linearly to a maximum load of 12 LT at amidships.



- Calculate the barge's displacement.
  - Draw a diagram representing the barge's displacement as a distributed force.
  - Calculate the barge's distributed buoyant force. Is the buoyant force uniformly distributed? Why or why not?
  - Calculate and draw the barge's load diagram.
  - At what points will the barge experience significant shear stress?
  - What longitudinal bending condition will the barge experience in calm water?
8. Sketch a section of a ship whose neutral axis is approximately 65% of the depth up from the keel. Use the elastic flexure formula to answer the following questions:
- What is the magnitude of bending stress at the neutral axis?
  - With the neutral axis located 65% of the depth up from the keel, which portion of this section will experience the greatest magnitude of bending stress?
  - Draw a diagram showing how the magnitude of bending stress varies from the deck to the keel. Assume the ship is in a sagging condition.
9. Using an appropriate diagram, show why significant shear stresses develop between the hull and superstructure if expansion joints are not used.

## Section 6.3 Framing Systems

10. What is the purpose of transverse elements in a ship's framing system? What types of ship are likely to have more transverse elements than longitudinal elements?
11. What is the purpose of longitudinal elements in a ship's framing system? What types of ship are likely to have more longitudinal elements than transverse elements?
12. What type of framing system do most Naval vessels use? Why?
13. If longitudinal bending moments are the major load on ship structures, explain why the stringers are usually smaller than the deck girders and longitudinals. What advantage do small stringers have over stringers that are sized similarly to the deck girders?
14. The magnitude of bending stress in the keel is usually the maximum bending stress that a ship's section will experience. Since the magnitude of bending stress is independent of material properties, why would a keel made of steel with a yield stress of 80,000 psi be more advantageous than a keel made of steel with a yield stress of 60,000 psi?
15. When a 5" 54 caliber naval gun fires, large recoil forces are exerted on a ship's structure. What material properties are desirable for the ship's structure to absorb the gun's recoil?
16. In addition to large bending stresses, the flight deck of an aircraft carrier is subjected to other large loads. What type of loadings would the flight deck experience, and what material properties would be desirable when selecting a material for the construction of the flight deck?
17. Watertight bulkheads are an integral part of a ship's structure. In addition to providing stiffness to the hull, what other types of structural loads would a watertight bulkhead be subject to?

## Section 6.4 Structural Failure Modes

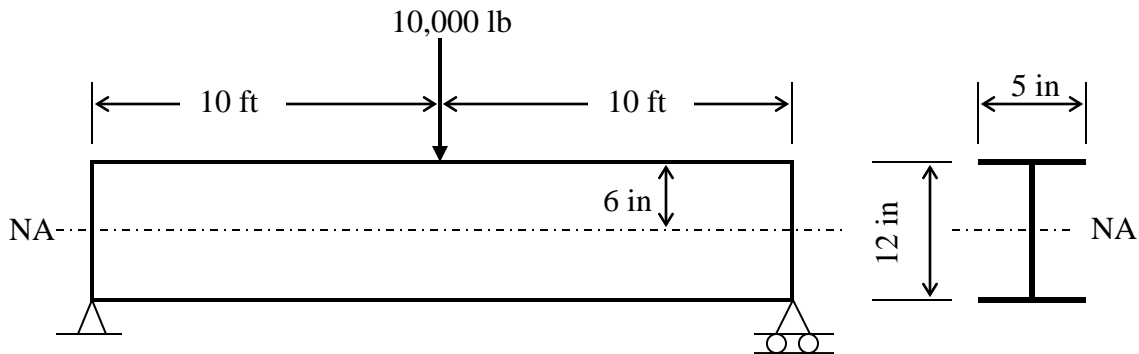
18. List four common modes of structural failure on a ship.
19. What is fatigue of a material? Name four factors which make a ship more susceptible to fatigue failure.
20. Describe the effects of material type, temperature, geometry, and rate of loading on brittle fracture.
21. Why is ductility a desirable property when selecting a material for a ship's structure?

22. A ship is being designed for use in the Arctic Ocean. To prevent structural failure, what factors should be taken into account when selecting a material to be used for the hull plating? Frame your answer in terms of strength, ductility, toughness, etc. Would your material selection criteria change if the ship were to be used exclusively in the Java Sea?
23. A simply supported steel I-beam, 20 ft in length, is supporting a 10,000 lb load as shown below. The steel has the following material properties:

$$E = 30 \times 10^6 \text{ psi}$$

$$\sigma_Y = 40,000 \text{ psi}$$

$$\sigma_{UTS} = 65,000 \text{ psi}$$



- Calculate the vertical reaction forces at each end of the beam.
- At its current loading condition, the beam is experiencing a bending moment of 100,000 ft-lb at its mid-point. The beam's second moment of area about its neutral axis is  $305 \text{ in}^4$ . Calculate the magnitude of bending stress at the top of the beam. Is the beam in tension or compression at this point?
- Is the current design adequate to prevent failure?
- Design specifications require that bending stress be  $\frac{1}{2}$  the yield stress. Is the design adequate to meet this requirement? If not, what can be done to meet design specifications?
- If the beam were constructed of a different material, how would this change the magnitude of bending stress?
- What failure mode will occur if the magnitude of bending stress exceeds yield stress?

24. A box-shaped oil barge is in the design process. The barge has a length of 325 ft, a depth of 15 ft, and a beam of 50 ft. When empty, the barge has a draft of 5 ft. When fully loaded, the barge has a draft of 10 ft. Your task is to select the material used to build the barge's structure. You have been given three materials to choose from. The material properties of each material are listed below.

Material #1:  $E = 30 \times 10^6$  psi  
 $\sigma_Y = 47,000$  psi  
 $\sigma_{UTS} = 71,000$  psi  
endurance limit = 34,000 psi at infinite life  
weight density = 490 lb/ft<sup>3</sup>  
cost: 7 cents per pound

Material #2:  $E = 30 \times 10^6$  psi  
 $\sigma_Y = 80,000$  psi  
 $\sigma_{UTS} = 100,000$  psi  
endurance limit = 48,000 psi at infinite life  
weight density = 490 lb/ft<sup>3</sup>  
cost: 17 cents per pound

Material #3:  $E = 10.4 \times 10^6$  psi  
 $\sigma_Y = 40,000$  psi  
 $\sigma_{UTS} = 47,000$  psi  
endurance limit = 14,000 psi at  $5 \times 10^8$  cycles  
weight density = 175 lb/ft<sup>3</sup>  
cost: 13 cents per pound

- What is the barge's displacement (LT) in salt water when empty? Note: when empty, the barge's weight is the weight of its structure only. The structural weight can be considered as uniformly distributed along the barge's length.
- What are some advantages and disadvantages of each material?
- What other information would you desire about each material before making a selection?
- Which material would you choose for the ship's structure?
- In order to prevent yield failure, one design specification requires that the maximum magnitude of bending stress be less than one half the yield strength of the material selected. Currently, calculations indicate that the magnitude of maximum bending stress is 42,000 psi. What can be done to reduce the magnitude of bending stress to an acceptable level?

# **COURSE OBJECTIVES**

## **CHAPTER 7**

### **7. RESISTANCE AND POWERING OF SHIPS**

1. Define effective horsepower (EHP) conceptually and mathematically
2. State the relationship between velocity and total resistance, and velocity and effective horsepower
3. Write an equation for total hull resistance as a sum of viscous resistance, wave making resistance and correlation resistance. Explain each of these resistive terms.
4. Draw and explain the flow of water around a moving ship showing the laminar flow region, turbulent flow region, and separated flow region
5. Draw the transverse and longitudinal wave patterns when a displacement ship moves through the water
6. Define Reynolds number with a mathematical formula and explain each parameter in the Reynolds equation with units
7. Be qualitatively familiar with the following sources of ship resistance:
  - a. Steering Resistance
  - b. Air and Wind Resistance
  - c. Added Resistance due to Waves
  - d. Increased Resistance in Shallow Water
8. Read and interpret a ship resistance curve including humps and hollows
9. State the importance of naval architecture modeling for the resistance on the ship's hull
10. Define geometric and dynamic similarity
11. Write the relationships for geometric scale factor in terms of length ratios, speed ratios, wetted surface area ratios and volume ratios
12. Describe the law of comparison (Froude's law of corresponding speeds) conceptually and mathematically, and state its importance in model testing
13. Qualitatively describe the effects of length and bulbous bows on ship resistance

14. Be familiar with the momentum theory of propeller action and how it can be used to describe how a propeller creates thrust
15. Define Coefficient of Thrust and Thrust Loading
16. Know the relationship between thrust loading and propeller efficiency
17. Define the following terms associated with the screw propeller:
  - a. Diameter
  - b. Pitch
  - c. Fixed Pitch
  - d. Controllable Pitch
  - e. Reversible Pitch
  - f. Right Handed Screw
  - g. Left Handed Screw
  - h. Pressure Face
  - i. Suction Face
  - j. Leading Edge
  - k. Trailing Edge
  - l. Blade Tip
  - m. Root
  - n. Variable Pitch
18. Be familiar with cavitation including the following:
  - a. The relationship between thrust loading and cavitation
  - b. The typical blade locations where cavitation occurs
  - c. Spot Cavitation
  - d. Sheet Cavitation
  - e. Blade Tip Cavitation
  - f. Operator action to avoid cavitation
  - g. The effect of depth on cavitation
  - h. The difference between cavitation and ventilation



## 7.1 Introduction to Ship Resistance and Powering

One of the most important considerations for a naval architect is the powering requirement for a ship. Once the hull form has been decided upon, it is necessary to determine the amount of engine power that will enable the ship to meet its operational requirements. Knowing the power required to propel a ship enables the naval architect to select a propulsion plant, determine the amount of fuel storage required, and refine the ship's center of gravity estimate.

Throughout history, naval architects have endeavored to increase the speed of ships. Increased speed enable a warship to close with its opponent, or conversely, to escape from an attack. Increased speed enables merchant vessels to reach port sooner and maximize profit for its owner.

Until the early 1800's, wind was the force used to propel ships through the water and ships could only go as fast as the wind would propel them. Additionally, because ships were constructed of wood, the structural limitations of wooden hull configurations drove hull designs to primarily meet the structural needs while hydrodynamics was only a secondary concern. With the advent of steam propulsion in the early 1800's, naval architects realized that ship speeds were no longer constrained by the wind and research began into the power required to propel a hull through the water using this new propulsion medium.

Testing of full-scale ships and models determined that the power required to propel a ship through the water was directly related to the amount of resistance a hull experiences when moving through the water.

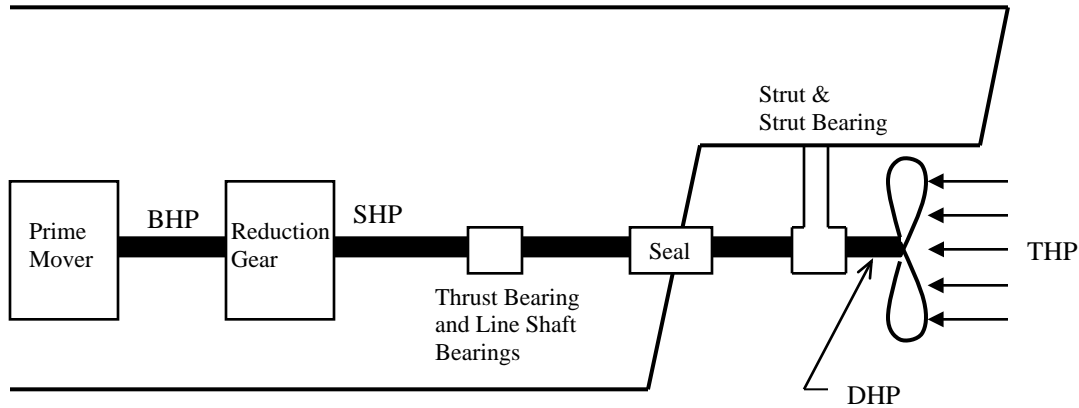
The development of iron hull construction produced radical changes in hull strength and hull design. Gone were the blunt bows and full hull forms of early sailing vessels. Capitalizing on the added strength of iron hulls, naval architects could design ships with finer bows and as a result, ship speeds increased.

About the time of the Civil War, the modern screw propeller was developed, replacing the paddle wheel as the prime mode of ship propulsion. The screw propeller, with many modifications to its original design, remains the principle method of ship propulsion to this day.

This chapter will investigate the differing forms of hull resistance, ship power transmission, and the screw propeller. Additionally, we will investigate ship modeling and how full-scale ship resistance and performance can be predicted using models in a towing tank.

## 7.2 The Ship Drive Train

The purpose of the propulsion system on a ship is to convert fuel energy into useful thrust to propel the ship. Figure 7.1 shows a simplified picture of a ship's drive train.



**Figure 7.1** Simplified ship drive train

**BHP – “Brake Horsepower”** is the power output of the engine. It is called “brake” because engines are tested by applying a mechanical load to the shaft using a brake. The power of a rotating engine is the product of the torque (ft-lb) and the rotational speed (with suitable unit corrections).

**SHP – “Shaft Horsepower”** is equal to the Brake Horsepower minus any mechanical losses in the reduction gear. The reduction gear reduces the RPM (revolutions per minute) of the engine to an efficient propeller speed, such as reducing from a few thousand RPM for gas turbines to a few hundred RPM for a warship. Reduction gears are very large, heavy, and expensive.

**DHP – “Delivered Horsepower”** is the power delivered to the propeller, which includes the losses due to the gearbox, the bearings and the stern tube seal. The delivered horsepower is usually 95%-98% of the Brake Horsepower, depending on the propulsion system.

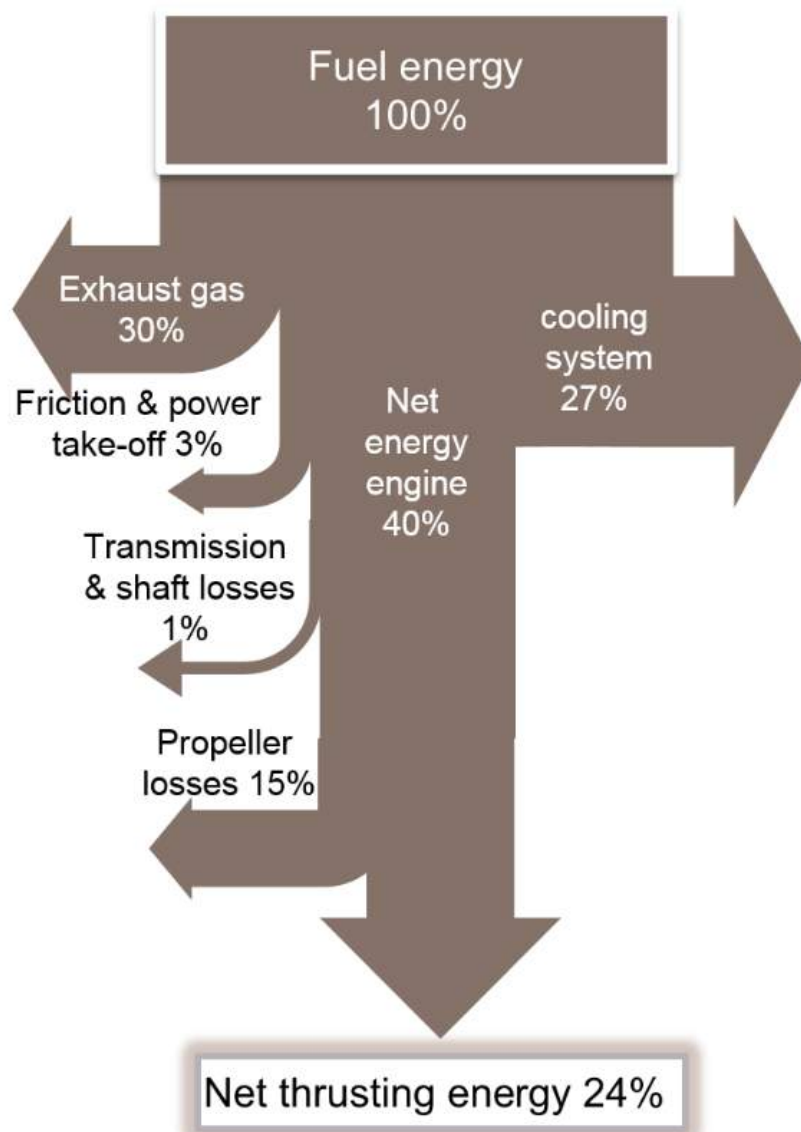
The propeller converts the rotational power into useful thrust. **THP – “Thrust Horsepower”** is the power from the propeller thrust, equal to the product of the speed of advance and the thrust generated by the propeller (with suitable unit conversions). This power includes the losses of the gearbox, shafting, and propeller.

**EHP – “Effective Horsepower”** is the power required to move the ship's hull at a given speed in the absence of propeller action. It is equal to the product of the resistance of a ship and the speed of the ship. This power is equal to the Brake Horsepower minus losses due to the gearbox, shafting and propeller, as well as interaction between the propeller and the hull.

Ordinarily in design, the Effective Horsepower is estimated first, and then efficiencies are assumed for each portion of the drivetrain to estimate the required Brake Horsepower to be installed.

Figure 7.2 shows a diagram of the energy losses in a typical shipboard propulsion system. The largest losses in the system are the thermodynamic and mechanical losses in the engines, which cause the loss of roughly 60% of the fuel energy before it becomes rotational power at the output of the engine (Brake Horsepower). This huge loss is why engineers study thermodynamics and also why mechanical engineers continually strive for more fuel efficient engines.

Following this are the losses in the gearbox, shafting and propellers, resulting in only one-quarter of the original fuel energy being converted to useful thrust energy to move the ship forward. The main areas that the Naval Engineer can control is the hull form to minimize the Effective Horsepower required to propel the ship, as well as the design of the propeller to minimize propeller losses.



**Figure 7.2** Typical Energy Losses in Shipboard Propulsion System (Courtesy of John Gallagher, MTU engines)

### 7.3 Propulsive Efficiency

Figure 7.3 shows a block diagram of a ship's drive train, starting with the Brake Horsepower from the prime mover, and ending with the Effective Horsepower to drive the ship.



**Figure 7.3** Block diagram of a ship's drive train

There are losses at each stage of the drivetrain, listed below:

$$\begin{aligned} \text{Gear Efficiency} \quad \eta_{gear} &= \frac{SHP}{BHP} \approx 0.95 - 0.99 \\ \text{Shaft Efficiency} \quad \eta_{shaft} &= \frac{DHP}{SHP} \approx 0.97 - 0.99 \\ \text{Propeller Efficiency} \quad \eta_{propeller} &= \frac{THP}{DHP} \approx 0.65 - 0.75 \\ \text{Hull Efficiency} \quad \eta_{hull} &= \frac{EHP}{THP} \end{aligned}$$

The gear, shaft and propeller efficiencies are all mechanical or fluid losses. “Hull Efficiency” includes the interaction between the hull and the propeller, which varies with ship type. Instead of having to deduce the effect of all the separate efficiencies of each component in the drive train, the separate efficiencies are often combined into a single efficiency called the *propulsive efficiency* ( $\eta_P$ ) or propulsive coefficient (PC).

$$\eta_P = PC = \frac{EHP}{SHP} = \eta_{gear} \eta_{shaft} \eta_{propeller} \eta_{hull}$$

The propulsive efficiency is the ratio of effective horsepower to shaft horsepower, therefore allowing the designer to make a direct determination of the shaft horsepower required to be installed in the ship. Common values of propulsive efficiency typically range from 55% to 75%.

**Example 7.1** Model testing has determined that a ship has an EHP of 30,000 HP at a speed of 19 knots. Assuming a propulsive efficiency of 70%, what SHP is required to be installed to achieve 19 knots?

$$\eta_p = \frac{EHP}{SHP}$$

$$SHP = \frac{EHP}{\eta_p} = \frac{30,000HP}{0.70}$$

$$SHP = 42,860HP$$

A total of 42,860 horsepower (43,000 HP) should be installed to achieve a speed of 19 knots.

Once a value of shaft horsepower has been determined, various combinations of prime movers can be considered based on power produced, weight, fuel consumption, etc for installation in the ship.

A “prime mover” is another term for an engine or motor (i.e. a source of mechanical power). Common prime mover types include steam turbines, gas turbines engines, diesel engines, and electric motors.

## 7.4 Effective Horsepower (EHP)

Shaft horsepower and brake horsepower are quantities that are purchased from the engine manufacturer. Likewise, the amount of thrust a propeller can produce is a product of analysis and calculation. However, the naval architect must still determine the amount of power (BHP or SHP) actually required to propel the ship through the water. The amount of power is determined through the concept of *Effective Horsepower* (EHP). Effective horsepower is defined as:

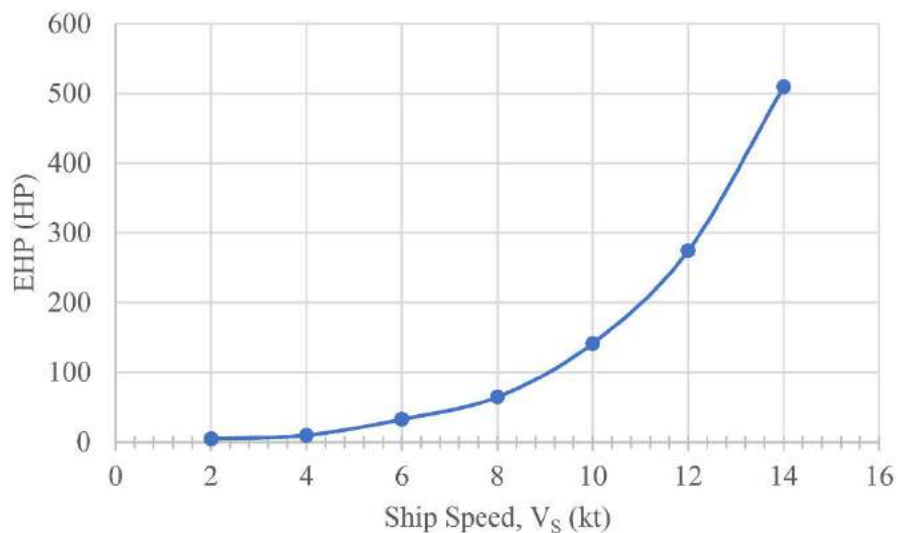
*“The horsepower required to move the ship’s hull at a given speed in the absence of propeller action.”*

Effective horsepower is often determined through model data obtained from towing tank experimentation. In these experiments, a hull model is towed through the water at a given speed while measuring the amount of force resisting the hull’s movement through the water. Model resistance data can then be scaled up to full-scale ship resistance. Knowing a ship’s total hull resistance and its speed through the water, the ship’s effective horsepower can be determined using the following equation:

$$EHP = \frac{R_T V}{550 \frac{ft-lb}{sec-HP}}$$

where:  $EHP$  is the effective horsepower (HP)  
 $R_T$  is the total hull resistance (lb)  
 $V_S$  is the ship’s speed (ft/sec)

Model testing is carried out over the expected speed range of the ship with resistance data collected at each testing speed. Effective horsepower is then calculated and plotted as shown in Figure 7.4. It will be observed from the figure that the doubling of speed of the Navy YP from 7 to 14 knots increases the power by a factor of 10! Speed and power are not linearly related.

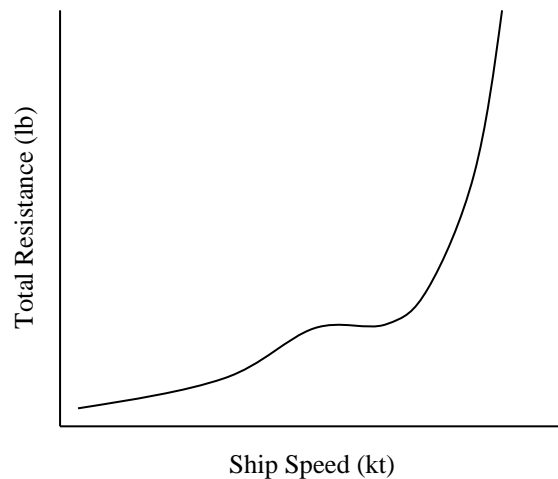


**Figure 7.4** Power Curve of effective horsepower for a Navy YP

## 7.5 Total Hull Resistance ( $R_T$ )

As a ship moves through calm water, the ship experiences a force acting opposite to its direction of motion. This force is the water's resistance to the motion of the ship, which is referred to as "total hull resistance" ( $R_T$ ). It is this resistance force that is used to calculate a ship's effective horsepower. A ship's calm water resistance is a function of many factors, including ship speed, hull form (draft, beam, length, wetted surface area), and water temperature.

Total hull resistance increases as speed increases as shown in Figure 7.5. Note that the resistance curve is not linear, but increases more steeply at higher speeds. In later sections of this chapter we will investigate why resistance increases so rapidly at high speeds. Also shown in Figure 7.5 is a bump, or "hump", in the total resistance curve. This hump is not a mistake, but a phenomenon common to nearly all ship resistance curves that will be discussed later. As shown in previous sections, the power required to propel a ship through the water is the product of total hull resistance and ship speed, and so engine power increases even more rapidly than resistance. Often, ship power is roughly proportional to the cube of the speed, so doubling (2x) the speed of a destroyer from 15 knots to 30 knots will require  $2^3 = 8$  times as much power!



**Figure 7.5** Typical curve of total hull resistance

For the ship operator planning a voyage, getting from Point A to Point B in a shortest amount of time (high speed) requires a lot more power than traveling the same distance at a slower speed. This increase in power is felt directly in the amount of fuel burned during the transit. A ship's fuel consumption curve is similar in shape to its horsepower and total resistance curves. Voyage planning requires careful attention to transit speed and fuel consumption rates to ensure that the ship arrives at its destination with an adequate supply of fuel onboard. The U.S. Navy generally requires that ships arrive with no less than 50 percent fuel onboard as a reserve.

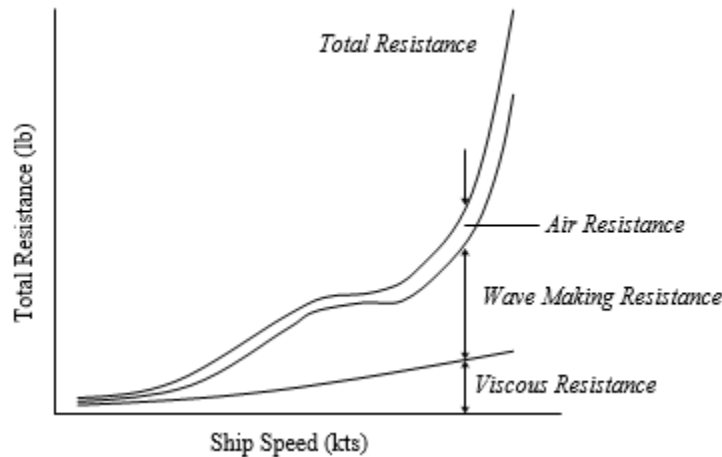
## 7.6 Components of Total Hull Resistance

As a ship moves through calm water, there are many factors that combine to form the total resistance force acting on the hull. The principle factors affecting ship resistance are the friction and viscous effects of water acting on the hull, the energy required to create and maintain the ship's characteristic bow and stern waves, and the resistance that air provides to ship motion. In mathematical terms, total resistance can be written as:

$$R_T = R_V + R_W + R_{AA}$$

Where:  $R_T$  = total hull resistance  
 $R_V$  = viscous (friction) resistance  
 $R_W$  = wave making resistance  
 $R_{AA}$  = air resistance caused by ship moving through calm air

Other factors affecting total hull resistance will also be presented. Figure 7.6 shows how the magnitude of each component of resistance varies with ship speed. At low speeds viscous resistance dominates, and at high speeds the total resistance curve turns upward dramatically as wave making resistance begins to dominate.



**Figure 7.6** Components of Hull Resistance

### 7.6.1 Dimensionless Coefficients

Naval architects, as well as all engineers and scientists, use dimensionless coefficients to describe the performance of a system or to compare different systems to each other. Automotive engineers use a “drag coefficient” to describe the performance of a car. Aviators use the “Mach number” to compare the speed of an aircraft to the speed of sound. Naval architects use many dimensionless coefficients to describe the design and performance of a ship's hull.

Dimensionless coefficients allow the naval architect to compare model test data to full-scale ship data, or to compare the performance of several ship types. The field of ship resistance and propulsion makes extensive use of standard dimensionless coefficients. The derivation of these



standard coefficients is accomplished through dimensional analysis. Dimensional analysis is beyond the scope of this text, however, you can learn about dimensional analysis from any text on fluid mechanics or from Volume 2 of “Principles of Naval Architecture” published by the Society of Naval Architects and Marine Engineers.

Just as total hull resistance is the sum of viscous, wave making, and air resistance, we can write an equation for total resistance in terms of dimensionless coefficients.

$$C_T = C_V + C_W$$

Where:  $C_T$  = coefficient of total hull resistance  
 $C_V$  = coefficient of viscous resistance  
 $C_W$  = coefficient of wave making resistance

Note that air resistance is not represented in dimensionless form. This dimensionless form of resistance is a product of model testing, and most models do not have superstructures.

Since total hull resistance is a function of hull form, ship speed, and water properties, the coefficient of total hull resistance is also a function of hull form, ship speed, and water properties. The coefficient of total hull resistance is found from the following equation:

$$C_T = \frac{R_T}{\frac{1}{2}\rho \cdot S \cdot V^2}$$

Where:  $R_T$  = total hull resistance (lb)  
 $\rho$  = water density (lb-s<sup>2</sup>/ft<sup>4</sup>)  
 $S$  = wetted surface area of the underwater hull (ft<sup>2</sup>)  
 $V$  = velocity (ft/s)

Naval architects also use a dimensionless form of velocity called the “*Froude number*” ( $F_n$ ), named in honor of William Froude (1810-1878), one of the pioneers in ship model testing.

$$F_n = \frac{V}{\sqrt{gL}}$$

where:  $V$  = velocity (ft/s)  
 $g$  = acceleration of gravity (ft/s<sup>2</sup>)  
 $L$  = length of ship or model (ft) ( $L_{PP}$ ,  $L_{BP}$ , or  $L_{WL}$ )

Another common, although not dimensionless, way of expressing velocity is through the *speed-to-length* ratio. This ratio is similar to the Froude number except that the gravity term is omitted. This is a dimensional value and **must use speed in knots**, and length in feet.

$$\text{speed-to-length ratio} = \frac{V_s}{\sqrt{L_s}}$$

## 7.6.2 Viscous Resistance ( $R_v$ )

Figure 7.7 shows a body submerged in an ideal (inviscid) fluid. As the fluid flows around the body, there is a pressure distribution normal to the body. In the forward section of the hull there is a component of pressure resisting motion, and in the aft section of the body there is a component of pressure assisting motion. In an ideal fluid these pressure forces are equal and the body experiences no resistance.

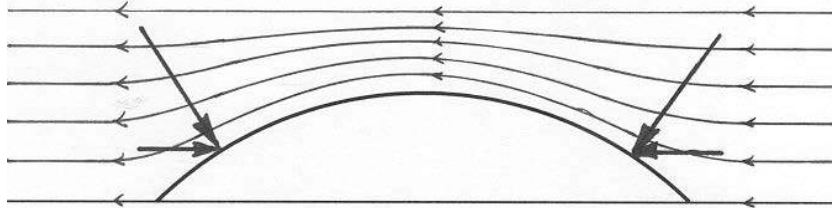


Figure 7.7 Ideal flow around a submerged body

Unfortunately, water is not an ideal fluid, and therefore the body will experience resistance. Figure 7.8 shows a hull submerged in a real fluid with viscosity. Fluid particles cling to the body, resulting in the formation of a “boundary layer,” where the flow rapidly changes speed, from zero speed at the side of the body, to the free-stream speed. Two forms of resistance happen as a result of viscosity **Friction Resistance** and **Viscous Pressure Resistance**. Friction arises from the shear stresses in the fluid and acts tangential to the body. Viscous pressure resistance acts normal to the body.

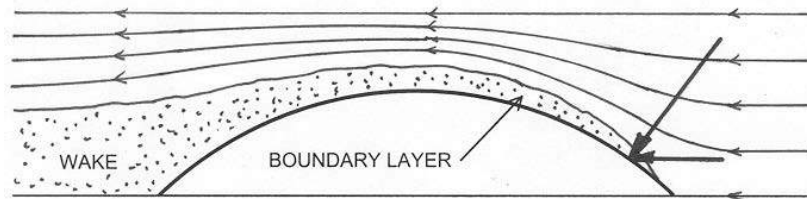


Figure 7.8 Flow around a body submerged in water

### 7.6.2.1 Friction Resistance

As a ship moves through the water, the friction of the water acting over the entire wetted surface of the hull causes a net force opposing the ship's motion. This frictional resistance is a function of the hull's wetted surface area, surface roughness, and water viscosity. Viscosity is a temperature dependent property of a fluid that describes its resistance to flow. Syrup is said to be a very viscous liquid; the fluid particles in syrup being very resistant to flow between adjacent particles and to other bodies. On the other hand, alcohol has a low viscosity with little interaction between particles.

Although water has low viscosity, water produces a significant friction force opposing ship motion. Experimental data have shown that water friction can account for up to 85% of a hull's total resistance at low speed ( $F_n \leq 0.12$  or speed-to-length ratio less than 0.4 if ship speed is expressed in knots), and 40-50% of resistance for some ships at higher speeds.

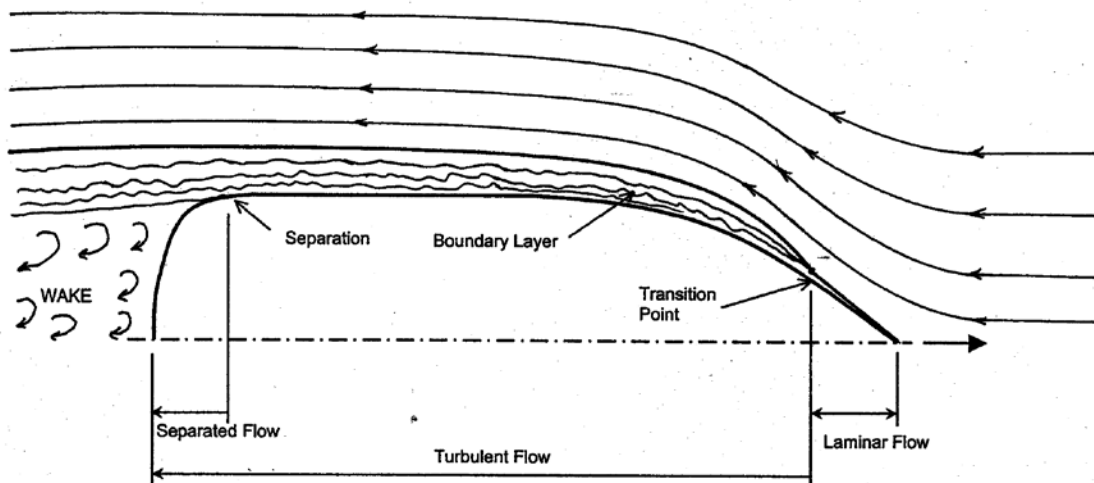
### 7.6.2.2 Viscous Pressure Resistance

In the forward portion of the hull pressure forces act normal to the surface; however, in the aft portion of the hull the boundary layer reduces the forward acting component of pressure. This reduction in the forward acting component results in a net resistance force due to pressure acting on the hull. This increase in resistance due to pressure is called “viscous pressure drag” or “form drag”, and is sometimes also referred to as the normal component of viscous resistance.

As you might expect, from looking at Figure 7.8, the shape of a ship’s hull can influence the magnitude of viscous pressure drag. Ships that are short in length with wide beams (a low length to beam ratio) will have greater form drag than those with a larger length to beam ratio. Also, ships that are fuller near the bow (e.g. bulk oil tanker) will have greater form drag than ships with fine bows (e.g. destroyer).

### 7.6.2.3 Laminar and Turbulent Flow

The flow of fluid around a body can be divided into two general types of flow: laminar flow and turbulent flow. The extent of the viscous resistance on a body depends on the type of flow it is experiencing. A typical flow pattern around a ship’s hull showing laminar and turbulent flow is shown in Figure 7.9



**Figure 7.9** Typical water flow pattern around a ship’s hull

Laminar flow is characterized by fluid flowing along smooth lines in an orderly fashion with a minimal amount of frictional resistance. For a typical ship, laminar flow exists for only a very small distance along the hull. As water flows along the hull, the laminar flow begins to break down and become chaotic and well mixed. This chaotic behavior is referred to as turbulent flow and the transition from laminar to turbulent flow occurs at the transition point shown in Figure 7.9.

Turbulent flow is characterized by the development of a layer of water along the hull moving with the ship along its direction of travel. This layer of water is referred to as the “boundary layer.” Water molecules closest to the ship are carried along with the ship at the ship’s velocity.

Moving away from the hull, the velocity of water particles in the boundary layer becomes less, until at the outer edge of the boundary layer velocity is nearly that of the surrounding ocean. Formation of the boundary layer begins at the transition point and the thickness of the boundary layer increases along the length of the hull as the flow becomes more and more turbulent. For a ship underway, the boundary layer can be seen as the frothy white band of water next to the hull. Careful observation of this band will reveal the turbulent nature of the boundary layer, and perhaps you can see some of the water actually moving with the ship. As ship speed increases, the thickness of the boundary layer will increase, and the transition point between laminar and turbulent flow moves closer to the bow, thereby causing an increase in frictional resistance as speed increases.

Mathematically, laminar and turbulent flow can be described using the dimensionless coefficient known as the Reynolds Number in honor of Sir Osborne Reynolds' (1883) contribution to the study of hydrodynamics. For a ship, the Reynolds Number is calculated using the equation below:

$$\mathcal{R}_n = \frac{LV}{\nu}$$

Where:

$\mathcal{R}_n$  is the Reynolds number

$L$  = length (ft) ( $L_{PP}$ ,  $L_{BP}$ , or  $L_{WL}$ )

$V$  = velocity (ft/sec)

$\nu$  = kinematic viscosity of water (ft<sup>2</sup>/sec)

For external flow over flat plates (or ship hulls), typical Reynolds number magnitudes are as follows:

Laminar flow:	$\mathcal{R}_n < 5 \times 10^5$
Turbulent flow:	$\mathcal{R}_n > 1 \times 10^6$
Transition from Laminar to Turbulent Flow:	$5 \times 10^5 < \mathcal{R}_n < 1 \times 10^6$

**Example 7.2** A ship 250 feet in length is traveling at 15 knots in salt water at 59°F ( $\nu = 1.2791 \times 10^{-5}$  ft<sup>2</sup>/sec). Calculate the ship's Reynolds number at this speed.

$$\mathcal{R}_n = \frac{LV}{\nu} = \frac{(250 \text{ ft})(15 \text{ kt}) \left(1.688 \frac{\text{ft}}{\text{s} \cdot \text{kt}}\right)}{1.2791 \times 10^{-5} \frac{\text{ft}^2}{\text{s}}}$$

$\mathcal{R}_n = 4.949 \times 10^8$       water flow around the ship is definitely turbulent

**Example 7.3** A model 5 feet in length is being towed at a speed of 5 ft/sec in fresh water at 59°F ( $\nu = 1.092 \times 10^{-5} \text{ ft}^2/\text{s}$ ). Calculate the model's Reynolds number.

$$\mathcal{R}_n = \frac{LV}{\nu} = \frac{(5 \text{ ft}) \left(5 \frac{\text{ft}}{\text{s}}\right)}{1.092 \times 10^{-5} \frac{\text{ft}^2}{\text{s}}}$$

$\mathcal{R}_n = 2.29 \times 10^6$  the model is also operating in the turbulent regime

Note: Ships have turbulent flow over nearly their entire length except when operating at very low speeds. Even at low speeds, laminar flow is present for only one or two feet of the hull length.

#### 7.6.2.4 Coefficient of Viscous Resistance ( $C_V$ )

The dimensionless form of viscous resistance is the coefficient of viscous resistance ( $C_V$ ). This coefficient is a function of the same properties that influence viscous resistance itself: hull form, speed, and water properties. The equations for the coefficient of viscous resistance that follow are empirical products of many years of towing tank testing, and are internationally recognized by the International Towing Tank Conference (ITTC). The coefficient of viscous resistance takes into account the friction of the water on the ship as well as the influence of hull form on viscous pressure drag.

$$C_V = C_F + K \cdot C_F$$

where:  $C_V$  = coefficient of viscous resistance

$C_F$  = tangential (skin friction) component of viscous resistance

$K \cdot C_F$  = normal (viscous pressure drag) component of viscous resistance

The skin friction coefficient (equation below) is based on the assumption that the hull is a flat plate moving through the water, and is a function of Reynolds number (ship speed, length, and water properties). The form factor ( $K$ ) accounts for the effect of hull form on viscous resistance. Both the skin friction coefficient and the form factor equation are empirically derived from many tests on flat plates and ships.

$$C_F = \frac{0.075}{[(\log_{10} \mathcal{R}_n) - 2]^2}, \quad \mathcal{R}_n = \frac{LV}{\nu}$$

$$K \approx 19 \left( \frac{\nabla}{LWL \cdot B \cdot T} \times \frac{B}{LWL} \right)^2$$

### 7.6.2.5 Reducing the Viscous Resistance

The viscous resistance of a ship is:

$$R_v = C_v \frac{1}{2} \rho V^2 S$$

where:  $C_v$  = coefficient of viscous resistance

$\rho$  = water density ( $lb \cdot s^2/ft^4$ )

$V$  = velocity (ft/s)

$S$  = wetted surface area of the underwater hull ( $ft^2$ )

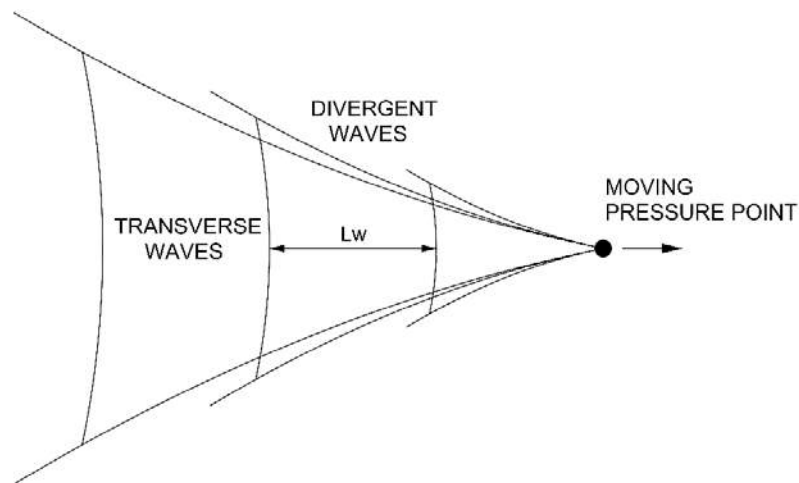
Ships are often designed to carry a certain amount of payload (weight and volume) at a given speed. Therefore, the means of reducing Viscous Resistance for a design is to reduce the coefficient of viscous resistance or to reduce the surface area for a given volume. A sphere has the smallest wetted surface area per unit volume, but it would be expected to have a lot of separation and a high form factor,  $K$ , also it would create a lot of waves at the surface.

Increasing the length of a ship, and reducing beam for a given speed tend to reduce the viscous resistance coefficient; however this increases wetted surface area. Thus, the design of a ship is a trade-off between a sphere (minimal wetted area) and a toothpick (minimum viscous coefficient), with suitable concerns for stability and seakeeping added in.

### 7.6.3 Wave Making Resistance ( $R_w$ )

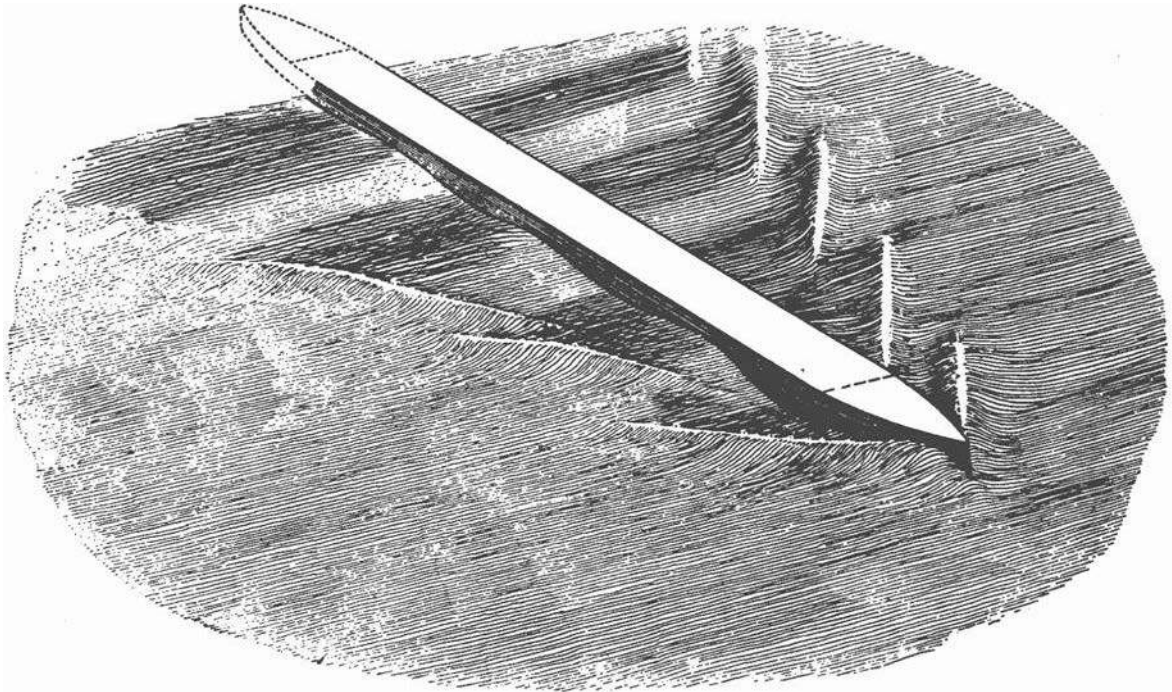
The second major component of hull resistance is the resistance due to wave making. The creation of waves requires energy. As ship speed increases, the height of the waves produced by the ship increases and therefore the energy required to produce these waves also increases. This lost energy is referred to as wave making resistance and often becomes a limiting factor in the speed of a ship.

An object moving through the water creates both divergent waves, which spread outward from the ship, and transverse waves, illustrated in Figure 7.10.



**Figure 7.10** Wave pattern generated by a moving object in the water

Sir William Froude (1810-1878) did much of the early research in wave making resistance and his results and conclusions in this field are used to this day. Figure 7.11 is Froude's 1877 sketch of the wave patterns produced by a ship. Compare Froude's sketch to the photographs of actual ships in Figures 7.12 and 7.13 and note the similarities.



**Figure 7.11** Froude's sketch of a characteristic wave train for ships.  
(reproduced from "Principles of Naval Architecture, Volume 2" published by the Society of Naval Architects and Marine Engineers)

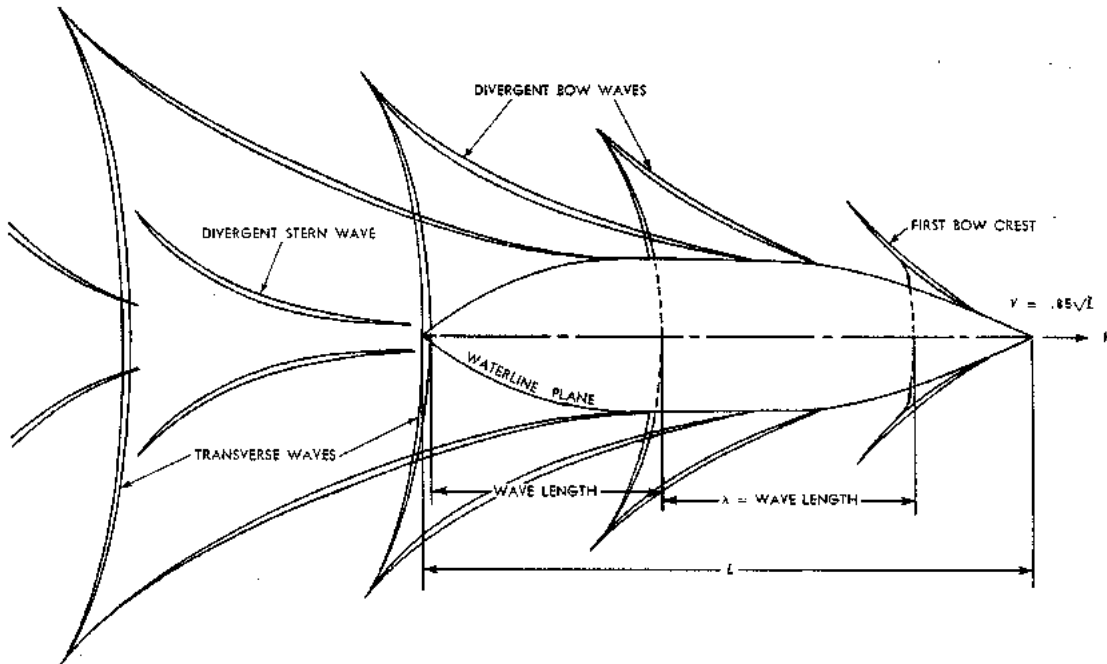


**Figure 7.12** USNS SPICA (left) conducting vertical replenishment with another ship. Note the divergent wave patterns emanating from SPICA. (U.S. Navy photo)



**Figure 7.13** Transverse wave pattern along the hull of a replenishment ship (U.S. Navy photo)

Unlike the simple wave pattern developed by a moving pressure point (Figure 7.10), a real ship creates many wave systems, most prominently the bow and stern wave systems, shown in Figure 7.14. These wave systems can interact with each other, either partially canceling the waves made by a ship (and reducing the wavemaking resistance) or by adding and increasing the wavemaking resistance. The effects waves have on each other waves as they collide and overlap is called constructive (adding) or destructive (reducing) interference.



**Figure 7.14** The bow and stern wave systems generated by a ship (reproduced from “Introduction to Naval Architecture” by Gillmer and Johnson)



### 7.6.3.1 Wave Length versus Ship Speed

The transverse wave travels at approximately the same speed as the ship, because the ship is producing this wave. At slow speeds the transverse waves have short wave length and several crests can be seen along the ship's length. From wave theory, the length of a free wave on the surface is related to velocity as follows:

$$L_w = \frac{2\pi V^2}{g}$$

where:  $L_w$  = wave length (ft)  
 $V$  = ship velocity (ft/s)  
 $g$  = acceleration due to gravity (ft/s<sup>2</sup>)

Figure 7.15 shows the appearance of the wave patterns along the side of the ship at various speeds. At low speeds, there are more wave crests on the side of the hull. At high speeds, the wavelength increases. The figure shows that at certain speeds, there is a crest at the stern, and at others, there is a trough. These crests and troughs can either partially cancel the stern wave system, or partially add to it, resulting in some speeds with higher resistance due to interference. This fact causes the plot of total resistance coefficient versus speed (Figure 7.16) to have "humps and hollows." It is best to operate the ship in a hollow for fuel economy. The figure shows a large increase in resistance at a speed-to-length ratio of 1.34. This is the speed at which the wavelength is equal to the length of the ship. It is known as "hull speed," which is the last efficient speed for a displacement ship.

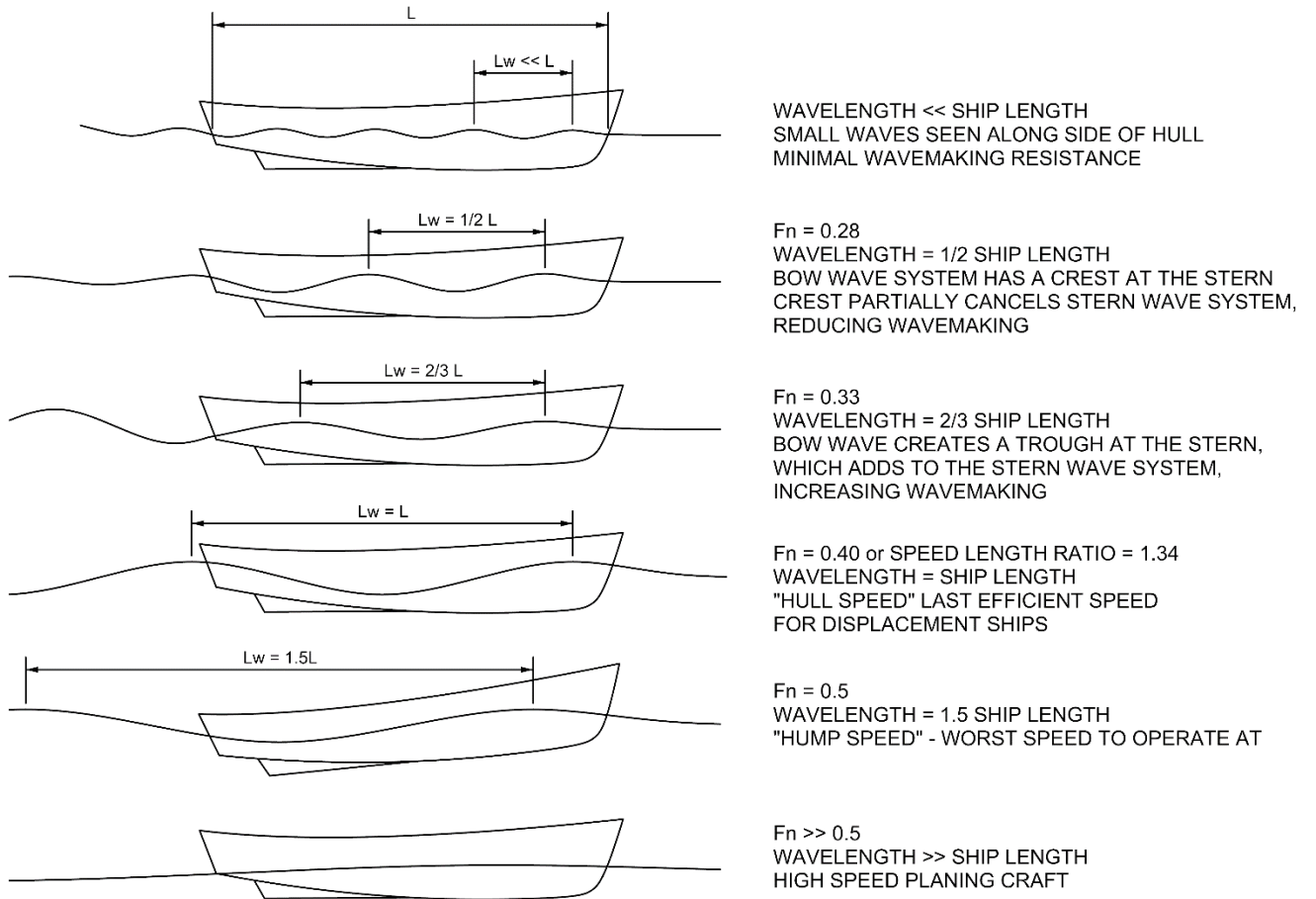
The speed where wavelength equals ship length can be solved for in the above equations and is:

$$V_s = 1.34\sqrt{L_s} \quad kt/\sqrt{ft}$$

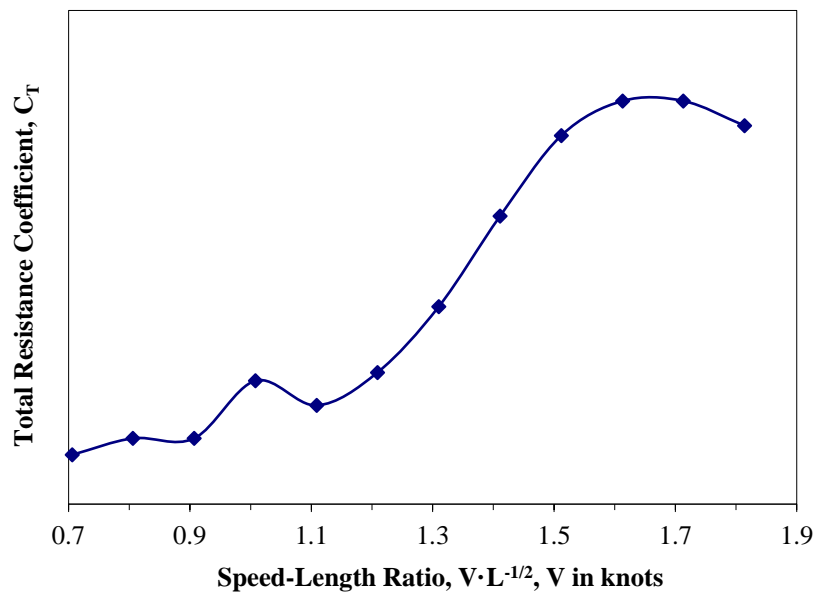
where:  $V_s$  = ship speed (knots)  
 $L_s$  = ship length (ft) (LWL or LPP)

This is called the "hull speed rule of thumb" and units are typically not expressed, but the units are in  $kt \cdot ft^{-1/2}$ .

Just above the "hull speed," the stern of the ship drops into a large wave trough, and the ship runs at a high trim angle. Anyone who has been on a planing boat will have noticed a particular speed, where the bow comes up very high. This is the worst speed to operate at in terms of efficiency and preventing hull damage. As the boat goes faster, the wavelength increases still further, and the hull begins to plane, reducing wavemaking resistance. The plot in Figure 7.16 shows the great increase in resistance that occurs above hull speed, and also its drop at even higher speeds. Ships rarely have enough power to reach these speeds.



**Figure 7.15** Wave Patterns vs. Speed



**Figure 7.16** Typical relationship between  $C_T$  and speed

### 7.6.3.2 Understanding and Reducing Wave Resistance

Wave theory states that the energy in a wave is proportional to the square of the wave height. Since the energy in a wave depends on the square of the wave height, any increase in wave height requires a subsequent increase in energy required to create the wave and an increase in wave making resistance. Thus, if wave height doubles, a four-fold increase in energy required to create the wave occurs. Therefore, as ship speed increases and wave height increases, wave making resistance becomes dominant.

$$E_{\text{wave}} = f(H^2)$$

So how does wave making resistance affect a ship and its operation? To illustrate, consider the following example:

The FFG-7 class ship has a waterline length of 408 ft and is powered by two gas turbine engines that produce approximately 41,000 SHP for a published maximum speed of 29 knots. At a speed of approximately 27 knots the length of the transverse wave is approximately the same length as the ship. With one gas turbine in operation (20,000 SHP), the ship is capable of speeds approaching 25 knots. It takes an additional 20,000 SHP (double the shaft horsepower) to increase speed by 4 knots! That increase in required horsepower is directly related to the effects of wave making resistance.

The question arises as how to reduce the effects of wave making resistance. In the design phase of a ship there are two things that can be done to reduce the effects of wave making, and therefore improve the performance of the ship:

- **Increasing length** of the ship increases the speed at which the length of the wave system generated by the ship is equal to ship length and therefore reduces the impact of wave making resistance.

As noted previously, the speed at which the wave length approaches ship length for an FFG-7 ( $L_{pp} = 408$  ft,  $\Delta = 4,000$  LT, rated at 41,000 SHP) is approximately 27 knots, whereas speed at which wave length approaches ship length for a NIMITZ-class carrier ( $L = 1090$  ft,  $\Delta = 97,000$  LT, approximately 280,000 SHP) is approximately 44 knots. At the FFG's top speed of 29 knots, the aircraft carrier is still in the relatively flat portion of the resistance/SHP curve. It would be very difficult to add enough propulsion machinery to the hull (space, weight, fuel, and center of gravity concerns) to increase the FFG-7's speed to an equivalent speed for the aircraft carrier. Therefore, longer ships use proportionally smaller engines to do the same speed as ships of less length. In other words, it requires fewer horsepower per ton to make the aircraft carrier (2.9 HP/LT) to achieve 30 knots than it does to make FFG-7 (10.3 HP/LT) achieve 29 knots. Figure 7.16 compares these factors. At a speed of 29 knots, the FFG-7 has a speed-length ratio of 1.4, giving the ship a large resistance coefficient. Compare the FFG to the aircraft carrier at 30 knots and a speed-length ratio of 0.90. The aircraft carrier has a much lower resistance coefficient and therefore requires significantly less horsepower per ton of displacement to achieve the same speed as the FFG.

- **Bulbous Bows.** Bulbous bows are one attempt to reduce the wave making resistance of surface ships by reducing the size of the bow wave system. The bulbous bow was developed by RADM David Taylor and was used as early as 1907 on the battleship *USS DELAWARE*. The “ram bows” of late 1800’s battle ships and even those of early Greek and Roman warships could also be considered early versions of the bulbous bow even though their bow designs were intended for other purposes. The idea behind a bulbous bow is to create a second bow wave that interferes destructively with the bow divergent wave, resulting in little to no wave at the bow. A smaller resultant bow wave improves the ship’s attitude in the water by producing less squat and trim by the stern. This more evenly trimmed ship results in less projected wetted surface area (i.e., less viscous resistance) and reduces the ship’s tendency to try to “climb” over its own bow wave as speed increases (i.e., delays the inception of large wave making resistance). A well-designed bulbous merchant ship bulb has been shown to reduce total resistance by up to 15%. This reduction in resistance translates into lower operating costs and higher profits for those merchant vessels that employ this design enhancement. Many warships also have bulbous bows. These bows often house the sonar transducers and keep them as far away as possible from the ship’s self-radiated noise. The bulbous bows of warships offer some reduction in wave making resistance and fuel savings. However, most warships cannot take full advantage of the bulbous bow since each bulb is generally “tuned” to the expected operating speed of the ship -- an easy task for a merchant which usually operates at a constant speed between ports, but not so simple for a warship whose operations necessitate frequent speed changes.

#### 7.6.4 Air Resistance ( $R_{AA}$ )

Air resistance is the resistance caused by the flow of air over the ship with no wind present. This component of resistance is affected by the shape of the ship above the waterline, the area of the ship exposed to the air, and the ship’s speed through the water. Ships with low hulls and small “sail area” or projected area above the waterline will naturally have less air resistance than ships with high hulls and large amounts of sail area. Resistance due to air is typically 4-8% of the total ship resistance, but may be as much as 10% in high sided ships such as aircraft carriers. Attempts have been made reduce air resistance by streamlining hulls and superstructures, however; the power benefits and fuel savings associated with constructing a streamlined ship tend to be overshadowed by construction costs.

#### 7.6.5 Other Types of Resistance Not Included in Total Hull Resistance

In addition to viscous resistance, wave making resistance, and air resistance, there are several other types of resistance that will influence the total resistance experienced by the ship.

##### 7.6.5.1 Appendage Resistance

Appendage resistance is the drag caused by all the underwater appendages such as the propeller, propeller shaft, struts, rudder, bilge keels, pit sword, and sea chests. In Naval ships appendages can account for approximately 2-14% of the total resistance. Appendages will primarily affect

the viscous component of resistance as the added surface area of appendages increases the surface area of viscous friction.

### **7.6.5.2 Steering Resistance**

Steering resistance is added resistance caused by the motion of the rudder. Every time the rudder is moved to change course, the movement of the rudder creates additional drag. Although steering resistance is generally a small component of total hull resistance in warships and merchant ships, unnecessary rudder movement can have a significant impact. Remember that resistance is directly related to the horsepower required to propel the ship. Additional horsepower is directly related to fuel consumed (more horsepower equals more fuel burned). A warship traveling at 15 knots and attempting to maintain a point station in a formation may burn up to 10% more fuel per day than a ship traveling independently at 15 knots.

### **7.6.5.3 Wind and Current Resistance**

The environment surrounding a ship can have a significant impact on ship resistance. Wind and current are two of the biggest environmental factors affecting a ship. Wind resistance on a ship is a function of the ship's sail area, wind velocity and direction relative to the ship's direction of travel. For a ship steaming into a 20-knot wind, ship's resistance may be increased by up to 25-30%.

Ocean currents can also have a significant impact on a ship's resistance and the power required to maintain a desired speed. Steaming into a current will increase the power required to maintain speed. For instance, the Kuroshio Current (Black Current) runs from South to North off the coast of Japan and can reach a speed of 4-5 knots. What is the impact of this current? For a ship heading south in the current and desiring to travel at 15 knots it is not uncommon to have the propulsion plant producing shaft horsepower for speeds of 18-19 knots. Therefore, the prudent mariner will plan his or her voyage to avoid steaming against ocean currents whenever possible, and to steam with currents wherever possible.

### **7.6.5.4 Added Resistance Due to Waves**

Added resistance due to waves refers to ocean waves caused by wind and storms, and is not to be confused with wave making resistance. Ocean waves cause the ship to expend energy by increasing the wetted surface area of the hull (added viscous resistance), and to expend additional energy by rolling, pitching, and heaving. This component of resistance can be very significant in high sea states.

### **7.6.5.5 Increased Resistance in Shallow Water**

Increased resistance in shallow water (the Shallow Water Effect) is caused by several factors.

- The flow of water around the bottom of the hull is restricted in shallow water, therefore the water flowing under the hull speeds up. The faster moving water increases the viscous resistance on the hull.

- The faster moving water decreases the pressure under the hull, causing the ship to “squat”, increasing wetted surface area and increasing frictional resistance.
- The waves produced in shallow water tend to be larger than do waves produced in deep water at the same speed. Therefore, the energy required to produce these waves increases, (i.e. wave making resistance increases in shallow water). In fact, the characteristic hump in the total resistance curve will occur at a lower speed in shallow water.

The net result of traveling in shallow water is that it takes more horsepower (and fuel) to meet your required speed. Another more troublesome effect of high speed operation in shallow water is the increased possibility of running aground. One notable occurrence was in 1992 when the liner *QUEEN ELIZABETH II*, ran aground at a speed of 25 knots on a reef near Cuttyhunk Island in Massachusetts. The ship’s nominal draft was 32 ft-4 inches and the charted depth of the reef was 39 feet. The 6.5-foot increase in draft was due to the shallow water effect known as *squat*.

Just as shallow water will adversely affect a ship’s resistance, operating in a narrow waterway such as a canal can produce the same effect. Therefore when operating in a canal, the ship’s resistance will increase due to the proximity of the canal walls and the decrease in pressure along the ships sides is likely to pull the ship towards the edge of the canal. The prudent mariner is advised to operate at moderate speeds when steaming in shallow and/or narrow waters.

#### 7.6.6 Resistance and the Operator

There is a direct correlation between a ship’s curve of total hull resistance, the EHP curve, the SHP curve, and the fuel consumption curve for a ship. What can the ship operator do to reduce the effects of viscous and wave making resistance?

- **Hull Cleaning.** The easiest method to reduce the effect of viscous resistance is to keep the hull clean and free of barnacles and underwater grasses. Section 7.6.2 indicated that frictional resistance is a function of surface roughness. Fouling of the hull can increase fuel consumption up to 15 percent. Keeping the underwater hull clean will reduce surface roughness and help minimize the effects of viscous resistance and conserve fuel. The Navy requires its ships to undergo periodic hull inspections and cleanings in order to reduce surface roughness. Ships are also periodically dry-docked and their bottoms are stripped and repainted to return the ships hull to a smooth condition.
- **Operate at a prudent speed.** To reduce the effects of wave making resistance, the operator should transit at speeds away from the humps in the resistance curve. From Figure 7.16 one such speed to avoid is when the speed-length ratio is approximately 1.0. For the FFG-7 this equates to a speed of approximately 20 knots. For best performance, operating at a speed-length ratio less than 0.9 is preferable. The standard transit speed for the US Navy is 14 knots, which puts most ships well below any point where the effects of wave making become a problem. For the FFG-7, a transit speed of 14 knots results in a speed-length ratio of approximately 0.7, well below the wave making threshold. At a speed of 14 knots, and aircraft carrier has a speed-length ratio of approximately 0.45, a speed where viscous resistance is the dominant component of resistance!

Traveling at high speeds corresponding to the humps in the  $C_T$  curve requires that the ship produce enough shaft horsepower to overcome the rapidly increasing wave making resistance. This rapidly increasing horsepower requirement means that fuel consumption will increase just as rapidly. For example, an FFG-7 with a clean hull traveling at 14 knots (speed-length ratio of 0.7) with one engine running will burn approximately 10,000 gallons of fuel per day. The same ship traveling at 29 knots (speed-length ratio of 1.4) with both engines in operation burns approximately 3,000 gallons of fuel **per hour!** Consider that the FFG-7 has a total fuel capacity of about 190,000 gallons, you can do the math and see why ships do not travel at high speeds for sustained periods.

Unlike warships whose maximum speed is determined by mission requirement, merchant ships are designed to travel at a speed corresponding to a hollow in the resistance curve. In fact, the service speed of a merchant ship is usually below the first hump speed. Most merchant ships have a service speed of approximately 15 knots, and if a length of 600 feet is assumed (speed-length ratio is 0.6), the ship is well below hump speed. Therefore less horsepower is required to propel the ship. Less horsepower equals smaller propulsion machinery, less fuel storage requirements, more cargo storage space, and therefore more savings in operating cost and more room for payload/mission systems.

## 7.7 Determining the Total Hull Resistance and EHP Curves

Now that you have learned about the various components of ship resistance and how ship speed, resistance, and power are related; we now need to study how the EHP curve for a ship is obtained. One of the key phases in the design process for a ship is the determination of the amount of power required to propel a ship at either its maximum speed or service speed. This is necessary so the type and size of propulsion plant can be determined. Propulsion plant size is critical to the estimate of the location of the ship's center of gravity (stability concerns), and the amount of space to be set aside to accommodate the propulsion plant. Recall from section 7.4 that a ship's effective horsepower is related to total hull resistance by the following equation:

$$EHP = \frac{R_T V_S}{550 \frac{ft \cdot lb}{sec \cdot HP}}$$

Therefore, to determine effective horsepower for a given speed all the naval architect needs to do is to determine the total hull resistance at that speed. This presents a problem during design, as the ship only exists on paper and/or in the computer. There are two methods of predicting resistance and EHP curves for a ship during the design process: computer modeling and traditional tow tank testing with a model of the ship.

### 7.7.1 Computer Modeling

This method of determining a ship's resistance curve involves modeling the ship's hull in a computer and then solving three-dimensional fluid flow equations for the flow of water around the ship's hull. These equations are solved through a method called "computational fluid dynamics" using the finite element method of analysis. This method requires a large amount of computer memory and the ability to solve thousands of simultaneous equations. Computer modeling of the hull and the flow of water around the hull produces fairly accurate results (if you have a large enough computer) and can be used to compare many different hull designs.

Computer modeling does, however, have its drawbacks. Fluid flow around a ship's hull is very complex, especially near the stern where the hull's shape changes rapidly, and in many cases the flow in this region is difficult to analyze with the computer. This often necessitates the other method of determining a ship's resistance curve: tow tank testing of a model.

### 7.7.2 Theory Behind Ship Modeling and Tank Testing

Tow tank testing of a ship model is the traditional method of determining a ship's total hull resistance and its EHP curves. In this method, a model of the ship's hull is built and towed in a towing tank, measuring hull resistance at various speeds. The model results are then scaled up to predict full-scale hull resistance and EHP.

In order for model test results and full-scale ship predictions to be useable, two fundamental relationships between the model and ship must be met: geometric and dynamic similarity.



### 7.7.2.1 Geometric Similarity

Geometric similarity is obtained when all characteristic dimensions of the model are directly proportional to the ship's dimensions. The model is then a scaled version of the real ship – a very accurately scaled version of the ship. The ratio of the length of the ship to the length of the model is typically used to define the scaling factor ( $\lambda$ ).

$$\text{Scale Factor} = \lambda = \frac{L_S}{L_M}$$

where:  $L_S$  = length of the ship, ft  
 $L_M$  = length of the model, ft

Note: the subscript “S” will be used to denote values for the full-scale ship and the subscript “M” will be used to denote values for the model.

From this it follows logically that the ratio of areas is equal to the scale factor squared and the ratio of volumes is equal to the cube of the scale factor. The characteristic area of importance for modeling is the wetted surface area of the underwater hull ( $S$ ), ft<sup>2</sup>, and the characteristic volume of importance is the underwater volume of the ship ( $\nabla$ ), ft<sup>3</sup>. These relationships are shown below:

$$\lambda^2 = \frac{S_S}{S_M}$$

$$\lambda^3 = \frac{\nabla_S}{\nabla_M}$$

### 7.7.2.2 Dynamic Similarity

In addition to geometric similarity between model and full-scale ship, there must also be dynamic similarity between the model and its environment and the full-scale ship and its environment. Dynamic similarity means that the velocities, accelerations, and forces associated with fluid flow around both the model and full-scale ship have scaled magnitudes and identical directions at corresponding locations along the hull. The model must behave in exactly the same manner as the full-scale ship.

Unfortunately, it is physically impossible to achieve true dynamic similarity between the model and full-scale ship. Resistance is a function of velocity, water and air pressure, kinematic viscosity of water ( $\nu$ ), air and water density, and the acceleration due to gravity. It is impossible to scale gravity (think of a model having a scale ratio of 36 ... now, try to establish a lab environment whose acceleration of gravity is 1/36<sup>th</sup> of 32.17 ft/sec<sup>2</sup>). Similarly, it is impossible to scale water and its properties. Two fluids that come close to being scale versions of water are gasoline and liquid mercury; both of which pose serious health and safety issues.

So, if true dynamic similarity cannot be achieved, how can towing tanks exist, let alone produce meaningful results? The answer lies in achieving partial dynamic similarity between model and ship and Froude's “Law of Comparison”, also referred to as the “Law of Corresponding Speeds”.

### 7.7.2.3 The Law of Comparison and Tow Tank Testing

In previous sections of this chapter, we discussed ship resistance and ship performance in terms of dimensionless coefficients:

$$C_T = C_V + C_W$$

where:  $C_T$  = coefficient of total hull resistance  
 $C_V$  = coefficient of viscous resistance  
 $C_W$  = wave making coefficient

In an ideal world when comparing a geometrically similar ship and model, the coefficients of total resistance, viscous resistance, and wave making resistance would be equal between ship and model. However, due to the viscous effects of water, this is not possible. The question is how to effectively take model data and calculate a coefficient of total hull resistance for the full-scale ship. This question was answered by Froude through his research on ship performance.

After many towing tank tests, Froude noticed that the wave pattern produced by a geometrically similar model and ship looked the same when the model and ship were traveling at the same speed to square root of length ratio. This is the Law of Corresponding Speeds, and is written as:

$$\frac{V_S}{\sqrt{L_S}} = \frac{V_M}{\sqrt{L_M}}$$

where:  $V_S$  = ship velocity (ft/s)  
 $V_M$  = model velocity (ft/s)  
 $L_S$  = ship length (ft)  
 $L_M$  = model length (ft)

Because the wave patterns of the model and ship were similar using this relationship, Froude determined that it would be correct to use the same value of wave making coefficient ( $C_W$ ) for both the model and ship when operating under these conditions, and therefore partial dynamic similarity between model and ship could be obtained. This can be summarized in the following mathematical relationships:

$$C_{WS} = C_{WM}$$

$$\text{if, } V_M = \frac{V_S \sqrt{L_M}}{\sqrt{L_S}} = \frac{V_S}{\sqrt{L_S}}$$

**Example 7.4** A new type of destroyer is undergoing model testing in the tow tank. The ship has a length of 435 feet and the model has a length of 18 feet. The ship is to have a maximum speed of 35 knots. At what speed should the model be towed to achieve partial dynamic similarity for a speed of 35 knots?

Model speed is found using the law of corresponding speeds:

$$V_M = \frac{V_S \sqrt{L_M}}{\sqrt{L_S}}$$

$$V_S = (35 \text{ knots}) \times (1.688 \text{ (ft/sec)/kt}) = 59.08 \text{ ft/sec}$$

$$V_M = \frac{(59.08 \frac{\text{ft}}{\text{sec}})(\sqrt{18 \text{ ft}})}{\sqrt{435 \text{ ft}}} = 12.02 \frac{\text{ft}}{\text{sec}}$$

Therefore, partial dynamic similarity ( $C_{WM} = C_{WS}$ ) is achieved for a speed of 35 knots if the model is towed at a speed of 12.02 ft/sec.

The purpose of towing tank testing is to tow the model at speeds that correspond to full-scale ship speeds, measure the model's resistance and determine the model's coefficient of wave making resistance. Knowing that the coefficient of wave making resistance of the model and full-scale ship are equal, one can easily determine the coefficient of total hull resistance for the ship. Once the full-scale resistance coefficient is known, the total hull resistance and EHP for the ship are calculated.

To summarize, resistance testing of a model in a towing tank utilizes the following generalized procedure:

- Determine the full-scale ship speed range for the test: minimum ship speed to a desired maximum speed.
- Determine towing speeds for the model using the Law of Comparison.
- Tow the model at each speed, recording the total hull resistance of the model.
- Determine the coefficient of total hull resistance for the model at each speed.
- Determine the coefficient of viscous resistance for the model at each speed.
- Calculate the wave making coefficient of the model at each speed
- $C_{WS} = C_{WM}$
- Determine the coefficient of viscous resistance for the ship at ship speeds corresponding to model towing speeds
- Determine the coefficient of total hull resistance for the ship at each speed.
- Determine the total hull resistance of the ship for each speed.
- Determine and plot the effective horsepower of the ship at each speed

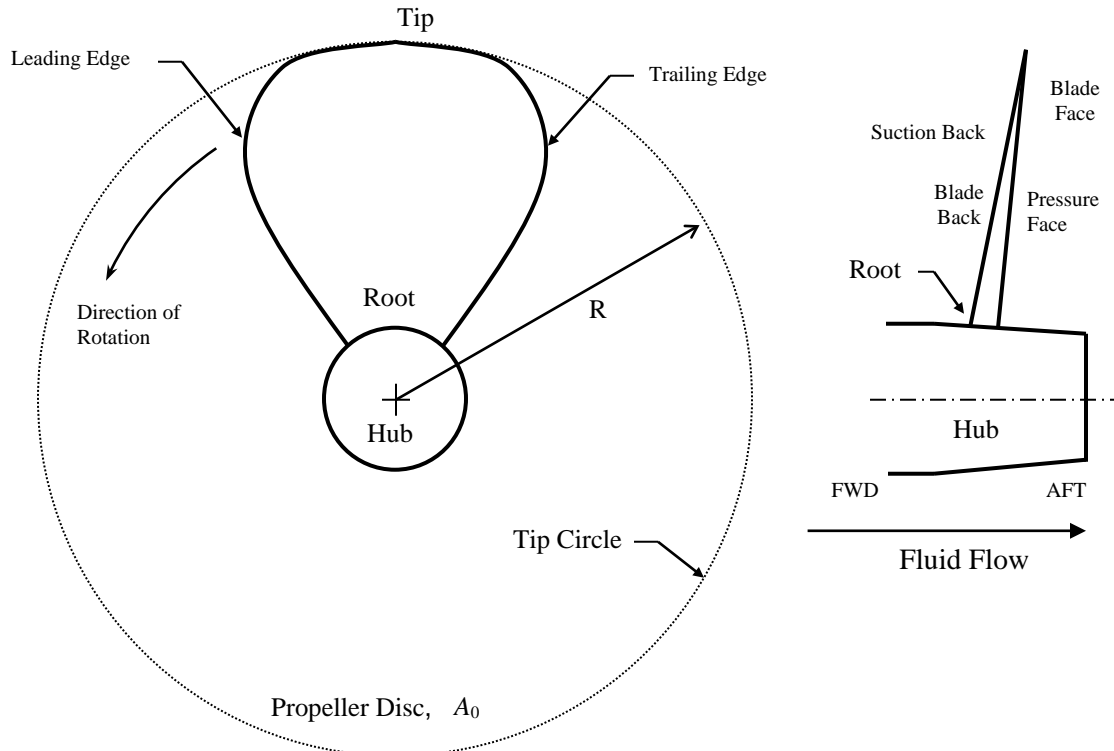
Once the full-scale EHP curve is known, a similar shaft horsepower curve can be determined based on the assumed propulsive coefficient. The bottom line of EHP testing in the towing tank

is to determine the amount of shaft horsepower that must be installed in the full scale ship in order to drive at its maximum speed. Once the maximum shaft horsepower is determined, the physical size and weight of the ship's propulsion plant can be resolved as well as the fuel storage requirements based on the expected steaming range (miles) of the ship. These factors are important in estimating the location of the ship's center of gravity as well as the design of the ship's structure.

## 7.8 The Screw Propeller

The screw propeller is the device most commonly used to transmit the power produced by the prime mover into the water and drives the ship. Screw design theory is very complicated, however, this course includes a few definitions, some basic theory, and propeller characteristics.

### 7.8.1 Screw Propeller Definitions



**Figure 7.17** Basic propeller geometry; left handed propeller viewed from astern.

- Propeller Radius (R) Distance from the propeller axis to the blade tip.
- Hub Connection between the blades and the propeller shaft
- Blade Tip Furthest point on the blade from the hub
- Blade Root Point where the blade joins the hub
- Tip Circle Circle described by the blade tips as the propeller rotates
- Propeller Disc ( $A_0$ ) Area described by the tip circle (propeller area,  $A_0$ )
- Leading Edge First portion of the blade to encounter the water
- Trailing Edge Last portion of the blade to encounter the water
- Pressure Face High pressure side of the propeller blade. Astern side of the blade when moving the ship forward
- Suction Back Low pressure side of the blade. Most of the pressure difference developed across the blade occurs on the low pressure side.
- Left Handed Screw Rotates counterclockwise when viewed from astern. Single screw naval vessels use this type of propeller.
- Right Handed Screw Rotates clockwise when viewed from astern. Twin screw naval vessels use one left handed and one right handed propeller.

### 7.8.2 Propeller Pitch (P)

Many times a propeller is referred to by its pitch. So, what is propeller pitch? Assuming the propeller shaft is rotating at a constant angular rate, and the ship is moving at a constant speed, as the propeller rotates and moves through the water, any point on the surface of a propeller blade will describe a helix in one 360° rotation of the shaft.

Propeller pitch ( $P$ ) is the ideal **linear distance** parallel to the direction of motion that would be traveled in one revolution of the propeller shaft; similar to what happens when you turn a wood screw one revolution into a block of wood.

The pitch angle ( $\phi$ ) of a propeller is the angle that any portion of the blade makes from perpendicular to the water flow. Since any point on a propeller blade describes a helix, sections taken at various radii of a propeller with a constant linear pitch ( $P$ ) will have varying pitch angles ( $\phi$ ) depending on the radius from the hub. This gives propellers their characteristic blade twist. The pitch of a propeller ( $P$ ) and pitch angle are related through the following equation:

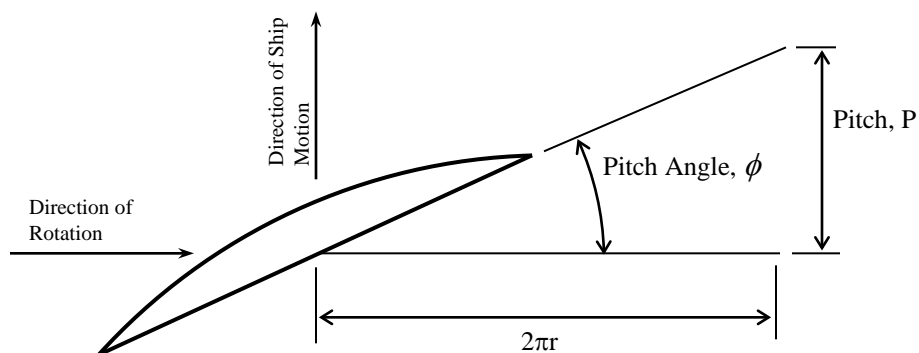
$$\tan \phi = \frac{P}{2\pi r}$$

where:  $P$  = propeller pitch (ft)

$\phi$  = pitch angle (degrees)

$r$  = radial distance of any point on the blade from the propeller shaft axis (ft)

This relationship is shown below in Figure 7.18.

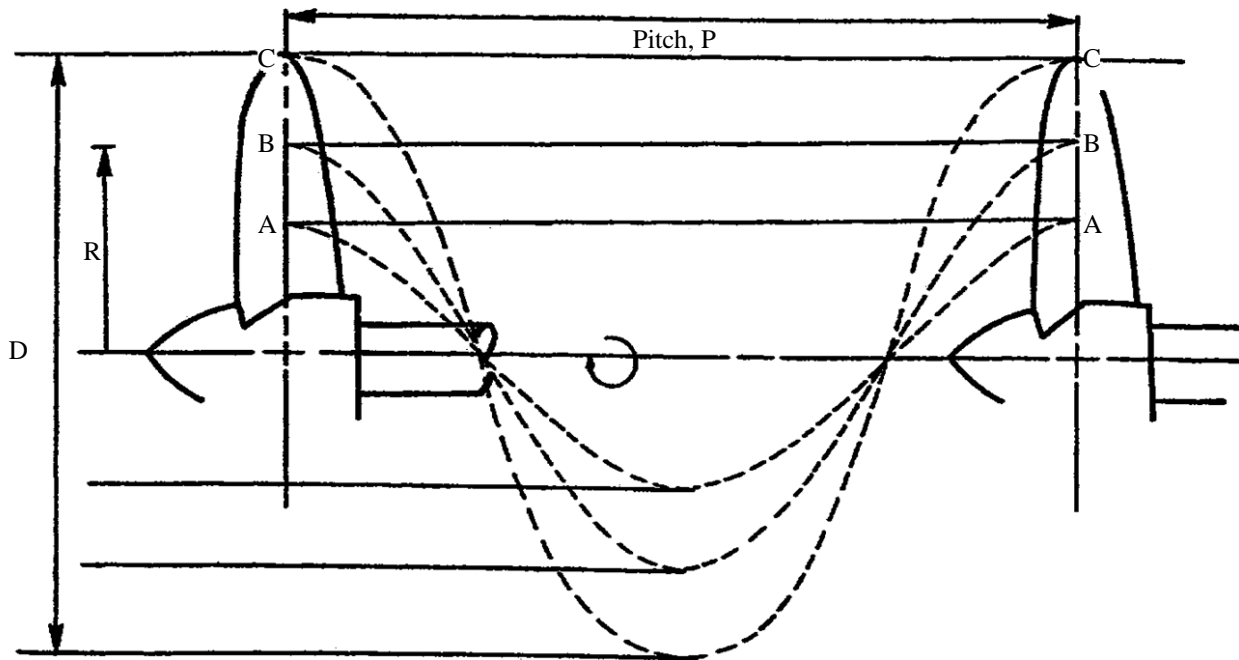


**Figure 7.18** Relationship between propeller pitch and pitch angle

Each point on a constant linear pitch ( $P$ ) propeller blade will travel the same linear distance in one rotation of the propeller. Therefore, when looking at a constant pitch propeller you will notice that the angle of the blades ( $\phi$ ) changes from root to tip.

Consider a constant pitch propeller that is 14 feet in diameter with a pitch of 15 feet. The hub has a diameter of 5 feet. Using the above equation, one can easily determine the pitch angle at any point along the blade. For instance, at the root the blade has a pitch angle of  $43.6^\circ$  and at the tip the blade has a pitch angle of  $18^\circ$ .

A typical propeller with constant linear pitch is illustrated below in Figure 7.19. Note how points 'A', 'B', and 'C' each travel the same distance in one revolution of the propeller. If a propeller had a flat blades with a constant pitch angle ( $\phi$ ) instead of helical blades with a constant linear pitch ( $P$ ), the tips would travel much farther than the root in one revolution through a solid, and the propeller would essentially fight against itself.



**Figure 7.19** Typical propeller operating through one revolution.  
(reproduced from “Introduction to Naval Architecture” by Gillmer and Johnson)

The linear pitch ( $P$ ) of real ship propellers is more-or-less constant all the way from the blade root to the blade tip. Some propellers have small variations in linear pitch ( $P$ ) at different radii to adapt to irregularities in the flow going into the propeller, or to minimize certain types of cavitation. These variations are usually less than 20%. Because of these small differences, the nominal pitch value for a propeller is taken at seventy percent of the blade radius ( $0.7R$ ).

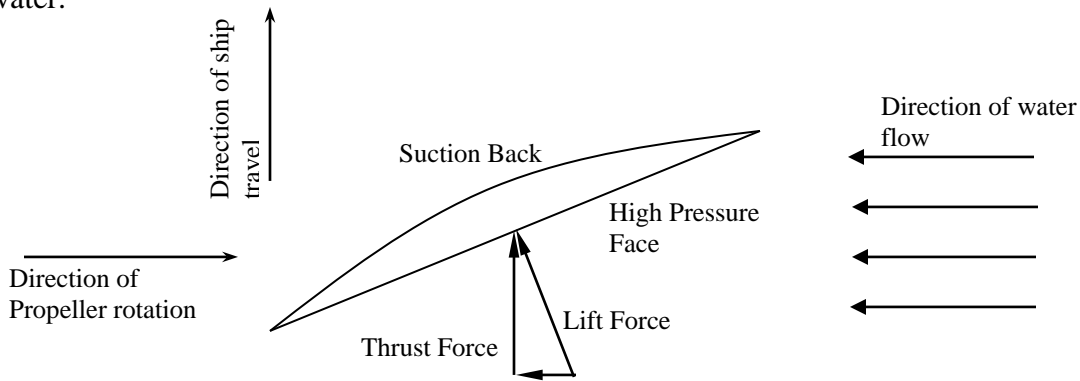
There are two main types of propellers seen in Naval applications – Fixed Pitch Propellers and Controllable Pitch Propellers:

**Fixed Pitch Propeller:** A fixed pitch propeller is a propeller whose blade is fixed with respect to the hub and cannot be changed while the propeller shaft is rotating. Most propellers in service today, from those attached to outboard engines or to the large screws of aircraft carriers, are fixed variable pitch propellers.

**Controllable Pitch Propeller:** This type of propeller design allows the position of the propeller blade with respect to the hub to be changed while the propeller shaft is rotating. This is accomplished by using an electro-hydraulic system to change the pitch angle of the blades. Sometimes this can be referred to as Controllable Reversible Propeller, or CRP, (on LSD *class* ships). While the entire propeller is classified as a controllable pitch propeller, the blades can also be variable pitch, producing a controllable variable pitch propeller. A controllable pitch propeller can significantly improve the control and ship handling capabilities of a ship. It also obviates the need for a prime mover reversing mechanism because the pitch angle can be changed such that the blades provide reverse thrust without changing the direction of shaft rotation. This type of propeller is found on DDG 51, CG 47, LPD-19, DDG-1000 and LSD 49 classes of ship.

### 7.8.3 How a Propeller Blade Works

A propeller blade works in the same manner as an aircraft wing. Water flow over the propeller blade creates a pressure differential across the blade which creates a lifting or thrust force that propels the ship through the water. If we were to make a cut through a propeller blade, we would see that the blade has a shape similar to an aircraft wing. Figure 7.20 illustrates this concept. Water velocity over the suction back of the blade is greater than the velocity across the high-pressure face of the blade. Using Bernoulli's equation (from Chapter 1), this velocity differential across the blade results in a pressure differential across the blade. The resultant lifting force can be resolved into thrust and resistance vectors. It is the thrust vector that pushes the ship through the water.



**Figure 7.20** Forces acting on a propeller blade

### 7.8.4 Theory of Propeller Action

(DERIVATION OPTIONAL)

There are several theories on fluid dynamics used to describe the operation of a screw propeller. These include momentum theory, impulse theory, blade element theory, and circulation theory. Each of these theories is used by naval architects to design a propeller and analyze its performance. The momentum theory is presented here because it gives some valuable insight into the operation of a propeller without the burden of advanced mathematics.



#### 7.8.4.1 Speed of Advance ( $V_A$ )

(DERIVATION OPTIONAL)

Before a study of momentum theory can proceed, it is necessary to understand the concept of the speed of advance ( $V_A$ ) of a propeller. As a ship moves through the water at some velocity ( $V_S$ ), it drags the surrounding water with it as explained earlier in the section on viscous resistance. At the stern of the ship, this causes the wake to follow along with the ship at a wake speed ( $V_W$ ). Consequently the propeller is experiencing a flow velocity less than the ship's velocity. The flow velocity through the propeller is called the speed of advance ( $V_A$ ). Figure 7.21 illustrates this concept.

$$V_A = V_S - V_W$$

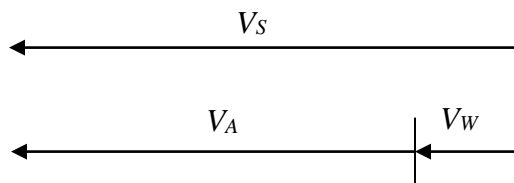


Figure 7.21 Speed of advance

#### 7.8.4.2 Momentum Theory

(DERIVATION OPTIONAL)

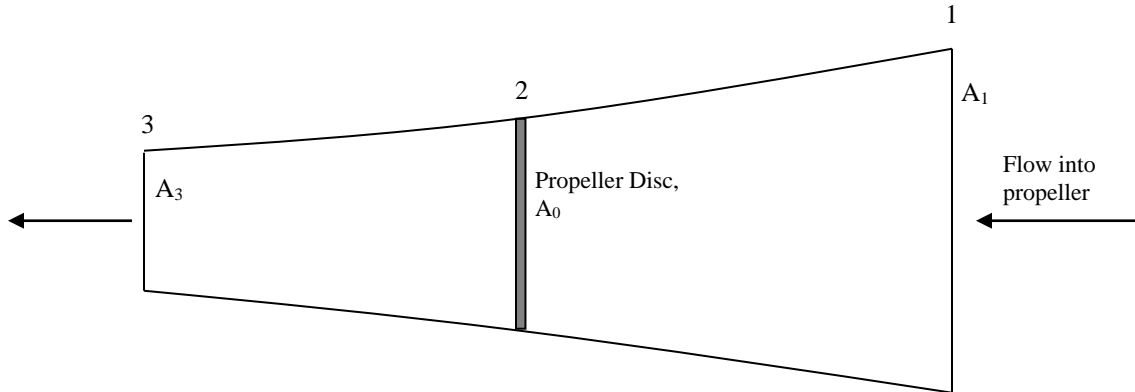
The momentum theory is used to describe the action of an “ideal” propeller. In this theory, the exact nature of the propeller (pitch, number of blades, shaft rpm, etc) is not important. The propeller itself is assumed to be a “disc” of area  $A_0$  (disc area). The propeller causes an abrupt increase in pressure as the fluid passes through the disc coupled with an increase in fluid velocity. The method by which this occurs is ignored.

Momentum theory makes the following assumptions regarding the propeller and the flow through the propeller:

1. The propeller imparts a uniform acceleration to the water passing through it and the thrust generated by the propeller is uniformly distributed over the entire disc.
2. The flow is frictionless.
3. There is an unlimited supply of water available to the propeller.

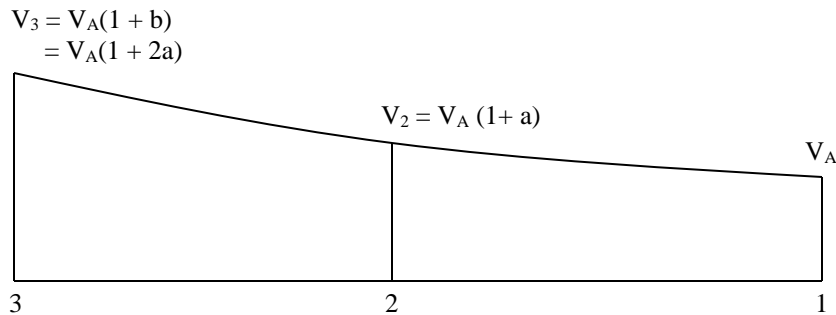
Figures 7.22 through 7.24 look at the propeller and a control volume of water around the propeller. The control volume extends from some station 1 ahead of the propeller to some station 3 astern of the propeller. Station 2 represents the propeller disc area ( $A_0$ ). Since the assumption is made that the propeller imparts a uniform acceleration to the water, this implies that the cross section area of the control volume must decrease from station 1 to station 3.

- Cross section area of the flow decreases through the propeller.



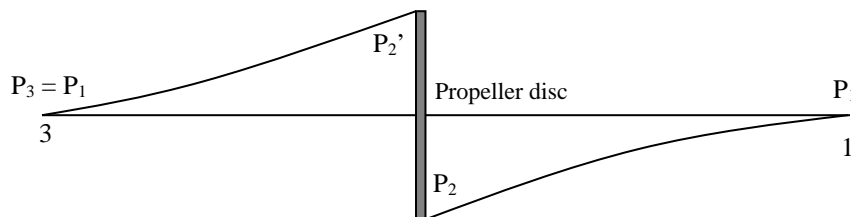
**Figure 7.22** Flow cross-sectional area

- Flow velocity increases from the speed of advance ( $V_A$ ) at point 1 to velocity  $V_3$  as cross section area of the flow decreases from station 1 to station 3. The “ $a$ ” and “ $b$ ” terms are an axial-inflow factor and will be discussed later.



**Figure 7.23** Flow velocity

- Pressure decreases as fluid velocity increases through the propeller. Note that the propeller causes an increase in pressure between the suction back ( $P_2$ ) and pressure face ( $P_2'$ ). Note that at some distance ahead and astern of the propeller, pressures are equal.



**Figure 7.24** Flow pressure

### 7.8.4.3 Determination of Propeller Thrust

(DERIVATION OPTIONAL)

Momentum theory states that the thrust produced by a propeller is equal to the change in momentum of the fluid per unit time as it passes through the control volume from station 1 to station 3.

The volume flow rate of water through the propeller disc is:

$$Q = V_A(1+a)A_0$$

Neglecting any effect of rotation that may be imparted to the flow by the propeller disc, the change in momentum per unit time between stations 1 and 3 is:

$$\begin{aligned} & \rho Q(V_3 - V_A) \\ &= \rho Q[V_A(1+b) - V_A] \end{aligned}$$

Therefore, the thrust produced by the propeller is:

$$T = \rho Q[V_A(1+b) - V_A] = \rho Q V_A b$$

Therefore, propeller thrust is a function of the mass flow rate of water through the propeller and the change in fluid velocity through the propeller. Thrust can be increased by either increasing the flow rate through the propeller disc or by increasing the velocity differential between stations 1 and 3.

Substituting the above expression for flow rate through the disc produces the following expression for propeller thrust:

$$T = \rho A_0 V_A^2 (1+a)b$$

The terms “*a*” and “*b*” are axial-inflow factors and are used to describe the increase in fluid velocity through the propeller from station 1 to station 3. It can be shown that axial inflow factors “*a*” and “*b*” are related by the following expression:

$$b = 2a \quad \text{or} \quad a = b/2$$

The significance of this relation is that one half of the increase in fluid velocity through the propeller is obtained prior to the fluid reaching the propeller disc. In other words, the decrease in pressure at the suction back of the propeller causes fluid velocity to increase. Substituting  $a = b/2$  into the equation for thrust produces the following expression for propeller thrust:

$$T = \rho A_0 V_A^2 b(1+b/2)$$

Rearranging this expression produces the following:

$$T = \frac{1}{2} \rho A_0 V_A^2 (2b + b^2)$$

We will use the above relationship for propeller thrust to describe thrust loading on the propeller and the efficiency of the propeller.

#### 7.8.4.4 Thrust Loading Coefficient ( $C_T$ )

(DERIVATION OPTIONAL)

The coefficient of thrust loading ( $C_T$ ) is the dimensionless form of thrust and is defined by the following equation:

$$C_T = \frac{T}{\frac{1}{2} \rho A_0 V_A^2}$$

Comparing this equation to the above relation for thrust reveals that:

$$C_T = 2b + b^2$$

#### 7.8.4.5 Ideal Propeller Efficiency ( $\eta_I$ )

(DERIVATION OPTIONAL)

The ideal efficiency of a propeller is the ratio of useful work obtained from the propeller and work expended by the propeller on the water. The work done on the water by the propeller thrust is  $TV_A(1 + a)$ , and the work obtained from the propeller is  $TV_A$ . The ideal propeller efficiency is:

$$\eta_I = \frac{TV_A}{TV_A(1 + a)}$$

However,  $a = b/2$ , and substituting this expression into the equation for ideal efficiency produces:

$$\eta_I = \frac{TV_A}{TV_A(1 + a)} = \frac{1}{1 + a} = \frac{1}{1 + b/2} = \frac{2}{2 + b} = \frac{2}{1 + (1 + b)}$$

Rearranging the expression for  $C_T$  produces the following expression for  $C_T$  and  $b$ :

$$\sqrt{1 + C_T} = (1 + b)$$

Substituting into the above expression for ideal propeller efficiency produces:

$$\eta_I = \frac{2}{1 + \sqrt{1 + C_T}}$$

### 7.8.5 Propeller Characteristics

Momentum theory, derived above, gives us the following relationships for the ideal efficiency:

$$\eta_I = \frac{2}{1 + \sqrt{1 + C_t}} \quad \text{where} \quad C_t = \frac{T}{\frac{1}{2} \rho A_o V_A^2}$$

where,

$\eta_I$  = ideal propeller efficiency

$C_t$  = Thrust Coefficient

$T$  = Propeller Thrust (lbf)

$\rho$  = density of water (lbf-s<sup>2</sup>/ft<sup>4</sup>)

$A_o$  = Disc area of propeller =  $\pi D^2/4 = \pi R^2$ , (ft<sup>2</sup>)

$D$  = propeller diameter =  $2R$ , (ft)

$V_A$  = Speed of advance of propeller through fluid (ft/s)

From these two relationships we can look at how different factors affect the performance of a propeller. For a given thrust ( $T$ ) and speed of advance ( $V_A$ ), the thrust loading coefficient will decrease as the propeller disc area ( $A_o$ ) increases. A decrease in propeller thrust loading results in an increase in the ideal propeller efficiency. Thus, **larger propellers reduce thrust loading and improve efficiency**. Propeller diameter is often constrained by the ship's draft, or by other limitations, such as rotational speed, but in general, the larger propeller will be more efficient.

The equation for ideal propeller efficiency given above should not be confused with actual propeller efficiency discussed in section 7.2.4. The ideal propeller efficiency is based on frictionless, irrotational flow through the propeller. Because of friction, rotational factors, and other losses, the actual efficiency of a propeller is approximately 20% less than the ideal efficiency given above. However, the idea of increasing the size of the propeller to improve efficiency is still valid.

Momentum theory does not address such matters as the pitch of a propeller, the number of blades in the propeller, or even propeller shaft rotation (rpm).

- Pitch is determined based on the propeller rotation speed and the speed of the ship. Slow turning propellers with a higher pitch are generally more efficient; however they require larger reduction gears. Propeller pitch rarely exceeds 1.4 times the diameter.
- RPM is related to the pitch and the speed of the ship.
- Number of blades depends mainly on vibration characteristics. Submarines can have seven-bladed propellers to be extra quiet.

For further information on propellers and propeller theory, read Volume 2 of "Principles of Naval Architecture", published by the Society of Naval Architects and Marine Engineers.

## 7.8.6 Propeller Cavitation

Cavitation is the formation and subsequent collapse of vapor bubbles in regions on propeller blades where pressure has fallen below the vapor pressure of water. Cavitation occurs on propellers that are heavily loaded, or are experiencing a high thrust loading coefficient.

### 7.8.6.1 Types of Cavitation

There are three main types of propeller cavitation:

- Tip** Blade tip cavitation is the most common form of cavitation. Tip cavitation forms because the blade tips are moving the fastest and therefore experience the greatest dynamic pressure drop.
- Sheet** Sheet cavitation refers to a large and stable region of cavitation on a propeller, not necessarily covering the entire face of a blade. The suction face of the propeller is susceptible to sheet cavitation because of its low pressures. Additionally, if the angle of attack of the blade is set incorrectly (on a controllable pitch propeller, for instance) it is possible to cause sheet cavitation on the pressure surface.
- Spot** Spot cavitation occurs at sites on the blade where there is a scratch or some other surface imperfection.

### 7.8.6.2 Consequences of Cavitation

The consequences of propeller cavitation are not good and can include the following:

- Reduction in the thrust produced by the propeller.
- Erosion of the propeller blades. As cavitation bubbles form and collapse on the tip and face of a propeller blade, pressure wave formed causes a small amount of metal to be eroded away. Excessive cavitation can erode blade tips and cause other imperfections on the blade's surface.
- Vibration in the propeller shafting.
- Increase in ship's radiated noise signature.

In the case of a warship, cavitation is to be avoided because the noise of cavitation can compromise the location of the vessel. This is especially important when operating in the vicinity of enemy submarines. The Prairie-Masker system, used on several different classes of warship (DDG-51 and CG-47, for instance) is highly effective at reducing machinery and cavitation noise. The Prairie portion of the system routes compressed air from the turbines to the leading edges and propeller blade tips (the most likely location for cavitation to form), where it is released into the water through small holes. The air bubbles released from the propeller helps reduce cavitation and dampen the effect of collapsing vapor bubbles caused by cavitation.

### 7.8.6.3 Preventing Cavitation

Several actions can be taken to reduce the likelihood of cavitation occurring:

- **Fouling** The propeller must be kept unfouled by marine organisms and free of nicks and scratches. Fouling causes a reduction in propeller efficiency as well as the increased chance for cavitation. Even a small scratch can cause significant spot cavitation and result in an increase in radiated noise as well as erosion of the blades. The Navy conducts regular underwater inspections and cleaning of its propellers to prevent the effects of fouling.
- **Speed** Every ship has a cavitation inception speed, a speed where tip cavitation begins to form. Unless operationally necessary, ships should be operated at speeds below cavitation inception.
- **Thrust** For ships with manual throttles (steam turbine), the Throttleman must not increase shaft speed and thrust too quickly when accelerating the ship. An analysis of the equation for the thrust coefficient ( $C_T$ ) reveals that high propeller thrust ( $T$ ) and low speed through the propeller ( $V_A$ ) increases the thrust loading coefficient which may result in cavitation.

$$C_t = \frac{T}{\frac{\rho A_0 V_A^2}{2}}$$

When accelerating the ship, the Throttleman should open the throttle slowly, allowing flow velocity to increase or decrease proportionally with propeller thrust. Ships may use an acceleration table to guide the Throttleman in opening throttles or hydrophones calibrated to detect cavitation from the propeller.

- **Pitch** Operators of ships with controllable pitch propellers must take care that propeller pitch is increased or decreased in a smooth manner. This is usually done as part of the ship's propulsion control system. Incorrect operation of the pitch control system may cause high thrust loading on the propeller blades and increase the likelihood of cavitation.
- **Depth** Since cavitation is a function of hydrostatic pressure, increasing hydrostatic pressure (i.e. depth) will reduce the likelihood of cavitation. Submarines are uniquely susceptible to depth effects and cavitation as the depth of the submarine affects hydrostatic pressure at the propeller blades. When operating at shallow depth, hydrostatic pressure is decreased and the propeller cavitates at lower shaft rpm and low thrust loading. As a submarine's depth increases, hydrostatic pressure increases and cavitation inception is delayed. Therefore, a submarine can operate at higher speeds at deeper depths with little worry about cavitation noise.

#### **7.8.6.4 Propeller Ventilation**

Ventilation is a propeller effect often confused with cavitation. If a propeller operates too close to the surface of the water, the localized low pressure created by the propeller blades can draw air under the water and cause effects similar to those mentioned for cavitation.

Ventilation is most likely to occur when operating in a very light displacement condition ( a condition common to merchant ships transiting in ballast), ships operating in rough seas where ship motion causes the propeller to go in and out of the water, and in ships with a large negative trim (trim down by the bow).



## PROBLEMS - CHAPTER 7

### Section 7.2 Ship Drive Train

1.
  - a. Draw a simplified picture of a ship's drive train with a prime mover, reduction gear, bearings, shaft seal, strut, and propeller.
  - b. Show where Brake Horsepower, Shaft Horsepower, Delivered Horsepower, and Thrust Horsepower would be measured.
  - c. Rank the powers in 1(b) from highest to lowest in magnitude.

### Section 7.3 Propulsive Efficiency

2. A ship with a drive train illustrated in Figure 7.1 has the following mechanical efficiencies:

$$\begin{array}{ll} \text{Reduction Gear} & \eta_{\text{gear}} = 95\% \\ \text{Bearings/Seal/Strut} & \eta_{\text{shaft}} = 98\% \end{array}$$

Calculate the power delivered to the propeller if the prime mover is producing 10,000 brake horsepower.

3. Towing tank testing has predicted that a ship will have an EHP of 33,000 HP when traveling at a speed of 25 knots. What will be the required SHP if the ship has a propulsive efficiency of 60%?
4. Towing tank testing has predicted that a ship will have an EHP of 50,000 HP when traveling at a speed of 30 knots. Determine the SHP required to propel the ship at 30 knots for each of the following propulsive efficiencies:
  - a. 55%
  - b. 60%
  - c. 65%

### Section 7.4 Effective Horsepower

5.
  - a. What is Effective Horsepower?
  - b. How is EHP determined in the design of a ship?
  - c. Why is the determination of EHP critical in the design of a ship?

6. A twin-screw ship has the following EHP data:

<b>Ship Speed</b>	<b>EHP</b>
<b>(knots)</b>	<b>(HP)</b>
0	1
6	50
10	110
11	180
12	250
13	360
14	520
15	820

- Plot the EHP curve for this ship. Ensure you make the plot large enough to be useful; you will need data from this plot for the remainder of the problem.
  - Assuming a propulsive efficiency of 55%, determine the top speed of the ship when it is operating both engines producing 700 SHP each.
  - Assuming the same propulsive efficiency, determine the ship's speed when operating one engine producing 700 SHP.
7. A ship has hull resistance data shown in the table below.

<b>Ship Speed</b>	<b>Total Hull Resistance</b>
<b>(knots)</b>	<b>(lbs)</b>
5	70,000
10	100,000
13	135,000
15	170,000
17	220,000
20	265,000
23	375,000
25	500,000

- Plot the resistance data and determine the effective horsepower required for a speed of 22 knots.
- If the ship has a propulsive efficiency of 60%, what shaft horsepower is required to achieve a speed of 22 knots?
- The ship is to have a maximum speed of 25 knots. How many shaft horsepower must be installed to achieve this speed?

## Section 7.5 – 7.6 Total Hull Resistance

8. What would happen to the total hull resistance if the ship's draft (i.e. displacement) were to increase?
9.
  - a. Name the components of total hull resistance in calm water.
  - b. Which component dominates at slow speeds? At high speeds?
10.
  - a. Define laminar and turbulent flow.
  - b. A ship with  $L_{PP} = 500$  feet is traveling at a speed of 25 knots. Calculate the Reynolds number for this ship and speed. Also determine the nominal length of laminar flow along the hull at this speed.
  - c. The same ship has slowed to a speed of 5 knots. Determine the new Reynolds number for the ship. Determine the nominal length of laminar flow along the hull associated with this speed.
11. Draw a waterplane view of a moving ship showing laminar flow at the bow, the transition point, boundary layer, flow separation, and wake.
12. How does an increase in ships speed affect viscous resistance?
13. A DDG ( $L_{pp} = 465$  ft) and an AOE ( $L_{PP} = 740$  ft) are steaming together at a speed of 23 knots. Which ship will have a greater skin friction coefficient ( $C_F$ )?
14. An FFG ( $\Delta = 4000$  LT,  $L_{pp} = 408$  ft, and  $T = 16$  ft) and a CVN ( $\Delta = 88,000$  LT,  $L_{PP} = 1080$  ft,  $T = 37$  ft) are steaming at the same Reynolds number. Which ship will have the greater coefficient of viscous resistance? Explain your answer.
15. Briefly describe the two major wave systems produced by a ship moving through calm water. Use a sketch to aid your description.
16. Why are there humps and hollows in the curve of total hull resistance? Sketch and label this curve.
17. How can the ship operator reduce the effects of wave making resistance?
18. Name and describe four other types of resistance not included in the total hull resistance.
19. Why does it take more power to achieve the same speed in shallow water than in deep water? What dangers are associated with operating at high speed in shallow water?
20. How can the operator take advantage of environmental factors to reduce resistance?

## Section 7.7 Determining Total Hull Resistance and EHP Curves

21. Briefly explain the terms geometric similarity and dynamic similarity.
22. Explain how geometric similarity and partial dynamic similarity are achieved in resistance testing.
23. A new class of supply ship is being tested in the towing tank. The ship has a length of 680 ft and the model is built to a scale factor of 29.57.
  - a. What length is the model?
  - b. The ship has a maximum speed of 20 knots. What speed must the model be towed at in order to achieve partial dynamic similarity?
  - c. What is the purpose of towing tank testing?

## Section 7.8 Screw Propellers

24. On a sketch of a screw propeller, show the hub, blade tip, blade root, propeller diameter, pressure face, and suction back.
25. Describe two methods for quantifying the pitch of a propeller.
26. Briefly describe the differences between fixed pitch, variable pitch, and controllable pitch propellers.
27. A propeller is described as having a pitch of 15 feet. What does this mean for the ship's operator?
28. Using the equations for the thrust loading coefficient and ideal propeller efficiency, answer the following:
  - a. Will a larger propeller be more or less efficient than a smaller propeller?
  - b. Will high thrust and low ship speed give high or low efficiency?
29. Briefly describe why propeller cavitation occurs.
30. What is the relationship between thrust loading and propeller cavitation?
31. Explain the following terms:
  - a. Tip cavitation
  - b. Sheet cavitation
  - c. Spot cavitation
32. What measures can the operator take to minimize propeller cavitation?

# COURSE OBJECTIVES

## CHAPTER 8

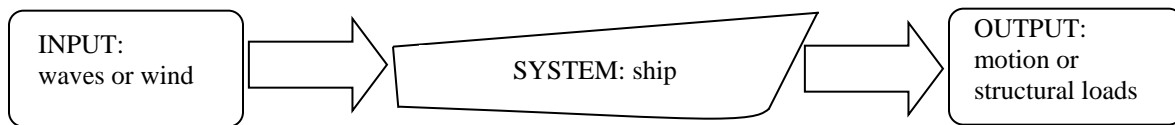
### 8. SEAKEEPING

1. Be qualitatively familiar with the creation of waves including:
  - a. The effects of wind strength, wind duration, water depth and fetch
  - b. The wave creation sequence
  - c. The superposition theorem and considering a sea as a wave spectrum
  
2. Be qualitatively familiar with simple harmonic motions including:
  - a. Free oscillations
  - b. Effect of damping
  - c. Forced oscillations and the effects of forcing function frequency on motion amplitude
  - d. Resonance
  
3. Calculate the ship-wave encounter frequency with a known ship speed and heading and known wave frequency and direction
  
4. Identify the 6 rigid body ship motions of Surge, Sway, Heave, Roll, Pitch and Yaw.
  
5. Qualitatively describe why heave, roll and pitch are simple harmonic motions
  
6. Qualitatively describe and calculate when rigid body motion resonance will occur
  
7. Qualitatively describe the structural response of a ship including:
  - a. Longitudinal bending
  - b. Torsional twisting
  - c. Transverse stressing
  
8. Qualitatively describe non-oscillatory dynamic responses including:
  - a. Shipping water
  - b. Forefoot emergence
  - c. Slamming
  - d. Racing
  - e. Added power
  - f. Broaching
  - g. Loss of stability
  
9. Qualitatively describe the way ship response can be improved including:
  - a. Different hull shape
  - b. Passive and active anti-roll devices
  - c. Ship operation

## 8.1 Introduction

So far in this course we have considered the ship to be in calm water. All the hydrostatic data such as TPI and MT1" are calculated for the ship at level trim in calm water. The curve of intact statical stability is produced assuming level trim and calm conditions. Even powering calculations such as the Froude expansion assumes calm water. Unfortunately, this is true for only a small percentage of a ship's operating life, the majority of the time it will encounter some sort of wave system.

In the most simple of models, the ship can be considered as a system that is excited by external moments and forces. The ship then responds to these external influences. Figure 8.1 shows the block diagram of this system.



**Figure 8.1** Block Diagram of Ship Response Model

For a ship, the external influences will be wind, waves, current and other natural phenomena. The responses of the ship will be the motions we associate with a ship underway such as roll, pitch, and slamming and its structural loads.

This chapter will examine the way the sea influences ship response, which responses are the most damaging to its operation and what the ship operator can do to reduce them. It will become evident that response will depend upon:

1. The size, direction and frequency of the external moments and forces.
2. The seakeeping and structural characteristics of the ship.

Only by considering the interaction of the two, will an understanding of the ship response be achieved.

## 8.2 Waves

As seen, the excitation forces and moments in the ship system shown at Figure 8.1 will be generated by wind and waves. Wind will play an important part in the response of any vessels that have significant height above the waterline; the motions of off shore structures are influenced by the direction and characteristics of the wind. It is also fairly obvious that the seakeeping and dynamic responses of yachts are wind dependent. However, to reduce the complexities of the study of ship response, we shall limit our examination of excitation forces and moments to those produced by wave systems.

Wave systems themselves can be very complicated. However, an understanding of them is vital if we are to predict ship responses with any level of accuracy.

### 8.2.1 Wave Creation

Waves will be created by anything that supplies energy to the water surface. Consequently, sources of wave systems are numerous. From our own experience we know that throwing a stone into a pool will generate a circular wave pattern. We also saw in the last chapter that a ship will generate several wave systems when traveling through water. The faster the ship speed, the larger the waves generated. It was also observed that the larger wave systems caused by higher ship speeds required an ever increasing amount of energy. This resulted in the rapid increase in EHP at high ship speeds. This phenomenon is caused by the relationship between wave height and wave energy.

$$\text{Wave Energy} = f(\text{Wave Height})^2$$

Hence a doubling in wave height is indicative of a quadrupling of wave energy. This explains the rapid increase in  $C_w$ , and in turn, EHP at high ship speeds. Conversely, this relationship also tells us that the energy content of a wave increases rapidly with wave height.

#### 8.2.1.1 Wave Energy Sources

The wave systems generated by a ship are insignificant compared with those found at sea. These systems must be generated by much larger energy sources.

- **Wind** Wind is probably the most common wave system energy source. Waves created by wind will be examined in detail in the next section.
- **Geological Events** Seismic activity on the sea bed can input significant quantities of

energy into the sea system and generate waves. Tsunamis (tidal waves) are the result of seismic activity in the deep ocean.

- **Currents** The interaction of ocean currents can create very large wave systems. These systems are usually created by the shape of the coastline and are often highly localized. The interaction of ocean currents explains the large wave systems that can occur at the Cape of Good Hope and Cape Horn.

### 8.2.1.2 Wind Generated Wave Systems

We have seen that the most common energy source of wave systems is the wind. Hence we will limit our discussion to wind generated wave systems. The size of these systems is dependent upon a number of factors.

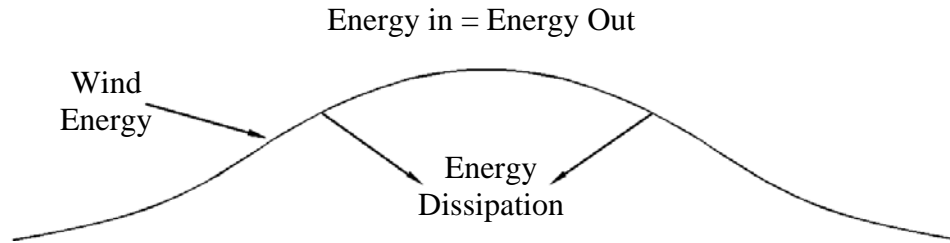
- **Wind Strength** Obviously the energy content of the wind is a function of its strength or speed. The faster the wind speed, the larger its energy content and so the more energy is transferred to the sea. Quite simply, large waves are created by strong winds.
- **Wind Duration** The length of time a wind has input energy into a sea will effect the energy content and hence the height of the wave system. As we will see, the longer the wind blows the greater the time the sea has to become fully developed at that wind speed.
- **Water Depth** Although not covered in this course, the equations for deep water and shallow water waves are very different. Consequently, water depth can have a significant effect on wave height. This is easily verified by observing the ever increasing height of a wave as it travels from deep water to the shallow water of a beach.
- **Fetch** Fetch is the area or expanse of water that is being influenced by the wind. The larger the fetch, the more efficient the energy transfer between the wind and sea. Hence large expanses of water will be rougher than small areas when subjected to the same wind.

The combination of these factors will then relate to the magnitude of the generated wave system.

### 8.2.1.3 Wave Creation Sequence

When examining the wave system creation sequence, it is important to be aware of the energy transfer that is constantly occurring in a wave. The energy of a wave is always being dissipated by the viscous friction forces associated with the viscosity of the sea. This energy dissipation increases with wave height. For the wave to be maintained, the energy being dissipated must be replaced by the energy source of the wave - the wind. Hence, without the continued presence of the wind, the wave system will die. Figure 8.2 demonstrates this principle.





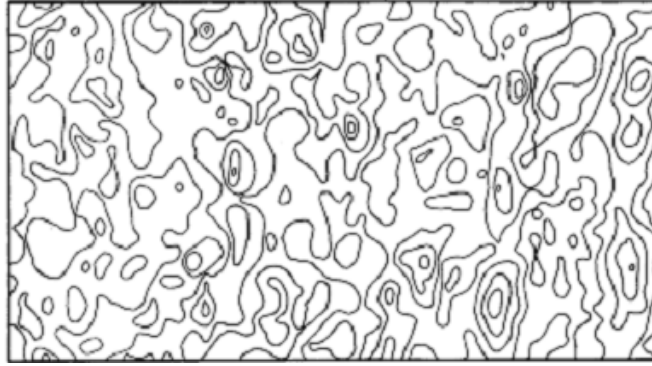
**Figure 8.2** The Wave Energy Cycle

The sequence of events in creating a wave system is as follows.

- **Initial**                      At first, the action of the wind over the water surface creates small ripples or high frequency, low wave length waves.
  
- **Growing**                      As the wind continues to blow, the wave frequency reduces and wave length increases with the energy content of the wave system.  
  
*Wind Energy > Wave Energy Dissipation*
  
- **Fully Developed**              In this condition, the sea has stopped growing and wave height and energy content is maximized.  
  
*Wind Energy = Wave Energy Dissipation*
  
- **Reducing**                      When the wind begins to reduce, the wave system can no longer be maintained. High frequency waves disappear first with ever lower frequency waves disappearing along with the system's energy.  
  
*Wind Energy < Wave Energy Dissipation*
  
- **Swell**                              Eventually, the wave system consists of the low frequency, long wave length waves associated with an ocean swell.

### 8.2.2 Wave Interaction

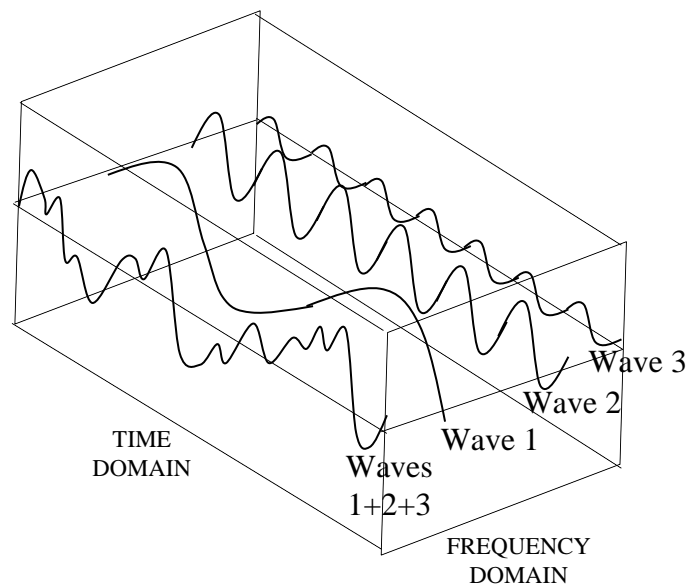
Unfortunately, the true shape and configuration of the sea is far more complicated than described above due to the interaction of several different wave systems. Observing an area of sea would lead us to believe that wave height and direction of travel is completely random. See an example in Figure 8.3.



**Figure 8.3** Topological Sketch of the North Atlantic  
 “Principles of Naval Architecture: Vol III” by SNAME

### 8.2.2.1 Superposition Theorem

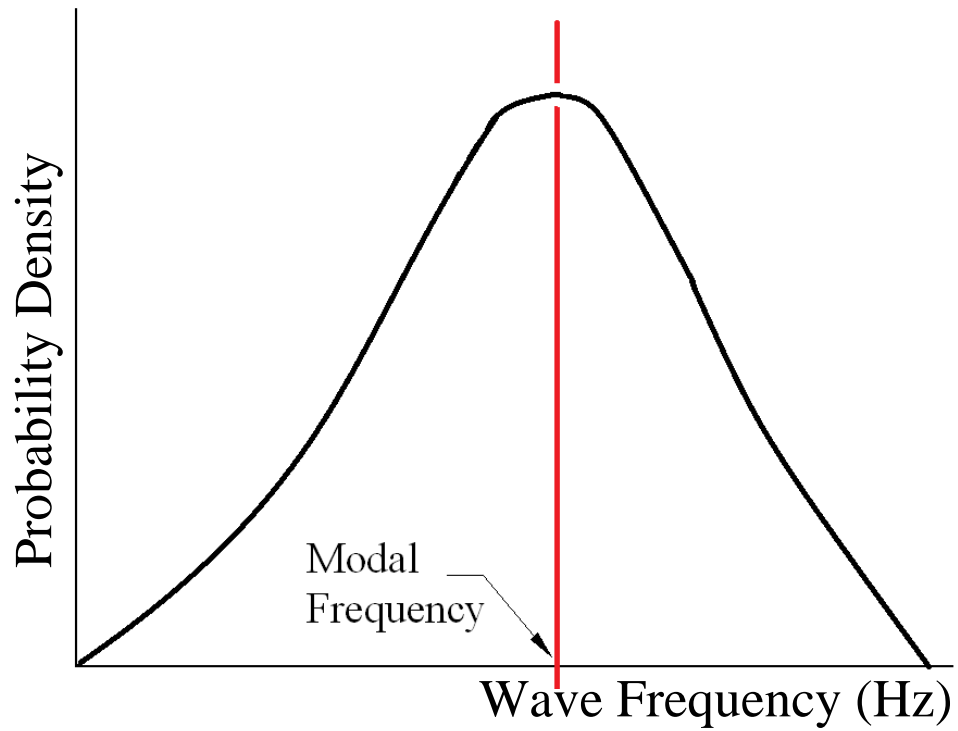
The confused state of the sea at any point can be modeled as the destructive and constructive interference pattern created between several wave systems. These wave systems are often at different phases in their development and at differing distances from the observation point. This modeling of the sea is made possible by the **Superposition Theorem** that implies that the complicated sea wave system is made up of many sinusoidal wave components superimposed upon each other. Each component sine wave has its own wavelength, speed and amplitude and is created from one of the wave energy sources. This is shown diagrammatically in Figure 8.4.



**Figure 8.4** Wave Creation from Superposition Theorem

### 8.2.3 Wave Spectrum

Figure 8.4 also shows that it is also possible to analyze the sea in the frequency domain. This is called the **Sea Spectrum**. Figure 8.5 shows a typical sea spectrum obtained through analysis of wave measurements (using accelerometers)



**Figure 8.5** Typical Spectrum of a fully developed sea

## 8.2.4 Wave Data

Examination of sea spectra such as this allows the creation of tables of sea characteristics such as the NATO Unclassified table reproduced below.

Sea State Number	Significant Wave Height (ft)		Sustained Wind Speed (Kts)		Percentage Probability of Sea State	Modal Wave Period (s)	
	Range	Mean	Range	Mean		Range	Most Probable
0-1	0-0.3	0.2	0-6	3	0	-	-
2	0.3-1.5	1.0	7-10	8.5	7.2	3.3-12.8	7.5
3	1.5-4	2.9	11-16	13.5	22.4	5.0-14.8	7.5
4	4-8	6.2	17-21	19	28.7	6.1-15.2	8.8
5	8-13	10.7	22-27	24.5	15.5	8.3-15.5	9.7
6	13-20	16.4	28-47	37.5	18.7	9.8-16.2	12.4
7	20-30	24.6	48-55	51.5	6.1	11.8-18.5	15.0
8	30-45	37.7	56-63	59.5	1.2	14.2-18.6	16.4
>8	>45	>45	>63	>63	<0.05	15.7-23.7	20.0

**Table 8.1** NATO Sea State Numeral Table for the Open Ocean North Atlantic.

Table 8.1 gives very useful information regarding likely wave system characteristics at different sea states. The modal wave periods are easily converted to modal wave frequencies via the following relationship.

$$\omega_w = \frac{2\pi}{T}$$

Wave frequency can then be used in further calculations (see 8.4.1).

The figure for significant wave height is often used to describe the height of the wave system. It corresponds to the average of the 1/3 highest waves. This value is typically estimated by observers of wave systems for the average wave height.

It is clear that although the sea appears very complicated, for each sea state there is a predominant modal frequency and wave height associated with that sea. Also, it is usual for these modal conditions to be generated by the wave energy source closest to the point of observation, this will almost always be the wind being experienced at the observation point. Consequently, as well as the modal period and wave height being known, its direction of movement will be in the same direction as the wind.

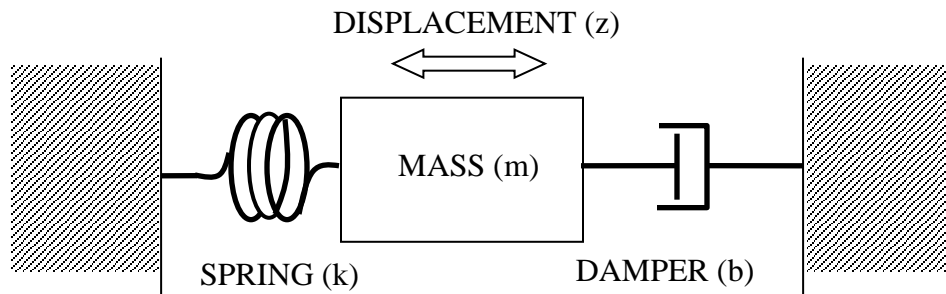
So the first part of the jig-saw is now in place. We know how to predict the magnitude, direction and frequency of excitation forces and moments in our simplified ship system discussed earlier. We now must study the way ships respond to these excitation forces and moments. However before we can proceed, we need to quickly review our knowledge of Simple Harmonic Motion.

### 8.3 Simple Harmonic Motion

Simple Harmonic Motion (SHM) is a natural motion that occurs in many engineering fields. Naval Engineering is no exception. A system will exhibit SHM when any displacement from its resting location causes it to experience a linear restoring force or moment.

- **Linear** The size of force or moment must be proportional to the size of displacement.
- **Restoring** The force or moment must oppose the direction of displacement.

A commonly used example of a system that exhibits SHM is the spring, mass, damper shown in Figure 8.6.



**Figure 8.6** Spring-Mass-Damper System

If the mass is displaced in either direction, the spring will either be compressed or placed in tension. This will generate a force that will try to return the mass to its original location - a restoring force. Provided the spring remains within its linear operating region, the size of the force will be proportional to the amount of displacement - a linear force.

If the mass is let go, the linear restoring force will act to bring the mass back to its original location. However, because of inertia effects, the mass will overshoot its original position and be displaced to the other side. At this point the spring creates another linear restoring force in the opposite direction, again acting to restore the mass to its central position.

This motion is repeated until the effects of the damper dissipate the energy stored by the system oscillations. The important point to note is that no matter which side the mass moves, the mass always experiences a linear restoring force - it exhibits SHM.

The mathematics behind the motion involves the analysis of a differential equation involving displacement ( $z$ ) with respect to time ( $t$ ).

If the effects of the damper are ignored:

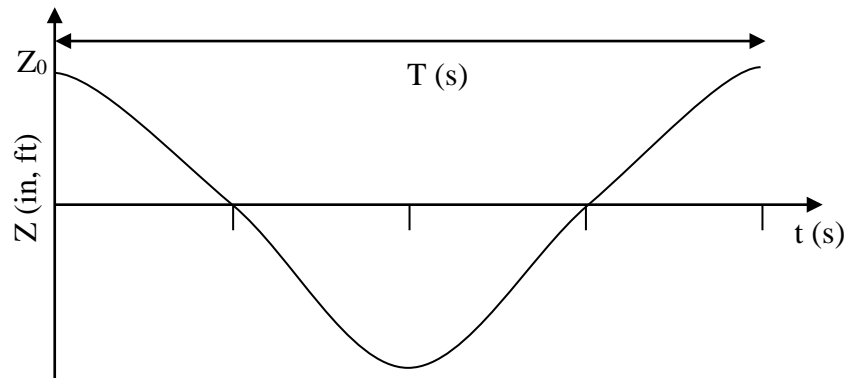
$$m \frac{d^2 z}{dt^2} + kz = 0$$

the solution is a simple cosine.

$$Z = Z_0 \cos(\omega_n t)$$

where  $Z_0$  is the initial displacement and  $\omega_n$  is the natural frequency of the system,  $t$  is time.

Figure 8.7 plots displacement ( $z$ ) against time ( $t$ ).



**Figure 8.7** Displacement vs Time Plot Without Damping

From this plot it is possible to find the period ( $T$ ) of the system motion and from this calculate the natural frequency. It is also possible to check the observed natural frequency against the known system parameters, mass ( $m$ ) and spring constant ( $k$ ).

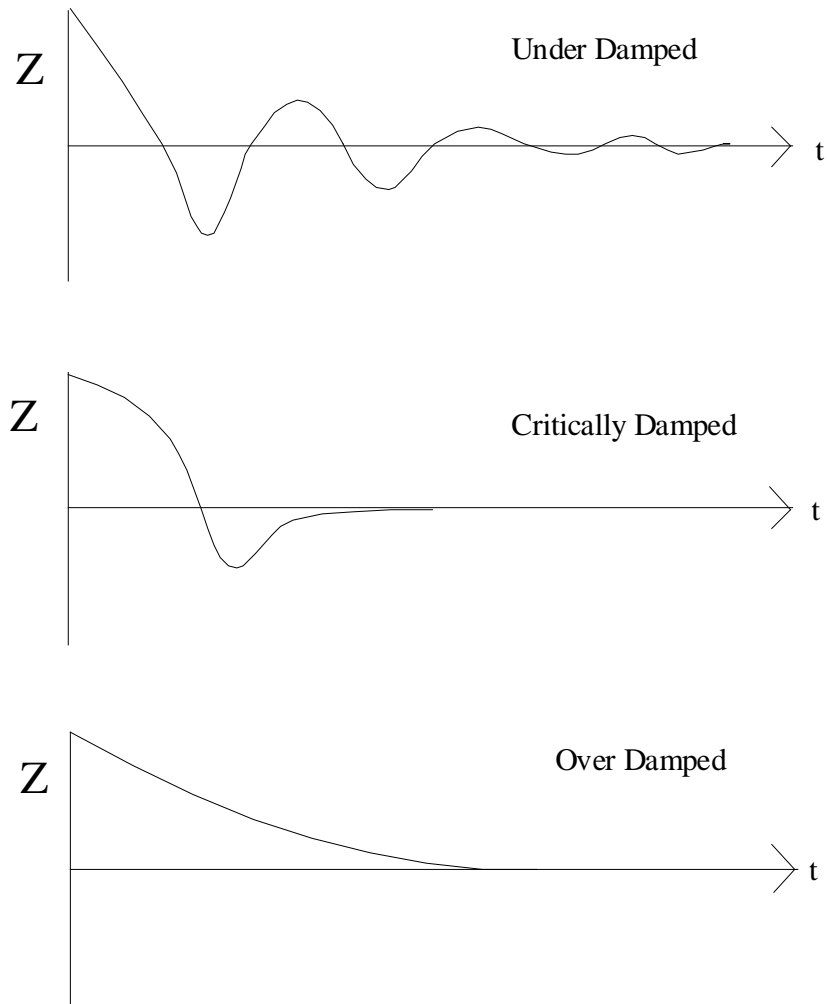
$$\omega_n = \frac{2\pi}{T} \quad \omega_n = \sqrt{\frac{k}{m}}$$

### 8.3.1 Damping

In reality, the amplitude of oscillation of the spring, mass, damper system plotted in Figure 8.7 will reduce with time due to damping effects. The damper works by dissipating the energy of the system to zero.

Changing the viscosity of the fluid in the damper the level of damping can be altered. A low level of damping will allow several oscillations before the system comes to rest. In this instance

the system is **under damped**. An important level of damping to the control engineer is **critical damping** where the system is allowed to overshoot once and then return to rest. Critically damped system return to rest in the shortest period of time. Large amounts of damping will cause the system to be **over damped**. No oscillations occur; the motion is a slow return to the resting position. Figure 8.8 shows a displacement v time plot for the 3 levels of damping.



**Figure 8.8** Displacement vs Time Plots for the three types of damping



### 8.3.2 Forcing Function and Resonance

The plots in Figures 8.7 and 8.8 consider SHM without any external exciting force or moment (apart from the force that initially displaces the system). To enable the spring, mass damper system to remain oscillating, it is necessary to inject energy into the system. This energy is required to overcome the energy being dissipated by the damper. In this system it would be applied as an external force, often called an **external forcing function**. Unfortunately, the presence of an external forcing function adds further complications to the analysis of system.

To create maximum displacement, the forcing function has to inject its energy to coincide with the movement of the mass, otherwise it is likely to inhibit oscillation rather than encourage it. So to maintain system oscillation, a cyclical force is required that is at the same frequency as the SHM system. When this occurs, the system is at **resonance** and maximum amplitude oscillations will occur. If the forcing function is applied at any other frequency, the amplitude of oscillation is diminished.

A mathematical analysis of the equations of motion supports this. The differential equation for the mass-spring system with forcing function (assuming the effects of the damper are ignored) becomes:

$$m \frac{d^2 z}{dt^2} + kz = F \cos \omega t$$

where F is the size of the forcing function and  $\omega$  is the frequency at which it is applied.

The solution becomes:

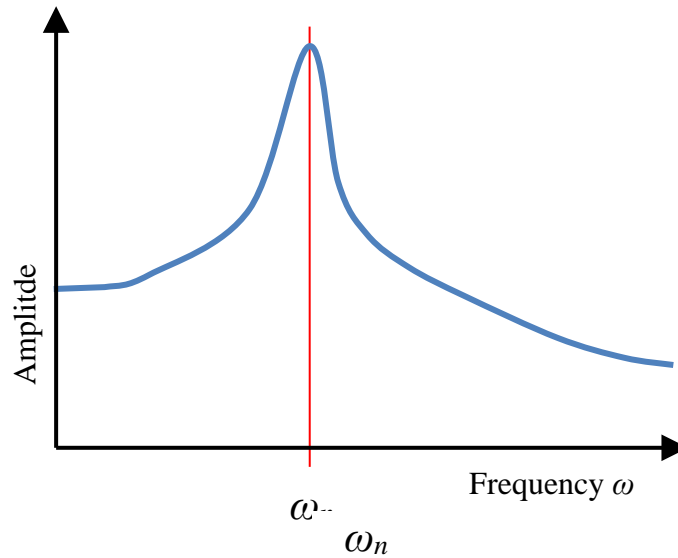
$$Z = \frac{F}{k} \frac{1}{1 - \left(\frac{\omega}{\omega_n}\right)^2} \cos \omega t$$

$$\text{when } \omega \ll \omega_n \qquad Z = F/k$$

$$\text{when } \omega \gg \omega_n \qquad Z = 0$$

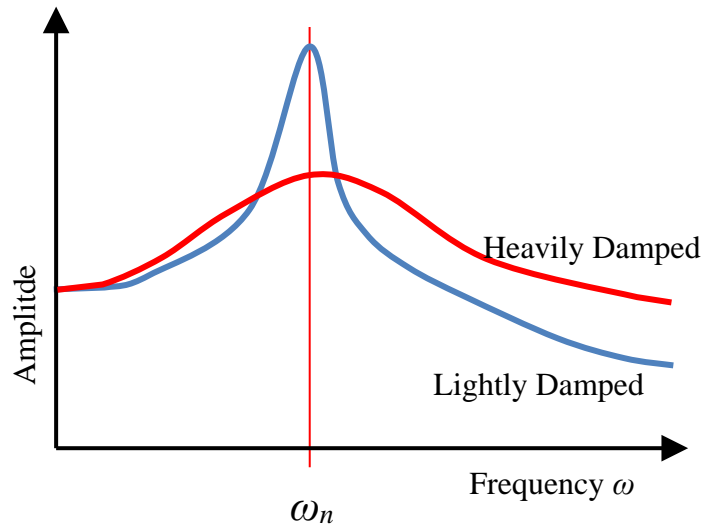
$$\text{when } \omega = \omega_n \qquad Z = \infty$$

Figure 8.9 shows a plot of system motion amplitude against the frequency of the forcing function. It is obvious where the natural frequency of the system falls.



**Figure 8.9** Motion Amplitude vs. Forcing Function Frequency

Figure 8.10 compares this type of plot for a system that is sharply tuned and one that is not. In general, SHM systems that are lightly damped will be more sharply tuned than those possessing higher levels of damping. Lightly damped systems are far more sensitive to the frequency of the forcing function.



**Figure 8.10** Comparison of Frequency Response between Lightly and more Heavily Damped Systems

## 8.4 Ship Response

The predictions of ship response when encountering a wave system is very complicated due to the confused state of typical wave systems. However, in most seas it is possible to determine the predominant direction of wave travel and a wave period. See Table 8.1. With this known, it is possible to work out ship response.

### 8.4.1 Encounter Frequency

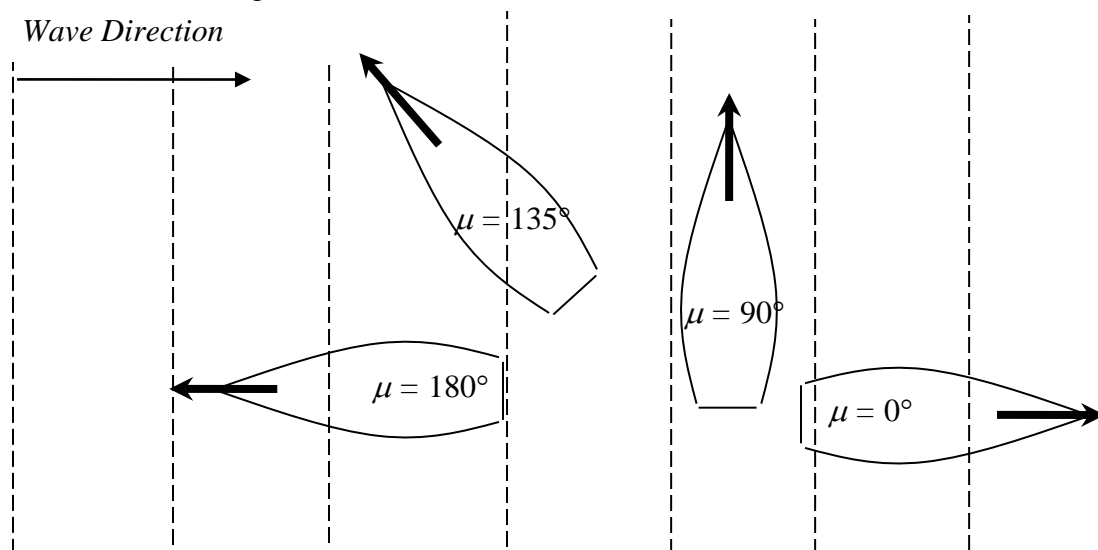
When we examined the SHM of a mass, spring, damper system we saw that the motion created by the excitation force was dependent upon the magnitude of the excitation force and its frequency. The response of a ship to its excitation force is no different. However, the frequency of the excitation force is not only dependent upon wave frequency and direction, but also the speed and heading of the ship. The important parameter is the **encounter frequency**  $\omega_e$  that allows for the relative velocity of the ship and sea waves.

$$\omega_e = \omega_w - \frac{\omega_w^2 \cdot V_s \cdot \cos(\mu)}{g}$$

where  $V_s$  is the ship speed in ft/s

$\mu$  is the heading of the ship relative to the direction of the sea ( $^\circ$  Rel)

Figure 8.11 shows the value of  $\mu$  for different sea - ship orientations. Hence for a given wave frequency ( $\omega_w$ ), the ship handler can alter  $\omega_e$  by changing course or speed.  $\mu = 0^\circ$  when the ship direction and the wave direction are the same. Note: due to the symmetry of the cosine function, it is sufficient to find  $\mu$  as the smaller angle formed from placing the ship's heading vector *tail-to-tail* with the vector representing the wave direction. [ $\cos(\mu) = \cos(360^\circ - \mu)$ ]. If you find  $\mu > 180^\circ$ , use the reflex angle (the balance of the circle).



**Figure 8.11** Values of  $\mu$  for Different Ship Orientations

**Example 8.1** A ship traveling at 20 knots on a course of 120 degrees is encountering waves coming from the north with a wave period of 12 seconds. What is the encounter frequency? (1 kt = 1.689 ft/s)

Solution:

$$\omega_w = \frac{2\pi}{T} = \frac{2\pi}{12s} = 0.52 \text{ rad/s}$$

The difference between the sea heading (180 degrees) and the ship heading (120 degrees) is 60 degrees.

$$\Rightarrow \mu = 60^\circ \quad \text{also} \quad V_s = 20 \text{ kts} \cdot \frac{1.689 \text{ ft/s}}{1 \text{ kt}} = 33.78 \text{ ft/s}$$

$$\omega_e = \omega_w - \frac{\omega_w^2 V \cos \mu}{g}$$

$$\omega_e = 0.52 \text{ rad/s} - \frac{(0.52 \text{ rad/s})^2 (33.78 \text{ ft/s}) \cos(60)}{32.17 \text{ ft/s}^2}$$

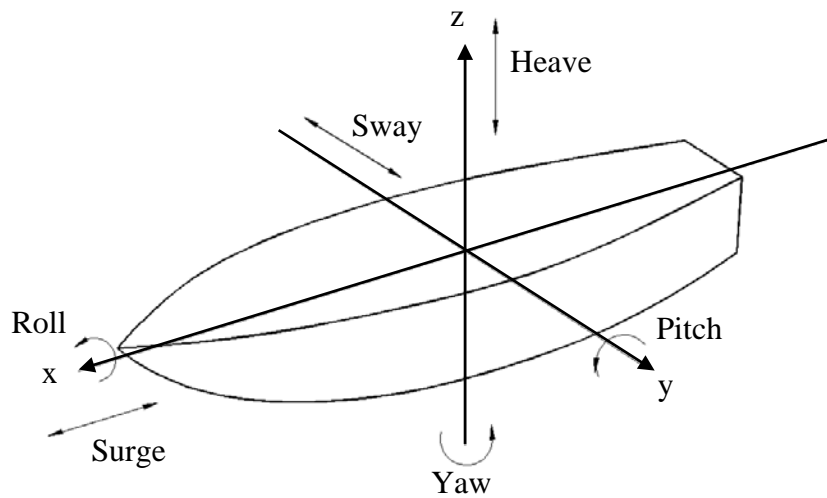
$$\omega_e = 0.52 \text{ rad/s} - 0.14 \text{ rad/s} = 0.38 \text{ rad/s}$$

With the encounter frequency known it is possible to make a prediction about ship responses. They can be grouped into 3 major sets.

- Rigid Body Motions.
- Structural Responses.
- Non-oscillatory Dynamic Responses.

#### 8.4.2 Rigid Body Motions

You may recall that the ship has 6 degrees of freedom about the xyz axis system, 3 rotary and 3 translatory. Figure 8.12 illustrates them, all can be considered as **rigid body motions**.

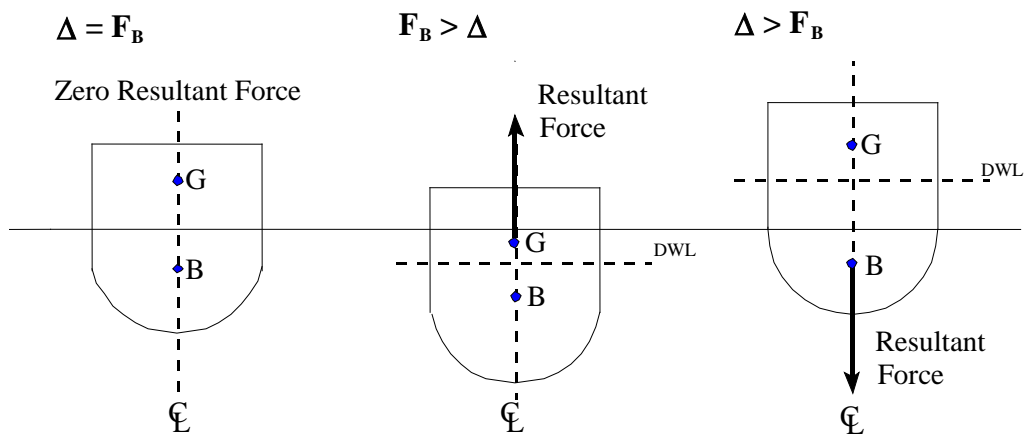


**Figure 8.12** The 6 Degrees of Freedom

Of the 6 rigid body motions, 3 exhibit SHM because they experience a linear restoring force. They are the motions of Heave, Pitch and Roll. Each will be examined in turn.

### 8.4.2.1 Heave

The action of the sea can cause the ship to move bodily out of the water or sink below its waterline. This causes an imbalance between displacement and the buoyant force that creates a resultant force which attempts to restore the ship to its original waterline. Figure 8.13 illustrates the generation of the restoring force.



**Figure 8.13** Generation of Heave Restoring Force

The restoring force is proportional to the distance displaced since the disparity between displacement and buoyant force is linear for different waterlines. The quantity that measures this force directly is the TPI of the ship.

Hence, heave motion has a linear restoring force. It is a SHM.

The up and down motion is completely analogous to the mass, spring, damper system we have studied.

$$\text{Spring Constant } (k) \equiv TPI \qquad \text{Mass } (m) \equiv \frac{\Delta}{g}$$

So taking this analogy further, it is possible to predict the natural heave frequency ( $\omega_{\text{heave}}$ ) of a ship.

$$\omega_{\text{heave}} \propto \sqrt{\frac{TPI}{\Delta}}$$

It should also be apparent that the TPI is heavily dependent upon the  $A_{WP}$  at the DWL, in fact the following relationship exists.

$$TPI = \frac{\rho g A_{WP}}{2240 \times 12} \qquad TPI \propto A_{WP} \text{ at DWL}$$

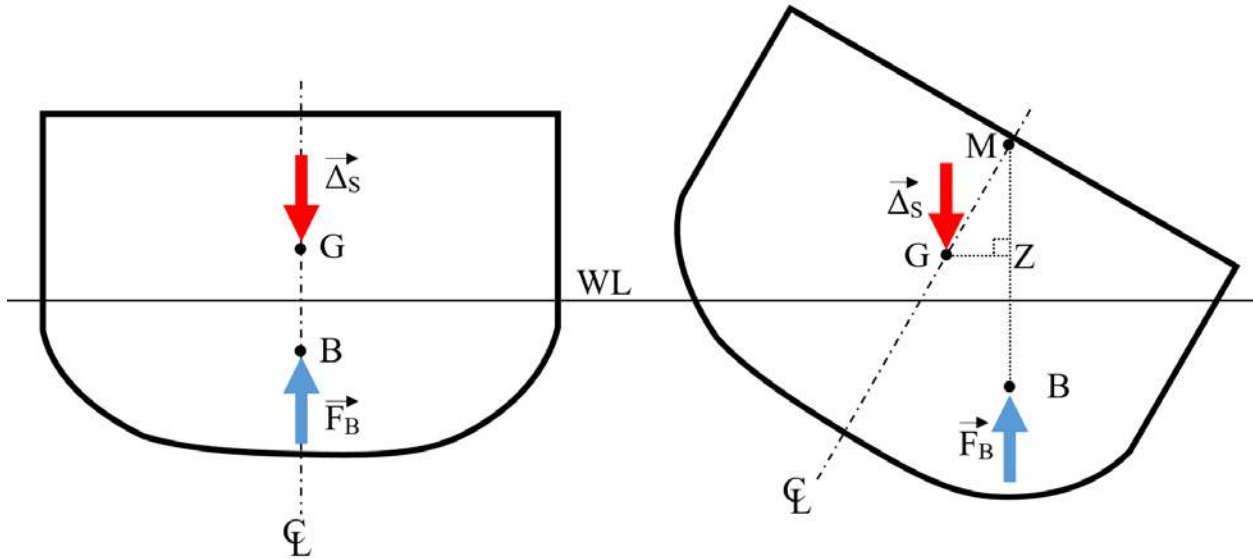
You may recall that TPI and  $A_{WP}$  are read off the same line on the curves of form.

Consequently, ships that have a large water plane area for their displacement will experience much greater heave restoring forces than ships with small water plane areas. So ‘beamy’ ships such as tugs and fishing vessels will suffer short period heave oscillations and high heave accelerations. Conversely, ships with small water plane areas will have much longer heave periods and experience lower heave accelerations. In general the lower the motion acceleration, the more comfortable the ride and the less chance of damage to equipment and personnel. This concept is taken to extremes in the case of off-shore floating platforms that have very small  $A_{WP}$  compared to their displacement.

The heave motion is quite heavily damped as the energy of the ship moving up and down creates waves that quickly dissipate the energy of the system away.

### 8.4.2.2 Roll

The rolling of ships has been studied in depth in earlier chapters so you should be aware that any transverse misalignment of B and G will create an internal righting moment. The misalignment can be created by a wave slope. Figure 8.14 refers.



**Figure 8.14** The Creation of the Internal Righting Moment

The magnitude of this righting moment depends upon the righting arm and ship displacement.

$$RM = \Delta \cdot \overline{GZ}$$

For small angles ( $\phi < 10^\circ$ ) this becomes:

$$RM = \Delta \cdot \overline{GM}_T \cdot \phi$$

So this time we see the creation of a linear restoring moment, and hence the presence of rotational SHM. Hence roll is also analogous to the linear motion of the mass, spring, damper system.

$$\text{Spring Constant } (k) \equiv \Delta \cdot \overline{GM}_T$$

$$\text{Mass } (m) \equiv I_{xx}$$

Taking this analogy a little further we can find an expression for the natural roll frequency ( $\omega_{roll}$ ).

$$\omega_{roll} \propto \sqrt{\frac{\Delta \cdot \overline{GM}_T}{I_{xx}}}$$

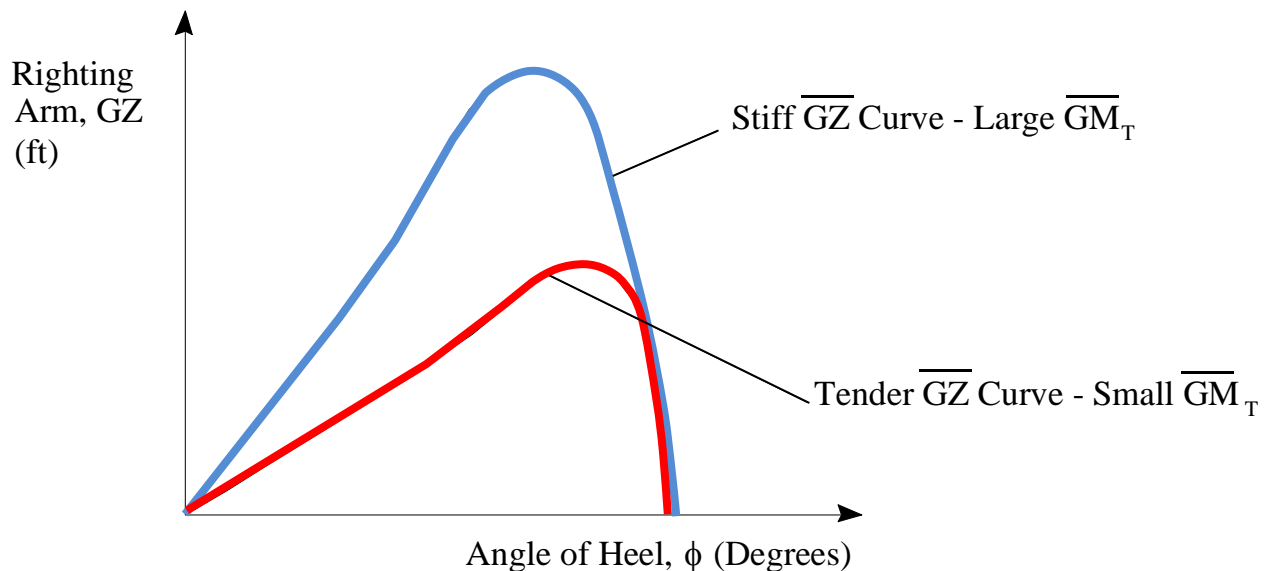
By rearranging this expression and knowing the relationship between natural roll frequency ( $\omega_{roll}$ ) and period of roll  $T_{roll}$ .

$$T_{roll} = \frac{CB}{\sqrt{GM_T}}$$

where:   
 B is the ship's Beam (ft)   
 $GM_T$  is the transverse metacentric height (ft)   
 C is a constant whose value can range from 0.35 - 0.55 ( $s/ft^{1/2}$ ) when  $GM_T$  and beam are measured in ft. The value of C is dependent upon the roll damping of the ship. When unknown, a value of 0.44 gives good results.

The equation shows that ships with large transverse metacentric heights will experience small period oscillations, large restoring forces and large transverse angular accelerations. As with the other rigid body motions, the high accelerations are more likely to cause damage to equipment and personnel.

You may recall that the  $GM_T$  can be found by measuring the slope of the GZ curve at the origin. Hence stiff GZ curves are indicative of large  $GM_T$ , tender GZ curves indicate small  $GM_T$ . Figure 8.15 indicates the difference between the 2 types. So stiff ships will tend to have violent roll motions. This is typical of short 'beamy' ships that have low length to beam ratios.



**Figure 8.15** Comparison of Stiff and Tender Curves of Intact Statical Stability



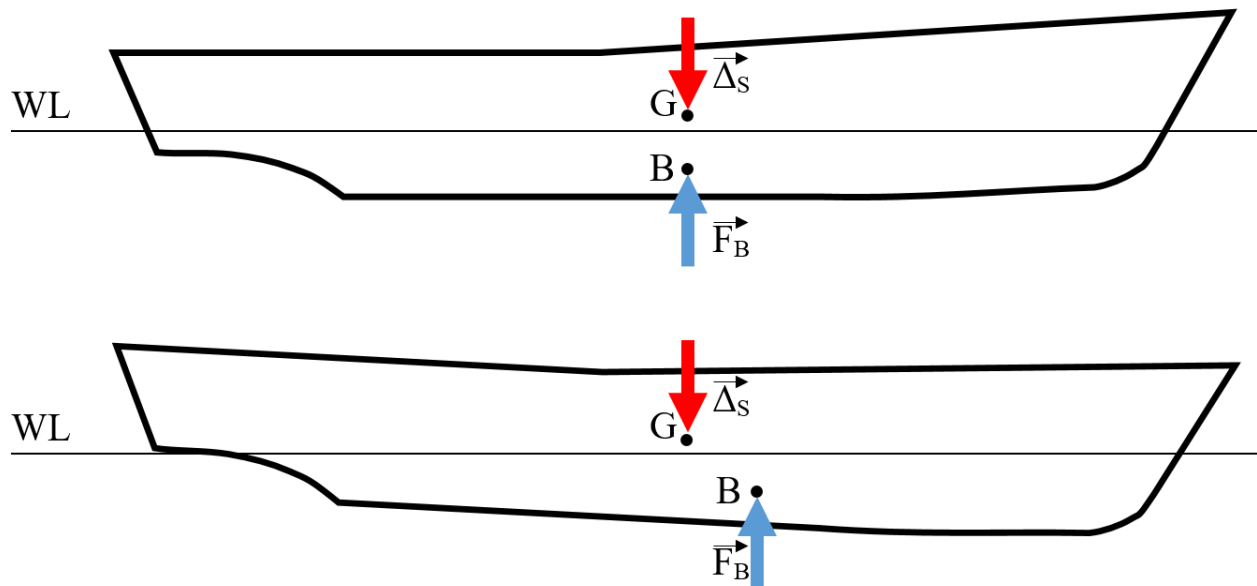
From this you should realize that the ideal value of  $GM_T$  for a ship is a compromise between good sea keeping qualities (small  $GM_T$ ) and good stability characteristics (large  $GM_T$ ). This compromise is a common feature in many engineering fields. In this instance, the naval architect aims for a  $GM_T$  of between 5 - 8% of a ship's beam. This offers a good compromise between seakeeping and stability.

Unlike the SHM of heave and pitch, roll motion experiences low damping effects because only low amplitude wave systems are generated by roll.

❗ **“Sallying” Experiment** - The equation for roll period above has another use in the ‘sallying’ experiment. It is possible to induce roll motion in a ship by the cyclical transverse movement of personnel, known as ‘sallying the ship’. Recording the roll period then allows an estimation of  $GM_T$  to be made.

### 8.4.2.3 Pitch

A ship heading into a sea (or in a stern sea) is liable to have situations where the slope of the waterline causes a movement in the center of buoyancy either forward or aft. This immediately creates an internal righting moment that attempts to restore the vertical alignment of B and G. Figure 8.16 illustrates this point.



**Figure 8.16** Generation of Pitch Restoring Moment

The internal righting moment is always acting to restore the ship and it is linear because it is dependent upon the  $MT1''$  value for the hull form. Hence, pitch motion is SHM.

Once again the situation is analogous to the mass, spring, damper system although we are now comparing angular motion with linear.

$$\text{Spring Const } (k) \equiv MTI''$$

$$\text{Mass } (m) \equiv I_{yy}$$

Ships that have large  $MTI''$  when compared with  $I_{yy}$  will experience large pitch restoring moments and as a consequence, large angular pitch accelerations. This will occur with ships that are long and slender and have the majority of their weight close to midships.

As with heave, pitch motions are quickly damped as the oscillation causes the generation of large wave systems pulling energy from the SHM.

#### 8.4.2.4 Resonance

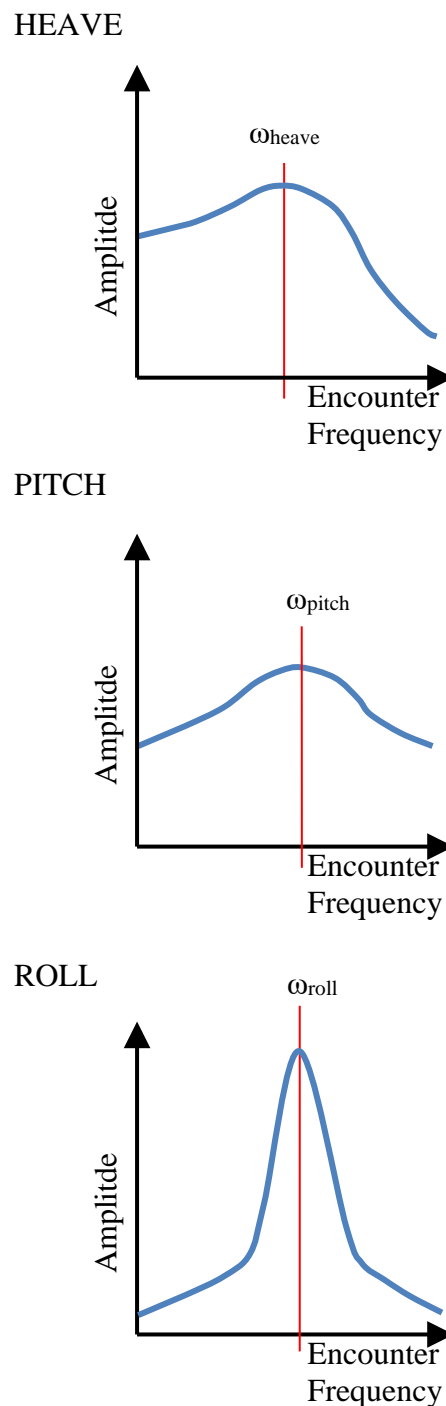
You will recall that a SHM system will experience maximum amplitude oscillations when the frequency of the forcing function is equal to the natural frequency of the system. This condition is called resonance. So to reduce the amount of motion it is important to ensure that resonance does not occur.

This can be applied to a ship. We have seen that the rigid body motions of heave, pitch and roll are SHMs and that it is possible to estimate their natural frequencies,  $\omega_{\text{heave}}$ ,  $\omega_{\text{pitch}}$  and  $\omega_{\text{roll}}$  respectively. To limit ship motion it is important that these do not coincide with the frequency of the ships forcing function, the encounter frequency ( $\omega_e$ ).

Fortunately, the SHMs of pitch and heave are well damped and as such are not sharply tuned. However, the low damping experienced by roll motion cause it to be sharply tuned and very susceptible to  $\omega_e$ . Figure 8.17 indicates the differences between the 3 motions.

Resonance can occur with all of them, however, extreme motions are *more likely to occur with roll than pitch and heave*.

Because of relatively small restoring forces and its sharply tuned response characteristic, many devices are used to try and limit the roll motion. These 'anti-roll' devices will be examined later in this chapter.



**Figure 8.17** Comparison of the Frequency Response of the Motions of Heave, Pitch & Roll

### 8.4.3 Structural Responses

We have already seen that the sea can have a considerable effect upon the stresses that a ship structure has to withstand. These include:

1. Longitudinal bending caused by the ship being placed in a ‘sagging’ or ‘hogging’ condition by the position of wave crests.
2. Torsion. Waves systems can create a twisting effect upon the ship structure. This is particularly evident in ships with large hold openings such as container ships.
3. Transverse stresses caused by the hydrostatic pressure of the sea.

Due to the cyclical nature of the external forces and moments generated by the wave system, the ship structure is subjected to these stresses listed above in a cyclical manner, the frequency of which being equivalent to the encounter frequency ( $\omega_e$ ).

As with any structure, the ship structure will have its own natural frequency. In fact it will have many, one associated with each of the major loads - longitudinal bending, torsion and transverse stresses. It will also have numerous others associated with the elements of ship structure such as stiffeners plates, machinery mounts etc. Just as with the rigid body motions, the amplitude of structural oscillations will be maximized when their natural frequency coincide with the encounter frequency ( $\omega_e$ ). This must be avoided otherwise it is possible that yield stresses and endurance limits will be exceeded causing plastic deformation and a much higher risk of fatigue failure.

### 8.4.4 Non-Oscillatory Dynamic Responses

In addition to the oscillatory responses discussed above, the ship will experience a number of other dynamic responses. These are typically non-oscillatory and are caused by the relative motions of the ship and sea. The relative motions can be extreme. They are maximized when a movement of the ship out of the water due to heave, pitch or roll combines with a lowering of the sea surface (a trough) or vice versa. When this occurs the following severe non-oscillatory dynamic responses may result.

- **Shipping Water (“Green Deck”)** The relative motion of the ship and sea system can cause situations where the bow of the ship becomes submerged. This is called ‘shipping water’ or ‘deck wetness’. As well as the obvious safety hazard to personnel, the extra weight of shipped water can place considerable loads on the ship structure.
- **Forefoot Emergence** This is the opposite case to ‘shipping water’ where the bow of the ship is left unsupported. The lack of support creates severe structural loads.
- **Slamming** Slamming is often the result of forefoot emergence. As the bow re-

enters the sea, the sudden impact of flat horizontal surfaces in the bow region creates a severe structural vibration felt through the length of the ship. See Figure 8.18.

- **Racing** Racing is the sterns version of forefoot emergence. It occurs when the relative motion of ship and sea causes the propeller to leave the water. The sudden reduction in resistance causes the whole ship power train to race. This causes severe wear and tear on propulsion machinery and auxiliaries.
- **Added Power** The effects of all these responses is to increase the effective resistance of the hull, consequently more power is required to drive the ship through the sea system.

As mentioned, the non-oscillatory dynamic responses above are all a consequence of the relative motion of the ship and sea. In particular, the larger the amplitude of the ship's heave and pitch motions the greater the possibility of shipping water, slamming etc. Hence, the frequency of these adverse ship responses can be reduced by making every attempt to reduce heave and pitch motions. This can be done by ensuring neither of these motions are at resonance. Changing the encounter frequency by alterations in course heading and speed may help.

- **Broaching** Broaching is the sudden and uncontrollable turning of a ship to a beam on orientation to the sea. If the sea is big enough and has sufficient wave slope, there is then a high risk of capsize.
- **Loss of Stability** In certain circumstances when in large sea systems, it is possible for a ship to surf. The prolonged change in shape of the water plane can have an adverse effect on stability.

Both these responses are the result of the ship traveling in large following seas at speeds close to the wave celerity. This should be avoided if at all possible.



**Figure 8.18** SEAL Team 6 operators experience slamming in high-speed assault craft

## 8.5 Ship Response Reduction

We have now examined the various responses associated with a ship when excited by a wave system's forcing function. Unfortunately, the presence of this forcing function cannot be avoided, in fact it is very rare for there to be no forcing function. See Table 8.1. Consequently, despite the Naval Architects best efforts, it is impossible to prevent ship response. However, there are a number of things that can be done to minimize it.

### 8.5.1 Hull Shape

When examining the simple harmonic rigid body responses of heave, pitch and roll, the type of hull shape particularly susceptible to each motion was considered. Taking this knowledge a little further, it is fairly obvious to deduce that the creation of a hull shape optimized for minimum response can be created.

Traditionally, the seakeeping dynamics of the hull form have been considered at a lower level of importance than hull resistance, strength and space efficiency. The seakeeping characteristics of ships have been left to chance. This is unfortunate when one considers the impact poor seakeeping can have upon the operational effectiveness of the ship.

This state of affairs was true for the design of USN ships until the arrival of DDG-51. This hull form was the first to be created with seakeeping considered as a high priority. The differences between the hull of the DDG-51 and hulls designed previously are obvious on comparison.

- Forward and aft section are V shaped - limits MT1" reducing pitch accelerations.
- Volume is distributed higher from keel - limits  $A_{WP}$  and TPI reducing heave accelerations.
- Large degree of flare in hull design - limits the half-breadths at the design waterline, which in turn limits  $I_{xx}$ , reducing the stiffness of the GZ curve, thereby reducing roll accelerations.

The result is a ship that should have increased operability in heavy seas by a reduction in angular and vertical motion accelerations. There should also be a reduction in the frequency at which the non-oscillatory dynamic responses such as slamming occur due to the reduction in heave and pitch motions.

### 8.5.2 Anti-Roll Devices

When examining the roll response of a ship in 8.4.2.3, it was evident that the low level of damping experienced by roll caused it to have a highly tuned response characteristic. This made it highly susceptible to the encounter frequency of the ship. In an attempt to damp roll motion more effectively, a number of devices can be incorporated into the ship design.

### 8.5.2.1 Passive Anti-Roll Devices

Passive devices are as named, devices that require no external input to damp roll motion.

- **Bilge Keel** Bilge keels are very common features on ships. They are typically located in pairs port and starboard and consist of flat plates projecting out from the hull at the point where the bilge turns up to the side wall of the ship. They can be very effective, reducing roll amplitudes by up to 35%.
- **Tank Stabilizers** In chapter 4 we discovered that the presence of free fluid surfaces have a detrimental effect upon ship stability by reducing the effective transverse metacentric height. However, if the flow of fluid from one side of the tank to the other is ‘throttled’, the relative motion of the C of G of the fluid can damp roll motion. The level of throttling is critical to the tank effectiveness and usually has to be altered on a ‘suck it and see’ basis while the ship is underway. The conventional shape of passive tank stabilizers are long and fairly narrow orientated with their longest side transversely. However, many other shapes have been tried, including a ‘U’ tube running from the port side weather deck all the way to the keel and back up to the starboard weather deck.
- **Others** Various other passive systems have been tried including delayed swinging pendulums, shifting weights and large gyroscopes. All suffer serious limitations with regard to the space they take up and safety.

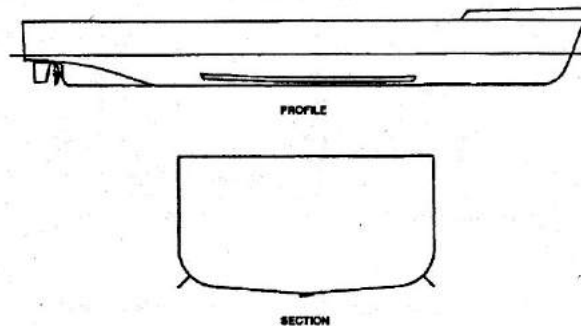


Figure 8.19 Bilge Keels

### 8.5.2.2 Active Stabilizers

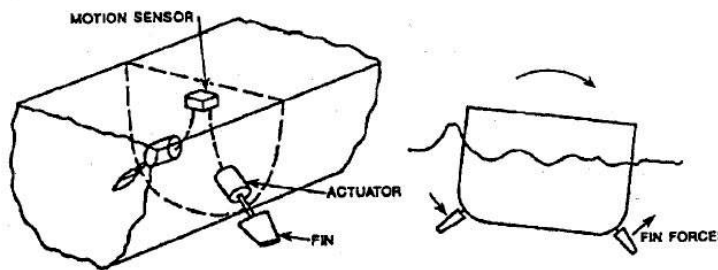
Active stabilizers rely on a control system that can detect ship motions and cause the stabilizer to respond with an action that limits the detected motions.

- **Fin Stabilizers** Fin stabilizers are very common systems found on many ships. They are positioned in similar locations to bilge keels and work in

pairs port and starboard. They incorporate their own control circuitry that immediately detects when the ship begins to roll. A control signal is then sent to the fin hydraulics that create an angle of attack to the oncoming water. Lift is generated creating a moment opposite in direction to the internal moment produced by the transverse movement of B. These were employed on the FFG-7 class.

- **Others**

There have been several other attempts including active tanks and the hydraulic movement of weights within the hull. All incur the same disadvantages suffered by weight shifting passive systems.



**Figure 8.20** Active Fin Stabilizers

### 8.5.2.3 Stabilizer Effects

The effect of both passive and active stabilizers are to lessen roll motion. Their presence lessens the extreme roll amplitudes that can be suffered by a ship by increasing roll damping. The increase in damping reduces the susceptibility of the ship to the encounter frequency of the ship. Resonance can still occur, however roll amplitude at resonance is reduced.

As the name suggests, anti-roll devices have little impact upon the motions of heave and pitch. The heavily damped nature of these motions negate the need for any prescribed anti-heave or anti-pitch device.

### 8.5.3 Ship Operation

This chapter has demonstrated the responses associated with a ship excited by the sea's forcing function. It should be apparent by now that nearly all responses are significantly influenced by the encounter frequency the ship is experiencing. If the encounter frequency is close to any of the rigid body natural frequencies significant angular or vertical accelerations can be experienced. This in turn can greatly increase the possibility of non-oscillatory dynamic motions. Similarly, structural loads can be severe if resonance occurs between their natural frequency and the encounter frequency.



As a consequence, the ship handler can have a significant effect upon the response of a ship by altering the encounter frequency. We have seen that encounter frequency ( $\omega_e$ ) is given by:

$$\omega_e = \omega_w - \frac{\omega_w^2 \cdot V_S \cdot \cos(\mu)}{g}$$

So by altering course or speed or both, the ship handler can reduce motion accelerations being created by the sea and structural loading.

Once the ship has been designed and built, the naval architect has done their part. Ship response reduction is then up to the ship handler. It is in your hands!

## PROBLEMS - CHAPTER 8

### Section 8.2 - Waves

1. List 4 factors that affect the height of a wave system. For each factor explain how it affects the wave system.
2. You are the Master of a 20,000 LT merchant ship heading up the Chesapeake Bay bound for the Port of Baltimore. The ship has a draft of 26 feet, and you are experiencing westerly winds of 40 knots, gusting to 55 knots. You have a choice of three routes up the Bay: an exposed deep water route up the center of the Bay, or either of an eastern or western route that is more sheltered from the effects of the wind, but the water more shallow than the deep water route. Which route would you choose? Explain your answer.
3. On the same sheet of graph paper plot the following sine waves. Or, you may program these waves into a spreadsheet and plot them. Assume all waves are in phase and have zero amplitude at time zero.
  - a. Wave amplitude 10 ft, wave period 6 seconds.
  - b. Wave amplitude 6 ft, wave period 4 seconds.
  - c. Wave amplitude 4 ft, wave period 3 seconds.
  - d. Using the superposition theorem, plot the wave that would be created by the combining the three waves, assuming all waves are traveling in the same direction. What is the maximum height of the resulting wave?

### Section 8.3 Simple Harmonic Motion

4. What are the two conditions that must be fulfilled for a motion to simple harmonic motion? Describe a condition that would produce simple harmonic motion.
5. In Chapter 7 we saw that ship resistance was a force that countered the thrust produced by the ship's propellers. In other words, two opposing forces act in the direction of surge. However, surge motion is not a simple harmonic motion for ships. Explain why.
6. An object is moving with simple harmonic motion.
  - a. For the motion to be maximized, what relationship must exist between the object's motion and the forcing function?
  - b. What would happen if the magnitude of the forcing function were doubled?
  - c. What would happen if the frequency of the forcing function were doubled?

## Section 8.4 Ship Response

7. A ship on a heading of  $120^{\circ}\text{T}$  at 16 knots experiences a wave system heading due south. The waves have a period of 5.2 seconds, and are 5 feet in height. At what frequency does the ship encounter these waves?
8. How does wave height affect the response of a ship?
9. What wave conditions would produce a maximum (resonant) response by a ship's structure?
10. The Navigator of an FFG-7 class ship requires an emergency operation to remove a ruptured appendix. Unfortunately, the ship is currently in the teeth of a Nor'easter raging at a Nato classification of Sea State 8, and the ship cannot conduct flight operations for a medevac. Therefore, the operation must proceed onboard. The ship's corpsman is confident he can conduct the operation provided the ship does not move about too much. The DCA suggests a spot 20 ft aft of amidships on a deck close to the waterline would be the best location to conduct the operation. Comment on his reasoning.
11. A ship has the following rigid body motion and structural response frequencies:

$$\omega_{\text{heave}} = 0.42 \text{ rad/s}$$

$$\omega_{\text{longbend}} = 0.50 \text{ rad/s}$$

$$\omega_{\text{pitch}} = 0.53 \text{ rad/s}$$

$$\omega_{\text{torsion}} = 0.41 \text{ rad/s}$$

$$\omega_{\text{roll}} = 0.50 \text{ rad/s}$$

The ship is currently traveling at 12 knots directly into a sea system rated at Sea State 7 using the Nato classification table.

- a. Using Table 8.1, what is the modal wave frequency associated with this system?
  - b. Comment on the motion being experienced by the ship.
  - c. The ship is about to alter course by  $45^{\circ}$ . Comment on the feasibility of this course change.
12. A warship is underway on a course of  $090^{\circ}\text{T}$  at a speed of 14 knots. The ship is 465 feet in length, a displacement of 8,000 LT, and its center of gravity is located 19 feet above the keel.

The ship has the following natural frequencies of rigid body motion and structural response:

$$\omega_{\text{heave}} = 1.17 \text{ rad/s}$$

$$\omega_{\text{longbend}} = 1.05 \text{ rad/s}$$

$$\omega_{\text{pitch}} = 1.07 \text{ rad/s}$$

$$\omega_{\text{torsion}} = 1.20 \text{ rad/s}$$

$$\omega_{\text{roll}} = 0.69 \text{ rad/s}$$

The ship is steaming in waves coming from the west. Waves are 450 feet in length, 8 feet in height, and are at a period of 9.4 seconds.

- a. Calculate the ship's encounter frequency and comment on the ship's response at this frequency.
  - b. The ship turns to a course of  $270^{\circ}\text{T}$ . Determine the ship's encounter frequency on this new course and comment on the ship's response.
  - c. In order to conduct flight operations, the ship turns into the wind on a course of  $325^{\circ}\text{T}$ . Calculate the new encounter frequency and comment on the motion of the ship. Flight operations require a steady deck ... is this a good course for flight operations?
  - d. The Navigator realizes that the ship is 4 hours ahead of schedule and recommends slowing the ship to 6 knots. Is this a wise choice with flight operations in progress?
  - e. As the ship burns fuel, its center of gravity rises. What is happening to the ship's metacentric height, stability, and roll response as fuel is burned?
13. An amphibious ship is on a course of  $315^{\circ}\text{T}$  at a speed of 14 knots while conducting flight operations. Winds are from the west at a speed of 10 knots and seas are from the east. Seas are at a height of 4 feet and have a period of 9.8 seconds and a length of 500 ft.

The ship is currently at a draft of 19 ft, and at this draft the ship has the following hydrostatic parameters and natural frequencies of rigid body and structural response:

$L_{pp} = 580 \text{ ft}$	$\omega_{\text{heave}} = 0.94 \text{ rad/s}$
$B = 84 \text{ ft}$	$\omega_{\text{pitch}} = 0.91 \text{ rad/s}$
$T = 19 \text{ ft}$	$\omega_{\text{roll}} = 0.57 \text{ rad/s}$
$\Delta = 19,000 \text{ LT}$	$\omega_{\text{longbend}} = 1.04 \text{ rad/s}$
$K_{M_T} = 25 \text{ ft}$	$\omega_{\text{torsion}} = 1.35 \text{ rad/s}$
$KG = 21.3 \text{ ft}$	

- a. Calculate the frequency at which the ship is encountering waves while conducting flight operations. Comment on the ship's rigid body and structural response.
- b. While on  $325^{\circ}\text{T}$ , the ship slows to a speed of 4 knots in order to conduct wet well operations and launch LCAC's. Determine the encounter frequency and comment on ship motions after slowing to 4 knots. Is  $325^{\circ}\text{T}$  a good course to launch LCAC's? Explain your answer.
- c. The ship turns to a course of  $090^{\circ}\text{T}$ , remaining at a speed of 4 knots. Calculate the new encounter frequency and comment how the ship will respond to waves on this new course.

- d. While on 090°T the ship adds ballast, increasing to a draft of 24 ft in order to launch AAV's. Adding ballast lowers the center of gravity such that  $KG = 20.3$  ft. Increasing draft to 24 ft reduces the ship's waterplane area (well deck is flooded), and therefore  $KM_T$  is reduced to 21.6 ft. How has ballasting the ship affected its stability and roll response?
14. This problem is designed to show the student how changing course and speed will affect a ship's response in a seaway. Additionally, we will also look at how wavelength and period affect a ship's encounter frequency.

For this problem, we will look at a cruise ship with the following parameters:

$L_{pp} = 930$ ft	$\omega_{roll} = 0.49$ rad/s	$\omega_{longbend} = 1.10$ rad/s
$B = 105$ ft	$\omega_{pitch} = 0.72$ rad/s	$\omega_{torsion} = 0.83$ rad/s
$T = 32$ ft	$\omega_{heave} = 0.71$ rad/s	
$\Delta = 47,000$ LT		

- a. The ship is underway at its cruising speed of 26 knots in waves with a length of 820 ft, and a period of 12.6 seconds. Calculate the ship's encounter frequency with these seas for the following angles of encounter: 0°, 45°, 90°, 135°, and 180°. How does each of these encounter angles affect the ship's rigid body and structural response?
- b. If the ship slows to 13 knots, calculate encounter frequencies for the same seas and encounter angles as in part (a). How does slowing speed affect the ship's response?
- c. Repeat parts (a) and (b) for the ship operating in waves that are 400 ft in length, and have a period of 8.84 seconds.
- d. Repeat parts (a) and (b) for the ship operating in waves that are 200 ft in length, and have a period of 6.24 seconds.
- e. How will wave height affect the ship's response in each wave condition?

15. A small frigate 340 feet in length is pursuing a target at a speed of 25 knots on a course of  $045^\circ\text{T}$ . Seas, 350 feet in length, are from the southwest at a height of 8 feet and a period of 8.27 seconds. The ship has the following natural frequencies of rigid body and structural response:

$$\omega_{\text{heave}} = 1.03 \text{ rad/s}$$

$$\omega_{\text{longbend}} = 0.75 \text{ rad/s}$$

$$\omega_{\text{pitch}} = 1.21 \text{ rad/s}$$

$$\omega_{\text{torsion}} = 1.12 \text{ rad/s}$$

$$\omega_{\text{roll}} = 0.67 \text{ rad/s}$$

- a. Determine the frigate's frequency of encounter with the waves and comment on its rigid body and structural response.
  - b. On its current course and speed, how are the waves affecting the power required to achieve a speed of 25 knots?
  - c. Is the current course of  $045^\circ\text{T}$  a good course for the ship's structure? Explain why or why not.
16. A young aviator who recently graduated from USNA is attempting to sleep in a rack that is resonating at about 110 Hz. The aviator, vaguely recalling that a ship's course and speed affects frequency, calls the OOD and asks him to alter course or speed so that the ship's encounter frequency will change and stop his rack from vibrating so badly. This would then allow the aviator to have a good night's sleep and significantly improve his performance in the cockpit the following day. Comment on this proposal.
17. Describe one active and one passive anti-roll device commonly used on ships. Why are there no similar anti-heave or anti-pitch devices?

# **COURSE OBJECTIVES**

## **CHAPTER 9**

### **9. SHIP MANEUVERABILITY**

1. Be qualitatively familiar with the 3 broad requirements for ship maneuverability:
  - a. Controls fixed straightline stability
  - b. Response
  - c. Slow speed maneuverability
2. Qualitatively describe what each requirement is dependant upon.
3. Briefly describe the various common types of rudder.
4. Understand the various dimensions of the spade rudder, in particular
  - a. Chord
  - b. Span
  - c. Rudder stock
  - d. Root
  - e. Tip
5. Qualitatively describe the meaning of:
  - a. Unbalanced Rudder
  - b. Balanced Rudder
  - c. Semi-balanced rudder
6. Qualitatively describe the sequence of events that causes a ship to turn
7. Qualitatively describe a rudder stall and understand what it means
8. Qualitatively describe the arrangement and devices that can be used to provide a ship with maneuverability at slow speeds:
  - a. Rudder position
  - b. Twin propellers
  - c. Lateral thrusters
  - d. Rotational thrusters

## **9.1 Introduction**

Ship maneuverability is a very complex and involved subject involving the study of equations of motion involving all six degrees of freedom. Analysis of these motion equations allows for predictions of ship maneuverability to be made. However, many assumptions are made, so model testing is required to verify analytical results. Once built, a ship's maneuvering characteristics are quantified during its Sea Trials.

To limit the level of complexity covered in this chapter, the analytical study of the equations of motion will be ignored. However, maneuverability requirements a ship designer strives to meet will be discussed along with the devices and their arrangements that can provide them.

After completing this chapter you will have an understanding of how a ship's rudder makes a ship turn and an appreciation of other devices that improve a ship's slow speed maneuverability.

Keep in mind that some ships do not have rudders, like the LCS, which uses high powered water jets for both propulsion and maneuvering.

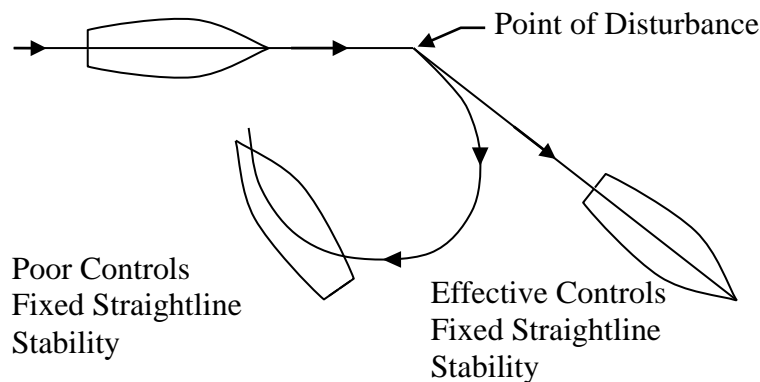


## 9.2 Maneuverability Requirements

When given the task of designing a ship, the Naval Architect is given a number of design requirements to meet. These include the obvious dimensions such as  $L_{PP}$ , Beam and Draft, but also other requirements such as top speed, endurance, operational mission, etc. Some of the more complicated requirements involve maneuverability. These can be split into three broad categories.

### 9.2.1 Directional Stability

In many operational circumstances, it is more important for a ship to be able to proceed in a straight line than turn. That is, with the rudder set at midships, and in the absence of external forces, the ship will travel in a straight line. This is termed **controls fixed straight line stability**. Our experience indicates that this scenario is rarely the case, and anything but a sea directly on the bow will create a yawing moment that has to be compensated for by movement of the ship's rudder. However, in principle, ships should be designed to achieve controls fixed straight line stability. An illustration of this stability is at Figure 9.1.



**Figure 9.1** Hull Forms with Different Levels of Directional Stability

Despite this requirement, many hull forms do not have this level of directional stability. In particular, ships which are relatively short and wide such as tugs or harbor utility vessels and in certain circumstances, small combatants tend to have poor controls fixed straight line stability. This can be overcome by increasing the amount of deadwood of the hull (fin-like vertical surface) at the stern. This is directly analogous to the flights on an arrow or dart. Without flights, the arrow will tend to yaw in flight. With flights, the arrow maintains a straight line direction of flight. Hence increasing the amount of deadwood will increase the directional stability properties of a hull. For a ship, the problem is worsened because the ship is pushed rather than pulled along. Try pushing the end of your pencil and maintain its motion in a straight line!

Controls fixed straight line stability is quantified during sea trials by the spiral maneuver where rate of turn is compared with rudder direction.

## 9.2.2 Response

In opposition to the requirement for controls fixed straightline stability, it is also required for the ship to turn in a satisfactory manner when a rudder order is given. In particular:

- The ship must respond to its rudder and change heading in a specified minimum time.
- There should be minimum overshoot of heading after a rudder order is given.

In practice, both these response quantities are dependant upon the magnitude of the rudder's dimensions, the rudder angle and ship speed.

### 9.2.2.1 Rudder Dimensions

As we will see in the next section, rudder dimensions are limited by the geometry of the ship's stern. However, it is not surprising that the larger the dimensions of the rudder, the more maneuverable the ship. Increasing the rudder dimensions decreases the response time and overshoot experienced by the hull.

The level of response required by a ship is driven by its operational role. For example, the ratio of rudder area to the product of length and draft ranges from 0.017 for a cargo ship to 0.025 for destroyers.

$$Rudder\ Area\ Ratio = \frac{RudderArea}{L_{PP}T}$$

### 9.2.2.2 Rudder Angle

Clearly, the response characteristics of a ship will depend upon the rudder angle ordered for a particular maneuver. It is common procedure for the levels of response to be specified with the ship using standard rudder. This is 20 degrees of wheel for the USN, but may vary for different ship types.

### 9.2.2.3 Ship Speed

Ship speed will also influence the level of maneuverability being experienced by the ship. In practice, for the majority of hull forms, greater ship speed will reduce response time but increase overshoot. This is because greater ship speed increases the rudder force being generated by a given rudder angle.

For this reason, during sea trials, ship response and overshoot is quantified at several ship speeds. Ship response is usually assessed by the zig-zag maneuver.

### **9.2.3 Slow Speed Maneuverability**

It is most important for ships to be maneuverable when traveling at slow speeds. This is because evolutions such as canal transits and port entrances are performed at slow speeds for safety reasons. Unfortunately, this is when the ship's rudder is least effective.

Levels of slow speed maneuverability are specified in terms of turning circle and other quantifiable parameters at speeds below 5 knots. Devices that can improve slow speed maneuverability will be discussed later.

### **9.2.4 Maneuverability Trade-Off**

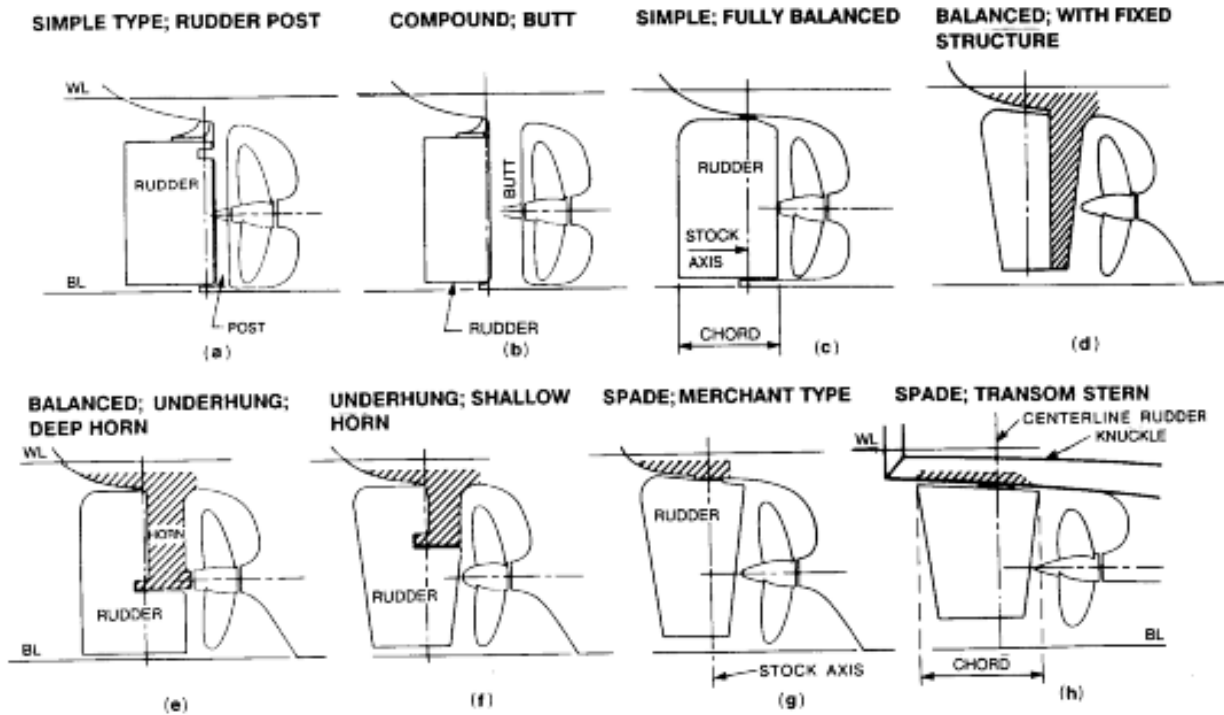
Unfortunately, the need for good directional stability (in particular controls fixed straightline stability) and minimum ship response oppose each other. For example, for a fixed rudder area, increasing the length of a ship will make it more directionally stable but less responsive to its rudder. As discussed, a similar effect is created by increasing the amount of vertical flat surface at the stern (deadwood).

However, increasing rudder area will always improve the response characteristics of a hull form and usually improve its directional stability as well. Unfortunately, rudder dimensions are limited by stern geometry. Also larger rudders will increase drag and so reduce ship speed for a given DHP from the propeller.

## 9.3 The Rudder

### 9.3.1 Rudder Types

Clearly, the rudder is the most important control surface on the hull. There are a multiplicity of different types. Figure 9.2 reproduced from the SNAME publication “Principles of Naval Architecture” shows some of them.



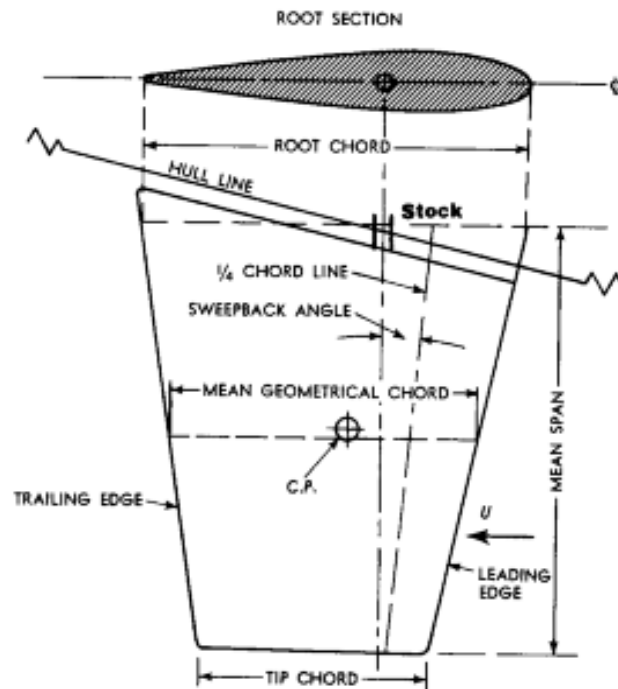
**Figure 9.2** Different Rudder Types

The magnitude of all the rudder types dimensions are limited by the hull, specifically the stern's properties.

- **Chord** The chord is limited by the position of the propeller (propeller/rudder clearance is specified by the American Bureau of Shipping for US ships) and the edge of the stern. Rudder protruding beyond the stern is inadvisable.
- **Span** The span (or the height of the rudder from the root to tip) is limited by the draft and the need for the rudder to remain above the ship baseline (or keel). This is a “grounding” consideration. Typically, the span of the rudder is approximately the size of the propeller diameter.

### 9.3.2 The Spade Rudder

The most common type of rudder found on military vessels is the spade rudder. Figure 9.3 from “Introduction to Naval Architecture” by Gilmer and Johnson shows the geometry of a typical semi-balanced spade rudder.



**Figure 9.3** A Semi-balanced Spade Rudder

The CVN and LPD-17 class has a balanced underhung rudder due to their size.

#### 9.3.2.1 Rudder Balance

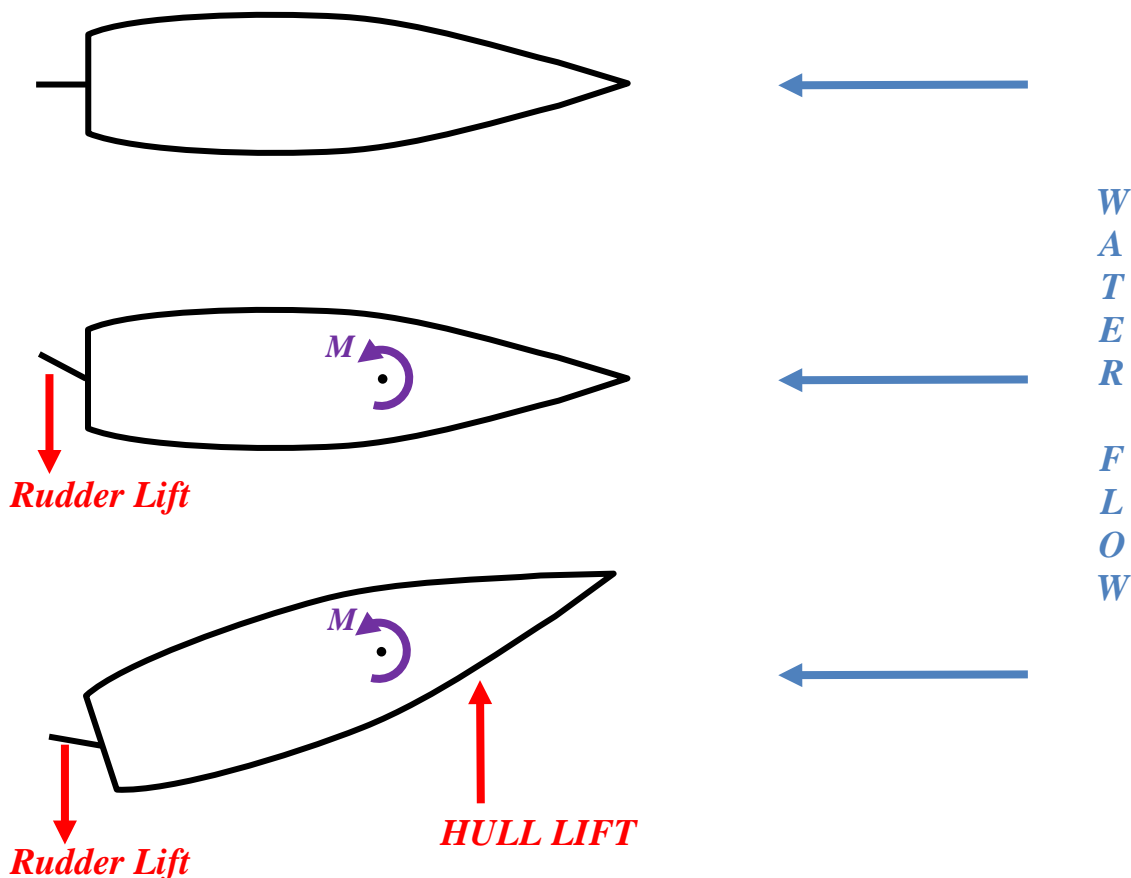
Whether a rudder is balanced or not is dependant upon the relationship of the center of pressure of the rudder and the position of the rudder stock.

- When they are vertically aligned, the rudder is said to be “fully balanced”. This arrangement greatly reduces the torque required by the tiller mechanism to turn the rudder.
- When the rudder stock is at the leading edge, the rudder is “unbalanced” as in Figure 9.2(a). This is a common arrangement in merchant ships where rudder forces are not excessive.
- The spade rudder in Figure 9.3 is semi-balanced. This is a sensible arrangement as it limits the amount of torque required by the tiller mechanism yet should ensure

the rudder returns to midships after the occurrence of a tiller mechanism failure.

### 9.3.3 Rudder Performance

It is a common misconception that the rudder turns a ship. In fact, the rudder is analogous to the flaps on an aircraft wing. The rudder causes the ship to orientate itself at an angle of attack to its forward motion. It is the hydrodynamics of the flow past the ship that causes it to turn. Figure 9.4 shows the stages of a ship turn.



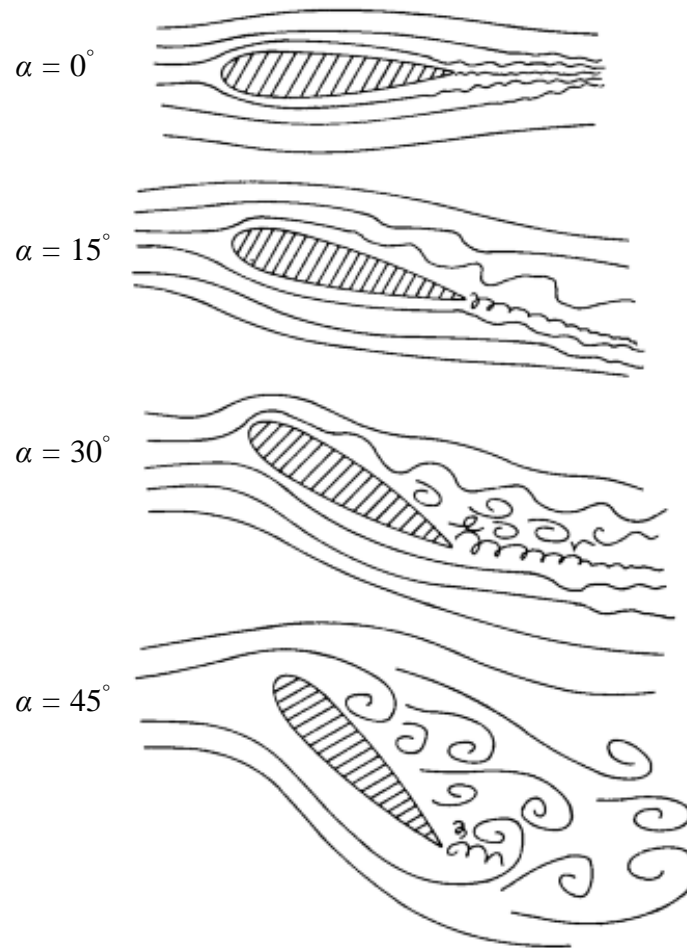
**Figure 9.4** The Stages of a Ship's Turn

The ship will continue to turn until the rudder angle is removed.

#### 9.3.3.1 Rudder Stall

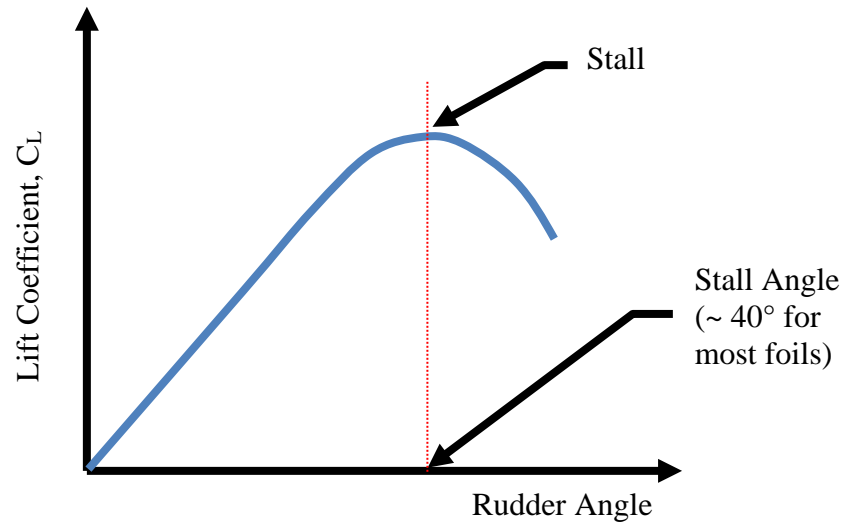
You will notice that a typical ship's rudder is limited to a range of angles up to about  $\pm 35^\circ$ . This is because at greater angles than these the rudder is likely to stall. Most U.S. Navy ships are outfitted with a hard and soft rudder stop to prevent the rudder angle from exceeding  $35^\circ$ . Figure 9.5 from Gilmer & Johnson shows the development of stall as rudder angle increases. At small angles, rudder lift is created due to the difference in flow rate across the port and starboard sides

of the rudder. However, as rudder angle increases, the amount of flow separation increases until a full stall occurs at 45 degrees.



**Figure 9.5** Rudder Flow Patterns at Increasing Rudder Angle

The amount of lift achieved by the rudder reduces significantly after a stall and is matched by a rapid increase in drag. Consequently, rudder angle is limited to values less than the stall angle. Figure 9.6 shows how rudder lift alters with rudder angle.



**Figure 9.6** How Lift Alters with Rudder Angle



## 9.4 Slow Speed Maneuverability

As mentioned previously, it is at slow speeds when ships need to be the most maneuverable. Unfortunately, at slow speeds the rudder is limited in its effectiveness due to the lack of flow across its surfaces. However, there are several modifications that have been developed to improve the situation.

### 9.4.1 Rudder Position

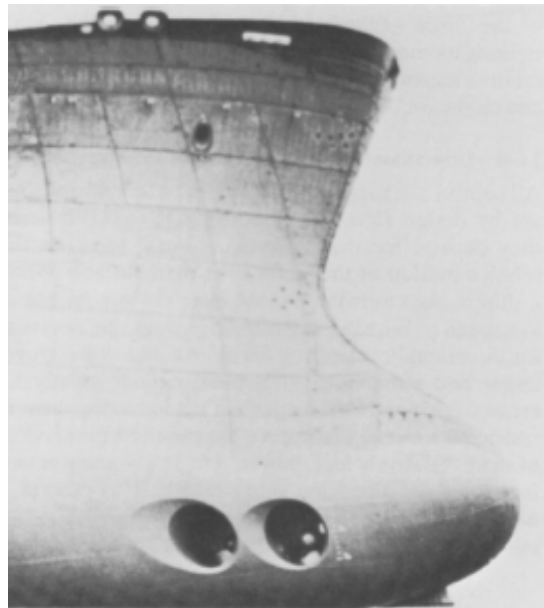
To improve the low flow rate experienced by the rudder at slow speeds, the rudder is often positioned directly behind the propeller. In this position, the thrust from the propeller acts directly upon the control surface. A skilled helmsman can then combine the throttle control and rudder angle to vector thrust laterally and create a larger turning moment with minimal advance and transfer.

### 9.4.2 Twin Propellers

The presence of two propellers working in unison can significantly improve slow speed maneuverability. By turning one propeller in the reverse direction and the other in the forward direction, very large turning moments can be created with hardly any forward motion. This maneuver is called a “twist.”

### 9.4.3 Lateral Thrusters

Lateral thrusters (or bow thrusters as they are usually positioned at the bow) consist of a tube running athwart ships inside of which is a propeller. They are usually electrically driven. With a simple control from the bridge, the helmsman can create a significant turning moment in either direction. Figure 9.7 shows a photograph of 2 lateral thrusters positioned in the bulbous bow of a ship. The photo is reproduced from “Introduction to Naval Architecture” by Gilmer and Johnson.

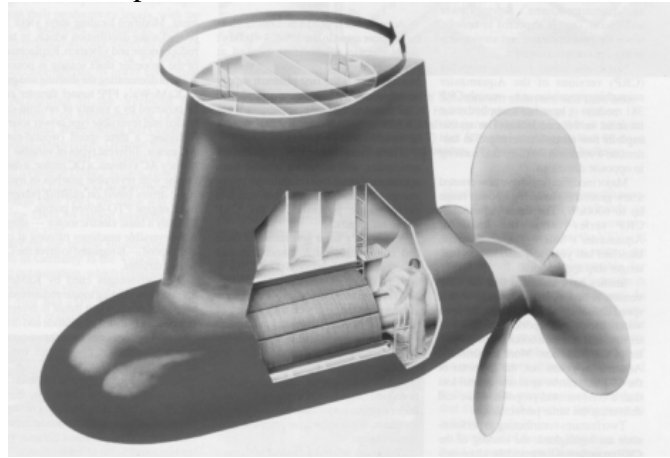


**Figure 9.7** Lateral Thrusters in the Bow of a Ship

### 9.4.4 Rotational Thrusters

These provide the ultimate configuration for slow speed maneuverability. Rotational thrusters' appearance and operation resembles an outboard motor. They consist of pods that can be lowered from within the ship hull. Once deployed, the thruster can be rotated through 360 degrees

allowing thrust to be directed at any angle. Figure 9.8 shows a typical “ro-thruster” design produced by Kvaerner Masa-Azipod of Finland.



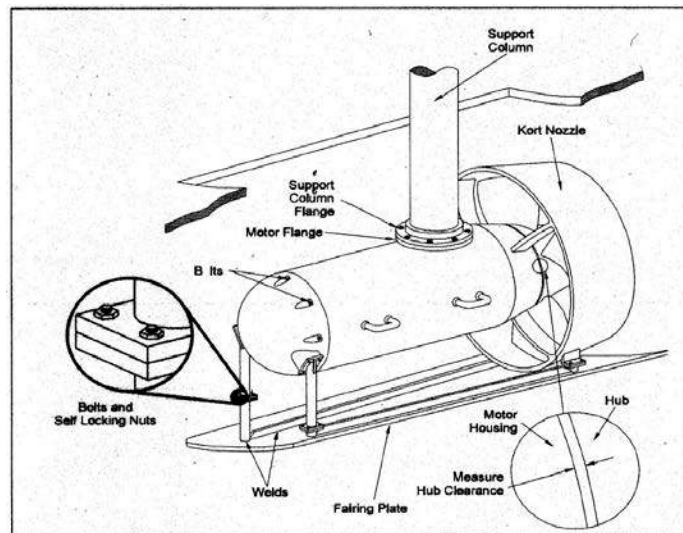
**Figure 9.8** Typical Rotational Thruster Design

Some highly specialized ships use “ro-thrusters” as their only means of propulsion. 2 or 3 “ro-thrusters” coupled with a complicated G.P.S. centered control system can keep a ship in a geostationary position over the sea bed and at the same heading in quite considerable tide and wave conditions. These ships are often associated with diver, salvage or seabed drilling operations.

Figure 9.9 on the following page shows a typical auxiliary propulsion unit used on ships and submarines. It can be used for both emergency propulsion and maneuverability.



In practice, the amount of slow speed maneuverability exhibited by a ship is largely dependent upon the amount of money the designer is willing to spend on lateral or rotational thrusters in the ship design. This economic question is highly involved and includes estimates of ship docking rates, the costs of hiring tugs etc.



**Figure 9.9** Auxiliary Propulsion Unit

## PROBLEMS - CHAPTER 9

1. A small 30 ft pleasure craft you own is very difficult to steer. In particular the smallest amount of wind or sea makes it almost impossible to keep on course. While the boat is out of the water for the winter, what modification could you make to the hull to improve its maneuvering characteristics?
2. A ship with  $L_{PP} = 500$  ft,  $B = 46$  ft, and  $T = 20$  ft is being designed for good maneuverability (i.e. short response times and minimum overshoot).
  - a. Estimate a suitable rudder area for this ship.
  - b. What would constrain the dimensions of this rudder from being larger.
3. Describe a design improvement that would alter a simple rudder such as that at Figure 9.2a into a semi-balanced rudder. Why is this a better design.
4. Describe using a sketch the stages of a ship's turn. Why does a ship slow down when it turns?
5. Describe three ways in which a ship's slow speed maneuverability can be improved.

# **COURSE OBJECTIVES**

## **CHAPTER 10**

### **10. SUBMARINES AND SUBMERSIBLES**

1. Be familiar with the basic layout and construction of submarines including:
  - a. Pressure Hull
  - b. Outer Hull
  - c. Main Ballast Tanks
  - d. Depth Control Tank
  - e. Trim Tanks
2. Calculate the effects of the following on submarine buoyancy and trim.
  - a. Water salinity
  - b. Water temperature
  - c. Depth
  - d. Transverse weight shifts
  - e. Longitudinal weight shifts
3. Quantify the stability of a submarine for a given BG
4. Qualitatively describe how the components of submarine resistance alter as the submarine submerges
5. Qualitatively describe the advantages and disadvantages of an odd bladed highly skewed submarine propeller
6. Be qualitatively aware of the following seakeeping characteristics of submarines:
  - a. Suction effect due to proximity to the surface
  - b. Suction effect due to surface waves
7. Be qualitatively aware of the following aspects of submarine maneuvering and control:
  - a. The use of fair-water planes and stern planes for depth control
  - b. The effect of hull lift

## 10.1 Introduction

Submarines and the desire to explore the ocean's depths date back as far as Alexander the Great and Ancient Greece. Besides the limited success of the *Hunley* in the Civil War, technology did not permit the submarine to become a viable weapon of war until the invention of the steam engine and the construction of the *Holland (SS-1)* in 1900.



*USS Holland at USNA*

The submarine played significant roles in both the major wars of this century. In World War I, the German U-boat attacks on Allied shipping demonstrated the vital role the submarine could and would play in future global maritime conflicts. During World War II, the United States submarine force capitalized on many technological advances in submarine construction and powering, as well as development of sonar and radar, to allow the boats to travel faster, deeper, and remain undetected by the enemy. The U.S. submarine force, which accounted for about two percent of the fleet, destroyed 1,314 enemy ships, totaling 5.3 million tons or 55% of all enemy ships lost. The U.S. submarine campaign in the Pacific Theater deprived Japan of vital raw materials and effectively shut down the Japanese war machine. With these great successes also came great losses. Fifty-three submarines (1 in WWI and 52 in WWII) and 4,022 submariners remain on “Eternal Patrol” – a casualty rate which matched or surpassed most infantry divisions.

The period following World War II brought great changes in submarine technology and tactics. The advent of nuclear power allowed submarines to stay submerged indefinitely and ushered in the era of “stealth weapons”. The teardrop hull design tested on the *USS Albatross* allowed submarines to achieve submerged speeds previously only imagined. The teardrop hull was originally tested on the *Holland* but was scrapped due to *Holland's* limited power and ventilation systems, which required mostly surface transit. The development of the ballistic missile allowed strategic missile submarines to patrol as the ultimate nuclear deterrent. The successes of the United States submarine force against the Soviets in the Cold War was a deciding factor in the fall of the Soviet Union.

The use of submarines in commercial fleets is severely limited. This is mainly due to their significant operating and construction costs. However, with the increasing use of the seas, in particular the retrieval of mineral wealth, the submarine or submersible will have an ever growing role. This chapter will explore the hydrostatic and hydrodynamic properties of submarines and compare them with those possessed by surface ships. In many instances the differences will be considerable. It will also look at the structure, construction and layout of submarines and their dynamic behavior through the water.

## 10.2 Submarine Construction and Layout

You will recall from Chapter 6 that ships are constructed with a structure dependent upon the primary load that they have to withstand.

- **Longitudinal Bending:** Wave action causes the ship to Hog or Sag creating successive compressive and tensile stresses in the structure, particularly the keel and weather deck. Longitudinals are used to combat these stresses.
- **Hydrostatic Pressure:** Water pressure attempts to crush the ship from the sides. Transverse frames combat this loading.

Most modern ships use a combination of longitudinals and transverse frames as they are subjected to both types of loading.

By far the most significant load the submarine has to withstand is hydrostatic pressure. Consequently, it should be no surprise to learn that they are transversely framed. Figure 10.1 illustrates typical submarine construction.



**Figure 10.1** A hull section of the SSN-21 class shown during assembly. The transverse frames are shown clearly at left (the hull is a ring stiffened cylinder)

### 10.2.1 Inner Hull

There are two hulls in a submarine. The inner hull or pressure hull (or “people tank”) holds all the pressure sensitive systems of the submarine including the submariners. The inner hull must withstand the hydrostatic pressure to the submarine’s maximum or “test” depth. You will recall that absolute pressure is given by the following:

$$P_{abs} = P_{atm} + \rho gh$$

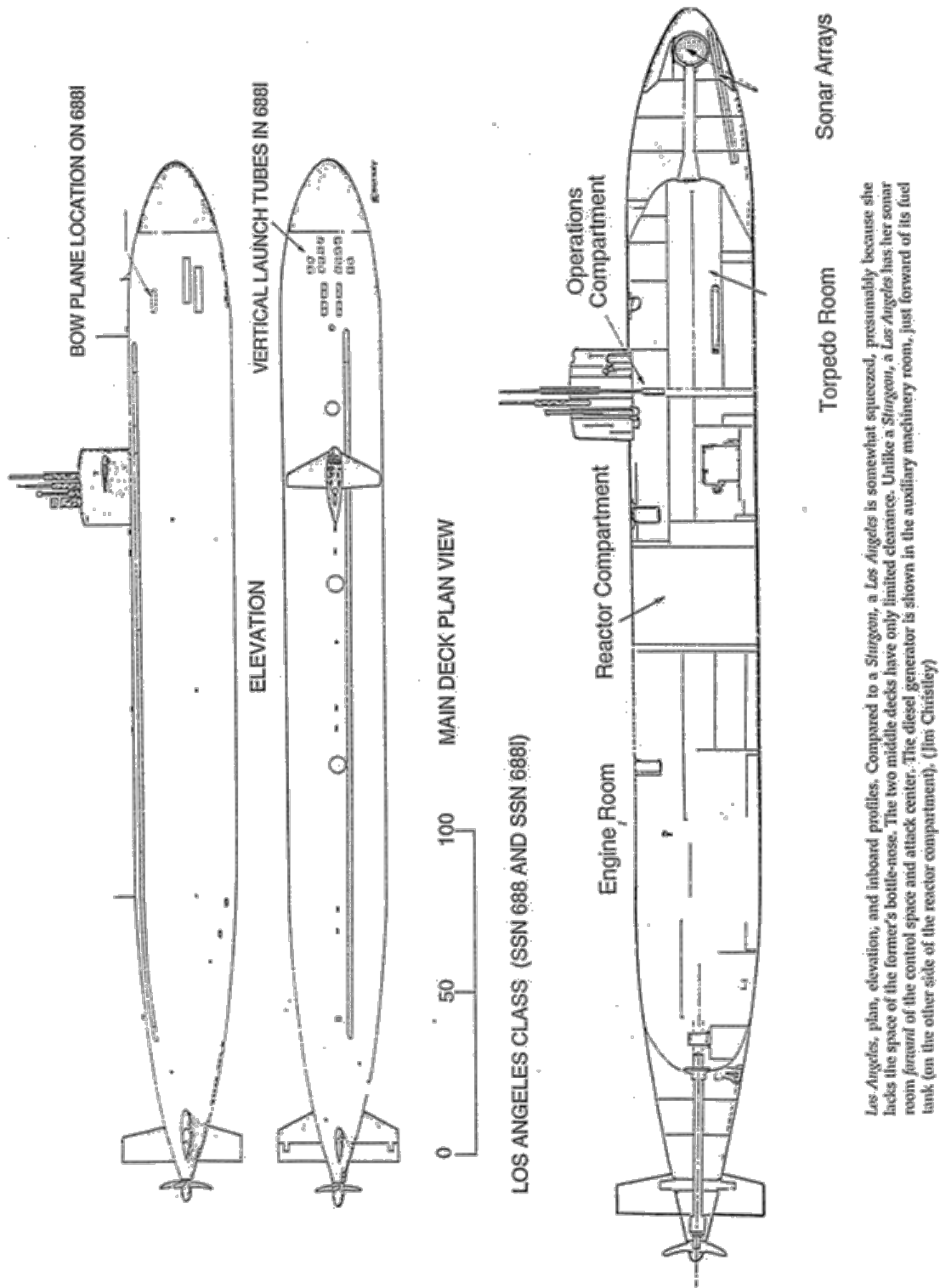
where:

$$\rho gh = \text{hydrostatic pressure} = P_{gage}$$

A useful thumb rule is that pressure increases by 44 psi per 100ft of depth.

Any ingress of water into the inner hull can have a considerable effect upon stability and may threaten the remaining structural integrity of the ship. Consequently, the inner hull has to be strong. As inferred above, the inner hull is transversely framed and due to the deep depths achievable by modern submarines it has thick plating. The number of transverse frames and thickness of plating used is a compromise between cost, weight, operating ability and space; more frames and thicker plating means higher cost, greater weight, less space for equipment and crew but a greater diving depth.

Inner hull sections are perfectly circular. Any “out of roundness” has a significant impact on its ability to support the hydrostatic load. For example, a 0.5% deviation from a perfect circle may reduce the hydrostatic load carrying capacity of a submarine structure by over 35%!



*Los Angeles*, plan, elevation, and inboard profiles. Compared to a *Sturgeon*, a *Los Angeles* is somewhat squeezed, presumably because she lacks the space of the former's bottle-nose. The two middle decks have only limited clearance. Unlike a *Sturgeon*, a *Los Angeles* has her sonar room forward of the control space and attack center. The diesel generator is shown in the auxiliary machinery room, just forward of its fuel tank (on the other side of the reactor compartment). (Jim Christley)

**Figure 10.2** 688 Class Submarine profiles  
 (Reproduced from *U.S. Submarines Since 1945* by Norman Friedman with the permission of Naval Institute Press, Annapolis, MD.  
 Profiles are the work of Mr. James L. Christley.)



It is also important that the inner hull remains within its elastic limit for material strength, even at high levels of stress. You will recall from Chapter 5 that this will occur provided the hull material remains below the yield stress  $\sigma_y$ . Consequently, very high strength steels are used with high yield stresses. Common steels used in U.S. submarines are HY-80 and HY-100 (the “HY” designates high yield and the following number is the steel’s yield stress in thousands of pounds per square inch). Some of the more advanced Russian Submarines use Titanium for their inner hulls.

### 10.2.2 Outer Hull

Figure 10.2 shows that in certain places down the length of a submarine, the inner hull reduces in cross section and is surrounded by an outer hull or submarine fairing. The outer hull is simply a smooth fairing that covers the non-pressure sensitive equipment of the submarine such as Main Ballast Tanks and anchors to improve the submarines hydrodynamic characteristics. The fairing does not need to withstand the diving depth hydrostatic pressure, so high strength materials are not required. Mild steel and Fiber Reinforced Plastics are commonly used.

Modern submarines also have anechoic tiles or a synthetic “skin” covering the outer hull to reduce the active sonar signature and dampen radiated noise from the submarine to the water.

### 10.2.3 Submarine Construction

Submarine construction is very expensive. High strength materials necessary to achieve deeper depths are expensive and difficult to use in manufacturing. High strength steels are notoriously difficult to bend, fabricate and weld. Quality control of the manufacturing process is also critical as any out of roundness can severely compromise submarine structural integrity.

Consequently, the number of shipyards with the expertise to manufacture submarines is limited. In the U.S., General Dynamics’ Electric Boat in Groton, Connecticut and Northrop Grumman Shipbuilding in Newport News, Virginia are the only submarine manufacturers.

### 10.2.4 Submarine General Arrangement

#### 10.2.4.1 Main Ballast Tanks

Recall in Chapter 2 Archimedes’ Principle states that for an object wholly or partially immersed in a fluid, the buoyant force will be equal to the weight of the displaced volume of water. This applies to submarines just as it did for surface ships, the only difference being that the submerged volume is equal to the entire hull volume.

Positively Buoyant:  
(floats)

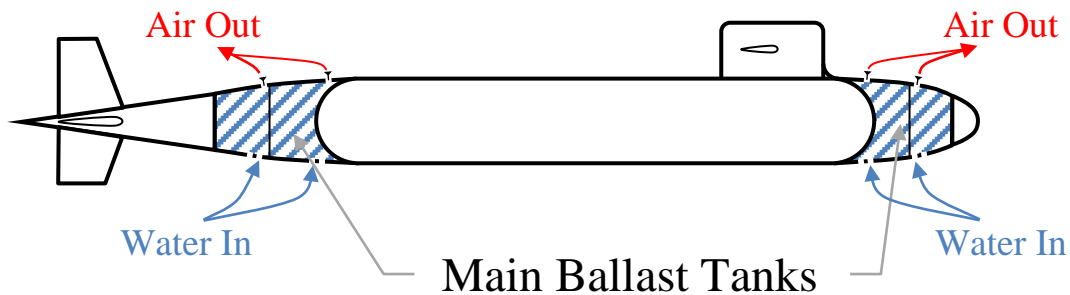
$$F_{B, \text{ SURFACE SHIP}} = \rho g \nabla_{\text{SUBMERGED}}$$

$$F_{B, \text{ SURFACED SUB}} = \rho g \nabla_{\text{SUBMERGED}} < \rho g \nabla_{\text{TOTAL}} > \Delta$$

Neutrally Buoyant:  $F_{B, SUBMERGED SUBMARINE} = \rho g \nabla_{SUBMERGED}$   
 $= \rho g \nabla_{TOTAL}$   
 Negatively Buoyant:  $F_{B, SUBMERGED SUBMARINE} = \rho g \nabla_{TOTAL} < \Delta$   
 (sinks)

Figure 10.3 shows the location of the Main Ballast Tanks (MBTs) on a submarine. These are by far the largest tanks on board as they have to be able to alter the displacement of the submarine from being positively buoyant (surfaced) when empty to somewhere near neutrally buoyant (submerged) when full.

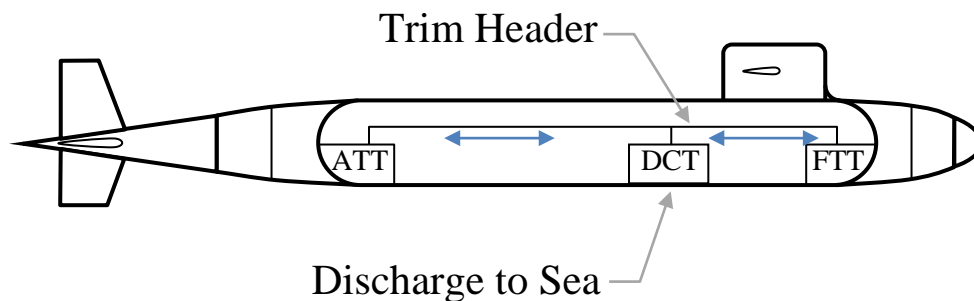
The Main Ballast Tanks are “soft tanks” because they do not need to withstand the hydrostatic pressure when the submarine is submerged. This is because they will be full at the submerged depth with the pressure equalized across them.



**Figure 10.3** Location of Typical Submarine’s Main Ballast Tanks

#### 10.2.4.2 Variable Ballast Tanks

In addition to the MBTs there are other tanks required to ‘fine tune’ the displacement and trim characteristics of the submarine once it is submerged. These are called variable ballast tanks. Figure 10.4 shows their usual location



**Figure 10.4** Location of Variable Ballast Tanks

- **Depth Control Tank (DCT):** The DCT is used to alter the buoyancy characteristics of the submarine once it is submerged. For reasons covered in the next section, environmental factors can often cause the submarine to move from a neutrally buoyant condition to being negatively or positively buoyant. Moving water in or out of the DCT can compensate for this. The DCT is termed a ‘hard tank’ because it can be pressurized to submergence pressure allowing its contents

to be “blown” overboard and also the submarine can ingest water into the tank from any depth.

- **Trim Tanks:** As the name suggests these are used to control the trim of the submarine. Submarines are very sensitive to longitudinal weight shifts, additions and removals. Moving water between the after and forward trim tanks (ATT and FTT in Figure 10.4) can compensate for these changes. They are ‘soft tanks’ because they are not required to withstand the external hydrostatic pressure. Submarines may also include additional Auxillary Trim Tanks (AUX) located near LCB like the DCT, but these are also ‘soft tanks.’

## 10.3 Submarine Hydrostatics

Just like a surface ship, submarines obey the principles of static equilibrium and Archimedes. The submarine experiences a buoyant force equal to the weight of liquid it displaces. When surfaced or neutrally buoyant, this buoyant force is equal to the weight of the submarine (its displacement).

### 10.3.1 Neutral Buoyancy

A surface ship automatically maintains static equilibrium by alterations in its draft and the reserve buoyancy above the waterline. That is, by changing the vessel's draft, its submerged volume is altered to reflect any changes to its displacement due weight removals or additions, changes in water density, or as a passing wave causing excess buoyancy.

Unfortunately, a submerged submarine is given no such luxury. The crew must actively maintain a state of static equilibrium by changing the weight of the submarine to match the (usually) constant buoyant force. The buoyancy is constant because the submerged volume of a submarine is constant (at a given depth) and there is no excess or reserve buoyancy as in a surface ship. Hence the submarine needs a DCT that will allow for compensation due to changes in the environment.

#### 10.3.1.1 Salinity

Water density ( $\rho$ ) will change whenever there is an alteration in its salinity level. This is a fairly frequent occurrence, for example:

- Changes in salinity are common when operating near river estuaries or the polar ice cap.
- Due to constant evaporation, the Mediterranean Sea has a higher salinity level than the oceans.



In the Straits of Gibraltar the colder, less saline water from the Atlantic mixes with the warmer, more saline water from the Mediterranean to produce strong currents ranging from two to four knots. This allows some submarines to pass through the Straits by covertly “riding” the subsurface currents. Unfortunately, these salinity differences can also cause very large changes in a submarine's buoyancy and internal waves. In the mid 1980's, a Soviet submarine covertly transiting the Straits learned this the hard way when it lost depth control and collided with the underside of a tanker!

**Example 10.1** The 8000LT USS Hardluck is submerging in Long Island Sound to conduct a “Tiger Cruise”. The water temperature is 75<sup>0</sup>F and Long Island Sound is diluted by 10% fresh water. The Diving Officer calculated the trim for the open ocean. How should the trim be corrected?

$$\begin{aligned} @ 75^0\text{F} \quad \rho_{\text{fresh}} &= 1.9350 \text{ lb-s}^2/\text{ft}^4 \\ \rho_{\text{salt}} &= 1.9861 \text{ lb-s}^2/\text{ft}^4 \end{aligned}$$

Solution:

In the open ocean the submarine is neutrally buoyant.

$$\Rightarrow \Delta = \rho g \nabla$$

$$\nabla = \frac{\Delta}{\rho g} = \frac{8000\text{LT} \quad 2240\text{lb} / \text{LT}}{1.9861\text{lb} - \text{sec}^2 / \text{ft}^4 \quad 32.17 \text{ ft} / \text{sec}^2}$$

$$\nabla = 280,470 \text{ ft}^3$$

The water in Long Island Sound is 10% fresh, 90% salt

$$\rho_{\text{LIS}} = 10\% \rho_{\text{FW}} + 90\% \rho_{\text{SW}}$$

$$\rho_{\text{LIS}} = 0.10 (1.9350\text{lb} - \text{sec}^2 / \text{ft}^4) + 0.90(1.9861\text{lb} - \text{sec}^2 / \text{ft}^4)$$

$$\rho_{\text{LIS}} = 1.9810\text{lb} - \text{sec}^2 / \text{ft}^4$$

So the buoyant force ( $F_B$ ) acting on the submarine in Long Island Sound can be found.

$$F_B = \rho g \nabla$$

$$F_B = (1.9810\text{lb} - \text{sec}^2 / \text{ft}^4)(32.17 \text{ ft} / \text{sec}^2)(280,470 \text{ ft}^3)$$

$$F_B = 1.787 \times 10^7 \text{ lb} = 7979\text{LT}$$

Hence submarine displacement (8000LT) is greater than the buoyant force (7979LT). The submarine is acting heavy. To compensate, 21LT of water must be pumped out of the DCT.

### 10.3.1.2 Water Temperature

Changes in water temperature are common throughout the ocean. Temperature affects water density, which in turn affects the magnitude of the buoyant force.

**Example 10.2** An 8000LT submarine exits the Gulf Stream where water is 85°F and enters 65°F water. How much water will the Diving Officer need to flood on or pump off?

$$\begin{aligned}\rho @ 85^\circ\text{F} &= 1.9827 \text{ lb}\cdot\text{s}^2/\text{ft}^4 \\ \rho @ 65^\circ\text{F} &= 1.9890 \text{ lb}\cdot\text{s}^2/\text{ft}^4\end{aligned}$$

Solution:

The submarine is neutrally buoyant in the Gulf Stream.

$$\begin{aligned}\Rightarrow \Delta &= \rho g \nabla \\ \nabla &= \frac{\Delta}{\rho g} = \frac{8000 \text{ LT } 2240 \text{ lb} / \text{LT}}{1.9827 \text{ lb} - \text{sec}^2 / \text{ft}^4 \cdot 32.17 \text{ ft} / \text{sec}^2} \\ \nabla &= 280,950 \text{ ft}^3\end{aligned}$$

As it leaves the Gulf Stream the water density changes which alters the size of the buoyant force.

$$\begin{aligned}F_B &= \rho g \nabla \\ F_B &= (1.9890 \text{ lb} - \text{sec}^2 / \text{ft}^4)(32.17 \text{ ft} / \text{sec}^2)(280,950 \text{ ft}^3) \\ F_B &= 1.798 \times 10^7 \text{ lb} = 8025 \text{ LT}\end{aligned}$$

So the submarine displacement is 25 LT smaller than its buoyant force. The Diving Officer will have to flood 25 LT of water into the DCT.

### 10.3.1.3 Depth

As a submarine increases its depth the increasing hydrostatic pressure increases the stress on the hull. This stress then strains the hull. The hull shrinks. So the submerged volume of a submarine decreases with depth which in turn reduces its buoyant force. So to maintain neutral buoyancy, water must be pumped from the DCT reducing the submarine displacement to keep pace with the smaller  $F_B$ .

This effect has been accentuated with the introduction of anechoic tiles mentioned in section 10.2. These tiles are compressed when operating at modern maximum diving depths but usually show little change in volume past moderate depths as the rubber material is compressed to its maximum.

### 10.3.2 Neutral Trim

The second goal the submarine crew is actively seeking is neutral trim. Trim is particularly sensitive on a submarine once submerged due to the lack of a waterline.

You may recall from Chapter 3 that the distance of the metacenter above the keel can be found by adding BM (the metacentric radius) to KB. This can be used in either the transverse or longitudinal directions to find  $KM_T$  or  $KM_L$  respectively. Figure 10.5 graphically illustrates the relationships for a surface ship.

$BM_L$  is very much larger than  $BM_T$  because ships tend to be longer than they are wider and so their second moment of area is much greater longitudinally than transversely.

$$\overline{BM}_L = \frac{I_L}{\nabla_S} \overline{BM}_T = \frac{I_L}{\nabla_S}$$

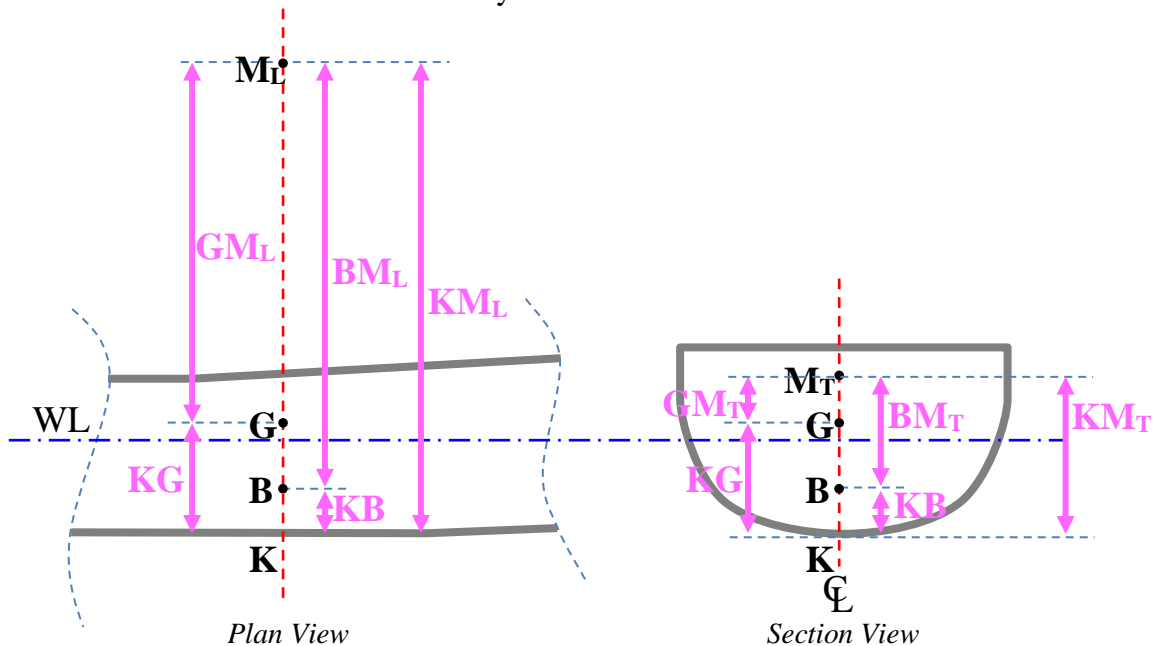
Ships are longer than they are wide

$$\Rightarrow I_L \gg I_T$$

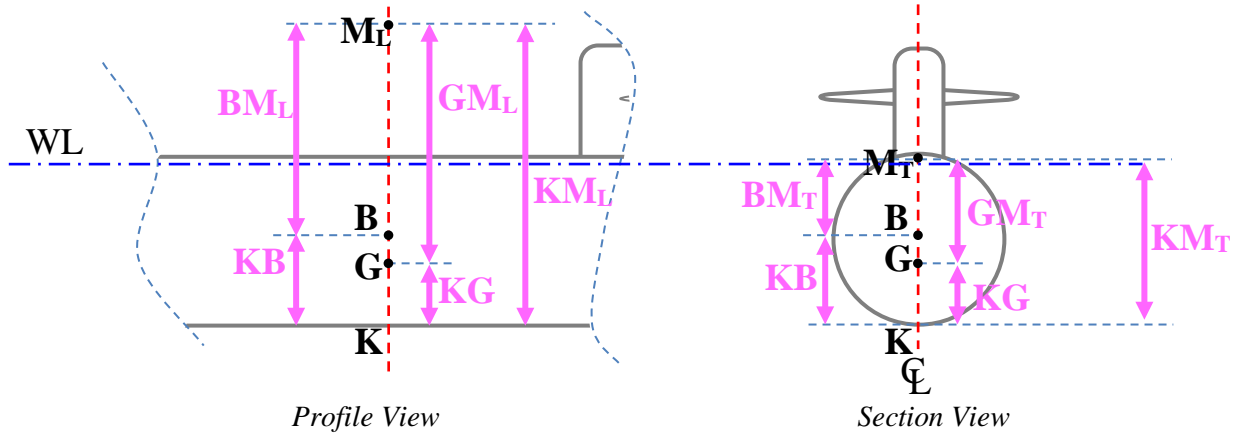
$$\Rightarrow \overline{BM}_L \gg \overline{BM}_T$$

The situation for the surfaced submarine is quite similar to the surface ship. Figure 10.6 illustrates the geometric relationships for a surfaced submarine. You will notice that G is situated below B; the importance of this will become evident in the next section.

For clarity,  $M_T$  has been shown significantly above the location of B, in practice the distance between the two locations is very small while the submarine is surfaced.



**Figure 10.5** K, B, G, and M Geometry for a Surface Ship



**Figure 10.6** K, B, G, and M Geometry for a Surfaced Submarine

As the submarine submerges, its waterplane disappears. With no waterplane there is no second moment of area of the waterplane and so no metacentric radius. Hence the center of buoyancy and the metacenter are both located at the centroid of the underwater volume - the half diameter point.

$$\overline{GM}_L = \overline{KB} + \overline{BM}_L - \overline{KG}$$

$$\overline{GM}_T = \overline{KB} + \overline{BM}_T - \overline{KG}$$

*but as the waterline disappears...*

$$I_L = I_T = 0$$

$$\overline{BM}_L = \overline{BM}_T$$

*So...*

$$\overline{GM}_L = \overline{KB} - \overline{KG}$$

$$\overline{GM}_T = \overline{KB} - \overline{KG}$$

*So...*

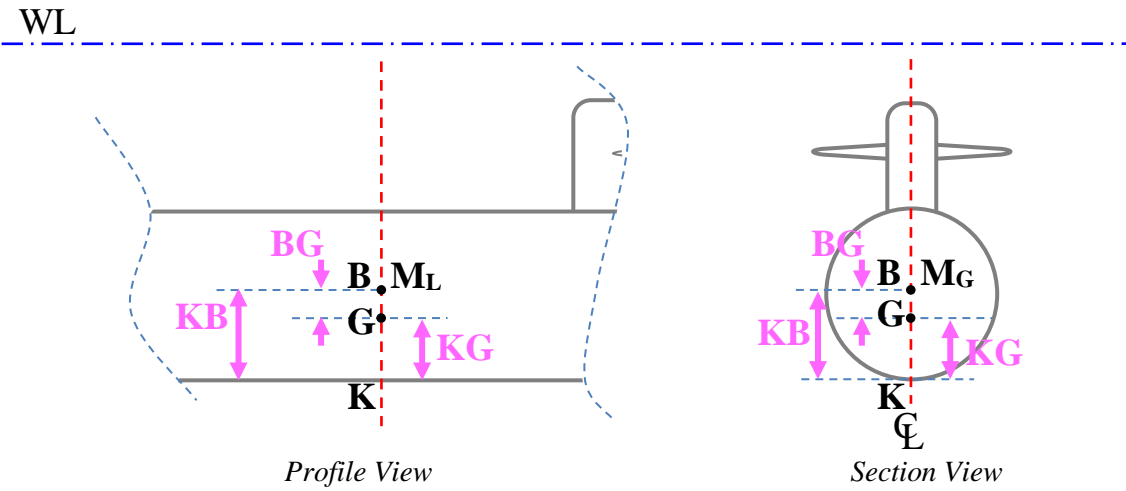
$$\overline{GM}_L = \overline{GM}_T = \overline{BG}$$

What actually happens is that as the submarine submerges, B moves vertically up very slightly because of the additional hull volume and sail being submerged and M moves vertically down as the water-plane disappears. When finally submerged, the positions of B, M<sub>T</sub> and M<sub>L</sub> are coincident. Figure 10.7 shows the geometric relationships for a submerged submarine.

**A consequence of this is the submerged submarine has the same initial stability characteristics longitudinally as it does transversely.**



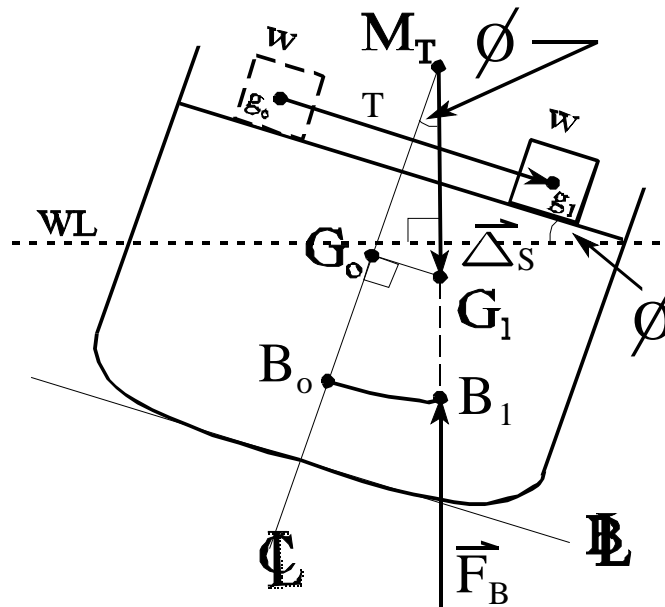
Because submarines are much longer than they are wide, the submerged submarine is very sensitive to trim. This accounts for the need for trim tanks.



**Figure 10.7** K, B, G, and M Geometry for a Submerged Submarine

### 10.3.2.1 Transverse Weight Shifts

You may recall from Chapter 3 that the analysis of a transverse weight shift in a surface ship involved the situation shown in Figure 10.8.



**Figure 10.8** The Inclining Surface Ship

From the geometry of the triangle  $G_0G_T M_T$  and from a knowledge of the size and distance the weight is being shifted, an equation can be formulated as follows.

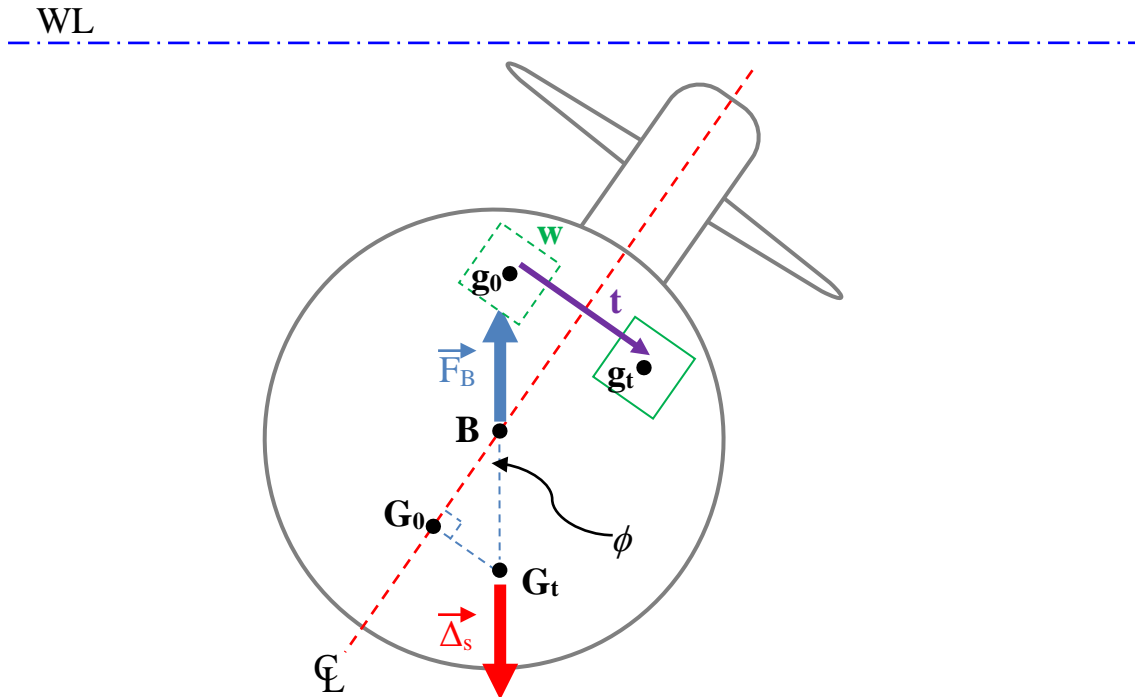
$$\tan \phi = \frac{\overline{G_0 G_t}}{\overline{G_0 M_T}} \quad \overline{G_0 G_t} = \frac{wt}{\Delta_s}$$

$$\Rightarrow \Delta_s \overline{G_0 M_T} \tan \phi = wt$$

This same equation is used to estimate the value of  $GM_T$  of a ship in the Inclining Experiment. With  $GM_T$  known it is then possible to calculate the vertical center of gravity, KG.

Unfortunately, this equation relies upon the existence of the triangle  $G_0G_T M_T$  which is only true at small angles. At larger angles the metacenter is not stationary and moves about causing any calculation using this system to be inaccurate. Angles of list at large angles are only available from an analysis of the curve of static intact stability, the list angle corresponding to the intercept of the Righting Arm Curve with the x axis.

For a submerged submarine, with both the Center of Buoyancy (B) and the Metacenter (M) are coincident, so the calculation of the heeling angle is greatly simplified. Figure 10.9 shows a submarine listing due to a transverse weight shift.



**Figure 10.9** The Inclining Submerged Submarine

The analysis of this situation involves the triangle  $G_0G_TB$  and a knowledge of the weight shift.

$$\tan \phi = \frac{\overline{G_0G_t}}{\overline{BG_0}} \quad \overline{G_0G_t} = \frac{wt}{\Delta_s}$$

$$\Rightarrow \Delta_s \overline{BG_0} \tan \phi = wt$$

This equation is valid for all list angles since the position of the center of buoyancy (B) will be constant for any list condition. If we know the distance from the center of buoyancy to the center of gravity ( $BG_0$ ), the submarine displacement  $\Delta_s$ , and the weight shift, the angle of list can always be determined quite easily.

One way to think of this is that your trim pivot point is no longer based on the centroid of the waterplane, F. Once submerged, the submarine will trim and list about the center of Buoyancy, which is the centroid of the total volume of the submarine. Equivalently, once the waterplane has disappeared in the diving evolution, the metacentric radius,  $\overline{BM}$ , collapses to zero, so the metacenter may be thought to still predict the movement of B. Thus as the sub trims or lists, B remains fixed with respect to the hull. This becomes the point about which trim and list angles develop.

**Example 10.3** A submerged submarine weighs 7200 LT with  $KB = 15$  ft,  $KG = 13.5$  ft. A piece of machinery weighing 6 LT is moved from 10 ft stbd of the centerline to a position 13 ft port of the centerline. Its distance above the keel does not change. What is the angle of list created by this movement?

Solution:

Using the equation we have just proved.

$$\Rightarrow \Delta_s \overline{BG_0} \tan \phi = wt$$

$$\tan \phi = \frac{wt}{\Delta_s \overline{BG_0}}$$

$$\tan \phi = \frac{6LT \cdot 23ft}{7200LT \cdot 1.5ft} = 0.0128$$

$$\phi = 0.73^\circ \text{ to port}$$

### 10.3.2.2 Longitudinal Weight Shifts

For a surface ship, the analysis of a longitudinal weight shift is involved. The process is complicated by the ship trimming about the center of floatation (F) which is seldom at midships.

For a submerged submarine, the analysis of longitudinal weight shifts is exactly the same as in the transverse case. This is because the characteristics of a submerged submarine are

exactly the same longitudinally as they are transversely, both being controlled by the distance  $BG_0$ . Hence the following equation holds for all angles of trim.

$$wl = \Delta_s \overline{BG_0} \tan \theta$$

Because submarines are much longer than they are wide, the value of the longitudinal moment arm ( $l$ ) can be much larger than the transverse moment arm ( $t$ ); this much larger moment arm ( $l$ ) necessitates the addition of trim tanks that can compensate for longitudinal weight shifts.

**Example 10.4** A submarine weighs 7200 LT and has zero trim.  $KB = 15$  ft,  $KG = 13.5$  ft. 40 submariners weighing 200 lb each move aft a distance of 300 ft.

- a. What will be the new trim angle?
- b. How much water must be transferred between the 2 trim tanks to return the trim to zero? The distance between trim tanks is 200ft.

Solution:

- a. Using the equation above.

$$wl = \Delta_s \overline{BG_0} \tan \theta$$

$$\tan \theta = \frac{wl}{\Delta_s \overline{BG_0}}$$

$$\tan \theta = \frac{40 (200lb) (300 ft) (1LT / 2240lb)}{(7200LT)(1.5 ft)} = 0.0992$$

$$\theta = 5.67^\circ \text{ by the stern}$$

- b. To return the trim to zero, the moment created by shifting the water must be equal and opposite to the moment created by the moving people.

$$40 (200 lb) (300 ft) = w (200 ft)$$

$$w = 12,000 \text{ lb pumped from ATT to FTT}$$

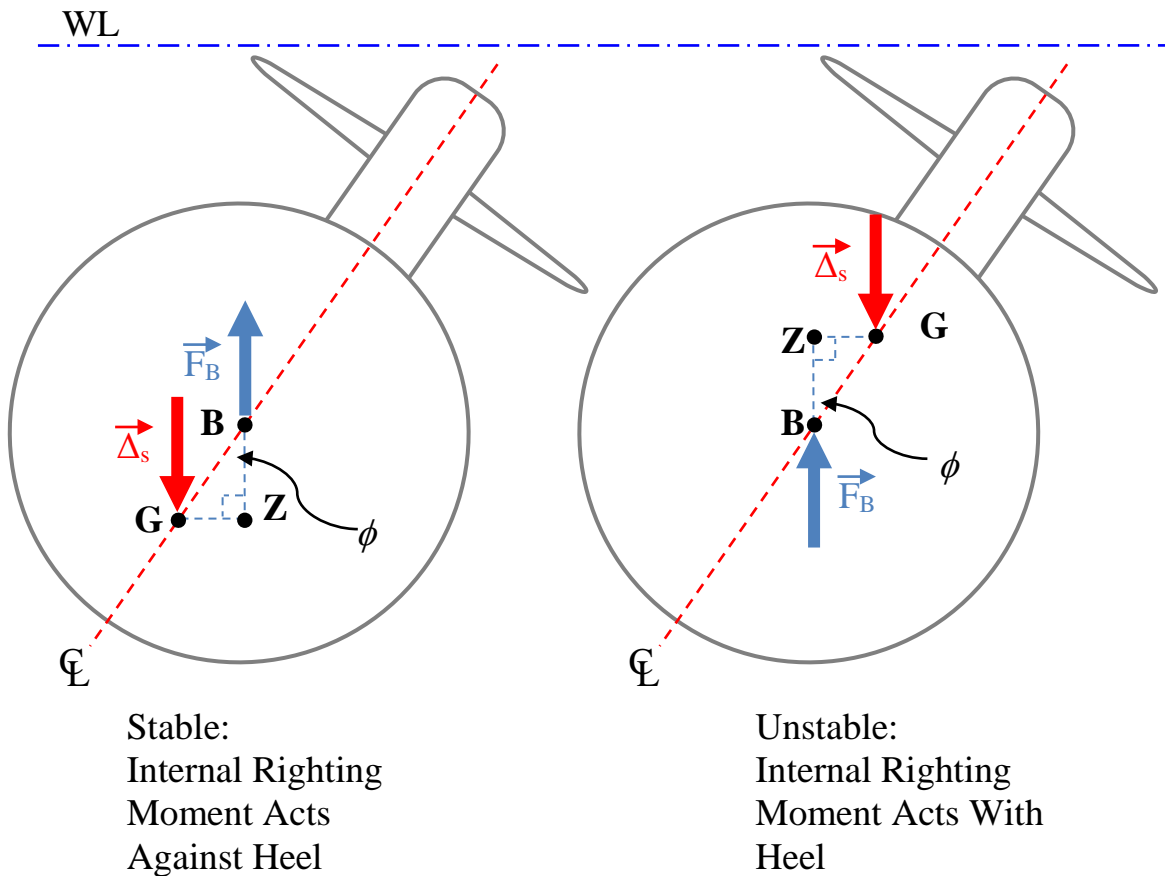


One may think that a submarine firing four torpedoes weighing nearly two tons apiece would develop a significant trimming moment by the stern. However, the neutrally buoyant torpedoes are impulsed out of the tubes by water which fills the space left by the torpedoes. As a result, the submarine remains neutrally buoyant overall and develops no trimming moment after firing a salvo of torpedoes.

## 10.4 Submarine Intact Stability

As with the case of weight shifts, the absence of a waterplane and the stationary nature of B greatly simplifies the analysis of submerged submarine hydrodynamics.

Earlier figures indicated that the Center of Gravity (G) has to be below the Center of Buoyancy (B) for the submarine to be stable. Figure 10.10 illustrates this point.

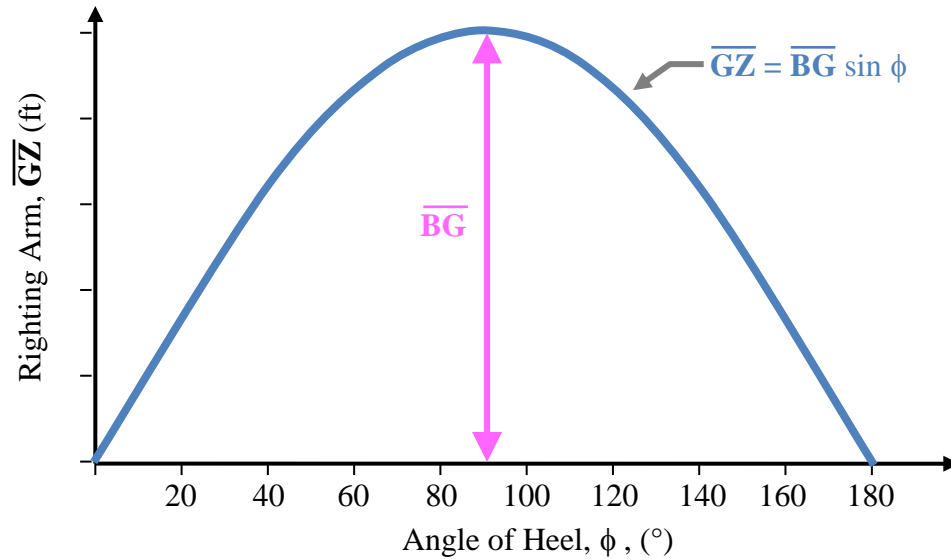


**Figure 10.10** Submarine Initial Stability

The level of stability is wholly dependent upon the distance between B and G (BG). Because this distance is constant, an analysis of the triangle BGZ reveals that the Righting Arm (GZ) is purely a function of the angle of heel.

$$\text{Righting Arm} = \overline{GZ} = \overline{BG} \sin \phi$$

This equation holds for all submerged submarines, in all conditions. Hence the curve of static intact stability will always be a sine curve with a peak value equal to BG. Figure 10.11 shows the curve for all submarines.



**Figure 10.11** Curve of Intact Statical Stability for Submerged Submarine

Stability characteristics will always be as follows.

- Range of Stability: The range of heeling angles through which a Righting Arm is maintained against the heeling motion.

$$\text{Range of stability} = 0 - 180^\circ$$

- Angle of Maximum Righting Arm: The angle of heel creating the maximum righting moment.

$$\text{Angle of } GZ_{\max} = 90^\circ$$

- Maximum Righting Arm: The size of the maximum righting arm.

$$GZ_{\max} = BG \cdot \sin(\phi) = BG \cdot \sin(90^\circ) = BG$$

- Dynamic Stability: The energy required to move the submarine slowly through all angles of heel until capsize

$$\begin{aligned} \text{Dynamic Stability} &= \Delta_S BG \int_0^{180} \sin(\phi) d\phi \\ &= 2\Delta_S BG \end{aligned}$$

## 10.5 Submarine Powering

Submarine powering suffers the same constraints inflicted on surface ships. However, submarines must also move through the water as quietly as possible to remain undetected.

### 10.5.1 Submarine Resistance

You will recall from Chapter 7 that the resistance of a surface ship is made up from a combination of three resistance forms. Submarines share the exact same equations as surface ships and with similar applications. The components of total resistance are written again below in both dimensional and non-dimensional terms:

$$R_T = R_V + R_W + R_{AA} \qquad C_T = C_V + C_W$$

where  $C_V$  = the viscous resistance of the hull, itself made up from factors associated with its skin resistance and its form.

$$C_V = (1 + K)C_F$$

$C_W$  = the wave making resistance of the hull. This element is caused from the energy the ship loses in making waves.

$R_{AA}$  = the ship's resistance in air (not applicable to a submerged submarine!)

Recall that as the surface ship speed changes, the resistance component that contributes most to the total resistance changes. At low speed, viscous resistance is the major factor. As speed increases, wave making becomes the dominant resistance component.

In the case of a surfaced submarine, this is no different. In fact, the effect is more pronounced. The surfaced submarine generates a very large bow wave and wavemaking resistance is a significant contributor to resistance even at slower speeds.

When the submarine submerges, the skin friction resistance will increase due to the greater wetted surface area. However, the wave making element disappears provided the submarine is deep enough to not cause surface interactions. Consequently, the modern submarine experiences less resistance when submerged than on the surface



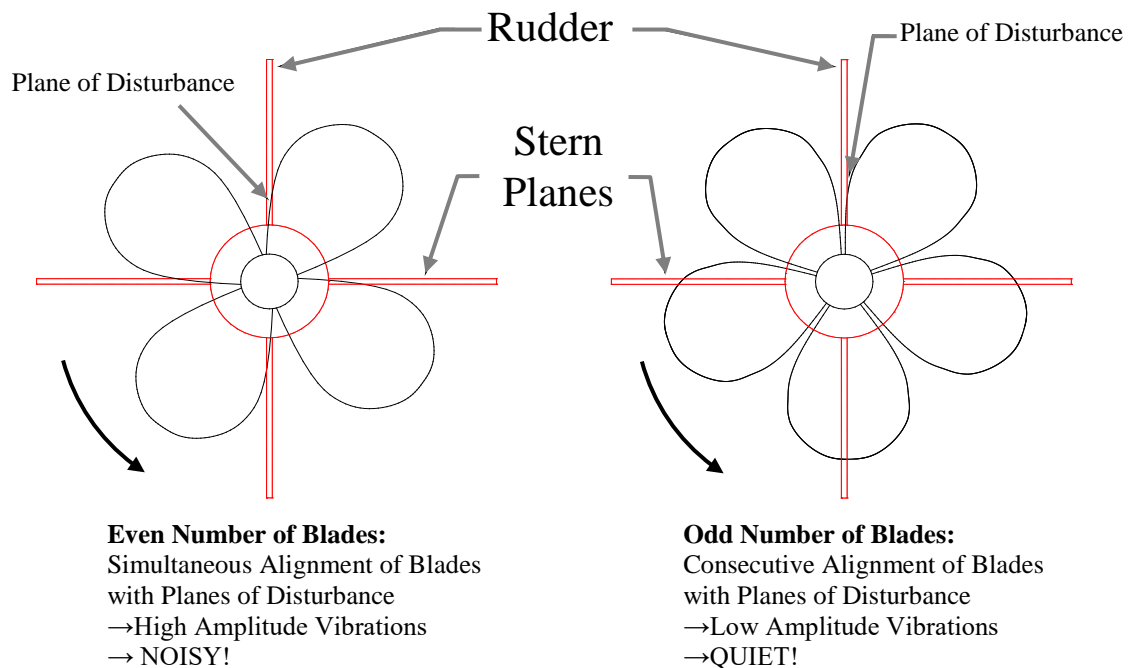
Modern submarines are capable of achieving submerged speeds more than two times greater than those achieved on the surface. A radical change in submarine design following World War II yielded the cigar-shaped, diesel-powered *USS Albacore*. Launched in 1953, this revolutionary submarine achieved submerged speeds in excess of 30 knots and laid the foundation for modern submarine hull design.

## 10.5.2 Submarine Propellers

Modern submarines use highly skewed propellers with an odd number of blades. The governing factors in submarine propeller design are cavitation and vibration, often at the expense of propeller efficiency.

### 10.5.2.1 Odd Blade Number

The number of blades is chosen to minimize vibration. An odd number of blades is used because there are an even number of appendages at the stern: a rudder at the top and bottom and stern planes both port and starboard. An odd number of blades guarantees that no two blades will be entering the disturbed flow behind the appendages at the same time. Therefore, the forces causing vibration will not reinforce each other. Figure 10.12 demonstrates this principle.



**Figure 10.12** Advantage of an Odd Number of Propeller Blades

### 10.5.2.2 Skewed Propeller

Skewing the propeller has several advantages.

- **Reduced Vibration.** The entire blade does not enter disturbed flow at the same time. In fact, the blade tip may be leaving as another part of the same blade is entering. The amount of the propeller subjected to a disturbance at any one time is reduced and therefore vibration is reduced.



- **Reduced Cavitation.** The shape is thought to produce a radial flow near the blade tips which sweeps cavitation sheets into the tip flow (vortices - or rotating flow). Here the cavitation bubbles collapse gradually reducing the noise level.

Unfortunately, highly skewed propellers have some disadvantages.

- Very inefficient for backing.
- Very difficult and expensive to manufacture.
- The unusual shape reduces the strength of the blades.

For the special considerations of submarine operation and the absolute need for stealth, the advantages of the highly skewed propeller outweigh the disadvantages.

## **10.6 Submarine Seakeeping**

You will recall from Chapter 8 that a surface ship will respond to any external forcing function. Of the six rigid body ship motions, heave, pitch and roll are simple harmonic motions because they experience a linear restoring force. If the encounter frequency matches the resonant frequency of heave, pitch, or roll, these motions will be maximized, particularly for roll which has a sharply tuned response characteristic for submarines (meaning it is lightly damped and is slow to cease its harmonic motion).

Because surface waves affect water velocities beneath the surface, a submerged submarine can experience the same motions as a surface ship. In fact, the motion of roll is often very pronounced due to the submarine's cylindrical shape.

### **10.6.1 Suction Force**

In addition to the usual surface ship motions, a submerged submarine running close to the surface is affected by suction forces caused by the water surface, waves and the shape of the hull.

#### **10.6.1.1 Water Surface Effect**

When a submarine is traveling near the surface, at periscope depth for instance, a low pressure is created on the top surface of the hull causing a net upward lifting force or suction force. The magnitude of the suction force depends upon speed, depth, and hull shape. A higher speed creates a bigger force. The closer the hull is to the surface, the greater the suction force. Large flat surfaces, like missile decks on SSBN's, create greater suction forces than round SSN hulls.

The effect can be minimized by traveling at very slow speeds while at periscope depth and trimming the submarine by the stern (since trimming by the bow would put the periscope under the water). This latter action places more of the hull farther away from the surface and changes the flow around the hull shape, thereby decreasing the magnitude of the suction force.

#### **10.6.1.2 Wave Action**

Wave action on the surface is also responsible for surface suction forces. Water particle velocity decreases with depth. Consequently, the top surface of the submarine experiences faster water velocity and lower pressure than the bottom surface.

The suction effect of surface waves may be minimized in two ways. First, and most obviously, the submarine can minimize or negate the effect of waves by diving deeper where waves do not exist. The submarine may also choose a heading angle relative to the direction of waves to minimize the suction effect. For example, a submarine traveling beam to the seas experiences greater rolling motions but minimizes the suction force. Unfortunately, this course would also present a less comfortable ride for the crew.

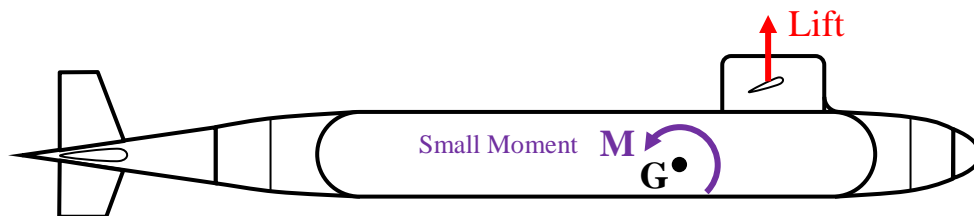
## 10.7 Submarine Maneuvering and Control

Just like a surface ship, a submarine controls its course with a rudder and its speed with the engines and screw propeller. However, the submarine has the added complication of controlling its depth.

Submarine depth control can be accomplished in many ways. Making the buoyant force equal the submarine displacement is the obvious technique and was discussed earlier in the chapter. However, a finer and more positive degree of control is often required. This is achieved by equipping the submarine with control surfaces. Submarines use a combination of stern planes, fairwater planes (on the sail), bow planes (on the hull), and sometimes, dihedrals to control depth.

### 10.7.1 Fairwater Planes

The fairwater planes are used primarily to maintain an ordered depth. Positioning the planes to the "up" position causes an upward lift force to be generated. Since the planes are located forward of the center of gravity, a small moment ( $M$ ) is also produced which causes the submarine to pitch up slightly. However, the dominant effect is the lift generated by the control surface. Figure 10.13 illustrates the effect.



**Figure 10.13** The Effect of the Fairwater Planes

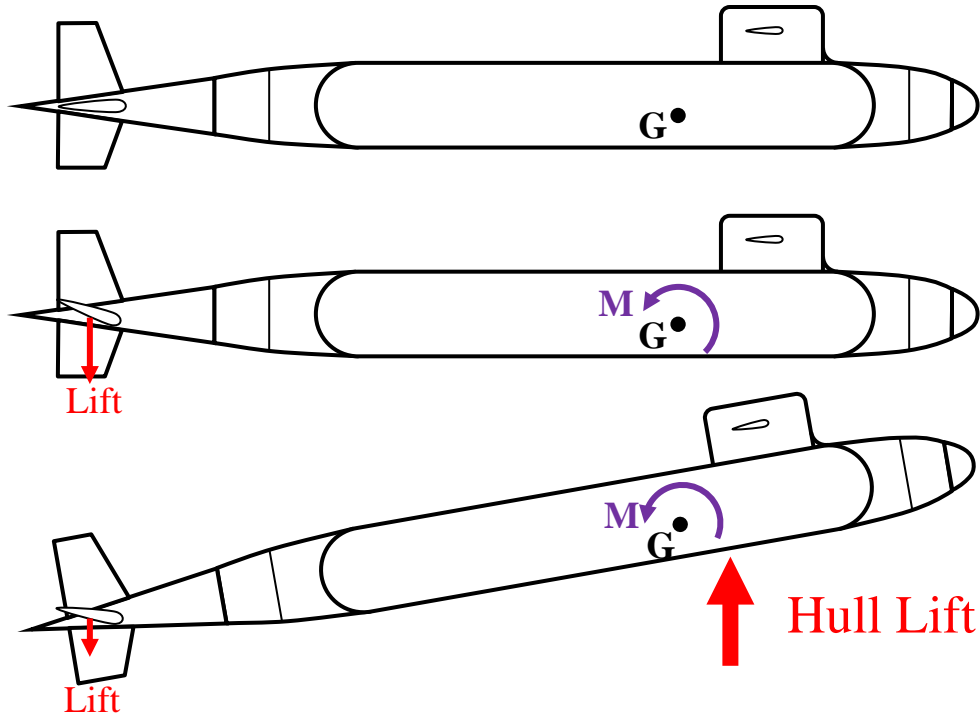
### 10.7.2 Bow Planes

Bow planes perform the same function and work by the same principles as the fairwater planes. As these planes tend to be located farther forward than fairwater planes they produce greater pitching moments and, accordingly, may be sized smaller than fairwater planes for the same ship maneuverability (thereby reducing hydrodynamic drag). Recent submarine designs feature retractable bow planes to enable the submarine to surface under ice.

### 10.7.3 Stern Planes

The stern planes have a much bigger effect on the pitch of the submarine because of their distance from the center of gravity. Positioning the planes as shown in Figure 10.14 creates a lift force in the downward direction. This creates a moment ( $M$ ) which causes the submarine to pitch up, much like the action of the surface ship's rudder discussed in Chapter 9. Once the submarine has an up angle, the hull produces an upward lift force. The net effect is that the submarine rises at an upward angle. Stern planes are often used

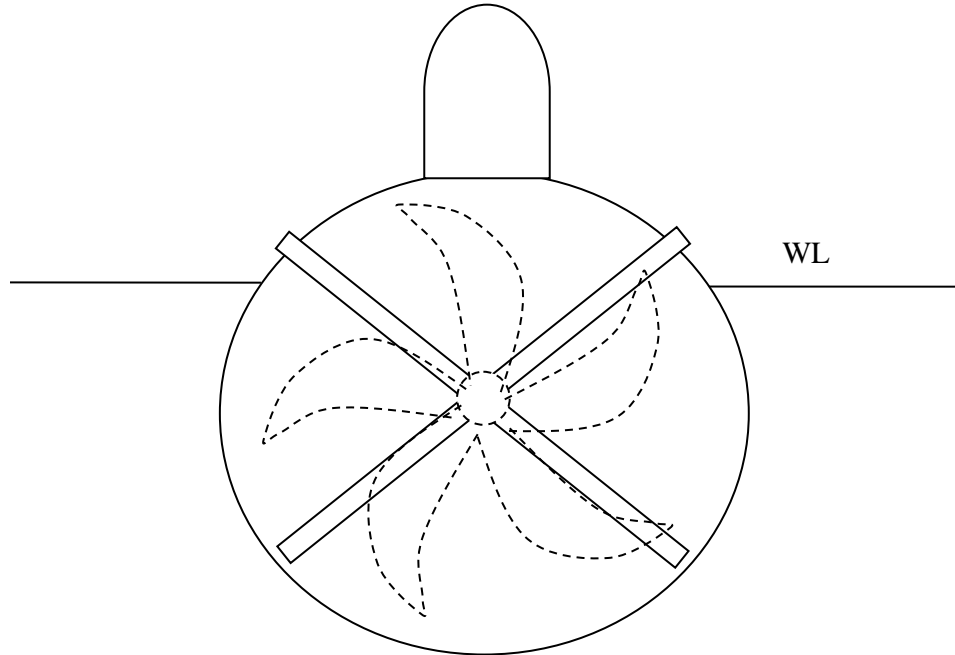
to correct a forward and aft trim problem until water can be moved between trim tanks. Additionally, stern planes are also the preferred method of depth control at higher speeds as the submarine “flies” through the water creating an angle of attack with between the hull and the water much like a plane flying through the air.



**Figure 10.14** The Effect of the Stern Planes

#### 10.7.4 X-Dihedrals

Some submarines employ an “X” configuration at the stern where the traditional “+” or cruciform shape of the rudder and stern planes are rotated 45 degrees. These four control surfaces at the stern are controlled by the operator through a control system which moves the planes to achieve the desired turning and/or trimming effect on the submarine. This unique stern configuration improves depth control and maneuvering and can eliminate the need for fairwater/bow planes. Because these control surfaces require a control system, they are difficult to control manually in the event of a casualty. Figure 10.15 illustrates this concept.



**Figure 10.15** X-Dihedral Stern Configuration

### **10.7.5 Snap Roll**

Submarines may experience a phenomenon during high speed turns which results in a large, undesired depth excursion – this is “snap roll”. Snap roll occurs when the submarine begins turning and develops a transverse velocity as it “slides” through the turn (think of advance and transfer). This transverse velocity component combines vectorially with the large forward velocity of the heeling submarine to create a lift force on the fairwater (and to a lesser extent, bow) planes which produces an even greater heeling moment on the ship. The large heeling angle, in turn, causes the rudder to act as a diving stern plane and may result in a significant depth excursion. This effect can be mitigated by limiting the rudder angle during high speed turns, thus limiting the diving plane effect of the rudder. In addition, the use of “X”-dihedrals may mitigate this effect.

## PROBLEMS - CHAPTER 10

### Section 10.2 Construction & Layout

1. Why are submarines constructed with a transverse framing system in preference to a longitudinal framing system?
2. What is “out of roundness?” What is the significance of this term in relation to submarine structures?
3. A deep-submergence research submarine is capable of operating at a depth of 2,375 feet. Calculate the hydrostatic pressure acting on the submarine’s hull at this depth. What factors would be involved in selecting a material for the submarine’s pressure hull?
4. Submarine pressure hulls are constructed out of high strength steel ( $\sigma_Y = 80,000$ - $100,000$  psi) or titanium alloys ( $\sigma_Y = 130,000$  psi). Why would pressure hulls be made out of such materials? Discuss your answer in terms of strength, ductility, temperature, and endurance.
5. What is the difference between hard tanks and soft tanks?
6. Draw a diagram showing the inner hull, outer hull, and main ballast tanks. Which of these must be able to withstand hydrostatic pressure when submerged?

### Section 10.3 Hydrostatics

7. Qualitatively describe the changes (if any) that occur to a surfaced submarine’s weight (displacement), displaced volume, and buoyant force as it transits from fresh water to salt water.
8. Qualitatively describe the changes (if any) that occur to a submerged submarine’s weight (displacement), displaced volume, and buoyant force as it moves from cold water to warm water.
9. How does increasing depth affect submarine buoyancy?
10. A SEAWOLF class submarine displaces 8,060 LT when surfaced, and also displaces 9,150 LT when submerged. What factors account for the weight change between the surfaced and submerged conditions?

11. A LOS ANGELES class submarine is neutrally buoyant at a displacement of 6,900 LT in salt water at a temperature of 45°F ( $\rho = 1.9933 \text{ lb-s}^2/\text{ft}^4$ ). The submarine transits into water that is one degree warmer ( $\rho = 1.9931 \text{ lb-s}^2/\text{ft}^4$ ). How many pounds of water must the Diving Officer add or remove from the depth control tank in order to maintain neutral buoyancy.
12. An OHIO class submarine has departed homeport enroute to its patrol area. The submarine is operating in the Gulf Stream ( $T = 70^\circ\text{F}$ ,  $\rho = 1.9876 \text{ lb-s}^2/\text{ft}^4$ ), and is neutrally buoyant at a displacement of 18,700 LT. The submarine exits the Gulf Stream and enters the colder water of the North Atlantic Ocean ( $T = 50^\circ\text{F}$ ,  $\rho = 1.9924 \text{ lb-s}^2/\text{ft}^4$ ). How many pounds of water must the Diving Officer add or remove from the depth control tank in order to maintain neutral buoyancy?
13. A submerged SSN-688 class submarine has been patrolling the arctic ice pack. While under the ice, the sub was neutrally buoyant at a displacement of 6,900 LT assuming water conditions of 70% salt water and 30% fresh water at a temperature of 30°F. The submarine is now transiting south into the North Atlantic where the ocean is 100% salt water at a temperature of 35°F. What action must the Diving Officer take to maintain neutral buoyancy?

$$\text{@ } 30^\circ\text{F} - \rho_{\text{fresh}} = 1.9399 \text{ lb-s}^2/\text{ft}^4$$

$$\text{@ } 35^\circ\text{F} - \rho_{\text{fresh}} = 1.9400 \text{ lb-s}^2/\text{ft}^4$$

$$\text{@ } 30^\circ\text{F} - \rho_{\text{salt}} = 1.9947 \text{ lb-s}^2/\text{ft}^4$$

$$\text{@ } 35^\circ\text{F} - \rho_{\text{salt}} = 1.9945 \text{ lb-s}^2/\text{ft}^4$$

14. A surfaced submarine's pressure hull is a right cylinder 30 feet in diameter and 300 feet in length. When at depth, the hydrostatic force compresses the hull's length by one inch. Neglecting any changes in diameter due to hydrostatic forces, calculate the change in buoyancy due to compression of the hull.
15. A submerged submarine is neutrally buoyant at a displacement of 6850 LT and is at zero trim;  $KB = 16.5 \text{ ft}$  and  $KG = 13.5 \text{ ft}$ . To enter its assigned patrol area, the submarine must pass through a choke point that may be mined. In order to detect possible mines with its sonar, the submarine's CO directs the Diving Officer to trim the sub 4 degrees down by the bow. If the sub's trim tanks are located 320 feet apart, how many pounds of water must be transferred between trim tanks to achieve the desired trim angle? How do the locations of the centers of buoyancy and gravity change once the sub has been trimmed?

16. A SEAWOLF class submarine is operating at neutral buoyancy and zero trim at a displacement of 9,100 LT;  $KB = 20$  ft and  $KG = 16.5$  ft. In preparation for an exercise, the crew loads 8 Mk48 torpedoes (3,434 lb each) into the tubes. To load the tubes, each torpedo is moved forward a distance of 30 feet.
- What is the effect of loading torpedoes on the submarine's LCG?
  - Calculate the trim angle that results from loading torpedoes.
  - Using an appropriate diagram, show the relationship between LCB and LCG before and after loading torpedoes.
  - If the submarine's trim tanks are located 310 feet apart, how many pounds of water must be transferred to restore the sub to level trim?
  - If  $KG$  increases, how does this affect the submarine's tendency to trim?
17. A submerged submarine has a trim angle of 2 degrees up. It is desired to pump water between the forward and aft trim tanks to correct the trim to zero degrees. The sub is neutrally buoyant at 7,500 LT,  $KG = 13.5$  ft and  $KB = 15.7$  ft. The trim tanks are 300 feet apart.
- Should water be pumped from the aft trim tank to the forward trim tank, or from the forward trim tank to the aft trim tank?
  - What is the effect of pumping water in the direction you chose in part (a) on the submarine's LCG?
  - What is the relationship between LCB and LCG in the initial condition? Final condition? Use a diagram to show this relationship.
  - How many pounds of water must be pumped to achieve zero trim?



## Section 10.4 Stability

18. A submerged submarine has a  $KB = 14.5$  ft and  $KG = 13$  ft. Its displacement is 6,500 LT.
  - a. Write the equation for the curve of intact statical stability.
  - b. Compute the submarine's maximum righting moment.
  - c. At what heeling angle does the maximum righting arm occur?
  - d. What is the range of stability?
  - e. Using integral calculus, compute the submarine's dynamic stability.
  - f. Repeat all of the above for  $KG = 14$  ft. Compare your results.

## Sections 10.5-10.7 Powering, Seakeeping & Control

19. A surfaced submarine traveling at full power can achieve a speed of 15 knots, yet when submerged at a depth of 400 ft can achieve 25 knots at full power. What accounts for the difference in speeds?
20. Why do submarines use an odd number of blades on their propellers?
21. Name two advantages and two disadvantages of skewed propellers for submarines.
22. Describe two sources of surface suction.
23. Draw a profile of a submarine showing the rudder, fairwater planes, and stern planes. What are each of these control surfaces used for?
24. What is snap roll?

# Appendices

## APPENDIX A

### TABLE of FRESH and SALT WATER DENSITY

(reprinted from 'Introduction to Naval Architecture' by Gillmer and Johnson, U.S. Naval Institute, 1982)

#### Values of Mass Density $\rho$ for Fresh and Salt Water

Values adopted by the ITTC meeting in London, 1963.

Salinity of salt water 3.5 percent.

Density of fresh water $\rho$ , lb-sec <sup>2</sup> /ft <sup>4</sup> (= slugs/ ft <sup>3</sup> )	Temp, deg F	Density of salt water $\rho_s$ , lb-sec <sup>2</sup> /ft <sup>4</sup>	Density of fresh water $\rho$ , lb-sec <sup>2</sup> /ft <sup>4</sup>	Temp, deg F	Density of salt water $\rho_s$ , lb-sec <sup>2</sup> /ft <sup>4</sup>
1.9399	32	1.9947	1.9384	59	1.9905
1.9399	33	1.9946	1.9383	60	1.9903
1.9400	34	1.9946	1.9381	61	1.9901
1.9400	35	1.9945	1.9379	62	1.9898
1.9401	36	1.9944	1.9377	63	1.9895
1.9401	37	1.9943	1.9375	64	1.9893
1.9401	38	1.9942	1.9373	65	1.9890
1.9401	39	1.9941	1.9371	66	1.9888
1.9401	40	1.9940	1.9369	67	1.9885
1.9401	41	1.9939	1.9367	68	1.9882
1.9401	42	1.9937	1.9365	69	1.9879
1.9401	43	1.9936	1.9362	70	1.9876
1.9400	44	1.9934	1.9360	71	1.9873
1.9400	45	1.9933	1.9358	72	1.9870
1.9399	46	1.9931	1.9355	73	1.9867
1.9398	47	1.9930	1.9352	74	1.9864
1.9398	48	1.9928	1.9350	75	1.9861
1.9397	49	1.9926	1.9347	76	1.9858
1.9396	50	1.9924	1.9344	77	1.9854
1.9395	51	1.9923	1.9342	78	1.9851
1.9394	52	1.9921	1.9339	79	1.9848
1.9393	53	1.9919	1.9336	80	1.9844
1.9392	54	1.9917	1.9333	81	1.9841
1.9390	55	1.9914	1.9330	82	1.9837
1.9389	56	1.9912	1.9327	83	1.9834
1.9387	57	1.9910	1.9324	84	1.9830
1.9386	58	1.9908	1.9321	85	1.9827
			1.9317	86	1.9823

NOTE: For other salinities, interpolate linearly.

## APPENDIX B

### TABLE of FRESH and SALT WATER KINEMATIC VISCOSITY

(reprinted from 'Introduction to Naval Architecture' by Gillmer and Johnson, U.S. Naval Institute, 1982)

#### Values of Kinematic Viscosity $\nu$ for Fresh and Salt Water

Values adopted by the ITTC meeting in London, 1963.  
Salinity of salt water 3.5 percent.

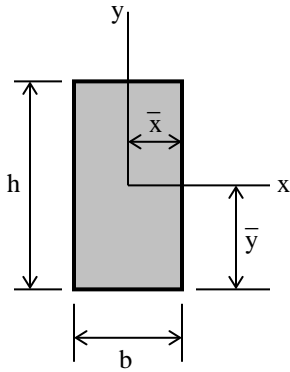
Kinematic viscosity of fresh water	Temp, deg F	Kinematic viscosity of salt water	Kinematic viscosity of fresh water	Temp, deg F	Kinematic viscosity of salt water
$\nu, \frac{\text{ft}^2}{\text{sec}} \times 10^5$	F	$\nu, \frac{\text{ft}^2}{\text{sec}} \times 10^5$	$\nu, \frac{\text{ft}^2}{\text{sec}} \times 10^5$	F	$\nu, \frac{\text{ft}^2}{\text{sec}} \times 10^5$
1.9231	32	1.9681	1.2260	59	1.2791
1.8871	33	1.9323	1.2083	60	1.2615
1.8520	34	1.8974	1.1910	61	1.2443
1.8180	35	1.8637	1.1741	62	1.2275
1.7849	36	1.8309	1.1576	63	1.2111
1.7527	37	1.7991	1.1415	64	1.1951
1.7215	38	1.7682	1.1257	65	1.1794
1.6911	39	1.7382	1.1103	66	1.1640
1.6616	40	1.7091	1.0952	67	1.1489
1.6329	41	1.6807	1.0804	68	1.1342
1.6049	42	1.6532	1.0660	69	1.1198
1.5777	43	1.6263	1.0519	70	1.1057
1.5512	44	1.6002	1.0381	71	1.0918
1.5254	45	1.5748	1.0245	72	1.0783
1.5003	46	1.5501	1.0113	73	1.0650
1.4759	47	1.5259	0.9984	74	1.0520
1.4520	48	1.5024	0.9857	75	1.0392
1.4288	49	1.4796	0.9733	76	1.0267
1.4062	50	1.4572	0.9611	77	1.0145
1.3841	51	1.4354	0.9492	78	1.0025
1.3626	52	1.4142	0.9375	79	1.9907
1.3416	53	1.3935	0.9261	80	0.9791
1.3212	54	1.3732	0.9149	81	0.9678
1.3012	55	1.3535	0.9039	82	0.9567
1.2817	56	1.3343	0.8931	83	0.9457
1.2627	57	1.3154	0.8826	84	0.9350
1.2441	58	1.2970	0.8722	85	0.9245
			0.8621	86	0.9142

NOTE: For other salinities, interpolate linearly.

## APPENDIX C

### PROPERTIES of COMMON GEOMETRIC SHAPES

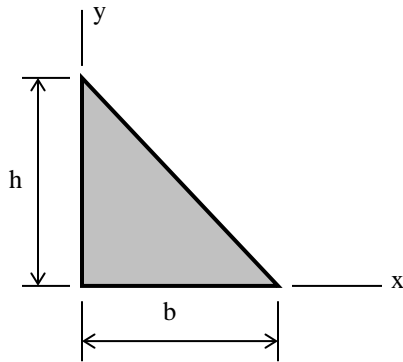
**Rectangle** (origin of axes at centroid)



$$A = bh \quad \bar{x} = \frac{b}{2} \quad \bar{y} = \frac{h}{2}$$

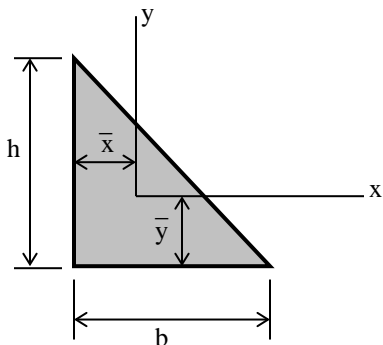
$$I_x = \frac{bh^3}{12} \quad I_y = \frac{hb^3}{12}$$

**Right Triangle** (origin of axes at vertex)



$$A = \frac{bh}{2} \quad I_x = \frac{bh^3}{12} \quad I_y = \frac{hb^3}{12}$$

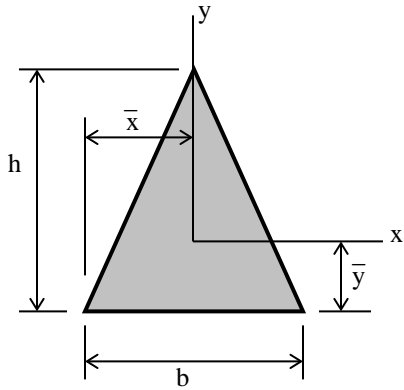
**Right Triangle** (origin of axes at centroid)



$$\bar{x} = \frac{b}{3} \quad \bar{y} = \frac{h}{3}$$

$$I_x = \frac{bh^3}{36} \quad I_y = \frac{hb^3}{36}$$

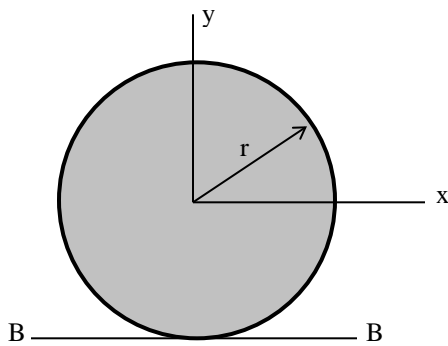
**Isosceles Triangle** (origin of axes at centroid)



$$A = \frac{bh}{2} \quad \bar{x} = \frac{b}{2} \quad \bar{y} = \frac{h}{3}$$

$$I_x = \frac{bh^3}{36} \quad I_y = \frac{hb^3}{48}$$

**Circle** (origin of axes at center)



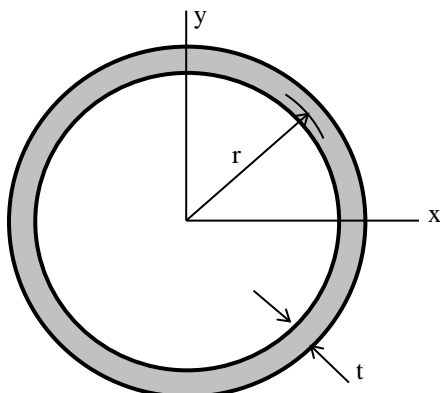
$$d = 2r \quad A = \pi r^2 = \frac{\pi d^2}{4}$$

$$I_x = I_y = \frac{\pi r^4}{4} = \frac{\pi d^4}{64}$$

$$I_{BB} = \frac{5\pi r^4}{4} = \frac{5\pi d^4}{64}$$

**Circular Ring with thickness “t”** (origin of axes at center)

Approximate formulas for the case when *t* is small



$$A = 2\pi r t = \pi d t$$

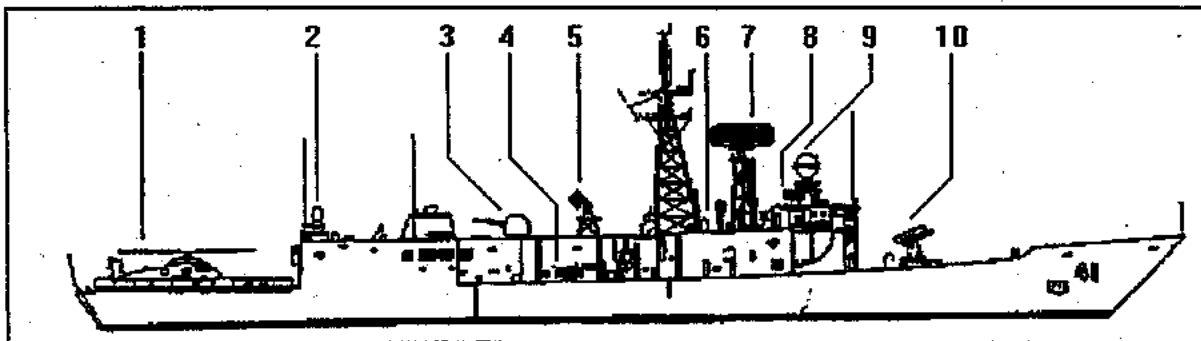
$$I_x = I_y = \pi r^3 t = \frac{\pi d^3 t}{8}$$

# Ship Data

# FFG-7: OLIVER HAZARD PERRY CLASS

<b>DISP:</b>	2,769 tons light except 3,210 tons for ships with LAMP III modification 3,658 tons full except 3,900-4,100 tons for ships with LAMPS III modification	<b>MISSILES:</b>	Mk 13 launcher for SM-1(MR)/Harpoon SSM
<b>LENGTH:</b>	413 ft waterline 445 ft overall except 455 ft for ships with LAMPS III modification	<b>GUNS:</b>	76 mm/62 cal Mk 75 20 mm Phalanx CIWS
<b>BEAM:</b>	45 ft	<b>ASW WEAPONS:</b>	6 torpedo tube Mk 32
<b>DRAFT:</b>	22 ft	<b>RADARS:</b>	SPS-49(V) 4 air search SPS-55 surface search
<b>PROPULSION:</b>	(2) gas turbines (General Electric LM 2500); 40,000 shp; 1 shaft	<b>SONAR:</b>	SQS-56 keel mounted SQR-19 TACTAS towed array
<b>SPEED:</b>	29 kts	<b>FIRE CONTROL:</b>	Mk 13 weapons direction system Mk 92 FCS STIR radar
<b>RANGE:</b>	4,200 nmi at 20 kts		SQQ-89(V)2 ASW system SYS-2(V)2 Integrated Automatic Detection and Tracking in FFG 50 and 61
<b>MANNING:</b>	214 (16 officers + 198 enlisted)	<b>EW SYSTEMS:</b>	SLQ-25 Nixie SLQ-32(V)2 except SLQ-32(V)5 with sidekick in FFG 30 and 53.
<b>HELICOPTER:</b>	(2) SH-60B LAMPS III in FFG 8, 36-61 SH-2F LAMPS I in FFG-7, 9-35		

FFG-7: 1. helicopter deck 2. 20 mm Phalanx CIWS 3. 76mm single gun mount 4. Mk 32 torpedo tubes 5. STIR fire control radar 6. SRBOC chaff launcher 7. SPS-49(V)2 air search radar 8. SLQ-32(V)2 ECM antenna 9. Mk 92 fire control radar 10. Mk 13 missile launcher.



Note: The U.S. Navy removed STIR fire control radar (#5) and Mk 13 missile launcher (#10) in a ship modification program.



**HYDROSTATIC PROPERTIES at LEVEL TRIM**

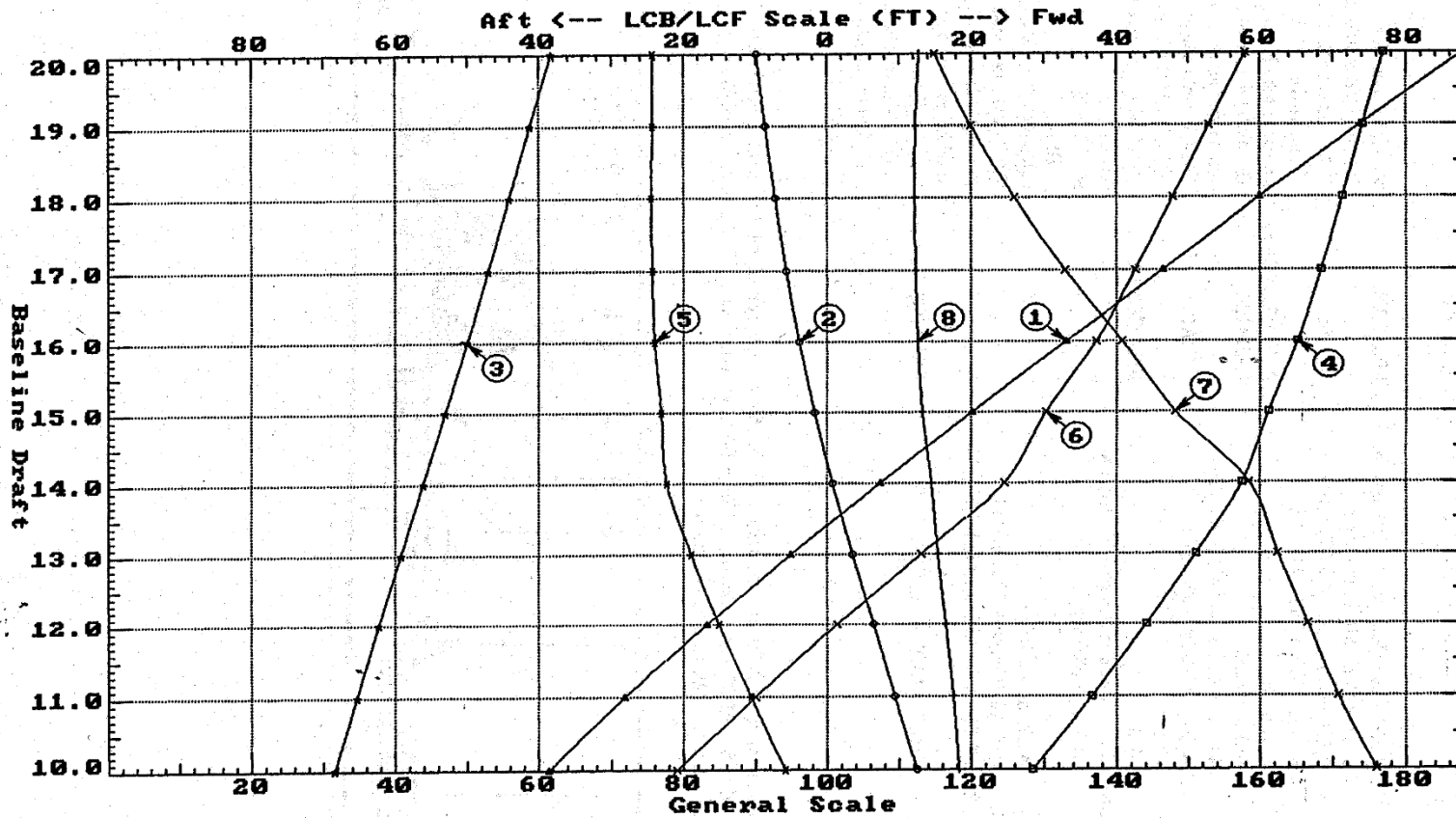


FIG 7

- |                        |                         |                            |
|------------------------|-------------------------|----------------------------|
| ① Displacement 1=30 LT | ④ Immersion 1=0.2 LT/IN | ⑥ Mom/Trim 1=5.78 FT-LT/In |
| ② LCB (use top scale)  | ④ WPA 1=84 Sq.FT        | ⑦ KML 1=7 FT               |
| ③ UCB (KB) 1=0.2 FT    | ⑤ LCF (use top scale)   | ⑧ KMT 1=0.2 FT             |

Specific Gravity = 1.025    Assumed KG = 0.00 FT  
"K" = Base\_Plane

**CROSS CURVES OF STABILITY - Stbd Heel  
at LEVEL TRIM (initial)**

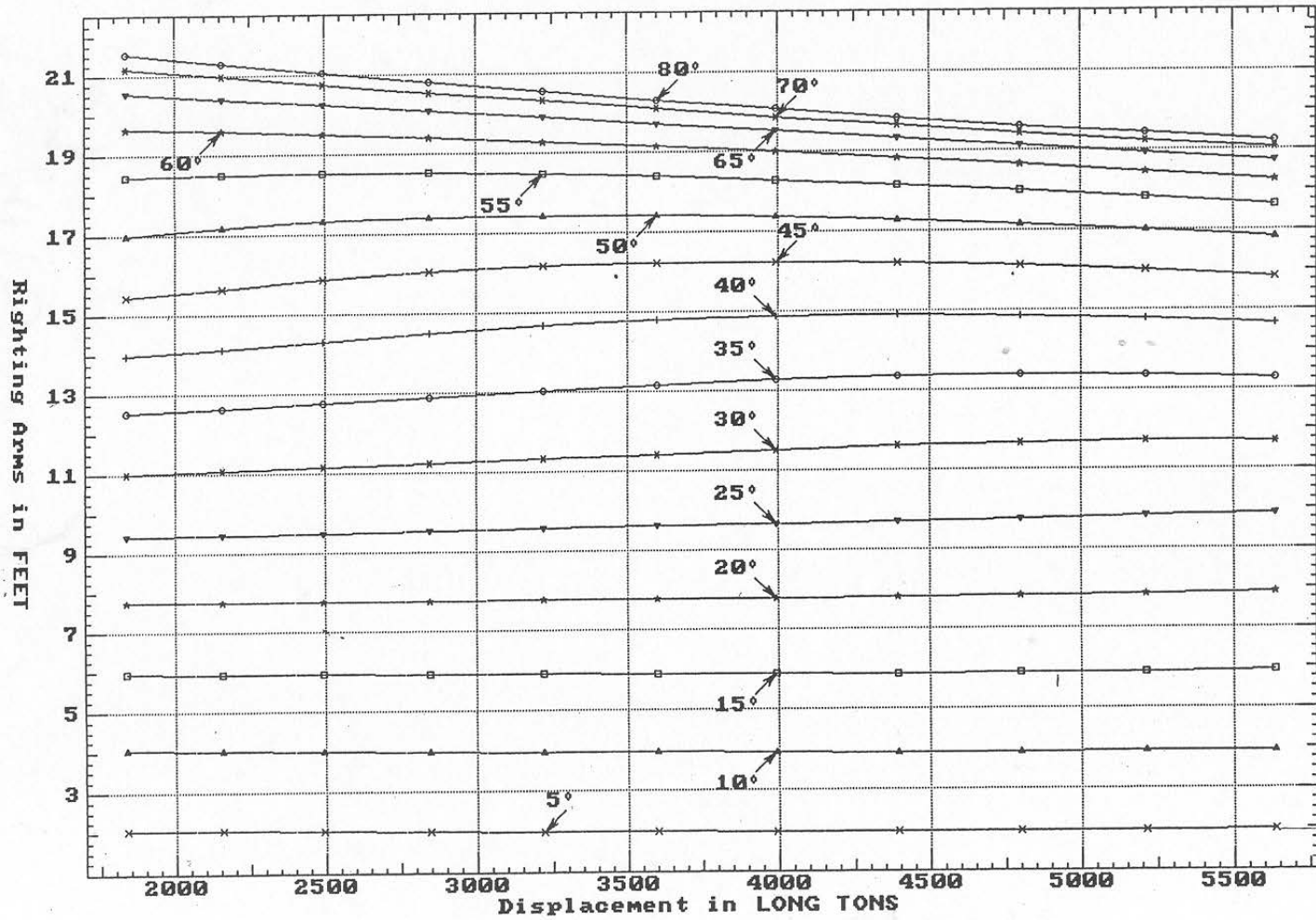


FIG 7

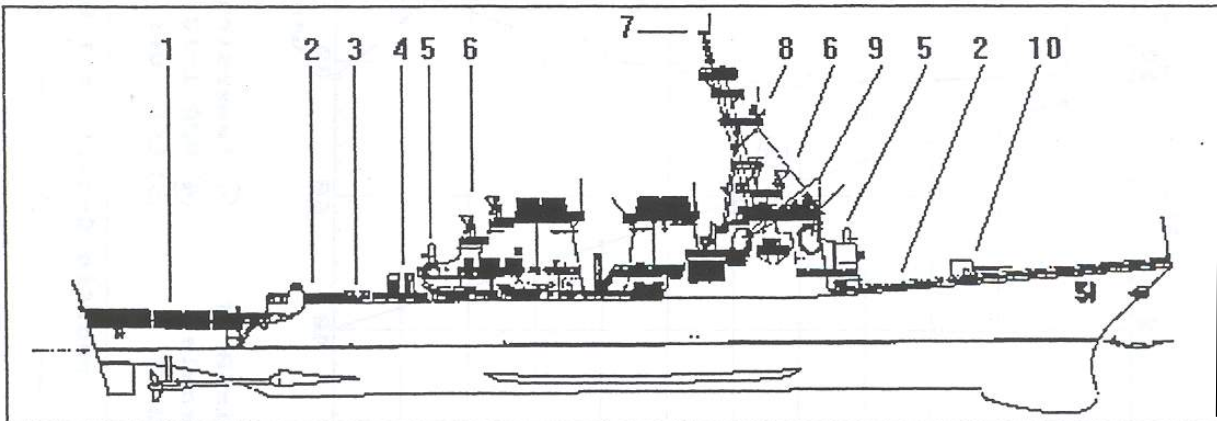
Specific Gravity = 1.025    Assumed KG = 0.00 FT  
"K" = Base Plane

# DDG-51: ARLEIGH BURKE CLASS

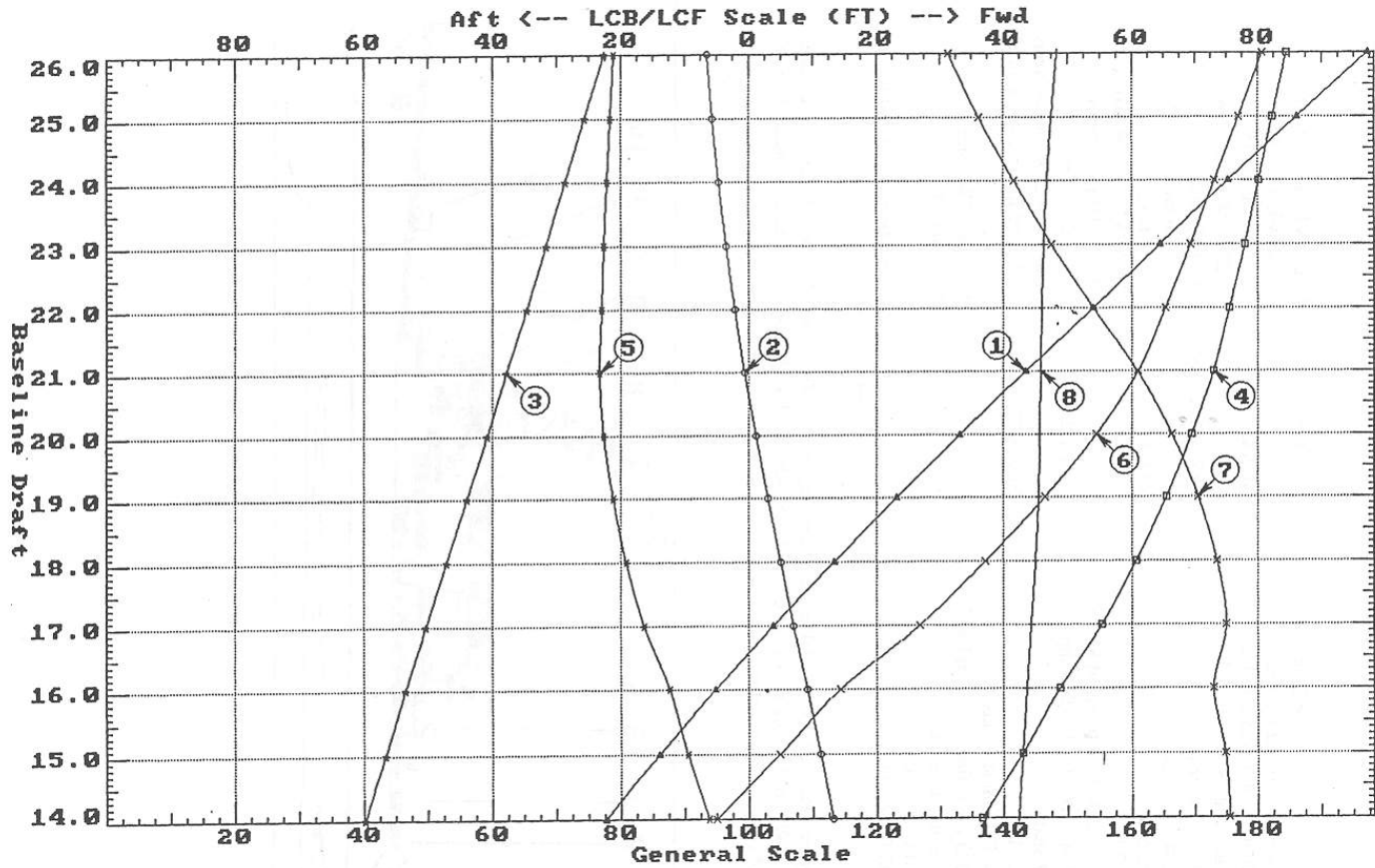
DISP:	DDG 51 6,624 tons light later units 6,682 ton light DDG 51 8,315 tons full load later units 8,373 tons full load	MISSILES:	90 cell VLS for SM-2(MR)/ Tomahawk/VLA ASROC
LENGTH:	465 ft waterline 504 ft overall	GUNS:	5-inch 54 cal Mk45 (2) 20mm Phalanx CIWS
BEAM:	66.5 ft	ASW WEAPONS:	VLA(ASROC)* 6 torpedo tubes Mk 32
DRAFT:	30 ft	RADARS:	SPS-64 navigation SPS-67(V)3 surface search (4) SPY-1D multi-function
PROPULSION:	(4) gas turbine (General Electric LM-2500-30); 100,000 shp; 2 shafts	SONARS:	SQS-53C bow mounted SQR-19 TACTAS towed array
SPEED:	31 kts	FIRE CONTROL:	(3) Mk 99 illuminators with SPG- 62 radar Mk 116 ASW control system Mk 160 GFCS
RANGE:	4,400 nmi at 20 kts		
MANNING:	325 (23 officer + 302 enlisted)		
HELICOPTER:	landing deck only		
EW SYSTEMS:	SLQ-25 Nixie SLQ-32(V)2		

\*note: VLA ASROC has not been introduced into the fleet.

**DDG-51:** 1. helicopter deck 2. Mk41 Mod 0 vertical launch system 3. Mk 32 torpedo tubes 4. Harpoon canisters 5. 20 mm Phalanx CIWS 6. SPG-62 radars 7. URN-25 TACAN 8. SPS-67 radar (above SPS-64 radar) 9. SPY-1 radar 10. 5 inch/54 cal single gun mount .



**HYDROSTATIC PROPERTIES at LEVEL TRIM**

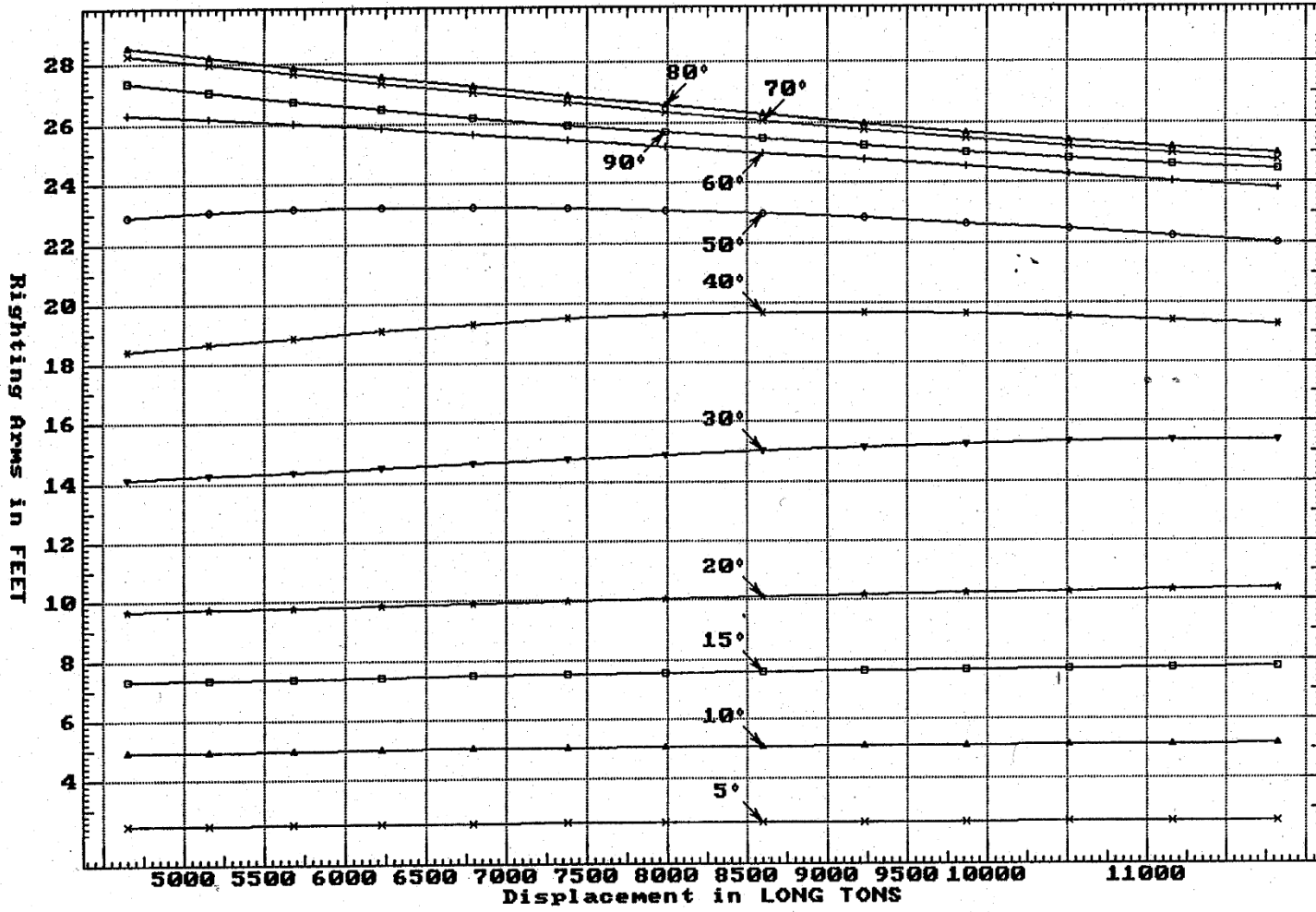


DDG51

- |                        |                         |                            |
|------------------------|-------------------------|----------------------------|
| ① Displacement 1=60 LT | ④ Immersion 1=0.3 LT/IN | ⑥ Mom/Trim 1=9.24 FT-LT/In |
| ② LCB (use top scale)  | ④ WPA 1=126 Sq. FT      | ⑦ KML 1=6 FT               |
| ③ UCB (KB) 1=0.2 FT    | ⑤ LCF (use top scale)   | ⑧ KMT 1=0.2 FT             |

Specific Gravity = 1.025    Assumed KG = 0.00 FT  
 "K" = Baseline

**CROSS CURVES OF STABILITY - Stbd Heel  
at LEVEL TRIM (initial)**



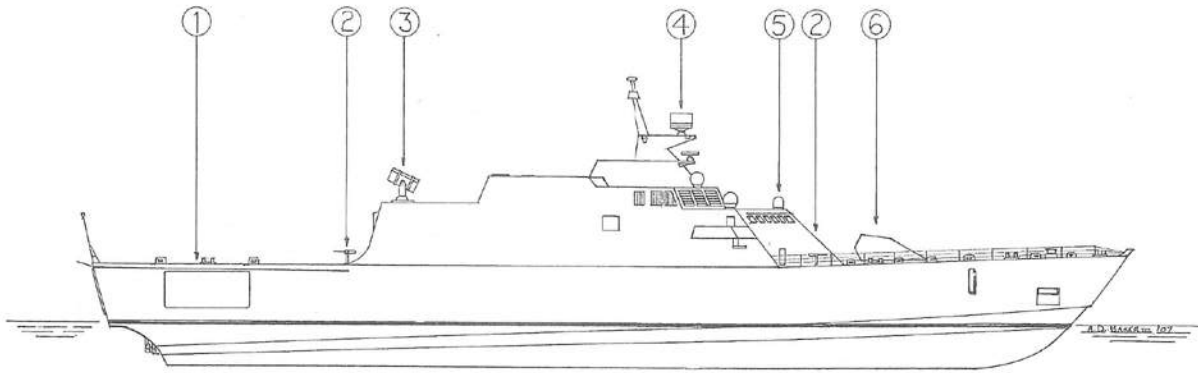
DDG51

Specific Gravity = 1.025    Assumed KG = 0.00 FT  
"K" = Baseline

Note: Hydrostatic and Stability curves provided only for LCS-1 FREEDOM class

## LCS-1: FREEDOM CLASS (monohull by Lockheed Martin)

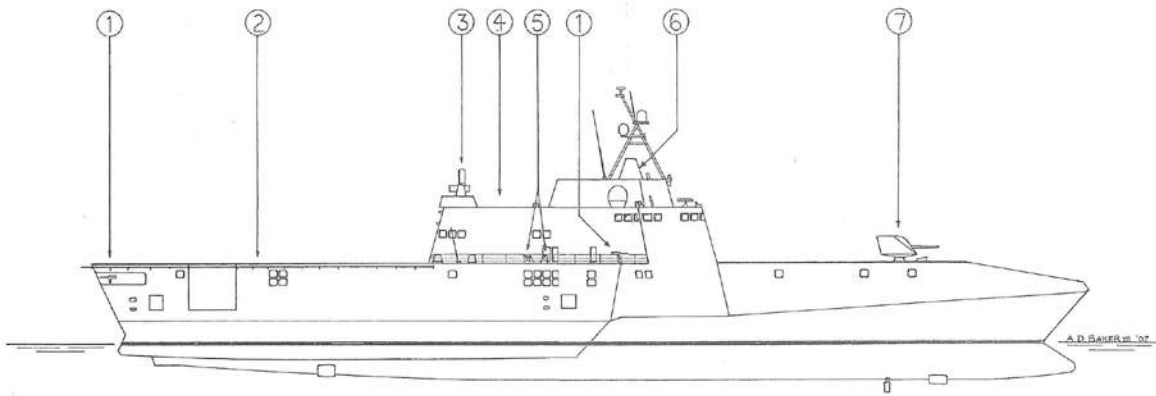
Displacement:	2,135 tons light 2,862 tons full load	Helicopters:	2 MH-60R/S Seahawk or 1 MH-60R/S Seahawk + 3 MQ-8B Fire Scout vertical-takeoff UAV
Length:	324 feet (98.79 m) waterline 378 feet (115.24 m) overall	Missiles:	1 21-cell RAM missile launcher Mark 49
Beam:	57 feet (17.38 m)	Guns:	1 57-mm/70-cal Bofors DP Mark 110 4 12.7-mm machine guns M240B (4 single) (see <i>Guns</i> note)
Draft:	14 feet (4.27 m)	Radars:	1 air/surface search (EADS TRS-3D) 1 navigation (Sperry Bridgemaster) 1 fire control (FABA)
Propulsion:	2 gas turbines (Rolls-Royce MT30); 48,280 hp; 2 diesels (Fairbanks-Morse/Colt-Pielstick 16PA6B); 17,370 hp; 4 waterjets	Sonars:	none
Speed:	40+ knots	Fire control:	COMBATSS-21
Range:	3,550 n.miles (6,580 km) at 18 knots 1,150 n.miles (2,130 km) at 45 knots	EW systems:	
Personnel:	approx. 40 (8 officers + 32 enlisted) + mission module and aviation detachments		



USS FREEDOM: (1) helicopter and UAV deck—above mission module space; (2) 7.62-mm machine guns M240B (port and starboard); (3) RAM 21-round launcher Mark 49; (4) TRS-3D 3-D surface/air search radar; (5) gunfire control director; (6) 57-mm/70-cal gun Mark 110.  
(© A. D. Baker III)

## LCS-2: INDEPENDENCE CLASS (trimaran by General Dynamics)

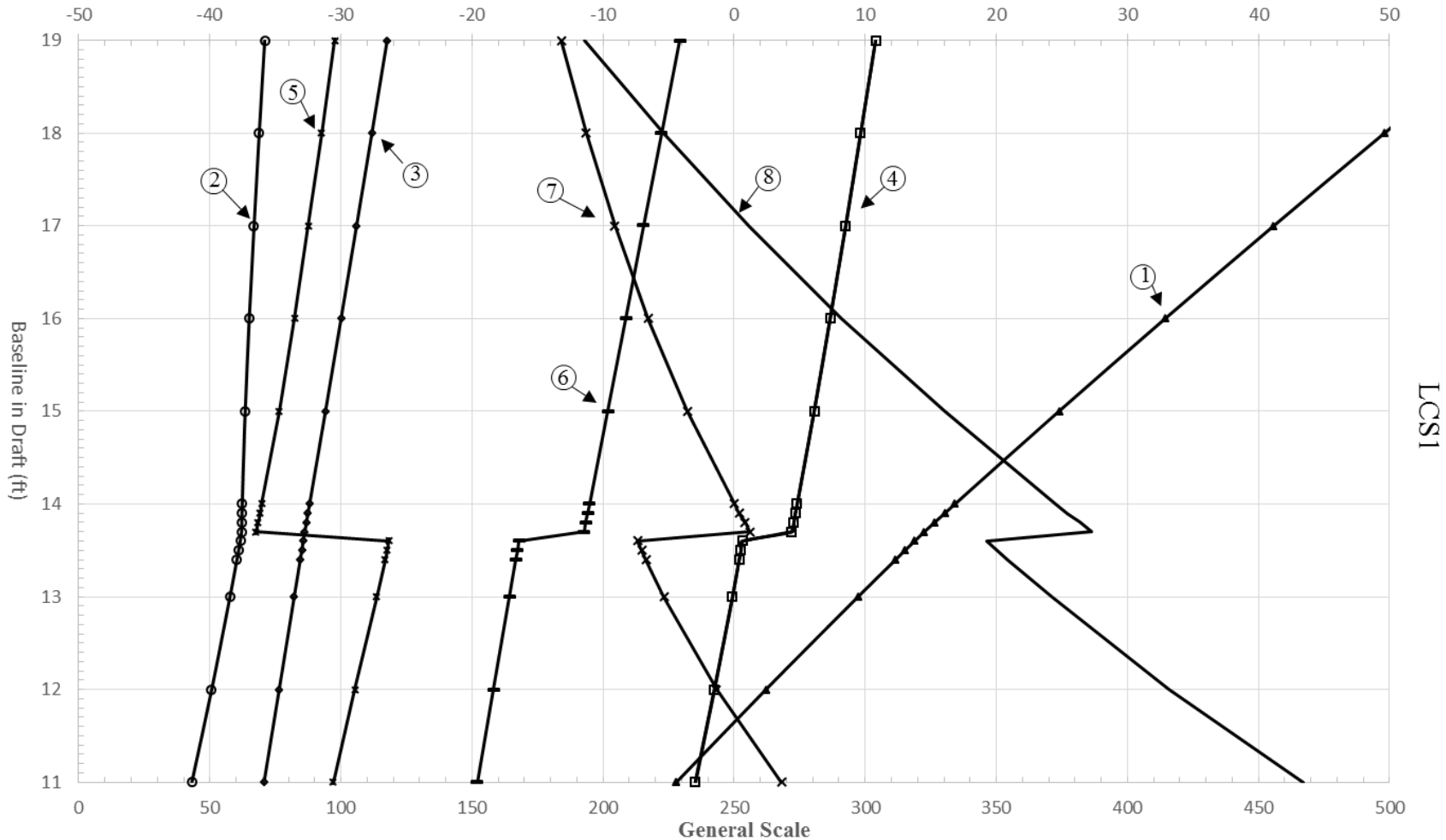
Displacement:	2,176 tons light 2,784 tons full load	Helicopters:	2 MH-60R/S Seahawk or 1 MH-60R/S Seahawk + 3 MQ-8B Fire Scout vertical-takeoff UAV
Length:	418 feet (127.44 m) overall	Missiles:	1 11-cell SeaRAM missile launcher Mark 15
Beam:	104 feet (31.71 m)	Guns:	1 57-mm/70-cal Bofors DP Mark 110 1 20-mm Phalanx CIWS Mark 15 (multi-barrel) (comounted in SeaRAM installation) 4 12.7-mm machine guns M240B (4 single)
Draft:	13 feet (3.96 m)	Radars:	1 surface/air search (Ericson Sea Giraffe 3D) 1 navigation (Sperry Bridgemaster-E)
Propulsion:	2 gas turbines (General Electric LM2500); 59,000 hp; 2 diesel engines (MTU 20V800), 4 waterjets	Sonars:	none
Speed:	40+ knots	Fire control:	integrated combat management system
Range:	4,300 n.miles (7,970 km) at 20 knots 1,840 n.miles (3,410 km) at 46 knots	EW systems:	
Personnel:	approx. 40 (8 officers + 32 enlisted) + mission module and aviation detachments		



USS INDEPENDENCE: (1) 12.7-mm machine guns M240B; (2) helicopter and UAV deck—above mission module space; (3) SeaRAM CIWS; (4) helicopter and UAV hangar; (5) decoy launchers (port and starboard); (6) Sea Giraffe radar antenna; (7) 57-mm/70-cal gun Mark 110.  
(© A. D. Baker III)

# HYDROSTATIC PROPERTIES AT LEVEL TRIM

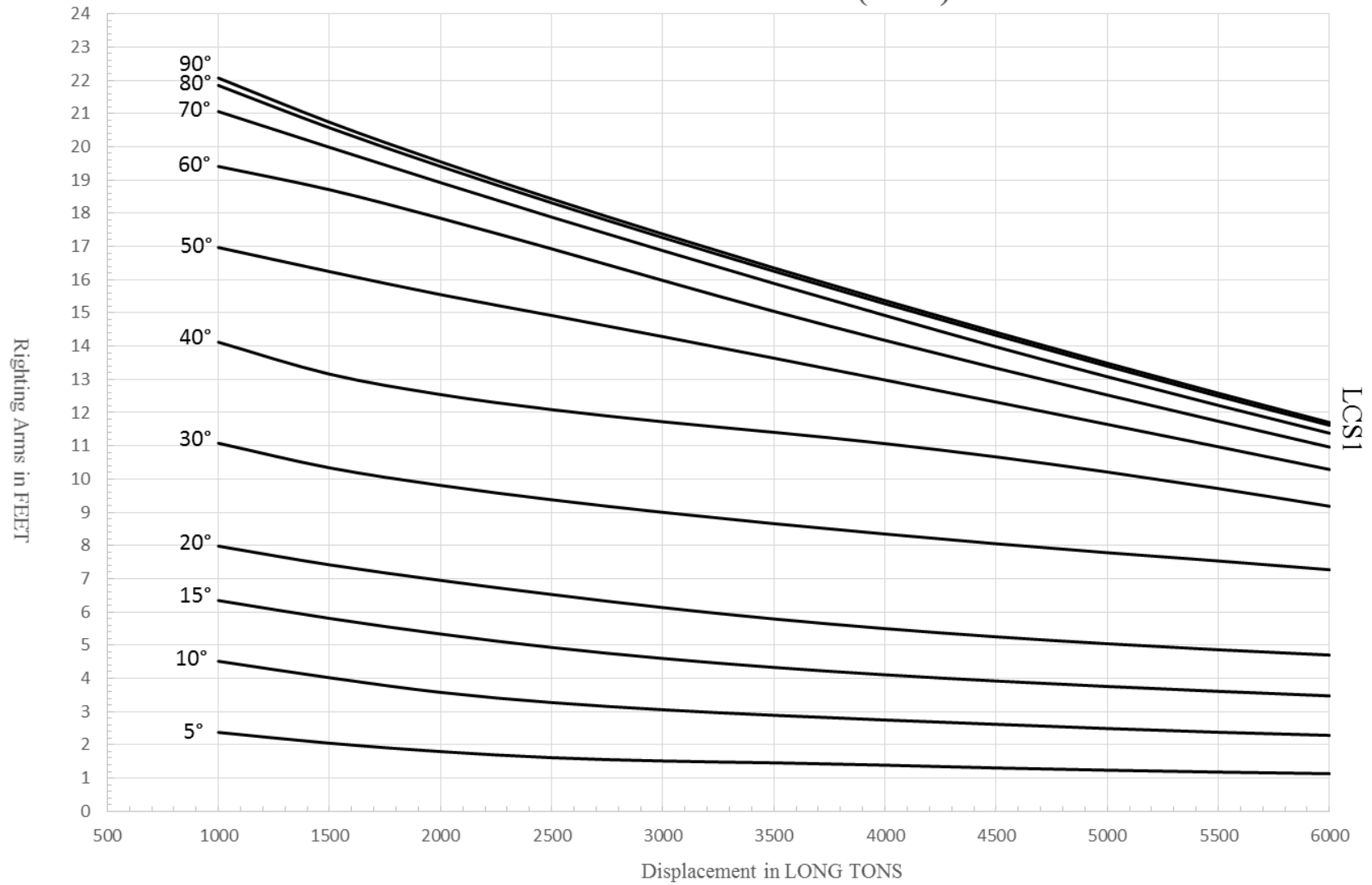
Aft <-- LCB/LCF (FT) --> Fwd



Specific Gravity = 1.025    Assumed KG = 0.00 ft    "K" = Baseline  
 Midship is specified as 170 ft fwd of the intesection of the BL and the Waterjet Transom



### CROSS CURVES OF STABILITY - Stbd Heel at LEVEL TRIM (initial)

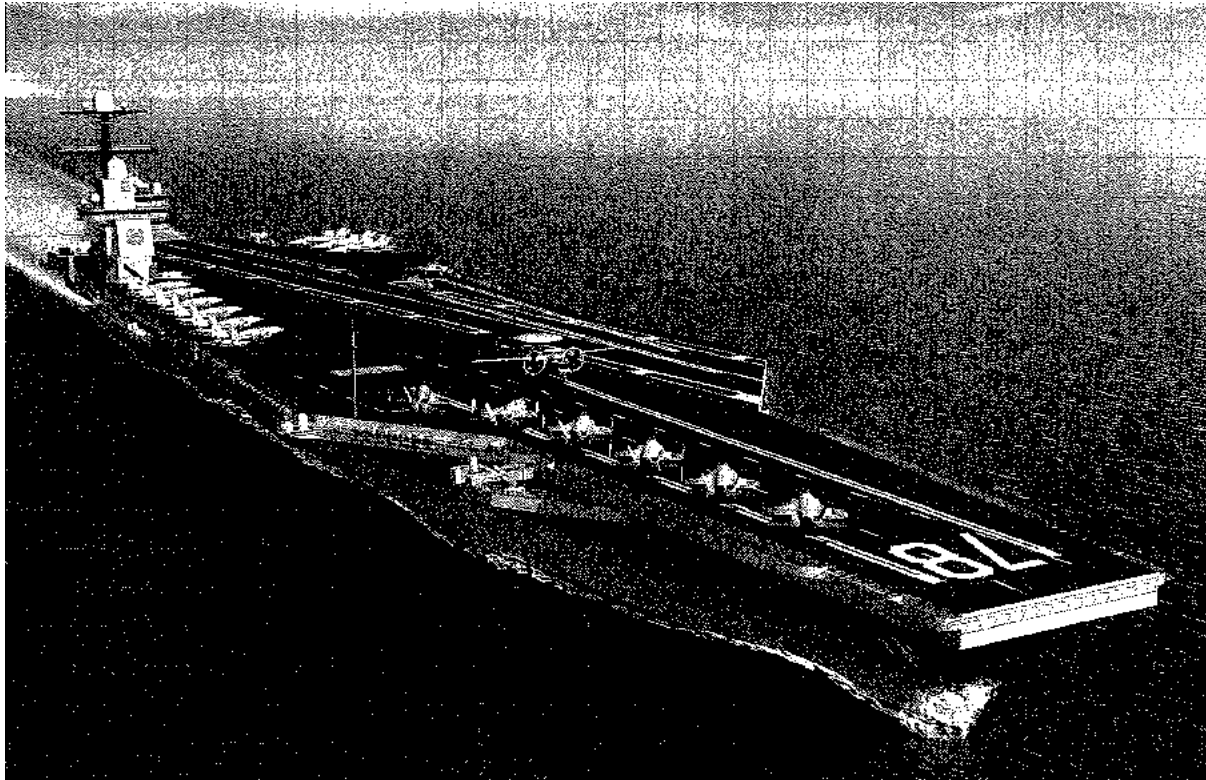


Specific Gravity = 1.025      Assumed KG = 0.00 ft  
"K" = Baseline

Note: Hydrostatic and Stability curves provided apply to both carrier classes

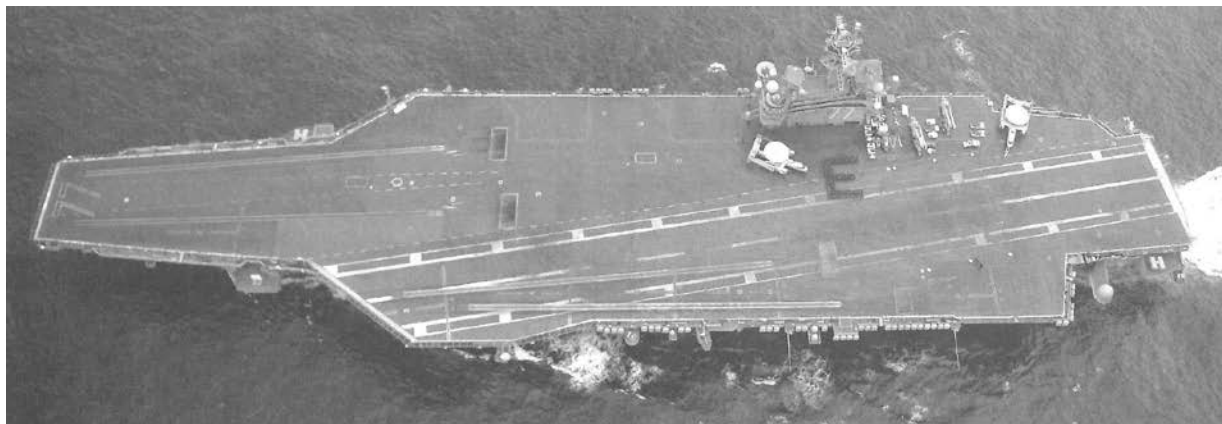
## CVN-78: FORD CLASS

Displacement:	100,000+ tons full load	Elevators:	3 deck edge
Length:	1,040 feet (317.2 m) waterline 1,092 feet (332.9 m) overall	Missiles:	Evolved Sea Sparrow Missile (ESSM) 2 21-cell RAM missile launchers Mark 49
Beam:	134 feet (40.85 m)	Guns:	none
Flight deck:	256 feet (78.05 m)	Radars:	Dual-Band Radar (air/surface search) SPY-3 multi-function 3-D air search navigation
Draft:	39 feet (11.89 m)	Fire Control:	
Propulsion:	4 steam turbines; 4 shafts	EW systems:	SLQ-25A Nixie torpedo countermeasures SLQ-32(V)4
Reactors:	2 A1B pressurized-water reactors (Bechtel)		
Speed:	approx. 30 knots		
Personnel:	approx. 2,800 ship + 1,865 air wing		
Aircraft:	approx. 65		
Catapults:	4 Electro-Magnetic Aircraft Launching System (EMALS)		

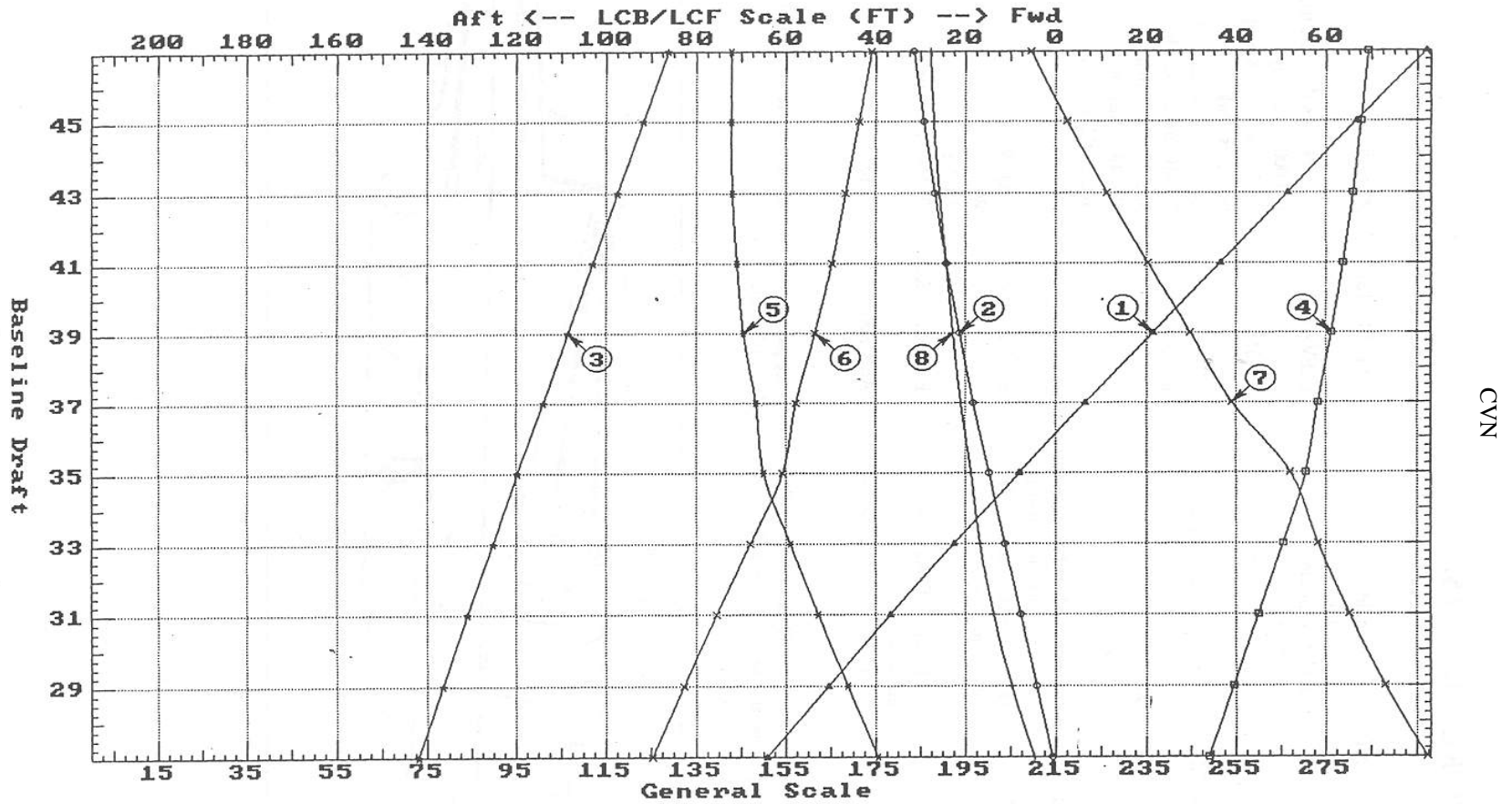


## CVN-68: NIMITZ CLASS

Displacement:		<u>Light</u>	<u>Full load</u>	Air wing:	approx. 1,865	
	CVN 68	77,264 tons	100,020 tons	Aircraft:	approx. 65	
	CVN 69	78,837 tons	101,635 tons	Catapults:	4 steam Mark 13-1 in CVN 68-71	
	CVN 70	78,434 tons	101,264 tons		4 steam Mark 13 2 in CVN 72 and later ships	
	CVN 71	80,777 tons	104,581 tons	Elevators:	4 deck edge (85 x 52 feet/25.9 x 15.85 m): 130,000-lb (58,500-kg) capacity	
	CVN 72	81,451 tons	104,263 tons	Missiles:	2 8-cell NATO Sea Sparrow launchers Mark 29 2 21-cell RAM missile launchers Mark 49	
	CVN 73	81,364 tons	104,178 tons	Guns:	2 20-mm Phalanx CIWS Mark 15 (multi-barrel) in most ships	
	CVN 74	80,506 tons	103,314 tons	Radars:	SPQ-9B track-while-scan in CVN 68-70, 73, 74, 76, 77 (ships with RAM missile)	
	CVN 75	81,069 tons	103,877 tons		SPS-48E 3-D air search	
	CVN 76	78,621 tons	101,429 tons		SPS-49(V)5 air search in CVN 71, 72, 75	
CVN 77	80,000 tons	102,000 tons		SPS-49a(V)1 air search in CVN 68-70, 73, 74, 76, 77		
Length:	1,040 feet (317.2 m) waterline				SPS-64(V)9 navigation in CVN 71, 72, 75	
	CVN 68	1,115 feet (339.94 m) overall			SPS-67(V)1 surface search	
	CVN 69, 70	1,098 feet (334.76 m) overall			SPS-73(V)12 navigation in CVN 68, 70, 73, 74	
	CVN 71-76	1,092 feet (332.93 m) overall			SPS-73(V)17 navigation in CVN 69, 76, 77	
	CVN 77	1,100 feet (335.37 m) overall			Mark 23 Target Acquisition System (TAS) in CVN 71, 72, 75 navigation (commercial)	
Beam:	134 feet (40.95 m)				Sonars:	none
Flight deck:	252 feet (76.93 m)				Fire control:	3 Mark 91 missile FCS
Draft:	CVN 68-70 37 feet (11.3 m)				EW systems:	SLQ-25A Nixie torpedo countermeasures SLQ-32(V)4
	CVN 71-77 38 feet 5 inches (11.7 m)					
Propulsion:	4 steam turbines (General Electric); 280,000 shp; 4 shafts					
Reactors:	2 pressurized-water A4W (Westinghouse)					
Speed:	30+ knots					
Personnel:	approx. 32,000 (160 officers+3,040 enlisted)					
Flag:	approx. 150 when embarked					



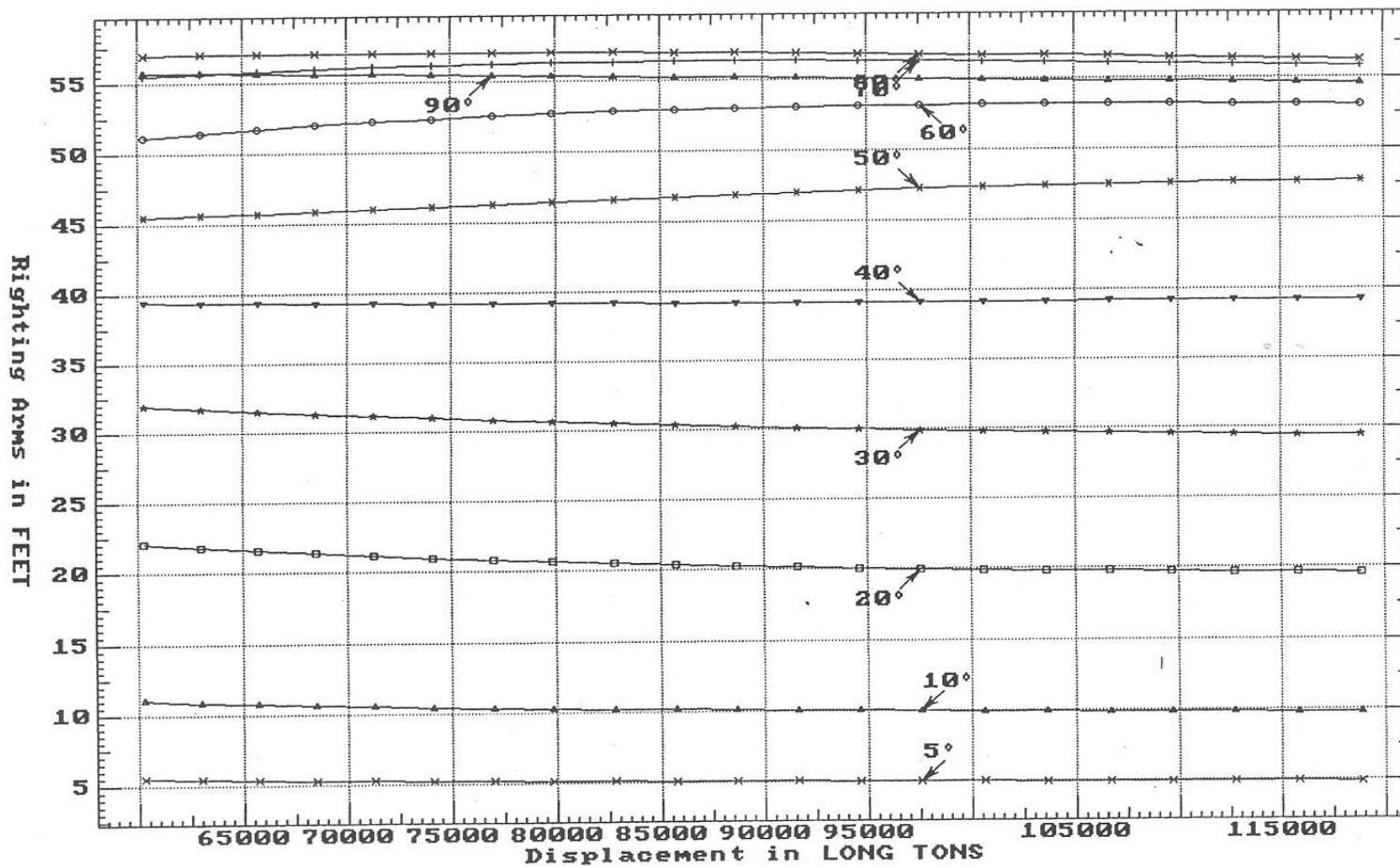
**HYDROSTATIC PROPERTIES at LEVEL TRIM**



- ① Displacement 1=400 LT
- ② LCB (use top scale)
- ③ UCB (KB) 1=0.2 FT
- ④ Immersion 1=0.9 LT/IN
- ④ WPA 1=378 Sq.FT
- ⑤ LCF (use top scale)
- ⑥ Mom/Trim 1=91.81 FT-LT/IN
- ⑦ KML 1=8 FT
- ⑧ KMT 1=0.3 FT

Specific Gravity = 1.025      Assumed KG = 0.00 FT  
 "K" = base\_Plane

**CROSS CURVES OF STABILITY - Stbd Heel  
at LEVEL TRIM (initial)**

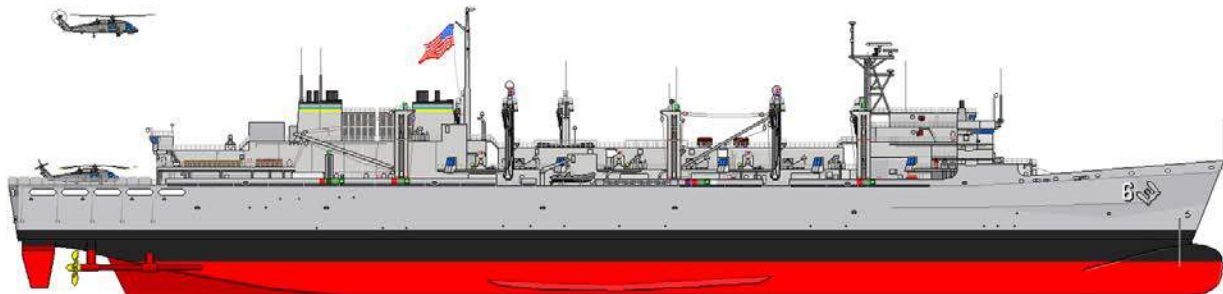


CVN

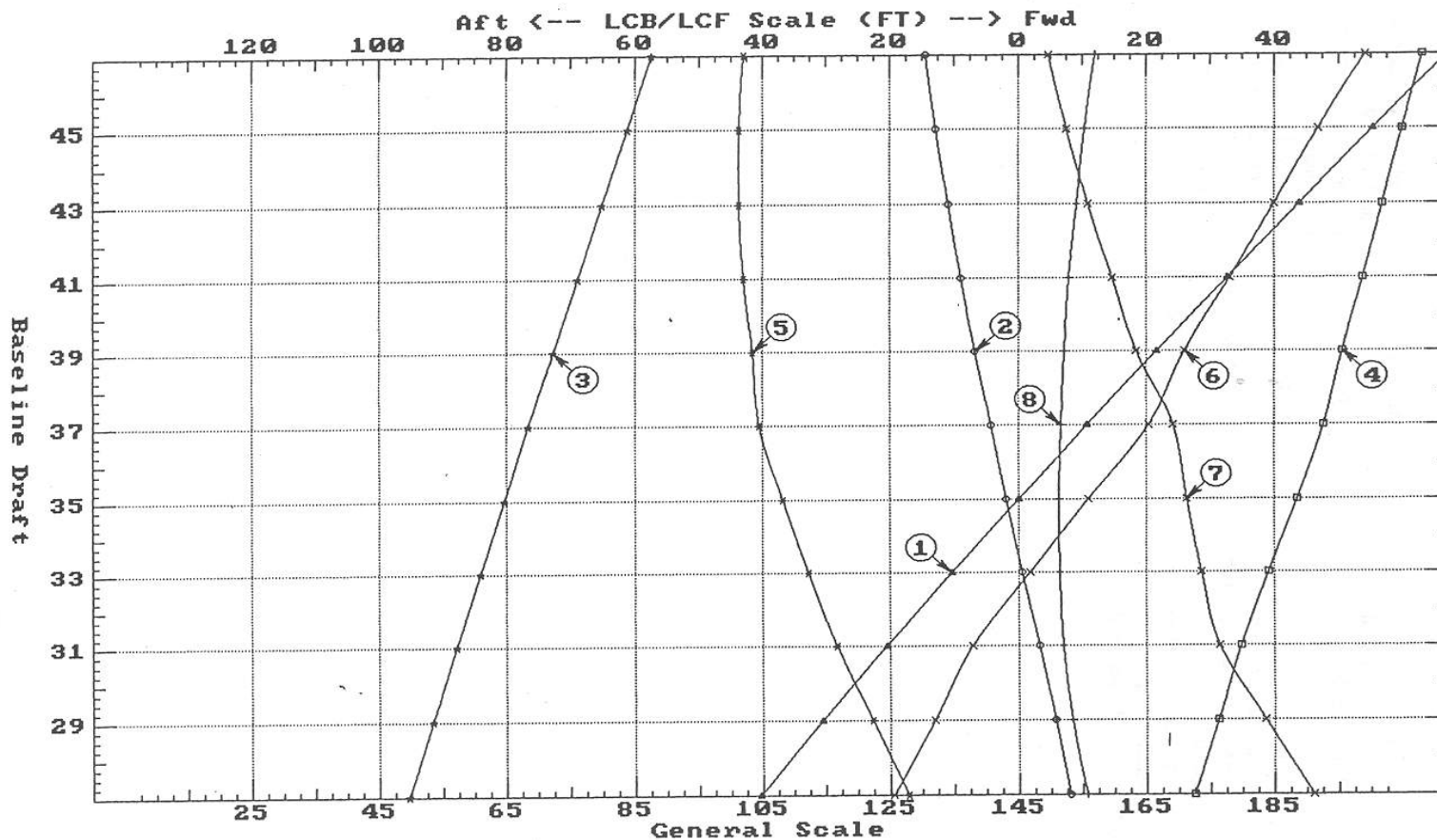
Specific Gravity = 1.025    Assumed KG = 0.00 FT  
"K" = Base\_Plane

## AOE-6: SUPPLY CLASS

DISP:	19,700 tons light 48,800 tons full load	MISSILES:	(1) 8 tube NATO Sea Sparrow launcher Mk29
LENGTH:	754 ft overall	GUNS:	(2) 20mm Phalanx CIWS (2) 25 mm cannon Mk 88
BEAM:	107 ft	RADARS:	SPS-64(V)9 navigation SPS-67 surface search
DRAFT:	39 ft	FIRE CONTROL:	(1) Mk 25 TAS (2) Mk 91 missile FCS
PROPULSION:	(4) gas turbine (General Electric LM 2500); 100,000 shp; 2 shafts	EW SYSTEMS:	SLQ-32(V)3
SPEED:	26 kts		
MANNING:	approx 660 (35 officer + 625 enlisted)		
HELICOPTER:	(3) UH-46 Sea Knight		



HYDROSTATIC PROPERTIES at LEVEL TRIM

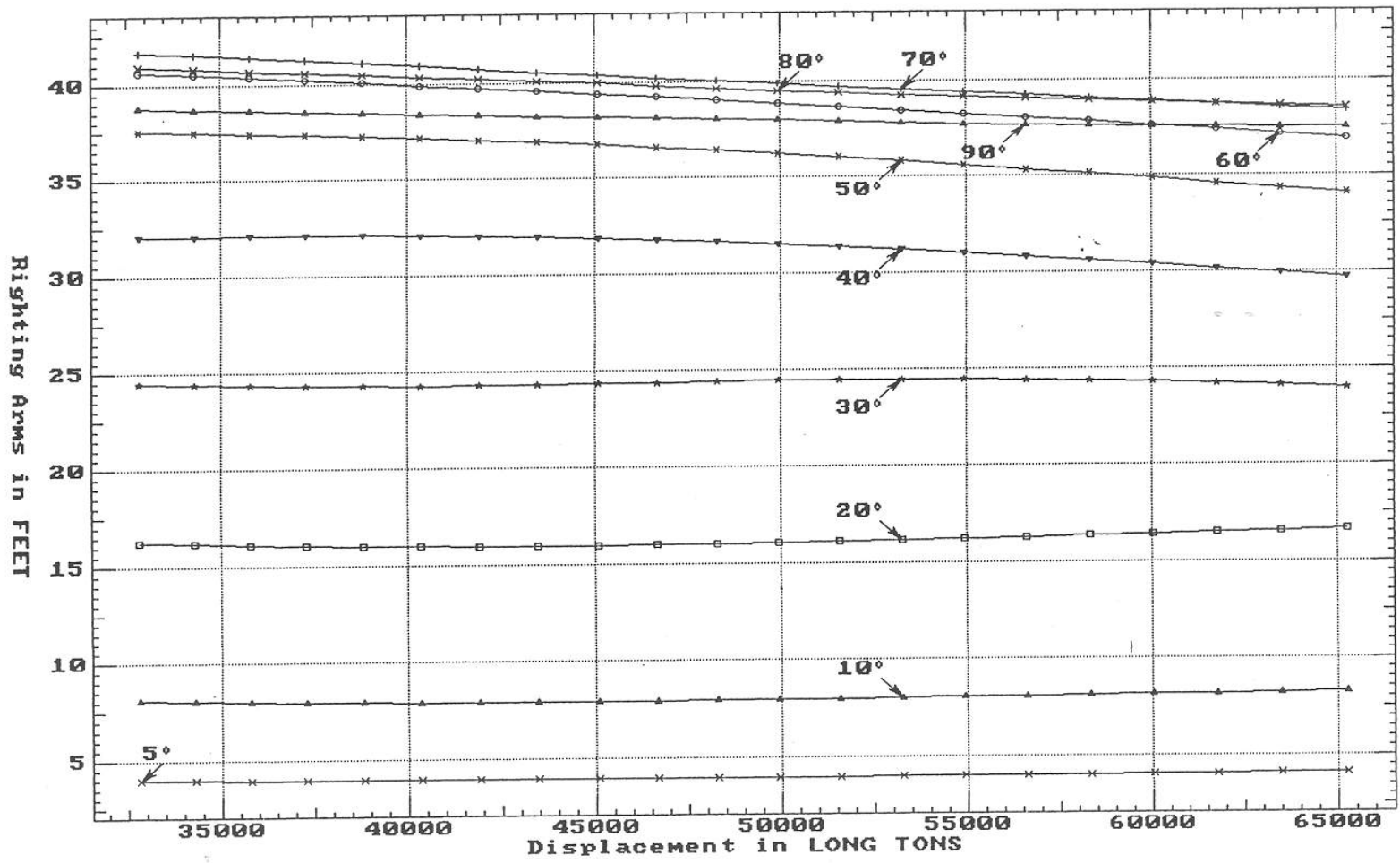


AOE6

- |  |   |  |
|--|---|--|
| <p>① Displacement 1=300 LT</p> <p>② LCB (use top scale)</p> <p>③ UCB (KB) 1=0.3 FT</p> | <p>④ Immersion 1=0.7 LT/IN</p> <p>④ WPA 1=294 Sq. FT</p> <p>⑤ LCF (use top scale)</p> | <p>⑥ Mom/Trim 1=31.66 FT-LT/In</p> <p>⑦ KML 1=6 FT</p> <p>⑧ KMT 1=0.3 FT</p> |
|--|---|--|

Specific Gravity = 1.025      Assumed KG = 0.00 FT  
 "K" = Baseline

**CROSS CURVES OF STABILITY - Stbd Heel  
at LEVEL TRIM (initial)**

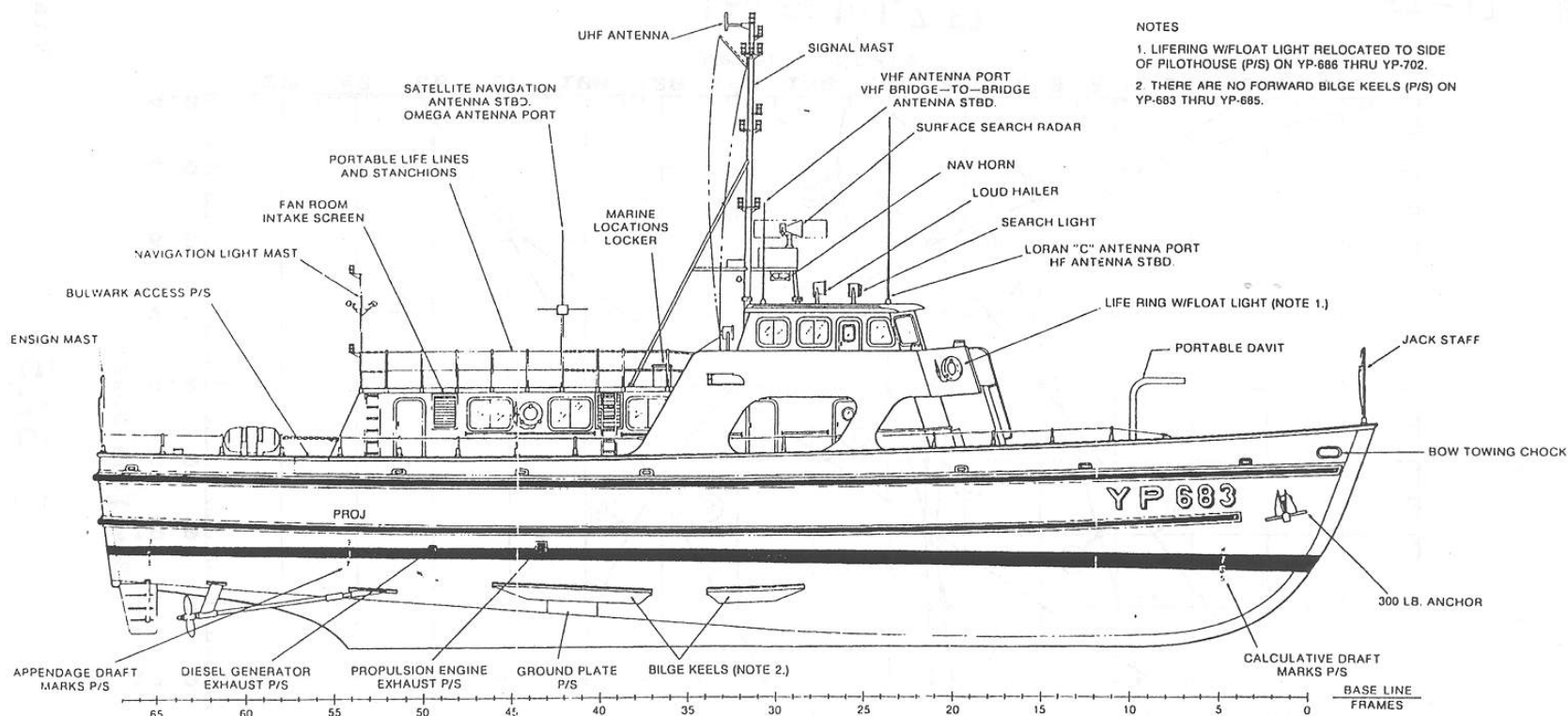


Specific Gravity = 1.025    Assumed KG = 0.00 FT  
"K" = Baseline

AOE6



# YP-676 & YP-703: YARD PATROL CLASS

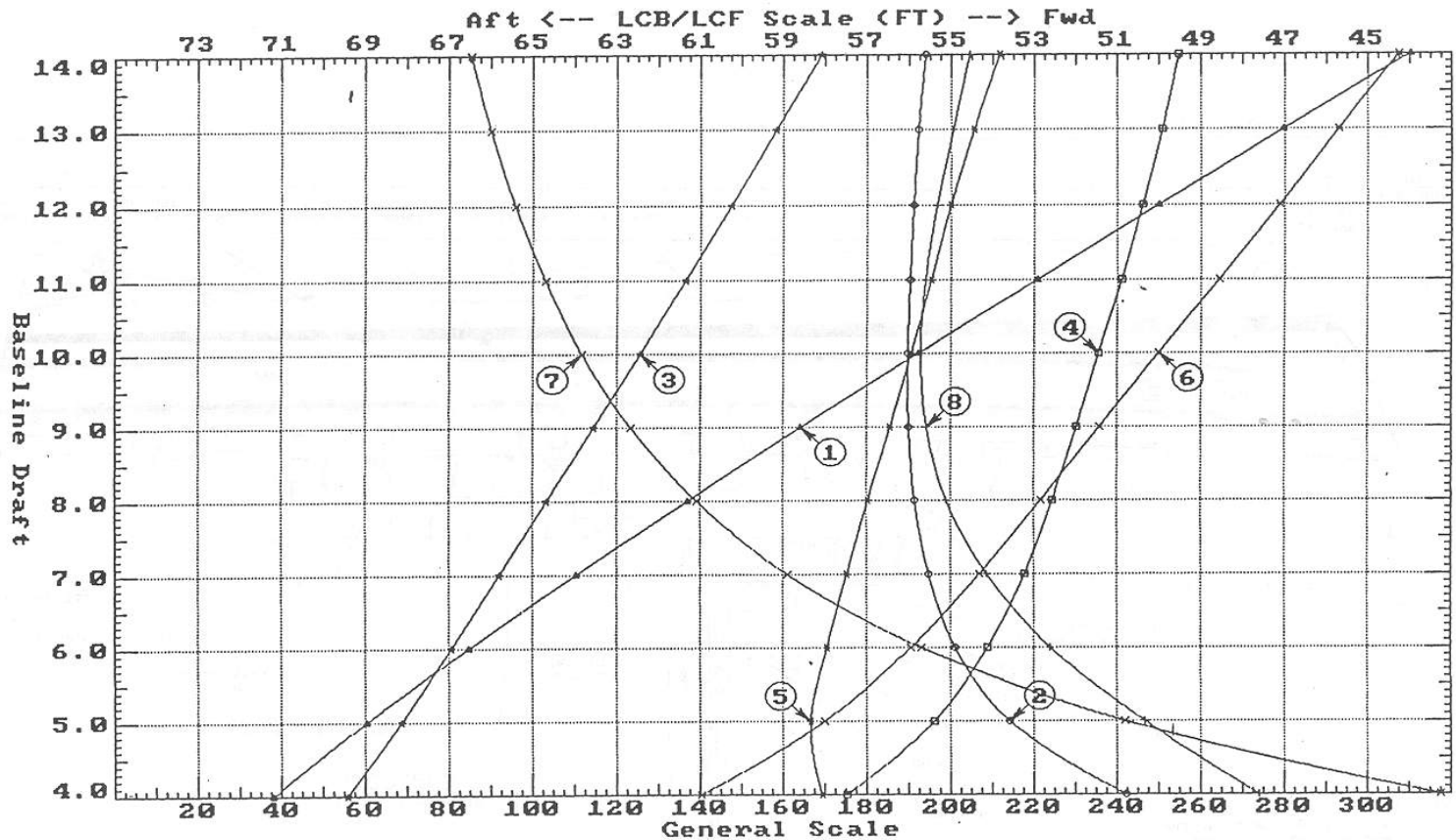


- NOTES
1. LIFERING W/FLOAT LIGHT RELOCATED TO SIDE OF PILOTHOUSE (P/S) ON YP-686 THRU YP-702.
  2. THERE ARE NO FORWARD BILGE KEELS (P/S) ON YP-683 THRU YP-685.

	<b>YP-676 Class</b>	<b>YP-703 Class</b>
Length, LOA / LPP (ft)	108 / 102	119 / 109
Beam (ft)	24	27.9
Draft (ft)	8	7.5
Speed (kt)	12	12.6
Range (n.m.)	1,800	1,680 @ 10 kt.
Propulsion	12V-71N Detroit diesel engine (437 SHP @ 2,100 RPM); 2 props	2x Cat C-18 diesel engines (2x 715 BHP @ 2,100 RPM); 2 props
Crew	2 officer, 4 crew, 24 midshipmen	4 officer, 6 crew, 30 midshipmen

Note: YP-676 Class ships: 676, 681, 683, 684, 686-692, 694, 695, 698, 700, 701  
 YP-703 Class ships: 703-708

**YP**      **HYDROSTATIC PROPERTIES at LEVEL TRIM**      **YP**



YP676

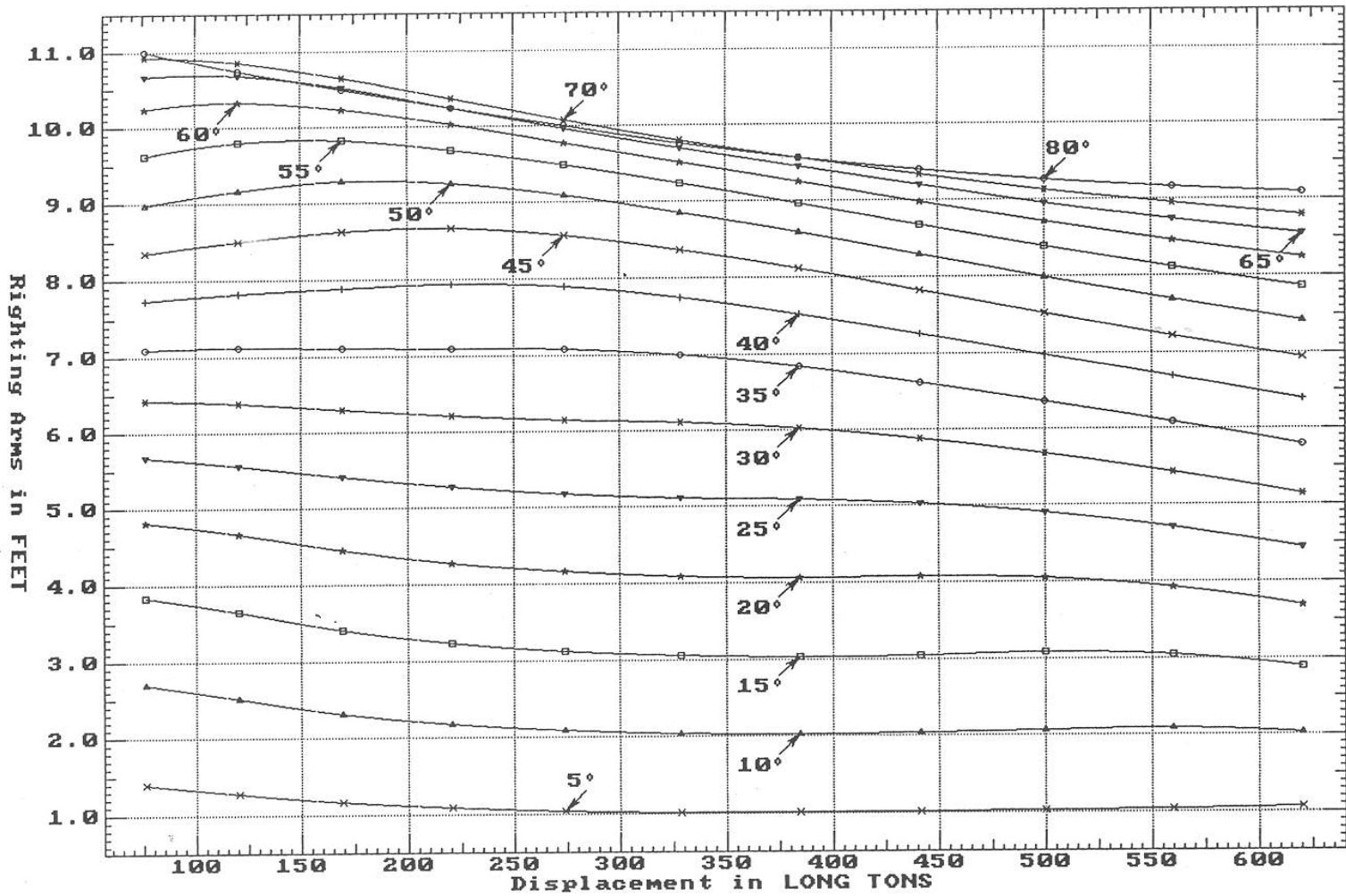
$L_{pp} = 101.7 \text{ FT}$

- |   |  |  |
|---|--|--|
| <p>① Displacement 1=2 LT</p> <p>② LCB (use top scale)</p> <p>③ UCB (KB) 1=0.05 FT</p> | <p>④ Immersion 1=0.02 LT/IN</p> <p>④ WPA 1=8.4 Sq. FT</p> <p>⑤ LCF (use top scale)</p> | <p>⑥ Mom/Trim 1=0.141 <math>\frac{\text{FT-LT}}{\text{INCH}}</math></p> <p>⑦ KML 1=1 FT</p> <p>⑧ KMT 1=0.06 FT</p> |
|---|--|--|

Specific Gravity = 1.025      Assumed KG = 0.00 FT

"K" = Baseline

**CROSS CURVES OF STABILITY - Stbd Heel  
at LEVEL TRIM (initial)**



Specific Gravity = 1.025    Assumed KG = 0.00 FT  
"K" = Baseline

YP676

## 27-B-1: Hydro Lab Stability Model



### Components:

Hull

Removable top hatch cover

Inclinometer

Pendulum with weight

Port-to-starboard list adjustment weights and horizontal bar

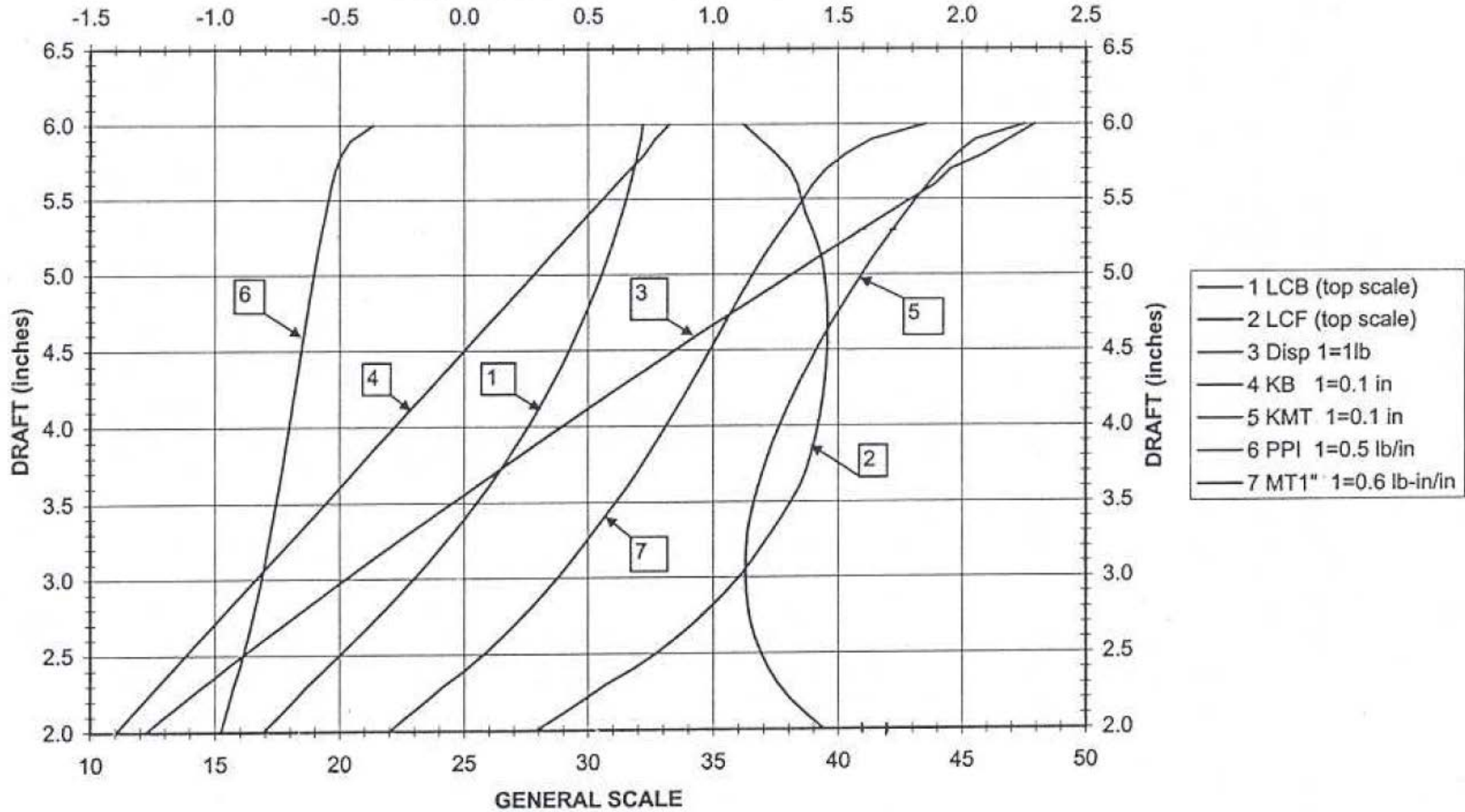
Brass nuts

Brass loose weights

# MODEL 27-B-1 CURVES of FORM

Fresh water at 59 deg F

LCB & LCF (inches from amidships) (- aft, + forward)



# **Laboratory Handouts**

# EN400

## LAB #1 PRELAB

### NUMERICAL INTEGRATION

#### Instructions:

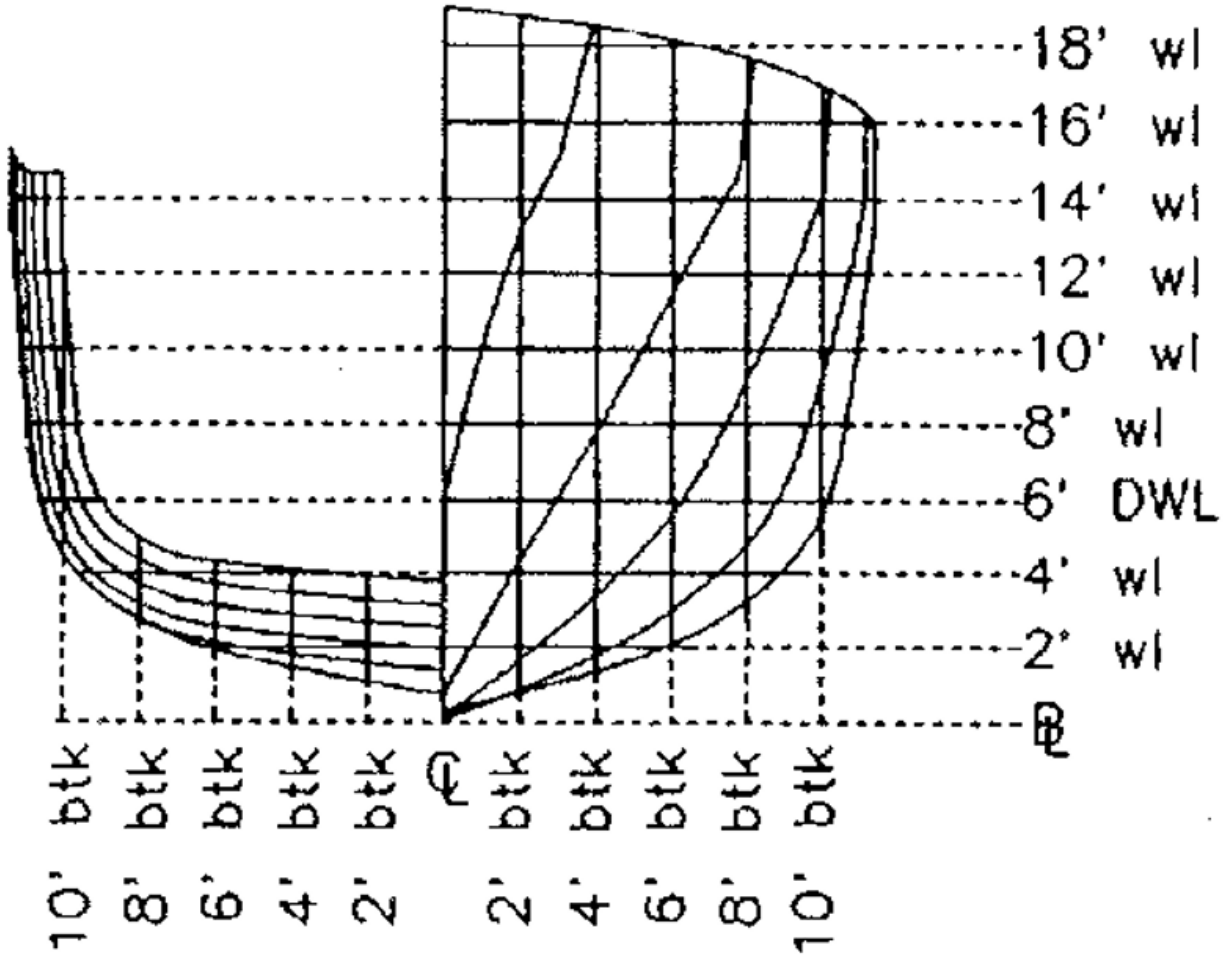
1. The prelab covers theories that will be examined experimentally in this lab.
2. The prelab is to be completed and handed in to your instructor at the beginning of the lab period.
3. If you can, answer the questions without referring to your notes. Only refer to your notes if you are confused or fail to understand a concept. This will greatly improve your understanding of the concepts this lab is designed to reinforce.
4. By conscientiously completing this prelab, you will have a thorough understanding of what the lab is trying to show. Your lab performance will be maximized.
5. For full credit, all work must be shown. Show generalized equations, substitution of numbers, units, and final answers. Engineering is communication. Work that is neat and shows logical progression is much easier to grade.

#### Student Information

Name(s): \_\_\_\_\_

Section: \_\_\_\_\_

Date: \_\_\_\_\_



**Figure 1** YP Body Plan

DWL = 6 ft

L<sub>pp</sub> = 101.7 ft

Half-breadths in feet from the centerline

STATION NUMBERS – Station 0 is the FP, Station 10 is the AP

Draft (ft)	0	1	2	3	4	5	6	7	8	9	10
10	1.1	5.2	8.6	10.1	10.8	11.1	11.0	10.8	10.6	10.1	9.7
9	0.8	4.7	8.1	9.7	10.6	10.9	10.8	10.7	10.4	10.0	9.6
8	0.5	4.1	7.6	9.4	10.4	10.8	10.7	10.6	10.2	9.9	9.5
7	0.3	3.6	7.0	9.1	10.2	10.7	10.6	10.5	10.1	9.7	9.4
6	0.1	3.0	6.3	8.7	10.0	10.6	10.5	10.2	9.8	9.5	9.0
5	0.0	2.4	5.5	8.2	9.5	10.1	10.1	9.7	9.3	8.8	8.0
4	0.0	1.9	4.5	7.3	8.8	9.4	9.5	9.1	8.4	7.3	3.5
3	0.0	1.3	3.5	6.2	7.5	8.2	8.6	7.5	5.0	0.0	0.0
2	0.0	0.8	2.3	4.5	5.3	6.0	5.5	2.0	0.0	0.0	0.0
1	0.0	0.2	1.0	2.2	2.2	1.7	0.0	0.0	0.0	0.0	0.0
0	0.0	0.0	0.0	0.0	0.0	0.0	0.0	0.0	0.0	0.0	0.0

**Table 1** YP Table of Offsets



## Verifying the Table of Offsets

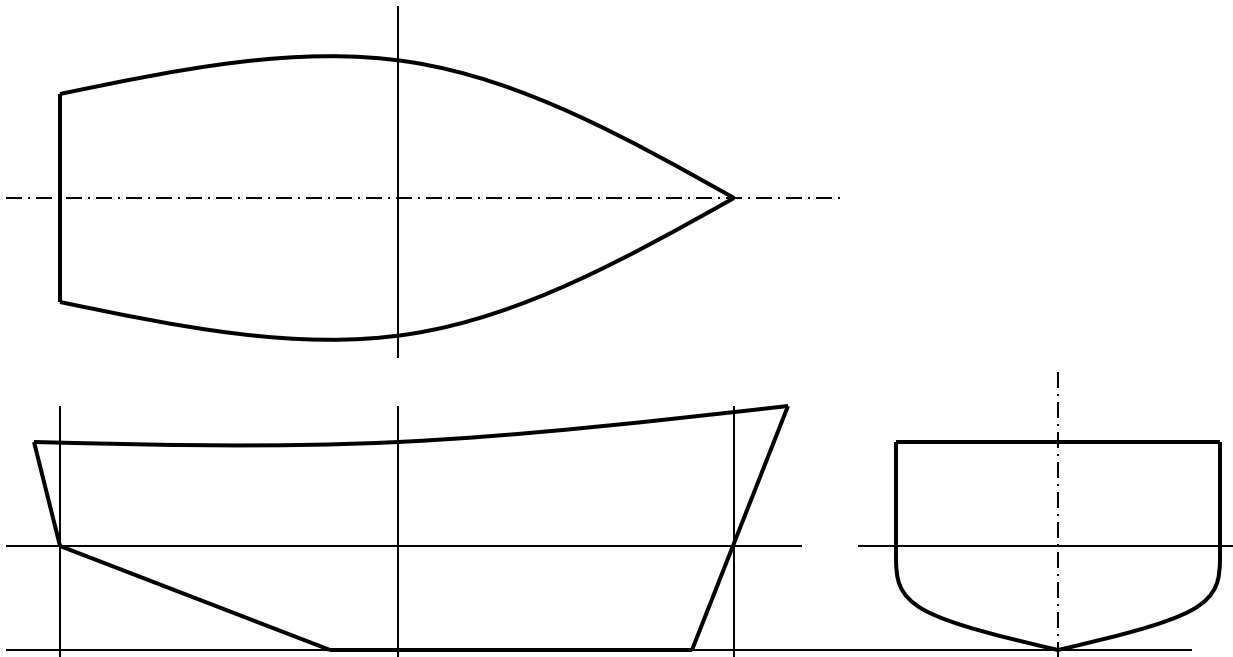
- Determine the half-breadths for the 6-foot waterline (DWL) by pulling the appropriate values from Table 1. Then verify the values by measuring them on the body plan in Figure 1. Show that you know how to find these points by circling them on the body plan in Figure 1. Insert the measured offsets and table values in the table below.

Station	0	1	2	3	4	5	6	7	8	9	10
Half-breadths from Table of Offsets (ft)											
Half-breadths from Body Plan (ft)											

## Hull Definitions

- Indicate the following items, on *each* diagram it is found in Figure 2:

- Waterline
- Waterplane
- Section area
- Forward perpendicular
- Aft perpendicular
- Centerline
- Baseline
- Midships
- Center of flotation



**Figure 2** Diagram for hull form definitions



### **Submerged Volume**

4. Using the following steps, show how the submerged volume of a ship is calculated using Simpson's first rule.
  - a. Sketch a 2-D graph of the volume you are integrating, labeling the axes and dimensions.
  - b. Applying Simpson's first rule, give the generalized equation for determining the underwater volume.

### **Waterplane Area**

5. Using the table of offsets and Simpson's first rule, follow the steps below to find the waterplane area at the 6-foot waterline.
  - a. Sketch the waterplane you are integrating, labeling the axes and dimensions.



# EN400

## LAB #1

### NUMERICAL INTEGRATION

#### Instructions:

1. This lab is conducted in the classroom.
2. Prior to arriving, read through the lab procedure so that you are familiar with the steps necessary to complete the lab.
3. Bring this handout, the completed prelab, and a calculator to the lab.
4. The lab is to be performed in small groups of 2 or 3. Your instructor will specify whether the group or each individual must submit the completed lab.
5. Follow the stages of the lab in consecutive order. The lab follows a logical thought pattern and jumping ahead without completing the intervening theory questions will limit your understanding of the concepts covered.
6. For full credit, all work must be shown on the lab. Show generalized equations, substitution of numbers, units, and final answers.

#### Student Information:

Name(s): \_\_\_\_\_

Section: \_\_\_\_\_

Date: \_\_\_\_\_

## Download File Template

Access the EN400 course website and download the Excel template of Lab #1.

If you have difficulty with Excel at any stage of this lab, use the “HELP” capability of the program to assist. If you are still confused, ask a neighbor or the instructor.

## Sectional Area

Go to the “Sectional Area and Submerged Volume” tab on the spreadsheet.

Program the sectional area calculation into the spreadsheet and calculate the sectional area for each of the 11 stations up to the 6-foot waterline by following the steps below.

Input the Simpson multipliers and waterline spacing (dz) into the appropriate spreadsheet cells. Use the function SUMPRODUCT to calculate the sectional areas.

1. Check your spreadsheet results by comparing the sectional area of station 5 with that calculated in the prelab.

Area of Station 5 up to the 6-ft waterline (spreadsheet calculation) (ft <sup>2</sup> )	
Area of Station 5 up to the 6-ft waterline (hand calculation) (ft <sup>2</sup> )	

2. Comment on any differences between the two values.

---

---

---

Repeat the procedures in Step 1, to reprogram the spreadsheet to calculate the sectional areas for each of the 11 stations up to the 2 ft, 4ft, 8 ft, and 10 ft waterlines. Use of the spreadsheet’s “copy” and “paste” functions, as well as locking some cells with “\$” may prove useful here.

Using the spreadsheet’s graphing capabilities, plot the sectional area curves at each draft on the same axes. As a reminder, the sectional area curve shows sectional (station) areas on the vertical-axis and FP-to-AP length on the horizontal-axis.

- Use the “X-Y Scatter” graph as the graph type
- Ensure each draft is its own series or curve on the graph
- Ensure the graph is correctly titled, each curve is properly labeled, and that the axes are labeled with the appropriate name, symbol, and units.

3. Print your graph on a separate sheet of paper or submit electronically, as directed.

4. What does the area under the curve of sectional areas represent? \_\_\_\_\_

\_\_\_\_\_

5. What is the naval architecture symbol for the area under the curve of sectional areas? \_\_\_\_\_

### Submerged Volume

Program the submerged volume calculation into the spreadsheet and calculate the submerged volumes of the YP at drafts of 2 ft, 4 ft, 6 ft, 8 ft, and 10 ft in the appropriate cells of the spreadsheet.

In the appropriate cells on the spreadsheet, calculate the YP's displacement in salt water at each draft.

6. Print the spreadsheet page or submit electronically, as directed.

### Waterplane Area

Click on the "Waterplane Area" tab. A new table of offsets should be revealed.

Program the waterplane area calculation into the spreadsheet and calculate the area of the 2-foot through 10-foot waterplanes by following the general steps below.

Input the Simpson multipliers and section spacing (dx) into the appropriate spreadsheet cells.

Use the function SUMPRODUCT to calculate the waterplane areas. Place the waterplane areas in the appropriate cells.

7. Check your spreadsheet calculations by comparing the waterplane area of the 6-ft waterline with that calculated in the prelab.

Waterplane area of 6-ft waterline (spreadsheet calculation) (ft <sup>2</sup> )	
Waterplane area of 6-ft waterline (hand calculation) (ft <sup>2</sup> )	

8. Comment on any differences between the two values.

\_\_\_\_\_  
\_\_\_\_\_  
\_\_\_\_\_

## Longitudinal Center of Flotation (LCF)

Program the LCF calculation into the spreadsheet and determine the position of LCF, as referenced to the forward perpendicular, for the 2, 4, 6, 8, and 10 foot waterlines in the appropriate cells of the spreadsheet.

9. Check your spreadsheet calculations by comparing your result for the 6-foot waterline with that calculated in the prelab.

LCF of the 6-foot waterline (spreadsheet calculation) (ft aft of FP)	
LCF of the 6-foot waterline (hand calculation) (ft aft of FP)	

10. Comment on any difference between the two values.

---

---

11. **Print** the spreadsheet page or submit electronically, as directed.

## Submitting the Lab

Your instructor will provide guidance on how to submit the printed lab and/or electronic spreadsheet file.



# EN400

## LAB #2 PRELAB

### ARCHIMEDES & CENTER of FLOTATION

#### Instructions:

1. The prelab covers theories that will be examined experimentally in this lab.
2. The prelab is to be completed and handed in to your instructor at the beginning of the lab period.
3. If you can, answer the questions without referring to your notes. Only refer to your notes if you are confused or fail to understand a concept. This will greatly improve your understanding of the concepts this lab is designed to reinforce.
4. By conscientiously completing this prelab, you will have a thorough understanding of what the lab is trying to show. Your lab performance will be maximized.
5. For full credit, all work must be shown. Show generalized equations, substitution of numbers, units, and final answers. Engineering relies on communication. Work that is neat and shows logical progression is much easier to grade.

#### Student Information

Name(s): \_\_\_\_\_

Section: \_\_\_\_\_

Date: \_\_\_\_\_

## Lab Apparatus

In this lab, two simple wooden hull shapes are used as floating bodies (one symmetrical shape and one asymmetrical shape). Their tops have been inscribed so that half-breadths can be measured and used to determine hull form characteristics. At the bow and stern are draft marks measured from the keel. The tank in which they will float has been fitted with a *weir* and a spillway through which any displaced water will run and be collected for measurement. This opening, in effect, provides a constant water level in the tank. A suitable container for collecting the water, a scale for weighing the hull shape and displaced water, and a ruler for taking measurements are provided.

## Theory

### Archimedes Principle and Static Equilibrium

In the first part of the lab, the displacement (weight) of the symmetrical hull will be determined by three different means:

- Weigh the model hull on a scale
- Weigh the volume of displaced water on the scale.
- Calculate buoyant force and displacement by calculating underwater volume from measurements.

1. Which of the techniques described above will give the most accurate weight?

\_\_\_\_\_ Why? \_\_\_\_\_

\_\_\_\_\_

2. Which of the techniques described above could be applied to a full-sized ship?

\_\_\_\_\_ Why? \_\_\_\_\_

\_\_\_\_\_

Archimedes Principle states that:

*An object partially or fully submerged in a fluid will experience a resultant vertical force equal in magnitude to the weight of the volume of fluid displaced by the object.*

This vertical force is called the “force of buoyancy” and it is given the symbol  $F_B$ .

3. Write the mathematical relationship described by Archimedes Principle that demonstrates the relationship between  $F_B$  and  $\nabla$ .

4. When placing the wooden models in the tank of water, if they float (positively buoyant) will they be in static equilibrium?

5. What are the two necessary conditions for an object to be in static equilibrium?

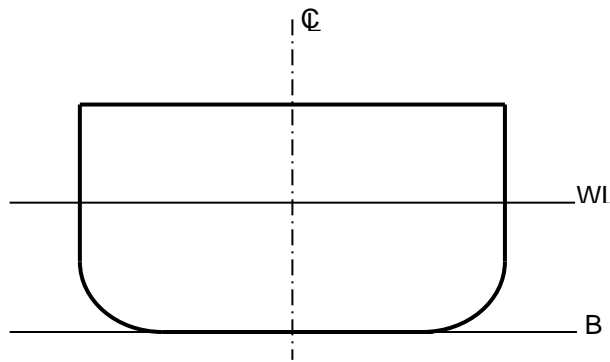
Condition 1: \_\_\_\_\_

Condition 2: \_\_\_\_\_

6. Using the conditions for static equilibrium, write the mathematical relationship between links the buoyant force ( $F_B$ ) being experienced by a floating body and its weight or displacement ( $\Delta$ ).

7. Combine the expressions given in (3) and (6) to give the mathematical relationship linking the submerged volume of a floating object ( $\nabla$ ) with its displacement ( $\Delta$ ).

8. On the section of a floating hull form below, draw the two force vectors ( $F_B$  and  $\Delta$ ), and clearly show and name the centroids through which they act.

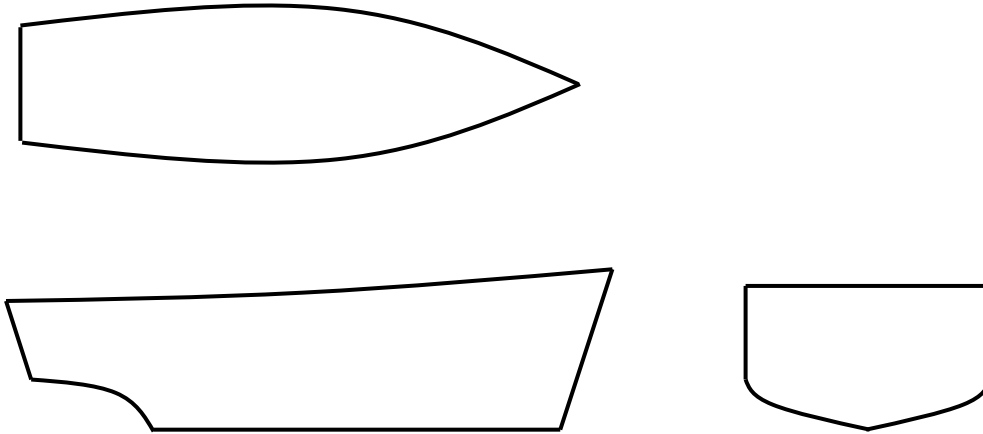


9. Describe how the positions of the two centroids displayed above are located on a ship, by filling in the table below.

	Referenced From	Acronym	Name
<b>Vertically</b>			
<b>Transversely</b>			
<b>Longitudinally</b>			

### Center of Flotation Theory

10. On the three orthogonal views of a hull form below, draw in the waterline, centerline, midships, and show the center of flotation on EACH view.



11. What is the significance of the center of flotation with regard to the waterplane?

---

12. Describe parallel sinkage:

---



---

13. Where would a weight have to be placed on a ship to achieve parallel sinkage?

---

14. Complete the table below to describe how the center of flotation is referenced on a ship.

	Referenced From	Acronym	Name
<b>Transversely</b>			
<b>Longitudinally</b>			

# EN400

## LAB #2

### ARCHIMEDES & CENTER of FLOTATION

#### Instructions:

1. This lab is conducted in the Hydromechanics Lab on the ground floor of Rickover Hall.
2. Prior to arriving, read through the lab procedure so that you are familiar with the steps necessary to complete the lab.
3. Bring this handout, the completed prelab, and a calculator to the lab.
4. The lab is to be performed in small groups of 2 or 3. Your instructor will specify whether the group or each individual must submit the completed lab.
5. Follow the stages of the lab in consecutive order. The lab follows a logical thought pattern and jumping ahead without completing the intervening theory questions will limit your understanding of the concepts covered.
6. For full credit, all work must be shown on the lab. Show generalized equations, substitution of numbers, units, and final answers.
7. Keep your workstation (including the floor) clean and dry. Ensure all equipment and the models are returned to their original location when you complete the lab.

#### Student Information:

Name(s): \_\_\_\_\_

Section: \_\_\_\_\_

Date: \_\_\_\_\_

## Part 1: Archimedes Principle and Determination of Displacement

1. Weigh the symmetrical model on the scale and record its weight below.

Scale weight of symmetrical model (lb)	
--	--

This weight corresponds to the displacement ( $\Delta$ ) of the model. The remainder of Part 1 of the lab verifies this weight using two different techniques.

### Displacement Measurement from Weight of Displaced Water

Fill the tank to a level just above the height of the weir and let the excess water flow into a bucket. Allow about 5 minutes for the water to stop dripping. Empty the bucket into a sink or drain – **DO NOT DUMP EXCESS WATER INTO THE TOW TANK.** Also ensure the small can is empty.

2. Weigh the empty bucket and record its weight in the table below.

Holding the large bucket under the weir, carefully lower the model into the tank making sure you keep the model upright. After the initial rush of water, the remaining dripping water can be caught in the small can.

Wait at least 5 minutes for the water to finish dripping over the weir. While you are waiting, complete steps (4) through (7).

3. Pour the water from the small can into the bucket and complete the table below. This table only requires data collected up to this point and application of course principles (Archimedes and Static Equilibrium)

Weight of Empty Bucket (lb)	
Weight of Collected Water and Bucket (lb)	
Weight of Collected Water (lb)	

Based on data up to this point in the Lab, what values would you expect for:

Magnitude of Buoyant Force, $F_B$ (lb)	
Displacement of Model, $\Delta$ (lb)	

4. Explain how you arrived at the value for the displacement of the model.

5. The mean draft ( $T_M$ ) is the average of the forward and aft drafts as measured at their respective perpendiculars. Use this relationship and observations of the floating model to complete the table below.

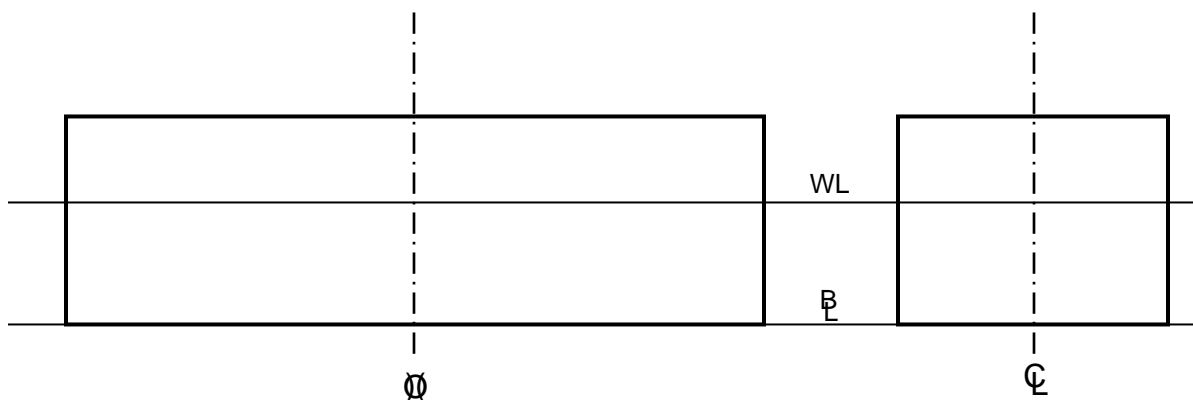
$T_{aft}$ (inches)	
$T_{fwd}$ (inches)	
$T_M$ (inches)	

6. Using your value for  $T_M$  and assuming that the model is of uniform density, estimate the following values that describe the location of the centers of buoyancy (B) and gravity (G) for the floating symmetrical model.

Note: Ignore the weight of the handles. The center of gravity of a homogenous object, such as the ship model, is the centroid of the volume of that entire model.

Centroid	Parameter	Value (inches)
Center of Buoyancy (B)	KB (VCB)	
	TCB	
	LCB	
Center of Gravity (G)	KG	
	TCG	
	LCG	

7. Confirm your understanding of these quantities by plotting the location center of buoyancy (B) and the center of gravity (G) on the shear and body views of the symmetrical model below. Ensure you accurately locate these centroids relative to the waterline.



### **Displacement Measurement from Submerged Volume Calculation**

8. In the space below, calculate the waterplane area of the symmetrical model using Simpson's first rule. For full credit, ensure you include the following steps:
  - a. Draw a sketch of the area you are determining.
  - b. Write the generalized equation for Simpson's first rule.
  - c. Calculate waterplane area and box your answer.

9. Now determine the submerged volume ( $\nabla$ ) of the model.

Note: On the symmetrical model with vertical sides, we can calculate volume as we would a cylinder (area \* height)



10. Why can't this technique be used to calculate the submerged volume of a normal hull form?
- 
11. Calculate the buoyant force from the value of submerged volume and the density of the water in the tank.
12. Now calculate the symmetrical model's displacement ( $\Delta$ ).

**Analysis of Results**

13. From the observations and calculations you have made, complete the following table. Calculate the percent error in that table cell, as compared to actual scale weight of model.

Technique	Displacement, $\Delta$ (lb)	Percent Error	Explanation of Error
Scale Weight of Model		N/A	N/A
Scale Weight of Displaced Water			
Simpson's Rule			

14. Explain how these values verify Archimedes Principle and the principle of static equilibrium?

---



---



---



---

## Part 2: Longitudinal Center of Flotation

15. Carefully place the non-symmetrical model in the tank and complete the table below.

Unloaded Condition	
T <sub>aft</sub> (inches)	
T <sub>fwd</sub> (inches)	
T <sub>M</sub> (inches)	
Trim (inches)	

16. By observing the shape of the non-symmetrical model, qualitatively estimate the position of the center of flotation (F). Circle one of the answers below.

Forward of midships

At midships

Aft of midships

Making sure you have a can ready to collect any displaced water; carefully load the model on the centerline at Station 4 with a 5-pound weight.

17. Record the model's drafts in the table below.

Loaded Condition	
T <sub>aft</sub> (inches)	
T <sub>fwd</sub> (inches)	
T <sub>M</sub> (inches)	
Trim (inches)	

18. Comparing data from the "Unloaded" and "Loaded" conditions, what change in trim ( $\delta_{TRIM}$ ) has occurred?

$$\delta_{TRIM} = \underline{\hspace{2cm}}$$

Why has this occurred? \_\_\_\_\_

19. What is the name of the point where the weight would have to be placed on the model in order to achieve zero change in trim ( $\delta_{TRIM} = 0$  inches)?

\_\_\_\_\_

20. By a trial and error basis, move the 5-pound weight so that parallel sinkage is achieved. When you are satisfied, complete the following table.

Loaded for $\delta_{Trim} = 0$ Condition	
T <sub>aft</sub> (inches)	
T <sub>fwd</sub> (inches)	
T <sub>M</sub> (inches)	
Trim (inches)	

21. Measure the location of the 5-pound weight to determine a value for the longitudinal center of flotation of the non-symmetrical hull. (Reference to amidships)

$$\text{LCF} = \underline{\hspace{2cm}}$$

22. Using the data collected, calculate the Pounds Per Inch Immersion (PPI) of the non-symmetrical model.
23. Using the collected data, calculate the model's Moment to Change Trim One Inch (MT1"). Recall that  $\delta_{\text{TRIM}} = w * l / \text{MT1}''$ , where w=weight, l=longitudinal distance.

# EN400

## LAB #3 PRELAB

### INCLINING EXPERIMENT

#### Instructions

1. The prelab covers theories that will be examined experimentally in this lab.
2. The prelab is to be completed and handed in to your instructor at the beginning of the lab period.
3. If you can, answer the questions without referring to your notes. Only refer to your notes if you are confused or fail to understand a concept. This will greatly improve your understanding of the concepts this lab is designed to reinforce.
4. By conscientiously completing this prelab, you will have a thorough understanding of what the lab is trying to show. Your lab performance will be maximized.
5. For full credit, all work must be shown. Show generalized equations, substitution of numbers, units, and final answers. Engineering relies on communication. Work that is neat and shows logical progression is much easier to grade.

#### Student Information

Name(s): \_\_\_\_\_

Section: \_\_\_\_\_

Date: \_\_\_\_\_

## Lab Apparatus

A small ship model, (27-B-1 model), will be inclined to port and starboard by shifting 4 x 0.2 lb weights in several combinations between three posts. The resulting moments will incline the ship and the angle of list from each weight shift will be measured with a pendulum assembly.

Before the inclining experiment can begin and the inclining weights and equipment added, the 27-B-1 model will be in its light-ship condition. This is with the model holding the solid floored tank internally with the solid floor down.

## Theory

The major goal of the inclining experiment is to find an accurate value for the vertical height of the center of gravity above the keel (KG). This is performed after a ship has been launched and fully equipped, or after any major refit where it is considered that there may have been a significant alteration to KG.

The life-sized experiment is conducted alongside the pier, in calm water, and with the ship free to list. The following major steps are then performed.

### Light-ship Condition

The Inclining Experiment is usually performed with the ship in its light-ship condition. The light-ship displacement ( $\Delta_{\text{light}}$ ) is defined by *Introduction to Naval Architecture, p131* as:

*The weight of the ship complete in every respect, including hull, machinery, outfit, equipment, water in the boilers at steaming level, and liquids in machinery and piping, but with all tanks and bunkers empty and no crew, passengers, cargo, stores, or ammunition on board.*

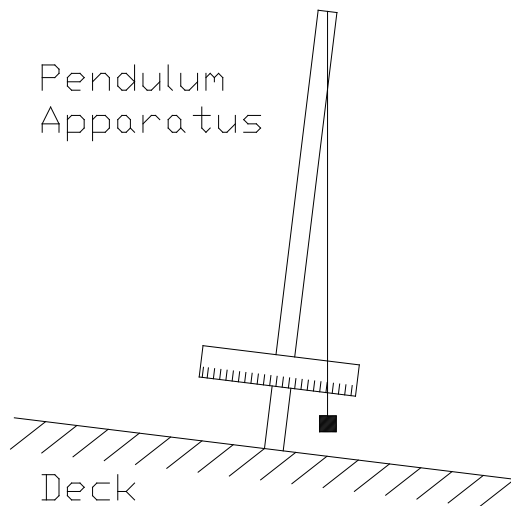
It is necessary to determine  $\Delta_{\text{light}}$ , the displacement of the light-ship. This is achieved in part by observing the forward and aft draft marks and consulting the ship's curves of form. In this step, it is also important to accurately know the density of the water the ship is floating in.

1. Why is water density important? \_\_\_\_\_  
\_\_\_\_\_
2. Show the equation that demonstrates the relationship between the displacement of a ship and the water density it is floating in.

## Addition of Inclining Weights and Apparatus

The inclining weights and apparatus are brought on board. Typically, the inclining weights are approximately 2% of  $\Delta_{\text{light}}$ . With the inclining weights and apparatus on board, the ship is said to be in an inclined condition. All quantities are then given the inclined suffix. For example  $\Delta_{\text{incl}}$ ,  $KG_{\text{incl}}$ .

The inclining apparatus consists of a pendulum on a mast that is positioned so that the pendulum is free to swing in the transverse direction. Figure 1 below shows the typical pendulum arrangement. It is used to record the tangent of the inclining angle.



3. On Figure 1, show the inclining angle ( $\phi$ ) and the adjacent and opposite sides ( $d_{\text{adj}}$  and  $d_{\text{opp}}$ ) to the triangle that allows the calculation of  $\tan \phi$ .

Based on the geometry, give the equation for  $\tan \phi$  in terms of these quantities

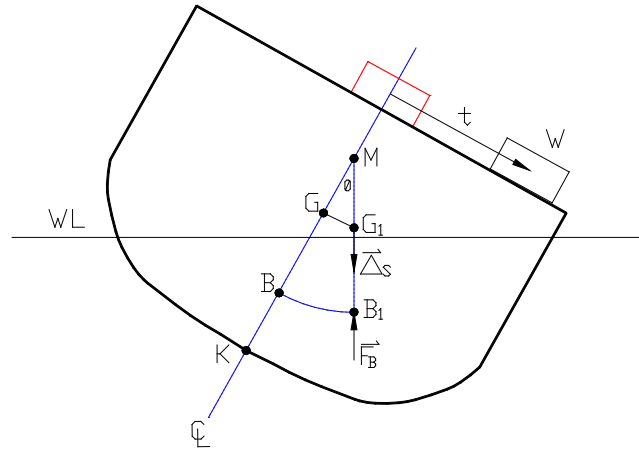
**Figure 1** Inclining Apparatus

The height of the center of gravity of the inclining apparatus and weights is important to know. On full scale ships, the weight of the pendulum is insignificant, but for our model it does have a significant effect.

These distances are often termed  $Kg_{\text{pendulum}}$  and  $Kg_{\text{weights}}$  respectively.

## Inclining the Ship

With these stages complete, the inclining can then proceed. The theory behind the experiment is evident when considering the diagram of the inclined ship in Figure 2.



**Figure 2** The Inclining Ship

4. Give the geometric relationship between the angle of inclination ( $\phi$ ) and the distances  $GG_1$  and  $GM_{incl}$ .

The distance  $GG_1$  can also be determined from the weight being shifted ( $w$ ) and the distance it is moved ( $t$ ).

$$TCG_{NEW} = \frac{TCG_{OLD}\Delta_{OLD} + w_i t c g_i}{\Delta_{NEW}}$$

$Tcg = t$ . When a ship's  $TCG_{OLD} = 0$ ft, then  $GG_1 = TCG$ :

$$GG_1 = \frac{wt}{\Delta}$$

5. Combine the geometric triangle and weight shift equations to solve for  $GM_{incl}$ .

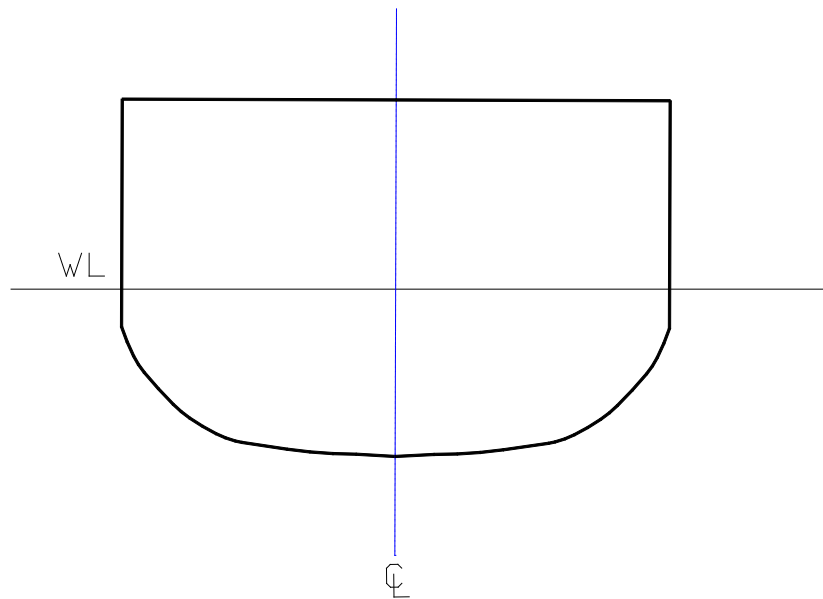
At each angle of inclination, the tangent of the inclining angle ( $\tan \phi$ ) is recorded. A plot is then made of inclining moment ( $wt$ ) against  $\tan \phi$ . This data plots as a straight line and a line of best fit can be placed through this data. The slope of this line can then be determined.

6. Write an expression for the slope in terms of the measured quantities.
7. Combine this with the previous expression to find  $GM_{incl}$  in terms of the slope of the plot.

### Finding $KG_{incl}$

With a value for  $GM_{incl}$  calculated, determining the distance  $KG_{incl}$  is fairly straightforward.

8. On Figure 3, insert the locations of the Keel (K), the center of buoyancy (B), the center of gravity (G) and the transverse metacenter (M). Assume all centroids are on the centerline. Also show the distances KM, GM and KG.



**Figure 3** The Upright Ship

9. Use Figure 3 to determine an expression for  $KG_{incl}$  in terms of  $GM_{incl}$  and  $KM$ .
10. Where would you obtain a value for  $KM$ ? \_\_\_\_\_



## Removing the Inclining Weights and Apparatus and Finding $KG_{light}$

The final stage in the experiment is to correct the value of  $KG_{incl}$  for the removal of the inclining weights and apparatus to obtain  $KG_{light}$ .

11. Give the general expression for the new  $KG$  of a ship after the removal or addition or shift of a weight.

This equation can be applied to the removal of the inclining equipment given the following:

- $w_{wt}$  - The weight of the inclining weights.
- $Kg_{wt}$  - The height of the center of gravity of the weights above the keel.
- $w_{pend}$  - The weight of the pendulum apparatus.
- $Kg_{pend}$  - The height of the center of gravity of the pendulum above the keel.

12. Apply all of the above terms to the general expression to find the mathematical expression for  $KG_{light}$ .

The calculation of  $KG_{light}$  is the **FINAL GOAL** of the inclining experiment. The height of  $G$  above the keel is vitally important in determining the stability characteristics of the ship, which will be explored in future labs.

# EN400

## LAB #3

### THE INCLINING EXPERIMENT

#### Instructions:

1. This lab is conducted in the Hydromechanics Lab on the ground floor of Rickover Hall.
2. Prior to arriving, read through the lab procedure so that you are familiar with the steps necessary to complete the lab.
3. Bring this handout, the completed prelab, and a calculator to the lab.
4. The lab is to be performed in small groups of 2 or 3. Your instructor will specify whether the group or each individual must submit the completed lab.
5. Follow the stages of the lab in consecutive order. The lab follows a logical thought pattern and jumping ahead without completing the intervening theory questions will limit your understanding of the concepts covered.
6. For full credit, all work must be shown on the lab. Show generalized equations, substitution of numbers, units, and final answers.
7. Keep your workstation (including the floor) clean and dry. Ensure all equipment and the models are returned to their original location when you complete the lab.

#### Student Information:

Name(s): \_\_\_\_\_

Section: \_\_\_\_\_

Date: \_\_\_\_\_

## Apparatus

1. Before beginning the experiment, ensure the 27-B-1 model number corresponds with the number on the solid floored tank, the pendulum assembly and the tank. Record the data below, as you will need to use the same model in the next three EN400 labs.

27-B-1 model number = \_\_\_\_\_

## Light-ship Condition

The first step is to ensure the model 27-B-1 is in its light-ship condition. This is achieved by the following:

- Ensure all detachable weights are off the model (4 x 0.2 lb weights and pendulum apparatus). **Do not** remove the transverse weights used to adjust list.
  - Ensure there is no loose water within the central compartment.
  - Ensure the **solid floored tank** with its solid side down is securely installed in the center compartment. (Note: improperly securing the tank may alter your data!)
2. **Important!** You will need to know the height of center of gravity for the inclining weights and pendulum for future calculations. Measure and record their respective kg's before placing the model in the tank.

Carefully place the 27-B-1 model in the water. Make sure it is floating freely and is not being inhibited by the tank sides and appendages.

3. Using the curves of form, determine the light ship weight,  $\Delta_{\text{light}}$ , for the actual water temperature. (The displacement from the curves of form is for fresh water @ 59 °F.)

4. In this inclining experiment, the inclining weights consist of 4 x 0.2 lb weights. Use the scale to determine the weight of pendulum apparatus ( $w_{\text{pendulum}}$ ). Record this data in the table below and calculate the weight of the inclined model ( $\Delta_{\text{incl}}$ ).

Displacement in light-ship condition, $\Delta_{\text{light}}$ (lb)	
Weight of inclining weights, $w_{\text{weights}}$ (lb)	
Weight of pendulum apparatus, $w_{\text{pendulum}}$ (lb)	
Displacement in inclined condition, $\Delta_{\text{incl}}$ (lb)	

The model should be freely floating in the tank with the inclining weights on the centerline post and the pendulum apparatus secure in its stowage. The model is now floating in its **inclined condition**. For best results, the model should be at zero list.

### Inclining the Ship

5. With the ship in its inclined condition, the actual inclining part of the experiment can proceed. Record the distances on the pendulum needed to determine  $\tan(\phi)$ .

6. Carefully move all 4 inclining weights to complete the following table:

Weight Combination	Weight creating the moment $w$ (lb)	Moment Arm $t$ (in) (+ Stbd, - Port)	Inclining Moment $w \cdot t$ (in-lb)	Pendulum deflection (in) (+ Stbd, - Port)	$\tan(\phi)$ (no units)
4 - Port Post 0 - Center Post 0 - Stbd Post					
3 - Port Post 1 - Center Post 0 - Stbd Post					
2 - Port Post 2 - Center Post 0 - Stbd Post					
1 - Port Post 3 - Center Post 0 - Stbd Post					
0 - Port Post 4 - Center Post 0 - Stbd Post					
0 - Port Post 3 - Center Post 1 - Stbd Post					
0 - Port Post 2 - Center Post 2 - Stbd Post					
0 - Port Post 1 - Center Post 3 - Stbd Post					
0 - Port Post 0 - Center Post 4 - Stbd Post					

7. Plot the results of the inclining experiment in Excel. Your plot should be inclining moment (wt) on the y-axis against the tangent of the heel angle ( $\tan\phi$ ) on the x-axis. **Remember to name and label your plot correctly.** Use Excel to determine the line of best fit. Record the Slope and its units below:

*Slope* = \_\_\_\_\_

8. What is the advantage of using a 'line of best fit' for multiple data points?

---



---

9. Complete the inclined ship diagram in Figure 4. Your diagram should include the initial and final centers of buoyancy (B and B1), the initial and final centers of gravity (G and G1), the metacenter ( $M_T$ ), the inclining angle ( $\phi$ ) and the 2 equal and opposite resultant forces ( $\Delta$  and  $F_B$ ).

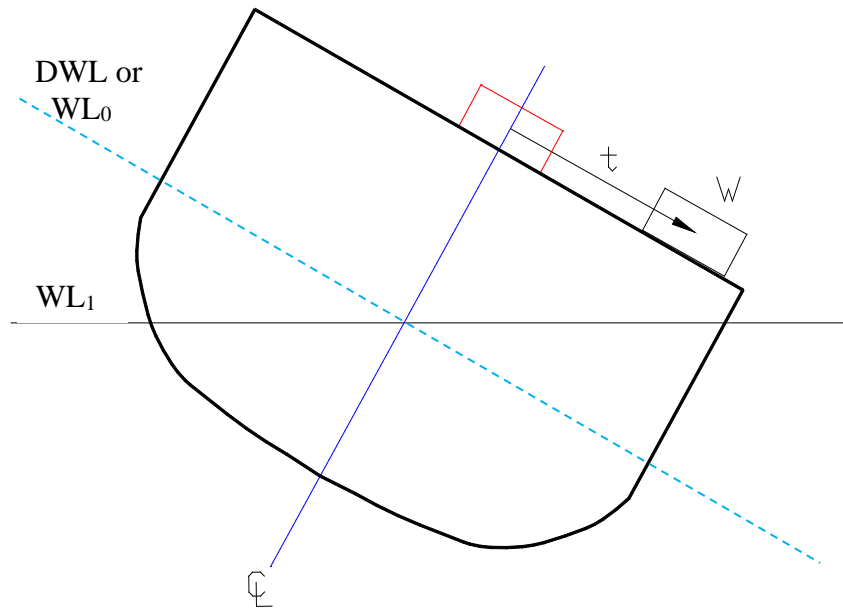


Figure 4: The Inclined Ship

10. Calculate the metacentric height of the 27-B-1 model in its inclined condition ( $GM_{incl}$ ).

**Calculating of  $KG_{incl}$  and Correcting for Removal of Inclining Equipment to find  $KG_{light}$**

11. Calculate  $KG_{incl}$ . Be sure to show any equations used.

12. The last step in the inclining experiment is to correct  $KG_{incl}$  for the removal of the inclining weights and apparatus to find  $KG_{light}$ .

Why is this necessary? \_\_\_\_\_  
\_\_\_\_\_

13. Write the equation and calculate  $KG_{light}$ .

14. Is this value for  $KG_{light}$  sensible (refer to the model)? \_\_\_\_\_

Why? \_\_\_\_\_  
\_\_\_\_\_

15. (For use for Lab 4): 27-B-1 model # \_\_\_\_\_

$KG_{light}$  \_\_\_\_\_



# EN400

## LAB #4 PRELAB

### RIGHTING ARM - VERTICAL AND TRANSVERSE SHIFTS IN THE CENTER OF GRAVITY

#### Instructions:

1. The prelab covers theories that will be examined experimentally in this lab.
2. The prelab is to be completed and handed in to your instructor at the beginning of the lab period.
3. If you can, answer the questions without referring to your notes. Only refer to your notes if you are confused or fail to understand a concept. This will greatly improve your understanding of the concepts this lab is designed to reinforce.
4. By conscientiously completing this prelab, you will have a thorough understanding of what the lab is trying to show. Your lab performance will be maximized.
5. For full credit, all work must be shown. Show generalized equations, substitution of numbers, units, and final answers. Engineering relies on communication. Work that is neat and shows logical progression is much easier to grade.

#### Student Information

Name(s): \_\_\_\_\_

Section: \_\_\_\_\_

Date: \_\_\_\_\_



## Theory

The 27-B-1 model is heeled by the presence of an external force, in this case the force in the wire ( $F_{\text{wire}}$ ). This force ( $F_{\text{wire}}$ ) is actually part of a moment couple, its equal and opposite partner being the force on the pin preventing the model from translating in the tank ( $F_{\text{pin}}$ ).

You will recall that a couple is a particular type of moment defined as:

*“.... a pair of forces of equal magnitude and opposite, parallel directions, separated by a distance (i.e. non-colinear)”*

1. What is the effect of a moment on a body? \_\_\_\_\_
2. What are the units of a moment? \_\_\_\_\_
3. When the 27-B-1 is heeled to a particular angle by  $F_{\text{wire}}$  you will find that it remains at that heel without further rotation or translation. Is the model in static equilibrium? \_\_\_\_\_  
Why? \_\_\_\_\_  
\_\_\_\_\_
4. On Figure 1:
  - a. Show the location and direction of the 2 forces:  $F_{\text{wire}}$  and  $F_{\text{pin}}$
  - b. Give the equation for the magnitude of the external moment created by these forces in terms of the quantities on the Figure.
5. Since the model is in static equilibrium at each angle of heel, there must be an equal and opposite moment being created by the model. This moment is being created by the 2 resultant forces due to the model's displacement ( $\Delta_S$ ) and its buoyant force ( $F_B$ ).
  - a. On Figure 1, show the location and direction of the 2 forces  $\Delta_S$  and  $F_B$ .
  - b. Show the righting arm between these 2 forces. Call this distance  $GZ$ .
  - c. Give the equation for the magnitude of the internal moment created by these forces in terms of the quantities on the Figure.

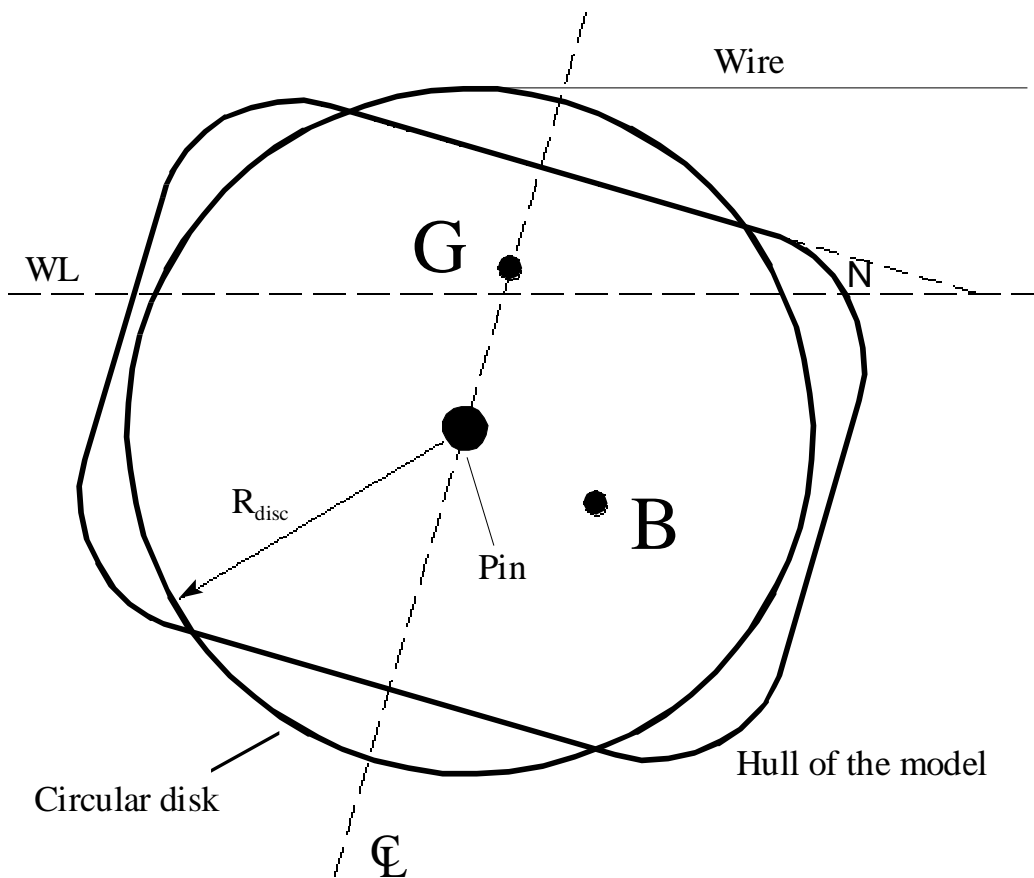


Figure 1: Simplified View of Heeling Model

6. Assuming the model is at static equilibrium, derive the equation that links the internal and external moments above.
  
7. Derive an equation that can be used to calculate the internal righting arm being developed by the model (GZ).

Using this apparatus and the equation above it will be possible to find the righting arm being developed by the 27-B-1 model at any angle of heel indicated on the protractor. The plot of righting arm, GZ against angle of heel is termed the **Curve of Intact Statical Stability** (Righting Arm Curve).

8. Use Figure 2 to plot a general curve of static stability (**starboard heels only**) for a ship with the following stability characteristics. **Ensure to label all axes.**
- a. Range of stability = 0 - 88°
  - b. Angle of maximum righting arm = 50°
  - c. Maximum righting arm = 3.5 ft
  - d. Righting arm at 30° of heel = 2.0 ft

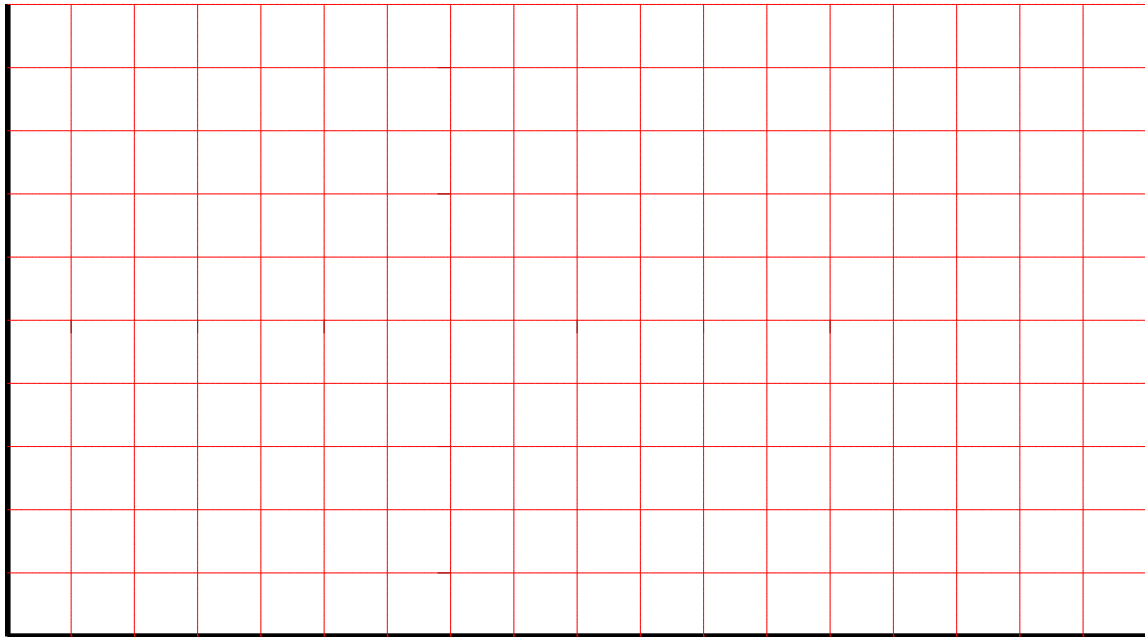


Figure 2: Graph for Plotting Curve of Static Stability

In this lab, the center of gravity of the ship will be shifted vertically and then horizontally. The effect of these shifts on the stability of the model will be calculated and then determined experimentally.

9. To show you understand the geometry of the heeling conditions, sketch the model in the following conditions and heeling angles. Your sketches should include the center of buoyancy (B), center of gravity (G), displacement ( $\Delta$ ), buoyant force ( $F_B$ ), angle of heel ( $\phi$ ), the waterline (WL), and righting arm (GZ) whenever applicable. Indicate which side of the ship is port and which is starboard.

<b>Normal Condition, 0° of heel</b>	<b>Normal Condition, 45° heeling angle</b>
<b>TCG to Stbd, 45° of heel to stbd</b>	<b>TCG to Stbd, 45° of heel to port</b>

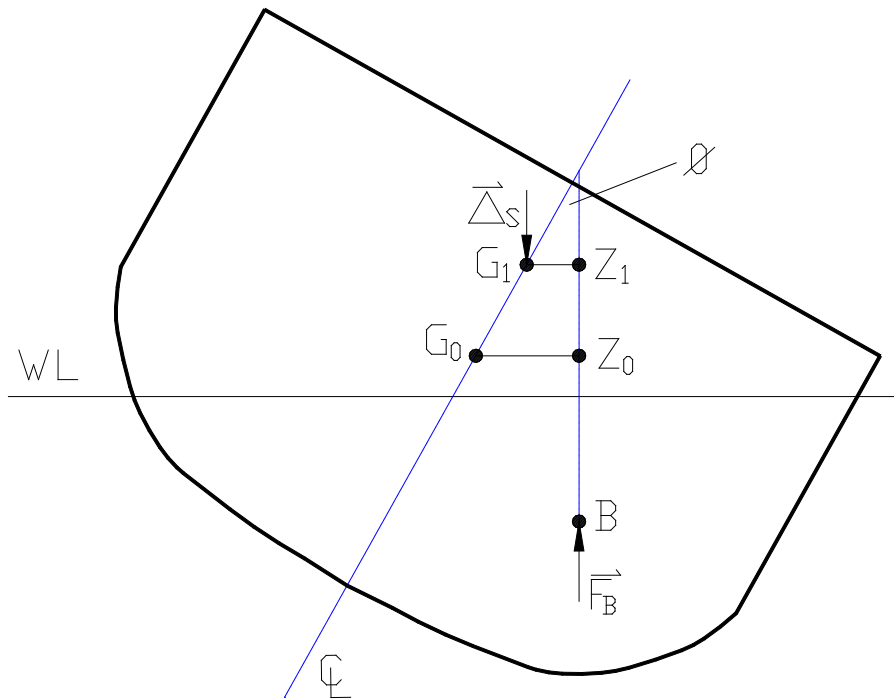


Figure 3: The Heeling Ship with a Vertical Shift in the Center of Gravity

10. Use Figure 3 to derive an equation for the new righting arm ( $G_1Z_1$ ) after a vertical shift in the center of gravity from  $G_0$  to  $G_1$ . Your equation should include the old righting arm ( $G_0Z_0$ ) and the angle of heel ( $\phi$ ).
  
11. From your answer above, what effect do you believe an increase in the distance  $KG$  will have upon the stability of a ship? \_\_\_\_\_  
 \_\_\_\_\_

In the next portion of the lab, the center of gravity of the ship will be shifted transversely. The effect this has upon the curve of intact statical stability will be measured. It should be possible to predict this effect by an analysis of the heeling ship shown in Figure 4.

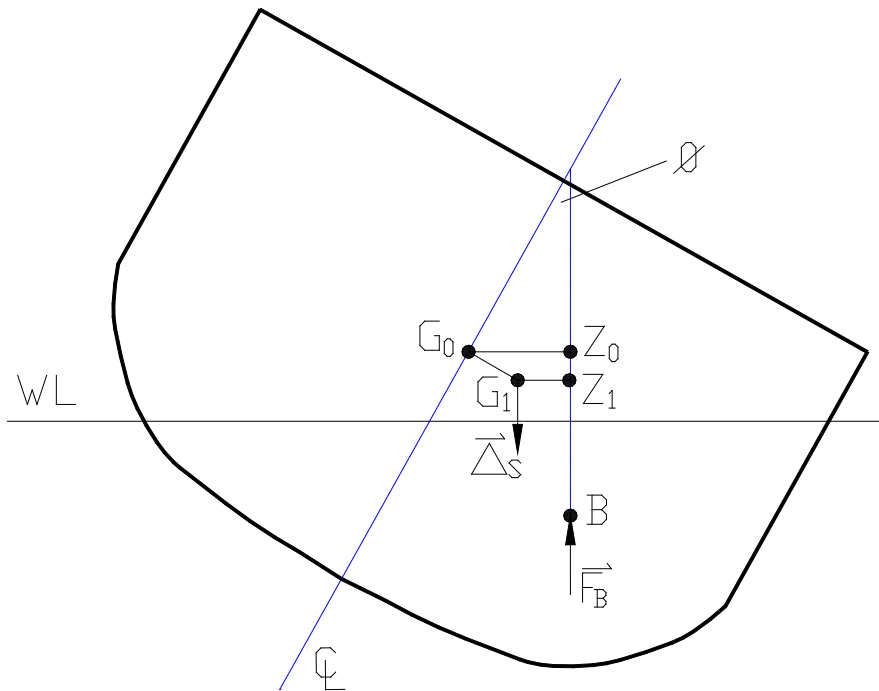


Figure 4: The Heeling Ship with a Transverse Shift in the Center of Gravity

12. Use Figure 4 to derive an equation for the new righting arm ( $G_1Z_1$ ) after a transverse shift in the center of gravity from  $G_0$  to  $G_1$ . Your equation should include the old righting arm ( $G_0Z_0$ ) and the angle of heel ( $\phi$ ).

## **IMPORTANT!!**

Before you can start the lab, you will need the information you acquired from the Inclining Experiment (Lab 3). Remember, you should use the **same 27-B-1 model** for all your EN400 laboratories

**27-B-1 model number from Lab 3:** \_\_\_\_\_

**KG<sub>light</sub> you calculated from Lab 3:** \_\_\_\_\_

# EN400

## LAB #4

### RIGHTING ARM - VERTICAL AND TRANSVERSE SHIFTS IN THE CENTER OF GRAVITY

#### Instructions

1. This lab is conducted in the Hydromechanics Lab on the ground floor of Rickover Hall.
2. Prior to arriving, read through the lab procedure so that you are familiar with the steps necessary to complete the lab.
3. Bring this handout, the completed pre-lab, and a calculator to the lab.
4. The lab is to be performed in small groups of 2 or 3. Your instructor will specify whether the group or each individual must submit the completed lab.
5. Follow the stages of the lab in consecutive order. The lab follows a logical thought pattern and jumping ahead without completing the intervening theory questions will limit your understanding of the concepts covered.
6. For full credit, all work must be shown on the lab. Show generalized equations, substitution of numbers, units, and final answers.
7. Keep your workstation (including the floor) clean and dry. Ensure all equipment and the models are returned to their original location when you complete the lab.

#### Student Information:

Name(s): \_\_\_\_\_

Section: \_\_\_\_\_

Date: \_\_\_\_\_

## Apparatus

1. Before beginning the experiment, ensure the 27-B-1 model number corresponds with the number on the solid floored tank, the protractor and the tank. **This should be the same as the model used in the Inclining Experiment (Lab 3).**

27-B-1 model number = \_\_\_\_\_ Lab 3  $KG_{light}$ : \_\_\_\_\_

## Light-ship Condition

The first step is to ensure the model 27-B-1 is in its light-ship condition. This is achieved by the following:

- Ensure all detachable weights are off the model (4 x 0.2 lb weights and pendulum apparatus). **Do not** remove the transverse weights used to adjust list.
- Ensure there is no loose water within the central compartment.
- Ensure the **solid floored tank** with its solid side down is securely installed in the center compartment.

## Normally Loaded Condition

The model must then be loaded to achieve its normally loaded condition. All quantities concerning the model can then have the suffix 'normal' once it has been loaded. The load consists of the following:

- Protractor device
- One weight (1.5 lb) mounted on the center post

2. Complete the table below, loading the model to its normally loaded condition.

Light-ship Condition	$\Delta_{light}$ (lb)		$KG_{light}$ (in)	
Protractor Device	$w_{protractor}$ (lb)		$Kg_{protractor}$ (in)	
1.5 lb Weight	$w_{1.5}$ (lb)		$Kg_{1.5}$ (in)	
Normally Loaded Condition	$\Delta_{normal}$ (lb)		$KG_{normal}$ (in)	

## Curve of Static Stability for Normally Loaded 27-B-1 Model

The stability lab can now begin. Perform the following steps:

- Secure all the weights and protractor on the model. Ensure the hatch cover is correctly fastened to avoid water entering while model is capsized.
- Float the model in its normally loaded condition so that its pins are inserted in the grooves on the tank.



- Connect the wire from the circular disc to the force gauge making sure it passes around the groove in the circumference of the plate.
- With the wire in a slack condition ( $F_{\text{wire}} = 0 \text{ lb}$ ), make sure the model is floating upright. Alter the locations of the transverse weights to achieve this.
- Zero the force gauge and **ensure the metallic button is depressed during the entire experiment.**

3. Heel the model to starboard, recording the force  $F_{\text{wire}}$  at 5 degree increments.

Starboard Measurements			Starboard Measurements Continued		
Angle of Heel $\phi$ (degrees)	Force in the Wire $F_{\text{wire}}$ (lb)	Righting Arm GZ (in)	Angle of Heel $\phi$ (degrees)	Force in the Wire $F_{\text{wire}}$ (lb)	Righting Arm GZ (in)

### Righting Arm After Vertical Rise in G

A vertical change in the Center of Gravity can now be created by inverting the solid floored tank. **Invert the tank** and re-assemble the model including all its weights.

4. The effects of a rise in Center of Gravity can be calculated prior to starting the experiment. Calculate  $KG_{\text{vertical}}$ . ( $W_{\text{tank}} = 2.2 \text{ lb}$ ,  $K_{\text{gtank}}$  before the inversion = 3 inches,  $K_{\text{gtank}}$  after the inversion = 5 inches)

5. Now determine the expected righting arm (**GZ**) for this vertical change in gravity by completing the table below.

Angle of Heel $\phi$ (degrees)	Normally Loaded Righting Arm, $G_0Z_0$ (in) <i>from step 3, above</i>	Sine Correction Term (in)	Corrected Righting Arm, $G_1Z_1$ (in)
0			
15			
30			
45			

6. Repeat the process you performed earlier to find the curve of static stability. Use the table below to record the data. (Record only what the instruments tell you, you should not be influenced by the calculated values obtained earlier.)

Starboard Measurements		
Angle of Heel $\phi$ (degrees)	Force in the Wire $F_{wire}$ (lb)	Righting Arm $GZ$ (in)

Starboard Measurements Continued		
Angle of Heel $\phi$ (degrees)	Force in the Wire $F_{wire}$ (lb)	Righting Arm $GZ$ (in)

7. Comment upon any differences between the calculated data points for the inverted righting arm with those found experimentally. \_\_\_\_\_

\_\_\_\_\_

8. Has this proved or disproved the accuracy of the sine correction? \_\_\_\_\_  
 Why? \_\_\_\_\_

**Righting Arm after a Transverse Shift**

Now the model can be moved into its transversely loaded condition. Give the model a starboard list by moving only the 1.5 lb weight. All quantities concerning the model can then have the suffix ‘trans’ once these weights have been shifted. **Leave the floor in the inverted position.**

9. Record the initial angle of list below. **Remember: starboard angles are positive, port angles are negative!**

Initial Angle of List (Degrees)	
---------------------------------	--

10. The effects on stability of a transverse shift in the center of gravity can be calculated prior to the collection of data. Calculate the new TCG after a weight shift.

11. Now determine the expected righting arm for this transverse shift in the center of gravity by completing the table below. (Record only what the instruments tell you, you should not be influenced by the calculated values obtained earlier.)

Angle of Heel $\phi$ (degrees)	Righting Arm From Vertical Shift $G_1Z_1$ (in) <i>from step 6, above</i>	Cosine Correction Term (in)	Corrected Righting Arm $G_2Z_2$ (in)
0			
15			
30			
45			



13. Comment upon any differences between the calculated data points for the corrected righting arm with those found experimentally. \_\_\_\_\_  
\_\_\_\_\_
14. Has this proved or disproved the accuracy of the cosine correction? \_\_\_\_\_  
Why? \_\_\_\_\_

### Summary

15. Using your experimental data from all three conditions, complete the following table.

Condition	Normally Loaded (Stbd heeling)	Vertical Shift (Stbd heeling)	Transverse Stbd Shift (Stbd heeling)	Transverse Port Shift (Stbd heeling)
Range of Stability (Deg)				
Maximum Righting Arm (in)				
Angle of Max GZ (Deg)				

16. What deduction can you make regarding the effect of an increase in KG on the stability of a ship? \_\_\_\_\_  
\_\_\_\_\_
17. What deduction can you make about the overall stability of a ship when heeling in the direction of a transverse weight shift? \_\_\_\_\_  
\_\_\_\_\_
18. What deduction can you make about the overall stability of a ship when heeling away from the direction of a transverse weight shift? \_\_\_\_\_  
\_\_\_\_\_
19. Plot all the experimental and calculated data in Excel on single plot. Include the normal, vertical shift, and transverse shift heeling conditions including the predictions from parts 5 and 11. **Ensure each curve is clearly labeled. Remember to label your axis and title your plot correctly.**

# EN400

## LAB #5 PRELAB

### FREE SURFACE EFFECT and DAMAGE STABILITY

#### Instructions:

1. The prelab covers theories that will be examined experimentally in this lab.
2. The prelab is to be completed and handed in to your instructor at the beginning of the lab period.
3. If you can, answer the questions without referring to your notes. Only refer to your notes if you are confused or fail to understand a concept. This will greatly improve your understanding of the concepts this lab is designed to reinforce.
4. By conscientiously completing this prelab, you will have a thorough understanding of what the lab is trying to show. Your lab performance will be maximized.
5. For full credit, all work must be shown. Show generalized equations, substitution of numbers, units, and final answers. Engineering relies on communication. Work that is neat and shows logical progression is much easier to grade.

#### Student Information

Name(s): \_\_\_\_\_

Section: \_\_\_\_\_

Date: \_\_\_\_\_

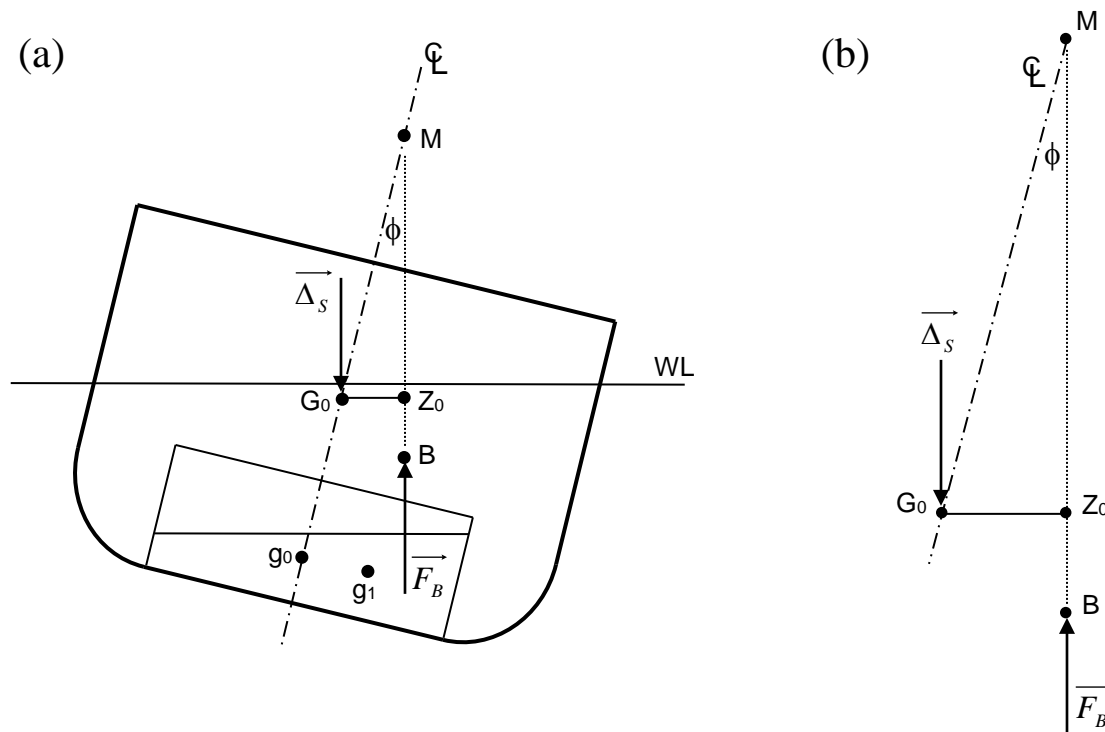
## Lab Apparatus

The apparatus used in this lab is exactly the same as for Labs 3 and 4. In this lab, the curve of intact static stability will be constructed for three conditions:

- Single compartment free surface tank within the model's central compartment
- Double compartment free surface tank within the model's central compartment
- Single compartment free surface tank combined with a transverse weight shift

## Theory

In this lab a free surface will be produced using half-full tanks of dyed water. The effect that the free surface has on the curve of intact static stability will be measured and compared with the normal loading condition. It is possible to predict this effect by an analysis of the heeling ship shown in Figure 1.



**Figure 1** (a) Ship heeling with partially filled tank, (b) enlarged view.

1. On the enlarged view of the heeling diagram in Figure 1, sketch the following:
  - a. The approximate location of the center of gravity of the ship created by the movement of fluid in the tank from  $g_0$  to  $g_1$ . Label this centroid  $G_1$ .
  - b. The new righting arm  $G_1Z_1$ .

2. With reference to Figure 1:
- a. What would happen to the location of  $G_I$  if the ship were heeling by an equal amount to port?
- 
- b. Would the overall stability be the same or different for starboard or port heeling?
- 

Free surface can also be seen as virtual rise of the ship's center of gravity,  $G_V$ , although the free surface actually causes a transverse shift in the center of gravity.

3. On Figure 1, label the virtual center of gravity,  $G_V$ , corresponding to the transverse weight shift caused by the free surface.
4. The distance  $G_O G_V$  is the virtual rise in the center of gravity and is called the "free surface correction" (FSC). Give the equation for the free surface correction.
5. Most ship tanks have rectangular cross sections. Find the equation for the 2<sup>nd</sup> moment of area about the tank centerline, ( $i_t$ ).

The distance  $G_V M$  is called the "effective metacentric height" ( $GM_{\text{eff}}$ ), and the ship will exhibit stability characteristics as if this were its real metacentric height.

6. Write the expression for the effective metacentric height ( $GM_{\text{eff}}$ ) in terms of  $KM_T$ ,  $KG$ , and FSC in the box below.
7. If the tank in Figure 1 were divided longitudinally into two tanks, how would this affect the effect of the free surface?
- 
-



8. In the box below, write an expression for the effective metacentric height if the single tank in Figure 1 were divided longitudinally into two separate tanks of equal width (*tank 1* and *tank 2*).

9. In Lab 4, you saw the effect that a transverse shift in the center of gravity had on the model's stability characteristics. What effect would a transverse shift in the center of gravity combined with a free surface have on the stability of a ship?

---

---

---

## IMPORTANT!!

Before you can start the lab, you will need the information you acquired from Lab 3 & 4. Remember, you should use the **same 27-B-1 model** for all your EN400 laboratories

**27-B-1 model number from Lab 3 & 4:** \_\_\_\_\_

**$\Delta_{\text{normal}}$  and  $\text{KG}_{\text{normal}}$  from Lab 4, step 2:** \_\_\_\_\_

**Righting Arm for  $0^\circ$ ,  $15^\circ$ ,  $30^\circ$ ,  $45^\circ$  heeling angles from Lab 4, step 3:** \_\_\_\_\_

**Angle of list due to transverse shift of 1.5 lb weight from Lab 4, step 9:** \_\_\_\_\_



**Plot the Curve of Intact Static Stability** for the model in normally loaded condition, with data from Lab 4. This plot is required to compare the stability characteristics of the model in its normally loaded condition and its characteristics with a free surface.

# EN400

## LAB #5

### FREE SURFACE EFFECT and DAMAGE STABILITY

#### Instructions:

1. This lab is conducted in the Hydromechanics Lab on the ground floor of Rickover Hall.
2. Prior to arriving in the Hydro Lab, read through the lab procedure so that you are familiar with the steps necessary to complete the lab.
3. Bring this handout, the completed prelab, and a calculator to the lab.
4. The lab is to be performed in small groups of 2 or 3. Your instructor will specify whether the group or each individual must submit the completed lab.
5. Follow the stages of the lab in consecutive order. The lab follows a logical thought pattern and jumping ahead without completing the intervening theory questions will limit your understanding of the concepts covered.
6. For full credit, all work must be shown on the lab. Show generalized equations, substitution of numbers, units, and final answers.
7. Keep your workstation (including the floor) clean and dry. Ensure all equipment and the models are returned to their original location when you complete the lab.

#### Student Information:

Name(s): \_\_\_\_\_

Section: \_\_\_\_\_

Date: \_\_\_\_\_

## Part 1: Free Surface Effects in Tanks

### Setup

1. Before beginning the experiment, ensure the 27-B-1 model number corresponds with the number on the solid floored tank, the protractor and the tank. **This should be the same as the model used in Lab 3 & 4.**

27-B-1 model number = \_\_\_\_\_

You should have three different tanks at your work station: the solid floored tank, a single compartment free surface tank, and a double compartment free surface tank.

2. For accurate comparisons to be made between the normally loaded condition and these three conditions (single, double, and damaged), the model must have approximately the same displacement and same KG at zero degrees of heel as the model in its normally loaded condition. Using the scale, find the weight of the 3 tanks and complete the table:

Tank:	Solid Floor	Single Compartment	Double Compartment
Weight (lb)			

3. From the geometry of the three tanks, would you estimate their centers of gravity to be in the same location or in different locations? \_\_\_\_\_
4. Before beginning the series of measurements, the displacement and KG of the normally loaded model as determined in Lab 4 should be recorded below:

Normally Loaded Condition	$\Delta_{\text{normal}}$ (lb)		KG <sub>normal</sub> (in)	
---------------------------	-------------------------------	--	---------------------------	--

### Single Compartment Condition

5. Calculate the effective metacentric height,  $GM_{\text{eff}}$ , with the single tank compartment.



8. How has the presence of a free surface affected the model's stability?  
\_\_\_\_\_
9. What happened to the center of gravity to cause this decrease in stability?  
\_\_\_\_\_
10. Do your calculated righting arms agree with your experimental results? \_\_\_\_\_  
Why? \_\_\_\_\_  
\_\_\_\_\_

**Double Compartment Condition**

11. Load the double tank compartment in the model. Now calculate the effective metacentric height,  $GM_{eff}$ , with the double tank compartment.
12. With the double compartment tank installed in the model's center compartment and deck weights on the centerline post, heel the model to starboard and record heeling data in the table below. Ensure you record the capsizing angle.

Starboard Measurements		
Angle of Heel (degrees)	Force in the Wire (lb)	Righting Arm (in)

Starboard Measurements Continued		
Angle of Heel (degrees)	Force in the Wire (lb)	Righting Arm (in)

13. Compare the stability for the model in the normally loaded, single compartment, and double compartment conditions.

<b>Starboard Heel Stability Comparison</b>			
<b>Condition</b>	<b>Normally Loaded</b>	<b>Single Compartment</b>	<b>Double Compartment</b>
Range of Stability (degrees)			
Maximum Righting Arm (inches)			
Maximum Righting Moment (in-lb)			
Angle of Maximum Righting Arm (deg)			

14. In which condition is the model most stable? \_\_\_\_\_  
 Why? \_\_\_\_\_
15. In which free surface condition is the model more stable? \_\_\_\_\_  
 Why? \_\_\_\_\_

## Part 2: Damage Stability

One of the worst scenarios for ship damage with respect to stability is the presence partially flooded compartment off centerline. The combined effect of a transverse weight addition and the free surface effect results in an exaggerated list angle and a dramatic decrease in overall stability.

To model an off-centerline free surface damaged condition, configure the 27-B-1 model as follows:

- Place the single compartment free surface tank in the model's center compartment.
- Place the 1.5 lb weight on the starboard weight post.

16. For the model's damaged condition:
- Record the model's initial angle of list: \_\_\_\_\_
  - How does this compare to the angle of list in created in Lab 4? \_\_\_\_\_

17. Heel the model (in the starboard direction) through its range of stability to find its curve of intact static stability in the damaged condition and record heeling data.

Starboard Measurements		
Angle of Heel $\phi$ (degrees)	Force in the Wire $F_{wire}$ (lb)	Righting Arm GZ (inches)

Starboard Measurements Continued		
Angle of Heel $\phi$ (degrees)	Force in the Wire $F_{wire}$ (lb)	Righting Arm GZ (inches)

18. From your data, complete the following table:

Starboard Heel Stability Comparison			
Condition	Normally Loaded	Single Compartment	Damaged Condition
Range of Stability (degrees)			
Maximum Righting Arm (inches)			
Maximum Righting Moment (in-lb)			
Angle of Maximum Righting Arm (deg)			

19. How has the off-center damaged condition affected the model's stability?

---



---



---

20. Counter-flooding, the intentional flooding of a tank or compartment, is occasionally used in response to damage, however, counter-flooding can render the ship even less stable. Based on your knowledge of hydrostatics and ship stability, describe the possible positive and negative effects of counter-flooding on ship survivability.

---

---

---

---

---

21. Plot the righting arm data for the normal, single (calculated and experimental), double, and damaged compartment on a single plot using Excel. **Label your title, axes and data correctly.**



# EN400

## LAB #6

### MATERIALS AND MATERIALS TESTING

#### Instructions

1. This lab is conducted in the Mechanical Engineering Materials Lab, on the ground floor of Rickover Hall, **Ri-025**.
2. Prior to arriving, read through the lab procedure so that you are familiar with the steps necessary to complete the lab.
3. Bring this handout and a calculator to the lab.
4. The lab is to be performed as a whole class. Your instructor will specify whether each small lab group or each individual must submit the completed lab.
5. Follow the stages of the lab in consecutive order. The lab follows a logical thought pattern and jumping ahead without completing the intervening theory questions will limit your understanding of the concepts covered.
6. For full credit, all work must be shown on the lab. Show generalized equations, substitution of numbers, units, and final answers.

#### Student Information:

Name(s): \_\_\_\_\_

Section: \_\_\_\_\_

Date: \_\_\_\_\_

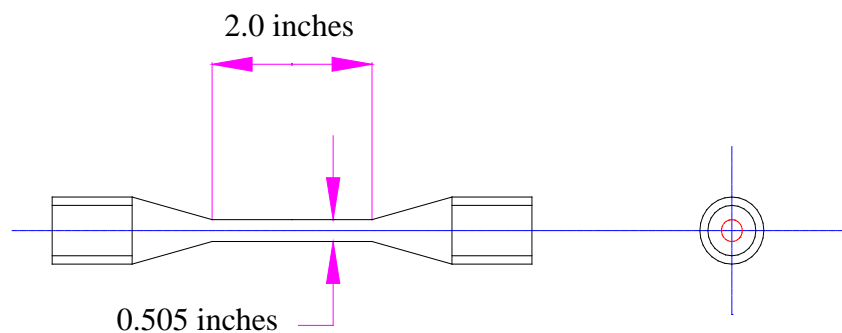
**Note: This lab does not have a pre-lab.**

## Part 1: Material Properties

### Strength

Recall that the strength of a material is defined as “a *measure of a materials ability to resist deformation and maintain its shape.*”

1. This is quantified in terms of yield stress ( $\sigma_y$ ) or ultimate tensile stress ( $\sigma_{UTS}$ ). Sketch a stress/strain diagram for a material showing these 2 quantities.
2. During the Instron machine tensile test demonstration, the output consists of a plot of force (lb) against elongation (in). These values are converted into stress and strain.
  - a. Give the equation that links the force,  $F$  (lb), to the stress,  $\sigma$  (psi), it is creating in a material.
  - b. Give the equation that links elongation,  $e$  (in), to the strain,  $\epsilon$  (in/in), created in a material.
3. The standard sample used in the Instron machine is drawn in Figure 1. It consists of a cylinder exactly 2 inches long with a cylindrical diameter of 0.505 inches.



**Figure 1** The Standard Material Sample

4. Use the specimen's dimensions, the force/elongation plots observed in class and equations in problem 2. to complete the following.

<b>Material:</b>	<b>1018 Steel</b>	<b>1045 Steel</b>	<b>2024 Aluminum</b>
Force at which material yields (lb)			
Yield Stress, $\sigma_y$ (psi)			
Maximum force (lb)			
Ultimate Tensile Stress, $\sigma_{UTS}$ (psi)			

5. From this data, which material has the highest  $\sigma_{UTS}$ ? \_\_\_\_\_  
 Which material has the lowest  $\sigma_{UTS}$ ? \_\_\_\_\_

### Ductility

Ductility is defined as follows: “a measure of a materials ability to deform before failure.”

It can be quantified by reading the value of strain at the fracture point ( $\epsilon_f$ ) or by calculating the reduction of cross-sectional area at fracture as a percentage of the original cross-sectional area. To enable the last calculation to be performed the diameters of the standard sample after fracture needs to be known.

6. Using the above information and lab data, complete the following:

<b>Material:</b>	<b>1018 Steel</b>	<b>1045 Steel</b>	<b>2024 Aluminum</b>
Diameter at Fracture (in)			
Elongation at Fracture (in)			
Strain at Fracture (in/in)			
Final X-Sectional Area, $A_f$ (in <sup>2</sup> )			
Loss in X-Section Area, $A_l$ (in <sup>2</sup> )			
% Reduction in Cross-Sec Area			

7. From this data, which material is the most ductile? \_\_\_\_\_  
 Which material is the least ductile? \_\_\_\_\_

## Toughness

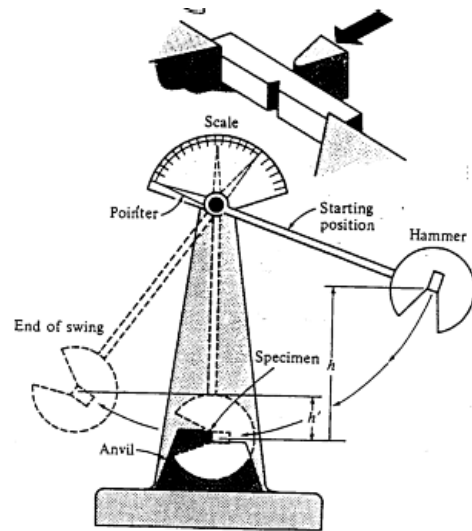
Toughness is defined as: “.....a measure of a material’s ability to absorb energy.” In fact, there are two measurements of toughness.

8. Material toughness can be found from force/elongation diagrams.
  - a. How is it calculated? \_\_\_\_\_  
\_\_\_\_\_
  - b. What are the units of toughness when measured this way? \_\_\_\_\_

Toughness can also be measured from a Charpy V-notch test, shown in Figure 2. This is a test that measures the energy absorbed by a material when fractured by a sudden impact.

Impact toughness is determined from finding the difference in potential energy before and after the hammer fractures the material. The Charpy V-notch test will be demonstrated in lab.

The weight of Charpy Apparatus hammer is 55 lb.  
The initial height of the hammer is 57.625 in.



**Figure 2** Charpy V-notch Test Apparatus

9. Using the potential energy equation ( $PE = m \cdot g \cdot h$ ), complete the table.

Initial E – Impact Toughness = Final E

	<i>Calc</i>	<i>Record</i>	<i>Calc</i>	<i>Calc</i>
<b>Material:</b>	<b>Initial Potential E (ft-lb)</b>	<b>Impact Toughness (ft-lb)</b>	<b>Final Potential E (ft-lb)</b>	<b>Final Height of Hammer (in)</b>
<b>1018 Steel</b>				
<b>1045 Steel</b>				
<b>Cold 1018 Steel</b>				
<b>2024 Aluminum</b>				

10. From this data, which material has the highest impact toughness? \_\_\_\_\_  
Which material has the lowest impact toughness? \_\_\_\_\_
11. Sketch the impact toughness against temperature curve for a regular steel. Make sure you label the axis correctly. Show where the material is behaving with brittle behavior and ductile behavior and indicate the transition temperature.
12. Of the 2 measures of toughness:
- Which measurement would be most relevant to a submarine hull as it slowly increases its depth? \_\_\_\_\_
  - Which measurement would be most relevant to a submarine hull when subjected to an underwater explosion? \_\_\_\_\_

### **Fatigue Testing**

13. What is the purpose of fatigue testing? \_\_\_\_\_  
\_\_\_\_\_
14. In the space below, sketch the plot obtained from a fatigue test at a number of different stress levels for steel and aluminum. Ensure you label the axis correctly and show any significant points.

15. Using the information in this sketch, what advantage does steel have over aluminum as a structural material? \_\_\_\_\_

\_\_\_\_\_

**Hardness**

Hardness is defined as “a measure of a material’s ability to resist indentation, abrasion & wear”

16. How is the hardness of a material measured? \_\_\_\_\_

\_\_\_\_\_

17. How is this related to the strength of a material? \_\_\_\_\_

\_\_\_\_\_

As a class, we will measure the hardness of 1018 and 1045 steel Charpy samples, using a Rockwell Indenter. To ensure an accurate hardness measurement, we must maintain a minimum spacing of 3 ball diameters from all sample edges and previous indents (this prevents our measurements from being influenced by edge effects and prior strain hardening).

18. Complete the table below. Estimate  $\sigma_{UTS}$  using the hardness-to-strength conversion chart in the lab.

	Hardness Readings: Rockwell Scale _____	Average Hardness Readings	Approximate $\sigma_{UTS}$
1018 Steel			
1045 Steel			

19. Compare your results for  $\sigma_{UTS}$  with those obtained from the tensile test portion of the lab.

## Part 2: Non-Destructive Testing

20. For the following non-destructive testing techniques, describe the type of material flaws and faults that they can find and one operational disadvantage they incur.

<b>Non-Destructive Testing</b>	<b>Material Flaws Detected</b>	<b>Disadvantage</b>
Radiographic		
Eddy Current		
Ultrasonic		
Magnetic Particle		
Visual / Dye Penetrant		

## Part 3: 3-D Printing

21. List two advantages of 3-D fabrication techniques over traditional (subtractive) fabrication methods.

22. **Fused Filament Fabrication (FFF)**. Describe, in your own words, the physical methods and mechanisms by which this fabrication technique produces a 3-D part.
23. **Stereolithography (SLA)**. Describe, in your own words, the physical methods and mechanisms by which this fabrication technique produces a 3-D part.
24. **Laser Powder Bed Fusion (L-PBF)**. Describe, in your own words, the physical methods and mechanisms by which this fabrication technique produces a 3-D part.



# EN400

## LAB #7

### HULL RESISTANCE and EFFECTIVE HORSEPOWER

#### Instructions

1. This lab is conducted in the Hydromechanics Lab on the ground floor of Rickover Hall.
2. Prior to arriving, read through the lab procedure so that you are familiar with the steps necessary to complete the lab.
3. Bring this handout and a calculator to the lab.
4. The lab is to be performed as a whole class. Your instructor will specify whether each small lab group or each individual must submit the completed lab.
5. Follow the stages of the lab in consecutive order. The lab follows a logical thought pattern and jumping ahead without completing the intervening theory questions will limit your understanding of the concepts covered.
6. For full credit, all work must be shown on the lab. Show generalized equations, substitution of numbers, units, and final answers.

#### Student Information:

Name(s): \_\_\_\_\_

Section: \_\_\_\_\_

Date: \_\_\_\_\_

**Note: This lab does not have a pre-lab.**

## Apparatus

The following model and ship data for the USNA YP is provided:

Model Data	Full-Scale Ship Data
Length between perpendiculars ( $L_M$ ) = 5 ft	Length between perpendiculars ( $L_S$ ) = 101.65 ft
Fresh water at 65°F	Salt water at 59°F

**Table 1** YP Data

## Background

Ship resistance is a function of many factors. Some factors include ship speed, hull form and size, displacement, hull fouling, water temperature, waves, current, and wind.

In the design of a ship, many towing tank tests of a model geometrically similar to the full-scale ship are performed to determine the ship's horsepower requirements and performance characteristics. Tests are done on several hull designs in order to select the "best" hull to be constructed. A carefully planned and executed series of model tests, although somewhat expensive, is extremely beneficial and cost efficient in selecting the final design of a ship's hull. Data collected on a model can be scaled up to predict the full-scale ship's performance.

Instead of testing a potential design for a ship, this lab will use an established hull design, the USNA YP, and will concentrate on the effect of an increase in ship displacement on the power required to propel the ship through the water.

Throughout the life of a ship, its displacement will change, whether through fuel and water consumption or because of equipment additions. History has shown that a ship's displacement (especially warships) will increase 10-15% over the life of a ship.

## Components of Hull Resistance

In the laboratory, the two most important components of hull resistance are viscous and wave making resistance. Mathematically, this is written as:

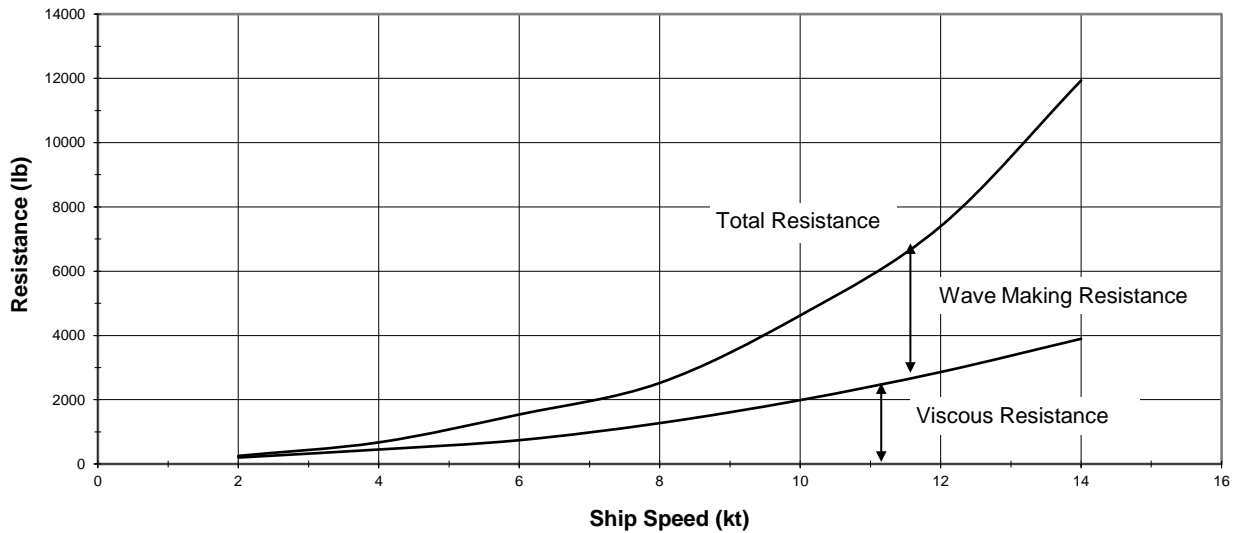
$$R_T = R_V + R_W$$

where:  $R_T$  = total hull resistance, lb  
 $R_V$  = viscous resistance, lb  
 $R_W$  = wave making resistance, lb

1. Figure 1 is a graph showing the components of resistance for a YP hull. Note how the wave making component of resistance increases as speed increases. At speeds of 4, 8, and 14 knots, what percentage of the total resistance can be attributed to wave making?

4 knots: \_\_\_\_\_ 8 knots: \_\_\_\_\_ 14 knots: \_\_\_\_\_

**Components of YP Hull Resistance**



**Figure 1** Components of YP total hull resistance

The “Hull Speed” of a ship is the speed at which the wavelength is equal to the length of the ship. Just above this speed, displacement ships experience a large increase in resistance. The hull speed (in knots) is as follows:

$$V_{HULL} = 1.34 \sqrt{LWL}$$

$LWL$  = Length of the waterline (ft) ( $\approx L_{PP}$ )

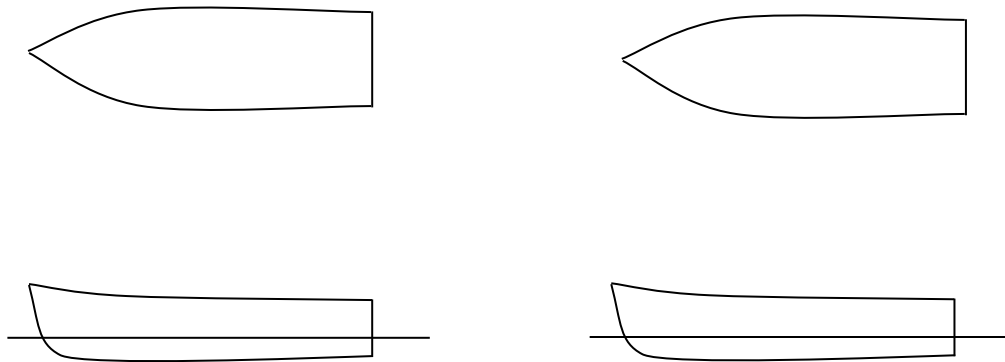
1.34 is a constant in units of  $\frac{kt}{\sqrt{ft}}$  (typically referenced as “the speed-to-length ratio”)

2. Calculate the  $V_{HULL}$  of the YP and plot it on Figure 1.

**Resistance for  $\Delta_s = 172 \text{ LT}$**

The model will now be towed in the tank at scaled speeds ( $V_m$ ) corresponding to full-scale ship speeds ( $V_s$ ) of 4, 7, 12, and 14 knots. Carefully observe the wave patterns created by the model.

3. In Figure 2, sketch the transverse and divergent wave patterns at speeds of 4 and 14 kts.



**Figure 2** Diagram of YP wake patterns at speeds of 4 and 14 knots.

4. A very good approximation of the total hull resistance for a ship is to multiply the total hull resistance of the model by the cube of the scale factor. Using the experimental data and this relationship, complete the table:

$$R_{TS} \cong R_{TM} \lambda^3$$

Recall:

$$\lambda = L_S/L_M \quad V_M = \frac{V_S}{\sqrt{\lambda}} \quad 1 \text{ knot} = 1.688 \text{ ft/s} \quad EHP = \frac{R_{TS} V_S}{550 \frac{\text{ft-lb}}{\text{s-HP}}}$$

where,  $\lambda$  = scale ratio

$EHP$  = Effective Horsepower

$L_S$  = length of ship (ft)

$L_M$  = length of model (ft)

$R_{TS}$  = total resistance of the ship (lb)

$R_{TM}$  = total resistance of the model (lb)

$V_S$  = speed of the ship (ft/s)

$V_M$  = speed of the model (ft/s)

<b>YP Resistance and EHP Data at <math>\Delta_s = 172 \text{ LT}</math></b>					
<b><math>V_S</math> (kt)</b>	<b><math>V_S</math> (ft/s)</b>	<b><math>V_M</math> (ft/s)</b>	<b><math>R_{TM}</math> (lb)</b>	<b><math>R_{TS}</math> (lb)</b>	<b>EHP (HP)</b>
<b>4</b>					
<b>7</b>					
<b>12</b>					
<b>14</b>					

**Table 2** Speed and resistance data

5. Show your understanding of these calculations by showing your work for a ship speed of 12 knots.

6. Why is the model being towed at speeds using the above equation (Froude's Law of Corresponding Speeds)?

---

---

7. Why does the model have a row of studs running vertically near its bow?

---

8. What are the advantages and disadvantages to using a larger model? \_\_\_\_\_

---

A smaller model? \_\_\_\_\_

---

**Resistance for  $\Delta_S = 139$  LT**

The following table contains bare hull EHP data for a YP at a displacement of 139 LT.

<b>YP EHP Data at <math>\Delta_S=139</math> LT</b>	
<b>Ship Speed, <math>V_s</math> (kt)</b>	<b>Effective Horsepower, EHP (HP)</b>
2	2
4	8
6	28
8	62
10	142
12	272
14	512

**Table 3** YP EHP Data

9. Plot your EHP results for 172LT and 139LT displacements using Excel. Submit Excel.
10. What happened to the effective horsepower of the YP after increasing its displacement to 172 LT? Why?

---

---

11. How does increasing speed affect the effective horsepower at a displacement of 172 LT? Specifically, what has happened to the horsepower requirement as speed increased from 4 to 7 knots, and from 12 to 14 knots?

---

---

12. The YPs were designed to have a maximum speed of 13.25 knots. Based on your data, explain why this value may have been chosen.

---

---

13. How would operating in shallow water affect the YP's effective horsepower?

---

## Added Resistance and Ship Hull Response in Regular Waves

To demonstrate how ocean waves affect resistance over and above calm water resistance, the model will now be towed at a constant speed corresponding to a full-scale speed of 12 knots in three different regular wave patterns. Full-scale wave height is approximately 4.2 ft (sea state 3). The three regular wave patterns will have the following characteristics:

- wave length five times the model's length
- wave length equal to the model's length
- wave length one-half the models length

14. During these runs, carefully observe the motion of the model, especially in pitch and heave. You will see a different response in each wave pattern. In the following table, record the dominant motion (pitch or heave) observed during each run.

YP Motion in Regular Waves		
Wave Pattern	$V_s$ (kt)	Dominant Response Motion
$L_{\text{wave}} = 5 \cdot L_M$	12	
$L_{\text{wave}} = L_M$	12	
$L_{\text{wave}} = \frac{1}{2} \cdot L_M$	12	

**Table 4** YP Motions

15. Which regular ocean wave pattern produced the largest amount of pitching motion?

---

16. Which regular ocean wave pattern produced the largest amount of heave motion?

---

17. Based on your observations of ship motion in the lab, list three factors, in addition to wavelength, that would affect the motion of a ship in waves.

a. \_\_\_\_\_

b. \_\_\_\_\_

c. \_\_\_\_\_

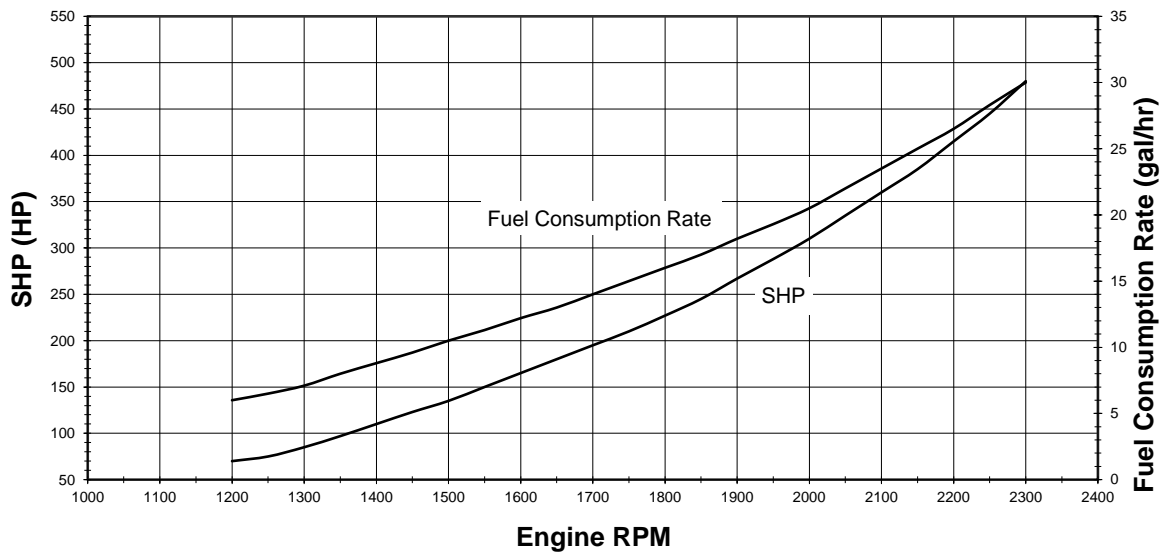
## Shaft Horsepower and Fuel Consumption

Once a ship's effective horsepower has been determined through model testing, the shaft horsepower required to drive the ship must be determined. Shaft horsepower is the value used when purchasing a ship's propulsion.

18. What element in the drive train causes the biggest propulsive losses? \_\_\_\_\_
19. YP's are equipped with two 437 HP diesel engines, each driving its own propeller shaft. Why would two engines be used instead of a single 875 HP engine driving a single propeller shaft?
- \_\_\_\_\_
- \_\_\_\_\_

Figure 3 is a plot representing the SHP and fuel consumption of a single propulsion engine. Use this plot to answer the remaining questions in this lab. To use the plot, use a desired SHP on the left axis, travel across to the curve labeled SHP, then down to the Engine RPM axis. At the discovered RPM, go up to the Fuel Consumption Rate curve, then travel right to find the Fuel Consumption Rate.

**YP Propulsion Diesel Engine SHP and Fuel Consumption**



**Figure 3** Shaft horsepower and fuel consumption data for a single YP diesel engine



20. From the experimental EHP data and assuming a propulsive coefficient of 55%, determine the total SHP required to travel in calm water at 10 and 12 knots for both displacements. Then, use Figure 3 to complete the following table:

<b>YP Fuel Consumption Table</b>						
$\Delta$ (LT)	$V_s$ (kt)	Total EHP (from plot)	Total SHP	SHP per Engine	Fuel Consumption Rate per Engine (gal/hr)	Total Fuel Consumption Rate (gal/hr)
139	10					
	12					
172	10					
	12					

**Table 5** YP Fuel Consumption

21. How has the increase in displacement affected the amount of fuel burned by the YP?

---



---

22. A YP is ordered to travel a distance of 1,800 nautical miles and arrive with 50% of 6,800 gallons of fuel onboard. Using two engines, at what speed must the YP travel in order to meet this requirement? (Use Table 1 and Figure 3)

<b>YP Engine RPM (2 engines)</b>	
<b>Engine (rpm)</b>	<b>Speed (kt)</b>
500	4
825	6
970	7
1125	8
1290	9
1460	10
1650	11
1850	12
2060	13
2100	13.25

**Table 6** YP Engine RPM

# EN400

## LAB #8

### PROPELLERS

#### Instructions

1. This lab is conducted in the Hydromechanics Lab on the ground floor of Rickover Hall.
2. Prior to arriving in the Hydro Lab, read through the lab procedure so that you are familiar with the steps necessary to complete the lab.
3. Bring this handout and a calculator to the lab.
4. The lab is to be performed as a class. Your instructor will provide submission instructions for the completed lab.
5. Follow the stages of the lab in consecutive order. The lab follows a logical thought pattern and jumping ahead without completing the intervening theory questions will limit your understanding of the concepts covered.
6. For full credit, all work must be shown on the lab. Show generalized equations, substitution of numbers, units, and final answers.
7. Wear hearing protection (provided by the lab staff) while the water tunnel is in operation.

#### Student Information:

Name(s): \_\_\_\_\_

Section: \_\_\_\_\_

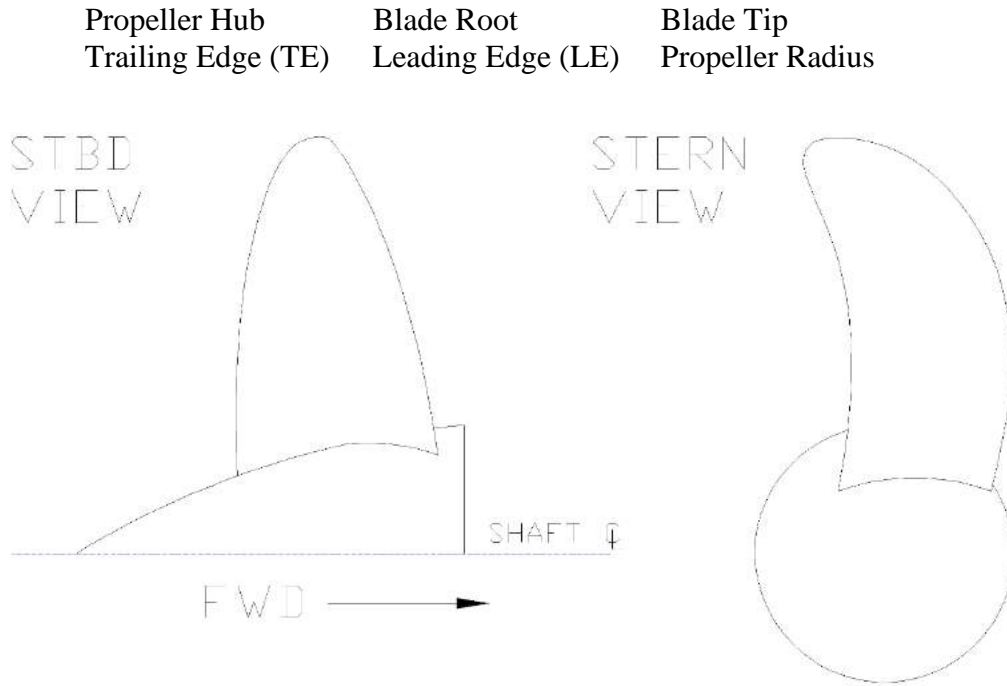
Date: \_\_\_\_\_

**Note: This lab does not have a Pre-Lab.**

# Part 1: Propeller Description

## Propeller Nomenclature

1. Label all of the following propeller parts on each of the two views provided in Figure 1. Only one blade has been drawn for clarity.



**Figure 1** Stbd and Stern Views of a Propeller Blade

2. What is meant by propeller pitch? \_\_\_\_\_  
\_\_\_\_\_
3. List two ways pitch can be measured.
  - a. \_\_\_\_\_
  - b. \_\_\_\_\_
3. Why are propellers twisted from hub to tip? \_\_\_\_\_  
\_\_\_\_\_
4. If a racing boat and a tug boat had the same powertrain, which would need more pitch in the propeller? \_\_\_\_\_

5. What is meant by a controllable pitch propeller (CPP)? \_\_\_\_\_  
\_\_\_\_\_
6. What advantage does CPP have over a fixed pitch propeller? (consider the whole drive train in your answer) \_\_\_\_\_  
\_\_\_\_\_
7. Considering a skewed propeller:
- a. What are its advantages? \_\_\_\_\_  
\_\_\_\_\_
- b. What are its disadvantages? \_\_\_\_\_  
\_\_\_\_\_
8. Sketch a highly skewed propeller and a propeller with no skew. **Ensure you show the direction of propeller rotation.**
9. Name 2 advantages provided by placing a propeller in a 'nozzle'?
- Advantage 1: \_\_\_\_\_
- Advantage 2: \_\_\_\_\_
10. What type of ships are often fitted with nozzles? \_\_\_\_\_

## Part 2: Circulating Water Channel Questions

### Cavitation

11. Sketch the cavitation pattern caused when blade tip cavitation is created.

12. Describe two problems created by cavitation.

Problem 1: \_\_\_\_\_

Problem 2: \_\_\_\_\_

13. What can the ship driver do to prevent the cavitation?

\_\_\_\_\_  
\_\_\_\_\_

14. One type of cavitation could not be demonstrated in the circulating water channel.

a. Name this type of cavitation. \_\_\_\_\_

b. What is it caused by? \_\_\_\_\_

c. How can it be prevented? \_\_\_\_\_

### Ventilation

15. What is ventilation? \_\_\_\_\_

\_\_\_\_\_

16. Give two ship conditions that could cause its propeller to ventilate.

Condition 1: \_\_\_\_\_

Condition 2: \_\_\_\_\_

# EN400

## LAB #9

### SEAKEEPING

#### Instructions

1. This lab is conducted in the Hydromechanics Lab on the ground floor of Rickover Hall.
2. Prior to arriving, read through the lab procedure so that you are familiar with the steps necessary to complete the lab.
3. Bring this handout and a calculator to the lab.
4. The lab is to be performed as a whole class. Your instructor will specify whether each small lab group or each individual must submit the completed lab.
5. Follow the stages of the lab in consecutive order. The lab follows a logical thought pattern and jumping ahead without completing the intervening theory questions will limit your understanding of the concepts covered.
6. For full credit, all work must be shown on the lab. Show generalized equations, substitution of numbers, units, and final answers.
7. Keep your workstation (including the floor) clean and dry. Ensure all equipment and the models are returned to their original location when you complete the lab.

#### Student Information:

Name(s): \_\_\_\_\_

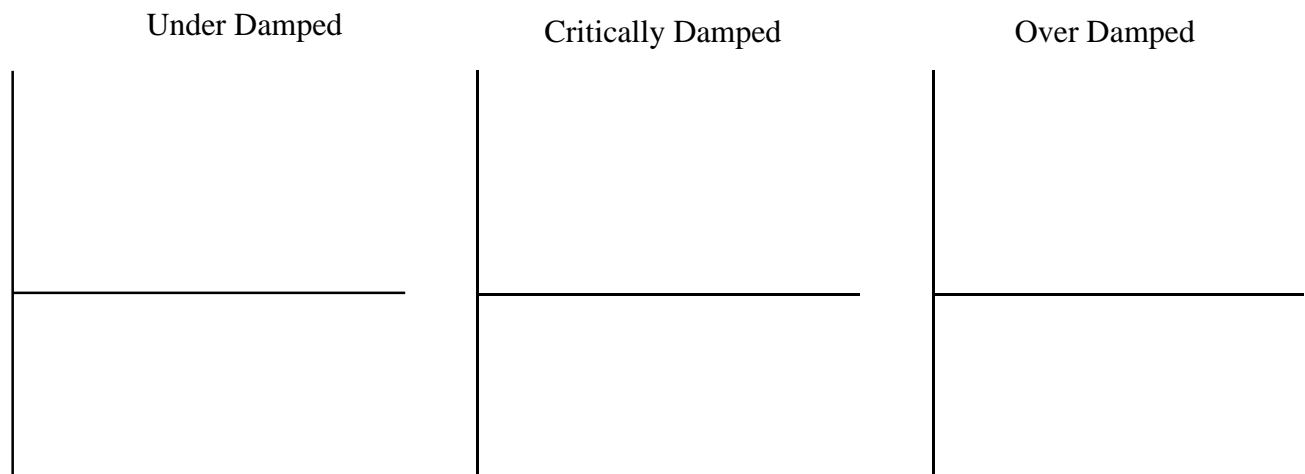
Section: \_\_\_\_\_

Date: \_\_\_\_\_

**Note: This lab does not have a pre-lab.**

## Part 1: General Questions

1. In your own words define “simple harmonic motion.”
2. Which of the six ship motions can exhibit simple harmonic motion?
3. What is unique about the motions that can exhibit simple harmonic motions?
4. In your own words, define “natural frequency” of a system.
5. In your own words, define a “forcing function” or “excitation force.”
6. What happens when the frequency of the forcing function is the same as the frequency of the natural frequency of the system?
7. In your own words, define “damping,” as related to simple harmonic motion.
8. On the axes below, sketch motion displacement against time. Label your axes



## Part 2: Mass/Spring System

### Apparatus

The apparatus for this part of the lab consists of a mass/spring system vertically aligned, per Figure 1. The vertical scale allows the motion displacement of the mass to be recorded.



**Figure 1** Mass/Spring System

### Theory

The equation that describes the natural period of heave without damping of a simple mass-spring system is:

$$T = 2\pi \sqrt{\frac{m}{k}}$$

where:      k is the spring force constant in lb/ft  
                  m is the mass of the system in lb-s<sup>2</sup>/ft  
                  T is the period in s

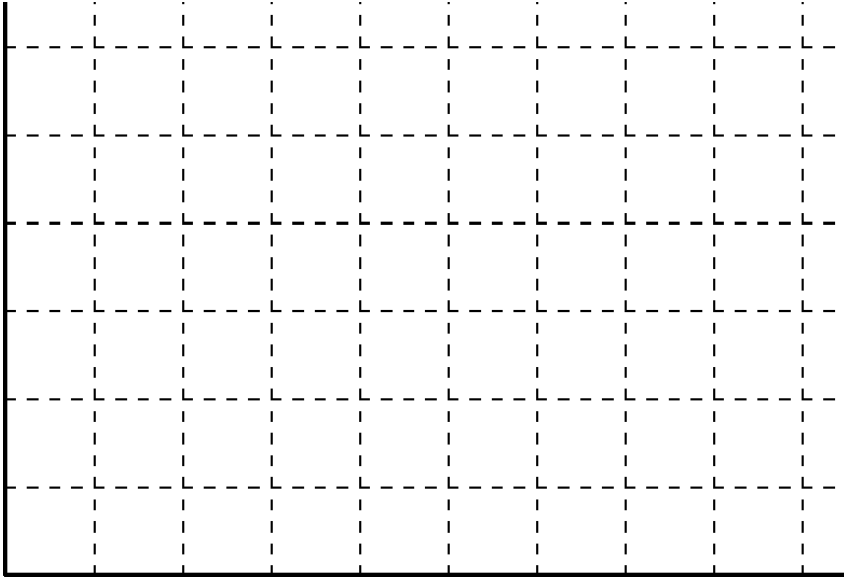
### Procedure

- Place different weights on the system and record the corresponding deflection in the table:  
(Note: the unloaded weight is appx 1.5 lb)

<b>Weight (lb)</b>						
<b>Displacement (in)</b>						



10. Plot this data on the grid below. **Ensure you label the axes correctly.**



12. Determine the slope of your plot and use it to calculate the spring constant,  $k$ .  
**(Hint:** Compare the units of the spring constant,  $k$ , with the units of the plot's slope.)
13. For a total weight of 2.5 lb on the mass/spring system, calculate its mass,  $m$ , in  $\text{lb}\cdot\text{s}^2/\text{ft}$ .
14. Use this data and the “Natural Period of Heave” equation to predict the period of oscillation for the mass/spring system.

$$T_{heave} = 2\pi \cdot \sqrt{\frac{m}{k}} \propto \sqrt{\frac{\Delta}{A_{WL}}}$$

15. Use the table below to find the period of oscillation of the mass/spring system. For each trial, record the time for at least 5 oscillations.

<b>Trial</b>	<b>Time for 5 Oscillations (s)</b>	<b>Period (s)</b>
<b>#1</b>		
<b>#2</b>		
<b>#3</b>		
<b>Average Period =</b>		

16. Calculate the percentage error of the experimentally found period of oscillation and that calculated.

### Follow-up Questions

17. The mass/spring system that has been analyzed can be used to model one of the ship motions. Which motion is this?
18. When modeled in this way, what ship parameter is equivalent to the mass,  $m$ ?
19. What ship parameter is equivalent to the spring constant,  $k$ ? (**Hint:** Consider units)
20. What damps the motion of the mass/spring system?
21. What damps the ship motions?
22. Which system (spring or ship) is subjected to the greater level of damping?

## Part 3: Roll Model

### Apparatus

This part of the lab is performed in the 120' towing tank. A ship model is tethered across the tank to prevent it from yawing or swaying down the tank. The model is instrumented to measure the amplitude of roll and heave motions.

### Theory

The equation that describes the natural period of roll of a ship is as follows:

$$T_{roll} = \frac{CB}{\sqrt{GM_T}}$$

where: C is the roll constant in s/ft<sup>0.5</sup>.  
B is the beam of the ship at the operating water line in ft.  
GM<sub>T</sub> is the metacentric height in ft.

The value of the roll constant C is usually found experimentally for each ship shape. If not known, a value of  $0.44 \frac{s}{\sqrt{ft}}$  is used.

### Procedure

23. Determine the roll period of the model and use this to find its metacentric height. This is often referred to as a “Sallying Experiment”. For each trial, record the time for at least 3 oscillations. **Wait for the water disturbance to subside between each trial.**

Trial	Time for 3 Roll Oscillations (s)	Roll Period (s)
#1		
#2		
#3		
Average Roll Period =		

24. Using the average roll period found above, calculate the metacentric height of the model.

25. Is the calculated metacentric height reasonable? \_\_\_\_\_

26. Using the value for the average roll period, calculate the natural frequency of the roll motion ( $\omega_{roll}$ ). Calculate this frequency in rad/sec.

Five wave systems will be created to simulate various encounter frequencies ( $\omega_e$ ). One encounter frequency will be at your computed value for natural frequency in roll and the rest will be above or below the natural frequency.

27. What frequency will produce the largest roll response from the model?

28. Observe the model response for each frequency and record the data.

Experiment	Wave Frequency	Roll Amplitude
#1		
#2		
#3		
#4		
#5		

29. How does the data agree with your prediction? \_\_\_\_\_

\_\_\_\_\_

30. Plot the response data in the area provided. Notice the response peak near the calculated natural frequency.

