

# INTRODUCTION TO ENGINEERING THERMODYNAMICS



*Claire Yu Yan*

University of British Columbia, Okanagan

# Introduction to Engineering Thermodynamics (Yan)

This text is disseminated via the Open Education Resource (OER) LibreTexts Project (<https://LibreTexts.org>) and like the hundreds of other texts available within this powerful platform, it is freely available for reading, printing and "consuming." Most, but not all, pages in the library have licenses that may allow individuals to make changes, save, and print this book. Carefully consult the applicable license(s) before pursuing such effects.

Instructors can adopt existing LibreTexts texts or Remix them to quickly build course-specific resources to meet the needs of their students. Unlike traditional textbooks, LibreTexts' web based origins allow powerful integration of advanced features and new technologies to support learning.



The LibreTexts mission is to unite students, faculty and scholars in a cooperative effort to develop an easy-to-use online platform for the construction, customization, and dissemination of OER content to reduce the burdens of unreasonable textbook costs to our students and society. The LibreTexts project is a multi-institutional collaborative venture to develop the next generation of open-access texts to improve postsecondary education at all levels of higher learning by developing an Open Access Resource environment. The project currently consists of 14 independently operating and interconnected libraries that are constantly being optimized by students, faculty, and outside experts to supplant conventional paper-based books. These free textbook alternatives are organized within a central environment that is both vertically (from advance to basic level) and horizontally (across different fields) integrated.

The LibreTexts libraries are Powered by [NICE CXOne](#) and are supported by the Department of Education Open Textbook Pilot Project, the UC Davis Office of the Provost, the UC Davis Library, the California State University Affordable Learning Solutions Program, and Merlot. This material is based upon work supported by the National Science Foundation under Grant No. 1246120, 1525057, and 1413739.

Any opinions, findings, and conclusions or recommendations expressed in this material are those of the author(s) and do not necessarily reflect the views of the National Science Foundation nor the US Department of Education.

Have questions or comments? For information about adoptions or adaptations contact [info@LibreTexts.org](mailto:info@LibreTexts.org). More information on our activities can be found via Facebook (<https://facebook.com/Libretexts>), Twitter (<https://twitter.com/libretexts>), or our blog (<http://Blog.Libretexts.org>).

This text was compiled on 01/29/2024

# TABLE OF CONTENTS

Licensing

About the Author

Acknowledgements

Preface

Nomenclature

## 1: Basic Concepts and Definitions

- 1.1: Chapter introduction and learning objectives
- 1.2: What is thermodynamics about?
- 1.3: System and surroundings
- 1.4: Extensive and intensive properties
- 1.5: State, process, and cycle
- 1.6: Chapter review

## 2: Thermodynamic Properties of a Pure Substance

- 2.1: Chapter introduction and learning objectives
- 2.2: Pure substance
- 2.3: Thermodynamic properties
- 2.4: Phase diagrams
- 2.5: Thermodynamic tables
- 2.6: Chapter review
- 2.7: Key Equations

## 3: Ideal and Real Gasses

- 3.1: Chapter introduction and learning objectives
- 3.2: Ideal gas and ideal gas equation of state
- 3.3: Real gas and compressibility factor
- 3.4: Chapter Review
- 3.5: Key Equations

## 4: The First Law of Thermodynamics for Closed Systems

- 4.1: Chapter introduction and learning objectives
- 4.2: Internal energy in a system
- 4.3: Heat transfer across a boundary
- 4.4: Work
- 4.5: The first law of thermodynamics for closed systems
- 4.6: Chapter review
- 4.7: Key equations

## 5: The First Law of Thermodynamics for a Control Volume

- 5.1: Chapter introduction and learning objectives
- 5.2: Enthalpy

- 5.3: Mass and energy conservation equations in a control volume
- 5.4: Applications of the mass and energy conservation equations in steady flow devices
- 5.5: Chapter review
- 5.6: Key equations

## 6: Entropy and the Second Law of Thermodynamics

- 6.1: Chapter introduction and learning objectives
- 6.2: Heat engine
- 6.3: Refrigerator and heat pump
- 6.4: The second law of thermodynamics- Kelvin-Planck and Clausius statements
- 6.5: Carnot cycles
- 6.6: Entropy and entropy generation
- 6.7: The second law of thermodynamics for closed systems
- 6.8: Specific entropy of a state
- 6.9: Applications of the second law of thermodynamics in closed systems
- 6.10: The second law of thermodynamics for open systems
- 6.11: Applications of the second law of thermodynamics in open systems
- 6.12: Chapter review
- 6.13: Key equations

## 7: Appendices

- 7.1: Appendix A - Thermodynamic Properties of Water
- 7.2: Appendix B - Thermodynamic Properties of Ammonia
- 7.3: Appendix C - Thermodynamic Properties of R134a
- 7.4: Appendix D - Thermodynamic Properties of Carbon Dioxide
- 7.5: Appendix E - Critical Properties of Selected Fluids
- 7.6: Appendix F - Triple Point of Selected Substances
- 7.7: Appendix G - Properties of Various Substances

[Index](#)

[Glossary](#)

[Detailed Licensing](#)

## Licensing

---

A detailed breakdown of this resource's licensing can be found in [Back Matter/Detailed Licensing](#).

## About the Author

---

Dr. Claire Yu Yan is an associate professor of teaching in the School of Engineering, Faculty of Applied Science, University of British Columbia, Okanagan. She teaches core engineering courses in the field of thermofluids, such as thermodynamics, fluid mechanics, fluid machinery, and heating, ventilation, and air conditioning (HVAC). In the past years, Dr. Yan has taught several thousands of students of diverse backgrounds. She has a strong passion for teaching innovations, in particular, open and engagement pedagogies and strives to make sustained contributions to support holistic student success and wellbeing through her teaching practices and scholarship of teaching and learning. Beyond teaching, Dr. Yan is an active contributor to UBC and the broader communities through her outreach program and committee work. Dr. Yan is a registered P.Eng. with EGBC (Engineers and Geoscientists BC), and a member of CEEA (Canadian Engineering Education Association) and ASEE (American Society for Engineering Education).

Email: [yu.yan@ubc.ca](mailto:yu.yan@ubc.ca)

Website: <https://engineering.ok.ubc.ca/about/contact/yu-claire-yan/>

## Acknowledgements

---

This book project is funded by UBC Okanagan ASPIRE-2040 Learning Transformations Fund (OER Stream). The author would like to thank two academic assistants, Amaiya Khardenavis and Wyatt Shenfield, for their help with book formatting and editing. The author would also like to thank the following colleagues, Donna Langille (UBC Okanagan library), Erin Fields (UBC Vancouver Library), Claire Swanson (UBC Vancouver Library), and Kristen Morgan (UBC Okanagan Centre for Teaching & Learning), for their continued support during the development of the book.



## Preface

---

This book aims to help students develop a fundamental understanding of classical thermodynamics and its engineering applications. It features concise explanations of key concepts, step-by-step engineering examples, and interactive practice problems at the end of each section.

The book consists of seven chapters. It is suitable for a one-term, introductory engineering thermodynamics course at the undergraduate level. It may also be used as self-learning materials or a supplement to other thermodynamics books.

### Chapter 1: Basic Concepts and Definitions

This chapter introduces basic concepts and definitions in thermodynamics, such as open and closed systems; extensive and intensive properties; equilibrium states, quasi-equilibrium processes, and cycles. It lays a foundation for students to understand the key concepts in the subsequent chapters.

### Chapter 2: Thermodynamic Properties of a Pure Substance

This chapter introduces thermodynamic properties, phase diagrams, and thermodynamic tables of pure substances. Students will learn how to determine thermodynamic properties of pure substances by using thermodynamic tables, and how to illustrate states and processes in phase diagrams. This chapter prepares students with essential skills for performing comprehensive analyses of various thermodynamic processes and cycles.

### Chapter 3: Ideal and Real Gases

This chapter explains the concepts of “ideal” gas, ideal gas law, real gas, and compressibility factor. Students will learn the difference between an “ideal” and real gases, and at what conditions the ideal gas model may be used as an approximation for evaluating properties, such as pressure, temperature, and volume of a gas.

### Chapter 4: The First Law of Thermodynamics for Closed Systems

This chapter explains the concepts of heat, work, and the first law of thermodynamics for closed systems. Through examples, students will learn how to apply the first law of thermodynamics to engineering problems involving closed systems.

### Chapter 5: The First Law of Thermodynamics for a Control Volume

This chapter extends the concept of energy conservation to open systems with a focus on steady-state, steady flows (SSSF). Students will learn how to use the first law of thermodynamics to analyze processes in typical SSSF devices, such as pipes, turbines, compressors, heat exchangers, expansion valves, and mixing chambers.

### Chapter 6: Entropy and the Second Law of Thermodynamics

This chapter introduces the concepts of reversible and irreversible processes, Carnot cycles, entropy and entropy generation, and the second law of thermodynamics. Students will learn the applications of the second law in both closed and open systems.



## CHAPTER OVERVIEW

### 1: Basic Concepts and Definitions

This chapter introduces basic concepts and definitions in thermodynamics, such as open and closed systems; extensive and intensive properties; equilibrium states, quasi-equilibrium processes, and cycles. It lays a foundation for students to understand the key concepts in the subsequent chapters.

- [1.1: Chapter introduction and learning objectives](#)
- [1.2: What is thermodynamics about?](#)
- [1.3: System and surroundings](#)
- [1.4: Extensive and intensive properties](#)
- [1.5: State, process, and cycle](#)
- [1.6: Chapter review](#)

---

This page titled [1: Basic Concepts and Definitions](#) is shared under a [CC BY-NC-SA 4.0](#) license and was authored, remixed, and/or curated by [Claire Yu Yan \(BC Campus\)](#) via [source content](#) that was edited to the style and standards of the LibreTexts platform; a detailed edit history is available upon request.

## 1.1: Chapter introduction and learning objectives

---

Classical thermodynamics is a macroscopic approach to the study of thermodynamics. This chapter introduces basic concepts and definitions used in classical thermodynamics. It lays the foundation for a comprehensive analysis of different thermodynamic processes and cycles to be presented in this book.

### Learning Objectives

After completing the chapter, you should be able to

- Explain the basic scope of engineering thermodynamics and its common areas of application
- Demonstrate an understanding of fundamental concepts, such as system and its surroundings, closed and open systems, extensive and intensive properties, equilibrium state, quasi-equilibrium process, and cycle

---

This page titled [1.1: Chapter introduction and learning objectives](#) is shared under a [CC BY-NC-SA 4.0](#) license and was authored, remixed, and/or curated by [Claire Yu Yan \(BC Campus\)](#) via [source content](#) that was edited to the style and standards of the LibreTexts platform; a detailed edit history is available upon request.

## 1.2: What is thermodynamics about?

You probably have this experience; when you rub your hands quickly for a few minutes, your hands will start to feel warmer. How is this common phenomenon related to thermodynamics? Well, when you rub your hands quickly, your muscles do work. This work is then converted to heat; therefore, you feel warmer. Heat and work are two forms of energy. Work can be converted to heat, as seen in this daily example. However, can heat be converted to work? Can we use heat to produce work?

Heat engine is a device that produces work continuously by absorbing heat from a high-temperature heat source and rejecting the waste heat to a low-temperature heat sink. Since the 17<sup>th</sup> century, various heat engines were invented in an attempt to harness work from heat. [Figure 1.1.1](#) illustrates Watt's engine invented by Scottish engineer James Watt in the late 18<sup>th</sup> century. Watt's engine is one of the most successful early heat engines. Its main components are a boiler (not shown in the figure) and a condenser, each connecting to a piston-cylinder device. The two valves,  $V$  and  $V'$ , control the flow of steam into and out of the cylinder. When valve  $V$  opens, valve  $V'$  remains closed. Steam from the boiler enters the cylinder, pushing the piston up until it reaches the top of the cylinder. Then valve  $V'$  opens, and valve  $V$  closes. The steam in the cylinder escapes to the condenser and is condensed, creating a vacuum in the cylinder. Consequently, the piston moves downward under atmospheric pressure. The reciprocating motion of the piston drives the pivoting beam  $DEF$ , which then powers the pump chained to the beam. Watt's engine demonstrates how heat is converted to work. This conversion relies on the phase change of a working fluid, e.g., water, in the Watt's engine. The boiler in the Watt's engine is the heat source, where the hot steam is generated; and the condenser is the heat sink, where the hot steam is cooled and condensed to liquid water. All heat engines need a working fluid circulating in a specially-arranged set of equipment, which operates between a high-temperature heat source and a low-temperature heat sink. [Figure 1.1.2](#) is a schematic drawing of a heat engine. The yellow circle represents the heat engine consisting of a set of equipment.

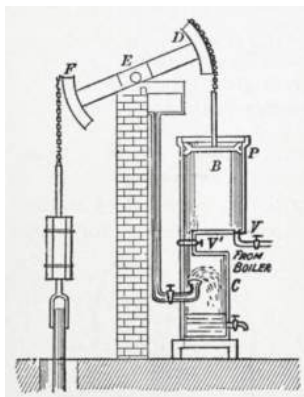

Figure 1.1.1 Watt's heat engine

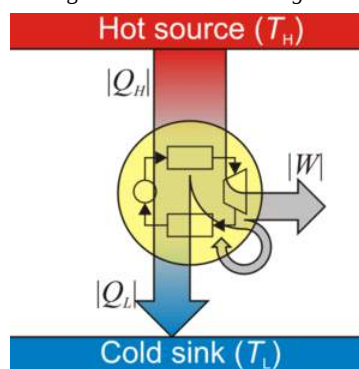

Figure 1.1.2 Schematic drawing of a heat engine

By examining [Figure 1.1.2](#), you might notice that a certain amount of heat is not converted to work. It is true that **not all of the heat from a heat source can be converted to useful work!** Heat engines and their underlying principles are governed by the two fundamental laws of thermodynamics, the first and second laws of thermodynamics. We will briefly introduce the two laws here and will provide detailed explanations in Chapters 4-6.

- **The first law of thermodynamics** is about energy conservation. Energy can neither be created nor destroyed. It can only be converted between different forms.

- **The second law of thermodynamics** explains why all real processes are irreversible, and how the irreversibility of a process is quantified with the concept of entropy generation. In reality, all processes always occur in the direction of producing positive entropy generation due to the existence of irreversibilities. From the second law of thermodynamics, we can estimate the theoretical limit of efficiency that a real thermodynamic process or system can possibly achieve.

**Thermodynamics** emerged in the early 19<sup>th</sup> century with the inventions of heat engines. It originally focused on the scientific theories of heat-work conversion, and the operations and efficiency improvement of heat engines. Nowadays, the applications of thermodynamics have extended to all fields related to energy conversion and conservation. In engineering fields, the principles of thermodynamics are widely used in the design of thermal systems, such as power plants using different energy sources (e.g., steam, gas, nuclear, hydro, wind, and solar), air conditioning and refrigeration systems, jet engines, biomedical devices, and chemical processes, to name but a few. [Figure 1.1.3](#) is a schematic drawing of a nuclear power plant, whose performance and efficiency are governed by the fundamental principles of thermodynamics.

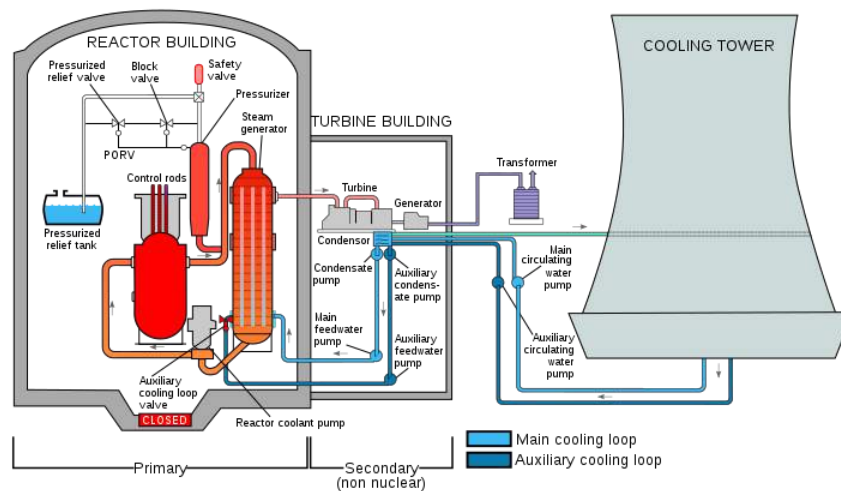

Figure 1.1.3 Nuclear Power Plant

### Media Attributions

- Watt's Heat Engine © [Caltrop](#) is licensed under a [Public Domain](#) license
- Schematic drawing of a heat engine © [Brundl15](#) is licensed under a [CC BY-SA \(Attribution ShareAlike\)](#) license
- Nuclear Power Plant © [Anybody](#) is licensed under a [CC BY-SA \(Attribution ShareAlike\)](#) license

This page titled [1.2: What is thermodynamics about?](#) is shared under a [CC BY-NC-SA 4.0](#) license and was authored, remixed, and/or curated by [Claire Yu Yan \(BC Campus\)](#) via [source content](#) that was edited to the style and standards of the LibreTexts platform; a detailed edit history is available upon request.

### 1.3: System and surroundings

In thermodynamics, a system refers to a selected quantity of matter in the case of closed systems or a selected region in space in the case of open systems, see [Figure 1.2.1](#). The rest of the universe outside the system is called surroundings, and the surface that separates the system and its surroundings is called boundary. A boundary may be fixed or movable, real or imaginary, rigid or flexible.

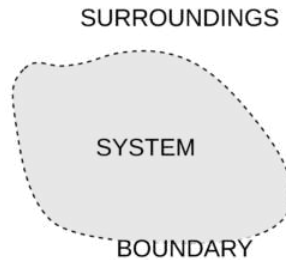

Figure 1.2.1 System and surroundings

A system interacts with its surroundings through two mechanisms:

1. **Mass transfer**
2. **Energy transfer** (i.e., in the form of heat and work)

A system of a fixed mass is a closed system, which can only interact with its surroundings through energy transfer. Mass cannot cross the boundary of a closed system. For example, a sealed bottle of soft drink, [Figure 1.2.2](#), can be modelled as a closed system because there is a fixed amount of liquid in the bottle. When you take the bottle out of your cooler, the liquid will warm up slowly due to the temperature difference between the bottle and the ambient air (surroundings). In other words, the system (the liquid in the bottle) interacts with its surroundings (the ambient air) through energy transfer (in the form of heat transfer). [Figure 1.2.3](#) illustrates a piston-cylinder device, which can also be modelled as a closed system. The amount of the fluid in the cylinder (the system) remains constant as the piston moves. Only the transfer of energy, in the form of heat and work, may happen across the system boundary consisting of the cylinder walls and the lower surface of the piston.



Figure 1.2.2 A sealed bottle of soft drink as an example of closed systems

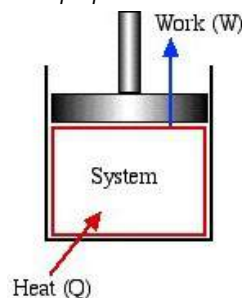

Figure 1.2.3 Piston cylinder device as an example of closed systems

An open system, also called control volume, is a selected region in space. An open system always exchanges mass with its surroundings. It may exchange energy with its surroundings in the form of heat and work, but energy transfer is not a necessary condition for a system to be an open system. In other words, an open system doesn't have to exchange heat or work with its

surroundings at all. [Figure 1.2.4](#) illustrates an open system, which typically encloses a device that involves mass flow through its inlet and outlet. [Figure 1.2.5](#) illustrates the outdoor condensing unit of an air conditioner. It may be treated as an open system because the coolant can enter and leave the condensing unit (the system) via its connecting coolant lines.

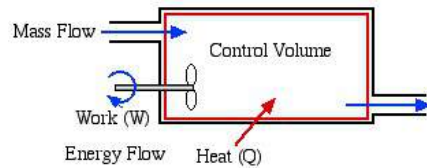

Figure 1.2.4 Open system (also called control volume)

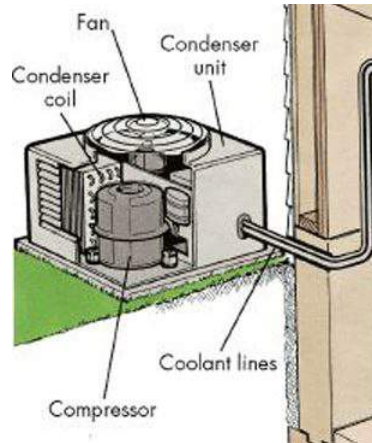

Figure 1.2.5 Outdoor condensing unit of an air conditioner as an example of open systems

If a system doesn't allow the exchange of mass and energy with its surroundings, it is called an isolated system. An isolated system is an idealized, hypothetical system. In reality, no device is absolutely isolated.

### Media Attributions

- System and Surroundings © [Krauss](#) is licensed under a [CC BY-SA \(Attribution ShareAlike\)](#) license
- Piston Cylinder © [Israel Urieli](#) adapted by [DIANA BAIKARTAROVA](#) is licensed under a [CC BY-SA \(Attribution ShareAlike\)](#) license
- Open system © [Israel Urieli](#) adapted by [DIANA BAIKARTAROVA](#) is licensed under a [CC BY-SA \(Attribution ShareAlike\)](#) license
- Outdoor condensing unit of an air conditioner © Jackie Bese is licensed under a [CC BY-SA \(Attribution ShareAlike\)](#) license

This page titled [1.3: System and surroundings](#) is shared under a [CC BY-NC-SA 4.0](#) license and was authored, remixed, and/or curated by [Claire Yu Yan \(BC Campus\)](#) via [source content](#) that was edited to the style and standards of the LibreTexts platform; a detailed edit history is available upon request.



## 1.4: Extensive and intensive properties

From the macroscopic perspective, a system is viewed as a continuous, homogeneous matter called continuum, which consists of a huge number of interacting molecules distributed throughout the system. The interactions between the molecules are so frequent that the physical or bulk properties of the system do NOT depend on the behaviour of individual molecules. This hypothesis is valid in a wide range of engineering applications. It allows the physical properties of a system, such as pressure, density, and temperature, to be defined as a continuous function at any point of the system.

The following thermodynamic properties are typically used to describe the interactions between a system and its surroundings:

- mass  $m$
- pressure  $P$
- temperature  $T$
- volume  $V$  and specific volume  $v$
- internal energy  $U$  and specific internal energy  $u$
- enthalpy  $H$  and specific enthalpy  $h$
- entropy  $S$  and specific entropy  $s$

These properties can be classified into two categories based on their dependence on the mass of a system. More detailed explanations of their physical meanings can be found in Chapter 2.

- Extensive properties depend on the mass of a system. Properties, such as mass  $m$ , volume  $V$ , internal energy  $U$ , enthalpy  $H$ , and entropy  $S$  are extensive properties. Their values change accordingly as the mass of a system changes.
- Intensive properties are independent of the mass of a system. Pressure  $P$ , temperature  $T$ , specific volume  $v$ , specific internal energy  $u$ , specific enthalpy  $h$ , and specific entropy  $s$  are intensive properties.

Let us consider a container of air at 101 kPa and 20°C. If the container is divided into two compartments and all other conditions remain unchanged, see [Figure 1.3.1](#), the air in each compartment is still at 101 kPa and 20°C. The pressure and temperature of the air are not affected by the changing mass in each compartment; therefore, pressure  $P$  and temperature  $T$  are intensive properties. On the other hand, the mass and volume of the air in each of the compartments are different from the original values in the container. Both of them depend on the mass of the system; therefore, mass and volume are extensive properties.

All specific properties are intensive properties, as they refer to the corresponding extensive properties per unit mass, e.g., specific volume  $v = V/m$  and specific internal energy  $u = U/m$ .

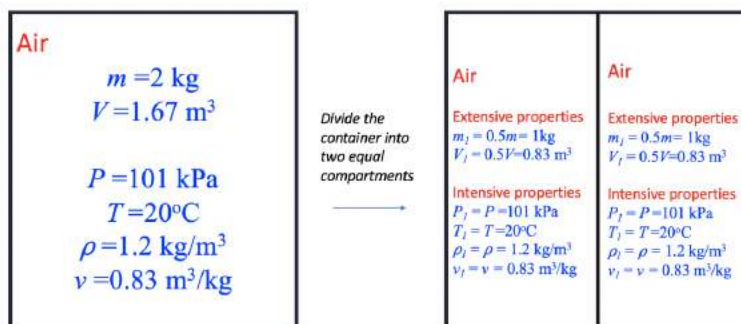

Figure 1.3.1 Intensive and extensive properties

This page titled [1.4: Extensive and intensive properties](#) is shared under a [CC BY-NC-SA 4.0](#) license and was authored, remixed, and/or curated by [Claire Yu Yan \(BC Campus\)](#) via [source content](#) that was edited to the style and standards of the LibreTexts platform; a detailed edit history is available upon request.

## 1.5: State, process, and cycle

If a system is isolated from its surroundings or is free from any unbalanced potentials, such as forced flows of mass or energy, the system will eventually reach a uniform condition called equilibrium. A system in equilibrium has uniform properties throughout the system. The following equilibrium conditions are commonly considered in thermodynamics.

- A system that features spatially-uniform temperature is in thermal equilibrium.
- A system free from chemical reactions is in chemical equilibrium.
- If there is no tendency for a system to change its pressure over time, the system is in mechanical equilibrium.
- For a system consisting of a mixture of multiple phases, such as liquid water and water vapour, if the composition of the mixture remains constant over time, the system is in phase equilibrium.

State refers to the condition of a system, which may be described by a unique set of properties, such as pressure, temperature, and specific volume. The state of a system in equilibrium is called equilibrium state. A system may change from one state to another state through a process. Let us consider a container of water initially at 10°C and 101 kPa, as an example. We set the water in the container as the system. The water is heated until its temperature reaches 50°C, while its pressure is kept constant 101 kPa. We may say that the water undergoes a constant-pressure, heating process with an initial state of 10°C and 101 kPa and a final state of 50°C and 101 kPa.

Typically, there are many possible paths that a system may take between two states; therefore, ***the exact path of a process is extremely important and must be clearly specified in order to describe a process!*** Here are the definitions of some common processes.

- Isobaric process: the pressure remains constant in a process.
- Isochoric process: the specific volume remains constant in a process.
- Isothermal process: the temperature remains constant in a process.
- Adiabatic process: no heat transfer occurs between a system and its surroundings in a process.
- Isentropic process: the entropy remains constant in a process.

Figure 1.4.1 shows a compression process as the piston moves from the right to the left. States 1 and 2 represent the initial and final states. Each point along the process path represents an equilibrium state. If all states in a process are equilibrium states, the process is called **quasi-equilibrium process**. In this book, we will deal with systems in equilibrium; therefore, all states thereafter refer to equilibrium states, and all processes refer to quasi-equilibrium processes.

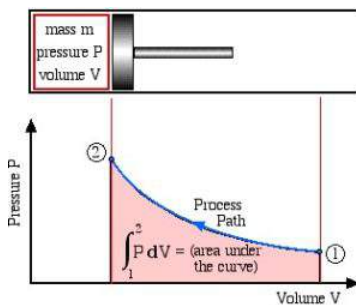

Figure 1.4.1 Schematic of a process. States 1 and 2 represent the initial and final states; each point along the process path represents an equilibrium state.

If a system undergoes a series of processes and finally returns to its initial state, we say that the system completes a **cycle**. Thermodynamic cycles are the basis for the operation of thermal equipment. For example, the vapour-compression refrigeration cycle is often used in conventional refrigerators and air conditioners, as shown in Figure 1.4.2. The cycle consists of four main devices: compressor, condenser, expansion valve, and evaporator. A working fluid called refrigerant circulates through these devices connected by tubes. The refrigerant in the cycle experiences phase changes between vapour and liquid, as shown in Figure 1.4.3. Phase diagrams (see details in Chapter 2) are commonly used to analyze a process or a cycle. Figure 1.4.4 illustrates the temperature-specific entropy,  $T-s$ , diagram for the vapour-compression refrigeration cycle, where the numbered dots represent

different states and the lines with arrows represent different processes in this cycle. For example, the number “1” in [Figure 1.4.3](#) and [Figure 1.4.4](#) refers to the state of the refrigerant at the inlet of the compressor or the exit of the evaporator. The line 1-2 in [Figure 1.4.4](#) refers to the compression process in the compressor.

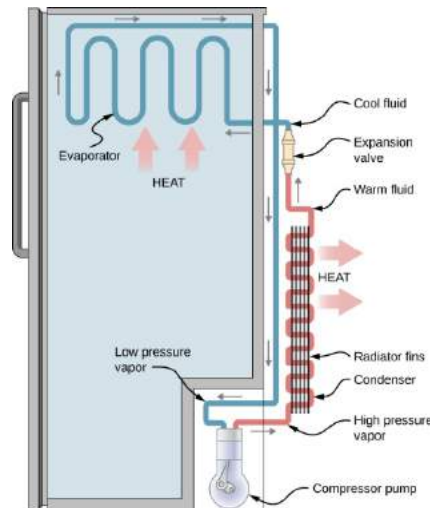

Figure 1.4.2 Refrigerator working on the vapour compression cycle

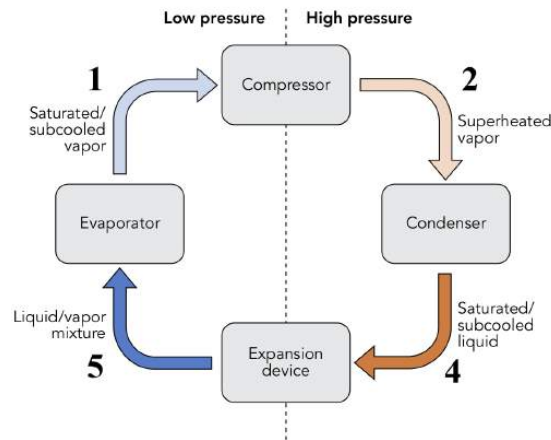

Figure 1.4.3 Vapour compression cycle

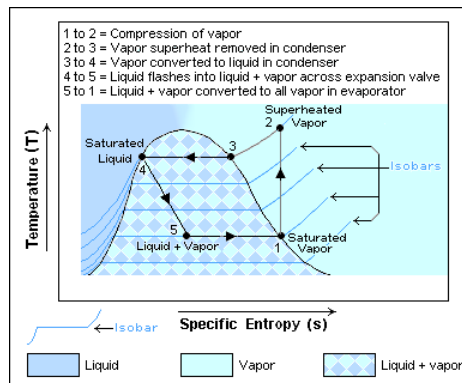

Figure 1.4.4 Temperature-specific entropy ( $T-s$ ) diagram of a vapour compression cycle

Otto cycle is another thermodynamic cycle. It is an ideal cycle that models the operation of internal combustion engines. [Figure 1.4.5](#) shows the cycle consisting of four strokes. The pressure-volume diagram, [Figure 1.4.6](#), illustrates different processes in this

cycle.

1. Intake stroke, line 0-1 in [Figure 1.4.6](#). During the intake stroke, the inlet valve opens and the outlet valve remains closed. Air is drawn into the cylinder as the piston moves to the bottom dead center (BDC).
2. Compression stroke, line 1-2 in [Figure 1.4.6](#). During the compression stroke, both valves remain closed. The air is compressed as the piston moves from BDC to the top dead center (TDC).
3. Ignition and power stroke, line 2-3-4 in [Figure 1.4.6](#). During this stroke, both valves remain closed. The piston is at TDC momentarily while the fuel-air mixture is ignited by the spark. The burning of the fuel-air mixture generates a large force, pushing the piston from TDC to BDC.
4. Exhaust stroke, line 4-1-0 in [Figure 1.4.6](#). During the exhaust stroke, the outlet valve opens and the inlet valve remains closed. The piston remains at BDC momentarily, allowing a certain amount of heat to release to the surroundings. Then the piston moves from BDC towards TDC to reject the exhaust and more heat to the surroundings.

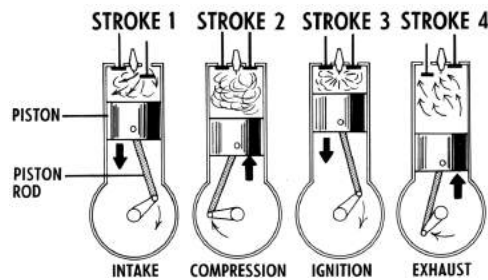

Figure 1.4.5 Four-stroke combustion engine

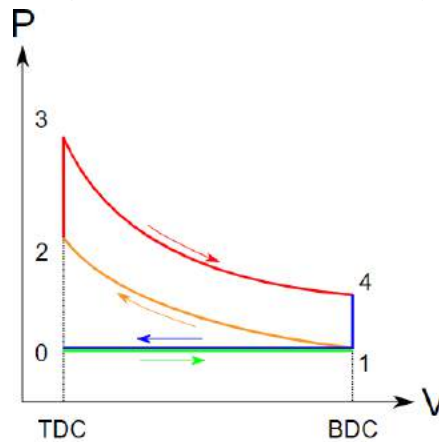

Figure 1.4.6 Pressure-volume diagram of an Otto cycle

### Media Attributions

- Schematic of a process © [Israel Urieli](#) adapted by [DIANA BAIRAKTAROVA](#) is licensed under a [CC BY-SA \(Attribution ShareAlike\)](#) license
- Refrigerator © [DigitalNet99](#) is licensed under a [CC BY-SA \(Attribution ShareAlike\)](#) license
- Vapour compression cycle © [WGisol](#) is licensed under a [CC BY-SA \(Attribution ShareAlike\)](#) license
- T-s diagram of a vapour compression cycle © [Keenan Pepper](#) is licensed under a [CC BY-SA \(Attribution ShareAlike\)](#) license
- Four-stroke combustion engine © [Pearson Scott Foresman](#) is licensed under a [CC BY-SA \(Attribution ShareAlike\)](#) license
- Pressure-volume diagram of an Otto cycle © [Luc1992](#) is licensed under a [CC BY-SA \(Attribution ShareAlike\)](#) license

This page titled [1.5: State, process, and cycle](#) is shared under a [CC BY-NC-SA 4.0](#) license and was authored, remixed, and/or curated by [Claire Yu Yan \(BC Campus\)](#) via [source content](#) that was edited to the style and standards of the LibreTexts platform; a detailed edit history is available upon request.

## 1.6: Chapter review

---

Thermodynamics has a wide range of applications in many engineering fields, in particular, the fields related to energy conversion and conservation. In this chapter, we have introduced some fundamental concepts and definitions used in the study of engineering thermodynamics.

An important skill that students need to develop, when performing thermodynamic analysis on devices, is to identify the system, its surroundings, and their interactions. There are three types of systems: closed system, open system, and isolated system, defined in terms of their ability to transfer mass and energy with the surroundings.

In this book, we consider systems in equilibrium. Each equilibrium state possesses a unique set of thermodynamic properties, which can be classified as extensive and intensive properties. When a system undergoes a process from one equilibrium state to another equilibrium state, its thermodynamic properties will change accordingly. The process path must be clearly specified when describing a process. Students need to understand the definitions of the common processes, including isobaric, isothermal, isochoric, adiabatic, and isentropic processes.

---

This page titled [1.6: Chapter review](#) is shared under a [CC BY-NC-SA 4.0](#) license and was authored, remixed, and/or curated by [Claire Yu Yan \(BC Campus\)](#) via [source content](#) that was edited to the style and standards of the LibreTexts platform; a detailed edit history is available upon request.

## CHAPTER OVERVIEW

### 2: Thermodynamic Properties of a Pure Substance

This chapter introduces thermodynamic properties, phase diagrams, and thermodynamic tables of pure substances. Students will learn how to determine thermodynamic properties of pure substances by using thermodynamic tables, and how to illustrate states and processes in phase diagrams. This chapter prepares students with essential skills for performing comprehensive analyses of various thermodynamic processes and cycles.

[2.1: Chapter introduction and learning objectives](#)

[2.2: Pure substance](#)

[2.3: Thermodynamic properties](#)

[2.4: Phase diagrams](#)

[2.5: Thermodynamic tables](#)

[2.6: Chapter review](#)

[2.7: Key Equations](#)

---

This page titled [2: Thermodynamic Properties of a Pure Substance](#) is shared under a [CC BY-NC-SA 4.0](#) license and was authored, remixed, and/or curated by [Claire Yu Yan \(BC Campus\)](#) via [source content](#) that was edited to the style and standards of the LibreTexts platform; a detailed edit history is available upon request.

## 2.1: Chapter introduction and learning objectives

---

An equilibrium state in a process has a unique set of thermodynamic properties. In this chapter, we will introduce common thermodynamic properties, phase diagrams, and thermodynamic tables. Through examples, we will demonstrate how to use thermodynamic tables to determine thermodynamic properties of a pure substance at a given state. The International Systems of Units (SI units) will be used for all properties and examples.

### Learning Objectives

After learning this chapter, you should be able to

- Demonstrate an understanding of common thermodynamic properties
- Interpret phase diagrams, including  $P - T$ ,  $P - v$ , and  $T - v$  diagrams for pure substances
- Use thermodynamic tables to determine properties of pure substances

---

This page titled [2.1: Chapter introduction and learning objectives](#) is shared under a [CC BY-NC-SA 4.0](#) license and was authored, remixed, and/or curated by [Claire Yu Yan \(BC Campus\)](#) via [source content](#) that was edited to the style and standards of the LibreTexts platform; a detailed edit history is available upon request.

## 2.2: Pure substance

---

A pure substance refers to a matter that has a homogeneous and definite chemical composition. A pure substance may exist in a single phase, such as liquid water, ice, and CO<sub>2</sub> gas. It can also exist as a multi-phase mixture, such as a mixture of liquid water and water vapour in equilibrium.

Air is a common working fluid used in many thermal devices. Can air be treated as a pure substance? Although air is a mixture consisting of roughly 78% of nitrogen, 21% of oxygen, and trace amounts of other gases and moisture, air is homogeneous and has distinct properties without phase changes in its composition in many thermodynamic processes. In such conditions, we can treat air as a pure substance.

---

This page titled [2.2: Pure substance](#) is shared under a [CC BY-NC-SA 4.0](#) license and was authored, remixed, and/or curated by [Claire Yu Yan \(BC Campus\)](#) via [source content](#) that was edited to the style and standards of the LibreTexts platform; a detailed edit history is available upon request.



## 2.3: Thermodynamic properties

Pure substances are widely used in thermodynamic cycles. For example, in the vapour-compression refrigeration cycle, [Figure 1.4.2](#), refrigerant R134a is used as the working fluid, which is circulated through a compressor, condenser, expansion valve, and evaporator via the connecting tubes.

In steam power plants, water is used as the working fluid. [Figure 2.2.1](#) shows a coal-fired steam power plant. Purified water flows vertically up the tube-lined walls of the boiler, where it turns into steam. Steam flows into the boiler drum (17), separating from any remaining water, and then flows into the pendant superheater (19), where its temperature and pressure increase rapidly to around 200 bar and 570°C. The superheated steam is piped to the high-pressure turbine (11), where both its pressure and temperature are reduced. The steam is then returned to the boiler reheater (21). After being reheated, it enters the intermediate-pressure turbine (9) and then the low-pressure turbine (6). The steam, now just above its boiling point, is brought into thermal contact with the cold water in the condenser (8), where it is condensed rapidly back into water. The water then passes a feed pump (7), a de-aerator (12), a feed heater (13), and an economizer (23) before being returned to the boiler drum.

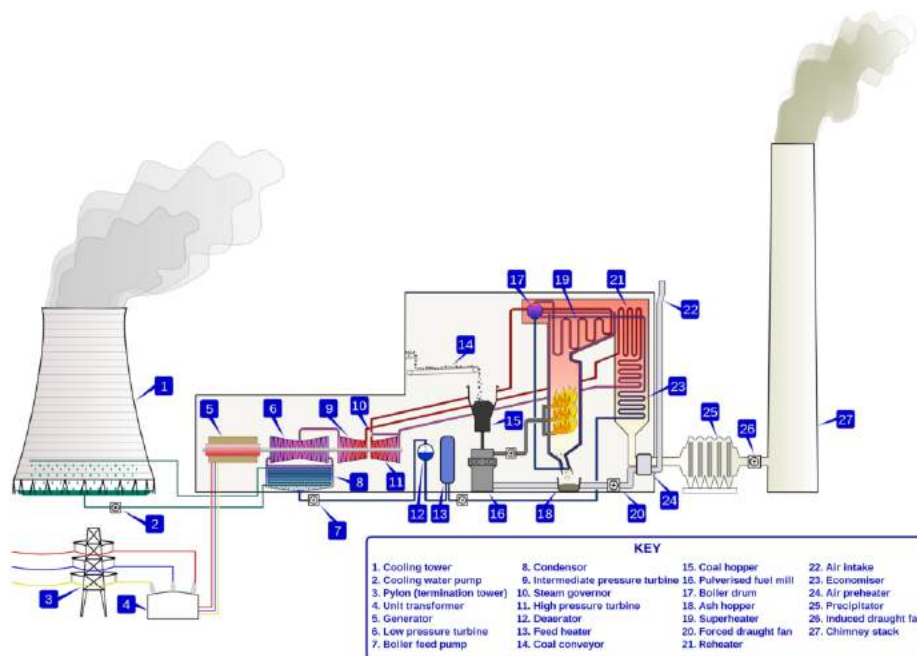

Figure 2.2.1 Steam power plant: water is used as the working fluid.

In both cycles, the working fluids, water and R134a, are pure substances. Their properties, such as pressure and temperature, continuously change as they flow through different devices in the cycles. How are the changes of fluid properties related to the overall performance of a device, such as the aforementioned steam power plant and refrigerator? To answer this question, we need to understand the thermodynamic properties of pure substances at different states of a process or a cycle.

The common properties of a pure substance include pressure, temperature, specific volume, density, specific internal energy, specific enthalpy, and specific entropy. These properties are interrelated to each other. Thermodynamic tables or equations of state are commonly used to determine the thermodynamic properties of a pure substance. Appendices A-D provide thermodynamic tables for selected pure substances. The ideal gas equation of state will be introduced in Chapter 3.

### 2.2.1 Pressure

Consider a normal force exerted by an object on a surface. Pressure is defined as the normal force per unit area of the surface.

$$P = F/A$$

where

$$F \quad (2.3.1)$$

$$A \quad (2.3.2)$$

In the SI units, force is usually expressed in Newtons, N, or kilo Newtons, kN, and area in meter squared, m<sup>2</sup>; therefore, pressure is expressed in Pascal, 1 Pa = 1 N/m<sup>2</sup>, or kilo-Pascal, 1 kPa = 1 kN/m<sup>2</sup>. Other common SI units include 1 bar =100 kPa, 1 atm =101.325 kPa, and 1 MPa = 10<sup>6</sup> Pa =1000 kPa.

Pressure depends on the normal force and the contact area. If you stand up tall on a flat horizontal surface, the pressure on your feet is your weight divided by the total contact area of your feet on the surface. If you lift up one foot, the pressure on your other foot will double as the contact area is decreased by half.

Pressure in a fluid acts equally in all directions at a given point in that fluid; therefore, *pressure is a scalar quantity*. It is important to note that although pressure is a scalar quantity, pressure force,  $F = PA$ , is a vector and is always perpendicular to the contact surface.

Pressure in a fluid is commonly measured by pressure gauges (Figure 2.2.2) or U-tube manometers (Figure 2.2.3). Most pressure gauges are calibrated to show the gauge pressure or vacuum pressure, which is the difference between the absolute pressure and the atmospheric pressure.

Gauge pressure:  $P_{gauge} = P_{abs} - P_{atm}$

Vacuum pressure:  $P_{vac} = P_{atm} - P_{abs}$

where

$$P_{abs} \tag{2.3.4}$$

$$P_{atm} \tag{2.3.5}$$

$$P_{gauge} \tag{2.3.6}$$

$$P_{vac} \tag{2.3.7}$$



Figure 2.2.2 Pressure gauge

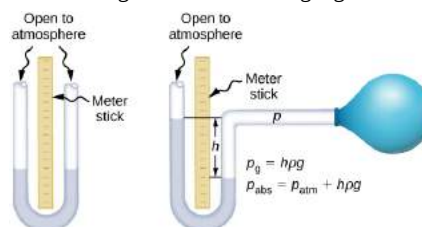

Figure 2.2.3 U-tube Manometer

✓ Example 2.3.1

Consider a piston-cylinder device containing a gas. The mass of the piston is 10 kg. The diameter of the piston is 20 cm. The atmospheric pressure is 1 atm = 101.325 kPa. What is the absolute pressure of the gas in the cylinder assuming the piston is in static equilibrium? The friction between the piston and the cylinder is negligible.

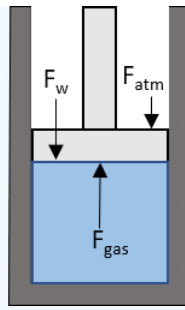

Figure 2.2.e1 Piston cylinder device showing acting forces

## Solution

There are three forces acting on the piston:

- Weight of the piston  $F_w = mg$
- Force due to the atmospheric pressure  $F_{atm} = P_{atm}A$
- Force due to the gas pressure  $F_{gas} = P_{gas}A$

As the piston is in static equilibrium, the resultant force on the piston is zero.

$$\sum F = F_{gas} - (F_w + F_{atm}) = 0 \quad (2.3.8)$$

Therefore, the absolute pressure of the gas is



The gauge pressure of the gas is

$$P_{gauge} = P_{gas} - P_{atm} = 3.12 \text{ kPa} \quad (2.3.9)$$

## 2.2.2 Temperature

Temperature is another measurable thermodynamic property, which indicates the hotness or coldness of a body. Thermometer is a common device for temperature measurement. If two bodies have the same temperature readings on a thermometer, the two bodies must have the same temperature. In other words, they are in thermal equilibrium. This seemingly obvious observation is called the *zeroth law of thermodynamics*: *if two bodies are in thermal equilibrium with a third, the three bodies must be in thermal equilibrium with each other*. This law establishes the basis for temperature measurement; it allows us to compare the temperatures of different bodies, no matter if they are in contact or not.

Temperature can be expressed on different temperature scales, such as Celsius or Kelvin scales in the SI units and Fahrenheit or Rankine scales in the Imperial units. For example, a room temperature may be expressed as 20°C or 68 F. All temperature scales are calibrated based on two easily reproducible temperatures, such as the freezing and boiling temperatures of water at the standard atmospheric pressure.

A temperature expressed in Kelvin in the SI units or in Rankine in the Imperial units is called absolute temperature. An absolute temperature of zero indicates the state of the minimum energy of a matter. Absolute temperature, also called thermodynamic temperature, is an important property in thermodynamic analyses. The conversion between the Celsius and Kelvin scales is

$$\begin{aligned} T(K) &= T(^{\circ}C) + 273.15 \\ \Delta T(K) &= \Delta T(^{\circ}C) \end{aligned}$$

## 2.2.3 Density and specific volume

Density is defined as the mass per unit volume of a body. Specific volume is the reciprocal of density.



where

$$m \quad (2.3.10)$$

$$\mathbb{V} \quad (2.3.11)$$

$$v \quad (2.3.12)$$

$$\rho \quad (2.3.13)$$

Both temperature and pressure may affect the density and specific volume of a fluid. The density and specific volume of a gas are strong functions of both temperature and pressure. For example, when a gas is compressed, its pressure will increase, causing the density of the gas to increase and the specific volume of the gas to decrease. When a gas is heated, its temperature will increase. Consequently, the density of the gas will decrease and the specific volume of the gas will increase.

On the contrary, the density and specific volume of a liquid depend much more strongly on the temperature than on the pressure; therefore, it is common to assume that the density and specific volume of a liquid are functions of temperature only.

### Example 2

A container consists of two sections separated by a membrane. Section A contains 0.5 kg of air. Its volume is 0.75 m<sup>3</sup>. Section B contains air of density 0.6 kg/m<sup>3</sup>. Its volume is 0.5 m<sup>3</sup>. If the membrane is broken, and the air in the two sections mixes and reaches a uniform state, what is the specific volume of the air at the final state?

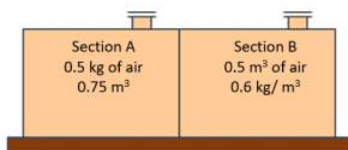

Figure 2.2.e2 Two sections filled with air

### Solution

The masses and volumes in sections A and B at the initial state are

$$m_A = 0.5 \text{ kg} \quad (2.3.14)$$

$$m_B = \rho \mathbb{V}_B = 0.6 \times 0.5 = 0.3 \text{ kg} \quad (2.3.15)$$

The two sections reach a uniform state at the final state; therefore,

$$m_{total} = m_A + m_B = 0.5 + 0.3 = 0.8 \text{ kg} \quad (2.3.16)$$

$$\mathbb{V}_{total} = \mathbb{V}_A + \mathbb{V}_B = 0.75 + 0.5 = 1.25 \text{ m}^3 \quad (2.3.17)$$

Therefore,

$$v_{total} = \mathbb{V}_{total} / m_{total} = 1.25 / 0.8 = 1.5625 \text{ m}^3 / \text{kg}$$

## 2.2.4 Internal energy and specific internal energy

The essence of the first law of thermodynamics is energy conservation. We need to understand different forms of energy in a system. Internal energy, kinetic energy, and potential energy constitute the total *stored energy* of a system if the system is free of magnetic, electric, and surface tension effects.

$$E = U + KE + PE \quad (2.3.18)$$

where

$$E \quad (2.3.19)$$

$$KE \quad (2.3.20)$$

$$PE \quad (2.3.21)$$

$$U \quad (2.3.22)$$

Internal energy is associated with the motions and structure of the molecules of a system in a microscopic level. A system, no matter how tiny it is, contains a significantly large number of molecules in various modes of random motions, such as translation, rotation, and vibration. Although it is difficult to predict the behaviour of individual molecules, the statistical average can be

calculated by using statistical theory. From a statistical standpoint, the internal energy of a system is considered to be the sum of the kinetic and potential energies of the collection of all molecules in the system. Maxwell explains the relation between the molecular velocity (a microscopic quantity) and the temperature (a macroscopic quantity) of a gas: as the temperature increases, the gas molecules move faster causing the mean microscopic kinetic energy of all molecules to increase; therefore, the internal energy of the system increases. In other words, the internal energy of a substance is strongly associated with the temperature of the substance; therefore, internal energy is a form of thermal energy. For example, the internal energy of 1 kg of water at 500 kPa increases from about 83.88 kJ to 167.47 kJ when its temperature increases from 20°C to 40°C. In general, temperature has a dominant effect on the internal energy of a system although other factors, such as pressure, phase, and chemical composition may also have an effect on the internal energy of a system.

From a macroscopic standpoint, a thermodynamic system, as a whole, has both kinetic and potential energies when it is in motion and is positioned at an elevation on Earth. The kinetic and potential energies are two forms of mechanical energy. They must be described with respect to an external reference frame. When a system experiences a change of elevation or velocity, the kinetic and potential energies of the system will convert between each other. For example, a rock falling from a cliff gains kinetic energy but loses potential energy because its elevation decreases with respect to the ground.

In general, the total stored energy of a thermodynamic system consists of the internal, kinetic, and potential energies. However, the kinetic and potential energies are insignificant compared to the internal energy in many cases, and thus can be neglected.

$$E, U, KE \quad (2.3.23)$$

$$e = u + ke + pe \quad (2.3.24)$$

where

$e = E/m$ : total specific energy, in J/kg or kJ/kg

$u = U/m$ : specific internal energy, J/kg or kJ/kg

$ke = KE/m$ : specific kinetic energy, J/kg or kJ/kg

$pe = PE/m$ : specific potential energy, J/kg or kJ/kg

The internal energy and specific internal energy are important properties for the analysis of closed systems, which will be explained in detail in Chapters 4-6.

## 2.2.5 Enthalpy and specific enthalpy

Enthalpy is an important thermodynamic property for the analysis of open systems or control volumes, where mass transfer is always accompanied by energy transfer. Enthalpy is calculated as the sum of the internal energy,  $U$ , and the flow work,  $PV$ , of the fluid flowing into or out of a control volume.

$$H = U + PV \quad (2.3.25)$$

Now, what is flow work and why is it written as  $PV$ ? Let us consider a fluid element entering a control volume of a pipe section, see [Figure 2.2.4](#). The control volume is illustrated as the red, dashed-lined rectangle. The fluid element, just before it enters the control volume, is at an equilibrium state and has an internal energy,  $U$ , and a pressure,  $P$ . The fluid element carries its internal energy as it flows into the control volume. In addition, the fluid element must overcome the resistance from the downstream flow in the pipe. In other words, a certain amount of work must be done to force the fluid element into the control volume. We call such work essential to maintain the continuous flow of a fluid through a control volume as flow work. Refer to [Figure 2.2.4](#), the flow work can be calculated as

$$W_{flow\ work} = FL = (PA)L = P(AL) = PV \quad (2.3.26)$$

where  $F = PA$  is the pressure force acting on the cross-section, or the left control surface, of the control volume.  $A$  is the cross-sectional area of the left control surface.  $L$  is the distance that the fluid element travels from its original position to where it just enters the control volume completely.  $V = AL$  is the volume of the fluid element.

For flow through an open system or control volume, both the internal energy carried by the fluid throughout the flow and the flow work required to maintain the flow contribute to the change of energy in a control volume. Therefore, it is common to combine the internal energy and the flow work as a new thermodynamic property, enthalpy,  $H$ .

Enthalpy, similar to the internal energy, is an extensive property because its value depends on the mass of a system. Its corresponding intensive property is called specific enthalpy, or enthalpy per unit mass of a substance.

$$h = H/m = u + Pv$$

where

$$h \quad (2.3.27)$$

$$H \quad (2.3.28)$$

$$m \quad (2.3.29)$$

$$P \quad (2.3.30)$$

$$u \quad (2.3.31)$$

$$v \quad (2.3.32)$$

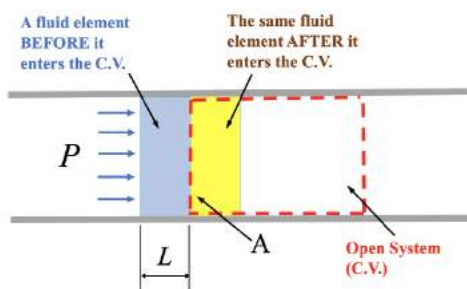

Figure 2.2.4 Flow work

## 2.2.6 Entropy and specific entropy

Some processes occur spontaneously in nature, such as salt dissolving in water. But some processes cannot occur spontaneously in nature. For example, water at 80°C and 10°C can mix in a container and eventually reach a thermal equilibrium. The mixture, however, cannot separate spontaneously into water at 80°C and water at 10°C. In other words, the process of separating the mixture is “irreversible” and cannot happen spontaneously. We may use a thermodynamic property called entropy to help us understand the physics of such phenomena.

Entropy is a measure of the lack of order resulting from the dispersal of energy and matter. Every spontaneous process is accompanied by an increase in the entropy (or disorder) of the universe. From a statistics point of view, it is more probable that the dispersal of energy and matter in a process is rather “random” than “orderly”. If we consider a fixed amount of gas in an isolated container, as illustrated in Figure 2.2.5. The probability of the molecules having a random distribution is much higher than the probability of them having an “orderly” distribution. Entropy is a concept to represent the degree of the “randomness” or “disorder” of a system. Such “disorder” was explained in statistical theories by early scientists such as Maxwell, Boltzmann, and Gibbs. Nowadays, entropy has been generally recognized as an important thermodynamic property associated with the “quality” aspect of the energy of a system; while energy represents the “quantity” aspect of the energy of the system. Both energy and entropy are of great importance in thermal analysis. The first law of thermodynamics, see Chapters 4 and 5, addresses the concepts of energy and energy conservation. The second law of thermodynamics is closely associated with the concepts of entropy and entropy generation, which explain why a process in nature only occurs in the direction of decreasing the quality of energy or increasing the entropy of the universe. These concepts will be explained in detail as we study the second law of thermodynamics in Chapter 6.

Entropy,  $s$ , is an extensive property as its value depends on the mass of a system. The common SI units for entropy include kJ/K and J/K. Its corresponding intensive property is called specific entropy,  $s = S/m$ . Its common SI units are kJ/kgK or J/kgK.

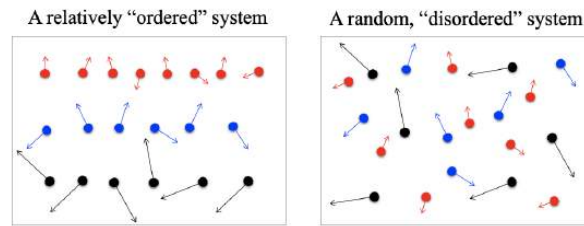

Figure 2.2.5 Illustration of ordered and disordered systems

### Media Attributions

- Steam Power Plant © BillC is licensed under a [CC BY-SA \(Attribution ShareAlike\)](#) license
- Pressure gauge © Nutzdatenbegleiter is licensed under a [CC BY-SA \(Attribution ShareAlike\)](#) license
- U-tube Manometer © OpenStax University Physics is licensed under a [CC BY-SA \(Attribution ShareAlike\)](#) license

---

This page titled [2.3: Thermodynamic properties](#) is shared under a [CC BY-NC-SA 4.0](#) license and was authored, remixed, and/or curated by [Claire Yu Yan \(BC Campus\)](#) via [source content](#) that was edited to the style and standards of the LibreTexts platform; a detailed edit history is available upon request.

## 2.4: Phase diagrams

$P - v$  (2.4.1)

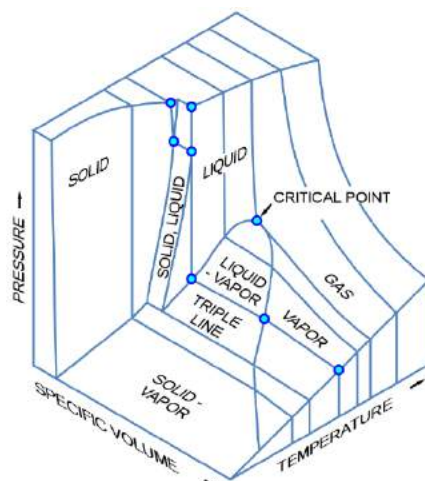

Figure 2.3.1 Pressure-specific volume-temperature (P-v-T) diagram

### 2.3.1 P-T diagram

Figure 2.3.2 shows a generic pressure-temperature,  $P - T$ , diagram, from which we can observe three single-phase regions, three curves representing the two-phase mixtures, and two unique points: the triple point and the critical point.

The single phase regions are labeled as solid, liquid, and vapour or gas in the  $P - T$  diagram. The liquid and vapour phases are often called compressed liquid and superheated vapour, respectively.

In the  $P - T$  diagram, the two-phase regions appear as curves separating different single phases. The curve that lies between the liquid and vapour phases is called vaporization line. Each point on the vaporization line represents an equilibrium state of saturation; the substance is either a saturated liquid, a saturated vapour, or a two-phase liquid-vapour mixture. The temperature and its corresponding pressure at each point on the vaporization line are called saturation temperature,  $T_{sat}$ , and saturation pressure,  $P_{sat}$ , respectively. Each saturation temperature corresponds to a unique saturation pressure, and vice versa. A liquid (or vapour) starts to evaporate (or condense) when its temperature and pressure reach  $T_{sat}$  and  $P_{sat}$ . The saturation properties of selected fluids can be found in the thermodynamic tables in Appendices A-D.

The curve that represents the transition between the solid and liquid phases is called fusion line. Each point on the fusion line has a unique set of temperature and pressure called freezing temperature and freezing pressure, respectively. Along the fusion line, the substance may exist as a saturated liquid, a solid, or a two-phase solid-liquid mixture.

The curve below the triple point is called sublimation line, across which a substance can change directly from solid to vapour or vice versa without a transition through the liquid phase. Each point on the sublimation line represents an equilibrium state, at which the substance may exist as a saturated vapour, a solid, or a two-phase solid-vapour mixture.

The vaporization, fusion and sublimation lines meet at the triple point, at which the three phases, solid, liquid, and vapour, coexist in equilibrium. Appendix F lists the triple points of a selection of pure substances. It is noted, from Figure 2.3.2, that the liquid phase cannot exist below the triple point pressure. When a substance is at a pressure lower than the triple point pressure, it can only transition between the solid and vapour phases.

The critical point in the  $P - T$  diagram is where the vaporization line ends. The pressure and temperature at the critical point are called critical pressure,  $P_c$ , and critical temperature,  $T_c$ , respectively. A state above the critical point has a pressure  $P > P_c$  and a temperature  $T > T_c$ ; therefore, it is referred to as a supercritical state. A substance at a supercritical state is called supercritical fluid, which has a unique characteristic: no distinct liquid and gas phases can exist anymore in the supercritical zone. In this book, we will mainly focus on the subcritical zone, where  $P < P_c$ .



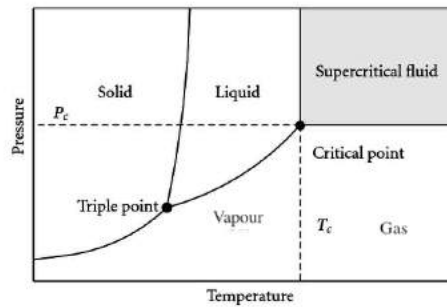

Figure 2.3.2  $P$ - $T$  diagram

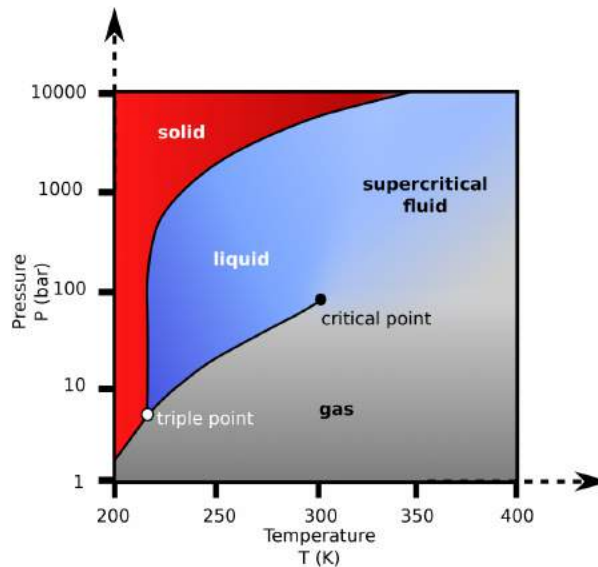

Figure 2.3.3  $P$ - $T$  diagram for CO<sub>2</sub>

### ✓ Example 2.4.1

Review the  $P$ - $T$  diagram for CO<sub>2</sub>, as shown in [Figure 2.3.3](#).

1. What is the lowest pressure for liquid CO<sub>2</sub> to exist?
2. Is CO<sub>2</sub> at 100 bar, 275 K a solid, liquid or gas?
3. CO<sub>2</sub> at 100 bar, 275 K is cooled in an isobaric process. At approximately what temperature will CO<sub>2</sub> start to change its phase? Will it change to a liquid or a solid? Draw the process line.

### Solution

1. From the  $P$ - $T$  diagram, the liquid phase can only exist when the pressure is great than the triple point pressure. From Appendix F, [Table F1](#), CO<sub>2</sub> has a triple point pressure of 517 kPa and a triple point temperature of 216.55 K (−56.60 °C), respectively; therefore, the lowest pressure for liquid CO<sub>2</sub> to exist is 517 kPa.
2. From the  $P$ - $T$  diagram, [Figure 2.3.e1](#), CO<sub>2</sub> at 100 bar, 275 K is in the liquid phase.
3. The isobaric process is shown as the horizontal, yellow line with a constant pressure of 100 bar, see [Figure 2.3.e1](#). At approximately 220 K, the isobaric process line meets the fusion line, and the liquid CO<sub>2</sub> starts to change to solid CO<sub>2</sub>.

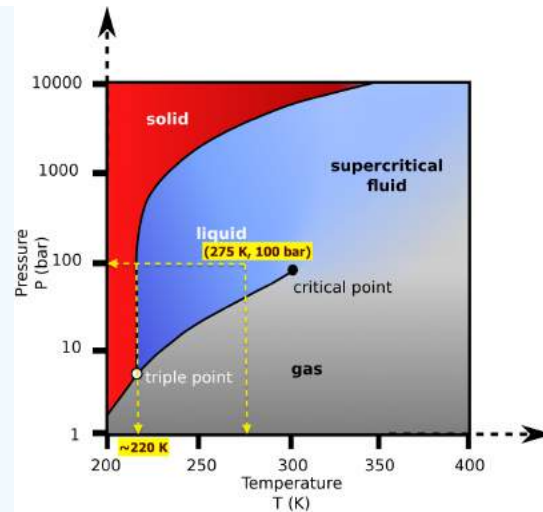

Figure 2.3.e1 P-T diagram for CO<sub>2</sub>, showing the solution to example 1

### 2.3.2 T-v and P-v diagrams

In many thermodynamic cycles, a working fluid experiences phase changes between liquid and vapour in the subcritical zone, such as water in a steam power plant and R134a in a vapour-compression refrigeration system. The liquid-vapour phase change can be illustrated in the  $T-v$  and  $P-v$  diagrams, as shown in Figures 2.3.4 and 2.3.5. In these diagrams, we can clearly see the three regions: compressed liquid region, saturated liquid-vapour region, and superheated vapour region. The curve that separates the compressed liquid region and saturated liquid-vapour region is called the saturated liquid line. Any point on the saturated liquid line represents a saturated liquid state. In a similar fashion, the curve that lies between the saturated liquid-vapour region and the superheated vapour region is called the saturated vapour line. Any point on the saturated vapour line represents a saturated vapour state. The two saturation lines meet at the critical point.

It is important to note that the liquid state is commonly called compressed liquid or subcooled liquid, and the vapour state is commonly called superheated vapour. In the liquid-vapour, two-phase region, the corresponding isothermal and isobaric processes coincide and remain as horizontal lines. This indicates that, during the phase change process, both temperature and pressure remain constant, i.e.,  $T = T_{sat}$  and  $P = P_{sat}$ .

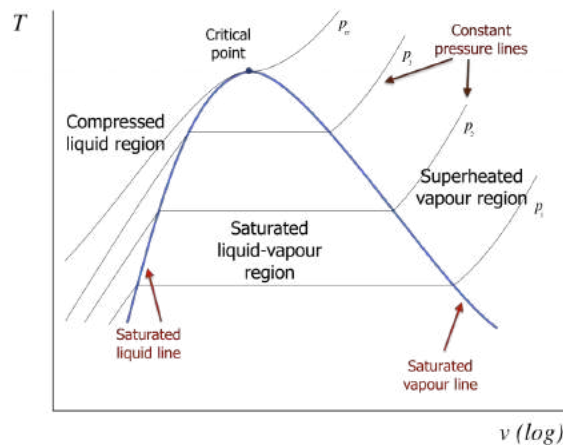

Figure 2.3.4 T-v diagram

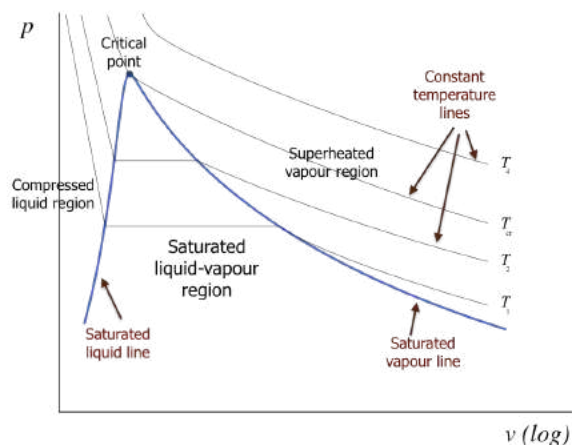

Figure 2.3.5 P-v diagram

### 2.3.3 The saturated liquid-vapour two-phase region

For a saturated liquid-vapour, two-phase mixture, we define quality  $x$  to denote the mass fraction of the saturated vapour in the mixture.

$$x = \frac{m_g}{m_{mix}}$$

where

$$m_g \tag{2.4.2}$$

$$m_{mix} \tag{2.4.3}$$

$$x \tag{2.4.4}$$

With the concept of quality, we can calculate the specific volume, specific internal energy, specific enthalpy, and specific entropy for a saturated liquid-vapour, two-phase mixture by using the following equations.

$$v = v_f + x(v_g - v_f) = (1 - x)v_f + xv_g$$

$$u = u_f + x(u_g - u_f) = (1 - x)u_f + xu_g$$

$$h = h_f + x(h_g - h_f) = (1 - x)h_f + xh_g$$

$$s = s_f + x(s_g - s_f) = (1 - x)s_f + xs_g$$

where

$$v \tag{2.4.5}$$

$$u \tag{2.4.6}$$

$$h \tag{2.4.7}$$

$$s \tag{2.4.8}$$

#### Media Attributions

- P-v-T phase diagram © Д.Ильин: vectorization is licensed under a [CC0 \(Creative Commons Zero\)](#) license
- P-T diagram © Xia Liao, Haichen Zhang, and Ting He is licensed under a [CC BY \(Attribution\)](#) license
- P-T Diagram for CO2 © Rifleman\_82 is licensed under a [CC0 \(Creative Commons Zero\)](#) license
- P-T diagram for CO2 (example 1 solution) © Rifleman\_82 is licensed under a [CC0 \(Creative Commons Zero\)](#) license
- T-v diagram © Olivier Cleynen is licensed under a [CC0 \(Creative Commons Zero\)](#) license
- P-v diagram © Olivier Cleynen is licensed under a [CC0 \(Creative Commons Zero\)](#) license

This page titled [2.4: Phase diagrams](#) is shared under a [CC BY-NC-SA 4.0](#) license and was authored, remixed, and/or curated by [Claire Yu Yan \(BC Campus\)](#) via [source content](#) that was edited to the style and standards of the LibreTexts platform; a detailed edit history is available upon request.

## 2.5: Thermodynamic tables

Thermodynamic tables are commonly used to determine the properties of a substance at a given state. This book includes the tables for four pure substances: water, ammonia, R134a, and carbon dioxide. The data in these tables are obtained from [NIST Chemistry WebBook, SRD 69](#), which consists of the thermophysical properties of various common fluids.

**Appendix A:** Thermodynamic Properties of Water

- [Table A1](#): Saturated water
- [Table A2](#): Superheated vapour, water
- [Table A3](#): Compressed liquid water

**Appendix B:** Thermodynamic Properties of Ammonia

- [Table B1](#): Saturated ammonia
- [Table B2](#): Superheated ammonia

**Appendix C:** Thermodynamic Properties of R134a

- [Table C1](#): Saturated R134a
- [Table C2](#): Superheated R134a

**Appendix D:** Thermodynamic Properties of Carbon Dioxide

- [Table D1](#): Saturated CO<sub>2</sub>
- [Table D2](#): Superheated CO<sub>2</sub>

Tables A1, B1, C1, and D1 are the tables for the saturated fluids. They are used to find the properties of the corresponding fluids in saturated liquid, saturated vapour, and two-phase regions. Tables A2, B2, C2, and D2 are the superheated vapour tables for finding the properties of the fluids in the superheated vapour region. Table A3 is the compressed liquid table for water.

In these tables, the specific volume, specific internal energy, specific enthalpy, and specific entropy are tabulated as functions of the pressure and temperature. Among those thermodynamic properties,  $P$ ,  $T$ , and  $v$  are measurable properties, and  $u$ ,  $h$ , and  $s$  cannot be measured directly; they are calculated with respect to predefined reference states. The reference states for the tables in this book are clearly stated in Appendices A-D.

$$u \tag{2.5.1}$$

How do we determine if a fluid is a compressed liquid, superheated vapour, or two-phase liquid-vapour mixture? How do we find the fluid properties at a certain state? By examining the tables in Appendices A-D, you probably have noticed that all properties in these tables are intensive properties. To determine the fluid properties at a certain state, we will need to know two intensive properties from this list:  $P$ ,  $T$ ,  $v$ ,  $u$ ,  $h$ ,  $s$ , and  $x$ . The following flow charts demonstrate the procedure.

**Case 1: both  $T$  and  $P$  are given.** You may draw a  $P$ - $T$  diagram (see [Figure 2.3.2](#)) to help you better understand the flow chart in [Figure 2.4.1](#).

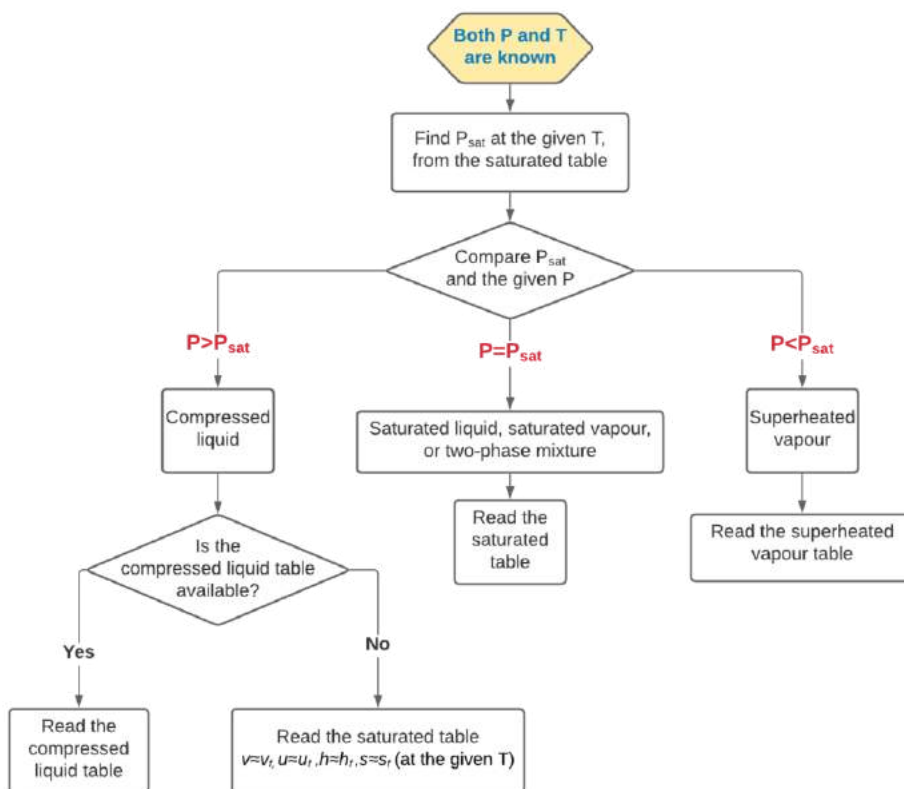

Figure 2.4.1 Flow chart for determining fluid properties from thermodynamic tables if  $P$  and  $T$  are known

Case 2: **both  $T$  and  $x$  are given.** You may draw a  $T - v$  diagram (see Figure 2.3.4) to help you better understand the flow chart in Figure 2.4.2.

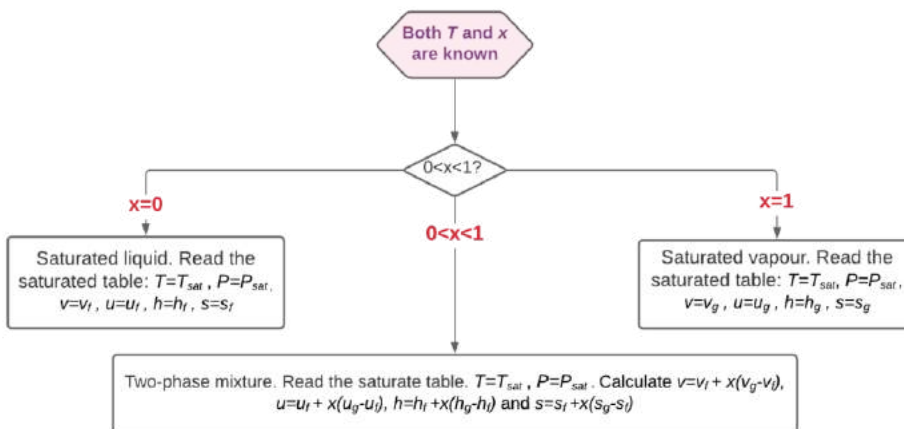

Figure 2.4.2 Flow chart for determining fluid properties from thermodynamic tables if  $T$  and  $x$  are known

Case 3: **both  $T$  and  $v$  are given.** You may draw a  $T - v$  diagram (see Figure 2.3.4) to help you better understand the flow chart in Figure 2.4.3.

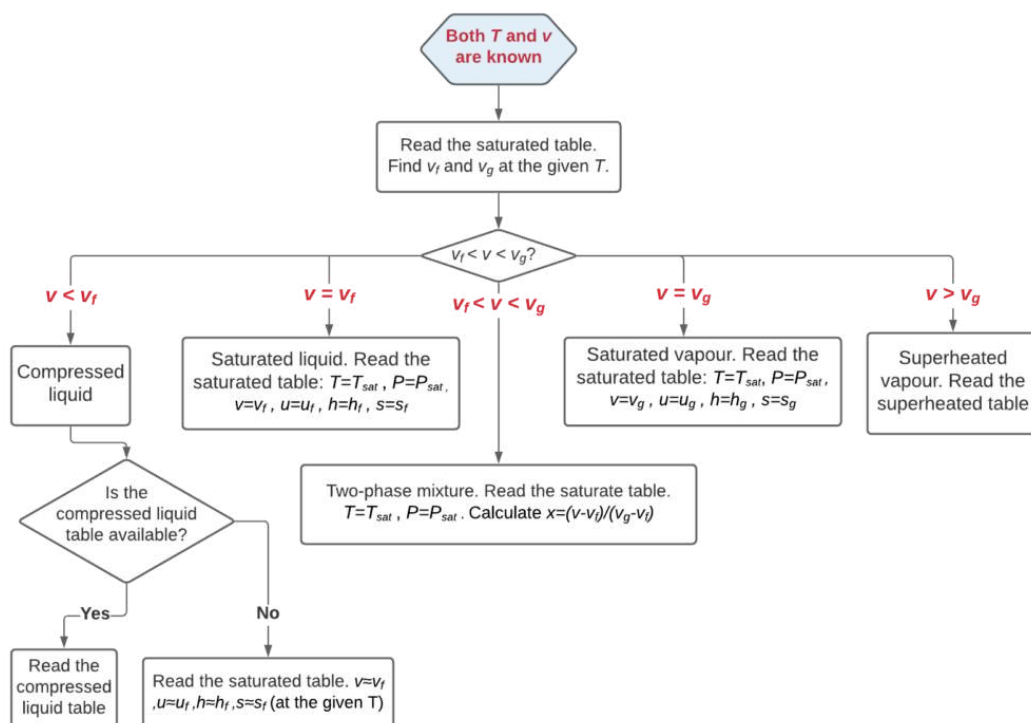

Figure 2.4.3 Flow chart for determining fluid properties from thermodynamics tables if  $T$  and  $v$  are known

$$u \tag{2.5.2}$$

The compressed liquid table is presented only for water in the pressure range of 0.5-50 MPa in this book. When the compressed liquid tables are not available for a specific fluid or in a specific range, the saturated liquid properties at the same temperature may be used as an approximation, i.e.,  $v \approx v_{f@T}$ ,  $u \approx u_{f@T}$ ,  $h \approx h_{f@T}$ , and  $s \approx s_{f@T}$ .

The tables in Appendices A-D are presented with a small temperature increment. Linear interpolations, see Figure 2.4.4, are often used if the given temperature or other properties cannot be found directly from these tables.

$$y = y_0 + (x - x_0) \frac{y_1 - y_0}{x_1 - x_0} \tag{2.5.3}$$

where  $(x, y)$  is the state, at which the property  $x$  is known and the property  $y$  is to be found.  $(x_0, y_0)$  and  $(x_1, y_1)$  indicate the properties of two known states, between which the unknown state  $(x, y)$  is located. To improve the accuracy, the two states should be selected as close as possible to the unknown state.

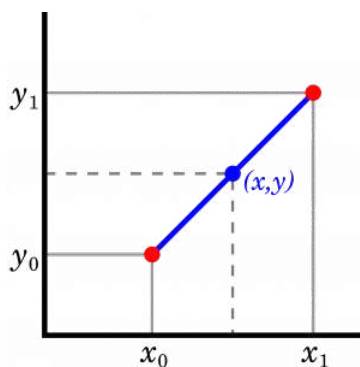

Figure 2.4.4 Linear interpolation

The following examples demonstrate how to use these tables to find the properties of a compressed liquid, superheated vapour, and liquid-vapour mixture.

### ✓ Example 2.5.1

Determine the properties of water at  $T=150^\circ\text{C}$  and  $P=100\text{ kPa}$ .

#### Solution

1. Both temperature and pressure are given for water. Use the flow chart for case 1, [Figure 2.4.1](#).
2. From [Table A1](#): at  $T=150^\circ\text{C}$ ,  $P_{sat} = 0.47617\text{ MPa} = 476.17\text{ kPa}$ .
3. Because  $P=100\text{ kPa} < 476.17\text{ kPa}$ , or  $P < P_{sat}$ , water at this state is a superheated vapour.
4. From [Table A2](#): at  $T=150^\circ\text{C}$  and  $P=100\text{ kPa}$ ,

$$v = 1.93665\text{ m}^3/\text{kg}, u = 2582.94\text{ kJ/kg}$$

$$h = 2776.60\text{ kJ/kg}, s = 7.6148\text{ kJ/kgK}$$

### ✓ Example 2.5.2

Determine the properties of ammonia at  $T=0^\circ\text{C}$  and  $v=0.2\text{ m}^3/\text{kg}$ .

#### Solution

1. Both  $T$  and  $v$  are given for ammonia. Use the flow chart for case 3, [Figure 2.4.3](#).
2. From [Table B1](#): at  $T=0^\circ\text{C}$ ,  $v_f=0.001566\text{ m}^3/\text{kg}$  and  $v_g = 0.289297\text{ m}^3/\text{kg}$ .
3. Because  $v_f < v < v_g$ , ammonia at this state is a liquid-vapour two-phase mixture. Its pressure and quality are

$$P = P_{sat} = 0.42939\text{ MPa} = 429.39\text{ kPa} \quad (2.5.4)$$

$$x = \frac{v - v_f}{v_g - v_f} = \frac{0.2 - 0.001566}{0.289297 - 0.001566} = 0.68965 \quad (2.5.5)$$

From [Table B1](#): at  $T=0^\circ\text{C}$ ,

$$u_f = 342.48\text{ kJ/kg} \text{ and } u_g = 1481.17\text{ kJ/kg}$$

$$h_f = 343.16\text{ kJ/kg} \text{ and } h_g = 1605.39\text{ kJ/kg}$$

$$s_f = 1.4716\text{ kJ/kgK} \text{ and } s_g = 6.0926\text{ kJ/kgK}$$

Therefore, the specific internal energy, specific enthalpy, and specific entropy of this two-phase mixture are



### ✓ Example 2.5.3

Refrigerant R134a has a specific enthalpy  $h = 420\text{ kJ/kg}$  at  $T=20^\circ\text{C}$ . Determine the pressure  $P$  and specific volume  $v$  of R134a at this state.

#### Solution

Solution:

1. Refer to case 4 as both  $T$  and  $h$  are given for R134a. Because the procedures for cases 3 and 4 are the same, the flow chart for case 3, [Figure 2.4.3](#), is used by replacing  $v$  with  $h$ .
2. From [Table C1](#): at  $T=20^\circ\text{C}$ ,  $h_g=409.75\text{ kJ/kg}$ . Because  $h = 420\text{ kJ/kg} > h_g$ , R134a at this state is a superheated vapour.
3. From [Table C2](#):

At  $T=20^{\circ}\text{C}$  and  $P_1 = 100 \text{ kPa}$ :  $h_1 = 420.31 \text{ kJ/kg}$ ,  $v_1 = 0.233731 \text{ m}^3/\text{kg}$

At  $T=20^{\circ}\text{C}$  and  $P_2 = 150 \text{ kPa}$ :  $h_2 = 419.33 \text{ kJ/kg}$ ,  $v_2 = 0.154053 \text{ m}^3/\text{kg}$

Because  $419.33 \text{ kJ/kg} < 420 \text{ kJ/kg} < 420.31 \text{ kJ/kg}$ , the pressure of R134a at the given state must be between 100 kPa and 150 kPa. Use linear interpolation to calculate the pressure and specific volume at the given state.

Pressure

$$\therefore \frac{P - P_1}{P_2 - P_1} = \frac{h - h_1}{h_2 - h_1} \quad (2.5.6)$$

$$\therefore \frac{P - 100}{150 - 100} = \frac{420 - 420.31}{419.33 - 420.31} \quad (2.5.7)$$

$$\therefore P = 115.82 \text{ kPa} \quad (2.5.8)$$

Specific volume

$$\therefore \frac{v - v_1}{v_2 - v_1} = \frac{h - h_1}{h_2 - h_1} \quad (2.5.9)$$

$$\therefore \frac{v - 0.233731}{0.154053 - 0.233731} = \frac{420 - 420.31}{419.33 - 420.31} \quad (2.5.10)$$

$$\therefore v = 0.208527 \text{ m}^3/\text{kg}$$

### Media Attributions

- Linear interpolation © ElectroKid is licensed under a [Public Domain](#) license

This page titled [2.5: Thermodynamic tables](#) is shared under a [CC BY-NC-SA 4.0](#) license and was authored, remixed, and/or curated by [Claire Yu Yan \(BC Campus\)](#) via [source content](#) that was edited to the style and standards of the LibreTexts platform; a detailed edit history is available upon request.



## 2.6: Chapter review

---

An important step in thermodynamic analysis is to predict the thermodynamic properties, in particular, the intensive properties at different states of a process or a cycle. In this chapter, we have introduced common thermodynamic properties of pure substances, and how to use phase diagrams and thermodynamic tables to determine the phase of a fluid and its corresponding properties at a given state. Below are the key takeaways:

- Pure substances may be used as working fluids in thermal devices. A pure substance may exist as a single-phase matter, such as solid, liquid, vapour or gas, or a saturated two-phase mixture.
- The state of a pure substance can be illustrated in the  $P - T$ ,  $T - v$ , and  $P - v$  phase diagrams.
- A state of a pure substance is fixed by **two independent, intensive properties**.
  - For a single-phase fluid, if two intensive properties from the list:  $T, P, v, u, h$ , and  $s$  are known, then the state is fixed.
  - For a two-phase mixture, if two properties from the list:  $T, P, v, u, h, s$  and the quality  $x$  are known, then the state is fixed.
- The properties of a fixed state can be extracted from the thermodynamic tables directly or by using linear interpolations.
- $P - T$ ,  $T - v$ , and  $P - v$  diagrams are of particular importance in thermodynamic analysis. It is highly recommended that students relate the appropriate phase diagrams to the flow charts in Section 2.4, when practicing how to locate a state and how to read thermodynamic tables.

---

This page titled [2.6: Chapter review](#) is shared under a [CC BY-NC-SA 4.0](#) license and was authored, remixed, and/or curated by [Claire Yu Yan \(BC Campus\)](#) via [source content](#) that was edited to the style and standards of the LibreTexts platform; a detailed edit history is available upon request.

## 2.7: Key Equations

### Pressure, temperature, and specific volume

Pressure	$P = F/A$
Absolute and gauge pressures	$P_{gauge} = P_{abs} - P_{atm}$
Absolute and vacuum pressures	$P_{vac} = P_{atm} - P_{abs}$
Density	$\rho = m/V$
Specific volume	$v = V/m = 1/\rho$
Conversion of temperatures in Kelvin and Celsius degrees	$T(K) = T(^{\circ}C) + 273.15$

### Energy, enthalpy, and entropy

Total stored energy in a system	$E = U + KE + PE$ $= mu + \frac{1}{2} mV^2 + mgz$ ( $V$ : velocity)
Total stored specific energy in a system	$e = \frac{E}{m} = u + \frac{1}{2} V^2 + gz$ ( $V$ : velocity)
Enthalpy	$H = U + PV$
Specific internal energy	$u = U/m$
Specific enthalpy	$h = H/m$ and $h = u + Pv$
Specific entropy	$s = S/m$

### Saturated liquid-vapour two-phase mixtures

Quality	$x = \frac{m_g}{m_{mix}}$
Specific volume	$v = v_f + x(v_g - v_f) = (1 - x)v_f + xv_g$
Specific internal energy	$u = u_f + x(u_g - u_f) = (1 - x)u_f + xu_g$
Specific enthalpy	$h = h_f + x(h_g - h_f) = (1 - x)h_f + xh_g$
Specific entropy	$s = s_f + x(s_g - s_f) = (1 - x)s_f + xs_g$

### Compressed liquid (when the compressed liquid tables are not available)

Specific volume	$v \approx v_{f@T}$
Specific internal energy	$u \approx u_{f@T}$
Specific enthalpy	$h \approx h_{f@T}$
Specific entropy	$s \approx s_{f@T}$

This page titled [2.7: Key Equations](#) is shared under a [CC BY-NC-SA 4.0](#) license and was authored, remixed, and/or curated by [Claire Yu Yan \(BC Campus\)](#) via [source content](#) that was edited to the style and standards of the LibreTexts platform; a detailed edit history is available upon request.

## CHAPTER OVERVIEW

### 3: Ideal and Real Gasses

This chapter explains the concepts of “ideal” gas, ideal gas law, real gas, and compressibility factor. Students will learn the difference between an “ideal” and real gases, and at what conditions the ideal gas model may be used as an approximation for evaluating properties, such as pressure, temperature, and volume of a gas.

[3.1: Chapter introduction and learning objectives](#)

[3.2: Ideal gas and ideal gas equation of state](#)

[3.3: Real gas and compressibility factor](#)

[3.4: Chapter Review](#)

[3.5: Key Equations](#)

---

This page titled [3: Ideal and Real Gasses](#) is shared under a [CC BY-NC-SA 4.0](#) license and was authored, remixed, and/or curated by [Claire Yu Yan \(BC Campus\)](#) via [source content](#) that was edited to the style and standards of the LibreTexts platform; a detailed edit history is available upon request.

## 3.1: Chapter introduction and learning objectives

### Learning Objectives

After completing the module, you should be able to

- Understand the limitation of the ideal gas equation of state
- Apply the ideal gas equation of state in solving engineering problems as appropriate
- Explain the difference between “ideal” and real gases
- Calculate the compressibility factor of a pure substance at a given state
- Identify if a substance may be treated as an ideal or real gas for a given condition based on its compressibility factor

Thermodynamic tables are commonly used to evaluate thermodynamic properties of a pure substance. This method is accurate, but may be time consuming for complicated calculations. It would be desirable if, for some special cases, a simple method with relatively good accuracy could be developed for evaluating thermodynamic properties.

This chapter introduces the concepts of “ideal” gas, ideal gas equation of state (EOS), real gas, and compressibility factor. It explains the difference between “ideal” and real gases, and at what conditions the ideal gas model may be used as an approximation for evaluating thermodynamic properties of simple gases.

---

This page titled [3.1: Chapter introduction and learning objectives](#) is shared under a [CC BY-NC-SA 4.0](#) license and was authored, remixed, and/or curated by [Claire Yu Yan \(BC Campus\)](#) via [source content](#) that was edited to the style and standards of the LibreTexts platform; a detailed edit history is available upon request.

## 3.2: Ideal gas and ideal gas equation of state

Consider a container of fixed volume filled with a gas. When the container is heated, the gas temperature will increase, causing the gas pressure to increase. The variations of gas pressure and temperature are governed by the equations of state. An equation of state (EOS) is an expression that relates pressure, temperature, and specific volume of a gas.

The simplest equation of state is the **ideal gas equation of state**, which is expressed as

$$Pv = RT \quad (3.2.1)$$

where

- $m$ : mass, in kg
- $V$ : volume, in  $\text{m}^3$
- $v$ : specific volume, in  $\text{m}^3/\text{kg}$
- $T$ : absolute temperature, in K
- $P$ : pressure, in kPa or Pa
- $R$ : gas constant in  $\text{kJ}/\text{kgK}$  or  $\text{J}/\text{kgK}$

A gas which obeys the ideal gas EOS is called an **ideal gas**. The ideal gas model is a hypothetical model. It approximates the  $P-v-T$  behaviour of a gas at high temperatures and low pressures in the superheated vapour region.

When a gas is at a state near the saturation region or its critical point, the gas behaviour deviates from the ideal gas model significantly. For example, [Figure 3.1.1](#) shows the  $T-v$  diagram for water. Steam in the shaded region is either at a high temperature or a low pressure. The ideal gas model is valid in this region with a relative error of less than 1%. Moving out of the shaded region and towards the saturated vapour line or the critical point, the relative error increases significantly because the ideal gas EOS can no longer represent the gas behaviour in these regions.

A common mistake that students tend to make is to use the ideal gas EOS in all calculations without evaluating its suitability for the given conditions. It is important to note that, although many gasses may be treated as ideal gases in a certain range of pressures and temperatures, **the ideal gas EOS is NOT valid for gases in all conditions**. Therefore, it cannot be used without verification. The compressibility factor in Section 3.2 explains how to verify if a gas is an “ideal” or real gas.

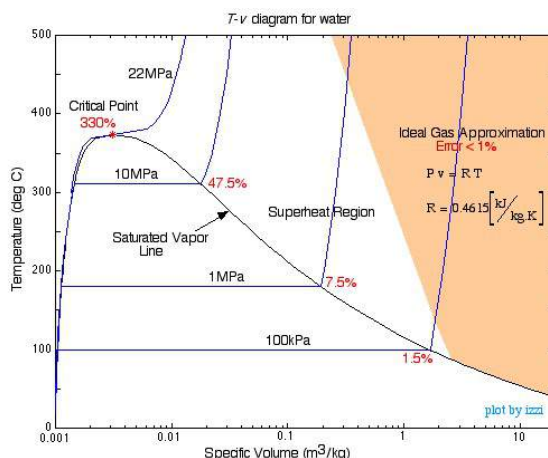

Figure 3.1.1 T-v diagram for water

### ✓ Example 3.2.1

Two tanks contain methane. For the given conditions, methane can be treated as an ideal gas.

- Tank 1 has a volume of  $0.3 \text{ m}^3$ , and is at a temperature of  $20^\circ\text{C}$  and a pressure of  $300 \text{ kPa}$ .
- Tank 2 contains  $1.5 \text{ kg}$  of methane, and is at a temperature of  $30^\circ\text{C}$  and a pressure of  $800 \text{ kPa}$ .

The partition between the two tanks is removed to allow methane in the tanks to mix and reach equilibrium. What is the equilibrium pressure if the temperature of the two tanks is  $25^\circ\text{C}$  at equilibrium?

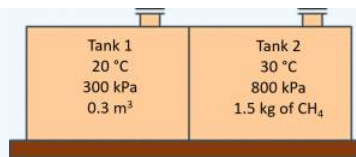

Figure 3.1.e1 Rigid tanks containing methane

### Solution

Methane is treated as an ideal gas at the given conditions.

From Table G1:  $R=0.5182$  kJ/kgK for methane.

Apply the ideal gas law  $PV = mRT$  to both initial and final conditions of methane in the two tanks.

Tank 1 at the initial condition:

$$P_1 V_1 = m_1 R T_1 \quad (3.2.2)$$

$$m_1 = \frac{P_1 V_1}{R T_1} = \frac{300 \times 0.3}{0.5182 \times (273.15 + 20)} = 0.5925 \text{ kg} \quad (3.2.3)$$

Tank 2 at the initial condition:

$$P_2 V_2 = m_2 R T_2 \quad (3.2.4)$$

$$V_2 = \frac{m_2 R T_2}{P_2} = \frac{1.5 \times 0.5182 \times (273.15 + 30)}{800} = 0.2945 \text{ m}^3 \quad (3.2.5)$$

The two tanks are in equilibrium at the final state.

$$m_3 = m_1 + m_2 = 0.5925 + 1.5 = 2.0925 \text{ kg} \quad (3.2.6)$$

$$V_3 = V_1 + V_2 = 0.3 + 0.2945 = 0.5945 \text{ m}^3 \quad (3.2.7)$$

$$P_3 V_3 = m_3 R T_3 \quad (3.2.8)$$

$$P_3 = \frac{m_3 R T_3}{V_3} = \frac{2.0925 \times 0.5182 \times (273.15 + 25)}{0.5925} = 543.8 \text{ kPa} \quad (3.2.9)$$

The equilibrium pressure of the two tanks at the final state is 543.8 kPa.

#### Important note:

- **The temperature must be expressed in Kelvin when applying the ideal gas EOS.**

### ✓ Example 3.2.2

Consider 1 kg of oxygen in a piston-cylinder device undergoing a thermodynamic cycle consisting of three processes.

- Process 1→2: isochoric
- Process 2→3: isothermal expansion
- Process 3→1: isobaric compression

At state 1,  $T_1 = 300$  K,  $P_1 = 1.5$  atm. At state 2,  $P_2 = 3$  atm. Treat oxygen as an ideal gas at the given conditions.

1. Sketch the cycle on a  $P-v$  diagram.
2. Determine the temperature,  $T_2$ , at state 2, and the specific volume,  $v_3$ , at state 3.

### Solution

The cycle on a  $P-v$  diagram

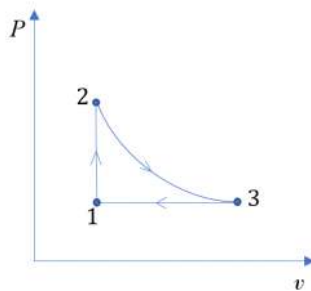

Figure 3.1.e2 P-v diagram of a cycle consisting of three processes

2. Oxygen is treated as an ideal gas at the given conditions.

From [Table G1](#):  $R=0.2598$  kJ/kgK for oxygen.

Apply the ideal gas law  $Pv = RT$  to the three processes.

Process 1→2 is an isochoric process; therefore, the specific volume remains constant in the process,  $v_1 = v_2$

$$\therefore Pv = RT \quad (3.2.10)$$

$$\therefore v_1 = \frac{RT_1}{P_1} \quad (3.2.11)$$

$$\therefore v_1 = v_2 \quad (3.2.12)$$

$$\therefore \frac{T_2}{T_1} = \frac{P_2}{P_1} \quad (3.2.13)$$

$$\therefore T_2 = T_1 \times \frac{P_2}{P_1} = 300 \times \frac{3}{1.5} = 600 \text{ K} \quad (3.2.14)$$

Process 2→3 is an isothermal expansion process; therefore,  $T_3 = T_2 = 600$  K,

Process 3→1 is an isobaric compression process; therefore,

$$P_3 = P_1 = 1.5 \text{ atm} = 1.5 \times 101.325 = 152 \text{ kPa} \quad (3.2.15)$$

$$v_3 = \frac{RT_3}{P_3} = \frac{0.2598 \times 600}{152} = 1.026 \text{ m}^3/\text{kg}$$

The temperature at state 2 is 600 K and the specific volume at state 3 is 1.026 m<sup>3</sup>/kg.

**Important note:**

- **The temperature must be expressed in Kelvin when applying the ideal gas EOS.**

**Media Attributions**

- T-v diagram for water © [Israel Urieli](#) adapted by DIANA BAIKARTAROVA is licensed under a [CC BY-SA \(Attribution ShareAlike\)](#) license

This page titled [3.2: Ideal gas and ideal gas equation of state](#) is shared under a [CC BY-NC-SA 4.0](#) license and was authored, remixed, and/or curated by [Claire Yu Yan \(BC Campus\)](#) via [source content](#) that was edited to the style and standards of the LibreTexts platform; a detailed edit history is available upon request.

### 3.3: Real gas and compressibility factor

$$P - v - T \quad (3.3.1)$$

The compressibility factor is a dimensionless correction factor to account for the deviation of the real gas behaviour from the “ideal” gas model. It is defined as

$$Pv = ZRT \quad (3.3.2)$$

where

$$Z \quad (3.3.3)$$

$$v \quad (3.3.4)$$

$$T \quad (3.3.5)$$

$$P \quad (3.3.6)$$

$$R \quad (3.3.7)$$

The compressibility factor of an ideal gas is exactly one. For real gases, the compressibility factor may be very different from one. [Figures 3.2.1](#) and [3.2.2](#) illustrate the compressibility factors of hydrogen and nitrogen, respectively, over a range of pressures and temperatures. It can be seen that the compressibility factor changes with both pressure and temperature. As the pressure approaches zero, the compressibility factor tends to converge to one. In other words, a real gas may behave like an ideal gas at “low” pressures regardless of its temperature.

From [Figures 3.2.1](#) and [3.2.2](#), it can be seen that the compressibility charts for different gases may vary largely. It is therefore more practical to use a generalized compressibility chart, as shown in [Figure 3.2.3](#), where the pressures and temperatures are normalized with respect to the critical pressure and critical temperature of a gas. The reduced pressure  $P_r$  and reduced temperature  $T_r$  are defined as

$$P_r = P/P_{crit}$$

$$T_r = T/T_{crit}$$

where

$P$ : pressure, in kPa or Pa

$P_{crit}$ : critical pressure, in kPa or Pa.  $P_{crit}$  and  $P$  must have the same unit.

$P_r$ : reduced pressure, dimensionless

$T$ : absolute temperature, in K

$T_{crit}$ : critical temperature, in K

$T_r$ : reduced temperature, dimensionless

The compressibility factor is thus plotted as a function of  $P_r$  and  $T_r$ . The generalized compressibility chart can be viewed as a graphical representation of the gas behaviour over a wide range of pressures and temperatures. It is valid for many substances, especially those that have simple molecular structures. From [Figure 3.2.3](#), it can be seen that the smallest compressibility factor occurs at the critical point,  $P_r = 1$  and  $T_r = 1$ . This indicates that a real gas deviates significantly from the ideal gas behaviour near its critical point. As  $P_r \rightarrow 0$  or  $T_r \geq 2$ , the compressibility factor  $Z \rightarrow 1$ . In other words, a real gas behaves like an ideal gas at “low” pressures and “high” temperatures.



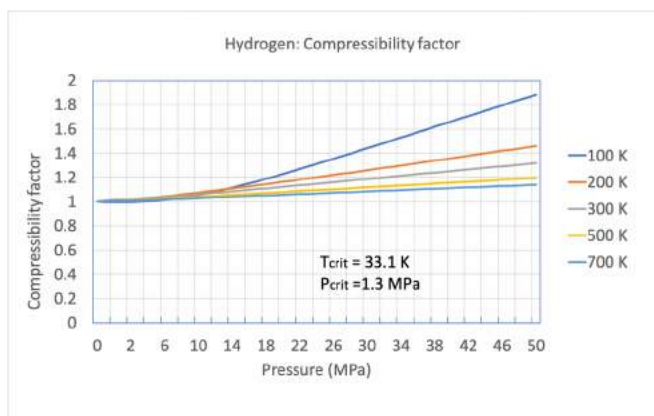

Figure 3.2.1 Compressibility factor of hydrogen

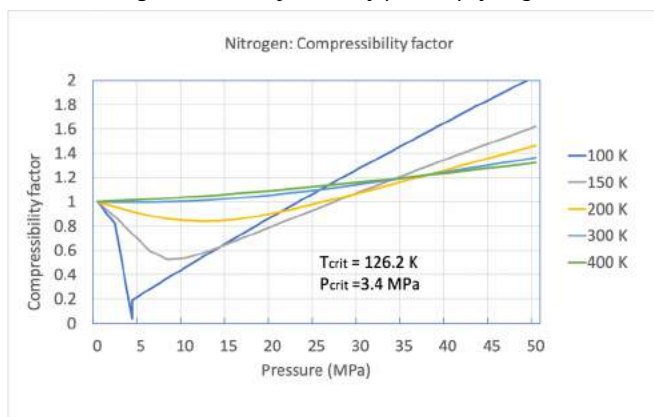

Figure 3.2.2 Compressibility factor of nitrogen

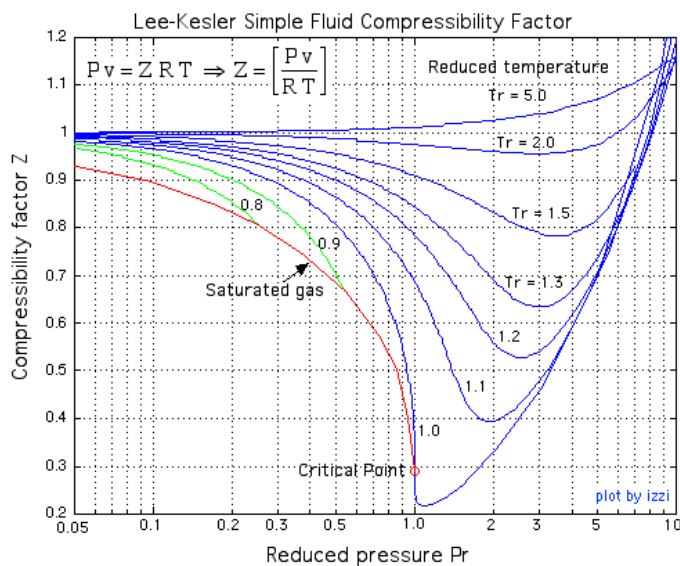

Figure 3.2.3 Lee-Kesler simple fluid compressibility factor

Typically, thermodynamic tables or real-gas EOS are used for evaluating the relation of pressure, temperature, and specific volume of real gases. If neither tool is available, the generalized compressibility chart may be used instead as a fast and reasonably accurate tool, especially for substances with simple molecular structures. Below is the procedure of how to use the generalized compressibility chart, followed by examples.

1. Find the critical pressure,  $P_{crit}$ , and critical temperature,  $T_{crit}$ , of a substance from [Appendix E](#)
2. Calculate the reduced pressure,  $P_r$ , and reduced temperature,  $T_r$ , of the substance at the given condition
3. Estimate the compressibility factor,  $z$ , from [Figure 3.2.3](#).

4. Apply  $Pv = ZRT$  to determine the unknown specific volume (if needed)

### ✓ Example 3.3.1

Find the compressibility factor of the following substances at the given conditions. Is it reasonable to treat them as ideal gases at the given conditions?

1. Methane at  $-50^{\circ}\text{C}$ , 4.1 MPa
2. Ammonia at  $600^{\circ}\text{C}$ , 500 kPa

### Solution

1. Methane at  $-50^{\circ}\text{C}$ , 4.1 MPa

First, find the critical properties of methane from [Table E1](#).

$$T_{crit} = 190.6 \text{ K} \quad (3.3.8)$$

Second, calculate the reduced temperature and reduced pressure.

$$T_r = \frac{T}{T_{crit}} = \frac{273.15 - 50}{190.6} = 1.17 \quad (3.3.9)$$

$$P_r = \frac{P}{P_{crit}} = \frac{4.10}{4.60} = 0.89 \quad (3.3.10)$$

From [Figure 3.2.3](#), the compressibility factor  $z \approx 0.78 \ll 1$ ; therefore, methane at the given condition cannot be treated as an ideal gas.

2. Ammonia at  $600^{\circ}\text{C}$ , 500 kPa

First, find the critical properties of ammonia from [Table E1](#).

$$T_{crit} = 405.4 \text{ K} \quad (3.3.11)$$

Second, calculate the reduced temperature and reduced pressure.

$$T_r = \frac{T}{T_{crit}} = \frac{273.15 + 600}{405.4} = 2.15 \quad (3.3.12)$$

$$P_r = \frac{P}{P_{crit}} = \frac{0.5}{11.34} = 0.04 \quad (3.3.13)$$

From [Figure 3.2.3](#), the compressibility factor  $z \approx 1$ ; therefore, ammonia can be treated as an ideal gas at the given condition. Note that the reduced temperature of ammonia is greater than 2 and the reduced pressure is very small, indicating the given state is far away from the critical point.

### ✓ Example 3.3.2

Calculate the specific volume of steam at 3 MPa,  $350^{\circ}\text{C}$  by using three methods: (1) superheated water vapour table, (2) ideal gas EOS, and (3) compressibility factor. How accurate is each of the methods?

### Solution

Method 1: use the steam table.

From [Table A2](#):  $P=3 \text{ MPa}$  and  $T=350^{\circ}\text{C}$ , therefore,  $v=0.09056 \text{ m}^3/\text{kg}$

Method 2: use the ideal gas EOS alone

From [Table G1](#):  $R=0.4615 \text{ kJ/kgK}$  for steam.

$$\therefore Pv = RT \quad (3.3.14)$$

$$\therefore v = \frac{RT}{P} = \frac{0.4615 \times (273.15 + 350)}{3000} = 0.09586 \text{ m}^3/\text{kg}$$

The relative error in comparison to method 1 is

$$\text{error}\% = \frac{|0.09586 - 0.09056|}{0.09056} \times 100\% = 5.85\% \quad (3.3.15)$$

Method 3: use the ideal gas EOS corrected by the compressibility factor

From [Table E1](#):  $P_{crit}=22.06$  MPa,  $T_{crit}=647.1$  K for water.

Calculate the reduced pressure and reduced temperature at the given condition:

$$P_r = \frac{P}{P_{crit}} = \frac{3}{22.06} = 0.136 \quad (3.3.16)$$

$$T_r = \frac{T}{T_{crit}} = \frac{273.15 + 350}{647.1} = 0.963 \quad (3.3.17)$$

Estimate the compressibility factor from [Figure 3.2.3](#):  $Z \approx 0.94$

Calculate the specific volume at the given condition by incorporating the compressibility factor

$$\therefore Pv = ZRT \quad (3.3.18)$$



The relative error in comparison to method 1 is

$$\text{error}\% = \frac{|0.09011 - 0.09056|}{0.09056} \times 100\% = 0.497\% \quad (3.3.19)$$

*Comment:*

Method 1 gives the most accurate value for specific volume among the three methods, as the steam table is specific for water vapour at different pressures and temperatures. Method 2 assumes steam as an ideal gas. This method is easy to use but gives the least accurate result. Method 3, by correcting the ideal gas EOS with the compressibility factor, improves the accuracy of the calculation.

### Media Attributions

- Lee-Kesler compressibility factor © Israel Urieli adapted by [Diana Bairaktarova](#) is licensed under a [CC BY-NC-SA \(Attribution NonCommercial ShareAlike\)](#) license

This page titled [3.3: Real gas and compressibility factor](#) is shared under a [CC BY-NC-SA 4.0](#) license and was authored, remixed, and/or curated by [Claire Yu Yan \(BC Campus\)](#) via [source content](#) that was edited to the style and standards of the LibreTexts platform; a detailed edit history is available upon request.

### 3.4: Chapter Review

---

The ideal gas EOS is the simplest model to relate the pressure, temperature, and specific volume of a gas. It can be used for thermodynamic analysis if the compressibility factor of a gas at a given condition approaches one, or the gas behaves like an “ideal” gas. It is important to note that, despite its simplicity, the ideal gas EOS cannot be used in all conditions. Its suitability at a given state must be verified.

A real gas doesn't obey the ideal gas EOS at a given state. For a real gas, the compressibility factor can be incorporated to improve the accuracy of the prediction of the  $P-v-T$  relation. The compressibility factor of a gas may be obtained from the generalized compressibility chart.

---

This page titled [3.4: Chapter Review](#) is shared under a [CC BY-NC-SA 4.0](#) license and was authored, remixed, and/or curated by [Claire Yu Yan \(BC Campus\)](#) via [source content](#) that was edited to the style and standards of the LibreTexts platform; a detailed edit history is available upon request.

## 3.5: Key Equations

---

	$Pv = RT$ and $PV = mRT$	
		$m :$ (3.5.1)
		$R :$ (3.5.2)
Ideal gas equation of state (mass form)		$V :$ (3.5.3)
		$v :$ (3.5.4)
		$T :$ (3.5.5)
Compressibility factor	$Z = Pv/RT$	

This page titled [3.5: Key Equations](#) is shared under a [CC BY-NC-SA 4.0](#) license and was authored, remixed, and/or curated by [Claire Yu Yan \(BC Campus\)](#) via [source content](#) that was edited to the style and standards of the LibreTexts platform; a detailed edit history is available upon request.

## CHAPTER OVERVIEW

### 4: The First Law of Thermodynamics for Closed Systems

This chapter explains the concepts of heat, work, and the first law of thermodynamics for closed systems. Through examples, students will learn how to apply the first law of thermodynamics to engineering problems involving closed systems.

- [4.1: Chapter introduction and learning objectives](#)
- [4.2: Internal energy in a system](#)
- [4.3: Heat transfer across a boundary](#)
- [4.4: Work](#)
- [4.5: The first law of thermodynamics for closed systems](#)
- [4.6: Chapter review](#)
- [4.7: Key equations](#)

---

This page titled [4: The First Law of Thermodynamics for Closed Systems](#) is shared under a [CC BY-NC-SA 4.0](#) license and was authored, remixed, and/or curated by [Claire Yu Yan \(BC Campus\)](#) via [source content](#) that was edited to the style and standards of the LibreTexts platform; a detailed edit history is available upon request.

## 4.1: Chapter introduction and learning objectives

The first law of thermodynamics is the law of energy conservation: ***the energy can neither be created nor destroyed; it is conserved in a system.*** This chapter explains the fundamental concepts of heat and work, and the first law of thermodynamics. Examples are given to illustrate the applications of the first law of thermodynamics in closed systems.

### Learning Objectives

After completing the chapter, you should be able to

- Determine the internal energy of real substances by using thermodynamic tables
- Calculate the internal energy of ideal gases by using constant-volume specific heat
- Calculate different forms of work, such as the boundary work in various processes and the spring work due to the deformation of a spring
- Explain the differences between work, heat, and energy stored in a system
- Explain the physical meaning of the first law of thermodynamics
- Apply the first law of thermodynamics to closed systems

This page titled [4.1: Chapter introduction and learning objectives](#) is shared under a [CC BY-NC-SA 4.0](#) license and was authored, remixed, and/or curated by [Claire Yu Yan \(BC Campus\)](#) via [source content](#) that was edited to the style and standards of the LibreTexts platform; a detailed edit history is available upon request.

## 4.2: Internal energy in a system

The total energy of a system may consist of internal energy, kinetic energy, potential energy, and other forms of energy. For a system free of magnetic, electric, and surface tension effects, its total energy and corresponding specific energy can be expressed as

$$E = U + KE + PE \quad (4.2.1)$$

$$e = u + ke + pe \quad (4.2.2)$$

where  $E, U, KE$ , and  $PE$  represent the total energy, internal energy, kinetic energy, and potential energy of a system, respectively;  $e, u, ke$ , and  $pe$  are their corresponding specific energies. Recall from Chapter 2, internal energy  $U$  is a form of thermal energy. A system at different states may have different internal energies due to different temperature and pressure at each state; therefore,  $u$  is a state function. It is important to note that the change in internal energy in a process depends on the initial and final states, not on the path of the process. For example, although the three processes in Figure 4.1.1 undergo different paths, their changes in internal energy,  $\Delta U$ , between the two states 1 and 2 are the same because the three processes have identical initial states and identical final states.

The first law of thermodynamics gives the relation between the total energy stored in a system and the energy transferred into or out of the system in the form of heat and work. In this chapter, we will firstly introduce the common methods of determining internal energy and work, and then the first law of thermodynamics and its applications to closed systems.

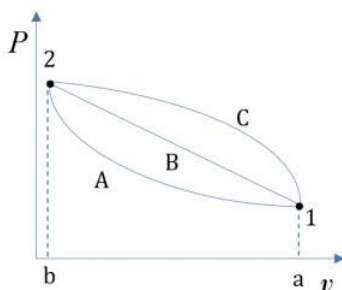

Figure 4.1.1 P- v diagram showing different process paths with the same initial and final states

### 4.1.1 Using thermodynamic tables to determine specific internal energy $u$

For pure substances with available thermodynamic tables, the specific internal energy can be read from the thermodynamic tables, then the internal energy can be found from

$$U = mu \quad (4.2.3)$$

where

$$m \quad (4.2.4)$$

$$U \quad (4.2.5)$$

$$u \quad (4.2.6)$$

#### ✓ Example 4.2.1

Complete the table, and label each state on the  $P$ - $T$ ,  $T$ - $v$  and  $P$ - $v$  diagrams.

	Substance	$T$ °C	$P$ kPa	$v$ m <sup>3</sup> /kg	$u$ kJ/kg	$x$	Phase
1	Water	60	500				
2	R134a	40		0.1			

#### Solution

1. Water at 60°C and 500 kPa



From Table A1:  $P_{sat} = 0.01995 \text{ MPa} = 19.95 \text{ kPa}$  at  $60^\circ\text{C}$ . The given pressure  $P = 500 \text{ kPa} > P_{sat}$ ; therefore, water at the given state is a compressed liquid.

From Table A3:  $v = 0.001017 \text{ m}^3/\text{kg}$  and  $u = 251.08 \text{ kJ/kg}$  for the given state.

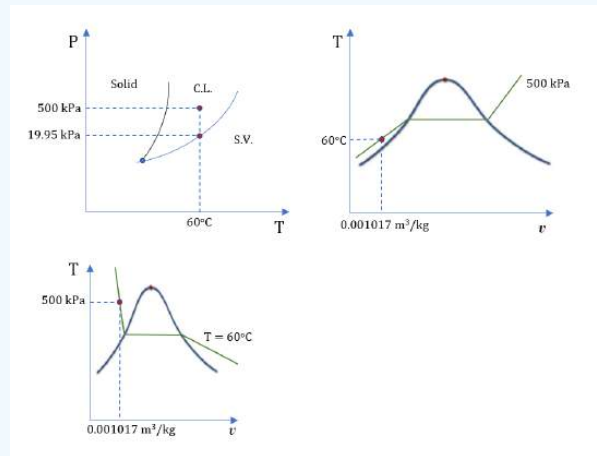

Figure 4.1.e1 Water is a compressed liquid at the given state, as illustrated on the phase diagrams.

## 2. R134a at $40^\circ\text{C}$ and $0.1 \text{ m}^3/\text{kg}$

From Table C1:  $v_g = 0.019966 \text{ m}^3/\text{kg}$  at  $40^\circ\text{C}$ . The given specific volume  $v = 0.1 \text{ m}^3/\text{kg} > v_g$ ; therefore, R134a at the given state is a superheated vapour.

From Table C2:

$$v = 0.080629 \text{ m}^3/\text{kg} \text{ and } u = 410.00 \text{ kJ/kg} \text{ at } 40^\circ\text{C} \text{ and } 300 \text{ kPa}$$

$$v = 0.123226 \text{ m}^3/\text{kg} \text{ and } u = 411.22 \text{ kJ/kg} \text{ at } 40^\circ\text{C} \text{ and } 200 \text{ kPa}$$

Use linear interpolation to find  $P$  and  $u$  at the given condition

$$\therefore \frac{P - 300}{200 - 300} = \frac{0.1 - 0.080629}{0.123226 - 0.080629} \quad (4.2.7)$$

$$\therefore P = 254.52 \text{ kPa} \quad (4.2.8)$$

$$\therefore \frac{u - 410.00}{411.22 - 410.00} = \frac{0.1 - 0.080629}{0.123226 - 0.080629} \quad (4.2.9)$$

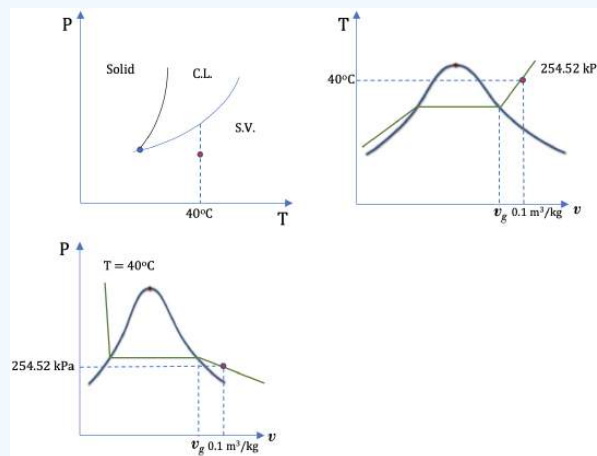

Figure 4.1.e2 R134a is a superheated vapour at the given state, as illustrated on the phase diagrams.

In summary, the table below gives the final answers to the question.

	Substance	$T$ °C	$P$ kPa	$v$ m <sup>3</sup> /kg	$u$ kJ/kg	$x$	Phase
1	Water	60	500	0.001017	251.08	n.a.	Compressed liquid
2	R134a	40	254.52	0.1	410.55	n.a.	Superheated vapour

### 4.1.2 Constant-volume specific heat

When a substance absorbs heat, its temperature tends to increase. Different substances require different amounts of heat for a given temperature rise. For example, it requires 4.18 kJ of heat to warm up 1 kg of water by 1°C. But it only requires 2.22 kJ of heat to warm up the same amount of gasoline by 1°C. In other words, water and gasoline have different energy storage capacities. Specific heat, also called heat capacity, is an important property used to quantify the energy storage capacity of a substance. Specific heat is defined as the energy required to raise the temperature of one unit mass (i.e., 1 kg) of a substance by one degree (i.e., 1°C, or 1 K),

$$C = \left( \frac{1}{m} \frac{\delta Q}{\partial T} \right) \quad (4.2.10)$$

where

$$C \quad (4.2.11)$$

$$m \quad (4.2.12)$$

$$\frac{\delta Q}{\partial T} \quad (4.2.13)$$

The specific heat of a substance may be measured in an isochoric or isobaric process; they are therefore called constant-volume specific heat,  $C_v$ , and constant-pressure specific heat,  $C_p$ , respectively. Both  $C_v$  and  $C_p$  are properties of a substance. They can be used to calculate the changes of specific internal energy,  $\Delta u$ , and specific enthalpy,  $\Delta h$ , respectively, in a process involving ideal gases, liquids and solids. The constant-volume specific heat is introduced below in detail and the constant-pressure specific heat will be introduced in Chapter 5.

Constant-volume specific heat is defined as the energy required to raise the temperature of one unit mass (i.e., 1 kg) of a substance by one degree (i.e., 1°C, or 1 K) in an isochoric process. Mathematically, it is expressed as,

$$C_v = \left( \frac{\partial u}{\partial T} \right)_v \quad (4.2.14)$$

where

$$C_v \quad (4.2.15)$$

$$u \quad (4.2.16)$$

$$T \quad (4.2.17)$$

The constant-volume specific heat of selected ideal gases can be found in Appendix G, [Table G1](#). For example, oxygen has  $C_v = 0.658$  kJ/kgK. If we heat up 1 kg of oxygen at 300 K in a sealed, rigid tank, it will require 0.658 kJ of heat for the temperature of the oxygen to rise from 300 K to 301 K.

It is important to note that although  $C_v$  is typically measured in isochoric processes, it is a property of a substance. The use of  $C_v$  is NOT limited to isochoric processes. As can be seen in the next section, for ideal gases  $C_v$  can be used to calculate the change in specific internal energy,  $\Delta u$ , in ANY processes.

### 4.1.3 Using $C_v$ to calculate $\Delta u$ for ideal gases

A gas behaves like an ideal gas as its compressibility factor  $Z \rightarrow 1$ . The specific internal energy of an ideal gas is a function of temperature only,  $u = f(T)$ ; therefore,

$$C_v = \left( \frac{\partial u}{\partial T} \right)_v = \left( \frac{du}{dT} \right)_v = f(T) \quad (4.2.18)$$

The change in specific internal energy between two states in any process involving ideal gases can be found from

$$\Delta u = u_2 - u_1 = C_v(T_2 - T_1) \quad (4.2.19)$$

where

$$u \quad (4.2.20)$$

$$T \quad (4.2.21)$$

$$C_v \quad (4.2.22)$$

The above equation provides a convenient way for estimating  $\Delta u$  of ideal gases in a process. Its accuracy depends on the change in temperature in a process. In many cases, especially, those with small temperature variations, this method is reasonably accurate and can be used for ideal gases when the thermodynamic tables are not available. If the thermodynamic tables are available or high accuracy is required for the process analysis, it is preferable to use the thermodynamic tables to determine  $u$  at different states first, and then  $\Delta u$ .

#### ✓ Example 4.2.2

Two kilograms of air is heated from 10°C to 40°C. Calculate the change in internal energy,  $\Delta U$ , in this process. Will your answer be different if the process is isochoric or isobaric?

#### Solution

Air is treated as an ideal gas. From [Table G1](#):  $C_v = 0.718 \text{ kJ/kgK}$ ; therefore,

$$\Delta u = C_v(T_2 - T_1) = 0.718 \times (40 - 10) = 21.54 \text{ kJ/kg}$$

$$\Delta U = m\Delta u = 2 \times 21.54 = 43.08 \text{ kJ} \quad (4.2.23)$$

The change in internal energy in this process is 43.08 kJ. As  $C_v$  is a property of the substance (e.g., air in this example), the answer will be the same regardless of the type of the process.

---

This page titled [4.2: Internal energy in a system](#) is shared under a [CC BY-NC-SA 4.0](#) license and was authored, remixed, and/or curated by [Claire Yu Yan \(BC Campus\)](#) via [source content](#) that was edited to the style and standards of the LibreTexts platform; a detailed edit history is available upon request.

## 4.3: Heat transfer across a boundary

---

The total energy stored in a system may change when energy is transferred into or out of the system. For a closed system, the energy transfer is achieved via two mechanisms: heat and work, as illustrated in [Figure 1.2.3](#).

Heat transfer takes place when a temperature difference exists between a system and its surroundings. As heat transfer must cross the system boundary, it is a *boundary phenomenon*. The heat transfer between two states during a process can be written as

$${}_1Q_2 = \int_1^2 \delta Q \quad (4.3.1)$$

Different from internal energy, heat transfer is NOT a state function. It is a path function because the amount of heat that is absorbed or rejected by a substance in a process depends not only on the initial and final states, but also on the process path. Although heat transfer is NOT a property of a system, it has a significant effect on the changes of properties of the system in a process.

Specific heat transfer refers to the amount of heat transfer per unit mass of a substance. It is defined as

$$q = \frac{Q}{m} \quad (4.3.2)$$

where

$$m \quad (4.3.3)$$

$$Q \quad (4.3.4)$$

$$q \quad (4.3.5)$$

---

This page titled [4.3: Heat transfer across a boundary](#) is shared under a [CC BY-NC-SA 4.0](#) license and was authored, remixed, and/or curated by [Claire Yu Yan \(BC Campus\)](#) via [source content](#) that was edited to the style and standards of the LibreTexts platform; a detailed edit history is available upon request.

## 4.4: Work

Work is a form of mechanical energy associated with a force and its resulting displacement. When a force  $F$  moves a body from one position to another, it does work on that body over the distance, see [Figure 4.3.1](#).

$${}_1W_2 = \int_1^2 F dx \quad (4.4.1)$$

The common SI units for work are kJ and J.

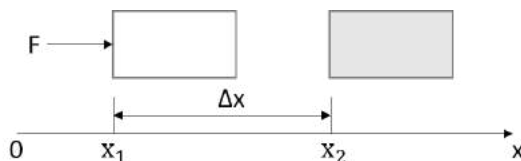

Figure 4.3.1 Work done due to a force acting on a block over a distance

### 4.3.1 Boundary work

Work associated with the expansion and compression of a gas is commonly called boundary work because it is done at the boundary between a system and its surroundings.

Let us consider a piston-cylinder device, as illustrated in [Figure 4.3.2](#). The gas in the cylinder exerts an upward force,  $F = PA$ , where  $P$  is the gas pressure, and  $A$  is the cross-sectional area of the piston. Upon receiving heat, the gas will tend to expand, pushing the piston up. We will assume the expansion process is quasi-equilibrium, and the piston moves up an infinitesimal distance  $d$ . The boundary work done by the gas to the surroundings in this infinitesimal process is  $dW = Fd = (PA)d = P(Ad) = P\Delta V$ ; therefore, the total boundary work between two states in a process can be written as

$${}_1W_2 = \int_1^2 P dV \quad (4.4.2)$$

where

$$P \quad (4.4.3)$$

$$V \quad (4.4.4)$$

$${}_1W_2 \quad (4.4.5)$$

Specific boundary work refers to the boundary work done by a unit mass of a substance. It can be written as

$${}_1w_2 = \int_1^2 P dv \quad (4.4.6)$$

where

$$P \quad (4.4.7)$$

$$v \quad (4.4.8)$$

$${}_1w_2 \quad (4.4.9)$$

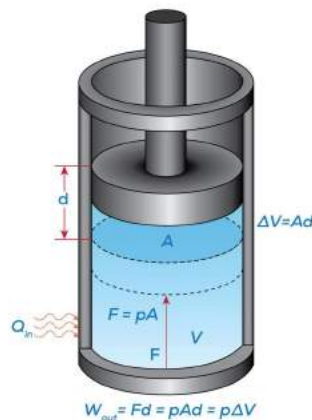

Figure 4.3.2 Boundary work caused by the expansion of gas in a piston-cylinder device

From the integral equations for  ${}_1W_2$  and  ${}_1w_2$ , we can tell that the boundary work and specific boundary work between any two states in a process can be illustrated graphically as the area under the process curve in the  $P-v$  and  $P-v$  diagrams, respectively. For example, the shaded area in Figure 4.3.3 represents the specific boundary work between states 1 and 2 in the compression process A. The three compression processes, A, B, and C in Figure 4.3.3 have different specific boundary work because of their different paths. By comparing the areas under the process curves, we can tell that process A has the smallest specific boundary work and process C has the largest specific boundary work.

Figure 4.3.3 demonstrates that the boundary work and specific boundary work in a quasi-equilibrium process are path functions; they depend on the initial and final states as well as the process path. Boundary work can be defined as positive or negative. Here is a common sign convention: the boundary work in an expansion process is positive. This is because the change of volume in an expansion process is positive. Likewise, the boundary work in a compression process is negative.

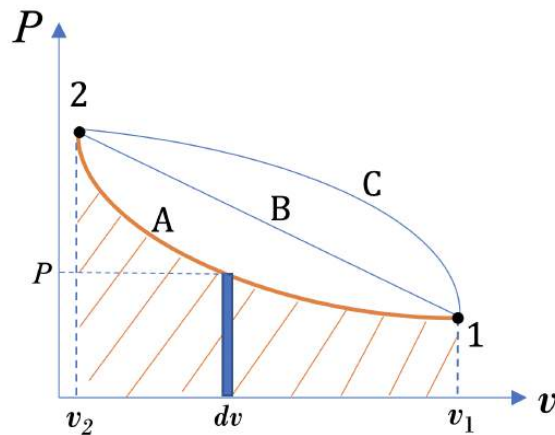

Figure 4.3.3 P-v diagram showing the specific boundary work as the shaded area under the P-v curve

#### Example 1

Consider a **rigid sealed** tank of a volume of  $0.3 \text{ m}^3$  containing nitrogen at  $10^\circ\text{C}$  and  $150 \text{ kPa}$ . The tank is heated until the temperature of the nitrogen reaches  $50^\circ\text{C}$ . Treat nitrogen as an ideal gas.

1. Sketch the process on a  $P-v$  diagram
2. Calculate the boundary work in this process
3. Calculate the change in internal energy in this process

#### Solution

1.  $P-v$  diagram

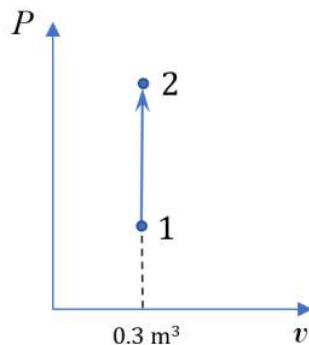

Figure 4.3.e1 Isochoric process in a rigid sealed tank

2. The boundary work is zero because the volume of nitrogen remains constant in the process.

$${}_1W_2 = \int_1^2 P dV = 0 \quad (4.4.10)$$

3. Change in internal energy in the process

From Table G1:

$R=0.2968$  kJ/kgK and  $C_v=0.743$  kJ/kgK

The mass of nitrogen:

$$\therefore PV = mRT \quad (4.4.11)$$

$$\therefore m = \frac{PV}{RT} = \frac{150 \times 0.3}{0.2968 \times (273.15 + 10)} = 0.5355 \text{ kg} \quad (4.4.12)$$

The change in internal energy:

$$\begin{aligned} \Delta U &= m\Delta u = mC_v(T_2 - T_1) \\ &= 0.5355 \times 0.743 \times (50 - 10) = 15.9 \text{ kJ} \end{aligned}$$

Nitrogen absorbs 15.9 kJ of heat in this process.

### Example 2

Consider 0.2 kg of ammonia in a reciprocating compressor (piston-cylinder device) undergoing an **isobaric** expansion. The initial and final temperatures of the ammonia are 0°C and 30°C, respectively. The pressure remains 100 kPa in the process.

1. Sketch the process on a  $P-v$  diagram
2. Calculate the boundary work in this process
3. Calculate the change in internal energy in this process

Solution:

1.  $P-v$  diagram

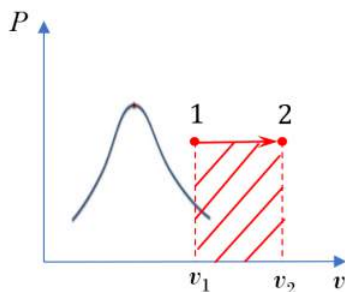

Figure 4.3.e2 An isobaric expansion process in the superheated vapour region

## 2. Boundary work

From Table B2: for the initial state 1 at  $T = 0^\circ\text{C}$ ,  $P = 100 \text{ kPa}$ ,

$$v_1 = 1.31365 \text{ m}^3/\text{kg} \quad u_1 = 1504.29 \text{ kJ/kg}$$

For the final state 2 at  $T = 30^\circ\text{C}$ ,  $P = 100 \text{ kPa}$ ,

$$v_2 = 1.46562 \text{ m}^3/\text{kg} \quad u_2 = 1554.1 \text{ kJ/kg}$$

Graphically, the specific boundary work is the shaded rectangular area under the process line in the  $P - v$  diagram.

$$\begin{aligned} {}_1W_2 &= m_1w_2 = m \int_1^2 Pdv = mP(v_2 - v_1) \\ &= 0.2 \times 100 \times (1.46562 - 1.31365) = 3.0394 \text{ kJ} \end{aligned}$$

## 3. Change in internal energy

$$\begin{aligned} \Delta U &= m\Delta u = m(u_2 - u_1) \\ &= 0.2 \times (1554.1 - 1504.29) = 9.962 \text{ kJ} \end{aligned}$$

### Example 3

Consider air undergoing an **isothermal** expansion. The initial and final pressures of the air are 200 kPa and 100 kPa respectively. The temperature of the air remains  $50^\circ\text{C}$  in the process. Treat air as an ideal gas.

1. Sketch the process on a  $P - v$  diagram
2. Calculate the specific boundary work in this process
3. Calculate the change in specific internal energy in this process

Solution:

1.  $P - v$  diagram

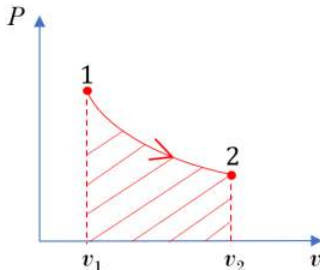

Figure 4.3.e3 Isothermal expansion process

2. Specific Boundary work

From Table G1:  $R = 0.287 \text{ kJ/kgK}$  for air. The ideal gas, air, undergoes an isothermal process.

$$\therefore Pv = RT \quad (4.4.13)$$

$$\therefore P = \frac{RT}{v} \quad (4.4.14)$$

$$\begin{aligned} {}_1W_2 &= \int_1^2 Pdv = \int_1^2 \frac{RT}{v} dv \\ &= RT \int_1^2 \frac{1}{v} dv = RT \ln \frac{v_2}{v_1} = RT \ln \frac{P_1}{P_2} \\ &= 0.287 \times (273.15 + 50) \ln \frac{200}{100} = 64.285 \text{ kJ} \end{aligned}$$

3. The process is isothermal; therefore, the temperature remains constant and the change in internal energy is zero.

$$\Delta u = C_v (T_2 - T_1) = 0 \quad (4.4.15)$$



### 4.3.2 Polytropic process and its boundary work

A polytropic process refers to any quasi-equilibrium thermodynamic process, which can be described with the following mathematical expression.

$$Pv^n = \text{constant} \quad (4.4.16)$$

where

$$P \quad (4.4.17)$$

$$v \quad (4.4.18)$$

$$n \quad (4.4.19)$$

$$n \quad (4.4.20)$$

By adjusting  $n$  to different values, the above two simple expressions can be used to represent the relations of pressure-volume or pressure-specific volume of various processes that are encountered in real thermal systems, including the isobaric, isochoric, and isothermal processes. Table 4.3.1 lists the polytropic exponents corresponding to an ideal gas undergoing an isobaric, isochoric, and isothermal process, respectively.

Table 4.3.1 Ideal gas equation of state expressed in polytropic relations

Process	Polytropic exponent	Ideal gas equation of state	Polytropic relation
Isobaric	$n = 0$	$P = \text{constant}$	$Pv^0 = \text{constant}$
Isothermal	$n = 1$	$\therefore T = \text{constant and } Pv = RT$ $\therefore Pv = \text{constant} \quad (4.4.21)$	$Pv^1 = \text{constant}$
Isochoric	$n = \infty$	$v = \text{constant}$	$Pv^\infty = \text{constant}$

Figure 4.3.4 shows different polytropic processes of an ideal gas. In many actual thermodynamic processes, the polytropic exponents are typically in the range of  $1 < n < k$ , where  $k = \frac{C_p}{C_v}$ .  $C_p$  and  $C_v$  are the constant-pressure and constant-volume specific heats, respectively.

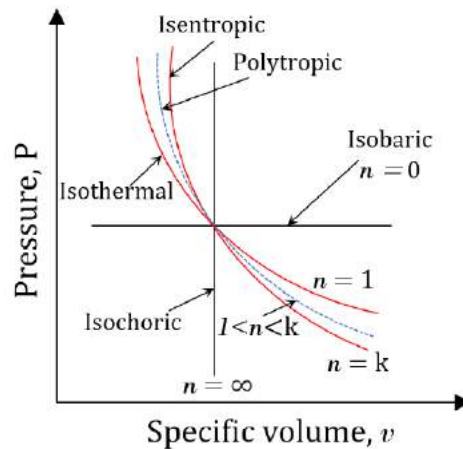

Figure 4.3.4 Different processes of an ideal gas

The boundary work and corresponding specific boundary work in a polytropic process can be calculated by using the following equations. Detailed derivations are left for the readers to practice.

The following expressions are valid for both real and ideal gases.

If  $n \neq 1$ ,

$$W_{1-2} = \frac{P_2 v_2 - P_1 v_1}{1-n}$$

$$w_{1-2} = \frac{P_2 v_2 - P_1 v_1}{1-n}$$

$$\frac{w_2}{1-n}$$

If  $n = 1$ ,

$${}_1W_2 = P_1 V_1 \ln \frac{V_2}{V_1} = P_2 V_2 \ln \frac{V_2}{V_1} \quad (4.4.22)$$

$$\frac{{}_1W_2}{P_1 V_1} = \frac{{}_1W_2}{P_2 V_2} = \ln \frac{V_2}{V_1}$$

$$\frac{w_2}{P_1 v_1} = \frac{w_2}{P_2 v_2} = \ln \frac{v_2}{v_1}$$

$$\frac{w_2}{P_1 v_1} = \frac{w_2}{P_2 v_2} = \ln \frac{v_2}{v_1}$$

The following two expressions are valid only for ideal gases in an isothermal process ( $n = 1$ ).

If  $n = 1$ ,

$$\ln \frac{V_2}{V_1} = \ln \frac{V_2}{V_1}$$

$$\ln \frac{v_2}{v_1} = \ln \frac{v_2}{v_1}$$

where

$${}_1W_2 \quad (4.4.23)$$

$${}_1w_2 \quad (4.4.24)$$

$$P \quad (4.4.25)$$

$$V \quad (4.4.26)$$

$$v \quad (4.4.27)$$

$$T \quad (4.4.28)$$

$$R \quad (4.4.29)$$

$$m \quad (4.4.30)$$

#### Example 4

Consider an ideal gas undergoing a **polytropic** process. At the initial state:  $P_1=200$  kPa,  $v_1=0.05$  m<sup>3</sup>/kg. At the final state:  $v_2=0.1$  m<sup>3</sup>/kg. For  $n=1.3$  and  $n=1$ ,

1. Sketch the two processes on a  $P-v$  diagram. Which process has a larger specific boundary work?
2. Calculate the specific boundary work and verify your answer to the question in part 1.

#### Solution:

##### 1. $P-v$ diagram

From the  $P-v$  diagram, the area under the process line for  $n = 1$  is greater than that for  $n = 1.3$ ; therefore, the isothermal process with  $n = 1$  has a larger specific boundary work.

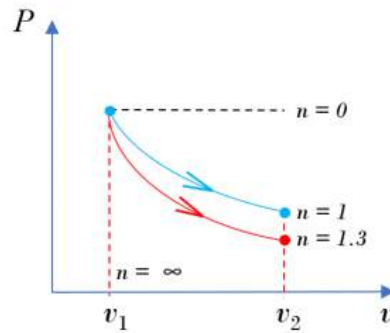

Figure 4.3.e4 Polytropic processes of an ideal gas illustrated on the P-v diagram

2. For  $n = 1.3$ , find the final pressure  $P_2$  first.

$$\therefore P_1 v_1^n = P_2 v_2^n \tag{4.4.31}$$

$$\therefore P_2 = P_1 \left( \frac{v_1}{v_2} \right)^n = 200 \times \left( \frac{0.05}{0.1} \right)^{1.3} = 81.225 \text{ kPa} \tag{4.4.32}$$



For  $n = 1$ , the process is isothermal; therefore,



Compare the specific boundary work in these two processes, the isothermal process ( $n=1$ ) has a larger specific boundary work than the polytropic process with  $n = 1.3$ . The calculation results are consistent with the observation from the  $P - v$  diagram.

### 4.3.3 Spring work

Spring work is a form of mechanical energy required to compress or expand a spring to a certain distance, see [Figure 4.3.5](#). Spring force and spring work can be expressed as follows:

$$F = Kx \tag{4.4.33}$$

$$W_{spring} = \int_1^2 F dx = \frac{1}{2} K (x_2^2 - x_1^2) \tag{4.4.34}$$

where

$$F \tag{4.4.35}$$

$$K \tag{4.4.36}$$

$$W_{spring} \tag{4.4.37}$$

$$x_1 \tag{4.4.38}$$

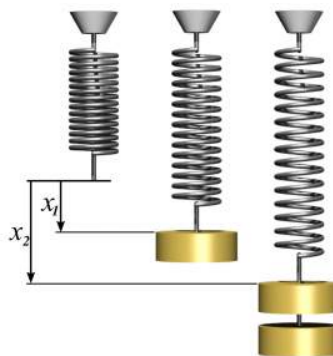

Figure 4.3.5 Work done by the spring force due to the displacement from the spring's rest position.

Example 5

A linear spring with spring constant  $K=100$  kN/m is mounted on a piston-cylinder device. At the initial state, the cylinder contains  $0.15$  m<sup>3</sup> of gas at  $100$  kPa. The spring is uncompressed. The gas is then heated until its volume expands to  $0.2$  m<sup>3</sup>. The piston's cross-sectional area is  $0.1$  m<sup>2</sup>. Assume the piston is frictionless with negligible weight and the process is quasi-equilibrium,

1. Write an expression of the gas pressure as a function of the gas volume in this process
2. Sketch the process on a  $P - v$  diagram
3. Calculate the total work done by the gas during this expansion process
4. If the spring is not mounted on the piston, the gas in the cylinder will expand isobarically after being heated. To reach the same final volume,  $0.2$  m<sup>3</sup>, how much work must be done by the gas in the expansion process?

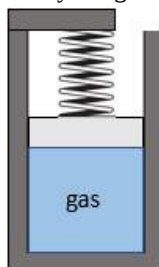

Figure 4.3.e5 Piston-cylinder device with a spring loaded on top of the piston

Solution:

1. Analyze the forces acting on the piston, see below.

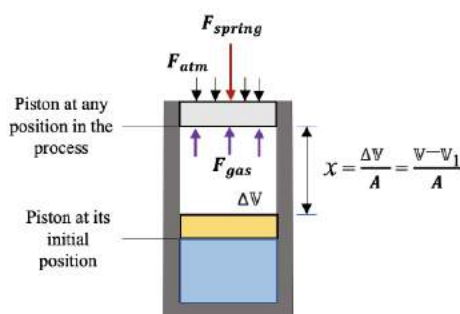

Figure 4.3.e6 Forces acting on the piston in equilibrium

Three forces acting on the piston are in equilibrium.

$$\therefore \sum F = 0 : F_{gas} = F_{spring} + F_{atm} \quad (4.4.39)$$

$$\therefore P_{gas} A = Kx + P_{atm} A = K \frac{V - V_1}{A} + P_{atm} A \quad (4.4.40)$$

$$\therefore P_{gas} = \frac{K(V - V_1)}{A^2} + P_{atm} \quad (4.4.41)$$

At the initial state: . Substitute the two values,

$$\therefore 100 = \frac{K(V - V_1)}{A^2} + P_{atm} \quad (4.4.42)$$

$$\therefore P_{atm} = 100 \text{ kPa} \quad (4.4.43)$$

with  $K=100$  kN/m,  $A = 0.1$  m<sup>2</sup>,  $P_{atm} = 100$  kPa and  $v_1= 0.15$  m<sup>3</sup>, the gas pressure can be expressed as a function of the gas volume.

$$\therefore P_{gas} = \frac{100(V - 0.15)}{0.1^2} + 100 \quad (4.4.44)$$

$$\therefore P_{gas} = 10^4 V - 1400 \quad (4.4.45)$$

where gas pressure is in kPa and  $v$  is in m<sup>3</sup>.

2.  $P - v$  diagram

From part 1,  $P_{\text{gas}}$  is a linear function of volume  $v$ .

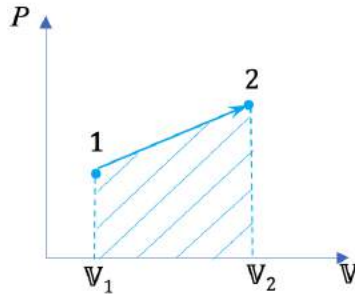

Figure 4.3.e7 P-V diagram showing the process from the initial to the final states

3. During the expansion process, the gas has to overcome the resistance from the spring and. At the same time, the gas pressure and volume increase until the gas reaches the final state. The total work done by the gas is the shaded area of the trapezoid in the  $P - v$  diagram.

At the final state,  $v_2 = 0.2 \text{ m}^3$ ; therefore,

$$P_{\text{gas},2} = 10^4 \times 0.2 - 1400 = 600 \text{ kPa} \quad (4.4.46)$$

The total work done by the gas is

$$\begin{aligned} {}_1W_2 &= \frac{(P_{\text{gas},2} + P_{\text{gas},1})(V_2 - V_1)}{2} \\ &= \frac{(600 + 100)(0.2 - 0.15)}{2} = 17.5 \text{ kJ} \end{aligned}$$

4. If the gas expands isobarically from  $v_1 = 0.15 \text{ m}^3$  to  $v_2 = 0.2 \text{ m}^3$ , the work done by the gas will be

$$\begin{aligned} {}_1W_{2a} &= P_{\text{gas},1}(V_2 - V_1) \\ &= 100 \times (0.2 - 0.15) = 5 \text{ kJ} \end{aligned} \quad (4.4.47)$$

$$W_{\text{spring}} = {}_1W_2 - {}_1W_{2a} = 17.5 - 5 = 12.5 \text{ kJ} \quad (4.4.48)$$

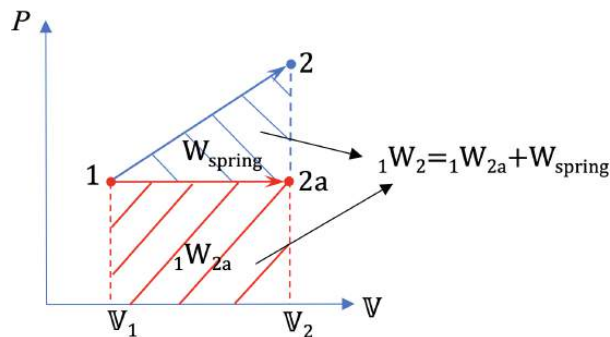

Figure 4.3.e8 P-V diagram showing the total work and its compositions

#### Media Attributions

- Boundary work © Kh1604 is licensed under a [CC BY-SA \(Attribution ShareAlike\)](#) license
- Work done by the spring force © Svjo is licensed under a [CC BY-SA \(Attribution ShareAlike\)](#) license

This page titled [4.4: Work](#) is shared under a [CC BY-NC-SA 4.0](#) license and was authored, remixed, and/or curated by [Claire Yu Yan \(BC Campus\)](#) via [source content](#) that was edited to the style and standards of the LibreTexts platform; a detailed edit history is available upon request.

## 4.5: The first law of thermodynamics for closed systems

The first law of thermodynamics is essentially an energy conservation law. Both heat and work are energy transfer mechanisms. They play an important role in the first law of thermodynamics. Table 4.4.1 summarizes the main differences between heat and work, and internal energy.

Table 4.4.1 Comparison of heat, work and internal energy

	Heat and Work	Internal Energy
Characteristic	Both heat and work are <b>energy transfer mechanisms</b> . They are <b>not properties</b> of a system.	Internal energy is a <b>property</b> of a system.
Interaction with the system	Both heat and work must cross the boundary between a system and its surroundings.	A system possesses a total energy and an internal energy.
Magnitude	Both heat and work are <b>path functions</b> ; their magnitudes depend on the states and the specific process path.	Internal energy is a <b>state function</b> ; its magnitude depends on the state only.

The first law of thermodynamics states that ***the change in the total energy stored in a system equals the net energy transferred to the system in the form of heat and work.***

$$\Delta \text{energy} = +\text{in} - \text{out} \quad (4.5.1)$$

The change in the total energy of a system during a process from states 1 to 2 can be expressed as

$$\Delta E = E_2 - E_1 = {}_1Q_2 - {}_1W_2 \quad (4.5.2)$$

If the changes in the kinetic and potential energies of the system are negligible, i.e.,  $\Delta KE = \Delta PE = 0$ , then the first law of thermodynamics for a closed system can be simplified as

$$\Delta U = U_2 - U_1 = {}_1Q_2 - {}_1W_2 \quad (4.5.3)$$

where

$$E \quad (4.5.4)$$

$$U \quad (4.5.5)$$

$$Q \quad (4.5.6)$$

$$W \quad (4.5.7)$$

Subscripts 1 and 2 refer to the initial and final states of a process.

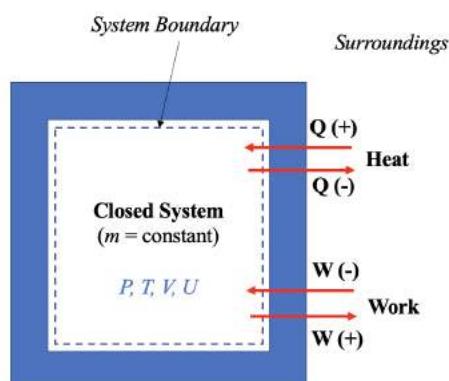

Figure 4.4.1 A common sign convention for heat and work transfer to a closed system

The following procedure may be followed when solving problems with the first law of thermodynamics.

1. Sketch the physical system described in the problem and show its main components.

2. Set up an appropriate closed system by drawing the system boundary. How a system is set up may determine if a means of energy transfer can be regarded as heat or work.
3. Indicate the heat and work transferred into or out of the system and their signs, see [Figure 4.4.1](#).
4. Identify the type of the processes (e.g., isobaric, isothermal, isochoric, polytropic, or isentropic). Show the processes on the  $P - v$  and  $T - v$  diagrams if possible, and list all of the known and unknown states.
5. Apply the first law of thermodynamics to the closed system, eliminating the terms that are not applicable to the system.
6. Solve for the unknowns by combining the first law of thermodynamics with the ideal gas law, thermodynamic tables, and other physical laws as appropriate.

The following examples demonstrate how to apply the first law of thermodynamics to closed systems.

### Example 1

Consider the vapour compression refrigeration cycle consisting of a compressor, condenser, expansion device, and evaporator as shown. The compressor must consume work,  $W_{in}$ , from an external energy source such as electricity. The evaporator and condenser absorb and reject heat,  $Q_L$  and  $Q_H$ , respectively. What is the relation between  $W_{in}$ ,  $Q_H$ , and  $Q_L$ ?

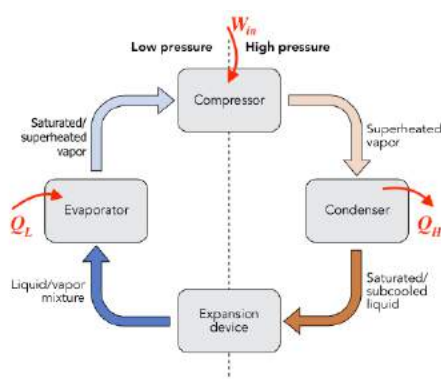

Figure 4.4.e1 Vapor compression refrigeration cycle consisting of a compressor, condenser, expansion device, and evaporator

### Solution:

The vapour compression refrigeration cycle can be regarded as a closed system with the initial and final states being identical; therefore,  $\Delta U = 0$ .

$$\therefore \Delta U = 0 = Q - W \quad (4.5.8)$$

$$\therefore Q_L - Q_H - (-W_{in}) = 0 \quad (4.5.9)$$

$$\therefore Q_H = Q_L + W_{in} \quad (4.5.10)$$

Note the sign convention for heat: in (+), out (-) and for work: in (-), out (+). This relation can be interpreted as the total energy transferred out of the cycle remains the same as the total energy transferred into the cycle.

### Example 2

A rigid tank has two rooms, both containing R134a at the following initial states.

Room A:  $m = 2 \text{ kg}$ ,  $P = 200 \text{ kPa}$ ,  $v = 0.132 \text{ m}^3/\text{kg}$

Room B:  $m = 3 \text{ kg}$ ,  $P = 500 \text{ kPa}$ ,  $T = 100^\circ\text{C}$

A crack is developed in the partition between the two rooms, which allows R134a in the tank to mix. Assume the mixing takes place slowly until R134a in the whole tank reaches a uniform state at  $50^\circ\text{C}$ . Find the heat transfer during this process. The process can be treated as a quasi-equilibrium process.

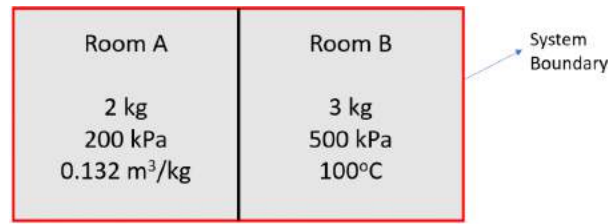

Figure 4.4.e2 A rigid tank with two rooms

Solution:

First, set the whole rigid tank as the closed system.

Because the volume of the tank remains constant, the boundary work during the mixing process is zero; therefore, from the first law of thermodynamics,

$$\therefore \Delta U = Q - W \quad (4.5.11)$$

$$\therefore \Delta U = Q \quad (4.5.12)$$

The heat transfer during the process depends on the internal energies of the initial and final states.

$$\begin{aligned} \Delta U &= U_3 - (U_1 + U_2) \\ &= (m_1 + m_2)u_3 - (m_1u_1 + m_2u_2) \end{aligned}$$

where the subscripts 1, 2, and 3 represent the initial states of R134a in rooms A and B, and the final state of R134a in the whole tank, respectively.

Second, find the specific internal energies,  $u_1$ ,  $u_2$ , and  $u_3$ .

Room A at the initial state:  $P = 200$  kPa,  $v = 0.132$  m<sup>3</sup>/kg

From Table C1, at  $T = -10^\circ\text{C}$ ,  $P_{sat} = 200.6$  kPa,  $v_g = 0.09959$  m<sup>3</sup>/kg. Since  $v > v_g$ , R134a at this state is a superheated vapour.

From Table C2, at  $P = 200$  kPa,  $T = 60^\circ\text{C}$ ,  $v = 0.132057$  m<sup>3</sup>/kg  $\approx 0.132$  m<sup>3</sup>/kg

$$u_1 = 427.51 \text{ kJ/kg}$$

$$V_A = m_1v_1 = 2 \times 0.132 = 0.264 \text{ m}^3 \quad (4.5.13)$$

Room B at the initial state:  $P = 500$  kPa,  $T = 100^\circ\text{C}$

From Table C1, at  $T = 100^\circ\text{C}$ ,  $P_{sat} = 3972.38$  kPa. Since  $P < P_{sat}$ , R134a at this state is a superheated vapour.

From Table C2, at  $P = 500$  kPa,  $T = 100^\circ\text{C}$

$$u_2 = 459.65 \text{ kJ/kg}$$

$$v_2 = 0.058054 \text{ m}^3/\text{kg}$$

$$V_B = m_2v_2 = 3 \times 0.058054 = 0.1742 \text{ m}^3 \quad (4.5.14)$$

The final state of R134a in the whole tank:  $T = 50^\circ\text{C}$

$$v_3 = \frac{V_{tot}}{m_{tot}} = \frac{V_A + V_B}{m_1 + m_2} = \frac{0.264 + 0.1742}{2 + 3} = 0.0876 \text{ m}^3/\text{kg}$$

From Table C1, at  $T = 50^\circ\text{C}$ ,  $v_g = 0.015089$  m<sup>3</sup>/kg. Since  $v_3 > v_g$ , R134a at the final state is a superheated vapour.

From Table C2,

$$\text{At } P = 200 \text{ kPa, } T = 50^\circ\text{C, } v = 0.127663 \text{ m}^3/\text{kg, } u = 419.29 \text{ kJ/kg}$$

$$\text{At } P = 300 \text{ kPa, } T = 50^\circ\text{C, } v = 0.083723 \text{ m}^3/\text{kg, } u = 418.19 \text{ kJ/kg}$$

Use linear interpolation,

$$\therefore \frac{P_3 - 200}{300 - 200} = \frac{0.0876 - 0.127663}{0.083723 - 0.127663} = \frac{u_3 - 419.29}{418.19 - 419.29} \quad (4.5.15)$$



$$\therefore P_3 = 291.2 \text{ kPa} \quad (4.5.16)$$

Last, substitute  $u_1$ ,  $u_2$  and  $u_3$  into the simplified first law,

$$\begin{aligned} Q &= \Delta U = (m_1 + m_2)u_3 - (m_1u_1 + m_2u_2) \\ &= 5 \times 418.287 - (2 \times 427.51 + 3 \times 459.65) \\ &= -142.535 \text{ kJ} \end{aligned}$$

During the mixing process, the heat is transferred from the tank to the surroundings; therefore, the sign for the heat transfer is negative.

### Example 3

Consider 0.5 kg of ammonia in a piston-cylinder device initially at  $P_1=100 \text{ kPa}$ ,  $T_1=0^\circ\text{C}$ . The ammonia is compressed until its pressure reaches  $P_2=150 \text{ kPa}$  in a polytropic process with  $n=1.25$ . Calculate the heat transfer in this process.

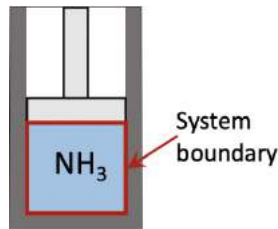

Figure 4.4.e3 Ammonia in a piston-cylinder device

#### Solution:

First, set ammonia in the piston-cylinder as the closed system. From the first law of thermodynamics,

$$\therefore \Delta U = Q - W \quad (4.5.17)$$

$$\therefore Q = W + \Delta U = W + m(u_2 - u_1) \quad (4.5.18)$$

Second, consider the boundary work in a polytropic process. The specific volumes are unknowns

$$W = \frac{P_2 V_2 - P_1 V_1}{1 - n} = \frac{m (P_2 v_2 - P_1 v_1)}{1 - n} \quad (4.5.19)$$

Third, find the specific volumes and specific internal energies at both initial and final states.

At the initial state:  $P_1 = 100 \text{ kPa}$ ,  $T_1 = 0^\circ\text{C}$ . From [Table B1](#),  $P_{sat} = 429.39 \text{ kPa}$  at  $0^\circ\text{C}$ . Since  $P_1 < P_{sat}$ , ammonia is a superheated vapour.

From [Table B2](#),

$$v_1 = 1.31365 \text{ m}^3/\text{kg}, u_1 = 1504.29 \text{ kJ/kg}.$$

At the final state  $P_2 = 150 \text{ kPa}$ . The process is polytropic with  $n=1.25$ .

$$\therefore P_1 v_1^n = P_2 v_2^n \quad (4.5.20)$$

$$\therefore v_2 = v_1 \left( \frac{P_1}{P_2} \right)^{1/n} = 1.31365 \times \left( \frac{100}{150} \right)^{1/1.25} = 0.94974 \text{ m}^3/\text{kg}$$

From [Table B1](#): at  $T = -25^\circ\text{C}$  and  $P = 151.47 \text{ kPa} \approx 150 \text{ kPa}$ ,  $v_g = 0.771672 \text{ m}^3/\text{kg}$ . Since  $v_2 > v_g$ , ammonia at the final state is a superheated vapour.

From [Table B2](#),

$$\text{At } P = 150 \text{ kPa}, T = 20^\circ\text{C}, v = 0.938100 \text{ m}^3/\text{kg}, u = 1535.05 \text{ kJ/kg}$$

$$\text{At } P = 150 \text{ kPa}, T = 30^\circ\text{C}, v = 0.972207 \text{ m}^3/\text{kg}, u = 1551.95 \text{ kJ/kg}$$

Use linear interpolation,

$$\therefore \frac{T_2 - 20}{30 - 20} = \frac{0.94974 - 0.938100}{0.972207 - 0.938100} = \frac{u_2 - 1535.05}{1551.95 - 1535.05} \quad (4.5.21)$$

\(\therefore T\_2 = 23.4 \text{ }^\circ\text{C}\)

\(\text{C}\)

Last, the heat transfer in this process can now be found from

$$\begin{aligned}
 Q &= W + \Delta U = m \frac{P_2 v_2 - P_1 v_1}{1 - n} + m(u_2 - u_1) \\
 &= 0.5 \left[ \frac{150 \times 0.94974 - 100 \times 1.31365}{1 - 1.25} + (1540.82 - 1504.29) \right] \\
 &= -3.928 \text{ kJ}
 \end{aligned}$$

During this process heat is rejected to the surroundings; therefore, the sign for heat transfer is negative.

#### Example 4

A piston-cylinder device contains steam initially at  $200^\circ\text{C}$  and  $200 \text{ kPa}$ . The steam is first cooled isobarically to saturated liquid, then isochorically until its pressure reaches  $25 \text{ kPa}$ .

1. Sketch the whole process on the  $P-v$  and  $T-v$  diagrams
2. Calculate the specific heat transfer in the whole process

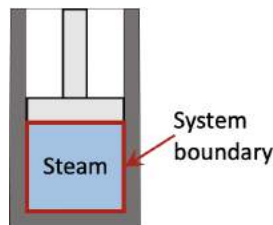

Figure 4.4.e4 Steam in a piston-cylinder device

#### Solution:

1.  $P-v$  and  $T-v$  diagrams

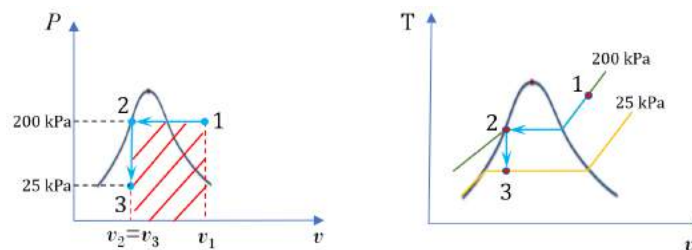

Figure 4.4.e5 P-v and T-v diagrams of the whole process

2. Calculate the specific heat transfer

First, set the steam in the piston-cylinder device as a closed system. From the first law of thermodynamics,

$$\therefore \Delta u = q - w \quad (4.5.22)$$

$$\therefore q = \Delta u + w = (u_3 - u_1) + w \quad (4.5.23)$$

Second, analyze the processes.

The process is isobaric from state 1 to state 2, then isochoric from state 2 to state 3. The specific work is the shaded area of the rectangle shown in the  $P-v$  diagram; therefore,

$$w = P_1(v_3 - v_1) \quad (4.5.24)$$

Third, determine the specific volumes and specific internal energies at states 1 and 3.

At state 1,  $P_1 = 200 \text{ kPa}$  and  $T_1 = 200^\circ\text{C}$ .

From [Table A2](#),

$$v_1 = 1.08048 \text{ m}^3/\text{kg}, u_1 = 2654.63 \text{ kJ/kg}$$

State 2 is saturated liquid water at  $P_2 = 200 \text{ kPa}$ .

From [Table A1](#),

$$\text{At } T = 120 \text{ }^\circ\text{C}, P = 198.67 \text{ kPa}, v_f = 0.001060 \text{ m}^3/\text{kg}$$

$$\text{At } T = 125 \text{ }^\circ\text{C}, P = 232.24 \text{ kPa}, v_f = 0.001065 \text{ m}^3/\text{kg}$$

Use linear interpolation,

$$\therefore \frac{v_2 - 0.001060}{0.001065 - 0.001060} = \frac{T_2 - 120}{125 - 120} = \frac{200 - 198.67}{232.24 - 198.67} \quad (4.5.25)$$

$$T_2 = 120.2 \text{ }^\circ\text{C}$$

At state 3,  $P_3 = 25 \text{ kPa}$ .  $v_3 = v_2 = 0.0010602 \text{ m}^3/\text{kg}$ .

From [Table A1](#),  $v_f < v_3 < v_g$ ; therefore, state 3 is a two phase mixture of saturated liquid and saturated vapour with  $T_3 = T_{sat} \approx 65^\circ\text{C}$ .

$$v_f = 0.001020 \text{ m}^3/\text{kg}, v_g = 6.19354 \text{ m}^3/\text{kg}$$

$$u_f = 272.09 \text{ kJ/kg}, u_g = 2462.42 \text{ kJ/kg}$$

The quality and specific internal energy of the two phase mixture are

$$x = \frac{v_3 - v_f}{v_g - v_f} = \frac{0.0010602 - 0.001020}{6.19354 - 0.001020} = 6.5 \times 10^{-6} \quad (4.5.26)$$



Note that state 3 is almost a saturated liquid with very small quality; therefore,  $u_3 \approx u_f$ .

Last, calculate the specific boundary work and specific heat transfer in this whole process



In this cooling process, the volume decreases, resulting in a negative specific boundary work. The temperature and the internal energy decrease too. As a result, the specific heat transfer is negative indicating a heat loss from the system to its surroundings.

### Media Attributions

- Vapor compression refrigeration cycle © WGISol is licensed under a [CC BY-SA \(Attribution ShareAlike\)](#) license

This page titled [4.5: The first law of thermodynamics for closed systems](#) is shared under a [CC BY-NC-SA 4.0](#) license and was authored, remixed, and/or curated by [Claire Yu Yan \(BC Campus\)](#) via [source content](#) that was edited to the style and standards of the LibreTexts platform; a detailed edit history is available upon request.

## 4.6: Chapter review

---

Energy can be transferred to and from a closed system by two mechanisms: heat transfer and work. Both heat transfer and work have a significant effect on the total energy as well as the internal energy stored in a system, as expressed in the first law of thermodynamics.

When applying the first law of thermodynamics to a closed system, it is important to evaluate the internal energy of the system at various states of a process, and the boundary work and heat transfer during the process.

- The internal energy is a property of a system. It is a state function and is independent of the process path. In general, the specific internal energy can be found by using thermodynamic tables. For ideal gases, solids or liquids, the specific internal energy can be calculated by using the constant-volume specific heat.
- Heat transfer and boundary work are not properties of a system. They are boundary phenomena and path functions. Their magnitudes depend on the initial and final states as well as the path of a process.
- The boundary work and specific boundary work in a process can be expressed graphically as the area under the process curve in the  $P - V$  and  $P - v$  diagrams, respectively; therefore, these diagrams are often used when evaluating the boundary work in a process.

---

This page titled [4.6: Chapter review](#) is shared under a [CC BY-NC-SA 4.0](#) license and was authored, remixed, and/or curated by [Claire Yu Yan \(BC Campus\)](#) via [source content](#) that was edited to the style and standards of the LibreTexts platform; a detailed edit history is available upon request.

## 4.7: Key equations

### Key equations

Constant-volume specific heat	$C_v = \left( \frac{\partial u}{\partial T} \right)_v$
Change in specific internal energy for <b>all fluids</b>	$\Delta u = u_2 - u_1$
Change in specific internal energy for <b>ideal gases</b>	$\Delta u = C_v (T_2 - T_1)$
Specific heat transfer	$q = \frac{Q}{m}$
Boundary work	${}_1W_2 = \int_1^2 P dV$
Specific boundary work	${}_1w_2 = \int_1^2 P dv$
Spring force	$F = Kx$
Spring work	$W_{spring} = \int_1^2 F dx = \frac{1}{2} K (x_2^2 - x_1^2)$
The first law of thermodynamics for <b>closed systems</b>	$\Delta U = U_2 - U_1 = {}_1Q_2 - {}_1W_2$ , assuming $\Delta KE = \Delta PE = 0$

### Equations for polytropic Processes

Process function	$Pv^n = \text{constant}$
Boundary work for <b>real gases</b>	<p>If <math>n \neq 1</math>,</p> $\frac{{}_1W_2}{1-n} = \frac{P_1 V_1 - P_2 V_2}{1-n}$ <p>If <math>n = 1</math>,</p> ${}_1W_2 = P_1 V_1 \ln \frac{V_2}{V_1} = P_2 V_2 \ln \frac{V_2}{V_1} \quad (4.7.1)$
	$\frac{{}_1W_2}{1-n} = \frac{P_1 V_1 \ln \frac{V_2}{V_1}}{1-n}$ ${}_1W_2 = \frac{P_1 V_1 \ln \frac{V_2}{V_1}}{1-n}$
Specific boundary work for <b>real gases</b>	<p>If <math>n \neq 1</math></p> $\frac{{}_1w_2}{1-n} = \frac{P_1 v_1 - P_2 v_2}{1-n}$ <p>If <math>n = 1</math>,</p> ${}_1w_2 = P_1 v_1 \ln \frac{v_2}{v_1} = P_2 v_2 \ln \frac{v_2}{v_1}$
	$\frac{{}_1w_2}{1-n} = \frac{P_1 v_1 \ln \frac{v_2}{v_1}}{1-n}$ ${}_1w_2 = \frac{P_1 v_1 \ln \frac{v_2}{v_1}}{1-n}$

<p>Boundary work for <b>ideal gases</b></p>	<p>If <math>n \neq 1</math></p> $\frac{W_2}{1-n} = \frac{P_1 V_1 - P_2 V_2}{1-n}$ <p>If <math>n = 1</math>,</p> $W_2 = P_1 V_1 \ln \frac{V_2}{V_1} = P_2 V_2 \ln \frac{V_2}{V_1} \quad (4.7.2)$ $W_2 = P_2 \frac{V_2}{\gamma} \ln \frac{V_2}{V_1}$ <p>(<math>T</math> in Kelvin)</p>
<p>Specific boundary work for <b>ideal gases</b></p>	<p>If <math>n \neq 1</math></p> $w_2 = \frac{P_2 v_2 - P_1 v_1}{1-n}$ <p>If <math>n = 1</math>,</p> $w_2 = P_1 v_1 \ln \frac{v_2}{v_1} = P_2 v_2 \ln \frac{v_2}{v_1}$ <p>(<math>T</math> in Kelvin)</p>

This page titled [4.7: Key equations](#) is shared under a [CC BY-NC-SA 4.0](#) license and was authored, remixed, and/or curated by [Claire Yu Yan \(BC Campus\)](#) via [source content](#) that was edited to the style and standards of the LibreTexts platform; a detailed edit history is available upon request.

## CHAPTER OVERVIEW

### 5: The First Law of Thermodynamics for a Control Volume

This chapter extends the concept of energy conservation to open systems with a focus on steady-state, steady flows (SSSF). Students will learn how to use the first law of thermodynamics to analyze processes in typical SSSF devices, such as pipes, turbines, compressors, heat exchangers, expansion valves, and mixing chambers.

[5.1: Chapter introduction and learning objectives](#)

[5.2: Enthalpy](#)

[5.3: Mass and energy conservation equations in a control volume](#)

[5.4: Applications of the mass and energy conservation equations in steady flow devices](#)

[5.5: Chapter review](#)

[5.6: Key equations](#)

---

This page titled [5: The First Law of Thermodynamics for a Control Volume](#) is shared under a [CC BY-NC-SA 4.0](#) license and was authored, remixed, and/or curated by [Claire Yu Yan \(BC Campus\)](#) via [source content](#) that was edited to the style and standards of the LibreTexts platform; a detailed edit history is available upon request.

## 5.1: Chapter introduction and learning objectives

Many thermal devices, such as compressors, turbines, and heat exchangers can be modelled as open systems. A common feature of these devices is that they all have inlets and outlets, through which a working fluid transfers both mass and energy into and out of the devices. This chapter extends the concept of energy conservation to open systems with a focus on steady-state, steady flows (SSSF). Examples are given to illustrate the applications of the first law of thermodynamics in typical SSSF devices such as turbines, compressors, heat exchangers, expansion valves, and mixing chambers.

### Learning Objectives

After completing the chapter, you should be able to

- Determine the enthalpy of real substances by using thermodynamic tables
- Calculate the enthalpy of ideal gases, solids, and liquids by using constant-pressure specific heat
- Calculate mass flow rate and volume flow rate
- Explain the differences between steady and transient flows
- Explain the physical meanings of mass and energy conservation
- Apply the conservation equations of mass and energy to steady-state, steady flow devices

This page titled [5.1: Chapter introduction and learning objectives](#) is shared under a [CC BY-NC-SA 4.0](#) license and was authored, remixed, and/or curated by [Claire Yu Yan \(BC Campus\)](#) via [source content](#) that was edited to the style and standards of the LibreTexts platform; a detailed edit history is available upon request.



## 5.2: Enthalpy

Enthalpy is an important thermodynamic property for the analysis of energy conservation in open systems. It combines the internal energy and flow work associated with the flowing fluid (see [Section 2.2.5](#) for details). The following sections explain how to determine the specific enthalpy at a given state.

### 5.1.1 Using thermodynamic tables to determine specific enthalpy $h$

As described in Chapter 2, thermodynamic tables can be used to determine thermodynamic properties, such as pressure, temperature, specific volume, specific internal energy, specific enthalpy, and specific entropy of a pure substance at a given condition. After the specific enthalpy is found, the enthalpy can then be calculated by using the following equation:

$$H = mh \quad (5.2.1)$$

where

$$H \quad (5.2.2)$$

$$h \quad (5.2.3)$$

$$m \quad (5.2.4)$$

#### Example 1

Find the missing properties of R134a and ammonia at the given conditions.

	Substance	$T, ^\circ\text{C}$	$P, \text{kPa}$	$h, \text{kJ/kg}$	$x$	Phase
1	R134a	20		380		
2	Ammonia	-20	200			

#### Solution

1. R134a at  $T = 20^\circ\text{C}$  has a specific enthalpy of  $h = 380 \text{ kJ/kg}$

From Appendix C, [Table C1](#), at  $T = 20^\circ\text{C}$ ,  $h_f = 227.47 \text{ kJ/kg}$ ,  $h_g = 409.75 \text{ kJ/kg}$ . Since  $h_f < h < h_g$ , R134a at this state is a two-phase mixture of saturated liquid and saturated vapour with a pressure of  $P = P_{sat} = 0.57171 \text{ MPa} = 571.71 \text{ kPa}$  and a quality of

$$x = \frac{h - h_f}{h_g - h_f} = \frac{380 - 227.47}{409.75 - 227.47} = 0.83679$$

2. Ammonia at a temperature of  $T = -20^\circ\text{C}$  and a pressure of  $P = 200 \text{ kPa}$

From Appendix B, [Table B1](#), at  $T = -20^\circ\text{C}$ ,  $P_{sat} = 0.19008 \text{ MPa} = 190.08 \text{ kPa}$ . Since  $P > P_{sat}$ , ammonia at this state is a compressed liquid with  $h \approx h_f = 251.71 \text{ kJ/kg}$ .

In summary,

	Substance	$T, ^\circ\text{C}$	$P, \text{kPa}$	$h, \text{kJ/kg}$	$x$	Phase
1	R134a	20	571.71	380	0.83679	Two-phase mixture
2	Ammonia	-20	200	251.71	n.a.	Compressed liquid

### 5.1.2 Constant-pressure specific heat

Constant-pressure specific heat is defined as the energy required to raise the temperature of a unit mass (i.e., 1 kg) of a substance by 1 degree (i.e.,  $1^\circ\text{C}$ , or 1 K) in an isobaric process. Mathematically, it is expressed as

$$C_p = \left( \frac{\partial h}{\partial T} \right)_p \quad (5.2.5)$$

where

$$C_p \quad (5.2.6)$$

$$h \quad (5.2.7)$$

$$T \quad (5.2.8)$$

The constant-pressure specific heat of selected substances can be found in [Appendix G](#). For example, the constant-pressure specific heat of air at 300 K is 1.005 kJ/kgK, see [Table G1](#). Let us consider one kilogram of air originally at 300 K in a piston-cylinder device. It will require 1.005 kJ of heat for the air temperature to increase from 300 K to 301 K if the piston-cylinder device is heated to allow the air to expand in an isobaric process.

It is important to note that both specific heats,  $C_v$  and  $C_p$ , are properties of a substance. Although they are typically measured in isochoric and isobaric processes, respectively, their applications are NOT limited to isochoric or isobaric processes. For ideal gases,  $C_v$  and  $C_p$  can be used to determine  $\Delta u$  and  $\Delta h$ , respectively, in ANY processes.

### 5.1.3 Using $C_p$ to calculate $\Delta h$ for ideal gases

The specific enthalpy of an ideal gas is a function of temperature only,  $h = f(T)$ ; therefore,

$$C_p = \left( \frac{\partial h}{\partial T} \right)_p = \left( \frac{dh}{dT} \right)_p = f(T) \quad (5.2.9)$$

The change of specific enthalpy of an ideal gas within a small temperature range can be calculated as

$$\Delta h = h_2 - h_1 = C_p(T_2 - T_1) \quad (5.2.10)$$

where

$$C_p \quad (5.2.11)$$

$$h \quad (5.2.12)$$

$$T \quad (5.2.13)$$

Subscripts 1 and 2 represent states 1 and 2 in a process, respectively.

The above formula is a simple, approximate method to estimate the change of specific enthalpy of an ideal gas due to temperature variations. It is reasonably accurate and may be used when the thermodynamic tables of an ideal gas are not available. [Table G1](#) lists the constant-pressure specific heat of selected substances at 300 K. Strictly speaking, since  $C_p = f(T)$ ,  $C_p$  at a different temperature should be calculated according to that specific temperature. However, [Table G1](#) is often used in approximate calculations as long as the temperature variations of the ideal gas remain in a small range.

The specific heat ratio,  $k$ , of an ideal gas is defined as the ratio of  $C_p$  to  $C_v$ .

$$k = \frac{C_p}{C_v} \quad (5.2.14)$$

The following equations relate  $C_v$ ,  $C_p$ ,  $k$ , and  $R$ . Detailed derivations are omitted here.

$$C_p = C_v + R \quad (5.2.15)$$

### 5.1.4 Using $C_p$ to calculate $\Delta h$ for solids and liquids

Liquids and solids are generally treated as incompressible substances because their volumes do not change with pressure or temperature significantly. For liquids and solids, the difference between the constant-volume specific heat and the constant-pressure specific heat is typically negligible; therefore,

$$C_p \approx C_v \quad (5.2.16)$$

$$\Delta h \approx \Delta u \approx C_p(T_2 - T_1) \quad (5.2.17)$$

#### Example 2

Consider a piston-cylinder device containing 2 kg of oxygen at 300 K, 200 kPa. The piston-cylinder device is made of 0.5 kg of aluminum. How much heat is required for the oxygen to reach a temperature of 600 K in an isobaric process? Assume the oxygen

and the piston-cylinder are always in thermal equilibrium during the isobaric process. The oxygen can be treated as an ideal gas in this heating process.

### Solution

First, set up a closed system as shown outlined in blue, which consists of the piston-cylinder and  $O_2$ .

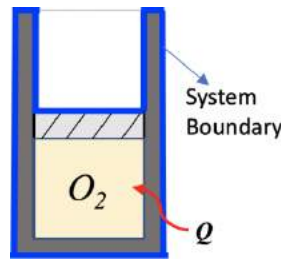

Figure 5.1.e1 Piston-cylinder device containing oxygen

Second, apply the first law of thermodynamics to the closed system. Note that, in the heating process, the temperatures and internal energies of both  $O_2$  and the piston-cylinder increase.

$$\therefore \Delta U_{tot} = Q_{tot} - W_{O_2} \quad (5.2.18)$$

$$\therefore Q_{tot} = \Delta U_{tot} + W_{O_2} = \Delta U_{al} + (\Delta U_{O_2} + W_{O_2}) \quad (5.2.19)$$

Third, calculate the change in internal energy of the piston-cylinder. From [Table G3](#), the constant-pressure specific heat for aluminum is  $c_{p,al} = 0.897$  kJ/kgK.

$$\begin{aligned} \Delta U_{al} &= m_{al} \Delta u_{al} = m_{al} \Delta h_{al} \\ &= m_{al} c_{p,al} (T_2 - T_1) \\ &= 0.5 \times 0.897 \times (600 - 300) = 134.55 \text{ kJ} \end{aligned}$$

Fourth, analyze the boundary work done by  $O_2$  and the change in internal energy of  $O_2$  in this isobaric process, where  $P_1 = P_2 = P$ .

$$\begin{aligned} \therefore W_{O_2} &= P(\nabla_2 - \nabla_1) \quad \Delta U_{O_2} = U_2 - U_1 \\ H &= U + P\nabla \\ \therefore \Delta U_{O_2} + W_{O_2} &= (U_2 - U_1) + P(\nabla_2 - \nabla_1) \\ &= (U_2 + P_2 \nabla_2) - (U_1 + P_1 \nabla_1) \\ &= H_2 - H_1 \\ \therefore \Delta U_{O_2} + W_{O_2} &= \Delta H_{O_2} \quad (5.2.20) \end{aligned}$$

From [Table G1](#), the constant-pressure specific heat for oxygen is  $c_{p,O_2} = 0.918$  kJ/kgK.

$$\begin{aligned} \therefore \Delta H_{O_2} &= m_{O_2} c_{p,O_2} (T_2 - T_1) \\ &= 2 \times 0.918 \times (600 - 300) = 550.8 \text{ kJ} \end{aligned}$$

Last, calculate the total heat transfer in this process.

$$\begin{aligned} Q_{tot} &= \Delta U_{al} + \Delta H_{O_2} \\ &= 134.55 + 550.8 = 685.35 \text{ kJ} \end{aligned}$$

This page titled [5.2: Enthalpy](#) is shared under a [CC BY-NC-SA 4.0](#) license and was authored, remixed, and/or curated by [Claire Yu Yan \(BC Campus\)](#) via [source content](#) that was edited to the style and standards of the LibreTexts platform; a detailed edit history is available upon request.

## 5.3: Mass and energy conservation equations in a control volume

### 5.2.1 Steady flow and transient flow

An open system allows both mass and energy to transfer across its boundary. Many thermal devices, such as compressors, turbines, and heat exchangers have inlets and outlets and can be modelled as open systems. Figure 5.2.1 is a schematic drawing of an open system with one inlet and one outlet. A control volume (C.V.), shown as the dash-lined rectangle in Figure 5.2.1, is selected for the analysis of the change of properties in the open system. A working fluid flows into and out of the control volume through the inlet and outlet. In addition, energy transfer occurs between the system and its surroundings in the form of heat and work. As a result, both mass and energy within the control volume may change over time.

If neither the mass nor the energy within the control volume change with respect to time, i.e.,  $\frac{dm_{CV}}{dt} = 0$  and  $\frac{dE_{CV}}{dt} = 0$ , the flow is called a steady flow. In a steady flow, the thermodynamic properties within a control volume do not change with respect to time; but they do not need to remain uniform everywhere within the control volume. The properties may vary from point to point, but at any given point, they must remain the same during the entire process. Many devices may be treated as steady flow devices after they have been in operation for a certain period of time under the same operating condition.

In a transient flow, the mass and energy within a control volume change with respect to time, i.e.,  $\frac{dm_{CV}}{dt} \neq 0$  and  $\frac{dE_{CV}}{dt} \neq 0$ . Consequently, other thermodynamic properties may also change with respect to time. Flow through a device during its start-up and shut-down periods is usually treated as a transient flow.

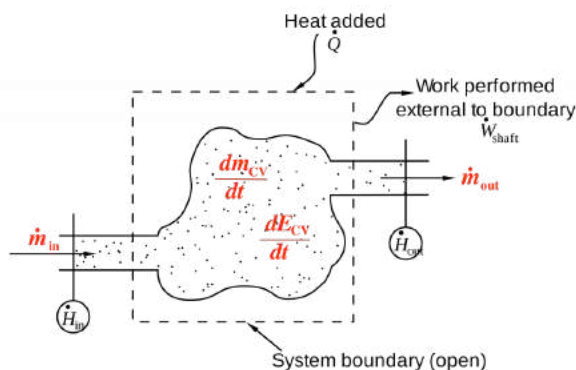

Figure 5.2.1 Flow through a control volume showing mass and energy transfers

### 5.2.2 Mass conservation equation

The mass flow rate and volume flow rate are defined as the mass and volume of a fluid flowing through an inlet or outlet per unit time, respectively. They are expressed as

$$\dot{V} = \frac{dV}{dt} = \dot{m}v = V_{avg,n}A \quad (5.3.1)$$

$$\dot{m} = \frac{dm}{dt} = \rho \dot{V} = \rho V_{avg,n}A \quad (5.3.2)$$

where

$$A \quad (5.3.3)$$

$$m \quad (5.3.4)$$

$$\dot{m} \quad (5.3.5)$$

$$V \quad (5.3.6)$$

$$\dot{V} \quad (5.3.7)$$

$$V_{avg,n} \quad (5.3.8)$$

$$\rho \quad (5.3.9)$$

$$v \quad (5.3.10)$$

The conservation of mass, also called the continuity equation, states that **mass cannot be created or destroyed. The time rate of change of mass in a control volume at a certain time equals the net mass flow rate into the control volume at that time.**

$$\Delta \text{mass} = +\text{in} - \text{out} \quad (5.3.11)$$

$$\frac{dm_{CV}}{dt} = \sum \dot{m}_i - \sum \dot{m}_e \quad (5.3.12)$$

Since  $\frac{dm_{CV}}{dt} = 0$  for steady flows, the mass conservation equation for steady flows is, therefore, written as

$$\sum \dot{m}_i = \sum \dot{m}_e \quad (5.3.13)$$

where  $\dot{m}_i$  and  $\dot{m}_e$  represent the mass flow rates through the inlets and outlets of a control volume, respectively.

### 5.2.3 Energy conservation equation

The exchange of energy between a control volume and its surroundings is achieved via three mechanisms: (1) heat transfer, (2) work, and (3) mass transfer. The conservation of energy in a control volume states that **the time rate of change of energy in a control volume at a certain time equals the net rate of energy transfer into the control volume at that time via the three mechanisms: heat transfer, work, and mass transfer.**

$$\Delta \text{energy} = +\text{in} - \text{out} \quad (5.3.14)$$

$$\frac{dE_{CV}}{dt} = \dot{Q}_{cv} - \dot{W}_{cv} + \sum \dot{m}_i \left( h_i + \frac{1}{2} V_i^2 + gz_i \right) - \sum \dot{m}_e \left( h_e + \frac{1}{2} V_e^2 + gz_e \right) \quad (5.3.15)$$

Since  $\frac{dE_{CV}}{dt} = 0$  for steady flows, the energy conservation equation for steady flows is, therefore, written as

$$\dot{Q}_{cv} - \dot{W}_{cv} + \sum \dot{m}_i \left( h_i + \frac{1}{2} V_i^2 + gz_i \right) - \sum \dot{m}_e \left( h_e + \frac{1}{2} V_e^2 + gz_e \right) = 0$$

]

where

$$h \quad (5.3.16)$$

$$\dot{m} \quad (5.3.17)$$

$$\dot{Q}_{cv} \quad (5.3.18)$$

$$V \quad (5.3.19)$$

$$\dot{W}_{cv} \quad (5.3.20)$$

$$z \quad (5.3.21)$$

Subscripts,  $i$  and  $e$ , refer to the inlet and outlet of the control volume, respectively.

#### Media Attributions

- Flow through a control volume © derivative work: Pbroks13 is licensed under a [Public Domain](#) license

This page titled [5.3: Mass and energy conservation equations in a control volume](#) is shared under a [CC BY-NC-SA 4.0](#) license and was authored, remixed, and/or curated by [Claire Yu Yan \(BC Campus\)](#) via [source content](#) that was edited to the style and standards of the LibreTexts platform; a detailed edit history is available upon request.

## 5.4: Applications of the mass and energy conservation equations in steady flow devices

Turbines and compressors are common energy conversion devices, in which the energy of a working fluid is converted to mechanical energy or vice versa. A typical turbine consists of rotor blades attached to a shaft, which is free to rotate. [Figure 5.3.1](#) shows the main components of a hydraulic turbine. During the operation of a turbine, a working fluid (e.g., steam, gas, wind or water) flows continuously over a row of highly curved blades, creating a torque on the blades. In this process, the energy of the working fluid is converted to the mechanical energy of the rotating shaft. Consequently, the pressure and temperature of the fluid gradually decrease in the turbine. [Figure 5.3.2](#) illustrates the energy conversion in a wind turbine. The wind energy is first converted to the mechanical energy of the shaft and gearbox, then converted to the electrical energy through the generator.

Compressors work in the opposite way to turbines. Compressors consume shaft power in order to increase the pressure of a working fluid, typically a gas. In a dynamic compressor, such as a centrifugal compressor, the increase of the gas pressure is achieved by forcing the gas into narrow passages formed by adjacent blades, which rotate around a shaft. [Figure 5.3.3](#) shows a centrifugal compressor driven by an electric motor. In a reciprocating compressor, the increase of the gas pressure is achieved by the decrease of the gas volume as the piston, driven by a crank-shaft, compresses the gas. [Figure 5.3.4](#) animates the expansion and compression processes in a reciprocating compressor. In both dynamic and reciprocating compressors, the mechanical energy of the rotating shaft or crank-shaft is converted to the energy stored in the fluid. As a result, the pressure of the fluid increases in the compressor.

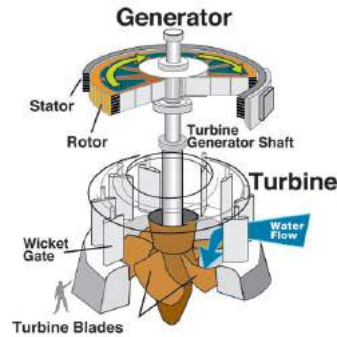

Figure 5.3.1 Hydraulic turbine

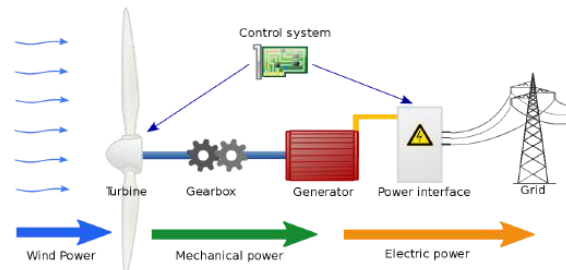

Figure 5.3.2 Wind turbine schematic showing the energy conversion

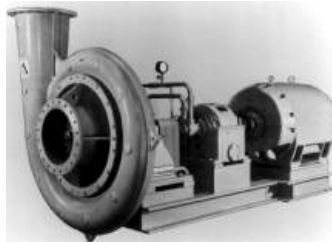

Figure 5.3.3 Centrifugal compressor

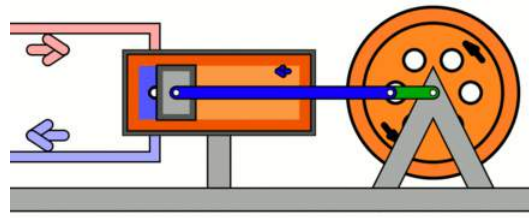

Figure 5.3.4 Reciprocating compressor: animation of the compression and expansion processes

Figure 5.3.5 illustrates the flow of energy through a turbine and a compressor. A typical turbine or compressor has one inlet and one outlet. We may apply the following assumptions to typical turbines and compressors:

- The flow through a turbine or a compressor is steady.
- The turbine or compressor is well-insulated:  $\dot{Q}_{cv} = 0$
- The changes in potential and kinetic energies are negligible compared to the change in enthalpy:  $\Delta PE = 0, \Delta KE = 0$

With these assumptions, the mass and energy conservation equations can be simplified as follows,

Turbine:

$$\dot{m}_i = \dot{m}_e = \dot{m} \tag{5.4.1}$$

$$\dot{W}_{shaft} = \dot{m}(h_i - h_e) \tag{5.4.2}$$

Compressor:

$$\dot{m}_i = \dot{m}_e = \dot{m} \tag{5.4.3}$$

$$\dot{W}_{shaft} = \dot{m}(h_e - h_i) \tag{5.4.4}$$

where

$$h \tag{5.4.5}$$

$$\dot{m} \tag{5.4.6}$$

$$\dot{W}_{shaft} \tag{5.4.7}$$

Subscripts,  $i$  and  $e$ , represent the inlet and exit of the turbine or compressor, respectively.

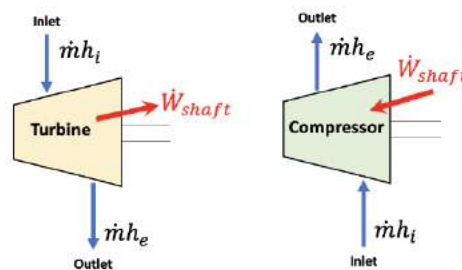

Figure 5.3.5 Flow of energy through a turbine and a compressor

Example 1

The inlet and outlet conditions of an air compressor are  $P_1=100$  kPa,  $T_1=20^\circ\text{C}$ , and  $P_2=300$  kPa, respectively. The mass flow rate of air through this compressor is 0.015 kg/s. How much power input from the shaft is required to drive this compressor? Apply the following assumptions in your analysis: (1) the flow is steady with negligible changes in the kinetic and potential energies; (2) the compressor is well-insulated; (3) air is an ideal gas; and (4) the process is polytropic with  $n=1.35$ .

Solution:

Analysis: the shaft power of the compressor is proportional to the change in enthalpy of air in the compressor. Because air is treated as an ideal gas, the change in enthalpy can be calculated in terms of the change in temperature. Therefore, we need to find the temperature at the outlet of the compressor first.

Air is an ideal gas and the process is polytropic; therefore,

$$Pv = RT \quad (5.4.8)$$

$$Pv^n = \text{constant} \quad (5.4.9)$$

Combine the above two equations and eliminate  $v$ ,

$$P^{n-1} = \frac{R^n}{\text{constant}} \times T^n \quad (5.4.10)$$

Apply the above equation to the process between the inlet condition, state 1, and the outlet condition, state 2. Note that  $R$  is the gas constant of air,

$$\begin{aligned} \therefore \left(\frac{P_2}{P_1}\right)^{n-1} &= \left(\frac{T_2}{T_1}\right)^n \quad (5.4.11) \\ \therefore T_2 &= T_1 \left(\frac{P_2}{P_1}\right)^{\frac{n-1}{n}} \\ &= (273.15 + 20) \left(\frac{300}{100}\right)^{\frac{1.35-1}{1.35}} \\ &= 389.75 \text{ K} = 116.6 \text{ }^\circ\text{C} \end{aligned}$$

From [Table G1](#),  $C_p = 1.005 \text{ kJ/kgK}$  for air. Apply the energy conservation equation to the compressor considering the first two assumptions in the question descriptions.

$$\begin{aligned} \dot{W}_{shaft} &= \dot{m}(h_2 - h_1) \\ &= \dot{m}C_p(T_2 - T_1) \\ &= 0.015 \times 1.005 \times (116.6 - 20) = 1.456 \text{ kW} \end{aligned}$$

The compressor consumes 1.456 kW of power when operating under the given conditions.

### 5.3.2 Throttling valves

Throttling valves are also called thermal expansion valves. They are used in vapour compression refrigeration systems to regulate the pressure in the evaporator as well as the superheat of the refrigerant flowing out of the evaporator. Throttling valves may be constructed as a porous plug, capillary tubes, or an adjustable valve such as an orifice, ball, or poppet valve. By restricting the refrigerant flow through the valve, a considerable pressure drop can be achieved. As the pressure of the refrigerant decreases, its corresponding saturation temperature decreases accordingly. Therefore, a phase change often occurs as the refrigerant passes through a throttling valve. [Figure 5.3.6](#) shows a thermal expansion valve in a vapour compression refrigeration system. The following assumptions are commonly used for the analysis of the mass and energy conservation in a typical throttling valve.

- The flow through a throttling valve is steady.
- The flow through a throttling valve is fast enough so that the heat transfer between the refrigerant and its surroundings is negligible. Therefore, the flow is commonly treated as adiabatic:  $\dot{Q}_{cv} = 0$
- No work exchange occurs between the refrigerant and its surroundings:  $\dot{W}_{cv} = 0$
- The changes in potential and kinetic energies are negligible compared to the change in enthalpy:  $\Delta PE = 0$ ,  $\Delta KE = 0$

Based on these assumptions, the mass and energy conservation equations in throttling valves can be written as

$$\dot{m}_i = \dot{m}_e \quad (5.4.12)$$

$$h_i = h_e \quad (5.4.13)$$

where

$$h \quad (5.4.14)$$

$$\dot{m} \quad (5.4.15)$$

Subscripts,  $i$  and  $e$ , represent the inlet and exit of the throttling valve, respectively.



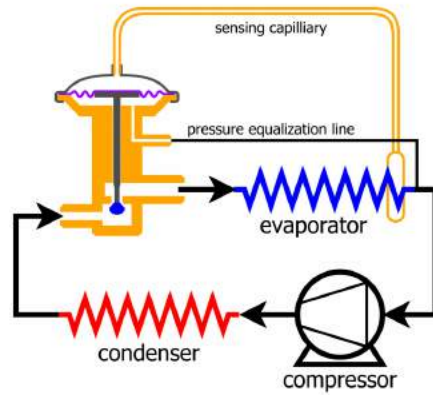

Figure 5.3.6 Thermal expansion valve in a vapour compression refrigeration system

### Example 2

A simplified transcritical CO<sub>2</sub> refrigeration cycle consists of four processes: compression (1→2), gas cooling (2→3), expansion (3→4), and evaporation (4→1), as shown in the  $P-h$  diagram, Figure 5.3.e1. The CO<sub>2</sub> gas enters the expansion valve at 10 MPa, 20°C (state 3) and is throttling to a pressure of 3 MPa (state 4). Determine the quality and temperature of CO<sub>2</sub> at state 4.

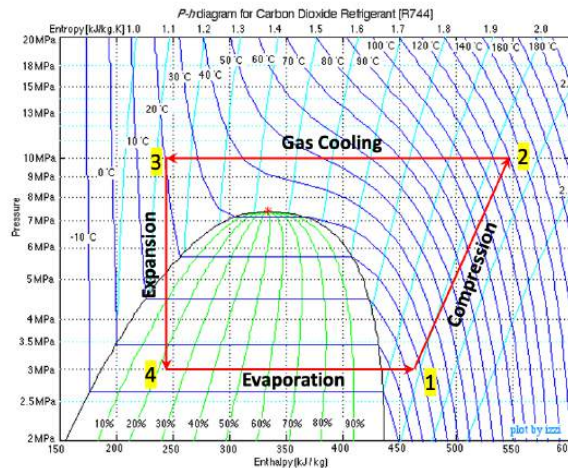

Figure 5.3.e1 P-h diagram for CO<sub>2</sub>

#### Solution:

The specific enthalpy remains constant in the expansion process; therefore  $h_3 = h_4$ .

At state 3,  $P_3 = 10 \text{ MPa}$ ,  $T_3 = 20^\circ\text{C}$ . From Table D2,  $h_3 = 242.70 \text{ kJ/kg}$

At state 4,  $P_4 = 3 \text{ MPa}$ ,  $h_4 = h_3 = 242.70 \text{ kJ/kg}$

From Table D1,

At  $T = -6^\circ\text{C}$ ,  $P = 2.96316 \text{ MPa}$ ,  $h_f = 185.71 \text{ kJ/kg}$ ,  $h_g = 433.79 \text{ kJ/kg}$

At  $T = -4^\circ\text{C}$ ,  $P = 3.13027 \text{ MPa}$ ,  $h_f = 190.40 \text{ kJ/kg}$ ,  $h_g = 432.95 \text{ kJ/kg}$

State 4 must be a two-phase mixture and its saturation temperature must be  $-6^\circ\text{C} < T_4 < -4^\circ\text{C}$ . Use linear interpolation to determine the saturation temperature,  $T_4$ , the specific enthalpy of the saturated liquid,  $h_{f,4}$ , and the specific enthalpy of the saturated vapour,  $h_{g,4}$ , of CO<sub>2</sub> at  $P_4 = 3 \text{ MPa}$ .

$$\therefore \frac{T_4 - (-6)}{(-4) - (-6)} = \frac{3 - 2.96316}{3.13027 - 2.96316} \quad (5.4.16)$$

$$\therefore T_4 = -5.56^\circ\text{C} \quad (5.4.17)$$

$$\therefore \frac{h_{f,4} - 185.71}{190.40 - 185.71} = \frac{h_{g,4} - 433.79}{432.95 - 433.79} = \frac{3 - 2.96316}{3.13027 - 2.96316} \quad (5.4.18)$$

$$\therefore h_{f,4} = 186.74 \text{ kJ/kg} \quad h_{g,4} = 433.60 \text{ kJ/kg}$$

The quality of the two phase mixture at state 4 is

$$x_4 = \frac{h_4 - h_{f,4}}{h_{g,4} - h_{f,4}} = \frac{242.70 - 186.74}{433.60 - 186.74} = 0.2267 \quad (5.4.19)$$

### 5.3.3 Nozzles and diffusers

Nozzles and diffusers are devices used to accelerate or decelerate flow by gradually changing their cross-sectional areas. They are widely used in many engineering systems, such as piping systems, HVAC (heating, ventilating, and air conditioning) systems, and steam and gas engines. Figure 5.3.7 illustrates a turbojet engine, which consists of a centrifugal compressor, a combustion chamber, a turbine, and a nozzle section. The gas leaving the turbine is accelerated in the nozzle section, creating a high velocity jet, and thus a high thrust.

The flow in nozzles and diffusers can be subsonic or supersonic. In this book, we will only discuss subsonic nozzles and subsonic diffusers; thereafter, the terms “nozzle” and “diffuser” refer to subsonic nozzle and subsonic diffuser, respectively.

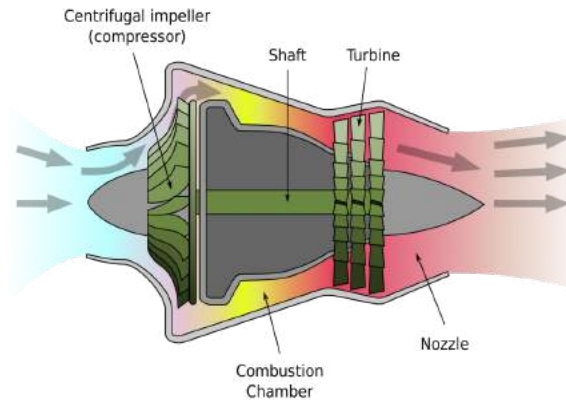

Figure 5.3.7 Schematic of turbojet engine consisting of a centrifugal compressor, a combustion chamber, a turbine, and a nozzle section

In a nozzle, the flow velocity increases and the pressure decreases as the cross-sectional area of the nozzle decreases. On the contrary, in a diffuser, the flow velocity decreases and the pressure increases as the cross-sectional area of the diffuser increases. Figure 5.3.8 shows a schematic of a nozzle and a diffuser. The following assumptions are commonly made when analyzing the mass and energy conservation in a typical nozzle or diffuser.

- The flow through a nozzle or diffuser is steady.
- The flow through a nozzle or diffuser is fast enough so that the heat transfer between the fluid and its surroundings is negligible. Therefore, the flow is commonly treated as adiabatic:  $\dot{Q}_{cv} = 0$
- No work exchange occurs between the fluid and its surroundings:  $\dot{W}_{cv} = 0$
- The change in potential energy is negligible compared to the changes in enthalpy and in kinetic energy:  $\Delta PE = 0$

With these assumptions, the mass and energy conservation equations in nozzles and diffusers can be written as

$$\dot{m}_i = \dot{m}_e \quad (5.4.20)$$

$$h_i + \frac{1}{2} V_i^2 = h_e + \frac{1}{2} V_e^2 \quad (5.4.21)$$

where

$$h \quad (5.4.22)$$

$$\dot{m} \quad (5.4.23)$$

$$V \quad (5.4.24)$$

Subscripts,  $i$  and  $e$ , represent the inlet and exit of the nozzle or diffuser, respectively.

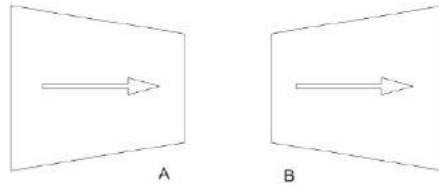

Figure 5.3.8 Nozzle (A) and diffuser (B)

### Example 3

The inlet and outlet diameters of a hydrogen nozzle are 44 mm and 20 mm, respectively. Hydrogen enters the nozzle at  $-30^\circ\text{C}$ , 5 bar, and 2 g/s, and exits the nozzle at 2 bar. Assuming the process is adiabatic and hydrogen is an ideal gas, what is the temperature and velocity of hydrogen at the nozzle outlet?

#### Solution:

Analysis: the energy conservation equation provides the relationship between the temperature, specific enthalpy, and velocity of the hydrogen. We will apply the mass and energy conservation equations to find the velocity and temperature at the nozzle outlet.



Figure 5.3.e2 Flow through a nozzle

From [Table G1](#):  $R = 4.124 \text{ kJ/kgK}$  and  $C_p = 14.307 \text{ kJ/kgK}$  for hydrogen.

Apply the mass flow rate and ideal gas law to the inlet of the nozzle:

$$\therefore \dot{m} = \rho_1 V_1 A_1 \quad (5.4.25)$$



Apply the mass conservation equation and the ideal gas law to the inlet and outlet of the nozzle:

$$\therefore \dot{m}_1 = \dot{m}_2 \quad (5.4.26)$$

$$\therefore \rho_1 V_1 A_1 = \rho_2 V_2 A_2 \quad (5.4.27)$$

and  $P_1 = \rho_1 R T_1$ ,  $P_2 = \rho_2 R T_2$

$$\begin{aligned} \therefore V_2 &= V_1 \frac{A_1 P_1 T_2}{A_2 P_2 T_1} = V_1 \frac{P_1 T_2}{P_2 T_1} \times \left(\frac{D_1}{D_2}\right)^2 \\ &= 2.638 \times \frac{5 \times T_2}{2 \times T_1} \times \left(\frac{44}{20}\right)^2 = 31.92 \frac{T_2}{T_1} \end{aligned}$$

Apply the energy conservation equation to the inlet and outlet of the nozzle:

$$h_1 + \frac{1}{2} V_1^2 = h_2 + \frac{1}{2} V_2^2 \quad (5.4.28)$$

and  $\Delta h = C_p(T_2 - T_1)$  for ideal gases

therefore,

$$C_p T_1 + \frac{1}{2} V_1^2 = C_p T_2 + \frac{1}{2} V_2^2 \quad (5.4.29)$$

Substitute  $V_2 = 31.92 \frac{T_2}{T_1}$  and rearrange

$$1 + \frac{V_1^2}{2C_p T_1} = \frac{T_2}{T_1} + \frac{1}{2C_p T_1} \left( 31.92 \frac{T_2}{T_1} \right)^2 \quad (5.4.30)$$

Substitute  $V_1 = 2.638$  m/s,  $T_1 = 273.15 - 30 = 243.15$  K,  $C_p = 14307$  J/kgK into the above relation, and rearrange,

$$0.00014643 \left( \frac{T_2}{T_1} \right)^2 + \frac{T_2}{T_1} - 1 = 0 \quad (5.4.31)$$

$$\therefore \frac{T_2}{T_1} = 0.99985 \quad (5.4.32)$$

$$\therefore T_2 = 0.99985 \times 243.15 = 243.11 \text{ K} = -30.04 \text{ }^\circ\text{C} \quad (5.4.33)$$

$$\therefore V_2 = 31.92 \frac{T_2}{T_1} = 31.91 \text{ m/s}$$

In this nozzle, the velocity increases significantly as the pressure decreases. The temperature remains almost constant.

**Important note:**

- *The temperatures in the calculations must be in Kelvin because the ideal gas law is used to derive other equations.*
- *The constant-pressure specific heat must be in J/kgK to ensure the consistency of the units.*

### 5.3.4 Ducts and pipes

Ducts and pipes are used to transport liquids and gases. Their configurations vary largely with applications; therefore, it is impractical to apply general assumptions to all ducts and pipes. Ducts and pipes may be analyzed specifically with the mass and energy conservation equations in [Section 5.2](#).

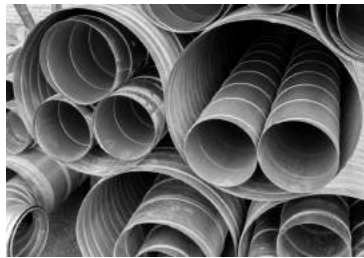

Figure 5.3.9 HVAC pipes

#### Example 4

Consider a vertical pipe section exposed to the ambient. The pipe has a constant diameter of 100 mm. Its inlet is 5 m above its outlet. Water at 10°C and 100 kPa enters the pipe at a velocity of 2 m/s, and exits at 12°C and 100 kPa. Assuming steady flow, what is the rate of heat transfer absorbed by the water in this pipe section?

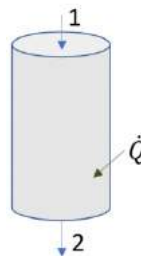

Figure 5.3.e3 Flow through a vertical pipe section

Solution:

From [Table A1](#), water is a compressed liquid at both inlet and outlet conditions, therefore,

$$v_1 \approx v_2 = v_f = 0.001 \text{ m}^3/\text{kg}$$

$$\rho_1 \approx \rho_2 = \frac{1}{v_f} = 1000 \text{ kg/m}^3$$

Mass flow rate is

$$\dot{m} = \rho_1 V_1 A_1 = 1000 \times 2 \times \pi \times 0.05^2 = 15.7 \text{ kg/s}$$

Apply the energy conservation equation to the pipe section

$$\dot{Q} + \dot{m} \left( h_1 + \frac{1}{2} V_1^2 + g z_1 \right) = \dot{m} \left( h_2 + \frac{1}{2} V_2^2 + g z_2 \right) \quad (5.4.34)$$

Since the diameter of the pipe section and the density of water remain constant in the pipe, the inlet and outlet velocity must be the same based on the mass conservation equation. From Table G2:  $C_p = 4.181 \text{ kJ/kgK} = 4181 \text{ J/kgK}$  for water.

$$\therefore V_1 = V_2 \quad (5.4.35)$$

$$\begin{aligned} \therefore \dot{Q} &= \dot{m}(h_2 - h_1 + g z_2 - g z_1) \\ &= \dot{m} C_p (T_2 - T_1) + \dot{m} g (z_2 - z_1) \\ &= 15.7 \times 4181 \times (12 - 10) + 15.7 \times 9.81 \times (-5) \\ &= 130580 \text{ W} = 130.6 \text{ kW} \end{aligned}$$

The water absorbs 130.6 kW of heat from the ambient.

**Important note:**

- **The constant-pressure specific heat must be in J/kgK in the calculations to ensure the consistency of the units.**

### 5.3.5 Mixing chambers

Mixing chambers are devices used to mix multiple streams of a fluid to achieve a desirable temperature or phase in the mixed flow. Figure 5.3.10 is a schematic of a mixing chamber in HVAC systems, where the outdoor fresh air mixes with the indoor return air in order to achieve a desirable air temperature and a targeted fresh air to return air ratio. The common assumptions for analyzing the mass and energy conservation in a mixing chamber are listed below:

- The flow through a mixing chamber is steady.
- No work exchange occurs between the mixing chamber and its surroundings:  $\dot{W}_{cv} = 0$
- The changes in potential and kinetic energies are negligible:  $\Delta PE = 0, \Delta KE = 0$
- The pressure variation in a mixing chamber is usually negligible.

With these assumptions, the mass and energy conservation equations in mixing chambers can be written as

$$\sum \dot{m}_i = \sum \dot{m}_e \quad (5.4.36)$$

$\dot{Q}_{cv} + \sum$

$\dot{Q}_{cv}$

where

$$h \quad (5.4.37)$$

$$\dot{m} \quad (5.4.38)$$

$$\dot{Q}_{cv} \quad (5.4.39)$$

Subscripts,  $i$  and  $e$ , represent the inlets and exits of the mixing chamber, respectively.



Figure 5.3.10 Schematic of a mixing chamber in HVAC (heating, ventilating and air conditioning) system

#### Example 5

Consider a well-insulated mixing chamber in an HVAC system, see [Figure 5.3.10](#). The cold outdoor air at  $-10^{\circ}\text{C}$  and 100 kPa mixes with the return air at  $22^{\circ}\text{C}$  and 100 kPa. The mass flow rates of the outdoor air and return air are 0.5 kg/s and 3 kg/s, respectively. Assume the flow is steady and the air is an ideal gas under the given conditions. What is the air temperature leaving the mixing chamber?

Solution:

Apply both mass and energy conservation equations to the mixing chamber:

$$\dot{m}_1 + \dot{m}_2 = \dot{m}_3 \quad (5.4.40)$$

$$\dot{m}_1 h_1 + \dot{m}_2 h_2 = \dot{m}_3 h_3 \quad (5.4.41)$$

$$\Delta h = C_p \Delta T \quad (5.4.42)$$

From the above three equations,

$$\begin{aligned} T_3 &= \frac{\dot{m}_1 T_1 + \dot{m}_2 T_2}{\dot{m}_1 + \dot{m}_2} \\ &= \frac{0.5 \times (-10) + 3 \times (22)}{0.5 + 3} = 17.43^{\circ}\text{C} \end{aligned}$$

The mixed air leaves the mixing chamber at a temperature of  $17.43^{\circ}\text{C}$ . In this calculation, the temperatures can be expressed either in  $^{\circ}\text{C}$  or Kelvin as long as the consistent units are used.

### 5.3.6 Heat exchangers

Heat exchangers are used to transfer heat between two flowing fluids. They can be found in many applications, such as HVAC systems, automotive systems, power generation plants, and chemical processing. Heat exchangers come in different types. For example, [Figure 5.3.11](#) shows a tube-within-shell heat exchanger, where heat is transferred between the shell-side fluid and the tube-side fluid. The tube-within-shell heat exchanger is a typical indirect heat exchanger, in which the two fluids don't mix during the heat transfer process.

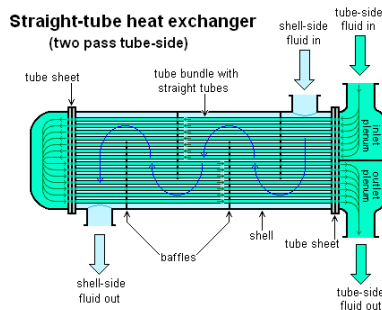

Figure 5.3.11 Schematic of a straight tube heat exchanger

Below are the common assumptions for analyzing the mass and energy conservation in an indirect heat exchanger:

- The flows through an indirect heat exchanger are steady.
- Each flow passage has only one inlet and one outlet.
- No work exchange occurs between the heat exchanger and its surroundings:  $\dot{W}_{cv} = 0$
- The changes in potential and kinetic energies are negligible:  $\Delta PE = 0, \Delta KE = 0$
- The pressure variation in a heat exchanger is usually negligible.

With these assumptions, the mass and energy conservation equations for an indirect heat exchanger can be written as

$$\dot{m}_{i,hot} = \dot{m}_{e,hot} \quad (5.4.43)$$

$$\dot{m}_{i,cold} = \dot{m}_{e,cold} \quad (5.4.44)$$

$\sum \dot{Q}_{cv}$

]

where

$$h \quad (5.4.45)$$

$$\dot{m} \quad (5.4.46)$$

$$\dot{Q}_{cv} \quad (5.4.47)$$

Subscripts, *i* and *e*, represent the inlet and exit of the heat exchanger, respectively.

Subscripts, *hot* and *cold*, represent the hot and cold streams, respectively, through the heat exchanger.

It is important to note that, although the mass and energy conservation equations derived for mixing chambers and heat exchangers look very similar, there exists a major difference between these two devices. In a mixing chamber, all flow streams mix and exit as a single stream; therefore, both mass and energy conservation equations are applied to the entire mixing chamber consisting of all flow streams. On the contrary, in an indirect heat exchanger, the cold and hot streams do NOT mix; therefore, the mass conservation equation must be applied to each flow stream individually. The energy conservation equation may be applied to the entire heat exchanger or each flow stream individually.

### Example 6

Consider the evaporator of a vapour compression refrigeration system using R134a as the working fluid. R134a enters the evaporator at  $-10^{\circ}\text{C}$  with a quality of 0.1 and exits as a saturated vapour. Air enters the evaporator in a separate stream at  $25^{\circ}\text{C}$  and exits at  $5^{\circ}\text{C}$ . Assume (1) the evaporator is well-insulated; (2) the flow is steady; (3) the pressure remains constant in the evaporator; and (4) air is an ideal gas. What is the mass flow rate of air required in this system if the mass flow rate of R134a is  $2 \text{ kg/s}$ ?

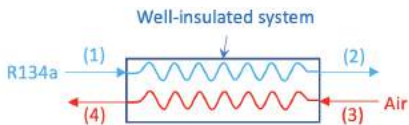

Figure 5.3.e4 Heat exchanger

#### Solution:

Apply the mass conservation equations to the R134a and air streams, separately.

$$\dot{m}_1 = \dot{m}_2 = \dot{m}_{R134a} \quad (5.4.48)$$

$$\dot{m}_3 = \dot{m}_4 = \dot{m}_{air} \quad (5.4.49)$$

Apply the energy conservation equation to the evaporator.

$$\therefore \dot{m}_1 h_1 + \dot{m}_3 h_3 = \dot{m}_2 h_2 + \dot{m}_4 h_4 \quad (5.4.50)$$

$$\therefore \dot{m}_{air} (h_3 - h_4) = \dot{m}_{R134a} (h_2 - h_1) \quad (5.4.51)$$

$$\therefore \dot{m}_{air} = \dot{m}_{R134a} \frac{(h_2 - h_1)}{(h_3 - h_4)} \quad (5.4.52)$$

Find the specific enthalpies of R134a at states 1 and 2 using thermodynamic tables.

At state 1,  $T_1 = -10^{\circ}\text{C}$ ,  $x = 0.1$ . From [Table C1](#),  $h_f = 186.70 \text{ kJ/kg}$ ,  $h_g = 392.67 \text{ kJ/kg}$



At state 2, R134a is a saturated vapour at  $T_2 = -10^{\circ}\text{C}$ ; therefore,

$$h_2 = h_g = 392.67 \text{ kJ/kg}$$

From [Table G1](#),  $C_{p,air} = 1.005 \text{ kJ/kgK}$ . Therefore,



The system requires an air supply at a rate of  $18.445 \text{ kg/s}$ .

#### Media Attributions

- Hydraulic turbine © U.S. Army Corps of Engineers is licensed under a [Public Domain](#) license
- Wind turbine schematic © Jalonsom is licensed under a [CC BY-SA \(Attribution ShareAlike\)](#) license

- Centrifugal compressor © UN document (USGOV) is licensed under a [Public Domain](#) license
- Reciprocating compressor © Birpat is licensed under a [CC BY-SA \(Attribution ShareAlike\)](#) license
- Thermal expansion valve © MasterTriangle12 is licensed under a [CC BY-SA \(Attribution ShareAlike\)](#) license
- P-h diagram for CO2 © Israel Urieli is licensed under a [CC BY-SA \(Attribution ShareAlike\)](#) license
- Turbojet © Original design: Emoscopes (talk)Vectorization: Tachymètre is licensed under a [CC BY \(Attribution\)](#) license
- Nozzle and diffuser © Nemuri is licensed under a [CC BY-SA \(Attribution ShareAlike\)](#) license
- HVAC pipes © W.carter is licensed under a [Public Domain](#) license
- Straight tube heat exchanger © H Padleckas is licensed under a [CC BY-SA \(Attribution ShareAlike\)](#) license

---

This page titled [5.4: Applications of the mass and energy conservation equations in steady flow devices](#) is shared under a [CC BY-NC-SA 4.0](#) license and was authored, remixed, and/or curated by [Claire Yu Yan \(BC Campus\)](#) via [source content](#) that was edited to the style and standards of the LibreTexts platform; a detailed edit history is available upon request.



## 5.5: Chapter review

---

In this chapter, we have introduced the mass and energy conservation equations for control volumes. The general conservation equations for control volumes are explained in [Section 5.2](#). When applying these conservation principles to a thermal device, it is important to evaluate the operation of the device, set up an appropriate control volume, and make appropriate assumptions. This is an important skill that students need to develop through practice.

[Section 5.3](#) demonstrates how to simplify the conservation equations for common steady-state steady-flow devices such as turbines and compressors, throttling valves, pipes and ducts, nozzles and diffusers, mixing chambers, and heat exchangers. It is important to understand that, the equations in [Section 5.3](#) are derived for these devices with certain assumptions. When applying these derived equations to a specific thermal device, a careful evaluation of the assumptions must be done to ensure the derived equations are appropriate for the given conditions.

---

This page titled [5.5: Chapter review](#) is shared under a [CC BY-NC-SA 4.0](#) license and was authored, remixed, and/or curated by [Claire Yu Yan \(BC Campus\)](#) via [source content](#) that was edited to the style and standards of the LibreTexts platform; a detailed edit history is available upon request.

## 5.6: Key equations

### Constant-pressure and constant-volume specific heats

Constant-pressure specific heat	$C_p = \left( \frac{\partial h}{\partial T} \right)_p$
Constant-volume specific heat	$C_v = \left( \frac{\partial u}{\partial T} \right)_v$
Relations between $C_p$ and $C_v$ for <b>ideal gases</b>	$k = \frac{C_p}{C_v} \quad C_p = C_v + R$ $C_v = \frac{R}{k-1} \quad C_p = \frac{kR}{k-1} \quad (5.6.1)$

### Specific enthalpy

Change in specific enthalpy	$\Delta h = h_2 - h_1$
Change in specific enthalpy for <b>ideal gases</b>	$\Delta h = h_2 - h_1 = C_p(T_2 - T_1)$ (assuming constant $C_p$ in the temperature range)
Relation between $\Delta h$ and $\Delta u$ for <b>solids and liquids</b>	$\Delta h \approx \Delta u \approx C_p(T_2 - T_1)$

### Mass conservation equations in a control volume

Volume flow rate	$\dot{V} = \frac{dV}{dt} = V_{avg, n} A = \dot{m}v$
Mass flow rate	$\dot{m} = \frac{dm}{dt} = \rho V_{avg, n} A = \rho \dot{V}$
<b>Transient flow</b>	$\frac{dm_{CV}}{dt} = \sum \dot{m}_i - \sum \dot{m}_e \neq 0$
<b>Steady flow</b>	$\frac{dm_{CV}}{dt} = \sum \dot{m}_i - \sum \dot{m}_e = 0$

### Energy conservation equations in a control volume

<b>Transient flow</b>	$\frac{dE_{CV}}{dt} \neq 0$ $\frac{dE_{CV}}{dt} = \dot{Q}_{cv} - \dot{W}_{cv} + \sum \dot{m}_i \left( h_i + \frac{1}{2} V_i^2 + g z_i \right) - \sum \dot{m}_e \left( h_e + \frac{1}{2} V_e^2 + g z_e \right)$
<b>Steady flow</b>	$\frac{dE_{CV}}{dt} = 0$ $\dot{Q}_{cv} - \dot{W}_{cv} + \sum \dot{m}_i \left( h_i + \frac{1}{2} V_i^2 + g z_i \right) - \sum \dot{m}_e \left( h_e + \frac{1}{2} V_e^2 + g z_e \right) = 0$

### Mass and energy conservation equations for steady-state, steady-flow (SSSF) devices

SSSF device	Assumptions	Mass conservation	Energy conservation
<b>Expansion device</b>	Adiabatic flow; Negligible work transfer with the surroundings; Negligible changes in kinetic and potential energies	$\dot{m}_i = \dot{m}_e$	$h_i = h_e$

SSSF device	Assumptions	Mass conservation	Energy conservation
<b>Nozzle and diffuser</b>	Adiabatic flow; Negligible work transfer with the surroundings; Negligible change in potential energy	$\dot{m}_i = \dot{m}_e$	$h_i + \frac{1}{2}V_i^2 = h_e + \frac{1}{2}V_e^2$
<b>Mixing chamber</b>	Negligible work transfer with the surroundings; Negligible changes in kinetic and potential energies	$\sum \dot{m}_i = \sum \dot{m}_e$	$\dot{Q}_{cv} + \sum \dot{m}_i h_i = \sum \dot{m}_e h_e$
<b>Heat exchanger</b>	Negligible work transfer with the surroundings; Negligible changes in kinetic and potential energies	$\dot{m}_i = \dot{m}_e$ (for each of the hot and cold streams, separately)	$\dot{Q}_{cv} + \sum \dot{m}_i h_i = \sum \dot{m}_e h_e$
<b>Turbine</b>	Adiabatic flow; Negligible changes in kinetic and potential energies	$\dot{m}_i = \dot{m}_e = \dot{m}$	$\dot{W}_{shaft} = \dot{m}(h_i - h_e)$
<b>Compressor</b>	Adiabatic flow; Negligible changes in kinetic and potential energies	$\dot{m}_i = \dot{m}_e = \dot{m}$	$\dot{W}_{shaft} = \dot{m}(h_e - h_i)$

This page titled [5.6: Key equations](#) is shared under a [CC BY-NC-SA 4.0](#) license and was authored, remixed, and/or curated by [Claire Yu Yan \(BC Campus\)](#) via [source content](#) that was edited to the style and standards of the LibreTexts platform; a detailed edit history is available upon request.

## CHAPTER OVERVIEW

### 6: Entropy and the Second Law of Thermodynamics

This chapter introduces the concepts of reversible and irreversible processes, Carnot cycles, entropy and entropy generation, and the second law of thermodynamics. Students will learn the applications of the second law in both closed and open systems.

- [6.1: Chapter introduction and learning objectives](#)
- [6.2: Heat engine](#)
- [6.3: Refrigerator and heat pump](#)
- [6.4: The second law of thermodynamics- Kelvin-Planck and Clausius statements](#)
- [6.5: Carnot cycles](#)
- [6.6: Entropy and entropy generation](#)
- [6.7: The second law of thermodynamics for closed systems](#)
- [6.8: Specific entropy of a state](#)
- [6.9: Applications of the second law of thermodynamics in closed systems](#)
- [6.10: The second law of thermodynamics for open systems](#)
- [6.11: Applications of the second law of thermodynamics in open systems](#)
- [6.12: Chapter review](#)
- [6.13: Key equations](#)

---

This page titled [6: Entropy and the Second Law of Thermodynamics](#) is shared under a [CC BY-NC-SA 4.0](#) license and was authored, remixed, and/or curated by [Claire Yu Yan \(BC Campus\)](#) via [source content](#) that was edited to the style and standards of the LibreTexts platform; a detailed edit history is available upon request.

## 6.1: Chapter introduction and learning objectives

### Learning Objectives

After completing the chapter, you should be able to:

- Demonstrate an understanding of reversible and irreversible processes and Carnot cycles
- Calculate the thermal efficiency of heat engines and the coefficient of performance (COP) of refrigerators and heat pumps
- Calculate the change in entropy in real substances, ideal gases, solids, and liquids
- Explain entropy generation, entropy transfer mechanisms, and the second law of thermodynamics
- Apply the second law of thermodynamics to closed systems
- Apply the second law of thermodynamics to various steady flow devices

Heat and work are two forms of energy. From the first law of thermodynamics, we may say “1 kJ of heat = 1 kJ of work”, but how do we interpret the “=” sign here? Does it mean that heat and work are equivalent?

Let us consider a daily example. In winter, you might need an electric resistance heater to warm up your room. From [Figure 6.0.1 \(a\)](#), the electric charges do work on the resistor as they flow in the direction of lower electric potential. In this process, the electric energy from the circuit is converted to heat, which is then dissipated in your room, or the surroundings. As a result, the room temperature will tend to rise. If the heater consumes 1 kW of electric power, it will generate and dissipate approximately 1 kW of heat to the surroundings. In terms of the amount of energy conversion, we can safely say that 1 kW of electric energy is no different from 1 kW of heat. However, is this energy conversion process reversible? If we simply cool the surroundings and provide 1 kW of heat to the resistor, is it possible to generate 1 kW of electric power from this 1 kW of heat? Unfortunately, the answers to both questions are no, see [Figure 6.0.1 \(b\)](#).

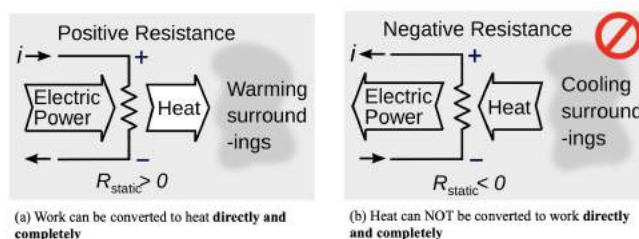

Figure 6.0.1 Electric resistance heater illustrating heat-and-work conversion and irreversible process

This example illustrates an important concept of heat-work conversion. Although heat and work can be converted between each other, they are not equivalent. Work can always be converted to heat *completely* and *directly*; but heat cannot be converted to work *completely* and *directly* even under an ideal condition, because heat is a form of energy of “low” quality (a more “random”, “disordered” system) and work is a form of energy of “high” quality (a highly “ordered” system). A natural, spontaneous process has a tendency to move toward a greater degree of randomness or disorder in a system. Therefore, an energy conversion process in nature tends to occur in the direction of converting energy from a “high” quality form to a “low” quality form. The first law of thermodynamics addresses the heat and work conversion quantitatively, but has no indication on whether or under what condition such conversion can actually happen. Satisfying the first law of thermodynamics does not ensure a process can take place in reality. Whether a process can happen or not is determined by the second law of thermodynamics.

This chapter introduces the concepts of reversible and irreversible processes, Carnot cycles, entropy generation and the second law of thermodynamics, and the applications of the second law to both closed and open systems.

### Media Attributions

- Electric resistance heater © Chetvorno is licensed under a [CC0 \(Creative Commons Zero\)](#) license

This page titled [6.1: Chapter introduction and learning objectives](#) is shared under a [CC BY-NC-SA 4.0](#) license and was authored, remixed, and/or curated by [Claire Yu Yan \(BC Campus\)](#) via [source content](#) that was edited to the style and standards of the LibreTexts platform; a detailed edit history is available upon request.

## 6.2: Heat engine

A heat engine is a continuously operating device that produces work by transferring heat from a heat source (high-temperature body) to a heat sink (low-temperature body) using a working fluid. In a heat engine cycle, a working fluid may remain as a single-phase fluid or experience phase changes.

A steam engine is a type of heat engine commonly used in steam power generating plants. It operates on Rankine cycles and uses water as the working fluid. We will use a steam engine to illustrate how heat is converted to work in heat engines. A typical steam engine consists of four main equipment: boiler, turbine, condenser, and pump, as shown in Figure 6.1.1. The  $T$ - $s$  diagram in Figure 6.1.2 illustrates the four processes in a Rankine cycle:

1. Water at a low pressure and a low temperature (state 1) is pumped to a boiler. The pump consumes power,  $\dot{W}_{pump}$ , in order to maintain a continuous supply of water to the boiler while increasing the pressure of the water entering the boiler (state 2). Process 1-2 may be assumed adiabatic.
2. In the boiler, the liquid water absorbs heat,  $\dot{Q}_H$ , from an external heat source and changes into high-temperature, high-pressure steam (state 3). The pressure drop in the boiler is usually negligible; therefore, process 2-3 may be assumed isobaric.
3. The high-temperature, high-pressure steam then expands in the turbine, making the turbine rotate continuously, and thus generating mechanical power,  $\dot{W}_{turbine}$ . During the expansion process, the temperature and pressure of the steam decrease. Consequently, the steam leaving the turbine (state 4) becomes a low-temperature, low-pressure, two-phase mixture. Process 3-4 may be assumed adiabatic.
4. The steam leaving the turbine then enters a condenser and is condensed to a saturated or compressed liquid (state 1). During this process, heat,  $\dot{Q}_L$ , is removed from the steam. The pressure drop in the condenser is usually negligible; therefore, process 4-1 may be assumed isobaric.

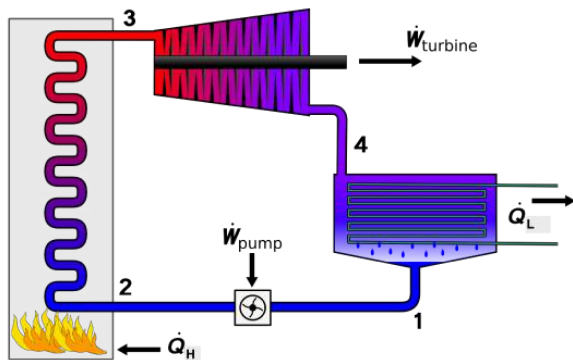

Figure 6.1.1 Rankine cycle

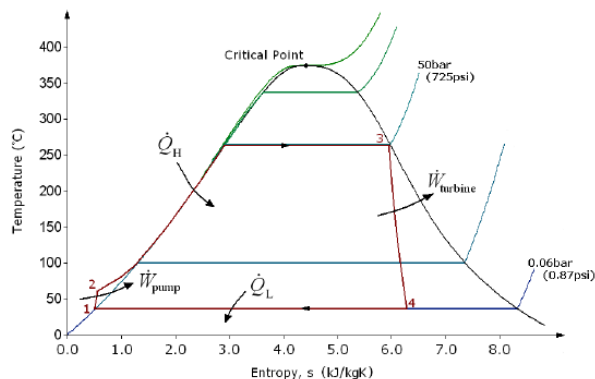

Figure 6.1.2  $T$ - $s$  diagram of a Rankine cycle

Figure 6.1.3 is a simplified schematic for analyzing the energy conservation in heat engines. Applying the first law of thermodynamics to the cycle, we can write

$$\dot{Q}_H - \dot{Q}_L = \dot{W}_{turbine} - \dot{W}_{pump} = \dot{W}_{net,out} \quad (6.2.1)$$

Clearly, the heat removed by the condenser,  $\dot{Q}_L$ , cannot be converted to useful work. It is *wasted* in order to complete the cycle. In other words, a heat engine cannot convert *all* the heat supplied by the heat source (e.g., boiler) to useful work, even under ideal conditions. Thermal efficiency is a dimensionless parameter used to measure the performance of a heat engine.

$$\eta_{th} = \frac{\text{desired output}}{\text{required input}} = \frac{\dot{W}_{net, out}}{\dot{Q}_H} = 1 - \frac{\dot{Q}_L}{\dot{Q}_H}$$

where

- $\dot{Q}_H$ : heat absorbed from the heat source, in kW
- $\dot{Q}_L$ : heat rejected to the heat sink, in kW
- $\dot{W}_{net, out}$ : net work output from the heat engine, in kW
- $\eta_{th}$ : thermal efficiency of the heat engine, dimensionless

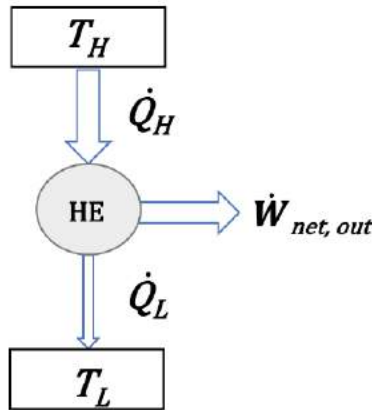

Figure 6.1.3 Schematic of a heat engine

### Example 1

Figures 6.1.e1 and 6.1.e2 illustrate a Rankine cycle consisting of a two-stage steam engine and a feedwater heater. The steam engine is enclosed in the red outlines in Figure 6.1.e1. The two stages of the turbine are labelled as HE1 and HE2, respectively. In stage 1, the steam absorbs heat,  $\dot{Q}_H$ , from the boiler and generates a power,  $\dot{W}_1$ . A portion of the exhaust steam from stage 1 then enters stage 2, further generating a power,  $\dot{W}_2$ . The remaining exhaust steam from stage 1 is used to preheat the feed water. If the thermal efficiencies of the two turbine stages are  $\eta_{th,1}$  and  $\eta_{th,2}$ , what is the overall thermal efficiency of the cycle as a function of  $\eta_{th,1}$  and  $\eta_{th,2}$ ? Assume 90% of the exhaust steam exiting from stage 1 enters stage 2 and generates the power,  $\dot{W}_2$ .

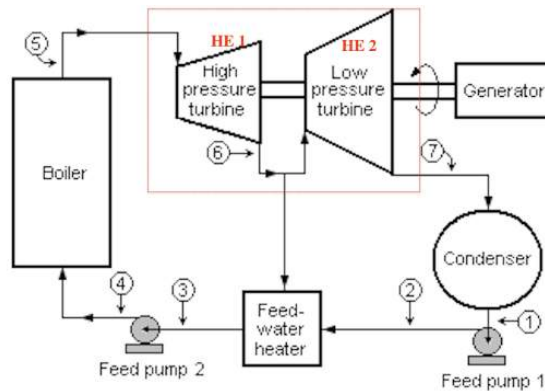

Figure 6.1.e1 Two-stage steam turbine with a feed-water heater

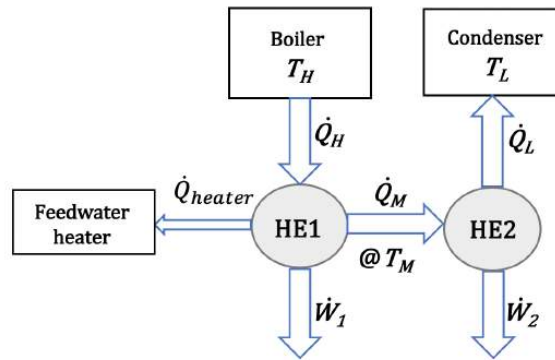

Figure 6.1.e2 Schematic of the two-stage heat engine

Solution:

The thermal efficiency of the first and second stages of the steam turbine can be written as

$$\eta_{th,1} = \frac{\dot{W}_1}{\dot{Q}_H} \quad (6.2.2)$$

The desired output of the cycle is the total power generated by the turbine and the required energy input comes from the boiler; therefore,

$$\eta_{th} = \frac{\dot{W}_{tot}}{\dot{Q}_H} = \frac{\dot{W}_1 + \dot{W}_2}{\dot{Q}_H} \quad (6.2.3)$$

Apply the first law of thermodynamics to the first stage, HE1. Note that 90% of the exhaust steam from stage 1 enters stage 2; therefore,

$$\dot{Q}_M + \dot{Q}_{Heater} = \dot{Q}_H - \dot{W}_1 \quad (6.2.4)$$

and

$$\dot{Q}_M = 0.9(\dot{Q}_H - \dot{W}_1) \quad (6.2.5)$$

Combine the above equations and rearrange,

$$\begin{aligned} \therefore \eta_{th} &= \frac{\dot{W}_1}{\dot{Q}_H} + \frac{\dot{W}_2}{\dot{Q}_H} \\ &= \eta_{th,1} + \frac{\eta_{th,2} \dot{Q}_M}{\dot{Q}_H} \\ &= \eta_{th,1} + \frac{\eta_{th,2} \times 0.9(\dot{Q}_H - \dot{W}_1)}{\dot{Q}_H} \\ \therefore \eta_{th} &= \eta_{th,1} + 0.9\eta_{th,2}(1 - \eta_{th,1}) \end{aligned} \quad (6.2.6)$$

**Media Attributions**

- Rankine cycle © Andrew Ainsworth is licensed under a [CC BY-SA \(Attribution ShareAlike\)](#) license
- Rankine cycle, T-s diagram © Andrew Ainsworth is licensed under a [CC BY-SA \(Attribution ShareAlike\)](#) license
- Two-stage steam turbine with a feedwater heater © Milton Beychok is licensed under a [CC BY-SA \(Attribution ShareAlike\)](#) license

This page titled [6.2: Heat engine](#) is shared under a [CC BY-NC-SA 4.0](#) license and was authored, remixed, and/or curated by [Claire Yu Yan \(BC Campus\)](#) via [source content](#) that was edited to the style and standards of the LibreTexts platform; a detailed edit history is available upon request.



## 6.3: Refrigerator and heat pump

### 6.2.1 Refrigerator

A refrigerator is a cyclic device, which absorbs heat from a heat sink and reject heat to a heat source by consuming work. The working fluid is called refrigerant, which usually undergoes phase changes in the cycle.

A typical vapour-compression refrigeration system consists of mainly four pieces of equipment, as shown in Figure 6.2.1:

1. An evaporator, through which the low-pressure, low-temperature refrigerant absorbs heat from a heat sink (e.g., a freezer compartment or a space to be refrigerated) and changes from a two-phase mixture to a saturated or superheated vapour.
2. A compressor, which is used to increase the pressure and temperature of the refrigerant vapour by consuming work.
3. A condenser, through which heat is rejected to a heat source (e.g. kitchen or outdoor air). At the exit of the condenser, the refrigerant is typically a two-phase mixture or a liquid.
4. An expansion valve, which is used to reduce the pressure and temperature of the refrigerant in order to achieve a liquid-vapour mixture of desirable quality at the exit of the expansion valve.

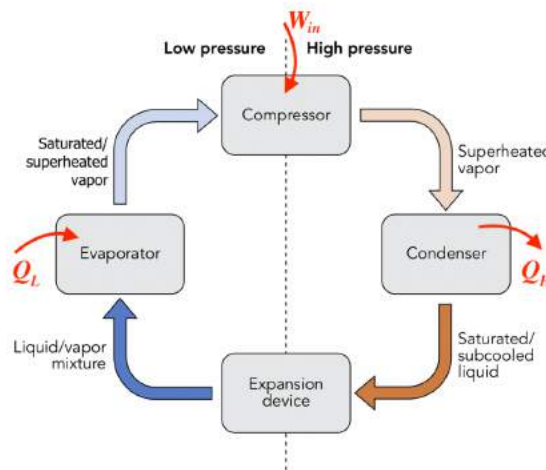

Figure 6.2.1 Vapor compression refrigeration cycle consisting of a compressor, condenser, expansion device, and evaporator

As heat cannot be transferred from a low-temperature body to a high-temperature body spontaneously in nature, refrigerators must consume work in order to operate between a heat sink and a heat source, even under ideal conditions.

Figure 6.2.2 is a schematic for analyzing the energy conservation in a refrigerator. The same schematic may be used to represent a heat pump by replacing the notation “Ref” with “HP” in the circular area.

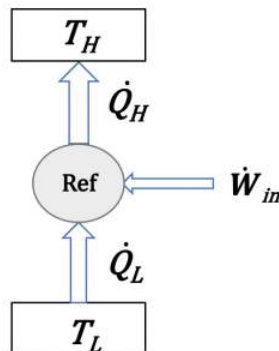

Figure 6.2.2 Schematic of a refrigerator (or a heat pump)

Applying the first law of thermodynamics to the cycle, we can write

$$\dot{Q}_H - \dot{Q}_L = \dot{W}_{in} \quad (6.3.1)$$

The main purpose of refrigerators is to remove heat,  $\dot{Q}_L$ , from a heat sink (cold space); therefore, we are interested in the amount of heat that can be removed per unit of power consumption. The dimensionless ratio of  $\frac{\dot{Q}_L}{\dot{W}_{in}}$  is called the coefficient of performance,

$COP_R$ , of the refrigerator. It is an indicator of the performance of a refrigerator.



Refrigerators are typically designed to consume a power  $\dot{W}_{in} < \dot{Q}_L$ ; therefore,  $COP_R > 1$  in a well-designed refrigerator. A higher  $COP_R$  indicates a better performance.

## 6.2.2 Heat pump

A heat pump uses the same vapour compression refrigeration cycle, see [Figure 6.2.1](#), as a refrigerator. It absorbs heat from a heat sink (e.g., outdoor air in the winter) and delivers (more) heat to a heat source (e.g., indoor air) by consuming work. Applying the first law of thermodynamics to the heat pump cycle, we can derive

$$\dot{W}_{in} = \dot{Q}_H - \dot{Q}_L \quad (6.3.2)$$

Different from refrigerators, the main purpose of heat pumps is to add heat,  $\dot{Q}_H$ , to a heat source, such as an indoor space of a building. Therefore, we are interested in the amount of heat,  $\dot{Q}_H$ , that can be transferred from the condenser to the heat source per unit power consumption. The dimensionless ratio of  $\frac{\dot{Q}_H}{\dot{W}_{in}}$  is called the coefficient of performance,  $COP_{HP}$ , of heat pump. It is an indicator of the performance of a heat pump. As  $\frac{\dot{Q}_H}{\dot{W}_{in}} > 1$  in a well-designed heat pump,  $COP_{HP} > 1$ .



### Example 1

Consider a vapour-compression refrigeration cycle, [Figure 6.2.1](#). The working fluid is ammonia.

- At the compressor inlet,  $P_1=0.2$  MPa,  $T_1=-10^\circ\text{C}$ ,  $\dot{m}_1 = 0.1$  kg/s
- At the compressor outlet,  $P_2=1.4$  MPa,  $T_2=150^\circ\text{C}$
- At the condenser outlet,  $P_3=1.4$  MPa,  $T_3=35^\circ\text{C}$
- At the evaporator inlet,  $P_4=0.2$  MPa

Assuming that the heat transfer and pressure drops in the connecting pipes are negligible, and  $\Delta PE = 0$ ,  $\Delta KE = 0$ ,

(1) determine the rate of heat absorbed by the evaporator,  $\dot{Q}_L$ , the power required by the compressor,  $\dot{W}_{in}$ , and the rate of heat rejected by the condenser,  $\dot{Q}_H$ .

(2) determine  $COP_R$  of the refrigeration cycle

(3) If the same vapour refrigeration cycle were used as a heat pump, what would the  $COP_{HP}$  be?

#### Solution:

(1) The rates of heat transfer in the evaporator and condenser and the power consumption in the compressor depend on the changes of enthalpies in these devices. First, determine the specific enthalpy of each state from Tables B1 and B2.

- State 1, compressor inlet:  $P_1 = 0.2$  MPa,  $T_1 = -10^\circ\text{C}$ . From [Table B2](#),  $h_1 = 1603.63$  kJ/kg.
- State 2, compressor outlet:  $P_2 = 1.4$  MPa,  $T_2 = 150^\circ\text{C}$ . From [Table B2](#),  $h_2 = 1940.26$  kJ/kg
- State 3, condenser outlet:  $P_3 = 1.4$  MPa,  $T_2 = 35^\circ\text{C}$ . From [Table B1](#), ammonia at this state is a compressed liquid; therefore,  $h_3 \approx h_{f@35^\circ\text{C}} = 509.23$  kJ/kg
- State 4, evaporator inlet:  $P_4 = 0.2$  MPa. Typically, the expansion valve is assumed well-insulated; therefore, the expansion process is adiabatic, and  $h_4 = h_3 = 509.24$  kJ/kg.

The rate of the heat absorbed by the evaporator

$$\dot{Q}_L = \dot{m}(h_1 - h_4) = 0.1 \times (1603.63 - 509.23) = 109.44 \text{ kW} \quad (6.3.3)$$

The power consumption by the compressor

$$\dot{W}_{in} = \dot{m}(h_2 - h_1) = 0.1 \times (1940.26 - 1603.63) = 33.66 \text{ kW} \quad (6.3.4)$$

The rate of the heat rejected by the condenser

$$\dot{Q}_H = \dot{m}(h_2 - h_3) = 0.1 \times (1940.26 - 509.23) = 143.10 \text{ kW} \quad (6.3.5)$$

From the above calculations, it is easy to verify that  $\dot{Q}_H = \dot{Q}_L + \dot{W}_{in}$

(2) COP of the refrigeration cycle

$$COP_R = \frac{\dot{Q}_L}{\dot{W}_{in}} = \frac{109.44}{33.66} = 3.25 \quad (6.3.6)$$

(3) If the same cycle is used as a heat pump, its COP will be

$$COP_{HP} = \frac{\dot{Q}_H}{\dot{W}_{in}} = \frac{143.10}{33.66} = 4.25 \quad (6.3.7)$$

Comment:

It is noted that both  $COP_R$  and  $COP_{HP}$  are greater than 1. By consuming a certain amount of power, the cycle transfers a much larger amount of heat (desirable output) either by the evaporator or by the condenser. In addition, it is always true that

$$COP_{HP} = COP_R + 1 \quad (6.3.8)$$

because

$$COP_{HP} = \frac{\dot{Q}_H}{\dot{W}_{in}} = \frac{\dot{Q}_L + \dot{W}_{in}}{\dot{W}_{in}} = COP_R + 1 \quad (6.3.9)$$

#### Media Attributions

- Vapor compression refrigeration cycle © WGISol is licensed under a [CC BY-SA \(Attribution ShareAlike\)](#) license

---

This page titled [6.3: Refrigerator and heat pump](#) is shared under a [CC BY-NC-SA 4.0](#) license and was authored, remixed, and/or curated by [Claire Yu Yan \(BC Campus\)](#) via [source content](#) that was edited to the style and standards of the LibreTexts platform; a detailed edit history is available upon request.

## 6.4: The second law of thermodynamics- Kelvin-Planck and Clausius statements

The first law of thermodynamics focuses on energy conservation. It does not describe any restrictions or possibilities for a process to take place. A process satisfying the first law of thermodynamics may or may not be achievable in reality. In fact, whether a process is possible is governed by both the first and the second laws of thermodynamics. There are two classical statements of the second law of thermodynamics; one imposes the limits on the operation of heat engines, and the other on the operation of refrigerators and heat pumps.

**Kelvin-Planck Statement:** *it is impossible for any device that operates on a cycle to receive heat from a single reservoir and produce only a net amount of work.* Figure 6.3.1 illustrates the Kelvin-Planck statement. Any device violating the Kelvin-Planck statement would produce a net work output equivalent to the amount of the heat received by the device, or  $\dot{W} = \dot{Q}_H$ , thus resulting in a thermal efficiency

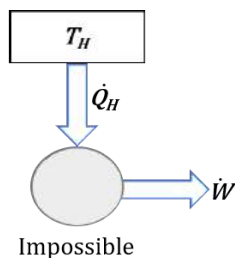

Figure 6.3.1 Schematic illustrating Kelvin-Planck statement

**Clausius statement:** *it is impossible to construct a device that operates in a cycle and produces no effect other than the transfer of heat from a lower-temperature body to a higher-temperature body.* Figure 6.3.2 illustrates the Clausius statement. Any device violating the Clausius statement would have zero work input and nonzero heat transfer received and delivered by the device, or  $\dot{W} = 0$ ,  $\dot{Q}_H = \dot{Q}_L \neq 0$ , and thus a

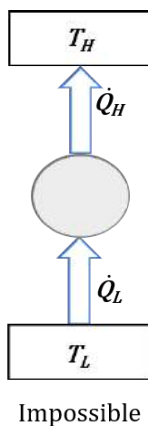

Figure 6.3.2 Schematic illustrating the Clausius statement

Although the Kelvin-Planck and Clausius statements refer to different cycles, they are equivalent in their consequences. Any device that violates the Kelvin-Planck statement must violate the Clausius statement, and vice versa.

Let us consider a combined system, which consists of a heat pump and an imagined engine operating between a heat source at a higher temperature  $T_H$  and a heat sink at a lower temperature  $T_L$ , as shown in Figure 6.3.3.

1. Let us assume the imagined engine violates the Kelvin-Planck statement; therefore, it can convert all of the heat absorbed from the heat source to useful power, or  $\dot{W} = \dot{Q}$ . The power generated from the imagined engine is then used to drive the heat pump.
2. For the heat pump, . Therefore, the heat released by the heat pump to the heat source is  $\dot{Q}_H = COP \cdot \dot{Q}$ .
3. Applying the first law to the heat pump, the heat absorbed by the heat pump from the heat sink must be  $\dot{Q}_L = \dot{Q}_H - \dot{Q} = (COP - 1)\dot{Q}$ .
4. Now let us compare the net heat absorbed by the combined system from the heat sink,  $\dot{Q}_L = (COP - 1)\dot{Q}$ , and the net heat rejected by the combined system to the heat source,  $\dot{Q}_H - \dot{Q} = (COP - 1)\dot{Q}$ . They are exactly the same! What the combined system does is to transfer heat from the heat sink (lower-temperature body) to the heat source (higher-temperature body) without consuming any power at all!

It is apparent that the combined system violates the Clausius statement because the imagined engine violates the Kelvin-Planck statement. Since the Kelvin-Planck and Clausius statements are equivalent, both of them may be used to describe the second law of thermodynamics.

A real process or device must satisfy both the first and the second laws of thermodynamics: the first law sets a constraint on the amount of energy that must be conserved in a process or a device; the second law indicates whether a process is possible in reality. Any device that violates either the first or the second law is called a perpetual-motion machine, which attempts to produce work from nothing or convert heat *completely* to useful work. In fact, no perpetual-motion machine can actually work.

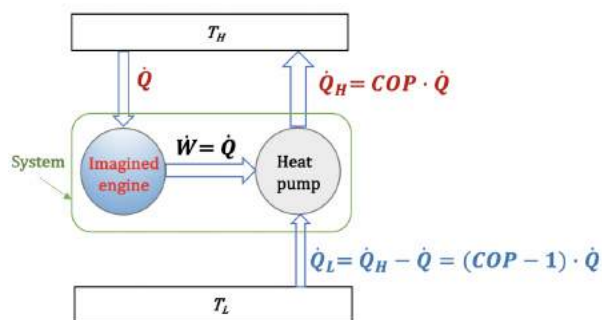

Figure 6.3.3 Schematic showing the equivalence of the Kelvin-Planck and Clausius statements

### Example 1

Consider the following scenarios proposed for a heat engine or a refrigerator. For each of the scenarios, determine if the proposed heat engine or refrigerator satisfies the first and second laws of thermodynamics.

- Proposed heat engine:  $\dot{Q}_H = 10 \text{ kW}$ ,  $\dot{Q}_L = 3 \text{ kW}$ ,  $\dot{W}_{net,out} = 5 \text{ kW}$
- Proposed refrigerator:  $\dot{Q}_H = 9 \text{ kW}$ ,  $\dot{Q}_L = 4 \text{ kW}$ ,  $\dot{W}_{in} = 0 \text{ kW}$

Solution:

- (1) Proposed heat engine: **Formula does not parse**

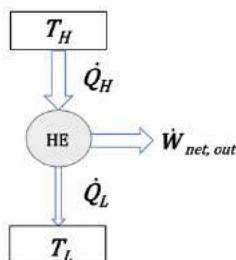

Figure 6.1.3 Schematic of a heat engine (reproduced)

The first law requires  $\dot{Q}_H = \dot{Q}_L + \dot{W}_{net,out}$ , and the second law requires  $\dot{Q}_L > 0$ . Since  $10 \neq 3 + 5$  and  $\dot{Q}_L = 3 \text{ kW} > 0$ , the proposed heat engine doesn't satisfy the first law of thermodynamics; but it satisfies the second law of thermodynamics or the Kelvin-Planck statement.

- (2) Proposed refrigerator: **Formula does not parse**

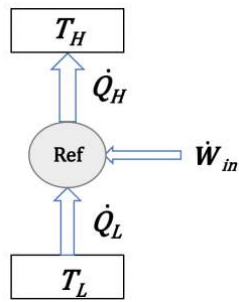

Figure 6.2.2 Schematic of a refrigerator (reproduced)

The first law requires  $\dot{Q}_H = \dot{Q}_L + \dot{W}_{in}$ , and the second law requires  $\dot{W}_{in} > 0$ . Since  $\dot{Q}_L = 0$  and  $\dot{W}_{in} = 0$ , the proposed refrigerator satisfies neither the first nor the second laws of thermodynamics. It violates the Clausius statement.

This page titled [6.4: The second law of thermodynamics- Kelvin-Planck and Clausius statements](#) is shared under a [CC BY-NC-SA 4.0](#) license and was authored, remixed, and/or curated by [Claire Yu Yan \(BC Campus\)](#) via [source content](#) that was edited to the style and standards of the LibreTexts platform; a detailed edit history is available upon request.

## 6.5: Carnot cycles

### 6.4.1 Irreversibilities

$$\eta_{th} \rightarrow 1 \quad (6.5.1)$$

A reversible process is a process that can be reversed *without leaving any change in either the system or its surroundings*, which means both the system and its surroundings always return to their original states during a reversible process. A fictitious, frictionless pendulum can be treated as a reversible process, see [Figure 6.4.1](#); it will never stop and always returns to its original state. However, in reality, friction always exists. A pendulum will gradually slow down and eventually stop.

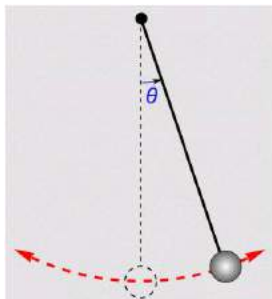

Figure 6.4.1 Frictionless pendulum as an example of a reversible process

Factors that render a process irreversible are called irreversibilities. Friction, unrestrained expansion, mixing of fluids, heat transfer through a finite temperature difference, electric resistance, inelastic deformation of solids, and chemical reactions are some examples of irreversibilities. All processes occurring in nature are irreversible due to the existence of irreversibilities. Some processes are more irreversible than others. A reversible process is commonly used as an idealized model to which an actual process can be compared. The efficiency of a reversible process is the theoretical limit that an actual, irreversible process can possibly achieve in a nearly ideal condition.

### 6.4.2 Carnot heat engine

A Carnot heat engine is an idealized cycle, which consists of four reversible processes. [Figures 6.4.2–6.4.4](#) show the schematic of a Carnot heat engine and its pressure-volume,  $P-v$ , and temperature-entropy,  $T-s$ , diagrams. The cycle consists of the following four reversible processes:

1. Process A→B: a reversible isothermal heat addition process of  $Q_H$  from a heat source at constant temperature  $T_H$ .
2. Process B→C: a reversible adiabatic expansion process, during which the temperature drops from  $T_H$  to  $T_L$ .
3. Process C→D: a reversible isothermal heat removal process of  $Q_L$  from a heat sink at constant temperature  $T_L$ .
4. Process D→A: a reversible adiabatic compression process, in which the temperature increases from  $T_L$  to  $T_H$ .

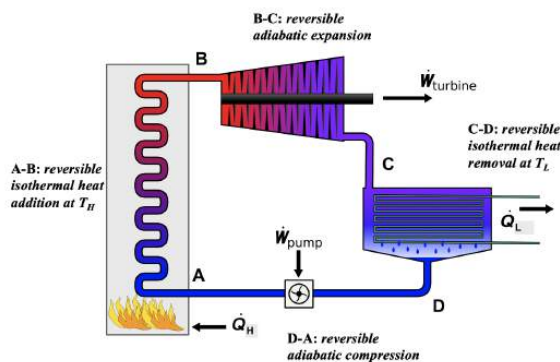

Figure 6.4.2 Carnot heat engine

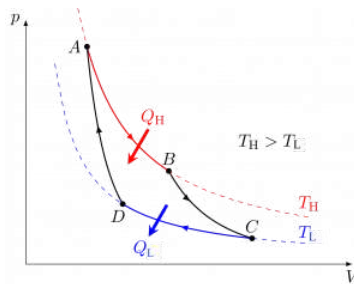

Figure 6.4.3 Carnot heat engine:  $P$ - $V$  diagram

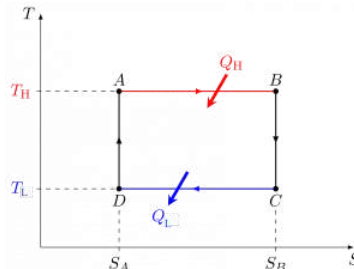

Figure 6.4.4 Carnot heat engine:  $T$ - $S$  diagram

Because the Carnot heat engine cycle is an ideal cycle consisting of only reversible processes, it produces the maximum power output and has the maximum thermal efficiency among all heat engines operating between the same heat source at  $T_H$  and the same heat sink at  $T_L$ . The thermal efficiency of a Carnot heat engine can be expressed as

$$\eta_{th, rev} = 1 - \left( \frac{Q_L}{Q_H} \right)_{rev} = 1 - \frac{T_L}{T_H} \quad (6.5.2)$$

where

$$T_H \quad (6.5.3)$$

$$T_L \quad (6.5.4)$$

$$Q_H \quad (6.5.5)$$

$$Q_L \quad (6.5.6)$$

$$\eta_{th, rev} \quad (6.5.7)$$

The thermodynamic temperature scale, or absolute temperature scale is defined so that  $\left( \frac{Q_L}{Q_H} \right)_{rev} = \frac{T_L}{T_H}$ .

In summary, the thermal efficiency of an actual heat engine is always less than that of the Carnot heat engine. It is impossible for any heat engine to achieve a better performance than the Carnot heat engine operating between the same heat source at  $T_H$  and the same heat sink at  $T_L$ .

- Irreversible, actual heat engine:  $\eta_{th} < \eta_{th, rev}$
- Carnot heat engine:  $\eta_{th} = \eta_{th, rev}$
- Impossible device:   $\eta_{th} > \eta_{th, rev}$

For a heat engine operating between a heat source at  $T_H$  and a heat sink at  $T_L$ , either increasing  $T_H$  or decreasing  $T_L$  can improve its thermal efficiency. In practice, much effort is made to increase the temperature of the heat source  $T_H$  within the material limits because the temperature of the heat sink  $T_L$  is usually constrained by the ambient temperature. In many large steam power plants, the temperature of the inlet steam (heat source) is in the range of 300~600°C (573~873 K) in order to improve the thermal efficiency of the heat engines.

#### Example 1



Consider a proposal to build a 500-MW steam power plant operating on a Rankine cycle by a lake. The steam generated by the boiler is at 250°C. The condenser is to be cooled by the lake water at a flow rate of 20 m<sup>3</sup>/s. As the cooling water will be discharged to the lake, the design team needs to evaluate its impact on the local aquatic ecosystem. Assume the cooling water supplied from the lake to the condenser is at a constant temperature of 18°C.

1. If the cycle were reversible (Carnot cycle), what is the thermal efficiency of the power plant? Estimate the temperature rise of the discharge water to the lake.
2. If the cycle were reversible (Carnot cycle), and the steam temperature increases to 300°C, how would the thermal efficiency of the power plant change?
3. The above two scenarios are ideal Carnot cycles. In fact, the projected thermal efficiency of the actual cycle is about 35%. Estimate the temperature rise of the discharge water to the lake in this case.

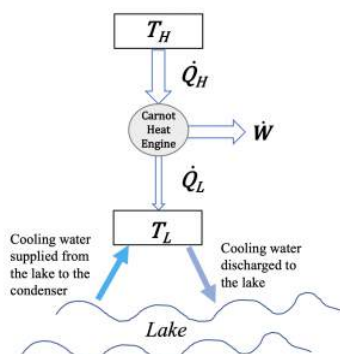

Figure 6.4.e1 A schematic of a Carnot heat engine. Heat is rejected to a nearby lake.

Solution:

1. The power plant is assumed to operate on a Carnot cycle between a heat source at the steam temperature of  $T_H = 250^\circ\text{C}$  and a heat sink at the cooling water temperature of  $T_L = 18^\circ\text{C}$ . The thermal efficiency of the Carnot cycle is

$$\eta_{th,rev} = 1 - \frac{T_L}{T_H} = 1 - \frac{273.15 + 18}{273.15 + 250} = 0.443 \quad (6.5.8)$$

$$\eta_{th,rev} = \frac{\dot{W}}{\dot{Q}_H} \quad (6.5.9)$$

Therefore, the heat rejected to the discharge water to the lake is

$$\begin{aligned} \dot{Q}_L &= \dot{W} \left( \frac{1}{\eta_{th,rev}} - 1 \right) \\ &= 500 \left( \frac{1}{0.443} - 1 \right) = 627.48 \text{ MW} \end{aligned}$$

From Table G2,  $C_p = 4.181 \text{ kJ/kgK}$  for water, and the density of water is  $\rho = 1000 \text{ kg/m}^3$ ; therefore,

$$\therefore \dot{Q}_L = \dot{m}C_p\Delta T = \rho\dot{V}C_p\Delta T \quad (6.5.10)$$

$$\therefore \Delta T = \frac{\dot{Q}_L}{\rho\dot{V}C_p} = \frac{627.48 \times 10^3}{1000 \times 20 \times 4.181} = 7.5^\circ\text{C} \quad (6.5.11)$$

2. For a Carnot cycle with  $T_H = 300^\circ\text{C}$  and  $T_L = 18^\circ\text{C}$ ,

$$\eta_{th,rev} = 1 - \frac{T_L}{T_H} = 1 - \frac{273.15 + 18}{273.15 + 300} = 0.492 \quad (6.5.12)$$

Comment:

Compare the two Carnot cycles, increasing the heat source temperature  $T_H$  can increase the thermal efficiency of the cycle. Similarly, decreasing the heat sink temperature  $T_L$  can also increase the thermal efficiency of the cycle.

3. The thermal efficiency of an actual cycle is always less than that of the Carnot cycle operating between the same heat source and heat sink. If the projected thermal efficiency of the actual cycle is 35%, then the heat absorbed by the discharge water will be

$$\begin{aligned}\dot{Q}_L &= \dot{W} \left( \frac{1}{\eta_{th}} - 1 \right) \\ &= 500 \times \left( \frac{1}{0.35} - 1 \right) = 928.57 \text{ MW}\end{aligned}$$

The temperature rise of the discharge water will be

$$\Delta T = \frac{\dot{Q}_L}{\rho \dot{V} C_p} = \frac{928.57}{1000 \times 20 \times 4.181} = 11.1 \text{ }^\circ\text{C} \quad (6.5.13)$$

Comment:

The actual cycle will cause a much higher temperature rise in the discharge water than the Carnot cycle due to the existence of the irreversibilities. A large amount of heat rejection to the lake could have a negative impact on the aquatic life and should be monitored closely.

### 6.4.3 Carnot refrigerator and Carnot heat pump

If the four processes, compression, evaporation, expansion and condensation, in a vapour-compression refrigeration system are all reversible, the cycle is reversible and is called the Carnot refrigeration cycle. A refrigerator or a heat pump operating in such a cycle is called a Carnot refrigerator or a Carnot heat pump.

Among all refrigerators (or heat pumps) operating between the same heat source at  $T_H$  and the same heat sink at  $T_L$ , the Carnot refrigerator (or heat pump) consumes the least amount of power, thus achieving the highest coefficient of performance,  $COP_{R, rev}$  or  $COP_{HP, rev}$ , as expressed below:

- Carnot refrigerator:  $COP_{R, rev} = \frac{T_L}{T_H - T_L} = \frac{1}{T_H/T_L - 1}$
- Carnot heat pump:  $COP_{HP, rev} = \frac{T_H}{T_H - T_L} = \frac{1}{1 - T_L/T_H}$

where

$$COP_{R, rev} \quad (6.5.14)$$

$$COP_{HP, rev} \quad (6.5.15)$$

$$T_H \quad (6.5.16)$$

$$T_L \quad (6.5.17)$$

#### Example 2

A heat pump provides 20 kW of heating to a house in winter. The house must be maintained at 24°C. If the COP of the heat pump is 5.5, and the outdoor temperature is 0°C, answer the following questions.

1. How much power is required to drive the heat pump? Compare the power consumption of this heat pump and an electric resistance heater providing the same amount of heating to the house.
2. If the cycle were a Carnot cycle, what would the power consumption be?
3. If the outdoor temperature decreases, will the COP of the heat pump increase, remain the same, or decrease?

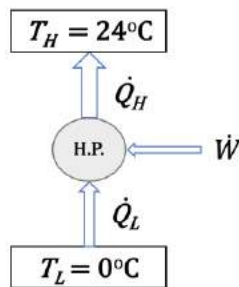

Figure 6.4.e2 Schematic of a heat pump

**Solution:**

1. The heat pump provides 20 kW of heating to the house; therefore,  $\dot{Q}_H = 20 \text{ kW}$

$$\therefore COP_{HP} = \frac{\dot{Q}_H}{\dot{W}} = 5.5 \tag{6.5.18}$$

$$\begin{aligned} \dot{W} &= \frac{\dot{Q}_H}{COP} \\ &= \frac{20}{5.5} = 3.636 \text{ kW} \end{aligned}$$

If an electric resistance heater is used to provide 20 kW of heating to the house, the electric resistance heater will consume 20 kW of electric power, assuming the efficiency of the heater is 100%. Therefore,

$$\Delta \dot{W} = 20 - 3.636 = 16.364 \text{ kW} \tag{6.5.19}$$

Compare the power consumption of the heat pump and electric heater, using heat pump will save 16.354 kW of power.

2. If the cycle were a Carnot cycle,

$$\begin{aligned} COP_{HP,rev} &= \frac{T_H}{T_H - T_L} \\ &= \frac{273.15 + 24}{(273.15 + 24) - (273.15 + 0)} = 12.38 \\ \therefore COP_{HP,rev} &= \frac{\dot{Q}_H}{\dot{W}_{rev}} \end{aligned} \tag{6.5.20}$$

$$\therefore \dot{W}_{rev} = \frac{\dot{Q}_H}{COP_{HP,rev}} = \frac{20}{12.38} = 1.615 \text{ kW} \tag{6.5.21}$$

The actual cycle achieves a much smaller COP and consumes a much greater power than the Carnot cycle due to the irreversibilities.

3. Since  $COP_{HP,rev} = \frac{T_H}{T_H - T_L} = \frac{1}{1 - T_L/T_H}$

As  $T_H$  is a constant room temperature,  $COP_{HP,rev}$  will decrease if the outdoor temperature  $T_L$  decreases. Because the Carnot cycle always has the maximum COP compared to any real cycle operating between the same heat source and heat sink, the COP of a real heat pump will also decrease if the outdoor temperature decreases; therefore, heat pumps are preferably used in mild winter conditions.

**Media Attributions**

- Frictionless pendulum © Chetvornoderivative work: Py4nf is licensed under a [CC0 \(Creative Commons Zero\)](#) license
- Carnot heat engine © Andrew Ainsworth is licensed under a [CC BY-SA \(Attribution ShareAlike\)](#) license
- Carnot heat engine: P-v diagram © Cristian Quinzacara is licensed under a [CC BY-SA \(Attribution ShareAlike\)](#) license
- Carnot heat engine: T-s diagram © Cristian Quinzacara is licensed under a [CC BY-SA \(Attribution ShareAlike\)](#) license

This page titled [6.5: Carnot cycles](#) is shared under a [CC BY-NC-SA 4.0](#) license and was authored, remixed, and/or curated by [Claire Yu Yan \(BC Campus\)](#) via [source content](#) that was edited to the style and standards of the LibreTexts platform; a detailed edit history is available upon request.

## 6.6: Entropy and entropy generation

### 6.5.1 The inequality of Clausius

The inequality of Clausius states that for any cycle, reversible or irreversible, there exists the following relation:

$$\oint \frac{\delta Q}{T} \leq 0 \quad (\text{“=” for reversible cycles; “<” for irreversible cycles}) \quad (6.6.1)$$

where  $\delta Q$  represents the differential amount of heat transfer into or out of a system through an infinitesimal part of the system boundary.  $\delta Q$  is positive for heat transfer into the system and is negative for heat transfer out of the system.  $T$  is the absolute temperature at the infinitesimal part of the system boundary, where the heat transfer occurs. The cyclic integral symbol  $\oint$  indicates that the integration must be done for the entire cycle. In other words, all heat transfer into and out of the system, as well as their corresponding boundary temperatures, must be considered in the integral.

The inequality of Clausius applies to all cycles. We will prove it by using the heat engine cycle, [Figure 6.1.3](#), as an example. For a reversible heat engine cycle operating between a heat source at a constant temperature of  $T_H$  and a heat sink at a constant temperature of  $T_L$ , the cyclic integral can be written as

$$\oint \left( \frac{\delta Q}{T} \right)_{rev} = \left( \frac{Q_H}{T_H} \right)_{rev} + \left( \frac{-Q_L}{T_L} \right)_{rev} \quad (6.6.2)$$

Note that for a reversible cycle,

$$\left( \frac{T_H}{T_L} \right)_{rev} = \left( \frac{Q_H}{Q_L} \right)_{rev} \quad (6.6.3)$$

Therefore, the following equation exists for a reversible cycle.

$$\oint \left( \frac{\delta Q}{T} \right)_{rev} = 0 \quad (6.6.4)$$

For an irreversible cycle operating between the same two heat reservoirs at constant temperatures of  $T_H$  and  $T_L$ , we assume that the heat absorbed from the heat source,  $Q_H$ , remains the same as that in the reversible cycle,

$$\therefore Q_{H,rev} = Q_{H,irrev} = Q_H \quad (6.6.5)$$

$$\therefore Q_{L,rev} < Q_{L,irrev} \quad (6.6.6)$$

$$\therefore \left( \frac{Q_H}{Q_L} \right)_{irrev} < \left( \frac{Q_H}{Q_L} \right)_{rev} \quad (6.6.7)$$

$$\therefore \left( \frac{Q_H}{Q_L} \right)_{irrev} < \left( \frac{T_H}{T_L} \right)_{rev} \quad (6.6.8)$$

$$\therefore \left( \frac{Q_H}{T_H} \right)_{irrev} < \left( \frac{Q_L}{T_L} \right)_{irrev} \quad (6.6.9)$$

Therefore,

$$\oint \left( \frac{\delta Q}{T} \right)_{irrev} = \left( \frac{Q_H}{T_H} + \frac{-Q_L}{T_L} \right)_{irrev} = \left( \frac{Q_H}{T_H} \right)_{irrev} - \left( \frac{Q_L}{T_L} \right)_{irrev} < 0 \quad (6.6.10)$$

Now, we have proven the inequality of Clausius for heat engine cycles. A similar procedure may be applied to prove the inequality of Clausius for refrigerator and heat pump cycles.

### 6.5.2 Definition of entropy

Why is the inequality of Clausius important? The cyclic integral is either equal to or less than zero depending on the nature of the cycle: reversible or irreversible. The inequality of Clausius provides a basis for introducing the concepts of entropy and entropy generation. Both concepts are important in the second law of thermodynamics.

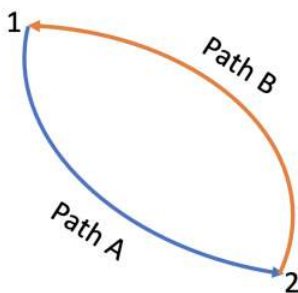

Figure 6.5.1 A reversible cycle consisting of path A and path B

Let us apply the inequality of Clausius to a reversible cycle consisting of two reversible processes 1→2 via path A and 2→1 via path B, see [Figure 6.5.1](#).

$$\begin{aligned} \therefore \oint \left( \frac{\delta Q}{T} \right)_{rev} &= \int_1^2 \left( \frac{\delta Q}{T} \right)_{pathA} + \int_2^1 \left( \frac{\delta Q}{T} \right)_{pathB} \\ &= \int_1^2 \left( \frac{\delta Q}{T} \right)_{pathA} - \int_1^2 \left( \frac{\delta Q}{T} \right)_{pathB} = 0 \end{aligned}$$

$$\therefore \int_1^2 \left( \frac{\delta Q}{T} \right)_{pathA} = \int_1^2 \left( \frac{\delta Q}{T} \right)_{pathB} \quad (6.6.11)$$

$$S \quad (6.6.12)$$

$$\Delta S = S_2 - S_1 = \int_1^2 \left( \frac{\delta Q}{T} \right)_{rev} \quad (6.6.13)$$

The infinitesimal change of entropy in a reversible process can thus be written as

$$dS = \left( \frac{\delta Q}{T} \right)_{rev} \quad (6.6.14)$$

where  $s$  is the entropy and  $T$  is the absolute temperature. The common SI units for entropy are kJ/K or J/K. It is important to note that entropy,  $S$ , is a state function;  $\Delta S$  in a process depends on the initial and final states, not on the path of the process.

Entropy is an extensive property; its corresponding intensive property is called specific entropy,  $s = \frac{S}{m}$ , and its common SI units are kJ/kgK or J/kgK.

### Example 1

Consider a reversible process and an irreversible process from states 1 to 2, as shown in the T-S diagram, [Figure 6.5.e1](#). Answer the following questions

- (1) Is the change in entropy,  $\Delta S$ , the same or different in these two processes?
- (2) Is it possible to show the heat transfer of the reversible process in the T-S diagram?
- (3) Is it possible to show the heat transfer of the irreversible process in the T-S diagram?

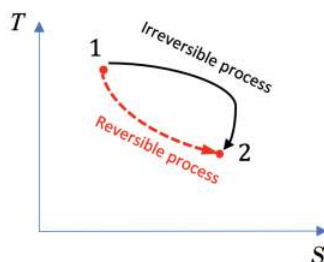

Figure 6.5.e1 T-S diagram for a reversible process and an irreversible process with the same initial and final states

Solution:

(1) Entropy is a state function. The two processes have the same initial and final states, therefore, the same  $\Delta S$ .

(2) From the definition of entropy, the heat transfer in the reversible process can be found from

$$Q_{rev} = \int_1^2 (\delta Q)_{rev} = \int_1^2 (T dS)_{rev} \quad (6.6.15)$$

This integral can be shown graphically as the shaded area under the  $T$ - $S$  curve of the reversible process, see [Figure 6.5.e2](#).

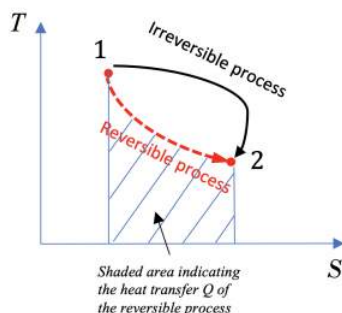

Figure 6.5.e2  $T$ - $S$  diagram: the shaded area represents the heat transfer of a reversible process.

(3) The heat transfer of the irreversible process cannot be simply calculated without additional information, and it cannot be shown in the  $T$ - $S$  diagram.

Example 2

A **reversible** process from states 1→2 in a piston-cylinder is shown in [Figure 6.5.e3](#). Determine whether the change in specific internal energy  $\Delta u = u_2 - u_1$ , specific work  $w$ , and specific heat transfer  $q$  are positive, zero, or negative.

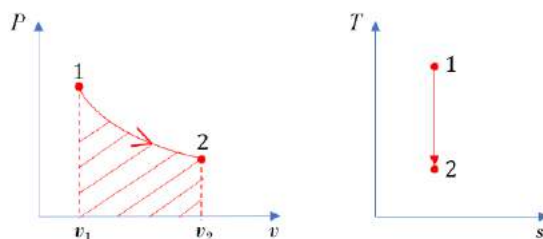

Figure 6.5.e3  $P$ - $v$  and  $T$ - $s$  diagrams of a reversible process

Solution:

The  $P$ - $v$  diagram shows an expansion process in the piston-cylinder. Its specific boundary work can be shown as the shaded area in the  $P$ - $v$  diagram, see [Figure 6.5.e3](#). It can also be expressed as

$${}_1w_2 = \int_1^2 P dv > 0 \quad (6.6.16)$$

From the definition of entropy,

$$dS = \left( \frac{\delta Q}{T} \right)_{rev} \quad (6.6.17)$$

The process is reversible; therefore,

$$(\delta Q)_{rev} = T dS \quad (6.6.18)$$

$$\therefore {}_1Q_2 = Q_{rev} = \int_1^2 (\delta Q)_{rev} = \int_1^2 T dS \quad (6.6.19)$$

The specific heat transfer is

$$\int_{s_1}^{s_2} q_2 = \int_{s_1}^{s_2} T ds$$

$$\int_{s_1}^{s_2} T ds$$

From the  $T-s$  diagram in Figure 6.5.e3,  $s_1 = s_2$ ; therefore,

$$\int_{s_1}^{s_2} T ds = 0 \quad (6.6.20)$$

The specific heat transfer in a reversible process can be shown graphically as the area under the process line in the  $T-s$  diagram.

Note: *this statement is only true for reversible processes; it is not valid for irreversible processes!*

Apply the first law of thermodynamics to the piston-cylinder (closed system),

$$\Delta u = q_2 - w_2 = 0 - w_2 < 0 \quad (6.6.21)$$

In conclusion, the reversible expansion process illustrated in the  $P-v$  and  $T-s$  diagrams in Figure 6.5.e3 has a positive boundary work and zero heat transfer (adiabatic). The specific internal energy decreases in the process.

### 6.5.3 Entropy generation, $S_{gen}$

Entropy generation is another important concept in the second law of thermodynamics. Let us consider a cycle consisting of two processes; process 2→1 is a reversible process and process 1→2 can be any process, either reversible or irreversible, see Figure 6.5.2. We will apply the definition of entropy and the inequality of Clausius in the following derivations.

$$\therefore \Delta S = S_2 - S_1 = \int_1^2 \left( \frac{\delta Q}{T} \right)_{rev} \quad (6.6.22)$$

$$\begin{aligned} \therefore \oint \frac{\delta Q}{T} &= \int_1^2 \left( \frac{\delta Q}{T} \right) + \int_2^1 \left( \frac{\delta Q}{T} \right)_{rev} \\ &= \int_1^2 \left( \frac{\delta Q}{T} \right) - \int_1^2 \left( \frac{\delta Q}{T} \right)_{rev} \\ &= \int_1^2 \left( \frac{\delta Q}{T} \right) - (S_2 - S_1) \leq 0 \end{aligned}$$

$$\therefore (S_2 - S_1) \geq \int_1^2 \left( \frac{\delta Q}{T} \right) \quad (6.6.23)$$

We may change the above inequality to an equation by introducing entropy generation,  $S_{gen} \geq 0$ , to the right side; therefore,

$$\Delta S = (S_2 - S_1) = \int_1^2 \left( \frac{\delta Q}{T} \right) + S_{gen} \quad (S_{gen} \geq 0) \quad (6.6.24)$$

This relation is valid for all processes with the “=” sign for reversible processes, and the “>” sign for irreversible processes. The differential form of the relation can be expressed as

$$dS = \frac{\delta Q}{T} + \delta S_{gen} \quad (\delta S_{gen} \geq 0) \quad (6.6.25)$$

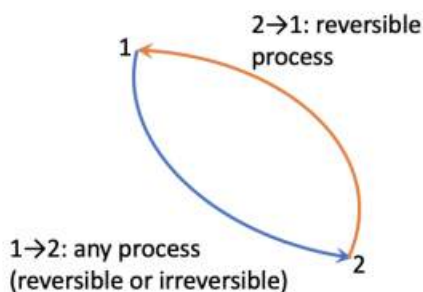

Figure 6.5.2 A cycle consisting of reversible and/or irreversible processes for introducing entropy generation

It is important to note that  $S_{gen}$  and  $\Delta S$  are different concepts.

- Entropy generation,  $S_{gen}$ , is a measure of the irreversibilities in a process.  $S_{gen}$  is NOT a property of the system. It depends on the path of a process; the more irreversible a process is, the larger  $S_{gen}$  is.
- Entropy  $s$  is a thermodynamic property of the system. It is a state function.  $\Delta S$  depends on the initial and final states only, not on the path of a process.
- In general,  $\Delta S \neq S_{gen}$ .  $\Delta S$  may be positive or negative, but  $S_{gen}$  must be positive for irreversible processes or zero for reversible processes.

Why is entropy generation important? how does it play a role in the universe? The universe is everything, including all the matter and energy that could possibly exist in all space and time. We may treat the universe as an isolated system because nothing exists outside the universe. From the entropy generation,  $S_{gen} \geq 0$ , we can prove that the entropy in the universe always increases due to the existence of irreversibilities in nature and in all human activities.

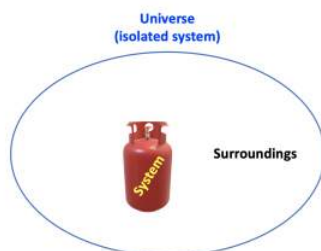

Figure 6.5.3 The universe as an isolated system

Let us define a system in the universe and everything outside the system boundary as the surroundings, see Figure 6.5.3. The change of entropy in the universe can be written as

$$\Delta S_{univ} = \Delta S_{sys} + \Delta S_{sur} \quad (6.6.26)$$

where  $\Delta S_{univ}$ ,  $\Delta S_{sys}$ , and  $\Delta S_{sur}$  represent the changes of entropy in the universe, the system, and its surroundings, respectively.

The change of entropy in the universe can be written in terms of entropy generation as

$$\Delta S_{univ} = \int_1^2 \left( \frac{\delta Q}{T} \right) + (S_{gen})_{univ} \quad (6.6.27)$$

Since the universe is an isolated system, heat transfer across the universe boundary  $Q = 0$ . In addition, since all real processes happening in the universe are irreversible, we can drop the “=” sign in the inequality; therefore,

$$(S_{gen})_{univ} = \Delta S_{univ} = \Delta S_{sys} + \Delta S_{sur} > 0 \quad (6.6.28)$$

The above relation indicates that the entropy generation in the universe is always a positive number due to the irreversibilities in all real processes. As a result, the entropy in the universe always increases. This concept can be expressed in a general format as follows if we divide the universe into a number of subsystems.

$$(S_{gen})_{univ} = \Delta S_{univ} = \Delta S_{sys,1} + \Delta S_{sys,2} + \dots + \Delta S_{sys,n} = \sum_{i=1}^n \Delta S_{sys,i} > 0 \quad (6.6.29)$$

where  $\Delta S_{sys,i}$  is the change of entropy in the subsystem,  $i$ , in the universe.

#### 6.5.4 The second law of thermodynamics expressed in terms of entropy generation, $S_{gen}$

The second law of thermodynamics was previously described with the Kelvin-Planck and Clausius statements. In fact, any device that violates the Kelvin-Planck or Clausius statements must have  $S_{gen} < 0$ .

Take a heat pump as an example. We may prove that any heat pump that violates the Clausius statement would have  $S_{gen} < 0$ . A heat pump that violates the Clausius statement would have  $Q_H = Q_L$  from the first law of thermodynamics, see Figure 6.5.4. Note that entropy is a state function. For the heat pump cycle, the initial and final states are the same; therefore,  $\Delta S = 0$ . The change of entropy in the heat pump cycle can be expressed as follows,

$$\because \Delta S = \int_1^2 \left( \frac{\delta Q}{T} \right) + S_{gen} = \frac{-Q_H}{T_H} + \frac{Q_L}{T_L} + S_{gen} = 0 \quad (6.6.30)$$



$$\therefore S_{gen} = \frac{Q_H}{T_H} - \frac{Q_L}{T_L} = Q_H \left( \frac{1}{T_H} - \frac{1}{T_L} \right) < 0 \quad (6.6.31)$$

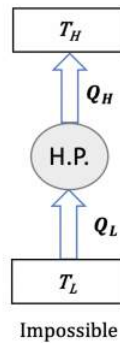

Figure 6.5.4 A heat pump violating the Clausius statement

Now, we have proven that any heat pump that violates the Clausius statement would have  $S_{gen} < 0$ . A similar procedure may be applied to prove that any heat engine that violates the Kelvin-Planck statement would have  $S_{gen} < 0$ .

In summary, the second law of thermodynamics requires that any process or cycle proceeds in the direction that obeys  $S_{gen} \geq 0$ , in which the “=” sign applies to the ideal Carnot cycles and the “>” sign applies to any real, irreversible cycles or processes.

- Actual, irreversible process or cycle:  $S_{gen} > 0$
- Carnot, reversible process or cycle:  $S_{gen} = 0$
- Impossible process or cycle:  $S_{gen} < 0$

This page titled [6.6: Entropy and entropy generation](#) is shared under a [CC BY-NC-SA 4.0](#) license and was authored, remixed, and/or curated by [Claire Yu Yan \(BC Campus\)](#) via [source content](#) that was edited to the style and standards of the LibreTexts platform; a detailed edit history is available upon request.

## 6.7: The second law of thermodynamics for closed systems

The change of entropy in a system is caused by entropy transfer and entropy generation.

$$\Delta \text{Entropy} = +\text{in} - \text{out} + \text{gen} \quad (6.7.1)$$

Entropy can be transferred to a system via two mechanisms: (1) heat transfer and (2) mass transfer. It is noted that work is a form of energy transfer; it does NOT contribute to entropy transfer!

For a closed system, entropy is transferred only by heat transfer, see [Figure 6.6.1](#); therefore, the second law of thermodynamics for a closed system undergoing a process from states 1 to 2 can be written as

$$S_2 - S_1 = \int_1^2 \frac{\delta Q}{T} + S_{gen} \cong \sum \frac{Q_k}{T_k} + S_{gen} \quad (S_{gen} \geq 0) \quad (6.7.2)$$

This equation is also referred to as the entropy balance equation for closed systems. The integral  $\int_1^2 \frac{\delta Q}{T}$  represents the entropy transfer caused by the heat transfer between the system and its surroundings (i.e., heat source and heat sink). Because this integral is difficult to calculate, a common practice is to approximate it with  $\sum \frac{Q_k}{T_k}$ , where  $Q_k$  is the heat transfer that takes place at location  $k$  of the system boundary, which has a constant temperature of  $T_k$ . If heat transfer occurs in multiple locations, all locations must be considered. Attention should be paid to  $T_k$ , which represents the temperature of the system boundary or the surroundings if the boundary and the surroundings are in thermal equilibrium.  $T_k$  is NOT the temperature of the system itself!

$$T_k = T_{reservoir} \quad (6.7.3)$$

$$T_k \neq T_{system} \quad (6.7.4)$$

The entropy balance equation is often used together with the first law of thermodynamics, thermodynamic tables (for real substances), or ideal gas equations (for ideal gases). We will demonstrate the applications of the entropy balance equation in [Section 6.8](#).

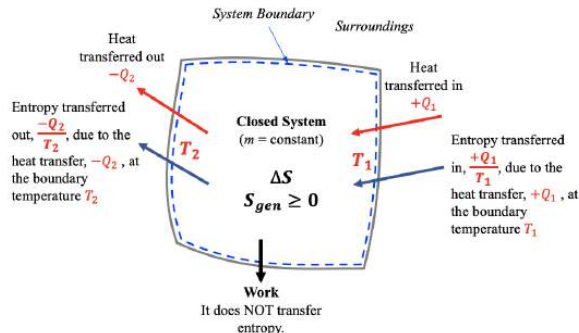

Figure 6.6.1 Entropy transferred into and out of a closed system due to heat transfer

This page titled [6.7: The second law of thermodynamics for closed systems](#) is shared under a [CC BY-NC-SA 4.0](#) license and was authored, remixed, and/or curated by [Claire Yu Yan \(BC Campus\)](#) via [source content](#) that was edited to the style and standards of the LibreTexts platform; a detailed edit history is available upon request.

## 6.8: Specific entropy of a state

### 6.7.1 Determining the specific entropy of pure substances by using thermodynamic tables

The specific entropy of a pure substance can be found from thermodynamic tables if the tables are available. The procedures are explained in Section 2.4. In addition to the  $P-v$  and  $T-v$  diagrams, the  $T-s$  diagram is commonly used to illustrate the relation between temperature and specific entropy of a pure substance. Figure 6.7.1 shows the  $T-s$  diagram for water.

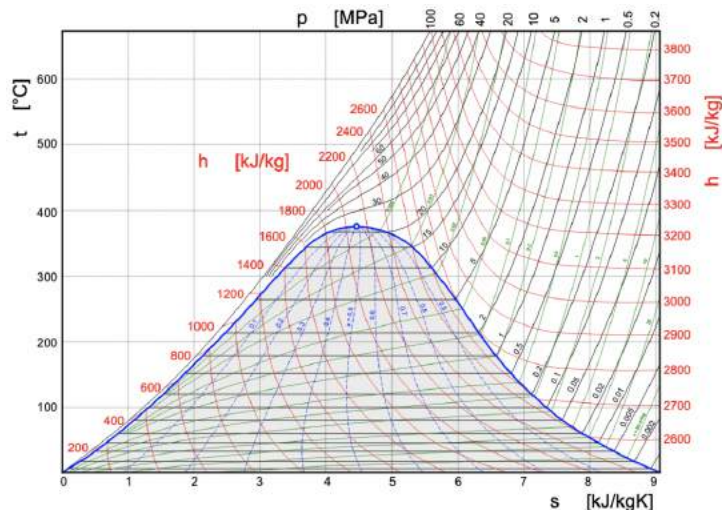

Figure 6.7.1 T-s diagram for water

#### Example 1

Fill in the table.

Substance	T, °C	P, kPa	v, m <sup>3</sup> /kg	Quality x	s, kJ/kg-K	Phase
Water	250		0.02			
R134a	-2	100				

#### Solution:

Water:  $T = 250\text{ °C}$ ,  $v = 0.02\text{ m}^3/\text{kg}$

From Table A1:  $T = 250\text{ °C}$ ,  $v_f = 0.001252\text{ m}^3/\text{kg}$ ,  $v_g = 0.050083\text{ m}^3/\text{kg}$

Since **Formula does not parse**, water at the given state is a two phase mixture; the saturation pressure is  $P_{sat} = 3976.17\text{ kPa}$ , and  $s_f = 2.7935\text{ kJ/kgK}$ ,  $s_g = 6.0721\text{ kJ/kgK}$

The quality is

$$x = \frac{v - v_f}{v_g - v_f} = \frac{0.02 - 0.001252}{0.050083 - 0.001252} = 0.383936 \quad (6.8.1)$$

The specific entropy is



R134a:  $T = -2\text{ °C}$ ,  $P = 100\text{ kPa}$

From Table C1: by examining the saturation pressures at 0 °C and -5 °C, we can estimate that the saturation pressure for  $T = -2$  °C is about 270 kPa; therefore, R134a at the given state is a superheated vapour.

From Table C2,

$$s \tag{6.8.2}$$

$$s \tag{6.8.3}$$

$$s \tag{6.8.4}$$

$$\therefore \frac{v - 0.207433}{0.2160303 - 0.207433} = \frac{s - 1.7986}{1.8288 - 1.7986} = \frac{-2 - (-10)}{0 - (-10)} \tag{6.8.5}$$

Formula does not parse and  $s = 1.8228$  kJ/kgK

In summary,

Substance	T	P kPa	v m <sup>3</sup> /kg	Quality x	s kJ/kg-K	Phase
Water	250	397.6	0.02	0.383936	4.0523	two-phase
R134a	-2	100	0.214529	n.a.	1.8228	superheated vapour

### Example 2

A rigid tank contains 3 kg of R134a initially at 0°C, 200 kPa. R134a is now cooled until its temperature drops to -20°C. Determine the change in entropy,  $\Delta s$ , of R134a during this process. Is  $\Delta S = S_{gen}$ ?

Solution:

The initial state is at  $T_1 = 0$ °C and  $P_1 = 200$  kPa. From Table C2 in Appendix C,

$$s_1 \tag{6.8.6}$$

The tank is rigid; therefore,  $v_2 = v_1 = 0.104811$  m<sup>3</sup>/kg.

From Table C1, at  $T_2 = -20$ °C:

$$v_f \tag{6.8.7}$$

$$s_f \tag{6.8.8}$$

Because Formula does not parse, the final state is a two-phase mixture.

$$x_2 = \frac{v_2 - v_f}{v_g - v_f} = \frac{0.104811 - 0.000736}{0.147395 - 0.000736} = 0.70964 \tag{6.8.9}$$



The total entropy change is

$$\Delta S = m(s_2 - s_1) = 3 \times (1.4971 - 1.7654) = -0.8049 \text{ kJ/K}$$

It is important to note that  $\Delta S \neq S_{gen}$  in general. The total entropy of R134a decreases in this cooling process, but the entropy generation is always greater than zero in a real process.

### 6.7.2 Determining the specific entropy of solids and liquids

The specific entropy of a solid or a liquid depends mainly on the temperature. The change of specific entropy in a process from states 1 to 2 can be calculated as,

$$s_2 - s_1 = C_p \ln \frac{T_2}{T_1} \quad (6.8.10)$$

where

$$s \quad (6.8.11)$$

$$C_p \quad (6.8.12)$$

$$T \quad (6.8.13)$$

### 6.7.3 Determining the specific entropy of ideal gases

The specific entropy of an ideal gas is a function of both temperature and pressure. Here we will introduce a simplified method for calculating the change of the specific entropy of an ideal gas in a process by assuming constant specific heats. This method is reasonably accurate for a process undergoing a small temperature change.

$$s_2 - s_1 = C_p \ln \frac{T_2}{T_1} - R \ln \frac{P_2}{P_1} \quad (6.8.14)$$

$$s_2 - s_1 = C_v \ln \frac{T_2}{T_1} + R \ln \frac{v_2}{v_1} \quad (6.8.15)$$

where

$$C_p \quad (6.8.16)$$

$$T \quad (6.8.17)$$

$$P \quad (6.8.18)$$

$$s \quad (6.8.19)$$

$$v \quad (6.8.20)$$

#### Example 3

Air is compressed from an initial state of 100 kPa, 27°C to a final state of 600 kPa, 67°C. Treat air as an ideal gas. Calculate the change of specific entropy,  $\Delta s$ , in this process. Is  $\Delta s = s_{gen}$ ?

Solution:

From [Table G1](#):  $C_p = 1.005 \text{ kJ/kgK}$ ,  $R = 0.287 \text{ kJ/kgK}$



It is important to note that  $\Delta s \neq s_{gen}$  in general. The specific entropy decreases in this process, but the rate of entropy generation is always greater than zero in a real process.

### 6.7.4 Isentropic relations for an ideal gas

If a process is reversible and adiabatic, it is called an **isentropic process** and its entropy remains constant. An isentropic process is an idealized process. It is commonly used as a basis for evaluating real processes. The concept of isentropic applies to all

substances including ideal gases. The following isentropic relations, however, are ONLY valid for ideal gases.

$$Pv^k = \text{constant} \quad (6.8.21)$$

where

$$k = \frac{C_p}{C_v} \quad (6.8.22)$$

$$T \quad (6.8.23)$$

$$P \quad (6.8.24)$$

$$v \quad (6.8.25)$$

It is noted that the isentropic relation  $Pv^k = \text{constant}$  for ideal gases is actually a special case of the polytropic relation  $Pv^n = \text{constant}$  with  $n = k = \frac{C_p}{C_v}$ .

#### Example 4

Derive the isentropic relation  $Pv^k = \text{constant}$

Solution:

For an ideal gas undergoing an isentropic process,

$$\Delta s = s_2 - s_1 = C_p \ln \frac{T_2}{T_1} - R \ln \frac{P_2}{P_1} = 0 \quad (6.8.26)$$

Substitute  $C_p = \frac{kR}{k-1}$  in the above equation and rearrange,

$$\therefore \frac{k}{k-1} \ln \frac{T_2}{T_1} = \ln \frac{P_2}{P_1} \quad (6.8.27)$$

$$\therefore \ln \left( \frac{T_2}{T_1} \right)^{\frac{k}{k-1}} = \ln \frac{P_2}{P_1} \quad (6.8.28)$$

$$\therefore \frac{P_2}{P_1} = \left( \frac{T_2}{T_1} \right)^{\frac{k}{k-1}} \quad (6.8.29)$$

Combine with the ideal gas law,  $Pv = RT$ ,

$$\therefore \frac{P_2}{P_1} = \left( \frac{T_2}{T_1} \right)^{\frac{k}{k-1}} = \left( \frac{P_2 v_2}{P_1 v_1} \right)^{\frac{k}{k-1}} \quad (6.8.30)$$

$$\therefore \frac{P_2}{P_1} = \left( \frac{v_1}{v_2} \right)^k \quad (6.8.31)$$

$$\therefore Pv^k = \text{constant} \quad (6.8.32)$$

#### Media Attributions

- T-s diagram for water © Kaboldy is licensed under a [CC BY-SA \(Attribution ShareAlike\)](https://creativecommons.org/licenses/by-sa/4.0/) license

This page titled [6.8: Specific entropy of a state](#) is shared under a [CC BY-NC-SA 4.0](https://creativecommons.org/licenses/by-nc-sa/4.0/) license and was authored, remixed, and/or curated by [Claire Yu Yan \(BC Campus\)](#) via [source content](#) that was edited to the style and standards of the LibreTexts platform; a detailed edit history is available upon request.

## 6.9: Applications of the second law of thermodynamics in closed systems

### 6.8 Applications of the second law of thermodynamics in closed systems

The first and second laws of thermodynamics are often used together with the thermodynamic tables or ideal gas equations in thermal analysis. The following strategy may be adapted when solving problems requiring the second law of thermodynamics:

1. Identify the process(es), e.g., isobaric, isothermal, isochoric, or isentropic process.
2. Determine the initial, final, and any intermediate states. Find the properties, such as,  $P, T, v, u, s$ , by using the thermodynamic tables or equations, e.g., for an ideal gas, solid, or liquid.
3. Determine the heat transfer,  $Q$ , or other unknowns by applying the first law of thermodynamics for closed systems.
4. Determine the entropy generation,  $S_{gen}$ , or other unknowns by applying the second law of thermodynamics for closed systems.

#### Example 1

A piston-cylinder contains ammonia at 2000 kPa, 80°C. The piston is loaded with a linear spring, see [Figure 6.8.e1](#). The outside ambient is at 15°C. The ammonia is now cooled down to saturated liquid at 15°C. Assuming the cylinder is always at the ambient temperature during the cooling process, determine the specific boundary work, the specific heat transfer, and the specific entropy generation in the process.

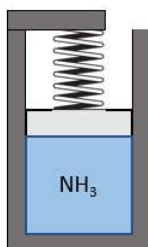

Figure 6.8.e1 A piston-cylinder device containing pressurized ammonia

#### Solution:

Analysis:

- Ammonia in the piston-cylinder device can be treated as a closed system.
- As the piston is loaded with a linear spring, the pressure of ammonia changes linearly with its specific volume, see the  $P-v$  diagram, [Figure 6.8.e2](#). Please refer to [example 5 in Section 4.3](#) for a detailed analysis. The specific boundary work can be found from

$${}_1w_2 = \int_1^2 P dv = \frac{1}{2}(P_1 + P_2)(v_2 - v_1) \quad (6.9.1)$$

- Apply both the first and second laws of thermodynamics to ammonia, we can then find the specific heat transfer and specific entropy generation.

The first law:  $\Delta u = {}_1q_2 - {}_1w_2$

The second law:  $\Delta s = \sum \frac{{}_1q_2}{T_{surr}} + s_{gen}$

- We will need to determine the following properties to complete the calculations.

State 1:  $P_1, v_1, u_1, s_1$

State 2:  $P_2, v_2, u_2, s_2$

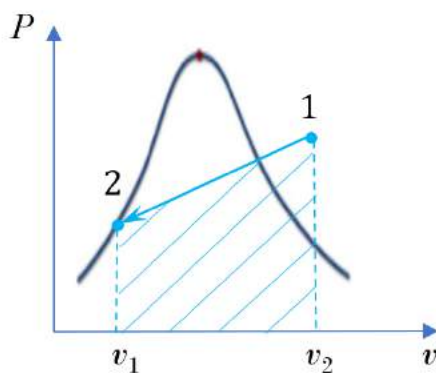

Figure 6.8.e2 P-v diagram of ammonia in a piston-cylinder device

Now let us solve the problem in detail.

From Table B1:  $T_1 = 80^\circ\text{C}$ ,  $P_{\text{sat}} = 4.14197 \text{ MPa}$ . Ammonia in state 1 is a superheated vapour because  $P_1 = 2000 \text{ kPa} = 2 \text{ MPa} < P_{\text{sat}}$ . From Table B2: for state 1 at  $T_1 = 80^\circ\text{C}$ ,  $P_1 = 2000 \text{ kPa}$ ,  $v_1 = 0.075952 \text{ m}^3/\text{kg}$ ,  $u_1 = 1583.81 \text{ kJ/kg}$ ,  $s_1 = 5.8292 \text{ kJ/kgK}$

$$u_2 \tag{6.9.2}$$

The specific boundary work is



The specific heat transfer is



The specific entropy generation is

$$\begin{aligned} s_{\text{gen}} &= \Delta s - \sum \frac{1q_2}{T_{\text{surr}}} \\ &= (s_2 - s_1) - \sum \frac{1q_2}{T_{\text{surr}}} \\ &= (1.7197 - 5.8292) - \frac{-1273.16}{(273.15 + 15)} = 0.3089 \text{ kJ/kgK} > 0 \end{aligned}$$

Comment:

- The cooling process is irreversible; therefore, the specific entropy generation,  $s_{\text{gen}} > 0$ .
- When applying the second law of thermodynamics, it is important to note that  $T_{\text{surr}}$  is the absolute temperature (in Kelvin) of the system boundary or the surroundings if the boundary is in thermal equilibrium with the surroundings.

**Example 2**

Three kilograms of  $\text{CO}_2$  at 150 kPa, 300 K is mixed with two kilograms of  $\text{CO}_2$  at 220 kPa, 500 K, in a rigid, well-insulated tank, see Figure 6.8.e3. Find the final state ( $P$ ,  $T$ ) and the entropy generation in this process. Assume  $\text{CO}_2$  is an ideal gas in this mixing process.

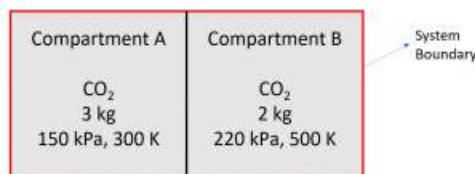

Figure 6.8.e3 A rigid tank with two compartments containing  $\text{CO}_2$

Solution:

Analysis:

- $\text{CO}_2$  in the whole tank can be treated as a closed system.



- The mixing occurs after the partition is removed. As the tank is well-insulated, the heat transfer between the system and the surroundings is zero in this mixing process: **Formula does not parse**
- Since the tank is rigid, the total volume of CO<sub>2</sub> remains constant; therefore, the boundary work is zero in the mixing process: **Formula does not parse**
- Apply the first law to the system (whole tank)

$$\Delta U = {}_1Q_2 - {}_1W_2 = 0 \quad (6.9.3)$$

- The entropy generation can be found by applying the second law to the system.

\[because \Delta S = \sum \frac{Q}{T\_{surr}} + S\_{gen}\]

\[T\_{surr}\} + S\_{gen}\]

$$\therefore S_{gen} = \Delta S \quad (6.9.4)$$

- To complete the calculation, we will apply the ideal gas relations to determine the final pressure, temperature,  $\Delta u$ , and  $\Delta s$ .

Now let us solve the problem in detail.

From [Table G1](#) for CO<sub>2</sub>:  $R = 0.1889$  kJ/kgK,  $C_p = 0.846$  kJ/kgK,  $C_v = 0.657$  kJ/kgK.

First, the volumes of compartments A and B at the initial state, state 1, can be found from the ideal gas law.

$$\therefore PV = mRT \quad (6.9.5)$$

$$\therefore V_A = \frac{m_{1A}RT_{1A}}{P_{1A}} = \frac{3 \times 0.1889 \times 300}{150} = 1.1334 \text{ m}^3 \quad (6.9.6)$$

$$\therefore V_B = \frac{m_{1B}RT_{1B}}{P_{1B}} = \frac{2 \times 0.1889 \times 500}{220} = 0.8586 \text{ m}^3 \quad (6.9.7)$$

The total volume of the tank is

$$V_{tot} = V_A + V_B = 1.1334 + 0.8586 = 1.992 \text{ m}^3 \quad (6.9.8)$$

Next, the final temperature can be calculated by applying the first law to the whole tank. Note that the tank is rigid and well insulated; therefore,  $\Delta U = 0$ .

$$\therefore \Delta U = (m_{1A} + m_{1B})u_2 - (m_{1A}u_{1A} + m_{1B}u_{1B}) = 0 \quad (6.9.9)$$

$$\therefore m_{1A}(u_2 - u_{1A}) + m_{1B}(u_2 - u_{1B}) = 0 \quad (6.9.10)$$

$$\therefore m_{1A}C_v(T_2 - T_{1A}) + m_{1B}C_v(T_2 - T_{1B}) = 0 \quad (6.9.11)$$

$$\begin{aligned} \therefore T_2 &= \frac{m_{1A}T_{1A} + m_{1B}T_{1B}}{m_{1A} + m_{1B}} \\ &= \frac{3 \times 300 + 2 \times 500}{3 + 2} = 380 \text{ K} \end{aligned}$$

Then, the final pressure can be determined from the ideal gas law.

$$\begin{aligned} P_2 &= \frac{(m_{1A} + m_{1B})RT_2}{V_{tot}} \\ &= \frac{(3 + 2) \times 0.1889 \times 380}{1.992} = 180.17 \text{ kPa} \end{aligned}$$

Last, the entropy generation can be calculated from the second law.

$$\begin{aligned} S_{gen} &= \Delta S \\ &= (m_{1A} + m_{1B})s_2 - (m_{1A}s_{1A} + m_{1B}s_{1B}) \\ &= m_{1A}(s_2 - s_{1A}) + m_{1B}(s_2 - s_{1B}) \end{aligned}$$

**Formula does not parse** \ 0\end{align\*}">





Comment:

The entropy in a process can increase or decrease. In this example, the entropy of CO<sub>2</sub> originally in compartment A increases and the entropy of CO<sub>2</sub> originally in compartment B decreases in this mixing process, but the entropy generation  $S_{gen} \geq 0$  because the mixing process is irreversible.

---

This page titled [6.9: Applications of the second law of thermodynamics in closed systems](#) is shared under a [CC BY-NC-SA 4.0](#) license and was authored, remixed, and/or curated by [Claire Yu Yan \(BC Campus\)](#) via [source content](#) that was edited to the style and standards of the LibreTexts platform; a detailed edit history is available upon request.

## 6.10: The second law of thermodynamics for open systems

Entropy can be transferred to a system via two mechanisms: (1) heat transfer and (2) mass transfer. For open systems, the second law of thermodynamics is often written in the rate form; therefore, we are interested in the time rate of entropy transfer due to heat transfer and mass transfer.

$$\dot{S}_{heat} = \frac{dS_{heat}}{dt} \cong \sum \frac{\dot{Q}_k}{T_k} \quad (6.10.1)$$

$$\dot{S}_{mass} = \sum \frac{dS_{mass}}{dt} = \sum \dot{m}_k s_k \quad (6.10.2)$$

where

$$\dot{m} \quad (6.10.3)$$

$$\dot{Q}_k \quad (6.10.4)$$

$$\dot{S}_{heat} \quad (6.10.5)$$

$$\dot{S}_{mass} \quad (6.10.6)$$

$$s_k \quad (6.10.7)$$

Applying the entropy balance equation,  $\Delta_{entropy} = +in - out + gen$ , to a control volume, see [Figure 6.9.1](#), we can write the following equations:

- General equation for both steady and transient flow devices

$\left[ \sum \frac{\dot{Q}_k}{T_k} + \sum \dot{m}_k s_k - \sum \dot{m}_k s_k + \dot{S}_{gen} \right]_{cv} = 0$

$\left[ \sum \frac{\dot{Q}_k}{T_k} + \sum \dot{m}_k s_k - \sum \dot{m}_k s_k + \dot{S}_{gen} \right]_{cv} = 0$

- For steady-state, steady-flow devices,  $\frac{dS_{c.v.}}{dt} = 0$ ; therefore,

$\sum \frac{\dot{Q}_k}{T_k} + \sum \dot{m}_k s_k - \sum \dot{m}_k s_k + \dot{S}_{gen} = 0$

$\sum \frac{\dot{Q}_k}{T_k} + \sum \dot{m}_k s_k - \sum \dot{m}_k s_k + \dot{S}_{gen} = 0$

- For steady and isentropic flow devices,  $\dot{Q}_{c.v.} = 0$  and  $\dot{S}_{gen} = 0$ ; therefore,

$\sum \dot{m}_k s_k - \sum \dot{m}_k s_k = 0$

$\sum \dot{m}_k s_k - \sum \dot{m}_k s_k = 0$

where

$$\dot{m} \quad (6.10.8)$$

$$\dot{Q}_{c.v.} \quad (6.10.9)$$

$$S_{c.v.} \quad (6.10.10)$$

$\left[ \sum \frac{\dot{Q}_k}{T_k} + \sum \dot{m}_k s_k - \sum \dot{m}_k s_k + \dot{S}_{gen} \right]_{cv} = 0$

$\left[ \sum \frac{\dot{Q}_k}{T_k} + \sum \dot{m}_k s_k - \sum \dot{m}_k s_k + \dot{S}_{gen} \right]_{cv} = 0$

$$\dot{S}_{gen} \quad (6.10.11)$$

$$s \quad (6.10.12)$$

$$T \quad (6.10.13)$$

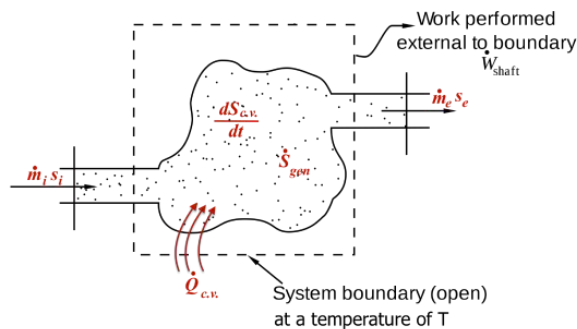

Figure 6.9.1 Flow through a control volume, showing the entropy transfers and entropy generation

Example 1

The diagrams in Figure 6.9.e1 show a reversible process in a steady-state, single flow of air. The letters *i* and *e* represent the initial and final states, respectively. Treat air as an ideal gas and assume  $\Delta KE = \Delta PE = 0$ . Are the change in specific enthalpy  $\Delta h = h_e - h_i$ , specific work *w*, and specific heat transfer *q* positive, zero, or negative values? What is the relation between *w* and *q*?

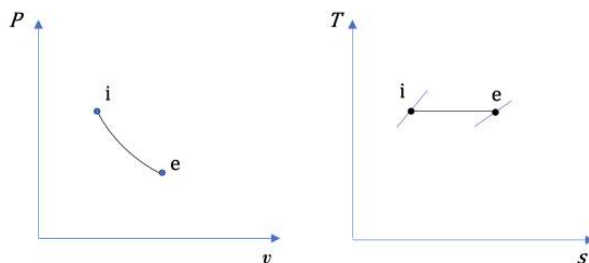

Figure 6.9.e1 T-s and P-v diagrams of a reversible process for an ideal gas

Solution:

The specific work can be evaluated mathematically and graphically.

(1) Mathematically,

$$\because v_e > v_i \tag{6.10.14}$$

$$\therefore w = \int_i^e P dv > 0 \tag{6.10.15}$$

(2) Graphically, the specific work is the area under the process curve in the *P-v* diagram; therefore *w* is positive, see Figure 6.9.e2.

In a similar fashion, the specific heat transfer can also be evaluated graphically and mathematically.

(1) Graphically,

$$\because ds = \left( \frac{\delta q}{T} \right)_{rev} \tag{6.10.16}$$

$$\therefore q_{rev} = \int_i^e T ds = T(s_e - s_i) > 0 \tag{6.10.17}$$

For a reversible process, the area under the process curve in the *T-s* diagram represents the specific heat transfer of the reversible process; therefore *q* = *q<sub>rev</sub>* is positive, see Figure 6.9.e2.

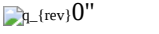
(2) The same conclusion,  class="latex mathjax" title="q\_{rev}>0" src="/@api/deki/files/59236/d00f283ba44c47860e35c0b010cd6fb7.png"/>, can also be derived from the second law of thermodynamics mathematically, as follows.

$$\dot{m}(s_e - s_i) = \sum \frac{\dot{Q}}{T_{surr}} + \dot{S}_{gen} \quad (6.10.18)$$

For a reversible process,  $\dot{S}_{gen} = 0$ , and the fluid is assumed to be always in thermal equilibrium with the system boundary, or  $T = T_{surr}$ ; therefore,

$$q_{rev} = \frac{\dot{Q}}{\dot{m}} = T(s_e - s_i) > 0 \quad (6.10.19)$$

The change in specific enthalpy can then be evaluated. For an ideal gas,

$$\Delta h = h_e - h_i = C_p(T_e - T_i) \quad (6.10.20)$$

$$\because T_e = T_i \quad (6.10.21)$$

$$\therefore h_e = h_i \quad (6.10.22)$$

Now, we can determine the relation between  $w$  and  $q_{rev}$  from the first law of thermodynamics for control volumes.

$$\because \dot{m}(h_e - h_i) = \dot{Q}_{rev} - \dot{W} = 0 \quad (6.10.23)$$

$$\therefore \dot{Q}_{rev} = \dot{W} \quad (6.10.24)$$

$$\therefore q_{rev} = w \quad (6.10.25)$$

In this reversible process, the specific heat transfer and specific work must be the same. Graphically, the two areas under the  $P-v$  and  $T-s$  diagrams must be the same.

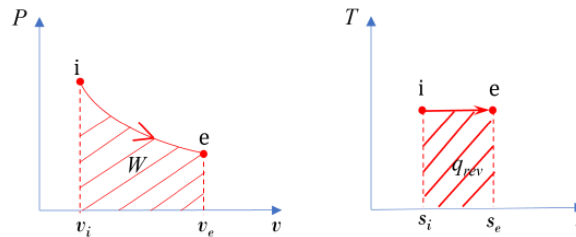

Figure 6.9.e2 T-s and P-v diagrams, showing the solutions for a reversible process of an ideal gas

#### Media Attributions

- Entropy transfers and entropy generation through a C.V. © Pbroks13 is licensed under a [Public Domain](#) license

This page titled [6.10: The second law of thermodynamics for open systems](#) is shared under a [CC BY-NC-SA 4.0](#) license and was authored, remixed, and/or curated by [Claire Yu Yan \(BC Campus\)](#) via [source content](#) that was edited to the style and standards of the LibreTexts platform; a detailed edit history is available upon request.

## 6.11: Applications of the second law of thermodynamics in open systems

When solving problems in a control volume, the first and second laws of thermodynamics are often used together with the continuity equation and the thermodynamic tables or the ideal gas equation. The following strategy may be adapted:

1. Set up a proper control volume to enclose the device of interest and identify the flow condition, i.e., steady or transient flow, through the control volume.
2. Determine the relations among the mass flow rates at the inlet(s) and outlet(s) by using the continuity equation.
3. Find the fluid properties at the inlet(s) and outlet(s), such as,  $P, T, v, h, s$ , by using the thermodynamic tables or equations, e.g., for an ideal gas, solid or liquid.
4. Determine the rate of heat transfer,  $\dot{Q}$ , or other unknowns by applying the first law of thermodynamics for open systems;
5. Determine the rate of entropy generation,  $\dot{S}_{gen}$ , or other unknowns by applying the second law of thermodynamics for open systems.

### Example 1

Steam is used to provide heating to air in a building through a well-insulated heat exchanger, see [Figure 6.10.e1](#).

- Saturated steam at 100°C enters the heat exchanger at a mass flow rate of 0.5 kg/s and leaves the heat exchanger as a saturated liquid at 100°C
- Air enters the heat exchanger at 5°C, 101 kPa, and leaves at 25°C, 101 kPa.

Assume air is an ideal gas. Determine the mass flow rate of air and  $\dot{S}_{gen}$  in this process.

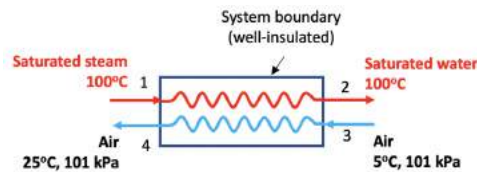

Figure 6.10.e1 Well-insulated heat exchanger

### Solution:

#### Analysis

- The mass flow rate of air can be found by using the first law of thermodynamics

$$\therefore \dot{m}_w(h_1 - h_2) = \dot{m}_a(h_4 - h_3) = \dot{m}_a C_p(T_4 - T_3) \quad (6.11.1)$$

$$\therefore \dot{m}_a = \dot{m}_w \frac{h_1 - h_2}{C_p(T_4 - T_3)} \quad (6.11.2)$$

- The rate of entropy generation can be found by using the second law of thermodynamics. Note that the heat exchanger is well-insulated.

$$\therefore \sum \dot{m}_e s_e - \sum \dot{m}_i s_i = \sum \frac{\dot{Q}_k}{T_k} + \dot{S}_{gen} \quad (6.11.3)$$

$$\begin{aligned} \therefore \dot{S}_{gen} &= \sum \dot{m}_e s_e - \sum \dot{m}_i s_i \\ &= (\dot{m}_w s_2 + \dot{m}_a s_4) - (\dot{m}_w s_1 + \dot{m}_a s_3) \\ &= \dot{m}_w(s_2 - s_1) + \dot{m}_a(s_4 - s_3) \end{aligned}$$

- The following properties are needed in order to complete the calculations:

- For the steam-water stream:  $h_1, h_2, s_1, s_2$
- For the air stream:  $s_3, s_4$

Now, let us solve the problem in detail.

From [Table A1](#), we can find the specific enthalpies and specific entropies of the saturated steam and saturated liquid water at 100°C.

$$h_1 = h_g = 2675.57 \text{ kJ/kg}, h_2 = h_f = 419.17 \text{ kJ/kg}$$

$$s_1 = s_g = 7.3541 \text{ kJ/kgK}, s_2 = s_f = 1.3072 \text{ kJ/kgK}$$

From Table G1 for air:  $C_p = 1.005 \text{ kJ/kgK}$ ,  $R = 0.287 \text{ kJ/kgK}$

$$\therefore s_4 - s_3 = C_p \ln \frac{T_4}{T_3} - R \ln \frac{P_4}{P_3} \quad (6.11.4)$$

$$\therefore s_4 - s_3 = 1.005 \ln \frac{273.15 + 25}{273.15 + 5} = 0.06978 \text{ kJ/kgK}$$

Now, we can complete the calculations. The mass flow rate of air is



The rate of entropy generation is

$$\begin{aligned} \dot{S}_{gen} &= \dot{m}_w(s_2 - s_1) + \dot{m}_a(s_4 - s_3) \\ &= 0.5 \times (1.3072 - 7.3541) + 56.13 \times 0.06978 \\ &= 0.8934 \text{ kW/K} > 0 \end{aligned}$$

Comment:

The heat transfer process is irreversible; therefore, the rate of entropy generation is greater than zero.

### Example 2

R134a at 300 kPa, 20°C is heated to 50°C isobarically in a heat exchanger. The mass flow rate of R134a is 1.5 kg/s. The heat at a rate of  $\dot{Q}_H$  is supplied by a heat pump, which absorbs heat at a rate of  $\dot{Q}_L$  from the ambient at 280 K, see Figure 6.10.e2. If  $COP_{HP} = 5$ , and there is no heat loss in the heat exchanger, find the power input,  $\dot{W}_{HP}$ , and the rate of heat transfer,  $\dot{Q}_L$ . Is this setup consisting of the heat exchanger and heat pump possible?

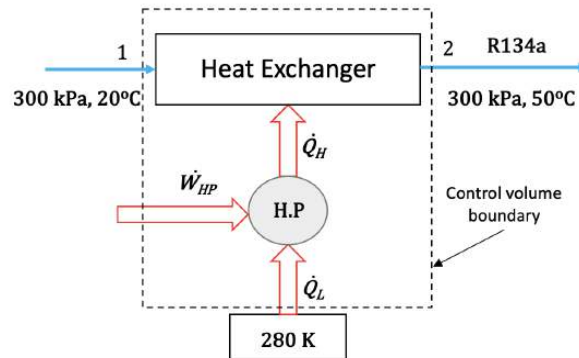

Figure 6.10.e2 A device consisting of a heat exchanger and a heat pump

### Solution:

The control volume is set up to enclose both the heat pump and heat exchanger, as shown in Figure 6.10.e2.

From Table C1, we can tell that, at the given pressures and temperatures, R134a remains a superheated vapour at both the inlet and the outlet of the heat exchanger. The specific enthalpies and specific entropies of R134a can be found in Table C2.

- At the inlet,  $P_1 = 300 \text{ kPa}$ ,  $T_1 = 20^\circ\text{C}$ ; therefore,  $h_1 = 416.24 \text{ kJ/kg}$ ,  $s_1 = 1.7876 \text{ kJ/kgK}$
- At the outlet,  $P_2 = 300 \text{ kPa}$ ,  $T_2 = 50^\circ\text{C}$ ; therefore,  $h_2 = 443.31 \text{ kJ/kg}$ ,  $s_1 = 1.8755 \text{ kJ/kgK}$

Apply the first law of thermodynamics to the control volume.

$$\dot{m}h_1 + \dot{Q}_L + \dot{W}_{HP} = \dot{m}h_2 \quad (6.11.5)$$

For the heat pump

$$COP_{HP} = \frac{\dot{Q}_H}{\dot{W}_{HP}} \quad (6.11.6)$$

Combine the above three relations, we can derive

$$\begin{aligned}\dot{W}_{HP} &= \frac{\dot{m}(h_2 - h_1)}{COP_{HP}} \\ &= \frac{1.5 \times (443.31 - 416.24)}{5} = 8.121 \text{ kW}\end{aligned}$$

$$\begin{aligned}\dot{Q}_L &= (COP_{HP} - 1)\dot{W}_{HP} \\ &= (5 - 1) \times 8.121 = 32.484 \text{ kW}\end{aligned}$$

Apply the second law of thermodynamics to the control volume.

$$\therefore \dot{m}(s_2 - s_1) = \sum \frac{\dot{Q}_k}{T_k} + \dot{S}_{gen} \quad (6.11.7)$$

$$\begin{aligned}\therefore \dot{S}_{gen} &= \dot{m}(s_2 - s_1) - \frac{\dot{Q}_L}{T_{surr}} \\ &= 1.5 \times (1.8755 - 1.7876) - \frac{32.484}{280} = 0.0158 \text{ kW/K} > 0\end{aligned}$$

Comment:

The rate of entropy generation in this control volume (consisting of both heat exchanger and heat pump) is positive; therefore, it is very likely that this setup can work in reality, and the processes in the heat exchanger and heat pump are irreversible.

To further verify this, we can calculate the rate of entropy generation for each individual device, i.e., heat exchanger and heat pump, separately. However, with the given information, there exists a challenge to evaluate the amount of entropy transfer due to

the heat transfer provided by the heat pump to the heat exchanger. Strictly speaking,  $\int \frac{\dot{Q}}{T_b}$  should be evaluated because the temperature of the heat exchanger varies, leading to a possible variation of temperature,  $T_b$ , at the boundary between the heat pump and the heat exchanger. The relation between the instantaneous rate of heat transfer from the heat pump to the heat exchanger,  $\dot{Q}$ , and the boundary temperature,  $T_b$ , must be obtained to enable a detailed analysis.

Here, let us perform a simplified calculation to demonstrate the concept. Assume that  $T_b$  remains constant as the average temperature between the inlet and the outlet of the heat exchanger, thus  $T_b = 35^\circ\text{C} = 308.15 \text{ K}$ .

Apply the second law of thermodynamics to the heat pump. Note that  $\dot{Q}_H = \dot{Q}_L + \dot{W}_{HP}$ , and  $\Delta s = 0$  for the heat pump cycle.

$$\begin{aligned}\dot{S}_{gen,HP} &= \dot{m}\Delta s - \frac{\dot{Q}_L}{T_{surr}} + \frac{\dot{Q}_H}{T_b} \\ &= 0 - \frac{32.484}{280} + \frac{32.484 + 8.121}{308.15} = 0.015755 \text{ kW/K} > 0\end{aligned}$$

Furthermore, the  $COP$  of the Carnot cycle operating between the heat sink of 280 K and the heat source of 308.15 K is

$$COP_{HP,rev} = \frac{308.15}{308.15 - 280} = 10.9 > 5 = COP_{HP} \quad (6.11.8)$$

Because  $\dot{S}_{gen,HP} > 0$  and  $COP_{HP} < COP_{HP,rev}$ , this heat pump cycle is an irreversible, realistic cycle.

Similarly, let us apply the second law of thermodynamics to the heat exchanger.



Because  $\dot{S}_{gen,HE} \approx 0$ , the process in this heat exchanger is almost ideal and reversible. It is noted that heat losses are typically unavoidable in real devices, but they are not considered in this example. Due to heat losses from the heat exchanger, the real process will have  $\dot{S}_{gen,HE} > 0$ . Consequently, the outlet temperature may not be able to reach  $50^\circ\text{C}$ .

### Example 3

Consider an adiabatic two-stage compressor having an intercooler, as shown in [Figure 6.10.e3](#).



- Air at 10°C, 101 kPa enters the first stage of the compressor and is compressed to 300 kPa, 150°C.
- After being cooled to 30°C in a well-insulated intercooler, the air then enters the second stage cylinder and is compressed to 900 kPa.

Assume that (1) the pressure drop in the intercooler is negligible, (2) air is an ideal gas, and (3) the two compression processes are polytropic with the same polytropic exponent. Determine

1. The total specific work of the two-stage compressor.
2. The specific entropy generation in each of the two stages.
3. The total specific entropy generation in the system consisting of the two-stage compressor and the intercooler, assuming a constant temperature of 30°C at the system boundary.
4. Assume there is no intercooler. The air from the first stage enters directly to the second stage and is compressed to 900 kPa, what is the air temperature at the exit of the second stage? What is the total specific work of the compressor? Assume the polytropic exponent remains the same in both stages.

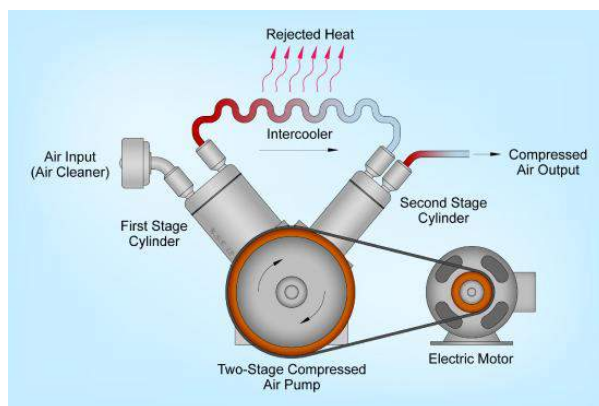

Figure 6.10.e3 Two stage compressor with an intercooler

Solution:

(1) Assume air is an ideal gas. From Table G1 for air:  $R = 0.287$  kJ/kgK,  $C_p = 1.005$  kJ/kgK.

The compressor is adiabatic with the following inlet and outlet conditions for each stage:

- Stage 1
  - Inlet  $P_1 = 101$  kPa,  $T_1 = 10^\circ\text{C}$
  - Outlet  $P_2 = 300$  kPa,  $T_2 = 150^\circ\text{C}$

Therefore, the specific work of stage 1 is



The polytropic exponent can be found by combining the polytropic relation and the ideal gas law.

$$\therefore P_1 v_1^n = P_2 v_2^n \tag{6.11.9}$$

$$\therefore \frac{P_2}{P_1} = \left( \frac{T_2}{T_1} \right)^{\frac{n}{n-1}} \tag{6.11.10}$$

$$\begin{aligned} \therefore n &= \frac{\ln \frac{P_2}{P_1}}{\ln \left( \frac{P_2 T_1}{P_1 T_2} \right)} \\ &= \frac{\ln \frac{300}{101}}{\ln \left[ \frac{300 \times (273.15 + 10)}{101 \times (273.15 + 150)} \right]} = 1.58486 \end{aligned}$$

- Stage 2

- Inlet  $P_3 = 300 \text{ kPa}$ ,  $T_3 = 30^\circ\text{C}$
- Outlet  $P_4 = 900 \text{ kPa}$

The air temperature at the outlet of stage 2 can be found from the polytropic relation.

$$\begin{aligned} \therefore \frac{P_4}{P_3} &= \left(\frac{T_4}{T_3}\right)^{\frac{n}{n-1}} & (6.11.11) \\ \therefore T_4 &= T_3 \left(\frac{P_4}{P_3}\right)^{\frac{n-1}{n}} \\ &= (273.15 + 30) \times \frac{900}{300}^{\frac{1.58486 - 1}{1.58486}} \\ &= 454.7 \text{ K} = 181.56^\circ\text{C} \end{aligned}$$

Therefore, the specific work of stage 2 is



The total specific work of the two stage compressor is

$$w_{tot} = w_1 + w_2 = 140.7 + 152.31 = 293 \text{ kJ/kg}$$

(2) Both stages are adiabatic; therefore, for each stage

$$\therefore \dot{m}(s_e - s_i) = \sum \frac{\dot{Q}_k}{T_k} + \dot{S}_{gen} \quad (6.11.12)$$

$$\therefore s_{gen} = \frac{\dot{S}_{gen}}{\dot{m}} = s_e - s_i = C_p \ln \frac{T_e}{T_i} - R \ln \frac{P_e}{P_i} \quad (6.11.13)$$

For stage 1,



For stage 2,



(3) To calculate the total specific entropy generation in the system consisting of the compressor and the heat exchanger, we can set up the control volume as shown in [Figure 6.10.e4](#).

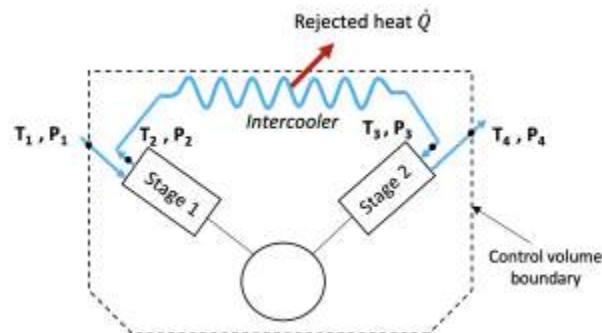

Figure 6.10.e4 Schematic of a two-stage compressor with an intercooler

The specific heat transfer rejected from the cooler to the surroundings is



Apply the second law of thermodynamics to the control volume as outlined in [Figure 6.10.e4](#), we can find the total specific entropy generation.

$$\therefore \dot{m}(s_e - s_i) = \sum \frac{\dot{Q}_k}{T_k} + \dot{S}_{gen} \quad (6.11.14)$$

$$\therefore \dot{m}(s_4 - s_1) = \frac{-\dot{Q}}{T_{surr}} + \dot{S}_{gen} \quad (6.11.15)$$

$$\therefore s_{gen} = \frac{\dot{S}_{gen}}{\dot{m}} = (s_4 - s_1) - \frac{-q}{T_{surr}} \quad (6.11.16)$$

Since



Therefore, the total specific entropy generation is

$$\begin{aligned} s_{gen} &= (s_4 - s_1) - \frac{-q}{T_{surr}} \\ &= -0.1517 + \frac{120.6}{(273.15 + 30)} = 0.246 \text{ kJ/kgK} > 0 \end{aligned}$$

Comment:

Compare the results from part (2) and part (3),  $s_{gen,1} + s_{gen,2} > s_{gen,1} + s_{gen,2}$ , because the heat transfer process in the heat exchanger is irreversible and generates additional entropy.

(4) If the air is directly compressed from  $P_1 = 101 \text{ kPa}$  to  $P_4 = 900 \text{ kPa}$  in a polytropic process with  $n = 1.58486$ , then its final temperature at the exit of stage 2 will be

$$\begin{aligned} \therefore \frac{P_4}{P_1} &= \left( \frac{T_4'}{T_1} \right)^{\frac{n}{n-1}} \\ \therefore T_4' &= T_1 \left( \frac{P_4}{P_1} \right)^{\frac{n-1}{n}} \\ &= (273.15 + 10) \left( \frac{900}{101} \right)^{\frac{0.58486}{1.58486}} \\ &= 634.7 \text{ K} = 361.5^\circ \text{C} \end{aligned} \quad (6.11.17)$$

The specific work of the compressor will be

$$w_{tot'} = C_p(T_4' - T_1) = 1.005 \times (361.5 - 10) = 353.3 \text{ kJ/kg}$$

Comment:

Intercoolers are commonly used in multiple-stage compressors. Without intercoolers, the air temperature in the compressor may increase significantly, which may reduce the efficiency of the compressor. In addition, by comparing the specific work in part 1 and part 4,  $w_{tot'} > w_{tot}$ , it is apparent that without intercoolers, the compressor will need to consume much more power in order to achieve the same final pressure.

### Media Attributions

- Two stage compressor with intercooler © Brian S. Elliott is licensed under a [CC BY-SA \(Attribution ShareAlike\)](#) license

This page titled [6.11: Applications of the second law of thermodynamics in open systems](#) is shared under a [CC BY-NC-SA 4.0](#) license and was authored, remixed, and/or curated by [Claire Yu Yan \(BC Campus\)](#) via [source content](#) that was edited to the style and standards of the LibreTexts platform; a detailed edit history is available upon request.

## 6.12: Chapter review

---

In this chapter, we have introduced two statements of the second law of thermodynamics including the Kelvin-Planck statement and the Clausius statement, and the ideal model of Carnot cycles. These concepts establish a theoretical foundation for evaluating the best possible performance, in terms of the thermal efficiency or COP, of heat engines, refrigerators, or heat pumps operating between two heat reservoirs.

The second law of thermodynamics can be expressed in terms of entropy generation. Due to the existence of irreversibilities, a real process or cycle always proceeds in the direction that obeys  $S_{gen} > 0$ . For an ideal, reversible process or cycle, such as the Carnot cycles,  $S_{gen} = 0$ . Any real or ideal process or cycle must satisfy both the first and the second laws of thermodynamics.

The first and second laws of thermodynamics are often used together with the thermodynamic tables or ideal gas equations in thermal analysis. When applying the second law of thermodynamics for closed or open systems, it is important to write an appropriate entropy balance equation. Entropy, entropy transfer, and entropy generation are three important concepts in the entropy balance equation. They have different physical meanings.

- Entropy is a measure of the degree of the “randomness” or “disorder” of a system. It is a thermodynamic property of the system and a state function. The change of entropy,  $\Delta S$ , in a process only depends on the initial and final states of the process.
- Entropy generation,  $S_{gen}$ , is a measure of the irreversibilities in a process. It is not a property of the system. It depends on the path of a process; the more irreversible a process is, the larger  $S_{gen}$  is.
- Entropy transfer always accompanies mass transfer and heat transfer in a process or a cycle. Entropy transfer is a boundary phenomenon. It relates to the mass flow rate or heat transfer across the system boundary, as well as the temperature of the boundary.

---

This page titled [6.12: Chapter review](#) is shared under a [CC BY-NC-SA 4.0](#) license and was authored, remixed, and/or curated by [Claire Yu Yan \(BC Campus\)](#) via [source content](#) that was edited to the style and standards of the LibreTexts platform; a detailed edit history is available upon request.



## 6.13: Key equations

### 6.12 Key equations

#### Heat engine

Net work output	$\dot{W}_{net, out} = \dot{Q}_H - \dot{Q}_L$
Thermal efficiency of any heat engine	$\eta_{th} = \frac{\text{desired output}}{\text{required input}} = \frac{\dot{W}_{net, out}}{\dot{Q}_H} = 1 - \frac{\dot{Q}_L}{\dot{Q}_H}$
Thermal efficiency of Carnot heat engine	$\eta_{th, rev} = 1 - \frac{T_L}{T_H}$

#### Refrigerator and heat pump

Net work input	$\dot{W}_{net, in} = \dot{Q}_H - \dot{Q}_L$
COP of any refrigerator	
COP of Carnot refrigerator	$COP_{R, rev} = \frac{T_L}{T_H - T_L} = \frac{1}{T_H/T_L - 1}$
COP of any heat pump	
COP of Carnot heat pump	$COP_{HP, rev} = \frac{T_H}{T_H - T_L} = \frac{1}{1 - T_L/T_H}$

#### Entropy and entropy generation

The inequality of Clausius	$\oint \frac{\delta Q}{T} \leq 0$ (= for reversible cycles; < for irreversible cycles)
Definition of entropy	Infinitesimal form : $dS = \left( \frac{\delta Q}{T} \right)_{rev}$ Integral form : $\Delta S = S_2 - S_1 = \int_1^2 \left( \frac{\delta Q}{T} \right)_{rev}$
Definition of entropy generation	 $\left( \frac{\delta Q}{T} \right)_{rev} \geq 0$ (= for reversible processes; > for irreversible process)

#### The second law of thermodynamics

For closed systems (control mass)	$S_2 - S_1 = \int_1^2 \frac{\delta Q}{T} + S_{gen}$ $\cong \sum \frac{Q_k}{T_k} + S_{gen} \quad (S_{gen} \geq 0)$ where $T_k$ is the absolute temperature of the system boundary, in Kelvin.
For steady-state, steady flow in a control volume (open systems)	$\sum \dot{m}_e s_e - \sum \dot{m}_i s_i = \sum \frac{\dot{Q}_{c.v.}}{T} + \dot{S}_{gen} \quad (\dot{S}_{gen} \geq 0)$
For steady and isentropic flow	$\sum \dot{m}_e s_e = \sum \dot{m}_i s_i$
Change of specific entropy between two states of a solid or liquid	$s_2 - s_1 = C_p \ln \frac{T_2}{T_1}$

Change of specific entropy between two states of an ideal gas	Assume constant $C_p$ and $C_v$ in the temperature range, $s_2 - s_1 = C_p \ln \frac{T_2}{T_1} - R \ln \frac{P_2}{P_1}$ $s_2 - s_1 = C_v \ln \frac{T_2}{T_1} + R \ln \frac{v_2}{v_1} \quad (6.13.1)$
Isentropic relations for ideal gases	$Pv^k = \text{constant}$ $\frac{P_2}{P_1} = \left(\frac{v_1}{v_2}\right)^k = \left(\frac{T_2}{T_1}\right)^{k/(k-1)}$ where $k = \frac{C_p}{C_v}$ and $T$ is in Kelvin

This page titled [6.13: Key equations](#) is shared under a [CC BY-NC-SA 4.0](#) license and was authored, remixed, and/or curated by [Claire Yu Yan \(BC Campus\)](#) via [source content](#) that was edited to the style and standards of the LibreTexts platform; a detailed edit history is available upon request.

## CHAPTER OVERVIEW

### 7: Appendices

- [7.1: Appendix A - Thermodynamic Properties of Water](#)
- [7.2: Appendix B - Thermodynamic Properties of Ammonia](#)
- [7.3: Appendix C - Thermodynamic Properties of R134a](#)
- [7.4: Appendix D - Thermodynamic Properties of Carbon Dioxide](#)
- [7.5: Appendix E - Critical Properties of Selected Fluids](#)
- [7.6: Appendix F - Triple Point of Selected Substances](#)
- [7.7: Appendix G - Properties of Various Substances](#)

---

This page titled [7: Appendices](#) is shared under a [not declared](#) license and was authored, remixed, and/or curated by [Claire Yu Yan \(BC Campus\)](#) via [source content](#) that was edited to the style and standards of the LibreTexts platform; a detailed edit history is available upon request.

## 7.1: Appendix A - Thermodynamic Properties of Water

Table A1: Saturated Water

T (°C)	P (MPa)	Specific Volume m <sup>3</sup> /kg		Specific Internal Energy kJ/kg		Specific Enthalpy kJ/kg		Specific Entropy kJ/kgK	
		$v_f$	$v_g$	$u_f$	$u_g$	$h_f$	$h_g$	$s_f$	$s_g$
0.01	0.00061	0.001000	205.991	0.00	2374.90	0.00	2500.92	0.0000	9.1555
5	0.00087	0.001000	147.011	21.02	2381.78	21.02	2510.06	0.0763	9.0248
10	0.00123	0.001000	106.303	42.02	2388.65	42.02	2519.21	0.1511	8.8998
15	0.00171	0.001001	77.8755	62.98	2395.49	62.98	2528.33	0.2245	8.7803
20	0.00234	0.001002	57.7567	83.91	2402.32	83.91	2537.43	0.2965	8.6660
25	0.00317	0.001003	43.3373	104.83	2409.13	104.83	2546.51	0.3672	8.5567
30	0.00425	0.001004	32.8783	125.73	2415.91	125.73	2555.55	0.4368	8.4520
35	0.00563	0.001006	25.2053	146.63	2422.67	146.63	2564.55	0.5051	8.3517
40	0.00738	0.001008	19.5151	167.53	2429.39	167.53	2573.51	0.5724	8.2556
45	0.00960	0.001010	15.2521	188.43	2436.08	188.44	2582.43	0.6386	8.1633
50	0.01235	0.001012	12.0269	209.33	2442.73	209.34	2591.29	0.7038	8.0748
55	0.01576	0.001015	9.56428	230.24	2449.34	230.26	2600.09	0.7680	7.9898
60	0.01995	0.001017	7.66723	251.16	2455.90	251.18	2608.83	0.8313	7.9082
65	0.02504	0.001020	6.19354	272.09	2462.41	272.12	2617.50	0.8937	7.8296
70	0.03120	0.001023	5.03954	293.03	2468.86	293.07	2626.10	0.9551	7.7540
75	0.03860	0.001026	4.12894	313.99	2475.24	314.03	2634.60	1.0158	7.6812
80	0.04741	0.001029	3.40516	334.96	2481.56	335.01	2643.02	1.0756	7.6111
85	0.05787	0.001032	2.82584	355.96	2487.81	356.02	2651.33	1.1346	7.5434
90	0.07018	0.001036	2.35906	376.97	2493.97	377.04	2659.53	1.1929	7.4781
95	0.08461	0.001040	1.98056	398.00	2500.04	398.09	2667.61	1.2504	7.4151
100	0.10142	0.001043	1.67177	419.06	2506.02	419.17	2675.57	1.3072	7.3541
105	0.12090	0.001047	1.41838	440.15	2511.90	440.27	2683.39	1.3634	7.2952
110	0.14338	0.001052	1.20929	461.26	2517.67	461.42	2691.06	1.4188	7.2381
115	0.16918	0.001056	1.03584	482.42	2523.33	482.59	2698.58	1.4737	7.1828
120	0.19867	0.001060	0.891212	503.60	2528.86	503.81	2705.93	1.5279	7.1291
125	0.23224	0.001065	0.770026	524.83	2534.27	525.07	2713.10	1.5816	7.0770
130	0.27028	0.001070	0.668004	546.10	2539.53	546.38	2720.08	1.6347	7.0264
135	0.31323	0.001075	0.581729	567.41	2544.65	567.75	2726.87	1.6872	6.9772
140	0.36154	0.001080	0.508454	588.77	2549.62	589.16	2733.44	1.7392	6.9293
145	0.41569	0.001085	0.445962	610.19	2554.42	610.64	2739.80	1.7908	6.8826
150	0.47617	0.001091	0.392453	631.66	2559.05	632.18	2745.93	1.8418	6.8371
155	0.54350	0.001096	0.346460	653.19	2563.51	653.79	2751.81	1.8924	6.7926
160	0.61824	0.001102	0.306782	674.79	2567.78	675.47	2757.44	1.9426	6.7491



T (°C)	P (MPa)	Specific Volume m <sup>3</sup> /kg	Specific Internal Energy kJ/kg		Specific Enthalpy kJ/kg		Specific Entropy kJ/kgK		
165	0.70093	0.001108	0.272431	696.46	2571.85	697.24	2762.81	1.9923	6.7066
170	0.79219	0.001114	0.242589	718.20	2575.73	719.08	2767.90	2.0417	6.6650
175	0.89260	0.001121	0.216581	740.02	2579.39	741.02	2772.71	2.0906	6.6241
180	1.00281	0.001127	0.193842	761.92	2582.83	763.05	2777.21	2.1393	6.5841
185	1.12346	0.001134	0.173901	783.91	2586.04	785.19	2781.41	2.1875	6.5447
190	1.25524	0.001141	0.156362	806.00	2589.01	807.43	2785.28	2.2355	6.5059
195	1.39882	0.001149	0.140892	828.18	2591.74	829.79	2788.82	2.2832	6.4678
200	1.55493	0.001157	0.127210	850.47	2594.20	852.27	2792.01	2.3305	6.4302
205	1.72430	0.001164	0.115078	872.87	2596.40	874.88	2794.83	2.3777	6.3930
210	1.90767	0.001173	0.104292	895.39	2598.31	897.63	2797.27	2.4245	6.3563
215	2.10584	0.001181	0.094680	918.04	2599.94	920.53	2799.32	2.4712	6.3200
220	2.31959	0.001190	0.086092	940.82	2601.25	943.58	2800.95	2.5177	6.2840
225	2.54972	0.001199	0.078404	963.74	2602.24	966.80	2802.15	2.5640	6.2483
230	2.79709	0.001209	0.071504	986.81	2602.90	990.19	2802.90	2.6101	6.2128
235	3.06253	0.001219	0.065298	1010.04	2603.20	1013.77	2803.17	2.6561	6.1775
240	3.34693	0.001229	0.059705	1033.44	2603.13	1037.55	2802.96	2.7020	6.1423
245	3.65117	0.001240	0.054654	1057.02	2602.67	1061.55	2802.22	2.7478	6.1072
250	3.97617	0.001252	0.050083	1080.79	2601.79	1085.77	2800.93	2.7935	6.0721
255	4.32289	0.001264	0.045939	1104.77	2600.49	1110.23	2799.07	2.8392	6.0369
260	4.69226	0.001276	0.042173	1128.97	2598.72	1134.96	2796.60	2.8850	6.0016
265	5.08529	0.001289	0.038746	1153.41	2596.45	1159.96	2793.49	2.9307	5.9661
270	5.50299	0.001303	0.035621	1178.10	2593.67	1185.27	2789.69	2.9765	5.9304
275	5.94639	0.001318	0.032766	1203.07	2590.33	1210.90	2785.17	3.0224	5.8944
280	6.41658	0.001333	0.030153	1228.33	2586.39	1236.88	2779.87	3.0685	5.8579
285	6.91466	0.001349	0.027756	1253.92	2581.81	1263.25	2773.73	3.1147	5.8209
290	7.44178	0.001366	0.025555	1279.86	2576.53	1290.03	2766.70	3.1612	5.7834
295	7.99911	0.001385	0.023529	1306.19	2570.49	1317.27	2758.70	3.2080	5.7451
300	8.58790	0.001404	0.021660	1332.95	2563.62	1345.01	2749.64	3.2552	5.7059
305	9.20943	0.001425	0.019934	1360.18	2555.85	1373.30	2739.43	3.3028	5.6657
310	9.86505	0.001448	0.018335	1387.93	2547.07	1402.22	2727.95	3.3510	5.6244
315	10.55620	0.001472	0.016851	1416.28	2537.17	1431.83	2715.05	3.3998	5.5816
320	11.28430	0.001499	0.015471	1445.31	2526.01	1462.22	2700.59	3.4494	5.5372
325	12.05100	0.001528	0.014183	1475.11	2513.41	1493.52	2684.33	3.5000	5.4909
330	12.85810	0.001561	0.012979	1505.80	2499.15	1525.87	2666.03	3.5518	5.4422
335	13.70730	0.001597	0.011847	1537.56	2482.96	1559.45	2645.35	3.6050	5.3906
340	14.60070	0.001638	0.010781	1570.62	2464.44	1594.53	2621.85	3.6601	5.3356
345	15.54060	0.001685	0.009769	1605.30	2443.09	1631.48	2594.90	3.7176	5.2762

T (°C)	P (MPa)	Specific Volume m <sup>3</sup> /kg		Specific Internal Energy kJ/kg		Specific Enthalpy kJ/kg		Specific Entropy kJ/kgK	
350	16.52940	0.001740	0.008802	1642.13	2418.14	1670.89	2563.64	3.7784	5.2110
355	17.57010	0.001808	0.007868	1681.96	2388.40	1713.72	2526.65	3.8439	5.1380
360	18.66600	0.001895	0.006949	1726.28	2351.78	1761.66	2481.49	3.9167	5.0536
365	19.82140	0.002017	0.006012	1777.79	2303.79	1817.77	2422.95	4.0014	4.9497
370	21.04360	0.002215	0.004954	1844.07	2230.26	1890.69	2334.52	4.1112	4.8012
373.95	22.06400	0.003106	0.003106	2015.73	2015.73	2084.26	2084.26	4.4070	4.4070

**Table A2: Superheated Vapor, Water**

T (°C)	v m <sup>3</sup> /kg	u kJ/kg	h kJ/kg	s kJ/kgK	v m <sup>3</sup> /kg	u kJ/kg	h kJ/kg	s kJ/kgK
	<b>P = 10 kPa (Sat. T = 45.80°C)</b>				<b>P = 50 kPa (Sat. T = 81.31°C)</b>			
Sat	14.6701	2437.16	2583.86	8.1488	3.24003	2483.21	2645.22	7.5930
50	14.8670	2443.30	2591.97	8.1741	-	-	-	-
100	17.1964	2515.49	2687.46	8.4489	3.41867	2511.49	2682.42	7.6953
150	19.5132	2587.91	2783.04	8.6892	3.88973	2585.73	2780.21	7.9413
200	21.8256	2661.34	2879.60	8.9049	4.35616	2659.96	2877.77	8.1592
250	24.1361	2736.09	2977.45	9.1015	4.82061	2735.12	2976.15	8.3568
300	26.4456	2812.28	3076.74	9.2827	5.28405	2811.56	3075.76	8.5386
350	28.7545	2890.00	3177.55	9.4513	5.74690	2889.44	3176.78	8.7076
400	31.0631	2969.32	3279.95	9.6094	6.20940	2968.86	3279.33	8.8659
450	33.3714	3050.27	3383.98	9.7584	6.67166	3049.89	3383.47	9.0151
500	35.6796	3132.89	3489.69	9.8998	7.13376	3132.58	3489.27	9.1566
550	37.9876	3217.24	3597.11	10.0344	7.59574	3216.96	3596.75	9.2913
600	40.2956	3303.32	3706.27	10.1631	8.05763	3303.08	3705.96	9.4201
650	42.6035	3391.17	3817.20	10.2866	8.51946	3390.96	3816.93	9.5436
700	44.9113	3480.79	3929.90	10.4055	8.98123	3480.60	3929.66	9.6626
750	47.2191	3572.18	4044.37	10.5202	9.44296	3572.02	4044.17	9.7773
800	49.5269	3665.35	4160.62	10.6311	9.90467	3665.20	4160.44	9.8882
850	51.8347	3760.27	4278.61	10.7386	10.3663	3760.13	4278.45	9.9957
900	54.1424	3856.91	4398.33	10.8429	10.8280	3856.79	4398.19	10.1000
950	56.4501	3955.25	4519.75	10.9442	11.2896	3955.14	4519.62	10.2014
1000	58.7578	4055.24	4642.82	11.0428	11.7513	4055.14	4642.70	10.3000
	<b>P = 100 kPa (Sat. T = 99.60°C)</b>				<b>P = 200 kPa (Sat. T = 120.21°C)</b>			
Sat	1.69393	2505.55	2674.95	7.3589	0.885682	2529.09	2706.23	7.1269
150	1.93665	2582.94	2776.60	7.6148	0.959855	2577.13	2769.10	7.2810
200	2.17243	2658.21	2875.45	7.8356	1.080480	2654.63	2870.73	7.5081

T (°C)	v m <sup>3</sup> /kg	u kJ/kg	h kJ/kg	s kJ/kgK	v m <sup>3</sup> /kg	u kJ/kg	h kJ/kg	s kJ/kgK
250	2.40615	2733.90	2974.51	8.0346	1.198890	2731.43	2971.21	7.7100
300	2.63885	2810.65	3074.53	8.2172	1.316230	2808.82	3072.07	7.8941
350	2.87095	2888.73	3175.83	8.3866	1.432970	2887.31	3173.90	8.0644
400	3.10269	2968.29	3278.56	8.5452	1.549330	2967.15	3277.02	8.2236
450	3.33420	3049.42	3382.84	8.6946	1.665460	3048.48	3381.57	8.3734
500	3.56553	3132.18	3488.73	8.8362	1.781420	3131.39	3487.67	8.5152
550	3.79675	3216.62	3596.30	8.9710	1.897260	3215.95	3595.40	8.6502
600	4.02788	3302.79	3705.58	9.0998	2.013010	3302.20	3704.80	8.7792
650	4.25895	3390.70	3816.60	9.2235	2.128700	3390.18	3815.92	8.9030
700	4.48997	3480.37	3929.37	9.3424	2.244330	3479.92	3928.78	9.0220
750	4.72094	3571.82	4043.91	9.4572	2.359930	3571.41	4043.39	9.1369
800	4.95189	3665.02	4160.21	9.5682	2.475500	3664.65	4159.75	9.2479
850	5.18280	3759.97	4278.25	9.6757	2.591030	3759.64	4277.84	9.3555
900	5.41370	3856.64	4398.01	9.7800	2.706550	3856.34	4397.65	9.4598
950	5.64458	3955.00	4519.46	9.8813	2.822050	3954.72	4519.13	9.5612
1000	5.87545	4055.01	4642.56	9.9800	2.937540	4054.76	4642.27	9.6599
T (°C)	v m <sup>3</sup> /kg	u kJ/kg	h kJ/kg	s kJ/kgK	v m <sup>3</sup> /kg	u kJ/kg	h kJ/kg	s kJ/kgK
	<b>P = 300 kPa (Sat. T = 133.52°C)</b>				<b>P = 400 kPa (Sat. T = 143.60°C)</b>			
Sat	0.60576	2543.15	2724.88	6.9916	0.462383	2553.10	2738.05	6.8955
150	0.63401	2570.98	2761.19	7.0791	0.470883	2564.43	2752.78	6.9306
200	0.71642	2650.96	2865.89	7.3131	0.534334	2647.19	2860.93	7.1723
250	0.79644	2728.93	2967.87	7.5180	0.595196	2726.39	2964.47	7.3804
300	0.87534	2806.98	3069.58	7.7037	0.654892	2805.12	3067.08	7.5677
350	0.95363	2885.88	3171.97	7.8750	0.713958	2884.45	3170.03	7.7399
400	1.03154	2966.00	3275.47	8.0347	0.772645	2964.85	3273.91	7.9002
450	1.10921	3047.53	3380.29	8.1849	0.831085	3046.58	3379.02	8.0508
500	1.18671	3130.59	3486.60	8.3271	0.889357	3129.79	3485.54	8.1933
550	1.26409	3215.26	3594.49	8.4623	0.947510	3214.58	3593.59	8.3287
600	1.34139	3301.61	3704.03	8.5914	1.005570	3301.02	3703.25	8.4580
650	1.41861	3389.67	3815.25	8.7153	1.063570	3389.15	3814.58	8.5820
700	1.49579	3479.46	3928.20	8.8344	1.121520	3479.00	3927.61	8.7012
750	1.57293	3571.00	4042.88	8.9494	1.179430	3570.59	4042.36	8.8162
800	1.65003	3664.28	4159.29	9.0604	1.237300	3663.92	4158.84	8.9273
850	1.72711	3759.30	4277.44	9.1680	1.295150	3758.97	4277.03	9.0350
900	1.80417	3856.03	4397.28	9.2724	1.352980	3855.73	4396.92	9.1394
950	1.88121	3954.45	4518.81	9.3739	1.410790	3954.17	4518.49	9.2409

T (°C)	v m <sup>3</sup> /kg	u kJ/kg	h kJ/kg	s kJ/kgK	v m <sup>3</sup> /kg	u kJ/kg	h kJ/kg	s kJ/kgK
1000	1.95823	4054.51	4641.98	9.4726	1.468580	4054.25	4641.69	9.3396
T (°C)	v m <sup>3</sup> /kg	u kJ/kg	h kJ/kg	s kJ/kgK	v m <sup>3</sup> /kg	u kJ/kg	h kJ/kg	s kJ/kgK
<b>P = 500 kPa (Sat. T = 151.83°C)</b>				<b>P = 600 kPa (Sat. T = 158.82°C)</b>				
Sat	0.37481	2560.71	2748.11	6.8207	0.315583	2566.79	2756.14	6.7593
200	0.42503	2643.32	2855.84	7.0610	0.352121	2639.34	2850.61	6.9683
250	0.47443	2723.82	2961.04	7.2724	0.393901	2721.21	2957.55	7.1832
300	0.52261	2803.25	3064.55	7.4614	0.434418	2801.36	3062.01	7.3740
350	0.57015	2883.01	3168.08	7.6346	0.474275	2881.56	3166.12	7.5481
400	0.61730	2963.70	3272.35	7.7955	0.513741	2962.54	3270.78	7.7097
450	0.66421	3045.63	3377.74	7.9465	0.552957	3044.68	3376.46	7.8611
500	0.71094	3129.00	3484.47	8.0892	0.592002	3128.20	3483.40	8.0041
550	0.75756	3213.90	3592.68	8.2249	0.630925	3213.22	3591.77	8.1399
600	0.80409	3300.43	3702.47	8.3543	0.669761	3299.84	3701.69	8.2695
650	0.85055	3388.63	3813.90	8.4784	0.708529	3388.11	3813.23	8.3937
700	0.89696	3478.54	3927.02	8.5977	0.747246	3478.08	3926.43	8.5131
750	0.94332	3570.18	4041.84	8.7128	0.785923	3569.77	4041.33	8.6283
800	0.98966	3663.55	4158.38	8.8240	0.824568	3663.18	4157.92	8.7395
850	1.03597	3758.64	4276.63	8.9317	0.863187	3758.31	4276.22	8.8472
900	1.08226	3855.43	4396.56	9.0362	0.901785	3855.13	4396.20	8.9518
950	1.12853	3953.90	4518.16	9.1377	0.940365	3953.62	4517.84	9.0533
1000	1.17479	4054.00	4641.40	9.2364	0.978931	4053.75	4641.11	9.1521
T (°C)	v m <sup>3</sup> /kg	u kJ/kg	h kJ/kg	s kJ/kgK	v m <sup>3</sup> /kg	u kJ/kg	h kJ/kg	s kJ/kgK
<b>P = 800 kPa (Sat. T = 170.40°C)</b>				<b>P = 1000 kPa (Sat. T = 179.87°C)</b>				
Sat	0.24034	2576.03	2768.30	6.6616	0.194362	2582.75	2777.11	6.5850
200	0.26088	2631.04	2839.75	6.8176	0.206022	2622.24	2828.26	6.6955
250	0.29321	2715.87	2950.44	7.0401	0.232747	2710.38	2943.12	6.9265
300	0.32416	2797.53	3056.86	7.2345	0.257988	2793.64	3051.63	7.1246
350	0.35442	2878.63	3162.17	7.4106	0.282504	2875.68	3158.18	7.3029
400	0.38428	2960.21	3267.64	7.5734	0.306606	2957.87	3264.47	7.4669
450	0.41389	3042.77	3373.88	7.7257	0.330447	3040.85	3371.30	7.6200
500	0.44332	3126.60	3481.25	7.8692	0.354113	3124.99	3479.10	7.7642
550	0.47263	3211.85	3589.96	8.0055	0.377655	3210.48	3588.14	7.9008
600	0.50185	3298.65	3700.14	8.1354	0.401108	3297.47	3698.58	8.0310
650	0.53101	3387.08	3811.88	8.2598	0.424494	3386.04	3810.53	8.1557
700	0.56011	3477.17	3925.26	8.3794	0.447828	3476.25	3924.08	8.2755
750	0.58917	3568.95	4040.29	8.4947	0.471121	3568.14	4039.26	8.3909

T (°C)	v m <sup>3</sup> /kg	u kJ/kg	h kJ/kg	s kJ/kgK	v m <sup>3</sup> /kg	u kJ/kg	h kJ/kg	s kJ/kgK
800	0.61820	3662.45	4157.01	8.6061	0.494382	3661.71	4156.09	8.5024
850	0.64721	3757.64	4275.41	8.7139	0.517618	3756.98	4274.60	8.6103
900	0.67619	3854.52	4395.48	8.8185	0.540832	3853.92	4394.75	8.7150
950	0.70516	3953.07	4517.19	8.9201	0.564028	3952.52	4516.54	8.8166
1000	0.73411	4053.24	4640.53	9.0189	0.587210	4052.74	4639.95	8.9155
T (°C)	v m <sup>3</sup> /kg	u kJ/kg	h kJ/kg	s kJ/kgK	v m <sup>3</sup> /kg	u kJ/kg	h kJ/kg	s kJ/kgK
<b>P = 1200 kPa (Sat. T = 187.95°C)</b>				<b>P = 1400 kPa (Sat. T = 195.03°C)</b>				
Sat	0.16326	2587.83	2783.74	6.5217	0.140778	2591.76	2788.85	6.4675
200	0.16934	2612.85	2816.06	6.5909	0.143025	2602.72	2802.96	6.4975
250	0.19241	2704.71	2935.60	6.8313	0.163561	2698.88	2927.86	6.7488
300	0.21386	2789.69	3046.32	7.0335	0.182324	2785.67	3040.92	6.9552
350	0.23455	2872.70	3154.16	7.2139	0.200292	2869.68	3150.09	7.1379
400	0.25482	2955.51	3261.29	7.3793	0.217820	2953.14	3258.08	7.3046
450	0.27482	3038.93	3368.71	7.5332	0.235078	3036.99	3366.10	7.4594
500	0.29464	3123.38	3476.94	7.6779	0.252156	3121.76	3474.78	7.6047
550	0.31434	3209.11	3586.31	7.8150	0.269109	3207.73	3584.48	7.7422
600	0.33395	3296.28	3697.01	7.9455	0.285970	3295.09	3695.45	7.8730
650	0.35349	3385.00	3809.18	8.0704	0.302764	3383.96	3807.83	7.9982
700	0.37297	3475.33	3922.90	8.1904	0.319505	3474.41	3921.72	8.1183
750	0.39242	3567.32	4038.22	8.3060	0.336206	3566.50	4037.18	8.2340
800	0.41184	3660.98	4155.18	8.4176	0.352874	3660.24	4154.26	8.3457
850	0.43123	3756.31	4273.78	8.5256	0.369516	3755.65	4272.97	8.4538
900	0.45059	3853.32	4394.03	8.6303	0.386137	3852.71	4393.30	8.5587
950	0.46994	3951.96	4515.90	8.7320	0.402741	3951.41	4515.25	8.6604
1000	0.48928	4052.23	4639.37	8.8310	0.419330	4051.72	4638.78	8.7594
T (°C)	v m <sup>3</sup> /kg	u kJ/kg	h kJ/kg	s kJ/kgK	v m <sup>3</sup> /kg	u kJ/kg	h kJ/kg	s kJ/kgK
<b>P = 1600 kPa (Sat. T = 201.37°C)</b>				<b>P = 1800 kPa (Sat. T = 207.11°C)</b>				
Sat	0.12374	2594.83	2792.82	6.4199	0.110368	2597.24	2795.91	6.3775
250	0.19241	2704.71	2935.60	6.8313	0.163561	2698.88	2927.86	6.7488
300	0.21386	2789.69	3046.32	7.0335	0.182324	2785.67	3040.92	6.9552
350	0.23455	2872.70	3154.16	7.2139	0.200292	2869.68	3150.09	7.1379
400	0.25482	2955.51	3261.29	7.3793	0.217820	2953.14	3258.08	7.3046
450	0.27482	3038.93	3368.71	7.5332	0.235078	3036.99	3366.10	7.4594
500	0.29464	3123.38	3476.94	7.6779	0.252156	3121.76	3474.78	7.6047
550	0.31434	3209.11	3586.31	7.8150	0.269109	3207.73	3584.48	7.7422
600	0.33395	3296.28	3697.01	7.9455	0.285970	3295.09	3695.45	7.8730

T (°C)	v m <sup>3</sup> /kg	u kJ/kg	h kJ/kg	s kJ/kgK	v m <sup>3</sup> /kg	u kJ/kg	h kJ/kg	s kJ/kgK
650	0.35349	3385.00	3809.18	8.0704	0.302764	3383.96	3807.83	7.9982
700	0.37297	3475.33	3922.90	8.1904	0.319505	3474.41	3921.72	8.1183
750	0.39242	3567.32	4038.22	8.3060	0.336206	3566.50	4037.18	8.2340
800	0.41184	3660.98	4155.18	8.4176	0.352874	3660.24	4154.26	8.3457
850	0.43123	3756.31	4273.78	8.5256	0.369516	3755.65	4272.97	8.4538
900	0.45059	3853.32	4394.03	8.6303	0.386137	3852.71	4393.30	8.5587
950	0.46994	3951.96	4515.90	8.7320	0.402741	3951.41	4515.25	8.6604
1000	0.48928	4052.23	4639.37	8.8310	0.419330	4051.72	4638.78	8.7594
T (°C)	v m <sup>3</sup> /kg	u kJ/kg	h kJ/kg	s kJ/kgK	v m <sup>3</sup> /kg	u kJ/kg	h kJ/kg	s kJ/kgK
	<b>P = 2000 kPa (Sat. T = 212.37°C)</b>				<b>P = 2500 kPa (Sat. T = 223.95°C)</b>			
Sat	0.09959	2599.12	2798.29	6.3390	0.079949	2602.06	2801.93	6.2558
250	0.11150	2680.25	2903.24	6.5475	0.087053	2663.26	2880.89	6.4107
300	0.12551	2773.17	3024.18	6.7684	0.098937	2762.24	3009.58	6.6459
350	0.13860	2860.45	3137.65	6.9583	0.109786	2852.53	3127.00	6.8424
400	0.15122	2945.91	3248.34	7.1292	0.120119	2939.78	3240.08	7.0170
450	0.16354	3031.13	3358.22	7.2866	0.130152	3026.19	3351.57	7.1767
500	0.17568	3116.87	3468.24	7.4337	0.139992	3112.77	3462.75	7.3254
550	0.18770	3203.58	3578.97	7.5725	0.149700	3200.10	3574.35	7.4653
600	0.19962	3291.51	3690.74	7.7043	0.159314	3288.51	3686.79	7.5979
650	0.21147	3380.83	3803.75	7.8302	0.168858	3378.21	3800.35	7.7243
700	0.22326	3471.64	3918.17	7.9509	0.178349	3469.33	3915.21	7.8455
750	0.23502	3564.03	4034.07	8.0670	0.187798	3561.98	4031.47	7.9620
800	0.24674	3658.03	4151.51	8.1791	0.197215	3656.18	4149.22	8.0743
850	0.25844	3753.65	4270.53	8.2874	0.206605	3751.98	4268.49	8.1830
900	0.27012	3850.90	4391.13	8.3925	0.215974	3849.38	4389.32	8.2882
950	0.28178	3949.76	4513.31	8.4945	0.225325	3948.37	4511.69	8.3904
1000	0.29342	4050.20	4637.04	8.5936	0.234661	4048.94	4635.59	8.4896
T (°C)	v m <sup>3</sup> /kg	u kJ/kg	h kJ/kg	s kJ/kgK	v m <sup>3</sup> /kg	u kJ/kg	h kJ/kg	s kJ/kgK
	<b>P = 3000 kPa (Sat. T = 233.85°C)</b>				<b>P = 4000 kPa (Sat. T = 250.35°C)</b>			
Sat	0.06666	2603.16	2803.15	6.1856	0.049776	2601.72	2800.82	6.0696
250	0.07063	2644.65	2856.53	6.2893	-	-	-	-
300	0.08118	2750.80	2994.33	6.5412	0.058870	2726.21	2961.69	6.3639
350	0.09056	2844.39	3116.06	6.7449	0.066473	2827.43	3093.32	6.5843
400	0.09938	2933.55	3231.69	6.9235	0.073431	2920.75	3214.47	6.7714
450	0.10789	3021.18	3344.84	7.0856	0.080043	3011.00	3331.17	6.9386
500	0.11620	3108.63	3457.22	7.2359	0.086442	3100.25	3446.02	7.0922

T (°C)	v m <sup>3</sup> /kg	u kJ/kg	h kJ/kg	s kJ/kgK	v m <sup>3</sup> /kg	u kJ/kg	h kJ/kg	s kJ/kgK
550	0.12437	3196.60	3569.70	7.3769	0.092700	3189.54	3560.34	7.2355
600	0.13245	3285.50	3682.83	7.5103	0.098859	3279.43	3674.87	7.3705
650	0.14045	3375.58	3796.94	7.6373	0.104945	3370.30	3790.08	7.4988
700	0.14841	3467.02	3912.24	7.7590	0.110976	3462.37	3906.28	7.6214
750	0.15632	3559.91	4028.87	7.8758	0.116966	3555.78	4023.64	7.7390
800	0.16420	3654.33	4146.92	7.9885	0.122922	3650.63	4142.32	7.8523
850	0.17205	3750.31	4266.46	8.0973	0.128852	3746.97	4262.38	7.9616
900	0.17988	3847.87	4387.50	8.2028	0.134759	3844.83	4383.87	8.0674
950	0.18769	3946.99	4510.06	8.3051	0.140649	3944.22	4506.82	8.1701
1000	0.19549	4047.67	4634.14	8.4045	0.146525	4045.13	4631.23	8.2697

**Table A3: Compressed Liquid Water**

T (°C)	v m <sup>3</sup> /kg	u kJ/kg	h kJ/kg	s kJ/kgK	v m <sup>3</sup> /kg	u kJ/kg	h kJ/kg	s kJ/kgK
	<b>P = 500 kPa (Sat. T = 151.83°C)</b>				<b>P = 2000 kPa (Sat. T = 212.38°C)</b>			
Sat	0.001093	639.54	640.09	1.8604	0.001177	906.15	908.50	2.4468
0.01	0.001000	0.01	0.51	0.0000	0.000999	0.04	2.03	0.0001
20	0.001002	83.88	84.38	0.2964	0.001001	83.79	85.79	0.2961
40	0.001008	167.47	167.97	0.5722	0.001007	167.28	169.30	0.5716
60	0.001017	251.08	251.58	0.8310	0.001016	250.81	252.84	0.8302
80	0.001029	334.86	335.37	1.0753	0.001028	334.51	336.57	1.0743
100	0.001043	418.94	419.47	1.3069	0.001042	418.51	420.59	1.3057
120	0.001060	503.49	504.02	1.5276	0.001059	502.96	505.08	1.5263
140	0.001080	588.71	589.25	1.7391	0.001079	588.07	590.22	1.7375
160	-	-	-	-	0.001101	674.08	676.28	1.9409
180	-	-	-	-	0.001127	761.30	763.56	2.1379
200	-	-	-	-	0.001156	850.14	852.45	2.3298
T (°C)	v m <sup>3</sup> /kg	u kJ/kg	h kJ/kg	s kJ/kgK	v m <sup>3</sup> /kg	u kJ/kg	h kJ/kg	s kJ/kgK
	<b>P = 5000 kPa (Sat. T = 263.94°C)</b>				<b>P = 10000 kPa (Sat. T = 311.00°C)</b>			
Sat	0.001286	1148.21	1154.64	2.9210	0.001453	1393.54	1408.06	3.3607
0.01	0.000998	0.09	5.07	0.0003	0.000995	0.16	10.11	0.0005
20	0.001000	83.61	88.61	0.2954	0.000997	83.31	93.28	0.2943
40	0.001006	166.92	171.95	0.5705	0.001004	166.33	176.37	0.5685
60	0.001015	250.29	255.36	0.8287	0.001013	249.43	259.55	0.8260
80	0.001027	333.82	338.96	1.0723	0.001024	332.69	342.94	1.0691
100	0.001041	417.65	422.85	1.3034	0.001038	416.23	426.62	1.2996
120	0.001058	501.91	507.19	1.5236	0.001055	500.18	510.73	1.5191

T (°C)	v m <sup>3</sup> /kg	u kJ/kg	h kJ/kg	s kJ/kgK	v m <sup>3</sup> /kg	u kJ/kg	h kJ/kg	s kJ/kgK
140	0.001077	586.79	592.18	1.7344	0.001074	584.71	595.45	1.7293
160	0.001099	672.55	678.04	1.9374	0.001095	670.06	681.01	1.9316
180	0.001124	759.46	765.08	2.1338	0.001120	756.48	767.68	2.1271
200	0.001153	847.91	853.68	2.3251	0.001148	844.31	855.80	2.3174
220	0.001187	938.39	944.32	2.5127	0.001181	934.00	945.81	2.5037
240	0.001227	1031.58	1037.71	2.6983	0.001219	1026.14	1038.34	2.6876
260	0.001275	1128.53	1134.91	2.8841	0.001265	1121.61	1134.26	2.8710
280	-	-	-	-	0.001323	1221.80	1235.03	3.0565
300	-	-	-	-	0.001398	1329.35	1343.33	3.2488
T (°C)	v m <sup>3</sup> /kg	u kJ/kg	h kJ/kg	s kJ/kgK	v m <sup>3</sup> /kg	u kJ/kg	h kJ/kg	s kJ/kgK
<b>P = 15000 kPa (Sat. T = 342.16°C)</b>				<b>P = 20000 kPa (Sat. T = 365.75°C)</b>				
Sat	0.001657	1585.35	1610.20	3.6846	0.002040	1786.41	1827.21	4.0156
0.01	0.000993	0.22	15.11	0.0006	0.000990	0.27	20.07	0.0006
20	0.000995	83.01	97.93	0.2932	0.000993	82.71	102.57	0.2921
40	0.001001	165.75	180.77	0.5666	0.000999	165.17	185.16	0.5646
60	0.001011	248.58	263.74	0.8234	0.001008	247.75	267.92	0.8208
80	0.001022	331.59	346.92	1.0659	0.001020	330.50	350.90	1.0627
100	0.001036	414.85	430.39	1.2958	0.001034	413.50	434.17	1.2920
120	0.001052	498.49	514.28	1.5148	0.001050	496.85	517.84	1.5105
140	0.001071	582.69	598.75	1.7243	0.001068	580.71	602.07	1.7194
160	0.001092	667.63	684.01	1.9259	0.001089	665.28	687.05	1.9203
180	0.001116	753.58	770.32	2.1206	0.001112	750.77	773.02	2.1143
200	0.001144	840.84	857.99	2.3100	0.001139	837.49	860.27	2.3027
220	0.001175	929.80	947.43	2.4951	0.001170	925.77	949.16	2.4867
240	0.001212	1020.98	1039.16	2.6774	0.001205	1016.07	1040.17	2.6676
260	0.001256	1115.12	1133.96	2.8586	0.001247	1109.02	1133.96	2.8469
280	0.001310	1213.36	1233.00	3.0409	0.001298	1205.55	1231.50	3.0265
300	0.001378	1317.63	1338.30	3.2279	0.001361	1307.15	1334.37	3.2091
320	0.001473	1431.93	1454.02	3.4263	0.001445	1416.59	1445.49	3.3996
340	0.001631	1567.89	1592.36	3.6555	0.001569	1540.20	1571.58	3.6086
360	-	-	-	-	0.001825	1703.60	1740.10	3.8787
T (°C)	v m <sup>3</sup> /kg	u kJ/kg	h kJ/kg	s kJ/kgK	v m <sup>3</sup> /kg	u kJ/kg	h kJ/kg	s kJ/kgK
<b>P = 30000 kPa</b>				<b>P = 50000 kPa</b>				
0.01	0.000986	0.33	29.90	0.0004	0.000977	0.33	49.17	-0.0009
20	0.000989	82.11	111.77	0.2897	0.000980	80.93	129.95	0.2845
40	0.000995	164.05	193.90	0.5607	0.000987	161.90	211.25	0.5528



T (°C)	v m <sup>3</sup> /kg	u kJ/kg	h kJ/kg	s kJ/kgK	v m <sup>3</sup> /kg	u kJ/kg	h kJ/kg	s kJ/kgK
60	0.001004	246.14	276.26	0.8156	0.000996	243.08	292.88	0.8055
80	0.001016	328.40	358.86	1.0564	0.001007	324.42	374.78	1.0442
100	0.001029	410.87	441.74	1.2847	0.001020	405.94	456.94	1.2705
120	0.001045	493.66	525.00	1.5020	0.001035	487.69	539.43	1.4859
140	0.001062	576.90	608.76	1.7098	0.001052	569.77	622.36	1.6916
160	0.001082	660.74	693.21	1.9094	0.001070	652.32	705.84	1.8889
180	0.001105	745.40	778.55	2.1020	0.001091	735.49	790.06	2.0790
200	0.001130	831.10	865.02	2.2888	0.001115	819.45	875.19	2.2628
220	0.001159	918.14	952.93	2.4707	0.001141	904.39	961.45	2.4414
240	0.001193	1006.87	1042.66	2.6491	0.001171	990.55	1049.09	2.6156
260	0.001231	1097.77	1134.71	2.8250	0.001204	1078.22	1138.44	2.7864
280	0.001277	1191.47	1229.77	3.0001	0.001243	1167.74	1229.89	2.9547
300	0.001332	1288.92	1328.89	3.1760	0.001288	1259.57	1323.96	3.1218
320	0.001401	1391.65	1433.69	3.3557	0.001341	1354.33	1421.37	3.2888
340	0.001493	1502.34	1547.14	3.5438	0.001405	1452.87	1523.11	3.4575
360	0.001628	1626.74	1675.57	3.7498	0.001485	1556.46	1630.70	3.6301
380	0.001873	1782.04	1838.22	4.0025	0.001588	1667.07	1746.49	3.8101

### Reference States, default for fluid

- **Enthalpy** H = 2551.013479 kJ/kg at 26.9 C and 0.0010 MPa.
- **Entropy** S = 9.103679 J/g\*K at 26.9 C and 0.0010 MPa.

Source: Eric W. Lemmon, Mark O. McLinden and Daniel G. Friend, “Thermophysical Properties of Fluid Systems” in **NIST Chemistry WebBook, NIST Standard Reference Database Number 69**, Eds. P.J. Linstrom and W.G. Mallard, National Institute of Standards and Technology, Gaithersburg MD, 20899, <https://doi.org/10.18434/T4D303>, (retrieved May 2021).

This page titled [7.1: Appendix A - Thermodynamic Properties of Water](#) is shared under a [not declared](#) license and was authored, remixed, and/or curated by [Claire Yu Yan \(BC Campus\)](#) via [source content](#) that was edited to the style and standards of the LibreTexts platform; a detailed edit history is available upon request.

## 7.2: Appendix B - Thermodynamic Properties of Ammonia

**Table B1: Saturated Ammonia**

T (°C)	P (MPa)	Specific Volume m <sup>3</sup> /kg		Specific Internal Energy kJ/kg		Specific Enthalpy kJ/kg		Specific Entropy kJ/kgK	
		$v_f$	$v_g$	$u_f$	$u_g$	$h_f$	$h_g$	$s_f$	$s_g$
-50	0.04084	0.001424	2.627750	118.37	1427.03	118.43	1534.34	0.5661	6.9112
-45	0.05449	0.001436	2.007080	140.23	1433.38	140.31	1542.75	0.6630	6.8100
-40	0.07169	0.001449	1.553280	162.22	1439.56	162.33	1550.92	0.7583	6.7141
-35	0.09310	0.001462	1.216780	184.34	1445.55	184.48	1558.83	0.8522	6.6232
-30	0.11943	0.001475	0.963963	206.58	1451.34	206.76	1566.47	0.9446	6.5367
-25	0.15147	0.001489	0.771672	228.94	1456.92	229.17	1573.81	1.0357	6.4543
-20	0.19008	0.001503	0.623730	251.42	1462.27	251.71	1580.83	1.1254	6.3757
-15	0.23617	0.001518	0.508679	274.01	1467.39	274.37	1587.52	1.2137	6.3005
-10	0.29071	0.001534	0.418303	296.72	1472.25	297.16	1593.86	1.3009	6.2285
-5	0.35476	0.001550	0.346635	319.54	1476.85	320.09	1599.82	1.3868	6.1593
0	0.42939	0.001566	0.289297	342.48	1481.17	343.16	1605.39	1.4716	6.0926
5	0.51575	0.001583	0.243039	365.55	1485.20	366.36	1610.55	1.5553	6.0284
10	0.61505	0.001601	0.205426	388.74	1488.92	389.72	1615.27	1.6380	5.9662
15	0.72853	0.001619	0.174614	412.06	1492.32	413.24	1619.53	1.7197	5.9060
20	0.85748	0.001639	0.149198	435.53	1495.38	436.94	1623.31	1.8005	5.8475
25	1.00324	0.001659	0.128092	459.16	1498.08	460.82	1626.59	1.8804	5.7904
30	1.16720	0.001680	0.110457	482.95	1500.40	484.91	1629.32	1.9597	5.7347
35	1.35077	0.001702	0.095633	506.93	1502.32	509.23	1631.49	2.0382	5.6802
40	1.55542	0.001726	0.083101	531.11	1503.81	533.79	1633.06	2.1161	5.6265
45	1.78266	0.001750	0.072450	555.51	1504.84	558.63	1633.99	2.1936	5.5736
50	2.03403	0.001777	0.063350	580.16	1505.37	583.77	1634.23	2.2706	5.5213
55	2.31113	0.001804	0.055538	605.09	1505.37	609.26	1633.73	2.3473	5.4693
60	2.61560	0.001834	0.048797	630.33	1504.79	635.12	1632.42	2.4239	5.4174
65	2.94913	0.001866	0.042955	655.91	1503.56	661.42	1630.24	2.5004	5.3655
70	3.31347	0.001900	0.037868	681.90	1501.62	688.20	1627.09	2.5770	5.3131
75	3.71045	0.001937	0.033419	708.34	1498.88	715.53	1622.88	2.6539	5.2601
80	4.14197	0.001978	0.029509	735.31	1495.24	743.50	1617.46	2.7312	5.2060
85	4.61002	0.002022	0.026058	762.88	1490.56	772.20	1610.69	2.8093	5.1505
90	5.11672	0.002071	0.022997	791.16	1484.67	801.76	1602.34	2.8884	5.0929
95	5.66432	0.002127	0.020268	820.29	1477.36	832.34	1592.16	2.9689	5.0328
100	6.25527	0.002190	0.017820	850.46	1468.32	864.16	1579.79	3.0513	4.9691
105	6.89227	0.002263	0.015610	881.91	1457.14	897.51	1564.72	3.1363	4.9007
110	7.57834	0.002350	0.013596	915.03	1443.19	932.84	1546.23	3.2249	4.8258

T (°C)	P (MPa)	Specific Volume m <sup>3</sup> /kg		Specific Internal Energy kJ/kg		Specific Enthalpy kJ/kg		Specific Entropy kJ/kgK	
115	8.31700	0.002456	0.011740	950.47	1425.51	970.89	1523.15	3.3190	4.7418
120	9.11249	0.002594	0.009993	989.44	1402.32	1013.08	1493.38	3.4218	4.6435
125	9.97022	0.002795	0.008283	1034.97	1369.69	1062.84	1452.28	3.5417	4.5199
130	10.89770	0.003202	0.006379	1100.28	1312.96	1135.17	1382.47	3.7153	4.3287
132.25	11.33930	0.004444	0.004444	1211.98	1211.98	1262.38	1262.38	4.0258	4.0258

**Table B2: Superheated Ammonia**

T (°C)	v m <sup>3</sup> /kg	u kJ/kg	h kJ/kg	s kJ/kgK	v m <sup>3</sup> /kg	u kJ/kg	h kJ/kg	s kJ/kgK
	<b>P = 50 kPa (Sat. T = -46.51°C)</b>				<b>P = 100 kPa (Sat. T = -33.58°C)</b>			
Sat	2.17495	1431.47	1540.22	6.8401	1.13809	1447.21	1561.01	6.5983
-30	2.34496	1458.80	1576.05	6.9927	1.15730	1453.48	1569.21	6.6323
-20	2.44645	1475.09	1597.42	7.0788	1.21016	1470.67	1591.69	6.7229
-10	2.54720	1491.30	1618.66	7.1611	1.26220	1487.57	1613.79	6.8085
0	2.64739	1507.47	1639.84	7.2402	1.31365	1504.29	1635.65	6.8900
10	2.74715	1523.67	1661.02	7.3163	1.36463	1520.91	1657.37	6.9681
20	2.84657	1539.91	1682.24	7.3899	1.41527	1537.50	1679.03	7.0433
30	2.94572	1556.23	1703.51	7.4613	1.46562	1554.10	1700.66	7.1159
40	3.04466	1572.64	1724.88	7.5306	1.51576	1570.75	1722.33	7.1862
50	3.14343	1589.17	1746.34	7.5981	1.56571	1587.48	1744.05	7.2544
60	3.24205	1605.83	1767.93	7.6639	1.61552	1604.30	1765.85	7.3209
70	3.34056	1622.63	1789.65	7.7281	1.66521	1621.23	1787.76	7.3857
80	3.43896	1639.57	1811.52	7.7910	1.71480	1638.30	1809.78	7.4490
90	3.53729	1656.68	1833.54	7.8525	1.76431	1655.51	1831.94	7.5108
100	3.63554	1673.95	1855.73	7.9127	1.81374	1672.88	1854.25	7.5714
110	3.73373	1691.40	1878.08	7.9718	1.86311	1690.40	1876.71	7.6308
120	3.83187	1709.02	1900.62	8.0299	1.91243	1708.10	1899.34	7.6891
130	3.92996	1726.83	1923.33	8.0869	1.96170	1725.97	1922.14	7.7464
140	4.02801	1744.83	1946.23	8.1431	2.01094	1744.02	1945.12	7.8027
150	4.12603	1763.03	1969.33	8.1983	2.06013	1762.27	1968.28	7.8581
160	4.22402	1781.42	1992.62	8.2527	2.10930	1780.70	1991.63	7.9126
170	4.32198	1800.01	2016.11	8.3063	2.15844	1799.34	2015.18	7.9664
180	4.41991	1818.81	2039.80	8.3592	2.20755	1818.17	2038.92	8.0194
190	4.51783	1837.81	2063.70	8.4113	2.25664	1837.21	2062.87	8.0716
200	4.61572	1857.03	2087.81	8.4628	2.30572	1856.45	2087.02	8.1232

T (°C)	v m <sup>3</sup> /kg	u kJ/kg	h kJ/kg	s kJ/kgK	v m <sup>3</sup> /kg	u kJ/kg	h kJ/kg	s kJ/kgK
--------	-------------------------	------------	------------	-------------	-------------------------	------------	------------	-------------

T (°C)	v m <sup>3</sup> /kg	u kJ/kg	h kJ/kg	s kJ/kgK	v m <sup>3</sup> /kg	u kJ/kg	h kJ/kg	s kJ/kgK
	<b>P = 150 kPa (Sat. T = -25.20 °C)</b>				<b>P = 200 kPa (Sat. T = -18.84 °C)</b>			
Sat	0.778759	1456.69	1573.50	6.4577	0.594648	1463.47	1582.40	6.3581
-20	0.797792	1466.08	1585.75	6.5066	–	–	–	–
-10	0.833689	1483.73	1608.78	6.5958	0.619287	1479.77	1603.63	6.4401
0	0.868939	1501.03	1631.37	6.6801	0.646486	1497.69	1626.98	6.5272
10	0.903705	1518.10	1653.66	6.7602	0.673171	1515.24	1649.87	6.6096
20	0.938100	1535.05	1675.77	6.8370	0.699467	1532.57	1672.46	6.6880
30	0.972207	1551.95	1697.78	6.9108	0.725463	1549.77	1694.86	6.7631
40	1.006090	1568.84	1719.75	6.9821	0.751222	1566.91	1717.15	6.8354
50	1.039780	1585.76	1741.73	7.0512	0.776793	1584.04	1739.40	6.9054
60	1.073330	1602.75	1763.75	7.1183	0.802212	1601.20	1761.64	6.9732
70	1.106750	1619.83	1785.85	7.1836	0.827505	1618.42	1783.93	7.0391
80	1.140070	1637.02	1808.03	7.2474	0.852693	1635.74	1806.28	7.1033
90	1.173310	1654.34	1830.34	7.3096	0.877795	1653.16	1828.72	7.1659
100	1.206470	1671.79	1852.76	7.3706	0.902823	1670.71	1851.27	7.2272
110	1.239570	1689.40	1875.34	7.4303	0.927789	1688.40	1873.95	7.2872
120	1.272610	1707.17	1898.06	7.4888	0.952700	1706.23	1896.77	7.3460
130	1.305610	1725.10	1920.94	7.5463	0.977565	1724.23	1919.75	7.4037
140	1.338570	1743.21	1944.00	7.6028	1.002390	1742.40	1942.88	7.4604
150	1.371500	1761.51	1967.23	7.6583	1.027180	1760.74	1966.18	7.5161
160	1.404390	1779.99	1990.65	7.7130	1.051930	1779.27	1989.66	7.5709
170	1.437260	1798.66	2014.25	7.7669	1.076660	1797.99	2013.32	7.6249
180	1.470100	1817.53	2038.05	7.8200	1.101370	1816.89	2037.17	7.6781
190	1.502920	1836.60	2062.04	7.8724	1.126050	1836.00	2061.21	7.7306
200	1.535710	1855.88	2086.24	7.9241	1.150710	1855.31	2085.45	7.7824
210	1.568500	1875.36	2110.64	7.9751	1.175360	1874.82	2109.89	7.8335
220	1.601260	1895.06	2135.25	8.0255	1.199990	1894.54	2134.54	7.8840

T (°C)	v m <sup>3</sup> /kg	u kJ/kg	h kJ/kg	s kJ/kgK	v m <sup>3</sup> /kg	u kJ/kg	h kJ/kg	s kJ/kgK
	<b>P = 300 kPa (Sat. T = -9.224 °C)</b>				<b>P = 400 kPa (Sat. T = -1.88 °C)</b>			
Sat	0.406085	1472.98	1594.81	6.2175	0.309410	1479.58	1603.34	6.1174
0	0.423819	1490.74	1617.89	6.3035	0.312249	1483.41	1608.31	6.1356
10	0.442489	1509.34	1642.08	6.3905	0.326987	1503.18	1633.97	6.2279
20	0.460728	1527.48	1665.70	6.4725	0.341246	1522.21	1658.71	6.3138
30	0.478641	1545.32	1688.91	6.5503	0.355149	1540.75	1682.81	6.3946
40	0.496302	1562.98	1711.87	6.6249	0.368782	1558.96	1706.48	6.4714
50	0.513762	1580.54	1734.67	6.6965	0.382202	1576.97	1729.85	6.5449

T (°C)	v m <sup>3</sup> /kg	u kJ/kg	h kJ/kg	s kJ/kgK	v m <sup>3</sup> /kg	u kJ/kg	h kJ/kg	s kJ/kgK
60	0.531063	1598.05	1757.37	6.7657	0.395454	1594.86	1753.04	6.6156
70	0.548233	1615.58	1780.05	6.8328	0.408571	1612.70	1776.12	6.6839
80	0.565296	1633.15	1802.74	6.8979	0.421576	1630.53	1799.16	6.7500
90	0.582269	1650.79	1825.47	6.9614	0.434489	1648.39	1822.19	6.8143
100	0.599166	1668.53	1848.28	7.0234	0.447324	1666.32	1845.25	6.8770
110	0.616000	1686.38	1871.18	7.0839	0.460094	1684.35	1868.38	6.9382
120	0.632778	1704.36	1894.19	7.1432	0.472807	1702.48	1891.60	6.9980
130	0.649508	1722.49	1917.34	7.2014	0.485473	1720.73	1914.92	7.0566
140	0.666198	1740.77	1940.63	7.2584	0.498096	1739.13	1938.37	7.1140
150	0.682851	1759.22	1964.07	7.3145	0.510683	1757.68	1961.95	7.1704
160	0.699473	1777.83	1987.68	7.3696	0.523238	1776.39	1985.69	7.2258
170	0.716066	1796.63	2011.45	7.4239	0.535764	1795.27	2009.58	7.2804
180	0.732635	1815.61	2035.40	7.4774	0.548266	1814.33	2033.64	7.3341
190	0.749181	1834.79	2059.54	7.5300	0.560745	1833.57	2057.87	7.3870
200	0.765708	1854.16	2083.87	7.5820	0.573204	1853.01	2082.29	7.4391
210	0.782217	1873.73	2108.39	7.6333	0.585645	1872.63	2106.89	7.4906
220	0.798710	1893.50	2133.11	7.6839	0.598070	1892.46	2131.69	7.5414
230	0.815188	1913.48	2158.04	7.7340	0.610480	1912.49	2156.68	7.5915
240	0.831653	1933.67	2183.17	7.7834	0.622877	1932.72	2181.87	7.6411
250	0.848105	1954.08	2208.51	7.8323	0.635261	1953.17	2207.27	7.6901
260	0.864547	1974.69	2234.06	7.8807	0.647635	1973.83	2232.88	7.7386

T (°C)	v m <sup>3</sup> /kg	u kJ/kg	h kJ/kg	s kJ/kgK	v m <sup>3</sup> /kg	u kJ/kg	h kJ/kg	s kJ/kgK
	<b>P = 500 kPa (Sat. T = 4.13 °C)</b>				<b>P = 600 kPa (Sat. T = 9.28 °C)</b>			
Sat	0.250324	1484.53	1609.69	6.0393	0.210353	1488.41	1614.62	5.9750
10	0.257544	1496.73	1625.50	6.0957	0.211117	1489.97	1616.64	5.9821
20	0.269459	1516.75	1651.48	6.1859	0.221513	1511.08	1643.99	6.0771
30	0.280985	1536.04	1676.54	6.2699	0.231480	1531.20	1670.09	6.1646
40	0.292219	1554.85	1700.96	6.3492	0.241132	1550.64	1695.32	6.2465
50	0.303228	1573.34	1724.95	6.4246	0.250546	1569.63	1719.96	6.3240
60	0.314060	1591.62	1748.65	6.4968	0.259773	1588.32	1744.18	6.3978
70	0.324751	1609.77	1772.15	6.5663	0.268852	1606.81	1768.13	6.4686
80	0.335327	1627.88	1795.54	6.6335	0.277812	1625.20	1791.89	6.5369
90	0.345807	1645.98	1818.88	6.6987	0.286674	1643.53	1815.54	6.6029
100	0.356208	1664.10	1842.21	6.7621	0.295454	1661.87	1839.14	6.6670
110	0.366541	1682.30	1865.57	6.8239	0.304166	1680.24	1862.73	6.7294
120	0.376818	1700.58	1888.99	6.8842	0.312819	1698.67	1886.36	6.7903

T (°C)	v m <sup>3</sup> /kg	u kJ/kg	h kJ/kg	s kJ/kgK	v m <sup>3</sup> /kg	u kJ/kg	h kJ/kg	s kJ/kgK
130	0.387045	1718.97	1912.49	6.9432	0.321422	1717.19	1910.05	6.8498
140	0.397230	1737.48	1936.10	7.0011	0.329982	1735.83	1933.82	6.9080
150	0.407378	1756.14	1959.83	7.0578	0.338505	1754.59	1957.69	6.9651
160	0.417494	1774.94	1983.69	7.1136	0.346995	1773.49	1981.68	7.0212
170	0.427580	1793.91	2007.70	7.1683	0.355455	1792.54	2005.81	7.0762
180	0.437642	1813.04	2031.86	7.2223	0.363891	1811.75	2030.08	7.1304
190	0.447681	1832.35	2056.19	7.2754	0.372303	1831.13	2054.51	7.1837
200	0.457700	1851.85	2080.70	7.3277	0.380695	1850.69	2079.11	7.2363
210	0.467700	1871.54	2105.39	7.3794	0.389069	1870.43	2103.88	7.2881
220	0.477684	1891.41	2130.26	7.4303	0.397427	1890.37	2128.82	7.3392
230	0.487654	1911.49	2155.32	7.4806	0.405769	1910.50	2153.96	7.3896
240	0.497610	1931.77	2180.58	7.5303	0.414099	1930.82	2179.28	7.4395
250	0.507554	1952.26	2206.04	7.5795	0.422416	1951.35	2204.80	7.4887
260	0.517487	1972.96	2231.70	7.6281	0.430721	1972.09	2230.52	7.5374

T (°C)	v m <sup>3</sup> /kg	u kJ/kg	h kJ/kg	s kJ/kgK	v m <sup>3</sup> /kg	u kJ/kg	h kJ/kg	s kJ/kgK
	<b>P = 800 kPa (Sat. T = 17.84°C)</b>				<b>P = 1000 kPa (Sat. T = 24.89°C)</b>			
Sat	0.159551	1494.11	1621.75	5.8725	0.128497	1498.03	1626.52	5.7916
20	0.161354	1499.04	1628.12	5.8943	–	–	–	–
30	0.169445	1521.03	1656.59	5.9898	0.132037	1510.15	1642.19	5.8437
40	0.177166	1541.90	1683.63	6.0776	0.138657	1532.67	1671.32	5.9383
50	0.184614	1561.99	1709.68	6.1595	0.144962	1554.01	1698.97	6.0252
60	0.191854	1581.56	1735.04	6.2367	0.151035	1574.55	1725.59	6.1063
70	0.198934	1600.77	1759.91	6.3103	0.156931	1594.54	1751.47	6.1829
80	0.205884	1619.74	1784.45	6.3808	0.162688	1614.15	1776.84	6.2558
90	0.212730	1638.57	1808.76	6.4487	0.168333	1633.51	1801.85	6.3256
100	0.219490	1657.33	1832.92	6.5143	0.173887	1652.71	1826.60	6.3929
110	0.226178	1676.06	1857.01	6.5780	0.179366	1671.83	1851.19	6.4579
120	0.232805	1694.81	1881.06	6.6400	0.184782	1690.91	1875.69	6.5210
130	0.239381	1713.61	1905.12	6.7004	0.190144	1709.99	1900.14	6.5824
140	0.245912	1732.49	1929.22	6.7595	0.195460	1729.12	1924.58	6.6423
150	0.252405	1751.47	1953.39	6.8173	0.200737	1748.32	1949.05	6.7008
160	0.258864	1770.56	1977.65	6.8739	0.205979	1767.61	1973.59	6.7581
170	0.265294	1789.78	2002.02	6.9295	0.211191	1787.01	1998.20	6.8143
180	0.271697	1809.15	2026.51	6.9842	0.216376	1806.54	2022.91	6.8695
190	0.278077	1828.68	2051.14	7.0380	0.221538	1826.21	2047.74	6.9237
200	0.284437	1848.36	2075.91	7.0909	0.226678	1846.02	2072.70	6.9770

T (oC)	v m <sup>3</sup> /kg	u kJ/kg	h kJ/kg	s kJ/kgK	v m <sup>3</sup> /kg	u kJ/kg	h kJ/kg	s kJ/kgK
210	0.290778	1868.23	2100.85	7.1430	0.231800	1866.01	2097.81	7.0295
220	0.297102	1888.27	2125.95	7.1945	0.236905	1886.16	2123.06	7.0812
230	0.303412	1908.49	2151.22	7.2452	0.241995	1906.48	2148.48	7.1322
240	0.309708	1928.91	2176.68	7.2953	0.247071	1926.99	2174.07	7.1826
250	0.315991	1949.53	2202.32	7.3448	0.252135	1947.69	2199.83	7.2323
260	0.322263	1970.34	2228.15	7.3937	0.257187	1968.59	2225.77	7.2814
270	0.328525	1991.36	2254.18	7.4420	0.262229	1989.68	2251.91	7.3300
280	0.334778	2012.58	2280.40	7.4899	0.267262	2010.97	2278.23	7.3780
290	0.341022	2034.01	2306.83	7.5372	0.272286	2032.47	2304.76	7.4256
300	0.347258	2055.66	2333.47	7.5841	0.277301	2054.18	2331.48	7.4726

T (oC)	v m <sup>3</sup> /kg	u kJ/kg	h kJ/kg	s kJ/kgK	v m <sup>3</sup> /kg	u kJ/kg	h kJ/kg	s kJ/kgK
	<b>P = 1200 kPa (Sat. T = 30.93°C)</b>				<b>P = 1400 kPa (Sat. T = 36.25°C)</b>			
Sat	0.107487	1500.79	1629.77	5.7244	0.092296	1502.73	1631.95	5.6666
40	0.112860	1522.88	1658.31	5.8169	0.094311	1512.44	1644.48	5.7069
50	0.118442	1545.65	1687.78	5.9096	0.099416	1536.87	1676.05	5.8062
60	0.123761	1567.28	1715.79	5.9950	0.104221	1559.71	1705.62	5.8963
70	0.128884	1588.12	1742.78	6.0748	0.108808	1581.49	1733.82	5.9797
80	0.133856	1608.42	1769.05	6.1502	0.113230	1602.53	1761.05	6.0579
90	0.138708	1628.34	1794.79	6.2221	0.117523	1623.05	1787.59	6.1320
100	0.143464	1648.01	1820.17	6.2911	0.121715	1643.22	1813.62	6.2028
110	0.148141	1667.52	1845.29	6.3575	0.125823	1663.15	1839.30	6.2707
120	0.152753	1686.94	1870.25	6.4218	0.129863	1682.93	1864.73	6.3362
130	0.157308	1706.33	1895.10	6.4842	0.133844	1702.62	1890.00	6.3997
140	0.161816	1725.71	1919.89	6.5450	0.137777	1722.27	1915.16	6.4613
150	0.166284	1745.14	1944.68	6.6043	0.141668	1741.93	1940.26	6.5213
160	0.170716	1764.63	1969.49	6.6622	0.145523	1761.63	1965.36	6.5800
170	0.175117	1784.21	1994.35	6.7190	0.149346	1781.40	1990.48	6.6373
180	0.179491	1803.90	2019.29	6.7746	0.153141	1801.25	2015.65	6.6935
190	0.183841	1823.72	2044.33	6.8293	0.156912	1821.22	2040.89	6.7486
200	0.188170	1843.67	2069.48	6.8830	0.160661	1841.31	2066.23	6.8027
210	0.192480	1863.77	2094.75	6.9358	0.164391	1861.53	2091.68	6.8559
220	0.196772	1884.04	2120.16	6.9879	0.168104	1881.91	2117.25	6.9083
230	0.201049	1904.47	2145.72	7.0392	0.171801	1902.44	2142.96	6.9599
240	0.205313	1925.07	2171.45	7.0898	0.175484	1923.14	2168.82	7.0108
250	0.209563	1945.86	2197.33	7.1398	0.179154	1944.01	2194.83	7.0610
260	0.213803	1966.83	2223.39	7.1891	0.182813	1965.07	2221.00	7.1106

T (°C)	v m <sup>3</sup> /kg	u kJ/kg	h kJ/kg	s kJ/kgK	v m <sup>3</sup> /kg	u kJ/kg	h kJ/kg	s kJ/kgK
270	0.218032	1988.00	2249.63	7.2379	0.186461	1986.31	2247.35	7.1595
280	0.222251	2009.36	2276.06	7.2861	0.190100	2007.74	2273.88	7.2079
290	0.226461	2030.92	2302.67	7.3338	0.193729	2029.37	2300.59	7.2558
300	0.230664	2052.69	2329.48	7.3810	0.197351	2051.19	2327.49	7.3031
310	0.234859	2074.66	2356.49	7.4277	0.200965	2073.23	2354.58	7.3500
320	0.239047	2096.84	2383.70	7.4740	0.204572	2095.46	2381.86	7.3964

T (°C)	v m <sup>3</sup> /kg	u kJ/kg	h kJ/kg	s kJ/kgK	v m <sup>3</sup> /kg	u kJ/kg	h kJ/kg	s kJ/kgK
	<b>P = 1600 kPa (Sat. T = 41.02°C)</b>				<b>P = 2000 kPa (Sat. T = 49.35°C)</b>			
Sat	0.080782	1504.06	1633.31	5.6156	0.064453	1505.33	1634.24	5.5281
50	0.085064	1527.59	1663.69	5.7110	0.064729	1507.24	1636.69	5.5357
60	0.089509	1551.82	1695.03	5.8066	0.068754	1534.87	1672.38	5.6445
70	0.093710	1574.63	1724.57	5.8939	0.072463	1560.13	1705.06	5.7411
80	0.097730	1596.48	1752.84	5.9751	0.075952	1583.81	1735.72	5.8292
90	0.101612	1617.64	1780.22	6.0516	0.079278	1606.42	1764.97	5.9109
100	0.105385	1638.34	1806.95	6.1242	0.082480	1628.26	1793.22	5.9876
110	0.109071	1658.71	1833.22	6.1937	0.085583	1649.58	1820.75	6.0604
120	0.112684	1678.85	1859.15	6.2605	0.088608	1670.52	1847.73	6.1300
130	0.116238	1698.86	1884.84	6.3250	0.091567	1691.20	1874.33	6.1968
140	0.119741	1718.79	1910.37	6.3876	0.094473	1711.71	1900.65	6.2613
150	0.123200	1738.69	1935.81	6.4484	0.097332	1732.11	1926.78	6.3237
160	0.126623	1758.60	1961.20	6.5077	0.100152	1752.47	1952.77	6.3845
170	0.130013	1778.56	1986.58	6.5657	0.102939	1772.81	1978.69	6.4436
180	0.133375	1798.58	2011.98	6.6223	0.105696	1793.19	2004.58	6.5014
190	0.136713	1818.70	2037.44	6.6779	0.108427	1813.62	2030.47	6.5579
200	0.140028	1838.93	2062.97	6.7324	0.111136	1834.13	2056.40	6.6133
210	0.143323	1859.28	2088.59	6.7860	0.113824	1854.73	2082.38	6.6676
220	0.146601	1879.77	2114.33	6.8387	0.116494	1875.45	2108.44	6.7210
230	0.149863	1900.40	2140.18	6.8907	0.119148	1896.30	2134.60	6.7735
240	0.153111	1921.20	2166.18	6.9418	0.121788	1917.29	2160.87	6.8252
250	0.156347	1942.16	2192.31	6.9923	0.124414	1938.44	2187.26	6.8762
260	0.159570	1963.30	2218.61	7.0420	0.127029	1959.74	2213.80	6.9264
270	0.162783	1984.61	2245.07	7.0912	0.129632	1981.21	2240.47	6.9760
280	0.165986	2006.12	2271.69	7.1398	0.132226	2002.86	2267.31	7.0249
290	0.169180	2027.81	2298.50	7.1878	0.134811	2024.68	2294.30	7.0733
300	0.172366	2049.70	2325.48	7.2353	0.137387	2046.70	2321.47	7.1211
310	0.175544	2071.79	2352.66	7.2823	0.139956	2068.90	2348.81	7.1684



T (°C)	v m <sup>3</sup> /kg	u kJ/kg	h kJ/kg	s kJ/kgK	v m <sup>3</sup> /kg	u kJ/kg	h kJ/kg	s kJ/kgK
320	0.178716	2094.08	2380.02	7.3288	0.142518	2091.30	2376.34	7.2152
330	0.181881	2116.57	2407.58	7.3749	0.145073	2113.90	2404.04	7.2615
340	0.185040	2139.28	2435.34	7.4206	0.147622	2136.70	2431.94	7.3074
350	0.188194	2162.19	2463.30	7.4658	0.150166	2159.71	2460.04	7.3529
360	0.191342	2185.32	2491.47	7.5106	0.152704	2182.92	2488.33	7.3979

T (°C)	v m <sup>3</sup> /kg	u kJ/kg	h kJ/kg	s kJ/kgK	v m <sup>3</sup> /kg	u kJ/kg	h kJ/kg	s kJ/kgK
	<b>P = 5000 kPa (Sat. T = 88.88°C)</b>				<b>P = 10000 kPa (Sat. T = 125.16°C)</b>			
Sat	0.023651	1486.10	1604.35	5.1060	0.008225	1368.34	1450.60	4.5150
100	0.026362	1532.44	1664.25	5.2690	–	–	–	–
110	0.028403	1566.88	1708.89	5.3871	–	–	–	–
120	0.030227	1597.55	1748.68	5.4897	–	–	–	–
130	0.031907	1625.81	1785.34	5.5818	0.009934	1433.77	1533.11	4.7211
140	0.033481	1652.43	1819.83	5.6663	0.011935	1505.07	1624.42	4.9451
150	0.034976	1677.89	1852.76	5.7451	0.013381	1554.67	1688.48	5.0983
160	0.036407	1702.51	1884.54	5.8193	0.014589	1595.47	1741.36	5.2219
170	0.037788	1726.51	1915.45	5.8898	0.015656	1631.40	1787.95	5.3283
180	0.039128	1750.06	1945.69	5.9573	0.016629	1664.22	1830.51	5.4232
190	0.040432	1773.27	1975.43	6.0222	0.017534	1694.94	1870.27	5.5100
200	0.041706	1796.24	2004.77	6.0849	0.018386	1724.14	1908.00	5.5906
210	0.042954	1819.05	2033.82	6.1457	0.019197	1752.22	1944.20	5.6663
220	0.044180	1841.75	2062.65	6.2047	0.019975	1779.47	1979.22	5.7381
230	0.045386	1864.39	2091.32	6.2623	0.020725	1806.07	2013.32	5.8065
240	0.046575	1887.00	2119.88	6.3185	0.021451	1832.18	2046.69	5.8722
250	0.047748	1909.63	2148.37	6.3735	0.022156	1857.92	2079.48	5.9355
260	0.048908	1932.29	2176.83	6.4274	0.022844	1883.37	2111.81	5.9967
270	0.050056	1955.01	2205.29	6.4802	0.023517	1908.61	2143.78	6.0561
280	0.051192	1977.81	2233.77	6.5322	0.024176	1933.70	2175.46	6.1139
290	0.052318	2000.70	2262.29	6.5833	0.024823	1958.69	2206.92	6.1703
300	0.053435	2023.71	2290.88	6.6336	0.025459	1983.61	2238.20	6.2254
310	0.054543	2046.84	2319.55	6.6832	0.026086	2008.50	2269.36	6.2793
320	0.055644	2070.10	2348.32	6.7321	0.026704	2033.39	2300.43	6.3321
330	0.056738	2093.51	2377.20	6.7804	0.027314	2058.31	2331.45	6.3839
340	0.057825	2117.06	2406.19	6.8281	0.027916	2083.27	2362.43	6.4349
350	0.058906	2140.78	2435.31	6.8752	0.028513	2108.30	2393.42	6.4850
360	0.059982	2164.66	2464.57	6.9218	0.029103	2133.40	2424.43	6.5344
370	0.061053	2188.72	2493.98	6.9679	0.029687	2158.60	2455.47	6.5830

T (°C)	v m <sup>3</sup> /kg	u kJ/kg	h kJ/kg	s kJ/kgK	v m <sup>3</sup> /kg	u kJ/kg	h kJ/kg	s kJ/kgK
380	0.062119	2212.95	2523.54	7.0135	0.030267	2183.91	2486.57	6.6310
390	0.063181	2237.36	2553.26	7.0586	0.030841	2209.33	2517.74	6.6784
400	0.064238	2261.95	2583.14	7.1034	0.031412	2234.88	2548.99	6.7252
410	0.065292	2286.74	2613.20	7.1477	0.031978	2260.56	2580.34	6.7714
420	0.066342	2311.72	2643.42	7.1916	0.032540	2286.39	2611.79	6.8171

### Reference States, default for fluid

- **Enthalpy** H = 1699.663687 kJ/kg at 26.9 C and 0.0010 MPa.
- **Entropy** S = 9.356091 kJ/kg-K at 26.9 C and 0.0010 MPa.

Source: Eric W. Lemmon, Mark O. McLinden and Daniel G. Friend, “Thermophysical Properties of Fluid Systems” in **NIST Chemistry WebBook, NIST Standard Reference Database Number 69**, Eds. P.J. Linstrom and W.G. Mallard, National Institute of Standards and Technology, Gaithersburg MD, 20899, <https://doi.org/10.18434/T4D303>, (retrieved May 2021).

This page titled [7.2: Appendix B - Thermodynamic Properties of Ammonia](#) is shared under a [not declared](#) license and was authored, remixed, and/or curated by [Claire Yu Yan \(BC Campus\)](#) via [source content](#) that was edited to the style and standards of the LibreTexts platform; a detailed edit history is available upon request.

## 7.3: Appendix C - Thermodynamic Properties of R134a

**Table C1: Saturated R134a**

T (°C)	P (MPa)	Specific Volume m <sup>3</sup> /kg		Specific Internal Energy kJ/kg		Specific Enthalpy kJ/kg		Specific Entropy kJ/kgK	
		$v_f$	$v_g$	$u_f$	$u_g$	$h_f$	$h_g$	$s_f$	$s_g$
-70	0.00798	0.000666	2.058960	111.19	338.59	111.20	355.02	0.6262	1.8264
-65	0.01138	0.000672	1.476490	117.26	341.35	117.27	358.16	0.6557	1.8130
-60	0.01591	0.000678	1.079030	123.35	344.15	123.36	361.31	0.6846	1.8010
-55	0.02183	0.000685	0.802362	129.49	346.96	129.50	364.48	0.7131	1.7902
-50	0.02945	0.000691	0.606198	135.65	349.80	135.67	367.65	0.7410	1.7806
-45	0.03912	0.000698	0.464726	141.86	352.65	141.89	370.83	0.7685	1.7720
-40	0.05121	0.000705	0.361076	148.11	355.51	148.14	374.00	0.7956	1.7643
-35	0.06614	0.000713	0.284018	154.40	358.38	154.45	377.17	0.8223	0.8223
-30	0.08438	0.000720	0.225945	160.73	361.25	160.79	380.32	0.8486	1.7515
-25	0.10640	0.000728	0.181623	167.11	364.13	167.19	383.45	0.8746	1.7461
-20	0.13274	0.000736	0.147395	173.54	366.99	173.64	386.55	0.9002	1.7413
-15	0.16394	0.000745	0.120671	180.02	369.85	180.14	389.63	0.9256	1.7371
-10	0.20060	0.000754	0.099590	186.55	372.69	186.70	392.67	0.9506	1.7334
-5	0.24334	0.000763	0.082801	193.13	375.51	193.32	395.66	0.9754	1.7300
0	0.29280	0.000772	0.069309	199.77	378.31	200.00	398.60	1.0000	1.7271
5	0.34966	0.000782	0.058374	206.48	381.08	206.75	401.49	1.0243	1.7245
10	0.41461	0.000793	0.049442	213.25	383.82	213.58	404.32	1.0485	1.7221
15	0.48837	0.000804	0.042090	220.09	386.52	220.48	407.07	1.0724	1.7200
20	0.57171	0.000816	0.035997	227.00	389.17	227.47	409.75	1.0962	1.7180
25	0.66538	0.000829	0.030912	233.99	391.77	234.55	412.33	1.1199	1.7162
30	0.77020	0.000842	0.026642	241.07	394.30	241.72	414.82	1.1435	1.7145
35	0.88698	0.000857	0.023033	248.25	396.76	249.01	417.19	1.1670	1.7128
40	1.01659	0.000872	0.019966	255.52	399.13	256.41	419.43	1.1905	1.7111
45	1.15992	0.000889	0.017344	262.91	401.40	263.94	421.52	1.2139	1.7092
50	1.31791	0.000907	0.015089	270.43	403.55	271.62	423.44	1.2375	1.7073
55	1.49151	0.000927	0.013140	278.09	405.56	279.47	425.15	1.2611	1.7050
60	1.68178	0.000950	0.011444	285.91	407.38	287.51	426.63	1.2848	1.7024
65	1.88982	0.000975	0.009960	293.92	408.99	295.76	427.82	1.3088	1.6994
70	2.11683	0.001004	0.008653	302.16	410.33	304.28	428.65	1.3332	1.6956
75	2.36412	0.001037	0.007491	310.68	411.32	313.13	429.03	1.3580	1.6910
80	2.63320	0.001077	0.006448	319.55	411.83	322.39	428.81	1.3836	1.6850
85	2.92583	0.001127	0.005499	328.93	411.67	332.22	427.76	1.4104	1.6771
90	3.24418	0.001194	0.004613	339.06	410.45	342.93	425.42	1.4390	1.6662

T (°C)	P (MPa)	Specific Volume m <sup>3</sup> /kg		Specific Internal Energy kJ/kg		Specific Enthalpy kJ/kg		Specific Entropy kJ/kgK	
95	3.59123	0.001294	0.003743	350.60	407.23	355.25	420.67	1.4715	1.6493
100	3.97238	0.001536	0.002681	367.20	397.03	373.30	407.68	1.5188	1.6109
101.06	4.05911	0.001954	0.001954	381.71	381.71	389.64	389.64	1.5621	1.5621

**Table C2: Superheated R134a**

T (°C)	v m <sup>3</sup> /kg	u kJ/kg	h kJ/kg	s kJ/kgK	v m <sup>3</sup> /kg	u kJ/kg	h kJ/kg	s kJ/kgK
	<b>P = 50 kPa (Sat. T = -40.45 °C)</b>				<b>P = 100 kPa (Sat. T = -26.36 °C)</b>			
Sat	0.369253	355.25	373.72	1.7650	0.192558	363.34	382.60	1.7475
-20	0.404876	368.97	389.21	1.8288	0.198410	367.81	387.65	1.7677
-10	0.421989	375.89	396.99	1.8590	0.207433	374.89	395.64	1.7986
0	0.438974	382.98	404.93	1.8885	0.216303	382.10	403.73	1.8288
10	0.455859	390.22	413.02	1.9176	0.225060	389.45	411.95	1.8584
20	0.472664	397.64	421.27	1.9463	0.233731	396.94	420.31	1.8874
30	0.489404	405.22	429.69	1.9745	0.242333	404.59	428.82	1.9160
40	0.506090	412.97	438.28	2.0024	0.250878	412.40	437.49	1.9441
50	0.522731	420.89	447.03	2.0299	0.259376	420.37	446.30	1.9718
60	0.539334	428.98	455.94	2.0571	0.267835	428.49	455.28	1.9991
70	0.555904	437.23	465.02	2.0839	0.276260	436.78	464.41	2.0261
80	0.572447	445.64	474.26	2.1105	0.284657	445.23	473.70	2.0528
90	0.588966	454.22	483.67	2.1367	0.293029	453.84	483.14	2.0792
100	0.605464	462.96	493.24	2.1627	0.301380	462.61	492.74	2.1053
110	0.621943	471.87	502.96	2.1884	0.309713	471.53	502.50	2.1311
120	0.638407	480.93	512.85	2.2139	0.318029	480.61	512.42	2.1566
130	0.654857	490.15	522.89	2.2391	0.326331	489.85	522.49	2.1819

T (°C)	v m <sup>3</sup> /kg	u kJ/kg	h kJ/kg	s kJ/kgK	v m <sup>3</sup> /kg	u kJ/kg	h kJ/kg	s kJ/kgK
	<b>P = 150 kPa (Sat. T = -17.13 °C)</b>				<b>P = 200 kPa (Sat. T = -10.07 °C)</b>			
Sat	0.131283	368.63	388.32	1.7388	0.099877	372.64	392.62	1.7334
-10	0.135816	373.84	394.21	1.7615	0.099915	372.70	392.68	1.7337
0	0.142013	381.19	402.49	1.7924	0.104811	380.24	401.20	1.7654
10	0.148081	388.64	410.86	1.8225	0.109552	387.82	409.73	1.7961
20	0.154053	396.23	419.33	1.8519	0.114185	395.49	418.33	1.8259
30	0.159950	403.95	427.94	1.8808	0.118737	403.29	427.04	1.8551
40	0.165787	411.82	436.68	1.9092	0.123226	411.22	435.87	1.8838
50	0.171576	419.83	445.57	1.9371	0.127663	419.29	444.83	1.9120
60	0.177323	428.01	454.60	1.9646	0.132057	427.51	453.92	1.9397

T (°C)	v m <sup>3</sup> /kg	u kJ/kg	h kJ/kg	s kJ/kgK	v m <sup>3</sup> /kg	u kJ/kg	h kJ/kg	s kJ/kgK
70	0.183036	436.33	463.79	1.9918	0.136415	435.88	463.16	1.9670
80	0.188719	444.82	473.12	2.0186	0.140744	444.40	472.54	1.9940
90	0.194377	453.45	482.61	2.0451	0.145046	453.06	482.07	2.0206
100	0.200014	462.25	492.25	2.0713	0.149326	461.88	491.75	2.0468
110	0.205631	471.20	502.04	2.0972	0.153588	470.86	501.57	2.0728
120	0.211233	480.30	511.98	2.1228	0.157832	479.98	511.55	2.0985
130	0.216819	489.56	522.08	2.1481	0.162062	489.26	521.67	2.1240
140	0.222394	498.97	532.33	2.1732	0.166278	498.69	531.95	2.1491

T (°C)	v m <sup>3</sup> /kg	u kJ/kg	h kJ/kg	s kJ/kgK	v m <sup>3</sup> /kg	u kJ/kg	h kJ/kg	s kJ/kgK
	<b>P = 300 kPa (Sat. T = 0.67 °C)</b>				<b>P = 400 kPa (Sat. T = 8.93 °C)</b>			
Sat	0.067704	378.68	399.00	1.7267	0.051207	383.24	403.72	1.7226
10	0.070931	386.06	407.34	1.7567	0.051506	384.12	404.72	1.7261
20	0.074254	393.96	416.24	1.7876	0.054214	392.32	414.01	1.7584
30	0.077478	401.93	425.18	1.8175	0.056797	400.50	423.22	1.7893
40	0.080629	410.00	434.19	1.8468	0.059293	408.73	432.45	1.8192
50	0.083723	418.19	443.31	1.8755	0.061724	417.05	441.74	1.8484
60	0.086770	426.50	452.54	1.9036	0.064105	425.47	451.11	1.8770
70	0.089779	434.95	461.89	1.9312	0.066443	434.01	460.58	1.9050
80	0.092755	443.54	471.37	1.9585	0.068748	442.67	470.17	1.9325
90	0.095705	452.27	480.99	1.9853	0.071023	451.47	479.88	1.9597
100	0.098631	461.15	490.74	2.0118	0.073275	460.41	489.72	1.9864
110	0.101537	470.17	500.63	2.0380	0.075505	469.48	499.68	2.0127
120	0.104426	479.34	510.67	2.0638	0.077717	478.69	509.78	2.0387
130	0.107299	488.66	520.85	2.0894	0.079914	488.05	520.02	2.0645
140	0.110160	498.12	531.17	2.1147	0.082097	497.55	530.39	2.0899
150	0.113009	507.74	541.64	2.1397	0.084268	507.20	540.91	2.1150
160	0.115847	517.50	552.25	2.1645	0.086429	516.99	551.56	2.1399

T (°C)	v m <sup>3</sup> /kg	u kJ/kg	h kJ/kg	s kJ/kgK	v m <sup>3</sup> /kg	u kJ/kg	h kJ/kg	s kJ/kgK
	<b>P = 500 kPa (Sat. T = 15.73 °C)</b>				<b>P = 600 kPa (Sat. T = 21.57 °C)</b>			
Sat	0.041123	386.91	407.47	1.7197	0.034300	389.99	410.57	1.7175
20	0.042116	390.55	411.61	1.7339	–	–	–	–
30	0.044338	398.99	421.16	1.7659	0.035984	397.37	418.96	1.7455
40	0.046456	407.40	430.63	1.7967	0.037866	406.01	428.73	1.7772
50	0.048500	415.86	440.11	1.8265	0.039659	414.63	438.43	1.8077

T (°C)	v m <sup>3</sup> /kg	u kJ/kg	h kJ/kg	s kJ/kgK	v m <sup>3</sup> /kg	u kJ/kg	h kJ/kg	s kJ/kgK
60	0.050486	424.40	449.64	1.8555	0.041389	423.30	448.13	1.8373
70	0.052427	433.04	459.25	1.8839	0.043070	432.04	457.88	1.8661
80	0.054332	441.78	468.95	1.9118	0.044711	440.87	467.70	1.8943
90	0.056205	450.65	478.76	1.9392	0.046319	449.82	477.61	1.9220
100	0.058054	459.65	488.68	1.9661	0.047900	458.88	487.62	1.9492
110	0.059880	468.78	498.72	1.9927	0.049459	468.06	497.74	1.9759
120	0.061688	478.04	508.88	2.0189	0.050998	477.37	507.97	2.0023
130	0.063479	487.44	519.18	2.0447	0.052520	486.82	518.33	2.0283
140	0.065257	496.98	529.60	2.0703	0.054027	496.39	528.81	2.0540
150	0.067022	506.66	540.17	2.0955	0.055522	506.11	539.42	2.0794
160	0.068776	516.48	550.86	2.1205	0.057006	515.96	550.16	2.1045
170	0.070521	526.44	561.70	2.1453	0.058480	525.95	561.04	2.1293

T (°C)	v m <sup>3</sup> /kg	u kJ/kg	h kJ/kg	s kJ/kgK	v m <sup>3</sup> /kg	u kJ/kg	h kJ/kg	s kJ/kgK
	<b>P = 800 kPa (Sat. T = 31.32 °C)</b>				<b>P = 1000 kPa (Sat. T = 39.38 °C)</b>			
Sat	0.025625	394.96	415.46	1.7140	0.020316	398.85	419.16	1.7113
40	0.027036	402.97	424.59	1.7436	0.020407	399.45	419.86	1.7135
50	0.028547	412.00	434.84	1.7758	0.021796	409.09	430.88	1.7482
60	0.029974	420.98	444.95	1.8067	0.023068	418.46	441.53	1.7806
70	0.031340	429.96	455.03	1.8365	0.024262	427.74	452.00	1.8116
80	0.032659	438.99	465.12	1.8654	0.025399	437.00	462.40	1.8415
90	0.033942	448.10	475.25	1.8937	0.026493	446.30	472.79	1.8705
100	0.035194	457.30	485.45	1.9214	0.027552	455.65	483.21	1.8988
110	0.036420	466.60	495.74	1.9486	0.028584	465.09	493.67	1.9264
120	0.037626	476.02	506.12	1.9754	0.029593	474.62	504.21	1.9536
130	0.038813	485.55	516.60	2.0017	0.030582	484.25	514.83	1.9803
140	0.039985	495.21	527.20	2.0277	0.031554	494.00	525.55	2.0065
150	0.041144	504.99	537.91	2.0533	0.032512	503.86	536.37	2.0324
160	0.042291	514.91	548.74	2.0786	0.033458	513.84	547.30	2.0579
170	0.043427	524.96	559.70	2.1036	0.034393	523.95	558.35	2.0831
180	0.044554	535.14	570.78	2.1283	0.035318	534.19	569.51	2.1081

T (°C)	v m <sup>3</sup> /kg	u kJ/kg	h kJ/kg	s kJ/kgK	v m <sup>3</sup> /kg	u kJ/kg	h kJ/kg	s kJ/kgK
	<b>P = 1200 kPa (Sat. T = 46.31 °C)</b>				<b>P = 1400 kPa (Sat. T = 52.42 °C)</b>			
Sat	0.016718	401.98	422.04	1.7087	0.014110	404.54	424.30	1.7062
50	0.017201	405.77	426.41	1.7223	–	–	–	–

T (°C)	v m <sup>3</sup> /kg	u kJ/kg	h kJ/kg	s kJ/kgK	v m <sup>3</sup> /kg	u kJ/kg	h kJ/kg	s kJ/kgK
60	0.018404	415.70	437.79	1.7570	0.015005	412.61	433.62	1.7345
70	0.019502	425.36	448.76	1.7895	0.016060	422.77	445.25	1.7689
80	0.020530	434.90	459.53	1.8204	0.017023	432.65	456.48	1.8012
90	0.021506	444.41	470.22	1.8502	0.017923	442.42	467.52	1.8320
100	0.022443	453.94	480.87	1.8792	0.018778	452.16	478.45	1.8617
110	0.023348	463.53	491.54	1.9074	0.019597	461.91	489.34	1.8905
120	0.024228	473.18	502.25	1.9350	0.020388	471.70	500.24	1.9186
130	0.025087	482.92	513.03	1.9621	0.021156	481.55	481.55	1.9460
140	0.025928	492.76	523.87	1.9886	0.021904	491.49	522.16	1.9730
150	0.026753	502.70	534.81	2.0148	0.022637	501.52	533.21	1.9994
160	0.027566	512.76	545.84	2.0406	0.023355	511.65	544.35	2.0254
170	0.028367	522.93	556.97	2.0660	0.024062	521.90	555.58	2.0510
180	0.029159	533.23	568.22	2.0911	0.024758	532.25	566.91	2.0763

T (°C)	v m <sup>3</sup> /kg	u kJ/kg	h kJ/kg	s kJ/kgK	v m <sup>3</sup> /kg	u kJ/kg	h kJ/kg	s kJ/kgK
	<b>P = 1600 kPa (Sat. T = 57.90 °C)</b>				<b>P = 2000 kPa (Sat. T = 67.48 °C)</b>			
Sat	0.012127	406.64	426.04	1.7036	0.009291	409.70	428.28	1.6976
60	0.012373	409.04	428.84	1.7120	–	–	–	–
70	0.013430	419.91	441.40	1.7491	0.009573	412.91	432.06	1.7086
80	0.014362	430.24	453.22	1.7831	0.010539	424.70	445.78	1.7481
90	0.015216	440.32	464.66	1.8150	0.011363	435.66	458.39	1.7833
100	0.016015	450.29	475.91	1.8456	0.012105	446.24	470.45	1.8160
110	0.016773	460.22	487.06	1.8751	0.012791	456.63	482.21	1.8471
120	0.017500	470.16	498.16	1.9037	0.013436	466.93	493.80	1.8770
130	0.018202	480.15	509.27	1.9316	0.014051	477.21	505.31	1.9059
140	0.018882	490.19	520.40	1.9589	0.014640	487.49	516.78	1.9340
150	0.019546	500.32	531.59	1.9856	0.015210	497.82	528.24	1.9614
160	0.020194	510.53	542.84	2.0119	0.015764	508.21	539.74	1.9883
180	0.021456	531.26	565.59	2.0632	0.016830	529.23	562.89	2.0405

T (°C)	v m <sup>3</sup> /kg	u kJ/kg	h kJ/kg	s kJ/kgK	v m <sup>3</sup> /kg	u kJ/kg	h kJ/kg	s kJ/kgK
	<b>P = 3000 kPa (Sat. T = 86.20°C)</b>				<b>P = 4000 kPa (Sat. T = 100.34 °C)</b>			
Sat	0.005281	411.50	427.34	1.6748	0.002563	395.13	405.38	1.6046
90	0.005752	418.53	435.78	1.6982	–	–	–	–
100	0.006641	433.18	453.10	1.7453	–	–	–	–
110	0.007327	445.79	467.77	1.7841	0.004273	429.17	446.26	1.7131

T (°C)	v m <sup>3</sup> /kg	u kJ/kg	h kJ/kg	s kJ/kgK	v m <sup>3</sup> /kg	u kJ/kg	h kJ/kg	s kJ/kgK
120	0.007917	457.57	481.32	1.8190	0.004993	445.13	465.10	1.7616
130	0.008447	468.92	494.26	1.8515	0.005549	458.71	480.90	1.8013
140	0.008937	480.05	506.86	1.8824	0.006024	471.28	495.38	1.8368
150	0.009396	491.05	519.24	1.9120	0.006450	483.32	509.12	1.8697
160	0.009832	502.00	531.50	1.9406	0.006842	495.07	522.43	1.9008
170	0.010250	512.93	543.68	1.9684	0.007208	506.64	535.47	1.9305
180	0.010652	523.89	555.84	1.9956	0.007554	518.11	548.33	1.9592

### Reference States, IIR Convention

- **Enthalpy**  $H = 200$  kJ/kg at 0°C for saturated liquid.
- **Entropy**  $S = 1$  kJ/kg-K at 0°C for saturated liquid.

Source: Eric W. Lemmon, Mark O. McLinden and Daniel G. Friend, “Thermophysical Properties of Fluid Systems” in **NIST Chemistry WebBook, NIST Standard Reference Database Number 69**, Eds. P.J. Linstrom and W.G. Mallard, National Institute of Standards and Technology, Gaithersburg MD, 20899, <https://doi.org/10.18434/T4D303>, (retrieved May 2021).

This page titled [7.3: Appendix C - Thermodynamic Properties of R134a](#) is shared under a [not declared](#) license and was authored, remixed, and/or curated by [Claire Yu Yan \(BC Campus\)](#) via [source content](#) that was edited to the style and standards of the LibreTexts platform; a detailed edit history is available upon request.



## 7.4: Appendix D - Thermodynamic Properties of Carbon Dioxide

**Table D1: Saturated CO<sub>2</sub>**

T (°C)	P (MPa)	Specific Volume m <sup>3</sup> /kg		Specific Internal Energy kJ/kg		Specific Enthalpy kJ/kg		Specific Entropy kJ/kgK	
		$v_f$	$v_g$	$u_f$	$u_g$	$h_f$	$h_g$	$s_f$	$s_g$
-50	0.68234	0.000866	0.055789	92.35	394.61	92.94	432.68	0.5794	2.1018
-48	0.73949	0.000872	0.051618	96.26	395.12	96.90	433.29	0.5968	2.0909
-46	0.80015	0.000878	0.047819	100.18	395.60	100.88	433.86	0.6142	2.0801
-44	0.86445	0.000883	0.044352	104.11	396.05	104.87	434.39	0.6314	2.0694
-42	0.93252	0.000889	0.041184	108.05	396.47	108.88	434.88	0.6486	2.0589
-40	1.00450	0.000896	0.038284	112.00	396.87	112.90	435.32	0.6656	2.0485
-38	1.08051	0.000902	0.035624	115.97	397.23	116.95	435.72	0.6826	2.0382
-36	1.16071	0.000909	0.033181	119.96	397.56	121.01	436.07	0.6995	2.0281
-34	1.24522	0.000915	0.030935	123.96	397.85	125.10	436.37	0.7163	2.0180
-32	1.33419	0.000922	0.028865	127.97	398.11	129.20	436.62	0.7331	2.0079
-30	1.42776	0.000930	0.026956	132.01	398.33	133.34	436.82	0.7498	1.9980
-28	1.52607	0.000937	0.025192	136.07	398.52	137.50	436.96	0.7665	1.9880
-26	1.62926	0.000945	0.023560	140.15	398.65	141.69	437.04	0.7831	1.9781
-24	1.73749	0.000953	0.022048	144.25	398.75	145.91	437.06	0.7997	1.9683
-22	1.85089	0.000961	0.020645	148.38	398.80	150.16	437.01	0.8163	1.9584
-20	1.96963	0.000969	0.019343	152.54	398.79	154.45	436.89	0.8328	1.9485
-18	2.09384	0.000978	0.018131	156.73	398.74	158.78	436.70	0.8494	1.9387
-16	2.22370	0.000987	0.017002	160.95	398.63	163.14	436.44	0.8659	1.9287
-14	2.35935	0.000997	0.015950	165.20	398.46	167.55	436.09	0.8825	1.9187
-12	2.50095	0.001007	0.014967	169.49	398.23	172.01	435.66	0.8991	1.9087
-10	2.64868	0.001017	0.014048	173.83	397.93	176.52	435.14	0.9157	1.8985
-8	2.80269	0.001028	0.013188	178.20	397.55	181.09	434.51	0.9324	1.8882
-6	2.96316	0.001040	0.012381	182.63	397.10	185.71	433.79	0.9491	1.8778
-4	3.13027	0.001052	0.011624	187.11	396.57	190.40	432.95	0.9660	1.8672
-2	3.30420	0.001065	0.010912	191.64	395.93	195.16	431.99	0.9829	1.8564
0	3.48514	0.001078	0.010241	196.24	395.20	200.00	430.89	1.0000	1.8453
2	3.67329	0.001093	0.009609	200.91	394.36	204.93	429.65	1.0172	1.8340
4	3.86884	0.001108	0.009011	205.66	393.39	209.95	428.25	1.0346	1.8223
6	4.07202	0.001124	0.008445	210.50	392.28	215.08	426.67	1.0523	1.8103
8	4.28306	0.001142	0.007909	215.44	391.02	220.34	424.89	1.0702	1.7977
10	4.50218	0.001161	0.007399	220.50	389.57	225.73	422.88	1.0884	1.7847
12	4.72966	0.001182	0.006912	225.69	387.92	231.29	420.62	1.1070	1.7710
14	4.96577	0.001205	0.006447	231.05	386.03	237.03	418.05	1.1261	1.7565

T (°C)	P (MPa)	Specific Volume m <sup>3</sup> /kg		Specific Internal Energy kJ/kg		Specific Enthalpy kJ/kg		Specific Entropy kJ/kgK	
16	5.21080	0.001231	0.006000	236.59	383.86	243.01	415.12	1.1458	1.7411
18	5.46511	0.001260	0.005569	242.38	381.33	249.26	411.77	1.1663	1.7244
20	5.72905	0.001293	0.005149	248.46	378.37	255.87	407.87	1.1877	1.7062
22	6.00308	0.001332	0.004737	254.93	374.83	262.93	403.27	1.2105	1.6860
24	6.28773	0.001379	0.004327	261.94	370.50	270.61	397.70	1.2352	1.6629
26	6.58368	0.001440	0.003908	269.78	364.98	279.26	390.71	1.2628	1.6353
28	6.89182	0.001526	0.003459	279.11	357.36	289.62	381.20	1.2958	1.5999
30	7.21369	0.001685	0.002898	292.40	344.23	304.55	365.13	1.3435	1.5433
30.9782	7.37730	0.002139	0.002139	316.47	316.47	332.25	332.25	1.4336	1.4336

**Table D2: Superheated CO2**

T (°C)	v m <sup>3</sup> /kg	u kJ/kg	h kJ/kg	s kJ/kgK	v m <sup>3</sup> /kg	u kJ/kg	h kJ/kg	s kJ/kgK
	<b>P = 400 kPa</b>				<b>P = 800 kPa (Sat. T = -46.00 °C)</b>			
Sat	–	–	–	–	0.046807	395.73	434.01	2.0771
-40	0.10499	405.37	447.36	2.2603	0.049662	399.96	439.69	2.1054
-20	0.11538	418.21	464.36	2.3302	0.055455	414.03	458.40	2.1825
0	0.12552	431.21	481.42	2.3951	0.060937	427.82	476.57	2.2516
20	0.13551	444.47	498.67	2.4561	0.066231	441.64	494.62	2.3153
40	0.14538	458.04	516.19	2.5139	0.071401	455.61	512.73	2.3751
60	0.15518	471.93	534.00	2.5690	0.076484	469.81	530.99	2.4316
80	0.16491	486.15	552.12	2.6218	0.081503	484.27	549.47	2.4855
100	0.17460	500.70	570.54	2.6725	0.086474	499.02	568.20	2.5371
120	0.18425	515.57	589.28	2.7214	0.091408	514.05	587.18	2.5866
140	0.19388	530.76	608.31	2.7687	0.096313	529.37	606.42	2.6343
160	0.20348	546.25	627.64	2.8143	0.101194	544.97	625.93	2.6805
180	0.21307	562.04	647.26	2.8586	0.106056	560.86	645.70	2.7251
200	0.22264	578.11	667.16	2.9016	0.110902	577.01	665.73	2.7683
220	0.23219	594.45	687.33	2.9433	0.115734	593.43	686.01	2.8103
240	0.24174	611.06	707.75	2.9839	0.120555	610.10	706.55	2.8511
260	0.25127	627.92	728.43	3.0235	0.125367	627.02	727.32	2.8908

T (°C)	v m <sup>3</sup> /kg	u kJ/kg	h kJ/kg	s kJ/kgK	v m <sup>3</sup> /kg	u kJ/kg	h kJ/kg	s kJ/kgK
	<b>P = 1000 kPa (Sat. T = -40.12 °C)</b>				<b>P = 1400 kPa (Sat. T = -30.58 °C)</b>			
Sat	0.03779	396.93	435.40	2.0467	0.027145	398.31	436.80	1.9990
-20	0.04342	411.80	455.21	2.1312	0.029569	406.95	448.34	2.0476
0	0.04799	426.05	474.04	2.2028	0.033153	422.32	468.73	2.1251

T (°C)	v m <sup>3</sup> /kg	u kJ/kg	h kJ/kg	s kJ/kgK	v m <sup>3</sup> /kg	u kJ/kg	h kJ/kg	s kJ/kgK
20	0.05236	440.17	492.53	2.2681	0.036483	437.13	488.21	2.1939
40	0.05660	454.36	510.96	2.3289	0.039661	451.80	507.33	2.2570
60	0.06074	468.73	529.47	2.3862	0.042739	466.52	526.35	2.3159
80	0.06482	483.32	548.14	2.4406	0.045746	481.38	545.43	2.3715
100	0.06885	498.17	567.01	2.4926	0.048700	496.44	564.62	2.4244
120	0.07284	513.28	586.12	2.5425	0.051615	511.73	583.99	2.4750
140	0.07680	528.67	605.47	2.5905	0.054499	527.26	603.56	2.5235
160	0.08074	544.33	625.07	2.6368	0.057358	543.04	623.34	2.5703
180	0.08465	560.26	644.92	2.6816	0.060197	559.07	643.35	2.6154
200	0.08856	576.46	665.02	2.7250	0.063019	575.36	663.58	2.6591
220	0.09244	592.91	685.36	2.7671	0.065828	591.89	684.05	2.7015
240	0.09632	609.62	705.94	2.8080	0.068625	608.66	704.73	2.7426
260	0.10019	626.57	726.76	2.8478	0.071413	625.67	725.65	2.7826
280	0.10405	643.76	747.81	2.8866	0.074192	642.91	746.78	2.8215

T (°C)	v m <sup>3</sup> /kg	u kJ/kg	h kJ/kg	s kJ/kgK	v m <sup>3</sup> /kg	u kJ/kg	h kJ/kg	s kJ/kgK
	<b>P = 2000 kPa (Sat. T = -19.50 °C)</b>				<b>P = 3000 kPa (Sat. T = -5.55 °C)</b>			
Sat	0.01885	398.78	436.83	1.9446	0.012124	396.93	433.52	1.8743
0	0.02193	416.15	460.00	2.0341	0.012931	403.43	442.22	1.9073
20	0.02453	432.27	481.32	2.1095	0.015116	423.12	468.46	2.0001
40	0.02693	447.78	501.65	2.1766	0.016980	440.52	491.46	2.0760
60	0.02922	463.09	521.54	2.2381	0.018683	457.04	513.09	2.1430
80	0.03143	478.40	541.27	2.2956	0.020287	473.21	534.07	2.2041
100	0.03359	493.80	560.97	2.3499	0.021824	489.25	554.73	2.2610
120	0.03570	509.36	580.76	2.4016	0.023313	505.32	575.26	2.3146
140	0.03777	525.12	600.67	2.4509	0.024766	521.48	595.77	2.3655
160	0.03982	541.09	620.73	2.4984	0.026191	537.77	616.35	2.4142
180	0.04186	557.27	640.99	2.5441	0.027594	554.24	637.02	2.4608
200	0.04387	573.69	661.43	2.5882	0.028979	570.89	657.83	2.5058
220	0.04587	590.34	682.08	2.6310	0.030350	587.74	678.79	2.5491
240	0.04786	607.21	702.92	2.6724	0.031708	604.79	699.91	2.5911
260	0.04983	624.31	723.98	2.7127	0.033057	622.04	721.21	2.6318
280	0.05180	641.63	745.24	2.7518	0.034396	639.49	742.68	2.6714
300	0.05377	659.17	766.70	2.7899	0.035729	657.15	764.34	2.7098

T (°C)	v m <sup>3</sup> /kg	u kJ/kg	h kJ/kg	s kJ/kgK	v m <sup>3</sup> /kg	u kJ/kg	h kJ/kg	s kJ/kgK

T (°C)	v m <sup>3</sup> /kg	u kJ/kg	h kJ/kg	s kJ/kgK	v m <sup>3</sup> /kg	u kJ/kg	h kJ/kg	s kJ/kgK
	P = 6000 kPa (Sat. T = 21.97 °C)				P = 10000 kPa			
Sat	0.00474	374.87	403.32	1.6862	–	–	–	–
20	–	–	–	–	0.001168	231.02	242.70	1.1251
40	0.00670	411.53	451.72	1.8462	0.001591	297.13	313.04	1.3563
60	0.00801	435.41	483.45	1.9445	0.003449	390.53	425.02	1.7045
80	0.00908	455.64	510.12	2.0223	0.004513	425.72	470.85	1.8384
100	0.01004	474.37	534.60	2.0898	0.005303	451.11	504.14	1.9302
120	0.01092	492.37	557.92	2.1507	0.005977	473.09	532.86	2.0052
140	0.01176	510.00	580.59	2.2069	0.006584	493.44	559.28	2.0708
160	0.01257	527.46	602.88	2.2596	0.007147	512.90	584.37	2.1301
180	0.01335	544.87	624.96	2.3094	0.007679	531.85	608.64	2.1849
200	0.01411	562.31	646.95	2.3569	0.008188	550.51	632.39	2.2362
220	0.01485	579.81	668.91	2.4024	0.008679	569.03	655.82	2.2847
240	0.01558	597.43	690.90	2.4461	0.009156	587.48	679.04	2.3308
260	0.01630	615.17	712.95	2.4882	0.009622	605.94	702.16	2.3750
280	0.01701	633.05	735.09	2.5290	0.010078	624.44	725.22	2.4175
300	0.01771	651.09	757.34	2.5685	0.010527	643.01	748.28	2.4584
320	0.01840	669.28	779.70	2.6069	0.010969	661.67	771.36	2.4980

### Reference States, IIR Convention

- **Enthalpy** H = 200 kJ/kg at 0°C for saturated liquid.
- **Entropy** S = 1 kJ/kg-K at 0°C for saturated liquid.

Source: Eric W. Lemmon, Mark O. McLinden and Daniel G. Friend, “Thermophysical Properties of Fluid Systems” in **NIST Chemistry WebBook, NIST Standard Reference Database Number 69**, Eds. P.J. Linstrom and W.G. Mallard, National Institute of Standards and Technology, Gaithersburg MD, 20899, <https://doi.org/10.18434/T4D303>, (retrieved May 2021).

This page titled [7.4: Appendix D - Thermodynamic Properties of Carbon Dioxide](#) is shared under a [not declared](#) license and was authored, remixed, and/or curated by [Claire Yu Yan \(BC Campus\)](#) via [source content](#) that was edited to the style and standards of the LibreTexts platform; a detailed edit history is available upon request.

## 7.5: Appendix E - Critical Properties of Selected Fluids

**Table E1: Critical Constants of Selected Fluids**

Substance	Formula	Molecular Mass (g/mol)	Temperature (K)	Pressure (MPa)	Specific Volume (m <sup>3</sup> /kg)
Water	H <sub>2</sub> O	18.015	647.1	22.06	0.003110
Ammonia	NH <sub>3</sub>	17.031	405.4	11.34	0.004444
Nitrogen	N <sub>2</sub>	28.013	126.2	3.40	0.003192
Hydrogen	H <sub>2</sub>	2.0160	33.1	1.30	0.031986
Oxygen	O <sub>2</sub>	31.999	154.6	5.04	0.002293
Carbon Dioxide	CO <sub>2</sub>	44.010	304.1	7.38	0.002139
Methane	CH <sub>4</sub>	16.043	190.6	4.60	0.006148
Ethane	C <sub>2</sub> H <sub>6</sub>	30.069	305.3	4.87	0.004841
Propane	C <sub>3</sub> H <sub>8</sub>	44.096	369.8	4.25	0.004536
Refrigerant, R12	CCl <sub>2</sub> F <sub>2</sub>	120.914	385.1	4.14	0.001770
Refrigerant, R22	CHClF <sub>2</sub>	86.468	369.3	4.99	0.001908
Refrigerant, R134a	CF <sub>3</sub> CH <sub>2</sub> F	102.03	374.2	4.06	0.001954

Source: Eric W. Lemmon, Mark O. McLinden and Daniel G. Friend, “Thermophysical Properties of Fluid Systems” in **NIST Chemistry WebBook, NIST Standard Reference Database Number 69**, Eds. P.J. Linstrom and W.G. Mallard, National Institute of Standards and Technology, Gaithersburg MD, 20899, <https://doi.org/10.18434/T4D303>, (retrieved May 2021).

This page titled [7.5: Appendix E - Critical Properties of Selected Fluids](#) is shared under a [not declared](#) license and was authored, remixed, and/or curated by [Claire Yu Yan \(BC Campus\)](#) via [source content](#) that was edited to the style and standards of the LibreTexts platform; a detailed edit history is available upon request.

## 7.6: Appendix F - Triple Point of Selected Substances

**Table F1: Triple Point of Selected Fluids**

Substance	Temperature K (°C)	Pressure kPa (atm)
Acetylene	192.4 K (−80.7 °C)	120 kPa (1.2 atm)
Ammonia	195.40 K (−77.75 °C)	6.060 kPa (0.05981 atm)
Argon	83.8058 K (−189.3442 °C)	68.9 kPa (0.680 atm)
Butane	134.6 K (−138.6 °C)	$7 \times 10^{-4}$ kPa ( $6.9 \times 10^{-6}$ atm)
Carbon dioxide	216.55 K (−56.60 °C)	517 kPa (5.10 atm)
Carbon monoxide	68.10 K (−205.05 °C)	15.37 kPa (0.1517 atm)
Ethane	89.89 K (−183.26 °C)	$1.1 \times 10^{-3}$ kPa ( $1.1 \times 10^{-5}$ atm)
Ethanol	150 K (−123 °C)	$4.3 \times 10^{-7}$ kPa ( $4.2 \times 10^{-9}$ atm)
Ethylene	104.0 K (−169.2 °C)	0.12 kPa (0.0012 atm)
Hexafluoroethane	173.08 K (−100.07 °C)	26.60 kPa (0.2625 atm)
Hydrogen	13.8033 K (−259.3467 °C)	7.04 kPa (0.0695 atm)
Hydrogen chloride	158.96 K (−114.19 °C)	13.9 kPa (0.137 atm)
Isobutane	113.55 K (−159.60 °C)	$1.9481 \times 10^{-5}$ kPa ( $1.9226 \times 10^{-7}$ atm)
Krypton	115.76 K (−157.39 °C)	74.12 kPa (0.7315 atm)
Mercury	234.3156 K (−38.8344 °C)	$1.65 \times 10^{-7}$ kPa ( $1.63 \times 10^{-9}$ atm)
Methane	90.68 K (−182.47 °C)	11.7 kPa (0.115 atm)
Neon	24.5561 K (−248.5939 °C)	43.332 kPa (0.42765 atm)
Nitric oxide	109.50 K (−163.65 °C)	21.92 kPa (0.2163 atm)
Nitrogen	63.18 K (−209.97 °C)	12.6 kPa (0.124 atm)
Nitrous oxide	182.34 K (−90.81 °C)	87.85 kPa (0.8670 atm)
Oxygen	54.3584 K (−218.7916 °C)	0.14625 kPa (0.0014434 atm)
Radon	202 K (−71 °C)	70 kPa (0.69 atm)
Water	273.16 K (0.01 °C)	0.611657 kPa (0.00603659 atm)
Xenon	161.3 K (−111.8 °C)	81.5 kPa (0.804 atm)

Source: Wikipedia contributors. (2021b, June 8). Triple point. Wikipedia. [https://en.Wikipedia.org/wiki/Triple\\_point](https://en.Wikipedia.org/wiki/Triple_point), (retrieved June 10, 2021).

This page titled [7.6: Appendix F - Triple Point of Selected Substances](#) is shared under a [not declared](#) license and was authored, remixed, and/or curated by [Claire Yu Yan \(BC Campus\)](#) via [source content](#) that was edited to the style and standards of the LibreTexts platform; a detailed edit history is available upon request.

## 7.7: Appendix G - Properties of Various Substances

**Table G1: Properties of various ideal gases (at 300K)**

Gas	Formula	R (kJ/kgK)	$C_p$ (kJ/kgK)	$C_v$ (kJ/kgK)	$k = C_p/C_v$
Air	—	0.287	1.005	0.718	1.4
Argon	Ar	0.2081	0.5203	0.3122	1.667
Butane	$C_4H_{10}$	0.1433	1.7164	1.5734	1.091
Carbon Dioxide	$CO_2$	0.1889	0.846	0.657	1.289
Carbon Monoxide	CO	0.2968	1.04	0.744	1.4
Ethane	$C_2H_6$	0.2765	1.7662	1.4897	1.186
Ethylene	$C_2H_4$	0.2964	1.5482	1.2518	1.237
Helium	He	2.0769	5.1926	3.1156	1.667
Hydrogen	$H_2$	4.124	14.307	10.183	1.405
Methane	$CH_4$	0.5182	2.2537	1.7354	1.299
Neon	Ne	0.4119	1.0299	0.6179	1.667
Nitrogen	$N_2$	0.2968	1.039	0.743	1.4
Octane	$C_8H_{18}$	0.0729	1.7113	1.6385	1.044
Oxygen	$O_2$	0.2598	0.918	0.658	1.395
Propane	$C_3H_8$	0.1885	1.6794	1.4909	1.126
Steam	$H_2O$	0.4615	1.8723	1.4108	1.327

**Table G2: Properties of various liquids (at 300K)**

Liquid	$C_p$ (kJ/kgK)
Ammonia	4.700
Ethanol	2.440
Gasoline	2.220
Mercury	0.1395
Methanol	2.140
Water	4.181

**Table G3: Properties of various solids (at 300K)**

Solid	$C_p$ (kJ/kgK)
Aluminum	0.897
Brick	0.840
Carbon, graphite	0.790
Concrete	0.880
Copper	0.385
Gold	0.129
Glass, silica	0.840

Solid	$C_p$ (kJ/kgK)
Glass, crown	0.670
Glass, flint	0.503
Glass, pyrex	0.753
Granite	0.790
Gypsum	1.090
Lead	0.129
Marble, mica	0.880
Magnesium	1.020
Sand	0.835
Silver	0.233
Soil	0.800
Steel	0.466
Tin	0.227
Tungsten	0.134
Wood	1.70
Zinc	0.387

Source: Wikipedia contributors. (May 1, 2021). Table of specific heat capacities. Wikipedia. [https://en.Wikipedia.org/wiki/Table\\_of\\_specific\\_heat\\_capacities](https://en.Wikipedia.org/wiki/Table_of_specific_heat_capacities), (retrieved June 10, 2021).

This page titled [7.7: Appendix G - Properties of Various Substances](#) is shared under a [not declared](#) license and was authored, remixed, and/or curated by [Claire Yu Yan \(BC Campus\)](#) via [source content](#) that was edited to the style and standards of the LibreTexts platform; a detailed edit history is available upon request.



# Index

---

## D

dire

## Glossary

**Absolute Pressure** | Absolute pressure is a pressure that is measured relative to an ideal reference, or absolute vacuum. It is the sum of the atmospheric pressure and the gauge pressure. Absolute pressure is ALWAYS a positive number.

**Absolute temperature** | Absolute temperature, also called thermodynamic temperature, is the temperature expressed on the **Kelvin** or **Rankine** scale. Absolute zero (0 K or 0 R) is the minimum possible temperature. Matter at absolute zero is in the state of lowest possible (minimum) energy.

**Adiabatic process** | An adiabatic process is a process, in which heat transfer does NOT occur between a system and its surroundings.

**Boundary** | Boundary or system boundary refers to the surface that separates the system and its surroundings.

**Boundary work** | Boundary work refers to the work done by a substance at the system boundary due to the expansion or compression of the substance.

**Chemical equilibrium** | Chemical equilibrium is a state in which the forward and backward reactions proceed at the same rate, causing no net change of the concentrations in either the reactants or the products. A system free from chemical reactions is in chemical equilibrium.

**Clausius statement** | It is impossible to construct a device that operates in a cycle and produces no effect other than the transfer of heat from a lower-temperature body (heat sink) to a higher-temperature body (heat source).

**Closed system** | A closed system is a system of a fixed mass. Mass transfer cannot happen between a closed system and its surroundings.

**Constant-pressure specific heat** | Constant-pressure specific heat is a property of a substance. It equals to the amount of energy required to raise the temperature of one unit mass (i.e., 1 kg) of the substance by one degree in an isobaric process.

**Constant-volume specific heat** | Constant-volume specific heat is a property of a substance. It equals to the amount of energy required to raise the temperature of one unit mass of the substance by one degree in an isochoric process.

**Continuum** | Continuum refers to a continuous homogeneous matter distributed throughout a system.

**Control volume** | Control volume is also called open system. It is a selected region in space, which allows mass and energy to transfer across the boundary between the system and its surroundings.

**Cycle** | A cycle consists of a series of processes. The final state of a cycle is always identical to its initial state.

**Density** | Density is the mass per unit volume of a body or a system.

**Enthalpy** | Enthalpy is a thermodynamic property. It is defined as the sum of the internal energy of a system and the flow work associated with the flowing fluid.

**Entropy** | Entropy is a thermodynamic property, which quantifies the degree of disorder of a system resulting from the dispersal of energy and matter in a process.

**Equation of state** | An equation of state is an expression that relates pressure, temperature and specific volume of a gas.

**Equilibrium** | Equilibrium refers to a uniform condition throughout a system.

**Equilibrium state** | An equilibrium state refers to a state of a system in equilibrium.

**Extensive property** | An extensive property refers to a thermodynamic property of a system, whose magnitude depends on the mass of the system. Examples of extensive properties include mass, volume, internal energy, enthalpy, and entropy.

**Fusion line** | Fusion line is a curve that represents the transition between the solid and liquid phases of a substance.

**Heat** | Heat is a form of energy. Heat transfer will take place between two objects if they are at different temperatures.

**Heat engine** | Heat engine is a device that produces work by absorbing heat from a high-temperature body (heat source) and rejecting the waste heat to a low-temperature body (heat sink).

**Heat sink** | A heat engine, refrigerator or heat pump must operate between a high-temperature body and a low-temperature body. The low-temperature body is called heat sink.

**Heat source** | A heat engine, refrigerator or heat pump must operate between a high-temperature body and a low temperature body. The high-temperature body is called heat source.

**Ideal gas** | An ideal gas is a gas that obeys the ideal gas equation of state,  $Pv=RT$ .

**Intensive property** | An intensive property is a thermodynamic property that does not depend on the mass of a system. Examples of intensive properties include pressure, temperature, density, specific volume, specific internal energy, specific enthalpy, and specific entropy.

**Internal energy** | Internal energy is a form of thermal energy. From a macroscopic level, it is strongly associated with the temperature of a system. From a microscopic level, it is associated with the motions and structure of the molecules of a system.

**Irreversibilities** | Irreversibilities refer to factors that render a process irreversible.

**Isentropic process** | An isentropic process refers to a process that is reversible and adiabatic. The entropy remains constant in an isentropic process.

**Isobaric process** | An isobaric process refers to a process whose pressure remains constant.

**Isochoric process** | An isochoric process refers to a process of constant specific volume.

**Isolated system** | An isolated system cannot exchange mass or energy with its surroundings.

**Isothermal process** | An isothermal process refers to a process whose temperature remains constant.

**Kelvin-Planck Statement** | It is impossible for any device that operates on a cycle to receive heat from a single reservoir and produce a net amount of work.

**Mechanical equilibrium** | Mechanical equilibrium refers to an equilibrium condition, in which the pressure of a system has no tendency to change over time.

**Open system** | Open system is also called control volume. It is a selected region in space, which allows mass and energy to transfer across the boundary between the system and its surroundings.

**Phase diagram** | Phase diagram is a graphical representation of a substance's state (solid, liquid or vapour) under different conditions of temperature and pressure.

**Phase equilibrium** | Phase equilibrium is an equilibrium condition. For a system consisting of a mixture of multiple phases, if the composition of the mixture remains constant over time, the system is in phase equilibrium.

**Pressure** | Pressure is the normal force exerted by an object on a surface per unit area of the surface.

**Process** | A process refers to the change in a system from one state to another state.

**Pure substance** | A pure substance refers to a matter that has a homogeneous and definite chemical composition. A pure substance may exist in a single phase or as a multi-phase mixture.

**Quasi-equilibrium process** | A quasi-equilibrium process refers to a process, in which all states are equilibrium states.

**Real gas** | A real gas refers to a gas, whose pressure, temperature and specific volume behaviour cannot be represented by the ideal gas equation of state.

**Reversible process** | A reversible process refers to a process that can be reversed without leaving any changes in either the system or its surroundings. In a reversible process, both the system and its surroundings can always return to their original states.

**Single phase** | Single phase refers to the solid, liquid or vapour (or gaseous) phase that a substance exists at a certain condition.

**Specific boundary work** | Specific boundary work is the boundary work done by one unit mass of a substance.

**Specific enthalpy** | Specific enthalpy is the enthalpy per unit mass of a system.

**Specific entropy** | Specific entropy is the entropy per unit mass of a system.

**Specific heat** | Specific heat, also called heat capacity, is a thermodynamic property to quantify the energy storage capacity of a substance. It is defined as the amount of heat required to raise the temperature of one unit mass of a substance by one degree.

**Specific internal energy** | Specific internal energy is the internal energy per unit mass of a system.

**Specific property** | A specific property is the corresponding extensive property per unit mass. Examples of specific properties include specific volume, specific internal energy, specific enthalpy, and specific entropy. Specific properties are intensive properties.

**Specific volume** | Specific volume is the volume per unit mass of a system. It is the reciprocal of density.

**State** | A state refers to a specific condition of a system that is described by a unique set of thermodynamic properties, such as pressure, temperature, specific volume, specific enthalpy, and so on.

**Steady flow** | A steady flow through a control volume refers to a flow, in which the properties, such as the mass and energy of the control volume remain unchanged over time.

**Sublimation line** | The sublimation line is the curve that represents the transition between the solid and vapour phases of a substance in a phase diagram.

**Surroundings** | In thermodynamic analysis, the universe is divided into two parts: a system and its surroundings. Surroundings refer to the rest of the universe outside of the system.

**System** | In thermodynamic analysis, the universe is divided into two parts: a system and its surroundings. A system refers to a selected quantity of matter or a region in space.

**Temperature** | Temperature is a measurable thermodynamic property that indicates the hotness or coldness of a body.

**Thermal equilibrium** | Thermal equilibrium is an equilibrium condition. A system in thermal equilibrium has a uniform temperature everywhere.

**Thermodynamics** | Thermodynamics is a branch of science. It originally focused on the scientific theories of heat-work conversion, and the operations and efficiency improvement of heat engines. Nowadays, the applications of thermodynamics have extended to all fields related to energy conversion and conservation.

**Transient flow** | A transient flow refers to a flow through a control volume, in which the properties, such as the mass and energy of the control volume change over time.

**Triple point** | The triple point refers to a unique state of a substance, at which the three phases, solid, liquid and vapour, coexist in equilibrium.

**Vapourization line** | The vapourization line refers to the curve that represents the transition between the liquid and vapour phases of a substance in a phase diagram.

**Work** | Work is a form of energy that is transferred to or from a body by applying a force on that body along a displacement.

## Detailed Licensing

### Overview

**Title:** [Introduction to Engineering Thermodynamics \(Yan\)](#)

**Webpages:** 72

**Applicable Restrictions:** Noncommercial

#### All licenses found:

- [CC BY-NC-SA 4.0](#): 70.8% (51 pages)
- [Undeclared](#): 29.2% (21 pages)

### By Page

- [Introduction to Engineering Thermodynamics \(Yan\) - CC BY-NC-SA 4.0](#)
  - [Front Matter - Undeclared](#)
    - [TitlePage - Undeclared](#)
    - [InfoPage - Undeclared](#)
    - [Table of Contents - Undeclared](#)
    - [Licensing - Undeclared](#)
    - [About the Author - Undeclared](#)
    - [Acknowledgements - Undeclared](#)
    - [Preface - Undeclared](#)
    - [Nomenclature - Undeclared](#)
  - [1: Basic Concepts and Definitions - CC BY-NC-SA 4.0](#)
    - [1.1: Chapter introduction and learning objectives - CC BY-NC-SA 4.0](#)
    - [1.2: What is thermodynamics about? - CC BY-NC-SA 4.0](#)
    - [1.3: System and surroundings - CC BY-NC-SA 4.0](#)
    - [1.4: Extensive and intensive properties - CC BY-NC-SA 4.0](#)
    - [1.5: State, process, and cycle - CC BY-NC-SA 4.0](#)
    - [1.6: Chapter review - CC BY-NC-SA 4.0](#)
  - [2: Thermodynamic Properties of a Pure Substance - CC BY-NC-SA 4.0](#)
    - [2.1: Chapter introduction and learning objectives - CC BY-NC-SA 4.0](#)
    - [2.2: Pure substance - CC BY-NC-SA 4.0](#)
    - [2.3: Thermodynamic properties - CC BY-NC-SA 4.0](#)
    - [2.4: Phase diagrams - CC BY-NC-SA 4.0](#)
    - [2.5: Thermodynamic tables - CC BY-NC-SA 4.0](#)
    - [2.6: Chapter review - CC BY-NC-SA 4.0](#)
    - [2.7: Key Equations - CC BY-NC-SA 4.0](#)
  - [3: Ideal and Real Gasses - CC BY-NC-SA 4.0](#)
    - [3.1: Chapter introduction and learning objectives - CC BY-NC-SA 4.0](#)
    - [3.2: Ideal gas and ideal gas equation of state - CC BY-NC-SA 4.0](#)
    - [3.3: Real gas and compressibility factor - CC BY-NC-SA 4.0](#)
    - [3.4: Chapter Review - CC BY-NC-SA 4.0](#)
    - [3.5: Key Equations - CC BY-NC-SA 4.0](#)
  - [4: The First Law of Thermodynamics for Closed Systems - CC BY-NC-SA 4.0](#)
    - [4.1: Chapter introduction and learning objectives - CC BY-NC-SA 4.0](#)
    - [4.2: Internal energy in a system - CC BY-NC-SA 4.0](#)
    - [4.3: Heat transfer across a boundary - CC BY-NC-SA 4.0](#)
    - [4.4: Work - CC BY-NC-SA 4.0](#)
    - [4.5: The first law of thermodynamics for closed systems - CC BY-NC-SA 4.0](#)
    - [4.6: Chapter review - CC BY-NC-SA 4.0](#)
    - [4.7: Key equations - CC BY-NC-SA 4.0](#)
  - [5: The First Law of Thermodynamics for a Control Volume - CC BY-NC-SA 4.0](#)
    - [5.1: Chapter introduction and learning objectives - CC BY-NC-SA 4.0](#)
    - [5.2: Enthalpy - CC BY-NC-SA 4.0](#)
    - [5.3: Mass and energy conservation equations in a control volume - CC BY-NC-SA 4.0](#)
    - [5.4: Applications of the mass and energy conservation equations in steady flow devices - CC BY-NC-SA 4.0](#)
    - [5.5: Chapter review - CC BY-NC-SA 4.0](#)
    - [5.6: Key equations - CC BY-NC-SA 4.0](#)
  - [6: Entropy and the Second Law of Thermodynamics - CC BY-NC-SA 4.0](#)
    - [6.1: Chapter introduction and learning objectives - CC BY-NC-SA 4.0](#)
    - [6.2: Heat engine - CC BY-NC-SA 4.0](#)
    - [6.3: Refrigerator and heat pump - CC BY-NC-SA 4.0](#)
    - [6.4: The second law of thermodynamics- Kelvin-Planck and Clausius statements - CC BY-NC-SA 4.0](#)
    - [6.5: Carnot cycles - CC BY-NC-SA 4.0](#)

- 6.6: Entropy and entropy generation - *CC BY-NC-SA 4.0*
- 6.7: The second law of thermodynamics for closed systems - *CC BY-NC-SA 4.0*
- 6.8: Specific entropy of a state - *CC BY-NC-SA 4.0*
- 6.9: Applications of the second law of thermodynamics in closed systems - *CC BY-NC-SA 4.0*
- 6.10: The second law of thermodynamics for open systems - *CC BY-NC-SA 4.0*
- 6.11: Applications of the second law of thermodynamics in open systems - *CC BY-NC-SA 4.0*
- 6.12: Chapter review - *CC BY-NC-SA 4.0*
- 6.13: Key equations - *CC BY-NC-SA 4.0*
- 7: Appendices - *Undeclared*
  - 7.1: Appendix A - Thermodynamic Properties of Water - *Undeclared*
  - 7.2: Appendix B - Thermodynamic Properties of Ammonia - *Undeclared*
  - 7.3: Appendix C - Thermodynamic Properties of R134a - *Undeclared*
  - 7.4: Appendix D - Thermodynamic Properties of Carbon Dioxide - *Undeclared*
  - 7.5: Appendix E - Critical Properties of Selected Fluids - *Undeclared*
  - 7.6: Appendix F - Triple Point of Selected Substances - *Undeclared*
  - 7.7: Appendix G - Properties of Various Substances - *Undeclared*
- Back Matter - *Undeclared*
  - Index - *Undeclared*
  - Glossary - *Undeclared*
  - Detailed Licensing - *Undeclared*