AUTOMOTIVE ELECTRICAL CIRCUITS AND WIRING

INTRODUCTION

CHARGING CIRCUIT

BATTERY CONSTRUCTION

BATTERY CASE, COYER, AND CAPS.

BATTERY CAPACITY

BATTERY CHARGING

PLACING NEW BATTERIES IN SERVICE

BATTERY MAINTENANCE

CLEANING THE BATTERY AND TERMINALS.

BATTERY TEST

CELL VOLTAGE TEST.

GENERATORS

REGULATION OF GENERATOR OUTPUT

GENERATOR MAINTENANCE

GENERATOR REPAIR

ARMATURE TEST.

ALTERNATORS

RECTIFIER ASSEMBLY.

ALTERNATOR OUTPUT CONTROL

ALTERNATOR TESTING

CHARGING SYSTEM TEST

CIRCUIT RESISTANCE TEST

STARTING CIRCUIT

PINION DRIVE ASSEMBLY

FIELD FRAME

NEUTRAL SAFETY SWITCH

STARTING MOTOR CIRCUIT TESTS

IGNITION CIRCUIT

IGNITION COIL

IGNITION DISTRIBUTOR

SPARK PLUG

SPARK PLUG WIRES

ELECTRONIC IGNITION SYSTEM

IGNITION TIMING DEVICES

IGNITION SYSTEM MAINTENANCE

A SPARK PLUG WIRE RESISTANCE TEST

ELECTRONIC IGNITION DISTRIBUTOR SERVICE

LIGHTING CIRCUIT

HEADLIGHTS HEADLIGHT SWITCH

DIMMER SWITCH

BLACKOUT LIGHTS

TURN-SIGNAL SYSTEMS

EMERGENCY LIGHT SYSTEM

INSTRUMENTS, GAUGES, AND ACCESSORIES

FUEL GAUGE

TEMPERATURE GAUGE

MECHANICAL SPEEDOMETERS AND TACHOMETERS

WINDSHIELD WIPERS

WIRING ASSEMBLIES

WIRE TERMINAL ENDS

WIRE SUPPORT AND PROTECTION

AUTOMOTIVE ELECTRICAL CIRCUITS AND WIRING

INTRODUCTION

Learning Objective: Identify charging, starting, ignition, and accessory-circuit components, their functions, and maintenance procedures. Identify the basic types of automotive wiring, types of terminals, and wiring diagrams.

The electrical systems on equipment used by the Navy are designed to perform a variety of functions. The automotive electrical system contains five electrical circuits. These circuits are as follows (fig. 2-1):

- Charging circuit
- Starting circuit
- Ignition circuit
- Lighting circuit
- Accessory circuit

Electrical power and control signals must be delivered to electrical devices reliably and safely so electrical system functions are not impaired or converted to hazards. This goal is accomplished through careful circuit design, prudent component selection, and practical equipment location. By carefully studying this chapter and the preceding chapter, you will understand how these circuits work and the adjustments and repairs required to maintain the electrical systems in peak condition.

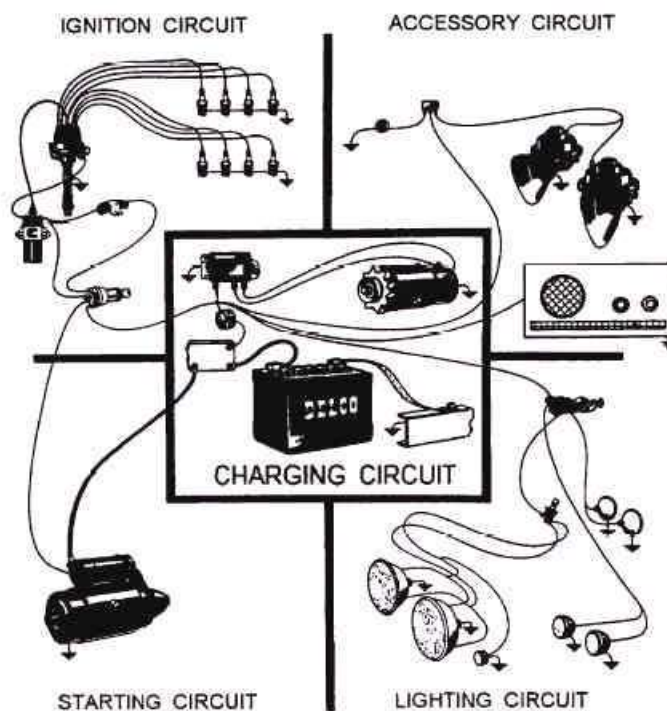

Figure 2-1.- Electrical circuits.

CHARGING CIRCUIT

Learning Objective: Identify charging-circuit components, their functions, and maintenance procedures.

The charging system performs several functions, which are as follows:

It recharges the battery after engine cranking or after the use of electrical accessories with the engine turned off.

It supplies all the electricity for the vehicle when the engine is running.

It must change output to meet different electrical loads.

It provides a voltage output that is slightly higher than battery voltage.

A typical charging circuit consists of the following:

BATTERY- provides current to energize or excite the alternator and assists in stabilizing initial alternator output.

ALTERNATOR or GENERATOR- uses mechanical (engine) power to produce electricity.

ALTERNATOR BELT- links the engine crankshaft pulley with alternator/ generator pulley to drive the alternator/ generator.

VOLTAGE REGULATOR- ammeter, voltmeter, or warning light to inform the operator of charging system condition.

STORAGE BATTERY

The storage battery is the heart of the charging circuit (fig. 2-2). It is an electrochemical device for producing and storing electricity. A vehicle battery has several important functions, which are as follows:

It must operate the starting motor, ignition system, electronic fuel injection system, and other electrical devices for the engine during engine cranking and starting.

It must supply ALL of the electrical power for the vehicle when the engine is not running.

It must help the charging system provide electricity when current demands are above the output limit of the charging system.

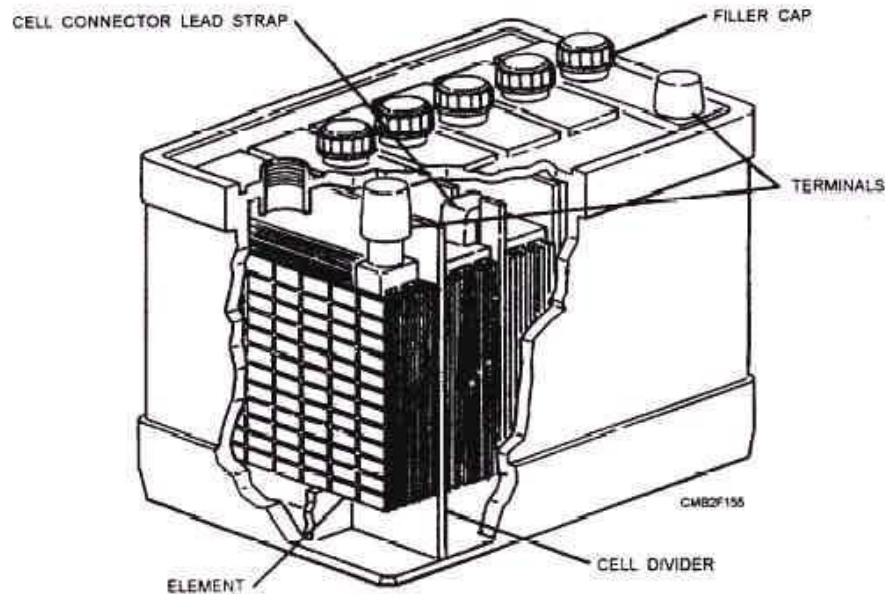

Figure 2-2.- Gross section of a typical storage battery.

It must act as a capacitor (voltage stabilizer) that smoothes current flow through the electrical system.

It must store energy (electricity) for extended periods.

The type of battery used in automotive, construction, and weight-handling equipment is a lead-acid cell-type battery. This type of battery produces direct current (dc) electricity that flows in only one direction. When the battery is discharging (current flowing out of the battery), it changes chemical energy into electrical energy, thereby, releasing stored energy. During charging (current flowing into the battery from the charging system), electrical energy is converted into chemical energy. The battery can then store energy until the vehicle requires it.

BATTERY CONSTRUCTION

The lead-acid cell-type storage battery is built to withstand severe vibration, cold weather, engine heat, corrosive chemicals, high current discharge, and prolonged periods without use. To test and service batteries properly, you must understand battery construction. The construction of a basic lead-acid cell-type battery is as follows:

Battery element

Battery case, cover, and caps

Battery terminals
Electrolyte

BATTERY ELEMENT.- The battery element is made up of negative plates, positive plates, separators, and straps (fig. 2-3). The element fits into a cell compartment in the battery case. Most automotive batteries have six elements.

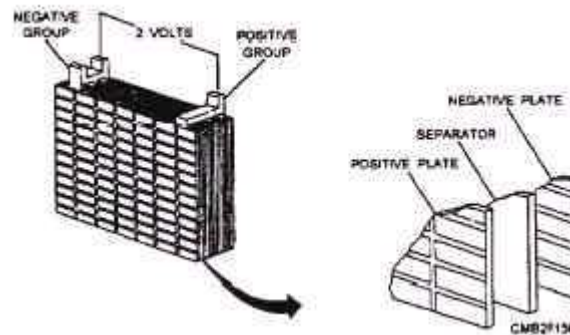

Figure 2-3.- Battery element.

Each cell compartment contains two kinds of chemically active lead plates, known as positive and negative plates. The battery plates are made of GRID (stiff mesh framework) coated with porous lead. These plates are insulated from each other by suitable separators and are submerged in a sulfuric acid solution (electrolyte).

Charged negative plates contain spongy (porous) lead (Pb) which is gray in color. Charged positive plates contain lead peroxide (PbO₂) which has a chocolate brown color. These substances are known as the active materials of the plates. Calcium or antimony is normally added to the lead to increase battery performance and to decrease gassing (acid fumes formed during chemical reaction). Since the lead on the plates is porous like a sponge, the battery acid easily penetrates into the material. This aids the chemical reaction and the production of electricity.

Lead battery straps or connectors run along the upper portion of the case to connect the plates. The battery terminals (post or side terminals) are constructed as part of one end of each strap.

To prevent the plates from touching each other and causing a short circuit, sheets of insulating material (microporous rubber, fibrous glass, or plastic-impregnated material), called separators, are inserted between the plates. These separators are thin and porous so the electrolyte will flow easily between the plates. The side of the separator that is placed against the positive plate is grooved so the gas that forms during charging will rise to the surface more readily. These grooves also provide room for any material that flakes from the plates to drop to the sediment space below.

BATTERY CASE, COVER, AND CAPS.

The battery case is made of hard rubber or a high-quality plastic. The case must withstand extreme vibration, temperature change, and the corrosive action of the electrolyte. The dividers in the case form individual containers for each element. A container with its element is one cell.

Stiff ridges or ribs are molded in the bottom of the case to form a support for the plates and a sediment recess for the flakes of active material that drop off the plates during the life of the battery. The sediment is thus kept clear of the plates so it will not cause a short circuit across them.

The battery cover is made of the same material as the container and is bonded to and seals the container. The cover provides openings for the two battery posts and a cap for each cell.

Battery caps either screw or snap into the openings in the battery cover. The battery caps (vent plugs) allow gas to escape and prevent the electrolyte from splashing outside the battery. They also serve as spark arresters (keep sparks or flames from igniting the gases inside the battery). The battery is filled through the vent plug openings. Maintenance-free batteries have a large cover that is not removed during normal service.

CAUTION

Hydrogen gas can collect at the top of a battery. If this gas is exposed to a flame or spark, it can explode.

BATTERY TERMINALS.- Battery terminals provide a means of connecting the battery plates to the electrical system of the vehicle. Either two round post or two side terminals can be used.

Battery terminals are round metal posts extending through the top of the battery cover. They serve as connections for battery cable ends. Positive post will be larger than the negative post. It may be marked with red paint and a positive (+) symbol. Negative post is smaller, may be marked with black or green paint, and has a negative (-) symbol on or near it.

Side terminals are electrical connections located on the side of the battery. They have internal threads that accept a special bolt on the battery cable end. Side terminal polarity is identified by positive and negative symbols marked on the case.

ELECTROLYTE. -The electrolyte solution in a fully charged battery is a solution of concentrated sulfuric acid in water. This solution is about 60 percent water and about 40 percent sulfuric acid.

The electrolyte in the lead-acid storage battery has a specific gravity of 1.28, which means that it is 1.28 times as heavy as water. The amount of sulfuric acid in the

electrolyte changes with the amount of electrical charge; also the specific gravity of the electrolyte changes with the amount of electrical charge. A fully charged battery will have a specific gravity of 1.28 at 80° F. The figure will go higher with a temperature decrease and lower with a temperature increase.

As a storage battery discharges, the sulfuric acid is depleted and the electrolyte is gradually converted into water. This action provides a guide in determining the state of discharge of the lead-acid cell. The electrolyte that is placed in a lead-acid battery has a specific gravity of 1.280.

The specific gravity of an electrolyte is actually the measure of its density. The electrolyte becomes less dense as its temperature rises, and a low temperature means a high specific gravity. The hydrometer that you use is marked to read specific gravity at 80° F only. Under normal conditions, the temperature of your electrolyte will not vary much from this mark. However, large changes in temperature require a correction in your reading.

For EVERY 10-degree change in temperature ABOVE 80° F, you must ADD 0.004 to your specific gravity reading. For EVERY 10-degree change in temperature BELOW 80° F, you must SUBTRACT 0.004 from your specific gravity reading. Suppose you have just taken the gravity reading of a cell. The hydrometer reads 1.280. A thermometer in the cell indicates an electrolyte temperature of 60° F. That is a normal difference of 20 degrees from the normal of 80° F. To get the true gravity reading, you must subtract 0.008 from 1.280. Thus the specific gravity of the cell is actually 1.272. A hydrometer conversion chart similar to the one shown in figure 2-4 is usually found on the hydrometer. From it, you can obtain the specific gravity correction for temperature changes above or below 80° F.



Figure 2-4.- Hydrometer conversion chart.

BATTERY CAPACITY

The capacity of a battery is measured in ampere-hours. The ampere-hour capacity is equal to the product of the current in amperes and the time in hours during which the battery is supplying current. The ampere-hour capacity varies inversely with the discharge current. The size of a cell is determined generally by its ampere-hour capacity. The capacity of a cell depends upon many factors, the most important of which are as follows:

1. The area of the plates in contact with the electrolyte
2. The quantity and specific gravity of the electrolyte
3. The type of separators
4. The general condition of the battery (degree of sulfating, plates buckled, separators warped, sediment in bottom of cells, etc.)
5. The final limiting voltage

Battery Ratings

Battery ratings were developed by the Society of Automotive Engineers (SAE) and the Battery Council International (BCI). They are set according to national test standards for battery performance. They let the mechanic compare the cranking power of one battery to another. The two methods of rating lead-acid storage batteries are the cold-cranking rating and the reserve capacity rating.

COLD-CRANKING RATING.- The cold-cranking rating determines how much current in amperes the battery can deliver for thirty seconds at 0° F while maintaining terminal voltage of 7.2 volts or 1.2 volts per cell. This rating indicates the ability of the battery to crank a specific engine (based on starter current draw) at a specified temperature.

For example, one manufacturer recommends a battery with 305 cold-cranking amps for a small four-cylinder engine but a 450 cold-cranking amp battery for a larger V-8 engine. A more powerful battery is needed to handle the heavier starter current draw of the larger engine.

RESERVE CAPACITY RATING.- The reserve capacity rating is the time needed to lower battery terminal voltage below 10.2 V (1.7 V per cell) at a discharge rate of 25 amps. This is with the battery fully charged and at 80° F. Reserve capacity will appear on the battery as a time interval in minutes.

For example, if a battery is rated at 90 minutes and the charging system fails, the operator has approximately 90 minutes (1 1/2 hours) of driving time under minimum electrical load before the battery goes completely dead.

BATTERY CHARGING

Under normal conditions, a hydrometer reading below 1.240 specific gravity at 80° F is a warning signal that the battery should be removed and charged. Except in extremely warm climates, never allow the specific gravity to drop below 1.225 in tropical climates. This reading indicates a fully charged battery.

When a rundown battery is brought into the shop, you should recharge it immediately. There are several methods for charging batteries; only direct current is used with each method. If only alternating current is available, a rectifier or motor generator must be used to convert to direct current. The two principal methods of charging are (1) constant current and (2) constant voltage (constant potential).

Constant current charging is be used on a single battery or a number of batteries in series. Constant voltage charging is used with batteries connected in parallel. (A parallel circuit has more than one path between the two source terminals; a series circuit is a one-path circuit). You should know both methods, although the latter is most often used.

CONSTANT CURRENT CHARGING.- With the constant current method, the battery is connected to a charging device that supplies a steady flow of current. The charging device has a rectifier (a gas-filled bulb or a series of chemical disks); thus, the alternating current is changed into direct current. A rheostat (resistor for regulating current) of some kind is usually built into the charger so that you can adjust the amount of current flow to the battery. Once the rheostat is set, the amount of current remains constant. The usual charging rate is 1 amp per positive cell. Thus a 21-plate battery (which has 10 positive plates per cell) should have a charging rate no greater than 10 amps. When using this method of charging a battery, you should check the battery frequently, particularly near the end of the charging period. When the battery is gassing freely and the specific gravity remains constant for 2 hours, you can assume that the battery will take no more charge.

The primary disadvantage of constant current charging is that **THE CHARGING CURRENT REMAINS AT A STEADY VALUE UNLESS YOU CHANGE IT.** A battery charged with too high current rate would overheat and damage the plates, making the battery useless. Do **NOT** allow the battery temperature to exceed 110° while charging.

CONSTANT VOLTAGE CHARGING.- Constant voltage charging, also known as constant potential charging, is usually done with a motor generator set. The motor drives a generator (similar to a generator on a vehicle); this generator produces current to charge the battery. The voltage in this type of system is usually held constant. With a constant voltage, the charging rate to a low battery will be high. But as the battery approaches full charge, the opposing voltage of the battery goes up so it more strongly opposes the charging current. This opposition to the charging current indicates that a

smaller charge is needed. As the battery approaches full charge, the charging voltage decreases. This condition decreases the ability to maintain a charging current to the battery. As a result, the charging current tapers off to a very low value by the time the battery is fully charged. This principle of operation is the same as that of the voltage regulator on a vehicle.

CHARGING PRACTICES.- It is easy to connect the battery to the charger, turn the charging current on, and, after a normal charging period, turn the charging current off and remove the battery. Certain precautions however are necessary both BEFORE and DURING the charging period. These practices are as follows:

1. Clean and inspect the battery thoroughly before placing it on charge. Use a solution of baking soda and water for cleaning; and inspect for cracks or breaks in the container.

CAUTION

Do not permit the soda and water solution to enter the cells. To do so would neutralize the acid within the electrolyte.

2. Connect the battery to the charger. Be sure the battery terminals are connected properly; connect positive post to positive (+) terminal and the negative post to negative (-) terminal. The positive terminals of both battery and charger are marked; those unmarked are negative. The positive post of the battery is, in most cases, slightly larger than the negative post. Ensure all connections are tight.
3. See that the vent holes are clear and open. **DO NOT REMOVE BATTERY CARS DURING CHARGING.** This prevents acid from spraying onto the top of the battery and keeps dirt out of the cells.
4. Check the electrolyte level before charging begins and during charging. Add distilled water if the level of electrolyte is below the top of the plate.
5. Keep the charging room well ventilated. **DO NOT SMOKE NEAR BATTERIES BEING CHARGED.** Batteries on charge release hydrogen gas. A small spark may cause an explosion.
6. Take frequent hydrometer readings of each cell and record them. You can expect the specific gravity to rise during the charge. If it does not rise, remove the battery and dispose of it as per local hazardous material disposal instruction.
7. Keep close watch for excessive gassing, especially at the very beginning of the charge when using the constant voltage method. Reduce the charging current if excessive gassing occurs. Some gassing is normal and aids in remixing the electrolyte.
8. Do not remove a battery until it has been completely charged.

PLACING NEW BATTERIES IN SERVICE

New batteries may come to you full of electrolyte and fully charged. In this case, all

that is necessary is to install the batteries properly in the piece of equipment. Most batteries shipped to NCF units are received charged and dry.

Charged and dry batteries will retain their state of full charge indefinitely so long as moisture is not allowed to enter the cells. Therefore, batteries should be stored in a dry place. Moisture and air entering the cells will allow the negative plates to oxidize. The oxidation causes the battery to lose its charge.

To activate a dry battery, remove the restrictors from the vents and remove the vent caps. Then fill all the cells to the proper level with electrolyte. The best results are obtained when the temperature of the battery and electrolyte is within the range of 60° F to 80° F.

Some gassing will occur while you are filling the battery due to the release of carbon dioxide that is a product of the drying process of the hydrogen sulfide produced by the presence of free sulfur. Therefore, the filling operations should be in a well-ventilated area. These gases and odors are normal and are no cause for alarm.

Approximately 5 minutes after adding electrolyte, the battery should be checked for voltage and electrolyte strength. More than 6 volts or more than 12 volts, depending upon the rated voltage of the battery, indicates the battery is ready for service. From 5 to 6 volts or from 10 to 12 volts indicate oxidized negative plates, and the battery should be charged before use. Less than 5 or less than 10 volts, depending upon the rated voltage, indicates a bad battery, which should not be placed in service.

If, before placing the battery in service, the specific gravity, when corrected to 80° F, is more than .030 points lower than it was at the time of initial filling or if one or more cells gas violently after adding the electrolyte, the battery should be fully charged before use. If the electrolyte reading fails to rise during charging, discard the battery.

Most shops receive ready-mixed electrolyte. Some units may still get concentrated sulfuric acid that must be mixed with distilled water to get the proper specific gravity for electrolyte.

MIXING ELECTROLYTE is a dangerous job. You have probably seen holes appear in a uniform for no apparent reason. Later you remembered replacing a storage battery and having carelessly brushed against the battery.

WARNING

When mixing electrolyte, you are handling pure sulfuric acid, which can burn clothing quickly and severely bum your hands and face. Always wear rubber gloves, an apron, goggles, and a face shield for protection against splashes or accidental spilling.

When you are mixing electrolyte, **NEVER POUR WATER INTO THE ACID. ALWAYS POUR ACID INTO WATER.** If water is added to concentrated sulfuric acid, the mixture may explode or splatter and cause severe burns. Pour the acid into

the water slowly, stirring gently but thoroughly all the time. Large quantities of acid may require hours of safe dilution.

Figure 2-5 shows you how much water and acid to mix for obtaining a certain specific gravity. For example, mixing 5 parts of water to 2 parts of acid produces an electrolyte of 1.300, when starting with 1.835 specific gravity acid. If you use 1.400 specific gravity acid, 2 parts water and 5 parts acid will give the same results.

Let the mixed electrolyte cool down to room temperature before adding it to the battery cells. Hot electrolyte will eat up the cell plates rapidly. To be on the safe side, do not add the electrolyte if its temperature is above 90° F. After filling the battery cells, let the electrolyte cool again because more heat is generated by its contact with the battery plates. Next, take hydrometer readings. The specific gravity of the electrolyte will correspond quite closely to the values on the mixing chart if the parts of water and acid are mixed correctly.

BATTERY MAINTENANCE

If a battery is not properly maintained, its service life will be drastically reduced. Battery maintenance should be done during every PM cycle. Complete battery maintenance includes the following:

Visually checking the battery.

Checking the electrolyte level in cells on batteries with caps. Adding water if the electrolyte level is low.

Cleaning off corrosion around the battery and battery terminals.

Specific Gravity Desired	Using 1.835 Sp. Gr. Acid		using 1.400 Sp. Gr. Acid	
	Parts of Water	Parts of Acid	Parts of Water	Parts of Acid
	1.400	3	2	--
1.345	2	1	1	7
1.300	5	2	2	5
1.290	8	3	9	20
1.275	11	4	11	20
1.250	13	4	3	4
1.225	11	3	1	1
1.200	13	3	13	10

CM82F158

Figure 2-5.- Electrolyte mixing chart.

Checking the condition of the battery by testing the state of charge.

VISUAL INSPECTION OF THE BATTERY.- Battery maintenance should always begin with a thorough visual inspection. Look for signs of corrosion on or around the battery, signs of leakage, a cracked case or top, missing caps, and loose or missing hold-down clamps.

CHECKING ELECTROLYTE LEVEL AND ADDING WATER.- On vent cap batteries, the electrolyte level can be checked by removing the caps. Some batteries have a fill ring which indicates the electrolyte level. The electrolyte should be even with the fill ring. If there is no fill ring, the electrolyte should be high enough to cover the tops of the plates. Some batteries have an electrolyte-level indicator (Delco Eye). This gives a color code visual indication of the electrolyte level, with black indicating that the level is okay and white meaning a low level.

If the electrolyte level in the battery is low, fill the cells to the correct level with **DISTILLED WATER** (purified water). Distilled water should be used because it does not contain the impurities found in tap water. Tap water contains many chemicals that reduce battery life. The chemicals contaminate the electrolyte and collect in the bottom of the battery case. If enough contaminants collect in the bottom of the case, the cell plates **SHORT OUT**, ruining the battery.

If water must be added at frequent intervals, the charging system may be overcharging the battery. A faulty charging system can force excessive current into the battery. Battery gassing can then remove water from the battery.

Maintenance-free batteries do **NOT** need periodic electrolyte service under normal conditions. It is designed to operate for long periods without loss of electrolyte.

CLEANING THE BATTERY AND TERMINALS.

If the top of the battery is dirty, using a stiff bristle brush, wash it down with a mixture of baking soda and water. This action will neutralize and remove the acid-dirt mixture. Be careful not to allow cleaning solution to enter the battery.

To clean the terminals, remove the cables and inspect the terminal posts to see if they are deformed or broken. Clean the terminal posts and the inside surfaces of the cable clamps with a cleaning tool before replacing them on the terminal posts.

CAUTION

Do **NOT** use a scraper or knife to clean battery terminals. This action removes too much metal and can ruin the terminal connection.

When reinstalling the cables, coat the terminals with petroleum or white grease. This will keep acid fumes off the connections and keep them from corroding again. Tighten

the terminals just enough to secure the connection. Overtightening will strip the cable bolt threads.

CHECKING BATTERY CONDITION.- When measuring battery charge, you check the condition of the electrolyte and the battery plates. As a battery becomes discharged, its electrolyte has a larger percentage of water. Thus the electrolyte of a discharged battery will have a lower specific gravity number than a fully charged battery. This rise and drop in specific gravity can be used to check the charge in a battery. There are several ways to check the state of charge of a battery.

Nonmaintenance-free batteries can have the state of charge checked with a hydrometer. The hydrometer tests specific gravity of the electrolyte. It is fast and simple to use. There are three types of hydrometers- the float type, the ball type, and needle type.

To use a **FLOAT TYPE HYDROMETER**, squeeze and hold the bulb. Then immerse the other end of the hydrometer in the electrolyte. Then release the bulb. This action will fill the hydrometer with electrolyte. Hold the hydrometer even with your line of sight and compare the numbers on the hydrometer with the top of the electrolyte.

Most float type hydrometers are **NOT** temperature correcting. However, the new models will have a built-in thermometer and a conversion chart that allow you to calculate the correct temperature.

The **BALL TYPE HYDROMETER** is becoming more popular because you do not have to use a temperature conversion chart. The balls allow for a change in temperature when submersed in electrolyte. This allows for any temperature offset.

To use a ball type hydrometer, draw electrolyte into the hydrometer with the rubber bulb at the top. Then note the number of balls floating in the electrolyte. Instructions on or with the hydrometer will tell you whether the battery is fully charged or discharged.

A **NEEDLE TYPE HYDROMETER** uses the same principles as the ball type. When electrolyte is drawn into the hydrometer, it causes the plastic needle to register specific gravity.

A fully charged battery should have a hydrometer reading of at least 1.265 or higher. If below 1.265, the battery needs to be recharged. or it may be defective. A discharged battery could be caused by the following:

- Defective battery
- Charging system problems
- Starting system problems
- Poor cable connections
- Engine performance problems requiring excessive cranking time

Electrical problems drawing current out of the battery with the ignition OFF defective battery can be found by using a hydrometer to check each cell. If the specific gravity in any cell varies excessively from other cells (25 to 50 points), the battery is bad. Cells with low readings may be shorted. When all of the cells have equal specific gravity, even if they are low, the battery can usually be recharged.

On maintenance-free batteries a charge indicator eye shows the battery charge. The charge indicator changes color with levels of battery charge. For example, the indicator may be green with the battery fully charged. It may turn black when discharged or yellow when the battery needs to be replaced. If there is no charge indicator eye or when in doubt of its reliability, a voltmeter and ammeter or a load tester can also be used to determine battery condition quickly.

BATTERY TEST

As a mechanic you will be expected to test batteries for proper operation and condition. These tests are as follows:

- Battery leakage test
- Battery terminal test
- Battery voltage test
- Cell voltage test
- Battery drain test
- Battery load test (battery capacity test)
- Quick charge test

BATTERY LEAKAGE TEST.- A battery leakage test will determine if current is discharging across the top of the battery. A dirty battery can discharge when not in use. This condition shortens battery life and causes starting problems.

To perform a battery leakage test, set a voltmeter on a low setting. Touch the probes on the battery, as shown in figure 2-6. If any current is registered on the voltmeter, the top of the battery needs to be cleaned.

BATTERY TERMINAL TEST.- The battery terminal test quickly checks for poor electrical connection between the terminals and the battery cables. A voltmeter is used to measure voltage drop across terminals and cables.

To perform a battery terminal test (fig. 2-7), connect the negative voltmeter lead to the battery cable end. Touch the positive lead to the battery terminal. With the ignition or injection system disabled so that the engine will not start, crank the engine while watching the voltmeter reading.

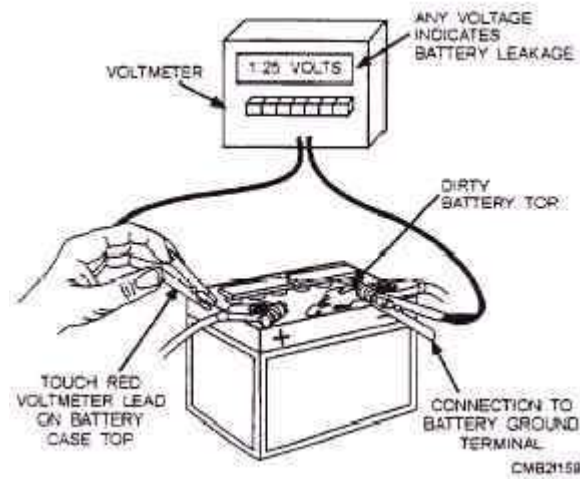

Figure 2-6.- Battery leakage test.

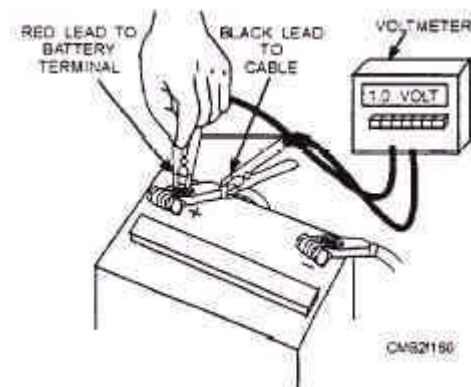

Figure 2-7.- Battery terminal test.

If the voltmeter reading is .5 volts or above, there is high resistance at the battery cable connection. This indicates that the battery connections need to be cleaned. A good, clean battery will have less than a .5 volt drop.

BATTERY VOLTAGE TEST.- The battery voltage test is done by measuring total battery voltage with an accurate voltmeter or a special battery tester (fig. 2-8). This test determines the general state of charge and battery condition quickly.

The battery voltage test is used on maintenance-free batteries because these batteries do not have caps that can be removed for testing with a hydrometer. To perform this test, connect the voltmeter or battery tester across the battery terminals. Turn on the vehicle headlights or heater blower to provide a light load. Now read the meter or tester. A well-charged battery should have over 12 volts. If the meter reads approximately 11.5 volts, the battery is not charged adequately, or it may be defective.

CELL VOLTAGE TEST.

The cell voltage test will let you know if the battery is discharged or defective. Like a hydrometer cell test, if the voltage reading on one or more cells is .2 volts or more lower than the other cells, the battery must be replaced.

To perform a cell voltage test (fig. 2-9), use a low voltage reading voltmeter with special cadmium (acid resistant metal) tips. Insert the tips into each cell, starting at one end of the battery and work your way to the other. Test each cell carefully. If the cells are low, but equal, recharging usually will restore the battery. If cell voltage readings vary more than .2 volts, the battery is BAD.

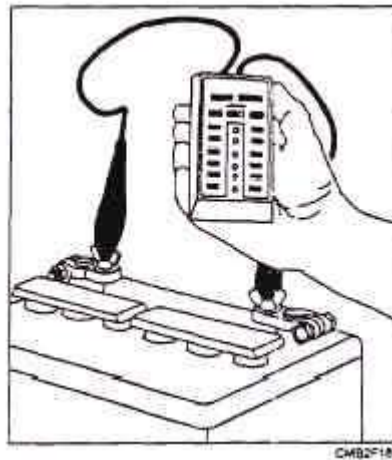

Figure 2-8.- Battery voltage test performed with a battery tester.

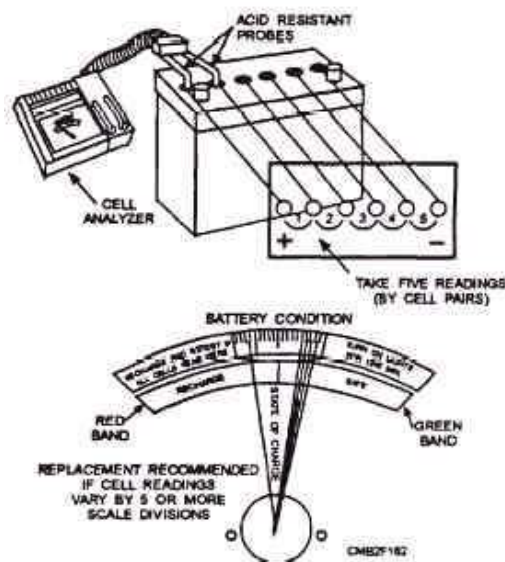

Figure 2-9.- Cell voltage test.

BATTERY DRAIN TEST.- A battery drain test checks for abnormal current draw with the ignition off. If a battery goes dead without being used, you need to check for a current drain.

To perform a battery drain test, set up an ammeter, as shown in figure 2-10. Pull the fuse if the vehicle has a dash clock. Close all doors and trunk (if applicable). Then read the ammeter. If everything is off, there should be a zero reading. Any reading indicates a problem. To help pinpoint the problem, pull fuses one at a time until there is a zero reading on the ammeter. This action isolates the circuit that has the problem.

BATTERY CAPACITY TEST.- A battery load test, also termed a battery capacity test, is the best method to check battery condition. The battery load test measures the current output and performance of the battery under full current load. It is one of the most common and informative battery tests used today.

Before load testing a battery, you must calculate how much current draw should be applied to the battery. If the ampere-hour rating of the battery is given, load the battery to three times its amp-hour rating. For example, if the battery is rated at 60 amp-hours, test the battery at 180 amps ($60 \times 3 = 180$). The majority of the batteries are now rated in SAE cold-cranking amps, instead of amp-hours. To determine the load test for these batteries, divide the cold-crank rating by two. For example, a battery with 400 cold-cranking amps rating should be loaded to 200 amps ($400 \div 2 = 200$). Connect the battery load tester, as shown in figure 2-11. Turn the control knob until the ammeter reads the correct load for your battery.

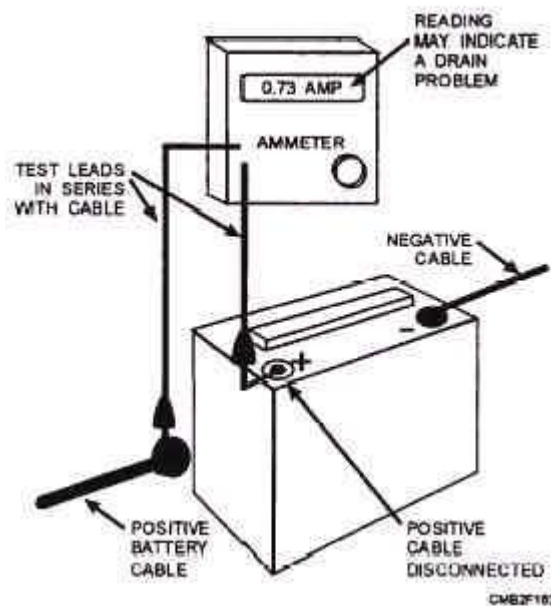

Figure 2-10.- Battery drain test setup.

After checking the battery charge and finding the amp load value, you are ready to test battery output. Make sure that the tester is connected properly. Turn the load control knob until the ammeter reads the correct load for your battery. Hold the load for 15 seconds. Next, read the voltmeter while the load is applied.

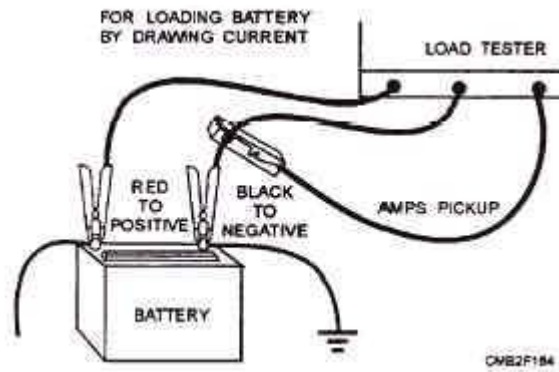

Figure 2-11.- Instrument hookup for battery capacity test.

Then turn the load control completely off so the battery will not be discharged. If the voltmeter reads 9.5 volts or more at room temperature, the battery is good. If the battery reads below 9.5 volts at room temperature, battery performance is poor. This condition indicates that the battery is not producing enough current to run the starting motor properly.

Familiarize yourself with proper operating procedures for the type of tester you have available. Improper operation of electrical test equipment may result in serious damage to the test equipment or the unit being tested.

QUICK CHARGE TEST.- The quick charge test, also known as 3-minute charge test, determines if the battery is sulfated. If the results of the battery load test are poor, fast charge the battery. Charge the battery for 3 minutes at 30 to 40 amps. Test the voltage while charging. If the voltage goes ABOVE 15.5 volts, the battery plates are sulfated and the battery needs to be replaced.

GENERATORS

The generator is a machine that applies the principle of electromagnetic induction to convert mechanical energy, supplied by the engine, into electrical energy. The generator restores to the battery the energy that has been used up in cranking the engine. Whether the energy required for the rest of the electrical system is supplied directly by the generator, by the battery, or by a combination of both depends on the conditions under which the generator is operating.

The two types of generators are as follows:

The dc generator supplies electrical energy directly to the battery and or electrical system through various regulating devices.

The ac generator (alternator) has the same function as the dc generator but because only direct current can be used to charge a battery, a component, called a rectifier,

must be used to convert from alternating to direct current. The ac generator (alternator) will be explained in further detail later in this chapter.

Direct-Current (dc) Generator

The dc generator (fig. 2-12) essentially consists of an armature, a field frame, field coils, and a commutator with brushes to establish electrical contact with the rotating element. The magnetic field of the generator usually is produced by the electromagnets or poles magnetized by current flowing through the field coils. Soft iron pole pieces (or pole shoes) are contained in the field frame that forms the magnetic circuit between the poles. Although generators may be designed to have any even number of poles, two- and four-pole frames are the most common. The field coils are connected in series. In the two-pole type frame, the magnetic circuit flows through only a part of the armature core; therefore, the armature must be constructed according to the number of field poles because current is generated when the coil (winding on the armature) moves across each magnetic circuit.

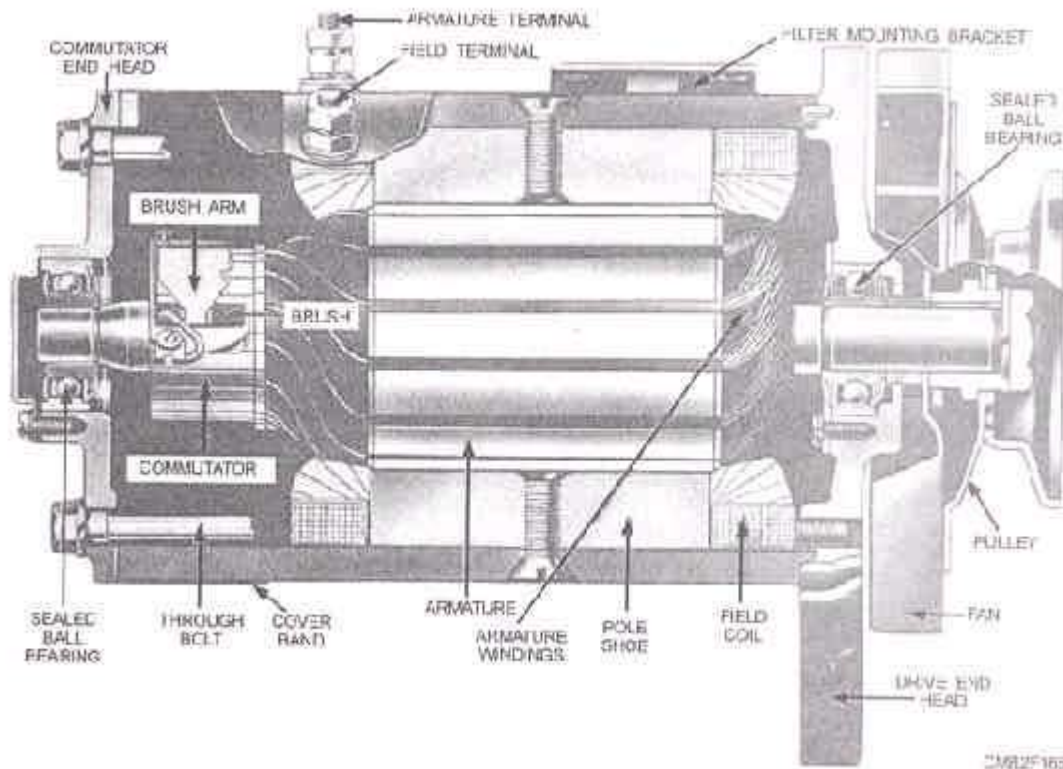

Figure 2-12.- Sectional view of a dc generator.

The current is collected from the armature coils by brushes (usually made of carbon) that make rubbing contact with a commutator. The commutator consists of a series of insulated copper segments mounted on one end of the armature, each segment connecting to one or more armature coils. The armature coils are connected to the external circuits (battery, lights, or ignition) through the commutator and brushes. Current induced in the armature coils thus is able to flow to the external circuits.

There are two types of field circuits, determined by the point at which the field circuit is grounded, which are as follows:

One circuit, referred to as the "A" circuit, shunts the field current from the insulated brushes through the field winding grounding externally at the regulator.

In the other, the "B" circuit, the field current is shunted from the armature series winding in the regulator to the generator field windings, grounding internally within the generator.

The three basic design factors that determine generator output are (1) the speed of armature rotation, (2) the number of armature conductors, and (3) the strength of the magnetic field. Any of these design factors could be used to control the generator voltage and current. However, the simplest method is to determine the strength of the magnetic field and thus limit the voltage and current output of the generator.

REGULATION OF GENERATOR OUTPUT

The fields of the generator depend upon the current from the armature of the generator for magnetization. Because the current developed by the generator increases in direct proportion to its speed, the fields become stronger as the speed increases and, correspondingly, the armature generates more current. The extreme variations in speed of the automotive engine make it necessary to regulate output of the generator to prevent excessive current or voltage overload. On the average unit of CESE, a charging current in excess of 12 to 15 amperes is harmful to a fully charged battery if continued for too long.

Regulators are of two types, functioning to regulate either voltage or current. The voltage regulator regulates the voltage in the electric system and prevents excessive voltage, which can cause damage to the electric units and overcharge the battery. The current regulator is a current limiter; it prevents the generator output from increasing beyond the rated output of the generator.

Regulation of voltage only might be satisfactory from the standpoint of the battery; however, if the battery were badly discharged or if a heavy electrical load were connected, the heavy current might overload itself to supply the heavy current demand. Therefore, both current and voltage controls are used in a charging system.

In most applications, a regulator assembly consists of a cutout relay, current regulator, and voltage regulator (fig. 2-13). Each unit contains a separate core, coil, and set of contacts. The regulator assembly provides full control of the shunt-type generator under all conditions. Either the current regulator or the voltage regulator may be operating at any one time, but in no case do they both operate at the same time.

When the electric load requirements are high and the battery is low, the current regulator will operate to prevent the generator output from exceeding its safe maximum. In this case, the voltage is not sufficient to cause the voltage regulator to operate. But if the load requirements are reduced or the battery begins to come up to

charge, the line voltage will increase to a value sufficient to cause the voltage regulator to operate. When this happens, the generator output is reduced; it is no longer sufficiently high to cause the current regulator to operate. All regulation is then dependent on the voltage regulator. Figure 2-14 shows a schematic wiring diagram of a typical dc charging circuit. In this circuit, two resistances are connected in parallel into the generator field circuit when the current regulator points open. This provides a low value of resistance, which is sufficient to prevent the generator output from exceeding its safe maximum. When the voltage regulator contact points open, only one resistance is inserted into the generator field circuit, and this provides a higher value of resistance. The voltage regulator must employ a higher resistance because it must reduce the generator output as it operates, and it requires more resistance to reduce the output than merely to prevent the output from going beyond the safe maximum of the generator.

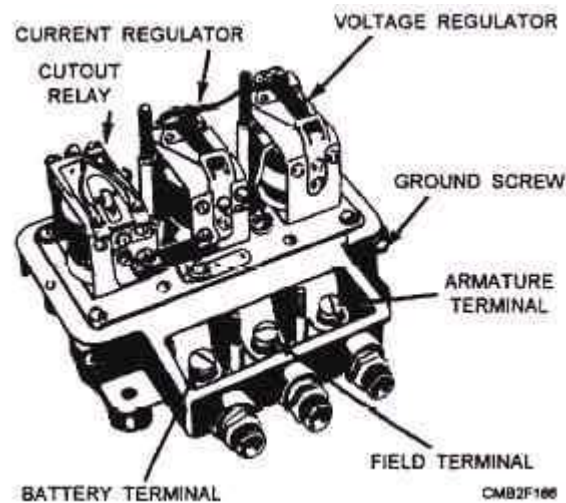

Figure 2-13.- Regulator assembly with cover removed.

For some special applications, you may find a combined current-voltage regulator. In this case, the regulators are combined in a single unit. The regulator assembly will consist of two (regulator and circuit breaker) instead of three units.

The regulators just described are known as electromagnetic vibrating-contact regulators. The points on the armatures of the regulators may open and close as many as 300 times in one second to achieve the desired regulation.

The transistor type regulator is being used in late model equipment. This regulator has no moving parts. It consists of transistors, diodes, condensers, and resistors. Some models have two filter condensers, while others have only one.

Adjustments are provided on some types of regulators and should be made only with the use of the manufacturer's instructions and the recommended testing equipment. TRIAL AND ERROR METHOD OF REPAIR WILL NOT WORK.

GENERATOR MAINTENANCE

The dc generator requires periodic cleaning, lubrication, inspection of brushes and commutator, and testing of brush spring tension. In addition, the electrical connections need attention to ensure clean metal-to-metal contact and tightness.

Some generators have hinged cap oilers. Lubricate these with a few drops of medium weight oil at each maintenance cycle. Do not overlubricate, because an excessive amount of oil can get on the commutator and prevent the brushes from functioning properly.

Visually and manually inspect the condition of all cables, clamps, wiring, and terminal connections. See that the generator drive pulley is tight on the shaft and that the belt is in good condition and adjusted properly. Also, ensure that the generator is securely mounted and has a good ground.

Remove the cover band, on generator so equipped, and inspect the inner surface of the generator cover band for tiny globules of solder. If any solder is found, the generator is producing excessive current and has melted the solder used in connecting the armature wires to the commutator bars. This condition requires removal of the generator to repair or replace the armature.

If no solder is found, inspect the commutator, brushes, and electrical connections. If the commutator is dirty or slightly rough, using 00 sandpaper can smooth it. NEVER use emery cloth on the commutator.

Once the commutator has been sanded, blow compressed air through the interior of the generator to remove any excess dirt and brush particles. Lift the brushes in the brush holder to see that they are free to operate and have sufficient tension to prevent arcing and burning of the commutator and brushes. If brushes are worn down to one half of their original length, replace them.

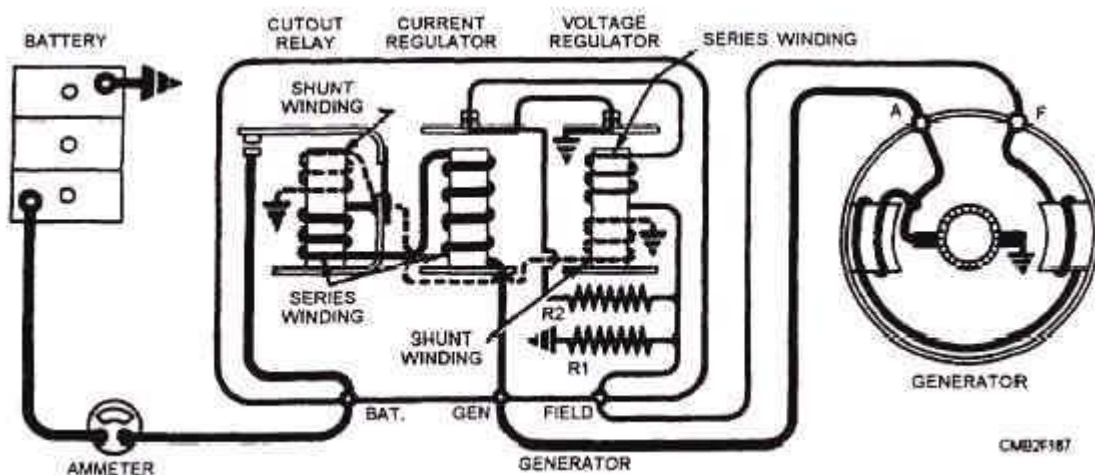

Figure 2-14.- Schematic wiring diagram of a typical dc charging circuit.

Most generators today are not equipped with cover bands. They may have open slots over the commutator or be sealed entirely. On those with open slots, the commutator can be sanded through the slots, but brush removal can only be accomplished by removing the commutator end frame. On sealed units, maintenance can only be performed after disassembly.

GENERATOR REPAIR

Generators are disassembled only when major repairs are to be made (fig. 2-15). Other than cleaning commutators and replacing worn-out brushes during periodic maintenance, generators require very few repairs during normal service life. However, if neglected, generators will develop problems that cannot be remedied in the field.

Before removing a generator suspected of being faulty, you should check the battery, as discussed earlier, and the generator output. Refer to the manufacturer's manual for correct generator output specifications and proper testing procedures. If the generator is operating properly and the battery, wiring, and connections are in operating condition, a defective voltage regulator is indicated in which, in most cases, the regulator is removed and replaced. However, if the generator is not producing the specified amperes at the specified engine speed, then it must be removed from the vehicle and either repaired or replaced.

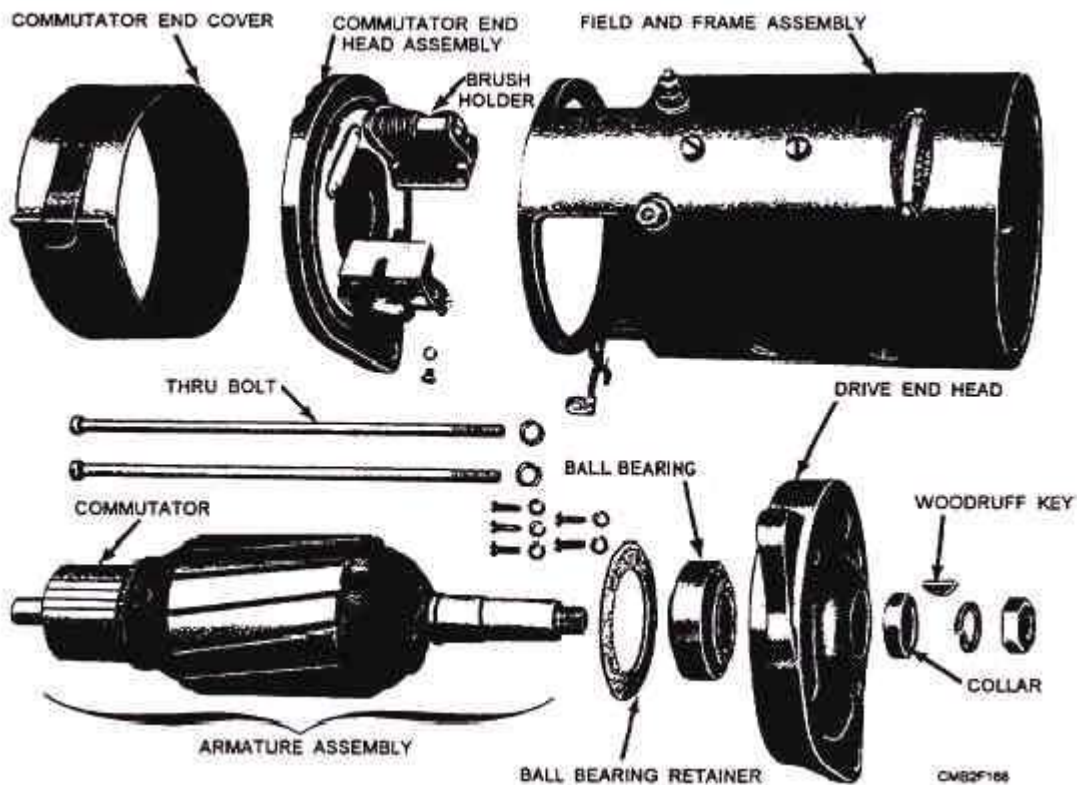

Figure 2-15.- Disassembled view of a two-brush generator.

TESTING FIELD COILS.- To test the generator field, you must disconnect the grounded ends from the frame. Place one probe of the test lamp circuit on the field terminal end of the coils and the other probe on the grounded end. If the lamp lights, the field circuit is complete. However, because of the resistance in the field coil wire, it should not bum with normal brilliancy. Normal brilliancy of the test light bulb indicates a possible short circuit between the coils of the field. If the light does not burn, the field is open-circuited.

A grounded field coil is located by placing one test probe on the field terminal and the other on the generator frame (fig. 2-16). If the test lamp lights, the field is grounded. The ground may be caused by frayed wires at the coil ends. In most cases, grounds and open field coil ends, the ohmmeter will measure the actual circuits in the field coils cannot be satisfactorily resistance of the coil. If the specified resistance of a repaired. The defective field coil must then be field coil is given in the manufacturer's manual, also replaced. obtained by measuring a new coil, you can compare values obtained through tests. For example, a short-Test for grounds, shorts, and open circuits in the circuited field coil would have practically no field coils can also be made with an ohmmeter. The resistance and the ohmmeter would register near zero; ohmmeter has test probes similar to the test lamp or the ohmmeter would register excessively high circuit. When these test probes are connected to the resistance in testing a coil having an open circuit. By following the manufacturer's instructions in using the ohmmeter, field coil tests can be made more quickly and accurately than by using a test lamp circuit.

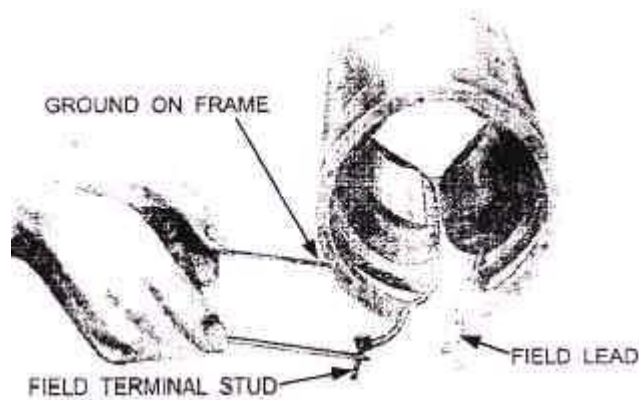

Figure 2-16.- Testing field coils for ground.

ARMATURE TEST.

There are two practical tests for locating shorts, opens, and grounds in armatures- the growler test and the bar-to-bar test.

To test for short circuits, place the armature on the V-block of the growler and turn on the current. With a thin metal strip (hacksaw blade is good) held over the core, as shown in figure 2-17, rotate the armature slowly through a complete revolution. If a

short is present, the steel strip will become magnetized and vibrate. To find out whether the armature coils of the commutator are short-circuited, clean between the commutator segments and repeat the test. Should the thin metal strip still vibrate, the armature is short-circuited internally and must be replaced.

Not all armatures can be tested for short circuits by the method just described. These armatures can be identified by excessive vibration of the saw blade all around the armature during the test. With these armatures, test for short circuits by using the milliamperage contacts on an ac millimeter, as shown in figure 2-18. In doing so, keep the armature stationary in the V-block and move the contacts around the commutator until the highest reading is obtained. Then turn the armature to bring each pair of segments under the contacts and read the milliammeter at the same time. The readings should be nearly the same for each pair of adjacent bars. If a coil is short-circuited, the milliammeter reading will drop to almost zero.

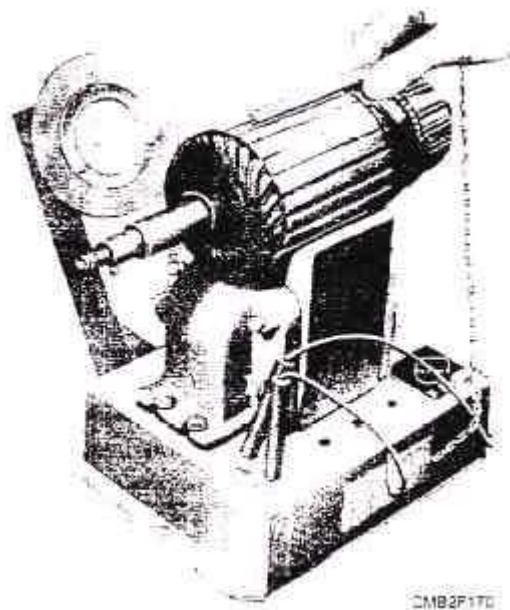

Figure 2-17.- Using an armature growler.

Test the armature for grounds by using the test light circuit, which is a part of most modern factory-built growlers (fig. 2-19). Place the armature on the V-block and touch one of the test probes to the armature core iron. Touch the other probe to each commutator segment in turn. If the armature is grounded, the bulb in the base of the growler will light. In contacting armature surfaces with the test probes, do not touch the bearing or the brush surfaces of the commutator. The arc would burn or pit the smooth finish. Replace the armature if it is grounded.

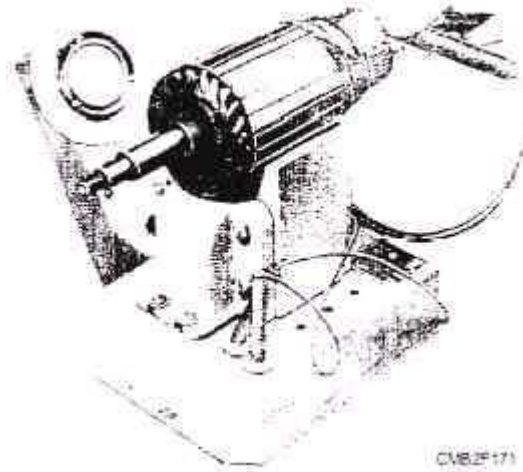

Figure 2-18.- Testing an armature for a short circuit with a milliammeter.

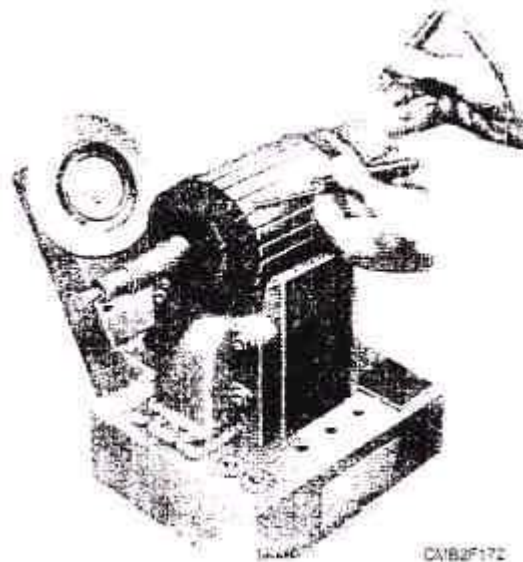

Figure 2-19.- Testing an armature for grounds.

In testing individual armature coils for open circuits, use the test probes, as shown in figure 2-20. Place them on the riser part of adjacent commutator bars, not on the brush surfaces. If the test lamp does not light, there is a break some where in the coil. Repeat this test on every pair of adjacent bars. Do this by walking the probes from bar to bar. Should you find an open coil, the fault may be at the commutator connectors where it is possible to make repairs with a little solder. If a coil is open-circuited internally, the armature should be discarded.

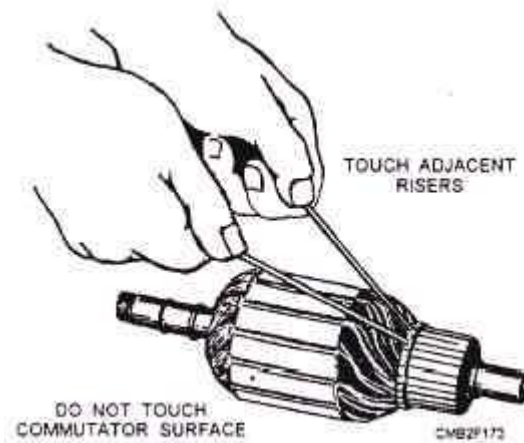

Figure 2-20.- Testing an armature for open circuits.

ALTERNATORS

The alternator (fig. 2-21) has replaced the dc generator because of its improved efficiency. It is smaller, lighter, and more dependable than the dc generator. The alternator also produces more output during idle which makes it ideal for late model vehicles.

The alternator has a spinning magnetic field. The output windings (stator) are stationary. As the magnetic field rotates, it induces current in the output windings.

Alternator Construction

Knowledge of the construction of an alternator is required before you can understand the proper operation, testing procedures, and repair procedures applicable to an alternator.

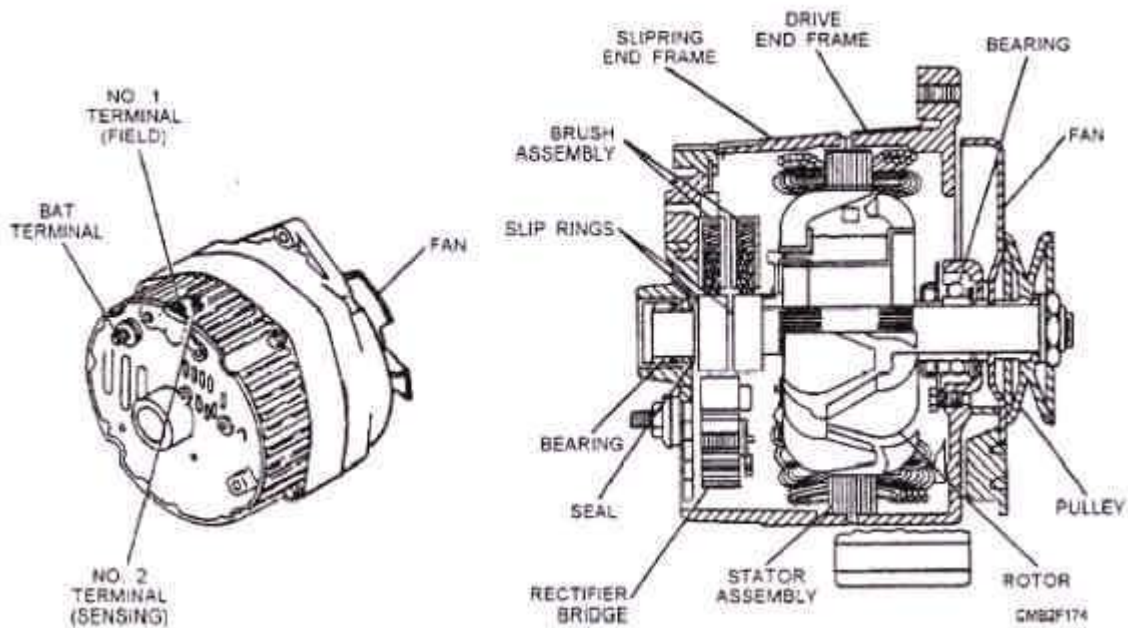

Figure 2-21.- Typical alternator.

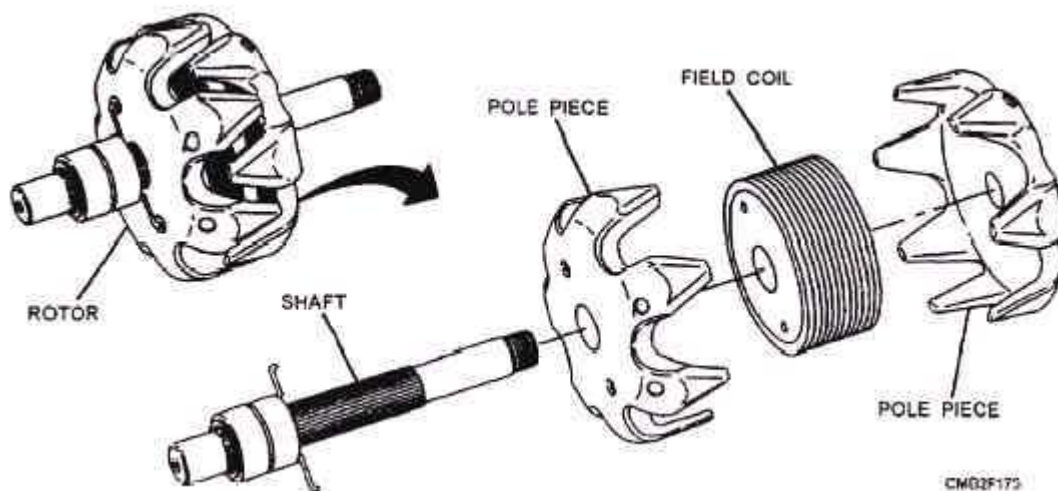

Figure 2-22.- Rotor assembly.

The primary components of an alternator are as follows:

ROTOR ASSEMBLY (rotor shaft, slip rings, claw poles, and field windings)

STATOR ASSEMBLY (three stator windings or coils, output wires, and stator core)

RECTIFIER ASSEMBLY (heat sink, diodes, diode plate, and electrical terminals)

ROTOR ASSEMBLY (fig. 2-22).- The rotor consists of field windings (wire wound into a coil placed over an iron core) mounted on the rotor shaft. Two claw-shaped pole pieces surround the field windings to increase the magnetic field.

The fingers on one of the claw-shaped pole pieces produce south (S) poles and the other produces north (N) poles. As the rotor rotates inside the alternator, alternating N-S-N-S polarity and ac current is produced (fig. 2-23). An external source of electricity is required to excite the magnetic field of the alternator.

Slip rings are mounted on the rotor shaft to provide current to the rotor windings. Each end of the field coil connects to the slip rings.

STATOR ASSEMBLY (fig. 2-24).- The stator produces the electrical output of the alternator. The stator, which is part of the alternator frame when assembled, consists of three groups of windings or coils which produce three separate ac currents. This is known as three-phase output. One end of the windings is connected to the stator assembly and the other is connected to a rectifier assembly. The windings are wrapped around a soft laminated iron core that concentrates and strengthens the magnetic field around the stator windings. There are two types of stators- Y -type stator and delta-type stator.

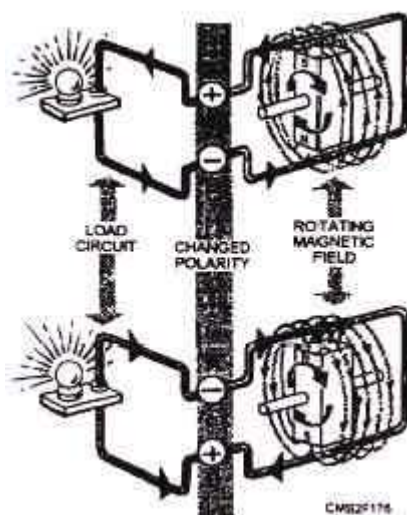

Figure 2-23.- Simple alternator illustrating reversing magnetic field and resulting current flow.

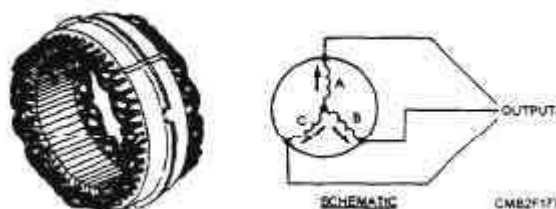

Figure 2-24.- Stator assembly.

The Y-type stator (fig. 2-25) has the wire ends from the stator windings connected to a

neutral junction. The circuit looks like the letter Y. The Y-type stator provides good current output at low engine speeds.

The delta-type stator (fig. 2-26) has the stator wires connected end-to-end. With no neutral junction, two circuit paths are formed between the diodes. A delta-type stator is used in high output alternators.

RECTIFIER ASSEMBLY.

The rectifier assembly, also known as a diode assembly, consists of six diodes used to convert stator ac output into dc current. The current flowing from the winding is allowed to pass through an insulated diode. As the current reverses direction, it flows to ground through a grounded diode. The insulated and grounded diodes prevent the reversal of current from the rest of the charging system. By this switching action and the number of pulses created by motion between the windings of the stator and rotor, a fairly even flow of current is supplied to the battery terminal of the alternator.

The rectifier diodes are mounted in a heat sink (metal mount for removing excess heat from electronic parts) or diode bridge. Three positive diodes are press-fit in an insulated frame. Three negative diodes are mounted into an uninsulated or grounded frame.

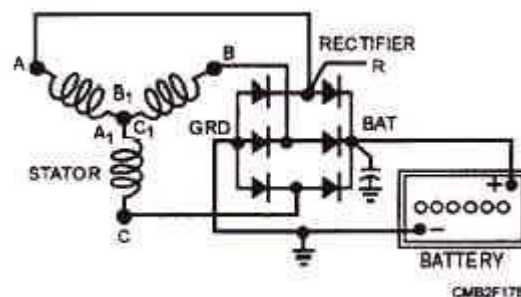

Figure 2-25.- Electrical diagram indicating a Y-type stator.

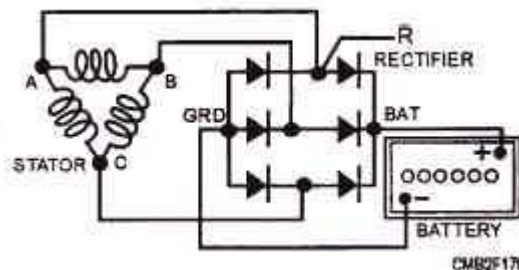

Figure 2-26.- Electrical diagram indicating a delta-type stator.

When an alternator is producing current, the insulated diodes pass only outflowing current to the battery. The diodes provide a block, preventing reverse current flow from the alternator. Figure 2-27 shows the flow of current from the stator to the battery.

A cross-sectional view of a typical diode is shown in figure 2-28. Note that the figure also shows the diode symbol used in wiring diagrams. The arrow in this symbol indicates the only direction that current will flow. The diode is sealed to keep moisture out.

Alternator Operation

The operation of an alternator is somewhat different than the dc generator. An alternator has a rotating magnet (rotor) which causes the magnetic lines of force to rotate with it. These lines of force are cut by the stationary (stator) windings in the alternator frame, as the rotor turns with the magnet rotating the N and S poles to keep changing positions. When S is up and N is down, current flows in one direction, but when N is up and S is down, current flows in the opposite direction. This is called alternating current as it changes direction twice for each complete revolution. If the rotor speed were increased to 60 revolutions per second, it would produce 60-cycle alternating current.

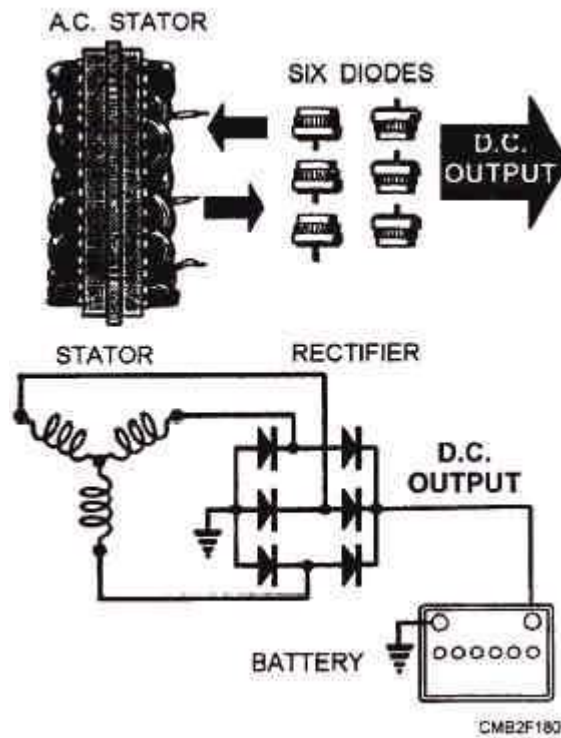

Figure 2-27.- Current flow from the stator to the battery.

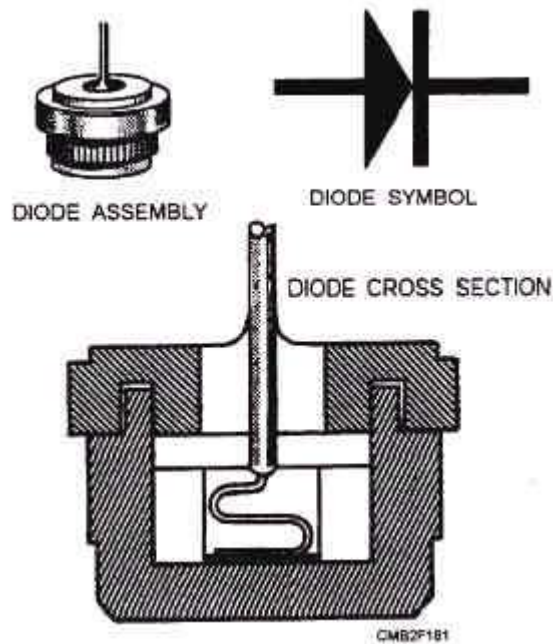

Figure 2-28.- Typical diode.

Since the engine speed varies in a vehicle, the frequency also varies with the change of speed. Likewise, increasing the number of pairs of magnetic north and south poles will increase the frequency by the number pair of poles. A four-pole generator can generate twice the frequency per revolution of a two-pole rotor.

ALTERNATOR OUTPUT CONTROL

A voltage regulator controls alternator output by changing the amount of current flow through the rotor windings. Any change in rotor winding current changes the strength of the magnetic field acting on the stator windings. In this way, the voltage regulator can maintain a preset charging voltage. The three basic types of voltage regulators are as follows:

Contact point voltage regulator, mounted away from the alternator in the engine compartment

Electronic voltage regulator, mounted away from the alternator in the engine compartment

Electronic voltage regulator, mounted on the back or inside the alternator

The contact point voltage regulator uses a coil, set of points, and resistors that limits system voltage. The electronic or solid-state regulators have replaced this older type. For operation, refer to the "Regulation of Generator Output" section of this chapter.

The electronic voltage regulators use an electronic circuit to control rotor field strength and alternator output. It is a sealed unit and is not repairable. The electronic circuit must be sealed to prevent damage from moisture, excessive heat, and vibration. A rubber like gel surrounds the circuit for protection.

An integral voltage regulator is mounted inside or on the rear of the alternator. This is the most common type used on modern vehicles. It is small, efficient, dependable, and composed of integrated circuits.

An electronic voltage regulator performs the same operation as a contact point regulator, except that it uses transistors, diodes, resistors, and capacitors to regulate voltage in the system. To increase alternator output, the electronic voltage regulator allows more current into the rotor windings, thereby strengthen the magnetic field around the rotor. More current is then induced into the stator windings and out of the alternator.

To reduce alternator output, the electronic regulator increases the resistance between the battery and the rotor windings. The magnetic field decreases and less current is induced into the stator windings.

Alternator speed and load determines whether the regulator increases or decreases charging output. If the load is high or rotor speed is low (engine at idle), the regulator senses a drop in system voltage. The regulator then increases the rotors magnetic field current until a preset output voltage is obtained. If the load drops or rotor speed increases, the opposite occurs.

Alternator Maintenance

Alternator testing and service call for special precautions since the alternator output terminal is connected to the battery at all times. Use care to avoid reversing polarity when performing battery service of any kind. A surge of current in the opposite direction could bum the alternator diodes.

Do not purposely or accidentally "short" or "ground" the system when disconnecting wires or connecting test leads to terminals of the alternator or regulator. For example, grounding of the field terminal at either alternator or regulator will damage the regulator. Grounding of the alternator output terminal will damage the alternator and possibly other portions of the charging system.

Never operate an alternator on an open circuit. With no battery or electrical load in the circuit, alternators are capable of building high voltage (50 to over 110 volts) which may damage diodes and endanger anyone who touches the alternator output terminal.

Alternator maintenance is minimized by the use of prelubricated bearings and longer lasting brushes. If a problem exists in the charging circuit, check for a complete field

circuit by placing a large screwdriver on the alternator rear-bearing surface. If the field circuit is complete, there will be a strong magnetic pull on the blade of the screwdriver, which indicates that the field is energized. If there is no field current, the alternator will not charge because it is excited by battery voltage.

Should you suspect troubles within the charging system after checking the wiring connections and battery, connect a voltmeter across the battery terminals. If the voltage reading, with the engine speed increased, is within the manufacturer's recommended specification, the charging system is functioning properly. Should the alternator tests fail, the alternator should be removed for repairs or replacement. Do NOT forget, you must ALWAYS disconnect the cables from the battery first.

ALTERNATOR TESTING

To determine what component(s) has caused the problem, you will be required to disassemble and test the alternator.

ROTOR TESTING.- To test the rotor for grounds, shorts, and opens, perform the following:

To check for grounds, connect a test lamp or ohmmeter from one of the slip rings to the rotor shaft (fig. 2-29). A low ohmmeter reading or the lighting of the test lamp indicates that the rotor winding is grounded.

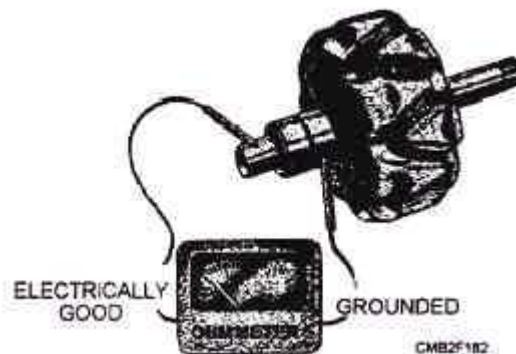

Figure 2-29.- Testing rotor for grounds.

To check the rotor for shorts and opens, connect the ohmmeter to both slip rings, as shown in figure 2-30. An ohmmeter reading below the manufacturer's specified resistance value indicates a short. A reading above the specified resistance value indicates an open. If a test lamp does not light when connected to both slip rings, the winding is open.

STATOR TESTING.- The stator winding can be tested for opens and grounds after it has been disconnected from the alternator end frame.

If the ohmmeter reading is low or the test lamp lights when connected between each pair of stator leads (fig. 2-31), the stator winding is electrically good.

A high ohmmeter reading or failure of the test lamp to light when connected from any one of the leads to the stator frame (fig. 2-32) indicates the windings are not grounded. It is not practical to test the stator for shorts due to the very low resistance of the winding.

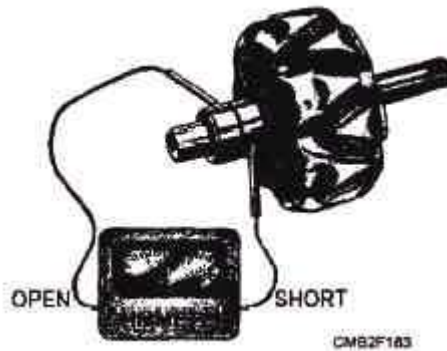

Figure 2-30.- Testing the rotor for opens and shorts.

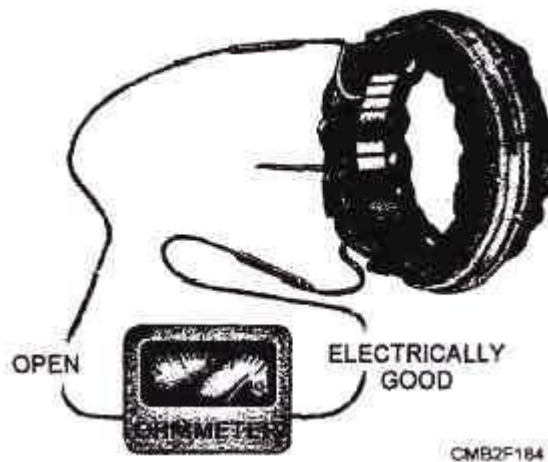

Figure 2-31.- Testing a stator for opens.

DIODE TESTING.- With the stator windings disconnected, each diode may be tested with an ohmmeter or with a test light. To perform the test with an ohmmeter, proceed as follows:

Connect one ohmmeter test lead to the diode lead and the other to the diode case (fig. 2-33). Note the reading. Then reverse the ohmmeter's leads to the diode and again note the reading. If both readings are very low or very high, the diode is defective. A good diode will give one low and one high reading.

An alternate method of testing each diode is to use a test lamp with a 12-volt battery. To perform a test with a test lamp, proceed as follows:

Connect one of the test leads to the diode lead and the other test lead as shown in figure 2-34. Then reverse the lead connections. If the lamp lights in both checks, the diode is defective. Or, if the lamp fails to light in either direction, the diode is defective. When a good diode is being tested, the lamp will light in only one of the two checks.

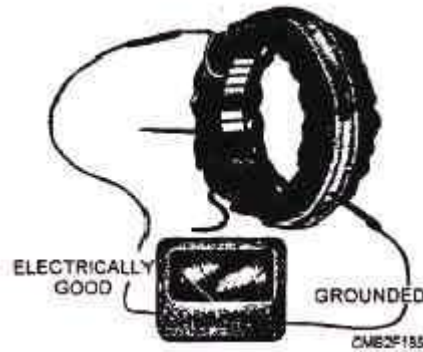

Figure 2-32.- Testing a stator for grounds.

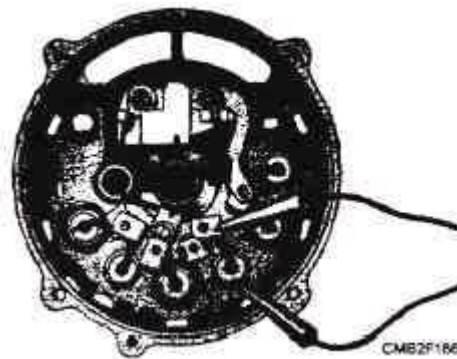

Figure 2-33.- Testing diodes with an ohmmeter.

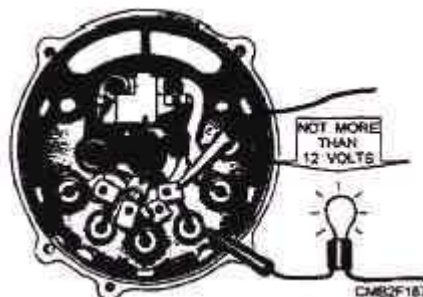

Figure 2-34.- Testing diodes with a test lamp.

After completing the required test and making any necessary repairs or replacement of parts, reassemble the alternator and install it on the vehicle. After installation, start the engine and check that the charging system is functioning properly. NEVER ATTEMPT TO POLARIZE AN ALTERNATOR. Attempts to do so serves no purpose and may damage the diodes, wiring, and other charging circuit components.

CHARGING SYSTEM TEST

Charging system tests should be performed when problems point to low alternator voltage and current. These tests will quickly determine the operating condition of the charging system. Common charging system tests are as follows:

Charging system output test-measures current and voltage output of the charging system.

Regulator voltage test- measures charging system voltage under low output, low load conditions.

Regulator bypass test- connects full battery voltage to the alternator field, leaving the regulator out of the circuit.

Circuit resistance tests- measures resistance in insulated and grounded circuits of the charging system.

Charging system tests are performed in two ways- by using a load tester or by using a volt-ohm-millimeter (VOM/ multimeter). The load tester provides the accurate method for testing a charging system by measuring both system current and voltage.

Charging System Output Test

The charging system output test measures system voltage and current under maximum load. To check output with a load tester, connect tester leads as described by the manufacturer, as you may have either an inductive (clip-on) amp pickup type or a non-inductive type tester. Testing procedures for an inductive type tester are as follows:

With the load tester controls set as prescribed by the manufacturer, turn the ignition switch to the RUN position. Note the ammeter reading.

Start the engine and adjust the idle speed to test specifications (approximately 200 rpm).

Adjust the load control on the tester until the ammeter reads specified current output. Do not let voltage drop below specifications (about 12 volts). Note the ammeter reading.

Rotate the control knob to the OFF position. Evaluate the readings.

To calculate charging system output, add the two ammeter readings. This will give you total charging system output in amps. Compare this figure to the specifications within the manufacturer's manual.

Current output specifications will depend on the size (rating) of the alternator. A vehicle with few electrical accessories may have an alternator rated at 35 amps, whereas a larger vehicle with more electrical requirements could have an alternator rated from 40 to 80 amps. Always check the manufacturer's service manual for exact values.

If the charging system output current tested low, perform a regulator voltage test and a regulator bypass test to determine whether the alternator, regulator, or circuit wiring is at fault.

Regulator Voltage Test

A regulator voltage test checks the calibration of the voltage regulator and detects a low or high setting. Most voltage regulators are designed to operate between 13.5 to 14.5 volt range. This range is stated for normal temperatures with the battery fully charged. Regulator voltage test procedure is as follows:

Set the load tester selector to the correct position using the manufacturer's manual. With the load control OFF, run the engine at 2,000 rpm or specified test speed. Note the voltmeter reading and compare it to the manufacturer's specifications.

If the voltmeter reading is steady and within manufacturer's specifications, then the regulator setting is okay. However, if the volt reading is steady but too high or too low, then the regulator needs adjustment or replacement. If the reading were not steady, this would indicate a bad wiring connection, an alternator problem, or a defective regulator, and further testing is required.

Regulator Bypass Test

A regulator bypass test is an easy and quick way of determining if the alternator, regulator, or circuit is faulty. Procedures for the regulator bypass test is similar to the charging system output test, except that the regulator be taken out of the circuit. Direct battery voltage (unregulated voltage) is used to excite the rotor field. This should allow the alternator to produce maximum voltage output.

Depending upon the system there are several ways to bypass the voltage regulator. The most common ways are as follows:

Sorting a test tab to ground on the rear of the alternator (if equipped).

Placing a jumper wire across the battery and field terminals of the alternator.

With a remote regulator, unplug the wire from the regulator and place a jumper wire across the battery and field terminals in the wires to the alternator.

CAUTION

Follow the manufacturer's directions to avoid damaging the circuit. You must NOT short or connect voltage to the wrong wires or the diodes or voltage regulator may be ruined.

When the regulator bypass test is being performed, charging voltage and current INCREASE to normal levels. This indicates a bad regulator. If the charging voltage and current REMAINS THE SAME, then you have a bad alternator.

CIRCUIT RESISTANCE TEST

A circuit resistance test is used to locate faulty wiring, loose connections, partially burnt wire, corroded terminals, or other similar types of problems.

There are two common circuit resistance tests- insulated resistance test and ground circuit resistance test.

INSULATED RESISTANCE TEST

To perform an insulated resistance test, connect the load tester as described by the manufacturer. A typical connection setup is shown in figure 2-35. Note how the voltmeter is connected across the alternator output terminal and positive battery terminal.

With the vehicle running at a fast idle, rotate the load control knob to obtain a 20-amp current flow at 15 volts or less. All accessories and lights are to be turned OFF. Read the voltmeter. The voltmeter should NOT read over 0.7-volt drop (0.1 volt per electrical connection) for the circuit to be considered in good condition. However, if the voltage drop is over 0.7 volt, circuit resistance is high and a poor electrical connection exists.

GROUND CIRCUIT RESISTANCE TEST

With the ground circuit resistance test the voltmeter leads are placed across the negative battery terminal and alternator housing (fig. 2-36).

The voltmeter should NOT read over 0.1 volt per electrical connection. If the reading is higher, this indicates such problems as loose or faulty connections, burnt plug sockets, or other similar malfunctions.

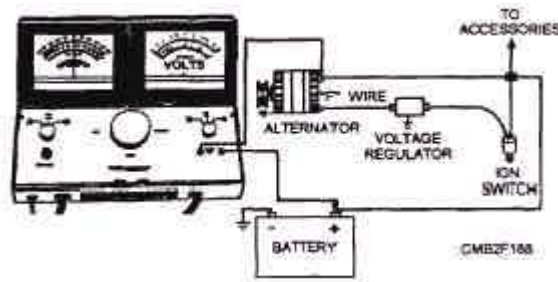

Figure 2-35.- Typical insulated resistance test setup.

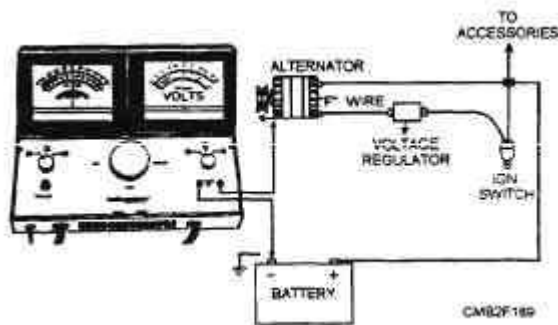

Figure 2-36.- Typical ground circuit resistance test setup.

STARTING CIRCUIT

Learning Objective: Identify starting-circuit components, their function, operation, and maintenance procedures.

The internal combustion engine is not capable of self-starting. Automotive engines (both spark-ignition and diesel) are cranked by a small but powerful electric motor. This motor is called a cranking motor, starting motor, or starter.

The battery sends current to the starter when the operator turns the ignition switch to start. This causes a pinion gear in the starter to mesh with the teeth of the ring gear, thereby rotating the engine crankshaft for starting.

The typical starting circuit consists of the battery, the starter motor and drive mechanism, the ignition switch, the starter relay or solenoid, a neutral safety switch (automatic transmissions), and the wiring to connect these components.

STARTER MOTOR

The starting motor (fig. 2-37) converts electrical energy from the battery into mechanical or rotating energy to crank the engine. The main difference between an electric starting motor and an electric generator is that in a generator, rotation of the armature in a magnetic field produces voltage. In a motor, current is sent through the

armature and the field; the attraction and repulsion between the magnetic poles of the field and armature coil alternately push and pull the armature around. This rotation (mechanical energy), when properly connected to the flywheel of an engine, causes the engine crankshaft to turn.

Starting Motor Construction

The construction of the all starting motors is very similar. There are, however, slight design variations. The main parts of a starting motor are as follows:

ARMATURE ASSEMBLY- The windings, core, starter shaft, and commutator assembly that spin inside a stationary field.

COMMUTATOR END FRAME- The end housing for the brushes, brush springs, and shaft bushings.

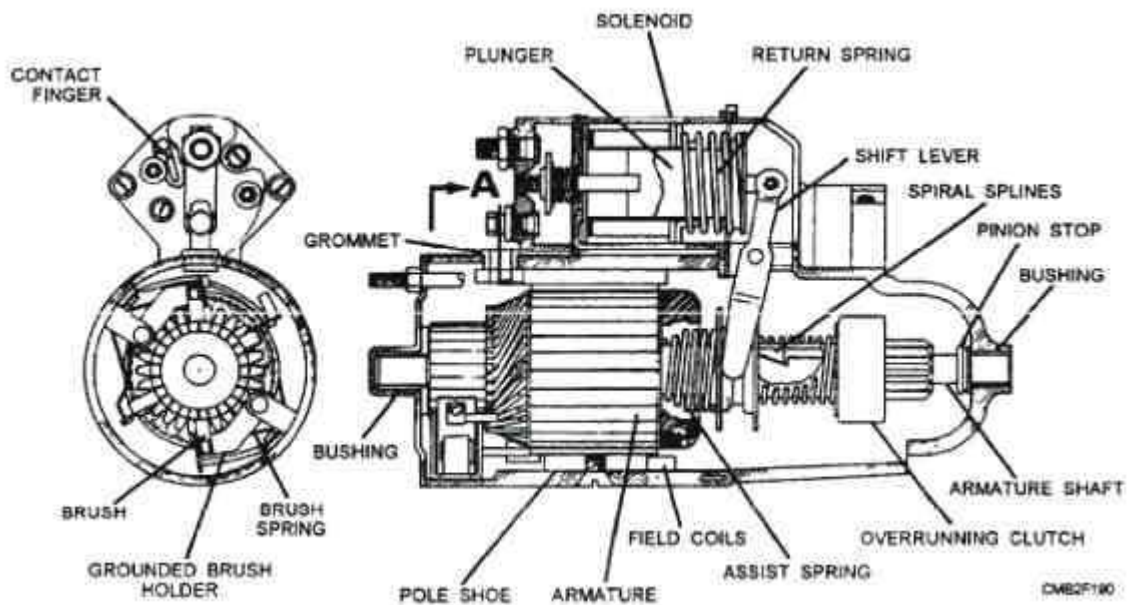

Figure 2-37.- Typical starting motor.

PINION DRIVE ASSEMBLY- The pinion gear, pinion drive mechanism, and solenoid.

FIELD FRAME- The center housing that holds the field coils and pole shoes.

DRIVE END FRAME- The end housing around the pinion gear, which has a bushing for the armature shaft.

ARMATURE ASSEMBLY.- The armature assembly consists of an armature shaft, armature core, commutator, and armature windings.

The armature shaft supports the armature assembly as it spins inside the starter housing. The armature core is made of iron and holds the armature windings in place. The iron increases the magnetic field strength of the windings.

The commutator serves as a sliding electrical connection between the motor windings and the brushes and is mounted on one end of the armature shaft. The commutator has many segments that are insulated from each other. As the windings rotate away from the pole shoe (piece), the commutator segments change the electrical connection between the brushes and the windings. This action reverses the magnetic field around the windings. The constant changing electrical connection at the windings keeps the motor spinning.

COMMUTATOR END FRAME.- The commutator end frame houses the brushes, the brush springs, and the armature shaft bushing.

The brushes ride on top of the commutator. They slide on the commutator to carry battery current to the spinning windings. The springs force the brushes to maintain contact with the commutator as it spins, thereby no power interruptions occurs. The armature shaft bushing supports the commutator end of the armature shaft.

PINION DRIVE ASSEMBLY

The pinion drive assembly includes the pinion gear, the pinion drive mechanism, and solenoid. There are two ways that a starting motor can engage the pinion assembly-(1) with a moveable pole shoe that engages the pinion gear and (2) with a solenoid and shift fork that engages the pinion gear.

The pinion gear is a small gear on the armature shaft that engages the ring gear on the flywheel. Most starter pinion gears are made as part of a pinion drive mechanism. The pinion drive mechanism slides over one end of the starter armature shaft. The pinion drive mechanism found on starting motors that you will encounter are of three designs- Bendix drive, overrunning clutch, and Dyer drive.

The BENDIX DRIVE (fig. 2-38) relies on the principle of inertia to cause the pinion gear to mesh with the ring gear. When the starting motor is not operating, the pinion gear is out of mesh and entirely away from the ring gear. When the ignition switch is engaged, the total battery voltage is applied to the starting motor, and the armature immediately starts to rotate at high speed.

The pinion, being weighted on one side and having internal screw threads, does not rotate immediately with the shaft but because of inertia, runs forward on the revolving threaded sleeve until it engages with the ring gear. If the teeth of the pinion and ring gear do not engage, the drive spring allows the pinion to revolve and forces the pinion to mesh with the ring gear. When the pinion gear is engaged fully with the ring gear, the pinion is then driven by the starter through the compressed drive spring and cranks the engine. The drive spring acts as a cushion while the engine is being cranked against compression. It also breaks the severity of the shock on the teeth when the

gears engage and when the engine kicks back due to ignition. When the engine starts and runs on its own power, the ring gear drives the pinion at a higher speed than does the starter. This action causes the pinion to turn in the opposite direction on the threaded sleeve and automatically disengages from the ring gear. This prevents the engine from driving the starter.

The OVERRUNNING CLUTCH (fig. 2-39) provides positive meshing and demeshing of the starter motor pinion gear and the ring gear. The starting motor armature shaft drives the shell and sleeve assembly of the clutch. The rotor assembly is connected to the pinion gear which meshes with the engine ring gear. Spring-loaded steel rollers are located in tapered notches between the shell and the rotor. The springs and plungers hold the rollers in position in the tapered notches. When the armature shaft turns, the rollers are jammed between the notched surfaces, forcing the inner and outer members of the assembly to rotate as a unit and crank the engine.

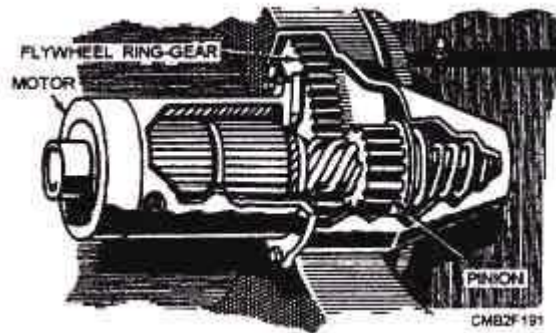

Figure 2-38.- Starting motor with a Bendix drive.

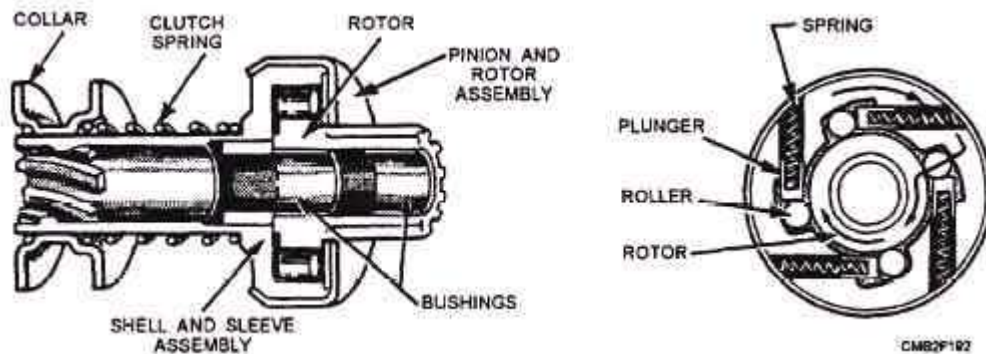

Figure 2-39.- Typical overrunning clutch.

After the engine is started, the ring gear rotates faster than the pinion gear, thus tending to work the rollers back against the plungers, and thereby causing an overrunning action. This action prevents excessive speed of the starting motor. When the starting motor is released, the collar and spring assembly pulls the pinion out of mesh with the ring gear.

The DYER DRIVE (fig. 2-40) provides complete and positive meshing of the drive pinion and ring gear before the starting motor is energized. It combines principles of both the Bendix and overrunning clutch drives and is commonly used on heavy-duty engines.

A starter solenoid is used to make the electrical connection between the battery and the starting motor. The starter solenoid is an electromagnetic switch; it is similar to other relays but is capable of handling higher current levels. A starter solenoid, depending on the design of the starting motor, has the following functions:

Closes battery-to-starter circuit.

Rushes the starter pinion gear into mesh with the ring gear.

Bypass resistance wire in the ignition circuit.

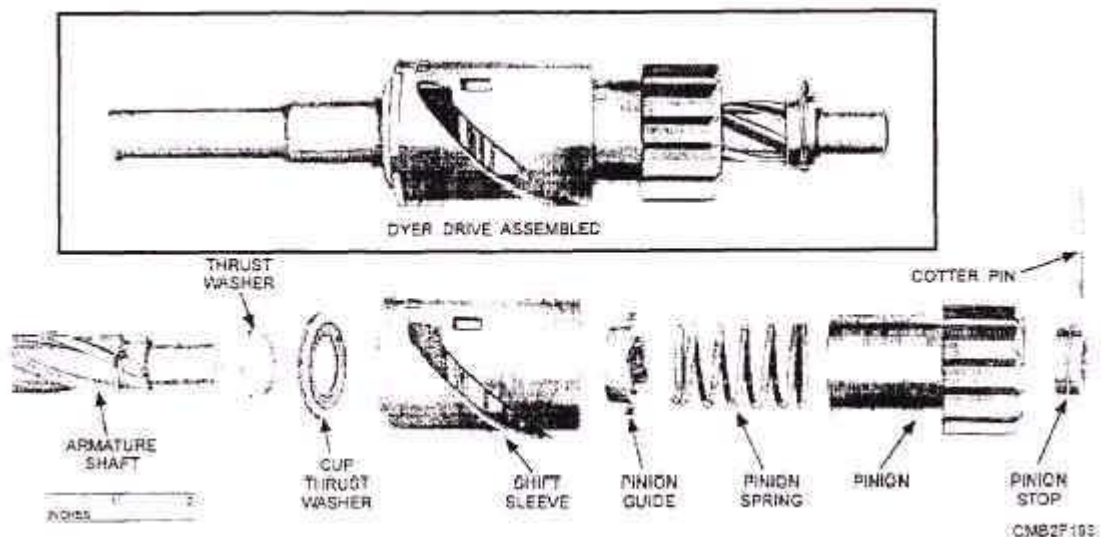

Figure 2-40.- Dyer drive.

The starter solenoid may be located away from or on the starting motor. When mounted away from the starter, the solenoid only makes and breaks electrical connection. When mounted on the starter, it also slides the pinion gear into the flywheel.

In operation, the solenoid is actuated when the ignition switch is turned or when the starter button is depressed. The action causes current to flow through the solenoid (causing a magnetic attraction of the plunger) to ground. The movement of the plunger causes the shift lever to engage the pinion with the ring gear. After the pinion is engaged, further travel of the plunger causes the contacts inside the solenoid to close and directly connects the battery to the starter.

If cranking continues after the control circuit is broken, it is most likely to be caused by either shorted solenoid windings or by binding of the plunger in the solenoid. Low

voltage from the battery is often the cause of the starter making a clicking sound. When this occurs, check all starting circuit connections for cleanliness and tightness.

FIELD FRAME

The field frame is the center housing that holds the field coils and pole shoes.

The field coil (winding) is a stationary set of windings that creates a strong magnetic field around the motor armature. When current flows through the winding, the magnetic field between the pole shoes becomes very large. Acting against the magnetic field created by the armature, this action spins the motor with extra power. Field windings vary according to the application of the starter motor. The most popular configurations are as follows (fig. 2-41):

TWO WINDINGS, PARALLEL- The wiring of the two field coils in parallel will increase their strength because they receive full voltage. Note that two additional pole shoes are used. Though they have no windings, their presence will further strengthen the magnetic field.

FOUR WINDINGS, SERIES-PARALLEL- The wiring of four field coils in a series-parallel combination creates a stronger magnetic field than the two field coil configuration.

FOUR WINDINGS, SERIES- The wiring of four field coils in series provides a large amount of low-speed torque, which is desirable for automotive starting motors. However, series-wound motors can build up excessive speed if allowed to run free to the point where they will destroy themselves.

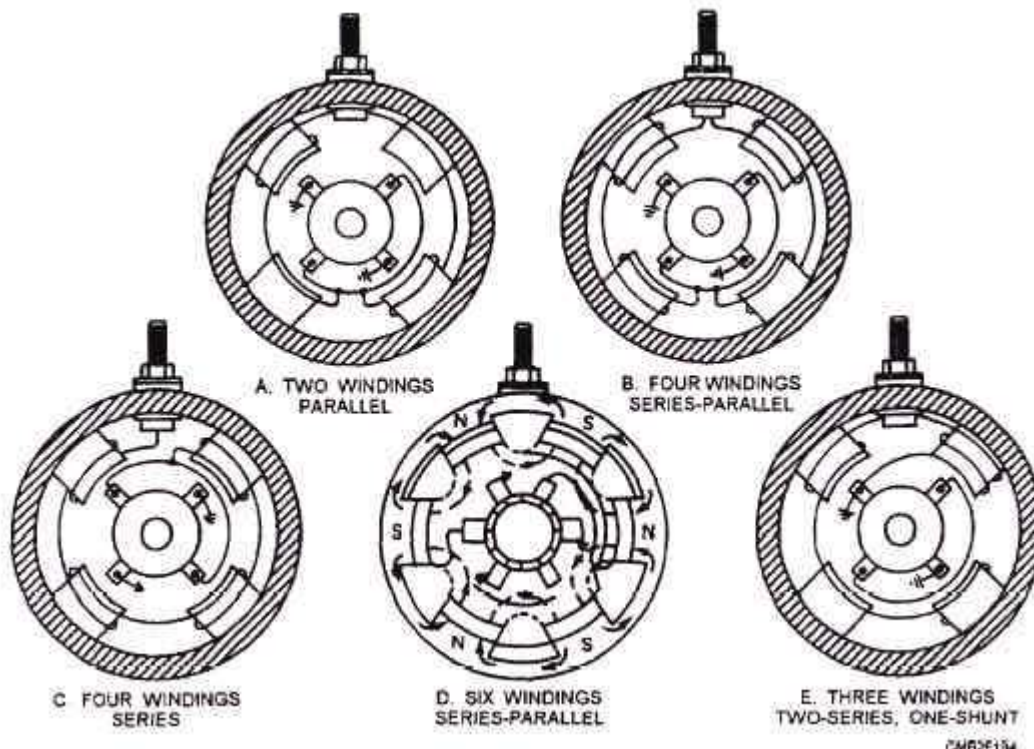

Figure 2-41.- Field winding configurations.

SIX WINDINGS, SERIES-PARALLEL

Three pairs of series-wound field coils provide the magnetic field for a heavy-duty starter motor. This configuration uses six brushes.

THREE WINDINGS, TWO SERIES, ONE SHUNT

The use of one filled coil that is shunted to ground with a series-wound motor controls motor speed. Because the shunt coil is not affected by speed, it will draw a steady heavy current, effectively limiting speed.

DRIVE END FRAME

The drive end frame is designed to protect the drive pinion from damage and to support the armature shaft. The drive end frame of the starter contains a bushing to prevent wear between the armature shaft and drive end frame.

Types of Starting Motors

There are two types of starting motors that you will encounter on equipment. These are the direct drive starter and the double reduction starter. All starters require the use of gear reduction to provide the mechanical advantage required to turn the engine flywheel and crankshaft.

DIRECT DRIVE STARTERS

Direct drive starters make use of a pinion gear on the armature shaft of the starting motor. This gear meshes with teeth on the ring gear. There are between 10 to 16 teeth on the ring gear for every one on the pinion gear. Therefore, the starting motor revolves 10 to 16 times for every revolution of the ring gear. In operation, the starting motor armature revolves at a rate of 2,000 to 3,000 revolutions per minute, thus turning the engine crankshaft at speeds up to 200 revolutions per minute.

DOUBLE REDUCTION STARTER

The double reduction starter makes use of gear reduction within the starter and the reduction between the drive pinion and the ring gear. The gear reduction drive head is used on heavy-duty equipment.

Figure 2-42 shows a typical gear reduction starter. The gear on the armature shaft does not mesh directly with the teeth on the ring gear, but with an intermediate gear which drives the driving pinion. This action provides additional breakaway, or starting torque, and greater cranking power. The armature of a starting motor with a gear

reduction drive head may rotate as many as 40 revolutions for every revolution of the engine flywheel.

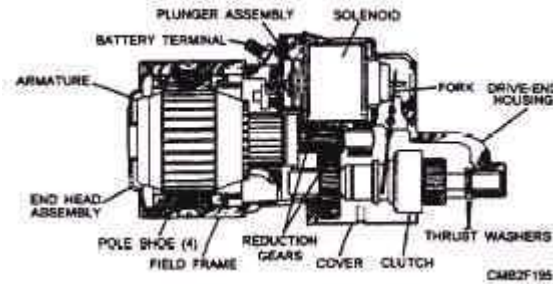

Figure 2-42.- Gear reduction starter.

NEUTRAL SAFETY SWITCH

Vehicles equipped with automatic transmissions require the use of a neutral safety switch. The neutral safety switch prevents the engine from being started unless the shift selector of the transmission is in NEUTRAL or PARK. It disables the starting circuit when the transmission is in gear. This safety feature prevents the accidental starting of a vehicle in gear, which can result in personal injury and vehicle damage.

The neutral safety switch is wired into the circuit going to the starter solenoid. When the transmission is in forward or reverse gear, the switch is in the OPEN position (disconnected). This action prevents current from activating the solenoid and starter when the ignition switch is turned to the START position. When the transmission is in neutral or park, the switch is closed (connected), allowing current to flow to the starter when the ignition is turned.

A misadjusted or bad neutral safety switch can keep the engine from cranking. If the vehicle does not start, you should check the action of the neutral safety switch by moving the shift lever into various positions while trying to start the vehicle. If the starter begins to work, the switch needs to be readjusted.

To readjust a neutral safety switch, loosen the fasteners that hold the switch. With the switch loosened, place the shift lever into park (P). Then, while holding the ignition switch in the START position, slide the neutral switch on its mount until the engine cranks. Without moving the switch, tighten the fasteners. The engine should now start with the shift lever in park or neutral. Check for proper operation after the adjustment.

If by adjusting the switch to normal operation is not resumed, it may be required to test the switch. All that is required to test the switch is a 12-volt test light.

To test the switch, touch the test light to the switch output wire connection while moving the shift lever. The light should glow as the shift lever is slid into park or neutral. The light should not work in any other position. If the light is not working properly, check the mechanism that operates the switch. If the problem is in the switch, replace it.

Starter Current Draw Test

STARTING CIRCUIT MAINTENANCE

The condition of the starting motor should be carefully checked at each PM service. This permits you to take appropriate action, where needed, so equipment failures caused by a faulty starter can be reduced, if not eliminated.

The starter current draw test measures the amount of amperage used by the starting circuit. It quickly tells you about the condition of the starting motor and other circuit components. If the current draw is lower or higher than the manufacturer's specifications, there is a problem in the circuit.

A visual inspection for clean, tight electrical connections and secure mounting at the flywheel housing is the extent of the maintenance check. Then operate the starter and observe the speed of rotation and the steadiness of operation. To prevent the starter from overheating, do NOT operate the starter for more than 30 seconds.

To perform a starter current draw test, you may use either a voltmeter or inductive ammeter or a battery load tester. These meters are connected to the battery to measure battery voltage and current flow out of the battery. For setup procedures, use the manufacturer's manual for the type of meter you intend to use.

If the starter is not operating properly, remove the starter, disassemble it, and check the commutator and brushes. If the commutator is dirty, it may be cleaned with a piece of No. 00 sandpaper. However, if the commutator is rough, pitted, or out-of-round or if the insulation between the commutator bars is high, it must be reconditioned using an armature lathe.

To keep a gasoline engine from starting during testing, disconnect the coil supply wire or ground the coil wire. With a diesel engine, disable the fuel injection system or unhook the fuel shutoff solenoid. Check the manufacturer's service manual for details.

With the engine ready for testing, crank the engine and note the voltage and current readings. Check the manufacturer's service manual. If they are not within specifications, there is something wrong with the starting circuit.

Brushes should be at least half of their original size. If not, replace them. The brushes should have free movement in the brush holders and make good, clean contact with the commutator.

Once the starter is checked and repaired as needed, it should be reassembled, making sure that the starter brushes are seated. Align the housings and install the bolts securely. Install the starter in the opening in the flywheel housing and tighten the attaching bolts to the specified torque. Connect the cable and wire lead firmly to clean terminals.

STARTING MOTOR CIRCUIT TESTS

There are many ways of testing a starting motor circuit to determine its operating condition. The most common tests are as follows:

The starter current draw test is used to measure the amount of amperage used by the starting circuit.

The starter circuit voltage drop tests (insulated circuit resistance test and starter ground test) are used to locate parts with higher than normal resistance quickly.

WARNING

Do NOT crank the engine for more than 30 seconds or starter damage can result. If the starter is cranked too long, it will overheat. Allow the starter to cool for a few minutes if more cranking time is needed.

Starting Circuit Voltage Drop Tests

A voltage drop test will quickly locate a component with higher than normal resistance. This test provides an easy way of checking circuit condition. You do NOT have to disconnect any wires and components to check for voltage drops. The two types of voltage drop tests are the insulated circuit resistance test and the starter ground circuit test.

INSULATED CIRCUIT RESISTANCE TEST

The insulated circuit resistance test checks all components between the positive terminal of the battery and the starting motor for excess resistance.

Using a voltmeter, connect the leads to the positive terminal of the battery and the starting motor output terminal.

With the ignition or injection system disabled, crank the engine. Note the voltmeter reading. It should not be over 0.5 volts. If voltage drop is greater, something within the circuit has excessive resistance. There may be a burned or pitted solenoid contact, loose electrical connections, or other malfunctions. Each component is then to be tested individually.

STARTER GROUND CIRCUIT TEST

The starter ground circuit test checks the circuit between the starting motor and the negative terminal of the battery.

Using a voltmeter, connect the leads to the negative terminal of the battery and to the end frame of the starting motor. Crank the engine and note the voltmeter reading. If it is higher than 0.5 volts, check the voltage drop across the negative battery cable. The engine may not be properly grounded. Clean, tighten, or replace the battery cable if needed. A battery cable problem can produce symptoms similar to a dead battery, bad solenoid, or weak starting motor. If the cables do NOT allow enough current to flow, the starter will turn slowly or not at all.

IGNITION CIRCUIT

Learning Objective: Identify ignition-circuit components, their functions, and maintenance procedures.

The ignition circuit supplies high voltage surges (some as high as 50,000 volts in electronic ignition circuits) to the spark plugs in the engine cylinders. These surges produce electric sparks across the spark plug gaps. The heat from the spark ignites the compressed air-fuel mixture in the combustion chambers. When the engine is idling, the spark appears at the spark plug gap just as the piston nears top dead center (TDC) on the compression stroke. When the engine is operating at higher speeds, the spark is advanced. It is moved ahead and occurs earlier in the compression stroke. This design gives the compressed mixture more time to bum and deliver its energy to the pistons.

The functions of an ignition circuit are as follows:

Provide a method of turning the ignition circuit ON and OFF.

Be capable of operating on various supply voltages (battery or alternator voltage).

Produce a high voltage arc at the spark plug electrodes to start combustion.

Distribute high voltage pulses to each spark plug in the correct sequence.

Time the spark so that it occurs as the piston nears TDC on the compression stroke.

Vary spark timing with engine speed, load, and other conditions.

PRIMARY AND SECONDARY CIRCUITS

The ignition circuit is actually made of two separate circuits which work together to cause the electric spark at the spark plugs. These two circuits are the PRIMARY and SECONDARY.

The primary circuit of the ignition circuit includes all of the components and wiring operating on low voltage (battery or alternator voltage). Wiring in the primary circuit uses conventional wire, similar to the wire used in other electrical circuits on the vehicle.

The secondary circuit of the ignition circuit is the high voltage section. It consists of the wire and components between the coil output and the spark plug ground. Wiring in the secondary circuit must have a thicker insulation than that of the primary circuit to prevent leaking (arcing) of the high voltage.

IGNITION CIRCUIT COMPONENTS

Various ignition circuit components are designed to achieve the functions of the ignition circuit. Basic ignition circuit components are as follows:

BATTERY- provides power for the circuit. (This was discussed earlier in this chapter.)

IGNITION SWITCH- allows the operator to turn the circuit and engine ON and OFF.

IGNITION COIL- changes battery voltage to high ignition voltage (30,000 volts and greater).

IGNITION DISTRIBUTOR- distributesignition voltage to the spark plug. Contains either mechanical contact points or an electronic switching circuit.

SPARK PLUG- device that provides an air gap in the combustion chamber for an electric arc.

Ignition Switch

The ignition switch (fig. 2-43) enables the operator to turn the ignition on for starting and running the engine and to turn it off to stop the engine. Most automotive ignition switches incorporate four positions, which are as follows:

OFF

The OFF position shuts off the electrical system. Systems, such as the headlights, are usually not wired through the ignition switch and will continue to operate.

ACCESSORY

The ACCESSORY position turns on power to the entire vehicle electrical system with the exception of the ignition circuit.

IGNITION ON

The IGNITION-ON position turns on the entire electrical system including the ignition circuit.

START

The START position will energize the starter solenoid circuit to crank the engine. The START position is spring-loaded to return to the IGNITION-ON position when the key is released automatically.

IGNITION COIL

The ignition coil (fig. 2-44) produces the high voltage required to make current jump the gap at the spark plugs. It is a pulse type transformer capable of producing a short burst of high voltage for starting combustion.

The ignition coil is made of two sets of windings (primary and secondary), two primary terminals (low voltage connections), an iron core (long piece of iron inside the windings), and a high voltage terminal (coil wire connection).

The primary winding is the outer winding and is made up of several hundred turns of heavy wire, wrapped around or near the secondary winding. The secondary winding is the inner winding and is made up of several thousand turns of heavy wire located inside or near the primary winding. The secondary windings are wound in the opposite direction of the primary, and the ends are attached internally to the primary windings and the high voltage terminal. Both windings are wrapped around an iron core and are housed inside the coil case.

To obtain the high current required for ignition, battery current flows through the ignition coil primary windings producing a strong magnetic field. The action of the iron core strengthens the magnetic field.

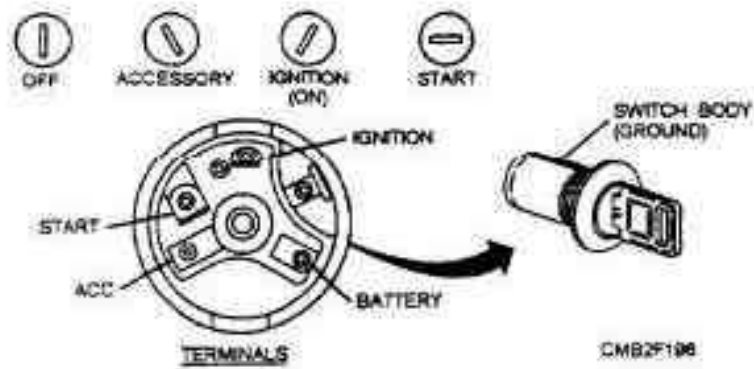

Figure 2-43.- Ignition switch and positions.

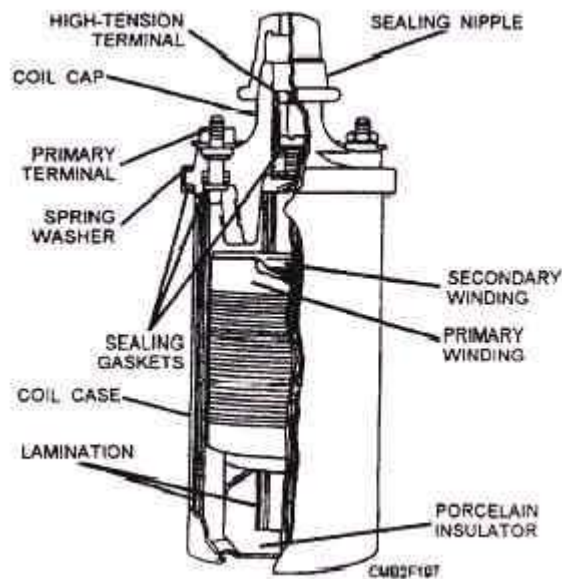

Figure 2-44.- Sectional view of an ignition coil.

When the current flowing through the coil is broken (the primary circuit is opened), the magnetic field collapses across the secondary windings. As the magnetic field collapses, a high electrical voltage is induced into the secondary circuit.

Since both the primary and secondary windings of the coil are stationary, some means other than movement of the windings must be found to change the magnetic field surrounding the coils. In practice, a switching device in the primary circuit creates this effect. There are two common methods to break current flow and fire the coil-mechanical contact points or an electronic switching device.

IGNITION DISTRIBUTOR

An ignition distributor can be a contact point or pickup coil type, as shown in figure 2-45. A contact point distributor is commonly found in older vehicles, whereas the

pickup coil type distributor is used on many modern vehicles. The ignition distributor has several functions, which are as follows:

It actuates the ON/ OFF cycles of current flow through the primary windings of the coil.

It distributes the high voltage surges of the coil to the spark plugs.

It causes the spark to occur at each spark plug earlier in the compression stroke as speed increases.

It changes spark timing with the changes in engine load. As more load is placed on the engine, the spark timing must occur later in the compression stroke to prevent spark knock.

In some cases, the bottom of the distributor shaft powers the engine oil pump.

In some electronic distributors, the distributors house the ignition coil and the electronic switching unit.

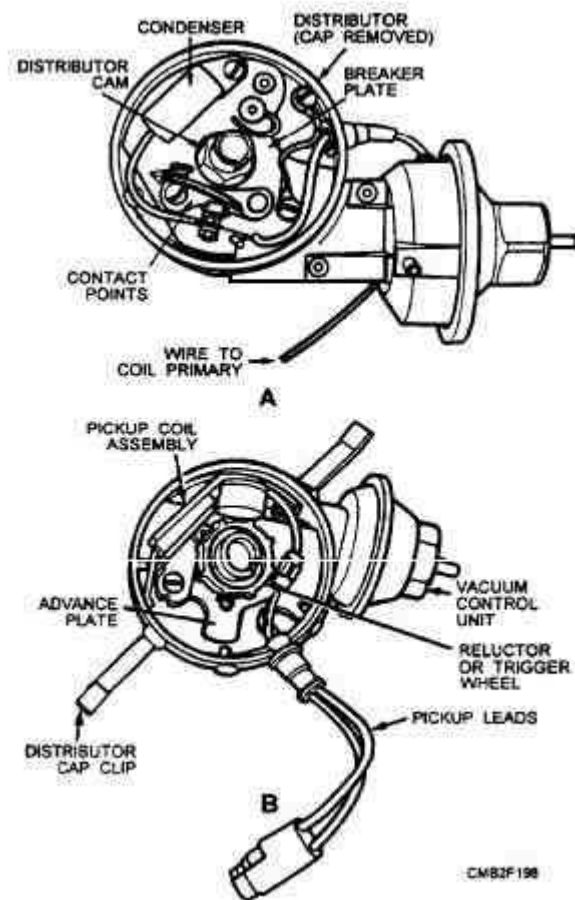

Figure 2-45.- Comparison of a (A) contact point distributor and a (B) pickup coil distributor.

DISTRIBUTOR CAP.- The distributor cap is an insulating plastic component that covers the top of the distributor housing. Its center terminal transfers voltage from the coil wire to the rotor. The distributor cap also has outer terminals that send electric arcs to the spark plugs. Metal terminals are molded into the plastic cap to provide electrical connections.

DISTRIBUTOR ROTOR.- The distributor rotor transfers voltage from the coil wire to the spark plug wires. The rotor is mounted on top of the distributor shaft. It is an electrical switch that feeds voltage to each spark plug wire in turn.

A metal terminal on the rotor touches the distributor cap center terminal. The outer end of the rotor ALMOST touches the outer cap terminals. Voltage is high enough that it can jump the air space between the rotor and cap. Approximately 4,000 volts are required for the spark to jump this rotor-to-cap gap.

SPARK PLUG

The spark plug consists of a porcelain insulator in which there is an insulated electrode supported by a metal shell with a grounded electrode. They have a simple purpose of supplying a fixed gap in the cylinder across which the high voltage surges from the coil must jump after passing through the distributor.

The spark plugs use ignition coil high voltage to ignite the fuel mixture. Somewhere between 4,000 and 10,000 volts are required to make current jump the gap at the plug electrodes. This is much lower than the output potential of the coil.

Spark plug gap is the distance between the center and side electrodes. Normal gap specifications range between .030 to .060 inch. Smaller spark plugs gaps are used on older vehicles equipped with contact point ignition systems.

Spark plugs are either resistor or non-resistor types (fig. 2-46). A resistor spark plug has internal resistance (approximately 10,000 ohms) designed to reduce the static in radios. Most new vehicles require resistor type plugs. Non-resistor spark plug has a solid metal rod forming the center electrode. This type of spark plugs is NOT commonly used except for racing and off-road vehicles.

Spark Plug Heat Range and Reach

The heat range of the spark plug determines how hot the plug will get. The length and diameter of the insulator tip and the ability of the spark plug to transfer heat into the cooling system determine spark plug heat range.

A hot spark plug has a long insulator tip that prevents heat transfer into the waterjackets. It will also bum off any oil deposits. This provides a self-cleaning action.

A cold spark plug has a shorter insulator tip and operates at a cooler temperature. The cooler tip helps prevent overheating and preignition. A cold spark plug is used in engines operated at high speeds.

Vehicle manufacturers recommend a specific spark plug heat range for their engines. The heat range is coded and given as a number on the spark plug insulator. The larger the number on the plug, the hotter the spark plug tip will operate. For example, a 54 plug would be hotter than a 44 or 34 plug.

The only time you should change from spark plug heat range specifications is when abnormal engine or operating conditions are encountered. For instance, if the plug runs too cool, sooty carbon will deposit on the insulator around the center electrode. This deposit could soon build up enough to short out the plug. Then high voltage surges would leak across the carbon instead of producing a spark across the spark plug gap. Using a hotter plug will burn this carbon deposit away or prevent it from forming.

Spark plug reach is the distance between the end of the spark plug threads and the seat or sealing surface of the plug. Plug reach determines how far the plug reaches through the cylinder head. If spark plug reach is too long, the spark plug will protrude too far into the combustion chamber and the piston at TDC may strike the electrode. However, if the reach is too short, the plug electrode may not extend far enough into the cylinder head and combustion efficiency will be reduced. A spark plug must reach into the combustion chamber far enough so that the spark gap will be properly positioned in the combustion chamber without interfering with the turbulence of the air-fuel mixture or reducing combustion action.

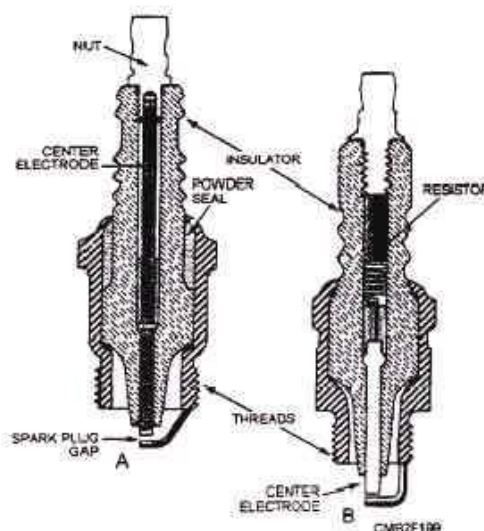

Figure 2-46.- Sectional view of a (A) non-resistor and (B) resistor spark plug.

SPARK PLUG WIRES

The spark plug wires carry the high voltage electric current from the distributor cap side terminals to the spark plugs. In vehicles with distributorless ignition, the spark plug wires carry coil voltage directly to the spark plugs. The two types of spark plug wires are as follows:

SOLID WIRE- Solid wire spark plug wires are used on older vehicles. The wire conductor is simply a strand of metal wire. Solid wires cause radio interference and are no longer used on vehicles.

RESISTANCE WIRE- Resistance spark plug wires consist of carbon-impregnated strands of rayon braid. They are used on modern vehicle because they contain internal resistance that prevents radio interference. Also known as radio interference wires, they have approximately 10,000 ohms per foot. This prevents high-voltage- induced popping or cracking of the radio speakers.

On the outer ends of the spark plug wires, boots protect the metal connectors from corrosion, oil, and moisture that would permit high voltage to leak across the terminal to the shell of the spark plug.

CONTACT POINT IGNITION SYSTEM

Before studying today's electronic ignition systems, you should have a basic understanding of the contact point ignition system. The two systems use many of the same components. These include the battery, the ignition coil, the ignition distributor, the spark plugs, and wires and cables that connect them.

Contact Point Ignitions System Components

The internal components of the distributor for a contact point ignition consist of the following:

DISTRIBUTOR CAM- The distributor cam is part of, or is attached to, the distributor shaft and has one lobe for each cylinder. As the cam rotates with the shaft at one half of engine speed, the lobes cause the contact points to open and close the primary circuit.

CONTACT POINTS- The contact points, also called breaker points, act like spring-loaded electrical switches in the distributor. Its function is to cause intermittent current flow in the primary circuit, thus causing the magnetic field in the coil to build up and collapse when it reaches maximum strength. Wires from the condenser and ignition coil primary circuit connect to the points.

CONDENSER- The condenser, also known as a capacitor, is wired in parallel with the contact points and grounded through the distributor housing. The condenser prevents arcing or burning at the distributor contact points when the points are first open. The

condenser provides a place where current can flow until the contact points are fully open.

Contact Point Ignition System Operation

With the engine running, the distributor shaft and distributor cam rotate. This action causes the distributor cam to open and close the contact points.

With the contact points wired to the primary windings of the ignition coil, the contact points make and break the ignition coil primary circuit. With the contact points closed, the magnetic field builds up in the coil. As the points open, the magnetic field collapses and voltage is sent to the spark plugs.

With the distributor operating at one half of engine speed and with only one cam for each engine cylinder, each spark plug only fires once during a complete revolution of the distributor cam.

To ensure that the contact points are closed for a set time, point dwell, also known as cam angle, is set by using a dwell meter. Point dwell is the amount of time given in degrees of distributor rotation that the points remain closed between each opening.

A dwell period is required to assure that the coil has enough time to build up a strong magnetic field. If the point dwell is too small, the current will have insufficient time to pass through the primary windings of the ignition coil, resulting in a weak spark. However, if the point dwell is too great, the contact points will not open far enough, resulting in arcing or burning of the points.

ELECTRONIC IGNITION SYSTEM

The basic difference between the contact point and the electronic ignition system is in the primary circuit. The primary circuit in a contact point ignition system is open and closed by contact points. In the electronic system, the primary circuit is open and closed by the electronic control unit (ECU).

The secondary circuits are practically the same for the two systems. The difference is that the distributor, ignition coil, and wiring are altered to handle the high voltage produced by the electronic ignition system.

One advantage of this higher voltage (up to 60,000 volts) is that spark plugs with wider gaps can be used. This results in a longer spark, which can ignite leaner air-fuel mixtures. As a result engines can run on leaner mixtures for better fuel economy and lower emissions.

Electronic Ignition System Components

The components of an electronic ignition system regardless of the manufacturer all perform the same functions. Each manufacturer has its own preferred terminology and location of the components. The basic components of an electronic ignition system are as follows:

TRIGGER WHEEL- The trigger wheel, also known as a reluctor, pole piece, or armature, is connected to the upper end of the distributor shaft. The trigger wheel replaces the distributor cam. Like the distributor cam lobes, the teeth on the trigger wheel equal the number of engine cylinders.

PICKUP COIL- The pickup coil, also known as a sensor assembly, sensor coil, or magnetic pickup assembly, produces tiny voltage surges for the ignition system's electronic control unit. The pickup coil is a small set of windings forming a coil.

ELECTRONIC CONTROL UNIT AMPLIFIER- The ignition system electronic control unit amplifier or control module is an "electronic switch" that turns the ignition coil primary current ON and OFF. The ECU performs the same function as the contact points. The ignition ECU is a network of transistors, capacitors, resistors, and other electronic components sealed in a metal or plastic housing. The ECU can be located (1) in the engine compartment, (2) on the side of the distributor, (3) inside the distributor, or (4) under the vehicle dash. ECU dwell time (number of degrees the circuit conducts current to the ignition coil) is designed into the electronic circuit of the ECU and is NOT adjustable.

Electronic Ignition System Operation

With the engine running, the trigger wheel rotates inside the distributor. As a tooth of the trigger wheel passes the pickup coil, the magnetic field strengthens around the pickup coil. This action changes the output voltage or current flow through the coil. As a result, an electrical surge is sent to the electronic control unit, as the trigger wheel teeth pass the pickup coil.

The electronic control unit increases the electrical surges into ON/ OFF cycles for the ignition coil. When the ECU is ON, current passes through the primary windings of the ignition coil, thereby developing a magnetic field. Then, when the trigger wheel and pickup coil turn OFF the ECU, the magnetic field inside the ignition coil collapses and fires a sparkplug.

Hall-Effect Sensor

Some electronic distributors have a magnetic sensor using the Hall effect. When a steel shutter moves between the two poles of a magnet, it cuts off the magnetism between the two poles. The Hall-effect distributor has a rotor with curved plates, called shutters. These shutters are curved so they can pass through the air gap between the two poles of the magnetic sensor, as the rotor turns. Like the trigger wheel, there are the same number of shutters as there are engine cylinders.

Each time a shutter moves through the air gap between the two poles of the magnetic sensor, it cuts off the magnetic field between the poles. This action provides a signal to the ECU. When a shutter is not in the way, the magnetic sensor is producing voltage. This voltage is signaling the ECU to allow current to flow through the ignition coils primary winding. However, when the shutter moves to cut off the magnetic field, the signal voltage drops to zero. The ECU then cuts off the current to the ignition coils primary winding. The magnetic field collapses, causing the coil secondary winding to produce a high voltage surge. This high voltage surge is sent by the rotor to the proper spark plug.

IGNITION TIMING DEVICES

Ignition timing refers to how early or late the spark plugs fire in relation to the position of the engine pistons. Ignition timing must vary with engine speed, load, and temperature.

Timing advance happens when the spark plugs fire sooner than the compression strokes of the engine. The timing is set several degrees before top dead center (TDC). More time advance is required at higher speeds to give combustion enough time to develop pressure on the power stroke.

Timing retard happens when the spark plugs fire later on the compression strokes. This is the opposite of timing advance. Spark retard is required at lower speeds and under high load conditions. Timing retard prevents the fuel from burning too much on the compression stroke, which would cause spark knock or ping.

The basic methods to control ignition system timing are as follows:

CENTRIFUGAL ADVANCE (controlled by engine speed)

VACUUM ADVANCE (controlled by intake manifold vacuum and engine load)

COMPUTERIZED ADVANCE (controlled by various sensors- speed, temperature, intake, vacuum, throttle position, etc.)

Centrifugal Advance

Centrifugal advance makes the ignition coil and spark plugs fire sooner as engine speed increases, using spring-loaded weights, centrifugal force, and lever action to rotate the distributor cam or trigger wheel. Spark timing is advanced by rotating the distributor cam or trigger wheel against distributor shaft rotation. This action helps correct ignition timing for maximum engine power. Basically the centrifugal advance consists of two advance weights, two springs, and an advance lever.

During periods of low engine speed, the springs hold the advance weights inward towards the distributor cam or trigger wheel. At this time there is not enough centrifugal force to push the weights outward. Timing stays at its normal initial setting.

As speed increases, centrifugal force on the weights moves them outwards against spring tension. This movement causes the distributor cam or trigger wheel to move ahead. With this design, the higher the engine speed, the faster the distributor shaft turns, the farther out the advance weights move, and the farther ahead the cam or trigger wheel is moved forward or advanced. At a preset engine speed, the lever strikes a stop and centrifugal advance reaches maximum.

The action of the centrifugal advance causes the contact points to open sooner, or the trigger wheel and pickup coil turn off the ECU sooner. This causes the ignition coil to fire with the engine pistons not as far up in the cylinders.

Vacuum Advance

The vacuum advance provides additional spark advance when engine load is low at part throttle position. It is a method of matching ignition timing with engine load. The vacuum advance increases FUEL ECONOMY because it helps maintain idle fuel spark advance at all times. A vacuum advance consists of a vacuum diaphragm, link, movable distributor plate, and a vacuum supply hose.

At idle, the vacuum port from the carburetor or throttle body to the distributor advance is covered, thereby NO vacuum is applied to the vacuum diaphragm, and spark timing is NOT advanced. At part throttle, the throttle valve uncovers the vacuum port and the port is exposed to engine vacuum. The vacuum pulls the diaphragm outward against spring force. The diaphragm is linked to a movable distributor plate, which is rotated against distributor shaft rotation and spark timing is advanced.

The vacuum advance does not produce any advance at full throttle. When the throttle valve is wide open, vacuum is almost zero. Thus vacuum is NOT applied to the distributor diaphragm and the vacuum advance does NOT operate.

Computerized Advance

The computerized advance, also known as an electronic spark advance system, uses various engine sensors and a computer to control ignition timing. The engine sensors check various operating conditions and sends electrical data to the computer. The computer can change ignition timing for maximum engine efficiency.

Ignition system engine sensors include the following:

ENGINE SPEED SENSOR (reports engine speed to the computer)

CRANKSHAFT POSITION SENSOR (reports piston position)

THROTTLE POSITION SWITCH (notes the position of the throttle)

INLET AIR TEMPERATURE SENSOR (checks the temperature of the air entering the engine)

ENGINE COOLANT TEMPERATURE SENSOR (measures the operating temperature of the engine)

DETONATION SENSOR (allows the computer to retard timing when the engine knocks or pings)

INTAKE VACUUM SENSOR (measures engine vacuum, an indicator of load)

The computer receives different current or voltage levels (input signals) from these sensors. It is programmed to adjust ignition timing based on engine conditions. The computer may be mounted on the air cleaner, under the dash, on a fender panel, or under a seat.

The following is an example of the operation of a computerized advance. A vehicle is traveling down the road at 50 mph; the speed sensor detects moderate engine speed. The throttle position sensor detects part throttle and the air inlet and coolant temperature sensors report normal operating temperatures. The intake vacuum sensor sends high vacuum signals to the computer.

The computer receives all the data and calculates that the engine requires maximum spark advance. The timing would occur several degrees before TDC on the compression stroke. This action assures that high fuel economy is attained on the road.

If the operator began to pass another vehicle, intake vacuum sensor detects a vacuum drop to near zero and a signal is sent to the computer. The throttle position sensor detects a wide, open throttle and other sensor outputs say the same. The computer receives and calculates the data, then, if required, retards ignition timing to prevent spark knock or ping.

IGNITION SYSTEM MAINTENANCE

Ignition troubles can result from a myriad of problems, from faulty components to loose or damaged wiring. Unless the vehicle stops on the job, the operator will report trouble indications, and the equipment is turned into the shop for repairs.

Unless the trouble is known, a systematic procedure should be followed to locate the cause. Remember, that electric current will follow the path of least resistance. Trace ignition wiring while checking for grounds, shorts, and open circuits. Bare wires, loose connections, and corrosion are found through visual inspection.

After checking the system, you must evaluate the symptoms and narrow down the possible causes. Use your knowledge of system operation, a service manual troubleshooting chart, basic testing methods, and common sense to locate the trouble. Many shops have specialized equipment that provide the mechanic a quick and easy means of diagnosing ignition system malfunctions.

Spark Plugs and Spark Plug Wires

Bad spark plugs cause a wide range of problems- misfiring, lack of power, poor fuel economy, and hard starting. After prolonged use, the spark plug tip can become coated with ash, oil, and other residue. The spark plug electrodes can also bum and widen the gap. This makes it more difficult for the ignition system to produce an electric arc between the electrodes.

To read spark plugs closely, inspect and analyze the condition of each spark plug tip and insulator. This will give you information on the condition of the engine, the fuel system, and the ignition system. The conditions commonly encountered with spark plugs areas follows:

NORMAL OPERATION (fig. 2-47) appears as brown to grayish-tan deposit with slight electrode wear. This indicates the correct spark plug heat range and mixed periods of high-and low-speed operation. Spark plugs, having this appearance, may be cleaned, regapped, and reinstalled.

CARBON FOULED (fig. 2-48) appears as dry, fluffy black carbon, resulting from slow operating speeds, wrong heat range (too cold), weak ignition (weak coil, worn ignition cables, etc.), faulty automatic choke, sticking manifold control valve, or rich air-fuel mixture. Spark plugs, having this appearance, may be cleaned, regapped, and reinstalled.

OIL FOULED (fig. 2-49) appears as wet, oily deposits with very little electrode wear, resulting from worn rings, scored cylinder, or leaking valve seals. Spark plugs, having this appearance, may be degreased, cleaned, regapped, and reinstalled.

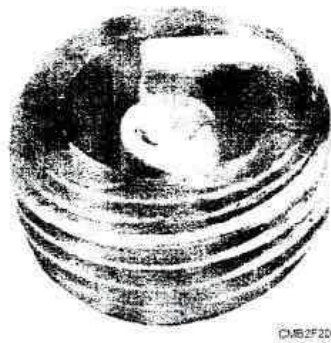

Figure 2-47.- Normal operation.



Figure 2-48.- Carbon fouled.

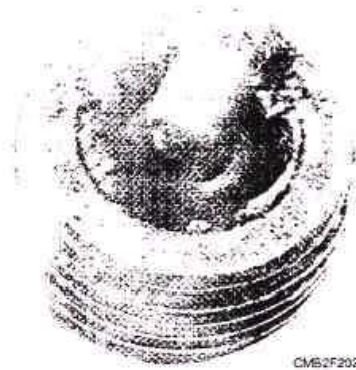

Figure 2-49.- Oil fouled.

ASH FOULED (fig. 2-50) appears as red, brown, yellow, or white colored deposits which accumulate on the insulator, resulting from poor fuel quality or oil entering the cylinder. Most ash deposits have no adverse effect on the operation of the spark plug as long as they remain in a powdery state. However, under certain conditions these deposits melt and form a shiny glaze on the insulator which, when hot, acts as a good electrical conductor. This allows current to follow the deposit instead of jumping the gap, thus shorting out the spark plug. Spark plugs, having a powdery condition, may be cleaned, regapped, and replaced. Those having a glazed deposit are to be replaced.

PREIGNITION DAMAGE (fig. 2-51) appears as burned or blistered insulator tips and badly worn electrodes, resulting from over-advanced timing, low-octane fuel, wrong spark plug heat range (too high), or a lean air-fuel mixture. Spark plugs, having this condition, are to be replaced with ones having the recommended heat range.

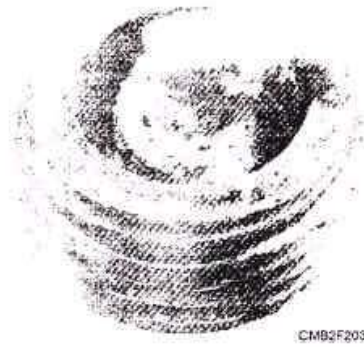

Figure 2-50.- Ash fouled.

When a spark plug is removed for cleaning or inspection, it should be regapped by the engine manufacturer's specifications. New spark plugs are also to be regapped before installation, as they may have been dropped or mishandled and are not within specifications.

A wire type feeler gauge should be used to measure spark plug gap. Slide the feeler gauge between the electrodes. If needed, bend the side electrode until the feeler gauge fits snugly. The gauge should drag slightly, as it is pulled in and out of the gap. Spark plug gaps vary from 0.30 inch on contact point ignitions to over 0.60 inch on electronic ignition systems.

When the spark plugs are being reinstalled, tighten them to the manufacturer's recommendation. Some manufacturers give spark plug torque, while others recommend bottoming the plugs on the seat and then turning an additional one-quarter to one-half turn. Refer to the manufacturer's service manual for exact procedures.

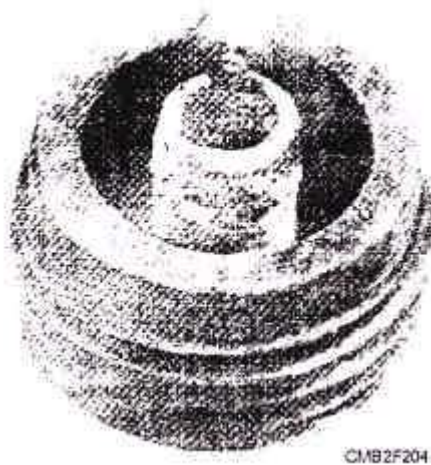

Figure 2-51.- Preignition damage.

A faulty spark wire can either have a burned or broken conductor, or it could have deteriorated insulation. Most spark plug wires have a resistance conductor that can be easily separated. If the conductor is broken, voltage and current cannot reach the spark plug. If the insulation is faulty, sparks may leak through to ground or to another wire instead of reaching the spark plugs. To test the wires for proper operation, you can perform the following:

A SPARK PLUG WIRE RESISTANCE TEST

will check the spark plug conductor or coil wire conductor. To perform a wire resistance test, connect an ohmmeter across each end of the wire. The meter will read internal wire resistance in ohms. Typically resistance should NOT be over 5,000 ohms per inch or 100,000 ohms total. Since specifications vary, compare your readings to the manufacturer's specifications.

A SPARK PLUG WIRE INSULATION TEST

checks for sparks arcing through the insulation to ground. To perform an insulation test with the hood up, block out as much light as possible, start the engine, and move a grounded screwdriver next to the insulation. If a spark jumps through the insulation to the screwdriver, the wire is bad. Spark plug leakage is a condition in which electric arcs pass through the wire insulation.

Installing new spark plug wire is a simply task, especially when one wire at a time is replaced. Wire replacement is more complicated if all of the wires have been removed. Then you must use engine firing order and cylinder numbers to route each wire correctly. Service manuals can be used to trace the wires from each distributor cap tower to the correct spark plug.

Distributor Service

The distributor is critical to the proper operation of the ignition system. The distributor senses engine speed, alters ignition timing, and distributes high voltage to the spark plugs. If any part of the distributor is faulty, engine performance suffers.

DISTRIBUTOR CAP AND ROTOR.- When problems point to possible distributor cap or rotor troubles, remove and inspect them. The distributor cap should be carefully checked to see that sparks have not been arcing from point to point. Both interior and exterior must be clean. The firing points should not be eroded, and the interior of the towers must be clean.

The rotor tip, from which the high-tension spark jumps to each distributor cap terminal, should not be worn. It also should be checked for excessive burning, carbon trace, looseness, or other damage. Any wear or irregularity will result in excessive resistance to the high-tension spark. Make sure that the rotor fits snugly on the distributor shaft.

A common problem arises when a CARBON TRACE (small line of carbonlike substance that conducts electricity) forms on the inside of the distributor cap or outer edge of the rotor. The carbon trace will short coil voltage to ground or to a wrong terminal lug in the distributor cap. A carbon trace will cause the spark plugs to either fire poorly or not at all.

Using a droplight, check the inside of the distributor cap for cracks and carbon trace. Carbon trace is black which makes it hard to see on a black-colored distributor cap. If carbon trace or a crack is found, replace the distributor cap or rotor.

CONTACT POINT DISTRIBUTOR SERVICE.- In a contact point distributor, there are two areas of concern- the contact points and the condenser.

Bad contact points cause a variety of engine performance problems. These problems include high-speed missing, no-start problem, and many other ignition troubles. Visually inspect the surfaces of the contact points to determine their condition. Points with burned and pitted contacts or with a worn rubbing block must be replaced. However, if the points look good, point resistance should be measured. Turn the engine over until the points are closed and then use an ohmmeter to connect the meter to the primary point lead and to ground. If resistance reading is too high, the points are burned and must be replaced.

A faulty condenser may leak (allow some dc current to flow to ground), be shorted (direct electrical connection to ground), or be opened (broken lead wire to the condenser foils). If the condenser is leaking or open, it will cause point arcing and burning. If the condenser is shorted, primary current will flow to ground and the engine will NOT start. To test a condenser using an ohmmeter, connect the meter to the condenser and to ground. The meter should register slightly and then return to infinity (maximum resistance). Any continuous reading other than infinity indicates that the condenser is leaking and must be replaced.

Installing contact points is a relatively simple procedure but must be done with precision and care in order to achieve good engine performance and economy. Make sure the points are clean and free of any foreign material.

Proper alignment of the contact points is extremely important (fig. 2-52). If the faces of the contact points do not touch each other fully, heat generated by the primary current cannot be dissipated and rapid burning takes place. The contacts are aligned by bending the stationary contact bracket only. **NEVER BEND THE MOVABLE CONTACT ARM.** Ensure the contact arm-rubbing block rests flush against the distributor cam. A small amount of an approved lubricate should be placed on the distributor cam to reduce friction between the cam and rubbing block. Once the points are installed, they can be adjusted using either a feeler gauge or dwell meter.

To use a feeler gauge to set the contact points, turn the engine over until the points are **FULLY OPEN**. The rubbing block should be on top of a distributor cam lobe. With the points open, slide the specified thickness feeler gauge between them. Adjust the points so that there is a slight drag on the blade of the feeler gauge. Depending upon

point design, use a screwdriver or Allen wrench to open and close the points. Tighten the hold-down screws and recheck the point gap. Typically point gap settings average around .015 inch for eight-cylinder engines and .025 inch for six- and four-cylinder engines. For the gap set of the engine you are working on, consult the manufacturer's service manual.

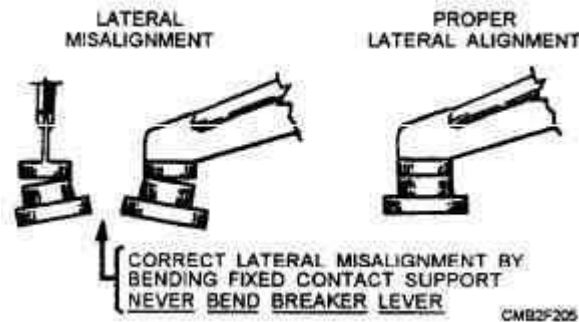

Figure 2-52.- Contact point alignment.

CAUTION

Ensure the feeler gauge is clean before inserting it between the points. Oil and grease will reduce the service life of the points.

To use a dwell meter for adjusting contact points, connect the red lead of the dwell meter to the distributor side of the ignition coil (wire going to the contact points). Connect the black lead to ground.

If the distributor cap has an adjustment window, the points should be set with the engine running. With the meter controls set properly, adjust the points through the window of the distributor cap using a Allen wrench or a special screwdriver. Turn the point adjustment screw until the dwell meter reads within manufacturer's specification. However, if the distributor cap does not have an adjustment window, remove the distributor cap and ground the ignition coil wire. Then crank the engine; this action will simulate engine operation and allow point adjustment with the dwell meter.

Dwell specifications vary with the number of cylinders. An eight-cylinder engine requires 30 degrees of dwell. An engine with few cylinders requires more dwell time. Always consult the manufacturer's service manual for exact dwell values.

Dwell should remain constant as engine speed increases or decreases. However, if the distributor is worn, you can have a change in the dwell meter reading. This is known as DWELL VARIATION. If dwell varies more than 3 degrees, the distributor should either be replaced or rebuilt. Also, a change in the point gap or dwell will change ignition timing. For this reason, the points should always be adjusted before ignition timing.

ELECTRONIC IGNITION DISTRIBUTOR SERVICE

Most electronic ignition distributors use a pickup coil to sense trigger wheel rotation and speed. The pickup coil sends small electrical impulses to the ECU. If the distributor fails to produce these electrical impulses properly, the ignition system can quit functioning.

A faulty pickup coil will produce a wide range of engine troubles, such as stalling, loss of power, or not starting at all. If the small windings in the pickup coil break, they will cause problems only under certain conditions. It is important to know how to test a pickup coil for proper operation.

The PICKUP COIL OHMMETER TEST compares actual pickup resistance with the manufacturer's specifications. If the resistance is too high or low, the pickup coil is faulty. To perform this test, connect the ohmmeter across the output leads of the pickup coil. Wiggle the wire to the pickup coil and observe the meterreading. This will assist in locating any breaks in the wires to the pickup. Also, using a screwdriver, lightly tap the coil. This action will uncover any break in the coil windings.

Pickup coil resistance varies between 250 and 1,500 ohms, and you should refer to the service manual for exact specifications. Any change in the readings during the pickup coil resistance test indicates the coil should be replaced. Refer to the manufacturer's service manual for instructions for the removal and replacement of the pickup coil.

Once the pickup coil has been replaced, it will be necessary to set the PICKUP COIL AIR GAP. The air gap is the space between the pickup coil and the trigger wheel tooth. To obtain an accurate reading, use a NON-MAGNETIC FEELER GAUGE (plastic or brass).

With one tooth of the trigger wheel pointing at the pickup coil, slide the correct thickness non-magnetic feeler gauge between the trigger wheel and the pickup coil. Move the pickup coil in or out until the correct air gap is set. Tighten the pickup coil screws and double-check the air gap setting.

Ignition Timing

The ignition system must be timed so the sparks jump across the spark plug gaps at exactly the right time. Adjusting the distributor on the engine so that the spark occurs at this correct time is called setting the ignition timing. The ignition timing is normally set at idle or a speed specified by the engine manufacturer. Before measuring engine timing, disconnect and plug the vacuum advance hose going to the distributor. This action prevents the vacuum advance from functioning and upsetting the readings. Adjustment is made by loosening the distributor hold-down screw and turning the distributor in its mounting.

Turning the distributor housing against the distributor shaft rotation **ADVANCES THE TIMING**. Turning the distributor housing with shaft rotation **RETARDS THE TIMING**. Refer to figure 2-53.

When the ignition timing is **TOO ADVANCED**, the engine may suffer from spark knock or ping. When ignition timing is **TOO RETARDED**, the engine will have poor fuel economy and power and will be very sluggish during acceleration. If extremely retarded, combustion flames blowing out of the open exhaust valve can overheat the engine and crack the exhaust manifolds.

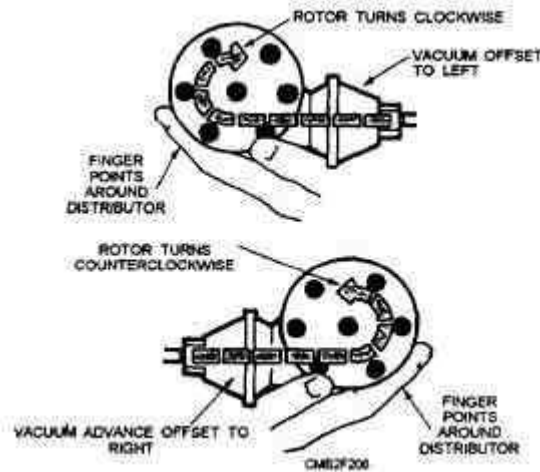

Figure 2-53.- Determining the direction of rotor rotation.

A timing light is used *to* measure ignition timing. It normally has three leads- two small leads that connect to the battery-and one larger lead that connects to the **NUMBER ONE** spark plug wire. Depending on the type of timing light, the large lead may clip around the plug wire (inductive type), or it may need to be connected directly to the metal terminal of the plug wire (conventional type).

Draw a chalk line over the correct timing mark. This will make it easier to see. The timing marks may be either on the front cover in harmonic balance of the engine, or they may be on the engine flywheel.

With the engine running, aim the flashing timing light at the timing mark and reference pointer. The flashing timing light will make the mark appear to stand still. If the timing mark and the pointer do not line up, turn the distributor in its mounting until the timing mark and pointer are aligned. Tighten the distributor hold-down screw.

CAUTION

Keep your hands and the timing light leads from the engine fan and belts. The spinning fan and belts can damage the light or cause serious personal injury.

After the initial ignition timing, you should check to see if the automatic advance mechanism is working. This can be done by keeping the timing light flashes aimed at the timing mark and gradually increasing speed. If the advance mechanism is operating, the timing mark should move away from the pointer. If the timing mark fails to move as the speed increases or it hesitates and then suddenly jumps, the advance mechanism is faulty and should either be repaired or replaced.

Replace the distributor vacuum line and see if timing still conforms to the manufacturer's specifications. If the timing is NOT advanced when the vacuum line is connected and the throttle is opened slightly, the vacuum advance unit or tubing is defective.

Most computer-controlled ignition systems have no provision for timing adjustment. A few, however, have a tiny screw or lever on the computer for small ignition timing changes.

A computer-controlled ignition system has what is known as BASE TIMING. Base timing is the ignition timing without computer-controlled advance. Base timing is checked by disconnecting a wire connector in the computer wiring harness. This wire connector may be found on or near the engine or sometimes next to the distributor. When in the base timing mode, a conventional timing light can be used to measure ignition timing. If ignition timing is not correct, you can rotate the distributor, in some cases, or move the mounting for the engine speed or crank position sensor. If base timing cannot be adjusted, the electronic control unit or other components will have to be replaced. Always refer to the manufacturer's service manual when timing a computer-controlled ignition system.

LIGHTING CIRCUIT

Learning Objective: Identify lighting-circuit components, their functions, and maintenance procedures.

The lighting circuit (fig. 2-54) includes the battery, vehicle frame, all the lights, and various switches that control their use. The lighting circuit is known as a single-wire system since it uses the vehicle frame for the return.

The complete lighting circuit of a vehicle can be broken down into individual circuits, each having one or more lights and switches. In each separate circuit, the lights are connected in parallel, and the controlling switch is in series between the group of lights and the battery.

The marker lights, for example, are connected in parallel and are controlled by a single switch. In some installations, one switch controls the connections to the battery, while a selector switch determines which of two circuits is energized. The headlights, with their high and low beams, are an example of this type of circuit.

In some instances, such as the courtesy lights, several switches may be connected in parallel so that any switch may be used to turn on the light.

When a wiring diagram is being studied, all light circuits can be traced from the battery through the ammeter to the switch (or switches) to the individual light.

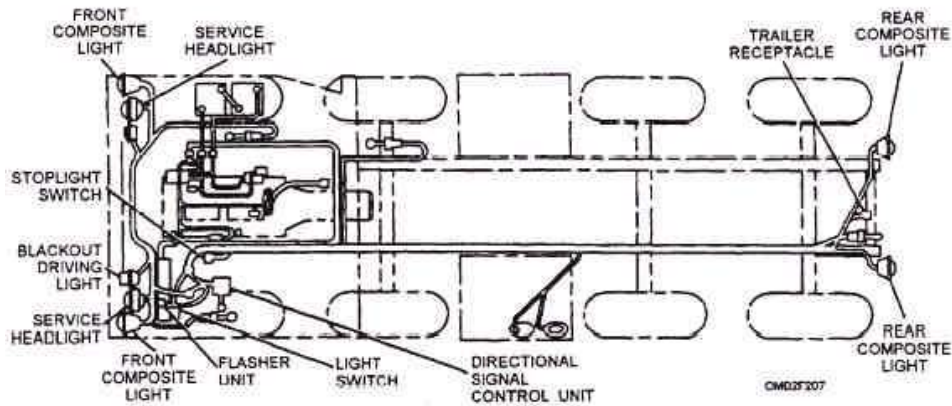

Figure 2-54.—Typical automotive lighting circuit.

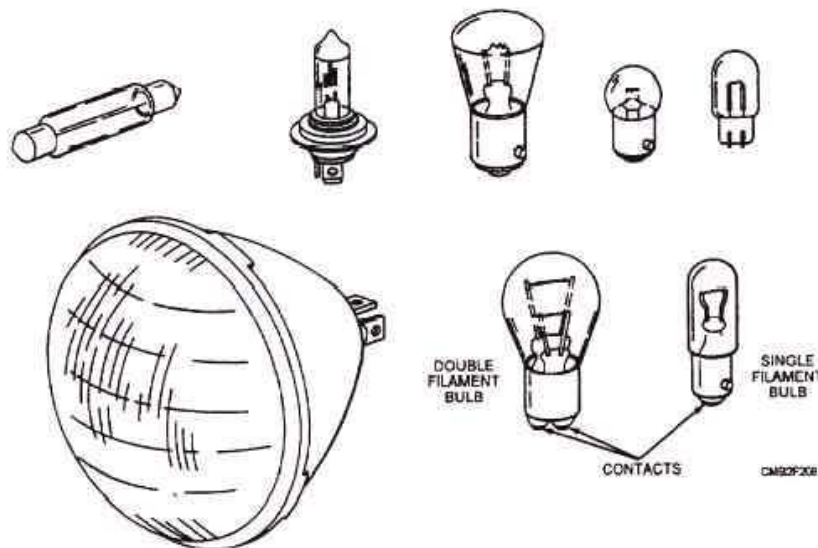

Figure 2-55.- Lamp construction and configurations.

LAMPS

Small gas-filled incandescent lamps with tungsten filaments are used on automotive and construction equipment (fig. 2-55). The filaments supply the light when sufficient current is flowing through them. They are designed to operate on a low voltage current of 12 or 24 volts, depending upon the voltage of the the vehicle will be of the single-or double-contact small one-half-candlepower bulbs to large 50- candlepower bulbs. The greater the candlepower of the lamp, the more current it requires when lighted. Lamps are identified by a number on the base. When you replace a lamp in a vehicle, be sure the new lamp is of the proper rating. The lamps within Lamps are rated as to size by the candlepower (luminous intensity) they produce. They range from types with nibs to fit bayonet sockets, as shown in lamp is also whiter than a conventional lamp, which increases lighting ability.

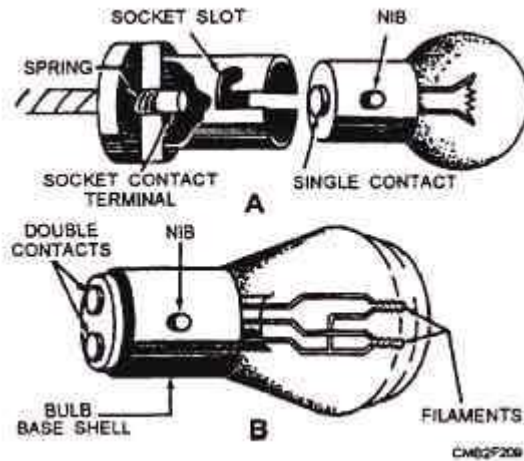

Figure 2-56.- (A) Single-contact bulb; (B) Double-contact bulb.

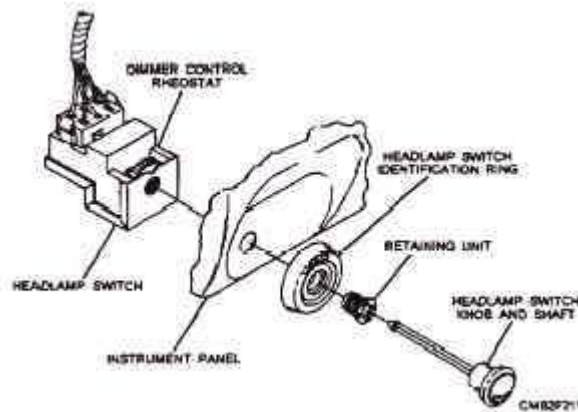

Figure 2-58.- Dash-mounted headlight switch.

HEADLIGHTS HEADLIGHT SWITCH

The headlights are sealed beam lamps (fig. 2-57) that illuminate the road during nighttime operation. Headlights consist of a lens, one or two elements, and an integral reflector. When current flows through the element, the element gets white hot and glows. The reflector and lens direct the light forward.

Many modern passenger vehicles use halogen headlights. A halogen headlight contains a small, inner halogen lamp surrounded by a conventional sealed housing. A halogen headlamp increases light output by 25 percent with no increase in current. The halogen

The headlight switch is an ON/ OFF switch and rheostat (variable resistor) in the dash panel (fig. 2-58) or on the steering column (fig. 2-59). The headlight switch controls current flow to the lamps of the headlight system. The rheostat is for adjusting the brightness of the instrument panel lights.

Military vehicles that are used in tactical situations are equipped with a headlight switch that is integrated with the blackout lighting switch (fig. 2-60). An important feature of this switch is that it reduces the possibility of accidentally turning on the lights in a blackout.

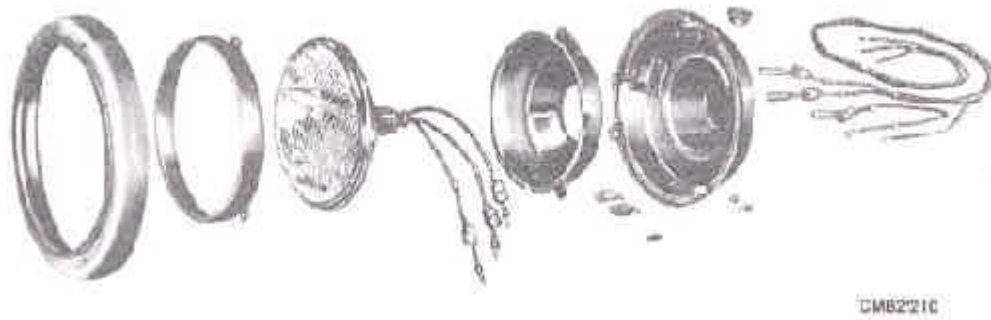

Figure 2-57.- A typical sealed beam headlight assembly.

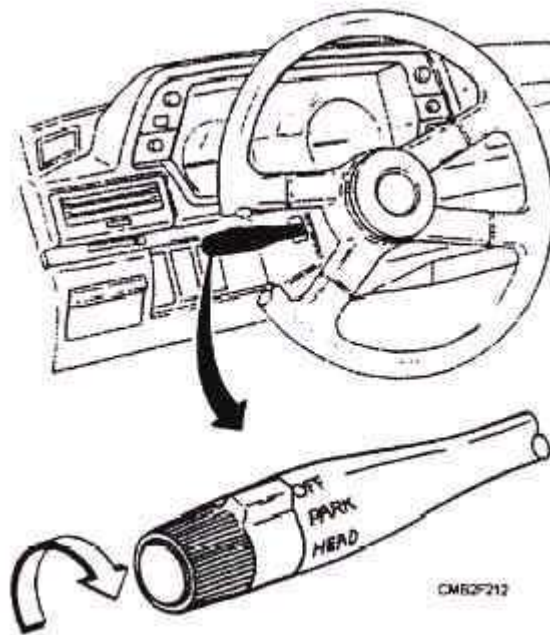

Figure 2-59.- Steering column mounted headlight switch.

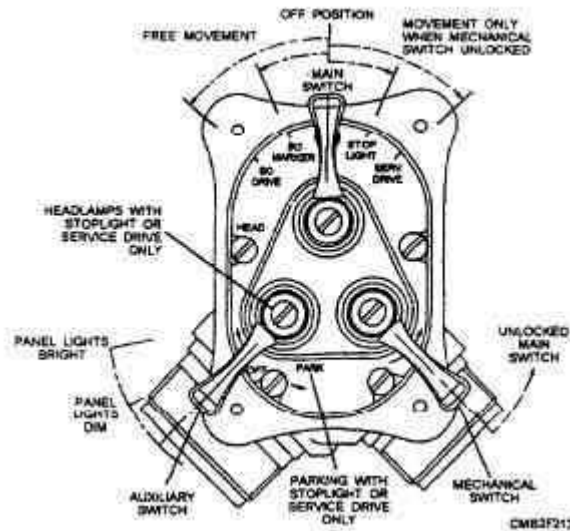

Figure 2-60.- Blackout light/ headlight switch.

With no lights on, the main switch can be turned to the left without operating the mechanical switch to get blackout marker lights (including blackout taillights and stoplights) and blackout driving lights. But for stoplights for daylight driving or headlights for ordinary night driving, you must first lift the mechanical switch lever and then turn the main switch to the right. The auxiliary switch gives panel lights when the main switch is in any of its ON positions. But it will give parking lights only when the main switch is in service drive (to the extreme right). When the main switch is off, the auxiliary switch should not be moved from the OFF position.

DIMMER SWITCH

The dimmer switch controls the high and low headlamp beam function and is normally mounted on the floorboard (fig. 2-61) or steering column (fig. 2-62). When the operator activates the dimmer switch, it changes the electrical connection to the headlights.

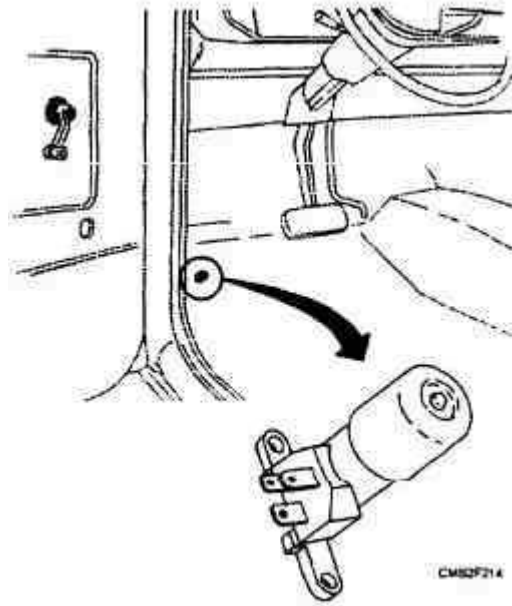

Figure 2-61.- Floor-mounted dimmer switch.

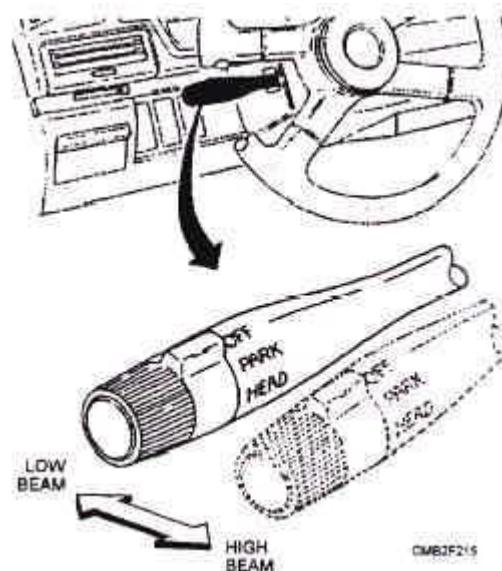

Figure 2-62.- Steering column mounted dimmer switch.

In one position, the high beams are turned on, and, in the other position, the dimmer changes them to low beam.

Aiming Headlights

The headlights can be aimed using a mechanical aimer or a wall screen. Either method assures that the headlight beams point in the direction specified by the vehicle manufacturer. Headlights that are aimed too high can blind oncoming vehicles. Headlights that are aimed too low or to one side will reduce the operator's visibility.

To ensure that the headlights are properly aimed, you should have a half a tank of fuel, the correct tire pressure, and only the spare tire and jack in the vehicle. Some manufacturers recommend that someone sit in the operator and passenger seats while aiming the lights.

HEADLIGHT AIMERS are a device for pointing the vehicle headlights in a specified position. They may be permanently installed on a track or may be portable. Some require a level floor, and others have internal leveling mechanisms to allow for uneven shop floors. To use the aimer, follow the instructions for the specific type of equipment.

The HEADLIGHT AIMING SCREEN is a series of measured lines marked on a shop wall or on a framed easel for aiming the headlights of a vehicle. The screen should be no less than 10 feet wide and 42 inches high. When it is mounted on an easel with casters, the screen should be no more than 12 inches from the floor. To comply with regulations of most localities, you should place the screen 25 feet ahead of the vehicle.

The accepted driving beam pattern for passenger vehicles will show the high intensity portion (hotspot) of the light rays centered on a horizontal line that is 2 inches below the center or horizontal reference line on the screen (fig. 2-63). This means that there will be a 2-inch drop of the light beam for every 25 feet of distance from the headlight.

Headlights on large trucks present a special problem because of the effect of a heavy load. At the same 25 feet, truck headlights should be aimed so that none of the high intensity portion of the light will project higher than a level of 5 inches below the center on the headlight being tested. This is necessary to compensate for the variations in loading.

When using a screen for aiming the headlights on a vehicle that uses a four-headlight system, adjust the hotspots of the No. 1 (inboard) lights so that they are centered on the vertical lines 2 inches below the horizontal line (fig. 2-64). The low beam of the No. 2 (outboard) lights is aimed so that the hotspot does not extend to the left of straight ahead or extend more than 6 inches to the right of straight ahead. The top of the hotspot of the No. 2 lights is aimed at the horizontal line. When the No. 2 lights are properly adjusted, the high beam will be correct.

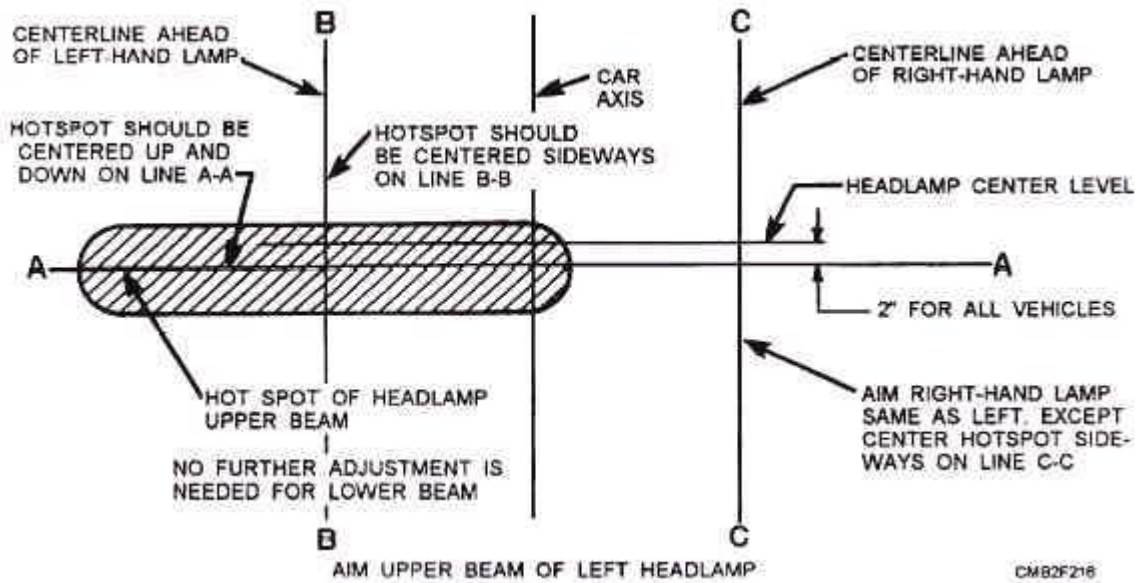

Figure 2-63.- Accepted beam pattern for aiming passenger vehicle headlights.

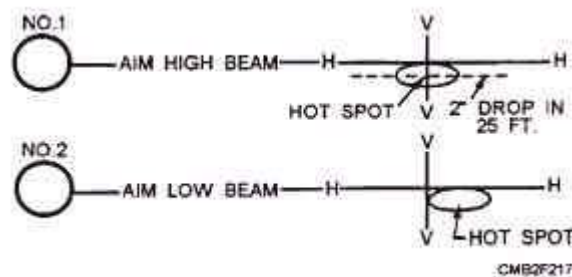

Figure 2-64.- Accepted beam pattern for a four-headlight system.

BLACKOUT LIGHTS

Blackout lighting is a requirement for certain combat operations. The purposes of blackout lighting are as follows:

To provide the vehicle operator with sufficient light to operate the vehicle in total darkness

To provide minimum lighting to show vehicle position to a leading or trailing vehicle when illumination must be restricted to a level not visible to a distant enemy

The three types of blackout lighting are as follows: The BLACKOUT DRIVING LIGHT (fig. 2-65) is designed to provide a white light of 25 to 50 candlepower at a distance of 10 feet directly in front of the light. The light is shielded so that the top of the low beam is directed not less than 2 degrees below the horizon. The beam distribution on a level road at 100 feet from the light is 30 feet wide.

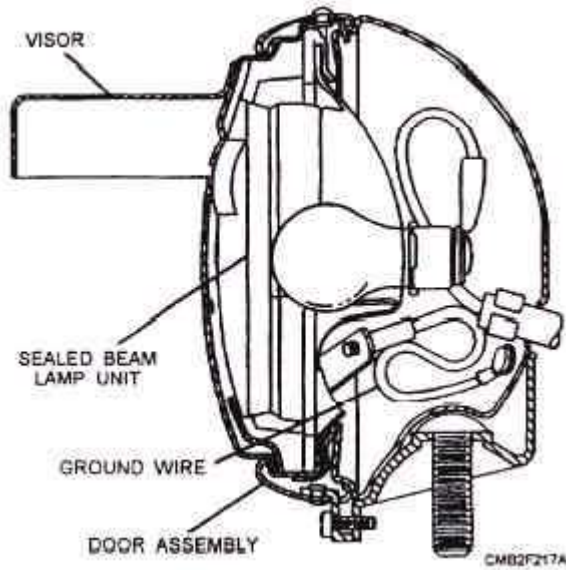

Figure 2-65.- Blackout driving light.

The BLACKOUT STOP/ TAILLIGHT and MARKER LIGHT (fig. 2-66) are designed to be visible at a horizontal distance of 800 feet and not visible beyond 1,200 feet. The lights also must be invisible from the air above 400 feet with the vehicle on upgrades and downgrades of 20 percent. The horizontal beam cutoff for the lights is 60 degrees right and left of the beams center line at 100 feet.

The COMPOSITE LIGHT (fig. 2-67) is currently the standard light unit that is used on the rear of tactical military vehicles. The composite light combines service stop, tail, and turn signals with blackout stop and taillighting.

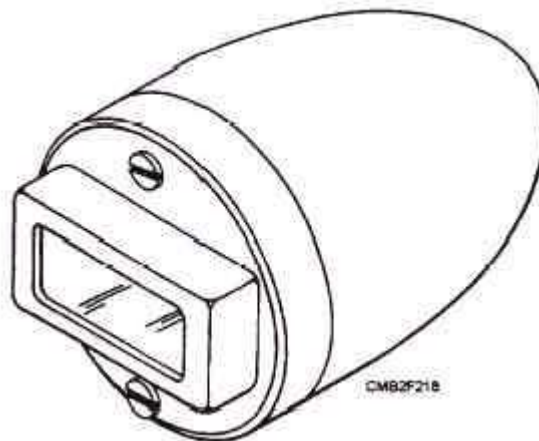

Figure 2-66.- Blackout stop/ taillight and marker light.

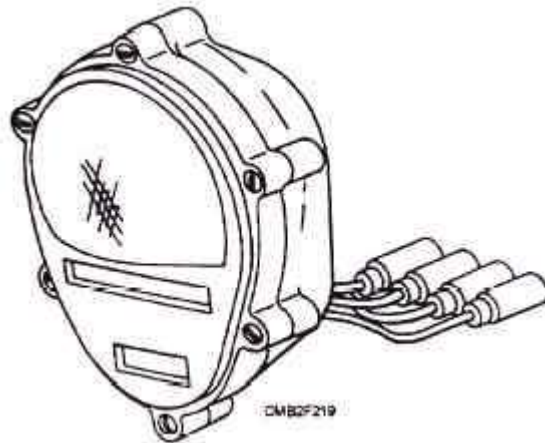

Figure 2-67.- Military composite light.

Blackout lighting control switches are designed to prevent the service lighting from being turned on accidentally. Their operation is described in the "Headlight Switch" section of this TRAMAN.

TURN-SIGNAL SYSTEMS

Vehicles that operate on any public road must be equipped with turn signals. These signals indicate a left or right turn by providing a flashing light signal at the rear and front of the vehicle.

The turn-signal switch is located on the steering column (fig. 2-68). It is designed to shut off automatically after the turn is completed by the action of the canceling cam.

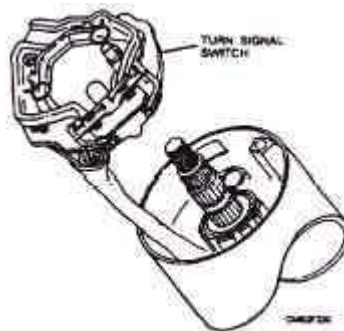

Figure 2-68.- Typical turn-signal switch.

A wiring diagram for a typical turn-signal system is shown in figure 2-69. A common design for a turn-signal system is to use the same rear light for both the stop and turn signals. This somewhat complicates the design of the switch in that the stoplight circuit must pass through the turn-signal switch. When the turn-signal switch is turned off, it must pass stoplight current to the rear lights. As a left or right turn signal is selected, the stoplight circuit is open and the turn-signal circuit is closed to the respective rear light.

The turn signal flasher unit (fig. 2-70) creates the flashing of the turn signal lights. It consists basically of a bimetallic (two dissimilar metals bonded together) strip wrapped in a wire coil. The bimetallic strip serves as one of the contact points.

When the turn signals are actuated, current flows into the flasher- first through the heating coil to the bimetallic strip, then through the contact points, then out of the flasher, where the circuit is completed through the turn-signal light. This sequence of events will repeat a few times a second, causing a steady flashing of the turn signals.

BACKUP LIGHT SYSTEM

The backup light system provides visibility to the rear of the vehicle at night and a warning to the equipped vehicles is combined with the neutral safety switch pedestrians, whenever the vehicle is shifted into reverse. The backup light system has a fuse, gearshift-or transmission-mounted switch, two backup lights, and wiring to connect these components.

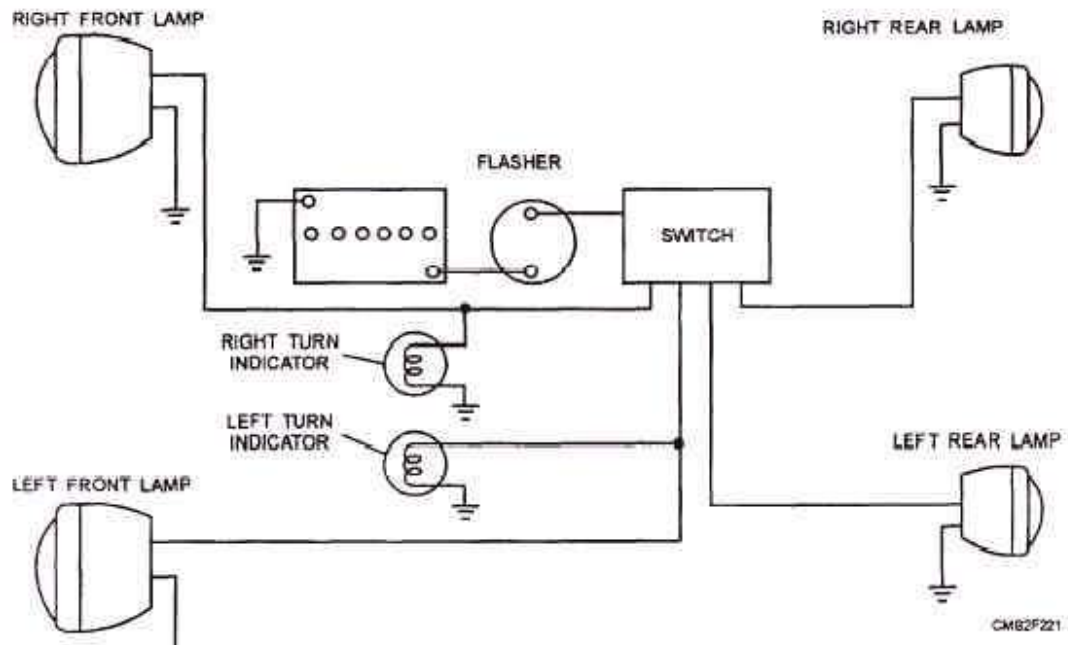

Figure 2-69.- Typical turn-signal wiring diagram.

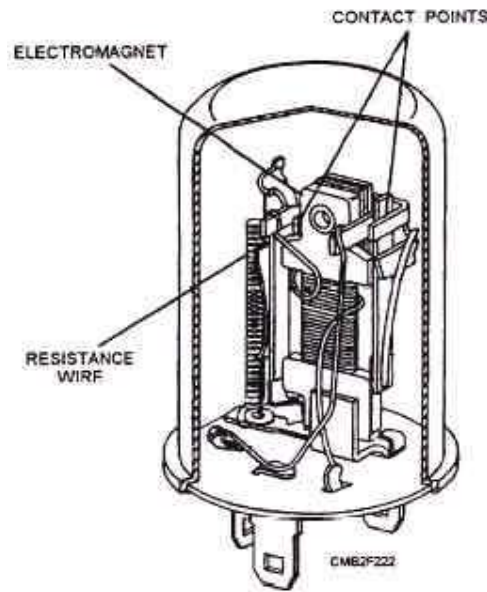

Figure 2-70.- Turn signal flasher.

The backup light switch closes the light circuit when the transmission is shifted into reverse. The most common backup light switch configurations are as follows:

The backup light switch mounted on the transmission and operated by the shift lever.

The backup light switch mounted on the steering column and operated by the gearshift linkage.

The transmission-or gearshift-mounted backup light switch on many automatic transmission-

STOPLIGHT SYSTEM

All vehicles that are used on public highways must be equipped with a stoplight system. The stoplight system consists of a fuse, brake light switch (fig. 2-71), two rear warning lights, and related wiring.

The brake light switch on most automotive equipment is mounted on the brake pedal. When the brake pedal is pressed, it closes the switch and turns on the rear brake lights. On construction and tactical equipment, you may find a pressure light switch. This type of switch uses either air or hydraulic pressure, depending on the equipment. It is mounted on the master cylinder of the hydraulic brake system or is attached to the brake valve on an air brake system. As the brakes are depressed, either air or hydraulic pressure builds on a diaphragm inside the switch. The diaphragm closes allowing electrical current to turn on the rear brake lights.

EMERGENCY LIGHT SYSTEM

The emergency light system, also termed hazard warning system, is designed to signal oncoming traffic that a vehicle has stopped, stalled, or has pulled up to the side of the road. The system consists of a switch, flasher unit, four turn signal lights, and related wiring. The switch is normally a push-pull switch and is mounted on the steering column.

When the switch is closed, current flows through the emergency flasher. Like a turn signal flasher, the emergency flasher opens and closes the circuit to the lights. This causes all four turn signals to flash.

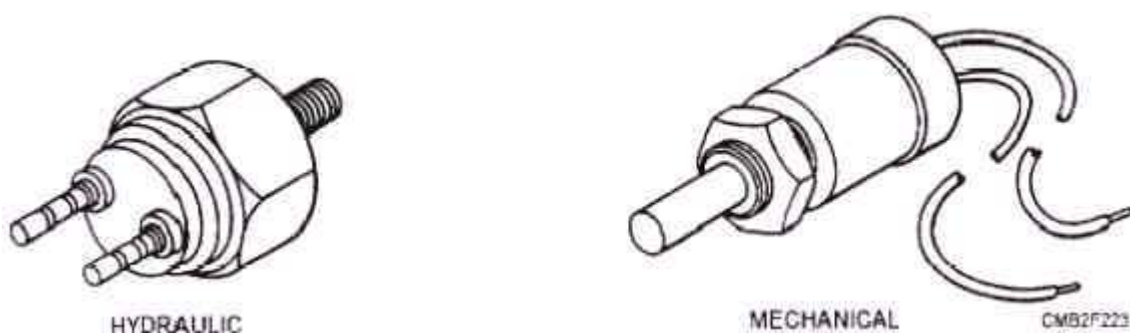

Figure 2-71.- Brake light switches.

CIRCUIT BREAKERS AND FUSES

Fuses are safety devices placed in electrical circuits to protect wires and electrical units from a heavy flow of current. Each circuit, or at least each individual electrical system, is provided with a fuse that has an ampere rating for the maximum current required to operate the units. The fuse element is made from metal with a low-melting point and forms the weakest point of the electrical circuit. In case of a short circuit or other trouble, the fuse will be burned out first and open the circuit just as a switch would do. Examination of a burnt-out fuse usually gives an indication of the problem. A discolored sight glass indicates the circuit has a short either in the wiring or in one of its components. If the glass is clear, the problem is an overloaded circuit. Be sure when replacing a fuse that it has a rating equal to the one burned out. Ensure that the trouble of the failure has been found and repaired.

A circuit breaker performs the same function as a fuse. It disconnects the power source from the circuit when current becomes too high. The circuit breaker will remain open until the trouble is corrected. Once the trouble is corrected, a circuit breaker will automatically reset itself when current returns to normal levels. The fuses and circuit breakers can usually be found behind the instrument panel on a fuse block (fig. 2-72).

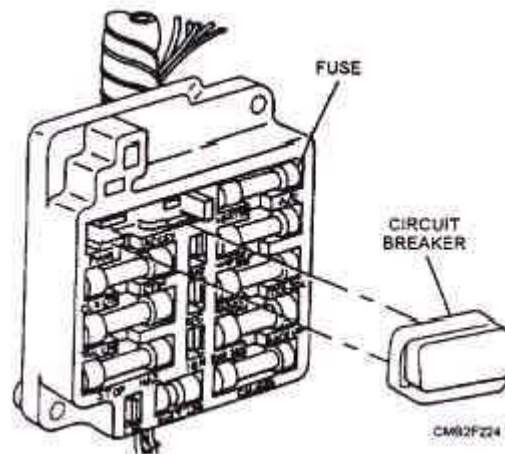

Figure 2-72.- Fuse block.

INSTRUMENTS, GAUGES, AND ACCESSORIES

Learning Objective: Identify instrument, gauges, and accessories, their functions, and maintenance procedures.

The instrument panel is placed so that the instruments and gauges can easily be read by the operator. They inform the operator of the vehicle speed, engine temperature, oil pressure, rate of charge or discharge of the battery, amount of fuel in the fuel tank, and distance traveled. Vehicle accessories, such as windshield wipers and horns, provide the operator with much needed safety devices.

BATTERY CONDITION GAUGE

The battery condition gauge is one of the most important gauges on the vehicle. If the gauge is interpreted properly, it can be used to troubleshoot or prevent breakdowns. The following are the three basic configurations of battery condition gauges- ammeter, voltmeter, and indicator lamp.

The AMMETER is used to indicate the amount of current flowing to and from the battery. It does NOT give an indication of total charging output because of other units in the electrical system. If the ammeter shows a 10-ampere discharge, it indicates that a 100 ampere-hour battery would be discharged in 10 hours, as long as the discharge rate remained the same. Current flowing from the battery to the starting motor is never sent through the ammeter, because the great quantities of amperes used (200 to 600 amperes) cannot be measured due to its limited capacity. In a typical ammeter (fig. 2-73), all the current flowing to and from the battery, except for starting, actually is sent through a coil to produce a magnetic field that deflects the ammeter needle in proportion to the amount of current. The coil is matched to the maximum current output of the charging unit, and this varies with different applications.

The VOLTMETER (fig. 2-74) provides a more accurate indication of the condition of the electrical system and is easier to interpret by the operator. During vehicle

operation, the voltage indicated on the voltmeter is considered to be normal in a range of 13.2 to 14.5 volts for a 12-volt electrical system. As long as the system voltage remains in this range, the operator can assume that no problem exists. This contrasts with an ammeter, which gives the operator no indication of problems, such as an improperly calibrated voltage regulator, which could allow the battery to be drained by regulating system voltage to a level below normal.

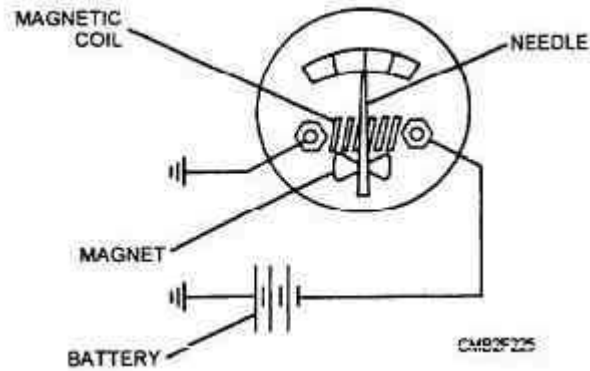

Figure 2-73.- Ammeter schematic.

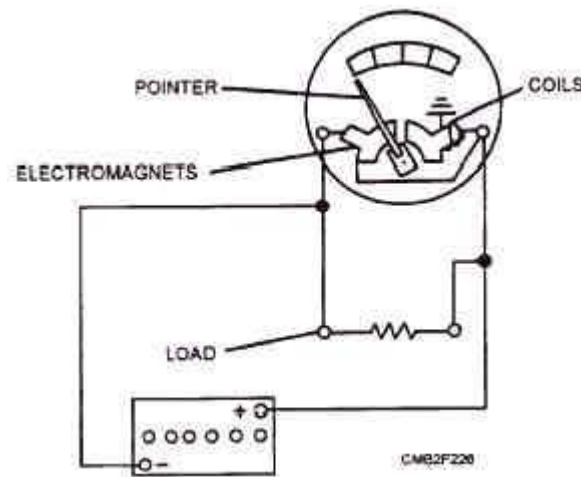

Figure 2-74.- Voltmeter schematic.

The INDICATOR LAMP has gained popularity as an electrical system condition gauge over the years. Although it does not provide as detailed analysis of the electrical system condition as a gauge, it is considered more useful to the average vehicle operator. This is because it is highly visible when a malfunction occurs, whereas a gauge usually is ignored because the average vehicle operator does not know how to interpret its readings. The indicator lamp can be used in two different ways to indicate an electrical malfunction, which are as follows:

1. LOW VOLTAGE WARNING LAMP (fig. 2-75) is set up to warn the operator whenever the electrical system voltage has dropped below the normal operational range.

2. NO-CHARGE INDICATOR (fig. 2-76) is set up to indicate whenever the alternator is not producing current.

FUEL GAUGE

Most fuel gauges are operated electrically and are composed of two units- the gauge, mounted on the instrument panel; and the sending unit, mounted in the fuel tank. The ignition switch is included in the fuel gauge circuit, so the gauge operates only when the ignition switch is in the ON position. Operation of the electrical gauge depends on either coil action or thermostatic action. The four types of fuel gauges are as follows:

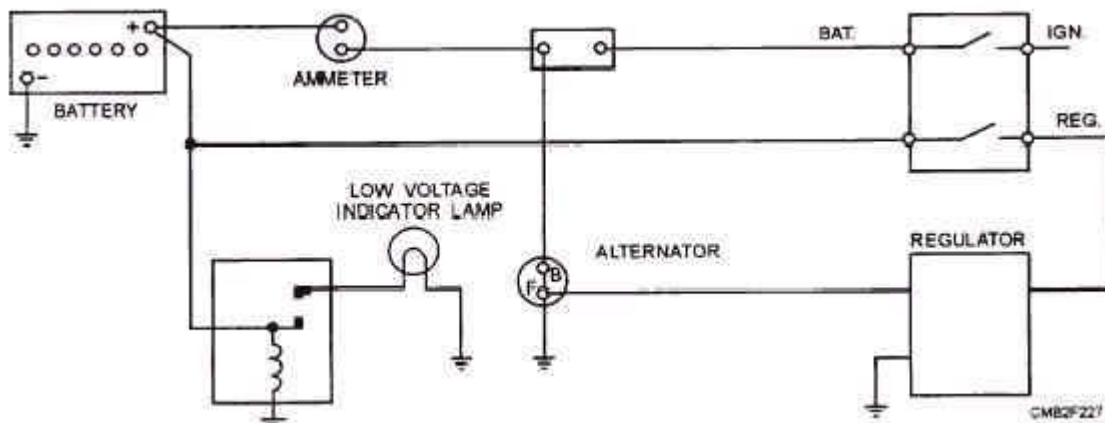

Figure 2-75.- Low voltage warning lamp schematic.

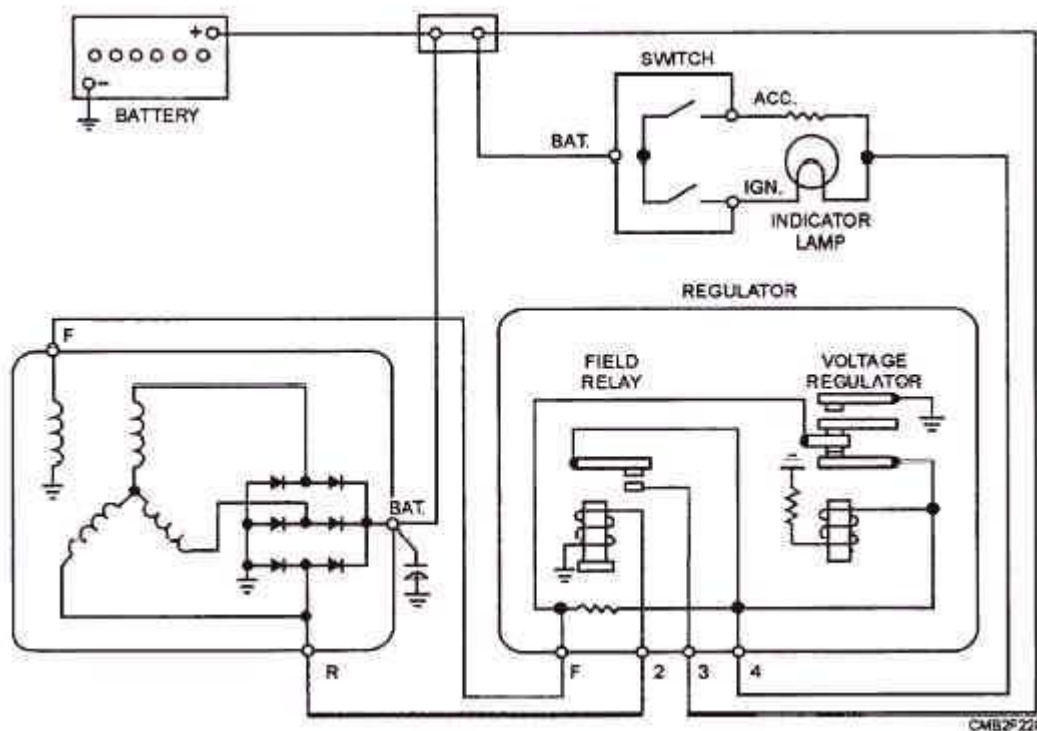

Figure 2-76.- No-charge indicator schematic.

The THERMOSTATIC FUEL GAUGE, SELF-REGULATING (fig. 2-77), contains an electrically heated bimetallic strip that is linked to a pointer. A bimetallic strip consists of two dissimilar metals that, when heated, expand at different rates, causing it to deflect or bend. In the case of this gauge, the deflection of the bimetallic strip results in the movement of the pointer, causing the gauge to give a reading. The sending unit consists of a hinged arm with a float on the end. The movement of the arm controls a grounded point that makes contact with another point which is attached to an electrically heated bimetallic strip. The heating coils in the tank and the gauge are connected to each other in series.

The THERMOSTATIC FUEL GAUGE, EXTERNALLY REGULATED (fig. 2-78), differs from a self-regulating system in the use of a variable resistance fuel tank sending unit and an external voltage-limiting device. The sending unit controls the gauge through the use of a rheostat (wire wound resistance unit whose value varies with its effective length). The effective length of the rheostat is controlled in the sending unit by a sliding brush that is operated by the float arm. The power supply to the gauge is kept constant through the use of a voltage limiter. The voltage limiter consists of a set of contact points that are controlled by an electrically heated bimetallic arm.

The THERMOSTATIC FUEL GAUGE, DIFFERENTIAL TYPE (fig. 2-79), is similar to the other type of thermostatic fuel gauges, except that it uses two electrically heated bimetallic strips that share equally in operating and supporting the gauge pointer. The pointer position is obtained by dividing the available voltage between the two strips (differential). The tank unit is a rheostat type similar to that already described; however, it contains a wire-wound resistor that is connected between external terminals of one of the gauges of the bimetallic strip. The float arm moves a grounded brush that raises resistance progressively to one terminal, while lowering resistance to the other. This action causes the voltage division and resulting heat differential to the gauge strips formulating the gauge reading.

The MAGNETIC FUEL GAUGE (fig. 2-80) consists of a pointer mounted on an armature. Depending upon the design, the armature may contain one or two poles. The gauge is motivated by a magnetic field that is created by two separate magnetic coils that are contained in the gauge. One of these coils is connected directly to the battery, producing a constant magnetic field. The other coil produces a variable field, whose strength is determined by a rheostat-type tank unit. The coils are placed 90 degrees apart.

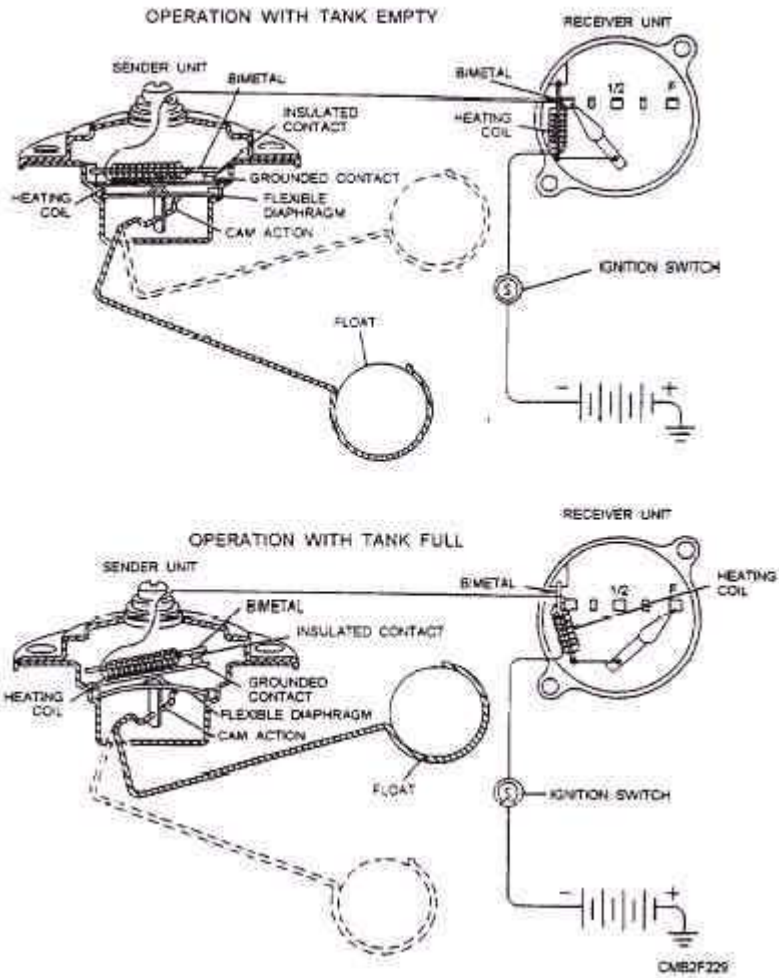

Figure 2-77.- Thermostatic fuel gauge, self-regulating. PRESSURE GAUGE

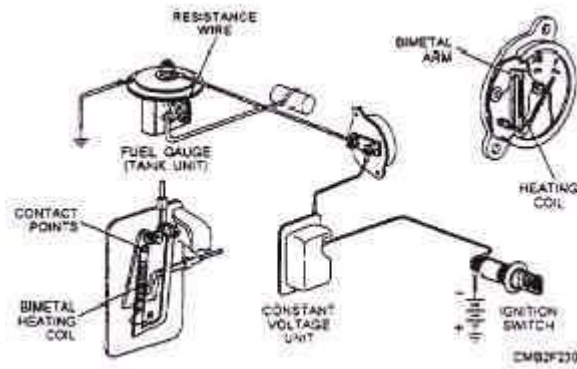

Figure 2-78.- Thermostatic fuel gauge, externally regulated.

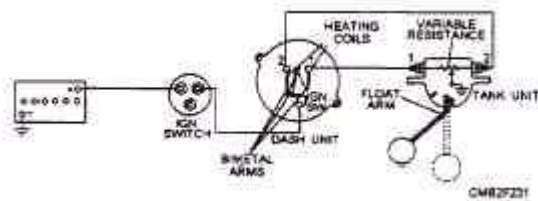

Figure 2-79.- Thermostatic fuel gauge, differential type.

A pressure gauge is used widely in automotive and construction applications to keep track of such things as oil pressure, fuel line pressure, air brake system pressure, and the pressure in the hydraulic systems. Depending on the equipment, a mechanical gauge, an electrical gauge, or an indicator lamp may be used.

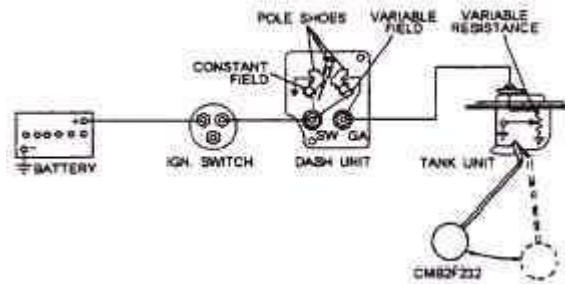

Figure 2-80.- Magnetic fuel gauge.

The MECHANICAL GAUGE (fig. 2-81) uses a thin tube to carry an actual pressure sample directly to the gauge. The gauge basically consists of a hollow, flexible C-shaped tube, called a bourbon tube. As air or fluid pressure is applied to the bourbon tube, it will tend to straighten out. As it straightens, the attached pointer will move, giving a reading.

The ELECTRIC GAUGE may be of the thermostatic or magnetic type as previous discussed. The sending unit (fig. 2-82) that is used with each gauge type varies as follows:

1. The sending unit that is used with the thermostatic pressure gauge uses a flexible diaphragm that moves a grounded contact. The contact that mates with the grounded contact is attached to a bimetallic strip. The flexing of the diaphragm, which is done with pressure changes, varies the point tension. The different positions of the diaphragm produce gauge readings.

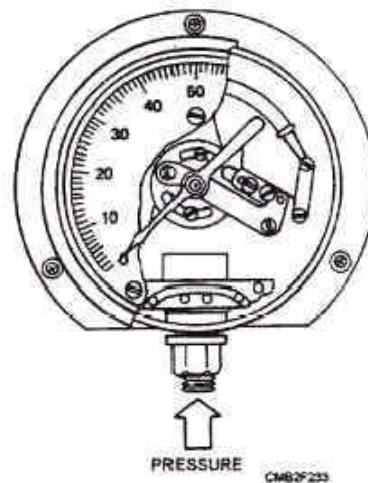

Figure 2-81.- Mechanical pressure gauge.

2. The sending unit that is used with the magnetic-type gauge also translates pressure into the flexing of a diaphragm. In the case of the magnetic gauge sending unit, however, the diaphragm operates a rheostat.

The INDICATOR LAMP (warning light) is used in place of a gauge on many vehicles. The warning light, although not an accurate indicator, is valuable because of its high visibility in the event of a low-pressure condition. The warning light receives battery power through the ignition switch. The circuit to ground is completed through a sending unit. The sending unit consists of a pressure-sensitive diaphragm that operates a set of contact points that are calibrated to turn on the warning light whenever pressure drops below a set pressure.

TEMPERATURE GAUGE

The temperature gauge is a very important indicator in construction and automotive equipment. The most common uses are to indicate engine coolant, transmission, differential oil, and hydraulic system temperature. Depending on the type of equipment, the gauge may be mechanical, electric, or a warning light.

The ELECTRIC GAUGE may be the thermostatic or magnetic type, as described previously. The sending unit (fig. 2-83) that is used varies, depending upon application.

1. The sending unit that is used with the thermostatic gauge consists of two bimetallic strips, each having a contact point. One bimetallic strip is heated electrically. The other strip bends to increase the tension of the contact points. The different positions of the bimetallic strip create the gauge readings.

2. The sending unit that is used with the magnetic gauge contains a device called a thermistor. A thermistor is an electronic device whose resistance decreases proportionally with an increase in temperature.

The MAGNETIC GAUGE contains a bourbon tube and operates by the same principles as the mechanical pressure gauge.

The INDICATOR LAMP (warning light) operates by the same principle as the indicator light previously discussed.

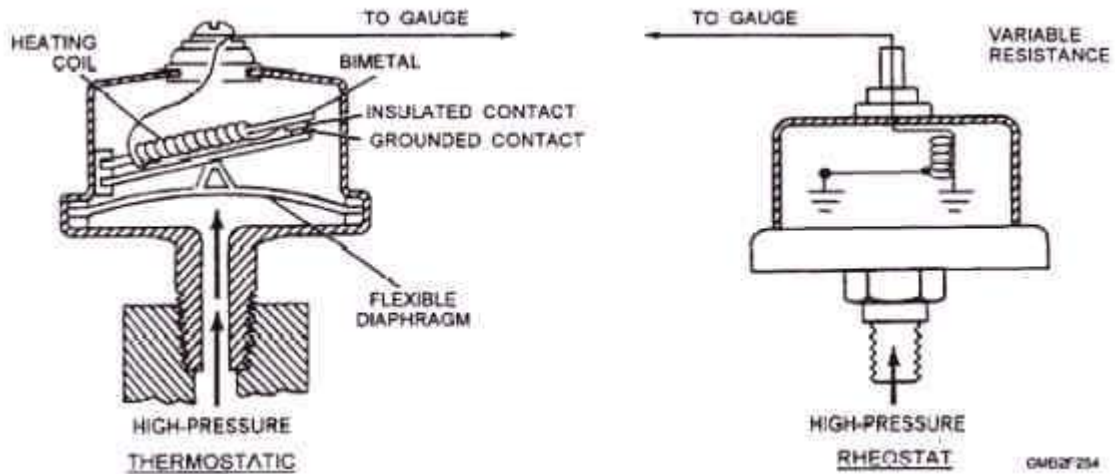

Figure 2-82.- Types of sending units for pressure gauges.

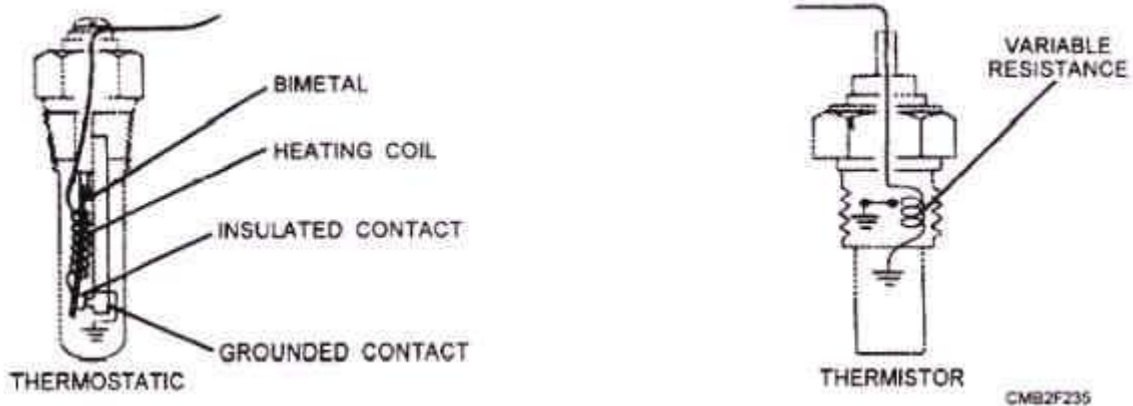

Figure 2-83.- Types of temperature gauge sending units.

SPEEDOMETER AND TACHOMETERS

Speedometers and tachometers in some form are used in virtually all types of self-propelled equipment. Speedometers are used to indicate vehicle speed in miles per hour (mph) or kilometers per hour (kph). In most cases, the speedometer also contains the odometer which keeps a record of the amount of mileage (in miles or kilometers depending on application) that a vehicle has accumulated. Some speedometers also contain a resettable trip odometer so those individual trips can be measured.

A tachometer is a device that is used to measure engine speed in revolutions per minute (rpm). The tachometer may also contain an engine-hour gauge which is installed on equipment that uses no odometer to keep a record of engine use. Speedometers and tachometers may be driven either mechanically, electrically, or electronically.

MECHANICAL SPEEDOMETERS AND TACHOMETERS

Both the mechanical speedometer and the tachometer consist of a permanent magnet that is rotated by a flexible shaft. Surrounding the rotating magnet is a metal cup that is attached to the indicating needle. The revolving magnetic field exerts a pull on the cup that forces it to rotate. The rotation of the cup is countered by a calibrated hairspring. The influence of the hairspring and the rotating magnetic field on the cup produces accurate readings by the attached needle. The flexible shaft consists of a flexible outer casing that is made of either steel or plastic and an inner drive core that is made of wire-wound spring steel. Both ends of the core are molded square, so they can fit into the driving member at one end and the driven member at the other end and can transmit torque.

Gears on the transmission output shaft turn the flexible shaft that drives the speedometer. This shaft is referred to as the speedometer cable. A gear on the ignition distributor shaft turns the flexible shaft that drives the tachometer. This shaft is referred to as the tachometer cable.

The odometer of the mechanical speedometer is driven by a series of gears that originate at a spiral gear on the input shaft. The odometer consists of a series of drums with digits printed on the outer circumference that range from zero to nine. The drums are geared to each other so that each time the one furthest to the right makes one revolution, it will cause the one to its immediate left to advance one digit. The second to the right then will advance the drum to its immediate left one digit for every revolution it makes. This sequence continues to the left through the entire series of drums. The odometer usually contains six digits to record 99,999.9 miles or kilometers. However, models with trip odometers do not record tenths, thereby contain only five digits. When the odometer reaches its highest value, it will automatically reset to zero. Newer vehicles incorporate a small dye pad in the odometer to color the drum of its highest digit to indicate the total mileage is in excess of the capability of the odometer.

Electric Speedometers and Tachometers

The electric speedometer and tachometer use a mechanically driven permanent magnet generator to supply power to a small electric motor (fig. 2-84). The electric motor then is used to rotate the input shaft of the speedometer or tachometer. The voltage from the generator will increase proportionally with speed, and speed will likewise increase proportionally with voltage enabling the gauges to indicate speed.

The signal generator for the speedometer is usually driven by the transmission output shaft through gears. The signal generator for the tachometer usually is driven by the distributor through a power takeoff on gasoline engines. When the tachometer is used with a diesel engine, a special power takeoff provision is made, usually on the camshaft drive.

Electronic Speedometers and Tachometers

Electronic speedometers and tachometers are self-contained units that use an electric signal from the engine or transmission. They differ from the electric unit in that they use a generated signal as the driving force. The gauge is transistorized and will supply information through either a magnetic analog (dial) or light-emitting diode (LED) digital gauge display. The gauge unit derives its input signal in the following ways:

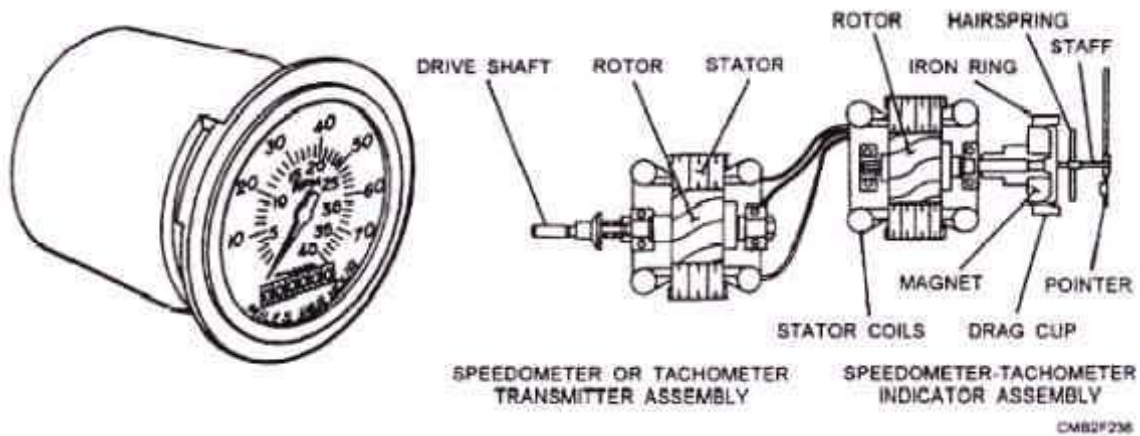

Figure 2-84.- Electric speedometer and tachometer operation.

An electronic tachometer obtains a pulse signal from the ignition distributor, as it switches the coil on and off. The pulse speed at this point will change proportionally with engine speed. This is the most popular signal source for a tachometer that is used on a gasoline engine.

A tachometer that is used with a diesel engine uses the alternating current generated by the stator terminal of the alternator as a signal. The frequency of the ac current will change proportionally with engine speed.

An electronic speedometer derives its signal from a magnetic pickup coil that has its field interrupted by a rotating pole piece. The signal units operation is the same as the operation of the reluctor and pickup coil described earlier in this TRAMAN. The pickup coil is located strategically in the transmission case to interact with the reluctor teeth on the input shaft.

HORN

The horn currently used on automotive vehicles is the electric vibrating type. The electric vibrating horn system typically consists of a fuse, horn button switch, relay, horn assembly, and related wiring. When the operator presses the horn button, it closes the horn switch and activates the horn relay. This completes the circuit, and current is allowed through the relay circuit and to the horn.

Most horns have a diaphragm that vibrates by means of an electromagnetic. When the horn is energized, the electromagnet pulls on the horn diaphragm. This movement

opens a set of contact points inside the horn. This action allows the diaphragm to flex back towards its normal position. This cycle is repeated rapidly. The vibrations of the diaphragm within the air column produce the note of the horn.

Tone and volume adjustments are made by loosening the adjusting locknut and turning the adjusting nut. This very sensitive adjustment controls the current consumed by the horn. Increasing the current increases the volume. However, too much current will make the horn sputter and may lock the diaphragm.

When a electric horn will not produce sound, check the fuse, the connections, and test for voltage at the horn terminal. If the horn sounds continuously, a faulty horn switch is the most probable cause. A faulty horn relay is another cause of horn problems. The contacts inside the relay may be burned or stuck together.

WINDSHIELD WIPERS

The windshield wiper system is one of the most important safety factors on any piece of equipment. A typical electric windshield wiper system consists of a switch, motor assembly, wiper linkage and arms, and wiper blades. The description of the components is as follows:

The WINDSHIELD WIPER SWITCH is a multiposition switch, which may contain a rheostat. Each switch position provides for different wiping speeds. The rheostat, if provided, operates the delay mode for a slow wiping action. This permits the operator to select a delayed wipe from every 3 to 20 seconds. A relay is frequently used to complete the circuit between the battery voltage and the wiper motor.

The WIPER MOTOR ASSEMBLY operates on one, two, or three speeds. The motor (fig. 2-85) has a worm gear on the armature shaft that drives one or two gears, and, in turn, operates the linkage to the wiper arms. The motor is a small, shunt wound dc motor. Resistors are placed in the control circuit from the switch to reduce the current and provide different operating speeds.

The WIPER LINKAGE and ARMS transfers motion from the wiper motor transmission to the wiper blades. The rubber wiper blades fit on the wiper arms.

The WIPER BLADE is a flexible rubber squeegee-type device. It may be steel or plastic backed and is designed to maintain total contact with the windshield throughout the stroke. Wiper blades should be inspected periodically. If they are hardened, cut, or split, they are to be replaced.

When electrical problems occur in the windshield wiper system, use the service manual and its wiring diagram of the circuit. First check the fuses, electrical connections, and all grounds. Then proceed with checking the components.

AUTOMOTIVE WIRING

Learning Objective: Identify the basic types of automotive wiring, types of terminals, and wiring diagrams.

Electrical power and control signals must be delivered to electrical devices reliably and safely so that the electrical system functions are not impaired or converted to hazards. To fulfill power distribution military vehicles, use one-and two-wire circuits, wiring harnesses, and terminal connections.

Among your many duties will be the job of maintaining and repairing automotive electrical systems. All vehicles are not wired in exactly the same manner; however, once you understand the circuit of one vehicle, you should be able to trace an electrical circuit of any vehicle using wiring diagrams and color codes.

ONE-AND TWO-WIRE CIRCUITS

Tracing wiring circuits, particularly those connecting lights or warning and signal devices, is no simple task. By studying the diagram in figure 2-72, you will see that the branch circuits making up the individual systems have one wire to conduct electricity from the battery to the unit requiring it and ground connections at the battery and the unit to complete the circuit. These are called **ONE-WIRE CIRCUITS** or branches of a **GROUND RETURN SYSTEM**. In automotive electrical systems with branch circuits that lead to all parts of the equipment, the ground return system saves installation time and eliminates the need for an additional wiring to complete the circuit. The all-metal construction of the automotive equipment makes it possible to use this system.

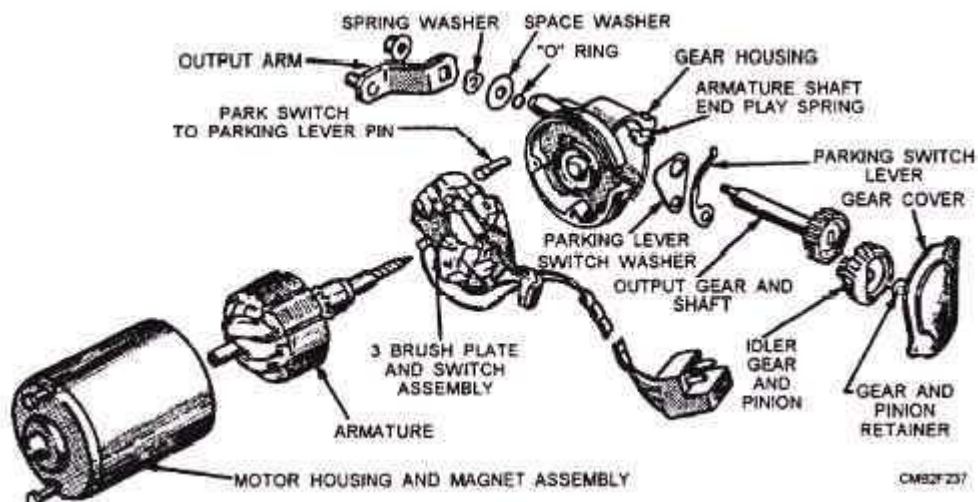

Figure 2-85.- Wiper motor assembly.

The TWO-WIRE CIRCUIT requires two wires to complete the electrical circuit- one wire from the source of electrical energy to the unit it will operate, and another wire to complete the circuit from the unit back to the source of the electrical power.

Two-wire circuits provide positive connection for light and electrical brakes on some trailers. The coupling between the trailer and the equipment, although made of metal and a conductor of electricity, has to be jointed to move freely. The rather loose joint or coupling does not provide the positive and continuous connection required to use a ground return system between two vehicles. The two-wire circuit is commonly used on equipment subject to frequent or heavy vibrations. Tracked equipment, off-road vehicles (tactical), and many types of construction equipment are wired in this manner.

WIRING ASSEMBLIES

Wiring assemblies consist of wires and cables of definitely prescribed length, assembled together to form a subassembly that will interconnect specific electrical components and/ or equipment. The two basic types of wiring assemblies are as follows:

The CABLE ASSEMBLY consists of a stranded conductor with insulation or a combination of insulated conductors enclosed in a covering or jacket from end to end. Terminating connections seal around the outer jacket so that the inner conductors are isolated completely from the environment. Cable assemblies may have two or more ends.

WIRING HARNESS assemblies (fig. 2-86) serve two purposes. They prevent chafing and loosening of terminals and connections caused by vibration and road shock while keeping the wires in a neat condition away from moving parts of the vehicle. Wiring harnesses contain two or more individual conductors laid parallel or twisted together and wrapped with binding material, such as tape, lacing cord, and wire ties. The binding materials do not isolate the conductors from the environment completely, and conductor terminations may or may not be sealed. Wiring harnesses also may have two or more ends.

WIRING IDENTIFICATION

Wires in the electrical system should be identified by a number, color, or code to facilitate tracing circuits during assembly, troubleshooting, or rewiring operations. This identification should appear on wiring schematics and diagrams and whenever practical on the individual wire. The assigned identification for a continuous electrical connection should be retained on a schematic diagram until the circuit characteristic is altered by a switching point or active component.

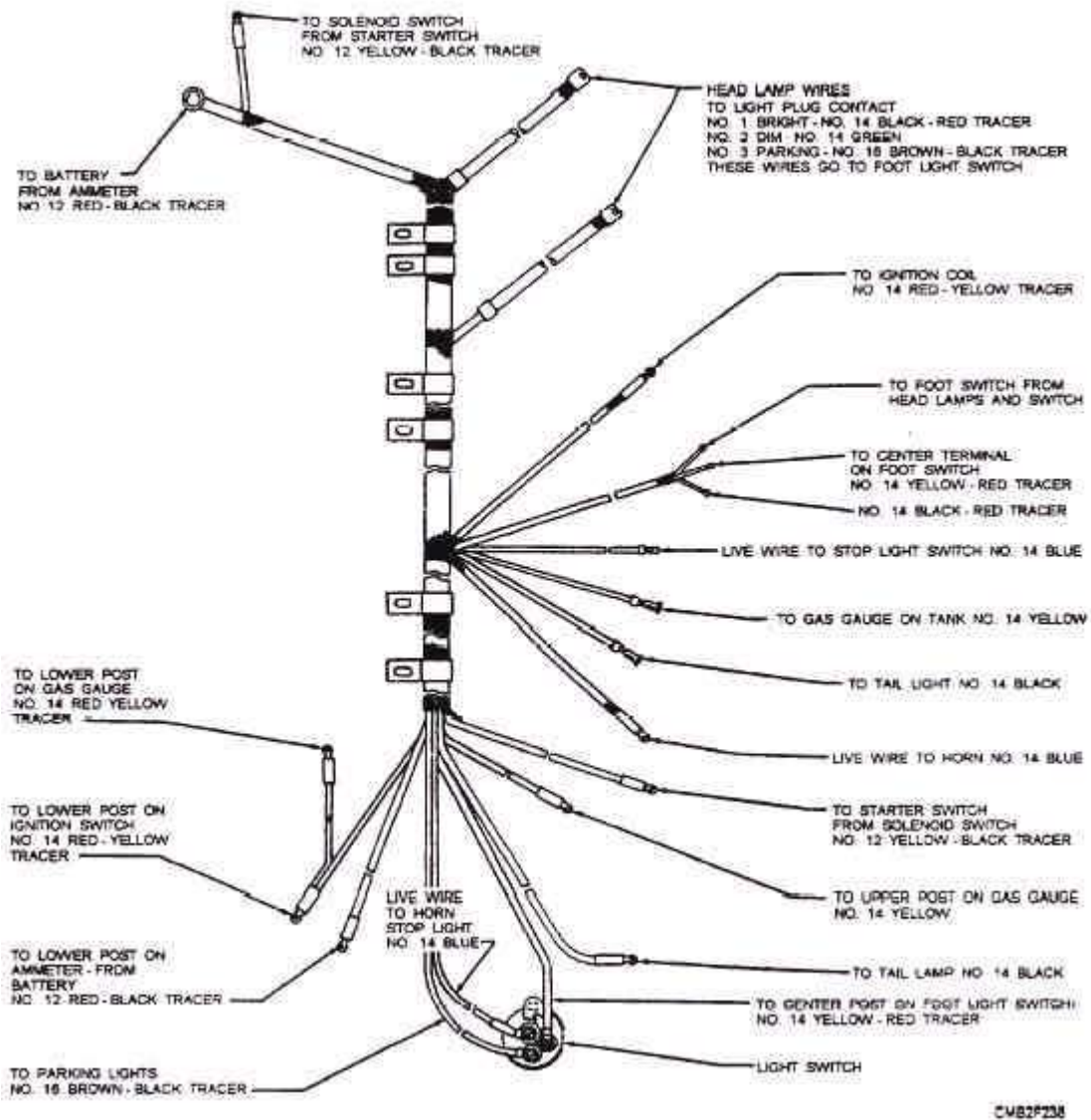

Figure 2-86.- A typical wiring harness.

Wiring color codes are used by manufacturers to assist the mechanics in identifying the wires used in many circuits and making repairs in a minimum of time. No color code is common to all manufacturers. For this reason, the manufacturer's service manual is a must for speedy troubleshooting and repairs.

Wiring found on tactical equipment (M-series) has no color. All the wires used on these vehicles are black. Small metal tags (fig. 2-87), stamped with numbers or codes, are used to identify the wiring illustrated by diagrams in the technical manuals. These tags are securely fastened near the end of individual wires.

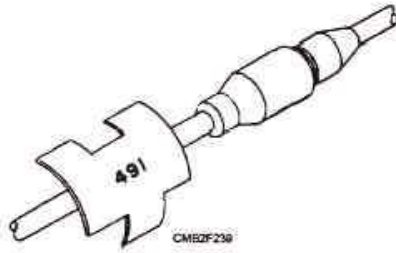

Figure 2-87.- Metal tag wire identification.

WIRING DIAGRAMS

Wiring diagrams (fig. 2-88) are drawings that show the relationship of the electrical components and wires in a circuit. They seldom show the routing of the wires within the electrical system of the vehicle.

Often you will find ELECTRICAL SYMBOLS used in wiring diagrams to simulate individual components. Figure 2-89 shows some of the symbols you may encounter when tracing individual circuits in a wiring diagram.

WIRE TERMINAL ENDS

Wire terminals are divided into two major classes- the solder type and the solderless type, which is also known as the pressure or crimp type. The solder type has a cup in which the wire is held by solder permanently. The solderless type is connected to the wire by special tools. These tools deform the barrel of the terminal and exert pressure on the wire to form a strong mechanical bond and electrical connection. Solderless type terminals are gradually replacing solder type terminals in military equipment.

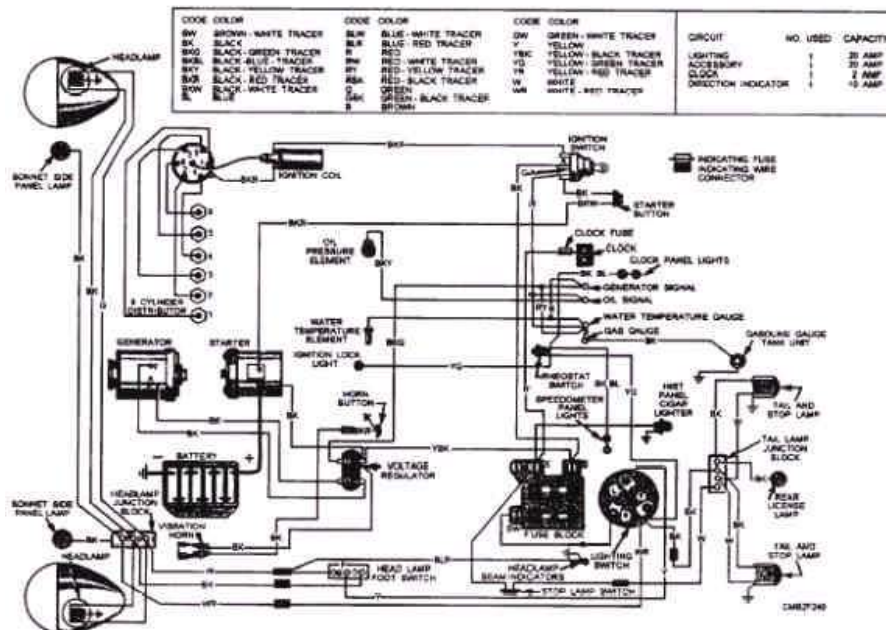

Figure 2-88.- Wiring diagram of a passenger vehicle showing standard equipment and color code for wires.

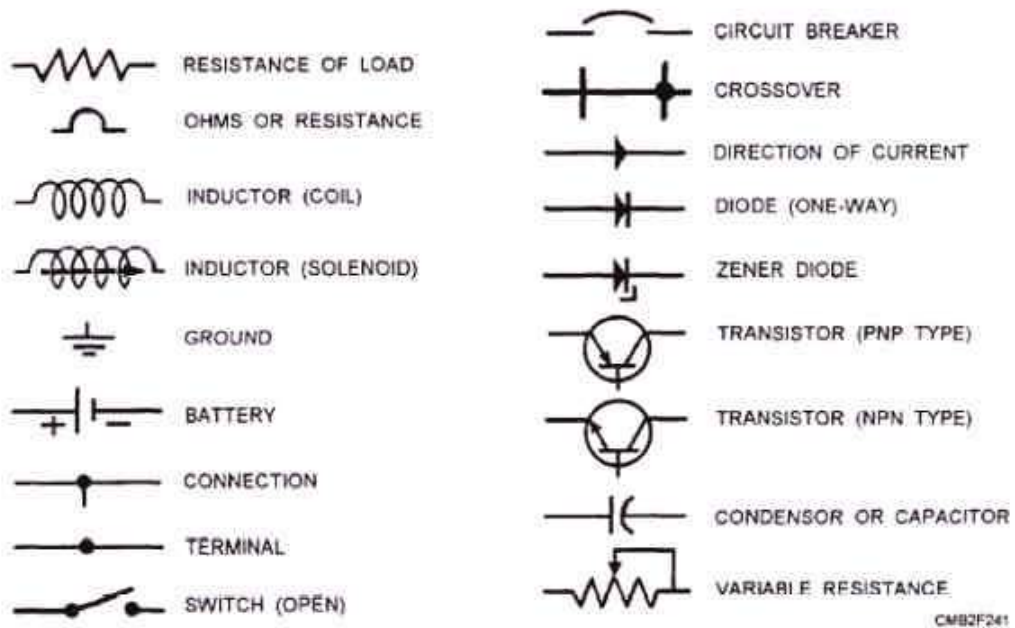

Figure 2-89.- Wiring diagram symbols.

Wire passing through holes in the metal members of the frame or body should be protected by rubber grommets. If rubber grommets are not available, use a piece of rubber hose the size of the hole to protect the wiring from chafing or cutting on sharp edges.

WIRE SUPPORT AND PROTECTION

Wire in the electrical system should be supported by clamps or fastened by wire ties at various points about the vehicle. When installing new wiring, be sure to keep it away from any heat-producing component that would scorch or bum the insulation.