

# better freshwater fish-farming

further improvement

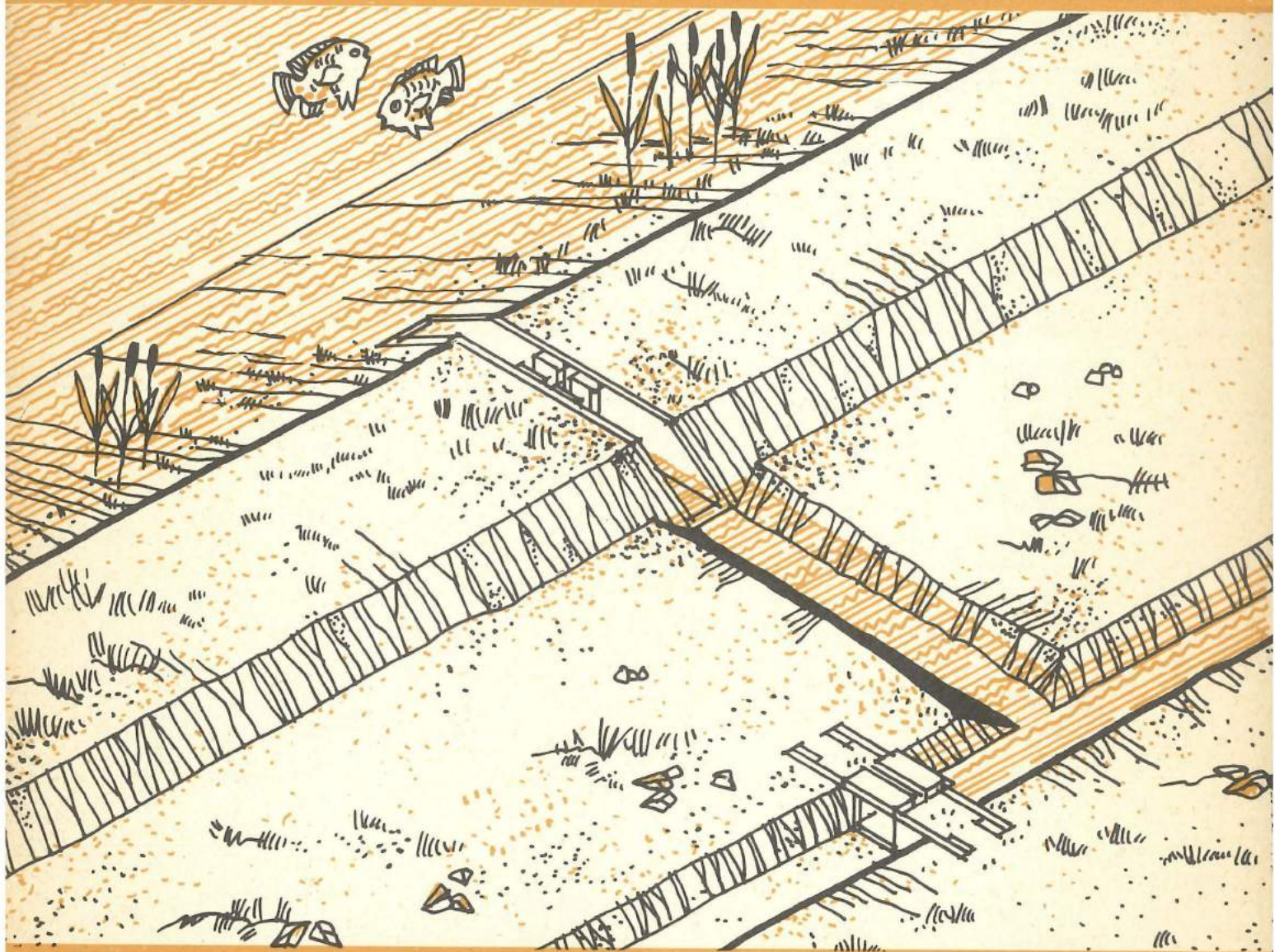

# BETTER FARMING SERIES

The titles published in this series were designed as hand books for an intermediate-level agricultural education and training course. They may be purchased as a set or as individual documents. New titles will be added from time to time.

1. The plant: the living plant; the root
2. The plant: the stem; the buds; the leaves
3. The plant: the flower
4. The soil: how the soil is made up
5. The soil: how to conserve the soil
6. The soil: how to improve the soil
7. Crop farming
8. Animal husbandry: feeding and care of animals
9. Animal husbandry: animal diseases; how animals reproduce
10. The farm business survey
11. Cattle breeding
12. Sheep and goat breeding
13. Keeping chickens
14. Farming with animal power
15. Cereals
16. Roots and tubers
17. Groundnuts
18. Bananas
19. Market gardening
20. Upland rice
21. Wet paddy or swamp rice
22. Cocoa
23. Coffee
24. The oil palm
25. The rubber tree
26. The modern farm business
27. Freshwater fish-farming: how to begin
28. Water: where water comes from
29. Better freshwater fish-farming: the pond
30. Better freshwater fish-farming: the fish
31. Biogas: what it is; how it is made; how to use it
32. Biogas 2: building a better biogas unit
33. Farming snails 1: learning about snails; building a pen; food and shelter plants
34. Farming snails 2: choosing snails; care and harvesting; further improvement
35. Better freshwater fish-farming: further improvement

**better  
freshwater  
fish-farming**

**further  
improvement**

P-69

ISBN 92-5-102161-9

## PREFACE

---

The first 26 volumes in FAO's Better Farming Series were based on the **Cours d'apprentissage agricole** prepared in Côte d'Ivoire by the **Institut africain de développement économique et social** for use by extension workers. Later volumes, beginning with No. 27, have been prepared by FAO for use in agricultural development at the farm and family level. The approach has deliberately been a general one, the intention being to constitute basic prototype outlines to be modified or expanded in each area according to local conditions of agriculture.

Many of the booklets deal with specific crops and techniques, while others are intended to give the farmer more general information which can help him to understand **why** he does what he does, so that he will be able to do it better.

Adaptations of the series, or of individual volumes in it, have been published in Amharic, Arabic, Bengali, Creole, Hindi, Igala, Indonesian, Kiswahili, Malagasy, SiSwati, Thai and Turkish. This volume has been prepared by the Inland Water Resources and Aquaculture Service, Fishery Resources and Environment Division.

Requests for permission to issue this manual in other languages and to adapt it according to local climatic and ecological conditions are welcomed. They should be addressed to the Director, Publications Division, Food and Agriculture Organization of the United Nations, Via delle Terme di Caracalla, 00100 Rome, Italy.



# OUTLINE OF THE BOOKLET

---

● <b>Introduction</b> .....	1
Ways to improve .....	2
● <b>The ponds</b> .....	3
Building even bigger ponds or more ponds	3
A nursery pond .....	8
Filling and emptying smaller ponds .....	8
Filling and emptying bigger ponds .....	12
● <b>Bringing water to your ponds</b> .....	24
Raising the level of your water supply .....	24
Digging a supply ditch .....	26
Digging a return ditch .....	28
Controlling the water in your supply ditch	30
Filling your ponds .....	34
How to fill your ponds .....	39
● <b>Better fertilizing</b> .....	40
● <b>The fish</b> .....	45
Growing fish all year round .....	45
Growing only male fish .....	47
Harvesting your fish .....	48
Harvesting many fish .....	48
Harvesting fish when you have a monk	50
● <b>Your farm and your fish-ponds</b> .....	54
● <b>Your fish-ponds and your health</b> .....	58





# INTRODUCTION

---

1. You learned how to begin growing your own fish in Booklet No. 27, **Freshwater fish-farming: how to begin.**

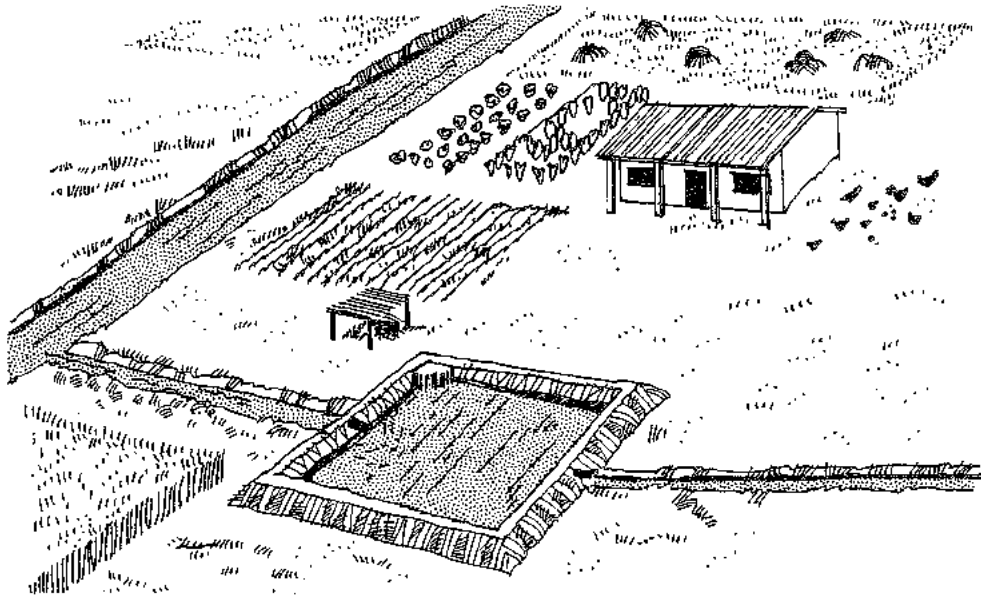

2. Booklet No. 29, **Better freshwater fish-farming: the pond,** told you how to build a bigger pond and how to build it better.

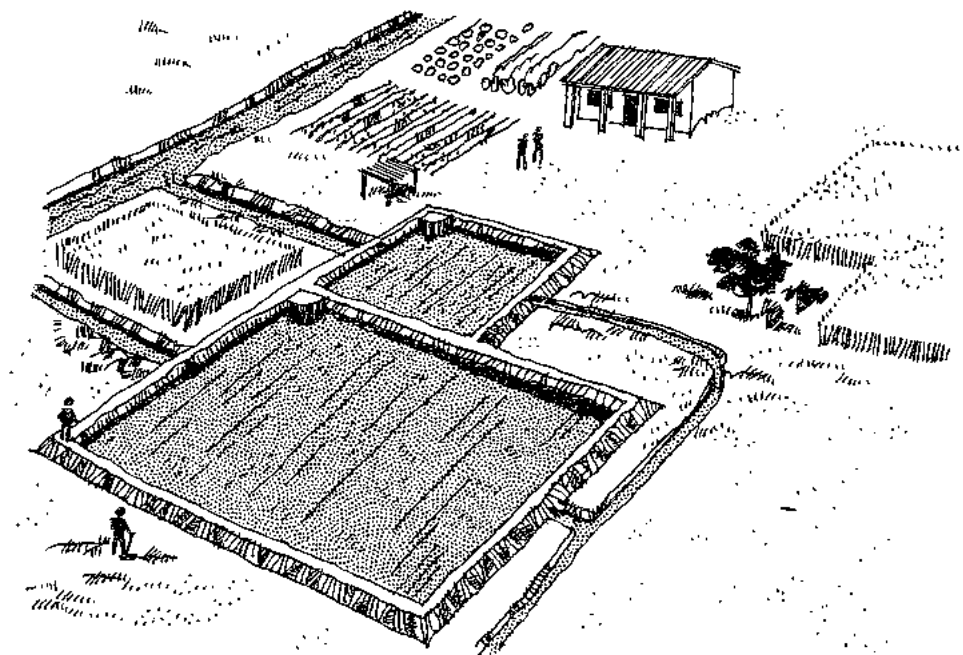

3. Booklet No. 30,  
**Better freshwater fish-farming: the fish,**  
told you how to grow more fish  
and how to grow them better.

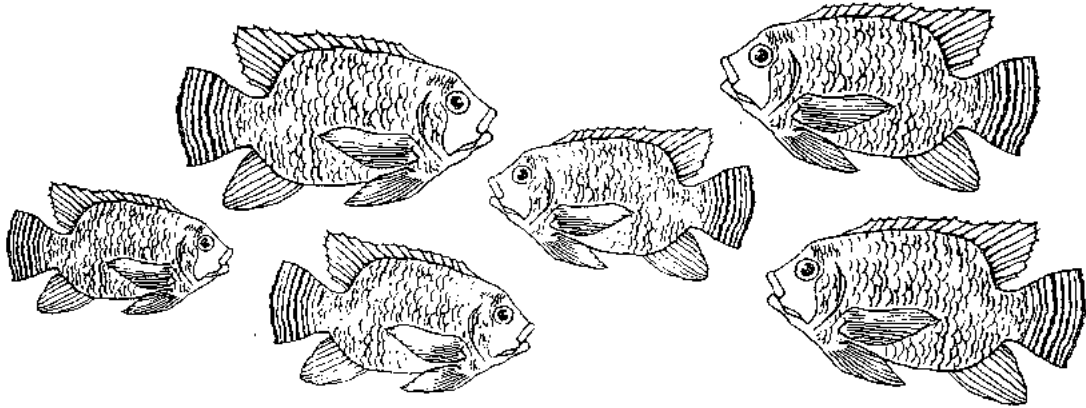

### **Ways to improve**

4. However, there are still more things that you can do to improve your fish-farming. You can
- build more and bigger ponds
  - improve your water supply and your water-supply ditches
  - build new and better kinds of inlets and outlets
  - fertilize your ponds better
  - grow fish in several ponds all year round
  - grow only male fish
  - harvest your fish better
  - manage your fish-farm, your farm animals, your gardens and your fields together so that they will grow better and produce more.
5. This booklet will help you to improve your fish-farming.

# THE PONDS

---

## Building even bigger ponds or more ponds

6. The easiest way to make an even bigger pond is to add a new part to one of your old ponds.
7. You can add a new part to your old pond of  $15 \times 15$  metres. You can make it twice as big. You can make it  $15 \times 30$  metres and still build the banks in the same way that you built them for the old part of the pond.

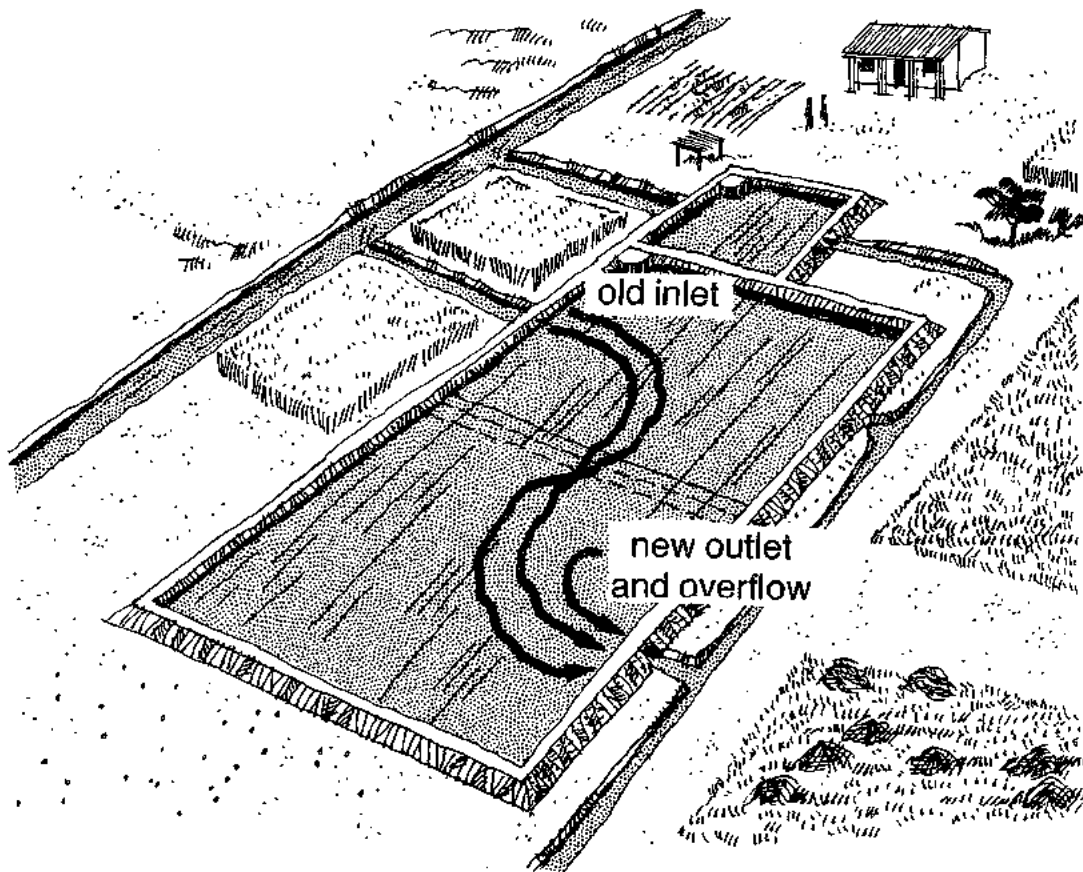

8. Booklet No. 29, Items 42 to 48, tells you how to make a smaller pond bigger.

9. If you do not want to make your old pond bigger, you can build one or more new ponds of  $15 \times 15$  metres next to your old pond ...

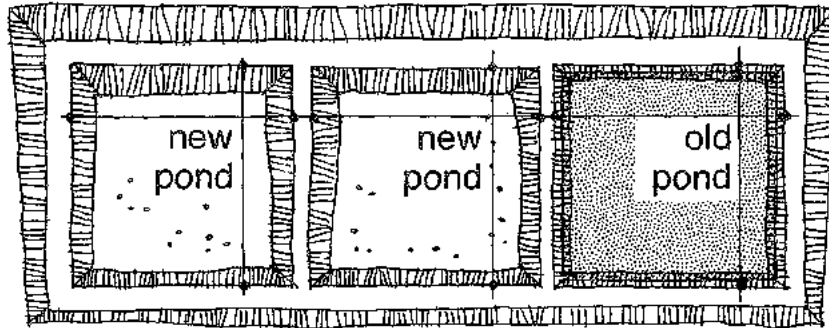

or in another place.

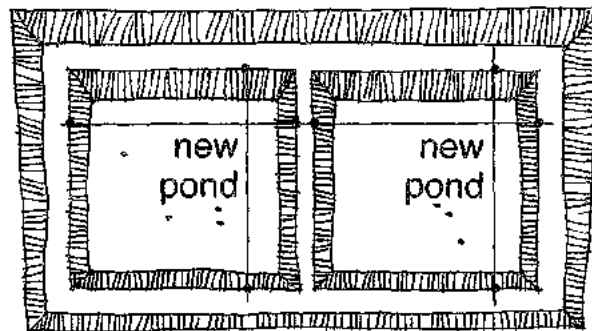

10. You can also build a pond of  $20 \times 20$  metres and still dig the bottom and build the banks in the same way as you did for your old ponds.

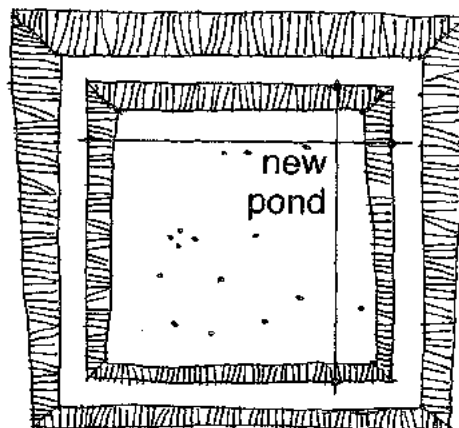

11. The top of the banks of a 20 × 20 metre pond should still be 1.50 metres wide as they were with your 15 × 15 metre ponds.

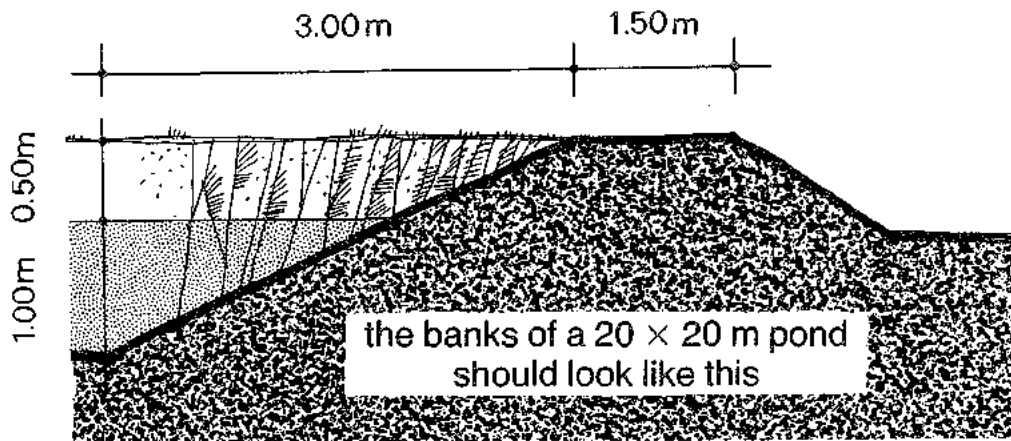

12. The water should be at least 0.60 metre deep in the shallow part and at least 0.90 metre deep in the deepest part.

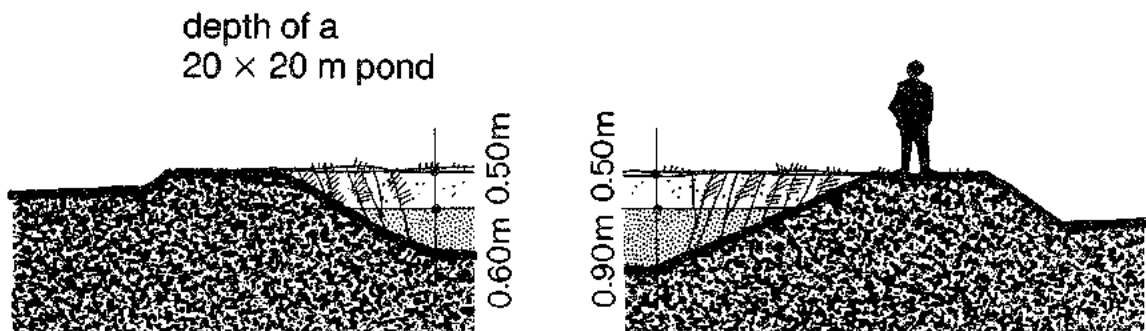

13. If you want a still bigger pond, you can build one of 20 × 30 metres, 20 × 50 metres or even 30 × 50 metres. The top of the banks of ponds this size should also be 1.50 metres wide but, because these ponds are bigger and deeper and hold much more water, the bottom part of the banks should be stronger than the banks you built for your smaller ponds.

14. Since you will be digging bigger and deeper ponds, you will take out more soil. Put all the soil you dig out on the lower part of the banks. This will make them thicker and stronger.
15. The drawing below will show you what the banks should look like when you are finished.

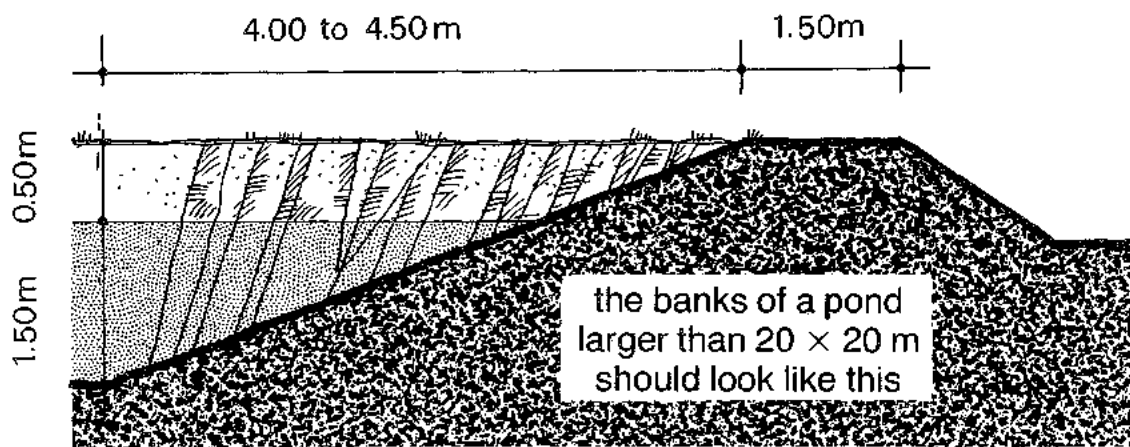

16. However, if you build ponds of this size, you should build them a little deeper. They should be at least 0.75 metre deep in the shallow end and at least 1.00-1.20 metres deep in the deepest part.

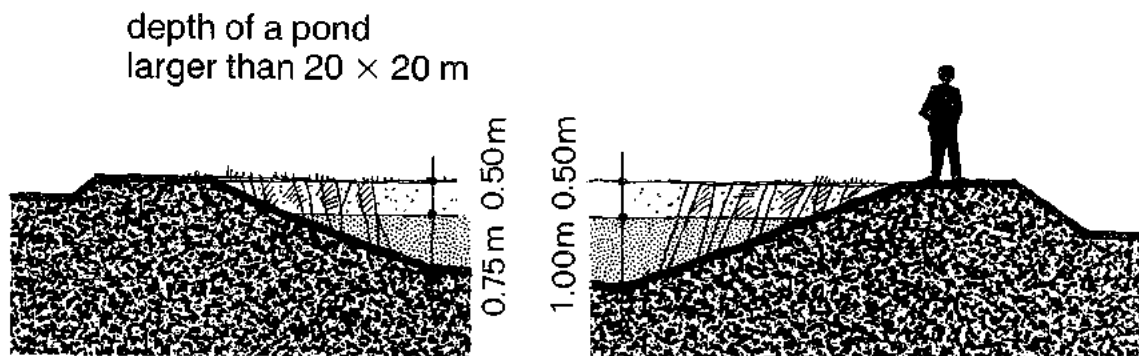

17. If you live in a place where the temperature falls below 20°C, make your ponds 1.50-1.80 metres deep. The water will be warmer in the deepest part and your fish can go there during the colder part of each day.

the deepest part  
is warmer

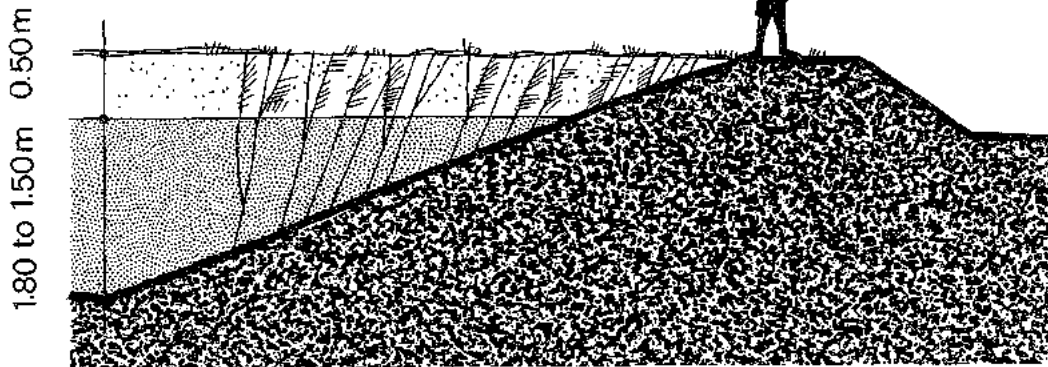

### Note

Remember when ponds are side by side, you will need only one bank between two ponds (see Item 45, Booklet No. 27). If you are building two ponds side by side at the same time, you can make the top of the bank between them 1.00 metre wide instead of 1.50 metres.

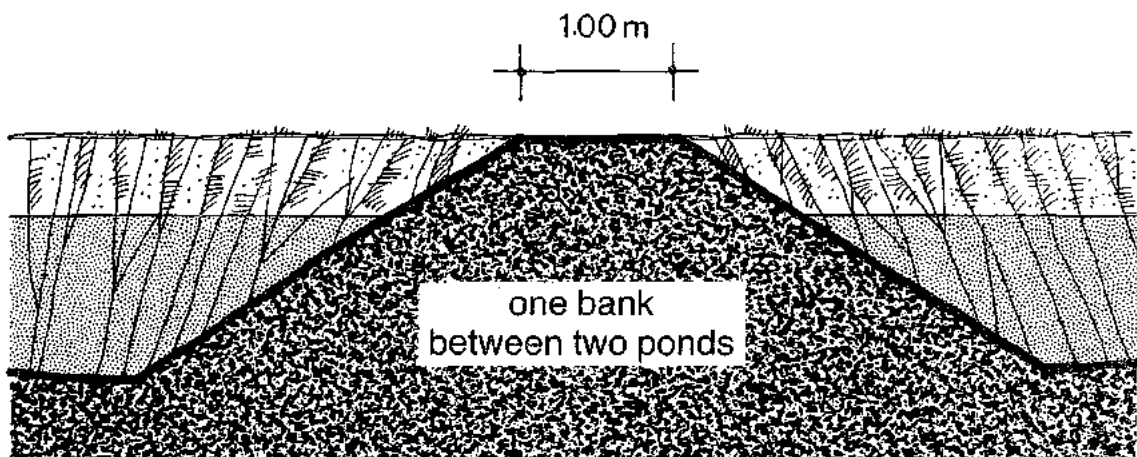

## A nursery pond

18. With bigger ponds or more ponds, you must be sure that you have a supply of baby fish all year round.
19. If you have two or three big ponds that together have an area of more than 500 square metres (one  $10 \times 10$  metre pond + two  $15 \times 15$  metre ponds = 550 square metres), **you should have your own nursery pond.**
20. If you do not already have a nursery pond, Booklet No. 30, Items 43 to 88, will tell you how to build one, how to care for the baby fish and what to do with them.

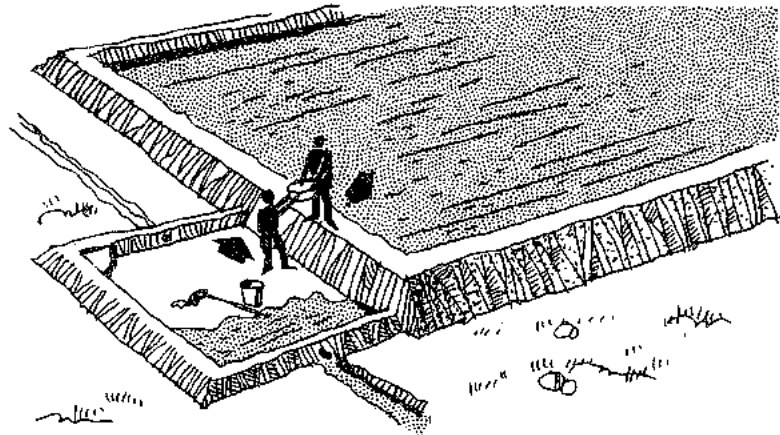

a nursery pond

## Filling and emptying smaller ponds

21. If the new ponds that you build are less than 500 square metres (a  $20 \times 20$  metre pond = 400 square metres), you can use pipes with screens for the inlet, outlet and overflow, just as you did in Booklet No. 29 for your  $15 \times 15$  metre ponds.



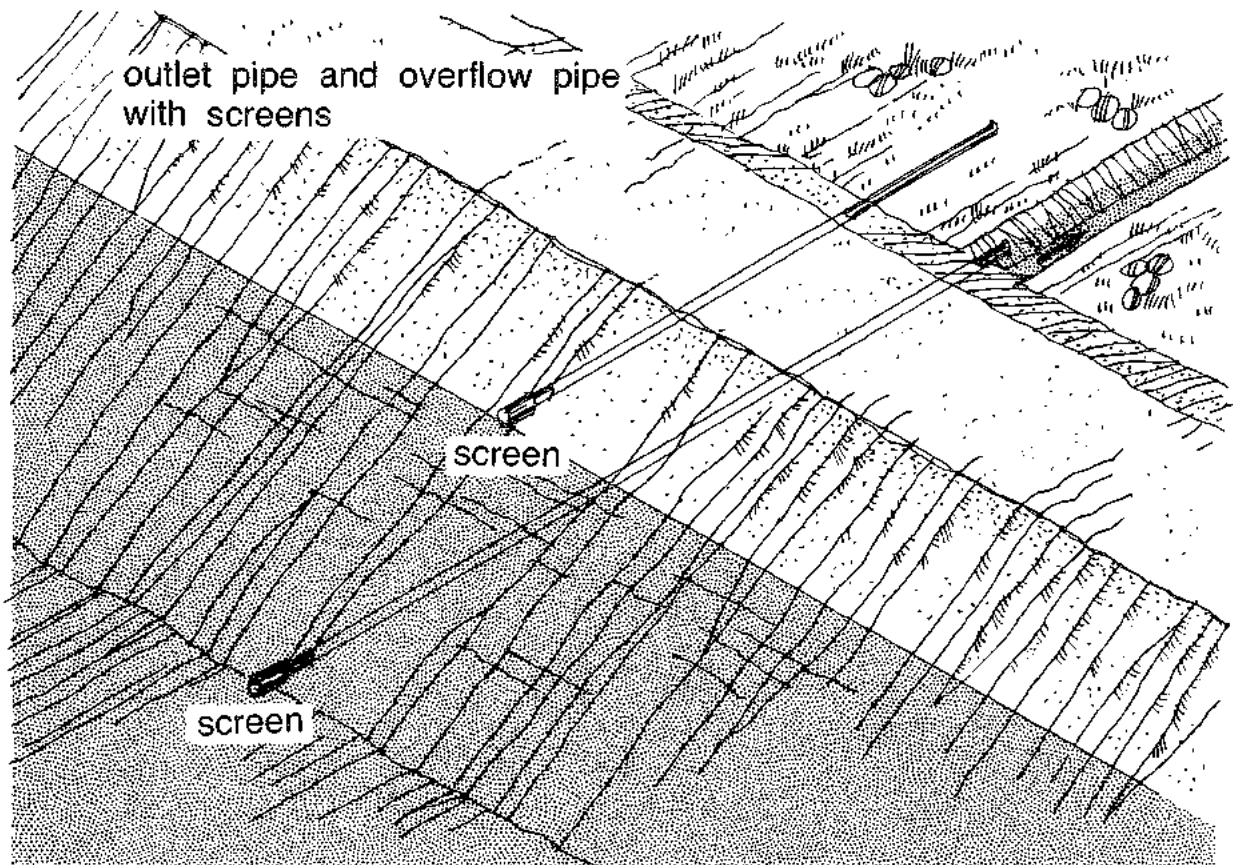
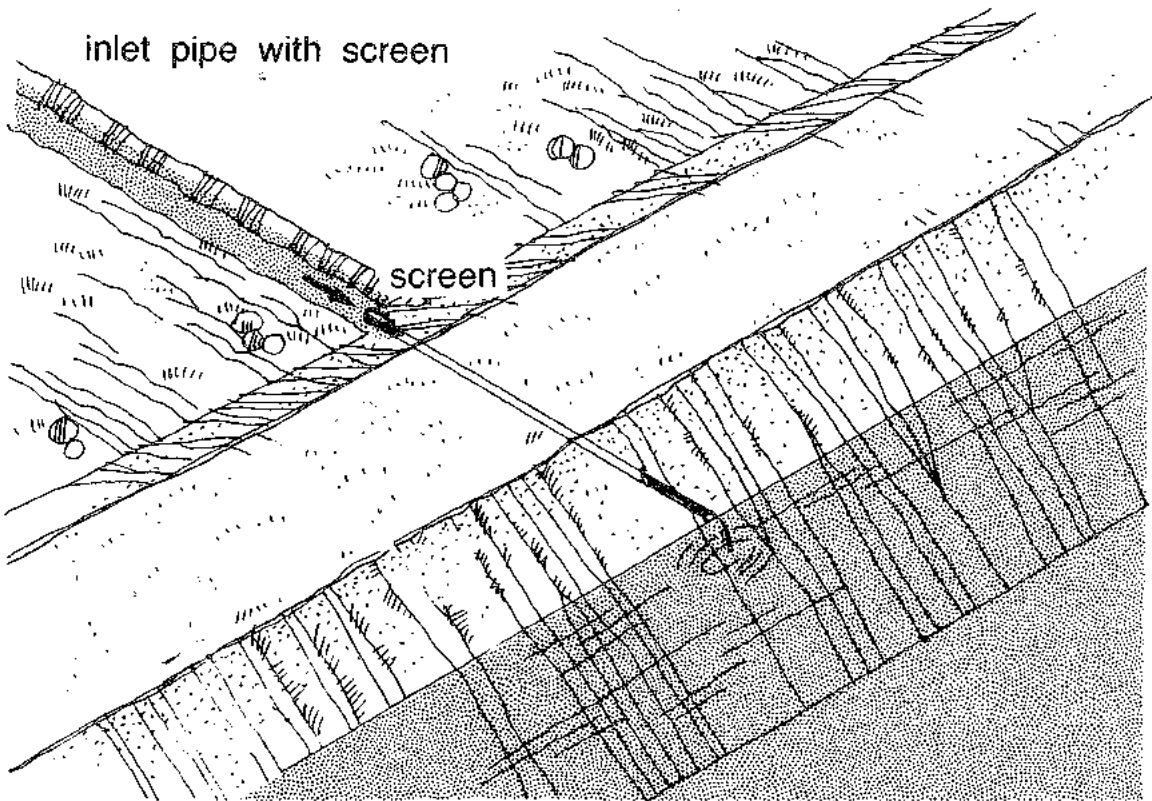

22. For the 15 × 15 metre pond you learned how to build in Booklet No. 29, you made the inlet and the outlet about 10 centimetres in diameter and the overflow about 6 centimetres in diameter. With an inlet or outlet of 10 centimetres, it will take about half a day to fill or empty a pond of this size.
23. If you have built a pond of 20 × 20 metres, your inlet, outlet and overflow should be a little bigger. You can make the inlet and the outlet about 15 centimetres in diameter and the overflow about 10 centimetres in diameter. With an inlet or outlet of 15 centimetres, it will take about one day to fill or empty a pond of this size.
24. You can further improve a pipe outlet by placing a collar of cement around the centre of the pipe.

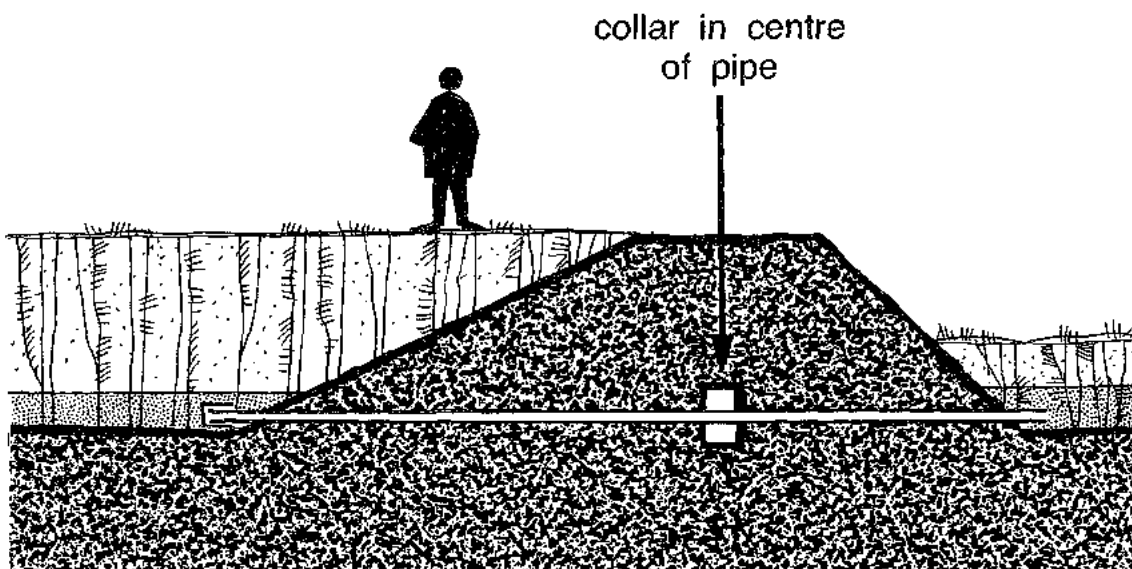

25. The collar will hold the pipe in place in the bank and keep water from seeping through the bank outside the pipe.

26. The drawings below show you how to build a wooden form to make a cement collar.

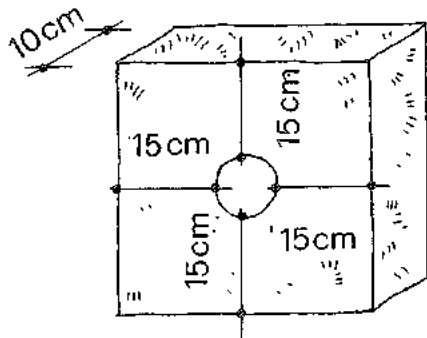

1 a collar should be about 10 cm thick and at least 15 cm from the pipe to each edge of the collar

2 build a wooden form to mould the cement around the pipe

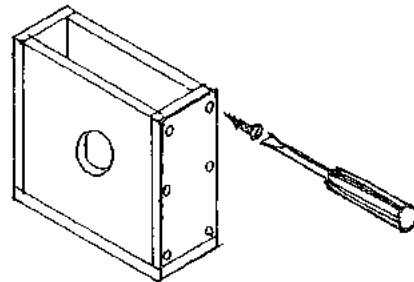

3 place the pipe in the form and fill the form with a mixture of one part cement to two parts sand, and some water

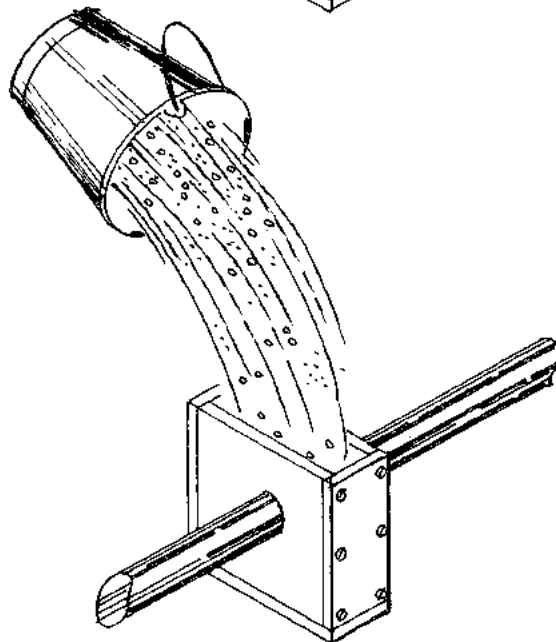

4 remove the form after the cement has completely dried

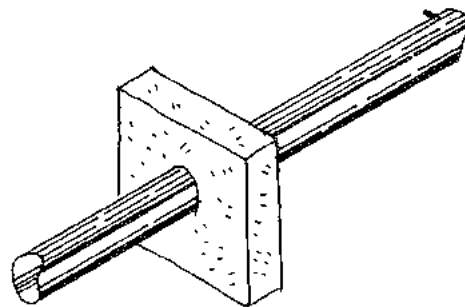

Note: you can make a form using nails; however, if you use wooden screws, you can take the form apart and use it again

## Filling and emptying bigger ponds

27. If the new ponds that you build are more than 500 square metres (a 20 × 30 metre pond = 600 square metres) it will take much too long to fill them using small pipes. You will need better and faster ways.

### A trench inlet

28. You can use a trench inlet just like the one on page 30 in Booklet No. 29 to fill a bigger pond quickly. However, you will also need a screen to keep out wild fish.
29. The drawing below shows you a trench inlet with a corrugated metal bottom and a screen made of woven material.

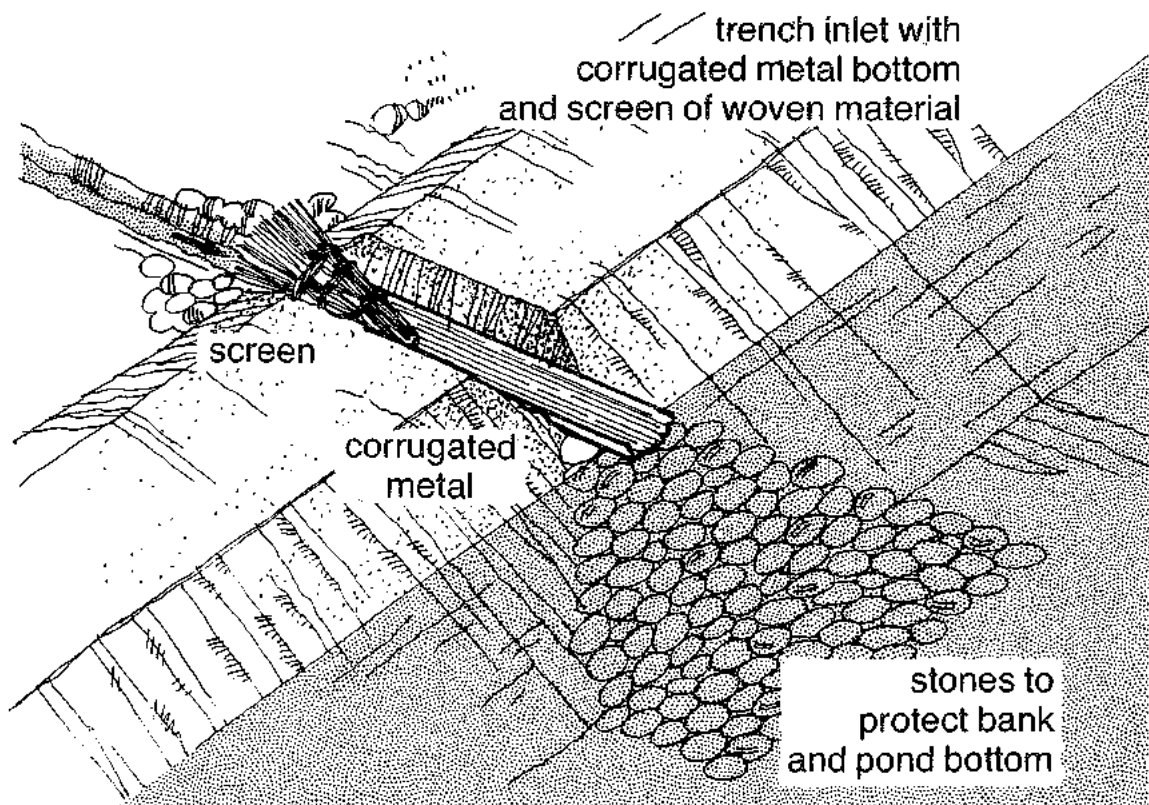

## Another kind of inlet

30. You can also build a kind of gate in the trench to control the flow of water into the pond.  
This is called a **sluice**.
31. A sluice has a wall on each side of the trench and a floor set into the bottom of the trench.  
There are slots in the walls to hold wooden boards or a screen.
32. Boards are put into the slots to **keep water out** of the pond or taken out to **let water in**.  
When you are filling the pond, put in a screen to keep out wild fish.

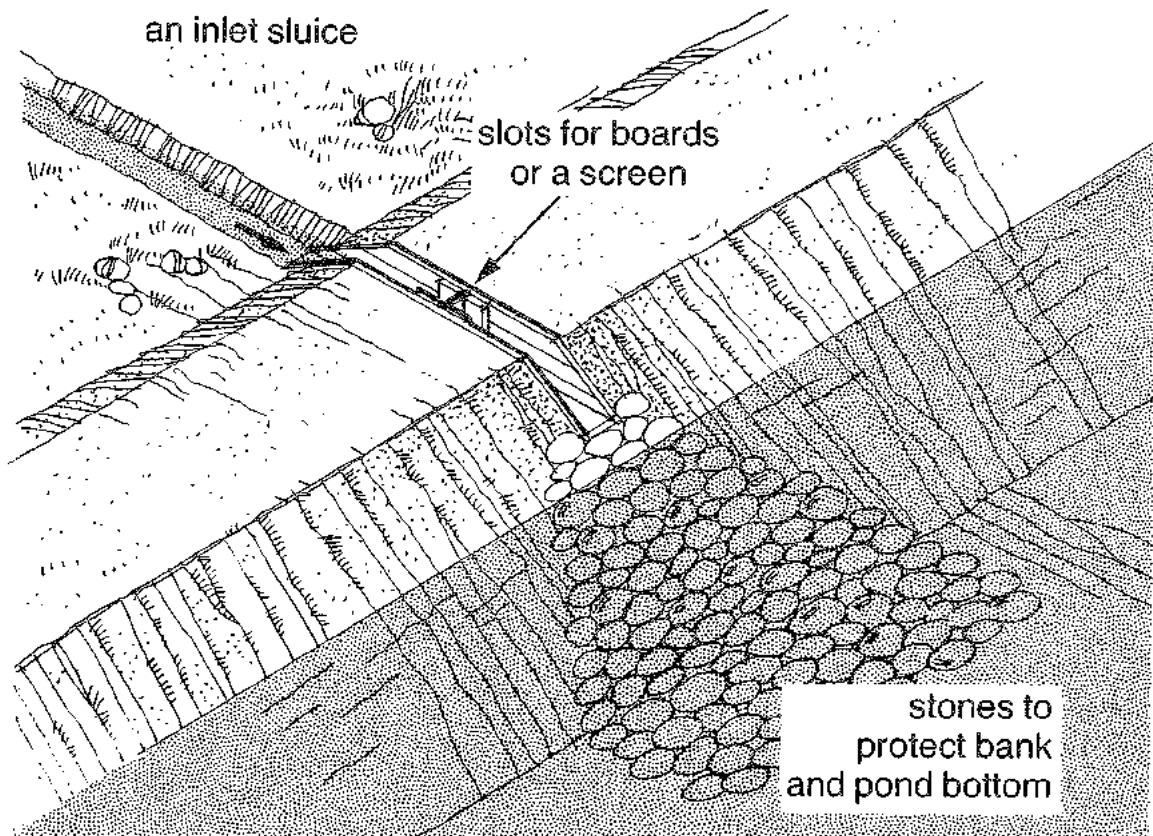

33. You can build a sluice from wood, or if you know how to build with bricks or blocks, you can use these.
34. The drawings below and on the next page show you how to build an inlet sluice using wood.

*Building a wooden inlet sluice*

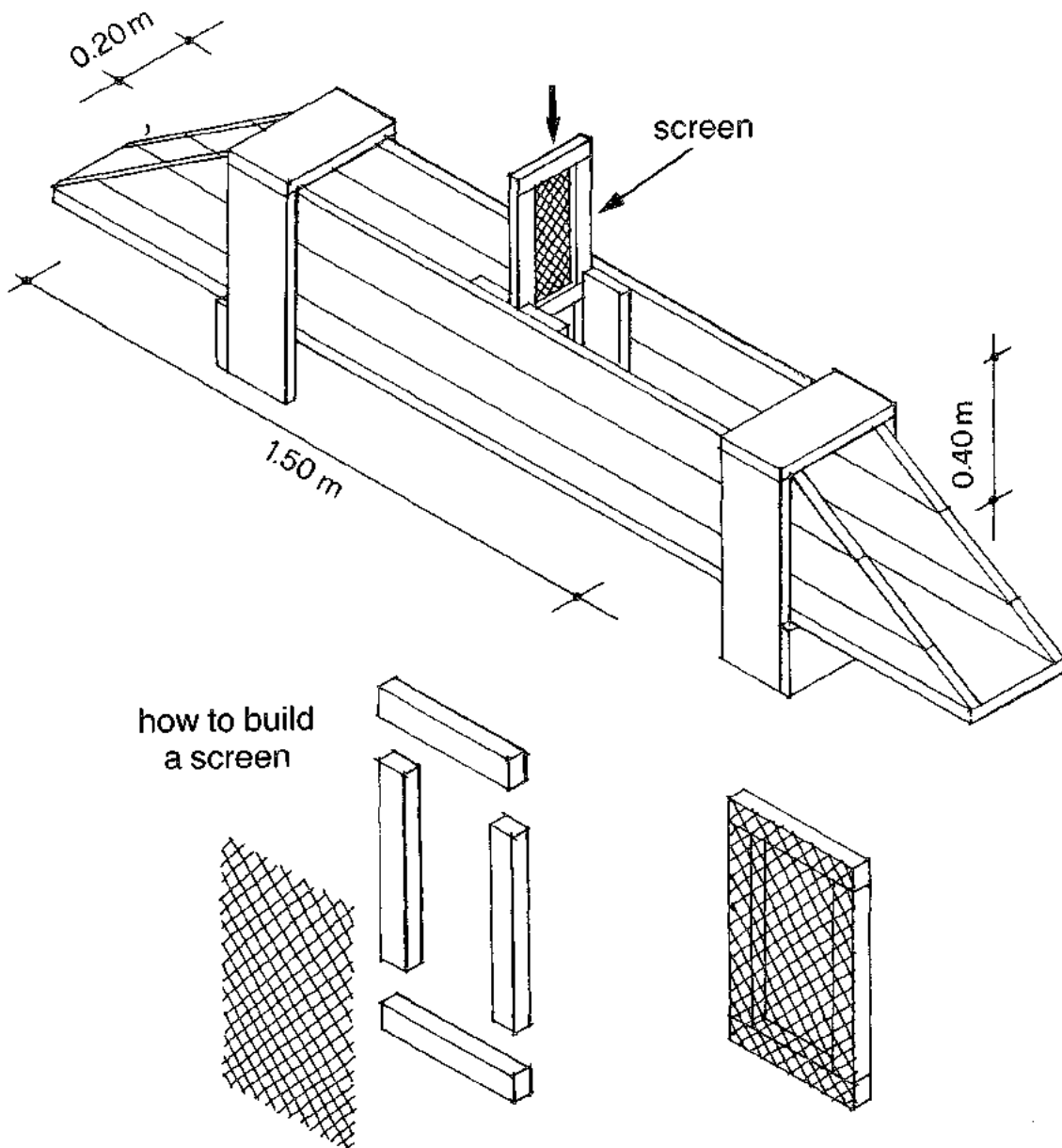

## Parts of a wooden inlet sluice

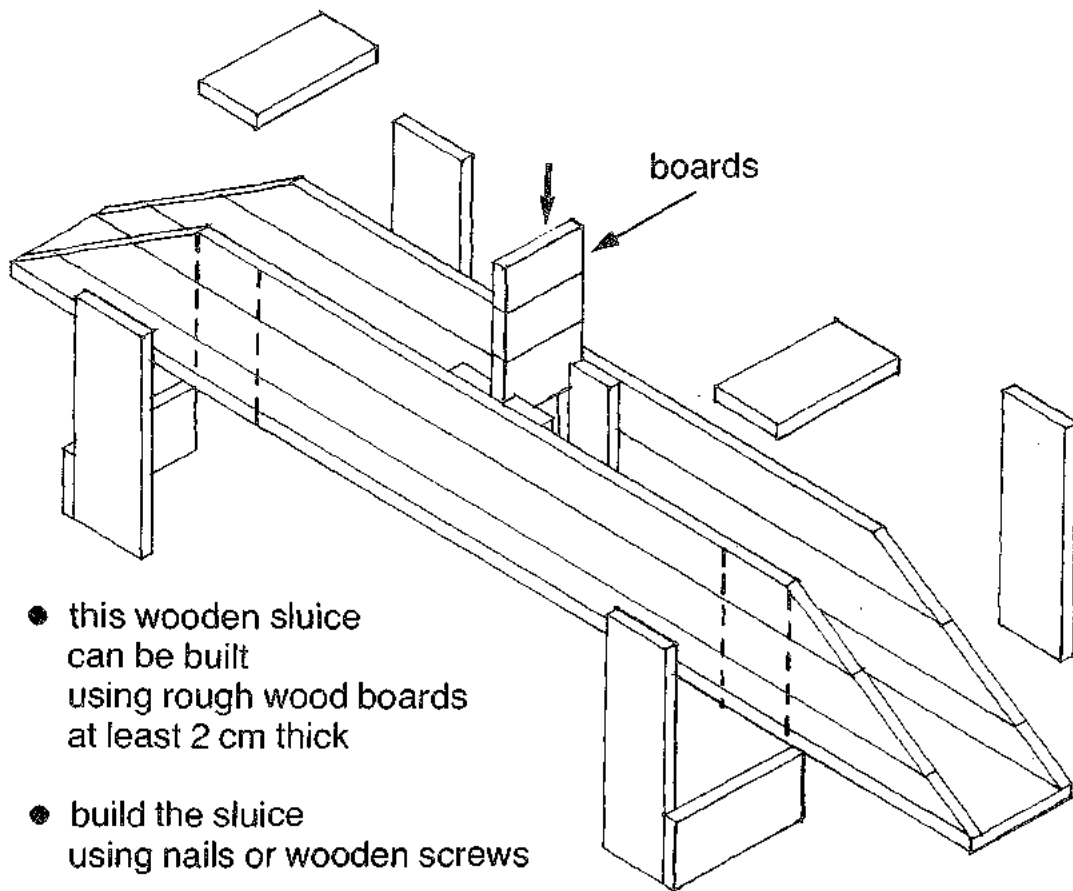

- this wooden sluice can be built using rough wood boards at least 2 cm thick
- build the sluice using nails or wooden screws
- this sluice is 20 cm wide and 40 cm deep

## Where to put an inlet sluice in the pond bank

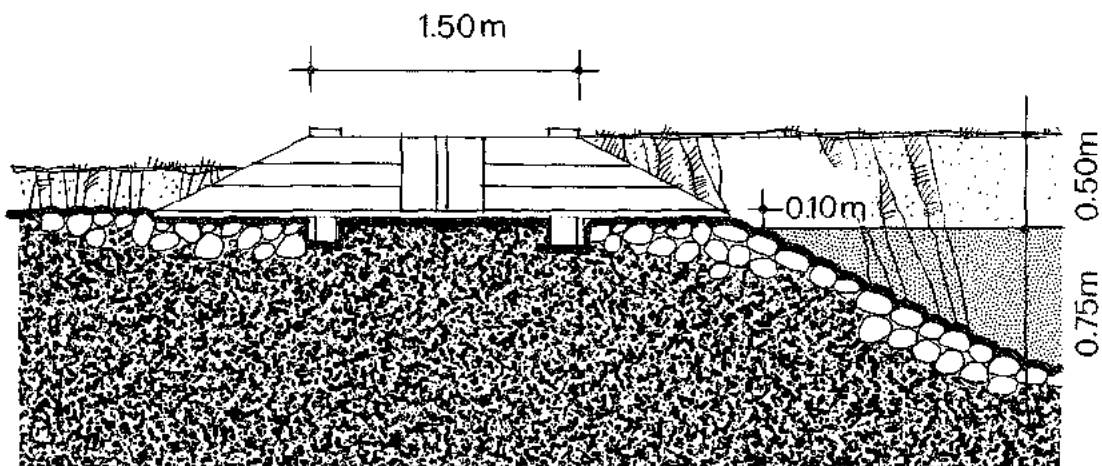

## Another kind of outlet

35. You can build another kind of outlet to empty a bigger pond faster. It is built inside the bank at the deep end of the pond. This kind of outlet is called a **monk**. When the pond is filled, the monk will be in the water.

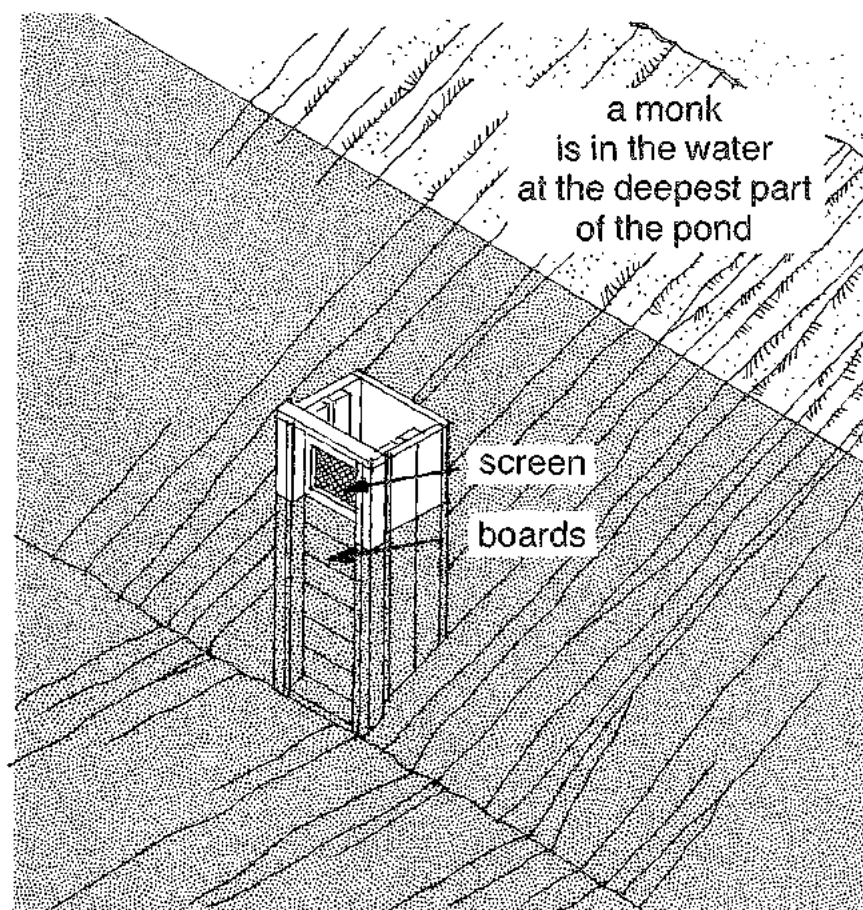

36. A monk is a tall box with two sides, a back, a front formed by wooden boards, and a bottom. Each side has two slots to hold two rows of the wooden boards.
37. Boards are put into the slots to **keep water in** the pond or taken out to **let water out**. You will learn more about this on pages 20 to 23 of this booklet.



38. A monk also has a screen like the one shown on page 14. The screen fits on top of the first row of boards and keeps your fish from getting out when the pond is too full or when you are emptying it.

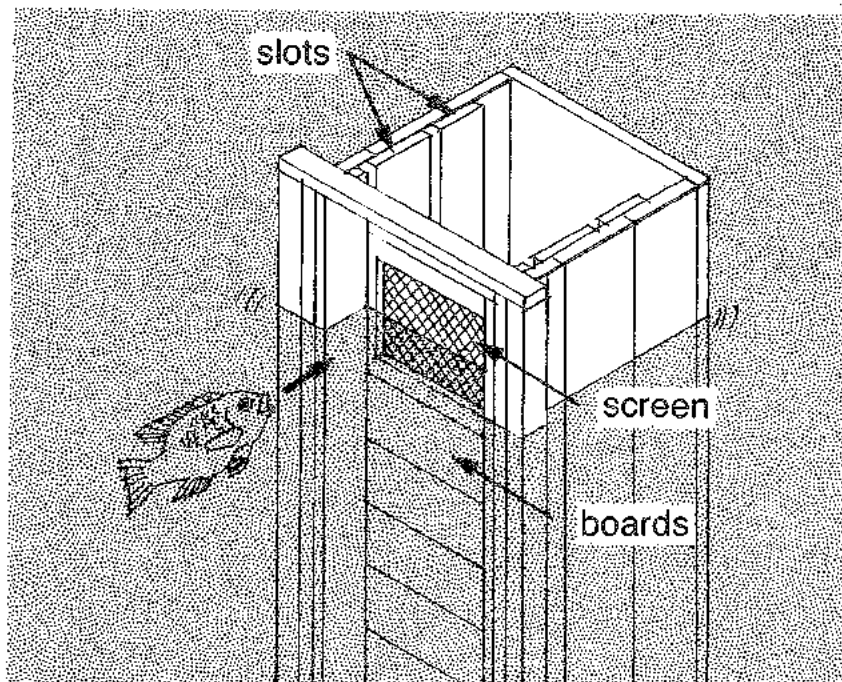

39. A monk also serves as an overflow. So, you will not need to have an overflow pipe like the one shown on page 9 of this booklet.
40. You can build a monk from wood, or if you know how to build with bricks or blocks, you can use these.
41. The drawings on the next pages will show you how to build a monk using wood, and how to fill and empty a pond using a monk.

## Building a wooden monk

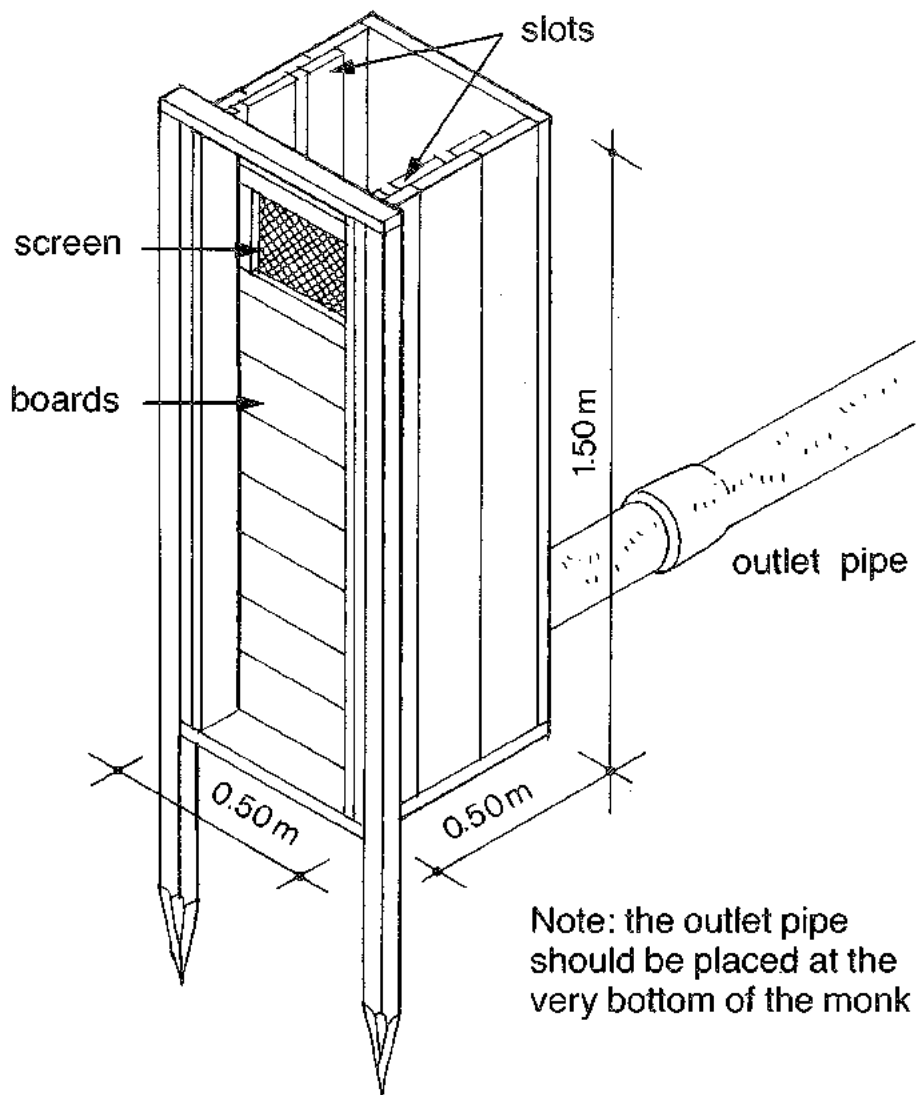

## Where to put a monk in the pond

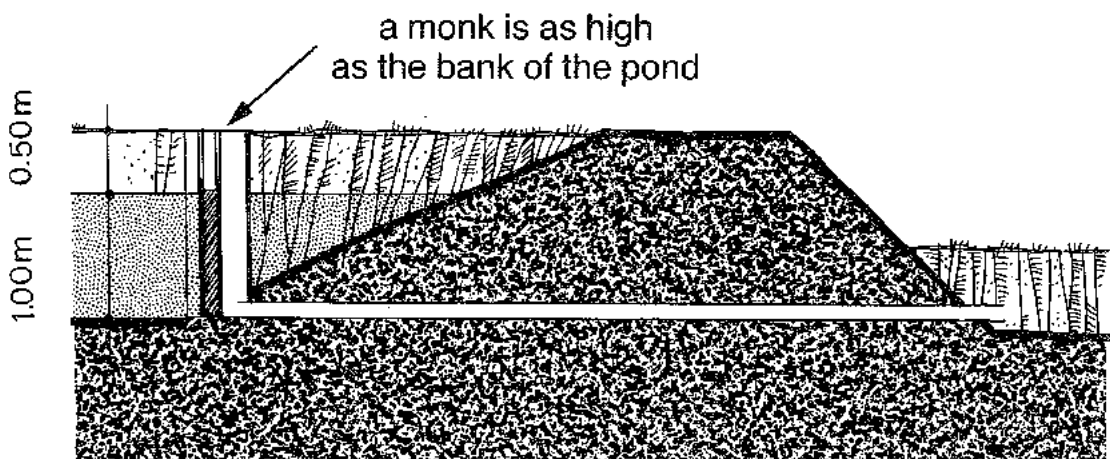

## *Parts of a wooden monk*

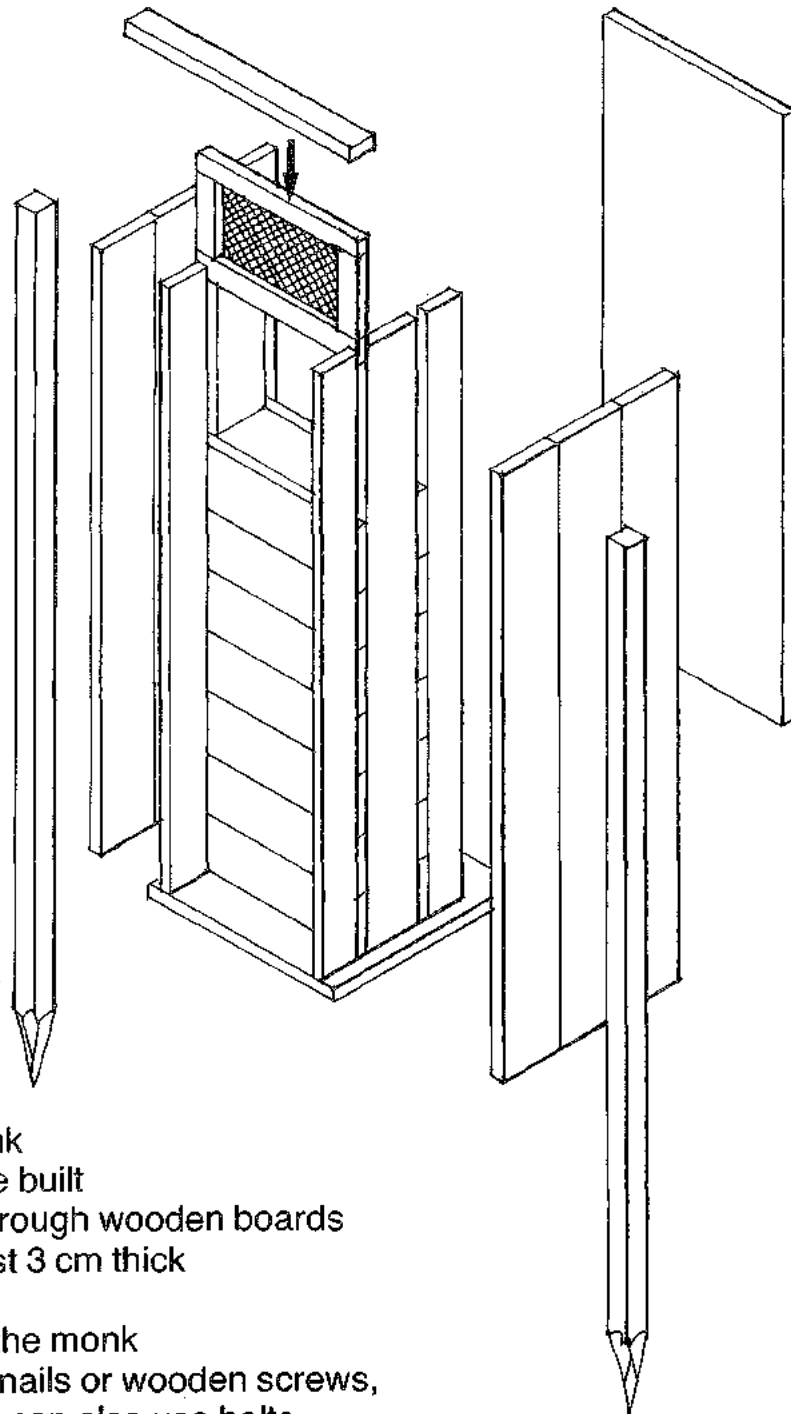

- a monk can be built using rough wooden boards at least 3 cm thick
- build the monk using nails or wooden screws, or you can also use bolts
- this monk is 0.50 m wide, 0.50 m deep and 1.50 m high

Note: try to use wood that will not easily rot when it is in the water

*How to fill a pond  
when you have a monk*

- 1 put both sets of wooden boards in the slots in the monk and put the screen in place on top of the first row of boards

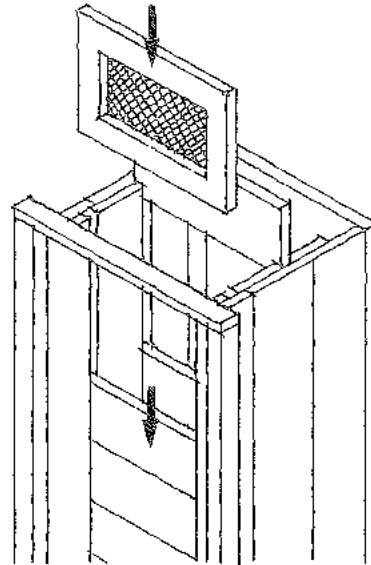

- 2 the boards should be as high as the water depth that you want in the pond

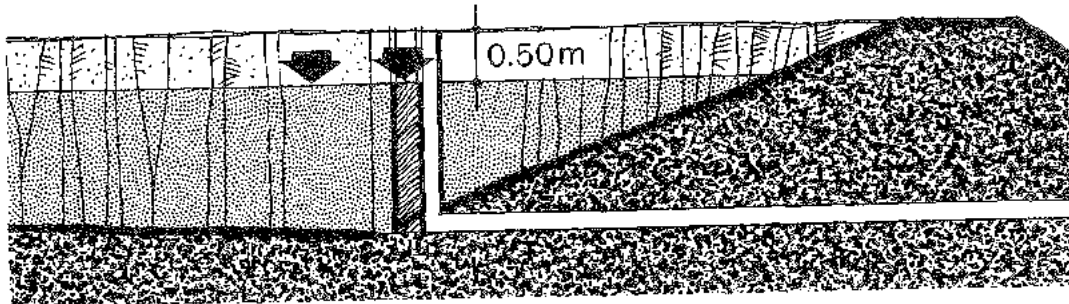

- 3 pack the space between them with good clay soil to keep water from leaking out

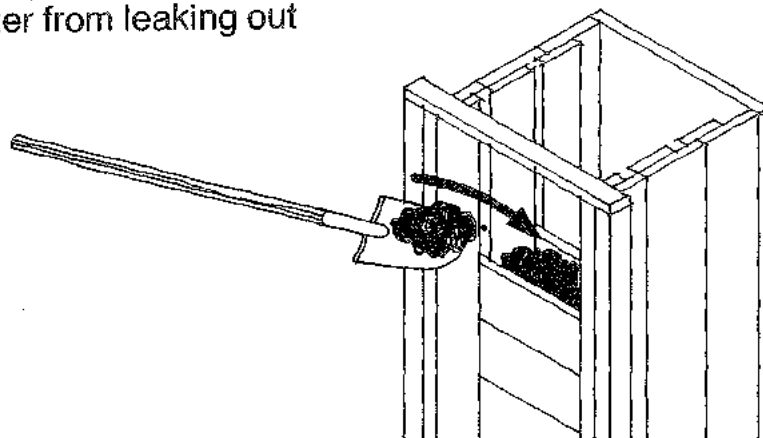

4 let water into the pond

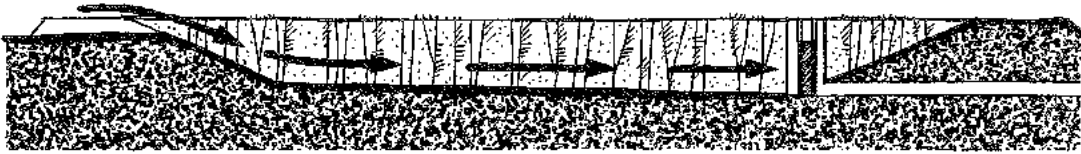

5 when the water reaches the top of the boards, stop the flow of water

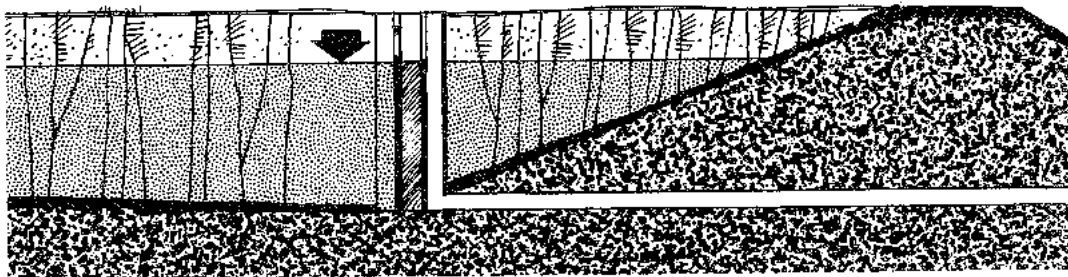

6 leave the screen in place to act as an overflow if the water becomes too high

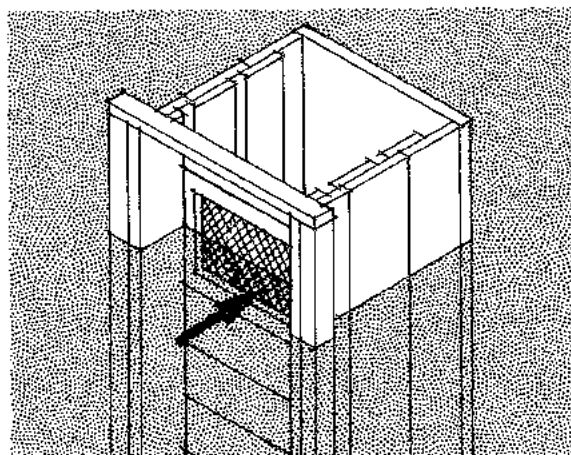

Note: you may have to let water into your pond from time to time if the water-level gets too low

*How to empty a pond  
when you have a monk*

- 1 take out the screen  
and remove  
the top board  
from each slot

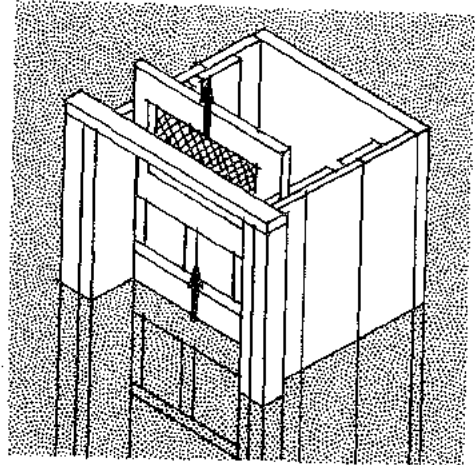

- 2 the water will begin to flow out  
and wash away the clay  
that was between the boards

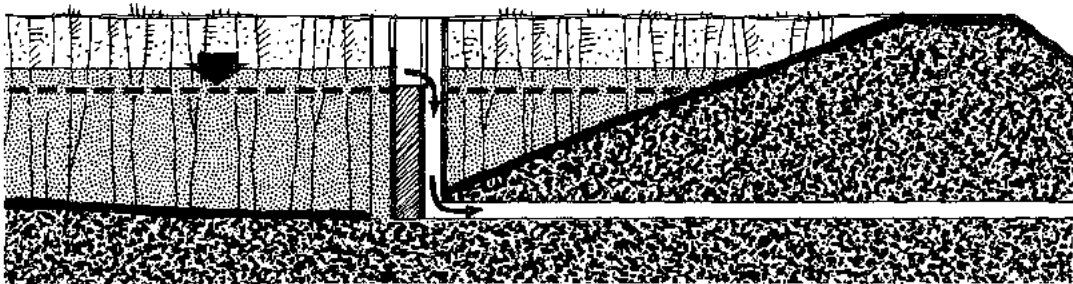

- 3 quickly put back the screen  
to keep the fish from getting out

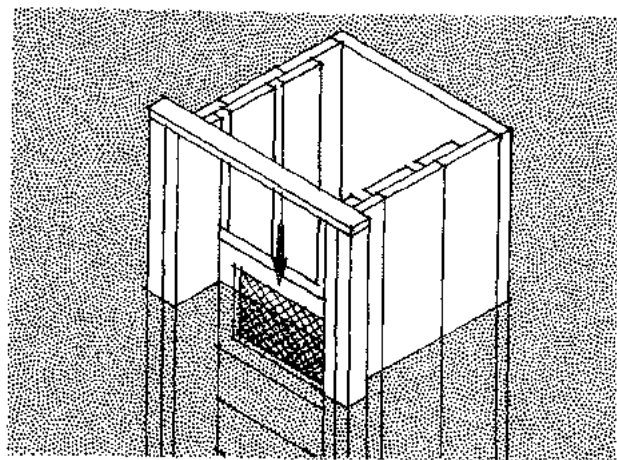

- 4 water will flow out  
until it reaches the level  
of the next row of boards

5 when this happens,  
take out the screen again,  
remove the top row of boards  
and quickly put back the screen

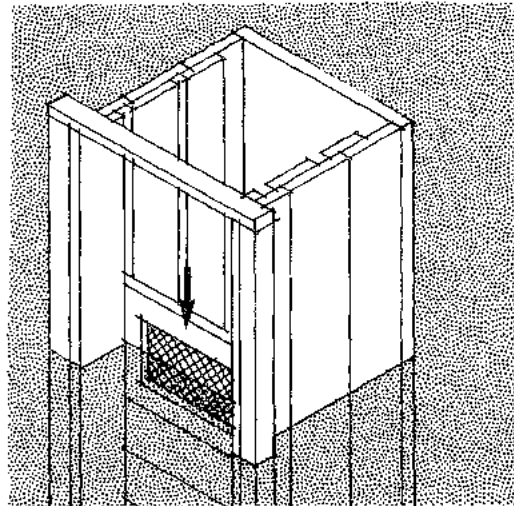
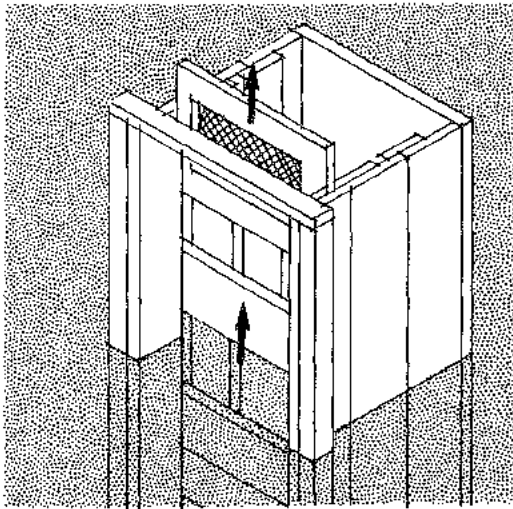

6 more water will flow out

7 continue to take out boards  
one row at a time,  
always putting back the screen,  
until the pond is empty

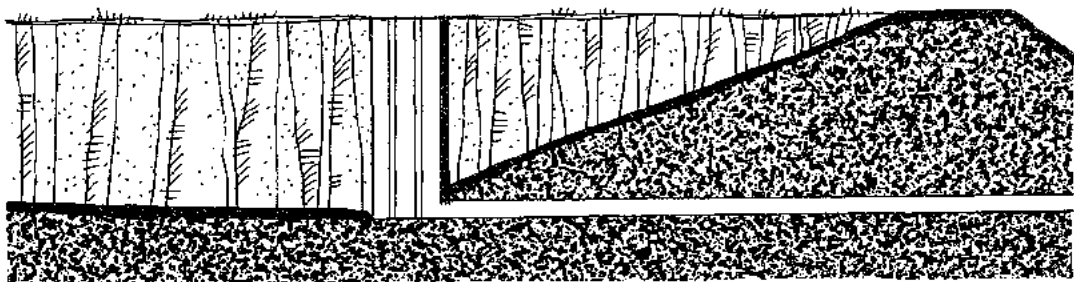

Note: later in this booklet,  
you will learn  
how to harvest fish  
when you have a monk

# BRINGING WATER TO YOUR PONDS

---

## Raising the level of your water supply

42. If the stream that supplies your water is not much higher than your ponds, it may be difficult to get the water to run down when you want to fill them.
43. By building a **barrage**, you can raise the level of the stream so that water will run down more easily into your fish-ponds.

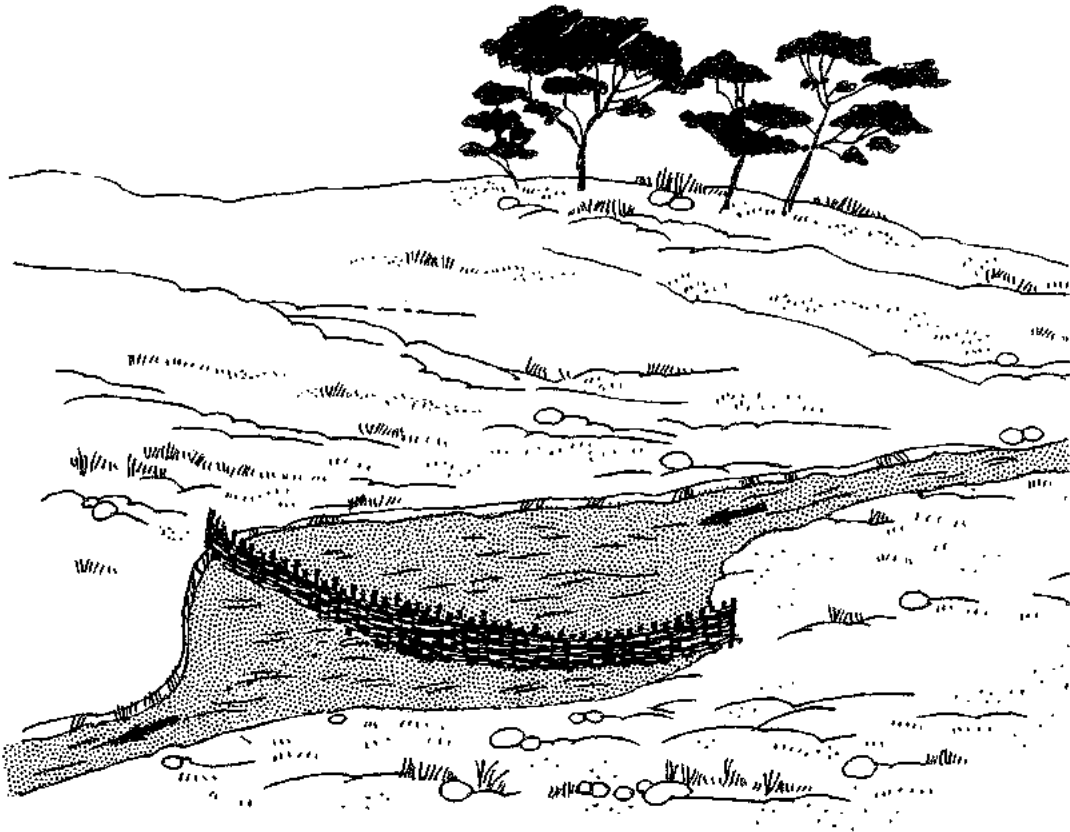

barrage of tree branches

44. You can build a simple barrage (using a woven mesh of tree branches like the one shown above). You can also use loose stones or rocks or logs set into the stream bottom (like the ones shown on the next page).



barrage of logs

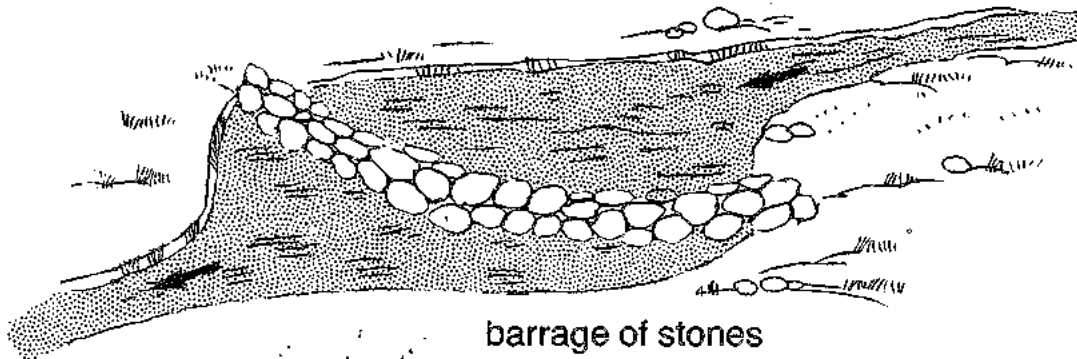
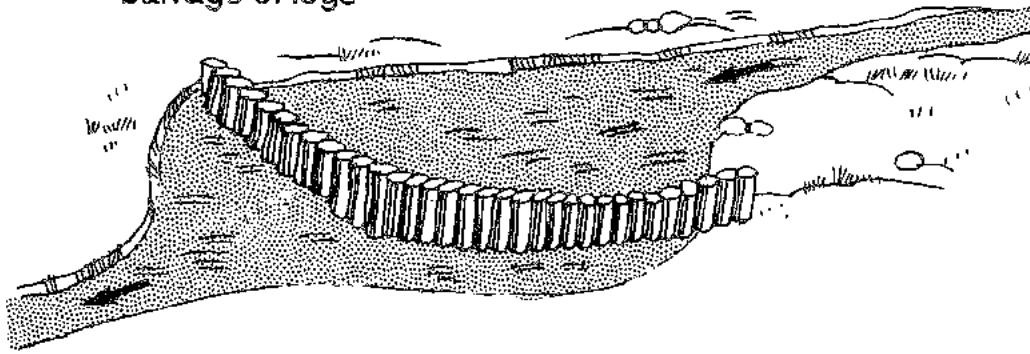

barrage of stones

45. A barrage does not hold back all of the water that runs down the stream. Depending on how it is built, some of the water will be held back and some of the water will flow through or over the barrage.
46. If the tree branches, logs or rocks are **placed tightly together**, the water level behind the barrage will be higher.
47. If the tree branches, logs or rocks are **not placed so tightly**, the water level behind the barrage will be lower.
48. If you build a barrage and too much water flows through, you can hold back more water by putting more branches, logs or rocks on the barrage.

## Digging a supply ditch

49. After you have built a barrage and the water behind it has reached its highest level, you will need to dig a supply ditch to take the water to your ponds.

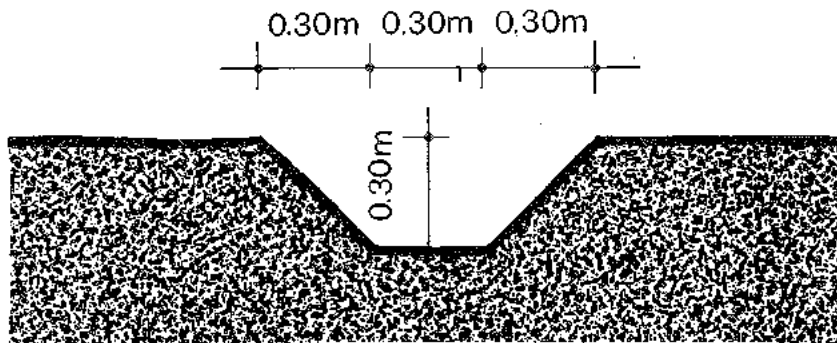

50. Begin by digging the supply ditch just behind the barrage where the water is deepest. However, dig it in such a way that the water in the stream will not flow into the ditch.
51. You can do this by starting the supply ditch about 1 metre away from the edge of the water. When you are ready to fill your ponds, you can remove this 1-metre strip (see Item 69) and the water will flow into the ditch.

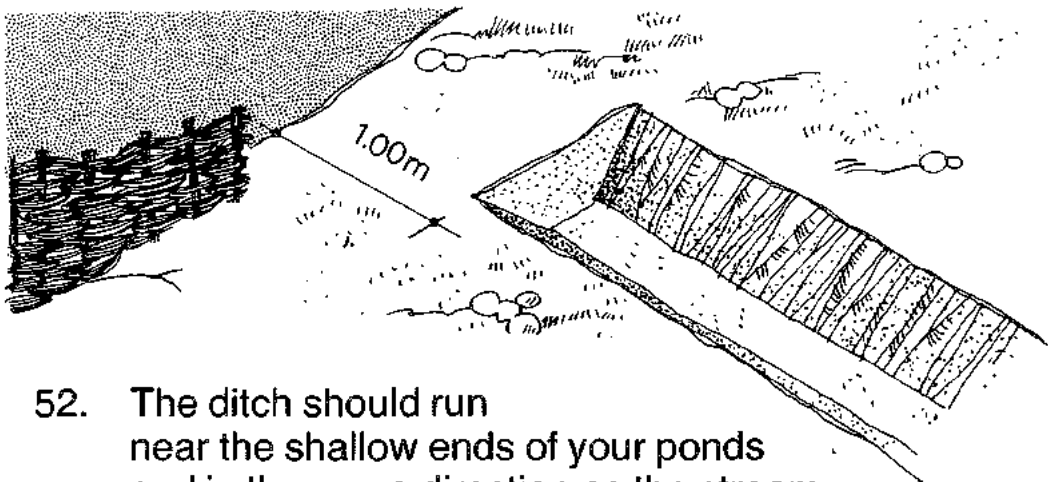

52. The ditch should run near the shallow ends of your ponds and in the same direction as the stream that supplies your water.

53. The ditch should have very little slope. You can use a straight board and a mason's level to help you to dig your ditch.
54. When you reach your highest pond, the ditch should be near the inlet. Continue to dig your water-supply ditch until you reach your lowest pond.
55. When the supply ditch is past the end of the lowest pond, continue to dig it downhill for about 10 metres. Then bring it slowly to the surface. That way, when you fill your ponds, any extra water will flow out at ground level.
56. Now, dig a small ditch to connect the inlet of each pond to the supply ditch.

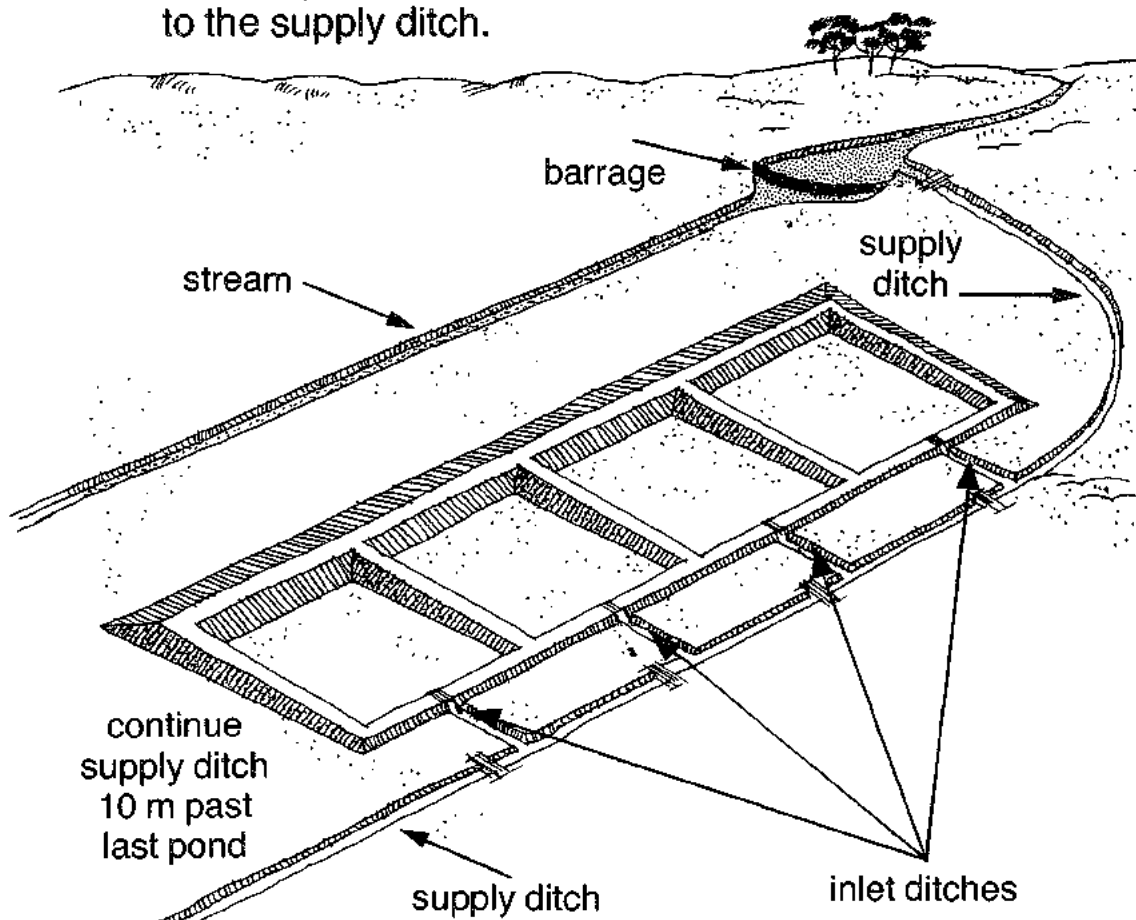

## Digging a return ditch

57. You will also need to dig one or more ditches to take the water back to the stream when you empty your ponds.
58. These are called return ditches and how you dig them will depend on how your ponds are placed and how near they are to the stream. Try to choose the easiest and shortest path to take the water back to the stream.
59. If your ponds are near the stream, the easiest way to get the water back is to dig a return ditch from the outlet of each pond straight to the stream. You can also use one ditch for two ponds (see the drawing on pages 38 and 39).

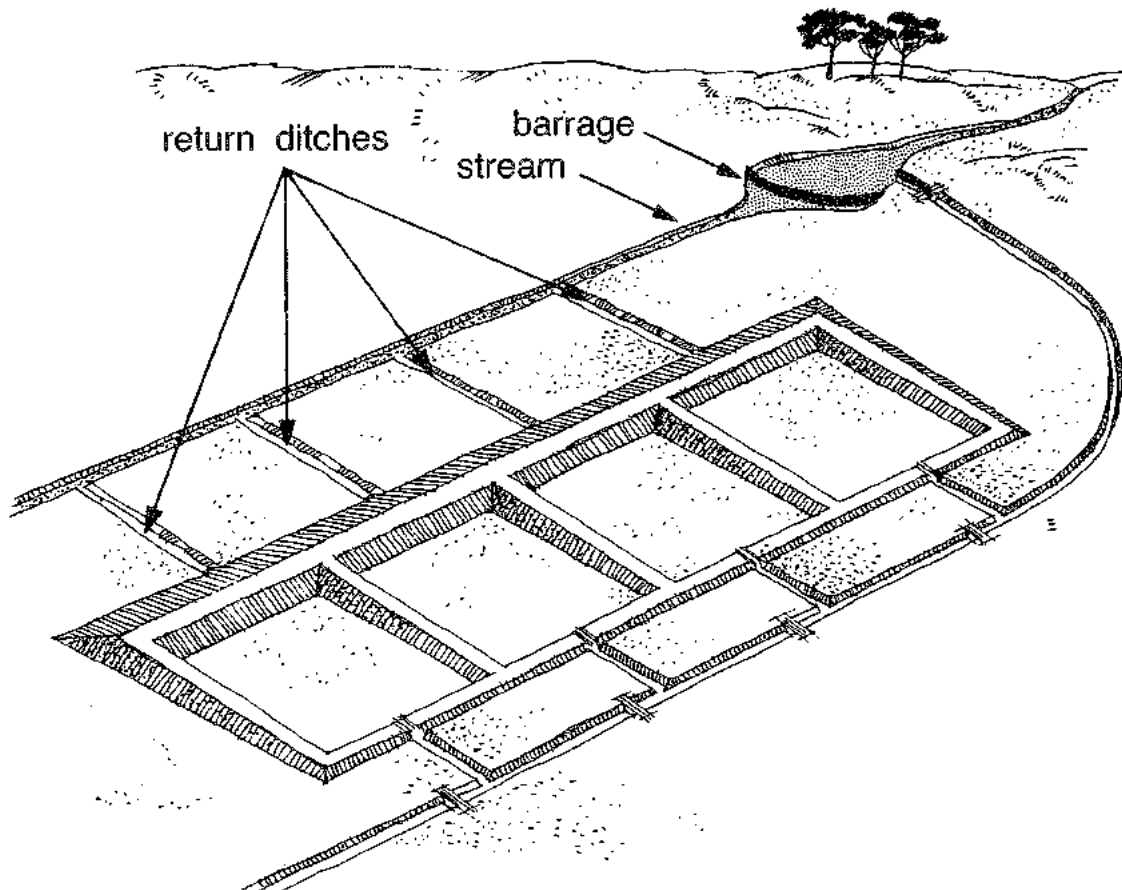

60. If your ponds are not near the stream or if you cannot dig a ditch straight to the stream, dig only one return ditch along the outlet side of your ponds, which can take all the water from all the ponds.
61. Start this ditch at the outlet of your highest pond. The ditch should run past the outlet of the lowest pond and then back to the stream.
62. Now, dig a small ditch to connect the outlet of each pond to the return ditch.

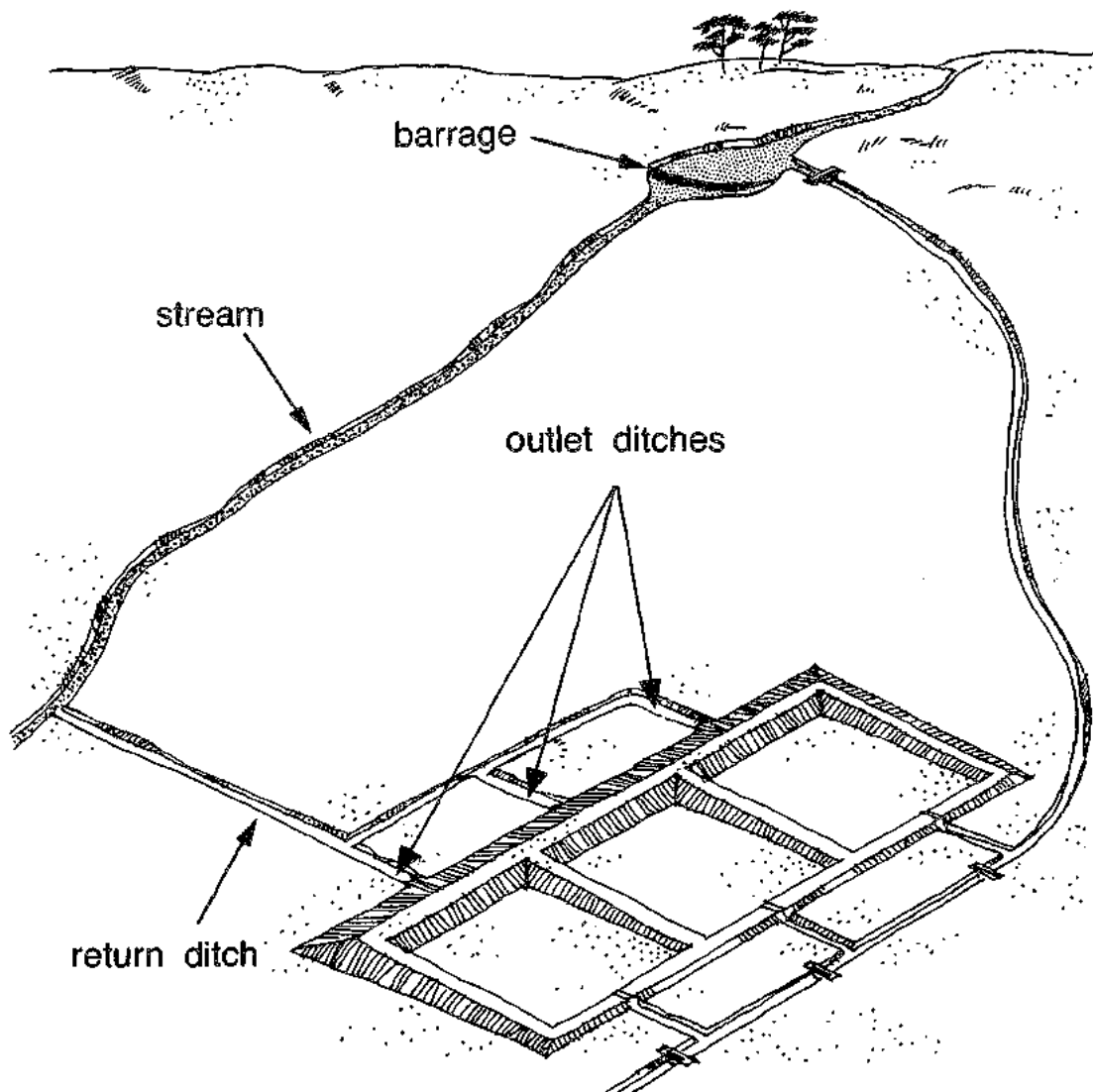

## Controlling the water in your supply ditch

63. When you have built your ditches, you will need a way to control the flow of water from the stream into your supply ditch and from your supply ditch into the inlet ditches of each of your ponds.

### From the stream into your supply ditch

64. To control the flow of water into your supply ditch, you can build a sluice somewhat like the one you learned to build for an inlet (see pages 14 and 15 in this booklet).
65. However, instead of one slot in each wall, this sluice will have three slots in each wall. Two sets of slots are for wooden boards and the third set is for a screen to keep out wild fish.
66. Build this sluice at the top of the supply ditch just behind the 1-metre strip of soil that you left at the edge of the water when you began digging the ditch.

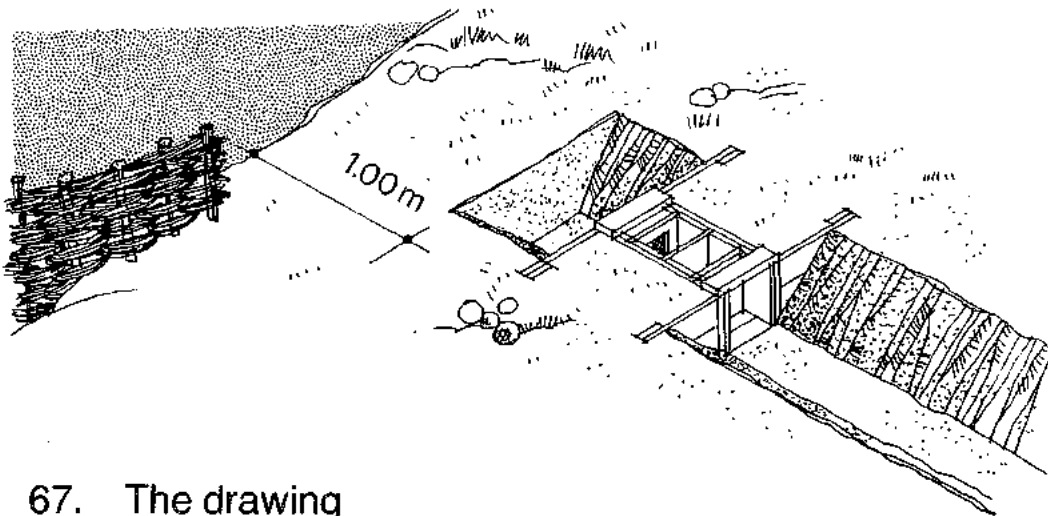

67. The drawing at the top of the next page shows you how to build a wooden sluice for the supply ditch at the stream.

*Building a wooden sluice  
for the supply ditch*

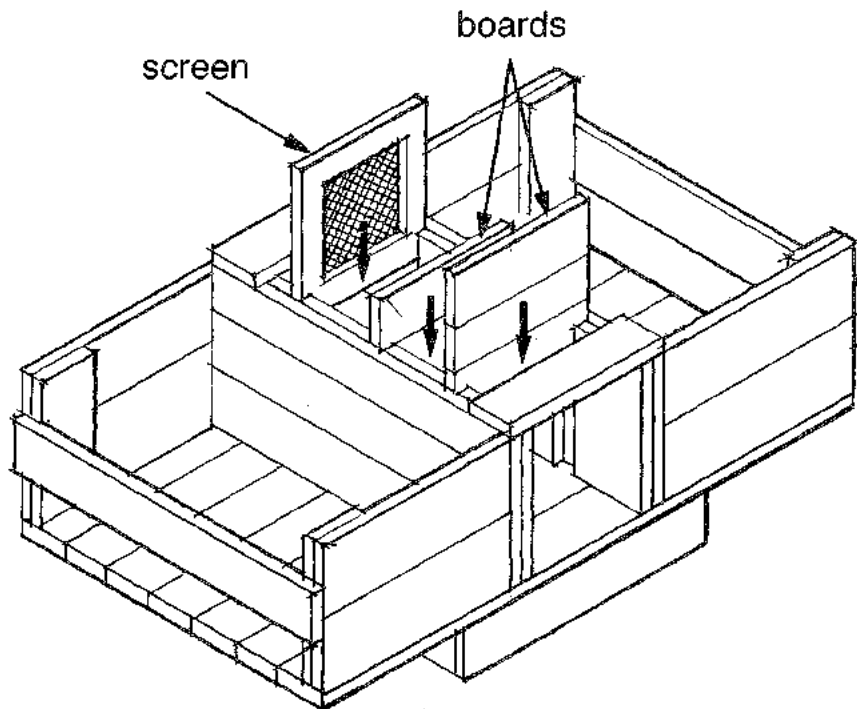

68. Pack the space between the boards with good clay soil to keep the water from leaking through. However, do not put in the screen until you are ready to use the sluice. Put it aside so that it will not be broken.

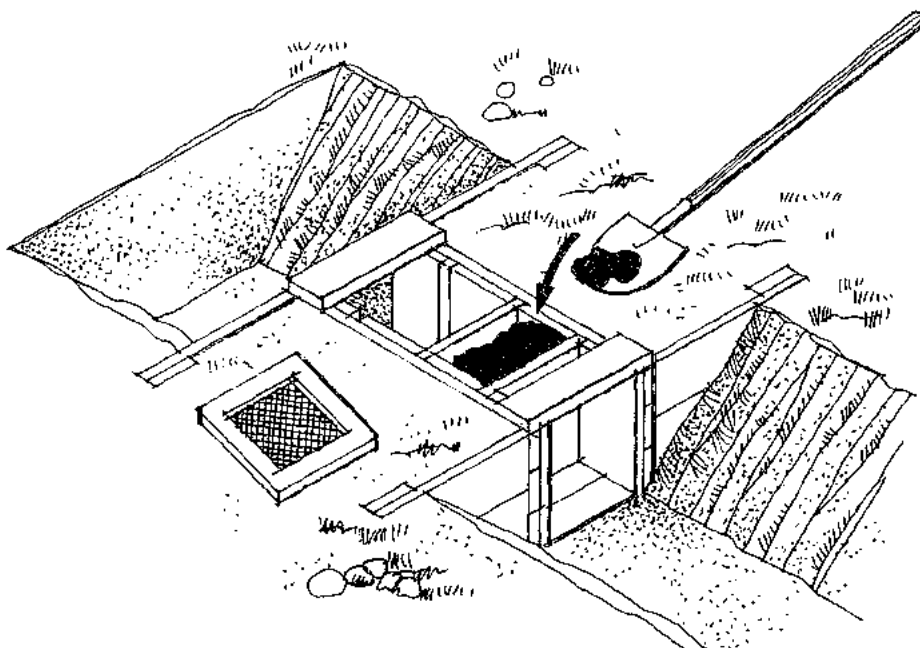

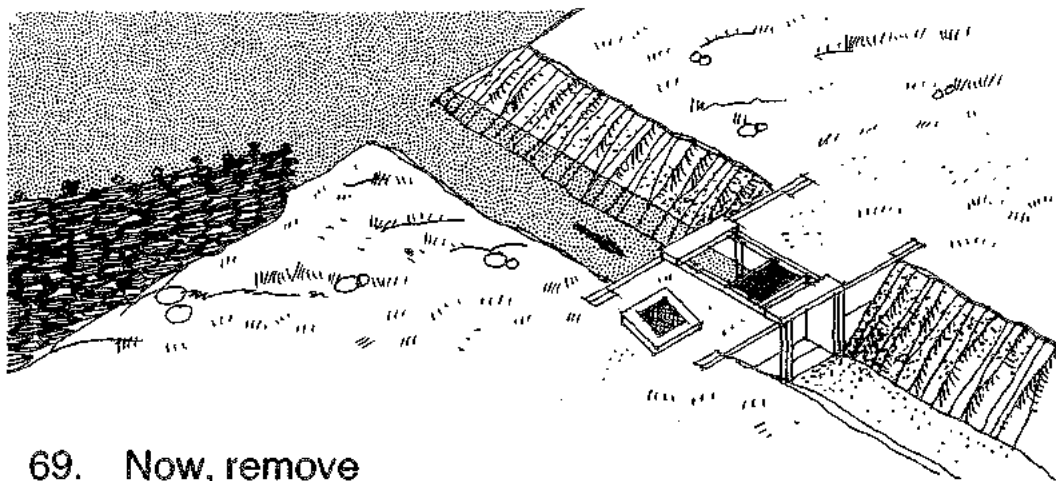

69. Now, remove the 1-metre strip of soil you left at the edge of the stream. The water will flow into the ditch up to the wooden planks in the sluice.

From the supply ditch into your ponds

70. You can build a smaller sluice to control the flow of water into your ponds. With this sluice you need only one set of boards. The drawing below shows you how.

*Building a wooden sluice for a pond inlet*

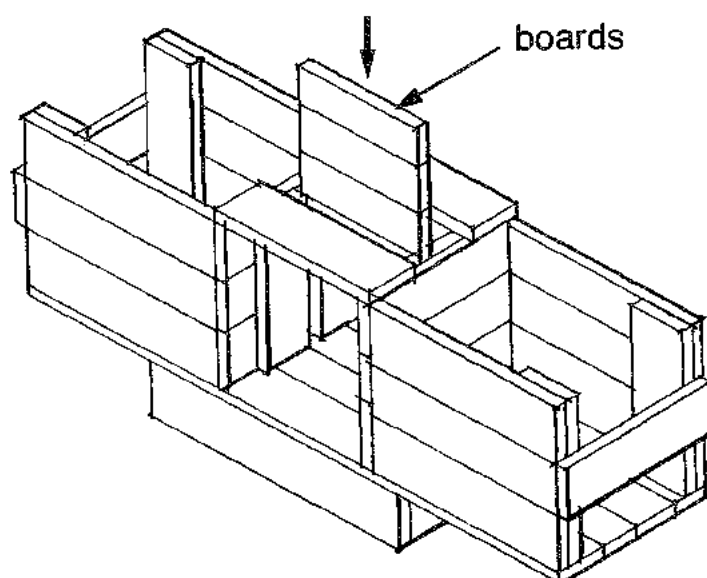



71. You will need one sluice for each of your ponds. Build them at the lower corners of each inlet ditch. The drawing below shows you where to put this kind of sluice.

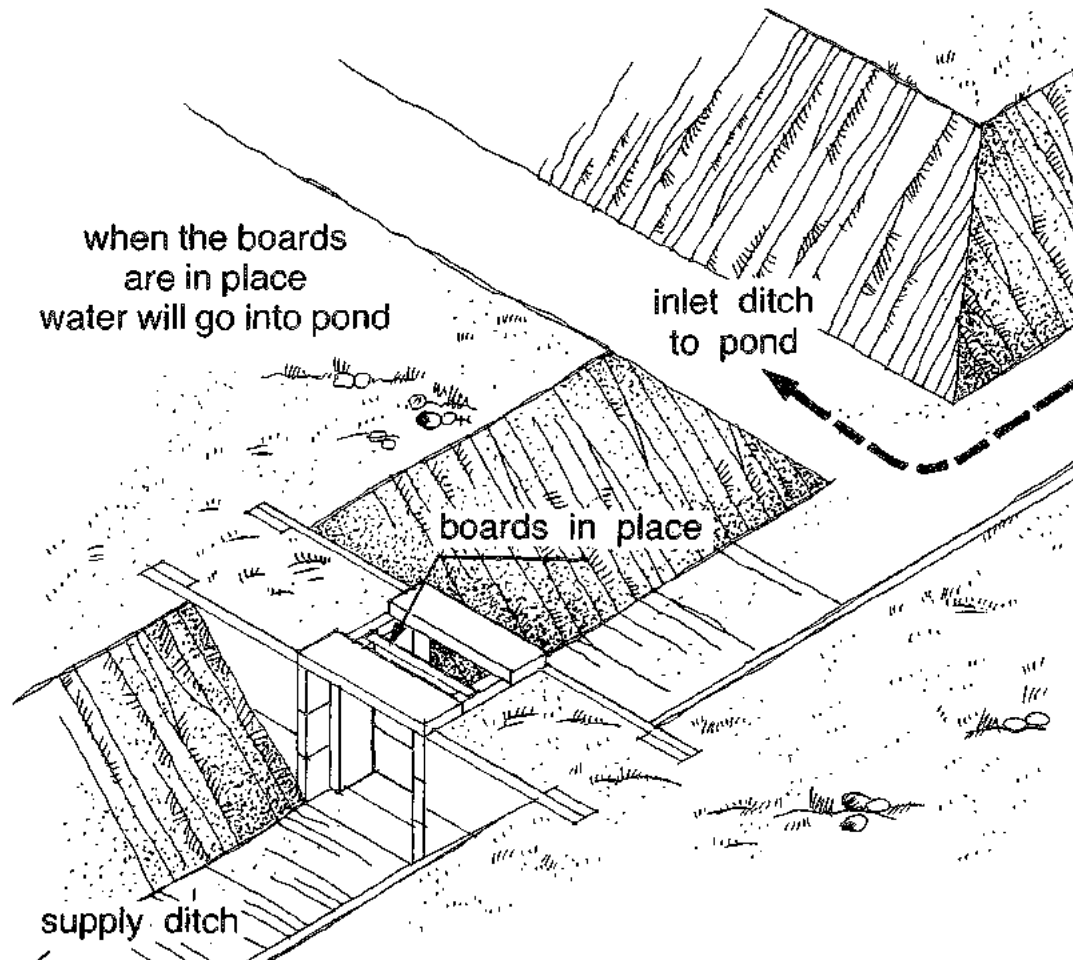

72. Slide wooden boards into the slots of this sluice to send all the water into a pond, or take them out to let all the water flow farther down the supply ditch into another pond.
73. You can also adjust the boards in each sluice so that part of the water will go into one pond and the rest will flow down to feed the other ponds.

## Filling your ponds

74. When you have finished digging your supply and return ditches and have built all of the sluices, you are ready to fill your ponds.

### Note

**Ponds are filled one by one.**

Items 75 and 77

will tell you, step by step, how to begin filling your ponds.

The large drawing on pages 38 and 39 will also help you to understand the various steps.

75. To fill the first pond do the following
- make sure that the outlet of the first pond you are going to fill is closed

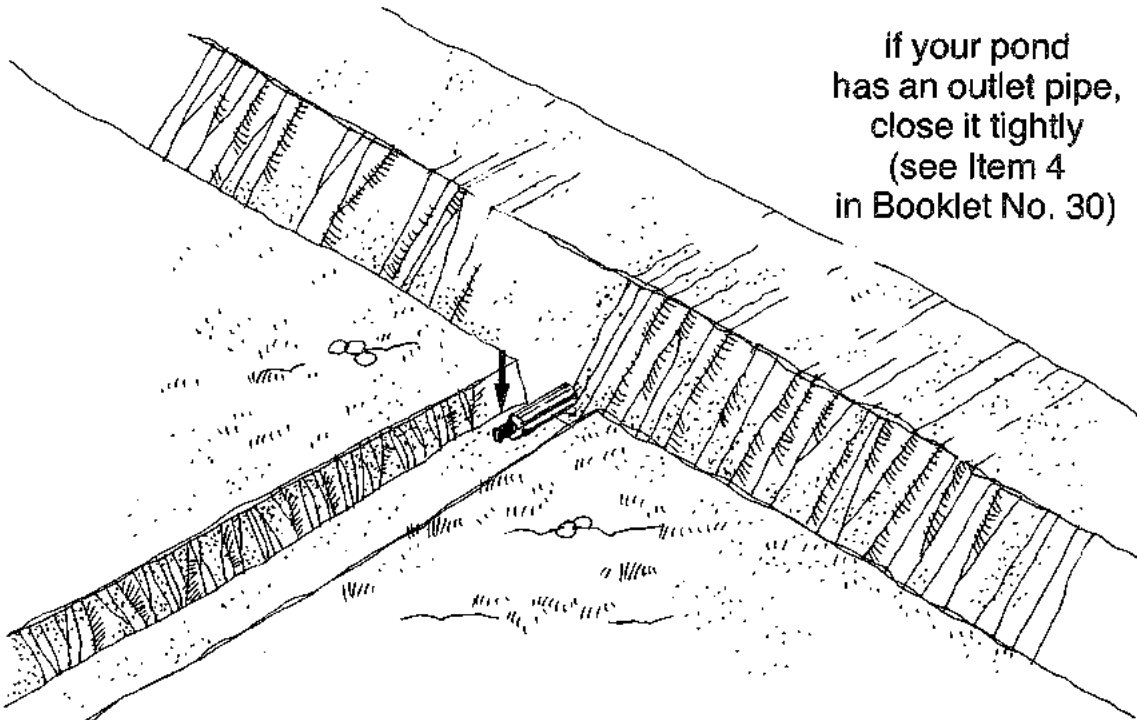

if your pond has an outlet pipe, close it tightly (see Item 4 in Booklet No. 30)

if your pond  
has a monk,  
put in the boards  
and put the screen on top

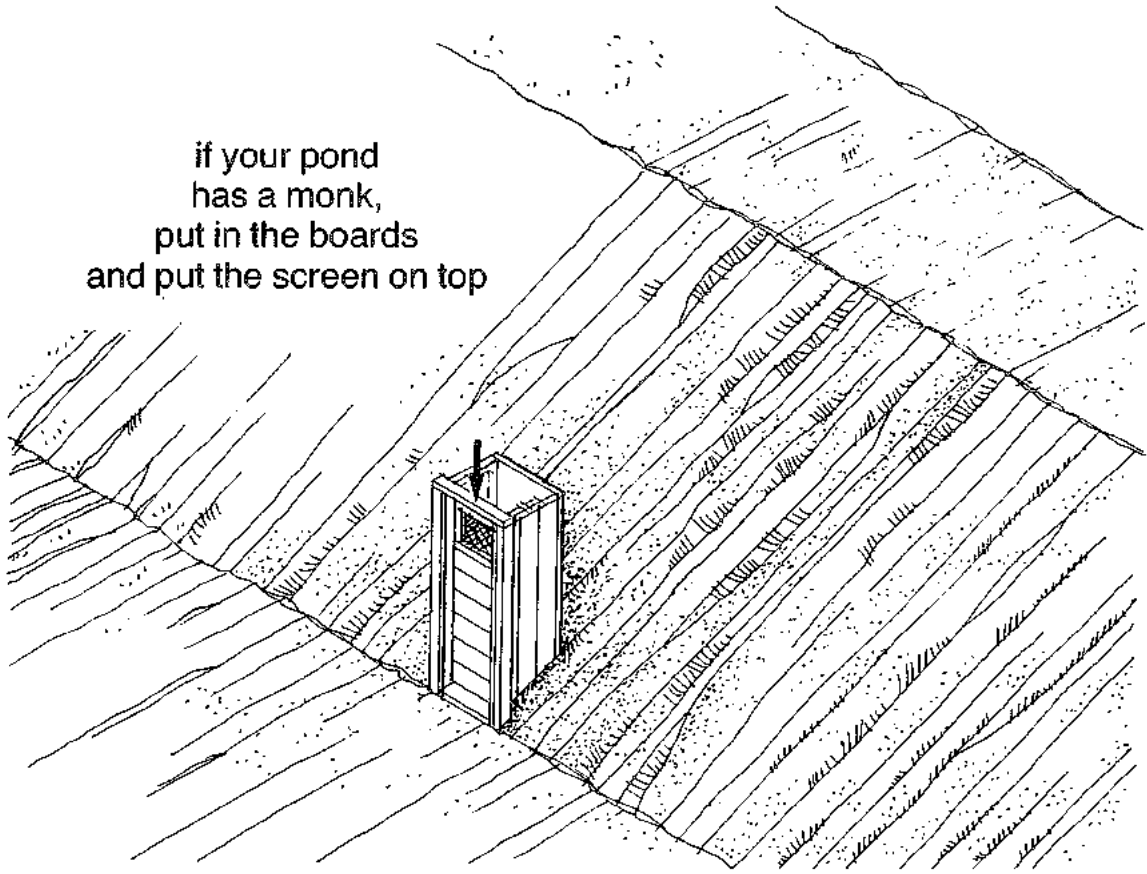

- put the wooden boards in the sluice  
at the corner of the inlet ditch  
to the first pond

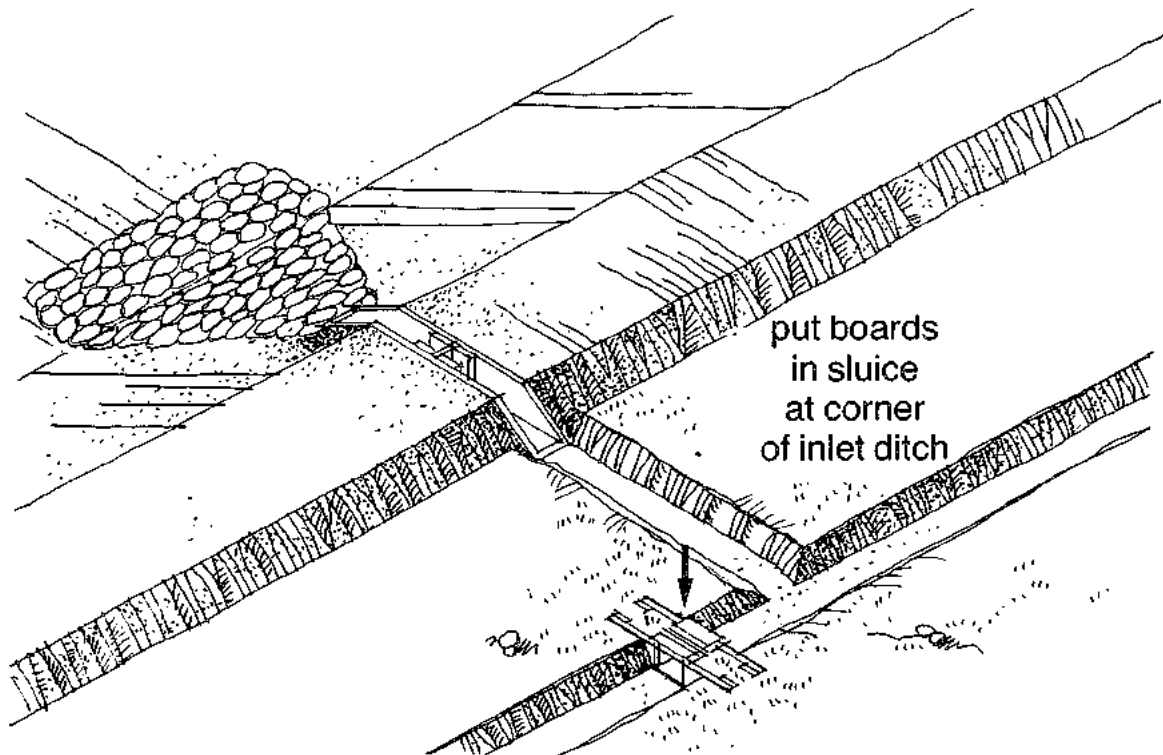

- take out the wooden boards of the inlet sluice to the first pond and put in the screen

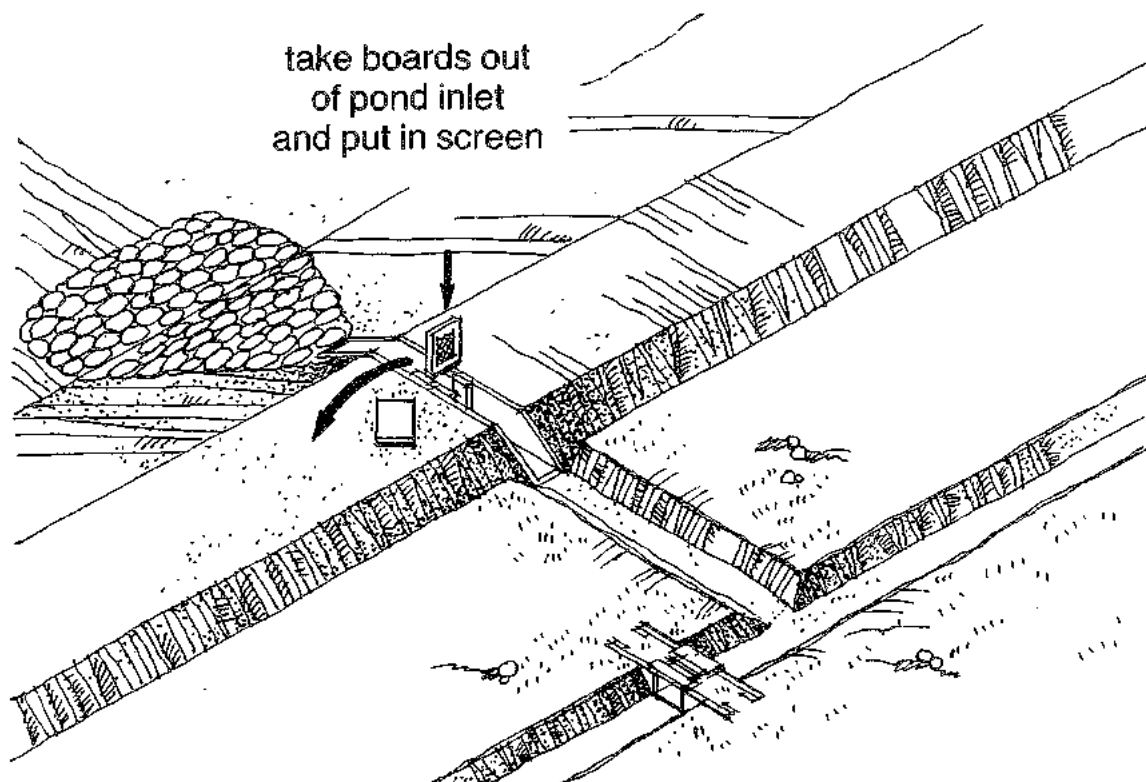

- put the screen in the sluice at the top of the supply ditch and take out the wooden boards one at a time until water begins to flow down the ditch and into the first pond.

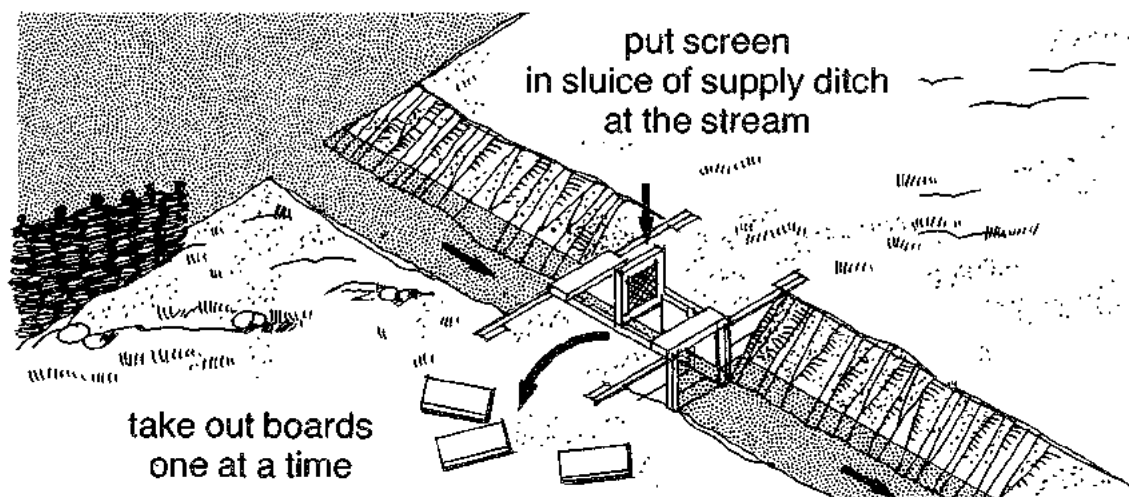

76. If you are going to fill another pond you should prepare it now, while the first pond is being filled.
77. To prepare the next pond, do the following
- make sure the outlet of the next pond you want to fill is closed
  - put the board in the sluice at the corner of the inlet ditch
  - take the boards out of the inlet sluice and put in the screen.
78. **Watch your first pond carefully.** When it is full of water **put back** the boards in the inlet sluice and **take out** the boards in the sluice at the corner of the inlet ditch (see Item 75 in this booklet).
79. The water will now flow further down the supply ditch and begin to fill the next pond.
80. **Continue to do this until all of the ponds are full.**
81. When your ponds are full of water, put a few of the wooden boards back in the sluice at the top of your supply ditch. **However, make sure that some water is always running into each of your ponds so that they will always be full.**

## ***Ponds are filled one by one***

### ● **The first pond**

- 1 close outlet
- 2 close sluice at corner of inlet ditch
- 3 open inlet sluice
- 4 open sluice at stream one board at a time

### ● **The first pond will begin to fill**

### ● **Prepare the second pond**

- 5 close outlet
- 6 close sluice at corner of inlet ditch
- 7 open inlet sluice

### ● **When the first pond is full close the inlet sluice (3) and open the sluice at corner of inlet ditch (2)**

### ● **The second pond will begin to fill**

### ● **Continue to do this until all ponds are full**

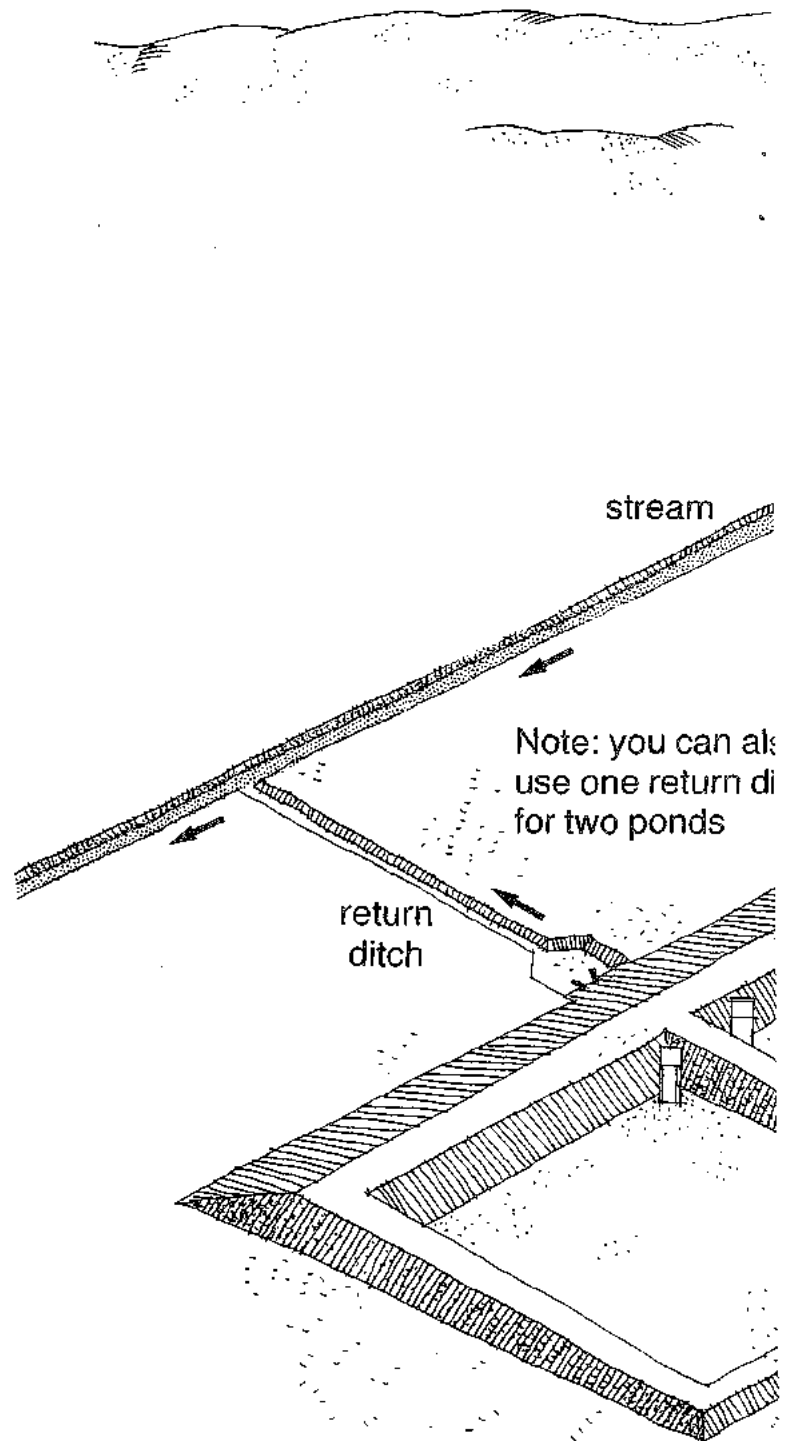

### **Note:**

**Make sure that some water is always running down the supply ditch and into each of your ponds so that they will always be full.**

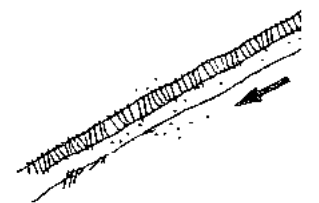

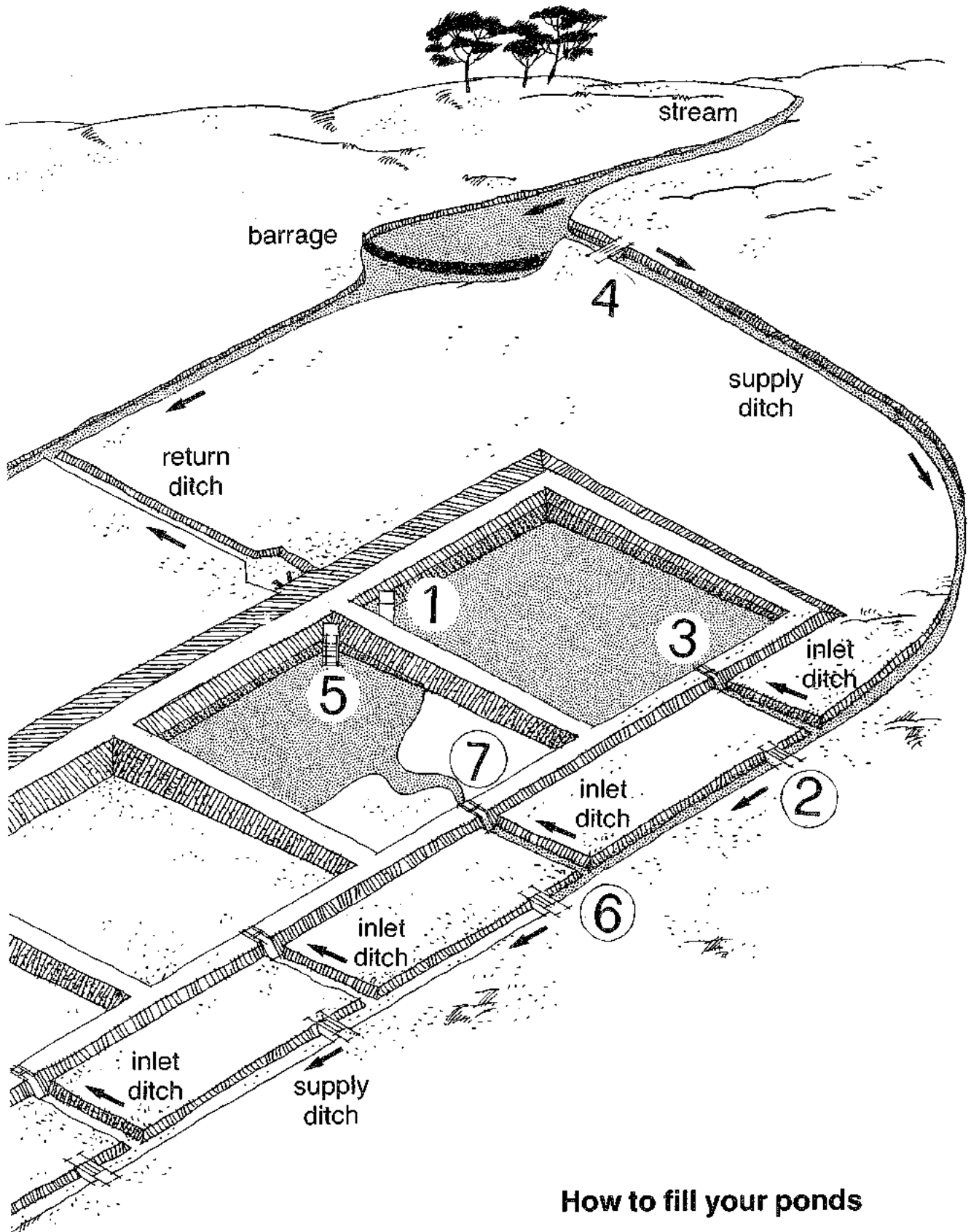

**How to fill your ponds**

## BETTER FERTILIZING

---

82. To grow the natural foods that your fish need, you can fertilize your bigger ponds just as you did your smaller ponds. You can fertilize them with
- compost made with animal manure
  - compost made with plant material
  - animal manure
  - plant material
83. However, with bigger ponds you will have to be especially careful to fertilize them very well.
84. In Items 15 to 31 in Booklet No. 30, you learned some things that you need to know to fertilize a pond. Here are some other things that you should know.
85. With your old smaller ponds, you built a crib in one corner in the shallow part of the pond to hold the fertilizer just like the one shown below.

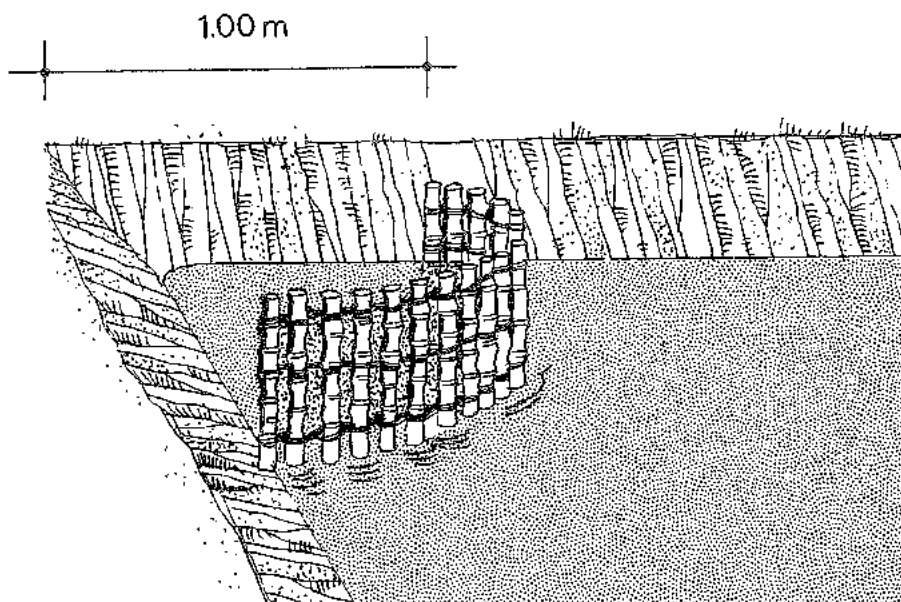



86. If you build a new pond that is bigger than 500 square metres, you should build two cribs in the corners of the shallow part of the pond. The drawings below show you where to put them.

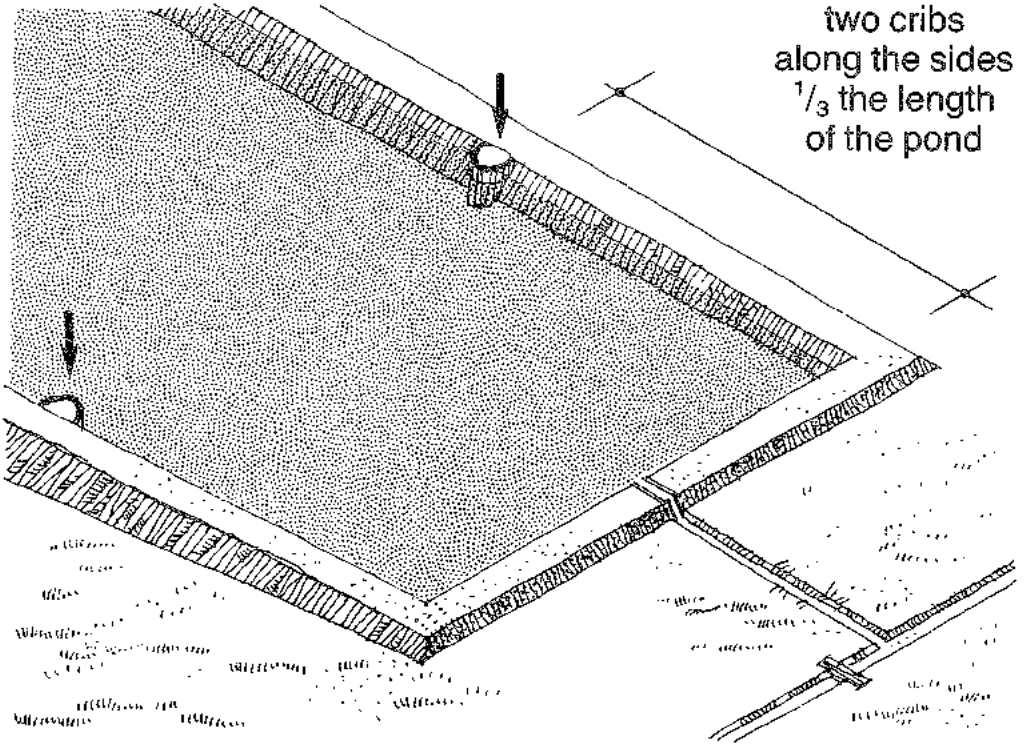
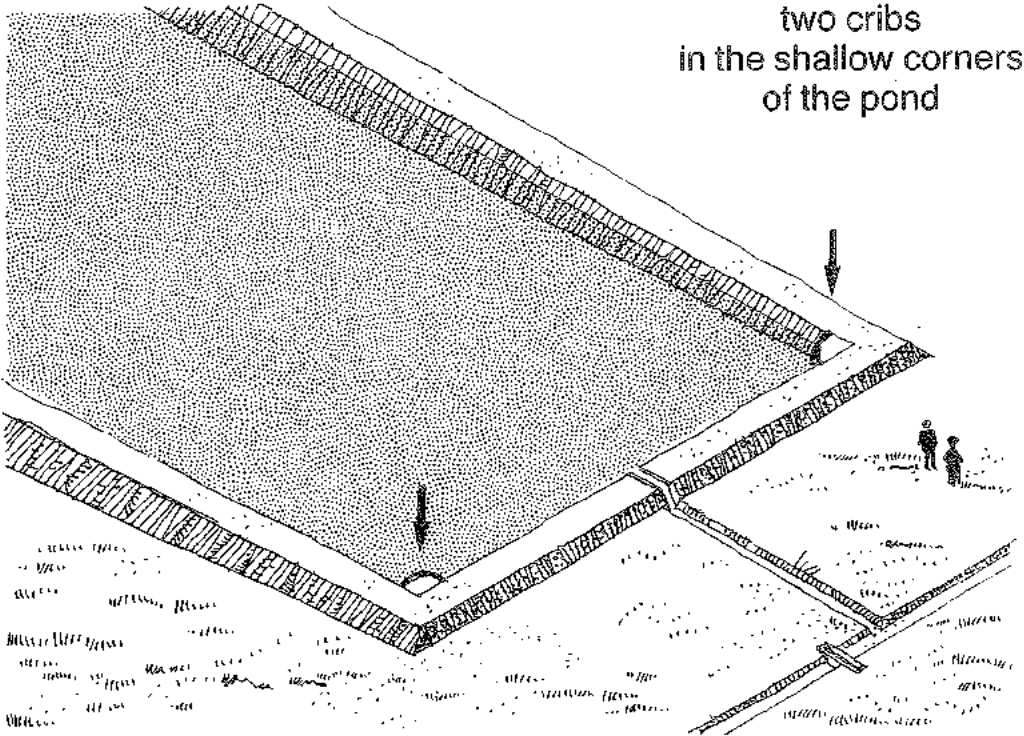

87. If you are going to fertilize your new bigger ponds with compost, you will need to put in

- 10 kilograms of compost for each 100 square metres of pond each week.

88. If you are going to fertilize your new bigger ponds with animal manure, you will need to put in

- 2 to 3 kilograms of poultry droppings for each 100 square metres of pond each week

2 to 3 kg

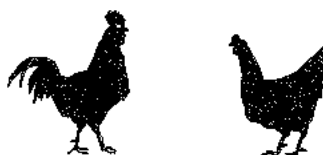

*or*

- 8 to 10 kilograms of pig dung for each 100 square metres of pond each week

8 to 10 kg



*or*

- 10 to 15 kilograms of cow dung for each 100 square metres of pond each week.

10 to 15 kg



89. If you are going to fertilize your new bigger ponds with animal manure but you do not have enough of any one kind of animal manure, you can make a mixture of several kinds.
90. You can make a mixture using 1 part of poultry droppings, 2 parts of pig dung and 3 parts of cow dung.

1 part



+

2 parts



+

3 parts



You will need to put in

- 10 kilograms of this mixture for each 100 square metres of pond each week.
91. When the water is green, you will know that there is enough natural food in the water for your fish.
92. In Booklet No. 30, you learned that when you have fertilized a pond it will take about a week for the water to turn green.

93. To make sure that the water in your pond is green enough, you should test it each week. To do this, put your arm in the water up to the elbow.

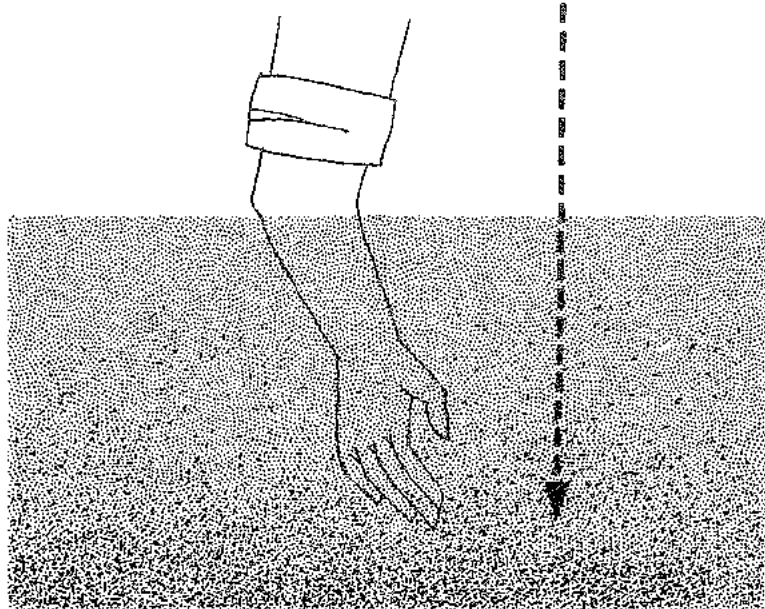

94. If you are just able to see the ends of your fingers, the water is green enough. If you are able to see the ends of your fingers well, you will know that the water is not green enough.
95. If the water is not green enough, add more fertilizer each week and test the water from time to time until you see that it is green enough.

### **Note**

Remember,  
you must still feed your fish  
the other kinds of food that they need  
to grow strong and healthy.  
Items 91 to 104 in Booklet No. 30  
tell you what to feed them  
and how to feed them.

# THE FISH

## Growing fish all year round

96. Now that you have several fish-ponds, you can grow fish all year round.
97. If you put baby fish in different ponds at different times, you will harvest them at different times. This way, you will not harvest too many fish at the same time and you can harvest fish all year round.

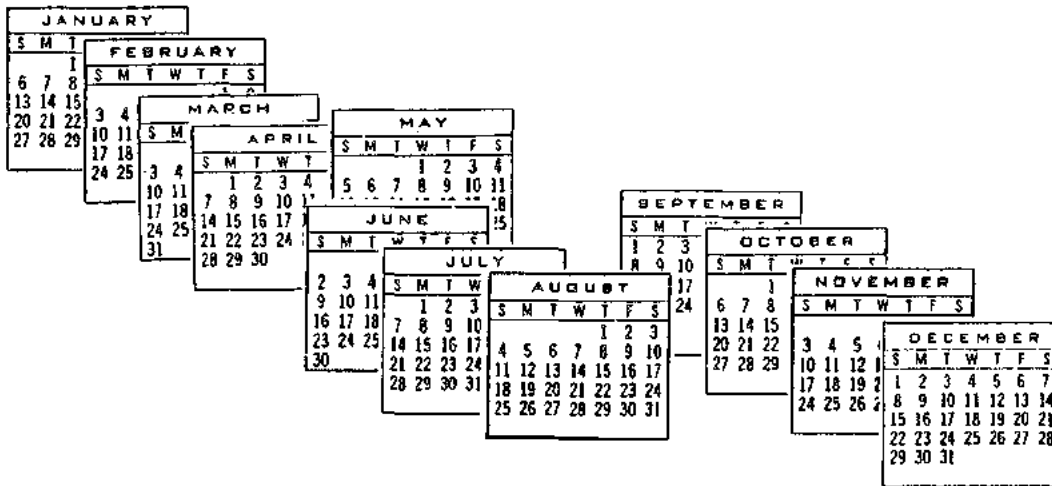

98. If you have three ponds and a good supply of baby fish, you can stock each pond in a different month of the year and harvest each pond six months later. The diagram on the next page will show you how to harvest and stock three ponds.
99. If you need help, your extension agent or fishery officer will be able to give you good advice on when to put in the baby fish and when to harvest them.

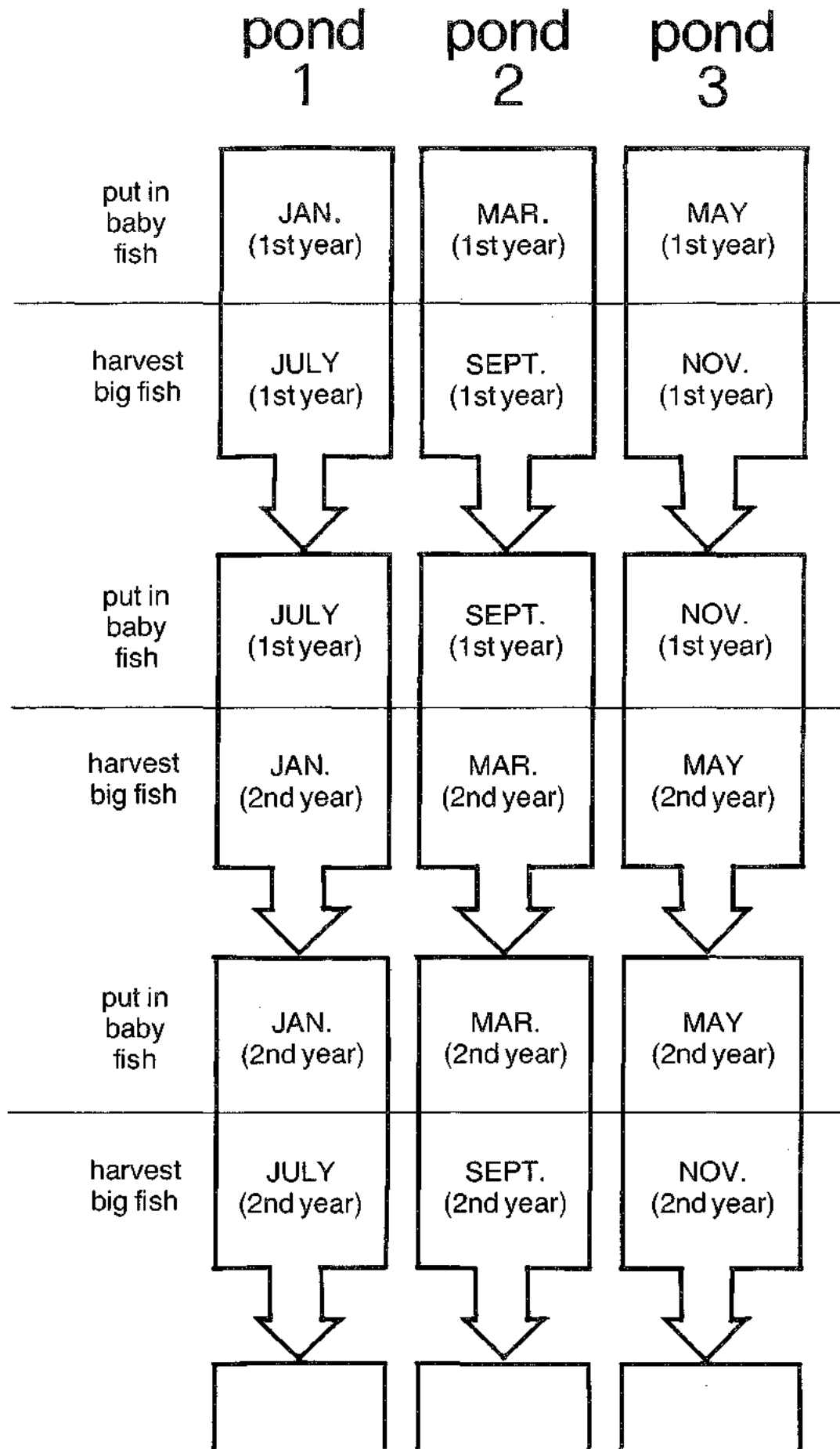

## Growing only male fish

100. You can further improve your fish-farming by growing only male tilapia in your ponds. Male tilapia grow bigger faster because without baby fish to feed, all the food that you put into your ponds will be eaten by the male fish.
101. If you decide to grow male fish, use fish that are at least 10 centimetres long so that you can harvest them sooner. A male fish of this length will be fully grown in three to four months.
102. If you have a nursery pond, you can get male fish from it. The drawing below shows you the difference between male and female tilapia.

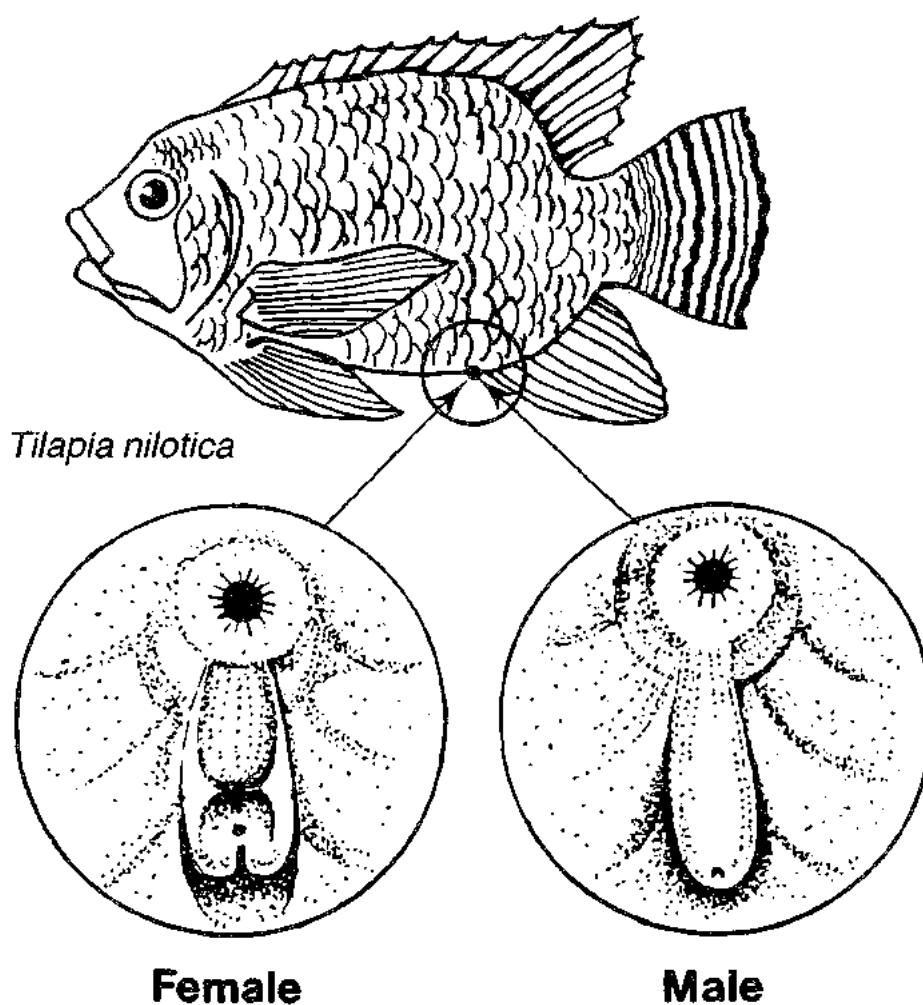

103. If you do not have a nursery pond, you may be able to buy male fish from another fish farmer or from a fish culture station.

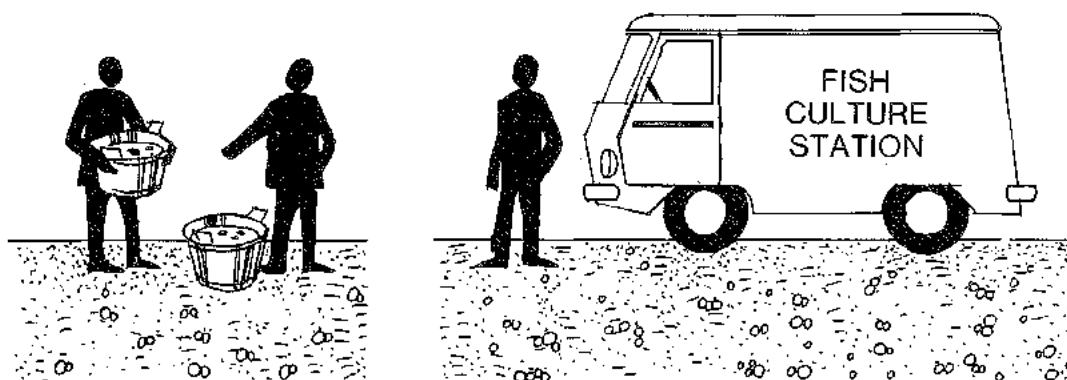

### **Harvesting your fish**

104. Items 91 to 98 in Booklet No. 27 and Items 114 to 144 in Booklet No. 30 tell you how to harvest your fish and what to do with them after they have been harvested.
105. Here are some other things that you should know about harvesting to improve your fish-farming further.

### **Harvesting many fish**

106. With bigger ponds and more ponds, you will harvest many more fish. You must be sure, however, that you will be able to use, sell or preserve all of the fish that you harvest.
107. If you will have too many fish to use, sell or preserve by harvesting all of them at the same time, harvest them at different times. You can harvest a few of your fish at two or three different times.



108. You can do this by draining part of the water from your pond and collecting only some of the fish on the first day you harvest. When you have used, sold or preserved these fish, you can harvest more of them.

drain all of the water  
and collect part of the fish



109. When you are ready to harvest the last of the fish, drain all of the water from the pond and harvest the remaining fish. **First**, collect the baby fish for your nursery pond and **then** collect the big fish.

drain all of the water  
and collect the remaining fish

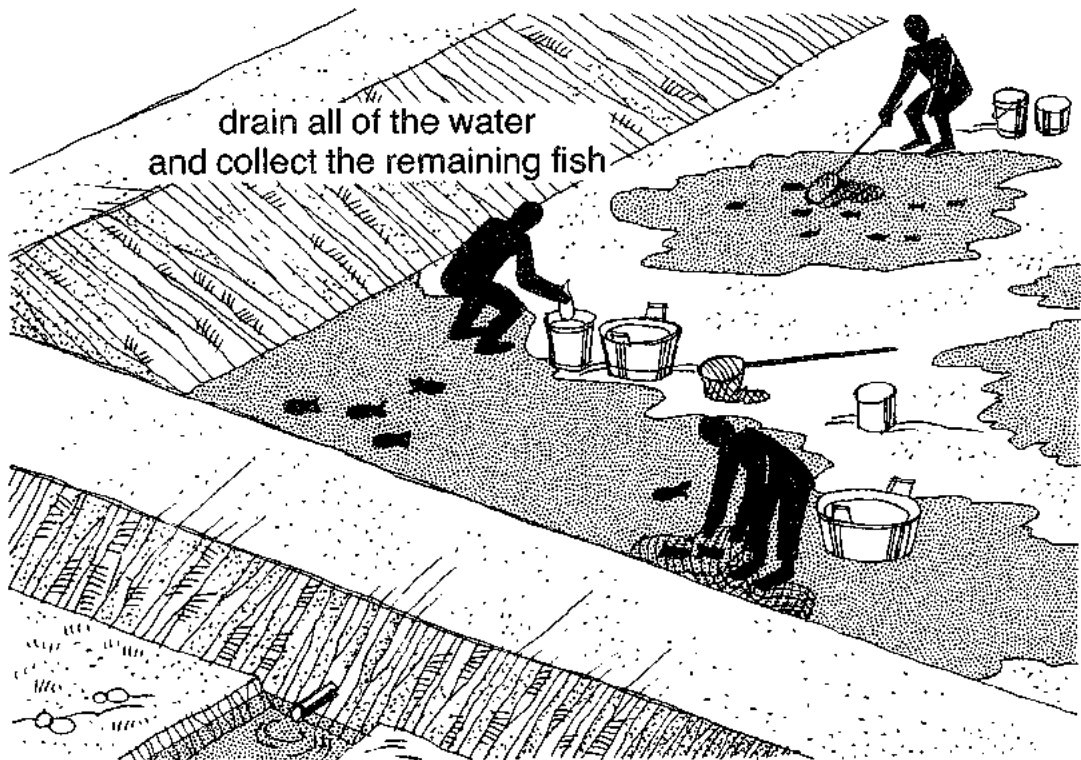

## Harvesting fish when you have a monk

110. If you have built a monk for the outlet of any of your ponds (see pages 18 to 23 in this booklet), you can harvest your fish in two ways:
- you can harvest inside your pond just in front of the monk
  - you can harvest outside your pond after the fish have passed through the monk.

### Harvesting inside the pond

111. To harvest your fish inside the pond, remove the wooden boards from the monk one row at a time. Each time you remove a row of boards from the monk, be sure to put the screen back on top to keep your fish from getting out.
112. When the water is partly drained from your pond, harvest part of the fish from the water just in front of the monk.
113. When you are ready to harvest the rest of your fish, continue to take out the boards **one by one**. However, put back the screen each time until the pond is empty. When all of the water is out, you can harvest the remaining fish. **First** collect the baby fish and **then** collect the big fish.

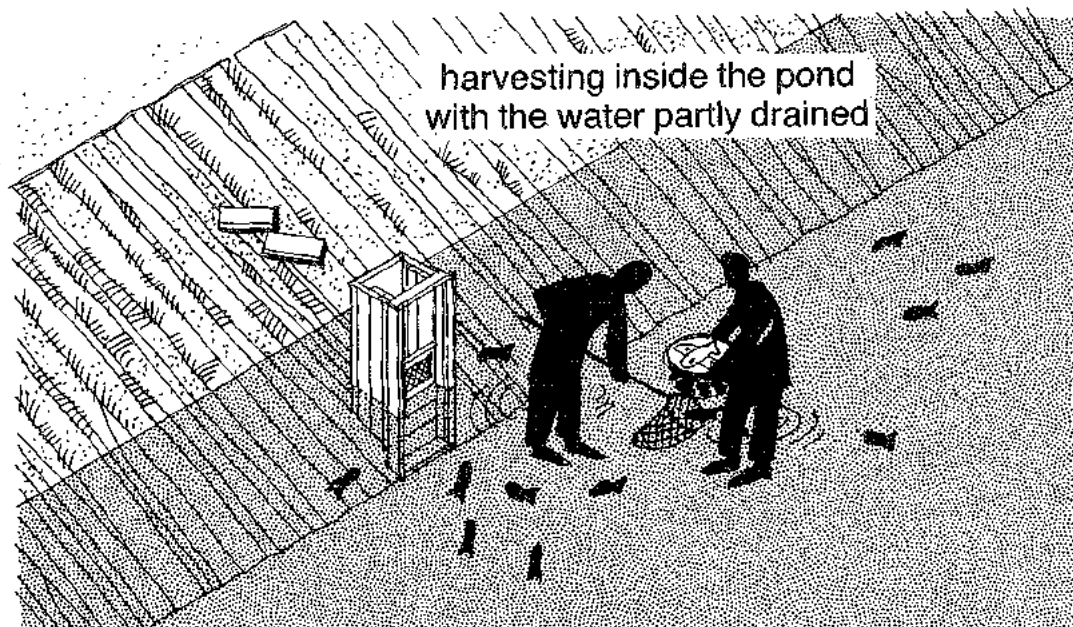

### Note

Muddy water is bad for baby fish.  
If you must walk in the water  
to collect the baby fish,  
let a little clean water flow through the pond  
to keep it from getting too muddy.

## Harvesting outside the pond

114. When you have a monk it is sometimes easier to harvest outside the pond using a screened wooden box to collect the fish, **after** they have passed through the monk.
115. The drawings below show you how to build a harvesting box, using strips of wood and screen, and how big it should be.

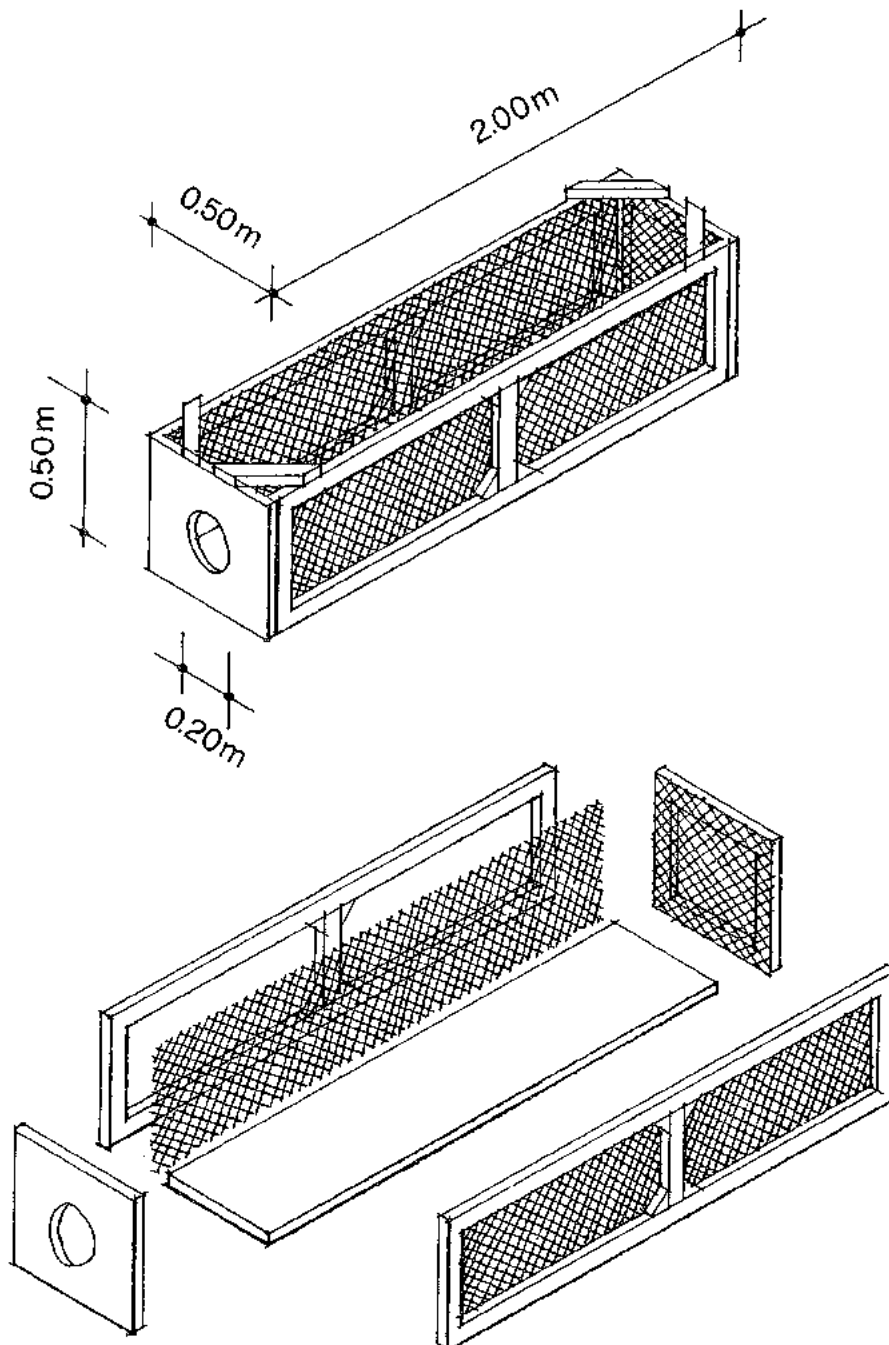

116. When you are ready to harvest your fish, put the harvesting box in the outlet ditch outside your pond at the end of the pipe from the monk. Make sure that the pipe is well inside the harvesting box so that the fish will not get out.

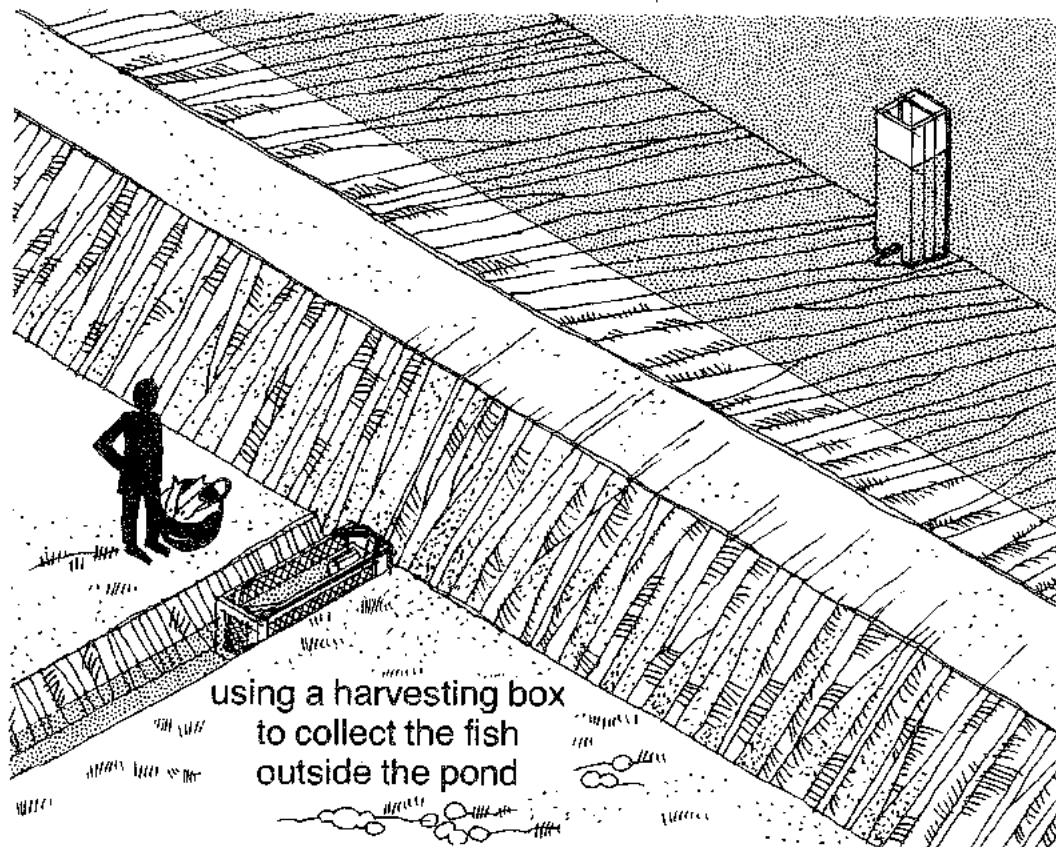

117. Now, take the screen out of your monk and remove the wooden boards one row at a time. The water will begin to flow out of your pond.
118. Do not put back the screen. When the level of the water in your pond is low enough, the fish will begin to pass over the boards and through the monk to the harvesting box. When they are in the box, you can collect them easily.

## YOUR FARM AND YOUR FISH-PONDS

---

119. Today, many farmers have learned that they can manage their fish-ponds together with their farm animals, gardens and fields so that they will all grow better and produce more.
120. Fish, animals and plants live and grow in different ways and produce different things that can help all of them to live and grow better.
121. You have already learned how to put animal manure into your ponds so that the water will be rich in the natural foods that your fish need to eat. In this way, the animals help the fish to live and grow better.
122. Here are some other ways to manage your farm animals, gardens and fields so that they will help each other to grow better and produce more.
123. You can raise ducks in your fish-ponds so that much of their manure will go into the water. This will help your fish to grow. At the same time, the ducks will feed on the plants that grow in your ponds and help to keep your ponds free of plants, weeds and snails.

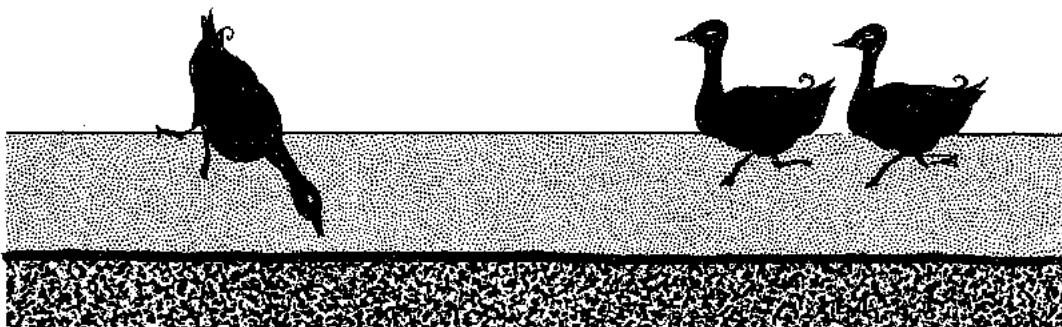

124. You can raise chickens or pigs near your ponds. If you build chicken coops or pig pens on the banks or over the ponds, you can sweep the manure into the ponds. Your ponds will supply water for the animals and the animals will supply fertilizer to help keep the water in your ponds rich.

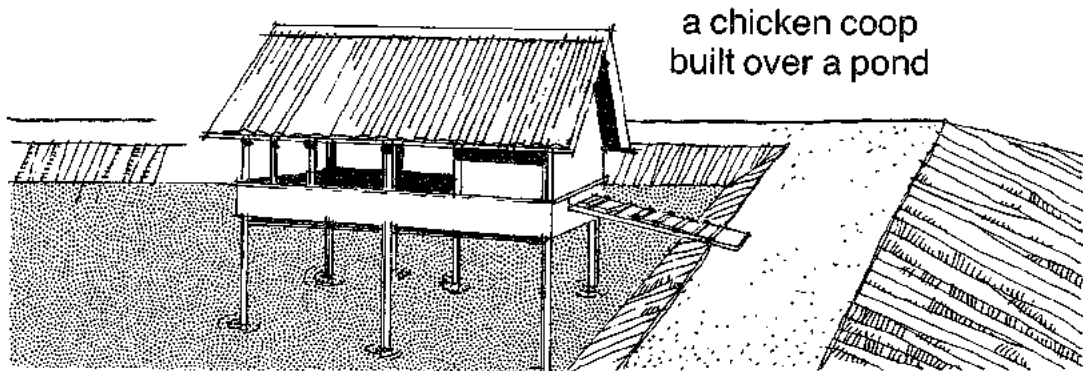

### Note

If you have built your ponds side by side, you can build a chicken coop or a pig pen on top of the bank between two ponds and sweep the manure into both ponds.

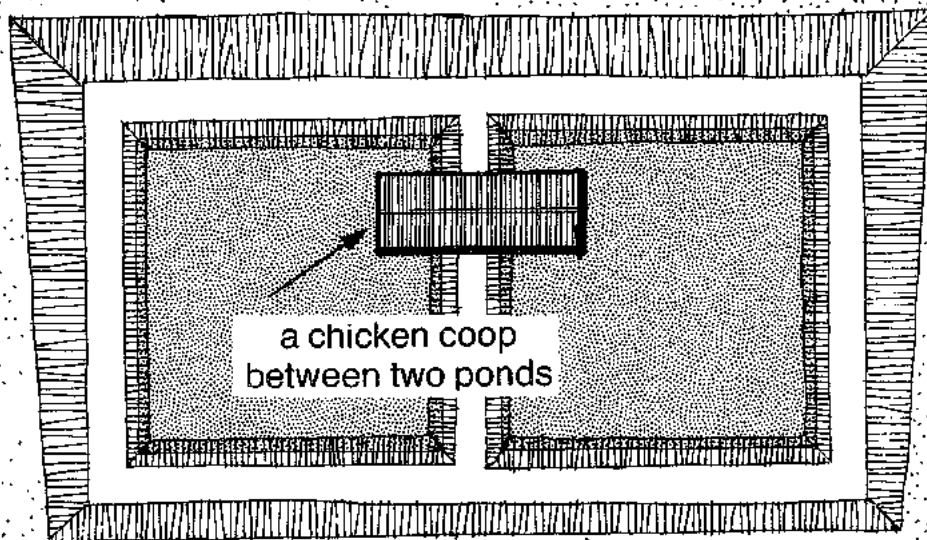

125. Begin with **either** four to five ducks, five to eight chickens **or** one to two pigs for each 100 square metres of pond. Later you may be able to keep even more.

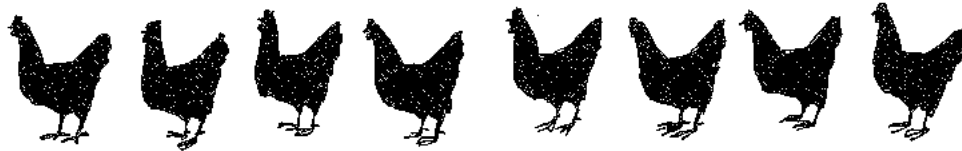

126. You can plant vegetables on the banks of your ponds. You can plant such things as tomatoes, beans, soybeans, groundnuts or maize.
127. You can also have a garden nearby. This way, you can use the water from your ponds to water your vegetables.
128. When you drain the water from your ponds to harvest the fish, you will find a layer of soft mud on the bottom. This soft mud is a very good fertilizer to put on your garden or fields, or on your pond banks if you are growing vegetables there.
129. Spoiled vegetables or vegetable wastes such as plant leaves and stalks can be fed to your chickens, ducks or pigs, or they can be put into your ponds for your fish to eat or to help keep the water green and rich.



- 1 fish for your family
- 2 vegetables for your family
- 3 meat for your family
- 4 waste food for your animals
- 5 spoiled or waste vegetables for your animals
- 6 animal manure for your ponds
- 7 water for your garden
- 8 fertilizer for your garden
- 9 water for your animals

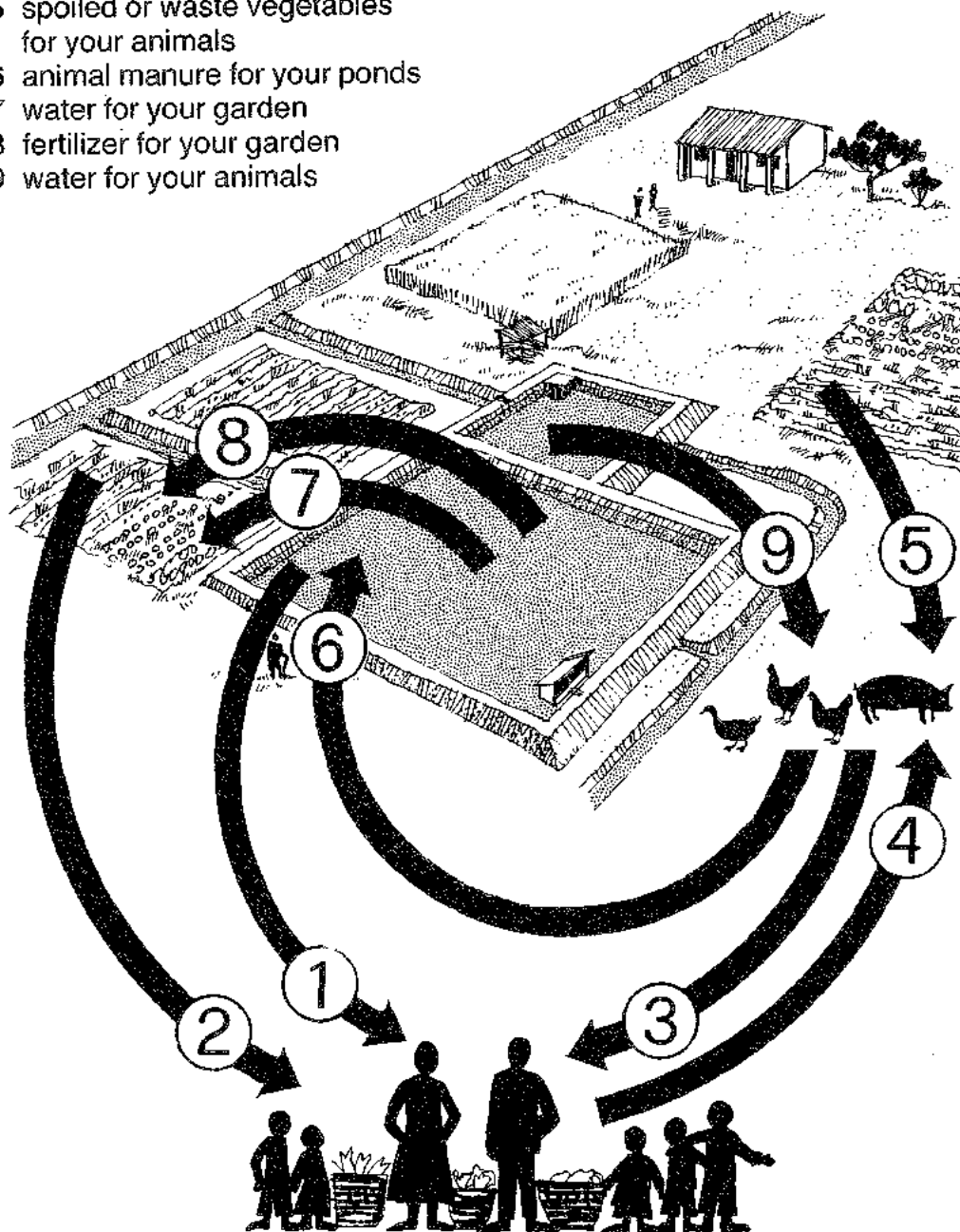

130. So, you can see that with very little extra work you can manage your fish, ducks, chickens, pigs, farm fields and garden in such a way that they will help each other to produce more.

131. If you want to know more about how to manage your farm and your fish-ponds together, your extension agent or fishery officer will be able to give you good advice.

# YOUR FISH-PONDS AND YOUR HEALTH

---

132. The following  
are some very important things  
that you should know  
to keep you and your family healthy.
133. A certain kind of **mosquito**  
and some kinds of **freshwater snails**  
carry diseases  
that can make you very sick.

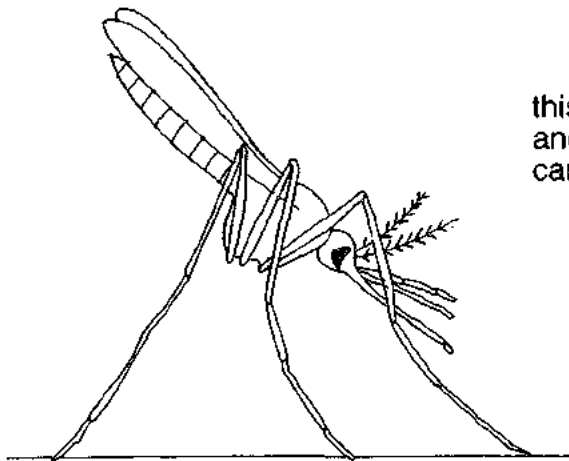

this mosquito  
and these snails  
carry diseases

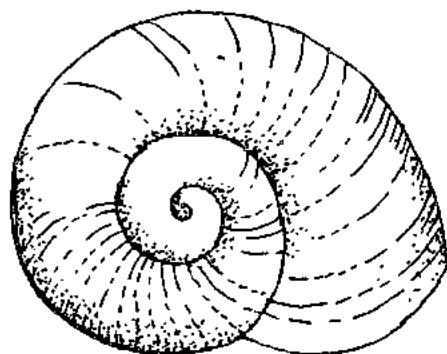
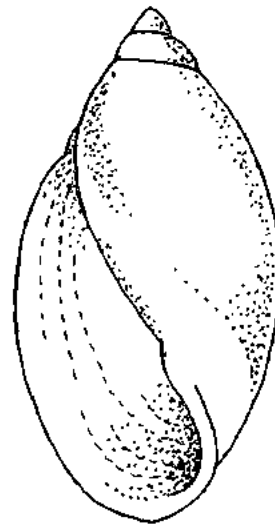

134. If the plants or weeds in your ponds  
or on the banks of your ponds  
become too thick,  
snails and mosquitoes  
can live and grow very easily.

135. So, from time to time, clean out the plants in your ponds and cut the weeds and grass on the banks. The weeds and grass on the banks should not hang into the water of any of your ponds.



136. **Never** use one of your ponds as a toilet, or you and your family may become sick.

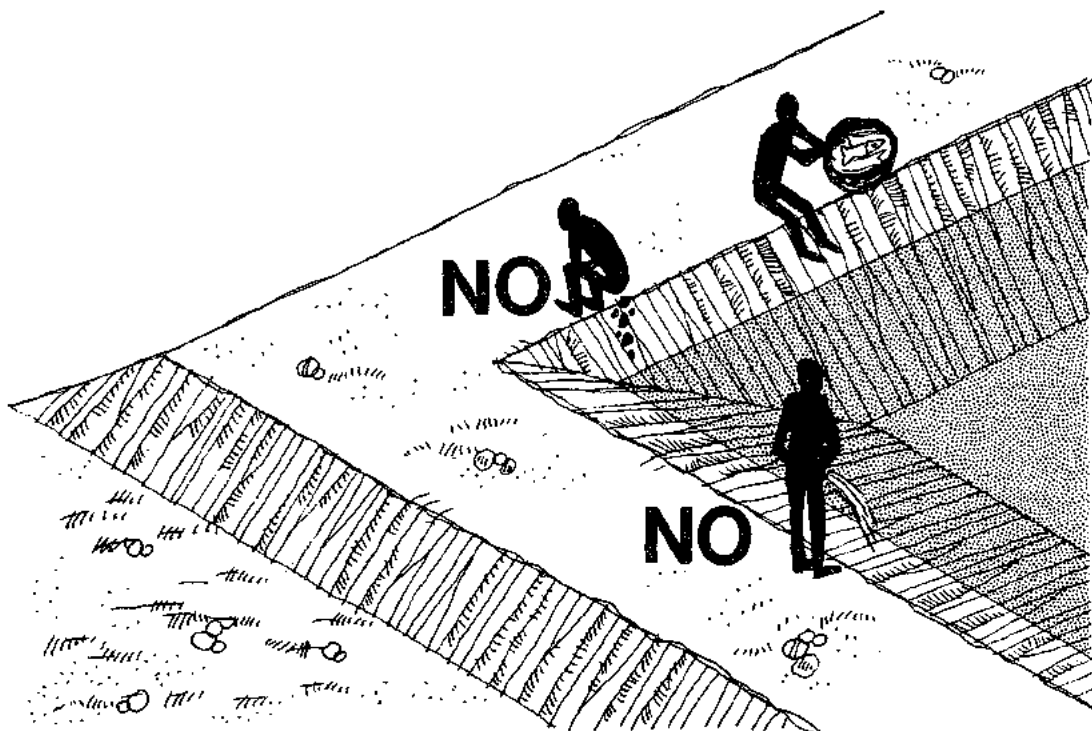

137. If you have a latrine, **use it**. However, a latrine should be at least 10 metres away from any of your ponds and from your water supply.

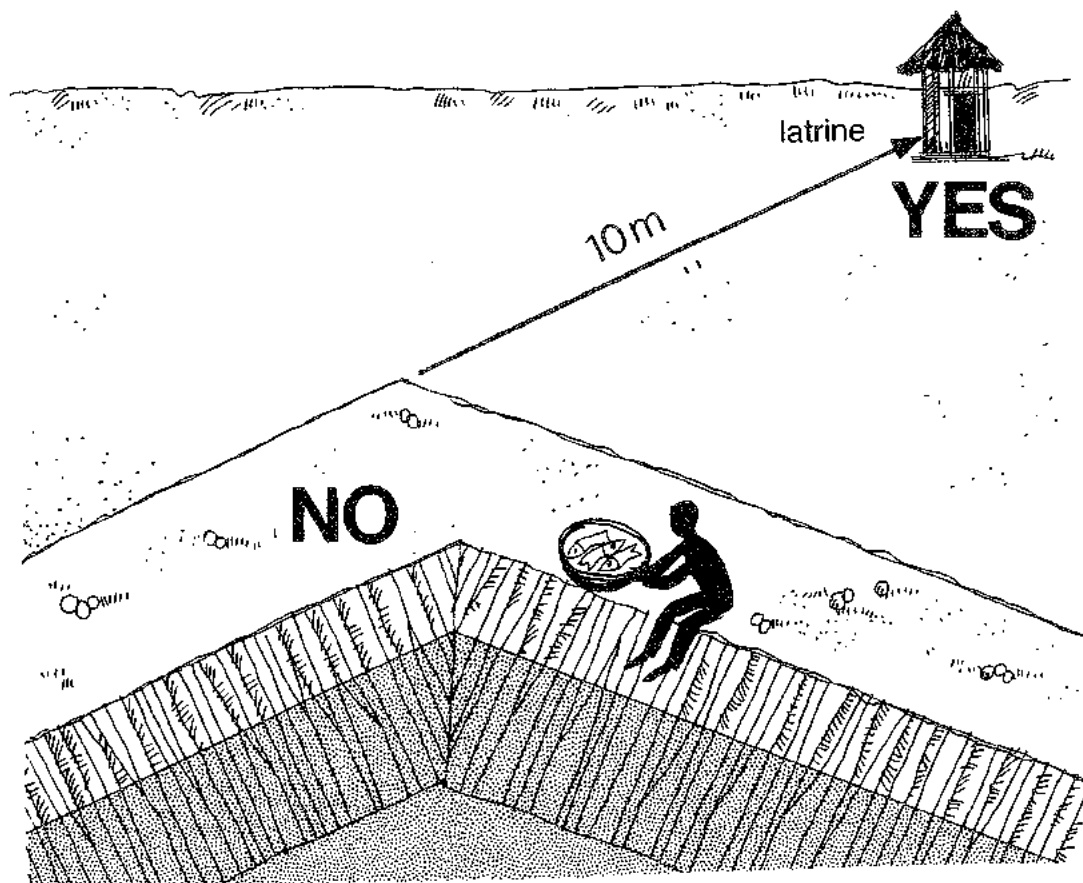

138. If you have to relieve yourself while you are working near your ponds, near the stream that supplies your water or near your supply or inlet ditches, first walk at least 10 metres away.

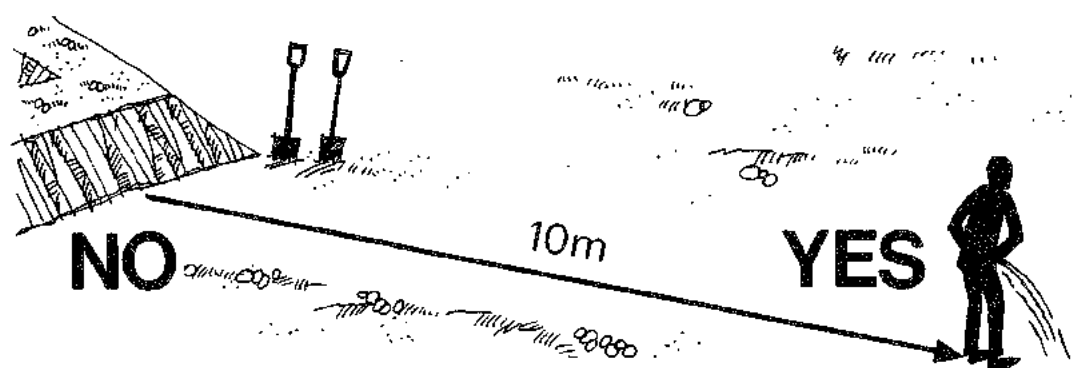

139. **Never** relieve yourself on or near your compost pile. Use your latrine, or relieve yourself at least 10 metres away.

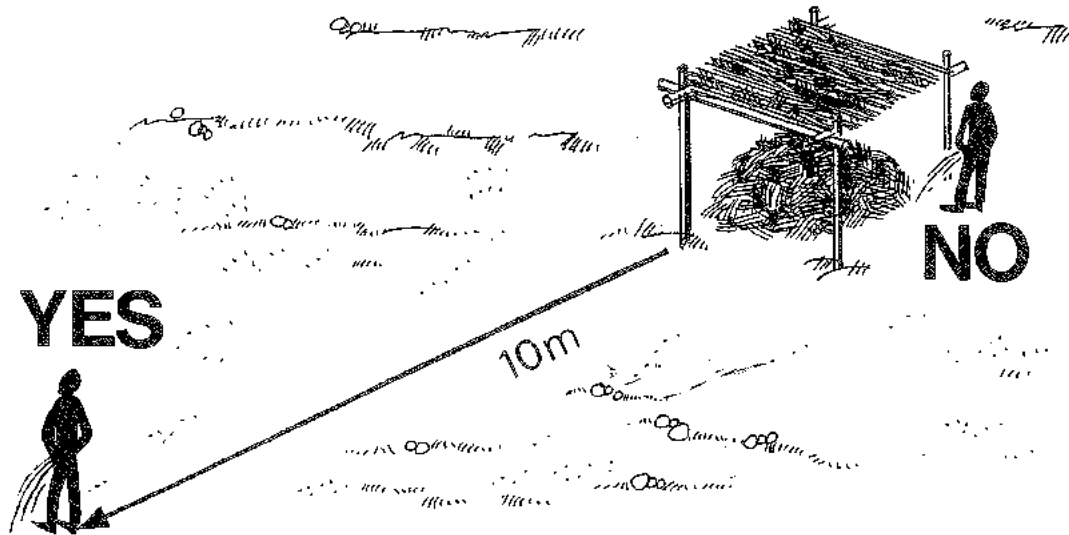

140. If you are careful about **all** of these things, it will help to keep you and your family from getting sick.



## WHERE TO PURCHASE FAO PUBLICATIONS LOCALLY

<b>Algeria</b>	Société nationale d'édition et de diffusion, 92, rue Didouche Mourad, Alger
<b>Argentina</b>	Librería Agropecuaria S.A., Pasteur 743, 1028 Buenos Aires.
<b>Australia</b>	Hunter Publications, 58A Gipps Street, Collingwood, Vic. 3066; Australian Government Publishing Service, Sales and Distribution Branch, Wentworth Ave, Kingston, A.C.T. 2604. Bookshops in Adelaide, Melbourne, Brisbane, Canberra, Perth, Hobart and Sydney.
<b>Austria</b>	Gerold & Co., Graben 31, 1011 Vienna.
<b>Bahrain</b>	United Schools International, PO Box 726, Manama.
<b>Bangladesh</b>	Association of Development Agencies in Bangladesh, House No. 46A, Road No. 6A, Dhanmondi R/A, Dhaka.
<b>Belgium</b>	M. J. De Lannoy, 202, avenue du Roi, 1060 Bruxelles. CCP 000-0808993-13.
<b>Bolivia</b>	Los Amigos del Libro, Perú 3712, Casilla 450, Cochabamba; Mercado 1315, La Paz.
<b>Botswana</b>	Botsalo Books (Pty) Ltd, PO Box 1532, Gaborone.
<b>Brazil</b>	Fundação Getúlio Vargas, Praia de Botafogo 190, C.P. 9052, Rio de Janeiro; Livraria Canuto Ltda, Rua Consolação, 348 - 2º andar, Caixa Postal 19198, São Paulo.
<b>Brunei Darussalam</b>	SST Trading Sdn. Bhd., Bangunan Tekno No. 365, Jln 5/59, PO Box 227, Petaling Jaya, Selangor.
<b>Canada</b>	Renouf Publishing Company Ltd, 61 Sparks Street, PO Box 1008, Station B, Ottawa, Ont. K1P 5R1; Tel.: (613) 238 8985. Toll-free calls in Canada: 1-800-267-4164; Telex: 053-4936.
<b>Chile</b>	Librería - Oficina Regional FAO, Avda. Santa María 6700, Casilla 10095, Santiago. Teléfono: 228-80-56.
<b>China</b>	China National Publications Import Corporation, PO Box 88, Beijing.
<b>Congo</b>	Office national des librairies populaires, B.P. 577, Brazzaville.
<b>Costa Rica</b>	Librería, Imprenta y Litografía Lehmann S.A., Apartado 10011, San José.
<b>Cuba</b>	Ediciones Cubanas, Empresa de Comercio Exterior de Publicaciones, Obispo 461, Apartado 605, La Habana.
<b>Cyprus</b>	MAM, PO Box 1722, Nicosia.
<b>Czechoslovakia</b>	ARTIA, Ve Smeckach 30, PO Box 790, 111 27 Prague 1.
<b>Denmark</b>	Munksgaard Export and Subscription Service, 35 Nørre Søgade, DK 1370 Copenhagen K.
<b>Dominican Rep.</b>	Fundación Dominicana de Desarrollo, Casa de las Gargolas, Mercedes 4, Apartado 857, Zona Postal 1, Santo Domingo.
<b>Ecuador</b>	Su Librería Cia. Ltda., García Moreno 1172 y Mejía, Apartado 2556, Quito.
<b>El Salvador</b>	Librería Cultural Salvadoreña, S.A. de C.V., 7ª Avenida Norte 121, Apartado Postal 2296, San Salvador.
<b>Finland</b>	Akateeminen Kirjakauppa, 1 Keskuskatu, PO Box 128, 00101 Helsinki 10.
<b>France</b>	Editions A. Pedone, 10, rue Soufflot, 75005 Paris.
<b>Germany, F.R.</b>	Alexander Horn Internationale Buchhandlung, Friederichstr. 39, Postfach 3340, 6200 Wiesbaden.
<b>Ghana</b>	Fides Enterprises, PO Box 14129, Accra; Ghana Publishing Corporation, PO Box 3632, Accra.
<b>Greece</b>	G.C. Eleftheroudakis S.A., 4 Nikis Street, Athens (T-126); John Mihalopoulos & Son S.A., 75 Hermou Street, PO Box 73, Thessaloniki.
<b>Guatemala</b>	Distribuciones Culturales y Técnicas «Artemis», 5ª Avenida 12-11, Zona 1, Apartado Postal 2923, Guatemala.
<b>Guinea-Bissau</b>	Conselho Nacional da Cultura, Avenida da Unidade Africana, C.P. 294, Bissau.
<b>Guyana</b>	Guyana National Trading Corporation Ltd, 45-47 Water Street, PO Box 308, Georgetown.
<b>Haiti</b>	Librairie "A la Caravelle", 26, rue Bonne Foi, B.P. 111, Port-au-Prince.
<b>Hong Kong</b>	Swindon Book Co., 13-15 Lock Road, Kowloon.
<b>Hungary</b>	Kultura, PO Box 149, 1389 Budapest 62.
<b>Iceland</b>	Snaebjörn Jónsson and Co. h.f., Hafnarstræti 9, PO Box 1131, 101 Reykjavik.
<b>India</b>	Oxford Book and Stationery Co., Scindia House, New Delhi 100 001; 17 Park Street, Calcutta 700 016; Oxford Subscription Agency, Institute for Development Education, 1 Anasuya Ave, Kilpauk, Madras 600 010.
<b>Indonesia</b>	P.T. Inti Buku Agung, 13 Kwitang, Jakarta.
<b>Iraq</b>	National House for Publishing, Distributing and Advertising, Jamhuriya Street, Baghdad.
<b>Ireland</b>	The Controller, Stationery Office, Dublin 4.
<b>Italy</b>	Distribution and Sales Section, FAO, Via delle Terme di Caracalla, 00100 Rome; Libreria Scientifica Dott. Lucio de Biasio "Aelou", Via Meravigli 16, 20123 Milan; Libreria Commissionaria Sansoni S.p.A. "Licosa", Via Lamarmora 45, C.P. 552, 50121 Florence.
<b>Japan</b>	Maruzen Company Ltd, PO Box 5050, Tokyo International 100-31.
<b>Kenya</b>	Text Book Centre Ltd, Kijabe Street, PO Box 47540, Nairobi.

## WHERE TO PURCHASE FAO PUBLICATIONS LOCALLY

<b>Korea, Rep. of</b>	Eulyoo Publishing Co. Ltd, 46-1 Susong-Dong, Jongro-Gu, PO Box 362, Kwangwha-Mun, Seoul 110.
<b>Kuwait</b>	The Kuwait Bookshops Co. Ltd, PO Box 2942, Safat.
<b>Luxembourg</b>	M. J. De Lannoy, 202, avenue du Roi, 1060 Bruxelles (Belgique).
<b>Malaysia</b>	SST Trading Sdn. Bhd., Bangunan Tekno No. 385, Jln 5/59, PO Box 227, Petaling Jaya, Selangor.
<b>Mauritius</b>	Nalanda Company Limited, 30 Bourbon Street, Port-Louis.
<b>Mexico</b>	Dilitsa S.A., Puebla 182-D, Apartado 24-448, México 06700, D.F.
<b>Morocco</b>	Librairie "Aux Belles Images", 281, avenue Mohammed V, Rabat.
<b>Netherlands</b>	Keesling Publishing Company B.V., Hogehilweg 13, 1101 CB Amsterdam; Post Box 1118, 1000 BC Amsterdam.
<b>New Zealand</b>	Government Printing Office, Government Printing Office Bookshops: 25 Rutland Street; Mail orders: 85 Beach Road, Private Bag, CPO, Auckland; Ward Street, Hamilton; Mulgrave Street (Head Office), Cubacade World Trade Centre, Wellington; 159 Hereford Street, Christchurch; Princes Street, Dunedin.
<b>Nicaragua</b>	Libreria Universitaria, Universidad Centroamericana, Apartado 69, Managua.
<b>Nigeria</b>	University Bookshop (Nigeria) Limited, University of Ibadan, Ibadan.
<b>Norway</b>	Johan Grundt Tanum Bokhandel, Karl Johansgate 41-43, PO Box 1177, Sentrum, Oslo 1.
<b>Pakistan</b>	Mirza Book Agency, 65 Shahrah-e-Quaid-e-Azam, PO Box 729, Lahore 3; Sasi Book Store, Zaibunnisa Street, Karachi.
<b>Panama</b>	Distribuidora Lewis S.A., Edificio Dorasol, Calle 25 y Avenida Balboa, Apartado 1634, Panamá 1.
<b>Paraguay</b>	Agencia de Librerías Nizza S.A., Casilla 2596, Eligio Ayala 1073, Asunción
<b>Peru</b>	Libreria Distribuidora «Santa Rosa», Jirón Apurímac 375, Casilla 4937, Lima 1.
<b>Philippines</b>	The Modern Book Company Inc., PO Box 632, Manila.
<b>Poland</b>	Ars Polona, Krakowskie Przedmiescie 7, 00-068 Warsaw.
<b>Portugal</b>	Livraria Bertrand, S.A.R.L., Rua João de Deus, Venda Nova, Apartado 37, 2701 Amadora Codex; Livraria Portugal, Dias y Andrade Ltda., Rua do Carmo 70-74, Apartado 2681, 1117 Lisbonne Codex.
<b>Romania</b>	Ilexim, Str. 13 Decembrie No. 3-5, Bucharest Sector 1.
<b>Saudi Arabia</b>	The Modern Commercial University Bookshop, PO Box 394, Riyadh.
<b>Singapore</b>	MPH Distributors (S) Pte. Ltd, 71/77 Stamford Road, Singapore 6; Select Books Pte. Ltd, 215 Tanglin Shopping Centre, 19 Tanglin Road, Singapore 1024; SST Trading Sdn. Bhd., Bangunan Tekno No. 385, Jln 5/59, PO Box 227, Petaling Jaya, Selangor.
<b>Somalia</b>	"Samater's", PO Box 936, Mogadishu.
<b>Spain</b>	Mundi-Prensa Libros S.A., Castelló 37, 28001 Madrid; Librería Agrícola, Fernando VI 2, 28004 Madrid.
<b>Sri Lanka</b>	M.D. Gunasena & Co. Ltd, 217 Olcott Mawatha, PO Box 245, Colombo 11.
<b>Sudan</b>	University Bookshop, University of Khartoum, PO Box 321, Khartoum.
<b>Suriname</b>	VACO n.v. in Suriname, Domineestraat 26, PO Box 1841, Paramaribo.
<b>Sweden</b>	Books and documents: C.E. Fritzes Kungl. Hovbokhandel, Regeringsgatan 12, PO Box 16356, 103 27 Stockholm. Subscriptions: Vennergren-Williams AB, PO Box 30004, 104 25 Stockholm.
<b>Switzerland</b>	Librairie Payot S.A., Lausanne and Geneva; Buchhandlung und Antiquariat Heinemann & Co., Kirchgasse 17, 8001 Zurich.
<b>Tanzania</b>	Dar-es-Salaam Bookshop, PO Box 9030, Dar-es-Salaam; Bookshop, University of Dar-es-Salaam, PO Box 893, Morogoro.
<b>Thailand</b>	Suksapan Panit, Mansion 9, Rajadamnern Avenue, Bangkok.
<b>Togo</b>	Librairie du Bon Pasteur, B.P. 1164, Lomé.
<b>Tunisia</b>	Société tunisienne de diffusion, 5, avenue de Carthage, Tunis.
<b>Turkey</b>	Kultur Yayinlari Is-Turk Ltd Sti., Ataturk Bulvari No. 191, Kat. 21, Ankara. Bookshops in Istanbul and Izmir.
<b>United Kingdom</b>	Her Majesty's Stationery Office, 49 High Holborn, London WC1V 6HB (callers only); HMSO Publications Centre, Agency Section, 51 Nine Elms Lane, London SW8 5DR (trade and London area mail orders); 13a Castle Street, Edinburgh EH2 3AR; 80 Chichester Street, Belfast BT1 4JY; Brazennose Street, Manchester M60 8AS; 258 Broad Street, Birmingham B1 2HE; Southey House, Wine Street, Bristol BS1 2BQ.
<b>United States of America</b>	UNIPUB, PO Box 1222, Ann Arbor, MI 48106.
<b>Uruguay</b>	Libreria Agropecuaria S.R.L., Alzaibar 1328, c.c. 1755, Montevideo.
<b>Yugoslavia</b>	Jugoslovenska Knjiga, Trg. Republike 5/8, PO Box 36, 11001 Belgrade; Cankarjeva Založba, PO Box 201-IV, 61001 Ljubljana.
<b>Zambia</b>	Kingstons (Zambia) Ltd, Kingstons Building, President Avenue, PO Box 139, Ndola.
<b>Other countries</b>	Requests from countries where sales agents have not yet been appointed may be sent to: Distribution and Sales Section, FAO, Via delle Terme di Caracalla, 00100 Rome, Italy.