

Welding

Intro to Welding

- A *weld* is made when separate pieces of material to be joined combine and form one piece when heated to a temperature high enough to cause softening or melting. Filler material is typically added to strengthen the joint.
- Welding is a dependable, efficient and economic method for **permanently** joining **similar** metals. In other words, **you can weld steel to steel or aluminum to aluminum, but you cannot weld steel to aluminum using traditional welding processes.**
- Welding is used extensively in all sectors of manufacturing, from earth moving equipment to the aerospace industry.

Welding Processes

- The number of different welding processes has grown in recent years. These processes differ greatly in the manner in which heat and pressure (when used) are applied, and in the type of equipment used. There are currently over 50 different types of welding processes; we'll focus on 3 examples of *electric arc welding*, which is the most common form of welding.
- The most popular processes are shielded metal arc welding (**SMAW**), gas metal arc welding (**GMAW**) and gas tungsten arc welding (**GTAW**).
- All of these methods employ an electric power supply to create an arc which melts the base metal(s) to form a molten pool. The filler wire is then either added automatically (GMAW) or manually (SMAW & GTAW) and the molten pool is allowed to cool.
- Finally, all of these methods use some type of flux or gas to create an inert environment in which the molten pool can solidify without oxidizing.

Shielded Metal Arc Welding (SMAW)

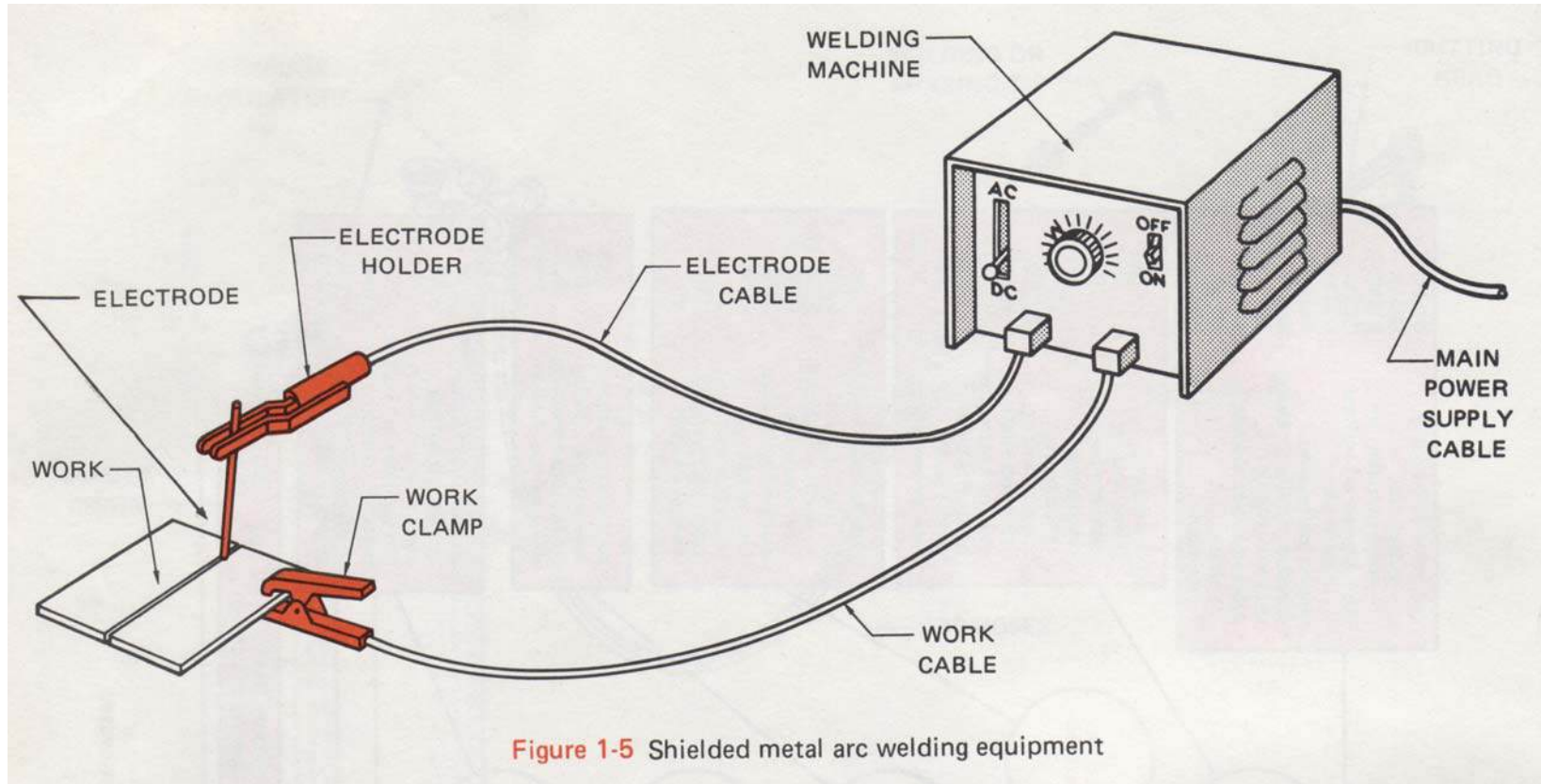

Shielded Metal Arc Welding (SMAW)

SMAW is a welding process that uses a flux covered metal electrode to carry an electrical current. The current forms an arc that jumps a gap from the end of the electrode to the work. The electric arc creates enough heat to melt both the electrode and the base material(s). Molten metal from the electrode travels across the arc to the molten pool of base metal where they mix together. As the arc moves away, the mixture of molten metals solidifies and becomes one piece. The molten pool of metal is surrounded and protected by a fume cloud and a covering of slag produced as the coating of the electrode burns or vaporizes. Due to the appearance of the electrodes, **SMAW is commonly known as 'stick' welding.**

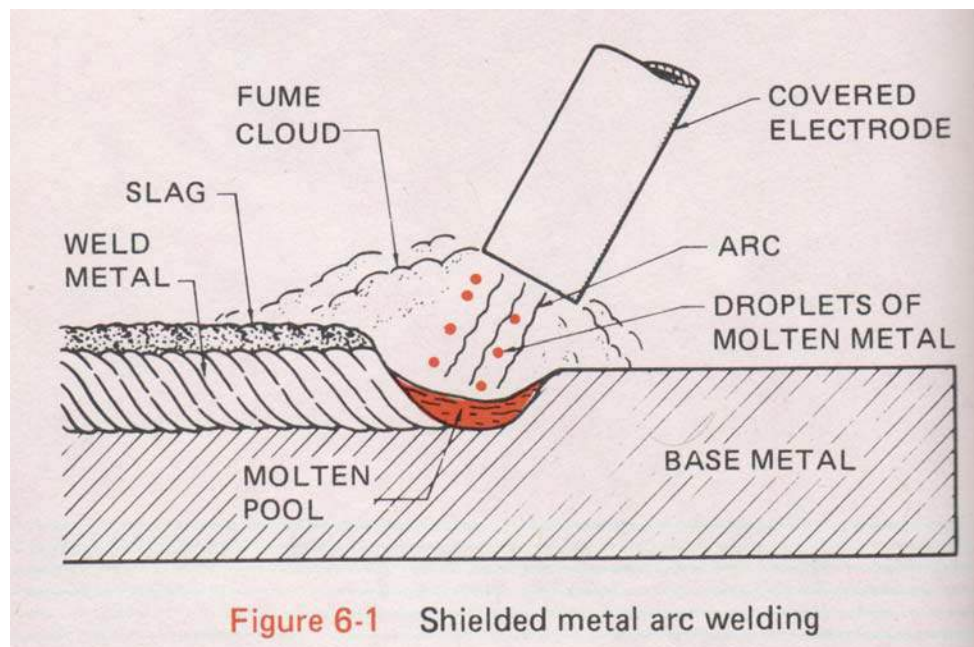

SMAW is one of the oldest and most popular methods of joining metal. Moderate quality welds can be made at low speed with good uniformity. SMAW is used primarily because of its low cost, flexibility, portability and versatility. Both the equipment and electrodes are low in cost and very simple. SMAW is very flexible in terms of the material thicknesses that can be welded (materials from 1/16" thick to several inches thick can be welded with the same machine and different settings). It is a very portable process because all that's required is a portable power supply (i.e. generator). Finally, it's quite versatile because it can weld many different types of metals, including cast iron, steel, nickel & aluminum.

Some of the biggest drawbacks to SMAW are (1) that it produces a lot of smoke & sparks, (2) there is a lot of post-weld cleanup needed if the welded areas are to look presentable, (3) it is a fairly slow welding process and (4) it requires a lot of operator skill to produce consistent quality welds.

Shielded Metal Arc Welding (SMAW) Photo

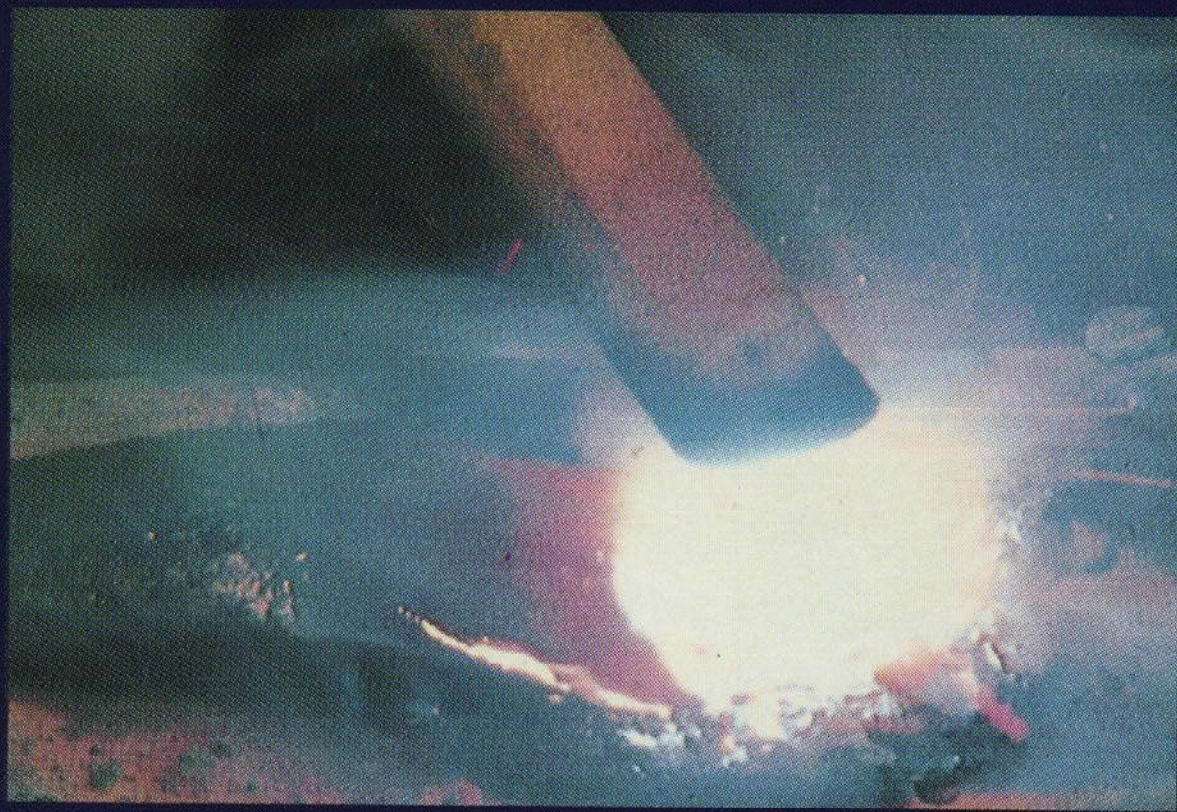

■ PLATE 18

E6012 electrode — the heavy slag can be seen solidifying on the weld bead.

Gas Metal Arc Welding (GMAW)

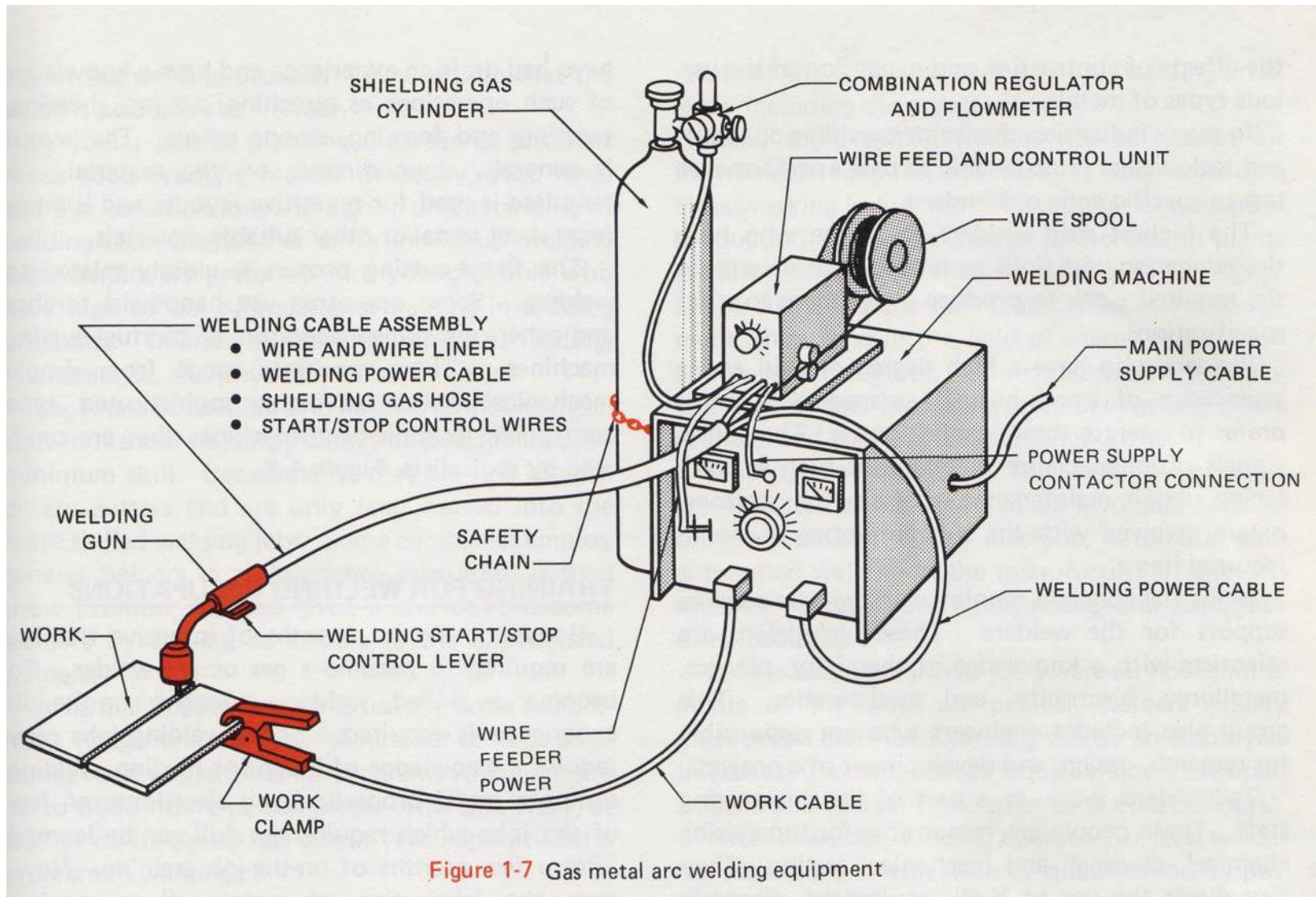

Gas Metal Arc Welding (GMAW)

In the GMAW process, an arc is established between a continuous wire electrode (which is always being consumed) and the base metal. Under the correct conditions, the wire is fed at a constant rate to the arc, matching the rate at which the arc melts it. The filler metal is the thin wire that's fed automatically into the pool where it melts. Since molten metal is sensitive to oxygen in the air, good shielding with oxygen-free gases is required. This shielding gas provides a stable, inert environment to protect the weld pool as it solidifies. Consequently, **GMAW is commonly known as MIG (*metal inert gas*) welding**. Since fluxes are not used (like SMAW), the welds produced are sound, free of contaminants, and as corrosion-resistant as the parent metal. The filler material is usually the same composition (or alloy) as the base metal.

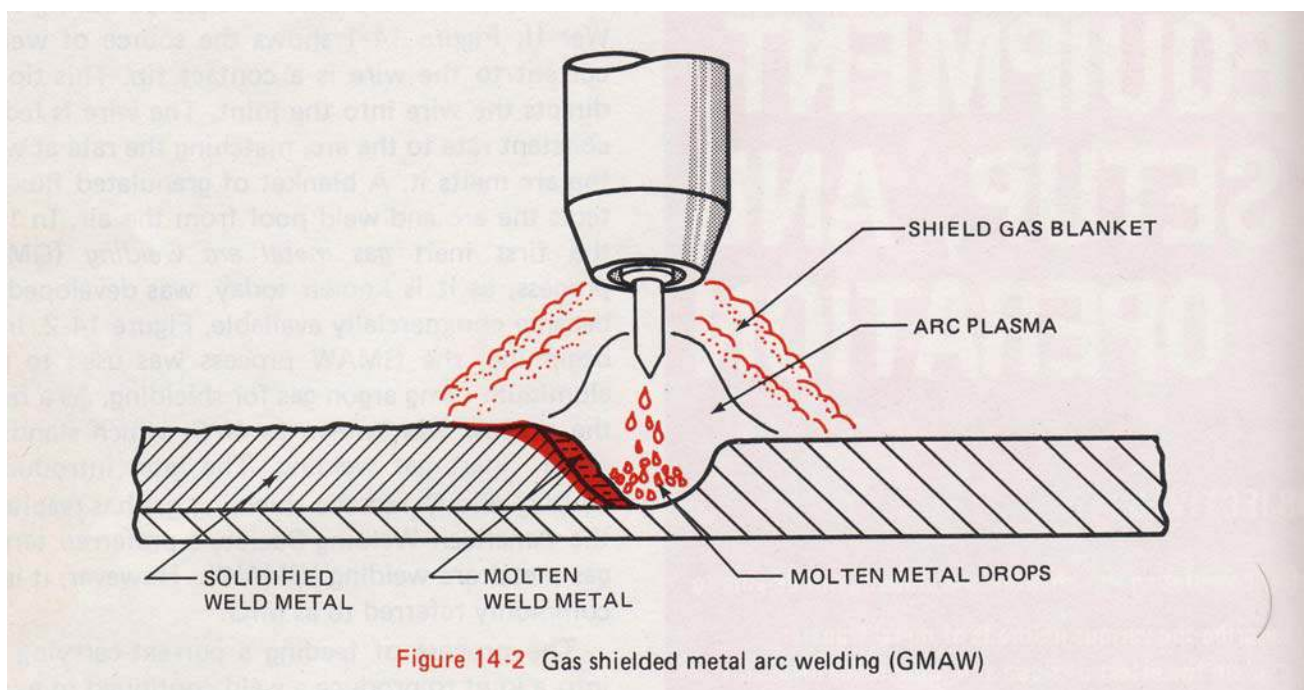

GMAW is extremely fast and economical. This process is easily used for welding on thin-gauge metal as well as on heavy plate. It is most commonly performed on steel (and its alloys), aluminum and magnesium, but can be used with other metals as well. It also requires a lower level of operator skill than the other two methods of electric arc welding discussed in these notes. **The high welding rate and reduced post-weld cleanup are making GMAW the fastest growing welding process.**

Gas Metal Arc Welding (GMAW) Photo

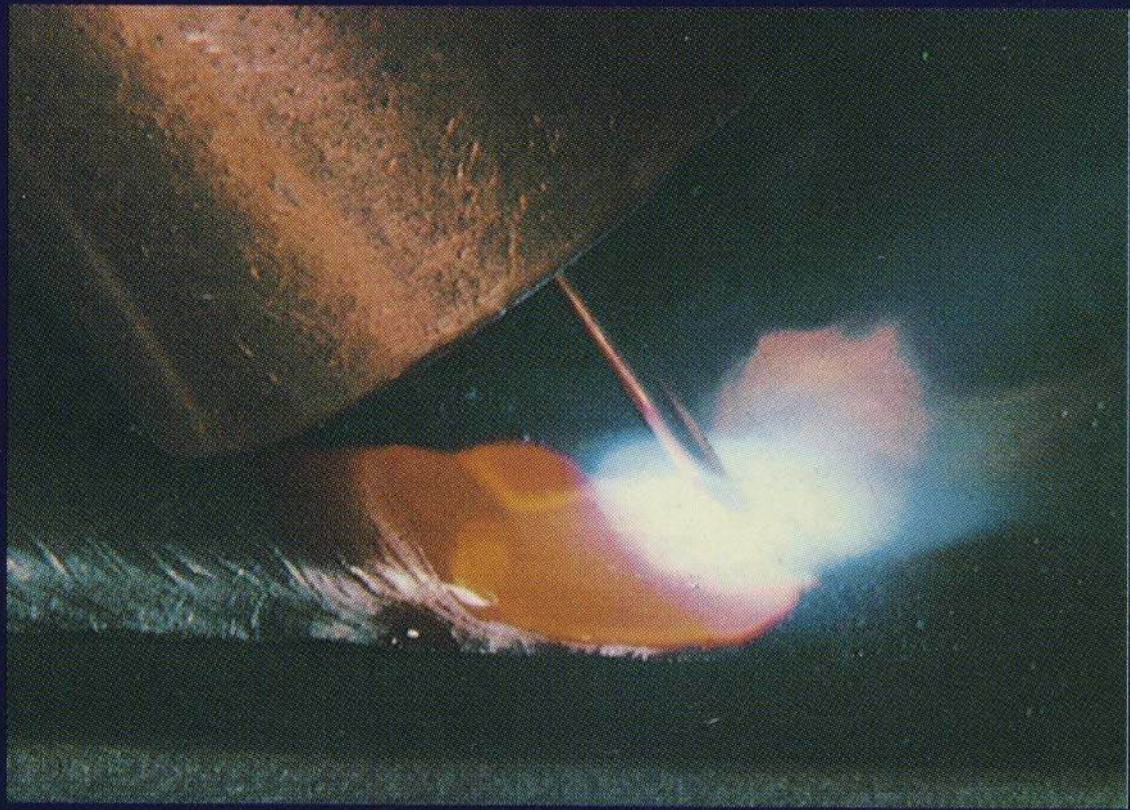
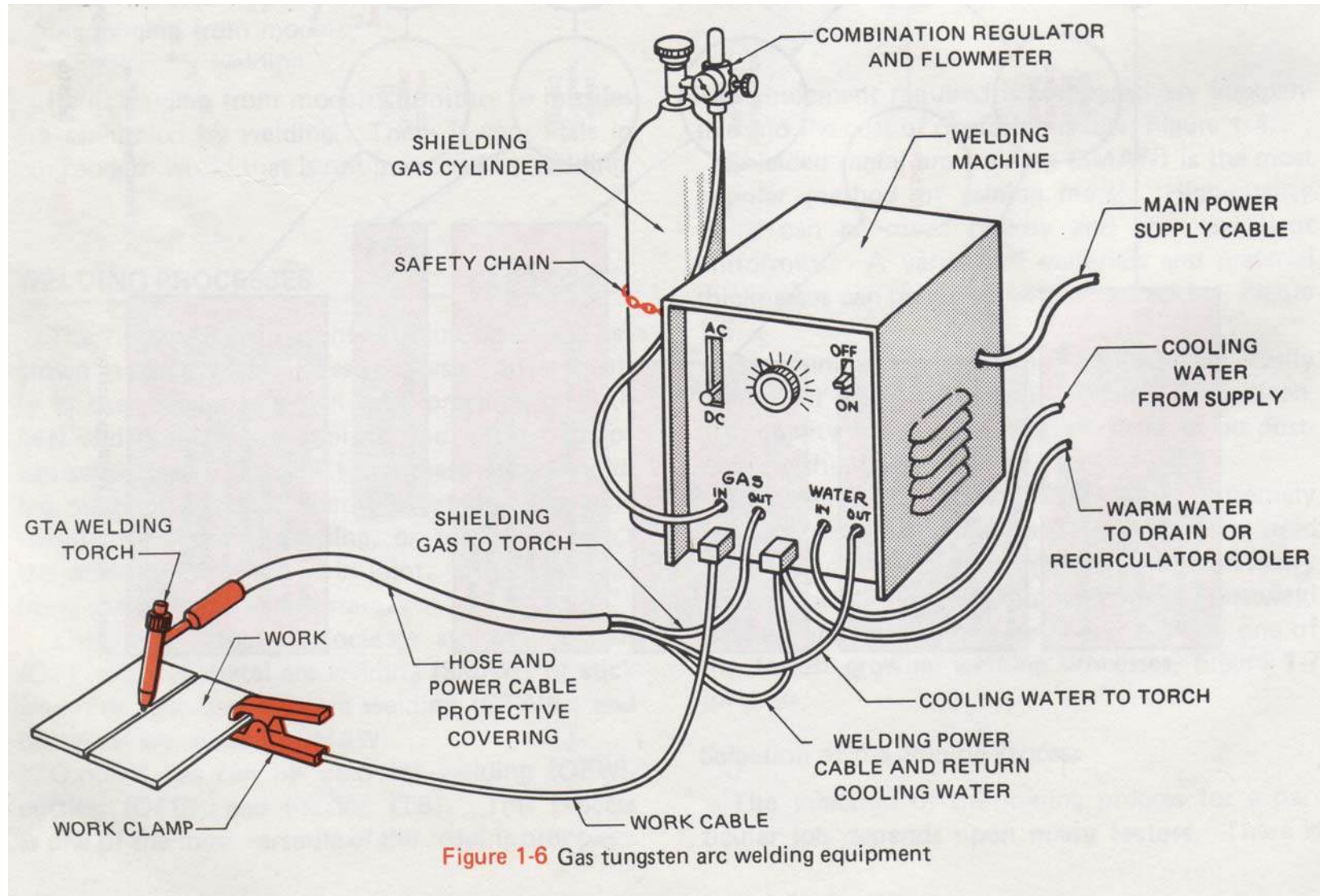

PLATE 37

Short-circuiting arc metal transfer with a leading angle

Gas Tungsten Arc Welding (GTAW)



Gas Tungsten Arc Welding (GTAW)

In the GTAW process, an arc is established between a tungsten electrode and the base metal(s). Under the correct conditions, the electrode does not melt, although the work does at the point where the arc contacts and produces a weld pool. The filler metal is thin wire that's fed manually into the pool where it melts. Since tungsten is sensitive to oxygen in the air, good shielding with oxygen-free gas is required. The same inert gas provides a stable, inert environment to protect the weld pool as it solidifies.

Consequently, **GTAW is commonly known as TIG (*tungsten inert gas*) welding.** Because fluxes are not used (like SMAW), the welds produced are sound, free of contaminants and slags, and as corrosion-resistant as the parent metal.

Tungsten's extremely high melting temperature and good electrical conductivity make it the best choice for a non-consumable electrode. The arc temperature is typically around 11,000° F. Typical shielding gasses are Ar, He, N, or a mixture of the two. As with GMAW, the filler material usually is the same composition as the base metal.

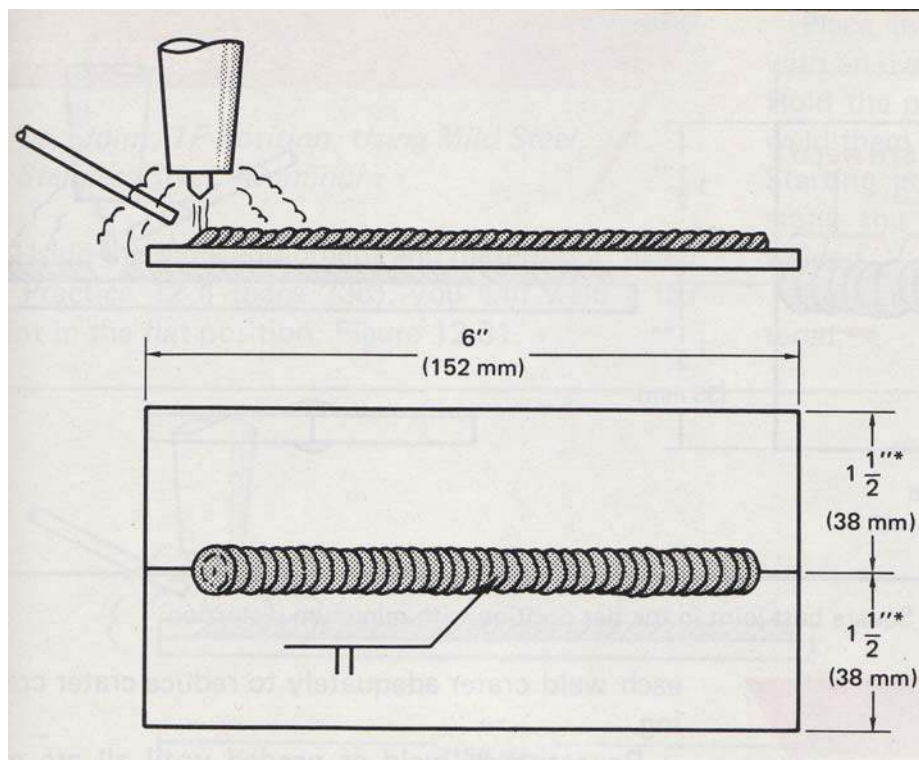

GTAW is easily performed on a variety of materials, from steel and its alloys to aluminum, magnesium, copper, brass, nickel, titanium, etc. Virtually any metal that is conductive lends itself to being welded using GTAW. Its clean, high-quality welds often require little or no post-weld finishing. **This method produces the finest, strongest welds out of all the welding processes.** However, it's also one of the slower methods of arc welding.

Gas Tungsten Arc Welding (GTAW) Photo

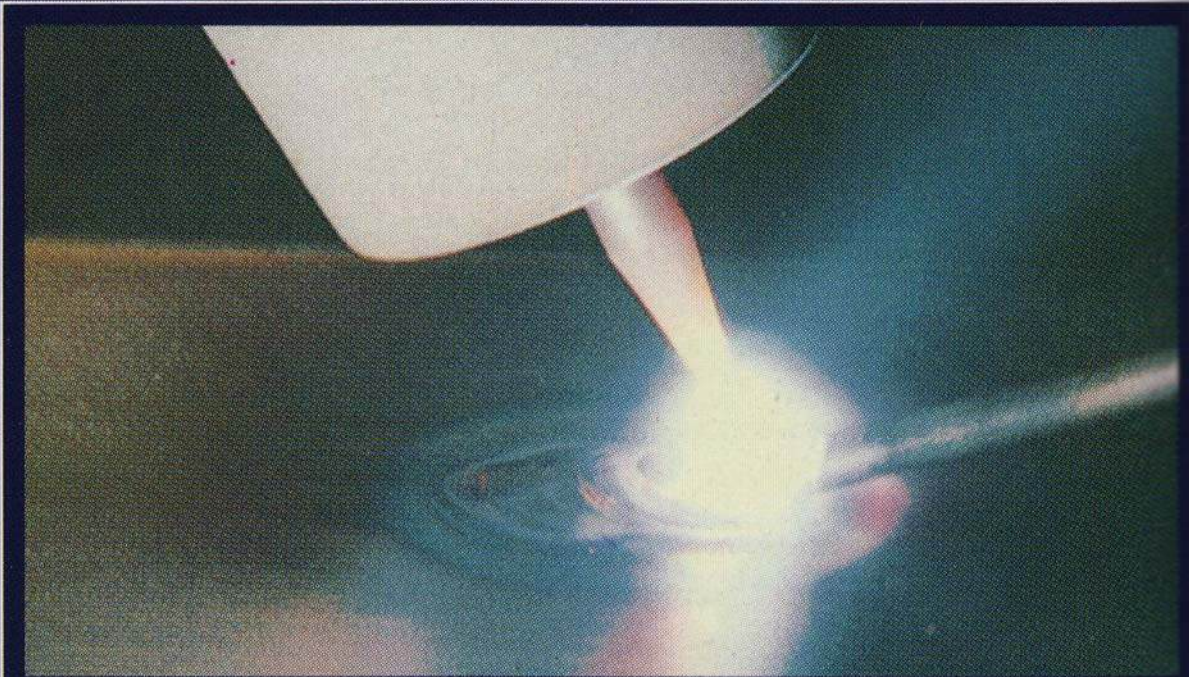

PLATE 32

The end of the filler rod is dipped into the leading edge of the molten weld pool.

Selection of the welding process

The selection of the joining process for a particular job depends upon many factors. There is no one specific rule governing the type of welding process to be selected for a certain job. A few of the factors that must be considered when choosing a welding process are:

- Availability of equipment
- Repetitiveness of the operation
- Quality requirements (base metal penetration, consistency, etc.)
- Location of work
- Materials to be joined
- Appearance of the finished product
- Size of the parts to be joined
- Time available for work
- Skill experience of workers
- Cost of materials
- Code or specification requirements

General guidelines for selecting one process over another

When selecting one process over the others, it is often useful to examine the principal pros/cons of each type of welding covered in this lecture:

Welding Process	Advantages	Disadvantages
SMAW	Cheap	Major post-weld cleaning
	Portable (no gas required)	Relatively 'dirty' method of welding (sparks/fumes)
	Versatile (can weld various metals & thicknesses)	Requires moderate skill
GMAW	Fastest of all 3 processes	Requires shielding gas
	Versatile (can weld various metals & thicknesses)	Minor post-weld cleaning
GTAW	Highest quality welds	Requires shielding gas
	No post-weld cleaning	Slowest of all 3 processes
	Versatile (can weld various metals & thicknesses)	Requires high degree of operator skill

Examples of Welds

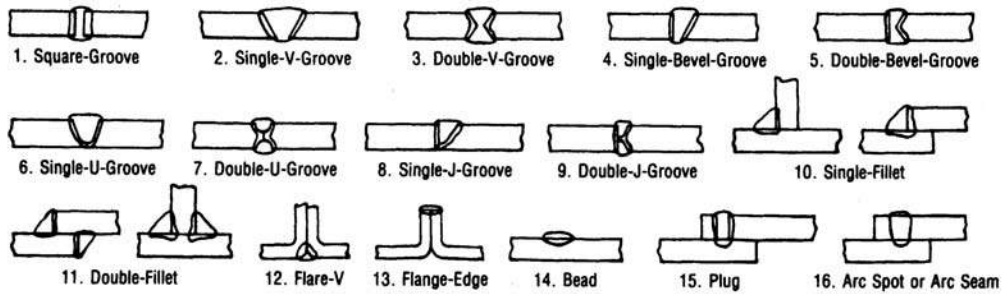

STANDARD WELD JOINTS

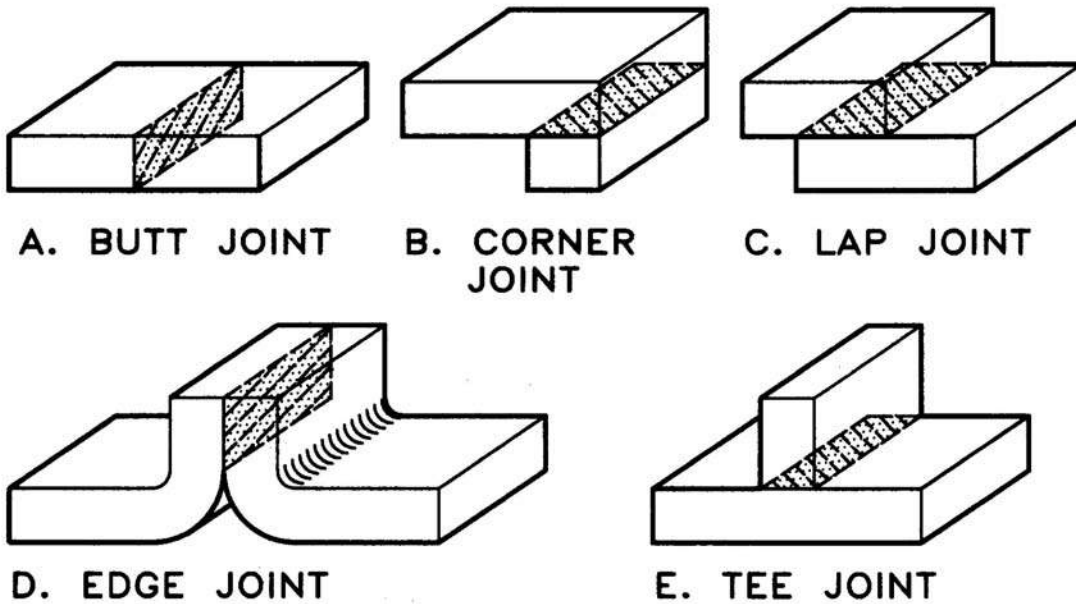

Figure 22.8 These diagrams depict the five standard weld joints.

Weld Ideographs

The ideograph is the symbol that denotes the type of weld desired, and it generally depicts the cross section representation of the weld. The following figure shows the ideographs used most commonly.

STANDARD WELDS AND IDEOGRAPHS

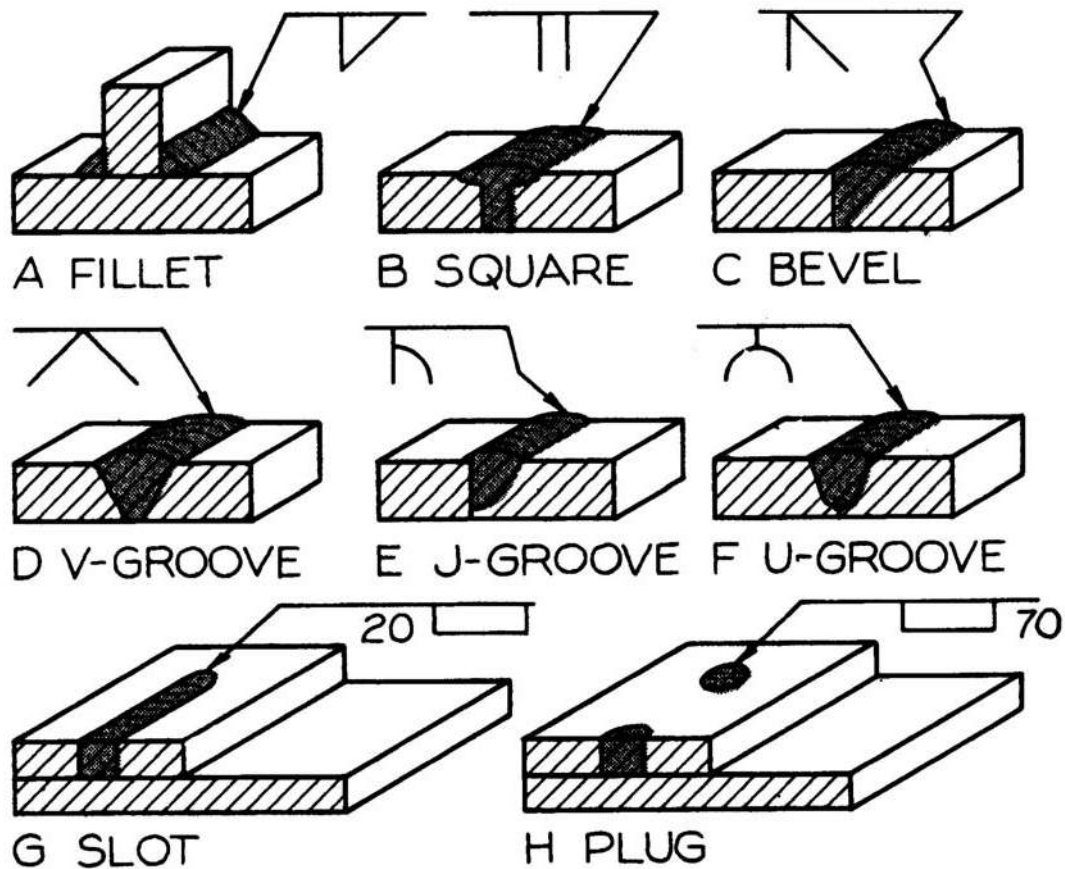

Figure 22.9 These views illustrate standard welds and their corresponding ideographs.

Fillet Weld Symbol Example

FILLET WELDS

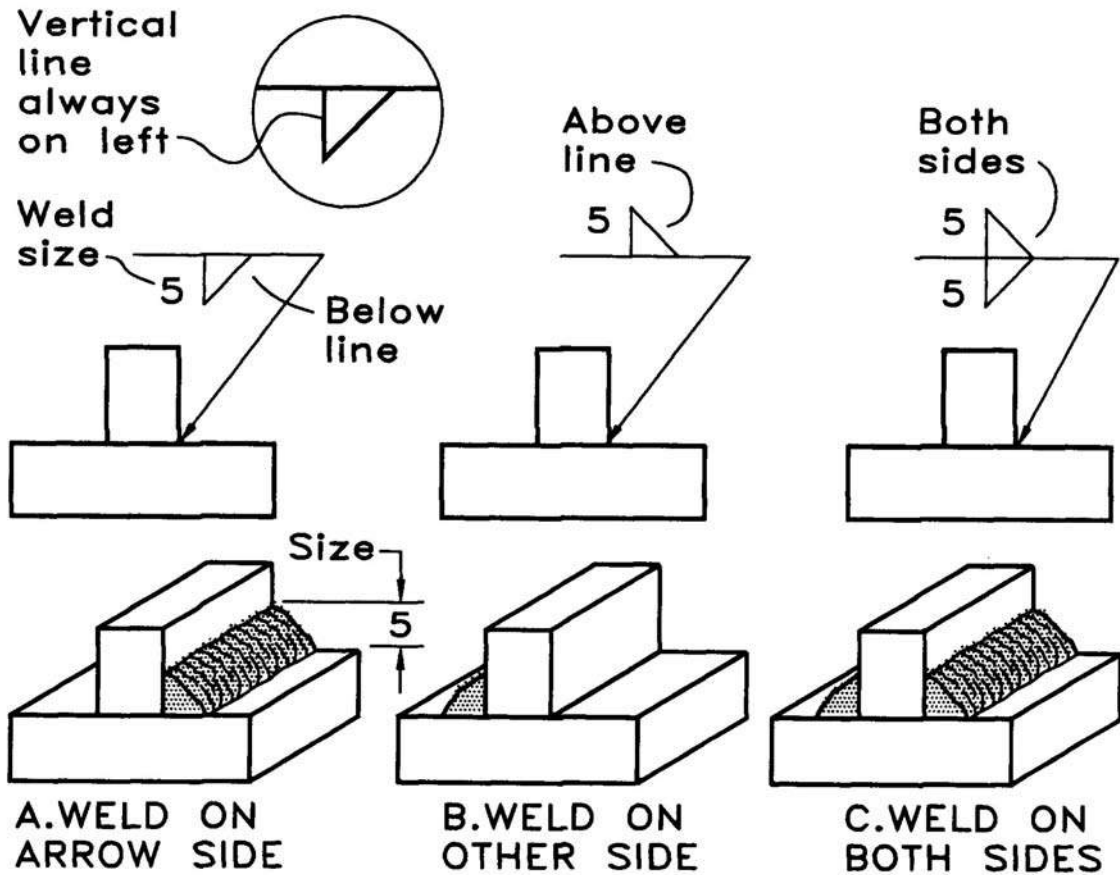

Figure 22.13 Fillet welds may be noted with abbreviated symbols. (A) When the ideograph appears below the horizontal line, it specifies a weld on the arrow side. (B) When it is above the line, it specifies a weld on the opposite side. (C) When it is on both sides of the line, it specifies a weld on each side.

SMAW (“Stick Welding”) Examples



Photo 1: Stick Welding a Large Hopper



Photo 2: Stick Welding Mild Steel Square Tubing

GMAW (“MIG Welding”) Examples

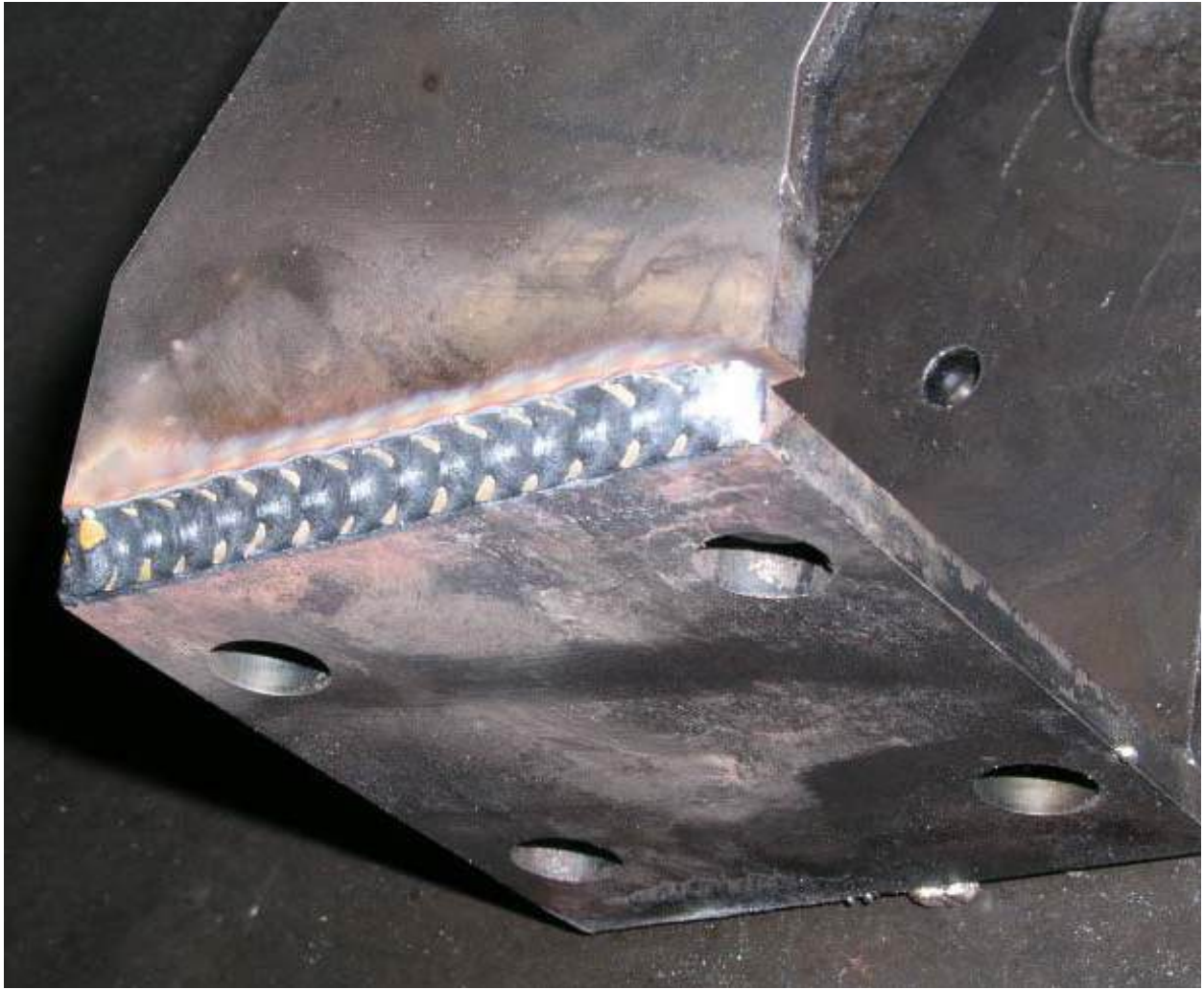

Photo 3: Fillet MIG Weld



Photo 4: U Groove MIG Weld

GTAW (“TIG Welding”) Examples



Photo 5: Fillet TIG Weld (4130 Structural Steel Tubing)

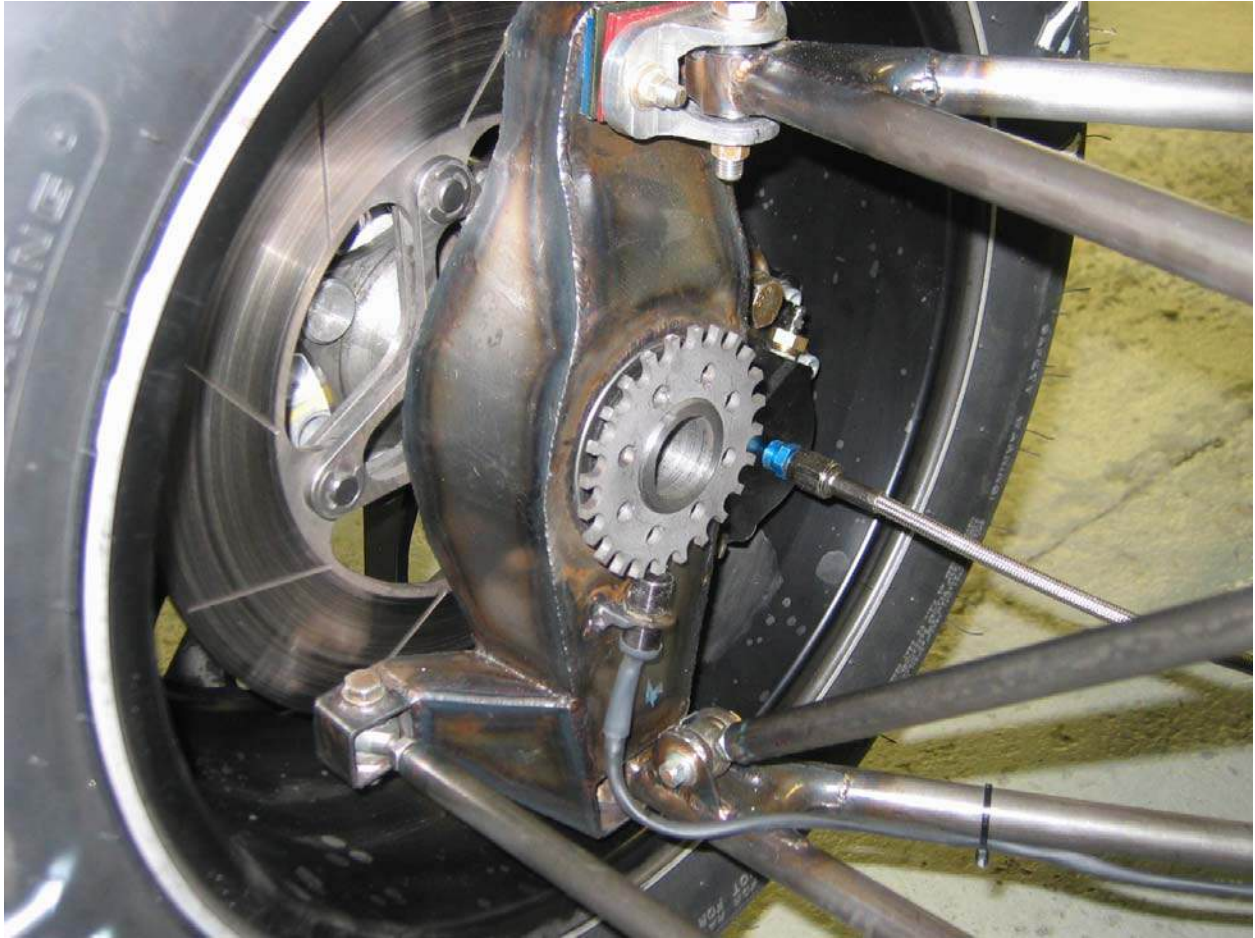

Photo 6: TIG Welded Formula Car Upright Assembly

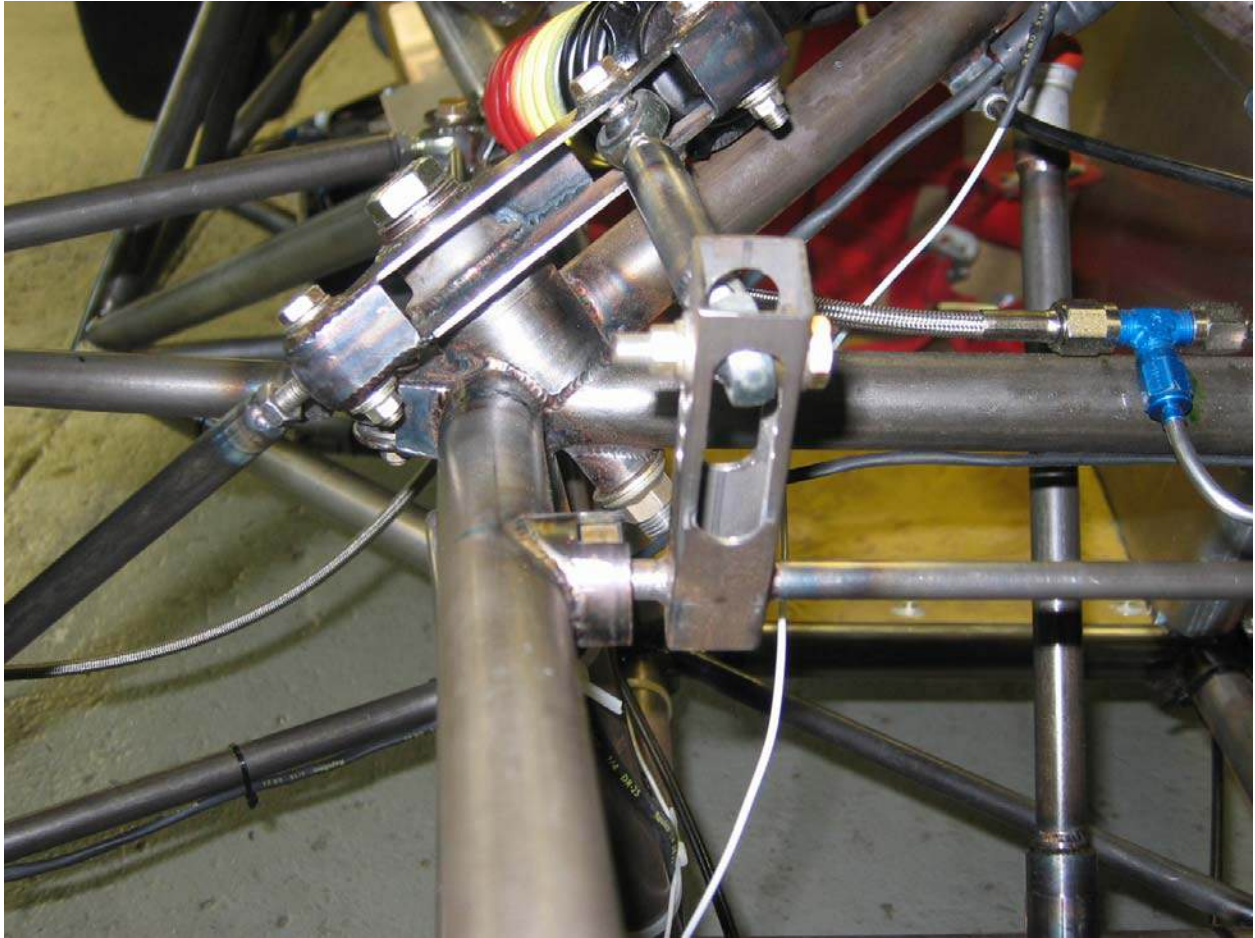

Photo 7: TIG Welded Formula Car Suspension Assembly

Copyright notice:

Much of the previous information and photo slides were taken from Larry Jeffus' and Harold Johnson's *Welding Principles and Applications*. This book contains a wealth of knowledge concerning the various electric arc welding processes summarized in these abbreviated lecture notes.