



Extension Bulletin E-1045 - Family Living Series

October -1976

Prepared by Margaret Boschetti
Extension Specialist in Human Environment and Design

MAKING SIMPLE REPAIRS ON WOOD FURNITURE

The home and its furnishings represent a large investment. Another large investment is the cost of repairing and maintaining house furnishings. To protect the one and control the other, probably the most important thing to remember is to take reasonable care in everyday use of your furniture.

Occasionally, furniture is damaged, or you may buy a piece of used furniture that needs minor repairs to restore it to full serviceability. This leaflet provides directions in making simple repairs on wood furniture.

Some repairs that you can do yourself may require more time, energy, and money than you want to invest, or would be better done by a professional. For instance, a broken chair leg or replacing veneer or refinishing an entire piece of furniture is messy and time-consuming. There are professional businesses that will dip a piece of furniture in a stripping solution that will take off paint, varnish, and the color out of the wood. This professional service will be more satisfactory than refinishing it yourself.

I. REPAIRING DRAWERS

What is the problem:

1. Loose fitting drawers.
2. Drawers that stick and are hard to remove.
3. Drawers that are coming unglued.

What you need:

Hammer	Scraper (such as screw driver, dull Knife)
White glue	Paraffin
Nails (small, 1/2" - 3/4")	Upholstery tacks or large thumbtacks
Sand paper (medium to fine)	Scrap wood or sheet metal (small pieces)

What to do:

Remove the drawer and empty out the contents. Check to see if there are any stray objects in the space. Determine the cause of the problem.

1. To repair loose-fitting drawers:

- a. *Cause:* Glides are worn down; the drawer will not close all the way. Place upholstery tacks or large smooth-headed thumbtacks along the worn out area (illustration 1).

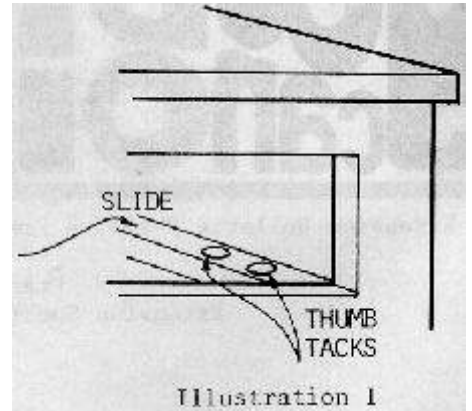

- b. *Cause:* Drawer stops are broken or missing. Replace with a small piece of scrap metal or wood attached on the drawer or the cabinet (illustrations 2a and 2b). Do not make them so large that the drawer can't be removed if tilted up or down when it is pulled all the way out.

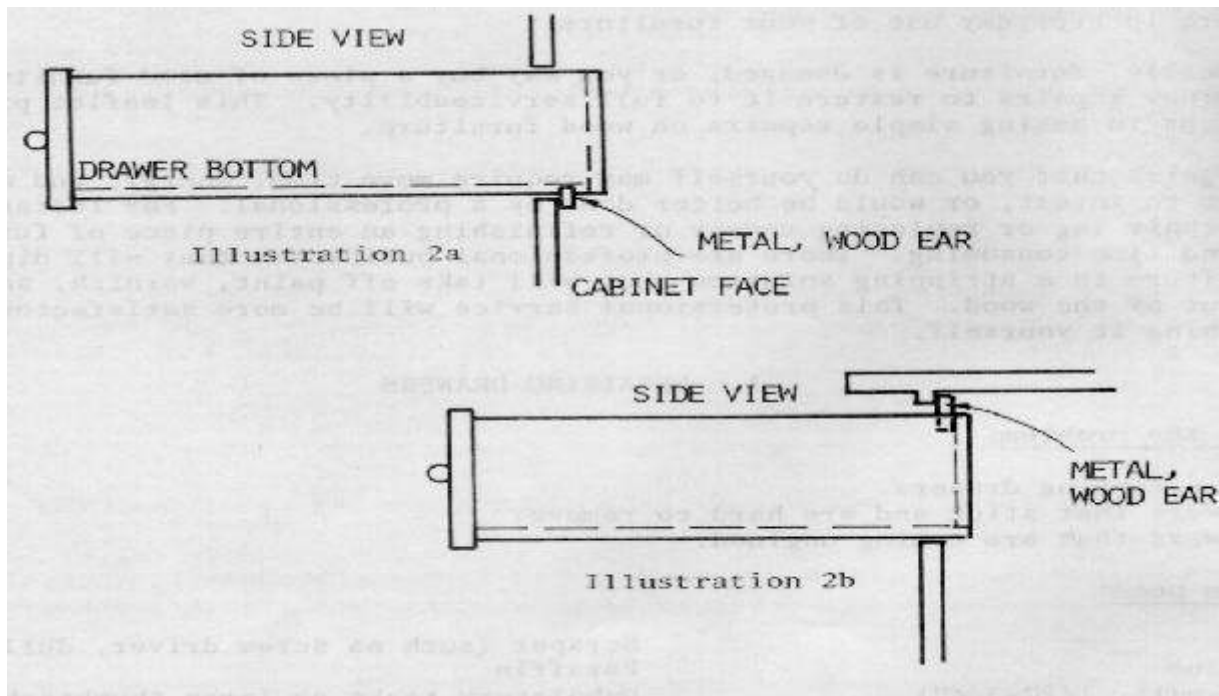

2. To repair drawers that stick:

- a. *Cause:* Drawer can't be removed. Pull it out as far as it will go and place a light bulb on an extension cord or several flash lights inside the drawer for 15 minutes. Use light in a wire cage or place in a glass dish to avoid scorching the wood. The heat from the lighted bulbs will make the wood contract and allow the drawer to be removed to make the necessary repairs.

- b. *Cause:* Drawer is swollen tight against guide rail. Lightly sand the shiny places on the top, bottom, or sides where drawer is rubbing. Then lightly sand the guide rails. Do not sand the whole drawer since it could become loose. Try the drawer after several sandings. Repeat if necessary.
 - c. Paraffin, the stick end of a candle, or a bar of soap can be used as a lubricant on drawer guides and the bottom edges.
3. To repair drawers that come unglued due to dampness or excessive use:

With a hammer, gently tap out the sides of the drawer in the direction they were assembled. Scrape off the old glue in the joints with a screwdriver or a dull knife. Apply glue to the side joints and assemble the sides to the front piece. Slip the drawer bottom plate into place. Apply glue to the back piece and put it into place. Wipe off all excess glue. Place drawer on its side and drive several small-headed nails into the joints from the side to the front piece and then the side to the back piece (illustrations 3a and 3b). Allow drawer to dry well before placing anything in it.

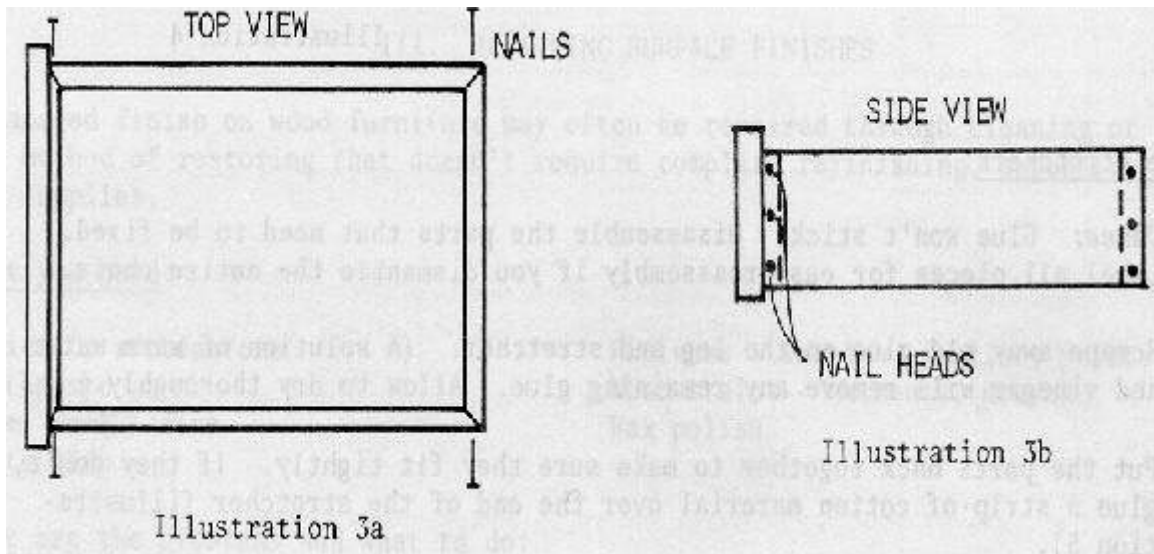

II. REPAIRING WOBBLY CHAIRS AND TABLES

What is the problem:

Wobbly chairs and tables are the result of loose braces and joints. Furniture will come apart if the wood becomes damp, or dries out and shrinks, or if the glue gets wet. If furniture parts do not fit tightly, they will work loose and come apart.

What you need:

Hammer	Pencils or pens
White glue	Toothpicks
Heavy rope or twine	Wax paper
Screw driver - adjustable wrench	

What to do:

Loose brace:

- a. *Cause:* Loose and/or missing screws. Sometimes replacing or tightening missing or loose screws will solve the problem (illustration 4).
- b. If the bolts or screws in the brace fall out, place three or four toothpicks into the bolt hole, squeeze in white glue. When dry, reinsert the bolt and tighten.
- c. *Cause:* Glue not sticking (see item 2 below).

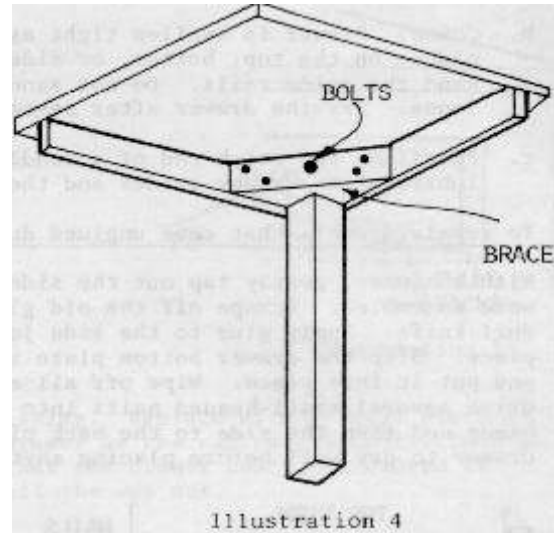

2. Loose stretchers:

- a. *Cause:* Glue won't stick. Disassemble the parts that need to be fixed. Label all pieces for easy reassembly if you dismantle the entire chair.
- b. Scrape away old glue on the leg and stretcher. (A solution of warm water and vinegar will remove any remaining glue. Allow to dry thoroughly.)
- c. Put the parts back together to make sure they fit tightly. If they don't, glue a strip-of cotton material over the end of the stretcher (illustration 5).

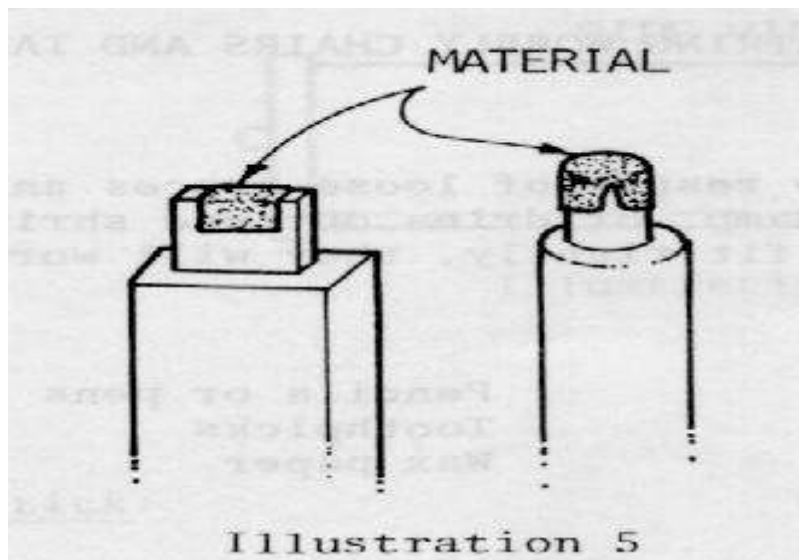

- d. Apply glue to cleaned stretcher end and reassemble chair. Wipe off excess glue. It is important that the joints remain tight while they dry. Tape loosely wrapped wax paper to the chair legs. Wrap tape or twine around the chair legs (over the wax paper) several times and tie in a square knot. Place a pencil or stick between the rope strands and twist it around several times (illustration 6). Slide it up or down so that one end rests against a stretcher or the seat, keeping the rope twisted while the glue dries. Turn chair right side up and place on level floor. If one leg is higher, gently tap corner. Allow to dry overnight, then remove the ropes.

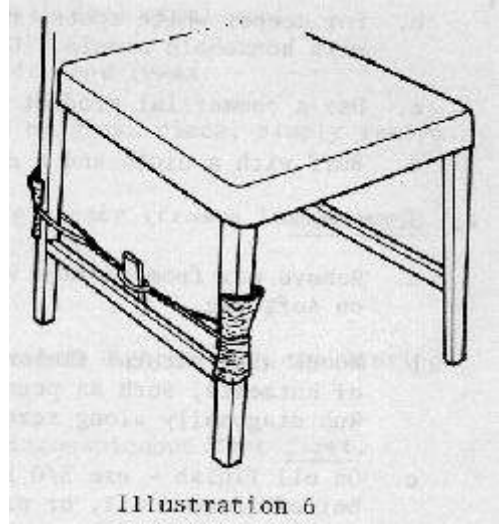

III. REPAIRING SURFACE FINISHES

A damaged finish on wood furniture may often be repaired through cleaning or a simple method of restoring that doesn't require complete refinishing, expensive tools and supplies.

What you need:

Pumice or rottenstone	Finishes - varnish, shellac, paint, etc.
Toothpaste	Wood stains - nutmeats, crayon
Steel wool - fine	Wax polish
White glue	

What are the problems and what to do:

1. Bruises and dents - a moderate depression in the surface that can be raised by application of water and heat. Remove wax with a cloth dampened in turpentine or mineral spirits. Place a damp cloth over the area and lightly touch with a medium hot iron (avoid touching wood surface with iron. Repeat process until wood fibers swell and are raised to the surface. Apply a clear wood sealer and let dry 24 hours. Rub with very fine steel wool; then wax.
2. Checking, crumbling, flaking - a cracking of the surface that is caused by dry, direct sunlight, sudden temperature change, and/or improper finish. Make a paste of powdered pumice or rottenstone with linseed oil. To remove very fine check lines, rub on surface with a soft cloth or 000 steel wool. If checking extends through finish to wood surface, then complete restoring and refinishing is recommended.
3. White marks - usually caused by water or excessive heat.
 - a. Make a paste of powdered pumice or rottenstone and linseed oil. Rub in lightly with 3/0 steel wool. Wipe dry.

- b. For deeper white spots, rub quickly and lightly with a damp cloth moistened with household ammonia. Gently rub dry.
- c. Use a commercial product specifically designed for removing white spots.
- d. Buff with a cloth and a dab of toothpaste.

4. Scratches

- a. Remove wax from surface with a few drops of turpentine or mineral spirits on soft rag.
- b. Woods with natural finish* - to disguise minor scratches, use broken pieces of nutmeats, such as pecan, English or black walnut, Brazil, or butternut. Rub diagonally along scratch until it darkens.
- c. On oil finish - use 3/0 steel wood pad dipped in lightweight mineral oil, boiled linseed oil, or paraffin oil. Rub carefully with wood grain. Wipe entire surface with a cloth slightly moistened with oil, then with a dry cloth. In badly scarred instances, use boiled linseed oil.
- d. On lacquer finish - use lacquer thinner to soften lacquer finish around scratch. Apply with a small brush or toothpick.
- e. On shellac finish - use shellac thinner or denatured alcohol solvent to soften shellac around scratch.
- f. On varnish finish - use gum turpentine to soften the varnish to cover a small scratch. Or use commercial scratch remover (use as label directs).
- g. On stained woods, natural finish - if possible, use a stain to blend with the old stain of same color and type originally used on piece. For instance: On wood stained yellowish brown, use base of walnut stain and small amount of yellowish maple on stain first. Dry and apply type of finish used originally.

5. Deep marks, cigarette burns - remove old wax. If area is burned, gently rub area with 3/0 steel wool or knife blade. Sponge with denatured alcohol to bleach. Fill the hole with lacquer stick or shellac stick of a color that matches wood finish. Apply several coats of original finish until blemish is even with wood surface. You may need to sand the spot to make it level.

6. Chipping - caused by a blow to the finish.

- a. Wet the edges of the chipped area with original finish and wipe off the overlap.
- b. Apply as many coats to the finish as needed to make it level to the surrounding area.

*To determine the finish on your furniture, test solvent in an inconspicuous place: For lacquer - use lacquer thinner; shellac - denatured alcohol or shellac thinner; varnish - turpentine or mineral spirits.

- c. Allow to dry between coats, then sand flat with fine steel wool.
 - d. Wash surface with damp cloth and mild suds, dry and re-wax.
7. Inlay damages are easy to repair if you have the original piece; simply remove the old glue and re-glue into place.
- a. If piece is missing, take a piece of matching veneer (from a lumber yard) and cut it slightly larger than the missing piece.
 - b. Fit piece in and trim off excess. Then glue.
 - c. If veneer can't be found, stain the hole somewhat lighter than the missing piece and use procedure for chipping.

REMINDER: Always test untried method in an inconspicuous spot first.

REFERENCES

1. Refinishing Furniture. Eldon Behr. Extension Bulletin E-514, Michigan State University, East Lansing, MI 48824.
2. Furniture Restoration. Gena Thames. Extension Bulletin, New Jersey Cooperative Extension Service, Rutgers State University, New Brunswick, NJ 08901.
3. Recipes for Home Repair. Alvin Ubell and Sam Bittman. Quadrangle: The New York Times Book Company, 10 East 53rd Street, New York, NY 10022. 1974

Prepared by Jane Castle, Graduate Student and Margaret Boschetti Extension Specialist, Human Environment and Design Department, Michigan State University.

Cooperative Extension Service Programs are open to all without regard to race, color, creed, or national origin. Issue in furtherance of Cooperative Extension work in agriculture and home economics, acts of May 8, and June 30, 1914, in cooperation with the U.S. Department of Agriculture. Gordon E. Guyer, Director, Cooperative Extension Service, Michigan State University, East Lansing, MI 48824. Price 10 cents. Single Copy Free to Michigan Residents. IP-IOM-9:76-UP