

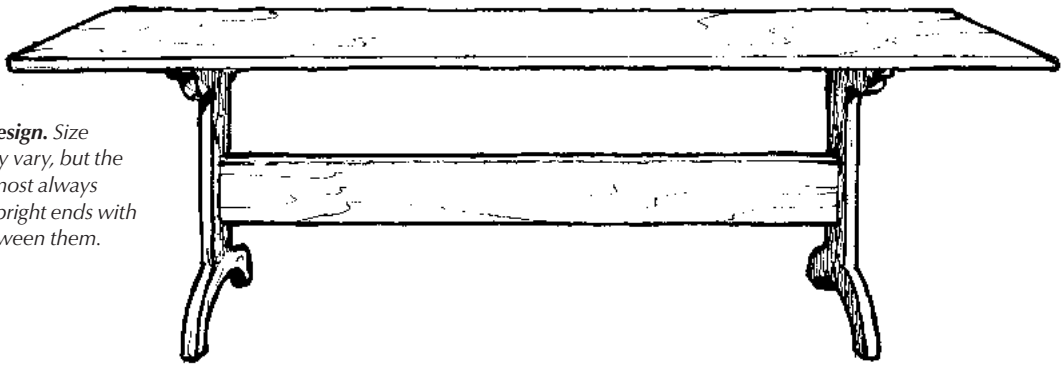

Free Furniture-Making Tips



Basic trestle design. Size and details may vary, but the trestle form almost always features two upright ends with a stretcher between them.



Design a Trestle Table

BY GRAHAM BLACKBURN

Choose your own styles and techniques:
simple, advanced, or somewhere in-between.

In furniture, the term “trestle” historically referred to a pair of diverging legs wide enough to be self-supporting, and joined at their upper end, sometimes by hinges. Two or more such trestles that support a wide board form a table, which can be easily folded up and moved.

The trestle table has a long history. Six hundred years ago in Europe, when only the rich had valuable furniture and carried it around with them from one castle to the next, portability was of prime importance. Large and relatively immobile tables would have been out of the question. Times may be more secure now, but given the rate at which many people change addresses, an easily disassembled and transported table remains an idea whose day is far from over.



Today, however, the term “trestle table” usually implies something more sophisticated than the original design, and most commonly describes a table that is supported not by a pair of trestles, nor by the usual arrangement of four corner legs, but by two pieces connected by a horizontal beam or stretcher, often secured in place by wedged mortises. That base assembly supports the actual tabletop.

In this article I discuss two different trestle table designs – one small and very basic; the other large and more advanced. The first could serve well as a side or entry table. The larger would make a fitting dining table or, if outfitted with drawers, a desk. As you design and build your own, feel free to mix and match the two to design a table that suits your needs.



"Great things are not done by impulse, but a series of small things brought together."

—Vincent Van Gogh (1853-1890),
Dutch post-Impressionist painter

Build a Basic Trestle Table

The trestle table form is adaptable for tables from small to large. All that is really necessary are two uprights, a stretcher and a tabletop. The uprights must, of course, be tall enough to support the tabletop at the required height, broad enough at the base to provide sufficient stability for the size desired and wide enough at the top to provide adequate connection for the tabletop.

If you wish to preserve the knock-down function of a true trestle table, the stretcher connecting the two supports should be removable, but fixed stretchers such as described in this first example are by no means uncommon.

Build From the Top Down

This top can be made from a single board or from several pieces glued together with edge joints. The gently curved ends of the top shown above at right echo the curved shape of the foot part of the uprights. Because the material used for this table is 1 1/4" thick, the lower edge of the top has been beveled to leave a 3/4"-thick face all around in order to lighten the look.

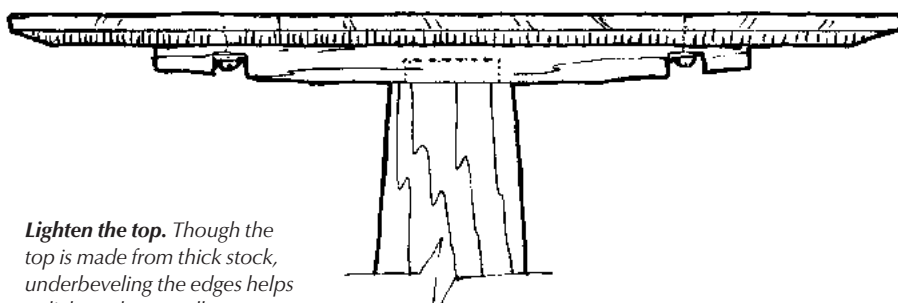

Lighten the top. Though the top is made from thick stock, underbeveling the edges helps to lighten the overall appearance of the table.



BASIC TRESTLE
SIDE TABLE

The uprights consist of three parts. The central part is gently tapered toward the top, where it is tenoned into a 1 1/2"-wide piece cut a little shorter than the width of the top. The bottom end of the upright is similarly tenoned into a curved foot piece, which is also a little narrower than the width of the top.

Join the two uprights with a stretcher that has a tenon cut at each end. This will be sturdier if the joint is a through-mortise-and-tenon, with wedges driven from the outside of the uprights.

On any table it is important to attach the top so that it will remain flat while allowing it to shrink or expand across its width with any changes in ambient moisture content—otherwise, checks and cracks will surely result. All that is needed with this simple design are screws secured through slots cut at each end of both top crossmembers and into the underside of the tabletop (as shown in the illustration below).

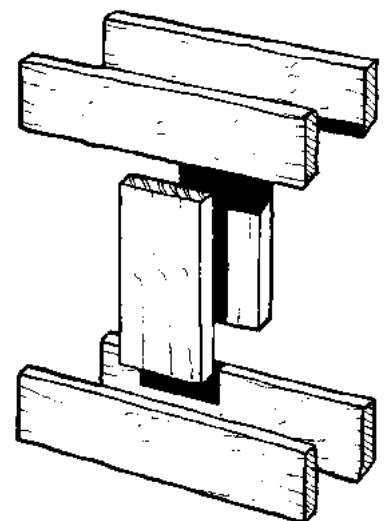

Start simple. Though you may shape them to your liking, the basic form of the "trestle" is nothing more than three boards joined together.

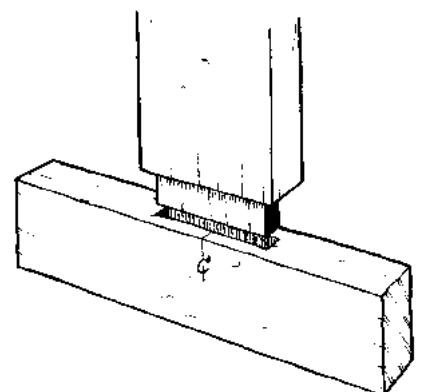

Build a strong joint. It is easiest to cut the mortise-and-tenon joinery on the ends while the stock is rectangular.

Build a More Advanced Model

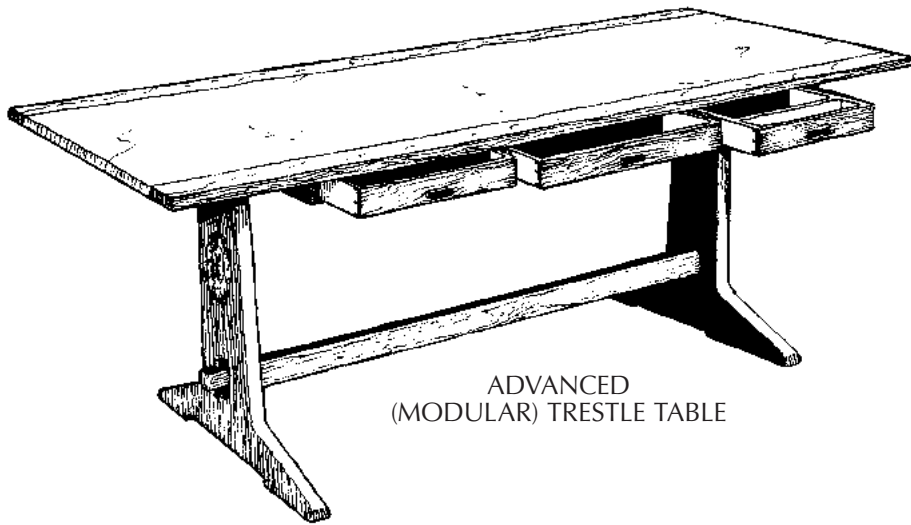

ADVANCED
(MODULAR) TRESTLE TABLE

Trestle tables may be thought of as modular, and as such may be built with differently sized parts to fit different areas. The same trestle may be used to support tops of different sizes, and parts of the trestle may be built to different measurements depending on your needs.

A table is, of course, subject to certain functional limitations: The top

should be around 29"-30" high if it is to be used for dining or writing, and a few inches lower if a keyboard is to be accommodated.

Any construction attached to the underside of the top should allow sufficient knee room for someone sitting on an average 18"-high chair, which means a lower limit of around 24". And the width of the top, if intended as a

dining table for facing diners, should be at least 30" wide.

Assemble the Trestle

The rest of the table consists of two ends, a stretcher held in the ends by removable wedges and an additional substructure framework connecting the tops of the two ends. This is a shallow framework holding three drawers. The drawers may be omitted, but the basic framework of the substructure is the key to the table's integrity and rigidity when assembled.

Make the ends first. Each end consists of three pieces: a top horizontal piece, a bottom horizontal piece and a vertical piece. The idea is to make the top piece a couple of inches or so shorter than the width of the top, thereby providing the support necessary to keep the top flat. The bottom piece should be an inch or so wider than the top cross-member to preserve the proportions of the ends and guarantee stability.

Prepare the joints for the end pieces, and after a dry assembly of both ends, trace the finished shape from a template made of cardboard, Masonite or paper to produce the required profile.

Cut the traced outline with bowsaw or band saw, and smooth the resultant curves with files and spokeshaves, rounding all arrises except those that will abut the underside of the top.

A Stretcher Spans the Trestle

The lower stretcher is a single piece, with a long tenon on both ends that fits

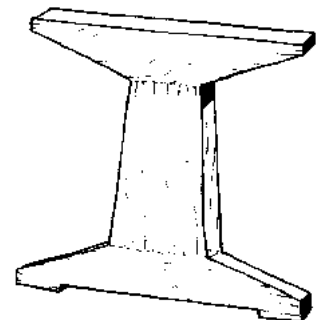

Shape the ends. Make a single template from a stiff material such as Masonite and use it to cut the trestle ends to identical shapes.

START WITH THE TOP

In lieu of other givens and requirements, the top is a good place to start your design because it is the most visible. It is also the part most easily varied. A straight-sided top can have advantages if the piece is to be placed against a wall, but there is no reason why some other shape might not be used.

To give the top a fatter look, finish the edges with an upward-facing bevel. If, on the other hand, the top looks too thick, a downward-facing bevel will achieve the opposite effect, making it appear thinner. If the top is just right, consider other edge treatments, from perfectly square to rounded over or moulded into quarter-rounds, thumbnails or ogees. —GB

A shapely top. Size and materials may obviously vary, but choosing a particular shape for the top is another easy way to give the table a different look.

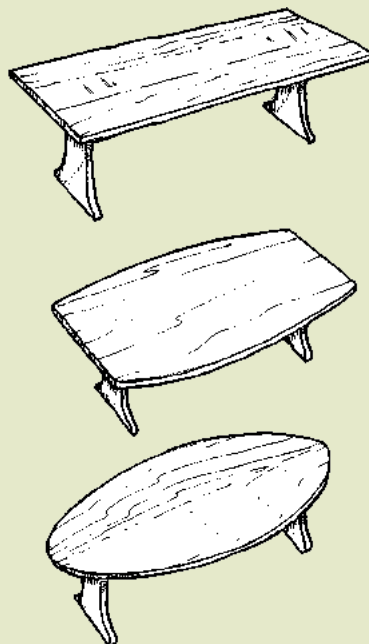

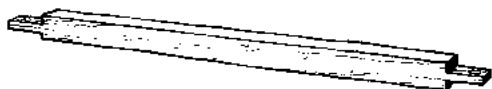

Span the gap. A single stretcher runs between the two trestle ends and is locked into place using tusk tenons.

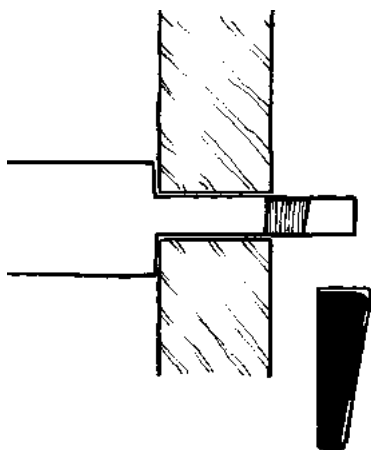

Wedge the stretcher. The tenoned stretcher runs all the way through the trestle ends and is mortised to accept an angled wedge. Note that the inside edge of the wedge mortise is inside the outside face of the end. The joint tightens as the wedge is tapped into place.

through mortises in the end pieces. After assembly of the stretcher and ends, mark the location of the wedge mortises on the stretcher's tenons.

A few tips are worth bearing in mind. First, the location of the stretcher must be carefully considered. If it is too low, it is liable to get in the way of your feet when sitting at the table; too high, and it will be uncomfortable to rest your feet on. The lower the stretcher, the greater stability it provides – but make sure the stretcher doesn't interfere with the joints that connect the upright and bottom parts of the ends.

The inner edge of the wedge mortise (the flat face) must be slightly behind the outer face of the trestle. Once the wedge is driven, this creates a clamping effect that holds the stretcher firmly in place to the ends, even if the wood should shrink.

The Substructure Framework

When the lower part of the trestle assembly is complete, make the top part

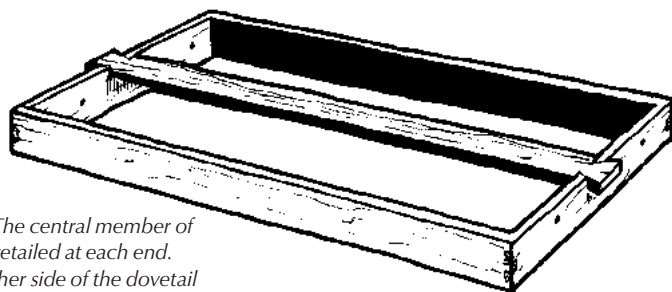

Solid substructure. The central member of the framework is dovetailed at each end. Screws placed on either side of the dovetail attach the framework to the ends.

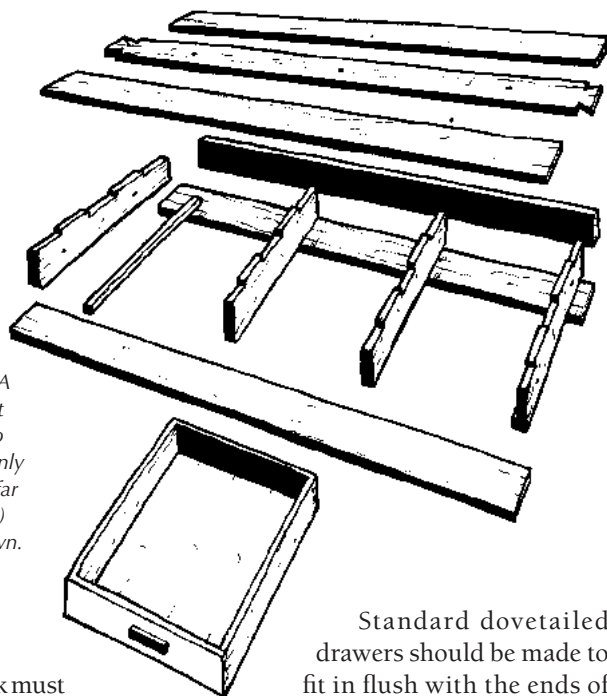

Simple drawer framework. A solid substructure can be left open on one or both sides to house drawers. For clarity, only two runners (unattached at far left, and attached at far right) and a single drawer are shown.

(the substructure) to match. The overall length of this framework must equal the distance between the tenon shoulders on the stretcher. The framework is shallow, no more than 3" deep, and narrower than the width of the top.

In addition to being fixed through slot-screw mortises in the upper parts of the end pieces, the tabletop is also secured by three screws inserted up through the central member. This has the advantage of ensuring that the substructure cannot sag should it be fitted with heavily loaded drawers.

The illustrated version has three drawers that fit flush with the front of the framework. These are carefully made to slide on small runners fixed to the sides of the four main front-to-back members of the substructure. At the back of the framework, fix a single piece to cover the backs of the drawer compartments. When viewed from the backside, the table will appear to have a normal skirt.

Standard dovetailed drawers should be made to fit in flush with the ends of the crossmembers, to which runners of 1/2"-square maple or some other hardwood should be fitted, flush with their bottom edges. **PWM**

Graham is the author and illustrator of numerous books of fiction, furnituremaking and general woodworking; visit blackburnbooks.com for more information. Graham writes in the south of France, dances in Buenos Aires and maintains a shop in Woodstock, N.Y.

ONLINE EXTRAS

For links to all online extras, go to:

■ popularwoodworking.com/apr13

VIDEO: See a free preview and purchase issues of Graham Blackburn's video magazine, "Woodworking in Action."

TO BUY Download step-by-step instructions for an American trestle table.

Our products are available online at:

■ ShopWoodworking.com

The Right Wood in the Right Spot

The end grain holds the secret to what stock to use where.

The single-most important factor in the appearance of any wood-working project is the selection of the material. This isn't what species to use or what color of finish; it is the choice of which board goes where. The wrong grain pattern in the wrong location can make even the most finely crafted piece look like junk.

While appearance is always subjective, there are traditional approaches to grain placement and orientation that are based on how wood behaves over time. In the grand scheme of things, these arrangements also appear harmonious to our eyes.

This is similar to music. You may want to write a non-traditional song, but the best-sounding notes and chords will be those that have evolved and been used for centuries. Good furniture design, regardless of style, calls for arranging the wood in ways that make sense both visually and structurally.

The key to understanding how any individual piece of wood will appear and function stems from where that piece of wood was when it was in the tree. It is rather simple to discover that by examining not the face, but the end of an individual board.

Moisture Matters

A living tree contains a lot of water, and when it is cut down and made into lumber that water migrates into the atmosphere. As the water leaves, the cells shrink first as the water within the cells disperses. Then the cell walls lose their moisture, and in the process the cells get smaller and change shape.

This is what causes lumber to warp as it dries, and the vast majority of warpage occurs during the initial drying process. Wood will always be in the process of releasing or absorbing



Character. Every piece of wood is an individual, and its appearance is determined by where it was located in the log.

moisture in response to changes in the environment.

Properly dried and conditioned wood won't likely change shape after milling, unless it is subjected to extremes of humidity. The Architec-

tural Woodworking Institute's "Quality Standards" recommends keeping relative humidity between 25 percent and 55 percent to avoid problems.

This includes the storage of lumber before milling, the conditions of the

CONTINUED ON PAGE 22

shop during project fabrication and the environment where the finished piece will be placed. Extreme levels of relative humidity, less than 20 percent or higher than 80 percent, are likely to cause problems. If you work within these guidelines, problems related to wood movement aren't likely to occur.

Even so, it is essential to understand what direction any piece of wood you use will move, and the consequences of that movement. Tradition is here to help you out, and if you follow tradition the chances of your finished project looking good are greatly increased.

As Wide as You Can

Much of what is written about using wide pieces of lumber only applies if

you're using material that is either not yet dry, or in the process of reaching equilibrium to a dramatic change in environment. If your wood is dry, at equilibrium with your shop environment, and conditions in the shop are close to those of your house, there is no good reason not to use wide boards for panels, case sides or tabletops.

Ripping wide boards and gluing them back together, with or without flipping them over (as you may have heard suggested), won't do a thing but waste your time and make your project uglier than it ought to be. That technique entered the literature as a way for factories to minimize the problems that come from using substandard and improperly dried material.

Wide pieces are often the most visible in a project, so you should take extra care in selecting the wood if you need to glue up a workpiece from narrower stock. The goal is to make the glued-up piece look as much as possible like a single board. Plan these glue-ups first as you select your material. Often you can use two rift-sawn (or partially rift-sawn) pieces on either side of a plain-sawn piece (see "Consider the Source," below).

Generally speaking, wood looks nicest if it is placed in furniture in the same orientation that it had in the tree. On plain-sawn pieces, orient the cathedrals so that they all point up, and arrange adjacent panels so that the upper peaks are at about the same level.

CONSIDER THE SOURCE

There are three main classifications of lumber, based on the pattern of the end grain on the board. These patterns are related to where the board was in the log. As wood dries, most of the shrinkage is in the circumference of the growth rings across the grain. Imagine the rings as elastic bands that have been stretched out. As they contract, each ring gets smaller, and longer rings in a board influence shorter rings adjacent to them.

Plain-sawn lumber is most likely to warp, twist and cup, because the concentric rings are disproportionately dispersed through the board. Trees are larger at the bottom than at the top, so the ring patterns taper along the length of a board. When the flat surface produced by milling crosses the tapered rings, it produces an arched pattern on the face, commonly called a "cathedral."

Quartersawn and rift-sawn lumber are more stable, both in initial drying and over time because the arrangement of the rings is more consistent throughout the board. The trade-off is in appearance; quartersawn and rift-sawn lumber exhibit straighter and tighter grain lines than plain-sawn material.

Most boards will have a combination of grain patterns. Plain-sawn faces show quarter sawn edges and vice versa. Rift-sawn boards will have straight grain on both the faces and edges. In many boards, the grain pattern will change across the width, with a rift-sawn pattern on one side and a plain-sawn pattern on the other.

—RWL

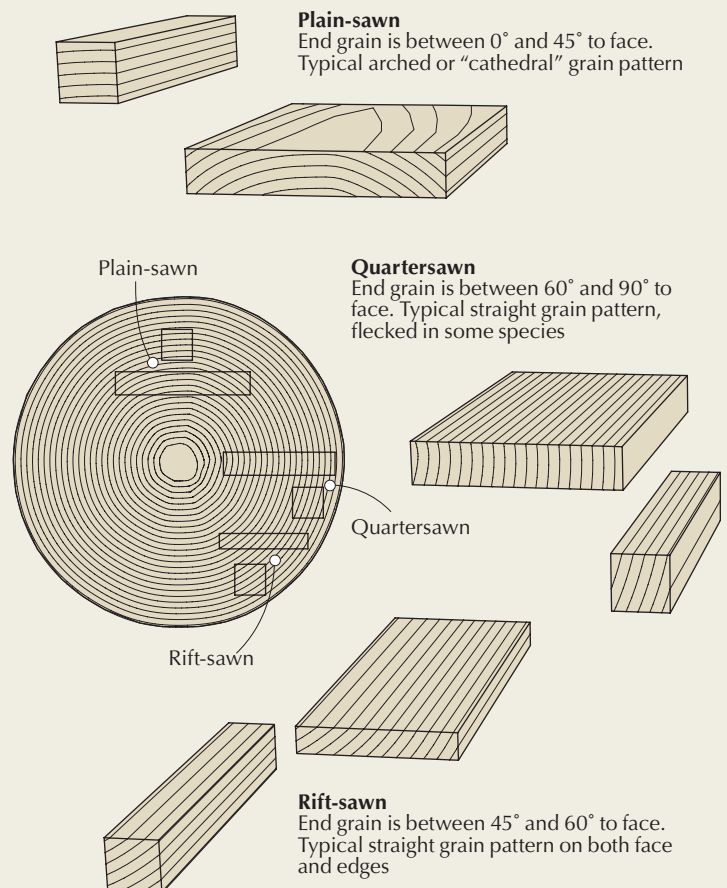

For the outer elements of pieces, orient the grain with the widest spacing at the bottom; if the grain slants, make each side slope toward the middle. This will give your furniture a solid stance; it won't look as if it is leaning to one side.

On the Straight & Narrow

Door frames and other frames are the ideal place to use quartersawn or rift-sawn material. The narrower, straight grain won't detract visually from the panel, and the stability of this material is good insurance to keep things straight – regardless of what happens environmentally.



Plain-sawn. Growth rings that arch across the end of a board create “cathedral” shapes on the face of the board. While attractive, plain-sawn lumber is most likely to cup or twist.



Rift-sawn. The growth rings slant across the end of rift-sawn lumber. The grain pattern on the faces and edges is straight and this cut is stable.



Quartersawn. The growth rings in quarter-sawn lumber are vertical, or nearly so. This type of wood will move more in thickness than in width.



Lumber can't read. Most pieces of wood will have a combination of grain patterns, with a different appearance on one side of the face than the other.

Rift-sawn material is also the best choice for legs or other square elements. The straight grain will look good from the front and the side. If you use quartersawn or plain-sawn material in this circumstance, you'll have to choose between a nice front or a nice side – you can't have both. This is especially important if the legs are carved or turned. The straight grain will make those tasks easier, and the finished appearance will be similar when viewed from any angle. **PWM**

Bob is the executive editor of this magazine. He can be reached at robert.lang@fwmedia.com.

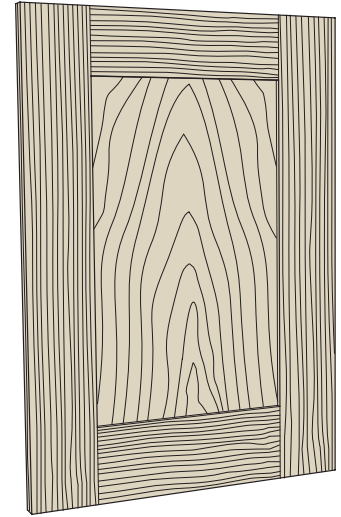

Harmonious composition. Rift or quartered lumber for the stiles and rails and a plain-sawn panel make an attractive and stable door. Even if glued from more than one piece, panels look best with this grain pattern.

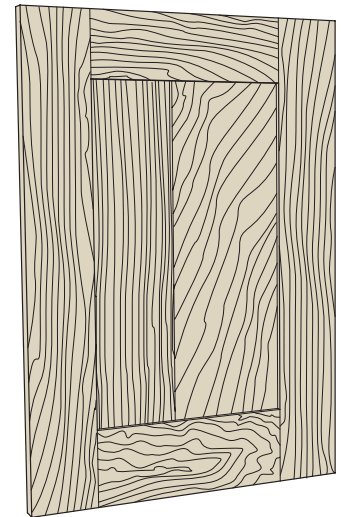

Disturbing noise. Wild grain, or grain running off the side of stiles and rails, detracts from the panel and the overall look. Mismatched panels should be avoided.

ONLINE EXTRAS

For links to all online extras, go to:

■ popularwoodworking.com/oct12

ARTICLE: Read “Why Wood Warps,” by Glen D. Huey, from the Summer 2009 issue of Woodworking Magazine.

MAGAZINE: For an in-depth look at “Composing With Wood Grain,” read the Spring 2009 issue of Woodworking Magazine.

Our products are available online at:

■ ShopWoodworking.com

Make a Chair That Rocks

BY JEFF MILLER

A little geometry and a simple prototype ensure a pleasant ride.

I recently set out to design and build a new rocking chair. I've designed and built a handful of rockers, but my past efforts didn't rock as well as I would have liked. I have confidence in my ability to make a comfortable "regular" chair, but it seemed like I was dealing with an entirely different problem with a rocker. So I decided to look a bit more carefully than before into what makes a rocking chair "work." I wanted to understand the geometry of a rocking chair in hopes that I could improve my overall results.

A rocking chair has a lot of factors in play. In addition to the usual requirements that a chair be structurally sound, comfortable and look good (these are my requirements at least), the rocker adds the challenge of dynamic motion. Does the chair tip back too far, or stay too upright? Does it rock back easily into a comfortable position, or does it take work to push the chair back? Does the rocking chair wander all over the room as you rock back and forth? Does it rock quickly, or is the rhythm more relaxed? Is it easy to settle into the chair? Is it possible to get up out of the chair without a huge effort?

Adding to those complications, I also noticed that, although the perceived comfort of any given (static) chair tends to be consistent for the majority of people, what's expected of a rocker seems to be a little more personal.

My "book" research was fascinating, although not very enlightening. There's



Rest in peace. A rocking chair should take some of the weight off your spine and soothe you with its rocking motion. The rockers and the center of gravity are key to the equation.

an awful lot of opinion, lore and conflicting information. Everyone who has made a rocker seems to have a strong opinion. Some people swear by a particular relationship between the seat and curve, or a special shape of curve for the rocker, only to be contradicted by the next person's opinion. There was little common ground in all the information. I think there are two main reasons for this. First, as I mentioned above, expect-

"Arguments with furniture are rarely productive."

— Kehlog Albran (fictional author)
"The Profit: Albran's Serial" (1973)

tations of what a rocking chair should be seem to be somewhat personal. And second, each chair really does seem to generate its own set of requirements.

What Makes a Rocking Chair Work

The most basic way to look at any rocking chair is to see it as the relationship between the center of gravity of the chair (plus the person sitting in it) and the shape of the rockers. What is a "center of gravity?" It's defined as the average location of the weight of an object. It also can be seen as the balance point of the entire object.

What it means in the case of a rocking chair is best explained with an example. Imagine a wheel standing on

edge that has a lead weight added to it somewhere between the center and the edge. Depending on how heavy the weight is in relation to the weight of the rest of the wheel, the center of gravity will shift a certain amount toward that weight. What happens to the wheel? It will roll so that the weight (the center of gravity) eventually ends up closest to the ground. If the wheel is shifted away from that position, it will always return there.

Of course, it won't settle there all at once, but will overshoot (due to inertia), then reverse and head back down, over and again until gravity and friction overcome the inertial forces and the wheel stops with the weight at the lowest point. The relative distance between the weight and the edge of the wheel will have a large effect on just how the wheel behaves, too.

Locate the weight close to the edge and it will settle there quickly. Locate it close to the center and the wheel will rotate much more slowly, farther and it will take longer to settle down.

Translating this back to an actual rocking chair, if you locate the center of gravity close to the center of the circle, you'll get a pretty wild ride, tipping way back then far forward; if it's too close to the rockers (the edge of the circle), you will just sit there.

This is the basic mechanism of the rocking chair. The location and orientation of the seat and the person – and therefore the center of gravity – in relation to the rockers control how it will rock. In reality, the exact location of the center of gravity varies, however, due to body type, body position and the configuration of the chair itself.

The chair influences this location not just through the seat and back positions, but also a little bit by the weight distribution of its components. Just where is the center of gravity? In general, the center of gravity of a person seated upright in a chair will be roughly an inch or so in front of the navel. But each chair is different, and not only is each person slightly different, but every sitting position (feet outstretched, feet tucked under, slouching, etc.) changes the location of the center of gravity.

The shape of the rockers themselves is a subject with even more contrasting

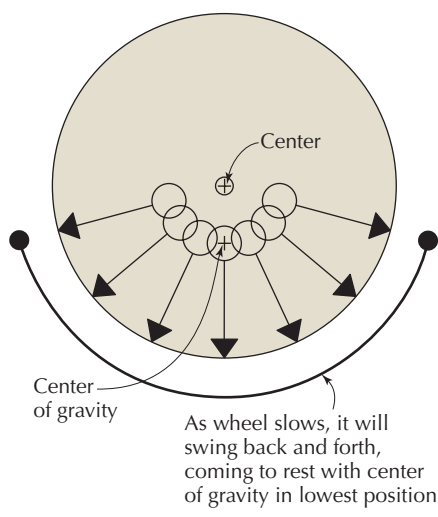

GRAVITY ROCKS

opinions and no clear answers. Suggestions abound for arcs of a certain radius, or an elliptical shape, or a catenary curve (the curve you get by hanging a chain or string between points), a cyma (which Sam Maloof called a cygnet curve due to its swan's neck shape), or some magical combination of the above. The essential fact is that very little of the rocker is actually involved in rocking.

A typical rocking motion only covers about 8" to 10" of the rocker. If you account for settling into the chair and for pushing it back pretty far, that might involve all of 14" of the rockers. This critical part of the curve is most likely very close to an arc of a circle, but slight variations can change the feel of the rock a little. Outside of the critical area, variations in the curve are either cosmetic or work to limit the possibility of tipping the chair over in an extreme situation (such as a child standing up on the chair and leaning back).

Of course, the radius of the arc is important in relation to the center of gravity. If the center of gravity is roughly 25" or 26" off the floor (a typical rocking chair would put it there), you can see that a rocker radius of only 30" would put the center of gravity close to the center of the circle. This would make for a very tippy chair (as well as a very odd-looking one).

At the other extreme, a rocker with a radius of 80" would tend to just sit there. A reasonable radius with this center of gravity would be in the 39" to

42" range. Why am I talking about the height of the center of gravity and not the seat height? The shapes and angles of rocker seats can be very different, and it's hard to define a consistent reference point that is significant from one chair to the next.

This may all create a better understanding of what's going on with a rocking chair, but despite that, not much practical information has emerged. You should be getting a little clearer understanding of why that is, though. Each chair really is different, and other than some basic parameters, it's difficult to apply any hard and fast rules to come up with a solution that works. In other words, there is no foolproof way to calculate how all of the various factors will come together.

Rocking Chair Goals

Let's look at what we want out of a rocking chair, then at how we can get there.

There are two main qualities that I think set a rocking chair apart from other chairs. First, the chair should tip you back to a position that takes pressure off your back. How does this happen? Sitting upright in a chair, your muscles are primarily responsible for keeping you upright.

As you tip back in a chair, your muscles don't need to work as hard to support your spine because the back of the chair, assisted by gravity, takes over more of that job. Assuming that the shape of the back is appropriate, this puts your spine in a relaxed and neutral position. And this feels good. What you want is for the chair to naturally tip you back to that neutral position (somewhere around 25° behind vertical seems to work well).

The other important quality is the rocking motion – the simple movement into and out of that neutral position when you move farther forward or back.

Why this rhythmic motion is so important is a little harder to explain. It seems to be naturally calming. It avoids the discomforts of sitting in a static position, works off nervous energy and is said to promote better blood flow. In terms of rocking chair design, the goal is simply to wind up with a rocking motion that feels comfortable.

Prototype to the Rescue

To sort all of this out into useful design information, I decided to do some hands-on research and build and play around with a functional prototype. This is something I encourage you to do as well before tackling a new rocking chair project. The prototype was fun to build, and extremely helpful.

I laid out a potential shape for the basic chair I wanted to build on two pieces of $\frac{3}{4}$ " plywood, roughly 21" wide x 40" long. I wasn't concerned with the look of the chair; I just wanted to get the positions of the seat and the back right to start with, then start my experiments with different shapes, sizes and locations for the rockers.

I made up a contoured seat by skinning a set of hardwood ribs with a piece of $\frac{3}{8}$ " bending plywood. If you plan to make a flat seat, just use another piece of plywood (you can attach it with cleats to the sides). I also happened to have a couple laminated slats that were quite comfortable left over from an earlier chair project. But for this purpose, it's just as good to cut some slats to shape.

I placed the seat where I thought it should go on one of the plywood sides, then marked out the locations for a pair of holes just below. I then put the two plywood sides back together, drilled $\frac{3}{8}$ " holes on my marks and inserted dowels so the seat would register in exactly the same place on both sides. I put the seat in place and screwed through the sides to attach it. I made up some cross pieces to hold the back slats, played around a little with the angle of the back slats then screwed the rails in place. The rough chair was comfortable. Break time. I had to think a bit about adding the rockers.

It's crucial on any rocking chair that the two rockers be shaped exactly the same and aligned perfectly with each other. The end result should be as if they were cut from the surface of a large cylinder. I started with two pieces of wood that were about 1" thick, $7\frac{1}{2}$ " wide and 36" long, and temporarily screwed them together face to face, with the edges aligned. Then I cut out and smoothed a potential shape, leaving the tops of the boards flat.

I used an approach similar to what I had used for locating the seat to be

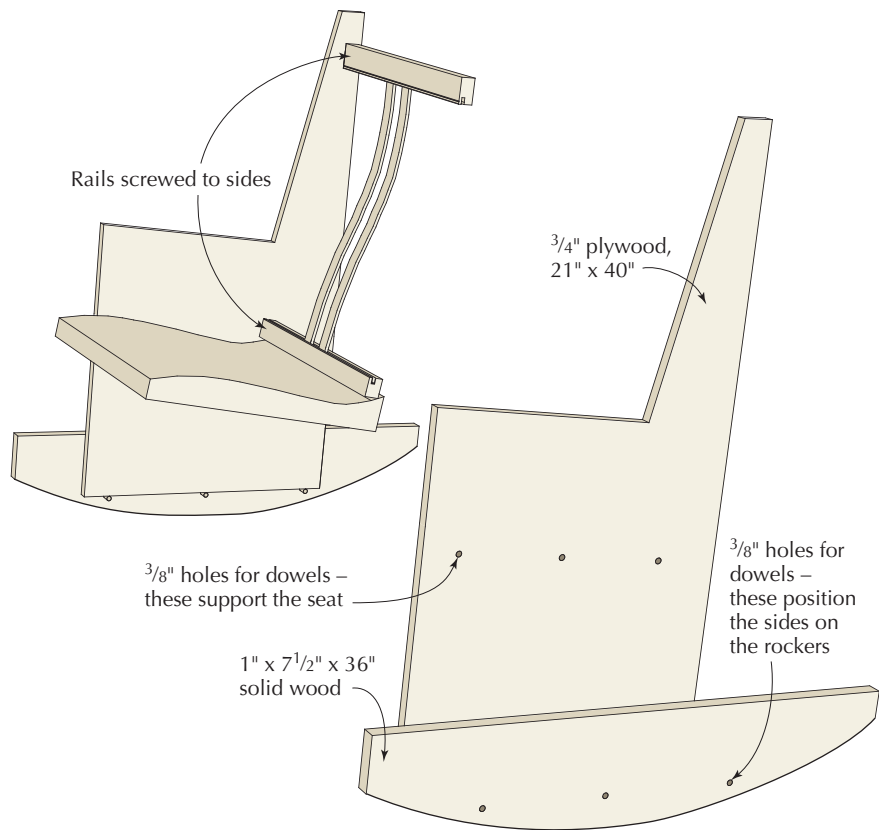

A ROCKING CHAIR MOCK-UP

sure I got the rockers properly aligned. Prior to separating the rockers I drilled a series of $\frac{3}{8}$ " holes $5\frac{1}{4}$ " down from the top edge. Inserting dowels into the holes on each side established a "track" so I could slide the set of rockers back and forth as needed along the bottom of the plywood sides. I just needed to measure from the ends an equal amount to line them up, then screw them into place. When I needed to move the rockers up and down, I simply drilled a new row of holes as necessary.

I experimented. The plywood and rockers got more holes as I tried different positions. I made up new rockers of different radii, and some different shapes. I adjusted angles. Finally, I made up a second prototype so I could compare two versions that seemed to work well.

What Did I Discover?

The prototype allowed me to isolate various elements of the design that I had been having trouble with before. I could play around with seat angles and

have that be somewhat separate from the height of the seat, and also from the way the chair rocked. To change the seat height I could either cut a little bit off the bottoms of the plywood sides or re-drill the rockers with a new set of holes.

I found it most helpful to be able to slide the rockers back and forth without having to think about leg lengths. Moving the rockers forward or back made predictable changes; the chair rocked back more easily as the rockers moved forward, and vice versa. I knew I had come upon a good configuration when I fell asleep in the chair at lunch one day.

Playing with the shape of the rockers also was interesting, although I thought that rocker location was the more significant factor. I found the difference between a 39" radius and a 40" radius very subtle. As I went larger or smaller, the differences were more noticeable. Smaller radii felt less stable; larger ones felt too unresponsive. And I did not notice huge differences with different rocker shapes. This was not altogether



Mock you to sleep. This mock-up of my rocker design allowed me to quickly change variables and immediately feel the outcome.

unexpected, because it is hard to see that much difference over the 8" to 10" of the rockers that actually come into play. For this particular chair I settled on a 39" radius.

Interesting, although less useful, was the realization that a perpendicular line drawn up from the point of contact between the rocker and the floor will pass through the center of gravity and



Where the action is. The 8" to 10" of curve below the seat is one of the key variables in the comfort of the rocker.

the center of the circle that generates the rocker arc. As I expected, this was not exactly the same when the chair was empty as it was with a person seated in it, but it was remarkably close.

The final version of the prototype worked well for most people. I was pesky about asking lots of students and visitors to the shop to try it out, and most found it comfortable. I did learn that preferences in arm height vary over a wide range, and that seemed to be the most common complaint from my testers. I had simply cut the plywood sides to a height that worked well for me. It would certainly pay to make adjustable arms if I were to do this again.

Turning the prototype into a real design was an interesting process. Somehow, I needed to pull all of the necessary information off the prototype. What I did wasn't anything fancy. I pulled one side off my prototype and traced all of the important elements – the rockers, the seat, the back and the arms – directly from the prototype to a piece of foam-core insulation that a neighbor had discarded (1/4" plywood is my usual choice).

I had an overall concept of the piece with its branching components, and I played around for a few hours filling in details around the pre-determined seat, back, arm and rocker locations

until I had a basic sketch to work with. A good eraser really helped with this! Then came the hard work of turning the sketches into a real piece of furniture.

The end results were very satisfying, although I did still have to do a little bit of functional tweaking on the actual chair design. I was surprised to discover that – at least with the design I came up with – those tweaks were minor, and the finished chair was actually quite close to the prototype. **PWM**

Jeff is a Chicago furniture maker and woodworking teacher at J. Miller Handcrafted Furniture (furnituremaking.com).

► **Go Online** FOR MORE ...

For links to all these online extras, go to:

► popularwoodworking.com/oct11

BLOG: Read Jeff's blog, which often deals with chair design.

ARTICLE: Read about a chair Jeff made where the seat and back are all screws.

WEB SITE: Visit greatchairdesign.com.

TO BUY: "Chairmaking & Design" by Jeff Miller.

IN OUR STORE: "500 Chairs: Celebrating Traditional and Innovative Designs."

Our products are available online at:

► ShopWoodworking.com

Get More Great Woodworking Resources!

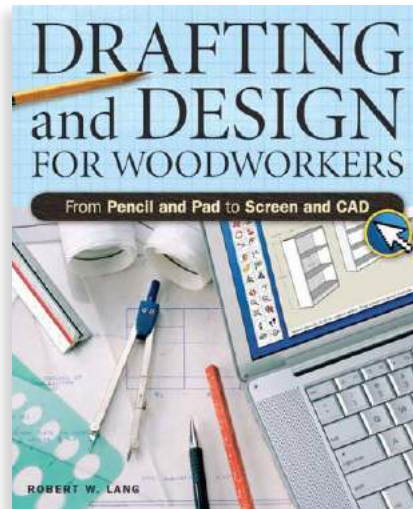

Your free download is an excerpt from the April 2013, October 2012 & October 2011 issues of *Popular Woodworking Magazine* and is just a sample of the great furniture-making content you can find in the ShopWoodworking.com store. Buy more projects today, and continue building your knowledge!

**Buy the full contents today,
and continue building
your knowledge!**