



Authors

Eva Haviarova, Associate Professor, Carl A. Eckelman, Professor, Department of Forestry and Natural Resources, Purdue University, and Daniel Warner, Technician

How to Build a Simple Chair for Schools or Homes in Disadvantaged Areas of the World Using Local Resources and Low-End Technology

Communities in developing countries have limited budgets for education. Even though they may provide a school building, they often don't have money to buy furniture to equip it. However, low-cost, durable, attractive school chairs can be produced in essentially any region of the world from locally available wood, wood residues, or semi-processed woody materials. These chairs could fill a need for economical, functional school furniture in developing countries.

The chair described here uses round mortise-and-tenon joints that can be made easily—yet have the tolerance and quality of fit of chair joints made in a first-class furniture factory. Production requires just two tools mounted in a lathe, drill press, or custom-made machine—a drill bit and a hole saw. Other kinds of joinery (square mortise and tenon, dowels, etc.) require more involved processes and are much more difficult to produce accurately. Use of a shrink-and-swell fit (discussed later) allows a chair to handle extreme seasonal changes.



Chair Parts List				
Part	Dimension (in)	Dimension (mm)	Material	Qty.
Stretcher	.875 x .875 x 14	23 x 23 x 355	Dense wood	10
Seat Stretcher	.875 x 1.5 x 14	23 x 35 x 355	Dense wood	1
Top Back Stretcher	.875 x 2.25 x 14	23 x 63 x 355	Dense wood	1
Bottom Back Stretcher	.875 x 1.5 x 14	23 x 35 x 355	Dense wood	1
Front Leg	1.5 x 1.5 x 13.25	35 x 35 x 335	Light wood	2
Back Leg	1.5 x 1.5 x 26	35 x 35 x 660	Light wood	2
Seat	14.75 x 15.5 x .75	375 x 394 x 19	Panel product	1
Carriage Bolt & Nut	diam. 0.5 length 1.5	diam. 13 length 38		2 each

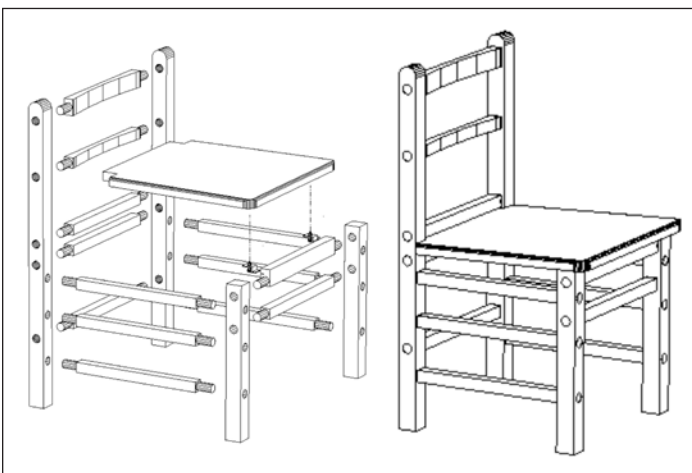

Lumber Selection

This chair design lends itself to using what are normally considered inferior wood materials. It is well suited for use of plantation wood and packing materials, as well as scrap material from commercial or industrial sources. Ideally, a two-species mix of wood is appropriate. The legs, both front and back, can be made of any soft, light, wood that is readily available. Because the legs have substantially more cross section than any of the other pieces, the strength of the wood is not as important.

The stretchers that run from front to back are especially important, however, and should be made of a harder, denser wood. These pieces should have straight grain along the entire length of the piece since severe cross grain will severely weaken them. Knots that are less than half the cross section of a piece are permissible as long as they are healthy and occur in the middle, not close to the ends where the joinery is cut.

Lumber Preparation

Parts made for the chairs must be cut as accurately as possible. Accuracy can be difficult to achieve without the proper equipment. The opposite long sides of the piece **must** be parallel and consistent in dimension from one piece to the next. These parts do not necessarily need to have a clean face like that produced by a planer or jointer, although this would add to the aesthetics of the chair. However, any twist or taper along the length of the piece may cause problems in the final assembly of the chair. If lumber dimensions are consistent piece-to-piece, setup and production runs produce more accurate parts.

If the equipment is available, the first step is to cross cut the material to length. Then rip it on a band saw to an oversized dimension. This band-saw setup can insure a rough thickness and width in one setup for most of the parts since only three parts are not square. Finally, joint and plane the piece. As in ripping on the band saw, planing can be done on the two edges not cut by the jointer, which eliminates the need for an additional machine setup. If no planer or jointer is available, parts should be ripped to final size on a saw.

Machines for Making Joinery

To cut the tenons, some sort of lathe, drill press, or custom-made machine must be used. Each style of cutting is explained below.

Lathe

For a typical lathe, make a sliding table that rests on the bed of the lathe that can move back and forth on the ways toward or away from the spindle. This table should be vertically adjustable and should have a fence and clamps that hold the piece to be machined in place. Set the fence (and thereby, the piece to be machined) so that it is parallel to the axis of the spindle. Mount a standard drill chuck in the headstock—and mount the hole saw in the drill chuck. The tenons are cut when the table is moved toward the hole saw.



Lathe with table setup to cut tenons

Drill Press

A drill press can also be used to cut the tenons provided the drill press is fitted with a cross-slide vise. The cross-slide vise holds an angle plate. The angle plate has a simple drill-press vise mounted to it that holds the work vertically. With the cross-slide vise, material can be located under the spindle of the drill press. Compared to a lathe, this drill-press setup makes it easier to cut pieces that require a variance in tenon location. However, this setup is not as rigid as a lathe setup.



Drill press setup with cross-slide vise, angle plate, and vertical vise

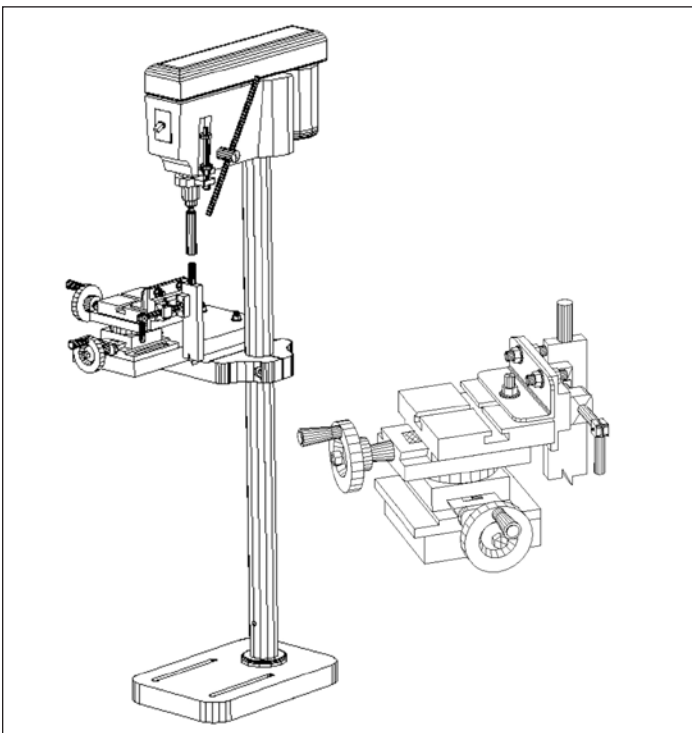

Custom Machine

You also can make a simple machine that cuts the tenons. This is ideal when machines are hard to come by and a shop that can make the machine is present near the worksite. This machine is similar in concept to the lathe. The hole saw is mounted in a drill chuck on the end of a motor. A bed and a sliding table are constructed so that the table slides parallel to the spindle. The sliding table has two tongues, one on each side, that fit into corresponding grooves in the sides of the two bed pieces of the table. You can construct this machine out of wood or metal.

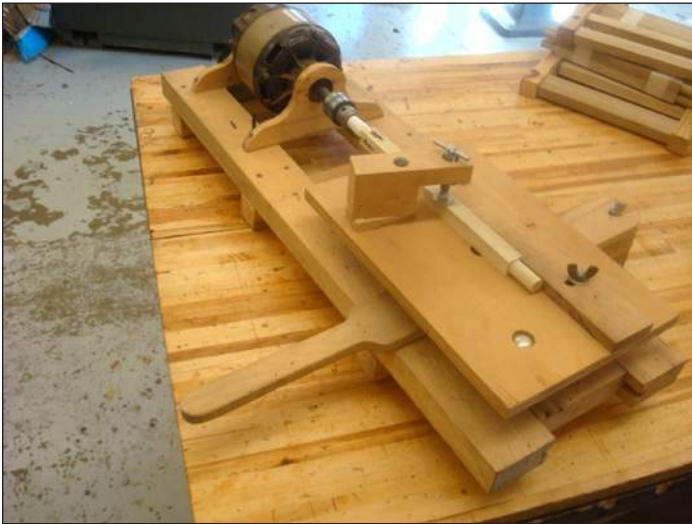
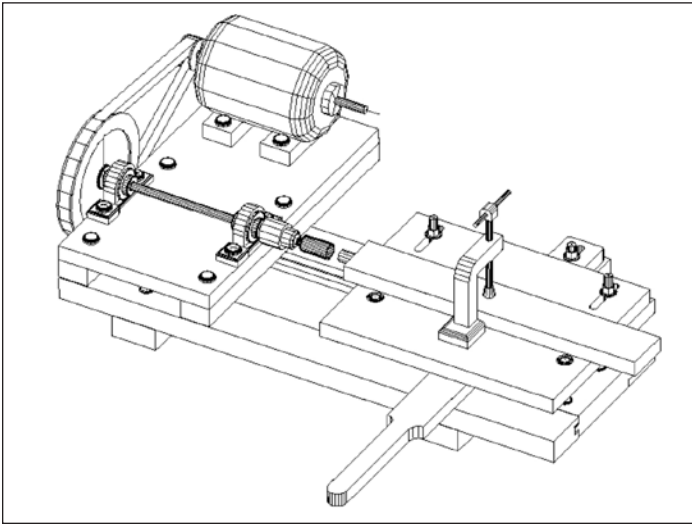

Custom-made machine

Tenons

After the tenons have been machined with a hole saw, the shoulders must be trimmed. Use a jig that supports both ends of the piece near the tenons. One end of the jig is fixed, whereas the other is adjustable. Align the fixed end with the band saw so that the shoulder is cut at the root of the tenon. Take care not to cut too deep. Cutting into the tenon severely weakens it. If a plug cutter is used as a cutting tool, shoulder cleaning is not an issue. However, the plug cutter is a more costly tool and does not provide a shoulder.

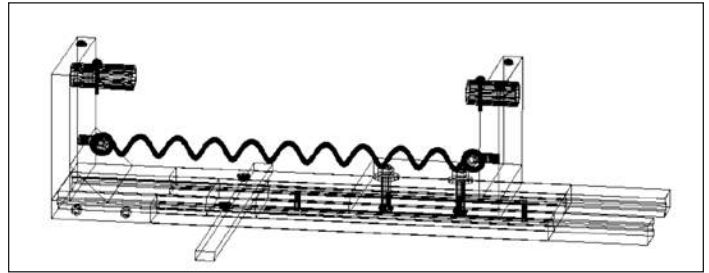

Trimming the tenons on a band saw with a jig

Mortises

The mortises are easily cut using a drill press and the jigs described here; however, when equipment is scarce, the lathe or custom-built tenon cutter can be adapted to drill the mortises.

One jig may be provided for drilling the holes. This jig consists of a stick of lumber with holes bored on two sides. A dowel fits into one of these holes and acts as a stop for the bottom or top of the leg when it is laid flat on a drill-press table. Each additional hole corresponds to a different hole location in the chair leg. To use the jig for some of the holes, it must be rotated 90 degrees. The jig is also marked with a center line, which should be centered on the drill. Also, the edge of the jig should be exactly half the thickness of the leg material away from the center of the drill bit.

If no jig is provided, do the following. First, mark on each front and back leg the exact position of every hole, measuring always from the bottom of the leg (ground up). Then, set up the drill press with a fence and stop, and drill the first hole in one of the legs. Without moving the stop, drill all the matching holes in each of the other three legs.



Dowel pin jig

Move the stop for each hole location and repeat. Note that on the sides of the chair the front and back legs have three stretchers that use the same setup, and so for three of the setups all four legs of the chair must be drilled.

A 23/32 (18 mm) bit drills the appropriate size hole if a standard whole saw of 7/8 inch (19.7 mm) is used to make the tenons. Occasionally, you may need to use a bit 1/64 inch (0.4 mm) larger or smaller. This largely depends on the machining properties of the wood used for the legs and stretchers. When drilling and dry-testing a joint, it should fit so that the tenon goes half way into the mortise with little more than hand force.

On the top front stretcher, two holes must be drilled and counter-bored. These are for the carriage bolts that attach the seat.

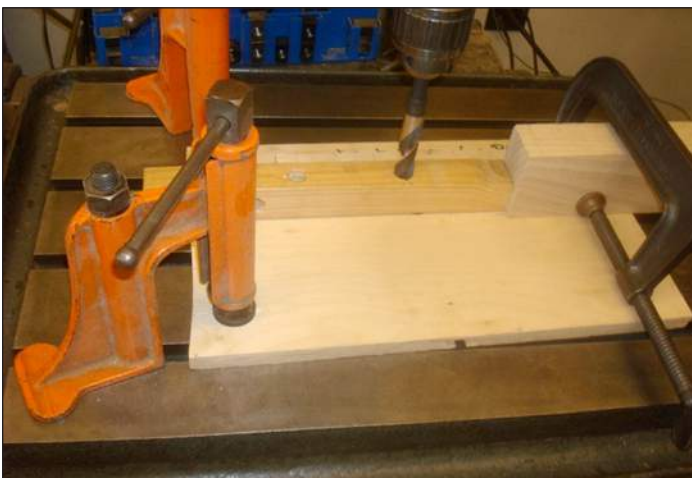

Alternate method of drilling mortises

Assembly

You can assemble a chair with glue or with a shrink-and-swell fit. The shrink-and-swell fit is done by drying the stretchers in an oven for 6 to 10 hours at around 190–215 degrees F (90–100 degrees C). When they come in contact with the much higher moisture content legs, the joints swell and tighten over time.

The assembly process is generally easy, if all parts have been machined properly. First, the front and back frames are assembled, and then the side stretchers are added to join the two ends.

To assemble the front frame, coat the walls of the holes with glue. A PVA type of glue is best. Good glue coverage insures a strong joint. Too much glue can make a mess and cause an unsightly finish.

Coat the tenons with glue and insert them into the holes quickly. Make sure the stretchers, especially the top stretcher, are oriented properly. Once the stretchers are between the two front legs, use a bar or pipe clamp to



Bar clamp used to incrementally bring legs together

press them together until the legs are seated against the shoulders of the tenons. Use of bar clamps is preferred to seating the parts in place with a hammer since hammering often damages the frame. A gentle twisting of the frame usually corrects a half that does not lie flat.

The rear frame uses the same procedure as the front—but take extra care to make sure that all the stretchers are in the right orientation. When placing the back frame into the bar clamp, move it up and down between and over the stretchers and move the two legs together incrementally. If this is not done, either the leg or the stretcher will crack. Now that the front and back are assembled, glue and insert all six of the side stretchers. Again, move the clamp as needed and bring the front and back together incrementally.

Once the main frame of the chair is assembled, the seat can be fitted and bolted down. After some final sanding to clean up the surfaces and break the sharp edges, the chair is ready for finish (wipe-on polyurethane finish is the preferable option, however any other finish could be considered).



Method for twisting front legs so they lay flat

Jan 2015

It is the policy of the Purdue University Cooperative Extension Service that all persons have equal opportunity and access to its educational programs, services, activities, and facilities without regard to race, religion, color, sex, age, national origin or ancestry, marital status, parental status, sexual orientation, disability or status as a veteran. Purdue University is an Affirmative Action institution. This material may be available in alternative formats.