



Essential Cabinetmaking Techniques



YOUR FIRST Cabin



I've built hundreds of single-door cabinets like this one. Some people use them as spice cabinets. Others use them in the bathroom as a medicine cabinet.

As I was building this particular cabinet, it occurred to me that it would be an excellent project for beginners. It has all the traditional components of larger-scale cabinetry, yet it doesn't need a lot of material or tooling. Once you've built this cabinet, you can build something bigger using the same principles.

Intermediate woodworkers might also pick up a trick or two because I build my cabinets just a bit differently.

Choose Your Wood

I used tiger maple for this project, but if this is your first cabinet, you might want to use poplar and then paint the finished item. Poplar is easy to work with and less expensive than maple, especially if the maple has some figure.

As in larger cabinets, most of the major components are made from $\frac{3}{4}$ "-thick stock: the case sides, top, bottom, plus the rails and stiles for the door and the face frame. This cabinet has a solid wood shiplapped back that's made from $\frac{1}{2}$ "-thick pieces; the door panel is $\frac{5}{8}$ " thick.

Face Frame: the Place to Start

It seems logical to begin by constructing the case. Don't. The size of your case and door are all determined by your face frame. Build it first and then you'll use your face frame to lay out your case and door. All face frames are made up of rails and stiles, much like a door. The stiles are the vertical pieces. The rails are the horizontal pieces that go between the stiles.

When you rip your stiles to width on your table saw, make the rip $\frac{1}{16}$ " wider than stated on the Schedule of Materials. You need this extra to overhang the sides of your case so you can trim it flush with a flush-cutting bit in a router. Once your pieces are cut to size, join the rails and stiles using mortise-and-tenon joints.

Begin by cutting the tenons on the rail ends. I know the books say to cut the mortise first, but I've found it's easier to lay out your mortises after your tenons are cut. Try it, and I think you'll agree.

by Troy Sexton

Troy Sexton designs and builds custom furniture and is a private woodworking instructor in Sunbury, Ohio, for his company, Sexton Classic American Furniture.

Troy is a contributing editor for Popular Woodworking.

Photo by Al Parrish

et

If you've never built a face frame cabinet, learn the tricks that ensure a square-looking case, tight joints and doors that work as you build this small spice cabinet.



SCHEDULE OF MATERIALS: SPICE CABINET

No.	Item	Dimensions T W L
2	Face frame stiles	3/4" x 2 1/4" x 30"
1	Top face frame rail	3/4" x 2 7/8" x 15 1/2"
1	Bot face frame rail	3/4" x 1 1/2" x 15 1/2"
2	Door stiles	3/4" x 2 1/2" x 25"
1	Top door rail	3/4" x 2 1/2" x 9 7/8"
1	Bot door rail	3/4" x 3 1/2" x 9 7/8"
1	Door panel	5/8" x 8 3/8" x 19 1/2"
2	Case sides	3/4" x 6" x 30"
2	Top & Bot	3/4" x 5 1/2" x 17"
4	Shelves	3/4" x 5 7/16" x 16 7/16"
	Back boards	1/2" x 17" x 30"
	Top moulding	3/4" x 2" x 36"

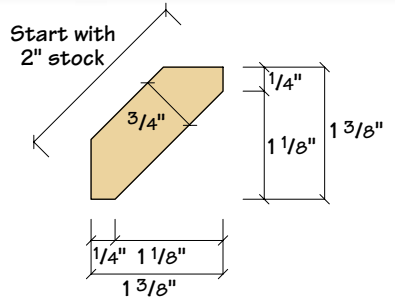
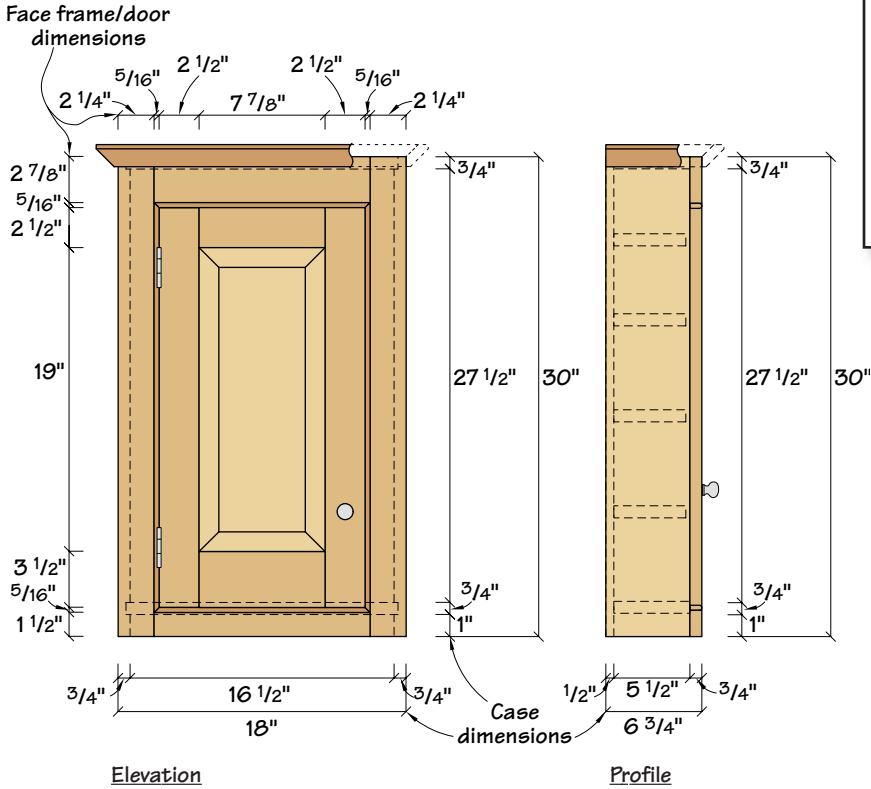

The tenons should be 3/8" thick (one-half as thick as your stock), centered on the rail and 1" long. I cut 1/2" shoulders on the tenons. If they're any smaller, the mortise might blow out. Now use your tenons to lay out your mortises on the stiles. Hold the tenon flat against the edge where the mortise will go and use the tenon like a ruler to mark your mortise.

Now cut your mortises. Make them all 1 1/16" deep, which will prevent your 1"-long tenons from bottoming out. You don't want your tenons to wobble in your mortises, yet you don't want to have to beat the tenon in place.

Dry-fit your face frame, then put glue on the mortise walls and clamp it up. While you're waiting for it to dry, turn your attention to the bead moulding that goes on the inside edge of the face frames.

Years ago, I used to cut the beading into the rails and stiles. Then I would have to miter the bead and cut away the beading where the rails and stiles were joined. It sounds like a pain, and it was. Now I simply make my bead moulding separate from my face frame and miter, nail and glue it in place. It looks just as good.

To make the bead moulding, put a 1/4" beading bit in your router and mount it in a router table. Then take a 3/4"-thick board that's about 4" wide and cut the bead on one edge. Take that board to your table saw, set your rip fence to make a 3/8"-wide cut and rip the bead from the wide board. Repeat this process three more times.



Adding this beaded moulding to the inside of the face frame creates a nice shadow line around the door. Miter, glue and nail it in place. Don't forget to putty your nail holes.

Fit your door in the face frame before you attach the face frame to the case. Everything lays flat on your bench as you work. You'll find this procedure is a faster and easier way to get perfect results.



Now take your strips and run them through your planer to reduce them in thickness to $\frac{5}{16}$ ". Miter the corners; then glue and nail them in place. Sand both sides of your face frame with 100 grit sandpaper and move on to building the door.

The Door

Why make the door next? Well, for one thing, it is easier to hang your door in your face frame before you nail the face frame to your case.

I build my doors so they are the same size as my opening, then I shave off a little so there's a $\frac{1}{16}$ " gap all around. This way if the door or face frame is out of square, I can taper the door edges to fit, hiding my error.

The door is built much like the face frame, using the same size mortises and tenons. The biggest difference is that you will need to cut a groove in your rails and stiles for the door panel, so your tenons must be haunched. A "haunch" is a little extra width in the tenon's shoulder that fills in the groove on the end of the stile.

Begin by cutting a $\frac{3}{8}$ "-deep x $\frac{3}{8}$ "-wide groove down the center of one long edge of your rails and stiles. Cut your tenons on your rails. Then cut your mortises on your stiles. Dry fit the pieces together and measure how big the center panel should be.

You want the panel to float to allow seasonal expansion and contraction, so cut the panel to allow $\frac{1}{8}$ " expansion on either side. Now raise the door panel using your table saw or a cutter in your router table. Practice on scrap pieces of $\frac{5}{8}$ " stock so you achieve the right lip, angle and fit.

When the panel is complete, sand the raised section, then glue up the door. Be careful not to get any glue in the groove that holds the panel. When the glue is dry, hang the door in your face frame.

Finally, the Case

The case is simple. The top and bottom pieces fit into $\frac{1}{4}$ "-deep dados and rabbets on the sides. The back rests in a rabbet on the sides and is nailed to the back edge of the top and bottom pieces.

You'll use your face frame to lay out



Here you can see how the bottom of the case acts as a door stop. This is one of the reasons I build my face frames first: I can make sure my bottom will be in perfect position.



Fit the face frame on the case. The stiles should hang $\frac{1}{16}$ " over the edge of the case so you can rout (or plane) them flush later.

your joints on the sides. You want the bottom piece to end up $\frac{3}{16}$ " higher than the top edge of the bottom rail on your face frame. This allows your bottom to act as a stop for the door. Mark the location of that $\frac{1}{4}$ "-deep dado and cut. The top piece rests in a $\frac{1}{4}$ "-deep x $\frac{3}{4}$ "-wide rabbet on the sides. Cut that using your table saw. Then cut the $\frac{1}{2}$ "-deep x $\frac{1}{4}$ "-wide rabbet on the back edge of the sides.

Drill holes for shelf pins and space them 1" apart on the sides. Sand the inside of the case. You'll notice that the top and bottom are $\frac{1}{2}$ " narrower than the sides. This is to give you a good place to nail the back pieces to the case. Assemble the case using glue and nails, making sure the top, bottom and sides are all flush at the front.

Attach the face frame to the case using glue and nails. Trim the face frame flush to the case using a bearing-guided flush-cutting bit in your router. Finish sand the cabinet to 180 grit.

Take your scrap pieces and use them to make a shiplapped back. Cut a $\frac{1}{4}$ " x $\frac{1}{2}$ " rabbet on the edges and then cut a bead on one edge using a $\frac{1}{4}$ " beading bit in your router table. You want to give the back pieces room to expand and contract, about

$\frac{1}{8}$ " between each board should be fine.

Cut the moulding for the top so it resembles the drawing detail at left. Finish sand everything, then nail the moulding to the top.

I like to peg the tenons in my doors to add a little strength. Drill a $\frac{1}{4}$ " diameter hole most of the way through the stile and tenon. Then whittle a square piece of stock so it's round on one end, put glue in the hole and pound it in place. Cut the peg nearly flush. You want it to be a little proud of the stile — it's a traditional touch.

Break all the edges of the case with 120-grit sandpaper, and putty all your nail holes. Paint, dye or stain the all the components (I used a water-based aniline dye). Then add two coats of clear finish and nail the back pieces in place. Hang the cabinet by screwing through the back boards into a stud in your wall. **PW**

SUPPLIES

Rockler 800-279-4441
#31495 hinges for door, \$5.79/pair

Horton Brasses Inc. 800-754-9127
#K-12 w/MSF (machine screw fitting), call for pricing



Photos by Al Parrish

A PRACTICAL Shop Cabinet

Easily organize, store and transport all your small woodworking accessories with this clever cabinet and inexpensive plastic tackle boxes – instead of drawers.

by Troy Sexton

Troy designs and builds custom furniture in Sunbury, Ohio, for his company, Sexton Classic American Furniture. He is a contributing editor to Popular Woodworking.

One of my favorite things to do when I have free time is to tinker around my shop, organizing my small stuff. I actually enjoy sorting through nails, bits and staples; and a pile of differently sized screws all thrown together drives me crazy. For this reason, I have become fond of Plano's plastic utility boxes. I have about 100 of them.

This might seem excessive, but I also use the boxes to organize and store fishing lures. In fact, these boxes often are advertised as miniature tackle boxes.

Any woodworker or angler knows that the amount of screws, nails, bits and lures one owns tends to grow exponentially, resulting in a lot of little stuff. (After sorting through



Cutting the dados is simple work with a dado set installed in your table saw. Cut four dados (one on each side piece and two on the divider), move the fence, then cut four more and so on.



Some heavy-duty screws will ensure this cabinet will stay put, even when fully stocked.



Two screw strips, one on the top and one on the bottom, allow you to screw your cabinet to your shop wall. Notice the notch cut into the divider to allow the screw strip to fit.

my fishing lures recently I realized I own almost 1,000.) Plano's boxes have dividers to keep everything organized and they're easy to carry around the shop, to a job site or on a boat. However, 100 loose boxes is a bit like a pile of differently sized screws. I needed a box to organize my boxes. The cabinet you see here is the result.

This project is simple and quick to build—as a shop project should be. The plastic boxes merely slide in and out on pieces of Masonite that are slipped into dados cut on the inside of each side piece and both sides of the cabinet's center divider. The cope-and-stick doors are entirely optional.

While any miniature tackle box will work, this cabinet fits

Plano's 3700-series utility boxes. For more information, see "About Plano Utility Boxes" below.

Rows of Dados

Cut the poplar top, bottom, sides, divider, plywood back and Masonite shelves to size, as stated in the cutting list. Now it's time to cut the dados. Install your dado stack in your table saw. The dados are $\frac{1}{4}$ " wide by $\frac{1}{4}$ " deep so you need only the outside cutters. There's no need to mess with chippers or shims.

I spaced my dados $2\frac{1}{4}$ " apart. You need to cut each dado on the inside of each side piece and on both sides of the center divider. Cut the first dado in the four places required, adjust your fence and then cut the next one. You're cutting 11 dados on each piece, which amounts to 44 dados. This method ensures you move your fence as little as possible.

With the dados complete, cut a $\frac{1}{4}$ " x $\frac{1}{4}$ " rabbet on the rear edge of the side pieces that will hold the $\frac{1}{4}$ "-thick plywood back.

Assembling the Cabinet

Once the dados are cut, round over the edges of the top and bottom pieces using your router and a $\frac{1}{2}$ "-radius roundover bit. Sand all the case pieces to #180 grit.

Lay out where the sides and divider will go on the top and bottom, as shown in the illustration

at right. Use these layout lines to drill your clearance holes, then screw the sides, top and bottom (but not the divider) together with #8 x 2" screws.

You need two screw strips to hang the cabinet on the wall—one on the top and one on the bottom, as shown in the drawing. While the screw strips fit between each side piece, you must first notch the center divider to make it work. Using your band saw, cut a $\frac{3}{4}$ "-wide by $1\frac{1}{2}$ "-long notch at the top and bottom of the back side of the divider. Screw the divider in place and then nail the screw strips in place as well, as shown above.

If you did everything correctly, the $\frac{1}{4}$ "-thick plywood back should fit snugly between each side piece and flat against each screw strip. Basically, it fits into a $\frac{1}{4}$ "-deep rabbet you created when assembling the cabinet. Cut your back to size, sand it smooth and, using your brad nailer, nail it in place.

Cope-and-stick Doors

The doors are optional. In a shop, they'll keep the boxes from getting dusty. Plus, they show off your craftsmanship. If and how you make them is up to you.

I made my two doors using stile-and-rail cutters on my router table. I used my table saw to raise the panel. First, cut all your door parts to size. Then, using your rail bit (sometimes called the cope-

cutting bit), cut the tenon on the four rails. Then cut the beaded moulding profile and groove on your four stiles with the stile bit from your stile-and-rail bit set.

It's always a good idea to do test cuts when using stile-and-rail bits. If you want additional instruction on using stile-and-rail bits, check out my "Frame & Panel Dresser" story in the February 2005 issue.

To raise the panel, head to your table saw and bevel the blade to 7°. Adjust the rip fence to leave a shoulder on the panel at the top of the blade and a thin-enough edge to fit into the grooves you just cut in your stiles and rails. Again, cutting a test piece first is a good idea to ensure a snug fit.

ABOUT PLANO UTILITY BOXES

I built this cabinet to hold any of the plastic utility boxes in Plano's 3700 series. I've been using Plano utility boxes for years and they work great. The 3750 has a good, solid latch and the 3770 is perfect for storing a combination of woodworking and fishing accessories. Most cost less than \$5 each and can be found at any large sporting-goods store. For more information about the boxes, call 800-226-9868 or visit planomolding.com. —TS

SUPPLIES

Plano
800-226-9868 or
planomolding.com

- plastic utility boxes
3700 series, price varies

Rockler
800-279-4441 or
rockler.com

- 4 • partial wrap-around hinges
#31495, \$6.39/pair
- 2 • narrow magnetic catches
#26559, \$1.49/each
- 2 • classic wooden knobs
#15257, \$3.39/pair

Prices correct at time of publication.

Sand the panels to #180 grit before gluing them up in the frame-and-panel assemblies. Don't sand the inside edges of the rail-and-stile pieces at the point where they mate to form the joints. You could easily create an ugly gap.

Glue up the door assemblies. It's a loose-panel assembly, so don't glue the frames' grooves. As the seasons change, you want your panel to expand and contract.

I used four Amerock partial wrap-around hinges to attach the doors to the cabinet and two magnetic catches to keep them shut. Don't forget the wooden knobs.

Initially I painted my cabinet

yellow, which is the color shown here. But I decided I didn't like the yellow, so later I painted it black and then distressed the finish. There's no need to finish the Masonite shelves. Simply cut them to finished size and slide them into place.

This cabinet is the perfect solution for my woodworking and fishing storage needs. Whenever people visit my shop they comment on its ingenuity. It's so simple! There's only one problem: I didn't build this cabinet big enough. I'm currently working on a chimney cabinet design to resolve this issue. **PW**

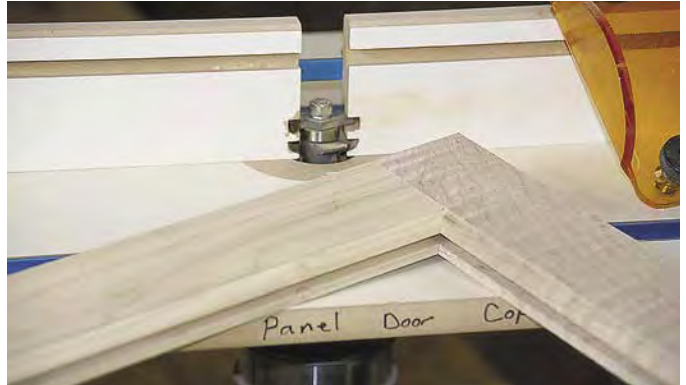

I built my cope-and-stick doors using a stile-and-rail bit set in my router. The doors are optional and can be made however you wish.

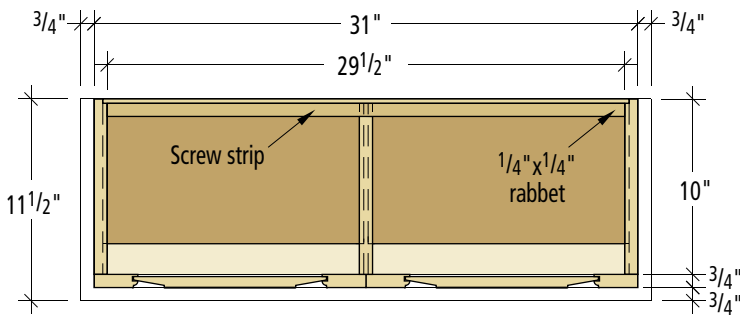

Plan - top removed

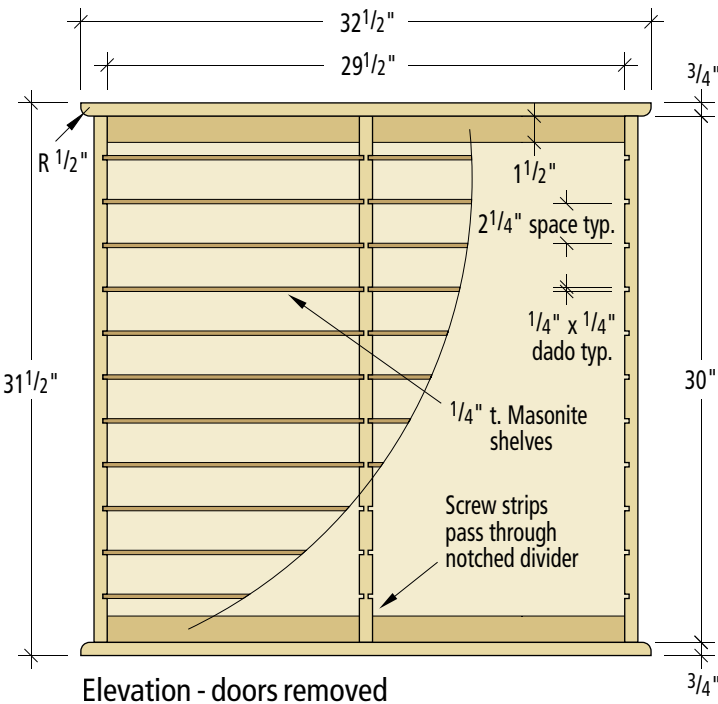

Elevation - doors removed

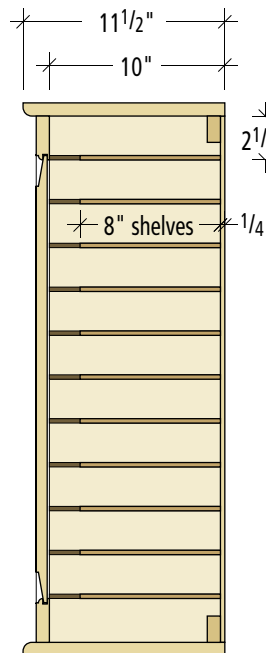

Section

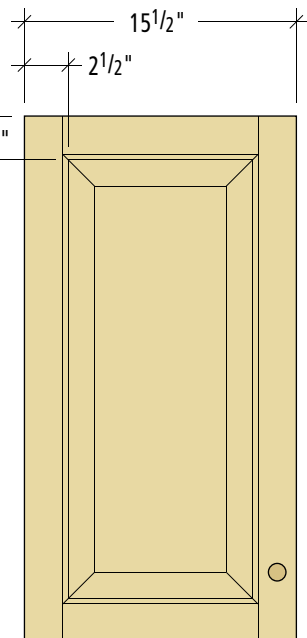

Door elevation

A PRACTICAL SHOP CABINET

NO.	ITEM	DIMENSIONS (INCHES)			MATERIAL
		T	W	L	
1	Top	3/4	11 1/2	32 1/2	Poplar
1	Bottom	3/4	11 1/2	32 1/2	Poplar
2	Sides	3/4	10	30	Poplar
1	Divider	3/4	9 3/4	30	Poplar
1	Back	1/4	30	30	Plywood
22	Shelves	1/4	8	14 13/16	Masonite
2	Screw strips	3/4	1 1/2	29 1/2	Poplar
4	Door stiles	3/4	2 1/2	30	Poplar
4	Door rails	3/4	2 1/2	11 1/4*	Poplar
2	Door panels	3/4	11 1/8*	25 11/16*	Poplar

*Finished size will vary depending on your set of rail-and-stile bits.



Under- the- Table **Saw** **Cabinet**

The first secret to creating a pleasant, productive woodshop is to get rid of your power tool stands. I mean that sincerely. Unless you pay a zillion dollars for top-of-the-line tools, the stands that come with most woodworking machines are engineering afterthoughts. The dead space beneath them wastes one of the most precious commodities in your workshop: space to work.

So the second secret is to replace each stand with something that does more than hold the tool up in the air. With a little ingenuity, you can create a stand that provides convenient storage for accessories, additional work surface, dust collection, and maybe even holds a second tool. It doesn't have to be a piece of fine cabinetry — a plywood box with some shelves and drawers is infinitely more useful than those skinny metal legs that come with most power tools.

The cabinet that cradles my table saw shows some of the possibilities. Although its odd shape makes it look complex, it's built up from three simple boxes. The largest box (the base) has a few shelves where I store the larger accessories. It also serves as a dust collector. The table saw rests over a cut-out in the top of the box. Wood chips fall down through this cut-out, slide down an inclined board, and are whisked away through a shop vacuum hook-up.

The box on the left side holds frequently used accessories: push sticks, saw inserts and a miter gauge. A notch in the sides of this box keeps my saw fence ready when I'm not using it. The box on the right has a few drawers where I keep stuff I don't use as often: saw blades, a dado cutter, a moulding head and some alignment tools.

I replaced the saw extension on each side of the table saw with the cabinet tops. These tops are

Oodles of storage, built-in dust collection, doubles as a huge router table — what more could you want?



To make the odd-shaped cabinet, I attached three plywood boxes to each other. Each box has shelves and drawers for storage. The base box includes a dust collector.

By Nick Engler

Nick is a contributing editor to Popular Woodworking, the author of 52 books on woodworking, and an inventor of woodworking tools, jigs and fixtures. His most recent project, a flying full-size replica of the Wright Brother's 1902 glider, is making its rounds to schools and museums across the country.



The saw cabinet offers plenty of storage, even a place to keep the fence when it's not in use.

made from medium density fiberboard (MDF) and covered with plastic laminate to make them more durable. The right top is a shade over 4-feet long to accommodate my saw's Unifence and to increase my ripping capacity. There's also a cut-out in this top that holds a router, making the saw stand double as the mother of all router tables.

For all the capability and convenience that a homemade tool stand like this offers, it's not a difficult project to build. The first step is to adjust the size of the cabinet to your table saw. The dimensions shown here are just suggestions. Start with the most important dimension: the height of the saw table above the floor. I made this cabinet to hold the saw table at 34", but

you may prefer it a little higher or lower. Also decide whether or not you need your saw to be mobile. I need the mobility, so I mounted the cabinet on 3" swivel casters. Without the casters, I would have made the cabinet a little taller.

The joinery is simple and straightforward. The plywood box parts interlock

with a few dadoes and rabbets, as shown in the Box Joinery Detail (right). This makes a strong, solid construction.

The doors are mounted with "overlay" cabinet hinges, covering the front edges of the boxes. I made frame-and-panel doors because I like their looks, but you don't have to get that fancy. Simple slabs of ply-

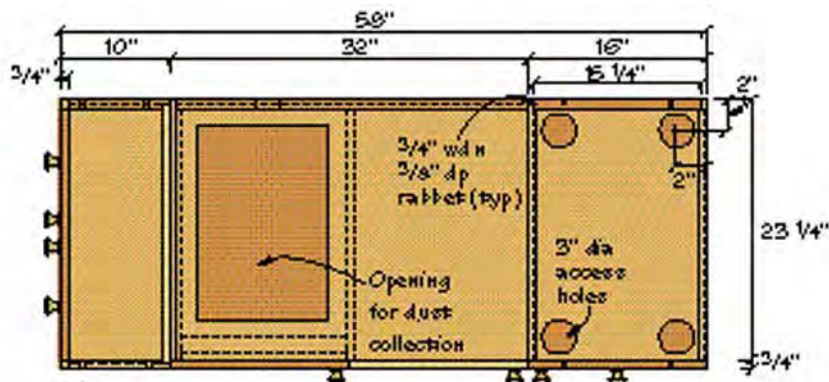

Plan
(without cabinet tops)

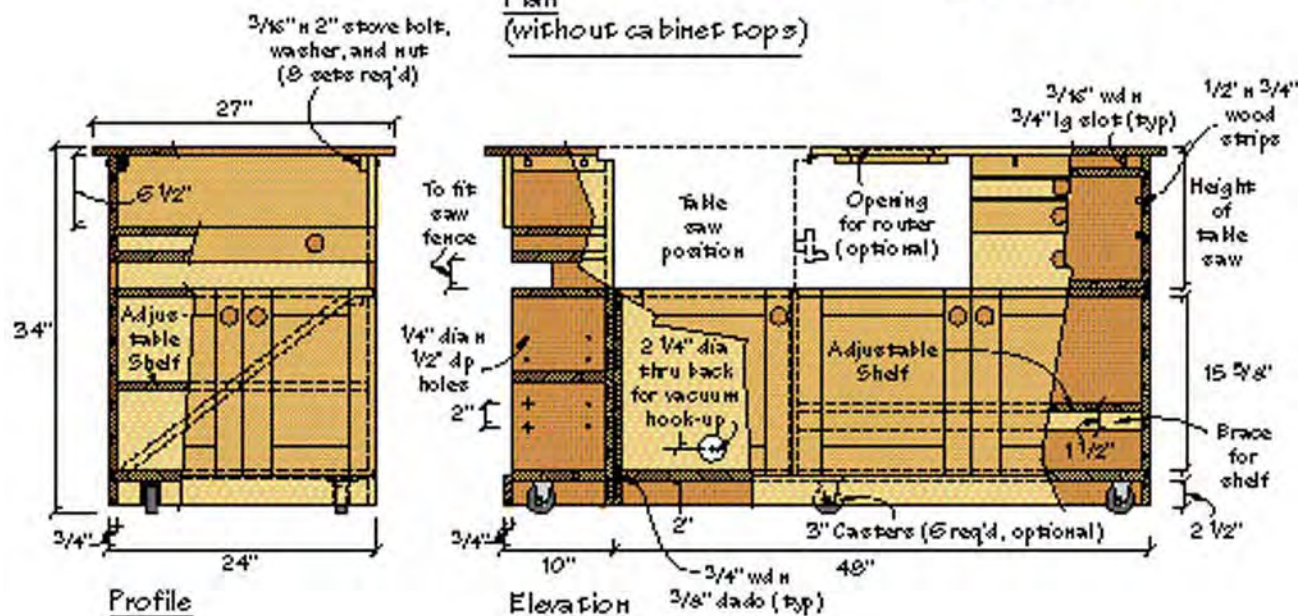

Profile

Elevation

The right cabinet top has a cut-out for a router, letting the saw stand double as a router table. For routing operations, I bolt a router table fence to the saw fence (right).

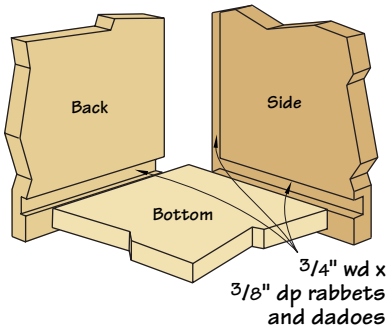
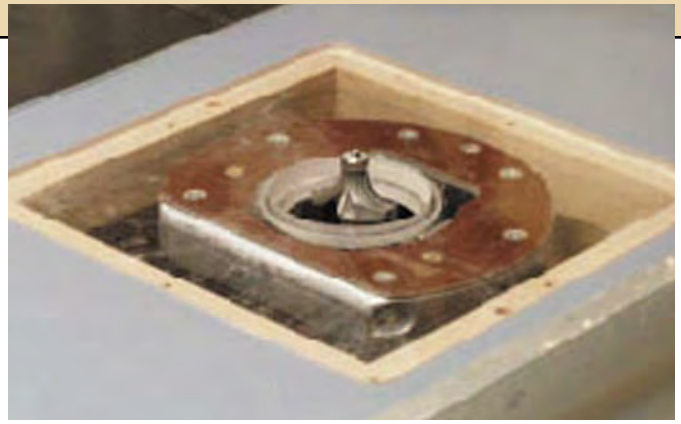

Box Joinery Detail

wood make fine doors.

The drawers slide on fixed plywood shelves or wood strips mounted to the sides of the boxes — no hardware required. Each drawer is a small box, assembled with rabbets, dados and grooves. The drawer faces are made to cover the front edges of the boxes, just like the doors.

The only joinery in this project that requires any real finesse is where the cabinet tops join the saw and the cabinet. I recycled the hardware that secured the saw's extension wings to attach the cabinet tops to the table saw. Where the tops joined the boxes, I attached cleats to the undersides, positioned the tops over the boxes, and drilled bolt holes through the box parts and the cleats. After removing

the tops, I enlarged the holes in the boxes to make vertical slots. The slots let me adjust the tops a fraction of an inch so I can get them perfectly level with the work surface of the table saw. The 3" diameter access holes in the top of the right box let me reach the bolts when I perform this adjustment. **PW**

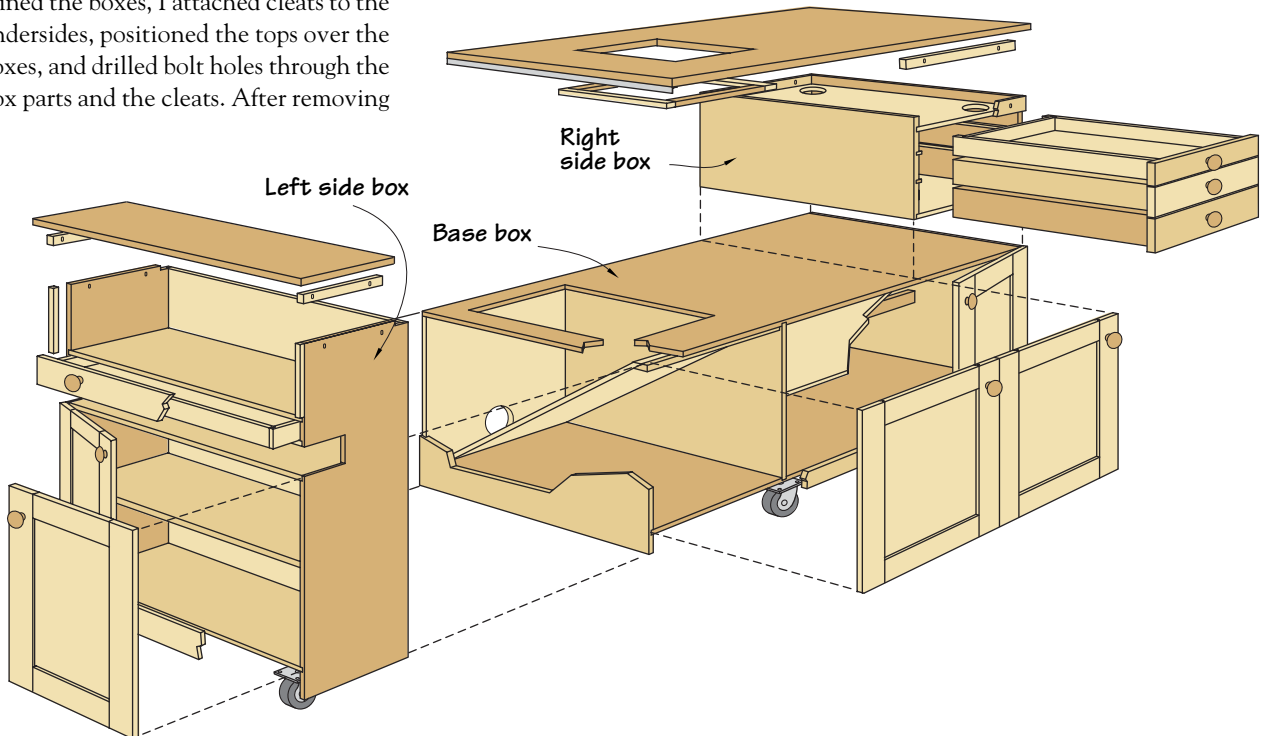
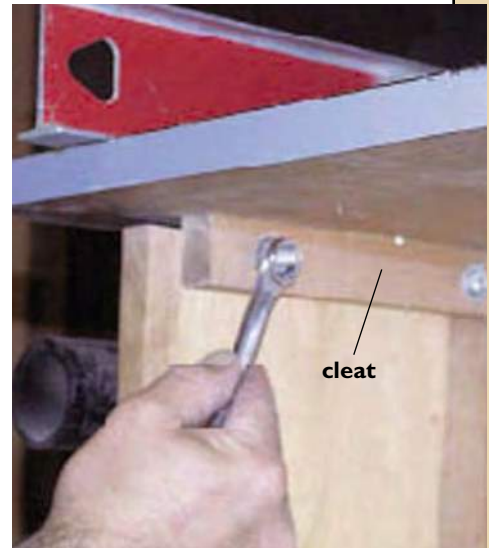

Illustration by Mary Jane Favorite

American Cabinet

BY TROY SEXTON

Besides a table and chairs, no piece fits the dining room better than this quintessentially American country-style cabinet with storage behind doors and a flat surface for serving food. This project fills both needs perfectly and is a study in simple construction. Build a face frame, attach that frame to a four-panel carcass, then add a top and a few simple details and you're set to store and serve.

Start the Cabinet Face First

Prepare the face-frame pieces according to the cut sheet, but add $\frac{1}{16}$ " to the width of the stiles so they can be trimmed flush to the frame later. This ensures the assembled face frame overhangs the case when following the cut sheet. Locate and lay out the mortise-and-tenon locations on the rails and stiles.

Because a bead wraps around the inside edges of the face frame (it's not an integral part of the frame) there is no need to leave shoulders on the tenons. In fact, with the center and upper rails

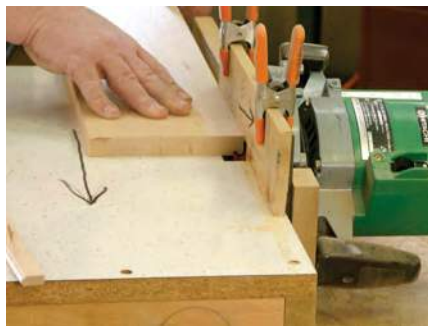

A SMOOTH FACE. Flatten the edge of the stock with a handplane or jointer before milling the bead. This guarantees a "show" face on the bead. Make certain to install the smooth face outward.

being narrow, I like to use the entire width of the rails as a tenon, which adds strength. The mortises are $\frac{3}{8}$ " wide and $1\frac{1}{16}$ " deep.

Cut the mortises into both stiles of the face frame. I use a dedicated mortise machine for this task, but you can also chop them by hand or use the drill press to start the mortises then square and clean out the slots with a chisel. The mortise for the top rail is open on the top edge of the stiles. These are the only mortises for the project.



ADDING A "POP." The bead is installed into the openings in the face frame. Careful measurements are key to a proper fit while glue and brads hold the bead in place.

Next, create the matching tenons on the ends of the rails. I set up a dado stack and hog away the waste material, leaving a snug-fitting tenon. With these tenons, because they are the width of the rails, cut only the face cheeks of each end.

Set the dado stack for a $\frac{3}{16}$ " deep cut. Set the fence to create a 1"-long tenon, then make passes for each face to form the tenon. The last pass is with the end of the rail tight against the fence. This ensures that all tenons are the same length. And that extra $\frac{1}{16}$ " of depth in the mortise is just a glue reservoir.

Check the fit of the first tenon and make any necessary small adjustments. Finish the tenons and assemble the face frame. Apply glue in the mortises and on the tenons then add clamps and allow the glue to dry.

Wrapping Up the Frame

The added beading gives the face frame a "pop" and is so simple to make. Start with a piece of stock surfaced on four sides and milled to $\frac{3}{4}$ " thick. Next, chuck a $\frac{1}{4}$ " corner-beading bit into the router table. My setup looks different because I position my router horizontally. With the setup in a standard router table you'll run the stock vertically to form the bead.

Run the profile on both edges of one face of the stock and rip those pieces off

EASY ON THE EYE AND SIMPLE TO BUILD.

Combine a face frame with a bead detail and simple case construction to build a cabinet that affords copious amounts of storage and easily fits into many places in the home.





SPRING TENSION. If the fit is correct, you should need to bow the bead in order to slide the piece into the face frame.

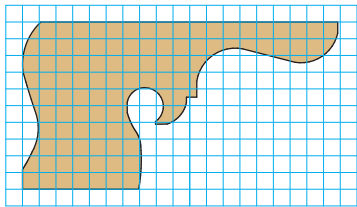

1 grid square = $\frac{1}{2}$ "

FOOT PROFILE

at the table saw to a $\frac{5}{16}$ " width. Then, after running the edges over the jointer to get a clean surface, it's back to the router table to make two more pieces. Make enough beading to wrap the door and drawer openings.

Before adding the bead, finish sand the face frame. If you do more than touch up the face frame by sanding after the bead is in place, you'll flatten the bead profile.

The beading is mitered to fit into the corners. The miter saw is the best tool for the job. Cut the pieces so they need to be bowed out just a bit in order to fit them in place. Too tight a fit won't work and too loose makes the job look sloppy.

With the bead pieces cut to fit, add a thin line of glue along the beading (the edge with saw marks) then tack the bead in place with small brads. The brads act as clamps until the glue sets.

The Case is Nailed

Begin the carcass by milling to size the panels for the sides, fixed shelves, adjustable shelf and the top. That's a good amount of work, but they are the only panels needed for the cabinet. You could

forego the milling for the top and adjustable-shelf panels at this time if you want to divide the job. These two panels are needed later.

At the table saw, set a dado stack for a $\frac{3}{4}$ "-wide x $\frac{1}{4}$ "-high cut. Position the fence to cut dados in the side panels for the fixed shelves. Locate the fence so the top face of the bottom panel ends up a $\frac{1}{4}$ " above the top edge of the bead on the lower face-frame rail (the $\frac{1}{4}$ " step acts as a door stop). Then set the fence so the top face of the top shelf is flush with the top edge of the bead on the face frame's middle rail. Gather these measurements from your assembled face frame.

Once the dados are cut, add an auxiliary fence to the table saw and bury the dado stack $\frac{1}{4}$ " into the extra fence. The $\frac{1}{2}$ " that's exposed is the amount needed for the rabbet that will house the cabinet's backboards. Rabbet the back edges of both case sides.

Before starting any assembly, drill $\frac{1}{4}$ " holes for the adjustable shelf. I have a jig for this task, but I've seen woodworkers use pegboard and a $\frac{1}{4}$ " drill bit, too. Clamp your hole-drilling jig against either fixed shelf, but make sure to use

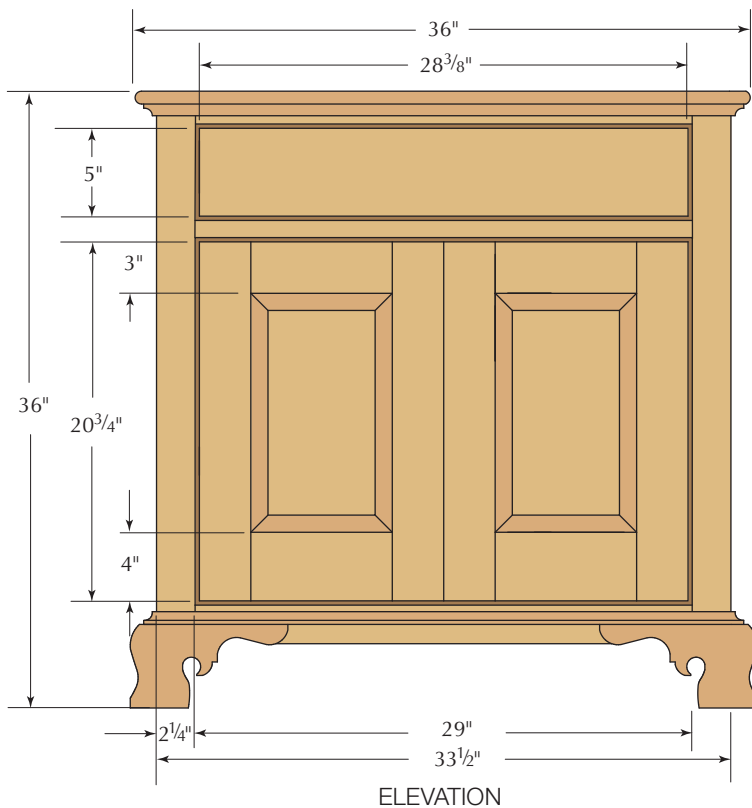

ELEVATION

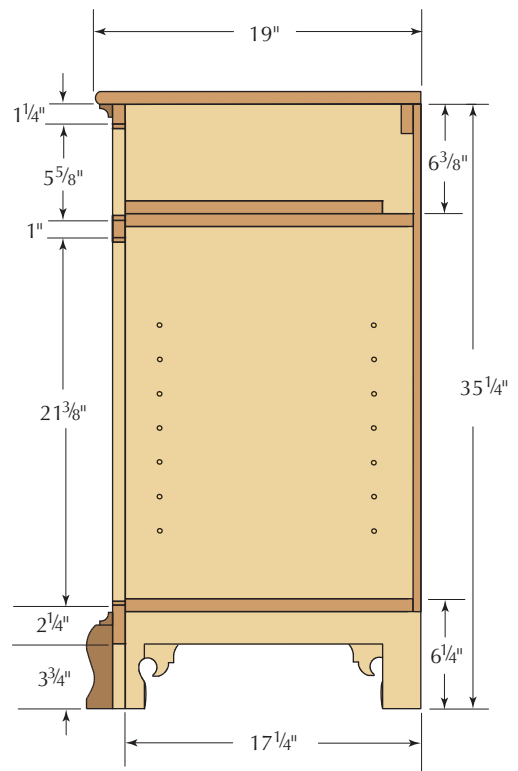

PROFILE



NO TIME TO SPARE. To keep the glue from running out of the dado joint you'll have to move quickly. Any hesitation with the case side inverted results in a lengthy glue clean-up.



A SIMPLE CONNECTION. What could be easier than connecting the sides to the shelves with brads? Drawing a line at the center of the joint provides a nailing location and translates into efficient work.



GET YOUR FACE ON. Check the fit of the face frame. If everything is correct, add a bead of glue to the case's front edge and position the frame on the case. You can add clamps if you like, but brads should hold the frame tight.

American Cabinet

NO.	ITEM	DIMENSIONS (INCHES)			DIMENSIONS (MILLIMETERS)			MATERIAL	COMMENTS
		T	W	L	T	W	L		
2	Face frame stiles	3/4	2 1/4	35 1/4	19	57	895	Cherry	
1	FF top rail	3/4	1 1/4	31 1/8	19	32	790	Cherry	1" tenon both ends
1	FF middle rail	3/4	1	31 1/8	19	25	790	Cherry	1" tenon both ends
1	FF bottom rail	3/4	2 1/4	31 1/8	19	57	790	Cherry	1" tenon both ends
6	FF bead stock	5/16	3/4	30	8	19	762	Cherry	
2	Sides	3/4	17 1/4	35 1/4	19	438	895	Cherry	
1	Top	3/4	19 1/4	36	19	489	914	Cherry	
2	Fixed shelves	3/4	16 3/4	32 1/2	19	425	826	Poplar	
1	Adjustable shelf	3/4	16 1/2	31 3/4	19	419	806	Poplar	
3	Door stiles	3/4	3	20 3/4	19	76	527	Cherry	
1	Door stile (wide)	3/4	3 1/2	20 3/4	19	89	527	Cherry	
2	Door top rails	3/4	3	9	19	76	229	Cherry	Cope/stick joint
2	Door bottom rail	3/4	4	9	19	102	229	Cherry	Cope/stick joint
2	Raised panels	5/8	8 7/8	14 1/2	16	225	369	Cherry	
1	Drawer front	3/4	5	28 3/8	19	127	721	Cherry	
2	Foot stock	1 1/4	5	30	32	127	762	Cherry	3 feet per piece
1	Moulding stock	3/4	5	30	19	127	762	Cherry	All cove mouldings
1	Cleat	3/4	1 1/2	32	19	38	813	Poplar	Attach to underside of top
2	Drawer guides	1/2	3/4	17	13	19	432	Poplar	
1	Back	1/2	33	29 3/4	13	838	756	Poplar	Shiplapped boards
1	Thumb-turn	1/2	3/4	1 3/4	13	19	45	Cherry	



TRIMMING THE FAT. The extra $\frac{1}{16}$ " added to the face frame stiles ensures the frame overhangs the sides of the case. Any remaining material must be removed. A flush-trim router bit with a bottom-mount bearing is the perfect solution.

the same shelf throughout the process; that keeps the holes aligned. I place the holes 2" in from the front edge and the same distance in from the rabbet at the back edge.

With the adjustable-shelf holes drilled, it's time to assemble the case. Place a bead of glue into the dados of one case side before slipping the fixed shelves into position. Now comes the

tricky part of the case construction. Add glue into the dados of the second case side and position the shelves so they slip into those dados. This is tricky because you need to get the joint assembled before the glue drips from the dados.

Align the shelves flush with the front edge of the case sides. Use a framing square to mark the location of the center of the shelves on the exterior of the sides, then with a brad nailer add five $1\frac{1}{2}$ " brads through the case sides and into the fixed shelves. Flip the case then install brads in the opposite side.

Putting a Face to the Cabinet

Dry-fit the face frame to the case checking both for overhang at the sides and that the fixed shelves line up with the beaded rails. If everything's a go, add a bead of glue to the front edge of the case then carefully position the frame. Tack it to the case with brads, again making sure to align the shelves to the rails. Allow the assembly to dry.

The next step is to trim the face frame to the case. This is where having the extra $\frac{1}{16}$ " on the frame makes life simple. Use a router with a flush-trim bit to flush the frame to the sides. I always climb-cut (work against the rotation of the router bit) as I trim. The last thing you want to have happen is to catch the grain and rip the face frame causing irreparable damage.

If you haven't milled the top to size, now's the time. With the top prepared, use a $\frac{3}{8}$ " roundover bit to profile the front and ends of the panel; shape both top and bottom. Take time to sand the edges before affixing the top to the case. Then, position the top on the case so that there is equal overhang on either end and the top piece is flush at the back. This time use a 2" brad through the top and into the sides and front top rail. A small bead of glue along the front rail reinforces the joint.

Flip the case onto the top to install the $\frac{3}{4}$ " x $\frac{3}{4}$ " cove moulding. Make enough for the transition moulding for the base at the same time. Finish sand the intersection of the case to the top before adding the cove; you won't be able to get to this area easily after the cove

is in place. Fit the moulding to the case with miters at the corners, then attach it to the case with brads. A bit of glue along the front and the first 4" back on each side adds strength as well as keeps the miters tight. At this time, add a cleat for the backboards. It is attached to the underside of the top and flush with the rabbets in the sides.

Fascia Feet

The ogee bracket feet are a facade. They are fit to the cabinet and look great, but they do not carry the cabinet's weight. Instead hold them slightly off the end of the face-frame stiles and the ends of the case sides as they're installed. If you want to simplify the building process even more, use a bracket-style foot in place of the ogee. Both designs work identically.

If you plan to forge ahead and create the ogee feet, begin by laying out the profile on the ends of the stock. Next cut a cove at the table saw just as you would to make a piece of cove moulding. Match the size of the cove to the foot profile. (For more information on making ogee bracket feet, see Lonnie Bird's article in the August 2005 issue, #156.)

With the cove profile complete, place the stock at the table saw fence with the top edge on the table. Adjust both the fence and the angle of the blade to remove as much of the profile of the curved top edge as possible without touching the lines. Make a couple passes adjusting the fence to remove more waste material with each pass. From here you should be able to finalize the shape of the feet with a rasp or power sander.

Next, cut the foot stock to length and create a 45° bevel on four of the pieces; you'll need two matching sets. The rear feet are simply cut square. Lay out the scrollwork on each foot, then at the band saw or scrollsaw cut to the lines and clean up any rough edges with a spindle sander or hand tools.

Adding the Feet

Position the feet on the case and remember to hold them about $\frac{1}{16}$ " off the bottom edge. You'll notice there is material showing behind the feet. Trace the

Supplies

Woodworker's Supply

800-645-9292 or woodworker.com

2 • Amerock non-mortising hinges
#891-749, \$3.69

1 bag • plated steel shelf pins
#857-330, \$4.09

Horton Brass

800-754-9127 or horton-brasses.com

1 • cupboard turn
#H-97, call for pricing

1 • solid brass knob
#P-97, call for pricing

Prices correct at time of publication.



MAKE COVE MOULDING SAFELY. The small cove moulding is made using a wide board at a router table. Next, rip the moulding to its final width at the table saw. Fit the cove to the case then attach with brads.

profile of each foot, then remove that waste with a jigsaw. Don't worry about the look; just get the waste out of the way. All the edges are covered with the feet and the cove moulding that wraps the case.

Nail from the back of the case to attach the feet. Add glue to the miters to help hold them tight. Next, install the remaining cove moulding at the top edge of the feet. The cove is attached to the case with brads. These miters should be reinforced with glue as well.

Drawer, Doors and Back

The drawer for this cabinet is made in a traditional method. The sides join the back with through dovetails and the front is attached to the sides with half-blind dovetails. The drawer bottom is slid into grooves in the sides and in the drawer front. It is secured in the drawer with nails that extend through the bottom into the drawer back. The drawer rides on the fixed upper shelf. Drawer guides, butted to the face frame and held with brads, keep the drawer running straight.

The door joints are cut with a cope-and-stick set at my router table. The right-hand door in the photo has a rabbet cut into the rear of the left stile. That rabbet fits over a matching rabbet cut in the right

stile of the left door. That stile is the 3½"-wide stock.

With the door frames dry fit, measure the raised-panel openings then make two raised panels using either a table saw or router bit. Check the fit of the panels then assemble the doors using glue in the rail-and-stile joint only. No glue is used in the raised-panel area. Install pegs to give the cabinet an antique look.

Once dry, carefully hang the doors to the opening with simple butt hinges. The left door is held to the case with a wooden thumb-turn located behind the right-hand stile. It catches the middle rail.

The backboards continue the bead detail from the case front. Create the shiplap joint then add the bead detail to the individual pieces. As always, I spaced the boards using Popsicle sticks and nailed them to the case – all after finishing the cabinet. The finish is a mixture of aniline dye with three coats of spray lacquer.

While this piece usually sits mainly in dining rooms, it is a great project for anywhere you need storage. If you build it, I'm certain you'll find a place to show it off and use it.



ONE FOOT AT A TIME. Place the feet on the case and mark the profile. Cut away the waste material after connecting the top edge of the feet across the case, both front and sides. Don't be too concerned with the task; the feet and transition moulding cover any raw edges.

Get More Great Woodworking Resources!

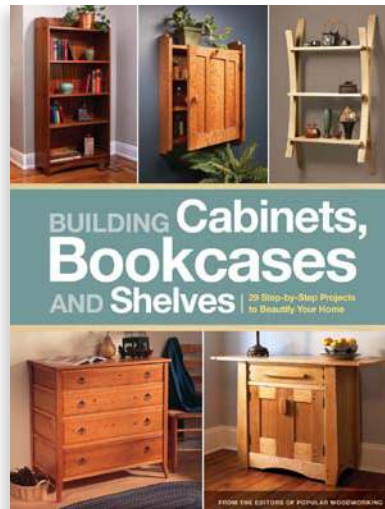

Your free download is an excerpt from the **October 2000**, **February 2001** and **June 2005** issues of *Popular Woodworking Magazine*, and from the PDF download *Building Cabinets, Bookcases and Shelves*. You'll find a lot more projects, tips and techniques at ShopWoodworking.com.

**Visit our online store today,
and continue building
your knowledge!**