

# Techniques and Procedures for Collecting, Preserving, Processing, and Storing Botanical Specimens

---

18/1996



Province of British Columbia  
Ministry of Forests Research Program

The use of trade, firm, or corporation names in this publication is for the information and convenience of the reader. Such use does not constitute an official endorsement or approval by the Government of British Columbia of any product or service to the exclusion of any others that may also be suitable. Contents of this report are presented for discussion purposes only.

**Citation:**

British Columbia Ministry of Forests. 1996. Techniques and procedures for collecting, preserving, processing, and storing botanical specimens. Res. Br., B.C. Min. For., Victoria, B.C. Work. Pap. 18/1996.

**Prepared for**

B.C. Ministry of Forests  
Research Branch  
31 Bastion Square  
Victoria, BC v8w 3E7

Copies of this report may be obtained, depending upon supply, from:

B.C. Ministry of Forests  
Forestry Division Services Branch  
Production Resources  
1205 Broad Street  
Victoria, BC v8w 3E7

©1996 Province of British Columbia

The contents of this report may not be cited in whole or in part without the approval of the Director of Research, B.C. Ministry of Forests, Victoria, BC

## ACKNOWLEDGEMENTS

---

This manual represents the combined efforts of many people who contributed their expertise: Gerry Allen, Gail Berg, Brenda Costanzo, George Douglas, Brian Egan, Trevor Goward, Joan Kerik, Olivia Lee, Del Meidinger, Alison Nicholson, John Pinder-Moss, Gloria Ruyle, Mike Ryan, and Pat Warrington. Fran Aitkens edited the manuscript, Beth Collins did the typesetting, and Donald Gunn provided the illustrations.

---

Acknowledgements .....	iii
<b>Introduction</b> .....	<b>1</b>
<b>PART I: VASCULAR PLANTS</b>	
<b>1. Collection of Specimens</b> .....	<b>2</b>
1.1 Gathering the Specimens .....	2
1.2 Recording the Data .....	5
<b>2. Preservation of Specimens</b> .....	<b>8</b>
2.1 Pressing .....	8
2.2 Drying .....	12
<b>3. Processing of Specimens</b> .....	<b>14</b>
3.1 Identification .....	14
3.2 Label Preparation .....	15
3.3 Mounting .....	15
3.4 Accessioning (Cataloguing) .....	18
<b>4. Storage of Specimens</b> .....	<b>19</b>
4.1 Organization .....	20
4.2 Handling .....	20
4.3 Maintenance .....	20
<b>PART II: BRYOPHYTES AND LICHENS</b>	
<b>1. Collection of Specimens</b> .....	<b>22</b>
1.1 Gathering the Specimens .....	22
1.2 Recording the Data .....	24
<b>2. Preservation of Specimens</b> .....	<b>24</b>
2.1 Basic Techniques .....	24
<b>3. Processing of Specimens</b> .....	<b>25</b>
3.1 Identification .....	25
3.2 Mounting .....	25
<b>APPENDICES</b>	
1 Suggested equipment list .....	27
2 Product and equipment suppliers .....	29
3 National and university herbaria .....	31
4 Regional herbaria .....	32
5 Glossary of terms .....	33
6 Useful botanical publications .....	37

**FIGURES**

1	Botanical specimens mounted on standard herbarium sheets .....	4
2	Sample page from a field notebook .....	5
3	Method for determining the Universal Transverse Mercator reference (UTM) .....	7
4	Plant press showing arrangement of parts .....	9
5	Arrangement of specimens on flimsies .....	10
6	Folding packets for bryophytes and lichens or for seeds/fragments .....	11
7	Portable light bulb plant dryer/storage box .....	12
8	Tying the herbarium knot .....	13
9	Standard label for a herbarium sheet .....	15
10	Arrangement of dried specimens on herbarium sheets .....	17
11	Placement of glue or linen straps across mounted specimens .....	17

Botanical collections are essential to our understanding of British Columbia's flora and plant communities. A good-quality **herbarium** reference collection provides the following:

- a tool for plant identification;
- a data source for research on the **taxonomy** and distribution of plant groups and for writing handbooks and **floras**;
- an historical record of plant locations, and of a collector's contribution to the science of botany;
- a repository for **voucher specimens** related to published scientific reports;
- an educational resource for learning to recognize the plant **species** of an area; and
- accurate and permanent documentation of botanical information that adds credibility to data collected in vegetation surveys.

This manual lists equipment and describes techniques and procedures for collecting, preserving, processing, and storing plant specimens. **Bryophytes** (mosses, liverworts, and hornworts) and **lichens** require different collection and preservation techniques, and are treated separately from **vascular** plants (seed plants, ferns, clubmosses and horsetails) in this report. In the appendices you will find information to assist you in obtaining supplies, contacting herbaria, or locating reference texts for British Columbia flora.

*Note:* Terms appearing in the glossary are initially set in bold face.

## PART I: VASCULAR PLANTS

### 1 COLLECTION OF SPECIMENS

---

Collection of botanical material involves two activities—gathering the specimens and recording the information. Even if you have a relatively good knowledge of the local flora, you may not be able to accurately identify all plants in the field. During vegetation sampling, collect representative specimens of all species that are important to meet your collection needs (except for known rare and endangered specimens, which can be photographically recorded). These specimens will later be used to confirm identification and provide a permanent record for future reference. Your collection may also represent a range extension or contribute to the knowledge of a plant's taxonomic or natural history. It may also show the “plasticity” or variations possible under different habitat conditions. Be sure to record accurate and consistent habitat information when collecting the specimens—it is generally difficult to remember and accurately record it later. A good-quality plant collection requires considerable advance preparation and a lot of effort. Since you may have only one chance to collect in a particular area, ensure that all details are followed carefully.

#### 1.1 Gathering the Specimens

**1.1.1 Collecting equipment** The equipment needed for collecting plant specimens will depend on the type of plants you are collecting. For a complete list, see Appendix 1.

##### ***Basic equipment***

- Waterproof field notebook to record habitat and location information.
- Soft lead pencils for writing in rain.
- Topographic maps and location information should include **Universal Transverse Mercator (UTM)** locations or latitudes and longitudes.
- Small **altimeter** for measuring elevations.
- Gardening gloves to prevent injury when handling irritating or thorny specimens.
- Strong plastic bags for storing branches or carrying individually bagged collections; 18 × 41 cm (4–6 mil) is adequate for most plant material.

- Waterproof tags and permanent felt markers.
- A shovel, trowel, or dandelion tool for digging underground stems, bulbs, **corms**, and roots.
- Pruning shears or secateurs to cut plant parts (e.g., fruit, cones, flowers, buds, leaves, bark) or for trimming large, woody plants to appropriate size.
- Paper lunch bags for storing cones.

***For aquatic specimens***

- A long, lightweight pole (telescoping if possible) with numerous prongs at one end, or a leaf rake with retractable prongs, or a long-handled cultivator.
- Plastic food containers with lids, or zipper bags.
- Snorkelling or scuba-diving equipment (useful if circumstances permit).
- A white plastic slate with wax marking pencil for recording data underwater.

**1.1.2. Collecting techniques** In the field, take care when selecting the plant material for collection. Do not collect species that are rare or endangered. Three species are protected by statute in British Columbia: western flowering dogwood (*Cornus nuttallii*), Pacific rhododendron (*Rhododendron macrophyllum*), and western trillium (*Trillium ovatum*). When you need to confirm a rare or protected species, photograph the plant and make a good written description and/or sketch. Take several close-up shots (with a ruler or other object for scale) showing the plant and parts necessary for positive identification.

Determine the amount of plant material you require, select a variety of individual plants for collection, then begin the actual collection of the specimens.

***Basic techniques***

- Select specimens in good condition, free of insect damage, rust, or disease.
- Select plants with mature parts (well-developed leaves, stems, roots, flowers, and/or fruits or other reproductive structures).
- Select specimens that represent the range of variation in the population, not just atypical specimens.
- Collect entire plants when possible, even if they are large (the plant can be divided for pressing).
- Collect enough plant material from each species to fill two standard **herbarium sheets** (30 × 42 cm) (see Figure 1).
- Collect at least stems, leaves, and flowers or fruit of herbaceous plants, and twigs, leaves, and flowers or catkins of trees and shrubs.
- Collect extra flowers and fruit for later dissection.
- Retain as much of the root system as possible. Remove excess soil as it may cause disfiguration and deterioration of some plants.
- Place all specimens of a single species from one locality into one collection bag.
- As each specimen is collected, assign a unique **collection number** (see Recording the Data).



### ***For aquatic specimens***

- Many aquatic plants are extremely fragile and readily break apart after removal from water. Handle them carefully at all times.
- Some characteristics useful for identification are destroyed by handling and subsequent pressing. Learn these characteristics and record the information immediately, for example, a cross-section of *Nuphar* **petioles**.
- Seal the holding containers properly to prevent leakage or loss of specimens or parts in transit.

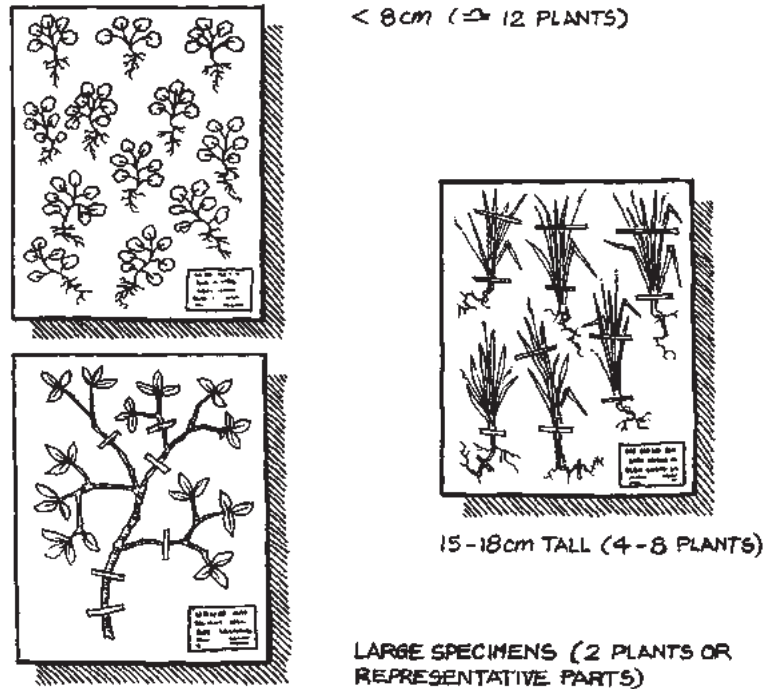

FIGURE 1 *Botanical specimens mounted on standard herbarium sheets.*

**1.1. Protection in the field** Specimens should be pressed in the field whenever possible (usually after returning to camp in the evening, and preferably daily) because delay causes a significant difference in the final result. If not pressed immediately, some delicate species like *Campanula* rapidly lose their colour and structure, and some *Asteraceae* petals and heads curl. However, in field sampling it may be several days before specimens can be pressed. Most plants will remain in reasonable condition for up to a week if handled properly and kept cool and moist. Watch the bagged plants closely for signs of deterioration. Follow these suggestions to keep unpressed plants fresh:

- Expel excess air from large plastic bags and seal.
- Keep collection bags in a cool place, near a stream, in the shade, or in a cooler.
- Sprinkle fresh water into the bags during hot weather, or add a moistened paper towel.
- Shake off excess moisture or “blot” plants collected in the early morning or during wet weather.

## 1.2 Recording the Data

A plant collection without accompanying data is of no use to the scientific community. Keep a careful record of collection data and field observations in a field notebook using a consistent, clear, and legible style. You can use the information later for the herbarium label or for preparing a collection report. File the completed field notebook as a permanent record.

The type of data recorded will depend on the collection. It usually includes collection number, date, name(s) of collector(s), location (latitude and longitude or northing and easting) and habitat information (elevation, water depth [for aquatic plants], slope, aspect, soil, moisture regime, associated vegetation, and **biogeoclimatic zone** and/or subzone). Observations about each plant species collected (e.g., flower colour, diameter, height, abundance, odour) should be recorded. To reduce the amount of writing needed in the field book and on labels, collect as many different plants as possible from the same site. Write the information common to all specimens (collector, slope, aspect, associated vegetation, etc.) at the top of the page, then list collection numbers with brief identifying information. Some collectors have a stamp made with standard headings to stamp directly onto the notebook page. More detailed information can then be filled in as the plant collection is made (see Figure 2).

Write legibly so that time is not wasted by someone trying to interpret your field notes. Notebook computers may, in the future, obviate the need for field books, but collecting can be wet, dirty work and they may not stand up to these conditions.

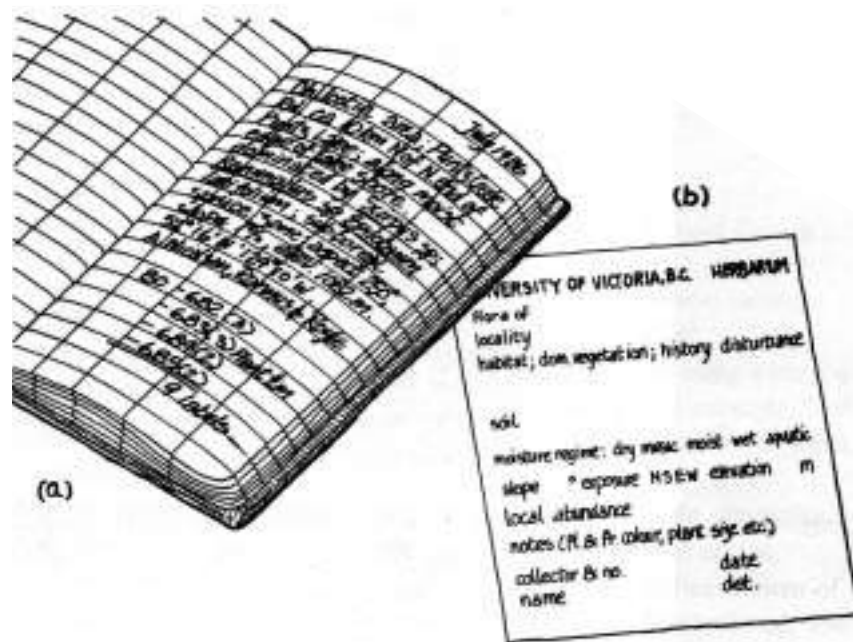

FIGURE 2 (a) Sample page from a field notebook and (b) sample field label (developed by Marc Bell) for collecting adequate field notes.

**1.2.1 Collection number** As soon as the specimen is bagged, record a collection number in the field notebook. Write the collection number on a waterproof tag and place it in the bag with the specimens, or label the outside of the bag using a permanent marking pen. If you are pressing right away, you can write the collection number on the **flimsy** (newsprint folder) in a corner or along the border. The collection number makes it easy to reference individual specimens or groups of specimens in a collection. Several numbering systems are in use, as follows:

- Some **taxonomists** assign collection numbers to specimens sequentially throughout their careers (up to six digits may be used), and can, therefore, use a rotating number stamp directly on the pressing paper. This method allows researchers to identify when in a taxonomist's career the plant was collected, to track the specimen from a published account, or to calculate the total number of specimens collected.
- Some collectors assign field numbers by year. The number consists of the last two digits of the collection year, a dash, then a sequential specimen number. For example, the first plant collected in 1991 would be 91-01, then, 91-02, and so on. This method is useful if the collector will return to the same area over a number of years, or for an organization that produces annual reports. It gives an immediate indication of when the specimen was collected. However, with the approach of the end of the century, this system may cause confusion (was 01-45 collected in 1901 or 2001?). Another system may be needed.
- For collections made during a vegetation or ecosystem classification project, collectors often use a project or locality abbreviation, followed by a plot number, a dash, and the specimen number. Each plant collected has a unique number, but is also immediately identified by sample site or plot and project. For example, on the Toby Creek project (TC) plot number 401, the first specimen is TC401-1, the second TC401-2, etc.

In all the numbering systems, plants of the same species collected at the same sampling site or plot are given the same number. For example, if 10 specimens of *Viola sempervirens* (enough to fill two herbarium sheets) are collected from site TC401, then all 10 plants receive the same collection number (e.g., TC401-3). An exception would be if the specimens are of different trees of the same species in the same area. In that case, separate specimen numbers would be assigned.

**1.2.2 Date of collection** To avoid confusion, write the date in full (August 7, 1991). Note that "8/07/91" could be interpreted as August 7, 1991 or July 8, 1991.

**1.2.3 Name(s) of collector(s)** Record all significant members of the collecting party. In the future, if one collector is unavailable to answer questions, the others may be contacted. First initial(s) plus the last name is sufficient.

**1.2.4 Location information** Provide enough information so that another person can follow the directions to the general area to observe more specimens of the same species. For example,

“Thirty miles NE of Hazelton, B.C. on the Kispiox Valley road; south bank of McCulley Ck. below the bridge.”

Use a good topographic map to determine latitude and longitude to the nearest 10 seconds, or the UTM co-ordinates, which are increasingly used in **Geographic Information Systems (GIS)** (see Figure ).

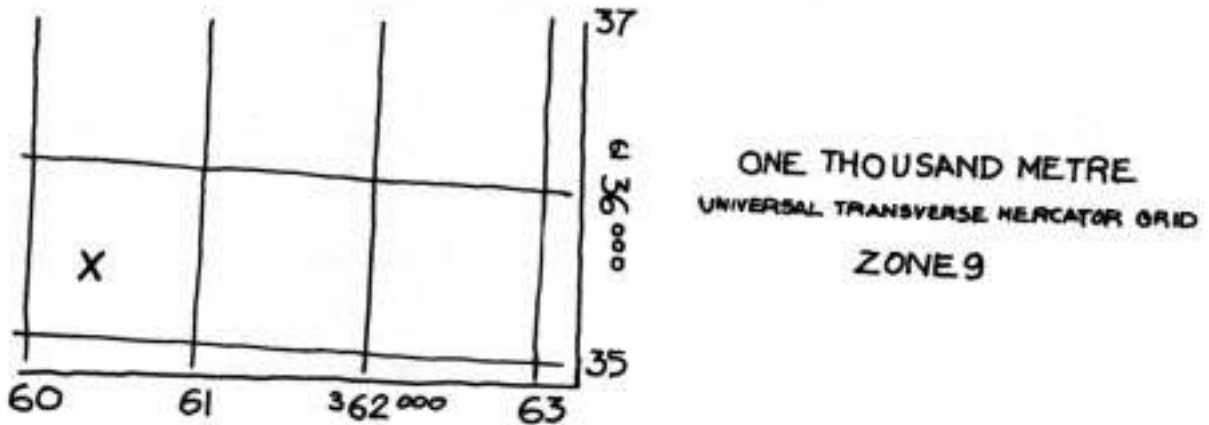

FIGURE Method for determining the Universal Transverse Mercator (UTM) reference. The system consists of zone, easting, and northing. The blue grid overprinted on many maps is the UTM system. The blue numbers near the map corners identify the full six- and seven-digit numbers for eastings and northings. The “x” in Figure 3 is located as: Zone 9 Easting 3 6 0 3 Northing 6 1 3 5 4.

### 1.2.5 Habitat information

**Elevation:** the vertical distance above sea level in metres; read from a topographical map, or use an altimeter.

**Slope:** the gradient of the site where the collection was made; measure using a **clinometer**. For example, a 50% slope would be 45°.

**Aspect:** the exposure or orientation of the slope; measure using a compass bearing (remember to allow for magnetic declination). For example, 250°.

**Associated vegetation:** a short list of other dominant species in the plant community being sampled.

**Biogeoclimatic zone/subzone:** zone, subzone and, if possible, site series.

**Soil:** type of soil encountered. You may want to be specific or not, depending on the purpose of the collection (see the Canadian System of Soil Classification). For example, coarse-, medium-, or fine-textured; soil depth, sand, loam, silt, clay, peat.

**Moisture regime:** the degree of wetness or dryness (**xeric, mesic, hygric, hydric**).

**Water depth:** for aquatic plants, note the depth at which they are rooted. Note whether the current water level is above or below the low or high water marks on the shore, and by how much. (If possible, note also the annual fluctuation in water level from low to high water marks.) Record if the plant reaches the surface, and what parts (if any) are emergent.

**1.2.6 Comments** You may want to make specific notes to help with later identification. Some important observations are:

***For herbaceous plants***

- A record of the abundance of the species is important for the records of rare species kept by the B.C. Conservation Data Centre in Victoria. Record the area covered in square meters, or estimate the number of plants if there are only a few.
- Flower and fruit (e.g., berries) colour may fade or change after collection—especially blues and purples—so record the fresh colour in your notes.
- Note the presence or absence of milky juice in plant stems.
- Note any flower or leaf fragrances, or any distinctive odours when the plant is bruised.

***For trees and shrubs***

- The height and growth form (i.e., spreading, scraggly, columnar) may help distinguish between species of the same **genus**. This information is essential when the whole plant is not collected.
- Flower and fruit colour for flowering trees or shrubs.

---

## 2 PRESERVATION OF SPECIMENS

---

The two main steps in preserving floral collections are pressing and drying.

Correct pressing prevents plant parts from curling or wrinkling during the drying process, and allows the requisite plant parts to be visible for identification. Care in pressing specimens will result in more useful and visually appealing herbarium specimens. The process consists of laying the plant specimens in folded sheets of newsprint separated by cardboard sheets, and placing them in a pressing frame, which is then tightened with straps.

Drying involves an adequate length of time and exposure to “dry” air, and maintenance of the specimens in the press, e.g., changing the newsprint to speed up the drying process and cinching the press daily as the specimens dry.

### 2.1 Pressing

**2.1.1 Pressing equipment** The main piece of equipment is a plant press (Figure 4). You can construct your own press or purchase one from a biological supply company (see Appendix 2). The frame usually consists of two back panels (about 45 × 30 cm) made of a lattice of hardwood strips. The back panels could also be made from plywood panels drilled with holes 2 to 5 cm in diameter. The frame is tightened with two heavy webbing straps (about 2 m long by 4 cm wide) with adjustable fasteners. You will need many flimsies (newsprint cut in sheets of about 45 × 60 cm). Roll-ends are available from some printers. Tabloid-size newspapers may be used, but there is little room for writing and the ink will dirty your hands and sometimes mark the plants. Sheets of corrugated cardboard (45 × 30 × 2 cm), felt blotting paper (45 × 30 cm), and soft foam sheets

(45 × 60 × 2 cm) are also needed to layer between plants in the press. Felt and foam are optional. Felt is good for speeding up drying of damp specimens and foam is useful for bulky branches or stems.

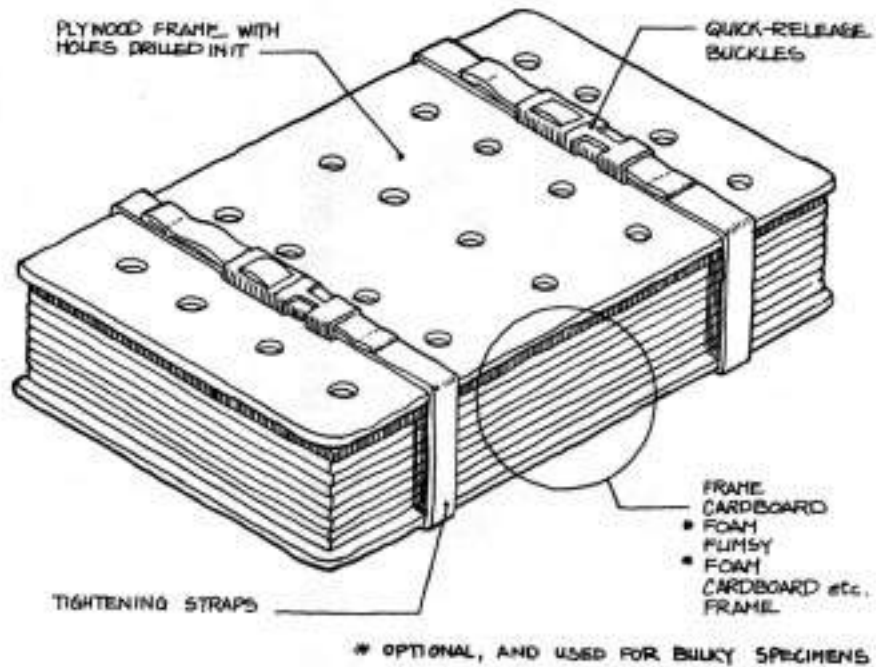
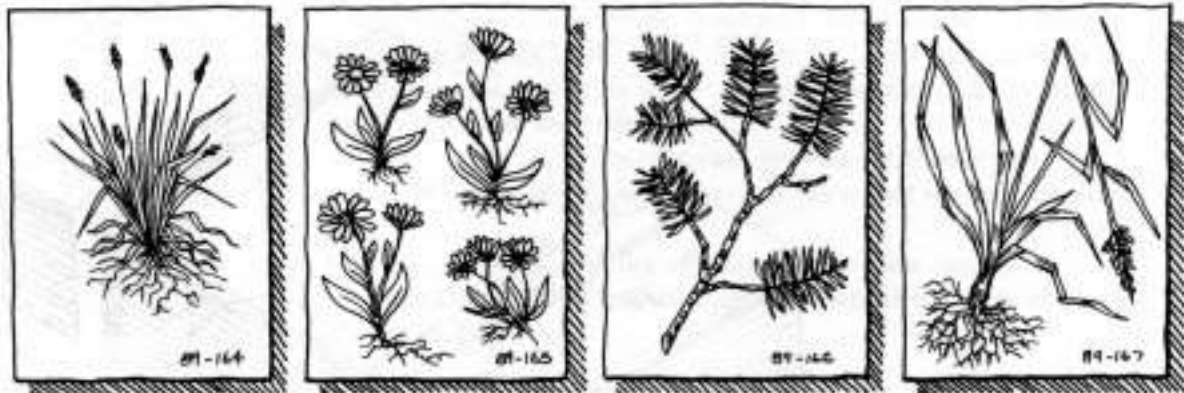

FIGURE 4 A plant press showing arrangement of parts.

**2.1.2 Pressing technique** The ideal place to press plant specimens is indoors on a large table. However, a picnic table, the back of a station wagon, the tailgate of a truck, or a flat, hard surface is adequate as long as it is out of the wind and rain. The following suggestions will ensure high-quality, pressed specimens.

**Basic techniques**

- Separate the frame parts. Make a separate stack for each part if you have plenty of room and it is not windy. Otherwise arrange the materials in the order they will be used: back panel, cardboard, newsprint, blotter (for damp plants, put on both sides of paper), foam (for large branches put on both sides of paper), cardboard, paper, etc.
- Fold a large number of the newsprint sheets in half to form 45 × 60 cm folders (flimsies).
- Lay the straps at one end of the table (both in the same direction). Place one back panel on top of the straps, and place two cardboard separator sheets on the panel.
- Place a folded newsprint sheet on another cardboard sheet (alternate the sides of the newsprint openings within the press to prevent a large bulge on one side). Write the field number on the bottom right corner of the newsprint sheet, inside and outside.
- Write the **family** name, if known, on the outside as well.
- Place plants to be pressed on the right half of the newsprint folder (see Figure 5).



(a) PLANT SPREAD OUT (b) FLOWERS FLATTENED SO OPEN (c) LARGE SPECIMENS CUT TO FIT PAGE (d) BOTH SIDES OF LEAF SHOWN

FIGURE 5 Arrangement of specimens on flimsies (newsprint folder).

- Arrange the plants carefully with a minimum of overlap.
- Open some flowers to show both the top and underside to illustrate the arrangement of floral parts and the presence or absence of **involucre bracts**. Open the flower and press it down with your thumb.
- Squash large fruits on the page or slice them in half to speed up the drying process.
- Place dry, loose seeds or fruits in sealed packets. Write the collection number on the outside of the packet. (See Figure 6 for folding seed packets.)
- Turn over some leaves or part of a single large leaf to show the underside (fern fronds as well).
- When the sheet is full, close the folder, lift the cardboard separator and the newsprint folder and place them on the press.
- Up to three sheets of specimens may be placed together without a cardboard separator if you use blotting paper between them. The number of sheets depends on the thickness and moisture content of the plants.
- Plants can be re-arranged easily by opening the press after two or three hours. The plants will be limp but still flexible.
- Check and change damp newsprint daily and remove specimens as they become dry.
- Cinch press daily (as plants dry the press will become loose).
- When the press is full, place two cardboard separators and the other back panel on top. Tighten the straps as much as possible. You can kneel on the press to achieve the desired tension. Make sure the pressure is even and that you do not end up with a “cock-eyed” press. The straps must be tightened again after 8 to 12 hours to take up the slack as the plants dry and shrink. Keep tightening the straps until the drying is finished.

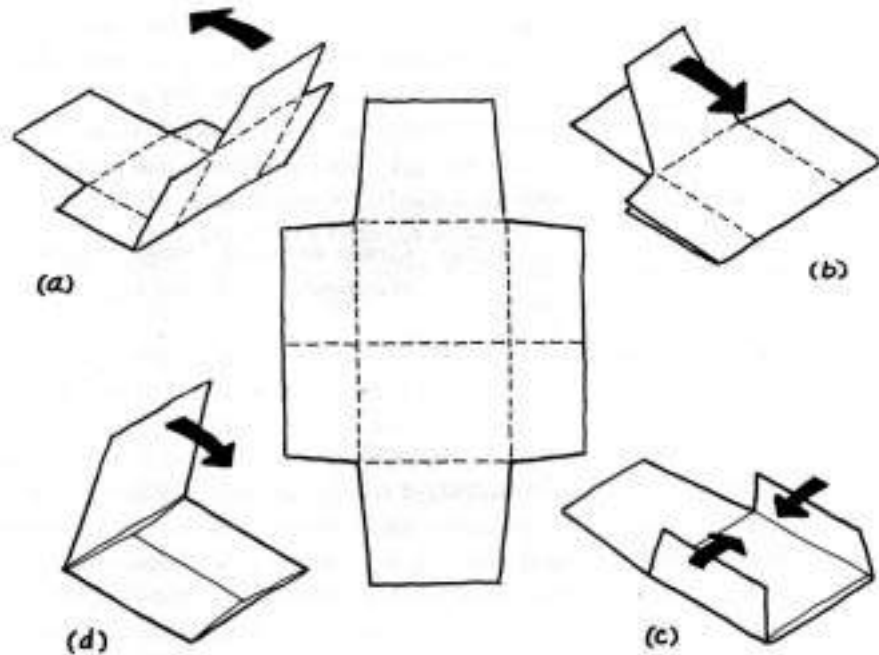

FIGURE 6 *Folding packets for bryophytes and lichens or for seeds/fragments.*

***For herbaceous plants***

- Place sheets of plants with high moisture content singly between cardboard separators, and check daily to see if the newsprint needs changing to facilitate drying.

***For trees and shrubs***

- Bend or cut stems of larger plants to fit the sheet, or place them on separate sheets. Designate the parts *a*, *b*, *c*, etc., but use the same collection number.
- Place foam sheets top and bottom, or a small roll of paper on top of or alongside bulky or thorny plants to distribute the pressure evenly.

***For aquatic specimens***

The delicate structures of many aquatic species require special care and attention. Some aquatic plants do not have structural tissues to give them rigidity and they collapse when removed from the water. Fragile stems tend to stick to newsprint or break off the plants with excessive handling. They need to be floated directly onto a sheet of thin mounting paper and arranged while the sheet is slowly withdrawn from the water.

- Partially fill a large sink, bathtub, or photographic developing tray with cool water. If you do not have a container, use the lake or pond where the collection was made.
- Float the plant in the water.
- Slide a herbarium sheet into the water under the plant. Check with the paper supplier to ensure that the paper you are using will not change shape when wet.
- Arrange the specimens in the water. Untangle feathery stems. Carefully lift up the sheet (with the specimens), letting the excess water run off.



- Place the sheet aside to drip dry before pressing. An old window screen makes a good support while the sheet dries.
- Place a piece of waxed paper or cheesecloth between the specimen and the newsprint to prevent sticking of mucilaginous plants like *Chara* and *Brasenia* (experimentation will determine which works best). Note that the arrangement cannot be altered once in place.
- Some bulky parts like *Typha* fruits, *Nuphar* flowers, and *Cicuta douglasii* roots need to be sliced longitudinally to make them flat enough to press.

**NOTE: *Cicuta douglasii*, Douglas' water-hemlock, roots are poisonous. Wash your hands and knives after preparing them.**

## 2.2 Drying

Drying is a crucial step in preserving collected plant material. To ensure that a specimen retains its colour and does not become brittle or scorched, the moisture must be removed rapidly, while using only a moderate heat. Good air circulation will speed up the process. Make sure the corrugated cardboard still has air spaces in between and is not crushed flat with use.

- During warm, dry weather, tie the press onto the roof-rack if you are travelling by car. The air will flow through the lattice panels and the corrugated separators when the vehicle is moving.
- Place the press inside a well-ventilated vehicle parked in a sunny spot.
- Plants will dry reasonably well in a heated room in a week if you change the papers regularly.

### 2.2.1 Drying equipment

- A forced-air heat vent, the back side of an air conditioner, or a hair dryer also get the job done, but they can pose fire hazards.
- Large commercial dryers are easily regulated, safe, and when properly vented, will not increase the room temperature or allow odours into the room.
- You can build a homemade dryer using one or two 60- or 100-watt light bulbs inside a wooden box (see Figure 7).

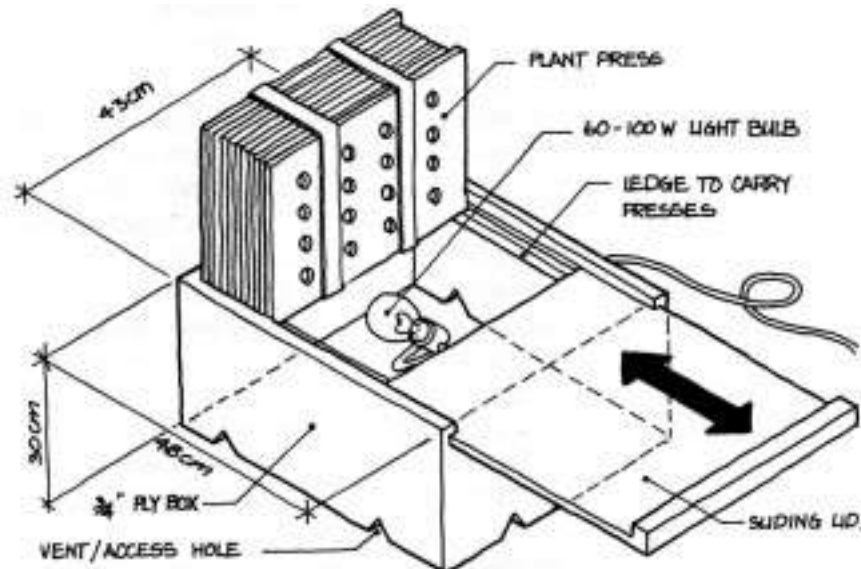

FIGURE 7 A portable light-bulb plant dryer/storage box.

### 2.2.2 Drying technique

All dryers require adequate ventilation above, below, and on all sides.

- If using a homemade light-bulb dryer, place the pressing frame on top of the dryer. Leave at least 15 cm between the bulb and the press. The light-bulb dryer will dry most plants in 24 hours.
- Warm air should flow through the corrugations in the cardboard and through the sheets enclosing the specimens.
- Open the press periodically and check the specimens to ensure that they don't become too dry, or begin to mildew.
- A specimen is considered dry when it does not feel cool to the touch when the press has been open for a few minutes.
- Many plants will shed seeds during the drying process. Package the seeds and mark the collection number on the package.
- Cones can be air dried in their paper collection bags.

After the specimens are completely dry, carefully remove them from the press and store them in bundles protected on either side by cardboard sheets. Tie the bundles with string using the quick-release herbarium knot (Figure 8). Seal the bundles in dark plastic bags and place a descriptive label on the outside. If necessary, the plants can be stored for several years in a cool, dry place before they are mounted. The plastic bag ensures that insects cannot get in or out, decreasing the chance of bringing an infestation to the collection.

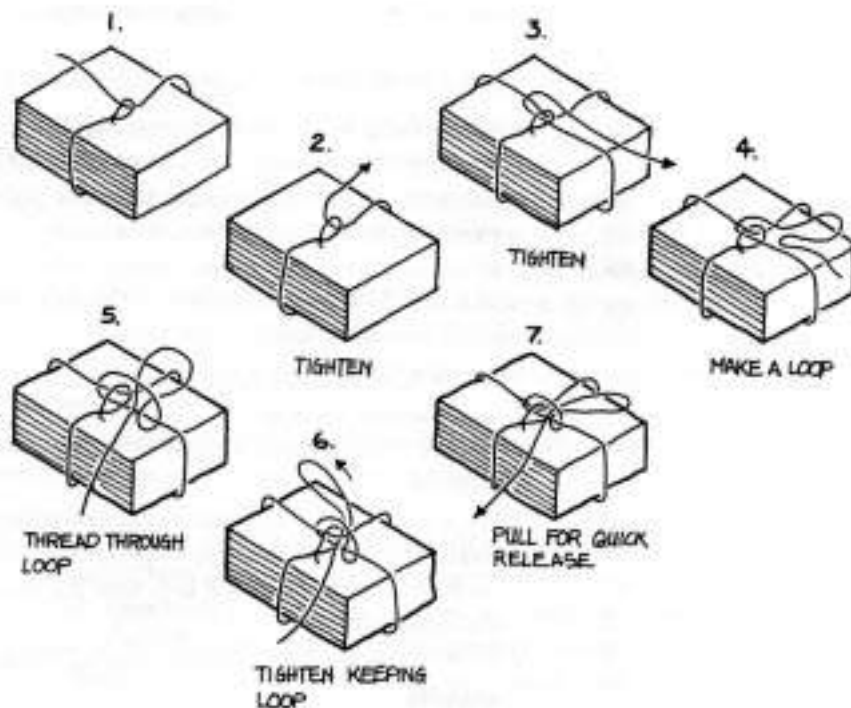

FIGURE 8 *Tying the herbarium knot.*

Processing dried specimens involves four steps:

- identification,
- label preparation,
- mounting, and
- **accessioning**.

The first three are critical in producing a high-quality, final product.

#### Identification

Specimens need to be correctly identified. If you have any doubt, send a duplicate specimen to a taxonomic expert for confirmation. Negotiate and document a definite time to complete the identification when you make the request, otherwise you may wait a long time for the information. *If the taxonomist will not be paid, it is usual to collect duplicates and offer some of the collection to keep.* If the taxonomist is paid for the work, then all the specimens are usually returned to the collector, unless specified otherwise. When the material is returned, the positively identified specimens will be an important addition to your herbarium. Plants should not be processed until the identification is certain.

To identify plant specimens you will need a basic knowledge of taxonomy and nomenclature, familiarity with the **morphological characteristics** of different plant families, access to a library of regional floras (and taxonomic papers to supplement these floras—see Appendix 5), and the ability to use a herbarium reference collection.

**.1.1 Identification equipment** The standard tools used for identification are:

- A dissecting kit, wetting solution (to moisten dry plants for dissection—see recipe in Appendix 2), a heavy glass plate (on which to place the specimens), dissecting microscope with high-intensity lighting, keys, and reference books.

**.1.2 Identification technique** The following suggestions may help in the identification process:

- Try to have more than one plant of a species available to dissect, or have extra flowers on hand.
- Dissect fresh material if possible, or use thoroughly moistened dry material.
- Have at least two different identification **keys**, since each may use different methods to arrive at genus/species.
- As you proceed down the key, note the numbers so you have a record of the route taken.
- Double-check all identifications using the key and herbarium specimens if available.

The correct identification of a specimen is not always easy. A significant portion of the local flora may belong to taxonomically difficult groups. For example, many of the *Asteraceae*, *Cyperaceae*, *Poaceae*, *Potamogetonaceae*, and numerous genera such as *Astragalus*, *Castilleja*, *Draba*, *Lupinus*, and *Salix* are difficult to identify.

### 3.2 Label Preparation

Labels for the dry specimens can be prepared before the plants are identified, recording information known at that time. The genus/species and identifier can be typed in later. Using a standardized label (Figure 9) ensures that all necessary data are transcribed from the field book to the

ROYAL BRITISH COLUMBIA MUSEUM, VICTORIA, B.C.  
**FLORA of BRITISH COLUMBIA**

Juncaceae Acc# \_\_\_\_\_

*Juncus biglumis* L.

Loc: Danihue Pass, Gladys Lake Ecological Reserve  
(lat: 67° 14' N Long: 124° 37' W Elev: \_\_\_\_\_)

Hab: edge of kettle lake in mud

Coll: Hans Roemer, John Pinder-Moss Field #: 88001  
Coll. Date: Aug 17, 1988

Det: A. Ceska 1991

FIGURE 9 Standard label for a herbarium sheet.

Tips for label preparation:

- If a large number of plants were collected from one site, identical information can be typed onto a template.
- The template can be photocopied or mass-produced by a computer program, so that only a few blank fields need to be filled in later.
- Finished labels may be arranged in order of field number to make them easily accessible, or placed into the flimsies with the specimens.
- Incorrectly named specimens that are later re-identified should have the correct name recorded on an **annotation label** supplied by the taxonomist.
- Once the specimen is mounted, the first name attached to the herbarium sheet must never be obscured, only annotated.

### 3.3 Mounting

Mounting the pressed plants involves skill and patience but can provide much satisfaction when the task is complete. Mounting techniques have changed considerably in the past 10 years, as has the quality of mounting supplies. The following equipment and procedures are used by technicians at the Royal British Columbia Museum herbarium and are designed to meet museum conservation standards. All supplies should be of museum quality since the longevity of the specimens is directly related to the substances with which they are in contact.

. .1 **Mounting equipment** Before starting, have ready acid-free mounting paper, cardboard sheets, glue in small, flexible, plastic squirt

bottles, wooden spacer blocks, weights, needle and linen thread (optional), paper seed envelopes (Kraft coin envelopes), and identified specimens with completed acid-free label. For a complete list see Appendix 1.

. 2 **Mounting technique** The best work area is a large surface such as a high counter or a drafting table with an appropriately sized stool. Ideally this area should be separate from the herbarium to prevent insects from being introduced into the main collection. Natural light makes the job more pleasant. Remember that the specimen(s) may have to be removed at some time and large amounts of glue make this task impossible. The following suggestions should ensure a high-quality collection:

- Wear old clothes or a lab coat; mounting can be a very messy business.
- Arrange supplies so the work can proceed in sequence, from left to right, or vice versa.
- Place the specimens to be mounted at one end of the table, with a garbage can nearby ready for waste plants or dirt.
- Glue the label to the bottom right corner of the herbarium sheet.
- Annotation or **determinavit** labels, if present, should be placed directly above or to the left of the main label. If they are too far apart, the incorrect identification on the main label may be used because the smaller annotation label is not noticed.
- Run a bead of glue only along the top edge of the label. Field labels or other information can be folded and affixed underneath. Make a note on the label if any extra information is glued under the herbarium label (e.g., additional information beneath). These should be rotated in location so you don't end up with a bulge on a stack.
- Leave space on the sheet for seed and fragment packets and for accession stamp/number—usually near the upper edge.
- Remove any soil clinging to the roots or stems. Gently crush with the blunt end of the probe, rub the roots between your fingers over the garbage can, or lay on a flat surface and tease with a dissecting probe.
- Use scissors or pruning shears to trim large specimens to fit the sheets. Make sure that important parts are not cut off.
- Sometimes the last particles can be dislodged by tapping the root gently on the inside of the garbage container. Try this only on robust specimens, as it will damage others.
- Place a sheet of mounting paper on a cardboard sheet. The cardboard makes it easier to move the finished product and stack it for drying.
- Arrange the plants on the mounting paper (Figure 10).
- Vary the arrangement of specimens on the sheet to avoid otherwise sloping stacks that will cause problems in storage (brittle plants will break under lopsided conditions).
- Salvage any valuable loose material, such as seeds or flowers, and place them in paper or wax paper packets (see Figure 6 for folding method). Glue fragment packets near the upper edge or sides of the sheet after the specimens are mounted.
- Avoid placing anything right at the edge of the mounting sheet, as it may stick out and get damaged. Leave approximately  $1\frac{1}{8}$  inches around sides for “finger space” to allow the sheet to be picked up without damaging the specimen.

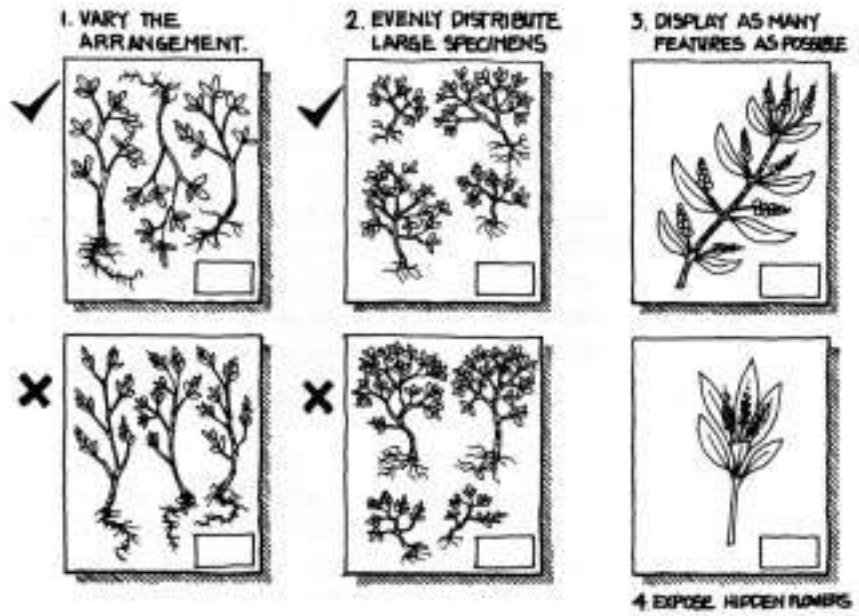

FIGURE 10 Arrangement of dried specimens on herbarium sheets.

- Hold the specimen down with weights, such as plastic-coated lead bars or large metal washers, until the glue dries. You can dip the washers in acrylic floor wax before using.
- Attach the specimen to the mounting paper with thin ribbons of glue running from the paper across the plant part to the paper (see Figure 11). The glue should not cover any parts necessary for identification, for example, the **nodes** and **ligules** of grass.

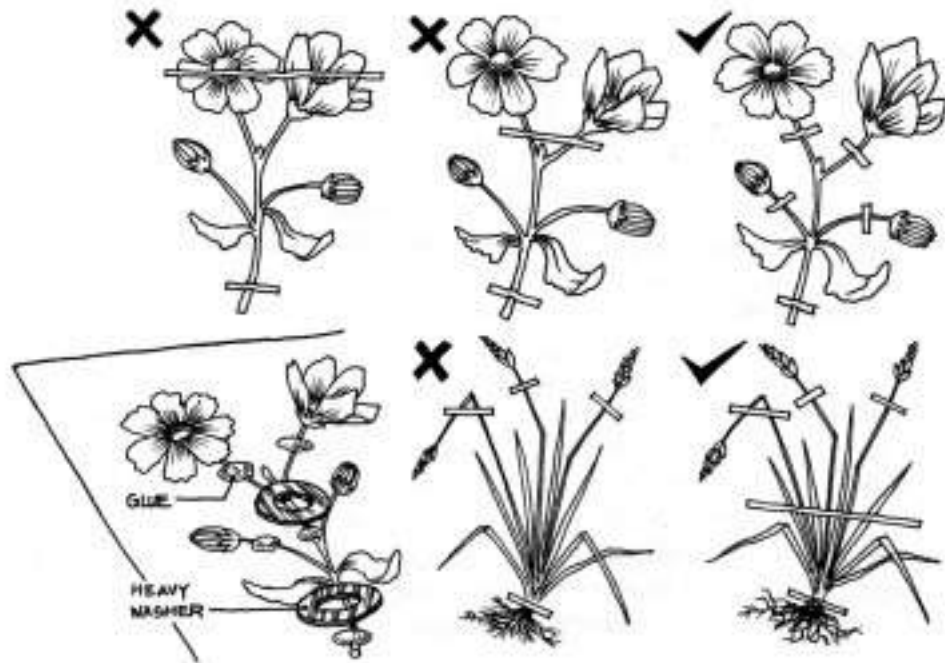

FIGURE 11 Placement of glue or linen straps across mounted specimens.

- The number of glue straps will vary with the material but the specimens should remain securely in place when the dry sheet is held upside down (Figure 10).
- A large leaf will benefit from a few dots of glue on the underside, and multi-stemmed specimens (like some grasses) will need long glue straps to catch all the stems.
- A dot of glue beneath the flower head may be needed if the head is large and cannot be held down with a strap of glue on the petiole.
- If only one flower is placed on the sheet, protect it by gluing a transparent flexible covering over it. Glue only the top edge of the cover so it can be flipped back to examine the protected parts.
- Use linen straps or white gummed mounting tape (available in rolls of various widths) cut to the size required to attach thick stems. For linen straps, use a needle to make small holes through the sheet on either side of the stem, thread through, and tie a knot on the back. If the knot is bulky, glue a small piece of paper over it, so that it won't damage the specimen beneath.

When the sheet is finished, move the mounted specimen(s)—supported by the cardboard—to one side, and place three or four wooden blocks along the edges of the paper. These blocks act as spacers so that mounted plants can be stacked to dry. The length of the blocks needed will depend on the space left near the edges of the sheet. Some herbaria have mobile stacking units with individual shelves for each specimen, which eliminates the use of blocks and the chance that the stack of plants will tip over. These units can also be sealed to prevent insect infestation.

#### ***For aquatic specimens***

- Aquatic plants require special care when the mounting sheet is removed from the newsprint. Specimens may adhere to the newsprint in several places.
- If specimens have been dried on thin mounting sheets, the paper may have become wavy during the drying process. You may want to glue the thin sheet to another sheet of mounting paper for more rigidity.
- Affix labels so that important parts are not obscured, and place glue where required.

#### · Accessioning (Cataloguing)

The final step before filing the mounted or packaged collections in the herbarium is to assign accession numbers and to record the specific associated data in a computer-based file or an accession book. The amount of information recorded varies, but the more information you record, the more valuable the specimen is for future researchers. These records become the index for the herbarium collection. In some larger, more progressive institutions, the labelling program serves a dual purpose, and accession numbers are assigned and recorded automatically when the labels are produced. This system saves time in a large collection. An accession book is adequate for a small collection. Accession numbers are assigned chronologically as specimens arrive, for example, starting with number 000001.

#### .4.1 Accession equipment

- A high-quality, hardbound book (if a computerized system is not in place).
- A custom-made herbarium stamp and a sequential numbering stamp.
- Rapidograph or Staedtler drafting pens.

**.4.2 Accession technique** After the strapping glue has dried, stamp each sheet of mounted plants with the customized herbarium stamp (usually a circular/elliptical stamp with the institution's name and an area in the centre for the circulation number) and assign a unique accession number. Choose a standard place on the herbarium sheet (you should remember to leave a space for this when mounting).

Record information in the accession book or computer file. Accession numbers are always unique unless duplicate sheets of the same genus/species, collected at the same time and place, have different histories. For example, if one sheet is sent to Ottawa for identification and has an annotation label, this sheet should have an accession number different from the duplicate sheet that was not sent out for identification. The reason for this is that the person who did the identification may refer to these plants in a publication, and anyone wishing to see the sheet can immediately distinguish it by the unique accession number.

Parts of a plant that will not fit on a single herbarium sheet can be designated by letter (a, b, c). For example, in a Douglas-fir collection, the branch could be assigned 2159 a, the cones 2159 b, and the bark 2159 c.

When you set up the accessions database, keep in mind that you may later want to sort it in different ways. Choose the software carefully and consult an experienced user before entering the information, or you may produce an inflexible and unusable database.

Each herbarium is assigned its own international code, therefore, when referring to a particular sheet, an author may use the code with the accession number for clarification (e.g., UVIC 2159 ) The code for the University of Victoria is UVIC; for the Royal British Columbia Museum it is v.

## 4 STORAGE OF SPECIMENS

---

Once specimens have been identified, mounted, labelled, and accessioned, they should be frozen at  $-20^{\circ}\text{C}$  for 48 hours to kill insects, then stored in cabinets in a specially equipped room called a herbarium. Specimens could also be frozen if they have been sitting out for awhile during any of the above stages. Plant specimens, properly stored and handled, can be kept for a hundred years or more. Most herbaria store specimens on shelves in sealed metal cabinets (wooden cabinets may harbour insects). Proper storage involves the organization, handling, and maintenance of the collection. In all instances, the sheets should be enclosed in labelled **mo type 1 $\frac{1}{2}$  inch double-score genus covers** and a species cover with the genus cover (see Appendix 2).



#### 4.1 Organization

To be useful and accessible, a herbarium collection must be well organized. Many large herbaria follow a taxonomic sequence according to evolutionary history. The first division would be primitive plants such as ferns, fern-allies, and **gymnosperms** (conifers). **Angiosperms** (flowering plants) are usually divided into **monocotyledons** and **dicotyledons**. However, this type of arrangement is by no means universal. Many large collections are arranged alphabetically within major divisions.

At smaller herbaria, where the emphasis is on plant identification and the users are not trained taxonomists, it is easier to arrange all the specimens alphabetically by species within genera, and genera within families. This system would work well for a weed collection held in an agricultural office which is used mainly for identification of problem plants.

For collections from outside the province or collections of historical or special significance (such as an **ethnobotany** collection), specimens may be further separated with identifying codes or colours on the genus covers. The Royal British Columbia Museum herbarium stamps the special collection name on the lower right corner of the genus cover and uses colour-coded covers for out-of-province localities. Researchers and technicians can quickly work through a genus without looking at each folder. A genus/species represented by many sheets collected in a province may be further categorized by collection date. For example, 46 sheets of *Equisetum arvense* collected in British Columbia could be grouped according to collection year. One genus cover might hold six sheets collected between 1896 and 1935, the next, 10 sheets collected between 1936 and 1950, etc. This arrangement is especially useful to researchers looking for historical records in a given locality.

#### 4.2 Handling

Since mounted specimens can be expected to provide a taxonomic history covering a century or more, it is important that herbarium users handle them properly. Post rules, such as the following, in a prominent place and explain them to new users:

- Lift genus covers, with herbarium specimens held flat inside covers, from the herbarium cabinet, causing minimum disturbance to adjacent covers.
- Support the genus cover with cardboard or your palm and arm, and carry it horizontally to the examining table.
- Do not turn individual sheets over like pages of a book. Lift each sheet right side up using two hands and place it in a new stack.
- Support individual sheets with a piece of cardboard if they have to be moved to a different area.
- Note any specimens in need of repair or showing insect damage and bring them to the attention of herbarium staff.
- The herbarium staff will return the specimens to the cabinets to ensure correct placement.

#### 4.3 Maintenance

Once the collection is stored, periodic checks must be made to ensure that the plants are stable and not affected by insects or excessive moisture. Insects can seriously damage a herbarium collection. Even with the most meticulous care and the best equipment, insects are certain to attack the specimens at some time. Over the years, various ways have been tried to prevent insect damage, such as dipping the specimens in insecticide or

fumigating the plants, cabinets, or entire rooms. However, these methods have not been completely satisfactory and the chemicals used are a potential health hazard. Recently, freezing of plant material has proven to be a simple, effective, and efficient means of killing insects.

**4.3.1 Insects** If insects are discovered in herbarium cabinets, the entire contents of that cabinet and of adjacent cabinets should be scrutinized for signs of infestation. Look for nibble marks on leaves, bits of **frass** (which can be mistaken for soil particles), cast-off larval exoskeletons, or egg cases. Any suspect material should be frozen to prevent the spread of the problem. While the cabinet is empty, it can be vacuumed and wiped out to ensure eradication of the insects and eggs. At the curator's discretion, parts of the collection may be frozen on a rotating schedule.

Specimens should be frozen after they are dried, particularly if they will be sitting for long periods, and especially just before they are filed. This will prevent unnecessary contamination of the main collection. To freeze herbaria specimens:

- Stack mounted specimens in plastic bags with corrugated cardboard in between stacks for support, seal with twist ties (to prevent freezer burn), then carefully stack in a standard chest freezer.
- Freeze at  $-20^{\circ}\text{C}$  for 48 hours, remove and set aside. The plants become dry and brittle when frozen, so they must be allowed to thaw and recover lost moisture before being removed from the bags and filed.

**4.3.2 Moisture** Excessive moisture can also ruin a collection. A **hygro-thermograph** is a useful instrument to install in the collection area. This simple apparatus plots the temperature and humidity on a graph over weekly periods. If the range of temperature and humidity is large, herbarium staff can adjust the environment to keep them within a reasonable range.

## PART II: BRYOPHYTES AND LICHENS

### 1 COLLECTION OF SPECIMENS

---

The techniques for collecting, preserving, and storing bryophytes and lichens are slightly different from those for plants, and are not as well documented. The following brief summary will help you to collect and preserve them properly.

Bryophytes and lichens are often ignored when the more showy flowers of the vascular plants attract attention. You will have to learn to “see differently” and look in different places, but you will be richly rewarded once you start noticing these wonderfully diverse plant groups. Lichens are classified according to their growth forms:

- **Crustose:** attached over the entire thallus to the **substrate**;
- **Foliose:** bilaterally symmetrical and usually attached to substrate by **rhizines**; and
- **Fruticose:** radially symmetrical, **algal** cells surrounded by an outer layer of fungal cells.

Bryophytes include mosses and liverworts. Liverworts can be **thalloid** or leafy, but mosses are always leafy.

#### 1.1 Gathering the Specimens

**1.1.1 Collecting equipment** In addition to the basic collecting equipment (bags, pruning shears, notebook, pencils, felt marking pens, maps, and altimeter) some specialized equipment is needed for collecting bryophytes and lichens.

#### ***Bryophytes***

- A knife for prying the specimen from the substrate.
- Paper bags.
- Small plastic zipper bags are useful, especially if a large number of specimens will be collected during wet spring weather. The plastic bags allow for rapid identification later—no need to open and close bags or dump out the specimens. However, watch the specimens closely for mould as mosses decay very quickly if kept wet. You may want to dry the specimens at room temperature, or keep them in paper bags for transportation.

### ***Lichens***

- Hand lens, paper bags, rock hammer (or a stone chisel and hammer), safety glasses, and spray bottle.

**1.1.2 Collecting technique** Unlike vascular plants, you do not have to collect enough material to fill a herbarium sheet. Collect only enough material to fill two  $13.5 \times 10$  cm packets or enough to fill the palm of your hand. You may need more if you are going to send some away to be identified. See Figure 6 for the procedure for folding packets. A small wooden frame inserted inside the packet will help protect delicate specimens from damage. Do not collect samples if you suspect that the species is rare. Make a good photographic record instead.

### ***Bryophytes***

- Collect specimens in the **sporophyte** phase whenever possible. The presence of sporophytes is often needed for accurate identification.
- If the liverwort is growing on a tree, collect some of the bark.

### ***Lichens***

- Before attempting to collect very dry, brittle lichens, mist them with a spray bottle.
- Try to collect lichen specimens growing on small rocks; if they are closely attached to the substrate, collect a portion of the attached substrate.
- For lichens growing on trees, include a small amount of bark or a piece of twig.
- If several lichen species are found growing together, separate and bag them individually.

**1.1.3 Collection number** Lichenologists use a number of different systems of assigning field numbers, but the choice is up to the individual collector. In most cases the same method used for assigning field numbers to vascular plants is also used for bryophytes and lichens.

### **1.1.4 Protection in the field**

#### ***Bryophytes***

- Bryophyte specimens should be kept cool and moist, or air dried immediately.
- If bryophytes are to be transported long distances in plastic bags, blow up the bags before sealing to prevent crushing the specimens. Ensure that they are kept cool and out of the sun, otherwise mould will quickly form and ruin the specimens.
- Many leafy liverworts have cellular oil bodies (necessary for identification) that are destroyed if allowed to dry out.
- Many thallose liverworts are impossible to identify after they have dried and should therefore be identified as soon as possible after collection, or refrigerated until they can be identified.

#### ***Lichens***

- Lichen specimens should be kept dry.

In addition to the information listed for vascular plants, you should record several other variables that are often important in identifying bryophytes and lichens.

#### 1.2.1 Habitat information

**Substrate:** Many identification keys use substrate as a character to separate species, e.g., rotten wood, living trunk, branch, humus, mineral soil, rock.

**Forest type:** This information indicates the degree of exposure, e.g., open, shady, humid, closed, exposed.

**Ecosystem:** The nature of the surrounding vegetation, e.g., lowland, subalpine, or specific biogeoclimatic zone and subzone.

## 2 PRESERVATION OF SPECIMENS

---

Since bryophytes and lichens are usually air dried to keep their three-dimensional form rather than pressed, you need not carry a plant press. You are only faced with the problem of finding a large, dry, airy space to dry your specimens. However, lichens and mosses may be lightly pressed if they are re-wetted and manipulated to conform to a particular shape. Drying is crucial, as the specimens may rot or become brittle if they are not properly dried.

- Specimens are superior when dried in the packets in which they will be stored, since they will conform to the shape of the envelope and maintain their three-dimensional form. However, staining of the packets can pose a problem in some instances.
- Moisten overly dry specimens with a spray bottle and gently work into the required form. Some light pressing may be beneficial in these circumstances.

#### 2.1.1 Bryophytes

- Mosses, such as *Sphagnum*, may retain water unless they are squeezed well when collected.
- Tease mosses apart before drying so that the natural growth pattern is clearly represented. Make sure that important structures are visible.

#### 2.1.2 Lichens

- Lichens with blue-green **cyanobacteria** (e.g., *Lobaria*, *Peltigera*, *Sticta*, and *Leptogium*) are more susceptible to rot and discoloration and should be dried as soon as possible after collection.

Processing bryophytes and lichens is quite different from processing vascular plants. Different tools and techniques are used for identification and the plants are not mounted on herbarium sheets, but are stored in envelopes. However, preparation and accessioning are the same as for the flowering plants.

### 3.1 Identification

Just as there are taxonomically difficult groups of vascular plants, bryophytes and lichens have them too. Within lichens, the genus *Usnea* and *Stereocaulon* are particularly hard to identify correctly. Several of the references specific to bryophytes and lichens listed in Appendix 5 give detailed instructions and techniques for identification. If the process is not clear from these texts, ask someone with experience.

#### 3.1.1 Identification equipment

- Dissecting kit that includes fine forceps.
- Dropper bottle filled with distilled water (so the colour of the lichen does not change when moistened).
- Slides and coverslips.
- Light microscope and dissecting microscope.
- Razor blades.
- Chemicals for colour tests of lichens.

### 3.2 Mounting

Bryophytes and lichens are best kept in folded packets in their original three-dimensional form rather than pressed and glued on a sheet (Figure 6).

#### 3.2.1 Mounting equipment

- Sheets of acid-free paper (14 cm × 28 cm), acid-free index cards (7.5 cm × 10 cm), glue, balsa strips or rough tissue.

#### 3.2.2 Mounting techniques

- Stamp or write the accession number on the label before it is glued to the packet to prevent damage to the specimens.
- If the specimen is not identified, the label can be put inside the envelope and completed at a later date.
- Insert a piece of acid-free mounting paper or file card into the packet to provide rigidity.
- Attach lichen specimens to the card by applying glue to the substrate and pressing it onto the card. If the substrate is bulky, it can be thin-sectioned before gluing.

- Brush watered-down glue lightly onto soil clinging to rhizines if removal would damage the specimen. When dry, you have a translucent, but stable mass that can be glued to the card.
- Lichens like *Calicium* are extremely delicate and rubbing against the packet can destroy them. To prevent this, glue balsa-wood strips (slightly thicker than the specimen) to the stiff card. This frames the lichen and the packet rubs the wood strips, not the specimen.
- You could also line the card with a piece of rough-textured tissue to prevent the lichens from sliding to the bottom of the packet on top of each other.

Bryophytes and lichens are stored in separate sections of the main herbarium. They are often filed alphabetically by genera without the familial arrangement used for vascular plants. Packets may be stored by placing them upright in drawers or in narrow boxes (such as shoe boxes). The shoe-box method conserves space and is suitable in situations where proper storage cabinets are not available. Care must be taken to allow considerable room between packets so the specimens do not get crushed. The same precautions concerning insect infestations should be taken when dealing with bryophyte and lichen collections as with vascular plant collections. See Storage of Specimens in Part 1.

Collecting  
vascular plants

**Basic Equipment**

Topographic maps  
 Waterproof tags  
 Permanent felt markers  
 Plastic and paper bags of various sizes  
 Knife  
 Leather gardening gloves  
 Waterproof field notebook  
 Small altimeter  
 Soft lead pencils/sharpener  
 Hand lens  
 Trowel or shovel  
 Dandelion tool  
 Pruning shears or secateurs  
 Pruning saw  
 Data stamp  
 Soil charts  
 Plant press with adjustable straps  
 Newsprint (flimsies)  
 Cardboard separator sheets (45 × 30 cm)  
 Foam sheets (45 × 30 × 2 cm)  
 Seed packets of acid-free paper  
 Felt blotting paper (45 × 30 cm)

Specialty  
collecting equipment

**Aquatic specimens**

Telescoping pole with prongs or a leaf rake  
 Plastic food containers with lids  
 Plastic zipper bags  
 White plastic slate, wax marking pencil  
 Snorkelling or scuba equipment

**Bryophytes and lichens**

Rock hammer (or stone chisel and hammer)  
 Spray bottle  
 Safety glasses  
 Hand lens  
 Plastic zipper bags  
 Fixed-blade knife  
 Paper bags

Drying

Portable light-bulb dryer or commercial plant dryer



**Appendix 1** *Continued*

Identification	Dissecting kit Wetting solution and dropper (see Appendix 2 for recipe) Heavy glass plate (approximately 20 × 20 cm) Dissecting microscope Associated floras and keys Terminology handbook Razor blades/scalpel Chemicals (for lichens) Needle-point scissors Slides and cover slips Adequate lighting
Mounting	Large table/counter Acid-free mounting paper ( 0 × 42 cm) Acid-free seed envelopes Glue in hand-held dispensers Finished acid-free labels Wooden spacer blocks (2" × 2" and various lengths) Weights, plastic-coated lead bars or metal washers Linen thread and needle/linen tape Probe/Dissecting needle Scissors or pruning shears Damp cloth for wiping glue spills Garbage can Cardboard sheets Lab coat, apron or old clothes Acid-free index cards Balsa-wood strips or rough tissue
Accessioning (cataloguing)	Accession book/computerized record Drafting pens (Rapidograph or Staedtler) Custom-made herbarium stamp Sequential numbering stamp
Storage	Chest freezer Herbarium cabinets/shelves Shoe boxes (for bryophytes and lichens) Species covers/genus covers (MO type 1½" double score) Coloured markers or labels Hygrothermograph Custom-made stamps for special collections

Paper suppliers	<p>Pacific Papers, P.O. Box 606, Cotati, CA 94931. Phone: 1-800-676-1151. Fax: 1-707-824-9106.</p> <p>Barber-Ellis, Price Daxion, Coast Paper, Crown Paper, Island Paper Mills, Queen's Printer, and others.</p> <p>Herbarium Supply Company, 955 West Catching Inlet (1992), Coos Bay, OR 7420.</p> <p>University Products Inc., P.O. Box 101, 517 Main Street, Holyoke, MA 01041.</p>
Altimeters	<p>Compact and accurate altimeters are now sold at a reasonable price in some bicycle and outdoor equipment stores, or by mail order.</p>
Cardboard separator sheets	<p>These sheets can be specially cut from large sheets of two-faced, corrugated cardboard, a minimum order of 10 sheets will provide approximately 200 (45 × 30 cm) mounting sheets. Make sure the supplier cuts them so the corrugations run side to side across the short distance. (This is important for rigidity and airflow.) Supplier: Instabox Vancouver Ltd. Phone: 604-420-3134.</p>
Cone boxes	<p>Cone boxes can be made of heavy paper or plastic and should be approximately 16 × 11 × 9 cm.</p> <p>Plastic boxes: Murphy Packaging, Huntingdon Valley Industrial Center, 1957 Pioneer Rd., Huntingdon Valley, PA 19006. Phone: 215-674-1260.</p> <p>Rigid paper boxes: Try any box manufacturer in the Yellow Pages, especially if they supply jewellery stores.</p>
Dissection kits	<p>Instead of buying the whole set you may be able to purchase instruments separately, e.g., forceps, scalpel, picks, and probes. Supplier: university bookstores, science or medical supply outlets.</p>
Foam sheets	<p>Purchase 1 cm or 2.5 cm-thick foam from a local supplier in partial rolls or sheets, then cut into 45 × 30 cm pieces to fit the plant press.</p>
Genus covers	<p>Manilla, acid-free "MO type ½" double score" with dimensions 30 × 42 cm when folded. Supplier: Herbarium Supply or Pacific Papers.</p>
Species covers	<p>Manila, acid free 16" × 11<sup>9</sup>/<sub>16</sub>" folded.</p>
Glue (pH neutral)	<p>Wilhold (registered trademark) Glu-Bird, White glue with Orthonol. Manufactured by DAP Inc. Dayton, OH 85401. Stock No. 2120. Supplier: Herbarium Supply or Pacific Papers. Resyn 5773, Vinyl acetate copolymer. Produced and distributed by Nacan Products Limited, 60 West Drive, Brampton, ON L6T 4W7.</p>

**Appendix 2** *Continued*

Herbarium cabinets	Cabinets can be made locally by sheet-metal manufacturers to required dimensions. RBCM suppliers: Professional Components, Box 2175, Sidney, BC V8L 3S6. Phone: 604-656-6165. Associated Sheet Metal Company, 875 Viewfield Road, Victoria, BC V9A 4V2. Phone: 604-385-4100. Lane Science Equipment, 105 Chambers Street, New York, NY 10007.
Hygrothermograph	Try scientific supply outlets. They are either battery operated or hand wound. Manufactured by Cole Parmer Instrument Company, Chicago, IL 60648.
Lead weights	Weights can be made from melted-down fishing weights poured into moulds. Discarded lead-alloy bars can be cut into desired lengths.
Maps	Maps are available in British Columbia at government agent offices or in retail stores (if agent no longer carries them). They can also be mail-ordered from Maps BC, 4th floor, 1802 Douglas St., Victoria, BC V8V 1X4. Phone: 604-387-1441. Prepayment required.
Mounting paper	Acid-free, heavy weight, 100% rag content, off-white 30 × 42 cm sheets. Supplier: Herbarium Supply, University Products Inc., Crown Paper or Pacific Papers.
Newsprint	Specially cut from larger sheets of unbleached newsprint. Minimum order of 500 sheets provides 1000 (45 × 60 cm) flimsies. Suppliers: various paper suppliers.
Notebooks	Duksbak or “Rite in the Rain” surveyor books have waterproof pages. Replacement pages are available. Suppliers: surveyor supply stores.
Packets for seed fragments, bryophytes, and lichens) Plant press	Acid-free paper is readily available and can be folded to make packets. Most wholesalers have a 500- or 1000-sheet minimum. Suppliers: various paper suppliers.  Ask a local woodworker to quote a price for making the hardwood end pieces of the frame. Frame straps can be sewn at home (or use two rivets), or on a commercial machine (i.e., at a shoe repair establishment) using webbing rivets and quick-release buckles available at many outdoor sports stores or tent and awning suppliers. Suppliers: Herbarium Supply (ready-made).
Spacer blocks	Ask a local carpenter to choose laminated (layered) wood to prevent warping, with minimal slivers and to cut blocks of 2 cm <sup>2</sup> to various lengths and sand smooth.
Wetting solution	Recipe courtesy of University of Victoria herbarium: 1 gram of dioctyl sulfosuccinate (sodium salt) mixed with 100 ml of 25% methanol. Try chemical supply houses for the ingredients.

**Royal British Columbia Museum Herbarium**

Belleville Street  
Victoria, BC V8V 1X4  
Phone: 604-387-3701

**University of Victoria Herbarium**

Biology Department  
Box 1700  
University of Victoria  
Victoria, BC V8W 2Y2  
Phone: 604-721-7097

**University of British Columbia Herbarium**

Botany Department  
University Boulevard  
Vancouver, BC V6T 1Z4  
Phone: 604-228-3344

**Vascular Plant Herbarium**

Biosystematics Research Centre  
Agriculture Canada  
William Saunders Building  
Central Experimental Farm  
Ottawa, ON K1A 0G6  
Phone: 613-996-1665

**Canadian Museum of Nature Herbarium**

Vascular Plant Section  
Botany Division  
P.O. Box 3443  
Station D  
Ottawa, ON K1P 6P4  
Phone: 613-990-6453

**Ministry of Forests**

515 Columbia Street  
Kamloops, BC V2C 2T7  
Phone: 604-398-4345  
(over 2000 specimens)

**Ministry of Forests**

3726 Alfred Street  
Smithers, BC VOJ 2N0  
Phone: 604-847-7484  
(4000 vascular, 1300 cryptograms)

**Ministry of Environment, Lands and Parks**

765 Broughton Street  
Victoria, BC V8W 1E2  
Phone: 604-387-9513  
(10 000 aquatic plants)

**Ministry of Forests**

540 Borland Street  
Williams Lake, BC V2G 1R8  
Phone: 604-398-4403  
(4000 specimens)

**Ministry of Forests**

1011 4th Avenue  
Prince George, BC V2L 3H9  
Phone: 604-565-6133  
(over 2000 specimens)

**Agriculture Canada**

Research Station  
3015 Ord Road  
Kamloops, BC V2B 8A9  
Phone: 604-376-5565

*Note:* Most small herbaria do not have a permanent staff member responsible for the collection, so always phone well in advance if you wish to use the collection. Local flora donations are usually more than welcome, especially if they are from remote or uncollected areas, or are specimens not generally collected. Make sure all data accompanies your collection and be prepared to donate some time as well.

**accessioning:** cataloguing mounted botanical specimens into a collection by assigning a sequential number (accession number) unique to each sheet or specimen packet.

**algae:** a collective term for several groups of relatively simple plants. In some **lichen** species, photosynthetic algal cells—usually grass-green in colour—provide the lichen fungus with its carbohydrate requirements. In other lichen species, the photosynthetic cells are **cyanobacteria**.

**altimeter:** an instrument for measuring height above sea level.

**angiosperms:** plants that produce flowers (e.g., asters, lilies, roses); the seeds are enclosed in an ovary. Compare **gymnosperms**.

**annotation label:** a label attached to a herbarium sheet (usually attached to the left of the original label), which confers or changes the scientific name of the specimen; the label shows the name of the person making the identification (**determinavit**) and the date of annotation.

**biogeoclimatic zone:** a unit of the system used in British Columbia to classify segments of the landscape (ecosystems); each unit is characterized by a unique set of variables (biological, geological, climatic) and supports a unique vegetation; units are identified by a letter code based on one or more of the dominant climax species (e.g., CDF zone = Coastal Douglas-fir zone).

**bryophyte:** a plant division containing mosses, liverworts, and hornworts; plants that do not contain a **vascular** system and always have alternation of generations with distinct **sporophyte** and **gametophyte** generations.

**clinometer:** an instrument for determining the angle of slope.

**collection number:** a number assigned to a specimen when it is collected. Collectors use several numbering systems, either sequential or coded to identify the year or project.

**corm:** a short, broad, underground stem composed of layers of leaf tissue.

**cortex:** in lichens, the hardened outer “skin” consisting of closely packed fungal threads.

**crustose:** a lichen growth form (“crusty”); the lichen is closely attached to the substrate, and has no lower cortex layer.

**cyanobacteria:** in some lichen species, the photosynthetic cells—usually blue-green in colour—from which the lichen fungus derives its carbohydrate requirements. In other lichen species, the photosynthetic cells are **algae**.

**determinavit:** the person who identifies a specimen, or who changes (annotates) a species identification; abbreviated on the **herbarium** or **annotation label** as DET.

*Appendix 5 Continued*

**dicotyledons:** a group of **angiosperms** having two seed leaves or cotyledons (e.g., buttercups, peas, roses). Compare **monocotyledons**.

**ethnobotany:** the study of the relationships between people and plants; the study of plants used by aboriginal peoples for food, clothing, medicine, or shelter.

**family:** in biology, a group of related **genera**.

**fimsy:** a folded newsprint sheet used in pressing plants.

**flora:** 1) the plant life characteristic of a particular geographic area; 2) a botanical manual from which plants can be identified with the use of **keys**.

**foliose:** a lichen growth form (“leaf-like”); the lichen is bilaterally symmetrical, usually attached to the **substrate** by **rhizines**, and has an upper and lower **cortex** layer.

**frass:** insect droppings; presence indicates an insect infestation in the collection.

**fruticose:** a lichen growth form (“shrub-like”); the lichen is radially symmetrical and has a surrounding cortex layer.

**gametophyte:** the non-reproductive phase of a plant that reproduces by alternation of generations (e.g., mosses). Compare **sporophyte**.

**genus (s.), genera (pl.):** a group of closely related **species**.

**genus cover:** a cardboard folder containing sheets of pressed specimens of one genus.

**Geographic Information System (GIS):** a digital information system that allows for input, storage, analysis, and manipulation of special data and associated attributes; for example, a specific locality can be linked to information on biogeoclimatic zone, drainage systems, legal ownership, soil, species, existing collections, research reports, etc.

**gymnosperms:** conifers and their allies (e.g., Douglas-fir, pine); the seeds are “naked” and usually borne in cones. Compare **angiosperms**.

**herbarium:** a reference collection of pressed, dried (preserved), botanical specimens.

**herbarium sheet:** acid-free, heavy weight, 100% rag content, off-white 30 × 42 cm sheets for mounting botanical specimens.

**hydric:** aquatic environment. Compare **hygric**, **mesic**, **xeric**.

**hygric:** damp environment. Compare **hydric**, **mesic**, **xeric**.

**hygrothermograph:** an instrument that measures and records changes in air temperature and humidity.

**involucre bracts:** small, leaf-like structures subtending a flower head or group of flowers.

*Appendix 5 Continued*

**key:** in botany, a plant identification tool; a series of steps where the presence or absence of a characteristic eliminates possible choices.

**lichen:** a plant formed by the permanent symbiotic relationship of a fungus with photosynthetic **algae** or **cyanobacteria** cells; these cells are interwoven with filaments of the fungus to form a plant body that may be **crustose**, **foliose**, or **fruticose** in growth form.

**ligule:** tongue or scale-like outgrowth from a leaf or from inside a grass sheath; found in club mosses and some grasses.

**mesic:** an environment that is neither dry nor moist (middle). Compare **hydric**, **hygric**, **xeric**.

**MO type ½ inch double-score genus covers:** Missouri Botanical Garden Herbarium (code = MO) genus covers, crimped twice to form a spine (double scored).

**monocotyledons:** a group of **angiosperms** having one seed leaf or cotyledon (e.g., lilies, grasses, orchids, sedges). Compare **dicotyledons**.

**morphological characteristics:** the forms and structures of plants used in identification (e.g., floral parts, reproductive parts, leaves, roots).

**nodes:** the point of attachment of leaves to stem.

**petiole:** the stalk of a leaf.

**rhizines:** in lichens, rootlike hairs or bundles of fungal threads that attach the **thallus** to the **substrate**.

**species:** the narrowest taxonomic grouping; a group of closely related animals or plants that are capable of interbreeding.

**sporophyte:** the spore-bearing or reproductive phase of a plant that reproduces by alternation of generations (e.g., mosses). Compare **gametophyte**.

**substrate:** the surface on which the plant grows (e.g., wood, bark, soil, rock).

**taxonomist:** a scientist who specializes in the classification of organisms.

**taxonomy:** the study of the classification of organisms.

**thalloid:** a liverwort growth form, having a **thallus**, as opposed to “leafy.”

**thallus (s.) thalli (pl.):** the vegetative body of a lichen.

**Universal Transverse Mercator (UTM):** a map location system based on a metric grid reference; the grid and instructions can be found on Natural Resources Canada topographic maps.

**vascular plant:** a plant containing tissues (xylem/phloem) for transporting water, which also give mechanical support.



**Appendix 5** *Concluded.*

**voucher specimen:** a specimen maintained in a collection or herbarium that is associated with specific research or referred to in a report; may include type specimens, or specimens from a flora or consultant report.

**xeric:** dry environment. Compare **hydric**, **hygric**, **mesic**.

Floras and  
field guides

- Anderson, J.P. 1959. Flora of Alaska and adjacent parts of Canada. Iowa State Univ. Press, Ames, Iowa.
- Calder, J.A. and R.L. Taylor. 1968. Flora of the Queen Charlotte Islands. Parts I–II, Can. Dept. Agric., Res. Br. Ottawa, Ont. Monogr. No. 4.
- Canada Soil Survey Committee. 1978. The Canadian system of soil classification. Can. Dep. Agric., Ottawa, Ont. Publ. 1646.
- Douglas, G.W., G.B. Straley, and D.V. Meidinger. 1989. The vascular plants of British Columbia. Parts I–IV. B.C. Min. For., Res. Br. Victoria, B.C.
- Frankton, C. and G.A. Mulligan. 1970. Weeds of Canada. Revised ed. Can. Dep. Agric. Ottawa, Ont. Publ. No. 948.
- Goward, T., B. McCune, and D. Meidinger. 1994. The Lichens of British Columbia, illustrated keys. Part 1, foliose and squamulose species. B.C. Min. For., Res. Br. Victoria, B.C. Spec. Rep. 8.
- Hitchcock, C.L. and A. Cronquist. 1981. Flora of the Pacific Northwest. Abridged ed. Univ. Wash. Press. Seattle, Wash.
- Hitchcock, C.L., A. Cronquist, M. Ownbey, and J.W. Thompson. 1955–1969. Vascular plants of the Pacific Northwest. Parts 1–5. Univ. Wash. Press. Seattle, Wash.
- Hosie, R.C. 1969. Native trees of Canada. 7th ed. Dept. Env., Can. For. Serv., Ottawa, Ont.
- Hulten, E. 1968. Flora of Alaska and neighboring territories. Stanford Univ. Press. Stanford, Calif.
- Kuijt, J. 1982. A flora of Waterton Lakes National Park. Univ. Alta. Press. Edmonton, Alta.
- Lawton, E. 1971. Moss flora of the Pacific Northwest. Hattori Bot. Lab. Nichinan. Miyazaki, Japan.
- Lyons, C.P. 1976. Trees, shrubs and flowers to know in British Columbia. J.M. Dent and Sons. Vancouver, B.C.
- MacKinnon, A. and J. Pojar (editors). 1994. Plants of coastal British Columbia. Lone Pine Publ. Edmonton, Alta.
- MacKinnon, A., J. Pojar, and R. Coupé (editors) 1992. Plants of northern British Columbia. Lone Pine Publ. Edmonton, Alta.
- Moss, E.H. 1959. Flora of Alberta. Revised by J. Packer. Univ. Toronto Press. Toronto, Ont.
- Schofield, W.B. 1992. Some common mosses of British Columbia. Roy. B.C. Mus. Victoria, B.C. Reprint of Handbook 28.
- Scoggan, H.J. 1978–1979. The flora of Canada. Parts 1–4. National Mus. Nat. Sci. Pub. Bot., No. 7:1–1626.

**Appendix 6** *Continued*

- Vitt, Dale H., J.E. Marsh, and R. Bovey. 1988. Mosses, lichens and ferns of northwest North America. Lone Pine Publ. Edmonton, Alta.
- Warrington, P.D. 1988. Aquatic plants of British Columbia: common names, selected references, synonymy and classification by life-forms and habitat. B.C. Min. Environ. and Parks, Water Manage. Br. Victoria, B.C.
- Welsh, S.L. 1974. Anderson's flora of Alaska and adjacent part of Canada. Brigham Young Univ. Press. Provo, Utah.
- Manuals
- Conrad, H.S. 1944. How to know the mosses. 2nd ed. Wm. C. Brown Co. Dubuque, Iowa.
- Conrad, H.S. 1979. How to know the mosses and liverworts. 2nd ed. Wm. C. Brown Co. Dubuque, Iowa.
- Douglas, G.W., A. Ceska, and G. Ruyle. 1983. A floristic bibliography for British Columbia. B.C. Min. For., Victoria, B.C. Land Manage. Rep. 15.
- Douglas, G.W., G.B. Straley, and D. Meidinger (editors). 1989. The vascular plants of British Columbia. Part 1, gymnosperms and dicotyledons (Aceraceae through Cucurbitaceae). B.C. Min. For., Res. Br. Victoria, B.C. Spec. Rep. 1.
- Douglas, G.W., G.B. Straley, and D. Meidinger (editors). 1990. The vascular plants of British Columbia. Part 2, dicotyledons (Diapensiaceae through Portulacaceae). B.C. Min. For., Res. Br. Victoria, B.C. Spec. Rep. 2.
- Douglas, G.W., G.B. Straley, and D. Meidinger (editors). 1991. The vascular plants of British Columbia. Part 3, dicotyledons (Primulaceae through Zygophyllaceae) and Pteridophytes. B.C. Min. For., Res. Br. Victoria, B.C. Spec. Rep. 3.
- Douglas, G.W., G.B. Straley, and D. Meidinger (editors). 1994. The vascular plants of British Columbia. Part 4, monocotyledons. B.C. Min. For., Res. Br. Victoria, B.C. Spec. Rep. 4.
- Habitat Monitoring Committee. 1990. Procedures for environmental monitoring in range and wildlife habitat management. B.C. Min. Environ. in co-operation with B.C. Min. For. Victoria, B.C.
- Hale, M.E. 1979. How to know the lichens. 2nd ed. Wm. C. Brown Co. Dubuque, Iowa.
- Luttmerding, H.A., D.A. Demarchi, E.C. Lea, T. Vold, and D.V. Meidinger. 1990. Describing ecosystems in the field, 2nd ed. B.C. Min. Environ. in co-operation with B.C. Min. For. Victoria, B.C. MOE Manual 11.
- Meidinger, D.V. 1987. Recommended vernacular names for common plants of British Columbia. B.C. Min. For. and Lands, Res. Br. Victoria, B.C.

**Appendix 6** *Concluded.*

- Checklists
- Meidinger, D.V. and J. Pojar. 1991. *Ecosystems of British Columbia*. B.C. Min. For. Res. Br. Victoria, B.C.
- Ireland, R.R., G.R. Brassard, W.B. Schofield, and D. Vitt. 1987. Checklist of the mosses of Canada II. *Lindbergia*, 13:1–62, Copenhagen, Denmark.
- Kartesz, J.T. and R. Kartesz. 1980. A synonymized checklist of vascular flora of the United States, Canada and Greenland, Volume II. The biota of North America. North Carolina Botanic Garden, Univ. N. Carolina Press. Chapel Hill, N.C.
- Noble, W.J., T. Ahti, G.F. Otto, and I.M. Brodo. 1987. A second checklist and bibliography of the lichens and allied fungi of British Columbia. *Nat. Mus. Can. Ottawa, Ont. Syllogeus* 61.
- Taylor, R.L. and B. MacBryde. 1977. *Vascular plants of British Columbia: A descriptive resource inventory*. The Botanical Garden, Univ. B.C. Press. Vancouver, B.C. Tech. Bull. No. 4.
- Techniques
- Brayshaw, T.C. 1973. *Plant collecting for the amateur*. 1, Roy. B.C. Mus. Victoria, B.C. Museum Methods Manual.
- Foreman, L. and D. Bridson. 1989. *The herbarium handbook*. Royal Botanic Garden. London, U.K.
- Warrington, P.D. 1983. *A field manual and guide to the collecting and preserving of B.C. aquatic plants*. B.C. Min. Environ., Water Manage. Br. Victoria, B.C.
- Taxonomy and Terminology
- Harns, G. and M.W. Harris. 1994. *Plant identification terminology. An illustrated glossary*. Spring Lake, Utah.
- Harrington, H.D. and L.W. Durrell. 1957. *How to identify plants*. The Swallow Press. Chicago, Ill.
- Holmgren, P.K., N.H. Holmgren, and L.C. Barnett (editors). 1990. *Index herbarium, Part I: The herbaria of the world*. New York Botanical Garden. New York, N.Y.
- Lawrence, G.H.M. 1955. *An introduction to plant taxonomy*. Macmillan Publ. Co. New York, N.Y.
- Stearn, W.T. 1973. *Botanical Latin. History, grammar, syntax, terminology and vocabulary*. 2nd ed. David and Charles Holdings, Newton Abbot Ltd. Devon, G.B.