

# How to Build a Table



All the Basics Plus  
One Beautiful Project Plan

# How Tables Work

BY ROBERT W. LANG

Numerous shapes, forms and functions share a common set of issues.

A good furniture maker is part artist and part engineer. An overemphasis on either side of this equation leads to furniture that is ugly, impractical or both. Tables are especially vulnerable in this regard. Tables serve many purposes and are simpler than cabinets or chairs. But this simplicity calls for a thorough knowledge of how wood works when in the form of a large flat surface and an underlying structure.

Regardless of style, there are many mistakes lying in wait to spoil the plans of the would-be table maker. Whether you are new to the craft and getting ready to make your first occasional table or are more experienced and aiming to build a showpiece for your dining room, there are many aspects of table design that you need to consider.

## Shape and Size

The design process begins with establishing practical parameters. A dining table needs to accommodate a certain number of people on a regular basis, and more on special occasions. An end table provides space for a lamp and a beverage, and an entry table may hold a vase, the mail or your keys.

In addition to being the right size for its use, a table must also fit in the available space. Seating 12 for Thanksgiving dinner is a worthy goal, but not at the expense of daily navigation through the dining room.

At this early stage of the process, a scale drawing of the room or a 3D model in SketchUp will allow you to consider alternatives. Changing your mind at this stage is much easier than it is after you start cutting wood.

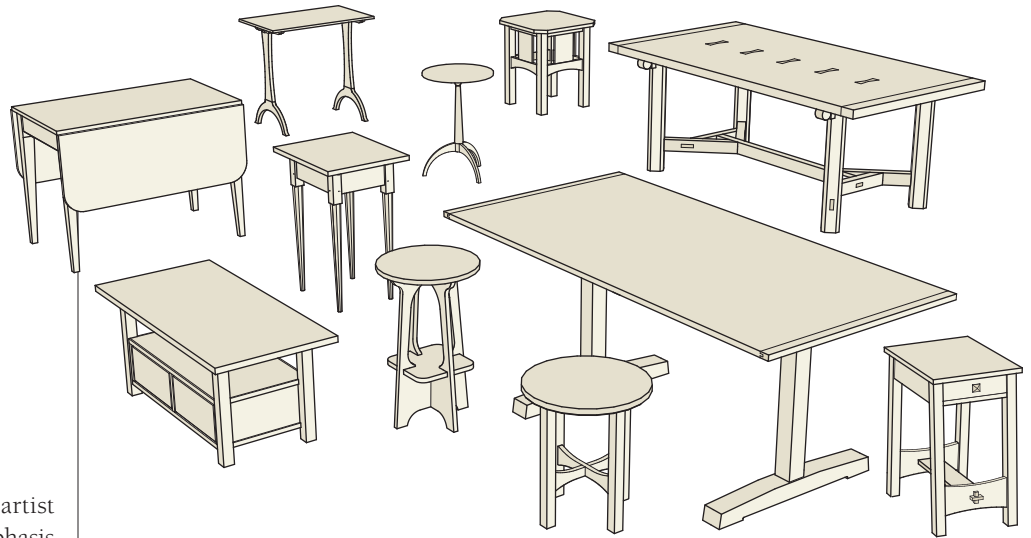

**Form follows function.** Tables of different sizes, made for different uses, share a common set of engineering problems.

If you find it difficult to visualize things on paper or on the computer screen, you can mock up sizes and shapes with cardboard. Put your idea together with packing tape, place it in the room and live with it for a day or two. You don't want to invest the effort to build the real thing only to hear, "I didn't realize it would be like that" from someone you love when you're done.

Consider also how shapes play a role. Rectangles are easy shapes to make, but sharp corners are painful reminders of too much table in too little space. Rounded shapes are more adaptable if you need to squeeze in an extra diner or two, but will be more demanding to build. Clipping square corners will protect

your hips or shins if you need to make the most of a tight space.

For dining tables, a simple ratio of human body to perimeter space rarely works. Consider the available space at corners or across the table, and how that affects the table's function. The drawings below give some examples, and an article adapted from my book "Drafting & Design for Woodworkers" (Popular Woodworking Books), gives many more (see "Go Online" at the end of the story).

Perfect the plan first, then work on establishing the proper height for the structural elements. Standard heights have evolved over the years for the distance from floor to tabletop for different types of tables. You may want to

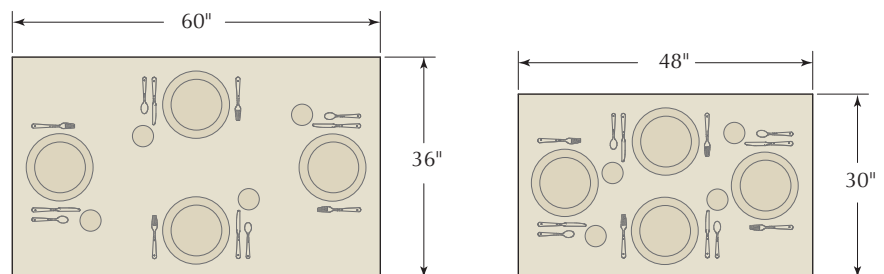

**How many for dinner?** A rule of thumb for seating is to allow 24"-30" per person around the perimeter of the table. But you also must consider the shape and overall size of the table. Extra space is needed at each corner, and while a narrow table may accommodate two settings across from each other, there may not be room for serving dishes in between. There is no substitute for a scaled layout. More examples are online at [popularwoodworking.com/apr10](http://popularwoodworking.com/apr10).

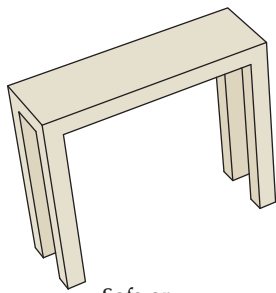

**Sofa or Entry Tables**  
28"-42" high  
12"-18" deep  
30"-48" wide

**End or Lamp Tables**  
16"-20" high  
18"-24" deep  
24"-42" wide

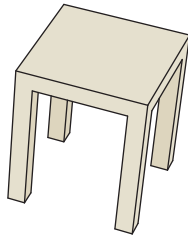

**Coffee or Cocktail Tables**  
16"-20" high  
18"-24" deep  
24"-42" wide

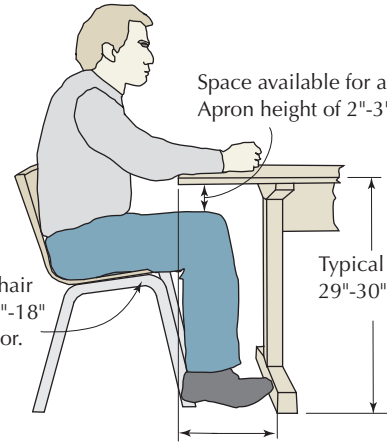
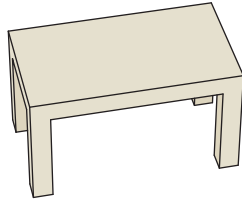

Space available for apron is limited. Apron height of 2"-3" is typical.

Typical chair seat is 16"-18" above floor.

Typical dining table is 29"-30" above floor.

Balance the need to support end of table with clearance for feet. 10"-12" minimum, 16"-18" ideal.

**Standard is a range.** This range of sizes for occasional tables is only a guideline; there are no laws in furniture design.

**Tight squeeze.** Dining tables and desks don't leave much room for experimentation. If in doubt, pull up a chair and grab a yardstick.

vary the height to suit your needs, but consider the consequences. Restaurants often provide tables an odd height to make people uncomfortable so they won't linger.

Desks and dining tables must also be able to accommodate a chair, and the person on the chair, with enough room between the table and wall to get in and out. Compare what you are considering to existing designs, and spend a few minutes with a yardstick, a folding chair and a card table and you'll find out if the dimensions you're considering will work in real life.

### Start on Top

With the overall parameters of size and shape established, stylistic and structural details are next in line. Here is where the balance between structure and style is most important. As you develop your plan, consider the forces that will be working against you. Considerations one and two are movement of the top, and leverage on the ends of the legs.

A solid-wood top will move across the grain as the seasons change. Moisture (or the lack of it) in the air will migrate to (or from) the top and it will change in width. The number of variables involved makes predicting how much change will take place a guessing game, but it will happen. This is a force that you can't control, but you can design around it.

In most table designs, the top and the base are individual units that work together. The connection between the two must be strong, with some provision for the top to shrink and swell. Cabinetmaker's buttons and figure-8 fasteners are time-tested solutions. If someone

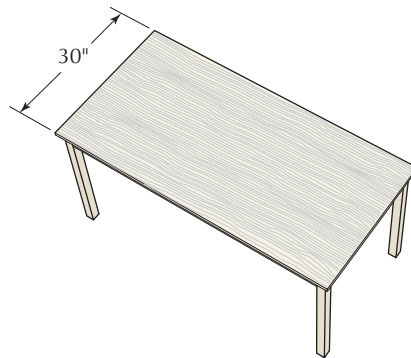

**Irresistible force.** Wood movement can't be stopped, but it can be accommodated. When attaching a top to a base, use fasteners that will slide or swivel.

suggests a method to you that includes the phrase, "that will keep it from moving," be aware that you are listening to a fool.

Wood movement can't be controlled, but it can be directed. In a dining table you can screw the top to the base in the center and use sliding fasteners on the perimeter to let the top move equally toward each long edge. On a desk, you can use a solid connection at the front edge to maintain appearances and force the results of the movement to the back.

In most tables, the wood grain will be in line with the longest dimension of the table. If you want an attractive table, use the widest material you can find and arrange the individual boards for the most attractive appearance. Historically, tables were made this way without suffering any dire results.

The common advice to use narrow strips and to alternate the direction of growth rings may have some merit if you're operating a large

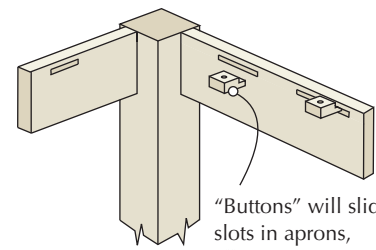

"Buttons" will slide in slots in aprons, allowing top to move.

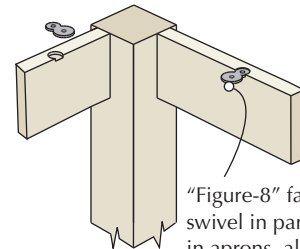

"Figure-8" fasteners swivel in partial hole in aprons, allowing top to move.

**Go with the flow.** Attach the top to the base structure with a method that allows the top to expand and contract with fluctuations in humidity.

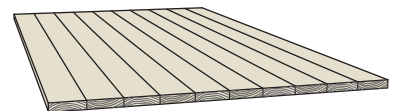
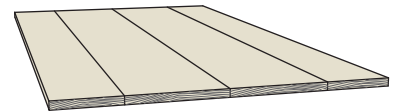

**No advantage to ugly.** If you want an attractive top, use the widest boards available and arrange them for appearance (top). Gluing tops from many thin strips with alternating end grain is often presented as good technique. In reality, it is more work, with more opportunities for failure—and it makes an ugly top (bottom).

Glue the central mortise and peg the outer mortises to accommodate the cross-grain construction.

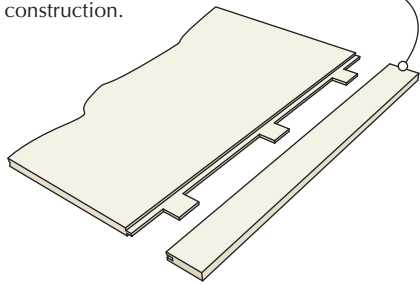

**Looks good, what do they do?** Breadboard ends might help keep a top from warping; they also might keep elephants away. If you use them, take care to attach them solidly.

factory, using suspect material and a finish that will take the life out of the wood. If you're carefully making one table at a time, this procedure will lead you to do more work than necessary to produce an ugly table.

Use the best material you can find for the top. It will be the prominent visual feature of your table, and bad decisions during construction will haunt you forever. I make tops first so I can pick the best material from what I have available, and I usually spend more time finding the right pieces to put together than I spend in actual fabrication.

Match the color and grain patterns, and

arrange the boards for appearance. You can overcome surfacing problems by adjusting tools and techniques, but you won't be able to change ugly. Let the wood acclimate to your shop and carefully mill each piece as flat and as straight as you can. Establish a flat surface for gluing to minimize the work you need to do on the assembled top.

Breadboard ends look nice, but their ability to keep a top flat is overstated. You won't be able to straighten out a large warped piece of wood with a skinny straight one. In addition to attaching the breadboard to the top with a tongue and groove, add three or five tenons. The tenon in the center is the only one that should be glued. Allow room for movement in the outer mortises, and use pegs to hold the joint tight. Get used to the fact that the only time you will see the end of the breadboard flush with the edge of the top will be the day you make it.

### A Sound Structure

The most common type of support structure is four legs connected by aprons. This design has been used for centuries, but there are weak points. As long as a table is sitting still, skinny legs and aprons are fine. Put some pressure on the bottom of the leg, however (think of dragging a heavy table or kicking a leg as you pass by), and there is enough leverage to break apart the joints or the wood around them.

Mortise-and-tenon joints offer the strongest connection, but two aprons intersecting a leg at a right angle introduce complications, especially if the legs are narrow. Rules based on making a framed panel won't apply for the size and location of the tenons.

Size the elements of the joints so that plenty of material remains around the mortises. Tenons don't have to be centered on an apron's

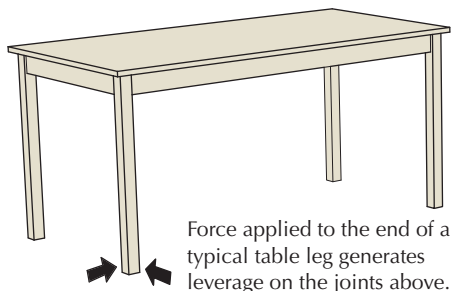

Force applied to the end of a typical table leg generates leverage on the joints above.

**The force may be against you.** Table legs make excellent levers if there is no supporting structure near the bottom end.

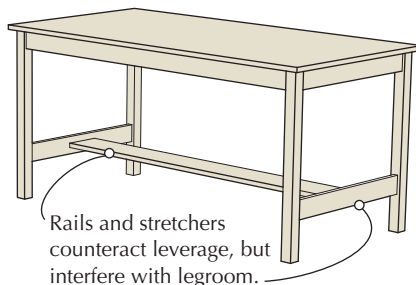

Rails and stretchers counteract leverage, but interfere with legroom.

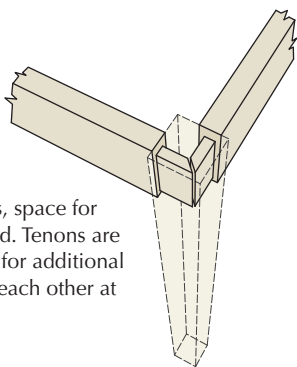

With narrow legs, space for mortises is limited. Tenons are mitered to allow for additional length, not to fit each other at the ends.

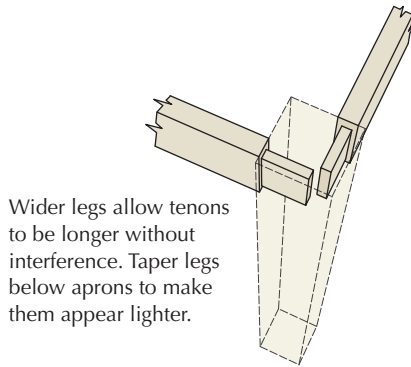

Wider legs allow tenons to be longer without interference. Taper legs below aprons to make them appear lighter.

**Two joints, one space.** Narrow legs leave little room for joinery. Mitering the ends increases the length of the tenons; there should be a gap between them where they meet.

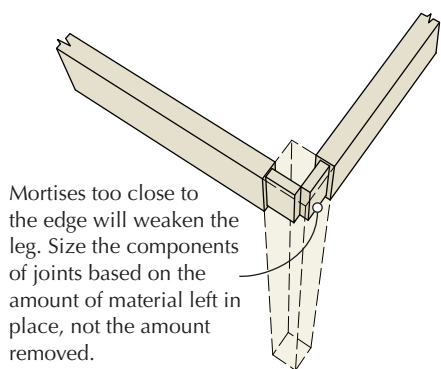

Mortises too close to the edge will weaken the leg. Size the components of joints based on the amount of material left in place, not the amount removed.

**Size and location matter.** How much material is left around a joint is just as important as the size of the joint. Don't put strong tenons in weak legs.

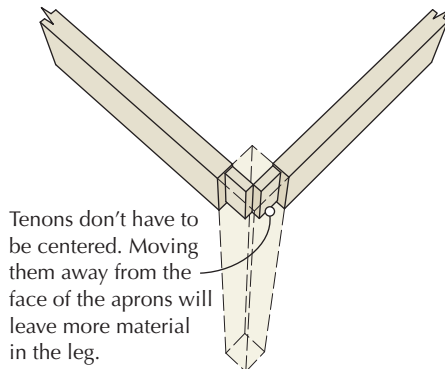

Tenons don't have to be centered. Moving them away from the face of the aprons will leave more material in the leg.

**Justifiable bias.** Moving tenons to the back face of a rail is one method to avoid a weak area around a tenon.

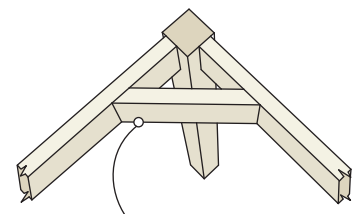

Braces across corners provide additional strength with thin legs and aprons. Metal brackets are available that can simplify this joint.

**This has your back.** No one that matters will ever look behind the legs and under the top. Add a wood or metal brace behind the corner if you need to.

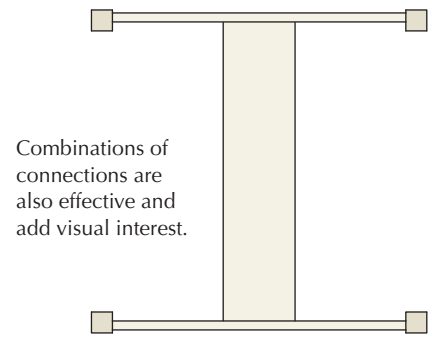
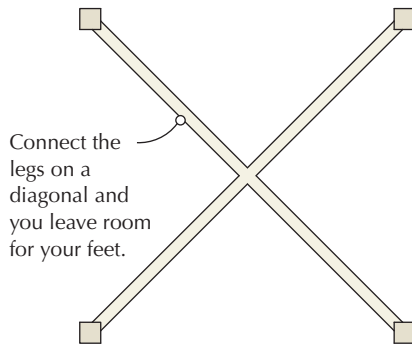
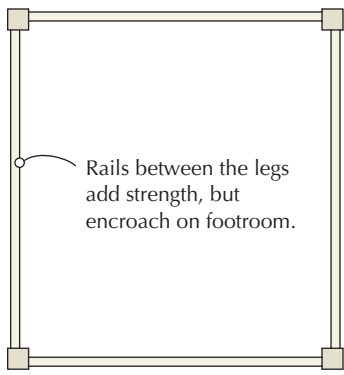

**Many ways to make a connection.** Look for a way to secure the legs without interfering with your feet.

thickness; they can be offset if need be. The longer the tenon the better, and mitering the ends of tenons that would otherwise intersect gains additional length.

Dominos, dowels and biscuits are easy alternatives for mortises and tenons, but won't be as strong or last as long. Of the three, Dominos are the most durable alternative as they most closely approximate a mortise-and-tenon joint. Biscuits should be used in pairs to maximize the meat of the joint. Dowels may seem strong enough in the short term, but over time either the dowels or the holes for them will move out of round and the joints will fail.

A brace at a 45° angle between the aprons and behind the leg will not be seen and will add support to smaller pieces. These braces can be made of wood as seen in the drawing on the previous page at bottom right, and held in place with screws or other joinery. There are also a variety of metal brackets available that serve the same purpose.

Even the best joinery won't eliminate the effects of leverage. The addition of rails and stretchers near the bottom of the legs will form a stronger base, but the trade-off is in both appearance and in use. More structure equals a heavier appearance and interferes with legroom.

On a desk or worktable, rails and stretchers may not be a problem, but in dining tables this can be an issue. Horizontal parts near the floor make inviting footrests and are areas where wear will quickly show.

Connecting rails can be like aprons running from leg to leg, or they can connect pairs of legs. These rails are then connected to each other by a stretcher running the length of the table. A third method is to join the legs from corner to corner, with the cross pieces joined to each other in the center.

The best joint to use is a mortise-and-tenon, but there are alternatives. A single dovetail

is effective for rails that join legs at the top of the leg. This allows the rail to be thin, and the wedge shape of the dovetail resists the outward movement of the legs. Sliding dovetails are traditionally used on small stands to join legs to a central pedestal.

### On a Pedestal

There are alternatives to placing a leg on each corner. Tables that are square or circular can be supported by legs attached to a central post. Keep the footprint as large as is practical to prevent the table from tipping if weight is placed on one end. Imagine the ends of the feet to be vertical legs to get an idea of how they will act in their supporting role.

*"You can use an eraser on the drafting table or a sledge hammer on the construction site."*

— Frank Lloyd Wright (1867 - 1959)  
American architect, interior designer & educator

In small pedestal tables, such as the iconic Shaker candlestand, the legs attach to the pedestal with sliding dovetails. In commercially made dining tables, the typical connection is with hanger bolts in the ends of the feet, held firm with nuts on the inside of a hollow post.

At the top of a pedestal table, a plate wider than the column is used as an intermediate connection for the top. With small tables the connection to the column can be a permanent joint. For larger tables, it's better to use screws or hanger bolts, down to the column and up to the tabletop.

To make a dining table extend, leave a few inches of space between the base and the top for an extension-slide mechanism. In most extension tables, the grain direction is rotated 90° to run across the table. This avoids making an end-to-end match where the two halves join. A side-to-side match will be less obvious when the table is closed.

While you could make your own slides, buying manufactured ones has advantages.

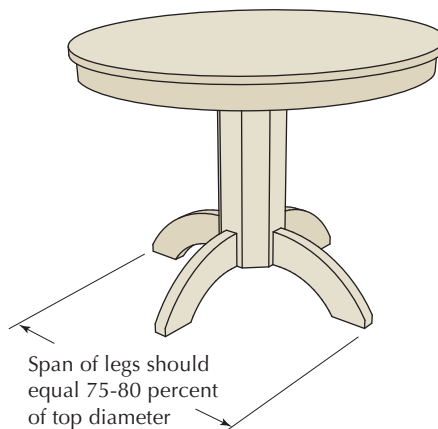

**Put it on a pedestal.** A central column with three or four feet is often a good solution in a limited space.

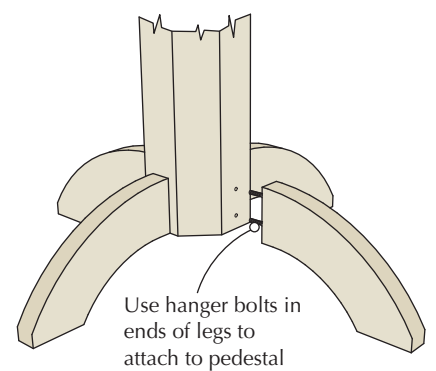

**Opportunity to over-think.** In factory-made tables, legs bolt on to a hollow pedestal. Small pedestals often connect the legs to the post with sliding dovetails.



There is a lot of engineering and fitting involved in making a slide that will work predictably for an extensive period of time.

Two types of slides are available: one for pedestal tables and one for tables with legs. The type for pedestal tables includes a gear mechanism that equalizes the movement from the center outward. The two types are also crowned in opposite directions to compensate for sagging as the table is opened. Equalized slides raise slightly at each end in the open position, and the other raises slightly in the center. When the leaves are in place, the surface will be level.

Get the hardware (or at least the actual sizes) first and engineer the table around it, with the appropriate space between the base and the top. Attach the slides with screws to the top and to the structure below. If your extension design incorporates an apron, attach the apron to the top. The joint in the apron will likely open as the top moves seasonally. A small piece of trim to cover the gap, attached to one apron only, is a common fix.

The aggregate width of the leaves should be a couple inches less than the opening range of the slides. Short dowels with dome-shaped ends will fit the leaves to each other, and to the tabletop.

End assemblies must be placed in from the end of the tabletop to provide legroom. The feet will become footrests and show wear and tear.

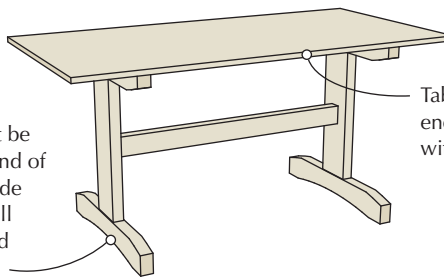

Tabletop must be thick enough to provide stiffness without additional support.

**On the beam.** Trestle tables are another alternative to four legs. Trestles provide a strong structure with a small amount of wood.

### On the Beam

Feet can also be placed laterally, and connected by posts and beams to make a trestle table. This time-tested alternative to four legs can simplify joinery and make maximum use of minimal amounts of material. Trestle tables are essentially a series of connected I-beams.

Each end has an obvious “I” shape, but looking down on the structure in plan view reveals that the two ends connected by central rails also form an “I.” The top in this scheme often plays a structural role, connecting the outer ends of the upper beams, thus keeping the post-and-beam assemblies at each end from twisting or racking.

Hybrid structures are often seen, and are a good creative outlet. You can have a trestle form at the base and conventional aprons at the top. Whatever the form, keep an eye on the structural elements. You want the table to be strong and attractive, and you don't want wood movement of the top causing problems.

Structural elements will have an impact on the appearance of the table. Elements associated with specific styles can look odd if placed inappropriately. The proportions of the elements will also impact the overall proportions and appearance of the final design. Tapers, bevels and curves can make parts appear smaller or thinner than they really are.

The last illustration shows an unfortunate, but common combination of design mistakes. For a design to look good, it has to make sense, and ignoring hundreds of years of techniques isn't wise. Learn the basics and build on a firm foundation – then get creative. **PWM**

Bob is senior editor of this magazine, and the author of “Drafting & Design for Woodworkers” and several other books. Visit his web site, [craftmanplans.com](http://craftmanplans.com).

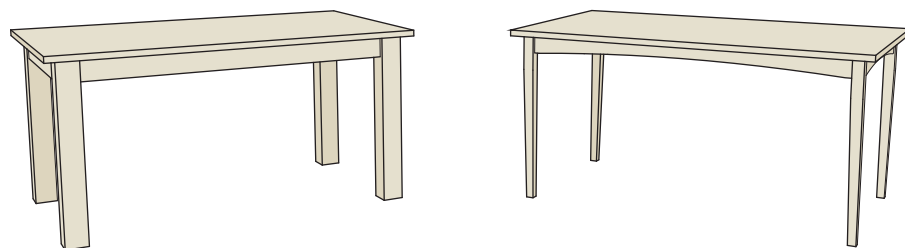

**Appearance can be deceiving.** Proportions of individual components have an impact on the overall perception of a design. These two tables are the same size, shape and basic structure, but make wholly different design statements.

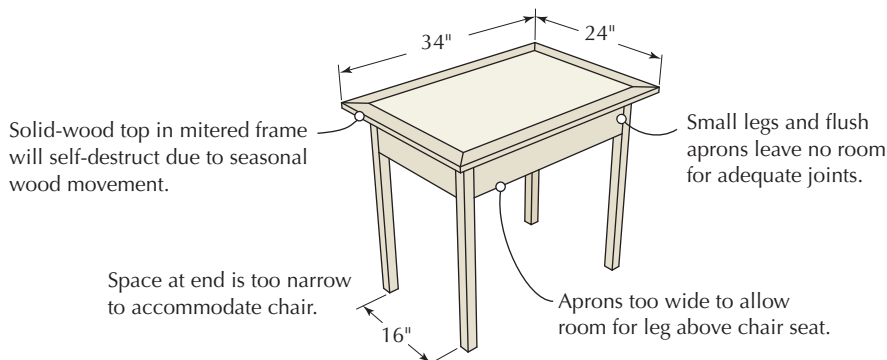

Solid-wood top in mitered frame will self-destruct due to seasonal wood movement.

Small legs and flush aprons leave no room for adequate joints.

Space at end is too narrow to accommodate chair.

Aprons too wide to allow room for leg above chair seat.

**Beginner's bad luck.** Table design isn't always intuitive. The drawing above shows several mistakes that beginning table builders tend to make.

### Go Online FOR MORE ...

3D models of the tables in the opening illustration are available for free download at:

► [popularwoodworking.com/sketchup](http://popularwoodworking.com/sketchup)

For an article excerpt from “Drafting and Design for Woodworkers” on dining table shapes and sizes, visit:

► [tinyurl.com/ybhanum](http://tinyurl.com/ybhanum)

For a catalog of manufactured solid wood table legs and kits, visit:

► [tablelegs.com](http://tablelegs.com)

To purchase the book “Drafting & Design for Woodworkers”, visit:

► [tinyurl.com/ybb2vxq](http://tinyurl.com/ybb2vxq)

All of our online products are available at:

► [WoodworkersBookShop.com](http://WoodworkersBookShop.com)

# Shaker Trestle Table



A classic design with extra stability and an antique finish.



I've built a number of trestle tables in the Shaker style over the years, usually following the style of an original table from one Shaker collection or another. But when I decided to do a trestle table for *Popular Woodworking* readers, I took a second look at some of the designs and decided I could add a feature and come up with a stronger table without sacrificing the simple Shaker lines.

The one shown here is a standard two-pedestal table with a single stretcher tying the bases together. One of the concerns I've always had with this design was the stability of the joint at the stretcher. Anyone who has been to a family dinner at my house knows that a sturdy table is important when everyone starts

hungrily reaching for platters of food. To solve the stability concern I doubled-up the hardware from another sturdy piece of furniture – the bed. By using a pair of bed bolts at each joint, this table becomes amazingly stout.

### Save Money on Wood

If you've seen my other furniture ([hueyfurniture.com](http://hueyfurniture.com)), you know I'm addicted to figured maple. Though they've tried to get me into treatment, I haven't yet accepted that I have a problem.

But when it came to choosing the wood for this table, even I had to admit that with such a simple piece, adding busy figure to the base would be gilding the lily. So I saved the good stuff for the top and chose to use painted poplar to build the base.

by Glen Huey

*Glen Huey builds custom furniture in his shop in Middletown, Ohio, for Malcolm L. Huey & Son. He is a contributing editor for Popular Woodworking and is the author of "Fine Furniture for a Lifetime." You can see more of his work at [hueyfurniture.com](http://hueyfurniture.com).*



Photos by Al Parrish



Nibbling away the mortise locations on the leg halves can be accomplished with a flat-tooth rip blade or a dado stack.

Step photos by the author

### Half a Foot, not Six Inches

Construction on the base begins with the feet blanks. The feet actually are two "half-feet" that you face-glue together. This allows you to conserve lumber (no sense trying to find 3" x 3" wood for a painted base) and you can make the mortise for the leg post before gluing the halves together. Mill out the two halves for each foot, then clamp the pairs together and lay out the two notches that will form the 1½" x 2¼" mortise for the post tenon.

There are many ways to remove the waste material from the notches, but I'm a table-saw guy, so that's where I headed. Use your miter gauge and make repeated passes across the blade to nibble away the waste area on all four pieces, as shown above.

With the notches cut, it's time to make the halves a whole. When gluing the two halves together, the last thing you want are the pieces to "creep," or slide on the glue, which will cause misalignment. My solution is to mount a 1" section of a #6 finish nail into one half by drilling a small hole and gluing in the nail piece with

the point out. As you glue the two halves, align the two sections and press them together. The nails "bite" into the wood and prevent creeping. Go ahead and clamp the pieces securely and set them aside to dry.

While the feet could be left flat at the floor, it's not as attractive as shaping them to leave "pads" at either end. It also helps the table to sit flat on uneven floors. To form the pads, clamp the two assembled feet together with the bottoms facing the same direction. Mark the pads on the feet according to the illustrations, then drill a ⅜" hole at the transition point at either end. The hole itself will create the small radius for the transition. After making the two holes per foot, head to the band saw to cut away the portion between the radius cuts to finish the pad shapes.

Some simple shaping using a couple of saws will give the feet an even more graceful look. First cut a 7° bevel on the ends of the feet using the table saw. Next, make a mark ¾" down from the top edge at the ends of each foot. Make another mark 10½" in to-



After gluing the halves together, I first drilled two  $\frac{3}{8}$ " holes to define the foot pad and then connected the dots. The rest was simple band saw work.

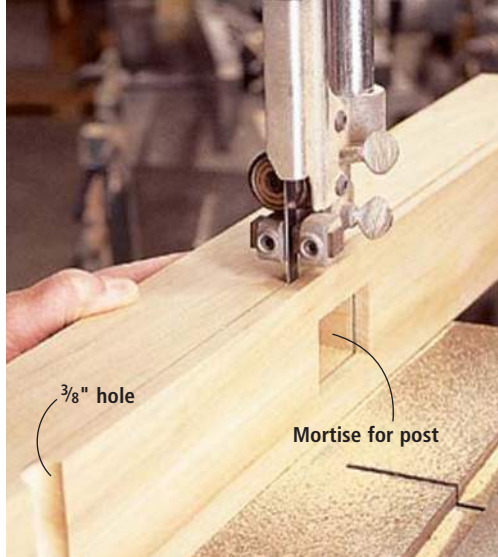

With the post cut to shape, the first step in forming the tenon is to define the shoulder on all four sides. The miter gauge (hidden behind the work) on my saw works well, while the rip fence allows you to set the shoulder location.



I use a high-sided shop-made tenoning jig to cut the cheeks on the tenon. You could also nibble away the waste à la the foot mortise if you don't have, or want to build, a tenoning jig.

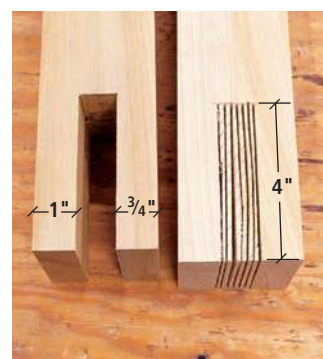

The top of the post is notched 4" deep, so the table saw won't cut it (pun intended). The band saw will and I use staggered cuts to remove much of the wood, then chisel out the excess. Notice the notch isn't centered on the post, but offset by  $\frac{1}{4}$ " to one side.

ward the mortise at the top of the leg. Connect the two marks and you have the slope for the top of each foot. Head to the band saw and cut the slopes. To finish the feet, sand the surfaces and round all the edges with a  $\frac{3}{16}$ " radius bit in your router.

### Going Vertical

The next step is the  $2\frac{7}{8}$ " x  $2\frac{7}{8}$ " posts. As with the feet, there's a good chance you'll need to glue up thinner pieces to form the posts.

Once assembled and milled to the size given in the cutting list, it's time to form the tenons to match the mortises in the feet. Start cutting the tenons by first defining the shoulder on the table. Then reset the table saw

and run the posts upright to form the cheeks. Cut two cheeks, then adjust the fence and cut the other two. Make the tenons slightly oversize and then trim them to achieve a snug fit.

At the tops of the posts, cut out a notch the width of the post to hold the cross braces. Lay out this notch using the photos above to locate them. Note that the notches aren't centered in the posts – rather, they're offset by  $\frac{1}{4}$ " to one side. An easy method to remove the 4" of waste is to hog the majority out with a band saw, then chisel away the remaining waste. To finish off the posts, use a chamfer bit in your router to make decorative cuts on each edge, stopping  $\frac{7}{8}$ " from the joinery at each end.

### Visible Means of Support

The part of the leg that actually supports the top is the cross brace. Mill the stock for the cross braces, then use the table saw to nibble away the shallow notches (as you did on the feet halves) on the two opposing sides of each brace. These notches will fit into the 4"-deep

notches at the tops of the leg posts, so test the fit to make sure it's snug, but not too tight.

While the cross braces are mostly hidden under the tabletop, they can be seen at times and therefore there's no sense leaving them square and chunky. Use the pattern (at right) to trace

## SHAKER TRESTLE TABLE

NO.	ITEM	DIMENSIONS (INCHES)			MATERIAL
		T	W	L	
4	Feet halves	$1\frac{11}{16}$	3	30	Poplar
2	Cross braces	$1\frac{1}{2}$	4	30	Poplar
2	Posts	$2\frac{7}{8}$	$2\frac{7}{8}$	$29\frac{3}{8}$	Poplar
1	Center brace	$1\frac{1}{2}$	2	28	Poplar
1	Stretchers	$1\frac{1}{2}$	6	$43\frac{1}{4}$	Poplar
1	Top	$\frac{7}{8}$	36	71	Cherry
2	Breadboard ends	$\frac{7}{8}$	$1\frac{1}{2}$	38*	Cherry
10	Top fasteners	$\frac{3}{4}$	$\frac{7}{8}$	$2\frac{1}{4}$	Cherry

\*Finished size is 36" long.

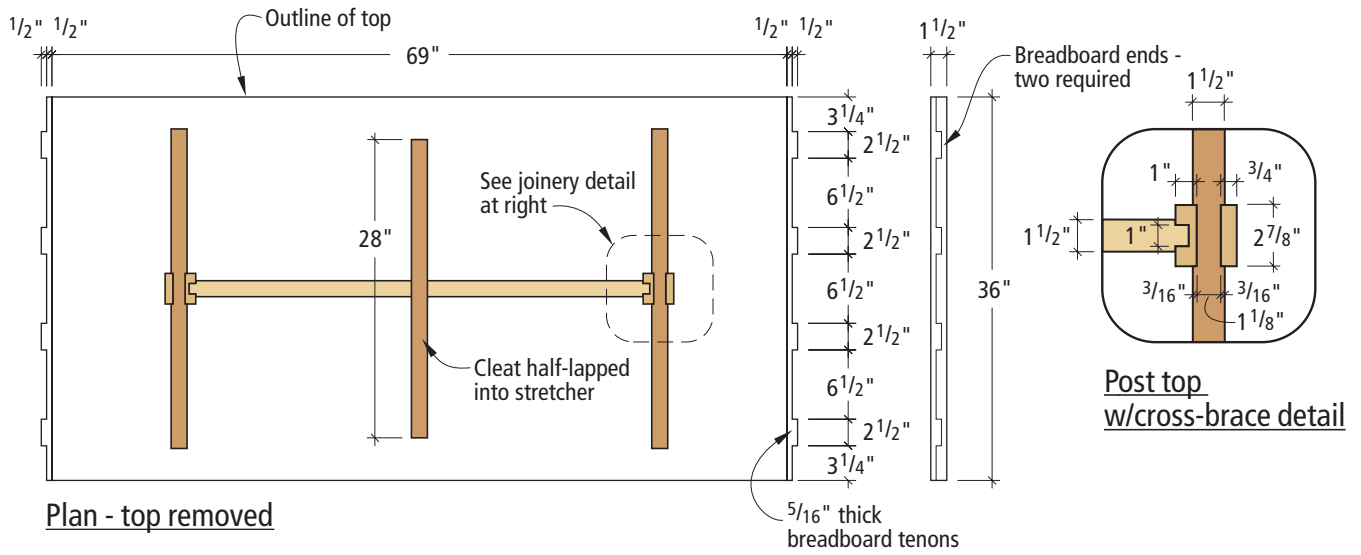

Plan - top removed

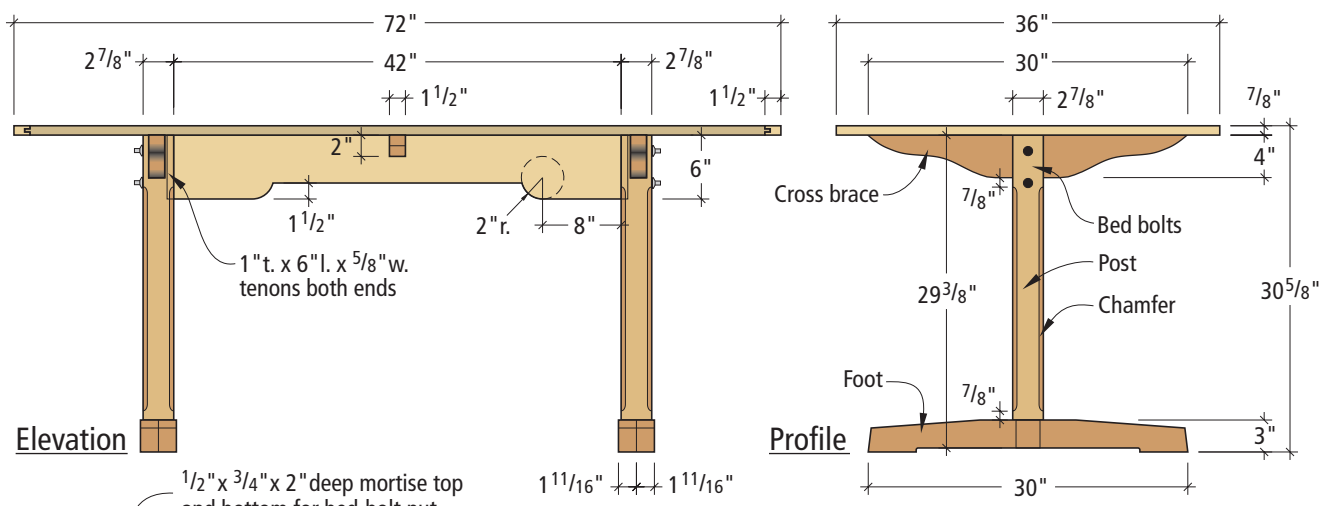

Elevation

Profile

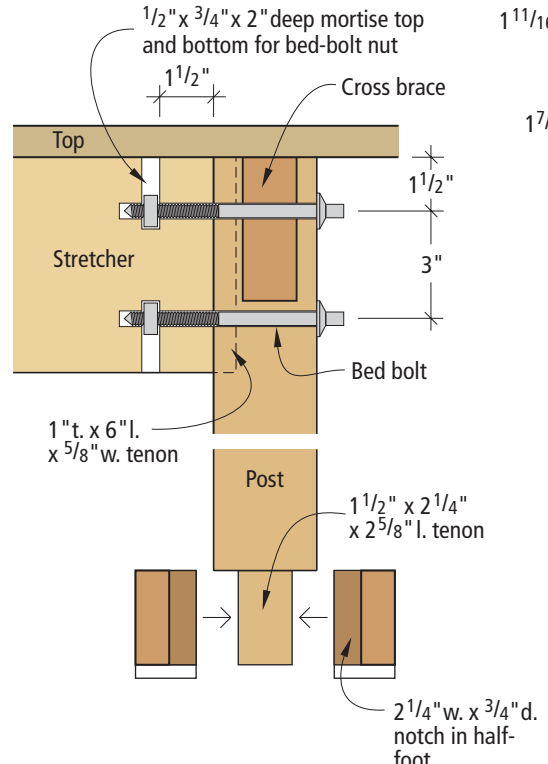

Section through post

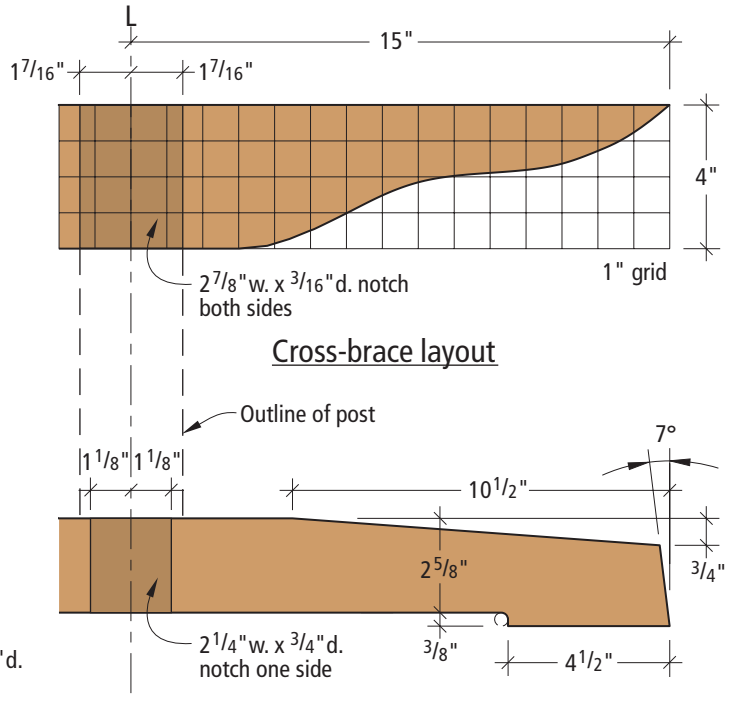

Half-foot layout

or mark the curved shape on the pieces themselves. Then use the band saw to cut out the shape on the braces, cutting wide of the line and then smoothing the curve with sandpaper.

Now glue the foot and cross brace to each post. To add a bit more strength after the glue has dried, drill two  $\frac{7}{16}$ " holes (on opposite sides of the leg) in each joint and pin the joint with dowels. Make sure to stagger the pins on each side so they don't run into each other. Using a knife or sandpaper, taper one end of each

peg a bit to make it easier to insert in its hole. After tapping the dowels in place, cut the extra length nearly flush to the leg surface and sand it smooth.

### Bridging the Gap

With the ends assembled it's time to attach the stretcher to tie everything together. This is the joint where you need all the strength you can muster. As I mentioned earlier, I used bed bolts here, but I started with the traditional method of cutting mortises in the legs and tenons on both ends of

the stretcher. Start by cutting the 1" x 6"-long x  $\frac{5}{8}$ "-deep mortises on the thicker side of each assembly. I used a Forstner bit to make most of the mortise (see below) then chiseled out the waste to square everything up, but you could use a router with a straight bit. To create the short tenons on the stretcher, I used a rabbeting bit in a router to cut rabbets on opposite faces of the stretcher.

If you haven't used bed bolts before, they're essentially heavy-duty bolts that screw into a square nut buried in a mortise in the other

piece. After cutting the rabbets on the stretcher, make two  $\frac{1}{2}$ " x  $\frac{3}{4}$ " x 2"-deep mortises at each end of the stretcher, one in the top edge and one in the bottom edge, to hold the bed-bolt nuts.

To add more stability to the table, a third center brace is half-lapped into the center top of the stretcher. Mill the stock for this part and use one of the finished cross braces as a pattern to shape the center brace. Next, use the illustration to lay out the decorative cut on the bottom edge of the stretcher. Then use the table

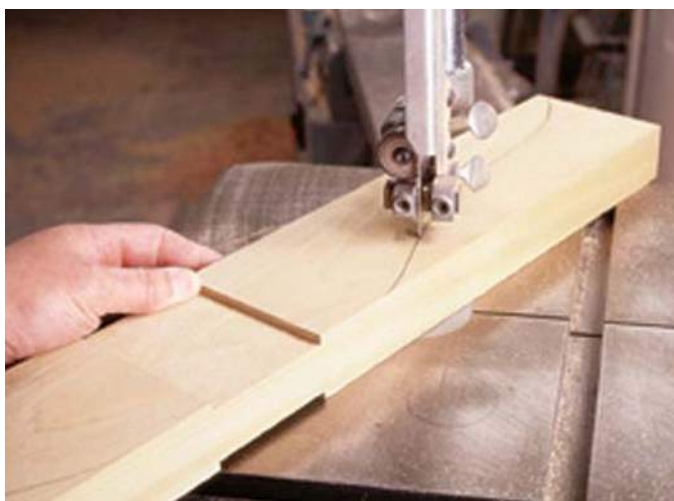

Sculpting a shape on the cross braces isn't necessary to keep the table sturdy, but it does keep it from looking clunky. After transferring the pattern onto the brace, I cut wide of the line on the band saw, then used a spindle sander to smooth the shape.



With the cross braces glued to the posts, they are pegged in position. Clamp them tight and check for square between the post and brace. Note that the pegs are at opposite corners of the joint. This allows room for the mortise (in the next step).

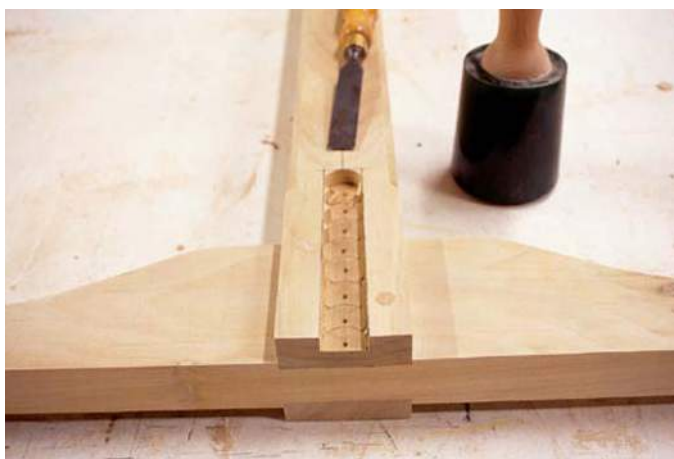

Here's the mortise for the stretcher. I removed most of the waste with a Forstner bit, then chiseled the mortise square.



Getting the holes for the bed bolts straight is important. And the best tool for that task is the drill press. The two  $\frac{7}{16}$ " holes are located in  $1\frac{1}{2}$ " from the top and bottom edges of the mortise.



saw and miter gauge to cut the half-lap joint for the center brace. This piece is attached with glue and a 2" wood screw, but don't attach it until you're done installing the bed bolts.

Use a drill press to make the holes in the trestle legs for the bed bolts. The holes are  $\frac{7}{16}$ " in diameter and are in the center of the stretcher mortises,  $1\frac{1}{2}$ " from both the top edge and bottom edge of the mortise. To finish making the hole for the bed bolt, slip a stretcher tenon into the end section, clamping the two pieces firmly. Use a long  $\frac{7}{16}$ " drill bit to finish the hole through the end of the stretcher and into the mortise area created for the bed-bolt nut. The straight hole at the drill press acts as a guide to drill the remainder of the hole straight. Clean out any waste from the

hole, place the nuts into the mortises, slide the bolt into the hole, and attach it to the nut. Tighten the connection with a wrench.

### Holding the Top in Place

I use wooden clips to hold the top in place on the base. The clips have a rabbet cut on one end that slips into slots cut into the cross braces on the base. I use a biscuit cutter set to make a cut for a #20 biscuit and start the slot  $\frac{1}{2}$ " down from the top of the brace. Because the tenon on the clip is almost  $\frac{1}{4}$ " thick, make two cuts with the biscuit joiner, lowering the cutter to finish the cut at  $\frac{1}{4}$ " wide. Place two slots on each inside of the cross braces and one on either side of the center brace.

Rather than trying to cut rabbets on the ends of the little wooden clips, start with a 5"-6" wide

piece of wood that is  $4\frac{5}{8}$ " long and  $\frac{3}{4}$ " thick. Cut a  $\frac{1}{2}$ " x  $\frac{1}{2}$ " rabbet along the end grain leaving a  $\frac{1}{4}$ " tongue. Then rip the piece into  $\frac{7}{8}$ "-wide strips and crosscut the ends to  $2\frac{1}{4}$ "-long pieces.

Pre-drill clearance holes in the wooden clips you've just made to accept a #8 x  $1\frac{1}{4}$ " wood screw.

### With a Cherry on Top

Again, trying to avoid admitting I have a curly maple addiction, I chose cherry for the top. Cut and glue the slab to the finished size given in the cutting list.

Appropriately, the Shakers used breadboard ends (traditionally called a "clamp") on their tops to hide the end grain and to help keep the top flat. The breadboard requires a tongue on each end of the top for the breadboard to fit over. I created the  $\frac{5}{16}$ "-thick x

## SUPPLIES

### Ball and Ball

800-257-3711 or  
ballandball.com  
4 • 6" bed bolts  
#U60-076, \$5.15 each

### Horton Brasses

800-754-9127 or  
horton-brasses.com  
4 • 6" bed bolts  
#H-73, \$3.50 each

### Olde Century Colors

800-222-3092 or  
oldecenturycolors.com  
1 • pint of lamp black acrylic  
latex paint  
#2022 (waterbase) or  
#1022 (oil-based), \$9.40

### Rockler

800-279-4441 or rockler.com  
1 • pint of Sam Maloof  
Oil/Wax Finish  
#58669, \$10.99  
10 • #8 x  $1\frac{1}{4}$ " slotted screws

*Prices correct as of publication deadline.*



After clamping the stretcher between the legs and drilling the bed bolt holes into the stretcher I simply dropped the nut into the previously cut mortises and bolted the base together.

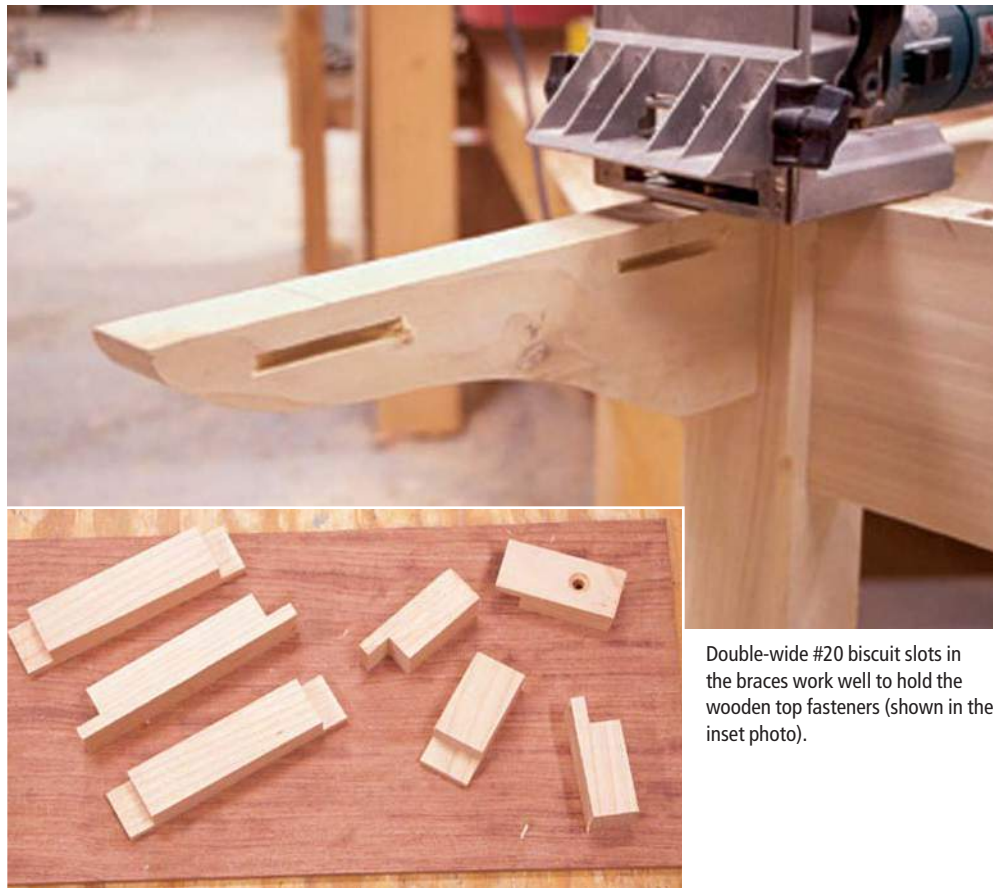

Double-wide #20 biscuit slots in the braces work well to hold the wooden top fasteners (shown in the inset photo).

1"-long tongue on the top using a straightedge to guide my router and a  $\frac{3}{4}$ " pattern bit.

Use a marking gauge at each edge to locate the tongue depth and align the straightedge to the mark. Set your bit to cut just behind the mark on the bottom side and just covering the mark on the top side to ensure the breadboards will fit snugly against the tabletop on the top side.

After the tongue is made, draw another line on it  $\frac{1}{2}$ " from the end, running the entire width of the top. At four equally spaced locations on the tongue, mark locations for the  $2\frac{1}{2}$ "-wide tenons. Trim the tongue around the tenons, leaving them extending the full 1". This is where the breadboards and top will be pinned.

Cut the two breadboard ends and plow the  $\frac{1}{2}$ "-deep groove the length of the ends for the tongue. Then lay out the areas that match up with the extended tongues and cut the  $\frac{1}{2}$ "-deep mortises in the bottom of the grooves.

Fit the breadboard ends to the top and clamp. At each extended tongue, drill a  $\frac{1}{4}$ " hole for the

pin. Use a scrap piece on the underside to prevent "blowout." Remove the ends and elongate the holes to accommodate wood movement. Apply glue to only the middle 4" of the tongue, re-install the ends, then drive the pins into the holes and apply glue to only the top edge of the hole. Trim the pins and the extra length of the breadboards flush.

### Finishing Touches

Sand the top with #150 grit sandpaper and rout the edges, top and bottom, with a  $\frac{3}{16}$ " roundover bit. Final sand to #180 grit and apply three to four coats of an oil/varnish blend following the product directions, then add a top coat of furniture wax.

After following the instructions in "Painting the Base" below to paint and age your base, attach the top to the base with the wooden clips and #8 x  $1\frac{1}{4}$ " wood screws.

You and your table are now ready for years of family dinners with no concerns about sliding the ham or vegetables onto the floor because of a banquet table that's less than sturdy. **PW**

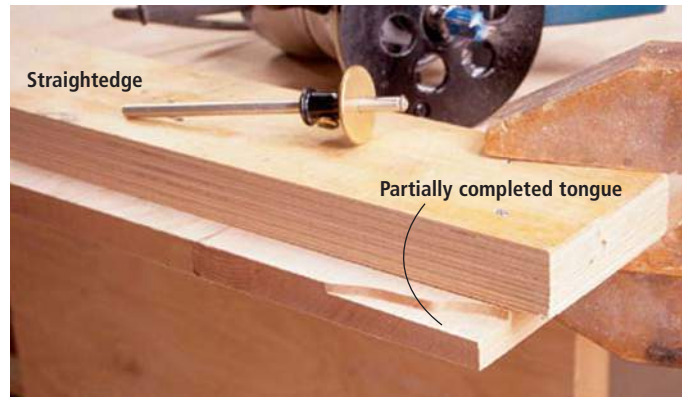

With the top milled to size, mark a  $\frac{5}{16}$ "-thick x 1"-wide tongue on each end with your marking gauge. Then use a straightedge and a  $\frac{3}{4}$ " pattern bit to shape the tongue on both sides of the top.

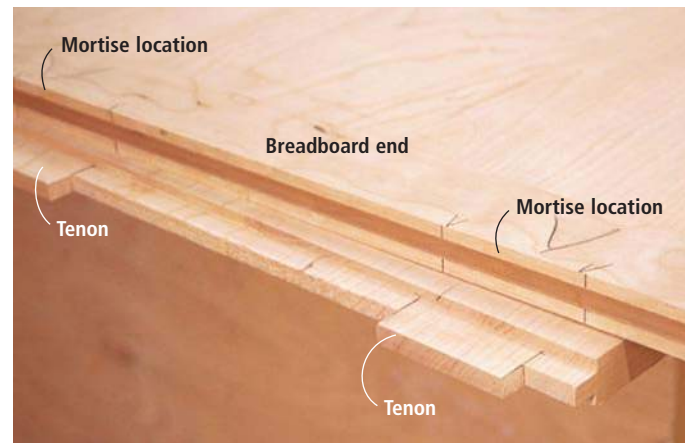

After marking and cutting the tenons on the breadboard tongue, use the finished tenons to locate the mortises in the already-grooved breadboard ends.

## PAINTING THE BASE

A simple coat of paint on the base may suffice for many, but it looked too new and shiny for my taste, so I added an antique finish to the piece.

Begin by staining the piece and applying two coats of shellac. Sand the finish.

Next, mix Olde Century Colors lampblack acrylic paint with fine sawdust particles and paint the mixture onto the base. As the paint dries, wipe with a very wet rag. The wiping will remove paint and dislodge some of the sawdust pieces leaving a "worn" surface.

Once the paint is dry, apply a coat of Maloof's Oil/Wax finish. Simply brush it on and wipe with a clean rag. This step provides a dull sheen to the paint, adding the look of years of polish.



A simple coat of paint looks too new and shiny for a traditional Shaker piece of furniture.



Here I've wiped the piece with a very wet cloth as the paint dried, which removed some of the paint, creating an antique finish.



# Get More Great Woodworking Resources!



Your free download is excerpted from the **April 2010** and **October 2003** issues of *Popular Woodworking Magazine* and is just a sample of the great furniture projects you can find in the ShopWoodworking.com store. Buy more projects today, and continue building your knowledge!

**Buy the full contents today,  
and continue building  
your knowledge!**