

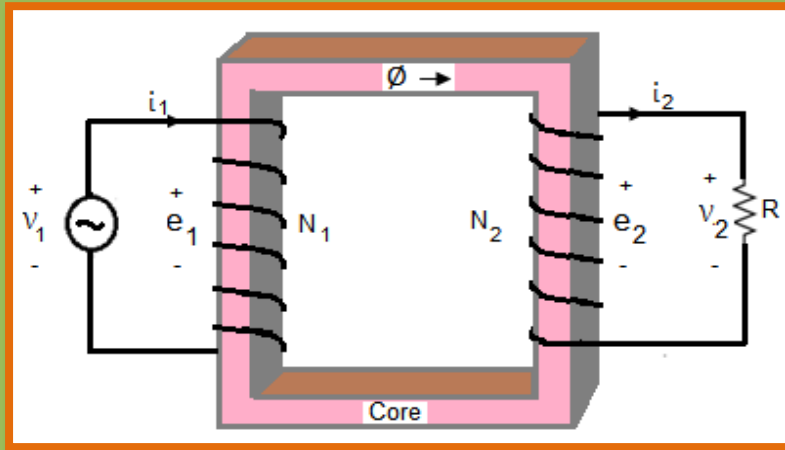

Basic Electrical Engineering



First Edition

2019

Dr. Gulzar Ahmad
Associate Professor
Department of Electrical Engineering
UET Peshawar, Pakistan

Table of Contents

Table of Contents	1
Preface	5
Chapter 1 Basic Circuit Elements and Fundamental Laws	6
1-1 Electrical Energy and Voltage	6
1-2 Resistor and Ohm's Law	8
1-3 Capacitor	10
1-4 Inductor and Faraday's Law	12
1-5 Kirchhoff's Voltage Law	21
1-6 Capacitors in a Series Circuit	24
1-7 Kirchhoff's Current Law	26
1-8 Capacitors in a Parallel Circuit	31
1-9 Source Conversion	34
1-10 Charging of a Capacitor	35
1-11 Discharging of Capacitor	40
Chapter 2 Mesh and Nodal Analysis	48
2-1 Mesh Analysis	48
2-2 Nodal Analysis	58
2-3 Representation of Phasors	66
2-4 Addition of Phasors	68
2-5 Subtraction of Phasors	69
2-6 Multiplication of Phasors	71
2-7 Division of Phasors	71

2-8	Impedance Network for Mesh Analysis	75
2-9	Impedance Network for Nodal Analysis	83
Chapter 3	AC Fundamentals and Series Circuits	92
3-1	Generation of AC Voltage	92
3-2	RMS or Effective Value of AC Voltage	97
3-3	RMS Value of AC Current	101
3-4	AC Voltage across a Resistor	112
3-5	AC Voltage across an inductor	115
3-6	AC Voltage across a Capacitor	118
3-7	RL Series Circuit	121
3-8	RC Series Circuit	131
3-9	RLC Series Circuit	141
3-10	Phasor Analysis of RL Series Circuit	153
3-11	Phasor Analysis of RC Series Circuit	159
3-12	Phasor Analysis of RLC Series Circuit	164
3-13	Resonant Circuit	171
Chapter 4	AC Parallel Circuit	177
4-1	Impedance Method for Inductive Circuit	177
4-2	Impedance Method for Capacitive Circuit	183
4-3	Impedance Method for Parallel Circuit	190
4-4	Admittance Method for Inductive Circuit	202
4-5	Admittance Method for Capacitive Circuit	209
4-6	Admittance Method for Parallel Circuit	216

4-7	Time Varying Quantities in Parallel Circuit	222
4-8	Anti Resonance	231
Chapter 5	Network Theorems	236
5-1	Thevenin's Theorem	236
5-2	Norton's Theorem	244
5-3	Maximum Power Transfer Theorem	252
5-4	Superposition Theorem	259
5-5	Reciprocity Theorem	266
Chapter 6	Three Phase Circuits	271
6-1	Star Connected Voltage Source	271
6-2	Star Connected Balanced Load	276
6-3	Delta Connected Balanced Load	283
6-4	Delta Connected Unbalanced Load	290
6-5	Three Phase Four Wire Star Connected Unbalanced Load	296
6-6	Star Delta Conversion	300
Chapter 7	Magnetic Circuits and Forces	303
7-1	Magnetic Flux	303
7-2	Magnetic Flux Density	303
7-3	Simple Magnetic Circuit	305
7-4	Series Magnetic Circuit	309
7-5	Parallel Magnetic Circuit	315
7-6	Single Phase Transformer	321
7-7	Force on a Current Carrying Conductor	324

7-8	Force on a Moving Charge	326
7-9	Force between two Current Carrying Conductors	328
7-10	Force on a Current Carrying Loop	330

Preface

Many books have been written on the subject. Many of them are quite lengthy and the beginner of Electrical Engineering may find the level very difficult. This book is intended to be easy and bringing the readers the important information regarding some basic and fundamental topics of electrical engineering. Important theoretical and mathematical results are given with the accompanying lengthy proofs, which I think is the main characteristic of the book. Solved numerical problems have been added to give the students the confidence in understanding the material presented. This book covers the topics of basic electrical engineering with the objective of learning and motivation. Easy explanation of topics and plenty of solved relevant examples is the principal features of this book. Four to five practice problems have been included at the end of each chapter in the first edition and hopefully it will be extended in the upcoming editions. The First chapter of the book includes the traditional topics of Ohm's law, Kichhoff's Laws, resistive analysis, features of capacitors and inductors. The second chapter presents Mesh and Nodal analysis for resistive networks as well as networks containing impedances. Phasor Algebra has been added to understand the analysis of the mentioned complex networks. Chapter three covers generation of ac voltage, its fundamentals, phasor analysis of series combinations and resonance. Chapter four discusses phasor analysis of parallel ac circuits and anti resonance. Chapter five has been dedicated to network theorems like Thevenin's theorem, Norton's Theorem, Maximum power transfer theorem, Superposition Theorem and Reciprocity Theorem. Three phase circuits with balanced and unbalanced loads have been analyzed in chapter six. Finally chapter seven describes the magnetic circuits, single phase transformer and magnetic force on current carrying conductors.

I have reflected my 20 years of teaching experience in the book. This book may be used as a reference book for the subjects of Basic Electrical Engineering and Linear Circuit Analysis. I will appreciate the comments and suggestions of my colleagues and students for the improvement of the book.

Regards

Dr. Gulzar Ahmad
Associate Professor
Department of Electrical Engineering
University of Engineering & Technology Peshawar, Pakistan

Chapter 1

Basic Circuit Elements and Fundamental Laws

1-1 Electrical Energy and Voltage

The amount of energy that is required to move a charge of Q coulomb from one point to another point against the electric field intensity is known as electrical energy. Constant electrical energy is denoted by W and time varying electrical energy is represented by w . The unit of electrical energy is watt second. Figure 1.1 explains electrical energy.

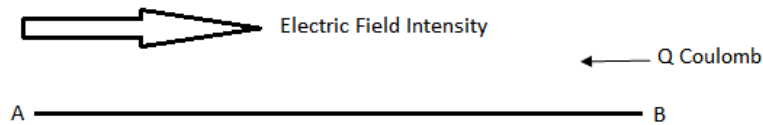

Figure 1.1: Electrical Energy

Electric field intensity is the force per unit positive charge in volts per meter and it is denoted by E . If d defines the distance between points A and B , then electrical energy can be calculated as

$$W = Fd \quad (1.1)$$

$$W = QEd \quad (1.2)$$

The amount of energy that is required to move a unit positive charge from one point to another point against the electric field intensity is known as voltage or potential difference between the two points. Time Constant voltage is denoted by V and time varying voltage is represented by v . The unit of voltage is volt. Figure 1.2 explains voltage between points A and B

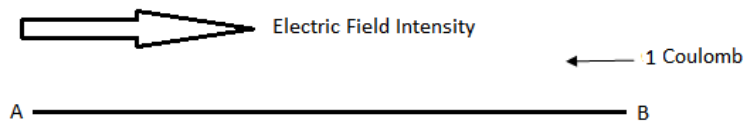

Figure 1.2: Voltage or Potential Difference

The voltage between points A and B is given by

$$V = \frac{W}{Q} \quad (1.3)$$

Therefore

$$V = Ed \quad (1.4)$$

The rate of motion of charge in a conductor defines current. Time constant current is represented by I and the time varying current is denoted by i . Current is given by equation 1.5.

$$I = \frac{Q}{t} \quad (1.5)$$

We know that energy per unit time is known as power. Time constant power is represented by P and the time varying power is denoted by p . The unit of power is watt and power is given by equation 1.6.

$$P = \frac{W}{t} \quad (1.6)$$

$$P = \frac{QV}{t} \quad (1.7)$$

Therefore electrical power can be calculated with the help of voltage and current

$$P = VI \quad (1.8)$$

D 1.1: A 12V battery is charged for 4 hours with a current of 2A. 60% of the energy is stored as chemical energy and the remaining energy is lost. If electricity costs Rs 0.02 per watt-second, then determine the cost of charging the battery, the amount of energy that is stored as chemical energy and the energy that is lost.

Solution:

$$V = 12V$$

$$I = 2A$$

$$t = 4 \times 3600 = 14400 \text{ seconds}$$

$$P = VI = 24 \text{ Watts}$$

$$W = Pt = 345600 \text{ Watt Second}$$

$$\text{Cost} = 345600 \times 0.02 = \text{Rs } 6912$$

The amount of energy stored as chemical energy = $345600 \times 0.6 = 207360 \text{ Joules}$

The amount of energy lost = $345600 - 207360 = 138240 \text{ watt-second.}$

1-2 Resistor and Ohm's Law

Resistor is a passive circuit element, if it is connected across a voltage source (active circuit element), it will take energy from the source. A resistor is connected across a variable voltage source as shown in Figure 1.3.

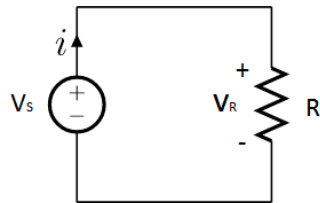

Figure 1.3: Circuit Diagram for Ohm's Law

Ohm's law states that *the voltage across a resistor is directly proportional to the current in the resistor provided the resistance of the resistor is held constant.*

Mathematically

$$v_R \propto i$$

By increasing voltage across the resistor, the current increases linearly as demonstrated in Figure 1.4.

$$v_R = iR \tag{1.9}$$

Where R is the constant of proportionality in equation 1.9. The resistance of a conductor depends upon the material, length and cross sectional area of the conductor and is given by

$$R = \frac{\rho \ell}{A} \tag{1.10}$$

Where ρ in equation 1.10 represents resistivity of the material of the conductor, ℓ represents length and A represents cross-sectional area. The current i in the above mentioned voltage source flows from the negative terminal of the voltage towards the positive terminal. This type of voltage is known as voltage rise. While the same current flows from the positive polarity of the voltage v_R towards the negative polarity, so this type of voltage is known as voltage drop. Kirchoff's voltage law states that *sum of the voltage rises in a loop is always equal to sum of the voltage drops.*

So

$$v_s = v_R$$

The graphical representation of ohm's law is given in Figure 1.4. The relationship between voltage and current is a straight line passing through the origin of the two coordinates. This type of relationship is called linear relationship. Any circuit element

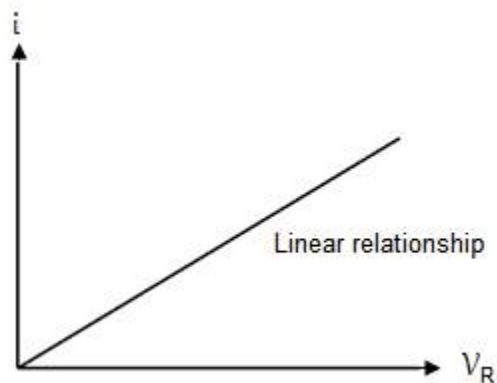

Figure 1.4: Graphical Representation of Ohm's Law

that has a linear relationship between voltage and current is known as linear circuit element. Resistor is a linear circuit element and other examples are inductor and capacitor. According to the law of conservation of energy the power supplied by the voltage source in Figure 1.3 will be equal to the power consumed by the resistor. The power consumed by the resistor is converted to heat energy that is dissipated in the air. The time varying power consumed by the resistor can be calculated with the help of any one the following three equations

$$p_s = p_R = v_R \times i \quad (1.11)$$

$$p_R = i^2 R \quad (1.12)$$

$$p_R = \frac{v_R^2}{R} \quad (1.13)$$

D 1.2: Let the voltage across the source in the circuit diagram of Figure 1.3 is 10V and resistance of the resistor is 5Ω . Determine the current in the resistor and power consumed by it.

Solution:

$$i = \frac{v_s}{R} = \frac{10}{5} = 2A$$

$$p_R = i^2 R = 4 \times 5 = 20W$$

1-3 Capacitor

It is a passive circuit element that stores electrical energy in its electric field and this is why it is known as energy storing device. It consists of two metallic plates having area of $A \text{ m}^2$. A dielectric material with dielectric constant of ϵ_r is placed between the two plates. The distance between the two plates of the capacitor is denoted by d . The symbol of a capacitor is shown in Figure 1.5.

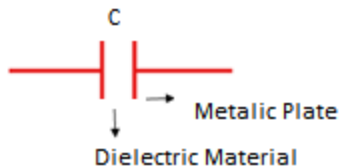

Figure 1.5: Symbol of Capacitor

The capacitance of a capacitor can be varied by varying any one the three parameters in equation 1.14.

$$C = \frac{A\epsilon}{d} \quad (1.14)$$

As mentioned earlier, A is the area of the metallic plate, ϵ is the permittivity of the dielectric material and d represents separation between the plates. A time varying

voltage is applied across the capacitor as shown in Figure 1.6. Charge starts accumulating on the plates of the capacitor and it depends on the applied voltage.

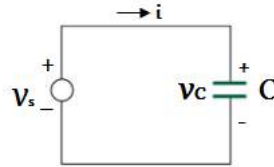

Figure 1.6: Capacitor in a Circuit

By increasing voltage across the capacitor charge on the plates will increase linearly and vice versa.

$$q \propto v_c$$

$$q = C v_c \quad (1.15)$$

Where C is the constant of proportionality. Differentiating both sides of the above equation with respect to time, we obtain

$$\frac{dq}{dt} = C \frac{dv_c}{dt} \quad (1.16)$$

As $\frac{dq}{dt}$ represents the time varying current in the capacitor, Therefore

$$i = C \frac{dv_c}{dt} \quad (1.17)$$

The above equation reveals that if we apply dc voltage source across a capacitor it will block the dc current. In other words capacitor behaves like an open circuit for dc voltage. The differential voltage across a capacitor can be determined using following equation.

$$dv_c = \frac{1}{C} i dt \quad (1.18)$$

Integrating both sides of equation 1.18, we obtain the time varying voltage across the capacitor

$$v_c = \frac{1}{C} \int i dt \quad (1.19)$$

According to KVL, the only voltage rise v_s in the loop will be equal to the only voltage drop v_c that is

$$v_s = v_c \quad (1.20)$$

According to the law of conservation of energy power supplied by the voltage source in Figure 1.6 will be equal to the power taken by the capacitor.

$$p_s = p_c = v_c \times i \quad (1.21)$$

Putting the value of i in equation 1.21, we get the following equation.

$$p_c = C v_c \frac{dv_c}{dt} \quad (1.22)$$

The differential energy that is stored in the electric field of this capacitor is given by

$$\begin{aligned} dw &= p_c \times dt \\ dw &= C v_c dv_c \end{aligned} \quad (1.23)$$

The integration on both sides gives the total energy that is stored in the electric field of this capacitor.

$$\begin{aligned} \int dw &= C \int v_c dv_c \\ w &= \frac{1}{2} C v_c^2 \end{aligned} \quad (1.24)$$

1-4 Inductor and Faraday's Law

Inductor is basically a coil of N turns as shown in Figure 1.7. A simple straight conductor also behaves like inductor but its inductive effect is very small as compared to a coil having N turns.

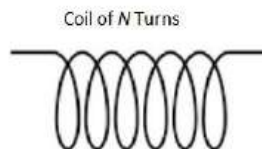

Figure 1.7: Symbol of Inductor

A time varying voltage is applied across the inductor as shown in Figure 1.8. Current starts flowing and this current generates time varying magnetic flux of Φ weber in the vicinity of the inductor. This time varying magnetic flux can be calculated with the help of following equation.

$$\Phi = \frac{L}{N} i \quad (1.25)$$

Inductance L is given by

$$L = \frac{N\Phi}{i} \quad (1.26)$$

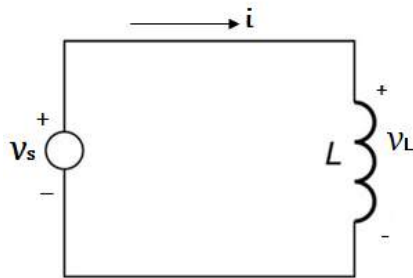

Figure 1.8: Inductor in a Circuit

Equation 1.26 reveals that a simple straight conductor also behaves like an inductor and its inductance can be calculated as

$$L = \frac{\Phi}{i} \quad (1.27)$$

Differentiating both sides of equation 1.25 with respect to time, we get

$$N \frac{d\Phi}{dt} = L \frac{di}{dt} \quad (1.28)$$

The inductor is located in its own time varying magnetic field and variation in the strength of the magnetic field will induce some voltage across this inductor, which is given by the mathematical model of Faraday's Law

$$v_L = \frac{Nd\Phi}{dt}$$

This is the time varying voltage across the inductor which can be determined with the help of following equation as well

$$v_L = \frac{Ldi}{dt} \quad (1.29)$$

The above equation reveals that if we apply a DC voltage across an inductor, then it will behave like an ideal conductor (short circuit) as the voltage across this inductor will be zero. The differential current in an inductor can be determined using following equation.

$$di = \frac{1}{L} v_L dt$$

Integrating both sides of the above equation, we obtain the time varying current in the inductor.

$$i = \frac{1}{L} \int v_L dt \quad (1.30)$$

According to KVL, the only voltage rise v_s in the loop will be equal to the only voltage drop v_L , that is

$$v_s = v_L \quad (1.31)$$

According to the law of conservation of energy power supplied by the voltage source in Figure 1.8 will be equal to the power taken by the inductor.

$$p_s = p_L = v_L \times i \quad (1.32)$$

Putting the value of v_L in equation 1.32, we obtain

$$p_L = Li \frac{di}{dt} \quad (1.33)$$

The differential energy that is stored in the magnetic field of this inductor is given by

$$dw = p_L \times dt \quad (1.34)$$

The integration on both sides gives the total energy that is stored in the magnetic field of this inductor

$$\int dw = L \int i di$$

$$w = \frac{1}{2} Li^2 \quad (1.35)$$

D 1.3: Consider the sketch for v_c as shown in Figure 1.9. Sketch i and p_c as a function of time. Capacitance of the capacitor is 10F.

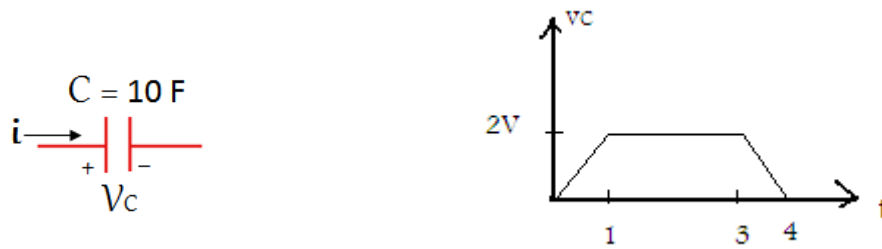

Figure 1.9: Capacitor and Sketch for the Voltage across the Capacitor

Solution:

We divide the graph into three regions.

Region # 1: $(0 \leq t \leq 1)$

In this region v_c is a straight line passing through the origin. Equation of this straight line is

$$v_c = mt + c$$

Where $m = 2$ is the slope of this line and as the line is passing through the origin therefore $c = 0$.

So

$$v_c = 2t$$

Region # 2: $(1 \leq t \leq 3)$

The voltage in this region is constant, therefore

$$v_c = 2 \text{ V}$$

Region # 3: $(3 \leq t \leq 4)$

In this region v_c is a straight line that does not pass through the origin. The equation of this straight line is

$$v_c = mt + c$$

The slope of this line is -2 and $c = 8$

Therefore

$$v_c = -2t + 8$$

Let us determine i in all these three regions

Region # 1: $(0 \leq t \leq 1)$

As

$$v_c = 2t$$

Therefore

$$i = C \frac{dv_c}{dt} = 20 A$$

Region # 2: $(1 \leq t \leq 3)$

As

$$v_c = 2 V$$

Therefore

$$i = C \frac{dv_c}{dt} = 0 A$$

Region # 3: $(3 \leq t \leq 4)$

As

$$v_c = -2t + 8 V$$

Therefore

$$i = C \frac{dv_c}{dt} = -20 A$$

Therefore sketch for the current is shown in Figure 1.10.

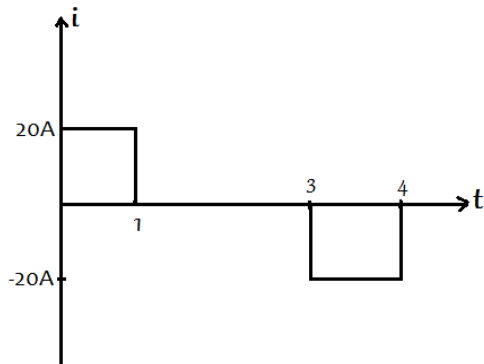

Figure 1.10: Sketch for the Current in the Capacitor

Let us determine p_C in all these three regions:

Region # 1: $(0 \leq t \leq 1)$

As

$$v_c = 2t$$

and

$$i = 20 \text{ A}$$

Therefore

$$p_C = v_c \times i = 40t \text{ W}$$

Region # 2: $(1 \leq t \leq 3)$

As

$$v_c = 2 \text{ V}$$

and

$$i = 0 \text{ A}$$

Therefore

$$p_C = v_c \times i = 0 \text{ W}$$

Region # 3: $(3 \leq t \leq 4)$

As

$$v_c = -2t + 8 \text{ V}$$

and

$$i = -20 \text{ A}$$

Therefore

$$p_C = v_C \times i = 40t - 160 \text{ W}$$

Therefore sketch for the power is shown in Figure 1.11.

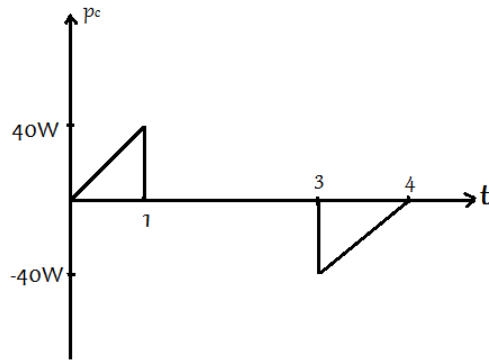

Figure 1.11: Sketch for the Power taken by the Capacitor

D 1.4: Consider the sketch for i as shown in Figure 1.12. Sketch v_L and p_L as a function of time. Inductance of the inductor is 10H.



Figure 1.12: Inductor and Sketch for Current in the Inductor

Solution:

We divide the graph into two regions.

Region # 1: $(0 \leq t \leq 1)$

In this region i is a straight line passing through the origin. Equation of this straight line is

$$i = mt + c$$

Where $m = 2$ is the slope of this line and as the line is passing through the origin, therefore $c = 0$.

So

$$i = 2t$$

Region # 2: $(1 \leq t \leq 2)$

In this region i is a straight line that does not pass through the origin. Equation of this straight line is

$$i = mt + c$$

The slope of this line is -2 and $c = 4$

Therefore

$$i = -2t + 4$$

Let us determine v_L in all these two regions

Region # 1: $(0 \leq t \leq 1)$

As

$$i = 2t$$

Therefore

$$v_L = L \frac{di}{dt} = 20 V$$

Region # 2: $(1 \leq t \leq 2)$

As

$$i = -2t + 4 V$$

Therefore

$$v_L = L \frac{di}{dt} = -20 V$$

Therefore sketch for the voltage is shown in Figure 1.13

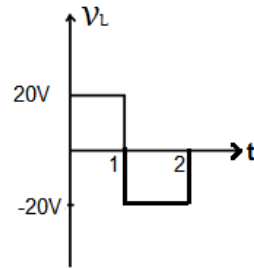

Figure 1.13: Sketch for the Voltage across the Inductor

Let us determine p_L in all these two regions:

Region # 1: $(0 \leq t \leq 1)$

As

$$i = 2t$$

and

$$v_L = 20 \text{ V}$$

Therefore

$$p_L = v_L \times i = 40t \text{ W}$$

Region # 2: $(1 \leq t \leq 2)$

As

$$i = -2t + 4 \text{ V}$$

and

$$v_L = -20 \text{ V}$$

Therefore

$$p_L = v_L \times i = 40t - 80 \text{ W}$$

Therefore sketch for the power is shown in Figure 1.14

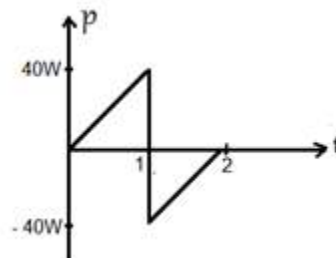

Figure 1.14: Sketch for the Power taken by the Inductor

1-5 Kirchhoff's Voltage Law

This law is known as KVL and is used to find out unknown electrical quantities in a circuit. This law states that *sum of the voltage rises in a loop is always equal to sum of the voltage drops in the loop*. Consider a series combination of three resistors as shown in Figure 1.15.

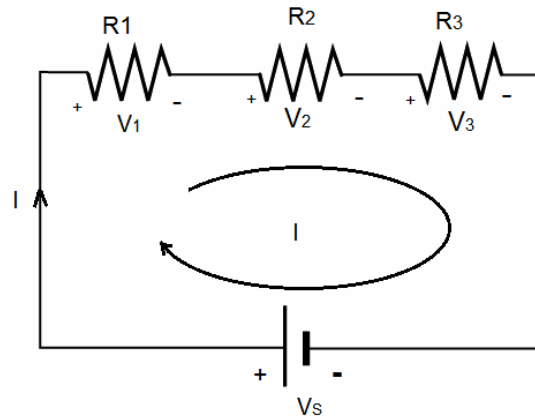

Figure 1.15: Series Circuit

A constant voltage is applied across this series circuit and this voltage source results in a current I that flows in the clockwise direction in the loop. We apply KVL to the given loop

$$V_s = V_1 + V_2 + V_3 \quad (1.36)$$

Equation 1.36 can be rearranged as

$$V_s + (-V_1) + (-V_2) + (-V_3) = 0$$

This equation justifies another statement of KVL. In light of this equation *algebraic sum of all the voltages in a specific direction in a loop is always equal to zero*. Keep it in mind that we place a plus sign with the voltage rise and a minus sign with the voltage drop in this regard.

Voltage drop across R_1 in accordance with ohm's law is given by

$$V_1 = IR_1 \quad (1.37)$$

Voltage drop across R_2 in accordance with ohm's law is given by

$$V_2 = IR_2 \quad (1.38)$$

Voltage drop across R_3 is given by

$$V_3 = IR_3 \quad (1.39)$$

Putting all these values in equation 1.36, we obtain

$$V_S = I(R_1 + R_2 + R_3) \quad (1.40)$$

The current in this series circuit can be found using equation 1.40. Now we replace the series combination of all the three resistors by a single resistor such that the resistance of this single resistor is equal to the total resistance of the series circuit. The equivalent circuit of the above mentioned series circuit is shown in Figure 1.16. Applying KVL to this equivalent circuit, we obtain the following equation

$$V_S = V_T \quad (1.41)$$

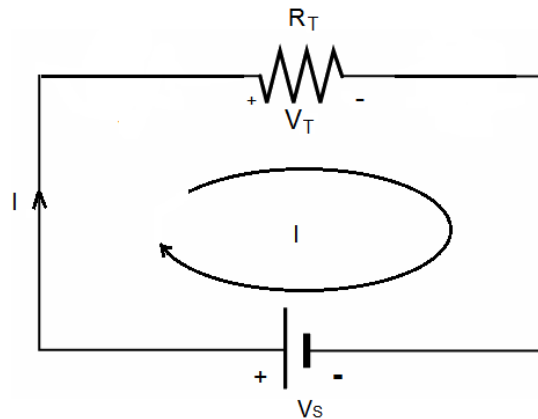

Figure 1.16: Equivalent Circuit

Voltage drop across R_T in accordance with ohm's law is given by

$$V_T = IR_T \quad (1.42)$$

Putting this value in equation 1.41, we obtain

$$V_S = IR_T \quad (1.43)$$

Comparing equation 1.43 with equation 1.40, we obtain total resistance of the series combination of Figure 1.15.

$$R_T = (R_1 + R_2 + R_3) \quad (1.44)$$

According to the law of conservation of energy power supplied by the voltage source in Figure 1.15 will be equal to the total power taken by the entire circuit.

$$\text{Power supplied by the voltage source} = P_S = V_S I$$

$$\text{Power consumed by } R_1 = P_1 = I^2 R_1$$

$$\text{Power consumed by } R_2 = P_2 = I^2 R_2$$

$$\text{Power consumed by } R_3 = P_3 = I^2 R_3$$

As $P_S = P_T$, therefore

$$P_T = (P_1 + P_2 + P_3) \quad (1.45)$$

D 1.5: Consider the series circuit as shown in Figure 1.17. The DC voltage source across this series combination is of 10V. Find the current, the voltage drop across each resistor and the power consumed by the entire circuit.

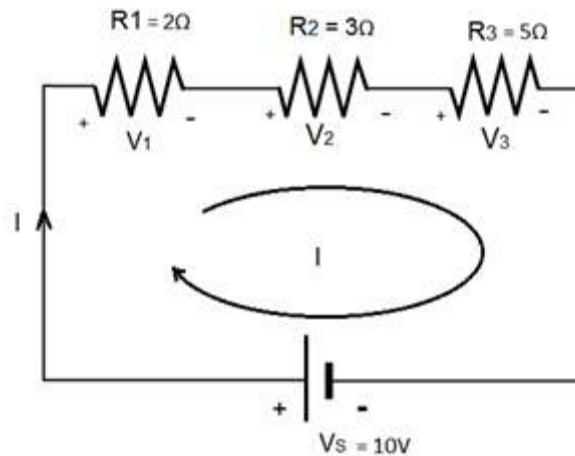

Figure 1.17: Series Circuit

Solution:

Using equation 1.40, we can calculate the current.

$$V_S = I(R_1 + R_2 + R_3)$$

$$I = \frac{V_S}{R_1 + R_2 + R_3} = \frac{10}{10}$$

$$I = 1A$$

Voltage drop across R_1 is

$$V_1 = IR_1 = 2V$$

Voltage drop across R_2 is

$$V_2 = IR_2 = 3V$$

Voltage drop across R_3 is

$$V_3 = IR_3 = 5V$$

Power supplied by the voltage source = $P_S = V_S I = 10 \times 1 = 10W$

1-6 Capacitors in a Series Circuit

Consider a series combination of three capacitors as shown in Figure 1.18. A time varying voltage is applied across this series circuit which results in a time varying current i that flows in the clockwise direction in the loop. We apply kVL to the given loop which states that sum of the voltage rises in this loop will be equal to sum of the voltage drops.

$$v_S = v_1 + v_2 + v_3 \quad (1.46)$$

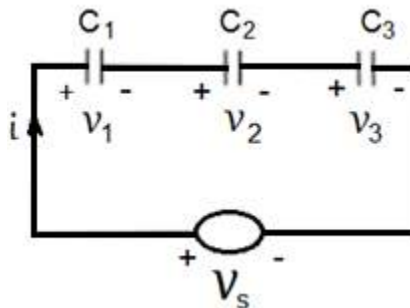

Figure 1.18: Series Circuit of Capacitors

Equation 1.46 can be rearranged as

$$v_S + (-v_1) + (-v_2) + (-v_3) = 0$$

This equation justifies another statement of KVL. In light of this equation KVL states that *algebraic sum of all the voltages in a specific direction in a loop is always equal to zero*. Keep it in mind that we place a plus sign with the voltage rise and a minus sign with the voltage drop in this regard.

Voltage drop across C_1 is

$$v_1 = \frac{1}{C_1} \int idt \quad (1.47)$$

Voltage drop across C_2 is

$$v_2 = \frac{1}{C_2} \int idt \quad (1.48)$$

Voltage drop across C_3 is

$$v_3 = \frac{1}{C_3} \int idt \quad (1.49)$$

Putting all these values in equation 1.46, we obtain

$$v_s = \frac{1}{C_1} \int idt + \frac{1}{C_2} \int idt + \frac{1}{C_3} \int idt \quad (1.50)$$

or

$$v_s = \left(\frac{1}{C_1} + \frac{1}{C_2} + \frac{1}{C_3} \right) \int idt \quad (1.51)$$

Now we replace the series combination of all the three capacitors by a single capacitor such that the capacitance of this single capacitor is equal to the total capacitance of the series circuit. The equivalent circuit of the above mentioned series circuit is given in Figure 1.19. Applying KVL to this equivalent circuit, we obtain the following equation.

$$v_S = v_T \quad (1.52)$$

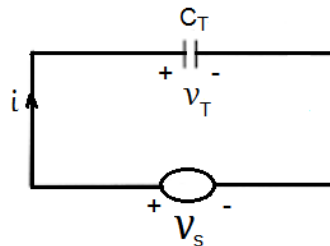

Figure 1.19: Equivalent Circuit

Voltage drop across C_T is

$$v_T = \frac{1}{C_T} \int i dt \quad (1.53)$$

Comparing equation 1.53 with equation 1.51, we obtain the total capacitance of the series combination of Figure 1.18.

$$\frac{1}{C_T} = \left(\frac{1}{C_1} + \frac{1}{C_2} + \frac{1}{C_3} \right) \quad (1.54)$$

1-7 Kirchhoff's Current Law

This law is known as KCL and is used to find out the unknown electrical quantities in a circuit. This law states that *sum of all the currents flowing towards a node is always equal to sum of all the currents flowing away from the node*. Consider the parallel combination of three resistors as shown in Figure 1.20. A constant voltage is applied across this parallel circuit and this voltage source results in current I_1 , I_2 and I_3 as shown in the figure. We apply KCL to the single node of this parallel circuit.

$$I_S = I_1 + I_2 + I_3 \quad (1.55)$$

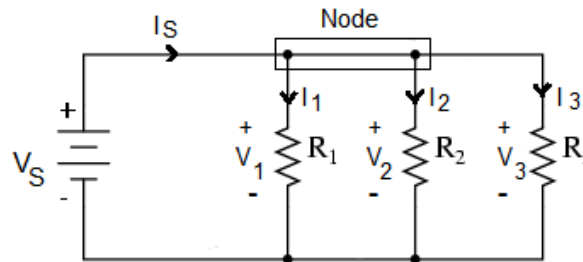

Figure 1.20: Parallel Circuit

It can be easily established that

$$V_S = V_1 = V_2 = V_3 \quad (1.56)$$

Voltage drop across R_1 is

$$V_1 = I_1 R_1$$

Therefore

$$I_1 = \frac{V_S}{R_1} \quad (1.57)$$

Voltage drop across R_2 is

$$V_2 = I_2 R_2$$

Therefore

$$I_2 = \frac{V_S}{R_2} \quad (1.58)$$

Voltage drop across R_3 is

$$V_3 = I_3 R_3$$

Therefore

$$I_3 = \frac{V_S}{R_3} \quad (1.59)$$

Putting all these values of currents in equation 1.55, we obtain

$$I_S = V_S \left(\frac{1}{R_1} + \frac{1}{R_2} + \frac{1}{R_3} \right) \quad (1.60)$$

Now we replace the parallel combination of all the three resistors by a single resistor such that the resistance of this single resistor is equal to the total resistance of the parallel circuit. The equivalent circuit of the above mentioned parallel circuit is shown in Figure 1.21. Applying Ohm's law to this equivalent circuit, we obtain the following equation.

$$I_S = \frac{V_S}{R_T} \quad (1.61)$$

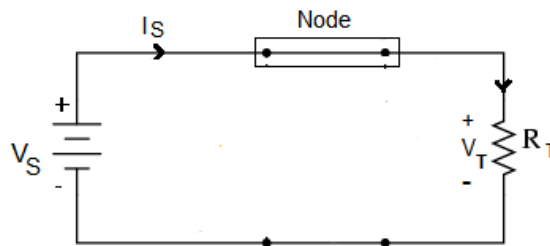

Figure 1.21: Equivalent Circuit

Comparing equation 1.61 with equation 1.60, we obtain the total resistance of the parallel combination of Figure 1.20.

$$\frac{1}{R_T} = \frac{1}{(R_1 + R_2 + R_3)} \quad (1.62)$$

According to the law of conservation of energy power supplied by the voltage source in Figure 1.20 will be equal to the total power taken by the entire circuit.

$$\text{Power supplied by the voltage source} = P_S = V_S I_S$$

$$\text{Power consumed by } R_1 = P_1 = I_1^2 R_1$$

$$\text{Power consumed by } R_2 = P_2 = I_2^2 R_2$$

$$\text{Power consumed by } R_3 = P_3 = I_3^2 R_3$$

As $P_S = P_T$ therefore

$$P_T = (P_1 + P_2 + P_3) \quad (1.63)$$

D 1.6: Consider the parallel circuit as shown in Figure 1.22. The DC voltage across this parallel combination is 16V. Find the currents and the power consumed by the entire circuit.

Solution:

Current through resistor R_1 is

$$I_1 = \frac{V_S}{R_1}$$

$$I_1 = \frac{16}{2} = 8A$$

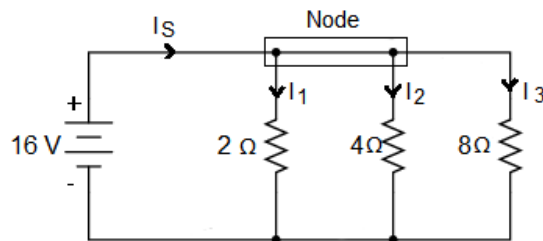

Figure 1.22: Circuit for D # 1.6

Current through resistor R_2 is

$$I_2 = \frac{V_S}{R_2}$$

$$I_2 = \frac{16}{4} = 4A$$

Current through resistor R_3 is

$$I_3 = \frac{V_S}{R_3}$$

$$I_3 = \frac{16}{8} = 2A$$

Power consumed by resistor R_1 is

$$P_1 = I_1^2 R_1 = 64 \times 2 = 128W$$

Power consumed by resistor R_2 is

$$P_2 = I_2^2 R_2 = 16 \times 4 = 64W$$

Power consumed by resistor R_3 is

$$P_3 = I_3^2 R_3 = 4 \times 8 = 32W$$

Total power consumed by the entire circuit is

$$P_t = P_1 + P_2 + P_3 = 224W$$

Current Supplied by the source is

$$I_S = I_1 + I_2 + I_3 = 14A$$

Power Supplied by the source is

$$P_S = V_S I_S = 16 \times 14 = 224W$$

D 1.7: Consider the parallel circuit as shown in Figure 1.23. Find the unknown currents, the node voltage V , the power consumed by the entire circuit and the power supplied by the current sources.

Solution:

Applying KCL to the node

$$I_S = I_1 + I_2 + I_3 \quad (1.64)$$

Sum of the current flowing towards the node is

$$I_S = 8A$$

Current through resistor R_1 is

$$I_1 = \frac{V}{R_1} = 3V$$

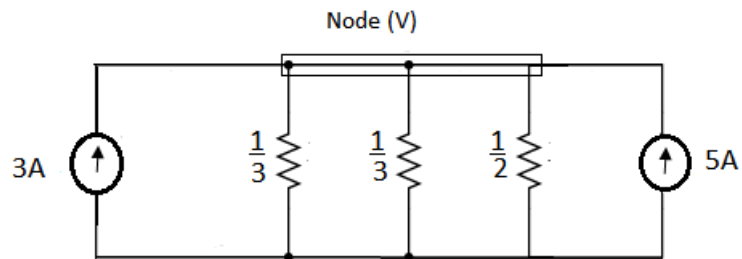

Figure 1.23: Circuit for D # 1.7

Current through resistor R_2 is

$$I_2 = \frac{V}{R_2} = 3V$$

Current through resistor R_3 is

$$I_3 = \frac{V}{R_3} = 2V$$

Putting the values in equation 1.64, we obtain

$$8 = 3V + 3V + 2V$$

$$V = 1 \text{ Volt}$$

So the current I_1 is 3A, the current I_2 is 3A and I_3 is 2A.

Power consumed by resistor R_1 is

$$P_1 = I_1^2 R_1 = 9 \times \frac{1}{3} = 3W$$

Power consumed by resistor R_2 is

$$P_2 = I_2^2 R_2 = 9 \times \frac{1}{3} = 3W$$

Power consumed by resistor R_3 is

$$P_3 = I_3^2 R_3 = 4 \times \frac{1}{2} = 2W$$

Total power consumed by the entire circuit is

$$P_t = P_1 + P_2 + P_3 = 8W$$

Power supplied by the first current source

$$P_{S1} = 1 \times 5 = 5W$$

Power supplied by the second current source

$$P_{S2} = 1 \times 3 = 3W$$

Total power supplied by the two current sources

$$P_S = 8W$$

1-8 Capacitors in a Parallel Circuit

Consider a parallel combination of three capacitors as shown in Figure 1.24. A time varying voltage is applied across this parallel circuit which results in time varying currents i_1 , i_2 and i_3 as shown in the figure.

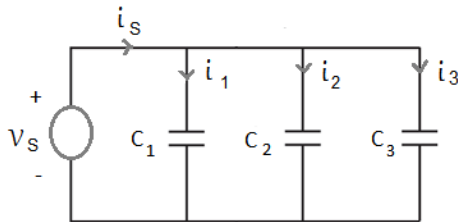

Figure 1.24: Parallel Circuit

We apply KCL to the single node of this parallel circuit.

$$i_s = i_1 + i_2 + i_3 \quad (1.65)$$

This is a parallel circuit and the voltage across each one of the three capacitors is equal to the source voltage. The current in C_1 is given by

$$i_1 = C_1 \frac{dv_s}{dt} \quad (1.66)$$

Current in C_2 is given by

$$i_2 = C_2 \frac{dv_s}{dt} \quad (1.67)$$

And current in C_3 can be calculated as

$$i_3 = C_3 \frac{dv_s}{dt} \quad (1.68)$$

Putting all these values in equation 1.65, we get the source current.

$$i_s = (C_1 + C_2 + C_3) \frac{dv_s}{dt} \quad (1.69)$$

Now we replace the parallel combination of all the three capacitors by a single capacitor such that the capacitance of this single capacitor is equal to the total capacitance of the parallel circuit. The equivalent circuit of the above mentioned parallel circuit is given in Figure 1.25. Applying KVL to this equivalent circuit, we obtain the following equation.

$$v_s = v_T \quad (1.70)$$

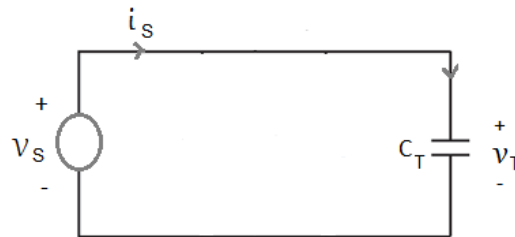

Figure 1.25: Equivalent Circuit

The source current in the equivalent circuit is calculated as

$$i_s = (C_T) \frac{dv_s}{dt} \quad (1.71)$$

Comparing equation 1.71 with equation 1.69, we get the total capacitance of the parallel circuit.

$$C_T = C_1 + C_2 + C_3 \quad (1.72)$$

D 1.8: Consider the circuit as shown in Figure 1.26. Find the unknown currents and voltages if the voltage across the capacitor is $v_C = 4e^{-t}$ volts.

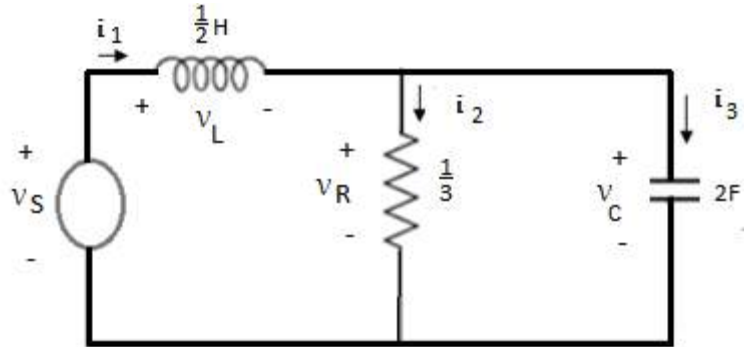

Figure 1.26: Circuit for D # 1.8

Solution:

As the time varying voltage across the capacitor is known so we can calculate it's current.

$$i_3 = C \frac{dv_C}{dt} = -8e^{-t} A$$

The resistor is in parallel with the capacitor, therefore

$$v_C = v_R = 4e^{-t} \text{ volts}$$

Current in the resistor is

$$i_2 = \frac{v_R}{R} = 12e^{-t} A$$

Applying KCL to the node

$$i_1 = i_2 + i_3 = 4e^{-t} A$$

Voltage across the inductor is

$$v_L = L \frac{di}{dt} = -2e^{-t} \text{ volts}$$

Applying KVL to the first loop of the given circuit, we obtain the source voltage.

$$v_S = v_L + v_R = 2e^{-t} \text{ volts}$$

1-9 Source Conversion

A voltage source can be converted into a current source and a current source can be converted into a voltage source. The internal resistance of an ideal voltage source is zero and the voltage across the two terminals of an ideal voltage source remains the same under load as well as no load condition. However, the voltage across the two terminals of a practical voltage source decreases under load condition due to the voltage drop in its internal resistance.

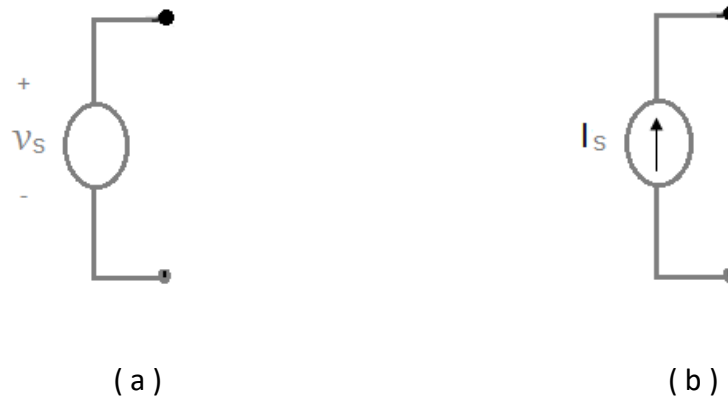

Figure 1.27: (a) Ideal Voltage Source (b) Ideal Current Source

The internal resistance of an ideal current source is infinity and the current delivered by a practical current source decreases under load condition due to the flow of current in its shunt internal resistance. An ideal voltage source and an ideal current source are shown in Figure 1.27. Consider a practical voltage source having an internal resistance of R_S ohms as shown in Figure 1.28 (a). It can be converted into a practical current source as shown in Figure 1.28 (b). The current I_S delivered by the current source is

$$I_S = \frac{V_S}{R_S} \quad (1.73)$$

The resistance R_S is connected in parallel with the current source which is its internal resistance. Conversely if we want to convert this current source into voltage source then voltage of the voltage source can be found as

$$V_S = I_S R_S \quad (1.74)$$

The internal resistance of the current source should be connected in series with the voltage source.

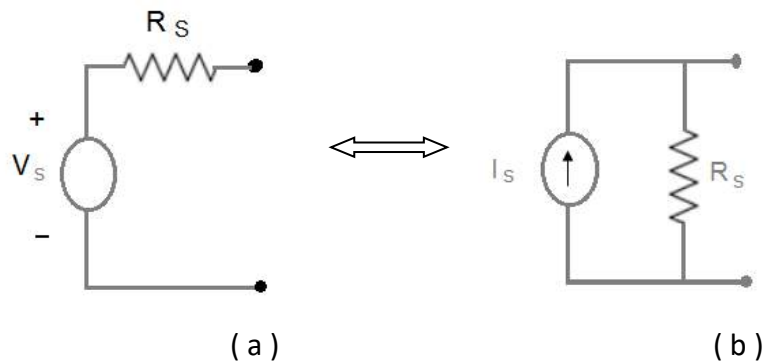

Figure 1.28: (a) Practical Voltage Source (b) Practical Current Source

1-10 Charging of a Capacitor

Consider the circuit shown in Figure 1.29. There is no voltage across the capacitor and it is charged with the help of DC voltage source.

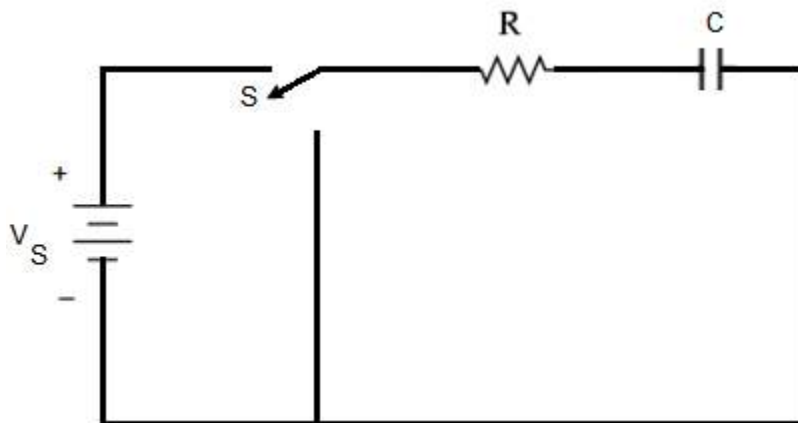

Figure 1.29: Arrangement for Charging of a Capacitor

The switch S of the circuit is open and there is no current in the circuit. A capacitor blocks DC current under steady state condition. If the switch S of the circuit is closed then initially there will be a charging current and once the capacitor is fully charged then there will be no more current in the series circuit. Obviously the charging current will be a time varying current. Switch S of the series circuit is closed at $t = 0$, as shown in Figure 1.30. The initial condition for the circuit is as under

$$\text{At time } t = 0, v_C = 0$$

There will be a time varying current in the circuit during charging period and this current will result in a time varying voltage drop across the resistor and a time varying voltage drop across the capacitor. RC is known as the time constant of this RC series circuit and it is denoted by τ .

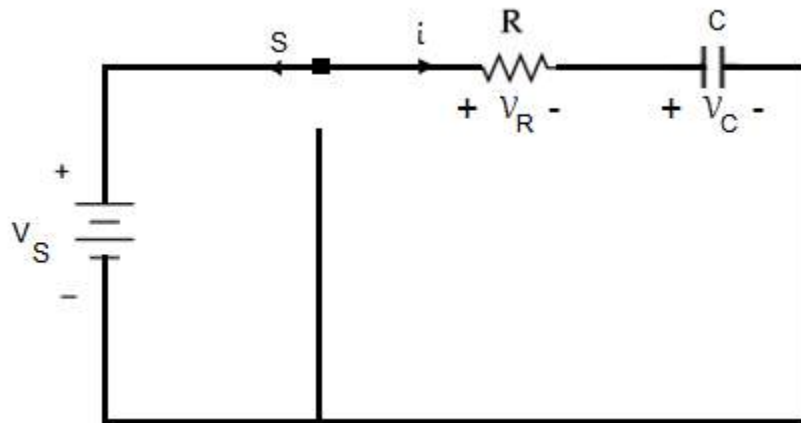

Figure 1.30: Charging Current in the Capacitor

Applying KVL to the loop, the following equation is obtained.

$$V_S = v_R + v_C \quad (1.75)$$

As

$$v_R = i R$$

Therefore

$$V_S = i R + v_C \quad (1.76)$$

The current in the capacitor is calculated as

$$i = C \frac{dv_C}{dt}$$

Putting the value of current in equation 1.76, the following equation is attained.

$$V_S = RC \frac{dv_C}{dt} + v_C \quad (1.77)$$

Equation 1.77 can be written as

$$\frac{-dv_C}{(V_S - v_C)} = \frac{-dt}{RC} \quad (1.78)$$

Integrating both sides of equation 1.78

$$\int \frac{-dv_C}{(V_S - v_C)} = \int \frac{-dt}{RC}$$
$$\ln(V_S - v_C) = \frac{-t}{RC} + K \quad (1.79)$$

Where K is the constant of integration which is calculated with the help of initial condition. Replacing t and v_C by zero in equation 1.79, we get the value of K

$$K = \ln V_S$$

So

$$\ln(V_S - v_C) = \frac{-t}{RC} + \ln V_S$$

$$\ln\left(\frac{V_S - v_C}{V_S}\right) = \frac{-t}{RC}$$

Anti logarithm on both side on both sides yields

$$\begin{aligned}\frac{V_S - v_C}{V_S} &= e^{-\frac{t}{RC}} \\ v_C &= V_S - V_S e^{-\frac{t}{RC}} \\ v_C &= V_S (1 - e^{-\frac{t}{RC}}) \end{aligned} \tag{1.80}$$

This is how the voltage across the capacitor increases with time. Sketch of this voltage as a function of time is shown in Figure 1.31.

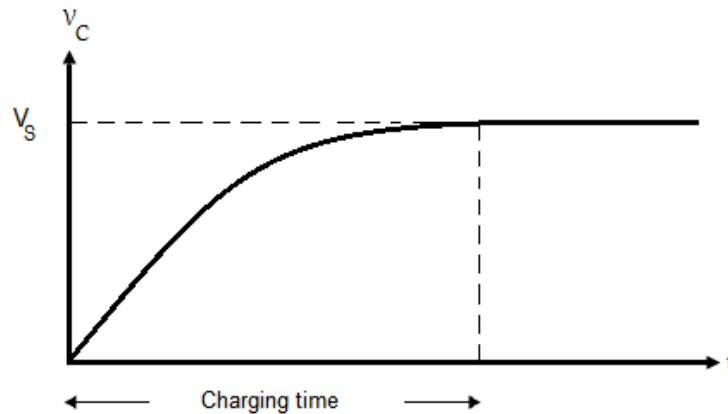

Figure 1.31: Voltage across the Capacitor

Under steady state condition voltage across the capacitor equals to voltage across the source, that is

$$v_C = V_S$$

Charge on the plates of the capacitor grows with respect to time as shown in Figure 1.32.

$$\begin{aligned}C v_C &= C V_S (1 - e^{-\frac{t}{RC}}) \\ q &= C V_S (1 - e^{-\frac{t}{RC}}) \end{aligned} \tag{1.81}$$

Differentiating both sides of equation 1.81 with respect to time gives the charging current.

$$\frac{dq}{dt} = \frac{V_S}{R} e^{-\frac{t}{RC}}$$

$$i = \frac{V_S}{R} e^{-\frac{t}{RC}} \quad (1.82)$$

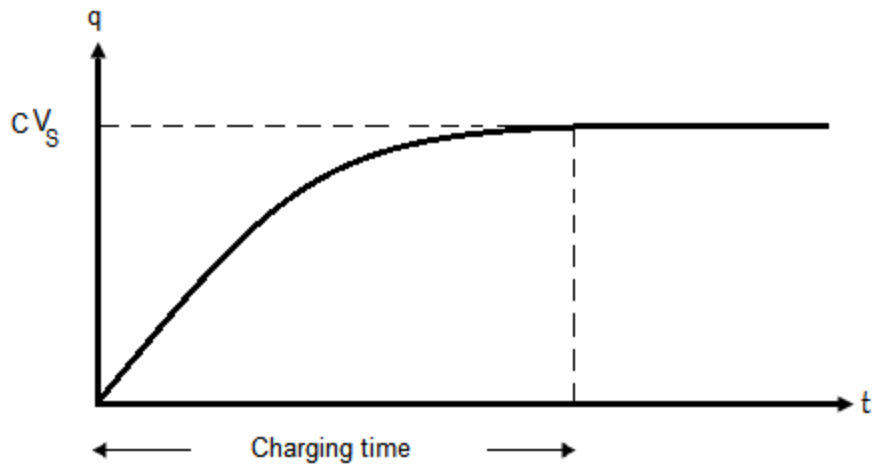

Figure 1.32: Charge on the Capacitor

The charging current is a time varying current as shown in Figure 1.33. Initially there is a

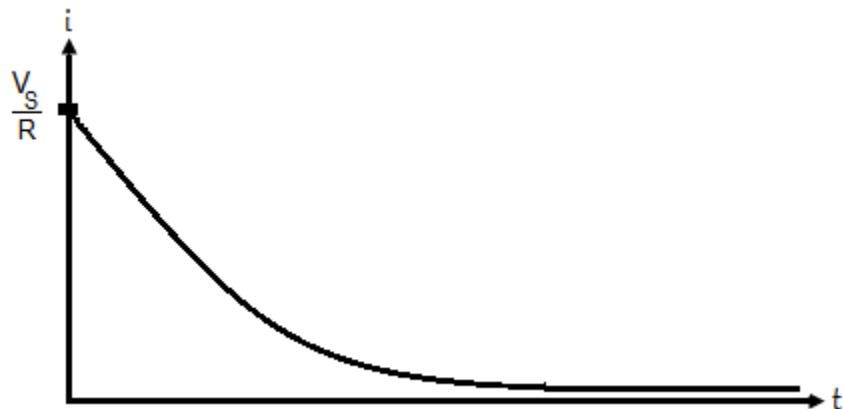

Figure 1.33: Charging Current

maximum value of the charging current in the circuit and then it decreases exponentially with respect to time. After some time there will be no current due to this exponential decay.

1-11 Discharging of Capacitor

It is assumed that the following circuit is in steady state condition and voltage across the capacitor is equal to voltage across the source.

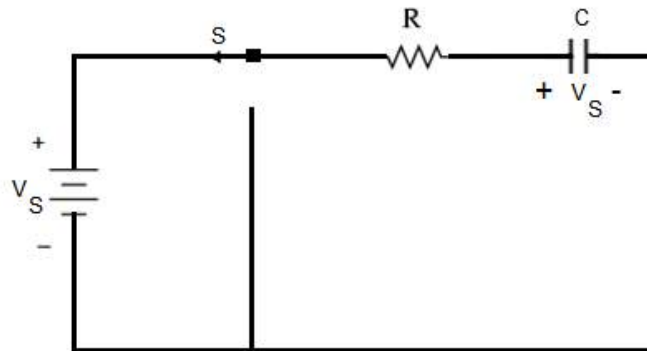

Figure 1.34: Arrangement for Discharging of a Capacitor

In order to disconnect the source from the circuit, position of the switch is changed at time $t = 0$, as shown in Figure 1.35. The initial condition for the circuit is

$$\text{At time } t = 0, v_C = V_S$$

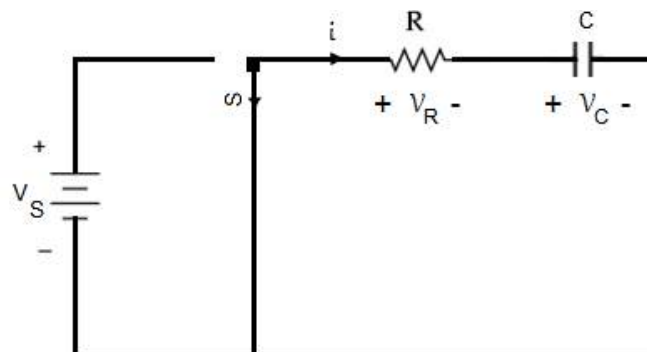

Figure 1.35: Discharging of a Capacitor

The capacitor discharges through the series resistor and the circuit obeys the following equation in accordance with KVL.

$$0 = v_R + v_C \quad (1.83)$$

As

$$v_R = i R$$

Therefore

$$0 = i R + v_C \quad (1.84)$$

Current in the capacitor is calculated as

$$i = C \frac{dv_C}{dt}$$

Putting the value of current in equation 1.84, the following equation is attained.

$$0 = RC \frac{dv_C}{dt} + v_C \quad (1.85)$$

Equation 1.85 can be written as

$$\frac{dv_C}{v_C} = \frac{-dt}{RC} \quad (1.86)$$

Integrating both sides of equation 1.86, we obtain

$$\int \frac{dv_C}{v_C} = \int \frac{-dt}{RC}$$
$$\ln (v_C) = \frac{-t}{RC} + K \quad (1.87)$$

Where K is the constant of integration which is calculated with the help of initial condition. Replacing t by zero and v_C by V_S in equation 1.87, we get the value of K

$$K = \ln V_S$$

So

$$\ln(v_C) = \frac{-t}{RC} + \ln V_S$$

$$\ln\left(\frac{v_C}{V_S}\right) = \frac{-t}{RC}$$

Anti logarithm on both sides yields

$$\frac{v_C}{V_S} = e^{-\frac{t}{RC}}$$

$$v_C = V_S e^{-\frac{t}{RC}} \quad (1.88)$$

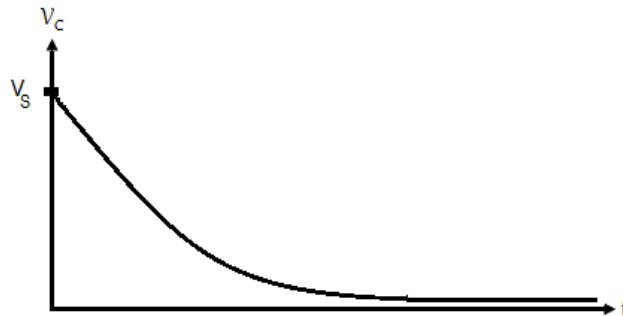

Figure 1.36: Voltage across Capacitor

This is how the voltage across the capacitor decreases with time. Sketch of this voltage as a function of time is shown in Figure 1.36.

$$C v_C = C V_S e^{-\frac{t}{RC}}$$

$$q = C V_S e^{-\frac{t}{RC}} \quad (1.89)$$

Charge on the plates of the capacitor decreases with respect to time as shown in Figure 1.37.

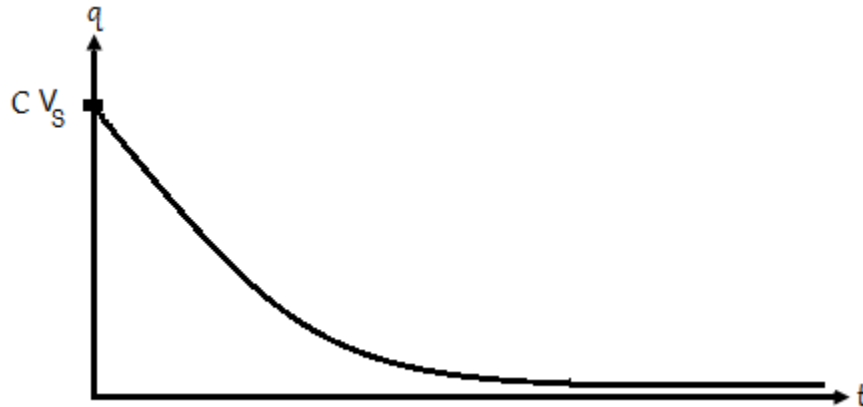

Figure 1.37: Charge on Capacitor

Differentiating both sides of equation 1.89 with respect to time, we obtain the discharging current.

$$\frac{dq}{dt} = -\frac{V_S}{R} e^{-\frac{t}{RC}}$$

$$i = -\frac{V_S}{R} e^{-\frac{t}{RC}} \quad (1.90)$$

The discharging current is a time varying current as shown in Figure 1.38. Initially the current has a maximum value and then it decreases exponentially with respect to time. Minus sign with the current shows that assumed direction of the discharging current is wrong.



Figure 1.38: Discharging Current

D 1.9: A $20\mu\text{F}$ capacitor is charged to a potential difference of 400V and then discharged through a $100\text{K}\Omega$ resistor. Calculate the time constant, initial value of discharging current and voltage across the capacitor after 2 second.

Solution:

Time constant of RC series circuit = $\tau = RC = 2 \text{ seconds}$

The discharging current is given by

$$i = \frac{V_S}{R} e^{-\frac{t}{RC}}$$

The initial value of the current takes place at $t = 0$

$$i = \frac{V_S}{R}$$

$$i = \frac{400}{100,000} = 4 \text{ mA}$$

Now

$$v_C = V_S e^{-\frac{t}{RC}}$$

At $t=2 \text{ sec}$

$$v_C = V_S e^{-1}$$

$$v_C = 400e^{-1} = 147.15 \text{ V}$$

D.10: $8\mu\text{F}$ capacitor is charged to a potential difference of 200V through a series $0.5\text{M}\Omega$ resistor. Calculate the time constant, initial value of charging current, current in the capacitor after 4 second, voltage across the capacitor after 4 second and the time taken for the potential difference across the capacitor to grow to 160V .

Solution:

Time constant of RC series circuit = $\tau = RC = 4 \text{ seconds}$

The charging current is given by

$$i = \frac{V_S}{R} e^{-\frac{t}{RC}}$$

The initial value of the current takes place at $t = 0$

$$i = \frac{V_S}{R}$$

$$i = \frac{200}{0.5 \times 10^6} = 400 \mu A$$

At $t = 4$

$$i = \frac{V_S}{R} e^{-1}$$

$$i = \frac{200}{0.5 \times 10^6} e^{-1} = 147.15 \mu A$$

At $t = 4$

$$v_C = V_S (1 - e^{-\frac{t}{RC}})$$

$$v_C = V_S (1 - e^{-1})$$

$$v_C = 200(1 - e^{-1}) = 126.4 V$$

Now to calculate t

$$v_C = V_S (1 - e^{-\frac{t}{RC}})$$

$$160 = 200(1 - e^{-\frac{t}{4}})$$

$$e^{-\frac{t}{4}} = 0.2$$

$$\frac{-t}{4} = \ln 0.2$$

$$t = 6.44 \text{ Sec}$$

Exercise

Q 1.1: Calculate the total current and all the branch currents in the following circuit.

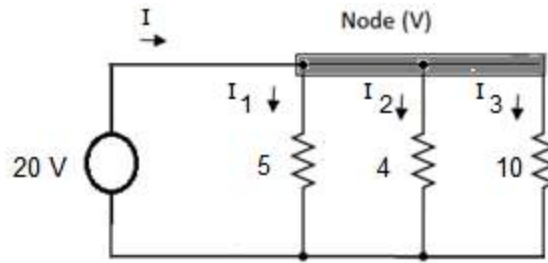

Figure 1.39

Answer: $I = 11\text{ A}$, $I_1 = 4\text{ A}$, $I_2 = 5\text{ A}$ and $I_3 = 2\text{ A}$

Q 1.2: Calculate voltage of the voltage source in the following circuit, if current in the inductor is $4e^{-2t}\text{ A}$.

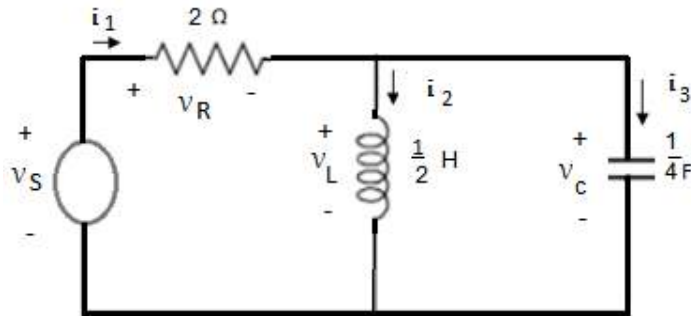

Figure 1.40

Answer: $v_S = 8e^{-2t}\text{ V}$

Q 1.3: A portion of the circuit is shown in Figure 1.41. Using KCL, calculate current in the capacitor $i_1 = 2 \sin t$, and $v_L = 8 \cos t$.

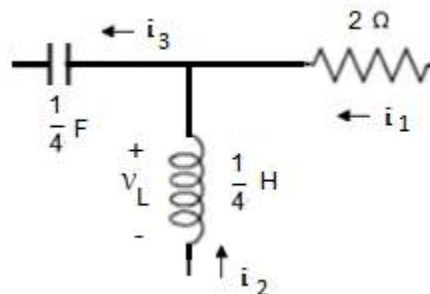

Figure 1.41

Answer: $i_3 = 4 \sin t$

Q 1.4: Sketch for voltage across the capacitor of 1F is shown in Figure 1.42. Sketch the current, charge and power as a function of time.

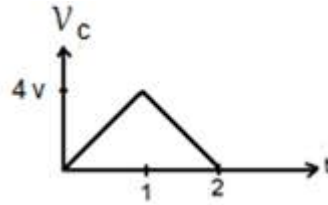

Figure 1.42 for Q 1.4

Chapter 2

Mesh and Nodal Analysis

2-1 Mesh Analysis

Consider a circuit having two loops as shown in Figure 2.1. We assume that the currents I_1 and I_2 flow in the clockwise direction in loop no 1 and loop no 2 respectively. The current in resistor R_1 is I_1 , while the current in resistor R_3 is I_2 . As resistor R_2 belongs to loop no 1 as well as loop no 2, therefore current in this resistor will either be $(I_1 - I_2)$

or $(I_2 - I_1)$ depending upon the numerical values of these two currents. While making calculations for loop no 1 we will assume that current through this common resistor R_2 is $(I_1 - I_2)$ and while making calculations for loop no 2 we will assume that current through the same common resistor R_2 is $(I_2 - I_1)$.

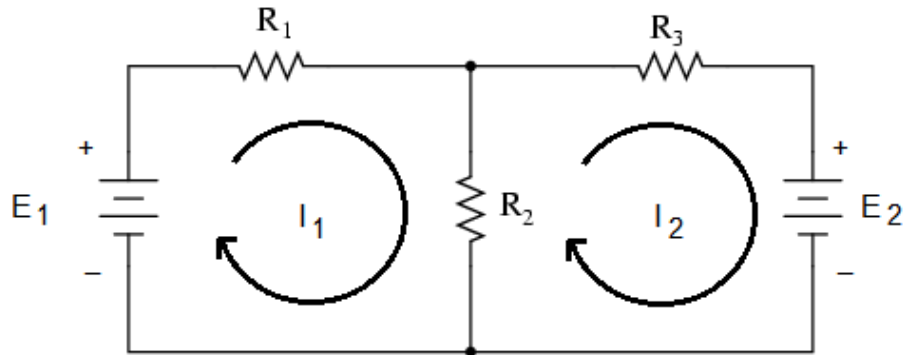

Figure 2.1: Circuit with two Loops

We apply KVL to loop no 1 which states that sum of the voltage rises in loop no 1 will be equal to sum of the voltage drops.

$$E_1 = I_1 R_1 + (I_1 - I_2) R_2 \quad (2.1)$$

Equation no 2.1 can be written as

$$(R_1 + R_2) I_1 + (-R_2) I_2 = E_1 \quad (2.2)$$

$(R_1 + R_2)$ is sum of all the resistances of loop no 1 and this sum is represented by R_{11} , which is known as the total self resistance of loop 1.

$$(R_1 + R_2) = R_{11} \quad (2.3)$$

If we ignore minus sign with R_2 in equation 2.2, then it is the resistance of the resistor that belongs to loop 1 as well as loop 2. This common resistor R_2 is represented by R_{12} , that is

$$(-R_2) = R_{12} \quad (2.4)$$

Putting these values in equation 2.2, we obtain the following equation

$$R_{11} I_1 + R_{12} I_2 = E_1 \quad (2.5)$$

Now let us apply KVL to loop 2

$$-E_2 = I_2 R_3 + (I_2 - I_1) R_2 \quad (2.6)$$

Equation no 2.6 can be written as

$$(R_2 + R_3)I_2 + (-R_2)I_1 = -E_2 \quad (2.7)$$

$(R_2 + R_3)$ is sum of all the resistance of loop no 2 and this sum is represented by R_{22} , that is known as the total self resistance of loop 2.

$$(R_2 + R_3) = R_{22} \quad (2.8)$$

If we ignore minus sign with R_2 for the time being in equation 2.7, then it is the resistance of the resistor that belongs to loop 2 as well as loop 1. This common resistor R_2 is represented by R_{21} , that is

$$(-R_2) = R_{21} \quad (2.9)$$

Putting these values in equation 2.7, we obtain the following equation

$$R_{21}I_1 + R_{22}I_2 = -E_2 \quad (2.10)$$

We ignore minus sign with E_2 for the time being and write equation 2.5 and equation 2.10 once again

$$R_{11}I_1 + R_{12}I_2 = E_1 \quad (A)$$

$$R_{21}I_1 + R_{22}I_2 = E_2 \quad (B)$$

Equations A & B are known as standard loop equations for a circuit having two loops. The number of standard loop equations depends on the number of loops in a circuit. As there are two loops in the mentioned circuit, this is why we have got two equations. Let us write standard loop equations for a circuit having three loops.

$$R_{11}I_1 + R_{12}I_2 + R_{13}I_3 = E_1$$

$$R_{21}I_1 + R_{22}I_2 + R_{23}I_3 = E_2$$

$$R_{31}I_1 + R_{32}I_2 + R_{33}I_3 = E_3$$

Now, let us write standard loop equations for a circuit having n loops.

$$R_{11}I_1 + R_{12}I_2 + R_{13}I_3 + \cdots + R_{1n}I_n = E_1 \quad (1)$$

$$R_{21}I_1 + R_{22}I_2 + R_{23}I_3 + \cdots + R_{2n}I_n = E_2 \quad (2)$$

$$R_{31}I_1 + R_{32}I_2 + R_{33}I_3 + \cdots + R_{3n}I_n = E_3 \quad (3)$$

.

.

$$R_{n1}I_1 + R_{n2}I_2 + R_{n3}I_3 + \cdots + R_{nn}I_n = E_n \quad (n)$$

Equations A & B can be written in matrices format

$$\begin{bmatrix} R_{11} & R_{12} \\ R_{21} & R_{22} \end{bmatrix} \begin{bmatrix} I_1 \\ I_2 \end{bmatrix} = \begin{bmatrix} E_1 \\ E_2 \end{bmatrix} \quad (2.11)$$

In generic form we have

$$[R] [I] = [V]$$

The size of $[R]$ is 2×2 and it depends on the no of loops in the circuit. As there are two loops in the given circuit, this is why the size of the R matrix is 2×2 . If there are three loops in a circuit, then the size of the R matrix will be 3×3 and so on. R_{11} and R_{22} lie on the diagonal of the R matrix and all these diagonal elements are positive. The off diagonal elements of the R matrix will either be negative or positive depending upon the directions of the loop currents I_1 and I_2 . For example we consider the off diagonal element R_{12} of the R matrix. As the loop currents I_1 and I_2 are in opposite directions in R_{12} , this is why there was a minus sign with this resistance. If the loop currents I_1 and I_2 are in the same directions in R_{12} , then there will be a plus sign with this resistance. Similarly E_1 & E_2 will either be positive or negative. Keeping in view the direction of the loop current I_1 , the voltage E_1 is a voltage rise, this is why there is a plus sign with this voltage. Keeping in view the direction of the loop current I_2 , the voltage E_2 is a voltage drop, this is why there is a minus sign with this voltage. We find the currents I_1 and I_2 with the help of crammer's rule.

$$I_1 = \frac{\begin{vmatrix} E_1 & R_{12} \\ E_2 & R_{22} \end{vmatrix}}{\begin{vmatrix} R_{11} & R_{12} \\ R_{21} & R_{22} \end{vmatrix}}$$

$$I_2 = \frac{\begin{vmatrix} R_{11} & E_1 \\ R_{21} & E_2 \end{vmatrix}}{\begin{vmatrix} R_{11} & R_{12} \\ R_{21} & R_{22} \end{vmatrix}}$$

D 2.1: Consider the circuit in Figure 2.2. Apply standard loop equations to calculate the power consumed by the circuit and the power supplied by the two sources.

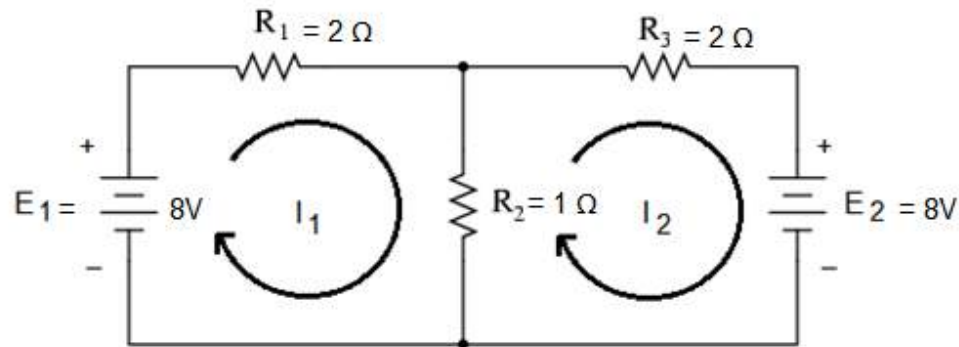

Figure 2.2: Circuit for D # 2.1

Solution:

As there are two loops in the entire network, so the standard loop equations in generic form will be

$$\begin{bmatrix} R_{11} & R_{12} \\ R_{21} & R_{22} \end{bmatrix} \begin{bmatrix} I_1 \\ I_2 \end{bmatrix} = \begin{bmatrix} E_1 \\ E_2 \end{bmatrix}$$

$$R_{11} = 2 + 1 = 3\Omega$$

$$R_{12} = R_{21} = -1\Omega$$

$$R_{22} = 2 + 1 = 3\Omega$$

$$E_1 = 8V$$

$$E_2 = -8V$$

The standard loop equations in matrices format for the given circuit are as follows

$$\begin{bmatrix} 3 & -1 \\ -1 & 3 \end{bmatrix} \begin{bmatrix} I_1 \\ I_2 \end{bmatrix} = \begin{bmatrix} 8 \\ -8 \end{bmatrix}$$

Applying Cramer's Rule

$$I_1 = \frac{\begin{vmatrix} 8 & -1 \\ -8 & 3 \end{vmatrix}}{\begin{vmatrix} 3 & -1 \\ -1 & 3 \end{vmatrix}}$$
$$I_1 = \frac{16}{8} = 2A$$
$$I_2 = \frac{\begin{vmatrix} 3 & 8 \\ -1 & -8 \end{vmatrix}}{\begin{vmatrix} 3 & -1 \\ -1 & 3 \end{vmatrix}}$$
$$I_2 = \frac{-16}{8} = -2A$$

The minus sign indicates that the assumed direction of the current I_2 is wrong.

Current through the 2Ω resistor of loop 1 = $I_1 = 2 A$

Current through the 2Ω resistor of loop 2 = $I_2 = -2 A$

Current through the 1Ω resistor = $(I_1 - I_2) = 4 A$

Power consumed by the 2Ω resistor of loop 1 = $P_1 = 8 W$

Power consumed by the 2Ω resistor of loop 2 = $P_2 = 8 W$

Power consumed by the 1Ω resistor = $P_3 = 16 W$

Power consumed by the entire circuit = $P_t = 32 W$

Power supplied by the source of loop 1 = $E_1 I_1 = 16 W$

Power supplied by the source of loop 2 = $E_2 I_2 = 16 W$

Total power supplied by the two sources = $32W$

D 2.2: Consider the circuit in Figure 2.3. Apply standard loop equations to calculate the power consumed by the circuit and the power supplied by the source.

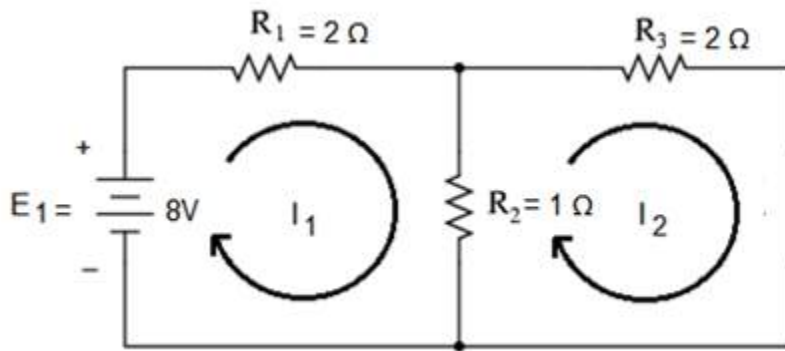

Figure 2.3: Circuit for D # 2.2

Solution:

As there are two loops in the entire network, so the standard loop equations in generic form will be

$$\begin{bmatrix} R_{11} & R_{12} \\ R_{21} & R_{22} \end{bmatrix} \begin{bmatrix} I_1 \\ I_2 \end{bmatrix} = \begin{bmatrix} E_1 \\ E_2 \end{bmatrix}$$

$$R_{11} = 2 + 1 = 3\Omega$$

$$R_{12} = R_{21} = -1\Omega$$

$$R_{22} = 2 + 1 = 3\Omega$$

$$E_1 = 8V$$

$$E_2 = 0V$$

The standard loop equations in matrices format for the given circuit are as follows

$$\begin{bmatrix} 3 & -1 \\ -1 & 3 \end{bmatrix} \begin{bmatrix} I_1 \\ I_2 \end{bmatrix} = \begin{bmatrix} 8 \\ 0 \end{bmatrix}$$

Applying Cramer's Rule

$$I_1 = \frac{\begin{vmatrix} 8 & -1 \\ 0 & 3 \end{vmatrix}}{\begin{vmatrix} 3 & -1 \\ -1 & 3 \end{vmatrix}} = \frac{24}{8} = 3A$$

$$I_2 = \frac{\begin{vmatrix} 3 & 8 \\ -1 & 0 \end{vmatrix}}{\begin{vmatrix} 3 & -1 \\ -1 & 3 \end{vmatrix}} = \frac{8}{8} = 1A$$

Current through the 2Ω resistor of loop 1 = $I_1 = 3\text{ A}$

Current through the 2Ω resistor of loop 2 = $I_2 = 1\text{ A}$

Current through the 1Ω resistor = $(I_1 - I_2) = 2\text{ A}$

Power consumed by the 2Ω resistor of loop 1 = $P_1 = 18\text{ W}$

Power consumed by the 2Ω resistor of loop 2 = $P_2 = 2\text{ W}$

Power consumed by the 1Ω resistor = $P_3 = 4\text{ W}$

Power consumed by the entire circuit = $P_t = 24\text{ W}$

Power supplied by the source = $E_1 I_1 = 24\text{ W}$

D 2.3: Consider the circuit in Figure 2.4. Apply standard loop equations to calculate the currents in R_1 , R_3 and R_5 .

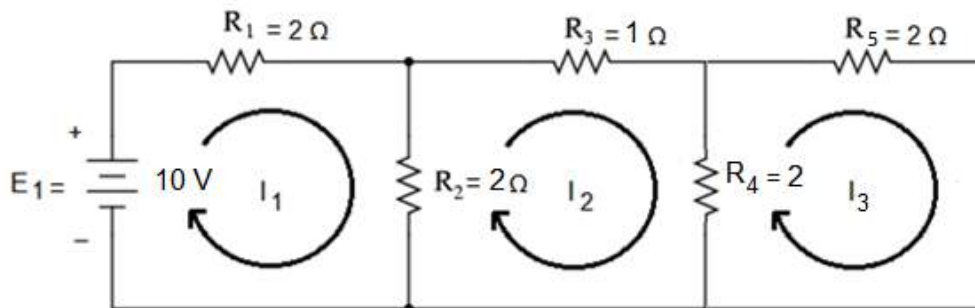

Figure 2.4: Circuit for D # 2.3

Solution: As there are three loops in the entire network, so the standard loop equations in generic form will be

$$\begin{bmatrix} R_{11} & R_{12} & R_{13} \\ R_{21} & R_{22} & R_{23} \\ R_{31} & R_{32} & R_{33} \end{bmatrix} \begin{bmatrix} I_1 \\ I_2 \\ I_3 \end{bmatrix} = \begin{bmatrix} E_1 \\ E_2 \\ E_3 \end{bmatrix}$$

$$R_{11} = 2 + 2 = 4\Omega$$

$$R_{12} = R_{21} = -2\Omega$$

There is no common resistor between loop 1 and loop 3 therefore

$$R_{13} = R_{31} = 0\Omega$$

and

$$R_{22} = 2 + 2 + 1 = 5\Omega$$

$$R_{23} = R_{32} = -2\Omega$$

$$R_{33} = 2 + 2 = 4\Omega$$

$$E_1 = 10\text{ V}$$

There is no voltage source in loop 2 as well as loop 3, therefore

$$E_2 = E_3 = 0\text{ V}$$

$$\begin{bmatrix} 4 & -2 & 0 \\ -2 & 5 & -2 \\ 0 & -2 & 4 \end{bmatrix} \begin{bmatrix} I_1 \\ I_2 \\ I_3 \end{bmatrix} = \begin{bmatrix} 10 \\ 0 \\ 0 \end{bmatrix}$$

Determinant of the R matrix is

$$\begin{vmatrix} 4 & -2 & 0 \\ -2 & 5 & -2 \\ 0 & -2 & 4 \end{vmatrix} = 64 - 16 = 48$$

Current through R_1 is I_1

$$I_1 = \frac{\begin{vmatrix} 10 & -2 & 0 \\ 0 & 5 & -2 \\ 0 & -2 & 4 \end{vmatrix}}{48} = \frac{160}{48} = 3.333\text{ A}$$

Current through R_3 is I_2

$$I_2 = \frac{\begin{vmatrix} 4 & 10 & 0 \\ -2 & 0 & -2 \\ 0 & 0 & 4 \end{vmatrix}}{48} = \frac{80}{48} = 1.67\text{ A}$$

Current through R_5 is I_3

$$I_3 = \frac{\begin{vmatrix} 4 & -2 & 10 \\ -2 & 5 & 0 \\ 0 & -2 & 0 \end{vmatrix}}{48} = \frac{40}{48} = 0.833 \text{ A}$$

D 2.4: Consider the circuit in Figure 2.4b. Apply standard loop equations to calculate the currents in R_1 , R_3 and R_5 .

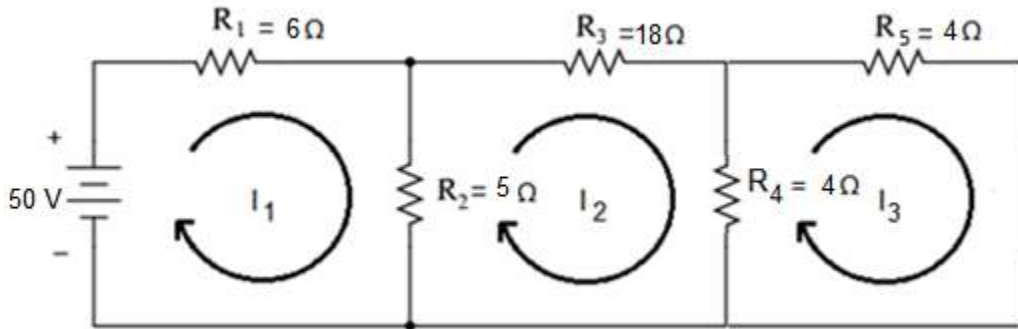

Figure 2.4b: Circuit for D # 2.4

Solution:

As there are three loops in the entire network, so the standard loop equations in generic form will be

$$\begin{bmatrix} R_{11} & R_{12} & R_{13} \\ R_{21} & R_{22} & R_{23} \\ R_{31} & R_{32} & R_{33} \end{bmatrix} \begin{bmatrix} I_1 \\ I_2 \\ I_3 \end{bmatrix} = \begin{bmatrix} E_1 \\ E_2 \\ E_3 \end{bmatrix}$$

$$R_{11} = 11\Omega$$

$$R_{12} = R_{21} = -5\Omega$$

There is no common resistor between loop 1 and loop 3 therefore

$$R_{13} = R_{31} = 0\Omega$$

$$R_{22} = 27\Omega$$

$$R_{23} = R_{32} = -4\Omega$$

$$R_{33} = 8 \Omega$$

$$E_1 = 50V$$

There is no voltage source in loop 2 as well as loop 3, therefore

$$E_2 = E_3 = 0V$$

$$\begin{bmatrix} 11 & -5 & 0 \\ -5 & 27 & -4 \\ 0 & -4 & 8 \end{bmatrix} \begin{bmatrix} I_1 \\ I_2 \\ I_3 \end{bmatrix} = \begin{bmatrix} 50 \\ 0 \\ 0 \end{bmatrix}$$

$$\begin{vmatrix} 11 & -5 & 0 \\ -5 & 27 & -4 \\ 0 & -4 & 8 \end{vmatrix} = 2000$$

Current through R_1 is I_1

$$I_1 = \frac{\begin{vmatrix} 50 & -5 & 0 \\ 0 & 27 & -4 \\ 0 & -4 & 8 \end{vmatrix}}{2000} = \frac{10,000}{2000} = 5 A$$

Current through R_3 is I_2

$$I_2 = \frac{\begin{vmatrix} 11 & 50 & 0 \\ -5 & 0 & -4 \\ 0 & 0 & 8 \end{vmatrix}}{2000} = \frac{2000}{2000} = 1 A$$

Current through R_5 is I_3

$$I_3 = \frac{\begin{vmatrix} 11 & -5 & 50 \\ -5 & 27 & 0 \\ 0 & -4 & 0 \end{vmatrix}}{2000} = \frac{1000}{2000} = 0.5$$

2-2 Nodal Analysis

Consider the circuit having two nodes as shown in Figure 2.5. The voltage at node 1 is V_1 and the voltage at node 2 is V_2 .

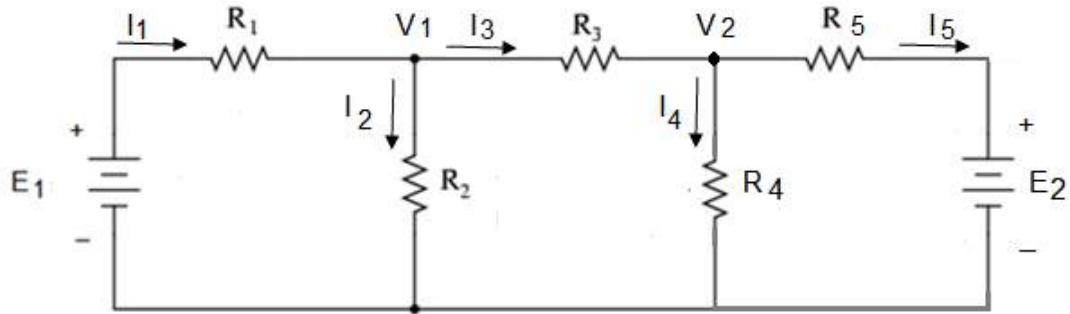

Figure 2.5: Circuit for Nodal Analysis

Applying KCL to node 1

$$I_1 = I_2 + I_3 \quad (2.12)$$

Applying KCL to node 2

$$I_3 = I_4 + I_5 \quad (2.13)$$

There are three loops in this circuit as shown in Figure 2.6. We apply KVL to all these three loops to find out equations for all the five currents.

Applying KVL to loop 1

$$E_1 = I_1 R_1 + V_1 \quad (2.14)$$

Therefore

$$I_1 = \frac{(E_1 - V_1)}{R_1} \quad (2.15)$$

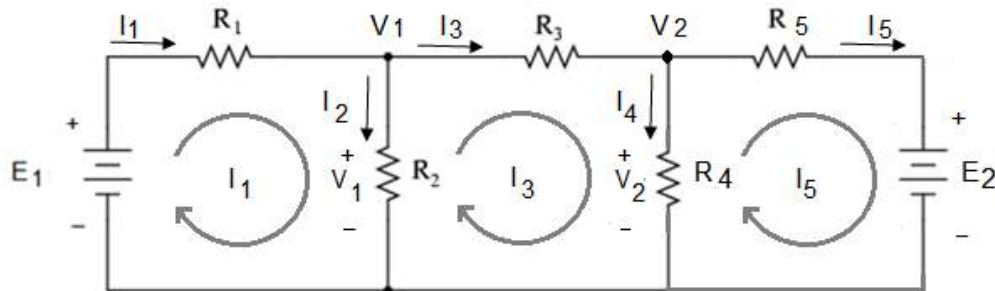

Figure 2.6: Circuit for Nodal Analysis with Loop Currents

The current I_2 can be calculated as

$$I_2 = \frac{V_1}{R_2} \quad (2.16)$$

Applying KVL to loop 2, we obtain V_1

$$V_1 = I_3 R_3 + V_2 \quad (2.17)$$

Therefore

$$I_3 = \frac{(V_1 - V_2)}{R_3} \quad (2.18)$$

The current I_4 can be calculated as

$$I_4 = \frac{V_2}{R_4} \quad (2.19)$$

Applying KVL to loop 3, we obtain V_2

$$V_2 = I_5 R_5 + E_2 \quad (2.20)$$

Therefore

$$I_5 = \frac{(V_2 - E_2)}{R_5} \quad (2.21)$$

Putting the values in equation 2.12

$$\frac{(E_1 - V_1)}{R_1} = \frac{V_1}{R_2} + \frac{(V_1 - V_2)}{R_3} \quad (2.22)$$

Rearranging this equation, we obtain

$$\left(\frac{1}{R_1} + \frac{1}{R_2} + \frac{1}{R_3} \right) V_1 + \left(-\frac{1}{R_3} \right) V_2 = \frac{E_1}{R_1} \quad (2.23)$$

Reciprocal of resistance is known as conductance that is represented by G . We replace

$\frac{E_1}{R_1}$ by I_{g1} , Therefore equation 2.23 can be written as

$$(G_1 + G_2 + G_3) V_1 + (-G_3) V_2 = I_{g1} \quad (2.24)$$

G_1 , G_2 and G_3 have been connected to node 1 as shown in Figure 2.7, this is why the sum of all these three conductance is represented by G_{11} . We ignore the minus sign with G_3

for the time being, as G_3 has been connected to node 1 as well as node 2, therefore it is represented by G_{12}

$$(G_{11}) V_1 + (G_{12}) V_2 = I_{g1} \quad (2.25)$$

Similarly putting the values of I_3 , I_4 and I_5 in equation in equation 2.13, we have

$$\frac{(V_1 - V_2)}{R_3} = \frac{V_2}{R_4} + \frac{(V_2 - E_2)}{R_5} \quad (2.26)$$

Rearranging this equation, we obtain

$$\left(-\frac{1}{R_3}\right) V_1 + \left(\frac{1}{R_3} + \frac{1}{R_4} + \frac{1}{R_5}\right) V_2 = \frac{E_2}{R_5} \quad (2.27)$$

Replacing $\frac{E_2}{R_5}$ by I_{g2} , Therefore equation 2.27 can be written as

$$(-G_3) V_1 + (G_3 + G_4 + G_5) V_2 = I_{g2} \quad (2.28)$$

G_3 , G_4 and G_5 have been connected to node 2 as shown in Figure 2.7, this is why the sum of all these three conductance is represented by G_{22} . We ignore minus sign with G_3 for the time being, as G_3 has been connected to node 1 as well as node 2, therefore it is represented by G_{21}

$$(G_{21}) V_1 + (G_{22}) V_2 = I_{g2} \quad (2.29)$$

We write equation 2.25 and equation 2.29 once again

$$(G_{11}) V_1 + (G_{12}) V_2 = I_{g1} \quad (2.30)$$

$$(G_{21}) V_1 + (G_{22}) V_2 = I_{g2} \quad (2.31)$$

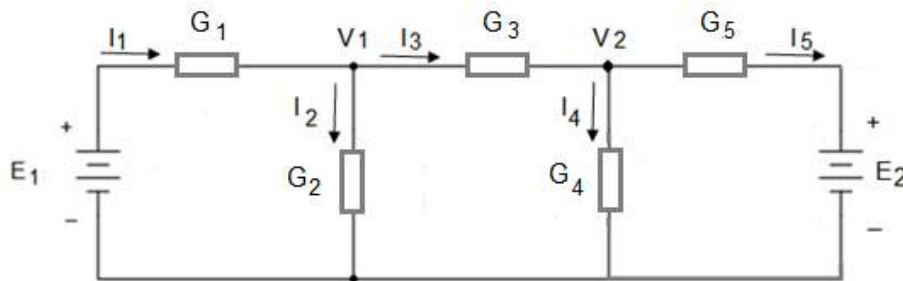

Figure 2.7: Equivalent Circuit with Conductance

These two equations are known as standard node equations for a circuit having two nodes. The number of standard node equations depends on the number of nodes in a circuit. As there are two nodes in the mentioned circuit, this is why we have got two equations. Let us write the standard node equations for a circuit having three nodes.

$$(G_{11}) V_1 + (G_{12}) V_2 + (G_{13}) V_3 = I_{g1} \quad (2.32)$$

$$(G_{21}) V_1 + (G_{22}) V_2 + (G_{23}) V_3 = I_{g2} \quad (2.33)$$

$$(G_{31}) V_1 + (G_{32}) V_2 + (G_{33}) V_3 = I_{g3} \quad (2.34)$$

Following are the standard node equations for a circuit having n nodes.

$$(G_{11}) V_1 + (G_{12}) V_2 + (G_{13}) V_3 + \dots + (G_{1n}) V_n = I_{g1} \quad (1)$$

$$(G_{21}) V_1 + (G_{22}) V_2 + (G_{23}) V_3 + \dots + (G_{2n}) V_n = I_{g2} \quad (2)$$

$$(G_{31}) V_1 + (G_{32}) V_2 + (G_{33}) V_3 + \dots + (G_{3n}) V_n = I_{g3} \quad (3)$$

.

.

.

$$(G_{n1}) V_1 + (G_{n2}) V_2 + (G_{n3}) V_3 + \dots + (G_{nn}) V_n = I_{gn} \quad (n)$$

Equations 2.30 & 2.31 can be written in matrices format as in equation 2.35.

$$\begin{bmatrix} G_{11} & G_{12} \\ G_{21} & G_{22} \end{bmatrix} \begin{bmatrix} V_1 \\ V_2 \end{bmatrix} = \begin{bmatrix} I_{g1} \\ I_{g2} \end{bmatrix} \quad (2.35)$$

In generic form we have

$$[G] [V] = [I]$$

Size of $[G]$ is 2×2 and it depends on the number of nodes in the circuit. As there are two nodes in the given circuit, this is why size of the G matrix is 2×2 . If there are three nodes in a circuit, then size of the G matrix will be 3×3 and so on. G_{11} and G_{22} lie on the diagonal of the G matrix and all these diagonal elements are positive. The off

diagonal elements of the G matrix are negative. We will find the currents V_1 and V_2 with the help of crammer's rule.

$$V_1 = \frac{\begin{vmatrix} I_{g1} & G_{12} \\ I_{g2} & G_{22} \end{vmatrix}}{\begin{vmatrix} G_{11} & G_{12} \\ G_{21} & G_{22} \end{vmatrix}}$$

$$V_2 = \frac{\begin{vmatrix} G_{11} & I_{g1} \\ G_{21} & I_{g2} \end{vmatrix}}{\begin{vmatrix} G_{11} & G_{12} \\ G_{21} & G_{22} \end{vmatrix}}$$

D 2.5: Consider the circuit in Figure 2.8 once again. Apply standard node equations to calculate all the three currents.

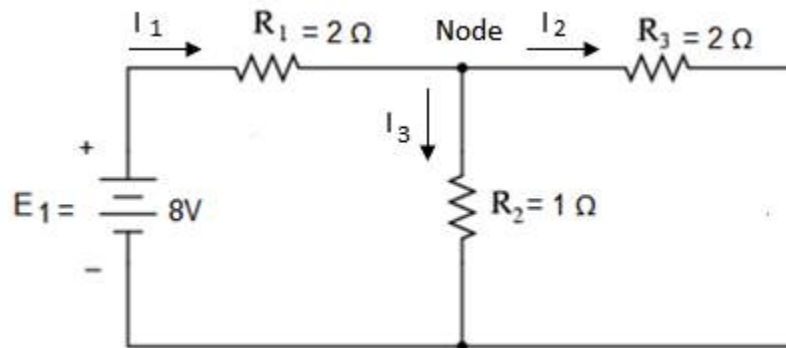

Figure 2.8: Circuit for D # 2.5

Solution:

As there is a single node in the given circuit, therefore the size of the G matrix will be 1×1 and the standard node equation will be in the following format.

$$[G_{11}][V_1] = [I_{g1}]$$

V_1 is voltage at the node

$$G_{11} = \frac{1}{2} + \frac{1}{2} + \frac{1}{1} = 2$$

$$I_{g1} = \frac{E_1}{R_1} = \frac{8}{2} = 4 A$$

So the standard node equation for the given circuit will be

$$2V_1 = 4$$

$$V_1 = 2 \text{ V}$$

$$I_1 = \frac{(E_1 - V_1)}{R_1} = \frac{(8 - 2)}{2} = 3 \text{ A}$$

$$I_2 = \frac{V_1}{R_3} = \frac{2}{2} = 1 \text{ A}$$

$$I_3 = \frac{V_1}{R_2} = \frac{2}{1} = 2 \text{ A}$$

D 2.6: Consider the circuit in Figure 2.9. Apply standard node equations to calculate all the five currents.

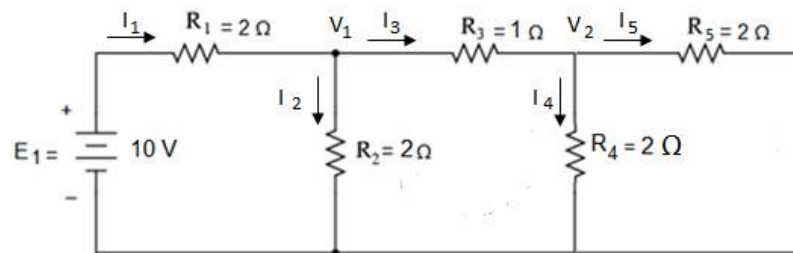

Figure 2.9: Circuit for D # 2.6

Solution:

As there are two nodes in the given circuit, therefore the size of the G matrix will be 2×2 and the standard node equations will be in the following format.

$$\begin{bmatrix} G_{11} & G_{12} \\ G_{21} & G_{22} \end{bmatrix} \begin{bmatrix} V_1 \\ V_2 \end{bmatrix} = \begin{bmatrix} I_{g1} \\ I_{g2} \end{bmatrix}$$

V_1 & V_2 are the voltages at node 1 and node 2 respectively

$$G_{11} = \frac{1}{2} + \frac{1}{2} + \frac{1}{1} = 2$$

$$G_{21} = G_{12} = -\frac{1}{1} = -1$$

$$G_{22} = \frac{1}{2} + \frac{1}{2} + \frac{1}{1} = 2$$

$$I_{g1} = \frac{E_1}{R_1} = \frac{10}{2} = 5 \text{ A}$$

$I_{g2} = 0 \text{ A}$; as no voltage source has been connected to node 2. So the standard node equations for the given circuit will be

$$\begin{bmatrix} 2 & -1 \\ -1 & 2 \end{bmatrix} \begin{bmatrix} V_1 \\ V_2 \end{bmatrix} = \begin{bmatrix} 5 \\ 0 \end{bmatrix}$$

$$V_1 = \frac{\begin{vmatrix} 5 & -1 \\ 0 & 2 \end{vmatrix}}{\begin{vmatrix} 2 & -1 \\ -1 & 2 \end{vmatrix}} = \frac{10}{3} = 3.333 \text{ V}$$

$$V_2 = \frac{\begin{vmatrix} 2 & 5 \\ -1 & 0 \end{vmatrix}}{\begin{vmatrix} 2 & -1 \\ -1 & 2 \end{vmatrix}} = \frac{5}{3} = 1.666 \text{ V}$$

$$I_1 = \frac{(E_1 - V_1)}{R_1} = \frac{(10 - 3.333)}{2} = \frac{6.67}{2} = 3.33 \text{ A}$$

$$I_2 = \frac{V_1}{R_2} = \frac{3.33}{2} = 1.666 \text{ A}$$

$$I_3 = \frac{(V_1 - V_2)}{R_3} = \frac{(3.33 - 1.66)}{1} = \frac{1.66}{1} = 1.66 \text{ A}$$

$$I_4 = \frac{V_2}{R_4} = \frac{1.66}{2} = 0.835 \text{ A}$$

$$I_5 = \frac{V_2}{R_5} = \frac{1.66}{2} = 0.835 \text{ A}$$

D 2.7: Consider the circuit in Figure 2.9b. Apply standard node equations to calculate all the five currents.

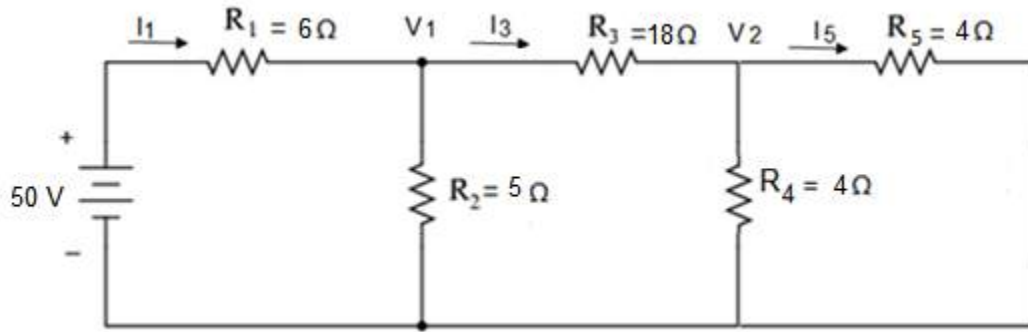

Figure 2.9b: Circuit for D # 2.7

Solution:

As there are two nodes in the given circuit, therefore the size of the G matrix will be 2×2 and the standard node equations will be in the following format.

$$\begin{bmatrix} G_{11} & G_{12} \\ G_{21} & G_{22} \end{bmatrix} \begin{bmatrix} V_1 \\ V_2 \end{bmatrix} = \begin{bmatrix} I_{g1} \\ I_{g2} \end{bmatrix}$$

V_1 & V_2 are the voltages at the node 1 and node 2 respectively

$$G_{11} = \frac{1}{6} + \frac{1}{5} + \frac{1}{18} = 0.422$$

$$G_{21} = G_{12} = -\frac{1}{18} = -0.055$$

$$G_{22} = \frac{1}{4} + \frac{1}{4} + \frac{1}{18} = 0.505$$

$$I_{g1} = \frac{E_1}{R_1} = \frac{50}{6} = 8.33 \text{ A}$$

$I_{g2} = 0 \text{ A}$; as no voltage source has been connected to node 2. So the standard node equations for the given circuit will be

$$\begin{bmatrix} 0.422 & -0.055 \\ -0.055 & 0.505 \end{bmatrix} \begin{bmatrix} V_1 \\ V_2 \end{bmatrix} = \begin{bmatrix} 8.33 \\ 0 \end{bmatrix}$$

$$V_1 = \frac{\begin{vmatrix} 8.33 & -0.055 \\ 0 & 0.505 \end{vmatrix}}{\begin{vmatrix} 0.422 & -0.055 \\ -0.055 & 0.505 \end{vmatrix}} = \frac{4.208}{0.21} = 20 \text{ V}$$

$$V_2 = \frac{\begin{vmatrix} 0.422 & 8.33 \\ -0.055 & 0 \end{vmatrix}}{0.21} = \frac{0.458}{0.21} = 2 \text{ V}$$

$$I_1 = \frac{(E_1 - V_1)}{R_1} = \frac{(50 - 20)}{6} = 5 \text{ A}$$

$$I_3 = \frac{(V_1 - V_2)}{R_3} = \frac{(20 - 2)}{18} = 1 \text{ A}$$

$$I_5 = \frac{V_2}{R_5} = \frac{2}{4} = 0.5 \text{ A}$$

2-3 Representation of Phasors

For the analysis of AC circuits, we need to represent the current and voltage with the help of phasor quantities. Phasor might be a scalar quantity or a vector quantity. Basically it depends on nature of the original quantity, if the original quantity is scalar, then the phasor will be a scalar phasor and if the original quantity is a vector then the phasor will be a vector phasor. There are four ways to represent a phasor.

(i) Rectangular Form

Phasor is a complex quantity that has a real component a and imaginary component b . Mathematically a phasor quantity is represented as

$$Z = a + jb \quad (2.36)$$

Where

$$j = \sqrt{-1}$$

This form of representation is known as rectangular form. Graphical representation of a phasor quantity is given in Figure 2.10.

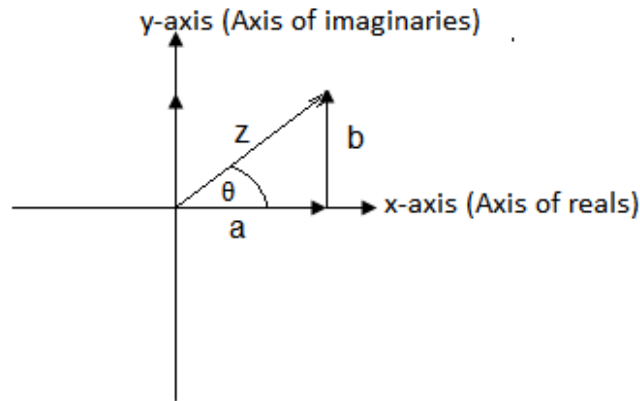

Figure 2.10: Graphical Representation of a Phasor

(ii) Trigonometric Form

Consider Figure 2.10, the magnitude of the real component a is given by

$$a = |Z| \cos \theta \quad (2.37)$$

and the magnitude of the imaginary component b is given by

$$b = |Z| \sin \theta \quad (2.38)$$

Putting the values of a and b in equation 2.36, we obtain

$$Z = |Z|(\cos \theta + j \sin \theta) \quad (2.39)$$

This form of representation is known as trigonometric form. Where $|Z|$ represents the magnitude of the phasor and θ represents the angle of the phasor. In order to find the magnitude of this phasor, we apply Pythagoras theorem on the right angle triangle shown in Figure 2.10.

$$|Z|^2 = a^2 + b^2$$

So magnitude of Z can be calculated as

$$|Z| = \sqrt{a^2 + b^2} \quad (2.40)$$

As

$$\tan \theta = \frac{b}{a}$$

So angle of Z can be calculated as

$$\theta = \tan^{-1} \frac{b}{a} \quad (2.41)$$

(iii) Exponential Form

We know that

$$e^{j\theta} = \cos \theta + j \sin \theta \quad (2.42)$$

and

$$e^{-j\theta} = \cos \theta - j \sin \theta \quad (2.43)$$

Putting the value of $\cos \theta + j \sin \theta$ in equation 2.39, we get

$$Z = |Z|e^{j\theta} \quad (2.44)$$

This form of representation is known as exponential form.

(iv) Polar Form

The two important parameters of a phasor quantity are its magnitude and its angle. If we know these two important parameters, we can represent the same phasor in trigonometric as well as exponential form. So simply we can represent a phasor as

$$Z = |Z| \angle \theta \quad (2.45)$$

The first quantity on the right hand side of equation 2.45 represents the magnitude of phasor and the second quantity represents its angle. This simple form is known as polar form.

2-4 Addition of Phasors

The addition of two or more than two phasors results in a new phasor. We consider two phasors Z_1 and Z_2 in exponential as well as polar form

$$Z_1 = |Z_1|e^{j\theta_1} = |Z_1| \angle \theta_1 \quad (2.46)$$

$$Z_2 = |Z_2|e^{j\theta_2} = |Z_2| \angle \theta_2 \quad (2.47)$$

Let us add these two phasors in exponential form

$$Z_a = Z_1 + Z_2$$

$$Z_a = |Z_1|e^{j\theta_1} + |Z_2|e^{j\theta_2} \quad (2.48)$$

It is very difficult to find out the magnitude as well as the angle of the resultant phasor from the right hand side of equation 2.48. So, it is difficult to add two or more than two phasors, if they are in exponential form. Now Let us add these two phasors in polar form.

$$Z_a = Z_1 + Z_2$$

$$Z_a = |Z_1|\angle\theta_1 + |Z_2|\angle\theta_2 \quad (2.49)$$

Once again, it is very difficult to find out the magnitude as well as the angle of the resultant phasor from the right hand side of equation 2.49. So, it is difficult to add two or more than two phasors if they are in polar form. So obviously, we have to convert these phasors into rectangular form for the sake of addition.

$$Z_1 = a_1 + jb_1$$

$$Z_2 = a_2 + jb_2$$

The addition of these two phasors results in a new phasor Z_a .

$$Z_a = Z_1 + Z_2$$

$$Z_a = (a_1 + jb_1) + (a_2 + jb_2)$$

$$Z_a = (a_1 + a_2) + j(b_1 + b_2) \quad (2.50)$$

The real component of the resultant phasor is $(a_1 + a_2)$ and its imaginary component is $(b_1 + b_2)$

2-5 Subtraction of Phasors

The subtraction of one phasor from another phasor results in a new phasor. We consider two phasors Z_1 and Z_2 in exponential as well as polar form

$$Z_1 = |Z_1|e^{j\theta_1} = |Z_1|\angle\theta_1 \quad (2.51)$$

$$Z_2 = |Z_2|e^{j\theta_2} = |Z_2|\angle\theta_2 \quad (2.52)$$

Let us subtract Z_2 from Z_1

$$Z_s = Z_1 - Z_2$$

$$Z_s = |Z_1|e^{j\theta_1} - |Z_2|e^{j\theta_2} \quad (2.53)$$

It is very difficult to find out the magnitude as well as the angle of the resultant phasor from the right hand side of equation 2.53. So, it is difficult to subtract one phasor from another one, if they are in exponential form. Now Let us subtract Z_2 from Z_1 in polar form.

$$Z_s = Z_1 - Z_2$$

$$Z_s = |Z_1|\angle\theta_1 - |Z_2|\angle\theta_2 \quad (2.54)$$

Once again, it is very difficult to find out the magnitude as well as the angle of the resultant phasor from the right hand side of equation 2.54. So, it is difficult to subtract one phasor from another one if they are in polar form. So obviously we have to convert these phasors into rectangular form for the sake of subtraction as well.

$$Z_1 = a_1 + jb_1$$

$$Z_2 = a_2 + jb_2$$

The subtraction of Z_2 from Z_1 results in a new phasor Z_s .

$$Z_s = Z_1 - Z_2$$

$$Z_s = (a_1 + jb_1) - (a_2 + jb_2)$$

$$Z_s = (a_1 - a_2) + j(b_1 - b_2) \quad (2.55)$$

The real component of the resultant phasor is $(a_1 - a_2)$ and its imaginary component is $(b_1 - b_2)$.

2-6 Multiplication of Phasors

The multiplication of two or more than two phasors results in a new phasor. We consider two phasors Z_1 and Z_2 in rectangular form

$$Z_1 = a_1 + jb_1$$

$$Z_2 = a_2 + jb_2$$

Let us multiply Z_1 by Z_2

$$Z_M = Z_1 \times Z_2$$

$$Z_M = (a_1 + jb_1) \times (a_2 + jb_2)$$

$$Z_M = (a_1a_2 - b_1b_2) + j(a_1b_2 + a_2b_1) \quad (2.56)$$

The real component of the resultant phasor is $(a_1a_2 - b_1b_2)$ and its imaginary component is $(a_1b_2 + a_2b_1)$. Now Let us multiply Z_2 and Z_1 in exponential form:

$$Z_M = Z_1 \times Z_2$$

$$Z_M = |Z_1|e^{j\theta_1} \times |Z_2|e^{j\theta_2} \quad (2.57)$$

$$Z_M = |Z_1||Z_2|e^{j\theta_1} \times e^{j\theta_2} \quad (2.58)$$

$$Z_M = |Z_1||Z_2|e^{j(\theta_1+\theta_2)} \quad (2.59)$$

The magnitude of the resultant phasor is $|Z_1||Z_2|$ and its angle is $(\theta_1 + \theta_2)$. We can multiply the two phasors in polar form as well

$$Z_M = Z_1 \times Z_2$$

$$Z_M = |Z_1|\angle\theta_1 \times |Z_2|\angle\theta_2$$

$$Z_M = |Z_1||Z_2|\angle(\theta_1 + \theta_2) \quad (2.60)$$

We argue that it is convenient to multiply two or more than two phasors in polar form.

2-7 Division of Phasors

The division of one phasor by another one results in a new phasor. We consider two phasors Z_1 and Z_2 in rectangular form

$$Z_1 = a_1 + jb_1$$

$$Z_2 = a_2 + jb_2$$

Let us divide Z_1 by Z_2

$$Z_d = \frac{Z_1}{Z_2}$$

$$Z_d = \frac{(a_1 + jb_1)}{(a_2 + jb_2)}$$

We multiply and divide the right hand side of the above equation by the conjugate of Z_2

$$Z_d = \frac{(a_1 + jb_1)}{(a_2 + jb_2)} \times \frac{(a_2 - jb_2)}{(a_2 - jb_2)}$$

$$Z_d = \frac{(a_1a_2 + b_1b_2)}{(a_2^2 + b_2^2)} + j \frac{(a_2b_1 - a_1b_2)}{(a_2^2 + b_2^2)}$$

Now Let us divide Z_1 by Z_2 in exponential form

$$Z_d = \frac{Z_1}{Z_2}$$

$$Z_d = \frac{|Z_1|e^{j\theta_1}}{|Z_2|e^{j\theta_2}}$$

$$Z_d = \frac{|Z_1|}{|Z_2|} e^{j\theta_1} \times e^{-j\theta_2}$$

$$Z_d = \frac{|Z_1|}{|Z_2|} e^{j(\theta_1 - \theta_2)}$$

This last equation reveals that this mathematical operation is convenient in polar form.

D 2.8: Convert the following phasor into trigonometric, exponential and polar form.

$$Z_1 = 3 + j4$$

Solution:

The magnitude of the phasor is calculated as

$$|Z| = \sqrt{(3^2 + 4^2)} = 5$$

The angle of the phasor is calculated as

$$\theta = \tan^{-1} \frac{4}{3} = 53.1^\circ$$

This phasor in trigonometric form is as under

$$Z = 5(\cos 53.1^\circ + j \sin 53.1^\circ)$$

This phasor in exponential form is as under

$$Z = 5e^{j53.1^\circ}$$

This phasor in polar form is as under

$$Z = 5 \angle 53.1^\circ$$

D 2.9: Convert the following phasor into rectangular form.

$$Z = 10 \angle 36.8^\circ$$

Solution:

Real component of this phasor is

$$a = 10 \cos 36.8 = 8$$

Imaginary component of this phasor is

$$b = 10 \sin 36.8 = 6$$

The same phasor in rectangular form can be written as

$$Z = 8 + j6$$

D 2.10: Add the following two phasors.

$$Z_1 = 10 \angle 36.8^\circ$$

$$Z_2 = 5 \angle 53.1^\circ$$

Solution:

We add the two phasors into rectangular form

$$Z_1 = 8 + j6$$

$$Z_2 = 3 + j4$$

$$Z_a = Z_1 + Z_2$$

$$Z_a = (8 + 3) + j(6 + 4)$$

$$Z_a = 11 + j10$$

Now we convert the resultant phasor into polar form

$$|Z_a| = \sqrt{(121) + (100)}$$

$$|Z_a| = 14.86$$

$$\theta = \tan^{-1} \frac{10}{11} = 42.27^\circ$$

$$Z_a = 14.86 \angle 42.27^\circ$$

D 2.11: Subtract Z_2 phasor from Z_1

$$Z_1 = 10 \angle 36.8^\circ$$

$$Z_2 = 5 \angle 53.1^\circ$$

Solution: We add the two phasors into rectangular form

$$Z_1 = 8 + j6$$

$$Z_2 = 3 + j4$$

$$Z_s = Z_1 - Z_2$$

$$Z_s = (8 - 3) + j(6 - 4)$$

$$Z_s = 5 + j2$$

Now we convert the resultant phasor into polar form

$$|Z_s| = \sqrt{(25) + (4)}$$

$$|Z_s| = 5.38$$

$$\theta = \tan^{-1} \frac{2}{5} = 21.8^\circ$$

$$Z_s = 5.38\angle 21.8^\circ$$

D 2.12: Multiply Z_2 and Z_1

$$Z_1 = 10\angle 36.8^\circ$$

$$Z_2 = 5\angle 53.1^\circ$$

$$Z_M = 50\angle 53.1^\circ + 36.8^\circ$$

$$Z_M = 50\angle 89.9^\circ$$

D 2.13: Divide Z_1 by Z_2

$$Z_1 = 10\angle 36.8^\circ$$

$$Z_2 = 5\angle 53.1^\circ$$

$$Z_d = \frac{Z_1}{Z_2}$$

$$Z_d = \frac{10\angle 36.8^\circ}{5\angle 53.1^\circ}$$

$$Z_d = 2\angle 36.8^\circ - 53.1^\circ = 2\angle -16.8^\circ$$

2-8 Impedance Network for Mesh Analysis

Consider a circuit having two loops as shown in Figure 2.11. We shall discuss the phasor values of AC voltage and AC current in Chapter 3. We shall discuss the impedance of the AC circuit in Chapter 3 as well. We assume that the currents I_1 and I_2 flow in the clockwise direction in loop no 1 and loop no 2 respectively. The current in Z_1 is I_1 , while the current in Z_3 is I_2 . As Z_2 belongs to loop no 1 as well as loop no 2, therefore the current in this impedance will either be $(I_1 - I_2)$ or $(I_2 - I_1)$ depending upon the numerical values of these two currents. While making calculations for loop no 1 we will assume that the current through this common impedance Z_2 is $(I_1 - I_2)$ and while making calculations for loop no 2 we will assume that the current through this same common impedance Z_2 is $(I_2 - I_1)$.

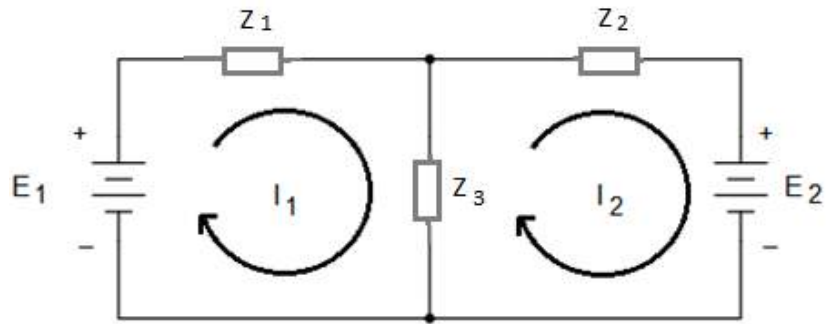

Figure 2.11: Circuit with two Loops

We apply KVL to loop no 1 which states that sum of the voltage rises in loop no 1 will be equal to sum of the voltage drops.

$$E_1 = I_1 Z_1 + (I_1 - I_2) Z_2 \quad (2.61)$$

Equation no 2.61 can be written as

$$(Z_1 + Z_2) I_1 + (-Z_2) I_2 = E_1 \quad (2.62)$$

$(Z_1 + Z_2)$ is sum of all the impedances of loop no 1 and this sum is represented by Z_{11} , which is known as the total self impedance of loop 1.

$$(Z_1 + Z_2) = Z_{11} \quad (2.63)$$

If we ignore minus sign with Z_2 in equation 2.62 for the time being then this impedance belongs to loop 1 as well as loop 2. This common impedance Z_2 is represented by Z_{12} , that is

$$(-Z_2) = Z_{12} \quad (2.64)$$

Putting these values in equation 2.62, we obtain the following equation

$$Z_{11} I_1 + Z_{12} I_2 = E_1 \quad (2.65)$$

Now let us apply KVL to loop 2

$$-E_2 = I_2 Z_3 + (I_2 - I_1) Z_2 \quad (2.66)$$

Equation no 2.66 can be written as

$$(Z_2 + Z_3) I_2 + (-Z_2) I_1 = -E_2 \quad (2.67)$$

$(Z_2 + Z_3)$ is sum of all the impedances of loop no 2 and this sum is represented by Z_{22} , that is known as the total self impedances of loop 2.

$$(Z_2 + Z_3) = Z_{22} \quad (2.68)$$

If we ignore minus sign with Z_2 in equation 2.67 for the time being then this impedance belongs to loop 1 as well as loop 2. This common impedance Z_2 is represented by Z_{21} , that is

$$(-Z_2) = Z_{21} \quad (2.69)$$

Putting these values in equation 2.67, we obtain the following equation

$$Z_{21}I_1 + Z_{22}I_2 = -E_2 \quad (2.70)$$

We ignore minus sign with E_2 for the time being and write equation 2.65 and equation 2.70 once again

$$Z_{11}I_1 + Z_{12}I_2 = E_1 \quad (A)$$

$$Z_{21}I_1 + Z_{22}I_2 = E_2 \quad (B)$$

Equations A & B are known as standard loop equations for a circuit having two loops. The number of standard loop equations depends on the number of loops in a circuit. As there are two loops in the mentioned circuit, this is why we have got two equations. Let us write the standard loop equations for a circuit having three loops.

$$Z_{11}I_1 + Z_{12}I_2 + Z_{13}I_3 = E_1 \quad (2.71)$$

$$Z_{21}I_1 + Z_{22}I_2 + Z_{23}I_3 = E_2 \quad (2.72)$$

$$Z_{31}I_1 + Z_{32}I_2 + Z_{33}I_3 = E_3 \quad (2.73)$$

Now, let us write the standard loop equations for a circuit having n loops.

$$Z_{11}I_1 + Z_{12}I_2 + Z_{13}I_3 + \cdots + Z_{1n}I_n = E_1 \quad (1)$$

$$Z_{21}I_1 + Z_{22}I_2 + Z_{23}I_3 + \cdots + Z_{2n}I_n = E_2 \quad (2)$$

$$Z_{31}I_1 + Z_{32}I_2 + Z_{33}I_3 + \cdots + Z_{3n}I_n = E_3 \quad (3)$$

.

$$Z_{n1}I_1 + Z_{n2}I_2 + Z_{n3}I_3 + \dots + Z_{nn}I_n = E_n \quad (n)$$

Equations A & B can be written in matrices format

$$\begin{bmatrix} Z_{11} & Z_{12} \\ Z_{21} & Z_{22} \end{bmatrix} \begin{bmatrix} I_1 \\ I_2 \end{bmatrix} = \begin{bmatrix} E_1 \\ E_2 \end{bmatrix} \quad (2.74)$$

In generic form we have

$$[Z] [I] = [V]$$

The size of $[Z]$ is 2×2 and it depends on the no of loops in the circuit. As there are two loops in the given circuit, this is why the size of the Z matrix is 2×2 . If there are three loops in a circuit, then the size of the Z matrix will be 3×3 and so on. Z_{11} and Z_{22} lie on the diagonal of the Z matrix and all these diagonal elements are positive. The off diagonal elements of the Z matrix will either be negative or positive depending upon the directions of the loop currents I_1 and I_2 . For example we consider the off diagonal element Z_{12} of the Z matrix. As the loop currents I_1 and I_2 are in opposite directions in Z_{12} , this is why there was a minus sign with this impedance. If the loop currents I_1 and I_2 are in the same directions in Z_{12} , then there will be a plus sign with this impedance. Similarly E_1 & E_2 will either be positive or negative. Keeping in view the direction of the loop current I_1 , the voltage E_1 is a voltage rise, this is why there is a plus sign with this voltage. Keeping in view the direction of the loop current I_2 , the voltage E_2 is a voltage drop, this is why there is a minus sign with this voltage.

We will find the currents I_1 and I_2 with the help of crammer's rule.

$$I_1 = \frac{\begin{vmatrix} E_1 & Z_{12} \\ E_2 & Z_{22} \end{vmatrix}}{\begin{vmatrix} Z_{11} & Z_{12} \\ Z_{21} & Z_{22} \end{vmatrix}}$$

$$I_2 = \frac{\begin{vmatrix} Z_{11} & E_1 \\ Z_{21} & E_2 \end{vmatrix}}{\begin{vmatrix} Z_{11} & Z_{12} \\ Z_{21} & Z_{22} \end{vmatrix}}$$

D 2.14: Using Standard Loop equations calculate all the three currents of the following circuit.

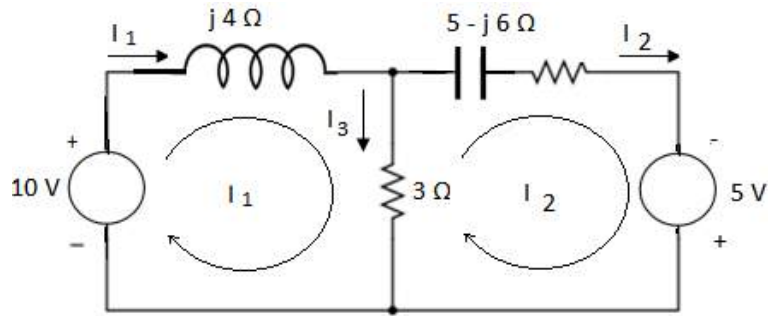

Figure 2.12: Circuit for D # 2.14

Solution:

Standard loop equations in matrices format are as under

$$\begin{bmatrix} Z_{11} & Z_{12} \\ Z_{21} & Z_{22} \end{bmatrix} \begin{bmatrix} I_1 \\ I_2 \end{bmatrix} = \begin{bmatrix} E_1 \\ E_2 \end{bmatrix}$$

Now

$$Z_{11} = 3 + j4 \Omega, \quad Z_{12} = Z_{21} = -3 \Omega, \quad Z_{22} = 8 - j6 \Omega, \quad E_1 = 10 V \text{ and } E_2 = 5V$$

So the standard loop equations in matrices format for this circuit are

$$\begin{bmatrix} 3 + j4 & -3 \\ -3 & 8 - j6 \end{bmatrix} \begin{bmatrix} I_1 \\ I_2 \end{bmatrix} = \begin{bmatrix} 10 \\ 5 \end{bmatrix}$$

The same equations can be written as

$$\begin{bmatrix} 5\angle 53.1^\circ & -3 \\ -3 & 10\angle -36.8^\circ \end{bmatrix} \begin{bmatrix} I_1 \\ I_2 \end{bmatrix} = \begin{bmatrix} 10 \\ 5 \end{bmatrix}$$

We will find the currents I_1 and I_2 with the help of crammer's rule.

$$I_1 = \frac{\begin{vmatrix} 10 & -3 \\ 5 & 10\angle -36.8^\circ \end{vmatrix}}{\begin{vmatrix} 5\angle 53.1^\circ & -3 \\ -3 & 10\angle -36.8^\circ \end{vmatrix}}$$

$$I_1 = \frac{112.4\angle -32.21^\circ}{41.44\angle 19.8^\circ}$$

$$I_1 = 2.71 \angle -12.41^\circ A$$

$$I_2 = \frac{\begin{vmatrix} 5\angle 53.1^\circ & 10 \\ -3 & 5 \end{vmatrix}}{\begin{vmatrix} 5\angle 53.1^\circ & -3 \\ -3 & 10\angle -36.8^\circ \end{vmatrix}}$$

$$I_2 = \frac{49.24\angle 23.96^\circ}{41.44\angle 19.8^\circ}$$

$$I_2 = 1.19\angle 4.16^\circ \text{ A}$$

$$I_3 = I_1 - I_2$$

$$I_3 = 2.71\angle -12.41^\circ - 1.19\angle 4.16^\circ$$

$$I_3 = 1.6\angle -25.31^\circ \text{ A}$$

D 2.15: Using Standard Loop equations calculate all the three currents of the following circuit

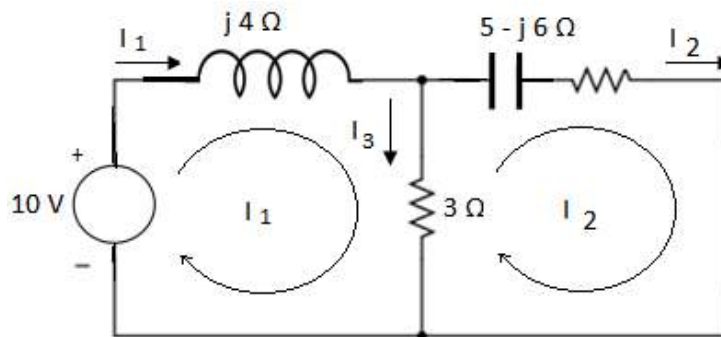

Figure 2.13: Circuit for D # 2.15

Solution:

Standard loop equations in matrices format are as under

$$\begin{bmatrix} Z_{11} & Z_{12} \\ Z_{21} & Z_{22} \end{bmatrix} \begin{bmatrix} I_1 \\ I_2 \end{bmatrix} = \begin{bmatrix} E_1 \\ E_2 \end{bmatrix}$$

Now

$$Z_{11} = 3 + j4 \Omega, Z_{12} = Z_{21} = -3 \Omega, Z_{22} = 8 - j6 \Omega, E_1 = 10 \text{ V and } E_2 = 0 \text{ V}$$

So the standard loop equations in matrices format for this circuit are

$$\begin{bmatrix} 3 + j4 & -3 \\ -3 & 8 - j6 \end{bmatrix} \begin{bmatrix} I_1 \\ I_2 \end{bmatrix} = \begin{bmatrix} 10 \\ 0 \end{bmatrix}$$

The same equations can be written as

$$\begin{bmatrix} 3 + j4 & -3 \\ -3 & 8 - j6 \end{bmatrix} \begin{bmatrix} I_1 \\ I_2 \end{bmatrix} = \begin{bmatrix} 10 \\ 0 \end{bmatrix}$$

$$\begin{bmatrix} 5\angle 53.1^\circ & -3 \\ -3 & 10\angle -36.8^\circ \end{bmatrix} \begin{bmatrix} I_1 \\ I_2 \end{bmatrix} = \begin{bmatrix} 10 \\ 0 \end{bmatrix}$$

We will find the currents I_1 and I_2 with the help of crammer's rules.

$$I_1 = \frac{\begin{vmatrix} 10 & -3 \\ 0 & 10\angle -36.8^\circ \end{vmatrix}}{\begin{vmatrix} 5\angle 53.1^\circ & -3 \\ -3 & 10\angle -36.8^\circ \end{vmatrix}}$$

$$I_1 = \frac{100\angle -36.81^\circ}{41.44\angle 19.8^\circ}$$

$$I_1 = 2.41 \angle 17^\circ \text{ A}$$

$$I_2 = \frac{\begin{vmatrix} 5\angle 53.1^\circ & 10 \\ -3 & 0 \end{vmatrix}}{\begin{vmatrix} 5\angle 53.1^\circ & -3 \\ -3 & 10\angle -36.8^\circ \end{vmatrix}}$$

$$I_2 = \frac{30}{41.44\angle 19.8^\circ}$$

$$I_2 = -0.72\angle 19.8^\circ \text{ A}$$

$$I_3 = I_1 - I_2$$

$$I_3 = 2.41 \angle 17^\circ - 0.72\angle -19.8^\circ$$

$$I_3 = 1.65 \angle 34.65^\circ \text{ A}$$

D 2.16: Using Standard Loop equations calculate the power supplied by the source and the powers consumed by the two resistors.

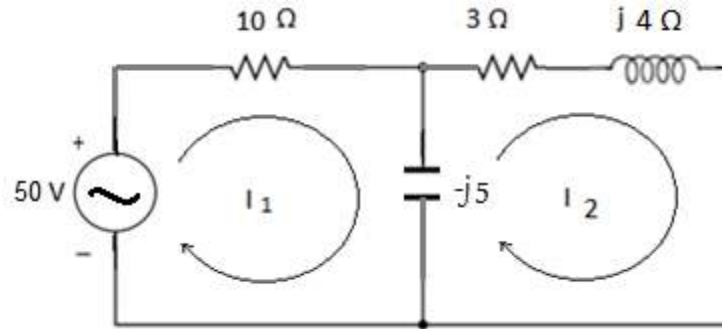

Figure 2.13b: Circuit for D # 2.16

Solution:

Standard loop equations in matrices format are as under

$$\begin{bmatrix} Z_{11} & Z_{12} \\ Z_{21} & Z_{22} \end{bmatrix} \begin{bmatrix} I_1 \\ I_2 \end{bmatrix} = \begin{bmatrix} E_1 \\ E_2 \end{bmatrix}$$

Now

$$Z_{11} = 10 - j5 \Omega, Z_{12} = Z_{21} = j5 \Omega, Z_{22} = 3 - j \Omega, E_1 = 50 V \text{ and } E_2 = 0V$$

So the standard loop equations in matrices format for this circuit are

$$\begin{bmatrix} 10 - j5 & j5 \\ j5 & 3 - j \end{bmatrix} \begin{bmatrix} I_1 \\ I_2 \end{bmatrix} = \begin{bmatrix} 50 \\ 0 \end{bmatrix}$$

We will find the currents I_1 and I_2 with the help of crammer's rules.

$$I_1 = \frac{\begin{vmatrix} 50 & j5 \\ 0 & 3 - j \end{vmatrix}}{\begin{vmatrix} 10 - j5 & j5 \\ j5 & 3 - j \end{vmatrix}}$$

$$I_1 = \frac{150 - j50}{50 - j25}$$

$$I_1 = \frac{6 - j2}{2 - j}$$

$$I_1 = \frac{6 - j2}{2 - j}$$

$$I_1 = \frac{6.32 \angle -18.4^\circ}{2.23 \angle -26.5^\circ} = 2.83 \angle 8.14^\circ \text{ A}$$

$$I_2 = \frac{\begin{vmatrix} 10 - j5 & 50 \\ j5 & 0 \end{vmatrix}}{\begin{vmatrix} 10 - j5 & j5 \\ j5 & 3 - j \end{vmatrix}}$$

$$I_2 = \frac{-j250}{50 - j25}$$

$$I_2 = \frac{250 \angle -90^\circ}{55.9 \angle -26.5^\circ} = 4.47 \angle -63.4^\circ \text{ A}$$

Power supplied by source

$$P_S = V_S I_1 \cos \theta_1$$

$$P_S = 50 \times 2.83 \times \cos 8.14 = 140 \text{ W}$$

Power consumed by 10 ohms resistor

$$P_1 = (2.83)^2 \times 10 = 80 \text{ W}$$

Power consumed by 3 ohms resistor

$$P_2 = (4.47)^2 \times 3 = 60 \text{ W}$$

2-9 Impedance Network for Nodal Analysis

Consider the circuit having two nodes as shown in Figure 2.14. The voltage at node 1 is V_1 and the voltage at node 2 is V_2 . Applying KCL to node 1

$$I_1 = I_2 + I_3 \quad (2.75)$$

Applying KCL to node 2

$$I_3 = I_4 + I_5 \quad (2.76)$$

There are three loops in this circuit as shown in Figure 2.15. We apply KVL to all these three loops to find out equations for all the five currents.

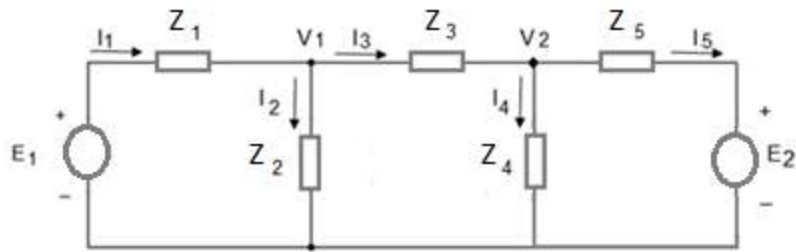

Figure 2.14: Impedance Circuit for Nodal Analysis

Applying KVL to loop 1

$$E_1 = I_1 Z_1 + V_1 \quad (2.77)$$

Therefore

$$I_1 = \frac{(E_1 - V_1)}{Z_1} \quad (2.78)$$

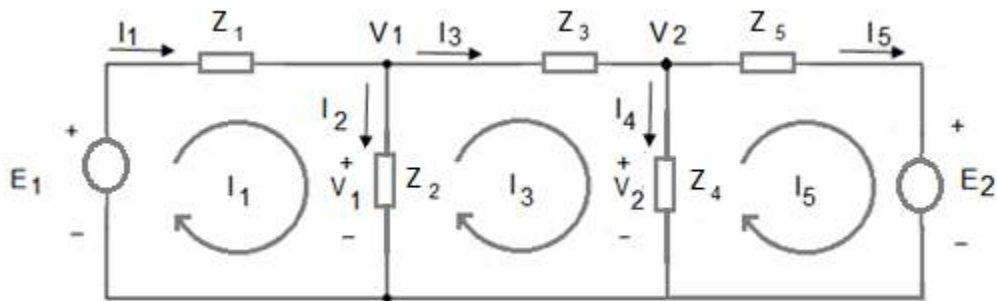

Figure 2.15: Circuit for Nodal Analysis with Loop Currents

The current I_2 can be calculated as

$$I_2 = \frac{V_1}{Z_2} \quad (2.79)$$

Applying KVL to loop 2, we obtain

$$V_1 = I_3 Z_3 + V_2 \quad (2.80)$$

Therefore

$$I_3 = \frac{(V_1 - V_2)}{Z_3} \quad (2.81)$$

The current I_4 can be calculated as

$$I_4 = \frac{V_2}{Z_4} \quad (2.82)$$

Applying KVL to loop 3, we get

$$V_2 = I_5 Z_5 + E_2 \quad (2.83)$$

Therefore

$$I_5 = \frac{(V_2 - E_2)}{Z_5} \quad (2.84)$$

Putting the values in equation 2.75

$$\frac{(E_1 - V_1)}{Z_1} = \frac{V_1}{Z_2} + \frac{(V_1 - V_2)}{Z_3} \quad (2.85)$$

Rearranging this equation, we obtain

$$\left(\frac{1}{Z_1} + \frac{1}{Z_2} + \frac{1}{Z_3} \right) V_1 + \left(-\frac{1}{Z_3} \right) V_2 = \frac{E_1}{Z_1} \quad (2.86)$$

Reciprocal of impedance is known as admittance that is represented by Y . We replace $\frac{E_1}{Z_1}$ by I_{g1} , Therefore equation 2.86 can be written as

$$(Y_1 + Y_2 + Y_3) V_1 + (-Y_3) V_2 = I_{g1} \quad (2.87)$$

Y_1, Y_2 and Y_3 have been connected to node 1 as shown in Figure 2.16, this is why the sum of all these three admittances is represented by Y_{11} . We ignore minus sign with Y_3 for the time being, as Y_3 has been connected to node 1 as well as node 2, therefore it is represented by Y_{12} .

$$(Y_{11}) V_1 + (Y_{12}) V_2 = I_{g1} \quad (2.88)$$

Similarly putting the values of I_3, I_4 and I_5 in equation in equation 2.76

$$\frac{(V_1 - V_2)}{Z_3} = \frac{V_2}{Z_4} + \frac{(E_2 - V_2)}{Z_5} \quad (2.89)$$

Rearranging this equation, we obtain

$$\left(-\frac{1}{Z_3} \right) V_1 + \left(\frac{1}{Z_3} + \frac{1}{Z_4} + \frac{1}{Z_5} \right) V_2 = \frac{E_2}{Z_5} \quad (2.90)$$

Replacing $\frac{E_2}{Z_5}$ by I_{g2} , Therefore equation 2.90 can be written as

$$(-Y_3) V_1 + (Y_3 + Y_4 + Y_5) V_2 = I_{g2} \quad (2.91)$$

Y_3 , Y_4 and Y_5 have been connected to node 2 as shown in Figure 2.16, this is why the sum of all these three impedances is represented by Y_{22} . We ignore minus sign with Y_3 for the time being, as Y_3 has been connected to node 1 as well as node 2, therefore it is represented by Y_{21} .

$$(Y_{21}) V_1 + (Y_{22}) V_2 = I_{g2} \quad (2.92)$$

We write equation 2.88 and equation 2.92 once again

$$(Y_{11}) V_1 + (Y_{12}) V_2 = I_{g1} \quad (2.93)$$

$$(Y_{21}) V_1 + (Y_{22}) V_2 = I_{g2} \quad (2.94)$$

These two equations are known as standard node equations for a circuit having two nodes. The number of standard node equations depends on the number of nodes in a circuit. As there are two nodes in the mentioned circuit, this is why we have got two equations.

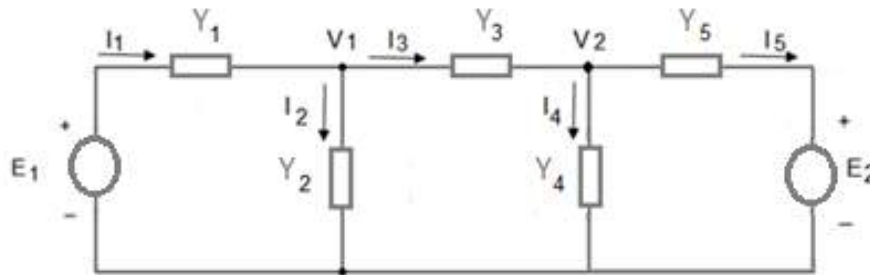

Figure 2.16: Equivalent Circuit with Admittance

Let us write the standard node equations for a circuit having three nodes.

$$(Y_{11}) V_1 + (Y_{12}) V_2 + (Y_{13}) V_3 = I_{g1} \quad (2.95)$$

$$(Y_{21}) V_1 + (Y_{22}) V_2 + (Y_{23}) V_3 = I_{g2} \quad (2.96)$$

$$(Y_{31}) V_1 + (Y_{32}) V_2 + (Y_{33}) V_3 = I_{g3} \quad (2.97)$$

Following are the standard node equations for a circuit having n nodes.

$$(Y_{11}) V_1 + (Y_{12}) V_2 + (Y_{13}) V_3 + \dots + (Y_{1n}) V_n = I_{g1} \quad (1)$$

$$(Y_{21}) V_1 + (Y_{22}) V_2 + (Y_{23}) V_3 + \dots + (Y_{2n}) V_n = I_{g2} \quad (2)$$

$$(Y_{31}) V_1 + (Y_{32}) V_2 + (Y_{33}) V_3 + \dots + (Y_{3n}) V_n = I_{g3} \quad (3)$$

.

.

.

$$(Y_{n1}) V_1 + (Y_{n2}) V_2 + (Y_{n3}) V_3 + \dots + (Y_{nn}) V_n = I_{gn} \quad (n)$$

Equations 2.93 & 2.94 can be written in matrices format

$$\begin{bmatrix} Y_{11} & Y_{12} \\ Y_{21} & Y_{22} \end{bmatrix} \begin{bmatrix} V_1 \\ V_2 \end{bmatrix} = \begin{bmatrix} I_{g1} \\ I_{g2} \end{bmatrix} \quad (2.98)$$

In generic form we have

$$[Y] [V] = [I]$$

Size of $[Y]$ is 2×2 and it depends on the number of nodes in the circuit. As there are two nodes in the given circuit, this is why size of the Y matrix is 2×2 . If there are three nodes in a circuit, then the size of the Y matrix will be 3×3 and so on. Y_{11} and Y_{22} lie on the diagonal of the Y matrix and all these diagonal elements are positive. The off diagonal elements of the Y matrix are negative. We will find the currents V_1 and V_2 with the help of crammer's rule.

$$V_1 = \frac{\begin{vmatrix} I_{g1} & Y_{12} \\ I_{g2} & Y_{22} \end{vmatrix}}{\begin{vmatrix} Y_{11} & Y_{12} \\ Y_{21} & Y_{22} \end{vmatrix}}$$

$$V_2 = \frac{\begin{vmatrix} Y_{11} & I_{g1} \\ Y_{21} & I_{g2} \end{vmatrix}}{\begin{vmatrix} Y_{11} & Y_{12} \\ Y_{21} & Y_{22} \end{vmatrix}}$$

D 2.17: Using Standard Node equations, calculate V_1 and V_2 .

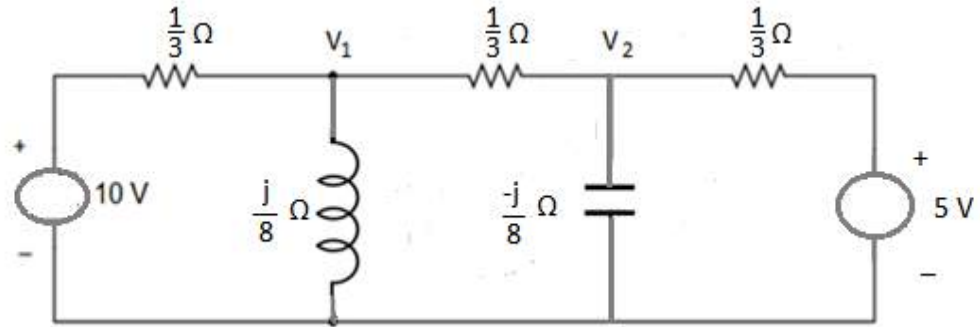

Figure 2.17: Circuit for D # 2.17

Solution:

Standard node equations in matrices format are as under

$$\begin{bmatrix} Y_{11} & Y_{12} \\ Y_{21} & Y_{22} \end{bmatrix} \begin{bmatrix} V_1 \\ V_2 \end{bmatrix} = \begin{bmatrix} I_{g1} \\ I_{g2} \end{bmatrix}$$

Now

$$Y_{11} = 6 - j8, \quad Y_{12} = Y_{21} = -3, \quad Y_{22} = 6 + j8, \quad I_{g1} = 30 \text{ A and } I_{g2} = 15 \text{ A.}$$

So the standard loop equations in matrices format for this circuit are

$$\begin{bmatrix} 6 - j8 & -3 \\ -3 & 6 + j8 \end{bmatrix} \begin{bmatrix} V_1 \\ V_2 \end{bmatrix} = \begin{bmatrix} 30 \\ 15 \end{bmatrix}$$

$$\begin{bmatrix} 10\angle -53.1^\circ & -3 \\ -3 & 10\angle 53.1^\circ \end{bmatrix} \begin{bmatrix} V_1 \\ V_2 \end{bmatrix} = \begin{bmatrix} 30 \\ 15 \end{bmatrix}$$

We find voltages V_1 and V_2 with the help of crammer's rule.

$$V_1 = \frac{\begin{vmatrix} 30 & -3 \\ 15 & 10\angle 53.1^\circ \end{vmatrix}}{\begin{vmatrix} 10\angle -53.1^\circ & -3 \\ -3 & 10\angle 53.1^\circ \end{vmatrix}}$$

$$V_1 = \frac{321.98\angle 46.84^\circ}{91}$$

$$V_1 = 3.615 \angle 46.84^\circ \text{ V}$$

$$V_2 = \frac{\begin{vmatrix} 10 \angle -53.1^\circ & 30 \\ -3 & 15 \end{vmatrix}}{91}$$

$$V_2 = \frac{216.33 \angle -33.7^\circ}{91}$$

$$V_2 = 2.38 \angle -33.7^\circ \text{ V}$$

D 2.18: Using Standard Node equations, calculate V_1 and V_2 .

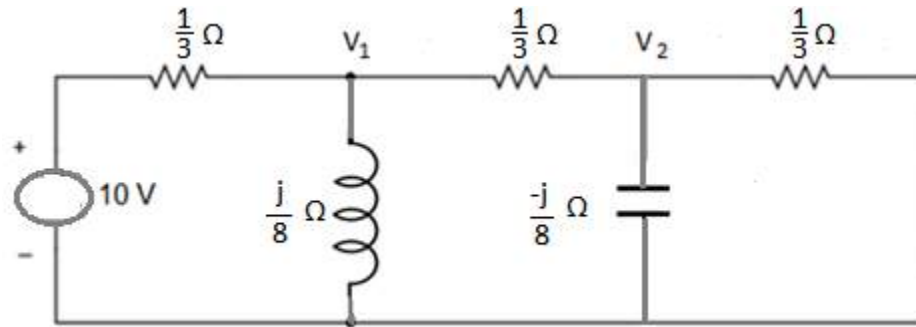

Figure 2.18: Circuit for D # 2.18

Solution:

Standard node equations in matrices format are as under

$$\begin{bmatrix} Y_{11} & Y_{12} \\ Y_{21} & Y_{22} \end{bmatrix} \begin{bmatrix} V_1 \\ V_2 \end{bmatrix} = \begin{bmatrix} I_{g1} \\ I_{g2} \end{bmatrix}$$

Now

$$Y_{11} = 6 - j8, \quad Y_{12} = Y_{21} = -3, \quad Y_{22} = 6 + j8, \quad I_{g1} = 30 \text{ A and } I_{g2} = 0 \text{ A.}$$

So the standard loop equations in matrices format for this circuit are

$$\begin{bmatrix} 6 - j8 & -3 \\ -3 & 6 + j8 \end{bmatrix} \begin{bmatrix} V_1 \\ V_2 \end{bmatrix} = \begin{bmatrix} 30 \\ 0 \end{bmatrix}$$

$$\begin{bmatrix} 10 \angle -53.1^\circ & -3 \\ -3 & 10 \angle 53.1^\circ \end{bmatrix} \begin{bmatrix} V_1 \\ V_2 \end{bmatrix} = \begin{bmatrix} 30 \\ 0 \end{bmatrix}$$

We find voltages V_1 and V_2 with the help of crammer's rules.

$$V_1 = \frac{\begin{vmatrix} 30 & -3 \\ 0 & 10\angle 53.1^\circ \end{vmatrix}}{\begin{vmatrix} 10\angle -53.1^\circ & -3 \\ -3 & 10\angle 53.1^\circ \end{vmatrix}}$$

$$V_1 = \frac{300\angle 53.1^\circ}{91}$$

$$V_1 = 3.296 \angle 53.1^\circ \text{ V}$$

$$V_2 = \frac{\begin{vmatrix} 10\angle -53.1^\circ & 30 \\ -3 & 0 \end{vmatrix}}{91}$$

$$V_2 = \frac{90}{91} = 0.98 \text{ V}$$

Exercise

Q 2.1: Using Standard Loop equations, find V_1 and current in R_S .

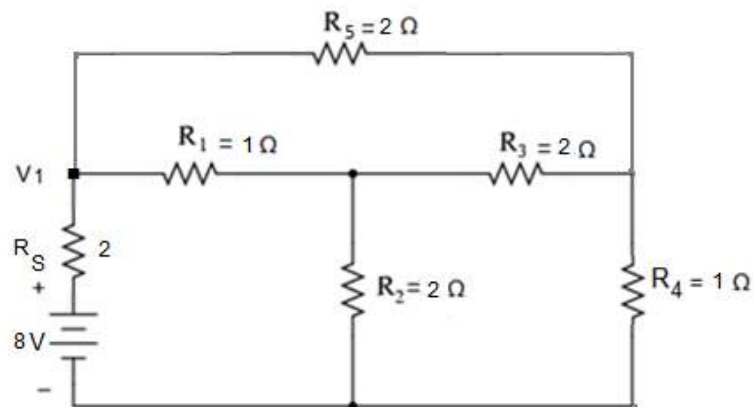

Figure 2.19: Circuit for Q # 2.1

Answer: $V_1 = 3.33 \text{ V}$ and $I_S = 2.33 \text{ A}$

Q 2.2: Consider the circuit in Figure 2.19, find V_1 and current in R_S with the help of Standard Node equations to verify the answers.

Q 2.3: Consider the circuit in Figure 2.20, find current in R_1 , R_2 and R_3 with the help of Standard Node equations.

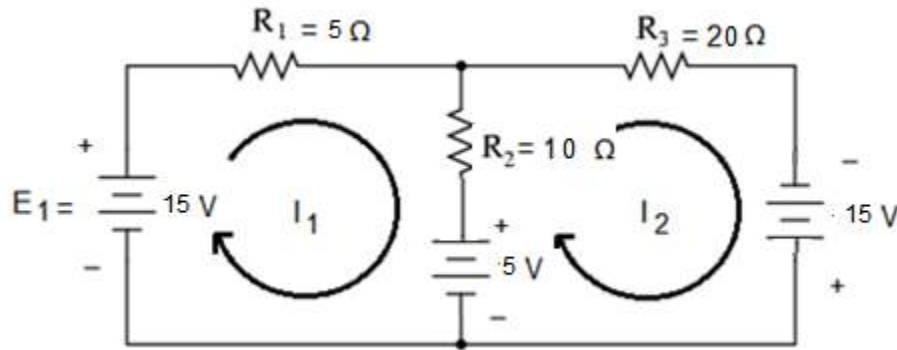

Figure 2.20: Circuit for Q # 2.3

Answer: $I_1 = 1.42 A$, $I_2 = 1.14 A$ and $I_3 = 0.288A$

Q 2.4: Consider the circuit in Figure 2.20, find current in R_1 , R_2 and R_3 with the help of Standard Loop equations to verify the answers.

Chapter 3

AC Fundamentals and Series Circuits

3-1 Generation of AC voltage

Consider a simple generator as shown in Figure 3.1. Magnetic flux flows from the isolated North Pole towards the isolated South Pole. A single conductor is placed on the rotating part of the generator and this rotating part of the generator is known as rotor. Two ends of the conductor are represented by a and a' . The rotor will be rotated in the counter clockwise direction. The portion of a generator that is stationary is known as stator.

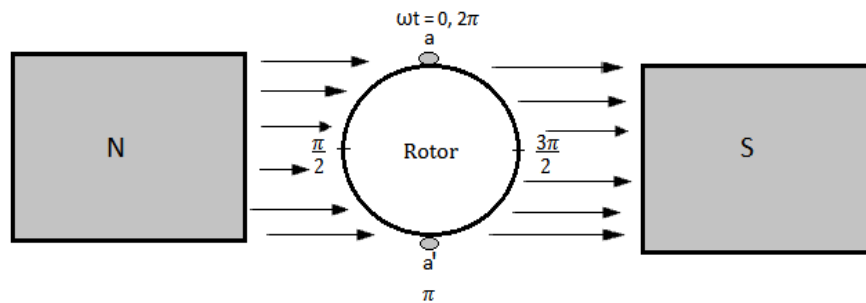

Figure 3.1: A simple Generator

Basically rotor is in the form of a cylinder. Side view of the rotor is shown in Figure 3.2.

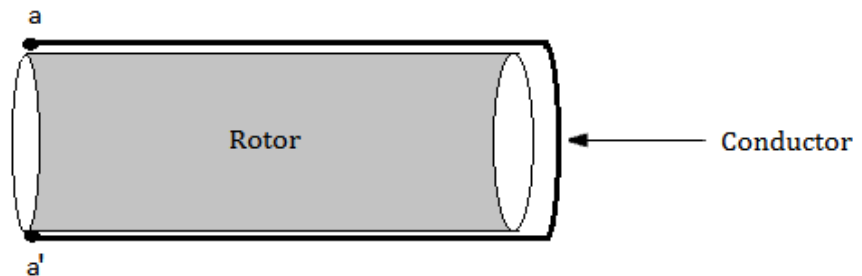

Figure 3.2: Side View of the Rotor

Faraday's law states that when a conductor rotates in a constant magnetic field, voltage is induced across the conductor. In other words, when a conductor cuts magnetic flux, voltage is induced in the conductor. Let us explain how a conductor cuts magnetic flux. When direction of motion of the conductor is parallel to the magnetic flux, it does not cut any flux and no voltage will be induced across the conductor in accordance with

Faraday's law. When direction of motion of the conductor makes an angle less than 90° with respect to the magnetic flux, it cuts some flux and some voltage will be induced across the conductor. When direction of motion of the conductor is perpendicular to the magnetic flux, it cuts maximum flux and maximum voltage will be induced across the conductor.

Let end a of the conductor starts rotation in the counter clockwise direction from its initial position i.e. $\omega t = 0$. The direction of motion of the conductor is parallel to the magnetic flux; it does not cut any flux so no voltage is induced across the conductor in accordance with Faraday's law. This scenario is shown in Figure 3.3.

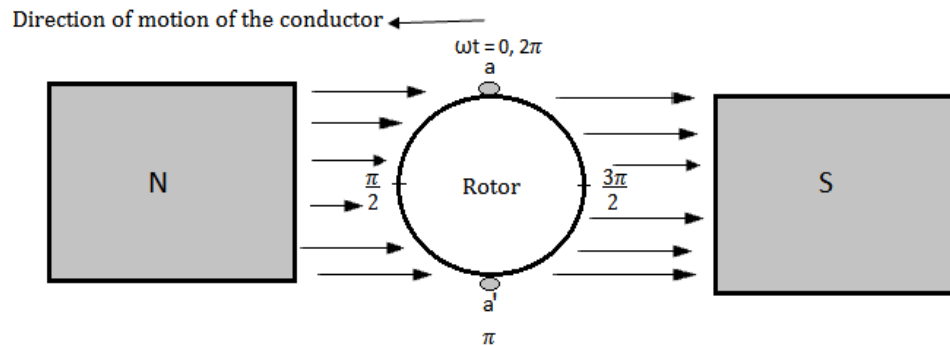

Figure 3.3: No Voltage Induction

Let end a of the conductor reaches new position i.e. $\omega t = \frac{\pi}{2}$. The direction of motion of the conductor at this position is perpendicular to the magnetic flux; it cuts maximum flux so maximum voltage is induced across the conductor in accordance with Faraday's law. This scenario is shown in Figure 3.4. We will show it with the help of Fleming's right hand rule that terminal a of the voltage source under this scenario will be positive.

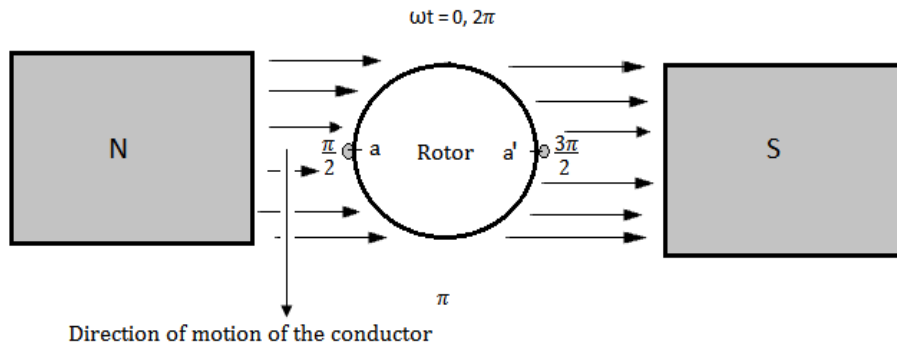

Figure 3.4: Maximum Voltage Induction

Let end a of the conductor reaches the new position i.e. $\omega t = \pi$. The direction of motion of the conductor is parallel to the magnetic flux; it does not cut any flux so no voltage is induced across the conductor in accordance with Faraday's law. This scenario is shown in Figure 3.5.

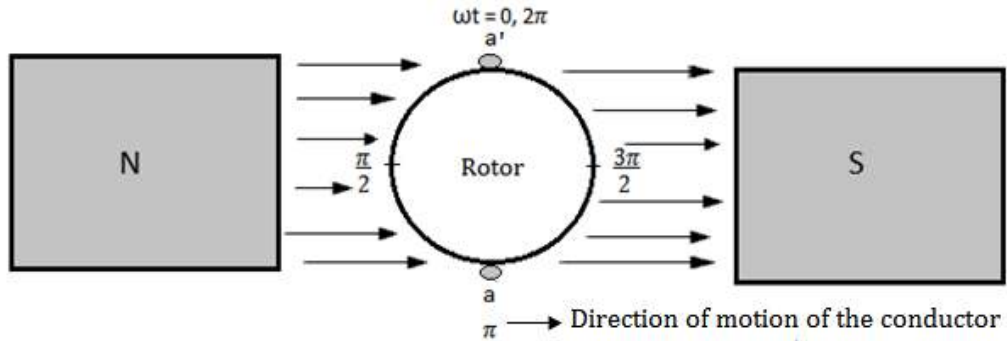

Figure 3.5: No Voltage Induction

Let end a of the conductor reaches new position i.e. $\omega t = \frac{3\pi}{2}$. Once again the direction of motion of the conductor at this position is perpendicular to the magnetic flux; it cuts maximum flux so maximum voltage is induced across the conductor. The conductor moves in the upward direction over here. This scenario is shown in Figure 3.6. We will show it with the help of Fleming's right hand rule that terminal a of the voltage source under this scenario will be negative.

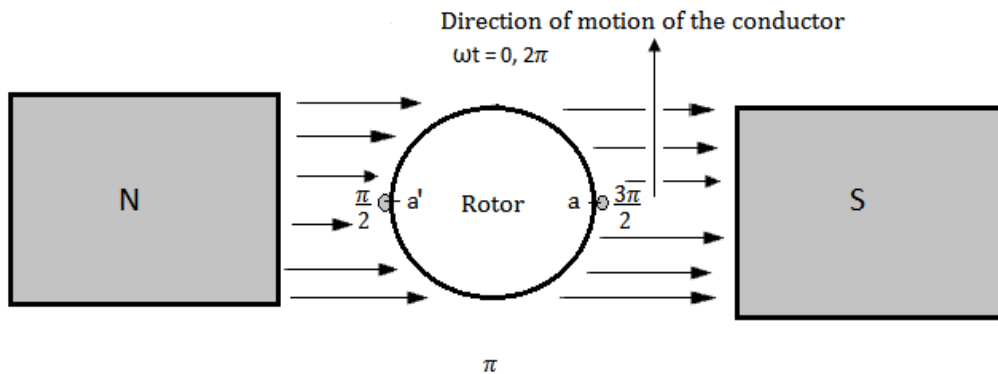

Figure 3.6: Maximum Voltage Induction

Let end a of the conductor moves back to its initial position i.e. $\omega t = 2\pi$, The direction of motion of the conductor is parallel to the magnetic flux; it does not cut any flux so no voltage is induced across the conductor. This scenario is shown in Figure 3.7.

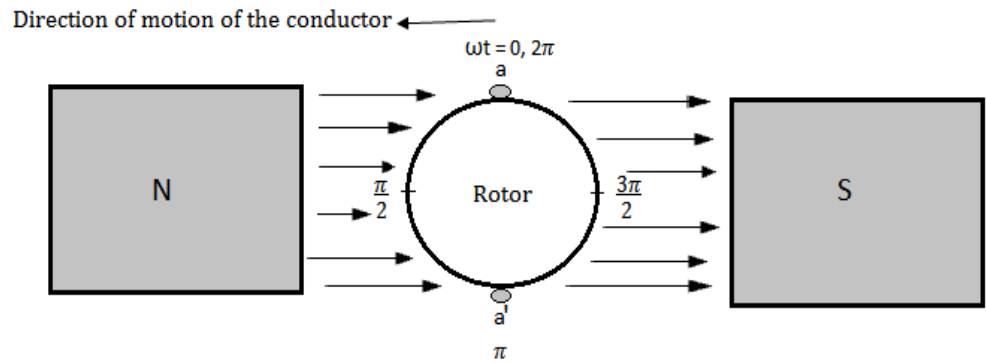

Figure 3.7: No Voltage Induction

If we plot voltage v_s with respect to ωt , we get a sinusoidal waveform for this AC voltage as shown in Figure 3.8.

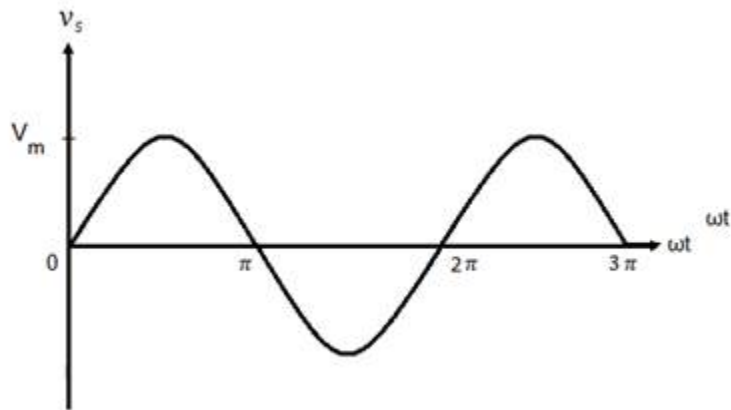

Figure 3.8: Waveform for AC Voltage

This AC voltage varies with time and it justifies the following equation that is known as the instantaneous equation of the AC voltage.

$$v_s = V_m \sin \omega t \quad (3.1)$$

V_m in the above equation is known as the peak or maximum value of AC voltage and ω is known as the angular frequency. The time taken by one cycle is known as time period that is denoted by T . The number of cycles per second is called frequency that is denoted by f .

In T seconds the AC voltage attains = 1 cycle.

In 1 second the AC voltage attains $= \frac{1}{T}$ cycles.

That is

$$f = \frac{1}{T} \quad (3.2)$$

The cycle of the waveform in Figure 3.8 repeats itself at

$$\omega t = 2\pi, 4\pi, 6\pi, \dots \dots \dots$$

So

$$\omega T = 2\pi$$

and

$$\omega = \frac{2\pi}{T}$$

That is

$$\omega = 2\pi f \quad (3.3)$$

As discussed earlier the single conductor of this simple generator will act as a voltage source. According to Fleming's right hand rule the thumb indicates direction of the motion of the conductor, index finger indicates direction of the flow of magnetic flux and the middle finger indicates direction of the induced current in the conductor. Fleming's Right Hand Rule as shown in Figure 3.9.

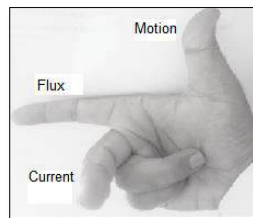

Figure 3.9: Fleming's Right Hand Rule

If we apply this rule on Figure 3.4, then end a of the conductor will be positive as shown in Figure 3.10, because the current flows from the negative terminal of a voltage source to the positive terminal.

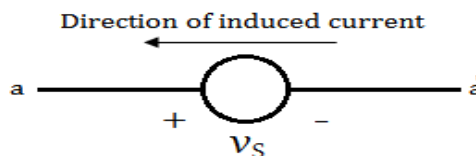

Figure 3.10: Direction of Induced Current

If we apply this rule on Figure 3.6, then end a of the conductor will be negative as shown in Figure 3.11, because the current flows from the negative terminal of a voltage source to the positive terminal.

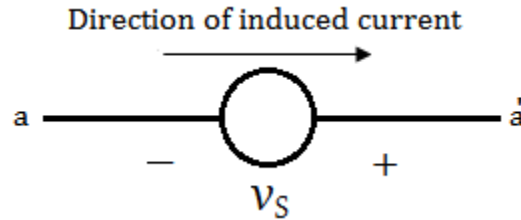

Figure 3.11: Direction of Induced Current

3-2 RMS Value or Effective Value of AC voltage

The RMS or effective value of AC voltage is constant. If average value of the AC power delivered by an AC voltage source to a resistor is equal to the power supplied by a DC voltage source to the same resistor, then the effective or RMS value of the AC voltage is equal to the DC voltage. Consider the circuit as shown in Figure 3.12. A DC voltage is applied across a resistor R and if we apply KVL to this loop, then we get the following equation.

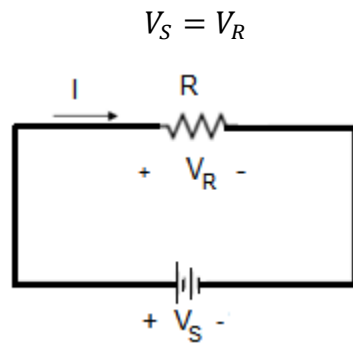

Figure 3.12: DC Voltage across a Resistor

DC power taken by the resistor is

$$P_R = \frac{V_S^2}{R} \quad (3.4)$$

Now let us apply an AC voltage across the same resistor R as shown in Figure 3.13. KVL states that voltage across the source will be equal to the voltage across the resistor.

$$v_S = v_R$$

The instantaneous equation of the AC voltage is

$$v_S = V_m \sin \omega t \quad (3.5)$$

The instantaneous equation of the AC power taken by the resistor can be calculated as

$$p_R = \frac{v_S^2}{R} \quad (3.6)$$

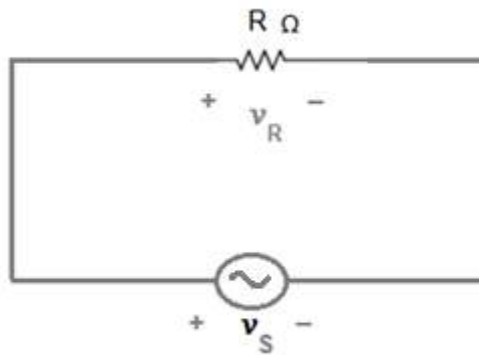

Figure 3.13: AC Voltage across the Resistor

$$p_R = \frac{V_m^2}{R} \sin^2 \omega t \quad (3.7)$$

The average value of this AC power is calculated as

$$P_R = \frac{1}{2\pi} \int_0^{2\pi} p_R d\omega t \quad (3.8)$$

Putting the value of p_R in equation 3.8, we get

$$P_R = \frac{1}{2\pi} \int_0^{2\pi} \frac{v_S^2}{R} d\omega t \quad (3.9)$$

If the power in equation 3.9 is equal to the DC power, then the effective value of the AC voltage will be equal to the DC voltage V_S . That is

$$\frac{V_S^2}{R} = \frac{1}{2\pi} \int_0^{2\pi} \frac{v_S^2}{R} d\omega t \quad (3.10)$$

or

$$V_S^2 = \frac{1}{2\pi} \int_0^{2\pi} v_S^2 d\omega t$$

Therefore the RMS or effective value of the AC voltage can be calculated with the help of the following equation.

$$V_{S_{rms}} = \sqrt{\frac{1}{2\pi} \int_0^{2\pi} v_S^2 d\omega t} \quad (3.11)$$

This equation can be written as

$$V_{S_{rms}} = \sqrt{\frac{1}{T} \int_0^T v_S^2 dt} \quad (3.12)$$

Putting the value of v_S in equation 3.11, we obtain the following equation.

$$V_{S_{rms}} = \sqrt{\frac{V_m^2}{2\pi} \int_0^{2\pi} \sin^2 \omega t d\omega t} \quad (3.13)$$

Let us replace $\sin^2 \omega t$ by

$$\frac{1 - \cos 2\omega t}{2}$$

$$V_{S_{rms}} = \sqrt{\frac{V_m^2}{4\pi} \int_0^{2\pi} (1 - \cos 2\omega t) d\omega t} \quad (3.14)$$

$$V_{S_{rms}} = \sqrt{\frac{V_m^2}{4\pi} \left[\int_0^{2\pi} d\omega t - \int_0^{2\pi} \cos 2\omega t d\omega t \right]} \quad (3.15)$$

As

$$\int_0^{2\pi} \cos 2\omega t \, d\omega t = 0$$

Therefore

$$V_{S_{rms}} = \sqrt{\frac{V_m^2}{4\pi} \left[\int_0^{2\pi} d\omega t \right]} \quad (3.16)$$

So

$$V_{S_{rms}} = \frac{V_m}{\sqrt{2}} \quad (3.17)$$

D 3.1: RMS value of the AC voltage in Pakistan is $220V$ and its frequency is 50 Hz , write the instantaneous equation of this AC voltage.

Solution:

$$V_{S_{rms}} = 220 \text{ V}$$

$$f = 50 \text{ Hz}$$

$$\omega = 2\pi f = 100\pi \text{ ras/sec}$$

As

$$V_{S_{rms}} = \frac{V_m}{\sqrt{2}}$$

Therefore

$$V_m = \sqrt{2} V_{S_{rms}}$$

$$V_m = 220\sqrt{2} \text{ V}$$

As

$$v_s = V_m \sin \omega t$$

Therefore

$$v_s = 220\sqrt{2} \sin 100\pi t \quad \text{volts}$$

3-3 RMS Value of AC current

The RMS or effective value of AC current is constant. If average value of the AC power delivered by an AC voltage source to a resistor is equal to the power supplied by a DC voltage source, then the effective or RMS value of the AC current is equal to the DC current. Consider the circuit as shown in Figure 3.14. A DC voltage is applied across a resistor R and the DC power taken by the resistor in terms of current is given by

$$P_R = I^2 R \quad (3.18)$$

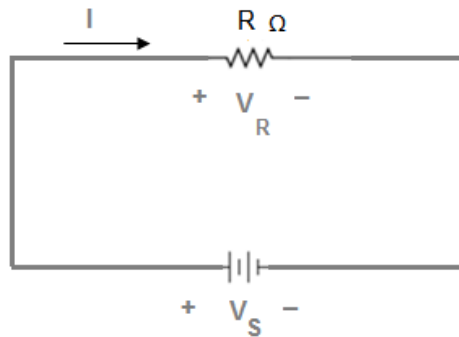

Figure 3.14: DC Current in the Resistor

Now let us apply an AC voltage across the same resistor R as shown in Figure 3.15. KVL states that the voltage across the source will be equal to the voltage across the resistor.

$$v_S = v_R$$

The instantaneous equation of the AC voltage is

$$v_S = V_m \sin \omega t \quad (3.19)$$

The instantaneous equation of the AC current in the resistor can be calculated as

$$i = \frac{v_S}{R} \quad (3.20)$$

$$i = \frac{V_m}{R} \sin \omega t \quad (3.21)$$

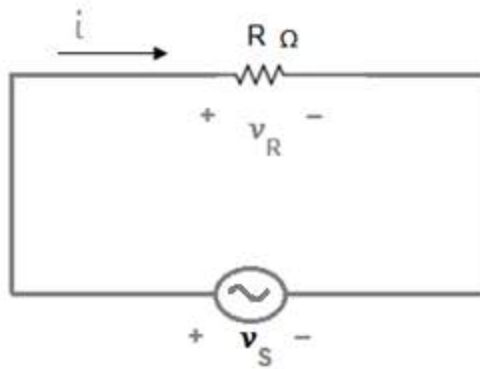

Figure 3.15: AC Current in the Resistor

As the maximum value of the current is

$$I_m = \frac{V_m}{R}$$

Therefore

$$i = I_m \sin \omega t \quad (3.22)$$

The instantaneous equation of the AC power taken by the resistor can be calculated as

$$p_R = i^2 R \quad (3.23)$$

$$p_R = I_m^2 R \sin^2 \omega t \quad (3.24)$$

The average value of this AC power is calculated as

$$P_R = \frac{1}{2\pi} \int_0^{2\pi} p_R d\omega t \quad (3.25)$$

Putting the value of p_R in equation 3.25, we get

$$P_R = \frac{1}{2\pi} \int_0^{2\pi} i^2 R d\omega t \quad (3.26)$$

If the power in equation 3.26 is equal to the DC power, then the effective value of the AC current will be equal to the DC current I . That is

$$I^2 R = \frac{1}{2\pi} \int_0^{2\pi} i^2 R d\omega t \quad (3.27)$$

or

$$I^2 = \frac{1}{2\pi} \int_0^{2\pi} i^2 d\omega t$$

Therefore the RMS or effective value of the AC current can be calculated with the help of the following equation.

$$I_{rms} = \sqrt{\frac{1}{2\pi} \int_0^{2\pi} i^2 d\omega t} \quad (3.28)$$

This equation can be written as

$$I_{rms} = \sqrt{\frac{1}{T} \int_0^T i^2 dt} \quad (3.29)$$

Putting the value of i in equation 3.28, we obtain the following equation.

$$I_{rms} = \sqrt{\frac{I_m^2}{2\pi} \int_0^{2\pi} \sin^2 \omega t d\omega t} \quad (3.30)$$

Let us replace $\sin^2 \omega t$ by

$$\frac{1 - \cos 2\omega t}{2}$$

$$I_{rms} = \sqrt{\frac{I_m^2}{4\pi} \int_0^{2\pi} (1 - \cos 2\omega t) d\omega t} \quad (3.31)$$

$$I_{rms} = \sqrt{\frac{I_m^2}{4\pi} \left[\int_0^{2\pi} d\omega t - \int_0^{2\pi} \cos 2\omega t d\omega t \right]} \quad (3.32)$$

As

$$\int_0^{2\pi} \cos 2\omega t d\omega t = 0$$

Therefore

$$I_{rms} = \sqrt{\frac{I_m^2}{4\pi} \left[\int_0^{2\pi} d\omega t \right]} \quad (3.33)$$

So

$$I_{rms} = \frac{I_m}{\sqrt{2}} \quad (3.34)$$

D 3.2: The maximum value of an AC current is 14.14 A as shown in the following figure. Calculate its average and RMS value.

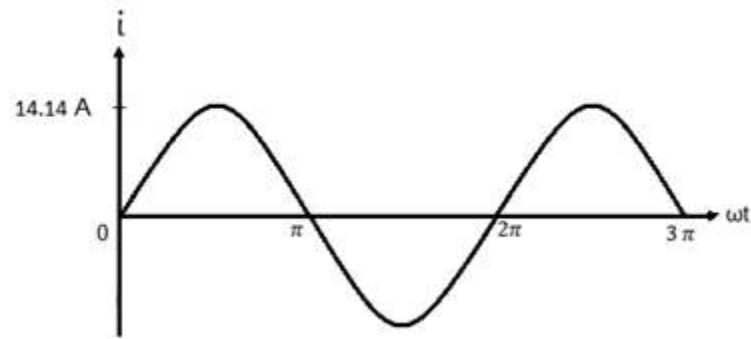

Figure 3.16: Circuit for D # 3.2

Solution:

$$I_m = 14.14 \text{ A}$$

As

$$I_{rms} = \frac{I_m}{\sqrt{2}}$$

Therefore

$$I_{rms} = \frac{14.14}{\sqrt{2}}$$

$$I_{rms} = 10 \text{ A}$$

Instantaneous expression for this AC current is

$$i = I_m \sin \omega t$$

The average value of this AC current is

$$I_{ave} = \frac{1}{\pi} \int_0^{\pi} i \, d\omega t$$

$$I_{ave} = \frac{1}{\pi} \int_0^{\pi} I_m \sin \omega t \, d\omega t$$

$$I_{ave} = \frac{I_m}{\pi} [-\cos \omega t]_0^\pi$$

$$I_{ave} = \frac{2 I_m}{\pi}$$

$$I_{ave} = \frac{2 \times 14.14}{\pi}$$

$$I_{ave} = 9 A$$

D 3.3: The maximum value of the time varying current in the following waveform is 2 A.

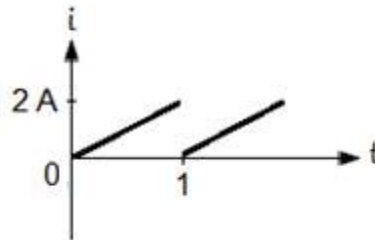

Figure 3.17: Waveform for D # 3.3

Calculate its average and RMS value.

Solution:

The pattern repeats itself after 1 second; therefore the time period of the waveform is 1 second.

$$T = 1 \text{ sec}$$

Equation of the current in 1st cycle is given by

$$i = 2t ; \quad 0 \leq t \leq 1$$

Average value of the current is calculated as

$$I_{ave} = \frac{1}{T} \int_0^T i dt$$

Putting the values in the above equation

$$I_{ave} = \frac{1}{1} \int_0^1 2t \, dt$$

$$I_{ave} = 2 \left[\frac{t^2}{2} \right]_0^1$$

$$I_{ave} = 2 \left[\frac{1}{2} \right]$$

$$I_{ave} = 1 \, A$$

RMS value of the current is calculated as

$$I_{rms} = \sqrt{\frac{1}{T} \int_0^T i^2 \, dt}$$

$$I_{rms} = \sqrt{\frac{4}{1} \int_0^1 t^2 \, dt}$$

$$I_{rms} = \sqrt{4 \left[\frac{t^3}{3} \right]_0^1}$$

$$I_{rms} = \sqrt{\frac{4}{3}}$$

$$I_{rms} = 1.154 \, A$$

D 3.4: The maximum value of the time varying current in the following waveform is 2 A .Calculate its average and RMS value.

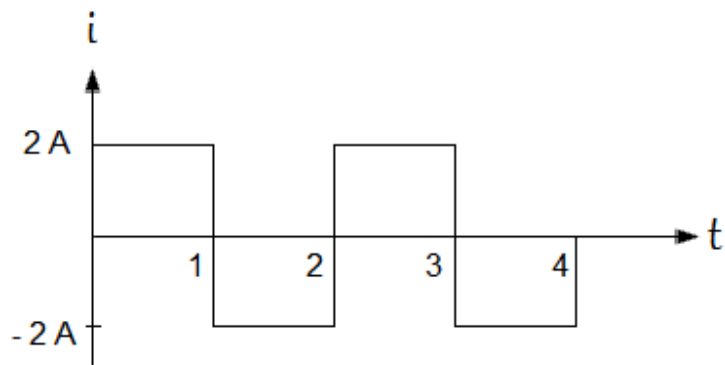

Figure 3.18: Waveform for D # 3.4

Solution:

The pattern repeats itself after 2 seconds; therefore the time period of the waveform is 2 seconds.

$$T = 2 \text{ sec}$$

We consider the equation of the current in 1st cycle

$$i = 2 A ; \quad 0 \leq t \leq 1$$

And

$$i = -2 A ; \quad 1 \leq t \leq 2$$

The average value of the current is calculated as

$$I_{ave} = \frac{1}{T} \int_0^T i dt$$

Putting the values in the above equation

$$I_{ave} = \frac{1}{2} \left[\int_0^1 2 dt + \int_1^2 -2 dt \right]$$

$$I_{ave} = \frac{2}{2} [(t)_0^1 - (t)_1^2]$$

$$I_{ave} = 0 A$$

The RMS value of the current is calculated as

$$I_{rms} = \sqrt{\frac{1}{T} \int_0^T i^2 dt}$$

$$I_{rms} = \sqrt{\frac{4}{2} \left[\int_0^1 dt + \int_1^2 dt \right]}$$

$$I_{rms} = \sqrt{2[1 + 1]}$$

$$I_{rms} = \sqrt{4}$$

$$I_{rms} = 2 A$$

D 3.5: The maximum value of the time varying current in the following waveform is 10 A. Calculate its average and RMS value.

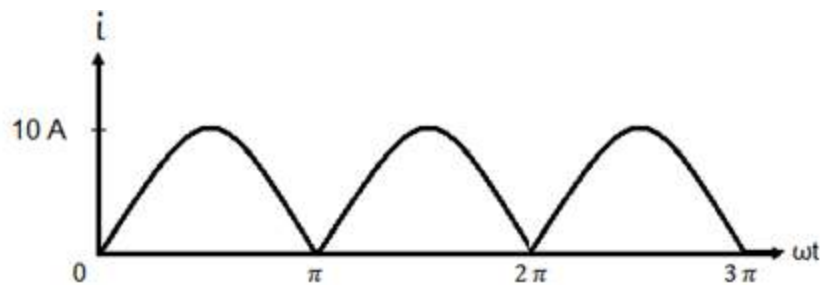

Figure 3.19: Waveform for D # 3.5

Solution:

The pattern repeats itself after π radians; therefore one cycle is from 0 to π , so we consider the equation of the current in 1st cycle

$$i = 10 \sin \omega t ; \quad 0 \leq \omega t \leq \pi$$

The average value of the current is calculated as

$$I_{ave} = \frac{1}{\pi} \int_0^{\pi} 10 \sin \omega t \, d\omega t$$

$$I_{ave} = \frac{10}{\pi} [-\cos \omega t]_0^{\pi}$$

$$I_{ave} = \frac{2 \times I_m}{\pi}$$

$$I_{ave} = \frac{20}{\pi}$$

$$I_{ave} = 6.366 \text{ A}$$

The RMS value of the current is calculated as

$$I_{rms} = \sqrt{\frac{1}{\pi} \int_0^{\pi} i^2 \, dt}$$

$$I_{rms} = \sqrt{\frac{100}{\pi} \int_0^{\pi} \sin^2 \omega t \, d\omega t}$$

$$I_{rms} = \sqrt{\frac{100}{2\pi} \left[\int_0^{\pi} (1 - \cos 2\omega t) \, d\omega t \right]}$$

$$I_{rms} = \sqrt{\frac{100}{2\pi} \left[\left\{ \int_0^{\pi} d\omega t - \int_0^{\pi} \cos 2\omega t \, d\omega t \right\} \right]}$$

$$I_{rms} = \sqrt{\frac{100}{2\pi} \left[\left\{ \int_0^{\pi} d\omega t \right\} \right]}$$

$$I_{rms} = \frac{10}{\sqrt{2}}$$

$$I_{rms} = 7.07 \text{ A}$$

D 3.6: The maximum value of the time varying current in the following waveform is 10 A. Calculate its average and RMS value.

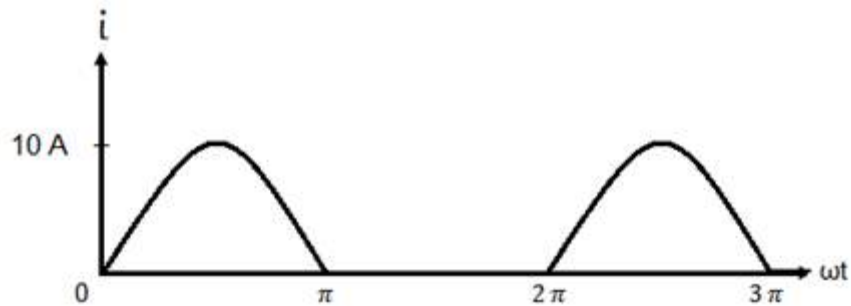

Figure 3.20: Waveform for D # 3.6

Solution:

The pattern repeats itself after 2π radians; therefore one cycle is from 0 to 2π , so we consider the equation of the current in 1st cycle

$$i = 10 \sin \omega t ; \quad 0 \leq \omega t \leq \pi$$

$$i = 0 ; \quad \pi \leq \omega t \leq 2\pi$$

Average value of the current is calculated as

$$I_{ave} = \frac{1}{2\pi} \left[\int_0^{\pi} 10 \sin \omega t \, d\omega t + \int_{\pi}^{2\pi} 0 \times d\omega t \right]$$

$$I_{ave} = \frac{10}{2\pi} [-\cos \omega t]_0^{\pi}$$

$$I_{ave} = \frac{2 \times I_m}{2\pi}$$

$$I_{ave} = \frac{10}{\pi}$$

$$I_{ave} = 3.18 \text{ A}$$

RMS value of the current is calculated as

$$I_{rms} = \sqrt{\frac{1}{2\pi} \int_0^{2\pi} i^2 dt}$$

$$I_{rms} = \sqrt{\frac{1}{2\pi} \left[\int_0^{\pi} 100 \sin^2 \omega t d\omega t + \int_{\pi}^{2\pi} 0^2 \times d\omega t \right]}$$

$$I_{rms} = \sqrt{\frac{100}{4\pi} \left[\int_0^{\pi} (1 - \cos 2\omega t) d\omega t \right]}$$

$$I_{rms} = \sqrt{\frac{100}{4\pi} \left[\left\{ \int_0^{\pi} d\omega t - \int_0^{\pi} \cos 2\omega t d\omega t \right\} \right]}$$

$$I_{rms} = \sqrt{\frac{100}{4\pi} \left[\left\{ \int_0^{\pi} d\omega t \right\} \right]}$$

$$I_{rms} = \sqrt{25}$$

$$I_{rms} = 5 \text{ A}$$

3-4 AC Voltage across a Resistor

Consider a simple circuit comprising a resistor and an AC voltage source as shown in Figure 3.21. Voltage across the source is equal to the voltage across the resistor in

accordance with KVL.

$$v_S = v_R$$

Instantaneous equation of the AC voltage is

$$v_S = V_m \sin \omega t \quad (3.35)$$

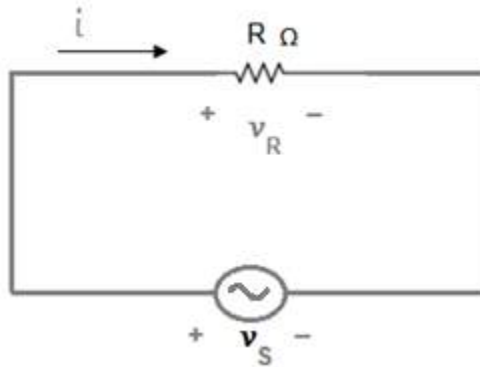

Figure 3.21: AC voltage across a Resistor

Waveform for this ac voltage is shown in Figure 3.22.

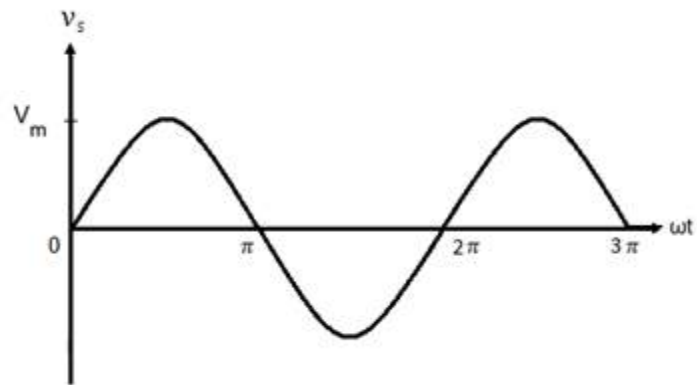

Figure 3.22: Waveform for AC voltage

Instantaneous equation of the AC current in the resistor can be calculated as

$$i = \frac{v_S}{R} \quad (3.36)$$

$$i = \frac{V_m}{R} \sin \omega t \quad (3.37)$$

As maximum value of the current is given by

$$I_m = \frac{V_m}{R}$$

Ratio of the maximum value of voltage to the maximum value of current defines resistance of the resistor

$$R = \frac{V_m}{I_m}$$

Therefore

$$i = I_m \sin \omega t \quad (3.38)$$

Waveform for this ac current is shown in Figure 3.23. The comparison of the voltage waveform with the waveform for the current reveals that current in a resistor is always in phase with the voltage across the resistor. In other words there is no phase difference between voltage across a resistor and current.

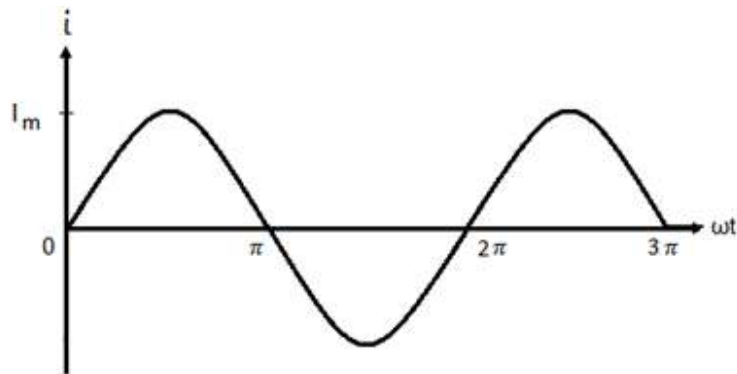

Figure 3.23: Waveform for AC Current

Instantaneous equation of the AC power taken by a resistor can be calculated with the help of equation 3.39.

$$p_R = i^2 R \quad (3.39)$$

$$p_R = I_m^2 R \sin^2 \omega t \quad (3.40)$$

Waveform for this ac power is shown in Figure 3.24.

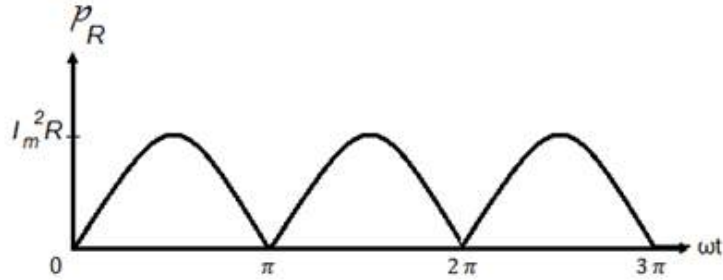

Figure 3.24: Waveform for AC Power

Average value of this AC power is calculated as

$$P_R = \frac{1}{\pi} \int_0^{\pi} p_R d\omega t \quad (3.41)$$

Putting the value of p_R in equation 3.41, we get

$$P_R = \frac{1}{\pi} \int_0^{\pi} I_m^2 R \sin^2 \omega t d\omega t \quad (3.42)$$

$$P_R = \frac{I_m^2 R}{\pi} \int_0^{\pi} \sin^2 \omega t d\omega t \quad (3.43)$$

Let us replace $\sin^2 \omega t$ by

$$\frac{1 - \cos 2\omega t}{2}$$

$$P_R = \frac{I_m^2 R}{2\pi} \int_0^{\pi} (1 - \cos 2\omega t) d\omega t \quad (3.44)$$

$$P_R = \frac{I_m^2 R}{2\pi} \left[\int_0^{\pi} d\omega t - \int_0^{\pi} \cos 2\omega t d\omega t \right]$$

As

$$\int_0^{2\pi} \cos 2\omega t d\omega t = 0$$

Therefore

$$P_R = \frac{I_m^2 R}{2\pi} \left[\int_0^\pi d\omega t \right]$$

$$P_R = \frac{I_m^2 R}{2}$$

$$P_R =$$

$$I^2 R \quad (3.45)$$

Where I in equation 3.45 stands for RMS value of AC current.

3-5 AC Voltage across an Inductor

Consider a simple circuit comprising an inductor and an AC voltage source as shown in Figure 3.25. Voltage across the source is equal to the voltage across the inductor in accordance with KVL.

$$v_s = v_L$$

Instantaneous equation of the AC current is

$$i = I_m \sin \omega t$$

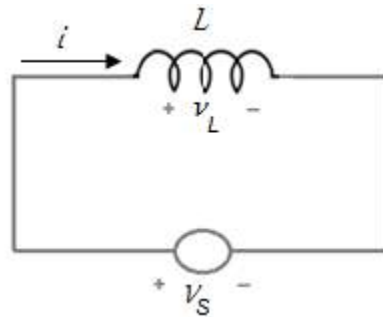

Figure 3.25: AC Voltage across an Inductor

Waveform for this ac current is shown in Figure 3.26. Instantaneous equation of the AC voltage across the inductor can be calculated as

$$v_L = L \frac{di}{dt}$$

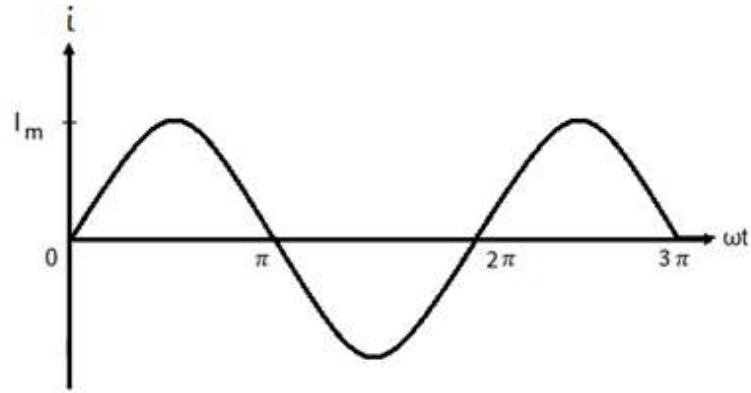

Figure 3.26: Waveform for AC Current

$$v_L = I_m(\omega L) \cos \omega t \quad (3.46)$$

Maximum value of this AC voltage is

$$V_{Lm} = I_m(\omega L)$$

So

$$\omega L = \frac{V_{Lm}}{I_m}$$

Where ωL represents the resistance offered by the inductor to the flow of AC current and this resistance is known as inductive reactance which is represented by X_L .

$$X_L = \omega L = 2\pi fL$$

As frequency of DC voltage is zero, therefore inductor does not offer any resistance to the flow of DC current. Equation no 3.46 can be written as

$$v_L = I_m X_L \cos \omega t \quad (3.47)$$

Or

$$v_L = I_m X_L \sin(\omega t + 90^\circ)$$

Waveform of this AC voltage across the inductor is shown in Figure 3.27.

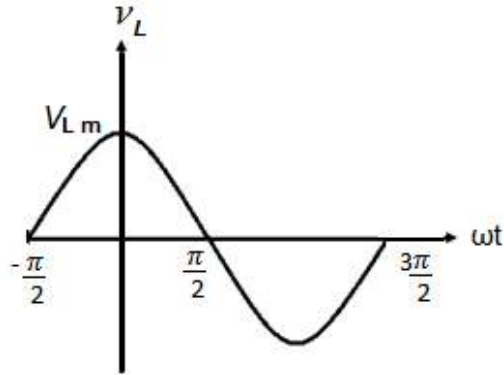

Figure 3.27: Waveform for AC Voltage across Inductor

Comparison of the voltage waveform with the waveform for the current reveals that current in an inductor lags behind the voltage by 90° . In other words there is a phase difference of 90° between voltage across an inductor and current. The instantaneous equation for the AC power taken by an inductor from the AC voltage source can be calculated as

$$p_L = V_L \times i$$

$$p_L = I_m X_L \cos \omega t \times I_m \sin \omega t$$

$$p_L = I_m^2 X_L \sin \omega t \cos \omega t$$

$$p_L = \frac{I_m^2 X_L}{2} \sin 2\omega t \quad (3.48)$$

Waveform for the time varying ac power taken by this inductor from the AC voltage source is given in Figure 3.28. When the current increases from 0 to $\frac{\pi}{2}$ the power flows toward the inductor and when the current decreases from $\frac{\pi}{2}$ to π , the same power flows back to the source. Average value of the AC power can be computed as

$$P_L = \frac{1}{\pi} \int_0^\pi \frac{I_m^2 X_L}{2} \sin 2\omega t d \omega t$$

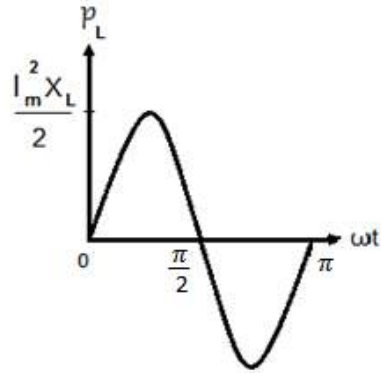

Figure 3.28: Waveform for AC Power taken by Inductor

$$P_L = \frac{I_m^2 X_L}{4\pi} \int_0^\pi 2 \sin 2\omega t d \omega t$$

$$P_L = \frac{I_m^2 X_L}{4\pi} [-\cos 2\omega t]_0^\pi$$

$$P_L = 0$$

Thus the average power consumed by an inductor under ideal condition is zero.

3-6 AC Voltage across a Capacitor

Consider a simple circuit comprising a capacitor and an AC voltage source as shown in Figure 3.29. Voltage across the source is equal to the voltage across the capacitor in accordance with KVL.

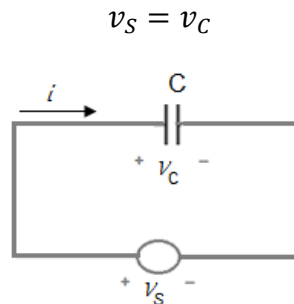

Figure 3.29: AC Voltage across a Capacitor

Instantaneous equation of the AC current is

$$i = I_m \sin \omega t$$

Waveform for this ac current is shown in Figure 3.30.

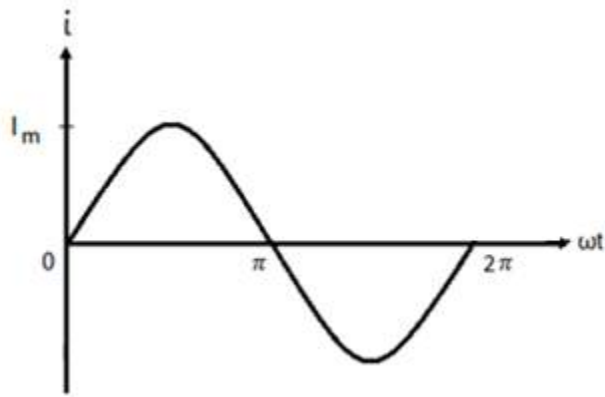

Figure 3.30: Waveform for AC Current

Instantaneous equation of the AC voltage across the capacitor can be calculated as

$$v_c = \frac{1}{C} \int \frac{di}{dt}$$

$$v_c = \frac{-I_m}{(\omega C)} \cos \omega t$$

Maximum value of this AC voltage is

$$V_{cm} = \frac{I_m}{(\omega C)}$$

So

$$\left(\frac{1}{\omega C} \right) = \frac{V_{cm}}{I_m}$$

Where $\frac{1}{\omega C}$ represents the resistance offered by the capacitor to the flow of AC current and this resistance is known as capacitive reactance which is represented by X_C .

$$X_C = \frac{1}{\omega C} = \frac{1}{2\pi f C}$$

As frequency of DC voltage is zero, therefore capacitor offers infinite resistance to the flow of DC current. In other words it blocks DC current and this characteristic of capacitor has lots of applications in electronic devices. Thus voltage across a capacitor can be written as

$$v_C = -I_m X_C \cos \omega t \quad (3.49)$$

Or

$$v_C = I_m X_C \sin(\omega t - 90^\circ)$$

Waveform of this AC voltage across the inductor is shown in Figure 3.31.

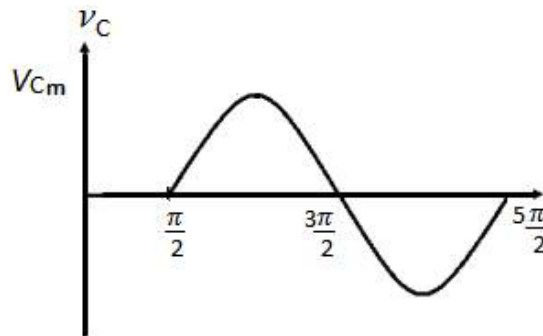

Figure 3.31: Waveform for AC Voltage across Capacitor

Comparison of the voltage waveform with the waveform for the current reveals that voltage across a capacitor lags behind the current by 90° . In other words there is a phase difference of 90° between voltage across a capacitor and current. The instantaneous equation for the AC power taken by a capacitor from the AC voltage source can be calculated as

$$p_C = V_C \times i$$

$$p_C = -I_m X_C \cos \omega t \times I_m \sin \omega t$$

$$p_C = -I_m^2 X_C \sin \omega t \cos \omega t$$

$$p_C = -\frac{I_m^2 X_C}{2} \sin 2\omega t \quad (3.50)$$

Waveform for the time varying ac power taken by this capacitor from the AC voltage source is given in Figure 3.32.

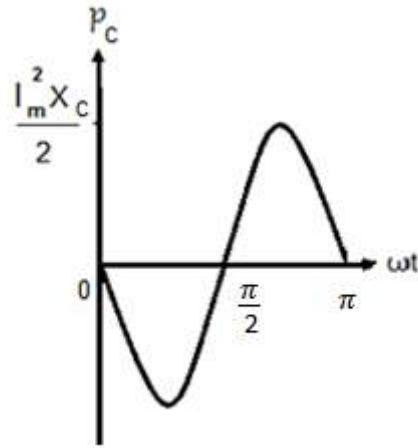

Figure 3.32: Waveform for AC Power taken by Capacitor

Average value of the AC power can be computed as

$$P_C = \frac{1}{\pi} \int_0^{\pi} \frac{-I_m^2 X_C}{2} \sin 2\omega t d \omega t$$

$$P_C = - \frac{I_m^2 X_C}{4\pi} \int_0^{\pi} 2 \sin 2\omega t d \omega t$$

$$P_C = - \frac{I_m^2 X_C}{4\pi} [-\cos 2\omega t]_0^{\pi}$$

$$P_C = 0$$

Thus a capacitor does not consume power under ideal condition.

3-7 RL Series Circuit

Consider a series circuit that consists of a resistor, an inductor and an AC voltage source as shown in Figure 3.33. Voltage across the source is equal to the sum of the voltage across the resistor and the voltage across the inductor in accordance with KVL.

$$v_s = v_R + v_L \quad (3.51)$$

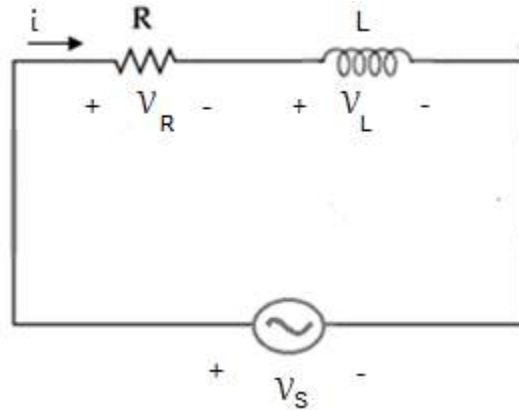

Figure 3.33: RL Series Circuit

Equation for the alternating current in this series circuit is

$$i = I_m \sin \omega t$$

Waveform for this ac current is shown in Figure 3.34. The AC current results in a voltage drop across the resistor that is in phase with the current.

$$v_R = iR$$

$$v_R = I_m R \sin \omega t$$

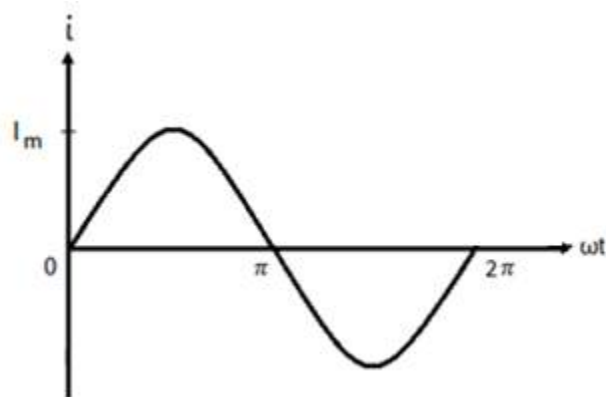

Figure 3.34: AC Current in RL Series Circuit

Waveform for the AC voltage across the resistor is shown in Figure 3.35.

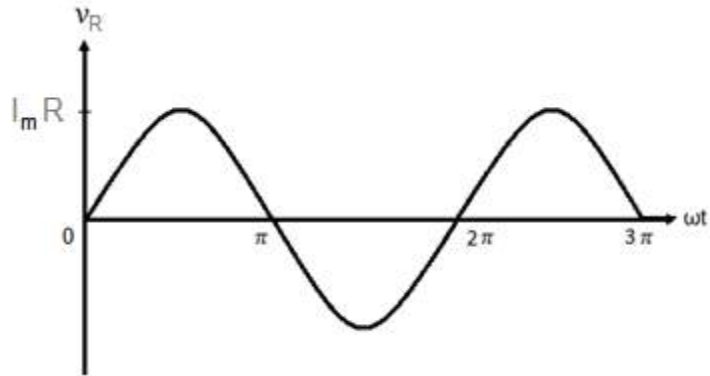

Figure 3.35: AC Voltage across Resistor

AC voltage across the inductor is calculated as

$$v_L = L \frac{di}{dt}$$

$$v_L = I_m X_L \cos \omega t$$

Voltage across the inductor leads the current by 90° as shown in Figure 3.36.

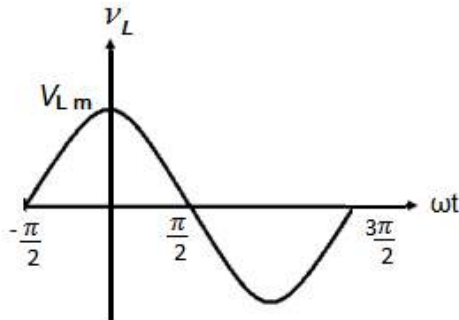

Figure 3.36: AC voltage across Inductor

Putting the values of v_R and v_L in equation 3.51, we obtain the following equation for source voltage.

$$v_S = I_m R \sin \omega t + I_m X_L \cos \omega t \quad (3.52)$$

The total resistance offered by the series circuit to the flow of AC current is called impedance. The impedance is represented by Z . The right hand side of equation 3.52 gives us the source voltage. The source voltage is AC voltage that varies sinusoidally with

time. This AC voltage will have a maximum value and a proper phase angle. It is difficult to find the maximum value of the source voltage and its phase angle from the right hand side of the mentioned equation. Therefore we write the general equation for the AC voltage.

$$v_S = V_m \sin(\omega t + \theta) \quad (3.53)$$

We replace the series combination of resistor and inductor in Figure 3.33 by a single circuit element such that the resistance of this single circuit element equals to the impedance of the series circuit. The equivalent circuit is shown in Figure 3.37.

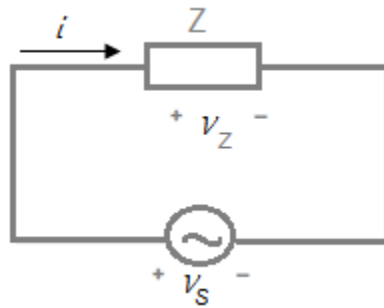

Figure 3.37: Equivalent Circuit

Applying KVL to the equivalent circuit, we get

$$v_S = v_Z$$

This equation implies that the maximum value of the source voltage will be equal to the maximum value of the voltage across Z .

$$v_m = v_{mZ}$$

The maximum voltage across the impedance Z is

$$v_m = v_{mZ} = I_m Z$$

Putting this value of v_m in equation 3.53, we obtain the following equation for the source voltage.

$$v_S = I_m Z \sin (\omega t + \theta) \quad (3.54)$$

$$v_s = I_m Z \cos \theta \sin \omega t + I_m Z \sin \theta \cos \omega t \quad (3.55)$$

Comparing equation 3.55 with equation 3.52, we have

$$R = Z \cos \theta \quad (3.56)$$

$$X_L = Z \sin \theta \quad (3.57)$$

Squaring and adding the above two equations

$$\begin{aligned} R^2 &= Z^2 \cos^2 \theta \\ + X_L^2 &= Z^2 \sin^2 \theta \\ \hline R^2 + X_L^2 &= Z^2 \end{aligned}$$

The impedance of the series circuit can be calculated as

$$Z = \sqrt{R^2 + X_L^2} \quad (3.58)$$

Dividing equation 3.57 by equation 3.56, we get

$$\tan \theta = \frac{X_L}{R}$$

So the phase angle of the source voltage can be computed with the help of following equation.

$$\theta = \tan^{-1} \frac{X_L}{R}$$

Power taken by R is

$$p_R = I_m^2 R \sin^2 \omega t$$

Power taken by L is

$$p_L = \frac{I_m^2 X_L}{2} \sin 2\omega t$$

According to law of conservation of energy the power supplied by the source will be equal to sum of the powers consumed by resistor and inductor.

$$p_s = p_R + p_L$$

$$p_s = I_m^2 R \sin^2 \omega t + \frac{I_m^2 X_L}{2} \sin 2\omega t \quad (3.59)$$

The average value of the AC power supplied by the source can be computed as

$$P_s = P_R + P_L$$

As the average value of the power consumed by resistor is $I^2 R$ and the average value of the power consumed by the inductor is zero, therefore

$$P_s = I^2 R$$

D 3.7: Consider the RL series circuit as shown in the following figure. The equation for AC current in this series circuit is

$$i = 10\sqrt{2} \sin 100\pi t$$

Find v_R , v_L , v_S , p_R and p_L

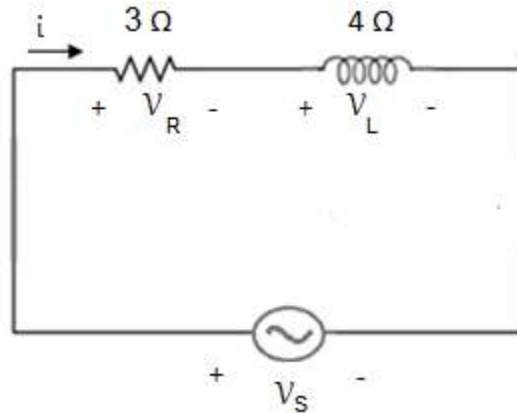

Figure 3.38: RL Series Circuit for D # 3.7

Solution:

Impedance of this RL series circuit is

$$Z = 3 + j4 \ \Omega$$

We convert this impedance into polar form

$$Z = 5 \angle 53.1^\circ \ \Omega$$

Maximum value of the current is

$$I_m = 10\sqrt{2} \ A$$

Angular frequency of the AC source is

$$\omega = 100\pi \ rad/sec$$

The time varying AC voltage across the resistor is

$$v_R = I_m R \sin \omega t$$

$$v_R = 30\sqrt{2} \sin 100\pi t$$

The time varying AC voltage across the inductor is

$$v_L = I_m X_L \cos \omega t$$

$$v_L = 40\sqrt{2} \cos 100\pi t \ volts$$

The time varying AC voltage across the source is

$$v_S = I_m Z \sin(\omega t + \theta)$$

$$v_S = 50\sqrt{2} \sin(100\pi t + 53.1^\circ) \ volts$$

Power taken by the resistor is given by

$$p_R = I_m^2 R \sin^2 \omega t$$

$$p_R = 600 \sin^2 100\pi t \ W$$

Power taken by the inductor is given by

$$p_L = \frac{I_m^2 X_L}{2} \sin 2\omega t$$

$$p_L = 400 \sin 200\pi t \quad W$$

D 3.8: Consider the RL series circuit as shown in Figure 3.38. Determine the RMS values of the AC current and all the three voltages. Calculate the average power consumed by the circuit as well.

Solution:

Maximum value of the current is

$$I_m = 10\sqrt{2} \quad A$$

So, the RMS value of the current is

$$I_{rms} = 10 \text{ A}$$

Maximum value of the voltage across R is

$$V_{Rm} = 30\sqrt{2} \quad V$$

So, the RMS value of the voltage across R is

$$V_{Rrms} = 30 \text{ V}$$

Maximum value of the voltage across L is

$$V_{Lm} = 40\sqrt{2} \quad V$$

So, the RMS value of the voltage across L is

$$V_{Lrms} = 40 \text{ V}$$

Maximum value of the voltage across the source is

$$V_m = 50\sqrt{2} \quad V$$

So, the RMS value of the voltage across the source is

$$V_S = 50 \text{ V}$$

Power consumed by the circuit is: $P_S = I^2 R$

$$P_S = 300 \text{ W}$$

D 3.9: Consider the RL series circuit as shown in the following figure. The equation for the AC current in this series circuit is

$$i = 5\sqrt{2} \sin 100\pi t$$

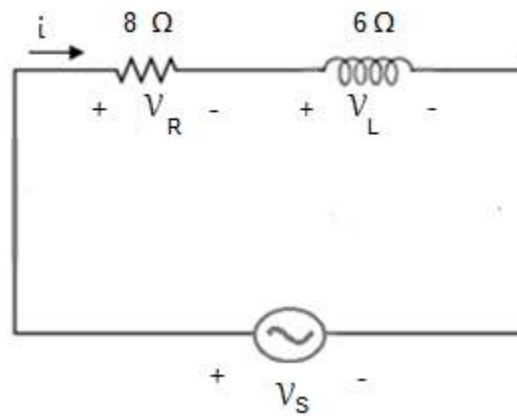

Figure 3.39: RL Series Circuit for D # 3.9

Find v_R , v_L , v_S , p_R and p_L

Solution:

Impedance of this RL series circuit is

$$Z = 8 + j6 \ \Omega$$

We convert this impedance into polar form

$$Z = 10 \angle 36.8^\circ \ \Omega$$

Maximum value of the current is

$$I_m = 5\sqrt{2} \text{ A}$$

Angular frequency of the AC source is

$$\omega = 100\pi \text{ rad/sec}$$

Instantaneous voltage across the resistor is

$$v_R = I_m R \sin \omega t$$

$$v_R = 40\sqrt{2} \sin 100\pi t$$

Instantaneous voltage across the inductor is

$$v_L = I_m X_L \cos \omega t$$

$$v_L = 30\sqrt{2} \cos 100\pi t \text{ volts}$$

Instantaneous voltage across the source is

$$v_S = I_m Z \sin(\omega t + \theta)$$

$$v_S = 50\sqrt{2} \sin(100\pi t + 36.8^\circ) \text{ volts}$$

Instantaneous power taken by the resistor is given by

$$p_R = I_m^2 R \sin^2 \omega t$$

$$p_R = 400 \sin^2 100\pi t \text{ W}$$

Instantaneous power taken by the inductor is given by

$$p_L = \frac{I_m^2 X_L}{2} \sin 2\omega t$$

$$p_L = 150 \sin 200\pi t \text{ W}$$

D 3.10: Consider the RL series circuit as shown in Figure 3.39. Determine RMS values of the AC current and all the three voltages. Calculate the average power consumed by the circuit as well.

Solution:

Maximum value of the current is

$$I_m = 5\sqrt{2} \text{ A}$$

So, the RMS value of the current is

$$I_{rms} = 5 \text{ A}$$

Maximum value of the voltage across R is

$$V_{Rm} = 40\sqrt{2} \text{ V}$$

So, the RMS value of the voltage across R is

$$V_{Rrms} = 40 \text{ V}$$

Maximum value of the voltage across L is

$$V_{Lm} = 30\sqrt{2} \text{ V}$$

So, the RMS value of the voltage across L is

$$V_{Lrms} = 30 \text{ V}$$

Maximum value of the voltage across the source is

$$V_m = 50\sqrt{2} \text{ V}$$

So, the RMS value of the voltage across the source is

$$V_s = 50 \text{ V}$$

Power consumed by the circuit is:

$$P_s = I^2 R$$

$$P_s = 200 \text{ W}$$

3-8 RC Series Circuit

Consider a series circuit that consists of a resistor, a capacitor and an AC voltage source as shown in Figure 3.40. Voltage across the source will be equal to the sum of the voltage across the resistor and the voltage across the capacitor in accordance with KVL.

$$v_s = v_R + v_C \tag{3.60}$$

Instantaneous equation for the alternating current in this series circuit is given by

$$i = I_m \sin \omega t$$

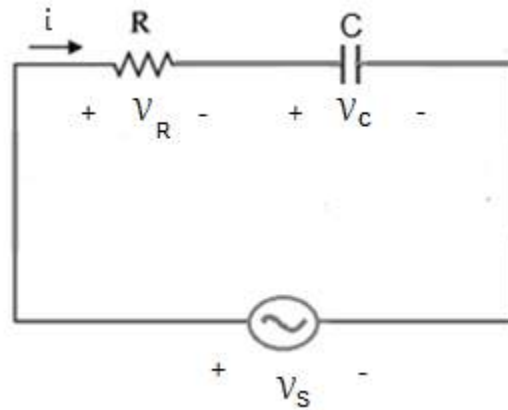

Figure 3.40: RC Series Circuit

Waveform for this ac current is shown in Figure 3.41.

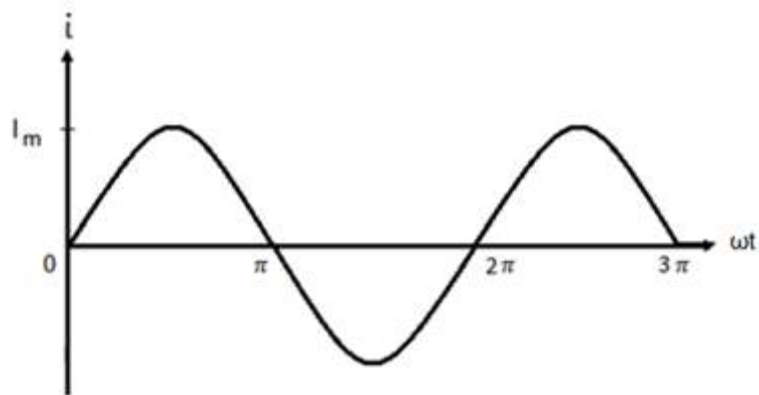

Figure 3.41: AC Current in RC Series Circuit

The AC current results in a voltage drop across the resistor that is in phase with the current.

$$v_R = iR$$

$$v_R = I_m R \sin \omega t$$

Waveform for the AC voltage across the resistor is shown in Figure 3.42. It follows the pattern of the waveform for the current and this is why they are in phase.

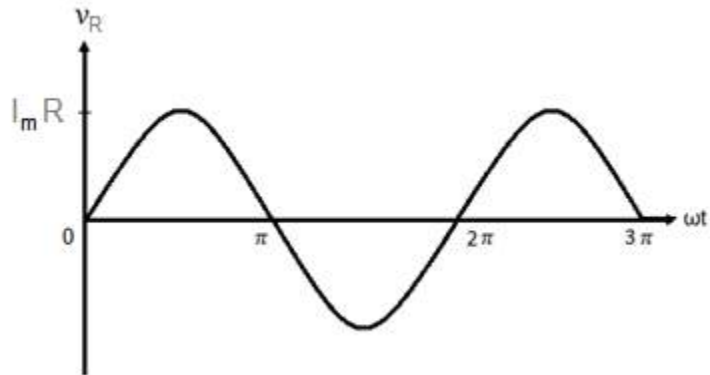

Figure 3.42: AC Voltage across Resistor

Instantaneous voltage across the capacitor is calculated as

$$v_C = \frac{1}{C} \int i dt$$

$$v_C = -I_m X_C \cos \omega t$$

Voltage across the capacitor lags behind the current by 90° as shown in Figure 3.43.

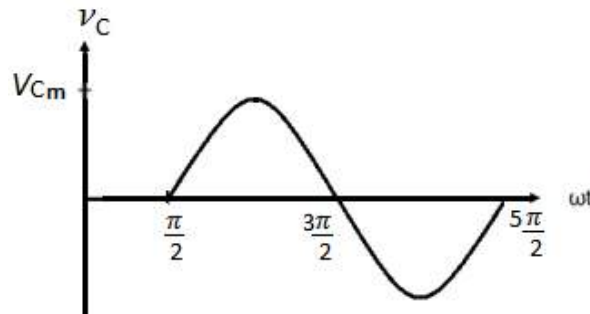

Figure 3.43: AC Voltage across Capacitor

Putting the values of v_R and v_C in equation 3.60, we obtain the following equation for source voltage.

$$v_S = I_m R \sin \omega t - I_m X_C \cos \omega t \quad (3.61)$$

The total resistance offered by the series circuit to the flow of AC current is called impedance. The impedance is represented by Z . The right hand side of equation 3.61 gives us the source voltage. The source voltage is AC voltage that varies sinusoidally with time. This AC voltage will have a maximum value and a proper phase angle. It is difficult to find the maximum value of the source voltage and its phase angle from the right hand side of the mentioned equation. Therefore we write the general equation for the AC voltage.

$$v_s = V_m \sin(\omega t - \theta) \quad (3.62)$$

We replace the series combination of resistor and capacitor in Figure 3.40 by a single circuit element such that the resistance of this single circuit element equals to the impedance of the series circuit. The equivalent circuit is shown in Figure 3.44.

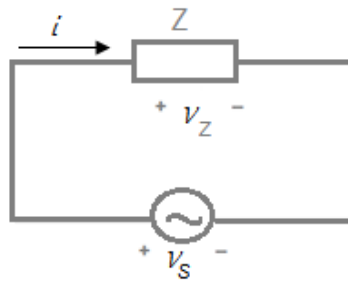

Figure 3.44: Equivalent Circuit

Applying KVL to the equivalent circuit, we get

$$v_s = v_Z$$

This equation implies that the maximum value of the source voltage will be equal to the maximum value of the voltage across Z .

$$v_m = v_{mZ}$$

Maximum voltage across the impedance Z is

$$v_m = v_{mZ} = I_m Z$$

Putting this value of v_m in equation 3.62, we obtain the following equation for the source voltage.

$$v_S = I_m Z \sin(\omega t - \theta) \quad (3.63)$$

$$v_S = I_m Z \cos \theta \sin \omega t - I_m Z \sin \theta \cos \omega t \quad (3.64)$$

Comparing equation 3.64 with equation 3.61, we have

$$R = Z \cos \theta \quad (3.65)$$

$$X_C = Z \sin \theta \quad (3.66)$$

Squaring and adding the above two equations

$$\begin{aligned} R^2 &= Z^2 \cos^2 \theta \\ + X_C^2 &= Z^2 \sin^2 \theta \\ \hline R^2 + X_C^2 &= Z^2 \end{aligned}$$

Impedance of the series circuit can be calculated as

$$Z = \sqrt{R^2 + X_C^2} \quad (3.67)$$

Dividing equation 3.66 by equation 3.65, we get

$$\tan \theta = \frac{X_C}{R}$$

So the phase angle of the source voltage can be computed with the help of following equation

$$\theta = \tan^{-1} \frac{X_C}{R}$$

The time varying power taken by the resistor is given by

$$p_R = I_m^2 R \sin^2 \omega t$$

The time varying power taken by the capacitor is given by

$$p_C = \frac{-I_m^2 X_C}{2} \sin 2\omega t$$

According to law of conservation of energy power supplied by the source will be equal to sum of the powers consumed by resistor and capacitor.

$$p_s = p_R + p_C$$

$$p_s = I_m^2 R \sin^2 \omega t - \frac{I_m^2 X_C}{2} \sin 2\omega t \quad (3.68)$$

The average value of the AC power supplied by the source can be computed as

$$P_s = P_R + P_C$$

As the average value of the power consumed by resistor is $I^2 R$ and the average value of the power consumed by the capacitor is zero, therefore

$$P_s = I^2 R$$

D 3.11: Consider the RC series circuit as shown in the following figure. The equation for the AC current in this series circuit is $i = 10\sqrt{2} \sin 100\pi t$. Find v_R, v_C, v_S, p_R and p_C .

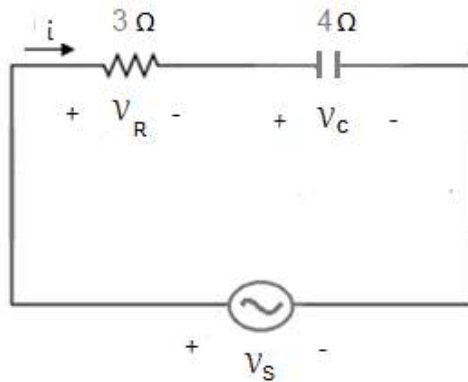

Figure 3.45: RC Series Circuit for D # 3.11

Solution:

Impedance of this RC series circuit is

$$Z = 3 - j4\ \Omega$$

We convert this impedance into polar form

$$Z = 5 \angle -53.1^\circ \Omega$$

Maximum value of the current is

$$I_m = 10\sqrt{2} \text{ A}$$

Angular frequency of the AC source is

$$\omega = 100\pi \text{ rad/sec}$$

The time varying AC voltage across the resistor is

$$v_R = I_m R \sin \omega t$$

$$v_R = 30\sqrt{2} \sin 100\pi t$$

The time varying AC voltage across the capacitor is

$$v_C = -I_m X_C \cos \omega t$$

$$v_C = -40\sqrt{2} \cos 100\pi t \text{ volts}$$

The time varying AC voltage across the source is

$$v_S = I_m Z \sin(\omega t - \theta)$$

$$v_S = 50\sqrt{2} \sin(100\pi t - 53.1^\circ) \text{ volts}$$

Power taken by the resistor is

$$p_R = I_m^2 R \sin^2 \omega t$$

$$p_R = 600 \sin^2 100\pi t \text{ W}$$

Power taken by the capacitor is

$$p_C = -\frac{I_m^2 X_C}{2} \sin 2\omega t$$

$$p_C = -400 \sin 200\pi t \text{ W}$$

D 3.12: Consider the RC series circuit as shown in Figure 3.45. Determine the RMS values of the AC current and all the three voltages. Calculate the average power consumed by the circuit as well.

Solution:

Maximum value of the current is

$$I_m = 10\sqrt{2} \text{ A}$$

So, the RMS value of the current is

$$I_{rms} = 10 \text{ A}$$

Maximum value of the voltage across R is

$$V_{Rm} = 30\sqrt{2} \text{ V}$$

So, the RMS value of the voltage across R is

$$V_{Rrms} = 30 \text{ V}$$

Maximum value of the voltage across C is

$$V_{Cm} = 40\sqrt{2} \text{ V}$$

So, the RMS value of the voltage across C is

$$V_{Crms} = 40 \text{ V}$$

Maximum value of the voltage across the source is

$$V_m = 50\sqrt{2} \text{ V}$$

So, the RMS value of the voltage across the source is

$$V_s = 50 \text{ V}$$

Power consumed by the circuit is: $P_s = I^2 R$

$$P_s = 300 \text{ W}$$

D 3.13: Consider the RC series circuit as shown in the following figure. The equation for the AC current in this series circuit is given by

$$i = 5\sqrt{2} \sin 100\pi t$$

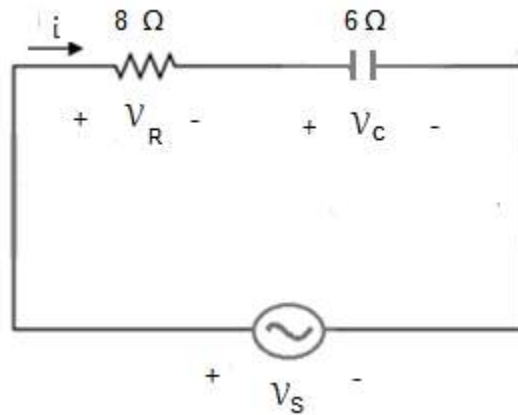

Figure 3.46: RL Series Circuit for D # 3.13

Find v_R , v_C , v_S , p_R and p_C .

Solution:

Impedance of this RL series circuit is

$$Z = 8 - j6 \ \Omega$$

We convert this impedance into polar form

$$Z = 10 \angle -36.8^\circ \ \Omega$$

Maximum value of the current is

$$I_m = 5\sqrt{2} \text{ A}$$

Angular frequency of the AC source is

$$\omega = 100\pi \text{ rad/sec}$$

Instantaneous voltage across the resistor is

$$v_R = I_m R \sin \omega t$$

$$v_R = 40\sqrt{2} \sin 100\pi t$$

Instantaneous voltage across the capacitor is

$$v_C = -I_m X_C \cos \omega t$$

$$v_C = -30\sqrt{2} \cos 100\pi t \text{ volts}$$

Instantaneous voltage across the source is

$$v_S = I_m Z \sin(\omega t - \theta)$$

$$v_S = 50\sqrt{2} \sin(100\pi t - 36.8^\circ) \text{ volts}$$

The time varying power taken by the resistor is

$$p_R = I_m^2 R \sin^2 \omega t$$

$$p_R = 400 \sin^2 100\pi t \text{ W}$$

The time varying power taken by the capacitor is

$$p_C = -\frac{I_m^2 X_C}{2} \sin 2\omega t$$

$$p_C = -150 \sin 200\pi t \text{ W}$$

D 3.14: Consider the RC series circuit as shown in Figure 3.46. Determine the RMS values of the AC current and all the three voltages. Calculate the average power consumed by the circuit as well.

Solution:

Maximum value of the current is

$$I_m = 5\sqrt{2} \text{ A}$$

So, the RMS value of the current is

$$I_{rms} = 5 \text{ A}$$

Maximum value of the voltage across R is

$$V_{Rm} = 40\sqrt{2} \quad V$$

So, the RMS value of the voltage across R is

$$V_{R_{rms}} = 40 \text{ V}$$

Maximum value of the voltage across C is

$$V_{Cm} = 30\sqrt{2} \quad V$$

So, the RMS value of the voltage across C is

$$V_{C_{rms}} = 30 \text{ V}$$

Maximum value of the voltage across the source is

$$V_m = 50\sqrt{2} \quad V$$

So, the RMS value of the voltage across the source is

$$V_s = 50 \text{ V}$$

Power consumed by the circuit is: $P_s = I^2 R = 200 \text{ W}$

3-9 RLC Series Circuit

Consider a series circuit that consists of a resistor, an inductor, a capacitor and an AC voltage source as shown in Figure 3.47. The voltage across the source will be equal to the sum of the voltage across the resistor, the voltage across the inductor and the voltage across the capacitor in accordance with KVL.

$$v_s = v_R + v_L + v_C \quad (3.69)$$

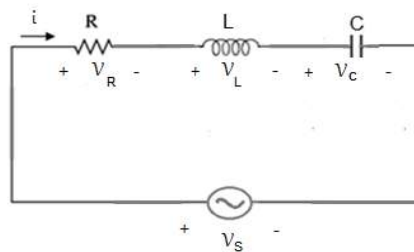

Figure 3.47: RLC Series Circuit

Equation for the alternating current in this series circuit is given by

$$i = I_m \sin \omega t$$

Waveform for this ac current is shown in Figure 3.48.

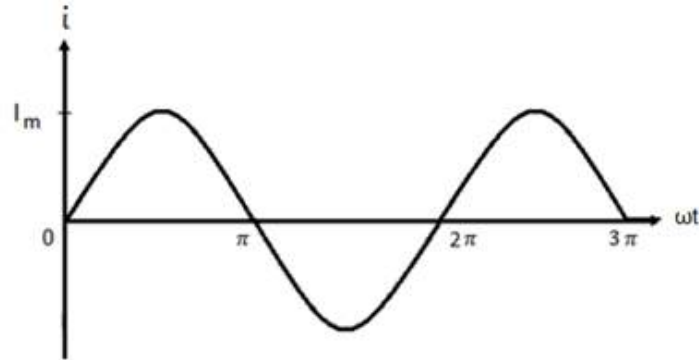

Figure 3.48: AC current in RLC Series Circuit

We already know that this AC current results in a voltage drop across the resistor that is in phase with the current.

$$v_R = iR$$

$$v_R = I_m R \sin \omega t$$

Waveform for the AC voltage across the resistor is shown in Figure 3.49. It follows the pattern of the waveform for the current and this is why they are in phase.

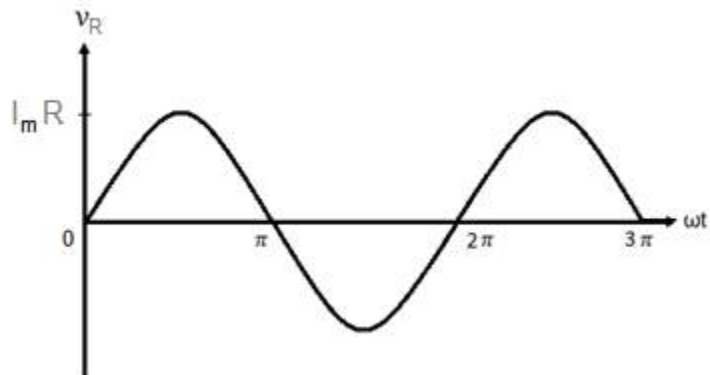

Figure 3.49: AC Voltage across Resistor

Instantaneous voltage across the inductor is calculated as

$$v_L = L \frac{di}{dt}$$

$$v_L = I_m X_L \cos \omega t$$

The voltage across the inductor leads the current by 90° as shown in Figure 3.50.

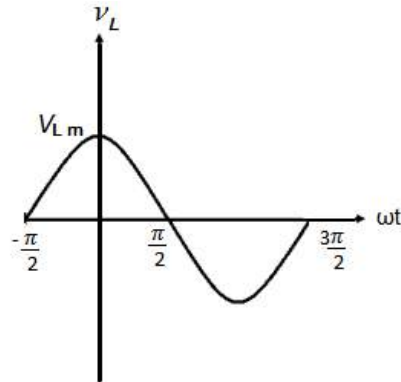

Figure 3.50: AC Voltage across Inductor

Instantaneous voltage across the capacitor is calculated as

$$v_C = \frac{1}{C} \int i dt$$

$$v_C = -I_m X_C \cos \omega t$$

The voltage across the capacitor lags behind the current by 90° as shown in Figure 3.51.

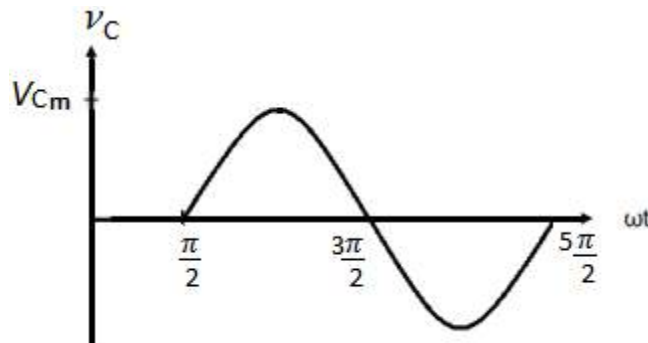

Figure 3.51: AC Voltage across Capacitor

Putting the values of v_R , v_L and v_C in equation 3.69, we obtain the following equation for source voltage.

$$v_S = I_m R \sin \omega t + I_m X_L \cos \omega t - I_m X_C \cos \omega t$$

$$v_S = I_m R \sin \omega t + I_m (X_L - X_C) \cos \omega t \quad (3.70)$$

Where $(X_L - X_C)$ is the net reactance of the RLC series circuit. The total resistance offered by the series circuit to the flow of AC current is called impedance. The impedance is represented by Z . The right hand side of equation 3.70 gives us the source voltage. The source voltage is AC voltage that varies sinusoidally with time. This AC voltage will have a maximum value and a proper phase angle. It is difficult to find the maximum value of the source voltage and its phase angle from the right hand side of the mentioned equation. Therefore we write the general equation for the AC voltage.

$$v_S = V_m \sin(\omega t \pm \theta) \quad (3.71)$$

We replace the series combination of resistor, inductor and capacitor in Figure 3.47 by a single circuit element such that the resistance of this single circuit element equals to the impedance of the series circuit. The equivalent circuit of the above mentioned series circuit is shown in Figure 3.52.

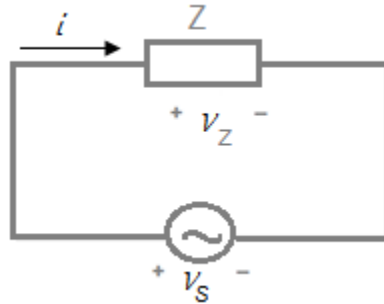

Figure 3.52: Equivalent Circuit

Applying KVL to the equivalent circuit, we get

$$v_S = v_Z$$

This equation implies that the maximum value of the source voltage will be equal to the maximum value of the voltage across Z .

$$v_m = v_{mZ}$$

The maximum voltage across the impedance Z is

$$v_m = v_{mZ} = I_m Z$$

Putting this value of v_m in equation 3.71, we obtain the following equation for the source voltage.

$$v_s = I_m Z \sin(\omega t \pm \theta) \quad (3.72)$$

$$v_s = I_m Z \cos \theta \sin \omega t \pm I_m Z \sin \theta \cos \omega t \quad (3.73)$$

Comparing equation 3.73 with equation 3.70, we have

$$R = Z \cos \theta \quad (3.74)$$

$$(X_L - X_C) = Z \sin \theta \quad (3.75)$$

Squaring and adding the above two equations

$$\begin{aligned} R^2 &= Z^2 \cos^2 \theta \\ + (X_L - X_C)^2 &= Z^2 \sin^2 \theta \\ \hline R^2 + (X_L - X_C)^2 &= Z^2 \end{aligned}$$

The impedance of the series circuit can be calculated as

$$Z = \sqrt{R^2 + (X_L - X_C)^2} \quad (3.76)$$

Dividing equation 3.75 by equation 3.74, we get

$$\tan \theta = \frac{(X_L - X_C)}{R}$$

So the phase angle of the source voltage can be computed with the help of following equation

$$\theta = \tan^{-1} \frac{(X_L - X_C)}{R}$$

If $X_L > X_C$, then θ is positive so this circuit will behave like inductive circuit, If $X_L < X_C$ then θ is negative so this series circuit will behave like capacitive circuit. If $X_L = X_C$ then θ is zero and this circuit will behave like resistive circuit. The last condition is known as resonance condition.

Power taken by the resistor is

$$p_R = I_m^2 R \sin^2 \omega t$$

Power taken by the inductor is

$$p_L = \frac{I_m^2 X_L}{2} \sin 2\omega t$$

Power taken by the capacitor is

$$p_C = \frac{-I_m^2 X_C}{2} \sin 2\omega t$$

According to law of conservation of energy the power supplied by the source will be equal to sum of the powers consumed by resistor, inductor and capacitor.

$$p_s = p_R + p_L + p_C$$

$$p_s = I_m^2 R \sin^2 \omega t + \frac{I_m^2 X_L}{2} \sin 2\omega t - \frac{I_m^2 X_C}{2} \sin 2\omega t \quad (3.77)$$

Average value of the AC power supplied by the source can be computed as

$$P_s = P_R + P_L + P_C$$

As the average value of the power consumed by resistor is $I^2 R$ and the average value of the powers consumed by the inductor as well as capacitor are zero, therefore

$$P_s = I^2 R$$

D 3.15: Consider the RLC series circuit as shown in the following figure. The equation for the AC current in this series circuit is $i = 10\sqrt{2} \sin 100\pi t$, find all the unknown electrical quantities.

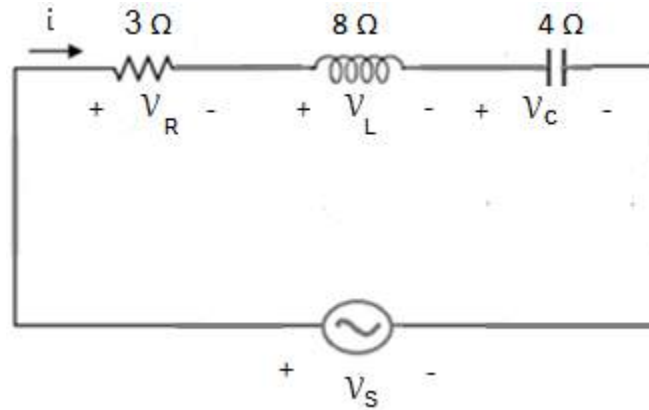

Figure 3.53: RLC Series Circuit for D # 3.15

Solution:

Impedance of the series circuit is given by

$$Z = \sqrt{R^2 + (X_L - X_C)^2}$$

$$Z = \sqrt{3^2 + (8 - 4)^2}$$

$$Z = 5 \Omega$$

Angle of the impedance is

$$\theta = \tan^{-1} \frac{(X_L - X_C)}{R}$$

$$\theta = \tan^{-1} \frac{4}{3}$$

$$\theta = 53.1^\circ$$

As $X_L > X_C$ and θ is positive, so this circuit will behave like inductive circuit. Maximum value of the current is given by

$$I_m = 10\sqrt{2} \text{ A}$$

Angular frequency of the AC source is

$$\omega = 100\pi \text{ rad/sec}$$

Instantaneous voltage across the resistor is

$$v_R = I_m R \sin \omega t$$
$$v_R = 30\sqrt{2} \sin 100\pi t$$

Instantaneous voltage across the inductor is

$$v_L = I_m X_L \cos \omega t$$
$$v_L = 80\sqrt{2} \cos 100\pi t \text{ volts}$$

Instantaneous voltage across the capacitor is

$$v_C = -I_m X_C \cos \omega t$$
$$v_C = -40\sqrt{2} \cos 100\pi t \text{ volts}$$

Instantaneous voltage across the source is

$$v_S = I_m Z \sin(\omega t + \theta)$$
$$v_S = 50\sqrt{2} \sin(100\pi t + 53.1^\circ) \text{ volts}$$

Instantaneous equation of the power taken by the resistor is

$$p_R = I_m^2 R \sin^2 \omega t$$
$$p_R = 600 \sin^2 100\pi t \text{ W}$$

Instantaneous equation of the power taken by the inductor is

$$p_L = \frac{I_m^2 X_L}{2} \sin 2\omega t$$
$$p_L = 800 \sin 200\pi t \text{ W}$$

Instantaneous equation of the power taken by the capacitor is

$$p_C = -\frac{I_m^2 X_C}{2} \sin 2\omega t$$

$$p_C = 400 \sin 200\pi t \quad W$$

D 3.16: Consider the RLC series circuit as shown in Figure 3.53. Determine the RMS values of the AC current and all the four voltages. Calculate the average power consumed by the circuit as well.

Solution:

Maximum value of the current is

$$I_m = 10\sqrt{2} \quad A$$

So, the RMS value of the current is

$$I_{rms} = 10 \text{ A}$$

Maximum value of the voltage across R is

$$V_{Rm} = 30\sqrt{2} \quad V$$

So, the RMS value of the voltage across R is

$$V_{Rrms} = 30 \text{ V}$$

Maximum value of the voltage across L is

$$V_{Lm} = 80\sqrt{2} \quad V$$

So, the RMS value of the voltage across L is

$$V_{Lrms} = 80 \text{ V}$$

Maximum value of the voltage across C is

$$V_{Cm} = 40\sqrt{2} \quad V$$

So, the RMS value of the voltage across C is

$$V_{Crms} = 40 \text{ V}$$

Maximum value of the voltage across the source is

$$V_m = 50\sqrt{2} \text{ V}$$

So, the RMS value of the voltage across the source is

$$V_S = 50 \text{ V}$$

Power consumed by the circuit is:

$$P_s = I^2 R$$

$$P_s = 300 \text{ W}$$

D 3.17: Consider the RLC series circuit as shown in the following figure. The equation for the AC current in this series circuit is $i = 5\sqrt{2} \sin 100\pi t$.

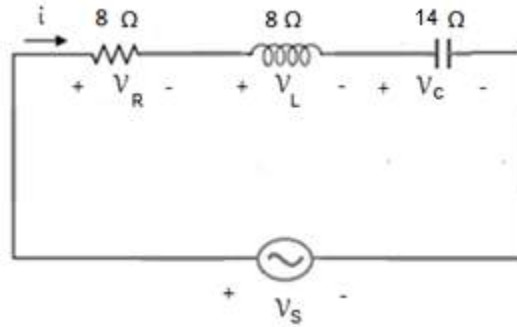

Figure 3.54: RLC Series Circuit for D # 3.17

Find all the unknown quantities.

Solution:

Impedance of this RLC series circuit is

$$Z = 8 - j6 \ \Omega$$

We convert this impedance into polar form

$$Z = 10 \angle -36.8^\circ \ \Omega$$

As $X_L < X_C$ and θ is negative so this circuit will behave like capacitive circuit.

Maximum value of the current is

$$I_m = 5\sqrt{2} \text{ A}$$

Angular frequency of the AC source is

$$\omega = 100\pi \text{ rad/sec}$$

Instantaneous equation of voltage across the resistor is

$$v_R = I_m R \sin \omega t$$

$$v_R = 40\sqrt{2} \sin 100\pi t$$

Instantaneous equation of voltage across the inductor is

$$v_L = I_m X_L \cos \omega t$$

$$v_L = 40\sqrt{2} \cos 100\pi t \text{ volts}$$

Instantaneous equation of voltage across the capacitor is

$$v_C = -I_m X_C \cos \omega t$$

$$v_C = -70\sqrt{2} \cos 100\pi t \text{ volts}$$

Instantaneous equation of voltage across the source is

$$v_S = I_m Z \sin(\omega t + \theta)$$

$$v_S = 50\sqrt{2} \sin(100\pi t - 36.8^\circ) \text{ volts}$$

Instantaneous power taken by the resistor is

$$p_R = I_m^2 R \sin^2 \omega t$$

$$p_R = 400 \sin^2 100\pi t \text{ W}$$

Power taken by the inductor is

$$p_L = \frac{I_m^2 X_L}{2} \sin 2\omega t$$

$$p_L = 200 \sin 200\pi t \quad W$$

Power taken by the capacitor is

$$p_C = -\frac{I_m^2 X_C}{2} \sin 2\omega t$$

$$p_C = -350 \sin 200\pi t \quad W$$

D 3.18: Consider the RLC series circuit as shown in Figure 3.54. Determine the RMS values of the AC current and all the four voltages. Calculate the average power consumed by the circuit as well.

Solution:

Maximum value of the current is

$$I_m = 5\sqrt{2} \quad A$$

So, the RMS value of the current is

$$I_{rms} = 5 \text{ A}$$

Maximum value of the voltage across R is

$$V_{Rm} = 40\sqrt{2} \quad V$$

So, the RMS value of the voltage across R is

$$V_{Rrms} = 40 \text{ V}$$

Maximum value of the voltage across L is

$$V_{Lm} = 40\sqrt{2} \quad V$$

So, the RMS value of the voltage across L is

$$V_{Lrms} = 40 \text{ V}$$

Maximum value of the voltage across C is

$$V_{Cm} = 70\sqrt{2} \quad V$$

So, the RMS value of the voltage across C is

$$V_{C_{rms}} = 70 \text{ V}$$

Maximum value of the voltage across the source is

$$V_m = 50\sqrt{2} \text{ V}$$

So, the RMS value of the voltage across the source is

$$V_s = 50 \text{ V}$$

Power consumed by the circuit is:

$$P_s = I^2 R$$

$$P_s = 200 \text{ W}$$

3-10 Phasor Analysis of RL Series Circuit

Consider a series circuit that consists of a resistor, an inductor and an AC voltage source as shown in Figure 3.55. Equation for the alternating current in this series circuit is given by

$$i = I_m \sin \omega t$$

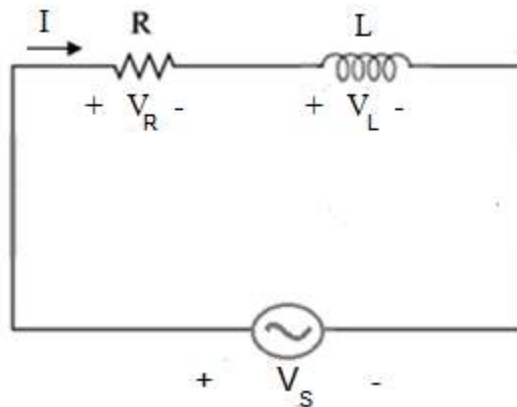

Figure 3.55: Phasor Analysis of RL Series Circuit

The phase angle of this ac current is zero, we want to write the phasor value of this current. RMS value of this AC current is given by

$$I_{rms} = \frac{I_m}{\sqrt{2}}$$

Therefore the Phasor value of the AC current

$$I = I_{rms} \angle 0^\circ \quad (\text{Polar form})$$

The above phasor is in polar form; let us convert it into rectangular form

$$I = I_{rms} \quad (\text{Rectangular form})$$

The time varying voltage across the resistor is

$$v_R = I_m R \sin \omega t$$

RMS value of this AC Voltage is

$$V_{Rrms} = \frac{I_m R}{\sqrt{2}}$$

$$V_{Rrms} = I_{rms} R$$

The phase angle of this AC voltage is zero. Therefore phasor value of the AC voltage across the resistor is

$$V_R = I_{rms} R \angle 0^\circ \quad (\text{Polar form})$$

We convert the above phasor into rectangular form

$$V_R = I_{rms} R \quad (\text{Rectangular form})$$

The time varying ac voltage across the inductor is

$$v_L = I_m X_L \sin(\omega t + 90^\circ)$$

RMS value of this AC Voltage is

$$V_{Lrms} = \frac{I_m X_L}{\sqrt{2}}$$

$$V_{L_{rms}} = I_{rms}X_L$$

As the phase angle of this AC voltage is 90° . Therefore the phasor value of the AC voltage across the inductor is given by

$$V_L = I_{rms}X_L \angle 90^\circ \quad (\text{Polar form})$$

We convert this phasor into rectangular form

$$V_L = j I_{rms}X_L \quad (\text{Rectangular form})$$

Consider the phasor diagram of the RL series circuit as shown in Figure 3.56. The phasor for the AC current in the series circuit is a reference phasor. The voltage across the resistor is in phase with the current and voltage across the inductor leads the current by 90° . We apply KVL to the series circuit which states that phasor sum of the voltage rises in the loop will be equal to the phasor sum of voltage drops.

$$V_S = V_R + V_L$$

Instantaneous equation of voltage across the source is

$$v_s = I_m Z \sin(\omega t + \theta)$$

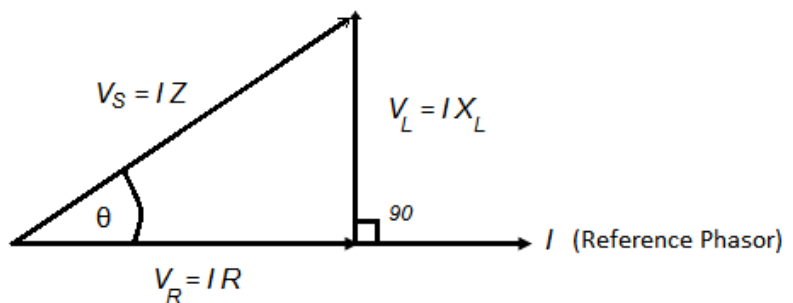

Figure 3.56: Phasor diagram of RL series circuit

RMS value of this AC Voltage is

$$V_{S_{rms}} = \frac{I_m Z}{\sqrt{2}}$$

$$V_{S_{rms}} = I_{rms}Z \quad (3.78)$$

As the phase angle of this AC voltage is θ , therefore the phasor value of the AC voltage is

$$V_S = I_{rms}Z \angle \theta \quad (\text{Polar form})$$

Ignoring the phasor for the AC current in the phasor diagram, we obtain a voltage triangle as shown in Figure 3.57.

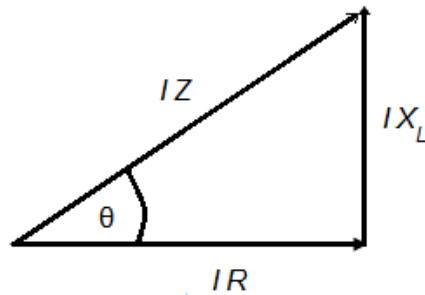

Figure 3.57: Voltage Triangle

If we divide all the three sides of the voltage triangle by current, we obtain another triangle that is known as Impedance Triangle as shown in Figure 3.58.

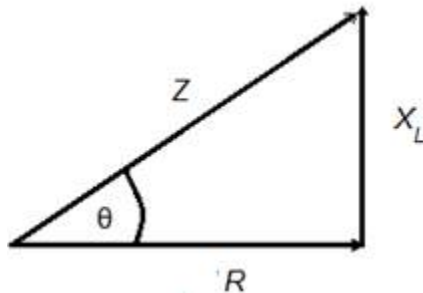

Figure 3.58: Impedance Triangle

It is clear from the impedance triangle that the impedance of the RL series circuit is a complex quantity, that is

$$Z = R + jX_L \quad (3.79)$$

The power factor of this RL series circuit is calculated with the help of following equation. Power factor is represented by pf and the power factor of an inductive circuit is known as lagging power factor.

$$\cos \theta = \frac{R}{Z}$$

$$pf = \cos \theta$$

The power supplied by the source is

$$P_s = I_{rms}^2 R$$

As

$$I_{rms} = \frac{V_{s_{rms}}}{Z}$$

Therefore the power supplied by the source is

$$P_s = V_{s_{rms}} \times I_{rms} \times \frac{R}{Z}$$

$$P_s = V_{s_{rms}} \times I_{rms} \times \cos \theta \quad (3.80)$$

D 3.19: The RMS value of the applied voltage across the series combination of Figure 3.59 is 100 V. Calculate the power supplied by the source and draw its phasor diagram.

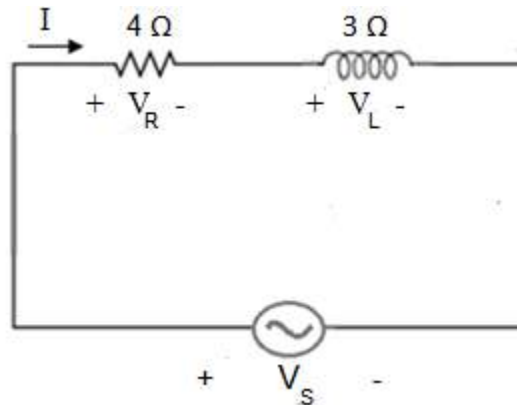

Figure 3.59: RL Series Circuit for D # 3.19

Solution:

$$Z = 4 + j3 \ \Omega$$

$$Z = 5 \angle 36.8^\circ \ \Omega$$

RMS value of the current

$$I_{rms} = \frac{V_{S_{rms}}}{Z}$$

$$I_{rms} = \frac{100}{5}$$

$$I_{rms} = 20 \text{ A}$$

Voltage across the resistor

$$V_{R_{rms}} = I_{rms}R$$

$$V_{R_{rms}} = 80 \text{ V}$$

Voltage across the inductor

$$V_{L_{rms}} = I_{rms}X_L$$

$$V_{L_{rms}} = 60 \text{ V}$$

Phasor diagram of this RL series circuit is as under

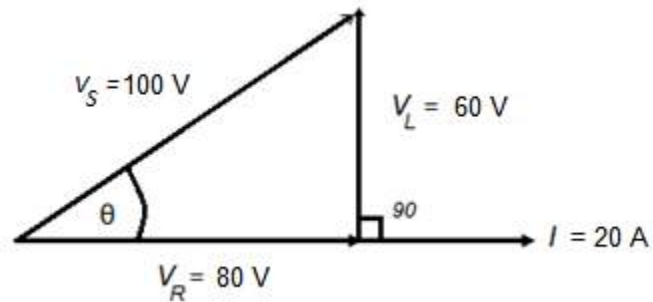

Power supplied by the source is

$$P_s = V_{S_{rms}} \times I_{rms} \times \cos \theta$$

As $\cos 36.8^\circ = 0.8$

$$P_s = 100 \times 20 \times 0.8$$

$$P_s = 1600 \text{ W}$$

3-11 Phasor Analysis of RC Series Circuit

Consider a series circuit that consists of a resistor, a capacitor and an AC voltage source as shown in Figure 3.60.

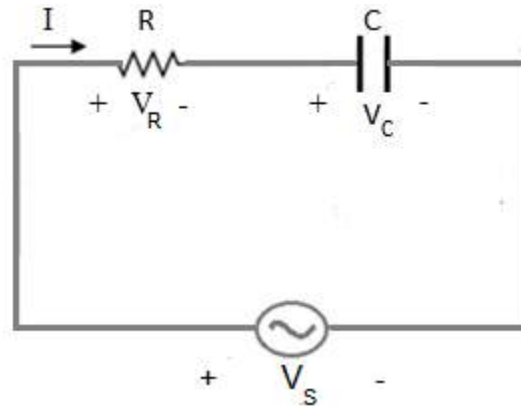

Figure 3.60: Phasor Analysis of RC Series Circuit

Equation for the alternating current in this series circuit is

$$i = I_m \sin \omega t$$

The phase angle of this ac current is zero, we want to write the phasor value of this current. RMS value of this AC current is given by

$$I_{rms} = \frac{I_m}{\sqrt{2}}$$

Therefore the Phasor value of the AC current

$$I = I_{rms} \angle 0^\circ \quad (\text{Polar form})$$

The above phasor is in polar form; let us convert it into rectangular form

$$I = I_{rms} \quad (\text{Rectangular form})$$

The time varying voltage across the resistor is

$$v_R = I_m R \sin \omega t$$

RMS value of this AC Voltage is

$$V_{R_{rms}} = \frac{I_m R}{\sqrt{2}}$$

$$V_{R_{rms}} = I_{rms} R$$

The phase angle of this AC voltage is zero. Therefore the phasor value of the AC voltage across the resistor is

$$V_R = I_{rms} R \angle 0^\circ \quad (\text{Polar form})$$

We convert the above phasor into rectangular form

$$V_R = I_{rms} R \quad (\text{Rectangular form})$$

The time varying ac voltage across the capacitor is

$$v_C = I_m X_C \sin(\omega t - 90^\circ)$$

RMS value of this AC Voltage is

$$V_{C_{rms}} = \frac{I_m X_C}{\sqrt{2}}$$

$$V_{C_{rms}} = I_{rms} X_C$$

As the phase angle of this AC voltage is -90° . Therefore the phasor value of the AC voltage across the capacitor is

$$V_C = I_{rms} X_C \angle -90^\circ \quad (\text{Polar form})$$

We convert this phasor into rectangular form

$$V_C = -j I_{rms} X_C \quad (\text{Rectangular form})$$

Consider the phasor diagram of the RC series circuit as shown in Figure 3.61. The phasor for the AC current in the series circuit is a reference phasor. The voltage across the resistor is in phase with the current and voltage across the capacitor lags behind the

current by 90° . We apply KVL to the series circuit which states that phasor sum of the voltage rises in the loop will be equal to the phasor sum of voltage drops.

$$V_S = V_R + V_C$$

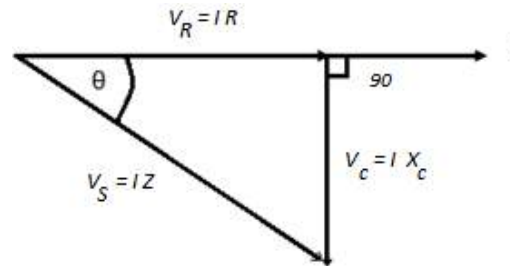

Figure 3.61: Phasor Diagram of RC Series Circuit

The time varying ac voltage across the source is

$$v_s = I_m Z \sin(\omega t - \theta)$$

RMS value of this AC Voltage is

$$V_{S_{rms}} = \frac{I_m Z}{\sqrt{2}}$$

$$V_{S_{rms}} = I_{rms} Z \quad (3.81)$$

As the phase angle of this AC voltage is θ . Therefore the phasor value of the AC voltage is

$$V_S = I_{rms} Z \angle -\theta \quad (\text{Polar form})$$

Ignoring the phasor for the AC current in the phasor diagram, we obtain a voltage triangle as shown in Figure 3.62.

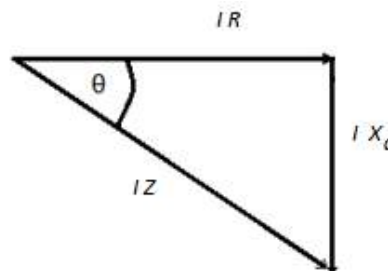

Figure 3.62: Voltage Triangle

If we divide all the three sides of the voltage triangle by current, we obtain another triangle that is known as Impedance Triangle as shown in Figure 3.63.

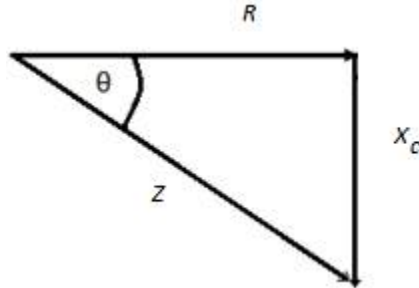

Figure 3.63: Impedance Triangle

It is clear from the impedance triangle that the impedance of the RC series circuit is a complex quantity, that is

$$Z = R - jX_C \quad (3.82)$$

The power factor of this RL series circuit is calculated with the help of following equation. Power factor is represented by pf and the power factor of a capacitive circuit is known as leading power factor.

$$\cos \theta = \frac{R}{Z}$$

$$pf = \cos \theta$$

The power supplied by the source is

$$P_s = I_{rms}^2 R$$

As

$$I_{rms} = \frac{V_{S_{rms}}}{Z}$$

Therefore the power supplied by the source is

$$P_s = V_{S_{rms}} \times I_{rms} \times \frac{R}{Z}$$

$$P_s = V_{S_{rms}} \times I_{rms} \times \cos \theta \quad (3.83)$$

D 3.20: The RMS value of the applied voltage across the series combination of Figure 3.64 is 100 V. Calculate the power supplied by the source and draw its phasor diagram.

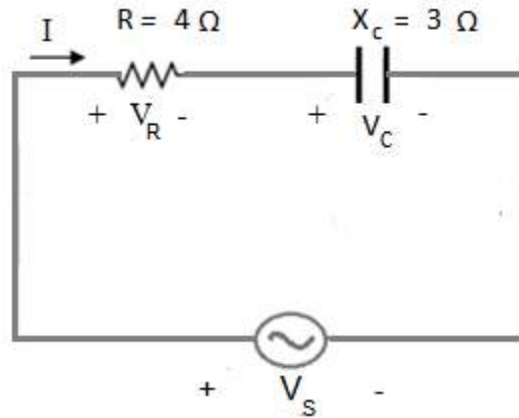

Figure 3.64: RC Series Circuit for D # 3.20

Solution:

$$Z = 4 - j3 \Omega$$

$$Z = 5 \angle -36.8^\circ \Omega$$

RMS value of the current

$$I_{rms} = \frac{V_{S_{rms}}}{Z}$$

$$I_{rms} = \frac{100}{5}$$

$$I_{rms} = 20 A$$

Voltage across the resistor

$$V_{R_{rms}} = I_{rms}R$$

$$V_{R_{rms}} = 80 V$$

Voltage across the capacitor

$$V_{C_{rms}} = I_{rms}X_C$$

$$V_{C_{rms}} = 60 V$$

The phasor diagram of this RC series circuit is as under

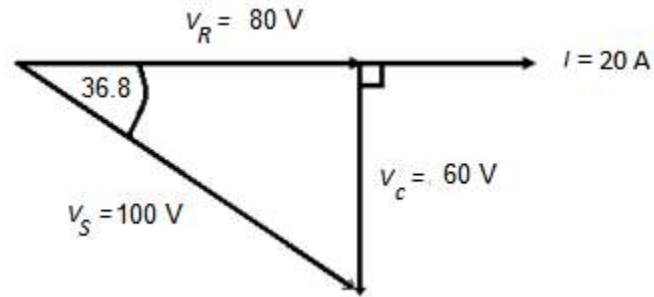

power supplied by the source is

$$P_s = V_{S_{rms}} \times I_{rms} \times \cos \theta$$

$$\text{As } \cos 36.8^\circ = 0.8$$

$$P_s = 100 \times 20 \times 0.8$$

$$P_s = 1600 \text{ W}$$

3-12 Phasor Analysis of RLC Series Circuit

Consider a series circuit that consists of a resistor, an inductor, a capacitor and an AC voltage source as shown in Figure 3. 65. Equation for the alternating current in this series circuit is given by

$$i = I_m \sin \omega t$$

The phase angle of this ac current is zero, we want to write the phasor value of this current. RMS value of this AC current is

$$I_{rms} = \frac{I_m}{\sqrt{2}}$$

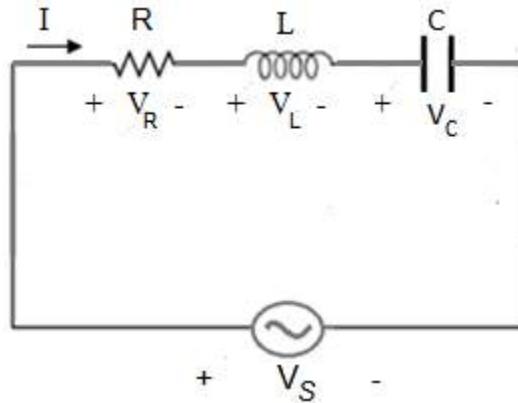

Figure 3.65: Phasor Analysis of RLC Series Circuit

Therefore the Phasor value of the AC current

$$I = I_{rms} \angle 0^\circ \quad (\text{Polar form})$$

The above phasor is in polar form; let us convert it into rectangular form

$$I = I_{rms} \quad (\text{Rectangular form})$$

Instantaneous equation of voltage across the resistor is

$$v_R = I_m R \sin \omega t$$

RMS value of this AC Voltage is

$$V_{R_{rms}} = \frac{I_m R}{\sqrt{2}}$$

$$V_{R_{rms}} = I_{rms} R$$

The phase angle of this AC voltage is zero. Therefore the phasor value of the AC voltage across the resistor is

$$V_R = I_{rms} R \angle 0^\circ \quad (\text{Polar form})$$

We convert the above phasor into rectangular form

$$V_R = I_{rms} R \quad (\text{Rectangular form})$$

Instantaneous equation of voltage across the inductor is

$$v_L = I_m X_L \sin(\omega t + 90^\circ)$$

RMS value of this AC Voltage is

$$V_{L_{rms}} = \frac{I_m X_L}{\sqrt{2}}$$

$$V_{L_{rms}} = I_{rms} X_L$$

As the phase angle of this AC voltage is 90° . Therefore the phasor value of the AC voltage across the inductor is

$$V_L = I_{rms} X_L \angle 90^\circ \quad (\text{Polar form})$$

We convert this phasor into rectangular form

$$V_L = j I_{rms} X_L \quad (\text{Rectangular form})$$

Instantaneous equation of voltage across the capacitor is

$$v_C = I_m X_C \sin(\omega t - 90^\circ)$$

The RMS value of this AC Voltage is

$$V_{C_{rms}} = \frac{I_m X_C}{\sqrt{2}}$$

$$V_{C_{rms}} = I_{rms} X_C$$

As the phase angle of this AC voltage is -90° . Therefore the phasor value of the AC voltage across the capacitor is

$$V_C = I_{rms} X_C \angle -90^\circ \quad (\text{Polar form})$$

We convert this phasor into rectangular form

$$V_C = -j I_{rms} X_C \quad (\text{Rectangular form})$$

We apply KVL to the series circuit which states that phasor sum of the voltage rises in the loop will be equal to the phasor sum of voltage drops.

$$V_S = V_R + V_L + V_C$$

Consider three different natures of the circuit to draw its phasor diagrams. If the circuit behaves like inductive circuit then the voltage across the resistor is in phase with the current and the net voltage across the inductor and capacitor leads the current by 90° as shown in Figure 3.66.

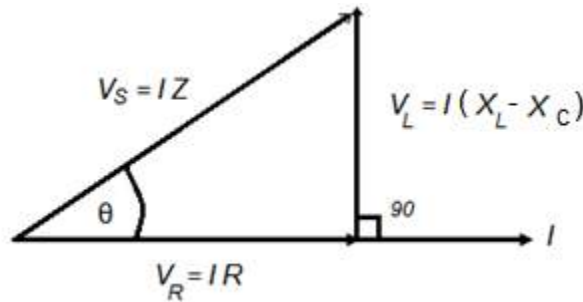

Figure 3.66: Phasor Diagram of RLC Series Circuit

If the circuit behaves like capacitive circuit then the voltage across the resistor is in phase with the current and the net voltage across the inductor and capacitor lags behind the current by 90° as shown in Figure 3.67.

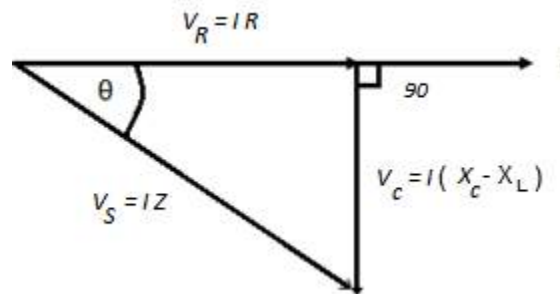

Figure 3.67: Phasor Diagram of RLC Series Circuit

If the circuit behaves like resistive circuit then the voltage across the resistor is in phase with the current and the net voltage across the inductor and capacitor is zero as shown in Figure 3.68.

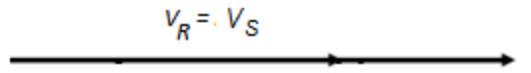

Figure 3.68: Phasor Diagram of RLC Series Circuit

Instantaneous equation of voltage across the source is

$$v_s = I_m Z \sin(\omega t \pm \theta)$$

RMS value of this AC Voltage is

$$V_{S_{rms}} = \frac{I_m Z}{\sqrt{2}}$$

$$V_{S_{rms}} = I_{rms} Z \quad (3.84)$$

As the phase angle of this AC voltage is θ . Therefore the phasor value of the AC voltage is

$$V_S = I_{rms} Z \angle \pm \theta \quad (\text{Polar form})$$

Let us assume that the series circuit behaves like inductive circuit, then its impedance triangle is shown in Figure 3.69.

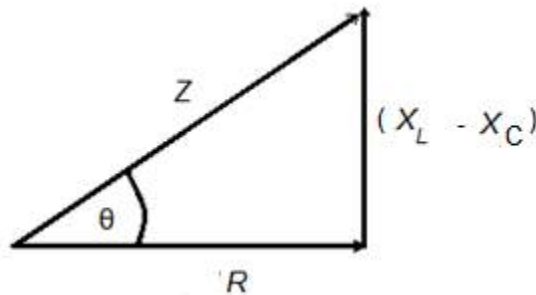

Figure 3.69: Impedance Triangle

It is clear from the impedance triangle that the impedance of the RLC series circuit is a complex quantity, that is

$$Z = R + j(X_L - X_C) \quad (3.85)$$

The power factor of this RLC series circuit is calculated with the help of following equation. Power factor is represented by pf .

$$\cos \theta = \frac{R}{Z}$$

$$pf = \cos \theta$$

The power supplied by the source is

$$P_s = I_{rms}^2 R$$

As

$$I_{rms} = \frac{V_{s_{rms}}}{Z}$$

Therefore the power supplied by the source is

$$P_s = V_{s_{rms}} \times I_{rms} \times \frac{R}{Z}$$

$$P_s = V_{s_{rms}} \times I_{rms} \times \cos \theta \quad (3.86)$$

D 3.21: The RMS value of the applied voltage across the series combination of Figure 3.70 is 100 V. Calculate the power supplied by the source and draw its phasor diagram.

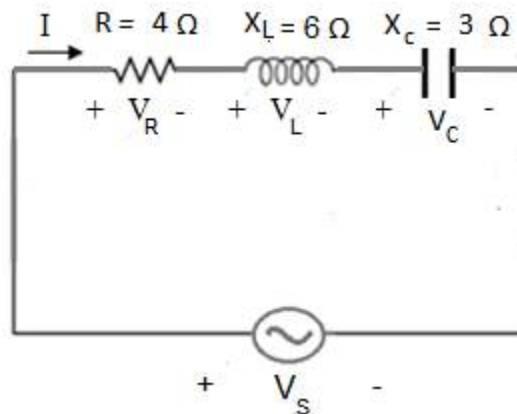

Figure 3.70: RLC Series Circuit for D # 3.21

Solution:

$$Z = 4 + j3 \Omega$$

$$Z = 5 \angle 36.8^\circ \Omega$$

RMS value of the current is

$$I_{rms} = \frac{V_{S_{rms}}}{Z}$$

$$I_{rms} = \frac{100}{5}$$

$$I_{rms} = 20 \text{ A}$$

Voltage across the resistor is

$$V_{R_{rms}} = I_{rms}R$$

$$V_{R_{rms}} = 80 \text{ V}$$

Voltage across the inductor is

$$V_{L_{rms}} = I_{rms}X_L$$

$$V_{L_{rms}} = 120 \text{ V}$$

Voltage across the capacitor is

$$V_{C_{rms}} = I_{rms}X_C$$

$$V_{C_{rms}} = 60 \text{ V}$$

The circuit is inductive and the phasor diagram of this RC series circuit is as under

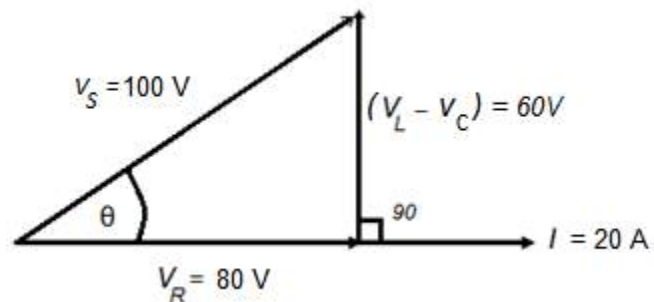

Power supplied by the source is

$$P_s = V_{S_{rms}} \times I_{rms} \times \cos \theta$$

$$\text{As } \cos 36.8^\circ = 0.8$$

$$P_s = 100 \times 20 \times 0.8$$

$$P_s = 1600 \text{ W}$$

3-13 Resonant Circuit

Consider RLC series circuit as shown in Figure 3.71. Frequency of the AC voltage source is varied from 0 to ∞ . As

$$X_L = 2\pi fL$$

So the inductive reactance will increase from 0 to ∞ and as

$$X_C = \frac{1}{2\pi fC}$$

So the capacitive reactance will decrease from ∞ to 0. At a particular frequency the inductive reactance of the circuit will become equal to the capacitive reactance and this frequency is known as resonant frequency.

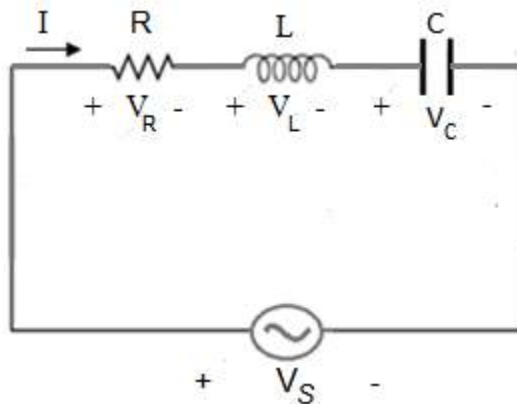

Figure 3.71: RLC Series Circuit

The resonant frequency is denoted by f_r . The following equation is justified under resonance condition.

$$X_L = X_C$$

$$2\pi f_r L = \frac{1}{2\pi f_r C}$$

$$f_r = \frac{1}{2\pi\sqrt{LC}}$$

Impedance of this RLC series circuit is calculated as

$$Z = R + j(X_L - X_C)$$

Obviously the series circuit will offer minimum impedance to the flow of AC current and there will be a maximum current in the circuit under resonance condition.

$$Z_{min} = R \quad (\text{under resonance condition})$$

$$I_{max} = \frac{V_S}{R}$$

The sketch of the impedance as a function of frequency is shown in Figure 3.72. By increasing frequency from 0 to f_r , the impedance decreases from ∞ to R and By increasing frequency from f_r to ∞ , the impedance increases from R to ∞ . The circuit behaves like capacitive circuit in region no 1 and the power factor of the circuit in this region is leading power factor. The same circuit behaves like inductive circuit in region no 2 and the power factor of the circuit in this region is lagging power factor.

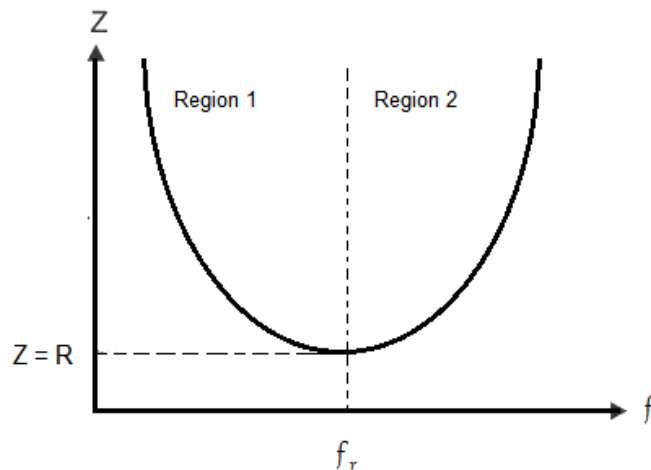

Figure 3.72: Impedance Curve

Sketch of the current as a function of frequency is shown in Figure 3.73. Initially the current in the circuit increases with increase in frequency, it reaches the maximum value at resonant frequency and then it decreases. This curve is known as resonance curve for RLC series circuit.

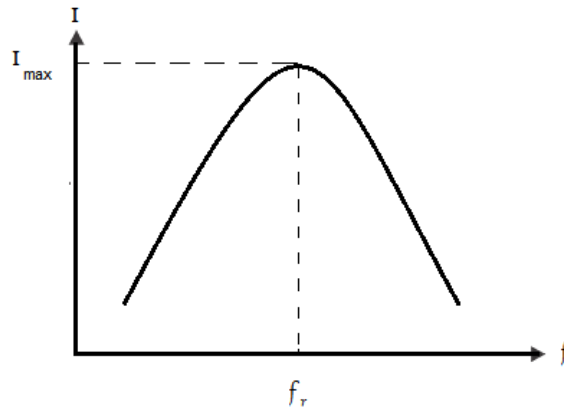

Figure 3.73: Resonance Curve

Graphical relationship between inductive reactance, capacitive reactance and frequency is shown in Figure 3.74. There is a linear relationship between the inductive reactance and frequency.

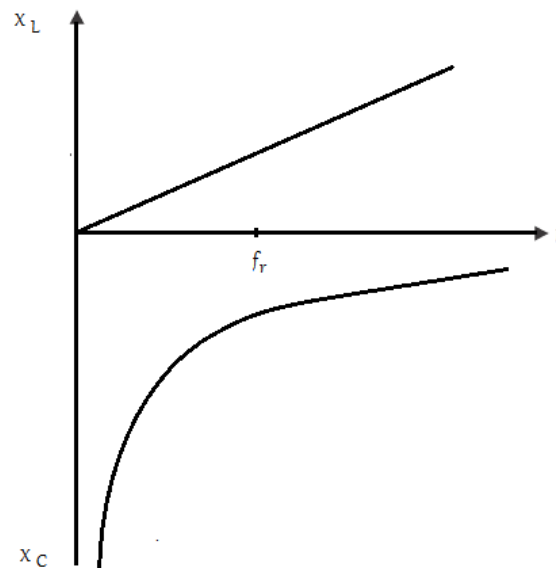

Figure 3.74: Reactance Graph

The voltage across the resistor is equal to the voltage across the source under resonance condition, that is

$$V_S = V_R$$

D 3.22: Calculate the resonant frequency, I, V_R and draw the phasor diagram under resonance condition.

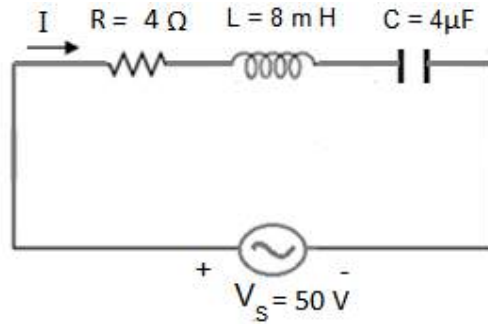

Figure 3.75: RLC Series Circuit for D # 3.22

Solution:

$$f_r = \frac{1}{2\pi\sqrt{LC}}$$

$$f_r = \frac{1}{2\pi\sqrt{8 \times 4 \times 10^{-9}}}$$

$$f_r = 889.7 \text{ Hz}$$

$$I_{max} = \frac{V_S}{R}$$

$$I_{max} = \frac{50}{10} = 5 \text{ A}$$

$$X_L = 2\pi f_r L = 44.72 \ \Omega$$

$$X_C = \frac{1}{2\pi f_r C} = 44.72 \ \Omega$$

$$V_R = I_{max}R = 50 V$$

The phasor diagram is shown in Figure 3.76. The three electrical quantities that is voltage across the source, voltage across the resistor and current in the series circuit are in phase.

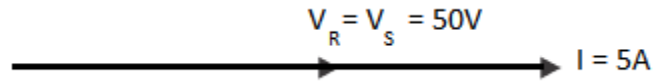

Figure 3.76: Phasor Diagram under Resonance Condition

Exercise:

Q 3.1: Consider the RL series circuit in Figure 3.77; determine the impedance, current in the circuit and power supplied by the voltage source, if the root mean square value of the source voltage is, $V_S = 20 V$.

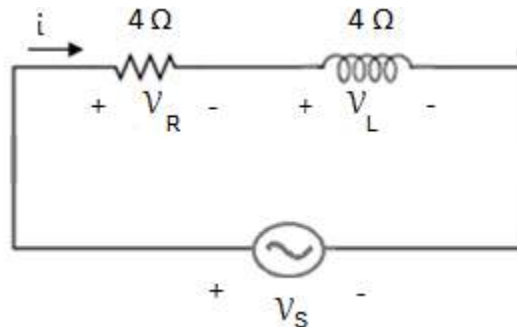

Figure 3.77: Circuit for Q 3.1

Answer: $Z = 5.65 \angle 45^\circ$, $I = 3.54 A$, $P_S = 50 W$

Q 3.2: Consider the circuit in Figure 3.78; determine the impedance, current in the circuit and power supplied by the voltage source, if $V_S = 30 V$

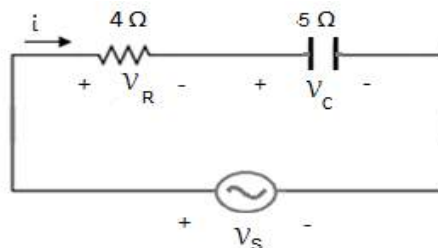

Figure 3.78: Circuit for Q 3.2

Answer: $Z = 5.38 \angle 68.2^\circ$, $I = 5.57 \text{ A}$, $P_S = 62 \text{ W}$

Q 3.3: Consider the circuit in Figure 3.79; determine the impedance, current in the circuit and power supplied by the voltage source, if $V_S = 50 \text{ V}$.

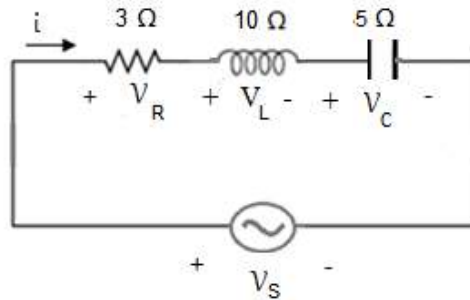

Figure 3.79: Circuit for Q 3.3

Answer: $Z = 5.83 \angle 59^\circ$, $I = 8.57 \text{ A}$, $P_S = 220.3 \text{ W}$

Q 3.4: Consider the circuit in Figure 3.79; find the instantaneous equations of the current and all the four voltages. The frequency of the source is 50Hz.

Answer: $i = 8.57\sqrt{2} \sin 100\pi t$,

$$v_R = 25.71\sqrt{2} \sin 100\pi t,$$

$$v_L = 58.71\sqrt{2} \sin \left(100\pi t + \frac{\pi}{2} \right)$$

$$v_C = 42.85\sqrt{2} \sin \left(100\pi t - \frac{\pi}{2} \right)$$

$$v_S = 50\sqrt{2} \sin (100\pi t + 59^\circ)$$

Chapter 4

AC Parallel Circuits

4-1 Impedance Method for Inductive Circuit

Consider a parallel circuit as shown in Figure 4.1. There are two inductive branches in the circuit. The total current delivered by the AC source is I . This current divides into two parts at the node. The current in the first branch is I_1 and the current in the second branch of the parallel circuit is I_2 . The voltage across the source appears across the first as well as the second inductive branch of the circuit.

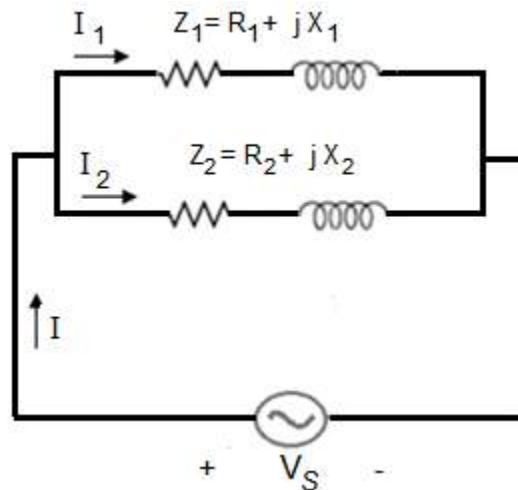

Figure 4.1: Inductive Parallel Circuit

Let the source voltage is

$$V_S = V_{S_{rms}} \angle 0^\circ$$

Impedance of first inductive branch is

$$Z_1 = R_1 + jX_1 = |Z_1| \angle \theta_1$$

Impedance of second inductive branch is

$$Z_2 = R_2 + jX_2 = |Z_2| \angle \theta_2$$

Current in first inductive branch is

$$I_1 = \frac{V_S}{Z_1}$$

$$I_1 = \frac{V_{S_{rms}} \angle 0^\circ}{|Z_1| \angle \theta_1}$$

$$I_1 = \frac{V_{S_{rms}}}{|Z_1|} \angle -\theta_1$$

$$I_1 = |I_1| \angle -\theta_1 \quad (4.1)$$

The current I_1 lags behind the source voltage by θ_1 . The same current in rectangular form is

$$I_1 = I_{a1} - jI_{b1} \quad (4.2)$$

Current in second inductive branch is

$$I_2 = \frac{V_S}{Z_2}$$

$$I_2 = \frac{V_{S_{rms}} \angle 0^\circ}{|Z_2| \angle \theta_2}$$

$$I_2 = \frac{V_{S_{rms}}}{|Z_2|} \angle -\theta_2$$

$$I_2 = |I_2| \angle -\theta_2 \quad (4.3)$$

The current I_2 lags behind the source voltage by θ_2 . The same current in rectangular form is

$$I_2 = I_{a2} - jI_{b2} \quad (4.4)$$

KCL states that phasor sum of the currents flowing towards the node is equal to phasor sum of the currents flowing away from the node. Thus the total current is equal to the phasor sum of I_1 and I_2 .

$$I = I_1 + I_2$$

$$I = (I_{a1} + I_{a2}) - j (I_{b1} + I_{b2})$$

$$I = I_a - j I_b$$

We convert the total current into polar form

$$I = |I| \angle -\theta \quad (4.5)$$

The phasor diagram of the parallel circuit is shown in Figure 4.2. The phasor for the source voltage is a reference phasor. The current I_1 lags behind the source voltage by θ_1 , The current I_2 lags behind the source voltage by θ_2 and The total current lags behind the source voltage by θ .

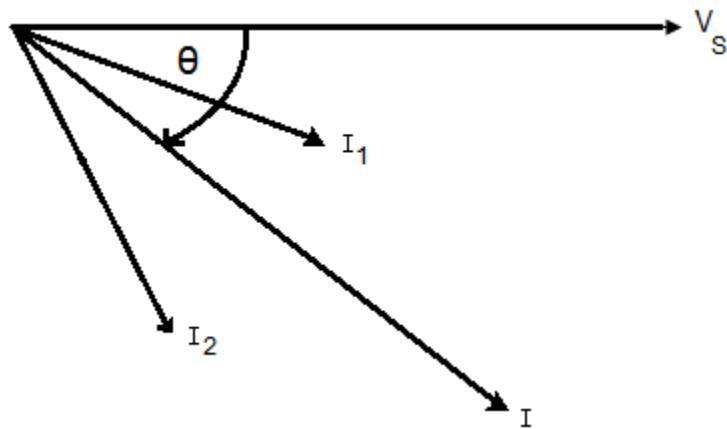

Figure 4.2: Phasor Diagram for Inductive Parallel Circuit

The impedance Triangles of first as well as second inductive branches are shown in Figure 4.3 and 4.4 respectively.

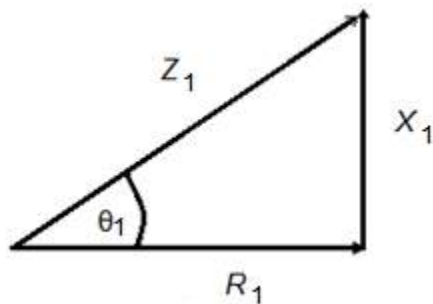

Figure 4.3: Impedance Triangle of First Branch

Power factor of first inductive branch is

$$pf_1 = \cos \theta_1$$

Where

$$\cos \theta_1 = \frac{R_1}{Z_1}$$

Power consumed by first inductive branch is

$$P_1 = V_{S_{rms}} I_{1_{rms}} \cos \theta_1 \quad (4.6)$$

or

$$P_1 = I_{1_{rms}}^2 R_1$$

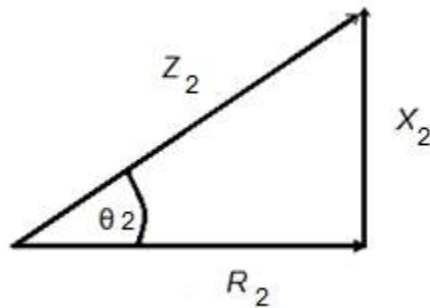

Figure 4.4: Impedance Triangle of Second Branch

Power factor of second inductive branch is

$$pf_2 = \cos \theta_2$$

Where

$$\cos \theta_2 = \frac{R_2}{Z_2}$$

Power consumed by second inductive branch is

$$P_2 = V_{S_{rms}} I_{2_{rms}} \cos \theta_2 \quad (4.7)$$

Or

$$P_2 = I_{2_{rms}}^2 R_2$$

The power supplied by the source

$$P_S = V_{S_{rms}} I_{rms} \cos \theta \quad (4.8)$$

Where $\cos \theta$ is the power factor of the entire circuit.

D 4.1: Consider the parallel circuit as shown in Figure 4.5. The RMS value of the source voltage is $100V$ and its phase angle is zero. Calculate the currents, power factors, powers taken by the two branches and power supplied by the source.

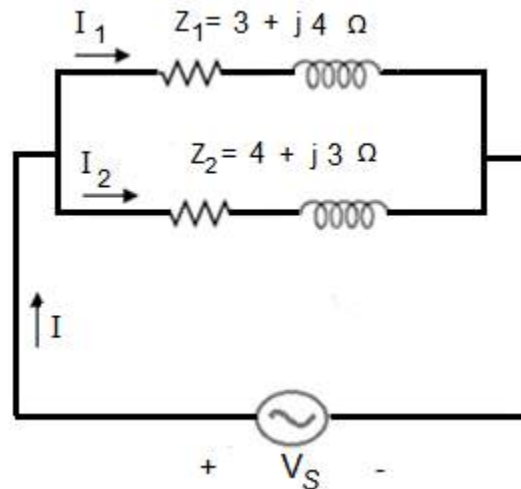

Figure 4.5: Parallel Circuit for D # 4.1

Solution:

Z_1 in polar form is

$$Z_1 = 5 \angle 53.1^\circ \Omega$$

Z_2 in polar form is

$$Z_2 = 5 \angle 36.8^\circ \Omega$$

Current in first inductive branch is

$$I_1 = \frac{V_S}{Z_1}$$

$$I_1 = \frac{100}{5\angle 53.1^\circ}$$

$$I_1 = 20\angle -53.1^\circ A$$

In rectangular form

$$I_1 = 12 - j16 A$$

Current in second inductive branch is

$$I_2 = \frac{V_S}{Z_2}$$

$$I_2 = \frac{100}{5\angle 36.8^\circ}$$

$$I_2 = 20\angle -36.8^\circ A$$

In rectangular form

$$I_2 = 16 - j12 A$$

The total current in accordance with KCL is

$$I = I_1 + I_2$$

$$I = (12 + 16) - j(16 + 12)$$

$$I = 28 - j28 A$$

In polar form

$$I = 39.6\angle -45^\circ A$$

Power factor of first inductive branch is

$$pf_1 = 0.6$$

Power consumed by first inductive branch is

$$P_1 = V_{S_{rms}} I_{1_{rms}} \cos \theta_1$$

$$P_1 = 100 \times 20 \times 0.6$$

$$P_1 = 1200 \text{ W}$$

Power factor of second inductive branch is

$$pf_2 = 0.8$$

Power consumed by second inductive branch is

$$P_2 = V_{S_{rms}} I_{2_{rms}} \cos \theta_2$$

$$P_2 = 100 \times 20 \times 0.8$$

$$P_2 = 1600 \text{ W}$$

The power supplied by the source

$$P_S = V_{S_{rms}} I_{rms} \cos \theta$$

$\cos \theta$ is the power factor of the entire circuit and it is equal to 0.707

$$P_S = 100 \times 39.6 \times 0.707$$

$$P_S = 2800 \text{ W}$$

4-2 Impedance Method for Capacitive Circuit

Consider a parallel circuit as shown in Figure 4.6. There are two capacitive branches in the circuit. The total current delivered by the AC source is I . This current divides into two parts at the node. The current in the first branch is I_1 and the current in the second branch of the parallel circuit is I_2 . The voltage across the source appears across the first as well as the second capacitive branch of the circuit.

Let the source voltage is

$$V_S = V_{S_{rms}} \angle 0^\circ$$

Impedance of first capacitive branch is

$$Z_1 = R_1 - jX_1 = |Z_1| \angle -\theta_1$$

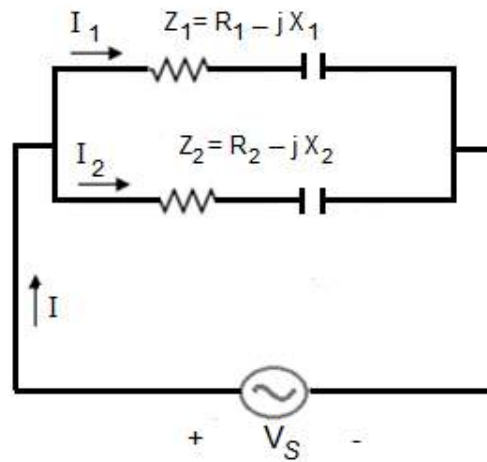

Figure 4.6: Capacitive Parallel Circuit

Impedance of second capacitive branch is

$$Z_2 = R_2 - jX_2 = |Z_2| \angle -\theta_2$$

Current in first capacitive branch is

$$I_1 = \frac{V_S}{Z_1}$$

$$I_1 = \frac{V_{S_{rms}} \angle 0^\circ}{|Z_1| \angle -\theta_1}$$

$$I_1 = \frac{V_{S_{rms}}}{|Z_1|} \angle \theta_1$$

$$I_1 = |I_1| \angle \theta_1 \quad (4.9)$$

The current I_1 leads the source voltage by θ_1 . The same current in rectangular form is

$$I_1 = I_{a1} + jI_{b1} \quad (4.10)$$

Current in second capacitive branch is

$$I_2 = \frac{V_S}{Z_2}$$

$$I_2 = \frac{V_{S_{rms}} \angle 0^\circ}{|Z_2| \angle -\theta_2}$$

$$I_2 = \frac{V_{S_{rms}}}{|Z_2|} \angle \theta_2$$

$$I_2 = |I_2| \angle \theta_2 \quad (4.11)$$

The current I_2 leads the source voltage by θ_2 . The same current in rectangular form is

$$I_2 = I_{a2} + jI_{b2} \quad (4.12)$$

KCL states that phasor sum of the currents flowing towards the node is equal to the phasor sum of the currents flowing away from the node. Thus the total current is equal to the phasor sum of I_1 and I_2 .

$$I = I_1 + I_2$$

$$I = (I_{a1} + I_{a2}) + j(I_{b1} + I_{b2})$$

$$I = I_a + j I_b$$

Total current in polar form is given by equation 4.13.

$$I = |I| \angle \theta \quad (4.13)$$

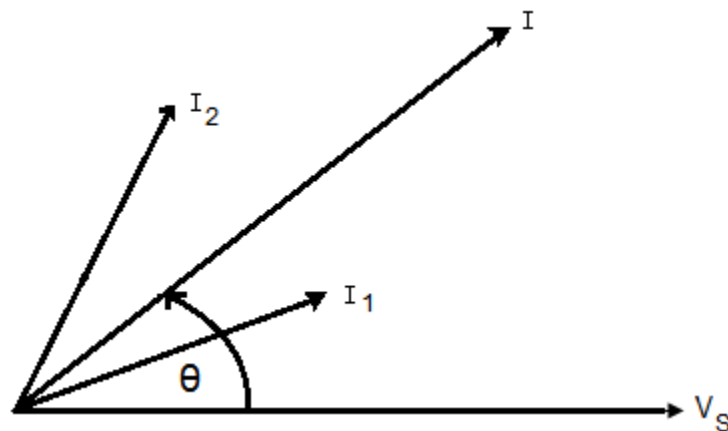

Figure 4.7: Phasor Diagram for Capacitive Parallel Circuit

Phasor diagram of the parallel circuit is shown in Figure 4.7. The phasor for the source voltage is a reference phasor. The current I_1 leads the source voltage by θ_1 , the current I_2 leads the source voltage by θ_2 and the total current leads the source voltage by θ . The impedance triangles of first as well as second capacitive branch are shown in Figure 4.8 and 4.9 respectively.

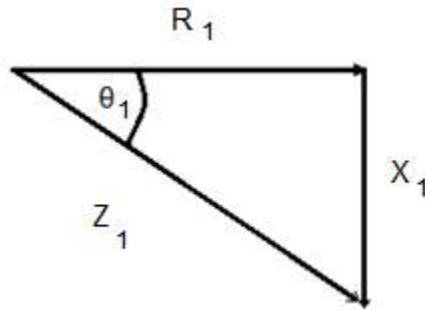

Figure 4.8: Impedance Triangle of first Branch

Power factor of first capacitive branch is

$$pf_1 = \cos \theta_1$$

Where

$$\cos \theta_1 = \frac{R_1}{Z_1}$$

Power consumed by first capacitive branch is

$$P_1 = V_{S_{rms}} I_{1_{rms}} \cos \theta_1 \quad (4.14)$$

or

$$P_1 = I_{1_{rms}}^2 R_1$$

Power factor of second capacitive branch is

$$pf_2 = \cos \theta_2$$

Where

$$\cos \theta_2 = \frac{R_2}{Z_2}$$

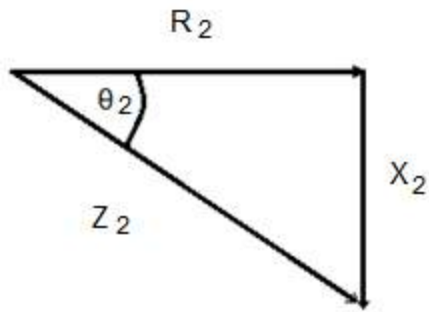

Figure 4.9: Impedance Triangle of second Branch

Power consumed by second capacitive branch is

$$P_2 = V_{S_{rms}} I_{2_{rms}} \cos \theta_2 \quad (4.15)$$

or

$$P_2 = I_{2_{rms}}^2 R_2$$

Using equation 4.16, power supplied by the source can be calculated.

$$P_S = V_{S_{rms}} I_{rms} \cos \theta \quad (4.16)$$

Where $\cos \theta$ is the power factor of the entire circuit.

D 4.2: Consider the parallel circuit as shown in Figure 4.10. The RMS value of the source voltage is $100V$ and its phase angle is zero. Calculate the currents, power factors, powers taken by the two branches and power supplied by the source.

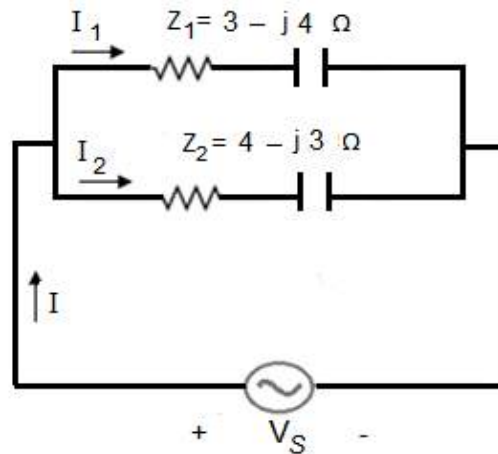

Figure 4.10: Parallel Circuit for D # 4.2

Solution:

Z_1 in polar form is

$$Z_1 = 5\angle -53.1^\circ \Omega$$

Z_2 in polar form is

$$Z_2 = 5\angle -36.8^\circ \Omega$$

Current in first capacitive branch is

$$I_1 = \frac{V_S}{Z_1}$$

$$I_1 = \frac{100}{5\angle -53.1^\circ}$$

$$I_1 = 20\angle 53.1^\circ A$$

In rectangular form

$$I_1 = 12 + j16 A$$

Current in second capacitive branch is

$$I_2 = \frac{V_S}{Z_2}$$

$$I_2 = \frac{100}{5\angle -36.8^\circ}$$

$$I_2 = 20\angle 36.8^\circ A$$

In rectangular form

$$I_2 = 16 + j12 A$$

The total current in accordance with KCL is

$$I = I_1 + I_2$$

$$I = (12 + 16) + j(16 + 12)$$

$$I = 28 + j 28 A$$

In polar form

$$I = 39.6 \angle 45^\circ A$$

Power factor of first capacitive branch is

$$pf_1 = 0.6$$

Power consumed by first capacitive branch is

$$P_1 = V_{s_{rms}} I_{1_{rms}} \cos \theta_1$$

$$P_1 = 100 \times 20 \times 0.6$$

$$P_1 = 1200 W$$

Power factor of second capacitive branch is

$$pf_2 = 0.8$$

Power consumed by second capacitive branch is

$$P_2 = V_{s_{rms}} I_{2_{rms}} \cos \theta_2$$

$$P_2 = 100 \times 20 \times 0.8$$

$$P_2 = 1600 W$$

Power supplied by the source

$$P_S = V_{s_{rms}} I_{rms} \cos \theta$$

$\cos \theta$ is the power factor of the entire circuit and it is equal to 0.707

$$P_S = 100 \times 39.6 \times 0.707 = 2800 W$$

4-3 Impedance Method for Parallel Circuit

Consider a parallel circuit as shown in Figure 4.11. There are two branches in the circuit. The total current delivered by the AC source is I . This current divides into two parts at the node. The current in the inductive branch is I_1 and the current in the capacitive branch of the parallel circuit is I_2 . Voltage across the source appears across the first as well as the second branch of the circuit.

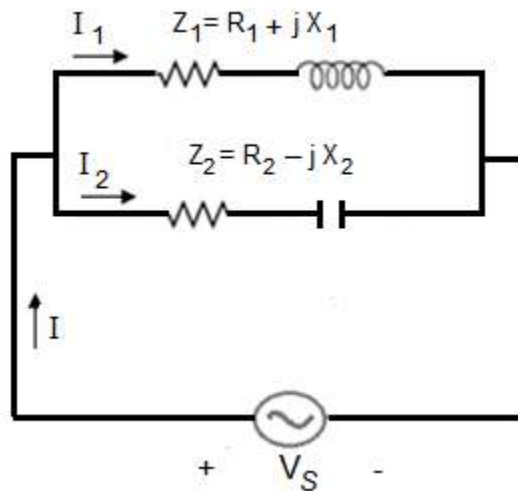

Figure 4.11: Parallel Circuit

Let the source voltage is in polar form

$$V_S = V_{S_{rms}} \angle 0^\circ$$

Impedance of inductive branch is

$$Z_1 = R_1 + jX_1 = |Z_1| \angle \theta_1$$

Impedance of capacitive branch is

$$Z_2 = R_2 - jX_2 = |Z_2| \angle -\theta_2$$

Current in inductive branch is

$$I_1 = \frac{V_S}{Z_1}$$

$$I_1 = \frac{V_{S_{rms}} \angle 0^\circ}{|Z_1| \angle \theta_1}$$

$$I_1 = \frac{V_{S_{rms}}}{|Z_1|} \angle -\theta_1$$

$$I_1 = |I_1| \angle -\theta_1 \quad (4.17)$$

The current I_1 lags behind the source voltage by θ_1 . The same current in rectangular form is

$$I_1 = I_{a1} - jI_{b1} \quad (4.18)$$

Current in second branch is

$$I_2 = \frac{V_S}{Z_2}$$

$$I_2 = \frac{V_{S_{rms}} \angle 0^\circ}{|Z_2| \angle -\theta_2}$$

$$I_2 = \frac{V_{S_{rms}}}{|Z_2|} \angle \theta_2$$

$$I_2 = |I_2| \angle \theta_2 \quad (4.19)$$

The current I_2 leads the source voltage by θ_2 . The same current in rectangular form is

$$I_2 = I_{a2} + jI_{b2} \quad (4.20)$$

KCL states that phasor sum of the currents flowing towards the node is equal to the phasor sum of the currents flowing away from the node. Thus the total current is equal to the phasor sum of I_1 and I_2 .

$$I = I_1 + I_2$$

$$I = (I_{a1} + I_{a2}) + j(I_{b2} - I_{b1})$$

$$I = I_a \pm j I_b$$

Total current in polar form is given by equation 4.21.

$$I = |I| \angle \pm \theta \quad (4.21)$$

We discuss three different conditions here. If θ is positive then the total current will lead the applied voltage and the entire circuit will act like a capacitive circuit. The power factor of the parallel circuit will be a leading power factor and the phasor diagram will be as shown in Figure 4.12. The phasor for the source voltage is a reference phasor. The current I_1 lags behind the source voltage by θ_1 , The current I_2 leads the source voltage by θ_2 .

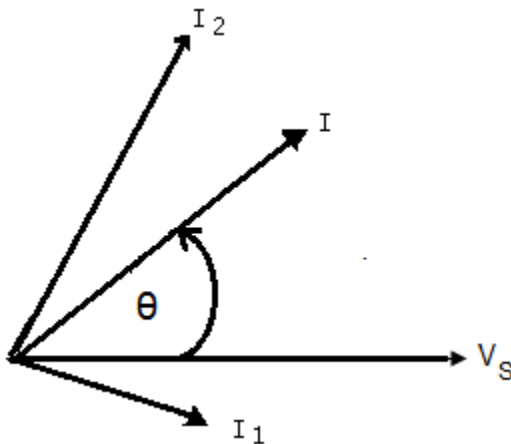

Figure 4.12: Phasor Diagram for Capacitive Behavior

If θ is negative then the total current will lag behind the applied voltage and the entire circuit will act like a inductive circuit. The power factor of the parallel circuit will be a lagging power factor and the phasor diagram will be as shown in Figure 4.13.

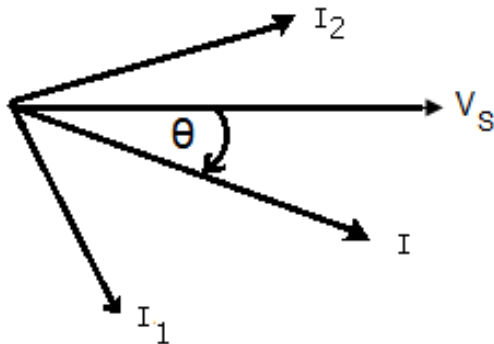

Figure 4.13: Phasor Diagram for Inductive Behavior

If θ is zero then the total current will be in phase with the applied voltage and the entire circuit will act like a pure resistive circuit. The power factor of the parallel circuit will be unity power factor and the phasor diagram will be as shown in Figure 4.14. This condition is known as anti-resonance condition.

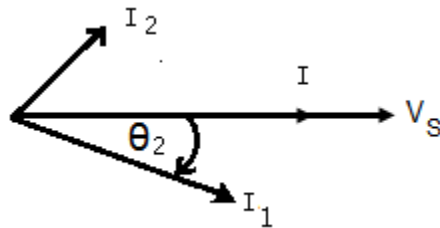

Figure 4.14: Phasor Diagram for Resistive Behavior

The impedance triangles of inductive as well as second branch are shown in Figure 4.15 and 4.16 respectively. Power factor of inductive branch is given by

$$pf_1 = \cos \theta_1$$

Where

$$\cos \theta_1 = \frac{R_1}{Z_1}$$

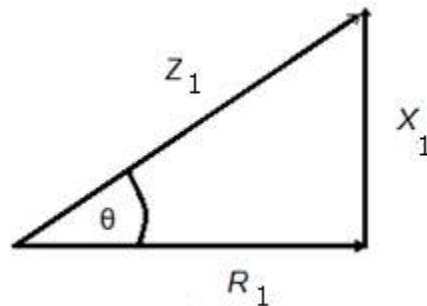

Figure 4.15: Impedance Triangle of Inductive Branch

Power consumed by inductive branch is

$$P_1 = V_{s_{rms}} I_{1_{rms}} \cos \theta_1 \quad (4.22)$$

Or

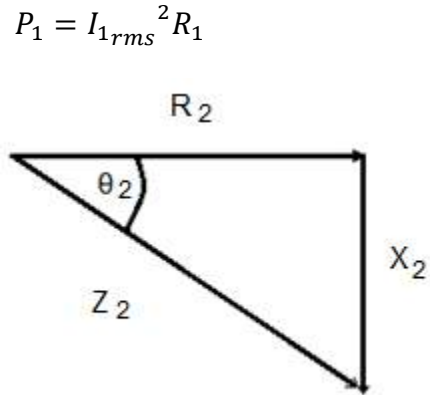

Figure 4.16: Impedance Triangle of Capacitive Branch

Power factor of capacitive branch is

$$pf_2 = \cos \theta_2$$

Where

$$\cos \theta_2 = \frac{R_2}{Z_2}$$

Power consumed by capacitive branch is

$$P_2 = V_{s rms} I_{2 rms} \cos \theta_2 \quad (4.23)$$

Or

$$P_2 = I_{2 rms}^2 R_2$$

The power supplied by the source

$$P_S = V_{s rms} I_{rms} \cos \theta \quad (4.24)$$

$\cos \theta$ is the power factor of the entire circuit.

D 4.3: Consider the parallel circuit as shown in Figure 4.17. The RMS value of the source voltage is $100V$ and its phase angle is zero. Calculate the currents, power factors, powers taken by the two branches and power supplied by the source.

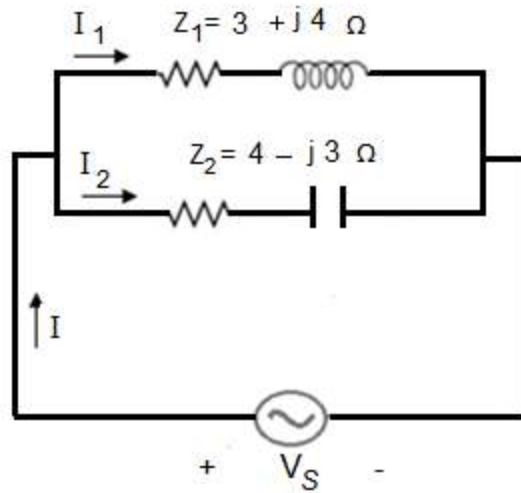

Figure 4.17: Parallel Circuit for D # 4.3

Solution:

Z_1 in polar form is

$$Z_1 = 5 \angle 53.1^\circ \Omega$$

Z_2 in polar form is

$$Z_2 = 5 \angle -36.8^\circ \Omega$$

Current in inductive branch is

$$I_1 = \frac{V_S}{Z_1}$$

$$I_1 = \frac{100}{5 \angle 53.1^\circ}$$

$$I_1 = 20 \angle -53.1^\circ A$$

In rectangular form

$$I_1 = 12 - j16 A$$

Current in capacitive branch is

$$I_2 = \frac{V_S}{Z_2}$$

$$I_2 = \frac{100}{5 \angle -36.8^\circ}$$

$$I_2 = 20 \angle 36.8^\circ \text{ A}$$

In rectangular form

$$I_2 = 16 + j12 \text{ A}$$

The total current in accordance with KCL is

$$I = I_1 + I_2$$

$$I = (12 + 16) + j(-16 + 12)$$

$$I = 28 - j4 \text{ A}$$

In polar form

$$I = 28.28 \angle -8.13^\circ \text{ A}$$

As θ is negative, the current lags behind the source voltage and entire circuit behaves like an inductive circuit. Power factor of inductive branch is given by

$$pf_1 = 0.6$$

Power consumed by inductive branch is

$$P_1 = V_{s_{rms}} I_{1_{rms}} \cos \theta_1$$

$$P_1 = 100 \times 20 \times 0.6$$

$$P_1 = 1200 \text{ W}$$

Power factor of capacitive branch is

$$pf_2 = 0.8$$

Power consumed by capacitive branch is

$$P_2 = V_{S_{rms}} I_{2_{rms}} \cos \theta_2$$

$$P_2 = 100 \times 20 \times 0.8$$

$$P_2 = 1600 \text{ W}$$

The power supplied by the source

$$P_S = V_{S_{rms}} I_{rms} \cos \theta$$

$\cos \theta$ is the power factor of the entire circuit and it is equal to 0.9899

$$P_S = 100 \times 28.28 \times 0.9899$$

$$P_S = 2800 \text{ W}$$

D 4.4: Consider the parallel circuit as shown in Figure 4.18. The RMS value of the source voltage is 100V and its phase angle is zero. Calculate the currents, power factors, powers taken by the two branches and power supplied by the source.

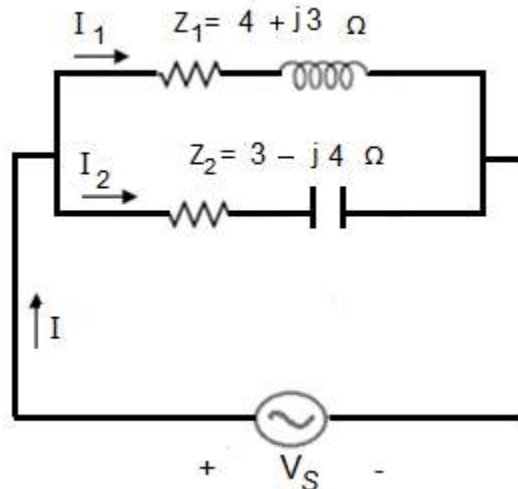

Figure 4.18: Parallel Circuit for D # 4.4

Solution:

Z_1 in polar form is

$$Z_1 = 5\angle 36.8^\circ \Omega$$

Z_2 in polar form is

$$Z_2 = 5\angle -53.1^\circ \Omega$$

Current in inductive branch is

$$I_1 = \frac{V_s}{Z_1}$$

$$I_1 = \frac{100}{5\angle 36.8^\circ}$$

$$I_1 = 20\angle -36.8^\circ A$$

In rectangular form

$$I_1 = 16 - j12 A$$

Current in capacitive branch is

$$I_2 = \frac{V_s}{Z_2}$$

$$I_2 = \frac{100}{5\angle -53.1^\circ}$$

$$I_2 = 20\angle 53.1^\circ A$$

In rectangular form

$$I_2 = 12 + j16 A$$

The total current in accordance with KCL is

$$I = I_1 + I_2$$

$$I = (12 + 16) + j(16 - 12)$$

$$I = 28 + j4 A$$

In polar form

$$I = 28.28 \angle 8.13^\circ A$$

As θ is positive, the current leads the source voltage and entire circuit behaves like a capacitive circuit. Power factor of inductive branch is $pf_1 = 0.8$, so power consumed by inductive branch is given by

$$P_1 = V_{s_{rms}} I_{1_{rms}} \cos \theta_1$$

$$P_1 = 100 \times 20 \times 0.8$$

$$P_1 = 1600 W$$

Power factor of capacitive branch is $pf_2 = 0.6$, so power consumed by capacitive branch is

$$P_2 = V_{s_{rms}} I_{2_{rms}} \cos \theta_2$$

$$P_2 = 100 \times 20 \times 0.6$$

$$P_2 = 1200 W$$

The power supplied by the source is

$$P_S = V_{s_{rms}} I_{rms} \cos \theta$$

$\cos \theta$ is the power factor of the entire circuit and it is equal to 0.9899

$$P_S = 100 \times 28.28 \times 0.9899$$

$$P_S = 2800 W$$

D 4.5: Consider the parallel circuit as shown in Figure 4.19. The RMS value of the source voltage is $100V$ and its phase angle is zero. Calculate the currents, power factors, powers taken by the two branches and power supplied by the source.

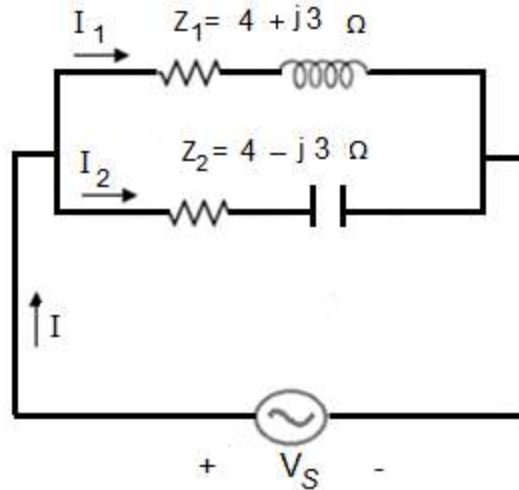

Figure 4.19: Parallel Circuit for D # 4.5

Solution:

Z_1 in polar form is

$$Z_1 = 5 \angle 36.8^\circ \Omega$$

Z_2 in polar form is

$$Z_2 = 5 \angle -36.8^\circ \Omega$$

Current in inductive branch is

$$I_1 = \frac{V_S}{Z_1}$$

$$I_1 = \frac{100}{5 \angle 36.8^\circ}$$

$$I_1 = 20 \angle -36.8^\circ A$$

In rectangular form

$$I_1 = 16 - j12 A$$

Current in capacitive branch is

$$I_2 = \frac{V_S}{Z_2}$$

$$I_2 = \frac{100}{5\angle -36.8^\circ}$$

$$I_2 = 20\angle 36.8^\circ \text{ A}$$

In rectangular form

$$I_2 = 16 + j12 \text{ A}$$

The total current in accordance with KCL is

$$I = I_1 + I_2$$

$$I = (16 + 16) + j(12 - 12)$$

$$I = 32 \text{ A}$$

In polar form

$$I = 32\angle 0^\circ \text{ A}$$

As θ is zero, the total current is in phase with source voltage and entire circuit behaves like a resistive circuit. Power factor of inductive branch is $pf_1 = 0.8$, so power consumed by inductive branch is

$$P_1 = V_{S_{rms}} I_{1_{rms}} \cos \theta_1$$

$$P_1 = 100 \times 20 \times 0.8$$

$$P_1 = 1600 \text{ W}$$

Power factor of capacitive branch is $pf_2 = 0.8$, so power consumed by capacitive branch is given by

$$P_2 = V_{S_{rms}} I_{2_{rms}} \cos \theta_2$$

$$P_2 = 100 \times 20 \times 0.8$$

$$P_2 = 1600 \text{ W}$$

The power supplied by the source

$$P_S = V_{S_{rms}} I_{rms} \cos \theta$$

$\cos \theta$ is power factor of the entire circuit and it is equal to 1

$$P_S = 100 \times 32 \times 1$$

$$P_S = 3200 \text{ W}$$

4-4 Admittance Method for Inductive Circuit

Consider a parallel circuit as shown in Figure 4.20. There are two inductive branches in the circuit. The total current delivered by the AC source is I . This current divides into two parts at the node. The current in the first branch is I_1 and the current in the second branch of the parallel circuit is I_2 . The voltage across the source appears across the first as well as the second inductive branch of the circuit. Let the source voltage is in polar form

$$V_S = V_{S_{rms}} \angle 0^\circ$$

Impedance of first inductive branch is

$$Z_1 = R_1 + jX_1$$

Impedance of second inductive branch is

$$Z_2 = R_2 + jX_2$$

Current in first inductive branch is

$$I_1 = \frac{V_S}{Z_1}$$

$$I_1 = V_S \left(\frac{1}{Z_1} \right)$$

The reciprocal of impedance is known as admittance and it is represented by Y .

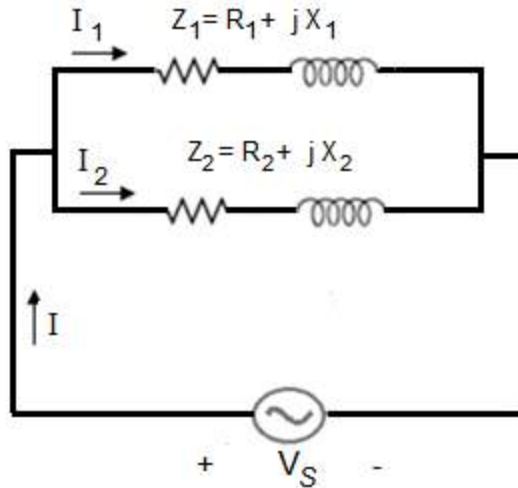

Figure 4.20: Inductive Parallel Circuit

$$Y_1 = \frac{1}{Z_1}$$

Therefore

$$I_1 = V_S Y_1 \quad (4.25)$$

$$Y_1 = \frac{1}{R_1 + jX_1}$$

$$Y_1 = \frac{1}{R_1 + jX_1} \times \frac{R_1 - jX_1}{R_1 - jX_1}$$

$$Y_1 = \frac{R_1}{R_1^2 + X_1^2} - j \frac{X_1}{R_1^2 + X_1^2} \quad (4.26)$$

The real component of admittance is known as conductance which is represented by G And imaginary component is known as susceptance which is represented by B . So

$$G_1 = \frac{R_1}{R_1^2 + X_1^2}$$

$$B_1 = \frac{X_1}{R_1^2 + X_1^2}$$

Putting the values in equation 4.25

$$I_1 = V_S(G_1 - jB_1)$$

$$I_1 = I_{a1} - jI_{b1}$$

$$I_1 = |I_1| \angle -\theta_1 \quad (4.27)$$

The current I_1 lags behind the source voltage by θ_1 . Current in second inductive branch is given by

$$I_2 = \frac{V_S}{Z_2}$$

$$I_2 = V_S \left(\frac{1}{Z_2} \right)$$

The admittance of the second branch is

$$Y_2 = \frac{1}{Z_2}$$

Therefore

$$I_2 = V_S Y_2 \quad (4.28)$$

$$Y_2 = \frac{1}{R_2 + jX_2}$$

$$Y_2 = \frac{1}{R_2 + jX_2} \times \frac{R_2 - jX_2}{R_2 - jX_2}$$

$$Y_2 = \frac{R_2}{R_2^2 + X_2^2} - j \frac{X_2}{R_2^2 + X_2^2} \quad (4.29)$$

The real component of admittance is known as conductance which is represented by G
And imaginary component is known as susceptance which is represented by B . So

$$G_2 = \frac{R_2}{R_2^2 + X_2^2}$$

$$B_2 = \frac{X_2}{R_2^2 + X_2^2}$$

Therefore

$$I_2 = V_S(G_2 - jB_2)$$

$$I_2 = I_{a2} - jI_{b2}$$

$$I_2 = |I_2| \angle -\theta_2 \quad (4.30)$$

Total current in the parallel circuit is given by

$$I = I_1 + I_2$$

$$I = (I_{a1} + I_{a2}) - j(I_{b1} + I_{b2})$$

$$I = I_a - j I_b$$

We convert the total current into polar form

$$I = |I| \angle -\theta \quad (4.31)$$

The admittance triangles of first as well as second inductive branches are shown in Figure 4.21 and 4.22 respectively.

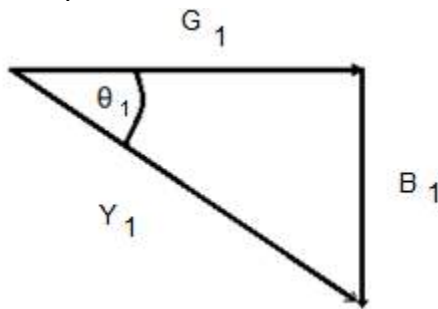

Figure 4.21: Admittance Triangle of first Branch

Power factor of first inductive branch is

$$pf_1 = \cos \theta_1$$

Where

$$\cos \theta_1 = \frac{G_1}{Y_1}$$

Power consumed by first inductive branch is

$$P_1 = V_{S_{rms}} I_{1_{rms}} \cos \theta_1$$

Or

$$P_1 = I_{1_{rms}}^2 R_1$$

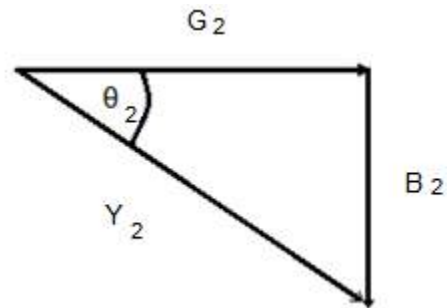

Figure 4.22: Admittance Triangle of second Branch

Power factor of second inductive branch is

$$pf_2 = \cos \theta_2$$

Where

$$\cos \theta_2 = \frac{G_2}{Y_2}$$

Power consumed by second inductive branch is

$$P_2 = V_{S_{rms}} I_{2_{rms}} \cos \theta_2$$

Or

$$P_2 = I_{2_{rms}}^2 R_2$$

The power supplied by the source

$$P_S = V_{S_{rms}} I_{rms} \cos \theta$$

D 4.6: Consider the parallel circuit as shown in Figure 4.23. The RMS value of the source voltage is $100V$ and its phase angle is zero. Calculate the currents, power factors, powers taken by the two branches and power supplied by the source.

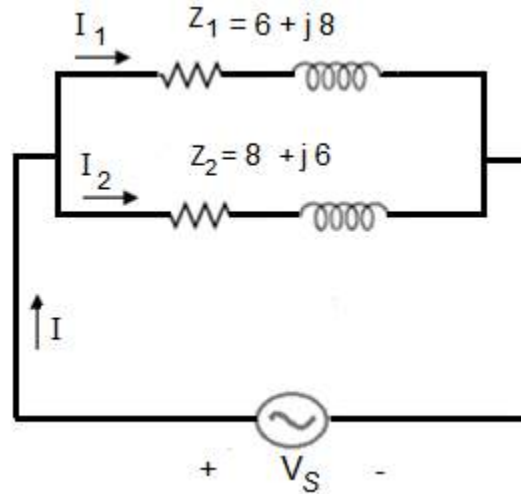

Figure 4.23: Parallel Circuit for D # 4.6.

Solution:

$$G_1 = \frac{R_1}{R_1^2 + X_1^2}$$

$$G_1 = \frac{6}{100} \quad \text{U}$$

$$B_1 = \frac{X_1}{R_1^2 + X_1^2}$$

$$B_1 = \frac{8}{100} \quad \text{U}$$

$$I_1 = V_S (G_1 - jB_1)$$

$$I_1 = 100 \left(\frac{6}{100} - j \frac{8}{100} \right)$$

$$I_1 = 6 - j8 \text{ A}$$

$$I_1 = 10 \angle -53.1^\circ \text{ A}$$

$$G_2 = \frac{R_2}{R_2^2 + X_2^2}$$

$$G_2 = \frac{8}{100} \text{ U}$$

$$B_2 = \frac{X_2}{R_2^2 + X_2^2}$$

$$B_2 = \frac{6}{100} \text{ U}$$

$$I_2 = 100 \left(\frac{8}{100} - j \frac{6}{100} \right)$$

$$I_2 = 8 - j6 \text{ A}$$

$$I_2 = 10 \angle -36.8^\circ \text{ A}$$

As

$$I = I_1 + I_2$$

$$I = 14 - j14 \text{ A}$$

$$I = 19.79 \angle -45^\circ \text{ A}$$

$$P_1 = I_1^2 R_1$$

$$P_1 = 600 \text{ W}$$

$$P_2 = I_2^2 R_2$$

$$P_2 = 800 \text{ W}$$

Power Supplied by the source

$$P_S = P_1 + P_2$$

$$P_S = 1400 \text{ W}$$

4-5 Admittance Method for Capacitive Circuit

Consider a parallel circuit as shown in Figure 4.24. There are two capacitive branches in the circuit. The total current delivered by the AC source is I . This current divides into two parts at the node. The current in the first branch is I_1 and the current in the second branch of the parallel circuit is I_2 .

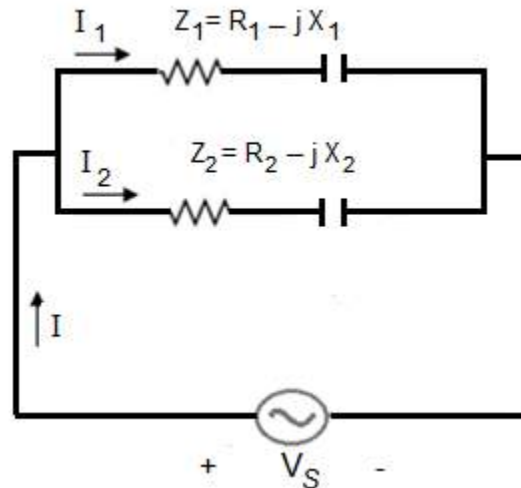

Figure 4.24: Capacitive Parallel Circuit

The voltage across the source appears across the first as well as the second branch of the circuit. Let the source voltage is

$$V_S = V_{S_{rms}} \angle 0^\circ$$

Impedance of first capacitive branch is

$$Z_1 = R_1 - jX_1$$

Impedance of second capacitive branch is

$$Z_2 = R_2 - jX_2$$

Current in first inductive branch is

$$I_1 = \frac{V_S}{Z_1}$$

$$I_1 = V_S \left(\frac{1}{Z_1} \right)$$

Admittance of the first branch is represented by Y_1 .

$$Y_1 = \frac{1}{Z_1}$$

Therefore

$$I_1 = V_S Y_1 \quad (4.32)$$

$$Y_1 = \frac{1}{R_1 - jX_1}$$

$$Y_1 = \frac{1}{R_1 - jX_1} \times \frac{R_1 + jX_1}{R_1 + jX_1}$$

$$Y_1 = \frac{R_1}{R_1^2 + X_1^2} + j \frac{X_1}{R_1^2 + X_1^2} \quad (4.33)$$

Therefore

$$G_1 = \frac{R_1}{R_1^2 + X_1^2}$$

$$B_1 = \frac{X_1}{R_1^2 + X_1^2}$$

Putting the values in equation 4.32

$$I_1 = V_S (G_1 + jB_1)$$

$$I_1 = I_{a1} + jI_{b1}$$

$$I_1 = |I_1| \angle \theta_1 \quad (4.34)$$

Current in second capacitive branch is

$$I_2 = \frac{V_S}{Z_2}$$

$$I_2 = V_S \left(\frac{1}{Z_2} \right)$$

The admittance of the second branch is

$$Y_2 = \frac{1}{Z_2}$$

Therefore

$$I_2 = V_S Y_2 \quad (4.35)$$

$$Y_2 = \frac{1}{R_2 - jX_2}$$

$$Y_2 = \frac{1}{R_2 - jX_2} \times \frac{R_2 + jX_2}{R_2 + jX_2}$$

$$Y_2 = \frac{R_2}{R_2^2 + X_2^2} + j \frac{X_2}{R_2^2 + X_2^2} \quad (4.36)$$

The real and imaginary components are

$$G_2 = \frac{R_2}{R_2^2 + X_2^2}$$

$$B_2 = \frac{X_2}{R_2^2 + X_2^2}$$

Therefore

$$I_2 = V_S (G_2 + jB_2)$$

$$I_2 = I_{a2} + jI_{b2}$$

$$I_2 = |I_2| \angle \theta_2 \quad (4.37)$$

Application of KCL on the node gives the total current.

$$I = I_1 + I_2$$

$$I = (I_{a1} + I_{a2}) + j (I_{b1} + I_{b2})$$

$$I = I_a + j I_b$$

We convert the total current into polar form

$$I = |I| \angle \theta \quad (4.38)$$

The total admittance of the circuit is equal to sum of Y_1 and Y_2

$$Y = Y_1 + Y_2$$

The admittance triangle of first branch is shown in Figure 4.25.

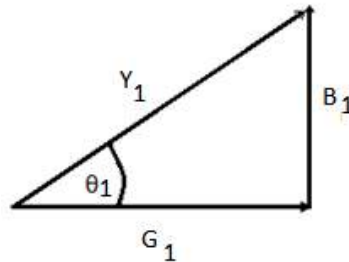

Figure 4.25: Admittance Triangle of first Branch

Power factor of first capacitive branch is

$$pf_1 = \cos \theta_1$$

Where

$$\cos \theta_1 = \frac{G_1}{Y_1}$$

Power consumed by first branch is

$$P_1 = V_{S_{rms}} I_{1_{rms}} \cos \theta_1$$

Or

$$P_1 = I_{1rms}^2 R_1$$

The admittance Triangle of second branch is shown in Figure 4.26.

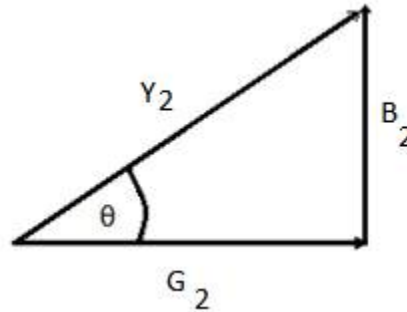

Figure 4.26: Admittance Triangle of second Branch

Power factor of second branch is

$$pf_2 = \cos \theta_2$$

Where

$$\cos \theta_2 = \frac{G_2}{Y_2}$$

Power consumed by second branch is

$$P_2 = V_{Srms} I_{2rms} \cos \theta_2$$

Or

$$P_2 = I_{2rms}^2 R_2$$

The power supplied by the source

$$P_S = V_{Srms} I_{rms} \cos \theta$$

Let us solve a few numerical problems related to parallel capacitive circuit to understand this topic.

D 4.7: Consider the parallel circuit as shown in Figure 4.27. The RMS value of the source voltage is $100V$ and its phase angle is zero. Calculate the currents, power factors, powers taken by the two branches and power supplied by the source.

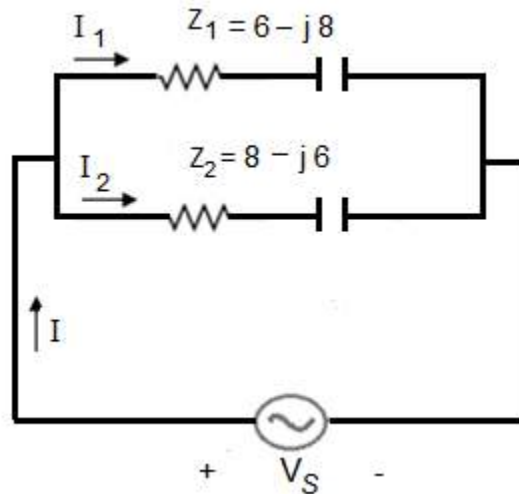

Figure 4.27: Parallel Circuit for D # 4.7

Solution:

$$G_1 = \frac{R_1}{R_1^2 + X_1^2}$$

$$G_1 = \frac{6}{100} \quad \text{U}$$

$$B_1 = \frac{X_1}{R_1^2 + X_1^2}$$

$$B_1 = \frac{8}{100} \quad \text{U}$$

$$I_1 = V_S (G_1 + jB_1)$$

$$I_1 = 100 \left(\frac{6}{100} + j \frac{8}{100} \right)$$

$$I_1 = 6 + j8 \text{ A}$$

$$I_1 = 10 \angle 53.1^\circ \text{ A}$$

$$G_2 = \frac{R_2}{R_2^2 + X_2^2}$$

$$G_2 = \frac{8}{100} \text{ S}$$

$$B_2 = \frac{X_2}{R_2^2 + X_2^2}$$

$$B_2 = \frac{6}{100} \text{ S}$$

$$I_2 = 100 \left(\frac{8}{100} + j \frac{6}{100} \right)$$

$$I_2 = 8 + j6 \text{ A}$$

$$I_2 = 10 \angle 36.8^\circ \text{ A}$$

As

$$I = I_1 + I_2$$

$$I = 14 + j14 \text{ A}$$

$$I = 19.79 \angle 45^\circ \text{ A}$$

$$P_1 = I_1^2 R_1$$

$$P_1 = 600 \text{ W}$$

$$P_2 = I_2^2 R_2$$

$$P_2 = 800 \text{ W}$$

Power Supplied by the source

$$P_S = P_1 + P_2$$

$$P_S = 1400 \text{ W}$$

4-6 Admittance Method for Parallel Circuit

Consider a parallel circuit as shown in Figure 4.28. There are two branches in the circuit. The total current delivered by the AC source is I .

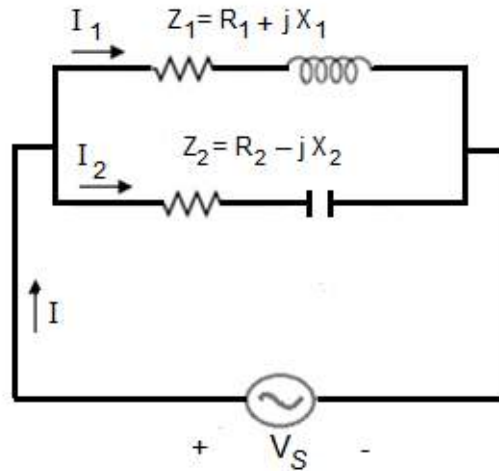

Figure 4.28: Parallel Circuit

This current divides into two parts at the node. The current in the inductive branch is I_1 and the current in the capacitive branch of the parallel circuit is I_2 . The voltage across the source appears across the first as well as the second capacitive branch of the circuit.

Let the source voltage is

$$V_S = V_{S_{rms}} \angle 0^\circ$$

Impedance of inductive branch is

$$Z_1 = R_1 + jX_1$$

Impedance of capacitive branch is

$$Z_2 = R_2 - jX_2$$

Current in inductive branch is

$$I_1 = \frac{V_S}{Z_1}$$

$$I_1 = V_S \left(\frac{1}{Z_1} \right)$$

Admittance of the first branch is represented by Y_1 .

$$Y_1 = \frac{1}{Z_1}$$

Therefore

$$I_1 = V_S Y_1 \quad (4.39)$$

$$Y_1 = \frac{1}{R_1 + jX_1}$$

$$Y_1 = \frac{1}{R_1 + jX_1} \times \frac{R_1 - jX_1}{R_1 - jX_1}$$

$$Y_1 = \frac{R_1}{R_1^2 + X_1^2} - j \frac{X_1}{R_1^2 + X_1^2} \quad (4.40)$$

Therefore

$$G_1 = \frac{R_1}{R_1^2 + X_1^2}$$

$$B_1 = \frac{X_1}{R_1^2 + X_1^2}$$

So current in inductive branch is

$$I_1 = V_S (G_1 - jB_1)$$

$$I_1 = I_{a1} - jI_{b1}$$

$$I_1 = |I_1| \angle -\theta_1 \quad (4.41)$$

Current in capacitive branch is

$$I_2 = \frac{V_S}{Z_2}$$

$$I_2 = V_S \left(\frac{1}{Z_2} \right)$$

Admittance of the capacitive branch is

$$Y_2 = \frac{1}{Z_2}$$

Therefore

$$I_2 = V_S Y_2 \quad (4.42)$$

$$Y_2 = \frac{1}{R_2 - jX_2}$$

$$Y_2 = \frac{1}{R_2 - jX_2} \times \frac{R_2 + jX_2}{R_2 + jX_2}$$

$$Y_2 = \frac{R_2}{R_2^2 + X_2^2} + j \frac{X_2}{R_2^2 + X_2^2} \quad (4.43)$$

So

$$G_2 = \frac{R_2}{R_2^2 + X_2^2}$$

$$B_2 = \frac{X_2}{R_2^2 + X_2^2}$$

Therefore

$$I_2 = V_S (G_2 + jB_2)$$

$$I_2 = I_{a2} + jI_{b2}$$

$$I_2 = |I_2| \angle \theta_2 \quad (4.44)$$

KCL gives you the total current.

$$I = I_1 + I_2$$

$$I = (I_{a1} + I_{a2}) + j(-I_{b1} + I_{b2})$$

$$I = I_a \pm j I_b$$

We convert the total current into polar form

$$I = |I| \angle \pm \theta \quad (4.45)$$

The nature of the circuit depends on the value of θ as discussed earlier. The admittance Triangle of inductive branches is shown in Figure 4.29.

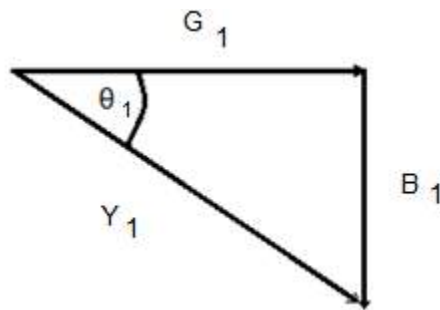

Figure 4.29: Admittance Triangle of first Branch

Power factor of inductive branch is

$$pf_1 = \cos \theta_1$$

Where

$$\cos \theta_1 = \frac{G_1}{Y_1}$$

Power consumed by inductive branch is

$$P_1 = V_{S_{rms}} I_{1_{rms}} \cos \theta_1$$

Or

$$P_1 = I_{1_{rms}}^2 R_1$$

The admittance triangle of capacitive branches is shown in Figure 4.30.

Power factor of capacitive branch is

$$pf_2 = \cos \theta_2$$

Where

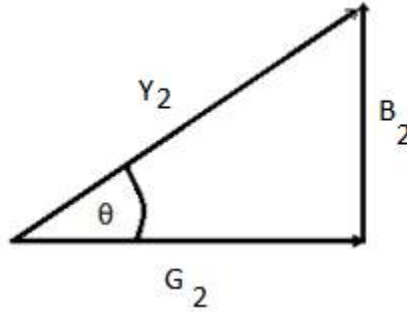

Figure 4.30: Admittance Triangle of second Branch

$$\cos \theta_2 = \frac{G_2}{Y_2}$$

Power consumed by capacitive branch is

$$P_2 = V_{S_{rms}} I_{2_{rms}} \cos \theta_2$$

Or

$$P_2 = I_{2_{rms}}^2 R_2$$

The power supplied by the source

$$P_S = V_{S_{rms}} I_{rms} \cos \theta$$

D 4.8: Consider the parallel circuit as shown in Figure 4.31. The RMS value of the source voltage is $100V$ and its phase angle is zero. Calculate the three currents in the circuit.

Solution:

$$G_1 = \frac{R_1}{R_1^2 + X_1^2}$$

$$G_1 = \frac{6}{100} \quad \text{U}$$

$$B_1 = \frac{X_1}{R_1^2 + X_1^2}$$

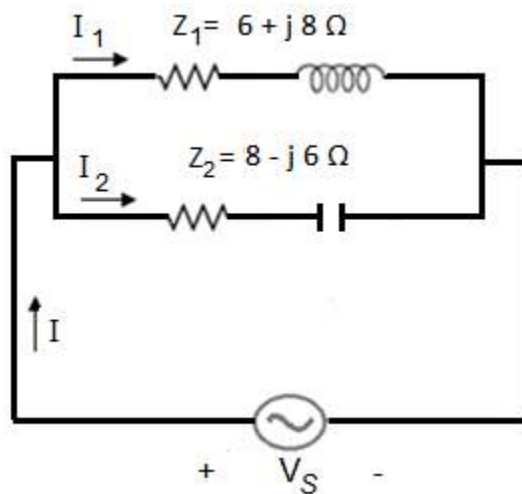

Figure 4.31: Circuit for D # 4.8

$$B_1 = \frac{8}{100} \quad \text{U}$$

$$I_1 = V_S (G_1 - jB_1)$$

$$I_1 = 100 \left(\frac{6}{100} - j \frac{8}{100} \right)$$

$$I_1 = 6 - j8 \text{ A}$$

$$I_1 = 10 \angle -53.1^\circ \text{ A}$$

$$G_2 = \frac{R_2}{R_2^2 + X_2^2}$$

$$G_2 = \frac{8}{100} \quad \text{U}$$

$$B_2 = \frac{X_2}{R_2^2 + X_2^2}$$

$$B_2 = \frac{6}{100} \quad \text{U}$$

$$I_2 = 100 \left(\frac{8}{100} + j \frac{6}{100} \right)$$

$$I_2 = 8 + j6 \text{ A}$$

$$I_2 = 10 \angle 36.8^\circ \text{ A}$$

As

$$I = I_1 + I_2$$

$$I = 14 - j2 \text{ A}$$

$$I = 14.14 \angle -8.13^\circ \text{ A}$$

The Circuit behaves like Inductive circuit.

4-7 Time Varying Quantities in Parallel Circuit

Case No 1

Consider a parallel circuit as shown in Figure 4.32. There are two inductive branches in the circuit. The total current delivered by the AC source is i . This current divides into two parts at the node. The current in the first branch is i_1 and the current in the second branch of the parallel circuit is i_2 . The voltage across the source appears across the first as well as the second inductive branch of the circuit.

Phasor value of source voltage is

$$V_S = V_{S_{rms}} \angle 0^\circ$$

Maximum value of the source voltage is calculated as

$$V_m = \sqrt{2} V_{S_{rms}}$$

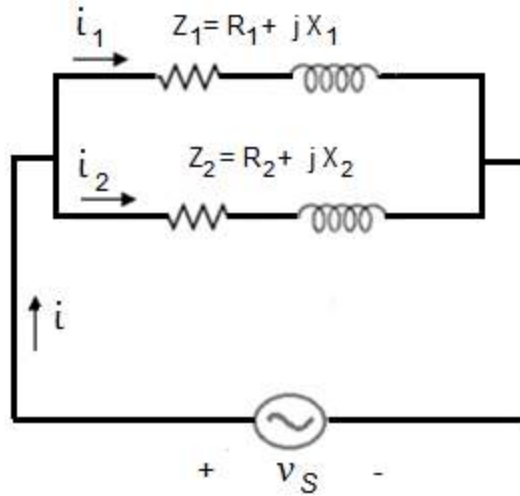

Figure 4.32: Inductive Parallel Circuit

The instantaneous voltage across the source is calculated as

$$v_S = \sqrt{2} V_{S_{rms}} \sin(\omega t + 0) \quad (4.46)$$

Current in first inductive branch is

$$I_1 = |I_1| \angle -\theta_1$$

Maximum value of the current I_1 is calculated as

$$I_{m1} = \sqrt{2} |I_1|$$

$|I_1|$ is the RMS value of the current in the first inductive branch. The instantaneous current in first branch is calculated as

$$i_1 = \sqrt{2} |I_1| \sin(\omega t - \theta_1) \quad (4.47)$$

The current i_1 lags behind the source voltage by θ_1 . Current in second inductive branch is

$$I_2 = |I_2| \angle -\theta_2$$

The current I_2 lags behind the source voltage by θ_2 . The maximum value of this current is calculated as

$$I_{m2} = \sqrt{2} |I_2|$$

$|I_2|$ is the RMS value of the current in the second inductive branch. The instantaneous current in second branch is calculated as

$$i_2 = \sqrt{2} |I_2| \sin(\omega t - \theta_2) \quad (4.48)$$

The total current in polar form is

$$I = |I| \angle -\theta$$

The current I lags behind the source voltage by θ . The maximum value of this current is calculated as

$$I_m = \sqrt{2} |I|$$

$|I|$ is the RMS value of the total current in the circuit. The total instantaneous current in circuit is calculated as

$$i = \sqrt{2} |I| \sin(\omega t - \theta) \quad (4.49)$$

Case No 2

Consider a parallel circuit as shown in Figure 4.33. There are two capacitive branches in the circuit. The total current delivered by the AC source is i . This current divides into two parts at the node. The current in the first branch is i_1 and the current in the second branch of the parallel circuit is i_2 .

Phasor value of source voltage is given by

$$V_S = V_{S_{rms}} \angle 0^\circ$$

Maximum value of the source voltage is calculated as

$$V_m = \sqrt{2} V_{S_{rms}}$$

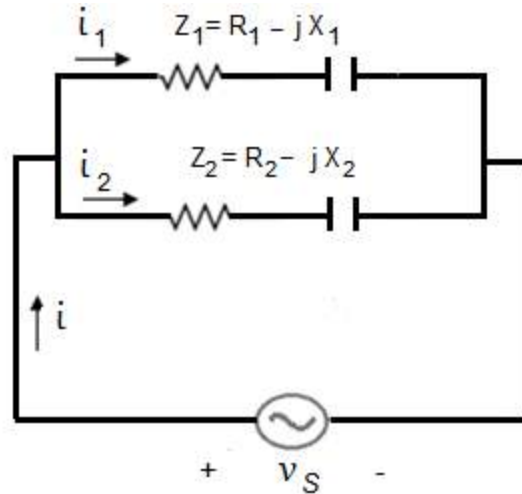

Figure 4.33: Capacitive Parallel Circuit

The instantaneous voltage across the source is calculated as

$$v_S = \sqrt{2} V_{S_{rms}} \sin(\omega t + 0) \quad (4.50)$$

Current in first capacitive branch is

$$I_1 = |I_1| \angle \theta_1$$

Maximum value of the current I_1 is calculated as

$$I_{m1} = \sqrt{2} |I_1|$$

$|I_1|$ is the RMS value of the current in the first capacitive branch. The instantaneous current in first branch is calculated as

$$i_1 = \sqrt{2} |I_1| \sin(\omega t + \theta_1) \quad (4.51)$$

The current i_1 leads the source voltage by θ_1 . Current in second capacitive branch is

$$I_2 = |I_2| \angle \theta_2$$

The current I_2 leads the source voltage by θ_2 . The maximum value of this current is calculated as

$$I_{m2} = \sqrt{2} |I_2|$$

$|I_2|$ is the RMS value of the current in the second branch. The instantaneous current in second branch is calculated as

$$i_2 = \sqrt{2} |I_2| \sin(\omega t + \theta_2) \quad (4.52)$$

The total current in polar form is

$$I = |I| \angle \theta$$

The current I leads the source voltage by θ . The maximum value of this current is calculated as

$$I_m = \sqrt{2} |I|$$

$|I|$ is the RMS value of the total current in the circuit. The total instantaneous current in circuit is calculated as

$$i = \sqrt{2} |I| \sin(\omega t + \theta) \quad (4.53)$$

Case No 3

Consider a parallel circuit as shown in Figure 4.34. There are two branches in the circuit. The total current delivered by the AC source is i . This current divides into two parts at the node. The current in the first branch is i_1 and the current in the second branch of the parallel circuit is i_2 .

Phasor value of source voltage is

$$V_S = V_{S_{rms}} \angle 0^\circ$$

Maximum value of the source voltage is calculated as

$$V_m = \sqrt{2} V_{S_{rms}}$$

The instantaneous voltage across the source is calculated as

$$v_s = \sqrt{2} V_{s_{rms}} \sin(\omega t + 0) \quad (4.54)$$

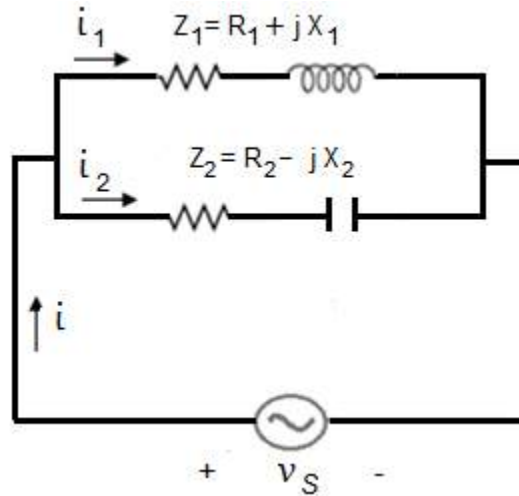

Figure 4.34: Parallel Circuit

Current in inductive branch is

$$I_1 = |I_1| \angle -\theta_1$$

Maximum value of the current I_1 is calculated as

$$I_{m1} = \sqrt{2} |I_1|$$

$|I_1|$ is the RMS value of the current in the inductive branch. The instantaneous current in first branch is calculated as

$$i_1 = \sqrt{2} |I_1| \sin(\omega t - \theta_1) \quad (4.55)$$

The current i_1 lags behind the source voltage by θ_1 . Current in capacitive branch is

$$I_2 = |I_2| \angle \theta_2$$

The current I_2 leads the source voltage by θ_2 . The maximum value of this current is calculated as

$$I_{m2} = \sqrt{2} |I_2|$$

$|I_2|$ is the RMS value of the current in the second inductive branch. The instantaneous current in second branch is calculated as

$$i_2 = \sqrt{2} |I_2| \sin(\omega t + \theta_2) \quad (4.56)$$

The total current in polar form is

$$I = |I| \angle \pm \theta$$

The maximum value of this current is calculated as

$$I_m = \sqrt{2} |I|$$

$|I|$ is the RMS value of the total current in the circuit. The total instantaneous current in circuit is calculated as

$$i = \sqrt{2} |I| \sin(\omega t \pm \theta) \quad (4.57)$$

D 4.9: Consider the parallel circuit as shown in Figure 4.35. The RMS value of the source voltage is $100V$ and its phase angle is zero. Calculate the instantaneous values of all three currents in the circuit. Let $f = 50 \text{ Hz}$.

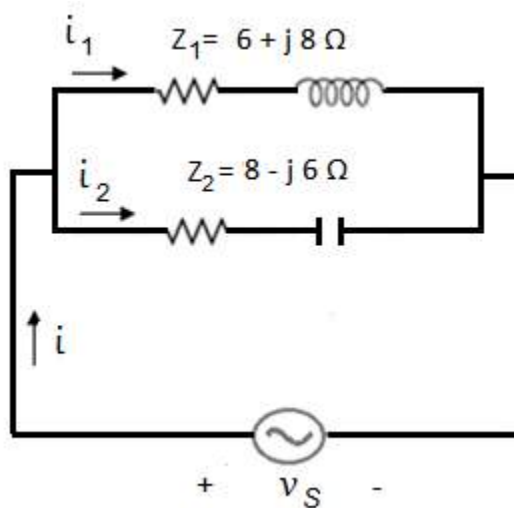

Figure 4.35: Circuit for D # 4.9

Solution:

Phasor value of source voltage is

$$V_S = 100 \angle 0^\circ \text{ V}$$

Maximum value of the source voltage is calculated as

$$V_m = 100\sqrt{2} \text{ V}$$

The instantaneous voltage across the source is calculated as

$$v_S = 100\sqrt{2} \sin(100\pi t + 0)$$

$$G_1 = \frac{R_1}{R_1^2 + X_1^2}$$

$$G_1 = \frac{6}{100} \quad \text{S}$$

$$B_1 = \frac{X_1}{R_1^2 + X_1^2}$$

$$B_1 = \frac{8}{100} \quad \text{S}$$

$$I_1 = V_S (G_1 - jB_1)$$

$$I_1 = 100 \left(\frac{6}{100} - j \frac{8}{100} \right)$$

$$I_1 = 6 - j8 \text{ A}$$

$$I_1 = 10 \angle -53.1^\circ \text{ A}$$

Maximum value of the current I_1 is calculated as

$$I_{m1} = 10\sqrt{2} \text{ A}$$

The instantaneous current in first branch is calculated as

$$i_1 = 10\sqrt{2} \sin(100\pi t - 53.1^\circ) \text{ A}$$

The current i_1 lags behind the source voltage by 53.1° .

$$G_2 = \frac{R_2}{R_2^2 + X_2^2}$$

$$G_2 = \frac{8}{100} \text{ } \Omega$$

$$B_2 = \frac{X_2}{R_2^2 + X_2^2}$$

$$B_2 = \frac{6}{100} \text{ } \Omega$$

$$I_2 = 100 \left(\frac{8}{100} + j \frac{6}{100} \right)$$

$$I_2 = 8 + j6 \text{ A}$$

$$I_2 = 10 \angle 36.8^\circ \text{ A}$$

The maximum value of this current is calculated as

$$I_{m2} = 10\sqrt{2} \text{ A}$$

Instantaneous equation of the current in second branch is calculated as

$$i_2 = 10\sqrt{2} \sin(100\pi t + 36.8^\circ) \text{ A}$$

As

$$I = I_1 + I_2$$

$$I = 14 - j2 \text{ A}$$

$$I = 14.14 \angle -8.13^\circ \text{ A}$$

Maximum value of this current is calculated as

$$I_m = 14.14\sqrt{2} \text{ A}$$

The total instantaneous current in circuit is calculated as

$$i = 14.14\sqrt{2} \sin(100\pi t - 8.13^\circ) \text{ A}$$

The circuit behaves like Inductive circuit.

4-8 Anti Resonance

Consider the parallel circuit as shown in Figure 4.36. Frequency of the AC voltage source is varied from 0 to ∞ . As

$$X_L = 2\pi fL$$

So the inductive reactance will increase from 0 to ∞ and as

$$X_C = \frac{1}{2\pi fC}$$

So the capacitive reactance will decrease from ∞ to 0.

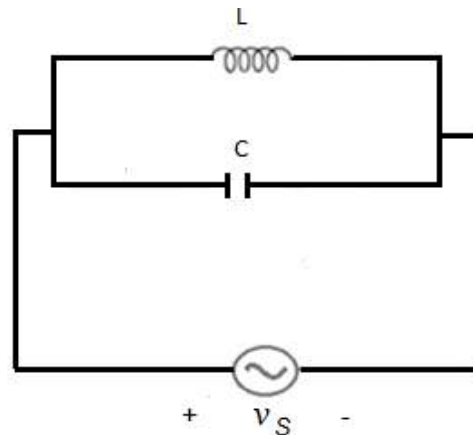

Figure 4.36: Anti Resonant Circuit

At a particular frequency the inductive reactance of the circuit will become equal to the capacitive reactance and this frequency is known as resonant frequency. On the other hand if we consider the susceptance of the inductive branch then it is given by

$$B_L = \frac{-j}{X_L}$$

$$B_L = \frac{-j}{2\pi fL}$$

So the inductive susceptance will decrease from ∞ to 0. While the susceptance of the capacitive branch is given by

$$B_C = \frac{j}{X_C} = j2\pi fC$$

Obviously the capacitive susceptance will increase from 0 to ∞ . At a particular frequency the inductive susceptance of the circuit will become equal to the capacitive susceptance and this frequency is known as anti-resonant frequency. The anti-resonant frequency is denoted by f_r . The following equation is justified under resonance condition.

$$B_L = B_C$$

$$2\pi f_r C = \frac{1}{2\pi f_r L}$$

$$f_r = \frac{1}{2\pi\sqrt{LC}} \quad (4.58)$$

Admittance of this parallel circuit is calculated as

$$Y = j(B_C - B_L)$$

Obviously the parallel circuit will offer zero admittance to the flow of AC current and there will be no current in the circuit under resonance condition.

$$Y_{min} = 0 \quad (\text{under resonance condition})$$

$$I_{min} = V_S Y = 0$$

The sketch of the admittance as a function of frequency is shown in Figure 4.37. By increasing frequency from 0 to f_r , the admittance decreases from ∞ to 0 and then by increasing frequency from f_r to ∞ , the admittance increases from 0 to ∞ . The circuit

behaves like inductive circuit in region no 1 and the power factor of the circuit in this region is lagging power factor. The same circuit behaves like capacitive circuit in region no 2 and the power factor of the circuit in this region is leading power factor.

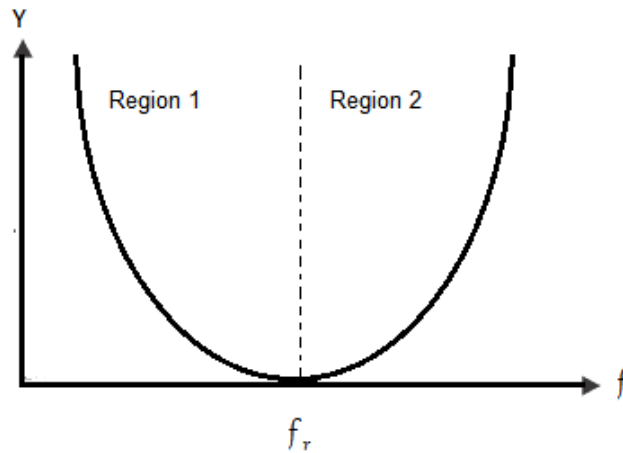

Figure 4.37: Admittance Curve

The sketch of the current as a function of frequency is shown in Figure 4.37. Initially the current in the circuit decreases with increase in frequency, it reaches the minimum value of zero at resonant frequency and then it increases. This curve is known as anti-resonance curve for the parallel circuit.

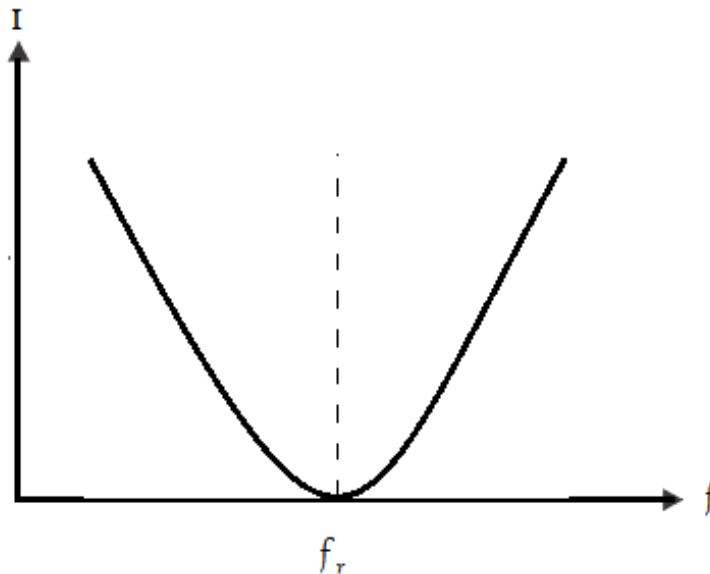

Figure 4.38: Anti-Resonance Curve

The graphical relationship between inductive susceptance, capacitive susceptance and frequency is shown in Figure 4.39. There is a linear relationship between the capacitive susceptance and frequency and the inductive susceptance decreases from infinity to zero.

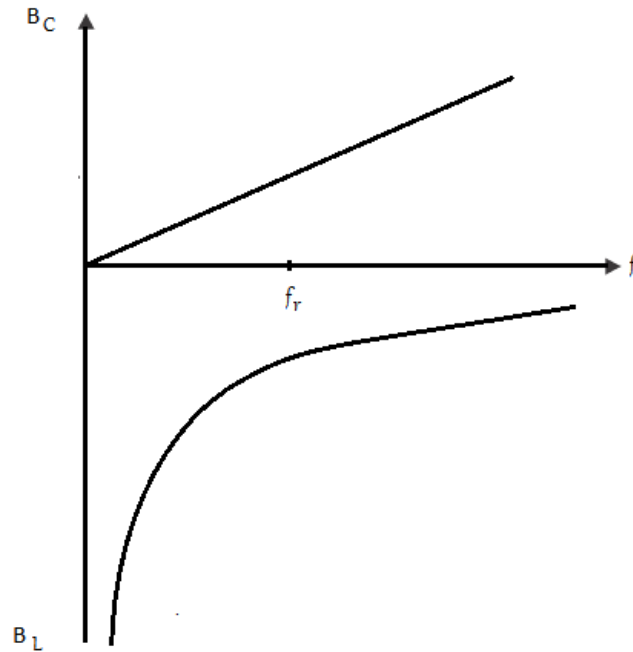

Figure 4.39: Susceptance Graph

Exercise:

Q 4.1: Consider the parallel circuit in Figure 4.40. Calculate all the currents in the circuit. RMS value of the source voltage is 100V.

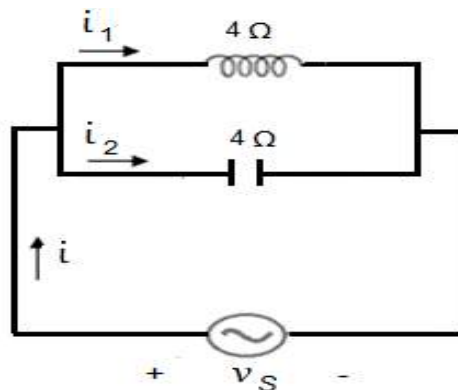

Figure 4.40: Circuit for Q 4.1

Answers: $I_1 = 25 \angle -90 \text{ A}$, $I_1 = 25 \angle 90 \text{ A}$, $I = 0 \text{ A}$

Q 4.2: Consider the parallel circuit in Figure 4.40. Write the instantaneous equations of all the currents in the circuit and the applied voltage. RMS value of the source voltage is 100V.

Answer: $i_1 = 25 \sqrt{2} \sin(100\pi t - 90) \text{ A}$, $i_2 = 25 \sqrt{2} \sin(100\pi t + 90) \text{ A}$

$v_s = 100 \sqrt{2} \sin(100\pi t) \text{ V}$

Q 4.3: Consider the parallel circuit in Figure 4.41. Calculate all the phasor currents in the circuit. RMS value of the source voltage is 100V. Determine the power supplied by the source.

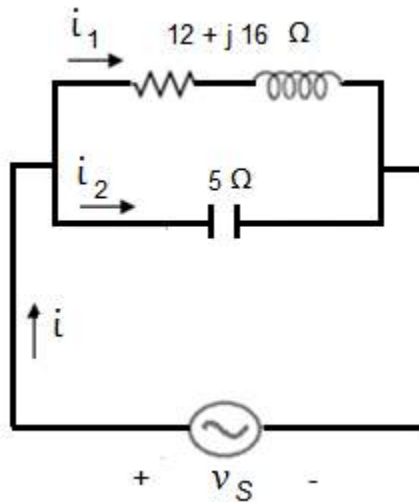

Figure 4.41: Circuit for Q 4.3

Answers: $I_1 = 5 \angle -53.1 \text{ A}$, $I_1 = 20 \angle 90 \text{ A}$, $I = 16.27 \angle 79.38 \text{ A}$, $P = 299.83 \text{ W}$

Q 4.4: Consider the parallel circuit in Figure 4.41. Write the instantaneous equations of all the currents in the circuit and the applied voltage. RMS value of the source voltage is 100V.

Answer: $i_1 = 5 \sqrt{2} \sin(100\pi t - 53.1) \text{ A}$, $i_2 = 20 \sqrt{2} \sin(100\pi t + 90) \text{ A}$
 $i = 16.27 \sqrt{2} \sin(100\pi t + 79.38) \text{ A}$, $v_s = 100 \sqrt{2} \sin(100\pi t) \text{ A}$

Chapter 5

Network Theorems

5-1 Thevenin's Theorem

Current in a passive circuit element, voltage across a passive circuit element and power consumed by a passive circuit element can be computed with the help of Thevenin's theorem. According to this theorem if we want to calculate current in a load resistor connected across terminals A & B of a linear bilateral complex network, then the load resistance of the network can be connected to a voltage source V_{Th} having an internal resistance of R_{Th} . V_{Th} is the open circuited voltage across terminals A & B of the complex linear bilateral network and R_{Th} is equivalent resistance of the network while looking back to the network from terminals A & B with all voltage sources replaced by short circuits. As an example consider a linear bilateral network as shown in Figure 5.1.

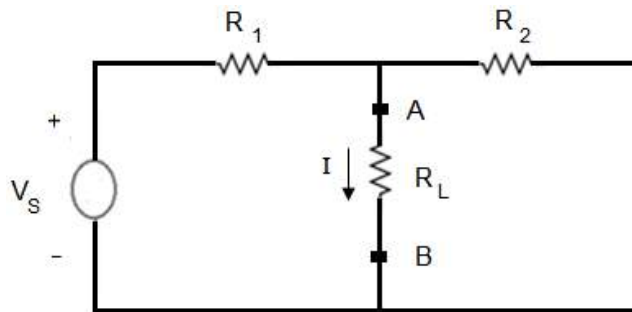

Figure 5.1: A Linear Bilateral Network

This network can be replaced by its Thevenin's equivalent circuit as shown in Figure 5.2.

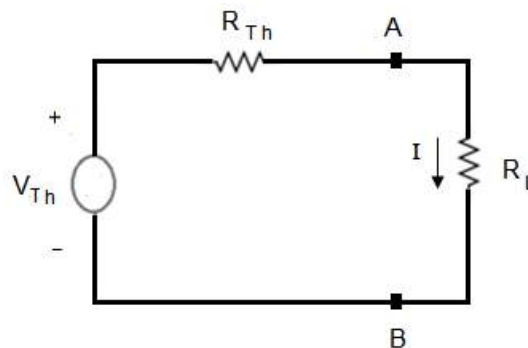

Figure 5.2: Thevenin's Equivalent Circuit

To calculate V_{Th} , the load resistance R_L is removed from terminals A and B of the linear bilateral network as shown in Figure 5.3. The voltage across terminals A and B is calculated that is equal to V_{Th} .

$$I_1 = \frac{V_S}{(R_1 + R_2)}$$

$$V_{Th} = I_1 R_2 \quad (5.1)$$

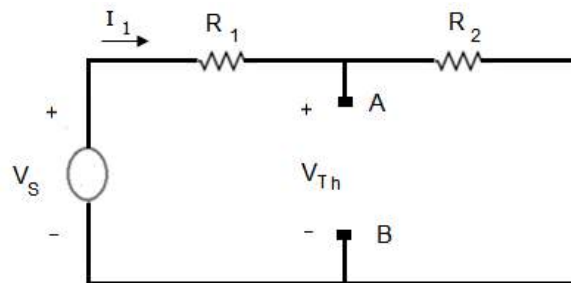

Figure 5.3: Circuit for Calculation of V_{Th}

To Calculate R_{Th} , the voltage source V_S of the linear bilateral network is short circuited as shown in Figure 5.4. R_{Th} is the equivalent resistance of this circuit while looking back to it from terminals A & B.

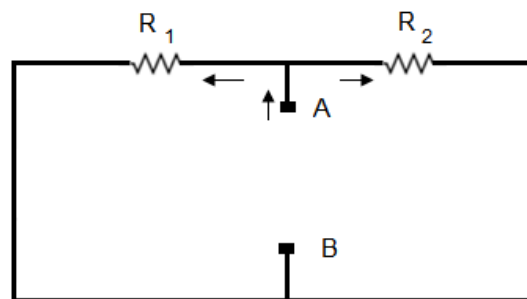

Figure 5.4: Circuit for Calculation of R_{Th}

$$R_{Th} = \frac{R_1 R_2}{R_1 + R_2}$$

The current I in the load resistance is calculated with the help of the Thevenin's equivalent circuit shown in Figure 5.2.

$$I = \frac{V_{Th}}{(R_{Th} + R_L)}$$

D 5.1: Using Thevenin's theorem find the current in the load resistor of the following circuit.

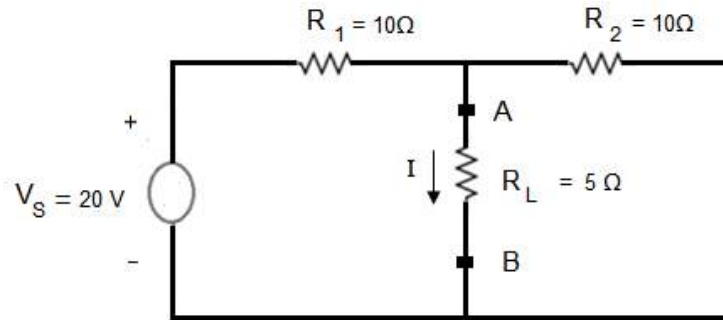

Figure 5.4: Circuit for D # 5.1

Solution:

To calculate V_{Th} , the load resistance R_L is removed from terminals A and B of the linear bilateral network as shown in Figure 5.5. The voltage across terminals A and B is calculated that is equal to V_{Th} .

$$I_1 = \frac{20}{(10 + 10)}$$

$$I_1 = 1 \text{ A}$$

$$V_{Th} = 1 \times 10 = 10 \text{ V}$$

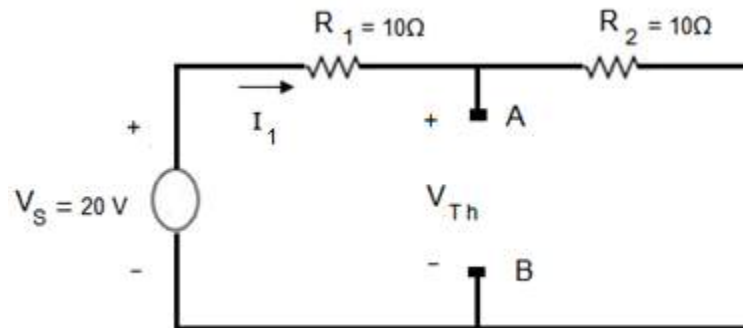

Figure 5.5: Circuit for Calculation of V_{Th}

To calculate R_{Th} , the voltage source V_S of the linear bilateral network is short circuited as shown in Figure 5.5b. R_{Th} is the equivalent resistance of this circuit while looking back to it from terminals A & B.

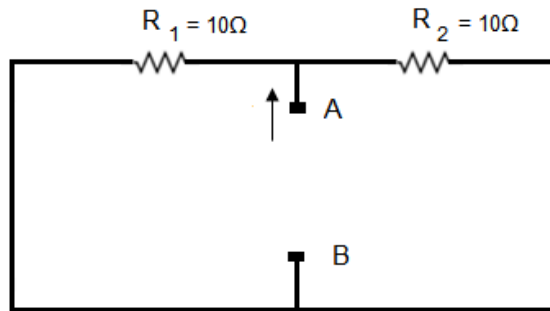

Figure 5.5b: Circuit for Calculation of R_{Th}

$$R_{Th} = \frac{10 \times 10}{10 + 10}$$

$$R_{Th} = 5 \Omega$$

The original circuit can be replaced by its Thevenin's equivalent circuit as shown in Figure 5.6.

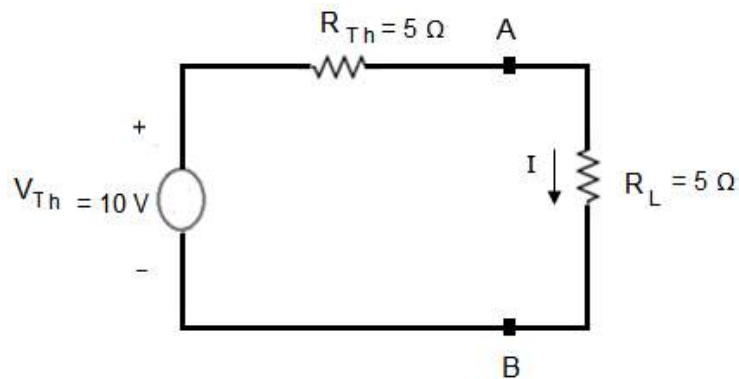

Figure 5.6: Thevenin's Equivalent Circuit

The current I in the load resistance is calculated with the help of the Thevenin's equivalent circuit.

$$I = \frac{V_{Th}}{(R_{Th} + R_L)}$$

$$I = \frac{10}{(5 + 5)}$$

$$I = 1 \text{ A}$$

D 5.2: Using Thevenin's theorem find the current in the load resistor of the following circuit.

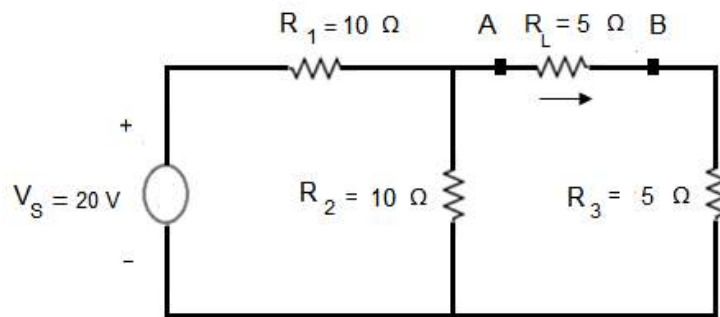

Figure 5.7: Circuit for D # 5.2

Solution:

To calculate V_{Th} , the load resistance R_L is removed from terminals A and B of the linear bilateral network as shown in Figure 5.8. The voltage across terminals A and B is calculated that is equal to V_{Th} .

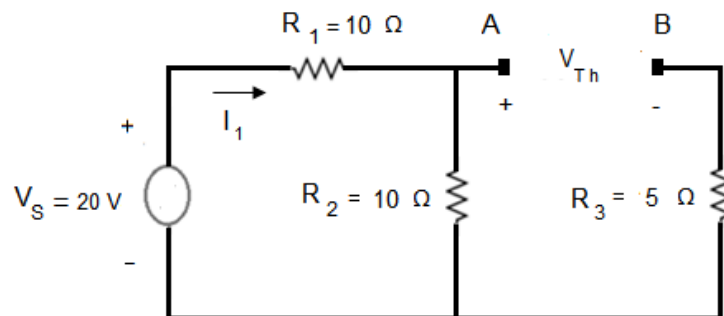

Figure 5.8: Circuit for Calculation of V_{Th}

$$I_1 = \frac{20}{(10 + 10)}$$

$$I_1 = 1 \text{ A}$$

$$V_{Th} = 1 \times 10 = 10 \text{ V}$$

To calculate R_{Th} , the voltage source V_S of the linear bilateral network is short circuited as shown in Figure 5.9.

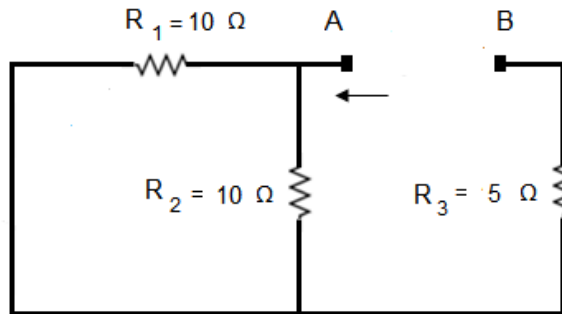

Figure 5.9: Circuit for Calculation of R_{Th}

R_{Th} is the equivalent resistance of this circuit while looking back to it from terminals A & B.

$$R_{Th} = 5 + \frac{10 \times 10}{10 + 10}$$

$$R_{Th} = 10 \Omega$$

The original circuit can be replaced by its Thevenin's equivalent circuit as shown in Figure 5.10. The current I in the load resistance is calculated with the help of the Thevenin's equivalent circuit.

$$I = \frac{V_{Th}}{(R_{Th} + R_L)}$$

$$I = \frac{10}{(10 + 5)}$$

$$I = 0.67 \text{ A}$$

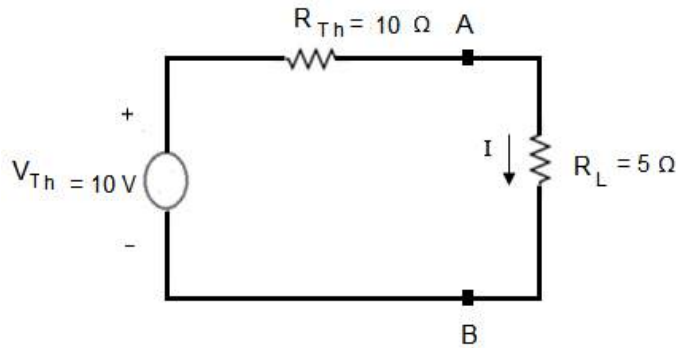

Figure 5.10: Thevenin's Equivalent Circuit

D 5.3: Using Thevenin's theorem find the current in capacitor of the following circuit

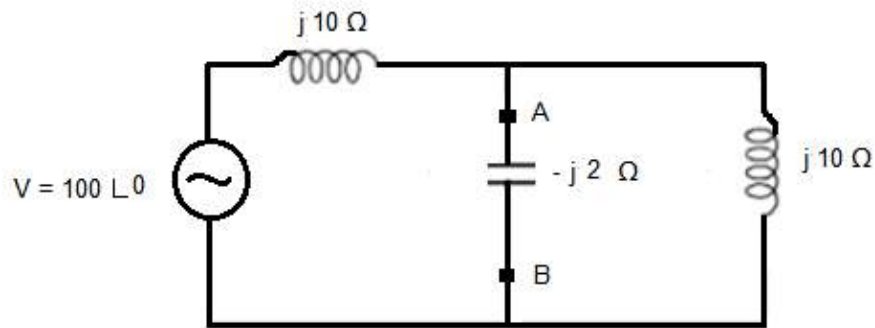

Figure 5.11: Circuit for D # 5.3

Solution:

To calculate V_{Th} , the capacitor is removed from terminals A and B of the linear bilateral network as shown in Figure 5.12. The voltage across terminals A and B is calculated that is equal to V_{Th} .

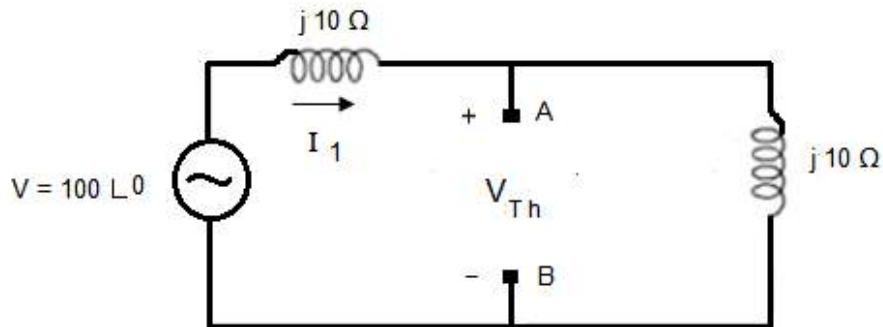

Figure 5.12: Circuit for Calculation of V_{Th}

$$I_1 = \frac{100}{(j10 + j10)}$$

$$I_1 = -j 5 A$$

$$V_{Th} = -j 5 A \times j 10 = 50 V$$

To calculate Z_{Th} , the voltage source V_S of the linear bilateral network is short circuited as shown in Figure 5.13. Z_{Th} is the equivalent impedance of this circuit while looking back to it from terminals A & B.

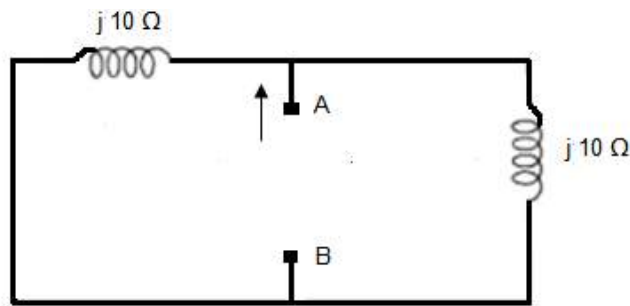

Figure 5.13: Circuit for Calculation of Z_{Th}

$$Z_{Th} = \frac{j 10 \times j 10}{j 10 + j 10}$$

$$Z_{Th} = j 5 \Omega$$

The original circuit can be replaced by its Thevenin's equivalent circuit as shown in Figure 5.14.

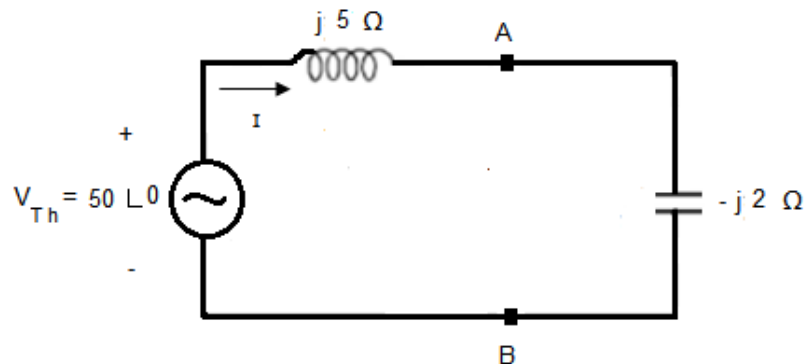

Figure 5.14: Thevenin's Equivalent Circuit

$$I = \frac{V_{Th}}{(Z_{Th} + Z_L)}$$

$$I = \frac{50}{j5 - j2}$$

$$I = 16.67 \angle -90^\circ A$$

5-2 Norton's Theorem

Current in a passive circuit element, voltage across a passive circuit element and power consumed by a passive circuit element can be computed with the help of Norton's theorem. According to this theorem if we want to calculate current in a load resistor connected across terminals A & B of a linear bilateral complex network, then the load resistance of the network can be connected to a current source I_{Sh} having internal resistance of R_{Th} . I_{Sh} is the short circuited current in terminals A & B of the complex linear bilateral network and R_{Th} is equivalent resistance of the network while looking back to the network from terminals A & B with all voltage sources replaced by short circuits and all current sources replaced by open circuits. As an example consider a linear bilateral network as shown in Figure 5.15.

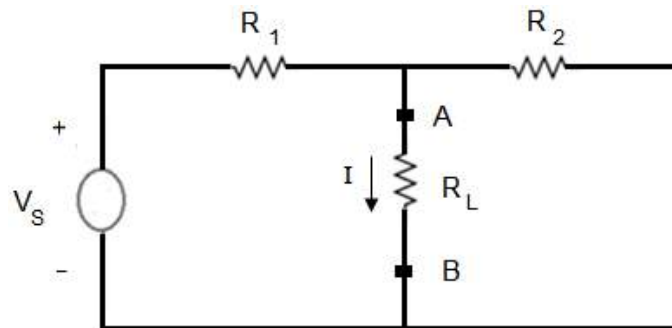

Figure 5.15: A Linear Bilateral Network

This network can be replaced by its Norton's equivalent circuit as shown in Figure 5.16. There is a practical current source in the Norton's equivalent circuit, whose shunt internal resistance is represented by R_{Th} . This shunt resistance R_{Th} is calculated the same way as explained in Thevenin's Theorem. The load resistor R_L is connected in parallel with the current source.

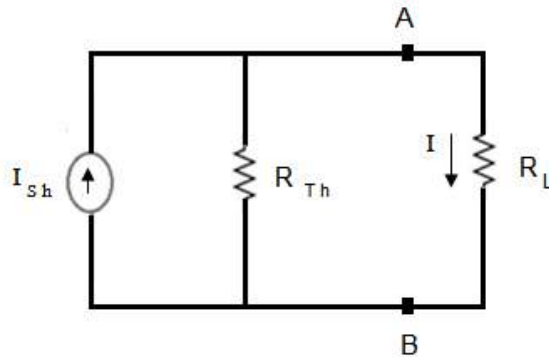

Figure 5.16: Norton's Equivalent Circuit

To calculate I_{sh} , the load resistance R_L is short circuited as shown in Figure 5.17. The current in terminals A and B is calculated that is equal to I_{sh} .

$$I_{sh} = \frac{V_S}{R_1}$$

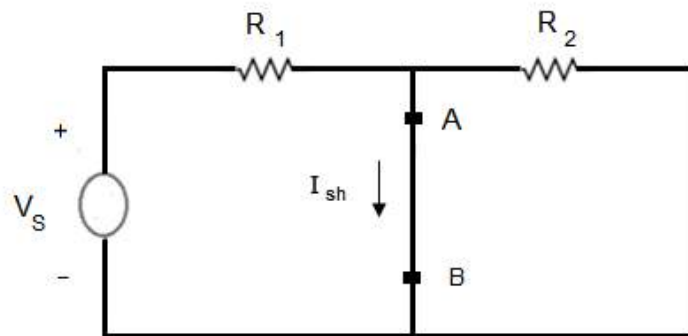

Figure 5.17: Circuit for Calculation of I_{sh}

We have already mentioned that the shunt resistance R_{Th} is calculated the same way as explained in Thevenin's Theorem. So in order to calculate R_{Th} , the voltage source V_S of the linear bilateral network is replaced by its internal resistance as shown in Figure 5.18. R_{Th} is the equivalent resistance of this circuit while looking back to it from terminals A & B.

$$R_{Th} = \frac{R_1 R_2}{R_1 + R_2}$$

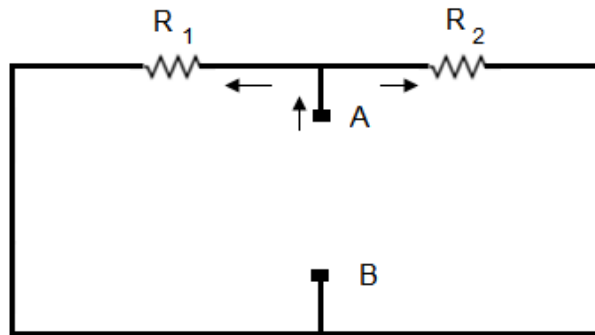

Figure 5.18: Circuit for Calculation of R_{Th}

The current I in the load resistance is calculated with the help of the Norton's equivalent circuit shown in Figure 5.16.

$$I = \frac{I_{Sh} \times R_{Th}}{(R_{Th} + R_L)}$$

D 5.4: Using Norton's theorem, find the current in the load resistor of the following circuit.

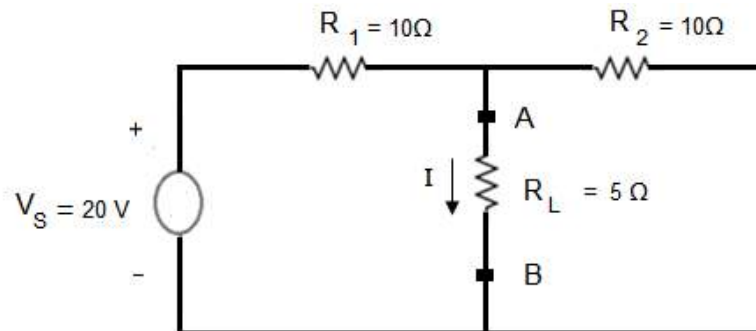

Figure 5.19: Circuit for D # 5.4

Solution:

To calculate I_{Sh} , the load resistance R_L is short circuited as shown in Figure 5.20. The current in terminals A and B is calculated, that is equal to I_{Sh} .

$$I_{Sh} = \frac{V_S}{R_1}$$

$$I_{Sh} = \frac{20}{10} = 2 \text{ A}$$

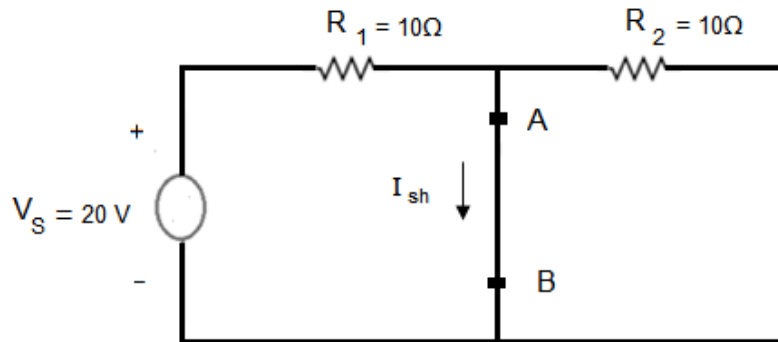

Figure 5.20: Circuit for Calculation of I_{Sh}

To calculate R_{Th} , the voltage source V_S of the linear bilateral network is short circuited as shown in Figure 5.21. R_{Th} is the equivalent resistance of this circuit while looking back to it from terminals A & B.

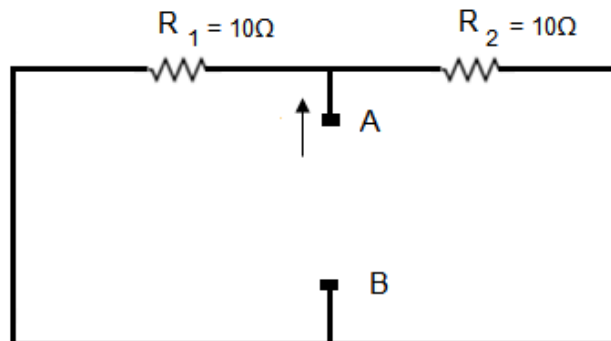

Figure 5.21: Circuit for Calculation of R_{Th}

$$R_{Th} = \frac{10 \times 10}{10 + 10}$$

$$R_{Th} = 5 \Omega$$

The original circuit can be replaced by its Norton's equivalent circuit as shown in Figure 5.22.

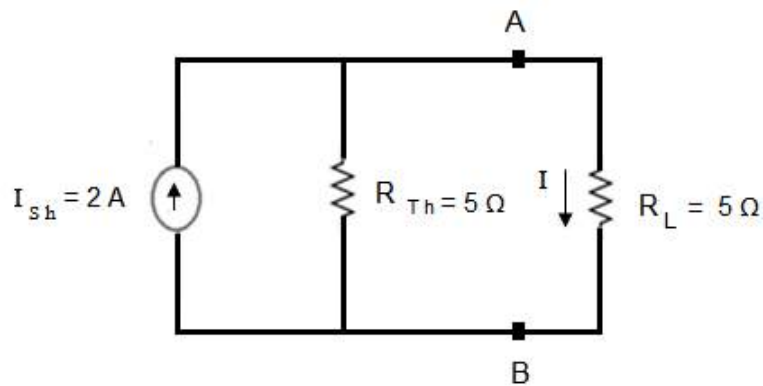

Figure 5.22 Norton's Equivalent Circuit

The current I in the load resistance is calculated with the help of the Norton's equivalent circuit.

$$I = \frac{I_{Sh} \times R_{Th}}{(R_{Th} + R_L)}$$

$$I = \frac{2 \times 5}{(5 + 5)}$$

$$I = 1 \text{ A}$$

D 5.5: Using Norton's theorem find the current in the load resistor of the following circuit.

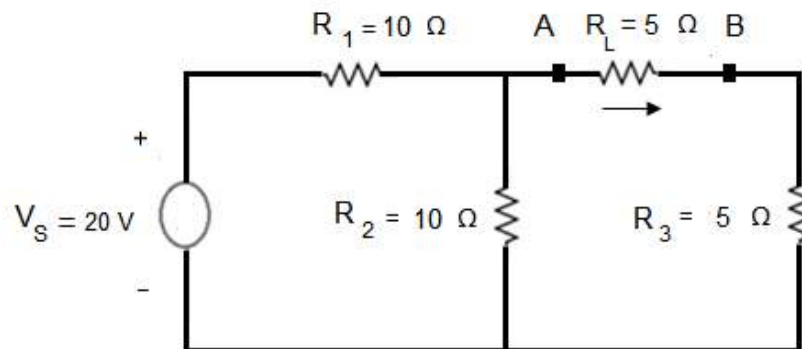

Figure 5.23: Circuit for D # 5.5

Solution:

To calculate I_{Sh} , the load resistance R_L is short circuited as shown in Figure 5.24. The current in terminals A and B is calculated that is equal to I_{Sh} .

$$I_{Sh} = \frac{\begin{vmatrix} 20 & 20 \\ -10 & 0 \end{vmatrix}}{\begin{vmatrix} 20 & -10 \\ -10 & 15 \end{vmatrix}}$$

$$I_{Sh} = \frac{200}{(300 - 100)}$$

$$I_{Sh} = 1 \text{ A}$$

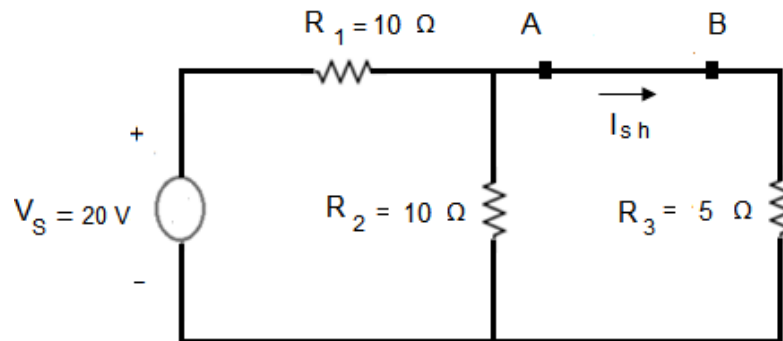

Figure 5.24: Circuit for Calculation of I_{Sh}

To calculate R_{Th} , the voltage source V_S of the linear bilateral network is short circuited as shown in Figure 5.25. R_{Th} is the equivalent resistance of this circuit while looking back to it from terminals A & B.

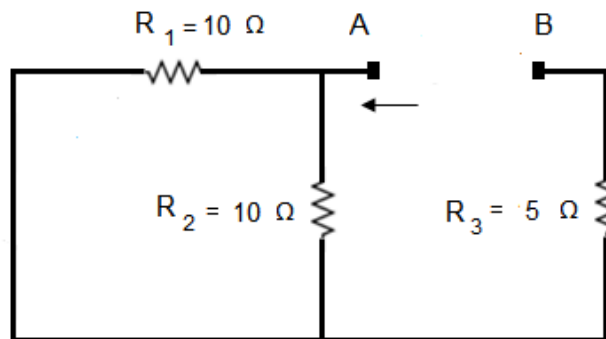

Figure 5.25: Circuit for Calculation of R_{Th}

$$R_{Th} = 5 + \frac{10 \times 10}{10 + 10}$$

$$R_{Th} = 10 \Omega$$

The original circuit can be replaced by its Norton's equivalent circuit as shown in Figure 5.26.

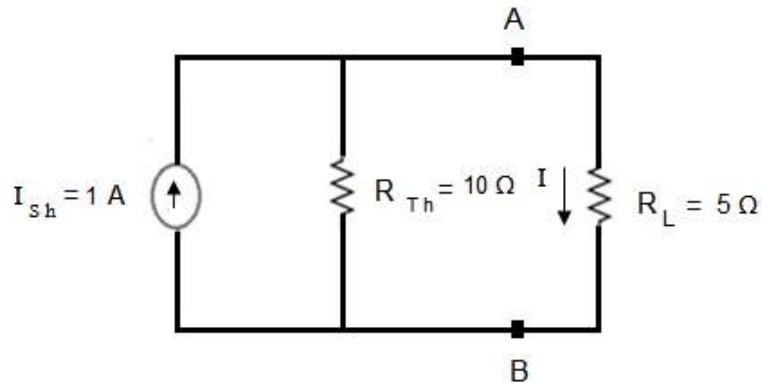

Figure 5.26: Norton's Equivalent Circuit

The current I in the load resistance is calculated as

$$I = \frac{I_{sh} \times R_{Th}}{(R_{Th} + R_L)}$$

$$I = \frac{1 \times 10}{(10 + 5)}$$

$$I = 0.67 \text{ A}$$

D 5.6: Using Norton's Equivalent theorem find the current in capacitor of the circuit shown in Figure 5.27.

Solution:

To calculate I_{sh} , the load resistance R_L is short circuited as shown in Figure 5.28. The current in terminals A and B is calculated that is equal to I_{sh} .

$$I_{sh} = \frac{100}{j10}$$

$$I_{Sh} = -j 10 A$$

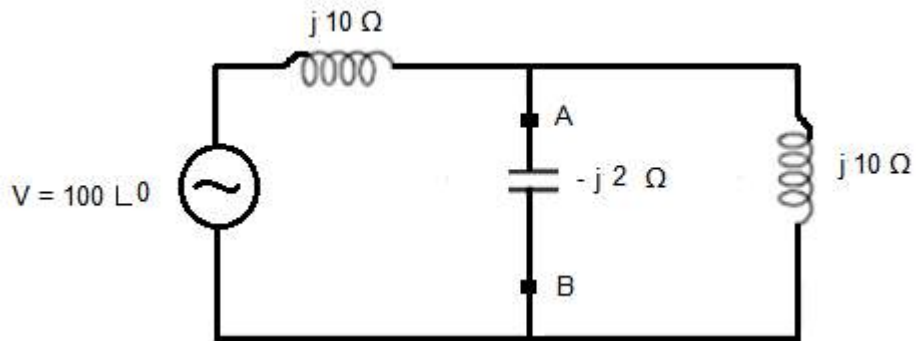

Figure 5.27: Circuit for D # 5.6

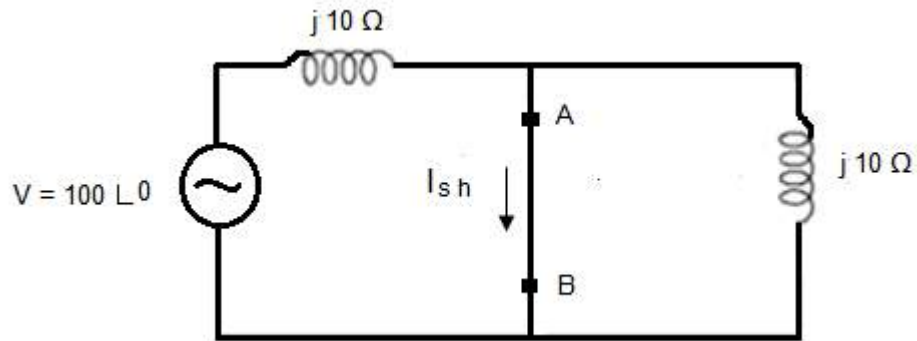

Figure 5.28: Circuit for Calculation of I_{Sh}

To calculate Z_{Th} , the voltage source V_S of the linear bilateral network is short circuited as shown in Figure 5.29. Z_{Th} is the equivalent impedance of this circuit while looking back to it from terminals A & B.

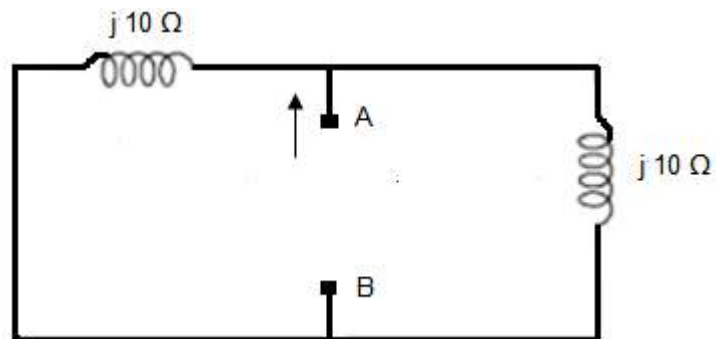

Figure 5.29: Circuit for Calculation of Z_{Th}

$$Z_{Th} = \frac{j 10 \times j 10}{j 10 + j 10}$$

$$Z_{Th} = j 5 \Omega$$

The original circuit can be replaced by its Norton's equivalent circuit as shown in Figure 5.30.

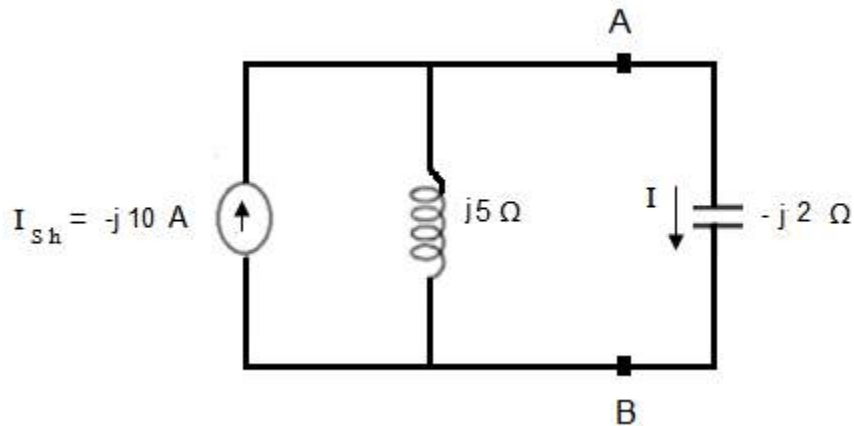

Figure 5.30: Norton's Equivalent Circuit

$$I = \frac{I_{sh} \times Z_{Th}}{(Z_{Th} + Z_L)}$$

$$I = \frac{-j 10 \times j 5}{(j 5 - j 2)}$$

$$I = \frac{50}{j 3}$$

$$I = 16.67 \angle -90^\circ \text{ A}$$

5-3 Maximum Power Transfer Theorem

This is a very important theorem and has lots of applications in power as well as communication engineering. This theorem states that a practical voltage source will transfer maximum power to the load resistance if the load resistance is equal to the internal resistance of the source. Consider a Thevenin's equivalent circuit as shown in

Figure 5.31.

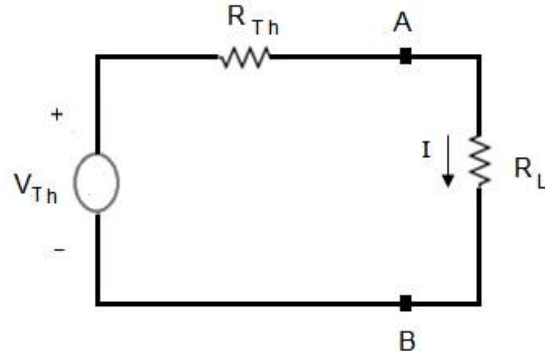

Figure 5.31: Thevenin's Equivalent Circuit

According to this theorem the source will transfer maximum power to the load resistance R_L if

$$R_L = R_{Th}$$

Let us prove this equation. The current in load resistance can be calculated as

$$I = \frac{V_{Th}}{(R_{Th} + R_L)}$$

$$P_L = I^2 R_L \tag{5.2}$$

Putting the value of current in equation 5.2, we obtain

$$P_L = \left[\frac{V_{Th}}{(R_{Th} + R_L)} \right]^2 R_L$$

$$P_L = V_{Th}^2 \left[\frac{R_L}{(R_{Th} + R_L)^2} \right]$$

We assume that the load resistance is variable. We change the value of R_L to find the condition for maximum power P_L . We differentiate P_L with respect to R_L and equate it to zero.

$$\frac{dP_L}{dR_L} = V_{Th}^2 \frac{d}{dR_L} \left[\frac{R_L}{(R_{Th} + R_L)^2} \right] = 0$$

$$V_{Th}^2 \left[\frac{(R_{Th} + R_L)^2 - 2R_L(R_{Th} + R_L)}{(R_{Th} + R_L)^4} \right] = 0$$

$$(R_{Th} + R_L)^2 - 2R_L(R_{Th} + R_L) = 0$$

$$R_{Th}^2 + R_L^2 + 2R_LR_{Th} - 2R_LR_{Th} - 2R_L^2 = 0$$

$$R_{Th}^2 - R_L^2 = 0$$

$$R_L = R_{Th} \quad (5.3)$$

As

$$P_L = \left[\frac{V_{Th}}{(R_{Th} + R_L)} \right]^2 R_L$$

So putting $R_L = R_{Th}$ in above equation, the maximum value of the power can be calculated as

$$P_{L \max} = \frac{V_{Th}^2 R_{Th}}{(R_{Th} + R_{Th})^2}$$

$$P_{L \max} = \frac{V_{Th}^2}{4R_{Th}}$$

Maximum power will be transferred to the load impedance Z_L of Figure 5.32, if it is equal to the conjugate of Z_{Th} , that is

$$Z_L = Z_{Th}^*$$

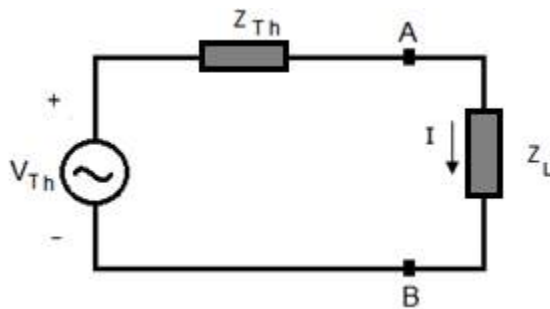

Figure 5.32: Thevenin's Equivalent Circuit

D 5.7: Consider the following circuit and find the value of R_L for the transfer of maximum power to it. Determine this maximum power as well.

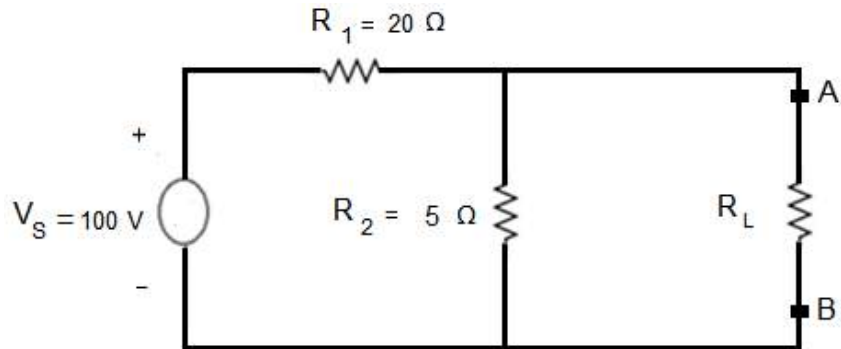

Figure 5.33: Circuit for D # 5.7

Solution:

The circuit is converted to Thevenin's equivalent circuit. To find V_{Th} , the load resistance R_L is removed from terminals A and B of the circuit as shown in Figure 5.34.

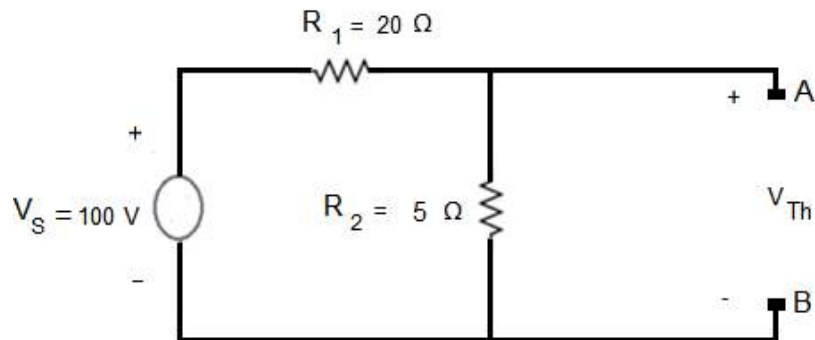

Figure 5.34: Circuit for Calculation of V_{Th}

The voltage across terminals A and B is calculated that is equal to V_{Th} .

$$V_{Th} = \left(\frac{100}{25}\right) \times 5$$

$$V_{Th} = 20 \text{ V}$$

To calculate R_{Th} , the voltage source V_S of the linear bilateral network is short circuited as shown in Figure 5.35. R_{Th} is the equivalent resistance of this circuit while looking back to it from terminals A & B.

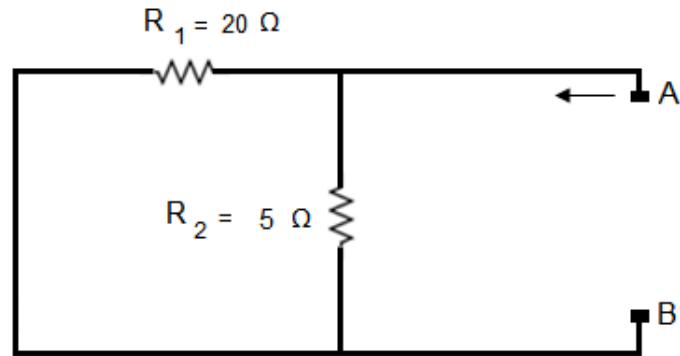

Figure 5.35: Circuit for Calculation of R_{Th}

$$R_{Th} = \frac{20 \times 5}{20 + 5}$$

$$R_{Th} = 4 \Omega$$

The Thevenin's equivalent circuit for Maximum power transfer theorem is shown in Figure 5.36.

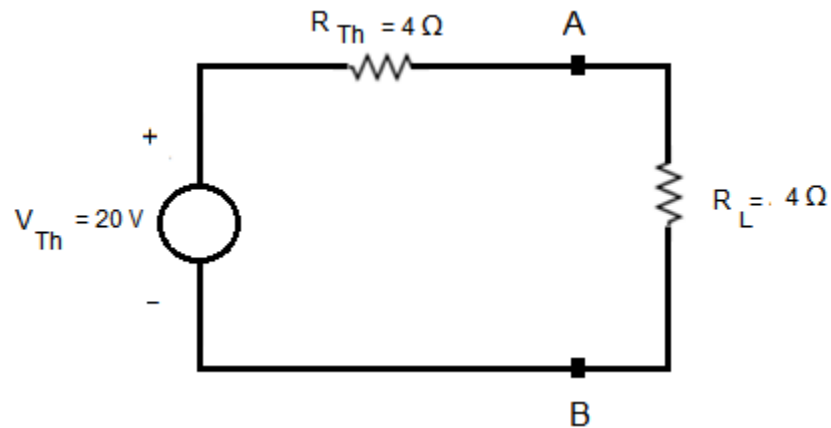

Figure 5.36: Thevenin's Equivalent Circuit

The condition for the maximum power to be delivered by the source to the load is

$$R_{Th} = R_{Th} = 4 \Omega$$

Now

$$P_{L \max} = \frac{V_{Th}^2}{4R_{Th}}$$

$$P_{L \max} = \frac{(20)^2}{4 \times 4}$$

$$P_{L \max} = 25 \text{ W}$$

D 5.8: Consider the following circuit and find the value of R_L for the transfer of maximum power to it. Determine this maximum power as well.

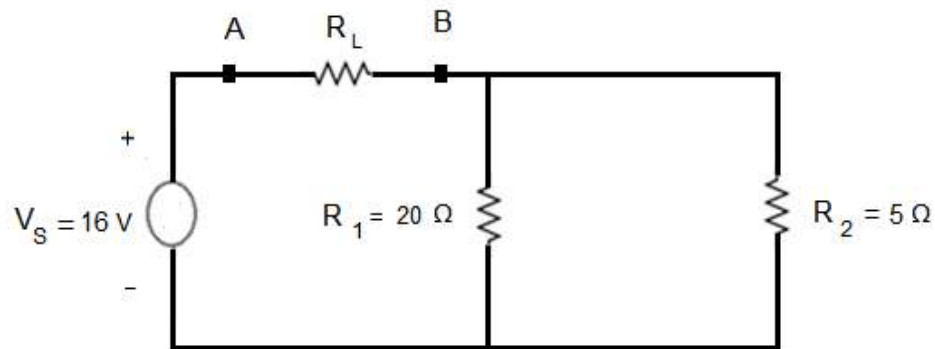

Figure 5.37: Circuit for D # 5.8

Solution:

The circuit is converted to Thevenin's equivalent circuit. To find V_{Th} , the load resistance R_L is removed from terminals A and B of the circuit as shown in Figure 5.38. Obviously there will be no flow of current in the following circuit and V_{Th} will be equal to the source voltage.

$$V_{Th} = V_S = 20 \text{ V}$$

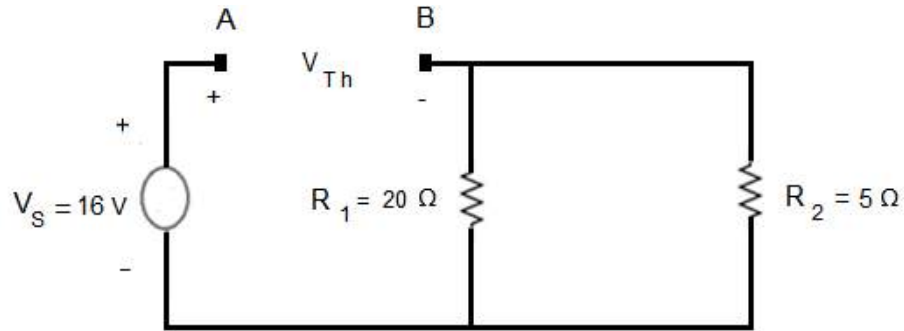

Figure 5.38: Circuit for Calculation of V_{Th}

To find R_{Th} , the voltage source V_S of the linear bilateral network is short circuited as shown in Figure 5.39. R_{Th} is the equivalent resistance of this circuit while looking back to it from terminals A & B.

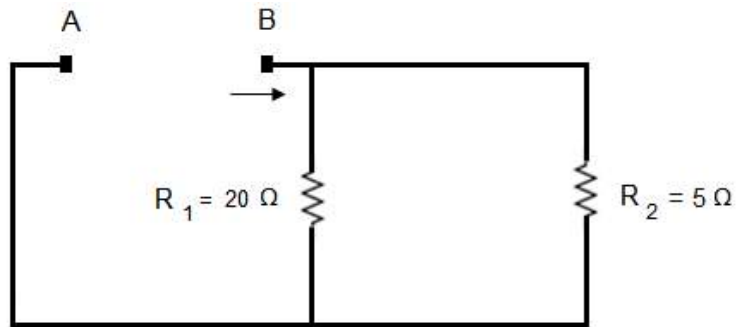

Figure 5.39: Circuit for Calculation of R_{Th}

$$R_{Th} = \frac{20 \times 5}{20 + 5}$$

$$R_{Th} = R_L = 4 \Omega$$

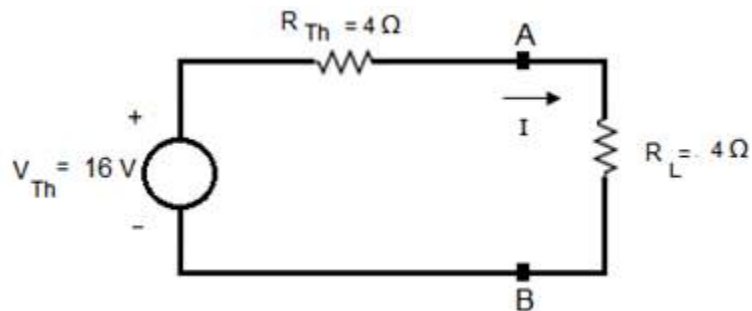

Figure 5.40: Thevenin's Equivalent Circuit

The Thevenin's equivalent circuit for Maximum power transfer theorem is shown in Figure 5.40.

$$I = 2 \text{ A}$$

Now

$$P_{L \max} = \frac{V_{Th}^2}{4R_{Th}}$$

$$P_{L \max} = \frac{(16)^2}{4 \times 4}$$

$$P_{L \max} = 16 \text{ W}$$

5-4 Superposition Theorem

This theorem has a number of applications in the course of Electromagnetic Field Theory. This theorem states that in any linear bilateral circuit that has more than one voltage source, the current in any element is the sum of the currents due to each voltage source separately and all other sources are replaced by their internal resistance. As an example consider the circuit given in Figure 5.41. The currents I_1 , I_2 and I_3 can be calculated with the help of Superposition theorem.

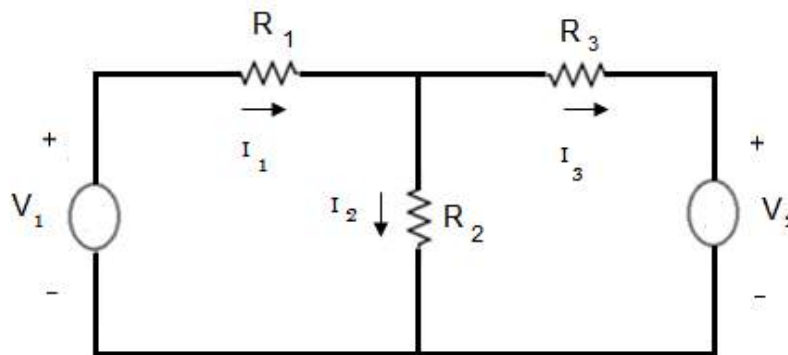

Figure 5. 41: Linear Bilateral Circuit for Superposition Theorem

The second voltage source is replaced by short circuit as shown in Figure 5.42 and the currents in all the three resistors are calculated due to voltage source V_1 independently.

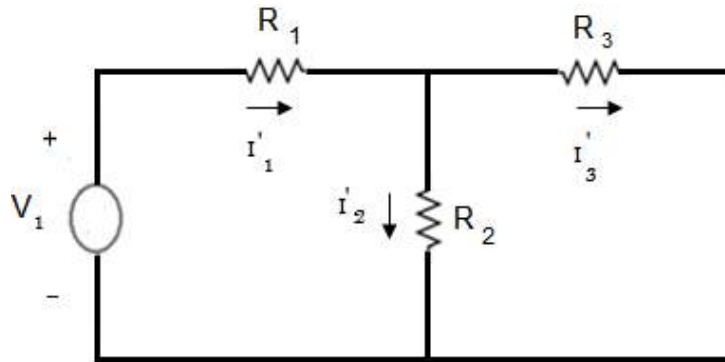

Figure 5.42: V_2 replaced by 0

After replacing V_2 by 0, The current in R_1 is I_1' , the current in R_2 is I_2' and the current in R_3 is I_3' . All these three currents in the circuits are caused by the voltage source V_1 . Now the first voltage source is replaced by short circuit as shown in Figure 5.43 and the currents in all the three resistors are calculated due to voltage source V_2 independently.

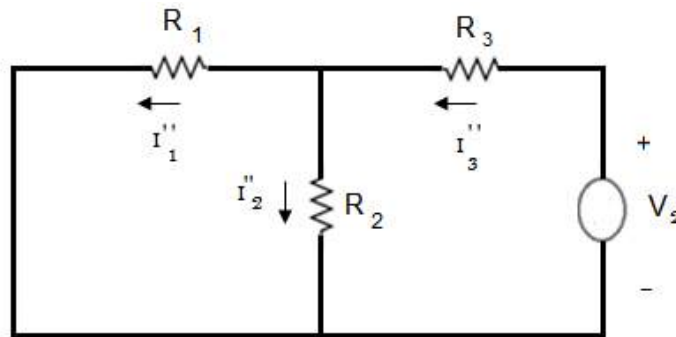

Figure 5.43: V_1 replaced by 0

After replacing V_1 by 0, The current in R_1 is I_1'' , the current in R_2 is I_2'' and the current in R_3 is I_3'' . All these three currents in the circuits are caused by the voltage source V_2 . According to Superposition Theorem

$$I_1 = I_1' - I_1'' \quad (5.4)$$

$$I_2 = I_2' + I_2'' \quad (5.5)$$

$$I_3 = I_3' - I_3'' \quad (5.6)$$

D 5.8: Consider the following circuit and find all the three currents using Superposition Theorem.

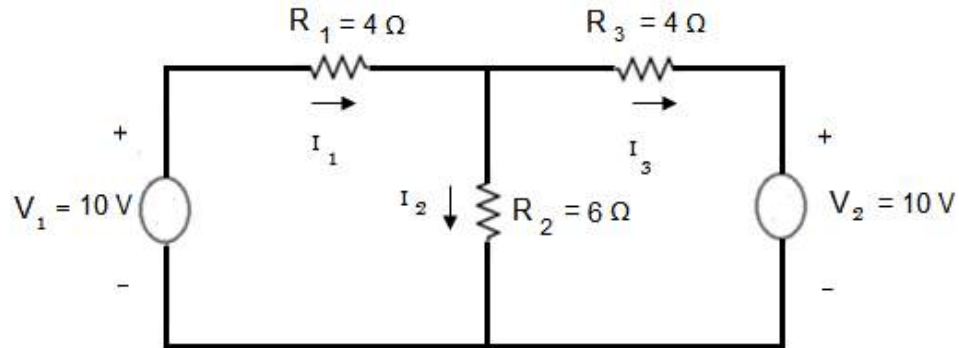

Figure 5.44: Circuit for D # 5.8

The second voltage source is replaced by short circuit as shown in Figure 5.45 and the currents in all the three resistors are calculated due to voltage source V_1 independently. After replacing V_2 by 0, The current in R_1 is I_1' , the current in R_2 is I_2' and the current in R_3 is I_3' . All these three currents in the circuits are caused by the voltage source V_1 .

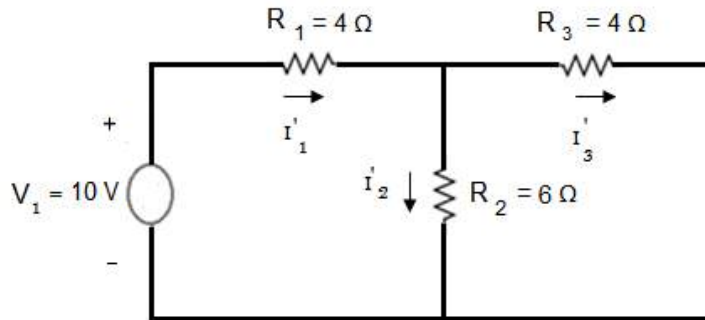

Figure 5.45: V_2 replaced by 0

Using Standard loop equations, we have

$$\begin{bmatrix} 10 & -6 \\ -6 & 10 \end{bmatrix} \begin{bmatrix} I_1' \\ I_3' \end{bmatrix} = \begin{bmatrix} 10 \\ 0 \end{bmatrix}$$

$$I_1' = \frac{\begin{vmatrix} 10 & -6 \\ 0 & 10 \end{vmatrix}}{\begin{vmatrix} 10 & -6 \\ -6 & 10 \end{vmatrix}}$$

$$I_1' = \frac{100}{64}$$

$$I_1' = 1.56 \text{ A}$$

$$I_3' = \frac{\begin{vmatrix} 10 & 10 \\ -6 & 0 \end{vmatrix}}{\begin{vmatrix} 10 & -6 \\ -6 & 10 \end{vmatrix}}$$

$$I_3' = \frac{60}{64}$$

$$I_3' = 0.94 \text{ A}$$

$$I_2' = 1.56 - 0.94 = 0.62 \text{ A}$$

Now the first voltage source is replaced by short circuit as shown in Figure 5.46 and the currents in all the three resistors are calculated due to voltage source V_2 independently. After replacing V_1 by 0, The current in R_1 is I_1'' , the current in R_2 is I_2'' and the current in R_3 is I_3'' . All these three currents in the circuits are caused by the voltage source V_2 .

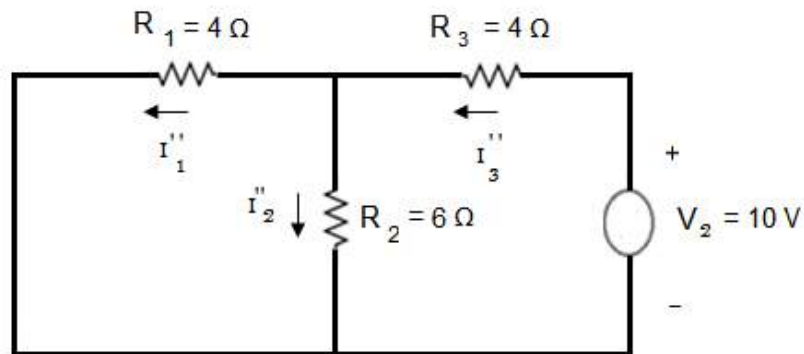

Figure 5.46: V_1 replaced by 0

Using Standard loop equations, we have

$$\begin{bmatrix} 10 & -6 \\ -6 & 10 \end{bmatrix} \begin{bmatrix} I_1'' \\ I_3'' \end{bmatrix} = \begin{bmatrix} 0 \\ 10 \end{bmatrix}$$

$$I_1'' = \frac{\begin{vmatrix} 0 & -6 \\ 10 & 10 \end{vmatrix}}{\begin{vmatrix} 10 & -6 \\ -6 & 10 \end{vmatrix}}$$

$$I_1'' = \frac{60}{64}$$

$$I_1'' = 0.94 \text{ A}$$

$$I_3'' = \frac{\begin{vmatrix} 10 & 0 \\ -6 & 10 \end{vmatrix}}{\begin{vmatrix} 10 & -6 \\ -6 & 10 \end{vmatrix}}$$

$$I_3'' = \frac{100}{64}$$

$$I_3'' = 1.56 \text{ A}$$

$$I_2'' = 1.56 - 0.94 = 0.62 \text{ A}$$

According to Superposition Theorem

$$I_1 = I_1' - I_1''$$

$$I_1 = 1.56 - 0.94 = 0.62 \text{ A}$$

$$I_2 = I_2' + I_2''$$

$$I_2 = 0.62 + 0.62 = 1.24 \text{ A}$$

$$I_3 = I_3' - I_3''$$

$$I_3 = 0.94 - 1.56 = -0.62 \text{ A}$$

D 5.9: Consider the following circuit and find voltage across R_3 and power consumed by R_3 using Superposition Theorem.

Solution:

The second voltage source is replaced by short circuit as shown in Figure 5.48 and the currents in R_3 is calculated due to voltage source V_1 independently. We determine the three currents in Figure 5.48 with the help of standard loop equations. You may apply any other convenient method in this regard.

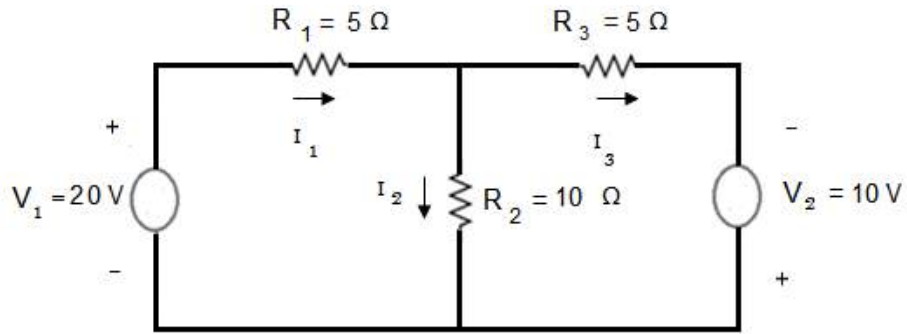

Figure 5.47: Circuit for D # 5.9

After replacing V_2 by 0, The current in R_3 is I_3' . This current is caused by the voltage source V_1 .

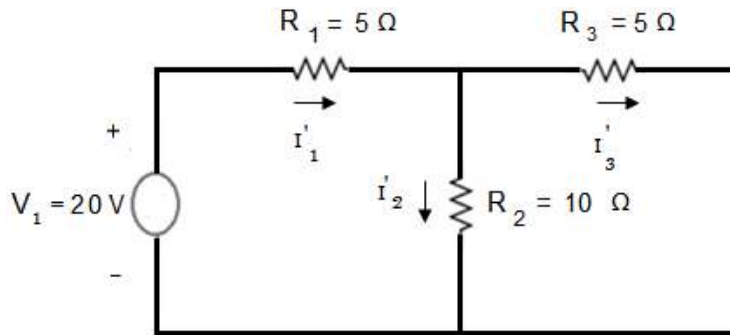

Figure 5.48: V_2 replaced by 0

Using Standard loop equations, we have

$$\begin{bmatrix} 15 & -10 \\ -10 & 15 \end{bmatrix} \begin{bmatrix} I_1' \\ I_3' \end{bmatrix} = \begin{bmatrix} 20 \\ 0 \end{bmatrix}$$

$$I_3' = \frac{\begin{vmatrix} 15 & 20 \\ -10 & 0 \end{vmatrix}}{\begin{vmatrix} 15 & -10 \\ -10 & 15 \end{vmatrix}}$$

$$I_3' = \frac{200}{125}$$

$$I_3' = 1.6 \text{ A}$$

Now the first voltage source is replaced by short circuit as shown in Figure 5.49 and the currents in R_3 is calculated due to voltage source V_2 independently. After replacing V_1 by 0, the current in R_3 is I_3'' . This current is caused by the voltage source V_2 .

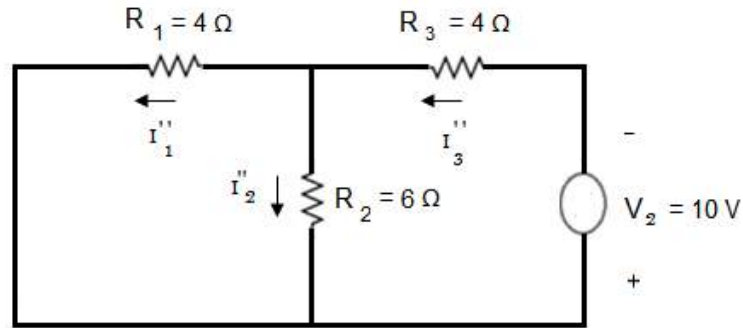

Figure 5.49: V_1 replaced by 0

Using Standard loop equations, we have

$$\begin{bmatrix} 15 & -10 \\ -10 & 15 \end{bmatrix} \begin{bmatrix} I_1'' \\ I_3'' \end{bmatrix} = \begin{bmatrix} 0 \\ -10 \end{bmatrix}$$

$$I_3'' = \frac{\begin{vmatrix} 15 & 0 \\ -10 & -10 \end{vmatrix}}{\begin{vmatrix} 15 & -10 \\ -10 & 15 \end{vmatrix}}$$

$$I_3'' = \frac{-150}{125}$$

$$I_3'' = -1.2 \text{ A}$$

According to Superposition Theorem

$$I_3 = I_3' - I_3''$$

$$I_3 = 1.6 + 1.2 = 2.8 \text{ A}$$

Voltage across R_3

$$V_{R_3} = 2.8 \times 5 = 14 \text{ V}$$

Power consumed by R_3 is $P = (2.8)^2 \times 5 = 39.2 \text{ W}$

5-5 Reciprocity Theorem

This theorem states that if a voltage V in one branch of a reciprocal circuit results in a current I in another branch, then if the voltage V is shifted from the first to the second branch, it will produce the same current in the first branch where the voltage has been replaced by its internal resistance. Consider the circuit given in Figure 5.50, the voltage V in the first branch induces a current I in the branch containing R_3 .

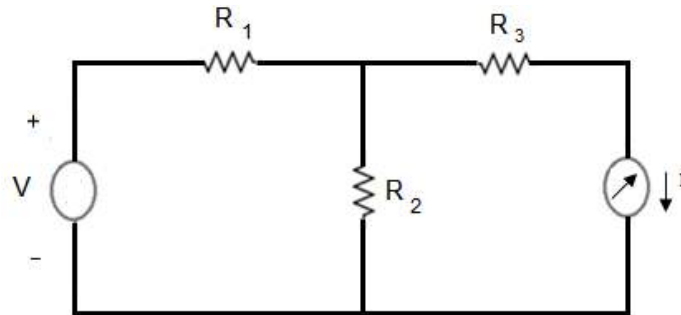

Figure 5.50: Source in the first Branch

If the voltage V is moved from the first branch to the third branch as shown in Figure 5.51, then it will induce the same current I in the branch containing R_1 in accordance with reciprocity theorem. There should be only one voltage source in the circuit and the polarities of the voltage source in the second branch should be in the direction of the current.

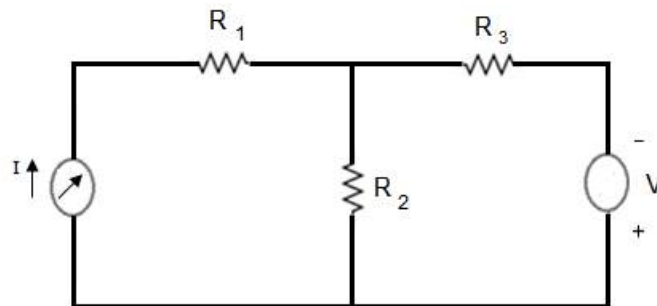

Figure 5.51: Source in the third Branch

D 5.10: Consider the following reciprocal circuit and verify the reciprocity theorem.

Solution:

Using standard loop equations we calculate I

$$I = \frac{\begin{vmatrix} 7 & 5 \\ -3 & 0 \end{vmatrix}}{\begin{vmatrix} 7 & -3 \\ -3 & 7 \end{vmatrix}}$$

$$I = \frac{15}{40}$$

$$I = 0.375 \text{ A}$$

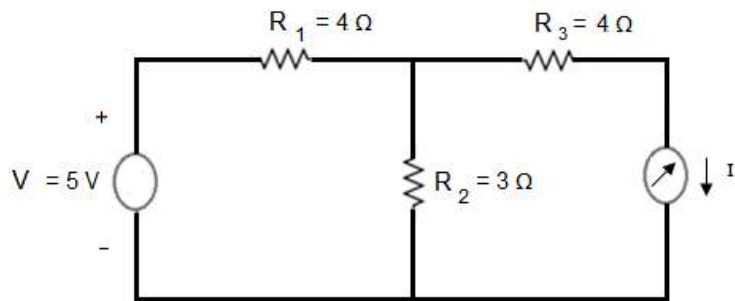

Figure 5.52: Circuit for D # 5.10

The voltage is moved to the branch containing Ammeter as shown in the following Figure.

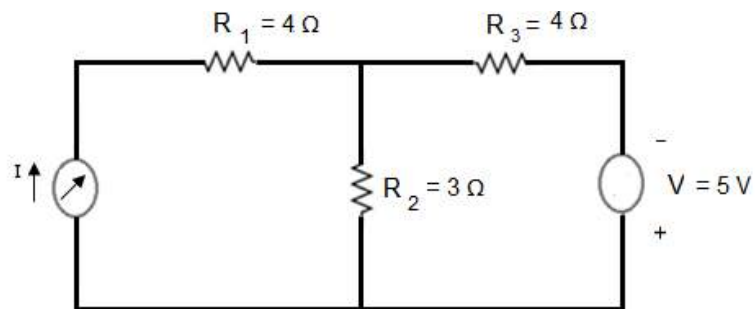

Figure 5.53: Circuit for D # 5.10

$$I = \frac{\begin{vmatrix} 0 & -3 \\ 5 & 7 \end{vmatrix}}{\begin{vmatrix} 7 & -3 \\ -3 & 7 \end{vmatrix}}$$

$$I = \frac{15}{40}$$

$$I = 0.375 \text{ A}$$

D 5.11: Consider the following reciprocal circuit and verify the reciprocity theorem.

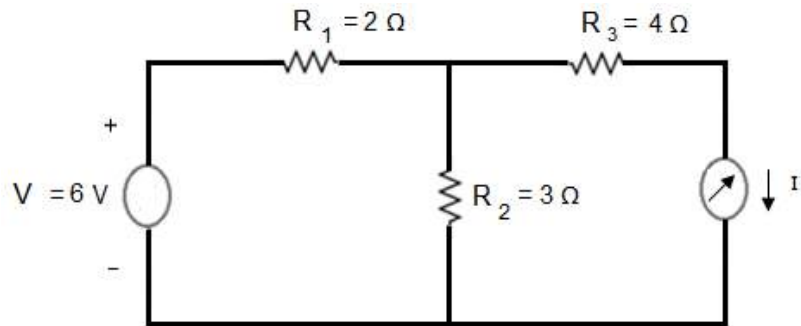

Figure 5.54: Circuit for D # 5.11

Solution:

Using standard loop equations we calculate I

$$I = \frac{\begin{vmatrix} 5 & 6 \\ -3 & 0 \end{vmatrix}}{\begin{vmatrix} 5 & -3 \\ -3 & 7 \end{vmatrix}}$$

$$I = \frac{18}{26}$$

$$I = 0.692 \text{ A}$$

The voltage is moved to the branch containing Ammeter as shown in the following Figure.

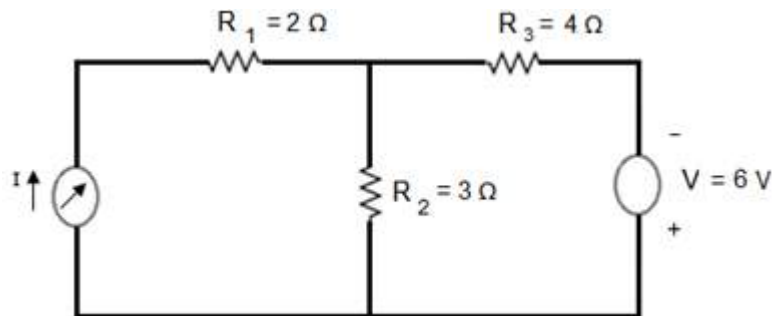

Figure 5.55: Circuit for D # 5.11

$$I = \frac{\begin{vmatrix} 0 & -3 \\ 6 & 7 \end{vmatrix}}{\begin{vmatrix} 5 & -3 \\ -3 & 7 \end{vmatrix}}$$

$$I = \frac{18}{26}$$

$$I = 0.692 \text{ A}$$

Exercise:

Q 5.1: Consider the circuit diagram as shown in Figure 5.56. Using Thevenin's Theorem, determine the current in the load resistor of 5Ω .

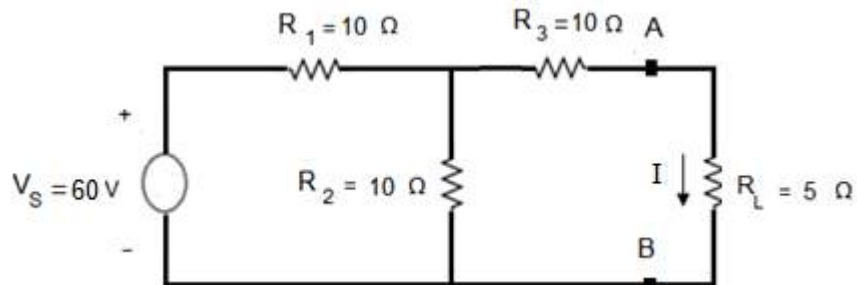

Figure 5.56: Circuit for Q # 5.1

Answer: 1.84 A.

Q 5.2: Consider the circuit diagram as shown in Figure 5.57. Using Norton's Theorem, determine the current in the load resistor of 2Ω .

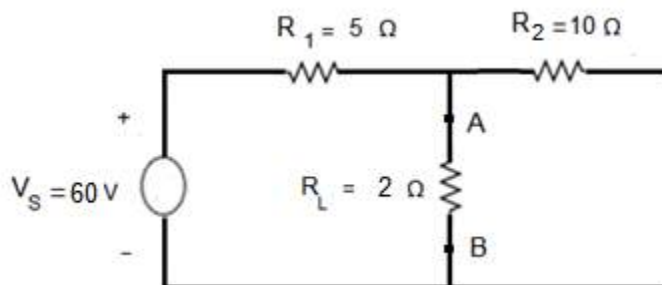

Figure 5.57: Circuit for Q # 5.2

Answer: 2.5 A.

Q 5.3: Consider the circuit diagram as shown in Figure 5.56. Determine the Maximum power transferred to the load resistor of 5Ω .

Answer: 16.92 W.

Q 5.4: Determine the current in resistor R_3 and verify Reciprocity Theorem.

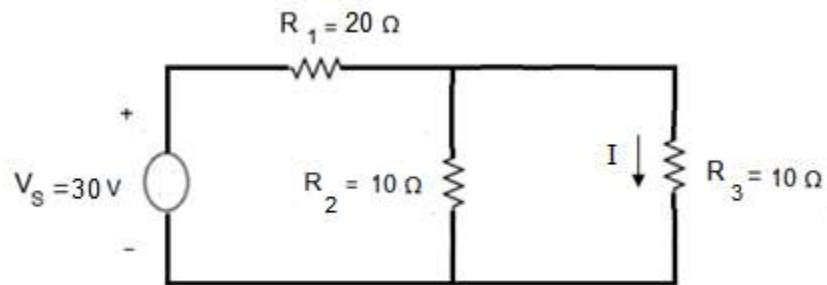

Figure 5.58: Circuit for Q # 5.4

Answer: 0.6 A

Chapter 6

Three Phase Circuits

6-1 Star Connected Voltage Source

Consider three phase star connected voltage source as shown in Figure 6.1. All the three voltages V_A , V_B and V_C are equal in magnitude and 120° apart.

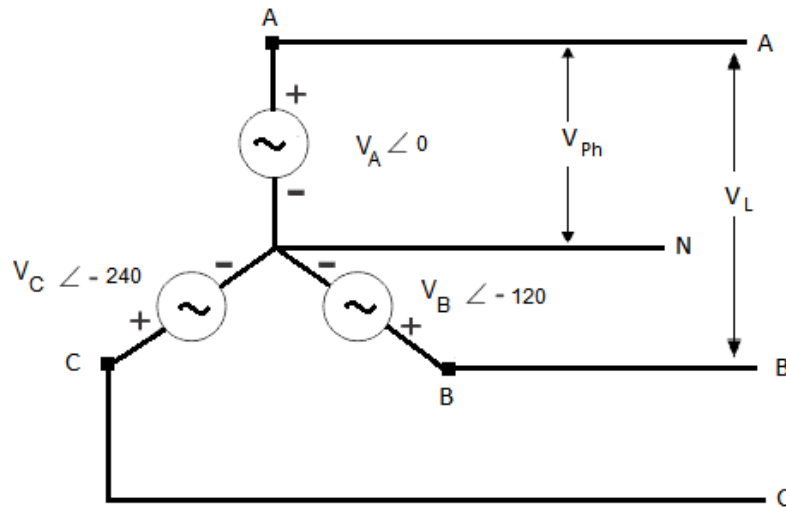

Figure 6.1: Star Connected Three Phase Voltage Source

The line to neutral voltage is known as phase voltage and the line to line voltage is known as line voltage. This system is known as three phase four wire balanced system. The phase voltages of ABC sequence are given as under

$$V_A = V_A \angle 0$$

$$V_B = V_B \angle -120$$

$$V_C = V_C \angle -240$$

The above mentioned phase voltages of ABC sequence may be written in the following format as well

$$V_A = V_A \angle 90$$

$$V_B = V_B \angle - 30$$

$$V_C = V_C \angle - 150$$

As all the three voltages V_A , V_B and V_C are equal in magnitude and 120° apart, therefore their phasor sum will be equal to zero.

$$V_A + V_B + V_C = V_A \angle 0 + V_B \angle - 120 + V_C \angle - 240 \quad (6.1)$$

$$V_A + V_B + V_C = V_{Ph} \angle 0 + V_{Ph} \angle - 120 + V_{Ph} \angle - 240$$

$$V_A + V_B + V_C = V_{Ph} (1 \angle 0 + 1 \angle - 120 + 1 \angle - 240)$$

$$V_A + V_B + V_C = V_{Ph} (1 + \cos -120 + j \sin -120 + \cos -240 + j \sin - 240)$$

$$V_A + V_B + V_C = V_{Ph} (1 - 0.5 + j 0.866 - 0.5 - j 0.866)$$

$$V_A + V_B + V_C = 0 \quad (6.2)$$

The phasor diagram of these three voltages is shown in Figure 6.2.

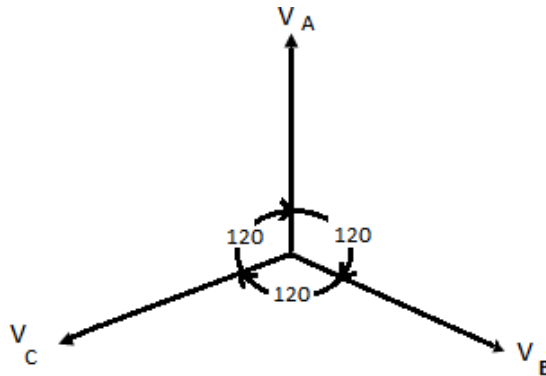

Figure 6.2: Phasor Diagram

The line voltages are V_{CB} , V_{AC} and V_{BA} and they are not equal to the phase voltages in star connected source. To find the relationship between the line and the phase voltage

in a star connected source, consider the following equations. The ABC sequence has been considered for the line to line voltages.

$$V_{CB} = V_B - V_C \quad (6.3)$$

$$V_{AC} = V_C - V_A \quad (6.4)$$

$$V_{BA} = V_A - V_B \quad (6.5)$$

If we consider Figure 6.3 then equations 6.3, 6.4 and 6.5 can be written as

$$V_A = V_{BA} + V_B$$

$$V_B = V_{CB} + V_C$$

$$V_C = V_{AC} + V_A$$

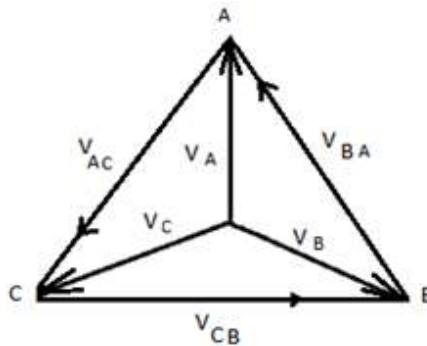

Figure 6.3: Line to Line and Line to Neutral Voltages

If we consider V_{CB} as a reference phasor, then V_{AC} and V_{BA} can be related to it with the help of the Phasor diagram as shown in Figure 6.4. All these line voltages are equal in magnitude and 120 degree apart. Obviously phasor sum of these line to line voltages will result in zero.

Mathematically

$$V_{CB} = V_{CB} \angle 0$$

$$V_{AC} = V_{AC} \angle -120$$

$$V_{BA} = V_{BA} \angle -240$$

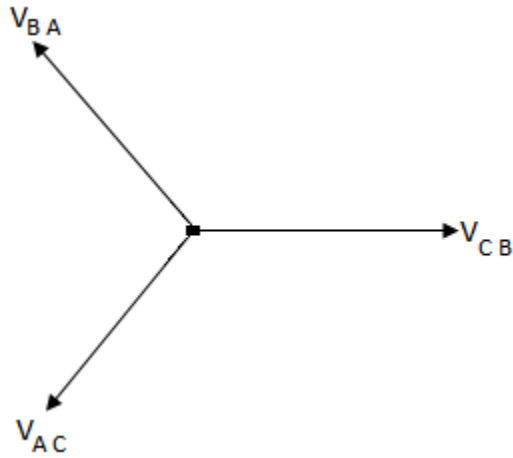

Figure 6.4: Phasor Diagram of the Line Voltages

The phasor sum of V_B and $-V_C$ results in the line voltage V_{CB} as shown in Figure 6.5. The angle between V_B and $-V_C$ is 60° .

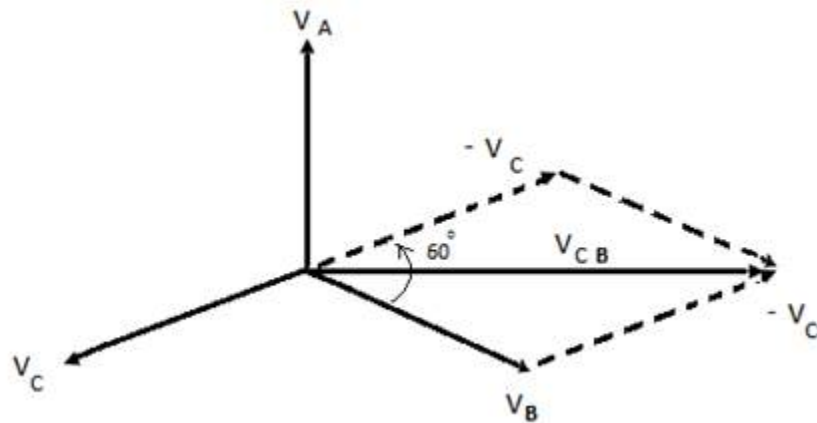

Figure 6.5: Relationship between Line and Phase Voltage

Reconsider the triangle in the above mentioned figure, the triangle is shown in Figure 6.6. It is clear from the given voltage triangle that

$$V_{CB} = \sqrt{(V_B + V_1)^2 + (V_2)^2} \quad (6.6)$$

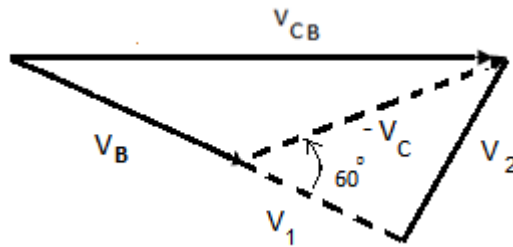

Figure 6.6: Voltage Triangle

$$V_{CB} = \sqrt{V_B^2 + V_1^2 + V_2^2 + 2V_B V_1} \quad (6.7)$$

Where $V_1 = V_C \cos 60$ and $V_2 = V_C \sin 60$. Putting these values in equation 6.7, we obtain

$$V_{CB} = \sqrt{V_B^2 + (V_C \cos 60)^2 + (V_C \sin 60)^2 + 2V_B V_C \cos 60}$$

$$V_{CB} = \sqrt{V_B^2 + V_C^2(\cos^2 60 + \sin^2 60) + 2V_B \times V_C \times \frac{1}{2}}$$

$$V_{CB} = \sqrt{V_B^2 + V_C^2 + V_B \times V_C}$$

$$V_{CB} = \sqrt{V_B^2 + V_C^2 + V_C^2}$$

As $V_B = V_C = V_{Ph}$ and $V_{CB} = V_L$

Therefore

$$V_L = \sqrt{V_{Ph}^2 + V_{Ph}^2 + V_{Ph}^2}$$

$$V_L = \sqrt{3} V_{Ph} \quad (6.8)$$

6-2 Star Connected Balanced Load

Consider three phase star connected balanced load across a star connected voltage source as shown in Figure 6.7. This configuration is known as star- star configuration. The phase currents in this configuration are equal to the line currents.

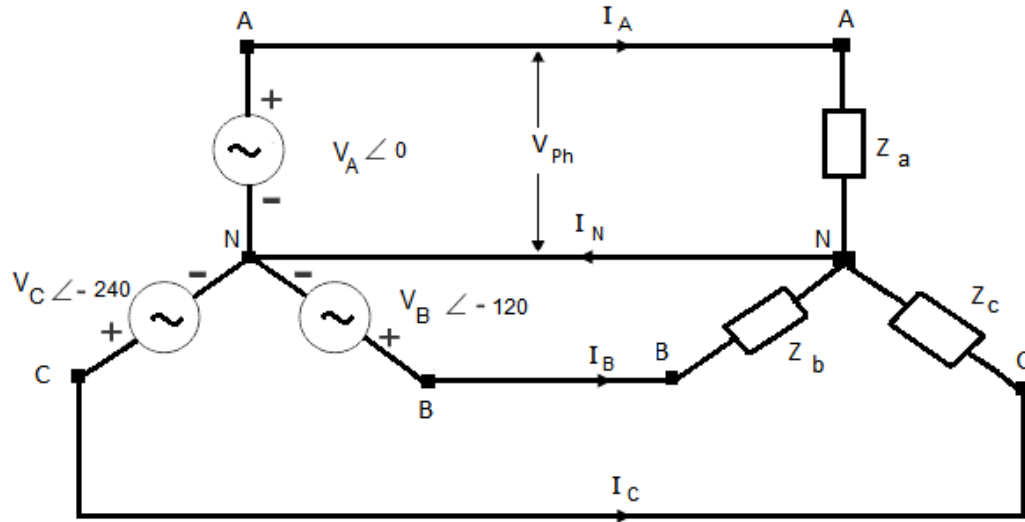

Figure 6.7: Star- Star Configuration

As the load is balanced, therefore

$$Z_a = Z \angle \theta$$

$$Z_b = Z \angle \theta$$

$$Z_c = Z \angle \theta$$

The phase voltages of ABC sequence are given as under

$$V_A = V_{Ph} \angle 0$$

$$V_B = V_{Ph} \angle -120$$

$$V_C = V_{Ph} \angle -240$$

The phase currents in the star connected load are equal to the line currents, That is

$$I_L = I_{Ph}$$

It has already been derived that

$$V_L = \sqrt{3} V_{Ph}$$

If the line impedance is ignored, then

$$I_A = \frac{V_{Ph}}{Z_a}$$

$$I_A = \frac{V_{Ph}}{Z} \angle -\theta$$

$$I_A = I_{Ph} \angle -\theta \quad (6.9)$$

$$I_B = \frac{V_{Ph}}{Z_b}$$

$$I_B = \frac{V_{Ph}}{Z} \angle -120 - \theta$$

$$I_B = I_{Ph} \angle -120 - \theta \quad (6.10)$$

$$I_C = \frac{V_{Ph}}{Z_c}$$

$$I_C = \frac{V_{Ph}}{Z} \angle -240 - \theta$$

$$I_C = I_{Ph} \angle -240 - \theta \quad (6.11)$$

All these three current are equal in magnitude and 120 degrees apart, their phasor sum will be equal to zero.

$$I_A + I_B + I_C = I_N = 0$$

Thus in the star connected three phase balanced system the neutral current is zero. In other words there is no need to connect the neutral wire in the three phase balanced system. The phasor diagram is shown in Figure 6.8.

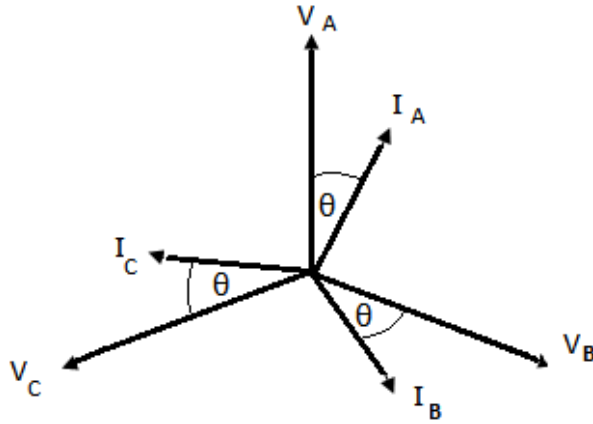

Figure 6.8: Phasor Diagram

Power consumed by Z_a

$$P_a = V_{Ph} \times I_{Ph} \times \cos \theta$$

Power consumed by Z_b

$$P_b = V_{Ph} \times I_{Ph} \times \cos \theta$$

Power consumed by Z_c

$$P_c = V_{Ph} \times I_{Ph} \times \cos \theta$$

The total power consumed by the load is

$$P_S = P_a + P_b + P_c$$

$$P_S = 3 \times V_{Ph} \times I_{Ph} \times \cos \theta$$

As

$$V_{Ph} = \frac{V_L}{\sqrt{3}}$$

Therefore

$$P_S = \sqrt{3} \times V_L \times I_L \times \cos \theta$$

D 6.1: Consider the three phase circuit as shown in Figure 6.9. Determine the three currents and the powers consumed by each branch of the load. Determine the power supplied by the voltage source as well. The star connected load is a balanced load with $Z_1 = 5\angle 53.1 \Omega$.

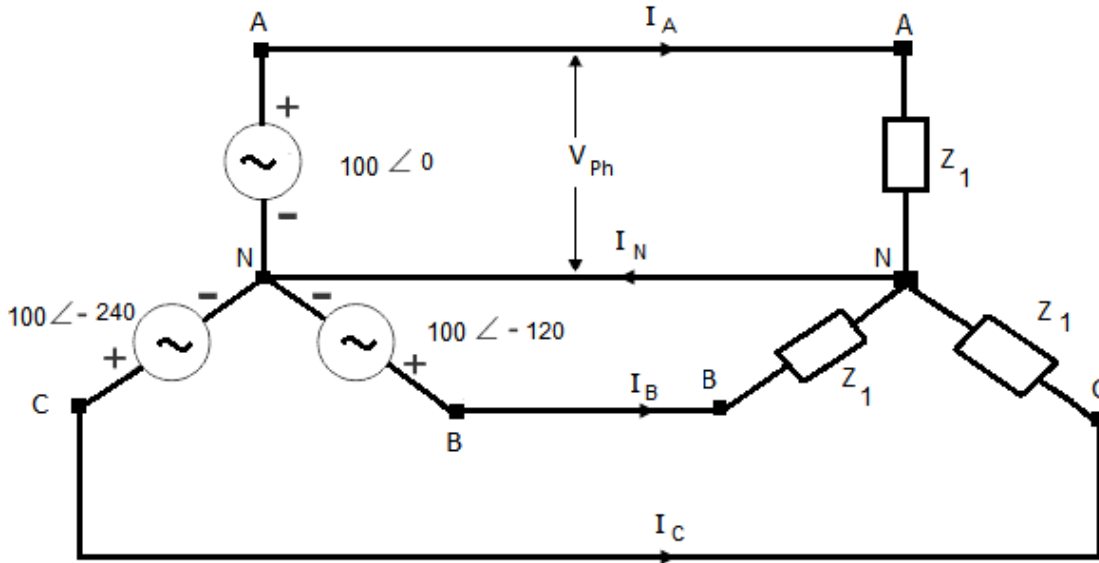

Figure 6.9: Three Phase Circuit for D # 6.1

The phase voltages of ABC sequence are given as under

$$V_A = 100 \angle 0 \text{ V}$$

$$V_B = 100 \angle -120 \text{ V}$$

$$V_C = 100 \angle -240 \text{ V}$$

The line voltage is

$$V_L = \sqrt{3} V_{Ph} = 173.2 \text{ V}$$

If the line impedance is ignored, then

$$I_A = \frac{V_A}{Z_1}$$

$$I_A = \frac{100}{5} \angle -53.1$$

$$I_A = 20 \angle -53.1 \text{ A}$$

$$I_B = \frac{V_B}{Z_1}$$

$$I_B = \frac{100}{5} \angle -120 - 53.1$$

$$I_B = 20 \angle -173.1 \text{ A}$$

$$I_C = \frac{V_C}{Z_c}$$

$$I_C = \frac{100}{5} \angle -240 - 53.1$$

$$I_C = 20 \angle -293.1 \text{ A}$$

All these three current are equal in magnitude and 120 degrees apart, their phasor sum will be equal to zero.

$$I_A + I_B + I_C = I_N = 0$$

The phase currents in the star connected load are equal to the line currents, That is

$$I_L = I_{Ph}$$

Power consumed by each branch

$$P_1 = V_{Ph} \times I_{Ph} \times \cos \theta$$

$$P_1 = 100 \times 20 \times 0.6$$

$$P_1 = 1200 \text{ W}$$

Total power consumed by the load is

$$P_t = 3 \times P_1 = 3600 \text{ W}$$

Power supplied by the source

$$P_S = 3 \times V_{ph} \times I_{ph} \times \cos \theta$$

$$P_S = 3 \times 100 \times 20 \times 0.6$$

$$P_S = 3600 \text{ W}$$

D 6.2: Consider the three phase circuit as shown in Figure 6.10. Determine the three currents and the powers consumed by each branch of the load. Determine the power supplied by the voltage source as well. The star connected load is a balanced load with $Z_1 = 10 \angle 36.8 \Omega$.

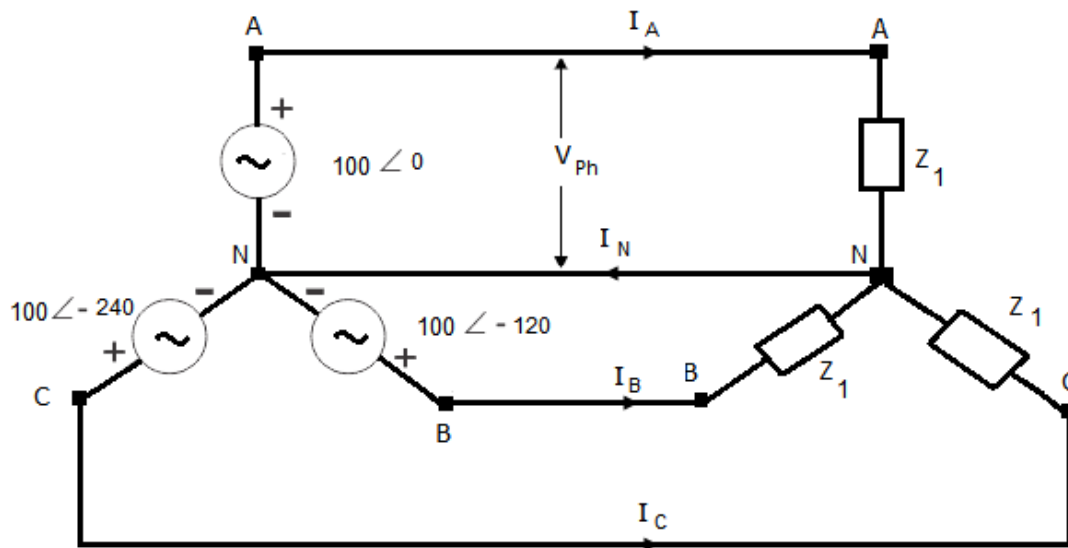

Figure 6.10: Three Phase Circuit for D # 6.2

The phase voltages of ABC sequence are given as under

$$V_A = 100 \angle 0^\circ \text{ V}$$

$$V_B = 100 \angle -120^\circ \text{ V}$$

$$V_C = 100 \angle -240 \text{ V}$$

If the line impedance is ignored, then

$$I_A = \frac{V_A}{Z_1}$$

$$I_A = \frac{100}{10} \angle -36.8$$

$$I_A = 10 \angle -36.8 \text{ A}$$

$$I_B = \frac{V_B}{Z_1}$$

$$I_B = \frac{100}{10} \angle -120 - 36.8$$

$$I_B = 10 \angle -156.8 \text{ A}$$

$$I_C = \frac{V_C}{Z_c}$$

$$I_C = \frac{100}{10} \angle -240 - 36.8$$

$$I_C = 10 \angle -276.8 \text{ A}$$

All these three current are equal in magnitude and 120 degrees apart, their phasor sum will be equal to zero.

$$I_A + I_B + I_C = I_N = 0$$

Power consumed by each branch

$$P_1 = V_{Ph} \times I_{Ph} \times \cos \theta$$

$$P_1 = 100 \times 10 \times 0.8$$

$$P_1 = 800 \text{ W}$$

Total power consumed by the load is

$$P_t = 3 \times P_1 = 2400 \text{ W}$$

Power supplied by the source

$$P_S = 3 \times V_{ph} \times I_{ph} \times \cos \theta$$

$$P_S = 3 \times 100 \times 10 \times 0.8$$

$$P_S = 2400 \text{ W}$$

6-3 Delta Connected Balanced Load

Consider three phase delta connected balanced load across a delta connected voltage source as shown in Figure 6.11. This configuration is known as delta- delta configuration. The phase voltages in this configuration are equal to the line voltages.

$$V_L = V_{ph}$$

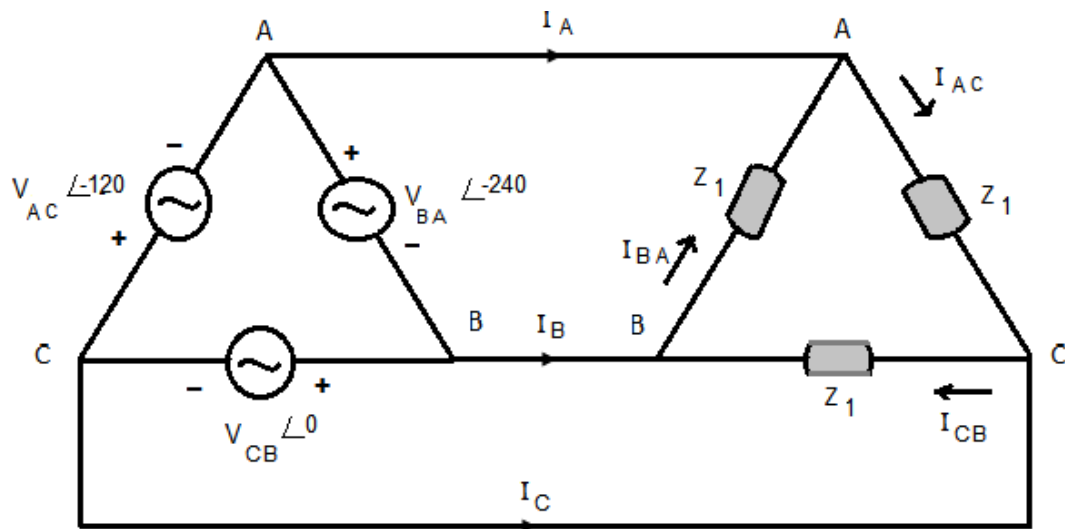

Figure 6.11: Delta Connected Balanced Load

As the load is balanced, therefore the load in any branch is

$$Z_1 = Z \angle \theta$$

The phase/ line voltages of ABC sequence are given as under

$$V_{CB} = V_{Ph} \angle 0$$

$$V_{AC} = V_{Ph} \angle -120$$

$$V_{BA} = V_{Ph} \angle -240$$

The phase currents in the delta connected load are not equal to the line currents; it will be proved later that

$$I_L = \sqrt{3} I_{Ph}$$

If the line impedance is ignored, then

$$I_{CB} = \frac{V_{CB}}{Z_1}$$

$$I_{CB} = \frac{V_{Ph}}{Z} \angle -\theta$$

$$I_{CB} = I_{Ph} \angle -\theta \quad (6.12)$$

$$I_{AC} = \frac{V_{AC}}{Z_1}$$

$$I_{AC} = \frac{V_{Ph}}{Z} \angle -120 - \theta$$

$$I_{AC} = I_{Ph} \angle -120 - \theta \quad (6.13)$$

$$I_{BA} = \frac{V_{BA}}{Z_1}$$

$$I_{BA} = \frac{V_{Ph}}{Z} \angle -240 - \theta$$

$$I_{BA} = I_{Ph} \angle -240 - \theta \quad (6.14)$$

All these three phase current are equal in magnitude and 120 degrees apart, their phasor sum will be equal to zero.

$$I_{CB} + I_{AC} + I_{BA} = 0$$

Apply KCL to node A which states that phasor sum of the currents flowing towards node A will be equal to the phasor sum of the currents flowing away from the node.

$$I_A = I_{AC} - I_{BA} \quad (6.15)$$

Apply KCL to node B

$$I_B = I_{BA} - I_{CB} \quad (6.16)$$

Apply KCL to node C

$$I_C = I_{CB} - I_{AC} \quad (6.17)$$

The phasor sum of these line currents is equal to zero.

$$I_A + I_B + I_C = 0$$

The phasor diagram of the phase currents is depicted in Figure 6.12.

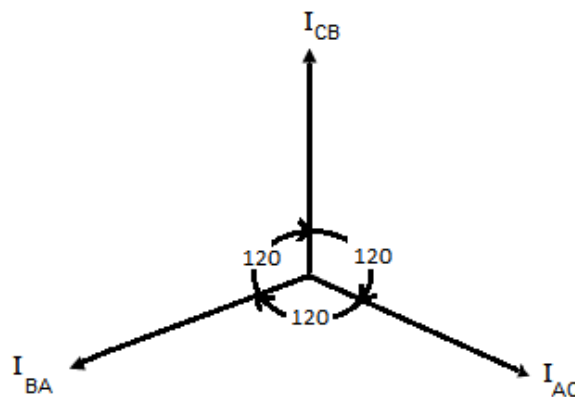

Figure 6.12: phasor Diagram of the Phase Currents

The phasor sum of I_{AC} and $-I_{BA}$ results in the line current I_A as shown in Figure 6.13.

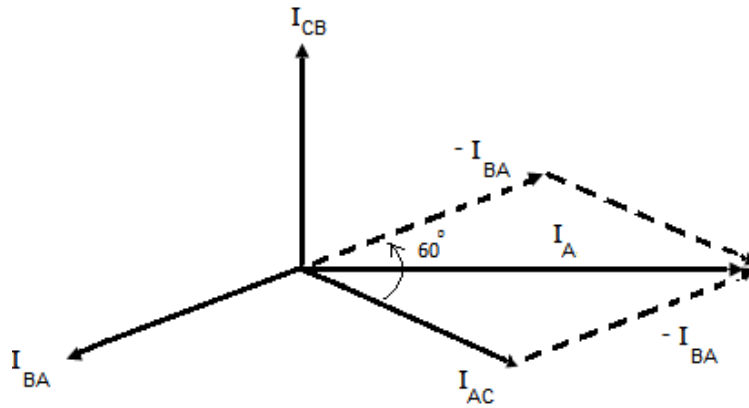

Figure 6.13: Relationship between Line and Phase Currents

Reconsider the triangle in the above mentioned figure, the triangle is shown in Figure 6.14.

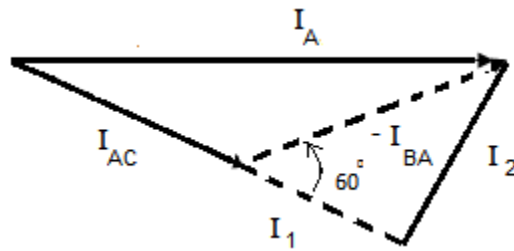

Figure 6.14: Currents Triangle

It is clear from the given current triangle that

$$I_A = \sqrt{(I_{AC} + I_1)^2 + (I_2)^2}$$

$$I_A = \sqrt{I_{AC}^2 + I_1^2 + I_2^2 + 2 I_{AC} I_1} \quad (6.18)$$

Where $I_1 = I_{BA} \cos 60$ and $I_2 = I_{BA} \sin 60$. Putting these values in equation 6.18, we obtain

$$I_A = \sqrt{I_{AC}^2 + (I_{BA} \cos 60)^2 + (I_{BA} \sin 60)^2 + 2 I_{AC} I_{BA} \cos 60}$$

$$I_A = \sqrt{I_{AC}^2 + I_{BA}^2 (\cos^2 60 + \sin^2 60) + 2 I_{AC} I_{BA} \times \frac{1}{2}}$$

$$I_A = \sqrt{I_{AC}^2 + I_{BA}^2 + I_{AC} I_{BA}}$$

As $I_{AC} = I_{BA} = I_{Ph}$ and $I_A = I_L$

Therefore

$$I_L = \sqrt{I_{Ph}^2 + I_{Ph}^2 + I_{Ph}^2}$$

$$I_L = \sqrt{3} I_{Ph} \quad (6.19)$$

Power consumed by each branch of the delta load

$$P_1 = V_{Ph} \times I_{Ph} \times \cos \theta$$

The total power consumed by the delta load is

$$P_t = 3 \times P_1$$

Power supplied by the source

$$P_s = 3 \times V_{Ph} \times I_{Ph} \times \cos \theta$$

As

$$I_{Ph} = \frac{I_L}{\sqrt{3}}$$

$$P_s = \sqrt{3} \times V_L \times I_L \times \cos \theta$$

D 6.3: Consider the three phase circuit as shown in Figure 6.15. Determine the phase currents, the line currents and the powers consumed each branch of the load. Determine the power supplied by the voltage source as well. The delta connected load is a balanced load with $Z_1 = 10 \angle 53.1 \Omega$. The line to line voltages of ABC sequence are;

$$V_{CB} = 100 \angle 0$$

$$V_{AC} = 100 \angle -120$$

$$V_{BA} = 100 \angle -240$$

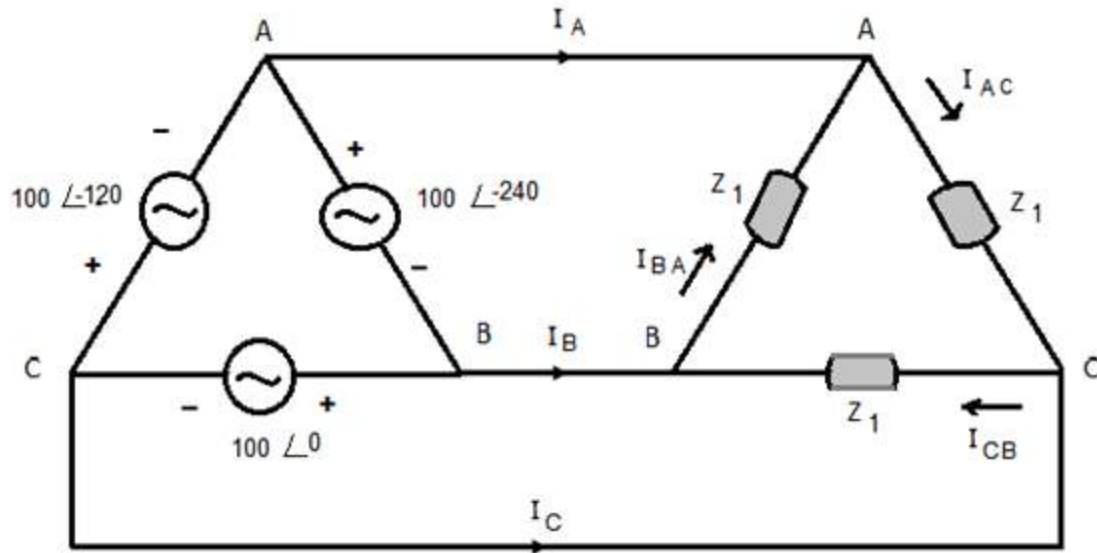

Figure 6.15: Circuit for D # 6.3

Solution:

$$Z_1 = Z_2 = Z_3 = 10 \angle 53.1 \Omega$$

$$I_{CB} = \frac{V_{CB}}{Z_1}$$

$$I_{CB} = \frac{100}{10} \angle -53.1$$

$$I_{CB} = 10 \angle -53.1 \text{ A}$$

$$I_{AC} = \frac{V_{AC}}{Z_1}$$

$$I_{AC} = \frac{100}{10} \angle -120 - 53.1$$

$$I_{AC} = 10 \angle -173.1 \text{ A}$$

$$I_{BA} = \frac{V_{BA}}{Z_1}$$

$$I_{BA} = \frac{100}{10} \angle -240 - 53.1$$

$$I_{BA} = 10 \angle -293.1 \text{ A}$$

All these three phase current are equal in magnitude and 120 degrees apart, their phasor sum will be equal to zero.

$$I_{CB} + I_{AC} + I_{BA} = 0$$

Apply KCL to node A

$$I_A = I_{AC} - I_{BA}$$

$$I_A = 10 \angle -173.1 - 10 \angle -293.1$$

$$I_A = -13.92 - j10.39$$

$$I_A = 17.37 \angle -143.2 \text{ A}$$

Apply KCL to node B

$$I_B = I_{BA} - I_{CB}$$

$$I_B = 10 \angle -293.1 - 10 \angle -53.1$$

$$I_B = -2.08 + j17.19$$

$$I_B = 17.37 \angle -263.1 \text{ A}$$

Apply KCL to node C

$$I_C = I_{CB} - I_{AC}$$

$$I_C = 10\angle -53.1 - 10\angle -173.1$$

$$I_C = 6 - j8 + 10 + j1.2$$

$$I_C = 16 - j6.8$$

$$I_C = 17.37\angle -23.1 \text{ A}$$

Power consumed by each branch of the delta load

$$P_1 = V_{Ph} \times I_{Ph} \times \cos \theta$$

$$P_1 = 100 \times 10 \times 0.6$$

$$P_1 = 600 \text{ W}$$

Total power consumed by the delta load is

$$P_t = 3 \times P_1 = 1800 \text{ W}$$

Power supplied by the source

$$P_S = 3 \times V_{Ph} \times I_{Ph} \times \cos \theta$$

$$P_S = 3 \times 100 \times 10 \times 0.6 = 1800 \text{ W}$$

or

$$P_S = \sqrt{3} \times V_L \times I_L \times \cos \theta$$

$$P_S = \sqrt{3} \times 100 \times 17.37 \times 0.6 = 1800 \text{ W}$$

6-4 Delta Connected Unbalanced Load

Consider three phase delta connected unbalanced load across a delta connected voltage source as shown in Figure 6.16. This configuration is known as delta-delta configuration. The phase voltages in this configuration are equal to the line voltages.

$$V_L = V_{Ph}$$

The phase/ line voltages of ABC sequence are given as under

$$V_{CB} = V_L \angle 0$$

$$V_{AC} = V_L \angle -120$$

$$V_{BA} = V_L \angle -240$$

As the load is unbalanced, therefore

$$Z_{CB} = Z_1 \angle \theta_1$$

$$Z_{AC} = Z_2 \angle \theta_2$$

$$Z_{BA} = Z_3 \angle \theta_3$$

If the line impedance is ignored, then

$$I_{CB} = \frac{V_{CB}}{Z_{CB}}$$

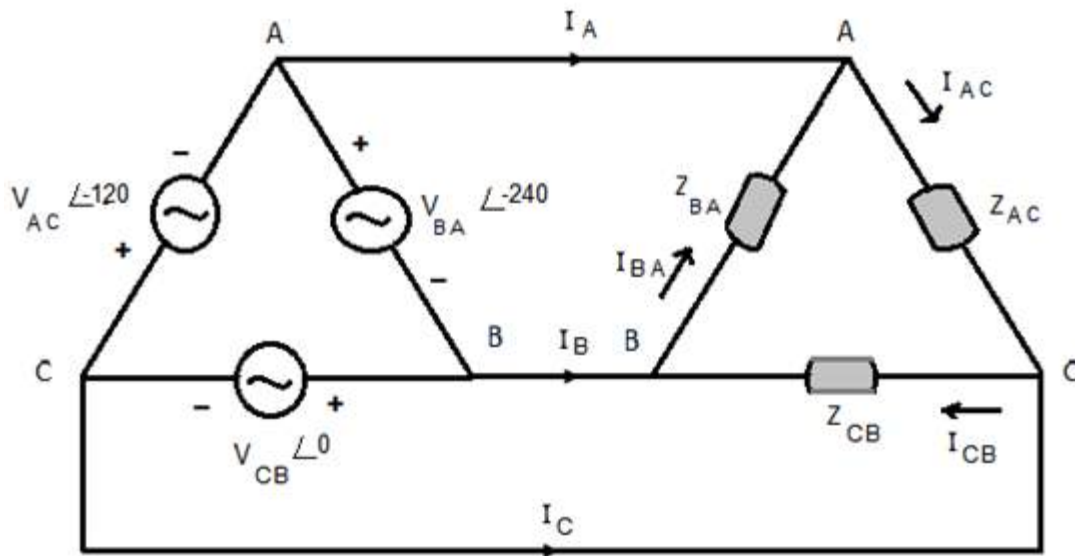

Figure 6.16: Delta Connected Unbalanced Load

$$I_{CB} = \frac{V_L}{Z_1} \angle -\theta_1$$

$$I_{CB} = I_1 \angle -\theta_1 \quad (6.20)$$

$$I_{AC} = \frac{V_{AC}}{Z_{AC}}$$

$$I_{AC} = \frac{V_L}{Z_2} \angle -120 - \theta_2$$

$$I_{AC} = I_2 \angle -120 - \theta_2 \quad (6.21)$$

$$I_{BA} = \frac{V_{BA}}{Z_{BA}}$$

$$I_{BA} = \frac{V_L}{Z_3} \angle -240 - \theta_3$$

$$I_{BA} = I_3 \angle -240 - \theta_3 \quad (6.22)$$

Apply KCL to node A which states that phasor sum of the currents flowing towards node A will be equal to the phasor sum of the currents flowing away from the node.

$$I_A = I_{AC} - I_{BA} \quad (6.23)$$

Apply KCL to node B

$$I_B = I_{BA} - I_{CB} \quad (6.24)$$

Apply KCL to node C

$$I_C = I_{CB} - I_{AC} \quad (6.25)$$

Since the phasor sum of the quantities on the right hand sides of equation 23 to 25 is zero, therefore phasor sum of the line currents is zero.

$$I_A + I_B + I_C = 0$$

Power consumed by branch CB

$$P_1 = V_L \times I_1 \times \cos \theta_1$$

Power consumed by branch AC

$$P_2 = V_L \times I_2 \times \cos \theta_2$$

Power consumed by branch BA

$$P_3 = V_L \times I_3 \times \cos \theta_3$$

The total power consumed by the unbalanced delta load is given by

$$P = P_1 + P_2 + P_3$$

D 6.4: Consider three phase delta connected unbalanced load across a delta connected voltage source as shown in Figure 6.17. Calculate the phase currents, line currents and powers. The phase/ line voltages of ABC sequence are

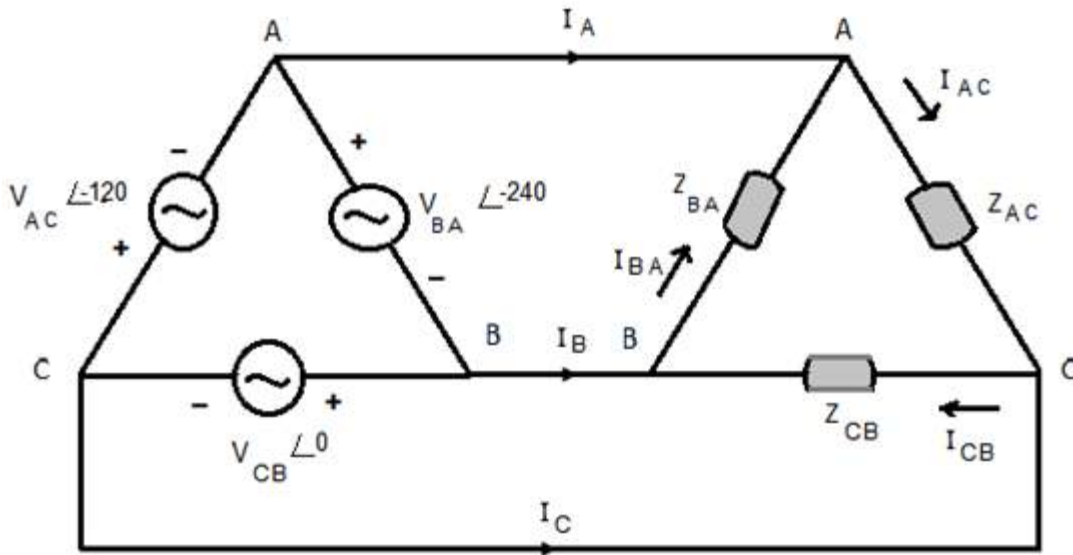

Figure 6.17: Delta connected Unbalanced Load for D # 6.4

$$V_{CB} = 100 \angle 0$$

$$V_{AC} = 100 \angle -120$$

$$V_{BA} = 100 \angle -240$$

The load is unbalanced, therefore

$$Z_{CB} = 10 \angle 0 \Omega$$

$$Z_{AC} = 10 \angle -30 \Omega$$

$$Z_{BA} = 10 \angle 30 \Omega$$

Solution:

$$I_{CB} = \frac{V_{CB}}{Z_{CB}}$$

$$I_{CB} = \frac{100}{10} \angle 0$$

$$I_{CB} = 10 \angle 0 \text{ A}$$

$$I_{AC} = \frac{V_{AC}}{Z_{AC}}$$

$$I_{AC} = \frac{100}{10} \angle -120 + 30$$

$$I_{AC} = 10 \angle -90 \text{ A}$$

$$I_{BA} = \frac{V_{BA}}{Z_{BA}}$$

$$I_{BA} = \frac{100}{10} \angle -240 - 30$$

$$I_{BA} = 10 \angle -270 = 10 \angle 90 \text{ A}$$

Apply KCL to node A which states that phasor sum of the currents flowing towards node A will be equal to the phasor sum of the currents flowing away from the node.

$$I_A = I_{AC} - I_{BA}$$

$$I_A = 10\angle -90 - 10\angle 90 = 20\angle -90 \text{ A}$$

Apply KCL to node B

$$I_B = I_{BA} - I_{CB}$$

$$I_B = 10\angle 90 - 10 = -10 + j10$$

$$I_B = 10\sqrt{2}\angle 135 \text{ A}$$

Apply KCL to node C

$$I_C = I_{CB} - I_{AC}$$

$$I_C = 10 - 10\angle -90$$

$$I_C = 10 + j10$$

$$I_C = 10\sqrt{2}\angle 45 \text{ A}$$

Power consumed by branch CB

$$P_1 = V_L \times I_1 \times \cos \theta_1$$

$$P_1 = 100 \times 10 \times 1 = 1000 \text{ W}$$

Power consumed by branch AC

$$P_2 = V_L \times I_2 \times \cos \theta_2$$

$$P_2 = 100 \times 10 \times \cos 30 = 866 \text{ W}$$

Power consumed by branch BA

$$P_3 = V_L \times I_3 \times \cos \theta_3$$

$$P_3 = 100 \times 10 \times \cos 30 = 866 \text{ W}$$

The total power consumed by the unbalanced delta load is

$$P = P_1 + P_2 + P_3 = 2732 \text{ W}$$

6-5 Three Phase Four Wire Star Connected Unbalanced Load

Consider three phase star connected unbalanced load across a star connected voltage source as shown in Figure 6.18.

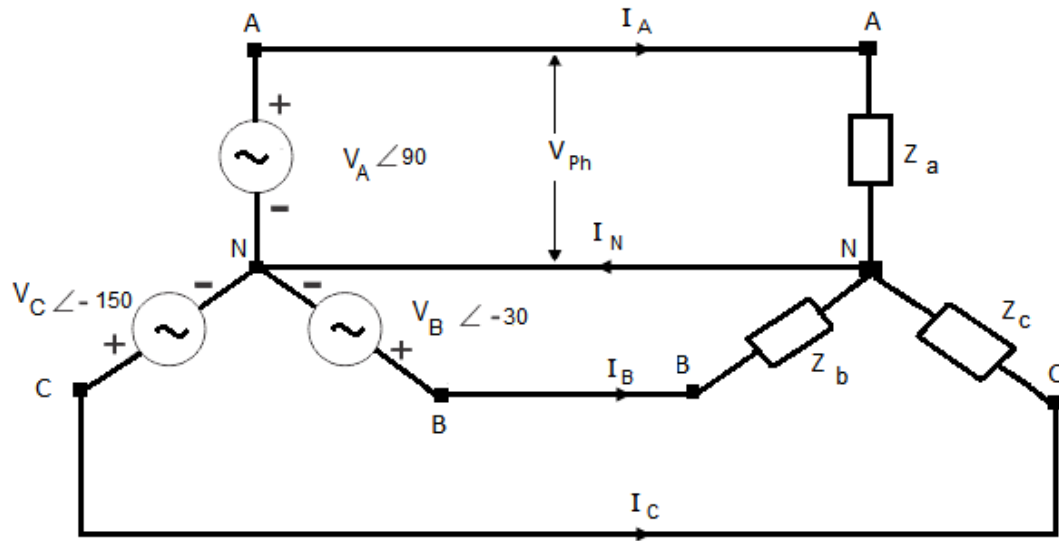

Figure 6.18: Star- Star Unbalanced Configuration

As the load is unbalanced, therefore

$$Z_a = Z_1 \angle \theta_1$$

$$Z_b = Z_2 \angle \theta_2$$

$$Z_c = Z_3 \angle \theta_3$$

The phase voltages of ABC sequence are given as under

$$V_A = V_{Ph} \angle 90$$

$$V_B = V_{Ph} \angle - 30$$

$$V_C = V_{Ph} \angle - 150$$

If the line impedance is ignored, then

$$I_A = \frac{V_A}{Z_a}$$

$$I_A = \frac{V_{Ph}}{Z_1} \angle 90 - \theta_1$$

$$I_A = I_1 \angle 90 - \theta_1 \quad (6.26)$$

$$I_B = \frac{V_B}{Z_b}$$

$$I_B = \frac{V_{Ph}}{Z_2} \angle -30 - \theta_2$$

$$I_B = I_2 \angle -30 - \theta_2 \quad (6.27)$$

$$I_C = \frac{V_C}{Z_c}$$

$$I_C = \frac{V_{Ph}}{Z_3} \angle -150 - \theta_3$$

$$I_C = I_3 \angle -150 - \theta_3 \quad (6.28)$$

The phasor sum all these three currents will be equal to neutral current.

$$I_A + I_B + I_C = I_N$$

Power consumed by Z_a

$$P_a = V_{Ph} \times I_1 \times \cos \theta_1$$

Power consumed by Z_b

$$P_b = V_{Ph} \times I_2 \times \cos \theta_2$$

Power consumed by Z_c

$$P_c = V_{Ph} \times I_3 \times \cos \theta_3$$

The total power consumed by the load is

$$P_S = P_a + P_b + P_c$$

D 6.5: Consider three phase four wire star connected unbalanced load across a star connected voltage source as shown in Figure 6.19. Calculate the phase currents, neutral current and powers. The phase voltages of ABC sequence are given as under

$$V_A = 100 \angle 90$$

$$V_B = 100 \angle -30$$

$$V_C = 100 \angle -150$$

The load is unbalanced, therefore

$$Z_A = 10 \angle 0 \Omega$$

$$Z_B = 10 \angle -30 \Omega$$

$$Z_C = 10 \angle 30 \Omega$$

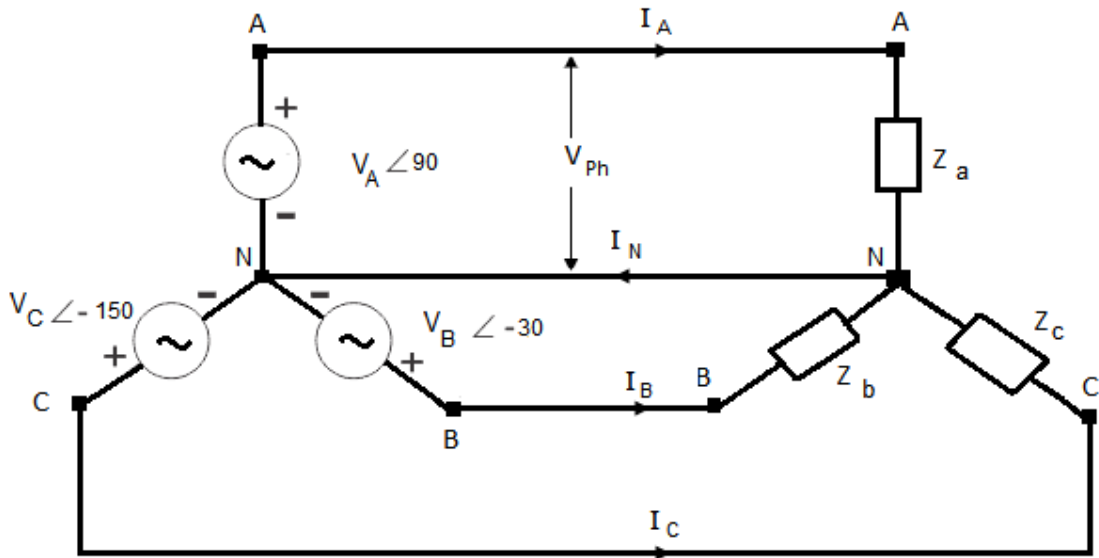

Figure 6.19: Star- Star Unbalanced Configuration for D # 6.5

Solution:

$$I_A = \frac{V_A}{Z_a}$$

$$I_A = \frac{100}{10} \angle 90 - 0$$

$$I_A = 10 \angle 90$$

$$I_B = \frac{V_B}{Z_b}$$

$$I_B = \frac{100}{10} \angle -30 + 30$$

$$I_B = 10 \angle 0$$

$$I_C = \frac{V_C}{Z_c}$$

$$I_C = \frac{100}{10} \angle -150 - 30$$

$$I_C = 10 \angle -180 = -10 A$$

The phasor sum all these three current will be equal to neutral current.

$$I_A + I_B + I_C = I_N$$

$$I_N = 10 \angle 90 + 10 - 10 = 10 \angle 90 A$$

Power consumed by Z_a

$$P_a = V_{Ph} \times I_1 \times \cos \theta_1$$

$$P_a = 100 \times 10 \times 1 = 1000 W$$

Power consumed by Z_b

$$P_b = V_{Ph} \times I_2 \times \cos \theta_2$$

$$P_b = 100 \times 10 \times \cos 30 = 866 W$$

Power consumed by Z_c

$$P_c = V_{Ph} \times I_3 \times \cos \theta_3$$

$$P_c = 100 \times 10 \times \cos 30 = 866 \text{ W}$$

The total power consumed by the load is

$$P_S = P_a + P_b + P_c = 2732 \text{ W}$$

6-6 Star Delta Conversion

The star connected load can be converted to delta connected load with the help of Figure 6.20 and equations 6.29-6.31.

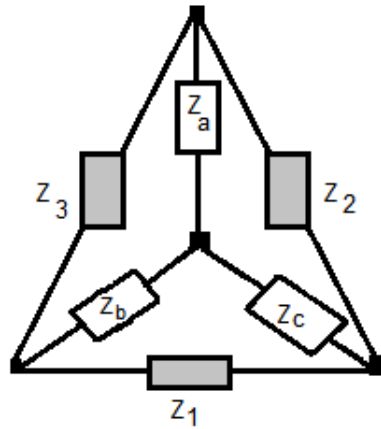

Figure 6.20: Star Delta Conversion

$$Z_1 = \frac{Z_a Z_b + Z_a Z_c + Z_c Z_b}{Z_a} \quad (6.29)$$

$$Z_2 = \frac{Z_a Z_b + Z_a Z_c + Z_c Z_b}{Z_b} \quad (6.30)$$

$$Z_3 = \frac{Z_a Z_b + Z_a Z_c + Z_c Z_b}{Z_c} \quad (6.31)$$

The delta connected load can be converted to star connected load with the help of Figure 6.20 and equations 6.32-6.34.

$$Z_a = \frac{Z_2 Z_3}{Z_1 + Z_2 + Z_3} \quad (6.32)$$

$$Z_b = \frac{Z_1 Z_3}{Z_1 + Z_2 + Z_3} \quad (6.33)$$

$$Z_c = \frac{Z_2 Z_1}{Z_1 + Z_2 + Z_3} \quad (6.34)$$

Exercise:

Q 6.1: Determine the phase currents and power supplied by the source in the following three phase circuit.

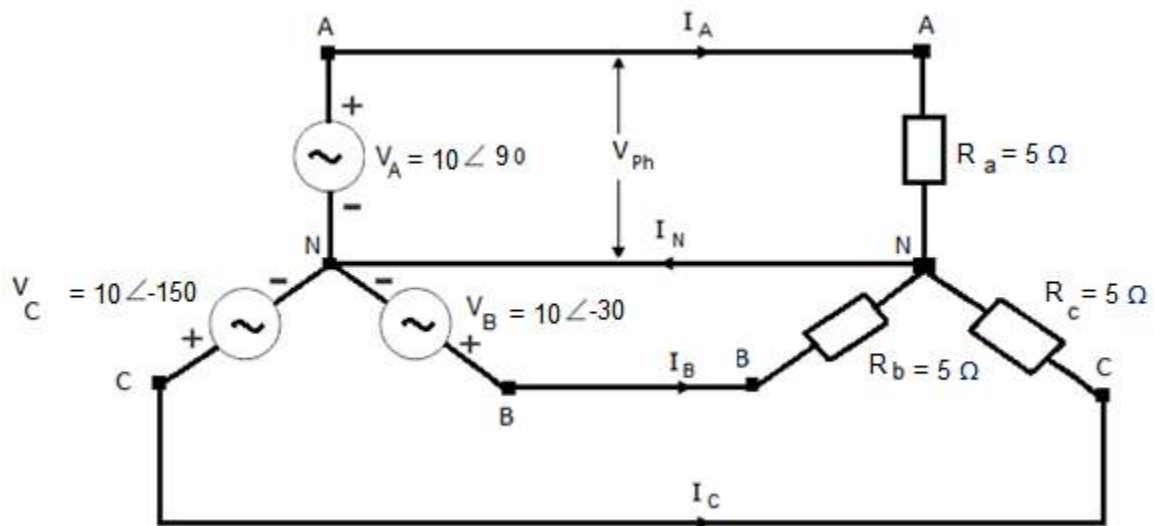

Figure 6.21: Three Phase Circuit for Q 6.1

Answer: $I_A = 2 \angle 90^\circ$ A, $I_B = 2 \angle -30^\circ$ A, $I_C = 2 \angle -150^\circ$ A, $P_S = 60$ W

Q 6.2: Consider the circuit shown in Figure 6.21. Write the instantaneous equations of all the phase voltages and phase currents.

Answer: $v_A = 10 \sqrt{2} \sin(100\pi t + 90)$, $v_B = 10 \sqrt{2} \sin(100\pi t - 30)$
 $v_C = 10 \sqrt{2} \sin(100\pi t - 150)$, $i_A = 2 \sqrt{2} \sin(100\pi t + 90)$
 $i_B = 2 \sqrt{2} \sin(100\pi t - 30)$, $i_C = 2 \sqrt{2} \sin(100\pi t - 150)$

Q 6.3: Determine the phase currents and power supplied by the source in the following three phase balanced circuit. $V_{Ph} = 60\text{ V}$ and $R_{BA} = R_{CB} = R_{AC} = 20\ \Omega$.

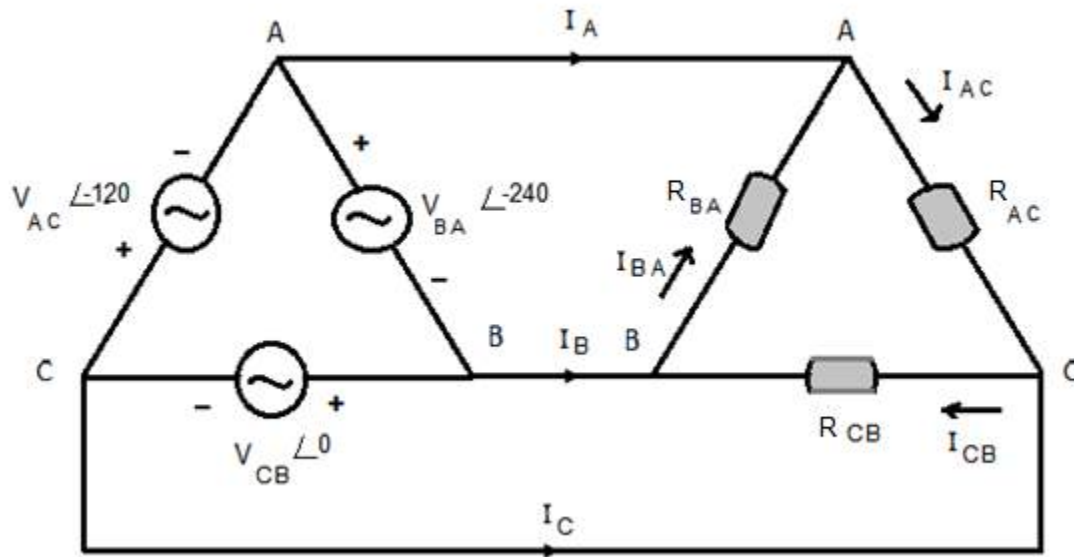

Figure 6.22: Three Phase Circuit for Q 6.3

Answer: $I_{CB} = 3\angle 0\text{ A}$, $I_{AC} = 3\angle -120\text{ A}$, $I_{BA} = 3\angle -240\text{ A}$, $P_S = 540\text{ W}$

Q 6.4: Consider the circuit shown in Figure 6.22. Write the instantaneous equations of all the phase voltages and phase currents.

Answer: $v_{CB} = 60\sqrt{2}\sin(100\pi t)$, $v_{AC} = 60\sqrt{2}\sin(100\pi t - 120)$

$v_{BA} = 60\sqrt{2}\sin(100\pi t - 240)$, $i_{CB} = 3\sqrt{2}\sin(100\pi t)$,

$i_{AC} = 3\sqrt{2}\sin(100\pi t - 120)$, $i_{BA} = 3\sqrt{2}\sin(100\pi t - 240)$,

Chapter 7

Magnetic Circuits and Forces

7-1 Magnetic Flux

Consider an isolated fixed North Pole that can move from one place to another place as shown in Figure 7.1. There will be magnetic field in the vicinity of this isolated North Pole. If we place a movable isolated north pole in the magnetic field of fixed North Pole it will move along a straight line due the force of repulsion. The path or line followed by an isolated north pole in a magnetic field is known as magnetic flux. It is a scalar quantity and is represented by Φ . The unit of flux is Weber.

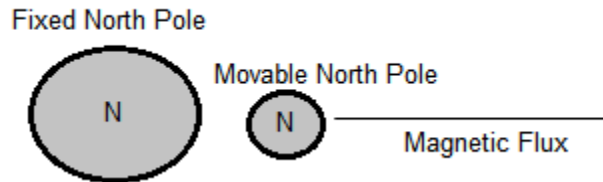

Figure 7.1: Magnetic Flux

We may change the place of the movable isolated North Pole around the fixed one and can trace many more lines. In other words the number of magnetic lines of forces set up in a magnetic circuit is called Magnetic Flux. It is analogous to electric current in an electric circuit.

7-2 Magnetic Flux Density

Consider lines of magnetic force Φ passing through a surface A as shown in Figure 7.2. All the lines are normal to the surface. The magnetic flux per unit area defines magnetic flux density and it is represented by B . It is a vector quantity and its unit is *weber/m²* or Tesla T . Mathematically

$$B = \frac{\Phi}{A}$$

So

$$\Phi = BA$$

There is another way to compute magnetic flux density. We consider differential magnetic flux $d\phi$ passing through a small portion of the given surface that is dA . According to the definition, the magnetic flux per unit area can be calculated as

$$B = \frac{d\phi}{dA}$$

Hence the differential magnetic flux passing through the differential area can be computed as under

$$d\phi = BdA$$

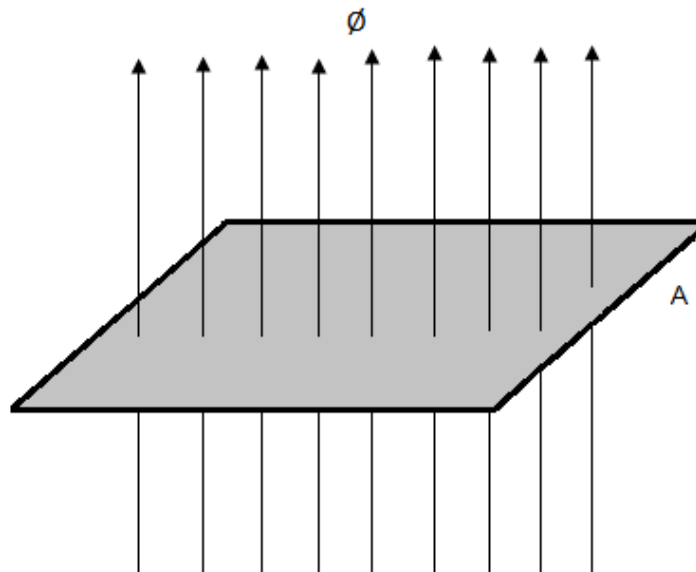

Figure 7.2: Magnetic Flux Density

Magnetic Flux density is related to magnetic field intensity with the help of following equation.

$$B = \mu H$$

The unit of magnetic field intensity is ampere per meter. It is a vector quantity as well.

7-3 Simple Magnetic Circuit

Magnetic circuit is analogous to electric circuit. The magnetic quantities which are analogous to electric quantities are given in Table 7.1.

Table 7.1: Analogous Quantities

Electric Quantities	Analogous Magnetic Quantities
Voltage= V	$MMF = NI$
Current	Magnetic Flux
Resistance	Reluctance
Conductivity	Permeability

Consider a simple electric circuit as shown in Figure 7.3. Current in the resistor results in

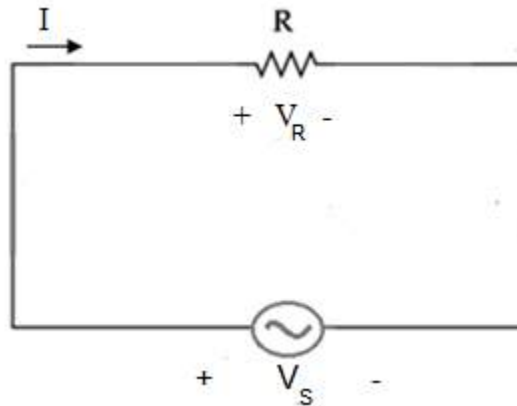

Figure 7.3: Simple Electric Circuit

a voltage drop across it that is equal to the voltage across the source in accordance with KVL.

$$V_S = V_R$$

$$V_R = IR \tag{7.1}$$

$$I = \frac{V_S}{R} \tag{7.2}$$

A simple magnetic circuit is analogous to a simple electric circuit as shown in Figure 7.4.

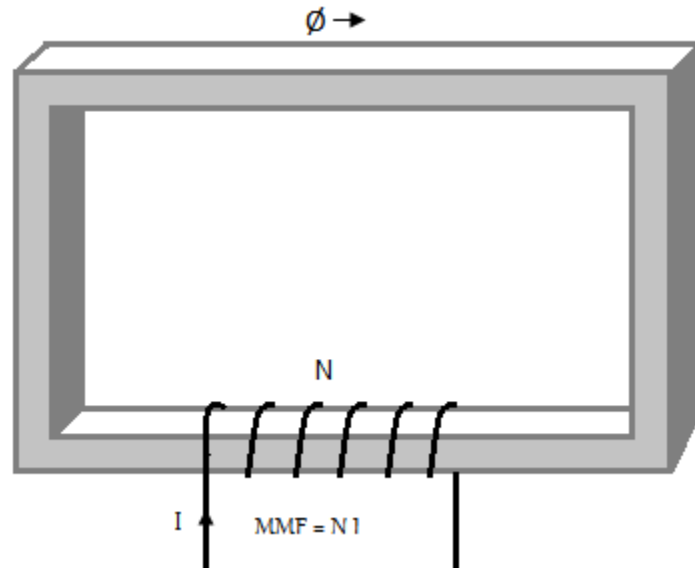

Figure 7.4: Simple Magnetic Circuit

Mean length of the rectangular material is ℓ , its permeability is μ and its cross sectional area is A . The current in the coil of N turns is I ampere. The current in the coil generates a magnetic flux of Φ Weber that circulates in the clockwise direction in the material. The direction of the flux in a magnetic circuit can be found with the help of right hand rule. The equivalent circuit of this simple magnetic circuit is shown in Figure 7.5.

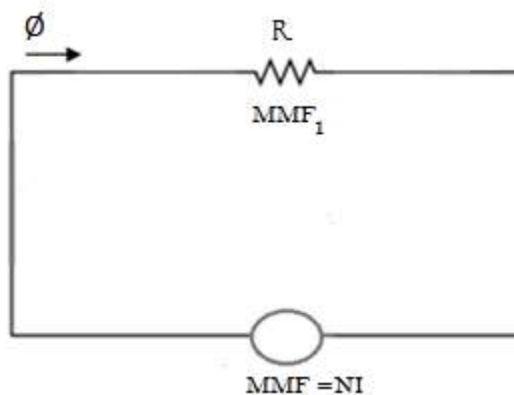

Figure 7.5: Equivalent Magnetic Circuit

The magnetic field intensity is directly proportional to the product of the number of turns and current and is inversely proportional to the mean length of the material of the magnetic circuit.

$$H \propto \frac{NI}{\ell}$$

The constant of proportionality is 1, so

$$H = \frac{NI}{\ell}$$

$$NI = H\ell$$

The product of the number of turns and current define magneto motive force which is denoted by *MMF*. So

$$MMF = NI = H\ell \quad (7.3)$$

As

$$H = \frac{B}{\mu}$$

And

$$B = \frac{\emptyset}{A}$$

Therefore

$$H = \frac{\emptyset}{\mu A}$$

Putting the value of *H* on the right hand side of equation 7.3, the following equation is obtained.

$$MMF = \emptyset \frac{\ell}{\mu A} \quad (7.4)$$

The reluctance offered by the material to the flow of magnetic flux is denoted by \mathcal{R} and is given by

$$\mathcal{R} = \frac{\ell}{\mu A}$$

Therefore the MMF can be computed with the help of following equation.

$$MMF = \Phi \mathcal{R} \quad (7.5)$$

Equation 7.5 is analogous to equation 7.1.

D 7.1: Consider the simple magnetic circuit as shown in Figure 7.6. Mean length, cross-sectional area and permeability of the rectangular ring material are $2m$, $4 \times 10^{-4}m^2$ and 16000 . The current in the coil of 1000 turns is 4 Ampere. Determine the magnetic flux in the circuit.

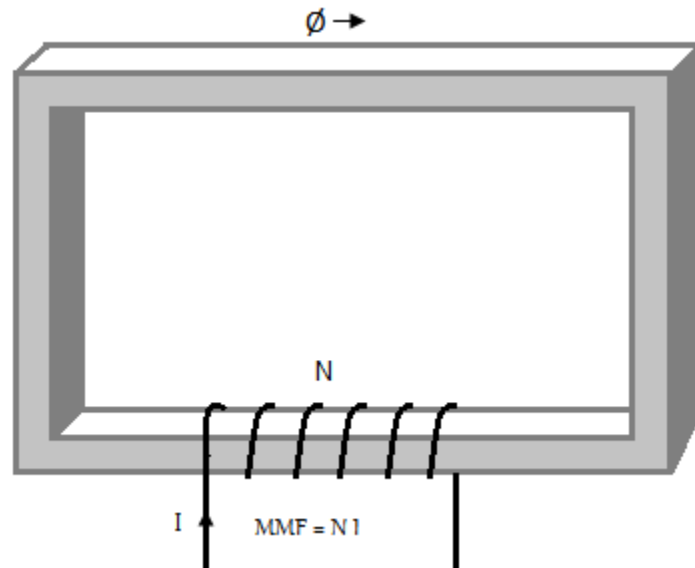

Figure 7.6: Magnetic Circuit for D # 7.1

Solution:

$\ell = 2m$, $A = 4 \times 10^{-4}m^2$, $\mu = 16000$, $N = 1000T$ and $I = 4A$
 The reluctance of the circuit is

$$\mathcal{R} = \frac{\ell}{\mu A}$$

$$\mathcal{R} = \frac{2}{16000 \times 4 \times 10^{-4}}$$

$$\mathcal{R} = 248.8 \times 10^3 \text{ AT/Wb}$$

$$MMF = NI = 4000 \text{ AT}$$

The equivalent circuit is shown in Figure 7.7.

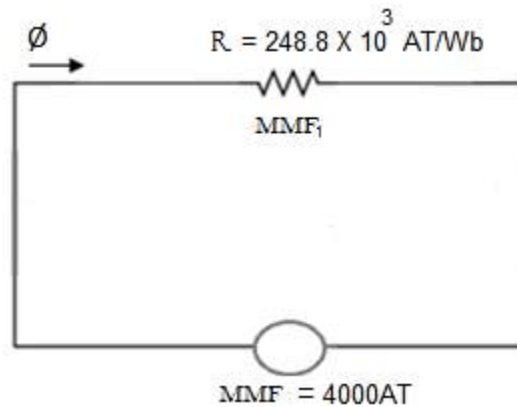

Figure 7.7: Equivalent Circuit

$$\emptyset = \frac{MMF}{\mathcal{R}}$$

$$\emptyset = \frac{4000}{248.8 \times 10^3} = 0.16 \text{ Wb}$$

7-4 Series Magnetic Circuit

Let us review the electrical series circuits as shown in Figure 7.8. According to KVL the voltage across the source will be equal to sum of the voltages across R_1 , R_2 and R_3 .

$$V_S = V_1 + V_2 + V_3 \quad (7.6)$$

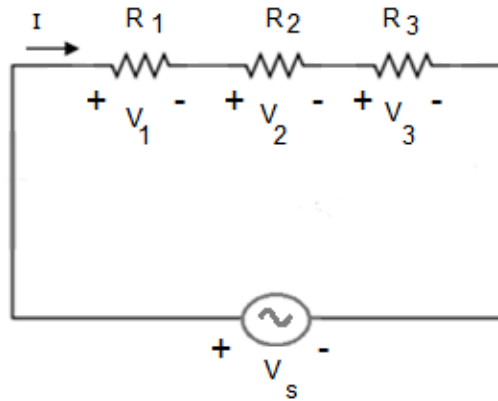

Figure 7.8: Electrical Series Circuit

Voltage across the resistor R_1 is given by

$$V_1 = IR_1 \quad (7.7)$$

Voltage across the resistor R_2 is

$$V_2 = IR_2 \quad (7.8)$$

Voltage across the resistor R_3 is

$$V_3 = IR_3 \quad (7.9)$$

Putting the values of V_1 , V_2 and V_3 in equation 7.6

$$V_s = I(R_1 + R_2 + R_3) \quad (7.10)$$

Where $(R_1 + R_2 + R_3)$ is the total resistance of the series circuit that is represented by R_T . A series magnetic circuit is analogous to electrical series circuit. Consider three different materials connected in series as shown in Figure 7.9. The current in the coil generates magnetic flux that flows in all the three materials of the circuit. Material no 2 is an airgap and its reluctance is very large. The reason behind it is that its relative permeability is very small. In order to analyze this series magnetic circuit, we require knowing the reluctance of each material. This has already been mentioned that reluctance is related to mean length, cross-sectional area, and permeability of the material.

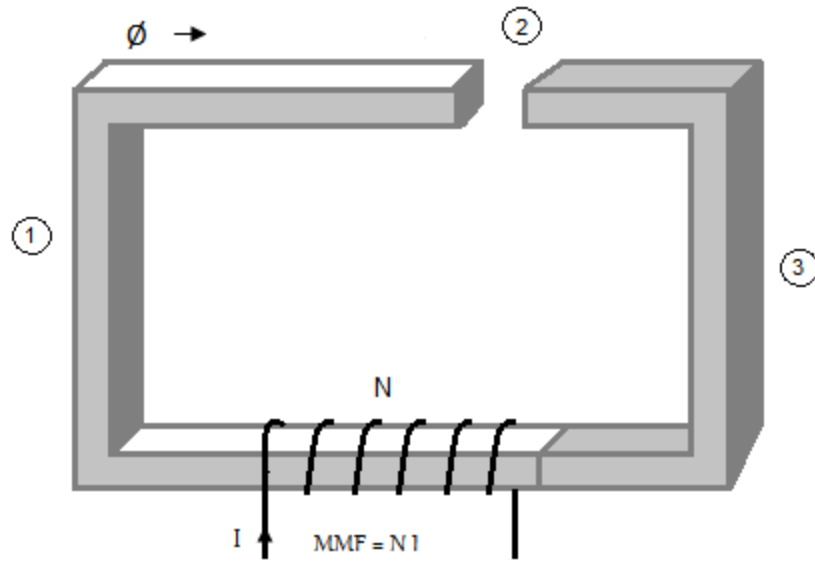

Figure 7.9: Series Magnetic Circuit

The characteristics of all the three materials are discussed in detail.

Material No 1

Mean length = ℓ_1

Cross-sectional area = A_1

Permeability = μ_1

Reluctance of the 1st material is given by

$$\mathcal{R}_1 = \frac{\ell_1}{\mu_1 A_1}$$

Material No 2

Mean length = ℓ_2

Cross-sectional area = A_2

Permeability = μ_2

Reluctance of the 2nd material is given by

$$\mathcal{R}_2 = \frac{\ell_2}{\mu_2 A_2}$$

Material No 3

Mean length = ℓ_3

Cross-sectional area = A_3

Permeability = μ_3

Reluctance of the 3rd material

$$\mathcal{R}_3 = \frac{\ell_3}{\mu_3 A_3}$$

Equivalent circuit of the above mentioned series magnetic circuit that comprises three different materials is shown in Figure 7.10.

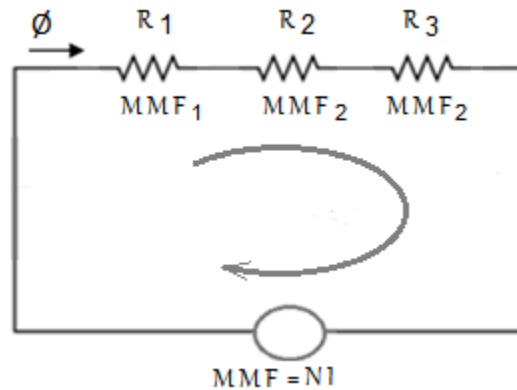

Figure 7.10: Equivalent Circuit

$$MMF = NI$$

We apply a law to the equivalent magnetic circuit and the law is analogous to KVL

$$MMF = MMF_1 + MMF_2 + MMF_3 \quad (7.11)$$

Equation 7.11 is analogous to equation 7.6. The MMF which is required to maintain the magnetic flux of \emptyset Wb in \mathcal{R}_1 is given by

$$MMF_1 = \phi \mathcal{R}_1 \quad (7.12)$$

This Equation no 7.12 is analogous to equation 7.7. The MMF which is required to maintain the magnetic flux of ϕ Wb in \mathcal{R}_2 is given by

$$MMF_2 = \phi \mathcal{R}_2 \quad (7.13)$$

This Equation no 7.13 is analogous to equation 7.8. The MMF which is required to maintain the magnetic flux of ϕ Wb in \mathcal{R}_3 is given by

$$MMF_3 = \phi \mathcal{R}_3 \quad (7.14)$$

Equation no 7.14 is analogous to equation 7.9. Putting the values in equation 7.11, we obtain

$$MMF = \phi (\mathcal{R}_1 + \mathcal{R}_2 + \mathcal{R}_3) \quad (7.15)$$

This last equation is analogous to equation 7.10 and $(\mathcal{R}_1 + \mathcal{R}_2 + \mathcal{R}_3)$ is the total reluctance of the series magnetic circuit that is denoted by \mathcal{R}_T .

D 7.2: Consider the series magnetic circuit that comprises two materials as shown in Figure 7.11. If the current in the coil of 1000 turns is 2A, then determine the flux in the circuit. The characteristics of the two materials are given as under.

Material No 1

$$\text{Mean length} = \ell_1 = 2 \text{ m},$$

$$\text{Crossectinal area} = A_1 = 4 \times 10^{-4} \text{ m}^2$$

$$\text{Permeability} = \mu_1 = 16000$$

Reluctance of the 1st material is

$$\mathcal{R}_1 = \frac{\ell_1}{\mu_1 A_1} = 248.8 \times 10^3 \text{ AT/Wb}$$

Material No 2

$$\text{Mean length} = \ell_2 = 1 \text{ m}$$

$$\text{Crossectinal area} = A_2 = 4 \times 10^{-4} \text{ m}^2$$

$$\text{Permeability} = \mu_2 = 1600$$

Reluctance of the 2nd material is

$$\mathcal{R}_2 = \frac{\ell_2}{\mu_2 A_2} = 124.4 \times 10^4 \text{ AT/Wb}$$

$$N = 1000 \text{ T}$$

$$I = 2 \text{ A}$$

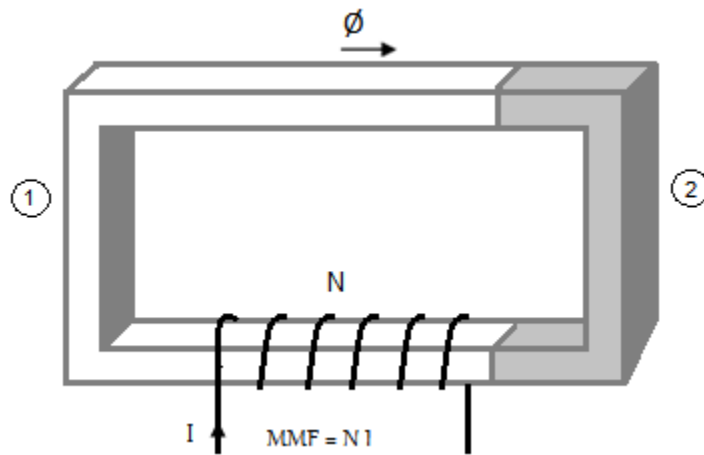

Figure 7.11: Series Magnetic Circuit

Solution: The equivalent circuit is shown in Figure 7.12. The total reluctance of the series circuit is

$$\mathcal{R}_T = (\mathcal{R}_1 + \mathcal{R}_2) = 149.28 \times 10^4 \text{ AT/Wb}$$

$$MMF = NI = 2000 \text{ AT}$$

AS

Therefore

$$MMF = \Phi (\mathcal{R}_1 + \mathcal{R}_2)$$

$$\Phi = \frac{MMF}{(\mathcal{R}_1 + \mathcal{R}_2)}$$

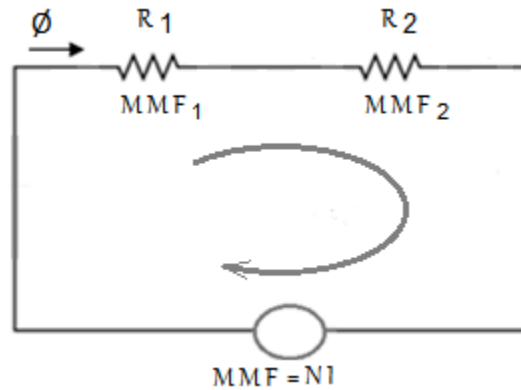

Figure 7.12: Equivalent Circuit

$$\Phi = \frac{2000}{(149.28 \times 10^4)}$$

$$\Phi = 1.33 \text{ m Wb}$$

7-5 Parallel Magnetic Circuit

Consider the series parallel circuit shown in Figure 7.13. Apply KCL to the node of the given circuit

$$I = I_1 + I_2 \tag{7.16}$$

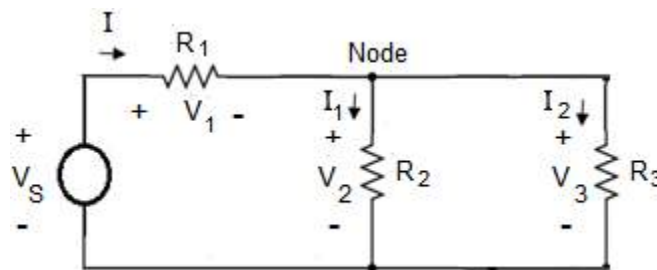

Figure 7.13: Series Parallel Electric Circuit

Application of KVL to loop 1 as well as loop 2 results in the following equations.

$$V_S = V_1 + V_2 \quad (7.17)$$

$$V_2 = V_3 \quad (7.18)$$

Obviously equation no 7.17 can be written in the following format

$$V_S = V_1 + V_3 \quad (7.19)$$

Where $V_1 = IR_1$, $V_2 = I_1R_2$ and $V_3 = I_2R_3$.

Consider a parallel magnetic circuit which is analogous to the above mentioned series parallel circuit. There are three limbs of the parallel magnetic circuit as shown in Figure 7.14. The section that carries the total magnetic flux \emptyset defines the left limb, the section that carries the magnetic flux \emptyset_1 defines the central limb and the section that carries the magnetic flux \emptyset_2 defines the right limb of the given magnetic circuit. The total magnetic flux that is generated by the current in the coil of left limb divides in to two parts at the node.

$$\emptyset = \emptyset_1 + \emptyset_2 \quad (7.20)$$

This equation is analogous to equation no 7.16. The characteristics of all the three sections of the parallel magnetic circuit are discussed in detail.

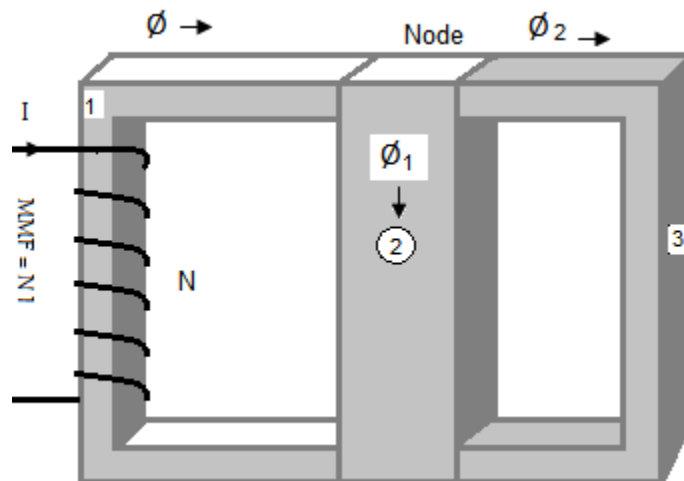

Figure 7.14: Parallel Magnetic Circuit

1. Left Limb

$$\text{Mean length} = \ell_1$$

$$\text{Crossectinal area} = A_1$$

$$\text{Permeability} = \mu_1$$

Reluctance of the left limb

$$\mathcal{R}_1 = \frac{\ell_1}{\mu_1 A_1}$$

2. Central Limb

$$\text{Mean length} = \ell_2$$

$$\text{Crossectinal area} = A_2$$

$$\text{Permeability} = \mu_2$$

Reluctance of the central limb

$$\mathcal{R}_2 = \frac{\ell_2}{\mu_2 A_2}$$

3. Right Limb

$$\text{Mean length} = \ell_3$$

$$\text{Crossectinal area} = A_3$$

$$\text{Permeability} = \mu_3$$

Reluctance of the right limb is given by

$$\mathcal{R}_3 = \frac{\ell_3}{\mu_3 A_3}$$

The equivalent circuit of the mentioned magnetic circuit is given in Figure 7.15. \mathcal{R}_1 defines the reluctance of the left limb, \mathcal{R}_2 defines the reluctance of the central limb while \mathcal{R}_3 defines the reluctance of the right limb of the parallel magnetic circuit.

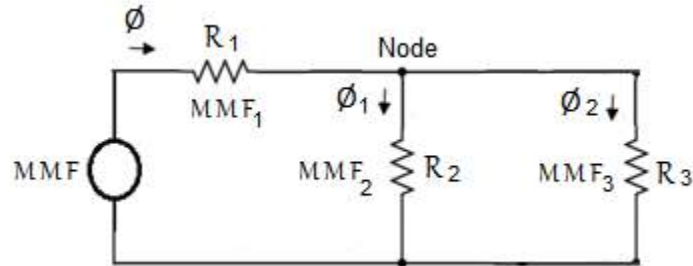

Figure 7.15: Equivalent Circuit

Application of a law that is analogous to KVL to loop 1 as well as loop 2 results in the following equations.

$$MMF = MMF_1 + MMF_2 \quad (7.21)$$

$$MMF_2 = MMF_3 \quad (7.22)$$

Where $MMF = NI$, the above two equations are analogous to equations 7.17 and 7.18. Obviously equation no 7.21 can be written in the following format,

$$MMF = MMF_1 + MMF_3 \quad (7.23)$$

Where $MMF_1 = \Phi \mathcal{R}_1$, $MMF_2 = \Phi_1 \mathcal{R}_2$ and $MMF_3 = \Phi_2 \mathcal{R}_3$.

D 7.3: Consider the parallel magnetic circuit as shown in Figure 7.16. The coil is placed on the left limb. Determine the current in the coil of 50 turns to produce the magnetic flux of $1.4 \times 10^{-4} \text{ Wb}$ in the right limb. The characteristics of the two materials are given as under.

1. Left Limb

$$\text{Mean length} = \ell_1 = 0.2 \text{ m},$$

$$\text{Crossectinal area} = A_1 = 6 \times 10^{-4} \text{ m}^2$$

$$\text{Permeability} = \mu_1 = 6.25 \times 10^{-3}$$

2. Central Limb

$$\text{Mean length} = \ell_2 = 0.05 \text{ m}$$

$$\text{Cross-sectional area} = A_2 = 6 \times 10^{-4} \text{ m}^2$$

$$\text{Permeability} = \mu_2 = 6.25 \times 10^{-3}$$

3. Right Limb

$$\text{Mean length} = \ell_3 = 0.2 \text{ m},$$

$$\text{Cross-sectional area} = A_3 = 6 \times 10^{-4} \text{ m}^2$$

$$\text{Permeability} = \mu_3 = 3.05 \times 10^{-3}$$

$$N = 50 \text{ T}$$

$$I = ? \quad \Phi_2 = 1.4 \times 10^{-4} \text{ Wb}$$

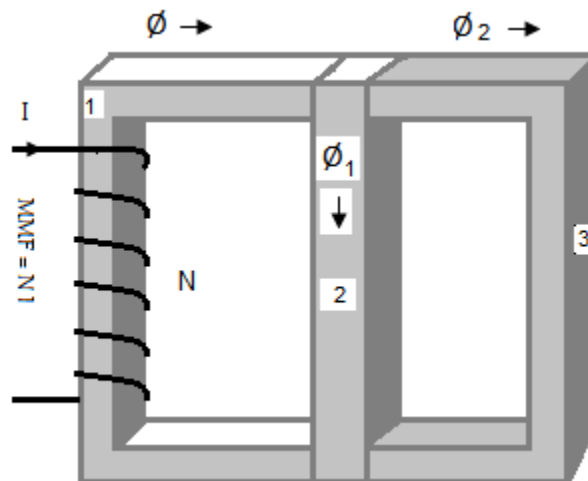

Figure 7.16: Parallel Magnetic Circuit

Solution: The equivalent circuit is shown in Figure 7.17. we determine the reluctance of each material;

Reluctance of the left limb

$$\mathcal{R}_1 = \frac{\ell_1}{\mu_1 A_1} = 53.33 \times 10^3 \text{ AT/Wb}$$

Reluctance of the central limb

$$\mathcal{R}_2 = \frac{\ell_2}{\mu_2 A_2} = 13.33 \times 10^3 \text{ AT/Wb}$$

Reluctance of the right limb

$$\mathcal{R}_3 = \frac{\ell_3}{\mu_3 A_3} = 109.28 \times 10^3 \text{ AT/Wb}$$

Let us determine flux in the central limb with following equation.

$$MMF_2 = MMF_3$$

$$\phi_1 \mathcal{R}_2 = \phi_2 \mathcal{R}_3$$

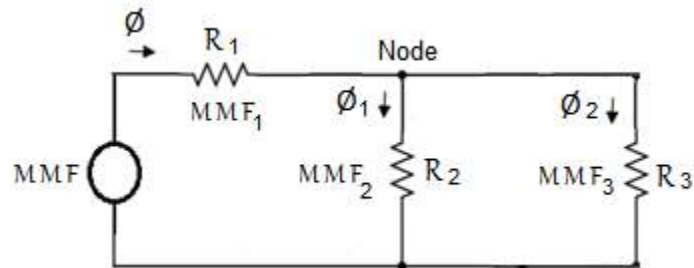

Figure 7.17: Equivalent Circuit

$$\phi_1 = \frac{\phi_2 \mathcal{R}_3}{\mathcal{R}_2}$$

$$\phi_1 = \frac{1.4 \times 10^{-4} \times 109.28 \times 10^3}{13.33 \times 10^3}$$

$$\phi_1 = 12.29 \times 10^{-4} \text{ Wb}$$

$$\phi = \phi_1 + \phi_2$$

$$\phi = 12.29 \times 10^{-4} + 1.4 \times 10^{-4} = 13.79 \times 10^{-4}$$

$$MMF = NI$$

AS

$$MMF = MMF_1 + MMF_2$$

Therefore

$$NI = \phi \mathcal{R}_1 + \phi_1 \mathcal{R}_2$$

$$50I = 13.79 \times 10^{-4} \times 53.33 \times 10^3 + 12.29 \times 10^{-4} \times 13.33 \times 10^3$$

$$50I = 89.95$$

$$I = 1.8 \text{ A}$$

7-6 Single Phase Transformer

A single phase ideal transformer is shown in Figure 7.18. The core of the transformer is either made of iron or steel. There are two windings of a single phase AC transformer; Winding on the primary side of a transformer is known as primary winding and winding on secondary side of a transformer is known as secondary winding. The core of a transformer provides a path of low reluctance to flow of magnetic flux. AC voltage is applied across the primary winding that results in a primary current i_1 . Primary current in the primary coil produces time varying magnetic flux that circulates either in clockwise or counter clockwise direction in the core. Equation for the primary current is

$$i_1 = I_{m1} \sin \omega t \quad (7.24)$$

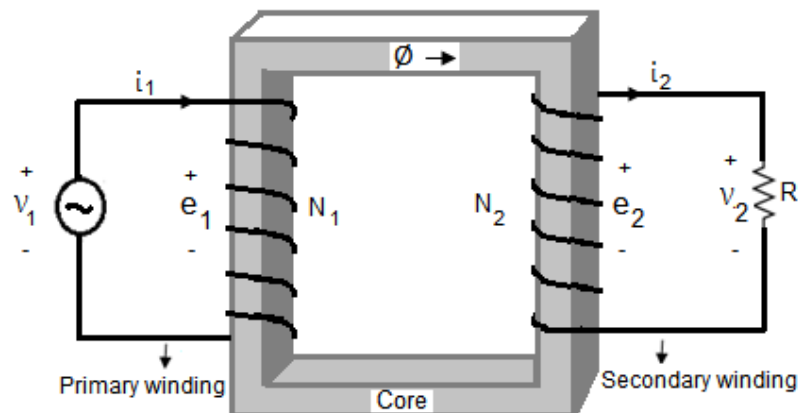

Figure 7.18: Single Phase Transformer

Equation for the time varying magnetic flux is

$$\phi = \phi_m \sin \omega t \quad (7.25)$$

This time varying magnetic flux induces a time varying voltage across the primary winding and this voltage is termed as self induced voltage. This self induced voltage across the primary winding of the transformer can be calculated with the help of Faraday's law.

$$e_1 = N_1 \frac{d\phi}{dt}$$

$$e_1 = N_1 \frac{d}{dt} (\phi_m \sin \omega t)$$

$$e_1 = N_1 \omega \phi_m \sin(\omega t + 90) \quad (7.26)$$

The induced voltage across the primary winding leads the primary current by 90° . According to KVL the voltage across the source in the primary loop equals to this induced voltage.

$$v_1 = e_1$$

Therefore equation for the primary voltage is

$$v_1 = N_1 \omega \phi_m \sin(\omega t + 90) \quad (7.27)$$

Maximum value of the Primary voltage is

$$V_{m1} = N_1 \omega \phi_m \quad (7.28)$$

RMS value of the Primary voltage is

$$V_1 = 0.707 N_1 \omega \phi_m \quad (7.29)$$

As the magnetic flux circulates in the core, it induces a voltage in the secondary winding of the transformer. This induction is called mutual induction and the induced voltage across the secondary winding can be found with the help of Faradays' mathematical model.

$$e_2 = N_2 \frac{d\phi}{dt}$$

$$e_2 = N_2 \frac{d}{dt} (\phi_m \sin \omega t)$$

$$e_2 = N_2 \omega \phi_m \sin(\omega t + 90) \quad (7.30)$$

The induced voltage across the secondary winding leads the primary current by 90° as well. According to KVL the voltage across the resistor in the secondary loop equals to this induced voltage.

$$v_2 = e_2$$

Therefore equation for the secondary voltage is

$$v_2 = N_2 \omega \phi_m \sin(\omega t + 90) \quad (7.31)$$

Maximum value of the secondary voltage is

$$V_{m2} = N_2 \omega \phi_m \quad (7.32)$$

RMS value of the secondary voltage is

$$V_2 = 0.707 N_2 \omega \phi_m \quad (7.33)$$

Dividing equation 7.29 by 7.33, we obtain the turn ratio of the transformer.

$$\frac{V_1}{V_2} = \frac{N_1}{N_2}$$

$$V_2 = \frac{N_2}{N_1} V_1 \quad (7.34)$$

If $N_2 > N_1$, then $V_2 > V_1$ and the transformer will step up level of the primary voltage and will be known as step up transformer. In this case the resistance of the secondary winding is greater than the resistance of primary winding. If $N_2 < N_1$, then $V_2 < V_1$ and the transformer will reduce level of the primary voltage and will be known as step down transformer. In this case resistance of the primary winding is greater than resistance of

the secondary winding. Under ideal condition there will be no losses in the transformer and VA on primary side will be equal to VA on secondary side.

$$V_1 I_1 = V_2 I_2$$

Therefore the turn ratio may be computed as

$$\frac{N_1}{N_2} = \frac{I_2}{I_1}$$

Schematic diagram of a single phase transformer is displayed in Figure 7.18b.

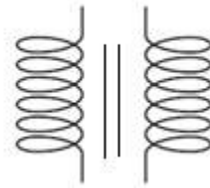

Figure 7.18b: Schematic Diagram of Transformer

7-7 Force on a Current Carrying Conductor

When a current carrying conductor is placed in magnetic field, it experiences a force. Force is a vector quantity having magnitude as well as direction. Vector quantities are represented by bold letters. Consider a current carrying conductor which is located in magnetic field as shown in Figure 7.19. This conductor will experience a force which is directly proportional to strength of the magnetic field, length of conductor, current in the conductor and sine of the angle between length and magnetic field.

$$F = ILB \sin \theta \quad (7.35)$$

The above equation means that if current in the conductor is parallel to the magnetic flux density, then no force will be exerted on the conductor. So, proper orientation of the magnetic field plays an important role. As force is a vector quantity, in order to find out the direction of this force, length of the conductor is considered as a vector quantity in the direction of the current.

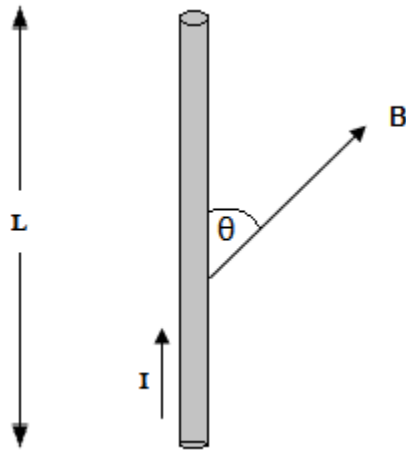

Figure 7.19: Current Carrying Conductor in a Magnetic Field

The direction of the cross product $\mathbf{L} \times \mathbf{B}$ is the direction of the force on the current carrying conductor. So the direction as well as magnitude of this force can be found with the following equation.

$$\mathbf{F} = I\mathbf{L} \times \mathbf{B} \quad (7.36)$$

Another way to find this force is to consider a very small portion of the current carrying conductor, represented by $d\mathbf{l}$ as shown in Figure 7.20.

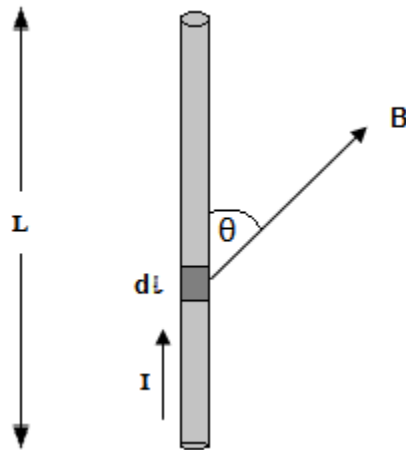

Figure 7.20: Differential Current Element in a Magnetic Field

$d\ell$ is a vector quantity and this differential vector is always in direction of the current. The differential force on the differential portion of the current carrying conductor is calculated with the help of equation 7.37.

$$d\mathbf{F} = I d\ell \times \mathbf{B} \quad (7.37)$$

If we want to compute the total force on the current carrying conductor, we need to integrate both sides of equation 7.37.

$$\mathbf{F} = \int I d\ell \times \mathbf{B} \quad (7.38)$$

7-8 Force on a Moving Charge

A current carrying conductor is placed in a magnetic field as shown in Figure 7.21. the force which is experienced by this conductor is given by

$$\mathbf{F} = \int I d\ell \times \mathbf{B} \quad (7.39)$$

Current in this conductor is due to motion of free charge as the rate of motion of charge defines current. The total free charge which is in motion in the above mentioned conductor is Q coulomb.

$$I = \frac{dQ}{dt}$$

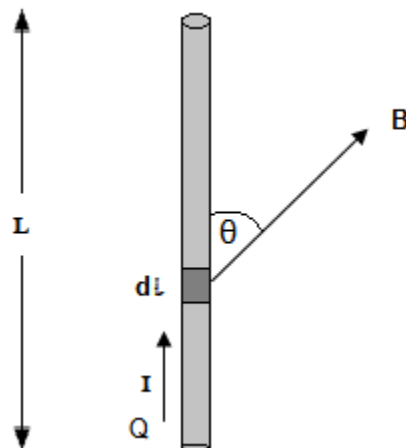

Figure 7.21: Current Carrying Conductor in a Magnetic Field

Multiplying both sides of the above equation by $d\boldsymbol{\ell}$, we obtain the following equation

$$I d\boldsymbol{\ell} = dQ \frac{d\boldsymbol{\ell}}{dt}$$

We assume that the free charge inside the conductor travels distance $d\boldsymbol{\ell}$ in time dt , then $\frac{d\boldsymbol{\ell}}{dt}$ represents velocity of the free charge inside the conductor. Velocity of the free charge is represented by \mathbf{V} . So

$$I d\boldsymbol{\ell} = dQ \mathbf{V}$$

In light of the above equation, the force on the current carrying conductor can be found as

$$\mathbf{F} = \int dQ (\mathbf{V} \times \mathbf{B}) \quad (7.40)$$

Let us assume that the free charge moves with a uniform velocity \mathbf{V} in a uniform magnetic field \mathbf{B} , then

$$\int dQ = Q$$

So force on the charge that moves in a magnetic field \mathbf{B} is given by

$$\mathbf{F} = Q (\mathbf{V} \times \mathbf{B}) \quad (7.41)$$

Now, let us assume that charge Q moves in a magnetic as well as electric field as shown in Figure 7.22.

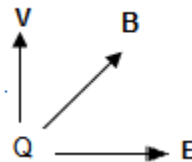

Figure 7.22: Moving Charge in a Magnetic as well as Electric Field

There are two sources that exert force on the moving charge, electric and magnetic field. In order to find the total force on the moving charge we apply Superposition theorem. The Force on the moving charge in the absence of electric field is given by

$$\mathbf{F}_1 = Q (\mathbf{V} \times \mathbf{B}) \quad (7.42)$$

Force on the moving charge in the absence of magnetic field is given by

$$\mathbf{F}_2 = QE \quad (7.43)$$

Vector sum of these two forces results in the total force on the moving charge

$$\begin{aligned} \mathbf{F} &= \mathbf{F}_1 + \mathbf{F}_2 \\ \mathbf{F} &= Q [(\mathbf{V} \times \mathbf{B}) + \mathbf{E}] \end{aligned} \quad (7.44)$$

This last equation is known as Lorentz Force Equation.

7-9 Force between two Current Carrying Conductors

Two current carrying conductors are placed in the magnetic fields of each other as shown as in Figure 7.23. The current I_1 in the first conductor will produce a magnetic field \mathbf{B}_1 in accordance with Biot-Savart Law and it will exert a force \mathbf{F}_2 on the second current carrying conductor. Similarly the current I_2 in the second conductor will produce a magnetic field \mathbf{B}_2 in accordance with Biot-Savart Law and it will exert a force \mathbf{F}_1 on the first current carrying conductor. The ongoing discussion implies that when two current carrying conductors are placed close to each other then there is either a force of attraction or a force of repulsion between them. The nature of the force depends upon the directions of the two currents which will be explored in the upcoming discussion. Force experienced by the first conductor due to the magnetic field of the second conductor is computed using the following equation.

$$\mathbf{F}_1 = \int I_1 d\boldsymbol{\ell}_1 \times \mathbf{B}_2 \quad (7.45)$$

Where $d\boldsymbol{\ell}_1$ is the differential length vector of the first current carrying conductor in direction of the current I_1 . Experimentally the force of repulsion between two current carrying conductors is found with an apparatus known as Current Balance. Force experienced by the second conductor due to the magnetic field of the first conductor is computed using the following equation.

$$\mathbf{F}_2 = \int I_2 d\boldsymbol{\ell}_2 \times \mathbf{B}_1 \quad (7.46)$$

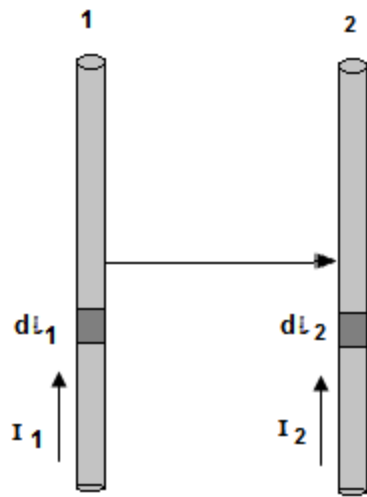

Figure 7.23: Two Current Carrying Conductors

Where $d\ell_2$ is the differential length vector of the second current carrying conductor in direction of the current I_2 . This fact should be kept in mind that bold letters in these equations denote vector quantities. This is law of nature that things tend to move from a place of higher potential to a place of lower potential. If we apply right hand rule on the two current carrying conductors of Figure 7.24, the magnetic flux cancel the effect of each other in the space between these two conductors.

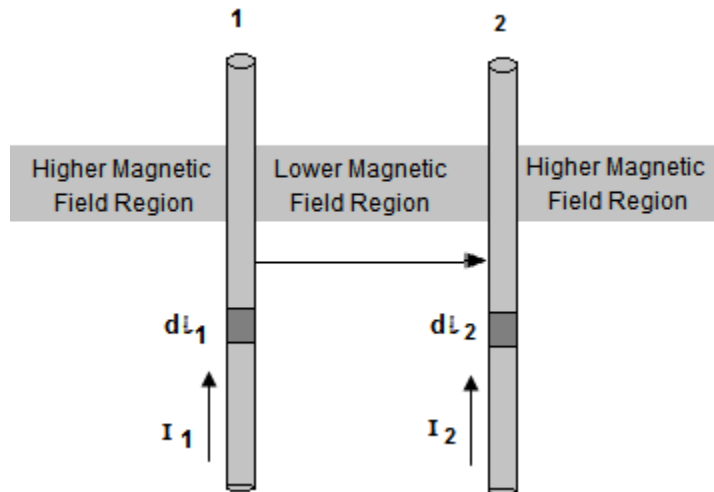

Figure 7.24: Force of Attraction between two Current Carrying Conductors

Obviously these two conductors will tend to move from a place of higher magnetic field to a place of lower magnetic field and there will be a force of attraction between them. So it is concluded that if the currents in these conductors are in same direction, then there will be a force of attraction between the conductors. If we apply right hand rule on the two current carrying conductors of Figure 7.25, the magnetic flux reinforce the effect of each other in the space between these two conductors.

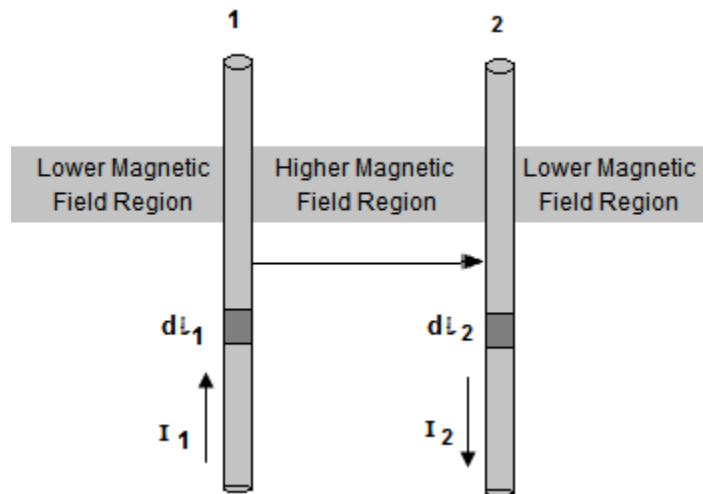

Figure 7.25: Force of Repulsion between two Current Carrying Conductors

Obviously these two conductors will tend to move from a place of higher magnetic field to a place of lower magnetic field and there will be a force of repulsion between them. So it is concluded that if the currents in these conductors are in opposite direction, then there will be a force of repulsion between the conductors.

7-10 Force on a Current Carrying Loop

A rectangular current carrying loop is placed in a magnetic field as shown in Figure 7.26. The loop carries current in the counter clockwise direction and is located in $Z = 0$ plane. \mathbf{a}_x , \mathbf{a}_y and \mathbf{a}_z are the unit vectors along x, y and z-axis respectively. Force will act on the current carrying loop and we need to find out the total force on the loop. In order to find the total force acting on the current carrying loop, we find the force on side ab , side bc , side cd and side da . Vector sum of forces on the four sides of the loop results in the total force. For calculation of these forces, we recall the following equation.

$$\mathbf{F} = I\mathbf{L} \times \mathbf{B} \quad (7.47)$$

Force on side ab

$$\mathbf{F}_{ab} = I\mathbf{L} \times \mathbf{B} \quad (7.48)$$

Where $\mathbf{L} = -L\mathbf{a}_z$ and $\mathbf{B} = B\mathbf{a}_x$

Therefore $\mathbf{L} \times \mathbf{B} = -L\mathbf{a}_z \times B\mathbf{a}_x = -LB\mathbf{a}_y$

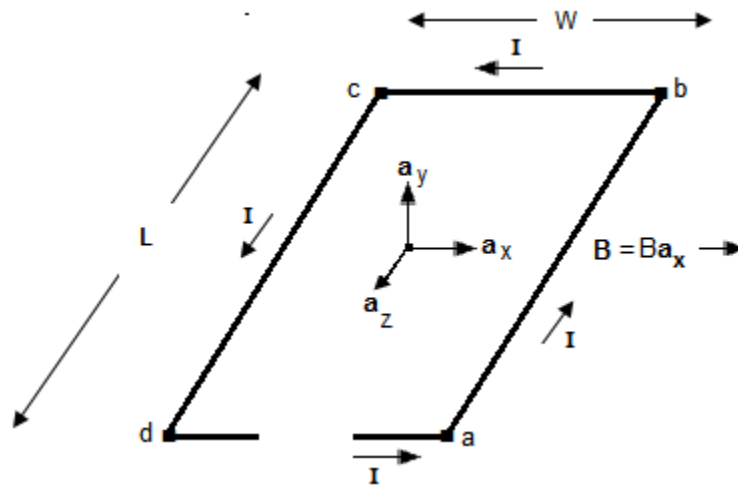

Figure 7.26: Current Carrying Loop

$$\mathbf{F}_{ab} = -ILB\mathbf{a}_y \quad (7.49)$$

Force on side bc

$$\mathbf{F}_{bc} = I\mathbf{L} \times \mathbf{B} \quad (7.50)$$

Where $\mathbf{L} = -W\mathbf{a}_x$ and $\mathbf{B} = B\mathbf{a}_x$

Therefore $\mathbf{L} \times \mathbf{B} = -W\mathbf{a}_x \times B\mathbf{a}_x = 0$

$$\mathbf{F}_{bc} = -IW\mathbf{a}_x \times B\mathbf{a}_x = 0 \quad (7.51)$$

Force on side cd

$$\mathbf{F}_{cd} = I\mathbf{L} \times \mathbf{B} \quad (7.52)$$

Where $\mathbf{L} = L\mathbf{a}_z$ and $\mathbf{B} = B\mathbf{a}_x$

Therefore $\mathbf{L} \times \mathbf{B} = L\mathbf{a}_z \times B\mathbf{a}_x = LB\mathbf{a}_y$

$$\mathbf{F}_{cd} = ILB\mathbf{a}_y \quad (7.53)$$

Force on side da

$$\mathbf{F}_{da} = I\mathbf{L} \times \mathbf{B} \quad (7.54)$$

Where $\mathbf{L} = W\mathbf{a}_x$ and $\mathbf{B} = B\mathbf{a}_x$

Therefore $\mathbf{L} \times \mathbf{B} = W\mathbf{a}_x \times B\mathbf{a}_x = 0$

$$\mathbf{F}_{da} = IW\mathbf{a}_x \times B\mathbf{a}_x = 0 \quad (7.55)$$

Force on side ab is in the direction of negative y-axis, while force on side cd is in the direction of positive y-axis as shown in Figure 7.27. In presence of these two forces the current carrying loop will rotate in the clockwise direction around z-axis with a uniform angular velocity and will be in state of equilibrium.

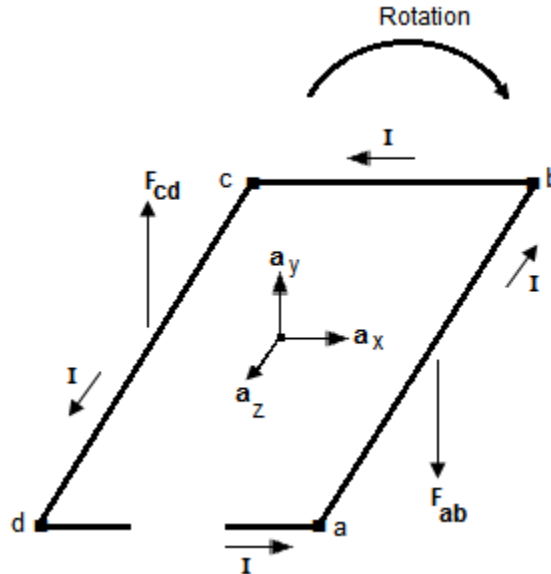

Figure 7.27: Rotation of Current Carrying Loop

The total force on the loop will be equal to the vector sum of all the four forces. That is

$$\mathbf{F} = \mathbf{F}_{ab} + \mathbf{F}_{bc} + \mathbf{F}_{cd} + \mathbf{F}_{da}$$

$$\mathbf{F} = -ILB\mathbf{a}_y + ILB\mathbf{a}_y = 0$$

Exercise

Q 7.1 : Consider a series magnetic circuit as shown in Figure 7.28. Determine the current in the coil of 400 turns, if it produces a magnetic flux of 2mWb. The details of the materials are;

1. Material 1

$$\text{Mean length} = \ell_1 = 0.2 \text{ m},$$

$$\text{Crossectinal area} = A_1 = 6 \times 10^{-4} \text{ m}^2$$

$$\text{Permeability} = \mu_1 = 6.25 \times 10^{-3}$$

2. Material 2

$$\text{Mean length} = \ell_2 = 0.05 \text{ m}$$

$$\text{Crossectinal area} = A_2 = 6 \times 10^{-4} \text{ m}^2$$

$$\text{Permeability} = \mu_2 = 6.25 \times 10^{-3}$$

3. Material 3

$$\text{Mean length} = \ell_3 = 0.2 \text{ m},$$

$$\text{Crossectinal area} = A_3 = 6 \times 10^{-4} \text{ m}^2$$

$$\text{Permeability} = \mu_3 = 3.05 \times 10^{-3}$$

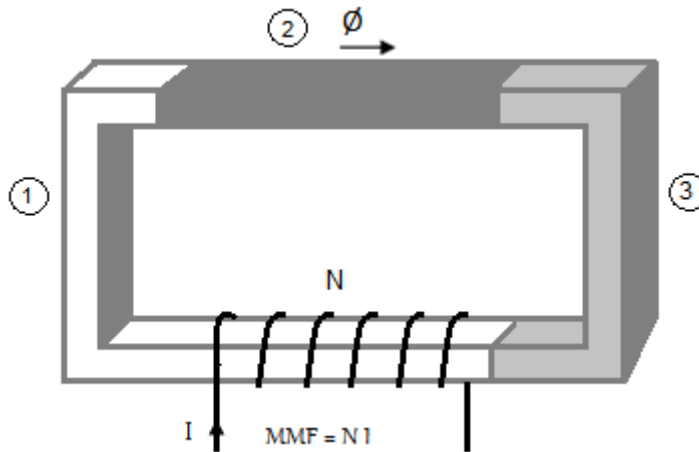

Figure 7.28: Circuit for Q 7.1

Answer: 0.88A

Q 7.2 : Consider a parallel magnetic circuit as shown in Figure 7.29. Determine the current in the coil of 400 turns, if it produces total magnetic flux of 2mWb in material 1.

(b) Find the flux in the central as well as right limb. The details of the materials are;

4. Material 1

$$\text{Mean length} = \ell_1 = 0.2 \text{ m},$$

$$\text{Crossectinal area} = A_1 = 6 \times 10^{-4} \text{ m}^2$$

$$\text{Permeability} = \mu_1 = 6.25 \times 10^{-3}$$

5. Material 2

$$\text{Mean length} = \ell_2 = 0.05 \text{ m}$$

$$\text{Crossectinal area} = A_2 = 6 \times 10^{-4} \text{ m}^2$$

$$\text{Permeability} = \mu_2 = 6.25 \times 10^{-3}$$

6. Material 3

$$\text{Mean length} = \ell_3 = 0.2 \text{ m},$$

$$\text{Cross-sectional area} = A_3 = 6 \times 10^{-4} \text{ m}^2$$

$$\text{Permeability} = \mu_3 = 3.05 \times 10^{-3}$$

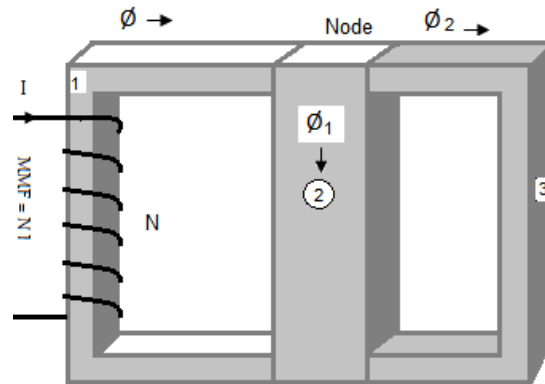

Figure 7.29: Circuit for Q 7.2

Answer: 0.32 A, 1.78 mWb and 0.217 mWb

Q 7.3 : Consider a charge of 2mC moving with a velocity of $3 \times 10^6 \mathbf{a}_x$ m/s in a magnetic flux density of $2 \times 10^{-3} \mathbf{a}_y$ T. Determine the magnetic force on it.

Answer: $12 \mathbf{a}_z$ N

Q 7.4 : Consider a charge of 2mC located in the electric field of $4 \times 10^3 \mathbf{a}_z$ V/m. Determine the electric force on it.

Answer: $8 \mathbf{a}_z$ N

Q 7.5 : Consider a charge of 2mC moving with a velocity of $3 \times 10^6 \mathbf{a}_x$ m/s in a magnetic flux density of $2 \times 10^{-3} \mathbf{a}_y$ T. if electric field of $4 \times 10^3 \mathbf{a}_z$ V/m also exists in the vicinity of the moving charge, then determine the net force on the charge.

Answer: $20 \mathbf{a}_z$ N

References:

1. **Basic Electrical Engineering**, 5th edition by Fitzgerald.
2. **Alternating Circuit Theory**, 4th edition by KY Tang.
3. **Electrical Technology**, by BL Theraja.



Dr. Gulzar Ahmad is an Associate Professor in the Department of Electrical Engineering at University of Engineering and Technology, Peshawar, Pakistan where he received his Bachelors degree in Electrical Power Engineering, Master degree in Electrical Power Engineering and PhD in Electrical Communication Engineering. He received another Master degree in Electrical Communication Engineering from George Washington University, USA in 2002. He is an author of about thirty eight research papers in the field of Electrical Engineering.

The book has been written for undergraduate students of Electrical Engineering. The author has reflected his 22 years of undergraduate level teaching experience in the book. This book is intended to be easy and bringing the readers the important information regarding some basic and fundamental topics of electrical engineering. Important theoretical and mathematical results are given with the accompanying lengthy proofs, which is the main characteristic of the book. Solved numerical problems have been added to give the students the confidence in understanding the material presented.