

Positive Origami

A compilation of Traditional Origami Models
To Learn and Teach

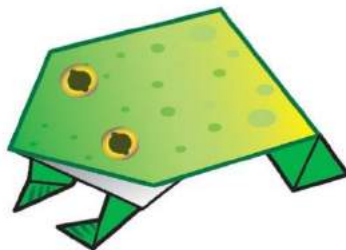

Mobile Craft 4U
Community Interest Company

By Zulay Newell

May 2017

Introduction

Hello and welcome to the wonderful world of Positive Origami!

I remember doing Origami for the first time when I was a child when my brother and I learned how to make a jumping frog and created thousands of them. Sadly, in later years I lost touch with this beautiful art, however, after an admission into hospital suffering Bipolar disorder, I managed to reignite my passion and Origami has played an important role in my recovery.

I have been learning, exploring and teaching other crafts since I left hospital in 2010 but Origami still remains my favourite papercraft! Sharing my passion for Origami has been a very rewarding experience and that is the reason I have compiled these traditional Origami models here.

I hope you will find the experience of learning Origami enjoyable as I do. Bear in mind that you will need to be patient and persevere. It takes time to get familiar with the Origami symbols but once you have learnt them you will be able to read any diagrams and fold any model.

I hope you will feel inspired to both create and pass on your new skills.

Good luck and all the best,

Zulay Newell

Mobile Craft 4U



The Origami symbols and terms are from Marcella Brina who is a talented Origami artist and kindly gave me the permission to use them here. The diagrams of the traditional models were done by David Petty who unfortunately died in December 2011. David made huge contributions to the world of Origami and his former colleague and friend Nick Robinson gave me the permission to use his traditional Origami diagrams here. You are free to reproduce this booklet for educational purposes only – all commercial reproduction is prohibited. Zulay Newell, May 2017.



Contents

Introduction _____	2
About Origami _____	7
Origami Symbols and Terms _____	8
Origami Bases	
Preliminary Base _____	10
Waterbomb base _____	10
Kite Base _____	11
Blintz Base _____	11
Fish Base _____	12
Bird Base _____	12
Origami Frog Base _____	13
Origami Models	
House _____	14
Organ _____	14
Pencil _____	15
Drinking cup _____	16
Salt Cellar / Fortuna teller _____	17
Dog _____	18
Cat _____	18
Rabbit _____	19
Envelope _____	20
Elforia _____	21
Purse _____	22



Seed Packet_____	23
Japanese Helmet_____	24
Crown_____	25
Dart_____	26
Snapper 2_____	27
Waterbomb_____	28
Shirt / Shorts_____	29
Happycoat_____	30
Bowtie_____	31
Yakko-san_____	32
Japanese Man_____	33
Butterfly_____	34
Waterbomb and Butterfly_____	35
Jumping Frog_____	36
Frog_____	37
Swan_____	39
Bird_____	40
Parakeet_____	41
Flapping Bird_____	42
Drinking Bird_____	43



Pigeon/Dove_____	44
Owl_____	45
Egg laying Hen_____	46
Hen_____	48
Swan Candy Dish_____	49
Crow_____	50
Phoenix_____	52
Heron_____	53
Crane_____	54
Tulip and Leaf_____	55
Waterlily_____	56
Camelia_____	57
Iris_____	58
Multibox_____	60
Simple Box_____	61
Sanbow_____	62
Star Box_____	64
Table_____	65
Pig_____	66
Sailboat_____	67
Sampan_____	69



Boat/ Snapper_____	70
Pagoda_____	71
Fish_____	72
Goldfish_____	73
Turtle_____	74
Four point Star_____	75
Star_____	76
Windmill_____	77
Blow top_____	78
Harlequin Cube_____	79
Triangular tray (Model designed by Zulay Newell) _____	80
Origami Japanese Kusudama _____	82
Useful websites _____	85



About Origami

What is Origami?

Simply, Origami is the art of paper folding without cutting or gluing. Origami is the Japanese name deriving from two words “ori” meaning to fold and “kami” meaning paper.

Brief History

The art of Origami arose in Japan in the 7th century. But its roots lie in Ancient China, where the paper was invented about 2000 years ago. Modern origami owes a great deal to the efforts of Yoshizawa, Akira. Master Yoshizawa published books with completely new models starting in the early 1950's. He, together with American Sam Randlett developed the standard set of origami diagram symbols that is still used today.

Origami paper

Almost any laminar (flat) material can be used for folding; the only requirement is that it should hold a crease. (Normal copy paper with weights of 70–90 g/m² can be used for all the origami models that you will find in here).

Origami Health benefits

Origami provides both mental and physical stimulation. Origami helps develop hand-eye coordination, fine motor skills and mental concentration. Use of the hands directly stimulates areas of the brain. Many find the folding of paper, a form of relaxation and most recently it has been associated with the practice of Mindfulness. Also, it teaches patience, hand coordination and exactness.

Origami is for:

Anyone who likes to be surprised and loves a challenge; for those who love beauty and want to study something new and for those seeking a hobby for joy and fulfilment.

About the Crane and Sadako

The Crane is a symbol of peace and friendship. Japanese legend says that anyone who folds 1,000 origami cranes will be granted a special wish.











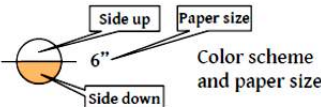
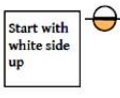
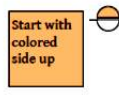

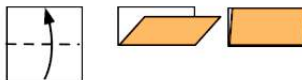

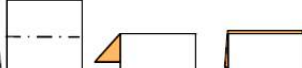

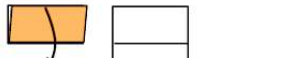

Sadako Sasaki was a Japanese girl who was only two years old when an American atomic bomb was dropped on Hiroshima on August 6, 1945. She became one of the most widely known *hibakusha* — a Japanese term meaning “bomb-affected person”. She is remembered through the story of the one thousand origami cranes. Sadako fell short of her goal of folding 1,000 cranes, having folded only 644 before her death, her friends completed the 1,000 and buried them all with her.



Origami symbols and terms

Diagrammed by Marcela Brina
<http://www.artisbellus.com/>



	<p>Indicates which side of the paper should be up when starting a model and the recommended paper size.</p>	 
	<p>Fold the paper toward you, forming a "valley".</p>	
	<p>Fold the paper backwards, forming a "mountain".</p>	
	<p>Indicate a previous crease than can be used as a reference.</p>	
	<p>Fold as indicated and then unfold.</p>	
	<p>Fold as indicated and then unfold.</p>	
	<p>Cut where indicated</p>	
	<p>Turn the paper over. The orientation of the arrow indicates the direction.</p>	
	<p>Rotate the paper. The orientation of the arrow indicates the direction. The number indicates the angle.</p>	
	<p>Indicate that the next steps will show the model enlarged.</p>	



	Reduced view	Indicate that the next steps will show the model reduced.	
	Partial zoom area	Indicate zoom area. It will be combined with enlarged view or reduced view arrows to indicate zoom in or out.	
	Repeat	Repeat the folds shown in the step in a different corner, edge or flap.	
	Push	Apply pressure where indicated. This symbol will usually be combined with another ones to explain a complex movement.	
	Petal fold	Lift only the upper layer while pushing on the folded edges. Then flatten the model	



Origami Bases

The origami bases folds are often the foundation or starting point of origami projects. Therefore, these are important folds to learn and master.

Preliminary Base

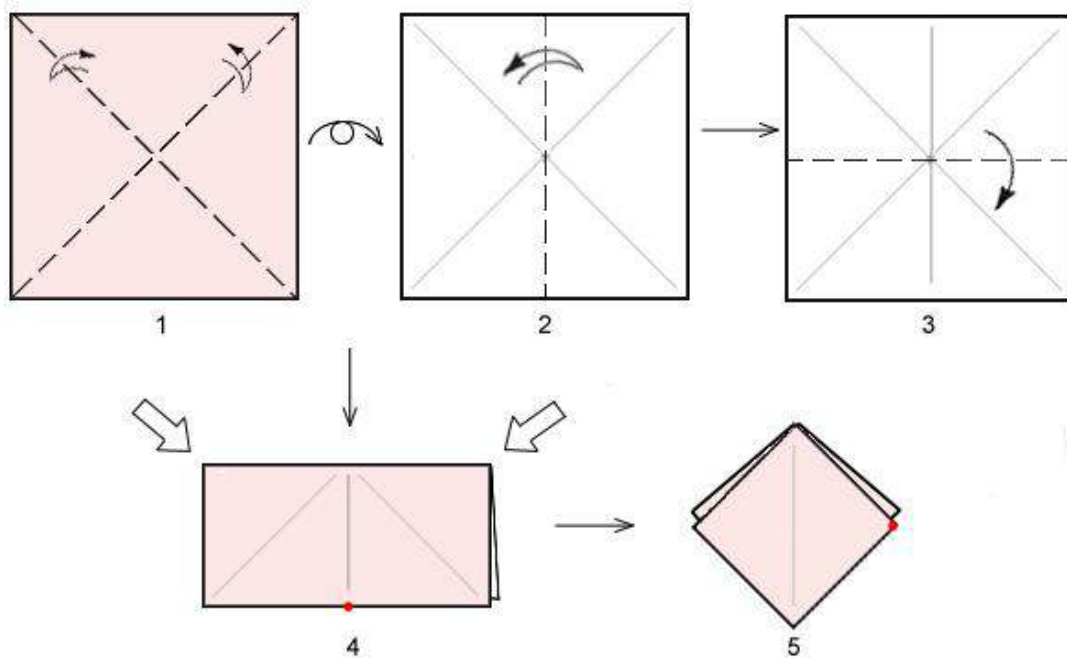

Waterbomb base

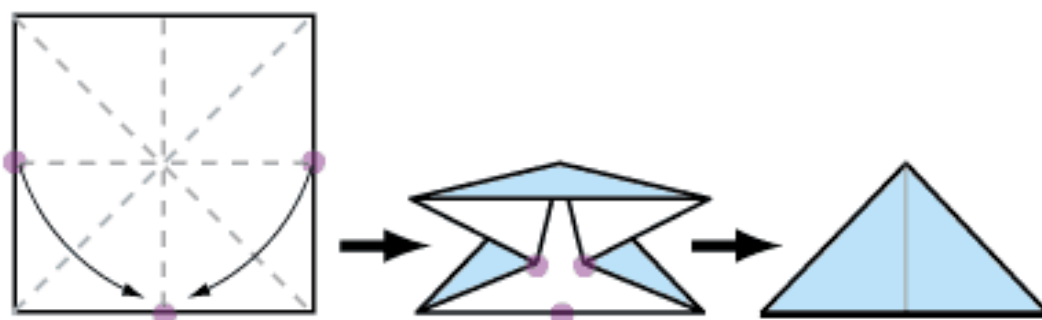

Kite Base

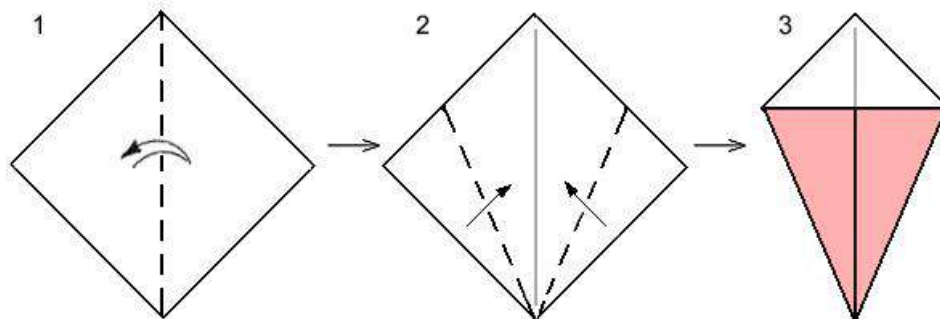

Blintz Base

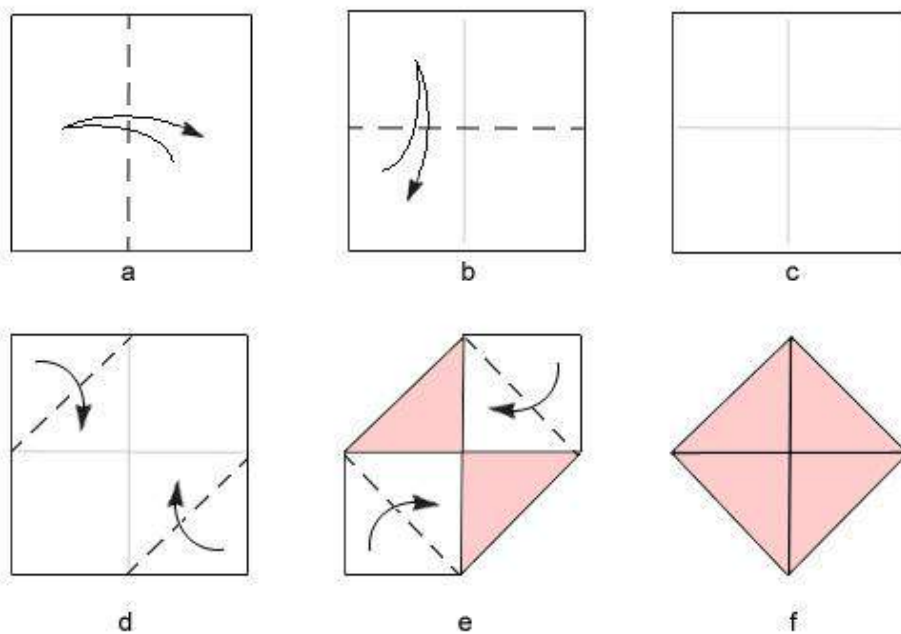

Fish Base

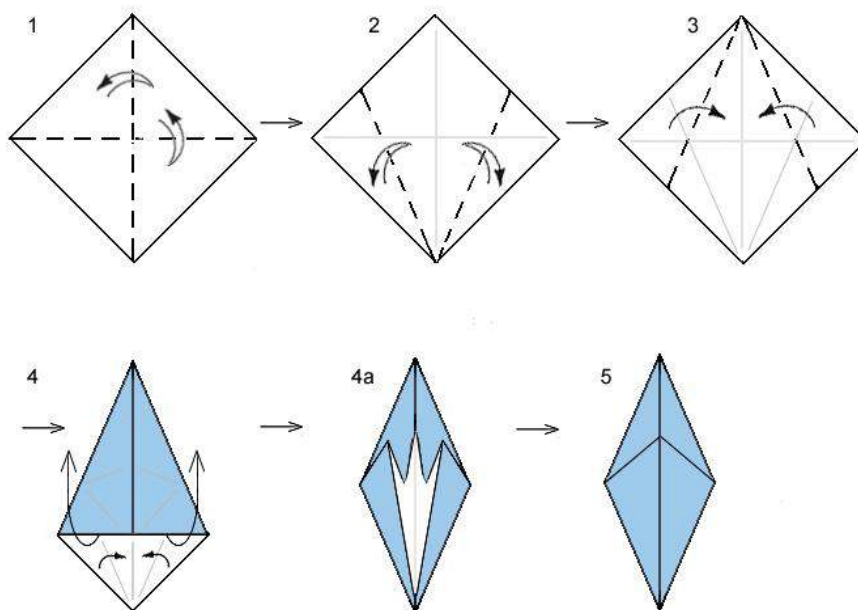

Bird Base (start with a preliminary base)

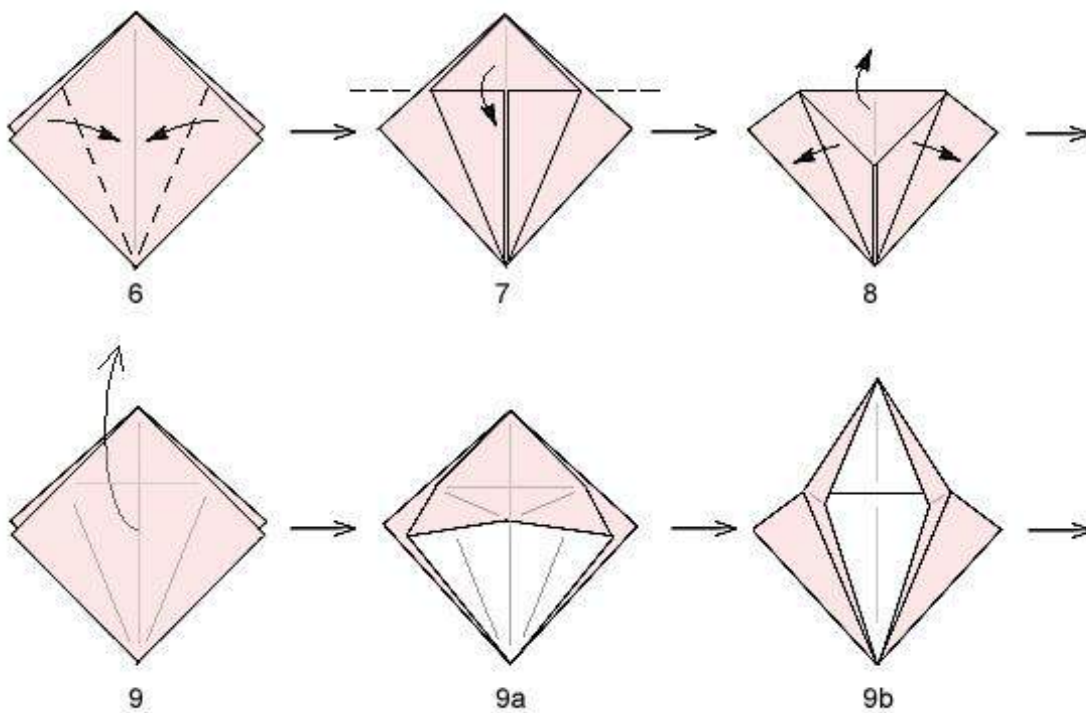

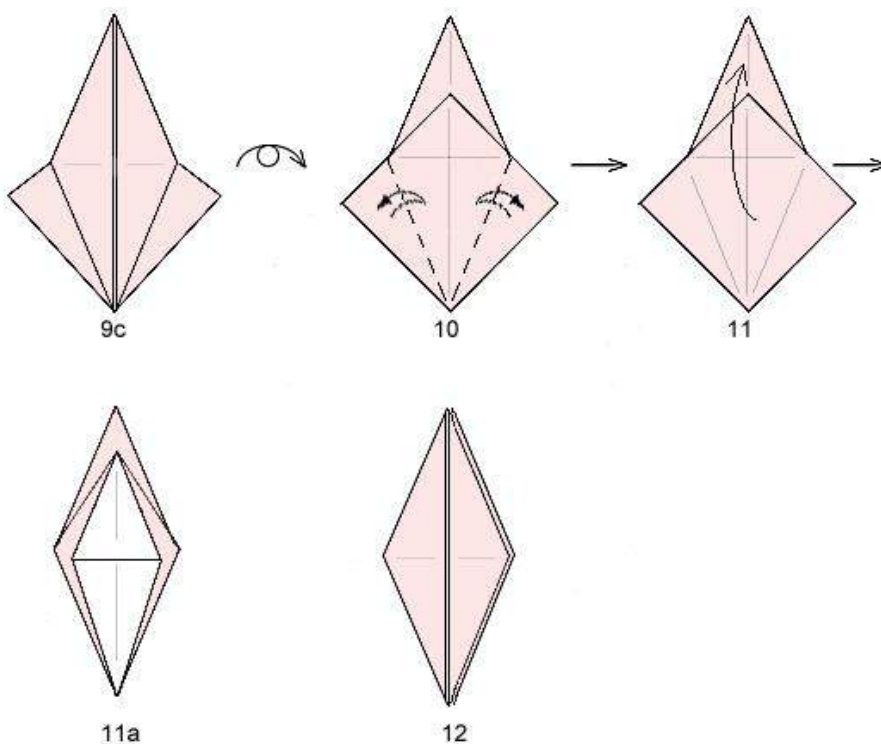

Origami Frog Base (start with a preliminary base)

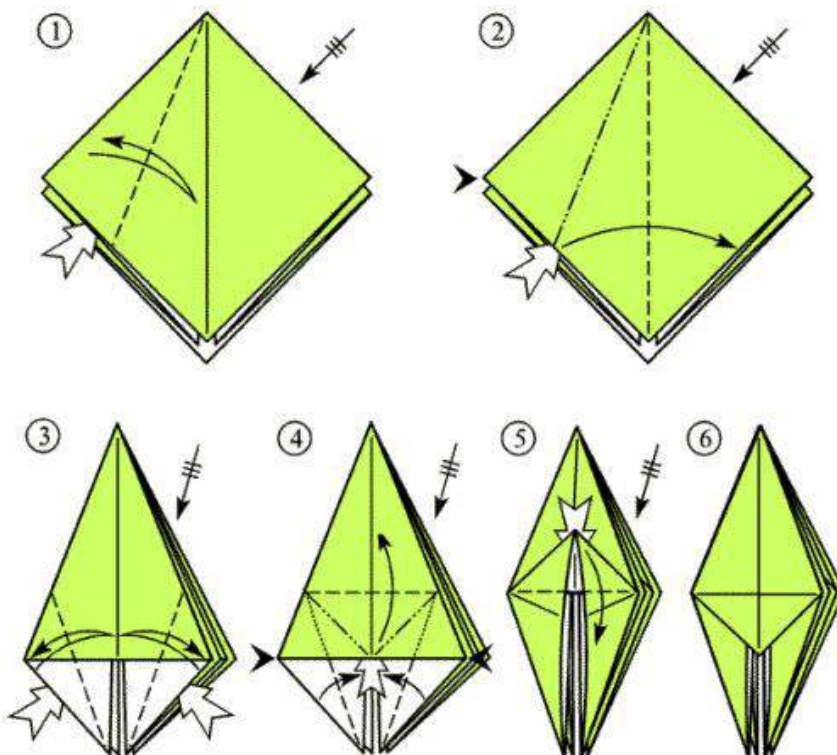

Origami models

HOUSE

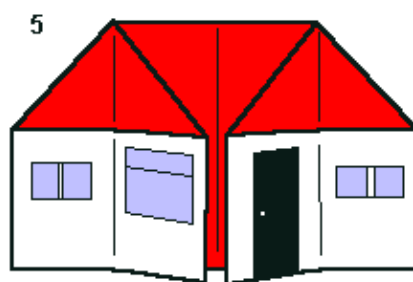
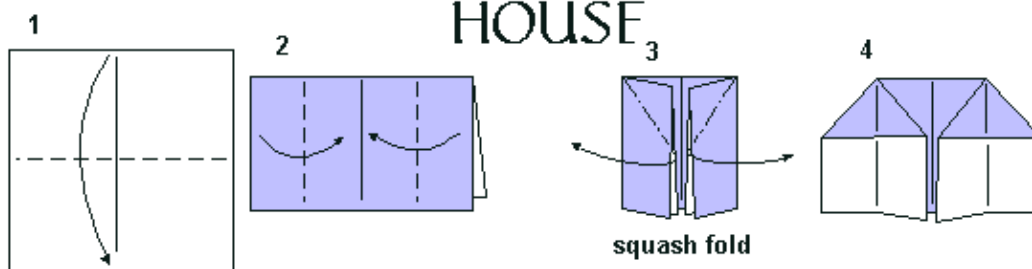

ORGAN

start with step 4 of house

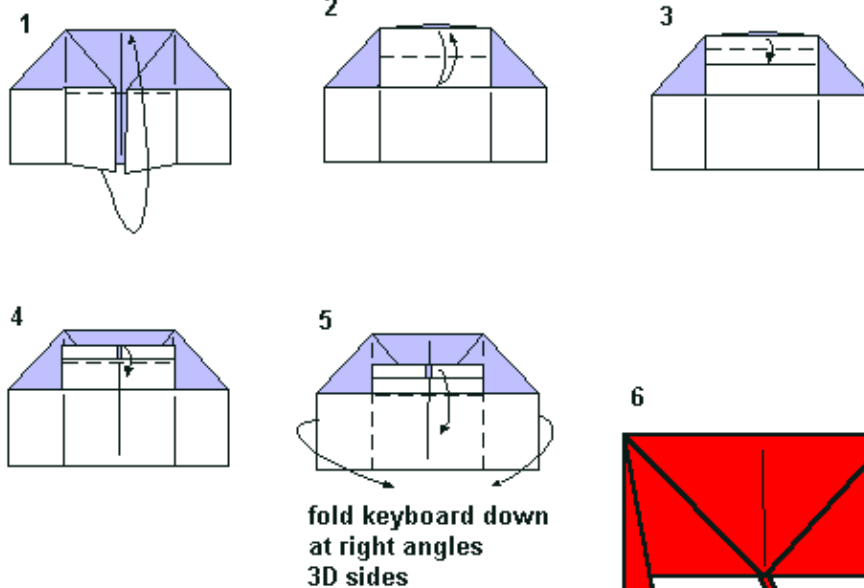

traditional models
© diagrams D.Petty

JANUARY '99



PENCIL - 4 x 1 rectangle

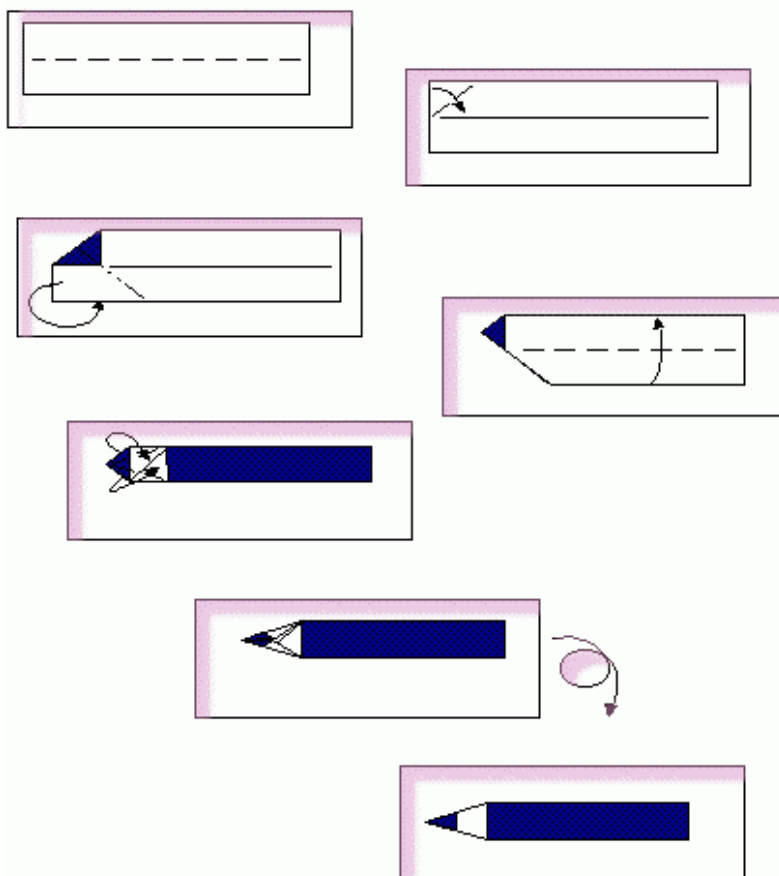

traditional model
©diagrams D. Petty



DRINKING CUP

1

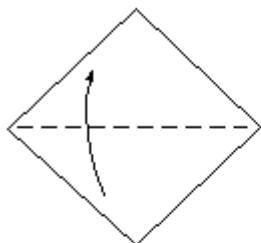

2



pinch only

3



marked points meet

4

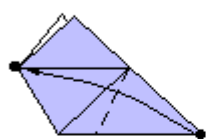

marked points meet

5

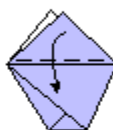

fold upper layer down

6



fold flap to back

6

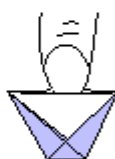

push finger inside and round out

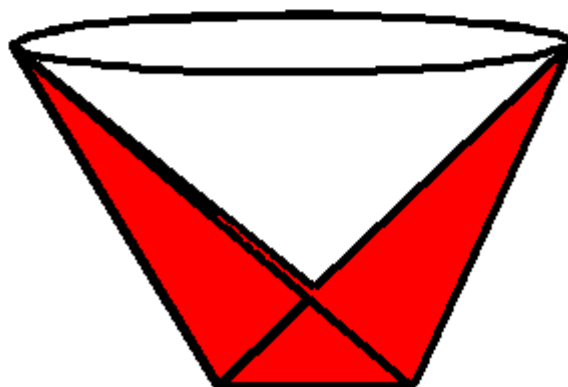

traditional model
© diagrams D.Petty

FEBRUARY '99



1 SALT CELLAR / FORTUNE TELLER

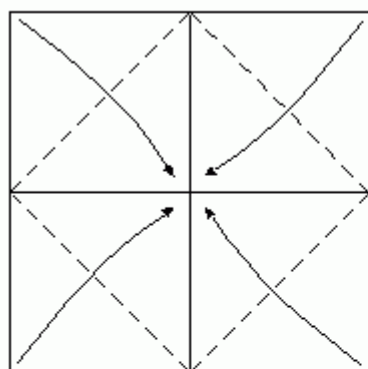

blintz

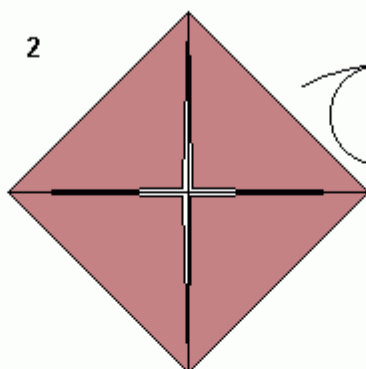

result, turn over

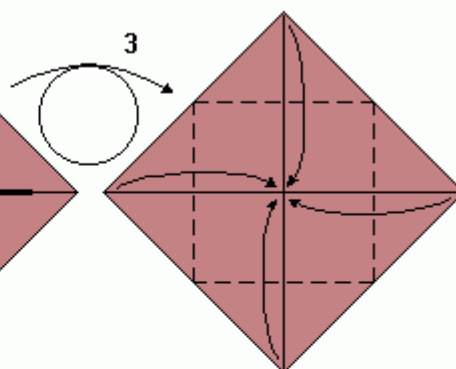

blintz, rotate

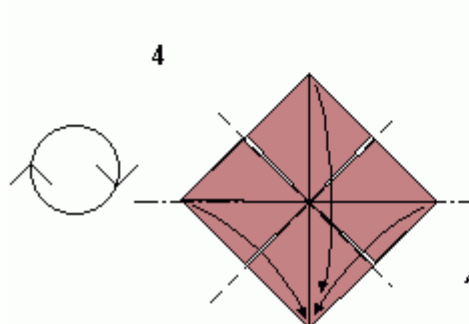

form preliminary base

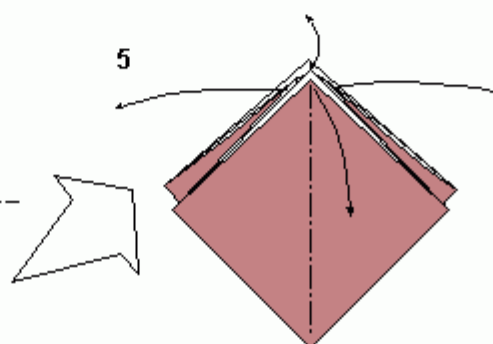

pull out the coloured flaps

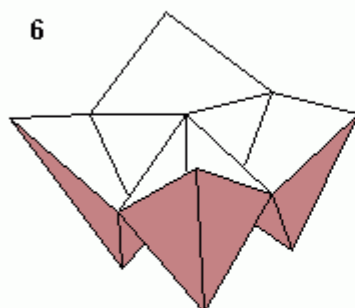

salt cellar complete

can be used as a sweet container

Japanese traditional models
diagrams © D.Petty

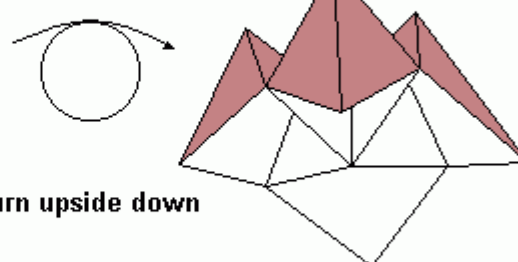

turn upside down

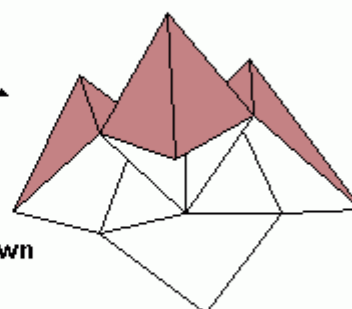

fortune teller

To operate, insert fingers into the four compartments, bringing fingers together to close completely. Separate pairs of fingers to expose different faces in the model. Write different messages on each face.



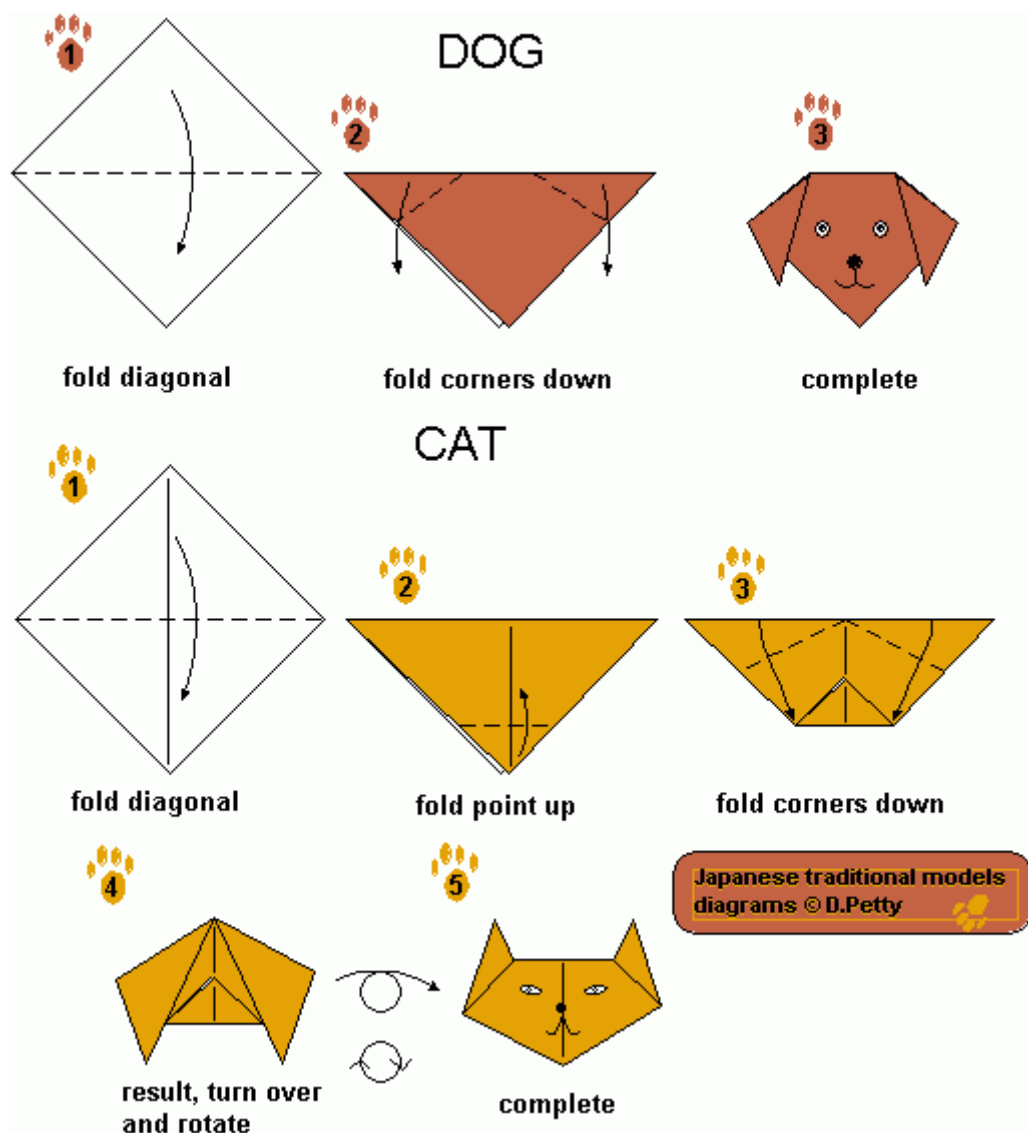

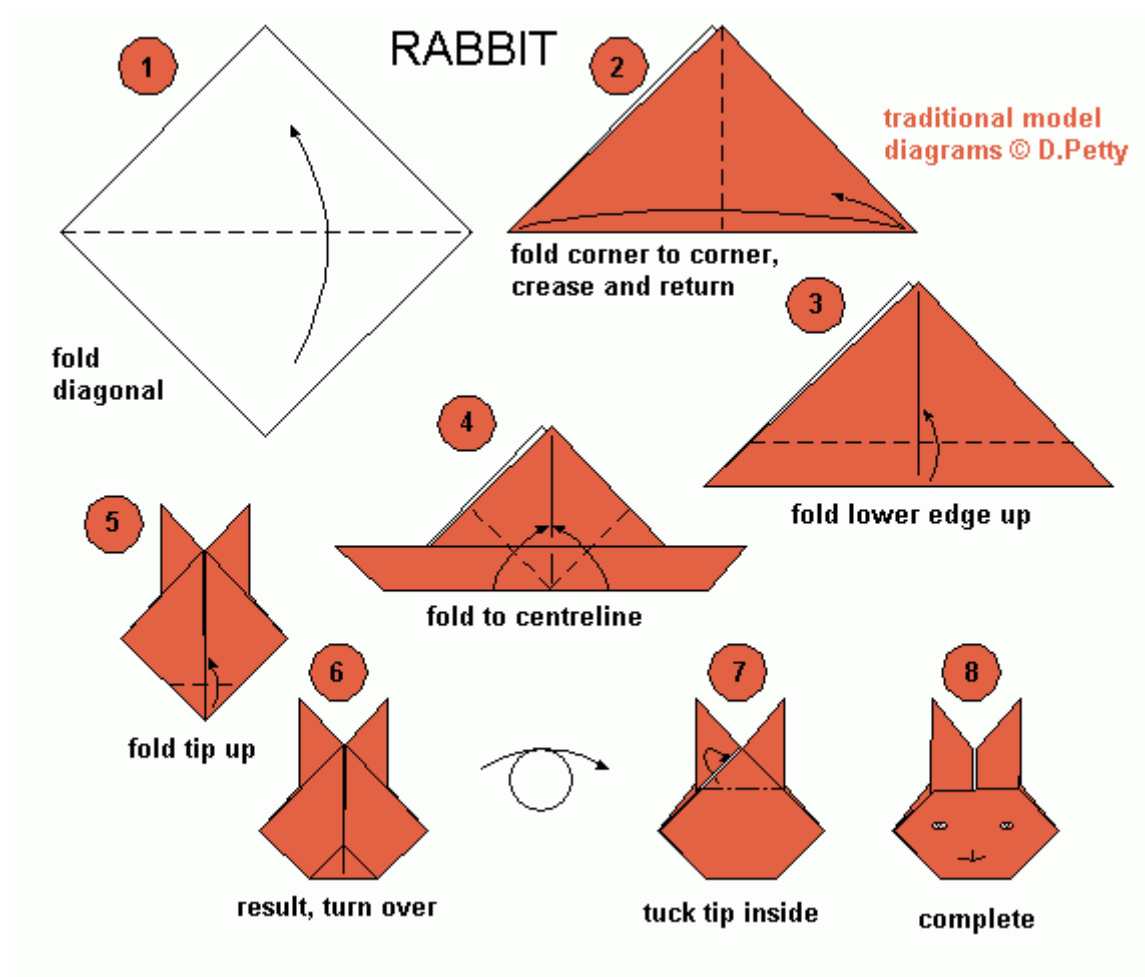

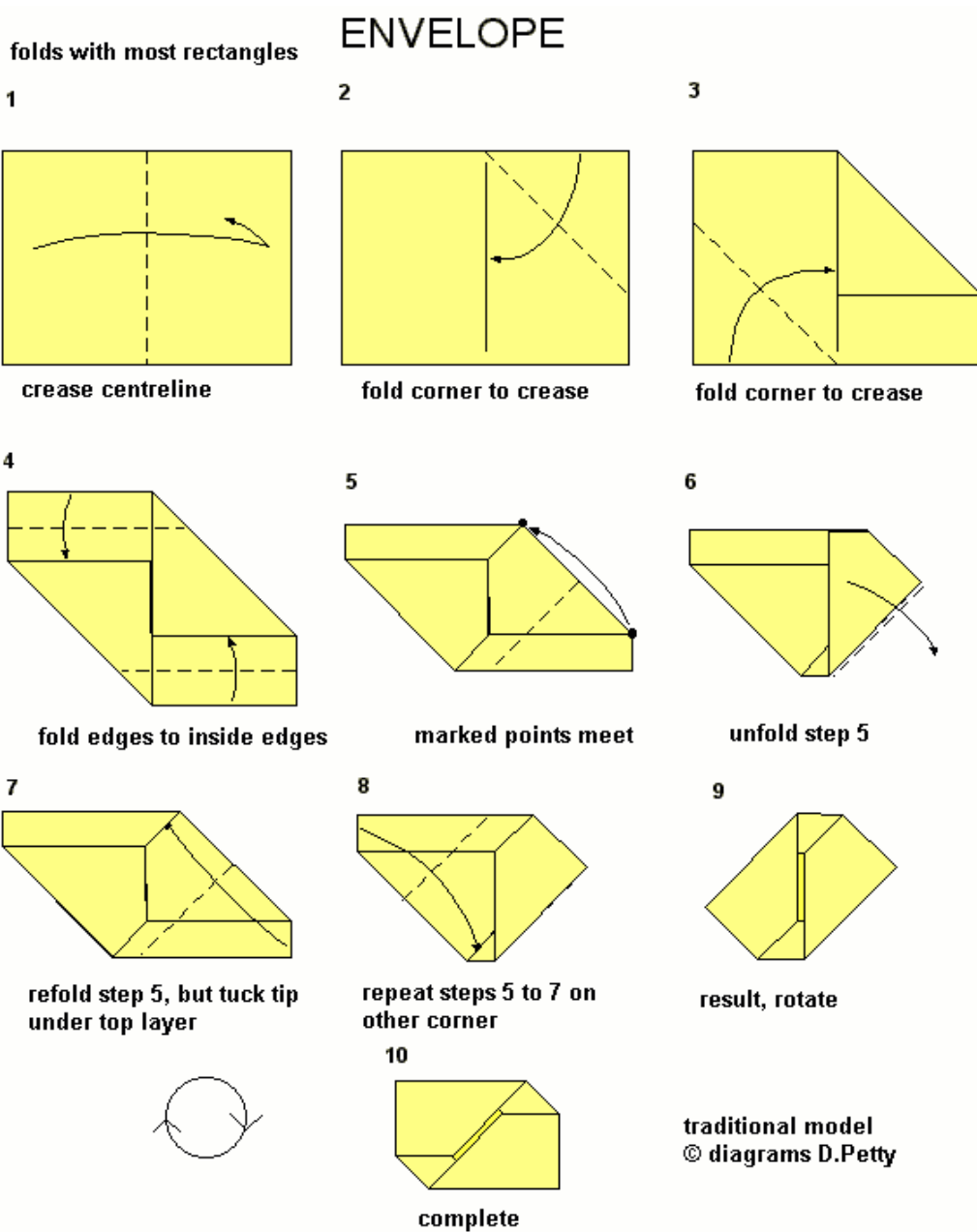

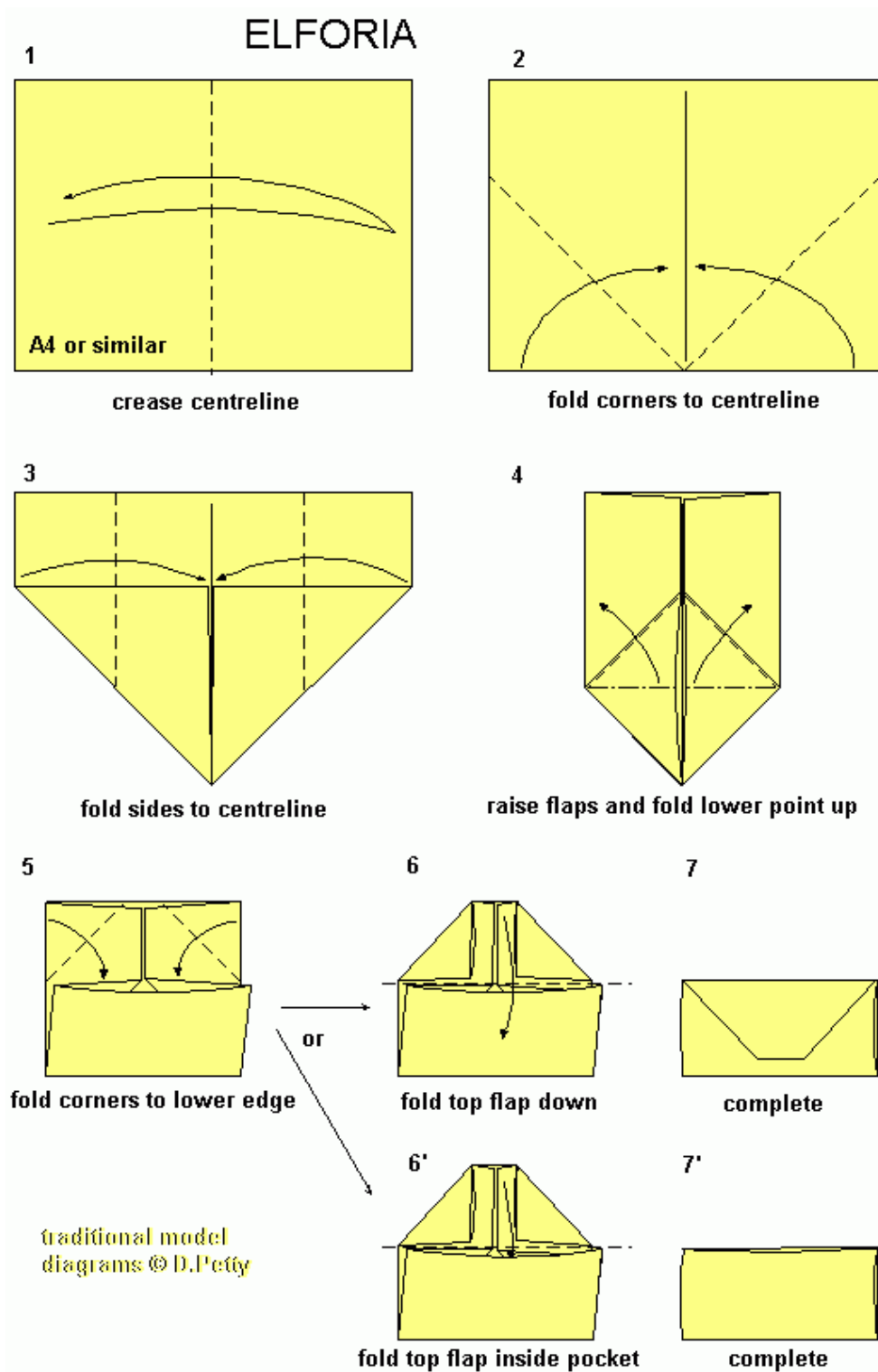

PURSE

1

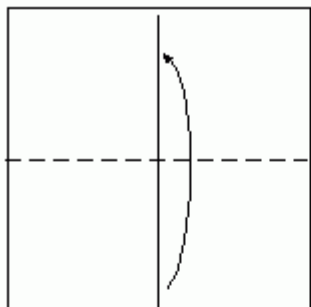

fold in half

2

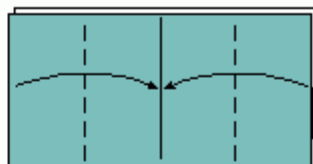

fold sides to centre

3

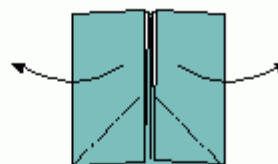

open and squash

4

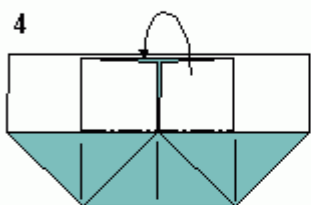

fold central portion inside

5

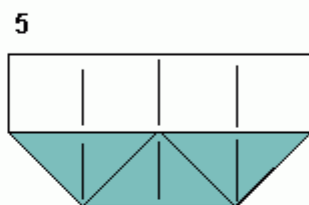

result, turn over

6

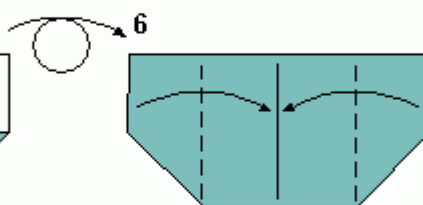

fold sides to centre

7

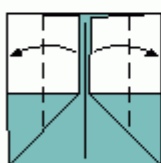

fold to edge

8

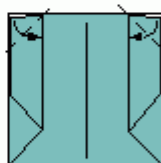

fold corners

9

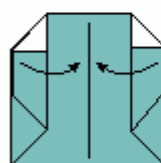

fold flaps back

10

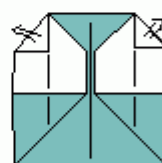

unfold corners

11

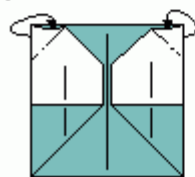

inside reverse

12

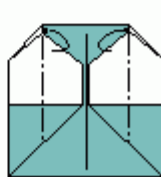

fold flaps behind reversed corners

13

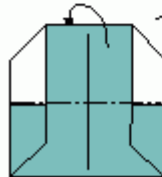

fold flap behind, turn over

14



complete
traditional model diagrams © D.Petty



SEED PACKET

fold with any rectangle

1

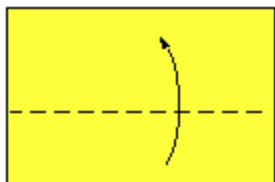

fold to leave strip
approx. 2cm wide

4

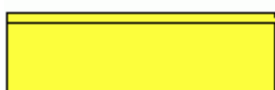

result, turn over

2



fold strip down

3



fold down again

5



fold corners

6



fold corners and
tuck under

7



result, turn over

traditional model
diagrams © D.Petty

8

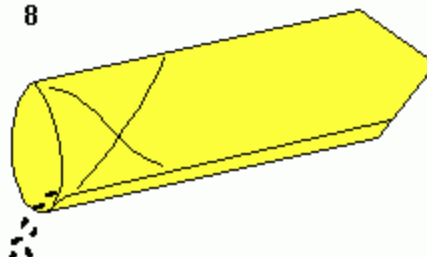

JAPANESE HELMET

1

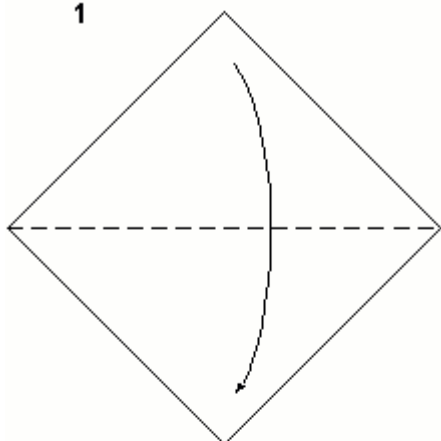

2

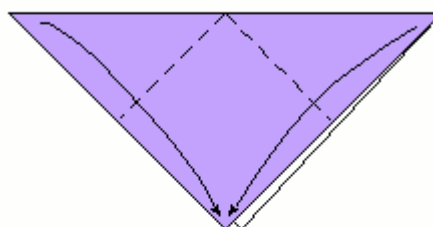

3

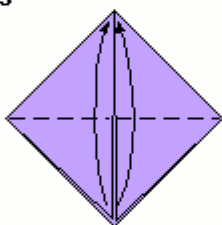

4

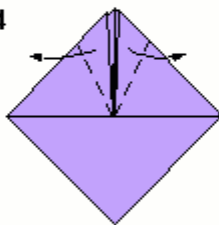

5

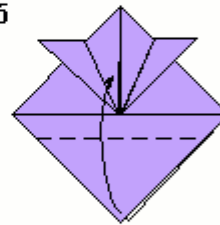

fold top layer only

6

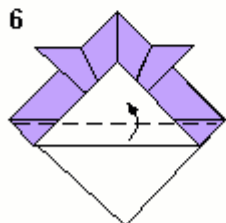

7

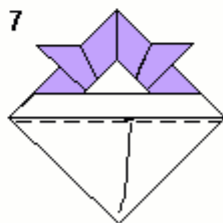

fold flap and tuck inside

8

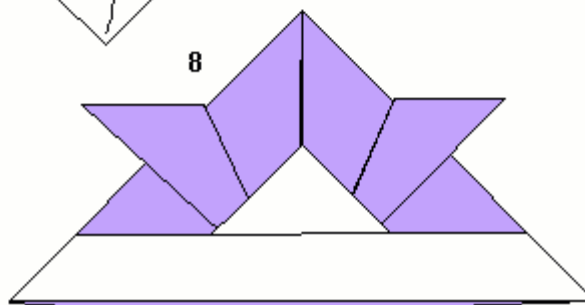

traditional model diagrams © D.Petty



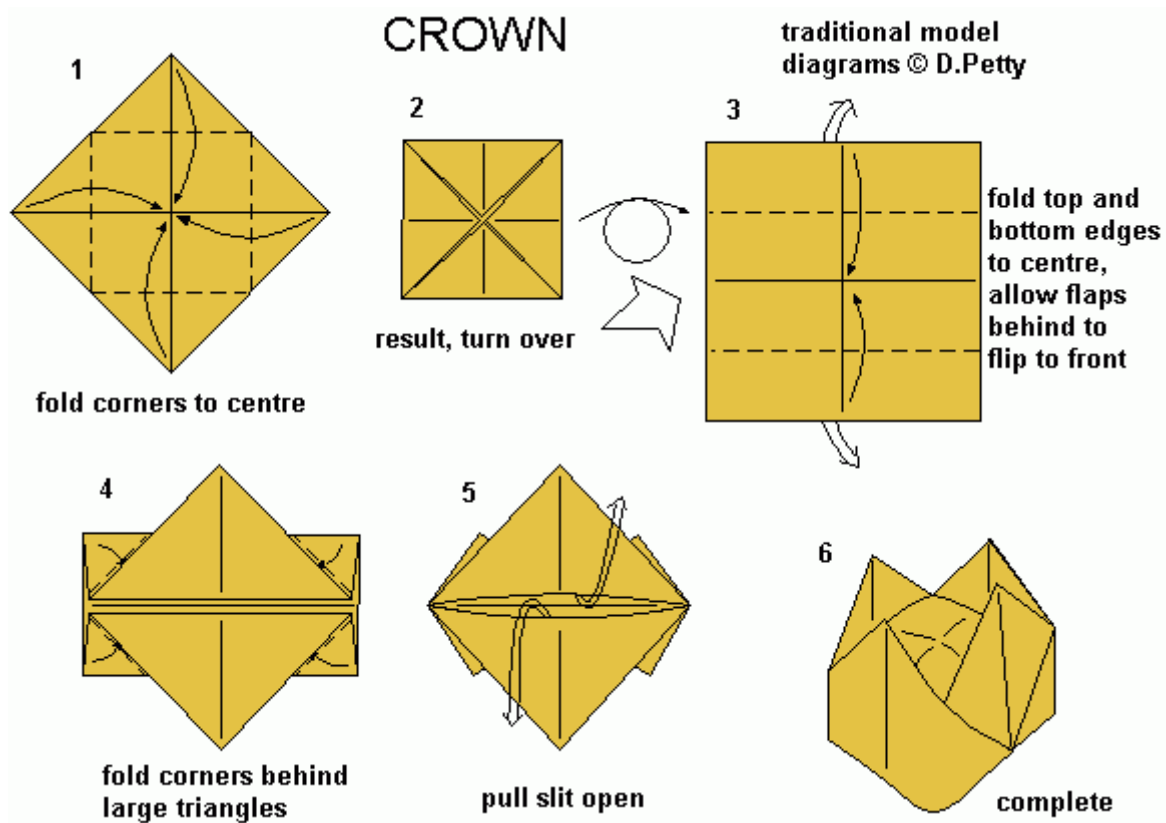

DART

folds from a rectangle (A4, lettersize etc.)

1



bring long edges together,
crease and unfold

2

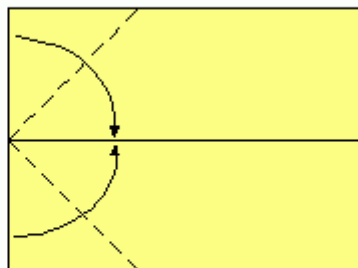

bring short edges to centre crease

3

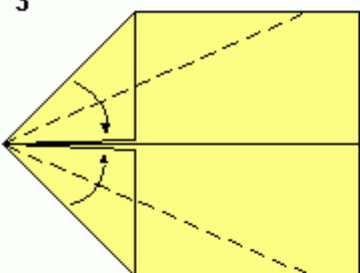

bring folded edges
to centre crease

4

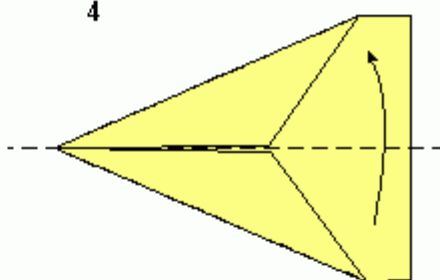

fold in half

5

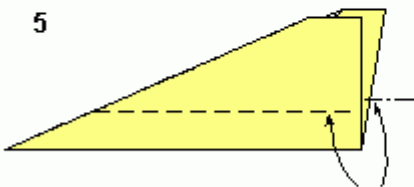

fold wings down at right angles

traditional model
© diagrams D.Petty

6

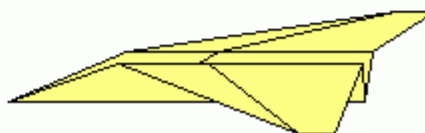

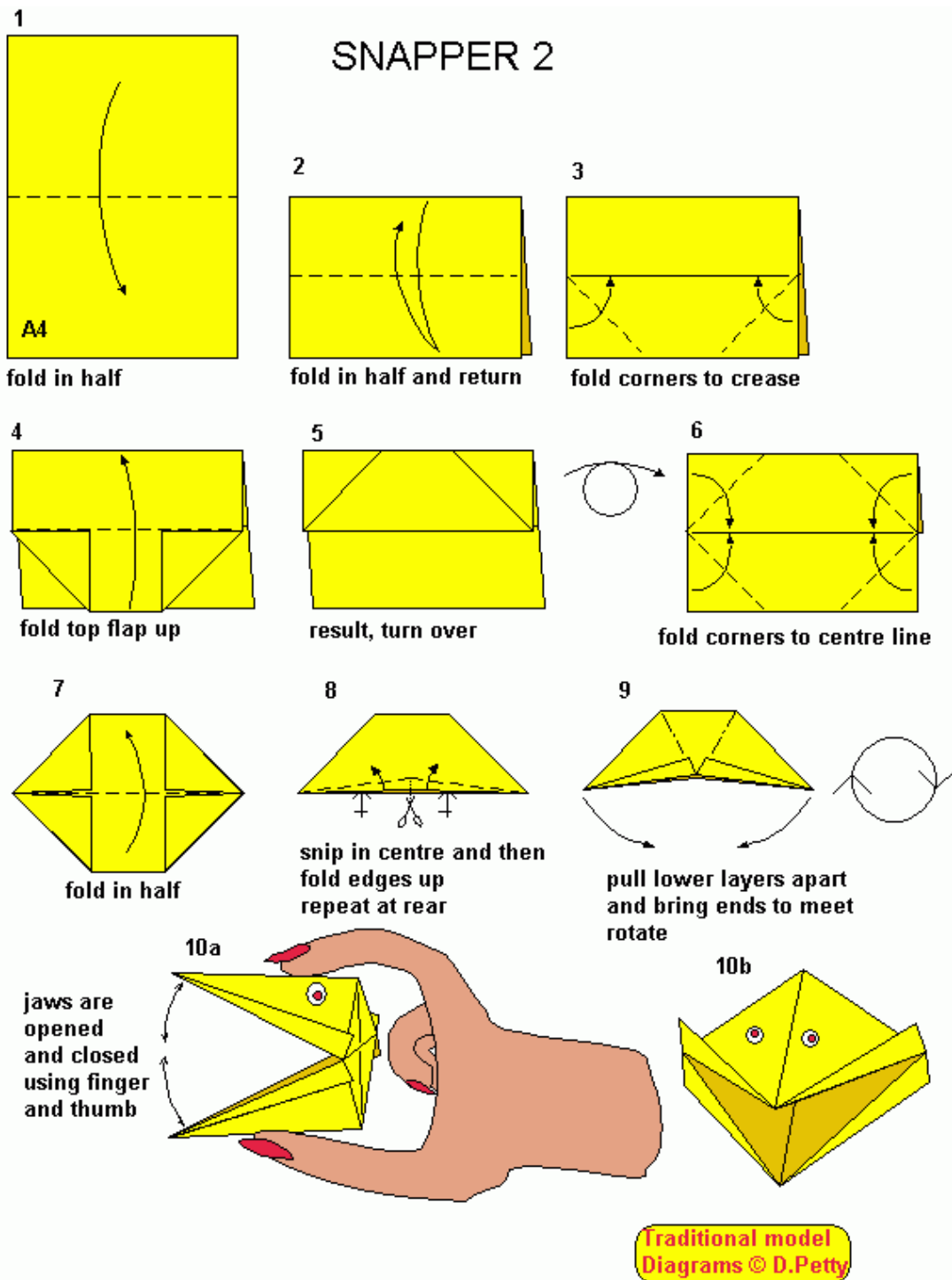

WATERBOMB

This model is also known as "Japanese playball"

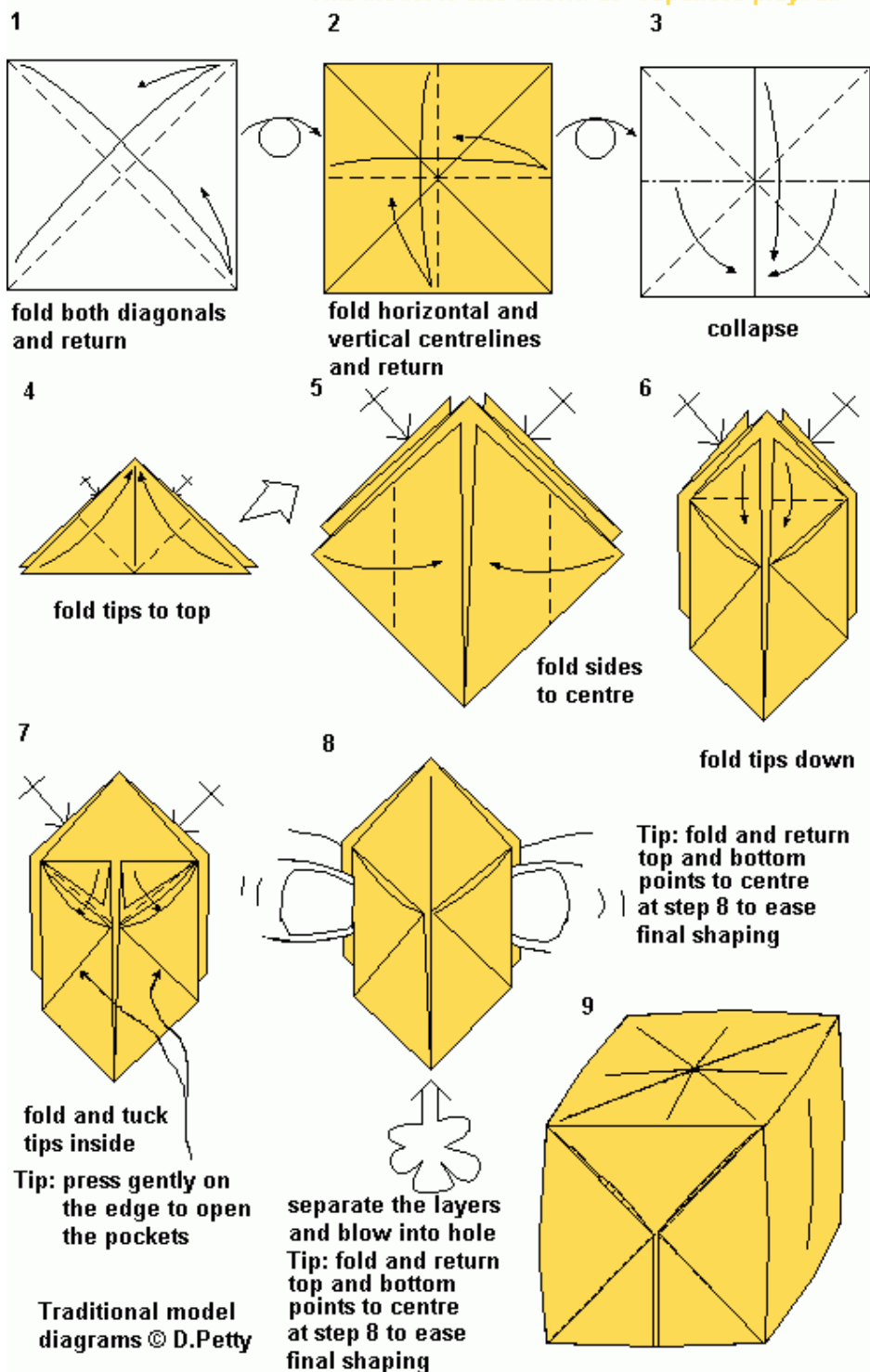

SHIRT

traditional model
© diagrams D.Petty

this model can be folded using a currency note

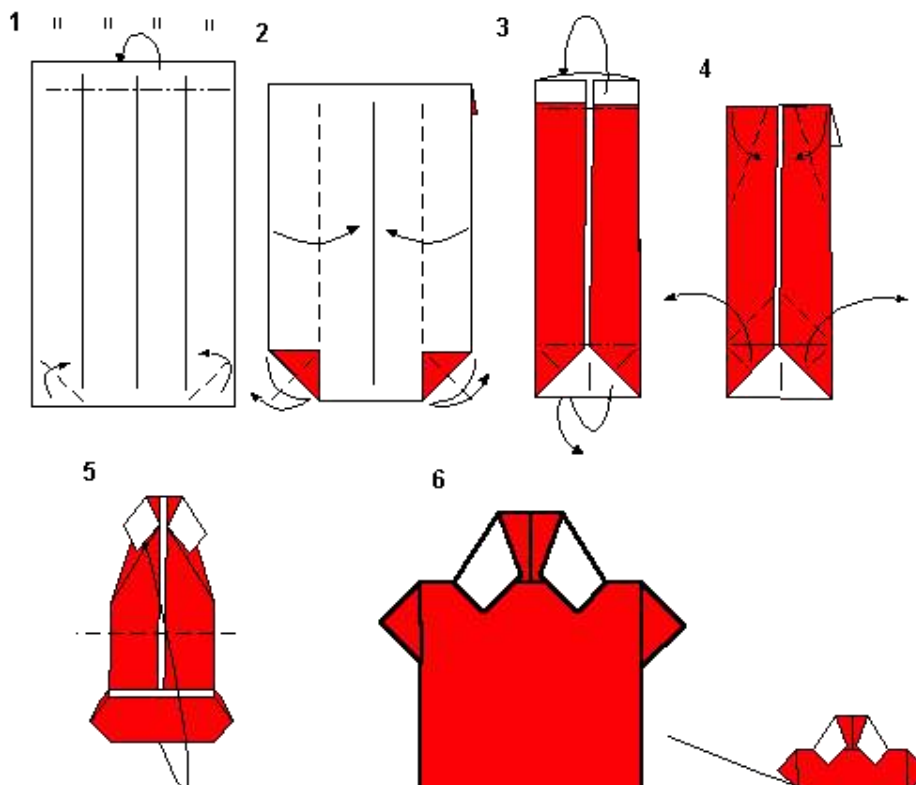

tuck under both collar tips make it in your favorite team colours

SHORTS

model & diagrams
© D.Petty

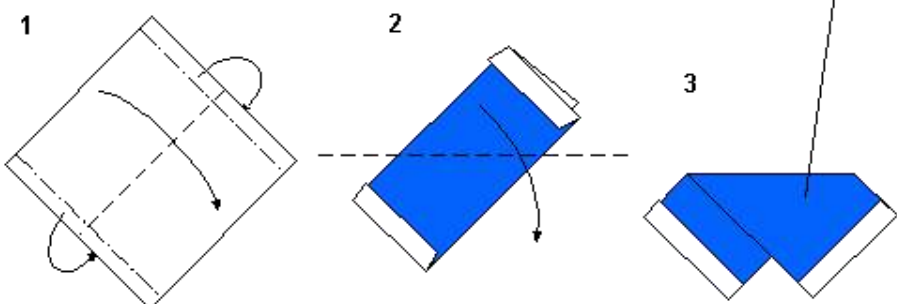

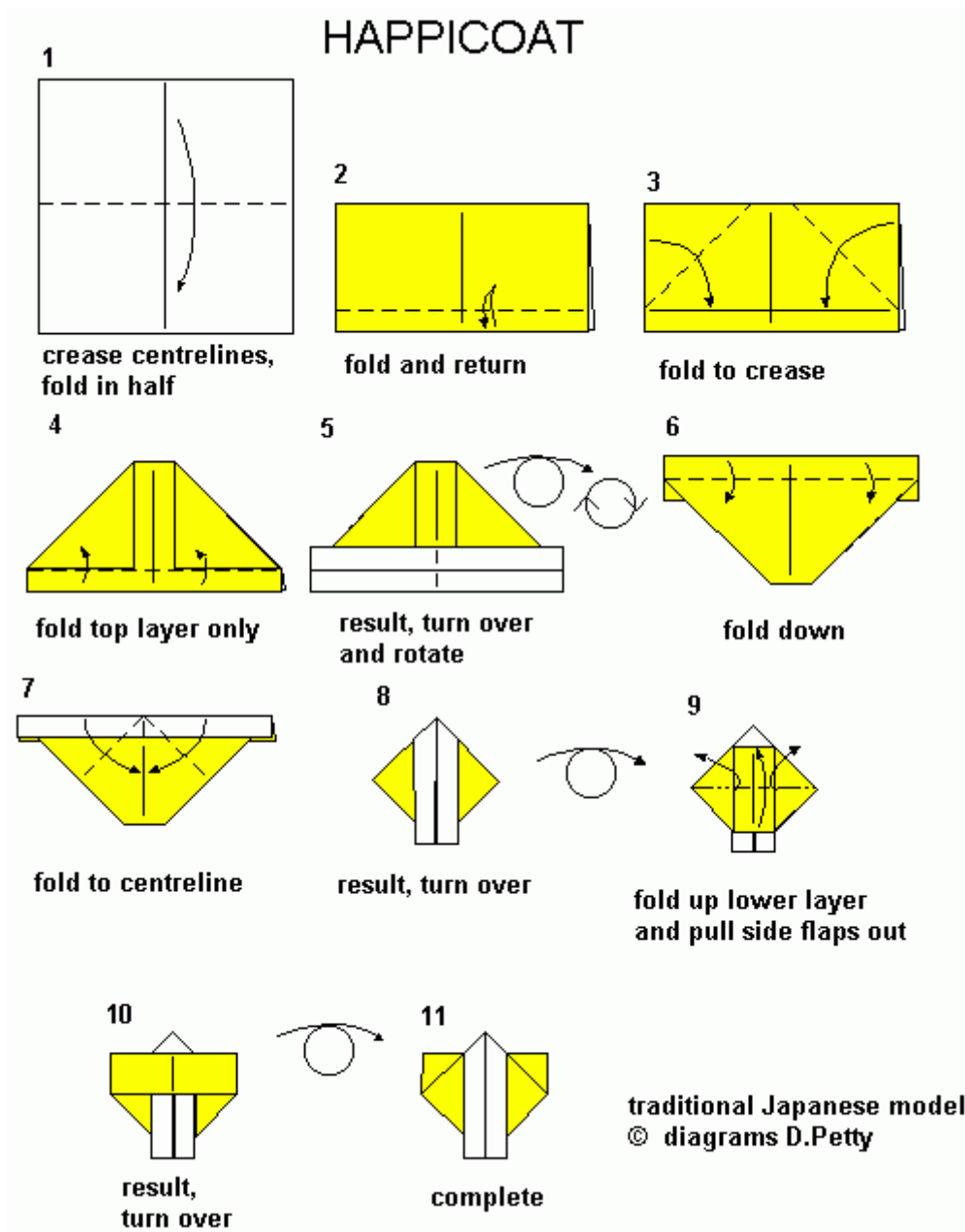

BOWTIE

this can be folded using a currency note

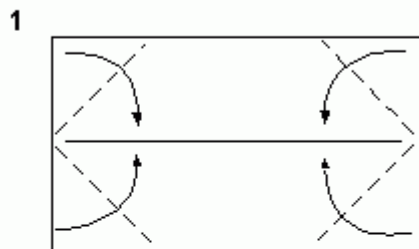

crease centreline then
fold corners in

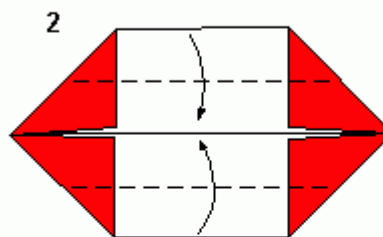

fold sides to centreline

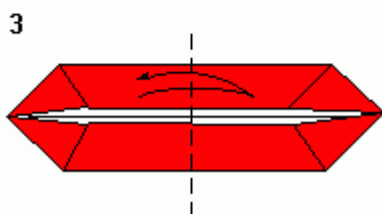

crease centreline



form waterbomb base

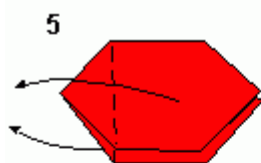

swing top and bottom
flaps over

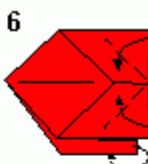

front corners fold
forward, rear ones
to back

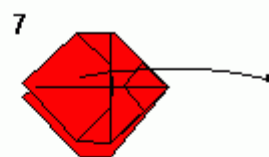

swing flap over and
flatten centre

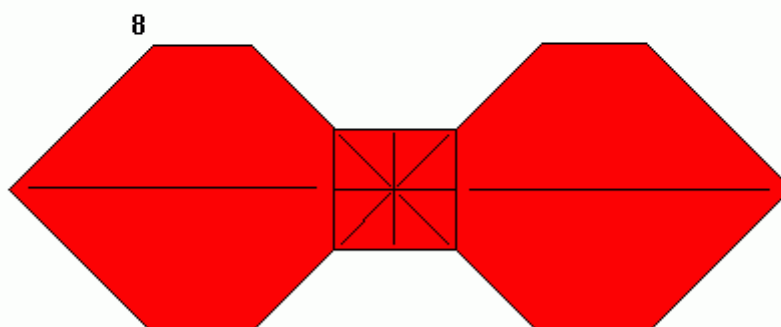

Traditional model
diagrams © D.Petty



YAKKO-SAN

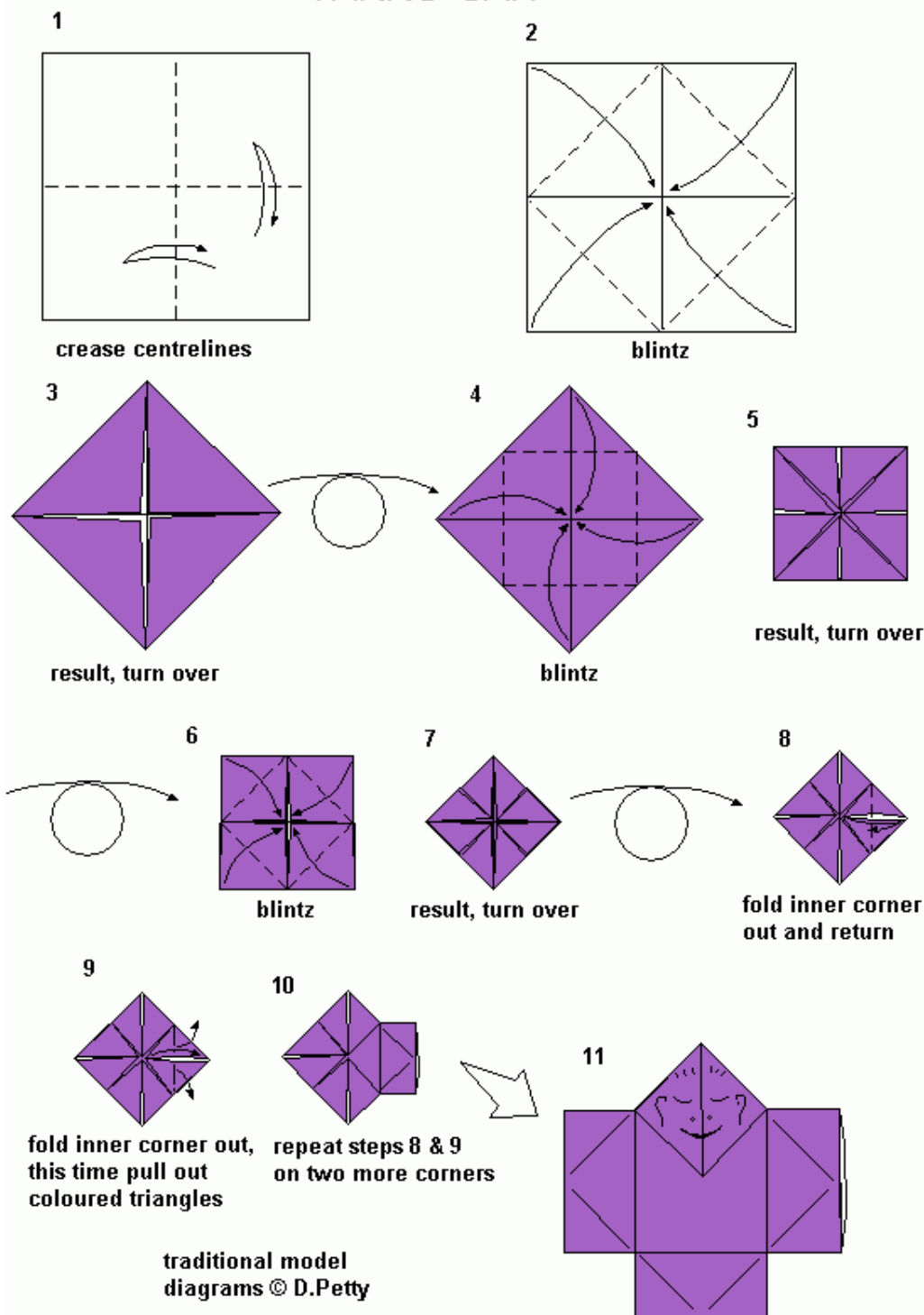

start - unfolded waterbomb base

JAPANESE MAN

Japanese traditional model diagrams © D.Petty

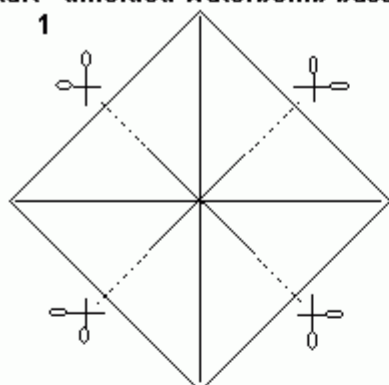

cut just less than halfway to centre

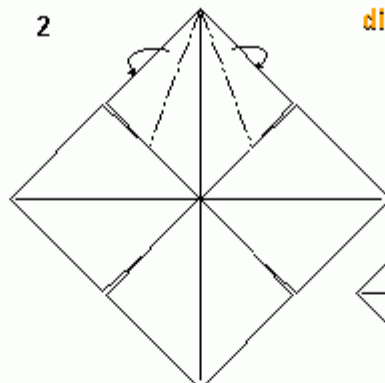

fold cut edges to rear

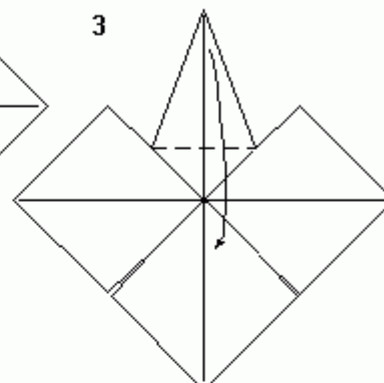

valley fold flap

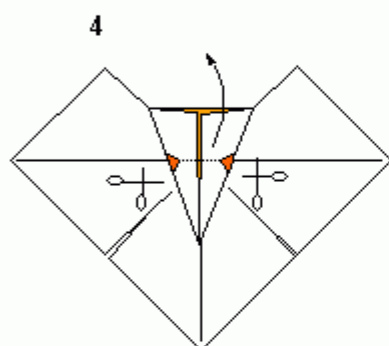

Cut away shaded triangles. Slit paper underneath along line joining triangle points. Return top flap

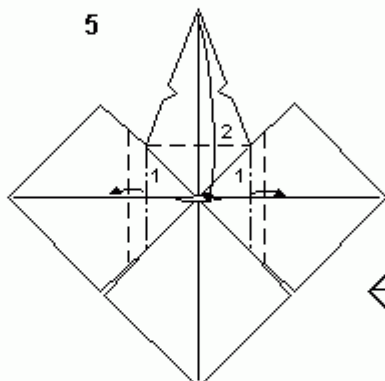

1. Pleat side flaps
2. tuck head through slit, as far as triangular cut outs

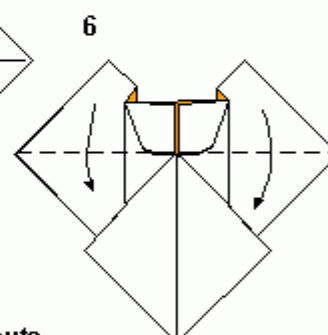

valley fold, allowing head to pop up from behind

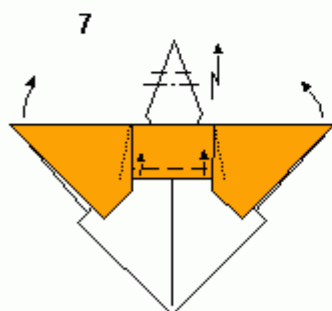

1. fold edge to form belt
2. pull side flaps up, to take out lower part of pleat (crease lies under top layer)
3. pleat head

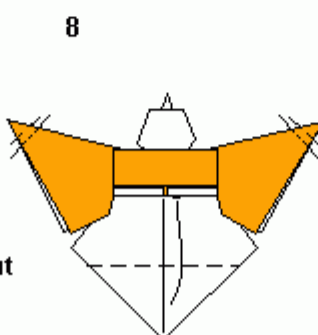

1. reverse fold to form hands
2. fold lower point and tuck under belt

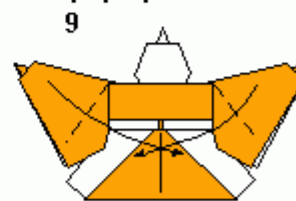

fold arms across body, use soft folds except near shoulder

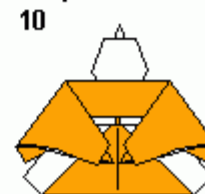

complete



BUTTERFLY

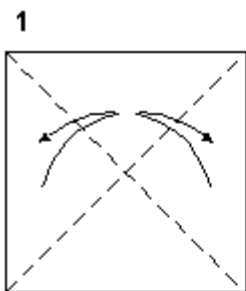

1
fold and return
both diagonals

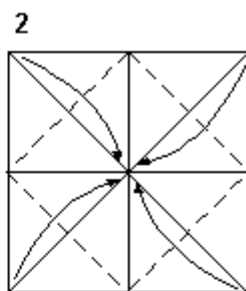

2
blintz

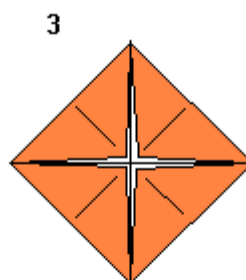

3
result, turn over

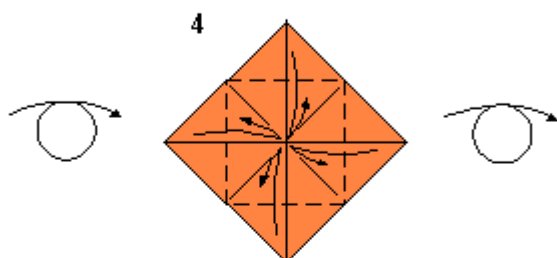

4
blintz and return
then turn over

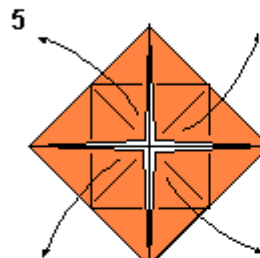

5
open out

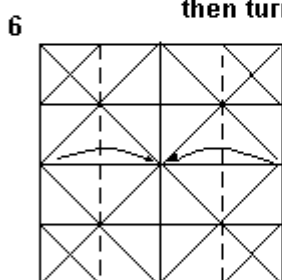

6
fold sides in

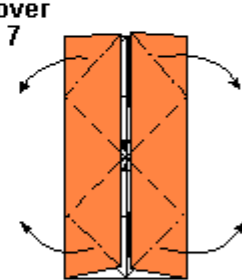

7
collapse



8
fold in half

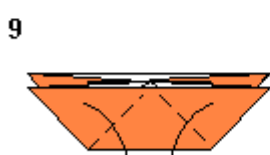

9
fold upper
points down

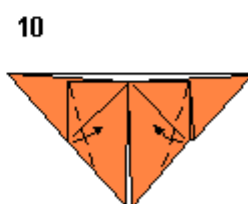

10
fold sides in

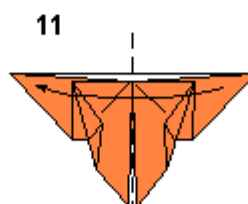

11
fold in half

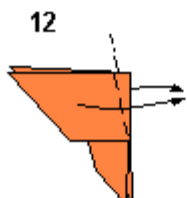

12
fold both wings

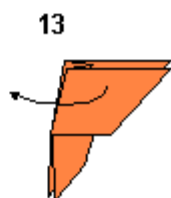

13
fold one wing

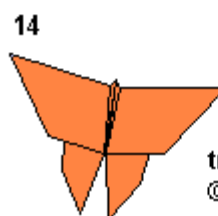

14
traditional model
© diagrams D.Petty



WATER BOMB and BUTTERFLY

Traditional models.

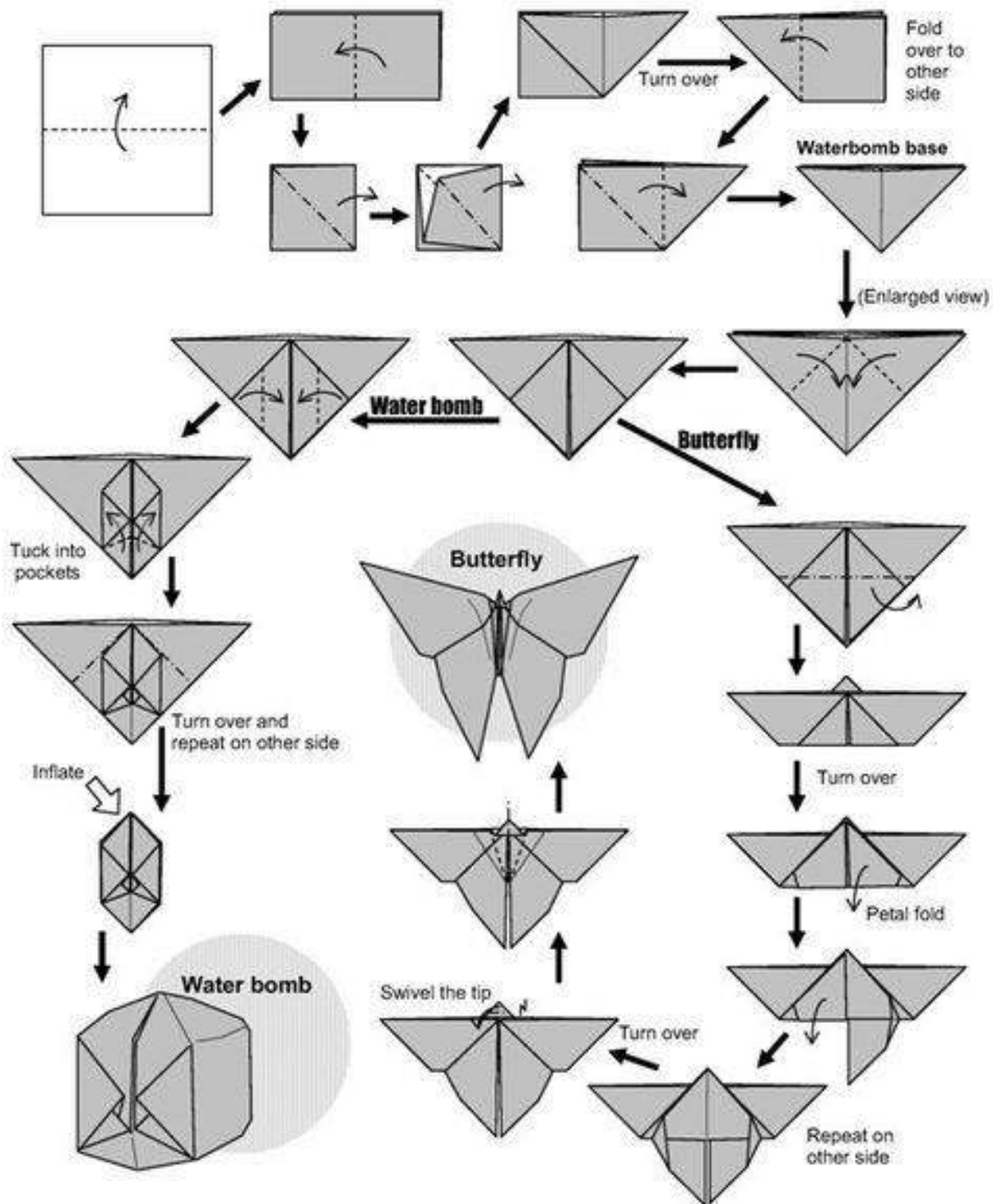

JUMPING FROG

can be folded from thick 2x1 paper, start at step 2

traditional model
© diagrams D.Petty

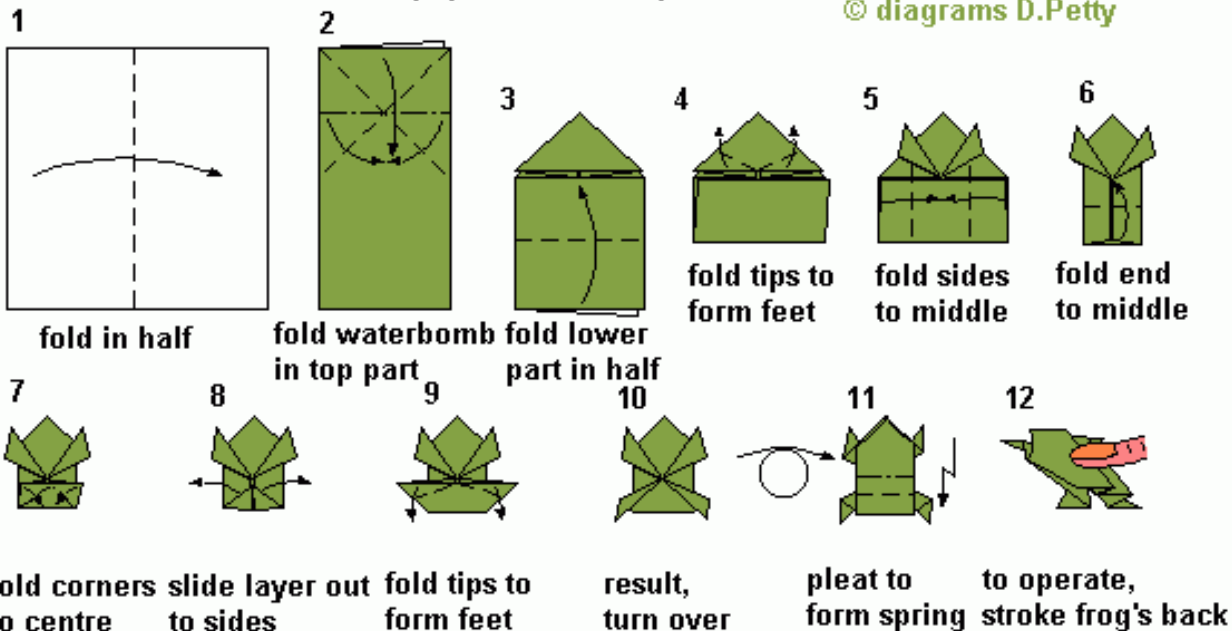

FROG

start with frog base

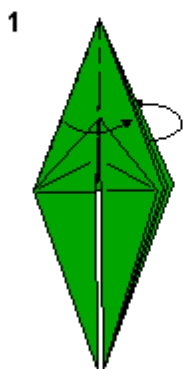

book fold front
and back flaps

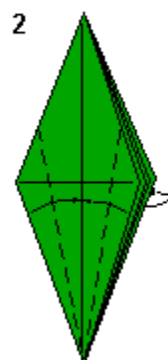

repeat behind



book fold again

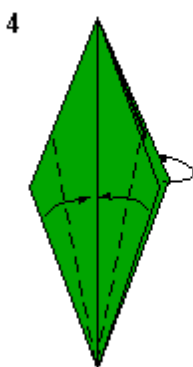

repeat at back

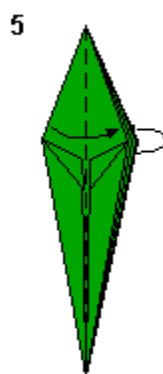

book fold yet again

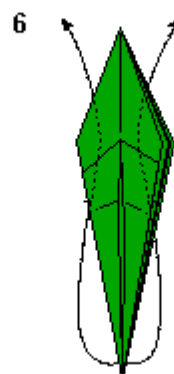

inside reverse fold

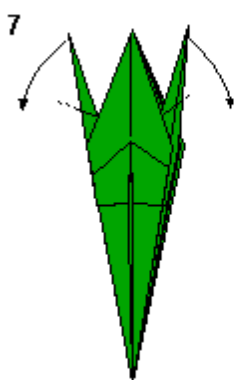

inside reverse fold

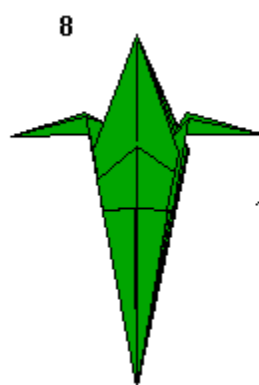

9

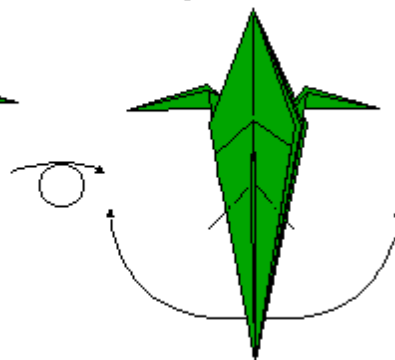

inside reverse fold



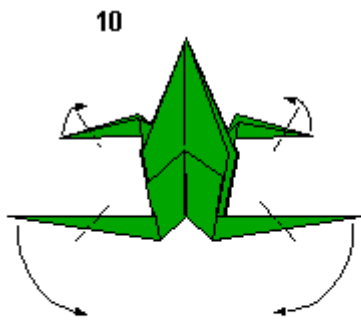

inside reverse fold

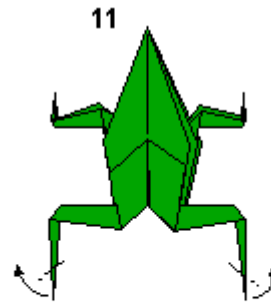

inside reverse fold

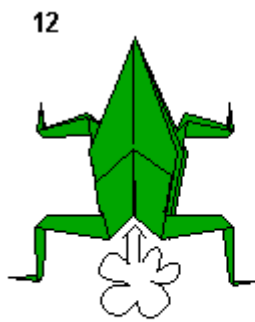

inflate

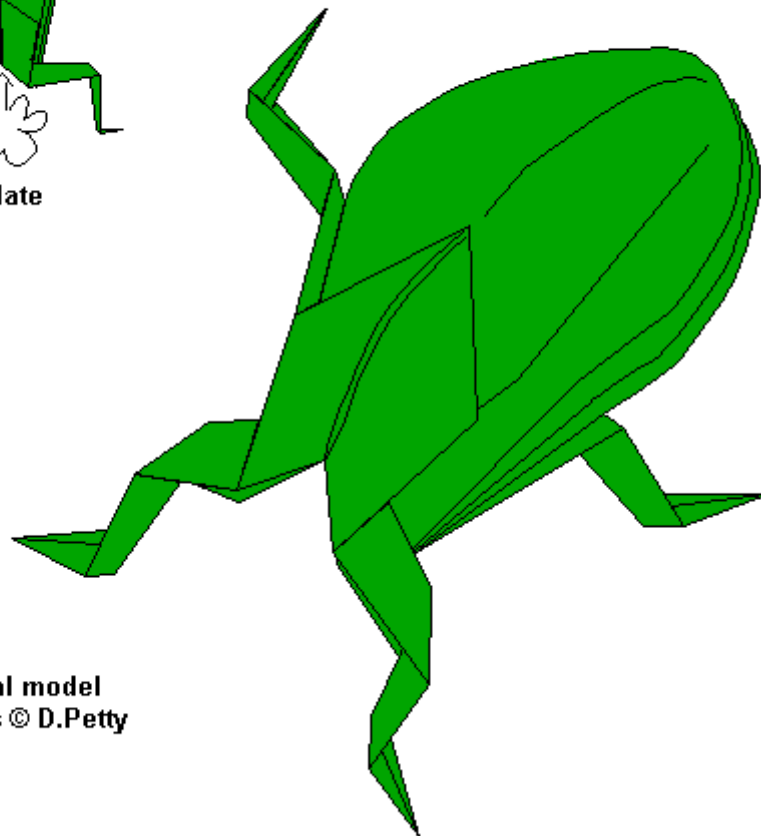

**traditional model
diagrams © D.Petty**



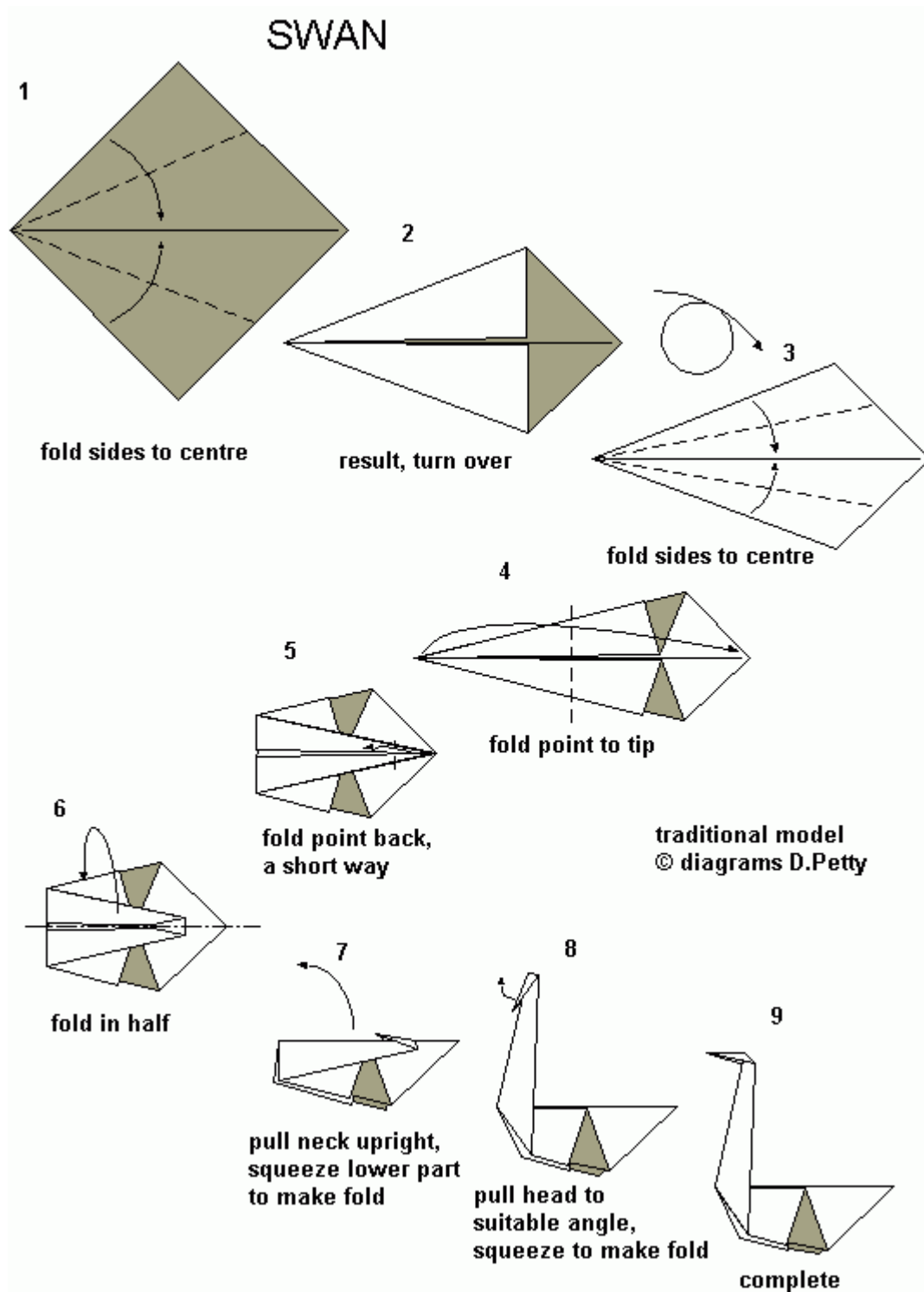

BIRD

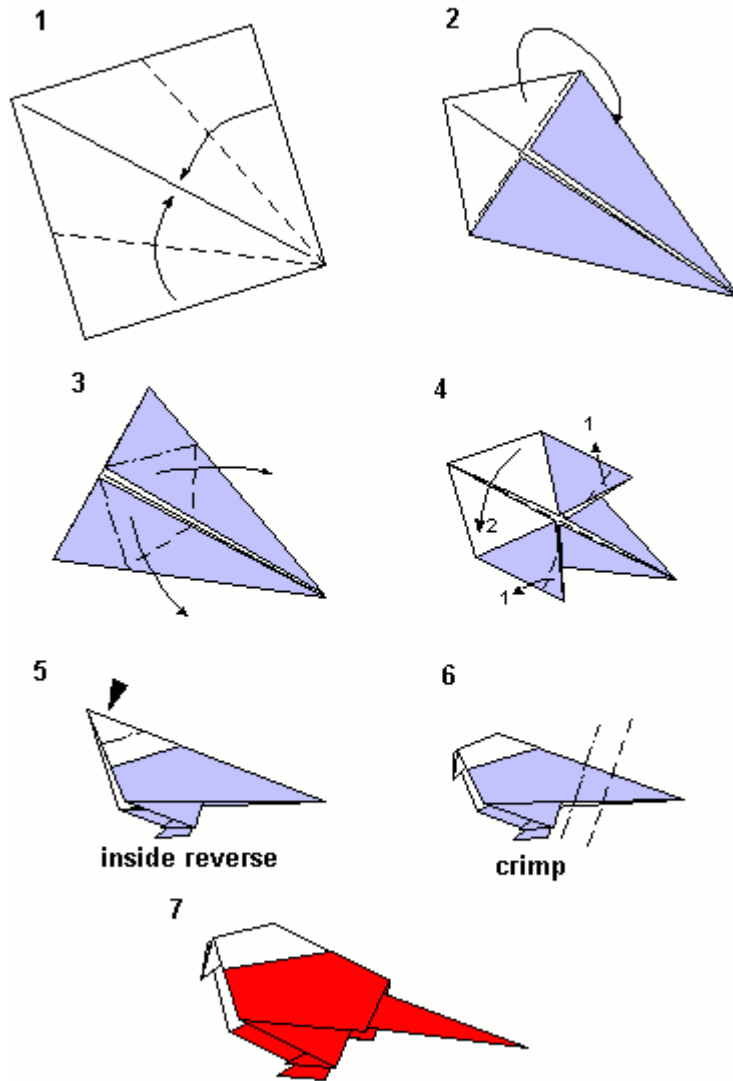

inside reverse

crimp

Model for Aug '99

traditional model
© diagrams David Petty



PARAKEET traditional model diagrams © D.Petty

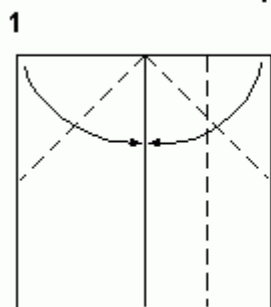

1
fold corners to
centreline

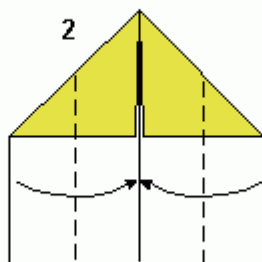

2
fold sides to
centreline

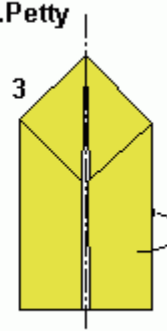

3
fold in half

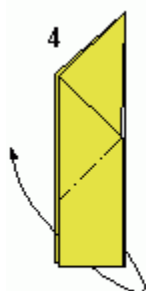

4
inside reverse
fold

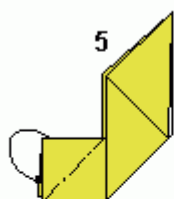

5
inside reverse
fold

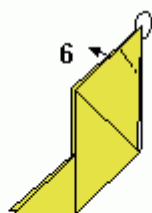

6
inside reverse
fold,
rotate



7
complete



FLAPPING BIRD

THE best known classic traditional model

© diagrams D.Petty

start - birdbase

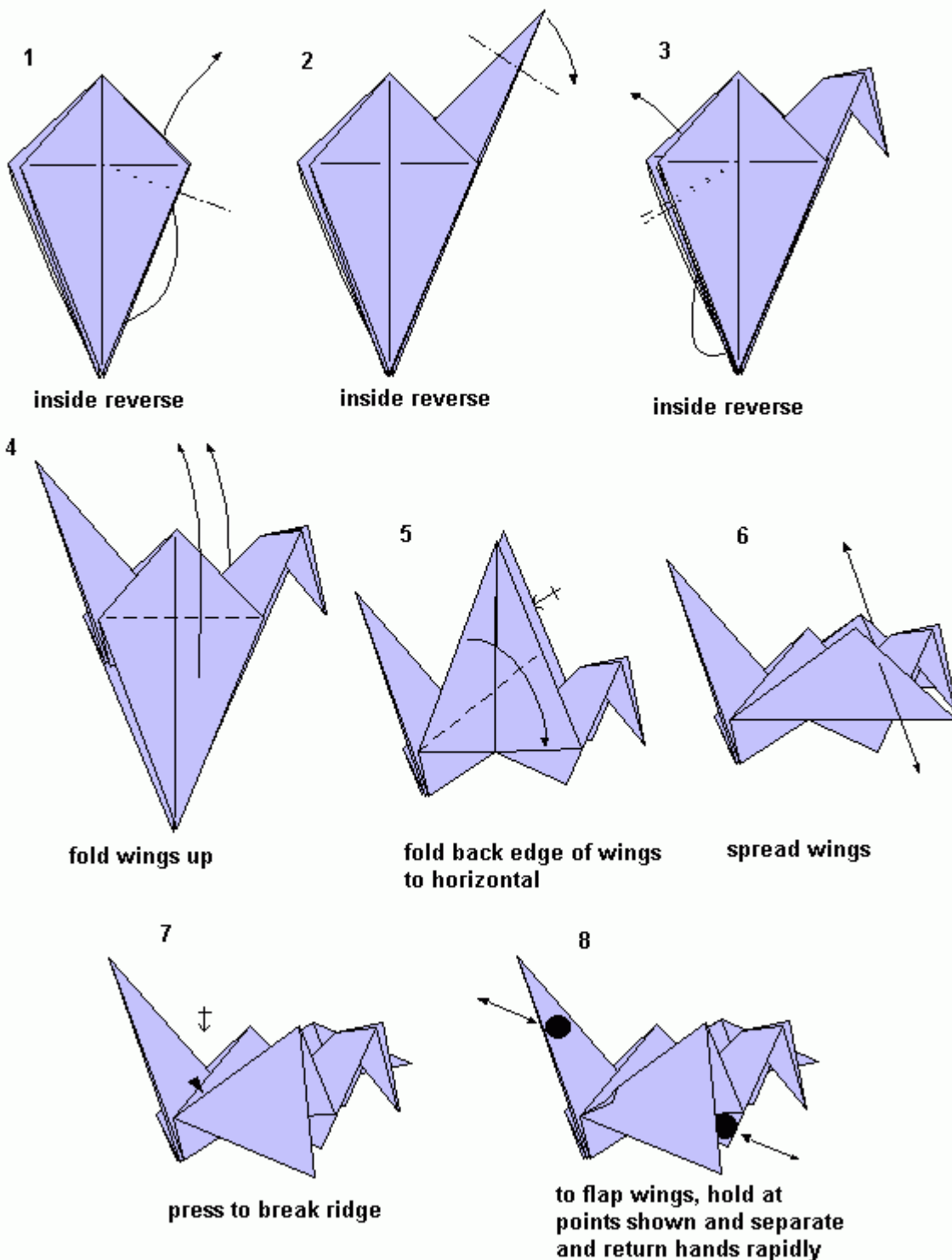

DRINKING BIRD

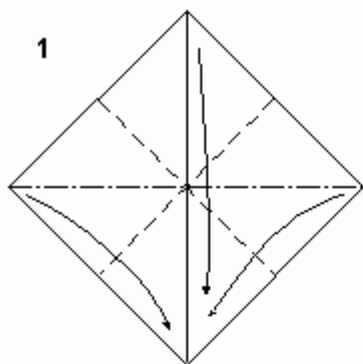

1 fold preliminary base

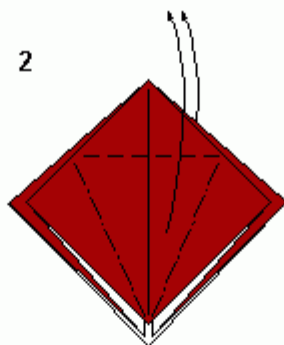

2 fold birdbase

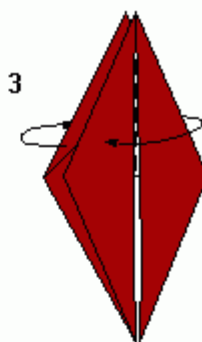

3 bookfold

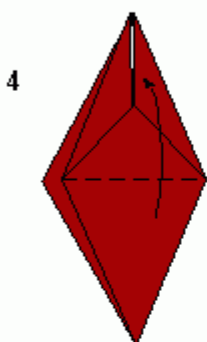

4 valley lower flap

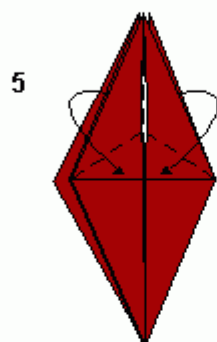

5 rabbit-ear top layer

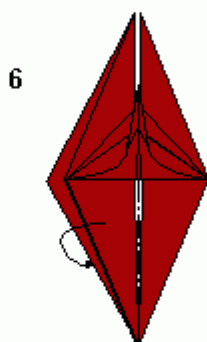

6 fold in half, rotate

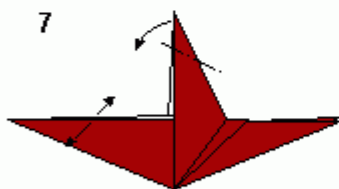

7 inside reverse head, widen out drinking trough

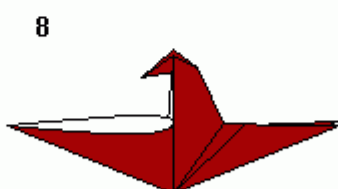

8 complete

traditional model diagrams © D.Petty

Operation

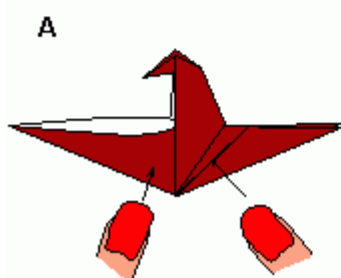

A grip under bowl with one hand, push thumb and forefinger under layer shown with other hand

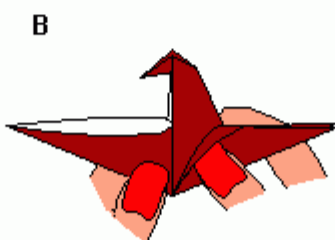

B push up the righthand layers

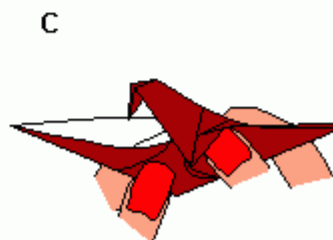

C -- the bird drinks, return to start position to repeat action



PIGEON/DOVE

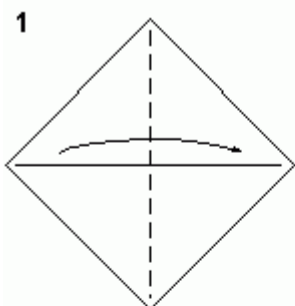

1
crease vertical centreline
then fold in half

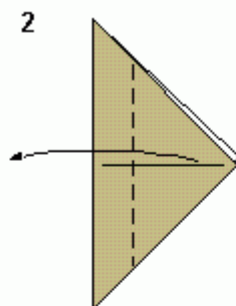

2
fold approx. 2/3

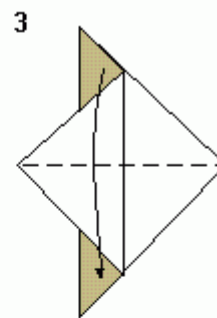

3
fold in half

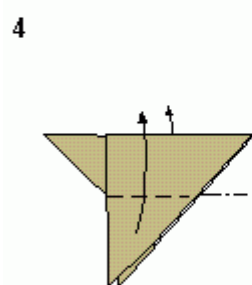

4
fold up wings,
front and back

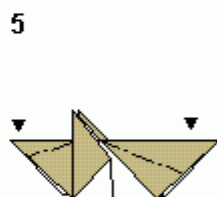

5
inside reverse to form
beak and tail

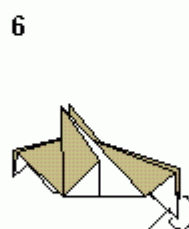

6
fold tip of tail inside

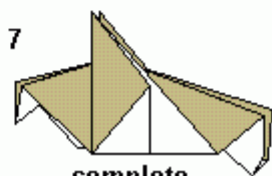

7
complete

traditional model
diagrams © D.Petty



OWL

start with birdbase

1

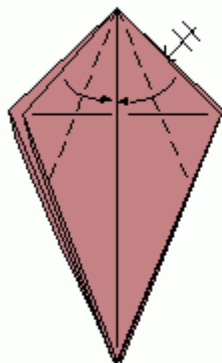

fold edges to centre,
repeat at back

2

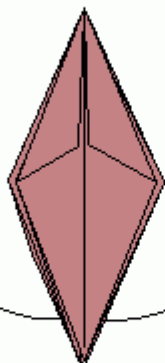

lift and twist flaps
to form wings

3

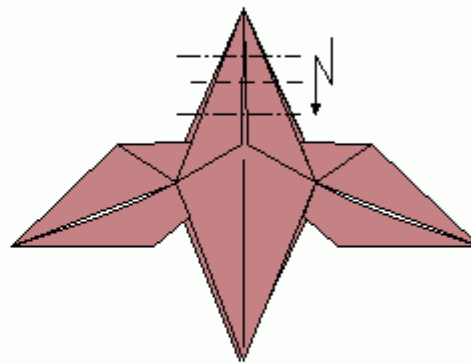

form head

4

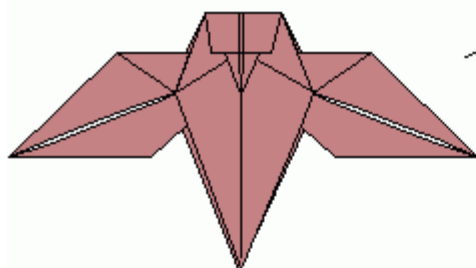

result, turn over

5

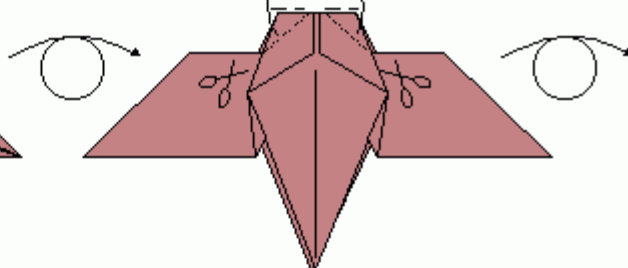

cut layer at back of head,
then fold up flaps
turn over

6

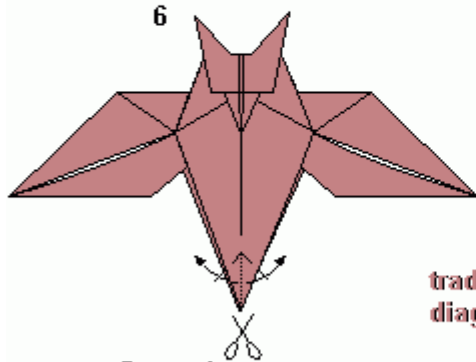

cut top flap only,
along centre,
fold out new flaps
to form feet

7

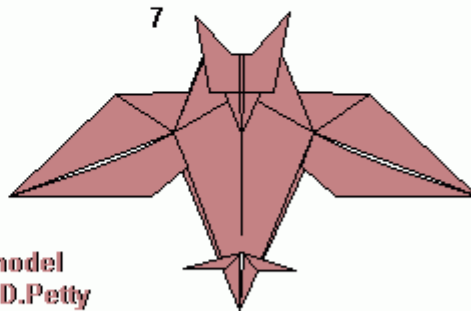

complete

traditional model
diagrams © D.Petty



EGG LAYING HEN

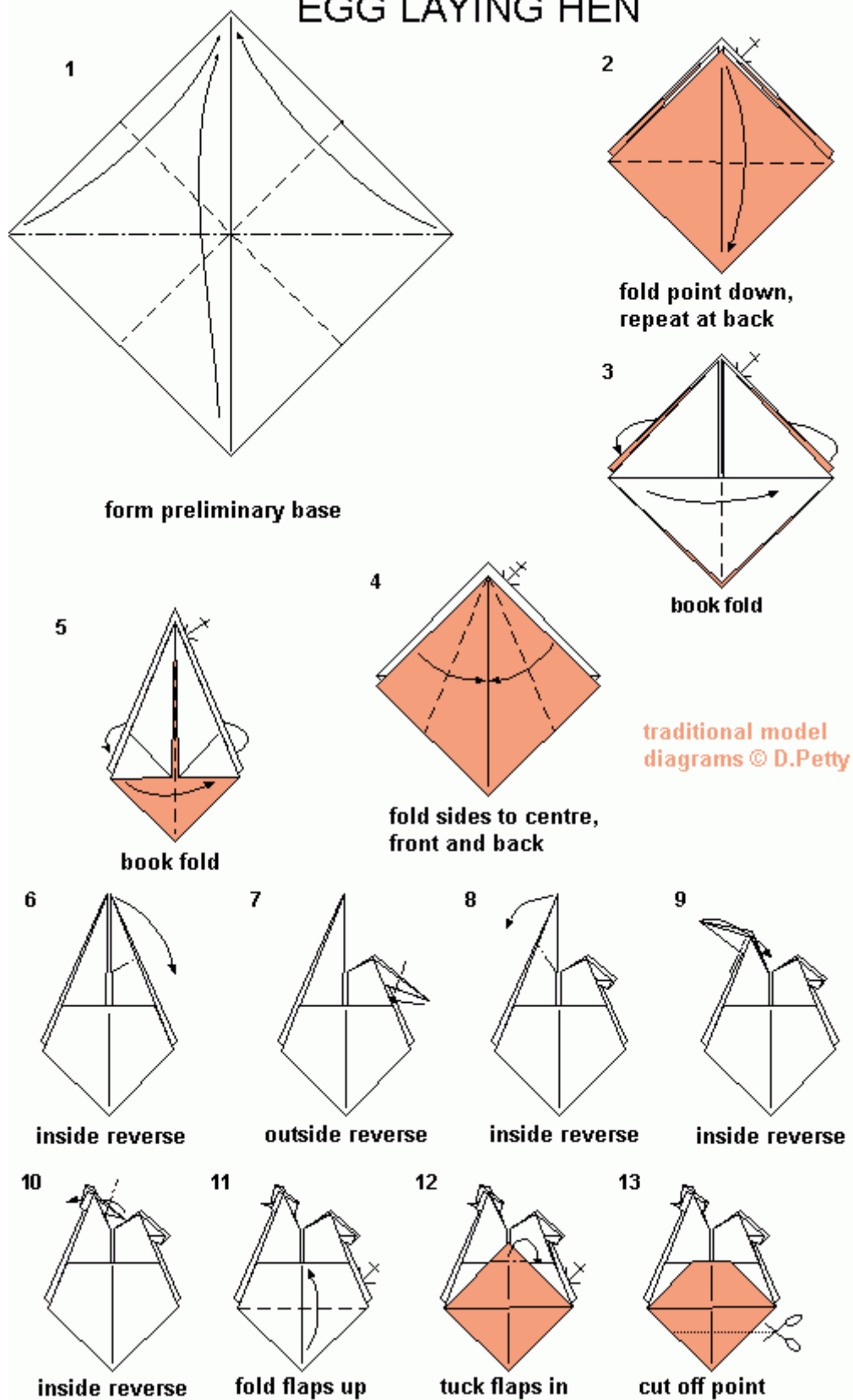

14 use cut off point

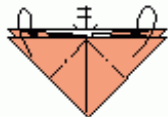

fold corners between layers, front and back

15



egg complete

16

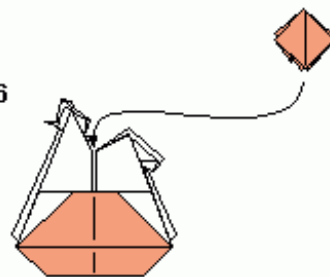

slide egg between flaps

17a

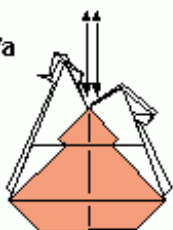

17b

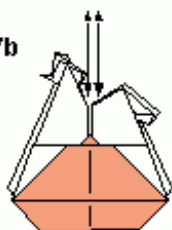

17c

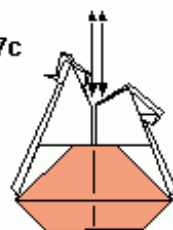

17c

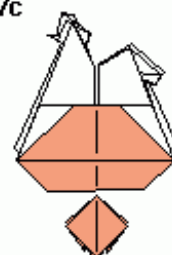

work flaps up and down work flaps up and down work flaps up and down

egg emerges



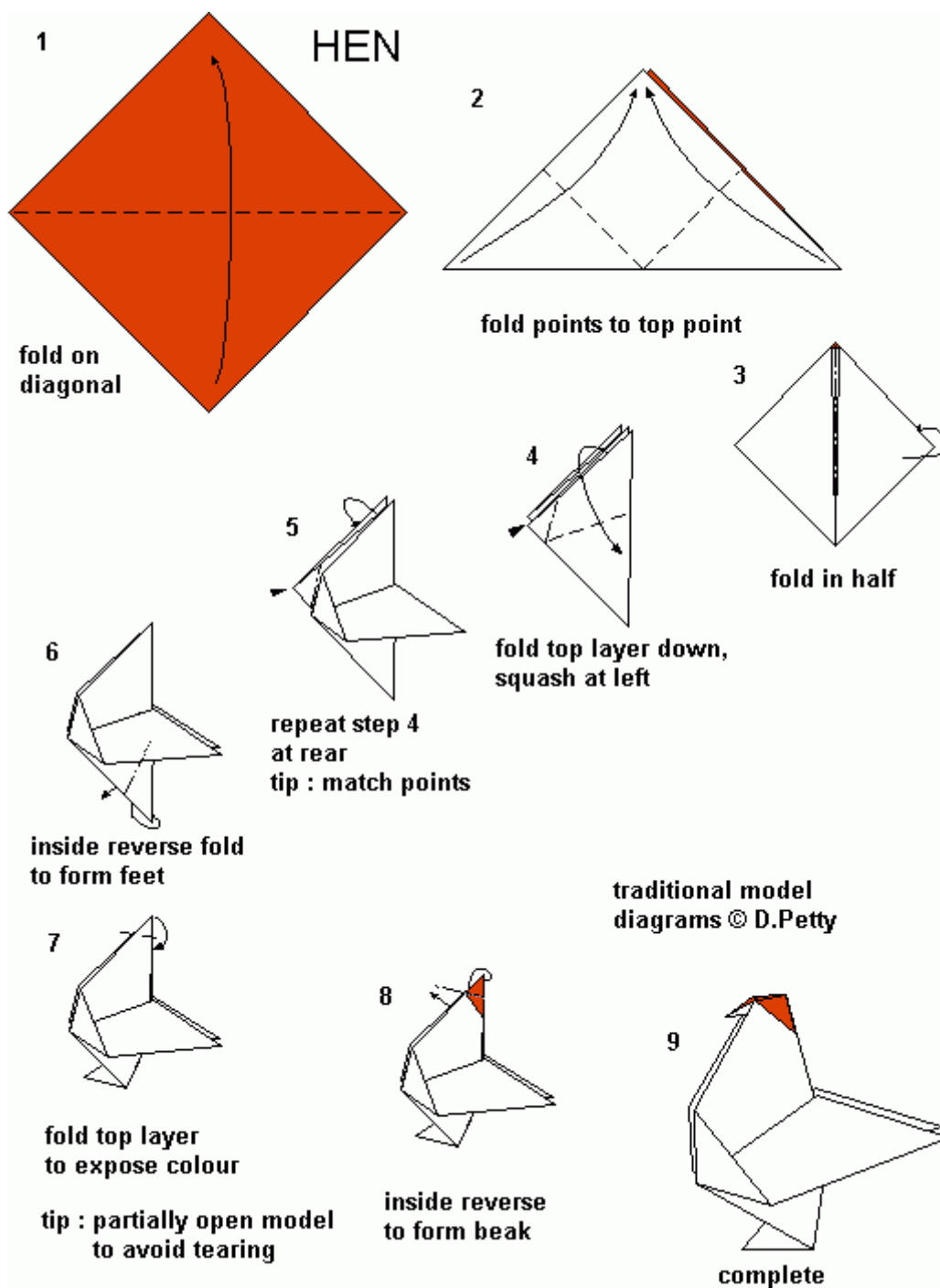

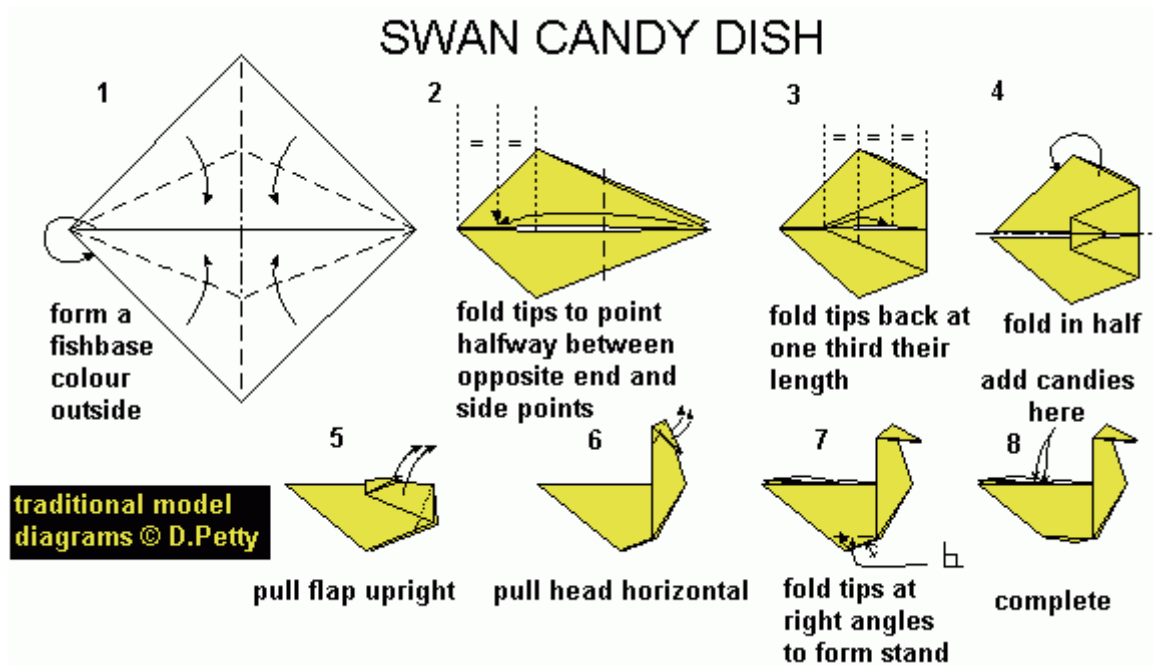

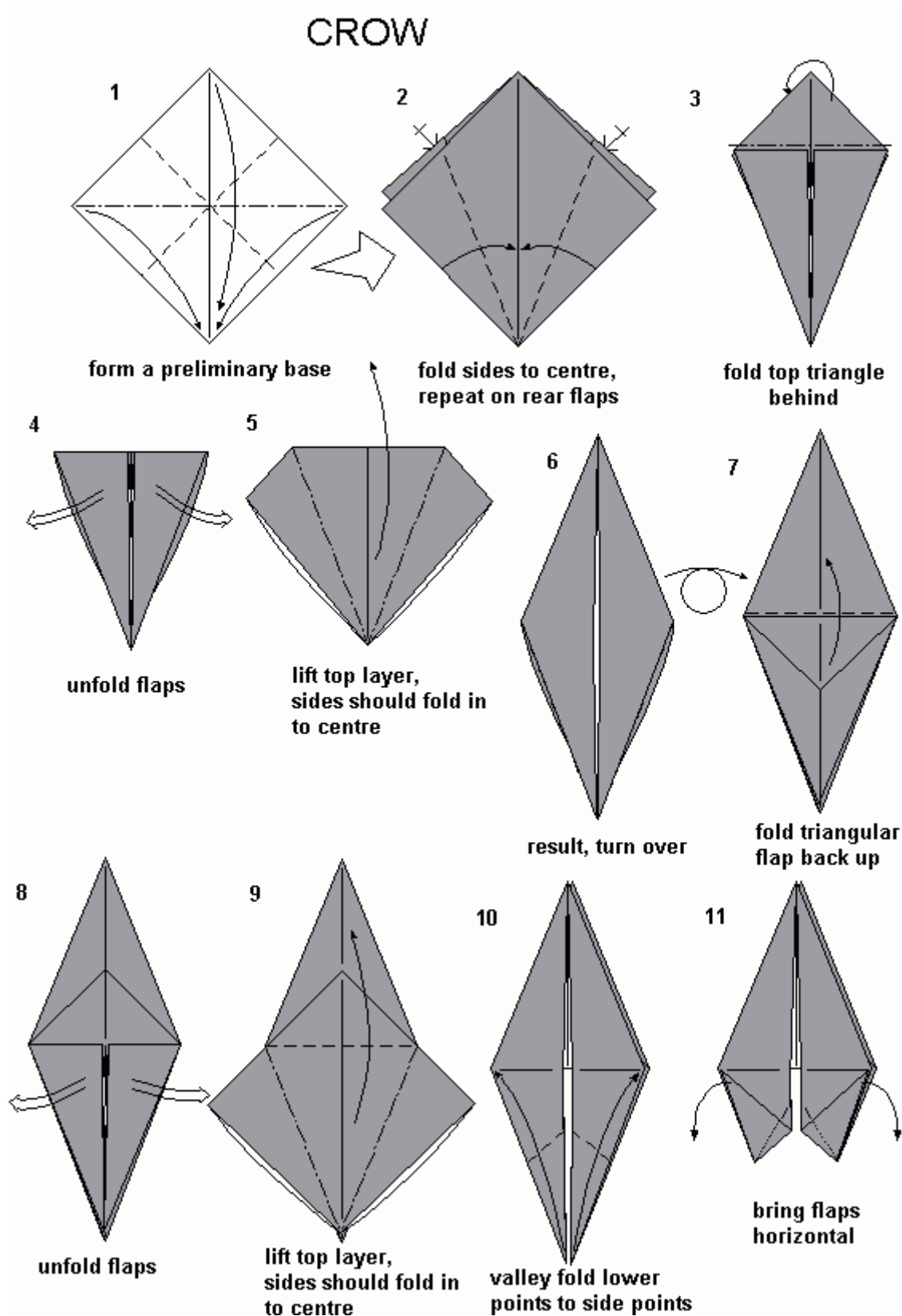

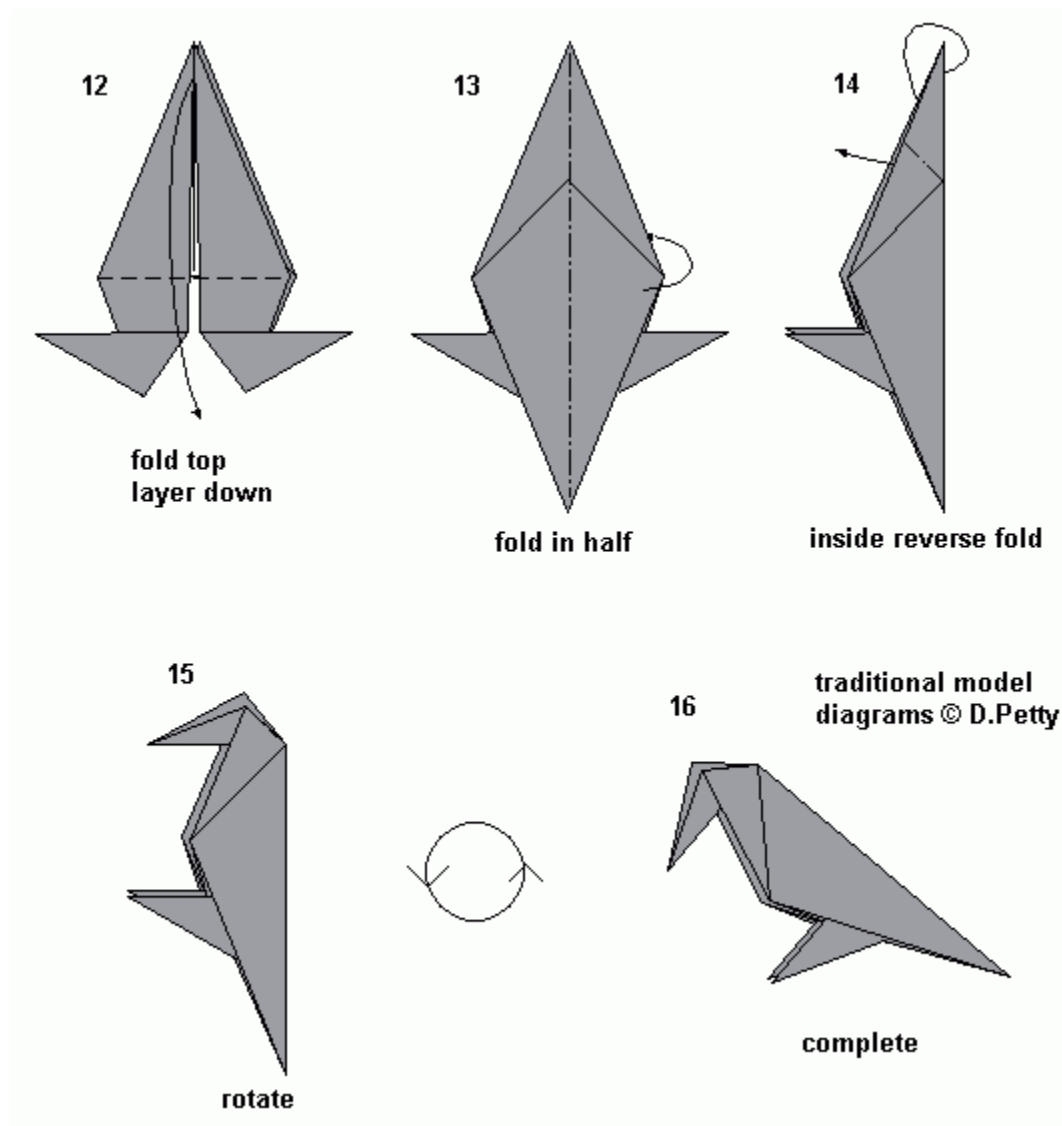

Tip: use thin paper.

PHOENIX

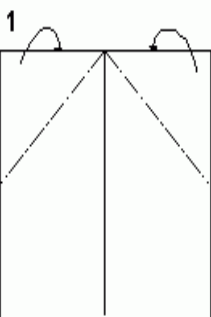

1
fold corners to rear

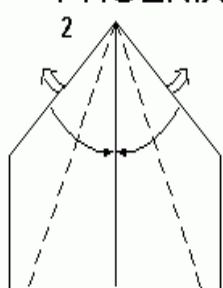

2
fold folded edges to centreline, allow rear flaps to flip to front

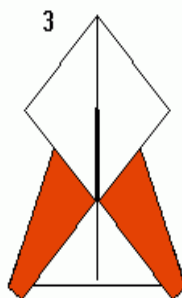

3
result, turn over

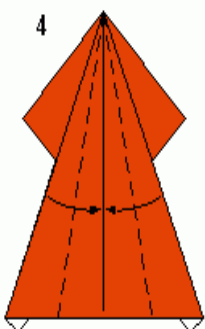

4
fold edges to centreline

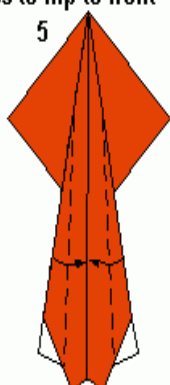

5
fold edges to centreline, note creases do not go to top point

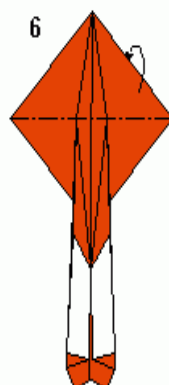

6
fold top triangle to rear

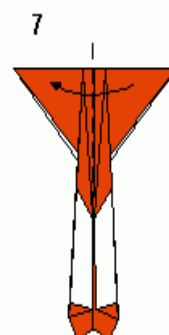

7
fold in half

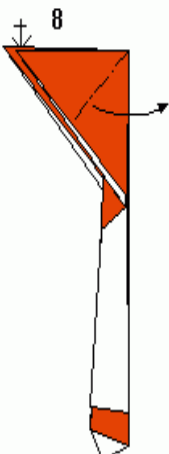

8
squash, repeat at rear

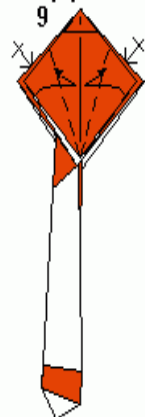

9
fold edges to centre and return

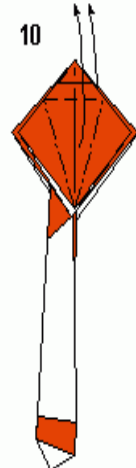

10
petal fold, front and back

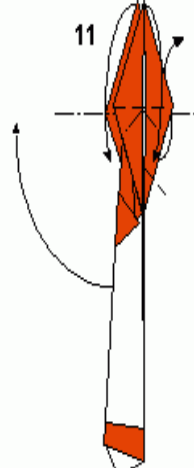

11
inside reverse fold lower flaps, then fold wings down to the horizontal

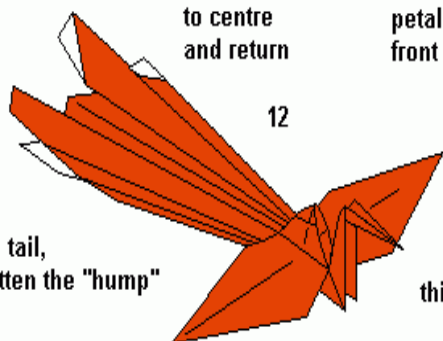

12
spread the tail, slightly flatten the "hump"

Japanese traditional model diagrams © D.Petty

this is a close relative of the "Crane"



HERON

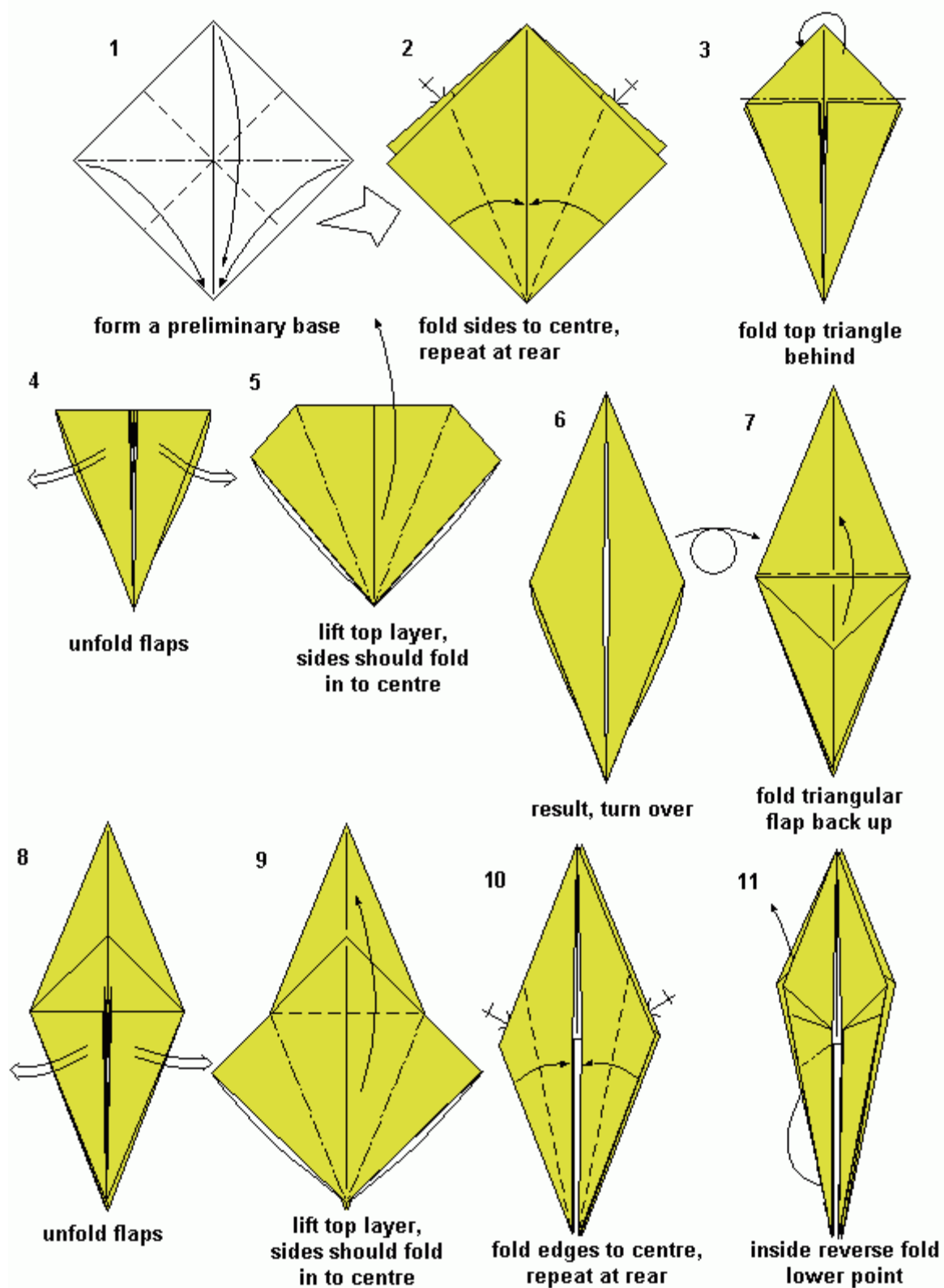

CRANE probably the second best known model in the world

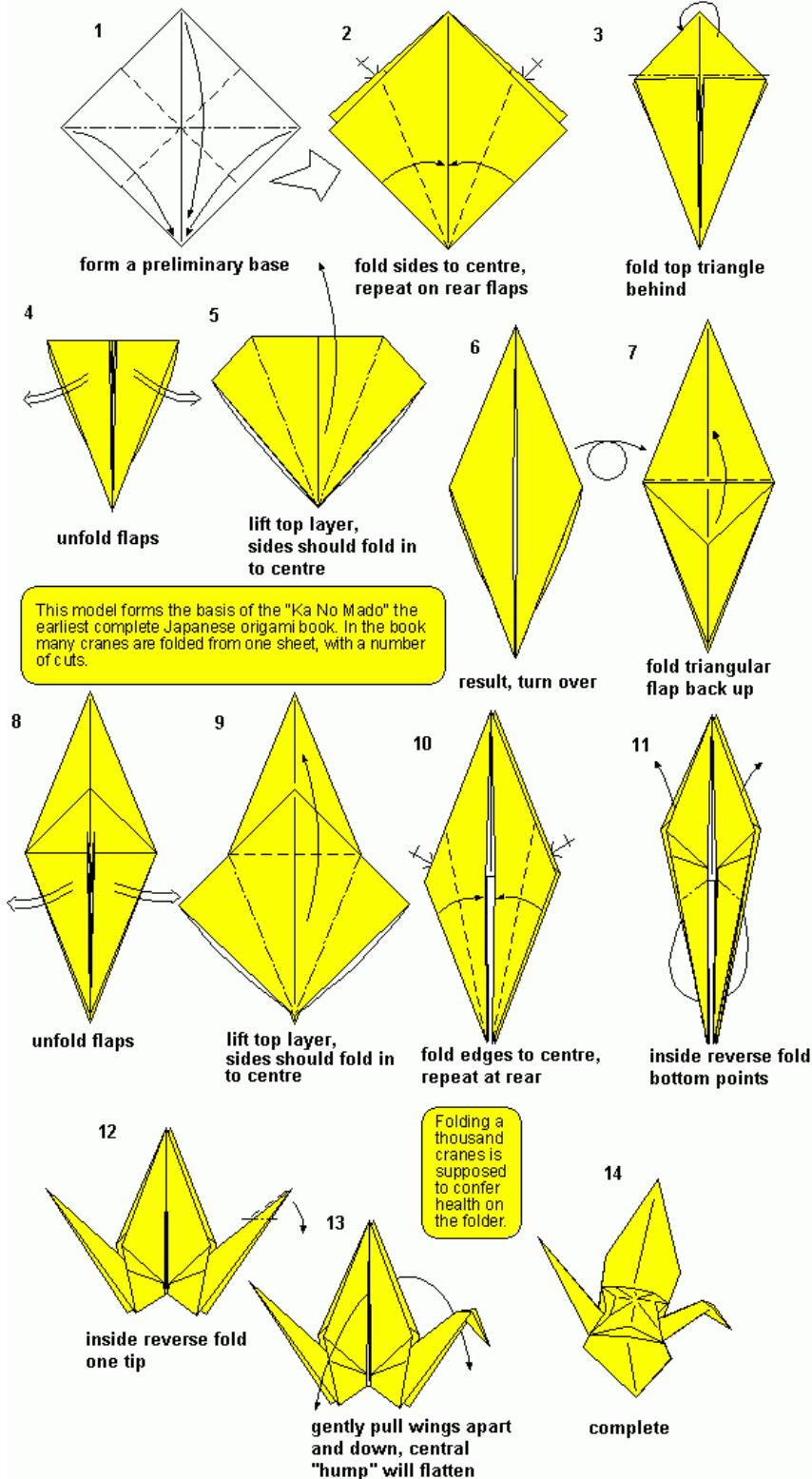

This model forms the basis of the "Ka No Mado" the earliest complete Japanese origami book. In the book many cranes are folded from one sheet, with a number of cuts.

Folding a thousand cranes is supposed to confer health on the folder.

Each year thousands of crane models are sent to the peace park in Hiroshima, Japan, to commemorate the dropping of the first atom bomb. The crane has now become a symbol of peace.

Traditional Japanese model
Diagrams © D.Petty



TULIP AND LEAF

1

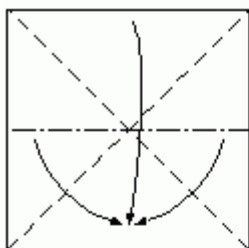

form waterbomb base

2

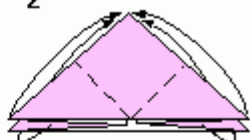

fold corners to top point, swing flap over repeat at rear

3

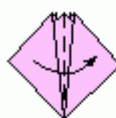

4

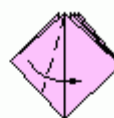

fold flap over

5



fold flap over and tuck in

6

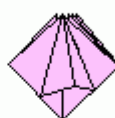

repeat steps 4-5 at rear

7



peel back the four flaps and inflate the base

8



bloom complete

Thai traditional model diagrams © D.Petty

1

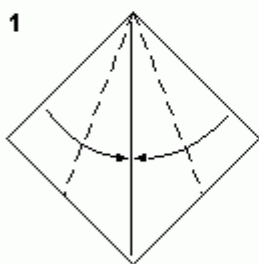

fold sides to centre

2

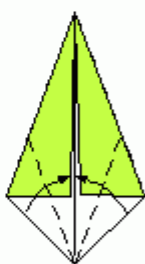

fold sides to centre

3



fold sides to centre

4



result, turn over



5

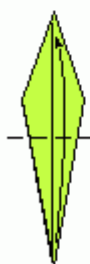

fold in half

6



fold in half

7



peel back outer leaf, add bloom

8

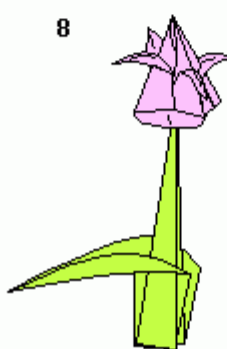

WATERLILY

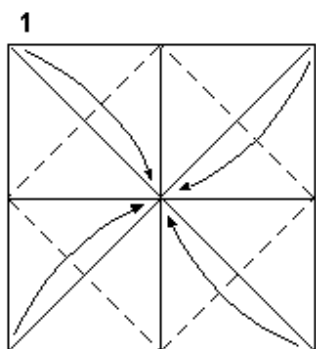

blintz

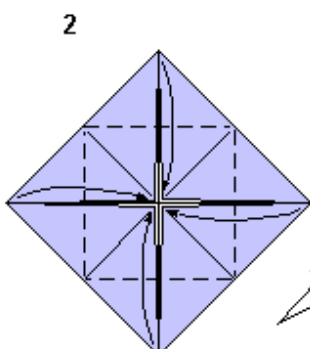

blintz

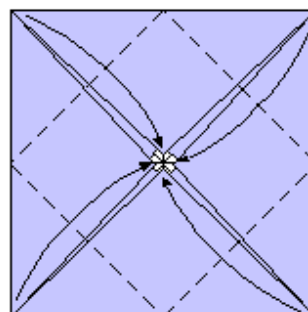

blintz

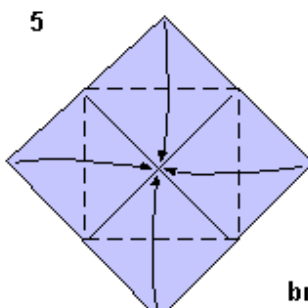
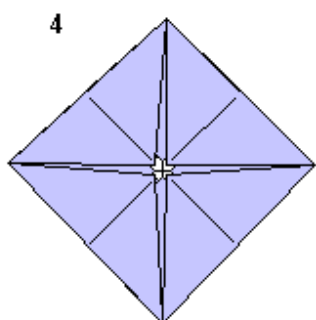

blintz

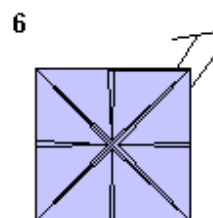

bring corner round to front (the adjacent flaps have to be partially opened to allow this without tearing the paper)

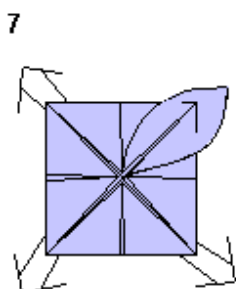

repeat step 6 on remaining corners

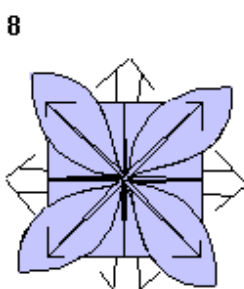

pull more corners from back

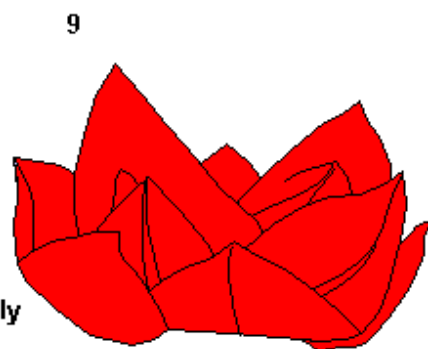

a glass, open end down, can be used to form the lily
it holds the central flaps and acts as a template
this technique is best left for cloth
serviettes

Oct '99 model of the month

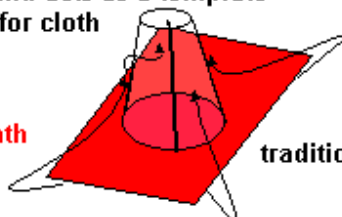

traditional model © diagrams David Petty



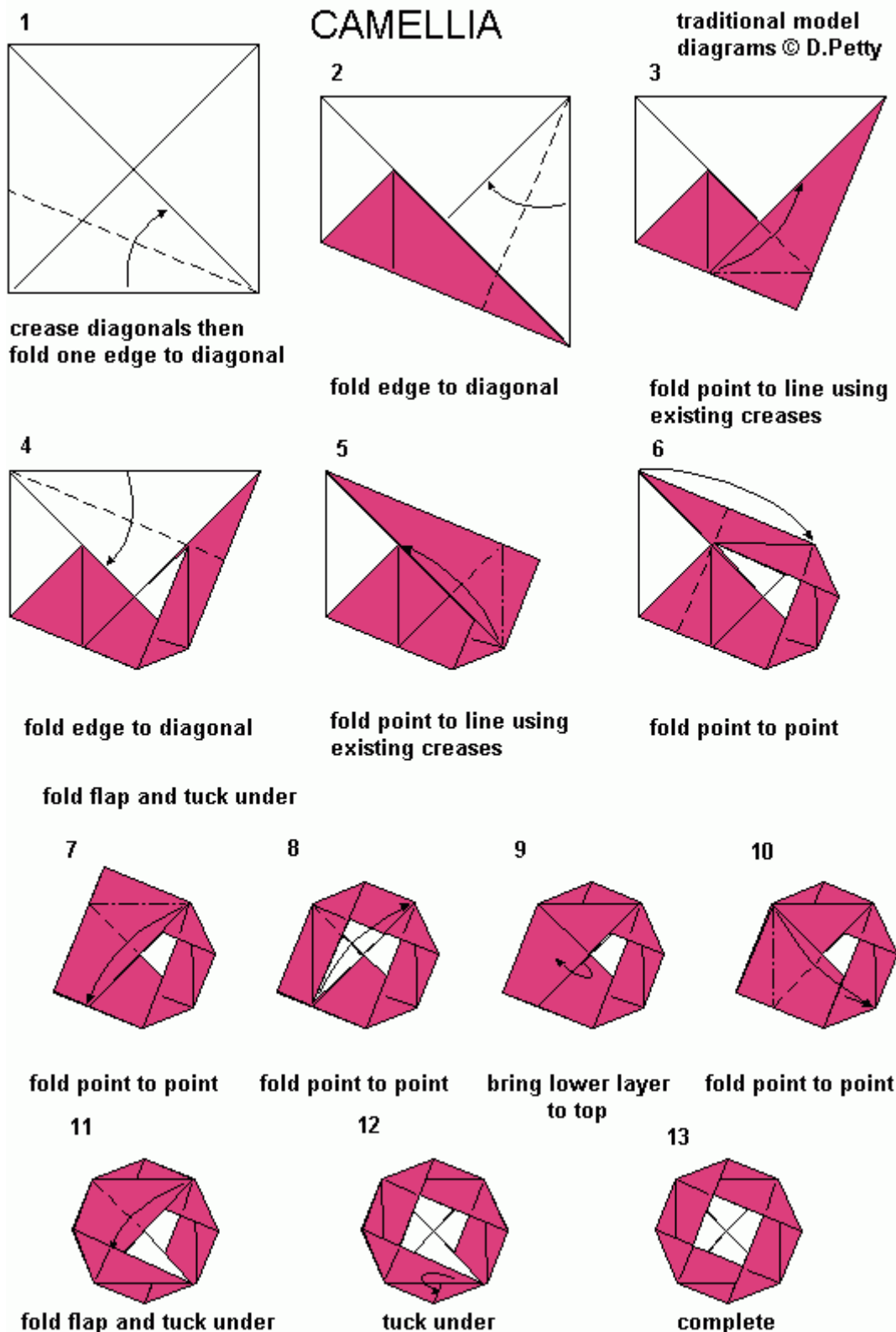

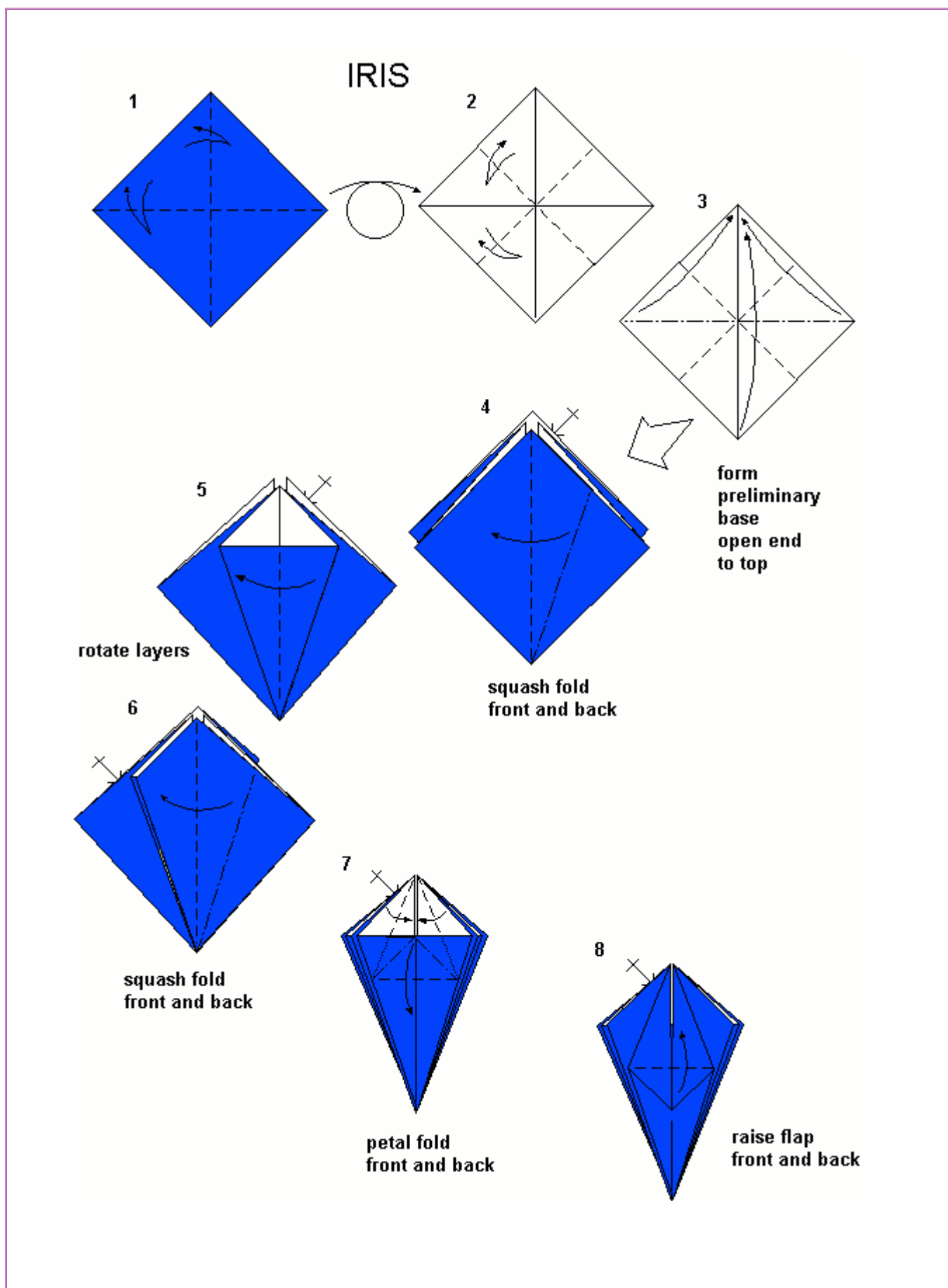

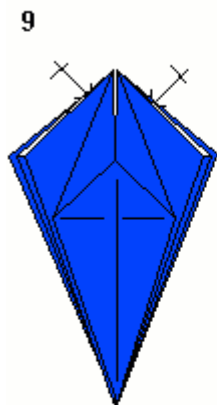

9
repeat petal fold
on side flaps

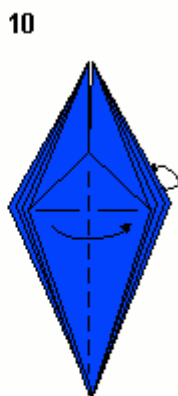

10
rotate layers

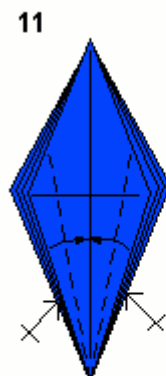

11
fold sides to centre
front and back

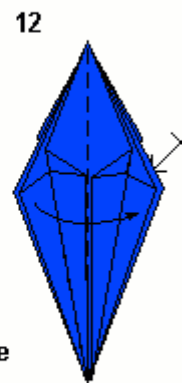

12
rotate layers

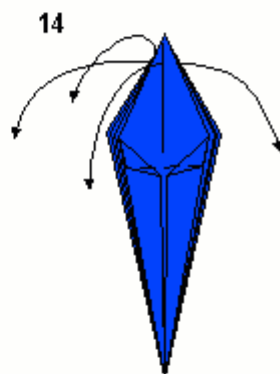

14
fold flaps down

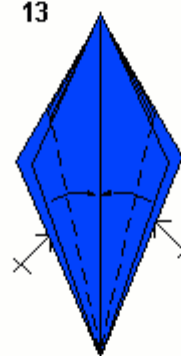

13
fold sides to centre
front and back

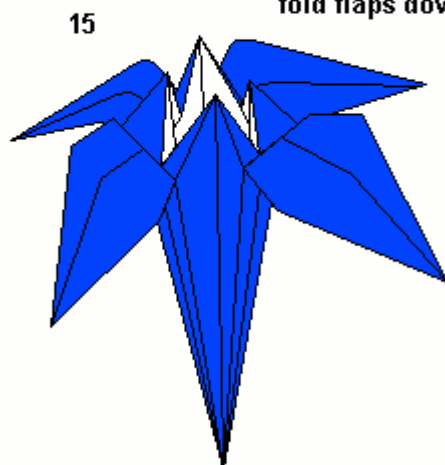

15

traditional model
© diagrams D.Petty



MULTIBOX folds from square or any rectangle

1

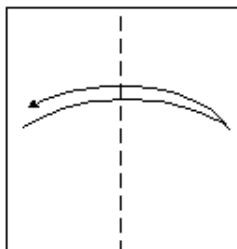

2

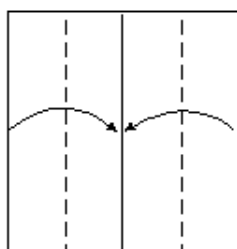

3

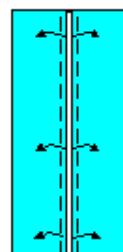

4

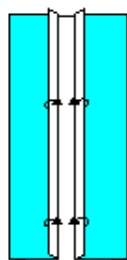

5



6

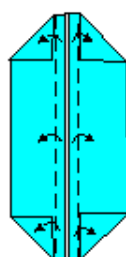

7

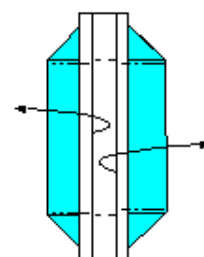

lift flaps and
form box

8

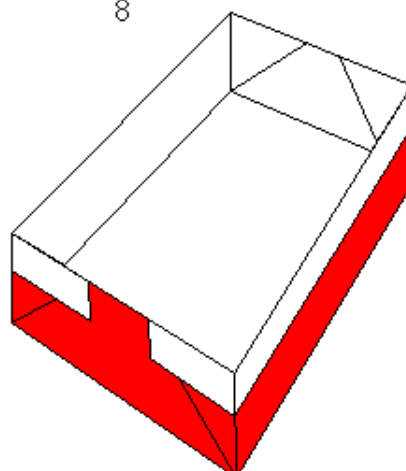

Traditional model
© diagrams D.Petty

December '98

This is your Christmas box!



SIMPLE BOX

In Japan this model is known as "Masu Box" = measuring box

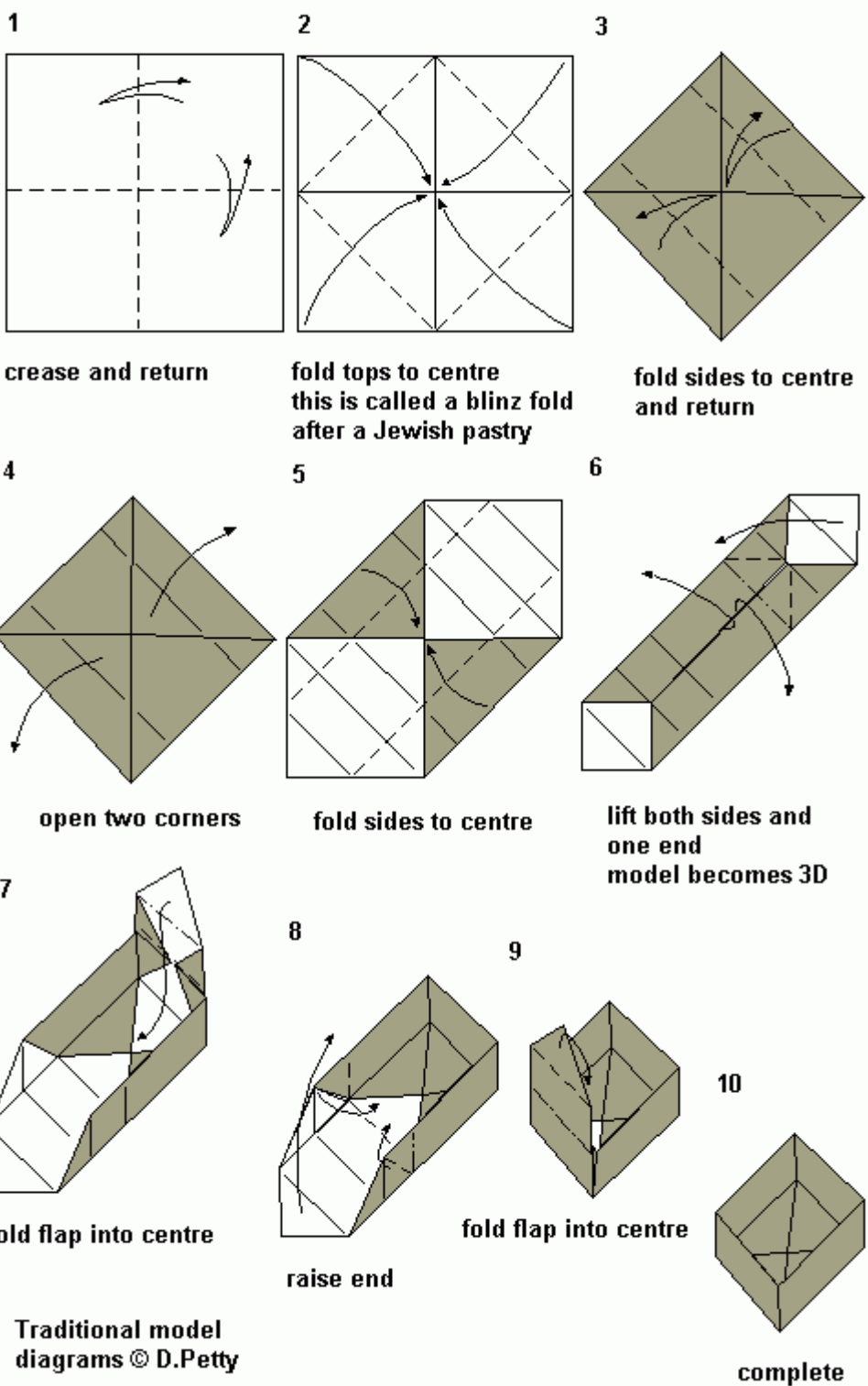

SANBOW

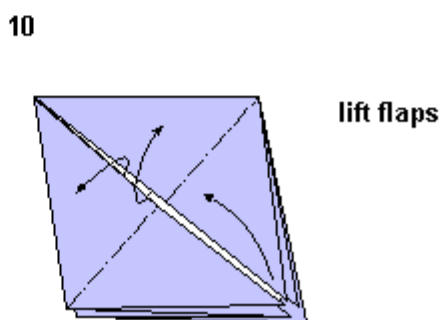
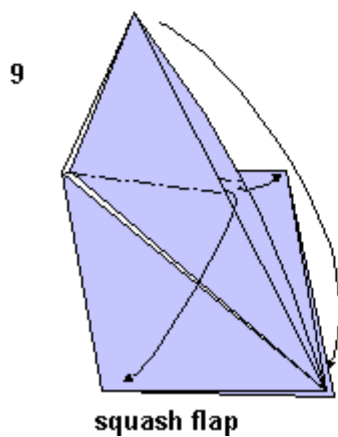
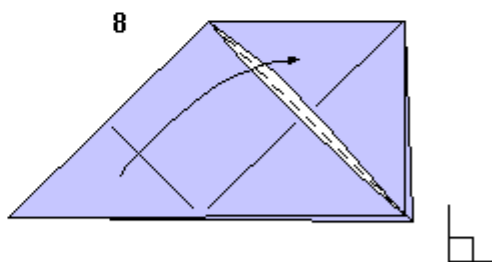
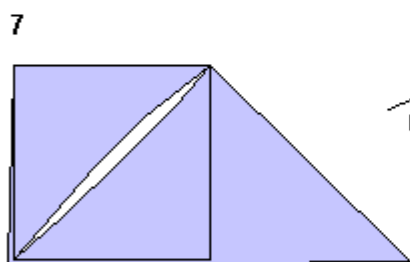
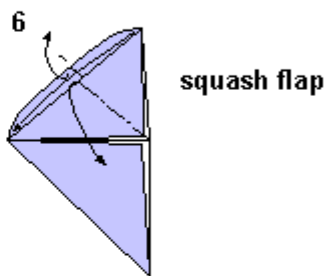
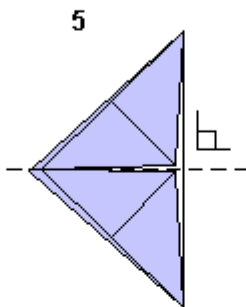
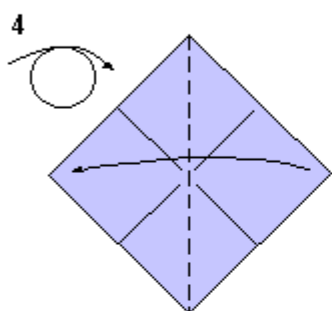
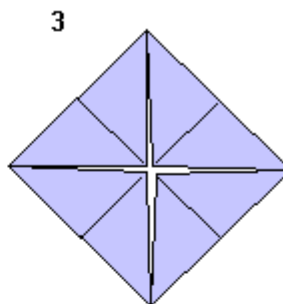
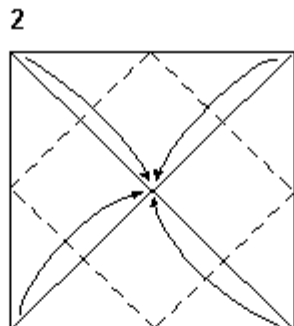
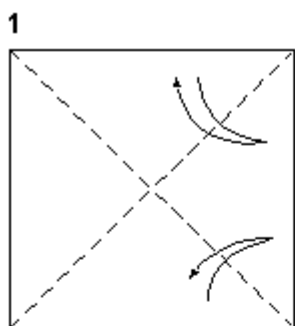

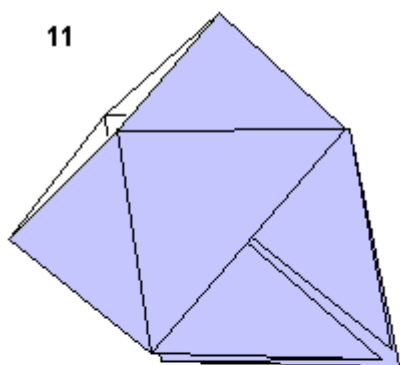

11

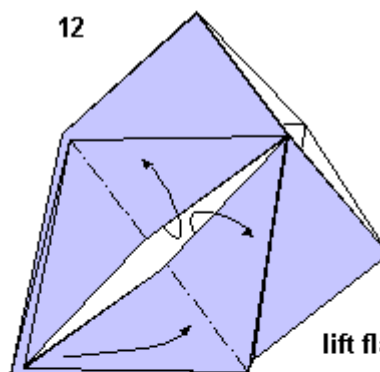

12

lift flaps

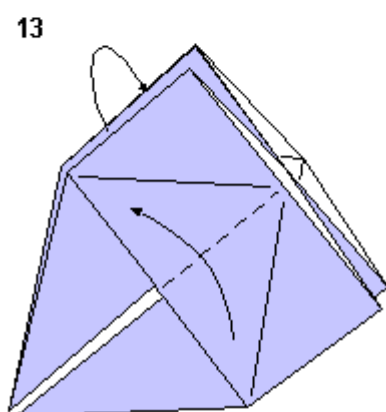

13

book fold

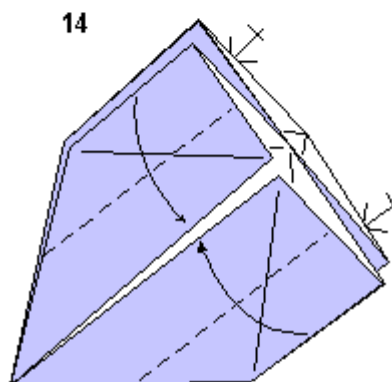

14

fold sides to centreline

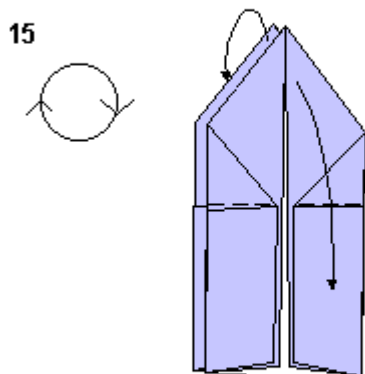

15

fold flaps down

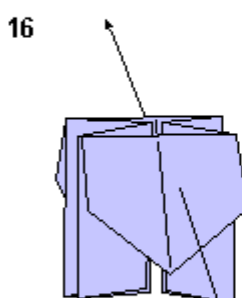

16

pull flaps to open out

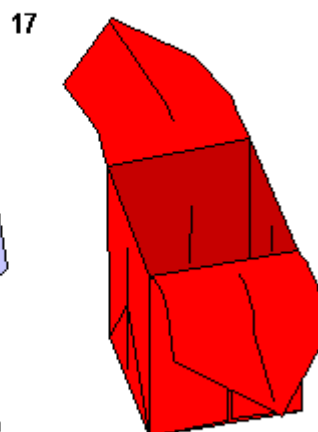

17

traditional model
© diagrams D.Petty



STAR BOX

Traditional model
diagrams © D.Petty

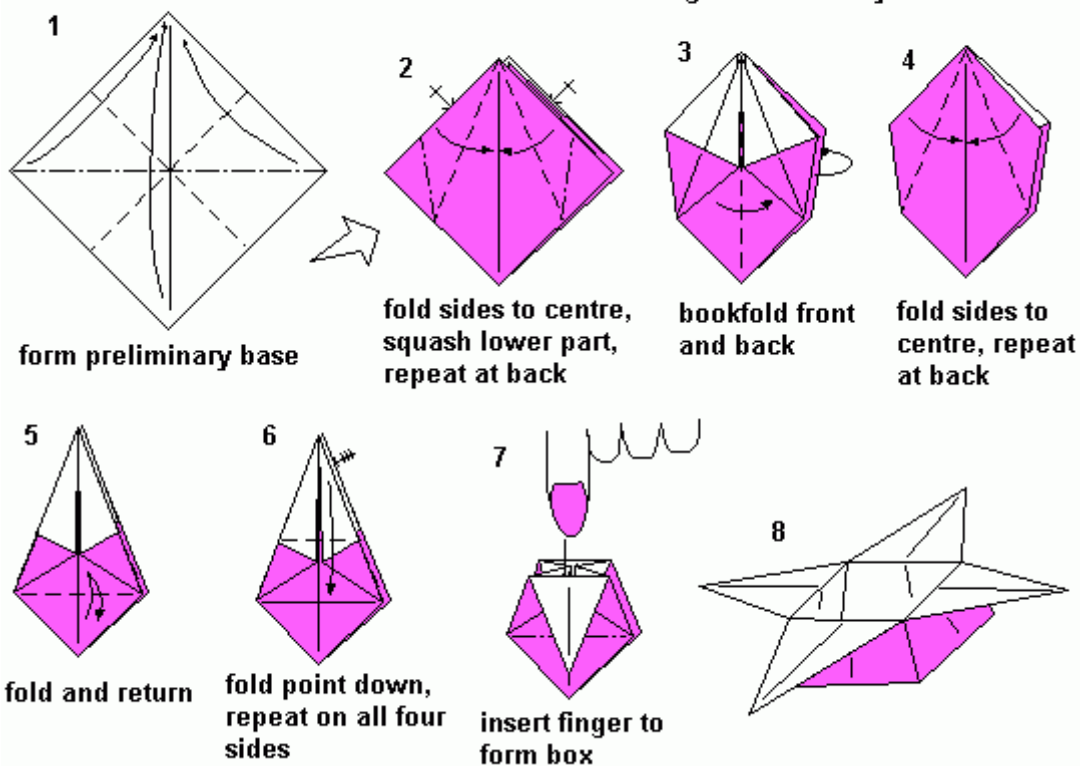

TABLE

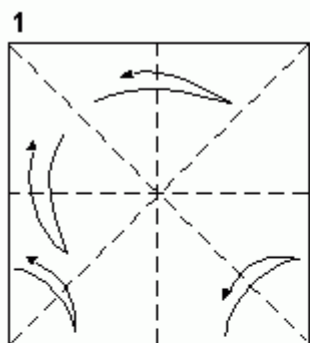

1
precrease

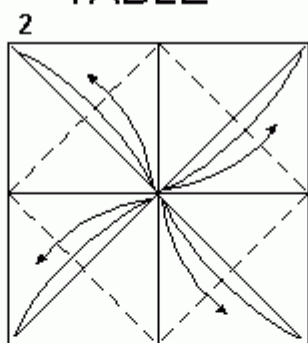

2
precrease

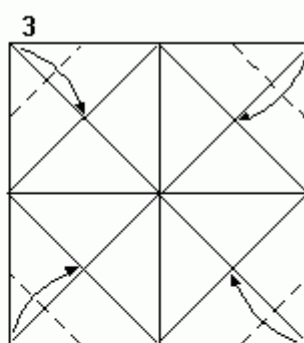

3
fold tips to existing creases

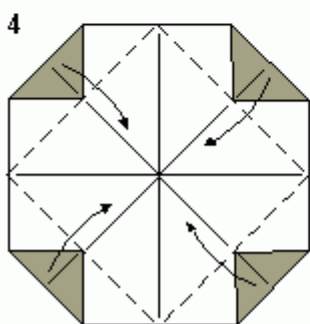

4
fold on existing creases

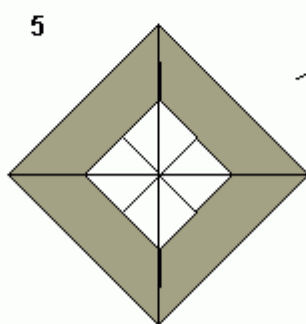

5
result, turn over

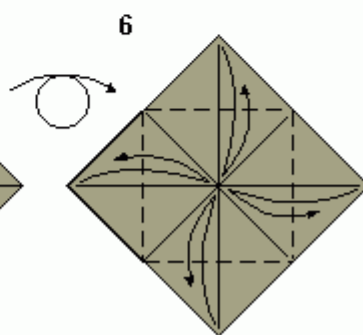

6
precrease

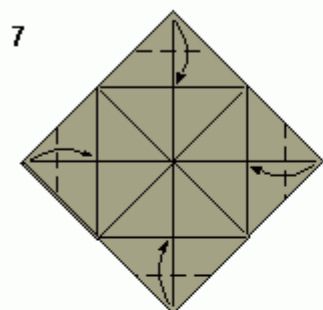

7
fold tips to existing creases

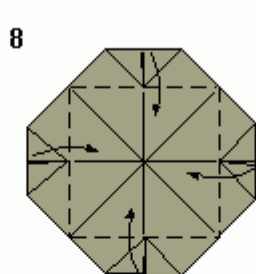

8
fold on existing creases

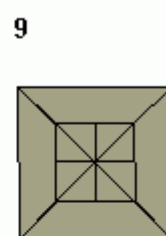

9
result, turn over

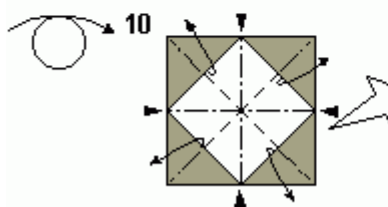

10
squeeze in at centres of sides, while lifting top flaps

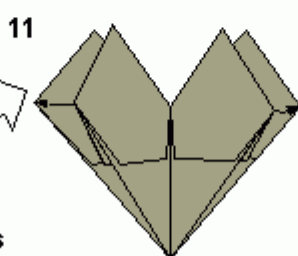

11
enlarged view, flatten symmetrically

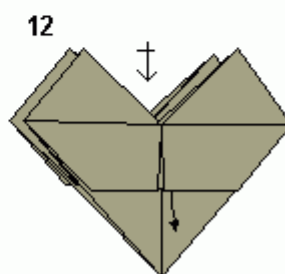

12
pull down hidden triangles front and back only



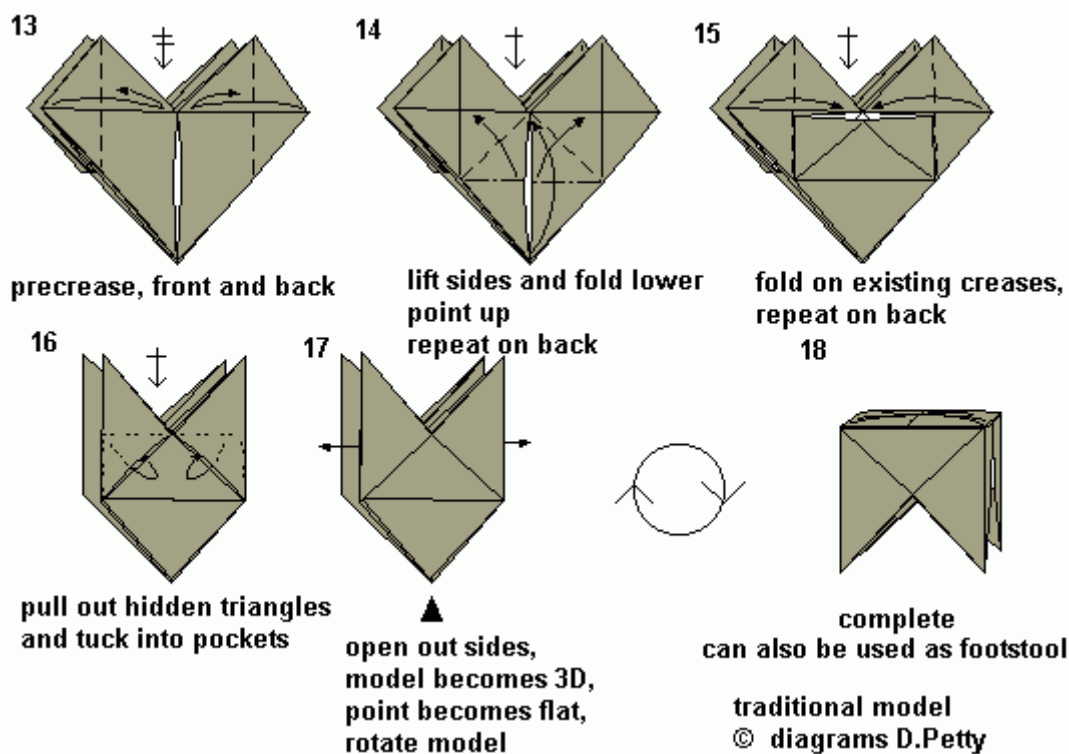

PIG

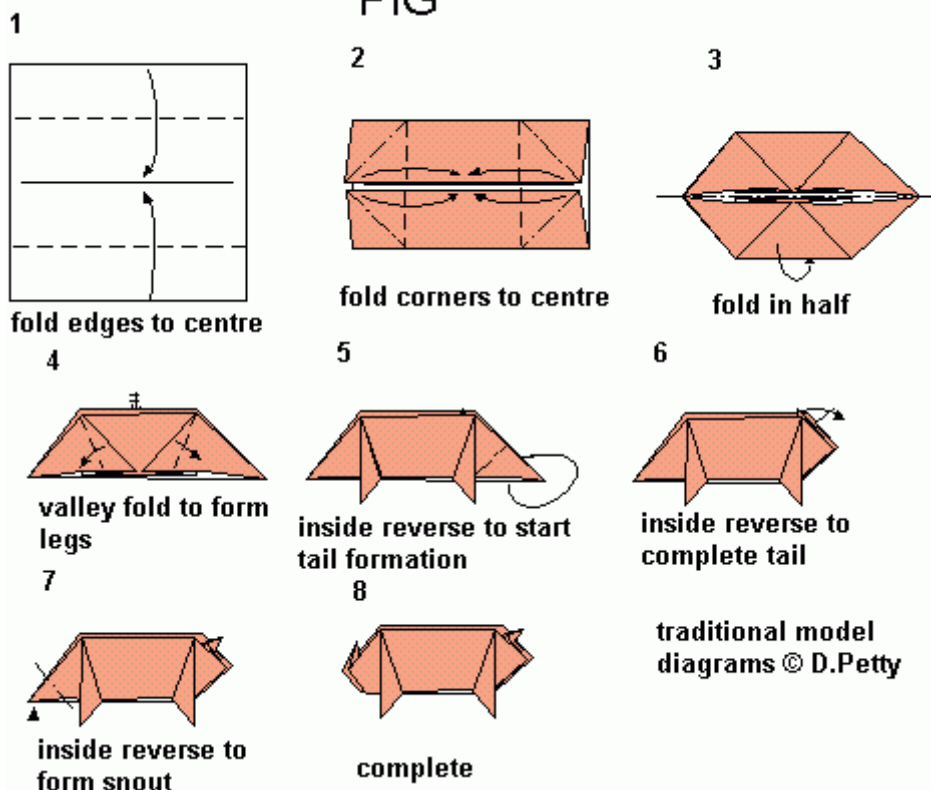

SAILBOAT

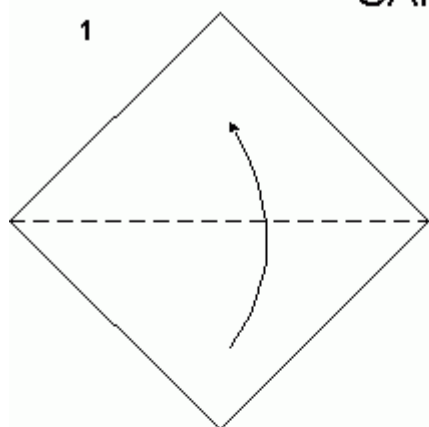

fold in half on diagonal

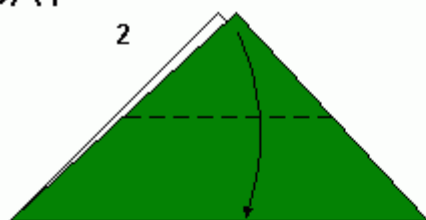

fold points to centre of bottom edge

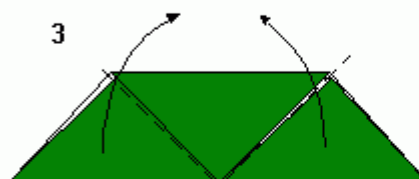

fold triangles up

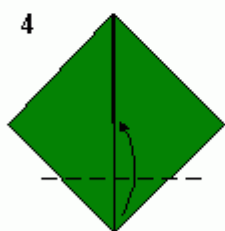

fold bottom corner to centre

traditional model
© diagrams D.Petty

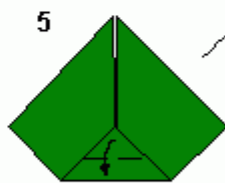

fold tip down,
turn over

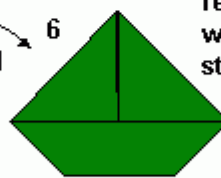
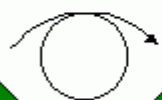

rear triangle
will form a
stand

see if you can rearrange the
folds to get white sails

this model is the logo of
Origami USA

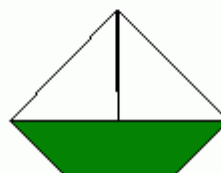

solution
next page



SAILBOAT

start with unfolded sailboat

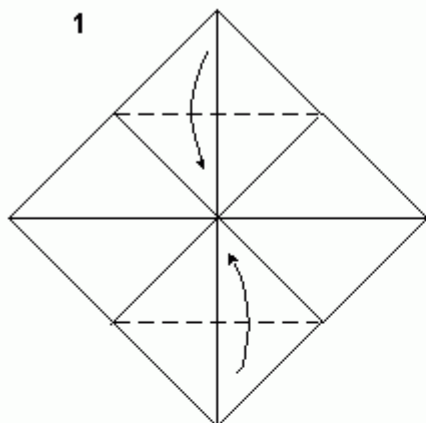

fold corners to centre

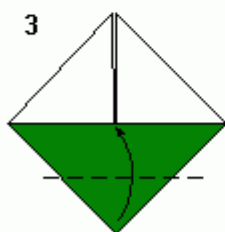
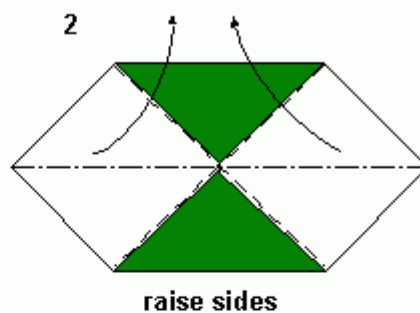

fold bottom corner to centre

traditional model
© diagrams D.Petty

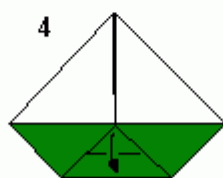

fold tip down,
turn over

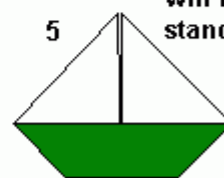

this model is the logo of
Origami USA



SAMPAN

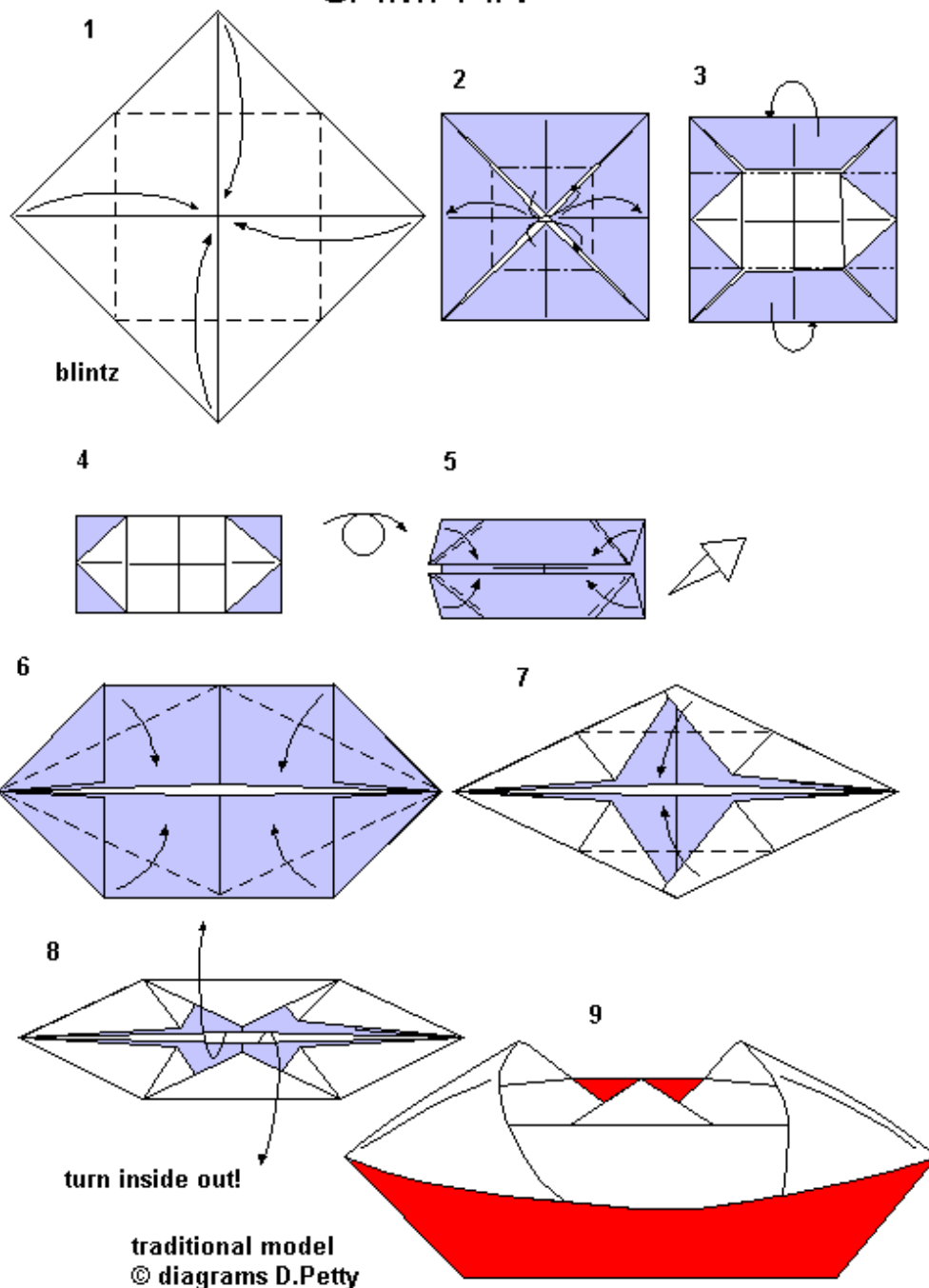

BOAT / SNAPPER

1

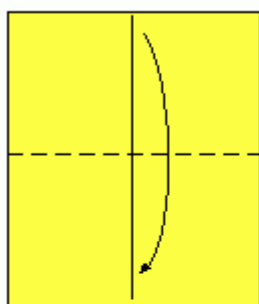

2

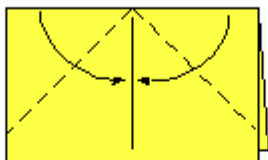

3

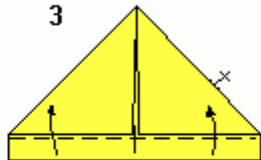

fold bottom edge up as
much as possible
do same at rear

4

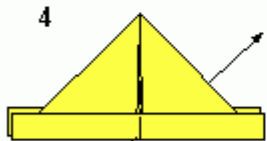

pull layers apart and
flatten

5

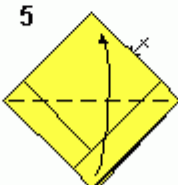

6

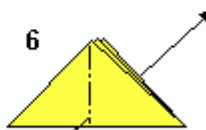

pull layers apart and
flatten

7

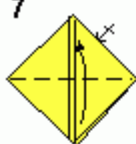

8



pull out inside
points

9

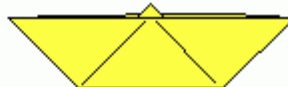

10

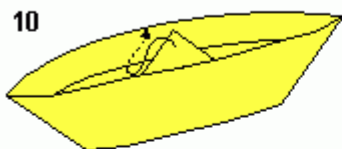

tuck sail under edge

11



pull sides apart
and make ends
meet using folds
as shown

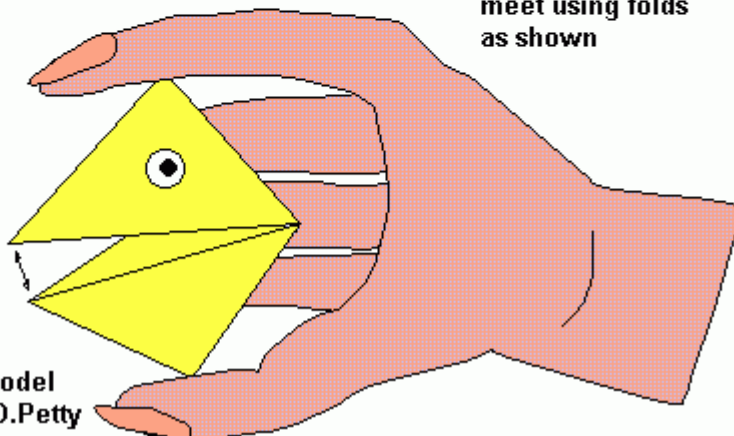

traditional model
© diagrams D.Petty



PAGODA

early example of modular folding

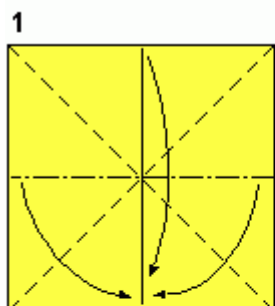

1 form waterbomb base

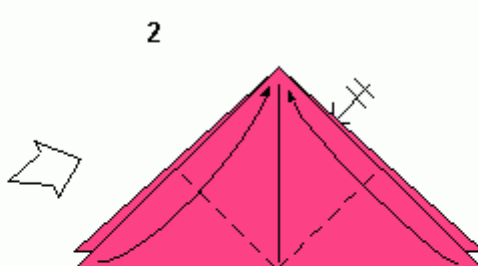

2 fold corners to top point

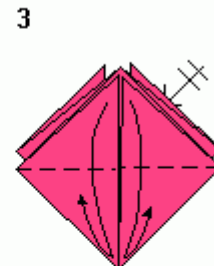

3 fold corners to bottom point and return

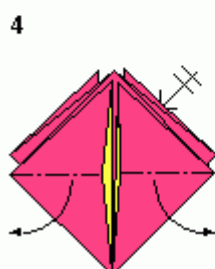

4 open each flap and squash

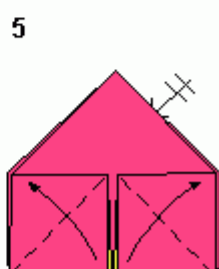

5 fold top layer only

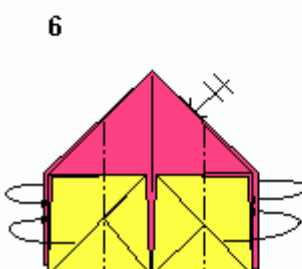

6 fold sides to centre

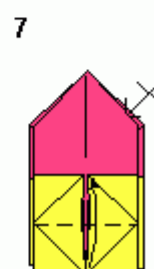

7 fold point up, repeat at back

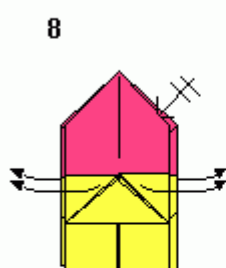

8 pull out corners

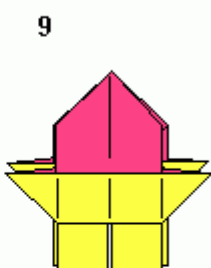

9 unit complete

Assembly

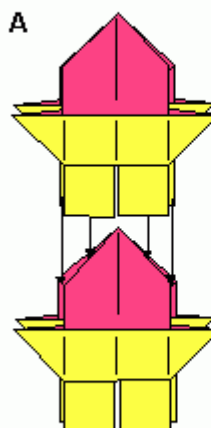

slide top unit into lower unit, flaps tuck into pockets in lower unit

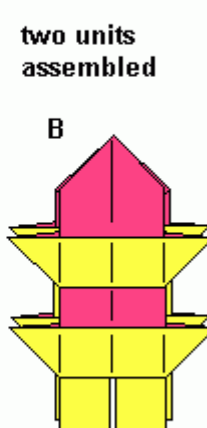

two units assembled

for best effect, fold units from successively reduced size paper e.g. 5" - 4.75" - 4.5" - 4.25" - 4" - 3.75" - 3.5" - 3.25" - 3"

Chinese traditional model diagrams © D.Petty



FISH

model of the month : April 2000

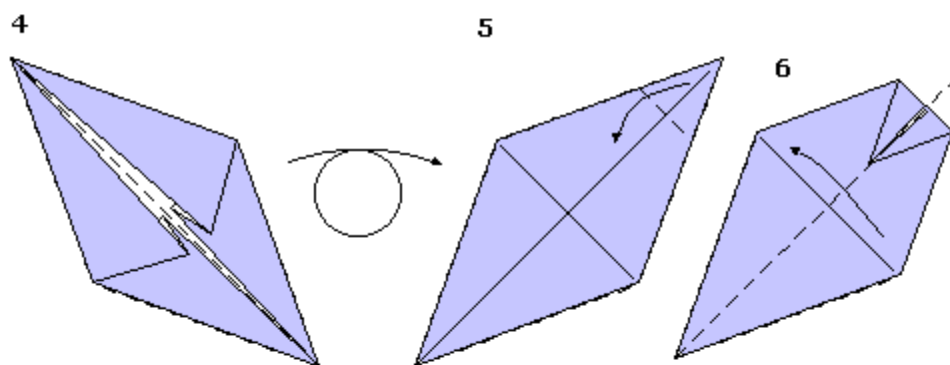
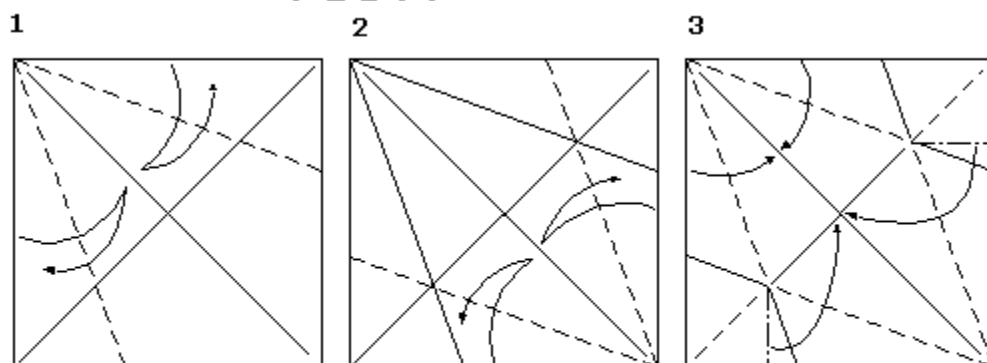

traditional model
diagrams © D.Petty

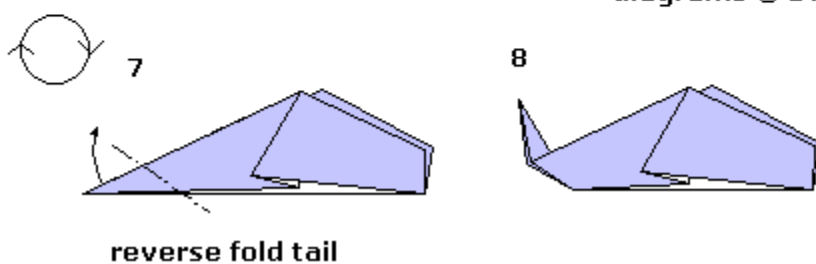

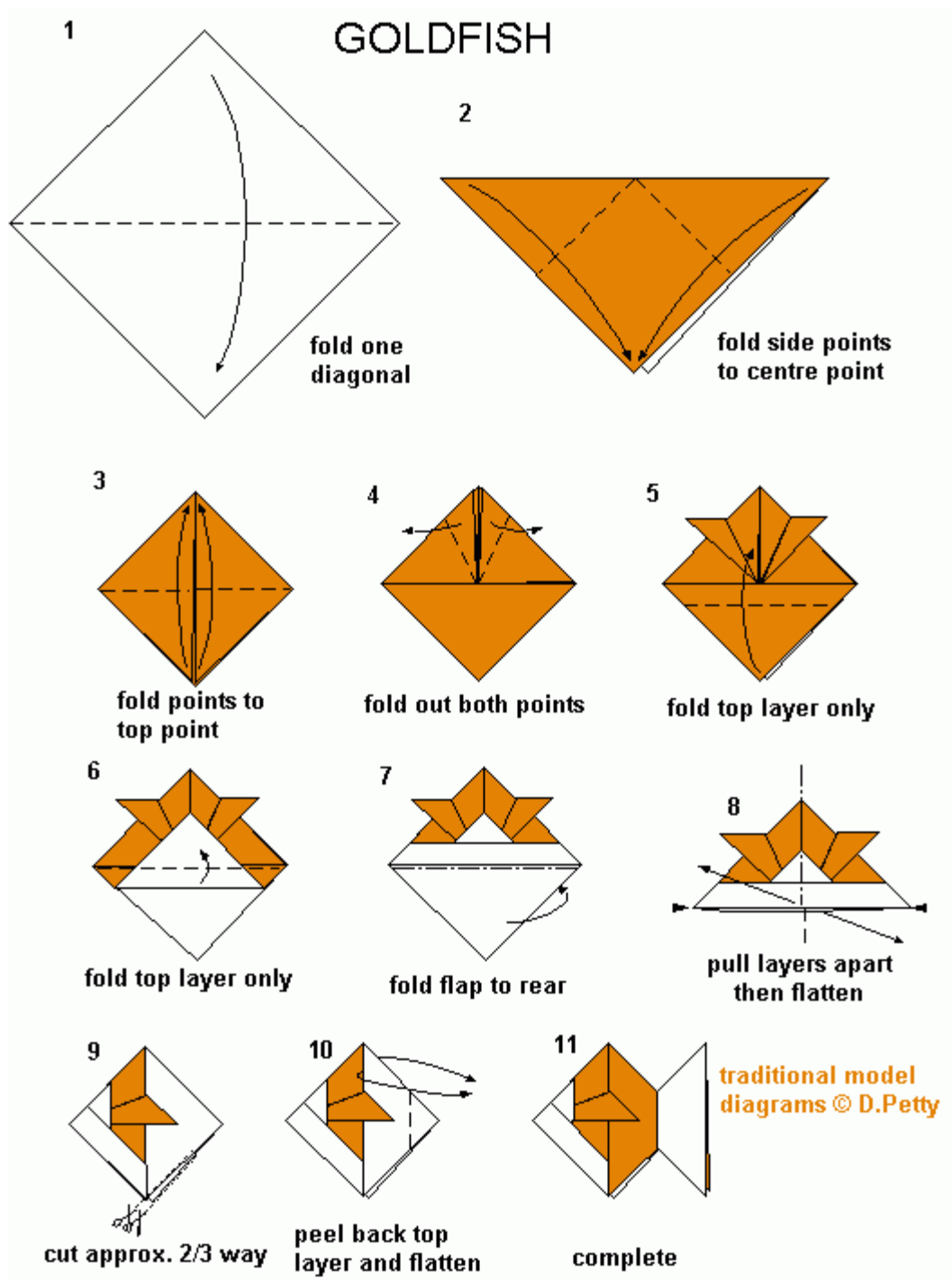

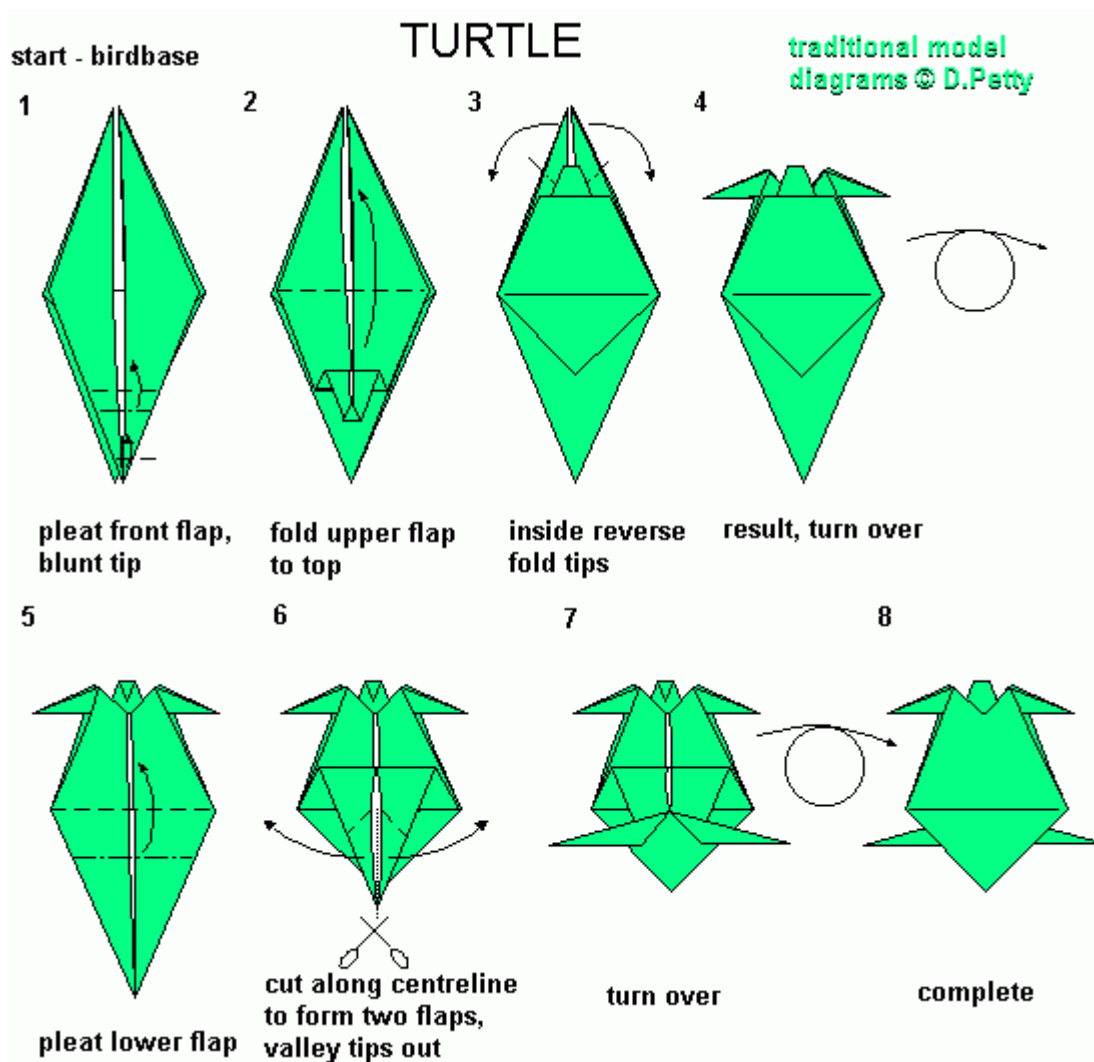

FOUR POINT STAR

two squares are required, folding is different for each

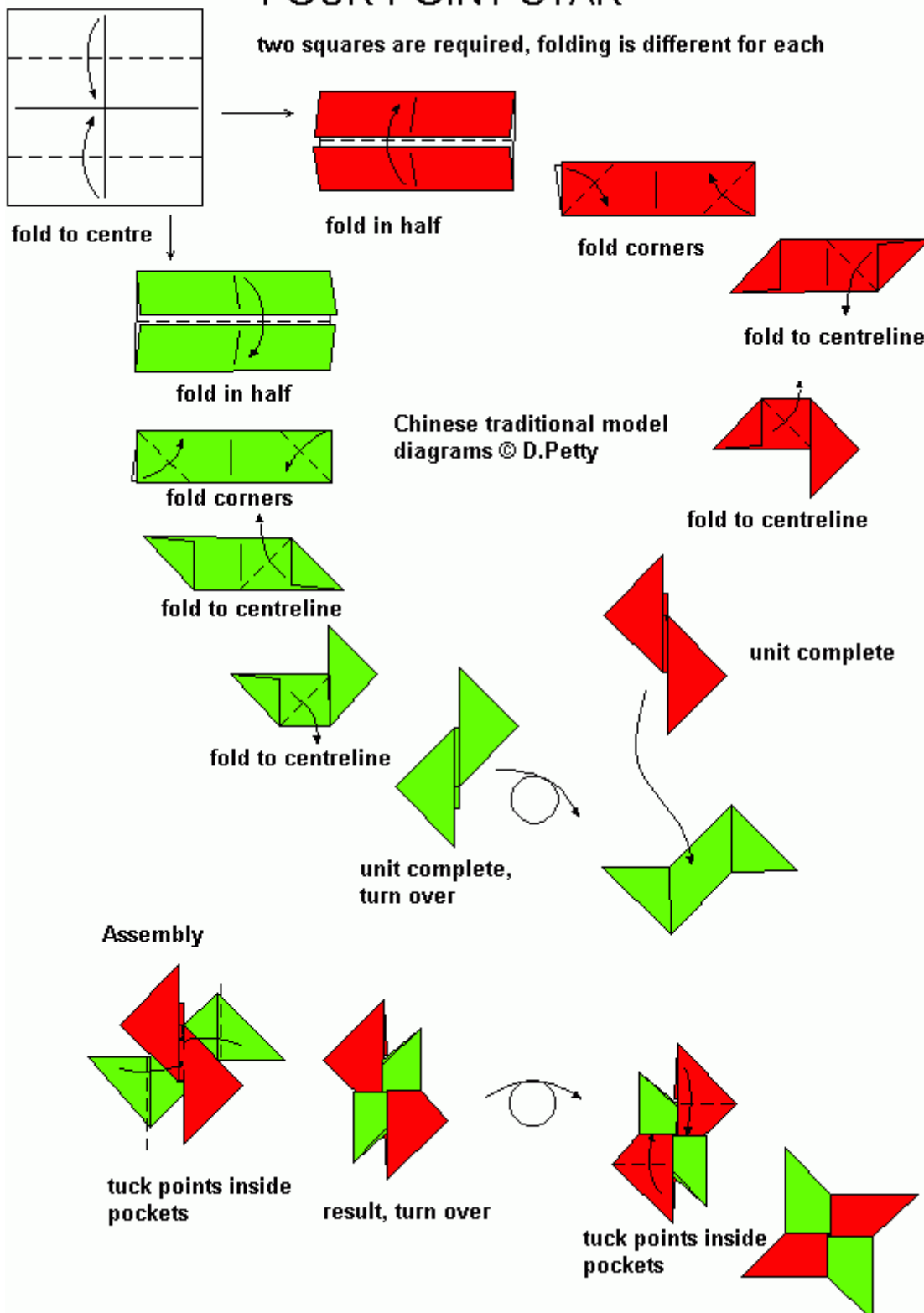

STAR

MAKING AN EQUILATERAL TRIANGLE FROM A RECTANGLE

newspaper can be used

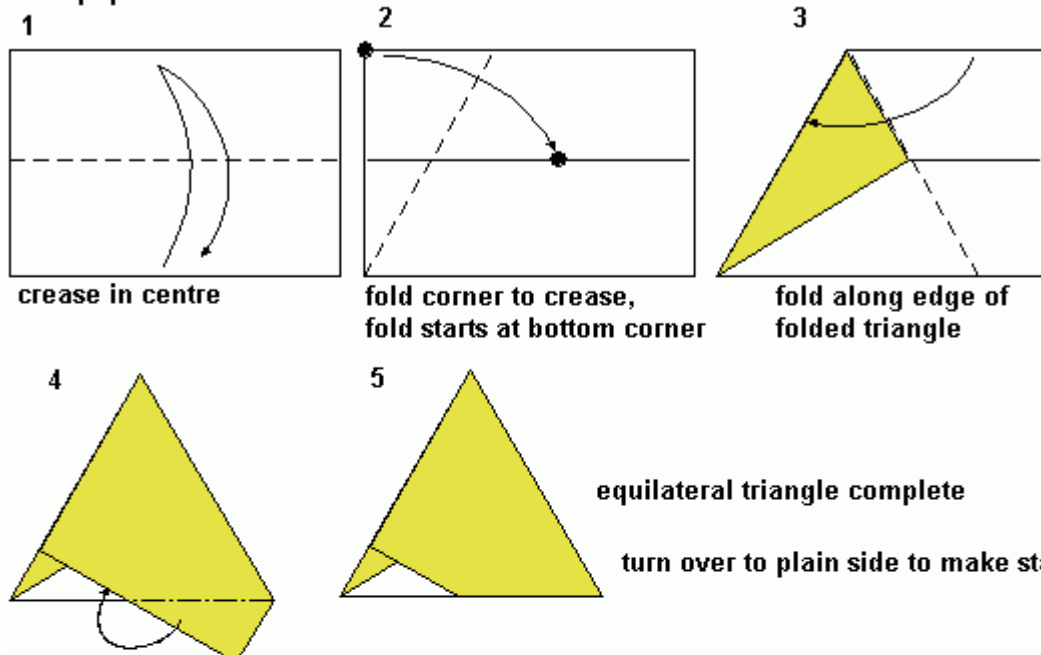

turn over to plain side to make star

tuck triangle inside

MAKING THE STAR

start with side without edges on top

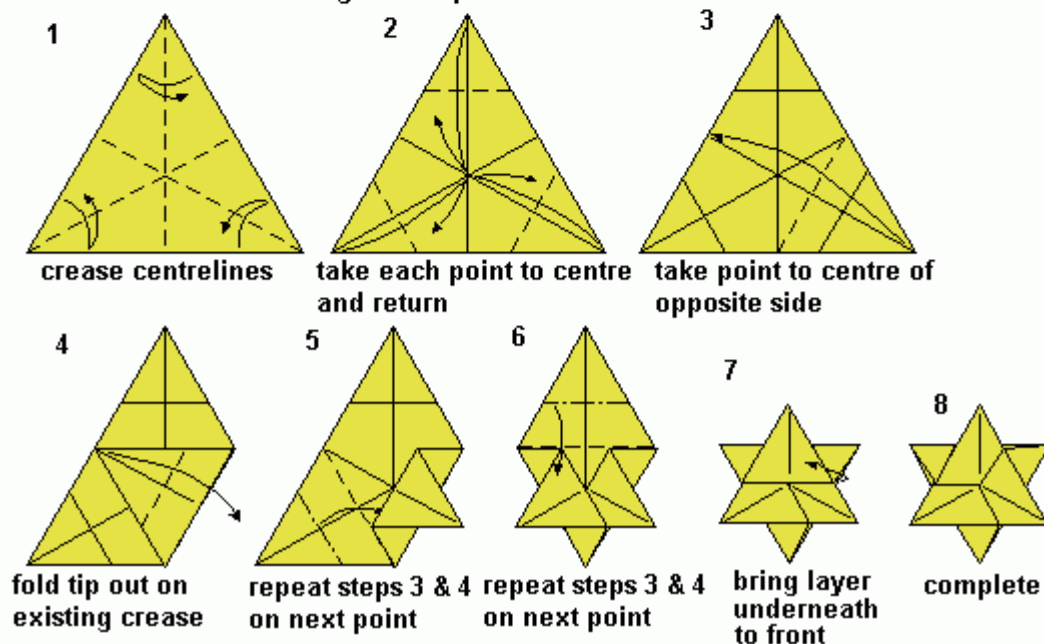

*traditional model
diagrams © D.Petty*



WINDMILL

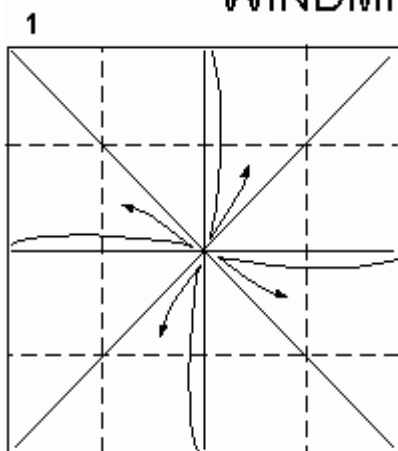

crease diagonals and horizontal and vertical centrelines, then quarterlines.

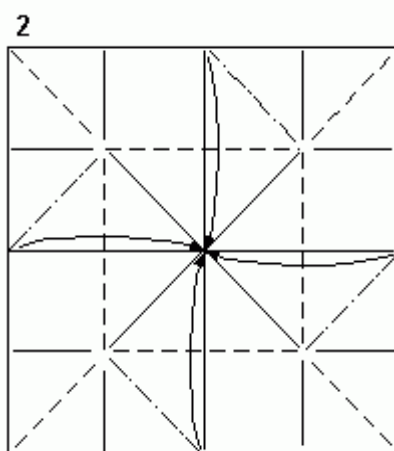

collapse using creases shown

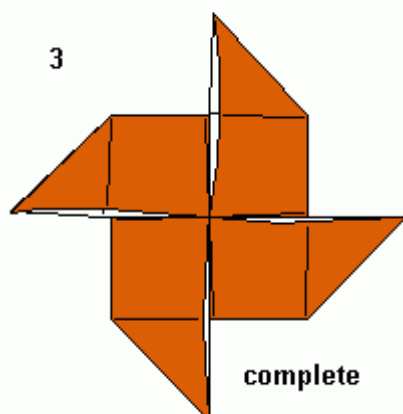

model may be pinned to a stick as shown.

traditional model diagrams © D.Petty



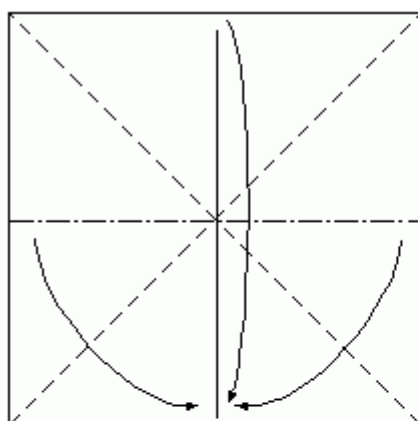

BLOW TOP

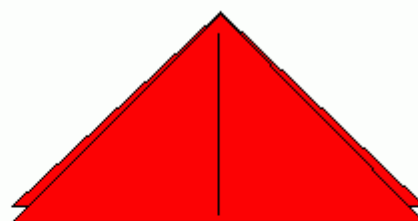

result, make a further 5 and set flaps at right angles

form waterbomb base

Assembly

4 units in position

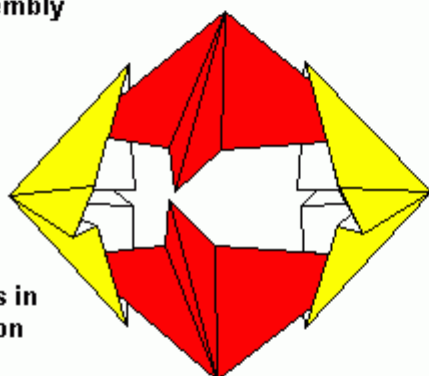

fifth unit is added as shown
sixth unit is added at rear, similarly to fifth unit

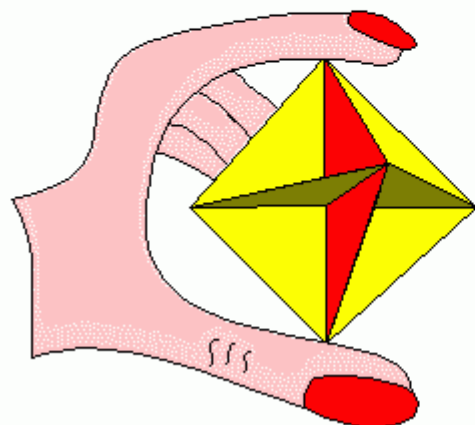
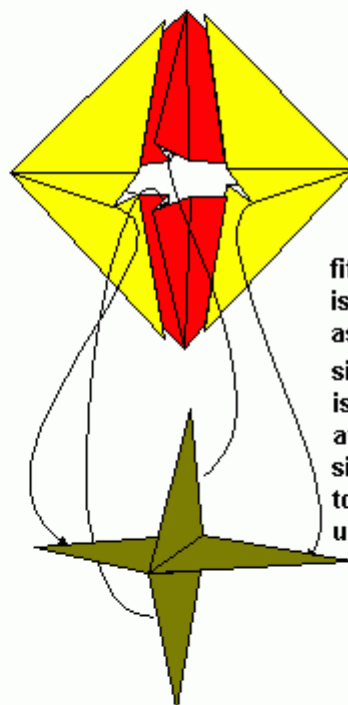

complete

hold at two points and blow off-centre to make it spin

traditional model diagrams © D.Petty



Harlequin Cube

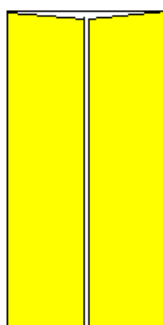
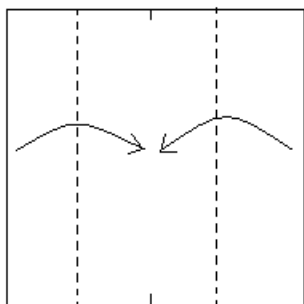

turn over



Fold through all the layers

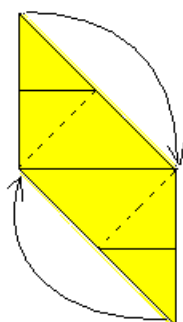

Crease sharply then return to the vertical

It should look something like this:

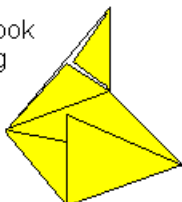

Make 6 of these, in pairs of 3 different colours.

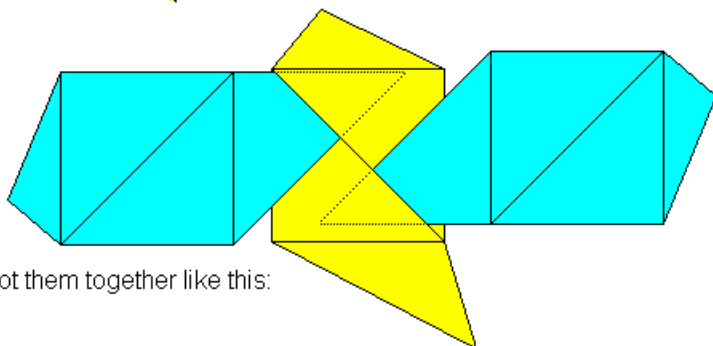

Slot them together like this:

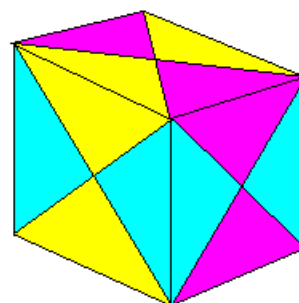

Triangular Tray

Zulay Newell (2011)

Model designed by Zulay Newell
 Diagrams drawn by Mark Bolitho
 Copyright © 2011. All rights reserved.

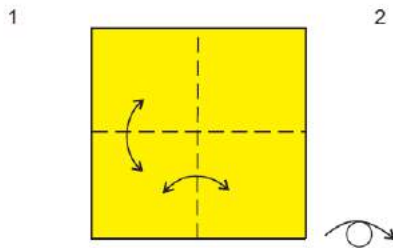
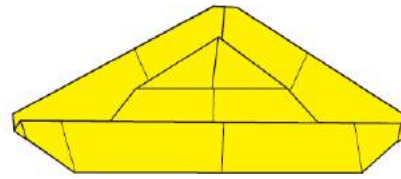
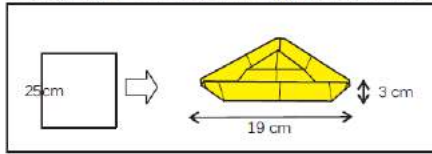

1 Fold and unfold the square in half lengthwise. Turnover.

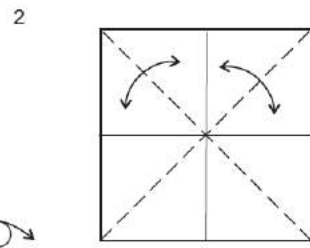

2 Fold and unfold the square in half and diagonally.

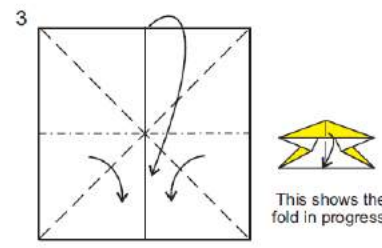

3 Re-fold the folds made in steps 1 and 2. This will bring all of the edges together.

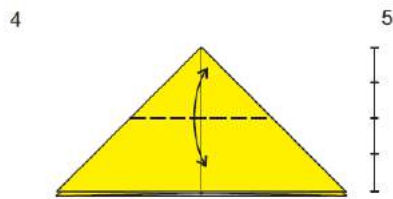

4 Fold and unfold the model along the middle.

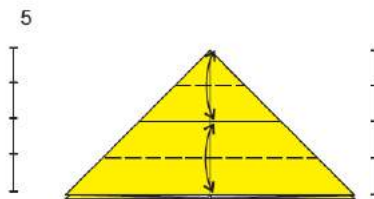

5 Fold and unfold the model between the outer edges and the crease made previously.

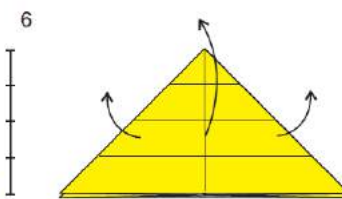

6 Unfold the model back to a square.

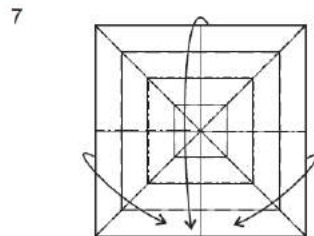

7 Fold the square back together, and refold the creases from step 5 inside the model.

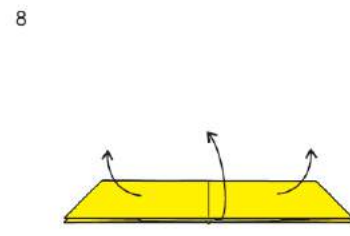

8 Unfold the model back to a square.

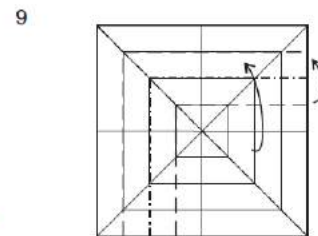

9 Pleat the left and upper layers together and fold the lower right triangle up.

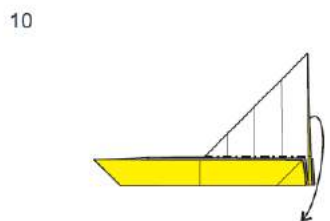

10 Reverse fold the triangle into the model.

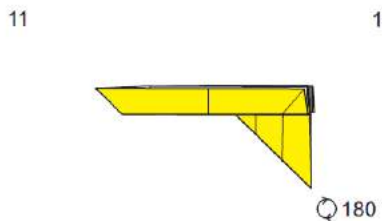

11 Rotate the model 180°

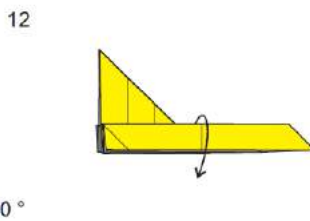

12 Open the model by folding down the front layer only.





13

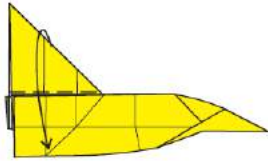

Fold the top corner over.

14

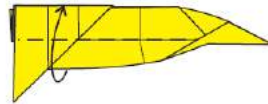

Fold the folded point and the lower layer up.

15



Fold the upper triangle down over the front layer.

16



180°

Rotate the model 180°

17



Open out the model on the right side and fan out the paper.

18

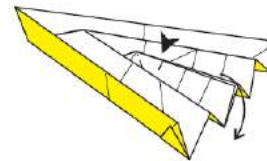

Fold down the two layers in the middle and form a three sides pyramid in the centre of the model.

19

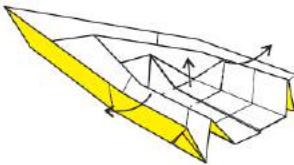

Pull the outer edges out and pop up the middle section to make another ridge.

20

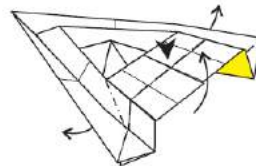

Fold in along the middle of the flat section and fold the outer layers out to create another ridge that completes the triangle.

21

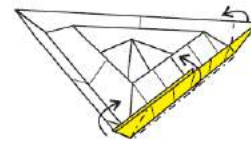

Fold one edge in to the adjacent sloped edge.

22

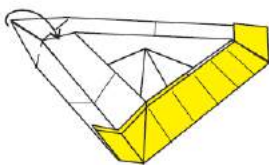

Fold the opposite corner in so that the outer corner touches the top of the adjacent ridge.

23

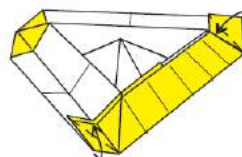

Fold in the corners of the edges where indicated.

24

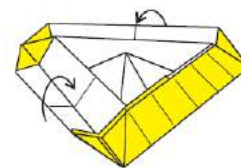

Fold the edges in to touch the adjoining sloping faces.

25

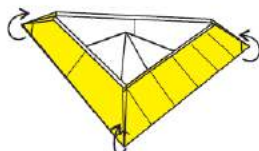

[optional fold: Fold in the tip of the three corners.]

26

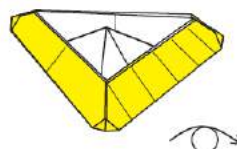

Turn the model over.

27

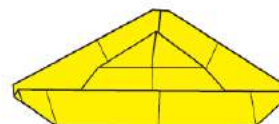

Complete.



Origami Japanese Kusudama

The Japanese **kusudama** (薬玉; lit. medicine ball) is a paper model that is usually (although not always) created by sewing multiple identical pyramidal units (usually stylized flowers folded from square paper) together through their points to form a spherical shape.

Kusudama originate from ancient Japanese culture, where they were used for incense and potpourri; possibly originally being actual bunches of flowers or herbs. The word itself is a combination of two Japanese words *kusuri*, Medicine, and *tama*, Ball. They are now typically used as decorations, or as gifts.

I have made many Kusudamas over the years to give as presents and they are always well received. They take time to make but the end result is always beautiful and rewarding. I gave one of my first Kusudamas to Chris at the Park Unit in the Hesketh Centre, Southport where I volunteered teaching Origami to the patients.

The Kusudama instructions that you will find in the next page can be founded here:

<http://origami-art.us/instructions/112-traditional-japanese-kusudama>

(there is also a video)



KUSUDAMA

(Traditional Japanese Decoration)

In pre-modern Japan, it was the custom to suspend a ball of sweet-smelling herbs above the bed of a sick person. These hanging balls, called *kusudama*, were also sometimes used as charms to ward off sickness. Nowadays they are used for their decorative qualities.

Instructions for making a traditional origami version (first carried in the Nippon Origami Association's journal *Origami*, April 1978) are given here. One ball is constructed from thirty-six squares of paper: these may be all the same colour or two or three matching colours, to suit your taste. Having made one ball, you may care to make a second and then a third, perhaps in different sizes, and suspend them above each other on the same thread. The Japanese like to attach streamers of paper or silk cord beneath them to catch the breeze. Complete kusudama-making kits are packaged by the art and crafts supplies firm Grimmhobby of Tokyo.

How to make a kusudama ★★☆☆

You will need thirty-six squares of coloured paper, a needle and thread, and a little glue. To make one unit, take one square and start by completing step 1 of the frog base (page 25), but with the coloured side of the paper inwards. Repeat on three other sides.

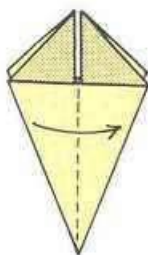

1

Take the left flap across to the right in a valley fold. Repeat behind.

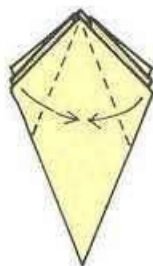

2

Fold in the raw edges so that they meet at the centre crease. Repeat on the three other sides.

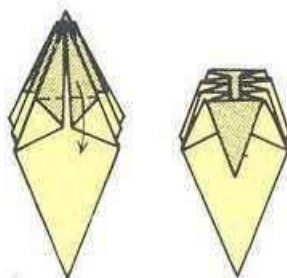

3

Fold the top point down as far as it will go. Repeat on the three other sides.

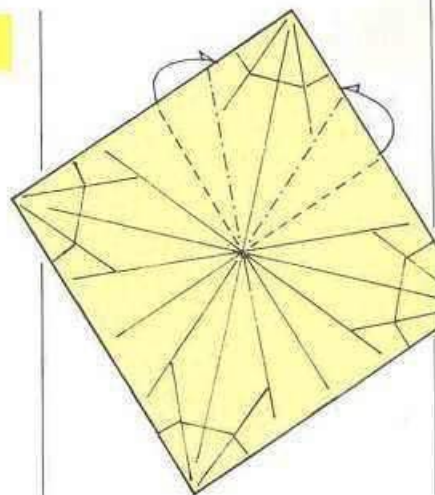

4

Now open out the paper. Take the centre of the top left and right edges behind to the centre.

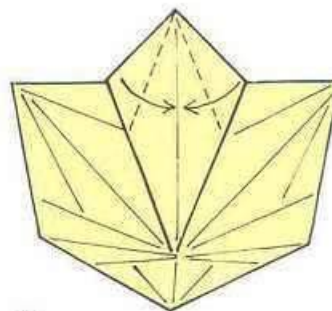

5

The form will begin to rise. Fold the raw edges to the centre crease, as shown.

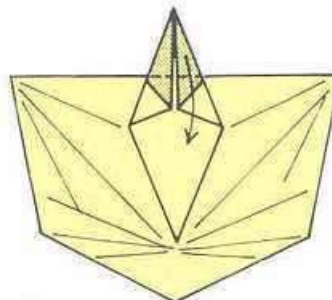

6

Fold the top point down along the line of the horizontal edge. ▶

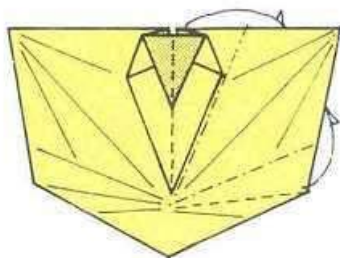

kusudama continued

**7**

Take the centre of two edges to the diagonal centre crease line at right, in effect repeating step 4 on the adjacent corner of the paper.

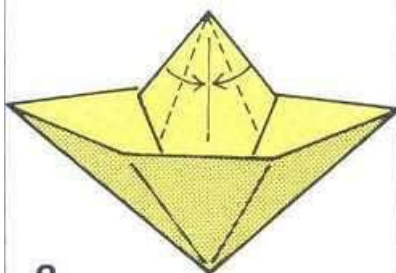
**8**

Fold in the raw edges to the centre crease of the newly formed flap.

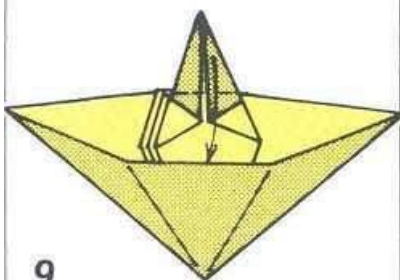
**9**

Fold the top point down along the line of the horizontal edge.

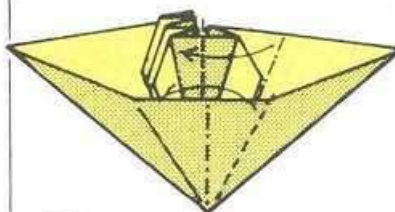
**10**

Crimp the right corner into the model, in effect repeating step 4 again.

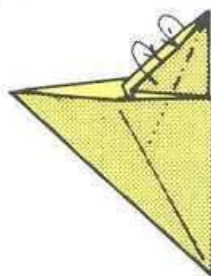
**11**

Fold in the raw edges, in mountain folds, to meet the right vertical edge.

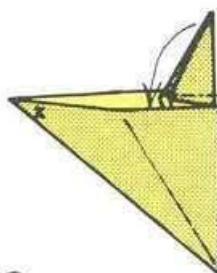
**12**

Inside reverse fold the top point down.

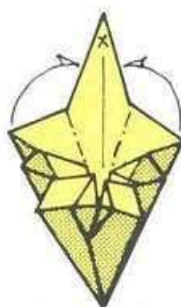
**13**

(New position) In effect, repeat step 4 on the remaining point X.

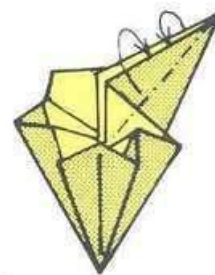
**14**

Tuck in the raw edges, in mountain folds.

**15**

Inside reverse fold the point down into the model.

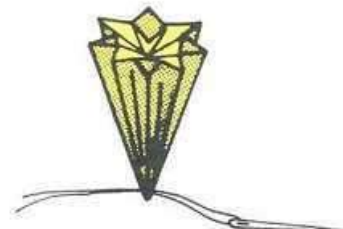
**16**

The completed unit. Tie a long thread to its base. Repeat steps 1–15 on the remaining squares to make a total of thirty-six units. ▶



KUSUDAMA

Assembly

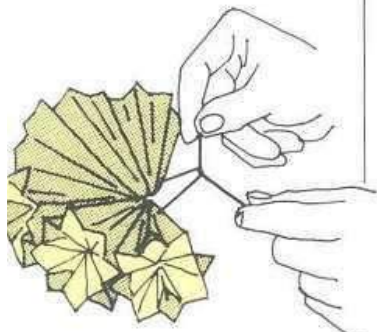
**1**

Pass a thread through the base points of six units and tie them together.

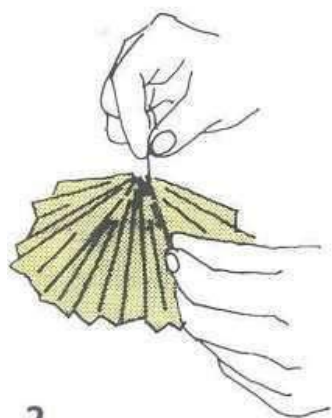
**2**

This will be the basis of the kusudama.

**3**

Slip the cluster over the thread to which a single unit has already been attached (step 16).

98

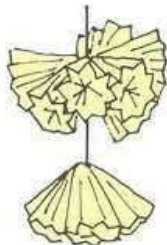
**4**

Now thread together eleven units, as in steps 1 and 2. Slip this cluster onto the main thread.

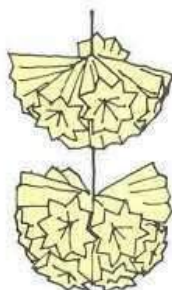
**5**

Thread together another eleven units and join this cluster to the kusudama which is now taking shape.

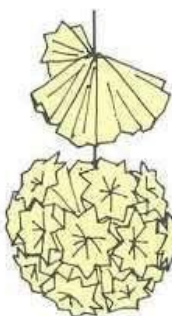
**6**

Thread together another six units and join this cluster to the others.

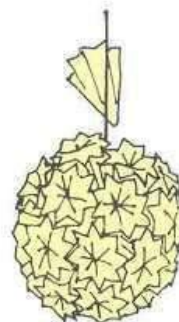
**7**

Finally, tuck in the last of the thirty-six units, after first dabbing a little glue to its side.

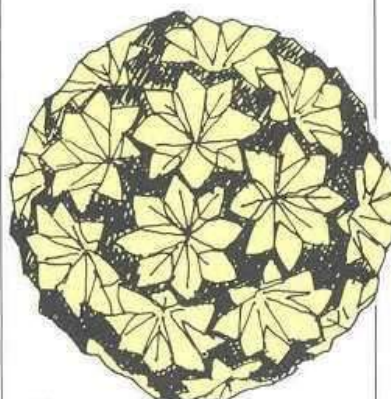
**8**

The completed kusudama.



Useful websites

www.britishorigami.info

This is a great place to start, I joined 7 years ago and it has been very helpful. The British Origami Society is a group devoted to the art of paper-folding. They have over 700 members worldwide and publish a bi-monthly magazine. They organise local and national meetings and have a unique library.

www.origami.org.uk

Great 3D instructions of few models.

www.origami-fun.com,

Here you'll find a complete paper folding resource.

www.origamispirit.com

This is a great website and blog from Leyla Torres, she features very explicit origami video instructions.

www.paperkawaii.com

Here you'll find excellent origami instructions, diagrams, photo & video tutorials.

www.kusudama.me

This is a website about Kusudamas, modular origami and paper art. You can find modular origami works of Lukashva Ekaterina, origami diagrams & tutorials.

www.happyfolding.com

Excellent website with lots of information and models to fold.

