

INTRODUCTORY LECTURES ON FLUID DYNAMICS

Roger K. Smith

Version: June 13, 2008

Contents

1	Introduction	3
1.1	Description of fluid flow	3
1.2	Equations for streamlines	4
1.3	Distinctive properties of fluids	5
1.4	Incompressible flows	6
1.5	Conservation of mass: the continuity equation	7
2	Equation of motion: some preliminaries	9
2.1	Rate-of-change moving with the fluid	10
2.2	Internal forces in a fluid	13
2.2.1	Fluid and solids: pressure	14
2.2.2	Isotropy of pressure	15
2.2.3	Pressure gradient forces in a fluid in macroscopic equilibrium .	15
2.2.4	Equilibrium of a horizontal element	16
2.2.5	Equilibrium of a vertical element	17
2.2.6	Liquids and gases	17
2.2.7	Archimedes Principle	18
3	Equations of motion for an inviscid fluid	22
3.1	Equations of motion for an incompressible viscous fluid	23
3.2	Equations of motion in cylindrical polars	26
3.3	Dynamic pressure (or perturbation pressure)	27
3.4	Boundary conditions for fluid flow	28
3.4.1	An alternative boundary condition	29
4	Bernoulli's equation	31
4.1	Application of Bernoulli's equation	32
5	The vorticity field	37
5.1	The Helmholtz equation for vorticity	41
5.1.1	Physical significance of the term $(\boldsymbol{\omega} \cdot \nabla) \mathbf{u}$	42
5.2	Kelvin's Theorem	44
5.2.1	Results following from Kelvins Theorem	45
5.3	Rotational and irrotational flow	47

<i>CONTENTS</i>	2
5.3.1 Vortex sheets	47
5.3.2 Line vortices	48
5.3.3 Motion started from rest impulsively	49
6 Two dimensional flow of a homogeneous, incompressible, inviscid fluid	50
7 Boundary layers in nonrotating fluids	56
7.1 Blasius solution ($U = \text{constant}$)	58
7.2 Further reading	59

Chapter 1

Introduction

These notes are intended to provide a survey of basic concepts in fluid dynamics as a preliminary to the study of dynamical meteorology. They are based on a more extensive course of lectures prepared by Professor B. R. Morton of Monash University, Australia.

1.1 Description of fluid flow

The description of a fluid flow requires a specification or determination of the *velocity field*, i.e. a specification of the fluid velocity at every point in the region. In general, this will define a *vector field* of position and time, $\mathbf{u} = \mathbf{u}(x, t)$.

Steady flow occurs when \mathbf{u} is independent of time (i.e., $\partial\mathbf{u}/\partial t \equiv 0$). Otherwise the flow is *unsteady*.

Streamlines are lines which at a given instant are everywhere in the direction of the velocity (analogous to electric or magnetic field lines). In steady flow the streamlines are independent of time, but the velocity can vary in magnitude along a streamline (as in flow through a constriction in a pipe) - see Fig. 1.1.

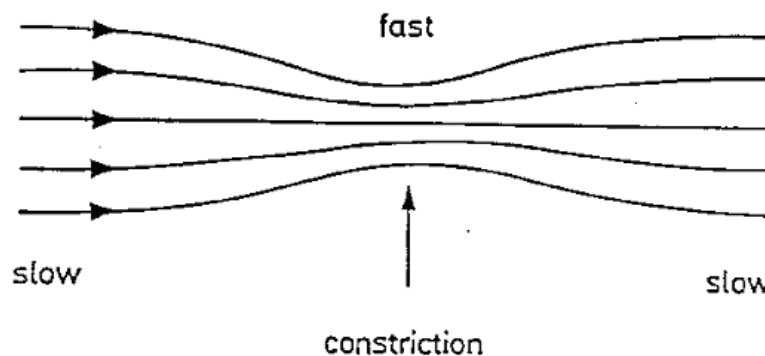

Figure 1.1: Schematic diagram of flow through a constriction in a pipe.

Particle paths are lines traced out by “marked” particles as time evolves. In steady flow particle paths are identical to streamlines; in unsteady flow they are different, and sometimes very different. Particle paths are visualized in the laboratory using small floating particles of the same density as the fluid. Sometimes they are referred to as *trajectories*.

Filament lines or streaklines are traced out over time by all particles passing through a given point; they may be visualized, for example, using a hypodermic needle and releasing a slow stream of dye. In steady flow these are streamlines; in unsteady flow they are neither streamlines nor particle paths.

It should be emphasized that streamlines represent the velocity field at a specific instant of time, whereas particle paths and streaklines provide a representation of the velocity field over a finite period of time. In the laboratory we can obtain a record of streamlines photographically by seeding the fluid with small neutrally buoyant particles that move with the flow and taking a short exposure (e.g. 0.1 sec), long enough for each particle to trace out a short segment of line; the eye readily links these segments into continuous streamlines. Particle paths and streaklines are obtained from a time exposure long enough for the particle or dye trace to traverse the region of observation.

1.2 Equations for streamlines

The streamline through the point P , say (x, y, z) , has the direction of $\mathbf{u} = (u, v, w)$.

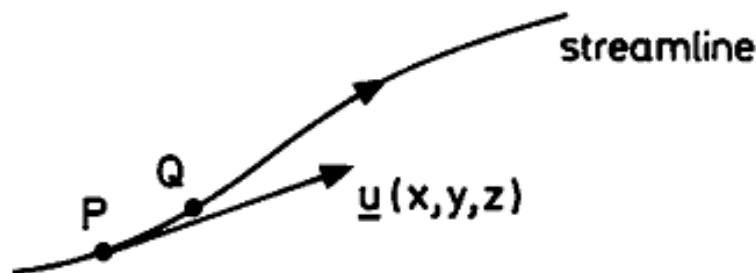

Figure 1.2: Velocity vector and streamline

Let Q be the neighbouring point $(x + \delta x, y + \delta y, z + \delta z)$ on the streamline. Then $\delta x \approx u \delta t$, $\delta y \approx v \delta t$, $\delta z \approx w \delta t$ and as $\delta t \rightarrow 0$, we obtain the differential relationship

$$\frac{dx}{u} = \frac{dy}{v} = \frac{dz}{w}, \quad (1.1)$$

between the displacement $d\mathbf{x}$ along a streamline and the velocity components. Equation (1.1) gives two differential equations (why?). Alternatively, we can represent the streamline parameterically (with time as parameter) as

$$\int \frac{dx}{u} = \int dt, \quad \int \frac{dy}{v} = \int dt, \quad \int \frac{dz}{w} = \int dt, \quad (1.2)$$

Example 1

Find the streamlines for the velocity field $\mathbf{u} = (-\Omega y, \Omega x, 0)$, where Ω is a constant.

Solution

Eq. (1.1) gives

$$-\frac{dx}{\Omega y} = \frac{dy}{\Omega x} = \frac{dz}{0}.$$

The first pair of ratios give

$$\int \Omega (x dx + y dy) = 0$$

or

$$x^2 + y^2 = \Gamma(z),$$

where Γ is an arbitrary function of z . The second pair give

$$\int dz = 0 \quad \text{or} \quad z = \text{constant}.$$

Hence the streamlines are circles $x^2 + y^2 = c^2$ in planes $z = \text{constant}$ (we have replaced $\Gamma(z)$, a constant when z is constant, by c^2).

Note that the velocity at P with position vector \mathbf{x} can be expressed as $\mathbf{u} = \Omega \mathbf{k} \wedge \mathbf{x}$ and corresponds with solid body rotation about the \mathbf{k} axis with angular velocity Ω .

1.3 Distinctive properties of fluids

Although fluids are molecular in nature, they can be treated as *continuous media* for most practical purposes, the exception being rarefied gases. Real fluids generally show some *compressibility* defined as

$$\kappa = \frac{1}{\rho} \frac{d\rho}{dp} = \frac{\text{change in density per unit change in pressure}}{\text{density}},$$

but at normal atmospheric flow speed, the compressibility of air is a relative by small effect and for liquids it is generally negligible. Note that sound waves owe their existence to compressibility effects as do “supersonic bangs” produced by aircraft flying faster than sound. For many purposes it is accurate to assume that fluids are

incompressible, i.e. they suffer no change in density with pressure. For the present we shall assume also that they are *homogeneous*, i.e., density $\rho = \text{constant}$.

When one solid body slides over another, *frictional forces* act between them to reduce the relative motion. Friction acts also when layers of fluid flow over one another. When two solid bodies are in contact (more precisely when there is a normal force acting between them) at rest, there is a threshold tangential force *below which* relative motion will not occur. It is called the *limiting friction*. An example is a solid body resting on a flat surface under the action of gravity (see Fig. 1.3).

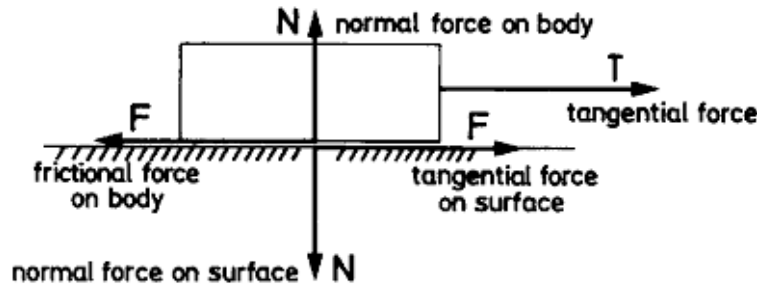

Figure 1.3: Forces acting on a rigid body at rest.

As T is increased from zero, $F = T$ until $T = \mu N$, where μ is the so-called coefficient of limiting friction which depends on the degree of roughness between the surface. For $T > \mu N$, the body will overcome the frictional force and accelerate. A distinguishing characteristic of most fluids in their inability to support tangential stresses between layers without motion occurring; i.e. there is no analogue of limiting friction. Exceptions are certain types of so-called *visco-elastic* fluids such as paint.

Fluid friction is characterized by *viscosity* which is a measure of the magnitude of tangential frictional forces in flows with velocity gradients. *Viscous forces* are important in many flows, but least important in flow past “streamlined” bodies. We shall be concerned mainly with *inviscid* flows where friction is not important, but it is essential to acquire some idea of the sort of flow in which friction may be neglected without completely misrepresenting the behaviour. The total neglect of friction is risky!

To begin with we shall be concerned mainly with *homogeneous, incompressible inviscid flows*.

1.4 Incompressible flows

Consider an element of fluid bounded by a “tube of streamlines”, known as a stream tube. In steady flow, no fluid can cross the walls of the stream tube (as they are everywhere in the direction of flow).

Hence for incompressible fluids the mass flux (= mass flow per unit time) across section 1 (= $\rho v_1 S_1$) is equal to that across section 2 (= $\rho v_2 S_2$), as there can be no

accumulation of fluid between these sections. Hence $vS = \text{constant}$ and in the limit, for stream tubes of small cross-section, $vS = \text{constant}$ along an elementary stream tube.

$vS = \text{constant}$ along an elementary stream tube.

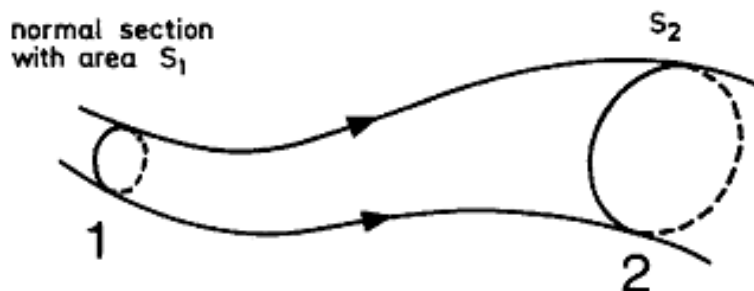

Figure 1.4:

It follows that, where streamlines contract the velocity increases, where they expand it decreases. Clearly, the streamline pattern contains a great deal of information about the velocity distribution.

All vector fields with the property that

$$(\text{vector magnitude}) \times (\text{area of tube})$$

remains constant along a tube are called *solenoidal*. The velocity field for an incompressible fluid is solenoidal.

1.5 Conservation of mass: the continuity equation

Apply the divergence theorem

$$\int_V \nabla \cdot \mathbf{u} \, dV = \int_S \mathbf{u} \cdot \mathbf{n} \, ds$$

to an arbitrarily chosen volume V with closed surface S (Fig. 1.5). Let \mathbf{n} be a unit outward normal to an element of the surface ds u.c. If the fluid is incompressible and there are no mass sources or sinks within S , then there can be neither continuing accumulation of fluid within V nor continuing loss. It follows that the net flux of fluid across the surface S must be zero, i.e.,

$$\int_S \mathbf{u} \cdot \mathbf{n} \, dS = 0,$$

whereupon $\int_V \nabla \cdot \mathbf{u} \, dV = 0$. This holds for an arbitrary volume V , and therefore $\nabla \cdot \mathbf{u} = 0$ throughout an incompressible flow without mass sources or sinks. This is the continuity equation for a *homogeneous, incompressible* fluid. It corresponds with mass conservation.

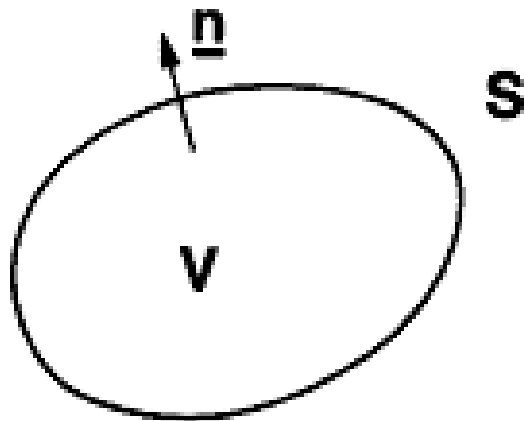

Figure 1.5:

Chapter 2

Equation of motion: some preliminaries

The equation of motion is an expression of Newton's second law of motion:

$$\boxed{\text{mass} \times \text{acceleration} = \text{force.}}$$

To apply this law we must focus our attention on a particular element of fluid, say the small rectangular element which at time t has vertex at $P [= (x, y, z)]$ and edges of length δx , δy , δz . The mass of this element is $\rho \delta x \delta y \delta z$, where ρ is the fluid *density* (or mass per unit volume), which we shall assume to be constant.

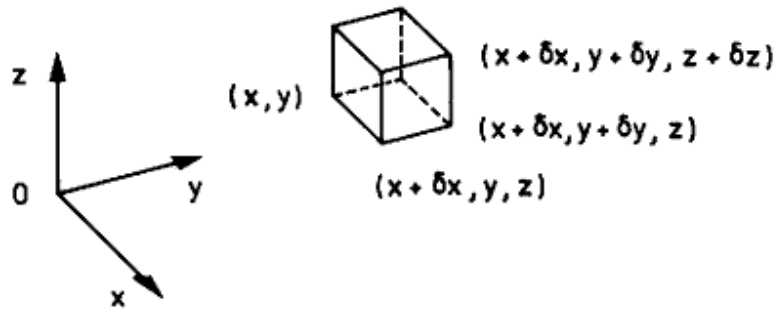

Figure 2.1: Configuration of a small rectangular element of fluid.

The velocity in the fluid, $\mathbf{u} = \mathbf{u}(x, y, z, t)$ is a function both of position (x, y, z) and time t , and from this we must derive a formula for the acceleration of the element of fluid which is changing its position with time. Consider, for example, steady flow through a constriction in a pipe (see Fig. 1.1). Elements of fluid must accelerate into the constriction as the streamlines close in and decelerate beyond as they open out again. Thus, in general, the acceleration of an element (i.e., the rate-of-change of \mathbf{u} with time for that element) includes a rate-of-change at a fixed position $\partial \mathbf{u} / \partial t$

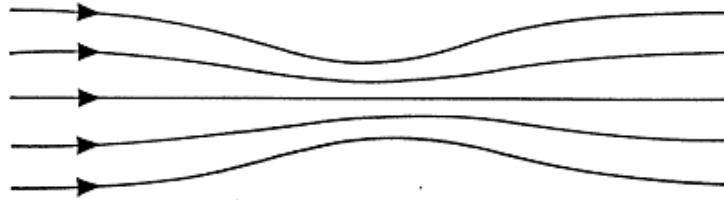

Figure 2.2:

and in addition a change associated with its change of position with time. We derive an expression for the latter in section 2.1.

The forces acting on the fluid element consist of:

- (i) *body forces*, which are forces per unit mass acting throughout the fluid because of external causes, such as the gravitational *weight*, and
- (ii) *contact forces* acting across the surface of the element from adjacent elements.

These are discussed further in section 2.2.

2.1 Rate-of-change moving with the fluid

We consider first the rate-of-change of a scalar property, for example the temperature of a fluid, following a fluid element. The temperature of a fluid, $T = T(x, y, z, t)$, comprises a scalar field in which T will vary, in general, both with the position and with time (as in the water in a kettle which is on the boil). Suppose that an element of fluid moves from the point $P [= (x, y, z)]$ at time t to the neighbouring point Q at time $t + \Delta t$. Note that if we stay at a particular point (x_0, y_0, z_0) , then $T(x_0, y_0, z_0)$ is effectively a function of t only, but that if we move with the fluid, T is a function both of position (x, y, z) and time t . It follows that the total change in T between P and Q in time Δt is

$$\Delta T = T_Q - T_P = T(x + \Delta x, y + \Delta y, z + \Delta z, t + \Delta t) - T(x, y, z, t),$$

and hence the total rate-of-change of T moving with the fluid is

$$\lim_{\Delta t \rightarrow 0} \frac{\Delta T}{\Delta t} = \lim_{\Delta t \rightarrow 0} \frac{T(x + \Delta x, y + \Delta y, z + \Delta z, t + \Delta t) - T(x, y, z, t)}{\Delta t}.$$

For small increments $\Delta x, \Delta y, \Delta z, \Delta t$, we may use a Taylor expansion

$$T(x + \Delta x, y + \Delta y, z + \Delta z, t + \Delta t) - T(x, y, z, t) + \left[\frac{\partial T}{\partial t} \right]_P \Delta t +$$

$$\left[\frac{\partial T}{\partial x} \right]_P \Delta x + \left[\frac{\partial T}{\partial y} \right]_P \Delta y + \left[\frac{\partial T}{\partial z} \right]_P \Delta z + \text{higher order terms in } \Delta x, \Delta y, \Delta z, \Delta t .$$

Hence the rate-of-change moving with the fluid element

$$\begin{aligned} &= \lim_{\Delta t \rightarrow 0} \left[\frac{\partial T}{\partial t} \Delta t + \frac{\partial T}{\partial x} \Delta x + \frac{\partial T}{\partial y} \Delta y + \frac{\partial T}{\partial z} \Delta z \right] / \Delta t \\ &= \frac{\partial T}{\partial t} + u \frac{\partial T}{\partial x} + v \frac{\partial T}{\partial y} + w \frac{\partial T}{\partial z} , \end{aligned}$$

since higher order terms $\rightarrow 0$ and $u = dx/dt$, $v = dy/dt$, $w = dz/dt$, where $\mathbf{r} = \mathbf{r}(t) = (x(t), y(t), z(t))$ is the coordinate vector of the moving fluid element. To emphasize that we mean the *total rate-of-change moving with the fluid* we write

$$\frac{DT}{Dt} = \frac{\partial T}{\partial t} + u \frac{\partial T}{\partial x} + v \frac{\partial T}{\partial y} + w \frac{\partial T}{\partial z} \quad (2.1)$$

Here, $\partial T/\partial t$ is the *local rate-of-change* with time at a fixed position (x, y, z) , while

$$u \frac{\partial T}{\partial x} + v \frac{\partial T}{\partial y} + w \frac{\partial T}{\partial z} = \mathbf{u} \cdot \nabla T$$

is the *advective rate-of-change* associated with the movement of the fluid element. Imagine that one is flying in an aeroplane that is moving with velocity $\mathbf{c}(t) = (dx/dt, dy/dt, dz/dt)$ and that one is measuring the air temperature with a thermometer mounted on the aeroplane. According to (2.1), if the air temperature changes both with space and time, the rate-of-change of temperature that we would measure from the aeroplane would be

$$\frac{dT}{dt} = \frac{\partial T}{\partial t} + \mathbf{c} \cdot \nabla T. \quad (2.2)$$

The first term on the right-hand-side of (2.2) is just the rate at which the temperature is varying *locally*; i.e., at a fixed point in space. The second term is the rate-of-change that we observe on account of our motion through a spatially-varying temperature field. Suppose that we move through the air at a speed exactly equal to the local flow speed \mathbf{u} , i.e., we move with an air parcel. Then the rate-of-change of any quantity related to the air parcel, for example its temperature or its x -component of velocity, is given by

$$\frac{\partial}{\partial t} + \mathbf{u} \cdot \nabla \quad (2.3)$$

operating on the quantity in question. We call this the *total derivative* and often use the notation D/Dt for the differential operator (2.3). Thus the x -component of acceleration of the fluid parcel is

$$\frac{Du}{Dt} = \frac{\partial u}{\partial t} + \mathbf{u} \cdot \nabla u, \quad (2.4)$$

while the rate at which its potential temperature changes is expressed by

$$\frac{D\theta}{Dt} = \frac{\partial \theta}{\partial t} + \mathbf{u} \cdot \nabla \theta. \quad (2.5)$$

Consider, for example, the case of potential temperature. In many situations, this is conserved following a fluid parcel, i.e.,

$$\frac{D\theta}{Dt} = 0. \quad (2.6)$$

In this case it follows from (2.5) and (2.6) that

$$\frac{\partial \theta}{\partial t} = -\mathbf{u} \cdot \nabla \theta. \quad (2.7)$$

This equation tells us that the rate-of-change of potential temperature at a point is due entirely to advection, i.e., it occurs solely because fluid parcels arriving at the point come from a place where the potential temperature is different.

For example, suppose that there is a uniform temperature gradient of $-1^\circ \text{C}/100 \text{ km}$ between Munich and Frankfurt, i.e., the air temperature in Frankfurt is cooler. If the wind is blowing directly from Frankfurt to Munich, the air temperature in Munich will *fall* steadily at a rate proportional to the wind speed and to the temperature gradient. If the air temperature in Frankfurt is higher than in Munich, then the temperature in Munich will rise. The former case is one of *cold air advection* (cold air moving towards a point); the latter is one of *warm air advection*.

Example 2

Show that

$$\frac{D\mathbf{F}}{Dt} = \frac{\partial \mathbf{F}}{\partial t} + (\mathbf{u} \cdot \nabla) \mathbf{F}$$

represents the total rate-of-change of any vector field \mathbf{F} moving with the fluid velocity (velocity field \mathbf{u}), and in particular that the acceleration (or total change in \mathbf{u} moving with the fluid) is

$$\frac{D\mathbf{u}}{Dt} = \frac{\partial \mathbf{u}}{\partial t} + (\mathbf{u} \cdot \nabla) \mathbf{u}.$$

Solution

The previous result for the rate-of-change of a scalar field can be applied to each of the component of \mathbf{F} , or to each of the velocity components (u, v, w) and these results follow at once.

Example 3

Show that

$$\frac{D\mathbf{r}}{Dt} = \mathbf{u}.$$

Solution

$$\frac{D\mathbf{r}}{Dt} = \frac{\partial \mathbf{r}}{\partial t} + (\mathbf{u} \cdot \nabla) \mathbf{r} = 0 + \left(u \frac{\partial}{\partial x} + v \frac{\partial}{\partial y} + w \frac{\partial}{\partial z} \right) (x, y, z) = (u, v, w)$$

as x, y, z, t are independent variables.

2.2 Internal forces in a fluid

An element of fluid experiences “contact” or internal forces across its surface due to the action of adjacent elements. These are in many respects similar to the normal reaction and tangential friction forces exerted between two rigid bodies, except, as noted earlier, friction in fluids is found to act only when the fluid is in non-uniform motion.

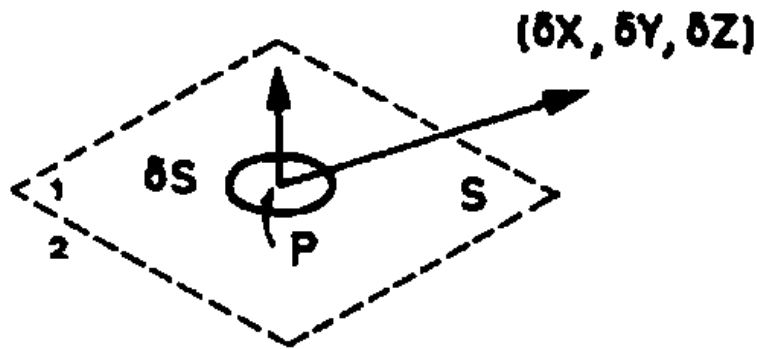

Figure 2.3: Forces on small surface element δS in a fluid.

Consider a region of fluid divided into two parts by the (imaginary) surface S , and let δS be a small element of S containing the point P and with region 1 below and region 2 above S . Let $(\delta X, \delta Y, \delta Z)$ denote the force exerted on fluid in region 1 by fluid region 2 across δS .

This elementary force is the resultant (vector sum) of a set of contact forces acting across δS , in general it will not act through P ; alternatively, resolution of the forces

will yield a force $(\delta X, \delta Y, \delta Z)$ acting through P together with an elementary couple with moment of magnitude on the order of $(\delta S)^{1/2} (\delta X^2 + \delta Y^2 + \delta Z^2)^{1/2}$.

The main force per unit area exerted by fluid 2 on fluid 1 across δS ,

$$\left[\frac{\delta X}{\delta S}, \frac{\delta Y}{\delta S}, \frac{\delta Z}{\delta S} \right]$$

is called the *mean stress*. The limit as $\delta S \rightarrow 0$ in such a way that it always contains P , if it exists, is the *stress* at P across S . Stress is a force per unit area. The stress \mathbf{F} is generally inclined to the normal \mathbf{n} to S at P , and varies both in magnitude and direction as the orientation \mathbf{n} of S is varied about the fixed point P .

The stress \mathbf{F} may be resolved into a *normal reaction* N , or *tension*, acting normal to S and shearing stress T , tangential to S , each per unit area.

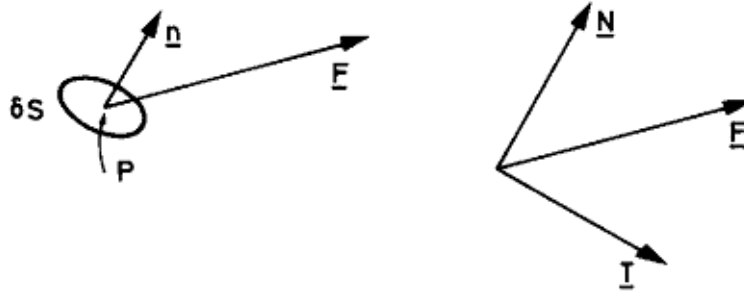

Figure 2.4: The stress on a surface element δS can be resolved into normal and tangential components.

Note that in the limit $\delta S \rightarrow 0$ there is no resultant bending moment as

$$\lim_{\delta S \rightarrow 0} \frac{\delta M}{\delta S} \lim_{\delta S \rightarrow 0} \sim (\delta S)^{1/2} \left[\left(\frac{\delta X}{\delta S} \right)^2 + \left(\frac{\delta Y}{\delta S} \right)^2 + \left(\frac{\delta Z}{\delta S} \right)^2 \right]^{1/2} = 0$$

provided that the stress is bounded.

The stress and its reaction (exerted by fluid in region 1 on fluid in region 2) are equal and opposite. This follows by considering the equilibrium of an infinitesimal slice at P ; see Fig. 2.5.

2.2.1 Fluid and solids: pressure

If the stress in a material *at rest* is always normal to the measuring surface for all points P and surfaces S , the material is termed a *fluid*; otherwise it is a *solid*. Solids at rest sustain tangential stresses because of their elasticity, but simple fluids do not possess this property. By assuming the material to be at rest we eliminate the shearing stress due to internal friction. Many real fluids conform closely to this

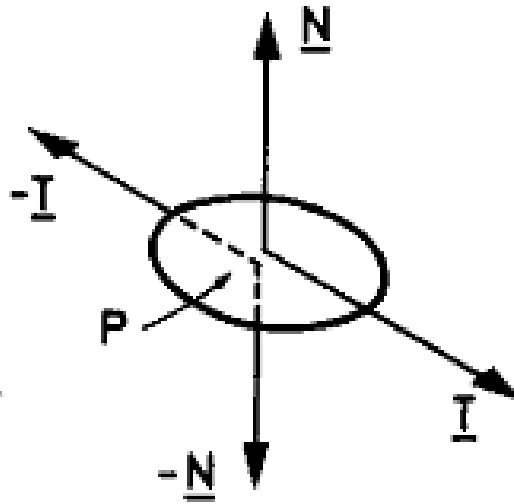

Figure 2.5: The stress and its reaction are equal and opposite.

definition including air and water, although there are more complex fluids possessing both viscosity and elasticity. A fluid can be defined also as a material offering no *initial* resistance to shear stress, although it is important to realize that frictional shearing stresses appear as soon as motion begins, and even the smallest force will initiate motion in a fluid in time. The property of internal friction in a fluid is known as viscosity.

Although the term tension is usual in the theory of elasticity, in fluid dynamics the term *pressure* is used to denote the hydrostatic stress, reversed in sign. In a fluid at rest the stress acts normally outwards from a surface, whereas the pressure acts normally inwards from the fluid towards the surface.

2.2.2 Isotropy of pressure

The pressure at a point P in a continuous fluid is isotropic; i.e., it is the same for all directions \mathbf{n} . This is proved by considering the equilibrium of a small tetrahedral element of fluid with three faces normal to the coordinate axes and one slant face. The proof may be found in any text on fluid mechanics.

2.2.3 Pressure gradient forces in a fluid in macroscopic equilibrium

Pressure is independent of direction at a point, but may vary from point to point in a fluid. Consider the equilibrium of a thin cylindrical element of fluid PQ of length δs and cross-section A , and with its ends normal to PQ . Resolve the forces in the direction P for the fluid at rest. Then pressure acts normally inwards on the curved

cylindrical surface and has no component in the direction of PQ (2.6). Thus the only contributions are from the plane ends.

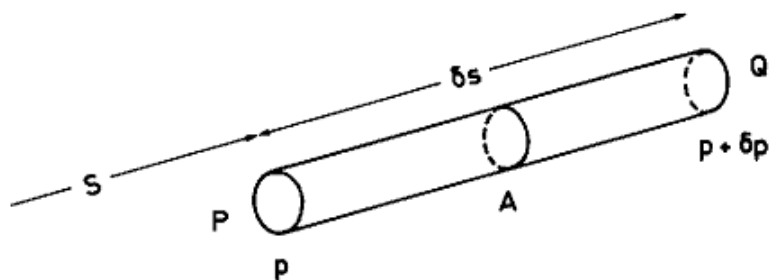

Figure 2.6: Pressure forces on a cylindrical element of fluid.

The net force in the direction PQ due to the pressure thrusts on the surface of the element is

$$pA - (p + \delta p)A = -\frac{\partial p}{\partial s}A \delta s = -\frac{\partial p}{\partial s} \delta V,$$

where dV is the volume of the cylinder. In the limit $\delta s \rightarrow 0$, $A \rightarrow 0$, the net pressure thrust $\rightarrow -(\partial p/\partial s) dV$, or $-\partial p/\partial s = -\hat{s} \cdot \nabla p$ per unit volume of fluid (\hat{s} being a unit vector in the direction PQ). It follows that $-\nabla p$ is the pressure gradient force per unit volume of fluid, and $-\hat{n} \cdot \nabla p$ is the component of pressure gradient force per unit volume in the direction \hat{n} .

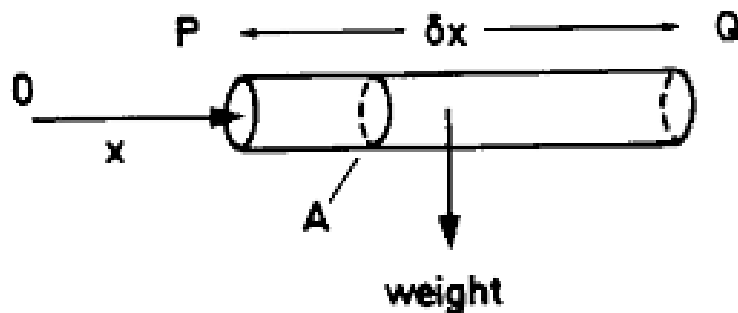

Figure 2.7: A horizontal cylindrical element of fluid in equilibrium.

2.2.4 Equilibrium of a horizontal element

The cylindrical element shown in Fig. 2.7 is in equilibrium under the action of the pressure over its surface and its weight. Resolving in the direction PQ , the x -direction, the only force arises from pressure acting on the ends

$$pA - (p + \delta s) A = -A \frac{\delta p}{\delta x} \delta x = -\frac{\delta p}{\delta x} \delta V$$

and hence in equilibrium in the limit $\delta V \rightarrow 0$,

$$-\frac{\delta p}{\delta x} = 0.$$

Alternatively, the horizontal component of pressure gradient force per unit volume is $-\mathbf{i} \cdot \nabla p = -\partial p / \partial x = 0$, from the assumption of equilibrium.

Thus p is independent of horizontal distance x , and is similarly independent of horizontal distance y . It follows that

$$p = p(z)$$

and surfaces of equal pressure (isobaric surfaces) are horizontal in a fluid at rest.

2.2.5 Equilibrium of a vertical element

For a vertical cylindrical element at rest in equilibrium under the action of pressure thrusts and the weight of fluid

$$-\mathbf{k} \cdot \nabla p \delta V + \rho g \delta V = 0, \text{ where } \mathbf{k} = (0, 0, 1).$$

Thus ¹ $\frac{dp}{dz} = \rho g$, per unit volume, since $p = p(z)$ only (otherwise we would write $\partial p / \partial z!$). Hence $\rho = \frac{1}{g} \frac{dp}{dz}$ is a function of z at most, i.e., $\rho = \rho(z)$.

2.2.6 Liquids and gases

Liquids undergo little change in volume with pressure over a very large range of pressures and it is frequently a good assumption to assume that $\rho = \text{constant}$. In that case, the foregoing equation integrates to give

$$p = p_0 + \rho g z,$$

where $p = p_0$ at the level $z = 0$.

Ideal gases are such that pressure, density and temperature are related through the ideal gas equation, $p = \rho R T$, where T is the absolute temperature and R is the specific gas constant. If a certain volume of gas is isothermal (i.e., has constant temperature), then pressure and density vary exponentially with depth with a so-called *e-folding* scale $H = R T / g$ (see Ex. 4).

¹Here z measures downwards so that $\text{sgn}(\delta z) = \text{sgn}(\delta p)$. Normally we take z upwards whereupon $dp/dz = -\rho g$.

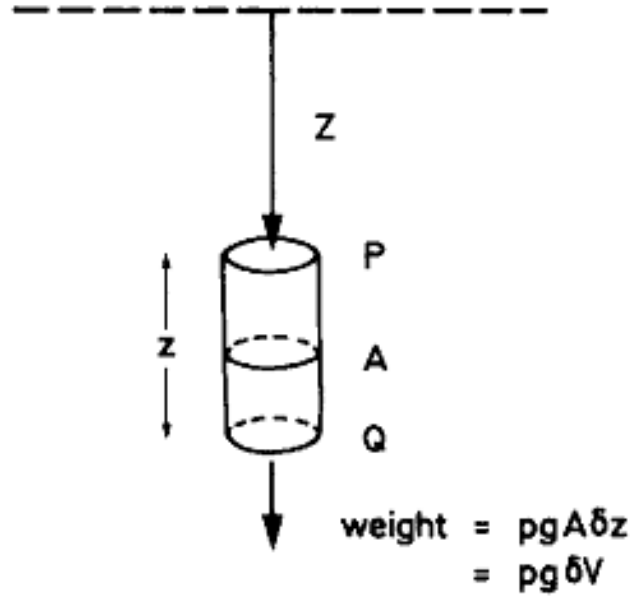

Figure 2.8: Equilibrium forces on a vertical cylindrical element of fluid at rest.

2.2.7 Archimedes Principle

In a fluid at rest the net pressure gradient force per unit volume acts vertically upwards and is equal to $-dp/dz$ (when z points upwards) and the gravitational force per unit volume is ρg . Hence, for equilibrium, $dp/dz = -\rho g$. Consider the vertically-oriented cylindrical element P_1P_2 of an immersed body which intersects the surface of the body to form surface elements δS_1 and δS_2 . These surface elements have normals $\mathbf{n}_1, \mathbf{n}_2$ inclined at angles θ_1, θ_2 to the vertical.

The net upward thrust on these small surfaces

$$= p_2 \cos \theta_2 \delta S_2 - p_1 \cos \theta_1 \delta S_1 = (p_2 - p_1) \delta S,$$

where $\delta S_1 \cos \theta_1 = \delta S_2 \cos \theta_2 = \delta S$ is the horizontal cross-sectional area of the cylinder. Since

$$p_1 - p_2 = - \int_{z_2}^{z_1} \rho g dz,$$

the net upward thrust

$$\begin{aligned} &= \left(\int_{z_2}^{z_1} \rho g dz \right) \delta S \\ &= \text{The weight of liquid displaced by the cylindrical element.} \end{aligned}$$

If this integration is now continued over the whole body we have *Archimedes Principle* which states that the resultant thrust on an immersed body has a magnitude equal

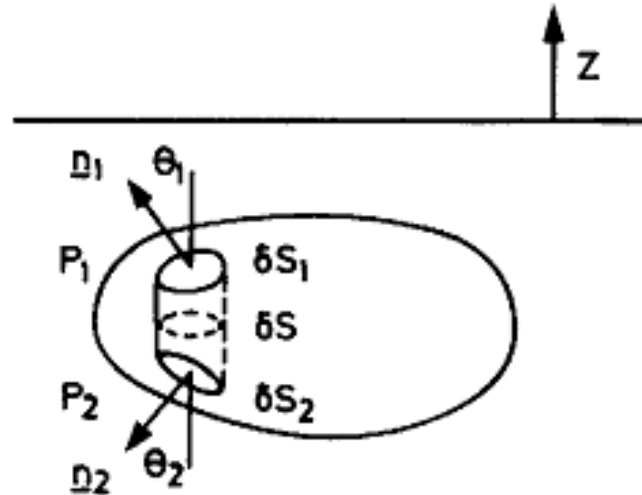

Figure 2.9: Pressure forces on an immersed body or fluid volume.

to the weight of fluid displaced and acts upward through the centre of mass of the displaced fluid (provided that the gravitational field is uniform).

Exercises

1. If you suck a drink up through a straw it is clear that you must accelerate fluid particles and therefore must be creating forces on the fluid particles near the bottom of the straw by the action of sucking. Give a concise, but careful discussion of the forces acting on an element of fluid just below the open end of the straw.
2. Show that the pressure at a point in a fluid at rest is the same in all directions.
3. Show that the force per unit volume in the interior of homogeneous fluid is $-\nabla p$, and explain how to obtain from this the force in any specific direction.
4. Show that, in hydrostatic equilibrium, the pressure and density in an isothermal atmosphere vary with height according to the formulae

$$\begin{aligned} p(z) &= p(0) \exp(-z/H_s), \\ \rho(z) &= \rho(0) \exp(-z/H_s), \end{aligned}$$

where $H_s = RT/g$ and z points vertically upwards. Show that for realistic values of T in the troposphere, the e-folding height scale is on the order of 8 km.

5. A factory releases smoke continuously from a chimney and we suppose that the smoke plume can be detected far down wind. On a particular day the wind is initially from the south at 0900 h and then veers (turns clockwise) steadily until it is from the west at 1100 h. Draw initial and final streamlines at 0900 and 1100 h, a particle path from 0900 h to 1100 h, and filament line from 0900 to 1100 h.
6. Show that the streamline through the origin in the flow with uniform velocity (U, V, W) is a straight line and find its direction cosines.
7. Find streamlines for the velocity field $\mathbf{u} = (\alpha x, -\alpha y, 0)$, where α is constant, and sketch them for the case $\alpha > 0$.
8. Show that the equation for a *particle path* in steady flow is determined by the differential relationship

$$\frac{dx}{u} = \frac{dy}{v} = \frac{dz}{w},$$

where $\mathbf{u} = (u, v, w)$ is the velocity at the point (x, y, z) . What does this relationship represent in unsteady flow?

9. A stream is broad and shallow with width 8 m, mean depth 0.5 m, and mean speed 1 m s^{-1} . What is its volume flux (rate of flow per second) in $\text{m}^3 \text{ s}^{-1}$? It enters a pool of mean depth 3 m and width 6 m: what then is its mean speed? It continues over a waterfall in a single column with mean speed 10 m s^{-1} at its base: what is the mean diameter of this column at the base of the waterfall? Will the diameter of the water column at the top of the waterfall be greater, equal to, or less at its base? Why?
10. Under what condition is the advective rate-of-change equal to the total rate-of-change?
11. Express $\mathbf{u} \cdot \nabla$ and $\nabla \cdot \mathbf{u}$ in Cartesian form and show that they are quite different, one being a scalar function and one a scalar differential operator.
12. Some books use the expression df/dt . Would you identify this with Df/Dt or $\partial f/\partial t$ in a field $f(x, y, z, t)$?
13. The vector differential operator del (or nabla) is defined as

$$\nabla \equiv \left[\frac{\partial}{\partial x}, \frac{\partial}{\partial y}, \frac{\partial}{\partial z} \right]$$

in rectangular Cartesian coordinates. Express in full Cartesian form the quantities: $\nabla \cdot \mathbf{u}$, $\nabla \wedge \mathbf{u}$, $\mathbf{u} \cdot \nabla$, $\nabla \cdot \nabla$ and identify each.

14. Are the two x -components in rectangular Cartesian coordinates,

$$(\mathbf{u} \cdot \nabla \mathbf{u})_x \text{ and } \left(\nabla \frac{1}{2} \mathbf{u}^2\right)_x$$

the same or different? Note that $(\mathbf{u} \cdot \nabla) \mathbf{u} = \nabla \left(\frac{1}{2} \mathbf{u}^2\right) - \mathbf{u} \wedge \boldsymbol{\omega}$, where $\boldsymbol{\omega} = \nabla \wedge \mathbf{u}$.

Chapter 3

Equations of motion for an inviscid fluid

The equation of motion for a fluid follows from Newton's second law, i.e.,

$$\text{mass} \times \text{acceleration} = \text{force}.$$

If we apply the equation to a unit volume of fluid:

- (i) the mass of the element is $\rho \text{ kg } m^{-3}$;
- (ii) the acceleration must be that *following the fluid element* to take account both of the change in velocity with time at a fixed point and of the change in position within the velocity field at a fixed time,

$$\frac{D\mathbf{u}}{Dt} = \frac{\partial\mathbf{u}}{\partial t} + (\mathbf{u} \cdot \nabla) \mathbf{u} = \frac{\partial u}{\partial t} + u \frac{\partial\mathbf{u}}{\partial x} + v \frac{\partial\mathbf{u}}{\partial y} + w \frac{\partial\mathbf{u}}{\partial z};$$

- (iii) the total force acting on the element (neglecting viscosity or fluid friction) comprises the contact force acting across the surface of the element $-\nabla p$ per unit volume, which is a *pressure gradient* force arising from the difference in pressure across the element, and any body forces \mathbf{F} , acting throughout the fluid including especially the gravitational weight per unit volume, $-g\mathbf{k}$.

The resulting *equation of motion* or *momentum equation* for inviscid fluid flow,

$$\rho \frac{D\mathbf{u}}{Dt} = -\nabla p + \rho \mathbf{F}, \text{ per unit volume,}$$

or

$$\frac{\partial\mathbf{u}}{\partial t} + (\mathbf{u} \cdot \nabla) \mathbf{u} = -\frac{1}{\rho} \nabla p + \mathbf{F}, \text{ per unit mass,}$$

is known as *Euler's equation*. In rectangular Cartesian coordinates (x, y, z) with velocity components (u, v, w) the component equations are

$$\begin{aligned}\frac{\partial u}{\partial t} + u \frac{\partial u}{\partial x} + v \frac{\partial u}{\partial y} + w \frac{\partial u}{\partial z} &= -\frac{1}{\rho} \frac{\partial p}{\partial x} + X, \\ \frac{\partial v}{\partial t} + u \frac{\partial v}{\partial x} + v \frac{\partial v}{\partial y} + w \frac{\partial v}{\partial z} &= -\frac{1}{\rho} \frac{\partial p}{\partial y} + Y, \\ \frac{\partial w}{\partial t} + u \frac{\partial w}{\partial x} + v \frac{\partial w}{\partial y} + w \frac{\partial w}{\partial z} &= -\frac{1}{\rho} \frac{\partial p}{\partial z} + Z,\end{aligned}$$

where $\mathbf{F} = (X, Y, Z)$ is the external force per unit mass (or body force). These are *three* partial differential equations in the *four* dependent variables u, v, w, p and four independent variables x, y, z, t . For a complete system we require four equations in the four variables, and the extra equation is the conservation of mass or *continuity equation* which for an incompressible fluid has the form

$$\nabla \cdot \mathbf{u} = 0, \quad \text{or} \quad \frac{\partial u}{\partial x} + \frac{\partial v}{\partial y} + \frac{\partial w}{\partial z} = 0.$$

3.1 Equations of motion for an incompressible viscous fluid

It can be shown that the viscous (frictional) forces in a fluid may be expressed as $\mu \nabla^2 \mathbf{u} = \rho \nu \nabla^2 \mathbf{u}$ where μ the *coefficient of viscosity* and $\nu = \mu/\rho$ the *kinematic viscosity* provide a measure of the magnitude of the frictional forces in particular fluid, i.e., μ and ν are properties of the fluid and are relatively small in air or water and large in glycerine or heavy oil. In a viscous fluid the equation of motion for unit mass,

$$\frac{\partial \mathbf{u}}{\partial t} + (\mathbf{u} \cdot \nabla) \mathbf{u} = -\frac{1}{\rho} \nabla p + \mathbf{F} + \nu \nabla^2 \mathbf{u}$$

local accel- eration	advective accelera- tion	pressure gradient force	body force	viscous force
-------------------------	--------------------------------	-------------------------------	------------	------------------

is known as the *Navier-Stokes equation*. We require also the continuity equation,

$$\nabla \cdot \mathbf{u} = 0,$$

to close the system of four differential equations in four dependent variables. There is no equivalent to the continuity equation in either particle or rigid body mechanics, because in general mass is permanently associated with bodies. In fluids, however, we must ensure that holes do not appear or that fluid does not double up, and we do this by requiring that $\nabla \cdot \mathbf{u} = 0$, which implies that in the absence of sources

or sinks there can be no net flow either into or out of any closed surface. We may regard this as a geometric condition on the flow of an incompressible fluid. It is not, of course, satisfied by a compressible fluid (c.f. a bicycle pump). We say that any incompressible flow satisfying the continuity equation $\nabla \cdot \mathbf{u} = 0$ is a *kinematically possible motion*.

The Navier-Stokes equation plus continuity equation are extremely important, but extremely difficult to solve. With possible further force terms on the right, they represent the behaviour of gaseous stars, the flow of oceans and atmosphere, the motion of the earth's mantle, blood flow, air flow in the lungs, many processes of chemistry and chemical engineering, the flow of water in rivers and in the permeable earth, aerodynamics of aeroplanes, and so forth....

The difficulty of solution, and there are probably no more than a dozen or so solutions known for very simple geometries, arises from:

- (i) the *non-linear* term $(\mathbf{u} \cdot \nabla) \mathbf{u}$ as a result of which, if \mathbf{u}_1 and \mathbf{u}_2 are two solutions of the equation, $c_1 \mathbf{u}_1 + c_2 \mathbf{u}_2$ (where c_1 and c_2 are constants) is in general *not* a solution, so that we lose one of our main methods of solution;
- (ii) the viscous term, which is small relative to other terms except close to boundaries, yet it contains the highest order derivatives

$$(\partial^2 \mathbf{u} / \partial x^2, \partial^2 \mathbf{u} / \partial y^2, \partial^2 \mathbf{u} / \partial z^2),$$

and hence determines the number of spatial boundary conditions that must be imposed to determine a solution.

The Navier-Stokes equation is too difficult for us to handle at present and we shall concentrate on Euler's equation from which we can learn much about fluid flow. Euler's equation is still non-linear, but there are clever methods to bypass this difficulty.

Example 4

Find the velocity field $\mathbf{u} = (-\Omega y, \Omega x, 0)$ for Ω constant as a possible flow of an incompressible liquid in a uniform gravitational field $\mathbf{F} \equiv g = (0, 0, -g)$.

Solution

- (i) This is a *kinematically-possible* steady incompressible flow, as \mathbf{u} satisfies the continuity equation

$$\nabla \cdot \mathbf{u} = \frac{\partial u}{\partial x} + \frac{\partial v}{\partial y} + \frac{\partial w}{\partial z} = 0 + 0 + 0 = 0.$$

(ii) We find the corresponding pressure field from Euler's equation.

$$\mathbf{u} \cdot \nabla \mathbf{u} = -\frac{1}{\rho} \nabla p + g.$$

If the given velocity field is substituted in the Euler's equation and it is rearranged in component form,

$$\frac{\partial p}{\partial x} = \rho \Omega^2 x, \quad \frac{\partial p}{\partial y} = \rho \Omega^2 y, \quad \frac{\partial p}{\partial z} = -\rho g.$$

We may now solve these three equations as follows.

$$\frac{\partial p}{\partial x} \equiv \left[\frac{\partial p}{\partial x} \right]_{y,z \text{ constant}} = \rho \Omega^2 x \Rightarrow p = \frac{1}{2} \rho \Omega^2 x^2 + \text{constant}$$

where "constant" can include arbitrary functions of both y and z (Check: $\partial p / \partial x = \rho \Omega^2 x + 0$). We continue in like manner with the other component equations:

$$\begin{aligned} \frac{\partial p}{\partial y} = \rho \Omega^2 y &\Rightarrow p = \frac{1}{2} \rho \Omega^2 y^2 + g(z, x), \\ \frac{\partial p}{\partial z} = -\rho g &\Rightarrow p = -\rho g z + h(x, y), \end{aligned}$$

where $f(y, z)$, $g(z, x)$ and $h(x, y)$ are *arbitrary functions*. By comparison of the three solutions we see that $f(y, z)$ must incorporate $\frac{1}{2} \rho \Omega^2 y^2$ and $-\rho g z$ and so forth. Hence the full solution is

$$p = \frac{1}{2} \rho \Omega^2 (x^2 + y^2) - \rho g z + \text{constant},$$

and we find that this solution does in fact satisfy each of the component Euler equations. On a free surface containing the origin $O(x = 0, y = 0, z = 0)$, $p = p_o \Rightarrow$ the constant $= p_o$, where p_o is atmospheric pressure, and $r^2 = x^2 + y^2$,

$$p = p_o + \frac{1}{2} \rho \Omega^2 r^2 - \rho g z.$$

(iii) The equation for the free surface is now given by $p = p_0$ over the whole liquid surface, which therefore has equation

$$z = \frac{\rho \Omega^2}{2 \rho g} r^2 = \frac{\Omega^2}{2g} r^2.$$

(iv) Streamlines in the flow are given by

$$\frac{dx}{u} = \frac{dy}{v} = \frac{dz}{w}, \quad \text{or} \quad \frac{dx}{-\Omega y} = \frac{dy}{\Omega x} = \frac{dz}{0},$$

yielding two relations

$$\begin{aligned} \int \Omega x \, dx + \int \Omega y \, dy = 0 & \Rightarrow x^2 + y^2 = \text{constant} \\ \int dz = 0 & \Rightarrow z = \text{constant} \end{aligned}$$

and streamlines are circles about the z -axis in planes $z = \text{constant}$. The velocity field represents rigid body rotation of fluid with angular velocity Ω about the axis Oz (imagine a tin of water on turntable!).

3.2 Equations of motion in cylindrical polars

Take the cylindrical polars (r, θ, z) and velocity (v_r, v_θ, v_z) . These are more complicated than rectangular Cartesians as v_r, v_θ change in direction with P (in fact OP rotates about Oz with angular velocity v_θ/r). Suppose that $\hat{\mathbf{r}}, \hat{\mathbf{n}}, \hat{\mathbf{z}}$ are the unit vectors at P in the radial, azimuthal and axial directions, as sketched in Fig. 3.1. Then $\hat{\mathbf{z}}$ is fixed in direction (and, of course, magnitude) but $\hat{\mathbf{r}}$ and $\hat{\mathbf{n}}$ rotate in the plane $z = 0$ as P moves, and it follows that $d\hat{\mathbf{z}}/dt = 0$, but that

$$\frac{d\hat{\mathbf{r}}}{dt} = \hat{\mathbf{n}}\dot{\theta}, \quad \frac{d\hat{\mathbf{n}}}{dt} = (-\hat{\mathbf{r}})\dot{\theta} = -\hat{\mathbf{r}}\dot{\theta}$$

Hence, as $\dot{\theta} = v_\theta/r$,

$$\mathbf{v} = (v_r\hat{\mathbf{r}} + v_\theta\hat{\mathbf{n}} + v_z\hat{\mathbf{z}}),$$

$$\dot{\mathbf{v}} = \dot{v}_r\hat{\mathbf{r}} + v_r\frac{d\hat{\mathbf{r}}}{dt} + \dot{v}_\theta\hat{\mathbf{n}} + v_\theta\frac{d\hat{\mathbf{n}}}{dt} + \dot{v}_z\hat{\mathbf{z}} = (\dot{v}_r - v_\theta^2/r)\hat{\mathbf{r}} + (\dot{v}_\theta + v_r v_\theta/r)\hat{\mathbf{n}} + \dot{v}_z\hat{\mathbf{z}}.$$

Recalling also that d/dt must be interpreted here as D/Dt , the acceleration is

$$\left[\frac{Dv_r}{Dt} - \frac{v_\theta^2}{r}, \frac{Dv_\theta}{Dt} + \frac{v_r v_\theta}{r}, \frac{Dv_z}{Dt} \right].$$

If we now write (u, v, w) in place of (v_r, v_θ, v_z) , Euler's equations in cylindrical polar coordinates take the form

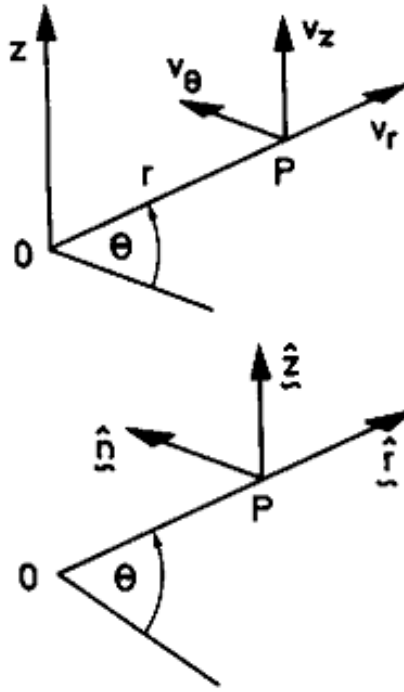

Figure 3.1: Velocity vectors and coordinate axes in cylindrical polar coordinates.

$$\begin{aligned}
 \frac{\partial u}{\partial r} + \frac{1}{r} \frac{\partial v}{\partial \theta} + \frac{\partial w}{\partial z} &= 0 \\
 \frac{\partial u}{\partial t} + u \frac{\partial u}{\partial r} + \frac{v}{r} \frac{\partial u}{\partial \theta} + w \frac{\partial u}{\partial z} - \frac{v^2}{r} &= -\frac{1}{\rho} \frac{\partial p}{\partial r} + F_r, \\
 \frac{\partial v}{\partial t} + u \frac{\partial v}{\partial r} + \frac{v}{r} \frac{\partial v}{\partial \theta} + w \frac{\partial v}{\partial z} + \frac{uv}{r} &= -\frac{1}{\rho r} \frac{\partial p}{\partial \theta} + F_\theta, \\
 \frac{\partial w}{\partial t} + u \frac{\partial w}{\partial r} + \frac{v}{r} \frac{\partial w}{\partial \theta} + w \frac{\partial w}{\partial z} &= -\frac{1}{\rho} \frac{\partial p}{\partial z} + F_z.
 \end{aligned}$$

3.3 Dynamic pressure (or perturbation pressure)

If in Euler's equation for an incompressible fluid,

$$\frac{D\mathbf{u}}{Dt} = -\frac{1}{\rho} \nabla p + \mathbf{g}, \quad (3.1)$$

we put $\mathbf{u} = 0$ to represent the equilibrium or rest state,

$$0 = -\frac{1}{\rho}\nabla p_0 + \mathbf{g} \quad (3.2)$$

This is merely the hydrostatic equation

$$\nabla p_0 = \rho \mathbf{g} \text{ or } \frac{\partial p_0}{\partial x} = 0, \frac{\partial p_0}{\partial y} = 0, \frac{\partial p_0}{\partial z} = -\rho g,$$

where p_0 is the hydrostatic pressure. Subtracting (3.1)-(3.2) we obtain

$$\frac{D\mathbf{u}}{Dt} = -\frac{1}{\rho}\nabla(p - p_0) = -\frac{1}{\rho}\nabla p_d$$

where $p_d = p - p_0 = (\text{total pressure}) - (\text{hydrostatic pressure})$ is known as the *dynamic pressure* (or sometimes, especially in dynamical meteorology, the *perturbation pressure*). The dynamic pressure is the excess of total pressure over hydrostatic pressure, and is the only part of the pressure field associated with motion.

We shall usually omit the suffix $_d$ since it is fairly clear that if \mathbf{g} is included we are using *total* pressure, and if no \mathbf{g} appears we are using the dynamic pressure,

$$\frac{D\mathbf{u}}{Dt} = \frac{\partial \mathbf{u}}{\partial t} + (\mathbf{u} \cdot \nabla) \mathbf{u} = -\frac{1}{\rho}\nabla p.$$

3.4 Boundary conditions for fluid flow

- (i) *Solid boundaries*: there can be no normal component of velocity through the boundary. If friction is neglected there may be free slip along the boundary, but friction has the effect of slowing down fluid near the boundary and it is observed experimentally that there is no relative motion at the boundary, either normal or tangential to the boundary. In fluids with low viscosity, this tangential slowing down occurs in a thin *boundary layer*, and in a number of important applications this boundary layer is so thin that it can be neglected and we can say approximately that the fluid slips at the surface; in many other cases the entire boundary layer separates from the boundary and the inviscid model is a very poor approximation. Thus, in an inviscid flow (also called the flow of an ideal fluid) the fluid velocity must be tangential at a rigid body, and:

$$\begin{array}{ll} \text{for a surface at rest} & \mathbf{n} \cdot \mathbf{u} = 0; \\ \text{for a surface with velocity } \mathbf{u}_s & \mathbf{n} \cdot (\mathbf{u} - \mathbf{u}_s) = 0. \end{array}$$

- (ii) *Free boundaries*: at an interface between two fluids (of which one might be water and one air) the pressure must be continuous, or else there would be a finite force on an infinitesimally small element of fluid causing unbounded acceleration; and the component of velocity *normal* to the interface must be continuous. If viscosity is neglected the two fluids may slip over each other. If there is liquid under air, we may take $p = p_0 =$ atmospheric pressure at the interface, where p_0 is taken as constant. If surface tension is important there may be a pressure difference across the curved interface.

3.4.1 An alternative boundary condition

As the velocity at a boundary of an *inviscid fluid* must be wholly tangential, it follows that a fluid particle once at the surface must always remain at the surface. Hence for a surface or boundary with equation

$$F(x, y, z, t) = 0,$$

if the coordinates of a fluid particle satisfy this equation at one instant, they must satisfy it always. Hence, moving with the fluid at the boundary,

$$\frac{DF}{Dt} = 0$$

or

$$\frac{\partial F}{\partial t} + \mathbf{u} \cdot \nabla F = 0,$$

as F must remain zero for all time for each particle at the surface.

Exercises

- 3.1 Describe briefly the physical significance of each term in the Euler equation for the motion of an incompressible, inviscid fluid,

$$\rho \frac{\partial \mathbf{u}}{\partial t} + \rho (\mathbf{u} \cdot \nabla) \mathbf{u} = -\nabla p + \rho \mathbf{g},$$

explaining clearly why the two terms on the left are needed to express the mass acceleration fully. To what amount of fluid does this equation apply?

- 3.2 The velocity components in an incompressible fluid are

$$u = -\frac{2xyz}{(x^2 + y^2)^2}, \quad v = \frac{(x^2 - y^2)z}{(x^2 + y^2)^2}, \quad w = \frac{y}{x^2 + y^2}.$$

Show that this velocity represents a kinematically possible flow (that is, that the equation of continuity is satisfied).

- 3.3 Find the pressure field in the inviscid, incompressible flow with velocity field

$$\mathbf{u} = (nx, -ny, 0).$$

- 3.4 If $\hat{\mathbf{r}}$, $\hat{\mathbf{n}}$ are the unit radial and azimuthal vectors in cylindrical polars (r, θ, z) show that

$$\frac{d\hat{\mathbf{n}}}{dt} = -\dot{\theta} \hat{\mathbf{r}}$$

- 3.5 State the boundary conditions for velocity in an inviscid fluid at (a) a stationary rigid boundary bisecting the $0x, 0y$ axes; (b) a rigid boundary moving with velocity $V\mathbf{j}$ in the direction of the y axis.
- 3.6 Write down Euler's equation for the motion of an inviscid fluid in a gravitational uniform field: (i) in terms of the total pressure p , and (ii) in terms of the dynamic pressure p_d . Relate p and p_d .
- 3.7 Explain briefly why $DF/Dt = 0$ provides an alternative form of the boundary condition for flow in a region of inviscid fluid bounded by the surface $F(x, y, z, t) = 0$. Find the boundary condition on velocity at a fixed plane $y + mx = 0$ and show that the equation $y = m(x + y - Ut)$ represents a certain inclined plane moving with the speed U in a certain direction. Find this direction and obtain the boundary condition at this plane.

Chapter 4

Bernoulli's equation

For steady inviscid flow under external forces which have a potential Ω such that $\mathbf{F} = -\nabla\Omega$ Euler's equation reduces to

$$\mathbf{u} \cdot \nabla \mathbf{u} = -\frac{1}{\rho} \nabla p - \nabla \Omega,$$

and for an incompressible fluid

$$\mathbf{u} \cdot \nabla \mathbf{u} + \frac{1}{\rho} \nabla (p + \rho \Omega) = 0.$$

We may regard $p + \rho \Omega$ as a more general *dynamic pressure*; but for the particular case of gravitation potential, $\Omega = gz$ and $\mathbf{F} = -\nabla\Omega = -(0, 0, g) = -g\mathbf{k}$.

We note that

$$\begin{aligned} \mathbf{u} \cdot (\mathbf{u} \cdot \nabla) \mathbf{u} &= u(\mathbf{u} \cdot \nabla) u + v(\mathbf{u} \cdot \nabla) v + w(\mathbf{u} \cdot \nabla) w \\ &= \mathbf{u} \cdot \nabla \frac{1}{2} (u^2 + v^2 + w^2) \\ &= (\mathbf{u} \cdot \nabla) \frac{1}{2} \mathbf{u}^2, \end{aligned}$$

using the fact that $\mathbf{u} \cdot \nabla$ is a scalar differential operator. Hence,

$$\mathbf{u} \cdot [\mathbf{u} \cdot \nabla \mathbf{u} + \nabla (p/\rho + \Omega)] = \mathbf{u} \cdot \nabla \left[\frac{1}{2} \mathbf{u}^2 + p/\rho + \Omega \right] = 0,$$

and it follows that $(\frac{1}{2} \mathbf{u}^2 + p/\rho + \Omega)$ is constant along each streamline (as $\mathbf{u} \cdot \nabla$ is proportional to the rate-of-change in the direction \mathbf{u} of streamlines). Thus for steady, incompressible, inviscid flow $(\frac{1}{2} \mathbf{u}^2 + p/\rho + \Omega)$ is a constant on a streamline, although the constant will generally be different on each different streamline.

4.1 Application of Bernoulli's equation

(i) Draining a reservoir through a small hole

If the draining opening is of much smaller cross-section than the reservoir (Fig. 4.1), the water surface in the tank will fall very slowly and the flow may be regarded as approximately steady. We may take the outflow speed u_A as approximately uniform across the jet and the pressure p_A uniform across the jet and equal to the atmospheric pressure p_0 outside the jet (for, if this were not so, there would be a difference in pressure across the surface of the jet, and this would accelerate the jet surface radially, which is not observed, although the jet is accelerated downwards by its weight). Hence, on the streamline AB ,

$$\frac{1}{2}u_A^2 + p_0/\rho = \frac{1}{2}u_B^2 + p_0/\rho + gh,$$

and as $u_B \ll u_A$ $u_A = \sqrt{2gh}$.

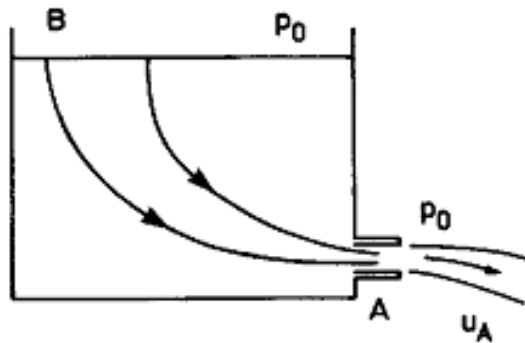

Figure 4.1: Draining of a reservoir.

This is known as Toricelli's theorem. Note that the outflow speed is that of free fall from B under gravity; this clearly neglects any viscous dissipation of energy.

(ii) Bluff body in a stream; Pitot tube

Suppose that a stream has uniform speed U_0 and pressure p_0 far from any obstacle, and that it then flows round a bluff body (Fig. 4.2). The flow must be slowed down in front of the body and there must be one *dividing streamline* separating fluid which follows past one side of the body or the other. This dividing streamline must end on the body at a *stagnation point* at which the velocity is zero and the pressure

$$p = p_0 + \frac{1}{2}\rho U_0^2.$$

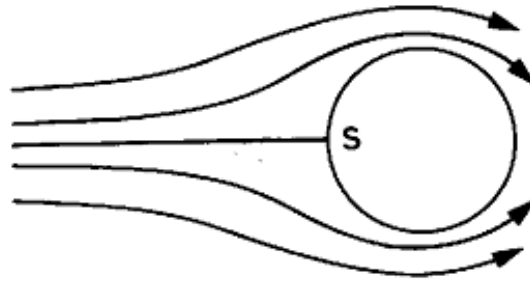

Figure 4.2: Flow round a bluff body in this case a cylinder.

This provides the basis for the *Pitot tube* in which a pressure measurement is used to obtain the free stream velocity U_0 . The pressure $p = p_0 + \frac{1}{2}\rho U_0^2$ is the *total* or *Pitot pressure* (also known as the *total head*) of the free stream, and differs from the static pressure p_0 by the dynamic pressure $\frac{1}{2}\rho U_0^2$. The

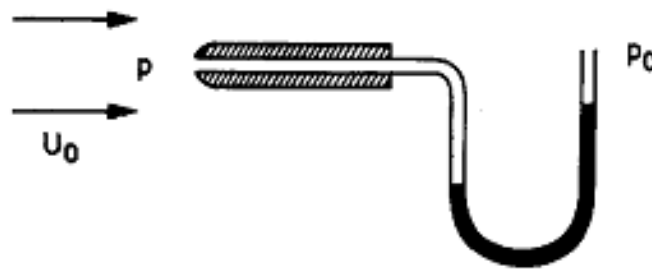

Figure 4.3: Principle of a Pitot tube.

Pitot tube consists of a tube directed into the stream with a small central hole connected to a *manometer* for measuring pressure difference $p - p_0$ (Fig. 4.3). At equilibrium there is no flow through the tube, and hence the left hand pressure on the manometer is the total pressure $p_0 + \frac{1}{2}\rho U_0^2$. The static pressure p_0 can be obtained from a *static tube* which is normal to the flow.

The *Pitot-static tube* combines a Pitot tube and a static tube in a single head (Fig. (4.4)). The difference between Pitot pressure ($p_0 + \frac{1}{2}\rho U_0^2$) and static pressure (p_0) is the dynamic pressure $\frac{1}{2}\rho U_0^2$, and the manometer reading therefore provides a measure of the free stream velocity U_0 . The Pitot-static tube can also be flown in an aeroplane and used to determine the speed of the aeroplane through the air.

(iii) Venturi tube

This is a device for measuring fluid velocity and discharge (Fig. 4.5). Suppose that there is a restriction of cross-sections in a pipe of cross-section S , with

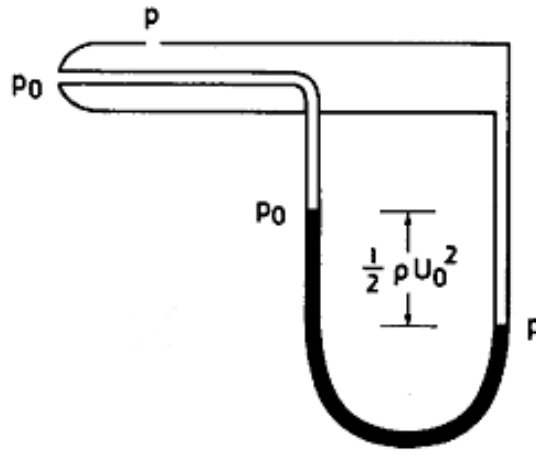

Figure 4.4: A Pitot-static tube.

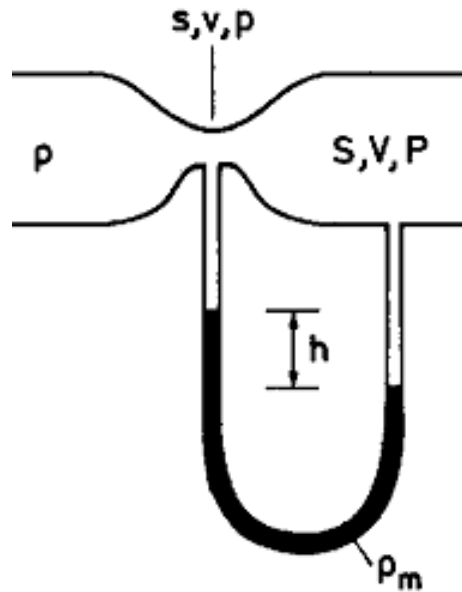

Figure 4.5: A Venturi tube.

velocities v , V and pressures p , P in the two sections, respectively, the pipe being horizontal. Then

$$\frac{p}{\rho} + \frac{1}{2}v^2 = \frac{P}{\rho} + \frac{1}{2}V^2$$

or

$$v^2 - V^2 = \frac{2}{\rho} (P - p) = \frac{2}{\rho} \rho_m gh = 2gh \frac{\rho_m}{\rho}.$$

The discharge

$$Q = vs = VS,$$

and substitution gives

$$\left[\frac{Q}{s}\right]^2 - \left[\frac{Q}{S}\right]^2 = 2gh\frac{\rho_m}{\rho},$$

i.e.,

$$Q = \frac{sS}{\sqrt{S^2 - s^2}} \sqrt{2gh\frac{\rho_m}{\rho}} \quad V = \frac{Q}{S} = \frac{s}{\sqrt{S^2 - s^2}} \sqrt{2gh\frac{\rho_m}{\rho}}.$$

Exercises

1. Hold two sheets of paper at A and B with a finger between the two at top and bottom, and blow between the sheets as illustrated in Fig. 4.6. The trailing edges of the sheets will not move apart as you might have anticipated, but together. Explain this in terms of Bernoulli's equation, assuming the flow to be steady.

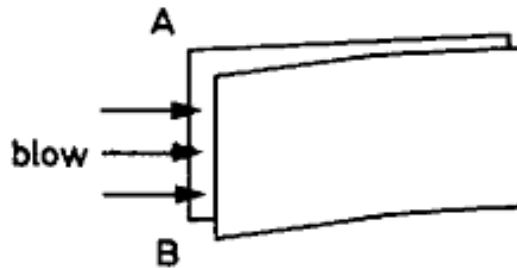

Figure 4.6:

2. Explain why there is an increase in pressure on the side of a building facing the wind.
3. A uniform straight open rectangular channel carries a water flow of mean speed U and depth h . The channel has a constriction which reduces its width by half and it is observed that the depth of water in the constriction is only $\frac{1}{2}h$. By applying Bernoulli's theorem to a surface streamline find U in terms of g and h .
4. Using Bernoulli's equation (often referred to as Bernoulli's theorem):
 - (i) show that air from a balloon at excess pressure p_1 above atmospheric will emerge with approximate speed $\sqrt{2p_1/\rho}$;

- (ii) find the depth of water in the steady state in which a vessel, with a waste pipe of length 0.01 m and cross-sectional area $2 \times 10^{-5} \text{ m}^2$ protruding vertically below its base, is filled at the constant rate $3 \times 10^{-5} \text{ m}^3 \text{ s}^{-1}$.
5. A vertical round post stands in a river, and it is observed that the water level at the upstream face of the post is slightly higher than the level at some distance to either side. Explain why this is so, and find the increase in the height in terms of the surface stream speed U and acceleration of gravity g . Estimate the increase in height for a stream with undisturbed surface speed 1 ms^{-1} .

Chapter 5

The vorticity field

The vector $\boldsymbol{\omega} = \nabla \times \mathbf{u} \equiv \text{curl } \mathbf{u}$ is called the *vorticity* (from Latin for a whirlpool). The vorticity vector $\boldsymbol{\omega}(\mathbf{x}, t)$ defines a *vector field*, just like the velocity field $\mathbf{u}(\mathbf{x}, t)$. In the case of the velocity, we can define streamlines that are everywhere in the direction of the velocity vector at a given time. Similarly we can define *vortex lines* that are everywhere in the direction of the vorticity vector at a given time. We will show that the vorticity is twice the local angular velocity in the flow.

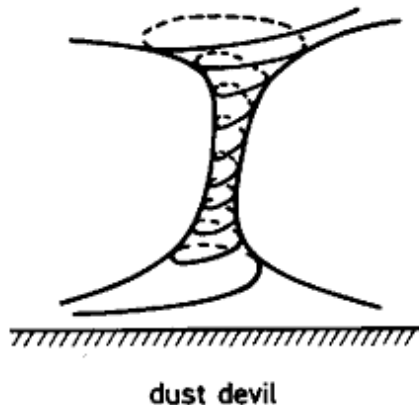

Figure 5.1:

- (i) Bundles of vortex lines make up *vortex tubes*.
- (ii) Thin *vortex tubes*, such that their constituent vortex lines are approximately parallel to the tube axis, are called *vortex filaments* (see below).
- (iii) The vorticity field is *solenoidal*, i.e. $\nabla \cdot \boldsymbol{\omega} = 0$. This very important result is proved as follows:

$$\nabla \cdot \boldsymbol{\omega} = \nabla \cdot (\nabla \times \mathbf{u})$$

$$= \frac{\partial}{\partial x} \left[\frac{\partial w}{\partial y} - \frac{\partial v}{\partial z} \right] + \frac{\partial}{\partial y} \left[\frac{\partial u}{\partial z} - \frac{\partial w}{\partial x} \right] + \frac{\partial}{\partial z} \left[\frac{\partial v}{\partial x} - \frac{\partial u}{\partial y} \right] = 0.$$



Figure 5.2:

From the divergence theorem, for any volume V with boundary surface S

$$\int_S \boldsymbol{\omega} \cdot \mathbf{n} \, ds = \int_V \nabla \cdot \boldsymbol{\omega} \, dV = 0,$$

and there is zero net flux of vorticity (or vortex tubes) out of any volume: hence there can be no sources of vorticity in the interior of a fluid (cf. sources of mass can exist in a velocity field!).

(iv) Consider a length P_1P_2 of vortex tube. From the divergence theorem

$$\int_S \boldsymbol{\omega} \cdot \mathbf{n} \, ds = \int_V \nabla \cdot \boldsymbol{\omega} \, dV = 0.$$

We can divide the surface of the length P_1P_2 into cross-sections and the tube wall,

$$S = S_1 + S_2 + S_{wall},$$

or

$$\int_S \boldsymbol{\omega} \cdot \mathbf{n} \, ds = \int_{S_1} \boldsymbol{\omega} \cdot \mathbf{n} \, ds + \int_{S_2} \boldsymbol{\omega} \cdot \mathbf{n} \, ds + \int_{S_{wall}} \boldsymbol{\omega} \cdot \mathbf{n} \, ds = 0. \quad (5.1)$$

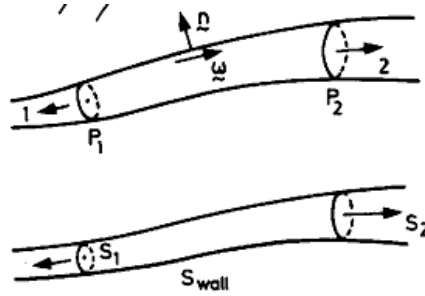

Figure 5.3:

However, the contribution from the wall (where $\omega \perp \mathbf{n}$) is zero, and hence

$$\int_{S_2} \omega \cdot \mathbf{n} ds = \int_{S_1} \omega \cdot (-\mathbf{n}) ds$$

where the positive sense for normals is that of increasing distance along the tube from the origin. Hence

$$\int_{S_{section}} \omega \cdot \mathbf{n} ds$$

measured over a cross-section of the vortex tube with \mathbf{n} taken in the same sense is constant, and taken as the *strength of the vortex tube*.

In a *thin* vortex tube, we have approximately:

$$\int_S \omega \cdot \mathbf{n} dS \approx \omega \cdot \mathbf{n} \int_S dS = \omega S$$

and $\omega \times \text{area} = \text{constant along tube}$ (a property of all solenoidal fields). Here, $\omega = |\omega|$.

(v) Circulation $\oint_C \mathbf{u} \cdot d\mathbf{r}$

From Stokes' theorem

$$\int_S (\nabla \times \mathbf{u}) \cdot \mathbf{n} dS = \oint_C \mathbf{u} \cdot d\mathbf{r}$$

Hence the line integral of the velocity field in any circuit C that passes once round a vortex tube is equal to the total vorticity cutting any cap S on C , and is therefore equal to the strength of the vortex tube. We measure the strength of a vortex tube by calculating $\oint_C \mathbf{u} \cdot d\mathbf{r}$ around *any circuit* C enclosing the tube once only. The quantity $\oint_C \mathbf{u} \cdot d\mathbf{r}$ is termed the *circulation*.

Vorticity may be regarded as *circulation per unit area*, and the component in any direction of ω is

$$\lim_{S \rightarrow 0} \frac{1}{S} \oint_C \mathbf{u} \cdot d\mathbf{r}$$

where C is a loop of area S perpendicular to the direction specified.

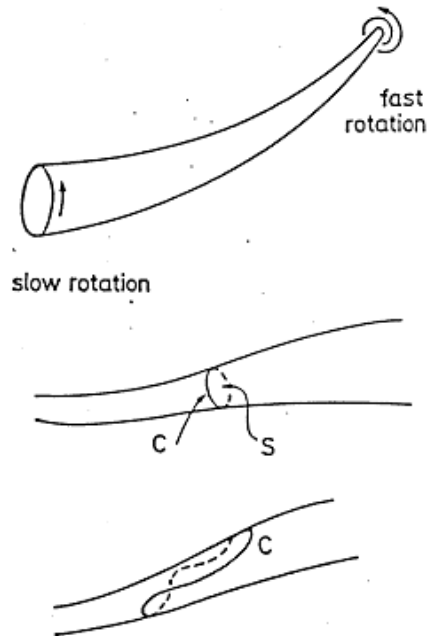

Figure 5.4:

Example 5

Show that $\frac{1}{2}u^2 + p/\rho + \Omega = \text{constant}$ along a vortex line for steady, incompressible, inviscid flow under conservative external forces.

Solution

As before

$$\mathbf{u} \cdot \nabla \mathbf{u} + \nabla (p/\rho + \Omega) = 0,$$

where

$$\mathbf{u} \cdot \nabla \mathbf{u} = \nabla \left(\frac{1}{2}u^2 \right) - \mathbf{u} \times (\nabla \times \mathbf{u}) = \nabla \left(\frac{1}{2}u^2 \right) - \mathbf{u} \times \boldsymbol{\omega}.$$

Hence

$$\mathbf{u} \times \boldsymbol{\omega} = \nabla \left[\frac{1}{2}u^2 + p/\rho + \Omega \right].$$

$$\mathbf{u} \cdot (\mathbf{u} \times \boldsymbol{\omega}) \equiv 0 = \mathbf{u} \cdot \nabla \left[\frac{1}{2}u^2 + p/\rho + \Omega \right] \quad (5.2)$$

$$\boldsymbol{\omega} \cdot (\mathbf{u} \times \boldsymbol{\omega}) \equiv 0 = \boldsymbol{\omega} \cdot \nabla \left[\frac{1}{2}u^2 + p/\rho + \Omega \right] \quad (5.3)$$

From Eq.(5.2) $\frac{1}{2}u^2 + p/\rho + \Omega = \text{constant}$ along a streamline, and from Eq.(5.3) $\frac{1}{2}u^2 + p/\rho + \Omega = \text{constant}$ along a vortex line. Thus we have a Bernoulli equation for vortex lines as well as for streamlines.

Exercises

1. Define the circulation round a closed circuit C and show that it is equal to the net vorticity cutting any cap on that circuit.
2. Show that vorticity may be interpreted as circulation per unit area of section.
3. Does fluid with velocity

$$\mathbf{u} = \left[z - \frac{2x}{r}, 2y - 3z - \frac{2y}{r}, x - 3y - \frac{2z}{r} \right]$$

possess vorticity (where $\mathbf{u} = (u, v, w)$ is the velocity in the Cartesian frame $\mathbf{r} = (x, y, z)$ and $r^2 = x^2 + y^2 + z^2$)? What is the circulation in the circle $x^2 + y^2 = 9, z = 0$? Is this flow incompressible?

4. Find the vorticity passing through the circuit $x^2 + y^2 = a^2, z = 0$ in the velocity field $\mathbf{u} = U(z, x, y)/a$.

5.1 The Helmholtz equation for vorticity

From Euler's equation for an incompressible fluid in a conservative force field.

$$\frac{\partial \mathbf{u}}{\partial t} + \mathbf{u} \cdot \nabla \mathbf{u} = -\frac{1}{\rho} \nabla p - \nabla \Omega$$

or

$$\frac{\partial \mathbf{u}}{\partial t} + \nabla \left(\frac{1}{2} \mathbf{u}^2 \right) - \mathbf{u} \times \boldsymbol{\omega} = -\nabla \left(\frac{p}{\rho} + \Omega \right);$$

taking the curl,

$$\nabla \times \frac{\partial \mathbf{u}}{\partial t} - \nabla \times (\mathbf{u} \times \boldsymbol{\omega}) + \nabla \times \left[\nabla \left(\frac{1}{2} \mathbf{u}^2 + \frac{p}{\rho} + \Omega \right) \right] = 0.$$

Using (i) $\nabla \times (\nabla \phi) \equiv 0$ for all ϕ , and (ii)

$$\begin{aligned} \nabla \times (\mathbf{u} \times \boldsymbol{\omega}) &= \mathbf{u} (\nabla \cdot \boldsymbol{\omega}) - \boldsymbol{\omega} (\nabla \cdot \mathbf{u}) + (\boldsymbol{\omega} \cdot \nabla) \mathbf{u} - (\mathbf{u} \cdot \nabla) \boldsymbol{\omega} \\ &= (\boldsymbol{\omega} \cdot \nabla) \mathbf{u} - (\mathbf{u} \cdot \nabla) \boldsymbol{\omega} \end{aligned}$$

as $\boldsymbol{\omega}$ is always solenoidal and \mathbf{u} is solenoidal in an incompressible fluid; we obtain

$$\frac{D\boldsymbol{\omega}}{Dt} = \frac{\partial \boldsymbol{\omega}}{\partial t} + (\mathbf{u} \cdot \nabla) \boldsymbol{\omega} = (\boldsymbol{\omega} \cdot \nabla) \mathbf{u},$$

which is the *Helmholtz vorticity equation*.

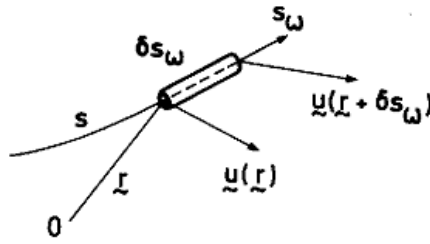

Figure 5.5:

5.1.1 Physical significance of the term $(\omega \cdot \nabla) \mathbf{u}$

We can understand the significance of the term $(\omega \cdot \nabla) \mathbf{u}$ in the Helmholtz equation by recalling that ∇ is a directional derivative and $(\omega \cdot \nabla) \mathbf{u}$ is proportional to the derivative in the direction of ω along the vortex line (see example 7).

$$\frac{D}{Dt} = (\omega \cdot \nabla) \mathbf{u} = |\omega| \hat{\omega} \cdot \nabla \mathbf{u} = \omega \frac{\partial \mathbf{u}}{\partial s_\omega},$$

where δs_ω is the length of an element of vortex tube. We now resolve \mathbf{u} into components \mathbf{u}_ω parallel to ω and \mathbf{u}_\perp at right angles to ω and hence to δs_ω . Then

$$\begin{aligned} \frac{\delta s_\omega}{\omega} \frac{D\omega}{Dt} &= \frac{\partial}{\partial s_\omega} (\mathbf{u}_\omega + \mathbf{u}_\perp) \delta s_\omega \\ &= \frac{\partial \mathbf{u}_\omega}{\partial s_\omega} \delta s_\omega + \frac{\partial \mathbf{u}_\perp}{\partial s_\omega} \delta s_\omega \\ &\approx \underbrace{[\mathbf{u}_\omega(r + \delta s_\omega) - \mathbf{u}_\omega(r)]}_{\text{rate of stretching of element}} + \underbrace{[\mathbf{u}_\perp(r + \delta s_\omega) - \mathbf{u}_\perp(r)]}_{\text{rate of turning of element}} \end{aligned}$$

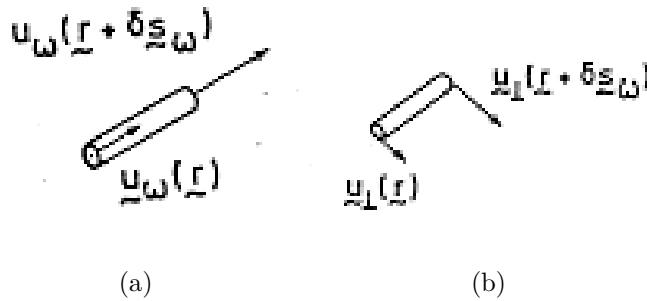

Figure 5.6:

- *stretching* along the length of the filament causes relative amplification of the vorticity field;
- *turning* away from the line of the filament causes a reduction of the vorticity in that direction, but an increase in the new direction.

Example 6

Discuss properties of the directional derivative.

Solution

Suppose that P is a point on the level surface ϕ of a scalar function, and that N and P' are points on the neighbouring surface $\phi + \delta\phi$ in the direction of the normal at P ($\hat{\mathbf{n}}$) and a specified curve ($\hat{\mathbf{s}}$). Then

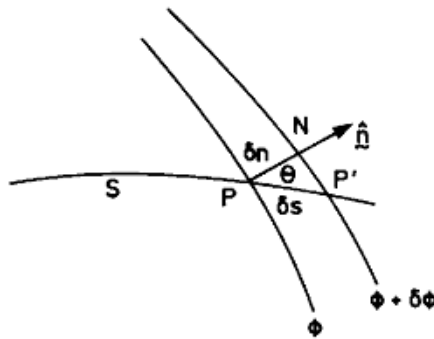

Figure 5.7:

$$\frac{\partial\phi}{\partial s} = \lim_{\delta n \rightarrow 0} \frac{\delta\phi}{\delta s} = \lim_{\delta n \rightarrow 0} \frac{\delta\phi}{\delta n} \frac{\delta n}{\delta s} = \frac{\partial\phi}{\partial n} \cos \theta.$$

$\nabla\phi = \hat{\mathbf{n}} \partial\phi/\partial n$ is the largest of the directional derivatives at P (as δn is the minimum separation distance between the surfaces, ϕ , $\phi + \delta\phi$) and has the direction $\hat{\mathbf{n}}$ of the outward normal at P . Then

$$\hat{\mathbf{s}} \cdot \nabla\phi = \hat{\mathbf{s}} \cdot \hat{\mathbf{n}} \frac{\partial\phi}{\partial n} = \frac{\partial\phi}{\partial n} \cos \theta = \frac{\partial\phi}{\partial s},$$

and $\boldsymbol{\omega} \cdot \nabla\mathbf{u} = |\boldsymbol{\omega}| \hat{\boldsymbol{\omega}} \cdot \nabla\mathbf{u} = \boldsymbol{\omega} \frac{\partial\mathbf{u}}{\partial s_\omega}$ where s_ω is distance along the vortex line.

5.2 Kelvin's Theorem

The ideas of vorticity and circulation are important because of the permanence of circulation under deformation of the flow due to pressure forces. We next look at the rate-of-change of circulation round a circuit moving with an incompressible, inviscid fluid:

$$\begin{aligned}\frac{D}{Dt} \oint \mathbf{u} \cdot d\mathbf{r} &= \oint \frac{D}{Dt} (\mathbf{u} \cdot d\mathbf{r}) \\ &= \oint \frac{D\mathbf{u}}{Dt} \cdot d\mathbf{r} + \oint \mathbf{u} \cdot \frac{D}{Dt} d\mathbf{r}.\end{aligned}$$

The first integral on the right may be written $\oint \left(-\frac{1}{\rho}\nabla p - \nabla\Omega\right) \cdot d\mathbf{r}$, and the second one $\oint \mathbf{u} \cdot \frac{D}{Dt} d\mathbf{r} = \oint \mathbf{u} \cdot d\mathbf{u}$ (see Example 7). Hence

$$\begin{aligned}\oint \frac{D\mathbf{u}}{Dt} \cdot d\mathbf{r} &= \frac{D}{Dt} \oint \mathbf{u} \cdot d\mathbf{r} = \oint \left[-\frac{1}{\rho}\nabla p - \nabla\Omega\right] \cdot d\mathbf{r} + \oint \mathbf{u} \cdot d\mathbf{u} \\ &= \oint \left[-\frac{1}{\rho}dp - d\Omega + d\left(\frac{1}{2}\mathbf{u}^2\right)\right] \\ &= \oint d\left(-\frac{p}{\rho} - \Omega + \frac{1}{2}\mathbf{u}^2\right) \\ &= 0\end{aligned}$$

as $-p/\rho - \Omega + \frac{1}{2}\mathbf{u}^2$ returns to its initial value after one circuit since it is a single valued function.

Example 7

Show that $\oint \mathbf{u} \cdot \frac{D}{Dt} d\mathbf{r} = \oint \mathbf{u} \cdot d\mathbf{u}$.

Solution

Suppose that the elementary vector $\vec{P}\vec{Q} = \delta\mathbf{r}$ at t is advected with the flow to $\vec{P}'\vec{Q}' = \delta\mathbf{r}(t + \delta t)$ at $t + \delta t$. Then

$$\delta\mathbf{r}(t + \delta t) \approx -\mathbf{u}(\mathbf{r})\delta t + \delta\mathbf{r}(t) + \mathbf{u}(\mathbf{r} + \delta\mathbf{r})\delta t,$$

or

$$\delta\mathbf{r}(t + \delta t) - \delta\mathbf{r}(t) \approx \mathbf{u}(\mathbf{r} + \delta\mathbf{r})\delta t - \mathbf{u}(\mathbf{r})\delta t,$$

or

$$\begin{aligned}\lim_{\delta t \rightarrow 0} \frac{\delta\mathbf{r}(t + \delta t) - \delta\mathbf{r}(t)}{\delta t} &= \lim_{\delta s \rightarrow 0} \frac{\mathbf{u}(\mathbf{r} + \delta\mathbf{r}) - \mathbf{u}(\mathbf{r})}{\delta s} \delta s \\ \frac{D}{Dt}(\delta\mathbf{r}) &\approx \frac{\partial\mathbf{u}}{\partial s} \delta s \approx \delta\mathbf{u}\end{aligned}$$

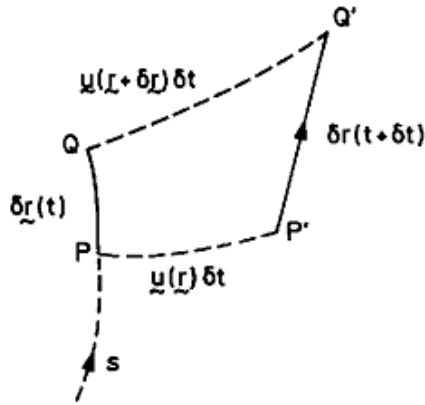

Figure 5.8:

in a fixed reference frame $0xyz$, where $|\delta\mathbf{r}| = \delta s$ and s is arc length along the path P . In the limit as $\delta\mathbf{r} \rightarrow d\mathbf{r}$, $\delta\mathbf{u} \rightarrow d\mathbf{u}$,

$$\frac{D}{Dt}(d\mathbf{r}) = d\mathbf{u}.$$

5.2.1 Results following from Kelvins Theorem

(i) **Helmholtz theorem: vortex lines move with the fluid**

Consider a tube of particles T which at the instant t forms a vortex tube of strength k . At that time the circulation round any circuit C' lying in the tube wall, but *not* linking (i.e. embracing) the tube is zero, while that in an circuit C linking the tube *once* is k . These circulations suffer no change moving with the fluid: hence the circulation in C' remains zero and that in C remains k , i.e. the fluid comprising the vortex tube at T continues to comprise a vortex tube (as the vorticity component normal to the tube wall - measured in C' - is always zero), *and* the strength of the vortex remains constant. A vortex line is the limiting case of a small vortex tube: hence vortex lines move with (are frozen into) inviscid fluids.

- (ii) **A flow which is initially irrotational remains irrotational** Circulation is advected with the fluid in inviscid flows, and vorticity is “circulation per unit area”. If initially for all closed circuits in some region of flow, it must remain so for all subsequent times. Motion started from rest is initially irrotational (free from vorticity) and will therefore remain irrotational provided that it is inviscid.
- (iii) **The direction of the vorticity turns as the vortex line turns, and its magnitude increases as the vortex line is stretched.**

The circulation round a thin vortex tube remains the same; as it stretches the area of section decreases and

$$\frac{\text{circulation}}{\text{area}} = \text{vorticity}$$

increases in proportion to the stretch.

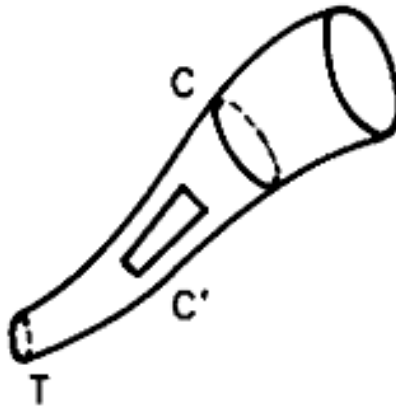

Figure 5.9:

Exercises

1. Explain the physical significance of each term in the Helmholtz equation for vorticity in inviscid incompressible flow.
2. Show that in two-dimensional flow, with $\mathbf{u} = (u(x, y), v(x, y), 0)$ vorticity is necessarily normal to the xy -plane, $\boldsymbol{\omega} = (0, 0, \zeta)$. Hence show that in two-dimensional inviscid incompressible flow the Helmholtz vorticity equation reduces to the form

$$\frac{D\boldsymbol{\omega}}{Dt} = 0,$$

so that if the distribution of vorticity is initially uniform it must remain so, and if the motion is initially irrotational (free from vorticity) it must remain so.

3. Explain the statement that in inviscid flows vorticity is “frozen into the fluid”.
4. Show that the circulation in any circuit embracing a vortex tube (i.e. passing once round it) in otherwise irrotational fluid is equal to the strength of the vortex tube

$$\oint_s \boldsymbol{\omega} \cdot \mathbf{n} \, dS$$

taken over *any* section of tube. Hence, or otherwise, show that a vortex tube cannot terminate in the interior of a fluid region.

5.3 Rotational and irrotational flow

Flow in which the vorticity is everywhere zero ($\nabla \times \mathbf{u} = 0$) is called *irrotational*. Other terms in use are *vortex free*; *ideal*; *perfect*. Much of fluid dynamics used to be concerned with analysing irrotational flows and deciding where these give a good representation of real flows, and where they are quite wrong.

We have neglected *compressibility* and *viscosity*. It can be shown that the neglect of compressibility is not very serious even at moderately high speeds, but the effect of neglecting viscosity can be disastrous. Viscosity *diffuses* the vorticity (much as conductivity diffuses heat) and progressively blurs the results derived above, the errors increasing with time.

There is no term in the Helmholtz equation

$$\frac{D\boldsymbol{\omega}}{Dt} = (\boldsymbol{\omega} \cdot \nabla) \mathbf{u}$$

corresponding to the generation of vorticity: the term $\boldsymbol{\omega} \cdot \nabla \mathbf{u}$ represents processing by stretching and turning of vorticity already present. It follows, therefore, that in homogeneous fluids all *vorticity must be generated at boundaries*. In real (viscous) fluids, this vorticity is carried away from the boundary by diffusion and is then advected into the body of the flow. But in inviscid flow vorticity cannot leave the surface by diffusion, nor can it leave by advection with the fluid as no fluid particles can leave the surface. It is this inability of inviscid flows to model the diffusion/advection of vorticity generated at boundaries out into the body of the flow that causes most of the failures of the model.

In inviscid flows we are left with a free slip velocity at the boundaries which we may interpret as a thin vortex sheet wrapped around the boundary.

5.3.1 Vortex sheets

Consider a thin layer of thickness δ in which the vorticity is large and is directed along the layer (parallel to $0y$), as sketched. The vorticity is

$$\eta = \frac{\partial u}{\partial z} - \frac{\partial w}{\partial x},$$

where $\partial u/\partial z$ is large (but not $\partial w/\partial x$, which would lead to very large w). We can suppose that within the vortex layer

$$u = u_0 + \omega z$$

changing from u_0 to $u_0 + \omega\delta$ between $z = 0$ and δ , with mean vorticity

$$\bar{\eta} = \frac{(u_0 + \omega\delta) - u_0}{\delta} = \omega.$$

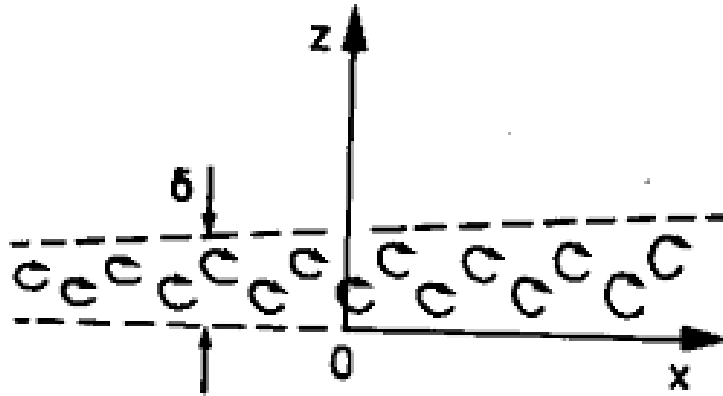

Figure 5.10:

This vortex layer provides a sort of roller action, though it is not of course rigid, and it also suffers high rate-of-strain.

If we idealize this vortex layer by taking the limit $\delta \rightarrow 0$, $\omega \rightarrow \infty$, such that $\omega\delta$ remains finite, we obtain a *vortex sheet*, which is manifest only through the free slip velocity. Such vortex sheets follow the contours of the boundary and clearly may be curved. They are infinitely thin sheets of vorticity with infinite magnitude across which there is finite difference in tangential velocity.

5.3.2 Line vortices

We can represent approximately also strong thin vortex tubes (e.g. tornadoes, waterspouts, draining vortices) by *vortex lines* without thickness. The circulation in a circuit round the tube tends to a definite non-zero limit as the circuit area (S) \rightarrow zero. If the flow outside the vortex is irrotational then all circuits round the vortex have the same circulation, the strength κ of the vortex:

$$\oint_C \mathbf{u} \cdot d\mathbf{r} \rightarrow \kappa \text{ as } C \rightarrow 0.$$

As a consequence, the velocity $\rightarrow \infty$ as the line vortex is approached, like $\kappa \propto (\text{distance})^{-1}$.

The effect of viscosity is to thicken vortex sheets and line vortices by diffusion; however, the effect of diffusion is often slow relative to that of advection by the flow, and as a result large regions of flow will often remain free from vorticity. Vortex sheets at surfaces diffuse to form *boundary layers* in contact with the surfaces; or if free they often break up into line vortices. Boundary layers on bluff bodies often *separate* or break away from the body, forming a *wake* of rotational, retarded flow behind the body, and it is these wakes that are associated with the *drag* on the body.

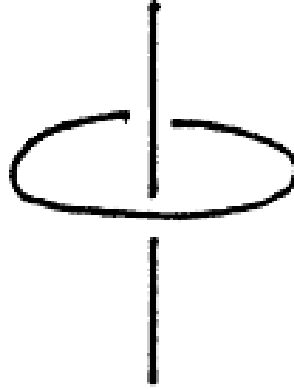

Figure 5.11:

5.3.3 Motion started from rest impulsively

Viscosity (which is really just distributed internal fluid friction) is responsible for retarding or damping forces which cannot begin to act until the motion has started; i.e. *take time to act*. Hence any flow will be *initially* irrotational everywhere except at actual boundaries. Within increasing time, vorticity will be diffused from boundaries and advected and diffused out into the flow.

Motion started from rest by an *instantaneous impulse* must be irrotational. For, if we integrate the Euler equation over the time interval $(t, t + \delta t)$

$$\int_t^{t+\delta t} \frac{D\mathbf{u}}{Dt} dt = \int_t^{t+\delta t} \mathbf{F} dt - \int_t^{t+\delta t} \frac{1}{\rho} \nabla p dt$$

or

$$[\mathbf{u}] \int_t^{t+\delta t} = \int_t^{t+\delta t} \mathbf{F} dt - \frac{1}{\rho} \nabla \int_t^{t+\delta t} p dt.$$

In the limit $\delta t \rightarrow 0$ for start-up by an instantaneous impulse, the impulse of the body force $\rightarrow 0$ (as the body force is unaffected by the impulsive nature of the start) and

$$\mathbf{u} - \mathbf{u}_0 = -\frac{1}{\rho} \nabla P,$$

where the fluid responds instantaneously with the impulsive pressure field $P = \int^{\delta t} p dt$, and the impulse on a fluid element is $-\nabla P$ per unit volume, producing a velocity from rest of

$$\mathbf{u}_0 = -\frac{1}{\rho} \nabla P.$$

This is irrotational as

$$\nabla \times v = -\frac{1}{\rho} \nabla \times (\nabla P) \equiv 0.$$

Chapter 6

Two dimensional flow of a homogeneous, incompressible, inviscid fluid

In two (x, z) dimensions, the Euler equations of motion are

$$\frac{\partial u}{\partial t} + u \frac{\partial u}{\partial x} + w \frac{\partial u}{\partial z} = -\frac{1}{\rho} \frac{\partial p}{\partial x}, \quad (6.1)$$

$$\frac{\partial w}{\partial t} + u \frac{\partial w}{\partial x} + w \frac{\partial w}{\partial z} = -\frac{1}{\rho} \frac{\partial p}{\partial z}, \quad (6.2)$$

and the continuity equation is

$$\frac{\partial u}{\partial x} + \frac{\partial w}{\partial z} = 0. \quad (6.3)$$

The vorticity ω has only one non-zero component, the y -component, i.e., $\omega = (0, \eta, 0)$, where

$$\eta = \frac{\partial u}{\partial z} - \frac{\partial w}{\partial x}. \quad (6.4)$$

Taking $(\partial/\partial z)$ (6.1) $-(\partial/\partial x)$ (6.2) and using the continuity equation we can show that

$$\frac{D\eta}{Dt} = 0. \quad (6.5)$$

This equation states that fluid particles conserve their vorticity as they move around. This is a powerful and useful constraint. In some problems, $\eta = 0$ for all particles. Such flows are called *irrotational*.

Consider, for example, the problem of a steady, uniform flow U past a cylinder of radius a . All fluid particles originate from far upstream ($x \rightarrow -\infty$) where $u = 0$,

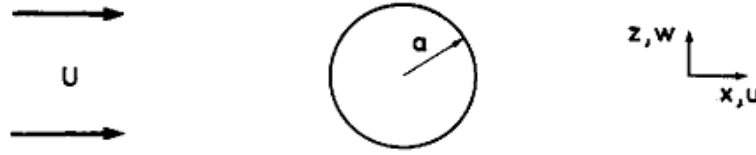

Figure 6.1:

$w = 0$, and therefore $\eta = 0$. It follows that fluid particles have zero vorticity for all time.

The inviscid flow problem can be solved as follows. Note that the continuity equation (6.3) suggests that we introduce a *streamfunction* ψ , defined by the equations

$$u = \frac{\partial \psi}{\partial z}, \quad w = -\frac{\partial \psi}{\partial x}. \quad (6.6)$$

Then Eq. (6.3) is automatically satisfied and it follows from (6.4) that

$$\eta = \frac{\partial^2 \psi}{\partial x^2} + \frac{\partial^2 \psi}{\partial z^2} \quad (6.7)$$

In the case of *irrotational flow*, $\eta = 0$ and ψ satisfies Laplace's equation:

$$\frac{\partial^2 \psi}{\partial x^2} + \frac{\partial^2 \psi}{\partial z^2} = 0. \quad (6.8)$$

Appropriate boundary conditions are found using (6.6). For example, on a solid boundary, the normal velocity must be zero, i.e., $\mathbf{u} \cdot \mathbf{n} = 0$ on the boundary. If $\mathbf{n} = (n_1, 0, n_3)$, it follows using (6.6) that $n_1 \frac{\partial \psi}{\partial z} - n_3 \frac{\partial \psi}{\partial x} = 0$, or $\mathbf{n} \wedge \nabla \psi = 0$ on the boundary. We deduce that $\nabla \psi$ is in the direction of \mathbf{n} , whereupon ψ is a constant on the boundary itself.

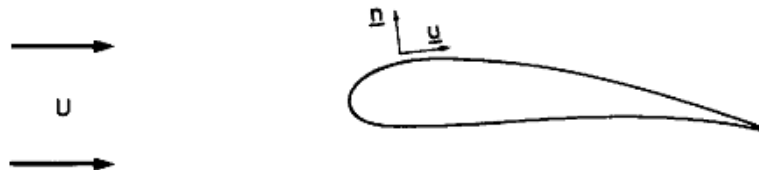

Figure 6.2:

Let us return to the example of uniform flow past a cylinder of radius a : see diagram below.

The problem is to solve Eq. (6.8) in the region outside the cylinder (i.e. $r > a$) subject to the boundary condition that

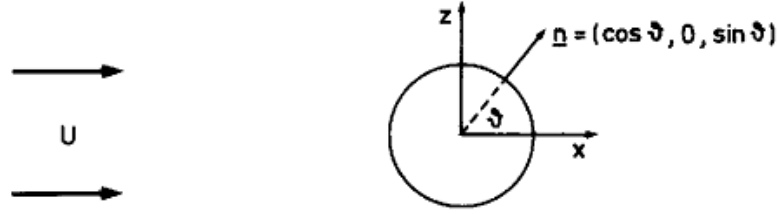

Figure 6.3:

$$u = \left(\frac{\partial \psi}{\partial z}, 0, -\frac{\partial \psi}{\partial x} \right) \rightarrow (U, 0, 0) \text{ as } r \rightarrow \infty, \quad (6.9)$$

and

$$\mathbf{u} \cdot \mathbf{n} = 0 \text{ on } r = a, \quad (6.10)$$

where $r = (x^2 + y^2)^{1/2}$. For this problem it turns out to be easier to work in cylindrical polar coordinates centred on the cylinder.

It is easy to check that the solution of (6.8) satisfying (6.9) and (6.10) is

$$\psi = U \left(r - \frac{a^2}{r} \right) \sin \theta. \quad (6.11)$$

Note that for large r , $\psi \sim Ur \sin \theta = Uz$, whereupon $u = \partial \psi / \partial z \sim U$ as required.

Now

$$\frac{\partial \psi}{\partial z} = \frac{\partial \psi}{\partial r} \frac{\partial r}{\partial z} + \frac{\partial \psi}{\partial \theta} \frac{\partial \theta}{\partial z}$$

and $z = r \sin \theta \Rightarrow \partial r / \partial z = 1 / \sin \theta$ and $1 = r \cos \theta \partial / \partial z$, whereupon

$$\frac{\partial \psi}{\partial z} = \frac{1}{\sin \theta} \frac{\partial \psi}{\partial r} + \frac{1}{r \cos \theta} \frac{\partial \psi}{\partial \theta}. \quad (6.12)$$

Similarly,

$$\frac{\partial \psi}{\partial x} = \frac{\partial \psi}{\partial r} \frac{\partial r}{\partial x} + \frac{\partial \psi}{\partial \theta} \frac{\partial \theta}{\partial x}$$

and $x = r \cos \theta \Rightarrow \partial r / \partial x = 1 / \cos \theta$ and $1 = -r \sin \theta \partial / \partial x$, whereupon

$$\frac{\partial \psi}{\partial x} = \frac{1}{\cos \theta} \frac{\partial \psi}{\partial r} - \frac{1}{r \sin \theta} \frac{\partial \psi}{\partial \theta}. \quad (6.13)$$

The boundary condition on the cylinder expressed by (6.10) requires that

$$\frac{\partial \psi}{\partial z} \cos \theta - \frac{\partial \psi}{\partial x} \sin \theta = 0$$

at $r = a$ and for all θ and, using (6.12) and (6.13), this reduces to

$$\frac{\partial \psi}{\partial \theta} = 0 \text{ at } r = a. \quad (6.14)$$

This equation implies that ψ is a constant on the cylinder; i.e., the surface of the cylinder must be a streamline. Substitution of (6.11) into (6.14) confirms that $\psi \equiv 0$ on the cylinder.

It remains to show that ψ satisfies (6.8). To do this one can use (6.12) and (6.13) to transform (6.8) to cylindrical polar coordinates; i.e.,

$$\frac{\partial}{\partial r} \left(r \frac{\partial \psi}{\partial r} \right) + \frac{1}{r} \frac{\partial^2 \psi}{\partial z^2} = 0. \quad (6.15)$$

It is now easy to verify that (6.11) satisfies (6.15) and is therefore the solution for steady irrotational flow past a cylinder. Note that the solution for ψ is unique only to within a constant value; if we add any constant to it, it will satisfy equation (6.8) or (6.15), but the velocity field would be unchanged.

It is important to note that we have obtained a solution without reference to the pressure field, but the pressure distribution determines the force field that drives the flow! We seem, therefore, to have by-passed Newton's second law, and have obviously avoided dealing with the nonlinear nature of the momentum equations (6.1) and (6.2). Looking back we will see that the trick was to use the vorticity equation, a derivative of the momentum equations. For a homogeneous fluid, the vorticity equation does not involve the pressure since $\nabla \wedge \nabla p \equiv 0$. We infer from the vorticity constraint [Eq. (6.7)] that the flow must be irrotational everywhere and use this, together with the continuity constraint (which is automatically satisfied when we introduce the streamfunction) to infer the flow field. If desired, the pressure field can be determined, for example, by integrating Eqs. (6.1) and (6.2), or by using Bernoulli's equation along streamlines.

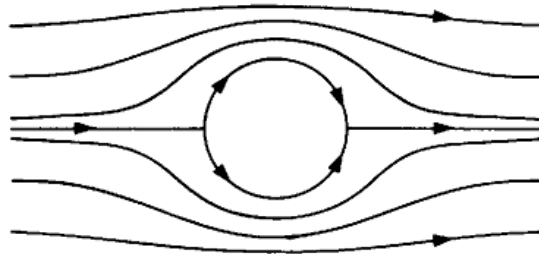

Figure 6.4:

Now the solution itself. The streamline corresponding with (11) are sketched in the figure overleaf. Note that they are symmetrical around the cylinder. Applying Bernoulli's equation to the streamline around the cylinder we find that the pressure distribution is symmetrical also so that the total pressure force on the upstream side

of the cylinder is exactly equal to the pressure on the downwind side. In other words, the net pressure force on the cylinder is zero! This result, which in fact is a general one for irrotational inviscid flow past a body of any shape, is known as *d'Alembert's Paradox*. It is not in accord with our experience as you know full well when you try to cycle against a strong wind. What then is wrong with the theory? Indeed, what does the flow round a cylinder look like in reality? The reasons for the breakdown of the theory help us to understand the limitations of inviscid flow theory in general and help us to see the circumstances under which it may be applied with confidence. First, let us return to the viscous theory.

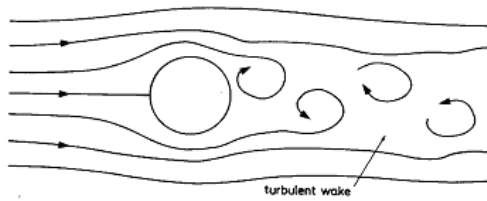

Figure 6.5:

The Navier-Stokes' equation is the statement of Newton's second law of motion for a viscous fluid. It reads

$$\frac{D\mathbf{u}}{Dt} = -\frac{1}{\rho}\nabla p + \nu\nabla^2\mathbf{u}. \quad (6.16)$$

The quantity of ν is called the *kinematic viscosity*. For air, $\nu = 1.5 \times 10^{-5} \text{ m}^2 \text{ s}^{-1}$; for water $\nu = 1.0 \times 10^{-6} \text{ m}^2 \text{ s}^{-1}$. The relative importance of viscous effect is characterized by the Reynolds' number Re , a nondimensional number defined by

$$Re = \frac{UL}{\nu},$$

where U and L are typical velocity and length scales, respectively. The Reynolds' number is a measure of the ratio of the acceleration term to the viscous term in (6.16). For many flows of interest, $Re \gg 1$ and viscous effects are relatively unimportant. However, these effects are always important near boundaries, even if only in a thin "boundary-layer" adjacent to the boundary. Moreover, the dynamics of this boundary layer may be crucial to the flow in the main body of fluid under certain circumstances. For example, in flow past a circular cylinder it has important consequences for the flow downstream. The observed streamline pattern in this case at large Reynolds numbers is sketched in the figure overleaf. Upstream of the cylinder the flow is similar to that predicted by the inviscid theory, except in a thin viscous

boundary-layer adjacent to the cylinder. At points on the downstream side of the cylinder the flow separates and there is an unsteady turbulent wake behind it. The existence of the wake destroys the symmetry in the pressure field predicted by the inviscid theory and there is net pressure force or *form drag* acting on the cylinder. Viscous stresses at the boundary itself cause additional drag on the body.

Chapter 7

Boundary layers in nonrotating fluids

We consider the boundary layer on a flat plate at normal incidence to a uniform stream U as shown.

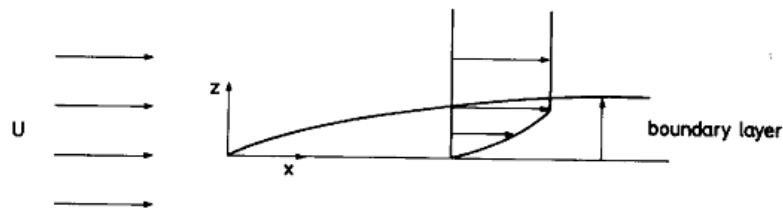

Figure 7.1:

The Navier Stokes' equations for steady two-dimensional flow with typical scales written below each component are:

$$u \frac{\partial u}{\partial x} + w \frac{\partial u}{\partial z} = -\frac{1}{\rho} \frac{\partial p}{\partial x} + \nu \left[\frac{\partial^2 u}{\partial x^2} + \frac{\partial^2 u}{\partial z^2} \right], \quad (7.1)$$

$$\left[\frac{U^2}{L} \quad \frac{UW}{H} \quad \frac{\Delta P}{\rho L} \quad \frac{\nu U}{L^2} \quad \frac{\nu U}{H^2} \right] \quad (7.2)$$

$$u \frac{\partial w}{\partial x} + w \frac{\partial w}{\partial z} = -\frac{1}{\rho} \frac{\partial p}{\partial z} + \nu \left[\frac{\partial^2 w}{\partial x^2} + \frac{\partial^2 w}{\partial z^2} \right], \quad (7.3)$$

$$\left[\frac{UW}{L} \quad \frac{W^2}{H} \quad \frac{\Delta P}{\rho H} \quad \frac{\nu W}{L^2} \quad \frac{\nu W}{H^2} \right] \quad (7.4)$$

and the continuity equation is

$$\begin{aligned} \frac{\partial u}{\partial x} + \frac{\partial w}{\partial z} &= 0, \\ \frac{U^2}{L} &= \frac{W}{H} \end{aligned} \quad (7.5)$$

From the continuity equation we infer that since $|\partial u/\partial x| = |\partial w/\partial z|$, $W \sim UH/L$ and hence the two advection terms on the left hand sides of (7.1) and (7.3) are the same order of magnitude: U^2/L in (7.2) and $(U^2/L)(H/L)$ in (7.4). Now, for a thin boundary layer, $H/L \ll 1$ so that the derivatives $\partial^2/\partial x^2$ in (7.1) and (7.3) can be neglected compared with $\partial^2/\partial z^2$. Then in (7.1), assuming that the pressure gradient term is not larger than both inertial or friction terms¹, we have

$$\frac{U}{L} \sim \frac{\nu U}{H^2} \geq \frac{\Delta P}{\rho L}.$$

The first two terms imply that

$$H \sim L Re^{-1/2}$$

where $Re = UL/\nu$ has the form of a Reynolds' number. Alternatively, this expression implies that the boundary thickness increases downstream like $x^{1/2}$ [i.e., $H \sim L^{1/2}(\nu/U)^{1/2}$]. Now from (7.4) we find that

$$\begin{aligned} \frac{\Delta P}{\rho H} / \frac{UW}{L} &\sim \frac{\rho U^2}{\rho H} / \frac{U^2 H}{L^2} \sim \frac{L^2}{H^2} \gg 1 \\ \frac{\Delta P}{\rho H} / \frac{\nu W}{H^2} &\sim \frac{\rho U^2}{\rho H} / \frac{\nu U}{HL} \sim \frac{UL}{\nu} = Re \gg 1. \end{aligned}$$

But if both the inertia terms and friction terms in (7.3) are much less than the pressure gradient term, the equation must be accurately approximated by

$$\frac{\partial p}{\partial z} = 0.$$

This implies that the perturbation pressure is constant across the boundary layer. It follows that the horizontal pressure gradient in the boundary layer is equal to that in free stream.

Collecting these results together we find that an approximate form of the Navier-Stokes' equations for the boundary layer to be

$$u \frac{\partial u}{\partial x} + w \frac{\partial u}{\partial z} = U \frac{dU}{dx} + \nu \frac{\partial^2 u}{\partial z^2}, \quad (7.6)$$

¹Note that if this were not true, steady flow would not be possible as the large pressure gradient would accelerate the flow further.

with

$$\frac{\partial u}{\partial x} + \frac{\partial w}{\partial z} = 0, \quad (7.7)$$

and $U = U(x)$ being the (possible variable) free stream velocity above the boundary layer, Equations (7.6) and (7.7) are called the boundary layer equations.

7.1 Blasius solution ($U = \text{constant}$)

Equation (7.6) reduces to

$$u \frac{\partial u}{\partial x} + w \frac{\partial u}{\partial z} = \nu \frac{\partial^2 u}{\partial z^2}, \quad (7.8)$$

and we look for a solution satisfying the boundary conditions $u = 0, w = 0$ at $z = 0$, $u \rightarrow U$ as $z \rightarrow \infty$ and $u = U$ at $x = 0$. Equation (7.7) suggests that we introduce a streamfunction ψ such that

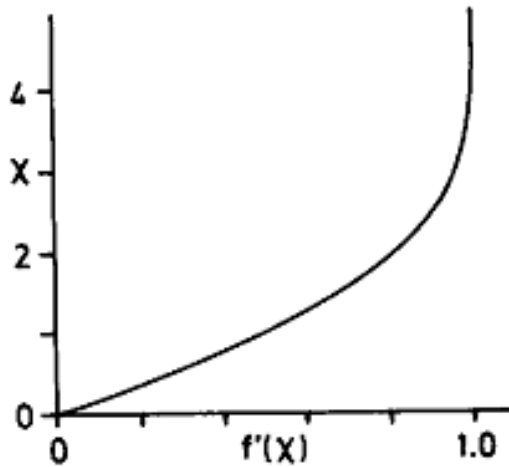

Figure 7.2:

whereupon ψ must satisfy the conditions $\psi = \text{constant}, \partial\psi/\partial z = 0$ at $z = 0$, $\psi \sim Uz$ as $z \rightarrow \infty$ and $\psi = Uz$ at $x = 0$. It is easy to verify that a solution satisfying these conditions is

$$u = \frac{\partial \psi}{\partial z}, \quad w = -\frac{\partial \psi}{\partial x}, \quad (7.9)$$

where

$$\chi = (U/2\nu x)^{1/2} z, \quad (7.10)$$

$f(\chi)$ satisfies the ordinary differential equation

$$f'' + ff' = 0, \quad (7.11)$$

subject to the boundary conditions

$$f(0) = f'(0) = 0; \quad f'(\infty) = 1. \quad (7.12)$$

Here, a prime denotes differentiation with respect to χ . It is easy to solve Eq. (7.11) subject to (7.12) numerically (see e.g. Rosenhead, 1966, *Laminar Boundary Layers*, p. 222-224). The profile of f' which characterizes the variation of u across the boundary layer thickness is proportional to χ and we might take $\chi = 4$ as corresponding with the edge of the boundary layer. Then (7.10) shows that the dimensional boundary thickness $\delta(x) = 4(2\nu x/U)^{1/2}$; i.e., increases like the square root of the distance from the leading edge of the plate. We can understand the thickening of the boundary layers as due to the progressive retardation of more and more fluid as the fictional force acts over a progressively longer distance downstream.

Often the boundary layer is relatively thin. Consider for example the boundary layer in an aeroplane wing. Assuming the wing to have a span of 3 m and that the aeroplane flies at 200 m s^{-1} , the boundary layer at the trailing edge of the wing (assuming the wing to be a flat plate) would have thickness of $4(2 \times 1.5 \times 10^{-5} \times 3/200)^{1/2} = 2.7 \times 10^{-3} \text{ m}$, using the value $\nu = 1.5 \times 10^{-5} \text{ m}^2 \text{ s}^{-1}$ for the viscosity of air. The calculation assumes that the boundary layer remains laminar; if it becomes turbulent, the random eddies in the turbulence have a much larger effect on the lateral momentum transfer than do random molecular motions, thereby increasing the effective value of ν , possibly by an order of magnitude or more, and hence the boundary layer thickness.

Note that the boundary layer is rotational since $\omega = (0, \eta, 0)$, where $\eta = \frac{\partial u}{\partial z} - \frac{\partial w}{\partial x}$, or approximately just $-\partial u/\partial z$.

7.2 Further reading

Acheson, D. J., 1990, *Elementary Fluid Dynamics*, Oxford University Press, pp406.

Morton, B. R., 1984: The generation and decay of vorticity. *Geophys. Astrophys. Fluid Dynamics*, **28**, 277-308.