

## INTRODUCTION TO AUTOMOBILE VEHICLE

An Automobile is a self propelled vehicle which contains the power source for its propulsion and is used for carrying passengers and goods on the ground, such as car, bus, trucks, etc.,

### TYPES OF AUTOMOBILE

☺ On the basis of load –

1. Heavy transport vehicle (HTV) or heavy motor vehicle (HMV),
2. Light transport vehicle (LTV), Light motor vehicle (LMV).

☺ On the basis of wheels –

1. Two wheeler vehicle, for example: Scooter, motorcycle, scooty, etc.
2. Three wheeler vehicle, for example: Auto rickshaw.
3. Three wheeler scooter for handicaps and tempo, etc.
4. Four wheeler vehicle, for example: Car, jeep, trucks, buses, etc.
5. Six wheeler vehicle, for example: Big trucks with two gear axles.

☺ On the basis of fuel used –

1. Petrol vehicle, e.g. motorcycle, scooter, cars, etc
2. Diesel vehicle, e.g. trucks, buses, etc.
3. Electric vehicle which use battery to drive.
4. Steam vehicle, e.g. an engine which uses steam engine.
5. Gas vehicle, e.g. LPG and CNG vehicles, where LPG is liquefied.

☺ On the basis of body style –

1. Sedan Hatchback car.
2. Coupe car Station wagon Convertible.
3. Van Special purpose vehicle, e.g. ambulance, milk van, etc.

☺ On the basis of Transmission –

1. Conventional vehicles with manual transmission, e.g. car with 5 gears.
2. Semi-automatic
3. Automatic: In automatic transmission, gears are not required to be changed manually.

☺ On the basis of drive –

1. Left hand drive
2. Right hand drive

☺ On the basis of driving axle –

1. Front wheel drive
  2. Rear wheel drive
  3. All wheel drive
- ☉ On the basis piston of engine –
1. Engine in Front - Most of the vehicles have engine in the front. Example: most of the cars,
  2. Engine in the Rear Side Very few vehicles have engine located in the rear. Example: Nano car.

### **VEHICLE CONSTRUCTION AND COMPONENTS**

The main components of an automobile refer to the following components;

1. Frame,
2. Chassis,
3. Body,
4. Power unit,
5. Transmission system

#### **FRAME**

The frame is the skeleton of the vehicle. It serves as a main foundation and base for alignment for the chassis.

1. Conventional frame,
2. Semi integral frame;
3. Integral or unitary frame.

#### **CHASSIS**

If the frame contains the base components its called as chassis. The components are like Engine, radiator, clutch, gearbox, silencer, road wheels, fuel tank, wirings, differential units, etc.,

#### **BODY**

Body is the superstructure of the vehicle and it is bolted to the chassis.

1. Car,
2. Truck,
3. Tractor,

4. Delivery van,
5. Jeep,
6. Bus, etc.,

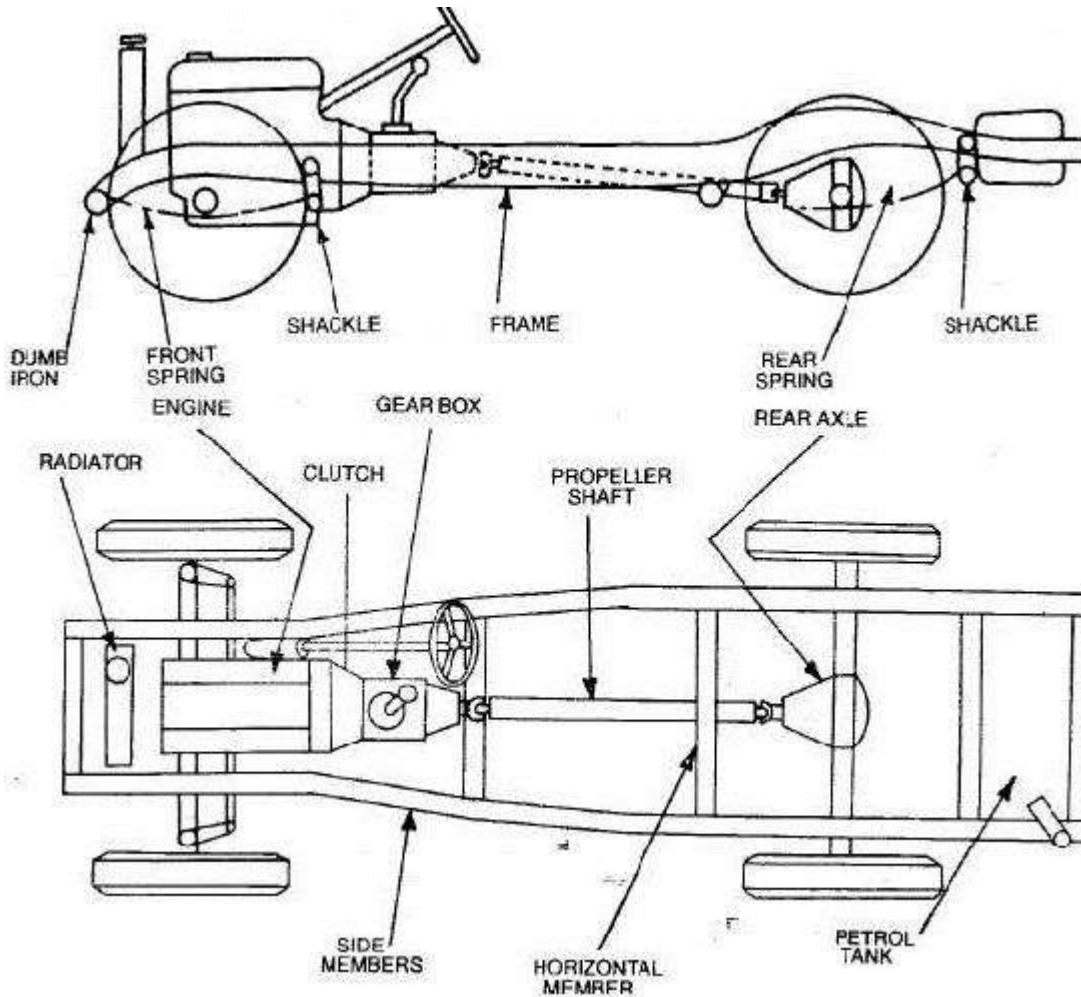

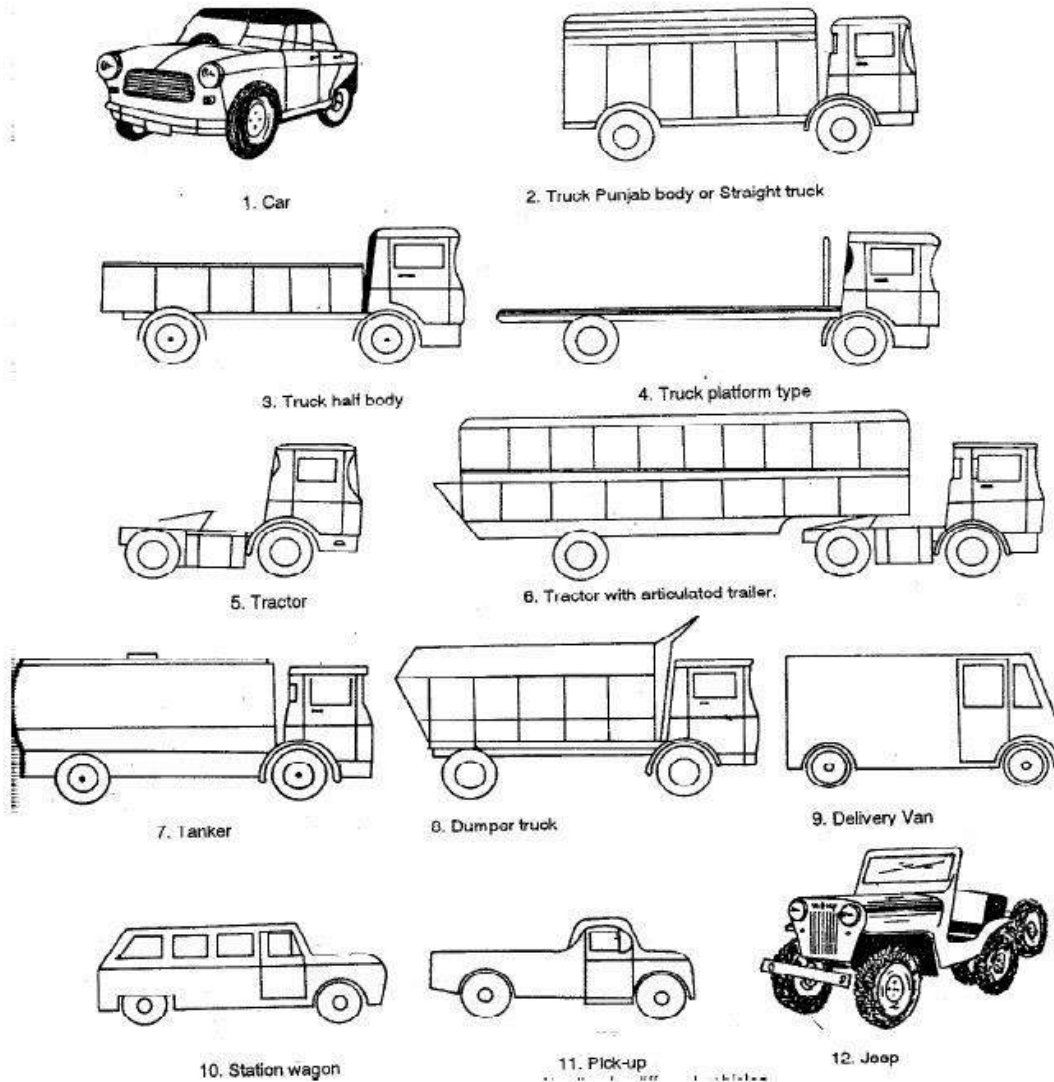

### COMPONANTS OF A ENGINE

Even though reciprocating internal combustion engines look quite simple, they are highly complex machines. There are hundreds of components that have to perform their functions satisfactorily to produce output power. There are two types of engines, viz., spark ignition (SI) and compression-ignition (CI) engine. Let us now go through the important engine components and the nomenclature associated with an engine.

### TERMS CONNECTED WITH I.C. ENGINE

1. Bore: The inside diameter of the cylinder is called bore.
2. Stroke: The linear distance along the cylinder axis between two limiting positions is called stroke.

3. Top Dead Center ( T.D.C.) : the top most position of the piston towards cover end side of the cylinder is called T.D.C.
4. Bottom dead Center (B.D.C.): The lowest position of the piston towards the[crank end side of the cylinder is called B.D.C.
5. Clearance Volume: The volume contained in the cylinder above the top of the]piston , when the piston is at top dead center , is called the clearance volume.
6. Swept Volume: The volume swept through by the piston while moving between T.D.C. to B.D.C, is called swept volume or piston displacement.
7. Compression Ratio: It is the ratio of Total cylinder volume to clearance volume.

#### Basic parts of an I.C. Engine

- a) ♂. Cylinder block
- b) ♂. Piston
- c) ♂. Piston rings
- d) ♂. Piston pin
- e) ♂. Connecting rod
- f) ♂. Crankshaft
- g) ♂. Cylinder head
- h) ♂. Intake valve
- i) ♂. Exhaust valve
- j) ♂. Camshaft
- k) ♂. Timing gears
- l) ♂. Spark plug

#### CARBURATION

Spark-ignition engines normally use volatile liquid fuels. Preparation of fuel-air mixture is done outside the engine cylinder and formation of a homogeneous mixture is normally not completed in the inlet manifold. Fuel droplets, which remain in suspension, continue to evaporate and mix with air even during suction and compression processes. The process of mixture preparation is extremely important for spark-ignition engines. The purpose of carburetion is to provide a combustible mixture of fuel and air in the required quantity and quality for efficient operation of the engine under all conditions.

*The carburetor is a device used for atomizing and vaporizing the fuel and mixing it with the air in varying proportions to suit the changing operating conditions of vehicle engines.*

### **FACTORS AFFECTING CARBURATION**

1. The engine speed
2. The vaporization characteristics of the fuel
3. The temperature of the incoming air and
4. The design of the carburetor

### **TYPES OF CARBURATOR**

1. Constant Choke Carburetor
2. Constant Vacuum Carburetor
3. Multiple Venturi Carburetor

### **TRANSMISSION SYSTEM**

#### **COMPONANTS**

1. Clutch
2. Gear box
3. U- joint
4. Shafts
5. Differential gear box

### **CLUTCH**

Clutch is a device which is used in the transmission system of automobile to engage and disengage the engine to the transmission or gear box. It is located between the transmission and the engine. When the clutch is engaged, the power flows from the engine to the rear wheels in a rear wheel- drive transmission and the vehicle moves. When the clutch is disengaged, the power is not transmitted from the engine to the rear wheels and vehicle stops even if engine is running.

It works on the principle of friction. When two friction surfaces are brought in contact with each other and they are united due to the friction between them. If one is revolved the other will also revolve.

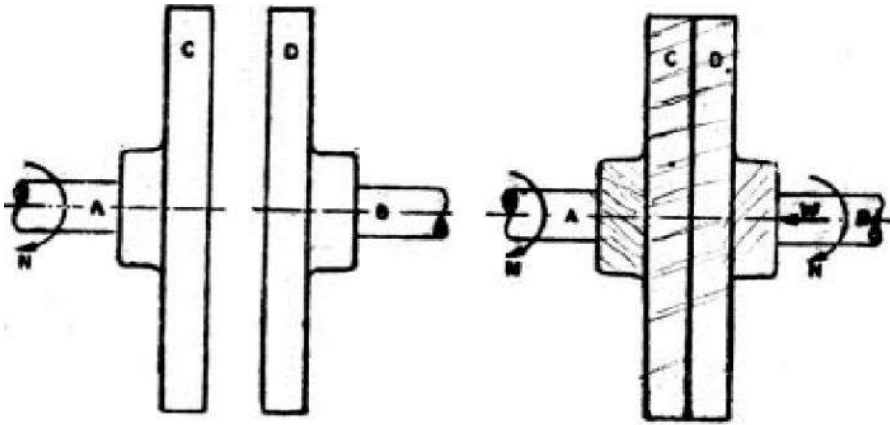

*Fig: Principle of Clutch*

The friction depends upon the surface area contact. The friction surfaces are so designed that the driven member initially slips on driving member when initially pressure is applied. As pressure increases the driven member is brought gradually to speed the driving member.

### **MATERIALS OF CLUTCH**

The friction materials of the clutch plate are generally of 3 types:

1. Mill Board Type
2. Molded type
3. Woven type

### **PROPERTIES OF CLUTCH**

1. Good Wearing Properties
2. High Resistance to heat
3. High coefficient of friction
4. Good Binders in it

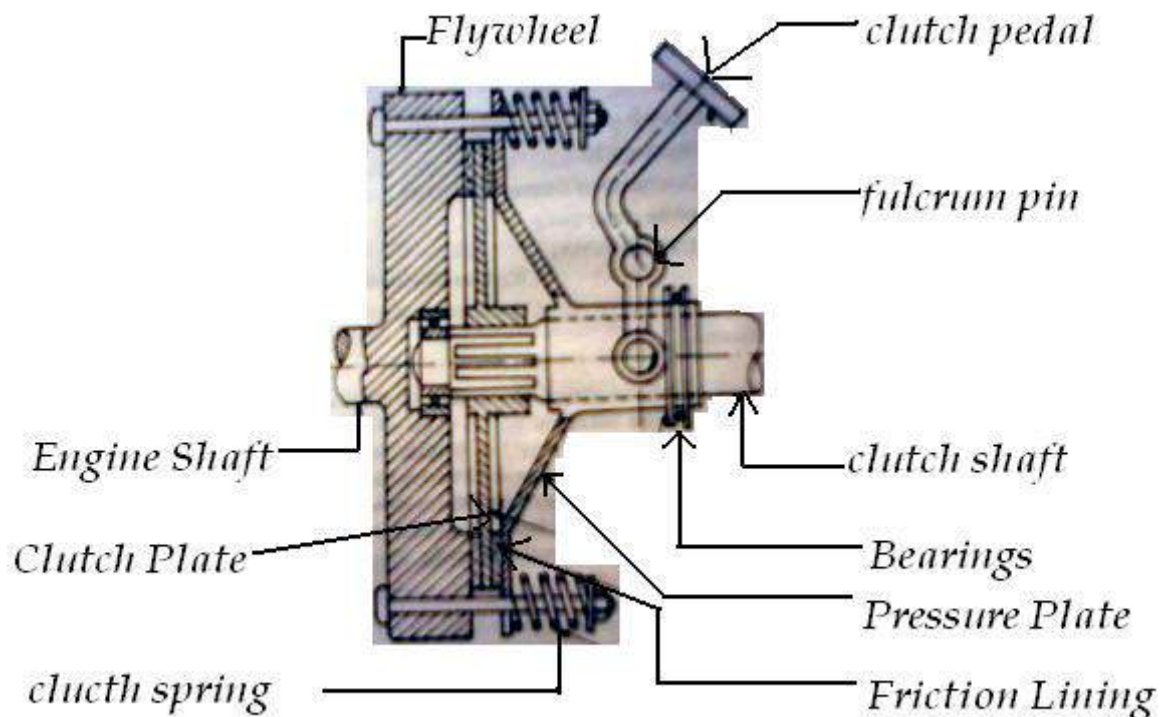

Fig: Single Plate Clutch

### SINGLE PLATE CLUTCH

It is the most common type of clutch plate used in motor vehicles. Basically it consists of only one clutch plate, mounted on the splines of the clutch shaft. The flywheel is mounted on engine crankshaft and rotates with it. The pressure plate is bolted to the flywheel through clutch springs, and is free to slide on the clutch shaft when the clutch pedal is operated. When the clutch is engaged the clutch plate is gripped between the flywheel and pressure plate. The friction linings are on both the sides of the clutch plate. Due to the friction between the flywheel, clutch plate and the pressure plate the clutch plate revolves with the flywheel. As the clutch plate revolves the clutch shaft also revolves. Clutch shaft is connected to the transmission gear box. Thus the engine power is transmitted to the crankshaft and then to the clutch shaft.

When the clutch pedal is pressed, the pressure plate moves back against the force of the springs, and the clutch plate becomes free between the flywheel and the pressure plate. Thus the flywheel remains rotating as long as the engine is running and the clutch shaft speed reduces slowly and finally it stops rotating. As soon as the clutch pedal is released, the clutch is said to be engaged, otherwise it remains disengaged due to the spring forces.



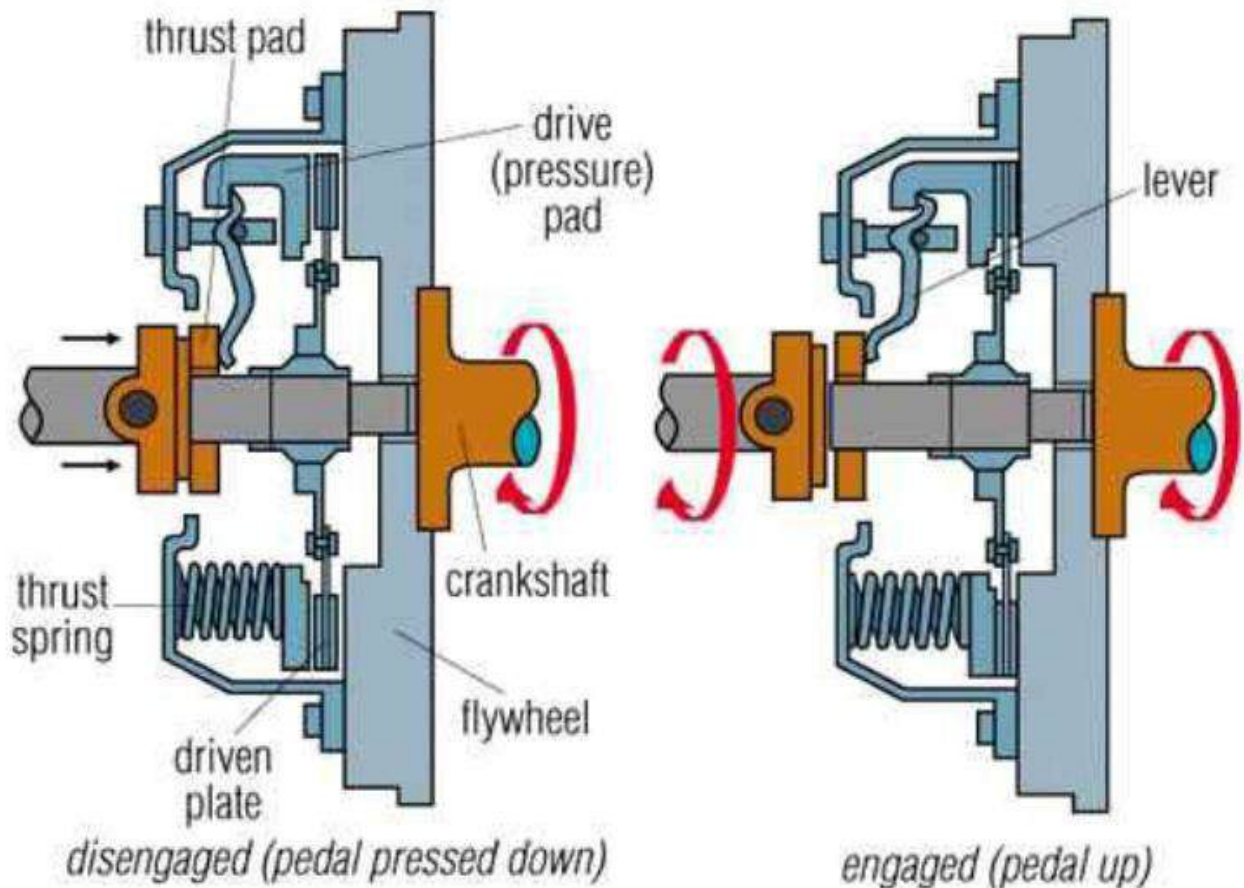

Fig: Clutch in Engaged & Disengaged Position

### MULTI PLATE CLUTCH

Multi-plate clutch consists of a number of clutch plates instead of only one clutch plate as in case of single plate clutch. As the number of clutch plates are increased, the friction surfaces also increase. The increased number of friction surfaces obviously increases the capacity of the clutch to transmit torque.

The plates are alternately fitted to engine and gear box shaft. They are firmly pressed by strong coil springs and assembled in a drum. Each of the alternate plate slides on the grooves on the flywheel and the other slides on splines on the pressure plate. Thus, each alternate plate has inner and outer splines.

The multi-plate clutch works in the same way as a single plate clutch by operating the clutch pedal. The multi-plate clutches are used in heavy commercial vehicles, racing cars and motor cycles for transmitting high torque. The multi-plate clutch may be dry or wet. When the clutch is operated in an oil bath, it is called a wet clutch. When the clutch is

operated dry it is called dry clutch. The wet clutch is used in conjunction with or part of the automatic transmission.

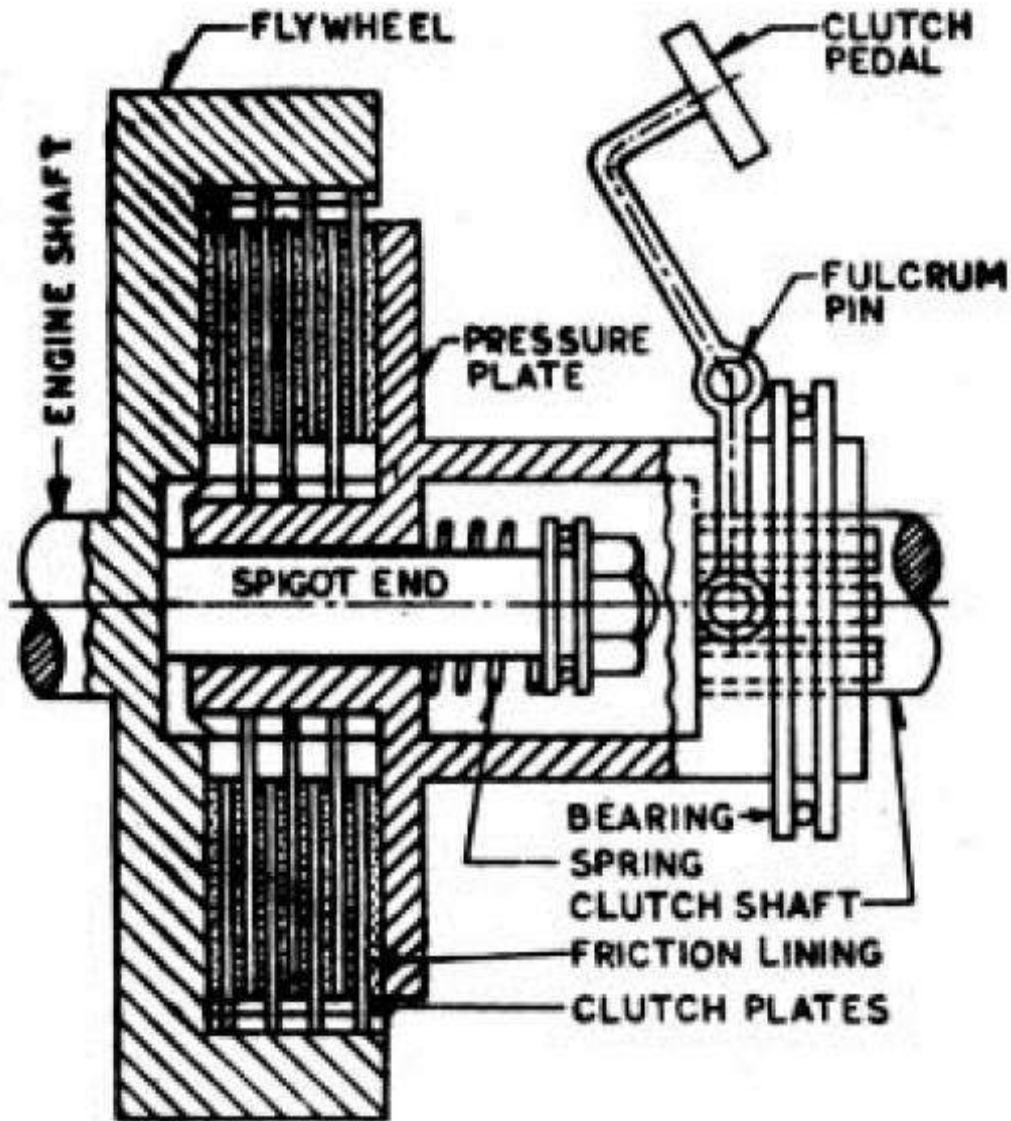
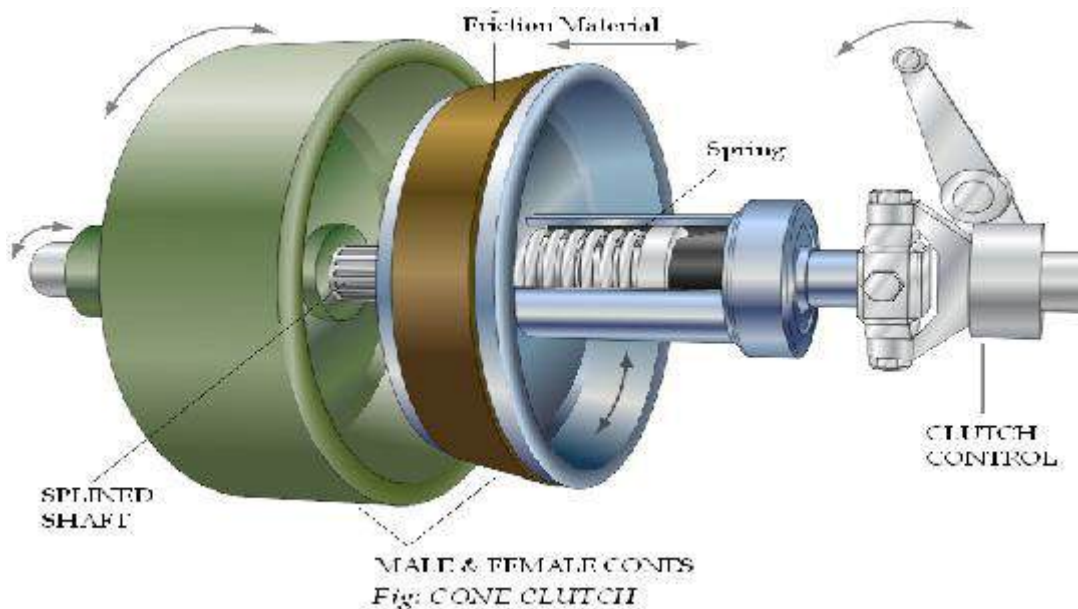

*Fig : Multi-Plate Clutch*

### CONE CLUTCH

Cone clutch consists of friction surfaces in the form of cone. The engine shaft consists of female cone. The male cone is mounted on the splined clutch shaft. It has friction surfaces on the conical portion. The male cone can slide on the clutch shaft. When the clutch is engaged the friction surfaces of the male cone are in contact with that of the female cone due to force of the spring. When the clutch pedal is pressed, the male cone slides against the spring force and the clutch is disengaged.

The only advantage of the cone clutch is that the normal force acting on the friction surfaces is greater than the axial force, as compare to the single plate clutch in which the normal force acting on the friction surfaces is equal to the axial force. The disadvantage in cone clutch is that if the angle of the cone is made smaller than 200 the male cone tends to bind in the female cone and it becomes difficult to disengage the clutch. Cone clutches are generally now only used in low peripheral speed applications although they were once common in automobiles and other combustion engine transmissions. They are usually now confined to very specialist transmissions in racing, rallying, or in extreme off-road vehicles, although they are common in power boats. Small cone clutches are used in synchronizer mechanisms in manual transmissions.



## **GEAR BOX**

A gearbox is a mechanical method of transferring energy from one device to another and is used to increase torque while reducing speed. Torque is the power generated through the bending or twisting of a solid material. This term is often used interchangeably with transmission. Located at the junction point of a power shaft, the gearbox is often used to create a right angle change in direction, as is seen in a rotary mower or a helicopter. Each unit is made with a specific purpose in mind, and the gear ratio used is designed to provide the level of force required. This ratio is fixed and cannot be changed once the box is constructed. The only possible modification after the fact is an adjustment that allows the shaft speed to increase, along with a corresponding reduction in torque. In a situation

where multiple speeds are needed, a transmission with multiple gears can be used to increase torque while slowing down the output speed. This design is commonly found in automobile transmissions. The same principle can be used to create an overdrive gear that increases output speed while decreasing torque.

### TYPES OF GEAR BOX

1. Sliding Mesh
2. Constant Mesh
3. Synchromesh.

### SLIDING MESH

It is the simplest gear box. The following figure shows 4-speed gear box in neutral position. 4 gears are connected to the lay shaft/counter shaft. A reverse idler gear is mounted on another shaft and always remains connected to the reverse gear of countershaft. This “H” shift pattern enables the driver to select four different gear ratios and a reverse gear.

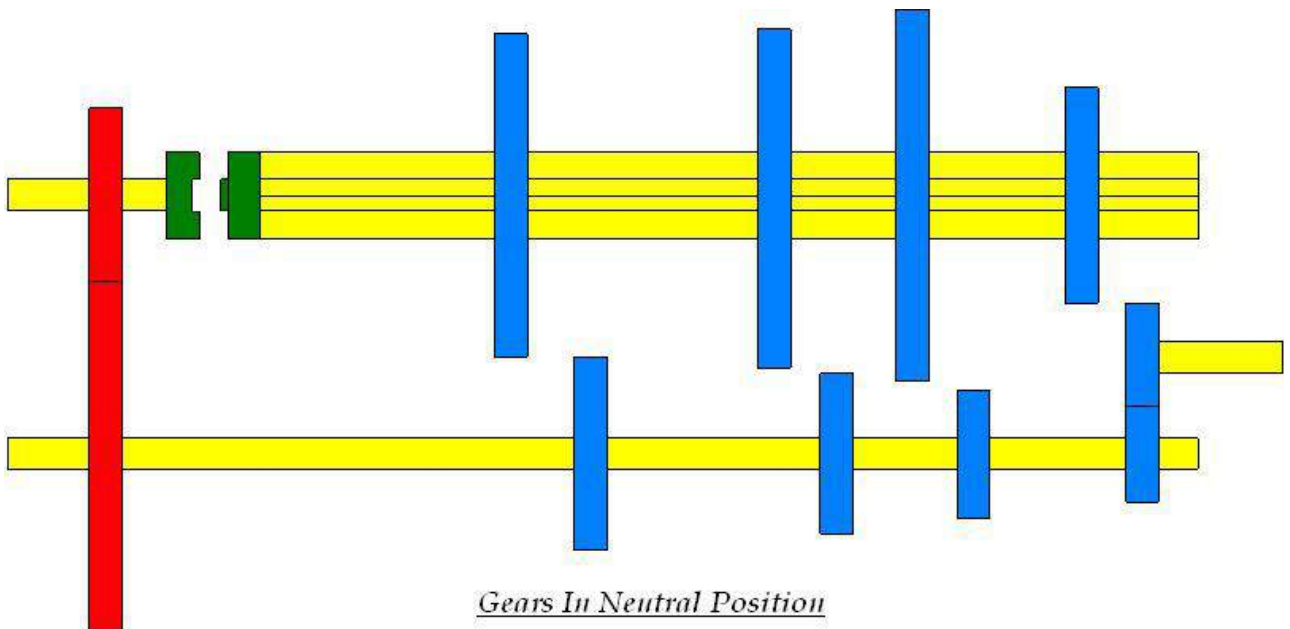

**GEARS IN NEUTRAL:** When the engine is running and clutch is engaged the clutch shaft gear drives the countershaft gear. The countershaft rotates opposite in direction of the clutch shaft. In neutral position only the clutch shaft gear is connected to the countershaft gear. Other gears are free and hence the transmission main shaft is not turning. The vehicle is stationary.

### CONSTANT MESH GEAR BOX

In this type of gear box, all gears of the main shaft are in constant mesh with the corresponding gears of the countershaft (Lay shaft). Two dog clutches are provided on the main shaft- one between the clutch gear and the second gear, and the other between the first gear and reverse gear. The main shaft is splined and all the gears are free on it. Dog clutch can slide on the shaft and rotates with it. All the gears on the countershaft are rigidly fixed with it.

When the left hand dog clutch is made to slide to the left by means of the gear shift lever, it meshes with the clutch gear and the top speed gear is obtained. When the left hand dog clutch meshes with the second gear, the second speed gear is obtained. Similarly by sliding the right hand dog clutch to the left and right, the first speed gear and reverse gear are obtained respectively. In this gear box because all the gears are in constant mesh they are safe from being damaged and an unpleasant grinding sound does not occur while engaging and disengaging them.

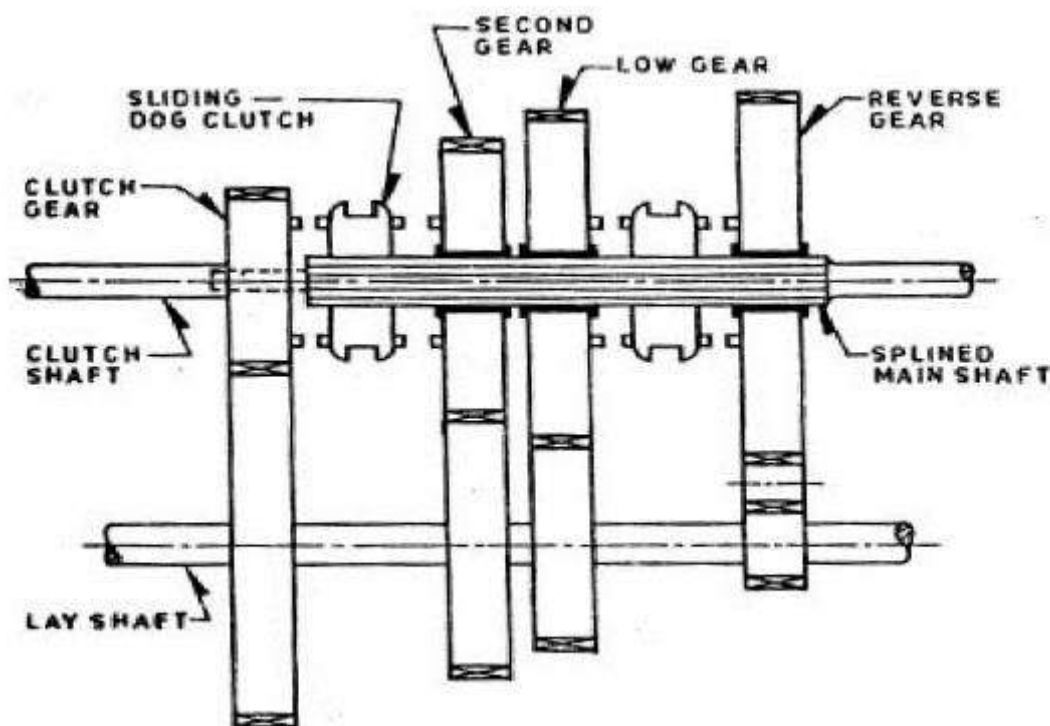

### SYNCHROMESH MESH GEAR BOX

In sliding Mesh Gear box the two meshing gears need to be revolve at equal peripheral speeds to achieve a jerk less engagement and it is true for constant mesh gear box in



which the peripheral speeds of sliding dog and the corresponding gear on the output shaft must be equal. The peripheral speed is given by  $v = \frac{\pi d_1 N_1}{60}$  and  $v = \frac{\pi d_2 N_2}{60}$  where  $d_1$  and  $N_1$  are pitch circle diameter and r.p.m. of gear and  $d_2$  and  $N_2$  diameter and r.p.m. of attached dog respectively. Now  $N_1 \neq N_2$  since  $d_1 \neq d_2$ . Thus there is a difference in gear and dog which necessitates double declutching. The driver has to disengage the clutch twice in quick succession therefore it is referred as double declutching.

The clutch is disengaged i.e. first declutching and the gear system is placed in its neutral position. Now the clutch is reengaged and acceleration pedal is pressed to adjust the engine speed according to driver's judgment. The clutch is disengaged (i.e. second declutching) again the appropriate gear is engaged and then the clutch is reengaged.

It is that gear box in which sliding synchronizing units are provided in place of sliding dog clutches as in case of constant mesh gear box. With the help of synchronizing unit, the speed of both the driving and driven shafts is synchronized before they are clutched together through train of gears. The arrangement of power flow for the various gears remains the same as in constant mesh gear box. The synchronizer is made of frictional materials. When the collar tries to mesh with the gear, the synchronizer will touch the gear first and use friction force to drive the gear to spin at the same speed as the collar. This will ensure that the collar is meshed into the gear very smoothly without grinding. Synchronesh gear devices work on the principle that two gears to be engaged are first brought into frictional contact which equalizes their speed after which they are engaged readily and smoothly.

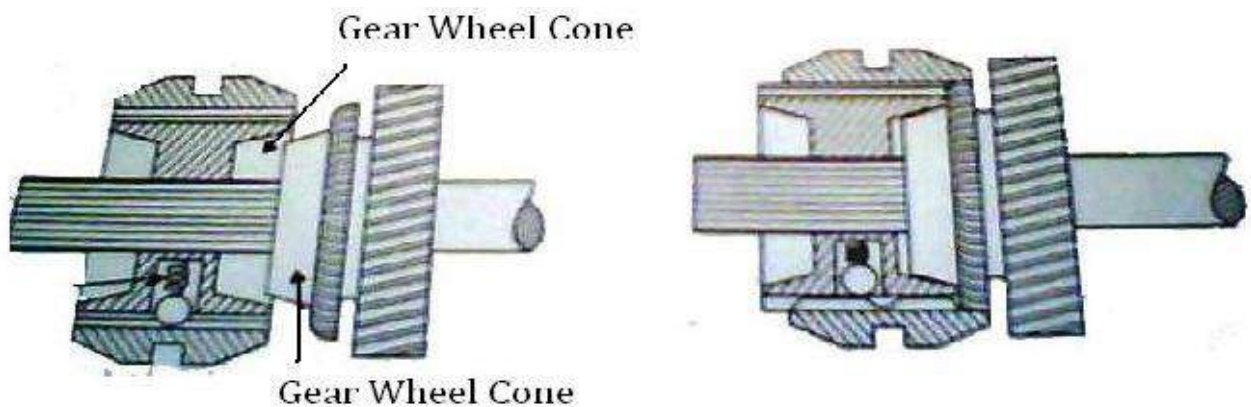
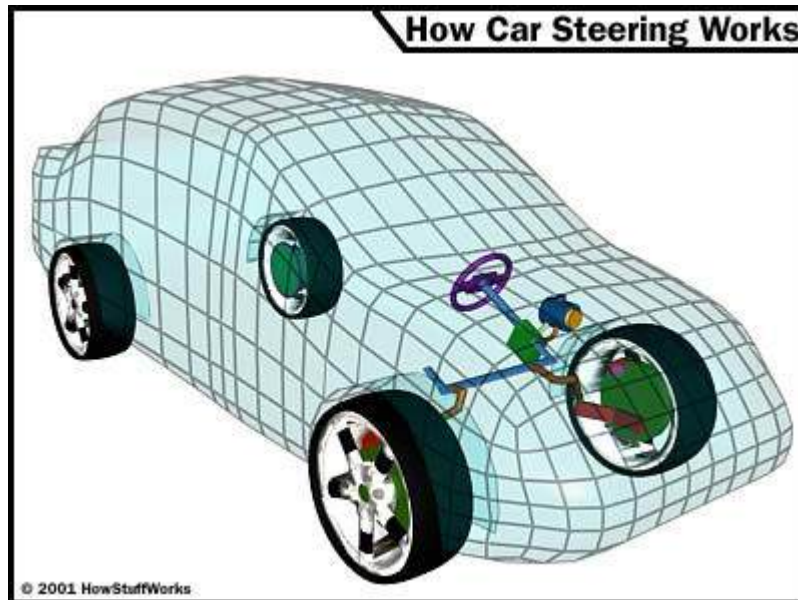

Fig: Synchro Mesh Unit

## Steering System

### How Does Steering Work?

You know that when you turn the steering wheel in your car, the wheels turn. Cause and effect, right? But a lot of interesting stuff goes on between the steering wheel and the tires to make this happen.



In this article, we'll see how the two most common types of car steering systems work: rack-and-pinion and recalcuating-ball steering. Then we'll examine power steering and find out about some interesting future developments in steering systems, driven mostly by the need to increase the fuel efficiency of cars. But first, let's see what you have to do turn a car. It's not quite as simple as you might think!

### Turning the Car

You might be surprised to learn that when you turn your car, your front wheels are not pointing in the same direction.

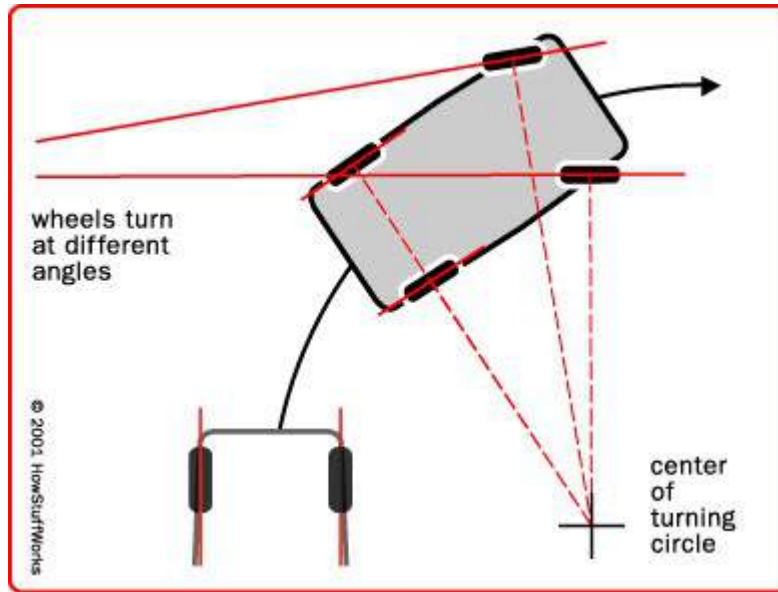

For a car to turn smoothly, each wheel must follow a different circle. Since the inside wheel is following a circle with a smaller radius, it is actually making a tighter turn than the outside wheel. If you draw a line perpendicular to each wheel, the lines will intersect at the center point of the turn. The geometry of the steering linkage makes the inside wheel turn more than the outside wheel.

There are a couple different types of steering gears. The most common are rack-and-pinion and recalcuating ball.

### Rack-and-pinion Steering

Rack-and-pinion steering is quickly becoming the most common type of steering on cars, small trucks and SUVs. It is actually a pretty simple mechanism. A rack-and-pinion gear set is enclosed in a metal tube, with each end of the rack protruding from the tube. A rod, called a tie rod, connects to each end of the rack.



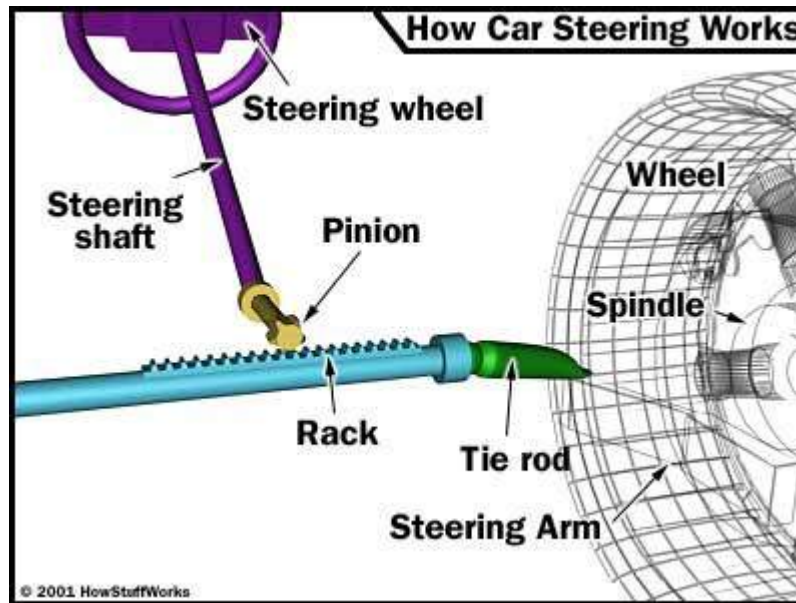

The pinion gear is attached to the steering shaft. When you turn the steering wheel, the gear spins, moving the rack. The tie rod at each end of the rack connects to the steering arm on the spindle (see diagram above).

The rack-and-pinion gear set does two things:

- It converts the rotational motion of the steering wheel into the linear motion needed to turn the wheels.
- It provides a gear reduction, making it easier to turn the wheels.

On most cars, it takes three to four complete revolutions of the steering wheel to make the wheels turn from lock to lock (from far left to far right).

The steering ratio is the ratio of how far you turn the steering wheel to how far the wheels turn. For instance, if one complete revolution (360 degrees) of the steering wheel results in the wheels of the car turning 20 degrees, then the steering ratio is 360 divided by 20, or 18:1. A higher ratio means that you have to turn the steering wheel more to get the wheels to turn a given distance. However, less effort is required because of the higher gear ratio.

Generally, lighter, sportier cars have lower steering ratios than larger cars and trucks. The lower ratio gives the steering a quicker response -- you don't have to turn the steering wheel as much to get the wheels to turn a given distance -- which is a desirable trait in sports cars. These smaller cars are light enough that even with the lower ratio, the effort required to turn the steering wheel is not excessive.

Some cars have variable-ratio steering, which uses a rack-and-pinion gear set that has a different tooth pitch (number of teeth per inch) in the center than it has on the outside. This makes the car respond quickly when starting a turn (the rack is near the center), and also reduces effort near the wheel's turning limits.

Power

Rack-and-pinion

when the rack-and-pinion is in a power-steering system, the rack has a slightly different design.

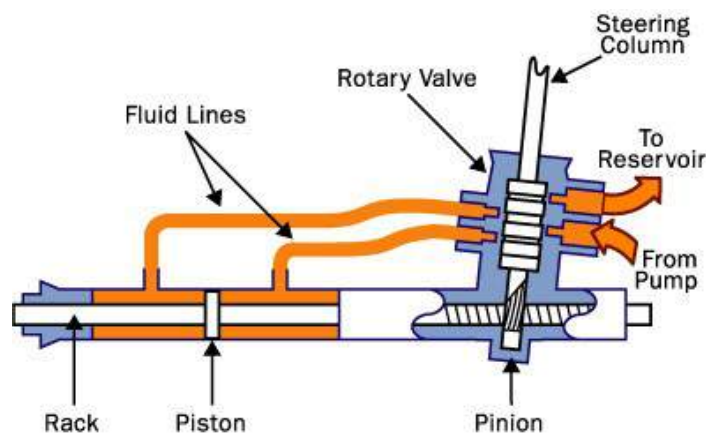

©2001 HowStuffWorks

Part of the rack contains a cylinder with a piston in the middle. The piston is connected to the rack. There are two fluid ports, one on either side of the piston. Supplying higher-pressure fluid to one side of the piston forces the piston to move, which in turn moves the rack, providing the power assist.

We'll check out the components that provide the high-pressure fluid, as well as decide which side of the rack to supply it to, later in the article. First, let's take a look at another type of steering.

Recalculating-ball Steering

Recalculating-ball steering is used on many trucks and SUVs today. The linkage that turns the wheels is slightly different than on a rack-and-pinion system.

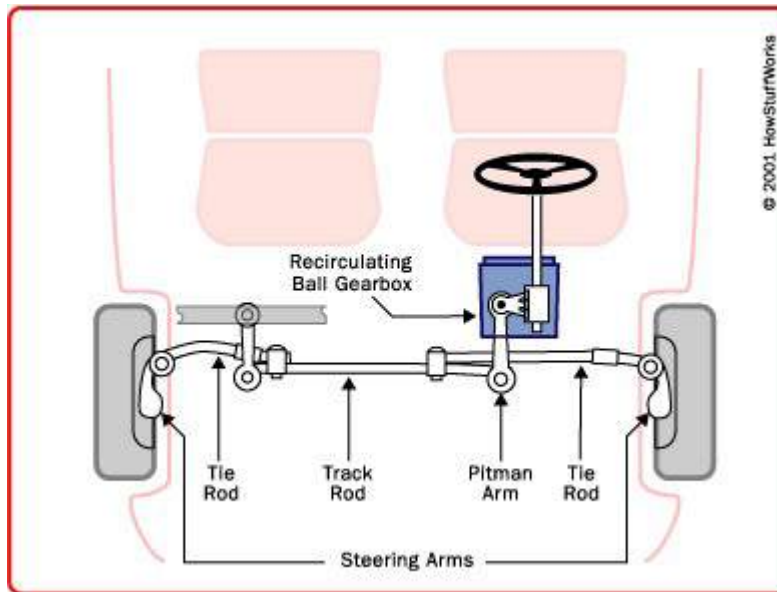

The recirculating-ball steering gear contains a worm gear. You can image the gear in two parts. The first part is a block of metal with a threaded hole in it. This block has gear teeth cut into the outside of it, which engage a gear that moves the pitman arm (see diagram above). The steering wheel connects to a threaded rod, similar to a bolt, that sticks into the hole in the block. When the steering wheel turns, it turns the bolt. Instead of twisting further into the block the way a regular bolt would, this bolt is held fixed so that when it spins, it moves the block, which moves the gear that turns the wheels.

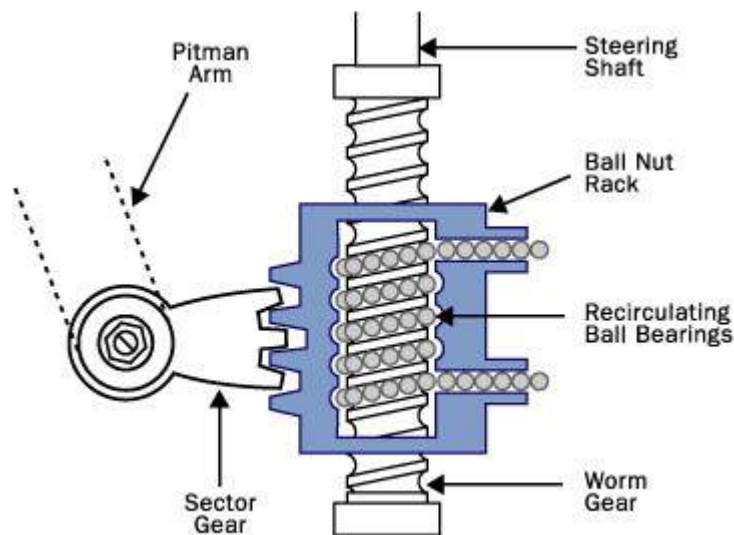

Instead of the bolt directly engaging the threads in the block, all of the threads are filled with ball bearings that re-circulate through the gear as it turns. The balls actually serve two purposes: First, they reduce friction and wear in the gear; second, they reduce slop in the gear. Slop would be felt when you change the direction of the steering wheel -- without

the balls in the steering gear, the teeth would come out of contact with each other for a moment, making the steering wheel feel loose.

Power steering in a recirculating-ball system works similarly to a rack-and-pinion system.

Assist is provided by supplying higher-pressure fluid to one side of the block.

Now let's take a look at the other components that make up a power-steering system.

### Power Steering

There are a couple of key components in power steering in addition to the rack-and-pinion or recirculating-ball mechanism.

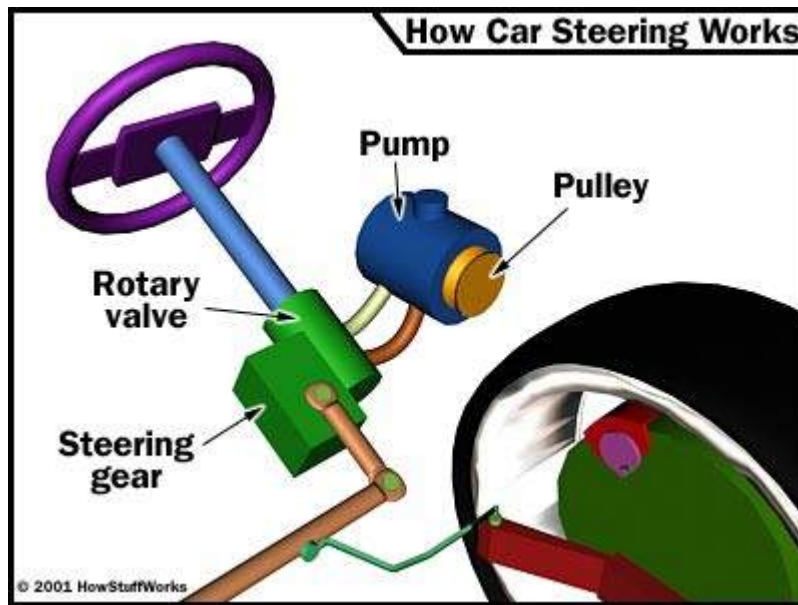

### Pump

The hydraulic power for the steering is provided by a rotary-vane pump (see diagram below). This pump is driven by the car's engine via a belt and pulley. It contains a set of retractable vanes that spin inside an oval chamber.

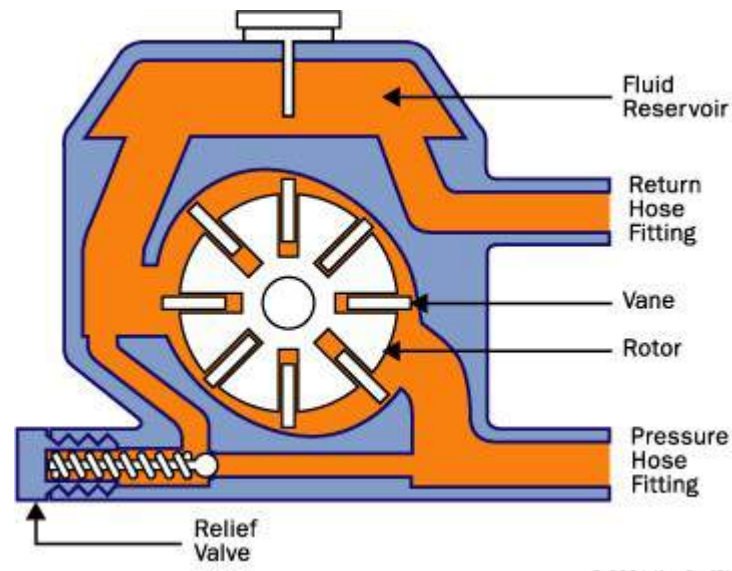

As the vanes spin, they pull hydraulic fluid from the return line at low pressure and force it into the outlet at high pressure. The amount of flow provided by the pump depends on the car's engine speed. The pump must be designed to provide adequate flow when the engine is idling. As a result, the pump moves much more fluid than necessary when the engine is running at faster speeds.

The pump contains a pressure-relief valve to make sure that the pressure does not get too high, especially at high engine speeds when so much fluid is being pumped.

### Rotary

### Valve

A power-steering system should assist the driver only when he is exerting force on the steering wheel (such as when starting a turn). When the driver is not exerting force (such as when driving in a straight line), the system shouldn't provide any assist. The device that senses the force on the steering wheel is called the rotary valve.

The key to the rotary valve is a torsion bar. The torsion bar is a thin rod of metal that twists when torque is applied to it. The top of the bar is connected to the steering wheel, and the bottom of the bar is connected to the pinion or worm gear (which turns the wheels), so the amount of torque in the torsion bar is equal to the amount of torque the driver is using to turn the wheels. The more torque the driver uses to turn the wheels, the more the bar twists.

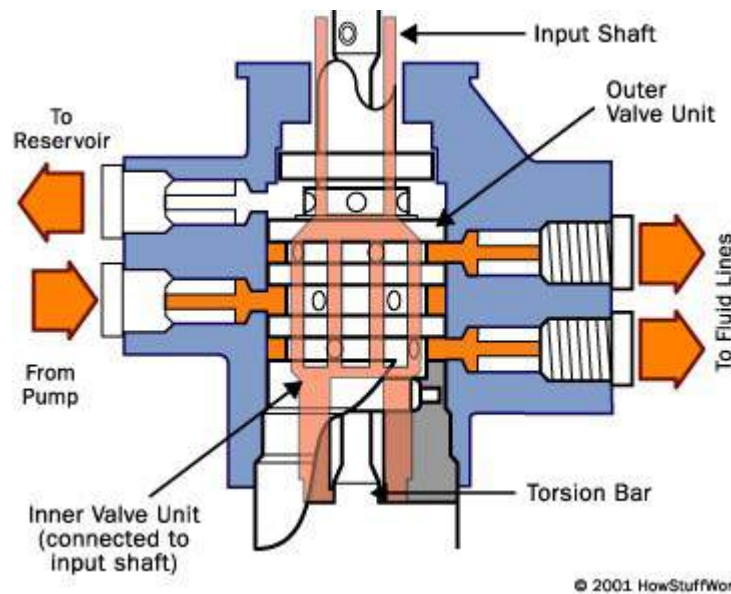

The input from the steering shaft forms the inner part of a spool-valve assembly. It also connects to the top end of the torsion bar. The bottom of the torsion bar connects to the outer part of the spool valve. The torsion bar also turns the output of the steering gear, connecting to either the pinion gear or the worm gear depending on which type of steering the car has.

As the bar twists, it rotates the inside of the spool valve relative to the outside. Since the inner part of the spool valve is also connected to the steering shaft (and therefore to the steering wheel), the amount of rotation between the inner and outer parts of the spool valve depends on how much torque the driver applies to the steering wheel.

When the steering wheel is not being turned, both hydraulic lines provide the same amount of pressure to the steering gear. But if the spool valve is turned one way or the other, ports open up to provide high-pressure fluid to the appropriate line.

It turns out that this type of power-steering system is pretty inefficient. Let's take a look at some advances we'll see in coming years that will help improve efficiency.

#### The Future of Power Steering

Since the power-steering pump on most cars today runs constantly, pumping fluid all the time, it wastes horsepower. This wasted power translates into wasted fuel.

You can expect to see several innovations that will improve fuel economy. One of the coolest ideas on the drawing board is the "steer-by-wire" or "drive-by-wire" system. These systems would completely eliminate the mechanical connection between the steering wheel and the steering, replacing it with a purely electronic control system. Essentially,

the steering wheel would work like the one you can buy for your home computer to play games. It would contain sensors that tell the car what the driver is doing with the wheel, and have some motors in it to provide the driver with feedback on what the car is doing. The output of these sensors would be used to control a motorized steering system. This would free up space in the engine compartment by eliminating the steering shaft. It would also reduce vibration inside the car.

General Motors has introduced a concept car, the Hy-wire that features this type of driving system. One of the most exciting things about the drive-by-wire system in the GM Hy-wire is that you can fine-tune vehicle handling without changing anything in the car's mechanical components -- all it takes to adjust the steering is some new computer software. In future drive-by-wire vehicles, you will most likely be able to configure the controls exactly to your liking by pressing a few buttons, just like you might adjust the seat position in a car today. It would also be possible in this sort of system to store distinct control preferences for each driver in the family.

In the past fifty years, car steering systems haven't changed much. But in the next decade, we'll see advances in car steering that will result in more efficient cars and a more comfortable ride.



### How Does Steering Work?

First, here's the quick answer as to how power steering works. A pump, driven by the engine, delivers pressurized hydraulic fluid to either side of the steering mechanism. This pressurized fluid pushing on the steering mechanism helps to steer the car and reduces steering effort. Remember, power steering is actually "power-assisted steering". It is not a drive-by-wire system. The power steering just helps the driver steer.

Here's the longer answer. There are two main parts to the power steering system: the pump and the steering gear. In most cases, the pump is attached to the front of the engine and driven by the accessory drive belt. The fluid reservoir (where you add fluid) is usually located on the pump. The pump should be sized to deliver sufficient fluid pressure at idle. As the pump spins faster as engine speed increases, a pressure relief valve is used to keep the pressure at the desired levels. In some cases, the engine driven pump may be replaced by an electric pump (therefore there won't be a belt running to the pump).

The interesting part of the system is the steering gear. There are two major types of steering gears used: rack and pinion, and recalcuating ball type (aka worm and sector). Rack and pinion tends to be more prevalent with newer cars, so I'll discuss that type first.

Here's a cut-away view of a power assist rack and pinion.

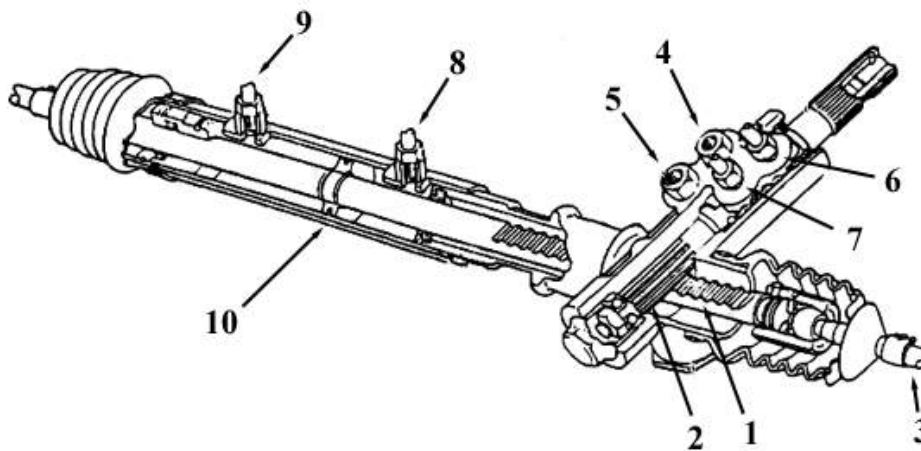

The pinion (2) is attached to the steering shaft which is attached to the steering wheel. Thus, as the steering wheel is turned, the teeth in the pinion mesh with the rack (1) and slides the rack left and right. The rack is attached to the tie rods (3) which in turn attach to the knuckle (not shown) and tire. That's manual steering with a rack and pinion.



In the power assist system, fluid from the pump (high pressure side) enters the steering gear at (4) and returns (low pressure side) at (5). A valve system inside the gear box directs fluid out at (6) and (7) which re-enters the gearbox at (8) and (9). This pressurized fluid acts on the power piston (10) to assist steering. Thus, if the driver is turning right, additional fluid is directed to the right side of the piston, which helps move the rack and therefore steer the tires.

Fluid is directed to either the right or left sides by means of a rotary valve and torsion bar. Through this mechanism, the fluid pressure (and thus the amount of "assist") is proportional to the torque due to steering effort, and not the direction that the wheels are turned. In other words, it is possible for the system to help you turn left, even if the steering wheel is right of center. Here is a sketch of the rotary valve. Only one quarter is shown (it's symmetrical).

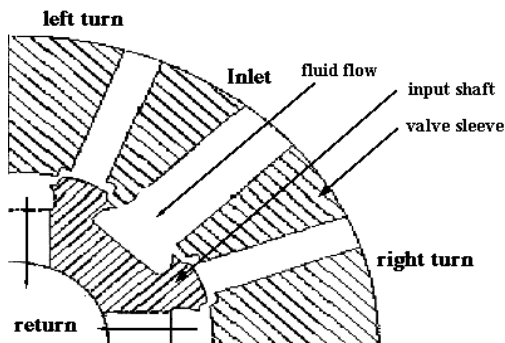

The torsion bar (a tensional spring) connects the steering shaft to the pinion. As stated at [autoshop-online.com](http://autoshop-online.com), "When the steering wheel is turned, resistance is created by the weight of the car and tire-to-road friction, causing a torsion bar in the rotary valve to deflect. This changes the position of the valve spool and sleeve, thereby directing fluid under pressure to the proper end of the power cylinder."

Here's another sketch of the rotary valve in a hard right turn.

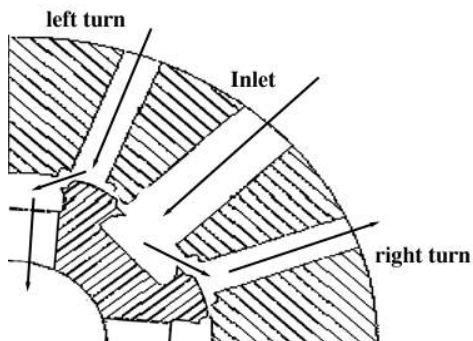

As you can see, as the torsion bar twists, it changes the alignment between the input shaft and valve sleeve, delivering more pressure to one side, and less to the other.

A recalculating ball type system uses a different gear system, but the power assist system is essentially the same. Here's a picture of a manual recalculating ball system.

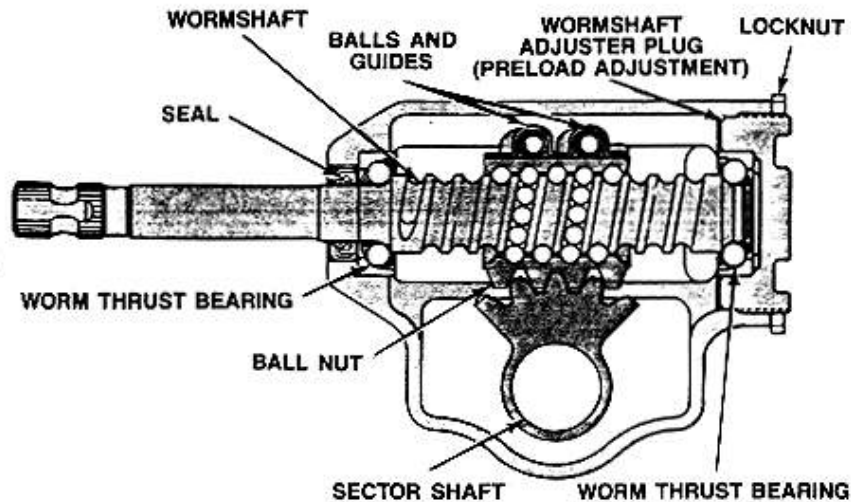

Essentially, the steering wheel turns a screw, which causes a "nut" to move back and forth along the screw. The movement of this nut causes the sector to move, causing the pitman arm to turn. In the power assisted version, pressure is applied in the same manner (via the torsion bar/rotary valve system) to either side of the "nut" to give power assist.

The most conventional steering arrangement is to turn the front wheels using a hand-operated steering wheel which is positioned in front of the driver, via the steering column, which may contain universal joints to allow it to deviate somewhat from a straight line. Other arrangements are sometimes found on different types of vehicles, for example, a tiller or rear-wheel steering. Tracked vehicles such as tanks usually employ differential steering — that is, the tracks are made to move at different speeds or even in opposite directions to bring about a change of course.

Rack and pinion, recalculating ball, worm and sector

Many modern cars use rack and pinion steering mechanisms, where the steering wheel turns the pinion gear; the pinion moves the rack, which is a sort of linear gear which meshes with the pinion, from side to side. This motion applies steering torque to the kingpins of the steered wheels via tie rods and a short lever arm called the steering arm.

Older designs often use the recalculating ball mechanism, which is still found on trucks and utility vehicles. This is a variation on the older worm and sector design; the steering

column turns a large screw (the "worm gear") which meshes with a sector of a gear, causing it to rotate about its axis as the worm gear is turned; an arm attached to the axis of the sector moves the pitman arm, which is connected to the steering linkage and thus steers the wheels. The recalcuating ball version of this apparatus reduces the considerable friction by placing large ball bearings between the teeth of the worm and those of the screw; at either end of the apparatus the balls exit from between the two pieces into a channel internal to the box which connects them with the other end of the apparatus, thus they are "recalculated".



Rack and pinion unit here mounted in the cockpit of an Ariel Atom sports car chassies [correct spelling is chassis !]. For most high volume production this is usually mounted on other side of this panel

The rack and pinion design has the advantages of a large degree of feedback and direct steering "feel"; it also does not normally have any backlash, or slack. A disadvantage is that it is not adjustable, so that when it does wear and develop lash, the only cure is replacement.

The recalcuating ball mechanism has the advantage of a much greater mechanical advantage, so that it was found on larger, heavier vehicles while the rack and pinion was originally limited to smaller and lighter ones; due to the almost universal adoption of power steering, however, this is no longer an important advantage, leading to the increasing use of rack and pinion on newer cars. The recalcuating ball design also has a perceptible lash, or "dead spot" on center, where a minute turn of the steering wheel in either direction does not move the steering apparatus; this is easily adjustable via a screw on the end of the steering box to account for wear, but it cannot be entirely eliminated or the mechanism begins to wear very rapidly. This design is still in use in trucks and other large vehicles, where rapidity of steering and direct feel are less important than robustness,

maintainability, and mechanical advantage. The much smaller degree of feedback with this design can also sometimes be an advantage; drivers of vehicles with rack and pinion steering can have their thumbs broken when a front wheel hits a bump, causing the steering wheel to kick to one side suddenly (leading to driving instructors telling students to keep their thumbs on the front of the steering wheel, rather than wrapping around the inside of the rim). This effect is even stronger with a heavy vehicle like a truck; recalcitrant ball steering prevents this degree of feedback, just as it prevents desirable feedback under normal circumstances.

The steering linkage connecting the steering box and the wheels usually conforms to a variation of Ackermann steering geometry, to account for the fact that in a turn, the inner wheel is actually traveling a path of smaller radius than the outer wheel, so that the degree of toe suitable for driving in a straight path is not suitable for turns.

#### Power steering

As vehicles have become heavier and switched to front wheel drive, the effort to turn the steering wheel manually has increased - often to the point where major physical exertion is required. To alleviate this, auto makers have developed power steering systems. There are two types of power steering systems—hydraulic and electric/electronic. There is also a hydraulic-electric hybrid system possible.

A hydraulic power steering (HPS) uses hydraulic pressure supplied by an engine-driven pump to assist the motion of turning the steering wheel. Electric power steering (EPS) is more efficient than the hydraulic power steering, since the electric power steering motor only needs to provide assist when the steering wheel is turned, whereas the hydraulic pump must run constantly. In EPS the assist level is easily tunable to the vehicle type, road speed, and even driver preference. An added benefit is the elimination of environmental hazard posed by leakage and disposal of hydraulic power steering fluid.

#### Speed Adjustable Steering

An outgrowth of power steering is speed adjustable steering, where the steering is heavily assisted at low speed and lightly assisted at high speed. The auto makers perceive that motorists might need to make large steering inputs while manoeuvring [sic!] for parking, but not while traveling at high speed. This feature is gradually becoming commonplace across all new vehicles.

## **Breaking System**

### **BREAKING SYSTEM**

A brake is a mechanical device which inhibits motion, slowing or stopping a moving object and preventing its motion. The rest of this article is dedicated to various types of vehicular brakes.

Most commonly brakes use friction between two surfaces pressed together to convert the kinetic energy of the moving object into heat, though other methods of energy conversion may be employed. For example regenerative braking converts much of the energy to electrical energy, which may be stored for later use. Other methods convert kinetic energy into potential energy in such stored forms as pressurized air or pressurized oil. Eddy current brakes use magnetic fields to convert kinetic energy into electric current in the brake disc, fin, or rail, which is converted into heat. Still other braking methods even transform kinetic energy into different forms, for example by transferring the energy to a rotating flywheel.

Brakes are generally applied to rotating axles or wheels, but may also take other forms such as the surface of a moving fluid (flaps deployed into water or air). Some vehicles use a combination of braking mechanisms, such as drag racing cars with both wheel brakes and a parachute, or airplanes with both wheel brakes and drag flaps raised into the air during landing.

Since kinetic energy increases quadratically with velocity ( $K=1/2 mv^2$ ), an object moving at 10 m/s has 100 times as much energy as one of the same mass moving at 1 m/s, and consequently the theoretical braking distance, when braking at the traction limit, is 100 times as long. In practice, fast vehicles usually have significant air drag, and energy lost to air drag rises quickly with speed. Almost all wheeled vehicles have a brake of some sort. Even baggage carts and shopping carts may have them for use on a moving ramp. Most fixed-wing aircraft are fitted with wheel brakes on the undercarriage. Some aircraft also feature air brakes designed to reduce their speed in flight.

When the brake pedal of a modern vehicle with hydraulic brakes is pushed, ultimately a piston pushes the brake pad against the brake disc which slows the wheel down. On the brake drum it is similar as the cylinder pushes the brake shoes against the drum which also slows the wheel down. Brakes may be broadly described as using friction, pumping, or electromagnetic. One brake may use several principles: for example, a pump may pass fluid through an orifice to create friction: Frictional brakes are most common and can be divided broadly into "shoe" or "pad" brakes, using an explicit wear surface, and hydrodynamic brakes, such as parachutes, which use friction in a working fluid and do not explicitly wear. Typically the term "friction brake" is used to mean pad/shoe brakes and excludes hydrodynamic brakes, even though hydrodynamic brakes use friction.

Friction (pad/shoe) brakes are often rotating devices with a stationary pad and a rotating wear surface. Common configurations include shoes that contract to rub on the outside of a rotating drum, such as a band brake; a rotating drum with shoes that expand to rub the inside of a drum, commonly called a "drum brake", although other drum configurations are possible; and pads that pinch a rotating disc, commonly called a "disc brake".

### **TYPES OF BREAKING SYSTEM**

⊛ By applications –

1. Foot Brake,
2. Hand brake.

⊛ By Method of power –

1. Mechanical brake,
2. Hydraulic brake.
3. Vacuum brake,

4. Electrical brake and

5. Air brake.

⊗ By method of operations –

1. Manual brake,

2. Servo brake.

3. Power operation.

⊗ By construction –

1. Drum type brake,

2. Disc type brake.

### **HYDRAUKIC BREAKING SYSTEM**

The disc brake or disk brake is a device for slowing or stopping the rotation of a wheel while it is in motion. A brake disc (or rotor in U.S. English) is usually made of cast iron, but may in some cases be made of composites such as reinforced carbon-carbon or ceramic-matrix composites.

This is connected to the wheel and/or the axle. To stop the wheel, friction material in the form of brake pads (mounted on a device called a brake caliper) is forced mechanically, hydraulically, pneumatically or electromagnetically against both sides of the disc. Friction causes the disc and attached wheel to slow or stop. Brakes (both disc and drum) convert motion to heat, but if the brakes get too hot, they will become less effective because they cannot dissipate enough heat. This condition of failure is known as brake fade.

### **CONSTRUCTION OF HYDRAUKIC BREAKING SYSTEM**

The most common arrangement of hydraulic brakes for passenger vehicles, motorcycles, scooters, and mopeds, consists of the following:

⊗ Brake pedal or lever

⊗ A pushrod (also called an actuating rod)

⊗ A master cylinder assembly containing a piston assembly

⊗ Reinforced hydraulic lines

Brake caliper assembly usually consisting of one or two hollow aluminum or chrome-plated steel pistons (called caliper pistons), a set of thermally conductive brake pads and a rotor (also called a brake disc) or drum attached to an axle. The system is usually filled with a glycol-ether based brake fluid (other fluids may also be used).

At one time, passenger vehicles commonly employed drum brakes on all four wheels. Later, disc brakes were used for the front and drum brakes for the rear. However disc brakes have shown better heat dissipation and greater resistance to 'fading' and are therefore generally safer than drum brakes. Many two-wheel vehicle designs, however, continue to employ a drum brake for the rear wheel.

In a hydraulic brake system, when the brake pedal is pressed, a pushrod exerts force on the piston(s) in the master cylinder, causing fluid from the brake fluid reservoir to flow into a reassure chamber through a compensating port. This results in an increase in the pressure of the entire hydraulic system, forcing fluid through the hydraulic lines toward one or more calipers where it acts upon one or two caliper pistons sealed by one or more seated O-rings (which prevent leakage of the fluid).

The brake caliper pistons then apply force to the brake pads, pushing them against the spinning rotor, and the friction between the pads and the rotor causes a braking torque to be generated, slowing the vehicle. Heat generated by this friction is either dissipated through vents and channels in the rotor or is conducted through the pads, which are made of specialized heat-tolerant materials such as kevlar or sintered glass.

Subsequent release of the brake pedal/lever allows the spring(s) in my master cylinder assembly to return the master piston(s) back into position. This action first relieves the hydraulic pressure on the caliper, then applies suction to the brake piston in the caliper assembly, moving it back into its housing and allowing the brake pads to release the rotor.

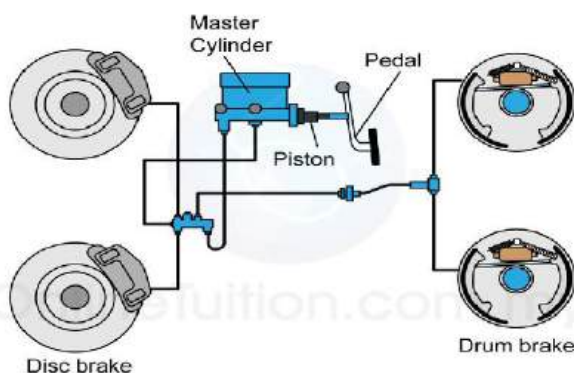

## ANTILOCK BREAKING SYSTEM



Anti-lock braking system (ABS) is an automobile safety system that allows the wheels on a motor vehicle to maintain tractive contact with the road surface according to driver inputs while braking, preventing the wheels from locking up (ceasing rotation) and avoiding uncontrolled skidding. It is an automated system that uses the principles of threshold braking and cadence braking which were practiced by skillful drivers with previous generation braking systems. It does this at a much faster rate and with better control than a driver could manage.

ABS generally offers improved vehicle control and decreases stopping distances on dry and slippery surfaces for many drivers; however, on loose surfaces like gravel or snow-covered pavement, ABS can significantly increase braking distance, although still improving vehicle control.

Since initial widespread use in production cars, anti-lock braking systems have evolved considerably. Recent versions not only prevent wheel lock under braking, but also electronically control the front-to-rear brake bias. This function, depending on its specific capabilities and implementation, is known as electronic brake force distribution (EBD), traction control system, emergency brake assist, or electronic stability control (ESC).

The anti-lock brake controller is also known as the CAB (Controller Anti-lock Brake).

Typically ABS includes a central electronic control unit (ECU), four wheel speed sensors, and at least two hydraulic valves within the brake hydraulics. The ECU constantly monitors the rotational speed of each wheel; if it detects a wheel rotating significantly slower than the others, a condition indicative of impending wheel lock, it actuates the valves to reduce hydraulic pressure to the brake at the affected wheel, thus reducing the braking force on that wheel; the wheel then turns faster.

Conversely, if the ECU detects a wheel turning significantly faster than the others, brake hydraulic pressure to the wheel is increased so the braking force is reapplied, slowing down the wheel. This process is repeated continuously and can be detected by the driver via brake pedal pulsation. Some anti-lock systems can apply or release braking pressure 15 times per second. Because of this, the wheels of cars equipped with ABS are practically impossible to lock even during panic braking in extreme conditions.

The ECU is programmed to disregard differences in wheel rotative speed below a critical threshold, because when the car is turning, the two wheels towards the center of the curve

turn slower than the outer two. For this same reason, a differential is used in virtually all road going vehicles. If a fault develops in any part of the ABS, a warning light will usually be illuminated on the vehicle instrument panel, and the ABS will be disabled until the fault is rectified.

### **COMPONANTS OF ABS**

- ⊖ Speed sensors
- ⊖ Valves
- ⊖ Pump
- ⊖ Controller

Speed sensors: A speed sensor is used to determine the acceleration or deceleration of the wheel. These sensors use a magnet and a coil of wire to generate a signal. The rotation of the wheel or differential induces a magnetic field around the sensor. The fluctuations of this magnetic field generate a voltage in the sensor. Since the voltage induced in the sensor is a result of the rotating wheel, this sensor can become inaccurate at slow speeds. The slower rotation of the wheel can cause inaccurate fluctuations in the magnetic field and thus cause inaccurate readings to the controller.

Valves: There is a valve in the brake line of each brake controlled by the ABS. On some systems, the valve has three positions. In position one, the valve is open; pressure from the master cylinder is passed right through to the brake. In position two, the valve blocks the line, isolating that brake from the master cylinder. This prevents the pressure from rising further should the driver push the brake pedal harder. In position three, the valve releases some of the pressure from the brake.

Pump: The pump in the ABS is used to restore the pressure to the hydraulic brakes after the valves have released it. A signal from the controller will release the valve at the detection of wheel slip. After a valve release the pressure supplied from the user, the pump is used to restore a desired amount of pressure to the braking system. The controller

will modulate the pumps status in order to provide the desired amount of pressure and reduce slipping.

Controller: The controller is an ECU type unit in the car which receives information from each individual wheel speed sensor, in turn if a wheel loses traction the signal is sent to the controller, the controller will then limit the brake force (EBD) and activate the ABS modulator which actuates the braking valves on and off.

## **PNEUMATIC BREAKING SYSTEM**

An air brake or, more formally, a compressed air brake system, is a type of friction brake for vehicles in which compressed air pressing on a piston is used to apply the pressure to the brake pad needed to stop the vehicle.

Air brakes are used in large heavy vehicles, particularly those having multiple trailers which must be linked into the brake system, such as trucks, buses, trailers, and semi-trailers in addition to their use in railroad trains.

## **CONSTRUCTION OF PNEUMATIC BREAKING SYSTEM**

Air brake systems are typically used on heavy trucks and buses. The system consists of service brakes, parking brakes, a control pedal, and an air storage tank. For the parking brake, there is a disc or drum brake arrangement which is designed to be held in the 'applied' position by spring pressure.

Air pressure must be produced to release these "spring break" parking brakes. For the service brakes (the ones used while driving for slowing or stopping) to be applied, the brake pedal is pushed, routing the air under pressure (approx 100–120 psi or 690–830 kPa) to the brake chamber, causing the brake to be engaged. Most types of truck air brakes are drum brakes, though there is an increasing trend towards the use of disc brakes in this application. The air compressor draws filtered air from the atmosphere and forces it into high-pressure reservoirs at around 120 psi (830 kPa).

Most heavy vehicles have a gauge within the driver's view, indicating the availability of air pressure for safe vehicle operation, often including warning tones or lights. Setting of the parking/emergency brake releases the pressurized air in the lines between the compressed air storage tank and the brakes, thus allowing the spring actuated parking

brake to engage. A sudden loss of air pressure would result in full spring break pressure immediately.

A compressed air brake system is divided into a supply system and a control system. The supply system compresses, stores and supplies high-pressure air to the control system as well as to additional air operated auxiliary truck systems (gearbox shift control, clutch pedal air assistance servo, etc.).

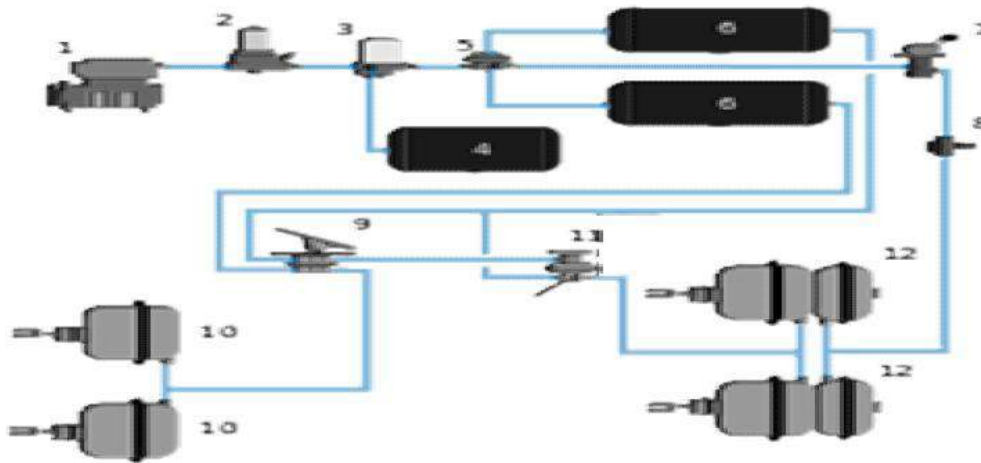

## **ADVANTAGES OF PNEUMATIC BREAKING SYSTEM**

Air brakes are used as an alternative to hydraulic brakes which are used on lighter vehicles such as automobiles. Hydraulic brakes use a liquid (hydraulic fluid) to transfer pressure from the brake pedal to the brake shoe to stop the vehicle. Air brakes have several advantages for large multi trailer vehicles:

- ⊗ The supply of air is unlimited, so the brake system can never run out of its operating fluid, as hydraulic brakes can. Minor leaks do not result in brake failures.
- ⊗ Air line couplings are easier to attach and detach than hydraulic lines; there is no danger of letting air into hydraulic fluid. So air brake circuits of trailers can be attached and removed easily by operators with little training.
- ⊗ Air not only serves as a fluid for transmission of force, but also stores potential energy. So it can serve to control the force applied. Air brake systems include an air tank that stores sufficient energy to stop the vehicle if the compressor fails.

- ⊘ Air brakes are effective even with considerable leakage, so an air brake system can be designed with sufficient "fail-safe" capacity to stop the vehicle safely even when leaking.

## **Suspension System**

### **INTRODUCTION**

Air suspension was offered as an option years ago by some car manufactures. However, it was not widely accepted for use in passenger cars. In recent years, some heavy duty trucks and buses have used in air-suspension. Now, with electronic air suspension, air springs are making a comeback.

In air-suspension systems, the four steel springs are replaced by four rubber cylinder, or air springs. Each rubber cylinder is filled with compressed air, with supports the car weight. When a wheel encounters a bump in the road, the air is further compressed & absorbs the shock.

The electronic air-suspension system includes an electric air compressor, a microcomputer control module (MCM), four air springs with built-in solenoid valves, three height sensors (two front and one rear), and the air-distribution system at lines and fittings.

The height sensors monitor the riding height, or vehicle trim height. They signal the control module of any change. If the height is too high, the control module opens the solenoid valves in the spring with too much air. This allows some of the air to escape, lowering the car. If height is too low, the control module turns on the air compressor.

---

### **ROLLING, BREAK DIP, BOUNCING AND PITCHING:-**

Centre of gravity of a vehicle is at a height but retarding and cornering forces are applied of necessity at road levels. During cornering, a turning couple about the longitudinal axis of the vehicle is produced due to the centrifugal force acting at e.g. and the forces at tire-road contact patch. These results in a motion called rolling. The left hand side suspensions move out of phase with right hand side.

Braking causes a tendency for the nose of the vehicle to dip. This phenomenon is called brake dip.

Other types of sprung mass motion are shown in fig. Pitching is defined as the rotating motion about a transverse line through the vehicle parallel to ground, the front suspension moves out at phase with the rear. Bounce is defined as the vertical motion of the center at gravity. The bounce can be front end bound or rear and bounce. Diagonal pitch is combination of pitch and roll.

Softness of springing is limited by relation of wheel base and track to c.g. height and the permissible values of dip and roll. Smaller vehicles usually have relatively stiffer springs because c.g. height can be reduced that much.

Suspension pitching and rolling axes should be arranged to pass through the c.g. of the vehicle so that the nose dip and the roll are confined to those due to tyre deflections only. However, such axis positions are difficult to obtain in practice.

#### **Road Irregularities and human susceptibility:-**

Some indication of the magnitudes of the disturbances caused by road irregularities can be gained from surface irregularity of Roads, DSIR Road Research Board Report, and 1936-7. It appears that surface undulations on medium – quality roads have amplitudes of 0.005m are characteristics of very good roads. The average pitch of these undulations is under 4m while most road vehicle wheels roll forwards at about 2m / rev. In Additional to the conventional tarmac roads, there are pave and washboard surface, the latter occurring largely on unsurfaced roads and tracks. Representative replies of these two types of surface are described in the MIRA proving ground, by A. Fogg, Proc. A.D. Inst. Mech. Engrs 1955-56.

#### **SPRINGING OF THE CAR:-**

If the front, and rear wheel axles were allowed to run in bearings fixed rigidly to the frame, the result would be extremely uncomfortable, the maximum speed of the car would be very limited, and the engine and transmission, as well as the bodywork, would be subjected to severe stresses, which in time would no doubt result in the fracture or breakdown of one or other of the working parts. It has become recognized, as a result of the long experience, that all types of vehicles used for locomotion, including railway trains, motor vehicle horse-drawn vehicles, pedal cycles and even children's prams, must be provided with some means of insulating the wheels and axles from the rest of the vehicle, so that the road or rail shocks received by the wheels when traveling over uneven ground will not be transmitted appreciably to the other parts. The axles at railway

carriages run in gunmetal axles boxes which can slide vertically in guides (known as 'horn plates') in the carriage frames, stiff springs bear down on the tops of these boxes and absorb most of the rail shocks; i.e., spring-insulate the carriage frames from the wheels and axles. The familiar leaf springs of horse-drawn vehicles serve also for the same purpose. Similarly, the pneumatic tyres and the spring

#### **BASIC FUNCTION OF THE SUSPENSION SYSTEM:-**

##### 1) To Provide Suitable Riding and Cushioning Properties –

The frame should have a high degree of isolation from the axle so that the effect of road and tyre irregularities and wheel out of balance forces are not transmitted to the vehicle frame.

##### 2) To Provide Good Road Holding –

Since the basic functions of driving, cornering and braking are obtained by virtue of the road tyre contact area, the suspension system should always maintain the wheels in contact with road to obtain these functions which would otherwise be lost.

In addition to these basic functions the vehicle suspension system must perform a No. of Complex functions which may conflict with each other. These functions are summarized below. These are general considerations which are applicable to passenger cars as well as heavy duty commercial vehicles as the case may be.

3) The suspension system must support the vertical load imposed by the weight of the vehicle, plus the body and payload weight.

##### 4) It must Provide Adequate Stability and Resistance to Sideways and Roll Over –

This is especially important for commercial trucks where substantial variations in the vertical center of gravity location can occur and also, in certain operations. Swaying, shifting and surging loads may be encountered cornering causes a tendency for the vehicle to roll.

##### 5) It must Transfer Driving and Braking Forces between Frame and Axles –

The suspension system must provide means to transfer the longitudinal forces generated during acceleration or deceleration.

##### 6) It must resist Drive and Brake Torque Wind-up –

When the driving and braking torques are applied to the ground through the tire-road contact areas, the front suspension springs have a tendency to 'wind-up'. Due to the spring wind-up, any point on the unsprung components other than the center of rotation is displaced. This will cause steering wheel rotation or change the angular position of the road wheel.

Spring wind-up also displaces the tie-rod towards the engine and may affect the clearance between tie-rod and engine exhaust system, and other components.

7) It must Resist the Cornering Effects –

When negotiating a Curve or a Turn. Normally a vehicle has a tendency to continue in straight line and when the front wheels are turned forces are generated that cause the vehicle to turn. The cornering forces cause a weight shift which results in compression on one spring and release of another which may result in a rotation of axle in the plan view. This is called axle roll steer. Another effect such load transfer can cause is the displacement of the steering arm ball from its normal load position and may result in what is called compliance steer.

8) It must maintain proper positioning of the castor on steering axle so that proper steering geometry is maintained. It should also maintain axles in alignment parallel to each other and perpendicular to the front.

9) In case of drive axles, the suspension system must provide for limited movement of drive shaft slip spines and in case of tandem axles the load transfer between the axles should be minimum.

**CLASSIFICATION OF SUSPENSION SYSTEM:-**

- a. Laminated or leaf springs.
- b. Coil Springs.
- c. Torsion bars.
- d. Air Springs.

**Leaf springs**

It consists of flat flexible plates made up of spring steel. Each plate is called leaf, it can be single or multi leaf type. There are following type of leaf springs.

- 1) Semi elliptical
- 2) Full elliptical
- 3) Quarter elliptical
- 4) Transverse elliptical

**Semi elliptical leaf spring**

A number of smaller leaves are clamped together with the main leaf. There is an U bolt which fits the spring into axle. The front end of spring is mounted on a rigid support with the



help of pins. The rear end is mounted on a shackle which gives flexible connection. Rubber bushes or phosphor bronze bushes are used in spring ways.

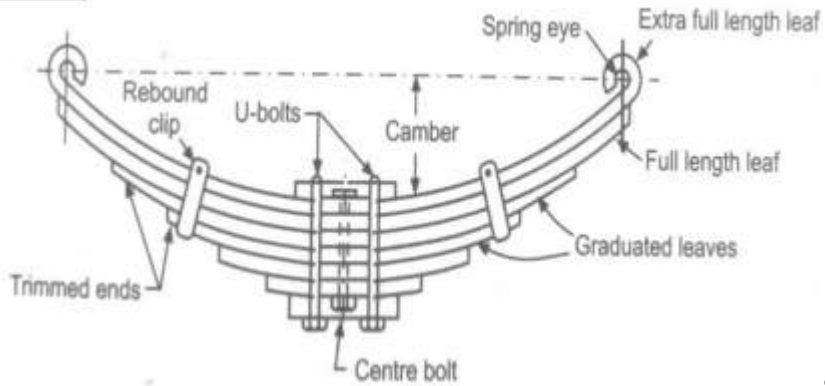

SEMI ELLIPTICAL

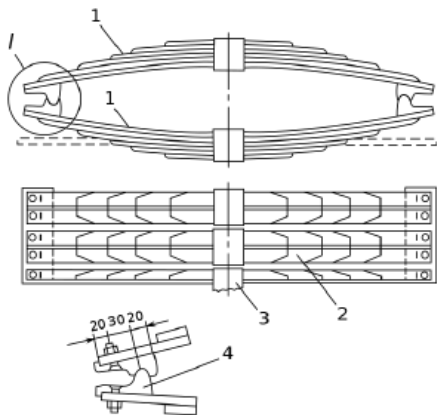

**FULL ELLIPTICAL**

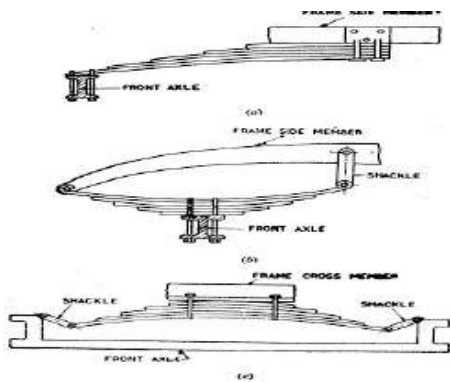

Fig. 6.6. Types of leaf spring.  
 (a) Quarter-elliptic, (b) Semi-elliptic, (c) Transverse.

**QUARTER AND TRANSVERSE LEAF SPRING**

**Full elliptical leaf spring**

Two semi elliptical leaf springs are connected together in such a way that one is fitted in inverted position. This type of spring is connected to a side frame member at centre of upper semi elliptic whereas at the lower semi elliptic centre is fitted the axle.

### **Quarter elliptic leaf spring**

It is half of the semi elliptic spring placed in inverted position.

### **Full elliptical leaf spring**

When a semi elliptic spring is fitted in inverted position, it is called transverse leaf spring. It is used above front axle, fitted parallel to it. This frame is bolted to the centre of the two ends are connected to each other.

## **COIL SPRING**

The coil spring is made of a length of spring steel rod, which is round in cross section, by winding it in the shape of a coil. Its end are made flat so that it can seat properly. Coil springs are used mainly in independent suspension system, although they can be used in convention suspension also.

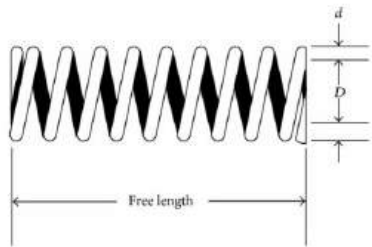

## **COIL SPRING**

### **Torsion bar**

Torsion bar is a spring steel rod which twists taking shear stresses. It is generally used in independent suspension system. The advantage of using torsion bar is that it is lighter in weight and it occupies less space than leaf spring.

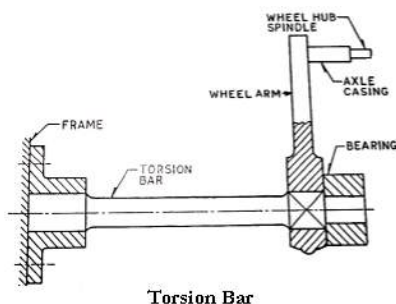

### **Shock absorber**

**Need** – As described when soft spring is used, it will give more vibrations to the vehicle body and chassis, thus causing discomfort to the occupants.

**Principle** – Shock absorber works on the principle of fluid friction. When a fluid under pressure is allowed to follow through small holes, a fluid friction is developed. This friction converts the pressure energy into heat, thus giving the damping effect. The friction developed because whole of the fluid cannot pass through the holes suddenly and it will object the flow of fluid.

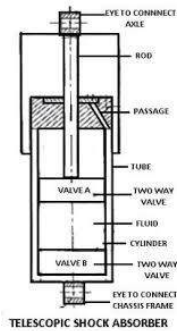

### **DESIRABLE CHARACTERISTICS OF A SUSPENSION SYSTEM:-**

The following are the desirable characteristics of a vehicle suspension below:

1) Maximum Deflection Consistent with Required Stability –

In order to provide good cushioning ability together with better riding qualities, the suspension system must provide maximum deflection. However, it should be consistent with the vehicle stability requirements.

2) Compatibility with other Vehicle Components –

Suspension system alone cannot completely determine the actual ride provided in a vehicle tyres, frame stiffness, wheelbase. Steering linkage all affect vehicle ride and hence the suspension system must be compatible with these components.

3) Minimize Wheel Hop –

For the purpose of suspension analysis the vehicle weight is divided into sprung weight and unsprung weight. Sprung weight is the weight of the vehicle that is supported on springs; rest is called unsprung weight. Frame and components attached to it come into the definition of sprung weight while wheels and wheel axles comes into unsprung weight. The resonance frequency. This wheel top frequency should be minimum wheel hop frequency and its amplitude greatly affect the road holding and hence, the cornering

and braking obtainable because cornering and braking forces are at necessity applied at the road level.

- 4) It must provide sprung mass frequency that is relatively constant between laden and unloaded conditions. Furthermore, this natural frequency must not be in resonance with tire rpm or with pavement expansion strips. Typical values of sprung mass frequency for passenger cars varies from 0.75 C/S to 2.5 C/S.

Alternative to this is provision of a variable rate spring which will be effective on a wide range of loading and under varying conditions

- 5) It must have low maintenance and operating costs. It's initial cost should also be low.
- 6) The total weight of the suspension system should be minimum.
- 7) It should minimize tire wear.

#### STRUCTURE OF ACTIVE SUSPENSION SYSTEM:-

The active suspension system has four functions – ride comfort control, vehicle attitude control, height control and stability (Maneuverability) control. These functions are carried out by controlling hydraulic cylinder which have gas springs support each wheel.

In the relatively low frequency band of less than 2 Hz, the pressure control valve receives pressure supply and discharge signals from the electric sensors, such as a G-sensor and controls the system.

In the intermediate frequency band of 2 – 6 Hz, a spool valve in the pressure control valve senses the pressure changes and mechanically (Mechanical servo function) operates to keep the line pressure constant, thereby preventing the transmission of vibrations to the vehicle body.

As shown in Fig, oil pressure generated in the oil pump is temporarily accumulated in the accumulator via an attenuator which reduces pressure pulsation. A pressure control valve in the integrated valve unit control high pressure to necessary levels and supplies pressure to each hydro-pneumatic cylinder or returns the oil in the hydraulic cylinders.

Generally, line pressure from the oil pump is changes according to the oil consumed by the pressure control valve. In this system, there is a PC valve in the pump. The PC valve balance the discharged flow rate and oil consumption properly, so that the line pressure is kept constant.

### **AIR SPRINGS:-**

A volume of air, enclosed either in a cylinder fitted with a piston or in a flexible bellows, can be used as a spring. Under the static load, the air is compressed to a predetermined pressure, and subsequent motion of the piston either increases or decreases the pressure and consequently increases or decreases the force acting on the piston. If this force is plotted against the piston travel, a curve similar to the compression curve of an engine indicator card will be obtained, so obviously the rate at which the force varies with the piston travel becomes greater as the air pressure increases. It follows that, whereas with metal spring, equal increments of force result in equal increments of deflection the rate of an air spring is not constant. This varying rate is an advantage in that a low rate can be obtained for small deflections from the mean riding position while keeping the total rise and fall of the axles within reasonable limits.

Air springs are fairly widely employed on vehicles that are laden and unlade weights differ greatly. This includes principally tractors for semi-trailers, the semi-trailers themselves and large drawbar trailers. They are also used to some extent on coaches, more especially in continental Europe and the USA, because of the very high quality ride obtainable with them, particularly if used with independent suspension. The disadvantages are high cost, complexity of compressed air ancillary system, and therefore risk of breakdown, more maintenance than other types of springing and freezing of moisture in the air in cold weather, which can cause malfunction of valves. Air suspension systems of this sort are, in general, too bulky and too complex for cars, though Citroen cars for instance have their hydro-pneumatic system.

In double-wishbone type suspensions a rubber bellows, circular in section and having two convolutions, is generally used and simply replaces the coiled spring of the conventional design. Rubber bellows type springs are used also in the Dunlop Stab lair suspension. Alternatively a metal air-container in the form of an inverted drum is fixed to the frame and a piston, or plunger, is attached to the lower wishbone. Since the piston is considerably smaller than the drum, sealing is affected by a flexible diaphragm secured to its periphery and the lip of the drum. This construction enables the load deflection characteristics of an air spring to be varied considerably by using profiled guides, such as E and F in fig, to control the form assumed by the diaphragm, and thus it's effective area, as the inner member moves relative to the other one.

Elongated convoluted bellows such as are indicated in fig, have been used in trucks and coaches, with radius rods to deal with the driving and breaking torques and thrusts, and a pan hard rod for lateral location.

#### **CONTROL SYSTEM FOR ACTIVE AIR SUSPENSION SYSTEMS:-**

Suspension control entails more than just regulation of the vertical movement of the wheels.

The many factors that have to be taken into account include comfort of the occupants, roll, both longitudinal and lateral weight transfer, and the maintenance of contact pressure between the wheels and the ground consistent with good stability and handling.

#### Effects of the Active Suspension :-

Balance of Frequency Response between Yaw and Roll – From wheel steering angle proportional control combined with yaw rate feedback controlled by the Active 4WS, significantly improves the steering response and convergence of yawing after a lane change. However, it tends to generate a lateral acceleration at high frequency causing an ordinary vehicle to develop a fast transient roll (initial roll from sharp steering and rollback) resulting in an uncomfortable feeling to the driver. With the attitude control of the Active Suspension, there is a positive feeling of stability with a high level of dynamic balance in the yaw and roll direction.

#### Stability & controllability in Lower and Higher Ranges of Lateral Acceleration:-

The use of the tires relative to slip angle and load is very important for the integrated control by the two systems. The important characteristic of the Active Suspension is that it does not only control the attitude of the vehicle when turning, but also improves critical controllability by roll stiffness distribution control.

Figure shows the effects of the rear steering control and roll stiffness distribution control on controllability and stability. As shown, the Active 4WS produces a large control effect in the range of less than 0.5G, while the Active Suspension produces a large control on roll rigidly distribution in higher G range. The new SOAERE provides sharp and stable steering performance in the range of less than 0.5G by implementing the Active 4WS. Improved performance by additional steering in a turn by the Active suspension's roll rigidly distribution control is obtained in higher G range.

#### **Emergency Lane Change Performance:-**

Emergency lane change performance is one of the characteristics that best demonstrate the effect of integrated control of the Active Suspension and Active 4WS. Speedy response

and convergence of yaw and lateral acceleration are essential. Controllability in the non-linear range is also momentarily required.

The quick response to steering by the integrated control of the Active 4WS and Active Suspension enable the vehicle to change lanes smoothly with good stability and without excess yaw

#### **ADJUSTABLE AND SELF-ADJUSTING SUSPENSION:-**

When steel torsion-bar springs are used, some method of adjusting the standing height at the suspension is needed. This is because, owing to the multiplying effect of the lever arm connected to the active end of the torsion bar, even a small tolerance on the angular relationship between the fittings at its ends can make a significant difference to the attitude of the vehicle. Moreover, it is generally difficult to maintain tight tolerance on the angular relationship between the ends, especially when the bar has been overstressed to increase its fatigue resistance. The adjustment device is generally a screw stop against which a short lever on the static end of the bar bears.

There are also variants of this principle, in which a worm-and-wheel drive is used, the wheel being on the Static end at the torsion bar and the worm on a spindle that can be rotated by the driver whilst sealed in the vehicle. Whereas the screw type adjustment is for the initial setting on the production line and only rarely used when the vehicle is being serviced, the worm and wheel or other mechanism – sometimes actuated by a small electric motor – is employed also for adjusting the fore-and-aft trim of the vehicle to cater for variations in the load distribution – for example, when heavy luggage is carried in the boot. While provision for such manual adjustment system is uncommon, automatic adjustment is the norm for air-suspension.

There are two distinctly different types of automatic adjustment system for air suspension. One is the Citroen arrangement as shown in fig, in which an engine-driven hydraulic pump supplies fluid under pressure to an accumulator and thence through leveling valves to combined air spring and strut – damaged units. This is the constant mass system, in which the mass of the air, or an inert gas, enclosed in the spring is constant. The principle is illustrated diagrammatically, but greatly simplified, in fig, where the hydraulic accumulator is omitted and a floating piston P is depicted instead of the flexible diaphragm of the Citroen system, and the hydraulic damping system is omitted from the chamber O. The constant mass of gas A is compressed above the floating piston.

Space O, between the floating piston P and the piston b attached to the axle, is filled with oil O, which moves up and down with the piston b and P, the air being correspondingly compressed or expanded. If the load is increased so that the assembly C, which is fixed to the body B, moves downwards, the valve V opens port D, so oil from the pump E passes into the space O. The piston P and assembly C, together with the body, therefore move upwards, and this continues until the port D closes again. Similarly, if the load decreases, the port F is opened and oil escapes from the space O until the port F closes again. Similarly, if the load decreases, the port F is opened and oil escapes from the space O until the port F closes again. This the basic ride height of the suspension can be kept constant. This self-adjusting action is damped so that the motions between the body and axle due to irregularities of the road do not influence the basic setting of the ride height.

**ADVANTAGES OF THE ACTIVE SUSPENSION: -**

- 1) The normal coil spring is not used in this suspension, thus eliminating its vibration. This improves riding comfort at low frequencies. The spring function has been replaced by the Hydro-pneumatic Suspension system. The pressure control range has been widened to maintain a flat vehicle position even while turning.
  - 2) The variable displacement piston pump is used to reduce energy consumption during non turning maneuvers, but still have sufficient flow in the turn. It features nine pistons to reduce pressure pulsation.
  - 3) Vertical G sensors are used for skyhook damping.
  - 4) Active Suspension has four control functions as follows.
    - a. Riding comfort control to absorb road surface irregularities.
    - b. Vehicle attitude control to maintain a constant vehicle attitude at all times.
    - c. Stability and controllability control to ensure stability in turning and straight driving.
    - d. Vehicle height control to maintain a constant height regardless of the load. These functions operate mutually for overall control.
-



## **Alternator, Dynamo and Battery**

### **DYNAMO**

A dynamo is an [electrical generator](#) that creates [direct current](#) using a [commutator](#). Dynamos were the first electrical generators capable of delivering power for industry, and the foundation upon which many other later [electric-power conversion](#) devices were based, including the [electric motor](#), the [alternating-current alternator](#), and the [rotary converter](#).

### **WORKING**

It is a d.c. generator which converts mechanical energy from engine shaft into direct current. A conductor wire loop is rotated in a magnetic field to induce electric current into d.c. with the help of a commutator. Its function is to generate d.c. electricity for charging the battery and functioning of other electrical system in the automobile.

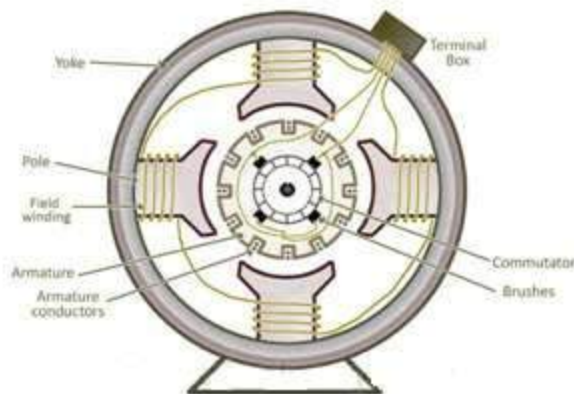

A DC generator can be used as a DC motor without any constructional changes and vice versa is also possible. Thus, a DC generator or a [DC motor](#) can be broadly termed as a DC machine. These basic constructional details are also valid for the construction of a DC motor. Hence, let's call this point as construction of a DC machine instead of just 'construction of a dc generator'.

**Basic constructional parts of a DC machine are described below.**

1. Yoke: The outer frame of a dc machine is called as yoke. It is made up of cast iron or steel. It not only provides mechanical strength to the whole assembly but also carries the magnetic flux produced by the field winding.

2. Poles and pole shoes: Poles are joined to the yoke with the help of bolts or welding. They carry field winding and pole shoes are fastened to them. Pole shoes serve two purposes;  
  
(i) they support field coils and (ii) spread out the flux in air gap uniformly.
  
3. Field winding: They are usually made of copper. Field coils are former wound and placed on each pole and are connected in series. They are wound in such a way that, when energized, they form alternate North and South poles.
  
4. Armature core: Armature core is the rotor of a dc machine. It is cylindrical in shape with slots to carry armature winding. The armature is built up of thin laminated circular steel disks for reducing eddy current losses. It may be provided with air ducts for the axial air flow for cooling purposes. Armature is keyed to the shaft.
  
5. [Armature winding](#): It is usually a former wound copper coil which rests in armature slots. The armature conductors are insulated from each other and also from the armature core. Armature winding can be wound by one of the two methods; lap winding or wave winding. Double layer lap or wave windings are generally used. A double layer winding means that each armature slot will carry two different coils.
  
6. Commutator and brushes: Physical connection to the armature winding is made through a commutator-brush arrangement. The function of a commutator, in a dc generator, is to collect the current generated in armature conductors. Whereas, in case of a dc motor, commutator helps in providing current to the armature conductors. A commutator consists of a set of copper segments which are insulated from each other. The number of segments is equal to the number of armature coils. Each segment is connected to an armature coil and the commutator is keyed to the shaft. Brushes are usually made from carbon or

graphite. They rest on commutator segments and slide on the segments when the commutator rotates keeping the physical contact to collect or supply the current.

## ALTERNATOR

An alternator is an [electrical machine](#) which converts mechanical energy into alternating electric energy. They are also known as synchronous generators.

## WORKING

According to the [Faraday's law of electromagnetic induction](#), whenever a conductor moves in a magnetic field EMF gets induced across the conductor. If the close path is provided to the conductor, induced emf causes current to flow in the circuit.

Let the conductor coil is placed in a magnetic field. The direction of magnetic flux will be from N pole to S pole. The coil is connected to slip rings, and the load is connected through brushes resting on the slip rings. The coil is rotating clockwise and the direction of induced current can be given by [Fleming's right hand rule](#).

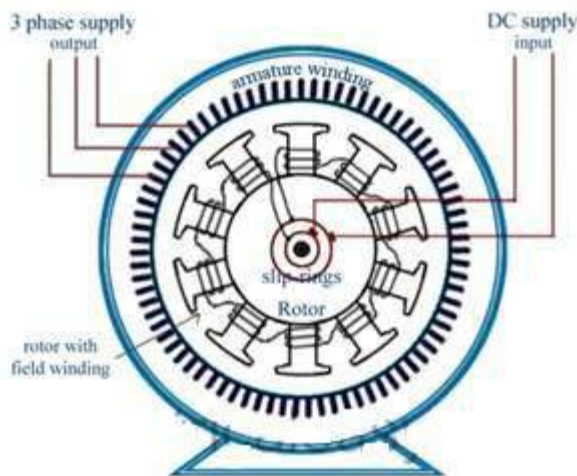

### **MAIN PARTS OF THE ALTERNATOR**

It consists of stator and rotor. But, the unlike other machines, in most of the alternators, field exciters are rotating and the armature coil is stationary.

1) **Stator:** Unlike in [DC machine](#) stator of an alternator is not meant to serve path for magnetic flux. Instead, the stator is used for holding armature winding. The stator core is made up of lamination of steel alloys or magnetic iron, to minimize the [eddy current losses](#). Armature winding is stationary in an alternator because

- (a) At high voltages, it easier to insulate stationary armature winding, which may be as high as 30 kV or more.
- (b) The high voltage output can be directly taken out from the stationary armature. Whereas, for a rotary armature, there will be large brush contact drop at higher voltages, also the sparking at the brush surface will occur.
- (c) Field exciter winding is placed in rotor, and the low dc voltage can be transferred safely.
- (d) The armature winding can be braced well, so as to prevent deformation caused by the high centrifugal force.

2) **Rotor:** There are two types of rotor used in an AC generator / alternator:

(a) Salient and (b) cylindrical type

(a) Salient pole type: Salient pole type rotor is used in low and medium speed alternators. Construction of AC generator of salient pole type rotor is shown in the figure above. This type of rotor consists of large number of projected poles (called salient poles), bolted on a magnetic wheel. These poles are also laminated to minimize the eddy current losses. Alternators featuring this type of rotor are large in diameters and short in axial length.

- (b) Cylindrical type: Cylindrical type rotors are used in high speed alternators, especially in turbo alternators. This type of rotor consists of a smooth and solid steel cylinder having slots along its outer periphery. Field windings are placed in these slots. The DC supply is given to the rotor winding through the slip rings and brushes arrangement.



## CHARGING OF AN ALTERNATOR

Synchronization of [alternator](#) means connecting an alternator into grid in parallel with many other alternators that is in a live system of constant voltage and constant frequency. Many alternators and loads are connected into a grid, and all the alternators in grid are having same output voltage and frequency (whatever may be the power). It is also said that the [alternator](#) is connected to infinite bus-bar. A stationary alternator is never connected to live bus-bars, because it will result in short circuit in the stator winding (since there is no generated emf yet). Before connecting an alternator into grid, following conditions must be satisfied.

- (a) Equal voltage: The terminal voltage of incoming alternator must be equal to the bus-bar voltage.
  
- (b) Similar frequency: The frequency of generated voltage must be equal to the frequency of the bus-bar voltage.
  
- (c) Phase sequence: The phase sequence of the three phases of alternator must be similar to that of the grid or bus-bars.
  
- (d) Phase angle: The phase angle between the generated voltage and the voltage of grid must be zero.

The first condition of voltage equality can be satisfied by a voltmeter. To satisfy the conditions of equal frequency and identical phases, one of the following two methods can be used.

(a) Synchronization using incandescent lamp.

(b) Synchronization using synchroscope.

**SYNCHRONIZATION OF ALTERNATOR USING INCANDESCENT LAMP**

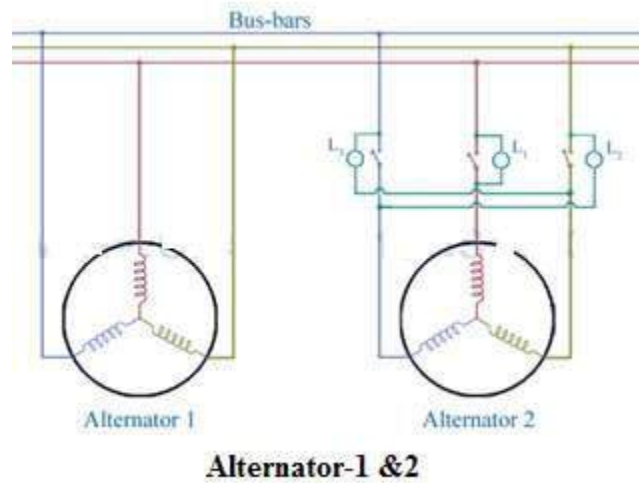

Let, alternator 2 is to be synchronized in a grid and the alternator 1 is already in the grid as shown in above figure. The alternator 2 is connected to grid through three synchronizing lamps (L<sub>1</sub>, L<sub>2</sub> and L<sub>3</sub>) as shown in above figure. If the speed of the alternator 2 is not such that the frequency of output voltage is equal to the frequency of the grid, there will also be a phase difference in the voltages, and in this case the lamps will flicker.

Three lamps are connected asymmetrically, because if they were connected symmetrically, they would glow or dark out simultaneously (if the phase rotation is same as that of bus-bars). Asymmetrically connected lamps indicate whether the incoming machine is running slower or faster. If the alternator 2 is running slower, the phase rotation of alternator 2 will appear to be clockwise relative to the phase rotation of the grid and the lamps will light up in the order 3,2,1;3,2,1

If the alternator 2 is running faster, the phase rotation of alternator 2 will appear to be anticlockwise relative to the phase rotation of the grid and the lamps will light up in the order 1,2,3;1,2,3.

When the speed of the alternator 2 reaches so that, the frequency and phase rotation of output voltage is similar to that of the grid voltage, lamp L1 will go dark and lamps L2 and L3 will dimly but equally glow (as they are connected between different phases and due to this there will be phase difference of 120 degree). The synchronization is done at this very moment. This method of synchronization is sometimes also known as 'two bright and one dark method'.

### SYNCHRONIZATION OF ALTERNATOR USING SYNCHROSCOPE

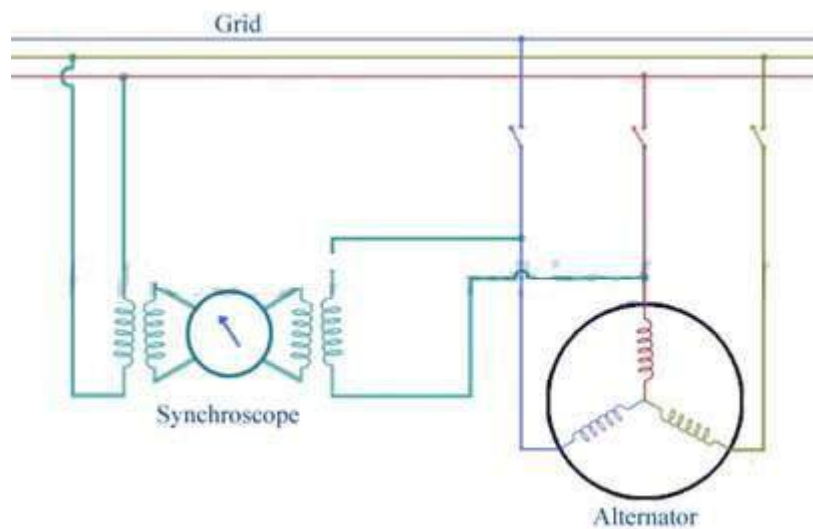

A synchroscope is a device which shows the correct instant of closing the synchronizing switch. Synchroscope has a pointer which rotates on the dial. The pointer rotates anticlockwise if the [machine](#) is running slower or it rotates clockwise if the machine is running fast. The correct instant of closing synchronizing switch is when the pointer is straight upwards.

**COMPARISON BETWEEN DYNAMO AND ALTERNATOR**

<b>Dynamo</b>	<b>Alternator</b>
It gives d.c. output.	It gives a.c. output.
Armature rotates in the stationary magnetic field to generate electricity.	Magnetic field rotates in conductors to generate electricity.
Cutout relay is used for one way current flow.	Rectifier diodes serve this purpose.
Separate regulators are used to control output current and voltage.	Rectifier circuit controls the output current and voltage.
It requires more maintenance.	It requires less maintenance.
Its initial cost is lower.	Its initial cost is higher.