

RVH6222

UNDERMOUNT WORKSTATION SINK

RUVATI®

SPECIFICATION SHEET

MATERIAL

- True 16 Gauge Thickness
- Premium T304 Grade Stainless Steel
- Nano-PVD colored finish: easy to clean, and long lasting

FEATURES

- Heavy duty sound guard padding and undercoating
- Slanted bottom with elegant drain grooves for easy draining
- Dual-Tier Ledge for Accessories



COLOR OPTIONS

BL: Black Stainless Steel

GG: Matte Gold Brass Tone

IN THE BOX

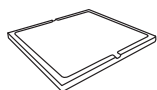

Cutting Board
[RVA1233]

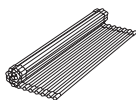

Roll-Up Rack
[RVA1385BL/GG]



Condiment
Serving Tray
[RVA1377]



Mixing Bowl and Platform
[RVA1288]



Basket Strainer
[RVA1022BL/GG]

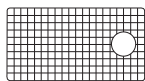

Rinse Grid
[RVA68222]

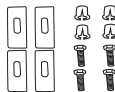

Mounting Clips
[RVA11031]



Cut-out
Template

NOMINAL DIMENSIONS

Exterior: 33½" (wide) x 19" (front-to-back)

Interior Bowl: 31⅞" (wide) x 14⅝" (front-to-back)

Bowl Depth: 10"

Minimum Cabinet Size: 36" wide

Drain Hole Size: 3½"

Installation Type:
Undermount

Inside Corners:
Rounded

Drain Location:
Offset

RUVATI USA

www.ruvati.com

Phone: 1.855.478.8284
Email: support@ruvati.com

OPTIONAL ACCESSORIES (SOLD SEPARATELY)

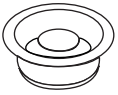

Garbage Disposal Flange
[RVA1041BL /GG]

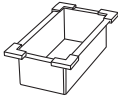

Collander
[RVA1310]

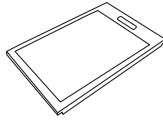

Cutting Board
[RVA1217]

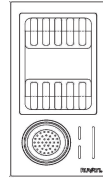

Caddy Drying Rack
[RVA1542]



cUPC certified by IAPMO to meet US and Canada plumbing standards.
Codes compliance: ASME A112.19.3/CSA B45.4

DIMENSIONS

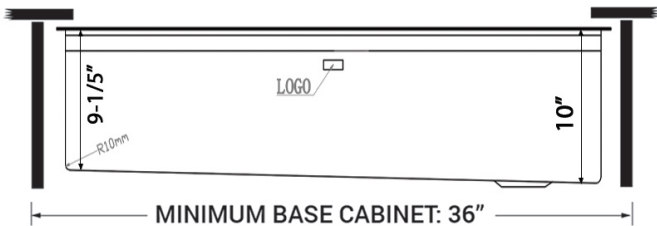
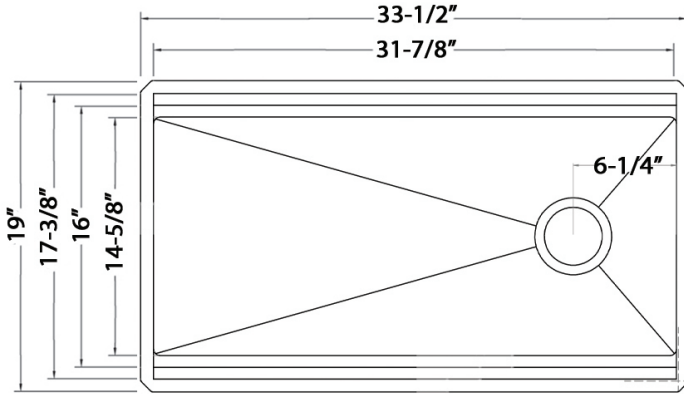

Register your product at www.ruvati.com/register.