

### **Course Description:**

This course focuses on electronic discrete components, their construction, working and application. An in-depth understanding of electrical and electronic components such as resistors, capacitors, inductors, semiconductor devices including diodes, transistors (BJT and FET), power electronic devices including thyristors, triacs and diacs, operational amplifiers and basic troubleshooting techniques are expected to be gained by the learner. Test equipment such as analogue and digital (voltmeters, ammeters and ohmmeters) are an important integral part of this course.

### **Course Objective:**

By the end of this course the student should be able to;

- Define, differentiate the construction, their types, uses and perform basic calculation for the following; resistors, capacitor and inductors.
- Understand the construction and switching of semiconductor devices such as diodes, BJTs, FETs, thyristors, triacs and diacs.
- Analyze operational amplifiers in terms of basic operation, definition of terms, application; buffer, adder, subtractor, gain.
- Use basic fault finding digital/analogue-(ohmmeter, ammeter and voltmeter) for basic troubleshooting techniques.

### **Course Content:**

#### **1. BASIC ELECTRONICS AND BASIC ELECTRICAL COMPONENTS:**

##### **Week 1 & 2**

- Introduction (brief account of terms and concepts and materials used in electrical and electronic applications).
- Electronic Devices: Fuses including purpose of fuse in a circuit, type of fuses, overload and over-current and their causes. Resistors; including-types of resistors (carbon, wire-wound, variable, potential divider).
- Resistor connections (series, parallel and combination of both)

##### **Week 3**

- Connections, calculations of voltage and currents, Ohm's law, symbols, codes.
- Thermistors; positive and negative coefficient, Block diagrams.

##### **Week 4 & 5**

##### **CAT 1**

- Capacitors; including- types construction and use, calculations (series and parallel), electrolytic capacitors.
- Inductors; including- types, construction and uses. Calculations.

#### **2. THE SEMICONDUCTORS THEORY:**

##### **Week 6 & 7**

- Intrinsic, extrinsic, semiconductors. The P-type and the N-type
- Formation of P-N junction, and the depletion layer.
- Forward and reverse bias of the P-N junction.
- The P-N junction diode: Voltage and current characteristics.
- Types of diodes (LED, Photo, Zener), Zener diodes stabilizer and characteristics, application.

#### **3. TRANSISTORS:**

##### **Week 9 & 10**

##### **CAT 2**

- Bipolar junction transistor (BJT): Construction, the NPN and PNP types.
- Modes of connection: Common base, common collector, and common emitter.



Capacitors; including- types construction and use, calculations, electrolytic capacitors. Inductors; including- types, construction and uses. Calculations. Diodes; including-PN junction, characteristics, forward and reverse bias, types of diodes(LED, Zener), Zener diodes stabilizer and characteristics, application. Transistors; including-types(BJT, JFET, MOSFET), common mode connection; biasing (saturation, cut-off). Thyristor and triacs(SCR); including-construction and symbol; comparison with conventional; relays and mechanical switch; PNP sandwich (two transistors analogy); High speed switch; application. Operational amplifier(OP-AMP); block diagram; basic operation; definition of terms; application, buffer, adder, subtractor, gain; Thermistors; positive and negative coefficient, Block diagrams; definition, use. Practical to include: Oscilloscope; including-measuring waveform in voltage and phase difference, using analog and digital multi-meters. Resistor, capacitor, inductor, inductor, diode and transistor characteristics, Thyristor/triac experiments and OPAMP experiments.

**REFERENCE MATERIALS:**

1. Albert Paul Malvino. "Principles of electronics" Mc Graw-hill.
2. Russel L. Meade "Foundation of Electronics, 2<sup>nd</sup> edition "Delma Publisher inc.
3. Jerrold H Krenz "Electronic concept an introduction" Cambridge University press.
4. Treror Linsely "Electronics for technicians" Edward Arnold.
5. Power Electronics: Circuits, Devices and Applications by Rashid M.H
6. Physics of semiconductor devices by S. M. Sze
7. Electronics theory and applications third edition, by dr SL Kakani
8. Principles of electronic by V. K. Mehta

## ICS 2200 ANALOGUE ELECTRONICS

Electronics is the study of conduction current in solids, gases, vacuum and liquids.

It is a branch of engineering that comes from the 2 words: Electrons – negatively charged particle in an atom, Mechanics – Study of motion of an electron.

Electronics is also study of electrons and how they can be used to perform different functions.

-The ability to control movement of electrons or electron flow is the basic of electronics; it specializes in digital computers, audio systems, communication systems, and automatic control.

### Analogue Signal

An analogue signal is one whose amplitude is changing with time continuously. This is shown in the diagram below.

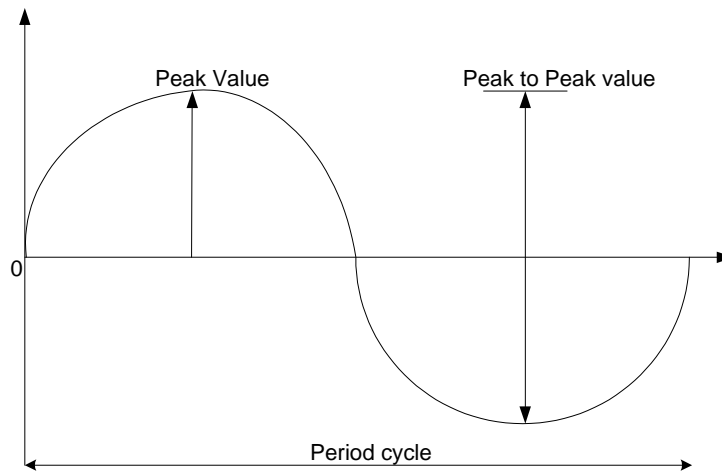

Characteristic of analogue signals:

- An analogue signal varies continuously with time. It is typical of nature e.g light, end waves and voice. They have been used for the last 100 years.

### Digital signal

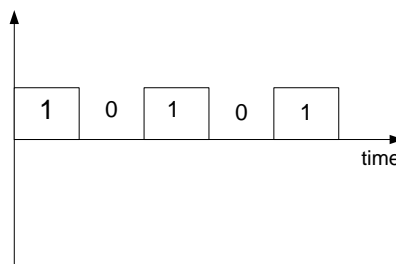

Characteristics of Digital Signals

- They do not vary with time. Occur in discrete form.
- Typical of technology. They can be produced from analogue signals through analogue to digital conversion.
- They have been used for about 50 years with invention of vacuum tubes and transistors.

### Applications of electronics

- Communication – satellites
- Medicine
- Entertainment - 3 stereos, HIFI systems, Ipod
- Industrial applications – Assembly lines
- Transport – Autopilot, tracking systems, missile guiding
- Military / defense/ security – Biometrics
- Astronomy
- Instrumentation – Electronic pianos

Radar – Radio detection and ranging can be used for all the above e.g in medicine to detect cancer

### PHYSICAL AND CHEMICAL STATES OF MATTERS

- **Matter** is anything that occupies spaces and has weight.
- The basic building block of matter is an atom.

Matter exists in three physical states –

- Solid
- Liquid
- Gas

When it exists in liquid or gas its dimension are determined by the container.

Chemical states of matter include:

- Elements
- Compounds
- Mixtures

- ❖ **Element:** - is a substance that cannot be broken into simpler substances. It has only one kind of atom e.g. Mg, K, Na, Oxygen.

Hydrogen	H	1
Helium	He	2
Lithium	Li	3
Beryllium	Be	4
Boron	B	5
Carbon	C	6
Nitrogen	N	7
Oxygen	O	8
Fluorine	F	9
Neon	Ne	10
Sodium	Na	11
Magnesium	Mg	12
Aluminium	Al	13
Silicon	Si	14
Phosphorous	P	15
Sulphur	S	16
Chlorine	Cl	17
Argon	Ar	18
Potassium	K	19
Calcium	Ca	20

- **Compound** - is formed by chemical combination of two or more elements e.g. NaCl, MgO, H<sub>2</sub>O etc.
- **Mixtures** – Combination of substances where the individual elements poses the same properties as when they were alone e.g. Air.

All matter is composed of atoms and molecules.

The smallest particle into which a compound can be divided and retain its physical properties is called a **molecule**.

The smallest particle into which an element can be divided and retain its chemical properties is called an **atom**.

**Electric charge:** - The quantity of electricity in a body

### THE ELECTRON THEORY

- Every atom has one or more electron and one nucleus. The nucleus contains the protons and Neutrons.
- The simplest atom is that of hydrogen and consists on one electron orbiting around the nucleus.
- The nucleus has only one proton apart. In a simple hydrogen atom the nucleus is made of protons and neutrons of approximately equal numbers.
- The electrical charge of an electron is negative and that of a proton is +ve and neutron is neutral.
- A normal atom is electrically neutral containing an equal number of +vely charged atoms and –vely charged electrons. Meaning that the charge per electron and proton is equal but opposite in polarity.

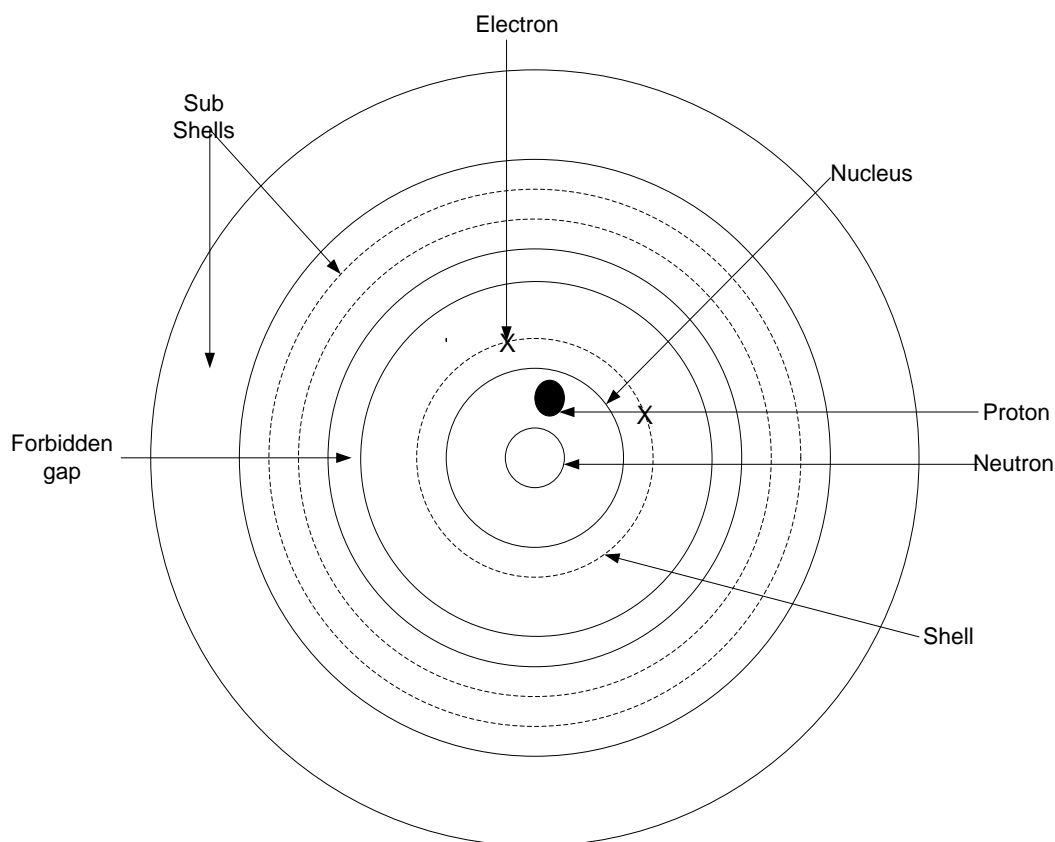

## THE ATOM MODEL

- One of the men who contributed greatly to the development and understanding of atomic structure Neil Bohrls.
- He developed a model for atoms which restricted the orbits of atom electrons to well defined shells of levels. i.e. Electron do not crowd together in mass rather more round in different orbits.
- An atomic level of such orbits is termed as a shell which can be defined as the spherical orbit of an electron or electrons.
- The figure above shows the structure of a carbon atom.
  
- **Nucleus** -is the innermost part of an atom. It contains protons and neutrons.
- **Electron**-negatively charged particle revolving in specified orbits called quantum energy levels.
- **Proton**-positively charged particle in the nucleus.
- **Neutron**-particle with no charge in the nucleus.
- **Shell**-section where electrons orbit, it has subshells and quantum energy levels. The number of electrons (N) in a shell is given by the general formulae  $N = 2n^2$  where n is the shell number.
- **Subshell**-section with electrons inside a shell, several of them make a shell. The number of electrons in a subshell is given by the general formula:  $2+4(m-1)$ , where m is the subshell number.
- **Forbidden gap**-section where electrons can not orbit, is between two subshells.
- The first theory of Bohrl was that an electron in an atom can revolve in certain specified orbits without the emission of radiant energy. The theory explains the stability of an atom.
- Second theory was that an electron may make a transition from one of its specified non radiating orbits to another of lower energy. When it does so a single photon is emitted whose energy difference between the initial and final states and whose frequency  $f$  is given by the relation below.

$$hf = E_i - E_f$$

Where h is plank's constant,  $E_i$  and  $E_f$  are the energies of initial and final state.

## THE EXCLUSION PRINCIPLE

- Paul's exclusion principle states that no two electrons can occupy the same quantum mechanical state since different states correspond to different distances from the nucleus.
- In a complex atom there's no room for all the electrons in state near the nucleus. Some are forced into states further away having higher energies.
- The maximum number of electrons per shell is given by  $2n^2$  where n is the shell number counting outwards from the nucleus.
- Sub-shell electrons =  $2 + 4(m-1)$ , where m is the subshell number

1 <sup>st</sup>	2é
2 <sup>nd</sup>	2é, 6é
3 <sup>rd</sup>	2é, 6é, 10é
4 <sup>th</sup>	2é, 6é, 10é, 14é
5 <sup>th</sup>	2é, 6é, 10é, 14é, 18é
6 <sup>th</sup>	2é, 6é, 10é, 14é, 18é, 22é

### **Example**

Determine the maximum no of electrons in the 3<sup>rd</sup> shell

$$\begin{aligned}\text{Max No} &= 2^n \\ N &= 3 \\ &= 2 \times 3^2 \\ &= 18es\end{aligned}$$

### **ATOMIC NUMBER & ATOMIC WEIGHT**

Atomic number of an element is determined by the number of protons in each of it's atoms of that element

$$\begin{aligned}B &= 5 \quad 2:3 \\ S &= 16 \quad 2.3.6\end{aligned}$$

Atomic weight of an element is determined by comparing the weight of it's atoms of carbon = 12

### **VALENCE ELECTORNS (State electron)**

- Are those electrons in the outermost shell of an atom. The number of valence electrons in an atom determines it'd stability or instability both electrically and chemically.
- For all the atoms with two shall the outermost shell is full when it has 8 *es* if the atom if the atom has fewer than 8*es* in the outermost shell then the atom is electrically and chemically unstable and active.
- Electrically the valence electrons can be moved from their own atoms and are some times referred to as free electrons.
- It's possible to detach an orbit electron from an atom leaving the atom with an access the charge. The atom in this state is called a +ve ion or cation.
- Alternatively the neutral atom may be given an addition orbit/electron in which case the atom assumes a negative charge. Which is called an -ve or anion.
- An ion is any atoms that is not electrically balanced and that has gained or lost electrons.

### ***Energies that change electrical balance include:-***

- a- Chemical energy – dry cells, batteries
- b- Mechanical energy e.g generators
- c- Light energy
- d- Heat energy (Friction)
- e- Magnetic energy

### **Conduction in a gas**

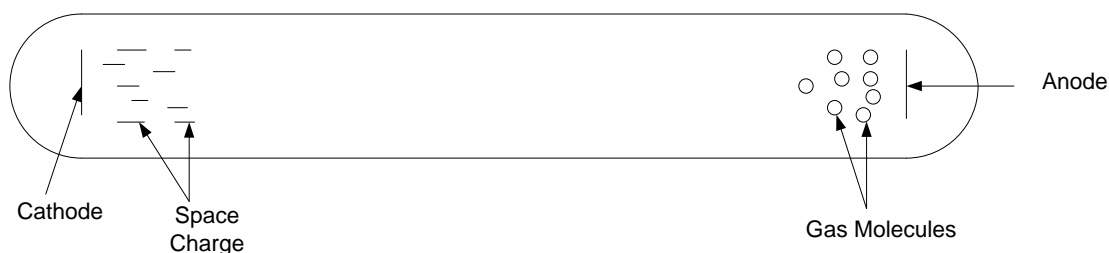

Conduction in gases takes place through ionization. Accelerating electrons strike the molecular and ionize it. The gas should have low pressure. It cannot conduct under normal pressure.



## Conduction in a vacuum

A vacuum can only conduct electromagnetic waves e.g. light

## Material used in electrical & electronic circuits

### Solids

Types of solids

- Conductors

- Insulators

-Semiconductors

### Conductors

- These are materials that allow current to pass through.
- They have 1-3 electrons in outermost shell.
- Have metallic bond
- Have free electrons.
- Have low resistance.
- The conduction band and valence band overlap and are very small.

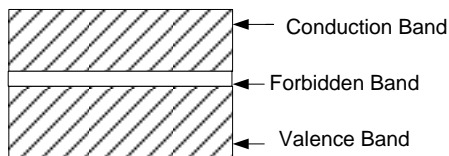

- Resistance increases with increase in temperature.
- $E_g = 0\text{eV}$

Examples of conductors are all metals.

### Insulators

- These are materials that do not allow current to pass through.
- They have 5 to 8 electrons in outermost shell.
- They have a structure that has covalent bonding that results in no free electrons that allow conduction of an electric current.
- Insulators have a very large energy gap between the conduction band and the valence band.
- $E_g = 5\text{eV}$

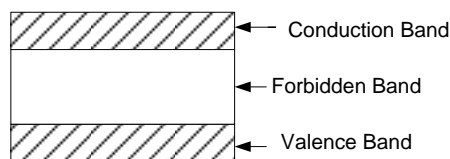

### Semiconductors

These are materials that have poor conductivity at low temperatures and good conductivity at high temperatures.

Characteristics of Semiconductors

- They have 4 electrons in outermost shell / band
- Their atomic structure has covalent bonds
- They have a moderate number of free electrons
- $E_g = 1.1\text{eV}$

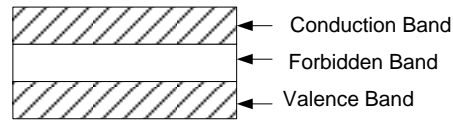

- They have a moderately sized of forbidden band
- There are two types : Intrinsic and Extrinsic

### Intrinsic semi conductors

These are semi conductors in their pure form e. g silicon, germanium. Conduction takes place through holes and electrons.

Silicon Structure 2:8:4

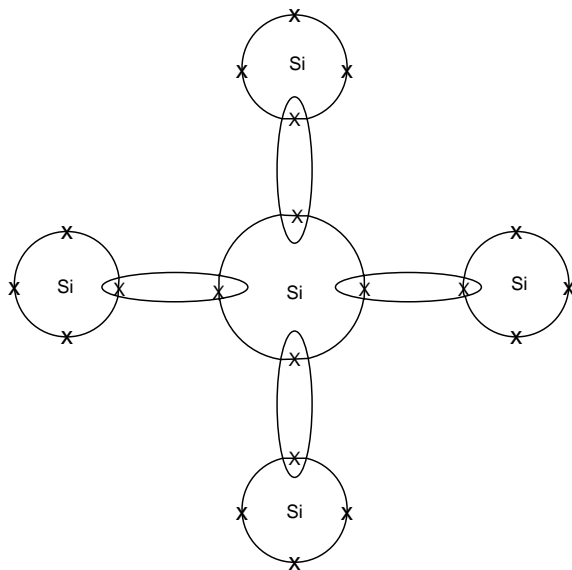

### Extrinsic Semiconductors

These are semiconductors to which impurities have been added through the process of doping.

There are two types: P-type  
N-type

#### P – Type

This is formed by process of adding trivalent impurities into the crystal structure of silicon. Trivalent impurities include boron

Boron 2:3

Silicon 2:8:4

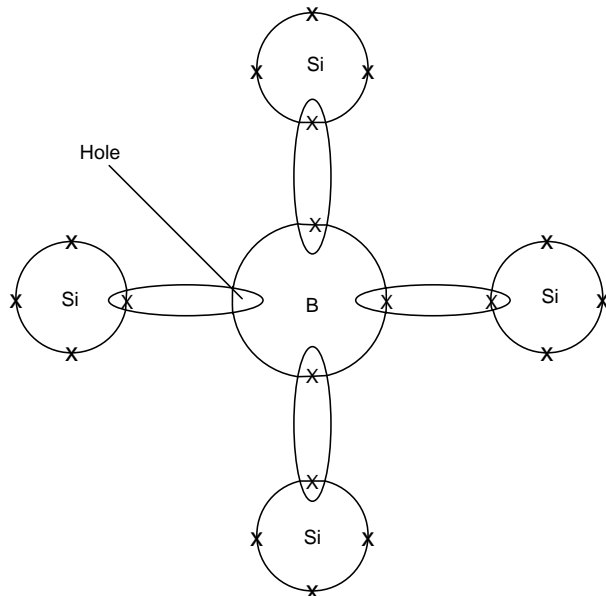

Holes are the majority carriers in P-type semiconductors thus it is an acceptor semiconductor. Conduction is by movement of holes. Holes move in the direction of conventional current.

### N – type

This is formed by adding pentavalent impurities e.g. phosphorous, arsenic, antimony.

Silicon 2:8:4

Phosphorous 2:8:5

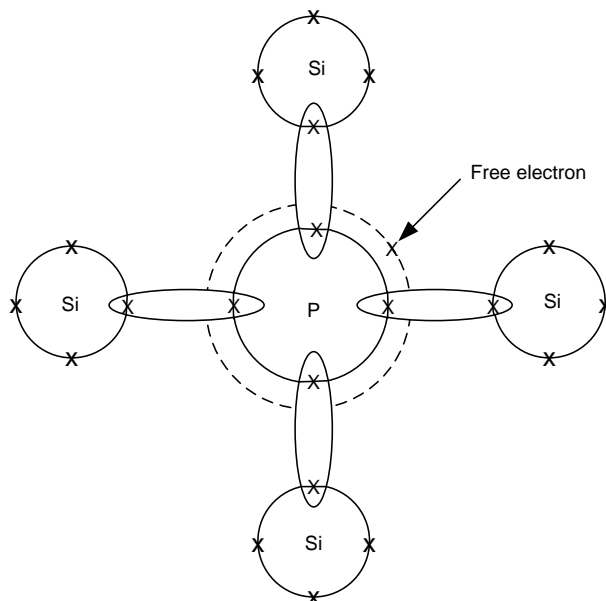

Majority charge carriers are electrons and thus conduction is by electron flow. Electron flow is opposite to the direction of flow of conventional current.

### Terms and concepts

Charge            Amount of current passing through a given point for a given time.  
 It is the ability to attract or repel electrons.  
 $Q = It$

- Current** Is the rate of flow of charge. SI unit is Amperes (A)  
 $I = Q/t$
- Voltage** Is the energy which drives charge across a circuit. It is also called electromotive force (emf). SI unit is volts (V)
- Potential difference** Is the energy which drives charge across a component in a circuit.  
 SI unit is also V
- Power** Rate of energy dissipation in a component. Is the amount of energy dissipated in a conductor carrying a current of 1A. If the p.d across the conductor 1V  
 $P = \text{Voltage} * \text{Current} = IV$   
 SI unit is Watts (W)

**RESISTORS.**

**Resistor** A resistor is a passive component which opposes the flow of current in Q circuit



- Passive component** (i) Does not add strength to a signal  
 (ii) Does not require power to operate

Active components e.g. diodes, transistor require power to operate and strength to a signal

**Resistance (R)** represented by the unit [ $\Omega$ ]. This is the opposition to the flow of current.

Factors affecting resistance of a conductor

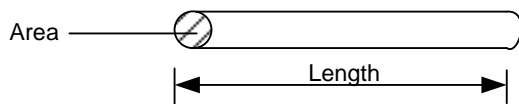

- (a) Length (m)  $R \propto L$
- (b) Cross sectional Area  $R \propto \frac{L}{A}$
- (c) Resistivity (symbol  $\rho$ ) and units ( $\Omega m$ )  $R \propto \rho$
- (d) Temperature

The formula for resistance is  $R = \rho \frac{L}{A}$

**COLOUR CODING**

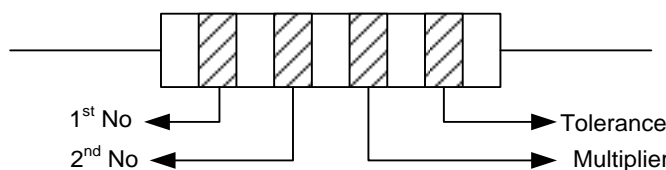

4 colour Band resistor

Number	Colour	Multiplier	Tolerance
0	Black	$10^0$	
1	Brown	$10^1$	$\pm 1\%$
2	Red	$10^2$	$\pm 2\%$
3	Orange	$10^3$	
4	Yellow	$10^4$	
5	Green	$10^5$	
6	Blue	$10^6$	
7	Violet	$10^7$	
8	Grey	$10^8$	
9	White	$10^9$	
-	Gold	$10^{-1}$	$\pm 5\%$
-	Silver	$10^{-2}$	$\pm 10\%$
-	No. band	-	$\pm 20\%$

Resistor color coding is the process of representing resistance of resistor using colour bands. The colour bands are indicated on the surface of the resistor.

Colour coding comes in 2 types: 4 colour resistors

5 colour resistors

For 4 colour band resistors the 1<sup>st</sup> colour band represent the 1<sup>st</sup> Number, 2<sup>nd</sup> colour representing the 2<sup>nd</sup> no, 3<sup>rd</sup> colour band representing multiplier / no of zeros, last colour band representative tolerance.

Tolerance is the deviation from the exact value and can be represented by %. For a five colour band resistor the 1<sup>st</sup> 3 bands representing the numbers, the fourth represents the multiplier, the last represents the tolerance.

### Converting from colour bands to resistance

Orange, Brown, Blue, Silver

$$3 \quad 1 \quad \times 10^6 \pm 10\%$$

Range due to tolerance gives  $31 \times 10^6 \pm 31 \times 10^5$

$$= 27.9 \times 10^6 \text{ to } 34.1 \times 10^6 \Omega$$

### Convert from resistance to colour bands

(i)  $36 \times 10^6 \Omega \pm 1\%$

Orange, Blue, Yellow, Brown

(ii)  $845678 \pm 10\%$

This can be approximated to  $850000 \pm 10\% = 85 \times 10^4 \pm 10\%$

This gives the following Grey, Green, Yellow, Silver

(iii)  $4K54 \pm 2\%$

This is equivalent to  $4.5 \times 10^3 \pm 2\% = 45 \times 10^2 \pm 2\%$

This gives the following colour code Yellow, Green, Red, Red

(iv) Give the values and the tolerances of the resistors below if the color-codes from right to left are.

- i. Brown, Orange, Black, Red

**Solution:**

Red, Black, Orange, Brown  
 $2 \quad 0 \quad 10^3 \quad 1\%$   
 $20 \times 10^3 \pm 1\%$

- ii. Yellow, brown, Green

**Solution:**

Green, Brown, Yellow

$5 \quad 1 \quad 10^4 \quad 20\%$   
 $51 \times 10^4 \pm 20\%$

### Ohms Law

The current passing through a conductor is proportional to the voltage applied across it provided all external factors are constant.

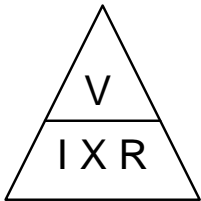

$$I \propto V$$

$$I = \frac{V}{R} \quad V = IR \quad R = \frac{V}{I}$$

$$P = IV = I^2R = \frac{V^2}{R}$$

### Resistor circuits

The circuit shown below has the resistors connected in series.

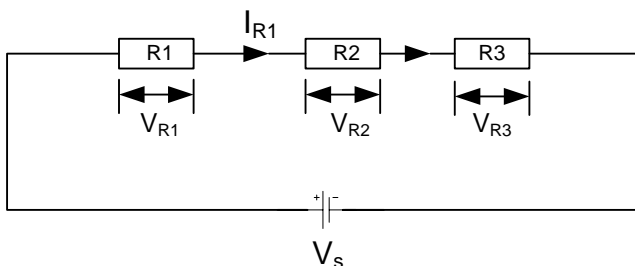

$$I = I_{R1} = I_{R2} = I_{R3}$$

$$V_s = V_{R1} + V_{R2} + V_{R3} = I_{R1}R_1 + I_{R2}R_2 + I_{R3}R_3 = I(R_1 + R_2 + R_3)$$

$$\text{Thus } R_t = R_1 + R_2 + R_3$$

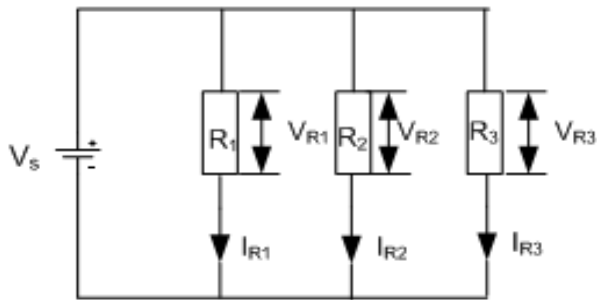

$$I = I_{R1} = I_{R2} = I_{R3}$$

$$V_s = V_{R1} = V_{R2} = V_{R3}$$

$$I_t = I_{R1} + I_{R2} + I_{R3} = \frac{V_{R1}}{R_1} + \frac{V_{R2}}{R_2} + \frac{V_{R3}}{R_3} = V_s \left( \frac{1}{R_1} + \frac{1}{R_2} + \frac{1}{R_3} \right)$$

$$\text{Thus } \frac{1}{R_t} = \left( \frac{1}{R_1} + \frac{1}{R_2} + \frac{1}{R_3} \right)$$

### Example

Three resistors  $R_1 = 900\Omega$ ,  $R_2 = 5K8$ ,  $R_3 = 7M4$  are connected in series across voltage supply of  $200V$

- (a) Calculate the total resistance (b) calculate the total current (c) Determine the current passing through each of the resistors (e) Voltage across each resistor

### Solution

$$(a) \quad R_t = 900 + 5800 + 7.4 \times 10^6 = 7406700 \Omega = 7.407 \times 10^6$$

$$(b) \quad I = \frac{V_s}{R_t} = \frac{200}{7406700} = 2.700 \times 10^{-5} A$$

$$(c) \quad V = IR$$

$$V_1 = \frac{200}{7406700} \times 900 = 0.0243 V$$

$$V_2 = \frac{200}{7406700} \times 5.8 \times 10^3 = 0.1566 V$$

$$V_3 = \frac{200}{7406700} \times 7.4 \times 10^6 = 199.8 V$$

### Parallel Circuit

$$(a) \quad \frac{1}{R_t} = \left( \frac{1}{900} + \frac{1}{5800} + \frac{1}{7.4 \times 10^6} \right)$$

$$\text{Therefore } R_t = 779.022 \Omega$$

$$(b) \quad I_t = \frac{V_s}{R_t} = \frac{200}{779.022} = 0.257 A$$

$$(c) \quad V_{Rt} = V_{R1} = V_{R2} = V_{R3} = 200V$$

(d) 
$$I_{R1} = \frac{V_{R1}}{R_1} = \frac{200}{900} = 0.222 \text{ A}$$

$$I_{R2} = \frac{V_{R2}}{R_2} = \frac{200}{5800} = 0.034 \text{ A}$$

$$I_{R3} = \frac{V_{R3}}{R_3} = \frac{200}{7.4 \times 10^6} = 2.703 \times 10^{-5} \text{ A}$$

**Combined circuit  
Example**

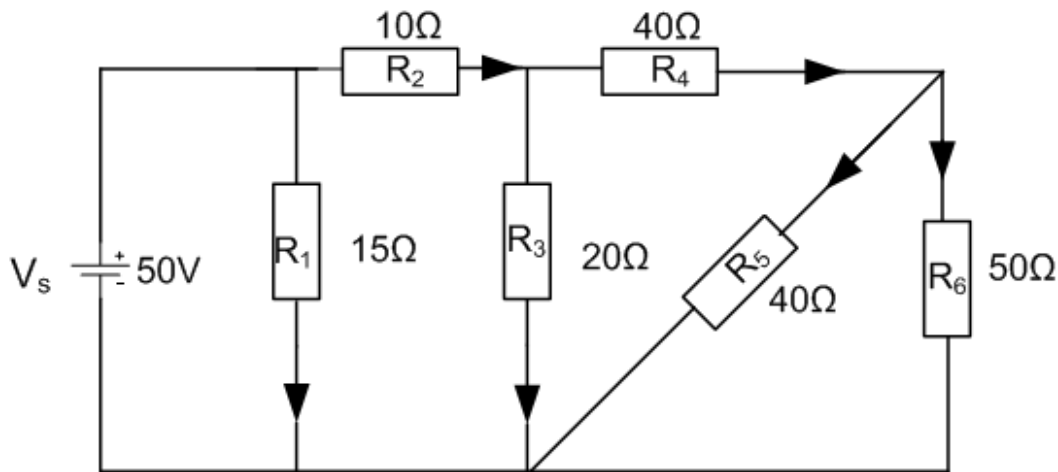

- (a) Total Resistance  
 (b) Total Current  
 (c) Current through each resistor  
 (d) Voltage through each resistor

**Solution**

(a) 
$$\frac{1}{R_a} = \left( \frac{1}{R_5} + \frac{1}{R_6} \right) = \left( \frac{1}{40} + \frac{1}{50} \right) = \frac{9}{200}$$

$$R_a = \frac{200}{9} = 22.22 \Omega$$

$$R_b = R_a + R_4 = 22.22 \Omega + 40 \Omega = 62.22 \Omega$$

$$\frac{1}{R_c} = \left( \frac{1}{R_b} + \frac{1}{R_3} \right) = \left( \frac{1}{62.22} + \frac{1}{20} \right) \text{ Thus } R_c = 15.135 \Omega$$

$$R_d = R_2 + R_c = 10 \Omega + 15.135 \Omega = 25.135 \Omega$$

$$\frac{1}{R_t} = \left( \frac{1}{R_1} + \frac{1}{R_d} \right) = \left( \frac{1}{15} + \frac{1}{25.135} \right) \text{ Thus } R_t = 9.39 \Omega$$

(b) 
$$I_t = \frac{V_s}{R_t} = \frac{50}{9.39} = 5.32 \text{ A}$$

(c) 
$$V_{R1} = V_{Rd} = V_{Rt} = 50V$$

$$I_{R1} = \frac{V_{R1}}{R_1} = \frac{50}{15} = 3.33 \text{ A}$$

$$I_{Rd} = \frac{V_{Rd}}{R_d} = \frac{50}{25.135} = 1.989 \text{ A}$$



$$I_{R2} = I_{Rc} = I_{Rd} = 1.989 \text{ A}$$

$$V_{R2} = I_{R2} \times R_2 = 1.989 \times 10 = 19.89 \text{ V}$$

$$V_{Rc} = I_{Rc} \times R_c = 1.989 \times 15.135 = 30.104 \text{ V}$$

$$V_{R3} = V_{R6} = V_{Rc} = 30.104 \text{ V}$$

$$I_{R3} = \frac{V_{R3}}{R_3} = 30. \frac{104}{20} = 1.505 \text{ A}$$

$$I_{Rb} = \frac{V_{Rb}}{R_b} = 30. \frac{104}{62} \cdot 22 = 0.484 \text{ A}$$

$$I_{R4} = I_{Ra} = I_{Rb} = 0.484 \text{ A}$$

$$V_{R4} = I_{R4} \times R_4 = 0.484 \times 40 = 19.35 \text{ V}$$

$$V_{Ra} = I_{Ra} \times R_a = 0.484 \times 22.22 = 10.754 \text{ V}$$

$$V_{R6} = V_{Ra} = V_{Rs} = 10.754 \text{ V}$$

$$I_{R5} = \frac{V_{R5}}{R_5} = 10. \frac{754}{40} = 0.269 \text{ A}$$

$$I_{R6} = \frac{V_{R6}}{R_6} = 10. \frac{754}{50} = 0.215 \text{ A}$$

### Example

Obtain the number of 2-watt resistors and their resistance value needed to yield an equivalent 1000Ω 10-watt resistor.

### Solution:

Series:

$$\text{No of resistors} = \frac{\text{Total wattage}}{\text{Wattage for onereisistor}} = \frac{10}{2} = 5 \text{ resistors}$$

$$R_t = R_1 + R_2 + R_3 + R_4 + R_5 = 5R$$

$$1000 = 5R$$

$$R = \frac{1000}{5} = 200\Omega$$

Parallel:

$$\text{No of resistors} = \frac{\text{Total wattage}}{\text{Wattage for onereisistor}} = \frac{10}{2} = 5 \text{ resistors}$$

$$\frac{1}{R_t} = \frac{1}{R_1} + \frac{1}{R_2} + \frac{1}{R_3} + \frac{1}{R_4} + \frac{1}{R_5} = \frac{5}{R} = \frac{1}{1000}$$

$$R = 1000 \times 5 = 5000\Omega$$

### Constant voltage source

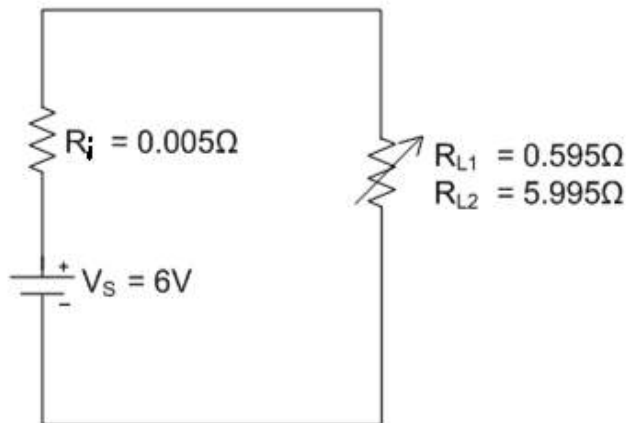

$R_i$  – Internal resistance

$R_L$  – Load resistance

$$R_i \ll R_L$$

It is a voltage source which has very low internal resistance / impedance as compared to the external impedance/ load resistance i.e.  $R_i \ll R_L$

$$Z = R + jX$$

$$Z = \frac{R + jX}{\sqrt{R^2 + X^2}} \angle \tan^{-1} \frac{X}{R}$$

$$R_t = R_i + R_{L1} = 0.005 + 0.595 = 0.6 \Omega$$

$$I_t = \frac{V_s}{R_t} = \frac{6}{0.6} = 10 \text{ A}$$

$$V_{RL} = I_t R_L = 10 \times 0.595 = 5.95 \text{ V}$$

2<sup>nd</sup> Case

$$R_t = R_i + R_{L2} = 0.005 + 5.995 = 6 \Omega$$

$$I_t = \frac{V_s}{R_t} = \frac{6}{6} = 1 \text{ A}$$

$$V_{RL} = I_t R_L = 10 \times 5.995 = 5.995 \text{ V}$$

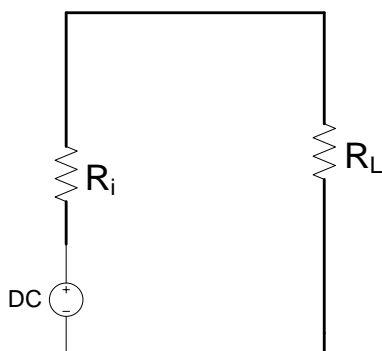

## Constant Current Source

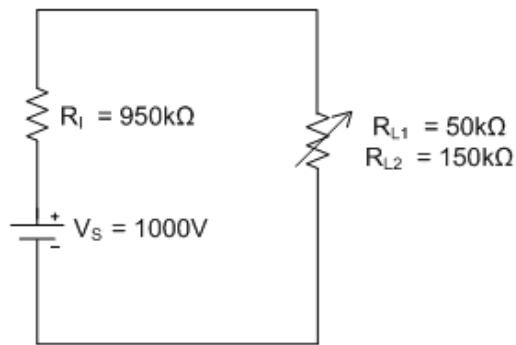

It has a very high internal resistance / impedance as compared to external / load resistance / impedance

1<sup>st</sup> Case

$$R_t = R_i + R_{L1} = 950 + 50 = 1000 \text{ k}\Omega$$

$$I_t = I_{RL} = \frac{V_s}{R_t} = \frac{1000}{1000 \times 10^3} = 1 \times 10^{-3} \text{ A}$$

2<sup>nd</sup> case

$$R_t = R_i + R_{L2} = 950 + 150 = 1100 \text{ k}\Omega$$

$$I_t = I_{RL} = \frac{V_s}{R_t} = \frac{1000}{1100 \times 10^3} = 0.909 \times 10^{-3} \text{ A}$$

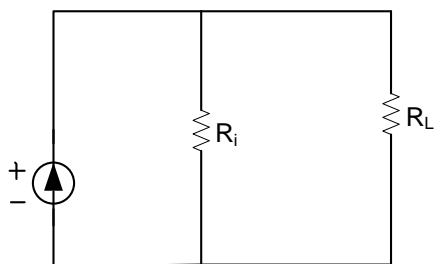

If you short circuit constant voltage source get a constant current source

## THEVENIN'S THEOREM

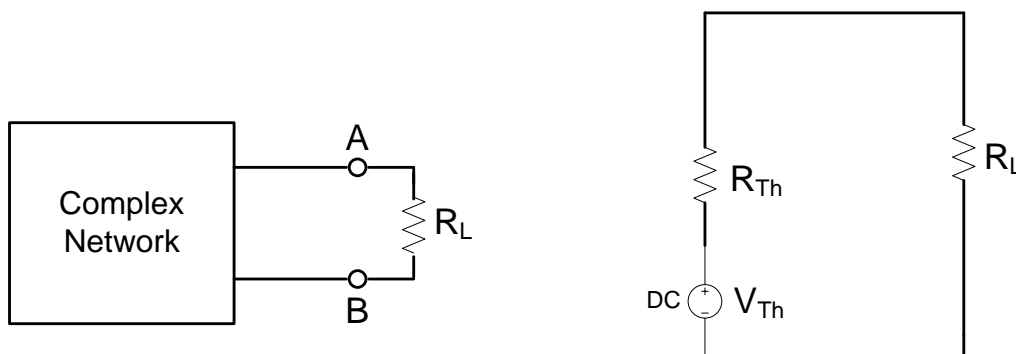

A complex network with resistance and voltage sources can be converted to a single resistor  $R_{Th}$  in series with a single voltage source  $V_{Th}$  where  $R_{Th}$  is the total resistance obtained when

looking into the complex network after the voltage sources have been replaced by their internal resistances or short circuits, when point A and B is open.  $V_{Th}$  is the voltage across the two terminals A and B when the load resistance is removed

**General case**

Convert the circuit below to Thevenin's equivalent circuit.

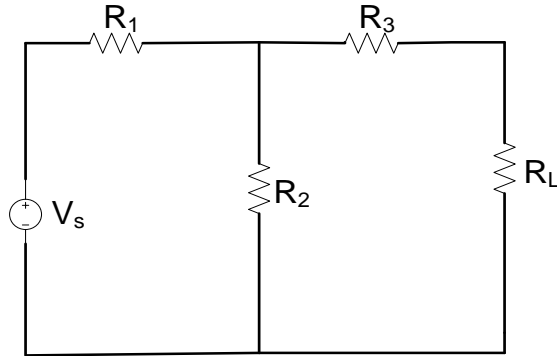

**Step 1 Get  $R_{Th}$**

Open  $R_L$ , short circuit the source and look into the network then get  $R_{Th}$ .

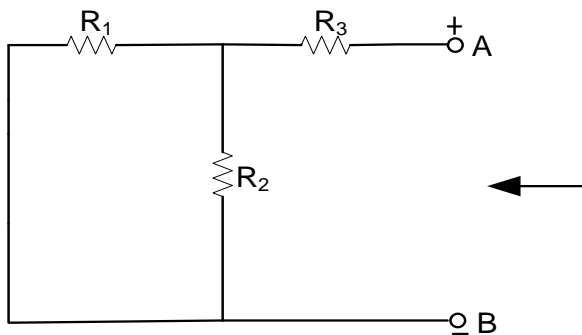

$$R_t = R_{Th} = R_3 + \frac{R_1 R_2}{R_1 + R_2}$$

**Step 2 Get  $V_{Th}$**

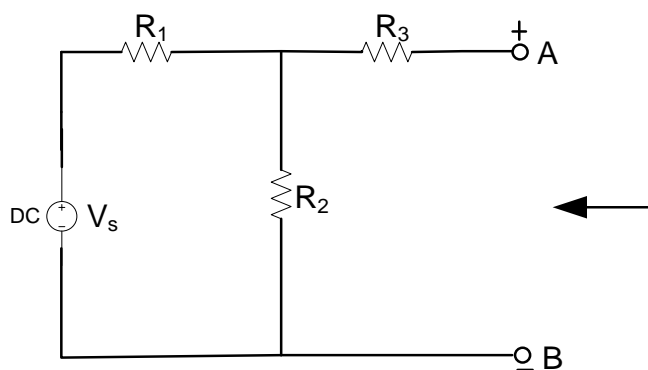

No current flow through terminals AB thus no current flow through  $R_3$ .

$$V_{R_3} = V_s \frac{R_2}{R_1 + R_2} = V_{Th}$$

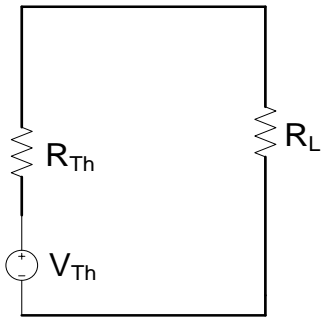

$$I_{RL} = \frac{V_{Th}}{R_{Th} + R_L}$$

### NORTONS THEOREM

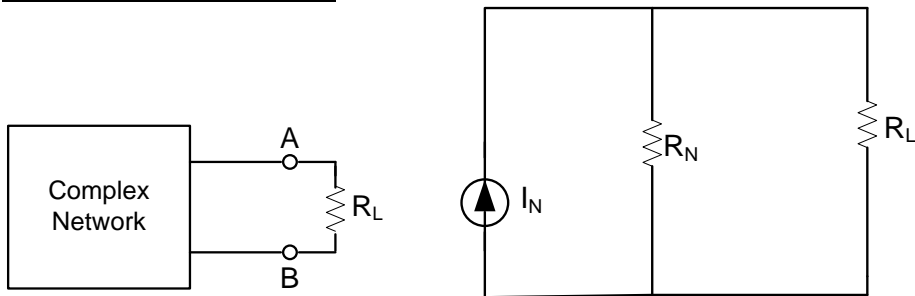

Norton's theorem states that a complex network with several resistance and several voltage sources can be converted to a single current source  $I_N$  in parallel with a single resistor  $R_N$ .

### General case

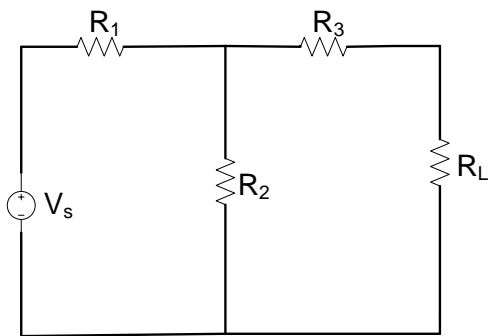

Short  $R_L$  and calculate the current passing through the short circuit  $I_N$ . Note that  $R_N = R_{Th}$

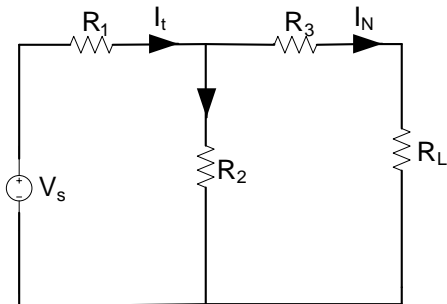

$$R_t = R_1 + \frac{R_2 R_3}{R_2 + R_3}$$

$$I_t = \frac{V_s}{R_t}$$

Using current divider theorem the value for  $I_N$  can be calculated as shown below

$$I_N = \frac{I_t R_2}{R_2 + R_3} = \frac{V_s R_2}{R_t (R_2 + R_3)} = \frac{V_s}{R_1 + \frac{R_2 R_3}{R_2 + R_3}} \times \frac{R_2}{R_2 + R_3}$$

$$I_N = \frac{V_s R_2}{R_1 R_2 + R_1 R_3 + R_2 R_3}$$

$$R_N = R_{Th}$$

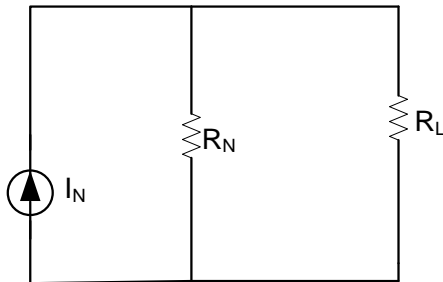
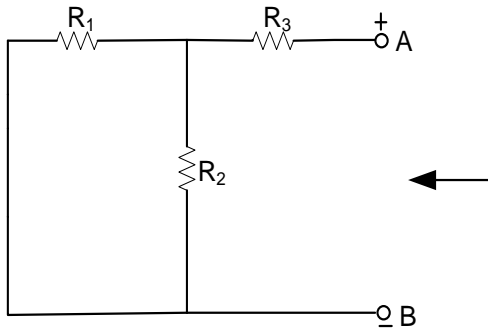

$$I_{RL} = \frac{I_N R_N}{R_N + R_L}$$

### Example

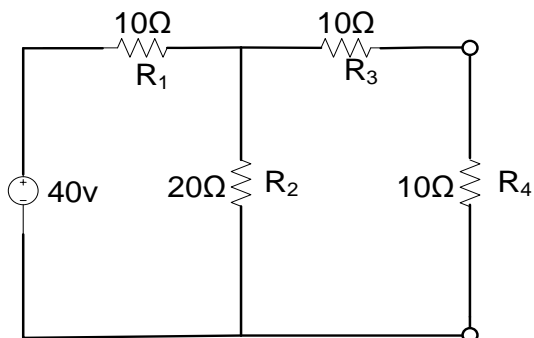

Calculate the current passing through  $R_4$  using Norton's Theorem.

### Solution

Step 1: Short-circuit  $R_4$

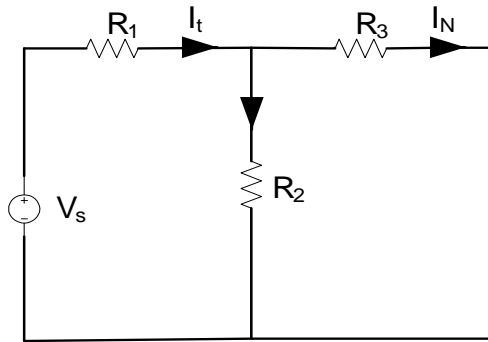

$$R_t = 10 + 20 // 10$$

$$= 10 + \frac{20 \times 10}{20 + 10} = 16.67 \Omega$$

$$I_t = \frac{V_s}{R_t} = \frac{40}{16.67} = 2.4 \text{ A}$$

$$I_{R3} = I_N = \frac{I_t R_2}{R_2 + R_3} = \frac{2.4 \times 20}{(20 + 10)} = \frac{48}{30} = 1.6 \text{ A}$$

Step 2: Find  $R_N$

Short-circuit the source

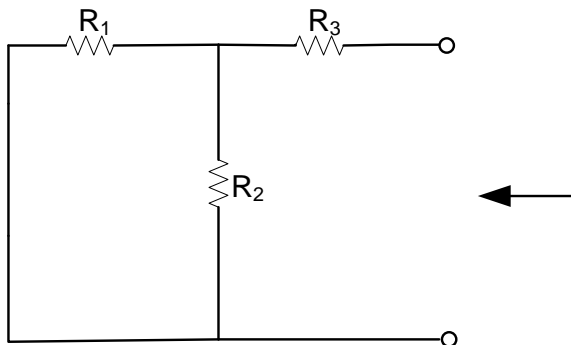

$$R_N = 10 + \frac{10 \times 20}{10 + 20} = 16.67 \Omega$$

The final circuit is shown below

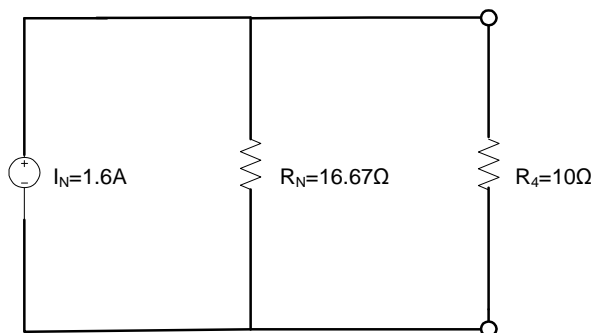

$$I_{R4} = \frac{1.6 \times 16.67}{10 + 16.67} = 1 \text{ A}$$

## Analysis of a circuit having more than one voltage source

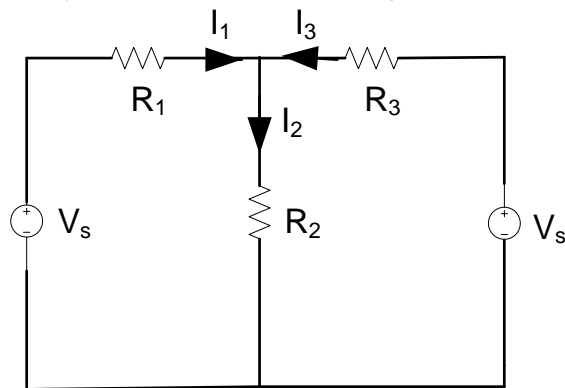

### Mesh analysis

#### Example

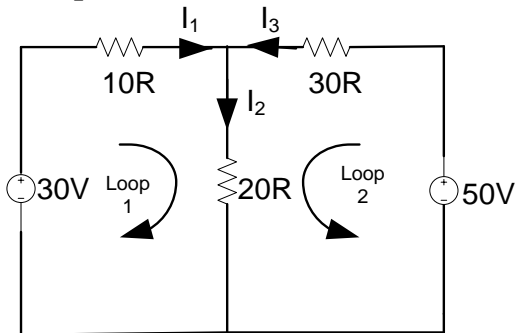

Calculate the values for  $I_1$ ,  $I_2$  and  $I_3$  in the circuit shown above.

#### Solution

Using Kirchoff's current law the two loops have the following expressions

$$10I_1 + 20I_2 = 30$$

$$30I_3 + 20I_2 = 50$$

$$\text{but } I_1 + I_3 = I_2$$

Therefore

$$10I_1 + 20I_1 + 20I_3 = 30I_1 + 20I_3 = 30$$

$$30I_3 + 20I_1 + 20I_3 = 50I_3 + 20I_1 = 50$$

Simplifying and eliminating  $I_3$  results in

$$4I_1 + 10I_3 = 10$$

$$15I_1 + 10I_3 = 15$$

$$I_1 = 0.4545 \text{ A, } I_2 = 1.273 \text{ A and } I_3 = 0.8185 \text{ A}$$

#### Factors considered when selecting a resistor

- Resistance value
- Power rating
- Tolerance
- Accuracy
- Durability
- Stability



- Flexibility
- Quality

## **Resistor Types**

Resistors can be broadly categorized as fixed, variable, and special-purpose. Each of these resistor types is discussed in detail with typical ranges of their characteristics.

### **Fixed Resistors**

The fixed resistors are those whose value cannot be varied after manufacture. Fixed resistors are classified into composition resistors, wire-wound resistors, and metal-film resistors.

**Wire-Wound Resistors.** Wire-wound resistors are made by winding wire of nickel-chromium alloy on a ceramic tube covering with a vitreous coating. The spiral winding has inductive and capacitive characteristics that make it unsuitable for operation above 50 kHz. The frequency limit can be raised by noninductive winding so that the magnetic fields produced by the two parts of the winding cancel.

**Composition Resistors.** Composition resistors are composed of carbon particles mixed with a binder. This mixture is molded into a cylindrical shape and hardened by baking. Leads are attached axially to each end, and the assembly is encapsulated in a protective encapsulation coating. Color bands on the outer surface indicate the resistance value and tolerance. Composition resistors are economical and exhibit low noise levels for resistances above 1 MW. Composition resistors are usually rated for temperatures in the neighborhood of 70°C for power ranging from 1/8 to 2W. Composition resistors have end-to-end shunted capacitance that may be noticed at frequencies in the neighborhood of 100 kHz, especially for resistance values above 0.3 MW.

**Metal-Film Resistors.** Metal-film resistors are commonly made of nichrome, tin-oxide, or tantalum nitride, either hermetically sealed or using molded-phenolic cases. Metal-film resistors are not as stable as the wire-wound resistors. Depending on the application, fixed resistors are manufactured as precision resistors, semiprecision resistors, standard general-purpose resistors, or power resistors. Precision resistors have low voltage and power coefficients, excellent temperature and **time stabilities**, low noise, and very low reactance. These resistors are available in metal-film or wire constructions and are typically designed for circuits having very close resistance tolerances on values. Semiprecision resistors are smaller than precision resistors and are primarily used for current-limiting or voltage-dropping functions in circuit applications. Semiprecision resistors have long-term temperature stability. General-purpose resistors are used in circuits that do not require tight resistance tolerances or long-term stability. For general-purpose resistors, initial resistance variation may be in the neighborhood of 5% and the variation in resistance under full-rated power may approach 20%. Typically, general-purpose resistors have a high coefficient of resistance and high noise levels. Power resistors are used for power supplies, control circuits, and voltage dividers where operational stability of 5% is acceptable. Power resistors are available in wire-wound and film constructions. Film-type power resistors have the advantage of stability at high frequencies and have higher resistance values than wire-wound resistors for a given size.

### **Variable Resistors**

**Potentiometers.** The potentiometer is a special form of variable resistor with three terminals. Two terminals are connected to the opposite sides of the resistive element, and the third

connects to a sliding contact that can be adjusted as a voltage divider. Potentiometers are usually circular in form with the movable contact attached to a shaft that rotates. Potentiometers are manufactured as carbon composition, metallic film, and wire-wound resistors available in single-turn or multiturn units. The movable contact does not go all the way toward the end of the resistive element, and a small resistance called the *hop-off* resistance is present to prevent accidental burning of the resistive element.

**Rheostat.** The rheostat is a current-setting device in which one terminal is connected to the resistive element and the second terminal is connected to a movable contact to place a selected section of the resistive element into the circuit. Typically, rheostats are wire-wound resistors used as speed controls for motors, ovens, and heater controls and in applications where adjustments on the voltage and current levels are required, such as voltage dividers and bleeder circuits.

### Special-Purpose Resistors

**Integrated Circuit Resistors.** Integrated circuit resistors are classified into two general categories: semiconductor resistors and deposited film resistors. Semiconductor resistors use the bulk resistivity of **doped** semiconductor regions to obtain the desired resistance value. Deposited film resistors are formed by depositing resistance films on an insulating substrate which are etched and patterned to form the desired resistive network. Depending on the thickness and dimensions of the deposited films, the resistors are classified into thick-film and thin-film resistors.

Semiconductor resistors can be divided into four types: diffused, bulk, pinched, and ion-implanted.

Diffused semiconductor resistors use resistivity of the diffused region in the semiconductor substrate to introduce a resistance in the circuit. Both *n*-type and *p*-type diffusions are used to form the diffused resistor.

## CAPACITORS

A component constructed from conductive plate and dielectric in between them and can be used to store charge. Capacitance is the ability of a capacitor to store charge.

Capacitance is measured in farads (F).

Factors affecting capacitance include

- (a) Dielectric material ( $\epsilon$ )- Permittivity is the ability of material to allow an electronic field to pass through, the extent to which a material affects magnetic field

$\epsilon_r$  = Relative permittivity,  $\epsilon_0$  = permittivity of free space  $8.854 \times 10^{-12}$  F/m or

$$\frac{1}{36\pi} \times \frac{10^{-9} \text{F}}{\text{m}}$$

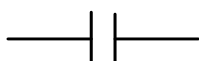

Ceramic capacitor

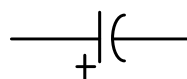

electrolytic capacitor

- (b) Capacitance is directly proportional to the effective area of the plates.  $C \propto A$   
 (c) Capacitance is inversely proportional to the distance of separation between the plates.

$$C \propto \frac{1}{d}$$

$$C = \epsilon_r \epsilon_0 \frac{A}{d}$$

**Charging and discharging of capacitors**  
**Charging**

### Series Connection of Capacitors

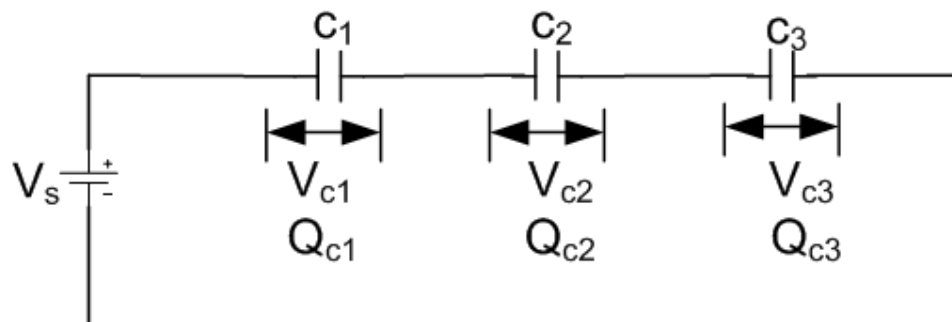

$$Q_t = Q_{c1} = Q_{c2} = Q_{c3}$$

$$V_s = V_{c1} + V_{c2} + V_{c3} = Q_t \left( \frac{1}{C_1} + \frac{1}{C_2} + \frac{1}{C_3} \right)$$

Therefore

$$\frac{1}{C_t} = \frac{1}{C_1} + \frac{1}{C_2} + \frac{1}{C_3}$$

## Parallel Connection of Capacitors

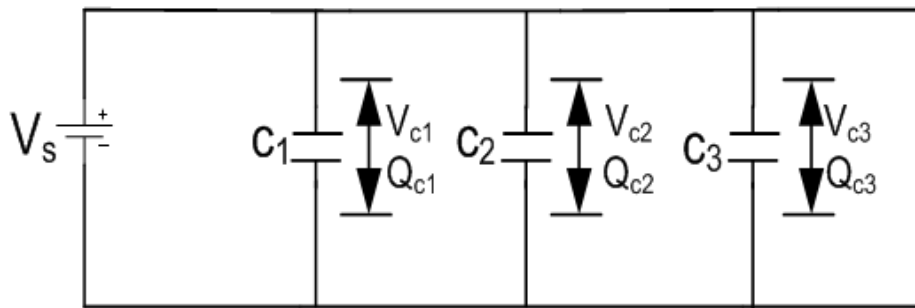

$$V_s = V_{c1} = V_{c2} = V_{c3}$$
$$Q_t = Q_{c1} + Q_{c2} + Q_{c3} = V_s(C_1 + C_2 + C_3)$$

Therefore

$$C_t = C_1 + C_2 + C_3$$

Energy stored in a capacitor is given by

$$E = \frac{CV^2}{2} = \frac{QV}{2} = \frac{Q^2}{2C}$$

Effect of capacitor on alternating current

Capacitive reactance ( $X_c$ ) is the opposition of flow of a.c by a capacitor. It is expressed using ( $\Omega$ ). The formula for capacitive reactance is

$$X_c = \frac{1}{2\pi fC} \ (\Omega)$$

Notice that the formula is dependent of frequency thus no current will pass through when using direct current since frequency is equal to zero.

## Types of Capacitors

Capacitors are used to filter, couple, tune, block dc, pass ac, bypass, shift phase, compensate, feed through, isolate, store energy, suppress noise, and start motors. They must also be small, lightweight, reliable, and withstand adverse conditions. Capacitors are grouped according to their dielectric material and mechanical configuration.

### Non-electrolytic capacitors

#### Ceramic Capacitors

*Ceramic capacitors* are used most often for bypass and coupling applications. Ceramic capacitors can be produced with a variety of  $K$  values (dielectric constant). A high  $K$  value translates to small size and less stability. High- $K$  capacitors with a dielectric constant  $>3000$  are physically small and have values between 0.001 to several microfarads.

Good temperature stability requires capacitors to have a  $K$  value between 10 and 200. If high  $Q$  is also required, the capacitor will be physically larger. Ceramic capacitors with a zero temperature change are called **negative-positive-zero (NPO)** and come in a capacitance range of 1.0 pF to 0.033 mF. An N750 temperature-compensated capacitor is used when accurate capacitance is required over a large temperature range. The 750 indicates a 750-ppm decrease in capacitance with a  $1^\circ\text{C}$  increase in temperature (750 ppm/ $^\circ\text{C}$ ). This equates to a 1.5% decrease in capacitance for a  $20^\circ\text{C}$  temperature increase. N750 capacitors come in values between 4.0 and 680 pF.

## Film Capacitors

*Film capacitors* consist of alternate layers of metal foil and one or more layers of a flexible plastic insulating material (dielectric) in ribbon form rolled and encapsulated.

## Mica Capacitors

*Mica capacitors* have small capacitance values and are usually used in high-frequency circuits. They are constructed as alternate layers of metal foil and mica insulation, which are stacked and encapsulated, or are silvered mica, where a silver electrode is screened on the mica insulators.

## Paper-Foil-Filled Capacitors

*Paper-foil-filled capacitors* are often used as motor capacitors and are rated at 60 Hz. They are made of alternate layers of aluminum and paper saturated with oil that are rolled together. The assembly is mounted in an oil filled, hermetically sealed metal case.

## Electrolytic Capacitors

**Electrolytic capacitors** provide high capacitance in a tolerable size; however, they do have drawbacks. Low temperatures reduce performance, while high temperatures dry them out. The **electrolytes** themselves can leak and corrode the equipment. Repeated surges above the rated working voltage, excessive ripple currents, and high operating temperature reduce performance and shorten capacitor life. Electrolytic capacitors are manufactured by an electrochemical formation of an oxide film on a metal surface. The metal on which the oxide film is formed serves as the **anode** or positive terminal of the capacitor; the oxide film is the dielectric, and the **cathode** or negative terminal is either a conducting liquid or a gel.

**Aluminum Electrolytic Capacitors.** *Aluminum electrolytic capacitors* use aluminum as the base material. The surface is often etched to increase the surface area as much as 100 times that of unetched foil, resulting in higher capacitance in the same volume. Aluminum electrolytic capacitors can withstand up to 1.5 V of reverse voltage without detriment. Higher reverse voltages, when applied over extended periods, lead to loss of capacitance. Excess reverse voltages applied for short periods cause some change in capacitance but not to capacitor failure. Large-value capacitors are often used to filter dc power supplies. After a capacitor is charged, the rectifier stops conducting and the capacitor discharges into the load, until the next cycle. Then the capacitor recharges again to the peak voltage. The  $D_e$  is equal to the total peak-to-peak ripple voltage and is a complex wave containing many harmonics of the fundamental ripple frequency, causing the noticeable heating of the capacitor.

**Tantalum Capacitors.** *Tantalum electrolytics* are the preferred type where high reliability and long service life are paramount considerations. Tantalum capacitors have as much as three times better capacitance per volume efficiency than aluminum electrolytic capacitors, because tantalum pentoxide has a dielectric constant three times greater than that of aluminum oxide. The capacitance of any capacitor is determined by the surface area of the two conducting plates, the distance between the plates, and the dielectric constant of the insulating material between the plates. In tantalum electrolytics, the distance between the plates is the thickness of the tantalum pentoxide film, and since the dielectric constant of the tantalum pentoxide is high, the capacitance of a tantalum capacitor is high. Tantalum capacitors contain either liquid or solid electrolytes. The liquid electrolyte in wet-slug and foil capacitors, generally sulfuric acid, forms the cathode (negative) plate. In solid-electrolyte capacitors, a dry material, manganese dioxide, forms the cathode plate.

**Foil Tantalum Capacitors.** *Foil tantalum capacitors* can be designed to voltage values up to 300 V dc. Of the three types of tantalum electrolytic capacitors, the foil design has the lowest capacitance per unit volume and is best suited for the higher voltages primarily found in older designs of equipment. It is expensive and used only where neither a solid-electrolyte nor a wet-slug tantalum capacitor can be employed. Foil tantalum capacitors are generally designed for operation over the temperature range of  $-55$  to  $+125^{\circ}\text{C}$  ( $-67$  to  $+257^{\circ}\text{F}$ ) and are found primarily in industrial and military electronics equipment.

*Solid-electrolyte sintered-anode tantalum capacitors* differ from the wet versions in their electrolyte, which is manganese dioxide. Another variation of the solid-electrolyte tantalum capacitor encases the element in plastic resins, such as epoxy materials offering excellent reliability and high stability for consumer and commercial electronics with the added feature of low cost. Still other designs of “solid tantalum” capacitors use plastic film or sleeving as the encasing material, and others use metal shells that are backfilled with an epoxy resin. Finally, there are small tubular and rectangular molded plastic encasements. *Wet-electrolyte sintered-anode tantalum capacitors*, often called “wet-slug” tantalum capacitors, use a pellet of sintered tantalum powder to which a lead has been attached. This anode has an enormous surface area for its size. Wet-slug tantalum capacitors are manufactured in a voltage range to 125 V dc.

## **INDUCTORS**

An inductor is a device which can store magnetic energy. It's made from a coiled wire.



Circuit symbol

Inductance is the ability to store magnetic energy. It is measured in Henrys (H).

Inductance depends on several factors

- (a) No. of turns
- (b) Medium surrounding the inductor/core and its permeability( $\mu$ ). Permeability is the ability of a material to affect the magnetic field H
- (c) Geometry of the conductor
- (d) Cross sectional area

Self –Inductance

This is the ability of material / coil to induce emf at the surroundings

Mutual inductance

This is the process by which changing voltage in a conductor induces emf in a second conductor which is in the opposite direction (Lenz's Law)

## **Types of inductors**



## Transformers

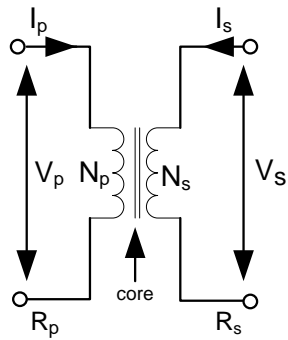

A transformer is a device which can change the level of voltage from high to low or vice versa. It is made from 2 coils wound on a core close to each other sometimes on top of the other. It uses mutual induction to operate.

The phase difference between the primary coil and secondary coil voltage is  $180^\circ$  as shown in the diagram below.

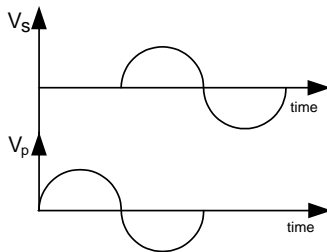

For an ideal transformer input power = output power ( $P_p = P_s$ ) since there is no power loss.

For practical transformer  $P_p > P_s$ . This necessitates the definition of efficiency of a transformer which is the ratio of output power to input power.

$$\eta = \frac{P_s}{P_p} \times 100 \quad \text{where } \eta \text{ is efficiency}$$

Losses in a transformer

- (a) Heat losses
- (b) Eddy currents leakage current
- (c) Hysteresis due to magnetization of the core
- (d) Mechanical losses e.g. sound

Step-up transformer

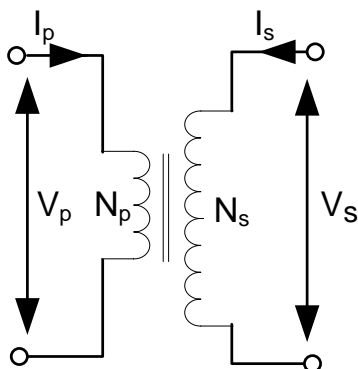

Step-down transformer

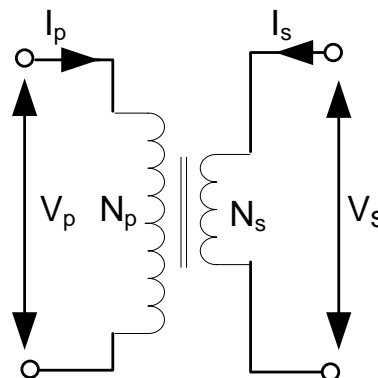

$$N_p < N_s, V_p < V_s \text{ and } I_p > I_s$$

$$N_p > N_s, V_p > V_s \text{ and } I_p < I_s$$

Transformation Ratio

$$n = \frac{V_p}{V_s} = \frac{N_p}{N_s} = \frac{I_s}{I_p}$$

This is the ratio by which the voltage is transformed.

### Example

A transformer has the following parameters:  $N_p = 400$ ,  $N_s = 2000$ ,  $V_s = 20V$ ,  $I_p = 0.5A$ ,  $\eta = 90\%$ . Find  $I_s$

$$\frac{I_s}{I_p} = \frac{N_p}{N_s}$$

$$I_s = \frac{N_p}{N_s} \times I_p = \frac{400 \times 0.5}{2000} = 0.1A$$

$$\frac{V_p}{V_s} = \frac{N_p}{N_s} \implies V_p = \frac{N_p \times V_s}{N_s} = \frac{400 \times 20}{2000} = 4V$$

$$\eta = \frac{P_s}{P_p} \times 100 = 90 \implies \frac{I_s \times V_s}{I_p \times V_p} = \frac{I_s \times 20}{40 \times 0.5} = 0.9$$

$$I_s = 0.09A$$

## SEMICONDUCTOR DIODES



A diode is a device which allows current to flow only in one direction. It is made from P – type and N – type semiconductors joined together. It has a depletion layer/ P – N junction / potential barrier.

### Formation of the depletion layer

Depletion layer is formed when a p – type and n- type semiconductor are joined. The electrons in the n – type semiconductor adjacent to the p – type semi conductor move to fit in the holes which are also at the junction. This results to the creation of positive and negative ions which don't have any charge carriers. This section is referred to as a depletion layer. It can also be called a potential barrier since the positive ions on the n– side are at a higher potential than the negative ions in the p - side. The movement of ions process is called diffusion.

The diffusion process stops after some time because the positive ions will repel the holes and the negative ions will repel the electrons.

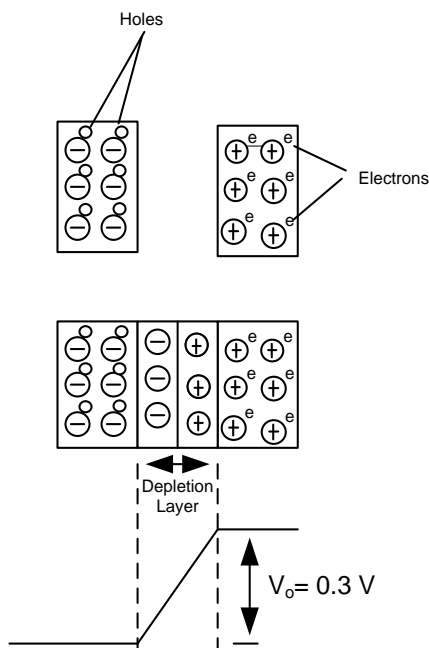

### Biasing of a Diode

Forward bias

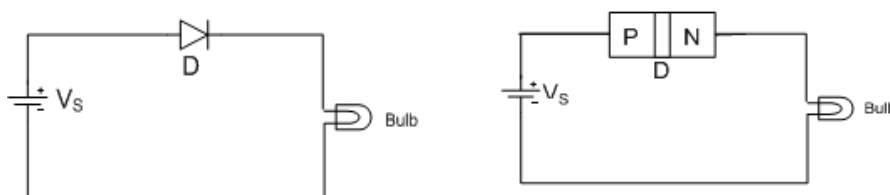

This is where the anode is connected to the power supply while the cathode is connected to the negative terminal. This leads to a continuous supply of electrons and continuous supply of holes at the junction which makes current to flow therefore the bulb lights up.

Germanium starts conducting at 0.2 – 0.3v, silicon 0.6 – 0.7v. The depletion layer disappears.

### Reverse Bias

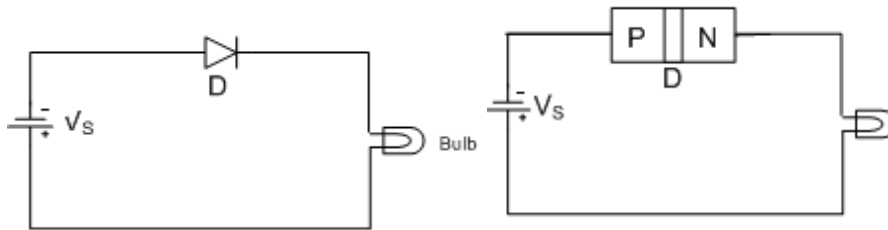

The anode is connected to negative terminal while the cathode is connected to positive terminal of power supply. The width of the depletion layer is enlarged due to majority charge carriers (electrons) moving away from the junction.

There's only minimal current which flows in the diode due to minority charge carriers. This current is referred to as leakage current and is expressed in terms of  $\mu\text{A}$  which cannot make the bulb light up.

### VI characteristics of a diode

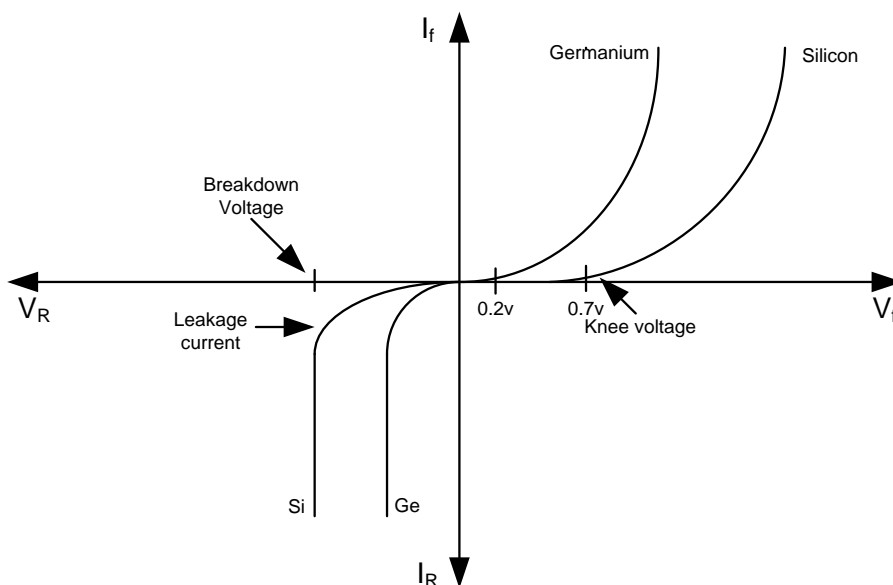
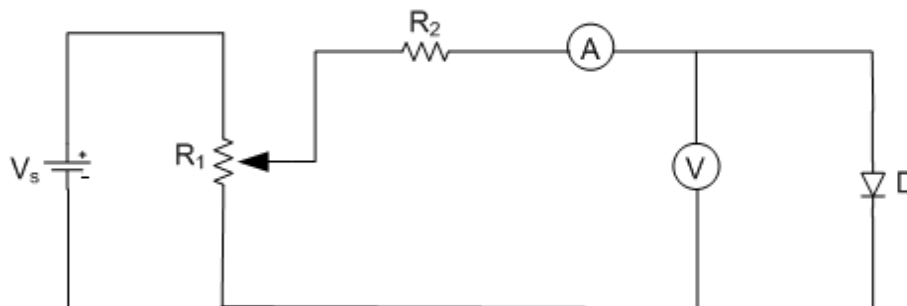

In the forward bias connection germanium starts conducting at 0.2V while silicon starts conducting at 0.7V. Further to increment of voltage leads to corresponding increment of current and the diode behaves like a normal conductor. The voltage at which the diodes start conducting current is called knee voltage. In reverse bias, when the voltage is at zero there is a very small amount of current which flows called leakage current. Increment of voltage does not affect that current if it is within the limit the diode can withstand. The current in a diode is affected by temperature.

If the voltage is increased beyond a point where the diode cannot withstand it breaks down. The minority electrons moving at high speed detach the electrons which are bonded thus breaking down the junction. This point can be called breakdown voltage or peak inverse voltage (PIV). The electrons at this point are called avalanche electrons. This current can damage the diode.

### Diode static equation

$$i_o = I_o \left( \frac{V_D}{e^{\eta V_T}} - 1 \right)$$

$i_o$  - Diode current

$I_o$  - Temp dependant saturation current

$V_D$  - Diode terminal voltage

$\eta$  - Empirical constant Ge = 1, Si = 2

$V_T$  - Thermal voltage

$$V_T = \frac{kT}{q}$$

$k$  = Boltzmann's constant =  $1.38 \times 10^{-28}$  J/K

$T$  = Absolute temp

$q$  =  $1.6 \times 10^{-19}$  C

Diode parameters

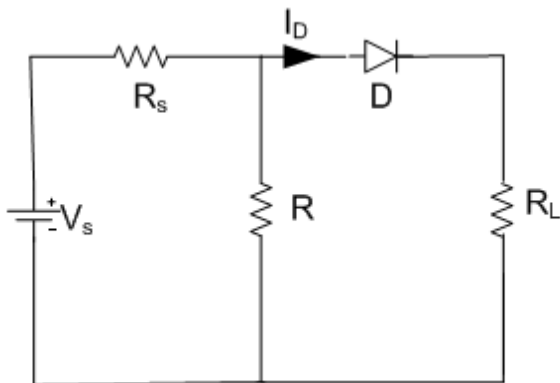

Using Thevenin's theorem

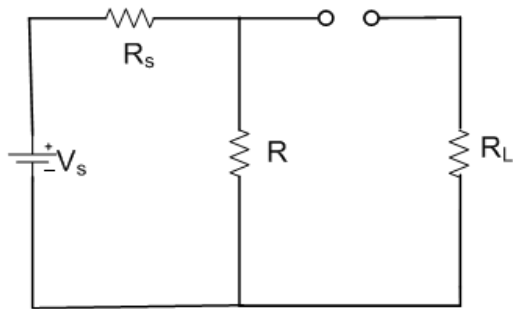

No current flows through  $R_L$

$$V_{Th} = V_s \frac{R}{R_L + R}$$

$R_{Th}$  can be calculated using the diagram below.

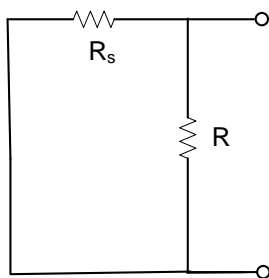

$$R_{Th} = \frac{R_s R}{R + R_s}$$

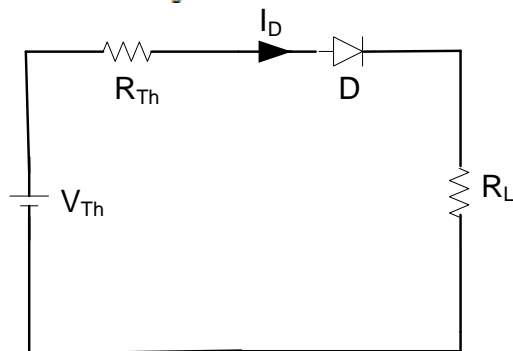

$$I_D = \frac{V_{Th}}{R_L + R_{Th}}$$

$r_{dc}$  – d.c. resistance

Plot a load line superimposed in characteristics of a diode. The d.c load line crosses the x axis at  $V_{Th}$  and y-axis at  $V_{Th} / R_{Th}$ . The x axis has  $V_D$  and the y axis has  $I_D$ .

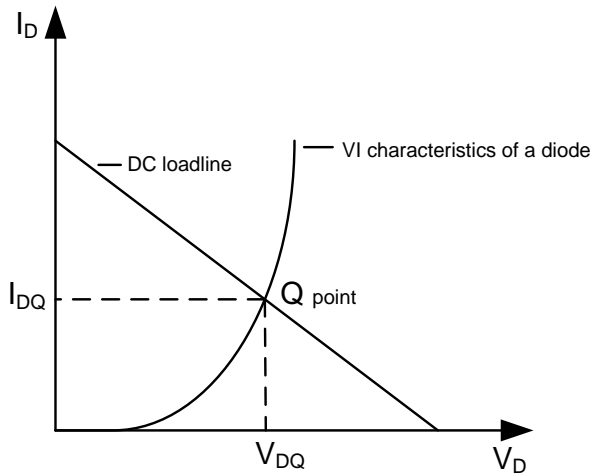

A Q point (quiescent point) gives the operating parameters of a diode or transistors

$$r_{dc} = \frac{V_{DQ}}{I_{DQ}}$$

Note that  $I_D$  represents d.c while  $i_d$  represents small signal a.c. quantities.

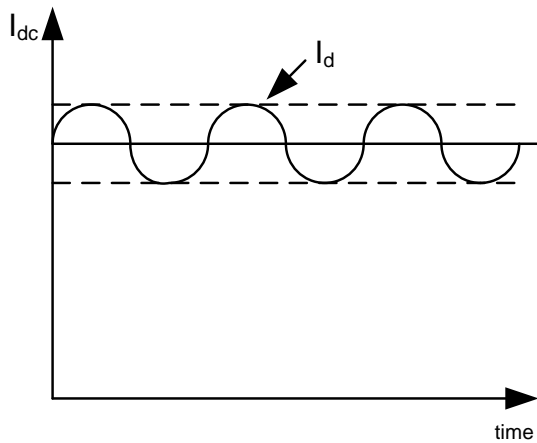

$r_{ac}$  - a.c resistance

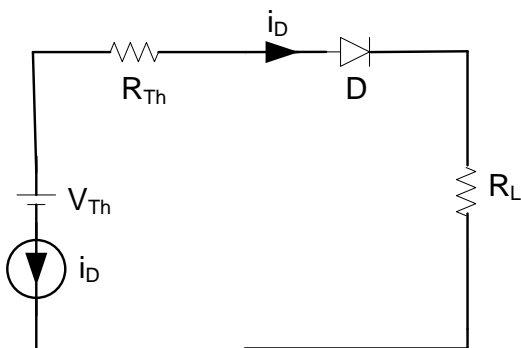

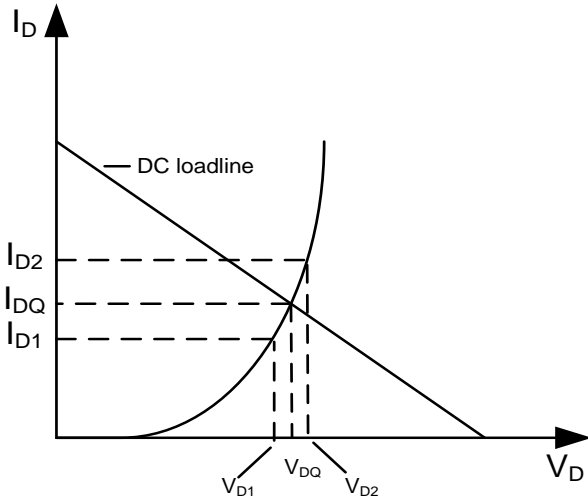

$$r_{ac} = \frac{\text{Change in } V_D}{\text{Change in } i_D} = \frac{V_{D2} - V_{D1}}{i_{D2} - i_{D1}} = \frac{\Delta V_D}{\Delta i_D}$$

### Diode Models

#### Approximate Model

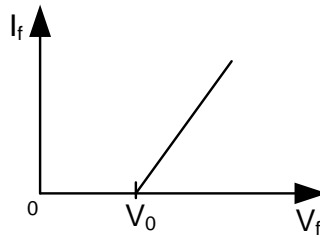
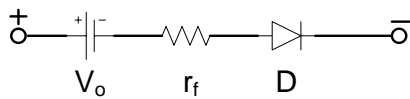

#### Simplified Model

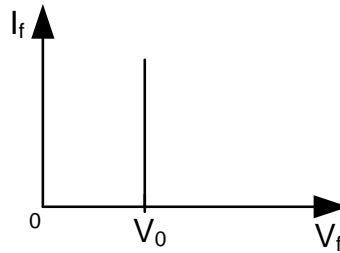
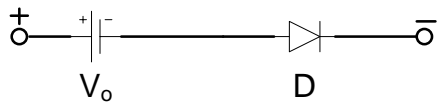

#### Ideal Model

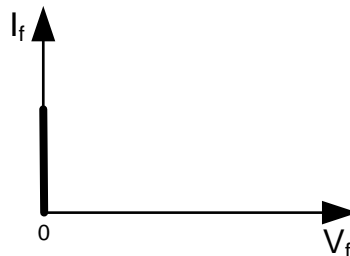
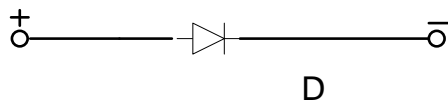

$V_o$  – Turn on voltage    0.3V – Germanium  
                                      0.6V-0.7V - Silicon



### Example

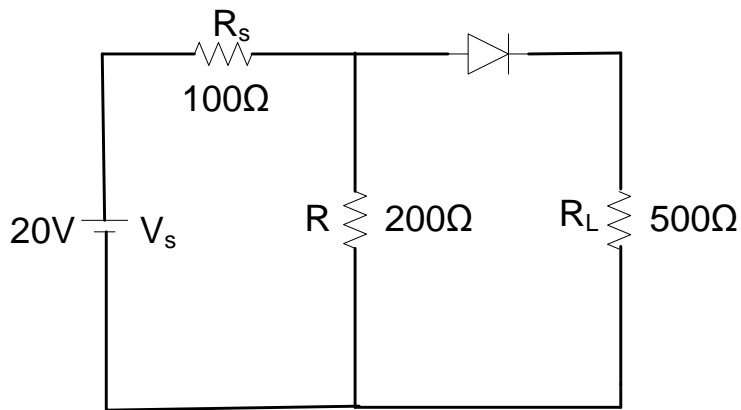

Draw the load line of the circuit.

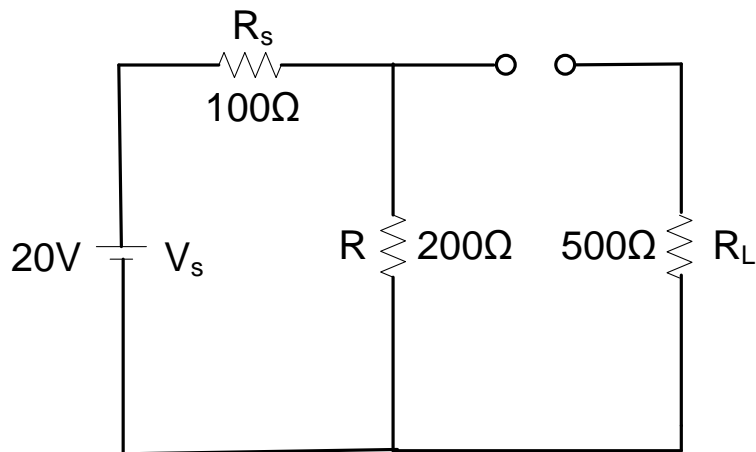

$$V_{Th} = \frac{20 \times 200}{100 + 200} = 13.33 \text{ V}$$

Calculate the value for  $R_{Th}$

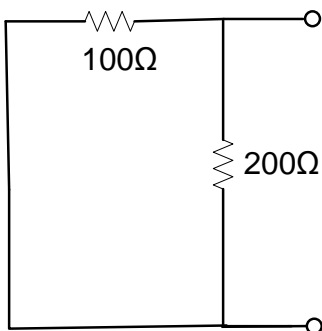

$$R_{Th} = \frac{R_s R}{R_s + R} = \frac{200 \times 100}{200 + 100} = 66.67 \text{ } \Omega$$

$$\frac{V_{Th}}{R_{Th}} = \frac{13.33}{66.67} = 0.2 \text{ A}$$

$$i_D = \frac{V_{Th}}{R_{Th}} - \frac{V_D}{R_{Th}}$$

Thus when  $i_D = 0$ ,  $V_D = V_{Th}$

$$V_D=0, i_D = \frac{V_{Th}}{R_{Th}}$$

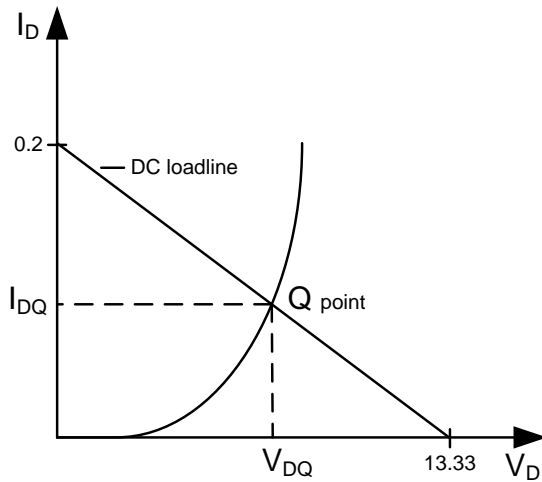

$$r_{dc} = \frac{V_{DQ}}{I_{DQ}}$$

### Example

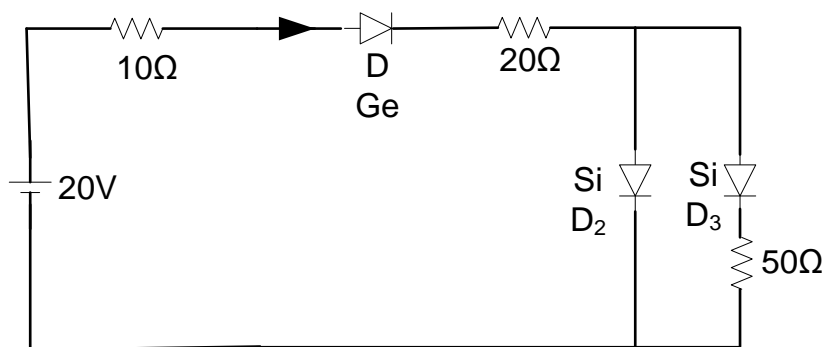

Calculate the dissipation of power in the  $20\Omega$  resistor.

Take  $G_e = r_f = 1\Omega$

$S_i = r_f = 2\Omega$

### Solution

Equivalent circuit

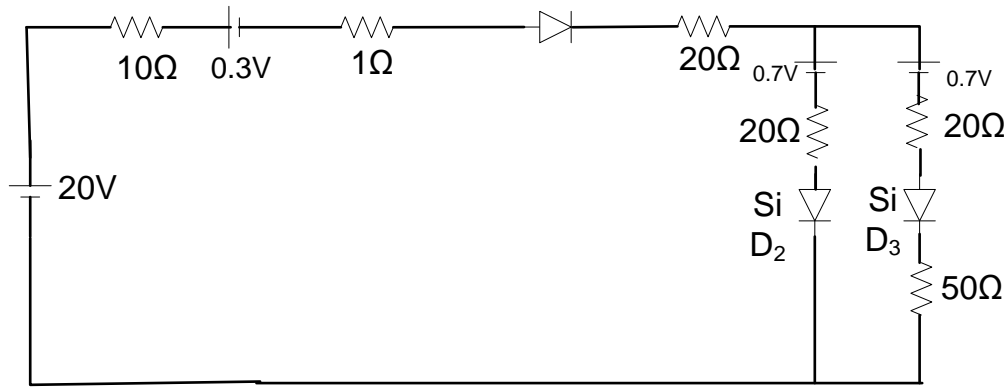

The  $D_2$  and  $D_3$  equivalent resistance  $\frac{52 \times 2}{52 + 2} = 1.926 \Omega$

Equivalent potential drops across the silicon diodes is 0.7V

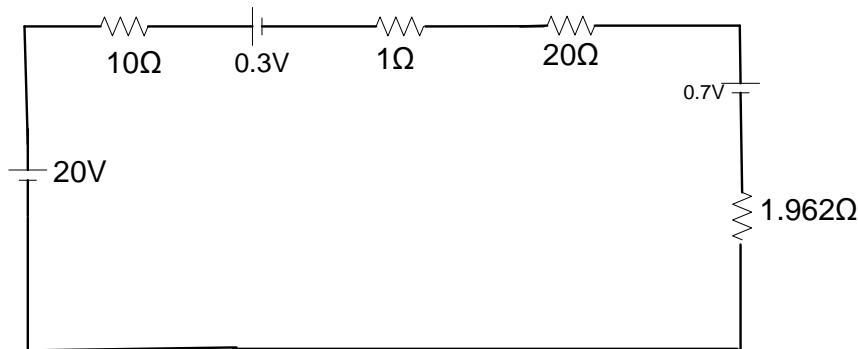

$$R_t = 32.926 \Omega$$

$$V_{Rt} = 20 - 0.3 - 0.7 = 19$$

$$I_t = \frac{V_{Rt}}{R_t} = \frac{19}{32.926} = 0.577A$$

$$P_{20R} = I_t^2 R = (0.577)^2 20 = 6.66W$$

## Types of Diodes

(a) LED

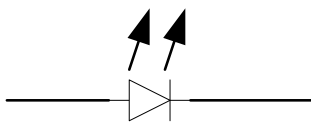

Circuit symbol

A light emitting diode (LED) is a diode which emits light when forward voltage is applied across it. It is a transducer which changes bacterial energy to light energy

## Construction

It is constructed using materials such as Gallium arsenide and Gallium phosphide. They can produce different colours depending on the materials used.

Gallium arsenide – Red  
Gallium phosphide – Green

### Operation

It is operated in the forward – bias mode .When forward voltage is applied, electrons in the conduction band move to the valence band to fill the holes. In the process they emit light energy

Characteristic Curve

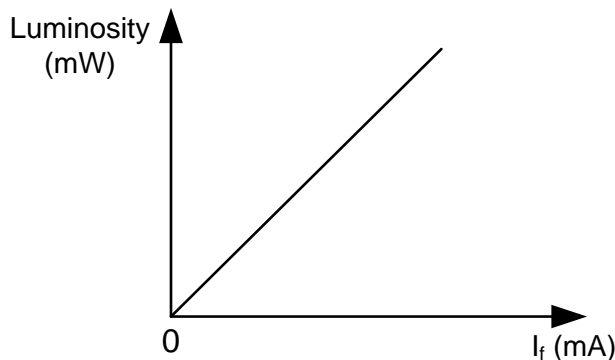

Voltage rating – 1 – 3 V  
Current rating – 20 – 10mA

### Applications

1. Digital displays e.g. seven segment
2. Indicators (power)
3. Networks (fiber optics) since it converts electrical energy to light energy.

## PHOTODIODE

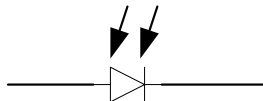

Circuit symbol

A photodiode is a diode made from photoconducting material such as germanium that changes light energy to electric energy. It is therefore a transducer.

### Construction

It is made from p-type and n-type semiconductors which are sensitive to light energy. They have a large surface area compared to normal diodes.

### Operation

Doping is higher than other diodes to increase reverse bias current. It is always operated in reverse bias. When a reverse voltage is applied electrons move from the valence band to the conduction band increasing the conductivity of the material. These are minority charge carriers.

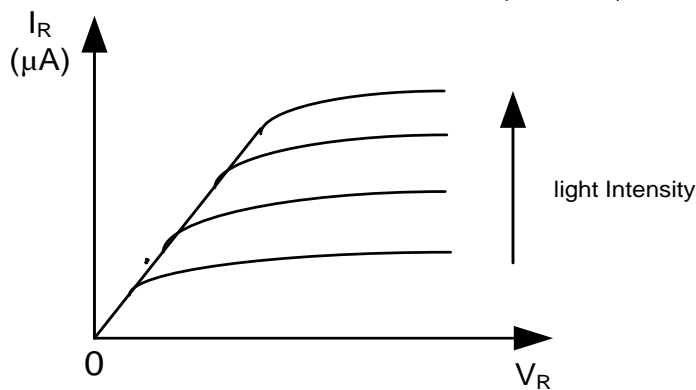
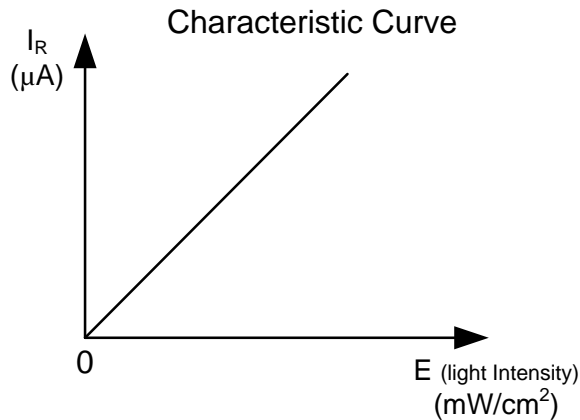

Dark current  $I_R = \frac{V_R}{R_R}$

where  $R_R$  is the dark resistance

### Applications

1. Automatic switching systems
2. Alarm circuits
3. Fiber optic networks to change light energy to electric energy
4. Counting

Factors affecting light intensity

1. Light intensity
2. Applied voltage
3. Material of the photodiode
4. Surface area

### TUNNEL DIODE



Circuit symbol

A tunnel diode is a diode exhibits negative resistance between 2 points of forward voltage

### Construction

It is very highly doped which makes the depletion layer small in size as a result electrons can move across the junction with application of minimal voltage or no voltage at all. This is called tunneling effect.

## Operation

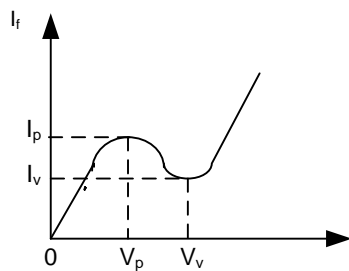

When forward voltage is applied due to tunneling effect there will be an increment of current up to a peak point. After that the tunneling effect is reduced which leads to a decrement of current up to a valley point. Further increment of voltage from this point leads to a corresponding increment of current where the diode starts behaving like a normal diode.

## Applications

1. Oscillators e.g. in tuning circuits
2. Fast switches

## VARACTOR DIODE

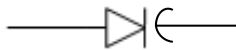

circuit symbol

A varactor diode is a diode which behaves like a variable capacitor.

## Construction

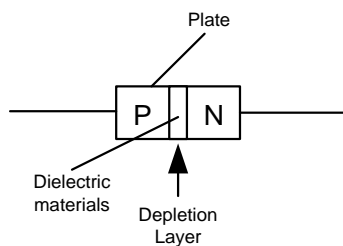

The p - type and n - type semiconductors act as the plates, P - N junction as the electric material and length of junction as distance between the plates.

## Operation

It is operated on reverse bias mode. When you increase the reverse bias voltage the thickness of the depletion layer is increased resulting in a reduction of the effective capacitance and vice - versa.

$$C = \frac{\epsilon A}{d}$$

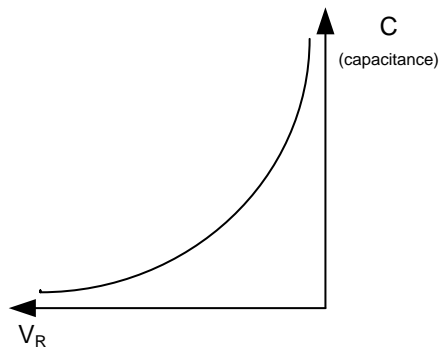

### Applications

(a) Tuning circuit log with inductors

$$f_r = \frac{1}{2\pi\sqrt{LC}}$$

where  $f_r$  is resonance frequency

## LINEAR POWER SUPPLY

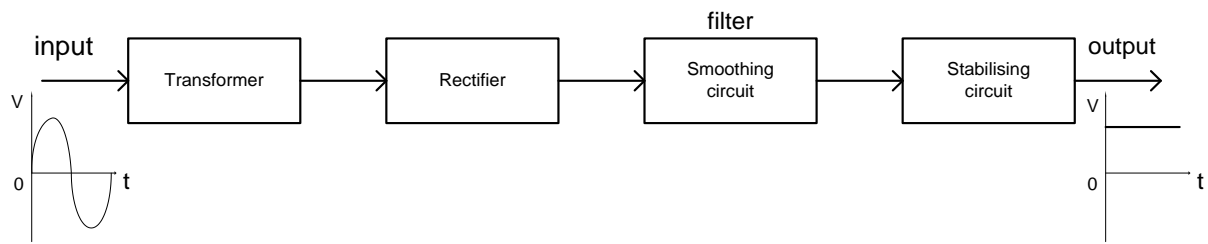

## RECTIFIERS

A rectifier is made from rectifier diodes which have a high power rating and peak inverse voltage/ breakdown voltage. The most common material used to make these diodes is silicon

There are two types

- (a) Half Wave Rectifier
- (b) Full Wave Rectifier

### Half wave – rectifiers (HWR)

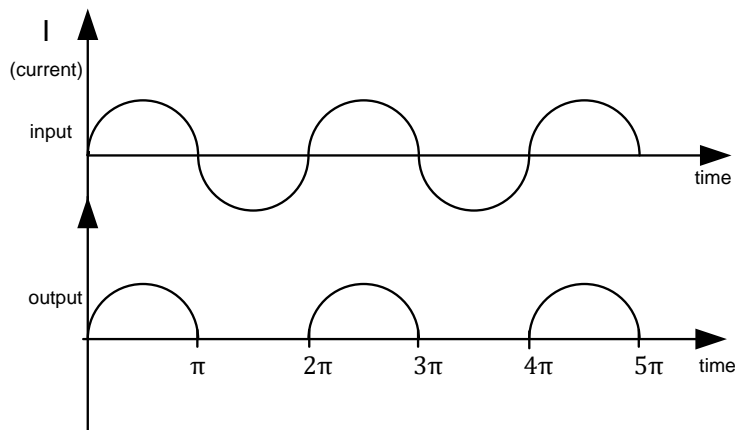
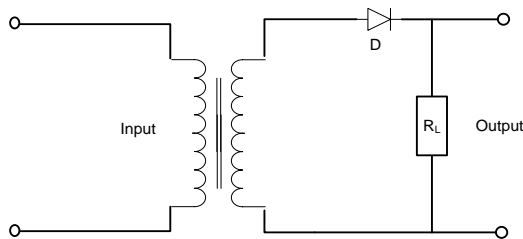

### Operation

During the first half cycle the diode is forward biased allowing current to pass through and therefore an output can be from the resistor  $R_L$ . During the second half cycle the diode is reverse biased as a result no current passes through and there is no output appearing at  $R_L$ .

Only the positive half cycles are appearing at the output and are referred to as ripples whose frequency is the same as that of the input waveform.



Average value (output)

$$I_{dc} = \frac{1}{2\pi} \int_0^{\pi} i \, d\theta \quad \text{where } i = I_m \sin\theta$$

$$I_{dc} = \frac{1}{2\pi} \int_0^{\pi} I_m \sin\theta \, d\theta$$

$$\frac{I_m}{2\pi} [-\cos\theta]_0^{\pi} d\theta = \frac{I_m}{2\pi} [-\cos\pi + \cos 0] = \frac{I_m}{\pi} = 0.3183 I_m$$

$$P_{dc} = I_{dc} V_{dc} = I_{dc}^2 R_L$$

Rms value of a.c output current

$$I_{rms}^2 = \frac{1}{2\pi} \int_0^{\pi} i^2 \, d\theta = \frac{1}{2\pi} \int_0^{\pi} (I_m \sin\theta)^2 \, d\theta = \frac{I_m^2}{2\pi} \int_0^{\pi} \frac{(1 - \cos 2\theta)}{2} \, d\theta = \frac{I_m^2}{4}$$

Therefore

$$I_{rms} = \frac{I_m}{2}$$

$$P_{ac} = I_{rms}^2 (R_L + r_f) = \left(\frac{I_m}{2}\right)^2 (R_L + r_f)$$

$$\eta = \frac{P_{dc}}{P_{ac}} = \frac{I_{dc}^2 R_L}{I_{rms}^2 (R_L + r_f)} = \frac{\left(\frac{I_m}{\pi}\right)^2 R_L}{\left(\frac{I_m}{2}\right)^2 (R_L + r_f)}$$

$$\eta = \frac{P_{dc}}{P_{ac}} = \frac{4}{\pi^2 \left(1 + \frac{r_f}{R_L}\right)} = 0.405 \left(\frac{R_L}{R_L + r_f}\right)$$

$$r_f \ll R_L, \eta = 0.405$$

= 40.5% is the efficiency of a half-wave rectifier

Ripple Factor

Ripple factor is the ratio of ac to dc current ( $I_{ac}/I_{dc}$ )

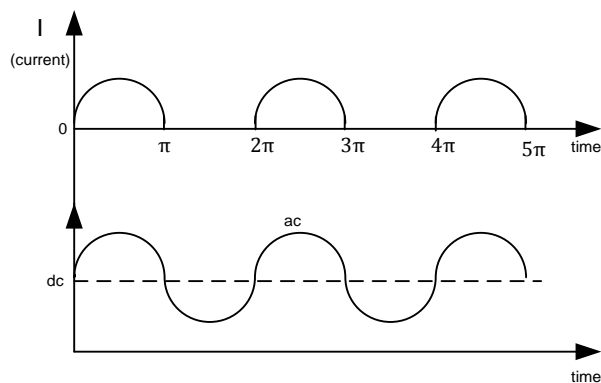

Effective rms value

$$I_{rms}^2 = I_{dc}^2 + I_{ac}^2$$

$$I_{rms} = \sqrt{I_{dc}^2 + I_{ac}^2}$$

$$I_{ac} = \sqrt{I_{rms}^2 - I_{dc}^2}$$

$$\frac{I_{ac}}{I_{dc}} = \sqrt{\frac{I_{rms}^2}{I_{dc}^2} - 1} = \sqrt{\frac{(I_m/2)^2}{(I_m/\pi)^2} - 1} = \sqrt{\frac{\pi^2}{4} - 1} = 1.21$$

## Full-wave Rectifier

### (a) Centre-Tapped Rectifier

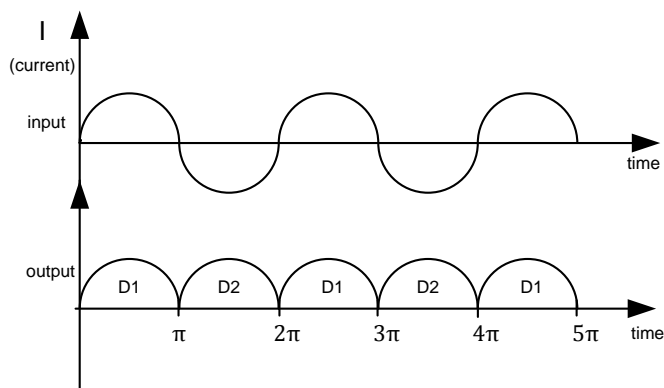
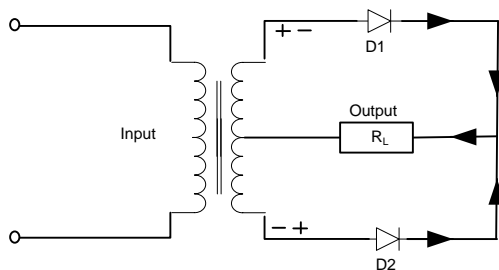

### Operation

When the input waveform is positive going i.e. first half cycle  $D_1$  is forward biased and  $D_2$  is reverse biased. There will be an output at  $R_L$  as a result of  $D_1$ . During the second half cycle  $D_2$  is forward biased and  $D_1$  is reverse biased. There will be an output as a result of  $D_2$ .

The two currents are in the same direction and therefore they appear on the positive side of the time – line as ripples whose frequency is twice that of the input waveform.

### Average value

$$I_{dc} = \frac{1}{\pi} \int_0^{\pi} i \, d\theta \quad \text{where } i = I_m \sin\theta$$

$$I_{dc} = \frac{1}{\pi} \int_0^{\pi} I_m \sin\theta \, d\theta$$

$$\frac{I_m}{\pi} [-\cos\theta]_0^\pi d\theta = \frac{I_m}{\pi} [-\cos\pi + \cos 0] = \frac{2I_m}{\pi} = 0.6366I_m$$

$$P_{dc} = I_{dc}V_{dc} = I_{dc}^2 R_L$$

$$P_{ac} = I_{rms}^2 R_L$$

Rms value of a.c output current

$$I_{rms}^2 = \frac{1}{\pi} \int_0^\pi i^2 d\theta = \frac{1}{\pi} \int_0^\pi (I_m \sin\theta)^2 d\theta = \frac{I_m^2}{\pi} \int_0^\pi \frac{(1 - \cos 2\theta)}{2} = \frac{I_m^2}{2}$$

Therefore

$$I_{rms} = \frac{I_m}{\sqrt{2}}$$

$$P_{ac} = I_{rms}^2 (R_L + r_f) = \left(\frac{I_m}{2}\right)^2 (R_L + r_f)$$

Efficiency of a full wave rectifier

$$\eta = \frac{P_{dc}}{P_{ac}} = \frac{I_{dc}^2 R_L}{I_{rms}^2 (R_L + r_f)} = \frac{\left(\frac{2I_m}{\pi}\right)^2 R_L}{\left(\frac{I_m}{\sqrt{2}}\right)^2 (R_L + r_f)^2}$$

$$\eta = \frac{P_{dc}}{P_{ac}} = \frac{8}{\pi^2 \left(1 + \frac{r_f}{R_L}\right)} = 0.811 \frac{811}{\left(1 + \frac{r_f}{R_L}\right)}$$

$$r_f \ll R_L, \eta = 0.811$$

= 81.1% is the efficiency of a full-wave rectifier

The full wave rectifier thus has very high efficiency

### Ripple Factor

Ripple factor is the ratio of ac to dc current ( $I_{ac}/I_{dc}$ )

$$I_{rms}^2 = I_{dc}^2 + I_{ac}^2$$

$$I_{rms} = \sqrt{I_{dc}^2 + I_{ac}^2}$$

$$I_{ac} = \sqrt{I_{rms}^2 - I_{dc}^2}$$

$$\frac{I_{ac}}{I_{dc}} = \sqrt{\frac{I_{rms}^2}{I_{dc}^2} - 1} = \sqrt{\frac{\left(\frac{I_m}{\sqrt{2}}\right)^2}{\left(\frac{2I_m}{\pi}\right)^2} - 1} = \sqrt{\frac{\pi^2}{8} - 1} = 0.48$$

## Bridge Rectifier

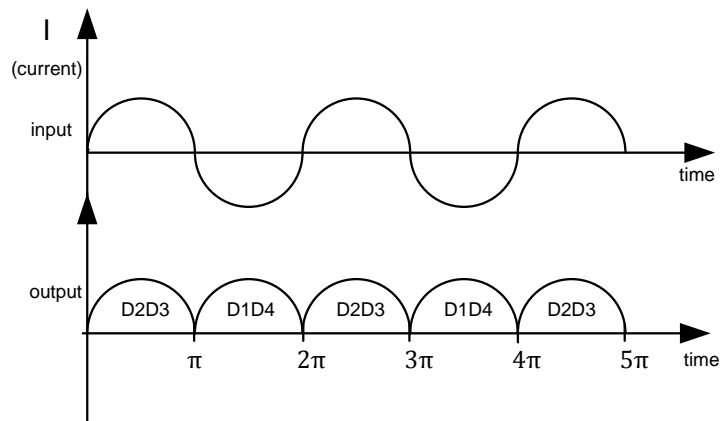
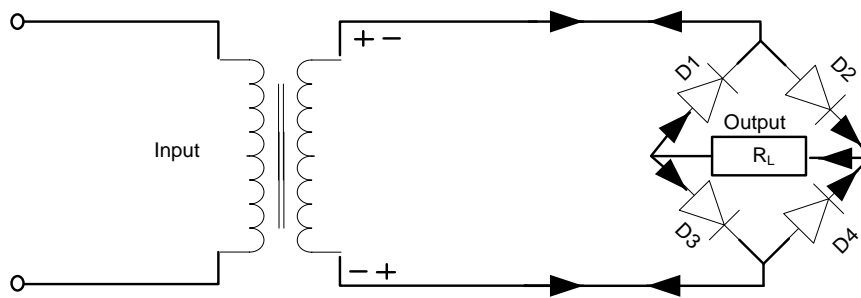

During the first half cycle  $D_2$  and  $D_3$  are forward biased while  $D_1$  and  $D_4$  are reverse biased therefore an output will appear at  $R_L$  as a result of  $D_2$  and  $D_3$ . During the second half cycle diode  $D_1$  and  $D_4$  are forward biased while diodes  $D_2$  and  $D_3$  are reverse biased therefore there will be an output at  $R_L$  is as a result of  $D_1$  and  $D_4$ .

The currents are in the same direction in the resistor  $R_L$  therefore they will appear on the positive side of the time – line. They are also called ripples and have a frequency twice that of the input waveform.

### Example

A half- wave rectifier with transformer of transformation ratio of 10:1 has the following parameters.

$$V_{in} = 250\sin wt \text{ V}$$

$$r_f = 20 \Omega$$

$$R_L = 800 \Omega$$

Calculate

$V_m$ ,  $I_{dc}$ ,  $I_{ac}$ ,  $P_{dc}$ ,  $\eta$ ,  $V_{dc}$ , ripple factor

### Smoothing circuits (filter)

This is a section in the power supply which removes the a.c component present in the output of a rectifier. It is made using of capacitors and inductors or a combination of both.

- (a) Capacitor filter
- (b) Choke input (inductor)
- (c) Capacitor input filter

## Capacitor Filter

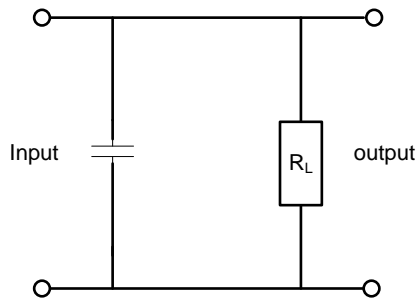

## Half-wave rectifier

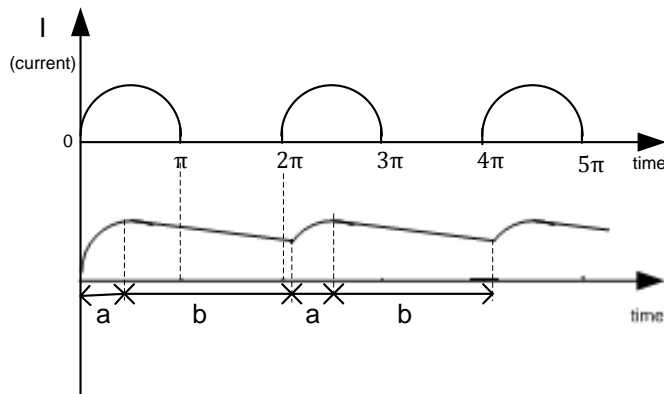

## Capacitor filter

a – Charging

$$V_C = V_S (1 - e^{(-t/RC)})$$

b – Discharging

$$V_C = V_S e^{(-t/RC)}$$

It consists of a capacitor and a resistor connected in parallel. During the appearance of the first ripple the capacitor will charge to a maximum  $V_m$ . The ripple will collapse very fast leaving the capacitor to discharge. Because the capacitor takes a longer time to discharge when the second ripple appears it finds the capacitor still discharging and picks up from there charging the capacitor again to a maximum  $V_m$ . The process continues so long as there is an input to the filter

This will result to an output with more of DC component than the input waveform

## Full wave rectifier

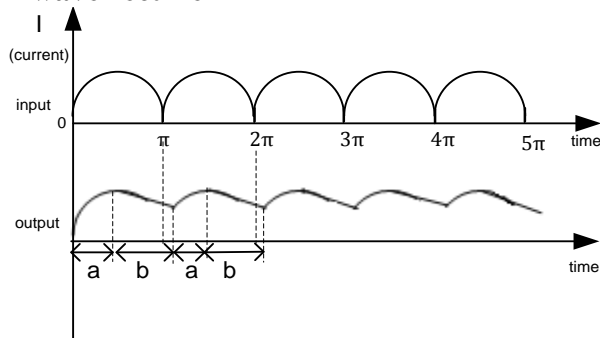

The operation is the same as that of a half-wave rectifier, the only difference being that the output of full-wave rectifier filter has more d.c component than the half waveform rectifier

filter. To get a more refined d.c, several circuits of the same kind can be connected after the first circuit.

Ripple factor is less than of half – wave rectifier i.e. ripple factor HWR > FWR

### Choke Input Filter

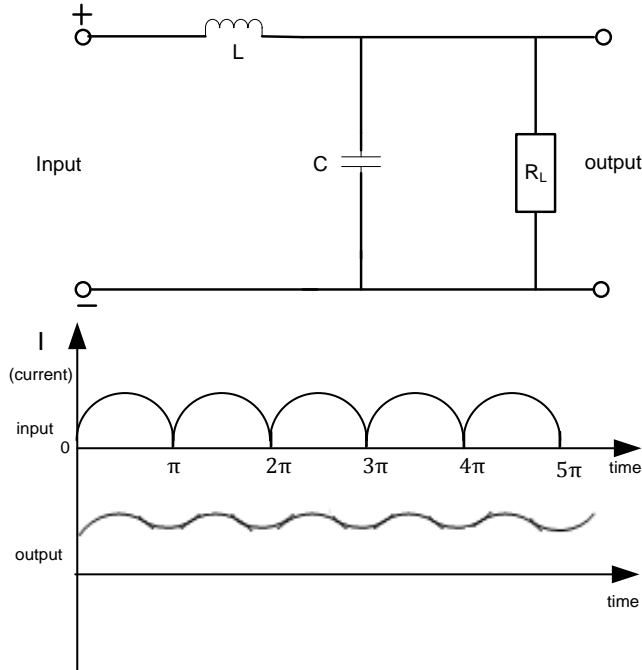

It consists of an inductor in series with a parallel combination of a capacitor and resistor. The inductor will oppose some of the a.c component present in the input. Whatever passes through the inductor is bypassed by the capacitor C. Therefore there will be a minimized a.c at the output. The d.c passes through the inductor without opposition and goes straight to the output since it cannot pass through the capacitor.

### Capacitor input filter (π filter)

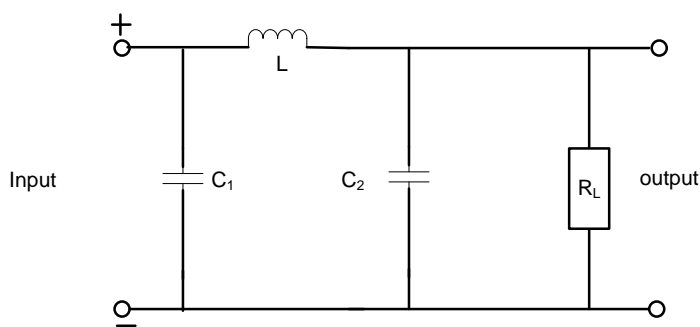

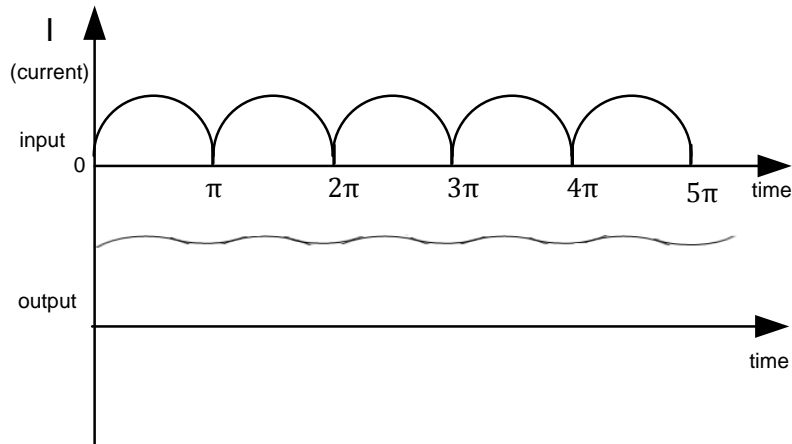

The first capacitor  $C_1$  bypasses of the a.c component present at the input. Whatever is left is blocked by the inductor  $L$  and whatever passes through the inductor is bypassed by  $C_2$ . The dc component passes through the inductor to the output. This results to a more refined d.c component. Several combinations of the circuit can produce even more refined d.c component.

### Stabilizing circuit / voltage regulator

It is constructed by use of zener diode or a transistor or both.

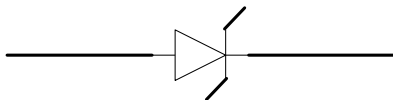

Zener diode circuit symbol

A zener diode uses the principle of reverse breakdown to provide a constant output voltage.

### Construction

The doping is higher than that of normal diodes. This will make it to breakdown without getting damaged. It breaks down earlier than the other diodes depending on the reverse voltage rating. It has a higher power rating

### Operation

It is operated in reverse bias mode. If the voltage is increased beyond breakdown voltage the diode breaks down. Any further increment of voltage will still give a constant output voltage as shown in the diagram below.

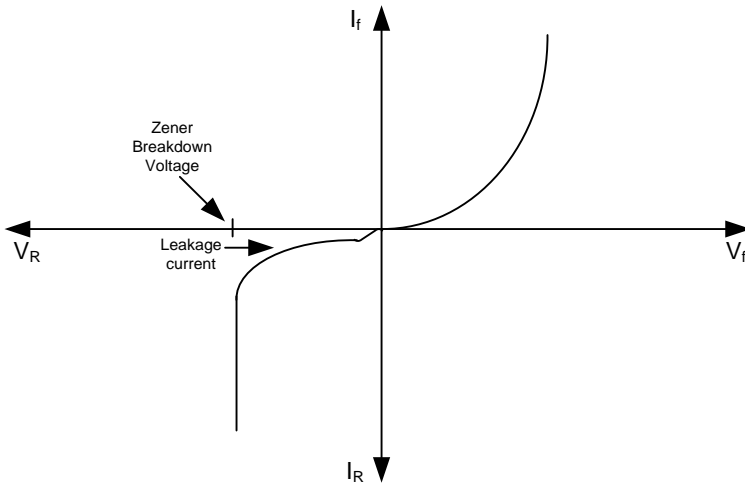

In forward bias it behaves like any other diode conducts at (Si – 0.7V, Ge- 0.3V). In reverse bias the diode breaks down when there is an increase of voltage beyond breakdown voltage. Only a small amount of current flows through before breakdown voltage called leakage current.

It is connected together with an external resistor to limit amount of current related to diode the rating.

### Equivalent circuit of the zener diode

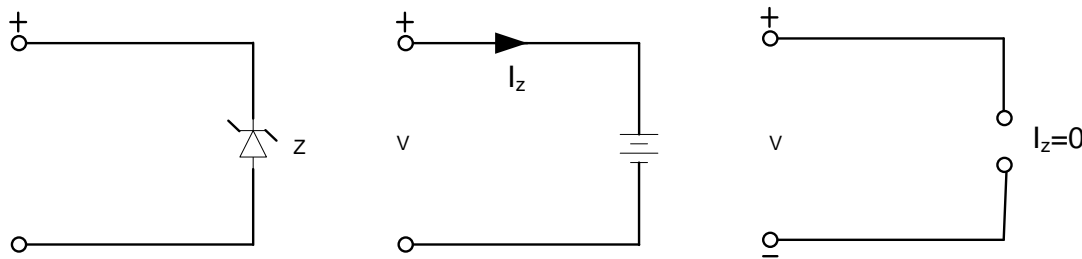

In the on state the zener diode is replaced by zener voltage or breakdown voltage  
 In off state it is replaced by an open circuit and assuming the leakage current  $I_z = 0$

### Zener Diode circuits Analysis

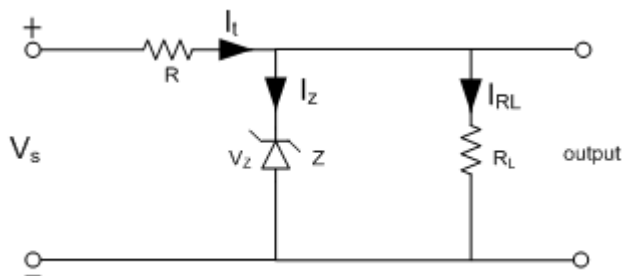



### Off state

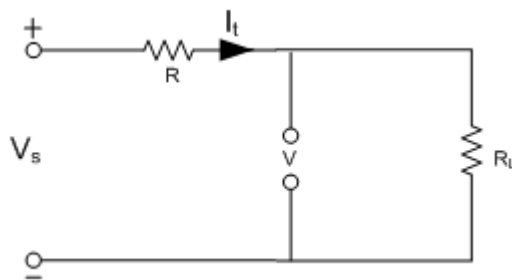

$$V_{RL} = \frac{V_S R_L}{R + R_L}$$

$$V > V_Z$$

### On state

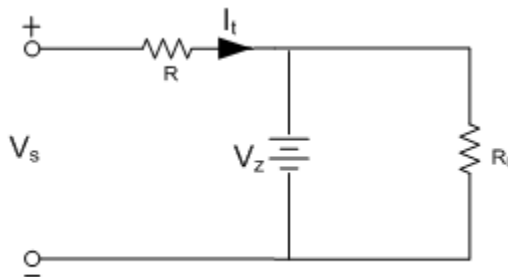

$$I_{RL} = \frac{V_Z}{R_L}$$

$$I_t = \frac{V_S - V_Z}{R} = I_{RL} + I_Z$$

### Example

$$R = 500\Omega$$

$$R_L = 800\Omega$$

$$V_S = 40V$$

$$V_Z = 15V$$

Calculate  $I_{RL}$ ,  $I_t$ ,  $I_Z$ ,  $P_Z$  in the on state and  $I_t$  in the off state.

### Solution

On state

$$I_{RL} = \frac{V_Z}{R_L} = \frac{15}{800} = 0.01875 \text{ A}$$

$$I_t = \frac{V_S - V_Z}{R} = \frac{40 - 15}{500} = \frac{25}{500} = 0.05 \text{ A}$$

$$I_Z = I_t - I_{RL} = 0.05 - 0.01875 = 0.03125 \text{ A}$$

$$P_Z = I_Z V_Z = 0.03125 \times 15 = 0.46875 \text{ A}$$

Off state

$$I_t = \frac{V_S}{R + R_L} = \frac{40}{500 + 800} = \frac{400}{1300} = 0.031 \text{ A}$$

$I_t$  in off and on state is different. In the on state diode bypasses most of the current shorting the resistor  $R_L$ .

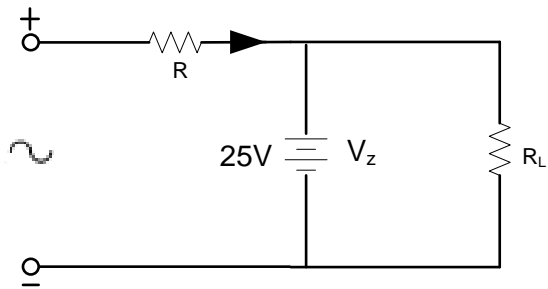

Voltage Clipping  
one side

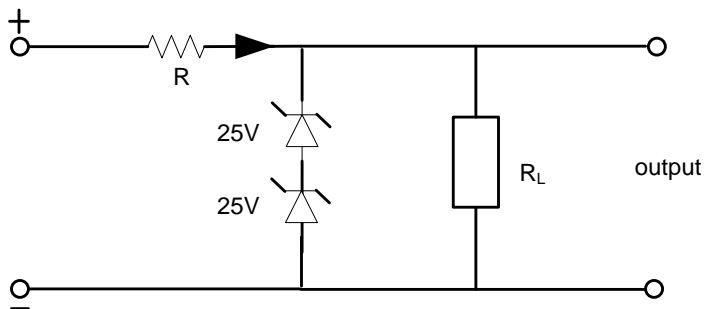
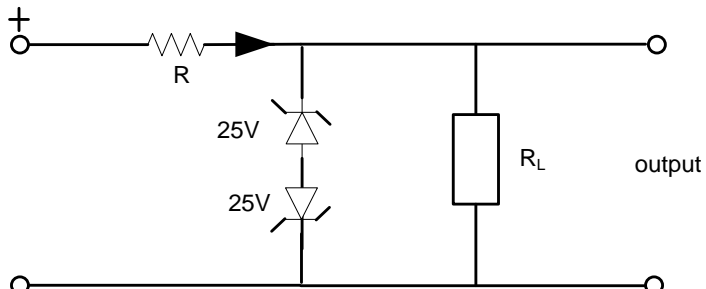
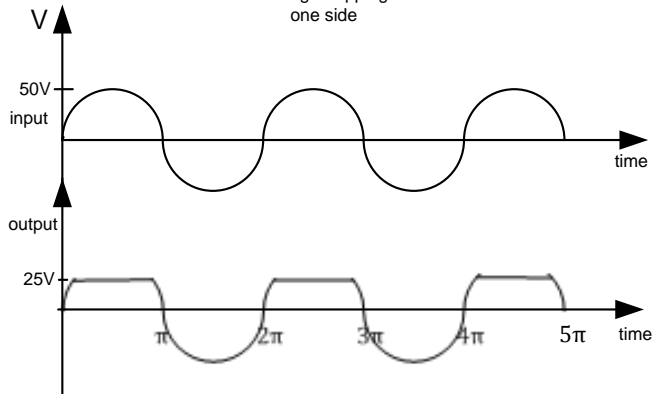

Voltage Clipping  
both sides

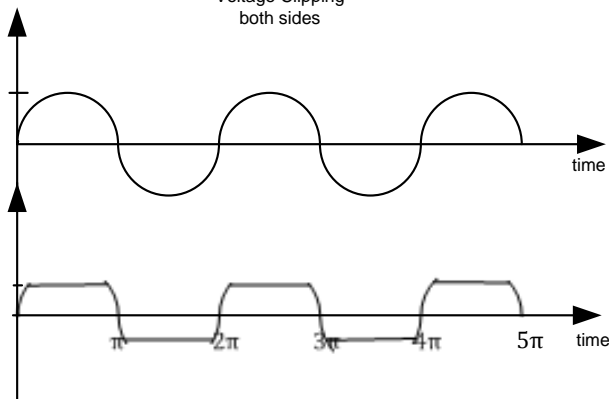

## TRANSISTORS

A transistor is an active device which can increase the strength of a signal. It is manufactured by use of p – type and n – type semiconductor materials.

Transistor = Transfer resistor

- a) Types BJT – Bipolar junction transistor – Linear amplifier to boost an electrical signal  
- Electronic switch
- b) FET - Field effect transistor

### Bipolar Junction Transistor

It is constructed by sandwiching n– type materials between 2 p – type materials or a p-type material between 2 n – type materials. It used electrons and holes as charge carriers.

It has 2 junctions  $J_1$  and  $J_2$

It has 3 terminals:     Emitter  
                              Base  
                              Collector

The emitter emits the majority charge carriers, collector collects the charge carriers, the base controls those charge carriers moving from the emitter to the collector.

There are two types of BJT transistors

- (i) PNP
- (ii) NPN

### NPN Transistor

#### Construction

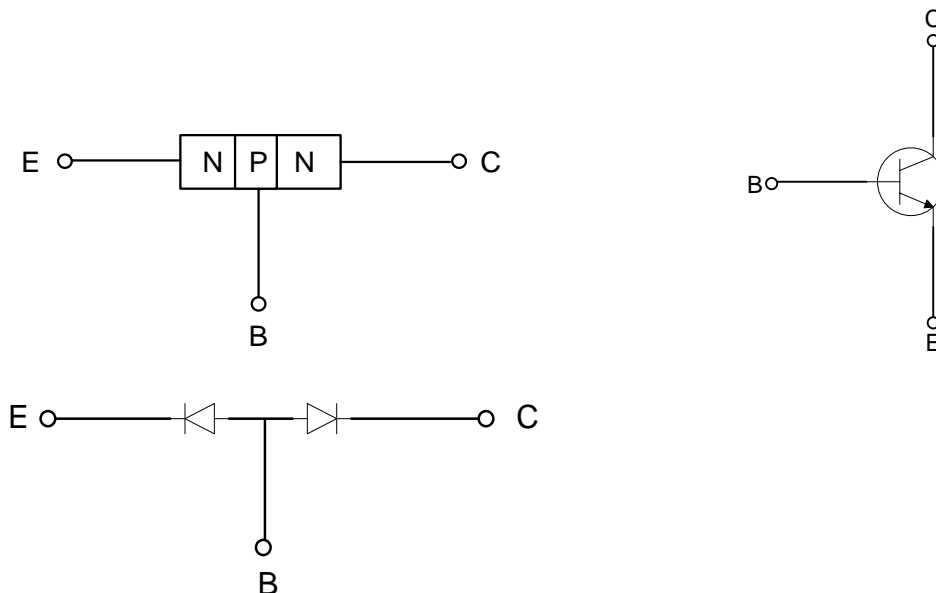

It is constructed by sandwiching a p – type material between 2 n – type materials. It is like 2 diodes connected back to back. The arrows in the circuit symbol indicate the direction of current when the transistor is in operation. The emitter is heavily doped so that it can emit a large amount majority charge carriers (electrons).

The base is very thin and very lightly doped so as to allow majority charge carriers to move from the emitter to the collector with minimal time possible and reduce the base current by

reducing the amount of charge comes recombining when the features above increase the collector current and reduce the base current. (Transistor amplifier)

The collector is larger in size than the other two and moderately doped. Large size makes it able to dissipate large amount of power without getting damaged. Moderate doping also reduced the amount of power dissipated.

$$P = I_C^2 R$$

$$R = \rho \frac{L}{A}$$

### Operation

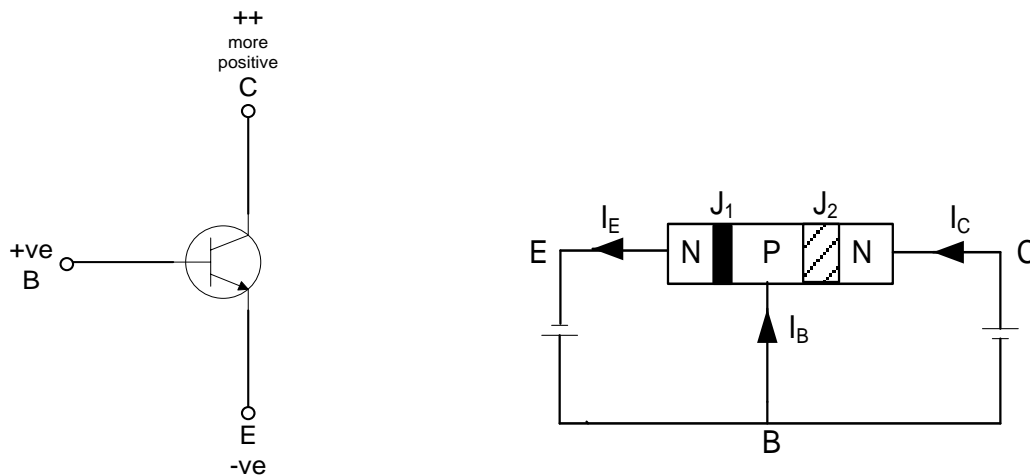

For a transistor to effectively operate the base emitter junction is supposed to be forward – biased while the collector-base junction is reverse biased. This is done by connecting the emitter to negative potential, the base to positive potential and the collector to more positive potential.

The negative potential at the emitter repels the electrons which are the majority charge carries. As they reach the base very few of them will combine with holes to form the base current  $I_B$  (5%). The rest will be attracted by the more positive potential at the collector and then they pass through the base to form the collector current (95% /98%)

Base and collector cannot be interchanged due to doping levels

Using KCL  $I_C + I_B = I_E$

## PNP transistor Construction

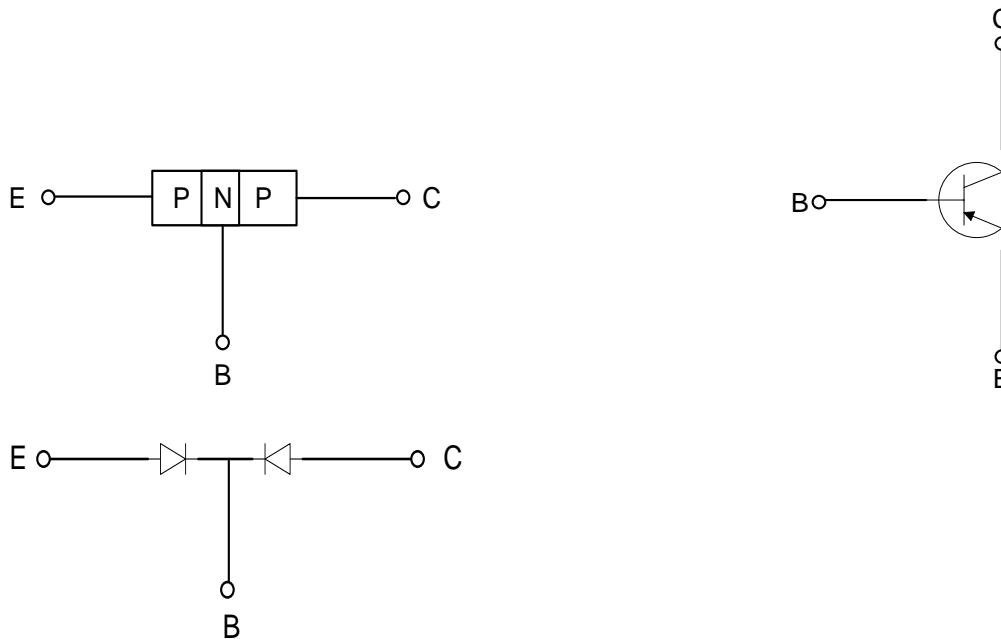

The n – type semiconductor is sandwiched between 2 p- type semiconductors. It is like 2 diodes connected front to front. The direction of the arrow in the circuit symbol indicates the direction of current when the transistor is in operation.

The size and doping levels for the emitter, base and collector are the same as those of the NPN transistor.

## Operation

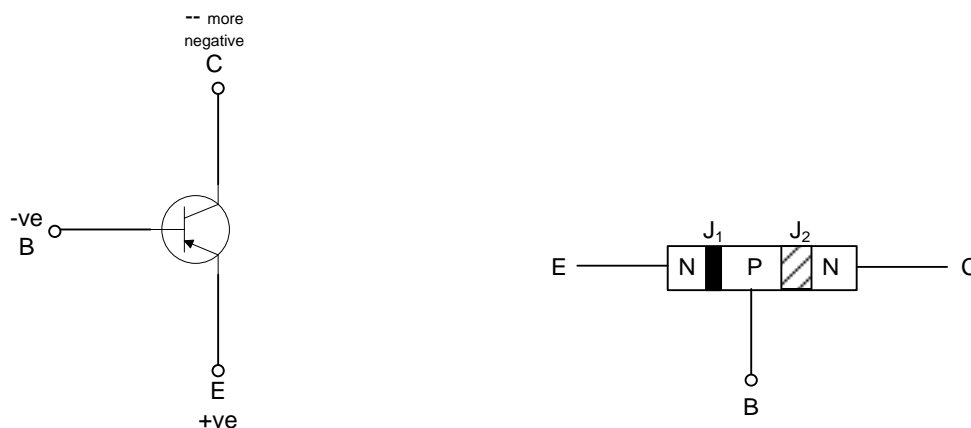

The B – E junction is forward biased while the collector – base junction is reverse biased. This is done by connecting the emitter at the positive potential, the base to a negative potential and collector to a more negative potential.

The positive potential at E repels the holes which are majority charge carriers which move through the base by being attracted by the more negative potential at the collector. A few of those charged carriers will recombine at the base to form  $I_B$  (base current 2% - 5%) while the rest move through to the collector to form the collector current (95%)

Using KCL

$$I_E = I_C + I_B$$

100% 95% 5%

### Transistor modes of connection (configurations)

A transistor has 3 terminals and since the input has 2 terminals and the output 2 terminals, one of the transistor terminals is made to be common so that the input and output can be measured. The common terminal is usually connected to the ground.

All the common connections should maintain a forward bias for the B – E junction and a reverse bias for the C – B junction. The configurations are given by common base (CB), Common emitter (CE) and common collector (CC). They can be used for different applications.

#### 1. Common Base (CB) connection

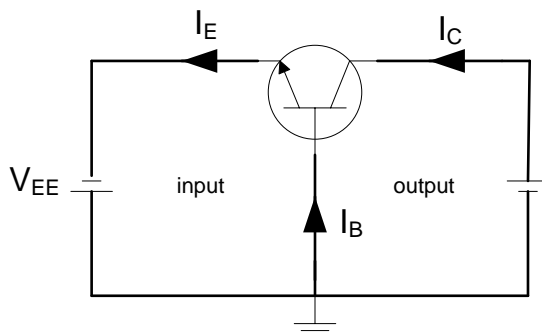

Negative potential obtained by rectification on lower side of the time line. The base is common to the input and the output.

### Parameters

Input

Input current =  $I_E$

Input voltage =  $V_{BE}$

Input resistance =  $\frac{V_{BE}}{I_E} = h_{iB}$

Input power =  $I_E V_{BE}$

Output

Output current =  $I_C$

Output voltage =  $V_{CB}$

Output resistance =  $\frac{V_{CB}}{I_C} = h_{oB}$

Output power =  $I_C V_{CB}$

Current gain =  $\frac{I_C}{I_E} = \alpha = h_{FB}$

$\alpha$  is the measure of the quality of a transistor, the higher the value of  $\alpha$ , the better the transistor in the sense that the collector current more closely equals the emitter current.

$$I_C = \alpha I_E \quad I_B = I_E - I_C = I_E - \alpha I_E = (1 - \alpha) I_E$$

Parameter	Instantaneous	d.c	Total
Emitter I	$i_e$	$I_E$	$i_E$
Collector I	$i_c$	$I_C$	$i_C$
Base I	$i_b$	$I_B$	$i_B$
BE voltage	$v_{be}$	$V_{BE}$	$V_{BE}$
Hybrid	$h_{ib}$	$h_{IB}$	$h_{IB}$

Reverse voltage gain =  $\frac{V_{BE}}{V_{CB}} = h_{RB}$

voltage gain =  $\frac{V_{CB}}{V_{BE}}$

Input impedance =  $h_i$   
 Output admittance =  $h_o$   
 Forward current gain =  $h_f$   
 Reverse voltage gain =  $h_{RB}$

Output impedance =  $\frac{V_{CB}}{I_c} = h_{OB}$

Power gain =  $\frac{\text{Output power}}{\text{Input power}} = \frac{V_{CB}I_c}{V_{BE}I_E} = A_p$

$A_v$  = Voltage gain  
 $A_i$  = Current gain  
 Power gain in decibels (dB) =  $10 \log_{10} A_p$   
 Voltage gain in dB =  $20 \log_{10} A_v$   
 Current gain in dB =  $20 \log_{10} A_i$

Application of CB - connection : Impedance matching

## 2. Common Emitter (CE) configuration

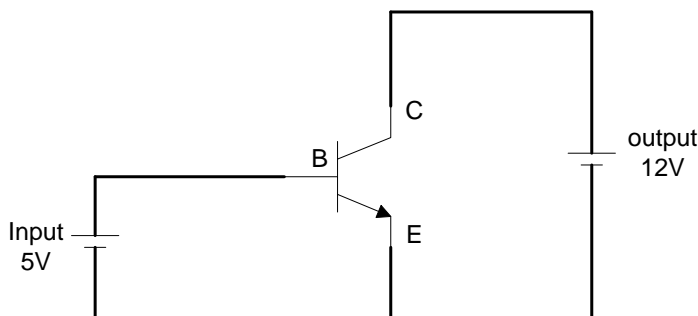

In this case the emitter is common to the input and output therefore it is grounded.  
 Parameters

Input  
 Input current =  $I_B$   
 Input voltage =  $V_{BE}$   
 Input resistance =  $\frac{V_{BE}}{I_B} = h_{iE}$   
 Input power =  $I_E V_{BE}$

Output  
 Output current =  $I_C$   
 Output voltage =  $V_{CE}$   
 Output resistance =  $\frac{V_{CE}}{I_C}$   
 Output power =  $I_C V_{CE}$

Current gain =  $\frac{I_C}{I_B} = \beta = h_{FE}$  - Forward current gain of common emitter configuration

$$h_{OE} = \frac{I_C}{V_{CE}} = \frac{1}{r_o}$$

$$\text{Reverse voltage gain} = \frac{V_{BE}}{V_{CE}}$$

This connection is used for impedance matching where the output has a lower impedance. It is mostly applied where a gain is required.

### Common Collector Connection

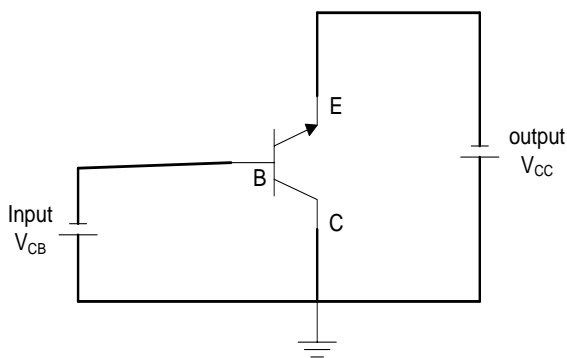

Input

$$\text{Input current} = I_B \cong \mu A$$

$$\text{Input voltage} = V_{CB} \cong 20V$$

$$\text{Input resistance} = \frac{V_{CB}}{I_B} \cong k\Omega$$

$$\text{Input power} = I_B V_{CB}$$

Gain

$$\text{Current gain} = \frac{I_E}{I_B} = \theta \text{ or } \gamma = h_{FC}$$

$$\theta = \frac{I_E}{I_C} = \frac{I_E}{I_C} \times \frac{I_C}{I_B} = \frac{\beta}{\alpha} = \frac{\beta}{\beta / (1 + \beta)} = 1 + \beta$$

$$\text{Voltage gain} = \frac{V_{CE}}{V_{CB}}$$

$$\cong 1$$

Output

$$\text{Output current} = I_E$$

$$\text{Output voltage} = V_{CE}$$

$$\text{Output resistance} = \frac{V_{CE}}{I_C}$$

$$\text{Output power} = I_E V_{CE}$$

$$I_E = I_B + I_C$$

$$= I_B + \beta I_B = (1 + \beta) I_B$$

$$\text{Output current} = (1 + \beta) \times \text{input current}$$

$$\text{Reverse Voltage gain} = h_{RC} = \frac{V_{CB}}{V_{CE}}$$

Applications

- (i) It can be used in current gain or power gain circuit
- (ii) It can be used for impedance matching to isolate two circuits.



## Relationship between current gains

$$\alpha = \frac{I_C}{I_E} \quad \beta = \frac{I_C}{I_B} \quad \theta = \frac{I_E}{I_B} \quad I_E = I_C + I_B$$

(i)  $\alpha$  in terms of  $\beta$

$$\alpha = \frac{I_C}{I_E} = \frac{I_C}{I_C + I_B} = \frac{\beta}{\beta + 1}$$

(ii)  $\beta$  in terms of  $\alpha$

$$\beta = \frac{I_C}{I_B} = \frac{I_C}{I_E - I_C} = \frac{\alpha}{1 - \alpha}$$

## Leakage Current

Transistors (BJT)

Leakage current is caused by the flow of minority charge carriers in a transistor and flows in the PN junction in the common base connection.

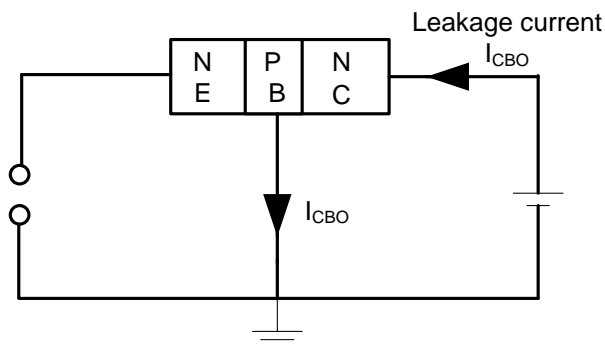

$I_{CBO}$  leakage current is the current which flows from C to B when the emitter is open.

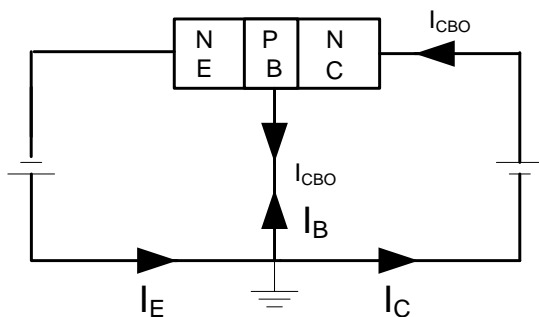

$$I_C = \alpha I_E + I_{CBO}$$

Majority carriers      minority carriers

$$I_C = \alpha(I_C + I_B) + I_{CBO}$$

$$I_C - \alpha I_C = I_B + I_{CBO}$$

$$I_C = \frac{\alpha}{1 - \alpha} I_B + \frac{1}{1 - \alpha} I_{CBO} = \beta I_B + (1 + \beta) I_{CBO}$$

Similarly

$$I_C = \alpha I_E + I_{CBO}$$

$$I_E - I_B = \alpha I_E + I_{CBO}$$

$$I_B = \underbrace{I_E - \alpha I_E} - I_{CBO}$$

$$I_B = I_{B\text{majority}} - I_{CBO}$$

$$I_B = (1 - \alpha)I_E - I_{CBO}$$

$I_{CBO}$  – Collector- to- base leakage current

$I_{CBO}$  is exactly like the reverse saturation current  $I_s$  of a reverse biased diode.

$I_{CBO}$  is extremely temperature dependent i.e. it doubles for every  $10^{\circ}\text{C}$  rise for germanium and  $6^{\circ}\text{C}$  for silicon.

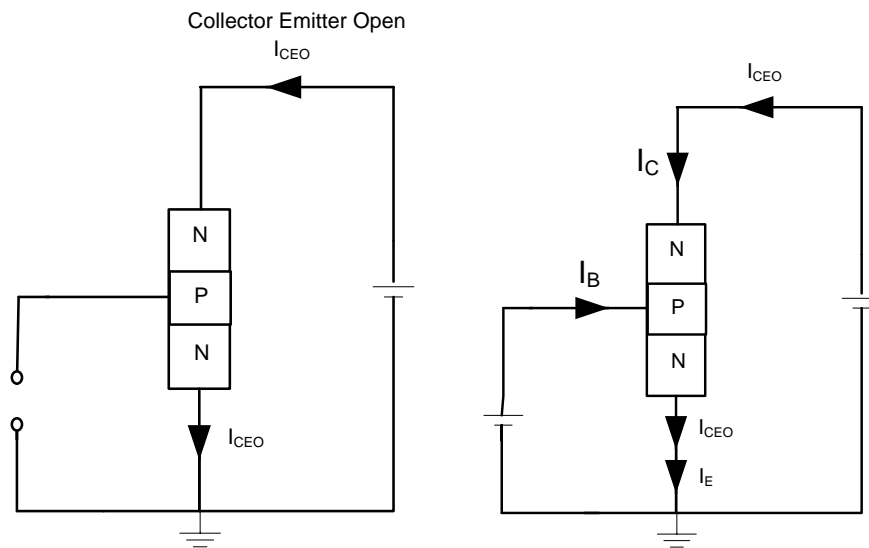

$$I_C = \frac{\alpha}{1 - \alpha} I_B + \frac{1}{1 - \alpha} I_{CBO}$$

$$I_C = \frac{1}{1 - \alpha} I_{CBO} = I_{CEO}$$

$I_C$  is magnified by a factor of  $1 + \beta$

$$I_C = \beta I_B + I_{CEO}$$

$$I_E = I_C + I_B = \beta I_B + I_{CEO} + I_B$$

$$I_E = (1 + \beta)I_B + I_{CEO} = (1 + \beta)I_B + \frac{1}{1 - \alpha} I_{CEO}$$

### Thermal Runaway

This is a situation where an increment of current leads to an increment of temperature in a semiconductor. The increment of temperature in turn leads to an increment of current, the process continues and if not kept in control can damage the transistor.

Si =  $10^{\circ}\text{C}$  rise in temperatures doubles the current

Ge =  $6^{\circ}\text{C}$  rise in temperature doubles the current

## TRANSISTOR STATIC CHARACTERISTICS

There are VI characteristics of transistors connected in different configurations. They help in determining the optimal operation of a transistor.

They are

- (i) Input characteristics - Graph of input current against input voltage
- (ii) Output characteristics - Graph of output current against output voltage
- (iii) Transfer characteristics - Graph of output current against input current

### Common base

#### (i) Input characteristics

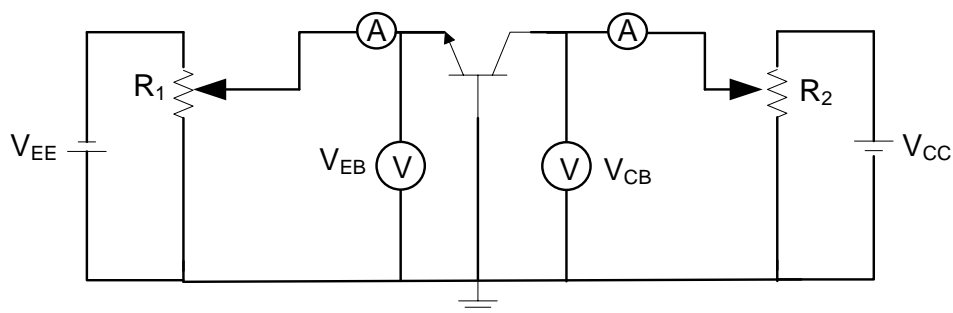

The input characteristics are given by the input current ( $I_E$ ) against input voltage ( $V_{BE}$ ) for a constant value of output voltage  $V_{CB}$ .

First,  $V_{CB}$  is kept at a constant value while  $V_{BE}$  is varied by the use of  $R_1$ . The corresponding  $I_E$  is noted and a curve is drawn

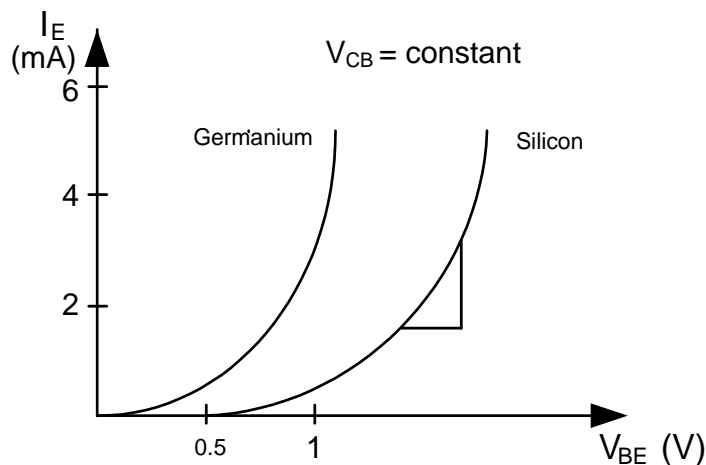

It behaves like a forward biased diode since the input base-emitter junction is forward biased. When  $V_{BE}$  is increased the transistor will start conducting at 0.7V (Si). Further increment of  $V_{BE}$  will lead to a corresponding increment of  $I_E$ .

$$\text{Admittance} = \frac{I_E}{V_{BE}}$$

**(ii) Output Characteristics**

$I_E$  is kept constant while  $V_{CB}$  is varied in discrete steps and  $I_C$  is measured.

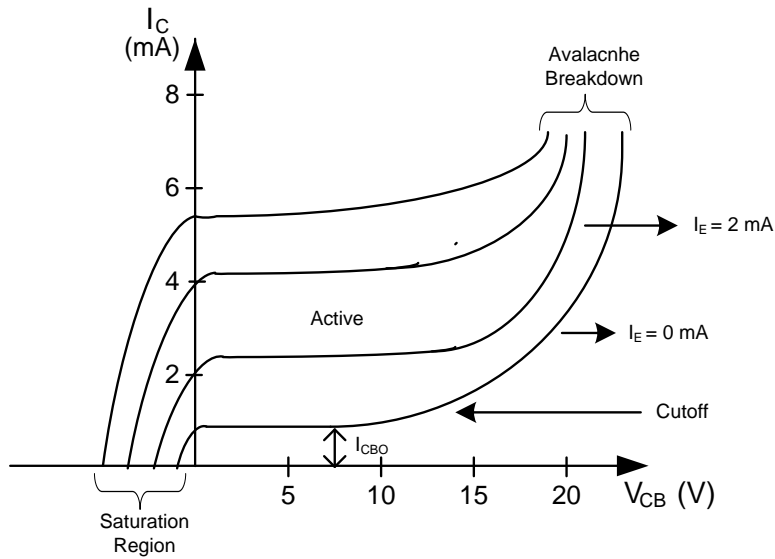

The graph can be used to get  $\alpha$ .  $I_C$  is practically independent of  $V_{CB}$  over the working range.

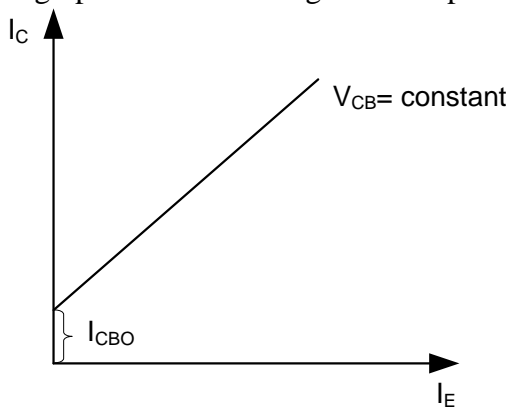

Gain can be calculated from the curve.

**Common Emitter Connection**

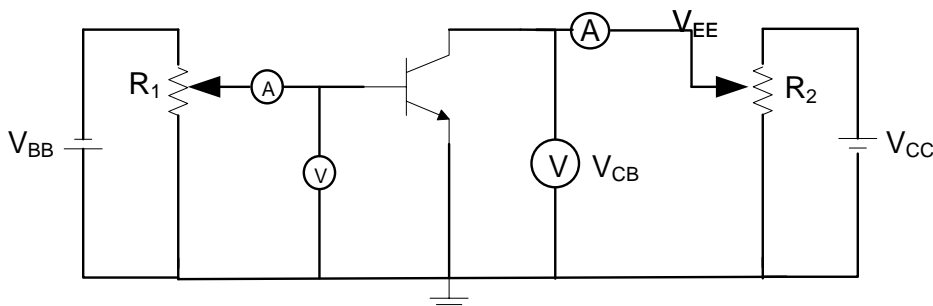

**Input characteristics**

This is a plot of  $I_B$  against  $V_{BE}$  for constant  $V_{CE}$ .  $V_{CC}$  is kept at a constant value while  $V_{BE}$  is varied at appropriate steps as  $I_B$  is measured for the corresponding steps.

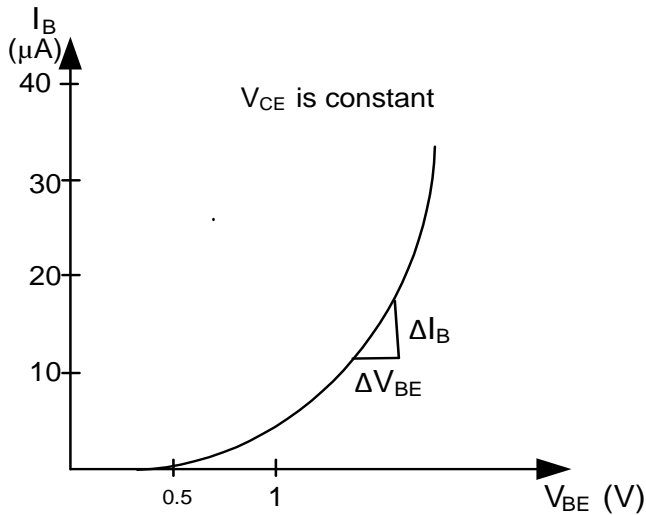

When  $V_{CE} = 0$ , the base – emitter junction is forward biased. The junction behaves as forward biased diode. At a constant value of  $V_{BE}$  when  $V_{CE}$  is increased, the width of the depletion region at the collector-base junction will increase and hence the width of the base will decrease. This effect causes a decrease in base current  $I_B$ , therefore the curve shifts to the right as  $V_{CE}$  increases. The curve is exactly the same as that of a forward biased diode where with increment of  $V_{BE}$  the transistor starts conducting at 0.7V (silicon) or 0.2V (Ge). Further increment of  $V_{BE}$  results in a corresponding increment of  $I_B$ . The graph can be used to determine the input admittance or impedance where from initial stages of the curve the resistance is high ( $4\text{k}\Omega$ ) which reduces as  $V_{BE}$  increases.

### Output characteristics

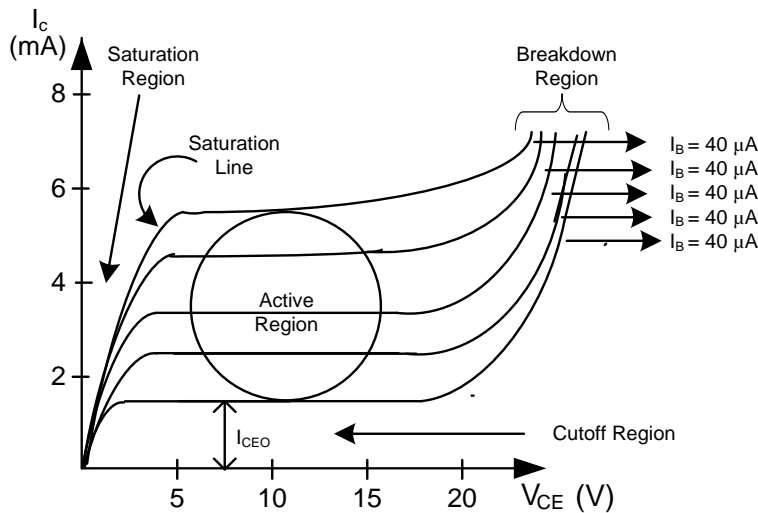

For  $I_B = 0$  and  $V_{CE} \cong 0$  the only current passing the transistor is leakage current  $I_{CEO}$ . When  $V_{CE}$  is increased there is in further increment of  $I_C$  and the transistor cannot hold any more and as a result it breaks down. If  $I_B$  is increased from zero to a few volts of  $V_{CE}$  the transistor will be in saturation mode. The curves will be similar to the one of  $I_B = 0$

## Regions of Transistor Operation

### Saturation region

This is where  $V_{CE} = 0$  up to a few volts ( $\cong 0.5V$ ). Both the collector-base junction and base-emitter junction are forward biased and therefore the collector is collecting all the electrons emitted by the emitter. The transistor behaves like a switch which is on

### Cut off region

This is where  $I_B = 0$ . Both junctions are reverse biased therefore only a small leakage current flows through which is called  $I_{CEO}$ . The transistor behaves like a switch which is off.

### Active Region

This is where  $V_{CE}$  range from a few volts to around 30V depending on the type of transistor.  $I_B$  is also slightly above 0. The transistor is normally biased where the collector base junction is reverse biased while the base-emitter junction is forward biased. Most of the applications of the transistor use this region to operate e.g. amplification.

### Breakdown region

$V_{CE}$  is beyond 30V depending on the type of transistor. The base-emitter junction is forward biased while collector-base junction reverse biased. At this part the transistor breakdown resulting to uncontrollable flow of current. This is called avalanche breakdown

## Transfer Characteristics

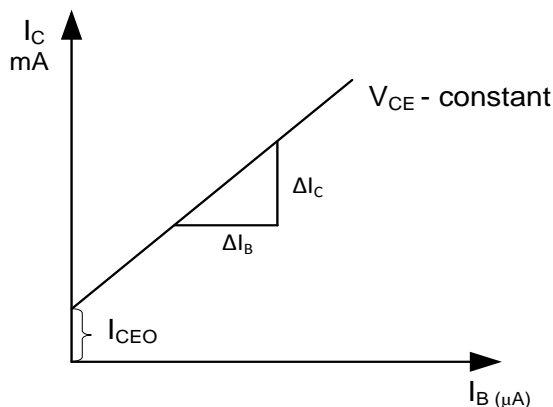

It is a plot of  $I_C$  against  $I_B$ . When  $I_B = 0$ ,  $I_C$  has got some value which is referred to as leakage current  $I_{CEO}$ . This graph can be used to determine the forward current gain for collector-emitter connection.

## Common Collector Connection

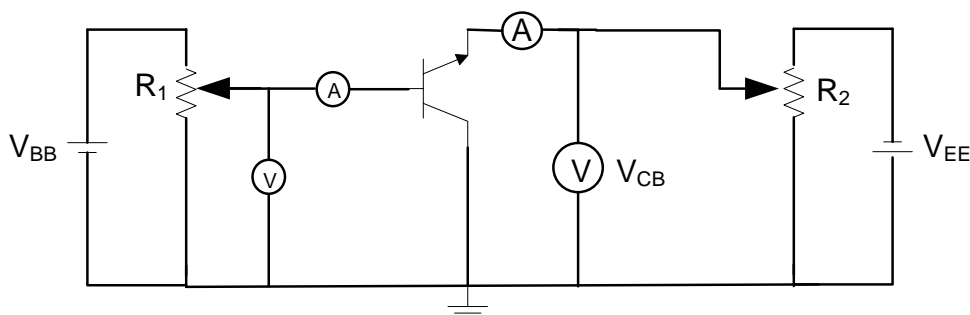

## Input Characteristics

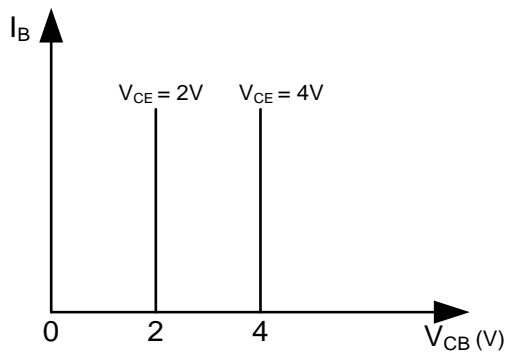

$$V_{CE} = V_{CB} + V_{BE}$$

It is a plot of  $I_B$  against  $V_{CB}$  while  $V_{CE}$  is kept constant.  $V_{CE}$  is dependent on both  $V_{CB}$  and  $V_{BE}$  by the use of the following relation

$$V_{CE} = V_{CB} + V_{BE}$$

If  $V_{CE}$  is kept constant and  $V_{CB}$  is increased  $V_{BE}$  will reduce up to a point where  $V_{CB}$  is equal to  $V_{CE}$ .  $I_B$  will be given by zero. The graph can be used to determine the input impedance and reverse voltage gain.

## Output Characteristics

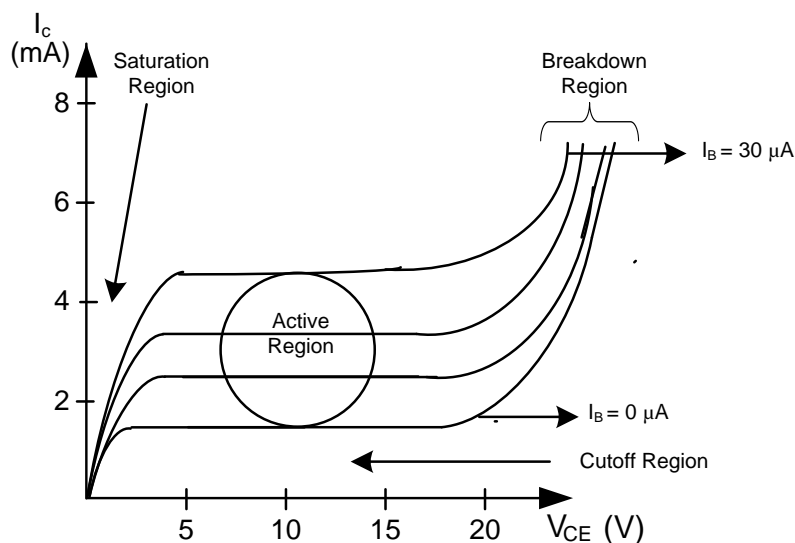

This is a plot of  $I_E$  against  $V_{CE}$  while  $I_B$  is kept constant. The plot is exactly same as that of the output characteristics for the collector-emitter junction connection because  $I_E$  is almost equal to  $I_C$ . This graph can be used to determine impedance or admittance and forward current gain for the common collector connection.

## Transfer Characteristics

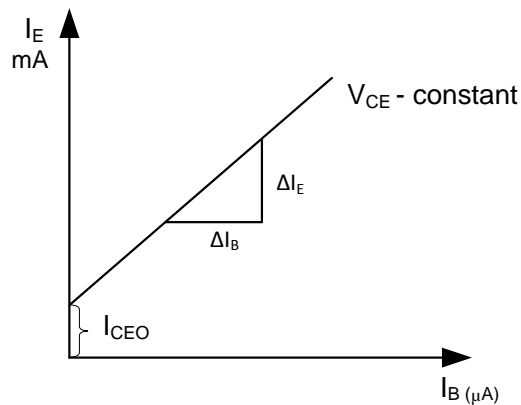

## Methods of transistor biasing

This is the process of connecting a transistor voltage supplies together with resistors so that it can operate normally. The collector-base junction is reverse biased and base-emitter junction is forward biased. The methods of biasing a transistor are listed below.

- (i) Base bias
- (ii) Base Bias with emitter feedback
- (iii) Base Bias with collector feedback
- (iv) Base Bias with collector and emitter feedback
- (v) Emitter Bias with two supplies
- (vi) Voltage divider bias

## Base Bias

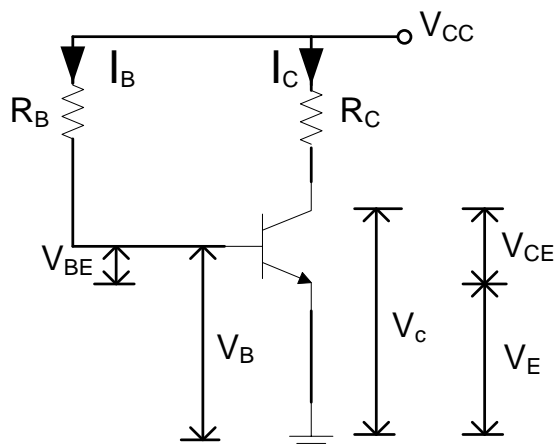

$$V_C = V_{CE} \quad \text{Stability factor } s = 1 + \beta$$

$$I_C + I_B = I_E$$

$$V_{CC} = I_C R_C + V_{CE}$$

$$V_{CC} = I_B R_B + V_{BE}$$

$$I_C = \frac{V_{CC} - V_{CE}}{R_C}$$

$$I_B = \frac{V_{CC} - V_{BE}}{R_B}$$

$$I_{C(\text{sat})} = \frac{V_{CC}}{R_C}$$

since  $V_{CE} \approx 0V$

$$\text{Max } V_{CE} = V_{CC}$$

$$I_C \cong 0A$$



### Base Bias with Emitter Feedback

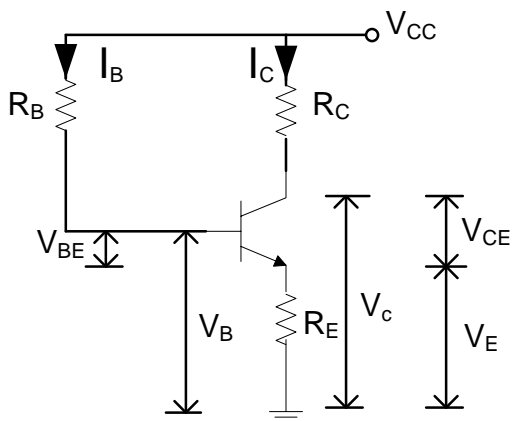

$$V_{CC} = I_C R_C + V_{CE} + I_E R_E$$

$$V_{CC} = I_B R_B + V_{BE} + I_E R_E$$

$$I_C = \frac{V_{CC} - V_{CE}}{R_C + R_E / \alpha} \quad \text{since } I_E = I_C / \alpha$$

$$I_C = \frac{V_{CC} - V_{CE}}{R_C + \frac{1 + \beta}{\beta} R_E}$$

$$I_B = \frac{V_{CC} - V_{BE}}{R_B + (1 + \beta) R_E} \quad \text{since } I_E = \beta I_B = (1 + \beta) I_B$$

$$V_C = V_{CE} + V_E$$

$$V_B = V_{BE} + V_E$$

$$V_E = I_E R_E$$

Negative feedback-output is fed back to input

### Base Bias with Collector Feedback

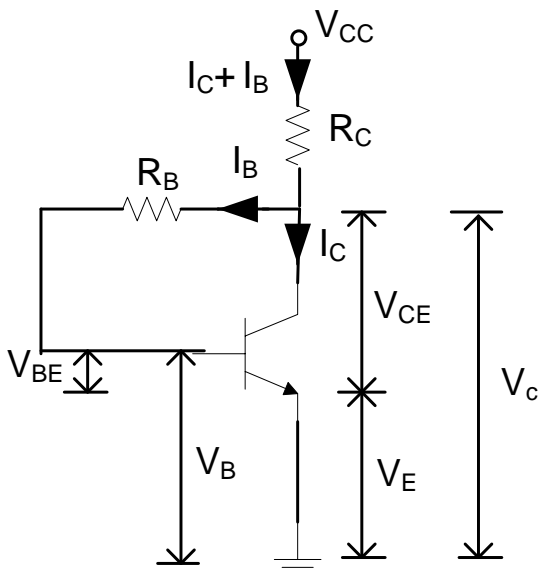

Equations

$$V_{CC} = (I_C + I_B)R_C + V_{CE}$$

$$V_{CC} = (I_C + I_B)R_C + I_B R_B + V_{BE}$$

$$V_C = V_{CE}$$

$$V_C = V_{CC} - (I_C + I_B)R_C$$

$$V_C = I_B R_B + V_{BE}$$

### Base Bias with Collector and Emitter Feedbacks

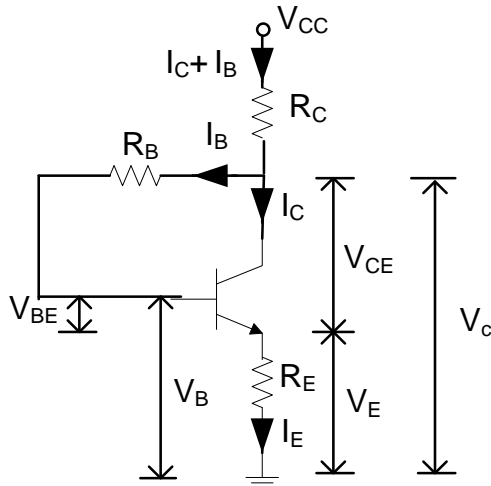

$$I_E = I_C + I_B$$

$$V_{CC} = (I_C + I_B)R_C + V_{CE} + I_E R_E$$

$$V_{CC} = (I_C + I_B)R_C + I_B R_B + V_{BE} + I_E R_E$$

$$V_E = I_E R_E$$

$$V_C = V_{CE} + V_E \quad V_C = V_{CC} - (I_C + I_B)R_C$$

$$V_C = I_B R_B + V_{BE} + I_E R_E$$

$$I_C(sat) \rightarrow V_{CE} = 0$$

$$V_{CC} = (I_C + I_B)R_C + I_E R_E$$

$$V_{CC} = I_E R_C + I_E R_E$$

$$I_E = \frac{I_C}{\alpha}$$

$$V_{CC} = \frac{I_C}{\alpha} (R_C + R_E)$$

$$\frac{I_C}{\alpha} = \frac{V_{CC}}{R_C + R_E}$$

$$I_C = \frac{V_{CC}}{R_C + R_E} (\alpha)$$

$$I_{sat} = \frac{V_{CC}}{R_C + R_E} \left( \frac{\beta}{1 + \beta} \right) = \frac{V_{CC}}{R_C + R_E}$$

$$V_{CE}(cutoff) \rightarrow I_C = 0$$

$$V_{CC} = (I_C + I_B)R_C + I_E R_E + V_{CE}$$

$$V_{CC} = V_{CE}$$

### Emitter bias with 2 power supplies

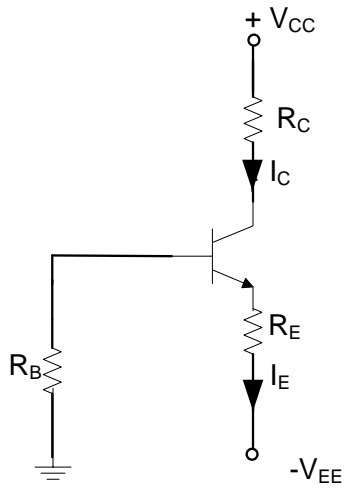

$$V_{CC} = I_C R_C + I_B R_B + V_{CE}$$

$$V_{CC} = I_C R_C + V_{CE} + I_E R_E + V_{EE}$$

$$V_{EE} = I_E R_E + I_B R_B + V_{BE}$$

### Voltage divider bias

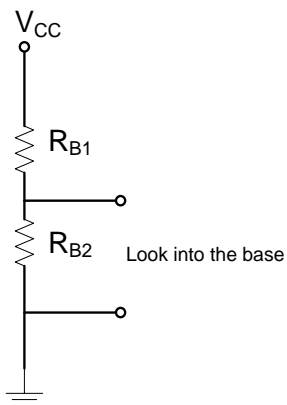
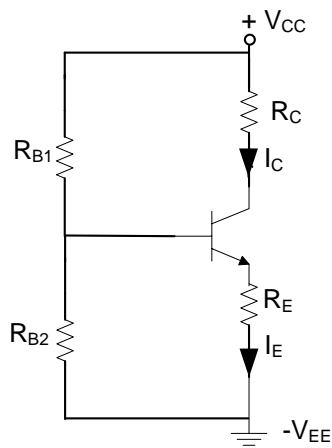

$$V_{Th} = \frac{V_{CC} R_{B2}}{R_{B1} + R_{B2}}$$

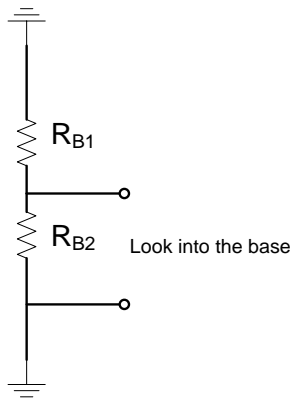

$$R_{Th} = \frac{R_{B1} R_{B2}}{R_{B1} + R_{B2}}$$

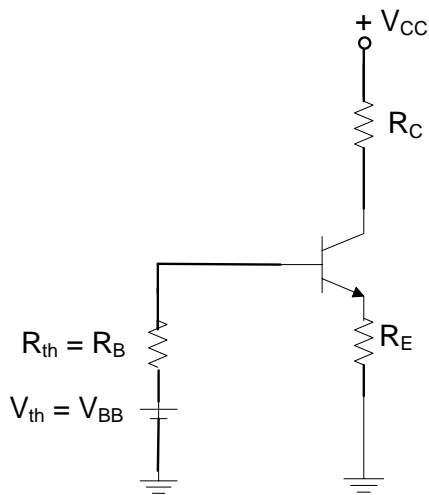
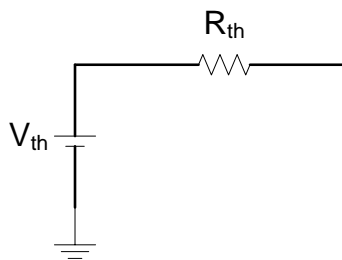

$$V_{CC} = I_C R_C + V_{CE} + I_E R_E$$

$$V_{CC} = I_C R_C + V_{CE} + I_B R_B - V_{BB}$$

$$V_{BB} = I_B R_B + V_{BE} + I_E R_E$$

$$V_C = V_{CC} - I_C R_C$$

$$V_C = V_{CE} + I_E R_E$$

## Single Stage Amplifier

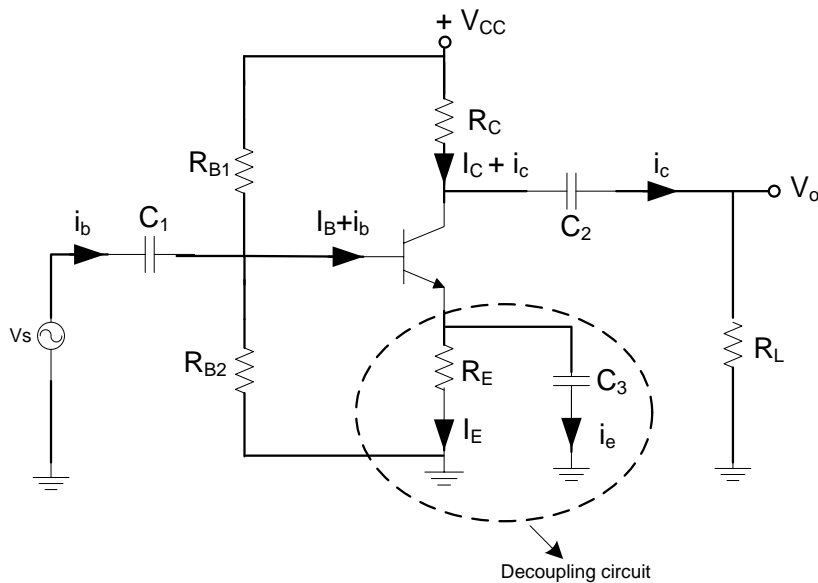

$R_{B1}$ ,  $R_{B2}$  – Potential dividers where  $R_{B1}$  is used to reverse bias the collector-base junction and  $R_{B2}$  is used to forward bias the base-emitter junction.

$R_C$  and  $R_L$  are used to facilitate the collection of the output signal

$R_E$  is used to feedback any change in  $I_C$  so as to stabilize the bias condition

$$V_2 = V_{BE} + I_E R_E$$

$C_1$  - Blocks any direct current from the source

$C_2$  - Blocks any direct current from appearing at the output

$C_3$  (decoupling capacitor) - Bypasses high frequency alternating current signal to the ground which interferes with the bias condition if fed back.

$$i_C = \alpha i_E$$

$$i_B = (1 - \alpha) i_E$$

$$\frac{i_C}{i_B} = \beta = \frac{\alpha}{1 - \alpha}$$

Since  $\alpha \cong 1$  then  $\beta$  has a very large value thus there is a large current gain from the base to the collector in the common emitter configuration.

### D.C load line

This is a line drawn on the output characteristics of a transistor connection and for common emitter connection it gives all the possible values of  $I_C$  and  $V_{CE}$  depending on the load seen by  $I_C$ . It is developed by opening all the capacitors and shorting all the a.c sources.

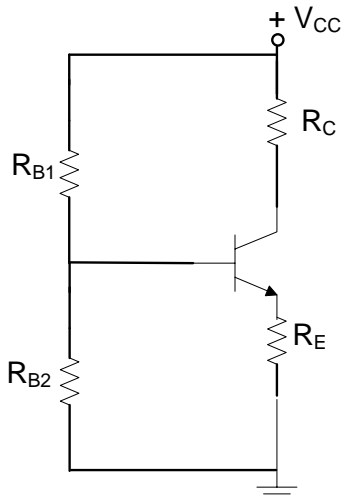
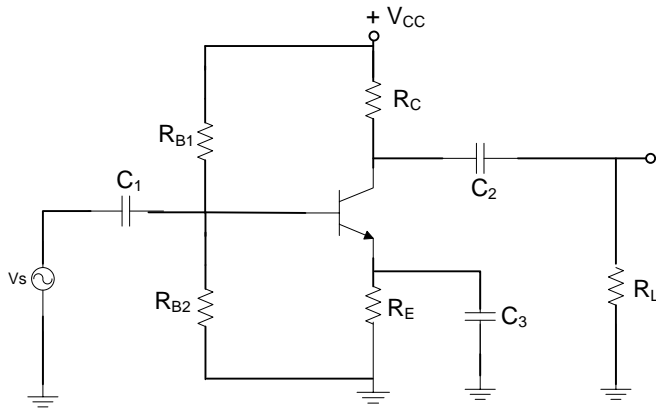

Using the common emitter equation

$$V_{CC} = I_C R_C + V_{CE} + I_E R_E$$

$$V_{CC} = I_C R_C + V_{CE} + \frac{I_C}{\alpha} R_E \quad \alpha \cong 1$$

$$I_C = \frac{V_{CC} - V_{CE}}{R_C + \frac{R_E}{\alpha}} \cong \frac{V_{CC} - V_{CE}}{R_C + R_E}$$

$$I_C = \frac{-V_{CE}}{R_C + R_E} + \frac{V_{CC}}{R_C + R_E}$$

$$y = mx + c \xrightarrow{\text{THUS}} m = \frac{-1}{R_C + R_E}, c = \frac{V_{CC}}{R_C + R_E}$$

$$\text{x-intercept } I_C \cong 0 \quad V_{CE} = V_{CC} \quad V_{CE(\text{cutoff})} = V_{CC}$$

$$\text{y-intercept } V_{CE} \cong 0V$$

$$I_C = \frac{V_{CC}}{R_C + R_E}$$

$$I_{C(\text{sat})} = \frac{V_{CC}}{R_C + R_E}$$

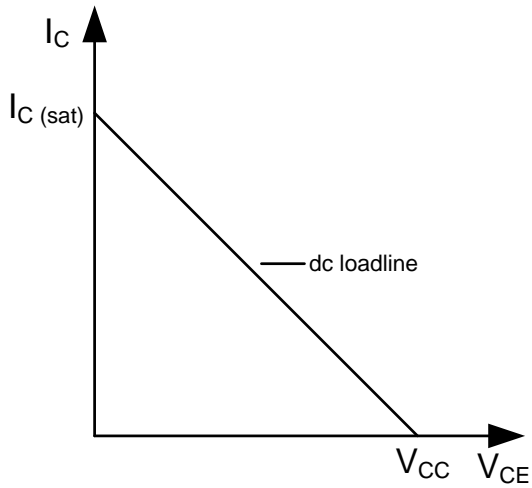

**Operating point/ Q – point / Quiescent point / silent / Quiet point**

This is the point at which the transistor operates without the a.c signal. The point at which the line of the current  $I_B$  intersects with the load line gives the operating point. It is located at the middle of the load line for the optimum transistor operation.

$$I_{CQ} = \frac{1}{2} I_{C(sat)}$$

$$V_{CEQ} = \frac{1}{2} V_{CC}$$

This way the maximum possible swing of an a.c signal can be obtained

D.C load and a.c signal

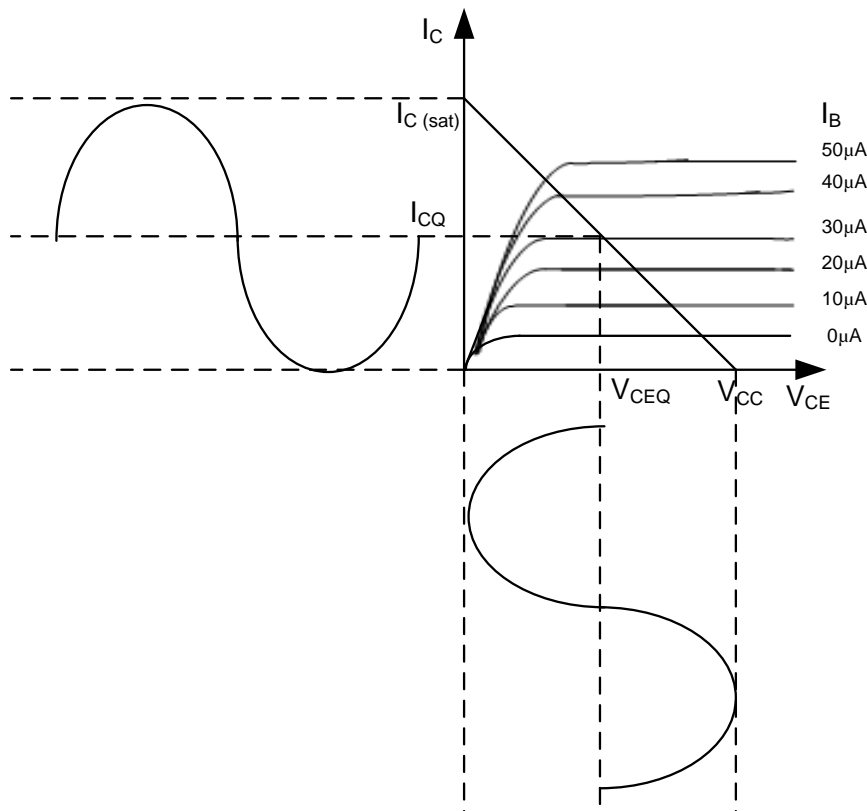

$$I_{pp} = 2I_{CQ}$$

$$V_{pp} = 2V_{CEQ}$$

where  $I_{pp}$  is the peak to peak current

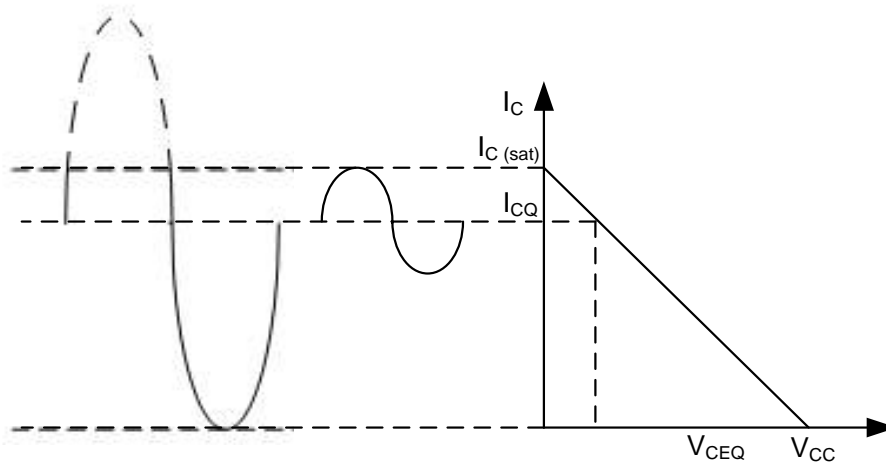

$$I_{C(sat)} - I_{CQ} < I_{CQ}$$

When the operating is close to  $I_{C(sat)}$  then clipping of the output waveform will occur due to saturation

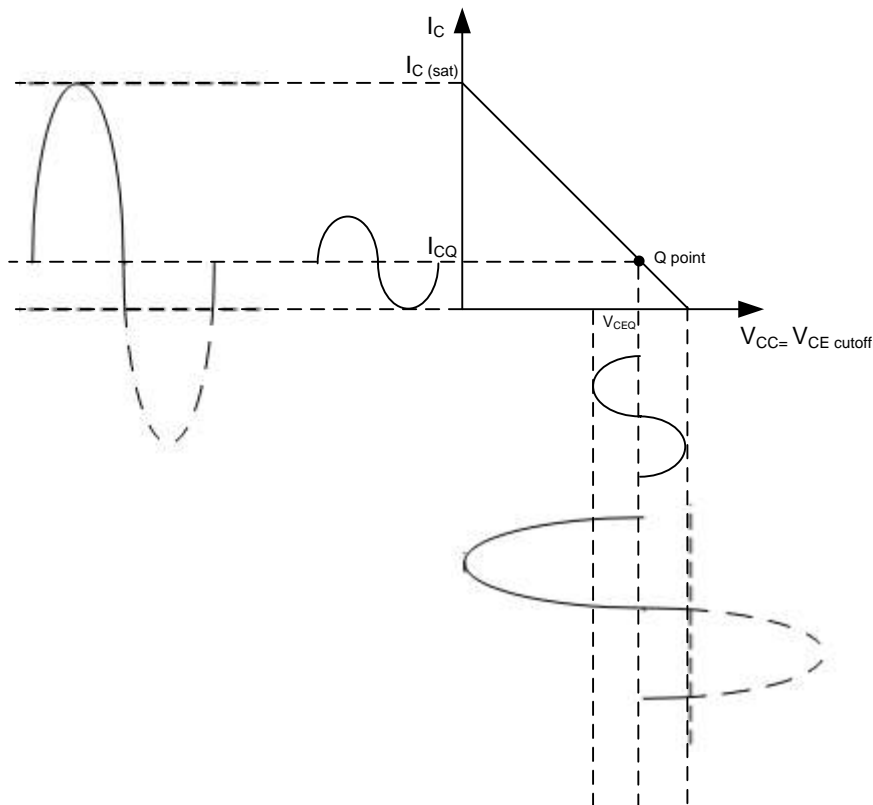

$$I_{C(sat)} - I_{CQ} > I_{CQ}$$

$$\text{Max} = 2I_{CQ}$$

When  $I_C$  is increasing from the Q – point,  $V_{CC}$  is decreasing since the load line has a negative gradient. When the operating point is close to  $V_{CE (cutoff)}$  clipping starts occurring due to cutoff value of  $V_{CE}$ .



### A.C load line

This is the line which give the different value of  $i_c$  and  $v_{ce}$  depending on the load as seen by  $i_c$ . ( $i_c = I_C(\text{d.c.}) + i_c(\text{a.c.})$ ). It is the line which obtained by adding a small signal to the already biased circuit.

### A.C equivalent circuit

Obtained by: shorting all capacitors  
Grounding all d.c sources

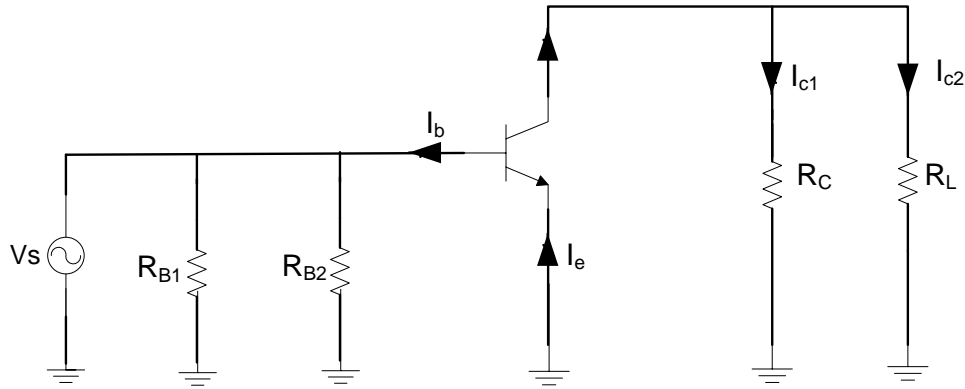

a.c load ( $R_{ac}$ )

$$R_{ac} = \frac{R_C R_L}{R_C + R_L} \quad R_{ac} < R_{dc} \text{ (always)}$$

$$I_{C(\text{sat})} = I_{CQ} + \frac{V_{CEQ}}{R_{ac}}$$

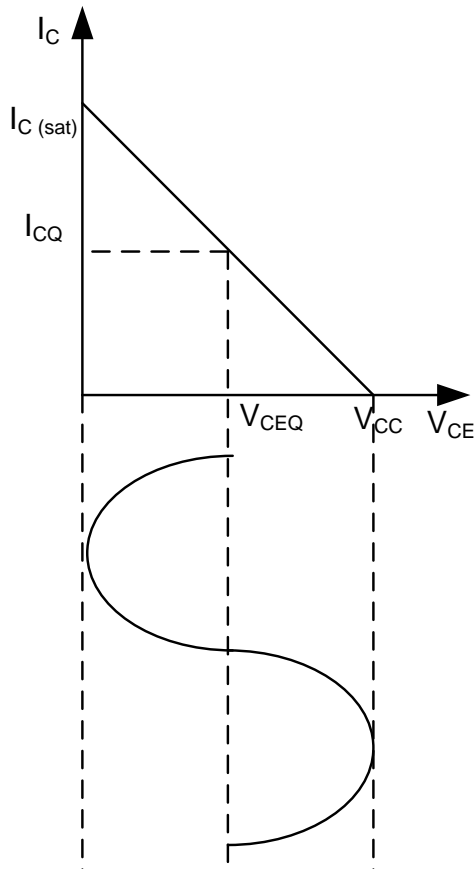

$$V_{CE(\text{cutoff})} = V_{CEQ} + I_{CQ}R_{ac}$$

$$V_{pp} = 2I_{CQ}R_{ac}$$

$$V_{pp} = 2V_{CEQ}$$

For clipping not to occur, then the lesser value is considered.

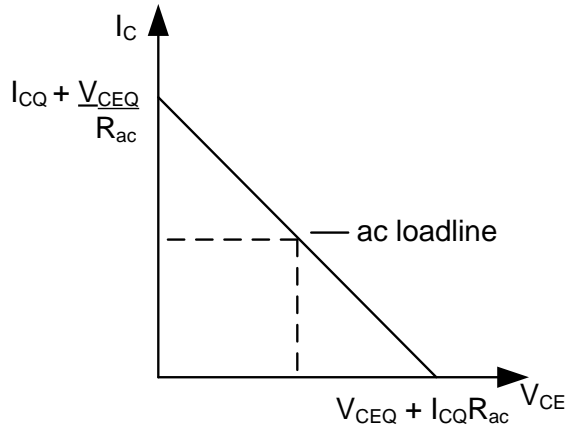

Since  $R_{ac} < R_{dc}$  the gradient of the a.c load line is steeper.

### Causes of transistor Q – point variation

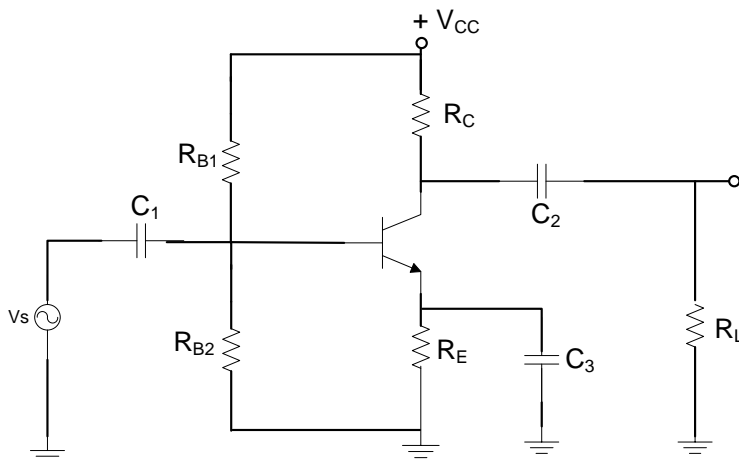

- (i) If any of the resistors of the amplifiers is faulty. Then resistors go faulty they became open

If  $R_C$  or  $R_E = \infty$

$$I_C = \frac{V_{CC}}{R_C + R_E} = \frac{V_{CC}}{\infty} \quad \text{the transistor is in cutoff.}$$

If  $R_{B2} = \infty$  then the transistor is off

- (ii) If any of the capacitors goes faulty the capacitor becomes a short  
 (iii) High temperature can cause thermal runaway.  
 (iv) Change of transistor

### Stability Factor

This is the rate of change of  $I_C$  with respect to  $I_{CBO}$

$$S = \frac{dI_C}{dI_{CBO}} \quad \text{where } I_B \text{ and } \beta \text{ are kept constant.}$$

### Common Emitter configuration

$$I_C = \beta I_B + (1 + \beta)I_{CBO}$$

$$\frac{dI_C}{dI_C} = \frac{d\beta I_B}{dI_C} + \frac{d(1 + \beta)I_{CBO}}{dI_C}$$

$$1 = \frac{d\beta I_B}{dI_C} + (1 + \beta) \frac{dI_{CBO}}{dI_C}$$

$$1 = \beta \frac{dI_B}{dI_C} + (1 + \beta) \frac{1}{S} \quad \text{thus } (1 + \beta) \frac{1}{S} = 1 - \beta \frac{dI_B}{dI_C}$$

$$S = \frac{(1 + \beta)}{1 - \beta \frac{dI_B}{dI_C}}$$

$$S = \frac{\left(1 + \frac{R_B}{R_E}\right)}{1 + \frac{R_B}{(1 + \beta)R_E}} \quad \begin{array}{l} R_B - \text{Resistance on the base side} \\ R_E - \text{Resistance on the emitter side} \end{array}$$

### Design of a single stage Low Power Amplifier

#### Specifications

Current through  $R_{B1}$  and  $R_{B2}$ ,  $I_1 \geq 10 I_B$

$I_C = 2\text{mA}$  (if  $> 2\text{mA}$  then clipping occurs hence to faithful amplification)  
(if  $> 15\text{mA}$  then the transistor burns out)

$I_C$  should be more than a.c signal by 20% to avoid clipping e.g. if the Q point is changed

#### Example

If a common emitter circuit connection has the following parameters:  $V_{CC} = 9\text{V}$ ,  $V_{CE} = 3\text{V}$ ,  $V_{BE} = 0.3\text{V}$ ,  $I_1 = 10I_B$ ,  $I_C = 2\text{mA}$ ,  $R_C = 2.2 \text{ k}\Omega$  and  $\beta = 50$ . Determine  $R_{B1}$ ,  $R_{B2}$  and  $R_E$ .

#### Solution

Using the common emitter equation

$$V_{CC} = I_C R_C + V_{CE} + I_E R_E = I_C R_C + V_{CE} + \frac{(1 + \beta)}{\beta} I_C R_E$$

$$9 = 2 \times 2.2 + 3 + \frac{51}{50} \times 2 \times R_E$$

$$R_E = 784 \Omega$$

$$I_B = \frac{I_C}{\beta} = \frac{2}{50} = 0.04 \text{ mA}$$

$$I_1 = 10 \times I_B = 10 \times 0.04 = 0.4 \text{ mA}$$

$$R_{B1} + R_{B2} = \frac{V_{CC}}{I_1} = \frac{9}{0.4 \times 10^{-3}} = 22.5 \text{ k}\Omega$$

$$V_B = V_{BE} + I_E R_E = 0.3 + \frac{51}{50} \times 2 \times 784 = 0.3 + 1.6 = 1.9 \text{ V}$$

$$R_{B2} = \frac{V_B}{I_1} = 1. \frac{9}{0.4 \times 10^{-3}} = 4.75 \text{ k}\Omega$$

$$R_{B1} = 22.5 - 4.75 = 17.75 \text{ k}\Omega$$

### Example

Hence determine the coordinates of the operating point and the stability factor  $S$  in a common emitter germanium transistor amplifier circuit, shown below, the bias is provided by self bias, i.e. emitter resistor and potential divider arrangement. The various parameters are:  $V_{CC}=16 \text{ V}$ ,  $R_C=3\text{k}\Omega$ ,  $R_E= 2\text{k}\Omega$ ,  $R_{B1}=56 \text{ k}\Omega$ ,  $R_{B2}=20 \text{ k}\Omega$  and  $\alpha=0.985$ .

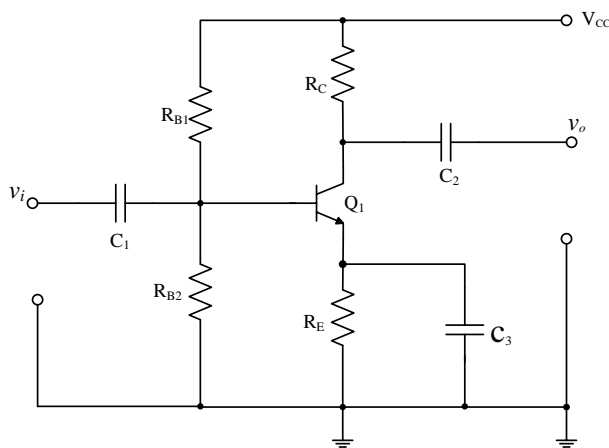

### Solution:

For a germanium transistor,  $V_{BE}=0.3\text{V}$ . As  $\alpha=0.985$ ,

$$\beta = \frac{\alpha}{1-\alpha} = \frac{0.985}{1-0.985} = 66$$

To find the coordinates of the operating point

$$\text{Thevenin's voltage, } V_T = \frac{R_2}{R_1 + R_2} V_{CC} = \frac{20 \times 10^3}{76 \times 10^3} \times 16 = 4.21\text{V}$$

$$\text{Thevenin's resistance, } R_B = \frac{R_1 R_2}{R_1 + R_2} = \frac{20 \times 10^3 \times 56 \times 10^3}{76 \times 10^3} = 14.737\text{k}\Omega$$

The loop equation around the base circuit is

$$V_T = I_B R_B + V_{BE} + (I_B + I_C) R_E, = \frac{I_C}{\beta} R_B + V_{BE} + \left( \frac{I_C}{\beta} + I_C \right) R_E$$

$$4.21 = \frac{I_C}{66} \times 14.737 \times 10^3 + 0.3 + I_C \left( \frac{1}{66} + 1 \right) \times 2 \times 10^3$$

$$3.91 = I_C (0.223 + 2.03) \times 10^3. \text{ Therefore, } I_C = \frac{3.91}{2.253 \times 10^3} = 1.73\text{mA}$$

Since  $I_B$  is very small  $I_C \approx I_E = 1.73\text{mA}$ , Therefore,  $V_{CE} = V_{CC} - I_C R_C - I_E R_E$

$$= V_{CC} - I_C(R_C - R_E) = 16 - 1.73 \times 10^{-3} \times 5 \times 10^3 = 7.35V$$

Therefore, the coordinates of the operating point are  $I_C = 1.73mA$  and  $V_{CE} = 7.35V$ .

To find the stability factor S.

$$S = (1 + \beta) \frac{1 + \frac{R_B}{R_E}}{1 + \beta + \frac{R_B}{R_E}} = (1 + 66) \frac{1 + \frac{14.737}{2}}{1 + 66 + \frac{14.737}{2}} = 7.537$$

### Problem

Given the following values for a common emitter circuit:  $R_{B1} = 47 \text{ k}\Omega$ ,  $R_L = 10 \text{ k}\Omega$ ,  $R_{B2} = 10 \text{ k}\Omega$ ,  $R_C = 3.3 \text{ k}\Omega$ ,  $R_E = 2 \text{ k}\Omega$ ,  $\beta = 200$ ,  $V_{CC} = 20V$

- (i) Draw d.c and a.c load lines and determine operating point.
- (ii) Determine whether the transistor is operating close to the saturation or cut off.

### Problem

Explain the operation of various biasing methods and their advantages and disadvantages. Use suitable expressions where necessary.

## UNIPOLAR TRANSISTOR / FIELD EFFECT TRANSISTOR

- Generally FET is a 3-terminal unipolar solid state device in which current is controlled by an electric field.
- There are 2 types of FETS
  - Junction FET (JFET).
  - Metal oxide semi-conductor FET (MOSFET).
- Both can either be: P-channel or N-channel

## JUNCTION FIELD EFFECT TRANSISTOR

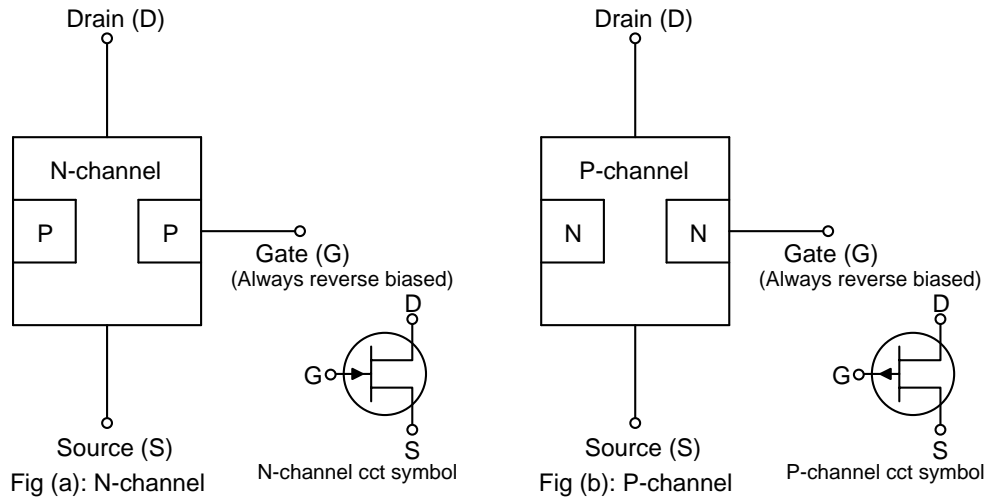

- As an illustration an N-channel is fabricated by diffusing 2-P type junctions on opposite sides of N-type semi-conductor material as shown in fig (a).
- These junctions form 2 PN diodes called gates and the area between them is called a channel.
- The 2 P-type regions are internally connected and a single lead is brought out called the gate terminal.
- Direct connections are made at the two ends of the bar.
- One is called the source terminal (S) and the other drain terminal (D).

### Operation

- The gates are always reverse biased and therefore the gate current  $I_g$  is practically zero.
- The source terminal is always connected to that end of the drain supply which provides the necessary charge carriers.
- As an example an N-channel JEET is discussed when either  $V_{GS}$  or  $V_{DS}$  or both are changed.

a) When  $V_{GS}=V_{DS}=0V$ .

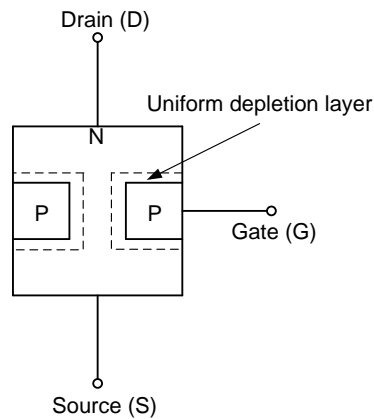

- Since  $V_{DS}=0$  the drain current  $I_D=0$  thus depletion regions around the PN junction are equal in thickness and symmetrical.

**b) When  $V_{GS}=0$  and  $V_{DS}$  is increased from zero.**

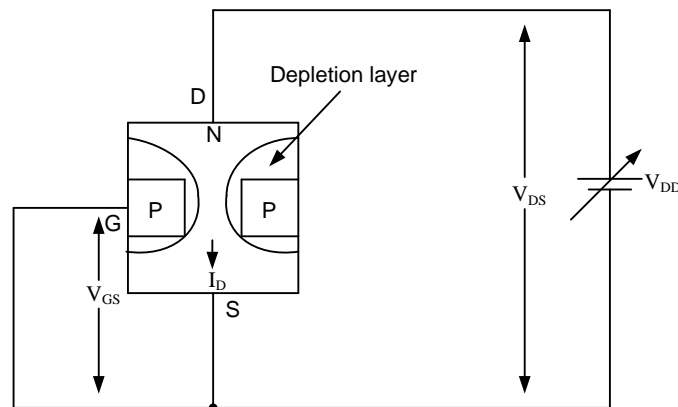

- Electrons which are the majority charge carriers flow through the channel from the source to the drain.
- Due to this flow there is a uniform voltage drop across the channel resistance.
- This voltage drop acts as reverse bias at the gate.
- The gate is more negative with respect to those points which are nearer to the drain than those to source, therefore the depletion regions penetrates more deeply into the channel at points which lie closer to the drain than source.

$$I_D = \frac{V_{DS}}{R_{DS}}$$

As  $V_{DS}$  is increased, the current  $I_D$  increases up to a maximum value  $I_{DSS}$  (saturation current).

- At this stage  $I_D=I_{DSS}$  which is constant.
- Under this condition the channel cross-sectional area becomes minimum and the channel is said to be pinched off and the corresponding value of  $V_{DS}$  is called pinch off voltage ( $V_P$ ).
- In case  $V_{DS}$  is increased beyond this point,  $V_P$ ,  $I_D$  does not increase. It remains constant until the JFET breaks down and  $I_D$  increases to an excessive value.

c) When  $V_{DS}=0$  and  $V_{GS}$  is decreased from zero.

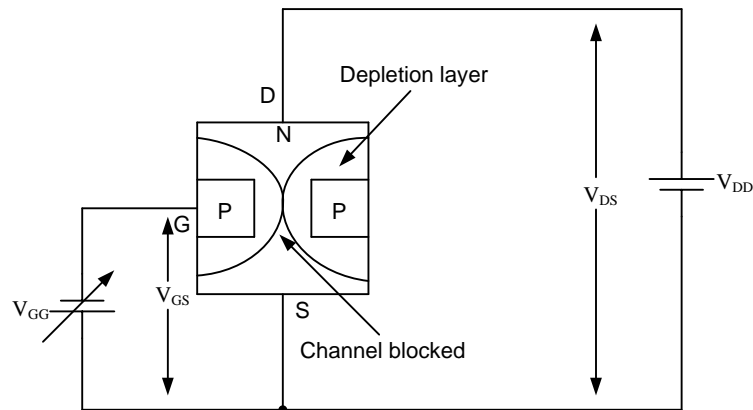

- $V_{GS}$  is made more negative, increasing the gate reverse bias and therefore increasing the thickness of depletion.
- As  $V_{GS}$  is increased to the -ve, a point is reached when the 2 depletion regions touch one another and the channel is cut off.
- This value of  $V_{GS}$  that cuts the channel off is called  $V_{GS(off)}$

d) When  $V_{GS}$  is -ve and  $V_{DS}$  is increased.

- As  $V_{GS}$  is made more -ve, values of  $V_P$  as well as breakdown voltage are decreased.
- N/B: Since the gate voltage controls the main current, JFET is called a voltage controlled device.
- A P-channel JFET operates exactly in the same manner as N-channel except that channel carriers are holes, and the polarities of both  $V_{DD}$  and  $V_{GS}$  are reversed.

### JFET CHARACTERISTICS

1. Drain characteristics
2. Transfer characteristics

#### Drain Characteristics

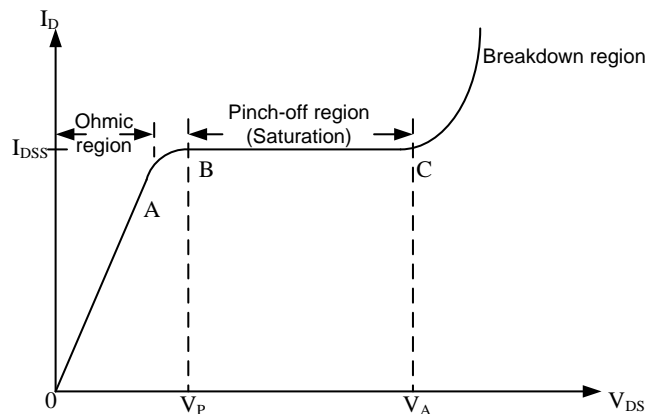

a) **Ohmic Region**

- $I_D$  varies directly with  $V_{DS}$  following ohms law where the transistor behaves like resistor.

b) **Pinch-off / Saturation region**

- This is also called the amplifier region where  $I_D$  is relatively independent of  $V_{DS}$ .



- In this region, the drain current is given by the following equation;

$$I_D = I_{DSS} \left( 1 - \frac{V_{GS}}{V_P} \right)^2$$

$$I_D = I_{DSS} \left( 1 - \frac{V_{GS}}{V_{GS(off)}} \right)^2$$

- A transistor operated in this region is a like a switch which is on.

### c) Breakdown Region

- It is also called the avalanche region.
- $I_D$  increases to an excessive value.

### d) Cut off region

- This is the region where the transistor is not conducting where  $V_{GS} = V_{GS(off)}$ .
- A transistor operated in this region is a like a switch which is off.

## Transfer characteristics

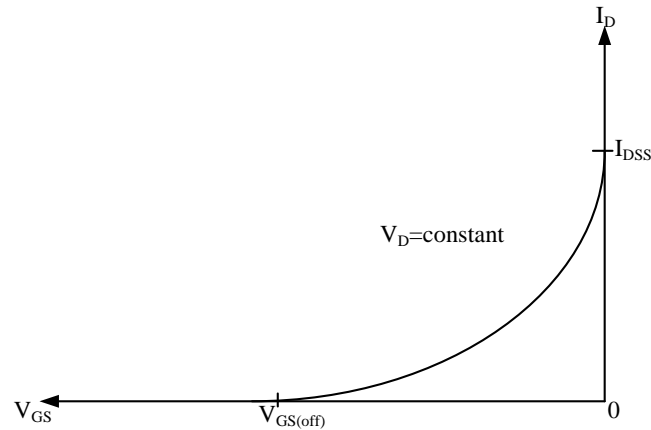

- This shows that when  $V_{GS}=0$ ,  $I_D=I_{DSS}$  and when  $I_D=0$ ,  $V_{GS}=V_{GS(off)}$ .
- The characteristics approximately follows the equation;

$$I_D = I_{DSS} \left( 1 - \frac{V_{GS}}{V_{GS(off)}} \right)^2$$

## MOSFET OR IGFET (insulated Gate FET)

- There are 2 types and are given by depletion enhancement MOSFET (DE) and enhancement only MOSFET.

### DE MOSFET

- It is called so because it can be operated both in depletion mode and enhancement mode by changing the polarity of  $V_{GS}$ .

## Construction

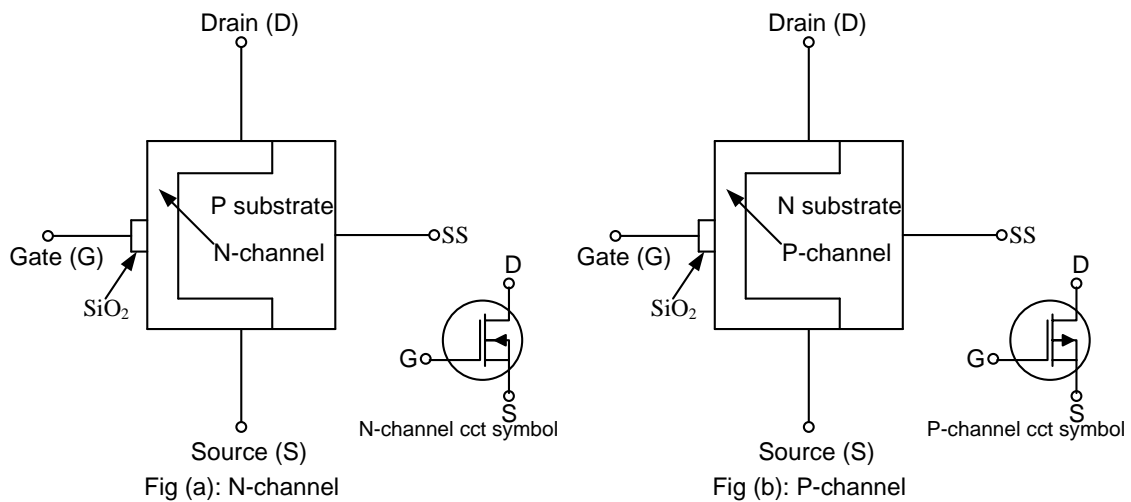

- As shown the gate is insulated from its conducting channel by an ultra thin metal oxide insulating film of silicon dioxide.
- The MOSFET is different from JFET in that the gate voltage that controls  $I_D$  can both be +ve and -ve unlike the JFET which is always reverse biased.
- Silicon dioxide and the channel form a parallel plate capacitor.

## Operation

### a) Depletion mode of N-channel (DE MOSFET)

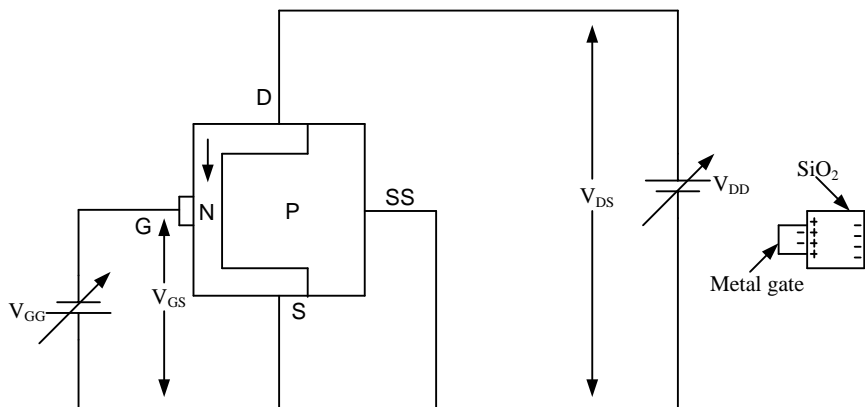

- When  $V_{GS}=0$  electrons flow from the source to the drain through the conducting channel.
- When the gate has -ve voltage, it depletes the N-channel off its electrons by inducing +ve charge in it; therefore the greater the -ve voltage on the gate, the greater is the reduction of electrons in the channel and therefore less conductivity.
- Too much of -ve voltage i.e.  $V_{GS}$  can cut off the channel and this voltage is called  $V_{GS}$  (off).

## b) Enhancement mode of the N-channel

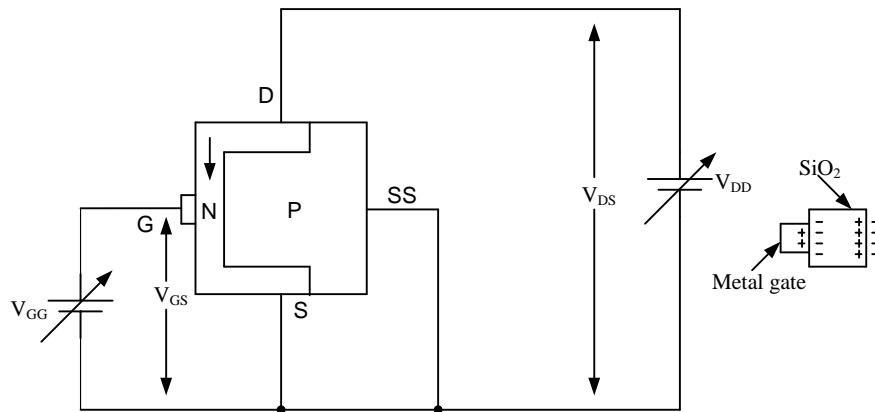

- When +ve voltage is applied to the gate the input gate capacitor creates free electrons in the channel which increases  $I_D$ .
- This increased number of electrons increases or enhances the conductivity of the channel.
- As the +ve gate voltage is increased, conductivity of source to drain is increased and therefore the current flowing increases.

## Characteristics of a DEMOSFET

### a) Static characteristics

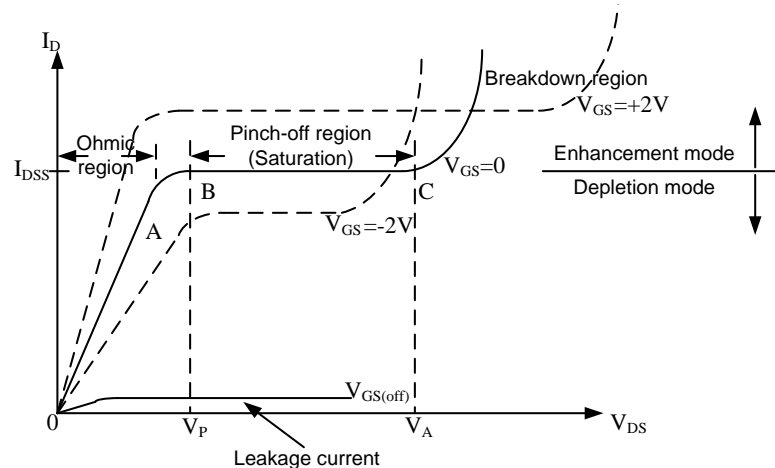

- It acts in the enhancement mode when the gate is +ve with respect to the source and in the depletion mode when the gate is -ve.

## b) Transfer characteristic

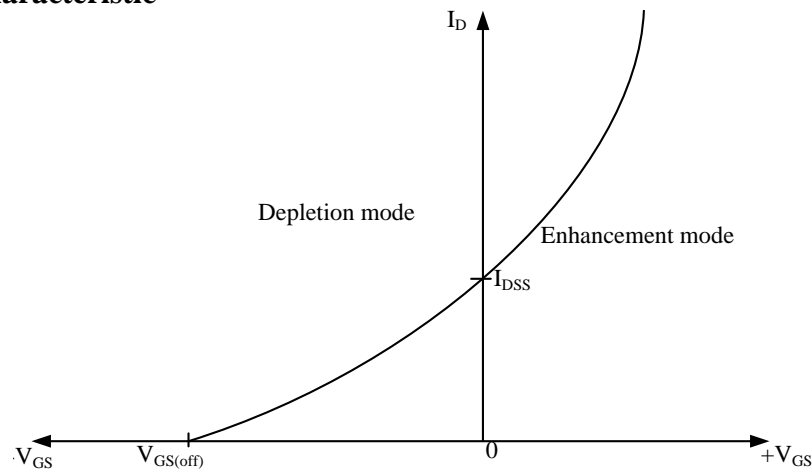

- For a given  $V_{DS}$ ,  $I_D$  flows even when  $V_{GS}=0$  but keeping  $V_{DS}$  constant as  $V_{GS}$  is made more -ve,  $I_D$  decreases till it becomes zero at  $V_{GS}=V_{GS(off)}$ .
- When used in the enhancement mode,  $I_D$  increases as  $V_{GS}$  is increased +vely.

## ENHANCEMENT ONLY N-CHANNEL MOSEFET (NMOS)

### Construction

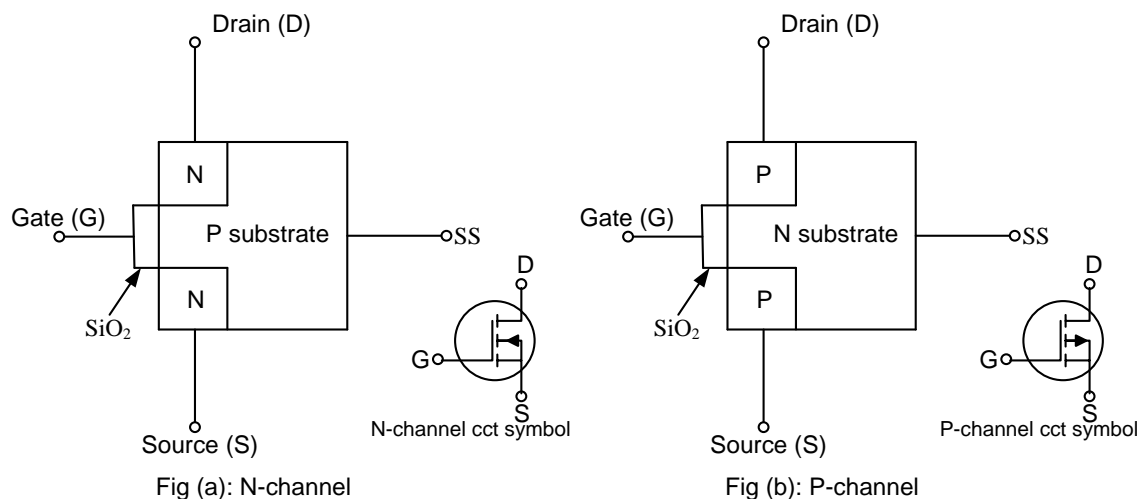

- There is a channel between the source and the drain which has a P substrate cutting into it.
- It operates with the +ve gates only.

### Operation

- When  $V_{GS} = 0$ ,  $I_D$  is non-existent.
- For  $I_D$  to flow a significant +ve gate voltage must be applied.
- This voltage produces a thin layer of electrons close to the metal oxide film which stretches from the source to the drain.
- This thin layer provides the channel with electrons hence N-types material referred to as N-type inversion layer or a virtual N-channel.

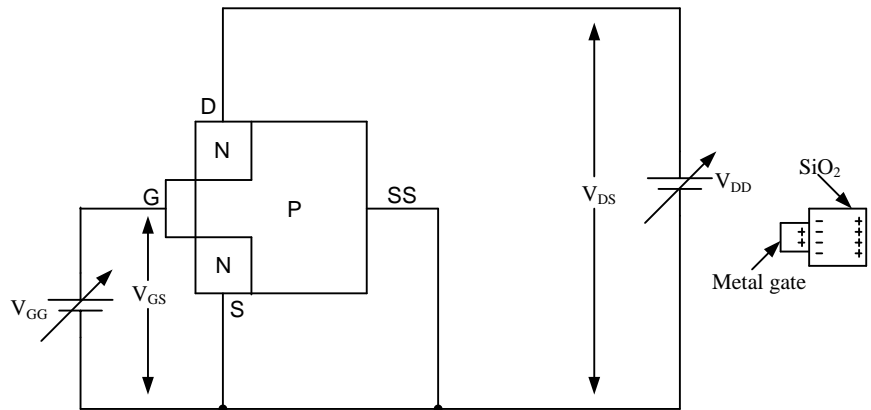

- The minimum gate source voltage which produces the N-type inversion layer is called threshold voltage  $V_{GS(th)}$ .
- For a given  $V_{DS}$  as  $V_{GS}$  is increased, the virtual channel deepens and  $I_D$  increases therefore;

$$I_D = K(V_{GS} - V_{GS(th)})^2$$

Where k is constant which depends on a particular MOSFET.

### Characteristics of an N-channel enhancement only MOSFET

#### a) Static characteristics.

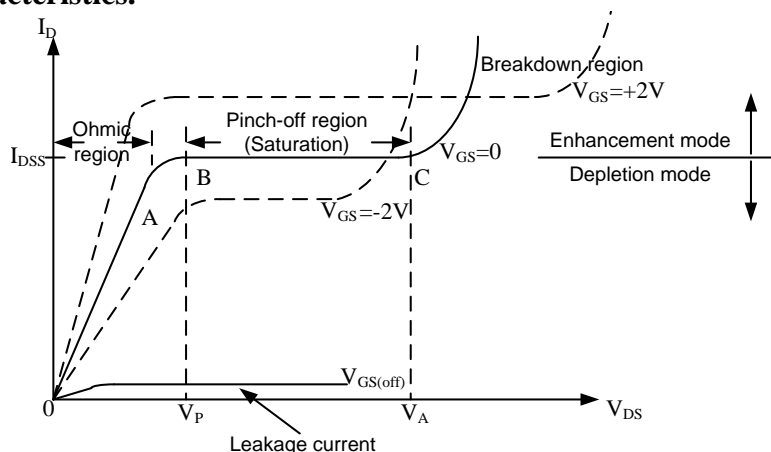

- Electrons which are the majority charge carriers flow through the channel from the source to the drain.
- Due to this flow there is a uniform voltage drop across the channel resistance.
- This voltage drop acts as reverse bias at the gate.
- The gate is more negative with respect to those points which are nearer to the drain than those to source, therefore the depletion regions penetrates more deeply into the channel at points which lie closer to the drain than source.

- $I_D = \frac{V_{DS}}{R_{DS}}$

- As  $V_{DS}$  is increased, the current  $I_D$  increases up to a maximum value  $I_{DSS}$  (saturation current).
- At this stage  $I_D = I_{DSS}$  which is constant.
- Under this condition the channel cross-sectional area becomes minimum and the channel is said to be pinched off and the corresponding value of  $V_{DS}$  is called pinch off voltage ( $V_P$ ).

- In case  $V_{DS}$  is increased beyond this point,  $V_P$ ,  $I_D$  does not increase. It remains constant until the JFET breaks down and  $I_D$  increases to an excessive value.

### b) Transfer characteristic.

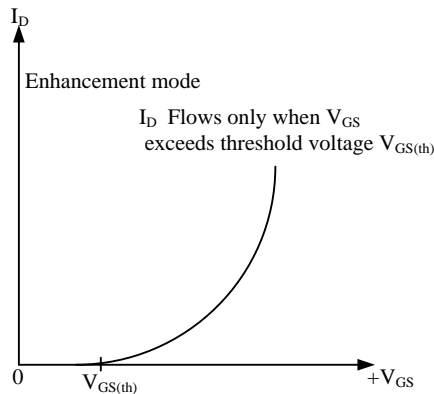

- For  $I_D$  to flow a significant +ve gate voltage must be applied.
- It starts conducting at  $V_{GS}=V_{GS(th)}$ .
- As  $V_{GS}$  is increased further there is a corresponding increment of  $I_D$ . This increment follows the following formula.

$$I_D = K(V_{GS} - V_{GS(th)})^2$$

Where  $k$  is constant which depends on a particular MOSFET.

### Parameters considered when purchasing JFET(s)

- The gate source breakdown voltage.
- The gate reverse leakage current.
- The gate source cut-off voltage.
- The drain current at zero gate voltage.
- The forward trans-conductance.
- The input capacitance.
- The switching consideration.
- The drain source on resistance.
- Power rating.

### Parameters considered when purchasing MOSEFET(s)

- Breakdown voltage.
- Forward trans-conductance.
- Drain source on resistance.
- Switching characteristics.
- Zero gate voltage drain current.
- Input capacitance.

### BIASING OF FETS

#### JFET (DC Biasing)

- It can be biased using either;
  - Separate power source  $V_{GG}$ .
  - Some form of self biasing.
  - Source biasing.
  - Voltage divider bias.

a) A separate power source  $V_{GG}$ .

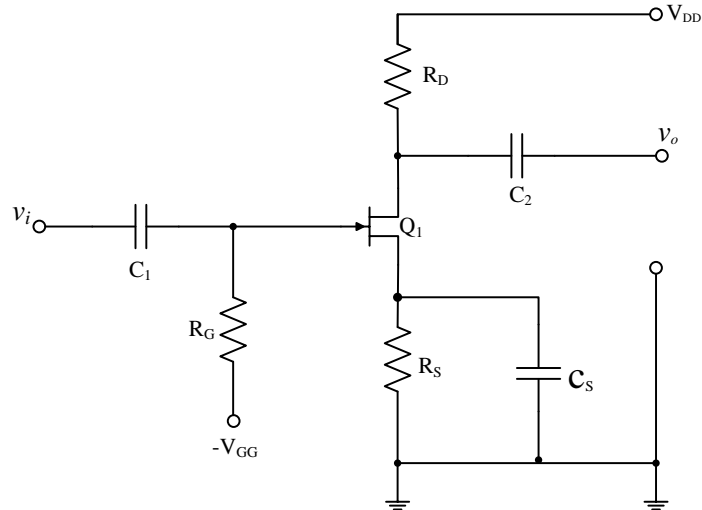

$$V_{DD} = I_D R_D + V_{DS} + I_S R_S$$

$$V_{GG} = I_G R_G + V_{GS} + I_S R_S$$

$$V_{GG} = V_{GS} + I_S R_S \text{ since } I_G \approx 0$$

b) Self biasing

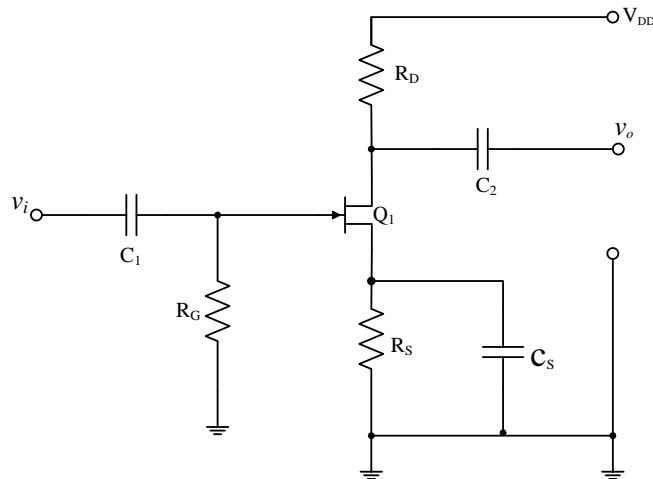

$$V_{DD} = I_D R_D + V_{DS} + I_S R_S$$

$$V_S = I_S R_S$$

$$V_D = V_{DD} - I_D R_D \text{ or } V_{DS} + I_S R_S$$

$$I_G R_G + V_{GS} + I_S R_S = 0$$

$$V_{GS} = -I_S R_S \text{ since } I_G \approx 0$$

- $V_{GS}$  bias is obtained from the flow of drain current  $I_D$  through  $R_S$  and  $V_S = I_S R_S$  and  $V_{GS} = -I_S R_S$ .
- The gate is kept at this much -ve potential (voltage) with respect to the ground.
- Addition of  $R_G$  does not upset this d.c bias because no gate current flows through it apart from the gate leakage current.
- Without  $R_G$  the gate would be floating which would collect some charge and cut off the JFET.
- Also  $R_G$  serves the purpose of avoiding short circuiting of the a.c input voltage  $V_{in}$ .

**c) Source Biasing**

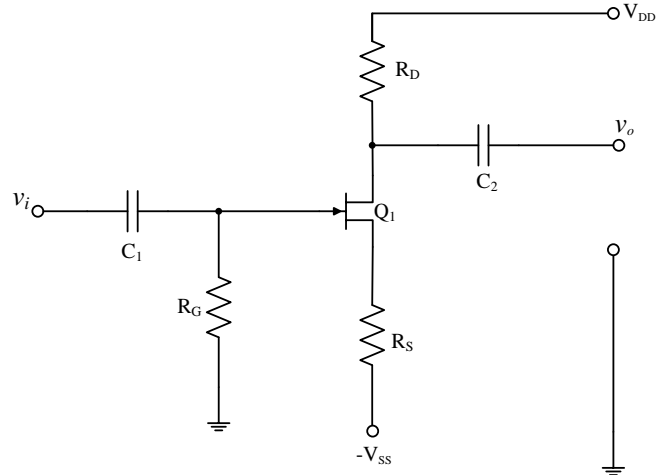

$$V_D = V_{DD} - I_D R_D$$

$$V_{SS} = I_G R_G + V_{GS} + I_S R_S$$

$$V_{SS} = V_{GS} + I_S R_S \text{ since } I_G \approx 0$$

**d) Voltage divider biasing**

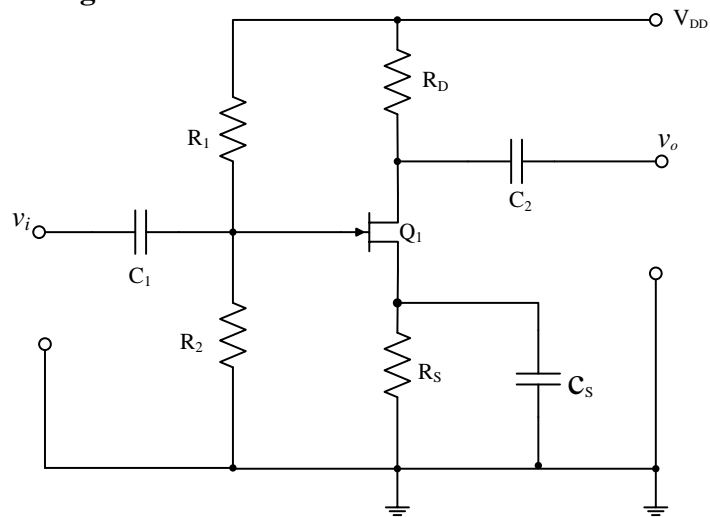

$$V_{DD} = V_{R_2} + V_{R_1}$$

$$V_{DD} = I_D R_D + V_{DS} + I_S R_S$$

$$V_{R_2} = \frac{V_{DD}}{R_1 + R_2} \times R_2$$

$$V_{R_2} = V_{GS} + I_D R_S$$



### Example

Find the values of  $V_{DS}$  in the circuit below if  $I_D=4\text{mA}$ ,  $V_{DD}=12\text{V}$ ,  $R_D=1\text{k}\Omega$  and  $R_S=500\Omega$ .

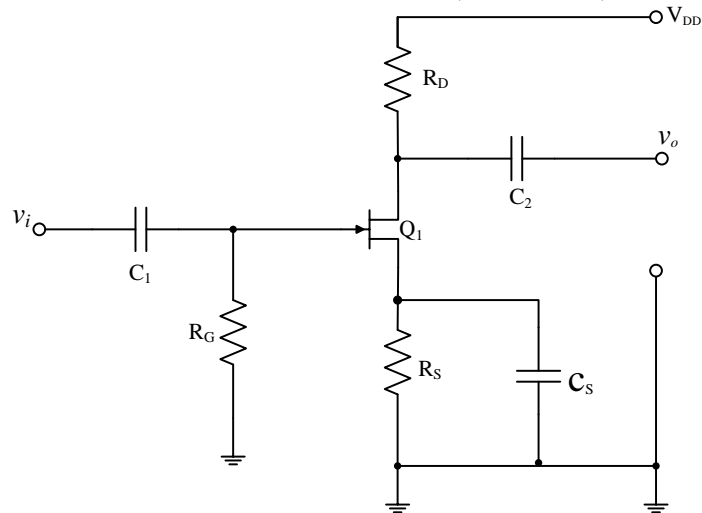

$$V_S = I_S R_S = 4 \times 10^{-3} \times 500 = 2\text{V}$$

$$V_D = V_{DD} - I_D R_D$$

$$V_D = 12 - 1.5 \times 10^{-3} \times 4 \times 10^{-3} = 6\text{V}$$

$$V_{DS} = V_D - V_S = 6 - 2 = 4\text{V}$$

### Example

In the amplifier given in the figure below  $V_{DD}=20\text{V}$ ,  $R_1=15.7\text{M}\Omega$ ,  $R_2=1\text{M}\Omega$ ,  $R_D=3\text{k}\Omega$ ,  $R_S=2\text{k}\Omega$  and  $I_{DQ}=1.5\text{mA}$ . Calculate  $V_{GSQ}$  and  $V_{DSQ}$ .

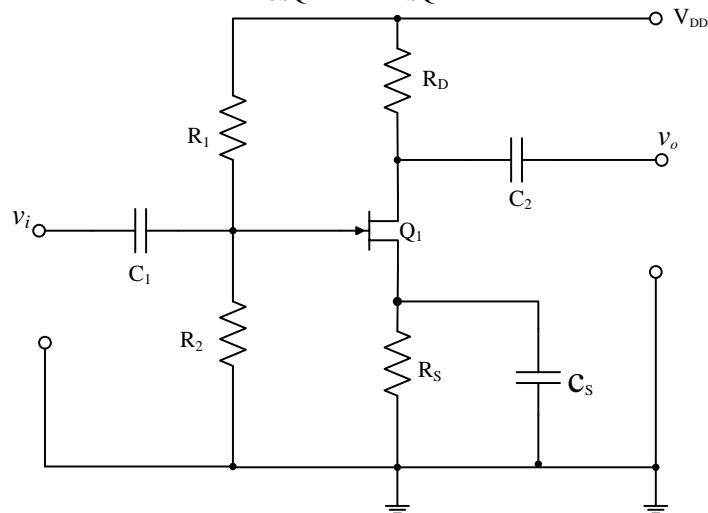

$$V_{R_2} = \frac{V_{DD}}{R_1 + R_2} \times R_2 = \frac{20}{15.7 + 1} \times 1 = 1.2\text{V}$$

$$V_{R_2} = V_{GSQ} + I_D R_S$$

$$V_{GSQ} = V_{R_2} - I_D R_S = 1.2 - 1.5 \times 10^{-3} \times 2 \times 10^3 = -1.8\text{V}$$

$$V_D = V_{DD} - I_D R_D = 20 - 1.5 \times 10^{-3} \times 3 \times 10^3 = 15.5\text{V}$$

$$V_S = I_S R_S = 1.5 \times 10^{-3} \times 2 \times 10^3 = 3\text{V}$$

$$V_{DS} = V_D - V_S = 15.5 - 3 = 12.5\text{V}$$

## BIASING OF E-ONLY MOSFETS

### a) Drain Feedback Bias.

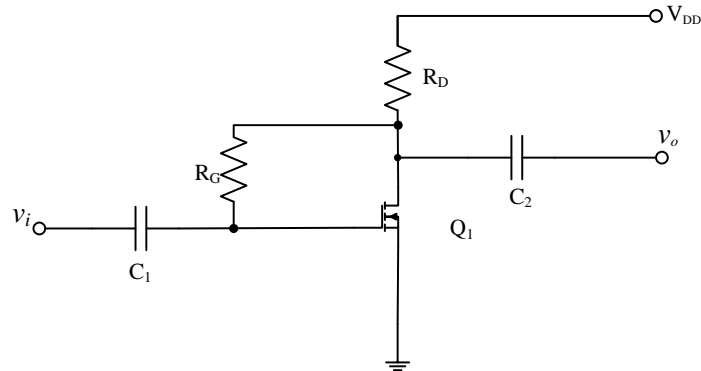

$$V_{GS} = -V_{DS}$$

$$V_D = V_{DD} - I_D R_D = V_{DS}$$

### b) Voltage Divider Bias.

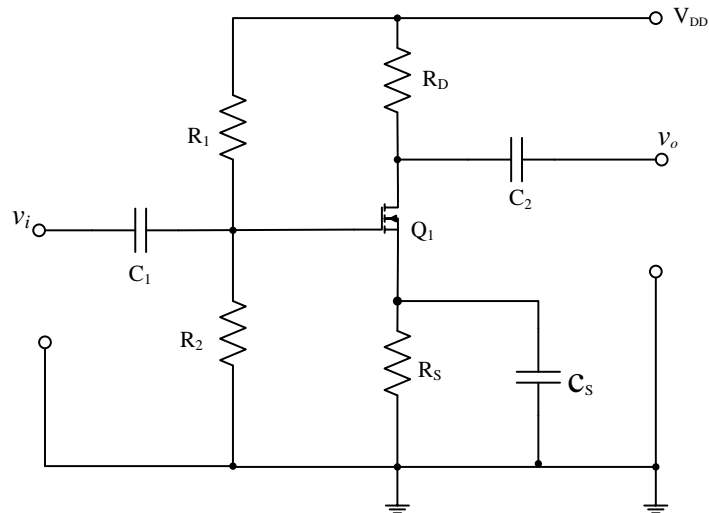

$$V_{DD} = V_{R_2} + V_{R_1}$$

$$V_{DD} = I_D R_D + V_{DS} + I_S R_S$$

$$V_{R_2} = \frac{V_{DD}}{R_1 + R_2} \times R_2$$

$$V_{R_2} = V_{GS} + I_D R_S$$

- Since for this MOSFET  $V_{GS}$  must be greater than  $V_{GS(th)}$ , it can be biased only in 2 ways i.e. drain feedback bias and voltage divider bias.
- For both cases, the gate voltage is made more +ve than the source by an amount greater than  $V_{GS(th)}$ .

### Example

For the E-MOSFET amplifier given above (voltage divider bias)  $I_D=4\text{mA}$ ,  $V_{GS}=10\text{V}$ ,  $R_1=6\text{k}\Omega$ ,  $R_2=9\text{k}\Omega$ ,  $R_D=1\text{k}\Omega$ ,  $R_S=0\Omega$ ,  $V_{DD}=25\text{V}$  and  $V_{GS(th)}=5\text{V}$ . Calculate  $V_{GS}$  and  $V_{DS}$  for the circuit.

$$V_{R_2} = \frac{V_{DD}}{R_1 + R_2} \times R_2 = \frac{25}{9 + 6} \times 9 = 15V$$

$$V_{R_2} = V_{GS} = 15V$$

$$K = \frac{I_D}{(V_{GS} - V_{GS(th)})^2} = \frac{4 \times 10^{-3}}{(10 - 5)^2} = 0.16mA/V^2$$

$$I_D = 0.16(15 - 5)^2 = 16mA$$

$$V_{DS} = V_{DD} - I_S R_S = 25 - 16 \times 10^{-3} \times 1 \times 10^3 = 9V$$

### Exercise

An N-channel E-MOSFET has the following parameters:  $I_{D\text{ on}}=4\text{mA}$  at  $V_{GS}=10\text{V}$  and  $V_{GS(\text{off})}=5\text{V}$ . Calculate the  $I_D$  for  $V_{GS}=8\text{V}$ . Ans.  $1.44\text{mA}$ .

### FET AMPLIFIERS DE MOSFET Amplifier

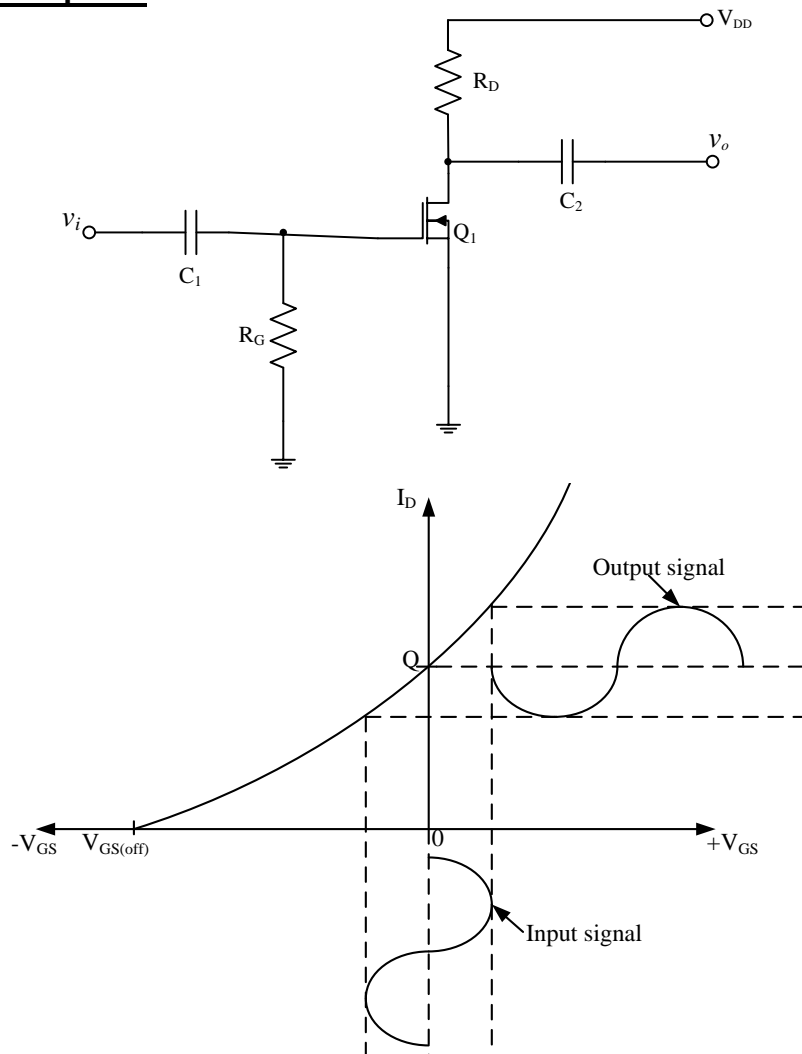

- A zero biased N-channel DEMOSFET with an a.c source capacitor coupled to the gate is given above.
- The input a.c  $V_{in}$  causes  $V_{GS}$  to swing above and below its zero value therefore producing a swing in  $I_D$ .

- The -ve swing in  $V_{GS}$  produces depletion and  $I_D$  is decreased.
- A +ve swing in  $V_{GS}$  produces enhancement mode making  $I_D$  to increase.

### E-MOSFET Amplifier

- The gate is biased with a +ve voltage such that  $V_{GS}$  is more than  $V_{GS(th)}$ .
- The signal voltage produces a swing in  $V_{GS}$  below and above its Q point value.
- This in turn causes a swing in  $I_D$  and hence in  $I_D R_D$ .

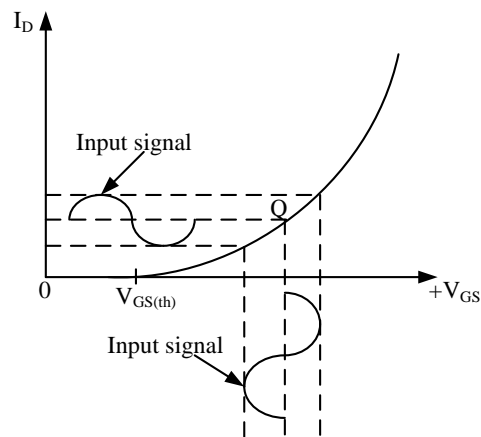
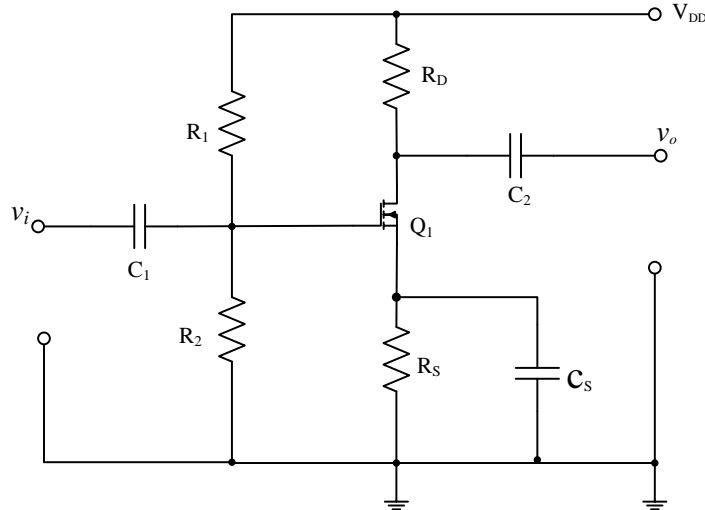

### FET CONFIGURATIONS

#### Common Source (CS)

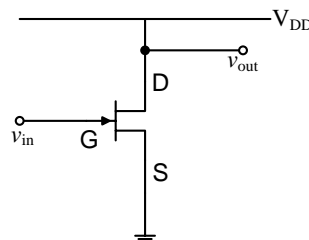

#### **Input parameters**

- Input voltage =  $V_{GS}$
- Input current =  $I_G$
- Input impedance =  $V_{GS}/I_G$
- Input power =  $I_G V_{GS}$

### Output Parameters

- Output voltage= $V_{DS}$
- Output current= $I_D$
- Output impedance= $V_{DS}/I_D$
- Output power= $I_D V_{DS}$
  
- Current gain = $I_D/I_G$
- Voltage gain = $V_{DS}/V_{GS}$

### Common Drain (CD)

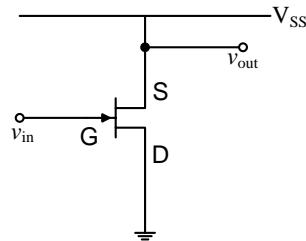

### Input parameters

- Input voltage= $V_{DG}$
- Input current= $I_G$
- Input impedance  $V_{DG}/I_G$
- Input power= $I_G V_{DG}$

### Output Parameters

- Output voltage= $V_{DS}$
- Output current= $I_S$
- Output impedance= $V_{DS}/I_S$
- Output power= $I_S V_{DS}$
  
- Current gain = $I_S/I_G$
- Voltage gain = $V_{DS}/V_{DG}$

### Common Gate (CG)

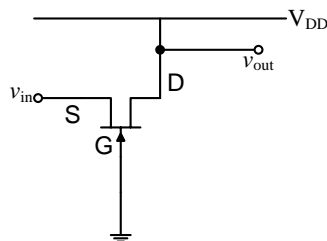

### Input parameters

- Input voltage= $V_{GS}$
- Input current= $I_S$
- Input impedance  $V_{GS}/I_S$
- Input power= $I_S V_{GS}$

### Output Parameters

- Output voltage= $V_{DG}$
- Output current= $I_D$

- Output impedance =  $V_{DG}/I_D$
- Output power =  $I_D V_{DG}$
- Current gain =  $I_D/I_S$
- Voltage gain =  $V_{DG}/V_{GS}$

### Applications of FETS(s)

- Input amplifiers in oscilloscopes, electronic voltmeters and other measuring and testing equipment because of the very high  $R_{in}$  (input resistance), which reduces the loading effect to the minimum.
- Logic circuits where it is kept off when there is a zero input while it is turned on with very little power input e.g. OR, NAND, AND & NOR gates.
- Mixer operations of FM and T.V receivers.
- Voltage variable resistors in operational amplifiers (OP-AMPS).
- Large scale integration IC's and computer memories because they come in small sizes.

### SILICON CONTROLLED RECTIFIER (SCR) (THYRISTOR)

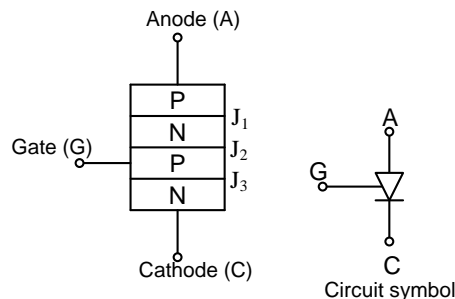

- It is a 4 layer P-N-P-N device which is basically a rectifier with a controller element.
- It consists of 3 diodes connected back to back with a gate connection.

### Construction

- It is a 3 terminal 4 layer transistor with the layers being alternately of P-type and N-type silicon.
- It has 3 junctions  $J_1$ ,  $J_2$  and  $J_3$  and the 3 terminals are given by the anode, cathode and the gate.
- The function of the gate is to control the firing of the SCR.

### Biasing

- With the polarity of the source as shown in (a)  $J_1$  and  $J_3$  are forward biased while  $J_2$  is reverse biased hence no current except leakage current flows through the SCR.
- With polarity as shown in (b)  $J_1$  and  $J_3$  are reverse biased while  $J_2$  forward biased. Again no current flows through the SCR.
- However if the anode voltage in (a) is increased to a critical value called the forward break-over voltage  $V_{BO}$  is reached when  $J_2$  breaks down and SCR suddenly switches to a highly conducting state.

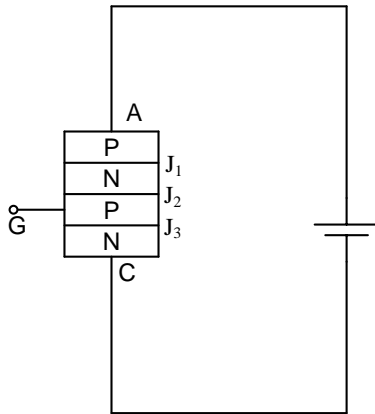

Fig. (a)

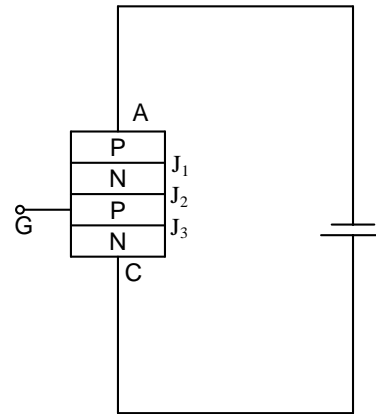
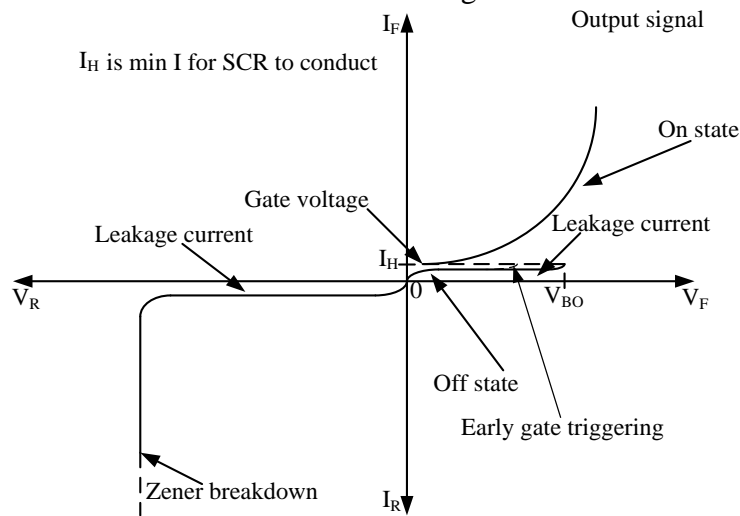

Fig. (b)

- Conduction can also be achieved by connecting the gate to a given voltage which forward biases  $J_2$ .
- In this condition the SCR has little forward resistance of the range  $0.1$  to  $1.2\Omega$  and the voltage drop across it is very low, about  $1V$ .
- For the case of (b) where the current flow is blocked by the 2 reverse biased junctions, when  $V$  is increased, a point is reached when zener breakdown occurs which may destroy the SCR.
- Therefore the SCR is a unidirectional device.
- This can be shown in the characteristics curve given below:-



### Two transistor analogy

- Its operation can be described using 2 transistor analogy therefore the SCR can be split into 2 three-layers as shown in (a) and represented using transistors as shown in (b).
- From (b) it can be noted that:  
The collector current of  $Q_1$  is also the base current of  $Q_2$  and the base current of  $Q_1$  is the collector current of  $Q_2$ .

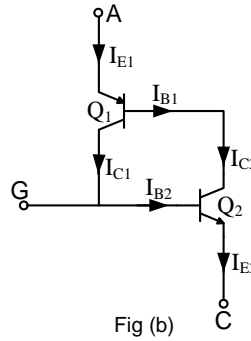
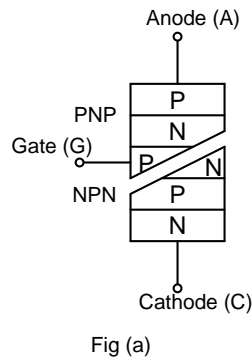

- If the voltage applied across A and C is increased such that  $J_2$  breaks down then the current through the device rises and therefore  $I_{E1}$  begins to increase and then;
  - $I_{C1}$  increases.
  - Since  $I_{C1} = I_{B2}$ ,  $I_{B2}$  also increases.
  - Therefore  $I_{C2}$  increases.
  - $I_{C2} = I_{B1}$  hence  $I_{B1}$  increases.
  - Consequently both  $I_{C1}$  and  $I_{E1}$  increase, therefore a regenerative action occurs whereby an initial increment in current produces further increase in the same current. Soon a maximum current is reached limited by external resistance.
  - The 2 transistors are fully turned on and the voltage across them falls to very low values.
- The typical turn on time is 0.1 to 1.0  $\mu$ s.

### Firing and triggering of SCR

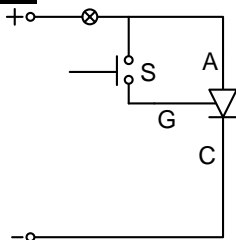

(a) dc firing circuit

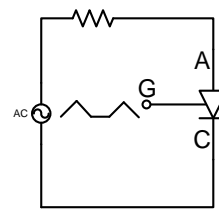

(b) pulse signal circuit

- It is operated normally with anode voltage slightly less than  $V_{BO}$  forward break- over voltage and is triggered into conduction by a low power gate pulse.
- Once it's on the gate has no control on the device current.
- This gate signal can be a d.c firing signal or a pulse signal.
- For (a) when the switch is open the SCR does not conduct and the lamp is off. When the switch is closed, a +ve voltage is applied to the gate which forward biases the centre the centre PN junction and the SCR is made to conduct and the lamp is on.
- The SCR remains in the conduction state until the supply voltage is removed
- Once fired the SCR remains on even when the triggering pulse is removed, therefore a number of techniques are used to turn it off and they are given by:-
  - Anode current interruption.
  - Reversing the polarity of anode-cathode voltage.
  - Reducing current through the SCR below the holding current  $I_H$  and this is referred to as low current drop out.

### Applications

- Power control.



- Relay controls.
- Regulated power suppliers.
- Static switches.
- Motor control.
- Invertors.
- Battery charges.
- Heater controls.
- Phase controls.

### **Phase control**

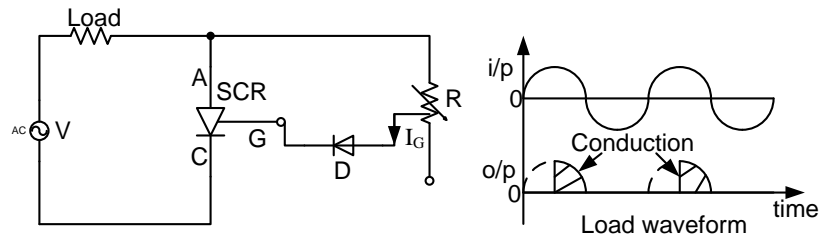

- The gate triggering is driven from the supply. The variable resistor R limits the gate current during the +ve half cycle of the supply.
- If R is set to a low value, the SCR will trigger almost immediately at the beginning of the +ve half cycle of the input.
- But if R is set to high resistance, the SCR may not switch on until the peak of the +ve half cycle.
- By adjusting R between the two extremes, the SCR is made to switch on somewhere between the beginning and peak of the positive half cycle between 0 and 90°.
- N/B: If  $I_G$  is not enough to trigger the SCR at 90°, then the device will not trigger at all.
- The diode D is used to protect the gate from -ve voltage which would otherwise be applied to it during the -ve half cycle.
- Therefore at the instant SCR switch on:

$$R = \frac{V - V_D - V_G - I_G R_L}{I_G}$$

### **Exercise**

- The circuit for phase control is connected to an a.c. supply  $V=50 \sin \theta^\circ$ ,  $R_L=50\Omega$  the gate current  $I_G=100\mu A$  and  $V_G=0.5V$ . Determine the range of adjustment of R for the SCR to be triggered between 30° between 90°; take  $V_D=0.7V$ .

$$R = \frac{V - V_D - V_G - I_G R_L}{I_G}$$

$$R = \frac{50 \sin 30 - 0.7 - 0.5 - (100 \times 10^{-6} \times 50)}{100 \times 10^{-6}}$$

$$R = 237950 = 238k\Omega$$

$$R = \frac{50 \sin 90 - 0.7 - 0.5 - (100 \times 10^{-6} \times 50)}{100 \times 10^{-6}}$$

$$R = 487950 = 488k\Omega$$

## Major considerations when ordering for SCR

- The peak forward and reverse breakdown voltages.
- Maximum forward current.
- Gate trigger voltage and current.
- Minimum holding current  $I_H$ .
- Power dissipation.
- Maximum change of voltage time  $dv/dt$  (switching).

## TRIAC (TRIODE A. C.)

### Construction

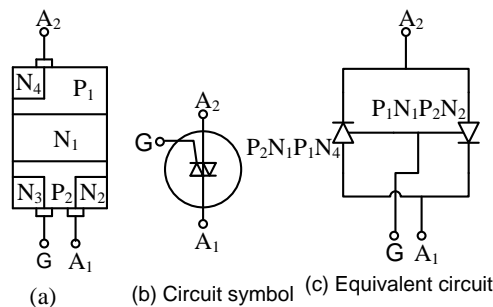

- It's a 5 layer bi-directional device which can be triggered into conduction by both +ve and -ve voltages at its anode and with both the +ve and -ve triggering pulses at the gates.
- It behaves like 2 SCR's connected in parallel upside down with respect to each other.

### Operation

#### a) When $A_2$ is +ve:

- The current flows from  $P_1N_1P_2N_2$ .
- The 2 junctions  $P_1N_1$  and  $P_2N_2$  are forward biased whereas  $N_1P_2$  junction is reverse biased.
- The gate can be either +vely or -vely biased to turn on the triac as follows:
  - +ve gate with respect to  $A_1$  forward biases the  $P_2N_2$  junction and breakdown occurs as in normal SCR.
  - -ve gate forward biases  $P_2N_3$  junction and current carriers injected into  $P_2$  turn on the triac.

#### b) When $A_1$ is +ve:

- Current flows from  $P_2N_1P_1N_4$
- 2 junctions  $P_2N_1$  and  $P_1N_4$  are forward biased whereas  $N_1P_1$  is reverse biased
- As earlier, conduction can be achieved by applying a +ve or -ve voltage to the gate as follows:
  - A +ve gate with respect to  $A_1$  injects current carriers by forward biasing  $P_2N_2$  junction and therefore initiates conduction.
  - A -ve gate injects current carriers by forward biasing  $P_2N_3$  junction thereby triggering conduction.

### VI Characteristics

- It shows that a triac has same forward blocking and forward conducting characteristics as an SCR but for either polarity of voltage applied to the main terminal.

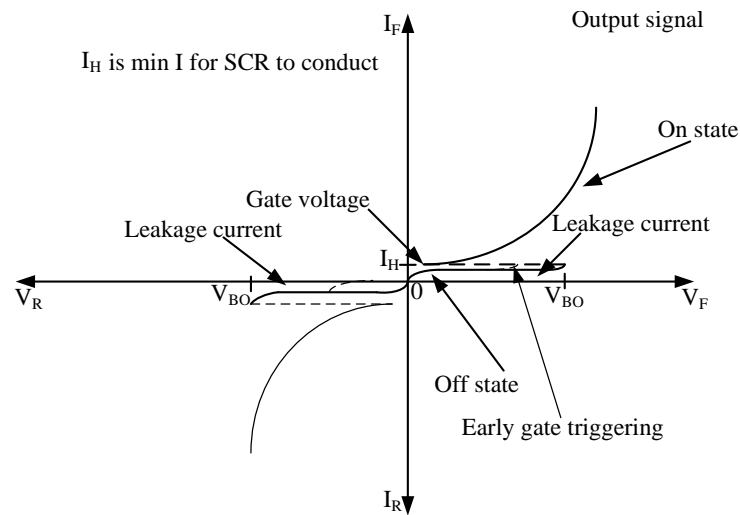

### Applications

- It can be used to control a.c. power to a load by switching on and off during the +ve and -ve half cycles.

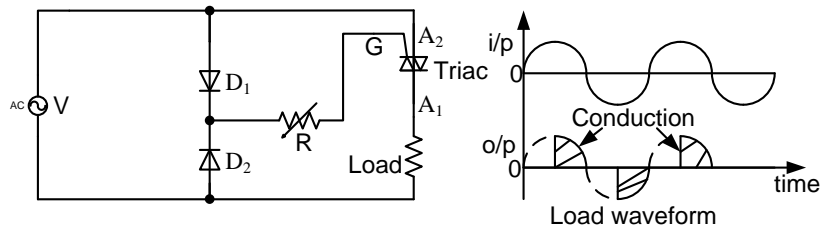

- During the +ve  $\frac{1}{2}$  cycle the input, diode  $D_1$  is forward biased,  $D_2$  is reverse biased and the gate is +ve with respect to  $A_1$ .
  - By adjusting  $R$ , the point at which conduction starts can be varied i.e from  $0$  to  $90^\circ$ .
  - It can be used as a static switch to turn a.c power on and off.
  - Minimizing radio interferences.
  - Light control.
  - Motor speed control.
- N/B: The only disadvantage of a triac is that it takes longer time to recover from off state hence its use is limited to a.c supply frequencies of up to 400Hz.

### Major considerations when ordering triacs.

- Break over voltage.
- Switching speed.
- Voltage symmetry.
- Maximum change of voltage with time.
- Break back voltage.
- Maximum current.
- Break over current / holding current (min).
- Power dissipation.

## DIAC (DIODE AC)

### Construction

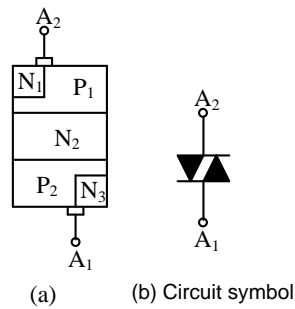

- It can breakdown in either direction.
- It has only 2 terminals and is like a triac without its gate.
- When anode  $A_1$  is +ve the current path is  $P_2N_2P_1N_1$ .
- Similarly when  $A_2$  is +ve the current path is  $P_1N_2P_2N_3$ .
- A diac is designed to trigger triacs or provide protection against over voltage.
- Its operation can be visualized as 2 diodes connected on series.
- Voltage applied across it in either direction turns on one diode and reverse biases the other, hence it can be switched from off to on state for either polarity of the applied voltage.
- The symmetrical by directional switching characteristics are given below:-

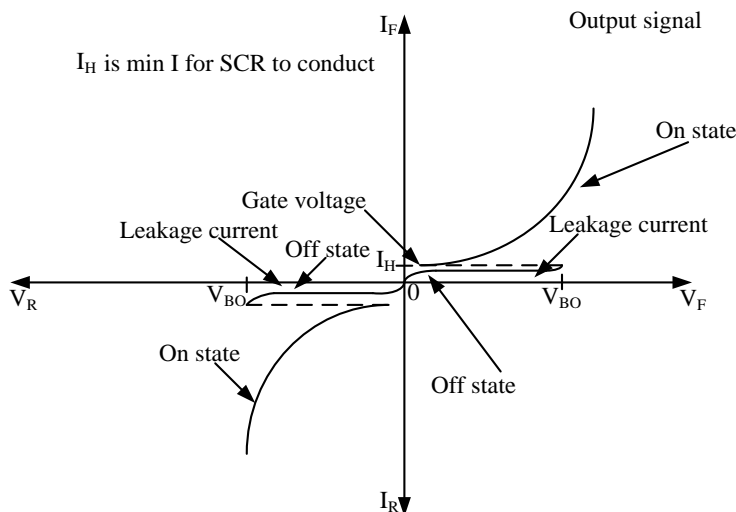

### Considerations

- Break over voltage (typically from 20-40V).
- Voltage symmetry.
- Break back voltages.
- Break over current (typically from 50-200 $\mu$ A).
- Power dissipation.

## SILICON CONTROLLED SWITCH

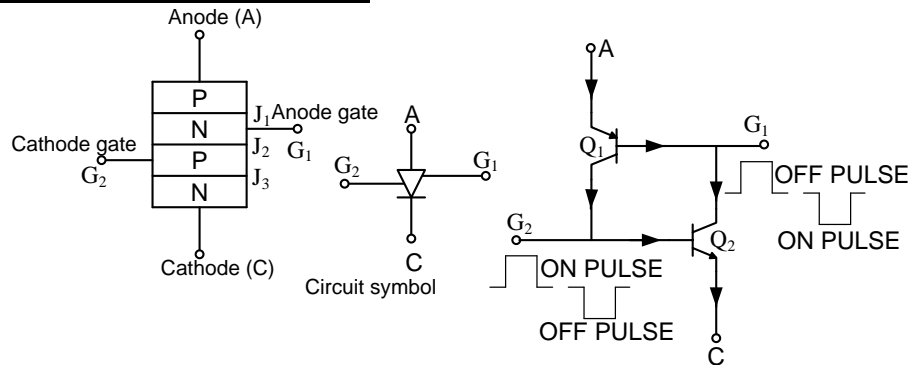

- It is a 4 layer 4 terminal PNP device having anode A cathode C, anode gate G<sub>1</sub> and Cathode gate G<sub>2</sub> as shown in figure above.
- It is a low current SCR with 2 gate terminals.
- The 2 transistor equivalent circuit is shown above.
- The device may be switched on or off by a suitable pulse applied at the gate.
- As shown a -ve pulse is required at the anode gate G<sub>1</sub> to turn the device on whereas a +ve pulse is required to turn it off.
- Similarly at cathode gate G<sub>2</sub> a -ve pulse is required to switch it off and a +ve pulse to turn it on.
- When a +ve pulse is applied to G<sub>1</sub> it forward biases Q<sub>1</sub> which is turned on.
- The resulting heavy collector current I<sub>C</sub> being the base current of Q<sub>2</sub> turns it on hence the SCS is switched on.
- A +ve pulse at G<sub>1</sub> will reverse bias EB junction Q<sub>1</sub> thereby switching the SCS off.

### V/I Characteristics

- They are essentially the same as those of SCR.
- As compared to SCR, an SCS has much reduced turn off time.
- Moreover it has higher controlled and triggering sensitivity and a more predictable firing situation.

### Applications

- It can be used in counter registers and timing circuits of computers.
- Pulse generators to generate pulses.
- Voltage sensors.
- Oscillators.

## OPERATIONAL AMPLIFIERS (OP-AMP)

- An OP-AMP is a very high-gain, high input resistance directly-coupled negative-feedback amplifier which can amplify signals having frequency ranging from 0Hz to 1MHz.
- It's named so because it was originally designed to perform mathematical operations such as summation, subtraction, multiplication, differentiation and integration.

### Op-Amp symbol

- The standard symbol is as shown in the figure below;
- The Op-amp's input can be single-ended or double-ended (or differential input) depending on whether input voltage is applied to one input terminal only or to both.
- Similarly, output can also be either single-ended or double-ended. But the most common configuration is two input terminals and a single output.
- All Op-amps have minimum of 5 terminals;
  - Inverting input terminal
  - Non-inverting input terminal
  - Output terminal
  - Positive bias supply terminal
  - Negative bias supply terminal

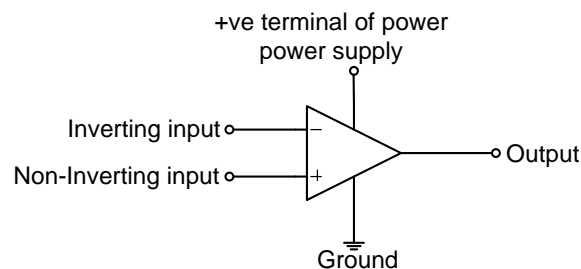

### Polarity convention

- In the figure above, input terminals are marked (-) and (+) which indicates the inverting and non-inverting terminals only i.e. a signal applied to the -ve input terminal will be amplified but phase-inverted at the output terminal.

### Ideal OP-AMP

- When Op-amp is operated without feedback it is said to be in the open-loop condition (i.e. the word open-loop means that feedback path or loop is open)

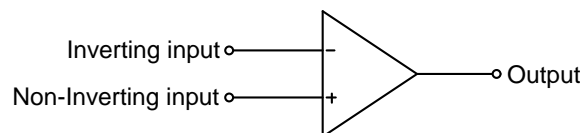

### Properties (characteristics)

- Infinite voltage gain ( $A_v = \infty$ )
- Infinite input resistance ( $R_{in} = \infty$ ), means input current is zero.
- Zero output resistance ( $R_o = 0$ ), means  $V_o$  is not dependent on the load resistance.
- Infinite bandwidth (can amplify signals of frequency ranging from zero to infinite).

### Properties of a practical Op-amp

- High voltage gain ( $A_v = 10^6$ )
- High input resistance ( $R_{in} = 10^6$ ), means input current is zero.

- Low output resistance ( $R_o=10^{-6}$ ), means  $V_o$  is not dependent on the load resistance.
- High bandwidth (can amplify signals of frequency ranging from zero to infinite).

### Virtual ground and summing point

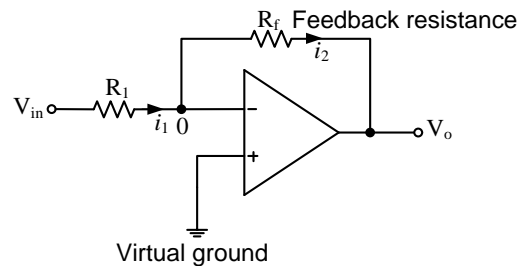

- The above circuit is an Op-amp which employs -ve feedback using resistor  $R_f$  to feed back a portion of the output to the input.
- Since input and feedback currents are algebraically added at point A, it's called the summing point.
- Since the input voltage  $V_1$  at the inverting terminal of an Op-amp is forced to very small value that, for all practical purposes is assumed to be zero, point A is essentially at ground voltage and thus called a virtual ground.  
NB: this is not the actual ground as shown above.
- $V_1$  is reduced to almost zero since when  $V_{in}$  is applied point A attains some +ve potential and at the same time  $V_o$  is brought into existence. Due to the -ve feedback, some fraction of the output voltage is fed back to point A out of phase with the voltage already existing there due to  $V_{in}$ . The algebraic sum of the two is almost zero such that  $V_1=0$ .
- Also a virtual short exists between the two terminals of an Op-amp because  $V_1=0$ . (It's virtual because no current flows (i.e.  $i=0$ ) despite the existence of a short).

### Applications of an Op-amp

- As a scalar or linear constant-gain amplifier, i.e. both inverting and non-inverting.
- As a unity follower (buffer).
- Adder or summer.
- Subtractor.
- Integrator.
- Differentiator.
- Comparator.

### Inverting amplifier (negative scalar)

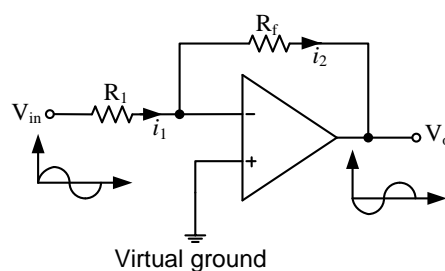

Applying KCL  $i_1 = i_2$

$$i_1 = \frac{V_{in} - 0}{R_1} = \frac{V_{in}}{R_1}$$

$$i_2 = \frac{0 - V_o}{R_f} = -\frac{V_o}{R_f}$$

$$\frac{V_{in}}{R_1} = -\frac{V_o}{R_f}$$

$$\text{Voltage gain} = A_v = \frac{V_o}{V_{in}} = -\frac{R_f}{R_1}$$

- Thus the closed-loop gain depends on the ratio of the two external resistors  $R_1$  and  $R_f$  and is independent of the amplifier parameters.

### **Non-Inverting amplifier (positive scalar)**

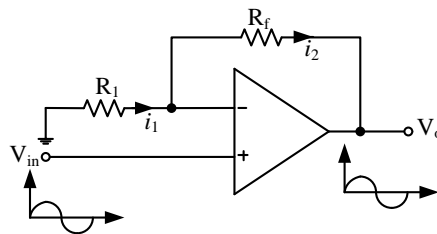

- The input voltage  $V_{in}$  is applied to the non-inverting terminal. The polarity of  $V_o$  is the same as that of  $V_{in}$ .
- Because of virtual short between the two Op-amp terminals, the voltage across  $R_1$  is the input voltage  $V_{in}$ . Also  $V_o$  is applied across the series combination of  $R_1$  and  $R_f$ .

$$i_1 = i_2$$

$$i_1 = \frac{0 - V_{in}}{R_1} = -\frac{V_{in}}{R_1}$$

$$i_2 = \frac{V_{in} - V_o}{R_f}$$

$$-\frac{V_{in}}{R_1} = \frac{V_{in} - V_o}{R_f}$$

$$-\frac{V_{in}}{R_1} = \frac{V_{in}}{R_f} - \frac{V_o}{R_f}$$

$$\frac{V_o}{R_f} = \frac{V_{in}}{R_1} + \frac{V_{in}}{R_f}$$

$$\text{Voltage gain} = \frac{V_o}{V_{in}} = \frac{R_f}{R_1} + \frac{R_f}{R_f} = 1 + \frac{R_f}{R_1}$$



## Unity follower

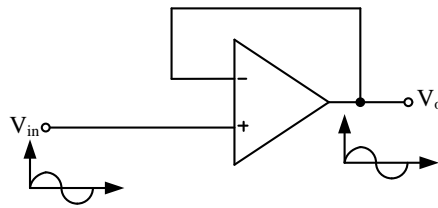

- Provides a gain of unity without any phase reversal.
- It's useful as a buffer or isolation amplifier because it allows input voltage  $V_{in}$  to be transferred as output voltage while at the same time preventing load resistance from loading down the input source. It's due to the fact that its  $R_o=0$  and  $R_{in}=\infty$ .
- From the gain of non-inverting Op-amp, we have;

$$\text{Voltage gain} = \frac{V_o}{V_{in}} = 1 + \frac{R_f}{R_1}$$

But since in this case  $R_1=R_f=0$ ,  
 $\text{Voltage gain} = 1 + 0 = 1$

## Adder or summer

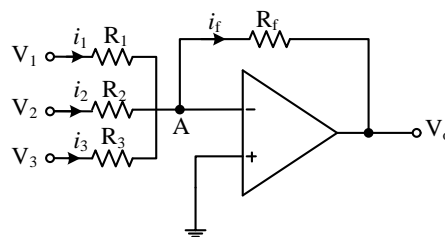

- Provides an output proportional to or equal to the algebraic sum of two or more input voltages each multiplied by a constant gain factor.
- Since point A is a virtual ground, then

$$i_1 = \frac{V_1 - 0}{R_1} = \frac{V_1}{R_1}$$

$$i_2 = \frac{V_2 - 0}{R_2} = \frac{V_2}{R_2}$$

$$i_3 = \frac{V_3 - 0}{R_3} = \frac{V_3}{R_3}$$

$$i_f = \frac{0 - V_o}{R_f} = -\frac{V_o}{R_f}$$

Applying KCL to the virtual point, we get

$$i_f = i_1 + i_2 + i_3$$

$$\text{Equating them results to } \frac{V_1}{R_1} + \frac{V_2}{R_2} + \frac{V_3}{R_3} = -\frac{V_o}{R_f}$$

$$\frac{V_o}{R_f} = -\left(\frac{V_1}{R_1} + \frac{V_2}{R_2} + \frac{V_3}{R_3}\right)$$

$$V_o = -R_f \left( \frac{V_1}{R_1} + \frac{V_2}{R_2} + \frac{V_3}{R_3} \right)$$

Taking  $R_1=R_2=R_3=R$  gives

$$V_o = -\frac{R_f}{R} (V_1 + V_2 + V_3)$$

If  $R_f=R$  then

$$V_o = -(V_1 + V_2 + V_3)$$

### Subtractor

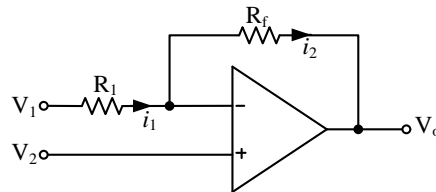

- Its function is to provide an output proportional to or equal to the difference of two input signals.
- Applying KCL to the virtual point, we get

$$i_1 = i_2$$

$$i_1 = \frac{V_1 - V_2}{R_1}$$

$$i_2 = \frac{V_2 - V_o}{R_f}$$

Equating the two results to  $\frac{V_1 - V_2}{R_1} = \frac{V_2 - V_o}{R_f}$

$$\frac{V_1}{R_1} - \frac{V_2}{R_1} = \frac{V_2}{R_f} - \frac{V_o}{R_f}$$

$$\frac{V_o}{R_f} = \frac{V_2}{R_1} + \frac{V_2}{R_f} - \frac{V_1}{R_1}$$

$$\frac{V_o}{R_f} = V_2 \left( \frac{1}{R_1} + \frac{1}{R_f} \right) - \frac{V_1}{R_1}$$

$$V_o = V_2 \left( \frac{R_f}{R_1} + \frac{R_f}{R_f} \right) - R_f \frac{V_1}{R_1}$$

$$V_o = V_2 \left( \frac{R_f}{R_1} + 1 \right) - R_f \frac{V_1}{R_1}$$

Omitting 1 results to

$$V_o = \frac{R_f}{R_1} (V_2 - V_1)$$

Taking  $R_f=R_1$  gives

$$V_o = V_2 - V_1$$